

MAY, 1953

*Radio-Television*  
**SERVICE  
DEALER**

N2B A 2K-952  
ROBERT G. WALRAVEN  
GREEN BAY WISC  
ROBERT BAY ST  
MAR 57



The Professional Radio-TVman's Magazine

**IN THIS ISSUE:**

- Vertical Sweep Circuits  
(TV Symposium Series)
- Horizontal Sync & Sweep Servicing, Part 2
- Fluctuating Line Voltage
- Phono Facts—1953, Part I
- Germanium and Radio-Electronics
- Video Speed Servicing Systems

**AM-FM-TV-SOUND**



# HERE'S WHY IRC EXACT DUPLICATES ARE DOUBLE-MONEY-BACK GUARANTEED

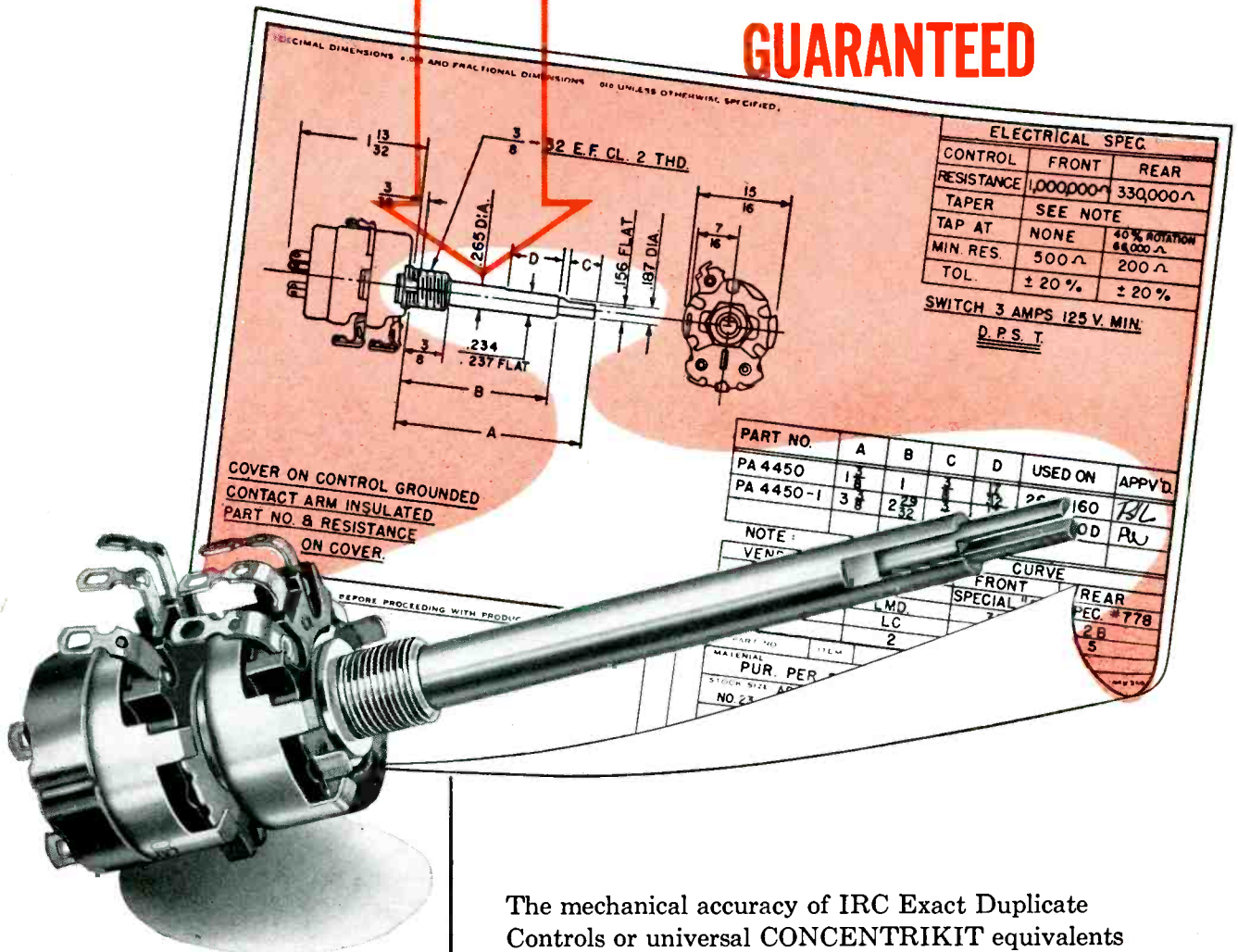

**ONLY IRC GUARANTEES**  
**SATISFACTORY MECHANICAL FIT**  
**AND ELECTRICAL OPERATION**  
**OR DOUBLE-YOUR-MONEY-BACK**

The typical manufacturer's specifications shown here are exactly duplicated by IRC QJ-180 control. CONCENTRIKIT assembly includes P1-229 and R1-312 shafts with B11-137 and B18-132X Base Elements, and 76-2 Switch.



Wherever the Circuit Says 

The mechanical accuracy of IRC Exact Duplicate Controls or universal CONCENTRIKIT equivalents is based on set manufacturers' procurement prints. Specifications on those prints are closely followed.

Shaft lengths are *never less* than the set manufacturer's nominal length—*never more* than  $\frac{3}{32}$ " longer.

Shaft ends are precisely tooled for solid fit.

Inner shaft protrusion is accurately duplicated for perfect knob fit.

Alterations are never needed.

For Exact Duplicate Controls, specify IRC. Most Service Technicians do.

## INTERNATIONAL RESISTANCE CO.

404 N. Broad Street, Philadelphia 8, Pa.

In Canada: International Resistance Co., Ltd., Toronto, Licensee

**OFFICIAL  
TV FUSE GUIDE**

**15c**

**LITTELFUSE**

Littelfuse 1953 TV Fuse Guide enlarged to include latest models

**Both New—Both Needed**

Littelfuse new One Call Kit adapted to include fuses being used in latest models—94 out of 100 times one call is all. Littelfuse Inc., Des Plaines, Ill.







Here's The NEW Smart Way To Buy Vibrators

# RADIART Seal-Vent VIBRATORS

In A Re-Usable Clear Plastic Box



*this is the way it looks fully packed*



*here is the re-usable box with dividers for a hundred uses at home or work*

- ★ The BEST Vibrator Money Can Buy
- ★ Save Time — Buy the ONE KIT that Gives You the Five Types that Serve 60% of the Replacement Requirements
- ★ A "BONUS" for You in the Re-Usable Plastic Box

Here's another PLUS for you from Radiart — the RADIART VIBRATOR KIT! In this handsome plastic box with sturdy dividers and a hinged cover are these 9 vibrators . . . all yours for the price of the vibrators alone! You get these 5 basic types that serve 60% of replacement applications . . . 2-5300 . . . 2-5301 . . . 2-5326 . . . 2-5342 and 1-5335. These are all the famous quality . . . with the sensational SEAL VENT. Original quantities are limited . . . so make sure of yours by seeing your RADIART jobber NOW!



**THE RADIART CORPORATION CLEVELAND 13, OHIO**

VIBRATORS • AUTO AERIALS • TV ANTENNAS • ROTATORS • POWER SUPPLIES



# EDITORIAL

by S. R. COWAN

## An Unintentionally Dangerous Suggestion

We are mildly "at odds" with "Business Week," a fine McGraw-Hill publication for executives, because in its April 7th issue it published an article on roof TV antenna checkups, which in our opinion, did a great disservice to the readers of BW who own TVsets, and because the article hurt the TV service profession primarily due to the way in which it was worded.

The BW article opined that now is the season of the year when one should checkup one's roof TV antennas, being certain that connections are sound electrically and mechanically; that fastenings are tight so elements or the antenna itself won't fall off, etc. To that basic suggestion we concur wholeheartedly because we have always advocated that TV antennas should be checked (by professionals) periodically, at six-month intervals preferably, not only to protect the set-owners investment and right to optimum performance, but also to preclude possible injury to others who could be injured by falling antenna elements.

What we strongly objected to is that the BW article bluntly directed the reader to do the antenna checkup, giving step-by-step procedure . . . and it did not suggest that the reader should commission his regular professional TV serviceman or service firm to do the checkup job for him.

We wrote the BW article author explaining that the job of installing, adjusting and repairing TV antennas, particularly when erected on roofs or high places, is a very dangerous one and that during the past few years many Novices, as well as professional technicians, have been maimed or killed in doing this type of work, either from falls or contact with high voltage power lines.

We have come to the conclusion that "something stringent" should be done to deter novices from doing such TV work. Quite likely no State or Municipality would pass a law prohibiting TV roof antenna work by laymen or set owners on their own rigs because such laws would probably be held unconstitutional as being in restraint of personal privilege. However, if insurance policy issuers were to include a clause in life and accident policies voiding them in cases where the holder, being a Novice, did such extra-hazardous work as antenna installing and repairing, such a financial restriction threat would in all likelihood deter a lot of folks from taking chances. Although insurers might also increase rates of TVmen, such would be offset by the extra income that would result from having less competition from their own customers.

### Catalog Section Offer Withdrawn

For a year we offered our subscribers free sections of Radio's Master Catalog if they merely requested same. Upwards

[Continued on page 68]



## Sanford R. Cowan

EDITOR & PUBLISHER

SAMUEL L. MARSHALL  
MANAGING EDITOR

ADOLPH SUCHY  
LEONARD LIEBERMAN  
Contributing Editors

COWAN PUBLISHING CORP.  
67 WEST 44TH ST.  
NEW YORK 36, N. Y.



Vol. 14 No. 5

MAY, 1953

Editorial .....	3
Trade Flashes .....	4
Sync Pulses, <i>by San D'Arcy</i> .....	10
Association News .....	22
Vertical Sweep Circuits (TV Symposium Series), <i>by Cyrus Glickstein</i> .....	25
Review of theory and servicing of modern vertical sweep circuits.	
Horizontal Sync & Sweep Servicing, Part 2, <i>by Leonard Lieberman</i> .....	28
Resumé of horizontal afc circuitry.	
Fluctuating Line Voltage, <i>by Verne Roberts</i> .....	35
A prevalent reason for "call-backs" is discussed.	
Phono Facts—1953, Part I, <i>by Maximilian Weil</i> .....	38
Excellent hints on Hi-Fi.	
Germanium and Radio-Electronics, <i>by Rufus P. Turner</i> .....	41
Background and applications of Germanium products in the radio-electronic industry.	
Video Speed Servicing Systems Data Sheets (VSSS) .....	44
Information this month covers the Crosley No. 265 chassis, the Silvertone No. 51-478.339 chassis, the Stromberg-Carlson No. 317 Series chassis, and the Sylvania No. 1-139 chassis.	
Circuit Court .....	54
Capehart CT52, CT57- heptode sync stripper. Capehart CX37- horizontal afc.	
Personnel Notes .....	55
Shop Notes .....	56
New Products .....	58
Trade Literature .....	68
Advertisers' Index .....	80

SANFORD L. CAHN, Advertising Director

HARRY N. REIZES, Advertising Manager

DAVID SALTMAN, Production Manager

NATHAN BOYCE, Circulation Mgr.

TED E. SCHELL, 2700 West 3rd St., Los Angeles 5, Calif., Dunkirk 2-4889

HAROLD F. MANN, Mid-West Sales, 333 No. Michigan Ave., Chicago. Franklin 2-7100  
RADIO-TELEVISION SERVICE DEALER is published Monthly by Cowan Pub. Corp., 67 West 44th St., New York 36, N. Y. Subscription price: \$2 per year in the United States, U.S. Poss. & Canada; elsewhere \$3. Single Copies 25c. Reentered as second class matter Sept. 25, 1950 at the Post Office at New York, N. Y. under the Act of Mar. 3, 1879. Copyright 1953, Cowan Pub. Corp.



# what 25,000 Servicemen told Bill Anderson (SYLVANIA Sales Service Engineer) about PHOTOFAC...



**W. J. ANDERSON**  
SYLVANIA Sales  
Service Engineer,  
Radio & TV Tube  
Sales

SYLVANIA ELECTRIC PRODUCTS INC.

"During the years of 1951 and 1952, Robert Grow and I have talked to approximately 25,000 servicemen located throughout the United States. We have an excellent idea concerning the response of these men to your PHOTOFAC Service and to your publications. In talking to servicemen, I have heard many fine compliments on the excellent job your organization is doing. Such comments as these are typical:

1. Very detailed and easy to read instructions on any set, as well as pictures and schematics.
2. The theory of operation of various stages and components is helpful, such as found in the PHOTOFAC INDEX.
3. The immense amount of useful information presented in such a short time after release of the manufacturer.
4. Pictures of the wave forms, as well as voltage measurements saves time and increases profit to the servicemen.

These and many more are typical of the comments from the servicemen. This may be of interest to you and your staff as you continue to lead the field in technical publications for the radio and television servicemen."

*W. J. Anderson*  
Sylvania Electric Products Inc.

## NOW! GET THE PROOF FOR YOURSELF!

**FREE**

We'll send you a Free Photofact Folder on any receiver listed in "PF Index & Technical Digest."

Learn for yourself—at our expense—how PHOTOFAC pays for itself by earning bigger repair profits for you! Select any Folder from the PF Index (if you haven't an index, get a copy from your distributor). When you write us for your Free Folder, be sure to state Photofact Set and Folder Number as shown in the Index. Get your Free Folder now. Examine, use, compare—see why you can't afford to be without PHOTOFAC!

HOWARD W. SAMS & CO., INC.  
2209 E. 46th St., Indianapolis 5, Ind.

**HOWARD W. SAMS & CO., INC.**

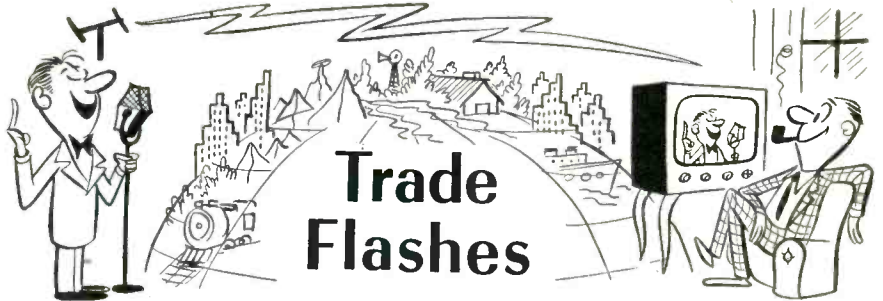

### I.R.E. Show

Over 30,000 radio engineers and scientists from around the world took part in the annual four-day convention of the Institute of Radio Engineers recently. In six concurrent sessions held at the Waldorf-Astoria Hotel and Grand Central Palace, some of the year's important research and development progress was presented in technical papers.

The transistor, the tiny device which is replacing the vacuum tube in many applications, received much attention from the 30,000 engineers and scientists attending the show. Six of the sixty-one technical papers presented during the day at the Waldorf-Astoria, Grand Central Palace and Belmont Plaza described the properties and uses of transistors in radio and television circuits.

R. D. Kell and A. C. Schroeder of RCA Laboratories presented a technical paper called "Optimum Utilization of the Radio Frequency Channel for Color TV." They pointed out that in order to produce a TV image in color, three communication signals must be available. The first of these may be used to transmit the scene brightness, the second the degree of color saturation and the third the hue or color. In order to provide this information and still keep the color system compatible with present black and white, a subcarrier is introduced on the main carrier. In essence, the color information rides "piggy back" on the signals of a standard black and white system.

### First Educational TV Station Receives Emerson Grant

Benjamin Abrams, President of Emerson Radio and Phonograph Corporation, who has been in the vanguard of the struggle for educational television, announced that station KUHT-TV, Houston, Texas, will receive a \$10,000 Emerson award as the first non-commercial educational television station in the United States.

KUHT-TV, scheduled to go on the air April 16th, is the first video station to comply with the conditions of

the Emerson \$100,000 educational television grant, announced last June by Mr. Abrams, under the terms of which the first ten stations to begin broadcasting on channels allocated by the Federal Communications Commission for non-commercial educational purposes will receive \$10,000 each.

### Technicians' Reputations On Upgrade

The reputation of the men who repair the nation's television and radio sets is on the upgrade.

Seventy per cent of radio and television setowners responding in a market research survey completed recently by General Electric's Tube Department reported that the quality of the service work done on their sets has been either good or excellent. John T. Thompson, manager of replacement sales for the G-E Tube Department, reports.

Seventy-eight per cent of the setowners felt that the charges for parts and labor were reasonable. Mr. Thompson told the national convention of the National Alliance of Television and Electronic Service Associations at the Continental Hotel here.

Mr. Thompson reported these figures representing the overall results of the G-E survey.

Quality of service: 34 per cent excellent; 36 per cent, good; 20 per cent fair; 10 per cent, poor.

Parts and labor charges: 78 per cent, reasonable; 22 per cent, high.

Speed of service: 44 per cent fast; 43 per cent, average; 13 per cent, slow.

The survey also showed that 90 per cent of the setowners contacted had their repairs done by a service dealer or service department of an appliance store, and that only seven per cent had their repairs done under a service contract.

### Radio-TV Production in 1952 Passes Billion Dollar Mark

Total television and radio set production during 1952 was valued at nearly \$1.3 billion at the factory level, the Radio-Television Manufacturers Association reported. The manufacturers' value of all radio-TV receivers



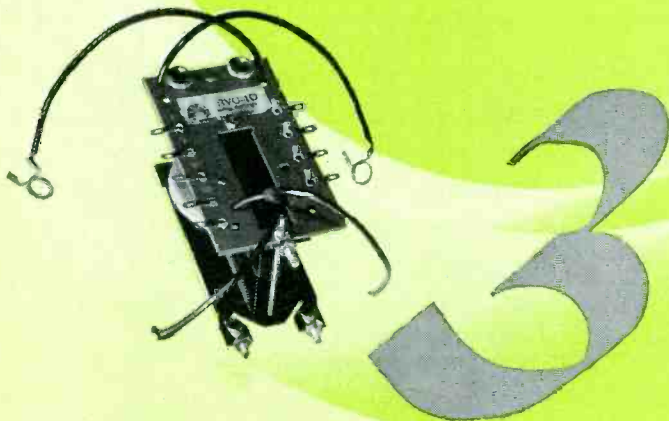
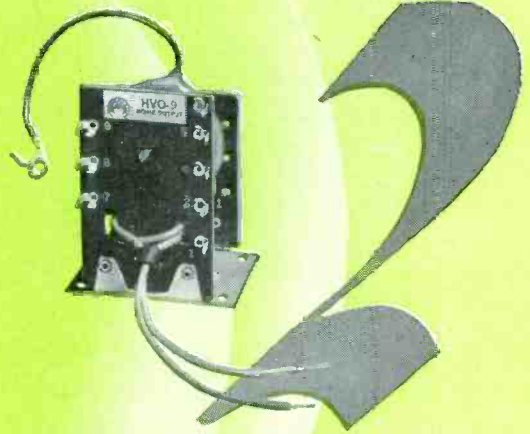
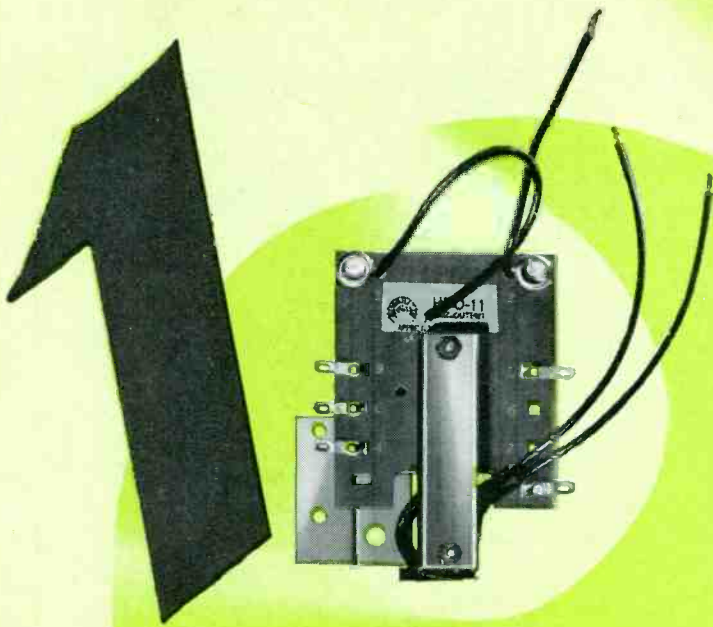

- 1 HVO-11 for under chassis replacement in Zenith sets having 12" to 19" round tubes.
- 2 HVO-9 Autoformer for RCA, Hoffman and Hallicrafters sets designed for picture tubes 21" and up.
- 3 HVO-10 for "fast retrace".

Merit's TV full-line offers the most complete line possible for universal replacement plus exact replacements where required. A new Merit TV Replacement Guide No. 405 covering practical recommendations for replacements in over 6000 models and chassis, and a new Auto Radio Replacement Guide Form No. 3 can be obtained from your Jobber or by writing: **MERIT COIL AND TRANSFORMER CORP.** 4425 N. Clark Street, Chicago 40.

MERIT IF-RF COILS INCLUDE A COMPLETE LINE OF TV REPLACEMENTS



# MERIT

FOR MAXIMUM COVERAGE WITH MINIMUM STOCK





**SAVE Up to \$1.00 each.**

**Form a Group,**

**Subscribe to "RTSD"—**

The Professional Radio-Television man's Magazine"— published monthly. All articles are exclusive and timely. Practically every issue is worth what an entire 1 year subscription costs.

The more in a group the bigger the savings. 6 men in a group save \$1.00 each; 4 men groups save 80c per man. Present "RTSD" subscribers may participate in or form a group with co-workers, or even competitors. Still active subscriptions are automatically extended 2 years. Start a Group today! The timely and exclusive technical data appearing in future issues of "RTSD" will make this the best investment you ever made. The special Group Rate offer may be withdrawn at any time—so hurry.

**Use This Coupon For Convenience**

(The coupon below can be used for from 1 to 6 subscription orders. Use it today!)



**TEAR OUT—MAIL TODAY**

**RADIO-TELEVISION SERVICE DEALER**  
67 West 44th Street, New York 36, N. Y.

Please enter 2 years subscription orders for the names given below. Our remittance is enclosed.

NOTE: If you do not wish to tear this order blank out, just print or type the information on a single sheet of paper, following the style given. Each subscriber's occupation must be clearly described.

<input type="checkbox"/> One 2-year subscription	In U.S.A. <b>\$3.00</b>
<input type="checkbox"/> Two 2-year subscriptions each	<b>2.50</b>
<input type="checkbox"/> Three 2-year subscriptions, "	<b>2.30</b>
<input type="checkbox"/> Four 2-year subscriptions, "	<b>2.20</b>
<input type="checkbox"/> Five 2-year subscriptions, "	<b>2.10</b>
<input type="checkbox"/> Six 2-year subscriptions, "	<b>2.00</b>

Name .....  
Address .....  
City ..... Zone ..... State .....  
Describe Title or Position and Type of Business .....

State whether a New Subscriber  or Renewal Order

Name .....  
Address .....  
City ..... Zone ..... State .....  
Describe Title or Position and Type of Business .....

State whether a New Subscriber  or Renewal Order

Name .....  
Address .....  
City ..... Zone ..... State .....  
Describe Title or Position and Type of Business .....

State whether a New Subscriber  or Renewal Order

Name .....  
Address .....  
City ..... Zone ..... State .....  
Describe Title or Position and Type of Business .....

State whether a New Subscriber  or Renewal Order

Name .....  
Address .....  
City ..... Zone ..... State .....  
Describe Title or Position and Type of Business .....

State whether a New Subscriber  or Renewal Order

Name .....  
Address .....  
City ..... Zone ..... State .....  
Describe Title or Position and Type of Business .....

State whether a New Subscriber  or Renewal Order

produced during the year was estimated as \$1,298,847,000 by the Association.

For 1951, RTMA had estimated the total manufacturers' value of radio-television production as \$1,272,922,897. This included 5,384,798 TV receivers worth \$956,986,300 and 12,627,362 radios with an estimated factory value of \$315,936,597.

The 1952 dollar volume of the set manufacturing industry was based on an estimated production of 6,096,279 television sets worth \$1,049,000,000 at the factory and a revised radio production estimate of 10,934,872 units valued at \$249,847,000.

The revised 1952 radio set manufacturing estimate showed the production of 4,043,128 home sets, 1,929,036 clock radios, 1,719,859 portables and 3,242,849 auto radios.

### Over 21.5 Million TV Sets Shipped

From 1946 through the end of 1952, over 21.5 million television sets were shipped to dealers throughout the country, according to a survey just prepared by the Radio-Television Manufacturers Association.

Although the report is not designed to show the actual number of television sets in use in the various areas—due to obsolescence, export from the area, dealers' inventory and other factors—it does give a picture of the original distribution of the 21,812,263 sets shipped to dealers during the seven year period.

### Reps' Total Membership Hits

600 Mark

With the addition of 22 new senior members and 33 new associates the past two months, the membership of "THE REPRESENTATIVES" national organization now stands at 414 seniors, 185 associates, and one honorary, making a total all-time high of 601 members, according to Royal J. Higgins, National Treasurer.

### Licenses Proposed For TV Men

Harrisburg, March 25—Legislation to require State examination and licensing of radio and television repairment was introduced in the House of Representatives recently by Rep. Vincent F. Gutendorf, Wilkes-Barre Republican.

Organized TV and radio repairmen, Representative Gutendorf said, are backing the licensing proposal.

Before taking a State test the applicant would be required to have 700 hours of theory and practical instruction in repair work, or two years of working experience under the supervision of a licensed repairman.

The Department of Public Instruction would administer the licensing

# M I R R O S C O P E

**MODEL 476**  
*Simpson*

Advanced design in oscilloscopes. Vertically mounted 5" cathode ray tube is reflected in the adjustable mirror. Mirroscope can be used by technician seated or standing merely by adjusting mirror angle—not necessary to move the instrument.

A quality instrument with tomorrow's features.—Dealer's net price, \$197.00.

Optically surfaced mirror gives distortion free image of cathode ray tube

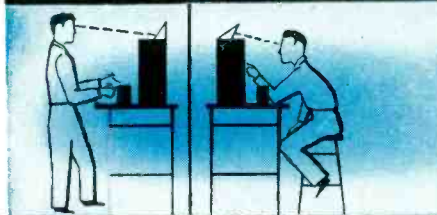

Ask your jobber for full information or write

**Simpson Electric Company**  
5200 West Kinzie Street  
Chicago 44, Illinois  
CO 1-1221

Another reason why Simpson is the world's largest manufacturer of test equipment. BURTON BROWNE ADVERTISING

This much space ordinarily required



Vertical design of microscope gives larger control panel area—better spacing of controls for easy adjustment. All connections made in front.

### MODEL 276 OSCILLOSCOPE CALIBRATOR



To take full advantage of your microscope—Model 276 Oscilloscope Calibrator. Accurate voltage readings of the oscilloscope wave forms. For use with any oscilloscope. Dealer's net price \$29.50.

Base is only 9" x 8"

Base dimension or bench area only 9" x 8"—less than half of the bench area used by old style oscilloscopes—you gain valuable working space with the microscope.

You save this bench space

law, with authority to charge up to \$25 for examinations and up to \$15 for annual renewal of licenses.

Gutendorf said the need for licensing of TV servicemen was poignantly demonstrated to him personally when "two truck drivers tried to install a television set in my own residence."

*Times-Leader Evening News*  
Wilkes-Barre, Pa. Mar. 25, 1953

### Electronic Parts Show Plans

Complete plans for the Management Round Table Seminars to be held at the 1953 Electronic Parts Show at the

Conrad Hilton Hotel in Chicago, May 20th were announced by Vin K. Ulrich, of National Union Radio, Hatboro, Pa., chairman of the Show educational program committee.

Two important subjects for electronic parts distributors will be discussed at the morning seminars. The first seminar is "More Profitable Business Operations for the Parts Distributor."

The second seminar, "Selling Sound," will take up proven methods

[Continued on page 12]





# Two heads are better than one!

And that's exactly why  
**CHANNEL MASTER'S**  
 amazing new

## TWIN CORNER REFLECTOR (Model No. 406)

is the most sensitive fringe-area antenna ever developed for UHF!

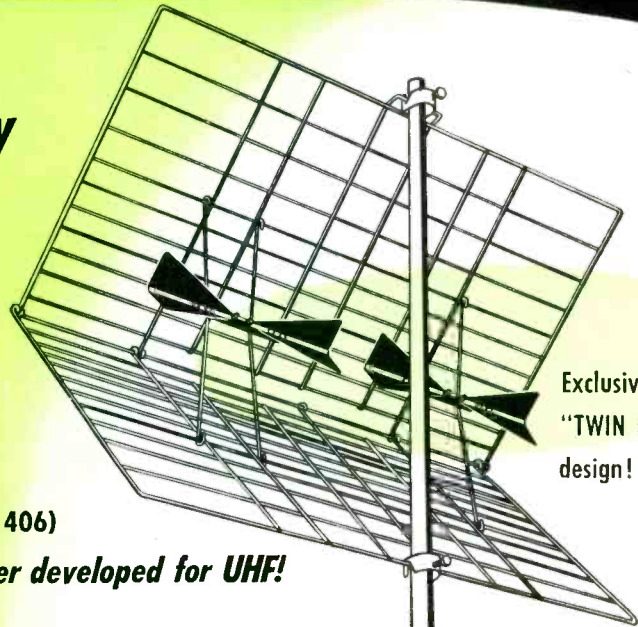

Exclusive  
 "TWIN DIPOLE"  
 design!

### TWO DIPOLES—HIGHER GAIN

The two dipoles of the Twin Corner Reflector provide TWICE as much gain as standard-type Corner Reflectors!

This two-dipole construction is an original Channel Master idea which successfully combines two separate Corner Reflectors into ONE ANTENNA STRUCTURE — requiring ONE simple installation.

This 2-in-1 combination gives you:

- • • the economy of one antenna.
- • • the convenience of one antenna.
- • • BUT the combined performance of TWO separate high gain antennas.

Model No. 406 furnishes far better picture quality — at far greater distances — on every UHF channel.

Eliminates UHF's "Twin Terrors." 100% vibration-proof construction prevents picture flicker. "Free space" terminals prevent dirt and rain water from shorting out the picture.

up to  
**16 DB gain**

gain above tuned  
 reference dipole

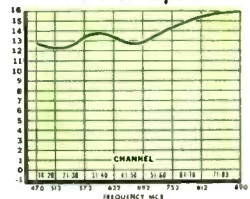

horizontal  
 polar pattern  
 (relative voltage)

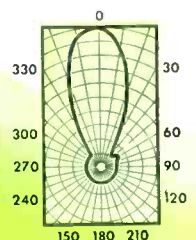

Channel 20

Extremely narrow  
 "Yagi-type" forward  
 lobe; no side lobes;  
 very high front-to-  
 back ratio

## 2 antennas in 1

The Twin Corner Reflector furnishes the performance of 2 antennas because it really is 2 separate antennas . . .

stacked side  
 by side . . .

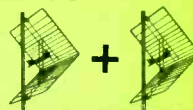

into 1 simple  
 structure . . .

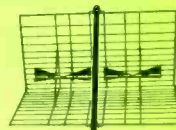

with just a  
 single down-  
 lead to the  
 set.

**CHANNEL MASTER**  
 engineering  
 pays off on **UHF!**



**CHANNEL MASTER CORP.**  
 ELLENVILLE, N. Y.

# At Last! a YAGI for the ENTIRE LOW BAND!

## CHANNEL MASTER'S Newest futuramic

Completely covers every low band channel-2 through 6

**NOW** the extraordinary high gain of a Yagi . . . the razor-sharp directivity of a Yagi . . . Not on just one channel — but clear across the entire Low Band!

Designed for service TODAY and TOMORROW in these 3 booming VHF markets:

**Areas in which present VHF stations are changing channels (on the Low Band).**

The Futuramic Yagi provides better reception than conventional Yagis on the present channels — and when the shift occurs this superior reception will continue on the new channel WITHOUT INTERRUPTION. And you can make your change-over installations NOW.

**Areas in which a new VHF station is being added to the present one (on the Low Band).**

The great number of single channel Yagis now in use will not bring in the new channel. If an additional Yagi is installed it will have to be tied into the present installation with separate leads and a switching system. However, one Futuramic will do the job of BOTH antennas — at lower cost — with better results on BOTH channels.

**Areas served at present by two or more VHF stations on the Low Band.**

You no longer have to compromise between conventional broad band antennas, and separate Yagis for each channel. The Futuramic gives you the full advantages of both. It combines highest gain and sharpest directivity with simple, economical installation.

horizontal polar pattern (relative voltage)

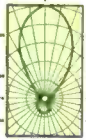

gain above tuned reference dipole

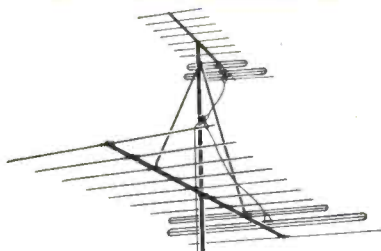
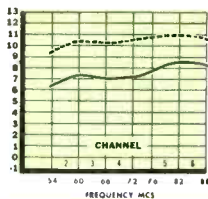

A high-low Futuramic combination is the most sensitive array ever designed for all-channel VHF reception. Just combine models 1173 and 1126.

Now — 6 great Futuramic models, designed for every reception area:

model no.	channels covered	list price
1173	7 — 13	\$20 <sup>83</sup>
1124	2, 3, and 4	\$40 <sup>97</sup>
1125	2, 3, 4, and 5	
1136	3, 4, 5, and 6	
1146	4, 5, and 6	
1126	2, 3, 4, 5, and 6	



CHANNEL MASTER CORP. ELLENVILLE, N. Y.



CHANNEL MASTER  
engineering  
pays off on **VHF!**



**AMPHENOL**

# Dealers and Servicemen—

May 18 to 21 your radio parts distributors are meeting in Chicago at the Electronics Parts Show. While there, they will consult with Amphenol on VHF-UHF market potentialities and the values of the different antenna designs. The past 20 years have proven the dependability of the Amphenol line to distributors and dealers. You know the INLINE VHF antennas—you can expect the same high standards in the new Amphenol UHF antennas.

*Building to the Future of Electronics*

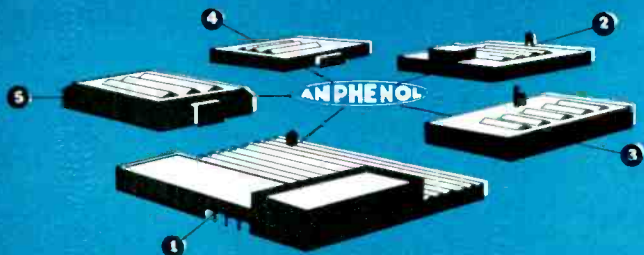

AMERICAN PHENOLIC CORPORATION  
chicago 50, illinois

# SYNC by

Leading manufacturers are cooperating with Service Dealers. Firms such as RCA, United Motors Service (Div. of General Motors), Sylvania, Raytheon, General Electric and Hytron (Div. of CBS), are presenting public relations programs that are greatly helping to establish the prestige of the radio-TV service dealer serving his community. By means of radio, TV commercials and advertisements in national magazines such as Life, Time, SatEvePost, etc., these firms suggest that set owners should patronize their local shops where there are factory trained personnel who are qualified to do what ever is required in the way of maintenance and repairs. (And, at the same time, these big firms are broadening their technical training programs so that technicians may more easily learn the new techniques, and problems, that have arisen since the advent of uhf.)

Thus the tie-in between service firms and nationally advertised brands becomes more effective than ever . . . and the shop that has the authority to display a decal or placard bearing a well-known Brand name benefits from the invaluable prestige. The public has been trained to respect well-known brand names. Such names are backed up by guarantees that "mean something"—meaning dependability. Sellers of brand-name products usually command a higher price for their services because of the implied reliability that rests behind them and the items they use. So, the wave of national advertising that is now in progress is a tangible type of support that our profession has needed and is glad to get.

**Accolades are in order for the FCC.** Now that the fiasco of color TV is water over the dam, FCC has matured considerably and apparently has done an exceptionally fine job of unfreezing TV so that TV-starved communities are quickly being permitted to enjoy the benefits of the new entertainment medium that is quickly changing the living and buying habits of the Nation.

**Madison, Wisc. (and other lawmakers) take note:** You can't force God to obey your edicts! It seems that the Wisconsin legislators are promulgating a Bill, which if passed, would require sellers of TVsets to issue to the buyer an unconditional 6-month warranty against defects in workmanship and materials. Such a law probably would be found unconstitutional because it is discriminatory. No laws enacted can make a manufactured device function properly for any given period of time, regardless of the integrity of the maker, the quality of material or skill of engineering employed. Breakdowns of unexplainable nature will occur, if for no other reasons than being an Act of God. Here's a true story to prove that inexplicable acts do occur. On April 1st, we visited a friend's home. He turned on a table model radio and it played nicely. He asked if we would be kind enough to hookup a pillow radio speaker attachment for him so his wife could play the set at night while in bed, without having the sound disturb him. We said we could and would. We turned the set off, took it to our work bench, plugged it into the line—and lo! Nothing happened! The set was dead . . . yet but a few moments before it was playing properly. A checkup showed a shorted condenser and bad tube.

Now, in like manner, many times servicemen have fixed a set, played it for the customer's assurance, given it to the owner to take home, and then the owner was chagrined to find that it didn't work when he got it home . . . or that it did work for only a few seconds before going dead. Such thing happen to watches, radios, TVsets, appliances and other manufactured devices. No law that requires a repairman to "make good" in such cases is a fair or justifiable law. God's will be done, now law-makers! Amen.

**Antenna Rotator Boom.**—The operation of the new UHF stations which have been and soon will be transmitting places almost every part of the country into some segment of fringe area. The sharply directional nature of a UHF



# PULSES

## San D'Arcy

signal requires pin-pointed orientation of the receiver's antenna for optimum reception,—and to accomplish this, naturally the use of a good antenna rotating device is called for.

Rotators are the most logical means for picking up two or more diversely situated signal sources known today. TVset owners living in any fringe area are penny-wise and pound-foolish if they fail to have properly installed, rotatable outdoor antennas installed right from the start. The TVset seller or installer who fails to make this point clear to the customer is lax in his duty and the set owner who fails to abide by the suggestion to buy a rotator is defeating his own purpose, i.e., that of obtaining optimum reception.

In like vein, the technician must appreciate the fact that some types and design of antenna have inherent high-signal gain features, particularly suitable for certain types of terrain, and even though these antennas sell for more money than less efficient types of antenna, it is incumbent upon the antenna installer to make his customer realize that it pays to spend more to get more signal and consequently more satisfaction from his investment. Cheap is cheap . . . and that adage is particularly true when it comes to uhf antenna installations. The terrain and circumstances surrounding an installation must be the determining factors regarding use of accessories, and not the mere price of the accessories. We know of \$500 TVset installations which are absolutely bad investments because a few dollars was skimmed on antennas, boosters, etc. On the other hand, particularly in the Maryland peninsular area, we know of \$200 TVset investments that have been reinforced with \$500 antenna and mast installations that are, to quote their owners, "worth their weight in gold." Results, not costs are what count. Do a job right, or don't do it at all. A good medical man never bargains with a patient. He either tries to accomplish a whole cure or he resigns from the case entirely. He doesn't haggle that for a certain sum he'll make the patient partially well, while for a larger amount he'll go all-out and perform complete recovery.

Subscribers being questioned by this publication regarding their business activities and title sometimes resent what they feel is an intrusion upon their privacy. You see, "Service Dealer" is a member of the Audit Bureau of Circulations. That extremely ethical, non-profit organization examines our records to determine whether or not a subscriber who we tabulate as a serviceman (or employed technician), is just that. When our circulation department asks subscribers to tell us what they do for a living, it is not that we are merely curious or prying into another's affairs. We must have verification from the subscriber himself as to what he does for a living, and as to his title with a firm, and knowledge whether or not the subscriber is a co-owner, employee, or even department manager. So, subscribers, if you ever get a request from us, or from any other publication which is a member of the Audit Bureau, about your work, please co-operate and send the information. It is always held in strict confidence and is merely used by the auditors of The Audit Bureau to verify that we, the publishers, have classified you properly on the records that we must submit semi-annually to the Bureau.

A TV joke going the rounds (and fit to publish) is this one: In a small town a rich widow married a man of moderate means, and no sooner had the honeymoon started than she began to remind him that it was her money that was paying the bills. Time after time when the man purchased something, the wife would say, "That's a nice thing to have, but we wouldn't have gotten it if it weren't for my money." One day the husband bought a television set, and

[Continued on page 62]

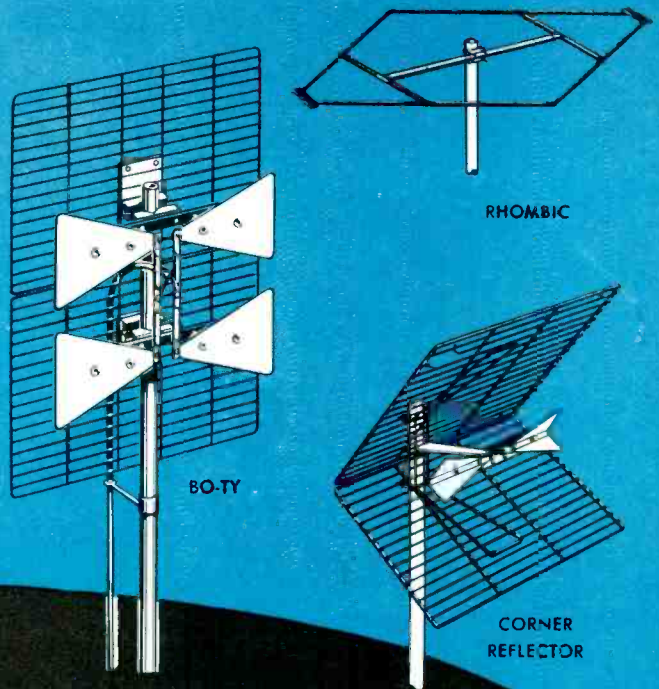

BO-TY

RHOMBIC

CORNER REFLECTOR

new

# UHF antennas

AMPHENOL

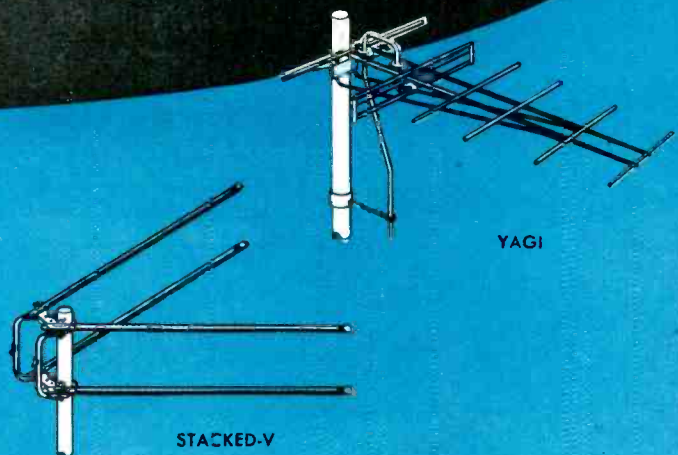

YAGI

STACKED-V

Your distributor will come back from the May Parts Show with complete information on these new Amphenol UHF antennas and their market potential in your territory. Be sure and contact him for the full story!

AMERICAN PHENOLIC CORPORATION  
chicago 50, illinois



## TRADE FLASHES

[from page 7]

of making profitable sound sales; techniques of promoting sales and types of publicity that increase sales, types of demonstrations and how to most effectively conduct them to turn interest into sales.

### Technician Aided By Jackson

It all happened as the result of the CBS "Strike it Rich" telecast last November 12. Royal O. Tippetts, a partially paralyzed electronics technician was represented on the "Helping Hand Mailbag" portion of the program. The Helping Hand star played for the cash award to help Mr.



Tippetts purchase material to equip a radio-television service shop in Spanish Fork, Utah.

### G.E. Receives Service Association Award

The National Alliance of Television and Electronic Service Associations recently awarded its Friends of Service Management Award to the General Electric Tube Department for "outstanding contributions to service management in creating better customer relations."

The plaque presentation was made by Frank J. Moch, president of NATESA, at the alliance's national convention at the Continental Hotel in Kansas City. John T. Thompson, manager of replacement sales for the G-E Tube Department, accepted the award.

Presentation of the award to G. E. followed an extensive public relations program launched by the G-E Tube Department on behalf of the service industry.

### Raytheon and Belmont Merge

Raytheon Television and Radio Corporation, formerly Belmont Radio Corporation, of Chicago, Illinois and

[Continued on page 16]

JUST OUT

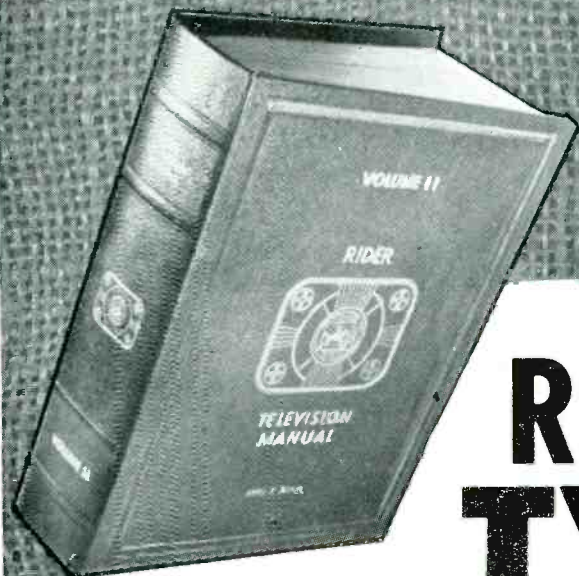

# RIDER'S TV II

with dependable replacement parts listings

**FACTORY-AUTHORIZED! FACTORY-APPROVED! TV SERVICING DATA!**

Most up-to-date, complete servicing data—direct from the manufacturer...you can't buy better servicing data! Sectionalized for latest information. Schematics...wave forms...chassis views...circuit changes...all production runs! Complete receiver manufacturer's parts list...cumulative replacement parts listings include cross-reference by chassis and models for instant identification.

Over 2200 (8½ x 11") pages  
in a (12x15") durable binder!  
Only \$24.00 at your jobber!

## TEK-FILE

TAILOR-MADE FOR EASY TV SERVICING

TV service information in 77 individual packs...the same data as in Rider TV Manuals...over 2800 models...new packs monthly...try a TEK-FILE Pack at \$2 each. Money refunded within 7 days if you're not completely satisfied.



**JOHN F. RIDER** PUBLISHER, INC.  
480 Canal Street, New York 13, N. Y.

West Coast Office:  
4216-20 W. Jefferson Blvd.  
Los Angeles, California

Export Agent:  
Roburn Agencies, Inc.  
39 Warren Street  
New York 7, New York

In Canada,  
Charles W. Pointon  
1926 Gerrard Street, East  
Toronto, Ontario

Cable Address: Roburnage N. Y.

For easier radio servicing...  
use Rider's 22 All-FM Radio Manuals

# Simplify

Your Search for the  
Right Protection

# Standardize

## on BUSS Fuses . .

the complete line for  
Television • Radio • Radar  
Instruments • Controls  
and Avionics

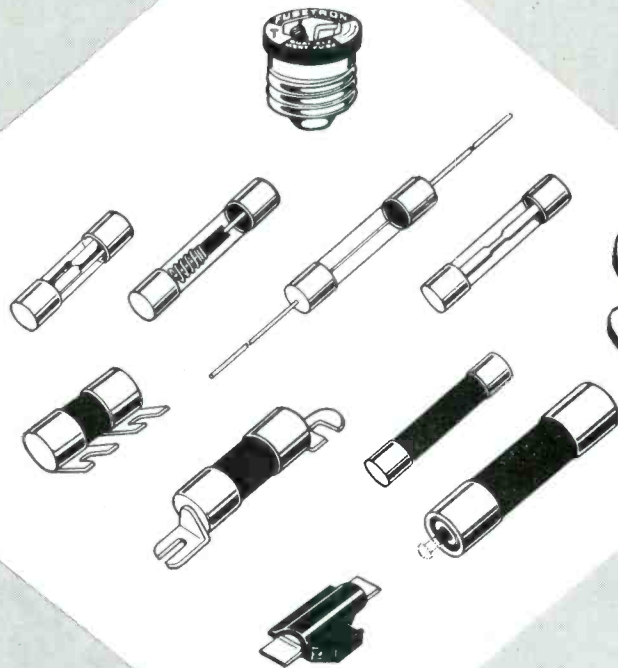

Plus a complete line of fuse clips,  
blocks and fuse holders

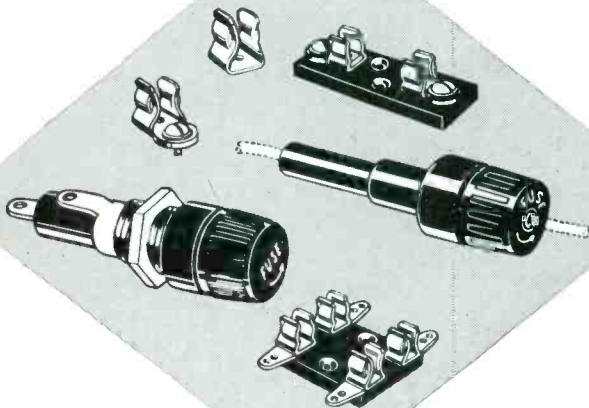

GIVE YOUR CUSTOMERS high quality fuses to match high quality workmanship. Install BUSS Fuses . . . famous for dependable protection in homes, on farms and in industry for 39 years.

**BUSSMANN Mfg. CO.,** Division of McGraw Electric Co.  
University at Jefferson, St. Louis 7, Missouri

RADIO-TELEVISION SERVICE DEALER • MAY, 1953

Whatever your protection requirements, you'll find the right fuse faster when you look first to BUSS. All types and sizes, from 1/500 ampere up, are included in the complete BUSS line. This can simplify your purchasing and stock handling.

To assure protection to both the product and your good name, every BUSS fuse is tested on a sensitive, electronic device for correct construction, calibration and physical dimensions.

BUSSMANN Mfg. Co. (Division of McGraw Electric Co.) SD-553  
University at Jefferson, St. Louis 7, Mo.

Please send me bulletin SFB containing facts on  
BUSS small dimension fuses and fuse holders.

Name \_\_\_\_\_

Title \_\_\_\_\_

Company \_\_\_\_\_

Address \_\_\_\_\_

City & Zone \_\_\_\_\_ State \_\_\_\_\_ 453



# TIGHT SEAL

... BONDED BLUE-POINT

# TOUGH SHELL

... MOLDED PLASTIC TUBULAR

... a  
in



**DRY ASSEMBLED**  
Insures uniform high quality and uncontaminated capacitors.

**ATTRACTIVE YELLOW MOLDED PLASTIC SHELL**  
Non-inflammable. Will not burn or melt under soldering iron or flame.

**BONDED SEAL**  
Positive, heat resistant, non-inflammable bond seals leads and shell, locks out humidity.

**FIRMLY SECURED LEAD**  
Can't be pulled out, even under soldering iron heat.

**BONDED SEAL**  
Positive, heat resistant, non-inflammable bond seals leads and shell, locks out humidity.

**MINERAL OIL IMPREGNATED\***  
Extremely stable over wide operating temperature range.

PATENT PENDING

*New*

# ASTRON BLUE-POINT BONDED Capacitors

**INDIVIDUALLY  
TESTED AND  
GUARANTEED**

To insure *still greater* dependability in the field, each and every Astron Blue-Point Capacitor is subjected to an exhaustive series of physical and electrical tests prior to final shipment. As a result, Astron proudly *guarantees* the excellence of every Blue-Point Capacitor you buy.

†Trade Mark

Export Division: Rocke International Corp., 13 E. 40th St., N.Y.C.  
In Canada: Charles W. Pointon, 1526 Gerrard St., East, Toronto.

**ASTRON**

RADIO-TELEVISION SERVICE DEALER • MAY, 1953

# Major Achievement

# Molded Capacitor

# Construction and

# Performance

Engineered and Produced Exclusively by ASTRON



PATENT  
PENDING

## Now—Heat and Moisture PROTECTION To a Degree Never Before Possible!

### Outstanding Performance in Hot and Humid Climates!

Here at last is a capacitor that affords *absolute protection* under every condition—a capacitor you can rely on completely—ASTRON BLUE-POINT, the *bonded* capacitor.

This capacitor is produced by an exclusive new design and manufacturing process (patent pending) developed by Astron engineers.

The all-important *blue point* which distinguishes this new capacitor actually *bonds* itself to the tough, heat-resistant outer shell and leads—forming the *tightest seal against moisture* ever produced!

The Blue-Point *dry-assembly* process—as used in hermetically sealed metal encased capacitors—prevents contamination, provides still further protection against moisture, and assures uniform *quality and dependability* for every Blue-Point.

The Blue-Point is mineral oil impregnated\* for continuous operation at 85°C. The blue point seal

itself makes ingenious use of a special thermo-setting, heat-resistant, non-inflammable *bonding agent* as a positive protection against moisture.

With the Astron Blue-Point, you may solder leads as close to the capacitor as you like. Leads will not pull out, nor will the heat of the soldering iron damage the lead or the connection.

Further, every Blue-Point is clearly marked with rated voltage and capacitance, and is imprinted with outside foil identification.

The Astron Blue-Point Capacitor gives you greater protection against heat and moisture at every stage—assuring long life and dependable performance from *every* unit—to a degree never before possible with molded plastic capacitors.

From now on, look for the Blue-Point—ask for exclusive Astron Blue-Point Capacitors by name . . . more than ever before, *depend on, insist on* . . . ASTRON!

\*For bulletin AB-20A, with complete engineering data and listings, write: Astron Corporation, 255 Grant Avenue, East Newark, N.J.

Astron manufactures a complete line of dry electrolytic capacitors, metallized paper capacitors, plastic molded capacitors, standard and subminiature paper capacitors and RF interference filters for every radio, television and electronic use.

DEPEND ON—INSIST ON



**CORPORATION**

**255 Grant Avenue**

**East Newark, New Jersey**

RADIO-TELEVISION SERVICE DEALER • MAY, 1953



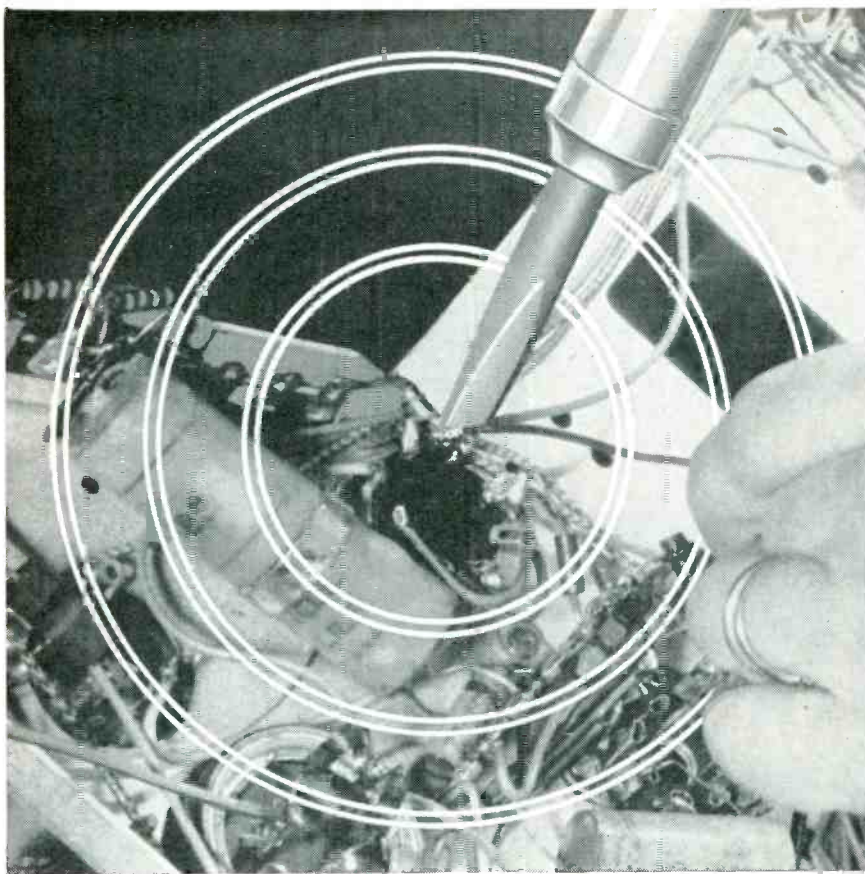

**You can't beat  
a soldered connection  
for electrical conductivity and permanence!**

SOLDERED connections eliminate loss of current, fire hazard, radio interference and excess heat which result from loose, corroded, arcing NON-SOLDERED connections.

For over 50 years experts have specified American Beauty Electric Soldering Irons. They know American Beauty Irons are built to LAST LONGER, OPERATE DEPENDABLY and BE SERVICED QUICKLY.

Build better with solder . . .  
Solder better with  
**American Beauty**  
SOLDERING IRONS

WRITE FOR FREE LITERATURE

*Dependable • Durable • Efficient*  
SINCE 1894

**AMERICAN ELECTRICAL HEATER COMPANY**  
DETROIT 2, MICHIGAN

A-100

**TRADE FLASHES**

[from page 12]

Oelwein, Iowa, a wholly owned subsidiary of Raytheon Manufacturing Company, Waltham, Mass., will be merged into the parent company as of the close of business on May 31, 1953, it was announced today. The new fiscal year of Raytheon Manufacturing Company begins on June 1, 1953, and the merger will be made to coincide with this.

**RCA TV-Set Ads To Feature**

**Kinescopes**

Television service dealers who use RCA kinescopes for replacement servicing are receiving extra national sales support during 1953 through RCA Victor advertising which spotlights the picture tube as an important quality feature of the company's television receivers.

RCA Victor is currently employing national consumer magazines, local newspaper insertions, and network radio and television in a comprehensive advertising program keyed to the theme that its latest TV sets are "five ways finer." RCA kinescopes are underscored as one of the five features.

**Philco Features Test Equipment**

Appearing in this issue is the second in a series of advertisements previewing new Philco Test Equipment designed to provide service technicians with currently developed, accurate test instruments for field and shop use.

The Philco Accessory Division has announced that information on new test equipment, as it is developed and produced, will be released through this medium to provide the widest possible distribution to keep Philco Dealers and Service Technicians informed of its availability.

The three test equipments being featured this month are the Philco Mutual Conductance Dynamic Tube Checker, Model 7052; the Philco Cathode-Ray Tube Checker, Model 7053; and the Philco 3-inch Oscilloscope, Model 7020.

Philco expects to place major emphasis on this campaign to supply service technicians with the ultimate in testing devices. This is directly in line with the overall plan to increase the accuracy of servicing techniques and provide superior service to owners of Philco appliances.

**Walsco Announces Contest Winners**

The big, nationwide search for the 1½ millionth Walsco antenna is at an end. Winners of the contest were disclosed by Jack Carter, Walsco sales



*In capacitors, your best bet,  
your best buy, is*



# PYRAMID

PYRAMID ELECTRIC COMPANY  
NORTH BERGEN, NEW JERSEY

*Write for free literature*



by every test



**ATR**

**AUTO RADIO VIBRATORS**

*Have Ceramic Stack Spacers*

**A COMPLETE LINE OF VIBRATORS**

Designed for Use in Standard Vibrator-Operated Auto Radio Receivers. Built with Precision Construction, featuring Ceramic Stack Spacers for Longer Lasting Life. Backed by more than 22 years of experience in Vibrator Design, Development, and Manufacturing.

"A" Battery Eliminators, DC-AC Inverters, Auto Radio Vibrators

- ✓ NEW MODELS
- ✓ NEW DESIGNS
- ✓ NEW LITERATURE



Free

See your jobber or write factory

**AMERICAN TELEVISION & RADIO Co.**

Quality Products Since 1931

SAINT PAUL 1, MINNESOTA—U. S. A.

manager, as plans are being made for a luxurious, all expense vacation for the lucky dealer and jobber, and their two guests.

Gene Streight of Streight Radio in Gary, Indiana and Ken Starkey of Chauncey's, Inc., in Chicago came up with the lucky 1½ millionth Walsco antenna and will soon be winging their way via Trans World Airlines to Florida for a full week of fun and sun. All expenses will be paid by Walsco.

Four months ago Walsco placed two certificates in a plain carton containing their 1½ millionth antenna. The jobber who sold that particular antenna, and the dealer who bought it, each were to receive two free, all-expense vacation trips to anywhere in the United States. The winners chose Miami, Florida.

**WTVI Goes on Air**

Literally thousands of television viewers increased their pleasure when station WTVI went on the air in the St. Louis area May 1.



One of the truckloads of Mallory uhf TV converters shipped to St. Louis area.

Station WTVI, owned by the Signal Hill Telecasting Corp., is located at Belleville, Ill. The station broadcasts on UHF Channel 54.

**C. D. Pettingell Passes Away**

The following message received from the staff of Vaco Products Co. expresses the sentiments of the staff of RSD as well.

"It is with profound sadness and regret that we report the passing of our president and co-founder, Mr. C. D. Pettingell. Death occurred Monday, February 23, following a post-operation illness of more than a year. Mr. Pettingell was born in Painesville, Ohio, August 7, 1884 and entered the tool and automotive business as a young man. 'Pete,' as he was affectionately known to the trade, leaves behind a host of business and personal friends throughout the United States and Canada, friendships formed over the 35 years of his energetic and devoted service to the industry."

**Sylvania TV Inventories Sold Out**

So great is the country-wide demand for Sylvania television sets that Ber-

WOULD YOU RISK **3¢** TO CREATE THE CUSTOMER CONFIDENCE THAT MEANS A MORE PROFITABLE FUTURE FOR YOU?

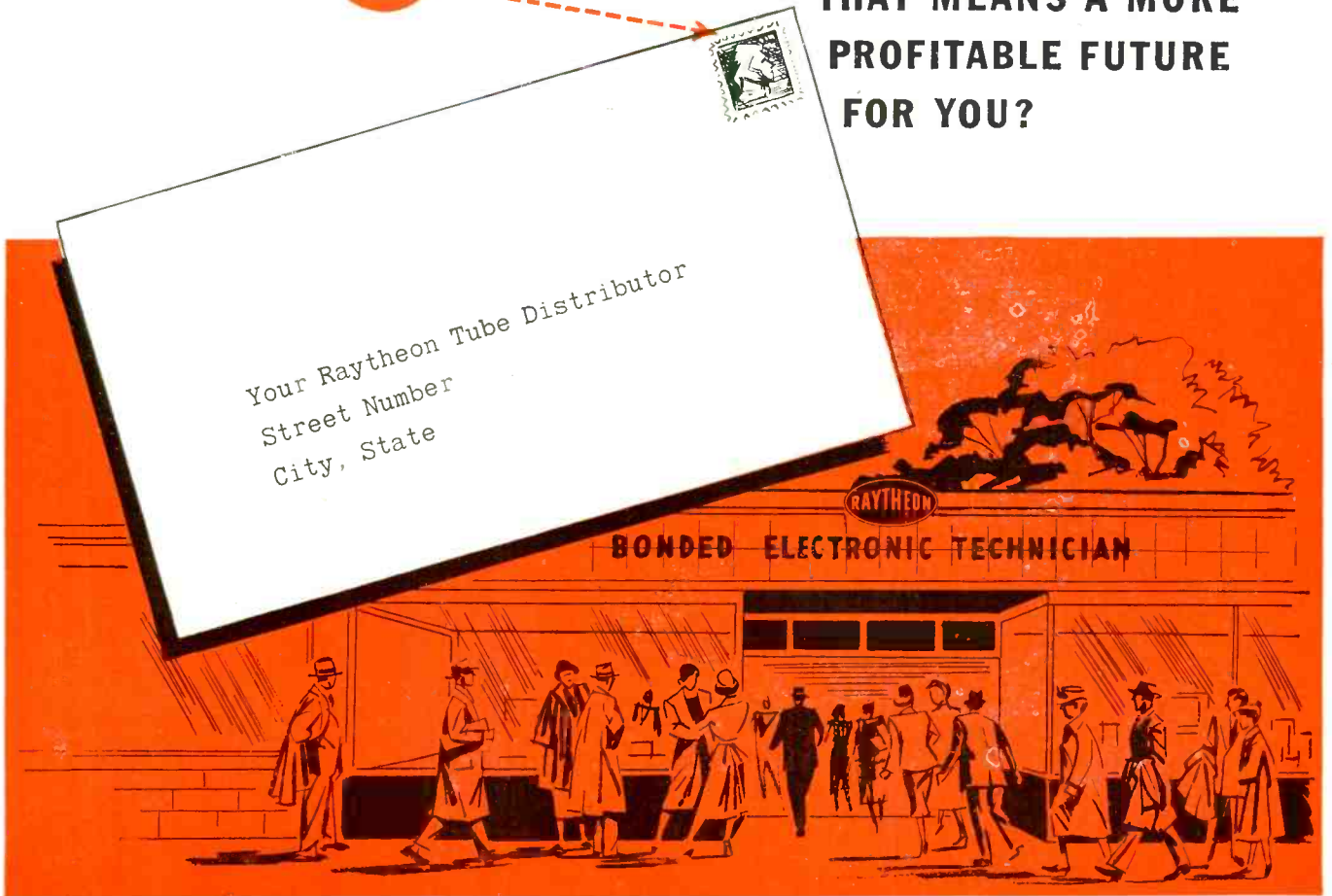

If the answer is *yes*, write your Raytheon Tube Distributor right now. Ask him if you can qualify as a *Raytheon Bonded Electronic Technician*.

Here's why:

As a *Raytheon Bonded Electronic Technician* your repair work is guaranteed for 90 days — a guarantee cash-protected by a bond backed by Continental Casualty Company. You receive a registered Bond Certificate, Identification Cards, Decals, Creed Displays and other sales and shop helps, designed to build your business by creating customer confidence in you and your shop.

If you can qualify for this complete Raytheon Bonded program that is increasing volume and profit for thousands of service dealers from coast to coast *it costs you nothing*. It is Raytheon's investment in *your* future.



RIGHT... FOR SOUND AND SIGHT



**RAYTHEON MANUFACTURING COMPANY**

Receiving Tube Division  
Newton, Mass., Chicago, Ill., Atlanta, Ga., Los Angeles, Calif.

*Excellence in Electronics.*

RAYTHEON MAKES ALL THESE  
RECEIVING AND PICTURE TUBES • RELIABLE SUBMINIATURE AND MINIATURE TUBES • GERMANIUM DIODES AND TRANSISTORS • NUCLEONIC TUBES • MICROWAVE TUBES



nard O. Holsinger, General Sales Manager of Sylvania's Radio and Television Division, announced that supplies of five new television models are being rushed to Sylvania distributors throughout the country. According to Mr. Holsinger, the introduction of new merchandise at this time was made necessary by the fact that Sylvania could not have anticipated the widespread consumer demand for Sylvania TV sets, particularly those with HaloLight.

**General Instrument Corp. Expands**  
General Instrument Corporation,

manufacturers of radio, television and electronic components, is enlarging its three plants, has acquired a fourth and is searching for a fifth in a large-scale expansion program geared to handle what is expected to be the biggest year in the firm's 30-year history.

**Preassembled Swing-Out Conical Patent Invalidated**

In a decision rendered March 17th, 1953, U. S. District Court, Eastern District, New York, held that a patent relating to a preassembled conical antenna was invalid. The antenna in question is the type in which the ele-

ments are collapsed on the crossarm and are swung out and locked in place, and the court ruling made it clear that this mechanical feature was an unpatentable item.

Such models have been supplied for years by many antenna manufacturers.

**Production Starts In New IRC Plant**

On March 13, 1953, the International Resistance Company, Philadelphia, started transferral operations to move a portion of its production facilities to a recently built, modern plant situated on a 66 acre site in Asheville, N. C. Production is already underway, in the spacious \$200,000 plant, of the various types of volume controls used in radios, television sets, phonographs, testing equipment, military equipment and numerous other devices. Operating at full strength, the plant will employ approximately 500 persons of which the majority will be women. H. J. McCaully, formerly assistant to IRC's Executive Vice-President, will manage the Asheville plant.

**Radio City Products Expands**

A 2½ acre tract of land has been leased by Radio City Products Co. at Easton, Pa., for the erection of a new one-story manufacturing plant to adjoin their present production center. The new building will provide for an additional 13,000 square feet, and thus give the company a total production area of 27,000 square feet. Administrative, sales and engineering will continue to be located at New York City.

**JFD Mfg. Co. Opens New Factory**

JFD Manufacturing Co. of Brooklyn, manufacturers of UHF and VHF TV antennas and accessories, opened a new factory at 6215 15th Avenue, just two blocks from the main office. The new, all-brick, efficiently designed factory provides 140,000 square feet of additional space for the rapidly expanding Brooklyn company.

**Magnavox Factory Service Parts Outlet Announced**

The Magnavox Company announced that Radio Electric Service Company, Philadelphia, has been named to merchandise factory replacement parts for Magnavox in the Philadelphia-Wilmington-Baltimore-Washington area.

R. J. Yeranko, Magnavox general service manager, said the new Philadelphia source of replacement parts would allow Magnavox dealers and service contractors in the area to render even better service on the Magnavox line of television receivers and TV-radio-phonograph combinations.

Magnavox parts jobbers now operate

[Continued on page 70]

COMING SOON - **Telechief!**

**SANGAMO'S NEW PREMIUM TUBULAR CAPACITOR** — designed to give you better TV performance!



**EXTRA VALUE at NO EXTRA COST!**

Sangamo combines an amazing new molding compound with a new impregnant to bring you a completely new paper tubular capacitor—developed by request to meet rigid specifications so tough that no previously existing paper tubular could approach them.

Thousands of Telechiefs have been tested under actual service conditions... have proved their ability to outlast and outperform all other tubulars.

The new molding compound, Sangamo Humidite, greatly

lengthens capacitor life. It has been proved, by severe tests, to give the best seal against moisture of any molding compound in the industry.

The new Sangamo impregnant holds rated capacity under all conditions and makes the Telechief really rugged.

Because we know that service men want only the *best* replacement parts—the new Telechief will soon be released to the service trade. Keep in touch with your Jobber.

*Those who know... choose Sangamo*



**SANGAMO ELECTRIC CO.** MARION ILLINOIS





# The Picture Tells the Story

TV Antennas exist for one reason — to provide a clear, strong, sharp picture!

TRIO ZIG-ZAG\* TV Antennas perform so well in this all important respect that they are America's most wanted.

Yes, a picture — the TV picture — tells the TRIO story more eloquently than anything else! Where all other antenna designs fail, high gain TRIO ZIG-ZAG TV Antennas consistently lock in sharp, clear pictures — from Maine to Texas, in city or country!

TRIO TV antennas look different, work different — provide a magnificent DIFFERENCE in picture quality!

\*Patent Pending

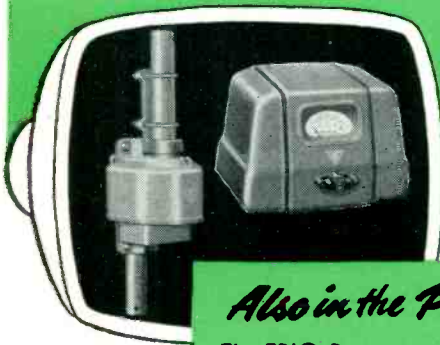

## Also in the Picture

The TRIO Rotator and Direction Indicator are the most dependable ever built. Developed after \$50,000 research. Fully guaranteed for a FULL two years!

\*New insulating sleeve, with longer leakage path and elimination of slit, does away with assembly errors — elements cannot short out. For maximum strength, new steel, electro-plated element clamps have been introduced.

## Best Buy in UHF Antennas LOW IN COST — HIGH IN PERFORMANCE

### NEW TRIO UHF BOW-TIE with reflector

Sturdy, broadband antennas of uniformly high gain that have been thoroughly field tested. Phasing strips installed, pre-assembled — a jiffy to attach reflector screen. Available in one, two and four bay models. Usual high-quality TRIO construction.

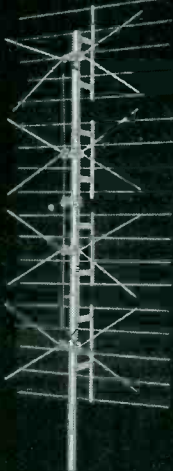

Model UBT-4  
Supplied With  
4 Foot Mast

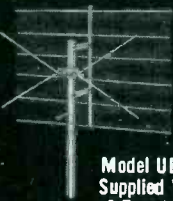

Model UBT-1  
Supplied With  
2 Foot Mast

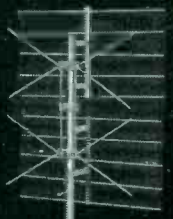

Model UBT-2  
Supplied With  
3 Foot Mast

## NEW TRIO UHF MULTI-CHANNEL YAGI ANTENNAS

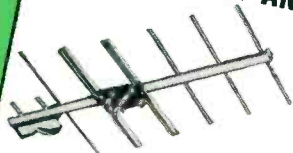

Broadband yagis developed by TRIO now successfully applied to UHF. Four models more than two needed for any one area.

- Model 6-UBY 14-26 for Channels 14-26
- Model 6-UBY 27-42 for Channels 27-42
- Model 6-UBY 43-60 for Channels 43-60
- Model 6-UBY 61-83 for Channels 61-83

These high gain six element yagis have sharper directivity, thereby eliminating ghosts. Thoroughly field tested. End of mast removes metal from field of reflectors or antenna elements. Mast clamp supplied. Completely assembled.



# TRIO MANUFACTURING CO.

GRIGGSVILLE, ILLINOIS



**NEW!**

**NICHOLS  
NEVER-STAIN  
TRADE MARK**

**Aluminum  
TV AND RADIO  
GROUND WIRE**

**RUST  
PROOF**



- ★ High Electrical Conductivity
- ★ Inconspicuous — Low Reflectivity
- ★ Pliable — Specially Tempered
- ★ Etched finish — clean
- ★ STD. No. 8 B & S Ga. (.128" dia.)

**Aluminum  
TV ANTENNA  
GUY CABLE**

**RUST  
PROOF**



- ★ Seven — 18 Ga. Stranded Wires
- ★ Flexible — Specially Tempered
- ★ High Strength Aluminum Alloy for all Types of Antennas.
- ★ Approx. break strength — 500 lbs.



\*Packed 2-500 ft. continuous coils per carton marked every 100 ft. with bright red tape.



PACKAGING DATA		
ITEM	PGK. NO.	DESCRIPTION
TV Grd. Wire	8	100 ft. coil per box. 10 boxes per ctn.
TV Grd. Wire	9*	2-500 ft. continuous coils.
TV Cable	50	100 ft. coil per box. 10 boxes per ctn.
TV Cable	60*	2-500 ft. continuous coils.

Order from your jobber or write us direct. Address Dept. TVI.

**NICHOLS**  
**WIRE & ALUMINUM CO.**  
DAVENPORT, IOWA  
World's Largest Manufacturer of Aluminum Nails

# ASSOCIATION NEWS



**The National Electronic Technician  
and Service Dealers Association**

NETSDA met in session, Sunday, April 12th, 1953, in Paterson, N. J., in conjunction with a three day Eastern Conference, April 10th, 11th, and 12th, held in the Alexander Hamilton Hotel, with the Paterson Association as host. Harold "Dusty" Rhodes, was General Chairman of the Conference and Roger K. Haines, President of NETSDA, presided during the National Meeting, which was held for reorganizational purposes. The following Committees were named for NETSDA's Expansion Program. Credentials, Max Leibowitz, N. Y., Edward Lukas, Pa. and W. H. Lockey, Philadelphia. Membership: Samuel Brenner, Philadelphia, Harold McFarland, N. Y., and Gordon DeLancey, N. Y. Publicity: Leon Helk, Penna., Dave Krantz, Pa. and O. Capitelli, N. Y. Steering Committee: Bert Bregenzer, Pa., Milan Krupa, Pa., and Max Leibowitz, N. Y.

Steps were taken to obtain a Charter of Incorporation for the National Association. Problems within the Service Industry were discussed. These will be carried on the agenda for the next meeting scheduled for Sunday, June 7th, at Long Island City.

The newly elected officers for 1953 are Roger Haines, Haddonfield, N. J., President. David Van Nest, Trenton, N. J., Vice President. John Wheaton, Long Island, N. Y., Cor. Sec. O. Capitelli, New York City, Rec. Sec. T. L. Clarkson, Harrisburg, Pa., Treasurer. Sergt.-at-Arms. Milan Krupa, of Wilkes-Barre, Pa.

*L. J. Helk*

**Radio and Television Association  
of Springfield and Vicinity (Ohio)**

We quote excerpts from a letter indicating how an association may be effective in curbing misleading advertising detrimental to the industry.

Miami Valley Distributing Company  
8 North Keewee Street  
Dayton, Ohio  
Gentlemen:

At our last meeting, held March 13, the members of the RTA have asked me to forward you their protests concerning the manner in which the present UHF situation is used for advertising purposes.

The main argument is the Virginia Patterson show, on which Virginia states that with the arrival of UHF, a TV receiver without a UHF tuner will not be worth a wooden nickel on trade-in.

As people of the trade, you must be aware that this represents a gross distortion of facts. It is a pity that our industry always resorts to such methods of advertising.

Instead of working together, we are fighting each other. Your advertisement, using the same idea, could be made a little more honest and just as effective. It might not sound as sensational, but consumers, dealers and servicemen would all be better off.

With a little cooperation from the stations, distributors and advertising agencies, we all can improve consumer relations, vital to all of us. Let's not keep on contradicting each other, and base advertising on facts, instead of wishes. Rumors for investigations in the so-called "TV-racket" will cease without trouble.

Respectfully,  
Paul Boller, Sec.  
Radio and Television Asso.

**Empire State Federation of  
Electronic Technicians Associations**

The Empire State Federation of Electronics Technicians Association, Ind. held a meeting at Binghamton, New York on April 19th, 1953. The following were elected for officers for 1953:

Max Leibowitz of ARTSNY, N.Y.C. President; John Wheaton of LIRTG

[Continued on page 71]



Burton Browne advertising



1,314  
TESTS

Quality-checks are a full-time job with Rauland—all the way down the line. From spectographic analysis of tube components to ionization test for vacuum—1,314 tests are your assurance that Rauland meets the highest engineering standards. Test-proved in our factories and laboratories, performance-proved in countless homes... it's plain to see why Rauland is the *proved* profit-getter, too. *The Rauland Corporation, 4245 N. Knox Avenue, Chicago 41, Illinois—Mulberry 5-5000.*

**ZENITH** Subsidiary

# RAULAND

PERFECTION THROUGH RESEARCH



# NO OTHER UHF ANTENNA COMBINES ALL

- 1 Extra high gain
- 2 All channel reception
- 3 Sharp vertical and horizontal directivity

# 3

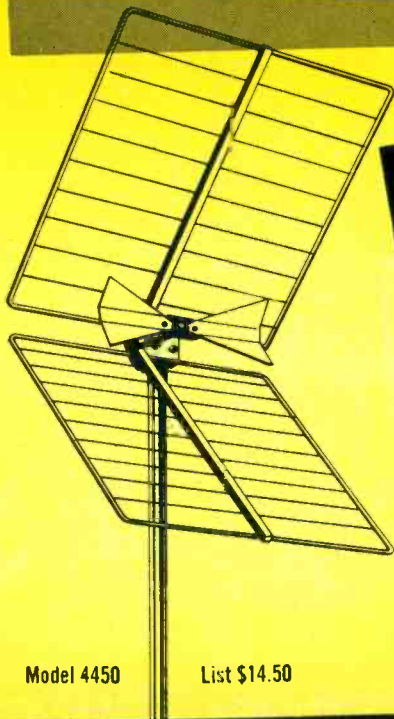

**WALSCO**

## CORNER REFLECTOR

Not 1... Not 2... but all 3 combined for amazing picture clarity

NOTHING... *absolutely nothing* compares with Walsco's Corner Reflector. It's the only UHF antenna that offers a 3-way combination that produces sharper, clearer TV pictures. Truly a masterpiece in precision electronic engineering.

**WALSCO** *A Model to Fit Every Installation*

Walter L. Schott Co.  
3225 Exposition Place  
Los Angeles 18, California

### COMPARISON CHART

	High Gain	All channel Performance	Sharp Directivity
WALSCO CORNER REFLECTOR	YES	YES	YES
ANTENNA B	NO	YES	NO
ANTENNA C	NO	YES	NO
ANTENNA D	YES	NO	YES

Overseas Representative: Ad Auriema, Inc., 89 Broad St., New York 4, New York

# TV SYMPOSIUM

## SERIES—No. 5

This installment discusses various types of vertical sweep circuits found in most TV receivers. Servicing procedures are also discussed.

# VERTICAL SWEEP CIRCUITS

by CYRUS GLICKSTEIN

VERTICAL sweep circuit design in current TV receivers, displays no radical innovations, in general. In keeping with the trend to conserve critical materials, fewer models use blocking oscillator circuits which require transformers. Multivibrator sweep generator circuits are used instead. A step-down autotransformer in the output stage is commonly used to match the yoke to the output tube.

A typical vertical sweep circuit is shown in Fig. 1. The integrating circuit is practically standard—a printed circuit assembly or couplate with the values as shown in Fig. 1.

The most important problem faced by TV manufacturers in the past two years or so has been to improve receiver design to meet the more stringent requirements of fringe area performance. Receiver performance has been stepped up by designing more sensitive tuners, higher gain in the signal circuits, fringe compensating switches for cutting out *agc* to the *rf* stage, noise suppression circuits to improve signal-to-noise ratio, and better sync separation. A few manufacturers have attempted to improve the design of the vertical oscillator circuit to make it less susceptible to random noise triggering.

Vertical instability (vertical roll), is one of the most common troubles

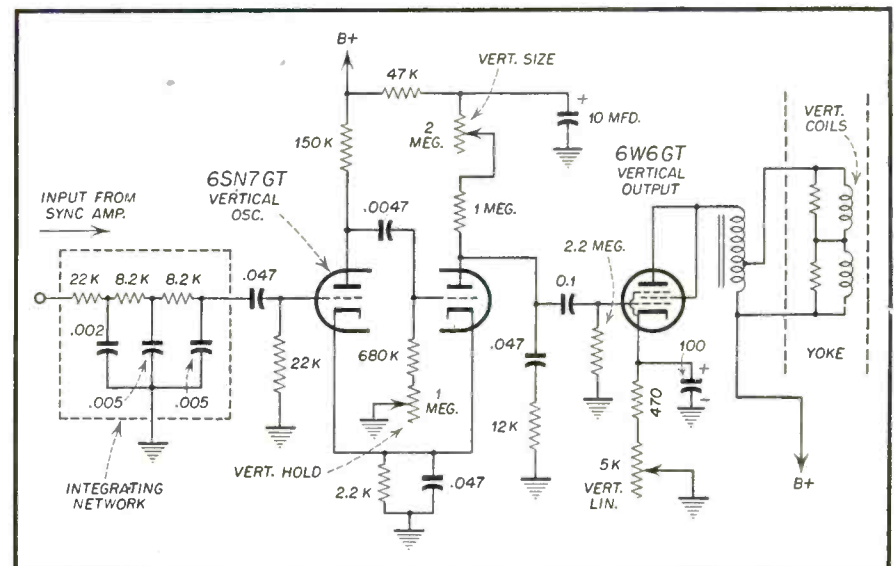

Fig. 1—Typical vertical sweep circuit using multivibrator sweep generator.

in fringe areas. This fault occurs because in these areas the signal level is low and the noise level is correspondingly high. The net result is more snow in pictures and poor synchronization. However, horizontal sync is less critical than vertical sync because of the *a/c* (automatic frequency control) circuits all receivers use in the horizontal sweep circuits. Conse-

quently, since direct (triggered) rather than flywheel sync is used in vertical circuits, the vertical oscillator tends to fall out of sync more readily if receiver performance is not at its peak.

#### Improved Vertical Circuit

Some receivers are using a modified design of the vertical sweep circuit to improve vertical stability, as in the



Bendix 21K3 receiver, Fig. 2. V18B and V19 are connected as a plate-coupled multivibrator. At the same time, V19 functions as the vertical output stage. The modified sawtooth wave is generated at the plate of V18B and is coupled to the grid of V19 by C64, the coupling condenser. Feedback from the plate of V19 to the grid of V18B is through the filter network C60 through C63, R90, R91, and R92.

C59 is the sawtooth charging condenser and R88 is the peaking resistor. The incoming sync pulses are integrated in the network consisting of C57A, C57B, R86, and R87. C58 couples the integrated sync pulse to the sweep circuit. The sawtooth condenser, C59, charges while V18B is cut off, as is usual in multivibrator operation. As the sawtooth voltage at the plate of V18B is generated, it is coupled to V19 through C64, amplified, coupled to the yoke through the output transformer and provides vertical deflection, V19 conducts throughout the trace period, while V18B is cut off throughout the trace period.

Assume now the sawtooth voltage at the plate of V18B is rising toward its maximum value. An integrated vertical sync pulse is applied across the peaking resistor, R88, through C58, coupling condenser. Since the vertical sync pulse is negative, and is applied to the plate of V18B while this stage is cut off, the pulse has no direct effect on V18B. However, the negative sync pulse is fed to the grid of V19 along with the sawtooth signal from V18B. The negative sync pulse as well as the sawtooth voltage is amplified in V19 and fed back instantaneously to the grid of V18B through the filter network. The now positive sync pulse triggers V18B. The tube conducts, the sawtooth condenser C59 discharges through V18B, and vertical retrace is effected. Only a sufficiently positive signal applied to the grid of V18B is able to make the tube conduct.

Note that the vertical sync pulse is amplified by going through V19. Fur-

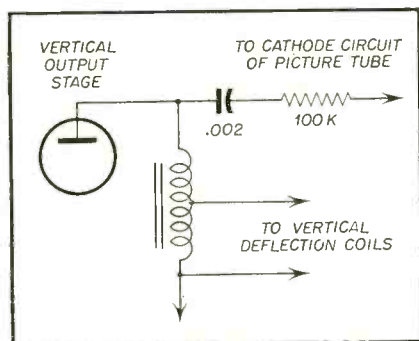

Typical circuit used to secure vertical retrace blanking.

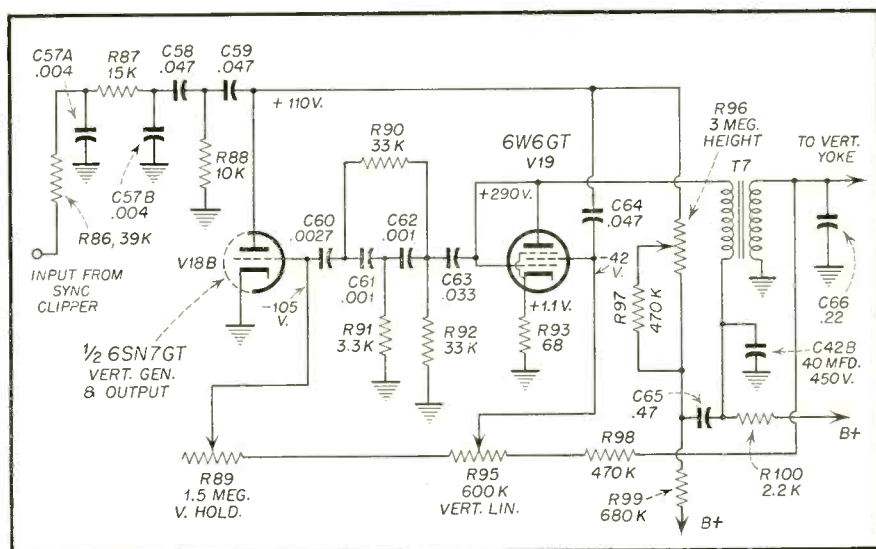

Fig. 2—Modified vertical sweep circuit of Bendix Model 21K3.

thermore, the filter network between the plate of V19 and the grid of V18B is designed to attenuate noise pulses so only the amplified vertical sync pulses will trigger V18B. An amplified sync pulse provides a steeper leading edge. The triggering is accomplished closer to a given amplitude point along the leading edge of the sync pulse at the end of each field. As a result, more exact triggering is secured, providing better interlace. Of course, with no incoming sync pulses, the circuit will operate at a frequency determined by the R-C values.

#### Vertical Retrace Blanking

Most current receiver models use vertical retrace blanking, Fig. 3. The square wave across the autotransformer or secondary of the vertical output transformer is coupled to the cathode of the CRT in most designs. The polarity of the coupled signal is such as to blank out the picture during vertical retrace time. The advantage of this feature is that it prevents vertical retrace lines from showing on the screen, especially during periods when the pix level is low.

#### Servicing Vertical Sweep Circuits

In servicing vertical sweep circuits, vertical troubles are generally clear-cut and not very difficult to isolate. In cases of vertical roll, the first step as usual is to check whether the vertical hold and other vertical controls are correctly set. The next step is to check for faulty tubes. The tubes which are most likely to be at fault are:

1. Vertical oscillator and amplifier tubes. Defects in these tubes can affect the frequency of the oscillator and cause vertical rolling or vertical jitter. In some receivers using 6BL7 vertical output tubes, it has been

found that irregularities in these tubes have been responsible for vertical instability. The manufacturer involved is planning to substitute a newer, more stable type, the 6BX7. When this newer tube is not available, try substitution of the 6BL7 with another tube of the same type. In some cases, removal of the vertical blanking circuit and changes in values of grid leak resistor and capacitor in the blocking oscillator stage are needed to make the circuit perform in a satisfactory manner.

2. Sync separator and clipper. A weak tube will not provide large enough sync signals to the integrating circuit to permit locking in the picture vertically.

3. RF amplifier tube. Leakage between tube elements will cause clipping of the sync pulses due to incorrect *agc* voltage.

4. Video amplifier. A defective tube can cause faulty operation by clipping sync pulses.

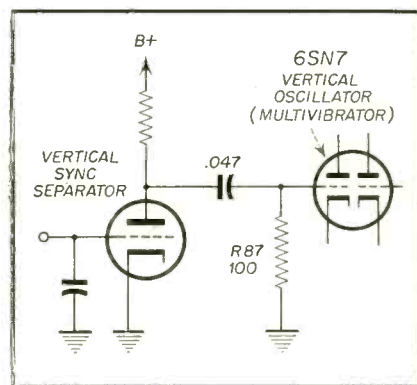

Fig. 4—Partial schematic of Emerson vertical sync circuit. Reduction in value of R87 makes vertical hold more stable under extreme noise conditions.

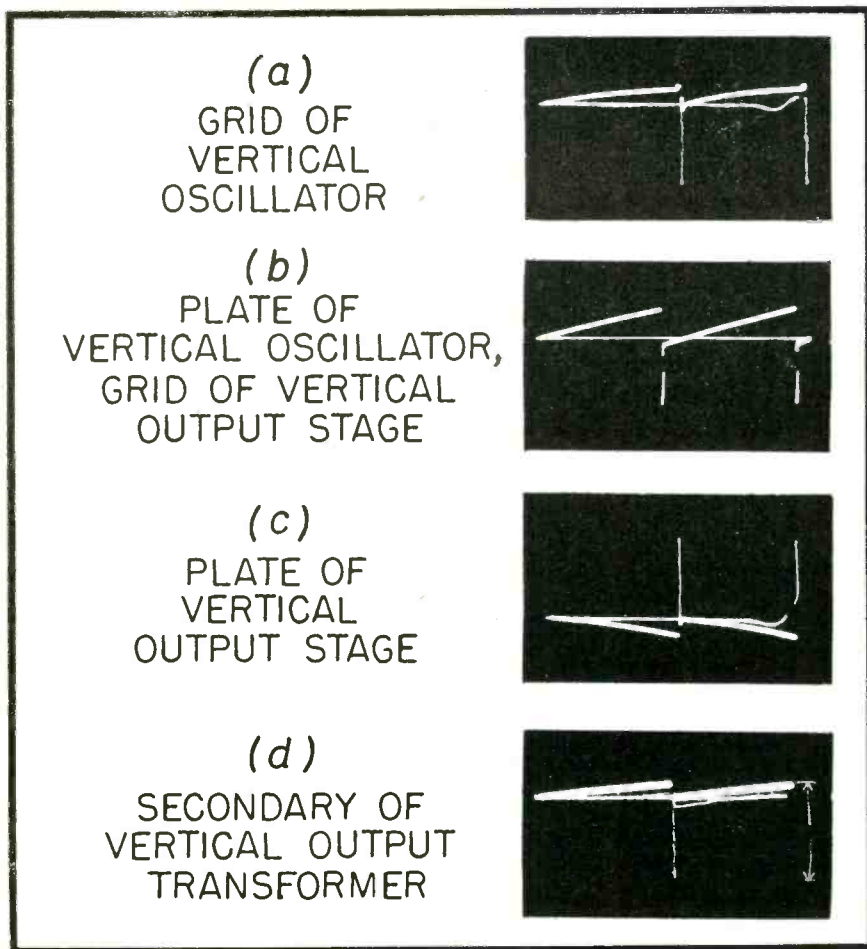

Fig. 5—Typical waveforms at indicated check points of vertical sweep circuit as seen on scope.

In recent Emerson models, *Fig. 4*, it has been found that changing the value of a resistor in the vertical sync circuit makes the vertical hold more stable under severe noise conditions. *R87* is lowered to a minimum of 47 ohms when additional vertical stability is required.

Other typical vertical sweep troubles are foldover at the bottom, insufficient height, non-linearity, no vertical deflection, and high sync buzz level.

After checking the settings of the vertical controls, the usual procedure is to change the vertical sweep tubes—oscillator and output tubes. In many cases, this is one tube only, a dual triode. In cases of faulty vertical sync, other tubes may be responsible as noted above. These other tubes should be changed before proceeding with further checks.

Troubles which indicate a distorted sawtooth (foldover, non-linearity, etc.), can be serviced more quickly when an oscilloscope is available. By checking the waveforms at the secondary of the vertical output transformer, the plate of the output stage, the grid of the output stage and the plate of the oscillator stage, it is often pos-

sible to localize the point at which the distortion is originating and to take further checks at that point. *Fig. 5* shows typical waveforms at these check-points as seen on the scope.

When there is no vertical deflection (horizontal line on the screen), quick checks can be made to isolate the trouble to the oscillator or output stage. A functioning oscillator should have a negative *dc* voltage at the grid of the discharge tube. This negative voltage should vary as the vertical hold control is rotated. To check for the presence of the sawtooth at the plate of the oscillator, the grid of the output stage and the plate of the output stage, an *ac* voltmeter, connected as an output meter, can be used. An output meter is simply an *ac* voltmeter with a condenser (.1  $\mu$ f is a good value) in series with the hot lead. In this way, the meter will register only *ac* voltages and will not respond to *dc* voltages which may be present. The meter will then simply indicate whether an *ac* (sawtooth) voltage is present at a given point but will not give specific information about the peak-to-peak voltage or the linearity of the waveform. If an *ac*

signal other than a sawtooth is at a given point, the meter would of course register. This type of meter check is therefore useful only to determine at which point the sawtooth has been lost, not to check faults like non-linearity, hum pickup, or low output.

Once the fault is isolated to a definite portion of the vertical sweep circuit, the defective part is found by the usual methods of voltage and resistance checking, condenser bridging, and, if necessary, parts substitution.

The following is a summary of common reasons for other vertical deflection faults:

#### Foldover at Bottom

1. Low line voltage (below 105V). When this fault is found in the home, check the line voltage first before further servicing.

2. If foldover appears at normal line voltages, try a new vertical output tube.

3. A weak rectifier tube giving low B+ can cause foldover. Substitute another rectifier tube.

4. Other possibilities are: a leaky coupling capacitor between the sweep generator and sweep output stage; change in value of resistor or condenser in the charging circuit of the sawtooth generator; defective blocking oscillator or output transformer.

#### Insufficient Height and/or Vertical Non-Linearity

1. In oscillator stage: leaky charging condenser or change in capacity; weak tube; increase in resistance of plate resistor in oscillator stage; leaky coupling capacitor between oscillator and output stage; defective blocking oscillator transformer.

2. In output stage: defective output transformer (some turns shorted): low B+ to output stage; open cathode condenser or change in capacity of cathode condenser; weak tube; shorted cathode condenser; change in value of cathode resistance (linearity control, etc.).

#### High Sync Buzz Level (possibly with Pix Jitter)

1. Breakdown of windings of vertical output or vertical blocking oscillator transformer.

2. Coupling of vertical buzz into the audio circuits.

There are several sources of buzz in TV receivers, including a defective power transformer, intercarrier buzz, and buzz originating in the vertical circuits. Two checks can be made to help localize the source of the buzz: (1) Vary the vertical hold control; (2) Check for buzz on all channels, including unused ones. In all cases

[Continued on page 79]



# HORIZONTAL SYNC & SWEEP SERVICING

## PART 2

by LEONARD LIEBERMAN

THE purpose of the horizontal *afc* system is to make each horizontal scanning line in the receiver start at the same time that it does at the studio camera. Each receiver horizontal scanning line is initiated by an oscillator whose operation was discussed in Part 1 of this series (*April RTSD*). The purpose of the *afc* system is to synchronize this oscillator with the transmitted sync pulse which coincides with the start of the camera retrace line.

The block diagram in *Fig. 1* illustrates a general block diagram of an *afc* system. The comparator, as the name indicates, compares the sync pulse with the output of the horizontal oscillator. This comparison might be in terms of frequency or phase. An

The second installment in this series treats with the various types of horizontal *afc* systems found in the greater majority of TV receivers found today. The third and final installment which runs in June deals with horizontal high voltage and deflection systems.

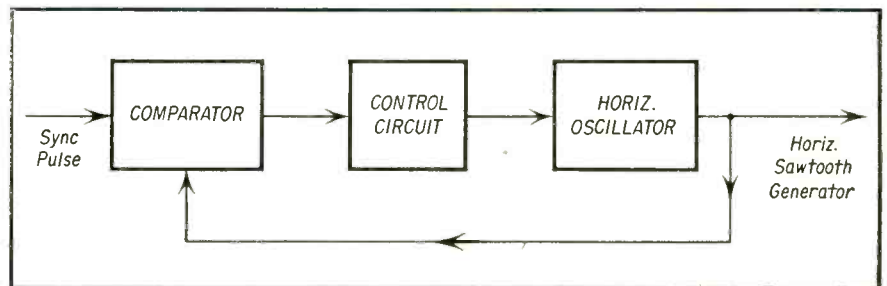

Fig. 1—Block diagram of *afc* system.

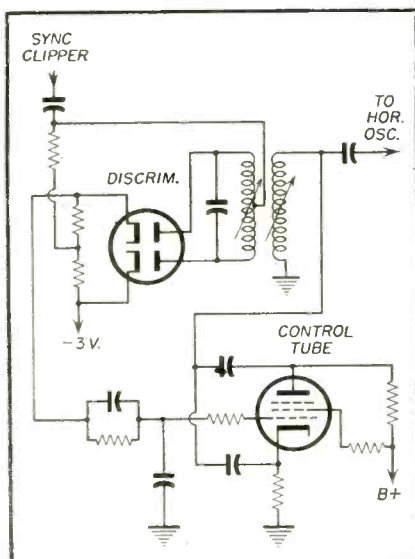

Fig. 2a—Sine wave discriminator.

error voltage is derived in the event that the frequency or phase of two sources do not coincide. This error voltage is then applied to a "control device" the purpose of which is set up circuit conditions which reduces the error voltage to zero. Zero error voltage means that the two sources are "locked" in frequency and phase.

*AFC* circuits are designed to compensate for horizontal oscillator drift, noise interference, *rf* oscillator drift or sync disruption (at the station itself or as a result of switching stations at the receiver). Factors which must be taken into consideration in the evaluation of different *afc* systems are: lock-in range (that is the amount of frequency difference between the sync pulse and the oscillator within which the *afc* system will bring

the oscillator into sync), noise immunity, ease of customer and serviceman adjustment, and long range reliability.

While in themselves, the various types of *afc* circuits could be adapted to any horizontal oscillator system they have each been associated with a specific oscillator. The sine wave discriminator type (*Fig. 2A*) is most always associated with a synclock horizontal oscillator system (*Fig. 2B*). Again, the "pulse width" *afc* circuit (*Fig. 3A*), is generally used in the "syncroguide" type of oscillator (*Fig. 3B*). Finally, the phase detector (*Fig. 4A*) is most usually used with the sinewave stabilized multi-vibrator (*Fig. 4B*).

The sine wave discriminator type of *afc* (which will be referred to as the



ANTENN-GINEERED<sup>®</sup>

**Snyder**  
PHILADELPHIA

**UHF-3  
BROAD-BAND  
YAGI**

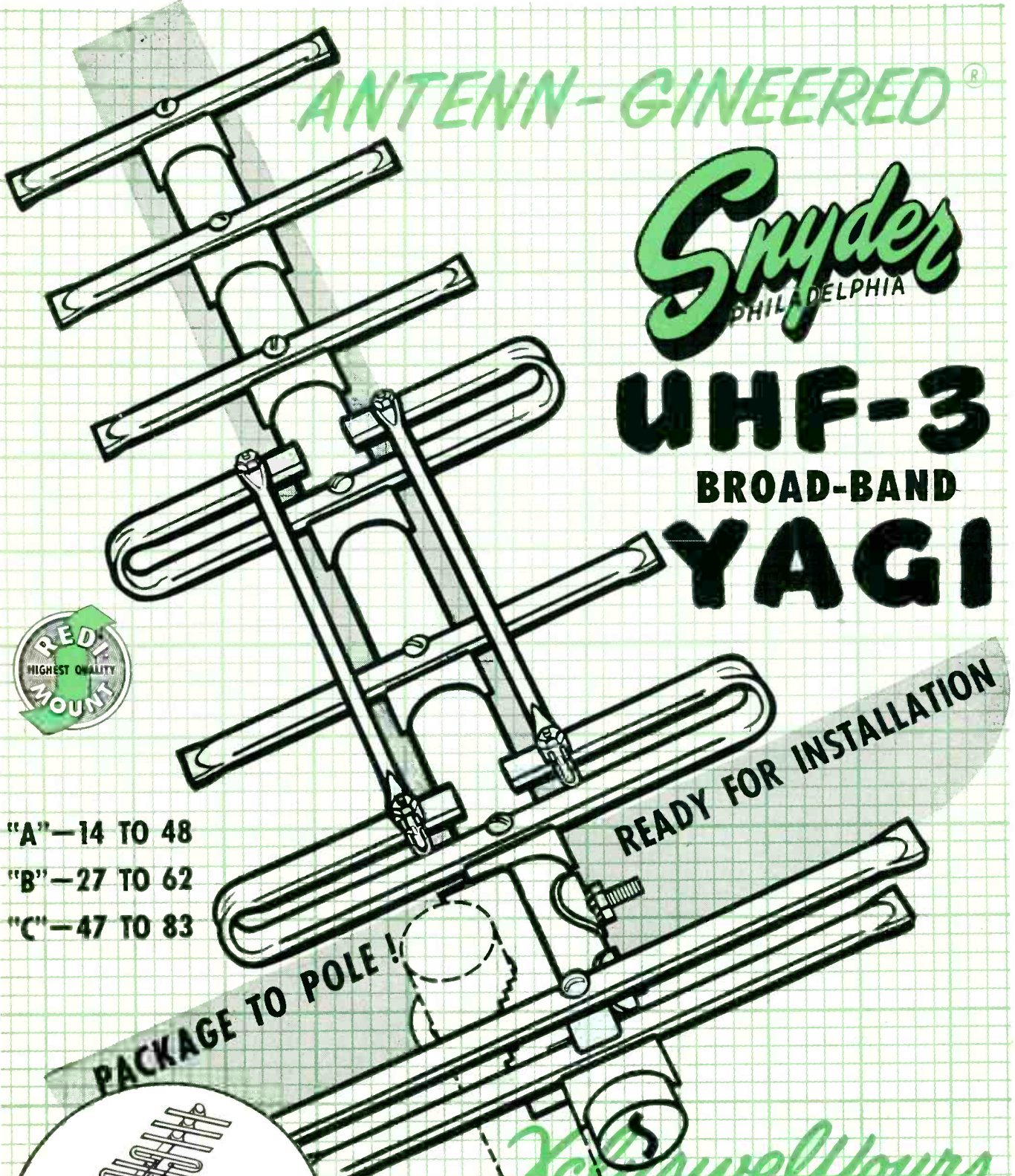

- "A"—14 TO 48
- "B"—27 TO 62
- "C"—47 TO 83

READY FOR INSTALLATION

PACKAGE TO POLE!

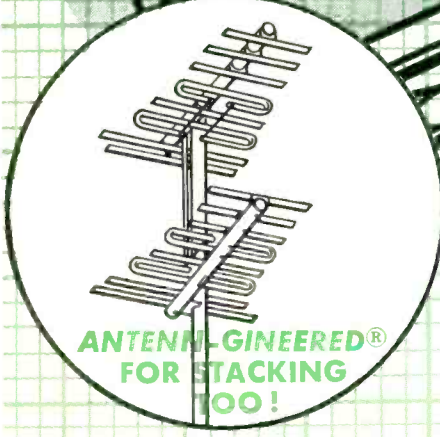

*Reliably Yours*

**SNYDER MFG. CO.**

ANTENN-GINEERS<sup>®</sup>  
**PHILADELPHIA**

EXPORT DIVISION: ROBURN AGENCIES INC., NEW YORK 7, N.Y.  
CANADIAN DISTRIBUTOR: VAN DER HOUT ASSOCIATES, LTD., TORONTO



syncrolock), is one of the early post-war systems which is still in current production. In evaluating its operation, it is sufficient to say that it is the standard of performance by which the other systems are judged. That is to say, when correctly adjusted, its noise immunity is such that the noise must be intense before it tears out horizontally. It has little tendency to horizontal oscillator drift or fold-over; and maintains relatively stable sync when the receiver is switched from station to station. However, this system is achieved at a comparatively high cost in dollars and cents. The system requires more tubes, expensive transformers and more components than do the others.

In order to reduce the costs so that TV sets might sell at a reasonable price without excessive deterioration of the horizontal system, the syncroguide and phase detector systems are currently being used by the large majority of TV set manufacturers.

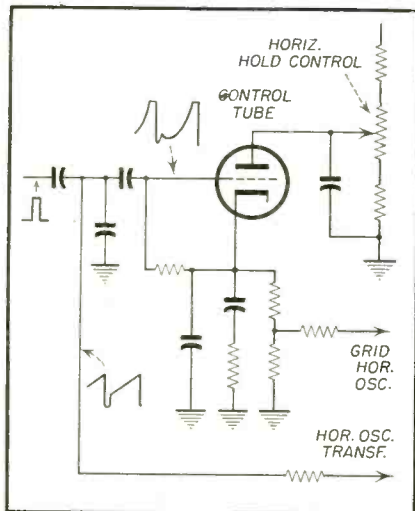

Fig. 3a—Pulse width comparator.

The syncroguide features a system which has a more curtailed lock-in range than the syncrolock but which is adequate for all except weak signal areas. Its noise immunity is good. Its disadvantages are the tendency towards fold-over and excessive service adjustments as the control oscillator tubes age. This circuit requires only one dual triode for its operation.

The phase detector type of *afc* has some advantages which the syncroguide lacks and some disadvantages of its own. The advantages are a wider lock-in range which permits larger oscillator drift or shows less tendency of dropping out of sync on changing stations. It suffers from less noise immunity. The oscillator with which it is associated usually is more critical to adjust and keep in frequency. As a result, even though the

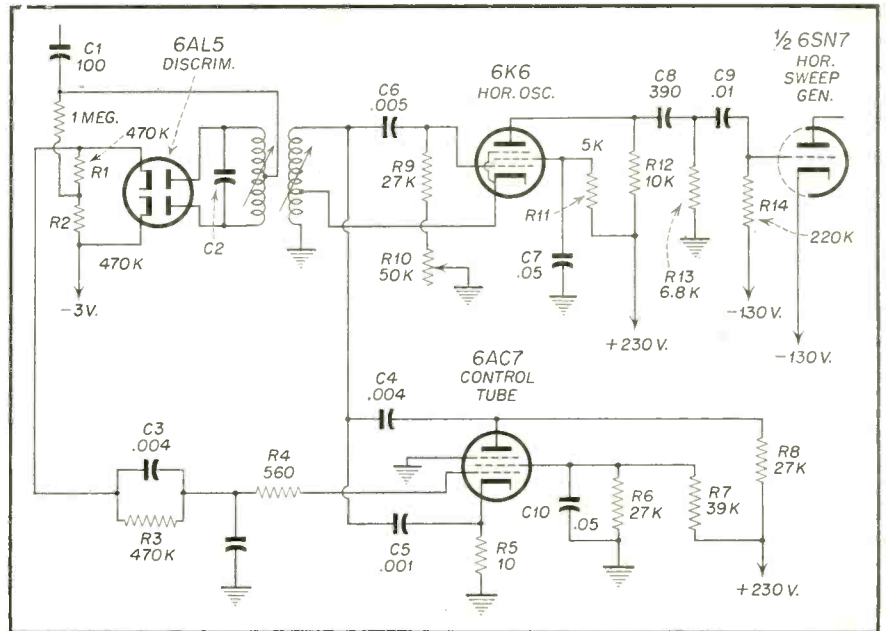

Fig. 2b—Syncrolock oscillator and afc system.

lock-in range is wider than the syncroguide the possibility of the oscillator drifting past this point is very great.

**Sinewave discriminator (syncrolock)**

The basic principle of the *afc* system used in the syncrolock system involves varying the resonant frequency of the tunable horizontal oscillator tank circuit. This frequency change is accomplished by means of a vacuum tube which is in parallel with the tuned circuit. If we could make the plate current of the tube lead or lag the voltage at the grid by approximately 90° we would have the equivalent of an inductor or capacitor across the tuned circuit. (Fig. 5) By increasing or decreasing the plate current we could make this equivalent L or C seem larger or smaller, and we

could thereby change the natural resonant frequency of the entire tuned circuit.

The amount of plate current which flows through the tube with a fixed input voltage decides how large a reactance the tube looks like. We, therefore, have a means of using the grid bias voltage for the horizontal oscillator control. In the circuit shown in Fig. 2B the in-sync state grid bias voltage comes from the -3 volts bias source. When the oscillator sinewave and the sync pulse arrive at the discriminator in phase, the currents of both tubes buck each other out. This is done by feeding the diodes the sync pulse at the transformer mid-point. The voltages applied to the diodes, therefore, are in phase. On the other

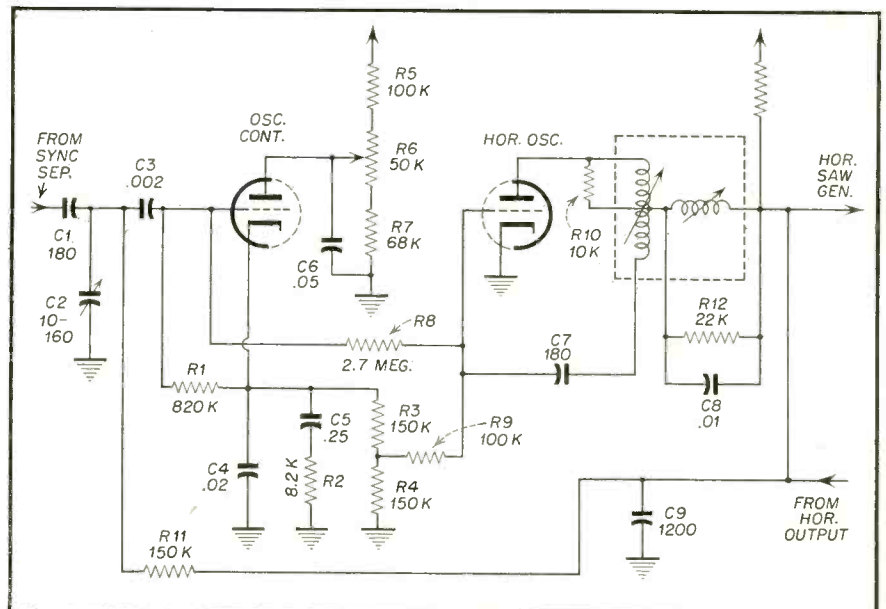

Fig. 3b—Syncroguide oscillator and afc system.

## A NEW CBS-HYTRON CTS-RATED\* TUBE

\***CTS-RATED:** Rated for Continuous Television Service. In TV receivers, five tubes work . . . like transmitting tubes . . . *hard!* Account for almost 90% of your replacements. You know them: rectifiers, deflection amplifiers, damper diode. Larger-screen sets aggravate this problem. CBS-Hytron recognizes your need for huskier tubes for these sockets. Brand new designs, not just improved tubes. CTS-Rated 5AW4 . . . another CBS-Hytron first . . . is your answer for the low-voltage rectifier socket. It is CTS-Rated: (1) For heavier average (250 ma. max. d-c) and peak (750 ma. max. d-c) currents, (2) With big safety margins at these currents. You can depend upon the 5AW4 for continuous, trouble-free service. Yes, more CBS-Hytron CTS-Rated tubes are coming. Watch for them.

# CBS-HYTRON 5AW4

## NEW HEAVY-DUTY WORK HORSE CUTS 5U4G CALL-BACKS

Worried about slumping TV set performance, because of heavily loaded 5U4G's? Forget it. Use new CBS-Hytron CTS-Rated\* 5AW4. A replacement for the 5U4G, the 5AW4 recaptures . . . and keeps . . . that new-set sparkle. Maintains full voltage, despite heavy load. Minimizes burn-outs. Avoids filament shorts while testing chassis on side. Loafs on tough jobs. Gives long, long, trouble-free life. The 5AW4 will cut your call-backs. Boost your profits. See it . . . buy it . . . soon. At your CBS-Hytron jobber's.

†Patent applied for

### COMPLETE 5AW4 DATA FREE

See your CBS-Hytron jobber. Or write direct today.



### MECHANICAL ADVANTAGES

**PLATE** — Note formed A-frame construction. Each plate of 5AW4 is formed into two cylinders containing the filament. Uniform filament-to-plate spacing and uniform filament performance avoid hot spots on filament, plate . . . and bulb. Over-size radiating fins and extra large surfaces between formed cylinders dissipate heat faster. Sturdy structure is rigidly supported at eight points.

**FILAMENT** — Massive, heavy-duty, 20-watt filament offers generous reserve of emission. Cuts burn-outs due to ionization attack and back emission. Transmitting-tube-type filament hook and spring suspension prevent sagging — yet reduce stresses on filament. Permit mounting 5AW4 in any position. Useful filament area is contained within formed cylinders of plate . . . to minimize internal voltage drop.

### New...Free DECAL

sells for you! *Sells* your magic ability to recapture new-set sparkle. Let this decal pull customers to you. Get it from your CBS-Hytron jobber today.



Manufacturers of  
Receiving Tubes Since 1921

CBS-HYTRON Main Office: Danvers, Massachusetts

A Division of Columbia Broadcasting System, Inc.

RECEIVING . . . TRANSMITTING . . . SPECIAL-PURPOSE AND TV PICTURE TUBES • GERMANIUM DIODES AND TRANSISTORS



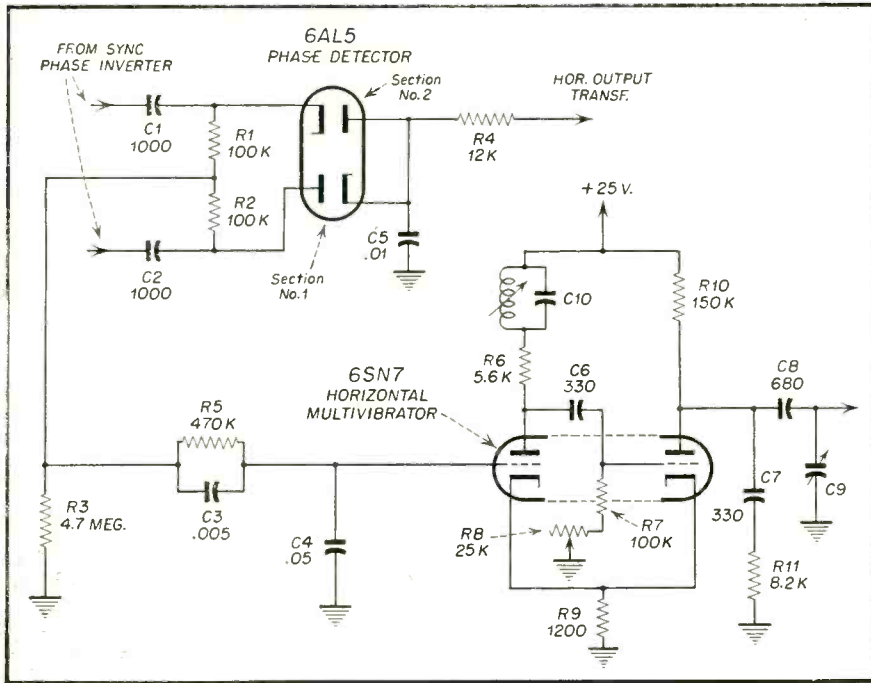

Fig. 4b—Phase detector afc and multivibrator oscillator.

tube will cause control tube plate current flow. This flow through the cathode resistors,  $R3$  and  $R4$  causes a greater voltage drop across  $R3$  and  $R4$  and thereby affects the grid bias of the oscillator.

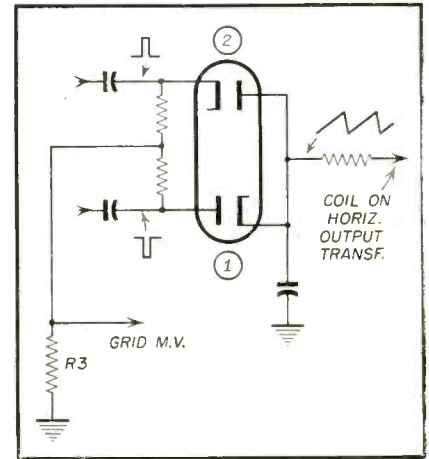

Fig. 4a—Phase detector.

Now let us examine precisely how this controls the oscillator frequency. Both the sync pulse and an integrated saw-tooth voltage waveform from the oscillator output are combined and coupled through  $C3$  to the grid of the horizontal of the control section (Fig. 7). This pulse causes the tube to conduct. The  $dc$  voltage at the cathode as a result of filtering by the

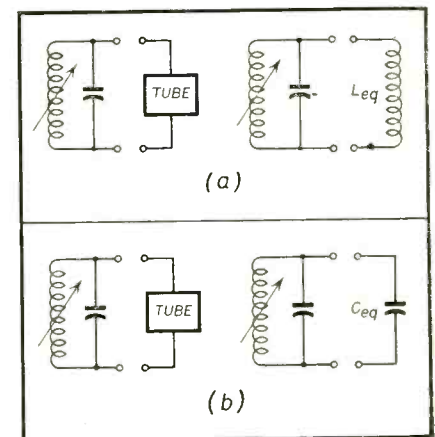

Fig. 5a—Replacement of a reactance tube by an equivalent inductor. The magnitude of  $L_{eq}$  is a function of the shunt current it draws. The smaller the current the larger  $L_{eq}$  appears to be.

Fig. 5b—Replacement of reactance tube by an equivalent capacitor.

cathode RC network is a function of the input pulse width. When the circuit is adjusted properly, the pulse shown in Fig. 7 is that of the center lock-in frequency. Figs. 7B and 7C show the pulse widths which will result when the oscillator is not in step with the sync pulse. The resulting  $dc$  bias departure from the preset in-

hand, the voltage applied to the diode plates from the oscillator is  $180^\circ$  out of phase. When the sync pulse and the horizontal oscillator frequency are in phase, the reactance tube bias is determined by the fixed bias source. If, however, they are not in phase, one section of the discriminator or the other will conduct more heavily, depending on whether the sync leads or lags, the oscillator pulse. See Fig. 6. This uneven current distribution will then cause the bias voltage applied to the reactance tube grid to increase or decrease. The change in bias changes the plate current and, therefore, the equivalent reactance in the direction which will bring the oscillator in phase with the sync pulse.

#### The Syncroguide AFC System

In the syncroguide and the phase detector afc systems, the horizontal

sweep waveform is started by a non-sinusoidal pulse. The time this pulse is started is determined by circuit characteristics which were discussed in the previous article (RTSD April 1953).

To briefly review these characteristics, the syncroguide oscillator (Fig. 3b) is actually of the blocking oscillator type. The oscillation frequency is basically determined by the frequency of the plate and grid tuned circuit. The time it takes the grid to come back into conduction is determined by the bias voltage on the grid. The exact conduction time and, therefore, the frequency can be set by varying the grid bias.

The grid of the oscillator is returned to a tap on the cathode bias network of the control tube. A positive pulse at the grid of the control

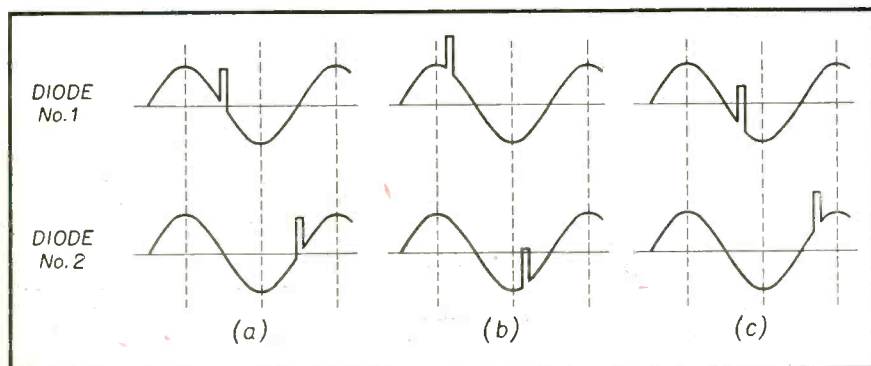

Fig. 6—Relation of sine wave and sync pulses. (a) Oscillator and sync in phase. (b) oscillator too high in frequency. (c) oscillator too low in frequency.



Mr. Roy True  
President of  
Radio Apparatus Corporation  
Indianapolis, Indiana

Makers of MONITORADIO—  
a line of receivers and transmitters for  
mobile or stationary communication systems.

says:

"Electronics is my business . . .  
my choice in Boosters is *Regency*"





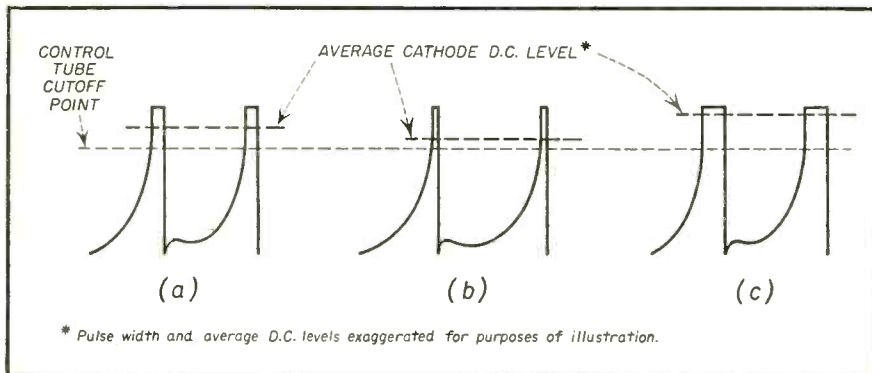

Fig. 7—Pulse width and average bias level in syncroguide system under "in sync" and "out-of-sync" conditions. (a) in sync. (b) oscillator too high in frequency. (c) oscillator too low in frequency.

sync bias causes the oscillator to be fired earlier in the case where it is too low in frequency and delays the firing time in the case where the oscillator is too high in frequency. As mentioned earlier, the syncroguide has a better noise immunity than the stabilized sine wave or phase detector system. To achieve this noise immunity, however, control tube recovery time has to be faster. This results in a greater possibility of fold-over.

#### Phase Detector

The phase detector *afc* is most usually found in conjunction with the sine wave stabilized multi-vibrator. In this system, the sync pulses are fed from a phase splitter circuit. They are applied 180° out of phase to a gating tube. This gate may be a diode as in Fig. 4a or a triode as in Fig. 8. The bias voltage for the multi-vibrator is taken off the mid-point of two load resistors. These resistors are connected in such a manner that when the oscillator and sync pulses are in phase the bias for the multi-vibrator is developed across *R3*. In this case, the multi-vibrator firing time is determined by the circuit constants as described in the previous article. When the oscillator is out of step with the sync pulse, this bias is changed.

The bias variation is achieved in the following manner in the diode case (Fig. 4A): The sync pulse arrives at plate #1 and cathode #2 of the

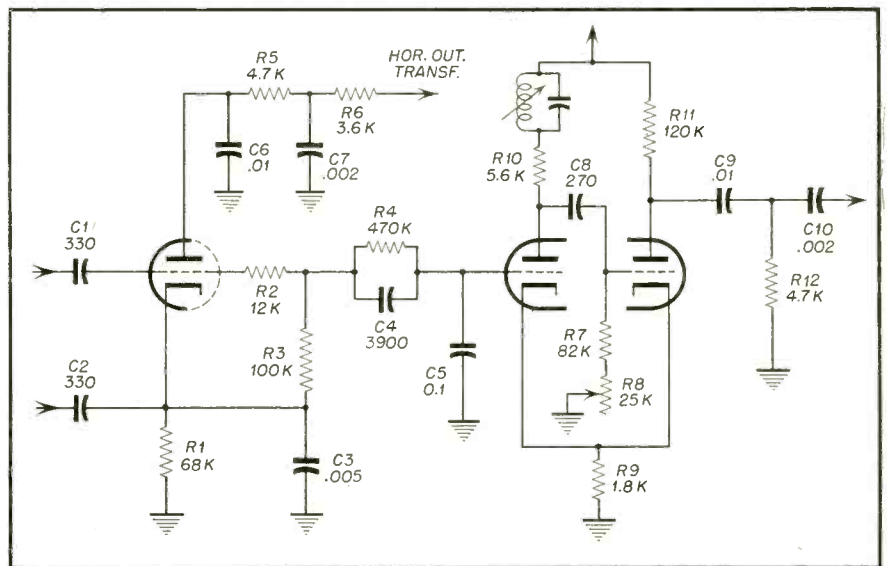

Fig. 8—Triode phase detector circuit.

diode 180° out of phase. Cathode #1 and plate #2 are tied together and are fed a saw-tooth waveform from the horizontal output transformer. If the

sync and oscillator pulses are in phase, the sync pulses arrive at the zero average *dc* point of the saw-tooth and cancel out. If the oscillator is not in sync with the transmitted pulse, the sync pulses arrive at a point above or below the zero point. As a result, one-half section conducts more heavily than the other. In this manner, the voltage at *R3* is changed and the firing time of the oscillator is varied.

Figure 8 shows a triode being used instead of a dual diode. In this case, the sync pulses are fed to the grid and cathode. The comparison saw-tooth is fed to the plate. Both pulses act in the same direction, since driving the cathode more negative is the same as a positive pulse on the grid. The amount of current across *R3* is determined by what part of the comparison waveform is at the plate at the time the sync pulses arrive at the grid and cathode.

#### Trouble Shooting

In all three systems, the main source of trouble lies in the *afc* tube. Since all the discussed systems depend on certain tube characteristics such as cathode current, balance of two tube sections, input capacity or gain, it can be seen that as the tubes age, these characteristics will change. In the syncrolock system, the components which are the most likely source of trouble are *C4* and *C5*. In the syncroguide the most common component sources of trouble are *R9* and *R11*. In the phase detector, the feed-back resistor and decoupling condenser *R4* and *C5*, most usually cause trouble. In the concluding article, we will discuss the theory and operation of the horizontal output section.

## TECHNICAL ARTICLES WANTED on

TV, AM RADIO, FM RADIO, PHONO MECHANISMS, Hi-Fi AUDIO, AUTO RADIO, TEST EQUIPMENT, ANTENNAS

pertaining to their

**Theory, Installation, Application, Service & Maintenance**

submit manuscripts to Managing Editor

**RADIO-TELEVISION SERVICE DEALER**

67 West 44th Street

New York 36, N. Y.

# Fluctuating LINE VOLTAGE

## THE BOOBY TRAP OF TV SERVICING

by VERNE ROBERTS

**Radio and TV receiver operation depends considerably on steady line voltage conditions. Where extreme voltage variations occur a voltage adjuster is necessary.**

**D**URING World War II the Air Force found, to its consternation, that eccentric results were being obtained from the Link Trainer tests, as evinced on their charts. Link Trainers were often used to test the ability and aptitude of potential pilots. Often the tests were conducted in large groups, which started together and were timed. After many such tests it was found that, according to the results of the charts, the top-notch personnel who completed the work quickly rated poorly, while the ones who took longer to finish obtained better ranking. It was inconsistent.

It happens that S. R. (Sandy) Cowan the publisher of this magazine, who was then engaged in a certain military consultative capacity,

studied the problem and after making preliminary tests found that when many Link Trainer batteries were put into operation at one time, the supplying line voltage dropped sharply, frequently to well below 100 volts.

When a battery of Links went into service many of the men who ultimately proved to be the most proficient finished their examinations quickly but their check-charts showed deficiencies and errors. In contrast the poorer students who "sweated it out" and took a longer time in so doing came up with better marks than their more capable colleagues. Research and survey proved that as some of the Trainers were shut off the *ac* line drain diminished, voltage rose, and as it came back to the nor-

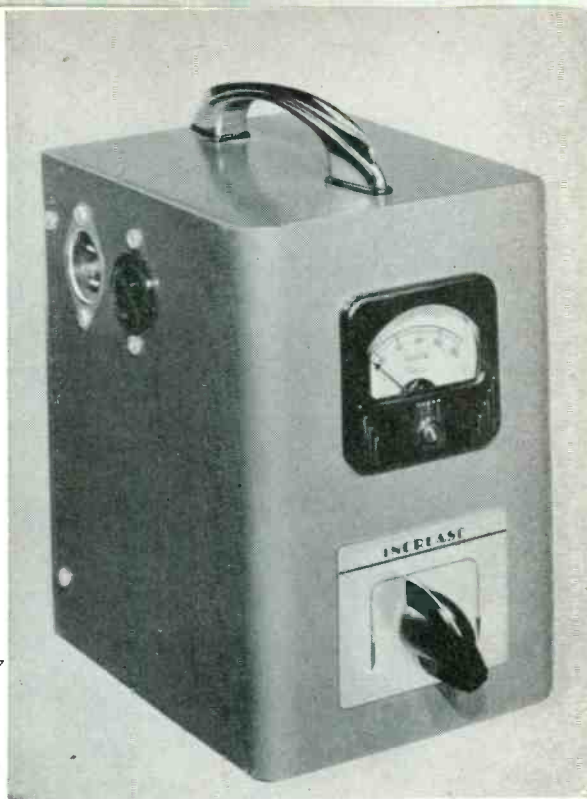

Radio Apparatus Corp. No. V-16  
Voltage Adjuster.

mal 110-117 volt range, the Trainers still in use by the slower students were recording more accurate reaction times. Thus true ability and proficiency was being penalized while check-charts of slower students gave them seemingly better marks in comparison. Naturally, when the *ac* line drop and return-to-normalcy factor was discovered and counter-measures employed, the Air Force obtained accurate readings and more reliable pilot ratings. The use of line-voltage regulators was responsible.

### Line Voltages Vary

Many buildings and homes throughout the country are still functioning as they did when they were built, at a time when a few 60-watt lamps were the only appliances on the lines supplied by public utilities. Then, a maximum of two fuses fed No. 14 wire which delivered current to lamp sockets and open electrical outlets. Now, in many cases, there is still the same basic situation. In the meantime, what has happened? Electric outlets have been added to supply electric irons, mangles, washers, clothes driers, room air-conditioners, dehumidifiers, ranges, refrigerators, deep-freezers, water heaters, room heaters, and fans. The only addition in the last few years which has decreased rather than increased current requirement is the fluorescent light. The electric companies have not been able to keep up with the demand, and, as a result, this has all helped to devise a trap for the un-

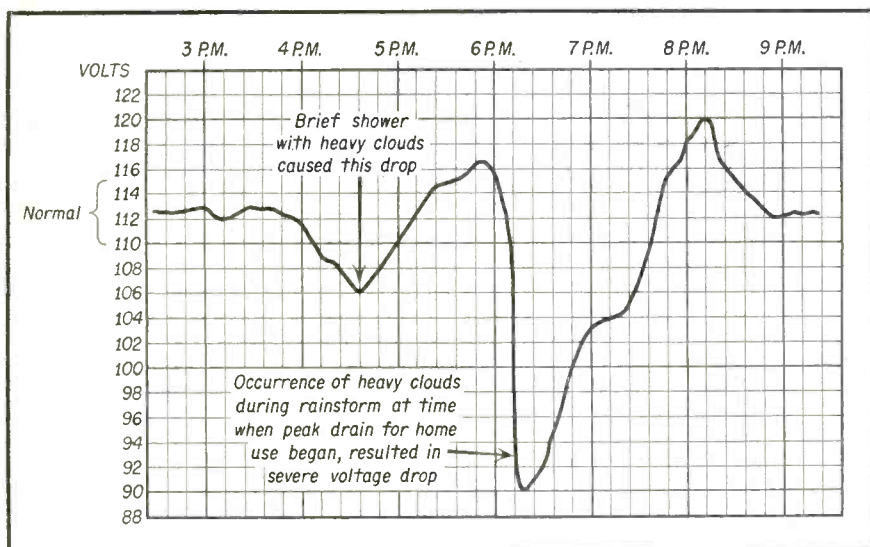

Line voltage variations in typical area during the course of a day's load on the line.



**have  
confidence**

**... THAT YOUR  
FRINGE AREA INSTALLATIONS  
ARE TOPS!**

**Suggest and Use  
the remarkable new Double CO-Lateral**

**FINCO 400-A**

**ALL CHANNEL**

**FINCO IS A NAME  
YOUR CUSTOMERS  
KNOW BECAUSE OF  
THIS POWERFUL  
NATIONAL ADVERTISING  
PROGRAM!**

**UHF and VHF**

**EXCELLENT RECEPTION  
120 to 150 MILES  
FROM STATIONS**

**FARM MAGAZINES** **RADIO** **LOCAL NEWSPAPERS** **TELEVISION** **LIFE**

**FINCO is acknowledged as the  
First and Foremost fringe area antenna**

Fringe area buyers more and more ask for the FINCO by name. Let them know you handle the best — advertise the low cost way with Finco co-op ad mats — tie-in with LIFE — watch your sales soar! Get the complete story from your jobber or write direct

The Finney Co.  
Dept. SD-25  
4612 St. Clair Ave.  
Cleveland 3, Ohio

**RUSH**

- information on the new 400-A and UHF Conversion Kit No. 12.
- FREE LIFE merchandising display material.
- Co-op newspaper ad mat brochure.

YOUR NAME .....

COMPANY NAME .....

ADDRESS .....

CITY ..... ZONE ..... STATE .....

YOUR JOBBER .....

**The FINNEY Company**

Dept. SD-25, 4612 St. Clair Ave. • Cleveland 3, Ohio



suspecting TV service organization or repair man.

What happens to a television set with low voltage? The line losses due to heavy current demand result in a fluctuating low to high voltage. A television set adjusted to the optimum voltage behaves in a peculiar way when voltage is low—flop-over, narrow picture, loss of sensitivity, and many other strange effects not apparent when the set is tested with optimum voltage values.

Let us consider the test bench. Perhaps it is adequately wired as far as the bench itself is concerned, but supply lines are long and have too small a gauge to maintain proper voltage on the bench. Furthermore, evening current demands by the neighborhood are sometimes not adequately fed by the power source, and at times as much as a 15-volt variance may be present on the test bench. Soldering irons, TV sets, room heaters, lights, and test equipment all add up. Perhaps one of the greatest factors contributing to the instability of sweep and marker generators is fluctuating line voltage beyond the limits of the voltage regulators usually incorporated in the better types of that equipment.

This problem of fluctuating or insufficient voltage does have a low-cost and easy answer—a voltage adjuster. Designed specifically for this purpose is the Radio Apparatus Corporation No. V-16 Voltage Adjuster. This adjuster has step-by-step increments, with a voltmeter to give constant line voltage monitoring. It is obvious from the difficulties encountered that, for accurate results, testing and alignment of television receivers should be at a known voltage. This is the only procedure that will give the assurance that presently established marker frequencies will be permanent and that the test equipment will produce the proper answers.

How many television callbacks have been necessary because the receiver was adjusted during the day, when the line voltage was up? A telephone call is received from the customer on the day following the adjustment, pointing out that the set did not function properly the night before. However, the callback on the second day indicates that everything is normal, thus creating confusion in the minds of both the customer and the serviceman. With a Voltage Adjuster, the night-before conditions can be simulated. The customer will then be able to identify the reaction of the night before, and the set can be readjusted to the indicated voltage—or the purchase of a television voltage booster



### MODEL 488 FIELD STRENGTH METER

Saves service time in TV antenna installation—makes service profits longer... Whether installation is fringe in the hills or in the bounce-filled canyons of the city, Model 488 gives you the best location quickly, accurately... Location of maximum signal areas, antenna orientation, comparison of antenna systems, adjustment of boosters and checking antenna and lead-in installations are only a few of the many functions of Model 488.

You're losing profits without one... Dealer's net price including operating instructions and shoulder strap, \$98.50.

See your jobber for full information or write Simpson Electric Company, 5200 West Kinzie Street, Chicago 44, Illinois. Phone CG 1-1221.

In Canada: Bach-Simpson, Ltd., London, Ont.

Another reason why Simpson is the world's largest manufacturer of test equipment

Simpson Electric Company

# Country

will provide a solution for the change in voltage condition. The No. V-16 weighs twelve pounds, [Continued on page 76]

The No. V-16 weighs twelve pounds,

[Continued on page 76]

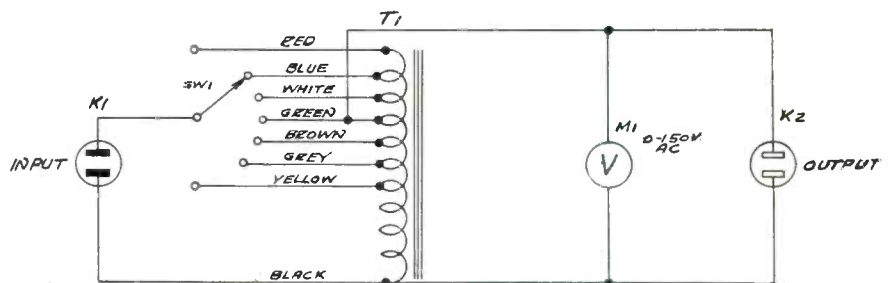

Circuit diagram of V-16 Voltage Adjuster.



# PHONO FACTS - 1953

by MAXIMILIAN WEIL

(President & Chief Engineer, Audax Company)

## PART I

**A compilation of 74 simple pointers which serve as a complete training course for the person who is confronted with the problem of selecting phonograph equipment. This is the first installment of a 2-part article.**

OF the hundreds of letters received by the writer from day to day, it is astonishing to find that such a large percentage are from readers of this publication. It is astonishing because many of these readers are in no way connected with the field of electronics, but they have gained a good understanding of audio equipment and are more critical in selection of apparatus.

Of the many questions in the field of sound reproduction that such letters contain, the most frequent ones are answered here.

It was back about 1935 that "high fidelity" became the talk of the industry. At that time, the R.M.A. issued a definition of high fidelity as—"equipment capable of reproducing frequencies to 7,500 cps or over." This was most unfortunate, as it made *wide range* and *high fidelity* synonymous. Since then, audio equipment has been built to kilocycles and more kilocycles.

On the one hand, the purchaser buys a high-fidelity audio system in the belief that the performance will be, as claimed, one of *fidelity*. That, to the purchaser, means *faithful* reproduction. To the technician, on the other hand, it means wide frequency range in most cases.

According to the above definition, the technician is not misrepresenting, if the audio system is capable of reproducing a wide frequency range. At the same time, however, the purchaser is in the firm belief that he is buying *faithful* reproduction. Accordingly, the deal is a sort of legal fraud, with both parties innocent of it.

Let us cite a few actual cases:

Mr. Smith, who had just bought a high-fidelity audio system on sales talk such as "crisp," "sharp as a razor," "you can hear the resin on the bow,"

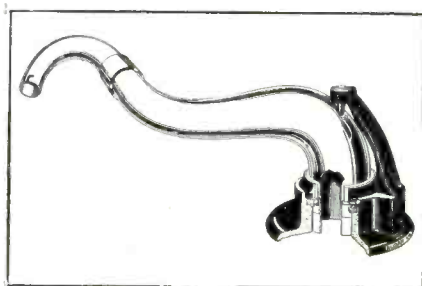

Fig. 1—One of the Audax developments in acoustic tone-arms—that used on the Orthophonic instruments of the mid-twenties.

etc., is much disappointed and disillusioned.

Says Mr. Smith, "It sounds very unpleasant. I decided to check up and went to a concert. At the actual concert, the music I heard was not 'crisp,' not 'sharp as a razor,' I didn't hear the resin on the bow and, what's more, I didn't want to." Smith then puts the treble-control to work, cutting off a lot of kilocycles for which he paid that extra money.

Take the case of Mr. Newman, who just paid over \$650.00 for a high-fidelity system. He is disappointed and complains. The seller answers, "This is 'high-fidelity,' you have to become used to it. . . ." Mr. Newman says, "That's nonsense, no one has to get used to it when at an actual concert and that is the real thing, Mr. High Fidelity himself."

The term high fidelity, as used in connection with audio apparatus, has always seemed to me unfortunate. Why *high* fidelity? Sounds very much like the man who keeps emphasizing that he is *highly* honest—as though there were different degrees of honesty.

Here is a quick test: Compare two pick-ups A and B of different make but whose wide-frequency characteristics are substantially the same. One will be found to perform with *fidelity*, with pleasing musical quality while the other will be harsh, strident, shrill. Yet, both have the same range.

It is now generally conceded that mere extension of frequency range does not, by itself, result in faithful reproduction.

The interchangeable use of *high fidelity* and *wide frequency range* is probably rooted too deeply by now. However, for the good of the audio industry, high fidelity should be re-defined in order to stop continued misunderstanding.

### Pickup Pointers

1. Of two singers covering the same range—each capable of reaching "High C"—one may be pleasing, the other just the reverse. With reproducers of different design, *both wide-range*, one will be pleasing, the other harsh.

2. Most critical factor in a reproducer is vibratory momentum.

3. The larger the vibrating mass, the greater the vibratory momentum.

4. At the comparatively low frequency of 1,000 cps, the vibrating mass has to make 2,000 reversals per second—a terrific rate. But, before it can reverse in direction, it has to come to a stop, and the record groove does the stopping.

5. Obviously, the tinier the vibrating mass, the easier and cleaner the reversal and the less the "hangover."

6. Hangover causes the worst type of distortion.

7. Needle radiation is caused by the stylus itself acting as a diaphragm. However, such radiation is very small and can be heard only when very near

Hi-Fi package installation. Photo—Courtesy of Garrard Sales and Stromberg-Carlson.



to it. Hold a steel needle, loosely, between thumb and forefinger and play it on a 78 r.p.m. record. The sound heard will be due to needle radiation.

8. Needle talk or needle noise (not to be confused with surface noise or scratch), is due to three factors.

- a. Heavy vibrating mass.
- b. Lack of sufficient lateral compliance.
- c. Lack of sufficient vertical compliance.

9. Needle noise is produced by stylus stiffness or heavy vibrating mass, or both, forcing the record itself to act as a diaphragm.

10. Needle noise is annoying when the record player is in the same room with the listener. However, the seriousness of needle noise is in the damage inflicted on the record groove by the factors which cause the noise.

11. The constant, inexorable pounding of the groove walls will soon show itself in increased distortion and gradual destruction of the disc.

12. High vertical compliance is as important as is high lateral compliance.

13. Lack of sufficient compliance greatly accelerates groove erosion.

14. Twice during each cycle the stylus hits a constricted part of the groove (pinch effect) with a terrific "bang." The effect of this is similar to what happens when the dangling chain on the rear of a truck bounces along the pavement.

15. When a reproducer possesses the desired vertical compliance, it is important that it be so designed as not to permit vertical generation. Such generation introduces second harmonic and vertical-noise distortion.

16. For the compliance to be effective, the lateral compliance of the tone-arm should be at least equal to the lateral compliance of the reproducer.

17. A practical and sure way to

judge reproducer compliance is by listening for needle-noise from across the room, when playing a 78-r.p.m. record . . . with the volume control in *off position*.

18. The louder the needle-talk, the greater the *lack* of compliance or the larger the vibrating mass—or both.

19. The reproducer must be designed so as not to permit frontal oscillations—to and fro movement of the stylus.

20. Science knows of no way to determine the musical quality of a pickup. As with musical instruments, it must be put to the only test that really matters . . . listening.

21. Frequency curves and other technical impedimenta are necessary guides in the laboratory. However, the important fact is that *the ear is the absolute and final judge of musical quality*.

22. The higher the quality of the pickup, the more important is correct matching. (See #81)

23. In general, the higher the quality of a pickup, the lower the output.

24. Reproducing sound from disc is based on *solid* mechanical coupling between stylus-point and groove—not mere touch, but solid coupling.

25. Most popular is the belief that the lighter the needle force, the lower the record-wear. In general, this is so down to a certain point. Reducing the needle force below that critical point will wear the record faster.

26. Even with infinite compliance, there is a definite downward limit to which the needle force can be reduced. This downward limit is determined by the point at which "groove skating" begins.

27. Reducing the needle force to the point of groove skating will result in distortion, and will damage the record rather than preserve it.

28. Tests show that as a factor in

record-wear, vibratory-momentum ranks as number one. It is even more destructive than a too low needle force.

29. In general, the pickup with the lowest vibrating mass and highest compliance will have the lowest distortion and the least record-wear, other things being equal.

#### Stylus

Much has been written on the subject of styli the past few years. Twelve years ago, there was an organized effort put behind the sale of "permanent" points (jewels) for use with pickups then in the homes. At that time the writer stated. . . .

"It is safe to say that more than 90 per cent of the pickups now in use will not work properly with a jewel-point. Any attempt to use a jewel-point with such pickups will result in serious injury to the record."

This was an understatement, if anything. Yet, thousands of jewel-points were sold for use with such pickups (needle force  $\frac{1}{8}$  to  $\frac{1}{4}$  pound), running hundreds of thousands of discs. These styli were sold for as high as \$50.00 each, net.

About four years ago, in an attempt to post the unsuspecting buyer, the writer decided on a lone crusade against the unscrupulous sale of "permanent" points. For several weeks, advertisements were run in 22 of the leading newspapers throughout the country. The cost of this campaign added up to a substantial figure. Apparently someone was being hurt by this campaign, for in October, 1949, the Federal Trade Commission called on the writer for details and explanation of the facts on which this campaign was based.

Some months later, the Commission issued injunctions ordering the vendors of jewel points to desist from



making any further claims as to the number of plays, etc.

### Stylus Pointers

30. *How many records can be played with a given jewel point?* This is one of the most frequently asked questions. Figures ranging from 2,500, 5,000, and even 10,000 plays have appeared in sales literature.

This is an important question and cannot be answered directly. It is like asking, "How many miles of wear can be obtained out of a pair of shoes?" It will depend on the kind of shoes they are, of course, the weight of the person wearing them, the nature of the walk and—most important—the nature of the ground walked upon, such as gravel, concrete, grass, etc.

The number of plays obtainable from any jewel point depends on the kind of jewel and on the needle force. It further depends a great deal on the reproducer with which the stylus is used, the arm structure, and the nature of the material of which the record is made—this latter being especially important.

31. A jewel point that is good for 184 hours play in one case may last only half that time or even less, when used with a different reproducer, different arm, different motor, different discs, etc.

32. It is important for the stylus point to have the correct radius for the particular use intended. For LP discs, a radius of .001 in. will give the best results; for 78 r.p.m. records, a radius of .0028 to .003 will give best results.

33. The included angle should be between 45 and 50 degrees.

34. It is highly important for the stylus point to have the greatest degree of polish the particular jewel is capable of acquiring.

35. With the advent of pickups with a needle force of 12 grams or less, the diamond has come to the fore as a desirable stylus.

36. The use of sapphire or diamond must be decided for each particular case. Each has some advantages over the other.

37. The natural sapphire is capable of acquiring extremely high polish.

38. The National Bureau of Standards rates the diamond as  $4\frac{1}{2}$  times as hard as the natural sapphire.

39. A diamond point will last longer than a sapphire point. However, *no* jewel point is permanent, be it diamond or sapphire. Therefore, periodic replacement is necessary for good reproduction and if the discs themselves are to be preserved.

40. A diamond is good for many more plays than a sapphire. However, there is no difference in the actual

musical results, everything else being equal.

41. The musical performance with a compromise stylus-point will be—just as the name implies—a *compromise*, at best.

42. In the case of stylus-assemblies, the mounting of the jewel is but a small part of the procedure. The complete stylus assembly must then be *laboratory calibrated* for proper frequency response, etc. (See #75)

43. *How does the user know when to change the stylus?* This is a question that keeps coming up over and over again. Here is a quick and simple method that will give a positive indication of the stylus condition:

Obtain a lacquer disc with unmodulated grooves cut on both sides of it—one side for a 3-mil stylus and on the other for a 1-mil stylus. Both types of grooves may be on one side of the disc. When-

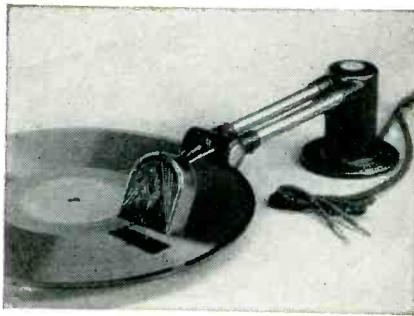

Fig. 2—Early commercial magnetic pickup, showing similarity in construction to acoustic model.

ever in doubt, play two or three grooves on this disc. If the stylus leaves the grooves unchanged in luster and smoothness, you may be sure it is in good condition. If, however, the groove walls show score marks or any other difference when compared with the unplayed grooves, you will know that the stylus needs replacement. An ordinary magnifying glass will be of assistance.

This method is simplicity itself. It does not require dismounting of the pickup or removal of the stylus. It actually demonstrates itself.

### Tone-Arm

In the old acoustic phonograph, the tone-arm had several highly important functions to perform. It was the connecting link between the reproducer ("sound-box") and the horn. This linkage had to provide lateral and vertical movements for the arm. At the same time these linkages had to be fairly air-tight. The tone-arm had to transmit the total acoustic energy

generated by the reproducer diaphragm. It had to act as an acoustic pre-amplifier and it had to maintain a pre-determined relation between stylus and record groove.

Arm resonance—the great destroyer of record grooves—is observed only when sufficient initial exciting energy at the critical frequency is transmitted to the arm.

The stylus in the acoustic reproducer possessed great stiffness—very, very low compliance—and transmitted to the arm a large percentage of the stylus-generated vibratory energy. To avoid devastating resonance, damping was introduced between the reproducer and the arm to minimize transfer of exciter-energy to the arm.

### Tone Arm Pointers

44. In electronic sound reproduction, the arm has only one function—to maintain the stylus in a pre-determined relation to the record grooves.

45. The arm structure and assembly should be such as to introduce no restraint to the free travel of the stylus across the disc.

46. The greater the length of the arm, the better.

47. The greater the distance between stylus-point and the vertical pivots, the smaller the *change* in the angle of incidence between stylus and record groove.

48. The greater the distance between stylus and vertical pivots, the less the pitch-distortion due to turntable wobble, record warpage, etc.

49. Up and down movements due to pinch effect and small record surface irregularities, as well as minor eccentricity, should be absorbed by the compliance of the stylus itself. A stylus capable of absorbing such movements frees the record from having to lift the total mass of the reproducer, practically eliminating record wear caused by this action. This is highly important because, no matter how light the reproducer, its total mass is considerable when compared to the tiny stylus point.

50. Since the tone arm guides the reproducer across the disc, it is important that the lateral compliance of the arm be at least equal to the compliance of the reproducer.

51. Where spring counterbalance is used, it should be checked periodically, preferably seasonally. This is an important factor with a highly-sensitized reproducer working with a needle force of 10 grams or less. A tiny variation of 4 or 5 grams means a variation of 50 per cent, resulting in groove skating and distortion.

52. For obvious reasons, the simpler

[Continued on page 79]

# GERMANIUM and RADIO - ELECTRONICS

by RUFUS P. TURNER

**I**N 1871, Dmitri Mendeleeff (also called Ivanovich), that celebrated map-maker of chemistry, predicted an element which he called *eka-silicon*. But this metal was not to be isolated during his lifetime.

The German chemist Clemens Winkler discovered the element fifteen years later, in 1886, and named it *germanium* in honor of his native land. Not common enough to be found in elementary chemistry textbooks just fifteen years ago, germanium is a word appearing frequently in today's newspapers.

Germanium is a grayish-white metal. In certain of its properties, it resembles carbon, while in others it resembles tin. It has an atomic weight of 72.6. Its compounds have not been widely applied.

Germanium dioxide, a white powder, has been used in medicine in the treatment of pernicious anemia. Little else was done with germanium in the more than half a century following its discovery, however, until in the United States during World War II, it brought the crystal detector of early radio days back from oblivion. Developmental work produced the germanium diode which not only was a more efficient and less fragile detector than were any of the early crystal gadgets, but also showed the remarkable ability to withstand rather high voltages without burning out. Furthermore, it required no searching out of elusive "sensitive spots" on the crystal surface.

The high voltage property of the germanium diode led naturally to the development of the transistor, the crystal triode, which promises ultimately to take over many of the functions now performed exclusively by vacuum tubes.

Today, approximately a dozen manufacturers in the United States and a few more in the rest of the

**Germanium devices assume an ever-increasing importance in radio, television, and electronics. Servicing of equipment in the very near future will demand a knowledge of these components.**

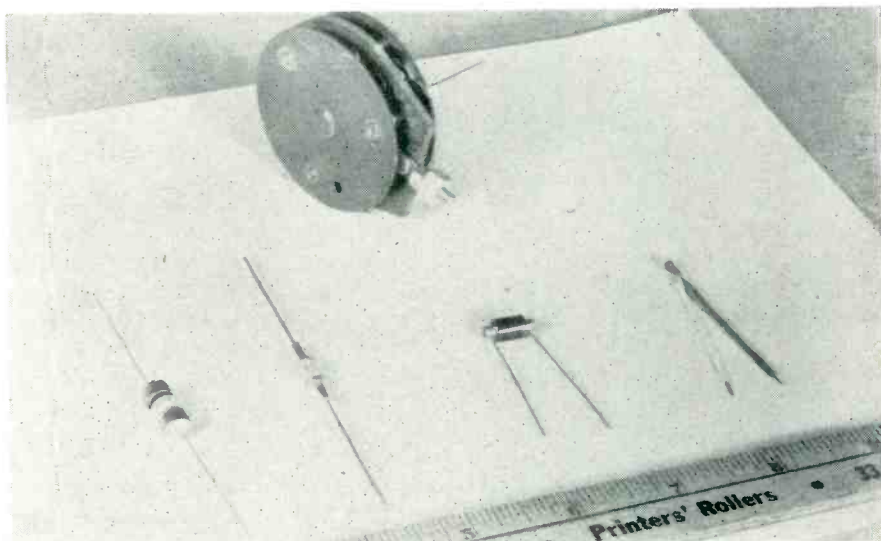

FIGURE 1.  
DIODE-TYPE GERMANIUM COMPONENTS

From left to right in front row: (1) ceramic-cartridge crystal diode, (2) glass-enclosed diode, (3) bakelite-molded diode, (4) sub-miniature germanium photocell. In the rear is one of the new germanium power rectifiers.

world annually produce many thousands of germanium devices for electronic use. Germanium diodes, triodes, power rectifiers, and photocells now are in full-scale production. Germanium devices are to be found in radios, television sets, radar equipment, guided missiles, electronic computers, and test instruments. Continued research and experimentation are bringing forth numerous new applications at an astounding rate.

#### Where Germanium Comes From

It is interesting to consider the sources of the raw material. In Nature, germanium occurs in small quantities in sulfide ores, such as argyrodite from Saxony and Bolivia (which is composed of germanium, silver, and sulfur) and as germanium dioxide in American zinc ores (in concentrations of about one-quarter of 1 per cent).

Germanium metal is separated



from the accompanying ore metals by a several-step process. Germanium tetrachloride is taken off by fractional distillation, and converted to germanium dioxide. The latter then is reduced to metallic germanium by heating it in the presence of hydrogen.

The largest source, however, is another miracle in modern recovery technique. It is the reclaiming of germanium from industrial chimney dusts. Thus, the flue wastes from the smelting of zinc and lead (municipal smog-control commissions please note!) furnish us today with most of our germanium for modern electronic magic. In the United States, the Eagle-Picher Co. is the largest producer of germanium. Recently, in England, processes have been developed to recover germanium from the flue dust of gas works. Since germanium is present to the extent of about one-tenth of 1 per cent in most British coals, this new source of the metal has made England independent of United States sources.

Electronic manufacturers obtain germanium dioxide powder from the producer and process it themselves to obtain high-purity germanium metal. At present, the dioxide costs in the vicinity of 150 dollars a pound. However, the amount of germanium used in each electronic device is exceedingly small. Before the germanium will operate satisfactorily as an electronic semiconductor, it must be "doped" carefully with controlled quantities of selected "impurities," such as tin, antimony, or bismuth.

#### Germanium Devices

The first germanium diodes, exemplified by the now common-place Type 1N34, were offered to the public around 1945. They had initial appeal only to researchers, military equipment designers, amateurs, and experimenters, and were uncommonly slow to catch on in the radio receiver industry. In fact, it is of interest to observe that another semiconductor device, the miniature selenium rectifier, offered at about the same time, far outstripped the germanium diode in establishing itself quickly as a radio receiver component. The picture is changed considerably today, however, with several million diodes being used in civilian radio and television equipment, not to mention the imposing annual consumption of these components by industry and the military.

Since the impact of germanium devices upon the design, application, and maintenance of radio and televi-

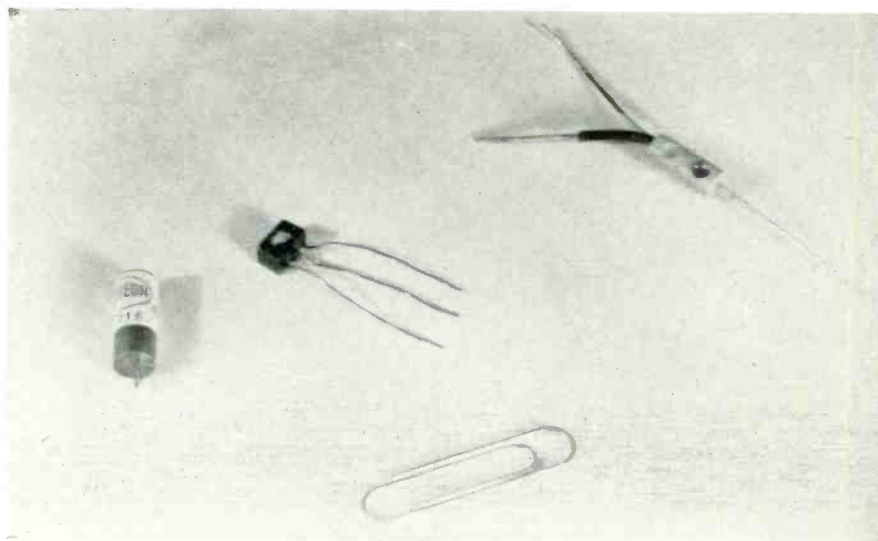

FIGURE 2.  
GERMANIUM TRANSISTORS

Left to right: (1) Plug-in point-contact-type transistor, (2) molded, junction-type, (3) molded point-contact type.

sion equipment will continue to be evidenced in ever-increasing amplitude, the readers of RTSD will be interested in the range of applications and electrical characteristics now afforded by simple germanium devices.

In view of the amount of research and development currently in progress and planned for the immediate future, we may expect that germanium diodes, transistors, power rectifiers, and photocells will appear in larger numbers in the electronic equipment technicians will be called upon to service in the clearly visible future. Our familiarity with these components must match our present acquaintance with electron tubes.

The following paragraphs have been prepared to summarize for the busy service dealer the scope of application of germanium devices and their important electrical characteristics.

#### Diodes

The principal diode characteristics are: maximum average forward (anode) current, maximum continuous reverse working voltage, and maximum peak anode current.

Present diode types offer a distribution of maximum average forward current ranging from 22.5 ma (e. g. Type 1N35) to 60 ma (1N56 and 1N56A). This is the safe current which can be delivered continuously by the diode in applications such as rectification and switching, or which may be passed continuously by the diode as a series circuit element.

Maximum continuous reverse working voltage extends from -25V (1N60

video detector diode) to -200V (1N39). This is the maximum negative voltage which may be applied safely and continuously to the anode terminal of the diode in such typical applications as detection, biased rectification, limiters, dampers, clippers, slicers, waveshapers, etc. It is of interest that several types have been developed with high resistance (low current) at specified reverse voltage levels (e. g.—1N35 and 1N54 10  $\mu$ a. at -10 V, 1N38 6  $\mu$ a. at -3 V 1N38A 5 $\mu$ a. at -3 V, 1N54A 7 $\mu$ a. at -10). These latter units find application where reverse biasing voltage is unavoidable, but efficient blocking action is demanded.

Maximum peak anode current is an expression of the ability of the diode to "take it." This characteristic ranges in present types from 60 ma (1N35) to 200 ma (1N56 and 1N56A). Closely related is the *maximum instantaneous forward surge current* which may be applied for 1 second without damage to the diode. This ranges from 100 ma (1N35) to 1 ampere (1N56 and 1N56A).

Germanium diodes are useful at frequencies up to 100 megacycles or more. They exhibit a shunt capacitance (which is due to a combination of internal and external factors) of 0.8 to 1  $\mu$ fd., can be used over the temperature range -50° to +75°C., and have exhibited an average, during the period since life tests began, of 10,000 hours.

In addition to their use in receivers

*(Continued on page 76)*

GET READY FOR **UHF!**

# Join the Alliance Profit Parade!



## SOLD THE MOST BECAUSE SEEN THE MOST!

BY 36 MILLION VIEWERS IN  
13 MILLION HOMES

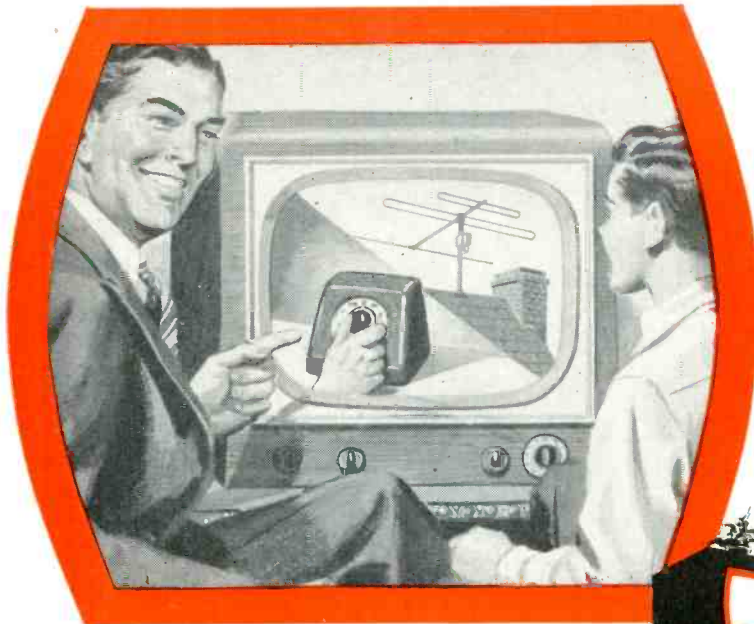

Alliance Tenna-Rotor, properly installed with a good directional, all-channel antenna (conical — in-line — colinear — or other conventional type) makes for perfect reception. Avoid frequent alterations—realignments—replacing of out-moded single-channel antennas, by turning one antenna to every station!

New UHF stations are highly directional! Channels are changing on many stations . . . this makes 'stay-put', single channel antennas obsolete! For top gain on all channels . . . UHF and VHF, Alliance Tenna-Rotor is the number one TV accessory!

"Just set it  
and forget it"



### PRE-SELLING Your Prospect **PAYS OFF!**

Alliance TV spots demonstrate, convince — **SELL!** They're packed with eye-compelling action! It pays to push the line with the *least* resistance — the most acceptance! Sold by *Television Dealers* everywhere.

### FROM COAST TO COAST

New products join the Alliance Profit Parade! The Alliance Cascamatic, automatic TV Booster with the famous "California Circuit" is the latest profit maker added to the Alliance line.

Pre-tuned to all VHF channels, this 3-tube booster mounts on back of set.

**ALLIANCE MANUFACTURING COMPANY • ALLIANCE, OHIO**



# VIDEO SPEED SERVICING SYSTEMS 8th INSTALLMENT

## INDEX FOR APRIL and MAY ISSUES

<i>Mfr.</i>	<i>Chassis No.</i>	<i>Section Affected</i>	<i>Month</i>	<i>Page</i>	<i>Card No.</i>
Airline	84HA3010	Pix	April	39	AI3010-1
Airline	84HA3010	Pix	April	39	AI3010-2
Airline	84HA3010	Pix	April	39	AI3010-3
Airline	84HA3010	Raster	April	40	AI3010-4
Airline	84HA3010	Sync	April	40	AI3010-5
Airline	84HA3010	Pix	April	40	AI3010-6
Arvin	TE-290	Sound	April	41	AR290-1
Arvin	TE-290	Raster	April	41	AR290-2
Arvin	TE-290	Sync	April	41	AR290-3
Arvin	TE-290	Pix	April	42	AR290-4
Arvin	TE-290	Pix and Sound	April	42	AR290-5
Arvin	TE-290	Sound	April	42	AR290-6
Crosley	265	Sync	May	45	CR265-7
Crosley	265	Pix	May	45	CR265-8
Crosley	265	Pix	May	45	CR265-9
Crosley	265	Sound	May	46	CR265-10
Crosley	265	Pix	May	46	CR265-11
Crosley	265	Pix	May	46	CR265-12
Magnavox	CT219	Sound	April	43	MA219-1
Magnavox	CT219	Pix	April	43	MA219-2
Magnavox	CT219	Pix	April	43	MA219-3
Magnavox	CT219	Pix	April	44	MA219-4
Magnavox	CT219	Pix	April	44	MA219-5
Magnavox	CT219	Pix	April	44	MA219-6
Philco	51T1433B (Code 121, 122)	Sync	April	45	PH1433-1
Philco	51T1433B (Code 121, 122)	Raster	April	45	PH1433-2
Philco	51T1433B (Code 121, 122)	Pix	April	45	PH1433-3
Philco	51T1433B (Code 121, 122)	Pix	April	46	PH1433-4
Philco	51T1433B (Code 121, 122)	Pix	April	46	PH1433-5
Philco	51T1433B (Code 121, 122)	Pix	April	46	PH1433-6
Silvertone	51-478.339	Raster	May	47	S1478-1
Silvertone	51-478.339	Pix	May	47	S1478-2
Silvertone	51-478.339	Sync	May	47	S1478-3
Silvertone	51-478.339	Sync	May	48	S1478-4
Silvertone	51-478.339	Sync	May	48	S1478-5
Silvertone	51-478.339	Raster	May	48	S1478-6
Stromberg-Carlson	317 Series	Pix	May	49	SC317-1
Stromberg-Carlson	317 Series	Pix	May	49	SC317-2
Stromberg-Carlson	317 Series	Sync	May	49	SC317-3
Stromberg-Carlson	317 Series	Pix	May	50	SC317-4
Stromberg-Carlson	317 Series	Raster	May	50	SC317-5
Stromberg-Carlson	317 Series	Pix	May	50	SC317-6
Sylvania	1-139	Pix	May	51	SY139-13
Sylvania	1-139	Pix	May	51	SY139-14
Sylvania	1-139	Pix	May	51	SY139-15
Sylvania	1-139	Pix	May	52	SY139-16
Sylvania	1-139	Pix	May	52	SY139-17
Sylvania	1-139	Pix	May	52	SY139-18

Mfr. Crosley Chassis No. 265

Card No. CR-265-7

Section Affected: Sync

Symptom: Loss of horizontal sync after set operates a few hours.

Cause: Component failure.

What To Do:

Change: C160 (.01  $\mu$ f-molded)—with a .01  $\mu$ f-600V paper capacitor.

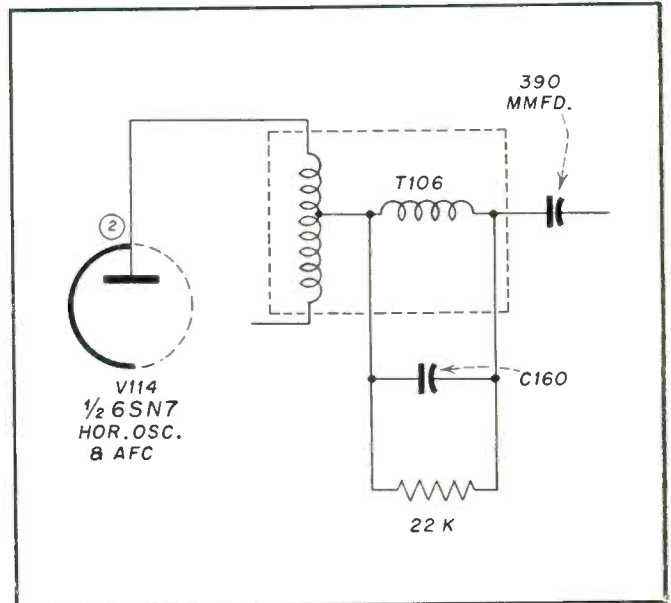

Mfr. Crosley Chassis No. 265

Card No. CR-265-8

Section Affected: Pix

Symptom: Pix interference and streaking.

Cause: Arcing between the plate leads of the horizontal output and damper tubes, V115 and V116.

What To Do:

Install: Fiberglass sleeving (part #39468-14) over the lead which goes from the cap of V115 to lug #2 of T107. (Place sleeving toward lug #2.)

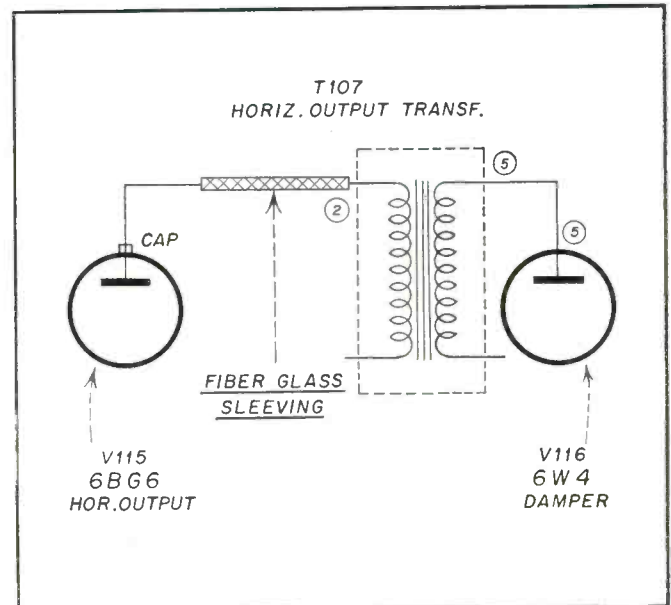

Mfr. Crosley Chassis No. 265

Card No. CR-265-9

Section Affected: Pix

Symptom: Insufficient width.

Reason For Change: Circuit improvement.  
(This change was started in later production models)

What To Do:

Add: .02  $\mu$ f capacitor across width coil L18.

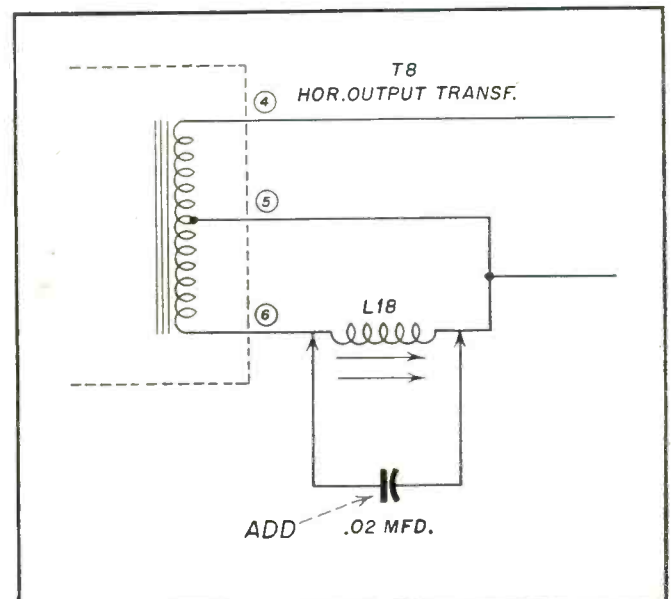



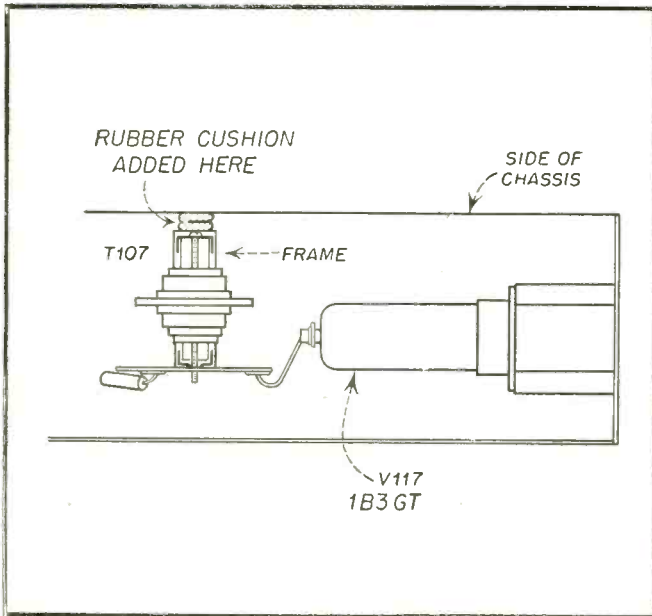

Mfr. Crosley Chassis No. 265

Card No. CR-265-10

Section Affected: Sound

Symptom: A high-pitched tone is heard.

Cause: Horizontal output transformer T107 "sings."

What To Do:

Remove: Rubber cushion from between the side of chassis and the frame of T107. Fold cushion and reinsert it in same place as shown in figure.

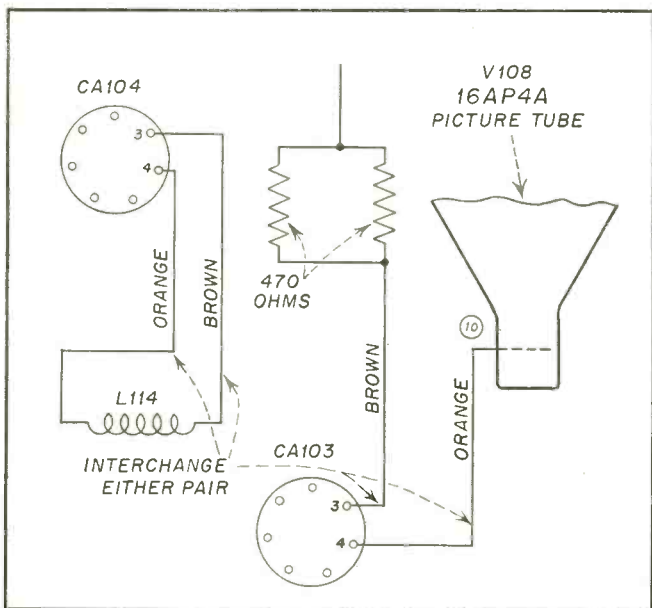

Mfr. Crosley Chassis No. 265

Card No. CR-265-11

Section Affected: Pix

Symptom: Neck shadow and difficult picture centering.

Cause: Reversed focus coil polarity.

What To Do:

Interchange: The brown and orange leads (pins #3 and #4 of socket CA103 or plug CA104. Center picture properly.

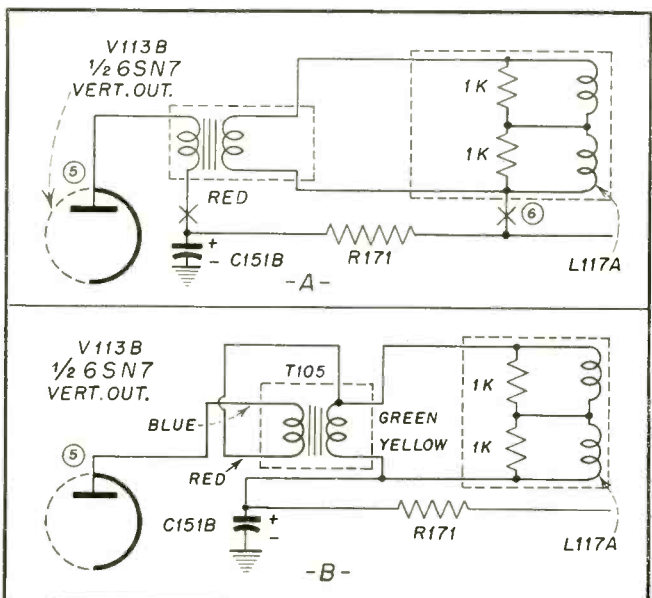

Mfr. Crosley Chassis No. 265

Card No. CR-265-12

Section Affected: Pix

Symptom: Insufficient height.

Reason For Change: Circuit improvement.

What To Do:

Change: R171 (5.6K) to 4.7K-1W 10%. (Fig. A)

Disconnect: Red lead of vertical output transformer T105 going to junction of R171-C151B (10  $\mu$ f electrolytic). (Fig. A) Also, lead going from lug #6 of vertical deflection yoke L117 to R171. (Fig. A)

Connect: Red lead of T105 to green lead of T105. (Fig. B) Also, yellow lead of T105 to junction of C151B-R171. (Fig. B)

Mfr. Silvertone Chassis No. 51-478.339

Card No. SI478-1

Section Affected: Raster

Symptom: Shading of raster (or pix) going from left to right or vice-versa.

Cause: Incorrect wiring or component failure.

What To Do:

Reverse: Wiring of blanking circuit germanium diode rectifier.

Check: For defective rectifier.

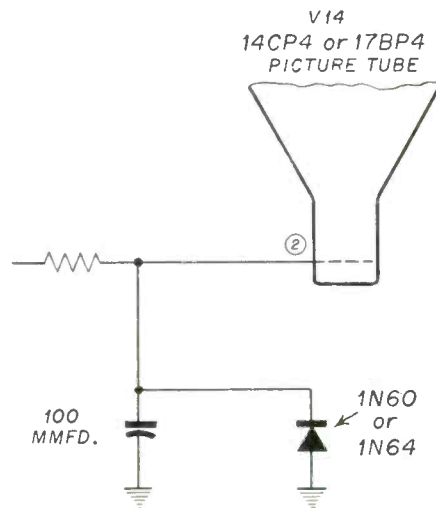

Mfr. Silvertone Chassis No. 51-478.339

Card No. SI478-2

Section Affected: Pix

Symptom: Excessive pix smearing.

Cause: Component failure.

What To Do:

Replace: Defective germanium diode video detector.

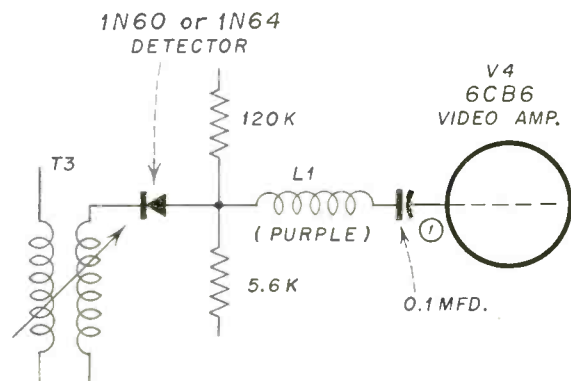

Mfr. Silvertone Chassis No. 51-478.339

Card No. SI478-3

Section Affected: Sync

Symptom: Vertical instability.

Cause: Component failure.

What To Do:

Replace: Defective C54 (.002  $\mu$ f).

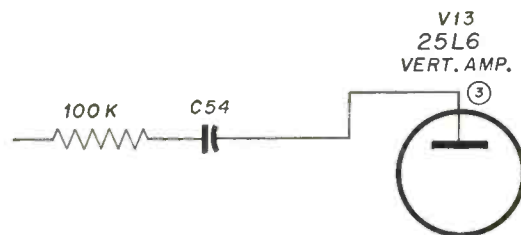



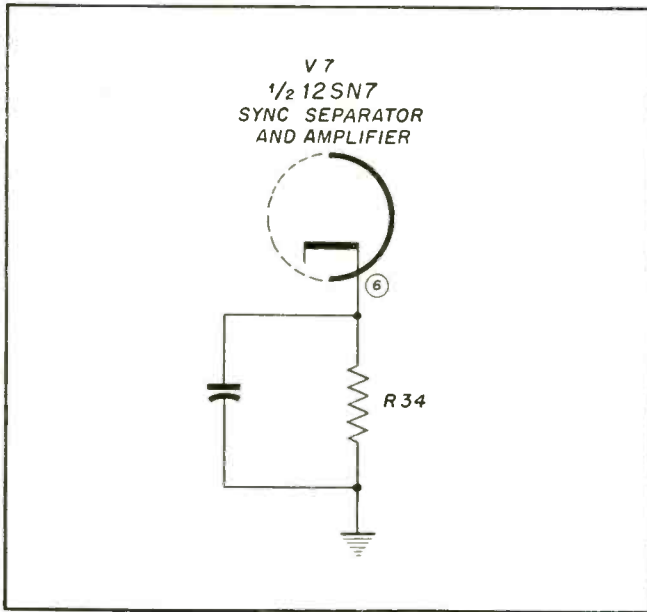

Mfr. Silvertone Chassis No. 51-478.339

Card No. SI478-4

Section Affected: Sync

Symptom: Unstable vertical and/or horizontal sync.

Cause: Insufficient bias for sync amplifier stage, V7.

What To Do:

Change: R34 (3.3K) to 6.6K.

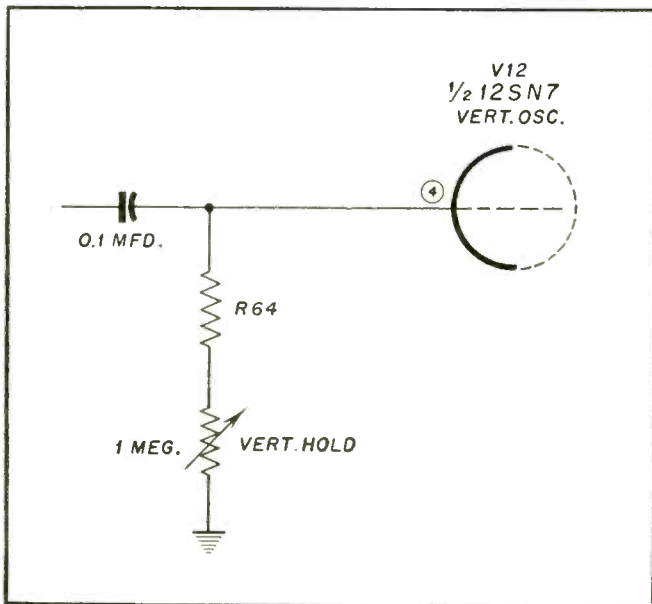

Mfr. Silvertone Chassis No. 51-478.339

Card No. SI478-5

Section Affected: Sync

Symptom: Vertical sync instability.

Cause: Vertical oscillator drift due to component changing value.

What To Do:

Replace: R64 (560K)—1/2W.

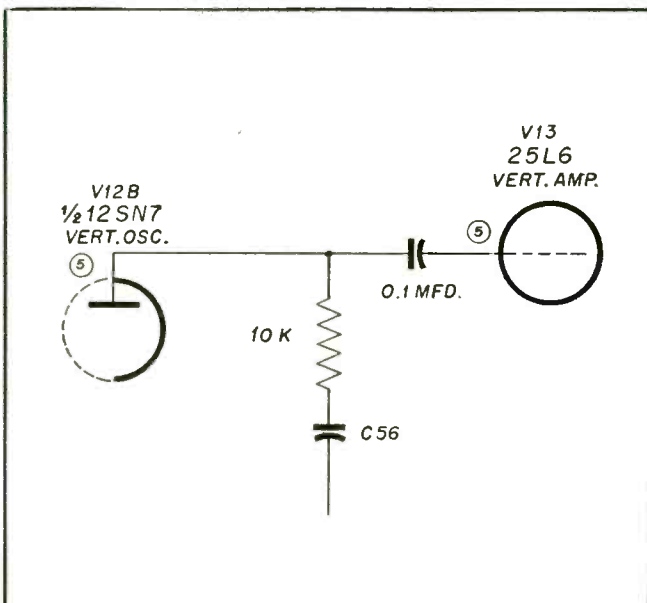

Mfr. Silvertone Chassis No. 51-478.339

Card No. SI478-6

Section Affected: Raster

Symptom: Compression at bottom of raster after the set has been operating for about an hour.

Cause: Component failure.

What To Do:

Replace: C56 (.05  $\mu$ F).

Mfr. Stromberg-Carlson Chassis No. 317 Series

Card No. SC317-1

Section Affected: Pix

Symptom: White bars (ringing) at left hand side of pix or raster.

Reason For Change: Incorrect yoke impedance.

What To Do:

Replace: Present yoke with Stromberg part #114724.

Connect: Red lead of new yoke to terminal #7 of terminal #5 as at present.

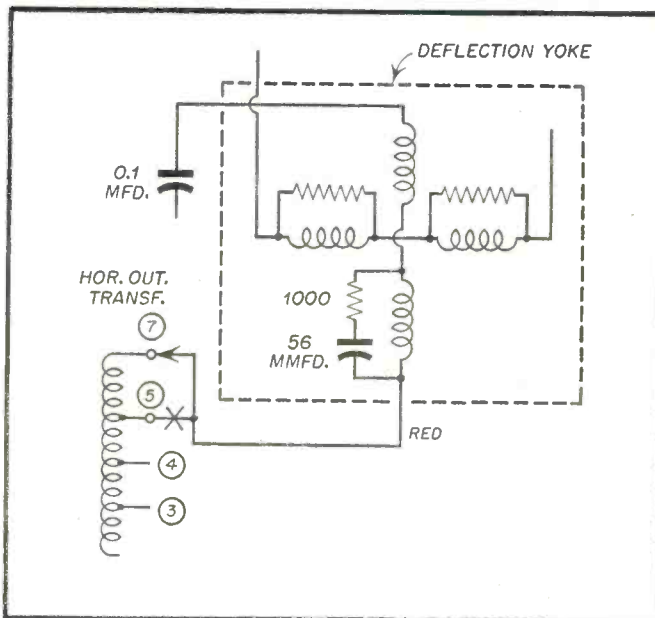

Mfr. Stromberg-Carlson Chassis No. 317 Series

Card No. SC317-2

Section Affected: Pix

Symptom: Loss of width with increased brightness.

Cause: Variations in CRT's.

What To Do:

Change: R110 (150K) to 270K.

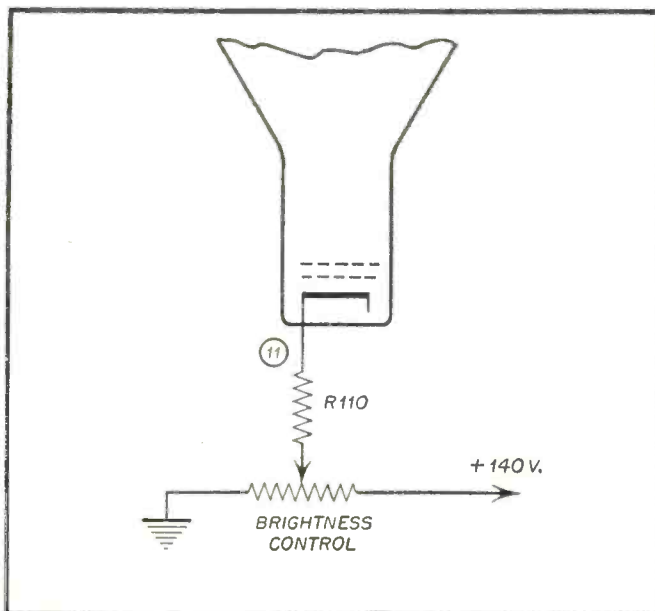

Mfr. Stromberg-Carlson Chassis No. 317 Series

Card No. SC317-3

Section Affected: Sync

Symptom: Vertical holds only at end of control.

Reason For Change: Compensate for component tolerances.

What To Do:

Change: R184 (1 meg) to 680K.

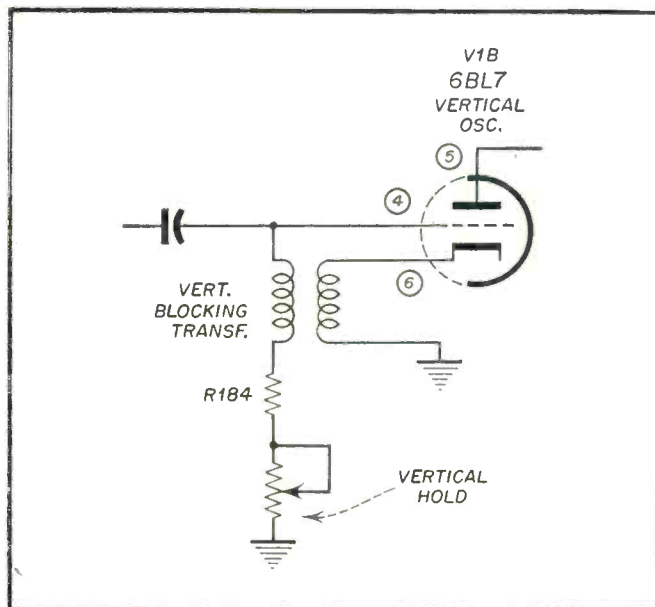



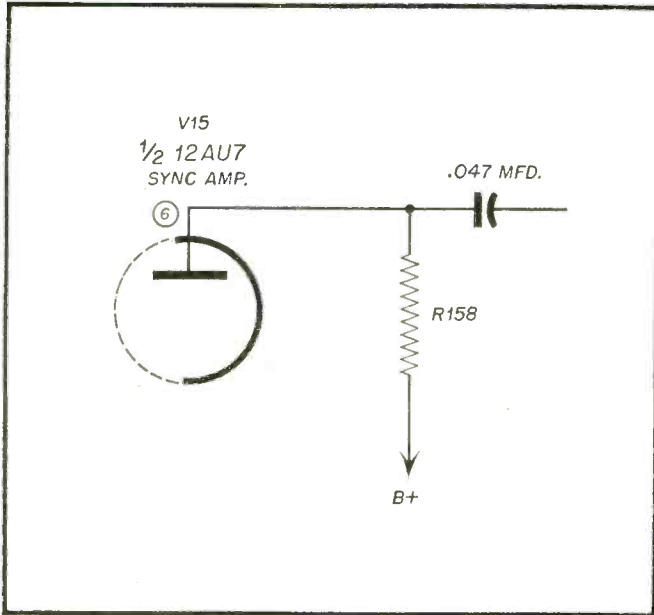

Mfr. Stromberg-Carlson Chassis No. 317 Series

Card No. SC317-4

Section Affected: Pix

Symptom: Left side of pix cut off.

Cause: Defective circuit component.

What To Do:

Check: R158 (10K).

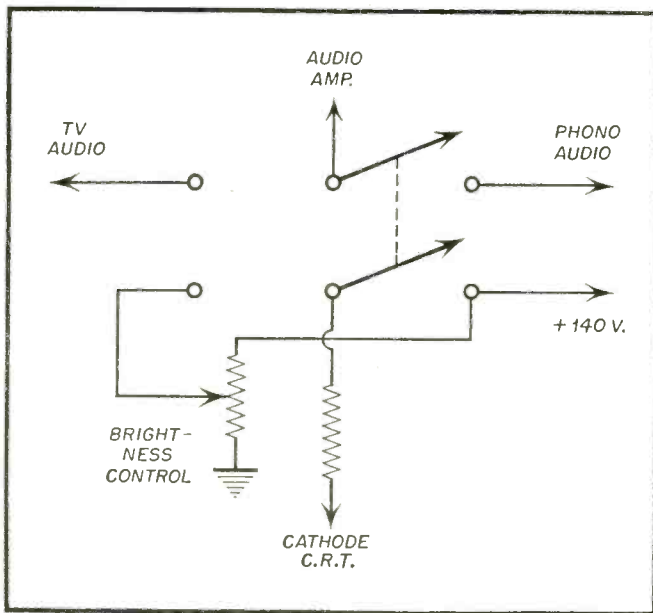

Mfr. Stromberg-Carlson Chassis No. 317 Series

Card No. SC317-5

Section Affected: Raster

Symptom: Light on screen does not go out when phono switch is on.

Reason For Change: Circuit improvement.

What To Do:

Rewire: Switch as shown.

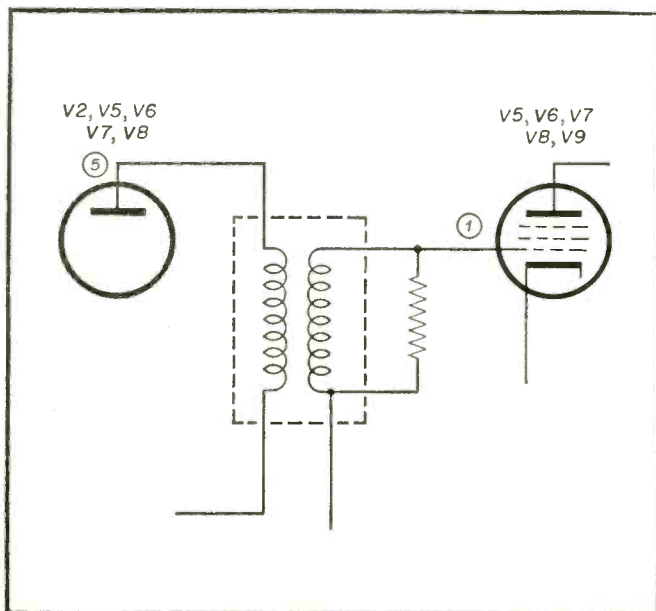

Mfr. Stromberg-Carlson Chassis No. 317 Series

Card No. SC317-6

Section Affected: Pix

Symptom: Poor picture, snowy, etc.

Cause: Component failure.

What To Do:

Check: Video if bifilars for primary to secondary short.

Mfr. Sylvania Chassis No. 1-139

Card No. SY139-13

Section Affected: Pix

Symptom: Poor horizontal sync in fringe area.

Reason For Change: Circuit improvement.

What To Do:

Connect: 2.2 meg resistor across R233 (2.2 meg) and R119 (2.2 meg).

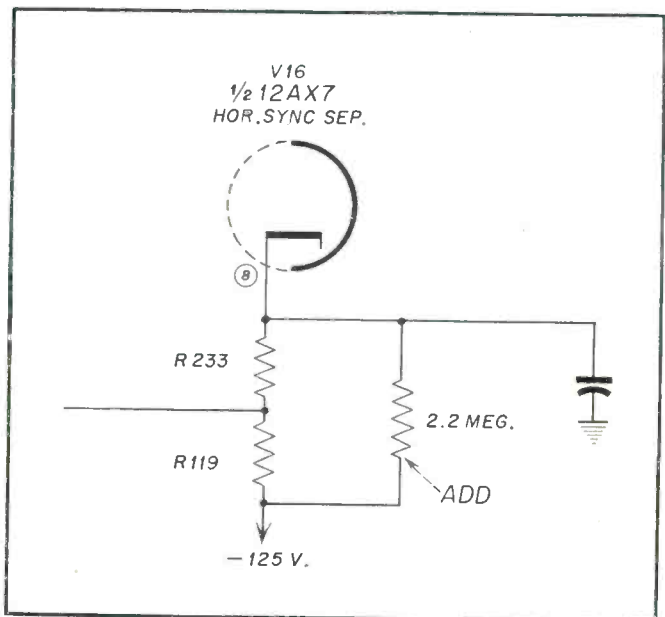

Mfr. Sylvania Chassis No. 1-139

Card No. SY139-14

Section Affected: Pix

Symptom: Vertical jitter.

Reason For Change: Circuit improvement.

What To Do:

Change: C147 from .00022  $\mu$ f to .005  $\mu$ f.

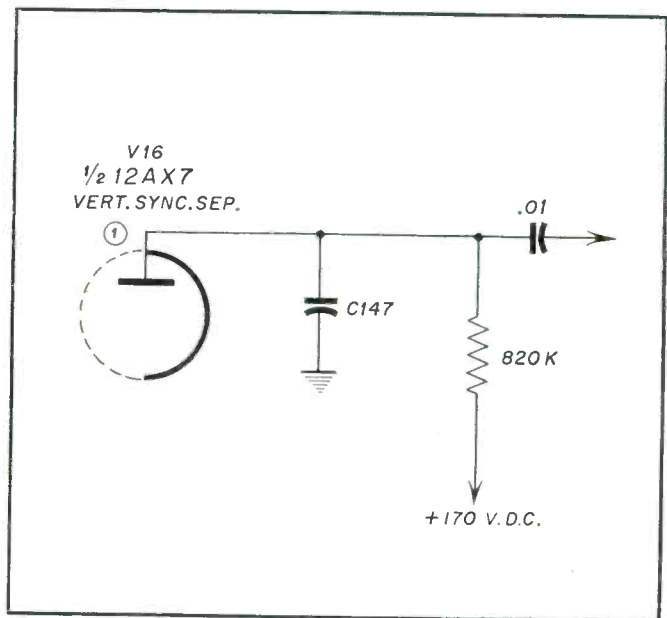

Mfr. Sylvania Chassis No. 1-139

Card No. SY139-15

Section Affected: Pix

Symptom: Loss of horizontal sync or sweep.

Cause: C120 leaking.

What To Do:

Replace: C120 (.0001  $\mu$ f) ceramic capacitor with a .0001  $\mu$ f mica.

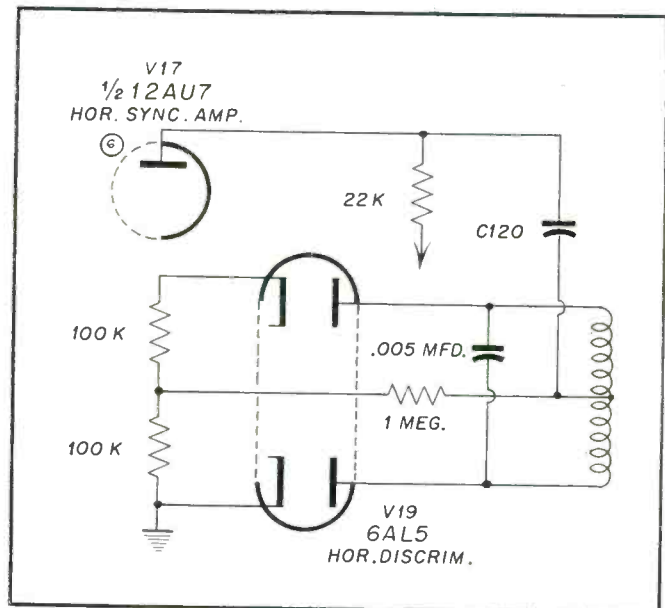



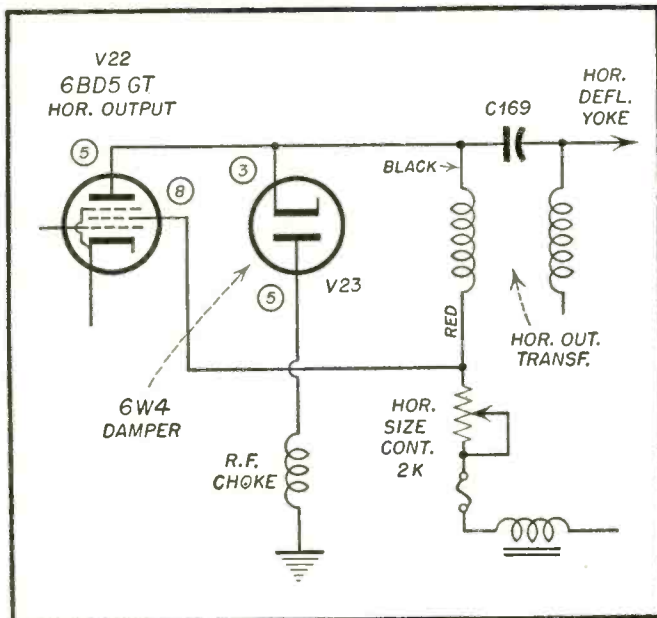

Mfr. Sylvania Chassis No. 1-139

Card No. SY139-16

Section Affected: Pix

Symptom: Horizontal size control burns up.

Cause: Component failure.

What To Do:

Check: C169 for short or leak.

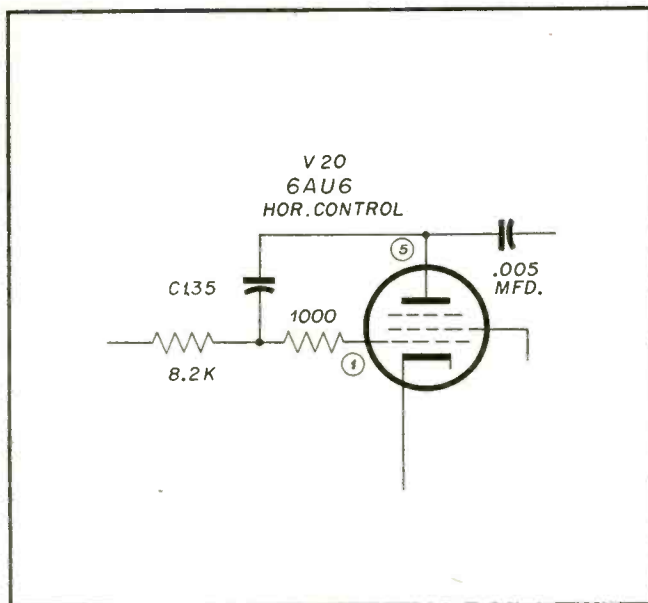

Mfr. Sylvania Chassis No. 1-139

Card No. SY139-17

Section Affected: Pix

Symptom: Pix "hooks."

Cause: Condenser leakage.

What To Do:

Replace: C135 .0001  $\mu$ f-500V ceramic with .0001  $\mu$ f-500V mica.

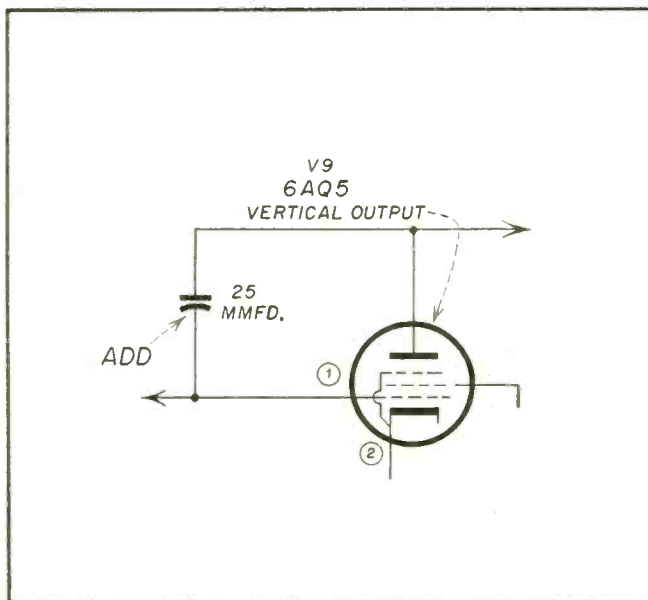

Mfr. Sylvania Chassis No. 1-139

Card No. SY139-18

Section Affected: Pix

Symptom: Horizontal white line in pix.

Reason For Change: Circuit improvement.

What To Do:

Add: 25  $\mu$ f condenser from plate pin #5 to grid pin #1 of 6AQ5.

# MANUFACTURERS FURTHER PUBLIC-SERVICEMAN RELATIONS

The manner in which manufacturers are pointing up the problems of the TV serviceman to the general public, thereby improving public relations and confidence is graphically illustrated in G. E.'s ambitious program in this direction. Shown below are examples of their efforts. From time to time the public relations campaigns of other leading manufacturers will be shown also.



HE GIVES PATERSON, N.J., A PROFESSIONAL TEAM OF ACE SERVICEMEN

Across the country, TV service has become accepted as a new "profession." One of the reasons is this new industry's high calibre of men. Take "Dusty" Rhodes of Paterson, N.J. He's on the Chamber of Commerce's Board of Directors. He's president of the Radio and Television Service Men of N. J. He's active on the Community Chest. In other words, he's a credit to his calling and his community.

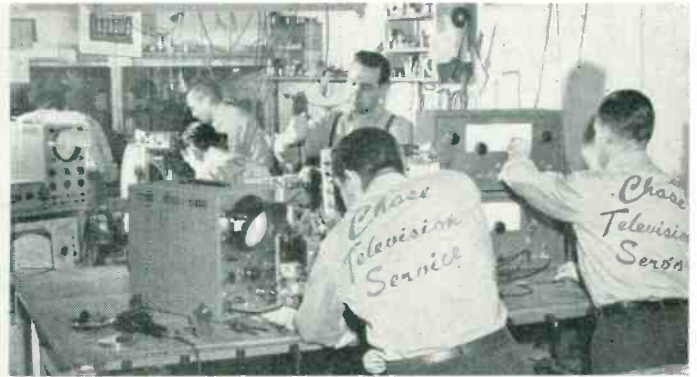

SOMETIMES THE "IMPOSSIBLE" TAKES A LITTLE LONGER. When a TVset can't possibly be serviced in a customer's home, it is taken back to the shop. Chase's highly trained staff have everything at their command—including \$30,000 worth of equipment—to do the job right, quickly and at the standard, fair rate.

"FAMOUS LAST WORDS" APPEARS IN TRADE PUBLICATIONS AND IS DESIGNED TO POINT OUT THE PITFALLS OF POOR BUSINESS TECHNIQUES.

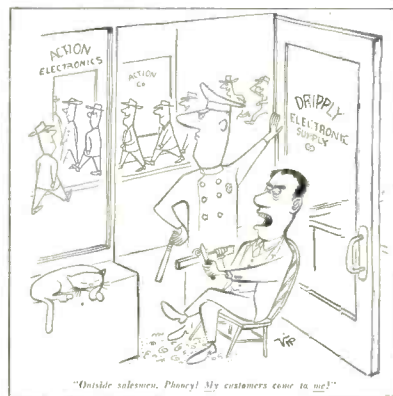

These Ads Appear In:  
LIFE,  
COLLIER'S,  
LOOK,  
AND VARIOUS  
TRADE  
PUBLICATIONS



SERVICE, and where to obtain it, is featured in this poster that works fulltime for the serviceman whose name and number show prominently at center. Floodlighting increases the board's usefulness.

OPERATION TELEVISION—RIGHT IN THE HOME. When your TV serviceman removes your TV chassis from its cabinet, ask him to show you the myriad tubes, coils, and other parts, inter-connected



by an "orderly maze" of wiring! Only high-skilled hands can safely probe for faults, make repairs—usually on the spot—that restore the picture and sound to normal. His tools and equipment are as complete for their purpose as the contents of a doctor's kit. Aided by his specialized training, your serviceman diagnoses TV troubles, and restores your set to "health," in the least time and at the least cost to you.



# CIRCUIT COURT

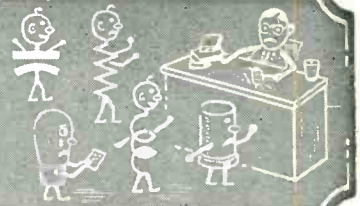

## Capehart CT52 & CT57—Heptode Sync Stripper

From the looks of the sets recently reaching the market, more and more of the manufacturer's are hopping on to the heptode sync stripper bandwagon. The Capehart CT52 (Fig. 1) is another in the parade. There are, however, some noteworthy features in this receiver.

In order to keep from loading the video amplifier output, and at the same time have better control of the two signals, the sync stripper signal is taken off the video detector. To obtain phase reversal, also greater amplitude needed for the second control grid of V14, the sync stripper, the signal from the detector is fed to a 6BA6 sync amplifier, V13.

The cathode of V13 is grounded. The grid leak resistor R52 (47K) with a signal across it causes the tube to cut off on the sync pulses. The plate is kept at approximately 25 volts due to the dc voltage across R54 and R55. This results in a high plate voltage signal during cut-off. The output is a positive going sync pulse with accompanying video information. In

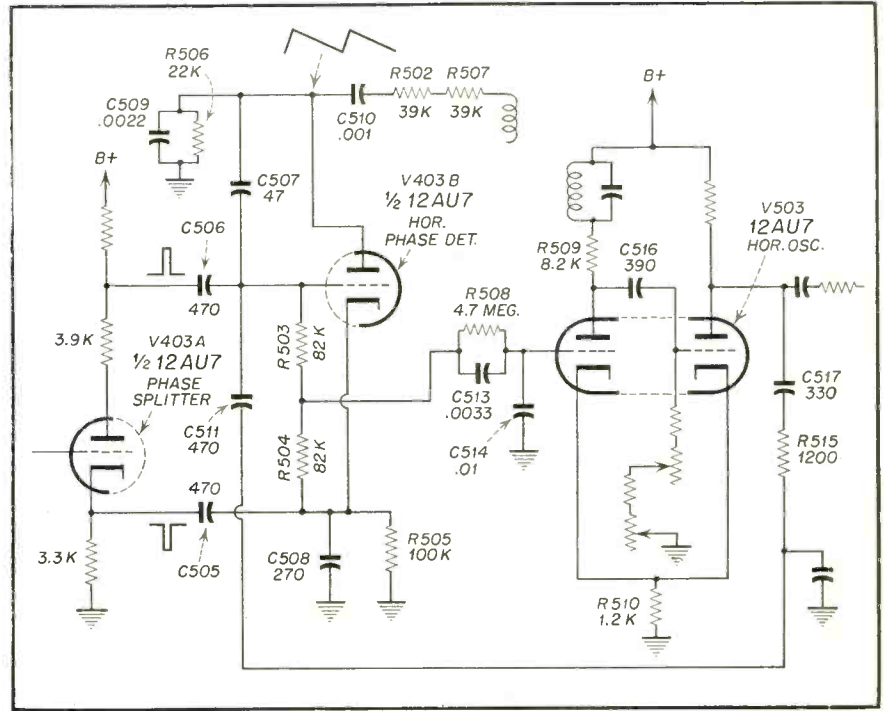

Fig. 2—Partial schematic Capehart CX37

addition to driving the 6BE6 sync stripper this signal also drive a keyed a/c tube.

The 6BE6 first control grid is driven from the video detector with a 2 volt peak to peak negative sync signal. This will hold the tube close to cut-off except when the positive signal from the sync amplifier appears at the second control grid at an amplitude corresponding only to the sync pulses. The feature of this circuit is the presence of R57 a 4.7 meg resistor which goes back to 130 volts B+. The purpose of this resistor is to buck out the negative voltage which would appear across R52, the 6BA6 grid resistor as a result of heavy noise pulses which would bias V14 to cut-off. This bucking voltage is applied in weak signal areas by means of the switch S. This action does not occur during the ordinary sync pulse because the network R56, C55 does not discriminate against sync pulse but does discriminate against sharp noise pulses.

### Capehart CX37—Horizontal AFC

The chassis model shown partially in Fig. 2 uses a triode phase detector. horizontal a/c system. In this application, a pulse is taken off the horizontal output transformer through R502 and R507. These resistors in combination with C510 and C509 act as an integrator and sharpen the pulse into a saw-

[Continued on page 80]

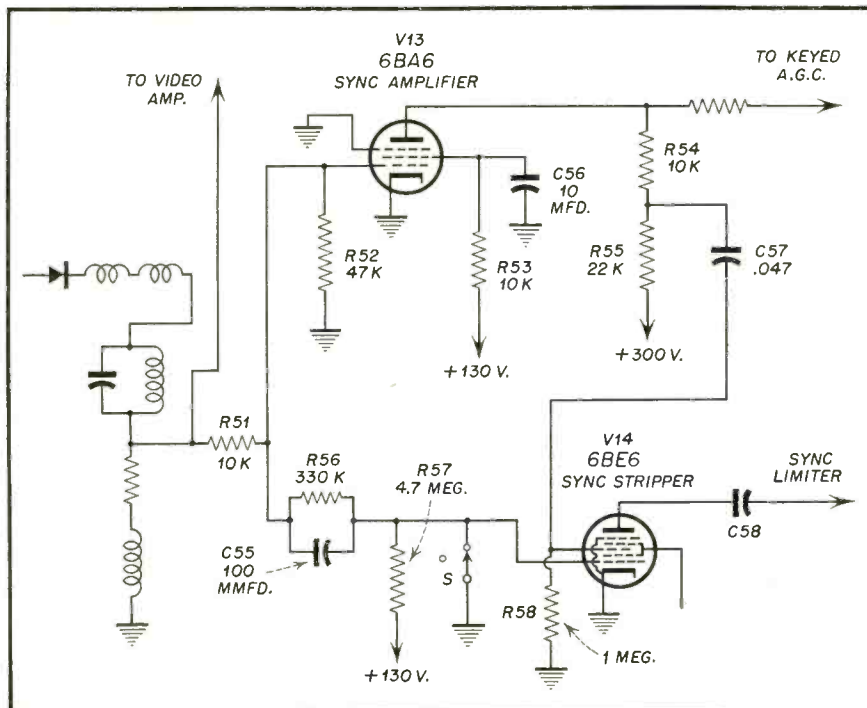
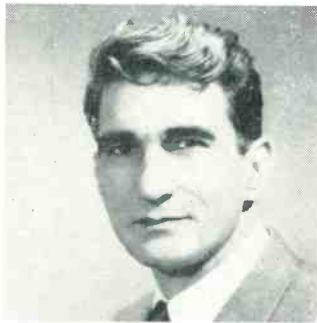

Fig. 1—Partial schematic Capehart CT52

# PERSONNEL NOTES

Meet the key men responsible for the manufacture and distribution of servicemen's products.

The appointment of Frank P. Hogan to be Zone Manager for Television and Radio for the Minneapolis-St. Paul Zone of the Crosley Division, Avco Manufacturing Corporation was announced by E. W. Gaughan, General Sales Manager for Crosley Electronics Activities.



Mr. Octave Blake, president of the Cornell-Dubilier Electric Corporation and chairman of the board of its subsidiary, the Radiart Corporation announces the election of Mr. Harry C. Crawford as president of the Radiart Corporation effective March 20, 1953, replacing L. K. Wildberg.

Gordon R. Rahmes of Schemetady has been appointed a district sales manager for General Electric replacement tubes, Gordon E. Burns, field sales manager of replacement sales for the G-E Tube Department, announced recently.



Bernard O. Holsinger, General Sales Manager Radio and Television Division, Sylvania Electric Products Inc., announced the appointment of F. Gilbert White as District Sales Manager responsible for the sale of Sylvania radio and television merchandise in the Missouri, Arkansas, Tennessee, Mississippi and Louisiana areas.



Jack Grand has been elected Chairman of the Board of Directors of Granco Products, Inc., 36-17 20th Avenue, Long Island City, N.Y. The company was recently organized for the design, manufacture and distribution of converters for ultra high frequency television reception and UHF measuring instruments.

John H. Briggs, President of The Gabriel Company, Cleveland, Ohio announces the appointment of Dr. John Ruze as Director in full charge of The Gabriel Laboratories, Needham Heights, Mass. Dr. Ruze is internationally recognized in the almost boundless field of electronics.



Mr. Charles E. Balz has been appointed sales manager of Burgess Battery Company, United States Battery Division, according to an announcement by Mr. F. J. Kirkman, Vice President and General Manager. Mr. Balz has been Assistant Sales Manager for the past two years, and for the previous ten years Advertising and Promotion Manager.



Latest addition to the technical staff at Littelfuse, Inc., manufacturers of quality fuses, is H. A. Triplett, who was named research director by President E. V. Sundt. Welcoming his new staff member to the Littelfuse "family" is Mr. Sundt (right), in the laboratory of the Des Plaines plant.



Officers of the recently merged Triad Transformer Corp. are: L. W. Howard, President; O. D. Perry, Executive Vice-President; Thomas P. Walker, Vice-President; Allan Wahlgren, Secretary-Treasurer; George Clark, Assistant to the President; Ernest Clover, Manager of Jobber Sales; E. M. Keillor, Chief Engineer; and Charles Shaw, Director of Purchases. Shown at left is L. W. Howard.

The appointment of Henry F. Argento as vice president and general manager of Raytheon Television and Radio Corporation, Chicago, a subsidiary of Raytheon Manufacturing Company, Waltham, Mass., was announced recently by C. F. Adams, Jr., president of Raytheon.



Presentation of a scroll recognizing "50 years of historic progress" is made to Peter L. Jensen (right) of Jensen Industries by Francis Florsheim, chairman of the Electronic Parts & Equipment Manufacturers. The scroll accompanied a television set given to Jensen by the Manufacturers at a special luncheon meeting held in Chicago.





# SHOP NOTES

Write up any "tricks-of-the-trade" in radio servicing that you have discovered. We pay from \$1 to \$5 for such previously unpublished "SHOP NOTES" found acceptable. Send your data to "Shop Notes Editor."

## Sharpening Bar Test Patterns

Some TV technicians use their *rf* signal generators occasionally as bar (line) generators for linearity checking. This is done by externally-modulating the signal generator which feeds the input of a TV receiver. When an audio modulating frequency is used, horizontal bars or lines appear on the TV screen. An *rf* modulating frequency (100 kc and higher) produces vertical bars. In each case; the higher the modulating frequency, the more numerous the lines. The signal generator output may be on any desired TV channel.

It is of interest to note, however, that the fuzziness noticed so often along the edges of the lines and erroneously suspected to indicate some trouble in the receiver may be eliminated by using square-wave modulating voltages instead of sine-wave. The square-wave modulation produces sharp, black bars with hard, straight edges.

Some of the audio oscillators found in repair shops will give either sine or square-wave output as desired. The output of other types (and of low-frequency *rf* oscillators) can be squared sufficiently for this application with crystal-diode clippers.

*Rufus P. Turner*  
Los Angeles, Calif.

## Servicing Tuners

When you see flashes in the picture, or the picture momentarily disappears and reappears you would do well to inspect the tuner. A quick check is to tap, not too gently, on the channel selector knob. If the defect occurs then, you've got tuner trouble. First, an inspection should be made for a loose or faulty tube. If all seem o.k. the chassis should be removed from the cabinet and any cover on the tuner removed in order to gain access to the tuning mechanism. We have found the following procedure to be adequate: If the tuner is a turret type, the metal contact buttons on each channel strip should be rubbed clean with a coarse cloth until each

button is restored to a bright shiny silver. On tuners using rotary wafer switches, apply a good type of liquid cleaner such as carbon "tet" to the rotor blade and each of the spring contacts on each wafer. Also, to make certain that the rotor blade makes a good connection with the spring contact points, each spring contact should be pinched together using a narrow-bladed screwdriver. Finally, to check the work, inspect the switch to see that, as the rotor blade is turned on each channel, the spring contacts actually spread to admit the blade. This may seem tedious, but experience has shown us that these details will pay off in a properly working tuner and a satisfied customer.

*Richard Blitzer*  
New York 32, N.Y.

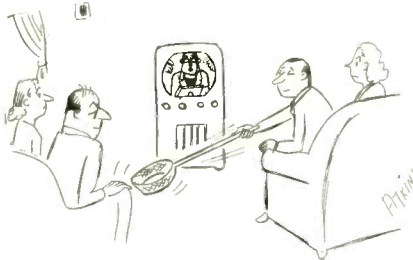

## Intermittent Sound In Admiral Chassis

Intermittent sound in the Admiral chassis 21B1, 21C1 or similar chassis can be caused by a corroded lead on the sound take-off coil, L201, which is connected to pin No. 1 of the 6AU6 1st sound *if* tube. The corrosion usually takes place at the point where the thin coil winding makes contact with the lug on the coil form. Sweating the joint does not help, but a satisfactory repair can be made by scraping the winding clean and resoldering.

*M. A. Convisar*  
B'klyn, N. Y.

## RCA KCS66-68 Pix Flashing

In the RCA KCS66 or 68 chassis a trouble may appear which is difficult to localize to any particular section.

It may resemble an intermittent flashing in the picture. Sometimes it appears as an arcing or ignition type interference. These troubles have been traced to a breaking down of C29 an 8  $\mu$  condenser in the cathode circuit of the 6BQ7, *rf* amplifier in *rf* unit. When the condenser is completely shorted a very snowy picture results.

*Frank Maderaski*  
Bristol, Conn.

## Intercarrier Buzz

I have serviced several receivers whereby a persistent or intermittent case of intercarrier buzz existed. With some receivers the buzz was present only during warm up periods, while, with other receivers the irritating distortion was intermittent. The buzz, when present, could be attenuated by a slight adjustment of the detector or discriminator secondary, however, this was no permanent cure and the buzz persisted. Backed by customer complaints, I investigated the object and found that in each case, the manufacturer had neglected to place a negative temperature coefficient compensating condenser across the detector or discriminator secondary. This resulted in the detuning of the secondary with changes of temperatures.

*Frank R. Fetrow, Jr.*  
Chicago, Ill.

## Barkhausen Oscillation

When certain conditions prevail the horizontal output stage acts as an oscillator and radiates energy which may be picked up by the input circuits of the receiver. This produces several white vertical bars on the left side of the picture and is termed Barkhausen oscillation.

I have found that the best method for killing the oscillations is to replace the horizontal output tube. Several substitutions may be necessary until a tube which will produce satisfactory operation is found. Any tube which produces such oscillations is not necessarily defective and may operate without any ill-effects whatsoever in other receivers.

If tube replacement will not stop oscillation, try inserting a 47 ohm resistor in the cathode, screen grid, or plate lead, or all three elements, depending on the severity of the oscillations. This method is employed by many manufacturers as a safeguard against any oscillation.

A permanent magnet placed around the bulb of the horizontal oscillator tube can be so adjusted to eliminate any oscillations. This cure is only temporary, however, and will have to be adjusted at least once a month for satisfactory operation.

*Frank R. Fetrow, Jr.*  
Chicago, Ill.

# 12 reasons why it pays to replace with SYLVANIA PICTURE TUBES

## Independent laboratory tests show these 12 outstanding qualities of Sylvania Picture Tubes

1. No tube failures (after 1500 hours).
2. No trend toward slumping emission or low light output.
3. No excessive leakage.
4. No excessive gas present.
5. Excellent grid control.
6. Excellent emission characteristics.
7. No stray emission.
8. Low electrical breakdown.
9. Very good color control.
10. Excellent spot centering.
11. Low screen burning (no rejections).
12. Excellent physical conditions.

**Only Sylvania showed  
no tube failures**



Here is proof that Sylvania Picture Tubes are *first* in long life and *finest* in all around performance of all tubes tested.

The above record was established in comparison tests of the tubes of 9 different manufacturers. All tests were conducted under identical conditions by an outside testing agency.

Set owners everywhere are being told again and again about Sylvania's superiority on the big, nationwide TV show "Beat the Clock."

### The Picture Tube for Reliable Replacement

Of course, the name Sylvania has always stood for highest quality. Now, more than ever before, Sylvania Picture Tubes mean better business for jobbers and service-dealers alike. If you would like the full story of these recent tests to show your customers how Sylvania Picture Tubes won over all others tested, simply mail the coupon now.

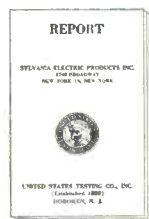

Send for this report



Sylvania Electric Products Inc.  
Dept. 3R-2205, 1740 Broadway, N.Y. 19, N.Y.

Please send me the official report of the tests made on Sylvania Picture Tubes in competition with other makes.

Name \_\_\_\_\_

Company \_\_\_\_\_

Street \_\_\_\_\_

City \_\_\_\_\_ Zone \_\_\_\_\_ State \_\_\_\_\_

# SYLVANIA

LIGHTING • RADIO • ELECTRONICS • TELEVISION

In Canada: Sylvania Electric (Canada) Ltd., University Tower Bldg.  
St. Catherine St., Montreal, P. Q.



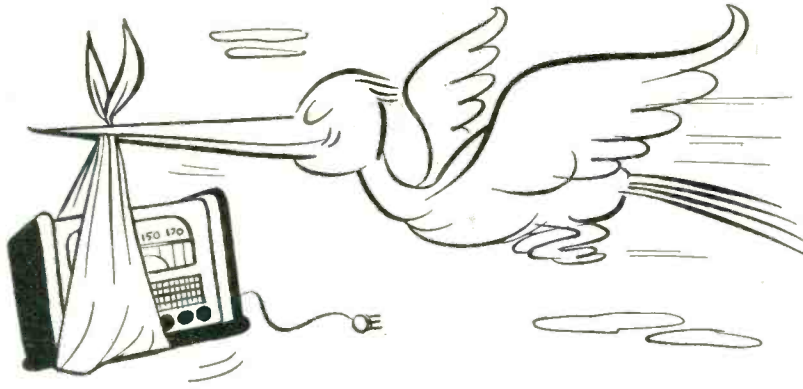

# New Products

## GUN TACKER

Arrow Fastener Company, Inc., manufacturers of the well-known T-32 automatic gun tacker, announce the new T-50 Gun Tacker that shoots heavier, longer, patented wedge-pointed high gauge carbon steel wire staples, up to 9/16" leg length.

Precision engineered in every detail, the high-powered spring action of the T-50 works on the principle of double leverage for smooth-action and tremendous power. It is specially designed to fit the contour of the hand for comfortable use; and the 1 1/4" movement at extreme point with total spread of 2-1/16" affords user faster, easier tacking.

The T-50 Gun Tacker has a patented non-clogging mechanism that prevents jamming or clogging of staples. This precision locked mechanism permits only one staple at a time to be ejected from the staple track. An easy-to-get-at mechanism permits easy dismantling



of working parts to remove dirt, dust, or grit for smooth efficient operation.

Further information about the T-50 and other Arrow stapling products can be obtained by writing direct to manufacturer—One Junius Street, Brooklyn 12, N.Y.

## OSCILLOSCOPE TEST PROBE SET

The Series SP-5 includes four of the most important test probes for general purpose as well as specialized TV signal-tracing, alignment, trouble-shooting and waveform analysis. The four probes are (1). High Impedance-Low Capacity Probe; (2). Signal Tracing-Crystal Probe; (3). Resistive-Isolating Probe; (4). Shielded-Direct Probe. Each probe has been engineered for its specific use, and distinctively colored heads and labeling permit positive identification of each one. A single, universal, coaxial-cable accommodates each probe through a quick-change connector. A specially de-

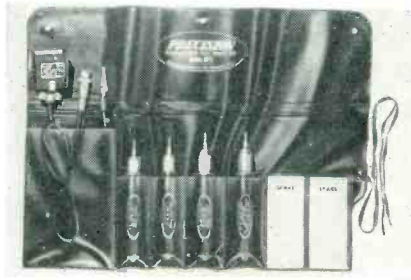

signed, shielded plug provides positive cable attachment to the ES-500 and ES-500A vertical input posts. Each probe head terminates in a clip-on type of probing tip permitting operator's hands to be free during procedures test.

The Series SP-5 Probe Set is furnished in a custom-designed vinyl-plastic carrying case which provides safe storage for each probe. It rolls up compactly for easy storage in a test bench drawer. Sells for \$21.50 list at radio parts distributors. Write for literature to Precision Apparatus Co., Inc., 92-27 Horace Harding Boulevard, Elmhurst 17, N.Y.

## UHF-VHF ANTENNA

The Fretaray All-Channel Antenna has been a combination broadside and colinear array that has an effective 8 elements on channels 2 to 6 and 24 elements on channels 7 to 13. Channel coverage.....2 to 83  
Frequency range.....5 mc's to 900 mc's  
Impedance.....275 ohms to 375 ohms  
Front to back ratio.....25 to 1  
Weight.....less than nine lbs.

The Fretaray All-Channel Antenna has been tried and proven in every major uhf area in the United States.

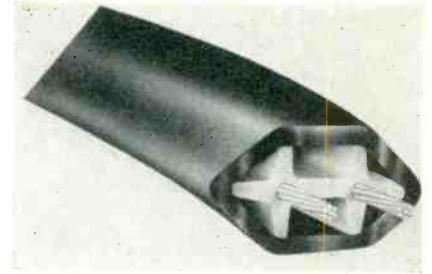
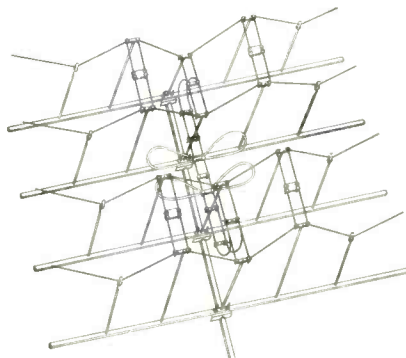

## TRANSMISSION LINE

A new tubular twin-lead for uhf, so designed that attenuation is negligible under all weather conditions (wet as well as dry), has been announced by Plastoid Corporation, manufacturers of "Synkote" wire and cable.

Known as "Synkote Ultratube," the new transmission line has the leads spaced several millimeters within the tube, equidistant from the outer insulation. Consequently, the magnetic field between them is unaffected by any moisture or salt which may condense on the outer covering, and signal strength is maintained at a maximum all the way down the line.

For additional information, write: Plastoid Corporation, 42-61 24th St., L.I.C. 1, N.Y.

## VHF-UHF INSERT

JFD Manufacturing Company, Inc., of Brooklyn, New York, announce production of a new universal insulator grommet for all TV down-leads.

Now that uhf is active throughout the country and requires either tubular, oval or rectangular lead for optimum reception, it was felt that it would be a basic requirement to provide a polyethylene insert for stand-off in-

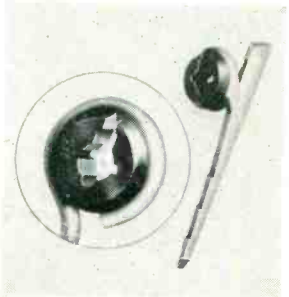

ulators that would secure both tubular and ribbon lead as well as oval, rectangular and coaxial for both uhf and vhf.

## UTAH TO INTRODUCE NEW LINES AT ELECTRONICS SHOW

Two new lines of products, a series of wall baffles and a new rear deck auto kit, will be introduced to the trade at the Electronics Parts Show by Utah Radio Products Co., Inc., of Huntington, Indiana.

The new series of wall baffles will be sold under the trade name of UTONE, are designed and engineered to give maximum of clean, brilliant, life-like tone. They were developed by Utah's sound engineers in cooperation with the expert wood craftsmen of their Caswell-Runyon affiliate, well-known manufacturer of quality radio cabinets and consoles.

The new Utah Rear Deck Auto Kit, is revolutionary in its design and construction. One of its unusual features is the versatility of its control system. Each rear deck speaker has its own off and on switch, permitting it to be turned on or off in conjunction with the front speaker, or operated independently of the front speaker. In addition, it has its own volume control to enable those in the back seat to get the amount of sound they desire for clarity and comfort.



while others plunged  
**WE WAITED**

while others promoted  
**WE TESTED**

while others gambled  
**WE ENGINEERED**

**NOW**  
**VEE-D-X**  
GUARANTEES YOU  
THE finest  
**BOW TIE**  
OF THEM ALL

**BASED ON A COMPLETELY  
New Antenna Formula**

- Eliminates insulators
- Permits all-metal construction
- Higher gain
- Flatter response over the

ENTIRE **UHF** BAND

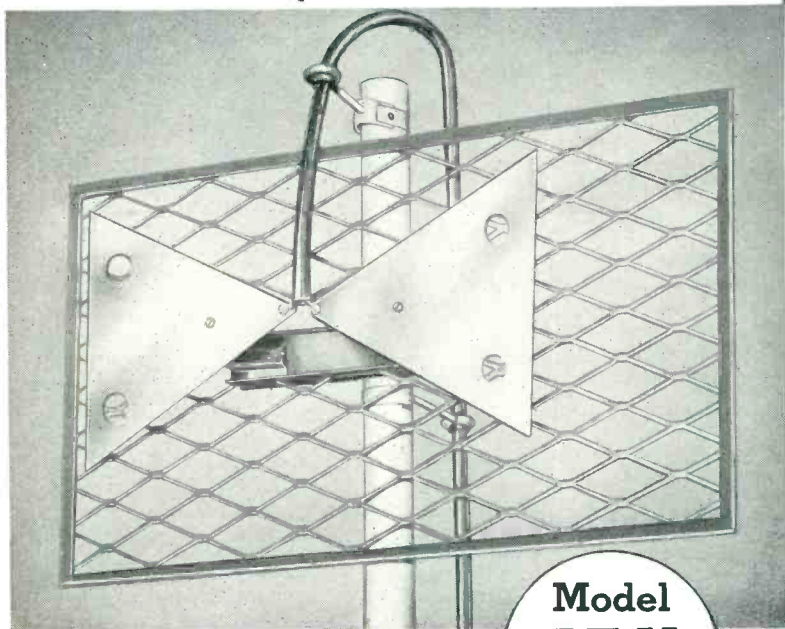

**Model  
BT-U**



The Aristocrat of Bow Ties

**Compare!**

- Precision-built
- Easiest to install
- Brilliant performer
- 8 db gain across the entire UHF band
- 50% additional gain on stacked arrays
- Engineered for super sharp picture reception from 470 to 890 mcs.
- Assembled in less than a minute
- Weather-resistant finish
- Compact packaging — only 12" by 20" by 1½" deep
- No insulators required

**LaPointe ELECTRONICS INC.**  
ROCKVILLE, CONNECTICUT

**EXCLUSIVE VEE-D-X FLEX-CLAMP**

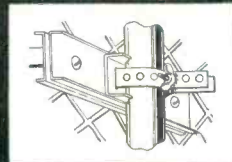
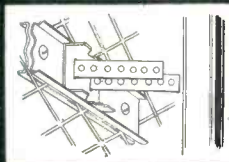

This exclusive VEE-D-X feature makes mounting of the BT-U amazingly fast and easy, especially when adding to existing installations at rooftop. No more fussing or fumbling with U-Bolts — just one screw to tighten and FLEX-CLAMP holds the antenna with a vise-like grip. FLEX-CLAMP completely facilitates probing — just loosen the screw and the antenna can be moved up or down the mast with ease. Will accommodate up to 1½" mast.

**VEE-D-X STACKED BOW TIE  
For fringe area reception**

This stacked array provides 50% additional gain on all UHF channels. A special phasing harness, VEE-D-X screen clips, plus exclusive FLEX-CLAMP, permit fast, easy installation of this unit. Order stacking harness Model BTH-U.

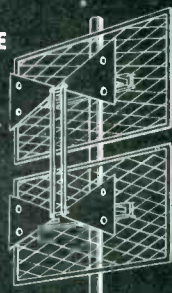



## UHF ANTENNAS

Unusually rugged construction to eliminate element vibration; rigid, hard-drawn antenna and reflector elements; low-loss terminal blocks; rigid reflector support brackets; easy assembly, requiring only bolting on reflector assembly, swinging elements to correct position and tightening wing nuts. Assembly is quick and easy. Anyone can do the job in minutes. Specially designed supports make it impossible for elements to shift after assembly.

Trio All-Channel uhf Bow-Tie antennas are made in three models covering requirements of reception in any area from metropolitan to ultra-fringe. The Trio UBT-1 is a single bow-tie with reflector, designed to give all channel uhf coverage in normal reception areas. Trio UBT-2 is a dual stack for uhf fringe areas

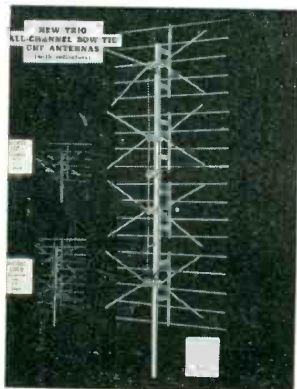

and the Trio UBT-4 is 4 stacks with reflectors designed especially for ultra-fringe area reception or where ghosts are a problem.

Forward gain of all Trio UBT uhf antennas is extremely high, with patterns only slightly wider than the Trio Multi-Channel uhf yagi models. The importance of good line match on uhf frequencies is not overlooked in Trio UBT uhf antennas. Standing wave ratio is extremely low on all UHF channels, assuring low-loss line operation.

TRIO engineers have adopted a reflector screen using horizontal type individual elements because of its rejection of vertically-polarized noise so commonly encountered at uhf frequencies.

## UNIVERSAL ANTENNA MOUNT

A patent granted for an antenna roof mount has just been issued to Walnut Machine, Inc., South Bend, Ind., for its universal mount. Known as the Wamco No. 177 Uni-base, it is priced at retail for \$2.95, and will be sold through jobbers exclusively.

Permitting any type of roof or side mounting, the new mount has a compound universal joint swivels 360° for mounting on any pitch of roof, for ridge mounting to fit any pitch of roof, and for vertical mounting to side of building. The holding clamps are adjustable to accommodate all masts 1/4" to 2", and have a full hinge action for raising mast and guying.

With only a base plate, "U" bracket, and two holding clamps, the Wamco Uni-base is easy for one man to mount.

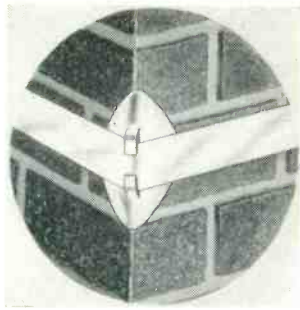
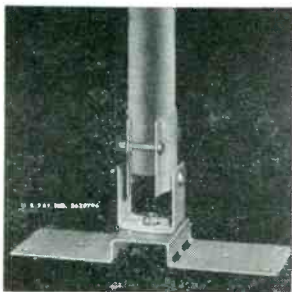

## CHIMNEY CORNER GUARD

South River Metal Products Co. Inc., South River, N. J. has just produced a new accessory for the protection of the Chimney Mount Television Antenna installation. It is called the Chimney Mount Corner Guard.

The Corner Guard is a formed, diamond shaped, aluminum protector that fits on to the chimney corners under the Chimney Mount banding.

The Corner Guard will: Prevent chipping of the Chimney corners; Prevent fraying of the Chimney Mount banding; and enable the serviceman to tighten the Chimney Mount banding uniformly by providing a smooth surface at each corner while he takes up the banding slack.

Best of all, a unique Snap-in feature allows the serviceman to place Corner Guards at each Chimney corner AFTER the Chimney Mount is already partially installed.

## UHF TV ANTENNA

In its new line of TV Aerials for uhf, Snyder Manufacturing Company of Philadelphia has listed its UHF-2 Bow Screen Aerial.

Described as an "All-In-One" TV Aerial, the Snyder UHF-2 covers uhf Channels 14 to 83 and vhf Channels 7 to 13.

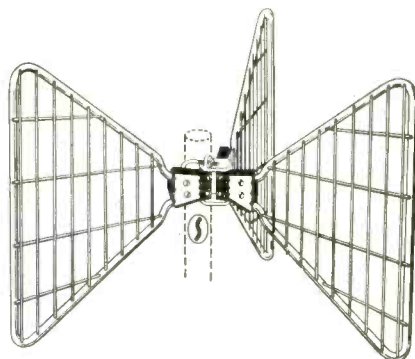

Individually packed, the Snyder UHF-2 has 2 fan type heavily galvanized elements. Other features of the aerial are a heavy section thermosetting plastic mount, rigid construction to eliminate vibration and a quick, convenient U-clamp mast mounting.

Catalogs illustrating the UHF-2 may be obtained by writing to Dick Morris, sales-manager of Snyder Manufacturing Company, Philadelphia 40, Pa.

## ANTENNA WALL PLATE AND CONNECTOR

Signs of rapid expansion in the Walseco line of TV accessories can be found in two new items recently introduced by the Walter L. Schott Company. They include a plastic, television antenna, wall plate, and a transparent antenna connector.

The wall plate is designed to fit all standard junction boxes or may be mounted close to wall or base board. A fiber gasket is included with the plate. They are available in brown or ivory plastic.

Walseco's polarized connectors are molded of transparent lo-loss plastic with one male prong and one receptacle on each plug. A 300 ohm twin lead easily can be attached to the plug

with set screws. The new connectors are as convenient for connecting leads to boosters and matching stubs as they are for television antennas.

For additional information and Walseco's new Product Catalog write to: the Walter L. Schott Co., 3225 Exposition Place, Los Angeles 18, Calif.

## INDOOR ANTENNA

After extensive laboratory and field work, the Radion Corporation of Chicago has begun production of a new indoor uhf antenna. Designated the "Bullseye" because of its compact flat loop, the new antenna is expected to give dealers the same means to selling TV sets in volume through low cost installation as the famous "Rabbit-Ears" vhf antenna, of which over 3,000,000 have been sold.



The "Bullseye" was developed by Ralph Leonard, President and Stanley Motyka, Chief Engineer of Radion. Technically it is a full wave loop, engineered for broadband coverage, low standing wave ration and low "Q".

For information on the "Bullseye" write or call Dan O'Connell, the Radion Corporation, 1130 W. W. Wisconsin Ave., Chicago, Ill.

## TENNA-TOP VHF TV BOOSTER

A new, improved Model 3012-A 3-tube automatic all-channel Tenna-Top vhf TV Booster is announced by Electro-Voice, Inc., Buchanan, Michigan. New multi-power low-noise broadband circuit multiplies the signal at the antenna where it counts the most. Has 3 tubes in balanced stages, including a power multiplier stage, to provide adequate gain for producing clear, sharp signals.

Mounts at antenna ahead of the lead-in—amplifies only the wanted TV signals, not local lead-in noise interference caused by automobile ignition systems, neon signs, diathermy, etc. Gives higher signal-to-overall-noise ratio. Gets better pictures, better sound in tough fringe or noisy locations. Gain is uniform across each entire band width. No signal drift—no limiting peaks.

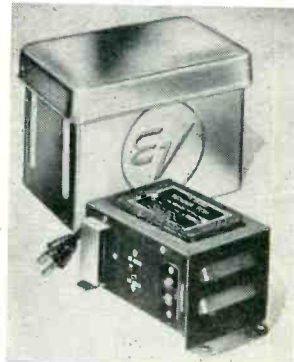

Booster unit is weather-resistant case mounts on antenna mast. Junction Box plugs in between TV receiver and A.C. electric outlet. Input and output, 300 ohm balanced line. Sturdy, stable, trouble-free. Model 3012-A Tenna-Top lists at \$59.50. For further information, write to Electro-Voice, Inc., Buchanan, Michigan, for Bulletin No. 182.

[Continued on page 64]

# G.E. AGAIN TELLS AMERICA THE TRUE STORY OF TV SERVICING

- Four powerful, informative ads in Look Magazine
- Reaching 13,187,140 readers
- Reporting the facts on typical TV Service Dealers
- Convince present and future set owners of the know-how and integrity of TV Service Dealers

● These ads, and those run in Life and Collier's last fall, and the booklet for set owners outlining the requirements of TV service, are all part of the public relations program G.E. is sponsoring in the interests of the TV Service industry.



**50,000 MEN LIKE "DUSTY" RHODES MAKE TV SERVICE A "PROFESSION"**

**HE GIVES PATERSON, N. J., A PROFESSIONAL TEAM OF AGE SERVICE MEN**

Across the country, TV service has become accepted as a new "profession." One of the reasons is this new industry's high calibre of men. Take "Dusty" Rhodes of Paterson, N. J. He's on the Chamber of Commerce's Board of Directors. He's president of the Radio and Television Service Men of N. J. He's active on the Community Chest. In other words, he's a credit to his calling and his community.

**J. PALMER MURPHY, manager, Greater Paterson Chamber of Commerce, says: "Dusty Rhodes is the kind of man any community would be happy to have—a definite asset."**

**RICHARD E. KINN, salesman, says: "I've seen many people to him—that shows how much I think of his service." Kinn's wife says: "His men are polite and efficient."**

**MRS. ROSE ZARROW, housewife, says: "Rhodes' service is wonderful. As soon as you call them they're here—no petty excuses—just like the minute men."**

**BEN MERRER, Rhodes' service manager, is a graduate of DeForest's Training School and attends technical seminars and courses.**

One of a series of informative advertisements on TV service. Tube Department, General Electric Company, Schenectady 5, N. Y.

**GENERAL ELECTRIC**

What are you doing to follow through on this effort in this locality?

**HERE'S WHAT YOU CAN DO:**

- 1 You can build customer goodwill through full explanation of service charges.
- 2 You can endorse sound business practices in your own service associations.
- 3 You can actively "sell" service business to increase your income and prestige in your community.
- 4 You can support those distributors and programs which advance the interests of the TV Service Dealer.

TUBE DEPARTMENT, SCHENECTADY, N. Y.

**GENERAL  ELECTRIC**



# first and only

LIGHTNING ARRESTOR  
SPECIALLY DESIGNED FOR

# UHF



MODEL  
LA-UH3



SEE US AT  
PARTS SHOW  
BOOTH 586



takes all transmission lines



TWIN LEAD

TUBULAR  
LEAD

OPEN LINE

By use of specially designed filter networks, r.f. is isolated from ground potential and the unit effectively operates to safeguard against static and lightning charges. LA-UH3 is another industry standard engineered by RMS . . . largest producer of TV lightning arrestors.

**Protect installations—customers—and your reputation. Ask your Jobber for RMS UHF lightning arrestors.**

WRITE FOR NEW CATALOG

# RMS

2016 BRONXDALE AVENUE, NEW YORK 60, N. Y.

## SYNC PULSES

[from page 11]

sat down to enjoy it. The wife walked in, looked at it, and said, "If it weren't for my money it wouldn't be here." The husband replied quietly, "And now, my dear, I deem it wise to tell you something. If it weren't for your money I wouldn't be here either."

**NIESA is born.**—A commercial enterprise called National Industrial Electronic Service Affiliates, Inc., (NIESA), with Henry A. Schwartz a president, has been formed with the objective of offering to manufacturers of industrial electronic apparatus, a network or national service organization which would be competent to function as field maintenance for the firms who employ the equipments. Now-a-days only the largest makers of industrial electronics devices have their own field service departments scattered around the country and the shortage of trained electronic technicians has handicapped smaller manufacturers whose prospects have often hesitated to make a purchase because no local or closely adjacent trained service organization was available.

Since the advent of electronics devices for industrial plant use we have advocated that radio and TV technicians should "look into" this bordering field with the idea of getting their share of the service and preventive maintenance work bound to be available. Here, there and everywhere, in large and small cities, major and relatively small manufacturing plants are employing an ever increasing number of specially designed and manufactured electronically-actuated devices. The basic radio (or electronic, if you prefer) circuit of these devices is generally of a familiar type known to all radio technicians having a good fundamental knowledge of radio theory. But, the use of relays, circuit breakers, photo-cells, contractors and divers thermal controls which are also incorporated in most electronics installations used by industry are relatively "strange animals" to even old-timers in radio repair work.

It's our duty to advise our readers, who being servicemen, that such an organization as NIESA is being formed, and that it might be advantageous to obtain all the facts about it. Perhaps they might decide that they want to participate as local representatives for their particular locality. Radio is big business. TV is getting to be bigger of industrial electronics installations might become. We business. There's no telling how big the servicing phase know of some service firms who specialize in that sort of work and whose yearly earnings are quite impressive. On the other hand, we also know of some purely radio-TV minded service firms who also do industrial servicing when opportunity presents itself and whose extra income from this source makes the effort quite worthwhile. Ask us for further particulars about NIESA if the project interests you.

**Possible Shortages**—Now that all ceilings and restrictions are off Government control, there'll be a scramble for such materials as aluminum and steel by big consumers such as the power companies, auto makers, etc. One auto uses more steel than 1500 TV masts and more aluminum than 200 antennas. While restrictions were in effect the auto firms only produced half their rated capacity. Yet, despite the lean auto production, oftentimes antennas and masts (just to cite typical items) were scarce because of the low material supply. What will the situation be in a few months when big auto production gets under way? Will the radio-TV industry find itself pinched? We hope not, but fear so. Yet we urge no unwarranted hoarding or over-buying. Keep inventories at just-above-normal requirements until we know the answers.



# No fuss No cuss

When you use **Centralab Blue Shaft Controls**

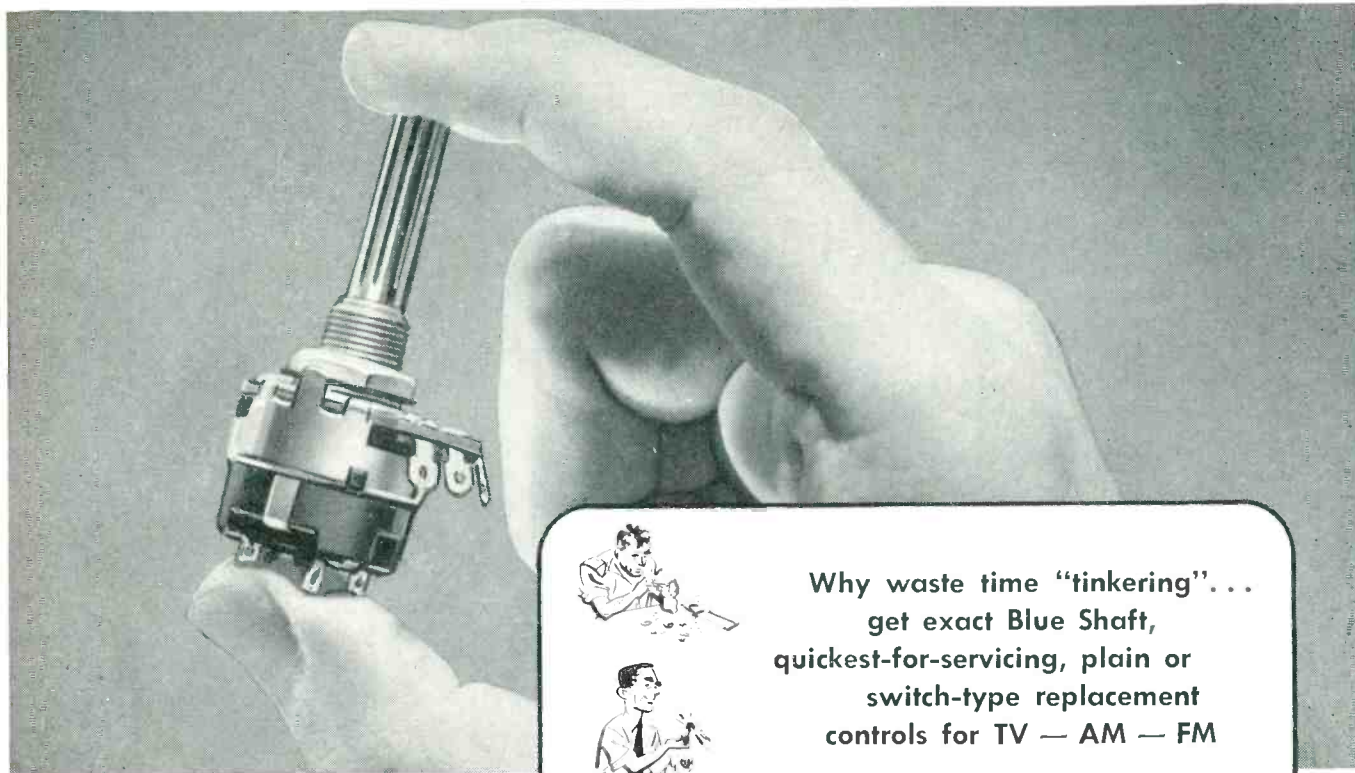

Why waste time "tinkering"...  
get exact Blue Shaft,  
quickest-for-servicing, plain or  
switch-type replacement  
controls for TV — AM — FM

**Don't fuss with an assembly job  
the factory does better, faster,  
and guarantees-at no extra cost.**

Yes, Blue Shaft Controls are your smartest service buy! Why? Because these *exact*, quickest-for-servicing replacements not only save you valuable bench-working time, but they're guaranteed *right* every time!

**Why it pays to standardize on Blue Shaft**

Centralab's famous Blue Shafts, plain or switch-type, are exclusive service items. The factory-attached and tested, high-amperage universal switches are *exact* for SPST — DPST or 3-wire. Blue Shafts are available in a range from 500 ohms to 10 megs in a wide variety of tapers and tapped units. All Centralab Blue Shaft Controls are packaged singly, or in handy kit assortments in plastic boxes of 12. You can

also get a special metal cabinet containing 22 controls. NO EXTRA CHARGE for the cabinet.

*Flexible "Fastatch,"† type KB, converts any plain type control with blue and white label on back cover to switch type... in seconds.*



**SERVICE ENGINEERS** — here's more good news — 26 new Blue Shafts added in '53 line!

# Centralab

A Division of Globe-Union Inc.  
Milwaukee 1, Wisconsin  
In Canada, 635 Queen Street East, Toronto, Ontario

**Blue Shafts give you exactness plus LOW COST**

Cat. No.	Ohms Max. Resistance	Taper	Circuit Location	List Price
B-60	500,000	C-2 (audio)	Volume or Tone	\$1.00
B-60-S*	500,000	C-2 (audio)	Volume or Tone	\$1.50
B-70	1 megohm	C-2 (audio)	Volume or Tone	\$1.00
B-70-S*	1 megohm	C-2 (audio)	Volume or Tone	\$1.50

\*Switch Type †Trademark

CENTRALAB, A Division of Globe-Union Inc.  
944 East Keefe Avenue, Milwaukee 1, Wisconsin

Ask your jobber or write direct for Cat. 28.

Name.....Position.....  
Company.....  
Address.....  
City.....State.....



## NEW PRODUCTS

[from page 60]

### UHF ADAPTOR

Channel Master Corp., Ellenville, N.Y., has announced the development of a new uhf antenna adaptor—the Econo-Dapter, Model No. 415.

The Econo-Dapter is a high gain, all-channel, uhf Triangular Dipole specifically designed to add uhf to the millions of vhf Super Fan installations now in existence.

This preassembled unit is easily fastened to the front end of any Super Fan. The precise distance is pre-fixed, and the uhf dipole is veed forward so that it is always parallel to the vhf fan elements which function as a highly efficient sheet reflector. It is designed for use with separate vhf and uhf leads to the TV set or converter and is recommended for installa-

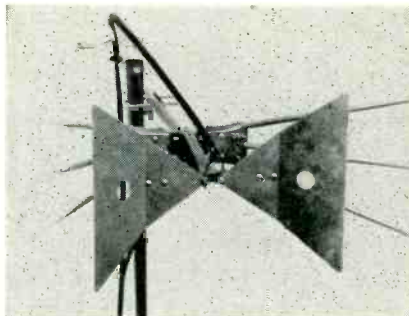

tions where cost must be held to an absolute minimum, or where separate antenna terminals are provided at the set or converter.

The Econo-Dapter features Channel Master's exclusive "free space" terminals which prevent the accumulation of dirt, ice, or rain-water between the feed points, which can short out the picture. Its ultra-rigid construc-

tion, including air space holes, prevents vibration which can cause picture flicker.

### DUAL POTENTIOMETERS

Dual Type AB molded composition potentiometers, consisting of two units mounted in tandem and controlled by the rotation of one shaft, are now being offered by Ohmite Manufacturing Company, Chicago.

Type AB molded composition potentiometers are distributed by Ohmite exclusively through radio and television parts distributors. These 2-watt potentiometers are designed for industrial, laboratory, and radio, television, and electronic service applications where reliabil-

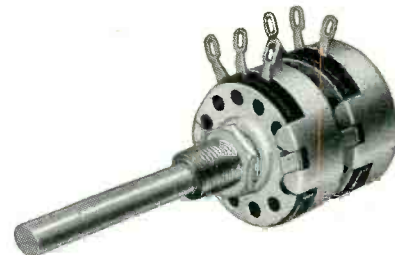

ity is particularly important. The resistance element is a thick, solid-molded ring, heat treated under pressure—not a sprayed film or paint-type resistor. The new dual units have a 2" long, round shaft, and independent electrical connections.

These exceptionally high quality, "noise-free" potentiometers are available in the linear curve type. Seven resistance values are available, ranging from 10,000 ohms to 1.0 megohm. For a complete description and dimensional drawings of these Dual Type AB potentiometers, write to Ohmite Manufacturing Company, 4897 Flournoy St., Chicago, Illinois, requesting Bulletin 131B.

### ANTENNA ROTATOR

The VEE-D-X Antenna Rotator, scheduled to be the feature VEE-D-X attraction at the Chicago Parts Show in May, has met with tremendous enthusiasm by distributors throughout the country.

The rotating unit itself has the most advanced mechanical and electronic design. It has the finest type of mast clamps—a unique new gear train—positive antenna stop—special weather resistant finish—fast easy line connections—and it will support over 200



lbs. The decorator styled control console is available in heather green or cordovan mahogany. It has a unique control lever with both compass and numerical reference points—a special control circuit that requires no screw driver adjustment—and a dial covered with a glass window to avoid electro-static charging. These are but a few features of the VEE-D-X Antenna Rotator and control console. The complete unit is factory tested and guaranteed. It lists for \$49.95.

[Continued on page 66]

## AT LAST—PHILCO REPLACEMENTS ...AND AT TREMENDOUS SAVINGS!

### Over 135 PHILCO TV Models Served by Halldorson's New Flyback Assemblies!

Here are the hard-to-duplicate replacement flybacks for Philco 1951-52-53 TV models. Halldorson FB407 and FB408 are "tailor-made" coil assemblies that fit core pieces, terminal panels, and mounting brackets of original Philco parts which are adaptable to quick coil changing. New H.V. filament leads are included. Halldorson FB409 is a complete unit designed to replace important Philco flybacks of unconventional construction. Easy-way instructions accompany each unit. Stock up today!

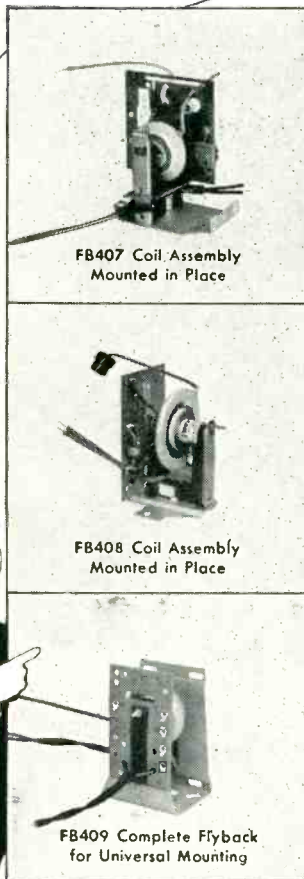

FB407 Coil Assembly  
Mounted in Place

FB408 Coil Assembly  
Mounted in Place

FB409 Complete Flyback  
for Universal Mounting

### Compare These Prices!

HALLDORSON NUMBER	REPLACES PHILCO NUMBER	DEALER'S NET
FB407	32-8533 32-8534	\$3.36
FB408	32-8555	3.57
FB409	32-8465-2 32-8484-2 32-8509 32-8509-2	5.97

Get descriptive Bulletin No. 112 listing all Philco Models covered

HALLDORSON TRANSFORMER COMPANY  
4500 Ravenswood Ave. • Chicago 40, Illinois



# Halldorson

QUALITY Transformers SINCE 1913

EXPORT: International Radio Corp., 39 Warren St., New York, N. Y. Cable Address—SOLITECOR.

We'll be looking for you in Booth No. 584 at the Electronics  
Parts Show, May 18-21, Conrad Hilton Hotel, Chicago

# 10 TIMES MORE POWERFUL THAN STACKED 10 ELEMENT YAGIS

## PHILCO *All-Purpose TV Antenna*

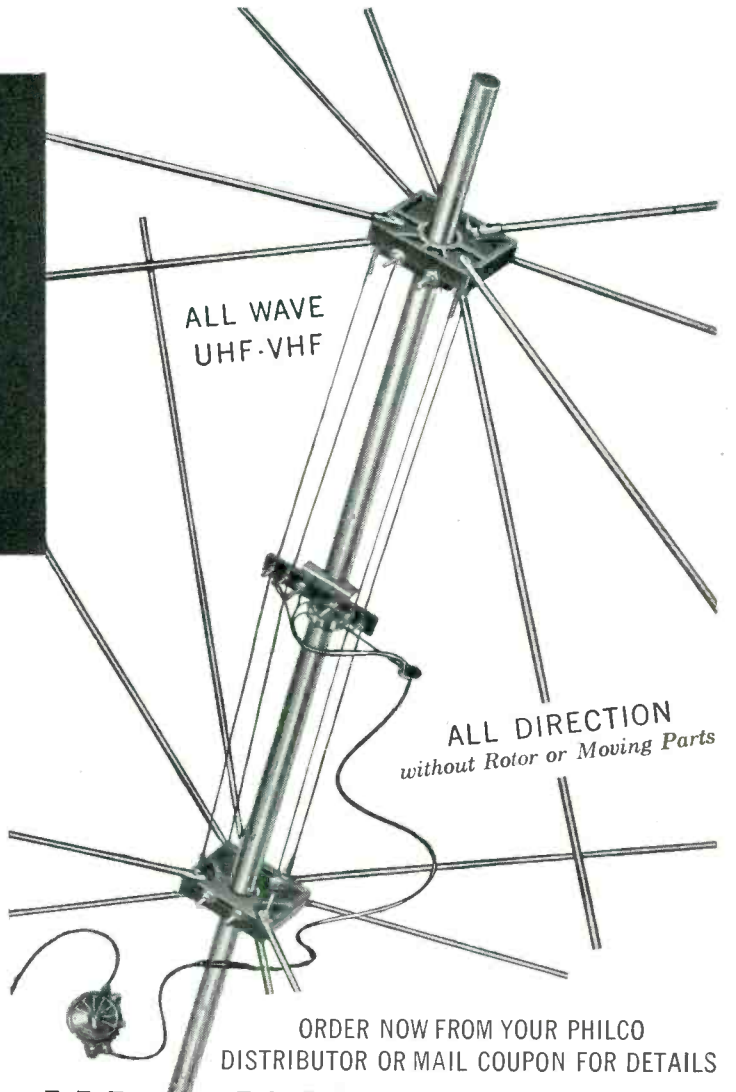

### NEW Design and Principle

By far the most powerful TV antenna on the market today . . . a sales value unsurpassed at its popular price. With the mere flip of a switch this exclusive all-purpose Philco antenna without rotor or moving parts of any kind instantly and automatically beams the set to the best possible signal for both UHF and VHF reception. No attenuators are necessary in strong signal areas since an off position of the switch will automatically attenuate the signal. Available in preassembled aluminum dowel reinforced elements of single bank and stacked arrays for metropolitan and fringe areas at your Philco distributor now.

### Up to 22.3 DB Gain over Tuned Dipole

DB GAIN OVER A TUNED DIPOLE CUT FOR EACH CHANNEL FREQUENCY

	2	3	4	5	6	7	8	9	10	11	12	13
Single Array	7.8	14.0	6.7	-1.7	16.3	2.5	6.0	9.6	12.1	10.8	15.0	12.8
Gain Chart	36"	18.8	3.5	7.4	17.3	0.0	-1.3	6.0	8.4	11.5	13.0	12.5
using	45"	6.5	14.3	6.0	-6.0	18.6	6.7	8.5	18.2	18.1	13.2	14.3
different	60"	5.8	2.2	9.6	-1.0	-2.0	1.5	-4.0	10.3	4.0	15.4	7.0
spacing	82"	8.4	15.5	13.0	10.5	21.3	3.0	14.0	-2.0	1.6	10.0	6.0
between	98"	2.5	8.0	9.5	-4.5	17.0	6.0	2.0	4.0	1.0	10.0	7.0
two single	114"	21.0	19.0	7.4	22.3	0.0	6.0	8.2	10.4	11.5	14.0	14.1
arrays	122"	7.4	17.0	13.4	2.5	21.5	8.5	17.3	16.2	12.1	14.8	15.6

The above tests were made using a 40-foot lead-in. However amazing results have been obtained on installations using a lead-in up to 150 feet without any appreciable difference in gain. These tests were made in real fringe areas.

For maximum gain in outer fringe areas, orient the antenna for the weakest channel desired. Location will determine the number of elements to be used.

ORDER NOW FROM YOUR PHILCO  
DISTRIBUTOR OR MAIL COUPON FOR DETAILS

PHILCO CORPORATION, Accessory Division  
Allegheny and A Streets  
Philadelphia 34, Pa.

Please send me information about the Philco All Purpose  
Antenna, with current trade price list.

NAME .....

STORE NAME .....

CITY ..... ZONE ..... STATE .....

Please check in space below

I am a Retail Dealer

I am a TV Serviceman



## NEW PRODUCTS

[from page 64]

### PHONO AND MIKE JACKS

A long standing need for phono and microphone jacks which defy moisture has been met by P. R. Mallory & Co. Inc., with perfection of watersealed jacks, types WS-1A and WS-A2B.

The new watersealed jacks can be used in many types of communications systems where rapid electrical connections must be made by the use of phone plugs, and which are subjected to high humidity conditions.

Tests have shown the Mallory watersealed jacks are capable of withstanding a six-foot head of water for a 24 hour period.

Type WS-1A is a phono jack with terminals for one circuit and ground. Type WS-A2B is a

microphone jack with terminals for two circuits and ground.

### TINY TRANSFORMER

A new line of Stancor audio transformers, the miniature units are made with nickel steel laminations, with an exceptional frequency response of  $\pm 1$  db. 30-15,000 cps, maximum level 0 db.

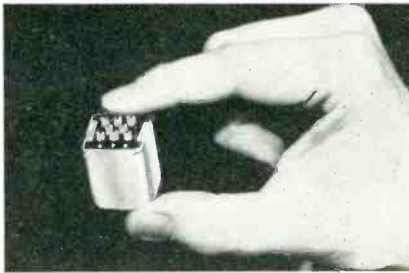

in  $\frac{7}{8}$  in. square, anodized aluminum cases with phenolic terminal boards. Total height, including terminals, is only  $1\frac{1}{4}$  in. The case has two 2-56 threaded inserts, 11/16 in. centers, for easy chassis mounting. The entire transformer weighs only 1.3 ounces.

The Tinytrans are listed by Stancor as TT-11, Mic., pickup or line to single grid application; TT-12, Mic., pickup or line to push-pull grids; TT-13, Dynamic Mic. to single grid and TT-14, single plate to single grid.

### VHF-UHF ANTENNAS &

#### ACCESSORIES

Telrex, Inc., of Asbury Park, New Jersey, originator and patentee of the very popular "Conical-V-Beam," announces the Duo-Band "Conical-V-Beam" Model No. 420; plus a Modification Kit, Model No. 410 to modify any existing "Conical-V-Beam" for optimum reception, Duo-Band—vhf, uhf coverage, with one transmission line.

The transition from vhf to uhf is automatic, without so-called isolation or filter networks which reduce the efficiency of response. In addition, the Telrex Duo-Band "Conical-V-Beam" actually improves the response on all vhf stations while providing optimum uhf response. Reports from the field are enthusiastic and it is forecast the Duo-Band "Conical-V-Beam" will set new standards of comparison.

### UHF LIGHTNING ARRESTOR

The new unit, model LA-UH3, incorporates specially designed filter networks to efficiently isolate rf from ground potential so that the arrestor operates to discharge static and lightning. High conductivity hardware is used

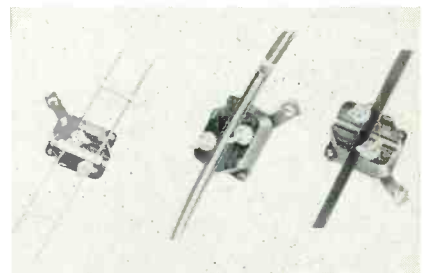

throughout. Model LA-UH3 is designed to accommodate all types of commonly used transmission lines, including twin lead, tubular lead, and open line. It can be mounted flat or to the mast.

For further information, write Radio Merchandise Sales, Inc., 2016 Bronxdale Ave., New York 60, N.Y.

### HIGH OPERATING TEMPERATURE

#### CAPACITOR

Meteor Type ADZ, a new paper capacitor providing operation to 125° C, without derating, is announced by Astron Corporation, 255 Grant Avenue, East Newark, New Jersey.

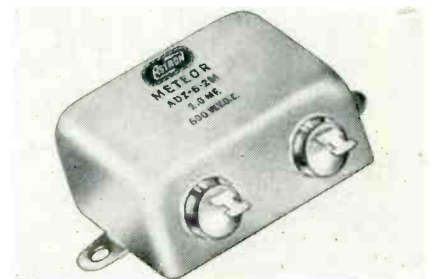

Available in the popular JAN-C-25 bathtub case styles CP-53 to CP-55, the new capacitors are furnished with glass-to-metal terminals to insure the hermetic seal and dependable operation at high temperatures and altitudes.

## RADIO and TV MEN ASKED FOR THIS KIT!

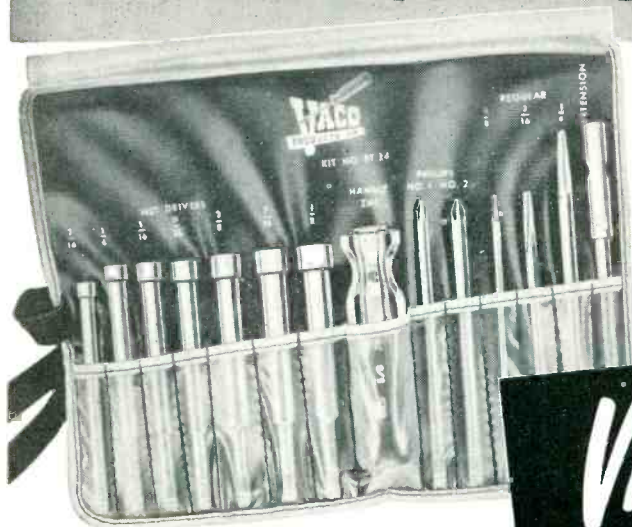

7 Nut Drivers  
2 Phillips Drivers  
3 Regular Drivers  
and  
Extension  
In One Package

**VACO**  
RT-14  
SERVICE KIT

You'll like this kit! Sales prove it! The RT-14's built-in convenience, easy storage and versatility have made it a favorite in both radio and TV fields. In one package you have all the nut drivers, Phillips and regular drivers you need for almost any situation. And every driver fits the one, heavy duty Vaco shock-proof, break-proof handle . . . fits the famous Vaco 6" extension that enables you to get into awkward recesses and tight spots. For full details, see your jobber or write, today!

#### Extension Doubles the Use of Each Driver!



Nut Driver—Less Extension—  
Length 3" out of handle



Regular or Phillips Screw Driver  
Less Extension—  
Length 3 $\frac{3}{4}$ " out of handle



Nut Driver—With Extension—  
Length 8" out of handle



Regular or Phillips Screw Driver  
With Extension—  
Length 8 $\frac{3}{4}$ " out of handle

**VACO PRODUCTS CO., 317 E. Ontario St., Chicago 11, Ill.**

In Southwest: 1325 McKinney Ave., Dallas 2, Texas  
In Canada: 204 Laurier Ave., W., Montreal 8, Quebec

GET THIS \$12.95

# SOLDERING GUN FREE!

With a supply of Admiral TV Masts  
ASK YOUR ADMIRAL DISTRIBUTOR



## 5 ft. and 10 ft. Self-Coupling TV MASTS

You may have found that masts are hard to get . . . due to the increased need for outside antennas in new station areas. Now your Admiral Distributor can give you *quick delivery*. What's more, you can get a genuine Wen Electronic Soldering Gun *free of extra charge* with quantity orders. This offer is good for a limited time only.

Admiral's huge production brings you these masts at the industry's lowest prices. Finest quality, too . . . made of cold-rolled seamless steel tubing, heavily electrogalvanized for utmost rust resistance. Both 5 and 10 foot masts are available with one end flared to take extensions . . . eliminates the need for separate mast couplers. Order from your Admiral Distributor by part number:

	20 gauge	18 gauge	16 gauge
5 ft. plain end	M 40		
5 ft. flared end	M 40A		
10 ft. plain end	M 41	M 42	M 43
10 ft. flared end	M 41A	M 42A	M 43A

**Admiral Corporation**, Accessories and Equipment Division, Chicago 47, Ill.



**A COMPLETE LINE OF ADMIRAL TV ANTENNAS . . . NOW AVAILABLE FROM YOUR ADMIRAL DISTRIBUTOR**

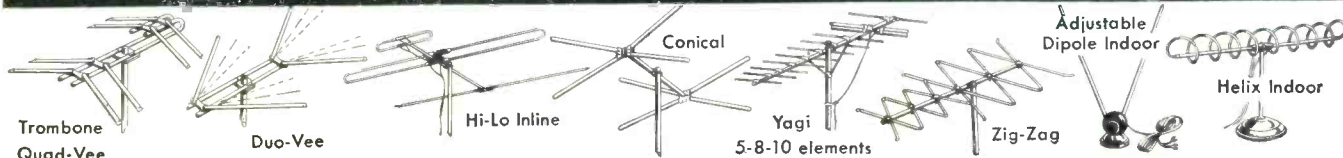



## EDITORIAL

[from page 3]

of 50,000 such sections were given away, and we would have continued the service had we not run into two snags which were unforeseen, and which cannot be surmounted.

This magazine is privileged to Second Class entry at the Post Office, but regulations under this mailing class defined the page announcements on the Catalog Sections being offered as being paid advertising, which increased our overhead terrifically. Then, too, this publication is a Member of the Audit Bureau of Circulations, and in evaluating any subscription submitted on an order form which stated

that the Sections were given as a part of our service the ABC auditors, just recently, concluded that such subscribers were being offered a premium. We contended otherwise but lost the argument. It being our practice never to give premiums to subscribers, we had no choice other than to abandon and discontinue our free Catalog Section offer.

However, it has been most gratifying to have received many thousands of unsolicited letters of commendation from our subscribers lauding our regular monthly 8-page section of 24 Video Speed Servicing Systems data. These short-cuts in troubleshooting tricky TV service problems are proving invaluable and we are now striving to find ways and means to enlarge the monthly section.

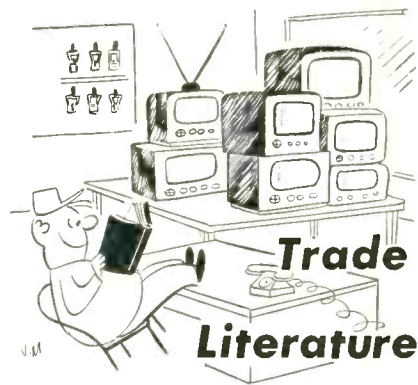

A booklet called "This Business of Radio and TV Servicing" is available from RCA tube, parts and test equipment distributors. It is believed the first publication of its kind.

Prepared by the Tube Department of the RCA Victor Division, Radio Corporation of America, the booklet also includes descriptions of business practices and essential test equipment used by successful service organizations throughout the industry.

\* \* \*

A touch of tomorrow in the latest components of today, is the theme of the interesting *Aerovox bulletin* that was distributed at the IRE Convention and otherwise obtainable from the Advertising Department, Aerovox Corporation, New Bedford, Mass.

The bulletin deals with recent electronic component developments, particularly high-temperature metallized-paper capacitors, Aerofilm capacitors, electrolytics operating above the present 85° C. range, and new micas for working temperatures up to 125° C.

\* \* \*

The national office of the National Electronic Distributors Association reports that the second edition of the *NEDA Battery Index* will be ready for distribution on or about May 15, 1953.

To date four of the major battery producers now include the NEDA battery numbers in their interchangeability charts, namely: Burgess Battery Co., National Carbon Co., Olin Industries, Inc., and Radio Corporation of America.

\* \* \*

Transvision, Inc., New Rochelle, New York, has just released a newly revised *Picture Tube Interchangeability Replacement Guide* (revised April, 1953). It is to the serviceman's interest to be able to easily substitute tube types, lest his stock would have to be unnecessarily large. Accordingly, the list shows popular types of picture tubes that may be used to replace hard-to-get types, noting such modifications (if any) that should be

# STANCOR *Exact* REPLACEMENT

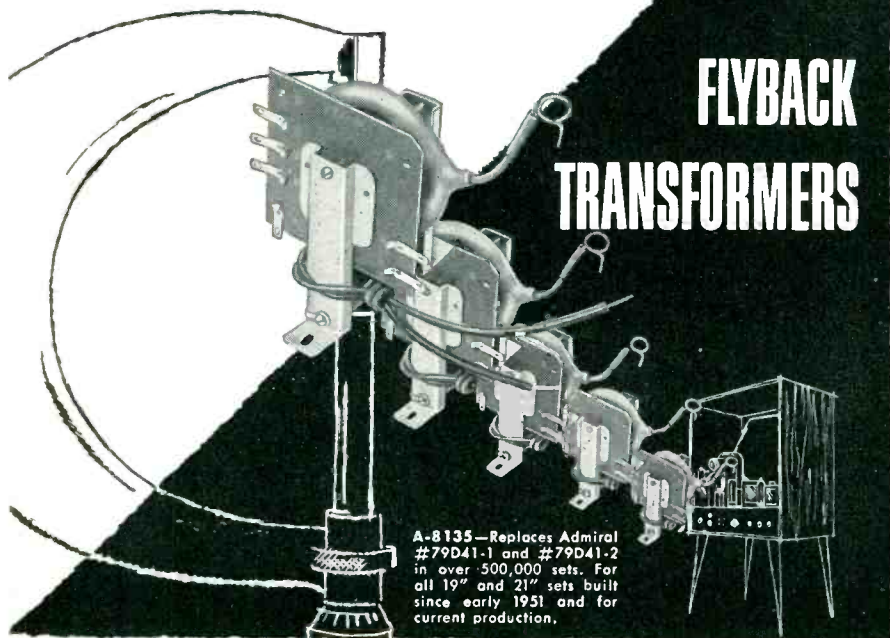

## FLYBACK TRANSFORMERS

**A-8135**—Replaces Admiral #79D41-1 and #79D41-2 in over 500,000 sets. For all 19" and 21" sets built since early 1951 and for current production.

Ask your distributor for Stancor bulletins 461 and 465, listing replacement applications of these transformers—or write directly to Stancor for your free copy.



**A-8132**—Replaces Muntz #TO-0031; used in 1951 and 1952 production. Covers approximately 300,000 Muntz sets.

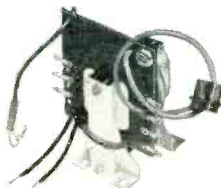

**A-8136**—Replaces Philharmonic #80-263, #80-265-2 and #80-265. Used in all sets built since early 1951 including AMC, Parhe, Silvertone, and other "private label" sets.

Stancor Transformers are listed in Howard W. Sams' Photofact Folders, John W. Rider's Tek-Files, and the Howard Company's Counterfacts.

## STANDARD TRANSFORMER CORPORATION



3586 ELSTON AVENUE • CHICAGO 18, ILLINOIS  
EXPORT SALES—  
Roburn Agencies, Inc., 39 Warren St., New York 7, N.Y.

made when direct replacement is difficult. This booklet is free. Write: Transvision, Inc., New Rochelle, N. Y.

\* \* \*

A completely revamped *product catalog #53* with a new and original format has just been released by the Walter L. Schott Company. The new Walsco catalog contains 40 pages of the most complete assortment of electronic hardware, tools, chemicals, antennas and accessories ever displayed by the company.

Many new Walsco items, and a few price changes, are also included in the colorful, well-planned pages of the catalog.

The new Walsco catalog may be obtained free by writing: The Walter L. Schott Company, 3225 Exposition Place, Los Angeles 18, California.

\* \* \*

*Pix-O-Fix TV Troubiefinder Guide*, by Alfred A. Ghirardi and R. G. Middleton, Rinehart Books, Publishers, is a practical professional servicing guide to identification of causes, location, and repair of everyday TV receiver troubles by the popular picture-analysis method. It consists primarily of a keyed picture chart which is rotatable and five auxiliary charts listing the probable causes of trouble for the picture obtained.

\* \* \*

*Printed Electronic Circuit Guide Number 2* is now being announced by the Centralab Division of Globe-Union Inc. Due to the great popularity of the original P.E.C. guide, the book has been completely revised and brought up to date. P.E.C. Guide No. 2 lists the 27 standard stock units furnished by Centralab through its distributors. Complete circuits, components, and applications are shown.

This guide can be obtained free of charge from any Centralab distributor, or by writing directly to Centralab, 900 East Keeke Ave., Dept. D44, Milwaukee 1, Wisconsin.

\* \* \*

Standard Transformer Corp., Chicago has prepared the *Stancor Tape-Wire Recorder Replacement Guide*, listing sixty-three models of twenty-two companies manufacturing tape and wire recorders. The Guide is published to fill a definite need for authoritative information on power transformer, filter choke and audio output transformer replacements.

Manufacturer and model number, manufacturer's part number and Stancor part numbers are listed for all models included in the Guide. The first of its kind available to distributors and service technicians.

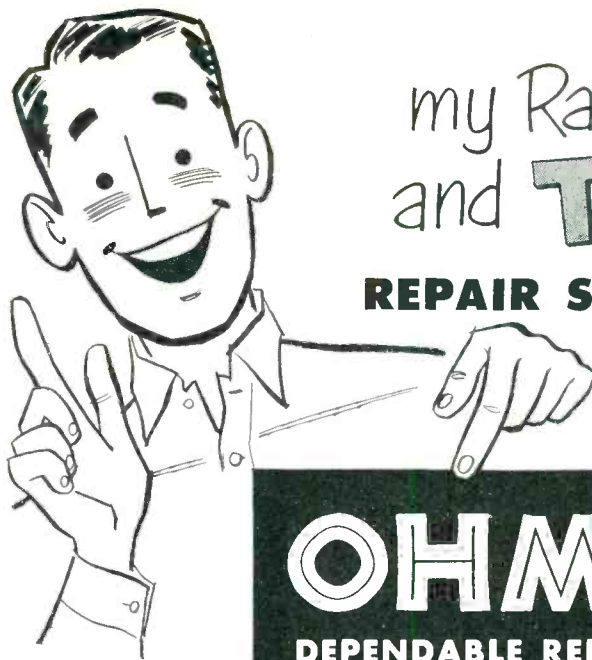

my Radio  
and **T.V.**

**REPAIR SECRET?**

**OHMITE®**

**DEPENDABLE REPLACEMENTS**

*Little Devil*® **COMPOSITION RESISTORS**



Tiny, yes... but what dependability, ruggedness, and stability! And they provide an *extra* margin of safety—being rated at 70C rather than 40C. Completely sealed and insulated by molded plastic, they meet all JAN-R-11 requirements... are available in 1/2, 1, and 2-watt sizes in all RTMA values.

**TYPE AB NOISE-FREE POTENTIOMETERS**

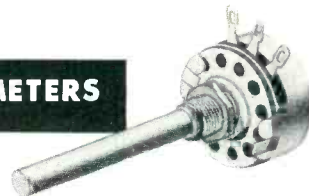

Because the resistance material in these units is solid-molded—not sprayed or painted on—continued use has practically no effect on the resistance. Often, the noise-level *decreases* with use... and they provide exceptionally long, trouble-free service. Rated at 2 watts, with a good safety factor.

**BROWN DEVIL® AND DIVIDOHM® RESISTORS**

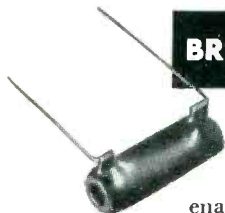

BROWN DEVIL fixed resistors and DIVIDOHM adjustable resistors are favorite vitreous-enamelled units! DIVIDOHM resistors are available in 10 to 200-watt sizes; BROWN DEVILS in 5, 10, and 20-watt sizes.



**WRITE FOR  
STOCK &  
CATALOG**

**OHMITE MFG. CO.**

4845 Flournoy St.  
Chicago 44, Ill.



*Be Right With...*

**OHMITE**

**RHEOSTATS • RESISTORS • TAP SWITCHES**



# KESTER

Since the most important single step in Radio-Television Servicing is soldering . . . it's just plain good sense to use the best — KESTER SOLDER . . . Key Name in Solder for More Than 50 Years.

**KESTER SOLDER COMPANY**  
4239 Wrightwood Avenue • Chicago 39, Illinois  
Newark 5, New Jersey • Brantford, Canada

# SOLDER

Engineered for the Purpose . . .

## Copperweld **GUY STRAND**

provides **REAL GUYING CONFIDENCE**



### Copperweld doesn't **STRETCH**

Soft wire guys frequently stretch badly in service and go slack. This means a wobbly antenna and poor reception. Copperweld Guy Strand is hard drawn—has the strength to stay taut—holds the antenna firmly in place—improves reception. And, it's easy to install.

### Copperweld combats **RUST**

A guy weakened by rust may go unnoticed until a storm brings down the antenna, causing damage many times the cost of the guy. Copperweld Guy Strand is protected against rust by a molten-welded layer of pure copper on each wire. Its strength is lasting.

Write today for further details.

**COPPERWELD STEEL COMPANY** • Glassport, Pa.

**Copperweld GUY STRAND**  
**ANTENNA WIRE • GROUNDING WIRE**  
**GROUND RODS AND CLAMPS . . .**

SOLD BY RECOGNIZED PARTS DISTRIBUTORS

LEADING UTILITIES rely on Copperweld Strand for guying poles and towers

## TRADE FLASHES

[from page 20]

in New York, Philadelphia, Boston and Cleveland. A factory operation in Los Angeles supplies parts to the western states. The Philadelphia address of Radio Electric Service Company is 7th and Arch Streets.

### Green Bay Honors

#### Philo T. Farnsworth

Philo T. Farnsworth, vice president and director of research of the Capehart-Farnsworth Corporation here, was honored by the city of Green Bay, Wisconsin, when Tuesday, March 17, the date of the opening of television station WBAY-TV there, was proclaimed "Philo T. Farnsworth Day" in Green Bay. Mr. Farnsworth is one of the inventors of electronic television.

### Raytheon Prepares For

#### Increased Sales

Last year the Receiving Tube Division of Raytheon Manufacturing Company made its 250,000,000 tube, completed 30 years in operation, and realized the greatest sales year in its history according to N. B. Krim, Vice-president and General Manager of the Receiving Tube Division.



Raytheon Sales Reps.

He predicted that within the next few years sales of the division's products would reach one and one-half times greater than at present with increased production of Receiving Tubes, TV Picture Tubes, Special Purpose Tubes and Germanium Products.

### Color TV Restrictions Revoked

Restrictions which had required the securing of NPA permission to mass-produce home-type color television receivers were removed by the National Production Authority, Department of Commerce through the revocation of the Color Television Order M-90.

In addition to allowing manufacture of color TV sets under certain conditions, amended M-90 also lifted restrictions on manufacture of color equipment for theater and commercial use. NPA said. At no time did the order restrict research and development, or ban color TV equipment for experimental, defense, industrial, hospital and educational uses.

## ASSOCIATIONS

[from page 22]

L.I. Vice President; Charles Kohl of VETA, Kingston, N. Y. Treasurer; Wayne Shaw of RSA, Binghamton, N. Y. Secretary; Andrew Wentworth RTG, Rochester, N. Y. Sergeant of Arms.

### TV Dealers of Fort Lauderdale

The Television Dealers of Fort Lauderdale is the newest of service organizations. The problems confronting Fort Lauderdale are the same as any other area. Their membership is small but will prove efficient.

Mr. Irving Dickler of Sunrise Radio & TV has been elected president. Other members of the organization are:

Aldrich Electric Co., Arrow Appliances Inc., Baird Electric Service, Budget Appliances Inc., Coastal Radio & TV, Andy Ferrara Appliance Co., Frank Lang Appliance.

General Radio & Sound Co., Hulls Radio & TV Service, Hurd's Radio and TV Service, Lang Electric Co., McFarlane's Inc., Powell Motor Co., Purchase Radio & TV Service, Searle's Radio & Appliance Co., Superior TV & Appliance.

### Associated Radio-TV Servicemen of New York

In the interest of more efficient organization, our growing membership has wisely chosen to form two chapters, appropriately called the Business and Technical chapters.

Meetings henceforth will be individually sponsored by both groups with attendance open to the general membership. Interesting technical subjects involving developments in the fast expanding TV fields should as in the past be of value and interest to the brawny members of ARTSNY. Business tactics and policy lectures will be welcomed by our participating members who hold the reigns of businesses which yield employment opportunities to the serviceman.

It is obvious that both technical and business acumen are required for a successful business. In many instances both are provided by one man, while in other instances it takes a serviceman and a business with combined efforts to produce a going business.

We can all put our shoulder to the wheel and provide the necessary cogs for an efficient ARTSNY organization and successful business and service.

*Max Leibowitz*

A round of applause and a great cry of well done, should be forthcoming from all of us for the terrific job that Transvision Inc. has done, by their well written public notices in acquaint-

**Free!**  
to servicemen

Reduces  
service time

Eliminates  
"call-backs"

New Phonograph  
Pickup Cartridge

# Replacement Manual

and Magnetic Recording Head Listing

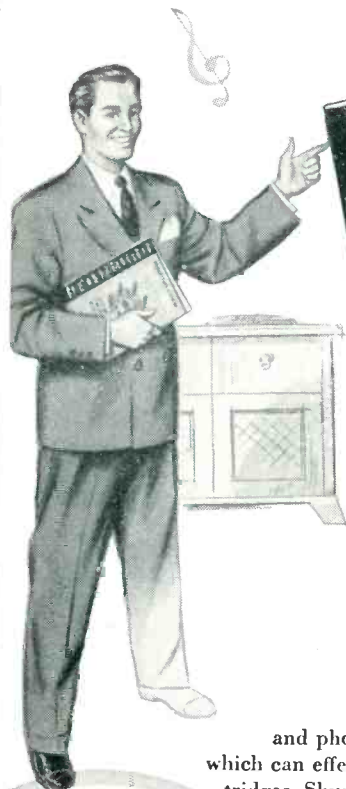

LISTS OVER 1,900 PHONOGRAPHS

and phonograph combinations which are equipped with, or which can effectively use Shure Crystal and Ceramic Pickup Cartridges. Shure Cartridges are superior or equivalent to the units they replace. This Replacement Manual covers the period from 1938 through 1952—and lists models by over 125

Manufacturers. The Magnetic Tape and Wire

Recording Head listing indicates the Shure Tape Heads used in original equipment. It also illustrates Tape and Wire Recording Heads—and shows typical operating data for the Tape Recording Heads.

Ask your  
SHURE  
DISTRIBUTOR  
for Manual  
No. 66A

**SHURE**

SHURE BROTHERS, Inc., Dept. T ★

225 WEST HURON STREET, CHICAGO 10, ILLINOIS

Manufacturers of Microphones  
and Acoustic Devices

Cable Address: SHUREMICRO



# ERIE 413

## HIGH VOLTAGE CERAMICONS®

Thousands and thousands  
are in use . . .

**and not one has ever failed**

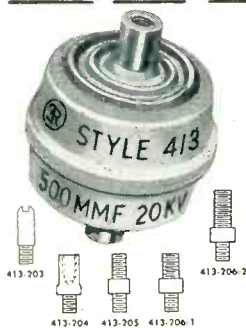

**ERIE 413**  
is fast becoming  
**THE REPLACEMENT**  
for high voltage  
TV filter  
applications

The ERIE 413 High Voltage Ceramicon is an innovation in capacitor design and has had wide acceptance by servicemen everywhere.

The Reason . . . ONE BODY, plus the correct combination of replacement terminals, permits any serviceman to carry a minimum stock, but at all times to have the correct replacement available. It's as simple as that and greatly reduces inventories. The illustrations on the left tell the story.

*ERIE components are stocked by leading electronic distributors everywhere.*

### ERIE

RESISTOR CORP.

ERIE RESISTOR CORPORATION . . . ELECTRONICS DIVISION

Main Offices: **ERIE, PA.**

Sales Offices: Cliffside, N. J. • Philadelphia, Pa. • Buffalo, N. Y. • Chicago, Ill.  
Detroit, Mich. • Cincinnati, Ohio • Los Angeles, Calif.

Factories: **ERIE, PA. • LONDON, ENGLAND • TORONTO, CANADA**

## Your One Complete Speaker Source

### UTAH REPLACEMENT SPEAKERS

Export Dept. Rocke International Corporation, N. Y. C.

# utah

## RADIO PRODUCTS CO., INC.

HUNTINGTON, INDIANA

A WHOLLY OWNED SUBSIDIARY OF NEWPORT STEEL CORPORATION

## MOSLEY 3-WAY TV ANTENNA SWITCH

*For Multiple*



Cat. No. F-20  
**MOSLEY 3-Way**  
TV Antenna Switch  
List Price .....\$3.75

### UHF and VHF ANTENNA INSTALLATIONS

- Install anywhere. Extension rod supplied for back of set mounting.
- Constant impedance—Low loss—Solderless.
- Sturdy rotary switch making silver-to-silver contact.
- In brown or ivory polystyrene case.
- Also available in Flush Wall Plate style.

*At Radio Parts Jobbers*

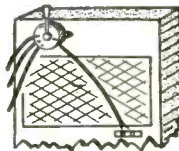

## MOSLEY Electronics

2125 Lackland Rd.  
Overland, Missouri

ing the public thru the medium of the N. Y. Times and the N. Y. Daily News, what our association ARTSNY together with Transvision, are doing so far as maintaining and establishing good ethics in the T.V. servicing industry. These newspaper ads packed a wallop and brought the name of ARTSNY to the public.

*Sid Perlin*

### Phila. Radio Servicemen's Association

At our last open meeting, held March 19, 1953 at the Franklin Institute, P.R.S.M.A., T.C.A. and the J.E.R.C.S. presented Sprague Products Co.; who had as their speaker, Leon Podolsky, Manager of the Field Engineering Department, whose topic was, "Modern Trends in Components for Television applications."

With the aid of slides Leon spoke on how to locate intermittent capacitors and how the new high capacity, small size vitamin Q capacitors are manufactured and the principles behind these new small size capacitors.

Leon also gave the boys a treat on important information about printed circuits and at the end of his talk there was a question and answer period.

The meeting was very well attended by over 200 servicemen who are anxious to know as much as possible about the parts that are used in a television receiver, their functions and how to repair a TV set.

These meetings are attracting a lot of servicemen who have not attended many meetings in the past year or so, glad to see you fellows are interested as we have more good meetings to come. (Read the meeting notices on page 6 of this issue.)

On Tuesday, April 7, 1953, at KYW Studio "A", P.R.S.M.A., T.C.A. and the J.E.R.C.S. presented the Philco Corporation and Dick Hershey, Assistant National Service Manager for Philco who spoke on TV Trouble Shooting. It was an illustrated lecture on the Do's and Don'ts of practical trouble shooting showing the quickest and easiest methods of locating trouble in a TV receiver for faster and better service to your customer.

Dick is a fellow who really knows TV service and showed you a lot of short cuts in servicing.

Thursday, April 23, 1953, at the Franklin Institute DuMont Laboratories presented with Carl Quirk as the speaker on UHF antennas for TV receivers and UHF installations.

Thursday, May 28, Hickock Electrical Instruments will have John Stinson as their speaker. John will speak on "Proper use of shop equipment." This meeting will be held at

# Order Yours Now!

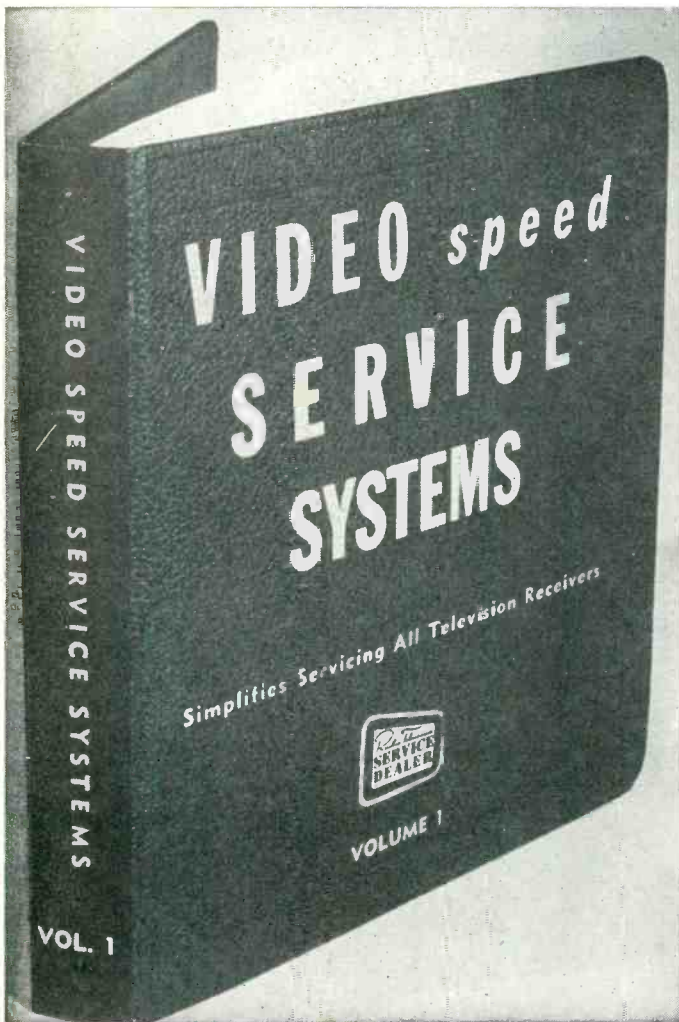

## VIDEO speed SERVICING SYSTEMS

**\$4.95** • (post paid)

**Distributors—order your supply now!**

Service Dealers—get your copy of VSSS from your Distributor. If he can't supply you, order direct by mail from us.

Contains over 600 Service Items representing over 1000 of the most-serviced Television models now in use. Over 25 different manufacturers' lines are covered.



The expansion type ring binder (of finest quality) is 9 x 12 inches, holds all 224 pages of VSSS Vol. 1, and has room for another year's supply of VSSS Data Sheets. Opens flat for bench use. TVset models and chassis are cross indexed for speedy reference.

Video Speed Servicing Systems IS GUARANTEED To Simplify Servicing All TVsets. 24 (or more) new Data Items are published in every issue of "Radio-Television Service Dealer" as a regular monthly feature.

### TEAR OFF AND MAIL NOW

RADIO-TELEVISION SERVICE DEALER  
67 West 44th Street, New York 35, N. Y.

S-53

Please send me post-paid VIDEO SPEED SERVICING SYSTEMS Volume 1. Enclosed herewith is

my  check  money order for \$\_\_\_\_\_ for \_\_\_\_\_ copies at \$4.95 each.

Name .....

Address .....

City ..... Zone ..... State .....



# STANDARD BRAND TUBES

Individually Boxed . . . . at **SLASHED PRICES**

These are **STANDARD BRANDS—No Seconds—No Rejects—No “Pulls”—No War Surplus or Rebrands**

Every tube is genuinely first quality, and is sold with full RTMA Guarantee. We have and ship promptly the types listed. We do NOT switch to offbrands or “hold back” on any item offered.

0Z4	\$.54	6AV6	\$.44	6S4	\$.61	12AV7	\$.89
1B3	.85	6AX4GT	.95	6SA7	.66	12BA6	.60
1S4	.90	6BA6	.60	6SK7	.62	12BE6	.67
1U5	.62	6BC5	.79	6SN7GT	.73	12BH7	.91
1X2B	.84	6BE6	.63	6SQ7M	.59	12SA7M	.70
5U4G	.54	6BG6G	1.72	6T8	.89	12SK7GT	.65
5Y3GT	.45	6BH6	.77	6V6GT	.64	12SQ7GT	.55
6AB4	.68	6BN6	1.08	6W4GT	.62	25BQ6GT	1.30
6AC7	1.05	6BQ6GT	1.22	6W6GT	.80	25L6GT	.63
6AF4	1.75	6C4	.49	12AT6	.52	35W4	.50
6AG5	.79	6CB6	.66	12AT7	.94	35Z5GT	.48
6AH6	.88	6J5GT	.54	12AU6	.53	50A5	.92
6AK5	1.31	6J6	.82	12AU7	.70	50B5	.63
6AU6	.59	6K6GT	.57	12AV6	.50	50L6GT	.64

Minimum order \$20.00. Terms: 25% with order, balance C.O.D. Orders shipped promptly F.O.B. New York City. Prices subject to change without notice. All tubes sold on Money-Back Guarantee.

## Elek-Tronic Bargain House

2 Embassy Court Great Neck, Long Island, N. Y.

**SERVICE DEALERS! SERVICE-MEN!** Here is your opportunity to buy only standard brand, individually boxed tubes at better than 60% off list. Save money—order by mail today!

Service Men!

**THE GUARDIAN  
SERIES 200  
RELAY...**

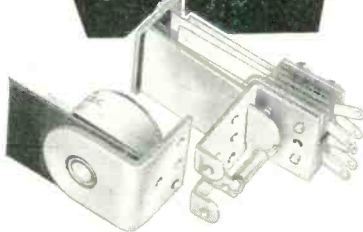

*Interchangeable*  
**COIL and CONTACT  
SWITCH ASSEMBLIES**  
Save Time—Cut Costs!

★ Coil assembly includes coil and field piece. Contact assembly consists of switch blades, armature, return spring and mounting bracket. Standard and Midget contact assemblies in either S.P.D.T. or D.P.D.T. are *interchangeable* and can be used with any of 13 coils described below.

### CONTACT SWITCH ASSEMBLIES

CAT. NO.	TYPE	AMPS	COMBINATION
200-1	Standard	8 amps	Single Pole Double Throw
200-2	Standard	8 amps	Double Pole Double Throw
200-3	Standard Contact Switch Parts Kit with complete assembly and wiring details		
200-4	Standard	12.5 amps	Double Pole Double Throw
200-5	Standard	8 amps	Four Pole Double Throw
200-M1	Midget	8 amps	Single Pole Double Throw
200-M2	Midget	8 amps	Double Pole Double Throw
200-M3	Midget Contact Switch Parts Kit with complete assembly and wiring details		

### 13 COILS ASSEMBLIES

CAT. NO.	A.C. COILS*	VOLTS	D.C. COILS	VOLTS
200-6A	6 A.C.	200-6D	6 D.C.	6 D.C.
200-12A	12 A.C.	200-12D	12 D.C.	12 D.C.
200-24A	24 A.C.	200-24D	24 D.C.	24 D.C.
200-115A	115 A.C.	200-32D	32 D.C.	32 D.C.
		200-110D	110 D.C.	110 D.C.
		200-5000D		

\*All A. C. coils available in 25 and 60 cycles

**GUARDIAN ELECTRIC**  
1613-F W. WALNUT STREET CHICAGO 12, ILLINOIS  
A Complete Line of Relays Serving the Radio Industry

**NOW**  
**UHF Antennas for**  
**Indoor and Outdoor Use!**

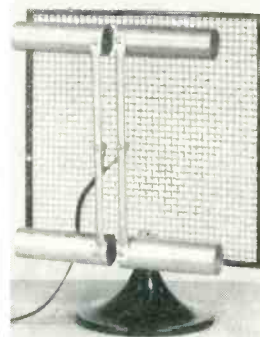

Model 210 Indoor

Literature available upon request.

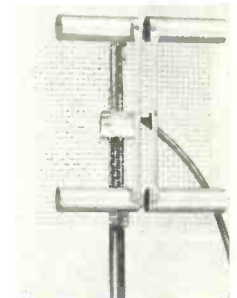

Model 200 Outdoor

“TRICRAFT” . . . manufacturers of the complete line of VHF Antennas now offers two new UHF antennas . . . the result of field research and testing in actual UHF territories . . . will provide the finest, sharpest pictures in any UHF area.

SOLD through recognized jobbers everywhere.



**Tricraft Products Co.**

1535 North Ashland Ave., Chicago 22, Ill.

Manufacturers of complete line of Television, FM & AM antennas and accessories.

the Franklin Institution, 20th and Parkway.

Another Big Date—May 26, 1953. The Philadelphia Radio Servicemen's Association will celebrate its 20th year with a 20th Anniversary Dinner to be held at McCallisters, 1811 Spring Garden Street, on this night. Bring your wife, girl friend or other friends or relatives who like a night out and enjoy a good time, with good eats.

**National Association of Television Electronic Service Associations**

Although the service industry is now roughly 32 years old, it has been a long time since it has had a truly national voice. One reason for this has been the fact that until three years ago, service management has had no national association. Now that TV itself has finally reached true national scope, service also has reached maturity. Problems of service are national; solutions too must be national. Thus it has become necessary that a publication devoted exclusively to discussing problems and solutions arise in various sections be instituted.

With this in mind, NATESA now inaugurates the NATESA Scope to fulfill this urgent need. It will serve as a means of discussing problems, offering solutions and, in general, act as a clearing house of facts, data and news of service activity and the activities of other segments of the TV industry where they affect service. Its columns will be open to anyone, regardless of the segment of the industry, who has anything to offer which would assist in making of the TV service industry a worthy partner of the other segments of the TV-Radio industry and a respected and profitable profession and business.

As regards our convention which was held on the 10th to 12th at the Hotel Continental in Kansas City, we are extremely happy to say that it was a terrific success. We are in the process of transcribing the tapes of the proceedings. Unfortunately, this will take a little bit of time. As soon as it is completed, a full report will be made.

In the meantime, perhaps a capsule report will help you. The time and place was mentioned before. 30 exhibitors had large display booths of various types of equipment and working exhibits. Addresses were made by John Thompson of GE on "Service Salesmanship," Lee Allen of Amphol on "UHF Technical Presentation," Frank Mansfield of Sylvania "Service Trends and Statistics," Lloyd Austin of Simpson Electric "UHF Test Equipment," Harold Rieth Regency Division of IDEA Mfg. "UHF Converters," Robert Artman of Em-

pire Coil "UHF Telecasting," Larry Kearns of LaPointe & Plascomold "UHF Antennae," Chet Jur of Merit Transformer "TV Servicing," Albert C. W. Saunders of Saunders Radio & Electronic School "Service Education," and Louis Calamaras of NEDA "Industry Problems." President Frank Moch made the presentation of NATESA Friends of Service Management Awards to Sylvania, GE and Sprague for services rendered to better consumer relations.

Arrangements, incidentally, are in progress for the September convention to be held in the City of Chicago.

Great credit for the success of this meeting is due to Jack McDowell of Kansas City who was the Convention Chairman and to the host association, Television Service Engineers of Kansas City.

**Radio and Television Technicians Guild of Florida, Inc.**

Another milestone in education to the public in regards to radio and TV service will be accomplished this month.

Better than ten thousand people will view the Home Show at Bay Front Park this year. At this Home Show the R&TTG will have a booth to display the working of Radio & TV Service. Here is our golden opportunity to convey to the Set Owner the intricate operation of his TV set. Not in engineering or technical terms, but in a language that the layman can understand. We will be able to show how several components, that break down, such as a dead Horizontal oscillator and a dead High voltage rectifier, etc., can cause a set to give the same indication of trouble.

There will be all kinds of questions asked those in attendance at the booth, questions from the ridiculous to the sublime. We have no doubt that the man in the booth will be equal to the task of giving clear and concise answers. This is our opportunity to put across to the public of the greater Miami area the caliber of the men in our field. Our sincerity and interest, as well as our knowledge, will speak for itself in creating a better feeling of the honesty and dependability of the Serviceman in the mind of the general public.

The Home Show is only one of several programs being designed to help the public realize that the service of electronic equipment is a profession and not a racket. With the co-operation of our allied industries we shall put our best foot forward in 1953.

All of the members of the Guild should be proud of the fact that they

**NEW RIDER BOOKS**

for easy tv servicing



**TV MANUFACTURERS' RECEIVER TROUBLE CURES VOL. 1., VOL. 2. AND VOL. 3**

A brand new series of practical books. Gives you exact directions for correcting TV receiver "bugs". Each cure is official, factory-authorized, direct from the receiver's manufacturer. It is positive! Helps correct the most difficult faults—picture jitter, hum, instability, buzz, tearing, etc. Vols. 1 to 3 cover approx. 40 different manufacturers. One service job will more than pay the cost of these books!

- Vol. 1 over 120 pages (5¼ x 8¼").....\$1.80
- Vol. 2 over 120 pages (5¼ x 8¼").....\$1.80
- Vol. 3 coming soon.....\$1.80

**TV SWEEP ALIGNMENT TECHNIQUES**

by Art Liebscher, *Test Equipment Specialist*

Never before has there been a book such as this on TV sweep alignment! Exclusive information not generally available to service technicians. Introducing the new Supermark method. Simplified procedures...time-saving...eliminates dual set-ups. Over 100 (5¼ x 8¼") pp., illus. \$2.10

**HOW TO USE METERS**

by J. F. Rider.

Panel type, Volt-Ohm-Milliammeters, Vacuum Tube Voltmeters for servicing radio and TV receivers, Audio Amplifiers, Power Supplies; for use and repair of Amateur Transmitters. Written for the service technician, the TV and Radio student, and hams.

**Obtaining And Interpreting TEST SCOPE TRACES**

by J. F. Rider.

Over 500 actual photographs of Test Scope Patterns explaining the causes for abnormal patterns in TV receivers, FM and AM radio receivers, audio systems and test equipment. No other book like it!

**UHF PRACTICES AND PRINCIPLES**

by A. Lytel

New, up-to-the-minute. Clear, easy-to-understand book covers both theory and applications of UHF. TV devices, converters, UHF test equipment, circuit components, tubes. 390 (5½ x 8½") pages. Cloth cover.....\$6.60

**TV TROUBLESHOOTING AND REPAIR GUIDE BOOK**

by R. G. Middleton

The finest practical book to make your TV servicing easy. Spot TV receiver troubles rapidly. Includes receiver waveforms, visual alignment, test equipment kinks, etc. 204 (8½ x 11") pages.....\$3.90

**ENCYCLOPEDIA ON CATHODE-RAY OSCILLOSCOPES AND THEIR USES**

by Rider & Usian

Covers practically every 'scope manufactured during the past 10 years—and applications. 992 (8½ x 11") pages. 3,000 illus. Cloth cover.....\$9.00

Buy these books now at your jobbers... leading bookstores... or—

**JOHN F. RIDER PUBLISHER INC.**  
Dept. SD5 480 Canal Street, New York 13, N. Y.



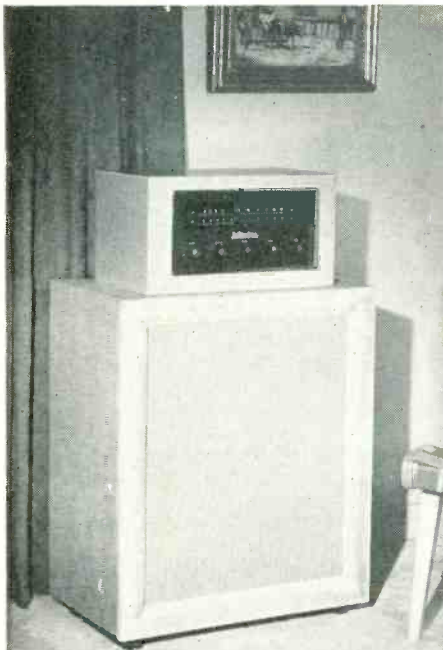

**\$3900** NET\*

15 or 12 in. Bass Reflex Cabinet

*Craftsmanship  
in Cabinets*

New—with more style and better tone at half the price.

Fits finest surroundings, yet economically engineered. 1/2-in. cellufoam acoustic lining.

Solid hardwood picture-frame front. Brahma-grain matching leatherette on top and sides.

Blonde or mahogany, same price. Ask your Parts Jobber or write for specification sheet.



**NEW BASS REFLEX  
CORNER BAFFLE**

Gives more effective coverage, looks better on wall. 1/2-inch cellufoam acoustic lining. Blonde or mahogany, same price.  
12" spkr. .... \$8.55 Net\*  
8" spkr. .... \$5.10 Net\*



**WALL BAFFLES**

Argos craftsmanship with resonant tone. Reinforced for extra strength. Blonde or mahogany, same price.  
Up to 12" spkr. .... \$2.34 to \$4.65 Net\*

\*Slightly higher west of Rockies



are a part of a group of professional men who are trying to be a credit to their community, rather than a detriment. True, there are a few who are riding on the coat tails of these members who are sincere. Those few cannot continue to do so. Every major city in the country that has an organization paralleling R&TTG has the same problems in their own way. The Guild contends that the best way to solve its biggest problem is by public education. No one can lick the world by himself. Neither could the Guild present an educational program, to the public, without the cooperation of all our local distributors, radio stations and our TV station.

**LINE VOLTAGE**

[from page 37]

or down in six-volt steps, total of twenty volts each side of center. The adjuster is equipped with plug-in power cord and socket for the operation of equipment and the TV receivers. On the front panel a voltmeter with switch in center position shows actual line voltage, and as it is turned up or down it indicates the voltage applied to the equipment.

Another useful function of this adjuster is on the test bench, to raise the voltage to determining arcing point, if any, in the high voltage power supply, before returning the set to the customer's home.

**GERMANIUM**

[from page 42]

as detectors, mixers, demodulators, harmonic generators, noise limiters, discriminators, clampers, dampers, sync strippers, *age* rectifiers, etc. germanium diodes are to be found in electronic test instruments. Such applications include rectifiers in VT voltmeter probes, detectors in oscilloscope demodulator probes, output rectifiers in audio VT millivoltmeters, rectifiers in *ac* test meters, sync amplitude limiters in oscilloscopes, wide-band amplitude modulators in *rf* signal generators, etc.

**Triodes**

The characteristics of germanium triodes or *transistors* are considered to be more or less fluid at this writing. However, certain electrical characteristics are beginning to crystallize and can be discussed here.

Present practical transistors are of

pass up the long shots!

cash in on the Favorite!

put yours on ALLIANCE!

See us at the Parts Show—  
Booth 225

Alliance Tenna-Rotors — Alliance TV Boosters

Alliance Manufacturing Company . Alliance, Ohio



For a Classy Chassis—Install a Set of Gemco Stray-X Filament Chokes



**GREAT EASTERN  
MANUFACTURING CO.**  
BROOKLYN 12, NEW YORK

**TECHNICAL ARTICLES  
WANTED**

on

TV, AM RADIO, FM RADIO, PHONO MECHANISMS, HI-FI AUDIO, AUTO RADIO, TEST EQUIPMENT, ANTENNAS

pertaining to their

**Theory, Installation, Application,  
Service & Maintenance**

submit manuscripts to  
Managing Editor

**Radio-Television Service Dealer**

67 West 44 Street New York 36, N. Y.

**FASTER  
STURDIER**  
Lower Installed Cost

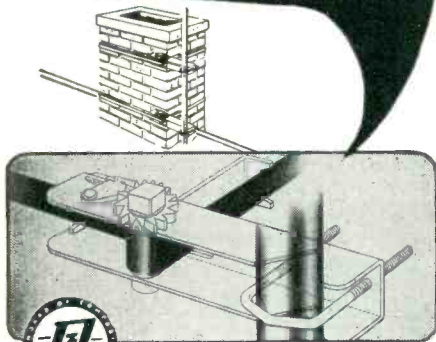

**SPEE-DEE  
CHIMNEY MOUNT**

**Model AK 85** The fastest-installed chimney mount ever devised for TV antennas! Rugged in design—simple to install. Simply thread strapping through ratchet, around chimney and back through ratchet—wind up ratchet tight—and the job's done! Heavy gauge, zinc-plated steel with large "U" bolt for up to 1 3/4" O.D. mast and full length galvanized steel strapping.

**THE RADIART CORPORATION**  
CLEVELAND 13, OHIO

**ILLINOIS CAPACITORS  
HAVE BEEN SERVING  
SERVICEMEN FOR OVER  
19 YEARS**



**TYPE IHT**

The complete dependability of ILLINOIS electrolytic capacitors has made them a favorite with servicemen everywhere!

For over 19 years, ILLINOIS CONDENSER COMPANY has been producing quality capacitors—and during this time has been responsible for many important advancements in electrolytic capacitor construction. Millions of ILLINOIS capacitors, now in service, are proving their absolute dependability.

Used as original equipment by leading TV and radio manufacturers, ILLINOIS electrolytics are "first choice" of servicemen for all replacements!

Write for new Catalog!



**ILLINOIS CONDENSER CO.**  
1616 NORTH THROOP STREET • CHICAGO 22, ILL.

two types: the point-contact type and the junction type. The point-contact type (See *RTSD* May 1942 and January 1951) is an arrangement of two closely-spaced whiskers contacting a germanium wafer. The three triode connections are made to the wafer and whiskers. The junction type dispenses with whiskers and utilizes three discrete thin conducting layers within a single thin slice of germanium crystal. Circuit connections are made to the separate layers. In each type, the input electrode is referred to as the *emitter*, the output electrode as the *collector*, and the germanium wafer as the *base*.

Point-contact transistors are in respectable production at present. Examples are Raytheon CK716 (*Fig. 2*) and General Electric G11 and G11A. The point-contact type has been in development for the longer period of time and its production techniques therefore are more nearly crystallized. The comparatively new junction type, on the other hand, is in limited production.

The junction-type transistor (*Fig. 2*) is the more rugged of the two. In most instances, it also has the higher signal output and is the most efficient. The first models have not shown as high a frequency response as the point-contact types, but recent experimental laboratory versions have been reported to operate at several hundred limits of 100 kc. to 1 to 3 mc. The junction type is the more temperature-dependent of the two.

Important transistor characteristics are emitter voltage, emitter current, collector voltage, collector current, power output, power gain, and current gain. Because the transistor is a current-operated device, it commonly exhibits low input impedance and higher output impedance.

The present CK716 point-contact transistor has the following characteristics for typical grounded-base amplifier application: Emitter voltage 0.5 V, emitter current 1 ma, collector voltage -15 V, collector current 2.5 ma, current amplification factor 1.2 minimum, input resistance 150 to 450 ohms, output resistance 10,000 to 40,000 ohms.

Maximum ratings of the General Electric Type G11 are: Emitter current 3 ma, emitter peak inverse voltage 50 V, oscillator voltage -30 V, collector current 7 ma. Typical operating characteristics as a grounded-base amplifier are: input resistance 475 ohms, output resistance 22,000 ohms, current amplification factor 2.2, power gain 17 db, cutoff frequency 2 mc

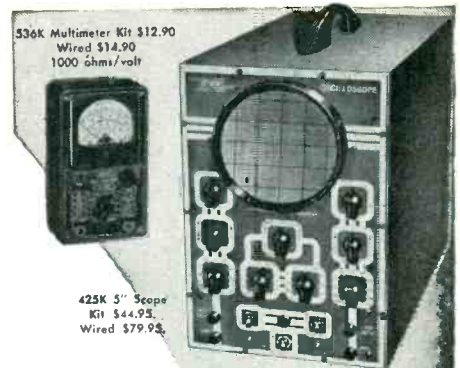

**YOU BUILD  
EICO**

**KITS  
IN ONE  
EVENING-**

**but they  
last a lifetime...  
and you save  
50%!**

**24 Kits and 25 Instruments —  
the Industry's most complete  
line of MATCHED  
TEST INSTRUMENTS!**

Over 1/4-million EICO Instruments are now in use the world over! That's the proof of EICO's leadership in Value to the Serviceman!

For latest precision engineering, finest components, smart professional appearance, lifetime performance and rock-bottom economy — see and compare the EICO line at your jobber's today before you buy any higher priced equipment! You'll agree with over 100,000 others that only EICO Kits and Instruments — no other — give you the industry's greatest values at lowest cost.

Write NOW for  
FREE latest Catalog  
D-5



**Laboratory  
Precision  
at Lowest Cost**



©1952 **INSTRUMENTS & KITS**  
**ELECTRONIC INSTRUMENT CO., Inc.**  
84 Withers Street, Brooklyn 11, N. Y.



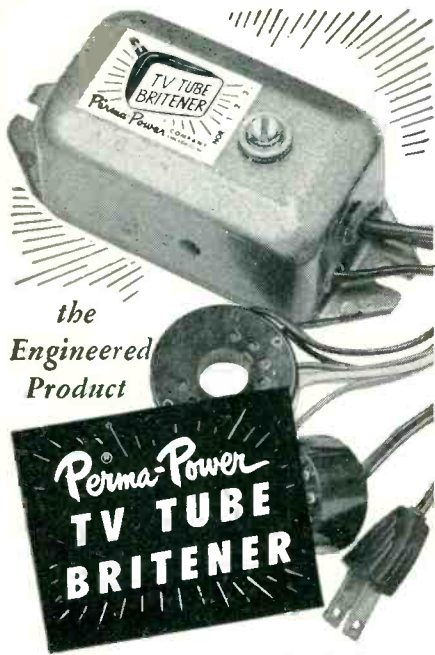

the  
Engineered  
Product

**extends useful life  
of older TV tubes!**

manufactured by

**Perma-Power COMPANY**

Chicago 25, Illinois

Manufacturers of Electronic Equipment Since 1928

**DON'T BE  
STAMPEDED**

You can always  
cash in with **ALLIANCE**  
**THE PRE-SOLD LINE!**

Be sure to look us up at the  
Parts Show—  
Booth 225

Alliance Tenna-Rotors — Alliance TV Boosters

Alliance Manufacturing Company, Alliance, Ohio

As audio amplifiers and oscillators, common transistors have delivered power outputs between 2 and 100 milliwatts, depending upon type and manufacture. Laboratory types with outputs of several watts have been reported.

It seems likely that one of the first applications of transistors in television receivers will be in video amplifiers.

#### Power Rectifiers

The germanium power rectifier appeared on the market during 1951. This component is noticeably more efficient than the selenium rectifier of the same current and voltage rating with which it competes. It has an internal voltage drop which is 1/5 or less than that of the selenium component and can be operated at higher frequencies.

Room-temperature characteristics of the early power-line-operated type (General Electric Type G10. Fig. 1), which may be compared to the characteristics of an equivalent selenium rectifier, are: input voltage 130 V rms, dc output current 400 ma, dc surge current 25 amperes, peak forward current 3 amperes, peak inverse voltage 400 V, full-load voltage drop 1.5 V maximum operating frequency 50 kc.

Characteristics of the lately-introduced General Electric diffused junction Type 4JA2A4 are: Peak inverse voltage 400 V, peak forward current 1.57 amperes dc output current 500 ma, dc surge current 25 amperes, full-load voltage drop 0.7 V, continuous reverse working voltage 185 V dc, maximum operating frequency 50 kc.

Other diffused junction rectifiers types are available with d.c. output current ratings of 75, 100, and 150 milliamperes.

#### Photocells

Advantages of the germanium photocell (also called *photodiode* and *phototransistor*) are its extremely small size and its improved frequency response over selenium and copper oxide types. Type 1N77 (Fig. 1) is only 0.08" in diameter and 5/16" long. Its maximum operating frequency is 100 kc. This unit is indicative of light-sensitive germanium devices which will appear.

The 1N77 has its maximum sensitivity in the infra-red region, at 1.7 microns, but it responds to the entire visible spectrum. It has no ultra-violet response.

The germanium photodiode, which is similar to an ordinary point-contact diode, operates by virtue of a change

## "lip" makes the difference!

In baseball, "LIP" often decides the game. In lightning arresters, too, "lips" make the difference. Only JFD offers you the unique strain-relief "lips"—which protect the twin-lead.

"Jumbo" model AT102 with UL approved stainless steel strap for Universal Mounting. Write for form 84 "Lightning Strikes A TV Antenna".

JFD MANUFACTURING COMPANY, Inc  
BROOKLYN 4, NEW YORK  
World's Largest Manufacturer of  
TV Antennas and Accessories

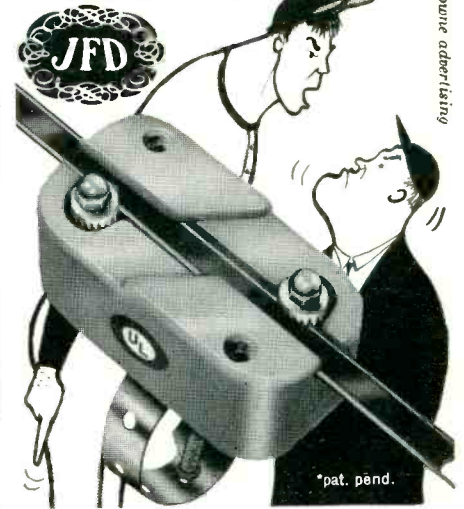

Burton bronze advertising

### ARROW GUN TACKER

**AUTOMATICALLY Replaces Hammer & Nails at Trigger-Rate Speed!**

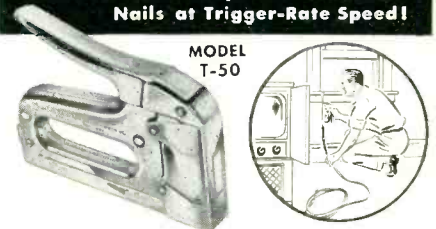

MODEL T-50

**USES STAPLES UP TO 9/16" LEG**

#### FOR TACKING

• Wires, cables • Built-in antennas • Speaker grill cloths • Small parts envelopes, technical data and MANY OTHER USES

Write for Literature and Jobber Set Up.

**ARROW FASTENER CO., INC.**  
1 Junius Street, Brooklyn 12, N. Y.



You can **S P R E A D** that picture with a **GEMCO Horizontal Re-framer**



**GREAT EASTERN MANUFACTURING CO.**  
BROOKLYN 12, NEW YORK

in its reverse-conduction characteristic which occurs when the contact area is illuminated. In the 1N77 operated at -50 volts *dc* and with a 20,000-ohm load resistance, for example, reverse current undergoes approximately 70 microamperes increase when the contact area is illuminated by a 1600-lumen test source.

The small size of this cell and its wide frequency range indicate that it might be expected to be used in light-meter probes, counting and sorting equipment where compactness is a desirable feature, and in sound-on-film reproducers.

#### Things to Come

Prediction is dangerous. However, present development trends indicate that we may expect additional germanium devices along the lines of diodes and diodes (similar to diode-semiconductor relays for sensitive control, tetrode and pentode amplifiers in addition to present triode transistors, combinations of amplifier-diode and diode-pentode tubes), com-

binations of amplifiers and power rectifiers (similar to amplifier-rectifier tubes like the 117N7), controlled power rectifiers (similar to the grid-controlled electronic and vapor-type rectifier tubes), germanium "thyatrons," contactless interrupters, etc.

Aside from the obvious future applications in communications and industrial electronics, it may reasonably be expected that germanium devices, with their compactness, low standby power requirements, and lack of power-consuming filaments, will enter such applications, several of which now are notable as "holdouts" on electron tubes, as home heating control, home refrigeration, automatic operation of domestic lighting and ventilation, automobile ignition systems, air conditioning, certain highly-portable electromedical equipment, timepieces, automatic light-controlled camera shutters, etc.

The service dealer must begin preparation now to handle his share of maintenance of this electronic equipment.

## PHONO FACTS [from page 40]

arm and the fewer the component parts, the better.

53. The greater the number of loosely coupled parts (not integral with the arm), the greater the possible number of resonance points.

54. The transmission of stylus-vibratory energy to the arm can be minimized, for all practical purposes, with a reproducer having high lateral and vertical compliances. Such condition prevents development of arm resonance.

55. The old practice of loading the arm with extra "dead" weight to push the resonance-point below a given frequency or to attain resonance at a certain frequency, should be avoided.

56. When used with a highly compliant reproducer, arm loading introduces distortion. Furthermore, since the extra weight has to be pushed across the disc by the record grooves, serious erosion results.

57. The "McProud test" is still the best and simplest for checking the combined tone-arm and reproducer compliance (tracking). For details, see *AUDIO ENGINEERING*, August 1950.

58. For years past, many attempts have been made at devising a tone-arm that would maintain tangency automatically. Patent Office records show prolific activity along that line for the past 20 years. The parallelogram idea was the basis in most of these attempts. Any such mechanism would mean an increased number of component parts and joints. Thus far, such devices have all proved themselves inferior and totally unsatisfactory.

These attempts overlook the highly important fact that the groove wall would have to do all the work to keep such mechanism in tangency. This would mean serious record wear. Furthermore, since the groove wall itself has to push such mechanism into tangency, obviously such tangency would then be too late to do any good. This condition is analogous to a trolley car moving slowly around a curve. The rail has to do all the work in constantly pushing the wheels to conform to the rail-radius. Everyone is acquainted with the fact that the outside rail on a curve wears out much faster.

(To Be Continued)

## VERTICAL SWEEP [from page 27]

where buzz is originating in vertical circuits, the pitch of the buzz will vary as the vertical hold control is rotated and the buzz will be heard on all channels, including unused ones.

If buzz has been traced to the vertical circuit by the above checks, the trouble can be localized further by removing or disabling (shorting the grid) of either vertical tube to check

Now... **INSURE BEST RECEPTION**

with the

**FINEST TV CHASSIS  
EVER DESIGNED**

**TRANSVISION**

**630 De Luxe**  
TYPE  
TV CHASSIS

with **High-Fidelity Sound**

Mfr. licensed under RCA patents

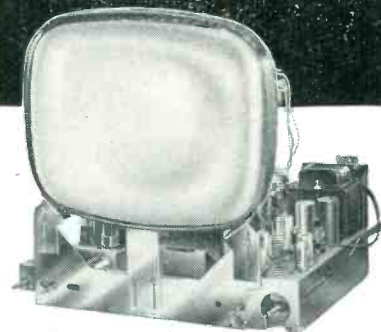

Embodies the latest and finest improvements, notably:

- Super Fringe Area Circuit
- Redesigned for Peak UHF Performance
- Hi-Fidelity Push-Pull Audio (40-13,000 Cycles)
- 12" Hi-Fidelity Speaker

**\$139**  
net  
Plus 10% Fed. Tax  
CRT EXTRA

In this space we can mention only a few of the other great features of this DeLuxe Chassis: 31 tubes (28 tubes, 3 rectifier tubes—plus CRT makes 32 tubes) . . . Only Sprague "Black Beauty" Molded Condensers used throughout . . . Allen Bradley and IRC RESISTORS . . . Handles up to 24" picture tube . . . Layout of most efficient type for ease of servicing . . . Carries standard RMA Guarantee . . . The choice of those who want the finest in chasses.

**CABINETS:** For details on Transvision's famous beautiful line of TV Cabinets, write for information on Agent's Program.

#### 1 YEAR GUARANTEE ON CRTs

17" Rectangular Glass CRT . . . net \$22.25  
20" Rectangular Glass CRT . . . net \$31.95  
21" Rectangular Glass CRT . . . net \$36.95

Order direct from factory:

**TRANSVISION INC., New Rochelle, N. Y.**  
FREE: Sample copy of "TV and Electronics Notes." Or send 50c for year's subscription.

#### MONEY-BACK GUARANTEE:

10-DAY TRIAL: Buy and try the Transvision 630 Type De Luxe Chassis for 10 days. Then, if you wish, you may return it. Your purchase price less 10% (our cost of handling and re-packing) will be promptly refunded.

Ask for  
**FREE**  
Circuit and  
Technical  
Data

TRANSVISION, INC.  
DEPT. SD-630 NEW ROCHELLE, N. Y.  
( ) Send me 630 Circuit and Technical Data.  
( ) Enclosed find \$\_\_\_\_\_ deposit. Balance  
C.O.D. Ship \_\_\_\_\_ chassis. \_\_\_\_\_ CRTs.  
( ) Enclosed find \$\_\_\_\_\_ in full.  
I accept your 10 Day Trial terms.

Name \_\_\_\_\_  
Address \_\_\_\_\_  
City \_\_\_\_\_ State \_\_\_\_\_



# South River

## ★★ NEWS ★★

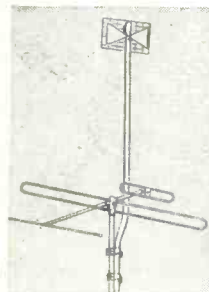

**ULTRA-HIGH  
FREQUENCY  
ANTENNA  
MOUNTING  
ADAPTERS  
MODEL  
UHM-1**

Minimizes attenuation of signal due to coupling effect between antennas.

Minimizes ghost effect due to close proximity of antennas.

Mounts UHF antenna without disturbing present installation. Of magnesium; extends 5' above present antenna.

Also available in Model UHM-2 which fastens below present antenna, 30" away from mast.

**SOUTH RIVER METAL  
PRODUCTS CO., INC.**  
SOUTH RIVER, N. J.

PIONEER AND OUTSTANDING PRODUCER  
OF FINEST LINE OF ANTENNA MOUNTS

playing  
**LONG SHOTS**  
is risky—  
you're **SURE**  
with **ALLIANCE**

See us at the Parts Show—  
Booth 225

Alliance Tenna-Rotors — Alliance TV Boosters  
Alliance Manufacturing Company, Alliance, Ohio

the effect on the buzz. One cause of vertical buzz is the mechanical vibration of either the vertical output transformer or the blocking oscillator transformer, when the set has one. This buzz, when checked closely, is heard as a vibration coming from the chassis rather than from the speaker.

Sometimes, vertical buzz is coupled into the audio circuits and can be heard in the speaker. Check the placing of leads from the vertical circuit to keep them away from the audio circuits (audio *if*, ratio detector, audio amplifier stages).

## CIRCUIT COURT

[from page 54]

tooth wave form of approximately 20 volts peak to peak. This wave form appears at the plate of V403B.

The grid of V403B is fed a positive going sync pulse from the plate of V403A through C506. The cathode is fed a negative going sync pulse. Between grid and cathode are two resistors, R503 and R504. They are both 82K. The circuit values are such that when the saw-tooth voltage at the plate and the sync pulses arrive in the proper phase relationship a fixed voltage is established at the center of R503 and R504.

This voltage is a result of grid current flow through R503 and R504 from the grid to the cathode. Due to this direction of the current flow, the center of the resistors is more negative than the cathode. This negative voltage is applied to the grid of V503, the horizontal oscillator through the R508-C513 network.

This equilibrium state occurs when the sync pulses arrive at the center of the saw-tooth. Since the saw-tooth is capacity-coupled to the plate of V403B, this mid-point is at the zero average *dc* plate voltage point. If the sync pulse and the saw-tooth are not in phase, the result is that the grid current flow will be greater or smaller depending on the phase relationship. This variation causes a change in the voltage at the center of R503-R504. The changed bias voltage affects the firing time of the horizontal oscillator. The action is in the direction of bringing the oscillator into step with the sync pulse.

To keep the center value of bias from changing as a result of a loss of sync, either at the transmitter or in the sync clipper, C507 and C511 feed pulses to the grid. These pulses are of such a phase relationship that the no sync pulse coming in.

## Advertising Index

Admiral Corporation .....	67
Alliance Manufacturing Co. 43, 76, 78, 80	
American Elec. Heater Co. ....	16
American Phenolic Corp. ....	10, 11
American Television & Radio Co. ....	18
Argos Products Co. ....	76
Arrow Fastener Co., Inc. ....	78
Astron Corporation .....	14, 15
Bussmann Manufacturing Co. ....	13
Centralab .....	63
Channel Master Corp. ....	8, 9
Copperweld Steel Co. ....	70
Electronic Instrument Co., Inc. (EICO) .....	77
Elek-Tronic Bargain House. ....	74
Erie Resistor Corp. ....	72
Finney Company, The. ....	36
General Electric Company. ....	61
Great Eastern Mfg. Co. ....	76, 78
Guardian Elec. Mfg. Co. ....	74
Halldorson Company, The. ....	64
Hytron Radio & Electronics Co. ....	31
Illinois Condenser Co. ....	77
International Resistance Co. ....	Cover 2
JFD Manufacturing Co., Inc. ....	78
Kester Solder Company. ....	70
LaPointe-Plascomold Corp. ....	59
Littelfuse, Inc. ....	1
Mallory, P. R. & Co., Inc. ....	Cover 3
Merit Coil & Transformer Corp. ....	5
Mosley Electronics .....	72
Nichols Wire & Aluminum Co. ....	22
Ohmite Manufacturing Co. ....	69
Perma-Power Company .....	78
Philco Corporation .....	65
Pyramid Electric Company. ....	17
Radiart Corporation .....	2, 77
Radio Merchandise Sales, Inc. ....	62
Rauland Corporation .....	23
RCA Tube Dept. ....	Cover 4
Raytheon Manufacturing Co. ....	19
Regency .....	33
Rider, John F. Publisher, Inc. ....	12, 75
Sams, Howard W. & Co., Inc. ....	4
Sangamo Electric Company .....	20
Schott, Walter L. Co. ....	24
Shure Brothers, Inc. ....	71
Simpson Electric Company. ....	7, 37
Snyder Manufacturing Co. ....	29
South River Metal Prods Co. ....	80
Standard Transformer Corp. ....	68
Sylvania Electric Products, Inc. ....	57
Transvision, Inc. ....	79
Tricraft Products Co. ....	74
Trio Manufacturing Co. ....	21
Utah Radio Products Co., Inc. ....	72
Vaco Products Co. ....	66

Depend on Mallory  
for  
Approved Precision Quality

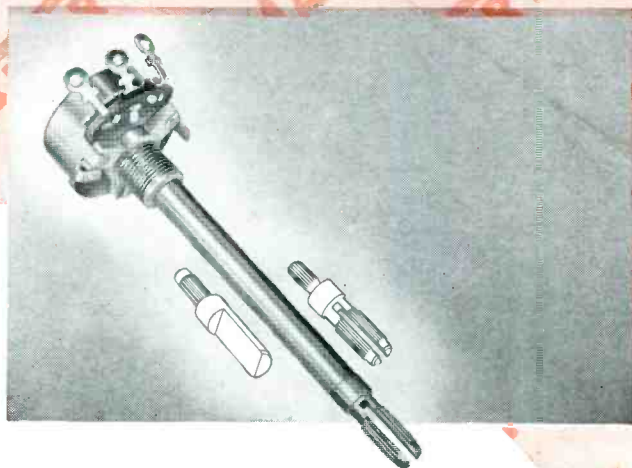

## "WE'LL HAVE IT BACK TOMORROW"

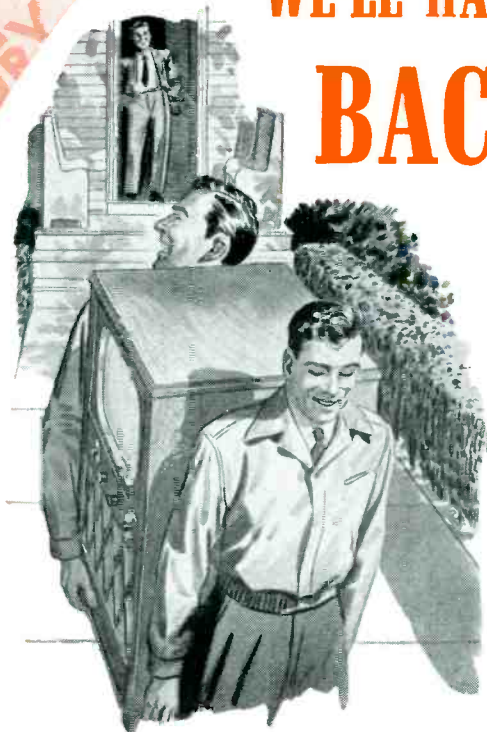

### **Mallory Dual Control Kits**

Three kits of controls and switches, selected to meet varying requirements in different parts of the country, will serve 50 different models of radio and television sets. You pay only for the controls and switches; attractive 3-drawer metal cabinet is free of extra cost. Get details from your Mallory Distributor.

Fast turnover . . . more jobs done per day . . . that's the answer to greater profits for any service shop. Every minute saved is time available for turning out more work.

That's why Mallory Midgetrols® were designed for fast, easy installation in any set . . . TV or radio.

*Round tubular shafts* can be cut accurately and quickly . . . fit split-knurl or flatted-type knobs.

*AC switches* can be attached instantly without disassembling the control.

*Unique design* simplifies inventory problems . . . makes them quickly available from your distributor.

Midgetrols are engineered to match the electrical characteristics of the original equipment of any TV or radio set. They will give equal, and often better, performance and life than the original control.

For all your service work, use Mallory Midgetrols. They are the answer to fast installation . . . precision quality on every job.

*This will save you time, too.* Ask your Mallory Distributor for a copy of the Mallory Control Guide. It is a complete cross reference between set manufacturers' part numbers and the equivalent Mallory control.

P. R. MALLORY & CO. Inc.  
**MALLORY**

CAPACITORS • CONTROLS • VIBRATORS • SWITCHES • RESISTORS  
RECTIFIERS • POWER SUPPLIES • FILTERS • MERCURY BATTERIES

**APPROVED PRECISION PRODUCTS**

P. R. MALLORY & CO., Inc., INDIANAPOLIS 6, INDIANA



# How's your

# "welcome" rating?

YOU can measure your "welcome rating" on the basis of how many times you have to visit a customer to satisfactorily complete one service call. The *less frequently* you are called back, the *more* your good services are appreciated. Fewer call-backs cut overhead . . . build confidence . . . leave you *more* time for *more* satisfied customers. Cutting call-backs is the most effective way of snowballing your profits.

The RCA trade-mark makes your call doubly effective. First, because customers have confidence in products bearing the RCA trade-mark. Second, because experience has proven that the superior quality of RCA Receiving Tubes and Kinescopes is your best measure of protection against costly call-backs due to premature tube failures. You can be sure that, with RCA Tubes, the job is well done.

Helping you to safeguard your reputation is a vital, everyday service of RCA Tubes. And that protection is yours at no extra cost.

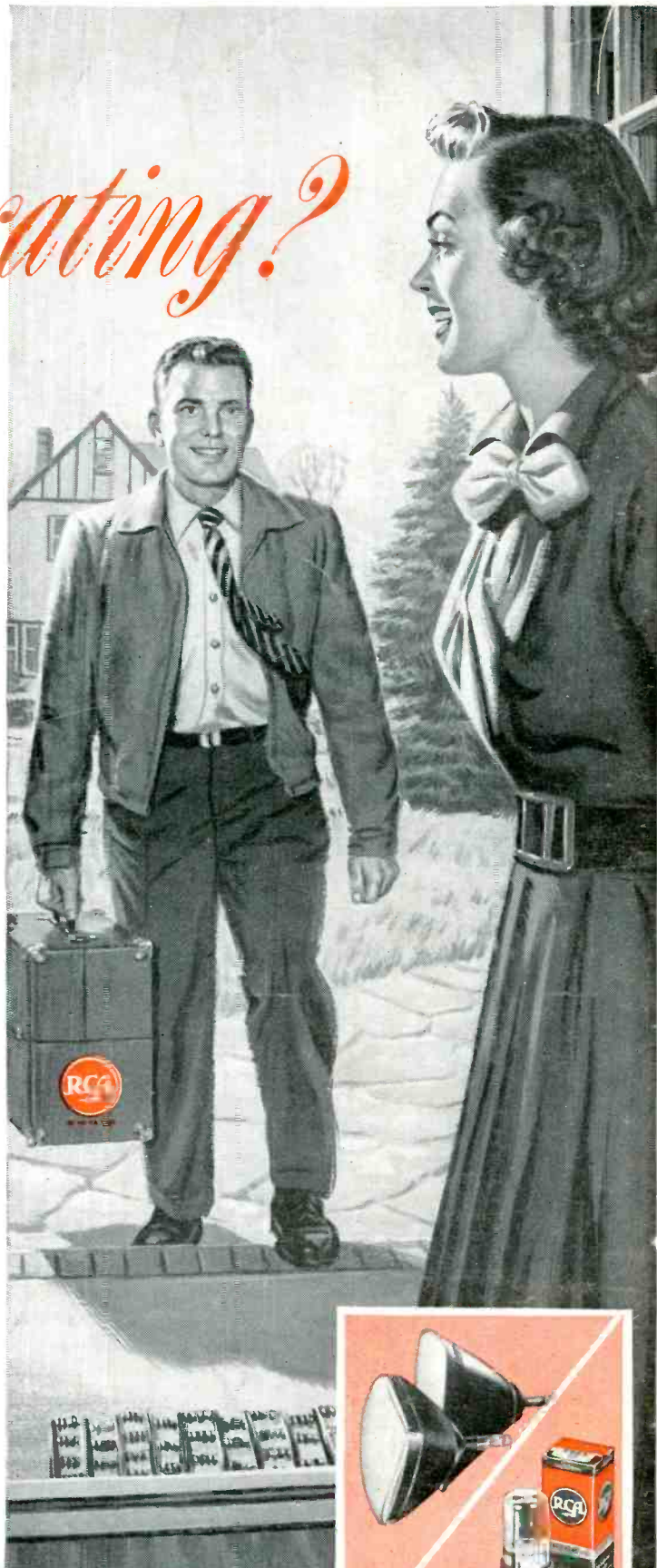

Unlock the  
door to  
bigger profits

Here's *your* key to better business . . . RCA's dynamic Dealer Identification Program. Ask your **RCA Tube Distributor** for your copy of the colorful, 16-page booklet "A Magic Pass-Key to Customer Confidence." It tells you how—for the first time—you can become a Registered Dealer . . . and get *extra* sales benefits.



**RADIO CORPORATION of AMERICA**

ELECTRON TUBES

HARRISON, N. J.