

OCTOBER, 1952

Radio *Magazine* SERVICE DEALER

ALIM 508 135 JAN 53
LEWIS ELEC SERVICE
TEMPLE PA



The Professional Radio-TVman's Magazine

IN THIS ISSUE:

- Video Detectors In Intercarrier Receivers
- Your Hi-Fi Market, Part 2
- TV Sync Circuits, Part 2
- Electronic Organ Installations
- Servicing TV Receivers With Intercarrier Buzz
- Trouble-Shooting Portable Radios
- Video Speed Servicing Systems

AM-FM-TV-SOUND

The only lightning arrester with the strain relief LIPS is
 manufactured by JFD. *A patent is its proof!*
 The twin-lead will bend only at a point separate from your contact—
 therefore, your twin-lead cannot break away.



Only the exclusive JFD strain relief lip prevents the
 contact washers used in all arresters from ripping your lead-in
 apart, strand by strand until the wire is torn through and
 the picture on your screen obliterated. Write for Form 84.

FOR RIBBON TWIN-LEAD

No. AT105 ("Little Giant" with hardware for wall
 or window sill mounting) List \$1.25

No. AT105S ("Little Giant" with UL approved stainless
 steel strap for pipe mounting) List \$1.50

No. AT102 ("Jumbo" with UL approved stainless steel
 strap for Universal Mounting) List \$2.25

FOR TUBULAR TWIN-LEAD

No. AT103 ("Jumbo" with UL approved stainless steel
 strap for Universal Mounting) List \$2.25

Available with four color, sales producing counter display, on request

JFD MFG. CO.

BROOKLYN 4, N.Y.
 BENSONDURST 6-3200

World's Largest Manufacturer
 of TV Antennas and Accessories

the secret is in the lips



"Little Giant" Lightning Arrester
 U.S. Pat. No. D-4664

the secret is in the lips

the secret is in the lips

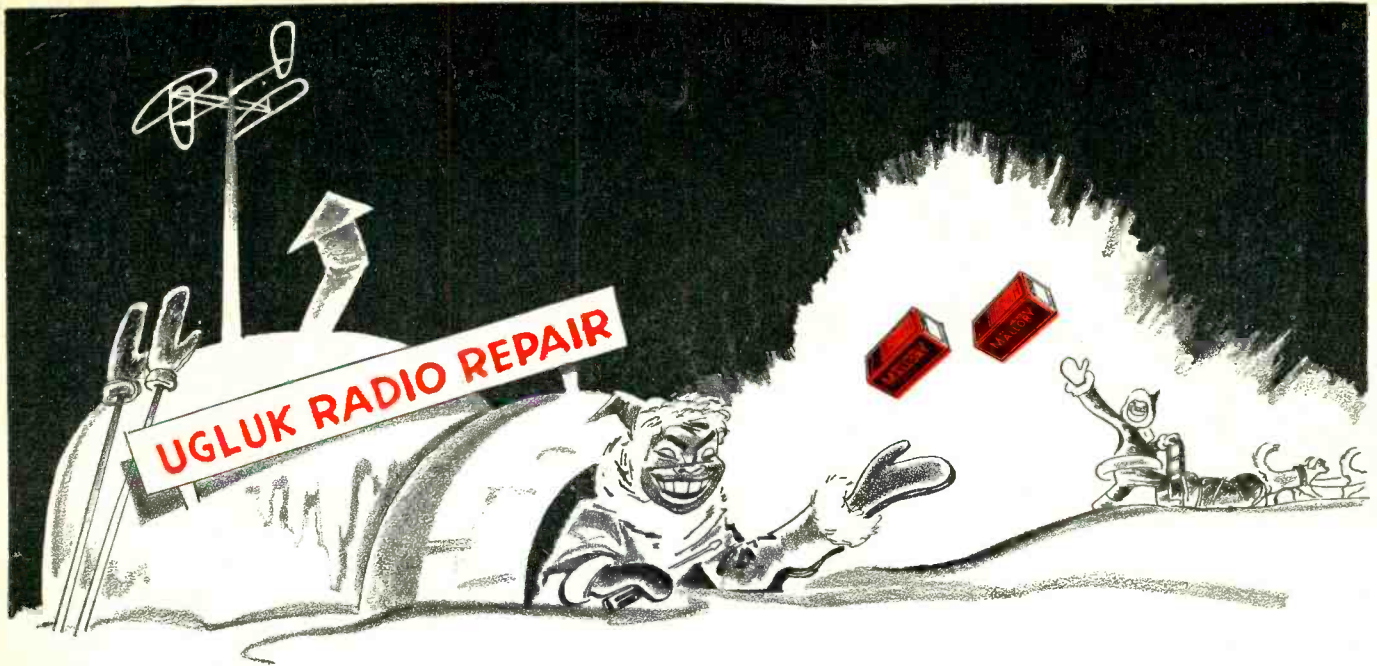

'Way Out Front with Servicemen . . . everywhere !

MALLORY VIBRATORS

Servicemen know they get dependable, trouble-free performance from Mallory vibrators. That's why a recent survey showed Mallory vibrators the choice of servicemen by a 2 to 1 margin. Count on Mallory vibrators for . . .

- 1—Slow contact impact for minimum wear.
- 2—High contact pressure for low resistance.
- 3—Fast contact break for reduced arcing, pitting.

Mallory *alone* gives you that three-way vibrator combination because of its patented, tuned mechanism. It's your assurance of long-lasting service that beats the comeback problem. Set makers count on Mallory, too . . . they use more Mallory vibrators as original equipment than all other brands combined. When you order vibrators . . .



You get a Handy Parts Cabinet at no additional cost with Mallory's Special Vibrator Deals

You keep your inventory down . . . and get the parts cabinet, too . . . with these Mallory deals you can service 47 different makes of radios with the assortment of 6 Mallory vibrators. All this is yours at your regular discount price. See your distributor today.

Make Sure! Make it Mallory!

P. R. MALLORY & CO. Inc.

MALLORY

CAPACITORS • CONTROLS • VIBRATORS • SWITCHES • RESISTORS
• RECTIFIERS • VIBRAPACK* POWER SUPPLIES • FILTERS

*Reg. U.S. Pat. Off.

APPROVED PRECISION PRODUCTS

P. R. MALLORY & CO., Inc., INDIANAPOLIS 6, INDIANA

**★ Build Your Service-
Sales Future on a Firm
Foundation with . . .**

**PRECISION
TEST EQUIPMENT**
Standard of Accuracy...

**...These 5 Matched "Precision"
Instruments provide a Complete
MODERN SERVICE LABORATORY for
TV-FM-AM at only moderate cost.**

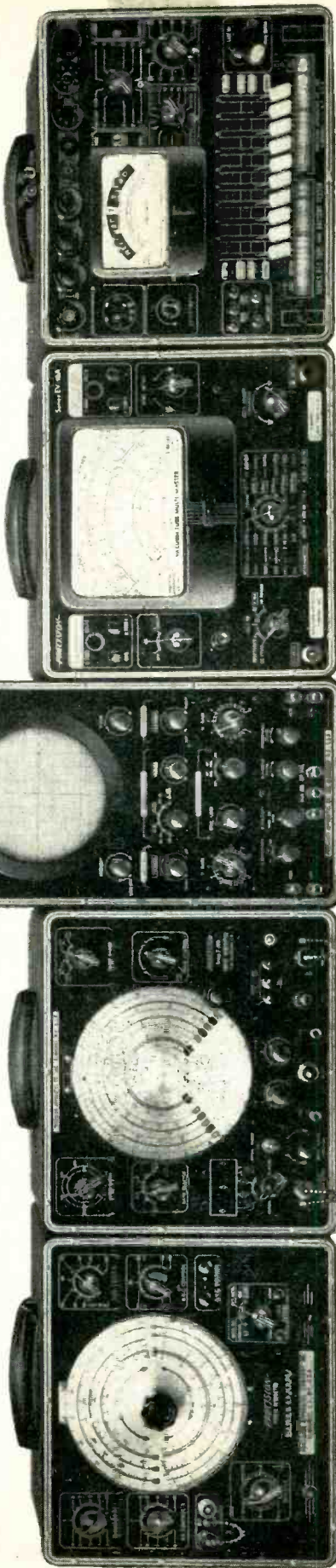

**SERIES E-200-C—Modern Multi-Band
SIGNAL and MARKER GENERATOR**
for A.M., F.M., and TV alignment.

Exceptional Accuracy and Stability! 1000 pt. vernier calibrating scale! 0-100% Modulation! A.V.C. — A.G.C. substitution-override network! Direct reading 88KC to 120 MC! Complete with Coaxial output cable and technical manual! In matched, heavy gauge steel case 10 1/2 x 12 x 6".

Net Price: \$73.25

**SERIES E-400—Wide Range H.F.
SWEEP SIGNAL GENERATOR**
Direct Reading from 2 to 480 MC.

Narrow and Wide Band Sweep for F.M. and TV, 0-1MC and 0-15MC • 1500 pt. vernier calibrating scale • Multiple Crystal Marker • 8 tubes including V.R. and rectifier • RG/62U Coaxial Terminated Output cable • Complete with 2 crystals • In matched copper-plated case 10 1/2 x 12 x 6".

Net Price: \$135.75

**SERIES ES-500A—20 MV.
High Sensitivity, Wide Range
5" C.R. OSCILLOGRAPH.**

Push-Pull "Y" and "H" amplifiers • 1 MC Band Width • High impedance, compensated "Y" input • Step Attenuator • Z axis modulation • 12 tubes incl. V.R. and 2 rect. • Light Shield • 8 1/4 x 14 1/2 x 18".

Net Price: \$173.70

**SERIES EV-10A—High Sensitivity
True Zero-Center VTVM—MEGOhmMETER**
— with large 7" meter.

58 ranges to 6000 Volts, 2000 Megs, ±70DB, 12 Amps • Direct Reading R.F. VTVM scales via optional RF-10A High Freq. probe • Voltage Regulated bridge type circuit • Constant 13 1/3 Megs input resistance to 600 V, 133 1/3 Megs at 6000 V • Complete with test cables and manual • Matched heavy gauge steel cabinet 10 1/2 x 12 x 6".

Net Price: \$97.20

**SERIES 612—Modern Free-point
Cathode Conductance TUBE TESTER,**
and dynamic A-B-C Battery Tester.

Incorporates RTMA recommended circuit principles! 10 lever free-point element selection! Built-in roller chart! Dual short-check sensitivity! Noise, Ballast and Pilot Test! Free replacement tube test data chart service! Complete, ready to operate! In matched heavy gauge steel cabinet 10 1/2 x 12 x 6".

Net Price: \$72.75

BUY PERFORMANCE—NOT SPECIFICATIONS!—BUY "PRECISION"
"PRECISION" PERFORMANCE, ACCURACY, WORKMANSHIP and VALUE have been setting a standard of comparison for over 19 years DO NOT BE MISLED It is not "PRECISION" test equipment unless it is manufactured by Precision Apparatus Co., Inc., Elmhurst, L. I., N. Y.

"Precision" Performance - Engineered Instruments are on display at leading radio parts and equipment distributors.



PRECISION APPARATUS CO., INC.
92-27 Horace Harding Boulevard, Elmhurst 14, New York
Export Division: 458 Broadway, New York, U.S.A. • Cables, Mohanex

In Canada: Atlas Radio Corp., Ltd., Toronto, Ontario

OTHER MATCHED COMBINATIONS

The instruments shown above illustrate one of many possible MATCHED COMBINATIONS of diversified "PRECISION" Test Equipment for TV-FM-AM. Each combination provides a selected and basic, modern, efficient Laboratory at moderate cost.

SERIES TV-4—Super-High Voltage Safety Test Probe.

Extends range of Series EV-10A (above) to 60 KV direct reading, with full safety to operator and equipment. Multiplier cartridges also available to match most VTVM's and 20,000 ohms/v. test sets.

Series TV-4: — Complete, for use with EV-10A.
Net Price: \$14.75



Convenient "Precision" Purchase Terms can be arranged with your favorite authorized Precision Distributor.

AM • FM • TV • AM • FM • TV

AM • FM • TV • AM • FM • TV

EDITORIAL

by S. R. COWAN

Introducing "Video Speed Service Systems"

When we launched this magazine in 1940 we adopted as our basic doctrine the idea that we must "Teach technicians how to do their work more efficiently, in less time and at greater profit." That credo has not and will not be changed.

Several years ago, with the advent of TV, it became quite apparent that the variations, complexities and inherent phenomena of TV circuitry were such as to require every technician to waste too much time in diagnosing and correcting the fault. Consequently millions of dollars which should have been earned by technicians for their services have been irrevocably lost—wasted in trouble-shooting-time for which they have not been paid.

Since 1948 we, other authors and publishers have come forth with commercial ideas, schematic services, indices, or books basically intended to correct the situation. Sorry to say, so far every one of us has fallen short of the goal. To us anything less than absolute perfection is nothing but a stop-gap, and it's time technicians got the benefit of the doubt. Now, in our Video Speed Service Systems section which starts as an 8-page form in this issue as a regular monthly feature, and which will be greatly expanded in subsequent issues, we believe we have the technician's "time-wasted" problem licked.

Straight from the shoulder VSSS tells technicians *what actually happens*, not what might happen in a receiver. It presents an accurate compilation of service information gathered from many sources such as manufacturers' service departments, independent service firms, and our own researchers. Look at the VSSS section now! See for yourself how it permits the technician to take a symptom which occurs in any given brand or model or chassis series, diagnose whether the symptom refers to picture, raster, sync or sound, and then have the cause and effect clearly defined along with the most accepted method of correcting the fault.

At this writing, because of our three years of planning, we have over 3,000 such case-histories ready for publication, but if we were to furnish them in bulk now the buyer would have to pay upwards of \$50 for the service. In addition, other cases are coming to light daily, and will continue to do so as long as new TV receivers appear on the market. Regardless of our cost factor we are presenting this service *now* because most important is the factor of timeliness. You want now what you *need* now. To that end, it is our plan to furnish, as a part of our regular issue, the complete series of many thousands of VSSS cases, without any extra charge to our subscribers. Newcomers to the TV service field will, in time, want to buy their own VSSS file, and copies collated in book form will be sold them at a nominal price. You subscribers may now start your own individual VSSS file. Every third issue will have a complete cross-reference index. So VSSS is born, and it will help kill your woes on Speedy Service in TV.



Sanford R. Cowan
EDITOR & PUBLISHER

Samuel L. Marshall
MANAGING EDITOR

COWAN PUBLISHING CORP.
67 WEST 44TH ST.
NEW YORK 36, N. Y.



Vol. 13, No. 10

OCTOBER, 1952

Editorial	3
Trade Flashes	4
Sync Pulses, <i>by San D'Arcy</i>	14
Trade Literature	18
Video Detectors In Intercarrier Receivers, <i>by Matthew Mandl</i>	23
Explanation of operation and service information.	
Your Hi-Fi Market, Part 2, <i>by Charles H. Graham</i>	26
Second installment deals with power amplifier requirements.	
TV Sync Circuits, Part 2, <i>by Leonard Lieberman</i>	29
Trouble shooting sync circuits features this installment.	
Electric Organ Installations, <i>by Clyde L. Tichenor</i>	31
Basic principles underlying the installation of electronic organs in churches, homes, etc.	
Servicing Intercarrier Buzz, <i>by Harry Mileat</i>	35
Helpful suggestions on the elimination of this source of trouble.	
Circuit & Service Data of the RCA (see original text)	38
Shop chart illustrating important service data on this chassis.	
Trouble-Shooting Portable Radios, <i>by Alexander Kauders</i>	40
Usual troubles and cures as applied to portable receivers.	
Video Speed Service Systems Data Sheets	41
Eight pages of service information presented in a style that enables the serviceman to readily identify the symptom and quickly repair the receiver. Twenty-four different case histories of actual and common receiver faults are given.	
UHF Tuners	50
Brief description of Crosley, Standard Tuner, and Stromberg-Carlson UHF Tuners.	
New Products	52
Association News	58
Personnel Notes	62
Advertisers' Index	72

SANFORD L. CAHN, Advertising Director HARRY N. REIZES, Advertising Manager
DAVID SALTMAN, Production Mgr. NATHAN BOYCE, Circulation Mgr.

TED E. SCHELL, 2700 West 3rd St., Los Angeles 5, Calif., Dunkirk 2-4889
RADIO-TELEVISION SERVICE DEALER is published Monthly by Cowan Pub. Corp., 67 West 44th St., New York 36, N. Y. Subscription price: \$2 per year in the United States, U.S. Poss. & Canada; elsewhere \$3. Single Copies: 25c. Reentered as second class matter Sept. 25, 1950 at the Post Office at New York, N. Y. under the Act of Mar. 3, 1879. Copyright 1952, Cowan Pub. Corp.

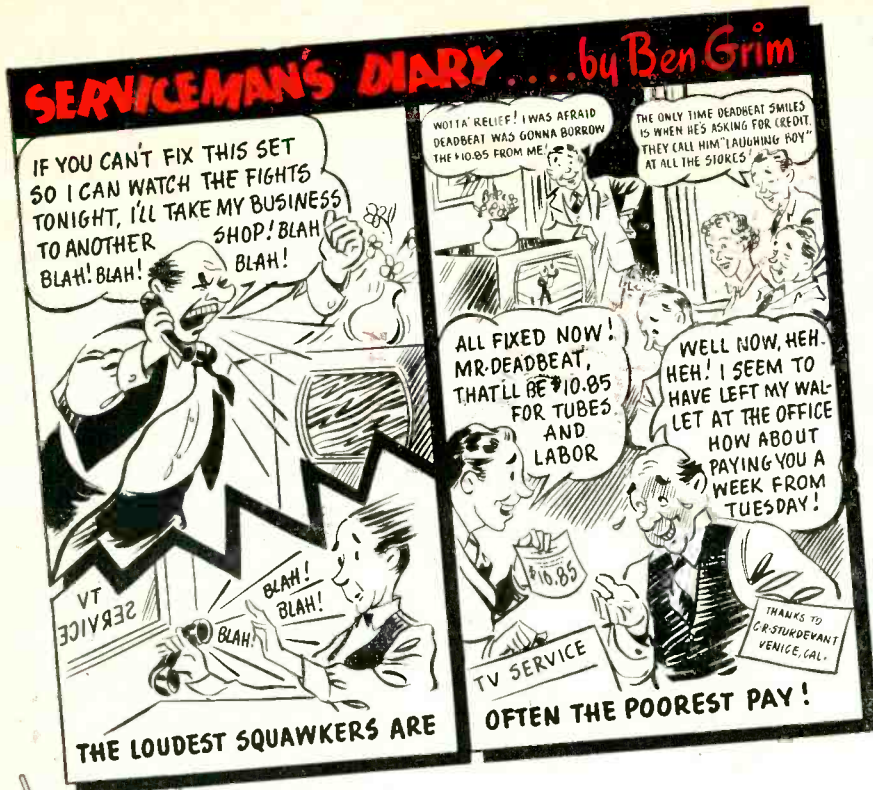

You're always right with Sprague's **85°C (185°F)** smaller, versatile and dependable

ATOMS

You only need to stock one 'lytic tubular for every application when you buy Sprague Atoms . . . whether it be an auto radio set . . . a home radio-phonograph combination . . . or a television receiver. Sprague Atoms are the smallest dependable electrolytics. They're always right size-wise to fit the most crowded chassis. And they're right temperature-wise to fit the hottest TV receiver!

Write for Catalog C-608 to Sprague Products Company, 71 Marshall St., North Adams, Mass.

(Distributors' Division of Sprague Electric Company)

INSIST ON ATOM® ELECTROLYTICS

MADE BY



THE WORLD'S LARGEST CAPACITOR MANUFACTURER

TRADE FLASHES

A "press-time" digest of production, distribution, and merchandizing activities

RTMA Service Committee Named

RTMA Board Chairman A. D. Plamondon, Jr., appointed the Association's Service Committee and re-appointed R. J. Yeranko as chairman. This RTMA standing committee currently is carrying out a public relations and educational program in connection with television set servicing. It also has cooperated with the Association of Better Business Bureaus in publishing a booklet containing advice for consumers on television receivers and their servicing.

Television Set Shipment to Dealers

Shipments of television sets to dealers during the first seven months of this year totaled 2,406,757, the Radio-Television Manufacturers Association reported recently. This compares with 2,588,816 television sets shipped to dealers during the same period of 1951. Set shipments in July 1952 totaled 288,247.

Du Mont Analyzes UHF Situations In Various Localities

If you've been wondering when new TV stations will come to your town, say experts at Allen B. Du Mont Laboratories, Inc., the answer is "it depends."

Out of 800 applications for new TV stations only 50 licenses have been approved so far. When you will get a new station in your home town depends on a number of factors.

Now that the "freeze" on new TV construction has been lifted, it seems as though everybody is trying to get in on the act, and the FCC has been swamped with applications for new stations. While the whole job of allocating the available 2,053 commercial channels is expected to take only a few years. Whether or not your town will get a new TV station sooner or later depends on:

1. How many stations are now operating in your city; if you live in a city where TV has already been established, chances are you won't see a new station for many months.

2. How close you are to a TV area; even though your city has no TV sta-

What Rauland means by "Perfection Through Research"

Rauland is one of the few companies devoting so much top engineering talent full time to picture tube improvement and perfection.

The result of this painstaking research has been to give you many more picture tube advancements since the war than has any other manufacturer . . .

more dependability and faster installation in the field for service dealers and service men . . . and greater assurance of customer satisfaction when you install Rauland replacement tubes.

That's why more and more jobbers, dealers and service men are standardizing on Rauland replacement tubes.

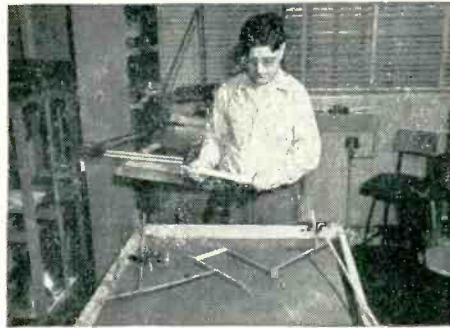
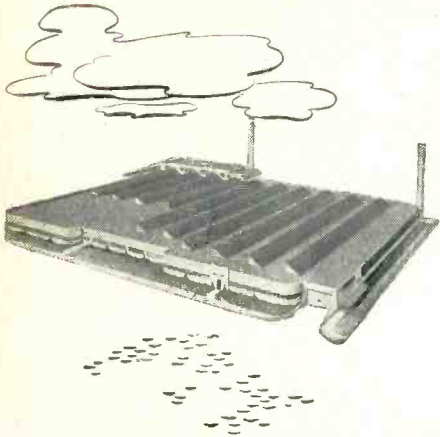

Rubber model for studying electron optical designing—basis for Rauland's exclusive Indicator Ion Trap.

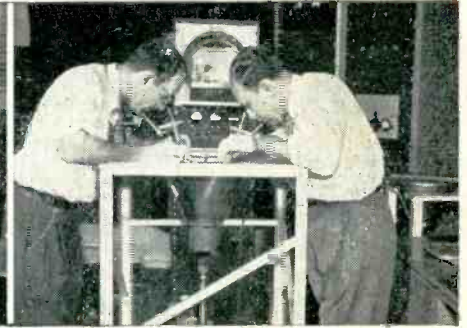

Alignment of the screen and parallax mask of tri-color tube containing approximately a million fluorescent dots.



All-electronic tri-color tube in electronic receiver system (left) in comparison with mechanical system (right).



Inspection and checking of perforations .0075" in diameter in masks of tri-color picture tubes.

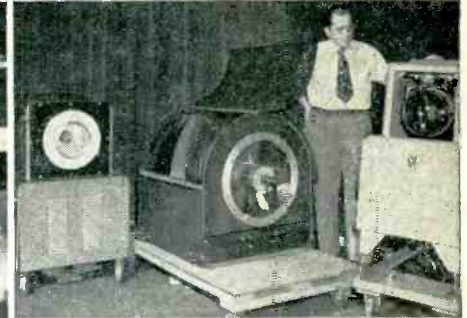

Rauland large-screen projectors using three different optical systems, all of which give theater-size pictures.



Careful study of the formation of thin metallic films in a vacuum . . . basis for the aluminizing of tubes.



Examination with polarimeter permits careful control of strains for superior glass-to-metal sealing.



A physicist using a Rauland-developed radiation meter in checking X-ray radiations from cathode ray apparatus.

THE RAULAND CORPORATION



Perfection Through Research

2425 N. KNOX AVENUE • CHICAGO 41, ILLINOIS



NEW!

2 GREAT BOOKS

By Milton S. Kiver

**IF YOU SERVICE TV
— YOU NEED THEM!**

**"TV Servicing Short-Cuts
Based on Actual Case Histories"**



shows you how to solve commonly recurring troubles

the book that really teaches fast, expert service techniques

This book describes a series of actual TV service case histories, each presenting a specific problem about a specific receiver. The symptoms of the

trouble are described and then followed by a step-by-step explanation of how the service technician localized and tracked down the defect. Finally, there is a detailed discussion of how this particular trouble can be tracked down and solved in any TV set. The discussions which follow each case history are invaluable—they explain how to apply the proper time-saving servicing techniques to any TV receiver. Here, in one volume, is the successful experience of experts—to make your service work easier, quicker, more profitable. Over 100 pages, 5½ x 8½, illustrated. Pays for itself on a single service job.

ORDER TK-1. Only \$1.50

**"HOW TO UNDERSTAND AND USE
TV TEST INSTRUMENTS"**



shows you how to get the most from your test instruments

Provides basic explanations of how each test instrument operates; describes functions of each control and shows their proper adjustment to place the instrument

in operation. Covers: Vacuum Tube Voltmeters, AM Signal Generators, Sweep Signal Generators, Oscilloscopes, Video Signal Generators, Field Intensity Meters, Voltage Calibrators. Describes each in detail; explains functions; tells proper use in actual servicing; shows how to avoid improper indications. Because this book gives you a clear, complete understanding of your test instruments, you get more out of them, save time, and add to your earning power. Over 175 pages, 8½ x 11, illustrated.

ORDER TN-1. Only \$3.00

HOWARD W. SAMS & CO., INC.

Order from your Parts Jobber today, or write direct to Howard W. Sams & Co., Inc. 2209 East 46th Street, Indianapolis 5, Ind.

My (check) (money order) for \$..... enclosed. Send the following books:

TK-1 (\$1.50) TN-1 (\$3.00)

Name.....

Address.....

City.....Zone.....State.....

tion, if you live near a town which does have TV, probably you will have to wait. The FCC's policy so far has been to allocate stations to "no TV" areas first.

3. How many applications there are for each channel; when more than one application is filed for a new station, a "conflict" arises that requires days, weeks and sometimes months of hearings to determine which applicant will be awarded the license.

4. Whether or not your local channels are UHF or VHF; most of the applications received by the FCC so far are for VHF channels, which means that more "conflicts" will have to be straightened out than for the UHF channels. In fact, many UHF channels are going begging, with no applicants asking for them up to now.

There are two ways to adapt a set for UHF, the experts say, one of which is a built-in turret tuner which requires only minor adjustment. For sets which have a continuous tuner, a fairly inexpensive external converter may be purchased. Both types have been successfully demonstrated by major manufacturers. So if TV reception is possible, even though it may not be your own home town station, you can go right ahead and buy your set.

The Du Mont statisticians predict that in a few short years virtually every home in the country will have access to TV. Even now, with only a little more than a hundred stations in operation over 18,000,000 sets are in use.

And just six years ago, in 1946, the Du Mont experts note, there were only 6400 sets in the whole country.

RCA Discloses New Community Antenaplex Service

New tower amplifier equipment for use in RCA community TV "Antenaplex" systems to provide high-gain TV signal amplification in areas where signal strength is low was announced by the Engineering Products Department, RCA Victor Division, Radio Corporation of America.

Community Antenaplex systems, in which one master television antenna serves an entire community, are now being used in an increasing number of American cities and towns previously denied television due to mountainous terrain, distance from existing TV stations, or other factors causing poor signal pick-up.

The new RCA Type SX-8CT tower amplifier system is designed for use in community Antenaplex systems for one, two, or three-channel service. The equipment is used specifically for boosting the incoming TV signals to

a level sufficient for carrying them to the next amplifying station. Associated converter equipment is used with the tower amplifier system for conversion of the incoming frequencies to those used in the outgoing channels of the tower amplifier. This results in a high-quality picture on the screens of TV sets in homes along the distribution line, as well as a more economical coaxial cable signal transmission.

G.E. Launches Cooperative Billboard Advertising Program

In a program believed to be the first of its kind in the television service industry, General Electric's Tube Department announced that it is making cooperative billboard advertising available to television service dealers through G-E tube distributors.

G. A. Bradford, manager of advertising and sales promotion for the G-E Tube Department, described the program as "another evidence of the coming of age of the television service industry."



Left to right: G. A. Bradford (G.E.), Leo Hochberger (York Radio and Refrigeration), Henry E. Plath, Jr. (Klinedinst firm), Mr. Klinedinst, and Joe Hochberger (York Radio).

Mr. Bradford said that preliminary reports from dealers and distributors indicate that the use of billboard advertising will meet with widespread dealer acceptance. He said that the first displays have already been put into operation through New York Radio and Refrigeration Parts Company at York, Pa., and that service dealers have already contracted for several hundred additional boards through other distributors throughout the country.

The billboard designs are aimed at the consumer, urging set owners to contact the particular service dealer involved for television service and repairs. Primary emphasis is placed on the service available from the service dealer and relatively little on the company products.

[Continued on page 10]

The Winning *COMBINATION* for a perfect *TV* picture!



THE *TV* TWINS

Here's What You Get — ALL YOU NEED
TO GET THE MOST OUT OF ANY TV SET!

- ★ CDR Rotor, Model TR-11 \$44.95
- ★ Thrust Bearing, Model TA-6 4.95
- ★ Radiart Booster, Model TVB-1 29.95
- ★ Connecting Kit, Model TA-7 1.00

If Bought Separately . . . \$80.85

**SPECIAL RETAIL
COMBINATION PRICE... \$74.95**

Model RAC-4497...

Regular Trade
Discount Applies

Here's a rare opportunity to really get the most out of any TV set—putting it to work at peak possible performance... and at a real savings! We have combined these 4 Radiart units into one package and at real savings! The quality can't be beat... and the two cabinets form a handsome piece of furniture for any home. Will handle any antenna array... meter dial on remote control cabinet... and the booster improves picture quality beyond compare! **ACT NOW!**



SUBSIDIARY OF



THE RADIART CORPORATION CLEVELAND 13, OHIO

VIBRATORS • AUTO AERIALS • TV ANTENNAS • ROTORS • POWER SUPPLIES

Service
Dealers



Switch to

Snyder
PHILADELPHIA

aerials

...engineered for
profits!



NEW **Directronic**

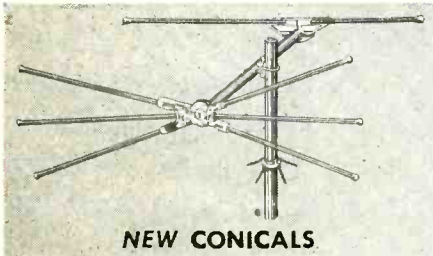

NEW CONICALS

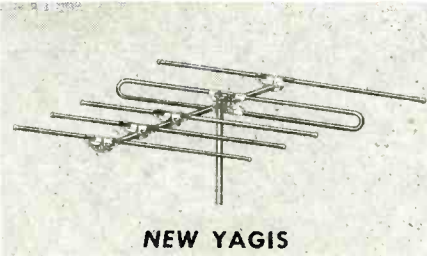

NEW YAGIS



NEW INDOORS

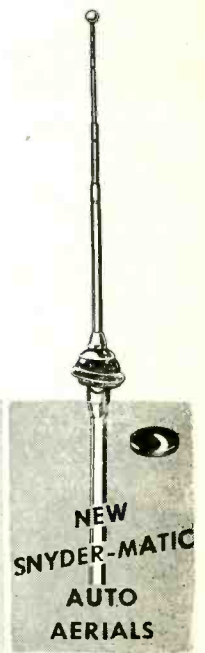

NEW
SNYDER-MATIC
AUTO
AERIALS

SNYDER MFG. CO.

ANTENN-GINEERS
PHILADELPHIA 40, PA.

WORLD EXPORT: ROBURN AGENCIES, INC., NEW YORK 7, N. Y.
CANADIAN DISTRIBUTOR: VAN DER HOUT ASSOCIATES, TORONTO



HERE'S PROOF!

Glass used
in second hand
tubes is
20% DIMMER
than NEW
GLASS used in

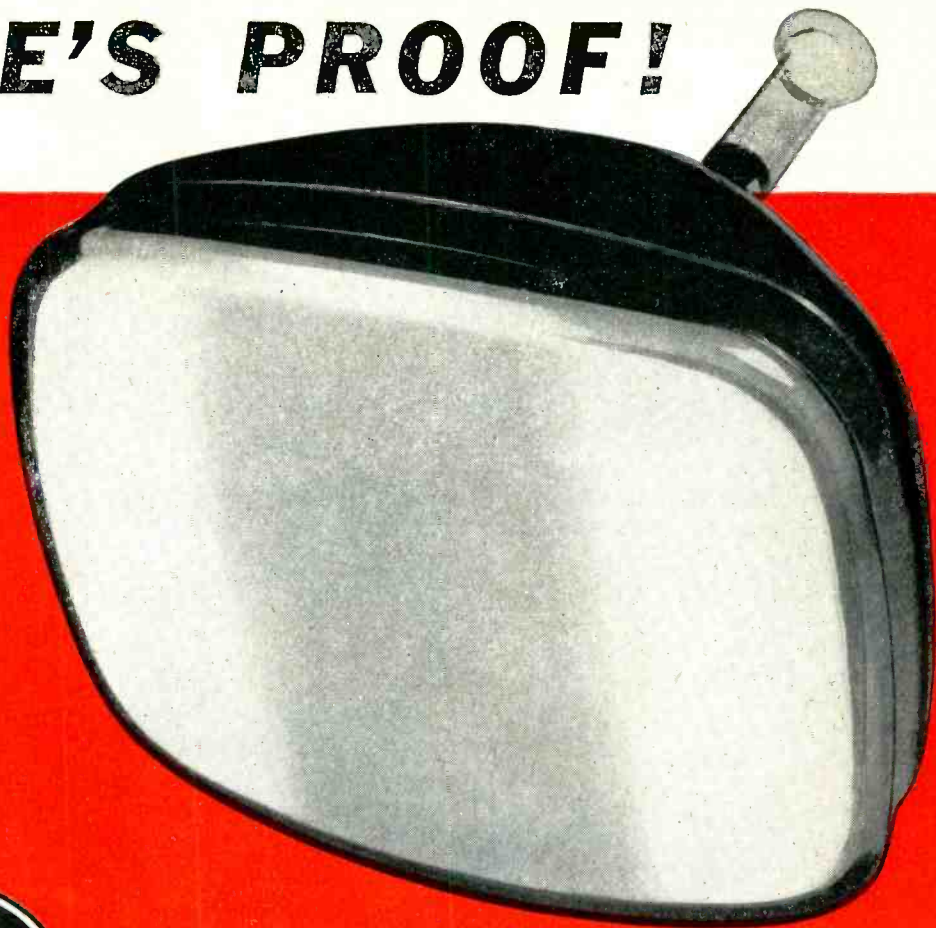

PICTURE TUBES

THE unretouched picture above demonstrates why you risk your reputation as a competent service dealer every time you sell your customers a second hand tube.

A standard Raytheon Tube was put on life test equipment and adjusted so that the raster did not cover the entire face of the tube. The tube was given the equivalent of 1000 hours of operation in a consumer set. The tube neck was then cut, the gun removed, the tube renecked and the screen washed out. The bulb was re-washed and rescreened and as you can see, the portion of the bulb that was scanned *is about 20% darker than the unscanned area.* In short,

scanning darkens glass and any used bulb that is rescreened will be 20% darker than a new bulb. The only way you can get new tube-brightness out of a second hand tube, is to increase the beam current. And since beam current comes from the cathode, increasing the beam current shortens tube life. For this reason, when you replace with second hand tubes your customer loses, and in the long run so do you!

It's good business to always replace with *new* tubes. And, of course, if you want the finest new tubes that money can buy...



... use RAYTHEON TELEVISION PICTURE TUBES
They're Right for Sight... and Right for You... and Always New!

Excellence in Electronics

RAYTHEON MANUFACTURING COMPANY

Receiving Tube Division
Newton, Mass., Chicago, Ill., Atlanta, Ga., Los Angeles, Calif.
RAYTHEON MAKES ALL THESE

RECEIVING AND PICTURE TUBES • RELIABLE SUBMINIATURE AND MINIATURE TUBES • GERMANIUM DIODES AND TRANSISTORS • NUCLEONIC TUBES • MICROWAVE TUBES

Service men — BOOST YOUR INCOME — SAVE HUNDREDS of DOLLARS

—these TRANSVISION Instruments are *real necessities*—a "must" for your shop if you are not to throw good money away.

Here's why: —

1. **TESTING**—you can accurately test Cathode Ray Tubes.
2. **REACTIVATING**—you can save many dim or worn out tubes by reactivation.
3. **SPARKING OUT ELECTRICAL LEAKAGE** — many Cathode Ray Tubes develop electrical leakage. This can now be repaired.

CRT TESTER-REACTIVATOR-SPARKER

3 Instruments in 1, making a complete CRT testing and repair unit. Compact, dependable, profitable.

It's a combination of the Transvision TESTER-REACTIVATOR and TESTER SPARKER in one handy instrument. It **TESTS PICTURE TUBES**—measures Cathode emission, locates shorts between elements, locates high resistance shorts or leakage as high as 3 megohms. **REACTIVATES DIM TUBES**. **SPARKS OUT ELECTRICAL LEAKAGE** in picture tubes.

Fully Guaranteed.

\$34⁹⁵
net



CRT TESTER-REACTIVATOR

2 Instruments in 1. As a REACTIVATOR it renews brightness, sharpness, and detail of old dim CR Tubes, without removal of tube. It's also an accurate TESTER: Measures Cathode emission, locates shorts between elements, locates high resistance shorts or leakage as high as 3 megohms. 110V-60 cycles; wt. 3 lbs. Fully Guaranteed.

\$19⁹⁵
net



CRT TESTER-SPARKER

2 Instruments in 1. As a PICTURE TUBE SPARKER, it sparks out electrical leakage between elements. Saves many picture tubes and small tubes which would usually be discarded. Cathode-grid leakage is an especially common occurrence. The Sparker also gives a rapid check of gas condition of the tube.

As a TESTER it provides a variable 8,000-14,000 D.C. supply—useful for analyzing hard-to-solve deflection problems. Fully Guaranteed.

\$19⁹⁵
net



FIELD STRENGTH METER for better TV installations.

Make more efficient, more profitable TV installations, and save half the work, with the Transvision Field Strength Meter. Especially good for fringe areas—measures field strength as low as 10 microvolts. A great buy at this low price.

Model FSM-1, complete with tubes **\$59** net

Order direct from TRANSVISION, INC., New Rochelle, N. Y.

RUSH THIS COUPON
TRANSVISION, INC., Dept. 5D-105 NEW ROCHELLE, N. Y.

Please send

\$ deposit enclosed; send C.O.D. in full enclosed; send prepaid.

Name Address

TRADE FLASHES

[from page 6]

CBS Service Information

As of Monday, August 25th, all service communications, requests for information, shipment of service parts, parts orders, etc. should be addressed to: Edward F. Morgan, Service Manager, CBS-Columbia Incorporated 4725—34th Street, Long Island City 1, New York.

For urgent requests, the temporary telephone number of the Service Department will be STillwell 4-9160. The permanent telephone number as of September 1st will be EXeter 2-3000.

Audio Fair

High Fidelity will be king, and court will be paid by more than 15,000 music lovers, hi-fi hobbyists, and professional audio engineers, at the 1952 Audio Fair, according to a recent attendance estimate voiced by Harry N. Reizes, Fair manager. If the rate of attendance growth established in previous years is maintained, the 1952 exhibit will firmly establish the Fair as the second largest annual electronic event in the country, exceeded only by the yearly convention of the Institute of Radio Engineers.

In order to better accommodate the increased attendance, this year's Fair will last four days instead of the usual three, opening October 29 and continuing through November 1, on the fifth and sixth floors of Manhattan's famous Hotel New Yorker—admission is free to all.

Sponsored each year by the Audio Engineering Society, and conducted in conjunction with the Society's annual convention, the Audio Fair has paralleled the Society in achieving world-wide recognition. Together they are regarded internationally as the most prominent of the annual displays and forums devoted to the science of reproduced sound.

New Hytron Mailing Address

Hytron Radio & Electronics Co. announce that effective immediately their mail address will be changed from 76 Lafayette Street, Salem, Massachusetts to 100 Endicott Street, Danvers, Massachusetts.

Denver TV Shipments

More than 23.8 thousand television receivers were shipped to dealers in the Denver market area during the months of July and August, according to a special statistical compilation made by the Radio-Television

[Continued on page 16]

BUSS FUSES

*Help Protect Your Product . . .
Your Profit . . . Your Reputation*

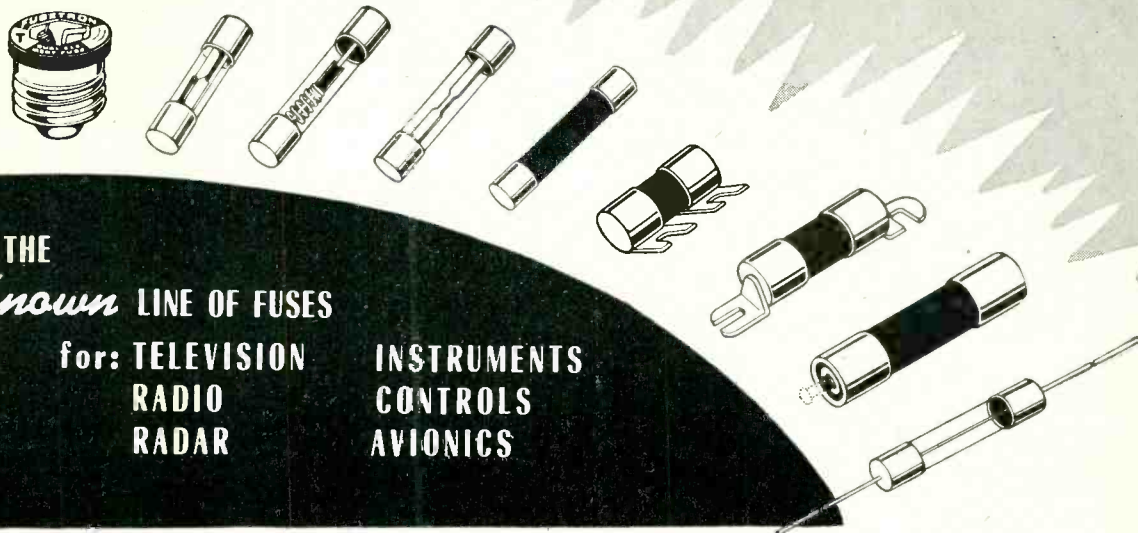

THE
Known LINE OF FUSES

for: TELEVISION
RADIO
RADAR

INSTRUMENTS
CONTROLS
AVIONICS

38 year's service to American homes, farms and industry is behind every fuse that bears the BUSS trademark. Your customers have confidence in BUSS . . . they know the BUSS name represents fuses of unquestioned high quality.

To maintain this high standard each and every BUSS fuse is tested in a highly sensitive electronic device that rejects any fuse that is not correctly calibrated — properly constructed and right in physical dimensions.

It's easy to select a BUSS fuse that's *right* for your fuse application. The complete BUSS line includes: Dual Element (Fusetron slow blowing type fuses), Renewable and One-Time types — available in all standard sizes, and many special sizes and designs.

THE BUSS TRADE-MARK HELPS INSURE YOUR PROFITS AND GOOD-WILL —

Since BUSS is the *Known* line you will never be bothered with kicks and comebacks because people won't blame troubles they have on fuses you furnished them.

Thus the BUSS Trade-Mark protects your profits and goodwill.

For More Information
CLIP THIS HANDY COUPON NOW . . .

. . . Plus
**A COMPLETE LINE OF FUSE CLIPS,
BLOCKS AND HOLDERS**

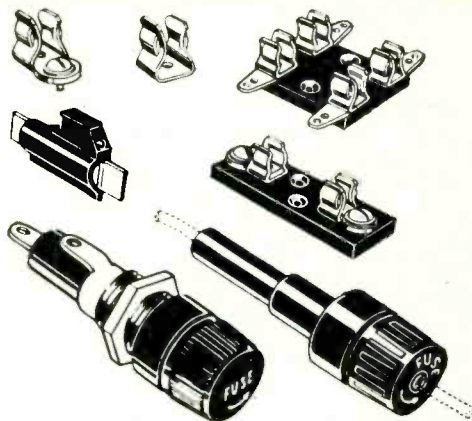

BUSSMANN Mfg. Co. (Division of McGraw Electric Co.)
University at Jefferson, St. Louis 7, Mo. SD-1052

Please send me bulletin SFB containing complete facts on BUSS small dimension fuses and fuse holders.

Name.....

Title.....

Company.....

Address.....

City & Zone..... State..... 952

BUSSMANN MFG. CO., Division McGraw Electric Company
University at Jefferson St. Louis 7, Mo.

RADIO-TELEVISION SERVICE DEALER • OCTOBER, 1952

TRIO ANNOUNCES SENSATIONAL NEW ZIG-ZAG ANTENNA

Patent Pending

- ★ **Higher Gain than any Yagi!**
- Plus**
- ★ **All-Channel VHF Performance!**

Here's the greatest advance in TV antennas since TRIO'S introduction of the dual channel yagi! The sensational new TRIO ZIG-ZAG antenna is basically a multiple element yagi type antenna on each channel, yet one 2-bay antenna — and in some models a single bay antenna — covers all VHF channels!

This sensational antenna has sharper directivity and higher front-to-back ratio. It provides snow-free pictures, and fade-free sound even in the most remote fringe areas.

Tremendous forward gain is accomplished without long, bulky, arrays that operate on only one channel. With the new fringe area model ZIG-ZAG antenna, one bay provides tremendous gain on all low channels, 2 thru 6, and the other bay provides similar high gain on channels 7 thru 13.

HOW THIS AMAZING ANTENNA WORKS

Trio ZIG-ZAG antennas utilize a new principle whereby an array is composed of a series of elements, one or more of which is resonant on any one channel while the remaining elements, which are non-resonant on that channel, provide parasitic voltages having the proper phase relative to the direct voltage. These act as very efficient directors and reflectors. All elements are directly connected to the feed-line.

The various models, listed below, are designed to provide a simple installation for all areas, from metropolitan to extreme fringe. Two bay models, like the single bay models, are operated with a single 300 ohm lead-in to the set, with less than a 3:1 standing wave ratio.

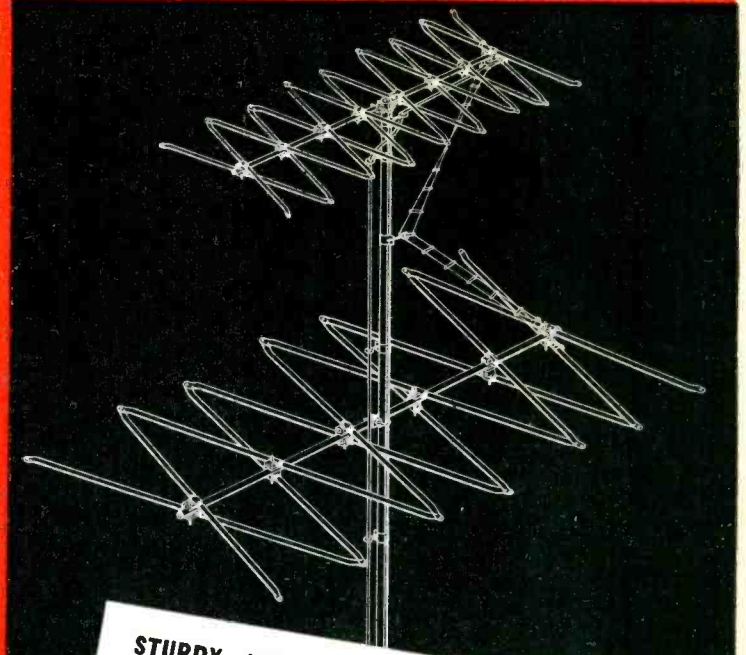

STURDY, VIBRATION-PROOF CONSTRUCTION
Rugged strength is designed into all models. Antenna is shipped with all hardware mounted on the boom with the exception of the mast clamp. Complete assembly consists only of matching color-coded elements to the color-coded boom and tightening nuts which furnish clamping action. Complete assembly is accomplished in minutes.

8 MODELS FROM WHICH TO CHOOSE:



FOR EXTREME FRINGE RECEPTION — ZZ16H provides over 14 DB voltage gain as compared with a resonant reference dipole on Channels 7 thru 13, and ZZ12L provides gain of 12 to 14 DB on Channels 2 thru 6. Gain of the ZZ12L is 12 DB on Channels 2 and 3 and is 14 on Channels 4, 5 and 6. These models have narrowest forward lobe and highest front-to-back ratio and should be used in areas where co-channel interference is a problem.

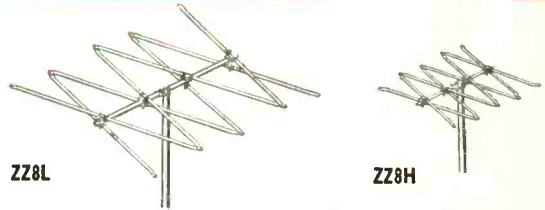

FOR NORMAL FRINGE RECEPTION — Where maximum gain is not necessary, these models are ideal. The ZZ8H for Channels 7 thru 13 and the ZZ8L for Channels 2 thru 6. Voltage gain is 9 DB on Channels 2 and 3 and 11 DB on Channels 4 thru 13. These models have patterns comparable to a well designed multi-element single channel yagi.



WRITE FOR CATALOG

FOR NEAR FRINGE RECEPTION — These models provide a voltage gain of 8 to 9 DB on Channels 2 thru 13. These models have pattern and gain comparable to a cut-to-channel yagi. ZZ6L covers Channels 2 thru 6. ZZ6H covers Channels 7 thru 13.

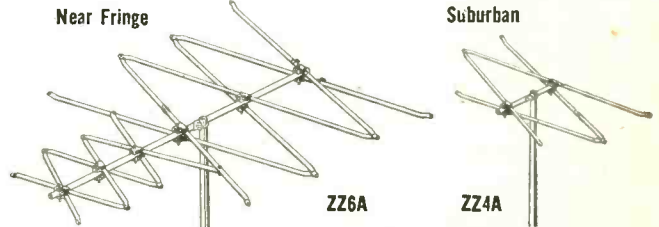

SINGLE BAY ALL-CHANNEL RECEPTION — Model ZZ4A is a single bay antenna providing adequate gain and directivity on all channels, 2 thru 13, in suburban areas. Model ZZ6A is also an all-channel single bay antenna providing greater gain for near fringe use.



TRIO MANUFACTURING COMPANY • GRIGGSVILLE, ILLINOIS

The TRIO ROTATOR

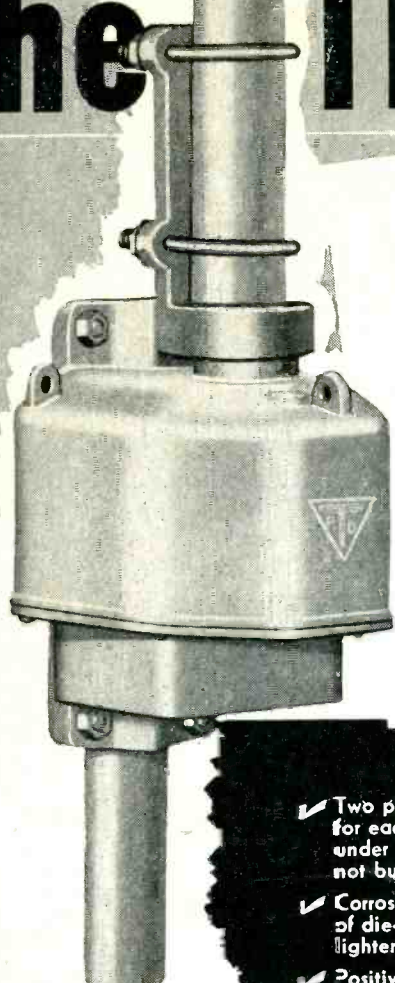

*Strongest
Ever Built*

The TRIO ROTATOR passes strength and endurance tests that impose weight loads 5 times greater than a Channel 4 yagi installation—endures without failure operation equalling 15 years normal use.

*Backed By
\$50,000
of Research*

To produce the best rotator made, TRIO spent \$50,000 in exhaustive testing, research and engineering. Exhaustive tests on all makes of rotators were independently conducted by one of the nation's largest manufacturer of TV sets. The TRIO ROTATOR was the only one that passed these grueling tests!

- ✓ Two powerful 24 volt motors used — one for each direction of rotation. Each motor under load only fraction of time — will not burn out!
- ✓ Corrosion resisting, weatherproof housing of die-cast aluminum for greater strength, lighter weight, perfect alignment of parts!
- ✓ Positive electrical stops at ends of 360° rotation prevent damaging or twisting of leads!
- ✓ Will support heavy TV arrays — even in 80 MPH winds!
- ✓ Permanently lubricated with special grease that functions perfectly in high and low temperature extremes!
- ✓ Ball-bearing end thrusts on all shafts, including motor! Main shaft vertical load carried on large oversized "Oilite" self-lubricating bearing!
- ✓ All motors, shafts and gears mounted on a rugged, one-piece casting for true alignment and longer life!
- ✓ 1 1/16" diameter tool steel main shaft and mast holder will withstand 4500 inch pounds bending moment!
- ✓ Rotator and mast holder fits any pipe size up to 2" OD!
- ✓ Precision built to extremely close tolerances!



Smartly Styled

DIRECTION INDICATOR

The handsome TRIO ROTATOR is easy to operate. There's no need to hold control for continuous operation! A light touch of the "finger tip" control starts rotation in either direction. Another touch stops antenna at desired position! Gracefully styled, the smart TRIO ROTATOR is a handsome accessory—not just another "box".



FULLY TESTED FULLY GUARANTEED

Every TRIO ROTATOR and DIRECTION INDICATOR is guaranteed against defective parts and workmanship for two years. Each TRIO ROTATOR is thoroughly factory tested to the equivalent of 3 months of constant operation. This, plus an additional torque test, guarantees each unit to be perfect in every detail of assembly!



Manufacturing Company
GRIGGSVILLE, ILLINOIS

whatever
your
viewpoint...

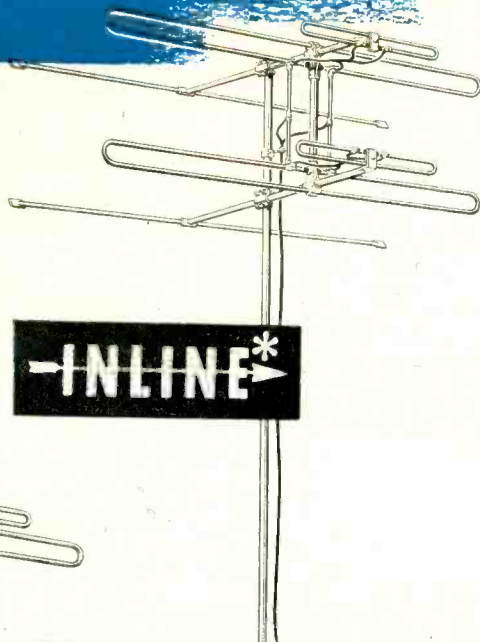

dealer,
installer or
set owner...

The Amphenol Inline is the antenna for you! Stocking problems are minimized because the one antenna gives superb performance on *all* channels. Saves duplicate inventory of accessories too, because the Amphenol Inline is packaged for a quick, easy installation including twin-lead, mounting clamps, mast and stand-off insulators.

The aerodynamically clean design of the Inline preserves the neat appearance of the home and most important of all, regardless of viewpoint, is the fact that no broadband antenna now in existence can match the quality of the picture made possible by the Amphenol Inline Antenna.

See your Authorized Amphenol Distributor for your free copy of this 20-page booklet containing all the factors which determine Better TV Picture Quality.



AMERICAN PHENOLIC CORPORATION

1830 South 54th Avenue • Chicago 50, Illinois

AMPHENOL

SYNC PULSES

by San D'Arcy

UHF-TV Service Clinics, Penna. and Md.—October 20, 21, 22, 23 and 24. All radio and TV technicians and service dealers are invited to attend the series of free, timely, technical lectures being given. Dates and places are as follows: Monday, Oct. 20th, at Franklin Court Auditorium, 31 W. Franklin St., Hagerstown, Md.; Tuesday, Oct. 21st in the Maple Grove Ballroom at Lancaster, Pa.; on Wednesday, Oct. 22nd in the Tile Room of Zembo Temple, 3rd and Division Sts., Harrisburg, Pa.; on Thursday, Oct. 23rd in the Music Room of the Reading Senior High School at Reading, Pa.; on Friday, Oct. 24th, at the YMCA Building, Newberry and Clark Ave., York, Pa. Meetings start at 8 p.m. sharp.

The speakers and their subjects are: Douglas H. Carpenter (VEE-D-X Antennas), subject "UHF TV Antennas and Installation Techniques"; Richard W. Mitchell (Regency Boosters), subject "UHF Tuners and Converters"; Mel Byron (Precise Instruments), subject "UHF Service Techniques"; and S. R. (Sandy) Cowan (Radio Television Service Dealer Mag.), subject "How To Determine What You Must Charge For Your Services."

Standards Are Needed—*With every passing day it is being more apparent that in their zeal to invent and produce better products, manufacturers are getting themselves into an invidious and harmful rut. Have you computed how many different types of TV picture tubes are on the market today? Not 100 or 400! Guess. Next month we'll give you the exact answer. But enough of that, for now.*

We're trying to bring out the fact that every one of the most recent manufacturing reports issued by RTMA shows that the great bulk of all current TV picture tube production is in the 21 inch or larger screen size. That means, to all practical purposes, that all 7 inch, 10, 16 or even 20 inch tube sets are now considered obsolete by TVset makers. Servicemen who need small size tubes are having fits getting them, and this has, to some degrees stimulated the prosperity of picture tube rebuilders. That the answer lies in collaboration amongst manufacturers, and the establishment of a limited number of standard sized tubes, is becoming more apparent. But the get-together for establishing standards is continually being postponed on the premise that some national law might be evoked. And rightly so. It would be. So, the law, in the case of TV should be amended in the public welfare, for that's just what it would do, protect the public's investment, in a case such as this.

TV Inventory and Profit Margins—Latest word from leading TVset manufacturers is that stocks on hand at distributors' warehouses is at the lowest level since mass production first began in 1949. That's a fine sign. But at the same time dealers are price-slashing all over trying to maintain high volume. Then, to add to the confusion, dealers are suggesting that manufacturers should increase their trade discounts so a larger margin of profit might be obtained. Talk about paradox!

First UHF TV installation—*According to G.E. the first high power UHF TV station will be installed for WHUM-TV, Reading, Pa., and should be "on-the-air" in late December. This unit costs over \$450,000 and is expected to permit Reading's new Channel 61 to cover a large part of Pennsylvania, Delaware, New Jersey and Maryland. Talk about new vistas being opened by UHF! The more the merrier.*

RADIO-TELEVISION SERVICE DEALER • OCTOBER, 1952

here's **YOUR** check list:

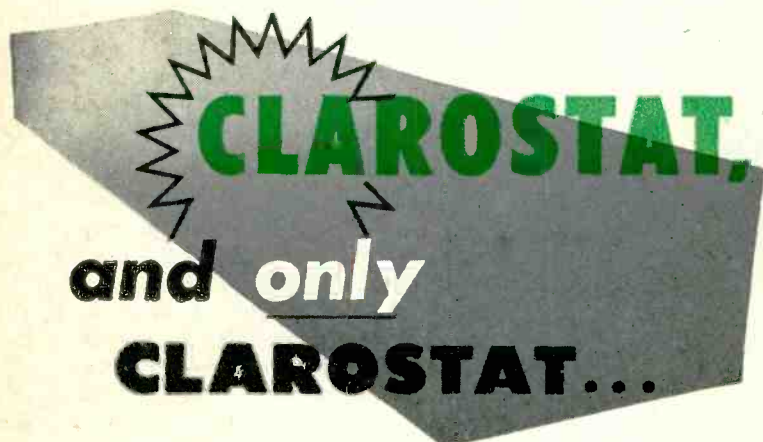

Provides *the complete line* of TV replacement controls. Proof? Just check for yourself the accompanying list of commonly needed controls. *See for yourself* the completeness of the Clarostat RTV Program. No other manufacturer offers such choice of exact-duplicate replacements.

Clarostat RTV (Exact-Duplicate) and Clarostat Standard Controls will take care of approximately 99% of all TV controls needed. Maximum replacements with only 272 RTV numbers to meet special requirements, and 110 Standard Controls through the use of 12 different types of instantly-attachable shafts (Pick-A-Shaft) for common requirements. All of which means maximum convenience to you in TV servicing.

plus

**24 HOUR DELIVERY CYCLE TO DISTRIBUTORS
THE MOST COMPLETE REPLACEMENT MANUAL**

CLAROSTAT MFG. CO., INC., DOVER, NEW HAMPSHIRE
IN CANADA: Canadian Marconi Co., Ltd., Toronto, Ont.

- Concentric control, carbon and 2-watt wire-wound sections.
- Concentric control, carbon and 2-watt wire-wound sections, with switch.
- Concentric control, 2-watt wire-wound sections.
- Concentric control, 2-watt wire-wound sections, with switch.
- Concentric control, carbon and 3-watt wire-wound sections.
- Concentric control, carbon and 3-watt wire-wound sections, with switch.
- Concentric control, 3-watt wire-wound sections.
- Concentric control, 3-watt wire-wound sections, with switch.
- Concentric control, carbon and 4-watt wire-wound sections.
- Concentric control, carbon and 4-watt wire-wound sections, with switch.
- Concentric control, 4 watt wire-wound sections.
- Concentric control, 4-watt wire-wound sections, with switch.
- 2-watt center-tapped wire-wound controls.
- 3-watt center-tapped wire-wound controls.
- 4-watt center-tapped wire-wound controls.
- 2-watt single wire-wound control.
- 3-watt single wire-wound control.
- 4-watt single wire-wound control.
- 25-watt single wire-wound control.
- Concentric dual controls using carbon sections and specially-designed push-pull switch, made only by Clarostat.

Clarostat supplies these exact-duplicate types when you cannot get them in any other line!

KEEP

Profits

IN HAND

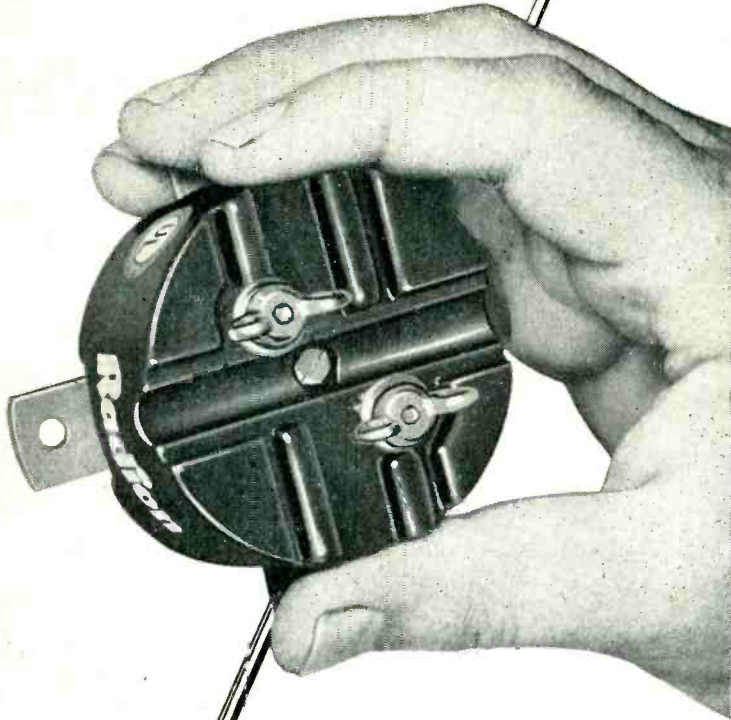

The TOP indoor TV antenna!
 The new ALL-PURPOSE lightning arrester!
 They make and KEEP your profit
 because they're installed simply—
 QUICKLY by deliveryman or customer.
 Don't dissipate profits
 in installation and service—
 specify RADION & keep your profits!

Send today for Radion Profit Plans!

Radion

The Radion Corporation
1130 W. Wisconsin Ave., Chicago 14, Ill.

TRADE FLASHES

[from page 10]

Manufacturers Association. Denver was without television broadcasting service until July 18 when the nation's first post-freeze TV station began operations.

The RTMA estimates show that 24,821 TV sets have been shipped to the Denver area since Jan. 1 and that 23,841 of these receivers were sent dealers during the months of July and August.

RTMA Members Get \$538 Millions In Order from U.S.

Orders for radio communications and other equipment received by member-companies of the Radio-Television Manufacturers Association from the U. S. government during the first half of 1952 totaled \$538,794,477, RTMA announced recently. This compares with government orders of \$508,709,882 received during the first half of 1951.

During the second quarter of this year the government placed \$322,499,543 worth of orders with RTMA members, a sharp increase over the orders placed during the first 1952 quarter.

1953 Electronics Parts Show

The 1953 Electronic Parts Show will be held at the Conrad Hilton Hotel in Chicago, May 18th-21st, Samuel L. Baraf, of New York, newly elected president of the Show Corporation announced following a three-day meeting of the Show Board of Directors at Three Lakes, Wisconsin, September 5th-7th.

The 1953 Parts Show will run from Monday through Thursday, from 10 A.M. to 6 P.M., with a supplementary program of seminars patterned after those at the 1952 Show. Both the Exhibition Hall and fifth and sixth floors of the Conrad Hilton will be utilized again in 1953, and in addition a new section will be added to the Exhibition Hall area to accommodate an estimated forty more booths next year, according to Kenneth C. Prince, Show Manager.

New E-V Promotion

One of the most unique, most powerful promotions in phono-cartridge history has been launched by Electro-Voice, Inc., Buchanan, Michigan.

The E-V Sales Plan is of fundamental importance to Distributors because the E-V Phono-Cartridge line is based on 6 Preferred Type cartridges

[Continued on page 65]



"WHY SHOULD I INSIST
ON **CBS-HYTRON**?"

"**YOU PROFIT MORE!**
HERE ARE
5 BIG REASONS WHY"

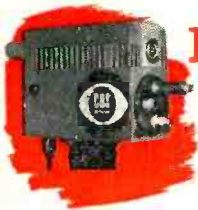

1. CBS-HYTRON IS FAMOUS . . . EASY TO SELL. The magic letters "CBS" are plugged for you on radio and TV station breaks . . . 102 BILLION times a year! CBS is known and respected by *all* your customers. CBS-Hytron is the profitable brand with endless sales assistance.



2. CBS-HYTRON SPECIALIZES IN RECEIVING TUBES. Since 1921, CBS-Hytron has concentrated on receiving types. Practice makes perfect. Put those years of know-how to work for you. Let time-proved CBS-Hytron dependability cut call-backs . . . make more money for you.



3. CBS-HYTRON LEADS IN TV TUBES. You know them. CBS-Hytron TV originals: 1AX2, 1X2A, 6BQ6GT, 12A4, 12B4, 12BH7, 12BY7, 12BZ7, 25BQ6GT, and the original rectangular 16RP4. Even CBS-Hytron standard TV tubes are designed-for-TV . . . tested-for-TV . . . to give you peak performance and profit.



4. CBS-HYTRON IS ULTRAMODERN. CBS-Hytron is the tube of the future. Made in the world's most modern plants. On manufacturing equipment years ahead of the rest of the industry. CBS-Hytron advanced design and precision construction keep you always ahead. Give you tomorrow's trouble-free performance today.

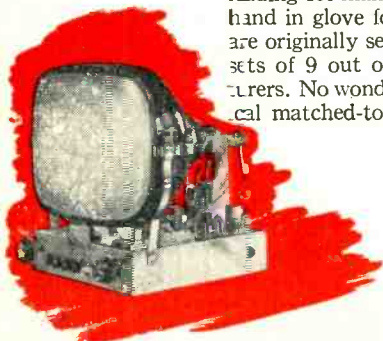

5. CBS-HYTRON IS MATCHED-TO-THE-SET. Combined engineering skills of leading set makers and CBS-Hytron work hand in glove for you. CBS-Hytron tubes are originally set-engineered right into the sets of 9 out of 10 leading set manufacturers. No wonder CBS-Hytron is your logical matched-to-the-set replacement tube.

IT PAYS TO BE FUSSY! Just any standard brand won't do. If you want: Trouble-free, advanced performance. Maximum customer satisfaction. Minimum call-backs. More profit. Five big reasons point the way: Insist on CBS-Hytron!



CBS-HYTRON
Germanium Diodes

Complete data yours for the asking. Write
CBS-Hytron, DANVERS, MASS., today.



one model

for

all

tv sets



Pat.
App.
For

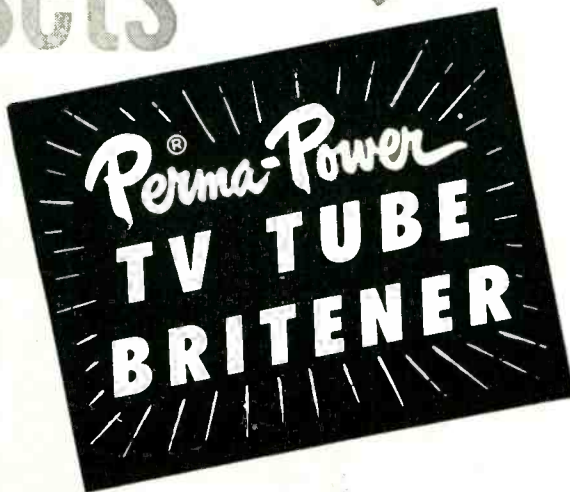

Order the
Engineered Product
— installs
permanently inside
cabinet in minutes
(no wiring or
soldering) — fully
automatic — 3 boost
positions to
select desired
tube brilliance.

- ★ For either Series — or Parallel-wired filaments.
- ★ Increases electron emission, makes dim tubes **BRITE**
- ★ Isolates filament, relieves cathode-filament shorts.



- ★ Line power supply, does not disturb any TV Set circuits.
- ★ Made to sell, packaged to sell.

Write for complete, illustrated literature.
SOLD through recognized wholesalers ONLY. ORDER TODAY!

Perma-Power COMPANY
4721 N. Damen Ave., Chicago 25, Ill.

"Manufacturers
of electronic
equipment
since 1928"

TRADE LITERATURE

The higher temperatures (-55°C to +125°C) and interesting applications of Aerolene-impregnated metallized-paper capacitors are presented in a bulletin entitled "High Temperature Metallized-Paper Capacitors" (Form No. HTMP252) obtainable on request from *Aerovox Corporation*, New Bedford, Mass.

* * *

A complete new catalog of crystals has just been issued by the *James Knights Company* of Sandwich, Illinois, manufacturers of stabilized quartz crystals.

* * *

Mark Simpson Manufacturing Co., Inc., has issued its new general catalog of 1952, revising catalog No. 50. Available from *Mark Simpson Mfg. Co.*, 32-28 49th Street, Long Island City 3, N. Y.

* * *

Allied Radio Corporation, Chicago, distributors of electronics parts and equipment, announces the release of their 1953 general catalog. Reflecting the continuing growth of the industry, ALLIED's new catalog contains 236 pages listing 18,000 items—the largest catalog in the company's history.

* * *

A new eight page, two-color catalogue illustrating and describing the fifteen 1953 models of Califone phonographs, transcription players and sound systems has just been released by the *Califone Corporation*, 1041 North Sycamore Avenue, Hollywood 38, California. Accompanying the catalogue is a combined specification and price sheet for easy selection of equipment to fit the customer's requirements.

* * *

Publication of the first television set-trade-in guide, the 1953 NARDA TV Blue Book, has been announced by the *National Appliance Guide Company*, 2132 Fordem Avenue, Madison 1, Wisconsin.

The manual, scheduled for mid-November distribution, will provide authentic, detailed, up-to-the-minute information about all popular TV sets of over 30 leading manufacturers, covering models produced from 1947 through 1952. The annual guide will

[Continued on page 59]

SYLVANIA
PRECISION

FREE!

The following manufacturers' products are cataloged in the 128 page Instrument & Test Equipment Section.

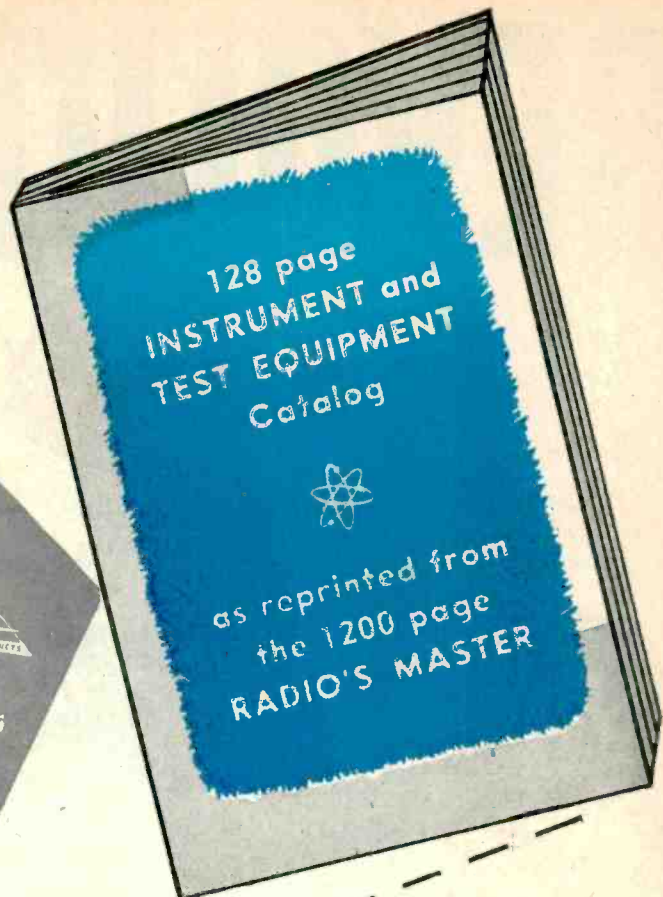

These manufacturers do not catalog test equipment in Radio's Master. Separate catalog sheets will accompany each booklet.

- Clipparc Instrument Lab.
- Dumont Laboratories, Inc.
- Galvanic Products Corp.
- Heath Company
- National Union Radio Corp.
- Oak Ridge Products
- Panaramic Radio Products
- Transvision, Inc.



RADIO-TELEVISION SERVICE DEALER subscribers can receive, without cost or obligation, a complete 128 page catalog section on Test Equipment and Instruments, as reprinted from the 1200 page RADIO'S MASTER, the Industry's Official Buying Guide.

This section catalogs in detail the products of the leading Instrument and Test Equipment manufacturers—all in 1 handy booklet. It is complete with descriptions, specifications and illustrations as written by each manufacturer. You will find this large catalog section extremely helpful and a handy reference.

This FREE offer is made possible by a special arrangement between RADIO-TELEVISION SERVICE DEALER and the publishers of RADIO'S MASTER. Be sure to get your copy . . . just mail coupon NOW.

GET YOUR FREE 128 page CATALOG

RADIO-TELEVISION SERVICE DEALER Ex
67 WEST 44th STREET, N. Y. 36, N. Y.

Please send, without cost or obligation, the 128 page Instrument and Test Equipment Catalog as reprinted from Radio's Master.

Name.....

Address.....

City..... Zone..... State.....

REVOLUTIONARY



NEW!

Extra long-playing

"Personal" type RCA radio batteries

These RCA long-life batteries have completely revolutionized the design and performance of "personal" type portable radios. They've opened up a brand-new replacement market for you that *never before existed*.

Think of it . . . the revolutionary, new RCA VS216, 67½-volt "B" Battery plays newly designed "personal" type portable radios *twice* as long as ordinary 67½-volt batteries. The new, companion RCA VS236 1½-volt "A" Battery (size G) provides up to *five times* the life of ordinary "A" batteries (size D).

New "personal" type portable radios designed to use one VS216 and two VS236 batteries can play up to *10 times longer* without a battery change than previous models using one 67½-volt "B" battery and one 1½-volt "A" bat-

tery of the ordinary type. This new battery complement offers savings in battery operating cost of as much as 25%!

Secret of the longer useful life of the new RCA VS216 "B" Battery is its use of "crown-type," alkaline dry cells. These cells use their active ingredients more effectively than do ordinary cells—resulting in greatly increased playing time.

The new RCA Victor Super "Personal" radio, model 2B400 series, has been designed to use the new RCA "balanced-life" battery complement. Tens of thousands of these as well as other makes of new "personal" type portables have been sold all over the country, creating a *ready-made* battery replacement business for you. It's alive, real and profitable today . . . ACT NOW. TMK ©



RADIO CORPORATION of AMERICA
RADIO BATTERIES **HARRISON, N. J.**

SOLVED!

One of TV's Greatest Problems

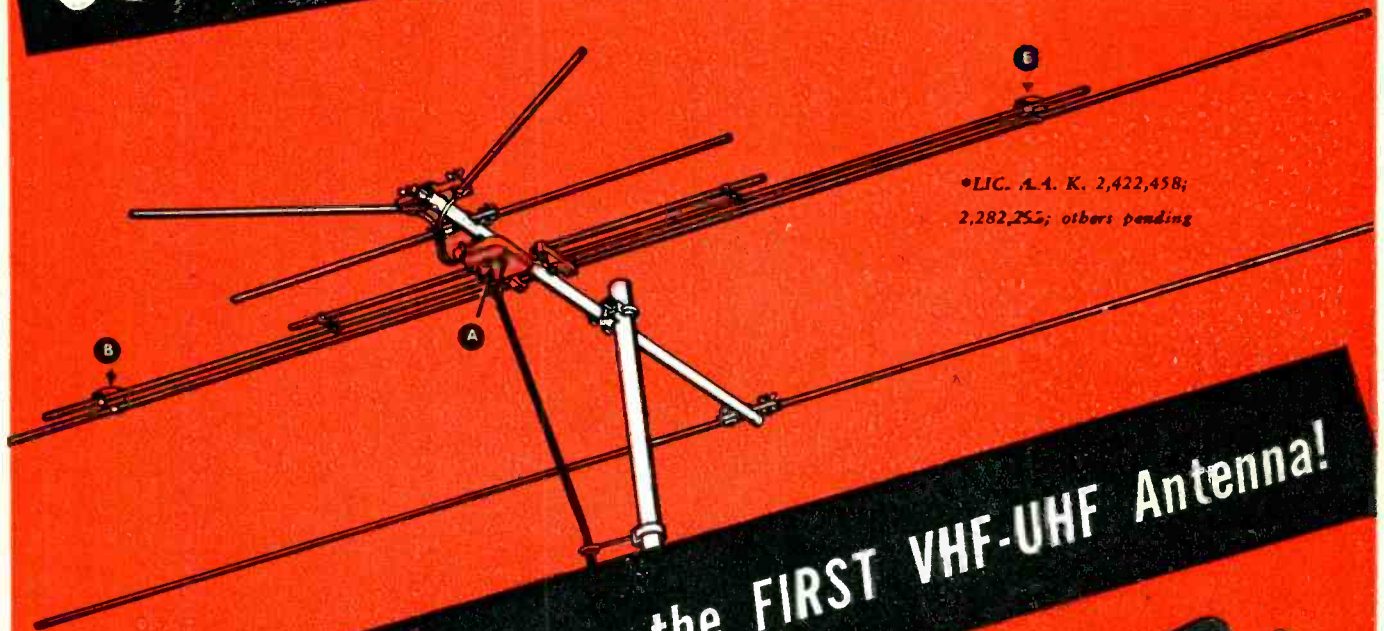

•LIC. A.A. K. 2,422,458;
2,282,255; others pending

VEE-D-X Perfects the **FIRST VHF-UHF Antenna!**

The New ULTRA Q-TEE

All-Channel **2-83** VHF - UHF

INSTALL IT NOW FOR VHF — AND IT'S READY FOR UHF

Here is the world's first and only all-channel (2-83) VHF-UHF antenna. Think of what this means! A tremendous boon to selling TV sets right now. You can install the Ultra Q-Tee for VHF today—and it's ready for UHF whenever it comes to any area. The Ultra Q-Tee greatly simplifies installation problems. It eliminates the need for two or more antennas, multiple transmission line and switches. Single bay design gives it excellent rooftop appearance and good wind resistance. Famous Vee-D-X pre-assembled construction makes it fast and easy to install using a single transmission line. What's more, the Ultra Q-Tee is low in price—lists at only \$14.25.

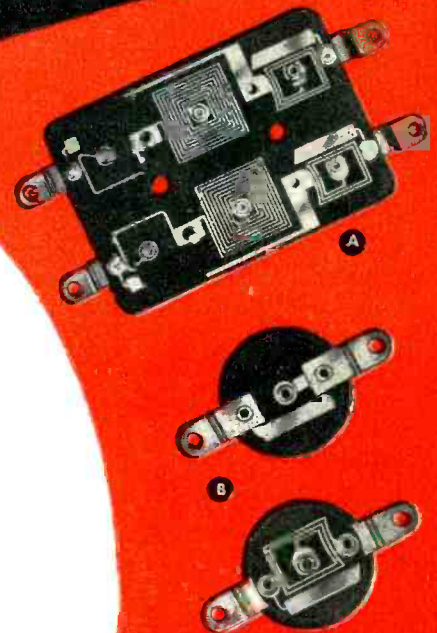

**The ULTRA Q-TEE Employs
Eight Printed Circuit
Channel Separators**

Secret of the Ultra Q-Tee's sensational operation is the unique and patented printed circuit band reject filter (channel separator). The two round filters (B) separate the VHF channels. The large rectangular six-section printed circuit filter (A) was developed especially for separation of the UHF channels and makes possible the use of a single transmission line. Write for literature!

THE LaPOINTE-PLASCOMOLD CORPORATION New Address - **ROCKVILLE, CONNECTICUT**

Copyright 1952—The LaPointe-Plascomold Corp.

RADIO-TELEVISION SERVICE DEALER • OCTOBER, 1952

THE WORLD'S FIRST BROAD BAND YAGI!

CHANNEL MASTER'S

NEW futuramic



The first antenna ever built that combines . . .

- Broad band coverage *with the*
- High gain and directivity of the Yagi

Designed for service TODAY and TOMORROW -- in these 3 booming VHF markets:

Horizontal Polar Pattern

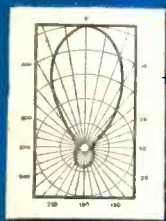

BOOM BRACED

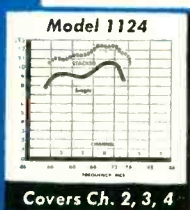

- Areas in which the FCC has ordered VHF stations to change channels (on the same band).

When a channel-shift takes place, the thousands of single-channel Yagis in use will become obsolete overnight. Unless such antennas are all changed on the same day the shift takes place, the set owner will have to get along without television for a period of time. However, you can install the Futuramic NOW. It will provide better reception than conventional Yagis on the present channels — and when the shift occurs, this superior reception will continue on the new channel without interruption!

- Areas in which a new VHF station is being added to the present one.

The great number of single-channel Yagis

now in use will not bring in the new channel. If an additional Yagi is installed, it will have to be tied into the present installation with separate leads and a switching system. However, ONE Futuramic will do the job of BOTH antennas — at lower cost — with better results on both channels.

- Areas served at present by two or more VHF stations (on the same band).

In such areas, the installation man has had to compromise between conventional broad band antennas, and separate Yagis for each channel. Only the Futuramic will give you the full advantages of both. It combines highest gain and sharpest directivity with simple, economical installation.

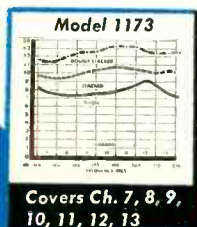
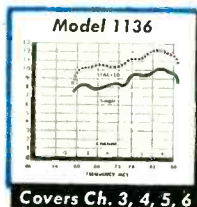
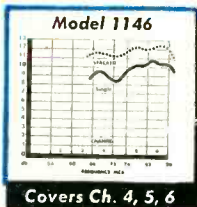
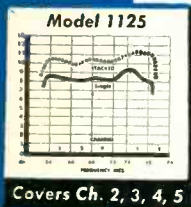

Model No.	Channels Covered	List Price
1173	7, 8, 9, 10, 11, 12, and 13	\$20.83
1124	2, 3, and 4	\$40.97
1125	2, 3, 4, and 5	
1136	3, 4, 5, and 6	
1146	4, 5, and 6	

SHATTERS all performance records!

- Channel for channel, the Broad Band Futuramic will outperform any conventional SINGLE-CHANNEL Yagi.
- On each of its specified channels, one single Low Band Futuramic will outperform any 4-bay conical or fan array.
- A single High Band Futuramic will outperform any 2-bay conical or fan array on every channel from 7 to 13.
- A high-low Futuramic combination is the most sensitive array ever devised for all-channel VHF reception.
- And the Futuramic uses Channel Master's famous Z-Match system for maximum stacking gain.

Write for complete technical literature.

CHANNEL MASTER CORP.

ELLENVILLE, N. Y.

VIDEO DETECTORS

In

INTERCARRIER RECEIVERS

This article presents a discussion of detector circuits used in early and modern intercarrier TV receivers. In addition to an explanation of the circuitry, the author points out some valuable servicing procedures.

By MATTHEW MANDL

BESIDES being called upon to demodulate the i-f carrier to produce the picture signal, modern video detectors often furnish a-g-c voltage, as well as sync waveforms for the separator, and sound i-f signals for the audio system. To accomplish the latter in intercarrier receivers, the video detector must heterodyne the video and sound i-f frequencies to produce the 4.5 mc difference to which the sound i-f stages are tuned. This is the big advantage of intercarrier receivers. Sound drift is minimized because the difference between the picture and sound carriers is always 4.5 mc. This also eliminates the disadvantage of the split-sound receivers, where best signal and sound are seldom obtained at the same setting of the fine tuning control.

Modern circuit versions differ from the older intercarrier types because of the improvements which resulted because of better design. Inasmuch as most manufacturers have now swung over to the improved intercarrier systems in their receivers, it will be worthwhile to analyze and compare the difference in several representative models.

Older Versions

Older intercarrier receivers generally took the sound i-f frequency of 4.5 mc from the output of a video amplifier stage following the detector as shown in *Fig. 1*. In such receivers the detector was a simple affair composed of a diode for rectification of the i-f carrier to produce the video signals.

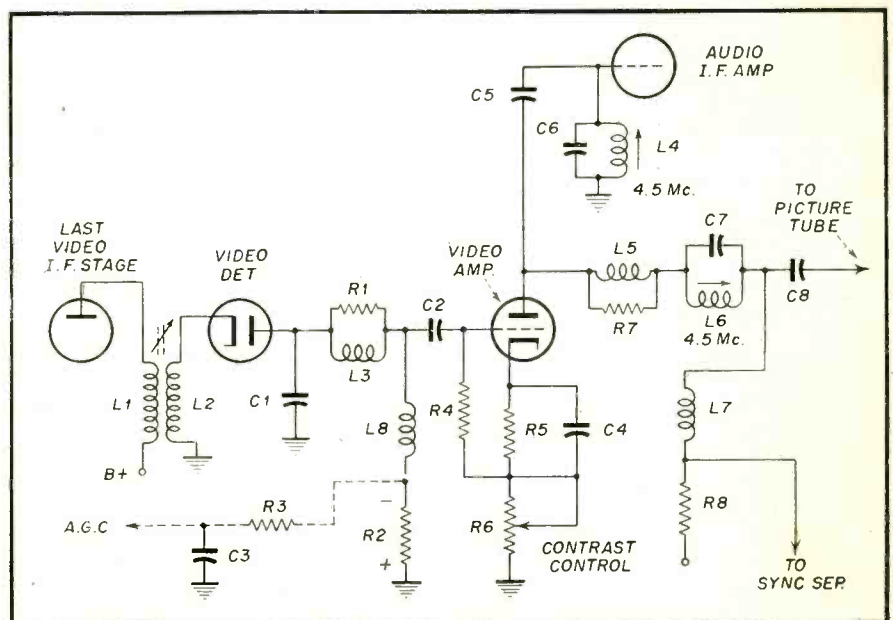

Fig. 1—Detector circuit used in early designs of intercarrier receivers.

As shown in *Fig. 1*, the last video i-f stage is coupled to the video detector through a conventional transformer composed of $L1$ and $L2$. This is slug-tuned and distributed capacities combined with interelectrode tube capacities furnished the necessary resonant circuit when combined with the primary and secondary of the interstage transformer. The capacitor $C1$ acts as a low-pass filter. Essentially, this permits the rectification process to derive the video signals but has a bypass effect on the higher i-f radio frequencies. $L3$ and $L8$ com-

prise the conventional series and shunt peaking coils while $R1$ is shunted across $L3$ to broaden the peaking effect and extend the high frequency response.

$R2$ is actually the load resistor of the video detector and it is across this that the composite video signal is developed during the detection process. The capacitor $C2$ couples the video signal to the grid of the video amplifier tube, though in many instances $C2$ is omitted inasmuch as no B+ is applied to the plate of the video detector. Where a-g-c is derived

from the detector, however, $C2$ blocks the d-c voltage from the grid of the video amplifier, while $R3$ and $C3$ filter the ripple component represented by the video signal so that a minus voltage can be applied to the r.f. and i.f. tubes for a-g-c purposes. When a-g-c is applied to this circuit it is attached to the top of $R2$ as shown by the dotted lines. Because of the rectification process of detection, current flow through the diode from cathode to plate and down through $R2$ would set up a minus potential at the top of $R2$ as shown in the illustration.

While a diode detector is substantially linear, when combined with circuit components a non-linear function is set up and this permits the heterodyning of two signals. In intercarrier receivers this is done, and in *Fig. 1* the picture signal is impressed upon the grid of the video amplifier as well as the difference frequency of 4.5 megacycles which represents the FM sound signal.

The composite video signal which is obtained at the plate of the video amplifier is sent to the picture tube via $C8$, the coupling capacitor. $L5$ and $R7$ comprise the peaking network similar to $R1$ and $L3$ in the video detector. $C7$ and $L6$, however, consists of a 4.5 megacycle trap to keep the sound i-f frequency out of the picture tube grid circuit. This 4.5 megacycle frequency would generate approximately 285 vertical bars (4.5 megacycles divided by the horizontal sweep frequency 15,750). Actually, the number of vertical bars would be somewhat less than 285 because of blanking. The vertical bars would, however, appear as closely spaced fine grain struc-

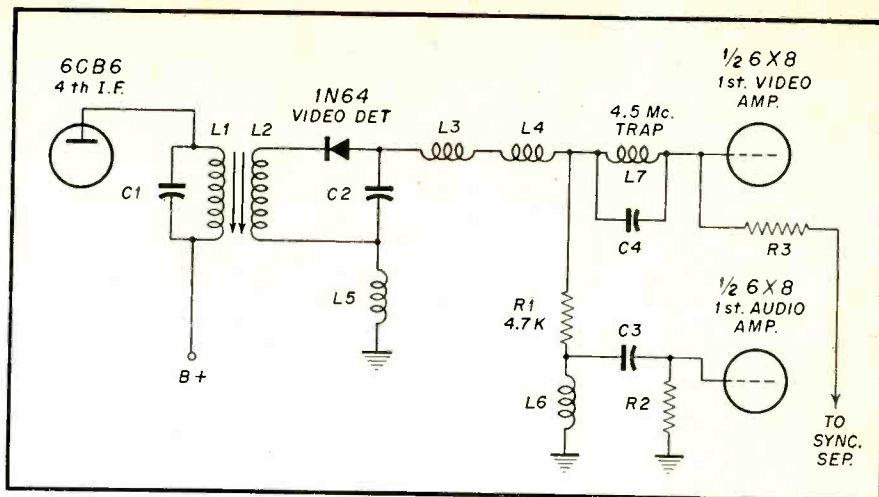

Fig. 2—Modern version of detector circuit used in intercarrier receivers.

tures and it is the purpose of the 4.5 megacycle trap to prevent the entry of this signal to the picture tube.

Because of the additional gain generated by the video amplifier, it is not necessary to amplify the sound i-f signal too much. For this reason it is coupled to a single audio i-f amplifier from the plate of the video amplifier via $C5$. A tuned resonant circuit in the grid of the sound i-f amplifier accepts the 4.5 frequency and tends to be sufficiently selective to eliminate other frequencies.

This circuit had a number of disadvantages. Intercarrier buzz was apt to be severe if the sound i.f. and the picture i.f. stages were not properly aligned. It became necessary to keep the sound i-f carrier approximately 95% below the picture i-f carrier in the stages preceding the detector. At the same time the nearness of the

amplified 4.5 signal to the picture tube made the settings of the 4.5 megacycle trap rather critical. These, and other defects have been minimized to a great extent in the more modern versions of the intercarrier receivers.

Newer Types

The newer versions in the later receivers take the 4.5 megacycle sound i-f frequency from the video detector instead of from video output amplifier. This means that there is less danger of the 4.5 megacycle frequency appearing at the picture amplifier tube because it is no longer necessary to give it the amplification required. Instead, two stages of sound i-f amplification are used to increase the gain to the required level when the signal is derived from the detector circuit directly.

Figure 2 illustrates a typical video detector circuit. This is used in the Capelhart CX-36 chassis, and similar circuits are to be found in other receivers. Here, a 1N64 germanium crystal is used instead of the vacuum tube diode detector. This eliminates the need for filament current and simplifies the circuit to some degree. $C2$ is the filter circuit previously mentioned which tends to bypass the i-f frequencies and keeps them from entering the subsequent circuit. $L3$, $L4$, $L5$, and $L6$ are the conventional peaking coils. $R1$ is the load resistor for the video detector across which the composite video signal is developed as well as the 4.5 sound i-f signal. $C3$ is used to couple the 4.5 megacycle signal directly to the grid of the first audio i-f stage. As previously mentioned, in such a system an additional stage is used to build the sound i-f signal up to the required level for application to the detector. Inasmuch

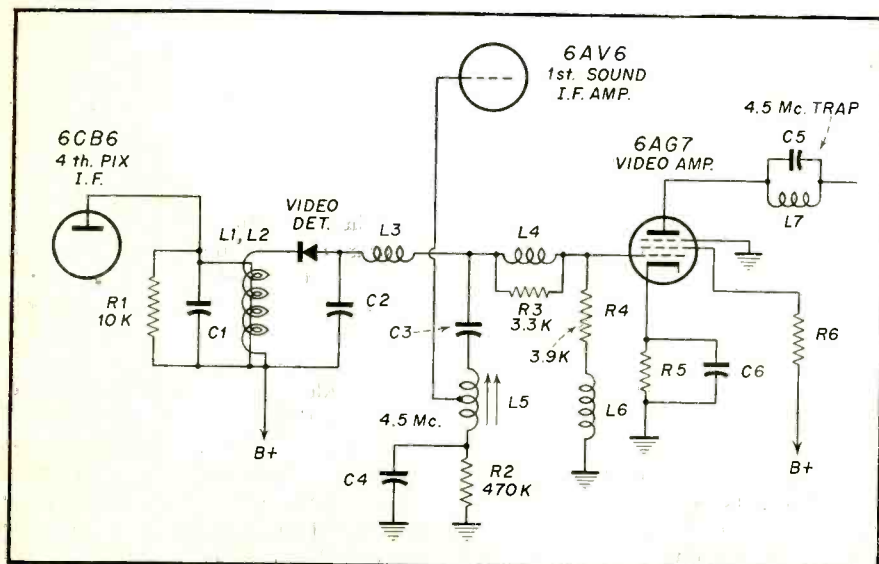

Fig. 3—Detector circuit used in the RCA Model 21T176 TV intercarrier receiver.



Fig. 4—Pattern produced when 4.5 mc reaches the grid of the picture tube.

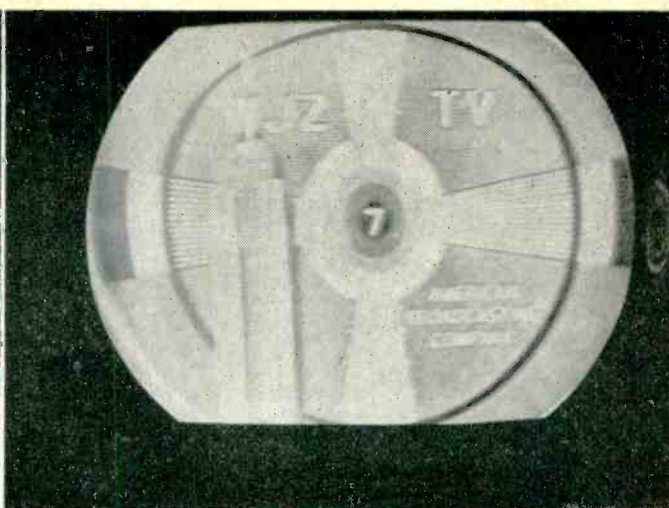

Fig. 5—Pattern produced because of a faulty video detector.

as two stages are used, one can function as a partial limiter or clipper for a more effective suppression of amplitude modulation which would result in intercarrier buzz and noise.

The composite video signal is applied to the grid of the first video amplifier via a 4.5 megacycle trap composed of $L7$ and $C4$. From this same circuit the composite video signal is sent to the sync separator via the series resistor $R3$. Thus, in the Capehart receiver the video detector not only furnishes the picture signal for the video amplifier tube but also heterodynes the two i-f carriers to produce the 4.5 mc signal for the first audio amplifier. Besides this, the sync separator tap is also applied to the detector circuit. It will be noted that the 4.5 megacycle signals are effectively trapped from the grid of the first video amplifier and for this reason are not amplified. This means that more effective trapping can be secured to reduce the fine vertical line interference mentioned previously.

Another modern circuit is that shown in *Fig. 3* which shows the video detector system used in the newer RCA receivers, Model 21T176 series. Here the sound i-f. take-off is somewhat different from the conventional method. Another germanium crystal detector is used as in the Capehart receivers. The load resistor in this instance is $R4$, the 3,900 ohm resistor shown at the grid of the video amplifier. $L3$, $L4$, and $L6$ are the usual peaking coils. A series resonant circuit is utilized which consists of $C3$ and $L5$. This is placed at virtual ground via $C4$. This means that this series resonant circuit will effectively shunt the 4.5 i-f frequency to ground and minimize the tendency for any of this signal entering the video amplifier.

Inasmuch as a series resonant cir-

cuit has a low impedance, the shunt circuit will develop a fairly high current through it. This means that the 4.5 megacycle signal develops a voltage across $L5$. This coil is tapped and applied to the grid of the first sound i-f amplifier. $R2$, the 470,000 ohm resistor, acts as the grid leak for the 6AU6 sound i-f. amplifier.

To prevent any of the 4.5 megacycle signal from getting to the picture tube grid, an additional trap is used in the plate of the 6AG7 video amplifier. This assures attenuation of any amplified 4.5 megacycle signal which may get through the video amplifier tube.

It will be noted that the picture i-f amplifier is coupled to the video detector with the "bifiler" type of coil construction. Here, the primary and secondary wires are wound together on the coil form so that a maximum degree of coupling can be secured. This assures a broad-band response for retaining the full 4 megacycles of picture information.

Servicing Factors

Because the video detector system utilizes a diode tube instead of a triode or pentode type, some of the troubles which occur in multi-element tubes are not present. At the same time, there is no B+ voltage applied to the plate and, therefore, less difficulties occur because of shorted capacitors or excessive load on the power supply because of partial shorts.

In the vacuum tube type such as shown in *Fig. 1*, however, some troubles which are familiar to other tubes will occur. A short between filament and cathode, for instance, will produce a sound bar on the picture screen just as it would with a cathode filament short with any tube in the video strip. A decline in emission of the

diode detector would also decrease signal strength. This could upset the fine balance between the video and sound carrier amplitudes and cause some intercarrier buzz. A reduction of output signal will also decrease the signal to noise ratio and cause the sound signal to be more susceptible to noise interference. Inasmuch as the video detector also uses peaking coils to extend the high frequency response, any defects in the latter will cause loss of high frequency components and impair fine detail in the scene produced on the screen. Because an emission check is not always a good indication of tube function, it is sometimes advisable to try a new detector tube when some doubt exists as to the quality of the existing one.

With the use of a germanium crystal such as shown in *Fig. 2*, similar defects can occur in picture quality if the crystal rectifier becomes defective or partially defective. Of course, since there is no filament, the hum bar symptom would not occur. When the crystal decreases in its rectification characteristic, however, deficiencies in picture quality will occur. On occasion when a crystal starts to develop a defect it is incapable of reproducing the composite video signal up to the required 3.5 or 4 megacycles for good picture detail.

Figure 4 illustrates such a condition. Here the picture quality is not too bad, but some of the high frequency components have been attenuated. This is indicated because the vertical wedge of the test pattern is not as sharp and clear as the horizontal wedge. The fact that the horizontal wedge shows the lines almost converging to the hub indicates that the beam has been properly focused. The

[Continued on page 71]

YOUR Hi-Fi MARKET

PART 2

by CHARLES B. GRAHAM

IN the first installment we attempted to set up standards to guide us in the selection of high-fidelity equipment. Having stated the goals, we are now ready to take up the components in detail, one-by-one. In this installment we will examine the amplifier the basic, or power amplifier, and in the next installment the preamplifier and control stages will be discussed.

Every high-quality amplifier includes a push-pull output stage (always class A, or AB), a phase inverter, and one or more stages of voltage amplification preceding the phase inverter. It also includes a power supply, output transformer, and a gain control at its input.

Split-Load Inverter

For a number of years phase inverter was accomplished by use of an interstage transformer. Then the dual triode came into wide use, and most quality console radios employed a pair of triodes (almost always high gain, 6SF5, 6SQ7, 6SC7, etc.) in which the voltage amplified and fed by triode No. 1 to the output tube No. 1 was tapped, fed back to triode No. 2, amplified and its phase inverted signal fed to output tube No. 2. This means of obtaining phase inversion attained great vogue because of its economy, and even today many amplifiers incorporate it. It rarely remains in good balance, though, and the phase inverter which most of the top amplifiers employ today is one called the "split load" inverter.

In the split load phase inverter a large unbypassed load is inserted in the cathode, usually in addition to the bypassed cathode bias resistor. This load resistor is equal in size to the plate resistor, so that an a-c signal equal to, but opposite in phase from, the plate signal appears across it. Customarily these loads are between 10K and 100K. This inverter has the additional advantage of allowing direct coupling to its grid from the preceding plate. This eliminates one coup-

The various requirements of properly designed power amplifiers are discussed in this installment. Of particular interest is the discussion on source and load impedances.

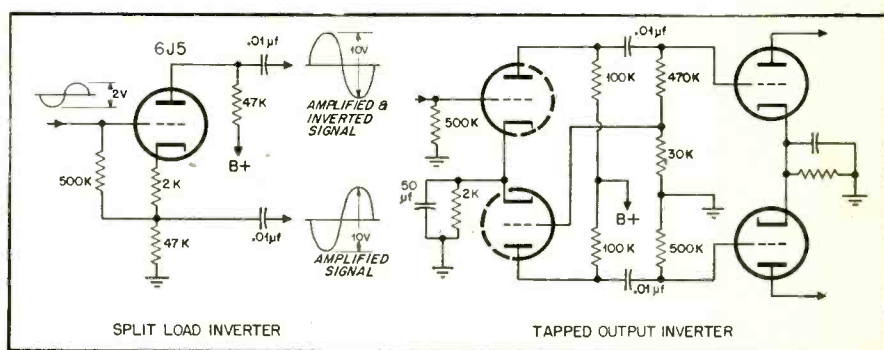

Fig. 1—The split load phase inverter may employ direct coupling from the preceding plate since $\frac{1}{2}$ the applied B voltage appears at the cathode. Typical voltages in above circuit: E_p -185, E_c -90, E_k -95.

ling condenser and a grid resistor, not only saving parts for the manufacturer, but getting rid of one source of phase shift and low frequency discrimination. See Fig. 1 for a comparison of this phase inverter with other types.

Most triode power amplifiers have, in addition to the stages mentioned above, a driver stage between the phase inverter and the output stage. This driver is required since there is considerably less power sensitivity in a triode output stage than in a pentode or beam tetrode. The driver stage must be balanced, with two amplifiers, since there are two output tubes. This driver stage with few exceptions contains a pair of triodes.

Inverse Feedback

The use of inverse feedback (plus improved output transformers) has been most responsible for the improvements of the past few years in amplifier characteristics. This powerful tool has made it possible to produce amplifiers of such quality that they

are usually capable of far better performance than any other section of the music reproducing system. It has become standard practice to obtain most of the inverse feedback through tapping a small voltage off of the secondary of the output transformer, and applying it to an unbypassed cathode resistor preceding the phase inverter stage.

In the late 1930s, when the 6V6 and 6L6 were just coming into wide usage, triode amplifiers went out of style for home sets because pentodes and beam power tubes with their high power sensitivity and efficiency allowed more economical construction, and resulted in higher-powered sets than had previously been practical. Later, as standards were raised, there began a swing towards the use of triodes, because the use of inverse feedback in large amounts was not widely understood. At that time output transformers of low leakage inductance (required if low distortion stages are to use pentode tubes) were not available.

Commercial Amplifiers

Lincoln Walsh then brought out the Brook 10 and 30 watt amplifiers, setting a standard for consumer sets which are still recognized for their excellent quality even by competitors. The Williamson amplifier followed, and the rush to triodes was on. The Brook 10-watter got the extra drive triodes require (2A3s, in this case) by means of a center-tapped choke as a load for the drive stage. This, coupled with careful design and production throughout, produced a 10 watt amplifier which really delivered 10 watts everywhere in the audio range with very low distortion. Previously no commercial amplifier had used triodes with a great deal of feedback because this amount of feedback usually required more driving signal to the output grids than could be economically obtained. Since then the various versions of the Williamson amplifier have come out (the very low distortion Leak amplifier, rated at 12 watts, employs a similar circuit). Following this, Altec Lansing, producers of low distortion amplifiers for years but always with pentodes and beam tube outputs) brought out a triode amplifier rated at 1 watt.

This amplifier got its additional necessary drive for the output stage through an elaborate system using two push-pull stages (four triodes) between the phase inverter and the output stage. It also had a center-tapped choke common to the cathode-follower of the drive stage and the grids of the output. Thus a pair of triode 6A5s, a cathode member of the 6B4-2A3-6A3 family, were able to produce 18 watts with low harmonic and IM content.

There seems little question that, granted an equal amount of feedback, triodes can produce power amplification with less distortion in the higher order (above 2nd) harmonics than 6L6s. But they require more drive. The Williamson circuit, in addition to employing a drive stage, includes balancing of the output currents and makes use of higher gain output tubes, the 807 (triode connected) or the British KT66. The old argument about which is better, triodes or beam tubes, is one we refuse to take sides in. Of course it is more economical to produce a 6L6 amplifier with a given percentage of distortion than a triode amplifier. But it's more difficult to design.

The most advanced designs in power amplifiers today are those of the McIntosh variety. They employ large amounts of feedback, together with specially designed and construc-

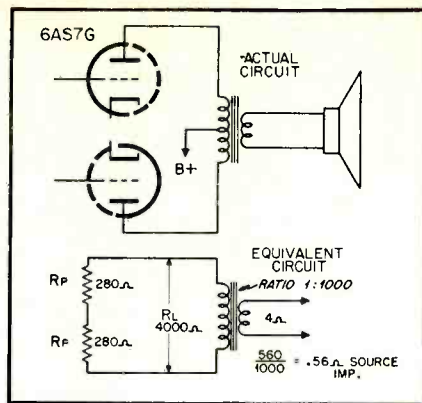

Fig. 2—The 6AS7-G has lower plate resistance than any other readily available power tube. This enables it to produce in the above circuit a damping factor of 8, even without any inverse feedback.

ted interstage and output transformers. They are in this way capable of producing from 20 to 50 watts with a pair of 6V6s, and 50 to 100 watts with 6L6s!

In reading manufacturer's specifications notice should be taken not of the outer frequency limits listed. Instead one should examine the amount of variation within those limits. How smooth is it? All amplifiers have some output at 20 kc, even the 50L6 tube model! "X db" is the figure which provides the important key to the quality. Wide range is not in itself particularly difficult to obtain today, especially since the response of the amplifier almost always far surpassed that of the electro-acoustic elements; the pickup, microphone and loudspeaker.

The power capability of the amplifier must be very carefully examined. After determining the necessary maximum power which an installation may require, we must obtain an amplifier which can supply that amount of power at all audio frequencies. This means that the amplifier should be supplied with a power curve. This is a graph of the power it can provide at rated distortion at all frequencies in the audio range. Not all manufacturers have come around to giving a graph for this characteristic, but the trend seem to be towards giving more and more information of this sort.

Source Impedance

The source impedance of the amplifier should be low. Put another way, the amplifier should have a large damping factor. Every electrical generator (and an amplifier is a generator) has its own value of internal impedance. If this value is small compared to the load which the loud-

speaker presents, the generator will have a large damping effect on the load (speaker). This happens because the loudspeaker itself becomes a generator when in motion. The amplifier acts a shunt to the EMF set up by the speaker and electrically "brakes" the loudspeaker. This reduces *hangover* and also smooths out some of the peaks in the speaker's response curve due to mechanical resonances. The lower the impedance of the shunt, the greater the braking effect.

The damping factor may be calculated by dividing the load impedance presented to the output stage by the plate resistance of the output tubes (if there is no inverse feedback applied). Inverse feedback reduces the effective source impedance, or in other words raises the damping factor. Some manufacturers refer the effective source impedance to the 8 ohm secondary tap. If the source impedance here is 4 ohms, then the damping factor is 2. A desirable *minimum* damping factor is about 4. As the damping factor is increased much beyond 4 progressively less and less improvement in performance is obtained. This is because the limiting factor then becomes the relatively large d-c resistance of the speaker's voice coil.

It was often the desirability of a good-sized damping factor (or a low source impedance) which dictated the choice of triodes, since they have much lower plate resistances than do pentodes and tetrodes. However, the use of inverse feedback produces large damping factors even with beam power tubes.

The source impedance of the amplifier should not be confused with the rating of the output transformer taps. The source impedance must of course be related, when given, to a particular tap. It makes little difference which tap is mentioned, since it is the *ratio* which matters. The source impedance is the value which the speaker "looks at" or "sees" back through the transformer. It is the plate resistance of the output stage, stepped down by the impedance ratio of the transformer. Examine Fig. 2, in which a very low plate resistance tube, the 6AS7-G twin power triode is demonstrated to present a very low source impedance to the load.

Distortion

Harmonic and intermodulation distortion (IM) should of course be carefully considered. These figures are much more important than consideration of whether the amplifier uses triodes or beam power tubes. (Although many of today's enthusiasts

are hard to convince on this point.) Remember, there is no essential superiority between triode output and beam output; one is no better than the other if the IM and harmonic contents are the same, both at the same power output, and if the source impedance is the same.

Harmonic distortion produces waves harmonically (and harmoniously) related to the original notes. They are exact multiples of the input tones. But IM produces tones which often have no harmonic (or harmonious) relationship to any of the tones in the input signal. A glance at Fig. 3 will show how harmonic distortion operates, producing no new tones, but instead simply altering (distorting) the original tones. Listener tests, on the other hand, have confirmed that IM, even when not immediately noticeable or heard, increases listener fatigue and tiredness.

IM distortion occurs when two or more frequencies are amplified in a non-linear system. The output signal then contains not only the two or more original tones and their harmonics. It also contains new tones which are the sum and difference tones of the original frequencies. (This phenomenon is made use of in the superheterodyne AM receiver, and in the BFO of communications sets.

In Fig 4 there is a simplified diagram of an IM test setup. It may be seen that two sine wave signals (one of 100 cps or less) and a higher one (usually 4 kc or higher) are amplified by a power amplifier. The output is sent through a high-pass filter and the percentage of modulation of the higher frequency by the lower is then measured. From this it can be seen that both the test frequencies and the ratio in which they are mixed will affect the IM figure produced. Therefore it is important that the manufacturer states not only the IM %, but what frequencies were used, what the ratio was (it is gradually being standardized at 4 to 1) and the power output at which the measurement was made, since non-linear amplification increases with increased power output.

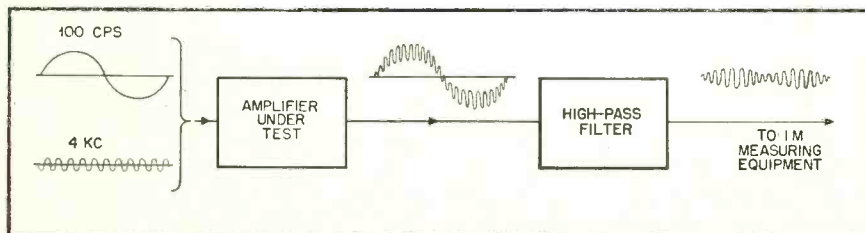

Fig. 4—The percentage of IM distortion is defined as the % of modulation of the higher frequency by the lower frequency.



Fig. 5—Trend in modern wide range amplifiers is shown in the size of the power and output transformers, which dwarf the 6L6 tubes above. This amplifier is conservatively rated at 20 watts. It employs only one 12AX7 and the output stage.

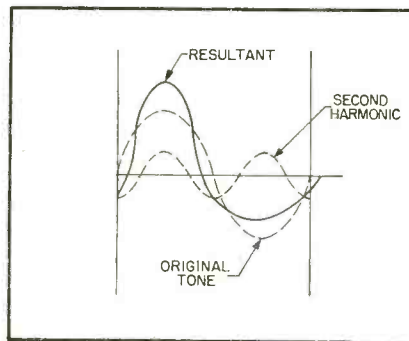

Fig. 3—When harmonic distortion occurs the resultant frequencies are not new ones, although the shape of the new waves is distorted from the original. Thus the tones sound different, but there are no new tones generated.

Noise

The noise level (including hum) should be at least 60 db below the rated output. This is based on the standards which the FCC has set up for FM broadcast stations. If the signal-to-noise ratio is less than this the amplifying system will introduce noise of its own, and the greatest ad-

vantage will not be taken of the low noise level of the original program material. Most high-quality amplifiers today have extremely low noise levels. This is due to careful design, push-pull output (which cancels even harmonics and power-supply hum in the output stage), inverse feedback, and special low-noise tubes and circuits in the low-level stages. We will examine in more detail the manner in which hum and other noise is kept low in the pre-amplifier and control stages in another installment.

Gain

It is no longer necessary to be concerned with the gain specified for an amplifier. All basic amplifiers are designed to give rated output with about 0.3 to 0.5 volts signal input, and most of their associated control sections will deliver this easily with any standard tuner, or crystal, or magnetic pickup.

Accessories

It is of some concern to the installer of high-quality audio to notice the switching, fuse, and a-c supply facilities incorporated into the power amplifier chassis. Many amplifiers have at least one a-c outlet available, and a three-way cube tap inserted here will provide power (and power control) conveniently for tuner, turntable or changer, and TV if required. After a few installations have been made it will be realized that this simple feature is a very definite ad-

[Continued on page 70]

TV SYNC CIRCUITS

PART 2

by LEONARD LIEBERMAN

This second installment discusses various sync take-off points, sync limiters, and methods of trouble-shooting the sync circuits. In the section devoted to the latter some interesting procedures will be observed.

THE bias on the sync tube is often made a function of signal strength in order to accommodate the variation in sync amplitudes. In many sets, a sufficient amplitude is assured prior to the stripper stage. Whether an additional stage is required, is determined by: (a) the sync take-off point and; (b) the polarity of the signal at the take-off point.

Sync Take-Off Point

The sync take-off point will sometimes be at the video second detector. This results from the fact that the detector can be so designed that the sync stripper stage does not load down the circuit at this point (RTSD April '52, "Video Detectors"). The signal at this point, however, is usually in the order of 2 to 5 volts peak-to-peak. Because of this an amplifier stage is usually inserted between this take-off point and the sync stripper. If the detector output is of the positive picture phase type, then the output of the amplifier is taken off the plate circuit. If, however, the detector output is picture phase negative (that is the sync pulse is in the most positive direction), then the amplifier output is taken off the cathode. (Fig. 9).

Other sync take-off points are the video amplifier plate (Fig. 11) and the d-c restorer diode load (Fig. 10) if one is used. These two systems have several advantages over the detector take-off point. They also present several special problems. The advantages of these take-off points are that the signal taken off has already been amplified by the video amplifier. This eliminates the need for a separate amplifier tube prior to the sync separator. In addition, by means of grid current flow in the video amplifier, the tops of the sync pulses can be compressed

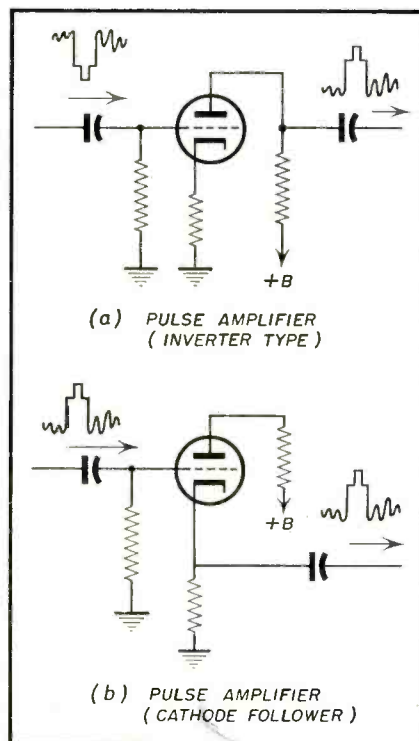

Fig. 9—Two types of pulse amplifier circuits of the negative picture phase type.

slightly resulting in a better impulse noise immunity. The disadvantages of these take-off points are that the input of a sync stripper across the video load resistor has a tendency to distort the amplifier response. This, in turn, causes the value of the sync take-off resistor to be critical. If it is too large, the amount of signal fed the sync stripper would be sufficient, but the loading of the video amplifier would cause distortion. If the resistor value is too small, the loading would be reduced but the amount of sync

fed into the sync system will be of insufficient amplitude. When the sync is taken off the d-c restorer diode, any sudden change in overall pix brightness level might cause a corresponding shift in the level at which the sync is taken off. This, in turn, will cause the vertical sync level to suddenly jump and cause a momentary vertical roll.

Sync Limiter

After the sync stripper, a limiter or leveler stage follows. This stage does two things, it insures that all pulses at its output are constant and also of the correct polarity to trigger the horizontal and vertical oscillators. The bias of this stage is such that the input pulse goes below cut-off and into the region of grid conduction and plate saturation. The purpose of this biasing and plate voltage arrangement is to clean out any noise pulses which might be present on the sync pulse and also to get rid of any video which might still be present.

All the previously mentioned functions can and have been performed by separate tubes. On the other hand there have been some circuit designs in which all the operations have been performed by a single pentode. In this tube the grid is adequately biased, the plate and screen voltages are low and the output is taken off the cathode resistor. While the first circuit is over-designed, the second type will cause considerable trouble outside of strong metropolitan reception areas. In general two or three triode sections are used.

One of the circuits used to counteract the effect of sharp noise pulses is called a "double-time constant." In this circuit a parallel resistor-condenser network is used in series with the

input grid of the stripper. The RC time of this network is such that it presents a high impedance to the high frequency content of the noise pulses. In this manner, most of the high frequency voltage is dropped across the network and very little across the tube input impedance.

Trouble-Shooting The Sync Circuits

The integrator and differentiator networks leading to the vertical and horizontal oscillators are generally considered part of the oscillator circuits. Accepting this limitation, let us analyze the troubles arising from the composite sync. Composite sync troubles are usually indicated by:

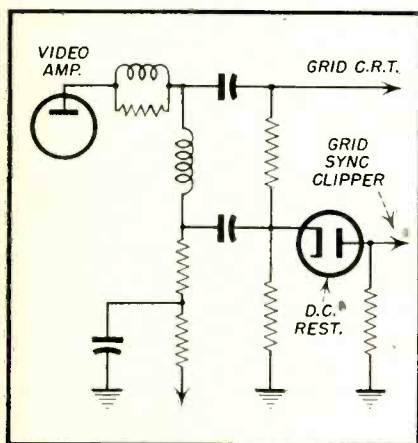

Fig. 10—D-C restorer as a sync take-off point.

1. Loss of both horizontal and vertical hold.
2. "Hooking" at the top of the picture.
3. A weave in the vertical lines.
4. A "watery" horizontal hold, that is the pix shifts from side to side.

For trouble shooting the sync system, the serviceman will find that the oscilloscope and a good meter (either

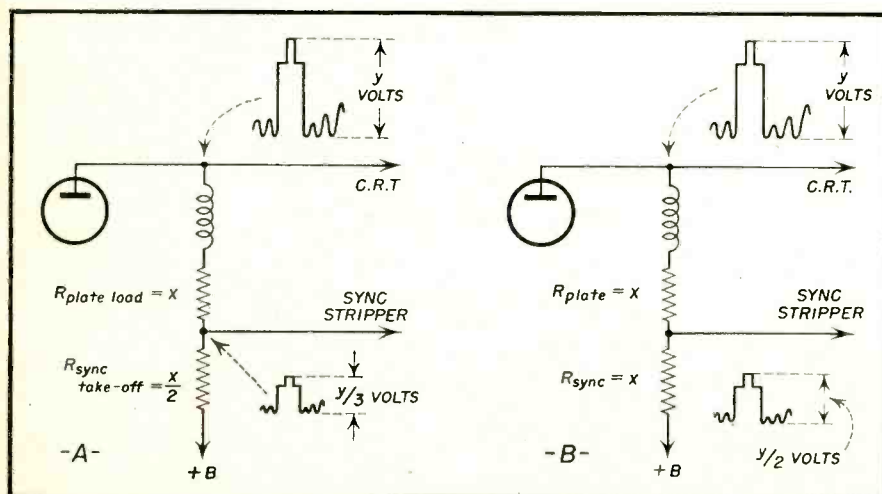

Fig. 13—Relationship between values of plate load resistance and sync take-off point on sync voltage.

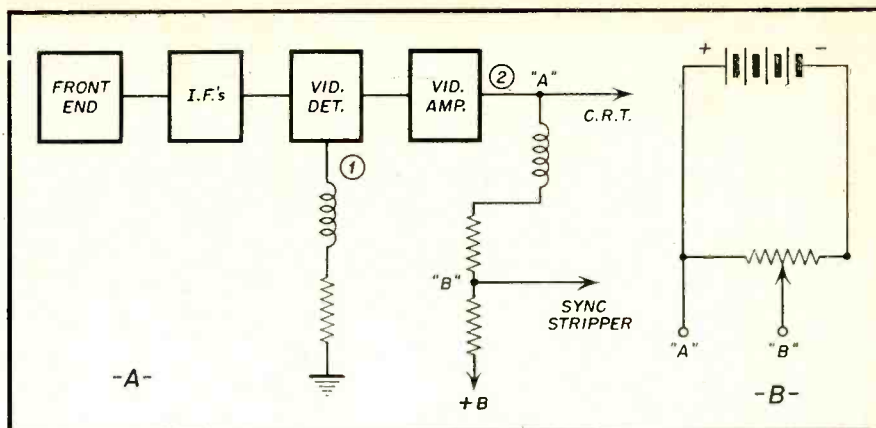

Fig. 12—Circuit points for checking sync level.

20,000 ohms/volt or a VTVM) are indispensable. The sources of sync troubles can be found in the r-f, i-f, video detector, a.g.c., video amplifier, sync and sweep circuits. With such widespread trouble sources, a systematic approach to trouble-shooting sync troubles is essential for profitable servicing. The analysis of sync troubles starts from the front end, however when trouble shooting the sync use the following order:

1. Sync section
2. Video amplifier
3. Horizontal and vertical sweep circuits
4. Video detector and a.g.c.
5. R-F, and H-F amplifiers

The r-f amplifier and the last i-f amplifier may cause compression of the sync pulse. In this connection, it is timely to remember what was mentioned earlier in this article, namely, that the reduced sync level may be caused at the transmitter. Using the oscilloscope at the video detector output, (Fig. 12a Point #1) if the sync level is normal for several stations but more than 25% or less

than 20% of the composite signal on the station causing trouble, check with the station before tearing into the set.

If the above check shows that the sync level is the same on all stations, connect a 6 volt battery with a potentiometer across it (Fig. 12b) to the a-g-c line. See if varying the bias causes the sync level to vary. In the

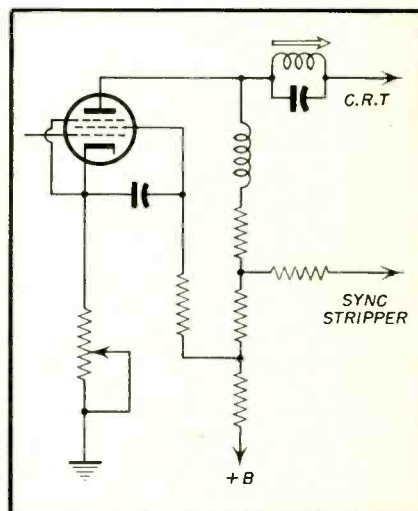

Fig. 11—Plate circuit of video amplifier as a sync take-off point.

event that it does, check the cathode resistors for a change in value and the coupling condensers (if any are used) for leakage. The reason for this check is to show whether the i-f's are being properly biased. If the i-f's are not properly biased, there may be clipping of the sync portion of the i-f envelope. (This type of sync clipping can also cause an audio buzz in intercarrier sets.)

When the sync is taken off after the video amplifier, two other types of sync troubles occur. The causes for these troubles are numerous, but they will show up in one of two ways: either complete absence of horizontal and

[Continued on page 67]

ELECTRONIC ORGAN INSTALLATIONS

by CLYDE L. TICHENOR

A general presentation of problems concerning present day electronic organ installation. It is found that the service technician is called upon more and more for the servicing of these equipments.

ELECTRONIC organs are found in ever increasing numbers across the nation, because of their lower cost and smaller space requirements. Naturally, this means more and more people are required to service and install them. Established pipe organ technicians are not being called upon for these services; rather, the organ retailers are turning for aid to radio and electronics service men, especially in the smaller towns and cities.

At the present time it is practically impossible for a radio technician with no previous knowledge to make a satisfactory electronic organ installation from the scattered information available. This article will help the technician who is confronted with an electronic organ installation problem. It supplies basic considerations and general installation details which, coupled with the manufacturer's literature, is all that should be required to make the average electronic organ installation. It is not the purpose of this article, nor is it possible in this limited space, completely to cover the subject of electronic organ installations.

Basic Facts

From the very beginning of its design to its final installation, an electronic organ's magnificent tones of the match the magnificent tones of the traditional pipe organ. It is this fact which dictates many of the rules and procedures which must be followed for a satisfactory installation.



Fig. 1—120 watts of audio power are used in the organ chamber behind the display pipes. The pipes add a traditional touch to an electronic organ installation in Westwood Hills Christian Church, adjoining the U.C.L.A. campus in Westwood, California.

The pipe organ has the greatest audible tonal range of any musical instrument, from 16 cycles per second to 8,192 cycles per second for its fundamental tones. The harmonics of the pipe organ's tone extend to the upper range of hearing, and pipe organs have the greatest magnitude, or loudness, of sound of any single musical instrument. Considering

these facts, it should be clear that faithful reproduction of these qualities is not the easiest audio-installation problem.

Most present day electronic organs have a frequency range from 32 to 8,192 cycles per second for their fundamental tones. Since they must duplicate the volume of the pipe organ, electronic organs require considerable amplification depending on the circumstances of the installation, such as: room size, audience capacity, interior decoration, etc. The tonal combinations of the electronic organ are equally as complicated as those of the pipe organ, and the better organists are usually very critical about tone quality.

Reverberation

Aside from good volume and undistorted tone, there are certain other characteristics we associate with organ music. The addition of these qualities to electronic organ music is very important, and adds the final touch to the illusion electronic organs create. The first of these, and a very important one, is reverberation. Reverberation, more commonly known as echo, is caused by the reflection of sounds between reflective surfaces such as the walls, floor and ceiling of a room. The surfaces of all objects in the room will have an effect on the reverberation proportional to their number, size, and reflectance. Reverberation time is the length of time required for a sound to decrease 1 millionth or 60 decibels from its orig-

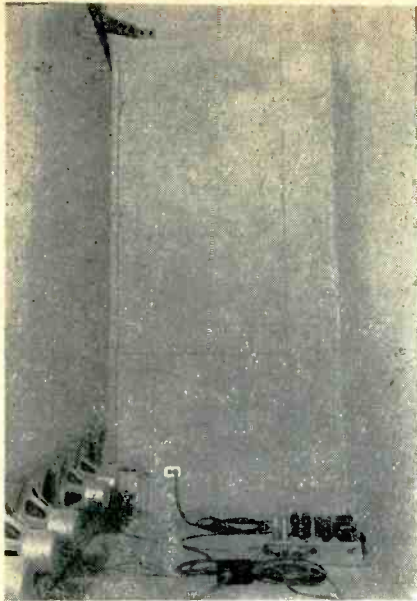

Fig. 2—This is the back part of the Westwood Hills Christian Church organ chamber. Seven speakers of the twelve total (two reversed in direction and phase) may be seen at the bottom of the special ten foot high baffle wall which divides the chamber in two across its length.

inal intensity. Because of their size, organs are traditionally found in large reverberative chambers and buildings, and we have become accustomed to hearing an echoing quality in their tone. Aside from this fact, a certain amount of reverberation adds a pleasing quality to most music. Many orchestra leaders recognize this fact and make their recordings in "live" (reverberative) studios, thereby adding a richer color and effect to their music.

Electronic organs do not have a natural reverberative quality in their tone. Reverberation is produced either in the organ chamber, the auditorium itself, or both. The reverberation time of any room may be calculated by the formula:

$$T = 0.05 \frac{V}{A} \text{, where:}$$

T = Time in seconds
 V = Room volume in cubic feet
 A = The total absorption of the acoustical material surfaces in the room. This is the sum of the square foot area of the walls times their absorption coefficient, the square area of the ceiling times its absorption coefficient, the square area of the floor times its absorption coefficient, and finally plus the surface area of any objects within the room, such as, drapes, chairs, people, etc., times their respective absorption coefficients. The absorption coefficients for several common examples at "C" above middle "C" are:
 smooth plaster, .08, wood, .03,

An audience has a sound absorptive effect upon reverberation produced

in the auditorium, but much less effect upon reverberation produced in the organ chamber. Good organ tone should have a reverberation time lasting about two seconds in a room with a full audience. In auditoriums, high ceilings and walls that are not treated with acoustic materials, increase reverberation time and lessen the audience effect. It should be noted that the sound absorbing capacity of the audience will lessen the reverberation time. Since tests seldom can be conducted with an audience present, the organ engineer should take advantage of opportunities when the audience is present and thereby learn to allow for audience effect from actual experience.

Acoustical absorption materials in general present a large surface area with many small holes wherein sound energy becomes lost or absorbed; phenomena such as multi-reflection, phase shift and cancellation, creation of thermal energy, etc., are generally believed to cause this absorption. These materials are used in auditoriums to hold audience noise at a minimum and allow for a more even sound distribution. For electronic organ installations, an excess of these materials is undesirable, for they lessen the reverberation quality and require an installation of greater amplification. Drapery, carpeting, and materials of similar texture have this same effect and must also be taken into consideration. Acoustics that are poor for speech, because of too much reverberation are generally good for electronic organ music.

Audio Power

Power is another important quality factor in electronic organ installations. An underpowered installation gives the effect of listening to recorded organ music, rather than to an actual organ. When a public address engineer would recommend 40 watts of power for an auditorium, an electronic organ engineer would most likely specify 80 watts. The following averages may be used as a base to work from:

TYPE OF BUILDING	AUDIO POWER
Average residence	20 to 40 watts
Churches (300 to 600 seats)	40 to 80 watts
Auditoriums (600 to 2,000 seats)	80 to 160 watts

Installation Methods

There are four general ways of installing electronic organ tone sources. These four ways are:

1. Cabinets supplied by the manufacturer and positioned without attachment to the building. The amount of power desired determines which

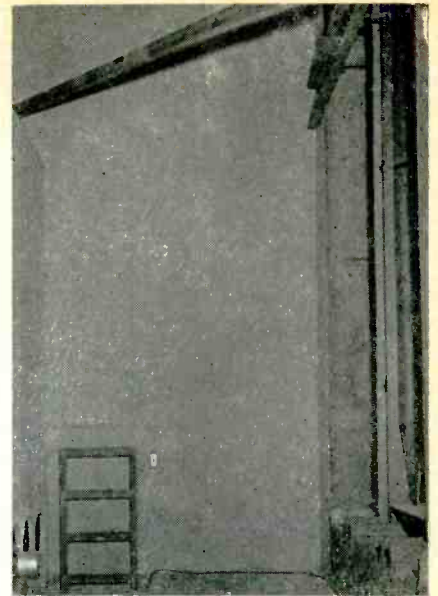

Fig. 3—This is the front part of the organ chamber immediately behind the display pipes. The chamber is about seventeen feet high and the speaker baffle wall is vibration mounted with heavy felt stripping wherever it adjoins the side walls and floor.

type of cabinet or the number required.

2. Cabinets or structures built into the structure of the building. These structures house one or more speakers and provide speaker baffling only. Standard uniform frequency coverage and the extremely low range of frequencies are important things to remember in designing speaker baffles for electronic organs. It is generally possible to design extremely large baffle planes if necessary because of the relatively large areas available as compared with radio sound installations. Using a wall as an infinite baffle, by making speaker holes in it, is generally very desirable. Many references are available for further research into speaker baffle design.

3. Chambers constructed in the auditorium that has poor reverberation. The chamber is primarily built to provide pre-reverberation with electronic organs. It provides a source of reverberation to make up for that which the auditorium lacks. In this type of installation either an existing chamber is used or one is built to house the standard cabinets provided by the manufacturer with enough additional area to provide the required reverberation. The manufacturers generally make a lower priced semi-finished cabinet for this purpose.

4. Custom built and designed speaker baffles built in a chamber, when the standard cabinets are not adaptable

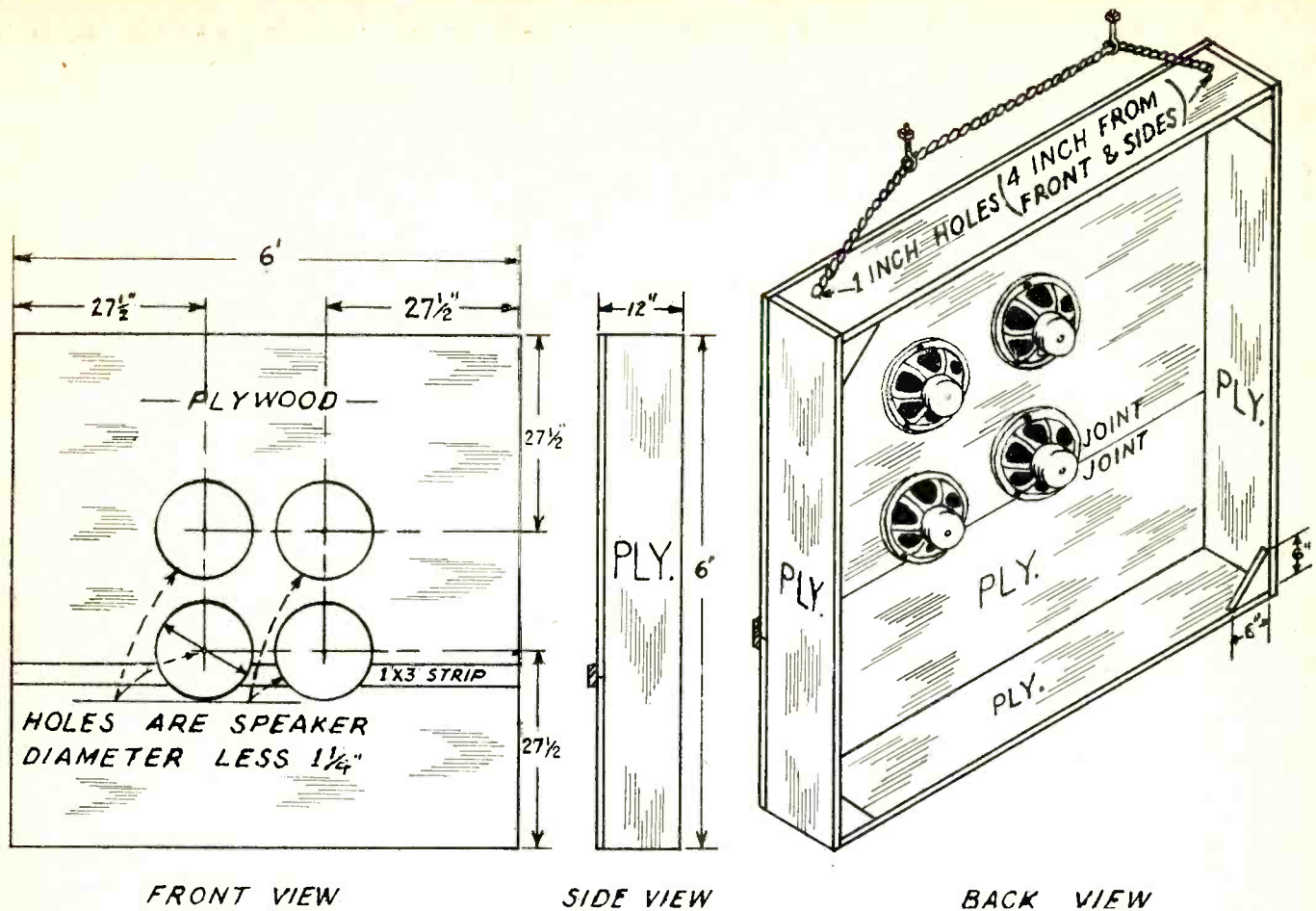

Fig. 4—Economical 4-Speaker mounting plan for electronic organs.

Construction Notes

All plywood surfaces, not less than $\frac{3}{4}$ inch thick. All adjoining surfaces nailed and glued. Final construction should permit vigorous pounding and shaking without rattles or other noises. All flat wood surfaces should be finished to a glassy gloss with varnish or shellac. The baffle should be hung with a strong rope, or a suitable foot support can be made (large rubber tacks can be used to prevent floor vibration).

Notes on Chambers

The chamber opening area should be 5% of the total inner surface area of the chamber, this includes walls, ceiling and floor. 20% of this area is allowable for grillwork or 1 inch in every 5 inches. The chamber opening's shape and position varies with different installations. The chamber opening grill cloth (if this is the case) should not be heavier than ordinary bad sheet material.

to the size or shape of the chamber. This type of interior construction provides the greatest flexibility of design, and can give a "tailor made" tone quality difficult to match by any other method. The Baldwin Piano Company is one of the few electronic organ manufacturers providing unmounted amplifier and speaker equipment especially suitable for this type of installation. An appreciation of proper speaker baffling is needed by people who use this method of installing electronic organ sound sources. Exponential horn installations, when possible, will result in less amplification being needed, greater apparent sound volume, more uniform fre-

quency coverage, with a greater savings in cost.

Designing Organ Tone Chambers

When a new church or auditorium is being built, or contemplated, the organ installation man will occasionally be called upon to specify the organ chamber. For practical purposes a chamber of less than 250 cubic feet of volume has no worthwhile effect on the reverberation time. Chambers must be sound reflective and should be completely lined or finished with hard material such as: smooth cement, Keen cement, hard plaster, or varnished sheetrock. These materials are listed in order of preference. Mason-

ite is sometimes used, but the other materials are more satisfactory. A special acoustic paint made by a Los Angeles firm will give rough cement or brick, and even thick cardboard, the sound reflective properties of plaster. Proper use of this paint can cut the cost of building a chamber by a factor of 10. The more cubic a chamber's dimensions are, the less its inner surface area will be and its reverberation time will accordingly be increased.

The size of the chamber opening depends upon the size of the chamber. A satisfactory relationship may be formed by making the square area of the opening approximately 5 per cent

of the total inner surface area of the chamber. This includes the walls, floor, and ceiling. About 20 per cent of the 5 per cent open area is allowable for whatever grillwork considered necessary. Thin louvered grills (like Venetian blinds) will give maximum open area and sound deflection if the louvers do not overlap one another. The top of one louver should be even horizontally with the bottom of the one above it but not overlapping. Deflection, if any, should be upward, never downward.

Unfortunately, few architects understand what is necessary for an electronic organ installation. They oftentimes provide a well for the console, but make no provisions for its associated equipment. This is especially true in church construction. There was an instance in Los Angeles where a church, just newly completed, had a large social hall adjoining its main chapel. In the walls between the two rooms was a large natural space for an organ chamber which could have opened into both auditoriums. The architect, who knew of the contemplated organ, had sealed this space in with six inch concrete walls. The music committee and the organ installation engineer were quite dismayed at this blunder. The present organ chamber opens into the main chapel only. Additional speaker cabinets had to be purchased for the social hall. The most appropriate and eye appealing installations are, of course, made by cooperation between the organ engineer and the architect. A conference before the church or building reaches the final planning stage is most desirable.

Locating The Tone Cabinets and Speaker Baffles

The last organ quality influenced by installation procedure is the apparent size of the tone source. It is unnatural to hear pipe organ tone coming from a definite spot in a room, such as is the case with a single tone cabinet. There is a definite "undirectional" quality associated with pipe organ tone because of the physical size of their installations. Most factory built electronic organ tone cabinets have their sound openings at the top and sides, or back. One company designs their tone cabinets so that the wood panels radiate the sound in all directions. These types of construction work well towards spreading the apparent area of tone. If possible, several cabinets placed in separated locations in churches and auditoriums, will heighten this effect. Placing these cabinets to the extreme

right and left of the chancel or front section of the auditorium is suggested. Sometimes, because of physical limitations, only one cabinet can be used, in which case a corner will usually lend itself more suitably than a flat wall. In certain Hammond organ cabinet installations this undirectional effect may be furthered by using a specially designed cabinet for Hammond organs—the Leslie Vibratone. These cabinets have a horizontally rotating drum which deflects the sound from the main speaker and gives the impression that the main speaker is rotating. This constant changing of direction helps to spread the apparent sound source; however, this is only true when using the cabinet vibrato.

In organ chambers the sound can only come through the opening of the chamber, but several things can be done to help spread this apparent tone source and obtain more even coverage. More than one opening is sometimes possible. The chamber opening may be provided with the already mentioned louvers to deflect the sound upwards. The reflecting surfaces of the ceiling and opposite wall will then help distribute the sound. This is a typical method used where the tone chamber opens into the chancel of a church.

The positions of the cabinets or speaker baffles in the chamber may best be determined by appraising the sound and moving the cabinets in the front corners of the chambers. This method is useful until some experience has been had with a particular company's equipment. Most electronic organ engineers prefer to place the cabinets in the front corners of the chambers. The cabinets are faced towards the back wall or back corners of the chamber, and the sound is reflected to the chamber opening from these back recesses. Reflecting all the tone in the chamber this way will increase the reverberation time. When amplification is at a minimum, it will be found that more apparent sound volume may be had by facing the speakers or cabinets to the opening at a sacrifice of some reverberation. Sometimes, the fullest effect can be obtained only with more than one chamber.

Locating The Organ

There is a strict relationship between the position of the sound source and the organ console. The position of the sound source and the console and other things which relate to it must all be considered jointly. If the organ is to accompany a choir or orchestra, there are three things to coordinate: the position of the console, the posi-

tion of the tone source, and the position of the soloist, choir, or orchestra. If the soloist, choir, or orchestra is too close to the tone source, there will be considerable complaint from them because of the great volume of sound. Placing the organist too close to his tone source is also undesirable for he will play his accompaniment far too softly. We should endeavor to keep the three positions—the tone source, the organist, and those to be accompanied an equal distance from each other. Form a triangular relationship between them, and when possible keep each at least 20 feet from the others. The intensity of sound that reaches the organist should closely approximate the volume that the audience hears, and placement of the console somewhere between the audience, the choir and tone source is suggested, so that the organist may more effectively balance the musical effect.

Home Installations

Residential or home installations are becoming quite numerous because of the relatively low cost of electronic organs and their smaller space requirements. The extreme lack of reverberation is a primary consideration in this type of installation because of the carpeting, drapery, and small rooms. Residential installations with adequate reverberation are indeed unusual. The installation man should exert his maximum efforts in this direction if this is what the owner wants. The primary factor in a residence installation is to please the owner. They do not all want good organ music. Unused attic space and adjoining hallways should be utilized as chambers. If this is objectionable, the cabinet is the only alternative. Artificial reverberation devices supplied by most manufacturers can save the installation when planning is hampered by extreme space limitations; however, artificial reverberation devices are not comparable to natural quality. Vibration is a major problem because of the many small knick-knacks and movable objects setting about in residences. These vibrating objects must usually be traced down individually and moved or padded. Care must be taken not to overpower built-in installations if they are in the interior of the house. Overpowering creates considerable vibration in adjoining walls and rooms. It is also a good idea to keep the console and tone source separated as far as possible, so that the player does not become overly conscious of the noise level produced

[Continued on page 561]

SERVICING

INTERCARRIER BUZZ

by HARRY MILEAT

THE advent of intercarrier in receiver design is one of the most important developments to come about in television receivers. This is because of economy in production: hence lower prices and easier operation of the television receiver by the consumer.

But, to the added burdens of servicemen it has also brought the now famous intercarrier buzz. From most of the servicemen I have talked to this buzz has been a bigger headache and barrier to good customer-servicemen relations than any other type of trouble. This is mainly because they believe intercarrier buzz is an inherent trouble and cannot be cured; and so they don't try to cure it. On the contrary, in the majority of cases, intercarrier buzz can be greatly minimized or eliminated.

The 4.5 megacycle sound i.f. is produced at the video detector by the heterodyning action of the video i.f. and the sound i.f. carriers which are 4.5 megacycles apart. This 4.5 megacycle difference is standard in all composite signals throughout the United States. For best results, the audio i.f. should be only 3% to 5% of the video i.f. at the detector. If it is higher in proportion an intercarrier buzz can develop. The i.f. slug position preceding the video detector has a notable effect on this buzz and its judicious adjustment has been known in many cases to have reduced or eliminated it. Caution should be taken in adjusting this slug so as not to decrease the over-all video response.

The buzz is also introduced at times by too strong a signal from the antenna, thereby causing clipping of the video signal. As we know, we need

This article is devoted to the subject of intercarrier buzz and the various methods by which it may be reduced in TV receivers.

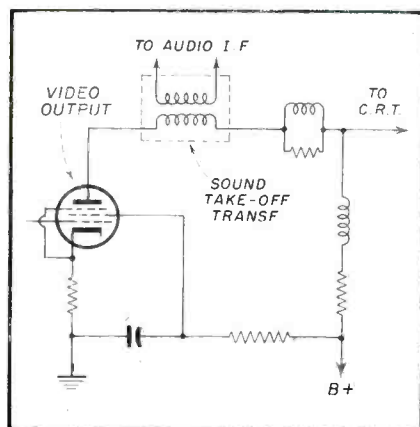

Fig. 1—Primary of sound take-off transformer connected to plate of video output.

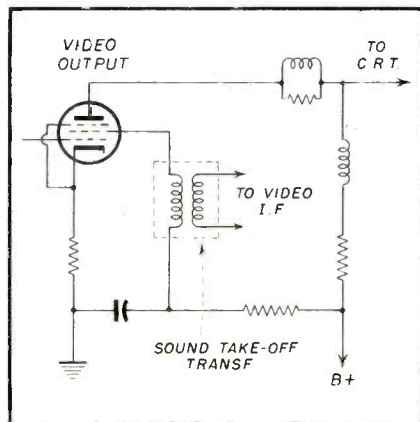

Fig. 2—Sound take-off transformer connected to screen of video amplifier.

the beat between the video and audio i.f.s to produce the desired sound i.f. Therefore, when the video is clipped to excess, there will be no beat and no 4.5 mc. i.f. will be produced. When this happens an audible number of times per second the buzz is produced. This is easily determined by removing one of the antenna twin leads. Pads can be introduced in the antenna circuit to decrease the signal strength. In the past, an overload was easily seen by the hook or curve in the picture. But present day sync and a-f-c circuits are so well designed that an overload can be present, either due to an excessive antenna signal or even a grid to cathode leakage in one of the video tubes, and it will not noticeably affect the sync. Yet it will cause an intercarrier buzz. It's a good idea in such cases to check all video tubes including the mixer and r.f. for possible defects.

After the serviceman has thoroughly checked the receiver, and it has become quite evident that there is no trouble present that is causing the buzz, he may be justifiably come to the conclusion that it is due to the design of the receiver in one way or another. There are many receivers on the market where the engineers have gone too far out on a limb in the interests of economy. This is especially true of various sets that are given certain aliases when they are distributed to a number of depart-

[Continued on page 63]



NOW-

Centralab's new miniature a lot more switch

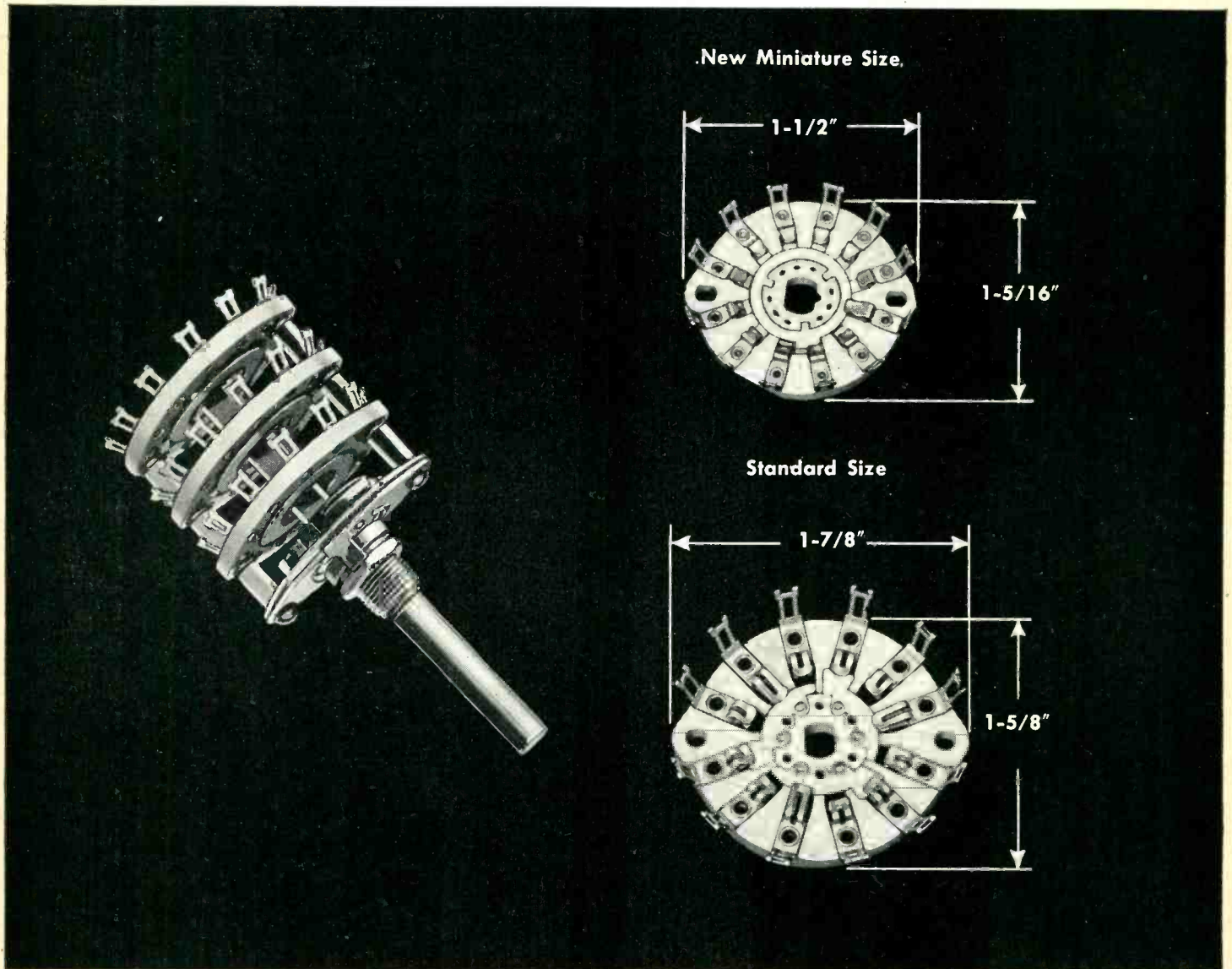

COMPARE the size of the new Centralab miniature switch with conventional standard size models

The new, miniature switch is a full $\frac{3}{8}$ " smaller in diameter than standard switches! More important, they allow more positions per pole, even with miniaturization. For example:

- 1 pole — 12 active positions per section
(former 1-pole switch had only 11 positions).
- 2 poles — 6 active positions per section
(former 2-pole switch had only 5 positions).

-in stock!

switch line offers you in a lot smaller package

THESE new series PA-2000 miniature switches give you more flexibility. And expert designing retains maximum protection.

Centralab miniature switches feature one-piece shaft construction, permitting more accurate indexing. They are available with one to six sections per shaft, one to 18 poles per switch. Sections are Steatite and can be had in shorting and non-shorting arrangements. Adjustable stop allows selection of positions or continuous rotation. *More, these switches are guaranteed to withstand a minimum of 50 hours of salt-spray tests.* No other units on the market as stock

items will do as well. Separate Steatite sections, index assemblies, hardware and accessories also available.

These features make it possible for you to use these Centralab switches for AM, FM or TV repair, intercom installations, mobile equipment, public address systems or any medium power application.

You save time and money when you insist on Centralab switches. That's because the complete Centralab line offers you the exact switch you want, when you need it, always available from one source. *And they're offered at attractive low prices!*

CHECK THESE NEW SMALLER DIMENSIONS!

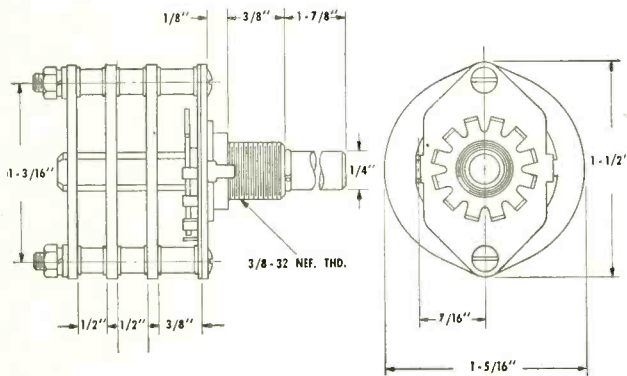

Total Number Poles	Total Positions	Number Sections	Poles Per Section	Cat. No. Shorting	Cat. No. Non-Shorting
1	2-12	1	1	PA-2000	PA-2001
2	2-6	1	2	PA-2002	PA-2003
2	2-12	2	1	PA-2004	PA-2005
3	2-5	1	3	PA-2006	PA-2007
3	2-12	3	1	PA-2008	PA-2009
4	2-6	2	2	PA-2010	PA-2011
4	2-12	4	1	PA-2012	PA-2013
5	2-3	1	5	PA-2014	PA-2015
5	2-12	5	1	PA-2016	PA-2017
6	2	1	6	PA-2018	PA-2019
6	2-5	2	3	PA-2020	PA-2021
6	2-6	3	2	PA-2022	PA-2023
6	2-12	6	1	PA-2024	PA-2025
8	2-6	4	2	PA-2026	PA-2027
9	2-5	3	3	PA-2028	PA-2029
10	2-3	2	5	PA-2030	PA-2031
10	2-6	5	2	PA-2032	PA-2033
12	2	2	6	PA-2034	PA-2035
12	2-6	6	2	PA-2036	PA-2037
15	2-3	3	5	PA-2038	PA-2039
18	2	3	6	PA-2040	PA-2041

SPECIAL

1	2-10	1	1	PA-2042	
MINIATURE SWITCHES WITH 60° INDEXING					
1	2-6	1	1		PA-2043
2	2-6	2	1		PA-2045

(1 1/2" spacing between sections)



The Centralab miniature switch line is only one of the more than 470 new items listed in Centralab's new Catalog 28. Get your copy of this 32-page index to the latest developments in the fast-changing electronics field. See your distributor or write direct.

Centralab

A Division of GLOBE-UNION INC.

944 E. Keefe Avenue • Milwaukee 1, Wisconsin

In Canada, 635 Queen Street East, Toronto, Ontario



CIRCUIT AND SERVICE DATA OF RCA MODELS 17T250DE, 17T26IDE; CHASSIS No. KCS74

17T250DE, 17T26IDE

CIRCUIT SCHEMATIC DIAGRAM

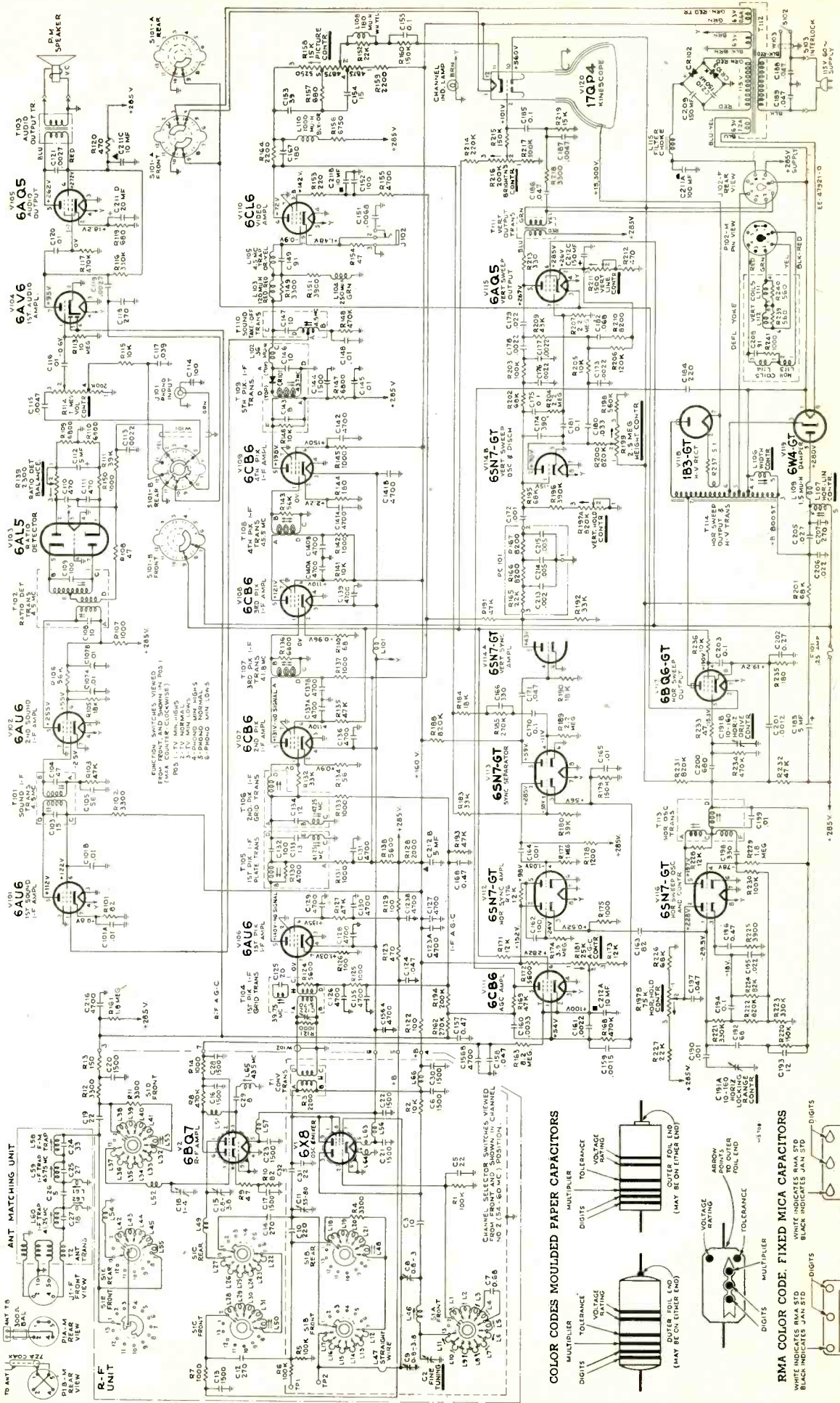

Figure 19—Circuit Schematic Diagram
In some receivers, a 6AG7 tube may be employed in place of the 6C16 video amplifier.
For waveform photographs and service suggestions, refer to the Fourth Edition of the 17T133 Service Data.

All resistance values less than 1 ohm are not shown.
Direction of arrows at controls indicates clockwise rotation.

All resistance values in ohms. K = 1000.
All capacitance values less than 1 in MF and above 1 in MUF unless otherwise noted.

Coil resistance values less than 1 ohm are not shown.
Direction of arrows at controls indicates clockwise rotation.

Color Codes Moulded Paper Capacitors:
MULTIPLIER: DIGITS, TOLERANCE, VOLTAGE, RATING, OUTER FOL END (MAY BE ON EITHER END)

RMA Color Code, Fixed Mica Capacitors:
WHITE INDICATES RMA STD
BLACK INDICATES JAN STD
DIGITS, MULTIPLIER, QUALITY, TOLERANCE, VOLTAGE, RATING, OUTER FOL END (MAY BE ON EITHER END)

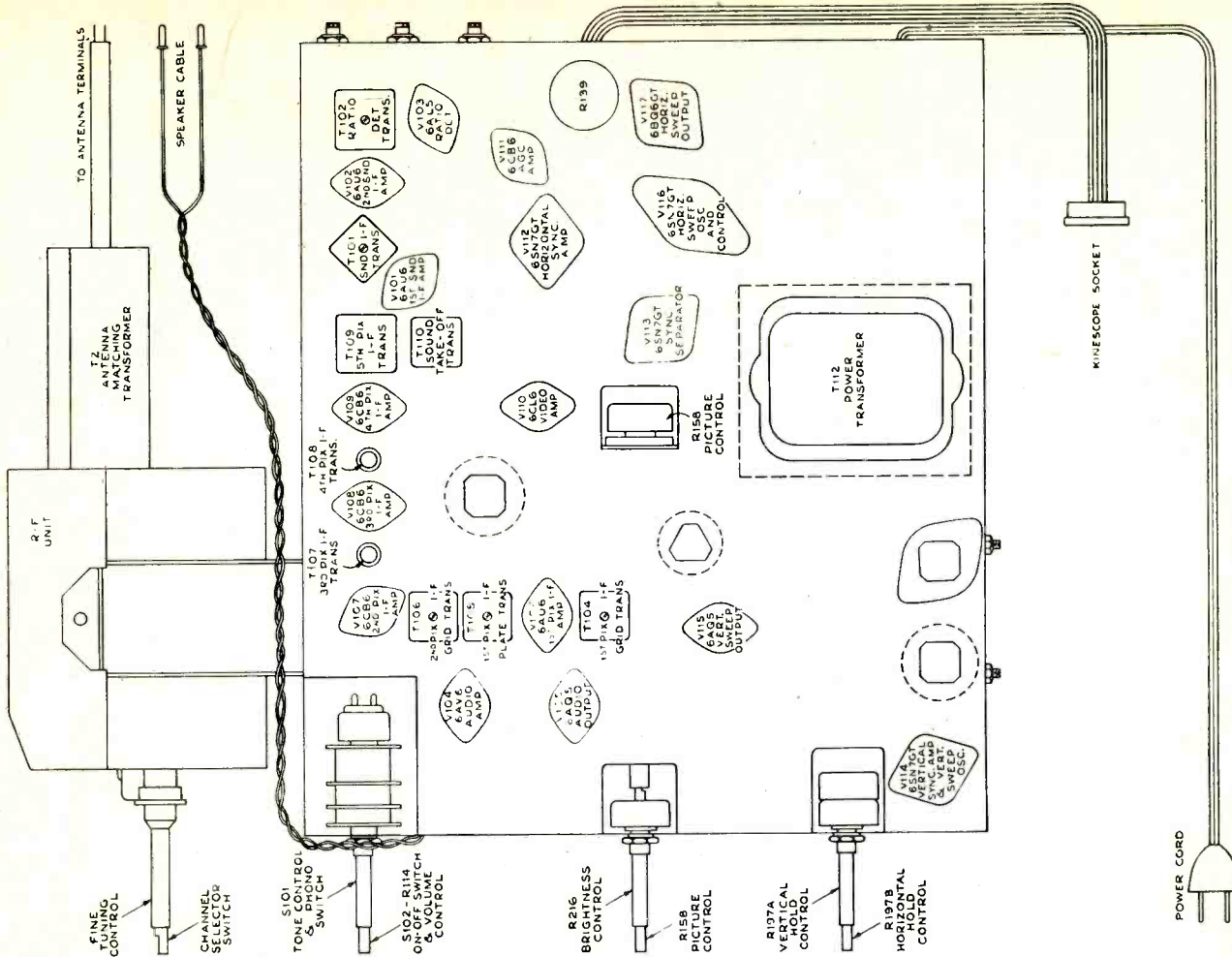
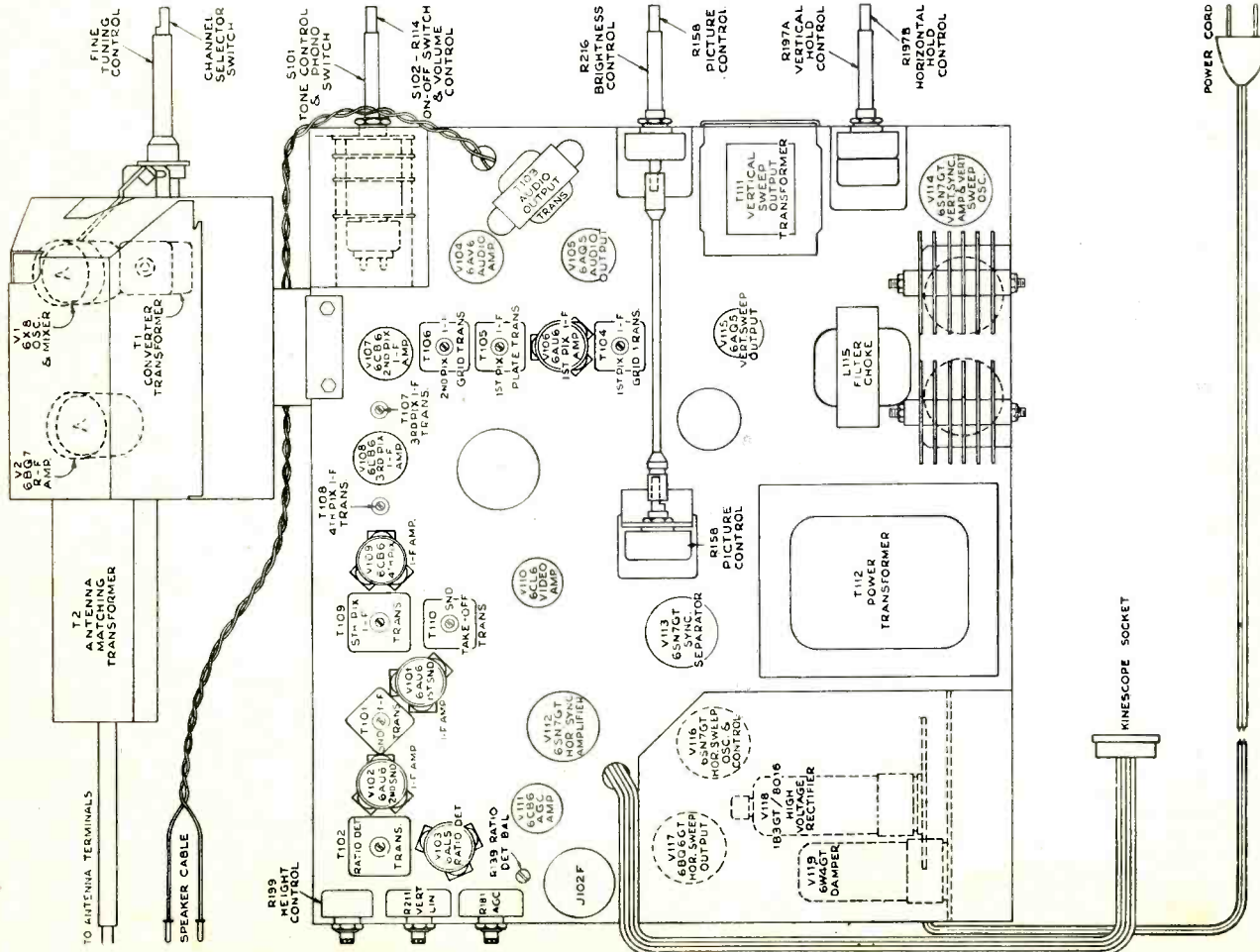

TROUBLE-SHOOTING PORTABLE RADIOS

by ALEXANDER KAUDERS

EVEN though most battery sets use the standard superheterodyne circuit, they nevertheless have peculiarities of their own, because of their different power supplies and the many miniature component parts used.

To give an example. In a standard radio you do not come across a defective plate or screen load resistor as often as in a battery set. The reason is very simple. In battery sets the manufacturer uses the resistor with no higher wattage rating than necessary in order to save space, while in a standard radio set he usually uses resistors with twice the required rating. The plate and screen load resistors of the first audio tube (e.g. 1S5, 1U5) increase in value very often.

In a standard receiver the B+ power supply is the cause of many troubles but in a 3-way portable it is one of the major source of complaints, because it furnishes filament voltage also. In an AC/DC set the emission of the rectifier and the efficiency of the filter condenser can drop quite a bit before the set stops playing. In an AC/DC-Battery set though this is not the case. An understanding what happens to a 3-way radio when the output of the power supply drops, should be of great assistance in repairing these sets.

When there is a slight drop of the voltage that is fed to the filaments, the output will be hoarse and distorted. As the filament voltage is further decreased the oscillator tube will stop oscillating, but you can still feed an i-f signal through. Naturally, when the filament voltage supply is diminished further the set will be completely inoperative.

When a 3-way portable coming into the shop is completely dead, it is advisable to test the tubes first for filament continuity. On the other hand if sound is coming out of the speaker it can be presumed in most cases that all the filaments are in working condition. The next step in trouble-

The author transmits some of his experiences and methods of servicing portable radio receivers. Discussed are some of the most usual types of service troubles encountered.

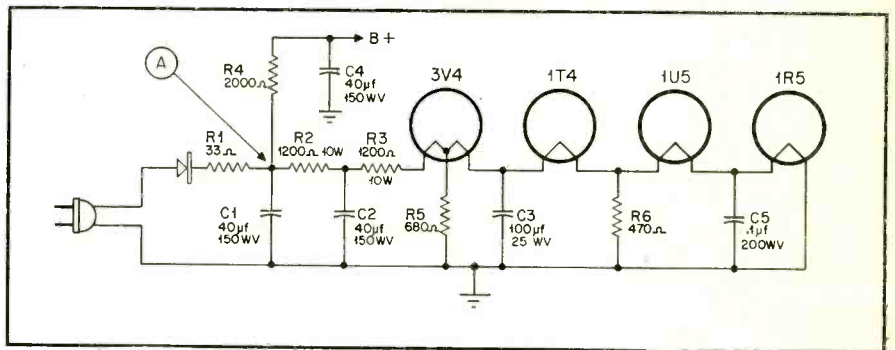

Fig. 1—Simplified voltage supply schematic.

R1—33 ohms	C1, C2, C4—40 uf, 150 wv.
R2, R3—1200 ohms, 10 watt	C3—100 uf, 25 wv.
R4—2000 ohms	C5—.1 uf
R5—680 ohms	
R6—470 ohms	

shooting the set is to take the chassis out of the cabinet and measure the voltage across the filament of one of the tubes. Care should be taken that the voltmeter leads do not touch any other potential at the same time, as this would burn out at least one tube. The correct d-c voltage in most cases would be 1.4 volts, except if the reading is taken across the output tube which is usually a 3S4, 3Q4 or 3V4. These latter tubes have two filament strings which require 2.8 volts if hooked up in series and 1.4 volts in parallel. If the correct voltage is obtained, then the standard troubleshooting methods can be used. If on the other hand the filament voltage supply is low, then the following trouble shooting and repair method is recommended.

Measure if the output of the rectifier at point A, Fig. 1 is according to manufacturer's specifications, which in most cases will be 115 to 120 volts d.c. If it is lower check for:

- (a) current limiting resistor $R1$ is open or has increased in value;
 - (b) filter condenser $C1$ shorted or leaky;
 - (c) rectifier (tube or selenium) weak output;
 - (d) shorted bypass condenser or other short in the B+ section.
- If the voltage is normal at the output of the rectifier, then the following component parts might be the cause for low filament voltage;
- (a) filter condenser $C2$ shorted or leaky;
 - (b) filament dropping resistor $R2$ or $R3$ increased in value or open;
 - (c) filament bypass condenser $C3$ shorted or leaky.

The latter mentioned condenser is of high capacity and low working voltage. The 10 W.V. condensers develop trouble much more frequently than the 25 W.V. condensers. If it

[Continued on page 67]

Mfgr: Admiral **Model No.** 21 Series

Card No. 21-1

Section Affected: Pix

Symptom: (A) Low sensitivity. Washed out pix.
(B) Pix contrast poor in weak signal area only.

Cause or Reason for Change: (A) C116 open
(B) Insufficient sensitivity in weak and fringe areas.

What To Do:

- (A) 1. Replace C116 with duplicate 800 μ f. miniature ceramic disc capacitor. This condenser is mounted on metal plate (shield) in TV Tuner (Fig. A).
- (B) 1. Check B+ voltage on r-f tuner; if less than 105v, replace R303 (1K) with 470 ohm resistor (Fig. B).
2. Connect 3.9k-1w resistor in series with R315 and a 3.9k-1w resistor in series with R322. This increases plate loads, hence gain of both Video Det. & AGC (V304) and Video Amp. (V305) Figs. C and D.

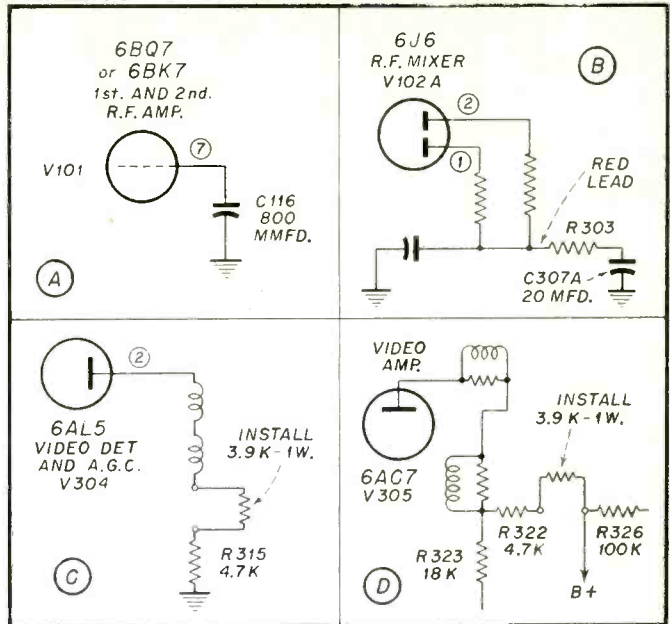

Mfgr: Admiral **Model No.** 21 Series

Card No. 21-2

Section Affected: Pix

Symptom: Vertical shadow bars at left of pix.

Cause or Reason for Change: Oscillation in output of horizontal sweep circuit.

What To Do:

1. Check circuit, tubes, and adjustments.
2. Connect filter between horizontal output transformer terminal No. 4 and No. 5 pin of 6W4GT. Filter consists of width coil used in 30A1 chassis (part No. 94A4-1 or -2), .005 μ f. 600v condenser, and 470-1w resistor connected in parallel. Vary inductance until bars disappear. Place filter inside high voltage shield. If necessary use two filters.
3. Dress pix tube cathode lead away from horizontal output tube.

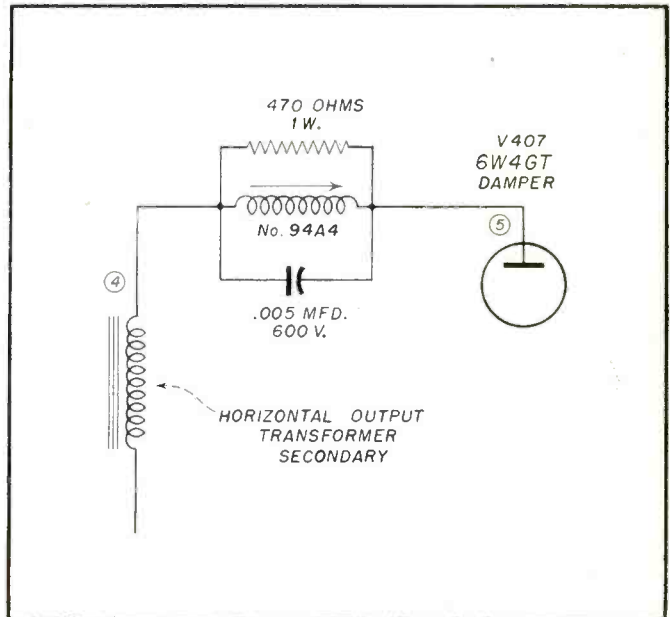

Mfgr: Admiral **Model No.** 21 Series

Card No. 21-3

Section Affected: Pix

Symptom: Horizontal wiggle moving up and down picture tube.

Cause or Reason for Change: In some areas where local power supply is not in phase with the transmitter this difficulty may be encountered.

What To Do:

1. Replace C416-.047 μ f with .1 μ f or .22 μ f condenser, preferably .1 μ f for better a-f-c action.

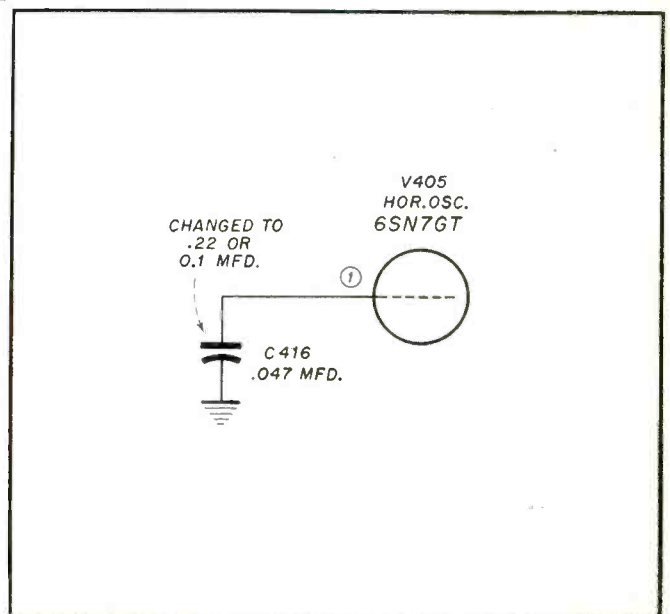

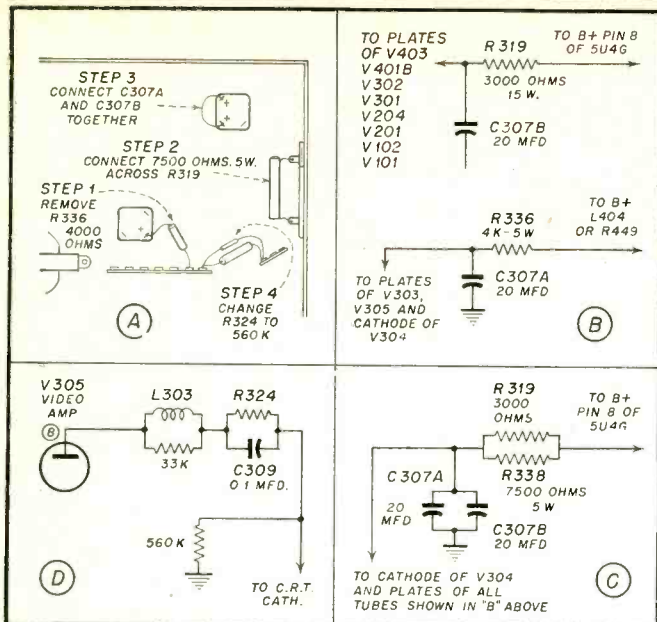

Mfgr: Admiral Model No. 21 Series using gated a-g-c

Card No. 21-4

Section Affected: Pix

Symptom: Picture cuts off on strong signal

Cause or Reason for Change: Strong signal drives video amplifier to cut-off. High B+ voltage which is applied to cathode of CRT drives pix tube grid to cut-off. Also gated a-g-c tube, which obtains voltage from video amplifier, becomes inoperative and system remains blocked.

What To Do:

1. Remove R336 (4k). Figs. A, B, and C.
2. Connect 7.5k-5w resistor across R319. Figs. A, B, and C.
3. Connect together the positive terminals of filter condensers C307A and C307B. Figs. A, B, and C.
4. Change R324 from 180k to 560k. Fig. D.

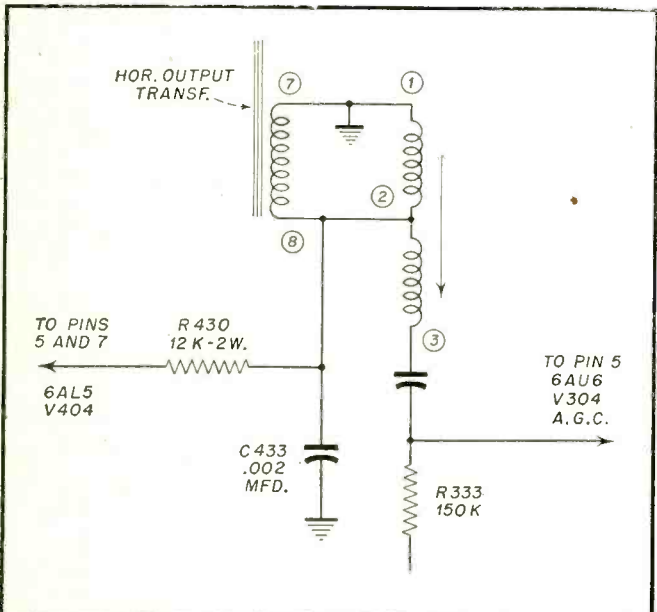

Mfgr: Admiral Model No. 21 Series with gated a-g-c

Card No. 21-5

Section Affected: Pix

Symptom: Picture cuts off on strong signal.

Cause or Reason for Change: Insufficient pulse amplitude to plate of a-g-c tube V304 (6AV6).

What To Do:

1. Replace 2-terminal width coil (No. 94A29-1) with 3-terminal coil and connect as shown.

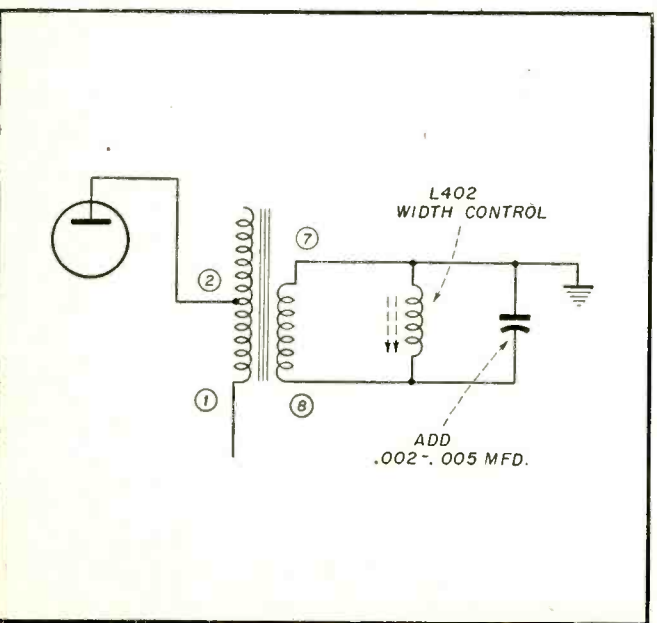

Mfgr: Admiral Chassis No. 21 Series

Card No. 21-6

Section Affected: Pix

Symptom: Vertical foldover—appears as bright band of light across bottom of picture.

Cause or Reason for Change:

- (A) Low line voltage (less than 1052).
- (B) Weak vertical output (V402) or rectifier (V501).
- (C) Insufficient vertical sweep.
- (D) Air gap of deflection yoke too wide.

What To Do:

- (A) Check line voltage. If less than 105 use step-up device.
- (B) Check 654 (V402) and 5U4G (V501).
- (C) Connect .002 to .005 μ f condenser across width control. Do not make this change in sets using gated a-g-c.
- (D) If air gap is greater than 1/32" tighten collar. If this does not reduce gap, remove collar and iron cores and smooth insulation between cores. It may be necessary to clip fibre sleeve with cutters in order to remove collar and iron cores.

Mfr: Philco Model No. 51-T1601T
 Card No. A-51-1 Code No. 121 & 122

Section Affected: Sync

Symptom: Picture Bounce.

Cause or Reason for Change: To reduce picture bounce.
 (This change was started in chassis beginning with run No. 6)

What To Do:

1. Remove R649-560K. Fig. A.
2. Connect 18K resistor (new schematic R649). Fig. B.
3. Change R635 from 47K to 82K-1W. Fig. B.
4. Change R634 from 33K to 47K. Fig. C.
5. Remove R108. Fig. D.
6. Install 100K resistor, between R100 and pin 5 of J101. Fig. E.
7. Install 150K resistor (new schematic R108) between pin 5 of J101 and ground. Fig. F.

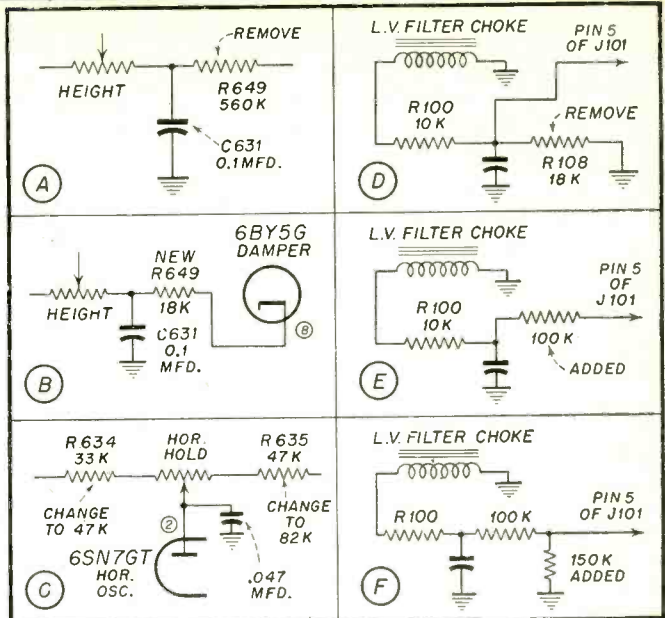

Mfgr: Philco Model No. 51-T1601T

Card No. A-51-2 Code No. 121 & 122

Section Affected: Raster

Symptom: Shadow on picture tube

Cause or Reason for Change: To reduce screen shadow

What To Do:

1. Remove R107, 3.3 ohm resistor in series with low voltage. Filter choke. Fig. A.
2. Junction of C101 and L101 connected to ground (Fig. A).
3. Remove connection of R643 from B+315 point to junction of C627 and pin 3 of J601. Fig. B.

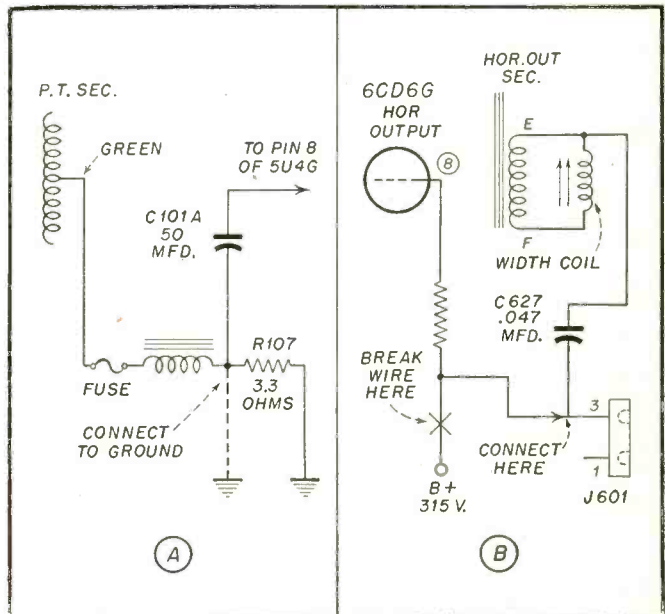

Mfgr: Philco Model No. 51-T1601T

Card No. A-51-3 Code No. 121 & 122

Section Affected: Pix

Symptom: Vertical foldover, poor interlace and linearity.

Cause or Reason for Change: R620 too low.

(This change was started in beginning with runs Nos. 2 and 5)

What To Do:

1. Change R620 from 3.3K to 6.8K

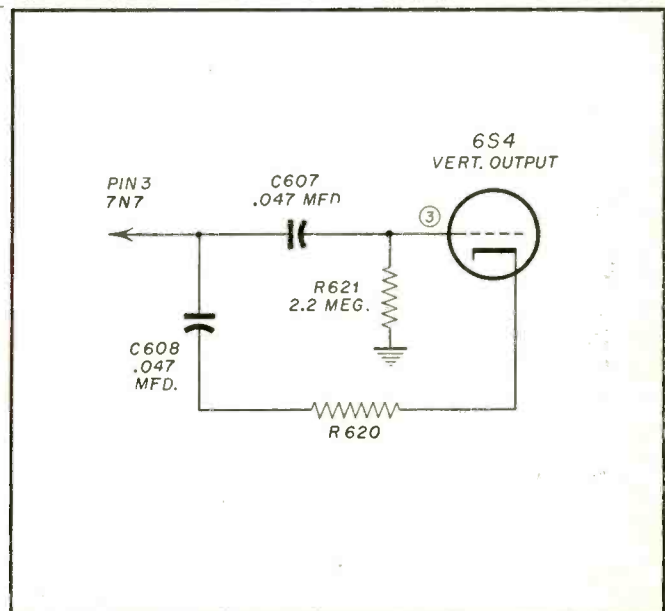

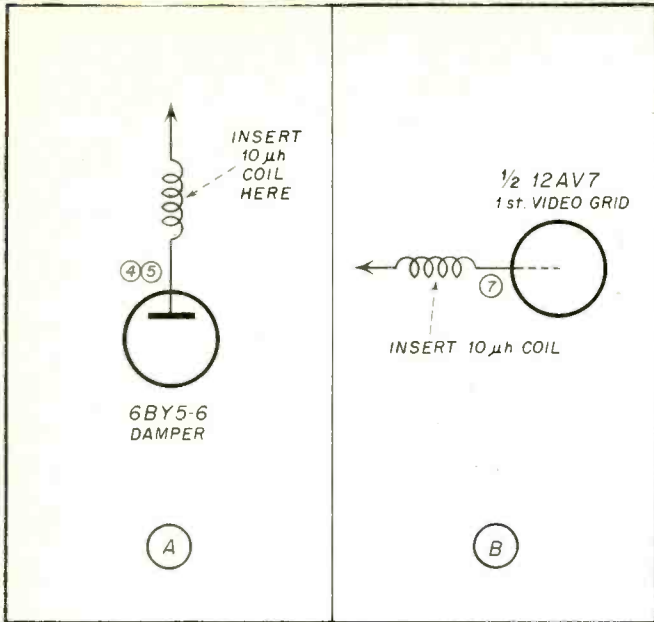

Mfgr: Philco Model No. 51-T1601T

Card No. A51-4 Code No. 121 and 122

Section Affected: Pix

Symptom: RF Interference on channel 5 when built-in aerial is used.

Cause or Reason for Change: To reduce r-f radiation.

What To Do:

1. Insert 10 uh choke (part No. 32-4112-24) in series with damper tube plate. Fig. A.
2. Insert 10 uh choke in series with first video grid.

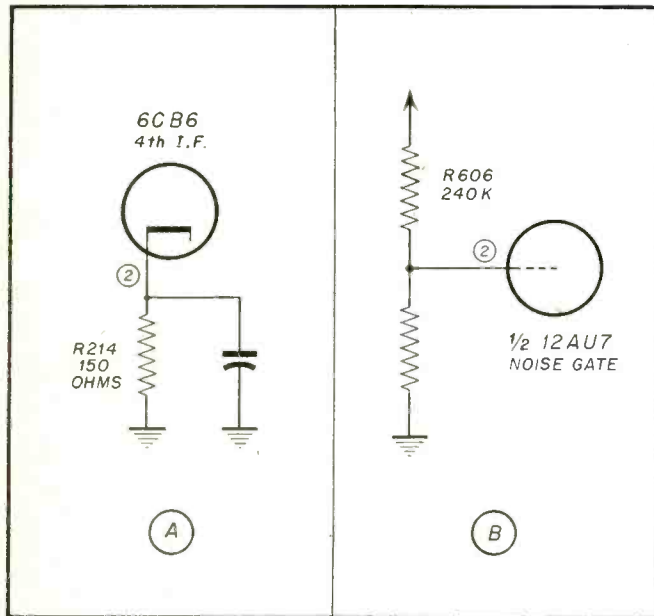

Mfgr: Philco Model No. 51-T1601T

Card No. A-51-5 Code No. 121 and 122

Section Affected: Sync

Symptom: Unstable sync in strong signal areas.

Cause or Reason for Change: To improve sync performance in strong signal areas.

What To Do:

1. Change R214 from 150 ohms to 220 ohms. Fig. A.
2. Change R606 from 240K to 180K. Fig. B.

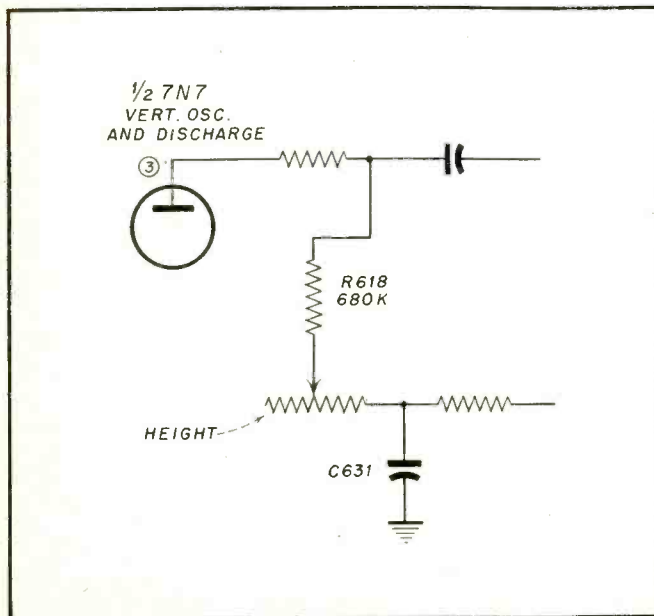

Mfgr: Philco Model No. 51-T1601T

Card No. A-51-6 Code No. 121 and 122

Section Affected: Sync

Symptom: Vert. sync affected by line voltage fluctuations.

Cause or Reason for Change: To reduce effect of line voltage fluctuations.

What To Do:

1. Change C631 from .1 μf. to 10 μf.-475V.

Mfgr: RCA Chassis No. KCS-34

Card No. A-50-1 Code No. K

Section Affected: Raster

Symptom: Ringing or wrinkles in raster.

Cause or Reason for Change: Balance of yoke capacitance to ground.

What To Do:

1. See if C169 (on yoke) is connected from term. No. 1 to term. No. 2 or wire-wound yoke of term. No. 2 to term No. 3 on ferrite yoke.
2. If condenser is properly connected move red lead from term. No. 4 of Hor. Out. Trans. to term. No. 5.

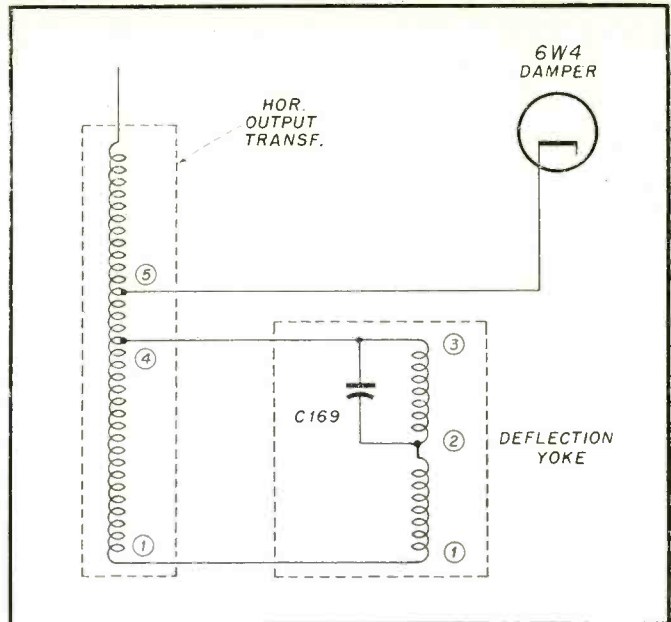

Mfgr: RCA Chassis No. KCS-34

Card No. A-50-2 Code No. K

Section Affected: Sync

Symptom: Poor hor. sync (wavy pix).

Cause or Reason for Change: Wrong or changed values of C135, R144, R217.

What To Do:

Replace with correct value:

C135—.01 μ f

R144—4.7K.

R217—2.7K

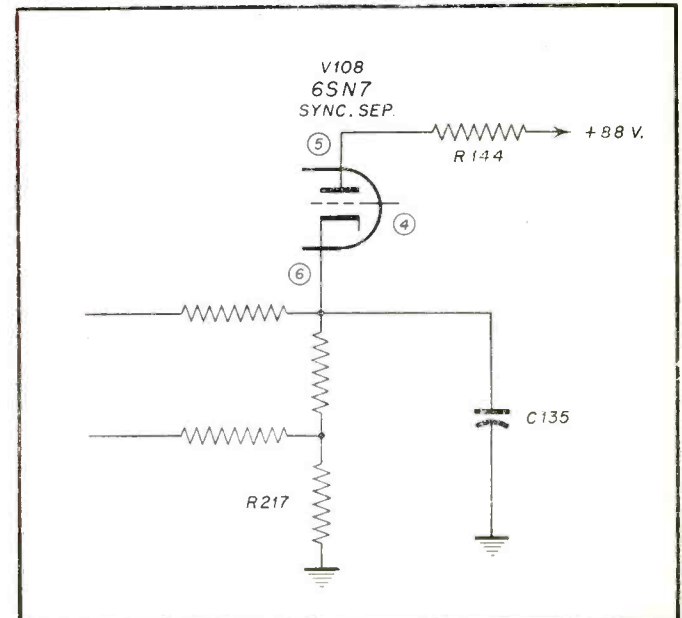

Mfgr: RCA Chassis No. KCS-34

Card No. A-50-3 Code No. K

Section Affected: Sync

Symptom: Poor vertical sync.

Cause or Reason for Change: Corrosion of ground connection.

What To Do:

Check C136 for good ground connection.

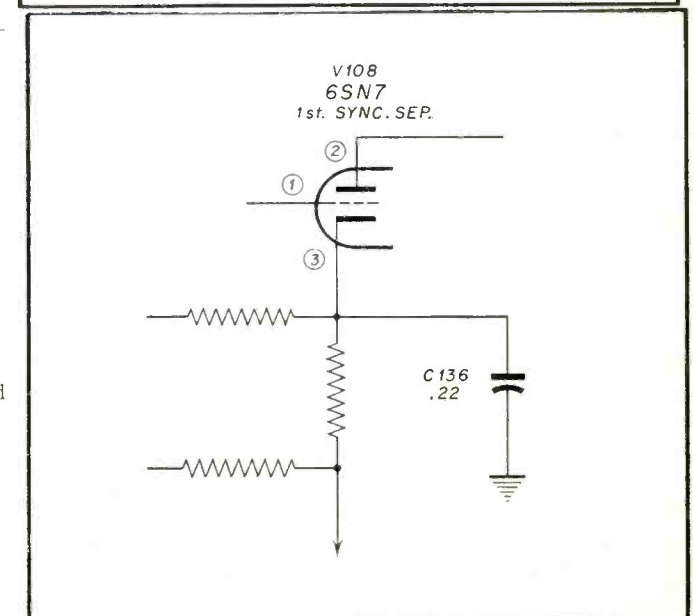

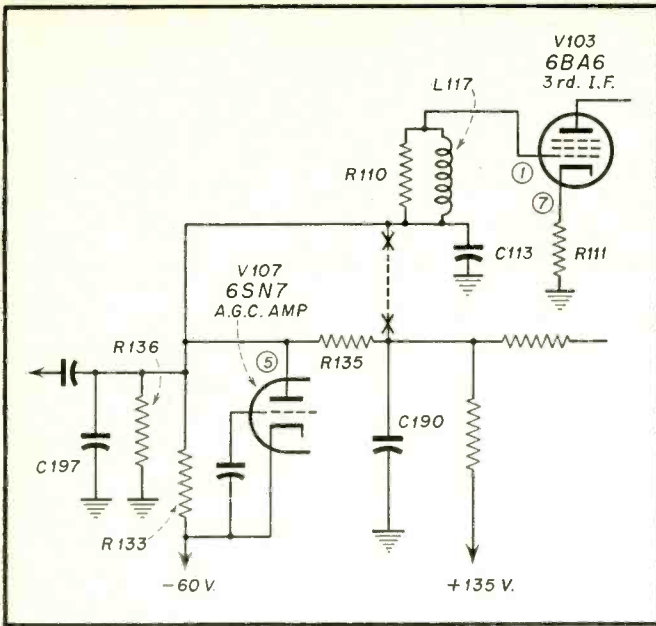

Mfgr: RCA Chassis No. KCS-34

Card No. A-50-4

Section Affected: Sound

Symptom: 60 cycle hum in strong signal areas.

Cause or Reason for Change: Insufficient 3rd i-f bias.

What To Do:

Re-connect junction of R110, L117 & C113 from junction of R135 and C190 to junction of R133, R136, and C197.

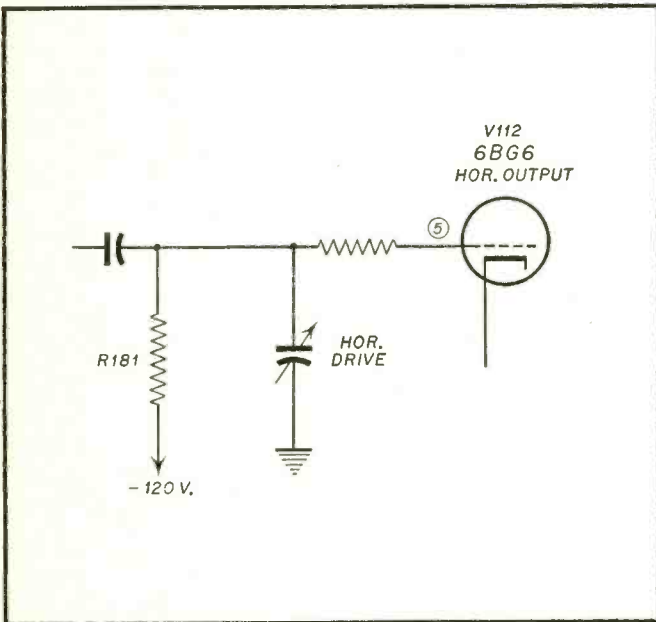

Mfgr: RCA Chassis No. KCS-34

Card No. A-50-5

Section Affected: Pix

Symptom: Poor width and/or poor horizontal linearity.

Cause or Reason for Change: Component value changes.

What To Do:

For poor width make R181-470K. For poor linearity make R181-1 meg. If both are poor make R181-560K or 680K.

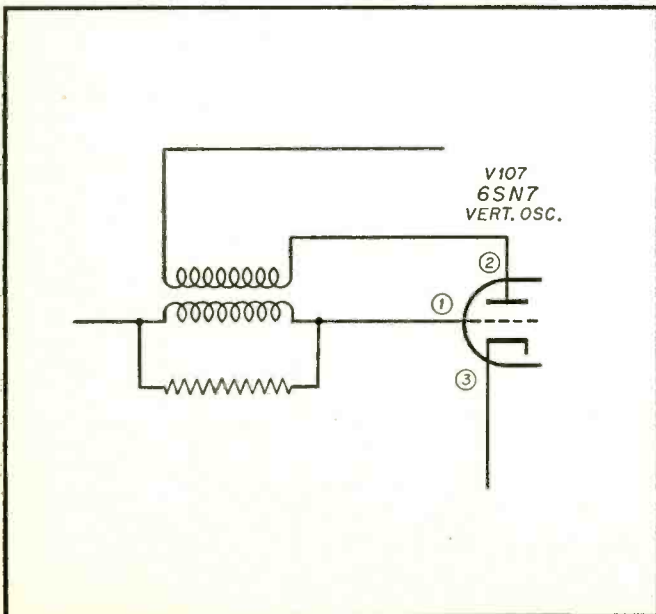

Mfgr: RCA Chassis No. KCS-34

Card No. A-50-6

Section Affected: Pix

Symptom: White bar or lines at the top of the picture

Cause or Reason for Change: Vert. osc. xfmr "Q" too high.

What To Do:

Connect 1 meg. resistor across xfmr primary (yellow and green leads).

Mfgr: Stromberg-Carlson Model Nos. 24C, 24RP

Card No. 24-1 Chassis No. 24

Section Affected: Pix

Symptom: Insufficient contrast control range.

Cause or Reason for Change: Too much tube bias.

What To Do:

1. Short out *R154* (220v) cathode resistor in series with *R155* (contrast control).
2. Remove plate and screen supply connection from (+)300v to (+)410v.

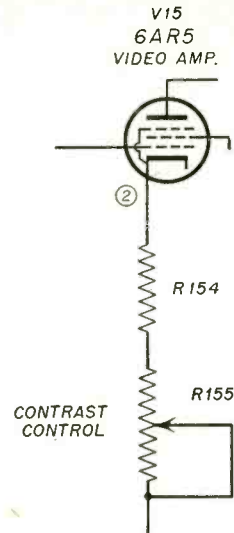

Mfgr: Stromberg-Carlson Model Nos. 24C, 24RP

Card No. 24-2 Chassis No. 24

Section Affected: Pix

Symptom: Poor picture, snowy

Cause or Reason for Change: Coupling Transformer shorted.

What To Do:

- Check bifilars for primary to secondary winding short.

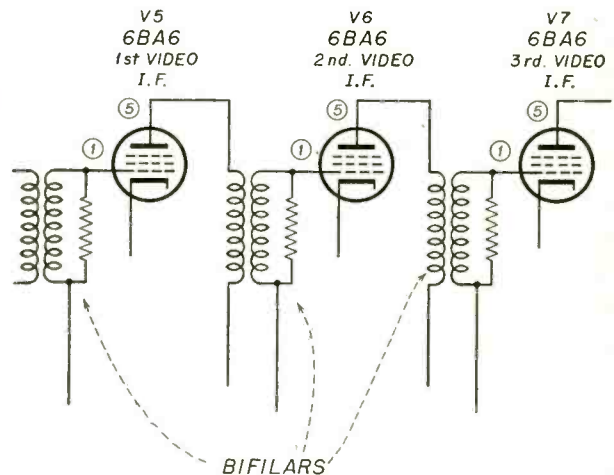

Mfgr: Stromberg-Carlson Model Nos. 24C, 24RP

Card No. 24-3 Chassis No. 24

Section Affected: Sync

Symptom: Insufficient vert. range.

Cause or Reason for Change: Variations in tube characteristics.

What To Do:

- Change *R204*-1.5 meg. resistor in series with the vertical hold control to 1.8 meg.

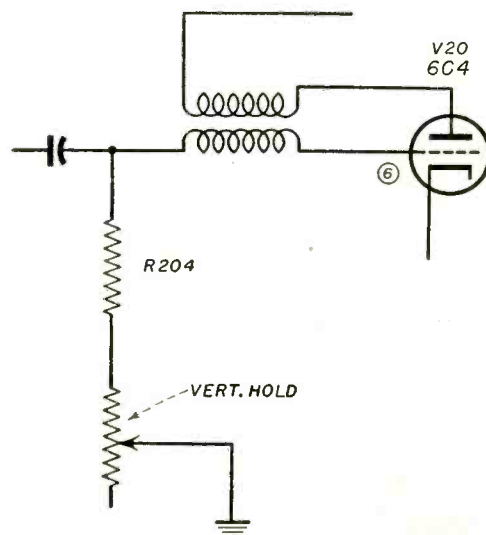

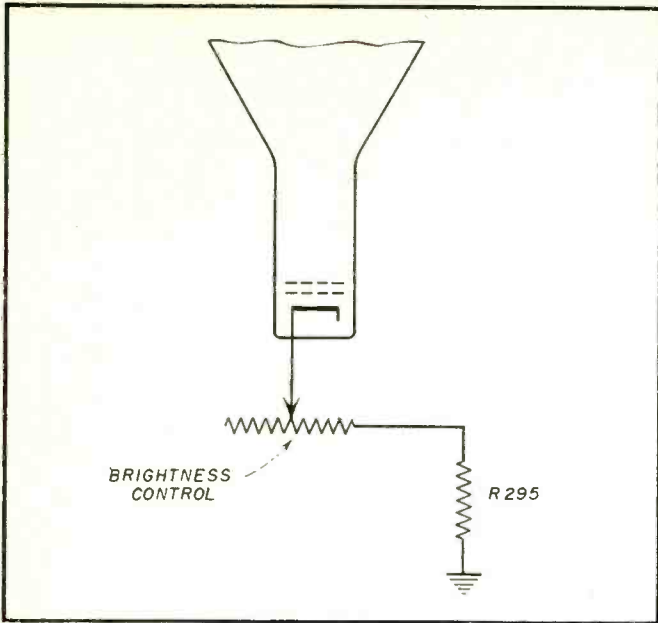

Mfgr: Stromberg-Carlson Model No. 24

Card No. 24-4

Section Affected: Pix

Symptom: Insufficient brightness control range.

Cause or Reason for Change: Variations in C.R.T. characteristics.

What To Do:

Change R295 (150K) resistor in series with brightness control to 100k.

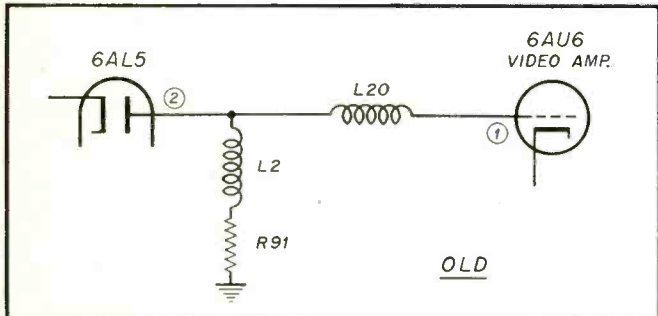

Mfgr: Stromberg-Carlson Model No. 24

Card No. 24-5

Section Affected: Pix

Symptom: Excessive trailing whites in pix.

Cause or Reason for Change: Improper video amplifier response.

What To Do:

1. Remove L20.
2. Change L2 to Stromberg part #114704.
3. Reconnect L2 from pin 2 of 6AL5 to pin 1 of 6Au6 and R91 to pin 1 of 6Au6.

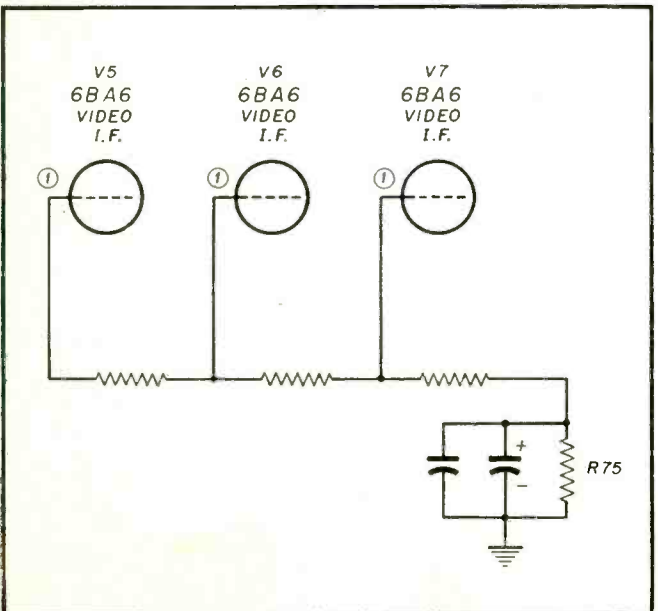
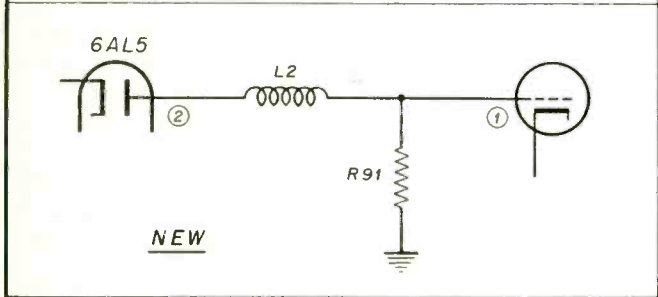

Mfgr: Stromberg-Carlson Model Nos. 24C, 24RP

Card No. 24-6 Chassis No. 24

Section Affected: Picture

Symptom: Picture pulls to one side.

Cause or Reason for Change: Improper AGC voltage.

What To Do:

Change R75-100k a-g-c return resistor to 220k.

CIRCUIT COURT



Magnavox (105 series)

Sync Amplifier Biasing

The circuit (Fig. 1) being analyzed is a method of biasing the sync amplifier so that the charging effect of noise pulses can be eliminated. In order to accomplish this, the sync pulse is taken off the load resistor of the video detector. The composite signal is fed to the cathode of $\frac{1}{2}$ of a 12AX7. The plate is connected across the input of the sync separator, also the sync take off resistor in the video amplifier plate. The grid is connected to a voltage divider in the grid circuit of the horizontal output tube.

The following is a description of the circuit action. The cathode is fed the signal, sync phase negative. The plate is fed the signal, sync phase positive. This would ordinarily cause the signal to be bucked out if the grid were connected to ground. The grid, however, is connected to a point where a saw-tooth wave of voltage is generated. This saw-tooth causes the conduction of the sync tube to vary. The grid gets less and less negative as the saw-tooth is generated. As a result, the maximum conduction occurs at a point just prior to the blanking pedestal and minimum conduction occurs during the period when the saw-tooth goes sharply negative. Due to this timing arrangement, the major amplification occurs at the sync pulse. The object which this circuit serves, is to reduce the noise pulses which might occur near the sync pulse. These noise pulses are the ones which most generally cause the sweep oscillators to be falsely triggered.

Dumont RA 160—Gated a-g-c

The Dumont RA 160 has many novel circuits. Among them is an amplified and gated a-g-c (Fig. 2). The overall action of the circuit can be briefly described as follows. The composite video signal is taken off at the sync take-off point. It is then fed to a cathode follower (V209A). The signal from V209A cathode is converted to a d-c voltage whose amplitude is proportional to the peak-to-peak video signal. This d-c voltage is applied to the grid of the a-g-c gate tube. Due to the fact that the gate tube only con-

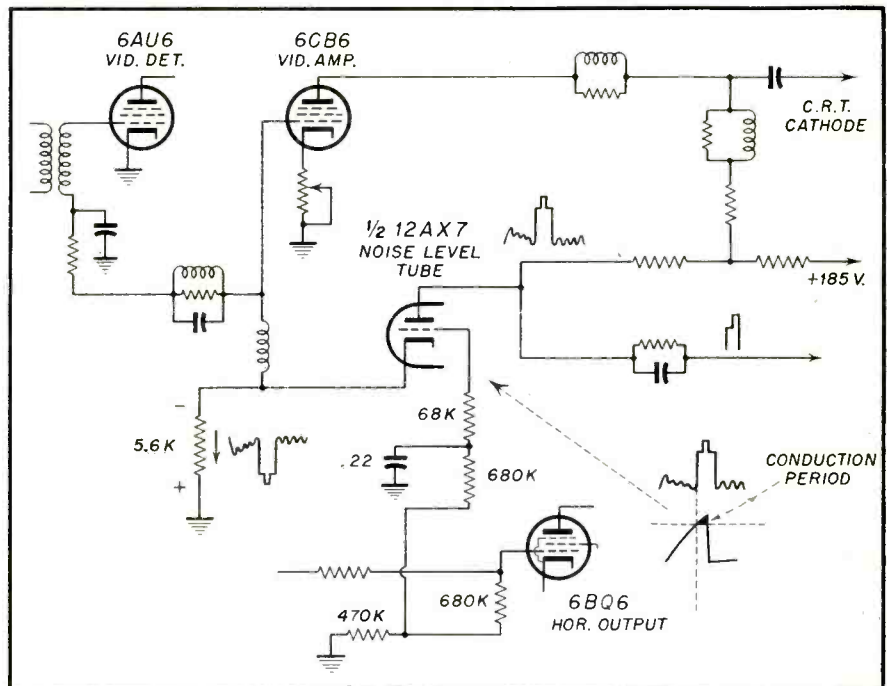

Fig. 1—Partial schematic of Magnavox 105 series noise limiting circuit.

ducts during a portion of each horizontal oscillator pulse, the output is a pulse whose amplitude is determined by the grid bias. The output of the gate tube plate is fed to an a-g-c rectifier. The rectifier output is a negative d-c which is applied to the r-f

amplifier and to the first and second i-f's.

Let us now go into the detailed operation of the circuit. The composite video signal is d-c coupled to the grid of V209A through R256. Part of the

[Continued on page 66]

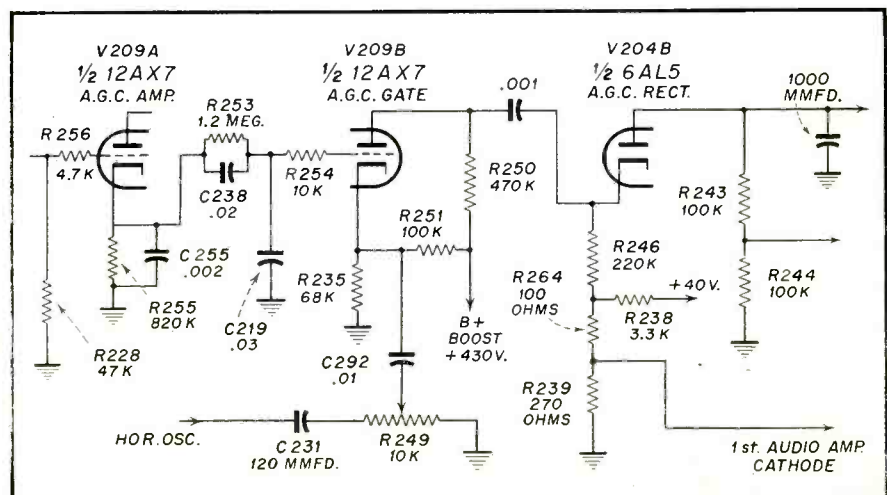

Fig. 2—Partial schematic of Dumont RA 160 a-g-c system.

UHF TUNERS

A brief description of the Crosley, Standard Tuner and Stromberg-Carlson UHF tuners designed to make available reception of the new UHF stations. Description of other tuners will follow in subsequent issues.



The Crosley Ultratuner enables standard Crosley VHF television receivers to add reception of UHF stations with no more installation necessary than attaching a wire to two screws. Any owner can install the Ultratuner in a matter of minutes, Crosley officials point out. The unit has a built-in antenna for UHF telecasts. An outside antenna for reception of distant stations can be simply attached to two screws. A simple flick of the control knob on the front of the Ultratuner automatically places either the UHF or VHF antenna into operation. With the Ultratuner, any television set ever built by Crosley can be converted to UHF reception.

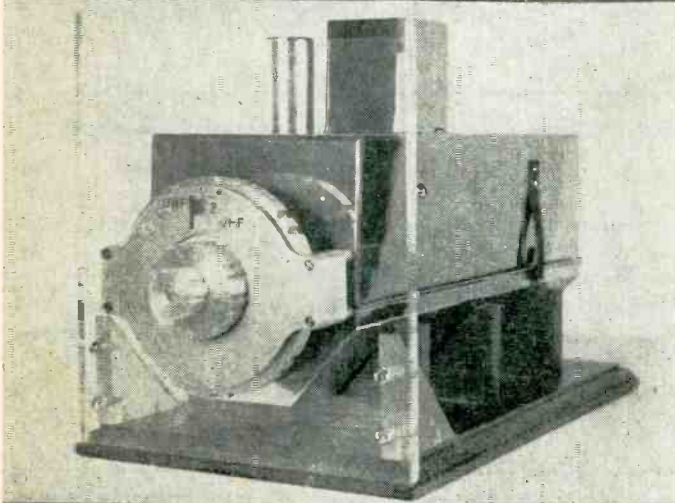

The Standard Coil UHF tuner is similar in design to the VHF tuner and covers both the VHF and UHF bands in one compact unit. Employing the "spot" or "detent" principle the new unit covers all 82 prospective TV channels. Channel selection is made simply by turning the dial until the desired channel number appears in the dial window. A fine tuner is utilized as in the VHF model. The new tuner is supplied with channels pre-tuned at the factory making it unnecessary for the serviceman to make any adjustments of this nature. The selecting dial of the tuner consists of three superimposed knobs. To get the station desired the viewer turns one knob for the tens digit, another for the units digit, and a third knob for fine tuning; the number of the desired station appears in the window.

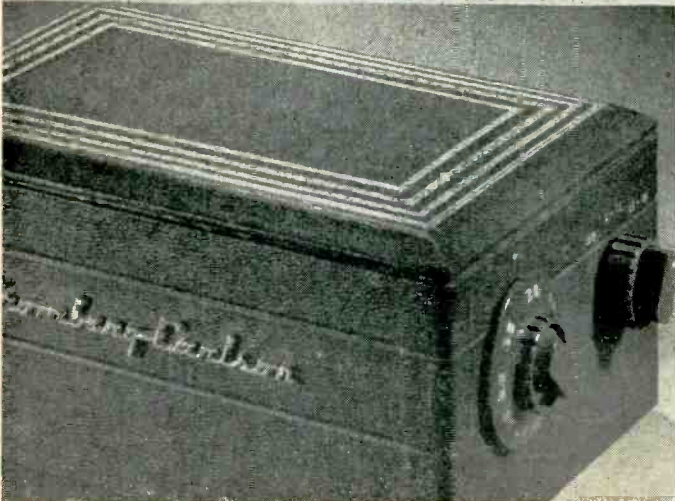

This Stromberg-Carlson converter is contained in an attractive green leatherette gold embossed case, eight inches wide, four inches high, and six inches deep, weighing approximately five pounds. It is connected between the antenna lead-in and the television receiver. Power for the television receiver is taken off a special socket in the rear of the converter chassis which in turn is plugged into the a-c line. The unit was designed for easy installation by the user. The turn of a single switch instantly selects either UHF or VHF reception, also automatically connecting the correspondingly correct UHF or VHF antenna.

Here's Why — the CDR Rotor

**...Is the NO. 1
all-purpose Rotor!**

It has EVERYTHING!

And it does have EVERYTHING... as you can plainly see! Just check over this impressive list of features — and you'll see why... ALREADY THE NEW CDR ROTOR is acclaimed as the outstanding unit in the field! No other rotor boasts all these features... that's why it's the best ALL-PURPOSE rotor money can buy.

MODEL TR-11 Complete rotor with handsome modern design plastic cabinet and meter control dial... finger-tip lever—using 4 WIRE CABLE.. \$44.95

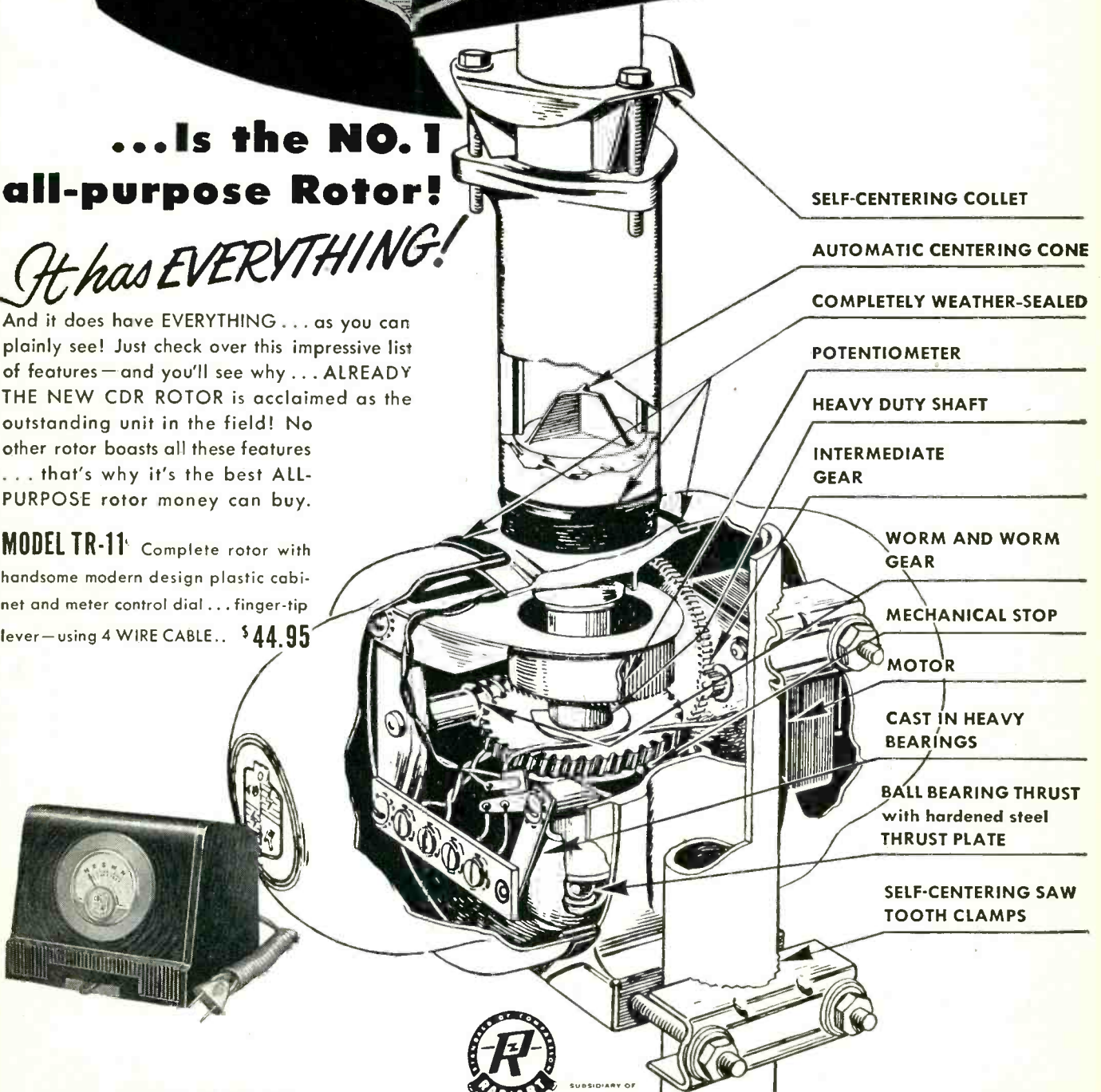

THE **RADIART** CORPORATION

CLEVELAND 13, OHIO

RADIO-TELEVISION SERVICE DEALER • OCTOBER, 1952



SUBSIDIARY OF

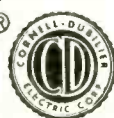

CORNELL-DUBILIER

SOUTH PLAINFIELD, NEW JERSEY

NEW PRODUCTS

WIRE WOUND CONTROLS

The availability of wire-wound controls with field-attached shafts is announced by Clarostat Mfg. Co. Inc. Dover, New Hampshire, manufacturers of resistance devices. The new controls may be used with any one of the 11 different Clarostat Pick-A-Shafts.

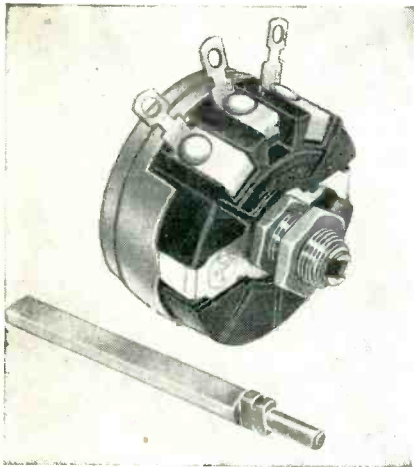

The Pick-A-Shaft wire-wound controls come in three series. Series A43 is the Clarostat Series 43 wire-wound control rated at 2 watts. Series A58 is the Clarostat Series 58 wire-wound control rated at 3 watts. Series A10 is the Clarostat Series 10 wire-wound control rated at 4 watts. A wide range of resistance values is available in each series.

A choice of any one of the 11 Clarostat Pick-A-Shafts is made with the purchase of the control. The procedure for attaching the shaft is fast, simple and sure. The shaft is inserted in the shaft fitting of the control, and a slight tap seats the shaft under a locking C-washer. The rigidity of the assembly compares to factory-attached units.

Conical-V-Beam Antennas

Telrex, Inc., Asbury Park, N. J., manufacturer of "Conical-V-Beams" announced through Ralph Ercolino, Sales Manager, the introduction of its new "Meteor" series of E-Z-Rig Conical-V-Beams, which is now in production.

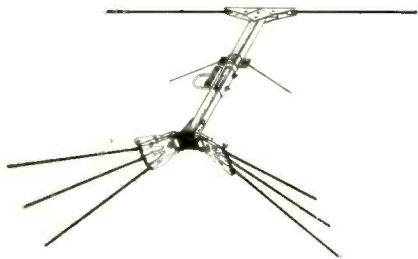

The central figure of the "Meteor" is the unique, all-aluminum "outrigger" pivot plate and mating pressure plate which reduce set-up time almost to the vanishing point. Tightening of a wing nut securely and evenly grips the solid dural element rods in the

jaws of a 3 inch. all aluminum element clamp, insuring permanent loss-free contact. Insulation is of tough laminated Westinghouse Micarta.

The "Meteor" E-Z-Rig will be available in the basic single unit, designated as Model ME-2X-TV as well as two bay array, Model ME-4X-TV, and a four bay unit, Model ME-8X-TV. Descriptive literature will be available through Telrex distributors or from Telrex, Inc., Asbury Park, N. J.

MINIATURE MICROPHONE

Production of a new, low-priced miniature microphone employing crystal element is announced by The Astatic Corporation, Conneaut, Ohio.

The Astatic Model 54M3 is a high output unit (-51 db below 1 volt per microbar) in simple yet radical new styling. The top grille is a circular metal stamping, one and three-



quarter inches in diameter and one-half inch deep, with gold plate finish. Housing and handle are combined in a single die cast unit, finished in dark chocolate brown baked enamel.

A die cast desk base with rubber feet is standard equipment. The microphone locks in the base with a half-turn of a pin-equipped, gold finished base adaptor, which also is threaded to fit standard floor stands.

AUTOMATIC BOOSTER

Blonder-Tongue Laboratories, Inc. of Westfield, N. J. announces a new fully automatic B-T Booster, Model HA-3. Listing at only \$39.50, this 3-stage TV amplifier will deliver gain in excess of 18 db over all channels.

Featuring a new low-noise circuit, the B-T Booster will give excellent performance and a substantially improved picture on even the



newest and most sensitive TV tuners. Signal gain exceeds that of conventional boosters.

Additional features include automatic on-off operation with TV set, a switch for attenuating strong signals. UHF adaptability and an attractive metal cabinet.

Model HA-3 offers low price, famous B-T automatic operation and unexcelled performance. Dealers will find a ready and profitable market, not only for new installations but also for replacement of obsolete boosters. This new unit is easily installed, concealed or displayed, in less than a minute.

LINE-MATCHING SPEAKER TRANSFORMER

A new line-matching speaker transformer for use in multiple sound installations in schools, hospitals, hotels, factories, and other public buildings is announced by the RCA Sound Products Section of RCA Victor Division.

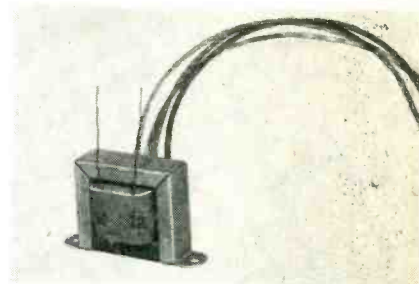

The new transformer, designated MI-12369, has excellent frequency response of 1 db from 100 to 12,000 cycles, a low distortion of 2 per cent maximum from 100 to 8,000 cycles at 5 watts, and a wide range of impedance available with a 3.2 to 4-ohm load, the company stated. The power handling capacity is 8 watts.

The new transformer has separate primary and secondary windings on a 5/8-inch by 5/8-inch core. The primary winding is tapped with 10-inch color coded leads to match several different line impedances used in multiple speaker installations. The transformer weighs 10 ounces and is 1-5/8 inches high, 2-13/16 inches long, and 1-9/16 inches wide. Mounting centers are 2-3/8 inches apart.

TV ANTENNAS

A new series of Zig-Zag TV Antennas has been announced by the Trio Manufacturing

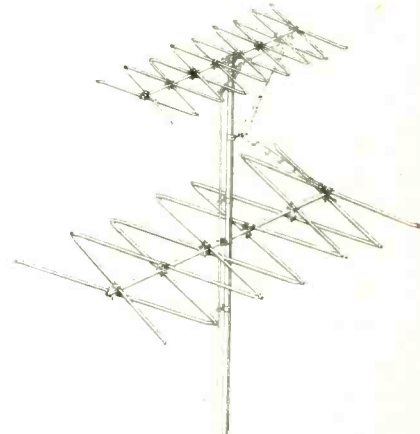

Company, Griggsville, Illinois. Construction of these new antennas is such that on any one channel there are resonant elements and the remaining elements act as very efficient directors and reflectors. All elements are end connected in one continuous series. This results in extremely high gain, excellent front-to-back ratios, sharp directivity and very low

For accurate
flexible and
quick tube
testing at
low cost...
model 3413-A

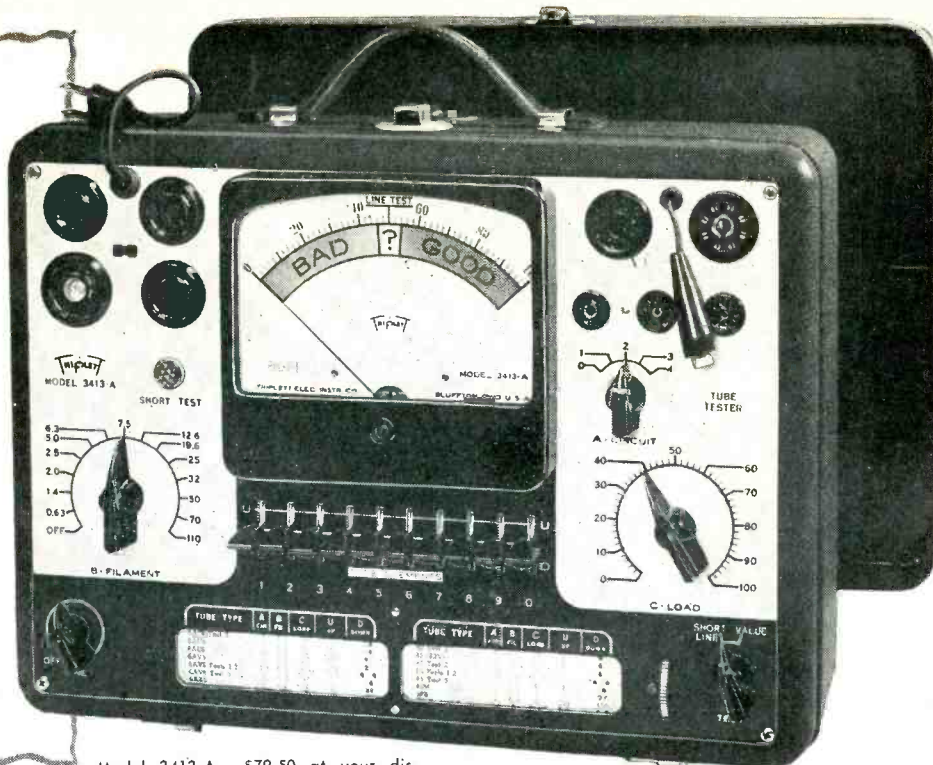

Model 3413-A...\$79.50 at your distributor. (Price subject to change.) BV Adapter, \$7.90 Add'l.

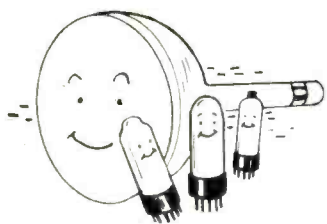

1. YOU CAN TEST MORE TYPES of tubes, also appliances for shorts and open circuits.

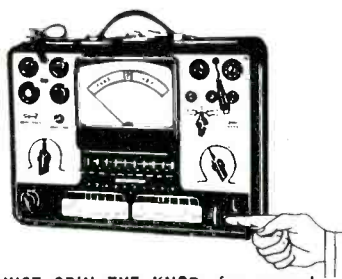

2. JUST SPIN THE KNOB—for correct, last-minute data, on the speed roll chart. Lists 700 tubes.

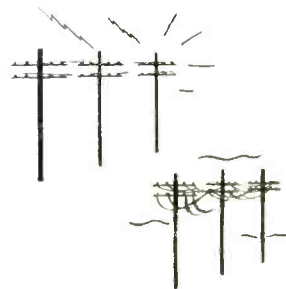

3. YOU CAN COMPENSATE for line voltage—just throw snap-action switch.

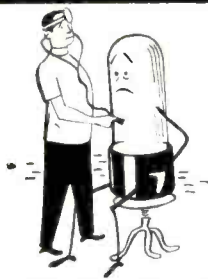

4. YOU CAN TEST EACH ELEMENT in each tube—by a simple flip of the switch.



5. YOU CAN TEST THE NEW TUBES—including those with low cathode current.



6. YOU GET NEW TUBE DATA—immediately, while it is still news. No waiting.

Nearly Half a Century of Service to the Service Man

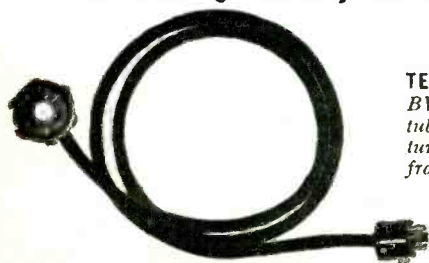

TESTS PICTURE TUBES, TOO! With this BV Adapter, Model 3413-A tests every tube in a TV receiver, including the Picture Tube—without even removing tube from receiver or carton! Saves time!

FOR THE MAN WHO TAKES PRIDE IN HIS WORK

Triplett

TRIPLETT ELECTRICAL INSTRUMENT CO., BLUFFTON, OHIO, U.S.A.

standing wave ratios. Eight models of the new Zig-Zag Antenna series completely cover all requirements for reception in ultra-fringe, near-fringe, suburban and metropolitan areas. The all-channel models, covering Channels 2 thru 13, present an excellent match to the single 300 ohm line required. Because of the new type construction featured in the Zig-Zag Antenna line, the manufacturer claims compactness, extreme sturdiness and easy,

27-INCH CRT

The General Electric Tube Department announces development of a 27-inch rectangular television picture tube.

The tube, largest picture tube made by G.E., is a magnetic-focus, magnetic-deflection, all-glass tube which features an aluminized backing on the screen which reflects light emitted from the back surface of the screen,

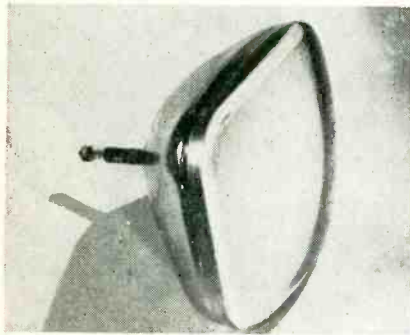

providing a picture which is up to 100 percent brighter than a non-aluminized 27-inch tube at the same voltage, and consequently has greatly increased black and white contrast.

Recommended operating conditions for the 27EP4: Anode voltage, 16,000 volts; grid no. 2 voltage, 300 volts; grid no. 1 voltage, -33 to -77 volts; ion-trpa field intensity, 38 gausses.

Full details on the 27EP4 may be obtained from the General Electric Tube Department, 1 River Road, Schenectady 5, N. Y.

SELENIUM RECTIFIERS

The "Minisel" line of subminiature Selenium Rectifiers, manufactured by Electronic Devices, Inc., Brooklyn, N. Y., features a variety of constructions for military and commercial applications, including arrangements for hermetic sealing and fungus proofing.

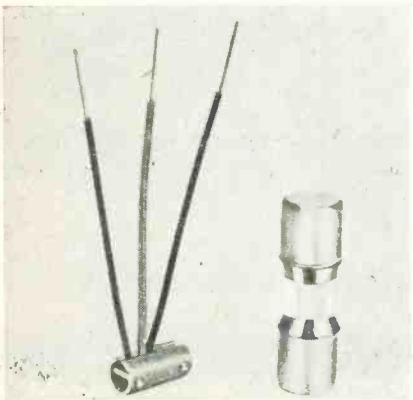

The rectifiers consist of matched 1/4" diam. round selenium rectifier cells encased in bakelite, glass or metal housing. The cells are carefully constructed by a new unique process so that there is little variance in char-

acteristics within the individual unit, and from unit to unit. This uniform distribution of internal losses makes for extremely long life. Standard units are finished to withstand excessive moisture. These units can be built in all common and in any special electrical configuration, including standard instrument and spark suppressor rectifiers.

SOUND CONSOLE

A new sound equipment console, called the Peerage, has been created by Electro-Voice, Inc., Buchanan, Michigan, to make High Fidelity reproduction more conveniently available to lovers of music in the home.

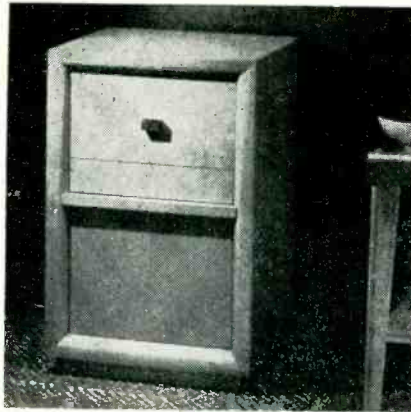

The Peerage is expressly designed to house in one compact unit virtually any combination of the popularly-known tuners, amplifiers and record changers. Planned by engineers and made by furniture craftsmen, the Peerage makes it quite simple to install, with ordinary tools, all the components needed for High Fidelity sound reproduction.

For details on mounting arrangements, internal compartment sizes and tuner-amplifier and changer combinations which fit the Peerage write for Bulletin No. 192 to Electro-Voice, Inc. Buchanan Michigan.

NEW YAGI ANTENNAS

A new line of extremely low cost yagis has been developed by Vee-D-X Engineers it was announced by The LaPointe-Plascomold Corporation. Known as the "Delta" line, it

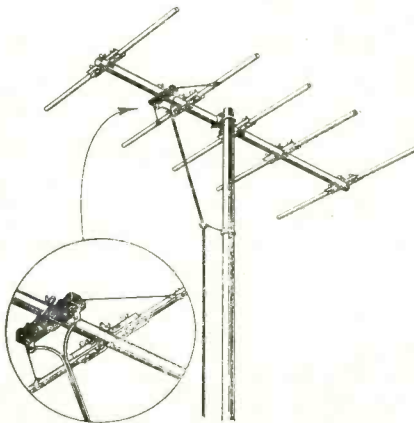

includes a five, eight, and a twelve element yagi and incorporates a delta matching system which is being used for the first time in a television antenna. This delta match will replace the standard driven element of the Vee-D-X JC yagi and will provide exact 300 ohm termination. Except for the new matching method the five element antenna, Model DC, is exactly the same as the Vee-D-X five element

JC, both in performance and in construction, Mr. Hess stated.

Developed to supplement the regular line of Vee-D-X yagis due to the wide demand for continually lower cost antennas, the "Delta" features all aluminum light-weight pre-assembled construction, high gain five element performance, six megacycle band width excellent front to back ratio, and the revolutionary new delta match.

ANTENNA ROTOR

The Radiart Corporation of Cleveland, Ohio, announces an all new rotor called the "CDR Rotor". Designed to be a "general-purpose" rotor, the "CDR Rotor" includes a modern design plastic cabinet with meter control dial and finger-tip control lever, using 4 wire cable. Features of the rotor operation include

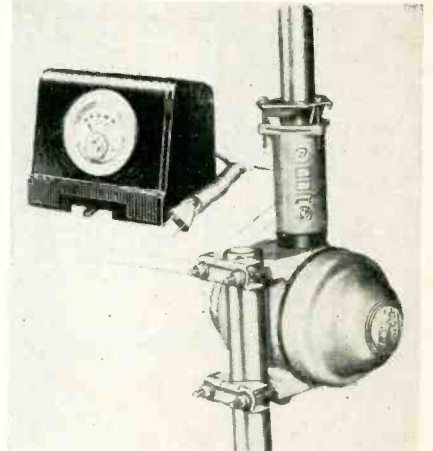

quick mounting antenna mast collet, speedy installation with no loose parts to assemble, high torque, instant locking eliminating drift, instantly reversible, competely weather-proof, streamlined housing offering less wind resistance with maximum strength and minimum weight. It will fit all standard towers and take

SELF-COUPLING MAST SECTIONS

A new television serial mast section has just been introduced to the trade, it was announced by Dick Morris, salesmanager of Snyder Manufacturing Company of Philadelphia.

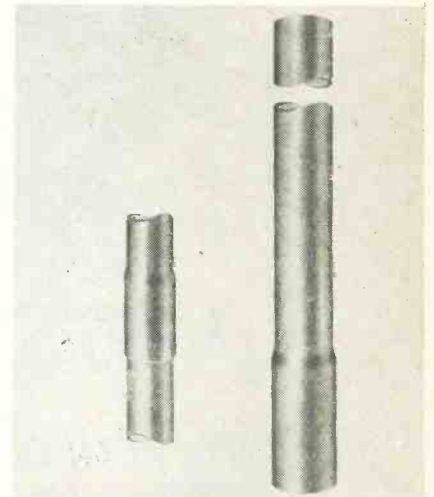

Included in the Snyder line of Redmount TV accessories, the aerial masts have been given the code designation MIO-X. Precision built and self-coupling, they have heavy duty 3-Cote finish inside and outside, being rust-proof Bonderized with a coat of primer paint and a coat of baked heavy plastic enamel.

Each MIO-X mast section is 10 feet long and sections come packed 10 to a package that has reinforced end supports.

FROM  MANUFACTURER...

TO  JOBBER... TO 

SERVICEMAN TO  CONSUMER



ASTRON CAPACITORS

MEAN A _____ LONG LINE

OF RELIABILITY & SATISFACTION.

You can *depend on* ASTRON Capacitors! They've earned a reputation for outstanding performance and reliability—a reputation that means something to YOU. When you replace with ASTRON, you build your reputation for high-quality service. Every step of the way, ASTRON means reliability... reliability that pays off in more satisfied customers, less callbacks, better earnings for you. Talk to your jobber about ASTRON Capacitors today, or write us for the name of the Astron Distributor nearest you.

DEPEND ON...
INSIST ON



ASTRON

255 Grant Avenue East Newark, N.J.

ELECTRONIC ORGANS

[from page 34]

by the amplifier and console. Separation also gives a more natural quality.

Special Installations

There is one exception to all the installation procedures covered which I should mention. Hammond organs, although capable of simulating many traditional organ tones, are often-times used expressly for popular music. In such cases the organist does not always try to effect true organ

tones. Instead he sets his tones up to his own preference, and more in mood with his music for which the Hammond organ is singularly noted, but bearing little or no resemblance to the pipe organ. In an installation such as this, the installer is allowed much more leeway, since reverberation and undirectional effect are not necessarily desirable. Ample power and even coverage are the only considerations.

ASSOCIATION NEWS

Empire State Federation of Electronic Technicians Associations

Endicott, New York was the gathering place for a meeting of the Empire State Federation of Electronic Technicians Associations Inc., Sunday, September 14. Enjoying the facilities of the Hotel Frederick were delegates and guests from five electronic technicians associations of New York State.

The most important business transacted at the meeting was the motion introduced and passed that "ES-FETA, Incorporated is in favor of State licensing of radio and TV Electronic technicians, this license to be so designed that standards of competency and ethics will be stabilized in order to protect the public."

The meeting adjourned at six thirty after designating Binghamton for the next meeting on November 16.

JOHN A. WHEATON
Publicity Director

NATESA Formulates A Plan to Create Confidence in TV Set Owners

Without doubt, every TV service shop, regardless of location or classification, that is either independent, distributor owned or factory operated has suffered serious loss of both income and prestige because of the low regard in which service is generally held by the public. The public has had some reason for such an attitude because of the shady operations of an extremely small minority of shops. The practices of a few service companies which have caused the greatest doubts in the public's mind have been (1) phony ads offering service at ridiculously low rates, (2) failure to fulfill the promises of these phony ads, (3) poor quality work, (4) excessive charges, (5) long delays, (6) failure to give simple guarantees, (7) failure to make good on legitimate complaints, (8) sloppy personnel, (9) sloppy, ill-equipped shops, and (10) use of second hand, inferior parts. Other factors contribute to the problem, many of which are outside the control of service. One major problem is the disinterested attitude of

[Continued on page 58]

2 NEW SERVICE AIDS

RADIO-TV ALL PURPOSE

TELE-SCOPIC PRODUCTS, INC.
Tele-Tool
N.Y.

TOOL KIT \$9.95

SERVICEMAN'S NET
COMPLETE 17-PIECE TOOL KIT

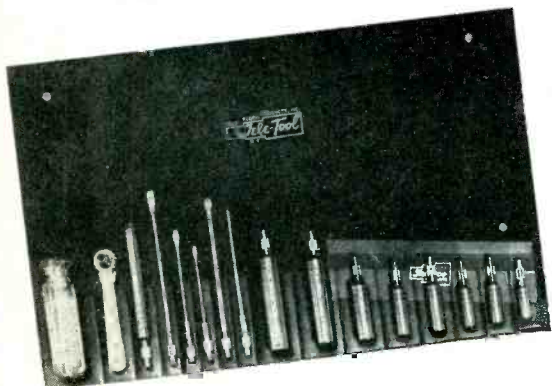

- 8 deep wall socket wrenches — 1/4" to 3/8"
- 1 ratchet handle—forward or reverse
- 3 screw driver blades — small, medium, large
- 2 recessed head screw drivers—medium, large
- 1 five inch tool extension
- 1 amber handle—4" x 1 1/8"
- 1 heavy duty roll-up container

Designed to reach every part of chassis. Instantaneous tool changing. High quality, case hardened polished steel. Positive grip wrenches.

TELE-SCOPIC PRODUCTS, INC.
Tele-Toter
N.Y.

CHASSIS HOLDER

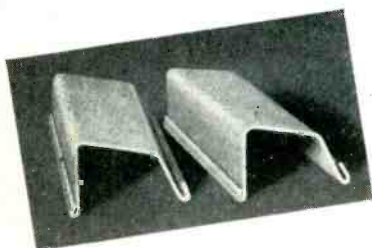

\$1.00 PER PAIR

SERVICEMAN'S NET

- SAFE — EASY — FIRM CHASSIS HANDLING — 6" smooth, round finger rail permits proper balance in carrying chassis. No more cut fingers or aching backs.
- IDEAL FOR SHOP OR FACTORY



AVAILABLE AT YOUR JOBBER — OR WRITE FOR CATALOGS

MANUFACTURED BY **TELE-SCOPIC PRODUCTS, Inc.**
111 W. 42nd ST., NEW YORK 36, N.Y.

FOR THE FIRST TIME... **ANYWHERE!**

A BROAD-BAND, 3-TUBE, 3-STAGE,
FULLY AUTOMATIC BOOSTER WITH
ALL-CHANNEL GAIN IN EXCESS OF 16 db.

and only
\$39⁵⁰
LIST

THE NEW **B-T**
BOOSTER
Fully Automatic

MODEL MA-3

Designed and Manufactured by
Blonder-Tongue Laboratories for
Better Television



NO Knobs to Set
NO Tuning
NO Band-Switching

COMPARE THESE SUPERIOR FEATURES:

- ★ Fully Automatic Broad Band Performance . . . NO Tuning.
- ★ Fully Automatic 'On and Shut-off' Power Control.
- ★ Full UHF Adaptability.
- ★ Gain on all channels in Excess of 16 db. Plus Attenuator Switch.
- ★ 3-Tube, 3-Stage Cascade push-pull Circuit.
- ★ Lower Noise Factor.

Standard RTMA Warranties Apply

Specify **B-T** Amplifiers and Accessories
for Easy-to-Install Master TV Systems

Write for complete Data.



BLONDER-TONGUE LABORATORIES, INC.

WESTFIELD, NEW JERSEY

ASSOCIATIONS

[from page 56]

the rest of the industry and their lack of desire to properly acquaint the public on the need of good service. Some definite progress is being made on this subject, the best of which is the series of GE ads now appearing in the consumer press.

Honest, qualified service companies, through their local associations and the national alliance NATESA, have

for a long time been aware of the problems. They have done an admirable job of protecting the public from frauds, incompetents and phonies. They have long sponsored a National Code of Ethics. This self policing has assured set owners really good service at honest rates when dealing with association members. Unfortunately, the phonies don't belong to associations; in fact, they would not be accepted. The industry generally has done nothing to encourage use of the self police dassociation members as opposed to the racketeers. In fact,

the industry has actually, generally, refused to cooperate in exposing the racketeers. As a result, the situation has deteriorated to such an extent that legitimate service companies are forced to compete with the racketeer on their price offers while at the same time they are expected to render honest service. This has depressed the rate which the public wants to pay, causing serious financial loss to honest service companies. It is further aggravated by the fact that the amount of money available from service jobs is so small that adequate wages cannot generally be paid for professional quality technicians. Hourly wages for good men run \$2.50 maximum. Compare this with a house wiring electrician who gets \$3.50 per hour and more, truck drivers getting \$2.50 per hour, or the TV factory aligner or trouble shooter getting \$1.90 per hour, none of whom need anywhere near the education and training, the continuous study to keep up to date or the knack of psychologically handling people, and it is obvious that the problem of keeping good men in the profession will rapidly become insurmountable. Because of this, today there are actually fewer men available than in 1948 even though far more sets need service.

Service has repeatedly asked other segments of the industry for cooperation in solving this mutual problem, without success. It is obvious that a solution must be found and instituted. Neither independent service, which has a huge investment in time, money and effort, the TV-Radio set owners who have no way to really distinguish between honest, reliable companies and the undesirables or for that matter the rest of the TV industry can afford to permit the present situation to degenerate further.

One alternative is a plan for qualifying and certifying service shops and servicemen, through industry wide cooperation. This plan is designed not to eliminate anyone who is qualified to do a good job on an honest basis, it is designed to encourage higher class persons to enter and stay in the service field by making it a good profession and a good business in which reasonable profits can be made for good service performed.

The other alternative is government imposed legislation and licensing. Independent service would prefer an industry controlled solution. It is up to the rest of the industry to decide what course will be followed. These are our plans.

[Continued on page 60]



Your reputation as a skilled Service Man depends a great deal on your choice of replacement parts. The performance of replacement speakers reflects upon your ability and knowledge. Be sure the reflection is favorable. Specify Utah* speakers—and your customers will say "That Service Man Knows His Business!"

*All Utah speakers have exclusive Utah Universal Angle Mounting.

FREE . . . WRITE TODAY FOR THE NEW UTAH
REPLACEMENT SPEAKER CATALOG S201

Export Dept. Rocke International Corporation, N. Y. C.

utah

RADIO PRODUCTS CO., INC.
HUNTINGTON, INDIANA

A WHOLLY OWNED SUBSIDIARY OF NEWPORT STEEL CORPORATION

TRADE LIT.

[from page 18]

tell the dealer how to evaluate trade-ins, how to service them, and how to re-sell them to his and the customer's mutual satisfaction.

In presenting * * * Ward "Signaline" TV antennas Ward distributors are using the new booklet "Ward for You in '52". This booklet includes complete technical information on the new antennas, plus descriptions of the large number of merchandising aids available to the dealer. Another feature of the booklet is suggestions on how dealers can boost sales in the TV, Auto and Communications markets. * * *

John F. Rider Publisher, Inc., 480 Canal Street, New York 13, N. Y., announces a new publication *High Fidelity Simplified* will be available at the organization's distributors in October.

The book is written for the every day high fidelity fan. It presents to the reader a complete picture of what high fidelity is, how it operates, and how to get the best possible performance from high fidelity equipment.

Here is the complete story of high fidelity from the point of origin, through the tuner or record player, into the amplifier, and then into the loudspeaker, and finally into the human ear. Taking into consideration defects and distortion in the loudspeaker, amplifier and other vital parts of the reproduction unit, the author gives a thorough explanation of the characteristics that are necessary for the most realistic results. Accurate details as well as blueprints are included for the construction of suitable enclosures for a high fidelity loudspeaker. The record player, the changer, the tuner and the tape recorder are discussed with regard to their use in high fidelity home system. The many photographs and illustrations further aid in clarifying the many phases of this constantly growing field. * * *

A handy new 12-page guide to precision automatic control components has been issued by the Transicoil Corporation, 107 Grand Street, New York 13, N. Y. Included are numerous photographs and diagrams of control components as well as full descriptions of basic Transicoil control motors, motor-driven induction generators, miniature gear trains, servo amplifiers, and combination units all of which are electrically and mechanically adaptable to match automatic

[Continued on page 61]

"KNOW-HOW" and "WHERE-WITH"

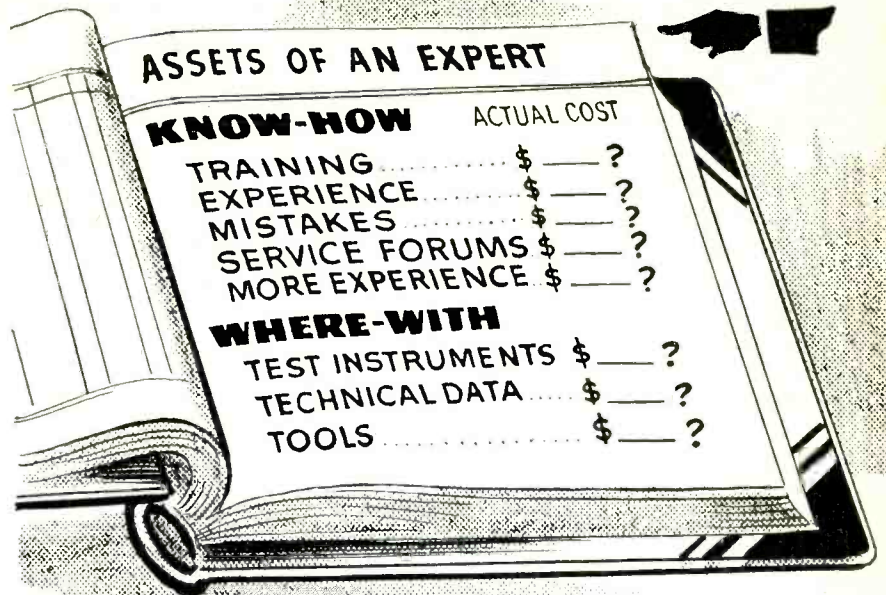

A technician with thorough electronic training and adequate experience has the "know-how" that radio and television owners will pay for when their sets are in trouble. When the technician has invested in testing instruments and other technical aids for diagnosing trouble, he has the "where-with" to help convert this "know-how" to efficiency and profits.

Every technician realizes that all of the "know-how" that it is possible to acquire (through study, experience, and mistakes) is not worth much until he can make it pay off. If he were to stop and figure how much his "know-how" actually cost him over the years, in both time and money, he would be amazed at the amount. The average technician spends thousands of dollars before he is classed as an expert. The "where-with" investment is small by comparison.

Successful service technicians always consider the dollars and cents invested in training, experience, testing instruments and other technical aids when they establish their service charges. They know that the only reason any technician can consistently locate trouble in minutes instead of hours is because, he has *both* the "know-how" and the "where-with."

Since 1927

SUPREME

Testing Instruments

"SUPREME BY COMPARISON"

MULTI-METERS * TUBE TESTERS * COMPOSITE VIDEO GENERATORS
 OSCILLOSCOPES * SIGNAL GENERATORS
 VACUUM TUBE VOLTMETERS * PANEL METERS
 SPECIAL PURPOSE INSTRUMENTS FOR GOVERNMENT AND INDUSTRY

Supreme, Incorporated

Greenwood 3, Mississippi

Columbia

The Improved Deluxe TELEVISION Service Light!



Now... with complete swivel for better lighting and easier servicing!

EVERY SERVICEMAN, experimenter, model-maker needs this handy item. No need to work in the dark... ample light is provided by a 7½ watt, 110 volt bulb that remains cool at all times.

Scientifically-designed, unbreakable aluminum reflector directs maximum light to point of work... A REAL TIME AND LABOR SAVER.

Wide opening spring clamp will hold firmly to sides of wherever it is attached to inside of TV cabinet. Rubber covering on clamp prevents scratching or marring of surface. Both hands are free to work with this service aid... HANDIER THAN A FLASHLIGHT.

Carried by leading jobbers!

Have you seen our other TV service aids... "TV Service Cord" and "TV Picture Tube Extension Cable"?

We manufacture cord sets and cables to government and civilian specifications.

Columbia

WIRE & SUPPLY CO.

2850 Irving Park Road • Chicago 18, Ill.

"National distributors and warehouse for ANACONDA densheath television and radio wires and cables"

ASSOCIATIONS (Cont.)

Shop Certificate Plan

A local committee, picked from the service association, the distributors and BBB will, upon request of any shop, inspect the facilities and equipment of that shop. Before making the inspection, the management will be expected to furnish a statement regarding the approximate amount of gross service business done in the previous 12 months, the number and classification of personnel, approximate dollar size of inventory of parts and tubes, type and quantity of test equipment in shop. A certificate of insurance should accompany the statement. These facts will be used to determine ability to properly render service.

After study of the submitted forms, each applicant will be cleared with the various local set distributors, the BBB and a commercial credit agency. Points to be considered are:

1. Shop space
2. Office facilities
3. Test equipment
4. Service data
5. Parts stocks
6. Insurance coverage
7. Credit record
8. Complaint record with distributors and BBB
9. Manpower

Upon passing investigation, the service shop will be issued a certificate and an emblem and be permitted to advertise as an industry approved service agency. Since adequate shop facilities are a must, it is important that the public be advised to buy service only from Certified Shops to be sure of getting a good deal. Certificate is subject to cancellation for due cause at the discretion of the certification committee.

Qualification of Technicians Plan

Refresher course will be conducted for

1. Association member employees
2. Outsiders who are actively engaged in the service business

The course consists of one lecture of approximately 3 hours per week (with a break of 10 minutes at half way point). Qualified distributors and factory service personnel will be asked to cooperate in the conduct of sessions. Course to consist of 10 sessions as follows:

1. Front ends
2. Video I.F.
3. Audio I.F.
4. Vertical sweep and sync
5. Horizontal sweep
6. Hi-voltage systems

7. Low voltage systems
8. Alignment
9. Record changers
10. Antennae

Upon completion of course, a clinic will be held. All set distributors in the area will be asked to have booths fully equipped and manned to answer all technical questions on their products. The 12th week, a written examination will be given on practical theory and practice. Questions asked in test will be determined on the basis of practical value by a committee from independent associations, distributor service manager, factory service managers and RTMA. A grade of 70% needed to pass. Those that pass will be issued a certificate attesting to the fact that the applicant has taken the course and passed the requirements.

The entire industry will be expected to publicize the course to the service industry and the certification to the public and will then recommend that only certified personnel be used by certified shops.

Code of Ethics

1. Employ qualified personnel to assure proper service. No student shall be passed off as a technician.
2. Make proper arrangements for the protection of reserve funds on contracts.
3. Carry adequate insurance coverage.
4. Avoid trick advertising which offers to service or deliver materials under conditions which are questionable or unfair to the set owner or your fellow members.
5. Employ approved methods of doing installations and maintenance.
6. Issue a standard guarantee.
7. Have available sufficient and proper test equipment to assure a good job.
8. Maintain an adequate service date library.
9. Render service no later than 24 hours.
10. Install only such parts and tubes as are really necessary. Use only new parts and tubes of a quality at least equal to original equipment.
11. Leave with or return to customer all parts and tubes replaced (except where impractical).
12. Issue an itemized bill.
13. Give estimates before major work is performed.
14. Service sets in home whenever possible.

- 15. Be honest, courteous, and treat each client in a professional manner.
- 16. Observe the Golden Rule.

TRADE LIST

[from page 59]

control requirements precisely. Copies of this Transicoil Bulletin MC1 are available on letterhead request to the manufacturer.

* * *
A series of 6 new tape recorders recently announced by *Mark Simpson Manufacturing Co., Inc.* is described in a new *catalog TR-52* which the company has just issued. There are models with fabricoid carrying case, sel-carrying case, and without carrying case, both with and without built-in AM Tuner.

* * *
48 pages containing over 1400 electrical wiring devices, lamps and specialty products, make up the New 1952-53 *Catalog* just issued by *Eagle Electric Mfg. Co., Inc.*, 23-10 Bridge Plaza South, Long Island City 1, N.Y.

* * *
Several new publications have just been issued by *RMS*, TV antenna, accessory and electronics manufacturer of New York City.

The first in a series of monthly trade house organs has been distributed to television servicemen and dealers. The organ, called *RMS TV Forum*, is a digest of technical data which is helpful to TV installers and service technicians.

A colorful four-page brochure has also been published on the subject of the firm's new *CVA-500 Fringeleader end-fired array* for vhf and uhf application.

This literature can be obtained from *RMS* distributors or by writing *RMS* 2016 Bronxdale Ave., Dept. A, N. Y. 60.

* * *
The *Daven Company* of Newark, New Jersey, announces the availability of its latest *brochure on Attenuators*. A wide variety of controls is shown, including radio frequency attenuators, special units for precision measuring equipment, tone compensating attenuators, stereophonic controls and "T", Balanced "H", ladder and potentiometer type audio attenuators. Each unit is discussed separately with photographs of the unit, complete descriptions, charts and diagrams. Write to the *Daven Company*, Dept. GI, 191 Central Avenue, Newark 2, New Jersey, for a copy of this informative brochure.

* * *

A handy, pocket-sized dual purpose *catalog* and envelope stuffer designed to increase distributor sales by clearly listing *Sprague's* complete line of *TVL Twist-Lok Electrolytic Capacitors* used in modern television and radio servicing is now available from the *Sprague Products Co.*, 71 Marshall Street, North Adams, Massachusetts.

* * *
Thordarson-Meissner announces the release of a new *Thordarson Transformer Catalog*. The new *Catalog*, designated the 400-K, features the addition of 42 new transformers de-

signed primarily for television receiver replacements.

* * *

The release of a completely new *speaker catalog* number S201 has been announced by *Utah Radio Products Company, Inc.*, 1123 E. Franklin St., Huntington, Indiana. This new three-color *catalog* covers their entire speaker line and is complete with photographs and descriptions of each model. Both electro-dynamic and permanent magnet types are listed for standard replacement, oval, television, auto, outdoor, public address, etc.



"CONICAL-V-BEAMS"

REGISTERED TRADE MARK

SOLVE BOTH of your antenna problems

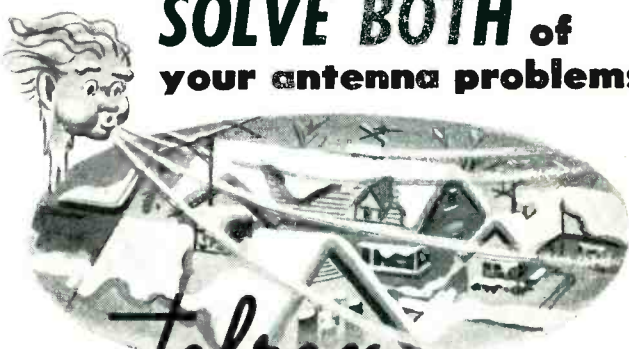

with telrex

-FOR TV, FM AND UHF!



THERE'S A TELREX FOR EVERY PURPOSE AND EVERY TYPE RECEPTION AREA -WRITE TODAY FOR NEW LITERATURE

1. PERFORMANCE AT EXTREME RANGE

Only Telrex offers the long distance, all-station champion. The Telrex 8X-TV, illustrated, will outperform any antenna or combination of cut-to-frequency antennas. It is unequalled for long distance reception up to 200 miles. If the 8X-TV does not provide a useable signal, TV reception is impossible or impractical.

2. WEATHER-DURABLE CONSTRUCTION

Install the all-weather, ruggedized antennas that withstand extremes of climate. Telrex production engineers have combined sterling-quality lightweight materials, superb engineering and metal working craftsmanship to produce antennas that you can install and forget! Factory ratings on all models are conservative.

ALSO! EXCLUSIVE MANUFACTURERS OF THE "FISHBONE" SERIES SINGLE CHANNEL 10 ELEMENT ARRAYS

telrex INC.

CONICAL-V-BEAMS

AMERICA'S OUTSTANDING TELEVISION BEAM

Be sure it's a "CONICAL-V-BEAM" - look for the telrex TRADEMARK

ASBURY PARK 5, N. J.

PERSONNEL NOTES



Fred R. Ellinger has been elected president of Waldom Electronics, Inc.

Richard A. Norman of Owensboro, Ky., has been appointed manager of manufacturing for General Electric's cathode ray tube operations at Electronics Park.

Martin L. Scher is the newly-appointed vice president and general manager of the I. T. & T. Distributing Corporation, New York distributor for the Capehart-Farnsworth Corporation, Fort Wayne, Indiana.

William G. Frick has been named manager of the Capehart-Farnsworth Corporation's Cleveland sales region.

F. D. Meadows has been appointed General Sales Manager of the Dage Electric Company and the Dage Electronics Corp. of Beech Grove.

Joseph Schlig, has been named advertising and sales promotion manager for the Electronic Tube Division, Westinghouse Electric Corporation. Announcement of the appointment was made here recently by H. G. Cheney, sales manager.

Harold M. Detrick has been appointed manager of manufacturing for the Westinghouse Television-Radio Division's Metuchen, New Jersey plant.

Roy A. Kertson has been appointed Factory Representative in San Diego for Mercury Television and Radio Corporation, Los Angeles.

At the annual September meeting of the Hickok Electrical Instrument Company, Cleveland, Ohio, three executives have been promoted to vice-presidencies. They are *Herb Johnson*, Sales Manager; *George Greer*, Works Manager; and *Frank Sawonik*, Director of Purchases.

R. E. Koehler has been promoted to the position of plant manager of the technical products division of the Capehart-Farnsworth Corporation.

Seymour Mintz, advertising director of Admiral Corporation, has been elected vice president in charge of advertising, it was announced by *Ross D. Siragusa*, president.

J. A. (Shine) Milling, executive vice-president of Howard W. Sams &

Co., Inc., Indianapolis, today was named chairman of the Government Relations committee of the Association of Electronic Parts and Equipment Manufacturers, trade group of 120 midwest firms.

Herbert Kabat, formerly assistant general sales manager, has been promoted to general sales manager of Olympic Radio & Television, Inc.

W. E. Boss has been appointed manager of the television market development section of the RCA Victor Home Instrument Department.

Thomas Ryan has been appointed District Sales Manager for the Radio and Television Division of Sylvania Electric Products Inc. His territory will include sales areas in and surrounding the following cities: Chicago and Peoria, Illinois; Milwaukee and Green Bay, Wisconsin; Minneapolis, Minnesota; Des Moines, Davenport and Sioux City, Iowa; South Bend, Indiana.

In recognition of the size and importance of its radio business, Philco Corporation is establishing a separate Radio Division so that even greater emphasis can be put on all phases of the Company's activities in the home and auto radio field, it was announced by *William Balderston*, president.

William H. Chaffee has been appointed vice president of this newly-formed Radio Division, it was announced by *Larry F. Hardy*, president of the Division, who also stated that the Television Division, which now receives separate divisional status, will continue to have the able direction of *Frederick D. Ogilby*, who has played such a prominent part in its successful operation.

The appointment of *Robert C. Gray* as area manager of the RCA Service Company in the Northeast Area was announced today by *J. P. Boksenbom*, vice president in charge of the company's consumer products division.

A. M. Wiggins, Vice-President for Engineering, Electro-Voice, Inc., Buchanan, Michigan, electronic manufacturer revealed six new appointments to the engineering staff. *Dr.*

THE ORIGINAL

Television tube caddy

TRADE MARK

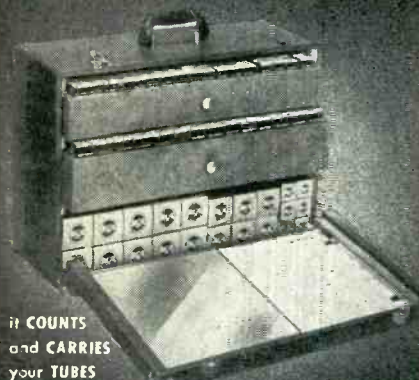

IT COUNTS
and CARRIES
your TUBES

CARRIES EASIER LOOKS NEATER PAYS FOR ITSELF

The Customer only knows what she sees. She probably wouldn't know a rectifier from a resistor, and couldn't read a meter. But she can read the writing on a wall—and on her floor when you set your tools down.

Servicemen who carry the Tube Caddy make the right impression. No "fishing" a tube out of the bottom of a tool kit. Every tube has its place. The customer recognizes systematic efficiency—the kind that builds confidence, and makes your business grow through recommendations from one customer to another.

Tube Caddy. Holds up to 249 tubes.
20x13½x9 in. . . Net to Dealer

\$13.50*

Tube Caddy Jr. Holds up to 143 tubes.
15½x13x8 in. . . Net to Dealer

8.95*

*Higher on West Coast
Also TV Cabinets, Wall Baffles
Ask your jobber today or write

ARGOS PRODUCTS CO.

312 D MAIN STREET • GENOA, ILLINOIS

APC

Craftsmanship in Cabinets

Carl F. Moen was named Senior Engineer, Norman Friedman, Lynn Talbott, James Wendt and Frank James were named Junior Engineers, and John English was appointed Mechanical Designer.

General Manager Elliot Peikoff has been recently named as Vice-President of Mercury Television.

Edgar Dailey has been appointed Chief Engineer of Snyder Manufacturing Company, it has been announced by the Philadelphia television, radio and automotive accessories firm.

Mr. James W. Farrow has been appointed Merchandise Manager of the Stromberg-Carlson Sound Equipment Division.

Robert G. Hamilton has been appointed Manager of Radio Sales of the Radio and Television Division of Sylvania Electric Products Inc.

Robert A. Penfield has been appointed advertising manager of the Radio and Television Picture Tube Division, Electronics, Parts, and Tungsten & Chemical Divisions of Sylvania Electric Products Inc., according to an announcement recently by Terry P. Cunningham, director of Advertising and Sales Promotion.

In an important move to improve and increase its service to the expanding electronics market, L. S. Thees, general sales manager of the Tube Department of RCA Victor, announced the creation of separate kinescope and receiving tube sales functions within its renewal sales organization, which is headed by H. F. Bersche. K. B. Schaffer has been appointed manager of kinescope renewal sales, D. M. Branigan will continue as manager of receiving tube renewal sales, and A. G. Petrsek has been appointed manager of electronic components renewal sales, replacing Mr. Shaffer. Edward Stanko, veteran RCA engineer and pioneer in radio and television in the 1920s, has been appointed to the newly created post of manager of engineering, technical products division, RCA Service Co. Inc.

Henry B. Nelson Jr. has been appointed district sales representative for the General Electric Tube Department at Cincinnati. Fred H. O'Kelley Jr., district representative for the General Electric Tube Department at Cincinnati for the past three years, has been appointed product manager for General Electric receiving tubes.

Richard A. Graver joined the Capehart-Farnsworth Corporation at Fort Wayne, Indiana, as vice president and general manager.

INTERCARRIER BUZZ

[from page 35]

ment and chain stores for special sales. The sound i-f transformers in these sets are not very efficient. Particularly the sound take-off transformer. The primary of the sound take-off transformer, as seen in Fig. 1, is usually located in the plate of the video output tube prior to the video load. This transformer has 3 main functions:

1. To couple the audio i-f to the audio i-f stage.
2. To trap the audio-out of the video. (Prevent sound bars.)
3. To reject video information away from the audio i-f stage.

If the picture information gains access to the audio section, it comes out of the speaker as a buzz. If the Q of the sound take-off transformer is not high enough.

1. It will still couple the audio to the audio i-f stage.
2. It will still prevent sound bars.
3. But it will not reject picture information from the audio i.f.

It has been found that replacing this take-off transformer with a higher quality type of transformer often proves very effective in minimizing or eliminating the intercarrier buzz. This applies often to the sound detector transformer also.

The great majority of television receivers employing intercarrier sound place the take-off transformer

ANOTHER RIDER

SMASH HIT

is on its way!

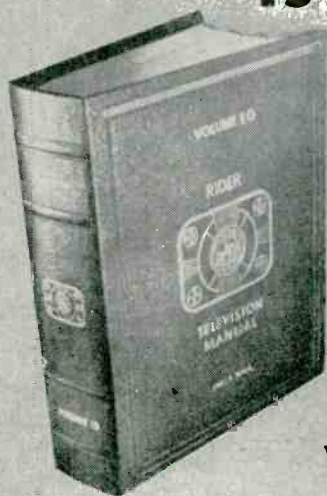

RIDER TV MANUAL VOL. 10

with replacement parts

Featuring a listing of dependable replacement parts. A FEATURE THAT CAN'T BE BEAT! In Rider's TV 10 you will find a reliable parts listing made up entirely of name-brand products. Products of such manufacturers as: Aerovox, I. R. C., Mallory, Sprague, Jensen, Clarostat, Ram, Stancor, Triad. Rider TV 10 selects correct replacement parts for you! Rider Manual TV 10 is scheduled for Nov. delivery. It contains ap-

proximately 2000 (8 1/2 x 11) pages of complete authorized, factory-issued servicing data... covering TV receivers manufactured from March to September 1952. Make sure to order your copy today... it's \$24.00.

John F. Rider, Publisher, Inc., 480 Canal Street, New York 13, N. Y. West Coast Office: 4216-20 W. Jefferson Blvd., Los Angeles, Calif.

Use

ERIE PRINTED CIRCUITS

ERIE Resistor began the development of Printed Circuits in 1940. Since then the advantages of Printed Circuits have been amply demonstrated and Erie has made important contributions in the field.

A complete line of Erie Printed Electronic Circuits is available, including Diode Filter, Triode Plate Filter, Vertical Integrator, Audio Output Circuit, and Pentode Plate Coupler.

Order through your jobber.

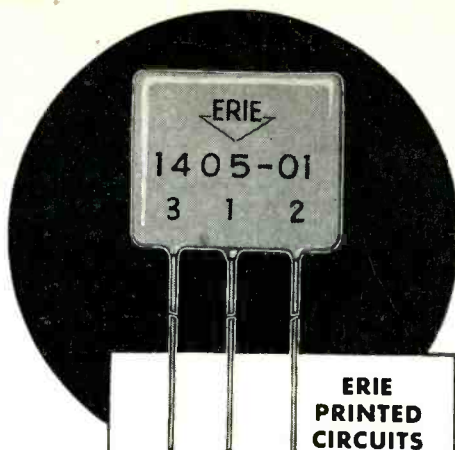

**ERIE
PRINTED
CIRCUITS**

offer these advantages:

- Fewer soldered connections mean less installation time.
- One installation unit replaces several.
- Fewer connections mean fewer wiring errors.
- Circuit stability is improved through simplification.
- Lower costs for procurement and stock maintenance.

ERIE
RESISTOR CORP.

ERIE RESISTOR CORPORATION . . . ELECTRONICS DIVISION

Main Offices: ERIE, PA.

Sales Offices: Cliffside, N. J. • Philadelphia, Pa. • Buffalo, N. Y. • Chicago, Ill.
Detroit, Mich. • Cincinnati, Ohio • Los Angeles, Calif.

Factories: ERIE, PA. • LONDON, ENGLAND • TORONTO, CANADA

PREFERRED

because of their
dependable service
and overall economy

Copperweld
TRADE MARK

RADIO and TV PRODUCTS



Uniform
COPPER COVERING
gives you

RESISTANCE } Same as copper
REACTANCE } at Radio
IMPEDANCE } Frequencies
CAPACITANCE }
also RUST-RESISTANCE and
SOLDERING QUALITIES
of Copper

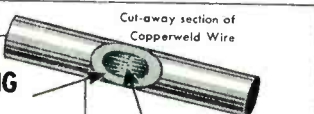

Tough
STEEL CORE
adds HIGH STRENGTH
MINIMUM ELONGATION
RESISTANCE TO FATIGUE

Perfect interlocking **MOLTEN-WELD**
between the copper and steel
eliminates electrolytic action.

NO OTHER WIRE HAS THIS MOLTEN-WELD

Write today for further details.

COPPERWELD STEEL COMPANY • Glassport, Pa.
SALES OFFICES IN PRINCIPAL CITIES

Copperweld GUY STRAND
ANTENNA WIRE • GROUNDING WIRE
GROUND RODS AND CLAMPS . . .

also HOOK-UP WIRE, TWIN-LEAD AND COAXIAL CABLES,
AND MANY OTHER ELECTRONIC WIRE PRODUCTS

in the plate of the video output tube, as seen in Fig. 1 or, in some cases, the screen as seen in Fig. 2. The reason the audio is taken off after the output tube in most cases is to give the audio as much gain as possible. Contrary-wise, the farther the sound take-off is from the detector, the more the chance for the buzz to develop. In weak areas, this take-off is necessary to obtain sufficient volume. Besides, there is rarely intercarrier buzz

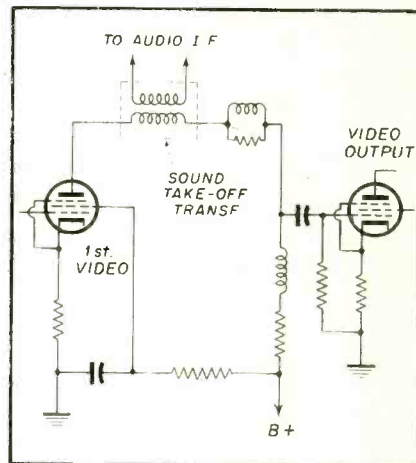

Fig. 3—Connections to 1st video amplifier

trouble with weaker than normal signals. Because of this the sound take-off transformer in normal and strong signal areas can be moved to the plate of the 1st video, if there is any, or to the video detector as seen in Figs. 3 and 4 respectively. There will be no appreciable change in volume and the buzz may be eliminated. The sound take-off operates in its best capacity in the video detector stage.

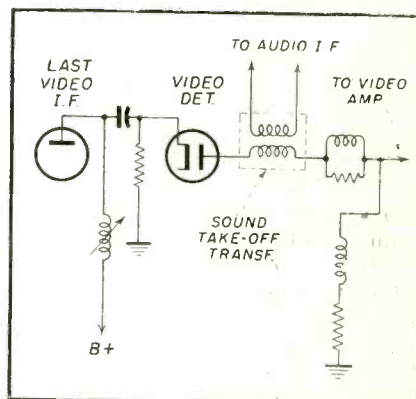

Fig. 4—Sound i-f take-off transformer connected to detector.

Many times the audio section is not tuned at exactly 4.5 megacycles causing a buzz to be present. It is therefore suggested that before making any changes in the television receiver, the serviceman should align the audio section at precisely 4.5 mc. Often, this alone will cure the buzz.

TRADE FLASHES

[from page 16]

which will directly replace over 92% of all cartridges in use. This minimizes the Distributor's inventory problem, eliminates obsolete stock, and increases his turnover and profit. It also simplifies and speeds phonocartidge replacements for the serviceman.

Aerovox Expands Ceramic Disc Capacitor Listings

In order to meet highly critical capacitance values still closer with standard ceramic disk capacitors, the Hi-Q Division of Aerovox Corporation now offers 40 numbers instead of the original 15, to and through the jobbing trade.

These expanded listings are included in the 1952-53 Aerovox Catalog now obtainable from any Aerovox distributor or from Aerovox Corporation, New Bedford, Mass.

TV Set Shipments

Shipments of television sets to dealers in the first half of this year totaled 2,118,510 units compared with 2,470,954 sets in the corresponding 1951 period, the Radio-Television Manufacturers Association reported.

Westinghouse Plans Service Schools

Westinghouse has chartered over one hundred television service schools to be conducted throughout the nation in September and October, A. H. Kutt-ruff, national service supervisor of the Westinghouse Television-Radio Division, announced recently. The majority of the staff of field service engineers of the division are devoting their time for the next two months to these schools for servicemen.

Video servicemen, independent service companies and all television dealers are being cordially invited by Westinghouse to attend these short practical courses featuring every latest tested service technique.

Highlights of each session will be a demonstration on an actual chassis of the functional, mechanical and electrical features of Westinghouse television with special emphasis on circuit arrangements. Valuable short cuts for pin-pointing the exact cause of various functional troubles, as well as advice on how to make the most efficient repairs in the shortest possible time will be presented.

Attending servicemen will get up the minute service information on the current line of Westinghouse television receivers with emphasis on the plug-in type U.H.F. receptor, which is

a Westinghouse exclusive. This exclusive feature offers set owners facilities for U.H.F. with no external converters and no extra controls.

Majestic Trademark Settled

Stipulations of settlement and discontinuance have been filed in the United States District Court in the Eastern District of New York in the trademark infringement action brought by Majestic Radio & Television, Division of The Wilcox-Gay Corporation against Saraceni & Gentile, Inc., manufacturers of custom

television cabinets which they had marketed under the name of "Majestic Products", and Television Company of America, their distributor.

Under the terms of the settlement, Saraceni & Gentile, and Television Company of America have agreed to permanently discontinue the use of the name "Majestic" or "Majestic Products" in connection with their television cabinets, and have also acknowledged the trademark rights of Majestic Radio & Television. Inasmuch as the defendants have denied any wilful infringement and any in-

Now... Get ALL Your DRIVERS

FROM VACO



Only Vaco offers the complete, fine quality line of drivers that daily is proving its superiority in service shops and on factory production lines... in terms of performance at low cost. Made of specially heat treated chrome vanadium blades mounted in break-proof, shock-proof plastic handles, Vaco drivers are the choice of experts in TV and radio.

SPECIAL RADIO AND TV DRIVERS

Investigate Vaco's new non-metallic aligners, non-magnetic beryllium copper focalizer screw drivers and other unusual products. They are made especially for radio and TV and have proved themselves most practical in delicate adjustment work.

NEW 27 PIECE TV SERVICE KIT

Also available from Vaco is a new 27-piece TV Service Kit made up at the request of TV men. You'll find a full description of this kit and other Vaco products in the new Vaco three-color catalog. Send for it, today.



At Your Supplier or Write to:

VACO PRODUCTS COMPANY

317 East Ontario Street • Chicago 11, Illinois
In Canada: Vaco-Lynn Products Co., Ltd.,
204 Laurier Ave., W., Montreal 8, Quebec

HI-FI Audio Servicemen are invited to attend the Fourth Annual **AUDIO FAIR**

OCTOBER 29th, 30th, 31st and NOVEMBER 1st.
HOTEL NEW YORKER—NEW YORK CITY



The most important annual event in the field of Audio. Of utmost interest to Government and Military Agencies, Broadcast Engineers, Recordists, Sound-On-Film Men, Public Address Men, Hobbyists, High Fidelity Enthusiasts, and Distributors and Dealers of quality audio and high fidelity equipment.

The Audio Fair is the largest and most concentrated exhibition of Audio Equipment held under one roof. Every up-to-the-minute development will be represented, shown and heard.

The General Public Invited to Attend. No Admission Charge

Sponsored by the **AUDIO** engineering society
(FOURTH ANNUAL CONVENTION)

NEW! MOSLEY WALL-THRU

For TV, FM and Amateur Transmission Line

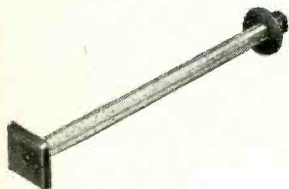

Cat. No. 625
List Price \$1.95

Cat. No. 625-PK
WALL-THRU, complete with
MOSLEY Universal TV Lead-
in Socket and Plug.
List Price \$3.00

- Fits Any Wall Up To 13" Thick!
- Completely Weather-Proof!
- For Standard Flat 300 Ohm Line or RG-59/U Co-ax Cable!
- MOSLEY Lead-In Socket Can Be Mounted Direct To Inside Plate!
- Precision Molded Polystyrene End Plates!
- Easily, Quickly Installed!

MOSLEY ELECTRONICS

2125 LACKLAND ROAD OVERLAND 14, MISSOURI



- 1220 pages
- 80,000 items
- 8,000 illustrations
- 8" x 11"—5 lbs.

Publisher's price
\$6.50—your price
through your regu-
lar parts dis-
tributor \$1.95.

The right part when you need it for service

This permanent, hard cover Official Buying Guide of the electronic-TV parts and equipment industry with its comprehensive detailed index, eliminates the need for maintaining files of small catalogs and manufacturers' literature. Radio's Master catalogs 90% of TV and electronic equipment. Not merely part number listings—complete descriptions, specifications and illustrations written and compiled by each manufacturer. Enables you to make comparisons or substitutions right now!



UNITED CATALOG PUBLISHERS, INC.
110 Lafayette St., New York 13

STATEMENT REQUIRED BY THE ACT OF AUGUST 24, 1912, AS AMENDED BY THE ACTS OF MARCH 3, 1933, AND JULY 2, 1946 (Title 39, United States Code, Section 233) SHOWING THE OWNERSHIP, MANAGEMENT, AND CIRCULATION OF Radio-Television Service Dealer, published monthly at New York, N. Y. for October 1, 1952.

1. The names and addresses of the publisher, editor, managing editor, and business managers are: Publisher, Sanford R. Cowan, 1620 Ocean Ave., Brooklyn 30, N. Y.; Editor, Sanford R. Cowan, 1620 Ocean Ave., Brooklyn 30, N. Y.; Managing Editor, Samuel L. Marshall, 262 Sullivan Place, Brooklyn 25, N. Y.; Business Manager, Sanford R. Cowan, 1620 Ocean Ave., Brooklyn 30, N. Y.

2. The owner is: (If owned by a corporation, its name and address must be stated and also immediately thereunder the names and addresses of stockholders owning or holding 1 percent or more of total amount of stock. If not owned by a corporation, the names and addresses of the individual owners must be given. If owned by a partnership or other unincorporated firm, its name and address, as well as that of each individual member, must be given.) COWAN PUBLISHING CORP., 67 West 44th Street, New York 36, N. Y.; Sanford R. Cowan, 1620 Ave., Brooklyn 30, N. Y.

3. The known bondholders, mortgagees, and other security holders owning or holding 1 percent or more of total amount of bonds, mortgages, or other securities are: None.

(Signed) S. R. COWAN, Publisher

Sworn to and subscribed before me, this 8th day of September, 1952.

HARRY N. REIZES, Notary Public

tention to infringe, Majestic Radio & Television has waived its claim for an accounting and for damages.

Littelfuse Occupies New Plant

Littelfuse, Inc., manufacturer of fuses since 1927, is now occupying its new plant at 1865 Miner Street, Des Plaines, Ill.

From its beginnings as Littelfuse Laboratories, back when rent was \$17.50 and the light bill was \$0.75, Ed Sundt has guided the fuse manufacturing company through 25 years of product development and production growth.

The new one-story brick building which now houses Littelfuse, Inc., is organized for 100 % efficiency in the flow of raw materials to finished products. Mr. Sundt attributes a great part of the Littelfuse success story to tightly maintained quality and production control.

CIRCUIT COURT

[from page 49]

signal goes to ground through R228. This overall bias is supplied by the difference of the amount of positive voltage which appears across the grid and the voltage which appears at the cathode. R255 (820K) is chosen in conjunction with C255 so that the video signal appearing in the cathode current will cause the cathode to be more positive than the grid. This signal initially cuts the tube off. The RC time of R255 and C255 is such that the tube comes into conduction on the peaks of the sync signal. Variations in signal strength will cause the cathode to grid bias to vary. Thus, the filtered voltage at the junction of R255, C255 and V209A will vary with signal strength. This is the first requirement of an a-g-c system.

R253, C238, R254 and C219 act as a filter to convert the sync pulse voltage appearing at the cathode of V209A into a d-c voltage. This voltage is applied to the grid of V209B, the gate tube. This tube is also biased to beyond cutoff. A positive voltage is applied to the cathode by means of R235, the cathode resistor and R251 going to the B+ boost supply. A negative saw-tooth from the horizontal discharge circuit is then fed to the cathode. The tube will then conduct for the period of time that the negative voltage is great enough to overcome the positive bleeder voltage. The amplitude of the saw-tooth can be adjusted by means of R249, the a-g-c control. The amplitude of the output

pulse is then determined by the d-c voltage present at the tube's grid.

We, therefore, have an output pulse which occurs only during a portion of the horizontal cycle and whose amplitude (once R249 is set) is determined by the amplitude of the received signal. The negative going pulse from the plate of V209B is fed to the cathode of the a-g-c diode. This causes the diode to conduct. The output is taken off the plate ground return resistors R243 and R244. This voltage, since the current flow is from plate to ground, is negative. The voltage is divided by means of R243 and R244 so as to supply a reduced a-g-c to the tuner. R238, R239, R264 and R246 act as a voltage divider to supply a slightly positive bias to V204B. This is done so that in a weak signal area there will be a delay in the application of the a-g-c voltage.

TROUBLE-SHOOTING PORTABLE RADIOS

[from page 40]

has to be replaced, a condenser having a minimum rating of 25 W.V. should be used. This filament bypass condenser might cause, if defective, whistling, hum, or low filament voltage, depending whether it is open, leaky or shorted.

As has been mentioned before, the cause for a slight drop in filament voltage is very often a slight decrease in efficiency of the rectifier and filter

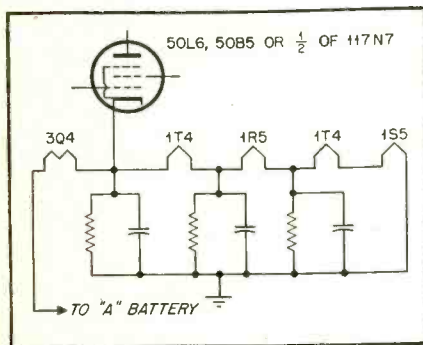

Fig. 2—Method of obtaining audio bias in portable radio receiver.

condensers. If the customer paid only \$15.00 for his portable he might not be willing to pay for the replacement of all these parts. In that case the filament voltage can be brought back to normal by decreasing resistor R2 or R3. This repair method is of course not recommended.

In some older 3-way portables a different method is used to supply

filament voltage. Two output tubes are used. One for the electric and one for the battery position. On the AC/DC position the filaments of the tubes with their bias resistors and bypass condensers are used as cathode bias for the audio output tube (see Fig. 2). If low filament voltage is encountered in these sets, the following troubleshooting procedure should be used:

- (a) substitute the rectifier and AC/DC output tube;
- (b) check the voltage readings on the pins of the output tube

(used on the electric position);
(c) check the resistors and condensers in the filament network.
Once the power supplies of 3-way portables is understood, their repair should be no more difficult than that of the standard radio.

TV SYNC CIRCUITS

[from page 30]

vertical sync hold, or hooking and weaving in the pix. The sources of the

SPEED UP YOUR SERVICING WITH "STANCOR TRIOS"



(Groups-of-three most frequently used Stancor TV Replacement Components listed below)

Don't Waste valuable time waiting for a replacement—carry it in stock!

STANCOR CHOKES	C-2325 C-2326 C-2327	COVER 70% of your TV REPLACEMENTS*
STANCOR DEFLECTION YOKES	DY-1 DY-8 DY-9	COVER 70% of your TV REPLACEMENTS*
HORIZONTAL DEFLECTION OUTPUTS	A-8127 A-8128 A-8130	COVER 45% of your TV REPLACEMENTS*
VERTICAL DEFLECTION OUTPUTS	A-8112 A-8115 A-8123	COVER 70% of your TV REPLACEMENTS*
VERTICAL BLOCKING OSCILLATORS	A-8111 A-8121 A-8122	COVER 65% of your TV REPLACEMENTS*

* Based on a statistical analysis of all replacement recommendations in the Stancor TV Replacement Guide.

Stancor Transformers are listed in HOWARD W. SAMS' Photofact Folders and JOHN RIDER'S Tek-Files.

FREE!

Stancor's new 24-page catalog listing over 475 transformers and related components for all types of electronic applications. Includes over 100 TV units. Get your free copy from your Stancor distributor or write Stancor direct!



STANDARD TRANSFORMER CORPORATION

3586 ELSTON AVENUE, CHICAGO 18, ILLINOIS

first trouble in the order of their occurrence are:

1. Defective sync tubes
2. Weak video amplifier tubes
3. Shorted or low resistance video amplifier plate load or sync take-off resistors.
4. Defective biasing in the sync systems.

Again the oscilloscope will show up this difficulty. The gain from the detector output (Point #1 Fig. 12a) to the video amplifier output (Point #2 Fig. 12a) is usually between 40 and 60 times. If this gain is not apparent on the scope when moving from one output to the other, start checking voltages. It will generally be found that the video amplifier cathode voltage is higher than the manufacturer's recommended voltage or the plate voltage is higher than recommended.

Once the tubes are checked and found O.K., then check, in order, the video amplifier cathode resistor, plate load resistor, sync take-off resistor and the grid resistor in the sync stripper grid. A leaky coupling condenser to the sync clipper will also result in little or no sync pulses being passed.

The other type of sync trouble is the reverse of the previous one. That is, the signal being taken off is excessive. This results in the sync stripper being

unable to separate the video information from the sync pulses. This trouble is more general than the previous one. It is also harder to track down if an understanding of how the sync separator works is not clear. Fig. 13 shows how the relationship between the values of the video plate load re-

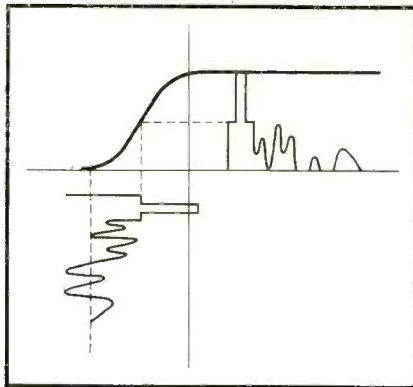

Fig. 14—Plate distortion resulting from overheating sync resistors.

sistor and the sync take-off affects the input to the sync amplifier. In a number of sets, the resistors in this circuit will be of a lower wattage than the peak surge dissipation across them. Since the average power across them

is less than their rated value, they will not burn open. However, continued surges across them cause them to overheat and increase in value. The sync take-off resistor is the most common offender in this respect. As a result, the input to the amplifier resembles Fig. 14 and the familiar "hook" occurs. The resistors while cold may measure correctly. So it is advisable again to use the scope to measure the peak to peak voltages. For instance, if the plate load resistor is 3.3K and the sync take-off resistor is 1.5K, the peak to peak voltage at point A (Fig. 12) should be about 3 times as large as it is at point B (1.5K/4.8K)

After checking these points, the next place to look is at the sync amplifier and leveler stages (assuming the amplifier follows the stripper). The pulses at the input and output of these stages should be of a constant level. The voltages as given in the manufacturer's instructions should be observed. In general, when these instructions are not available, the voltage on the clipper and leveler stage plates will be very low, usually 35-50 volts measured from cathode to plate. The grids will show a bias at all times between cathode and grid. The amplifier voltages will be roughly the usual

NEW HELIX DELTA BEAMS

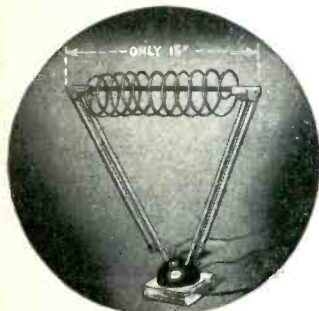

Combines beauty with a signal gain never before achieved in an indoor antenna. In average locations, the dipoles remain folded. In poor signal areas the dipoles can be snapped instantaneously into a horizontal position, increasing the antenna's pulling power by over 50%.

List Price **\$9.95**

- Tuned to High and Low Channels
- High Gain
- Completely Factory Assembled
- Anodized in Beautiful Rose Gold
- Clear Crystal Base

MOST POWERFUL ALL-CHANNEL INDOOR TV ANTENNA

- The Helix Coil
- The Folded Dipole
- The Straight Dipole
- The Delta Match Transformer

Finger-Tip Control. Antenna orients to any position by turning halfball. Base remains stationary. A flick of the wrist snaps dipole into horizontal position for difficult locations and fringe areas.

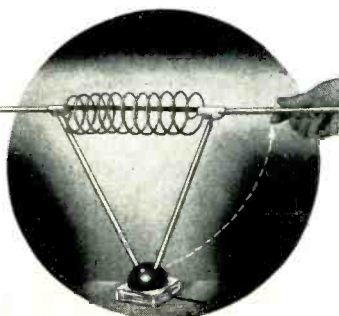

Send for Free Bulletin **K-G** ELECTRONICS CORPORATION
510 N. DEARBORN, CHICAGO 10

THIS IS IT! THE RELAY WITH Interchangeable Coil FOR A WIDE RANGE OF RADIO APPLICATIONS

GUARDIAN Series 200

Interchangeable COIL and CONTACT Switch Assembly

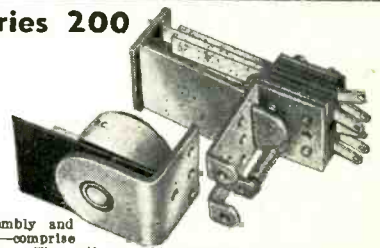

Two basic parts—a coil assembly and a contact switch assembly—compose this simple, yet versatile relay. The coil assembly consists of the coil and field piece. The contact assembly consists of switch blades, armature, return spring and mounting bracket. The new Guardian Midget Contact Assembly which is interchangeable with the Standard Series 200 coil assembly, is also available in either single pole, double throw; or double pole, double throw.

CONTACT SWITCH ASSEMBLIES

CAT. NO.	TYPE	COMBINATION	
		Single Pole	Double Pole
200-1	Standard	Double Throt	Double Throt
200-2	Standard	Double Pole	Double Throt
200-3	Contact Switch Parts Kit		
200-4	Standard	Double Pole	Double Throt
200-M1	Midget	Single Pole	Double Throt
200-M2	Midget	Double Pole	Double Throt
200-M3	Midget Contact Switch Parts Kit		

13 COIL ASSEMBLIES

A.C. COILS*		D.C. COILS	
CAT. NO.	VOLTS	CAT. NO.	VOLTS
200-6A	6 A.C.	200-6D	6 D.C.
200-12A	12 A.C.	200-12D	12 D.C.
200-24A	24 A.C.	200-24D	24 D.C.
200-115A	115 A.C.	200-32D	32 D.C.
		200-110D	110 D.C.

*All A.C. coils available in 25 and 60 cycles

GUARDIAN  **ELECTRIC**
1606-L W. WALNUT STREET CHICAGO 12, ILLINOIS

A COMPLETE LINE OF RELAYS SERVING RADIO AMATEURS

RADIO-TELEVISION SERVICE DEALER • OCTOBER, 1952



SAVE Up to \$1.00 each.

**Form a Group,
Service Dealers**

Subscribe to "RTSD"—

"The Professional Radio-Television man's Magazine"—published monthly. All articles are exclusive and timely. Practically every issue is worth what an entire 1 year subscription costs.

The more in a group the bigger the savings. 6 men in a group save \$1.00 each; 4 men groups save 80c per man. Present "RTSD" subscribers may participate in or form a group with co-workers, or even competitors. Still active subscriptions are automatically extended 2 years. Start a Group today! The timely and exclusive technical data appearing in future issues of "RTSD" will make this the best investment you ever made. The special Group Rate offer may be withdrawn at any time—so hurry.

Use This Coupon For Convenience

(The coupon below can be used for from 1 to 6 subscription orders. Use it today!)



TEAR OUT—MAIL TODAY

RADIO-TELEVISION SERVICE DEALER
67 West 44th Street, New York 36, N. Y.

Please enter 1 year subscription orders for the names given below. Our remittance is enclosed.

NOTE: If you do not wish to tear this order blank out, just print or type the information on a single sheet of paper, following the style given. Each subscriber's occupation must be clearly described.

<input type="checkbox"/>	One 2-year subscription	In U.S.A. \$3.00
<input type="checkbox"/>	Two 2-year subscriptions each	2.50
<input type="checkbox"/>	Three 2-year subscriptions, "	2.30
<input type="checkbox"/>	Four 2-year subscriptions, "	2.20
<input type="checkbox"/>	Five 2-year subscriptions, "	2.10
<input type="checkbox"/>	Six 2-year subscriptions, "	2.00

Name

Address

Describe Title or Position and Type of Business

State whether a New Subscriber or Renewal Order

Name

Address

Describe Title or Position and Type of Business

State whether a New Subscriber or Renewal Order

Name

Address

Describe Title or Position and Type of Business

State whether a New Subscriber or Renewal Order

Name

Address

Describe Title or Position and Type of Business

State whether a New Subscriber or Renewal Order

Name

Address

Describe Title or Position and Type of Business

State whether a New Subscriber or Renewal Order

Name

Address

Describe Title or Position and Type of Business

State whether a New Subscriber or Renewal Order



At your RMS Jobber

CVA-500 end-fired array — excellent reception in the fringe. Rugged — up fast, stays fast.

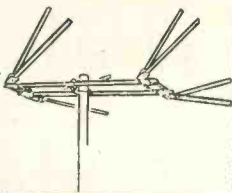

The little man

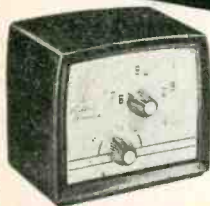

SP-6J Triode Tube Boosters — new beauty, excellent performance in semi-fringe and fringe. U/L approved

is always there

SP-6 Pentode Tube Booster with external gain control — ideal in the extreme fringe. U/L approved.



with everything

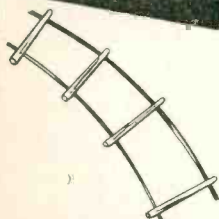

HG-450 Hi-Gain open transmission line is Copperweld far stronger!

you need for

LA-3 lightning arrester — static discharge eliminator for twin lead or open line. Mounts flat or to mast. U/L approved.



TV installation

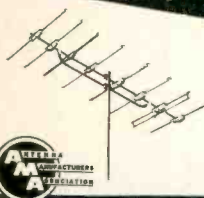

STYLE 8 and 10 element yagis . . . real uniquely steel-braced.



ask him for RMS products
RMS, New York 60, N. Y.

amplifier voltages, namely, some grid bias, and a higher plate voltage in the order of over 175 volts to cathode.

In some sets, not using a vertical buffer stage, trouble in the vertical oscillator stage will be reflected back to the common inter-sync separation point. It will cause what seems to be composite sync trouble. These inter-sync stages and their associated circuits will be discussed in another series of articles. The concluding article in this series will discuss the present day high efficiency sync circuits and some of the newer designs in the engineering boards.

[To be continued]

YOUR HI-FI MARKET

[from page 28]

vantage, if not to the customer, certainly to the installer. If there is no fuse provided at the a-c input to the amplifier one should be provided. The simplest way to do this is to change the plug of the a-c line cord to an Elmenco fused plug. These cost about a quarter, and the 3AG (a good standard size) fuses employed can be inserted, removed or checked (with needle test prods) without disassembling the plug. Every custom-builder should keep a supply of these fused plugs handy. If the tuner or TV set or tape recorder obtain their power through other than the power amplifier chassis and are unfused, fused plugs should be placed on their power cords. The turntable does not require this precaution.

The size of a power amplifier often provides clues to its performance. A ten watt amplifier properly rated will carry a larger power transformer if it is a triode job, than will a beam output one. But you should be suspicious of the "25 watt amplifier" whose "stack" is the size of a PA amplifier of ten years ago, pentode, beam output, or whatever it is.

The size of the output transformer of most high-fidelity amplifiers is also frequently an indication of its quality. A big transformer does not always insure quality, but wide response at high power just can't be had from the small (usually open-frame) outputs used on so-called 20 watt amplifiers in commercial consoles until recently. If the output transformer is mounted on the loudspeaker, under the amplifier chassis, or if it is of the open frame type, it is usually indicative of an amplifier not of the real hi-fidelity variety.

In a later installment on loudspeakers we will discuss the power requirements of various size rooms and try

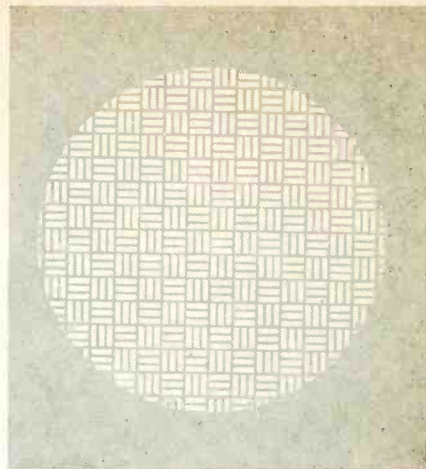

MODEL 12-A

The Model 12-A Flush Mounting Grille is made to house a 12" speaker. The 14 1/2" x 17" solid border is bonderized and prime coated for painting. The grille proper is furnished with a beautiful chrome plate or finished for painting the same as the border. The 12-A Grille mounted on each side of the stage in any auditorium will enhance the appearance of the room and when used with the NP-1268 PM Speaker, an all around pleasing and satisfactory sound installation can be assured. Write for literature on our Grilles, Baffles, Cabinets, and Speakers.

WRIGHT INC.

2239 Univ. Ave., St. Paul 4, Minn.

TECHNICAL ARTICLES WANTED

on TV, AM RADIO, FM RADIO, PHONO MECHANISMS, HI-FI AUDIO AUTO RADIO, TEST EQUIPMENT, ANTENNAS pertaining to their

Theory, Installation, Application, Service & Maintenance

submit manuscripts to
Managing Editor

Radio-Television Service Dealer

67 West 44 Street New York 36, N. Y.

BUSINESS FORMS for RADIO-TV SERVICE

Job Tickets, Sales Books, Work Sheets, Service Contracts, Service Charts, Call Routing System, Master Service Card System, Pricing System. All Designed for Radio and TV Service to help service dealers and technicians in dealing with their customers. See them at your Radio and TV Parts Distributor.

CATALOG FREE — Write Now

OELRICH PUBLICATIONS
4135 N. Lawler Ave., Chicago 41, Ill.

Send Free Catalog Enclosed is 25¢ for Catalog and Kit of Sample Sheets

Name _____

Address _____

City _____

FOR THOSE
HOT SPOTS

**AEROVOX AFH
ELECTROLYTICS**



Especially for elevated temperatures and high ripple currents, particularly in TV applications.

Light weight. High capacitance. Compact container. And of course the handy twist-prong mounting and easily-wired terminals. Single-, dual-, triple- and quadruple-section units. Connections clearly indicated on rear label. Expanded listings provide outstanding selection of voltages, capacitances, combinations.

Ask your distributor for Aerovox AFH electrolytics. Consult the Aerovox expanded listings.



**FOR RADIO-ELECTRONIC
INDUSTRIAL APPLICATIONS**
AEROVOX CORPORATION
NEW BEDFORD, MASS., U. S. A.

Canada: AEROVOX CANADA LTD., Hamilton, Ont.
Export: 41 E. 42nd St., New York 17, N. Y.

to show how to arrive at the power ratings mentioned in the first installment. Until then it is necessary to state arbitrarily some of the specifications for a basic power amplifier for a high-fidelity audio installation.

(1)—*Power capability*, at all frequencies which are to be reproduced—10 to 30 watts.

(2)—*Frequency response* smooth (within ± 2 db inside the desired limits, and no peaks outside those limits.)

(3)—*Harmonic distortion* 3% or less; *IM distortion* (at rated output) 5% or less. (40 to 100 cps & 4 kc to 9 kc, 4/1 ratio).

(4)—*Damping factor*—4 or greater (or *source impedance* ratio to output winding impedance, 1 to 4 or more).

Finally, consideration must be given to general detail of construction, ruggedness of parts (one amplifier uses only oil-filled condensers in the power supply for trouble free operation over long periods), and provision for a-c outlet, filament, and plate supplies for pre- and control-amplifiers, if needed.

[To be Continued]

VIDEO DETECTORS

[from page 25]

vertical wedge would indicate the rapidity with which the signal information can change from a dark to a light spot and the obscure wedge indicates a deficiency of some of the higher frequency components.

In Fig. 4 some of the fine grain vertical tweed lines are also visible indicating that some of the 4.5 megacycle signal has reached the grid of the picture tube. While these tweed lines are faint when photographed, they are readily perceptible when viewing the picture and are quite annoying because of the grainy appearance it gives the picture in a vertical plane.

Figure 5 shows a test pattern produced in the same receiver sometime later when the crystal detector has become more defective. You will note that the picture detail is very poor under this condition and that the contrast is not as good as it should be. Lack of sufficient contrast indicates a decline in the output from the video detector and the contrast control had to be advanced fully in order to procure the illustration shown in Fig. 5.

Germanium crystals can be checked with an ohmmeter. The resistance in one direction should be substantially higher than the resistance in the



For Inverting D. C. to A. C. . . .
Specially Designed for operating A. C. Radios, Television Sets, Amplifiers, Address Systems, and Radio Test Equipment from D. C. Voltages in Vehicles. Ships, Trains, Planes and in D.C. Districts.



A Full Size
LIGHTNING ARRESTER
at the Price of a Midget



LIGHTNING ARRESTER

MODEL TA5 Real protection against lightning and static charges — the RADIART Lightning Arrester has all the features! Fits anywhere... inside or out... handles standard or jumbo leads... no wire stripping necessary... does not unbalance the line... low internal capacity... no loss of signal... internal resistance "leaks off" static discharges! UNDERWRITERS LABORATORIES APPROVED.

THE **RADIART** CORPORATION
CLEVELAND 13, OHIO

1953 ALLIED CATALOG



236-PAGE
BUYING GUIDE

Complete
Up-to-Date
FREE!

EVERYTHING IN RADIO, TV
AND INDUSTRIAL ELECTRONICS

Service Technicians, Engineers: You'll want the latest ALLIED Catalog. It's complete, authoritative—packed with the world's largest stocks of test instruments, amplifiers, P.A. systems, tubes, parts, tools and accessories. Save time and money at ALLIED. Send today for your FREE 236-page Catalog.

ALLIED RADIO

ALLIED RADIO CORP., Dept. 26-K-2
833 W. Jackson Blvd., Chicago 7, Illinois
 Send FREE 1953 ALLIED Catalog

Name _____
Address _____
City _____ Zone _____ State _____

FREE—SEND FOR IT

other. Depending on the type crystal, resistances may vary from below 500 ohms in one direction to well over 10,000 ohms in the other. A substantially lower ratio than this would be cause for suspicion that the crystal is not a good rectifier. Direct substitution is a good means for proving such suspicions.

The alignment of the 4.5 megacycle trap is simple and no test equipment is required. The slug of the 4.5 megacycle trap is adjusted until the vertical line interference on the picture tube disappears or is at a minimum.

In some receivers using the older intercarrier system, the 4.5 megacycle trap also formed part of the sound

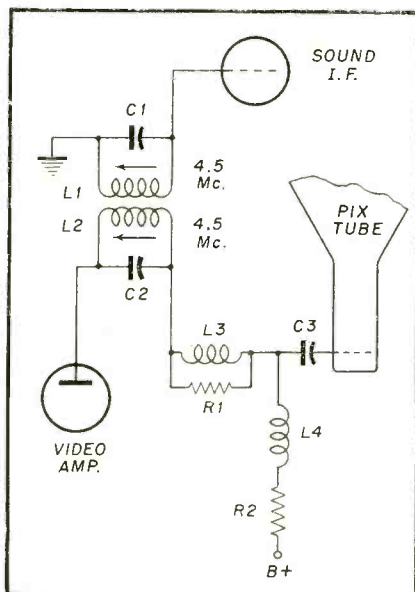

Fig. 6—In older intercarrier sets sound i-f produces trap effect.

take-off transformer as shown in Fig. 6. When this is the case, alignment again can be made without the use of a test pattern inasmuch as the sound signal in intercarrier receivers is always 4.5 megacycles. Thus, with a station tuned in, the composite video signal from the output of the video amplifier of Fig. 6 would also contain a strong 4.5 megacycle sound i-f component. Thus, the slug tuning of the L_2 , C_2 , resonant circuit can be made initially for best sound output. (The fine tuning of the receiver should be set for best picture quality.)

After the resonant circuit, L_2 and C_2 has been tuned for maximum sound output, the secondary section comprising L_1 and C_1 should be adjusted for maximum sound. After this the L_2 and C_2 circuit should again be adjusted for the point which produces maximum sound with a minimum of the 4.5 megacycle beat interference on the picture tube screen.

AD INDEX

Aerovox Corporation	71
Allied Radio Corp.	72
American Phenolic Corp.	14
American Television & Radio Co.	71
Argos Products Co.	62
Astron Corporation	55
Audio Fair	66
Blonder-Tongue Laboratories, Inc.	57
Bussmann Manufacturing Co.	11
Centralab	36, 37
Channel Master Corp.	22
Clarostat Mfg. Co., Inc.	15
Columbia Wire & Supply Co.	60
Copperweld Steel Co.	64
Erie Resistor Corp.	64
Guardian Elec. Mfg. Co.	68
Hytron Radio & Electronics Co.	17
JFD Manufacturing Co., Inc.	Cover 2
K-G Electronics Corp.	68
LaPointe-Plascomold Corp.	21
Mallory, P. R. & Co., Inc.	1
Mowely Electronics	66
Oelrich Publications	70
Perma-Power Company	18
Precision Apparatus Co., Inc.	2
Radiart Corporation	7, 51, 72
Radio Merchandise Sales, Inc.	70
Radion Corporation, The	16
Rauland Corporation	5
Raytheon Manufacturing Co.	9
RCA Tube Dept.	
RCA Batteries	20
RCA Electron Tubes	Cover 4
Regency	Cover 3
Rider, John F. Publisher, Inc.	63
Sams, Howard W. & Co., Inc.	6
Snyder Manufacturing Co.	8
Sprague Products Co.	4
Standard Transformer Corp.	67
Supreme, Inc.	59
Telescopic Products	56
Telrex, Inc.	61
Transvision, Inc.	10
Trio Manufacturing Co.	12, 13
Triplett Elec. Instrument Co.	53
United Catalog Publishers	66
Utah Radio Products Co., Inc.	58
Vaco Products Co.	65
Wright, Inc.	70

Regency

HIS CHOICE IS

LARGEST SELLING VHF BOOSTER...

AT ANY PRICE!

VICTOR MUCHER, PRESIDENT
CLAROSTAT MFG. CO., INC.
PHOTOGRAPHED IN HIS OFFICE,
NEW HAMPSHIRE HOME

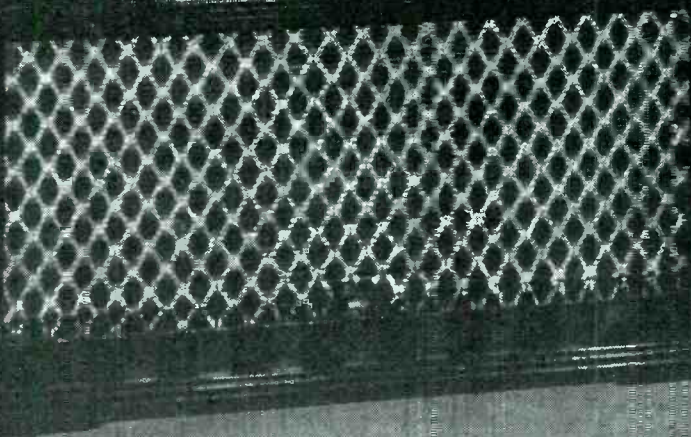
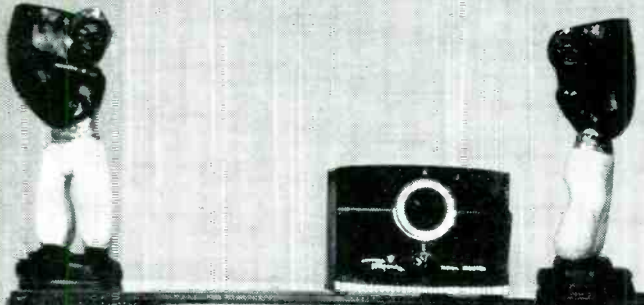

BURTON BROWNE ADVERTISING

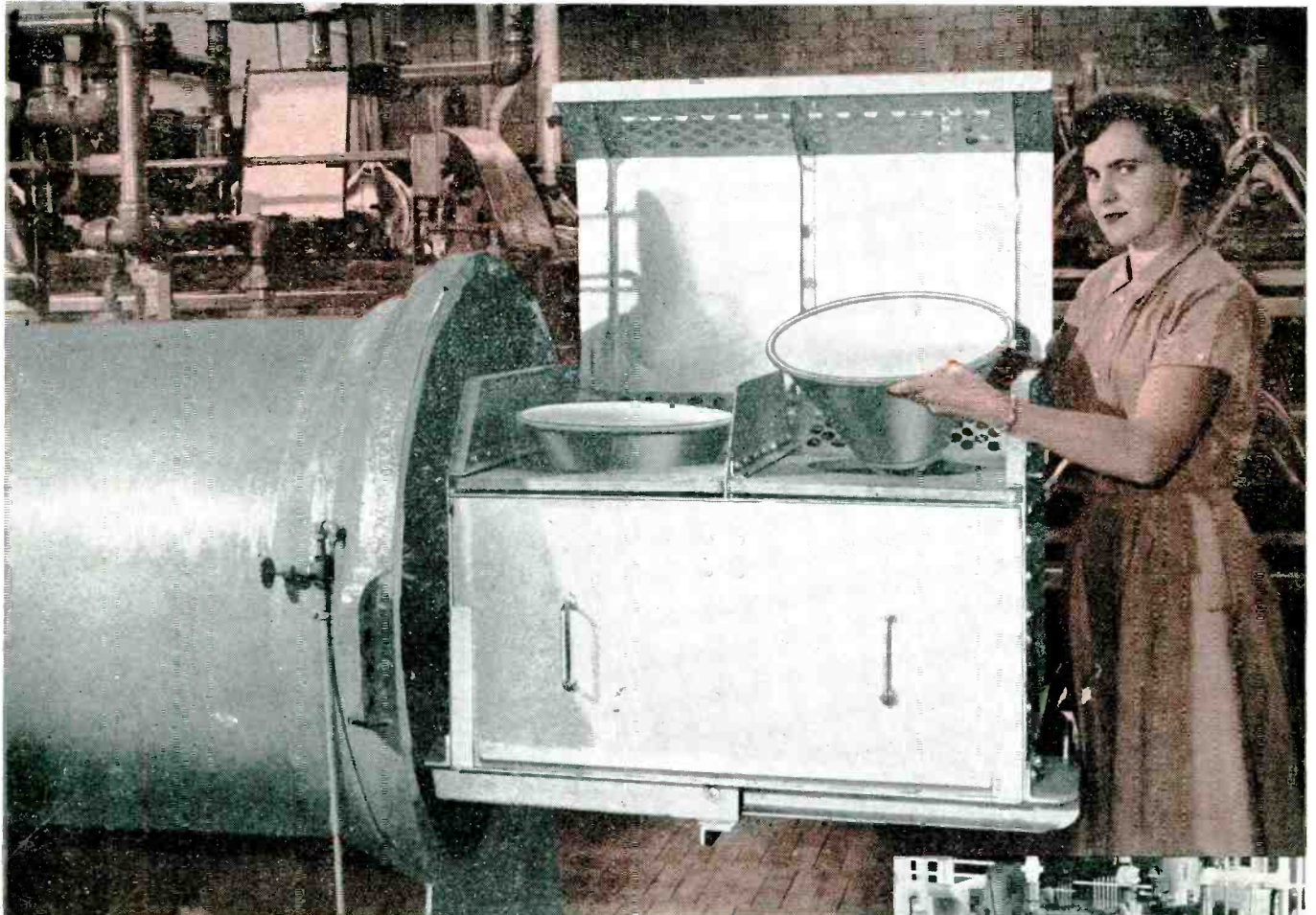

Top: Picture tubes being placed into carriage before being rolled into chamber. Right: Operator admitting compressed air into chamber.

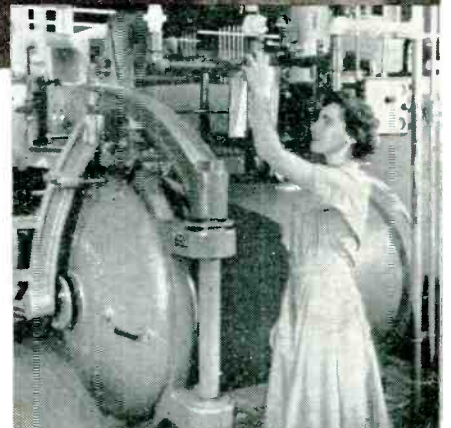

The **Torture Chamber** that tests the strength of RCA Picture Tubes

How *strong* is a picture tube? Well, certainly no stronger than its envelope. And that means that poor sealing of glass-to-glass or glass-to-metal, improper annealing of the glass—and even thermal or physical shock during manufacture—can contribute to structural weakness.

How *strong* should a picture tube be? Obviously, it must at least have adequate strength to be handled, transported, and installed safely. To insure safety, RCA has established a rigid standard of strength based on

air-pressure tests evolved through unequaled years of experience.

Throughout the day, glass and metal picture tubes of each size are picked at random from the production lines, and placed in an air-compression chamber where they are subjected to "torturing" pressure for several minutes. Any tubes failing this test are examined by RCA production inspectors who can trace the fault and correct it on the production line almost as soon as it appears. Result . . . *structurally weak tubes never reach your shop.*

RCA's constant vigilance at *all* stages of manufacture is your assurance that only top-quality RCA picture tubes leave the factory. In this way, RCA closely guards its own reputation . . . *and yours as well.*

With RCA Receiving Tubes, as well as RCA Kinescopes, **TOP-QUALITY CONTROL** makes the difference.



RADIO CORPORATION of AMERICA

ELECTRON TUBES

HARRISON, N. J.

TMK. ®