

JUNE, 1952

Radio-Television **SERVICE DEALER**

LAIM SOB 135 JAN 53
BERK'S ELEC SERVICE
TEMPLE PA



The Professional Radio-TVman's Magazine

IN THIS ISSUE:

Picture Tube Failures

Video Amplifiers, Part 2

A New Service Dealer Sales Plan

Oscilloscope Wave Shapes

AM-FM-TV-SOUND

Where **Clarostat Standard** replacements are feasible **OK**; but where critical requirements must be matched-insist on



STANDARD: Simple snap-together Clarostat replacement — Series AG 15/16" control with Series SWB Ad-A-Switch and Series FKS-1/4 fine knurled slotted Pick-A-Shaft.

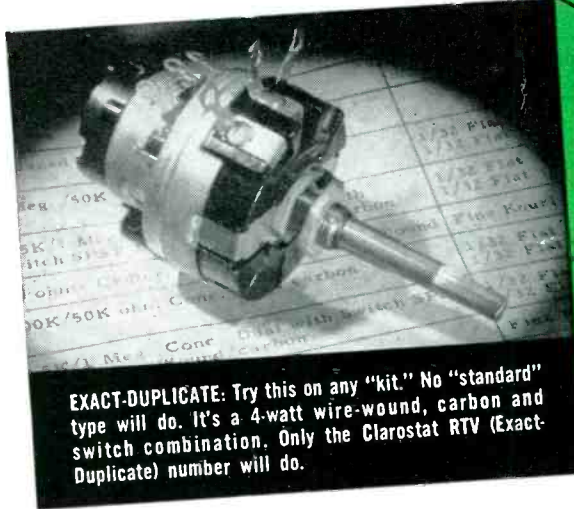

EXACT-DUPLICATE: Try this on any "kit." No "standard" type will do. It's a 4-watt wire-wound, carbon and switch combination. Only the Clarostat RTV (Exact-Duplicate) number will do.

Clarostat *Standard* controls are handiest among standard replacements. First, there's the choice of either 1 1/8" or 15/16" sizes. Then there's the choice of AD-A-SWITCHES, instantly attachable to the given control. Third, there's the choice of ten PICK-A-SHAFTS, any one instantly attachable to the given control. Definitely, minimum stock takes care of maximum replacement needs. But . . .

Where replacement needs are so critical that even the versatile Clarostat Standard controls will not do — particularly with dual concentrics — the *Clarostat RTV program* comes to your rescue. Almost 300 exact-duplicate numbers . . . covering over 5,500 TV models of approximately 125 set manufacturers . . . in most instances *exact* matches of the original equipment. Install them — forget them!

Your Clarostat distributor stocks both STANDARD and RTV replacements for your convenience. And Clarostat provides the outstanding servicing data.

CLAROSTAT

Exact Duplicate

Controls

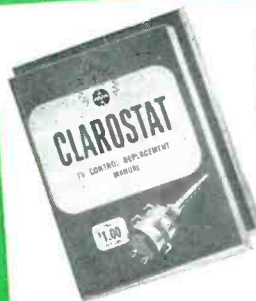

The Clarostat TV Control replacement Manual (and supplements) tells you what control to use. Ask your distributor for it!

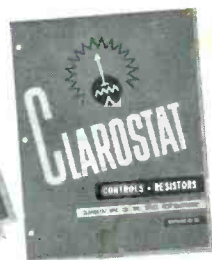

Clarostat latest catalog No. 51 lists the greatest choice yet of controls and resistors. Ask your distributor for your copy.

Controls and

CLAROSTAT MFG. CO., INC., DOVER, NEW HAMPSHIRE
Export: 25 Warren Street,
New York 7, N. Y., U. S. A.



Resistors

In Canada:
Canadian Marconi Co., Ltd.,
Toronto, Ont.

Why take a chance?

Some people make their living by taking chances. But you must make your living by earning customer satisfaction—so why take chances by ordering capacitors by rating only? Order by rating *and* brand!



Make Sure! Make it Mallory!

Customer satisfaction with your service pays off in repeat business . . . word-of-mouth advertising . . . cash in the bank. You can build it by using Mallory capacitors on all your service work.



Top-notch TV and radio set makers accept Mallory FP's as *the* standard of capacitor quality. You get longer life even with higher temperatures and greater ripple current . . . dependable operation even at 185° F. (85° C.).



Mallory Plascaps* leave ordinary plastic tubulars far behind! Dependable performance . . . no leaks . . . no premature "shorts" . . . no off-center cartridges . . . and no unsoldered leads. It will pay you to use Mallory Plascaps—the first completely engineered plastic tubular!

Back of every Mallory capacitor is the knowledge and experience gained in 25 years of research and development work. Mallory produced the first dry electrolytic capacitor . . . pioneered in making smaller, longer-lasting capacitors with outstanding heat-resistant qualities. There's just no sense in taking chances on capacitor performance. Always be sure . . . always order Mallory capacitors for all your service work.

Depend on your Mallory Distributor for quality products at competitive prices.

P. R. MALLORY & CO. Inc.
MALLORY

CAPACITORS • CONTROLS • VIBRATORS • SWITCHES • RESISTORS
• RECTIFIERS • VIBRAPACK* POWER SUPPLIES • FILTERS

*Reg. U.S. Pat. Off.

APPROVED PRECISION PRODUCTS

P. R. MALLORY & CO., Inc., INDIANAPOLIS 6, INDIANA

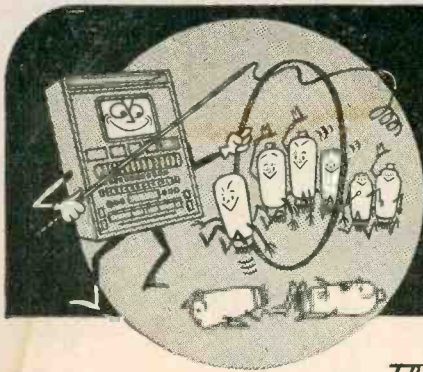

THE INSTRUMENT THAT DEMANDS **OVERALL PERFORMANCE** FROM THE TUBE UNDER TEST!

-PRECISION- SERIES 10-12

Electronamic* Tube PERFORMANCE Tester

with 12 element free-point Master Lever Selector System

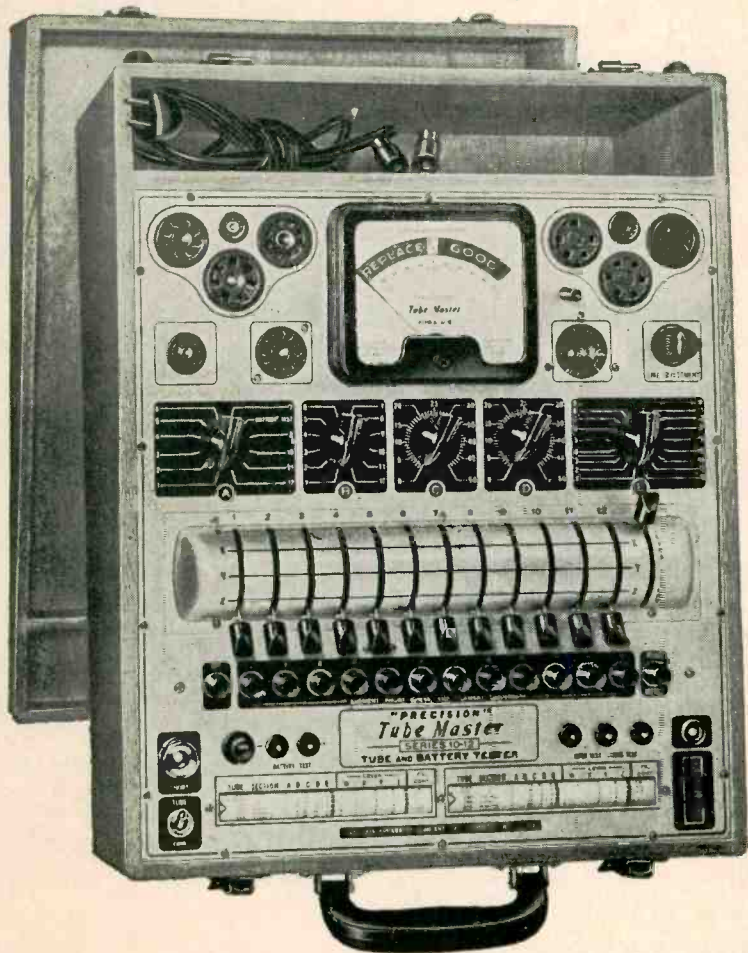

Model 10-12-P (illustrated): in sloping, portable hardwood case with tool compartment and hinged removable cover. Sizes 13 3/4" x 17 1/4" x 6 3/4" \$104.50
Model 10-12-C (Counter Type) \$109.25
Model 10-12-PM (Panel Mount) \$109.25

To test modern tubes for only one characteristic will not necessarily reveal **OVERALL PERFORMANCE CAPABILITIES**. Modern tube circuits look for more than just mutual conductance or other single factor.

It has been conclusively proven that even though a tube may work well in one circuit, it might fail to work in another—simply because different circuits demand different relative performance characteristics, such as amplification factor, plate resistance, power output, emissive capability, etc.

In the PRECISION "ELECTRONAMIC" Circuit, the tube under test is made to *perform* under appropriately phased and selected individual element potentials, encompassing a wide range of plate family characteristic curves. This **COMPLETE PATH OF OPERATION** is electronically integrated by the indicating meter circuit in the positive performance terms of *Replace-Weak-Good*.

The efficiency of this "Electronamic" test results from encompassing several fundamental tube characteristics, **NOT JUST ONE**. Accordingly, when a tube passes this demanding **OVERALL PERFORMANCE** test, it can be relied upon, to a very high degree, to work satisfactorily.

*REG. U.S. PAT. OFF. T. M. 430,006

Compare these features

- ★ Facilities to 12 element prongs.
- ★ Filament voltages from 3/4 to 117 V.
- ★ Tests Noval 9 pins; 5 and 7 pin acorns; double-capped H.F. amplifiers; low power transmitting tubes, etc., regardless of filament or any other element pin positions.
- ★ Isolates each tube element regardless of multiple pin positions.
- ★ Dual Hi-Lo short check sensitivity for special purpose tube selection.
- ★ Simplified, High Speed, 12 element Short-Check system, uses consecutive push-button switching.
- ★ Battery Tests under dynamic load conditions.
- ★ 4 1/2" Full Vision Meter.
- ★ Built-in Dual-Window, high speed, geared roller chart.
- ★ Free Replacement Roll Charts & supplementary tube test data service.

See the "Precision" Master "Electronamic" Tube Testers at leading Radio Equipment Distributors. Write for new, 1952 "Precision" catalog.



PRECISION APPARATUS CO., INC.

92-27 Horace Harding Boulevard, Elmhurst 8, New York
Export Division: 458 Broadway, New York 13, U.S.A. • Cables—Morhanex
In Canada: Atlas Radio Corp. Ltd., 560 King Street, W., Toronto 2B

Convenient "PRECISION" Purchase Terms can be arranged with your local and favorite authorized "PRECISION" Distributor.

AM • FM • TV •

AM • FM • TV

EDITORIAL

by S. R. COWAN

TV Still A Killer

Between May 1st and 14th Associated Press releases reported four accidental deaths, in various parts of the country, because of laymen trying to service their own TVsets. Two men died when they allowed an antenna transmission line to hit high tension wires; one died when changing a picture tube while the set was still turned on and the third was electrocuted when "He allowed his screw-driver to touch something" as he tried to fix his own receiver, so quote his widow.

We wonder how many of these four corpses bought copies of "Fix-it Yourself" service books. There's no way of telling but it would be interesting to know.

About Hams and TVI

On May 1st FCC reopened to amateurs the 21 to 21.45 mc bands. (Some diathermy machines use the same frequencies.) Thus, it was to be expected that TVset owners might find amateurs interfering with their programs. To date only a few such instances have been reported, but it is expected that ever-increasing numbers of complaints will come to light as time passes, and as more hams get on their newly authorized frequencies. You must remember that when a ham is working on 21/21.45 mc he is doing so with the blanket authorization of FCC and the law's fullest protection, and if some TVset owner finds himself "bothered" he has no choice other than that of correcting the situation by having his set fixed so it will not be subject to interference. It's not within our province to discuss the merits of basic TVset design and manufacture. Some of the cheaper sets on the market and in homes are not built with proper screening and protection, and these will have to be serviced by competent technicians if they run into trouble. To that end, a complete series of technical articles on the subject of filtering and rectifying is scheduled for publication in this journal. Interference can take effect from so many different originating points that it will require quite a long time in which to cover the subject properly.

Color TV In News Again

NPA Administrator Henry Fowler said, on May 6th that "The ban on production of color TVsets for home use might be relaxed very soon." Such news will startle no one for it is meaningless. Color TV by incompatible methods is the horse-and-buggy type of system that has no place in a world of jet propulsion. So, let's forget color TV for now, or at least until FCC gives a compatible method their okay. At such a time any announcement about there being color TV will mean something.



Sanford R. Cowan
EDITOR & PUBLISHER

Samuel L. Marshall
MANAGING EDITOR

COWAN PUBLISHING CORP.
67 WEST 44TH ST.
NEW YORK 36, N. Y.



Vol. 13 NO. 6

JUNE, 1952

Editorial	3
Trade Flashes	4
Sync Pulses, by <i>San D'Arcy</i>	14
Picture Tube Failures, by <i>David Gnessin</i>	17
Chemical, mechanical and other reasons why picture tubes go bad.	
New Tubes	20
The 1AX2, long-life, reliable, high-voltage rectifier.	
Videc Amplifiers, Part 2, by <i>Leonard Lieberman</i>	21
Video amplifier compensation and auxiliary control circuits.	
A New Service-Dealer Sales Plan, by <i>Richard Mattison</i>	23
How a Service Dealer can sell TV sets with a minimum of capital and a maximum of credit.	
Oscilloscope Wave Shapes, by <i>Allan Lytel</i>	25
Basic wave shapes that may be obtained on your scope and which enable you to understand more fully its operation.	
Trade Literature	28
New catalogs, booklets, periodicals, manuals, and textbooks.	
Shop Notes	29
RCA-Improved Kinescope dust seal. Reactivating C.R.T.'s 12VP4 substitution. Chrysler 1951 auto sets—Fuses blow. Ford auto set—Intermittent.	
Association News	30
Association activities from all over the country.	
Personnel Notes	32
Appointments, promotions, changes, and assignments of personalities in the trade.	
New Products	34
Ad Index	48

SANFORD L. CAHN, Advertising Director HARRY N. REIZES, Advertising Manager
DAVID SALTMAN, Production Mgr. CHARLES LO CICERO, Circulation Mgr.
TED E. SCHELL, 112 West 9th St., Los Angeles 15, Calif., VAndike 8921

RADIO-TELEVISION SERVICE DEALER is published Monthly by Cowan Pub. Corp., 67 West 44th St., New York 36, N. Y. Subscription price: \$2 per year in the United States, U.S. Poss. & Canada: elsewhere \$3. Single Copies: 25c. Reentered as second class matter Sept. 25, 1950 at the Post Office at New York, N. Y. under the Act of Mar. 3, 1879. Copyright 1952, Cowan Pub. Corp.

SERVICEMAN'S DIARY... by Ben Grim



NEW!
UNIVERSAL
REPLACEMENT
HI-VOLTAGE
"DOORKNOB"
CERAMIC...



FURNISHED WITH
SCREW-IN TERMINALS
TO MEET EVERY NEED!

An ingenious screw-in terminal system makes Sprague's new type 20DK-T5, 500 mmf, 20,000 volt molded case ceramic capacitor fit most every TV set. All you have to do is select the proper set of terminals, two twists of the wrist, and there you are!

With this new Sprague development, you need only one capacitor in your kit to service sets up to 21" tubes.

Sprague's 20DK-T5 "Doorknob" ceramic is molded in genuine thermosetting plastic, non-flammable and moisture-resistant. Guard rings are molded in both faces to lengthen the surface leakage path. Write for complete catalog C-608 to Sprague Products Co., 71 Marshall St., North Adams, Mass.



WORLD'S LARGEST
CAPACITOR MANUFACTURER

Don't Be Vague!
Insist On Sprague

TRADE FLASHES

A "press-time" digest of
 production, distribution,
 and merchandizing
 activities

First Quarter Radio-TV Production, More Than 40 Per Cent Under 1951

Radio and television set production in the first quarter of this year dropped more than 40 per cent under the output in the corresponding 1951 period, the Radio-Television Manufacturers Association reported recently. The output in the first three months of 1952 totaled 3,692,631 receivers compared with 6,432,230 in the first quarter of last year.

Production of radios and TV sets was down 44 and 40 per cent, respectively, in the first quarter, RTMA estimated. The radio output aggregated 2,367,800 units and TV sets produced numbered 1,324,831 in the period. A breakdown of the radio output showed 959,117 home sets, 241,019 portables, 806,240 auto sets and 361,424 clock receivers.

Radios with FM circuits manufactured in the first three months of this year totaled 123,685 sets. In addition, 27,107 TV sets containing FM facilities were produced. Production in March, a five-week period, showed 510,561 TV receivers and 975,892 radios compared with 870,000 TV sets and 1,720,079 radios in the corresponding 1951 month.

First RTMA Annual Award To Be Presented Gen. Sarnoff

Brig. Gen. David Sarnoff, Chairman of the Board of Directors of the Radio Corp. of America, was elected as first recipient of the RTMA Annual Award for outstanding contributions to the advancement of the radio-television industry by the Association's Board of Directors during meetings April 24-25 at the General Brock Hotel, Niagara Falls, Ontario. The award will be made to General Sarnoff at the RTMA Industry Banquet on June 26, at the Palmer House, Chicago. The award was authorized by the RTMA Board of Directors in February. It will be made annually to the person, company or organization which the RTMA Directors believe has per-

Makeshift replacements... reduce picture quality

Replacements with Raytheon Television Tubes assure picture quality

Right for Sight



RAYTHEON PICTURE
TUBES

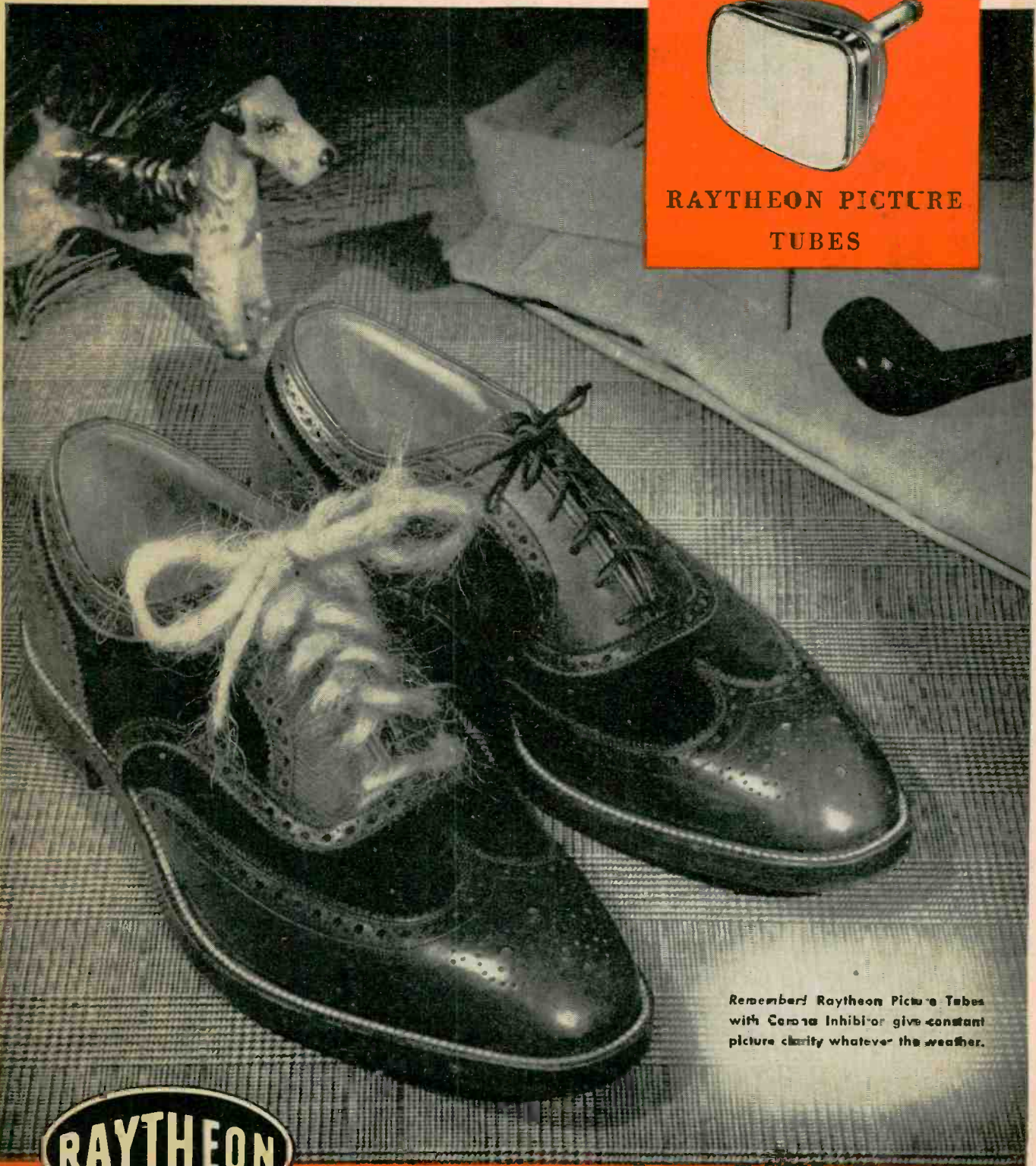

Remember! Raytheon Picture Tubes with Camera Inhibitor give constant picture clarity whatever the weather.



RAYTHEON MANUFACTURING COMPANY

Receiving Tube Division

Newton, Mass., Chicago, Ill., Atlanta, Ga., Los Angeles, Calif.

RECEIVING AND PICTURE TUBES • RELIABLE SUBMINIATURE AND MINIATURE TUBES • GERMANIUM DIODES AND TRANSISTORS • RAD. AC TUBES • MICROWAVE TUBES •

PHOTOFACT Users Write Our Best ADS!

Hundreds of unsolicited letters tell what the world's finest Radio & TV Data means to Service Technicians



Morris Auslander
Auslander Radio & TV
Queens Village, L.I., N.Y.

"SAMS' has been my bible. When I lacked experience, I was, with your data to guide me, more than able to undertake servicing. For the beginner technician, a knowledge of theory, combined with willingness to learn—plus SAMS—is a combination that will carry one to the peak of successful servicing."



David F. Kocsis
629 W. Parkway
Flint, Michigan

"Whenever I need information, I know I can rely on you. Your PHOTOFACTS convinced me of that long ago...it's wonderful service."



Harold W. McConnell
Radio & TV Service
Washington, Penna.

"Your diagram service was greatly improved by the DC voltages and P-P voltages and wave forms placed on the schematics. This is a great aid to the serviceman, and I hope you will continue to keep up the good work."

NOW! GET THE PROOF FOR YOURSELF!

FREE

We'll send you a Free Photofact Folder on any receiver listed in "PF Index & Technical Digest."

Learn for yourself—at our expense—how PHOTOFACT pays for itself by earning bigger repair profits for you! Select any Folder from the PF Index (if you haven't an Index, get a free copy from your distributor). When you write us for your Free Folder, be sure to state Photofact Set and Folder Number as shown in the Index. Get your Free Folder now. Examine, use, compare—see why you can't afford to be without PHOTOFACT!

HOWARD W. SAMS & CO., INC.
2201 East 46th Street • Indianapolis 5, Indiana

formed a distinctive service for the industry.

Gen. Sarnoff was nominated for the award by the Annual Awards Committee headed by Director Leslie F. Muter and he was the unanimous choice of the Committee. Chairman Muter said the award will recognize his many achievements which over a period of years have helped bring the industry to its present stature.

Nearly 86 Million Receiving Tubes Sold During First 1952 Quarter

Nearly 86 million receiving tubes were sold in the first quarter of this year, according to a report from member-companies of the Radio-Television Manufacturers Association. Total sales for the first quarter were 85,934,322 units compared with 118,277,243 in the same 1951 period.

Large Rectangular Picture Tubes Represented 98 Percent of Sales in Quarter

Rectangular television picture tubes 16 inches and larger in size represented 98 per cent of the sales to set manufacturers in the first quarter of this year, according to the Radio-Television Manufacturers Association. A year ago 84 per cent of the tubes sold to manufacturers were rectangular in form and 94 per cent of their purchases, both round and rectangular tubes, were 16 inches in size and larger.

Municipal TV-Service Regulations

The following item appeared in "Retailing Daily," Friday, May 2, 1952:

Lincoln, Neb., May 1.—An ordinance providing for a \$3 inspection fee for instalment of television antennas has been introduced in the city council by Councilman Pat Ash. All new television antennas would have to be registered with the city and inspected by the city electrical inspector under terms of the ordinance, which also provides a \$100 maximum fine for conviction of violation.

The ordinance was patterned largely after laws in other cities which were studied by the city councilmen. It would also empower the electrical inspector to check any antenna currently in operation, but does not require a check of all now being used.

Mr. Ash explained that the ordinance is aimed at making antennas stable against high winds and grounding them against lightning.

The following item appeared in "Retailing Daily," Monday, May 4, 1952:

TEST-ADJUST TELEVISION SETS AT *Your* CONVENIENCE

Even without station test pattern or in remote, weak signal areas!

A television set will produce a picture only when it is supplied with a COMPOSITE VIDEO SIGNAL. To check any TV set properly, you must have a COMPOSITE VIDEO SIGNAL.

Every TV station sends a COMPOSITE VIDEO SIGNAL when telecasting a program or a test pattern. This COMPOSITE VIDEO SIGNAL is composed of — (1) a synchronizing and blanking signal to lock the free running raster into a frame of two interlaced fields, and — (2) a video signal to control the amount of light and produce the picture (which may be a program scene or a test pattern for analysis purposes).



SUPREME MODEL 665

The SUPREME COMPOSITE VIDEO GENERATOR provides the same type of sync and blanking signal as the TV station—even the equalizing pulses. In addition, it incorporates a video section which generates a special test pattern for analysis and adjustment of TV sets. Other patterns or pictures can be presented by using auxiliary equipment connected to the special "gated" video input section of this versatile instrument. The Model 665 should not be confused with the cross-hatch or bar-pattern generators. The Supreme Model 665 supplies a COMPOSITE VIDEO SIGNAL.

Why lose time and money waiting for that ideal scene or test pattern to check a TV set? In fringe or weak signal areas, you are strictly in the "driver's seat" with a SUPREME COMPOSITE VIDEO GENERATOR. Write SUPREME, Inc., Dept. C-7, GREENWOOD, MISSISSIPPI for descriptive folder.

Our 25th Year

SUPREME

Testing Instruments

"SUPREME BY COMPARISON"

TUBE TESTERS • OSCILLOSCOPES
SIGNAL GENERATORS • MULTI-METERS
FOR RADIO AND TELEVISION

NOW

... VOLUME III!

96 new photos over 200 pages!

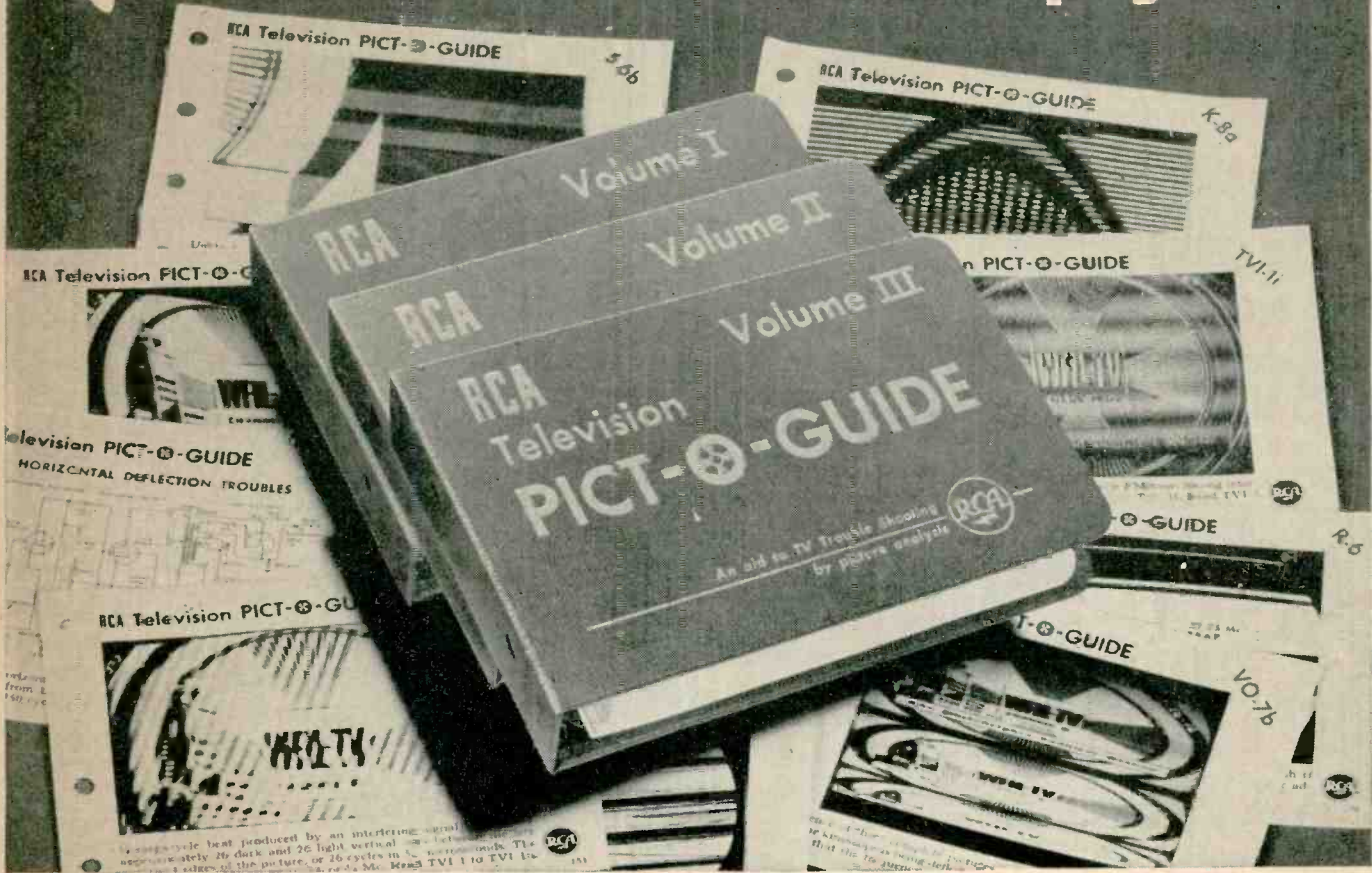

TMKS.©

YOURS

—Vol. I, II, or III... with each order for 75 RCA receiving tubes or 3 RCA kinescopes

THE RCA Tube Department proudly announces the publication of Volume III of the famous RCA TELEVISION PICT-O-GUIDE... another significant addition to the PICT-O-GUIDE series, recognized as the most useful, practical servicing information in the industry for helping you locate and solve TV troubles by picture analysis.

Authored by John R. Meagher, RCA's noted TV Service Authority, Volume III contains completely new data on television interference, built-in and external ghosts, hum troubles, and a host of

trouble-shooting techniques applicable to all TV sets. It's information you can't afford to be without.

For a limited time only, you can have your choice of PICT-O-GUIDE Volume I, II, or III with each order for 75 RCA receiving tubes or 3 RCA kinescopes. It's as simple as that.

This is your chance to get the complete set of three matched volumes to bring your library up-to-date. But don't miss out on this limited offer! Place your qualifying tube order with your RCA Tube Distributor at once.

PLUS THIS BONUS

"TV Servicing Supplement"—*Trouble Shooting "Tough" Sets or "Dogs."* This indispensable book by John Meagher tells you how to handle the really tough TV sets... the ones that take the most time to analyze and repair. It's a "Post-graduate course" in TV trouble-shooting. You get a bonus copy with each Pict-O-Guide volume you earn. This is a bonus offer you won't want to miss!

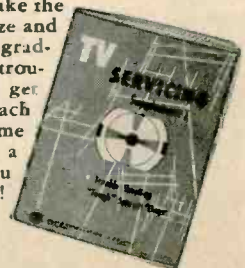

RADIO CORPORATION of AMERICA

ELECTRON TUBES

HARRISON, N. J.

Los Angeles, May 4.—The Board of Supervisors here, at the week-end strengthened the county ordinance which regulates the business of repairing television sets.

Following a report from County Manager Arthur J. Will that the law in its present form is reasonably adequate in protecting the public but that a more rigid supervision of the repair industry is indicated, the Board ordered the following new clause inserted in the ordinance: Revocation of license will be the penalty invoked against any repairman who charges for parts not installed or makes any

false statements relating to repairs or service.

The same penalty will result where serial numbers on the TV sets are altered or mutilated.

NEDA Dominion Chapters Adopts 5-Point Program

A five-point program was recommended by the Old Dominion Chapter of the National Electronic Distributors Association when they convened for a two-day session April 18 and 19 in Hotel John Marshall, Richmond, Virginia.

Points recommended include:

1. That advertising (or promotion-

al) funds be made available by the manufacturers at dealer level. This is for promotion of brand name merchandise (of the parts industry) directly to the public.

2. That rebuilt picture tubes be branded as such.

3. That tube manufacturers stop the sale of sub-standard tubes from their production lines.

4. That manufacturers consider the adoption of a uniform policy to channel all small orders from industrials through distributors.

5. That the question of Service Licensing requires the concerted action of the industry against all licensing programs. It was resolved that the Chapter recommend that a Service-men-Dealer Advisory Committee be appointed by the president of the Show Corporation for the purpose of actively campaigning on this issue. It was recommended, too, that this committee explore the possibility of establishing an educational program for the serviceman, dealer and distributor customer.—This program to be concerned with both technical and business administration problems.

Du Mont Honored At Exhibit

Allen B. Du Mont Laboratories, Inc., and its president, Dr. Allen B. Du Mont are both honored by the "Industrial Progress, U.S.A." exhibit of the Edison Institute, which was opened to the public view recently (Sunday May 4) at the Henry Ford Museum, Dearborn, Michigan. The exhibit will shortly embark on a cross-country tour to all cities of the United States of more than 100,000 population.

Dr. Du Mont, along with Thomas A. Edison and Dr. Lee DeForest is named in the exhibit as an outstanding contributor to the field of home entertainment. The Du Mont organization has been singled out as the only television or radio manufacturer to place its products in the home entertainment exhibit.

New Rep Directory

At the regular meeting of the N.Y. Chapter of THE REPS was held at Rosoff's Restaurant in Times Square, on Tuesday, April 8th. John Kopple, Chairman of the Roster Printing Committee, announced that the Reps Roster-Directory would be off the press by May 1st. Those desiring copies should write to John Kopple, 60 E. 42nd Street, or to Wally Shulan, 136 Liberty Street, both in New York City.

The Directory will be printed in three sections. One section will list the Member Reps alphabetically. The

"CONICAL-V-BEAMS"
REGISTERED TRADE MARK

"BAT WING"

by *Telrex* — the finest **TOP-OF-SET** antenna ever produced!

SUPER-PERFORMANCE!
Beyond a doubt, the finest top-of-set TV antenna ever offered the trade. Outperforms any other indoor type and requires no tuning or pruning. No fuss, bother or time consuming adjustments. **SUPERIOR STYLING!** Featuring modern design that enhances any living room. Rich aluminum elements are mounted on a finely finished, tip-proof base. **WRITE FOR NEW LITERATURE** with complete information on the whole Telrex line for TV, UHF and FM.

CLOVER-V-BEAM E-Z RIG design. A high gain, compact array for attic or outdoor installation.

NEW! Telrex "FISHBONE". Ten WORKING elements. Guaranteed to outperform any yagi on the market.

NEW! "CONICAL-V-BEAMS" WITH HI-V-REFLECTOR Standard on all Monarch and Universal Series antennas.

"CONICAL-V-BEAMS" are covered by Patent No. 23,346
CANADIAN and FOREIGN PATENTS PENDING

Be sure it's a **"CONICAL-V-BEAM"** — look for the *Telrex* TRADEMARK

Telrex INC.
CONICAL-V-BEAMS

AMERICA'S OUTSTANDING TELEVISION BEAM

ASBURY PARK 5, N. J.

For the **clearest** picture of campaign progress...



Rauland PICTURE TUBES

Man, what a year for TV—and TV service profits! The richest menu of regular attractions ever offered to viewers... PLUS the party conventions, the campaign, the elections and inauguration! When viewers need replacement picture tubes, they'll want them fast—and good.

So remember that Rauland alone

offers these replacement profit advantages:

- The *most complete* line of replacement picture tubes... a far better supplement for your regular tube line than a second line of receiver tubes.
- The faster, *surer* installation adjustment made possible by the patented Indicator Ton Trap.

• The dependable, uniform *extra* quality that so many smart service men depend on for assured customer satisfaction.

Remember, Rauland research has developed more "firsts" in picture tube progress since the war than any other maker. And this leadership pays off... in your customers' satisfaction.

THE RAULAND CORPORATION



Perfection Through Research
4245 N. KNOX AVENUE • CHICAGO 41, ILLINOIS



103 BIG PRIZES FOR

To be given in G.E.'s great **B\$S\$B***

THREE BRAND-NEW

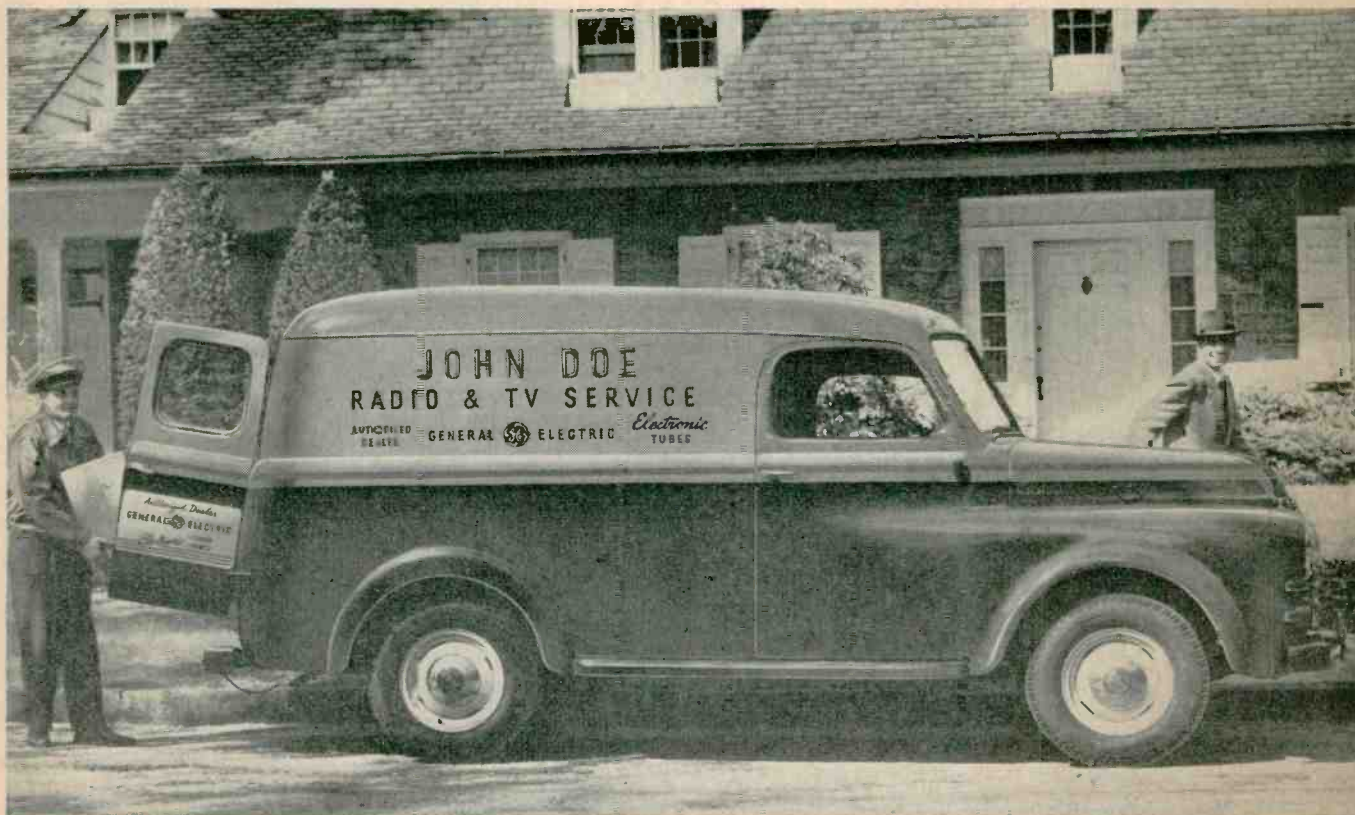

LOOK AT THESE BEAUTIFUL PRIZES YOU CAN WIN!



MEN'S CALENDAR WATCH, a handsome Benrus with gold expansion band, *plus* gold wind-proof cigarette lighter and matching gold cuff links and tie bar. All fitted in a smart and distinctive case.



LADIES' WRIST WATCH, a beautiful Benrus hinged-cuff "Embraceable" with safety chain; also, chic gold earrings and a stunning pendant-and-brooch combination. Can be a wonderful gift from you.

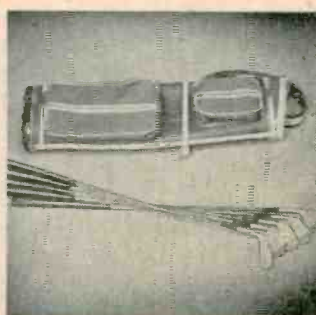

MATCHED GOLF IRONS, Wilson, with long-lasting nylon Wilson golf bag. Nos. 2, 5, 7, 9, and putter, Gene Sarazen Stroke-master model. Clubs, nationally distributed, can be filled in any time.

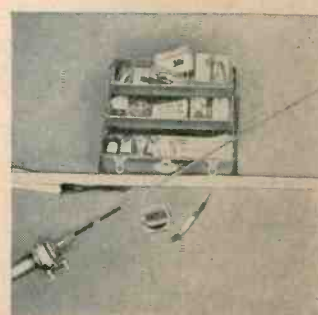

FISHING KIT, 27 items in a double-tray cork-lined tackle box. Gep glass casting rod, Green Hornet level-wind reel, fish rule and scale, Pflueger spoons and spinners, plugs, hooks and leaders.

SERVICE DEALERS!

Promotion Contest topped by

'52 DODGE TRUCKS!

***B. S. B.—Bigger Summer Business** tells the story! Increase your profits and walk off with a brand-new Dodge panel truck! General Electric's B. S. B. Contest offers you this double bonus.

The contest's loaded with 103 prizes! It's primed with new sales-getting helps for you, as shown at right. Contest starts now and ends August 15—weeks that are summer radio-TV check-up time for millions.

Yardstick of the contest will be how successfully you promote your own service business in terms of *planning, originality, and results*. G. E. will support you with special full-page tie-in ads in national magazines read by 35,000,000.

First prize to each of the three top winners will be a new '52 Dodge panel truck, handsomely lettered with your name and address.

100 other prizes—all big values, all mighty attractive!

ENTER NOW—HERE'S HOW!

● **Phone, write, or see your G-E tube distributor** for (1) descriptive folder that gives all details about the contest, (2) streamers, mailers, and other promotion items to help you win!

From the folder you will learn exactly what the contest covers, how to obtain and fill in your entry blank, how to make your promotion a success, what records to keep, and what type report to send in when the contest is over.

Five men of national prominence in the radio-TV service industry will serve as judges. Their names and positions are given in the contest folder. Act today! Profits plus a costly prize are waiting for you!

**G-E SMASH PROMOTION PROGRAM
WILL HELP YOU WIN!**

THIS MONTH ONLY!
SPECIAL \$ YOUR PRICE
8 POINT TV SET CHECK-UP **KEEP YOUR SET IN TOP CONDITION!**

We install
GE Aluminized TV Picture Tubes
"up to 100% brighter"
As advertised in LIFE and SATURDAY EVENING POST

8 Point TV CHECK-UP MONTH
Your TV Set too needs a CHECK-UP

NOW IS THE TIME FOR THIS!
GE Aluminized TV Picture Tubes

Authorized Dealer
GENERAL ELECTRIC
Electronic TUBES PARTS

GENERAL ELECTRIC

161-1A3

**BE SAFE...
BE SURE...**

**INSTALL VEE-D-X
LIGHTNING ARRESTERS**



VEE-D-X lightning arresters provide your customers with the finest, safest arresters ever made for TV and FM—including both two and four wire installations.



**\$1.25
LIST**

MODEL RW-200

Most popular full size arrester for standard 2-wire transmission line. Exclusive saw-tooth contact points assure positive electrical connection.

MODEL RW-204 \$1.50 LIST

For four-wire transmission. Same in appearance as the RW-200.



**\$2.00
LIST**

MODEL RW-300

For Extra Heavy Duty

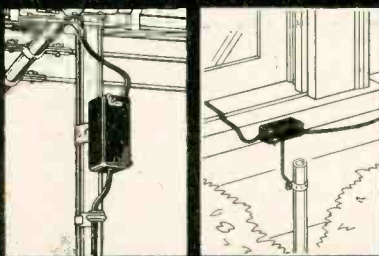

Models RW-200 and RW-204 are also available, at no extra cost, with strap for mast or pipe mounting. No wire stripping required on any VEE-D-X arrester.

THE LaPOINTE-PLASCOMOLD CORP.
Windsor Locks, Conn.

→ [From page 8]

second section will list the Manufacturers Represented, alphabetically, and the third listing will be by products. This Directory should be of particular value to all Purchasing Agents, and help them expedite locating products and sources.

New TV Allocations To Create Shortage Of TV Technicians

Anticipated construction of 2,000 new television stations in the U. S. will create a need for 170,000 new TV technicians, according to Leonard C. Lane, President of the Radio-Television Training Association, 1629 Broadway, New York 19, N. Y.

Speaking before a special meeting of the Association to appraise the lifting of the FCC's 3½-year-old TV freeze, Mr. Lane said, "Television will soon be plagued with a manpower shortage of trained workers such as TV repairmen, FCC license holders, personnel who can operate cameras, control boards, sound equipment and dozens of other devices in a TV station."

To help in the effort that trade schools and correspondence courses will make to meet this demand for future TV technicians, Mr. Lane announced to the Association the inauguration of a program of special aptitude tests for men considering this career.

"Estimating five or six service calls per set per year," said Mr. Lane, "a reasonable figure particularly in view of forthcoming use of the lesser-known UHF band—as many as 100,000 new TV servicemen may be required for the repair and installation of the 30 to 40 million new TV receivers Americans will be buying in the next four or five years."

"In addition," he continued, "some 10 to 40 technicians, exclusive of graduate engineers, will be needed to man each of the 2,000 new TV transmitters, plus 20,000 extra technical personnel required for expanded operations of TV manufacturers.

RCA Opens Tube Drive

The Tube Department of the RCA Victor Division kicked off a double-barreled promotion drive designed to accelerate consumer demand for RCA television picture and receiving tubes, and to support radio service dealers in their local business-building efforts.

Carrying the primary sales message that there is an RCA picture tube for virtually every make or model of television receiver, the comprehensive program is aimed at the television set

[Continued on page 40]

**SO IMPORTANT — it was
Featured in Special Article
in
The New York Times**

Jan. 28, 1952
FREE copy
of article on request

**UNIT REACTIVATES
TV PICTURE TUBES**

Small Electronic Device Tests Sets at Home and May Add Year or More of Use

By T. R. KENNEDY Jr.

A small electronic device that can be applied to home television receivers to test and reactivate the picture tube without removing the tube from the set, resulting in renewed brightness in many and considerably longer useful life, has been placed on the market for the first time by a New York manufacturer.

In some cases, it was said, the picture tube may be made almost as good as new and given as much as a year's useful life before replacement is necessary. The instrument is small and compact. It weighs three pounds, as large as the average lunch box, costs little and is simple to operate. Picture tubes, some of them new and never in a receiver, have shown remarkable improvement in brilliance and definition after a few minutes of reactivation in the last few days.

Although the principle of its operation is not new—cathode-ray tube manufacturers have used it for years in the initial manufacturing of picture tubes—its incorporation in a small instrument

The almost immediate urgent need for such an instrument, which also soon may be produced in kit form for home assembly, is apparent. Eight to ten million TV picture tubes. Transvision engineering estimates, have now been in use for three to four years or more, and "probably are in need of test and reactivation to renew their brightness." Unfortunately, test and reactivation was pointed out, seldom can be detected short of comparing the old tubes with new ones in lately produced sets. Furthermore, picture tubes in their original cartons in stores may have lost some of their brightness, which has been described as a "fading" or "aging process" to which all large cathode-ray tubes and similar devices are subject. Such tubes, in the current sizes most in use today, cost from \$25 to \$65. New picture tubes can be tested and reactivated without removing them from their cartons, and tubes in TV sets without removing the tubes from the receivers. It is done by attaching a standard picture-tube socket to the tube, which is then inserted into the instrument, turning a switch on a glow of a small neon bulb as a condition of the tube is indicated directly on a dial of the tester, which is plugged into an AC home electric socket. The receiver, meanwhile, is not turned on. In some cases the test and reactivation is accomplished in less than a minute.



**Transvision CR TUBE
TESTER - REACTIVATOR**

performs 2 vital functions:

- Tests Picture Tubes
- Renews Brightness of Dim Picture Tubes

It's a TESTER:

Without removing picture tube from set, you apply this precise instrument to:—

- Measure Cathode emission
- Locate shorts between elements
- Locate high resistance shorts or leakage as high as 3 megohms

It's a REACTIVATOR

for dim CR Picture Tubes

Revives dim TV Picture Tubes without removal of tubes from sets. Reactivation works on tubes with low light output, if there's no mechanical break in tube. 110V—60 cycles. Weighs only 3 lbs. One or two applications pays for instrument.

SATISFACTION GUARANTEED
or money refunded if you return the instrument in 10 days in good condition. **\$19.95 NET**

—RUSH THIS COUPON—
TRANSVISION, INC.
DEPT. SD6 NEW ROCHELLE, N. Y.

() Send me ___ CR Tube Tester-Reactivator(s).
() Enclosed find \$___ deposit. Balance C.O.D.
() Enclosed find \$___ in full. Send prepaid.

Name _____
Address _____
City _____ State _____

Adds every UHF Channel... to any TV receiver...



Mallory UHF Converter

THAT'S RIGHT! The Mallory UHF converter adds all UHF channels to any TV set... in any UHF broadcast area. And installation involves only the connection of power lines and antenna leads; no internal adjustments of the receiver are necessary.

Here are the Mallory features that will help you make the most of the new UHF market...

- Reception of all UHF channels
- No sacrifice of VHF channels
- Built-in UHF antenna
- High quality picture definition
- Fast, easy installation

The Mallory UHF converter is small, attractive—precision-built to high Mallory standards. For complete information on this versatile converter, contact your Mallory distributor today.



*Make Sure...
Make it Mallory*

P. R. MALLORY & CO., Inc.
MALLORY CAPACITORS... CONTROLS... VIBRATORS...
SWITCHES... RESISTORS... RECTIFIERS...
VIBRAPACK POWER SUPPLIES... FILTERS
*Reg. U.S. Pat. Off.
APPROVED PRECISION PRODUCTS

P. R. MALLORY & CO., Inc., INDIANAPOLIS 6, INDIANA

SYNC PULSES

by San D'Arcy

The TVset Sales Slump everywhere is causing grave concern to all phases of the industry except servicing. Technicians are still swamped and have a backlog of repair jobs. Happily, too, reports come that conventional AM and auto-radio repair volume is on the upturn.

However, a fairly complete analysis of the new-set sales picture is justified to guide one in coming to certain conclusions. To begin with, in the first quarter of 1952 only 1,277,512 TVsets were shipped to dealers compared with 1,814,767 in the same period of 1951 and 1,227,930 in the first quarter of 1950. (Remember, in 1950, TV production was just starting to reach its stride and in the 3rd quarter of 1950 almost 2,000,000 TVsets were made.) So, TVset sales this year are running about 30% behind last year's sales, unitwise, and because of the vast reduction in average sales price, this year retailers find their \$ volume is more than 50% under what it was for the same period last year.

Of great interest is the fact that during the 1st quarter of this year certain states that have heretofore not required many new receivers now show up sharply. For example, Alabama got 15,518, Arizona 3,180 and Arkansas 3,689. In contrast, a drop-off in deliveries to large states with well-founded TV coverage is recorded, such as California only buying 114,661 sets, New York 155,236 and Pennsylvania 125,589, which in each case represents figures over 60% below deliveries for the same period last year.

That TV is creeping into new market areas even before the operation of transmitters becomes effective is apparent by the report that during the 1st quarter of this year Idaho got 18 TVsets, Montana got 15, Nevada 8, North Dakota 12 and Wyoming 12.

Extended Coverage For 25 TV Areas Forecast—An expansion of telecasting coverage in 25 TV areas and a consequent stimulation of television receiver sales in these areas this year are expected by the RTMA Sales Man-

[Continued on page 40]

QUALITY
Telesco
PRODUCTS



\$12.95

Dealer's Net

Rep. and Jobber
Inquiries Invited.

THE TELE-TOOL KIT

A NEW ALL-PURPOSE RADIO-TV TOOL KIT

- One 17-unit tool kit most compactly designed, which does the work of more than 25 individual tools. This kit fulfills almost every mechanical need for Radio-TV work.
- Designed to fit over the longest variable control shafts used.
- Includes a 5" extension and a right angle ratchet handle; thus enabling the service technician to reach screws and nuts which are ordinarily inaccessible.
- Tools slip in and out of handles and extension easily as a result of the tapered spring grip which is part of the tool design.
- 8 deep-wall socket wrenches, sizes are stamped on tools: 1/4", 9/32", 5/16", 11/32", 3/8", 7/16", 1/2", 9/16".
- 3 blade-type screw drivers: large, medium, small (set screw size).
- 2 recessed-head screw drivers: large, medium (latter suitable for small size recessed-head screws also).
- Heavy duty amber plastic handle (shock proof) - 4" long, 1 1/8" diam.
- Heavy gauge plastic roll-up container with heavy duty clear plastic pockets electronically welded for strength and wear. Translucent pockets helps you keep an automatic inventory of all your tools.
- Socket tools are ground flat for easy removal of oval-faced stamped nuts.
- All metal tools are made of steel, case-hardened and plated.
- Roll-up container requires comparatively little space and fits easily into most tube carriers. May be used as apron or hung up on bench or wall.

A FEW TYPICAL TELE-TOOL KIT APPLICATIONS

Securing antenna mast brackets.
Installing and removing nuts on speakers with long studs.
Tightening or removing transformer screws and nuts located in hard-to-get-at places.

Tightening tuner mounting screws and nuts which cannot be reached with ordinary tools.
Tightening, installing, or removing long shaft variable controls.



Order from your distributor
TELE-SCOPIC PRODUCTS
262 Sullivan Pl.
Brooklyn 25, N. Y.



Cat. No. 343-PK

List Price \$1.05

Compact TV Lead-in terminal or tap socket. Molded polystyrene. In brown or ivory. With mating transmission line plug.



Cat. No. 311
List Price \$.20
Solderless Transmission Line Socket mates with Input Adapter, right, for convenient lead-in connection to set or booster.

Cat. No. 304
List Price \$.30
Input Adapter attaches to antenna terminal strip on set or booster. Mates with Line Socket, left, for quick connect-disconnect.



MOSLEY ELECTRONICS 2125 Lackland Road, Overland, Missouri

SIMPSON MODEL 480 GENESCOPE FOR ACCURATE TESTING

approved by
service managers of:

admiral
zenith
motorola
emerson
hoffman
hallicrafters

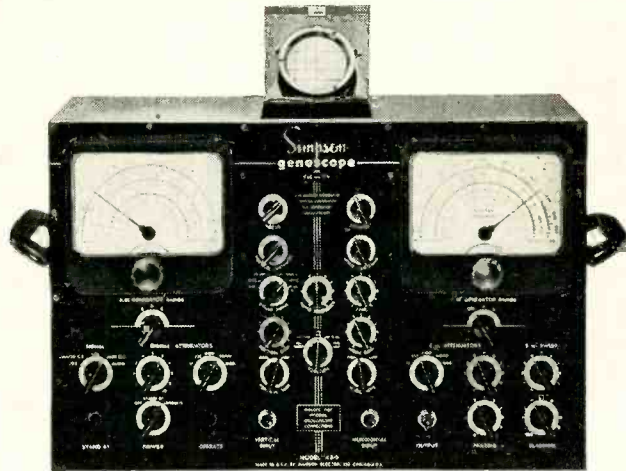

- Provides all the necessary signal sources for proper alignment and servicing of FM and TV receivers • Includes the Simpson High Sensitivity Oscilloscope, complete in every detail and equipped with a high frequency crystal probe for signal tracing • Independent, continuously variable attenuators and step attenuators for both AM and FM units offer complete control of output at all times—from the high level required for front end adjustment to extremely low levels for fringe area peaking operations • Multiple shielding, generous bypassing and adequate line filtering reduces signal leakage to a negligible factor • A 0-15 megacycle sweep is provided by means of a noiseless specially designed sweep motor based on the principles of the D'Arsonval meter movement for fine control and lasting accuracy • The exclusive Simpson output cable (illustrated on the right) includes a variable termination network which is quickly adapted to provide open, 75 or 300 ohm terminations—the addition of a pad provides attenuation and isolation. The use of appropriate resistors across certain terminals will provide any other termination required. A .002 MFD blocking condenser can be added on any termination for use on circuits containing a DC component • The FM generator output voltage is constant within .2 DB per MC of sweep. Model 480 \$395.00

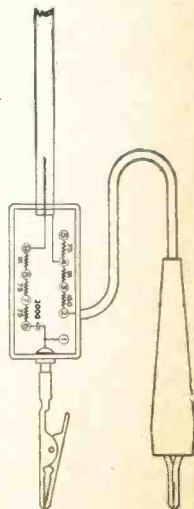

Also available without the oscilloscope as Simpson Model 479 TV-FM Signal Generator. Model 479 \$269.00

Simpson Instruments That Stay Accurate Are Available From All Leading Electronic Distributors

SIMPSON ELECTRIC COMPANY

5200 W. Kinzie St., Chicago 44, Illinois • Phone: COLUMBUS 1-1221 • In Canada: Bach-Simpson, Ltd., London, Ont.

ANOTHER CBS-HYTRON FIRST YOU'LL BE BUYING SOON



CBS-HYTRON 1AX2

NEW HEAVY-DUTY TV HIGH-VOLTAGE RECTIFIER CAN TAKE IT!

TV high-voltage rectifiers take a beating: Terrific variations occur in applied filament voltage... 0.8 to 2.4 volts! Sudden arcs in the rectifying system place destructive electromechanical stresses on the filament. And the increasingly larger TV picture tubes demand peak emission and peak inverse voltage simultaneously. The new CBS-Hytron 1AX2 was especially designed to take such rough treatment and come up smiling.

1AX2 DATA

The CBS-Hytron 1AX2 is a compact, 9-pin miniature TV pulse rectifier. Plate is brought out to top cap and filament is oxide-coated. Absolute maximum ratings are: peak inverse plate voltage, 25,000 volts; d-c load current, 1.0 ma.; and steady-state peak plate current, 11.0 ma.

Typical Operation — TV Pulse Rectifier

Filament voltage	1.4 v \pm 10%
Filament current	650 ma
Positive-pulse plate voltage	20,000 v
Negative-pulse plate voltage	5,000 v
Peak inverse plate voltage	25,000 v
D-c output voltage	20,000 v
D-c load current	300 μ a

BOTTOM VIEW
OF SOCKET

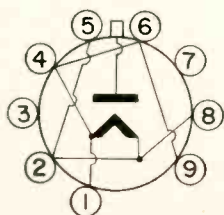

ADVANTAGES OF NEW CBS-HYTRON 1AX2

- 1 Rugged, high-wattage filament of CBS-Hytron 1AX2 has adequate peak emission for the new, larger TV picture tubes. 1AX2 may be run simultaneously at both its peak inverse voltage and maximum d-c current.
- 2 Higher load of 1AX2 filament on transformer tends to regulate filament voltage. Eliminates need for limiting resistor. Yet lower plate-to-filament capacitance (0.7 μ mf) of 1AX2 prevents loss of high voltage.
- 3 Insulated tension bar (patent applied for) through center of 1AX2 coiled filament limits destructive movement of filament by electromechanical stresses.
- 4 Filament of 1AX2 is located in base and shielded to eliminate bombardment of cool ends of filament by gas molecules.
- 5 An overloaded 1X2A may be replaced with its big brother, the CBS-Hytron 1AX2, by simply removing the limiting resistor. In rare cases, it may be necessary to add another turn to the secondary of the filament transformer to obtain the required 1.4 volts for the 1AX2.



MAIN OFFICE: SALEM, MASSACHUSETTS

RADIO-TELEVISION SERVICE DEALER • JUNE, 1952

PICTURE TUBE FAILURES

By DAVID GNESSIN

PROBABLY not since early amateur days when it was found that certain techniques of treatment of thorium-coated filament tubes could permit the use of these tubes long after their normal life-span was completed has the question of using 'dead' picture tubes as the basis of supplying added life in video sets stirred so raging a controversy. Presented herewith is an analysis of what is involved in the Picture Tube Picture. Thus informed as to the facts in the matter, you may select the course which seems most profitable for your particular application.

Certain facts about picture tubes should be presented first as a review of current Picture Tube history:

1. Picture tubes in television sets in American homes today number well over 10,000,000. Presumably they are all operating.

2. Picture tubes as part of television sets in the home have in a number of cases continued giving pictures of good quality after as much as two years of regular daily use. At least one television picture tube manufacturer now offers a two-year warranty on new picture tubes.

3. Several large picture tube manufacturers now give credit allowance on 'dead' picture tubes when purchase of new one is made (if old glass is uninjured).

4. Systems for reactivating picture tubes with poor emission have been released for use in the trade. These use the old picture tube, possibly without even removing it from the TV set.

5. Rebuilding service is now available to the trade where the serviceman takes his worn-out tube to be *opened up* and rebuilt. Generally he pays so much per inch for the service. This may include removing all internal elements, washing out the old screen, to be followed by complete rebuilding

A discussion of the chemical action taking place in the cathode emission of a CRT. This article will answer many of the questions that have puzzled you on CRT behavior.

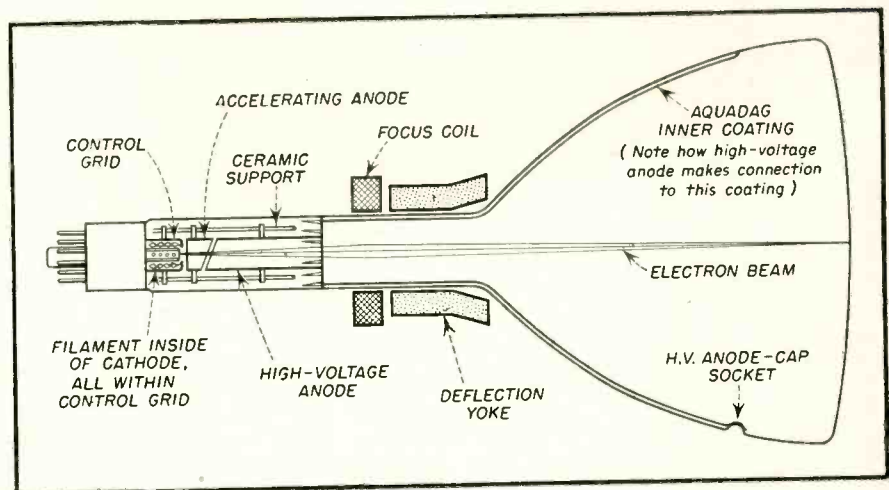

Fig. 1. Typical CRT cross section.

with all new parts except envelope. Alternatively, rebuilding may be done without individual contact, where instead the company picks up the 'duds' where they may be obtained, rebuilds them, then offers them as stock items for sale.

6. Most reputable picture tube manufacturers will make an adjustment in the event the picture tube fails within the guaranteed period, provided the serviceman properly identifies the problem and transports the tube to the factory (or authorized distributing point) *with certain exceptions*. One leading picture tube manufacturer lists 48 picture tube faults for which no compensation can be granted. See *Chart 1*.

Why Does A Picture Tube Fail?

Let's study the mechanics of the Picture Tube to see what *might* fail,

then find out what are the statistics of actual failures. To get a better picture of the inside of the picture tube we have cut one open to show the construction. By far the most popular in the millions of television picture tubes now on the market, the magnetically-deflected, magnetically focussed kinescope somewhere between 10" and 20" in size can be seen in longitudinal section with the important parts identified. Note the *electron gun* structure near the tube base (left) providing the electron beam which finds its way to the screen (right). See *Fig. 1*.

It might readily be noted that a large part of the picture tube is *space*; evacuated for better action. The bulk of picture tube troubles may be found in the electron-gun structure, shown below somewhat enlarged. See *Fig. 2*.

We're going to carry this somewhat farther and state that the essence of the electron beam lies in the cathode structure, with its cathode coating. From the outside of the picture tube the cathode may not be seen directly since it is almost entirely enclosed by the control grid. The drawings make this clear. (We are constantly enlarging the size of the elements involved until now we see a very large cross-section of the cathode and its coating. See Fig. 3.

The requirements for the cathode coating are pretty carefully outlined: "...A metallic filament properly coated with the oxides of the calcium, barium, strontium group gives copious electron emission at temperatures so low (dull red heat) that a pure tungsten filament would give no measurable emission. Because of this emission efficiency the oxide-covered cathode has been extensively developed."—Morecroft "Electron Tubes."

Becker, in his "Physics" comes to the conclusion that some of the barium (oxide... author) is reduced and notes that the emission really takes place from an irregular surface (probably one atom thick) of metallic barium on the surface of the oxide. It is extremely interesting to notice that the filament (cathode... author) covered with this thin layer of barium, on the surface of the barium oxide, is much more efficient in electron emission than a pure barium filament would be; if by chance the layer of barium becomes more than one atom thick, the emission decreases. (This was also noted by Morecroft.)

Accordingly, we can summarize the cathode requirements as follows:

1. The cathode material is a hard metal (nickel). This metal alone is a poor emitter.
2. A pure barium coating is not the most efficient emitter.
3. Barium compounded as an oxide, while an emitter, needs reduction for efficiency.
4. Pure barium in a very thin layer on the surface of a barium oxide coating on the cathode is an ideal emitter. Only a very thin layer (an atom or so in thickness) is efficient. If that thin layer is altered emission will drop sharply.

We see then that we must go to the field of chemistry for help. How is it possible to deposit a monatomic layer of pure barium on the outside of a coating of barium oxide applied to the surface of the cathode? Once deposited, how can that layer be replenished as it is consumed?

In the original construction, the

PICTURE TUBE FAULTS FOR WHICH NO COMPENSATION CAN BE GRANTED

- | | |
|--------------------------------------------------------------------------------------------------------------------------------------------------------------------------------------------------------------------------------------------------------------------------------------------------------------------------------------------------------------------------------------------------------------------------------------------------------------------------------------------------------------------------------------------------------------------------------------------------------------------------------------------------------------------------------------------------------------------------------------------------------------------------------------------------------------------------------------------------------------------------------------------------------------------------------------------------------------------------------------------------------------------------------------------------------------------------------------------------------------------------------|---------------------------------------------------------------------------------------------------------------------------------------------------------------------------------------------------------------------------------------------------------------------------------------------------------------------------------------------------------------------------------------------------------------------------------------------------------------------------------------------------------------------------------------------------------------------------------------------------------------------------------------------------------------------------------------------------------------------------------------------------------------------------------------------------------------------------------------------------------------------------------------------------------------------------------------------------------------------------------------------------------------------------------------------------------------------------------------------------------------------|
| <p>I. Electrical Defects</p> <ul style="list-style-type: none"> A. Shorted elements B. Open or intermittent connection to elements C. Excessive element leakage D. Current out of limits (ion trap, focus coil, second grid, heater) E. First grid cut-off voltage out of limits F. Element breakdown under high voltage G. Low emission H. Arcing and singing (poor internal anode coating) I. Beam improperly centered J. Magnetized metal cone <p>II. Physical Defects</p> <ul style="list-style-type: none"> A. Air leaker B. Gassy tube C. Neck shadow D. Broken tube if caused by defective glass E. Defective outside paint F. Loose elements in tube G. Physical dimensions out of limits H. Incorrect type marking <p>III. Base Defects</p> <ul style="list-style-type: none"> A. Loose base if due to poor cementing B. Cracked base C. Improper base orientation D. Defective pin soldering | <p>IV. Screen Defects</p> <ul style="list-style-type: none"> A. Uniformity of color out of limits (including streaks, watermarks, blue areas, dark areas, dark edges, etc.) B. Insufficient screen area C. Holes and cracks in screen out of limits D. Dark or discolored spots in screen if out of limits E. Dirt and lint marks out of limits F. Excessive aluminum areas showing through screen G. Ion burn out of limits H. Excessive screen burn <p>V. Glass Face Defects</p> <ul style="list-style-type: none"> A. Blisters (large bubbles) out of limits B. Seeds (small bubbles) out of limits C. Chill wrinkle out of limits D. Mold mark out of limits E. Excessive impact marks F. Excessive cords G. Stones, scale, knots and embedded dirt out of limits H. Rouge, rust and unglazed scale out of limits I. Shear marks, scum and spew out of limits J. Dirt on mold marks, oil spots and cold glass marks out of limits |
|--------------------------------------------------------------------------------------------------------------------------------------------------------------------------------------------------------------------------------------------------------------------------------------------------------------------------------------------------------------------------------------------------------------------------------------------------------------------------------------------------------------------------------------------------------------------------------------------------------------------------------------------------------------------------------------------------------------------------------------------------------------------------------------------------------------------------------------------------------------------------------------------------------------------------------------------------------------------------------------------------------------------------------------------------------------------------------------------------------------------------------|---------------------------------------------------------------------------------------------------------------------------------------------------------------------------------------------------------------------------------------------------------------------------------------------------------------------------------------------------------------------------------------------------------------------------------------------------------------------------------------------------------------------------------------------------------------------------------------------------------------------------------------------------------------------------------------------------------------------------------------------------------------------------------------------------------------------------------------------------------------------------------------------------------------------------------------------------------------------------------------------------------------------------------------------------------------------------------------------------------------------|

Following is a list of possible defects for which the manufacturer cannot accept responsibility when these conditions appear on picture tubes:

- | | |
|-------------------------------------------------------------------------------------------------------------------------------------------------------------------------------------------------------------|------------------------------------------------------------------------------------------------------------------------------------------------------------------------------------------------------------------------------|
| <ul style="list-style-type: none"> A. Scratched face B. Patterns or holes burned in screen C. Broken tubes caused by mishandling D. Base loose due to mishandling | <ul style="list-style-type: none"> E. Bump checks in glass tube F. Base pins bent due to mishandling G. Base broken due to mishandling H. External coating defaced due to handling |
|-------------------------------------------------------------------------------------------------------------------------------------------------------------------------------------------------------------|------------------------------------------------------------------------------------------------------------------------------------------------------------------------------------------------------------------------------|

Chart 1. List of picture tube faults for which no compensation can be granted. (Rauland)

cathode is made of pure nickel, contaminated with a small quantity of manganese. See cathode detail, Fig. 3. A paste of Barium Carbonate ($BaCO_3$) is applied to the surface of the cathode. The picture tube is assembled. Now the tube is heated externally while the bulb is exhausted of air and other gases given off in the heating. Simultaneously the filament of the picture tube is heated up by putting approximately eleven volts across it under controlled conditions.

Now heated to incandescence the following chemical reaction takes place: $BaCO_3 \longrightarrow BaO + CO_2$
Simplified: the barium carbonate, upon heating breaks up into carbon-dioxide (a gas) and barium oxide (remaining as a coating on the cathode). The carbon-dioxide released is sucked out of the tube by the evacuating process, leaving only barium oxide covering the cathode. The tube is

flame-sealed now. The base is attached. The tube is ready for further processing.

We agreed that a layer of barium oxide is not the most efficient emitter. To make the change we "age" the tube. In this process a controlled filament voltage heats the cathode while an external current of controlled magnitude passes through it. Here the barium oxide is subjected simultaneously to heat (from the filament) and electrolysis (by the current passing through it in series with the external circuit). This chemical change must be studied slowly:

See "Exaggerated Atomic Detail" Fig. 4 drawing below. Note that in the presence of heat and electrolysis the barium oxide becomes unstable. The manganese in the cathode, acting as a catalyst, frees the barium oxide molecule of the barium atom. This free barium atom drifts to the surface

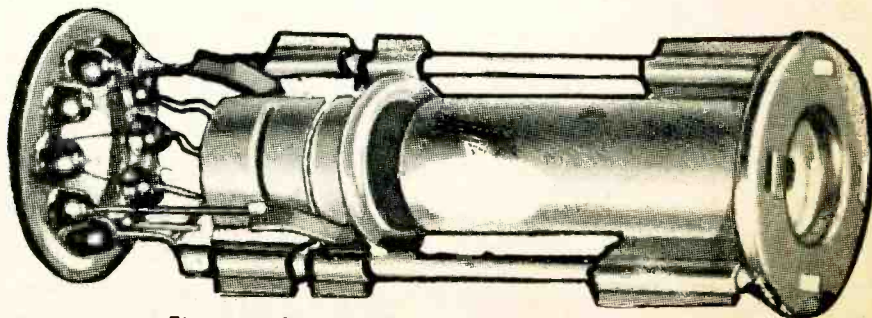

Fig. 2. Enlarged view of electron gun structure.

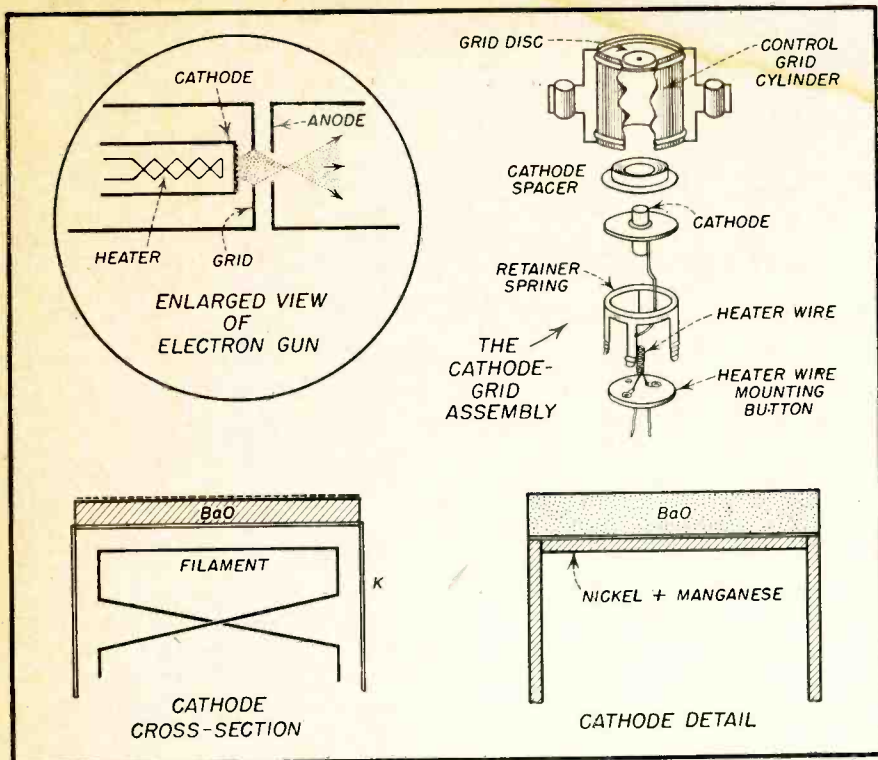
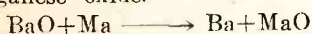

Fig. 3. Details of cathode construction and composition in typical cathode-ray tube.

of the barium oxide mass where surface tension and surface potential holds it in the form of a monatomic layer. If you must have an explanation of what happens to the left-over oxygen atom, you can consider that it unites with the manganese to form manganese oxide.



If you must have a physical place where the manganese oxide is kept, consider it as remaining somewhere in the space between the cathode proper and the barium oxide layer. Actually, a catalyst like manganese can be removed entirely unchanged by the catalytic action.

Here, then is a nice effect:— We've formed a very fine layer of barium on the surface of the barium-oxide, fulfilling the requirements of maximum

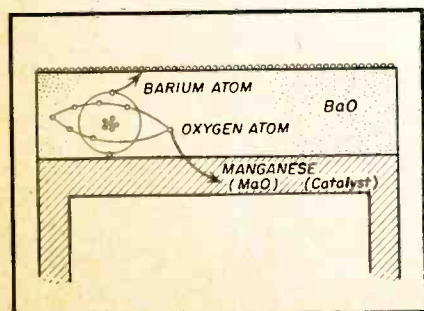

Fig. 4. Exaggerated atomic detail of cathode action.

electron emission qualities of the cathode. What is more, as the pure barium layer is depleted, the catalytic action is free to continue, replenishing the monatomic layer of pure barium as required. Since the ageing process is a controlled one, it is now turned off, and the picture tube is released for service in the industry. In use, the combined heat of filament, plus the current of its own beam provides the heat and electrolysis necessary to perpetuate (within limits) the emitting layer.

In use the television picture tube is exposed to certain gases and vapors released from solids fixed or circulating in the picture tube. These gases cathode, combining with it, effectively 'poisoning' it. If this poisoning affinity operates at a faster rate than the barium-formation rate of picture tube operation then the picture looks dim for our kinescope. With reduced emission we have resulting reduction in electrolytic action, with consequent reduction in formation of barium layer, causing a vicious cycle of picture-dimming. This is probably the most common failure of TV picture tubes.

CRT Dimming in Idleness

A rather hard-to-explain phenomenon is rather well established in the industry that picture tubes go bad

from simply standing about and not being used. Even greater is the loss of emission from this lack of use than from normal active use over a prolonged equivalent period.

When the tube is being used, the gases which are given off by the walls and other components and which normally would poison the cathode are ionized by the flow of electrons. When gases are ionized, they combine much more readily with the getter material remaining in active state. This keeps the gas content of the tube at a low level and reduces poisoning of the cathode. When the tube is not being used, the gases which come off from the walls are not as easily absorbed by the getter, and for this reason, poison the cathode more quickly. Since the tube is not being used, it is not reforming the lost pure barium. Emission is thus reduced, due to causes above, producing a dim picture in a tube which might be classified as brand-new! Now, do you wonder why tube manufacturers must set up a limit to CRT warranty?

Thus, whether the tube has grown dim in normal use (or abuse) in the TV set, or whether chemical change has rendered the tube dim in prolonged storage, causing it to "die-a-borning", or—if sheer old age has used up all the emitting material, the effects will be essentially the same. . . . The picture will take a longer time to form and will have a washed-out look. Large areas will be flat-white or sickly blue without contour, difficult to correct with the controls. Brightness will be down to a value causing it to be necessary to operate with the brightness control all the way up and the window blinds all the way down. Contrast control action may have to be modified to provide acceptable picture. The result is labelled 'Low Emission' and the dealer starts studying catalogs for replacement.

To further add to the trouble of providing an active cathode emitting surface, we have to consider that only a small part of the available cathode surface is useful for providing an electron beam. See the cross-section of Electron-Beam Emission in Fig. 5.

One can readily observe by inspection the very small useful emitting area of the cathode surface. The remainder of the cathode contributes *nothing* to electron emission. Consider, if you will, a worn-out central cathode emitting surface. The resultant beam, consisting of stray electrons from outside the useful cathode emitting area is essentially *hollow*. Here we have a

[Continued on page 44]

NEW TUBES

The 1AX2

LONG-LIFE, RELIABLE, HIGH-VOLTAGE RECTIFIER

By Engineering Dept., Hytron Radio & Electronics Co.

ONE of the most common causes of service failures in television receivers has been the high-voltage rectifier tube. A study of these failures indicates several possible causes of short life. Prominent among these causes is the wide range of filament voltages encountered in television sets in the field. Line-voltage variations, adjustment of horizontal drive control, differences in horizontal oscillator tubes as well as horizontal amplifier tubes, and different flyback transformer designs—all add together to produce a situation wherein the filament of the high-voltage rectifier tube may be operating at values as low as 0.8 volts or as high as 2.4 volts. With a bogey design of 1.25 volts, it was quite natural that poor life could result from such widespread disregard of ratings.

Another factor contributing to early failure is the effect of electromechanical stressing of the filament caused by the very high electrostatic fields existing between it and the surrounding plate structure. Sudden changes in this potential, as when high-voltage arcs occur anywhere in the system, subject the filament to stresses which often cause breakage where the filament is attached to its support rods. Due to the use of tungsten wire for the filament base in both of the popular high-voltage rectifier tubes

(1X2A and 1B3GT), it is not possible to obtain a true weld of the tungsten to the nickel support rods. Instead, it is imbedded into the support rods, making a good mechanical and electrical joint, but not as good as would be possible with a complete flow of the metals.

In designing the 1AX2, recognition of these factors has resulted in a much more reliable high-voltage rectifier tube. The position of the filament has been changed and it is now located in the base of the structure, surrounded by a shield which eliminates bombardment of its cool ends by gas molecules. The filament itself is made much more rugged by using a spiral of a special nickel alloy ribbon. The use of a nickel-base filament wire permits true welding of this filament to its supports. In addition, an insulated tension bar is passed through the center of the coiled filament to limit the amount of movement that can be caused by electrostatic stress.

This new, more rugged filament is rated at a higher wattage than previous rectifiers for this type of service for very good reasons. In order to support the higher average currents required by the larger television picture tubes, the high-voltage rectifier must be capable of meeting its full ratings for both current and voltage simultaneously. None of the present popular rectifier types do this consistently. To meet this requirement necessitates adequate wattage and area in the filament to support the peak emission current. The 1AX2 can be operated at full ratings for both D.C. current and peak inverse voltage simultaneously.

A further advantage of this high-wattage filament design is its effect on the regulation of typical flyback transformer filament windings. The increased wattage required by the filament does not detrimentally affect overall efficiency of the system, because of another plus feature which offsets the added power requirements

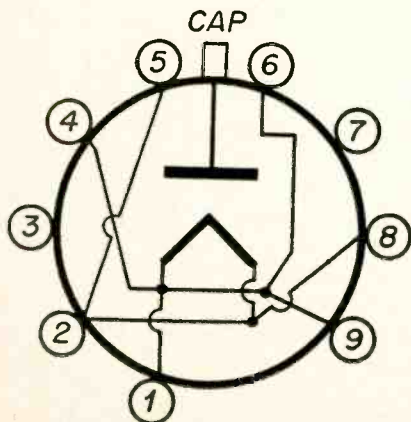

1AX2 Basing diagram (bottom view)

MECHANICAL DATA	
Filament	Oxide Coated
Bulb	T8 1/2
Base	9-Pin Miniature Button
Top cap	Shielded Miniature C1-B3 or C1-2
Maximum diameter	7/8"
Maximum overall length	2 11/16 1/8"
Pin connections	Basing: JETEC 9Y
Pin 1 - Filament and Shield	Pin 5 - Same as Pin #2
Pin 2 - Filament	Pin 6 - Same as Pin #1
Pin 3 - No connection	Pin 7 - No connection
Pin 4 - Same as Pin #1	Pin 8 - Same as Pin #2
	Pin 9 - Same as Pin #1
Top Cap - Plate	
Mounting position	any
ELECTRICAL DATA	
Direct interelectrode capacitances*	
Filament to plate	0.7 μf
Ratings Design Center Values	
Filament voltage (ac or dc) (Note A)	1.4 volts 10%
Maximum peak inverse plate voltage (Absolute)	25,000 volts
Maximum dc load current	1.0 ma
Maximum steady state peak plate current	11.0 ma
Typical operating conditions and characteristics - TV Pulse Rectifier Service	
Filament voltage	1.4 volts
Filament current	650 ma
Positive pulse plate voltage	20,000 volts
Negative pulse plate voltage	5,000 volts
Peak inverse plate voltage	25,000 volts
D. C. output voltage	20,000 volts
D. C. load current	300 μa
* Without shield	
Note A: Absolute maximum filament ratings are 15%, or, minimum 1.19 maximum 1.81 volts.	

CHARACTERISTICS CHART

and results in no loss of high voltage in most applications. This added feature is the lower plate-to-cathode capacity of the 1AX2 compared to that of the other popular high-voltage rectifiers. This P/K capacity is 20% less than that of the 1X2A and 50% less than that of the 1B3GT.

Another feature of the 1AX2 is the elimination of the need for a filament series-limiting resistor in most designs. Because of the centering of the design at 1.4 volts, it was determined that 90% of all existing designs could use the 1AX2 without any limiting resistor and that the 1AX2 could be used as a service replacement in the majority of sets now in the field by simply removing whatever series-limiting resistor is presently employed. The high current drain required by the 1AX2 filament offers a simple limiting or regulating effect upon the supply which tends to narrow the voltage spread. As with all filamentary tubes, it is important to keep the filament voltage applied to the 1AX2 within its ratings, if maximum life is desired. The heavier filament current of the 1AX2, however, actually helps to minimize variations in filament voltage caused by the many variables mentioned in the opening paragraph. For this reason, its filament has been called a "self-regulating" filament when used in typical television applications.

In replacing earlier rectifier tubes with the 1AX2, it may be found that the available filament voltage is too low, even after removing the limiting resistor. Such cases will be in the minority, but where they occur it will usually be found an easy matter to increase the turns of the filament winding from one to two turns to obtain the required amount of voltage.

VIDEO AMPLIFIERS

PART 2

by LEONARD LIEBERMAN

Series-Shunt Peaking

To derive the maximum gain for a given frequency response, the most popular circuit used in the majority of TV sets is a combination of series and shunt peaking as shown in Fig. 8. Commercial examples of the basic circuit and variations are shown in Fig. 9. With this combination and the proper selection of L_{sh} and L_{se} , R_L can be made 80% higher than the simple shunt peak network.

It is a common commercial practice to make L_{se} a part of a parallel resonant trap at 4.5 mc. The value of the condenser in the trap is such that it does not enter into the L_{se} , C_i calculations. As a trap this parallel network presents a high impedance to any 4.5 mc beat frequency which might be introduced into the CRT input. Another common practice is to shunt the various peaking coils with a high value resistor. This is done to cut down the "Q" of the peaking coils which is generally high. If this were not done, the voltage rise, as L_{se} , C_i approached resonance, would be abrupt, and ringing and phase shift would result.

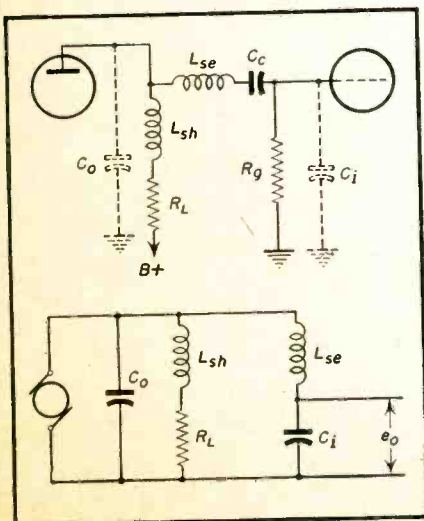

Fig. 8. Series-Shunt peaking

This series has been extended to three installments. In this second installment the author discusses auxiliary control circuits associated with video amplifiers.

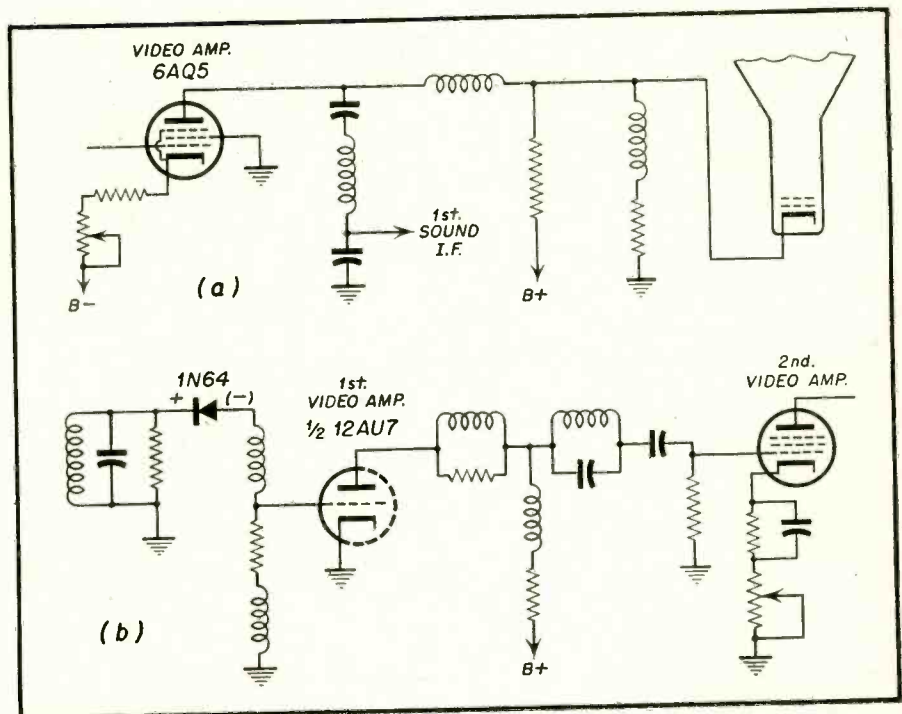

Fig. 9. Commercial examples of series-shunt peaking. Top (a). Sylvania Model I-139; Bottom (b). Stromberg Model 324

An additional means of high frequency peaking is utilized in sets employing the contrast control as the cathode resistor. It can be seen that variation of the contrast control will change the gm . This will change the output capacity of the tube. To maintain a uniform high frequency response, it is customary to connect a small condenser usually between 47 and 56 μf across the control.

Direct Coupled Amplifiers

A number of manufacturers have been using direct coupled amplifiers. Some of these are only direct coupled

from video load resistor through to the amplifier grid. Some are direct coupled only between the amplifier plate and CRT input. Other manufacturers using two triode amplifiers use direct coupling between the triodes. And lastly, some sets are direct coupled from video resistor through to the CRT input (Fig. 10). Direct coupling in the video amplifier is used for two different reasons. One, to eliminate the need for a d-c restorer; two, to counteract the effect of noise bursts on the picture. The reasons for these statements are as follows:

With the use of a coupling condenser from the plate of the amplifier to the grid of the CRT, the d-c level of the picture is eliminated (Fig. 11). This d. c. represents the background illumination of the scene being transmitted. By direct coupling, we eliminate the need for circuitry which would restore this d-c value at the grid of the CRT.

Noise bursts or pulses result in sudden charges across the coupling condensers. This sudden charging shows up as blotches of black with comet-like trailing white streaks. It becomes most annoying when whole groups of lines are displaced or appear as black or white strips across the entire picture. This condition is called flashing. The input grid to the video amplifier is usually the greatest offender in this respect. In sets which use twin triodes for video amplification, the coupling condenser between triodes will often be the source of this trouble.

Noise Limiting

Due to the d-c voltages involving high d-c B supplies in direct coupling, many manufacturers use condenser-coupled circuits. In order to obtain the same advantages in condenser coupled circuits as in direct coupling, grid current flows in video amplifier tubes and CRTs are made use of. Many sets using a positive sync phase will have the bias on the video amplifier so set that the tops of the sync will drive the tube into grid conduction. This results in a slight compression of sync pulses but it also clips those noise pulses which may be of greater amplitude than the sync pulse or which are riding on the sync pulses themselves. It is these noise pulses which generally cause the sync to be unstable or the picture to display objectionable flashing (Fig. 12).

D-C Restoration

The no-signal grid bias on the CRT

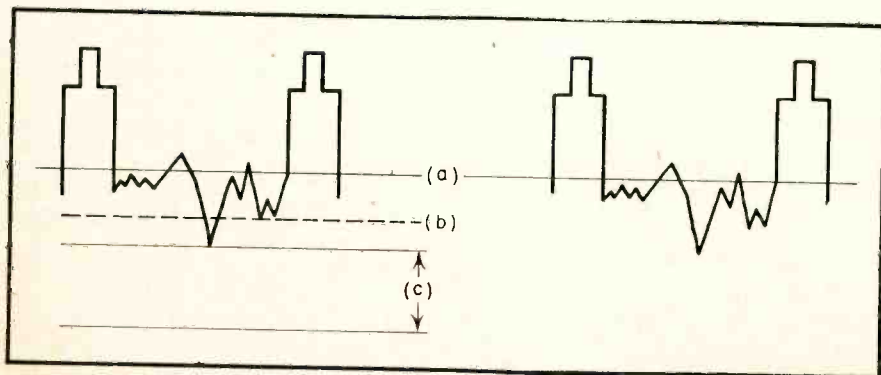

Fig. 10. Commercial example of direct-coupled video amplifier—Stromberg Model 119C

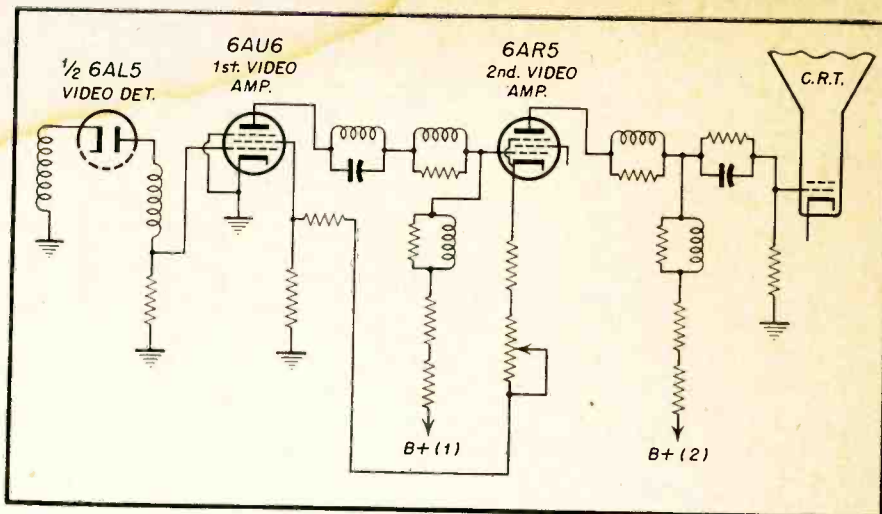

Fig. 11. D-C restoration. (a) A-C zero level with d-c eliminated. (b) Zero level of overall scene. (c) Zero level of general background illumination.

is carefully chosen. The grid of the capacity coupled CRT will then tend to partially rectify the signal and draw a grid current through the grid leak resistor. The current drawn will

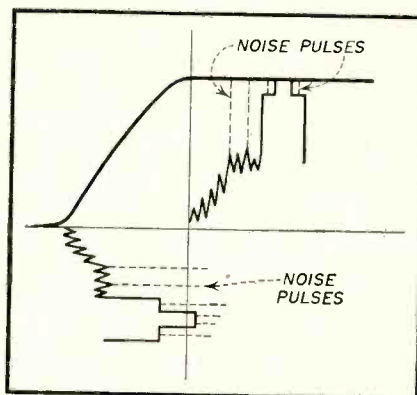

Fig. 12. Video amplifier grid noise limiting.

be proportional to the overall signal brightness and will tend to increase or decrease as the average scene brightness changes.

Sync Take-off

The great majority of present-day set manufacturers feed the sync separator tube from the output of the video amplifier. There are a number of reasons for this; first, with the good amplifier response of current amplifier circuits, there is no serious deterioration of the sync pulse wave-shape in the amplifier plate circuit. Second, with the amplified signal taken off the video amplifier plate, the need for an additional sync amplifier stage is eliminated. The sync amplifier stage was used to amplify the signal in order that when separated, the sync signal would be of sufficient amplitude so that it could be clipped or limited without any video information or noise pulses appearing in the sync pulse circuits.

Most sync take-off resistors are part of a voltage divider in the plate loading circuit. Depending on the type of a-g-c and sync stripping (separating) circuitry used, the value of this resistor could be critical. If the amount of video amplifier output taken off the divider is high, under certain circumstances the video will not be entirely separated from the sync. This will result in a bending of vertical forms such as columns or drape folds which extend from the top to the bottom of the picture. If the value is too small, not enough sync will be developed. This of course, will result in unstable pictures which are susceptible to noise interference. In keyed a-g-c systems, this incorrect value of sync amplitude will of necessity lead to an incorrect a-g-c which in turn would lead to further incorrect sync amplitudes with a resultant in unsatisfactory operation of the a-g-c system.

[To Be Continued]

A NEW SERVICE-DEALER SALES PLAN

By **RICHARD MATTISON**

(Pres. Mattison Television and Radio Corp.)

A NEW plan is presented to the Radio TV Service-Dealer which enables him to conduct a TV receiver sales organization with a minimum of inventory (one receiver) and any number of cabinet styles.

The service dealer who would like to engage in custom-built TV receiver sales is often stymied by two prerequisites he doesn't have or finds it hard to obtain. These are Capital and operating Credit. Capital is required to take on a substantial line of receivers, and operating Credit is required to enable the seller to sell his merchandise on the installment plan.

The Mattison Plan—Investment

This Plan enables the TV Service-Dealer to purchase:

As many cabinets as he would need in order to provide the appearance of the requisite showroom. Thus, with a few hundred dollars the dealer is enabled to simulate a stock with an appearance of substantial value. The Company has its own cabinet factory and provides a wide variety of styles, woods and finishes from

which the Service-Dealer can choose models.

Credit

The greater part of TV receiver sales is on the installment plan. Thus, as a second feature of this Plan, installment financing has been arranged nationally through local banks and credit institutions. A service dealer on making a TV sale on the installment plan merely contacts the bank or credit institution handling this business (as arranged by Mattison all over the country), and if all pertinent details are attended to, he will receive the full amount of the sale.

Service Plan

As an example of the quality control exercised, every set is put through a heat-run for four hours and final air check test on all channels *within 48 hours from the date of shipment*. For this reason this set is not offered to any but legitimate and well-equipped service dealers.

Service contracts on these receivers can become lucrative ventures because of the high quality components used

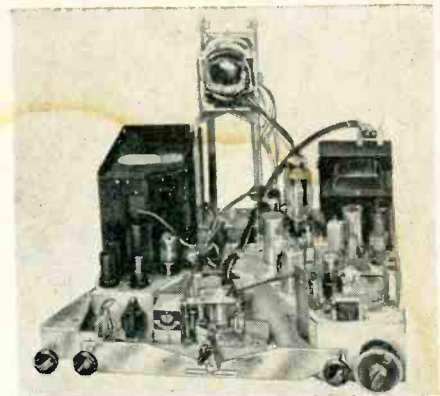

Front view of Mattison receiver.

in the receivers, the exacting quality-control exercised in their construction and the close knit factory-to-dealer service relationship. As an example of the latter, a consultation service is maintained between factory and dealer whereby the dealer may submit his problem to the factory and obtain an answer and possible solution to his troubles almost immediately.

If the dealer requires immediate service on a replacement part, the factory will ship the specified part, C.O.D. Then, on receipt of the defective part, a check for the amount paid will be returned to the service-dealer. Orders for replacement parts are honored within 48 hours of receipt of orders.

Warranty

The receiver carries the standard RTMA Warranty, and is guaranteed for 90 days from the *date of installation*. The guarantee on the picture tube extends to the guarantee of the picture tube manufacturer, which in many cases is 1 year.

Technical Data

The new Silver Rocket 630 chassis provides the following important features.

1. The d-c restorer circuit has been isolated to act solely as such, providing a fully "Automatic Brilliance" control.
2. The Horizontal Hold is improved to a point where phase or frequency drift is practically non-existent throughout all operating conditions, ambient temperature changes, or types of installation.
3. Operation of the Brightness Control or the Contrast Control has no effect whatever on the stability of the sync; and does not distort the picture in any way at all normal settings.
4. The stability of the horizontal and vertical sync has been immeasurably improved, and holds firmly under severe noise condi-

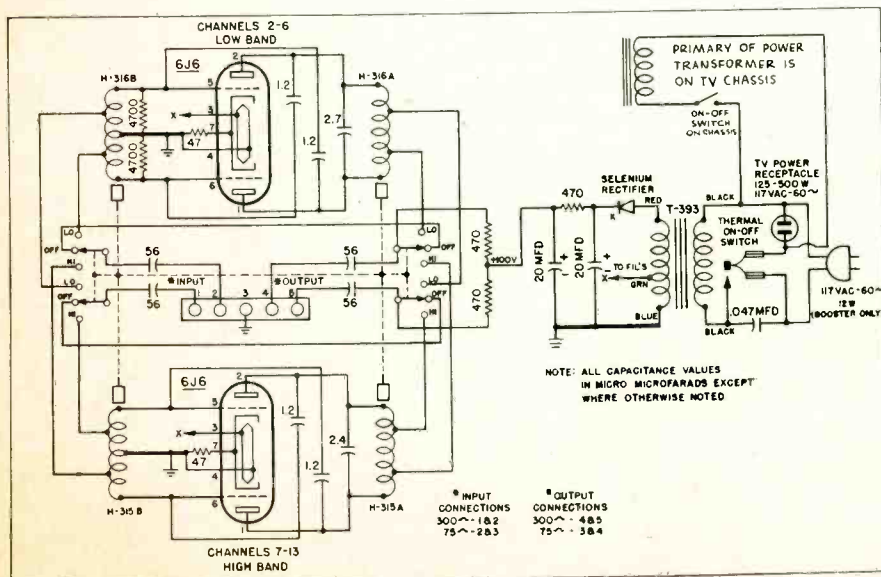

Schematic of TV Booster

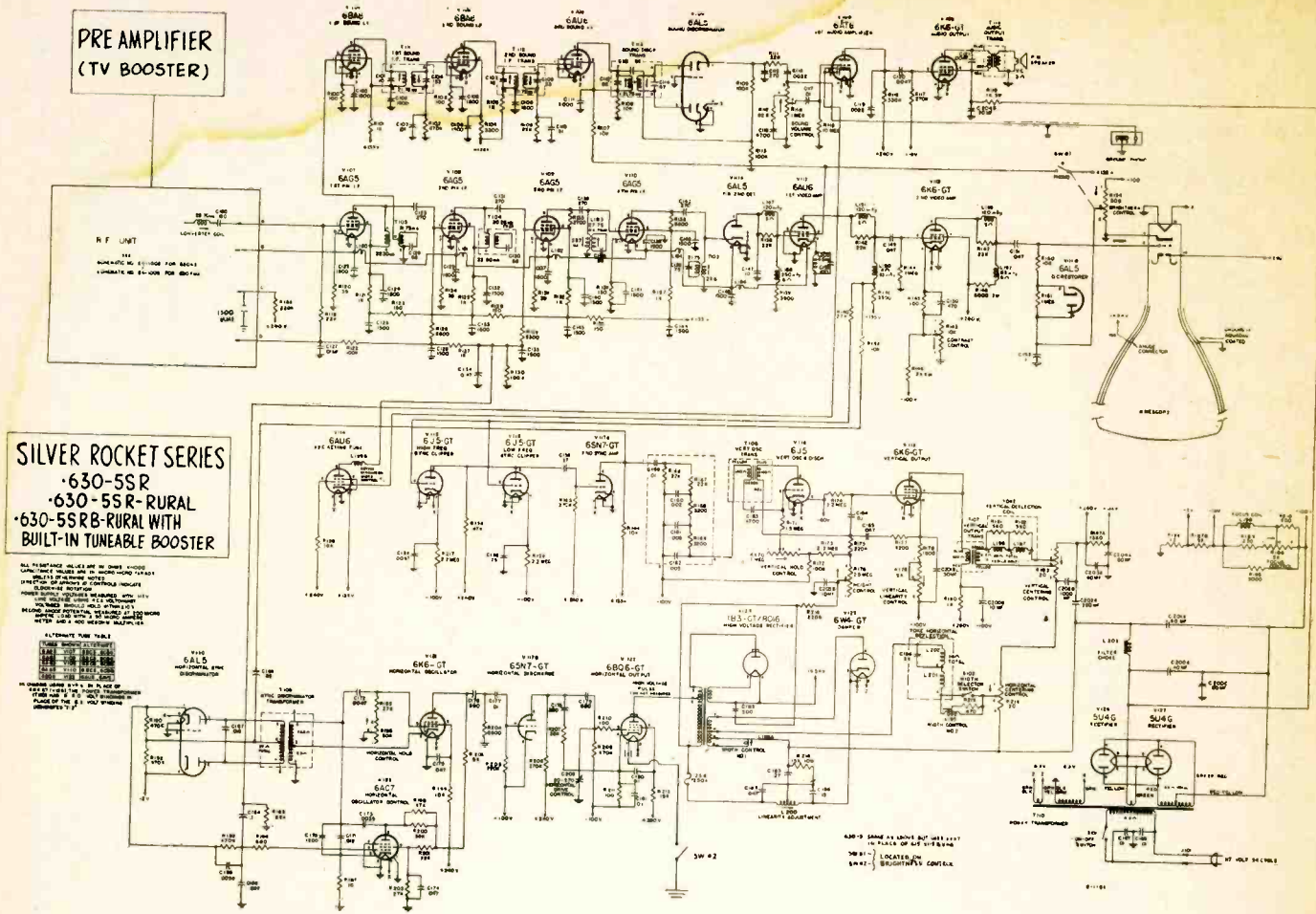

Circuit diagram of Mattison 630-55R receiver.

- tions, ambient temperature variations, variations in line voltage, etc.
- The operation of this chassis is independent of inconsistencies in the manufacture of kinescopes. Thus, despite even leakage in the gun, the sync and the other functions of the receiver all perform normally.
 - The trap circuit has been greatly improved to more efficiently eliminate the 4.5 mc. pebble; resulting also in substantially more gain in the video i.f., and further improved reception and a-g-c action in fringe areas.

Basically, one of the circuit improvements consists of the removal of the sync signal take-off from the d-c restorer (V-111B). The d-c restorer now acts solely as a d-c restorer and does no clipping. This, in effect produces "Automatic Brilliance" control in the receiver. Also, the fullest range of d-c restoration is now accomplished, and automatically this provides the normal transmitted picture background in reception at all times, requiring little attention to Brightness resettings.

The sync signal is now taken off the first video amplifier (V-112). At this point the sync pulses are fully independent of brightness or contrast settings. The keyed a-g-c system (through V-114) keeps the sync pulses amplitude constantly at its normal peak level, under all operating conditions. This permits uniform clipping action, and makes most effective use of the Syncrolock hold system.

Thus, it will be found that, under all conditions (such as severe noises, temperature or weather changes, or fringe area weak signals) the sync will hold "like a rock" in both phase and frequency, once it is set up. This sync pulse take-off also renders the chassis operation immune to leaky gun structures of kinescopes.

The immunity of the sync circuit under severe noise conditions, has been immeasurably improved with the following sync clipper-amplifier circuit: Stages V-115 and V-116 are now respectively "high frequency" and "low frequency" sync clipper-amplifiers. These two sync clippers operate in conjunction, the former being of a small time-constant, and the latter a large time-constant. The noise im-

munity of the short time-constant clipper is thus combined with vertical sync pulse passing by the large time-constant clipper. This results in fully stabilized horizontal and vertical controls under all encounterable field conditions.

An absorption trap is now used in the video i-f (T105) resulting in a cleaner picture free of the 4.5 mc pebble when on tune for every channel. The absorption trap is highly efficient in trapping the 4.5 mc, and does not cut video gain, resulting in improved reception in fringe areas, and greater fringe range. The sync system now can hold excellently in distant and weak signal reception areas.

Other circuit features of this receiver include a new super cascode circuit tuner which minimizes "snow." The Cascode Circuit Tuner improves the noise factor between 35 and 50%, betters the gain 2 to 1, and increases power sensitivity. This tuner is adaptable for UHF. Also included is a new Parallax distortion corrected deflection yoke for razor-sharp edge-to-edge focus. A phono connector controlled

[Continued on page 40]

OSCILLOSCOPE WAVE SHAPES

By **ALLAN LYTEL**

(author of "UHF Principles")

Presenting a basic discussion of various types of wave shapes that may be obtained on the oscilloscope using basic sources of input signals. Absorbing this material will lead to a better understanding of scope operation.

THE oscilloscope pattern depends fundamentally on both the horizontal and vertical deflecting signals. In a television receiver both of these signals are saw-tooth waves and the resulting pattern or raster is a series of horizontal lines. Picture information is supplied by means of Intensity Modulation providing a picture made of alternate light or dark dots.

In the test oscilloscope the internal circuits produce and amplify a time base whose function it is to spread out the input vertical signal so that this signal appears as it would on a graph. The vertical signal usually is presented as a linear function of time. In addition to its function as a wave shape indicator, the oscilloscope also may be used as a peak reading volt-meter or as a frequency comparison device.

Without the horizontal time base, a single vertical trace will be available on the screen. The internal time base generator is turned off. This provides

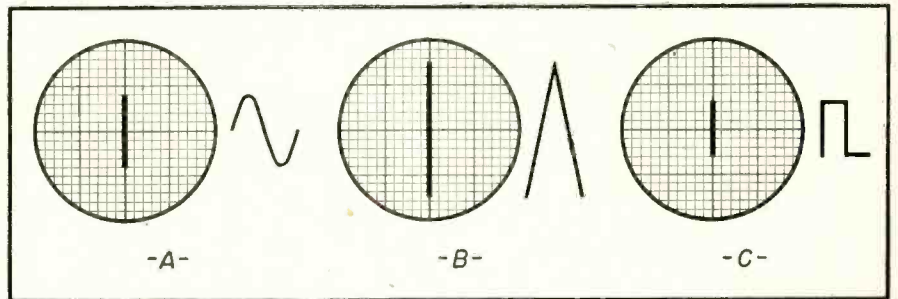

Fig. 1. Vertical deflection signals.

for no internal time base although an external Time Base may be used connected to the Horizontal Input terminals. Without a separate source of horizontal sweep and with the horizontal amplifier turned off as above, only the positioning controls and the Vertical Gain Control will be effective.

A single vertical line caused by an application of vertical voltage is caused by the electron beam being

moved up and down the screen at a rate dependent upon the frequency of the incoming signal. The positioning controls may be used to move this vertical line either up and down the screen or from side to side. When used in this manner, any type of input signal as in *Fig. 1*, whether it be a sine wave, a saw-tooth voltage, or a pulse, will appear as a vertical line. The cathode ray tube is a peak voltage indicating device and the amplitude of any applied vertical signal may be found by means of a calibrated screen. A known voltage is needed in order to calibrate the tube face after which the oscilloscope may be used as a peak reading ac voltmeter.

A connection of this type is advantageous since any frequency of applied signal may be used and there is no need for synchronization of the Time Base. The scale divisions and hence the amplitude of the applied signal are found more readily using a single vertical line than with a picture presentation spread out on a time base.

Figure 2 is the oscilloscope presenta-

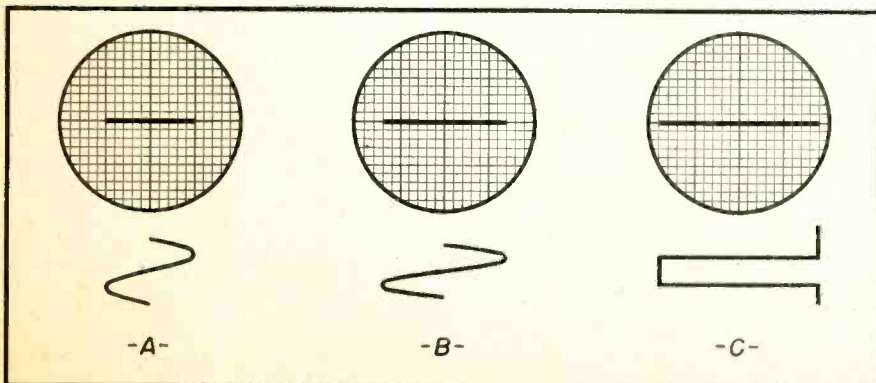

Fig. 2. Horizontal deflection signals.

tion with an External Horizontal signal passing through the Horizontal Amplifier. The internal Sweep Generator is turned to "off" position thus the Sweep Frequency controls have no effect on the Horizontal signal. The shape of the input signal has no effect on this Horizontal line. In Part A of the figure a sine wave causes a horizontal deflection and an increase in the size of the signal causes a greater horizontal deflection as in Part B. In Part C a square wave pulse is used to deflect the beam. Only the amplitude of the signal may be determined when it is used in this way. The wave shape and the frequency of the signal are immaterial.

Saw-Tooth Deflection

With a linear saw-tooth sweep voltage, one complete sine wave representing 360 cycles will be produced when the sweep frequency and the applied vertical sine wave frequency are exactly the same. Increasing the vertical signal frequency to 3, 4, and 5 times the horizontal sweep frequency results in 3, 4, and 5 complete sine wave signals as shown in Fig. 3. Another interpretation may be made of these patterns: Drawing A may be said to represent either a vertical signal of three times the sweep or a sweep frequency of one-third of the applied signal. The same thing may be applied to Parts B and C where the sweep frequency is one-fourth and one-fifth the applied sine wave signal respectively.

If the sweep frequency is higher than the applied sine wave an incomplete pattern will be seen on the screen which may take several different configurations. If the horizontal sweep is twice the signal frequency, there are two possibilities for a pattern as shown in Figs. 4, A and B. Both of these are representations of a sweep frequency two times the sine wave signal frequency. Since there are two complete horizontal lines, the horizontal oscillator is higher in frequency by a factor of two.

A saw-tooth voltage from a TV receiver under test may be used as the

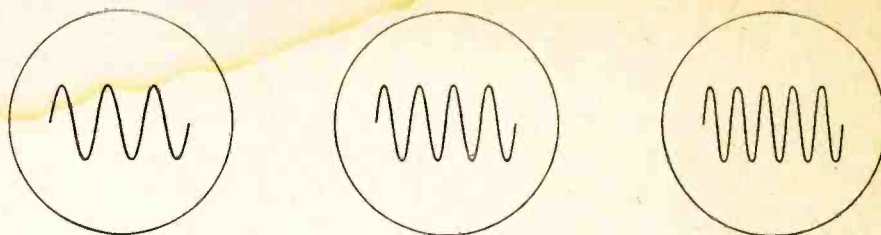

Fig. 3. In (A) V equals 3 and H equals 1. In (B) V equals 4 and H equals 1. In (C) V equals 5 and H equals 1. These are comparative values of frequency.

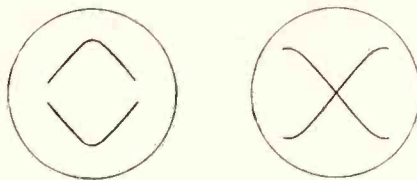

Fig. 4. Horizontal sweep is higher than the signal frequency by a factor of 2.

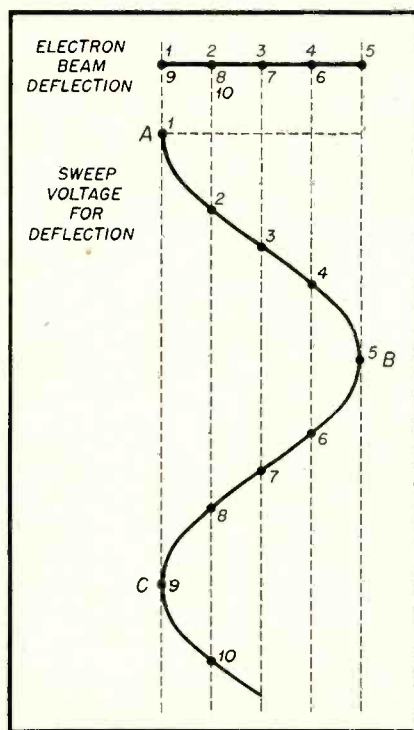

Fig. 6. Application of sinusoidal time base in scope.

vertical signal as shown in Fig. 5-A. Rectangular voltage wave shapes or square waves are also present in some types of servicing work. These may be seen as oscilloscope patterns by using the internal time base oscillator of the oscilloscope as in Fig. 5 B and C. Square wave voltages may be used in a servicing technique to find the frequency response and phase shift characteristics of an amplifier. A "perfect" or undistorted square wave is one in which the leading and trailing edges are straight vertical lines and whose top is perfectly flat as in B. When this signal is applied to the amplifier being tested, the distortion of the output square wave as in C may be used to trouble shoot the amplifier. In this case the undistorted square wave is applied as the input to the amplifier and the oscilloscope is connected across the output. Various interpretations of the square wave distortion may be used to give indications of the types and nature of the defect of a particular amplifier.

External Sweep Signals

The time base sweep oscillator internal in the oscilloscope has a frequency which may be varied by the Coarse and Fine Frequency controls and whose exact timing may be changed by the use of a synchronization signal. Whenever the applied vertical signal is a voltage whose amplitude is a linear function of time the internal sweep oscillator may be used. Thus the horizontal time base generator of the oscilloscope may be used for viewing wave forms of the radio or TV receiver.

A sweep generator for alignment usually has a sinusoidal variation of its output frequency rather than a saw-tooth variation. Where a sweep generator is to be used for alignment, the internal time base generator of the oscilloscope is usually *not used*. Using a sweep generator to provide a frequency modulated vertical signal almost always requires the sweep generator to supply the horizontal time base for the oscilloscope as well. In this application, the horizontal time base oscillator of the oscilloscope is turned

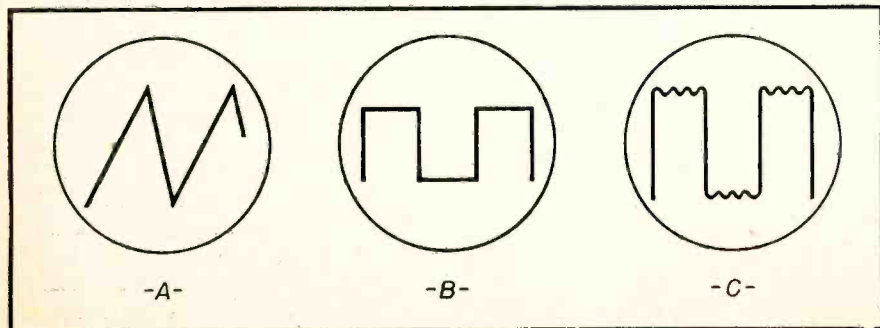

Fig. 5. Non-Sinusoidal signals.

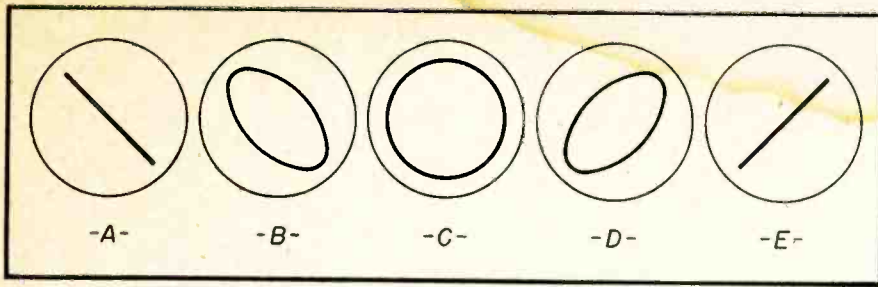

Fig. 8. Lissajous figures obtained when both frequencies are the same.

off but the horizontal amplifier is in operation.

A sweep signal from the frequency modulated sweep generator is applied to the Horizontal Input of the oscilloscope, and the width of the time base may be varied by changing the Horizontal Gain Control. If the sweep generator uses a sinusoidal frequency modulation, the oscilloscope must use a sinusoidal sweep. Viewing the visual trace under these conditions is exactly the same as if the sweep generator had a saw-tooth frequency modulation and a tooth signal were used for the horizontal time base of the oscilloscope. Fig. 6 shows the application of a sinusoidal time base in the oscilloscope. A voltage between A and B is used to move the electron beam from left to right exactly as a saw-tooth voltage would do.

Since this is a sine wave, there is a non-linear increase in voltage with respect to time. When there is no vertical deflection, the horizontal sinusoidal sweep may be divided into five units of equal voltage changes between A and B. Each equal change of voltage moves the electron beam from the left toward the right. These single points are plotted as increases in electron beam deflection so that the maximum applied voltage at point B (or Point 5) brings the electron beam to the right hand side of the screen. Between B and C the electron beam moves back again toward the left side of the screen. The trace time from left to right is exactly as long as the retrace time from right to left. If the vertical signal is frequency modulated at a sinusoidal rate, a complete visual trace response curve will be presented. It is important, however, that the sinusoidal time base be recognized since there is equipment which has only a sinusoidal time base and no saw-tooth horizontal sweep. The Philco Model 7008, as an example, is a television sweep generator and an oscilloscope in one unit. The only time base available for the oscilloscope is this sinusoidal signal. Therefore, while the test oscilloscope has separate vertical ter-

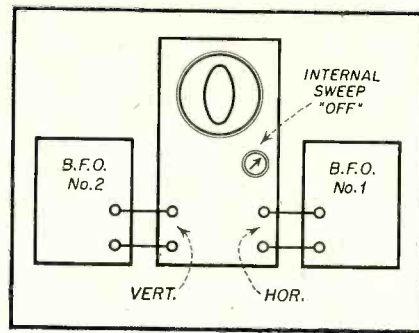

Fig. 7. Hook-up for obtaining Lissajous figures.

minals for the application of an outside signal, it is impossible to present any linear voltage with respect to time since the only sweep is sinusoidal.

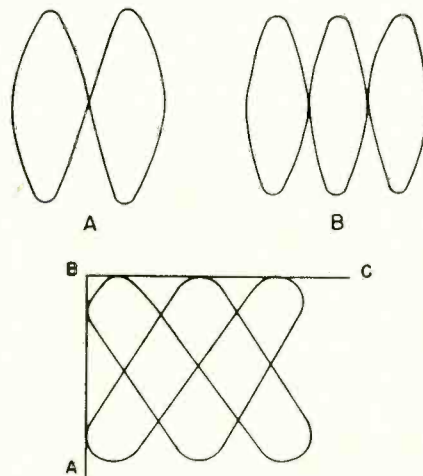

Fig. 9. Frequency comparison between sine waves.

A Frequency Determination of Two Line Waves

One of the uses for an oscilloscope is as a calibrating device for comparing an unknown frequency against a fixed standard such as the 60 cps line frequency. For example, an audio oscillator having frequency adjustments may be calibrated by adjusting the oscilloscope for a 60 cps time base sweep. The test oscillator has its output connected as the Vertical Signal Input. The oscillator tuning dial is adjusted for 60 cps and one complete

sine wave will be present on the screen. Moving the dial the 120 cps should be two sine waves and at 180 cps there should be three sine waves. There are limitations to this method of calibration however. The length of the time base prevents the application of a great number of sine waves and counting the individual cycles becomes tedious and involved.

An alternate method of frequency determination between two signals is the use of Lissajous figures. The oscilloscope is used with the internal time base generator turned off. One sine wave signal is feed to the Vertical Input while the second sine wave signal is feed to the Horizontal input as in Fig. 7. The two gain controls are adjusted to provide approximately equal deflection in both the horizontal and vertical sense. If both signals are of the same frequency, a pattern will be obtained which appears to be either a circle (Fig. 8-C) or an ellipse (Figs. 8-B or 8-D). Since the two signals are not synchronized the pattern usually appears as a circle turning over and over. That is, the pattern may appear as a circle, an ellipse, or a straight line. The straight line may be thought of as viewing the circle from the side rather than the front. The two signals are of approximately the same frequency when the signal on the screen appears as one of these patterns, and it slowly changes from one to the other as in Fig. 8.

Closed loop figures may be used to obtain frequency calibrations and in their most simple form they indicate a whole number or integral relation between the two frequencies. In Fig. 9 Part A the vertical frequency is twice that of the horizontal signal and a picture with two complete loops is presented. This figure may be used whenever it is desired to obtain a 2 to 1 ratio of the vertical and horizontal frequencies. A ratio of three to one is shown in Part B of the figure consisting of three complete loops and the vertical frequency is now three times the horizontal frequency. When using these closed loop figures for frequency calibration, they often seem to turn around or rotate in a horizontal sense. The frequency of the oscillator to be calibrated should be adjusted to provide a stationary pattern if possible or at least a very slowly moving pattern.

Any frequency determination may be made using closed loop figures by comparing the number of loops which touch the vertical line AB to the number of loops which touch the hori-

[Continued on page 42]

TRADE LITERATURE

Distribution of the latest edition of the "Picture Tube Data Chart" by the cathode-ray tube division, Allen B. Du Mont Laboratories, Inc., was announced recently.

The chart, printed on heavy stock, and suitable for wall mounting, lists the electrical and physical characteristics for any modern RTMA-registered TV picture tubes. Now in its fifth printing, this service aid has become a trade "staple" for those concerned with television receiver design, research or servicing.

The charts are obtainable from local Du Mont cathode-ray tube distributors.

* * *

Proceedings of the National Electronics Conference—1951—volume 7, National Electronics Conference, 852 E. 83rd Street, Chicago 19, Illinois. 736 pages, charts, diagrams, tables, 9¼ by 6¼ inches, cloth, \$5.00. This book contains the papers—or digests thereof—presented at the 1951 conference. The seventy-nine papers cover electronic research, development and application in audio systems, components, computers, high frequency measurement, information theory, magnetic amplifiers, medical and industrial applications, micro-wave and propagation, servo theory, signal detection, television and tubes.

Volumes 2, 4, 5 and 6 may also be obtained for \$5.00 per copy.

* * *

A complete, concise *Replacement Vibrator Guide* is now being made available to radio servicemen throughout of the country by P. R. Mallory & Co., Inc., Indianapolis.

The guide contains complete cross-reference charts, specifications, and illustrated installation instructions for replacing car-radio and other types of mobile communication equipment vibrators and their accessory buffer capacitors with recommended Mallory replacements.

These listings are supplemented by detailed diagrams and instructions showing installation procedures for vibrators and also by an automobile battery ground chart. To provide complete information on the use of buffer capacitors of proper value, a series of reference circuits are pictured to show

how the buffer is wired into the supply.

The *Replacement Vibrator Guide* is another step in the continuance of Mallory's 25-year policy of supplying convenient, up-to-date replacement information and service aids.

* * *

John F. Rider Publisher, Inc., 480 Canal St., New York 13, N. Y., announces a completely new troubleshooting service for electronic technicians—*Tell-A-Fault*. It gives practical information—no theory is included.

Specifically, *Tell-A-Fault* deals with the troubleshooting (symptoms and cures) of all types of television receivers—also radio receivers, record changers, and recorders. Special emphasis, however, is given to television.

Tell-A-Fault service consists of (1) time-saving pictorial symptom and cure sheets, which list TV trouble symptoms as they appear on picture tubes—also fault locations and explanations of test oscilloscope patterns for each type of circuit found in TV receivers. (2) circuit guides, which are examples of the great many different circuits used in various TV receivers. The circuit guides assist the service technician in localizing faults. The symptom sheets are correlated with the circuit guides so that the technician can immediately identify the symptom and trouble with the particular kind of circuit. (3) servicing short cuts section, which tells the fastest techniques for isolating faults, how to make measurements rapidly, how to construct labor-saving troubleshooting devices, etc. (4) section on how to use all kinds of test equipment for TV, radio and other servicing. This information is specific by brand names and models.

Complete information on the *Tell-A-Fault* troubleshooting service can be obtained by writing to the publisher. The first issue of *Tell-A-Fault* will be out in June, 1952.

* * *

Catalog TH-52, just released by *Triad Transformer Manufacturing Co.*, Los Angeles, covers Triad's line of Multiple and Single Terminals. The catalog contains actual size illustrations, specifications and dimensional drawings, plus recommended

installation procedure, general information and several typical installation applications. Copies of Catalog TH-52 may be obtained by writing Triad Transformer Manufacturing Co., 2254 Sepulveda Blvd., Los Angeles 64, California.

* * *

To mark the tenth anniversary of the use of the RCA Electron Microscope, the Engineering Products Department of *RCA Victor Division* has issued a new brochure entitled, "*The Electron Microscope at Work in Industry.*"

The new booklet emphasizes only typical applications of the electron microscope by industries in the automotive, chemical processing, metal fabrication, petroleum, rubber, food, drug, textile and radio and electric fields. The use of the instrument in pure research, and in medicine, bacteriology and biology has been described in previous RCA brochures.

Copies of the new brochure, Form 2R8195, are available by writing the Scientific Instrument Section of the RCA Victor Division, Camden 2, N. J.

* * *

Publication of "*Your Guide to Channel Master Television Antennas,*" a new 12-page booklet describing more than 50 different types of antennas, accessories, and kits, has been announced by *Channel Master Corporation*, Ellenville, N. Y.

The two-color booklet, concise and easy to read, describes the specific reception problems that each antenna is designed to solve. It includes the latest types, such as Channel Master's new 10 Element impedance-matching Yagi, the BIG 10.

The booklet includes Channel Master towers, mounting accessories, and "the world's most complete line of Telescoping Masts," including the new BIG TOP series, which have a 13¾' top section designed for mounting 4 bay arrays.

Every item is fully illustrated, and laboratory-verified gain curves and polar diagrams of many antennas are included in "*Your Guide To Channel Master Television Antennas.*" It is available to all installation and service men, free of charge.

SHOP NOTES

Write up any "tricks-of-the-trade" in radio servicing that you have discovered. We pay from \$1 to \$5 for such previously unpublished "SHOP NOTES" found acceptable. Send your data to "Shop Notes Editor."

RCA—Improved Kinescope Dust Seal

All RCA television receivers in current production use an improved type of kinescope dust seal. This seal is made of special (anti-corona) sponge rubber and is arranged to fit the space between the mask and kinescope cone. It is available from RCA Victor distributors as Stock Number 76631 for use on instruments having either 17 inch or 21 inch kinescopes. This same dust seal is also recommended for use with other RCA television receivers previously manufactured using 19 inch, 17 inch or short-neck 16 inch kinescopes.

If it should be necessary to remove the kinescope, the dust seal should be removed first. When replacing the dust seal, care should be used in its installation so that its advantages will be retained. The illustration below shows the assembly of the kinescope, mask and dust seal in Model 17T155. The assembly in other models is very similar.

Installation of #76631 Dust Seal:

1. Apply cement (see note below) around entire periphery of both the kinescope and the mask surfaces which are in contact with the dust seal.

Caution: Do not apply cement to the high voltage clip.

The spring mounting clips should be pushed securely in place so that they do not protrude beyond the mask flange.

2. Install dust seal, starting at bottom center of mask, with tapered side against the kinescope, pushing it securely into the space between the flange of the mask and the cone of the kinescope.

Caution: Avoid stretching the seal during installation.

The seal, when pushed in properly, should be bottomed against the flange of the kinescope.

3. After the seal has been installed completely around the kinescope, overlap the two ends one (1) inch and cut off square. Apply cement to the two ends, push back the lap and butt the two ends together.

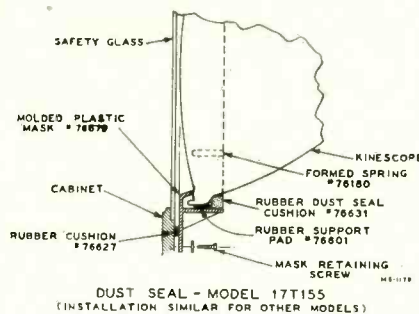

Push seal in to make a secure fit all around the kinescope.

Note:

The rubber cement commonly used for sticking papers together is recommended for cementing the dust seal. It may be obtained in small bottles having a brush applicator at most stationery stores.

RCA Service Co. Inc.

Reactivating C.R.T.'s

First let us determine whether the tube is low in emission (soft-weak) or the coating on the face is bad (silvery). Raise the brightness and contrast controls. If the white portion of the pix becomes silvery, the only solution is a new tube. If the pix is still weak and the tube is fairly new, then there's a good chance of building it up again. If the tube is old, well maybe that's all. First adjust the Ion trap. Still soft? O.K. In order to build up the small amount of electrons being emitted by the cathode, it must be heated. Electronically we will attempt to take off a portion of the old coating of the cathode and reveal what's beneath it. A new coating.

We will do this with only the cathode-grid and filament of the tube, by placing a B+ voltage on the grid and grounding the cathode through a 0-60 milliammeter with the filaments on. Don't ground the cathode directly. Tap in on ground and off quickly, and watch the milliammeter. If it doesn't deflect full scale then repeat a little slower. It would be best if a variable power supply were built and

the B+ were adjusted for a reading of 10-15 ma. You will find by adjusting to say, 12 ma., the needle will climb gradually after the needle seems to have stopped. Shut everything off and try it in the set. If this reactivating is attempted in the set or customer's house with voltages from the set, apply B+ to the grid at about 30 sec. intervals and see how it looks while operating. *Caution:* there is a maximum to the amount of current you can draw off the cathode, after that the tube will get softer instead of brighter. If a milliammeter is used make sure the reading is climbing, not falling. How long will the reactivated C. R. T. last? It's hard to say. Maybe one day; maybe 5 months.

Submitted by:
Shingler Radio-TV Labs
McVeytown, Penna. . .

12VP4 Substitution

In some of the old Sylvania TV sets a 12VP CRT is used. If a 12LP4 is handy, apply 250 to 300 volts to pin #10 not used on 12VP4. Results are good.

Submitted by:
Emanuel Spandorf
Bronx, N. Y.

Chrysler 1951 Auto Sets—Fuses Blow

To whip stubborn cases of blowing fuses in the 1951 series Chrysler auto sets manufactured by Philco for all four Chrysler cars. Separate fuse holder and install battery lead in set. Solder lead to spark plate post in radio instead of just plugging it in. The tip on these leads is very light metal and will not keep any tension on post of spark plate. When loose, fuse will blow when set is turned off.

Submitted by:
Al Pratesi
White Plains, N. Y.

Ford Auto Set—Intermittent

Ford Model MI (8A-18805A) auto set. In auto, set cut off and on intermittently, mostly after being played a few minutes. But on service bench set played good.

Finally located trouble to oscillator coil which was shorting out. At bottom of coil is a sleeve to which coil ends and connecting wires are anchored by means of small staples. A staple had penetrated through to the coil and was shorting it out. Removal of staple, placing sleeve lower to get it off the coil wire, and cementing in place with coil cement remedied this condition completely.

Submitted by:
Kenneth Futrell
Muncie, Indiana

ASSOCIATION NEWS

Local, State and National Associations are urgently requested to send in news of their activities so that we may print them in these columns.

Lackawanna County Appliance, Radio and TV Dealers Association

Members of the Lackawanna County Appliance, Radio and TV Dealers Association met on April 15th, 1952, in the studio auditorium of Station WQAN in Scranton, Pa. They heard John McGoldrick chief engineer of WNBF-TV, Binghamton discuss TV station operations and the recent F.C.C. lifting of the freeze on new TV channels. Gino Ricciardelli, assistant chief engineer of WNBT-TV also spoke. Thomas F. Leahy, manager of the Scranton Better Business Bureau introduced the speakers. A number of Luzerne County dealers and technicians attended the meeting.

Among the guests were Edward Lukas, Pres. of Luzerne County Servicemen's Association, and James Jerome, Pres. of the Lackawanna Technicians Association.

Sidney Cronin, Pres. of the Lackawanna Dealers Association acted as host, while Ernest L. Courtemanche of LRTA (Lackawanna County) was chairman of arrangements for the joint meeting.

Radio & Television Technicians Guild of Florida, Inc. (RTTGF)

The first issue of the new RTTGF 4-page bulletin appeared during May, under the editorship of Thomas M. Middleton. *Heartiest Congratulations.* With the connection of co-ax TV transmission to Miami the sales and service business is about to experience a tremendous boom in this area. RTTGF continues to contribute to the Blood Bank.

Akron Radio Technicians Association

On March 25, 1952 elections were held. Walter Dickerson was elected President; John Mintz, Vice President. Joseph Vegh was elected Secretary-Treasurer, and Robert Kastle, long-term Trustee.

Walter Dickerson's first step as President was to call a meeting of officers on April 3, 1952 to set forth a complete reorganization of the eight year old association. Committees for entertainment, publicity, new membership and developments, and training were set up. John Mintz, an electrical engineer, will head the training activities. On April 15, 1952, the first meeting was held by the new officers and the membership. The following goals were set for the coming year:

1. To give better training to employees.
2. To hold meetings at another service shop each time so that each shop's arrangements can be studied by the membership.
3. To try to set a minimum service charge on television service calls.
4. To increase membership.
5. To devise a way to decrease customer distrust of the radio television service technicians.

This organization is for the betterment of the individual servicemen. It offers hospitalization and doctor plan to its members with group plan rates.

Coming activities include: special speakers from the electronic field, field trips to local radio and television transmitters, films, installation training, and customer relations training.

Joseph Vegh—Sec. Treas.

Empire State Federation of Electronic Technicians Associations Inc.

An excellent attendance was recorded, in spite of the inclement weather, at the annual meeting of the Empire State Federation of Electronic Technicians Associations (ESFETA), in the Hotel Arlington, Binghamton, Sunday, April 27. Thirty delegates and guests from seven member associations of New York State, and also representatives from the newly formed group, the Southern Tier Television Technicians of Elmira, participated in

an interesting and informative meeting, the most important business being the annual election of officers.

Elected for the new term of office were the following: O. (Cappy) Capitelli, ARTSNY, N.Y., President; Herb Snyder, Binghamton, Vice President; Dave Violet, RTG Rochester, Secretary; Charles Kohl, UETA, Kingston, Treasurer; and John Hague, Endicott, Sergeant-at-arms. New Directors are: Hal Hazard, Binghamton; Sid Gent, Endicott; Thomas Thorne, Hudson Valley (Poughkeepsie); Ray Trumpait, Kingston; Jack Wheaton, Long Island TRTG; Max Liebowitz, ARTSNY, New York City; and Andy Wentworth, RTG Rochester.

The newly formed association in Elmira was congratulated through its representatives on its great strides, and other associations in New York State or in other states were again urged to exchange information for mutual benefit through the new Secretary, Mr. Dave Violet, 294 Joseph Avenue Rochester 5, New York.

The next meeting of ESFETA will be held in Rochester on June 15, 1952.

J. A. Wheaton

National Alliance of Television & Electronic Service Associations (NATESA)

Association Of Television Service Companies Of St. Louis . . . Vince Lutz, President together with his fine group of officers conducted a very nice 3 day state wide convention. Present at the meeting was a large delegation from Television Service Engineers of Kansas City headed by President Wade, Secretary McDowell, Treasurer Richards and at least 5 other members. TSE should be highly commended for their cooperation and active support of NATESA and other affiliates. Under the able leadership of

[Continued on page 47]

CIRCUIT COURT

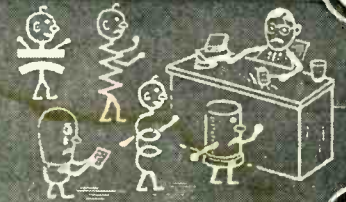

RCA 21T176

The circuits described in this article are a good example of design which increases set efficiency while reducing component and tube complement. Section A of Fig. 1 involves the video amplifier coupling to the CRT. The video amplifier input is conventional with the grid direct coupled to the video detector. The cathode goes to ground through *R55*, a 48 ohm resistor. There is a jack in the cathode circuit for color adaptor or "slave" viewing unit. It is also a convenient point for inserting the lead of an oscilloscope for checking the action of the video amplifier. The suppressor grid is grounded. The screen is connected to B+ and by-passed by a 5 μ f condenser. The plate goes to +210 volts through *L34* and *R56*. The signal appearing across *L34* and *R56* also appears across the parallel network consisting of *R2*, *C31*, *C32*, *C33* and *R59*.

The CRT cathode is above ground by the amount of d-c voltage appearing across the network from *R61* through to the junction of *R58* and *R59*, the point on a bleeder network between +210 and +130. It is usually about 120 volts d.c. To maintain the video amplifier response regardless of the setting of the contrast control, the control is tapped. *C31*, *C32* and *C33* act as compensating condensers. The amount of signal fed to the CRT is determined by the a-c voltage divider action of the contrast control.

Section B—Horizontal Sync Amp.

In sections B, C and D, the same sync signal is used to drive separate vertical and horizontal sync amplifier circuits and also develop the a-g-c level on the keyed a-g-c tube. Section B is the horizontal sync amplifier and clipper circuit. *V5* which goes back to +370 volts develops sufficient voltage on its cathode to keep the tube at virtual cut-off. The grid is directly coupled to the sync take-off resistor *R56*. It will develop a signal voltage of polarity such that the top half of a signal wave shape will drive the tube into conduction. The video output is of negative picture phase type with the sync pulses appearing in the positive direction. *V5* will, therefore, clip

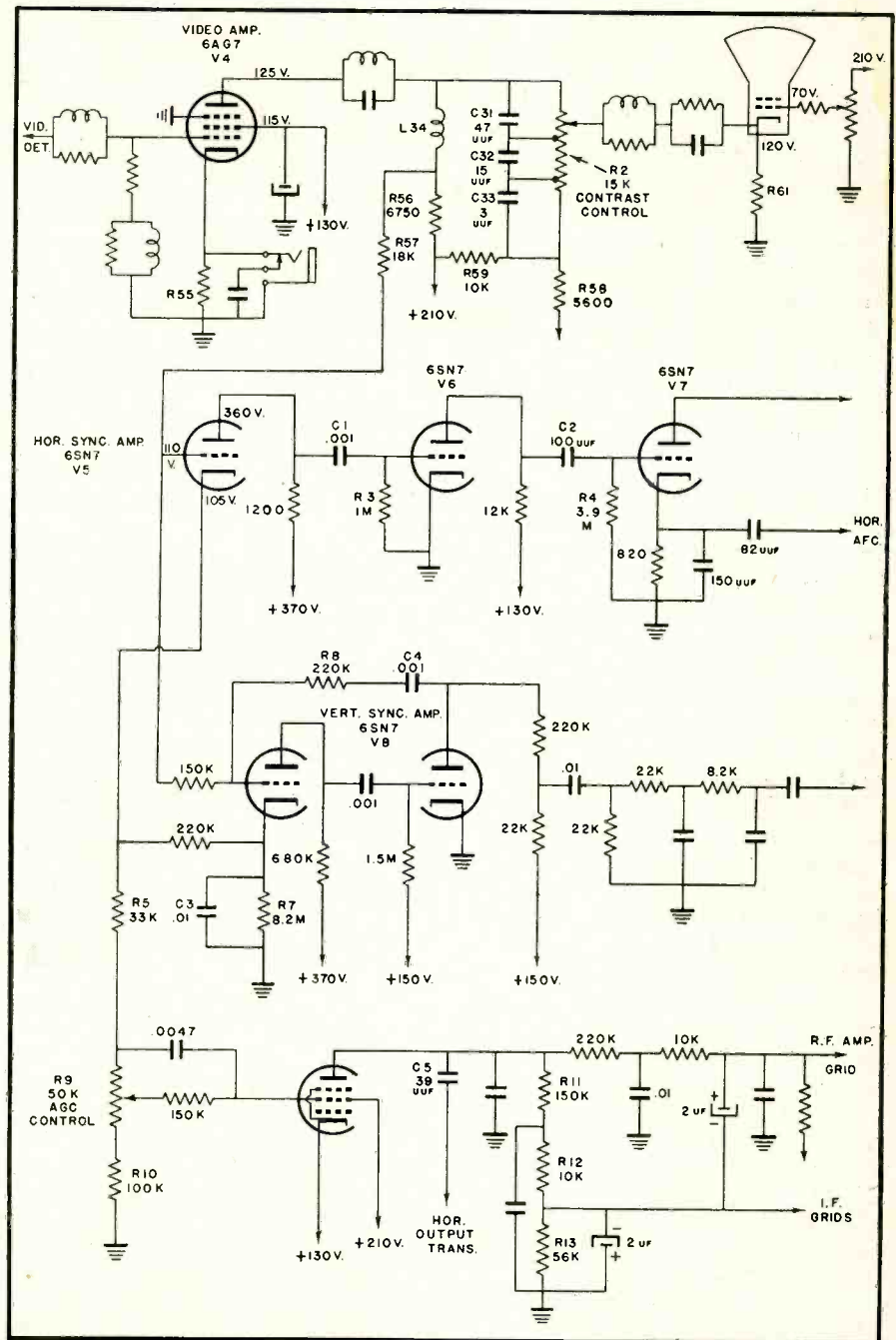

Fig. 1. Partial schematic of RCA 21T176; video amplifier, horizontal sync amplifier, vertical sync amplifier, and a.g.c.

off most of the video information and feed through only the sync and blanking pulses. The vertical pulses are differentiated out by *C1R3* and *C2R4*.

V6 operated at a low plate voltage and as a result of plate saturation and

grid current flow, the positive and negative portions of the sync input signal are further clipped. To maintain the desired output pulse polarity;

V7 is operated as a cathode follower

[Continued on page 40]

PERSONNEL NOTES

• • •

George E. Harris, of the George E. Harris and Company, Wichita, Kansas, has been appointed Sales Representative for the Halldorson Transformer Company, Chicago, effective May 1. Mr. Harris and his associate, Mr. John B. Pilkington, will call on distributors for the Halldorson Company in Kansas, Missouri, Nebraska, and Iowa, and will handle the complete Halldorson transformer and TV replacement line.

Richard Brennan has been named personnel manager of the Communications and Electronics Division of Motorola Inc., Chicago, according to an announcement from Robert W. Galvin, Executive Vice President.

South River Metal Products Co., Inc., South River, New Jersey, announced here the appointment of two new Sales Representatives to handle the South River Line of Television Antenna Mountings and Accessories manufactured by this Company. The Anderson Sales Company of Boston, Massachusetts, comprised of *Robert, Richard* and *Donald Anderson*, will give exclusive coverage for the South River Line in New England. *Gordon C. Leroy*, has been appointed exclusive South River Representative for all of New York State north and west of Westchester and Sullivan Counties.

CBS-Columbia Inc., announces the appointment of *Henry E. Hinz* as Chief Mechanical Engineer.

C. V. Bradford, a veteran of the RCA Victor Division, has been appointed manager of the company's East Central region, with headquarters in Cleveland. His appointment was announced by C. M. Odorizzi, operating vice president of the RCA Victor Division, Radio Corporation of America.

Douglas J. Sullivan has been appointed manager of employee and plant community relations for the General Electric Company Tube Department. *Kenneth C. DeWalt* of Syracuse, manager of General Electric cathode ray tube operations since

1949, has been named manager of engineering for the G-E Tube Department with headquarters in Schenectady. Robert E. Lee, assistant manager of G-E cathode ray tube operations, has been named to succeed Mr. DeWalt.

Hytron Radio & Electronics Co., a Division of Columbia Broadcasting System, Inc., Salem, Massachusetts, announces the appointment of *Norman Fyler* as Supervisor of Development TV Picture Tubes. This appointment



Mr. Norman Fyler

follows the announcement of an organization change in Hytron's Television Picture Tube Manufacturing Division.

Tricraft Products Company, Chicago manufacturer of television antennas and accessories, announces that *Lou Potashnik* is no longer employed by, or affiliated with Tricraft Products Company. Future sales will be handled by Joseph Marks, General Manager.

W. S. Hartford will retire May 15, as vice-president in charge of sales of Webster-Chicago Corporation, manufacturer of phonographs, record-changers and magnetic wire and tape recorders. *Norman C. Owen* has been named general sales manager. Owen has been sales manager of the distributor division. He replaces W. S. Hart-

ford, vice-president in charge of sales, who retires May 15.

The election of *John H. Beedle*, works manager of Raytheon Manufacturing Company, Waltham, Mass., as an assistant vice president of the corporation was announced by C. F. Adams, Jr., president.

Craftsmen, Inc., 4401 No. Ravenswood, Chicago custom TV, radio and electronics equipment manufacturers, announces the appointment of *A. S. Johnson* as executive assistant.

Kenneth C. Meinken, Sr., President of National Union Radio Corporation in Orange, N. J., has announced the appointment of *Kenneth C. Meinken, Jr.* as Vice-President in Charge of Equipment Sales of Cathode Ray Tubes, Receiving Tubes and government business, effective May 5, 1952.

Mr. F. W. Timmons has been appointed Eastern Sales Manager. Mr. Timmons will be responsible for Receiving Tube and Picture Tube accounts on the eastern seaboard, as well as some industrial accounts using Special Purchase Cathode Ray Tubes.

The appointment of *Fred Voorhaar* as Sales Promotion Manager, is announced by Technical Appliance Corporation, Sherburne, N. Y. In his new position Mr. Voorhaar will direct the sales promotion activities of the entire Taco organization. This will include the promotion of TV, FM and AM antennas, and the various Tacoplex Master Antenna Distribution Systems.

R. M. Karet announces the following personnel changes in the set-up of JKM Incorporated, manufacturers' representatives. *Oden F. Jester* and *John S. Margolin* are no longer associated with the company. *R. M. Karet*, head of JKM, and formerly sales manager of the Jobber Division of Utah Radio Products Company, will continue to serve as manufacturers' representative under the firm name of JKM Incorporated at the same address as before, 510 N. Dearborn St., Chicago 10, Illinois.



INDIVIDUAL NEEDLE PACKAGE

NEW...

the Complete Phonograph Needle Line

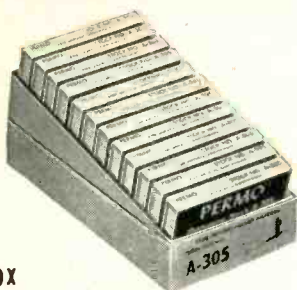

"12 IN 1"
DISPLAY BOX

NEW...

Specific Cartridge To Needle Data



"36 IN 1"
DISPLAY CASE

NEW...

Practical Packaging and Display

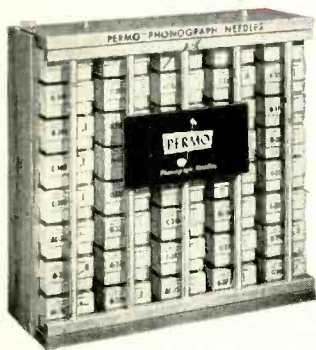

"40 DOZEN
IN 1"
DISPLAY
CABINET

NEW...

Simple Inventory Control — Accurate Re-order System

Buy the line that's complete in every detail!

PERMO *phono-needles*

See Your Distributor...

EXTRA: Write for your complete 36-page catalog now — it's just off the press! Gives full details on the profit-packed Permo line.

PERMO

PERMO, Inc., 6415 RAVENSWOOD AVENUE, CHICAGO 26, ILLINOIS

MANUFACTURERS OF "FIDELITONE", "PERMO-POINT" AND "PERMO" PRODUCTS
LONG-LIFE PHONOGRAPH NEEDLES • RECORDING TAPE AND WIRE • RECORD BRUSHES

NEW PRODUCTS

YAGI "FISHBONE"

Telrex, Incorporated of Asbury Park, New Jersey, announces production of a new antenna for TV, UHF and FM. The new array, called the "Fishbone", is designated Model WB-1 by the manufacturer.

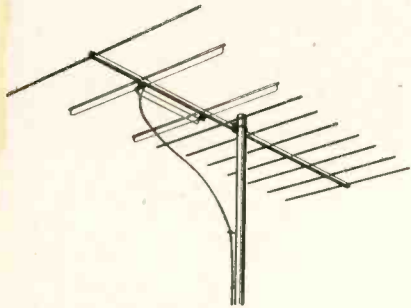

Field and actual service tests conducted on the past three months show the "Fishbone" to be their most powerful single channel array ever produced. The array features ten Working elements. The Model WB-1 is easily installed and ruggedly constructed for lasting installations. It is recommended for suburban and outlying fringe area single channel reception.

ALL-SPEED RECORD-PLAYER ATTACHMENT

Designed to meet market demand for a low-priced all-speed record player is this completely automatic RCA Victor record-player attachment (Model 2JS1), which can be connected to play through virtually any radio or television re-



ceiver. Engineered for quick adjustment to 45, 78, or 33-1/3-rpm playing speed, the instrument features a novel slip-on spindle which houses the 45-rpm record-changing mechanism. The attachment is housed in a compact, maroon-colored cabinet, is complete with a plug-in phono-jack cable, and measures only 8 inches high to the top of the spindle, 13 3/4 inches wide, and 13 3/4 inches deep.

"DOORKNOB" TV CAPACITOR

The new Sprague Type 20DK-T5 molded-case ceramic capacitor recently announced by The Sprague Products Company, 71 Marshall St., North Adams, Mass. offers a simple solution to a vexing problem faced almost daily by television technicians.

This 500 mmf., 20,000 volt "doorknob" filter has been designated as a truly universal re-



placement for the dozen or more similar types used as original manufacturer's parts but which differ only in the type of terminal used.

This new capacitor is equipped with female-threaded brass inserts on both faces of the plastic case and is furnished with a complete set of thread-in terminals which fit the insert. From these, the serviceman can select any two he needs to fit the particular receiver upon which he is working.

Thus, only one Sprague universal capacitor instead of a dozen or more exact replacements need be carried in the service kit to assure on-the-spot repairs.

BOOSTER

Turner Company, Cedar Rapids, Iowa, announces a new model of the highly popular Turner TV Booster will soon be in general



distribution. The Model TV-2, pictured here, is encased in mahogany plastic, representing an improvement in appearance in addition to engineering and performance refinements.

The new Model TV-2 employs the now famous Cascode circuit. The Cascode circuit is noted for its low noise factor, and, in combination with the Inductuner, is the chief reason for the outstanding performance records established throughout the country by the first Turner model.

The Turner TV-2 tunes continuously over TV channels 2 to 13, with single-knob tuning. A three way control switch turns on set only, set and booster, or turns off both set and booster simultaneously. The unit is supplied complete with twin-lead lines for quick connection to the receiver. A single terminal strip accommodates either 75-ohm coaxial or 300-ohm twin-lead transmission lines.

RADIO-TV TOOL KIT

National Union Radio Corporation, 350 Scotland Road, Orange, New Jersey, has just announced a new all-purpose tool kit designed especially for television and radio service work.

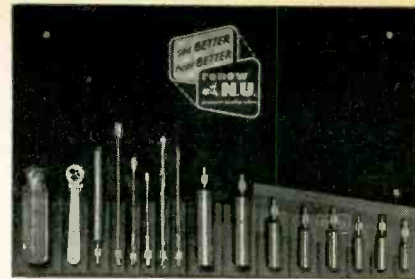

This 17 piece kit is contained in an extremely attractive and durable plastic roll, which can also be worn as an apron, or fastened to the wall.

This tool kit, available free from National Union distributors, with the purchase of only 250 tubes, contains specially-designed socket wrenches with hollow shafts to accommodate volume controls and extra-long bolts. There is provided a regular type handle as well as a right-angle ratchet drive. Also included are various sizes screw driver blades for both slotted and Phillips head screws. The tools are precision made of the finest carbon steel, fully hardened, and finished with a highly polished rust-resistant plating.

VHF-UHF TUNER TUBE

Development of a new television receiving tube which will permit construction of a television tuning unit to tune in present television channels and soon-to-be used ultra-high-fre-

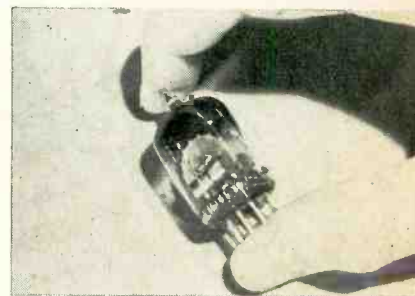

quency channels was announced recently. The General Electric Tube Department said that development of the new tube completes the tube requirements for a combined tuning system for television receivers. Three types of receiving tubes should be used for a combined tuner, according to G-E tube engineers. They include a mixer tube, the type announced today; an oscillator tube, and a radio-frequency amplifier.

Like its predecessors, the new mixer tube has a frequency range which covers the entire band of television frequencies. The new mixer tube has been designated type 6AM4. The previously-announced oscillator is type 6AF4, and the r-f amplifier is type 6AJ4.

The 6AM4 is a miniature high-mu triode designed for use as a grounded-grid mixer. A conversion gain (voltage) of approximately four times can be realized when this tube is used as a mixer at 900 megacycles with 150 volts on the plate. Other technical data follows: Maximum ratings—plate voltage, 150 volts; plate dissipation, 2 watts; heater cathode voltage, 80 volts. Average characteristics—plate voltage, 150 volts; cathode bias resistor, 100 ohms; amplification factor, 90; approximate plate resistance, 10,000 ohms; transconductance, 9,000 micromhos; plate current 7.5 milliamperes.

LIGHTNING ARRESTERS

Three new models of the RW Series VEE-D-X Lightning Arresters are now being manufactured by The LaPointe Plascomold Cor-

IT'S ALL NEW

**the Rotor of Tomorrow
HERE TODAY!**

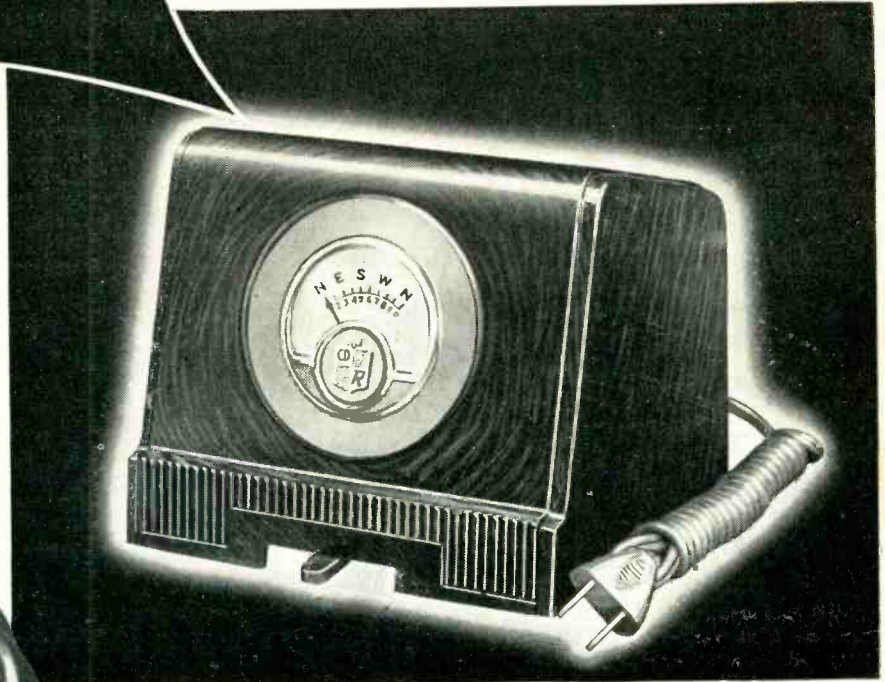
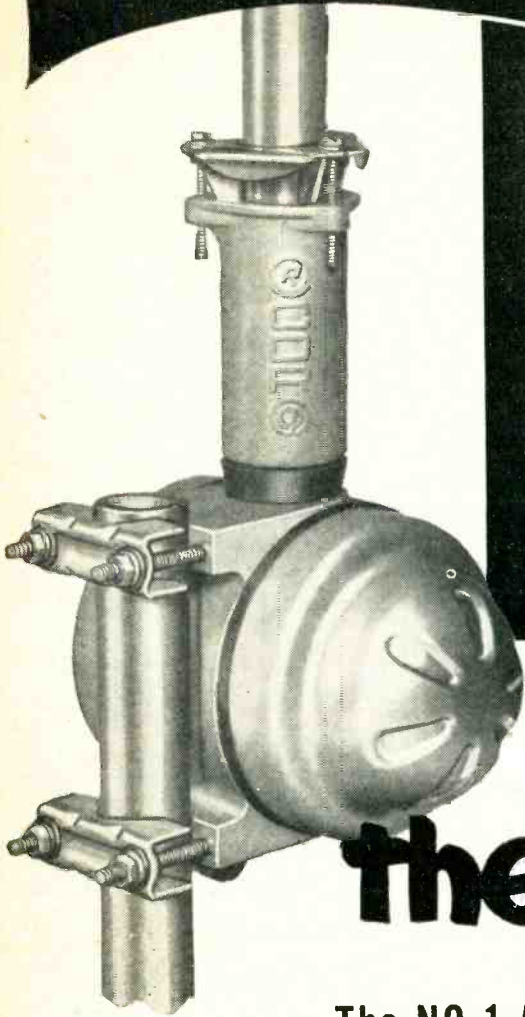

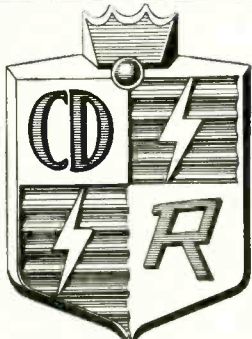
the  **Rotor**

The NO. 1 ALL-PURPOSE ROTOR *That Has Everything!*

Designed to give the trade everything they've asked for. To do this, it's taken time . . . lots of time and money and engineering skill . . . and NOW WE HAVE IT . . . the best possible ALL-PURPOSE ROTOR! It's TOPS! Order them at your jobber NOW . . . be the FIRST with the BEST in your area!

MODEL TR-11 Complete rotor with handsome modern design plastic cabinet and meter control dial . . . fingertip lever . . . using 4-wire cable **\$44.95**

- ★ Quick Mounting Antenna Mast Collet
- ★ Speedy Installation—No Loose Parts to Assemble
- ★ Takes Antenna Masts up to 1½" OD
- ★ High Torque
- ★ Instant Locking—will not drift
- ★ Instantly Reversible—makes complete revolution in 45 seconds
- ★ Completely Weather-proofed—Thoroughly Water-proofed
- ★ Less wind resistance
- ★ High strength with low weight
- ★ Fits standard towers

THE RADIART CORPORATION
CLEVELAND 13, OHIO



CORNELL-DUBILIER
SOUTH PLAINFIELD, NEW JERSEY

poration. These include a strap mount for masts and pipes, a heavy-duty open wire model, and a single screw type for simplified installation.

The RW-200-S and RW-204S feature specially engineered straps and unique gripping prongs for non-slip mounting on all size masts and pipes. The electrical characteristics of these models are similar to the standard RW-200 and RW-204 arresters.

Model RW-310 open wire arrester is similar to the heavy-duty RW-300, but is designed with brass connecting blocks and prong-tooth washers that provide positive connections and assure accurate wire spacing.

New models, RW-210 and RW-214, also modifications of the RW-200 and RW-204, are manufactured with a single wood screw for quick, easy mounting on all wood surfaces.

With the addition of these new models, VEE-D-X now offers a complete range of models for all applications and installation requirements. All VEE-D-X Lightning Arresters are UL approved.

TV ANTENNA

JFD Jetenna, the conical with the jet-action assembly, has absolutely no separate parts to put together—the slowest part is opening the carton! Just swing out the elements, tighten two "T" bolts and two wing nuts and it's assembled! Front elements automatically fan out as they are swung forward. Reflector elements are spring-loaded to lock into position for tightening. 1" square seamless crossarm, seamless elements and element brackets are of high tensile strength aluminum—unbreakable head is of all weather, high dielectric material.

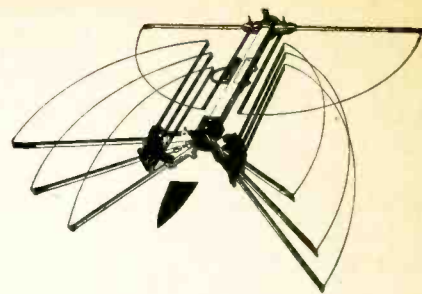

Solid, unbreakable "vibration dampers" do not absorb moisture or swell and will not rot out. See your jobber or write for further information about this revolutionary new antenna.

YAGI ANTENNA

Development of a new type of Yagi antenna, the Z-MATCH Yagi, that achieves 100% perfect match to 300 ohm line for both single and stacked arrays, has been announced by Channel Master Corporation, Ellenville, N. Y.

Complaints by installation men led to the discovery that the small amount of additional gain achieved in stacking Yagi antennas of all makes is due to the existence of 2:1 mismatch which is unavoidable in stacking conventional Yagis. The Z-MATCH Yagi, however,

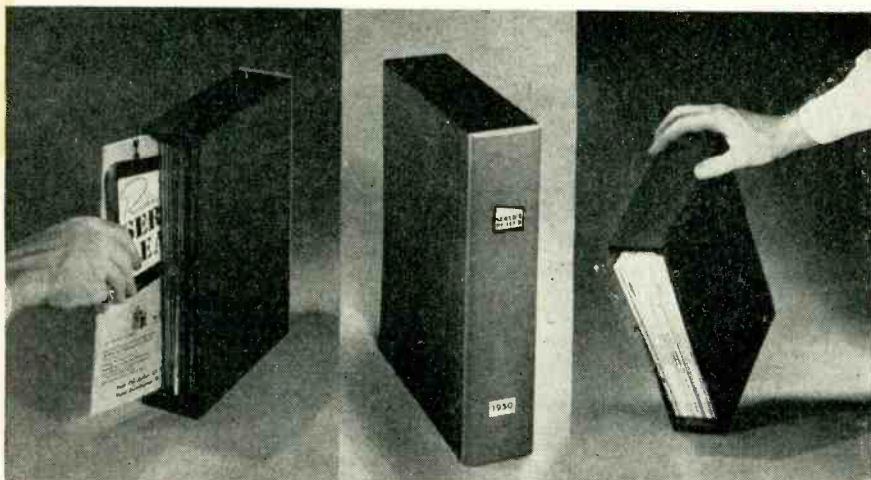

(B) (C) (A)

A New Magazine Holder

- (A) Side and front view reveals handsome appearance; fitting well into any library shelf.
- (B) Small crosspiece at bottom prevents magazines from falling out when SAMARTO magazine holder is turned upside down. Also eliminates books dropping out when holder is removed from shelf.
- (C) Removing or inserting magazine into holder is simplicity itself as this illustration reveals. Merely put the magazine into the opening and it will fall into position below the cross-piece thereby being kept secure in the holder. When taking out a magazine, merely raise it slightly above crosspiece as shown.

This indispensable magazine holder features:

- Sturdy wood frame construction.
- Durable and attractive simulated leather covering.
- Spacious accommodations for one year's issues of RTSD.
- All magazines are immediately visible and available for instant removal or storage.

all for only

\$1.95

POSTPAID

RADIO-TELEVISION SERVICE DEALER
67 WEST 44TH ST., NEW YORK 36, N. Y.

Sirs: Enclosed herewith is my check (or money order) for \$..... for
..... magazine holders.

Name

Address

City

Zone

State

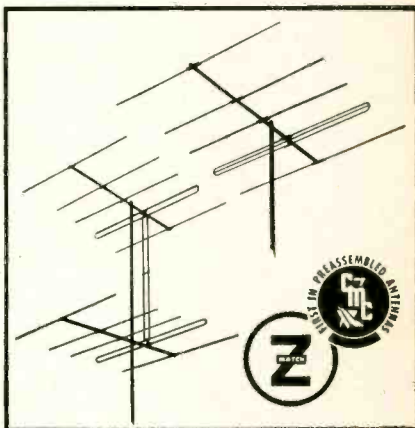

features adjustable impedance, and automatically provides a perfect match for both single and stacked arrays. In addition, this antenna has wider spaced elements which result in higher gain, narrower lobe and better rear rejection on all installations.

No extra connecting rods are needed with the Z-MATCH Yagi. When antennas are stacked, the center bars of the folded dipoles are removed. This reduces the impedance of each antenna and automatically creates a perfect 300 ohm match for the complete stacked Yagi array. The removed center bars are then used as perfect 1/2 wave connecting rods.

H-F TRIMMER

Erie Resistor's new Style 535 Trimmer has been developed, according to the company, in response to the need for a compact, small,



stable high frequency trimmer at a low price. The "535" is easily mounted, completely self-contained, in that no additional hardware is required for mounting.

The trimmer has low inductance and extreme-

Bill Clemens says—

Midget Radio Service (a 3-Man Shop)
129 S. Elizabeth St., Lima, Ohio

**"TRIPLITT 660 saves us
50 to 100 man hours
per month."**

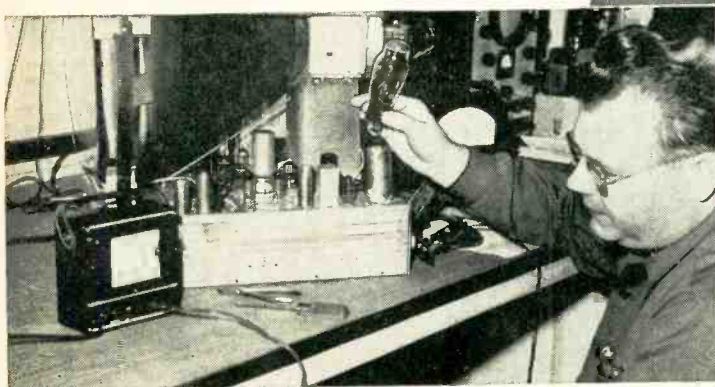

1. **ISOLATING THE TROUBLE**—Plug the power cord of the chassis into LOADCHEK and note the reading. With your eye on the large meter remove the rectifier tube and you can tell immediately which side of the tube the trouble is on. You have already eliminated 50% of your probing time.

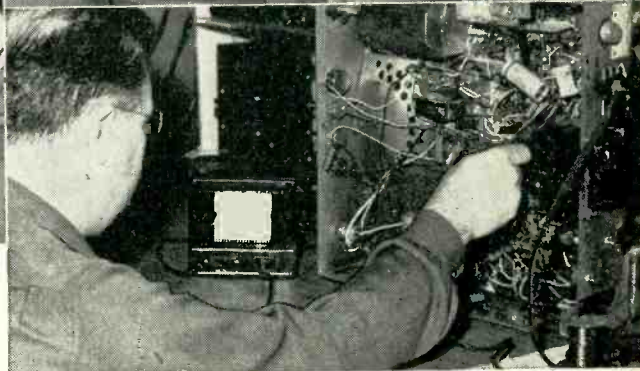

2. **LOCATING THE SHORT**—With Loadchek you can quickly check the shorted side, part by part, without laying down tools or picking up test leads. Here, the trouble was a short in the transformer, spotted without having to warm up set. Overloads are found the same way.

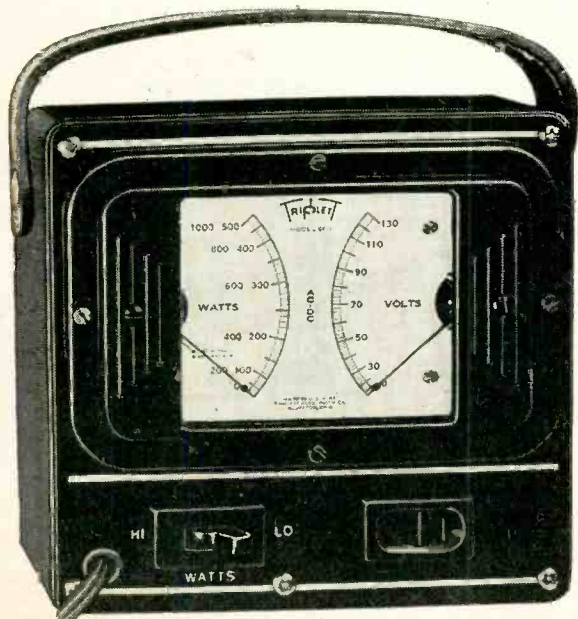

Locates trouble in a hurry

The above pictures illustrate but one of the many time-saving uses of Triplitt 660 Loadchek. This versatile instrument accurately measures power consumption, enables you to see instantly any deviation from normal load, without disconnecting a single part... finds trouble in a hurry.

For Radio and TV servicing—for almost any kind of electrical trouble-shooting—LOADCHEK saves hours of painstaking work every day. At its moderate cost no service technician can afford to be without it. Try one today—and see! Write for free booklet.

TRIPLITT ELECTRICAL INSTRUMENT CO., BLUFFTON, OHIO, U.S.A.



Triplitt

Suggested U. S. A. DEALER NET \$29⁵⁰

Prices subject to change without notice.

ly low loss, due to employment of ribbon type leads and high temperature styrene dielectric. Adjustment is uniform, straight-line, and noiseless. The trimmer is a natural for UHF and is provided with a soldering tab for ground.

Erie resistor will gladly supply samples to manufacturers interested.

DUAL-CONCENTRIC CONTROLS

The adaptation of a proven design for locking shafts at a desired setting is now available on a dual-concentric control is announced by Clarostat Mfg., Co., Inc., Dover, New Hampshire manufacturers of control resistors and resistance devices.

The use of this construction will allow the replacement of two panel units requiring locked semi-permanent settings. It is a dual-concentric unit with concentric operating shafts and tapered jam nuts are used for locking the individual controls at any desired settings. This

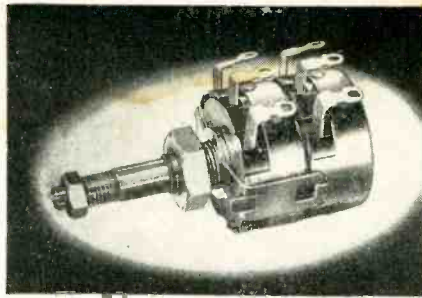

type control requires one-half the panel space of two single units.

CERAMIC CAPACITORS

By settling on a 6000 volt rating for its new tubular ceramic capacitors, Aerovox

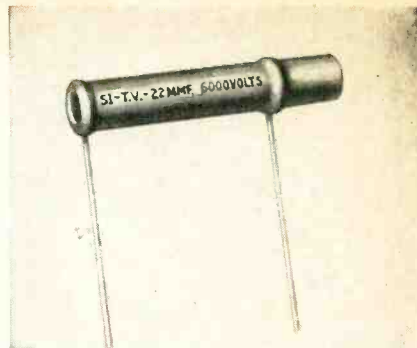

Corporation of New Bedford, Mass., simplifies the ordering and stocking problems yet insures adequate safety factor in avoiding voltage breakdowns.

Type SI-TV High-Voltage Tubular Ceramic Capacitors are of the well-known Hi-Q brand manufactured by the Electrical Reactance Corporation, an Aerovox subsidiary. For distribution to and through Aerovox jobbers to the service and experimenter trade. These ceramics are available in just the one 6000 volt rating, but in eleven capacitance values from 4.7 to 47 mmf. Like the other items of the Aerovox Hi-Q Ceramics line, these units come packed five to the unique Aerovox window carton.

IMPROVED CAPACITY BRIDGE

Simpson Electric Co., Chicago, has announced engineering changes on their Model 381 Capacity Bridge which make it an entirely new, more compact and easier to use instrument. The Model 381 circuit enables even the inexperienced to make capacity measurement with ease. Simplicity and ease of operation are features of this new instrument. Merely press a button for the desired range, adjust the bridge arm for maximum meter deflection and read the capacity on the scale.

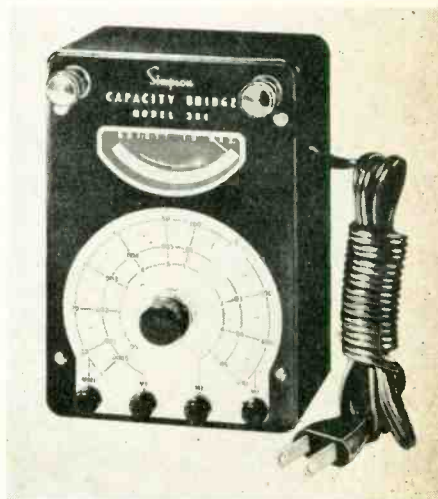

The small size of this tester, together with its wide range of capacity measurement and low price makes the Model 381 an ideal instrument for Radio and Television service dealers, broadcast engineers, electric repair shops, X-ray servicing, industrial maintenance departments or any other service where condensers are tested. The Model 381 comes in a bakelite case with an etched aluminum panel. Dealer's net price is \$28.50.

the BIG 10

fabulous

10 element

Yagi

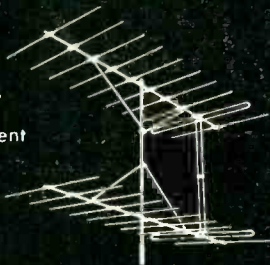

- The highest gain Yagi in TV history: 12 DB single, 14½ DB stacked (78% stacking gain).
- "Boom Braced" (low band) to prevent picture flicker.

600 Series

5 element

Yagi

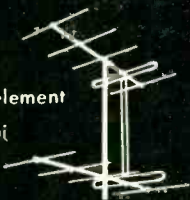

- Highest gain of any 5 element Yagi: over 9 DB single, 12 DB stacked.
- Full 100% stacking gain!

do
you
get
these

Major Benefits

in your present TV installations?

1. Adjustable impedance eliminates mismatch to 300 ohm line in single and stacked arrays.
2. Wider spaced elements, on longer cross-arms, for still higher gain.
3. Up to 100% additional gain in stacking.
4. And you don't pay for stacking bars!

4

major benefits are provided by Channel Master Z-Match Yagis which are essential to better, more profitable fringe installations. No other Yagi gives you any of them! However, in the Z-Match Yagi, you get all 4 features — at no extra cost.

Write for new catalog

List Prices

Ch.	600	BIG 10
7-13	7.65	13.89
2-3	17.65	31.94
4-5	16.67	28.47
6	16.67	25.69



CHANNEL MASTER CORP.
ELLENVILLE, N. Y.



You are **DOUBLY** safe
when you use

BUSS FUSES



The BUSS
slide-cover
metal box
protects fuses
— handier to
use.

The name BUSS represents over 37 years
specializing in fuses.

Each individual BUSS fuse is tested in an
electronic device to insure proper operation.

You can always be sure a BUSS fuse will open to
protect—but will not open needlessly.

Complete **TELEVISION
FUSE LIST** Shows proper fuse to use

- How fuse is mounted • What fuse protects •

© 1951, Bussmann Mfg. Co.

Division McGraw Electric Co.

ADMIRAL to CENTURY

CLARION to MAJESTIC

MAJESTIC to SENTINEL

SETCHELL-CARLSON to ZENITH

AUTO RADIO FUSE LIST

Did You Get Your Copy
of the *NEW*

**BUSS
TELEVISION
FUSE LIST?**

It's free!

The new BUSS Television Fuse List
gives complete up-to-the minute information
on all fuses used in today's T-V sets. Plus —
the latest Auto Radio Fuse List.

Shows what fuse to use — how fuse is
mounted — and circuit fuse protects.

Chart can be hung on wall for ready
reference — or — carried in pocket or tool kit
when making service calls.

On back of chart are illustrations and
dimensions of all fuses specified in listings, to
be of added assistance in selecting proper fuse
to use.

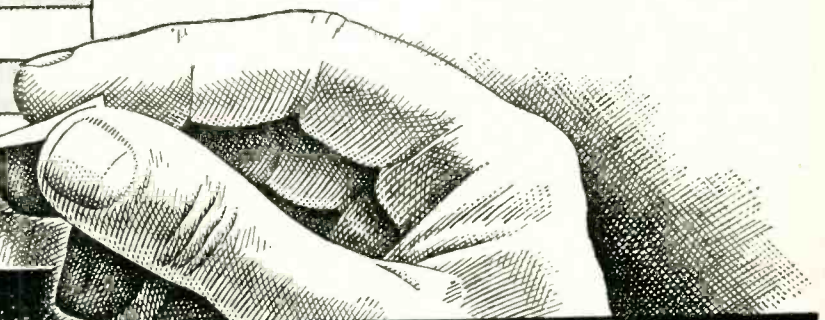

*IF You Can Use a Copy...
Send the Coupon Today*

This complete fuse list helps
Service or Counter men know
what fuses are needed to service
any T-V set — and helps store-
keeper know what fuses he should
stock.

BUSSMANN MFG. CO.

University at Jefferson St. Louis 7, Mo.
Division of McGraw Electric Company

BUSSMANN Mfg. Co. (Division of McGraw Electric Co.)
University at Jefferson, St. Louis 7, Mo.

SD-652

Please send a copy of the BUSS Fuse Application Chart.

Name _____

Title _____

Company _____

Address _____

City & Zone _____ State _____ 552

high HICKOK sensitivity

5^{inch} OSCILLOGRAPH with DC AMPLIFIERS

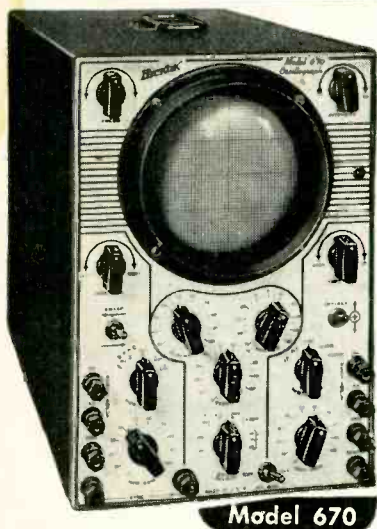

Model 670

Accurate television service requires a GOOD "Scope". This HICKOK 670, designed with D.C. amplifiers provides excellent square wave response on high or low frequency. The extra sensitivity—to 10 MV per inch—in this HICKOK 670, properly shows the response curve, even when TV receiver is far out of alignment.

Features . . .

Wide band vertical amplifier useable beyond 2MC. Polarity reversing switches. Push-pull amplifiers. Direct connections to horizontal and vertical plates. Fixed sweep frequency for accurate viewing of wave forms 30 and 7875 cycles. Recurrent linear sweep 3 to 50,000 cycles. Astigmatic focus control for sharper trace. Horizontal amplifier 0 to 100 KC. Sweep oscillator 3 to 50 KC.

You'll like this Model 670. It's a perfect companion to the 610A for accurate TV alignment; or the Model 630 for accurate wave form analysis. Write for complete technical details.

THE HICKOK ELECTRICAL INSTRUMENT CO.
10533 Dupont Avenue • Cleveland 8, Ohio

TRADE FLASHES

[from page 12]

owner and designed to reach him both in the home and at the point of service, according to L. S. Thees, general sales manager of the RCA Tube Department.

The program embraces national radio and television advertising, a variety of in-store and window display material, direct mail literature, a special kit of six basic sales aids for use by radio service dealers in tie-in promotions, and a promotion-plan catalog.

SYNC PULSES

[from page 14]

agers Committee which recently studied the immediate effects of lifting the "freeze" on TV station construction.

The first TV areas to benefit from the reprocessing of TV applications starting July 1, the committee study shows, will be cities in which 30 channel shifts of existing TV stations have been ordered by the Federal Communications Commission. This will result from expected increases in transmitting power which will be available to these stations at the same time they change channels.

The data on the station power increases were presented to the committee, of which R. J. Sherwood, of The Hallicrafters Co., is chairman, by W. L. Stickel, of Allen B. DuMont Laboratories. Mr. Stickel told the committee that TV markets in these 25 areas may be expected to be extended several miles by reason of the power increases which will vary according

Areas	Stations	Present Channels	Proposed Assignments
Chicago	WBKB	4	2
Pittsburgh	WDTV	3	2
Cleveland	WXEL	9	8
	WBK	4	3
Milwaukee	WTMJ-TV	3	4
Cincinnati	WLWT	4	5
	WKRC-TV	11	12
	WCPC-TV	7	9
Providence, R. I.	WJAR-TV	11	10
Atlanta, Ga.	WLTV	8	11
Norfolk-Portsmouth			
Newport News, Va.	WTAR-TV	4	3
Louisville, Ky.	WAVE-TV	5	3
	WHAS-TV	9	11
Birmingham, Ala.	WBRC-TV	4	6
Albany-Troy			
Schenectady, N. Y.	WRGB	4	6
Columbus, Ohio	WLWC	3	4
Rochester, N. Y.	WHAM-TV	6	5
Memphis, Tenn.	WMCT	4	5
Dayton, Ohio	WLWD	5	2
	WHO-TV	13	7
Syracuse, N. Y.	WSYR-TV	5	3
Grand Rapids, Mich.	WOOD-TV	7	8
Wilmington, Del.	WDEL-TV	7	12
New Haven, Conn.	WMHC-TV	6	8
Johnstown, Pa.	WJAC-TV	13	6
Davenport, Ia. - Moline			
Rock Island, Ill.	WOC-TV	5	6
Lancaster, Pa.	WGAL-TV	4	8
Huntington, W. Va.			
Ashland, Ky.	WSAZ-TV	5	3
Bloomington, Ind.	WTTT	10	4
Ames, Ia.	WOI-TV	4	5

Chart showing proposed Channel shifts

to the channels involved.

The FCC has stated that it will give priority to the processing of applications for the channel shifts ordered in its recent allocations report and to requested power increases beginning July 1. In most instances, hearings will be unnecessary, it was indicated.

In the accompanying chart is shown the cities in which TV channel transfers have been ordered, the stations in proposed channel assignments.

SALES PLAN

[from page 24]

from the front of the chassis is provided. High voltage is automatically disconnected when phono is in operation.

The front focus control provides convenient and necessary adjustment to compensate for the changes in current drain at the various contrast and brightness settings when switching from local to DX reception. A picture clarifier clears picture of hash. Full 4 megacycle over-all video i-f band width is provided as well as a new keyed a-g-c circuit with complete noise immunity.

The focus coil, speaker and yoke assembly have removable plugs for easy servicing. This receiver will drive 16", 17", 19", 21", and 24" CRTs.

CIRCUIT COURT

[from page 31]

and the horizontal pulse, clipped and shaped, is fed to the horizontal AFC tube.

Section C—Vertical Sync Amplifier

Close observation of the connections of Section C input shows that V5 and V8 are actually connected in parallel. Both their grids are directly connected to the sync take-off point through R57 and both cathodes are connected to the top of R5 as a common cathode resistor. (see Fig. 2). R6 is used for isolation and also to develop a higher positive voltage on V8's cathode. R7 and C3 act as a stabilizing or filtering network whose time constant is so long that there will be little or no change in the voltage appearing at V8 cathode between vertical sync pulses. The amplitude of the voltage of V8's cathode is a function of the sync amplitude appearing at the tube's grid. This determines how heavily V8

Radio-Television SERVICE DEALER

Yours for the Asking

- **FREE!** 68 page catalog section from Radio's Master.
- Catalogs the products of 30 manufacturers of Recording, Phono Equipment and Accessories.
- Complete descriptions, specifications and illustrations of such products as: Recorders, Phono Motors, Turntables, Record Changers, Cartridges, Pickups, Discs, Tape, Needles, etc.

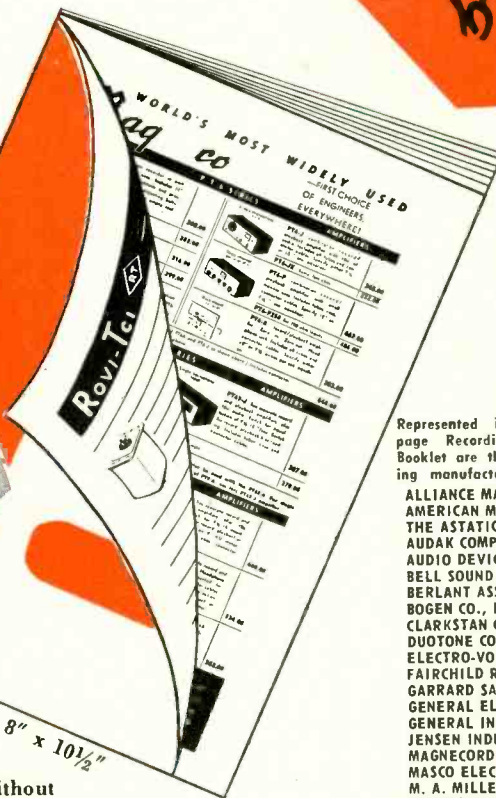
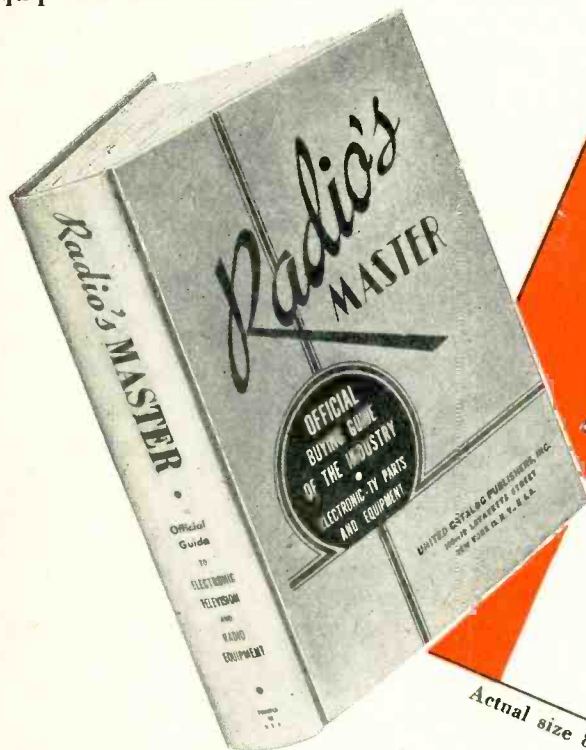

Actual size 8" x 10 1/2"

Represented in RADIO'S MASTER 68 page Recording & Phono Equipment Booklet are the products of the following manufacturers:

ALLIANCE MANUFACTURING CO.
AMERICAN MICROPHONE CO.
THE ASTATIC CORP.
AUDAK COMPANY
AUDIO DEVICES, INC.
BELL SOUND SYSTEMS, INC.
BERLANT ASSOCIATES
BOGEN CO., INC.
CLARKSTAN CORP.
DUOTONE CORP.
ELECTRO-VOICE, INC.
FAIRCHILD RECORDING EQUIPMENT CO.
GARRARD SALES CORP.
GENERAL ELECTRIC COMPANY
GENERAL INDUSTRIES CO.
JENSEN INDUSTRIES, INC.
MAGNECORD, INC.
MASCO ELECTRONIC SALES
M. A. MILLER MFG. CO.
MINNESOTA MINING & MFG. CO.
NEWCOMB AUDIO PRODUCTS CO.
ORRADIO INDUSTRIES, INC.
PERMO, INC.
PICKERING & CO., INC.
PRESTO RECORDING CORP.
RECORDISC CORP.
RECOTON CORP.
REEVES SOUNDRAFT CORP.
REK-O-KUT COMPANY
SHURE BROS., INC.
V-M CORPORATION
WALCO PRODUCTS, INC.
WEBSTER-CHICAGO CORP.
WEBSTER ELECTRIC CO.

Radio-Television Service Dealer subscribers will receive without cost or obligation, a complete 68 page catalog section as reprinted from the Industry's Official 1100 page Radio's Master, 16th edition.

This section catalogs in detail the products of the leading Recording and Phono Equipment manufacturers — all in 1 handy booklet. It is complete with descriptions, specifications and illustrations as written by each manufacturer. Whether you buy, sell or specify these products, you will find this booklet extremely helpful.

This offer is made possible by a special arrangement between Radio-Television Service Dealer Magazine and the publishers of Radio's Master. Be sure to get your copy now. Fill in the coupon and mail.

If you need catalog data on any other products, let us know.

RADIO-TELEVISION SERVICE DEALER
67 WEST 44th STREET, N. Y. 18, N. Y.

Please send me, without cost or obligation, the 68 page Recording & Phono Equipment and Accessories Booklet as reprinted from Radio's Master.

Name
Address
City..... Zone..... State.....

MAIL TODAY

SMALLEST
IN SIZE...

BIGGEST IN
PERFORMANCE



Still the smallest! And most copied! Singles, duals, triples, quads.

PRB Dandees include a host of new features. New sizes. New construction. New insulated stranded-wire leads. New stud terminals for diameter reduction. New safety sleeves. Aluminum case. Vented.

Higher voltage listings meet new radio/electronic circuit potentials.

Also PRSB units featuring entirely separate negative and positive leads.

Ask your distributor for Aerovox Dandees. Consult latest listings for greater selection of voltages, capacitances, combinations.



FOR RADIO-ELECTRONIC &
INDUSTRIAL APPLICATIONS
AEROVOX CORPORATION
NEW BEDFORD, MASS., U. S. A.

In Canada: AEROVOX CANADA LTD., Hamilton, Ont.
Export: 41 E. 42nd St., New York 17, N. Y.

will conduct. The d-c operation of $V8$ is similar to that of $V5$. There is one other interesting feature in this network. $V9$ acts as a clipper and limiter in the same manner that $V6$ does. To sharpen up the vertical sync pulse leading and trailing edges a portion of the output from $V9$ is fed back in phase to the grid of $V8$ through $C4$ and $R8$.

Section D—AGC

The purpose of establishing a constant d-c level by means of $R7C3$ is threefold:

1. to stabilize the voltage cathode of $V5$.
2. to stabilize the cathode voltage of $V8$
3. to provide a stable voltage by means of which the grid of the a-g-c tube can be biased.

As in most conventional a-g-c systems, the plate goes back to the horizontal output transformer through $C5$. This feeds the pulse which causes the plate to conduct. The cathode goes to +130 volts. In order for the tube to work, therefore, the grid must be connected to a positive voltage point. This point is established by the voltage developed on $R7C3$ and the amount is governed by the relationship of $R5$, $R6$, $R9$ and $R10$. $R9$ enables the biasing point to be varied so that the a-g-c operation can be made adaptable to different reception conditions. The resistor network also acts as an a-c

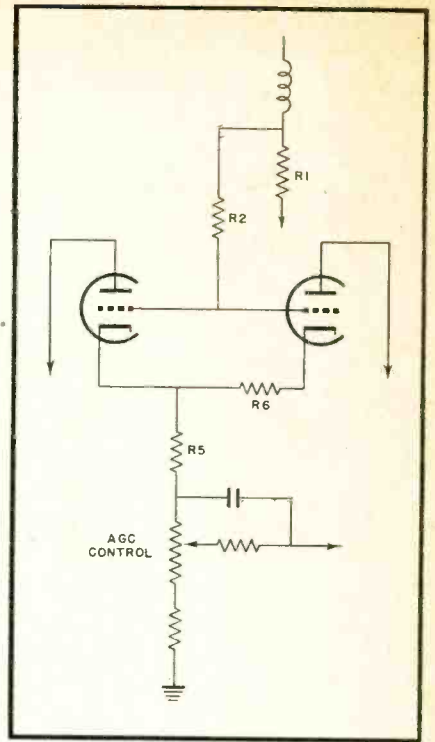

Fig. 2. Simplified schematic of vertical sync tubes.

voltage divider. The sync pulse is taken off $R9$ and fed to the grid of $V10$ at the same time that the keying pulse from the horizontal output transformer arrives at the plate. $V10$ conducts through $R11$, $R12$, and $R13$ to establish the a-g-c voltage.

OSCILLOSCOPE WAVE FORMS

[from page 27]

horizontal line BC . The formula which is used is given by:

$$\frac{\text{HORIZONTAL AXIS FREQUENCY}}{\text{VERTICAL AXIS FREQUENCY}} = \frac{\text{number of loops touching } AB}{\text{number of loops touching } BC}$$

In Part C of Fig. 9 there are two loops tangent at AB and three loops tangent at BC . Therefore the ratio of horizontal frequency is to vertical frequency as 2 is to 3. If the horizontal frequency is 100 cps, the vertical frequency is 150 cps.

This method of Frequency determination or comparison between two

signals extends the use of the oscilloscope as a visual indication of calibration. In Fig. 10 several of the many possibilities for these closed loop patterns are shown. The highest frequency signal will produce more closed loops and where the two signals have an integral relationship.

Part A has five times the vertical frequency as compared to the horizontal signal. In Part B , the vertical amplitude of this signal has been reduced and the frequency relationship is now seven to one with the vertical

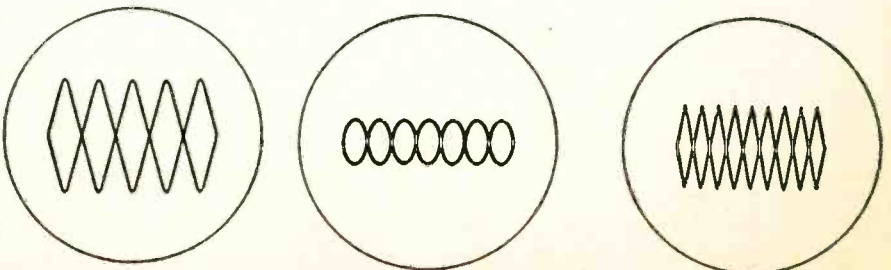
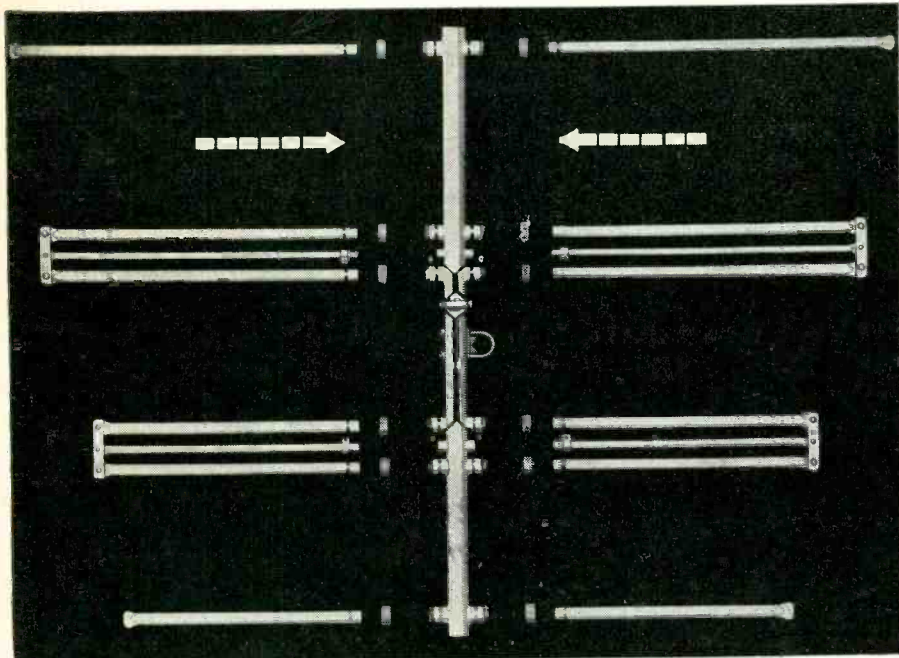

Fig. 10. Vertical frequency higher than horizontal

Announcing the New **TRIO 'MINIT-UP'**

STRONGEST TV ANTENNA EVER DESIGNED...

PLUS-ONE MAN/MINUTE ASSEMBLY!



This — is it!

The new TRIO MINIT-UP . . . a revolutionary TV antenna that combines "minute quick" assembly with strength never before attained in *any* TV antenna!

Strong statements, to be sure — but absolutely true. Take a good look at the illustrations . . . see how simple, how fool proof, how "minute quick" assembly is! Note well, also, the many superior construction details that make the new TRIO "MINIT-UP" a veritable tower of strength!

Feature upon feature makes this new TRIO MINIT-UP the biggest good news in TV antennas yet!

This "exploded" view graphically illustrates the extreme simplicity of MINIT-UP's assembly. Note the color code bands that show instantly where each element is attached. Note the serrated connectors that provide a firm grip with hand or glove — in any weather. Here, indeed, is the last word in TV antennas. Featuring easy assembly, rugged strength — it's the New TRIO "MINIT-UP"!

Model 445MG High Gain MINIT-UP for channels 4 and 5
Model 479MU High Gain MINIT-UP for channels 7 and 9

(TRIO's conventional single channel yagis also available with "MINIT-UP" construction)

Patent pending — no licensing arrangements granted for duplicating principle of this antenna.

MINIT-UP STOPS ANTENNA "CALL BACKS"!

TRIO TV Antennas have long been recognized as "leaders in performance"! Now — with new design features and "minute quick" assembly — TRIO is, easily, the "leader in construction"!

Dealers and Installers will find TRIO's MINIT-UP the most profitable TV antenna they can install. MINIT-UP goes up fast — and stays up! Every detail of design and construction is employed to make MINIT-UP the most rugged TV antenna on the market today!



ONE MAN

MINIT-UP



TRIO Manufacturing Company
GRIGGSVILLE, ILLINOIS

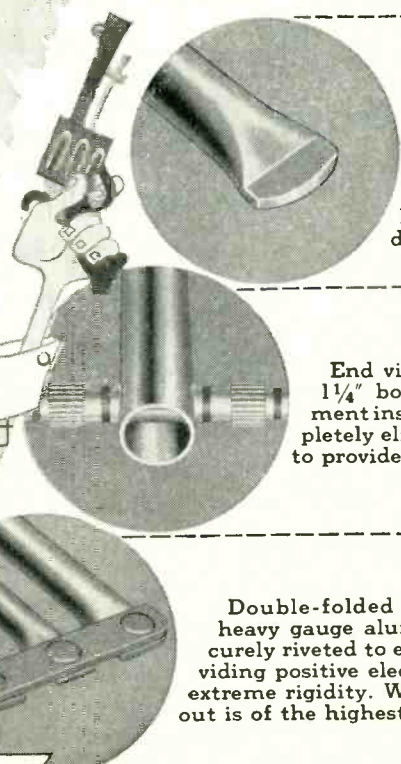

Yagi elements of .035" thick seamless aluminum, are full 5/8" in diameter. Ends are crimped for greater strength and to cut down vibration. Prevents entrance of dirt and moisture.

End view of the heavy gauge 1 1/4" boom showing how element inserts are swaged to completely eliminate vibrations and to provide tremendous strength.

Double-folded dipole sections have heavy gauge aluminum brace bars securely riveted to element ends thus providing positive electrical connection and extreme rigidity. Workmanship throughout is of the highest order.

ATR

AUTO RADIO VIBRATORS

have Ceramic Stack Spacers



A COMPLETE LINE OF VIBRATORS . . .

Designed for Use in Standard Vibrator-Operated Auto Radio Receivers. Built with Precision Construction, featuring Ceramic Stack Spacers for Longer Lasting Life. Backed by more than 20 years of experience in Vibrator Design, Development, and Manufacturing.

NEW MODELS
NEW DESIGNS
NEW LITERATURE

"A" Battery Eliminators, DC-AC Inverters
Auto Radio Vibrators

See your jobber or write factory

AMERICAN TELEVISION & RADIO CO.
Quality Products Since 1931
SAINT PAUL 1, MINNESOTA-U. S. A.

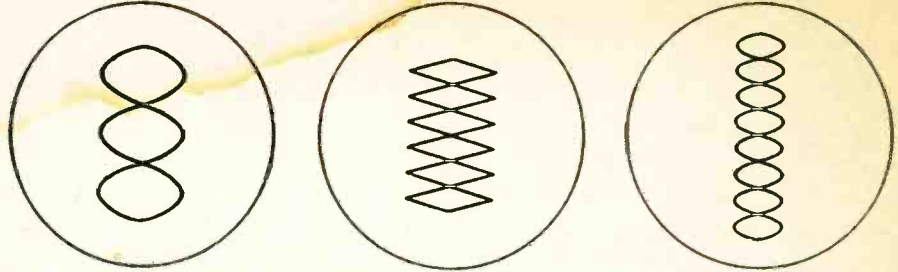

Fig. 11. Horizontal frequency higher than vertical

oscillator again being higher in frequency. Depending upon the screen diameter, there is a limit to the numerical relationship between the horizontal and vertical signals which may be easily read and interpreted. Part C of the figure has a 9 to 1 frequency relation. All of the patterns in Fig. 10 have a higher vertical frequency than horizontal, since there are more closed loops created by the horizontal deflection plates.

If the horizontal frequency is higher than the vertical frequency, the entire pattern on the screen is rotated by 90 degrees as shown in Fig. 11. Part A is a 3 to 1 figure with the horizontal oscillator higher in frequency than the vertical signal. If the vertical input frequency is kept constant and the horizontal signal is increased, the following two patterns are obtained. Part B is a 6 to 1 ratio, and Part C is an 8 to 1 relation.

PICTURE TUBE FAILURES

[from page 18]

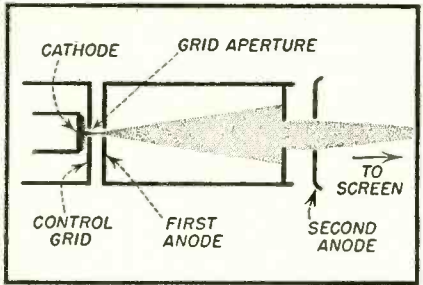

Fig. 5. Cross section of electron beam emission

large, hollow spot reaching the screen. It has to be large, since its electron content is sheer overflow. If it is reduced by the brightness control it practically vanishes. Any attempt to focus it bunches it somewhat tighter, but still maintains it as a bright ring with a dark center. Since this is almost a 180° phase reversal in spot analysis it is not surprising to find that one of the symptoms of such a case is a 'negative' picture. This tube is dead.

Mechanical Failures

Should any element in a picture tube open up completely, or act as an intermittent open circuit in certain phases of operation, the diagnosis is: *Open Element*. So too, can certain faults develop in which elements may touch one another, causing short circuits, directly or intermittently. These are classified as *Shorts*.

The analysis of operation of the elements within the picture tube is best made with a tester (such as Oak Ridge meter-type, or Transvisor

Calibrated Dial type). In the event elements are found open or shorted the tube can be classified as faulty and unfit for use.

Due to certain intermittent nature, the fault may not show up outside of actual use in the set. This would then have to be shown by a CRT Dynamic Analyzer, connected to give continuous indication while the tube is in use.

In the event the picture tube shows no breaks or shorts, but indicates merely low emission, there's a good chance it can be reactivated without taking the tube out of the television set. The Transvision CRT Reactivator is unique in this respect. It duplicates the manufacturer's ageing schedule described before in this paper. Successes up to 90% have been established in group tests made with this type of instrument. The manufacturer conservatively suggests a 70% success may be anticipated. Let us investigate this process:

First the CRT is determined as having low emission. This can be determined by inspection in the set and/or checked by the dual-function instrument, as checker-reactivator. Then the CRT socket is removed, replaced by the output socket of the Tester-Reactivator. Self-powered, the instrument now sets up a chemical process where heat and electrolysis permits chemical decomposition of the barium-oxide layer on the cathode, permitting a drift of pure barium to be

[Continued on page 47]

"It pays to replace with the BEST" Federal-

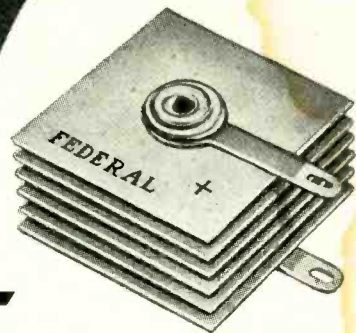

The Original Miniature Selenium Rectifier!

IT PAYS YOUR CUSTOMERS in finest quality and dependable, long-life performance—proved by over 30,000,000 units shipped to the field!

IT PAYS YOU, Mr. Serviceman, in customer satisfaction and goodwill—and a good profit on every job!

Here Are Other Specific Reasons Why "Federal" Is Your No. 1 Choice for Servicing the Big, Growing Radio-TV Replacement Market:

- Tests by receiver manufacturers show a life expectancy of well over RTMA guarantee.
- Over 250,000 tests prove superior immunity to shelf-aging.
- Federal's synthetic barrier layer stops change during long storage.
- Quality rigidly controlled. All units fully tested before release.
- Units available either packed in the attractive Federal resale box or in bulk.
- Constant research keeps you up-to-date on rectifier progress.

SAVE TIME—SERVE YOURSELF
from *Federal's* NEW

RECTIFIER DISPENSER

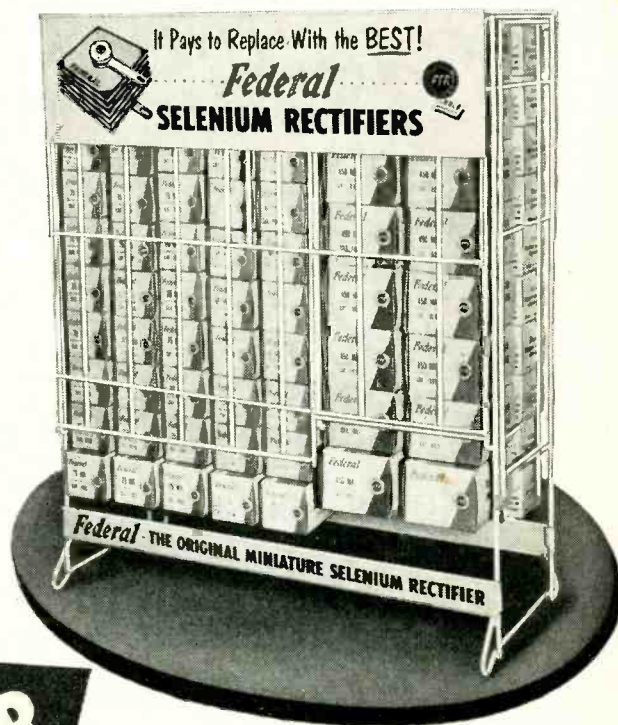

LOOK FOR IT
ON YOUR
DISTRIBUTOR'S
COUNTER!

America's Oldest and Largest Manufacturer of Selenium Rectifiers

Federal Telephone and Radio Corporation



SELENIUM-INTELIN DIVISION
100 KINGSLAND ROAD, CLIFTON, NEW JERSEY
In Canada: Federal Electric Manufacturing Company, Ltd., Montreal, P. Q.
Export Distributors: International Standard Electric Corp., 67 Broad St., N. Y.





SAVE Up to \$1.00 each.

**Form a Group,
Service Dealers**

Subscribe to "RTSD"—

"The Professional Radio-Television man's Magazine"—published monthly. All articles are exclusive and timely. Practically every issue is worth what an entire 1 year subscription costs.

The more in a group the bigger the savings. 6 men in a group save \$1.00 each; 4 men groups save \$.75 per man. Present "RTSD" subscribers may participate in or form a group with co-workers, or even competitors. Still active subscriptions are automatically extended 1 year. Start a Group today! The timely and exclusive technical data appearing in future issues of "RTSD" will make this the best investment you ever made. The special Group Rate offer may be withdrawn at any time—so hurry.

Use This Coupon For Convenience

(The coupon below can be used for from 1 to 6 subscription orders. Use it today!)



TEAR OUT — MAIL TODAY

RADIO-TELEVISION SERVICE DEALER
67 West 44th Street, New York 36, N. Y.

Please enter 1 year subscription orders for the names given below. Our remittance is enclosed.

NOTE: If you do not wish to tear this order blank out, just print or type the information on a single sheet of paper, following the style given. Each subscriber's occupation must be clearly described.

	In U.S.A.	Foreign Rates
<input type="checkbox"/> One 1-year subscription	\$2.00	\$3.00
<input type="checkbox"/> Two 1-year subscriptions, each	1.75	2.75
<input type="checkbox"/> Three 1-year subscriptions, "	1.50	2.50
<input type="checkbox"/> Four 1-year subscriptions, "	1.25	2.25
<input type="checkbox"/> Five 1-year subscriptions, "	1.10	2.00
<input type="checkbox"/> Six 1-year subscriptions, "	1.00	1.50

Name

Address

Describe Title or Position and Type of Business

State whether a New Subscriber or Renewal Order

Name

Address

Describe Title or Position and Type of Business

State whether a New Subscriber or Renewal Order

Name

Address

Describe Title or Position and Type of Business

State whether a New Subscriber or Renewal Order

Name

Address

Describe Title or Position and Type of Business

State whether a New Subscriber or Renewal Order

Name

Address

Describe Title or Position and Type of Business

State whether a New Subscriber or Renewal Order

Name

Address

Describe Title or Position and Type of Business

State whether a New Subscriber or Renewal Order

redeposited on the surface to form a new emitting surface.

This is a controlled process, taking up to two hours or more in stubborn cases, not to be confused with *flashing* or sputtering techniques which 'boil' off a quantity of cathode coating. The tube is thoroughly reactivated and aged, after which the two sockets are again exchanged and the instrument is *entirely removed*. The television set has been *disconnected* throughout this entire process. (As a matter of fact the picture tube might just as well have been in its packing carton during the processing.) The tube can now be retested, and if found to be good, can be put back into service without delay. The extent of the new life of the tube may be as great as that of the newly manufactured tube. (In any event, so long as active material remains on the cathode, reactivation may be repeated as often as is required.)

The maximum voltage developed by this type of CRT Tester-Reactivator is 100 volts, safe enough for even a tyro technician to use with safety.

Where injured elements make reactivation impossible the picture tube may be rebuilt. Briefly, this process consists of opening up the picture tube glass, removing the gun and internal assembly, cleaning, and rebuilding with all new elements (except glass envelope). Thus, like rebuilt automobile engines, they must meet performance standards, selling up to *new price*, and are acceptable in the industry up to the standards of the *rebuilding or manufacturing company*.

In any case, your old picture tube now may be worth up to \$5 or more even if you can't get a glimmer out of it!

ASSOCIATIONS

[from page 30]

Vince Lutz, a nucleus of a Missouri State Wide Alliance was established. Plans were laid for a drive to enlist other Missouri groups and to help form associations where now none exist. Parades, TV Queens, special editions of TV Review and Governors Proclamations were the order of the day. F. J. Moch, NATESA President spoke before the meeting on Sunday.

Television Service Engineers Of Kansas . . . Jack McDowell came up with a good "gimmick" for use at association meetings and conventions. He sported a beautiful necktie on which was emblazoned the TSE emblem. This idea may interest you. Suggest you drop him a line at 7919

THIS *New* PACKAGE

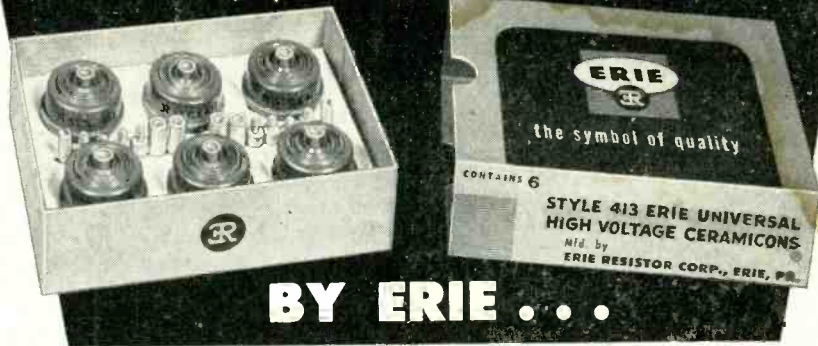

BY ERIE . . .

the solution for *all* your high voltage TV filter replacement problems

• This package contains six (6) Style 413 Erie Universal High Voltage TV Filter Ceramicon and an assortment of 14 adapter terminals.

Carry one of these handy

package assortments with you on all your TV service calls. You are assured of having, at all times, the CORRECT REPLACEMENT UNIT for any receiver rated at 20 KV or lower.

Order through your jobber.



Electronics Division
ERIE RESISTOR CORP., ERIE, PA.

LONDON, ENGLAND . . . TORONTO, CANADA
Cliffside, N. J. • Philadelphia, Pa. • Buffalo, N. Y. • Chicago, Ill.
Detroit, Mich. • Cincinnati, Ohio • Los Angeles, Calif.

THIS IS IT! THE RELAY

WITH *Interchangeable Coil*

FOR A WIDE RANGE OF RADIO APPLICATIONS

GUARDIAN Series 200

Interchangeable
COIL and CONTACT
Switch Assembly

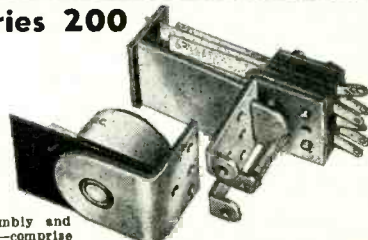

Two basic parts—a coil assembly and a contact switch assembly—comprise this simple, yet versatile relay. The coil assembly consists of the coil and field piece. The contact assembly consists of switch blades, armature, return spring and mounting bracket. The new Guardian Midget Contact Assembly which is interchangeable with the Standard Series 200 coil assembly, is also available in either single pole, double throw; or double pole, double throw.

CONTACT SWITCH ASSEMBLIES

CAT. NO.	TYPE	COMBINATION	
		Single Pole	Double Throw
200-1	Standard	Double Pole	Double Throw
200-2	Standard	Double Pole	Double Throw
200-3	Contact Switch	Double Pole	Double Throw
200-4	Parts Kit	Double Pole	Double Throw
200-M1	Standard	Single Pole	Double Throw
200-M2	Midget	Double Pole	Double Throw
200-M3	Midget Contact Switch	Parts Kit	Double Throw

13 COIL ASSEMBLIES

A.C. COILS*		D.C. COILS	
CAT. NO.	VOLTS	CAT. NO.	VOLTS
200-6A	6 A.C.	200-6D	6 D.C.
200-12A	12 A.C.	200-12D	12 D.C.
200-24A	24 A.C.	200-24D	24 D.C.
200-115A	115 A.C.	200-32D	32 D.C.
		200-110D	110 D.C.

*All A.C. coils available in 25 and 60 cycles

GUARDIAN  ELECTRIC

1606-G W. WALNUT STREET

CHICAGO 12, ILLINOIS

A COMPLETE LINE OF RELAYS SERVING RADIO AMATEURS

A Full Size
LIGHTNING ARRESTER
at the Price of a Midget



LIGHTNING ARRESTER

MODEL TA5 Real protection against lightning and static charges — the RADIART Lightning Arrester has all the features! Fits anywhere... inside or out... handles standard or jumbo leads... no wire stripping necessary... does not unbalance the line... low internal capacity... no loss of signal... internal resistance "looks off" static discharges! UNDERWRITERS LABORATORIES APPROVED.

THE RADIART CORPORATION
CLEVELAND 13, OHIO

Depend On . . .
Insist on . . .

ASTRON
CAPACITORS



You can depend on Astron for a complete line of multi-tested dry electrolytic and molded paper tubular capacitors for every radio, and television replacement job. Far quality next time... insist on Astron.

Write for catalog AC-3

ASTRON CORPORATION
255 Grant Avenue, E. Newark, N. J.

Sante Fe Drive—Overland Park, Kansas.

Radio & TV Servicemen of N. J. This group has been coming through regularly with information on their operations. They were one of the first to send through photos and data for the NATESA publication. J. Palmer Murphy and his active officers and members were also among the first to express their ideas on NETSDA affair. This group is blessed with very active officers in President Rhodes, Vice-President Bremy, Treasurer Weinberg and Legal Council Gelman.

Associated Radio & TV Service Dealers of Columbus, Ohio . . . Fred Colton. President sent through a nice bunch of pix for publication. ARTSD is developing consumer education TV programs.

Association Of Television Service Engineers Of Mass . . . Eastern Vice-President Russ Cummings wrote to advise that his group is in conference with the Mass. RTG headed by Al Saunders with the purpose of closer state-wide cooperation.

Albany Television Headquarters . . . Eastern Secretary Milt Klarsfeld advises that his group is expanding its scope of operation to cover varied electronic service operations.

Tisa-Chicago . . . TISA has been conducting a wide investigation of TV service frauds. TISA succeeded in closing down the biggest offender who operated under 5 names. The case is before the Cook County Grand Jury. The publicity given this investigation, 20 articles in the Chicago papers many across the country, 8 telecasts, 25 radio programs has resulted in many service calls to TISA headquarters for the name of the nearest member. Another indication of the effectiveness of the investigation is the fact that roughly 60 applications have been received for membership of which 15 have been accepted, 15 immediately rejected and 30 are pending full investigation by the Membership Committee. If you have a fraud problem in your city, TISA highly recommends direct action.

Mid-Year Meeting . . . As you already know, the NATESA meeting will take place in Chicago at the Conrad Hilton Hotel, Saturday, June 14th and Sunday, June 15th. Business meeting Saturday 7:00 PM—Dinner Sunday 12:00 Noon. All times are Central Daylight Saving Time. Please get your reservations in early. Much important business and officer vacancies to be filled. Let's make this meeting another big success.

Frank J. Moch, President

TECHNICAL ARTICLES WANTED

on
TV, AM RADIO, FM RADIO, PHONO
MECHANISMS, HI-FI AUDIO, AUTO
RADIO, TEST EQUIPMENT, ANTENNAS

pertaining to their

**Theory, Installation, Application,
Service & Maintenance**

submit manuscripts to
Managing Editor

Radio-Television Service Dealer
67 West 44 Street New York 36, N. Y.

AD INDEX

Aerovox Corporation	42
American Television & Radio Co.	44
Astron Corporation	48
Bussmann Manufacturing Co.	39
Channel Master Corp.	38
Clarostat Mfg. Co., Inc.	Cover 2
Erie Resistor Corp.	47
Federal Telephone & Radio Corp.	45
General Electric Co.	10, 11
Guardian Elec. Mfg. Co.	47
Hickok Elec. Instrument Co.	40
Hytron Radio and Electronics Co.	16
LaPointe Plascomold Corp.	12
Mallory, P. R. & Co., Inc.	1, 13
Mosely Electronics	14
Permo, Inc.	33
Precision Apparatus Co., Inc.	2
Radiart Corporation	35, 48
Rauland Corp.	9
Raytheon Mfg. Co.	5
RCA Tube Dept.	7, Cover 4
Regency Div. I.D.E.A. Inc.	Cover 3
Sams, Howard W. & Co., Inc.	6
Simpson Electric Co.	15
Sprague Products Company	4
Supreme, Inc.	6
Telescopic Products	14
Telrex, Inc.	8
Transvision, Inc.	12
Trio Manufacturing Co.	43
Triplett Elec. Instrument Co.	37

HIS CHOICE IS

Regency

LARGEST SELLING VHF BOOSTER AT ANY PRICE!

MR. BEN FARMER
SALES MANAGER, RAU AND CORPORATION
ONE OF THE FIRST TV-DX ENTHUSIASTS
PHOTOGRAPHED IN HIS CHICAGO SUBURBAN HOME

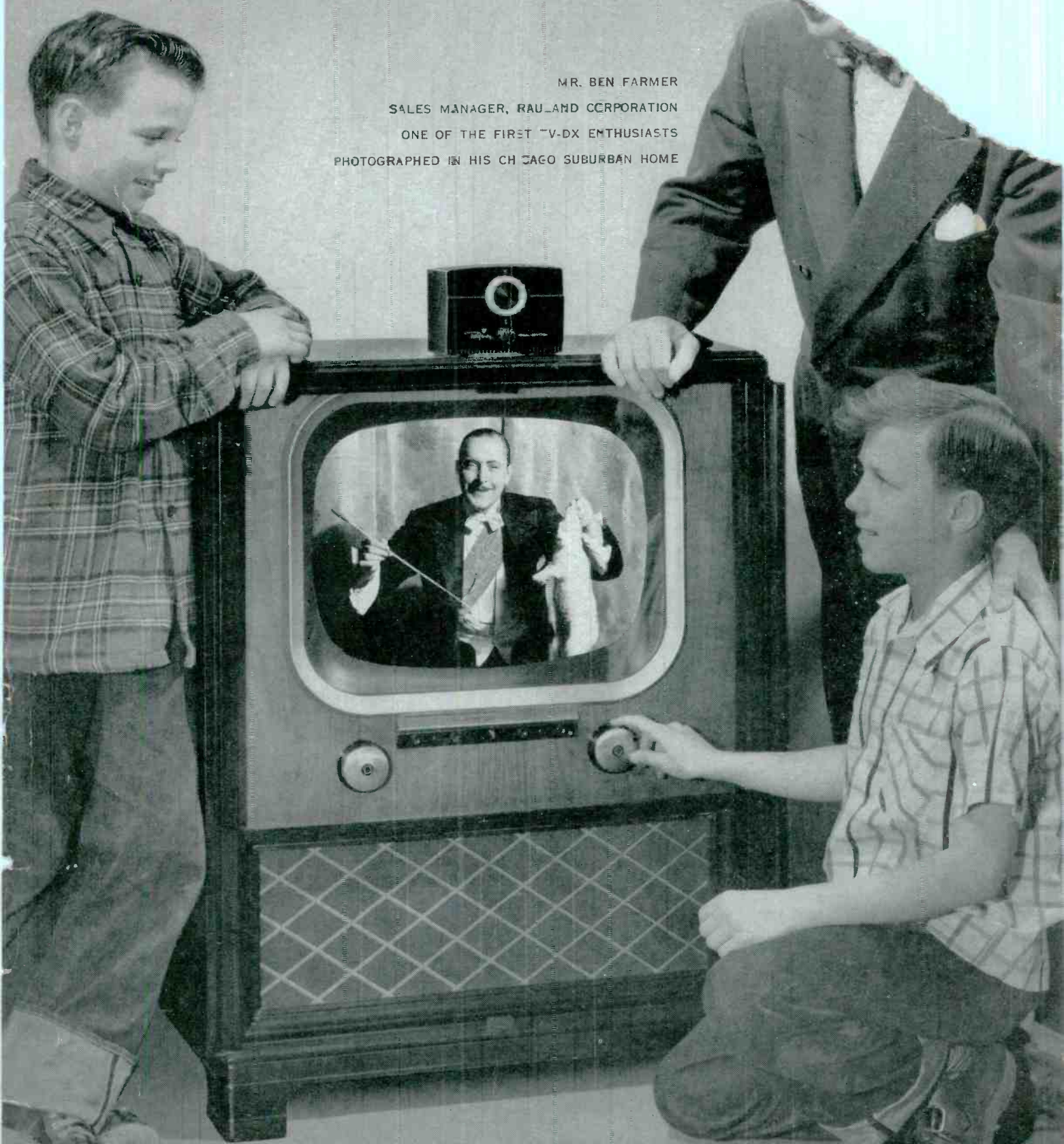

ALSO MAKERS OF THE

Regency

 UHF CONVERTER

www.americanradiohistory.com

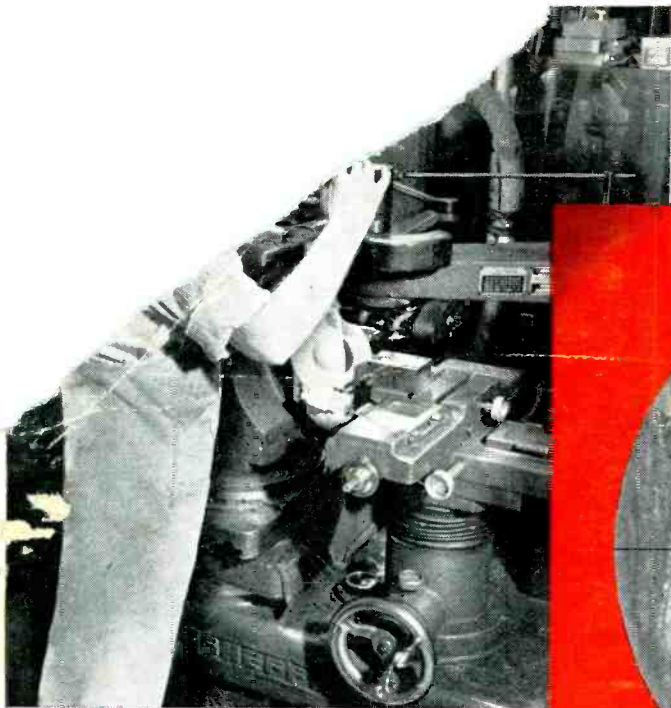

1. The machine that grinds the die.



2. The die that forms the cathode sleeve.



3. The cathode sleeve that helps make the tube.



Take a look at **quality** being born

DIMENSIONAL ACCURACY of the cathode sleeve is a vital factor in providing top-quality tube performance. And cathode-sleeve accuracy begins with the forming die.

What you see above are the two sections of a typical cathode-sleeve forming die, just as it is viewed by the die maker through a 30-power microscope. The die is finished in a

"profile grinder" which employs a 50-to-1 pantograph that traces a template and precisely guides the grinding operation. The result is a die accurate to better than one ten-thousandth of an inch!

Such painstaking precision finishing of dies used to stamp, punch, and form critical tube parts is one more step contributing to the top

quality of RCA Tubes. In this way, RCA closely guards its own reputation for quality ... and yours as well.

With RCA Kinescopes, as well as with RCA Receiving Tubes, **TOP-QUALITY CONTROL** makes the difference.



RADIO CORPORATION of AMERICA
ELECTRON TUBES

HARRISON, N. J.

TMKS. (R)