

OCTOBER, 1950

# Radio-Television SERVICE DEALER



The Professional Radio-TVman's Magazine

## IN THIS ISSUE:

Know the Cathode Ray Tube  
Reducing Losses in Transmission Lines  
A Comparison of AM & FM Servicing Problems  
Master TV Antenna Systems in Motels  
Replacement Needle Chart  
Front Ends  
An Oscillator Injector for Audio Testing

**AM-FM-TV-SOUND**

**Paid Circulation Of This Issue: Over: 25,000**  
**Total Distribution Of This Issue: Over: 26,000**

**For  
Long Life**  
*in spite of heat...*



## MALLORY CAPACITORS Give Outstanding Service!

Every Mallory FP Capacitor is designed to perform consistently during more than 2000 hours of operation at a temperature of 85°C.

One reason why Mallory Capacitors operate so long at high temperatures is the unusual care taken in production to prevent *contamination*, which causes corrosion . . . shortens the life of ordinary capacitors.

Result: with the Mallory FP line you may service

both radio and TV sets, without the need for buying special types for the high temperature jobs. Yet Mallory Capacitors cost no more!

You will find it pays to rely on the complete Mallory capacitor line . . . electrolytic, paper, ceramic and Mallory Plascap plastic tubulars.

See your Mallory Distributor, now. Remember, you pay no premium for Mallory Precision Quality!

### The Amazing MALLORY PLASCAP\*—The New Standard in Plastic Tubular Capacitors



These four exclusive features make your service jobs surer . . . easier. No oil leakage, no unsoldered leads, no messy wax coatings, no insulation problems!

✓ **TRISEAL CONSTRUCTION.** Sealed three ways . . . with moisture-free Maltrotol, tough outer plastic shell, exclusive Mallocene!

✓ **FASTITE LEADS.** Permanently fastened . . . sealed with Mallocene . . . unaffected by soldering-iron heat!

✓ **DISTORTION-FREE WINDING.** No flattened cartridges due to molding pressures . . . no failure due to "shorts"!

✓ **TRU-CENTER CARTRIDGE.** Cartridge centered every time . . . uniform insulation guaranteed at all points!

*Your Mallory Distributor is ready to serve you!*

\*Trade Mark



P. R. MALLORY & CO. Inc.  
**MALLORY**

CAPACITORS • CONTROLS • VIBRATORS • SWITCHES • RESISTORS  
• RECTIFIERS • VIBRAPACK\* POWER SUPPLIES • FILTERS

\*Reg. U. S. Pat. Off.

**APPROVED PRECISION PRODUCTS**

**P. R. MALLORY & CO., Inc., INDIANAPOLIS 6, INDIANA**

**IT'S HERE!**

**The New HIR**

a fully automatic  
**ANTENNA  
ROTATOR**  
*by*  
**ALLIANCE**

*with the most  
accurate indicator  
on the market!*



**Just set the pointer and forget it!**  
*Works in any weather  
Guaranteed for one year*

The famous Model DIR also available  
with handy—North—South—East—West  
indicator. Approved by Underwriters'  
Laboratories—guaranteed for one year!

*And Remember—*

Only Alliance delivers a  
national TV campaign to  
five million viewers around  
60 stations.

*It pays to stock and sell  
Alliance Tenna-Rotor!*

**AUTOMATIC**—the new deluxe model HIR Alliance Tenna-Rotor is fully automatic. Turn the indicator knob and the antenna turns to any setting on the dial and stops.

**FASTER INSTALLATION** — Easily accessible connections. Uses special "Zip" feature 4-conductor cable. No expensive callbacks necessary.

**NEVER OUT OF DATE**—mark the best antenna position for each station right on the dial with removable stickers. New channels can be added at any time by customer.

**MYSTIC LIGHT** — light moves along the dial, shows position while antenna turns. Pointer indicates antenna position at all times. Dial shows North—East—South—West directions.

**Alliance Manufacturing Co.**  
**Alliance, Ohio**

Export Department: 401 Broadway, New York, N. Y., U. S. A.

**alliance**  
**TENNA • ROTOR**

(TV ANTENNA ROTATOR)

# EDITORIAL

by S. R. COWAN

## Permanent Needles

The service profession has been blamed by the set-owning public for many wrongs caused by others, to wit: when a TV set manufacturer advertises that his sets will work on an indoor or built-in antenna and the serviceman finds that it won't, most likely the set-owner accuses the technician of trying to bilk him of the cost of an outdoor installation because he prefers to believe a big corporation's advertisements rather than an independent serviceman's honest diagnosis.

Current advertising that radio or TV phono-combinations feature a pickup having a "permanent" needle are now getting servicemen into the bad graces of owners who are told by a technician that his pickup's needle is defective and needs replacing. "How can a pickup with a permanent needle ever require a new needle?" asks the uninformed record-player owner. How can a serviceman answer this question?

The solution is simple. The Better Business Bureau and the Fair Trade Commission should issue directives which will force manufacturers and all retailers to make absolutely clear that there is not and never has been a phonograph needle which is permanent, in the sense that the dictionary defines the word.

## Another Parks' Blunder

Mal Parks, who for a few years has been associated with radio parts jobbers' magazines, recently got the idea that he is qualified to publish a monthly magazine on TV servicing and business methods. He brought out his first issue of the so-called non-technical publication in August and in it made an announcement which will probably win for him condemnation by the entire radio TV servicing fraternity. Imagine this: Parks had the nerve to state that in his second issue one of the feature articles will be "How to repair any radio or TV set in the home for \$1.95." From where we sit Parks would set our profession back to the dark days of 1935 when the set-owning public was only willing to pay \$1.95 for a home-call repair job. Perhaps he doesn't realize that most cost-accounting experts now-a-days urge that a fee of at least \$2 be charged merely for an estimate when the set-owner brings his small, cheap portable into the store.

For over a quarter of a century yours truly has tried to lift the earnings and living standards of the servicing profession up to reasonable limits. Now, without thought or reason, a new-comer to the field, knowing nothing about it from either a practical or technical point of view, has the temerity to try to wreck a professional. We have in our office six radios. All are only moderately defective. We urge Parks to come up and fix any one or all of them at \$1.95 each. He'd go broke — and so would anyone else that tried it.



**Sanford R. Cowan**  
EDITOR & PUBLISHER

**Samuel L. Marshall**  
MANAGING EDITOR

**COWAN PUBLISHING Corp.**  
342 MADISON AVENUE  
NEW YORK 17, N. Y.

Vol. 11, No. 10

October, 1950

Know the Cathode Ray Tube, Part I, by Allan Lytel.....	17
An illuminating study of the electrostatic CRT—theory and application.	
Reducing Losses in Transmission Lines, by Norman L. Chalfin.....	20
Methods of improving reception by proper adjustments involving the transmission line download.	
A Comparison of AM and FM Servicing Problems, by J. Jacobson.....	22
Simplified discussion of the basic operation and troubleshooting in these types of receivers.	
Master TV Antenna Systems in Motels, by Ira Kamen.....	25
Practical examples of various types of installations of this type.	
Jensen Needle Replacement Chart.....	27
Front Ends, Part 4, by Samuel L. Marshall.....	28
Discussion of the mechanical and electrical methods of channel switching in TV tuners.	
Oscillator Injector for Audio Servicing, by Rufus P. Turner.....	30
Construction of a vitally needed instrument.	
Shop Notes.....	32
Intermittent operation with microphonics in RCA 8-R-71. Poor brightness control. Westinghouse Models H-198, H-199, and H-203, oscillation and poor sensitivity on FM band. G.E. Hi-Channel interference trap. Admiral—all models, sync buzz in intercarrier receivers.	
Circuit Court.....	34
Capehart 115P2, 413P, 414P. Admral 6Q1	
New Products.....	36

SANFORD L. CAHN  
National Advertising Sales Manager  
SELMA WILE, Circulation Manager  
HARRY N. REIZES  
Advertising Manager  
DAVID SALTMAN, Adv. Production Manager  
BRANCH: J. C. GALLOWAY 816 W. 5th St., Los Angeles 13, Calif. Mutual 8335

RADIO-TELEVISION SERVICE DEALER is published Monthly by Cowan Pub. Corp., 342 Madison Ave., N. Y. 17, N. Y. Subscription price: \$2 per year in the United States, U. S. Poss. & Canada: elsewhere \$3. Single copies: 25c. Reentered as second class matter Sept. 25, 1950 at the Post Office at New York, N.Y. under the Act of Mar. 3, 1879. Copyright 1950 by Cowan Pub. Corp.

# **A BETTER DEAL**

**You demand TV  
Snap On Holders Ten to a Box**



**Here they are in Plastic  
And it doesn't cost a penny more  
Plastic box is free  
Servicemen want to buy 'em by the box  
And everyone wants  
the box with 100 uses**

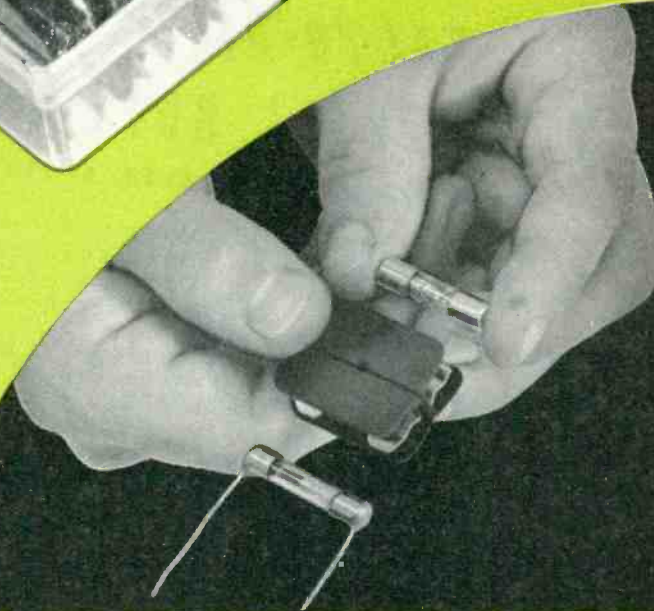

## **TV SNAP ON FUSE HOLDER**

No. 09402

Time saver for pigtail replacement. Snap on  
blown pigtail, then use regular fuse in other  
side. No soldering. Demand item with service  
men. Bigger TV profits.

\$3.00 per box, list

# **LITTELFUSE**

4757 N. RAVENSWOOD AVE., CHICAGO 40, ILLINOIS

# SYNC PULSES

by San D'Arcy

**Price Trends.** Every major TV set manufacturer has announced that next season's lines will be priced from 3% to 8% higher than current models. As a matter of fact, most radio and TV lines will list about 10% higher. This is welcome news to the service fraternity because the public was getting the idea that because TV set prices were going down, so, in like manner, TV installation and service charges should also automatically decline. There was no sound basis upon which the public was entitled to expect lowered service fees except for the bad habit that has always plagued our industry, to wit: the public simply expects to take advantage of a profession that never did price its services high enough.

**Installment Buying Controls.** Government controls on installment buying will probably be put into effect by mid-October. Under the new Economic Control Laws that Congress is expected to pass to help curb inflationary price increases and at the same time reduce unwise public spending, retailers will no longer be able to sell such items as radio, TV sets, and appliances on such low terms as nothing down or 10% down and 24 months to pay. Instead, it is likely that dealers will have to get at least 15% down and hold the balance of payments due to within an 18 or 21 months period. Here again is good news for the service profession, because a set buyer who orders a \$200 radio or TV set and only has to plunk down \$20 cash to get delivery oftentimes thinks he is getting a "bad deal" from a service contractor who asks for as little as \$45 for an installation and service contract. Never mislead yourself! Any time the average man can squeeze the serviceman into a defensive position he'll do so, and the service contractor who is careless enough to agree to handle a service contract on a time payment basis cannot possibly profit on the arrangement. Get your contracts signed and paid for in full right from the outset . . . work on the TV set owner's financing, not on your own.

**TV Censorship Negated.** Some states have laws which require their censorship boards to pass approval upon motion pictures before they can be shown in theatres. Recently the U. S. Court of Appeals ruled that state motion picture censorship boards have no authority to require TV stations to submit for approval motion pictures to be used on telecasts. The ruling was based on the premise that the FCC and not state boards enjoy the authority to determine what can or cannot be sent out over the air-waves. It is a good ruling. Let's hope the FCC doesn't get too critical in regard to some of the extremely low-cut necklines that occasionally appear on live talent TV shows. If nothing else, such pleasant views as are afforded by a plunging neckline add to the thrill and mystery of TV viewing. For example, a serviceman was asked recently if he could arrange to "tip over" the

[Continued on page 12]

RADIO-TELEVISION SERVICE DEALER • SEPTEMBER, 1950

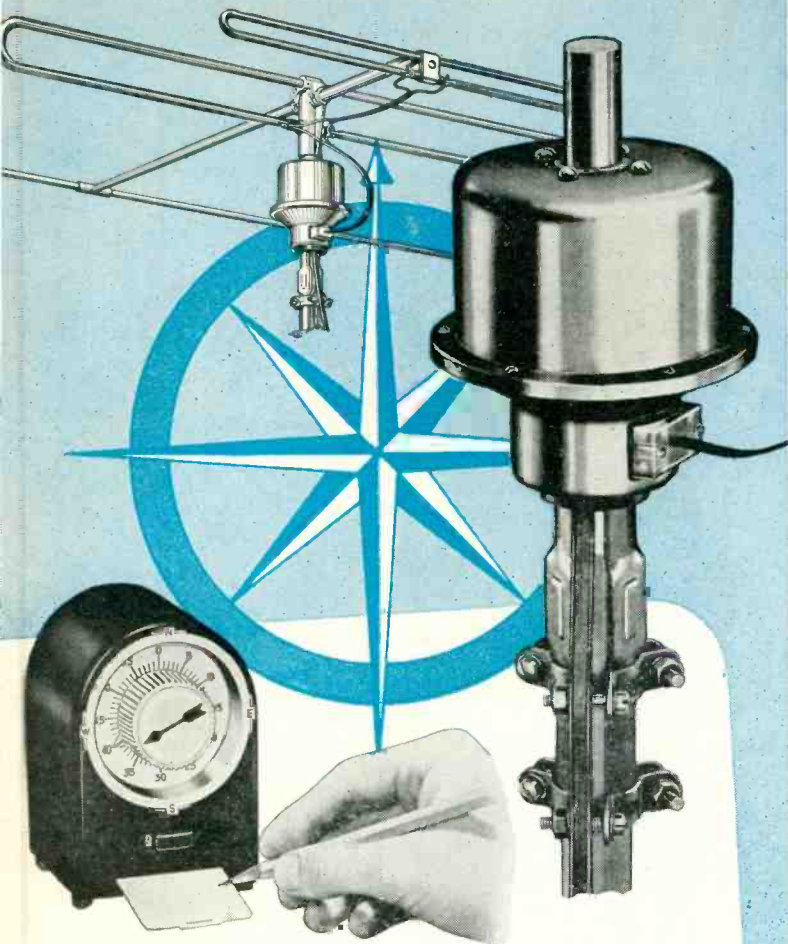

## "AUTO-DIAL"

### TV ANTENNA ROTATOR With *Automatic* TRAVEL ACTION

AMPHENOL takes pride in announcing the new "Auto-Dial" TV Antenna Rotator. It features an entirely new and different principle of rotator control called "automatic travel action," and represents the greatest single advance in antenna rotators.

There are no tiresome buttons or switches to hold while the antenna is turning. An effortless turn of the knob to the correct setting and "Auto-Dial" takes over. Automatically—just like magic—the antenna follows to point directly at the TV station—then stops!

So accurately does it perform that even a child can "log" antenna positions, accurately returning to them time after time. Rotation is in steps of 6 degrees, accurately calibrated on the indicator. Because of this important feature, servicemen can now determine whether an antenna is functioning properly, whether it has the required front-to-back ratio and whether it is properly located for the best possible picture.

#### FEATURES

- Completely Automatic—no tiresome buttons or switches to hold while antenna turns!
- Antenna Rotates Rapidly—one revolution every 22 seconds!
- Heavy-Duty Motor, Sturdy Construction—easily handles stacked arrays!
- Housing of cold-rolled steel, copper flashed and with attractive baked-on enamel finish!
- Neoprene Sealed at Factory Against Dirt and Moisture!
- Accommodates Mast Sizes from 3/4" to 2" Diameter!

See It At Your Jobber Or Write For Illustrated Folder  
Another AMPHENOL Development For Your Greater TV Enjoyment

# AMPHENOL

AMERICAN PHENOLIC CORPORATION

1830 SO. 54TH AVENUE

CHICAGO 50, ILLINOIS

# Set a new mark in TV Set Service



...with this new **SYLVANIA Marker Generator** Type 501

**FOR THE BEST IN TEST EQUIPMENT ...SEE SYLVANIA**

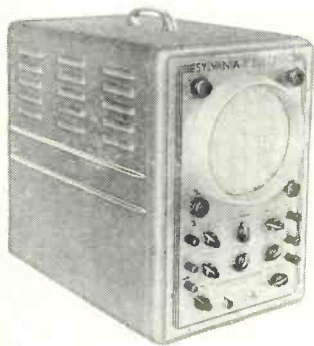

**Sylvania TV Oscilloscope**  
(Type 400)

This new, high-gain, wide-band instrument accurately displays any TV pulse, wave-shape, or signal. Sensitivity: 0.01 volts/inch. Band width useful to 4.0 mc. Frequency compensated attenuator.

**Sylvania TV Sweep Signal Generator**  
(Type 500)

A compact, efficient instrument equipped with electronically controlled sweep circuits to eliminate the complexities found in mechanical sweeps. Ideal companion instrument for Type 501 Marker Generator.

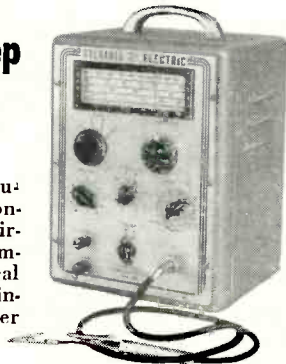

It's here at last! The new Sylvania TV Marker Generator we promised you.

Now you can offer better TV service than ever before. This new Sylvania instrument provides *two* separate signals for marking an oscilloscope trace of response curves, accurate adjustment of traps, frequency spotting, measuring band width, and correct adjustment of the popular 4.5 mc. intercarrier sound circuits.

Single switch provides continuously variable and crystal-controlled signals *separately* or *simultaneously*, or standby operation. VFO covers 15 to 240 mc. range. Second oscillator furnishes crystal-controlled signals without tuning, when standard makes of crystals are inserted in a panel socket.

Mail the coupon for full information or see your Sylvania distributor today!

Sylvania Electric Products Inc.  
Department R-1610  
Emporium, Pa.

Please send me illustrated folders describing the full line of Sylvania Test Equipment.

Name \_\_\_\_\_

Company \_\_\_\_\_

Street \_\_\_\_\_

City \_\_\_\_\_ Zone \_\_\_\_\_ State \_\_\_\_\_

# SYLVANIA ELECTRIC

RADIO TUBES; TELEVISION PICTURE TUBES; ELECTRONIC PRODUCTS; ELECTRONIC TEST EQUIPMENT; FLUORESCENT TUBES, FIXTURES, SIGN TUBING, WIRING DEVICES; LIGHT BULBS; PHOTOLAMPS; TELEVISION SETS

## QUESTION

Why do so many television sets use Sprague KOOLOHM Resistors for all 5- and 10-watt wire wound power resistor requirements?

## ANSWER

Because Koolohms far surpass other wire wound resistor types in the essential characteristic of resistance stability. Also because, being doubly insulated, Koolohms can be mounted anywhere—even directly against a metal chassis. Koolohms are highly heat- and moisture-resistant. One type—the standard type handles any job. No need to worry about choosing special coatings. Moreover, Koolohms cost no more than ordinary resistors, and are actually cheaper in many cases.

## SERVICE HINT

Play safe by using Sprague Koolohms in all your work—not only in television, but wherever you want a really first class job. And remember: Koolohms can be used safely at their full wattage ratings, even in enclosed places. No need to buy a 10-watt resistor when the circuit only needs 5-watts. A 5-watt Koolohm dissipates a full 5 watts!

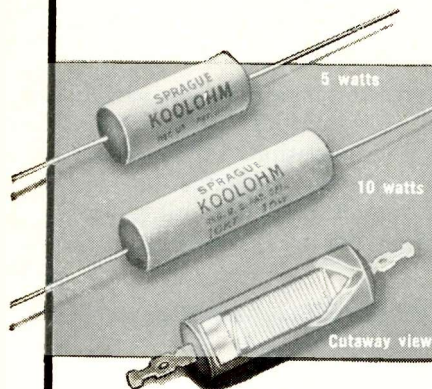

Wound with ceramic-insulated wire. More resistance in less space. Doubly protected, insulated and sealed by outer ceramic jacket. Highly resistant to moisture and heat.

**SPRAGUE**  
**KOOLOHM**  
Reg. U. S. Pat. Off.  
**WIRE WOUND RESISTORS**

SPRAGUE PRODUCTS CO., North Adams, Mass.  
(Distributors' Division of  
Sprague Electric Company)

# TRADE FLASHES

A "press-time" digest of production,  
distribution & merchandising activities

### 1951 Audio Fair

The nation's second AUDIO FAIR is to be sponsored by the Audio Engineering Society at the Hotel New Yorker, in New York City, October 26, 27 and 28, 1950, according to an announcement made today by Theodore Lindenberg, president of the society.

Subjects expected to be covered by exhibits and papers include all phases of audio, recording and reproduction on tape, disc and film for professional and home use, for radio, television and theatre.

### Large Pix Tubes Dominate Sales

Large type television picture tubes—14 inches and over—now constitute more than 89 percent of cathode ray tube sales to TV receiver manufacturers, the Radio-Television Manufacturers Association reported today. Manufacturers' purchases of picture tubes in this category amounted to only 15 percent at the end of last year. The popular 12 through 13.9 inch tube of last year amounted to only 10 percent of sales to manufacturers in June, RTMA said.

June sales of cathode ray tubes to set manufacturers as reported to RTMA showed a total of 566,942 tubes valued at \$15,054,810 compared with 599,667 units valued at \$14,260,114 in May.

Total sales of cathode ray tubes of all types, including oscillographs, camera pick-up, etc., aggregated 604,832 units valued at \$16,075,359 during June.

### RTMA To Set Antenna Ad Standards

The Antenna Section of RTMA (Radio and Television Manufacturers Association) has decided that the need for promotion of ethical advertising practices in the antenna field is urgent. It was decided that, along with the 31C Committee, formed to set up antenna engineering standards, there should be a sub-committee to

formulate a publicity campaign to be ready at the time the standards are set up. Douglas Carpenter, Sales Engineer of LaPointe Plascomold Corp., (Vee-D-X) Unionville, Conn., was appointed Chairman of this Committee.

Serving with him are Mr. Larry Kline of the Ward Products Corporation and Mr. Carl V. Wisner of the American Phenolic Corporation. Mr. Carpenter stated that the Committee job was two-fold: first, to undertake plans for a publicity campaign to advertise the fact that members' products, in their advertising, will be RTMA approved. Second, to develop an approval seal that would quickly identify all such advertising and which could also be applied to the products themselves.

### "Hal" Bersche Forecasts Billion Dollar Market

An enormous upsurge of the market served by the electronics parts distributor to a total value of one billion dollars by 1955, barring the possibility of a shift to wartime economy, was forecast by H. F. "Hal" Bersche, Renewal Sales Manager of the RCA Tube Department, at the convention of the National Electronic Distributors Association here.

Basing his remarks on statistics representing the past and present growth of the electronics renewal market and the opinions of government and industry leaders, Mr. Bersche drew this picture of the opportunity confronting the electronics distributor in 1955:

A home and auto radio renewal market represented by over 800 million tube sockets in 1955—up from 600 million sockets in 1950.

Thirty-eight million television receivers manufactured by 1955, representing 700 million receiving-tube sockets and a replacement market for some 350 thousand kinescopes.

A corps of 130,000 service technicians in 1955.

[Continued on page 35]



# Controlling the Nation's TV AND RADIO!

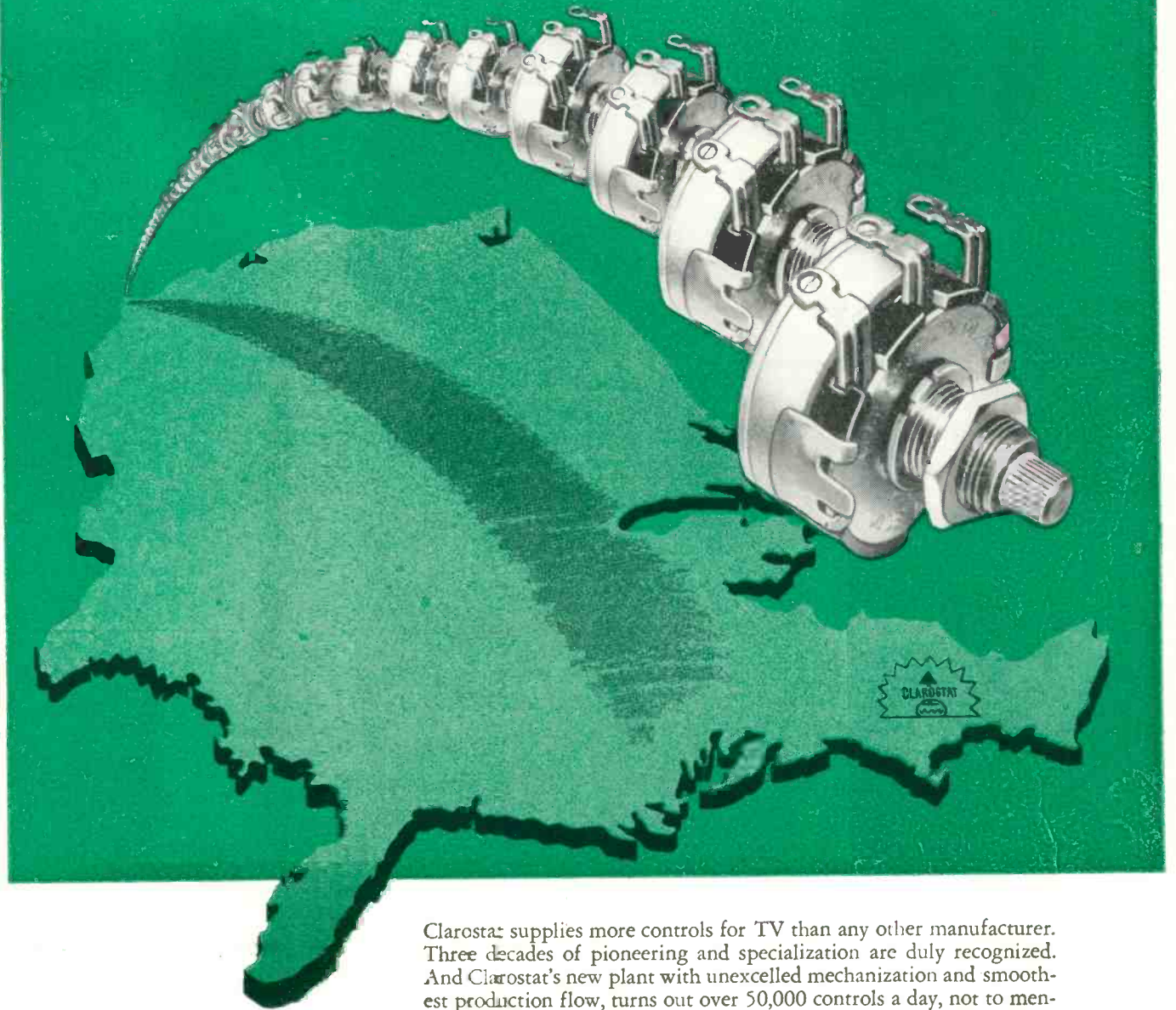

Clarostat supplies more controls for TV than any other manufacturer. Three decades of pioneering and specialization are duly recognized. And Clarostat's new plant with unexcelled mechanization and smoothest production flow, turns out over 50,000 controls a day, not to mention resistors of many different types, in meeting the major portion of today's TV and radio requirements. Obviously, for quality, uniformity, dependability, economy, it's CLAROSTAT.

And for quicker, safer, more profitable servicing of today's TV and radio sets, it's again Clarostat for the right replacement controls and resistors. Stocked by leading distributors. Listed in Howard Sam's Photofact Folders. Described in latest catalog, sent on request.



## Controls and Resistors

CLAROSTAT MFG. CO., INC. • DOVER, NEW HAMPSHIRE  
IN CANADA: CANADIAN MARCONI CO. LTD., MONTREAL, P. Q., AND BRANCHES



**Subscribe to "RSD" -**

**Form A Group,**

**Service Dealers**

**SAVE Up to \$1.00 each.**

"The Professional Radioman's Magazine"—published monthly. All articles are exclusive and timely. Practically every issue is worth what an entire 1 year subscription costs

★ The more in a group the bigger the savings. 6 men in a group save \$1.00 each; 4 men groups save \$ .75 per man. Present "RSD" subscribers may participate in or form a group with co-workers, or even competitors. Still active subscriptions are automatically extended 1 year. Start a Group today! The timely and exclusive technical data appearing in future issues of "RSD" will make this the best investment you ever made. The special Group Rate offer may be withdrawn at any time—so hurry.

**Use This Coupon For Convenience**

(The coupon below can be used for from 1 to 6 subscription orders. Use it today!)



**TEAR OUT — MAIL TODAY**

RADIO SERVICE-DEALER MAGAZINE  
342 Madison Ave., New York 17, N. Y.

Please enter 1 year subscription orders for the names given below. Our remittance is enclosed.

**NOTE:** If you do not wish to tear this order blank out, just print or type the information on a single sheet of paper, following the style given. Each subscriber's occupation must be clearly described.

	In U.S.A. & Canada	Foreign Rates
<input type="checkbox"/> One 1-year subscription	\$2.00	\$3.00
<input type="checkbox"/> Two 1-year subscriptions, each	1.75	2.75
<input type="checkbox"/> Three 1-year subscriptions, "	1.50	2.50
<input type="checkbox"/> Four 1-year subscriptions, "	1.25	2.25
<input type="checkbox"/> Five 1-year subscriptions, "	1.10	2.00
<input type="checkbox"/> Six 1-year subscriptions, "	1.00	1.50

Name .....

Address .....

Describe Title or Position and Type of Business .....

State whether a New Subscriber  or Renewal Order

Name .....

Address .....

Describe Title or Position and Type of Business .....

State whether a New Subscriber  or Renewal Order

Name .....

Address .....

Describe Title or Position and Type of Business .....

State whether a New Subscriber  or Renewal Order

Name .....

Address .....

Describe Title or Position and Type of Business .....

State whether a New Subscriber  or Renewal Order

Name .....

Address .....

Describe Title or Position and Type of Business .....

State whether a New Subscriber  or Renewal Order

Name .....

Address .....

Describe Title or Position and Type of Business .....

State whether a New Subscriber  or Renewal Order

12 Improvements IN NEW 1951

MODEL O-6

PUSH-PULL

# Heathkit OSCILLOSCOPE KIT

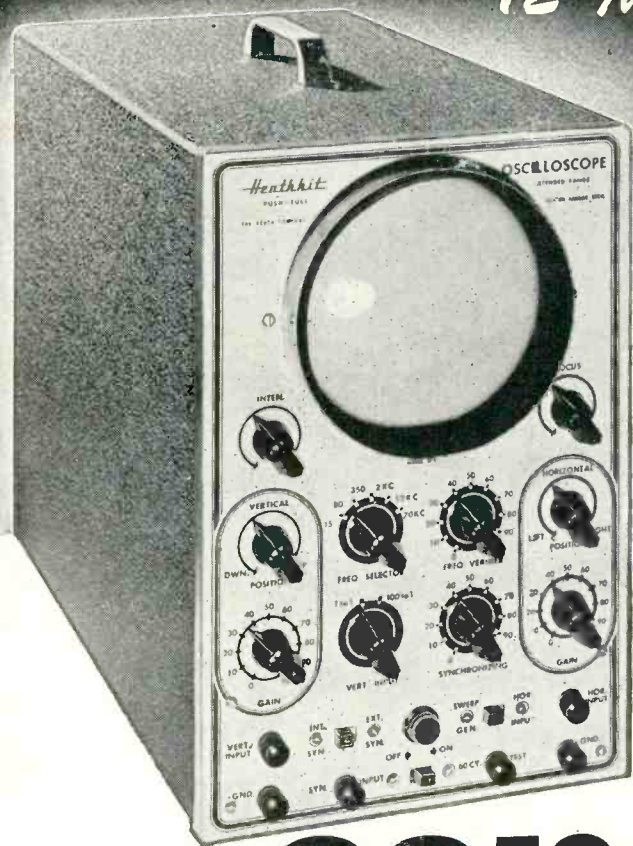

Only **\$39.50**

## New INEXPENSIVE MODEL S-2 ELECTRONIC SWITCH KIT

Twice as much fun with your oscilloscope — observe two traces at once — see both the input and output traces of an amplifier, and amazingly you can control the size and position of each trace separately — superimpose them for comparison or separate for observation — no connections inside scope. All operation electronic, nothing mechanical — ideal for classroom demonstrations — checking for intermittents, etc. Distortion, phase shift and other defects show up instantly. Can be used with any type or make of oscilloscope. So inexpensive you can't afford to be without one.

Has individual gain controls, positioning control and coarse and fine switching rate controls — can also be used as square wave generator over limited range. 110 Volt transformer operated comes complete with tubes, cabinet and all parts. Occupies very little space beside the scope. Better get one. You'll enjoy it immensely. Model S-2. Shipping Wt., 11 lbs.

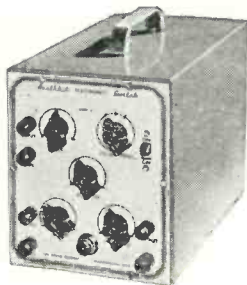

Only **\$19.50**

- ★ New AC and DC push-pull amplifier.
- ★ New step attenuator frequency compensated input.
- ★ New non frequency discriminating input control.
- ★ New heavy duty power transformer has 68% less magnetic field.
- ★ New filter condenser has separate vertical and horizontal sections.
- ★ New intensity circuit gives greater brilliance.
- ★ Improved amplifiers for better response useful to 2 megacycles.
- ★ High gain amplifiers .04 Volts RMS per inch deflection.
- ★ Improved Allegheny Ludlum magnetic metal CR tube shield.
- ★ New synchronization circuit works with either positive or negative peaks of signal.
- ★ New extended range sweep circuit 15 cycles to over 100,000 cycles.
- ★ Both vertical and horizontal amplifier use push-pull pentodes for maximum gain.

The new 1951 Heathkit Push-Pull Oscilloscope Kit is again the best buy. No other kit offers half the features — check them.

Measure either AC or DC on this new scope — the first oscilloscope under \$100.00 with a DC amplifier.

The vertical amplifier has frequency compensated step attenuator input into a cathode follower stage. The gain control is of the non frequency discriminating type — accurate response at any setting. A push-pull pentode stage feeds the C.R. tube. New type positioning control has wide range for observing any portion of the trace.

The horizontal amplifiers are direct coupled to the C.R. tube and may be used as either AC or DC amplifiers. Separate binding posts are provided for AC or DC.

The multivibrator type sweep generator has new frequency compensation for the high range it covers; 15 cycles to cover 100,000 cycles. The new model O-6 Scope uses 10 tubes in all — several more than any other. Only Heathkit Scopes have all the features.

New husky heavy duty power transformer has 50% more laminations. It runs cool and has the lowest possible magnetic field. A complete electrostatic shield covers primary and other necessary windings and has lead brought out for proper grounding.

The new filter condenser has separate filters for the vertical and horizontal screen grids and prevents interaction between them.

An improved intensity circuit provides almost double previous brilliance and better intensity modulation.

A new synchronization circuit allows the trace to be synchronized with either the positive or negative pulse, an important feature in observing the complex pulses encountered in television servicing.

The magnetic alloy shield supplied for the C.R. tube is of new design and uses a special metal developed by Allegheny Ludlum for such applications.

The Heathkit scope cabinet is of aluminum alloy for lightness of portability.

The kit is complete, all tubes, cabinet, transformer, controls, grid screen, tube shield, etc. The instruction manual has complete step-by-step assembly and pictorials of every section. Compare it with all others and you will buy a Heathkit. Model O-6. Shipping Wt., 30 lbs.

EXPORT DEPT.  
13 East 40th St.  
NEW YORK CITY (16)  
CABLE: ARLAB-N.Y.

The **HEATH COMPANY**

... BENTON HARBOR 12, MICHIGAN

# The New Sangamo *Arrowhead* Tubular Electrolytic

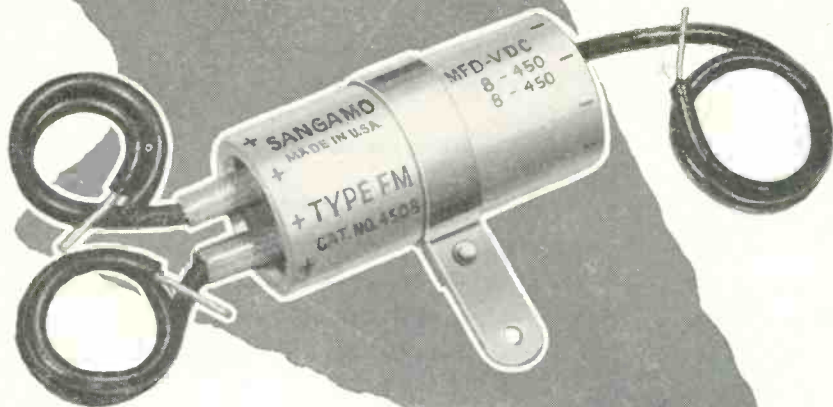

**SMALLER THAN  
ANY OTHER  
DUAL TYPE**



▶ THE LITTLE INDIAN SAYS: ▶

**“terrific for TV!”**

The new Sangamo Type FM “ARROW-HEAD” tubular electrolytic capacitor is equipped with flexible, insulated wire leads and stud terminals to make installation easier by eliminating the problem of crossed wires and the need for insulating sleeves. Sangamo Arrowheads are much smaller than wax end filled types with insulated leads—*smaller than any other type with dual leads!*

These capacitors are housed in round alumi-

num containers which are encased in heavy insulating sleeves with mounting strap attached, and they are especially designed for the rugged television requirements where 85° C operating temperatures are encountered.

A trial of these new dry electrolytic capacitors will convince you. See your Jobber, or write for Catalog No. 800, which gives full information on the Arrowhead and the rest of the Sangamo Tribe.

*Your Assurance of*



*Dependable Performance*

**SANGAMO ELECTRIC COMPANY**  
SPRINGFIELD, ILLINOIS

IN CANADA: SANGAMO COMPANY LIMITED, LEASIDE, ONTARIO

EC60-10A

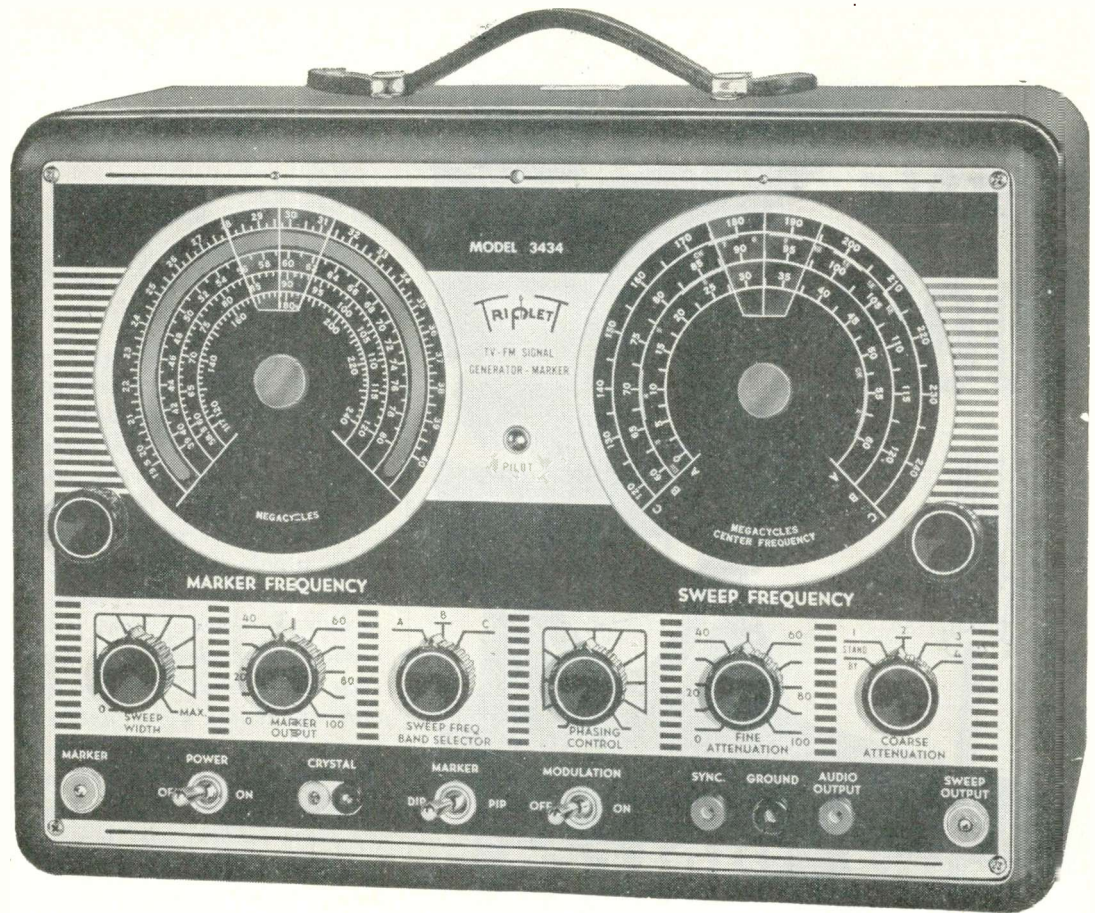

# TV Sweep Generator with MIRROR-SCALE MARKER

## MODEL 3434 for quick checks in all stages

Large Marker dial has a mirror scale for easier reading and reset accuracy. Straight line frequency tuning condensers provide linear scale markings. No "SKIPS" in frequency—continuously variable Sweep width control. Triplet-engineered shielding—all critical circuits enclosed. Copper plated steel construction. All these features (see Tech. Data) combined with the two built-in markers for simultaneous use set Model 3434 apart as one of the fundamental contributions to the rapid, accurate and profitable Servicing of Television.

### TECH DATA

#### Frequency Coverage:

- |   |  |
|---|--|
| <ul style="list-style-type: none"> <li>● SWEEP CENTER FREQUENCY<br/>Range 1— 0-60 MC<br/>Range 2— 60-120 MC<br/>Range 3—120-240 MC</li> <li>● SWEEP WIDTH:<br/>0-12 MC (Continuously Variable)</li> <li>● MARKER FREQUENCY<br/>19.5 to 40 MC (fundamental), 39 MC to 240 MC (harmonic)</li> </ul> | <ul style="list-style-type: none"> <li>● CRYSTAL FREQUENCIES<br/>To 20 MC on Fundamentals. Harmonics up to 216 MC. (Crystals Not Furnished)</li> <li>● MODULATION<br/>400 Cycle on both Crystal and Marker Frequencies</li> <li>● AUDIO:<br/>400 cycles</li> </ul> |
|---|--|

The steel case is finished in black suede baked enamel, size 15 11/32"x11 1/32"x8 1/4". Leather handle. Panel is black, white and red etched on aluminum. Copper plated feet for grounding.

FOR THE MAN WHO TAKES PRIDE IN HIS WORK

# Triplet

TRIPLET ELECTRICAL INSTRUMENT COMPANY - BLUFFTON, OHIO, U.S.A.

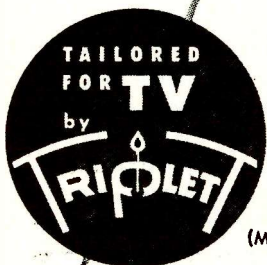

ONLY \$169.50 AT YOUR DISTRIBUTOR  
(MODEL 3435 WITHOUT BUILT-IN MARKER, \$99.50 NET)

# SYNC PULSES

[from page 4]

picture of a certain TV set so the owner would get just a bit of an extra break the next time a babe with a deep-V neckline appeared. And . . . the serviceman in question is trying to figure out if such a stunt can be done . . . for he wants to try it on his own teleset.

**Shortages.** According to a press release by R. C. Sprague, president of RTMA, "there is no immediate danger of a serious shortage of replacement parts for radios and TV-sets." He admitted that some distributors were being forced to allocate certain components and he went on record to the effect that a small minority of dealers and servicemen were trying to hoard some items that are in short supply. Frankly, we disagree with Mr. Sprague. There are, and for several months there have been, serious shortages of many types of tubes and components needed by servicemen in their daily work of trying to keep radios and TV sets in operating condition. Conditions are getting worse, not better, every day. The reason is no secret. Most component and tube manufacturers are favoring manufacturers of radio and TV receivers, sending them practically all of their output. In contrast, the parts jobbers who serve the serviceman's needs are getting practically no merchandise despite their fervent pleas. Even manufacturers of boosters are having a helluva time getting parts and tubes needed because, as said before, much more than the lion's share of all tube and components output is going to the set makers. This condition is not a healthy one and the RTMA should try to correct it at once because the matter, serious as it is now, can easily become considerably worse. You see, some of the set makers are now starting to handle government orders for communications equipment in addition to their own regular schedules of manufacturing sets for civilian use and they are making ever greater demands upon the tube and component suppliers for deliveries. In fairness to all, and especially to the service profession which has always been a profitable market for tube and component makers, our present plight must be appreciated, and alleviated. Based on past sales records we would welcome a percentage-wise allocation of tubes and components output for the jobbing trade with the express understanding that whatever allocation is made to jobbers for replacement use must be sold by jobbers for that purpose only and not be diverted from servicemen to the jobbers' industrial electronics customers who are also clamoring for merchandise.

**TV Microwaving Starts.** The microwave relay system between Chicago and New York began operations Sept. 1st. It allows great flexibility in network tieups and reinforces the coaxial cable already in use. The coaxial line could carry one TV program and several telephone conversations whereas the microwave system permits simultaneous transmission of many TV programs in either or both directions plus hundreds of two-way telephone conversations. Four major networks using the microwave system are expected to pipe shows back and forth between the present-day major terminals with a resultant improvement in TV showmanship technique.

# Magic tools

for that "professional touch"

## WALSCO

### TV & radio alignment tools

WALSCO quality-built alignment tools give the technician the most complete line of precision instruments for every receiver.

Ask your parts jobber for  
WALSCO tools.  
Fully guaranteed.

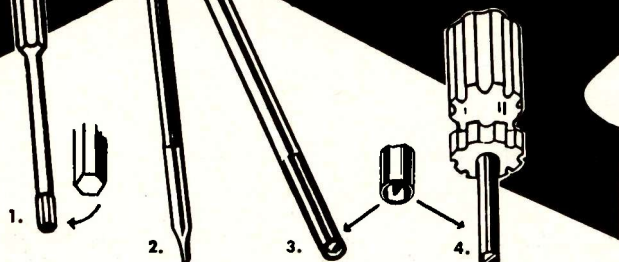

1. Combination hex stud and small screwdriver for I.F. alignment on Zenith, Hoffman, Belmont, and similar T.V. sets. Molded of toughest, pure nylon. Catalog No. 2526.
2. Tough, extra long (12") front-end aligner for Admiral, Emerson, RCA, etc. Replaceable nylon tip. Catalog No. 2523.
3. Duplex I.F. aligner with recessed blades. One side for #6, other side for #4 studs. Unbreakable plastic. Catalog No. 2519.
4. Short (2") I.F. tool with recessed blade. Perfect for cramped quarters.

WRITE FOR WALSCO CATALOG 51

**WALSCO** Walter L. Schott Co., Beverly Hills, Calif. • Chicago 6, Ill.

# TELE-ROTOR

C-D and RADIART  
**TELE-ROTOR**  
HEAVY DUTY MODELS



Tested... proven... and accepted as the outstanding rotator... this heavy duty TELE-ROTOR has no match! Powerful beyond any normal requirement... sturdy enough to hold and turn any TV antenna array under *any* weather conditions. Servicemen and dealers everywhere are recommending the heavy duty TELE-ROTOR with assurance of dependable TROUBLE-FREE performance! Complete with handsome control cabinet that indicates antenna position instantly.



**Model TR-2** . . . . rotator with "Compass Control" cabinet having illuminated "perfect pattern" dial . . . . . (Uses 8 wire cable) . . . . . **\$44.95**

**Model TR-1** . . . . rotator and control cabinet with end of rotation light . . . . . (Uses 4 wire cable) . . . . . **\$39.95**

**ATX-8** . . . . 8-wire color-coated cable, 10c ft.

**PRE-SOLD TO YOUR CUSTOMERS**  
**Through A National TV Spot Campaign**  
**In Major TV Markets**

Be Sure of Your Installations... Next Year

Use *Aptitude-Tested*

**MIKE CABLE** *Now*

Now, you can be sure of your installations with Belden Microphone Cables. They are *Aptitude-Tested* and rated to give you safe and complete knowledge of their characteristics. Furthermore, Belden Mike Cables are built for maximum service. Put them to work for you now—and be sure . . . specify Belden.

Belden Manufacturing Company  
4689-R W. Van Buren Street  
Chicago 44, Illinois

No. 8411  
Nominal Capacitance 37 mmf per ft. Use for lapel microphone.

No. 8401  
Nominal Capacitance 25 mmf per ft. For crystal, ribbon, carbon microphones.

No. 8422  
Nominal Capacitance 32 mmf per ft. Use for carbon microphones.

No. 8410  
Nominal Capacitance 33 mmf per ft. Use for crystal, ribbon, and carbon microphones.

No. 8424  
Use for Interconnecting power cable for all electronic uses. Also used as a microphone cable.

No. 8423  
Nominal Capacitance 54 mmf per ft. Use for carbon microphones.

No. 8412  
Nominal Capacitance 68 mmf per ft. Use for carbon microphones.

**Belden**  
*Radio WIRE*

The *Aptitude-Tested* **LINE**



# TELE-ROTOR

C-D and RADIART  
**TELE-ROTOR**  
HEAVY DUTY MODELS



Tested... proven... and accepted as the outstanding rotator... this heavy duty TELE-ROTOR has no match! Powerful beyond any normal requirement... sturdy enough to hold and turn any TV antenna array under *any* weather conditions. Servicemen and dealers everywhere are recommending the heavy duty TELE-ROTOR with assurance of dependable TROUBLE-FREE performance! Complete with handsome control cabinet that indicates antenna position instantly.

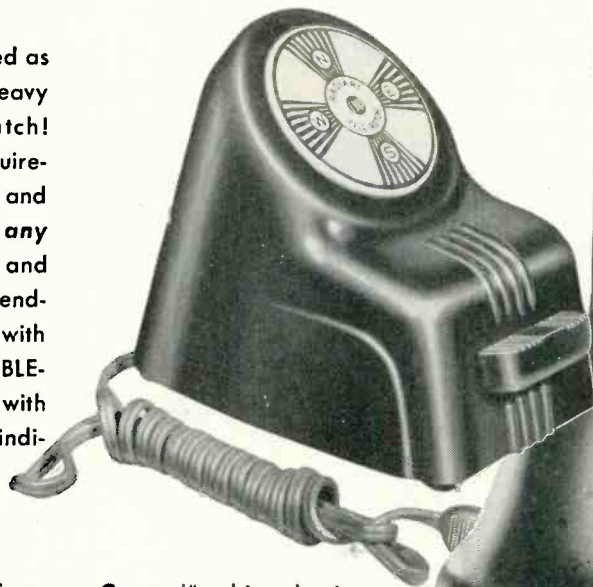

**Model TR-2** . . . . rotator with "Compass Control" cabinet having illuminated "perfect pattern" dial . . . . . (Uses 8 wire cable) . . . . . **\$44.95**

**Model TR-1** . . . . rotator and control cabinet with end of rotation light . . . . . (Uses 4 wire cable) . . . . . **\$39.95**

**ATX-8** . . . . 8-wire color-coated cable, 10c ft.

**PRE-SOLD TO YOUR CUSTOMERS**  
**Through A National TV Spot Campaign**  
**In Major TV Markets**

# Covers the Entire TV Rotator Field!

There's A Correct *TELE-ROTOR* For Every Application

C-D and RADIART  
**TELE-ROTOR**  
U. S. DEVICES MODELS



Here is the new standard TELE-ROTOR for all average installations! Featuring the ALL IN LINE design . . . with true in-line thrust between antenna and mast — the 3/4" STEEL shaft rotates on a case hardened steel ball. In-line reamed oilless bearings keep the shaft in perfect alignment and offer smooth trouble-free rotation and performance.

NOW — Powered by the same husky motor that has proven its superiority in the heavy duty TELE-ROTOR . . . You can depend on this easily installed unit to perform accurately and dependably.

**Model 501-A** rotator with control cabinet having end of rotation light. Light flashes every 7.2° showing antenna is turning. (Uses 5 wire cable) **\$34.95**

**Model 502-A** rotator with control cabinet having indicating meter for "hairline" tuning (Uses 5 wire cable) . . . . **\$44.95**

ATX-10 . . . 5-wire cable, 6 1/2 c. ft.

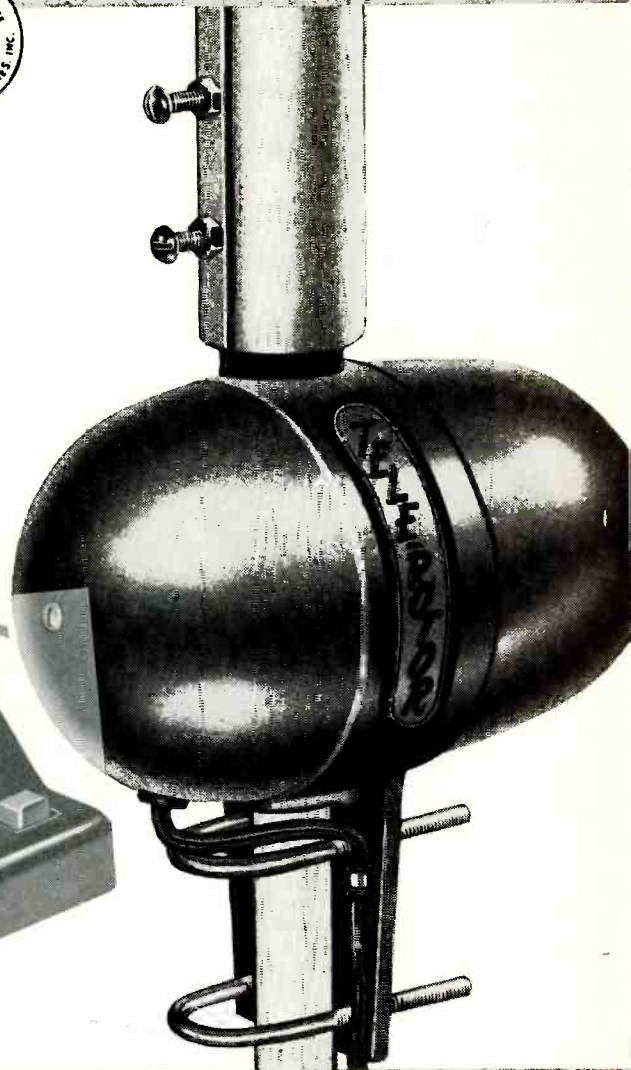
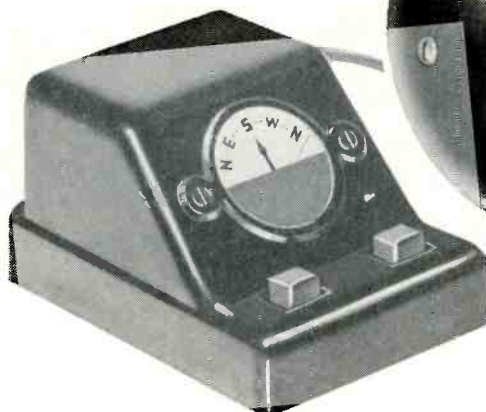

**CORNELL-DUBILIER SOUTH PLAINFIELD, N. J.**

**THE RADIART CORPORATION CLEVELAND 2, OHIO**

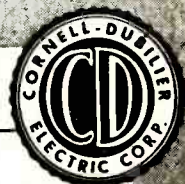

# MORE HYTRON RECTANGULARS FOR YOU!



**NEW SIZES**  
Smaller 14-inch, larger  
17-inch and 20-inch tubes  
join Hytron's original  
16RP4 rectangular



## THE ORIGINAL HYTRON 16RP4 STARTED SOMETHING

Its rectangular design really clicked. Because it is logical . . . compact . . . economical. Everyone seems to want Hytron rectangular TV picture tubes. We just haven't been able to make enough.

But now we can serve you better. With a new, ultra-modern plant devoted to rectangulars. The original Hytron 16RP4. Also the new Hytron 14-, 17-, and 20-inch tubes.

It's smart to pick Hytron rectangulars. Nine out of ten leading TV set makers do. Take advantage yourself of Hytron's leadership . . . its wide line . . . its stepped-up production. Ask for the original and best in rectangulars. Demand Hytron.

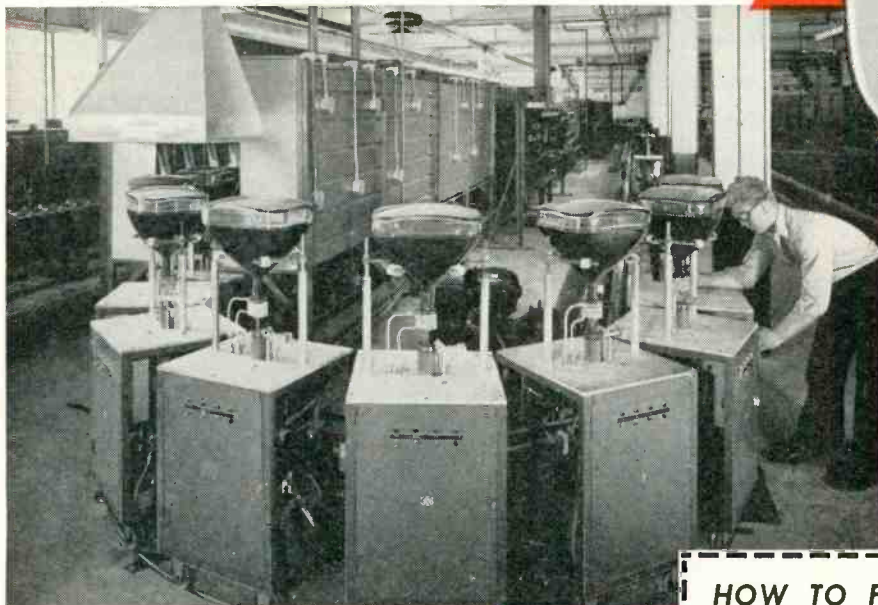

## NEW PLANT

Hytron's big new TV tube plant at Newburyport, Mass., uses latest of fast, automatic, precisely-controlled equipment to give you more tubes . . . better tubes.



### New HYTRON TUBE PULLER

Makes pulling 7-pin miniatures a cinch. New, seventh Hytron shop tool now available at Hytron jobbers. Order yours today! Only 75¢ net.



MAIN OFFICE: SALEM, MASS.

## HOW TO FIND YOUR HYTRON JOBBER

Want to learn where to buy original Hytron tubes? And the famous Hytron service-shop tools? It's easy. Fill in and mail this coupon today.

**HYTRON RADIO & ELECTRONICS CORP.,**  
Salem, Massachusetts

Please rush a list of Hytron jobbers near me! (PLEASE PRINT)

NAME .....

STREET .....

CITY .....

STATE .....

S.

# Know the CATHODE RAY TUBE

Part 1

by Allan Lytel

**This 2-part article describes in minute detail the theory and operation of an electrostatic cathode ray tube and the functions of the various controls associated with its correct adjustment. Also discussed are the various types of fluorescent screens and their applications. The final portion deals with a complete analysis of a commercial 'scope.**

**T**HE cathode ray tube in the test oscilloscope and the television receiver has the same functional operation in which a sharply focused electron beam impinges upon a fluorescent screen causing light excitation. The cathode ray tube oscilloscope used for servicing and alignment procedures uses the electrostatically deflected and focused tube. Television receivers may use either the electrostatically focused and deflected tube or the electromagnetic type. *Figure 1* illustrates the 7JP4 which is of the electrostatic variety; this is used in the

smaller direct view television receivers. Tubes having a larger screen diameter than 7 inches are almost all of the electromagnetic type. *Figure 2* is the 12LP4 electrostatically focused and deflected cathode-ray tube. The direct connection to the bulb of this tube connects to the inside graphite coating which acts as the second anode.

Electrostatic deflection and focus is found in the cathode ray tubes used in oscilloscopes. The electron gun has a cathode emitting element which functions in much the same manner as with cathode emission from any ordinary vacuum tube. Additional cylindrical elements are used to focus the electron beam by means of electrostatic fields into a sharp pin-point at the screen. The electron beam must be a well-defined small spot in order to provide a sharply focused image. The focusing methods employed are very significant in determining some of the limitations of cathode ray tube operation and design. For example, the number of electrons which reach the screen determine how fast the electron beam may write or present information. If too few electrons are present on the screen, the image is not bright enough for a fast writing rate or a high frequency signal. If the beam is improperly focused, the visual image will be blurred.

Focusing is accomplished in a manner quite similar to optical focusing,

and the electron gun may be explained by using fundamental optical principles.

## CRT Operation

*Figure 3* illustrates the functional operation of the electrostatic cathode ray tube. The heater element or filament, increases the temperature of the cathode until electrons are emitted from the cathode surface. The control grid, while it has a cylindrical shape, performs the same function as the control grid in any amplifier tube. If the potential of the control grid is greater

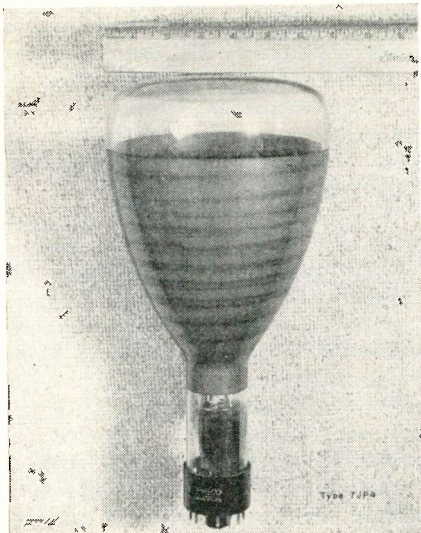

Fig. 1. A typical 7-inch electrostatic tube.



Fig. 2. A commercial 12-inch electrostatic tube.

than the cathode, a large number of electrons will flow from the cathode to the control grid. These electrons will pass through the hole or aperture in the control grid disc and continue on to form the electron stream.

Where the control grid is made sufficiently negative, in relation to the cathode, it will function to prevent electron flow from the cathode through the control grid. Since electrons are negative charges themselves, they will be repelled by an excessive negative potential on the control grid hence they will not pass through the aperture. It is possible in the test oscilloscope to apply a signal potential to the control grid and cause intensity modulation. As its name implies, intensity modulation changes the number of electrons in the stream at any given instant. And as the electron stream moves across the tube face, a positive going signal on the control grid will increase the electrons flowing to the screen hence will produce a bright spot on the screen. This method is used to provide markers along the visual image. The intensity of the electron beam is then a function of the relative potential existing between the control grid and cathode.

There are two additional cylindrical elements in the electron gun. Going from the cathode toward the screen, there is the first anode and the second anode. The first anode has a higher potential than the control grid hence it has a tendency to accelerate the electron flow toward the fluorescent screen. This first anode is known also as the *focusing anode* since focusing is largely accomplished by means of the difference of potential between the first anode and control grid. This potential difference creates what is known as an electrostatic lens existing between the control grid and first anode. A variable control is provided over the potential of this focusing anode and this is usually brought out to the front panel of the scope, as the *Focusing Control*.

The second anode provides additional acceleration for the electron stream, and the anode is electrically connected to the graphite coating on the inner surface of the cathode ray tube envelope. The acceleration of electrons in the tube is largely accomplished by means of this element and the velocity by which electrons strike the fluorescent screen depends primarily on the potential of the second anode. The graphite inner coating of the tube has the high potential of the second anode since the two are connected together. Electrons which bounce off the fluorescent screen use the graphite coating as a return path through the gun.

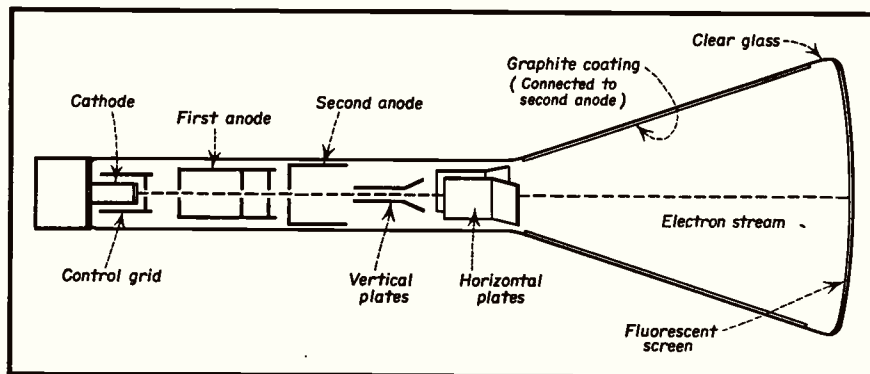

Fig. 3. Cross section drawing of a simple cathode ray tube.

Two sets of deflection plates form the final elements in this tube! These plates which are mounted vertically will deflect the electron beam from side to side. The electron beam will tend to move toward the more positive plate and away from the more negative plate. The same action occurs in the vertical deflection plates which are mounted horizontally. If the upper plate is positive, the electron beam will tend to move upward. The electron stream will again move away from a negatively charged plate and toward a positively charged plate. The vertical deflection plates which are

The section of clear glass between the fluorescent material and the second anode effectively insulates or acts as a high resistance between the graphite coating inside the tube and the fluorescent screen of the tube face. The fluorescent screen creates visible light when electrons strike it and the amount of illumination depends on the velocity and number of electrons. The grid structure determines the number of electrons striking the screen and the potential of the second anode determines their velocity so the combination of these two elements determines the intensity of the emitted light from the fluorescent screen.

#### The Electron Gun

As shown in *Figure 4* the cathode is mounted so that it fits directly over the heater element; a cathode spacer keeps this element properly centered in the tube neck. The control of emitted electrons which originated in the cathode is accomplished by means of cylindrical electrodes, the first of which is the control grid. This is made up of two pieces, the control grid cylinder and the control grid disc. The disc is a circular piece of metal which caps the control grid cylinder and contains a small hole or aperture which allows electrons to flow from the cathode through the control grid. The size of this aperture also functions to decrease the spot size on the screen, since it removes the outer electrons which cannot pass through.

The open end of the control grid cylinder fits over the cathode assembly. As shown in the drawing, the control grid cylinder extends forward beyond the aperture. This extension is known as the control grid skirt which assists in its action. The grid opening effectively provides a limitation on the sides of the electron stream by the very physical size of the aperture. The potential difference between the control grid and cathode is an important factor in determining the number of electrons which leave the control grid and form the electron

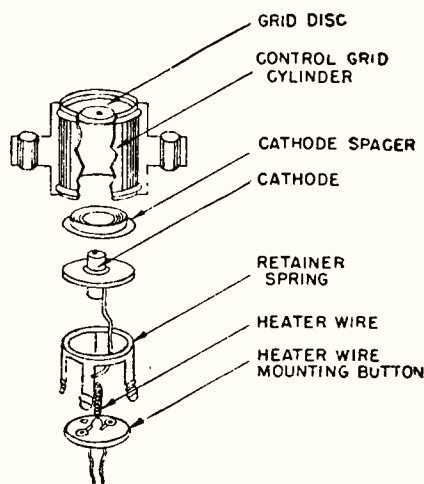

Fig. 4. Cathode-grid assembly.

named because they deflect the electron stream vertically, although they are mounted horizontally, are closest to the second anode. In this position, they will have the greatest effect on the electron stream since the signal voltage which is a vertical deflection voltage is usually smaller than the horizontal sweep voltage. For this reason the vertical deflection plates are mounted in their most sensitive position nearest the second anode.

The inner coating on the cathode ray tube face is the fluorescent screen.

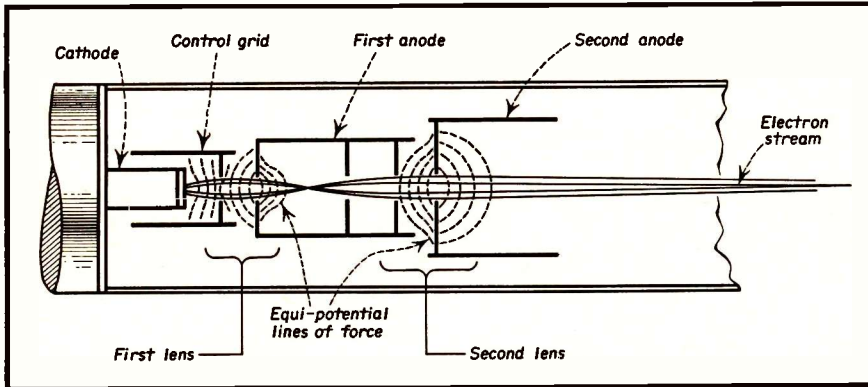

Fig. 6. The electrostatic field in an electron gun. The equipotential lines of force form electrostatic lenses.

stream. A sufficiently high negative potential on the control grid in relation to the cathode is capable of completely preventing any electron flow through the aperture; this condition is known as visual out-off since no electrons reach the screen and there is no illuminated spot on the screen. The opening in the control grid may be effectively opened and closed by changing the grid voltage. A very negative grid voltage effectively decreases the diameter of this aperture to zero; an increase in potential on the grid effectively increases the aperture size and allows greater electron flow.

Figure 5 illustrates the focusing action of the complete electron gun. An analogy may be drawn between this electronic focusing and the optical focusing of light rays. A lens which is thicker in the center than it is at the edges is known as a converging lens since it takes parallel light rays and brings them to a common point known as the focus. This is accomplished by means of the refractive quality of the glass which bends the outer light rays more than the inner light rays and brings them to the common point or focus. Effectively the electron gun has two electronic lenses; one is between the control grid and first anode and the second is between the first and second anodes. By means of electrostatic forces, the electron stream is made to focus at a point inside the first anode; this point is known as the cross-over point and corresponds to the focus of a convergent lens. The second lens again acting as a convergent lens forms an image or a sharp point on the fluorescent screen.

#### Electrostatic Focusing

The electron beam which is emitted from the cathode is focused by virtue of the inter-relation between the control grid, first anode and second anode. This focusing action may be explained by means of an analogy with ordinary lenses used in optical focusing. Figure

6 illustrates the electron gun and the electrostatic fields which exist between the control grid and the first anode as well as the electrostatic fields which exist between the first and second anode. There is a voltage difference between the control grid and first anode. As the electron stream travels from the cathode through the control grid and first anode, it is variously affected by this electric field. The strength and effect of this electrostatic field may be discussed by plotting lines which represent areas of equal

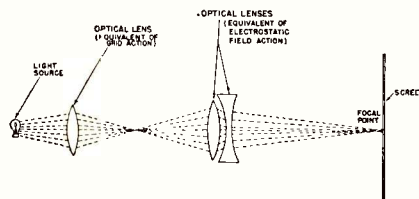

Fig. 5. Optical analogy of electrostatic focusing.

potential. As an example, the line marked 10 volts represents the area which has this voltage force acting upon it due to the inter-relation of control grid and first anode. If these lines were to be plotted, we would establish what are known as equipotential lines. This changing potential which the electron beam encounters in its passage causes the electron beam to be focused inside the first anode. Electrons which would tend to separate because of their mutual repulsion are forced by these electrostatic fields to converge on the focus point. The electrons which travel down the center line will not be affected by the equi-potential lines and as an individual electron tends to move away from the center, these lines of course have a greater effect.

The electron stream may be said to be acted upon by these equi-potential lines in a perpendicular direction,

that is, the electron stream has a tendency to be forced to act in a direction at right angles to these voltage gradient lines. These lines, while they represent the focus of all points which have the same potential, may be thought of as the means by which electrons are focused; this is sometimes known as an electrostatic lens.

Since the first and second anodes are at a positive potential relative to the control grid, electrons would have a tendency to travel toward and actually hit these anodes except for the action of the electrostatic lens.

Focusing is accomplished by means of two electrostatic lenses. The first is between the control grid and first anode while the second is between the first anode and second anode as shown in the drawing. This second lens effectively produces the image of the cross-over point in the first anode on the fluorescent screen. Electrons diverge after the cross-over point on their way to form a sharp image impinging on the fluorescent screen. The equi-potential lines between the first and second anode form the second electrostatic lens which converges this electron beam and completes the focusing action. The voltage on the first anode is made variable and this is known as the Focusing Control, since the potential difference between these two anodes will determine the strength of the lens hence the exact focus on the fluorescent screen. The use of the cathode ray oscilloscope will demonstrate that the intensity control which varies the control grid voltage and the focus control which varies the first anode voltage, operate so that they affect each other; for example, when the brightness or intensity is changed by adjusting the control grid voltage, the focus usually needs re-adjustment as well. The inter-action between these two voltages changes both the brightness and focus although the control grid primarily controls intensity of electron flow and the first anode controls the focus.

In the total electron stream, there are inevitably some electrons on the outer fringes of the beam which cannot be adequately controlled hence must be removed. The first anode has three openings, or apertures. The control grid has one and the second anode has one. Electrons which strike the disc in any electrode are removed from the electron beam. This in effect sharpens the focusing action. The three apertures in the first anode of the electron gun sharpen the electron beam and these three apertures are of different sizes. Going from the cathode toward the screen, the first hole is

[Continued on page 46]

# Reducing Losses In TRANSMISSION LINES

by **NORMAN L. CHALFIN**

**T**ELEVISION receiver installation technicians receive weak signal complaints on some channels even in normally high signal areas. This can be due to the effects of an undesirable standing wave ratio in the transmission line.

When a transmission line is not properly terminated at each end in a load which matches its characteristic impedance, a high standing wave ratio is set up. Standing waves result when a signal is not fully absorbed at the receiving end and is reflected back out of phase along the transmission line with the incoming signal. The effect results in weaker signals at the receiver. The mismatch also produces a fault noticeable in the TV picture. This is a series of ghosts in the image.

Since most of the TV receivers have an inductive input, it can be possible to have a perfect match at some one frequency or channel and have a mismatch to a greater or lesser degree above and below that frequency or channel. For this reason it is possible to have signal strengths of different levels at the receiver although the channels produce the same level at the receiver location, in the antenna itself.

## Applications of Stubs

A transmission line can be a tuned circuit for one particular channel because of certain characteristics of lines. These are pretty well known. A quarter wave section of parallel wire transmission line loaded at the far end, is in effect a parallel resonant circuit. A half wave section acts as a series resonant circuit.

If we consider odd quarter wave sections tacked on at the end of a long line having "n" wave length, a chart can be drawn for all the quarter wave sections having "n" plus  $\frac{1}{4}$  and "n" plus  $\frac{3}{4}$  wave lengths as they refer to all the channels in the present TV bands. In the chart accompanying

**Transmission lines used in television installations, unless perfectly matched to the antenna and the receiver, become tuned elements, and as such may affect reception at certain channels. In this article the author explains the underlying theory and applications of this effect.**

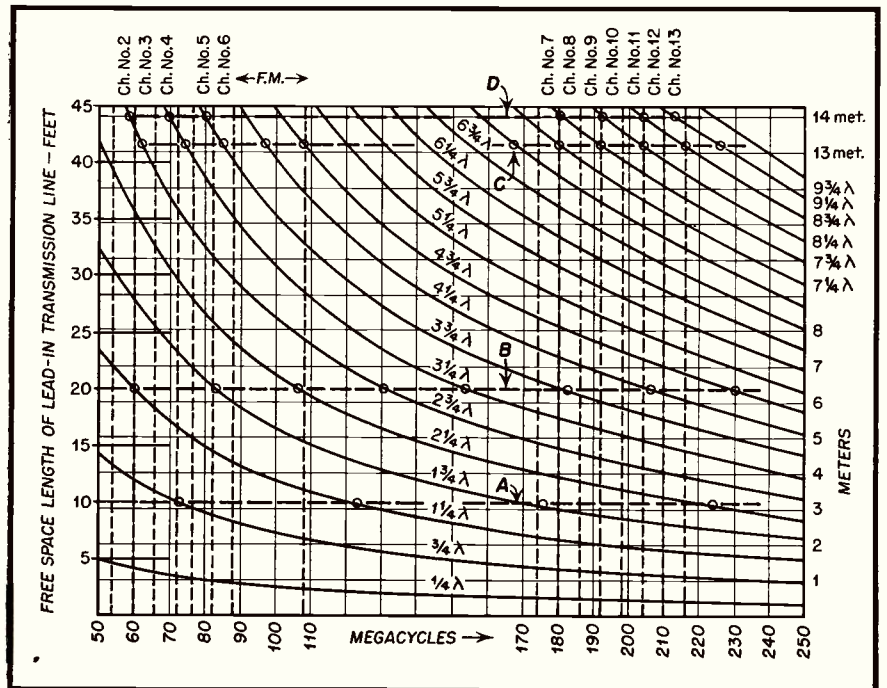

Fig. 1. Chart of frequency vs. odd quarter-wavelengths.

this article (Fig. 1.) we have drawn the odd quarter wave length lines up to about 45 feet, for the free space condition for the range from 50 to 250 megacycles. Wherever these lines cross a TV channel, it indicates that approximately this length is resonant at the particular channel. It will be seen that a number of free space resonant points along the transmission line of a particular length pass through different channels. These coincidences show that a particular

length of line may be selected which will give a resonant effect at all the channels. In the New York, Chicago, and Los Angeles areas, channels, 2,4,5, 7,9,11,13, are used. At 45 feet (D on the chart), there are coincidences on all these channels.

Because the chart is drawn for free space dimensions and does not take into account the different loading components that might be used on a front end's input the values must be considered approximate.

### Use of Chart

To illustrate the application of the chart several horizontal lines have been drawn across the chart (A, B, C, D). The intersections of these horizontal lines with the odd quarter wave lines are circled at several points. Note that the horizontal line A crosses the  $\frac{3}{4}$  wave line in the guard band between channels four and five, while it crosses the  $1\frac{1}{4}$  wave line at 124 Mc, and it also crosses the  $1\frac{3}{4}$  wave line at channel 7 and  $2\frac{1}{4}$  wave line at 225 Mc. This length, approximately 10 feet, or 3.2 Meters, would be most desirable only for channel 7, and conceivably nowhere else in the TV bands. A lead-in of parallel wire transmission line this length would not be very good for general use. This is one of the problems in the use of indoor antennas right close to the receiver. Referring to the line "B" there are two coincidences in the low band one in the FM band and two in the high band. Other things being equal a 20' lead-in of parallel wire would be better than the 10' length.

As the lead in wire is longer and longer there will be more and more coincidental crossovers with different channels. The crossovers may not necessarily be exactly on the channel frequencies themselves, the lengths may be just a little over or under an odd quarter wave added to the long line of n plus wavelengths.

### Shunting Stubs With Capacitors

A quarter wave section of transmission line (parallel or coaxial) can be tuned with a small capacitance across it. The shunting of the line



Fig. 3. Method of adjusting stubs for proper reception of desired station.

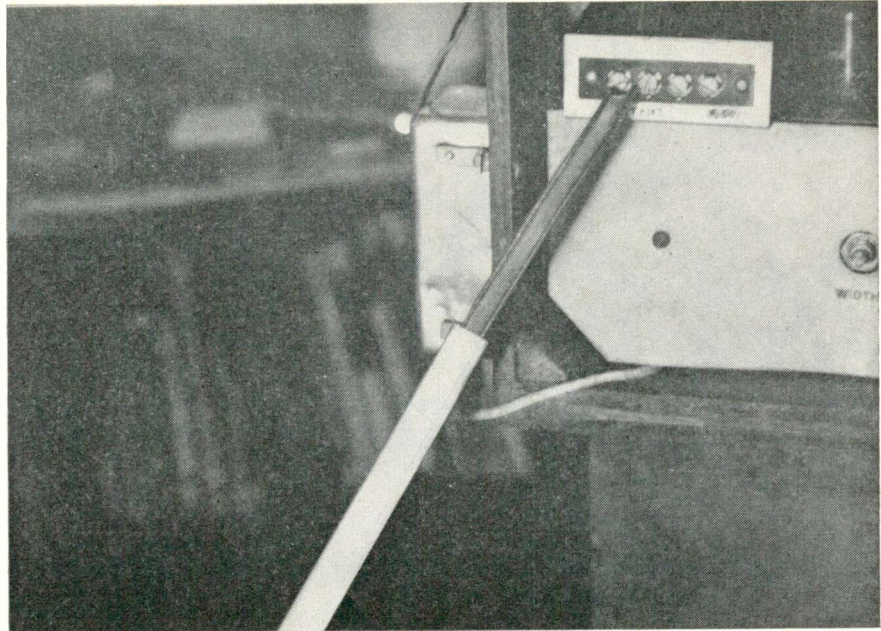

Fig. 4. Connecting stub to receiver. During the process of adjustment the stub is run up and down the downlead until optimum reception is obtained. By optimum reception is meant best all-round reception.

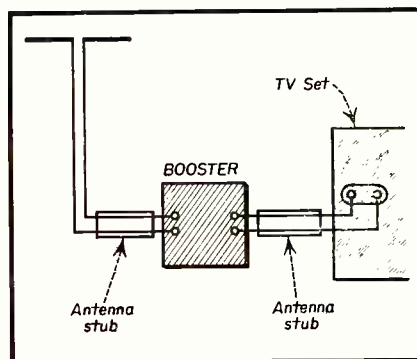

Fig. 2. Connecting stubs to boosters.

with capacitance will resonate the line section at a frequency for which a longer free space length would be required. The formula for this condition can be written:

$$\tan L = \frac{X_c}{Z_0}$$

Tan L is the Tan of the electrical length in degrees.

$X_c$  is the reactance of the shunt capacity at the frequency in use.

$Z_0$  is the characteristic impedance of the transmission line.

The resultant value Tan L will be a figure—the tan of an angle less than  $90^\circ$ . The ratio of the angle which is less than  $90^\circ$  to the  $90^\circ$  angle will be the ratio of the reduction in length from the free space quarter wave length. This applies for any odd quarter wave length or any integer plus an odd quarter wave length. Thus if the angle  $45^\circ$  appears from the calcu-

lation the actual length of the shunted  $\frac{1}{4}$  wave line (capacitance loaded) will be  $1/2$  of the free space length.

$$45^\circ/90^\circ = 1/2$$

The shunting reactance can be a small fixed or variable capacitance. This usually offers too much loading. A comparatively simple method of providing the necessary loading can be employed in a small piece of aluminum foil wrapped around the ribbon transmission wire. This is flimsy and usually becomes torn or damaged in handling. A commercial device that can be used to effectively load a transmission line is the Tenastub, (see Figs. 3 and 4) fabricated from aluminum sheet so that it clamps the line and still permits sliding for best tuning.

Employing a device of this nature for transmission line tuning and matching is a simple process. The aluminum clamp is slipped over the transmission line at the output end nearest to the TV set. It is then slid along away from the set until the voltage received by the receiver is a maximum. (This will be maximum contrast or the brightest image on the TV screen).

In the installation of boosters, the length of the connecting wire between the booster and the antenna connection posts of the TV receiver is sometimes a source of loss in efficiency in the operation of the booster. If the length of the wire in combination with the reactive elements at the out-

[Continued on page 47]



# A Comparison of AM & FM Servicing Problems

by **J. Jacobson**

*Instructor, Delehanty Institute*

**This article covers in an elementary manner the basic circuit features of AM and FM receivers and compares the two methods of reception both as to function and servicing. Methods of observing audio waveforms for both systems of reception are included.**

**A** comparison of an AM type receiver, shows that both types have many things in common. In fact, many of the trouble shooting techniques used in AM servicing may also be employed in the servicing and repair of FM receivers. On the other hand, many of the so-called short cuts used in the repair of AM receivers must be discarded and new techniques, in accordance with the higher frequencies and method of detection, must be employed when servicing the modern FM receiver.

Figure 1 shows a block diagram of a typical a-c superheterodyne receiver covering the AM band from 550 to 1600 kc. A typical FM superheterodyne receiver block diagram is shown in Fig. 2, covering the 88 to 108 mc band. A step-by-step procedure will be used, describing the best methods in trouble shooting both receivers, and describing the operation of each individual stage.

## Test Equipment

Although many servicemen manage to get along with a minimum of test equipment, it pays in the long run to have the necessary tool and test instrument at hand. The following instruments therefore will be found in the "pays to be prepared" type of service shop; VTVM or 25,000

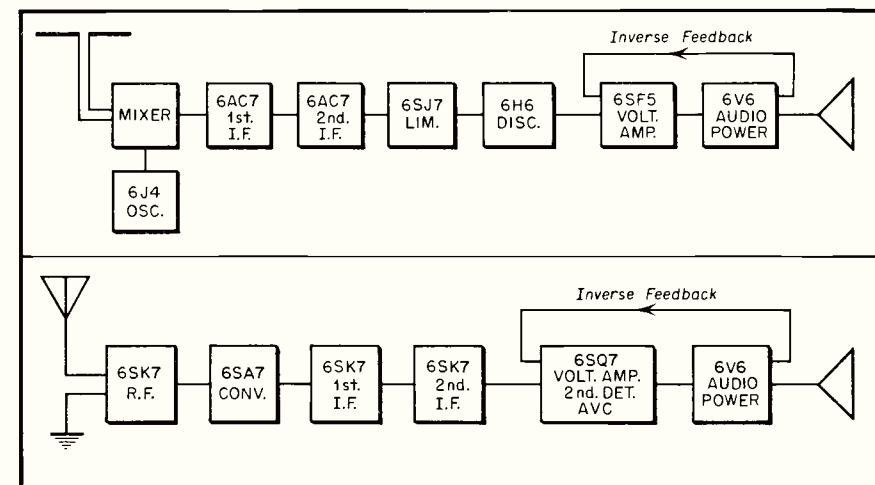

Fig. 1 (Bottom). Block diagram of typical AM receiver.

Fig. 2 (Top). Block diagram of typical FM receiver.

ohm per volt voltmeter, ohmmeter (unless included in the VTVM), signal generator covering the AM band, sweep signal generator covering the FM band, variable audio signal generator covering from 30 to 2000 cps, and a cathode ray oscilloscope.

These instruments provide an ideal means of locating trouble in receivers using the "stage-by-stage" method of trouble-shooting. After the trouble has been corrected and the receiver is operating, the performance of each

individual stage may be analyzed with the use of these instruments. Diagnosis of radio receivers has often been associated with the doctor's diagnosis of a patient. The patient usually undergoes a complete physical examination and X-ray to locate some obscure defect. The cathode ray 'scope is the radioman's X-ray and it will promote his ability when put to good use.

Referring to both diagrams discloses the fact that both sets use a

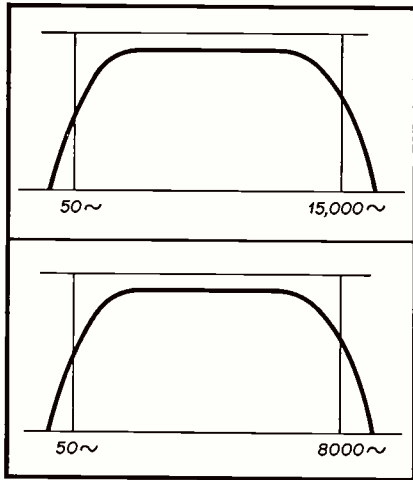

Fig. 3 (Top). FM audio response.  
Fig. 4 (Bottom) AM audio curve.

6V6 in the power output stage. Trouble-shooting either set for no audio power output into the speaker would require the same procedure in both types of sets. However, in order to insure the best fidelity, the check on the audio response would not be the same in both cases. It may be recalled that the FM transmitting station, transmits a wave containing audio information ranging from 50 to 15,000 cps. The audio information contained in the carrier of an AM station, on the other hand, is not as great and only encloses a 50 to 5000 cps range. Therefore, if our FM set is to take advantage of this transmitted high fidelity range, no "frequency bottleneck" should be allowed to exist in any of the audio stages including the power output stage.

#### Power Amplifier Frequency Response

When checking the power amplifier stage for frequency response in the FM set, good judgement should be used. For example, if the set is of an expensive make, and includes an

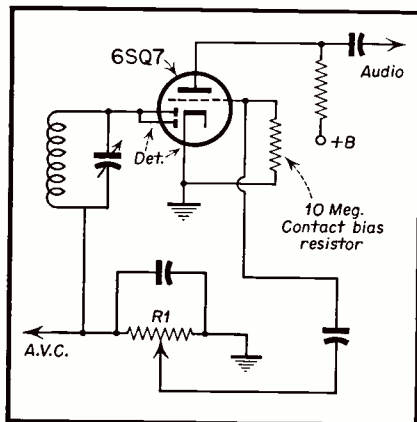

Fig. 5. Typical AM amp-det.

excellent speaker, good baffle and high quality output transformer, everything possible should be done to insure that as broad a band of audio frequencies as possible will be delivered to the listener. By injecting a signal from the output of the variable audio signal generator onto the 6V6 grid, and connecting the 'scope across a resistance equal to the d-c resistance of the voice coil, a good all-around picture of audio response may be obtained. By varying the audio generator between the lowest and highest audio frequencies, distortion and non-linear response of the last stage may be easily corrected. Figure 3 shows an audio response curve of a high fidelity type FM receiver.

The same checking procedure may also be used when it is desired to know the frequency response of the

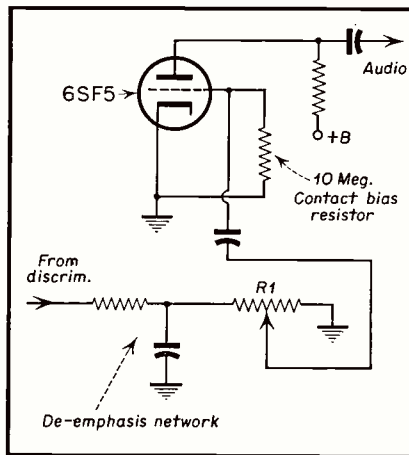

Fig. 6. Typical FM amplifier.

6V6 power output stage of the AM set. However, due to the narrower transmitted audio frequency range, the requirements of response of the receiver are not as great as the FM set. The audio response curve obtained across the output stage of a good quality AM receiver is shown in Fig. 4. It may be seen that in both circuits, inverse feedback is used. This results in lowered distortion, increased bandwidth, at the cost of lowered audio output.

#### Audio Voltage Amplifier

Referring to Figs. 5 and 6, and going back to the previous stage, we encounter the 6SQ7 in the AM set and the 6SF5 in the FM set. The 6SQ7 as used in the AM receiver, in addition to functioning as an audio voltage amplifier, also acts as a second detector and a-v-c tube. However, by comparing the triode portion of the 6SQ7 to the 6SF5, it may be

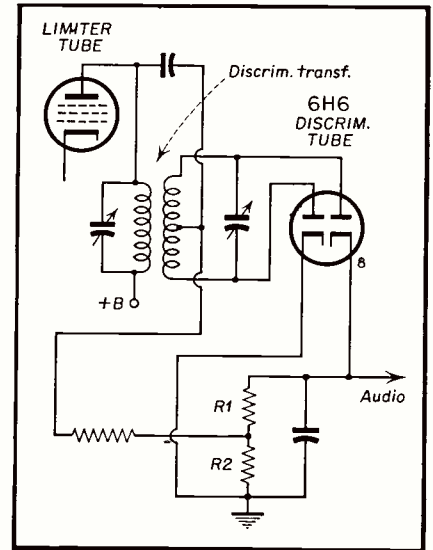

Fig. 7. Typical FM detector.  
(Foster-Seeley discriminator)

seen that both tubes perform similar functions. Contact bias is used in both cases, thus saving the need for a cathode bias resistor and by-pass condenser. By impressing a signal from the variable audio signal generator onto the grid of either tube, an insight into the behavior of that particular stage may be also determined. A new overall response curve may be plotted to determine whether that particular stage is possibly contributing to an audio "squeeze" thus narrowing the audio bandwidth. It should still be borne in mind that the transmitted audio response of an AM station is only one third that of an FM station. An improper value of coupling condenser for instance, if of too small a value, will nullify the effects of an expensive speaker and baffle.

Before continuing to other stages it may be seen that in either type of set, a properly operating audio

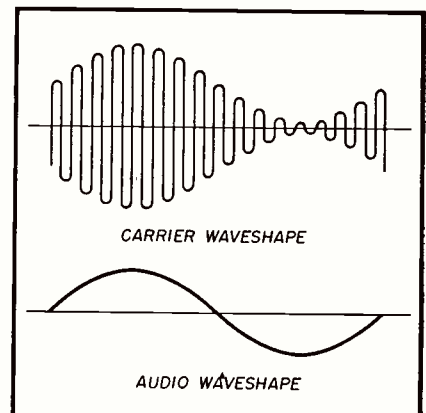

Fig. 8. Modulated carrier and audio waveshapes in AM system.

system will result when: a) the distortion is at a minimum, b) no audible hum exists, c) the power output is adequate for the size room, and d) the baffle area is large to give good low frequency response.

### AM vs FM Detector

The AM detector may readily be located by referring to the two diodes and cathode of the 6SQ7 tube. The 6H6 as seen in the FM diagram of Fig. 7 functions as the FM detector. The detector circuit is of the familiar Foster-Seeley Discriminator variety. Although both the AM and FM type of detectors accomplish the same thing in the end, namely to extract the audio information from the carrier, the methods of doing this are entirely different. Fig. 8 shows the carrier of an AM station which is being fully modulated by a sine wave audio tone. This is the waveshape appearing across the secondary winding of the last i-f transformer. The diode plates of the 6SQ7, which only pass current when the above waveshape is going through its positive phase, cause a rectified current to flow through the load resistor *R1* which is the resistive element of the volume control. Figure 9 shows the waveshape across *R1* which is now an audio waveform. Trouble-shooting a diode detector of this type may be accomplished by inserting the proper type of signal across the secondary circuit of the second i-f transformer. This calls for an amplitude modulated signal obtainable from the AM signal generator. However, some signal genera-

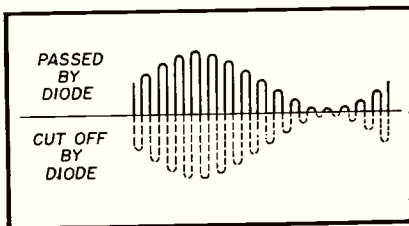

Fig. 9. Audio waveform across diode load resistor.

tors do not have sufficient amplitude to place the signal directly across the diode circuit. It may then be necessary to "back-up" one stage to the grid of the last i-f amplifier tube. By adjusting the frequency of the signal generator to the i-f frequency and modulating with a variable audio test tone, an audio pattern will result if the 'scope is connected across the volume control. The diode detector circuit contributes to the overall audio response of the receiver. Therefore, by connecting the 'scope across

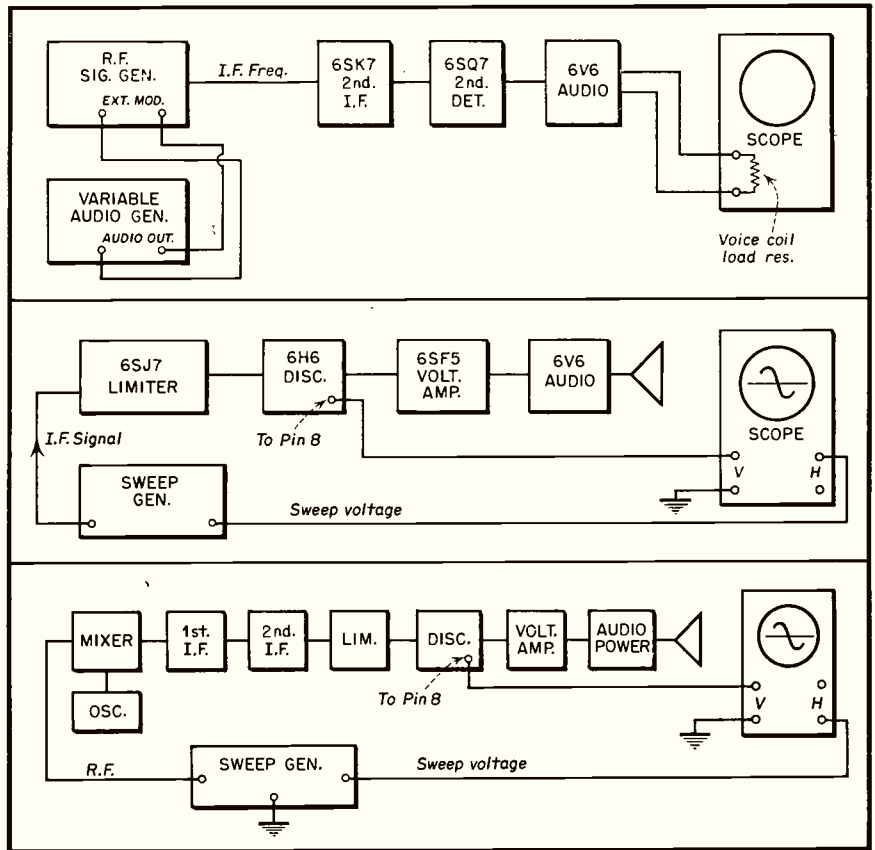

Fig. 10 (Top). Instrument set-up for checking audio and last i-f response in an AM receiver.

Fig. 11 (Center). Checking a discriminator for output and balance.

Fig. 12 (Bottom). Checking overall response of an FM receiver.

the voice coil circuit and injecting a modulated i-f signal across the last i-f grid, an overall response curve of the detector and audio system may be obtained. It may also be seen that the band pass characteristics of the last i-f transformer will be included in the curve. It will however be necessary to substitute the variable audio signal generator for the 400 cycle test tone which is a fixed frequency in most signal generators, when making the check. The variable audio generator is simply connected to the terminals of the signal generator marked "External Modulation". Figure 10 shows a block diagram of the instrument set-up.

An FM receiver of good design usually incorporates a de-emphasis network. This usually consists of a combination of R and C so designed that it accounts for a gradually falling audio response, as the audio frequency increases. This is necessary, as it may be recalled that at the transmitting station a pre-emphasis network is used in order to give the audio tones of the higher frequency ranges a "boost" over noise normally developed in their high fidelity amplifiers. This is just as necessary as

the need for a person to "boost" his voice in conversation when riding through a noisy train tunnel. Therefore the de-emphasis network in the FM receiver removes this unnaturally amplified signal and again "levels it off" therefore, due consideration should be given to the audio response curve when it includes the de-emphasis network.

When checking a Foster-Seeley Discriminator in the FM receiver, a completely different procedure is used. The 6H6 tube dual diode tube depends for its correct operation on a series bucking voltage developed across the split diode load resistor marked *R1* and *R2* which cancel out when an i-f signal is impressed across the primary of the discriminator coil, and is frequently modulated at a sine wave audio rate. The above statement also includes the correct adjustment of the discriminator coil trimmer condensers. Trouble shooting a Foster-Seeley discriminator can be accomplished with the aid of the 'scope, and FM sweep generator. Figure 11 shows how the discriminator stage

[Continued on page 44]

# Master J-U ANTENNA SYSTEMS In Motels

by **IRA KRAMEN**

Director of TV Development  
Brach Manufacturing Co.



**The Motel has earned a position in the American way of life by providing "all of the comforts of Home" along the nation's highways. Therefore, it was to be anticipated that public acceptance of television meant that this new public service would have to be incorporated into the better Motels which are spread wherever TV is received.**

**A** Motel TV System installation needs the same care and consideration as a garden apartment installation. Like garden apartments, most Motels are assembled in units of 4, 8, or 16 which usually precludes the installation of an amplified type of master system because of the high equipment and maintenance cost involved. In addition, the greatest number of Motels are at least more than ten miles from the urban areas where the TV signals are transmitted, which means that one high gain directional antenna usually is sufficient to provide adequate signal for non-amplified antenna system on all TV channels.

## Antennas

Figure 1 shows a typical antenna installation on the roof of one building of a Motel. A Stacked 6-Bar Type of antenna was selected because it has higher gain on the upper TV channels than the 4-Bar Type of conical. Selection of an antenna with higher gain on Channels 7-13 is important as all other installation conditions are unfavorable to Channels 7-13 reception. There is always less signal available from the high channels (due to atmospheric losses), the transmission lines have more loss

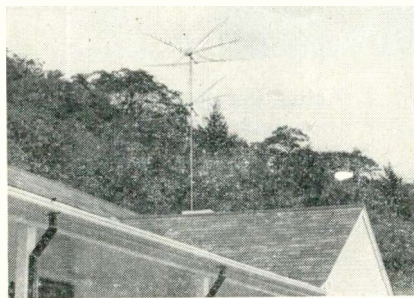

Fig. 1. Typical antenna installation on roof of one building of Motel.

on the upper channels and there is always a higher standing wave ratio on the transmission line (which manifests itself by signal loss) due to the mismatch of most TV set front ends to the transmission line on the upper channels.

## Distribution

Figure 2 shows the layout of a master antenna installation in a secondary signal area Motel. It may be noted that 72 to 300 ohm matching transformers were provided to convert the 72 ohm output of the master system distribution device (Fig. 3 shows actual installation assembly) so that

low loss 300 ohm line could be employed throughout the installations. In stronger signal or noisy areas, RG59/U or RG11/U Cable could be run from antenna to distribution device and between all TV sets and the distribution device as shown in Fig. 4.

In primary signal areas where more than five millivolts of signal is available and a stacked antenna is employed, it is possible to run 16 television sets from one antenna in the manner shown in Fig. 5.

The distribution devices shown in Figs. 2, 3, and 4 performs all of the functions of a master antenna system in the following manner:

1. It divides the antenna signal it receives into four equally balanced parts.
2. It rejects all signals below 50 megacycles which prevents i-f interference in the form of diathermy or short wave signals from entering the installed system. The matching transformers (shown in Fig. 3) also reject signals below 50 megacycles which adds to the filtering efficiency of the installed TV system.
3. The TV receivers connected to the distribution unit are isolated from

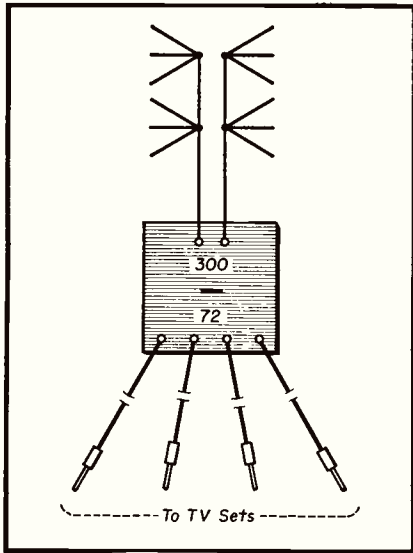

Fig. 2. 300 to 72 ohm system.

each other by approximately 20 db which is sufficient to prevent interaction between TV receivers whose front ends conform to the R. M. A. re-radiation standards. In recent tests latest models of RCA, G.E., Philco, and many other TV receivers were found to be within 25% of the R.M.A. Standards. This isolation is important as actual survey reports have shown that in Motels with TV systems three out of four sets (see Fig. 5) were in operation during the period from 6-12 P.M.

A branching type of system was found to be more practical in installation than the series tap-off type of arrangement common with most multiple dwelling installations. The distribution device, which is the heart of the installation (shown in Fig. 3) is located centrally with respect to



Fig. 6. Receiver installation.

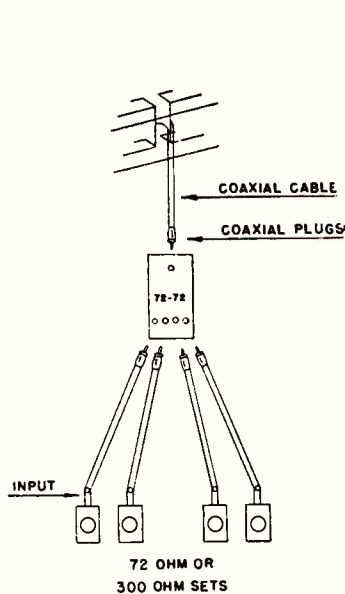

Fig. 4 (Left). Method of using 72 ohm coaxial downlead to four 72-ohm type sets.

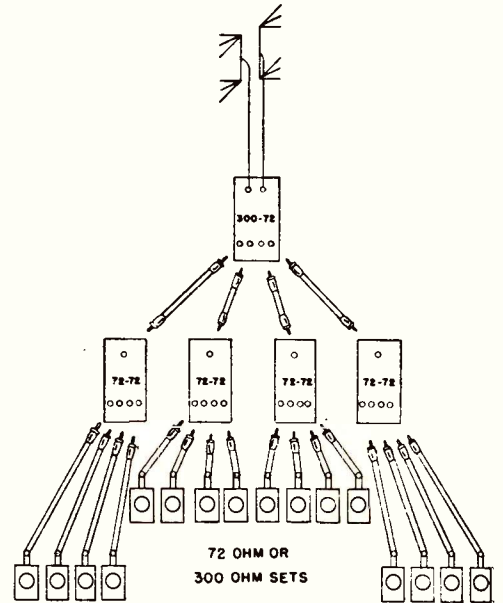

Fig. 5 (Right). Method of using 300 ohm downlead to sixteen 72-ohm sets.

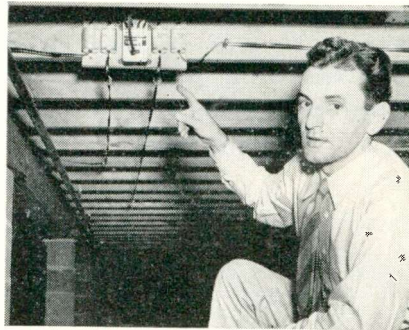

Fig. 3. Actual installation of distribution system in cellar.

four Motel rooms which are always located in a one story proposition. By being able to locate the distribution device centrally, the installer is assured that all TV sets will have the same TV signal level and that there will be no weak signal Motel rooms. When TV series tap-off systems are installed, the last TV set connected to the transmission line always has the weakest signals. Equal signal levels in all rooms makes the TV sets interchangeable without adjustment. There are many cases in fringe areas where two-set operation from one antenna is the best that can be hoped for if stable reception is to be assured without an amplifier. Figure 6 is a photograph of a 2-set coupling device which enables two sets to operate from one antenna and has all the filtering and isolation circuits described for the 4:1 distribution device. In both cases, the installation of the 2 or 4:1 distribution device

should be on a rooftop in a watertight box (see Figure 7) or in the cellar where the transmission lines can be disconnected from the Motel room without entering the rooms. Motel operators tell the serviceman that sometimes it is desirable to disconnect the TV service from guests who are playing their TV receivers too loudly or too late at night.

In conclusion, it may be said that Motel TV represents a new multi-million dollar market for TV receiver manufacturers, installers, and servicemen who will make it possible for the American family who "hits the road" in "51" to be assured of seeing its favorite programs from coast to coast.

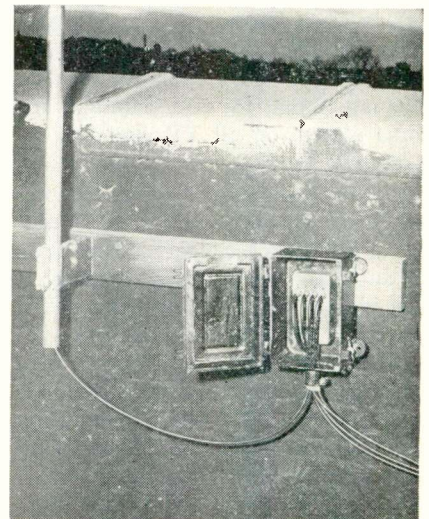

Fig. 7. Roof installation.

# JENSEN REPLACEMENT NEEDLE GUIDE

This guide has been reproduced by courtesy of Jensen Industries, Inc., 329 Wood St., Chicago 12, Illinois.  
Copies of this chart may be obtained at no cost from jobbers, or writing the manufacturer direct.

## S E R V I C E D E A L E R

CARTRIDGE MFG	JENSEN NEEDLE NO.	ILLUSTRATION (Actual Size)	CARTRIDGE NUMBERS	POINT MATERIAL	POINT SIZE
Athatic	Q-M		QT-M, QT2-M, QT3-M; LOD, LOD-1	Omnium	Standard
Athatic	A-80		QT-33-M, CQ-M; LOD, LOD-1	Omnium	Micro-Groove
Athatic	Q-33(M)		CO-AG-M; CQ-AG-J	Omnium	All Groove
Athatic	A-81		QT-1; QT2-J; QT3-J; LOD, LOD-1	Sapphire	Standard
Athatic	A-81-LP		QT-33-J; CQ-J; LOD, LOD-1	Sapphire	Micro-Groove
Athatic	D-33(M)		LT-3D; LT-4D; LT-4D1; ND	Omnium	Standard
Athatic	D-33(M)		LT-3D; LT-4; LT-4D; LT-4D1	Omnium	Micro-Groove
Athatic	D-AG(M)		LT-4-AG	Omnium	All Groove
Athatic	G-78(M)		CC-78-M; MG-78-M	Omnium	Standard
Athatic	A-84		CC-M; GC-1M; MG-1M	Omnium	Micro-Groove
Athatic	G-AG(M)		CC-AG-M; MG-AG-M	Omnium	All Groove
Athatic	T(M)		LT-1-M; LT-2M; LT-3M	Omnium	Standard
Athatic	T-33(M)		LT-33	Omnium	Micro-Groove
Athatic	C-3(M)		MD-3	Omnium	Standard
Athatic	C-1(M)		MD-1	Omnium	Micro-Groove
Athatic	U-78(M)		U-78-M	Omnium	Standard
Athatic	U(M)		UA	Omnium	Micro-Groove
Athatic	C-7(J)		MD-3	Sapphire	Standard
Athatic	C-1(J)		MD-1	Sapphire	Micro-Groove
Athatic	A-3(M)		AC-78; ACD Series	Omnium	Standard
Athatic	A-1(LP)		AC; AC-3(M); AC-3(M)	Omnium	Micro-Groove
Athatic	A-AG(M)		AC-AG-M; AC-AG-J	Omnium	All Groove
Athatic	Nylon 1-M		Nylon 1-J; Nylon 1-M	Omnium	Standard
Shure	A62A		P-30; P-37; P-70; P-72; P-74AD; P-76; P-77; P-79; P-85; P-88; P-89; P-94; PN-30; W-22A; W-61B; W-65B	Omnium	Standard
Shure	A-63MG		Admiral 409A(1); P-73; P-74AD; P-75V; P-76V	Omnium	Micro-Groove
Shure	A-66U		Admiral 409A(1.1); P-71; P-81; P-37	Omnium	Unipoint
Shure	A-61A		P-30; P-37; P-70; P-72; P-74AD; P-76; P-77; P-79; P-85; P-88; P-89; P-94; PN-30; W-22A; W-23A; W-60A	Sapphire	Standard
Shure	A-65MG		P-71; P-81; P-37	Sapphire	Micro-Groove
Shure	A-67U		P-71; P-81; P-37	Sapphire	Unipoint
RCA	7245		7033S; 7033P	Sapphire	Standard
RCA	7408		7408P	Sapphire	Micro-Groove
RCA	7504		7033S; 7033P	Omnium	Standard
RCA	7506		7408P	Omnium	Micro-Groove
RCA	39863		72551; 9890; 39919; 39550; 38998; 7033Z; 39851	Sapphire	Standard
RCA	38449		72551; 9890; 39919; 39550; 38998; 7033Z; 39851	Omnium	Standard
RCA	75497		75475	Sapphire	Standard
RCA	75496		75475	Sapphire	Micro-Groove
RCA	75497		75475	Omnium	Standard
RCA	75496		75475	Omnium	Micro-Groove
Electro-Voice	S-3		M12 S; M12 S-1; M12 S-2; S-4S; 22-S; 34S	Sapphire	Standard
Electro-Voice	S-1		101T; 221T	Sapphire	Micro-Groove
Electro-Voice	S-13		101T; 221T	Sapphire	Twin Point
Electro-Voice	O-13		101T; 221T	Omnium	Twin Point
Electro-Voice	O-3		M12; M12; L12	Omnium	Standard
Electro-Voice	O-1		14; 34;	Omnium	Micro-Groove
Electro-Voice	O-2		33; 33S	Omnium	All Purpose
Columbia	101		45-1609	Sapphire	Micro-Groove
Columbia	102 & 103		CQ	Sapphire	Micro-Groove
Webster-Electric	W-02		H-1	Omnium	Standard
Webster-Electric	F-14		F14; F14-1; F14-2; F14-3; F14-4	Omnium	Dual
Webster-Electric	A-35		A1; A8	Sapphire	Standard
Webster-Electric	A-15		A1; A2; A3; A4; A5; A6; A8	Sapphire	Micro-Groove
Webster-Electric	A-30		A1M; A1M-1; A3M; A6M	Omnium	Standard
Webster-Electric	A-10		A1M; A1M-1; A2M; A3M; A5M	Omnium	Micro-Groove
Webster-Electric	Q1		Q1	Omnium	Standard
Webster-Electric	G3		G3M	Omnium	Standard
Webster-Electric	G1		G3M; G3M-1	Omnium	Micro-Groove
Webster-Electric	W5		W5	Omnium	Standard
Webster-Electric	A7		A7A	Omnium	Micro-Groove
Webster-Electric	A9		A9A	Omnium	All Purpose
Webster-Electric	A7		Q3; A7; F13'	Omnium	All Purpose
Webster-Electric	C9		C9	Omnium	All Purpose
Webster-Electric	Q2		Q2	Omnium	Standard
Webster-Electric	F16-3		F16; F16-1; F16-2	Omnium	Standard
Webster-Electric	F16-1		F16; F16-1; F16-2	Omnium	Micro-Groove
Webster-Electric	F15-3		F15; F15-1	Omnium	Standard
Webster-Electric	F15-1		F15; F15-1	Omnium	Micro-Groove
Webster-Electric	F7		F7; F7-1; F7-2; Q2; F13	Omnium	Micro-Groove
Webster-Electric	JP-30		F10; F11; F11-1	Omnium	Standard
Webster-Electric	JP-30-LP		F10; F11; F11-1	Omnium	Micro-Groove
General Electric	RPJ-001		RPX-040; RPX-041; RPX-046	Sapphire	Standard
General Electric	RPJ-005		RPX-040; RPX-041; RPX-046	Sapphire	Micro-Groove
General Electric	RPJ-010		RPX-050	Sapphire	Dual
Philo	45-1396		Dynamic Reproducer 76-1022	Sapphire	Standard
Philo	45-1613		45-1609	Omnium	Micro-Groove
Philo	35-2693		76-4649	Omnium	Dual
Philo	45-1613		45-1609	Sapphire	Micro-Groove
Philo	45-1597		35-2671	Omnium	Standard
Philo	45-1631		35-2671	Sapphire	Standard
Webster-Chicago	NE-215		21P247; 21P402; 21P403	Omnium	Dual
Webster-Chicago	NE-316		21P404	Omnium	Dual
American Microphone	S-1		S-1; S-1A; S-2; S-2A	Omnium	Standard
American Microphone	CO-2		C-3	Omnium	Standard
American Microphone	CO-1		C-1	Omnium	Micro-Groove
American Microphone	CO-2		C-2	Omnium	All Purpose
Crosley	145720		145749	Sapphire	Standard
Naganoak	560102		560101	Omnium	Standard
Naganoak	560138		560133	Omnium	Twin Point

## R A D I O T V

# FRONT

by SAMUEL L. MARSHALL

In the first three articles in this discussed the input, r-f mixer, commercial types. In this install methods of band selection features are analyzed. In the next install given variable inductance and

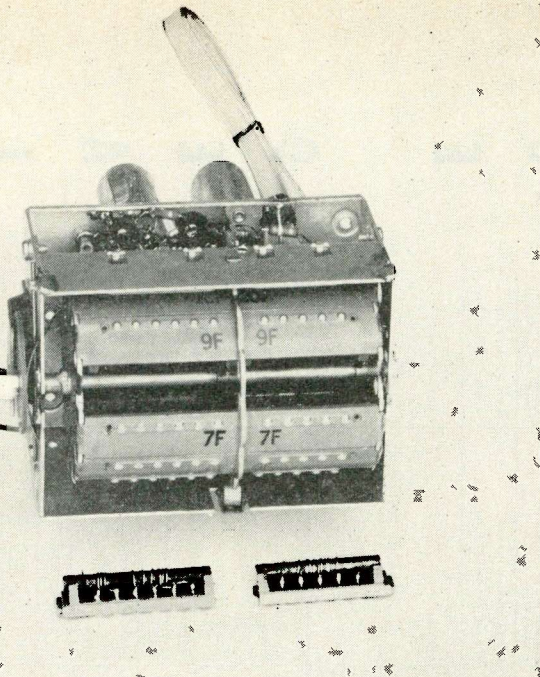

Fig. 3-31: Standard Tuner Model TV 101.

**H**AVING discussed the basic circuits employed in Front Ends we are now ready to analyze electrical and mechanical methods of band selection. Four basic types of electrical band selections are generally used. These are:

- 1) Individual coils for each channel and for each stage.
- 2) Tapped coils for each channel and for each stage.
- 3) A variable inductance for each stage.
- 4) A variable condenser for each stage.

### Individual Coils

A simplified circuit in which individual coils are used for each channel is shown in Fig. 3-30. Mechanically, the coils may be switched into the circuits by turret-tuning mechanisms of the types illustrated in Fig. 3-31, or by a rotary band-switch of the wafer type shown in Fig. 3-32.

Each oscillator coil is provided with an adjustment screw which permits alignment of the oscillator on each channel. Alignment of the antenna and r-f circuits is provided by trimmers (omitted for the sake of simplicity) which adjust the gain of the unit over the entire bandwidth. A fine tuning variable condenser, as shown, enables the operator to sharply tune the oscillator on any band, thereby providing for variations in frequency in the oscillator stage which might seriously affect the picture fidelity, or in the case of a split sound receiver result in a loss of sound.

One of the circuit variations in this type of tuner is the use of

fixed coils in the Channel 2 position shunted by individual coils for each

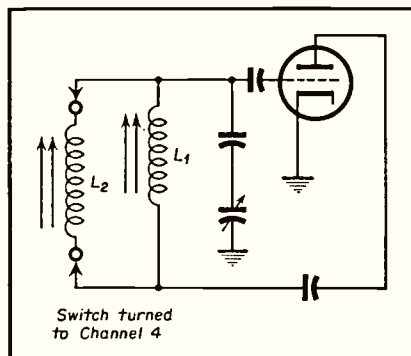

Fig. 3-33: Shunt coil switching.

of the succeeding channels from 3 to 13. Thus referring to Fig. 3-33,

which partially details the oscillator section of this type of tuner,  $L_1$  is the Channel 2 coil, and  $L_2$  can be any one of the eleven remaining coils between Channels 3 to 13. It might be pointed out that when two inductors are connected in parallel the resultant inductance of the combination is less than the value of the smallest inductor and the resonant frequency increases.

It is general practice to short-circuit out unused coils. Figure 3-34 illustrates a circuit detail showing this principle. When the shorting switch is in Channel 2 position all the remaining coils from Channel 3 to 13 are shorted out. As the switch is rotated in a clockwise direction each coil in turn is individually freed from the short-circuit.

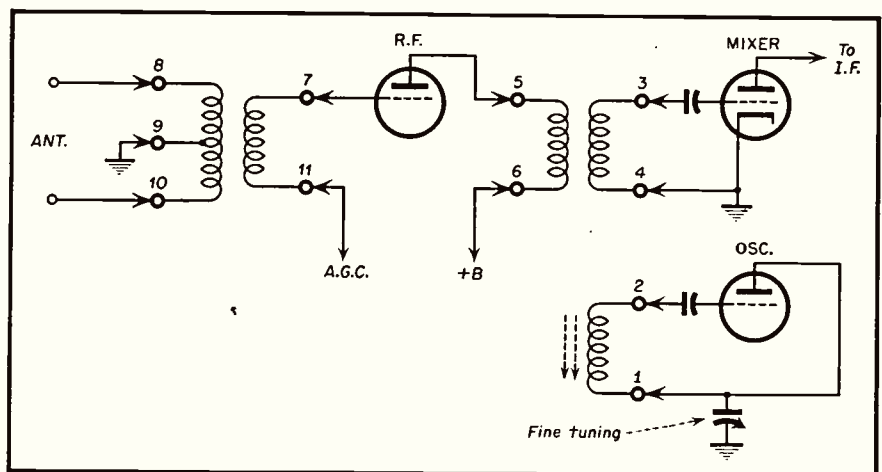

Fig. 3-30: Band selection details of circuit using individual coils and turret tuning for each channel. An example of this mechanism is the Standard Tuner Model TV 101 shown in Fig. 3-31 above.

# ENDS

## Part 4

series on Front Ends, the author and oscillator circuits of various ment the electrical and mechanical of individual and tapped coil tuners will be variable condenser type tuners.

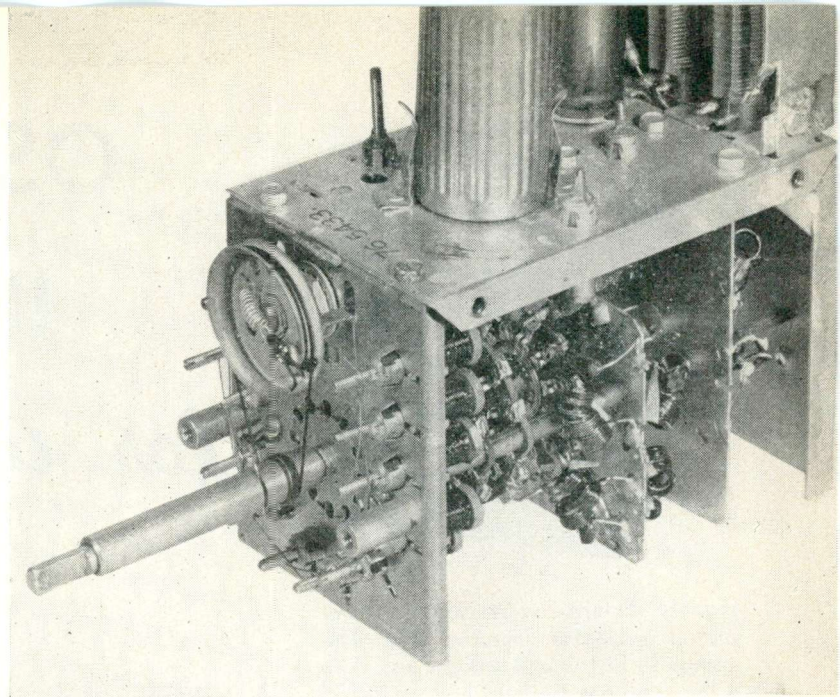

Fig. 3-32: Wafer type switching mechanism of Philco Tuner.

### Tapped Coils

A second method of band selection is the use of tapped coils. The partial schematic of a simplified circuit of this type is shown in Fig. 3-35. Starting with the first coil, which is tuned to Channel 13, additional coils are connected in series by means of the band-switch. As each new coil is added, the series combination determines the channel designation. Thus, as the bandswitch is rotated from Channel 13 to Channel 2, each higher band coil inductance is added to the succeeding lower band coil inductance to form the total inductance at the succeeding lower band channel.

Unused coils are usually short-circuited by an additional section

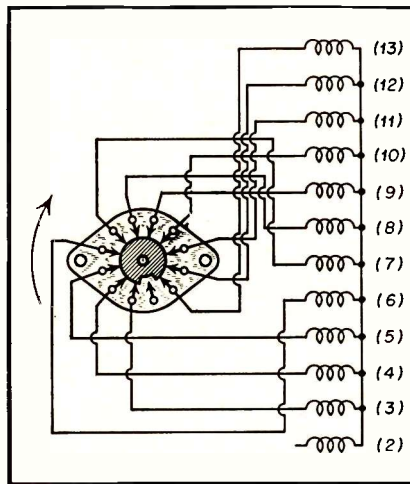

Fig. 3-34: Coil shorting switch.

on the wafer-type band-switch which

is universally used with tapped coil tuners.

Frequency alignment of these coils is usually effected by providing adjustable screw-type slugs for each coil in the oscillator circuit. Although individual coil adjustments are not provided in the antenna and r-f circuits, overall bandwidth adjustments are provided by either making some of the coils adjustable, or including auxiliary trimmers, or both.

In some receivers (G. E. 16T1) the oscillator inductances for Channels 12 through 7 are fixed. This tuner is illustrated in Fig. 3-36. Frequency control on these channels is obtained effectively by means of the fine tuning capacitor which is connected across the oscillator tank circuit.

Other receivers, such as the Magnavox in their type "S" tuner, utilize series tapped coils in the antenna and r-f stages, but in the oscillator stage make use of series tapped coils in the low frequency channels and individual coils in the high frequency channels.

Another type of tapped coil method of band selection used in the popular RCA 630 TS receiver is shown in simplified form in Fig. 3-37. The plate circuits of the r-f tube are connected to a parallel pair of series-taped inductors which may be considered as a one-quarter wave section of a balanced transmission line which is tuned from Channels 13 to 2 by moving a shorting bar along the switch contacts. The first coils in this series, which are adjustable, provide the correct line length for Chan-

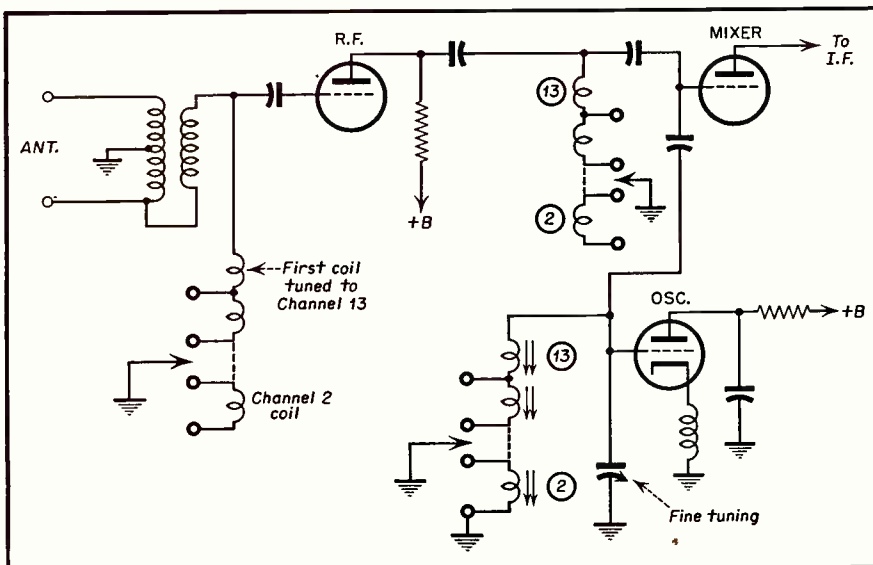

Fig. 3-35: Simplified circuit of series-coil switching.

[Continued on page 46]



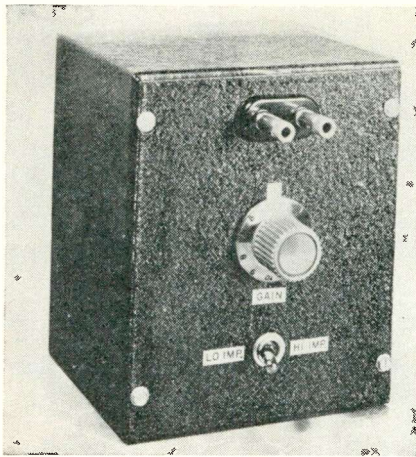

Fig. 1. External view of the completed oscillator injector unit. The complete instrument weighs less than 3 lbs., and can be held and operated comfortably in one hand. Its signal output is strong enough to operate a speaker well enough for test purposes.

# OSCILLATOR INJECTOR

## for Audio Servicing

by RUFUS P. TURNER

**A simple self-contained electromechanical oscillator of wide versatility which may be constructed quickly by the serviceman.**

**B**ULKY audio systems often must be given a quick dynamic check "on location" prior to rendering a work estimate and removing the setup, or parts of it, at the repair shop. But it is not always convenient to carry a variable-frequency audio oscillator to the location of a defective audio amplifier. Nor is a variable-frequency instrument necessarily needed for a quick test of this sort. A single-frequency signal source having good waveform, a frequency near the center of the audio spectrum, and reasonably high output amplitude will suffice for signal-injection testing of amplifiers, lines, filters, and loudspeakers.

The device described in this article was developed by the author to meet the demand for an easily portable, single-frequency audio signal injector. This instrument is extremely simple, since it is electromechanical in nature. It is tubeless and is powered by a single battery which, in normal usage, should give a year's service. The unit can be built in a couple of hours by any radio service technician possessing basic tools, and it is not expensive. This oscillator-injector gives a stable 1000-cycle signal with good waveform and with voltage and power sufficient even for checking a loudspeaker.

Because it is battery-operated and light in weight, the oscillator-injector may be carried and used easily in out-of-the-way places.

Aside from its intended use as a simple signal source in the spot testing of audio amplifiers, the unit may be employed as a modulator (for r-f signal generators and small transmitters), as a signal source for impedance bridges, in filter tests, line tests, and in any other application requiring an efficient single-frequency audio oscillator.

### Description

The heart of the oscillator-injector is a 1000-cycle microphone hummer (General Radio Type

572-B). This hummer consists essentially of a tuned, vibrating reed (actuated by a field coil) with a microphone button attached nearby for transducer action. This is the simplest type of tubeless, precision oscillator. Two output impedances are provided—10 and 300 ohms. The voltage output across the low impedance is 2.2 volts r. m. s., and is 13.5 volts r. m. s. across the high impedance.

A "dry cell"-type 6-volt battery (see Fig. 2) is employed to drive the hummer. Both the hummer

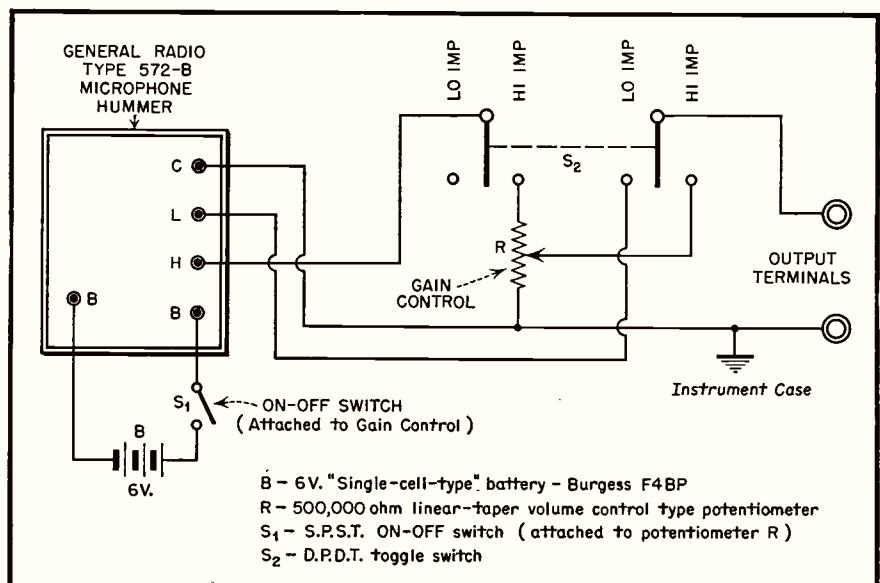

Fig. 3. Circuit diagram of the oscillator-injector showing connections to be made to microphone hummer.

and battery are shown in the photograph. The battery (Burgess F4BP) is no larger than a regular 1½-volt dry cell, its dimensions being only 2½" x 2½" x 4". Although the hummer is a laboratory-type device, it is not expensive.

The complete circuit diagram of the oscillator-injector is given in *Fig. 3*. Here, the ON-OFF switch  $S_1$ , is attached to the gain control,  $R$ . The d. p. d. t. switch,  $S_2$ , connects the two output terminals either to the low- or high-impedance terminals of the hummer. When  $S_2$  is thrown to its high-impedance position, gain control  $R$  is cut into the circuit automatically. The gain control ordinarily is not needed when using the low-impedance output and, for that reason, switch  $S_2$  has been arranged to cut it out of the circuit in the low-impedance position.

### Construction

The instrument is built into a standard metal "utility" box, 6 inches high, 5 inches wide, and 4 inches deep. *Figure 1* shows the external appearance of the completed instrument.

Internal assembly is simple. The hummer is held to one inner wall of the metal box by means of mounting screws supplied with the hummer. Rubber grommets are placed around the screws, between the heavy base of the hummer and the box wall, as shock mounts to prevent vibrations from being conveyed to the tuned reed. The battery is held to the opposite wall of the box by means of a thin metal bracket.

The front plate of the box (see *Fig. 1*) holds the output terminal posts, gain control, and impedance switch. The small dial attached to the gain control (National HRS-3) is graduated 0 to 10.

Insulated, flexible hookup wire is employed throughout in wiring of the instrument. It is not necessary to use shielded leads. The completely enclosed-in-metal construction provides adequate shielding of the instrument.

The completed oscillator-injector weighs a little under three pounds and can be held and operated comfortably in one hand. Undoubtedly, it could be made even lighter by employing four 1½-volt flashlight cells in series, in lieu of the larger 6-volt battery.

### Use of the Instrument

Since the instrument is battery-operated and tubeless, it is ready for instant operation. No warm-up time is required. The 1000-cycle

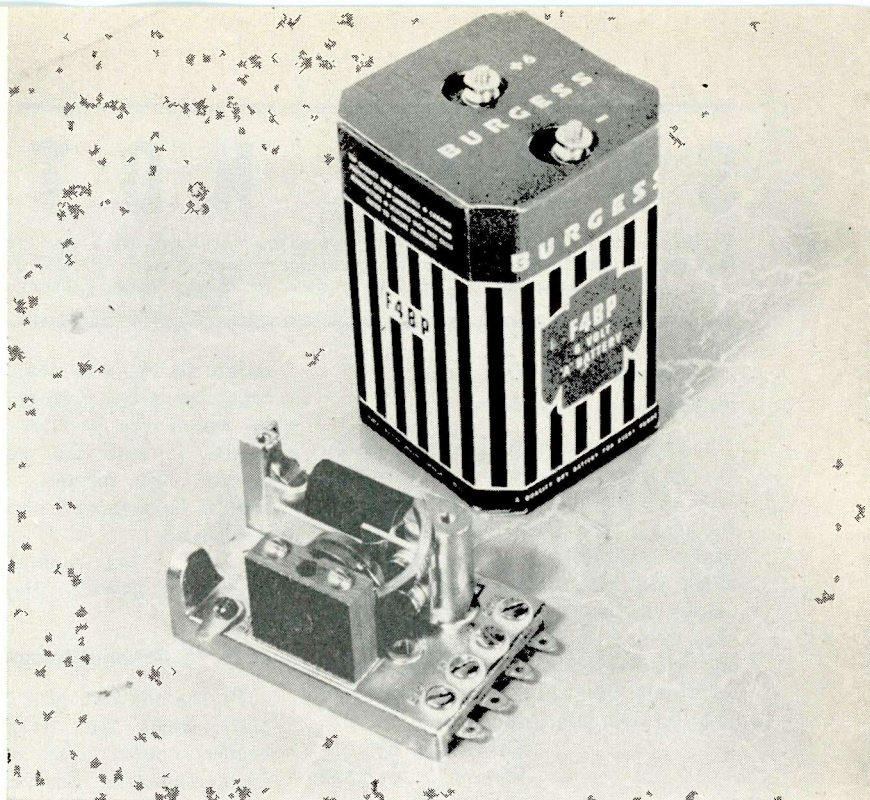

**Fig. 2. Essential components of the instrument. The little 1000 cycle microphone hummer and the accompanying "dry-cell-type" 6-volt battery are the heart of the instrument.**

signal is available as soon as switch  $S_1$  is closed.

When using the oscillator-injector, connect a pair of shielded test leads between the instrument's output terminals and the input of the amplifier under test. Switch  $S_2$  will be thrown to its high-impedance position for most tests. With the switch in this position, the gain control may be advanced through its entire range to give an output voltage continuously variable from zero to 13½ volts. A fixed output voltage of 2.2 v. is provided when switch  $S_2$  is in its low-impedance position. The actual voltage level at low impedance is very dependent upon the degree of impedance matching between the instrument and device under test.

Both the low- and high-impedance outputs are sufficiently strong to actuate a loudspeaker directly when the oscillator-injector signal voltage is applied to the voice coil. This is invaluable when the condition of a speaker must be ascertained apart from the associated amplifier.

When using the instrument as a signal injector in audio signal tracing, connect the grounded output terminal to the chassis of the amplifier under test. Connect a shielded test lead and shielded probe to the "high" terminal. By means of the probe, apply the signal successively to the control grid terminal of each tube working

backward through the amplifier from the output stage to the input. If d-c voltages are to be encountered, as when the signal is injected into plate circuits, connect a 0.1- or 0.25-uf., 600-volt capacitor between the "high" output terminal and the test lead, to protect the instrument from the d-c voltage.

By using a linear-taper potentiometer at  $R$ , the dial of this component will be reasonably direct-reading and may be used for approximate determinations of stage gain: Set the oscillator-injector gain control to give a satisfactory reference voltage at the output of the amplifier under test, when the signal is injected into a given stage. Transfer the signal probe to the grid of the succeeding tube and change the gain control setting to restore the reference voltage. The gain of the stage then will be approximately the ratio of the two corresponding settings of the gain control dial.

Make it a practice to switch-off the instrument immediately after using, in order to preserve the battery. Also, examine the battery at frequent intervals, in order to spot "juicing" which might easily ruin the hummer unit.

We believe this oscillator-injector unit will be most useful in a number of ways to the busy radio technician who needs a reliable, strong test signal easily obtained with a minimum of control.

# SHOP NOTES

Write up any "tricks-of-the-trade" in radio servicing that you have discovered. We pay from \$1 to \$5 for such previously unpublished "SHOP NOTES" found acceptable. Send your data to "Shop Notes Editor".

## Intermittent Operation With Microphonics In RCA 8-R-71

This has been caused in this model by the intermittent opening of the .005  $\mu\text{f}$  100 volt cathod by-pass condenser on the 6AU6 i-f amplifier. A caution should be observed in replacement. Cut the leads on the new condenser as short as possible, but be sure to mount it the same as the old one physically and across the same terminals, otherwise the set will probably be unstable and distorted.

Submitted by:  
Wayne E. Lemons  
Buffalo, Mo.

## Poor Brightness Control

In TV sets where the brightness control can't be adjusted to blank out the raster, the trouble often can be attributed to the CRT shorted from control grid to cathode. Nine out of ten times this short can be opened by "flashing" the tube.

This is done by removing the CRT socket, attaching the high-voltage lead to pin 2 (grid), and intermittently touching a grounded lead to pin 11 (cathode).

However, if the short won't open after five or six "flashings", concede that it's shorted hopelessly; since prolonged "flashing" will result in a burnt out high-voltage rectifier tube.

Submitted by:  
Paul Weiser  
Brooklyn, N. Y.

## Westinghouse Models H-198, H-199 And H-203—Oscillation and Poor Sensitivity on FM Band

In later production, a resistor was added and a capacitor deleted in order to minimize effects caused by production variances in 6AV6 tubes. The resistor (470,000 ohms,  $\frac{1}{4}$  watt) was inserted in the lead between terminal #2 of the 1st 455 kc. I-F transformer and the selector switch. The capacitor that was deleted had been connected between the AVC line and ground. This capacitor is shown as C38 on the Model H-198 schematic and as C37 on the Models H-199 and H-203 schematics.

In case of oscillation and poor sensitivity on the FM band, a check

should be made to determine that the capacitor is not present in any chassis in which the resistor has been inserted. If both the resistor and capacitor are present, the capacitor should be removed and the receiver re-aligned.

Westinghouse Elec. Corp.  
Service Dep't.

## G. E. Hi Channel Interference Trap

By the addition of a 1.5-15  $\mu\text{f}$ . trimmer (Stock No. RCY-002) to the head-end unit, high channel interference such as Channel #8 being on Channel #5 and Channel #10 on Channel #6 can be reduced considerably or eliminated. As shown dotted in the diagram below, the trimmer is connected between the low side of L3 and to ground. The rotor side of the trimmer should be connected to ground at the ground lance to which R1 and C1 are soldered.

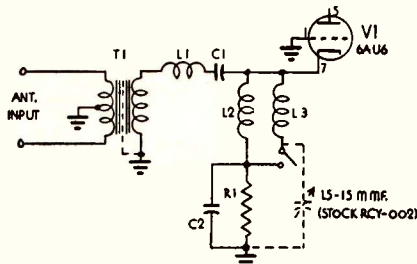

The channel selector switch S1 is open on low channel reception connecting the added trimmer in series with L3. This makes a series resonant circuit of these components which when properly adjusted will effectively reduce the subject interference. On high channel reception, the trimmer is switched in parallel with C2 (1500  $\mu\text{f}$ .), making the trap circuit inoperative so that it has no effect on the normal high channel operation.

**Adjustment:** With the receiver tuned to the low channel and the interfering high channel station operating, two minimum points of interference will be observed when turning the trimmer from the maximum capacity position. The 1st minimum indicates that the trap is tuned to attenuate the high channel fundamental and the 2nd minimum indicates that the trap is tuned to attenuate the 2nd harmonic of the local oscillator. The best point of adjustment for the least interference is the 2nd minimum

point or when the trap is tuned to the 2nd harmonic of the local oscillator. NOTE—The first minimum gives an attenuation of 45 db, while the second minimum gives approximately 83 db attenuation, making it very important to tune for the minimum interference at the lowest capacity setting of the trimmer.

General Elec. Co.  
Service Dep't.

## Admiral Models—Sync Buzz In Intercarrier Receivers

We have received some field reports indicating excessive sync buzz under certain operating conditions in intercarrier receivers.

Our investigations indicate that there are three causes for excessive sync buzz other than the conditions described in the trouble shooting chart on page 7 of Service Manual S286 under "Elimination of Audio Buzz": sync buzz due to misalignment of the sound IF, sync buzz due to modulation system used at the transmitter and residual sync buzz indicated by buzz being heard with the volume control set at a level below sound from the station.

After you have tried the suggestions in Service Manual S286 under "Elimination of Audio Buzz and buzz is still excessive, the following procedures should be followed.

### Sync Buzz Due to Misalignment:

In many instances, sync buzz may be eliminated by using a television station for alignment, in place of a 4.5 mc generator. The alignment should be made using the following procedure:

1. Tune in the station with loudest sync buzz.
2. Connect vacuum tube volt meter between test point Y and ground.
3. Adjust A5 and A6 for maximum reading.
4. Connect vacuum tube voltmeter between test point Z and ground, with scale set to zero center.
5. Adjust A7 for zero center reading.
6. Set sharp tuning control at the center position and adjust the channel oscillator slug for minimum sync buzz. The oscillator slug adjustment should be made over a wide range to be sure the minimum buzz position has been found.
7. Repeat step 6 for all other channels in your area.

[Continued on page 43]

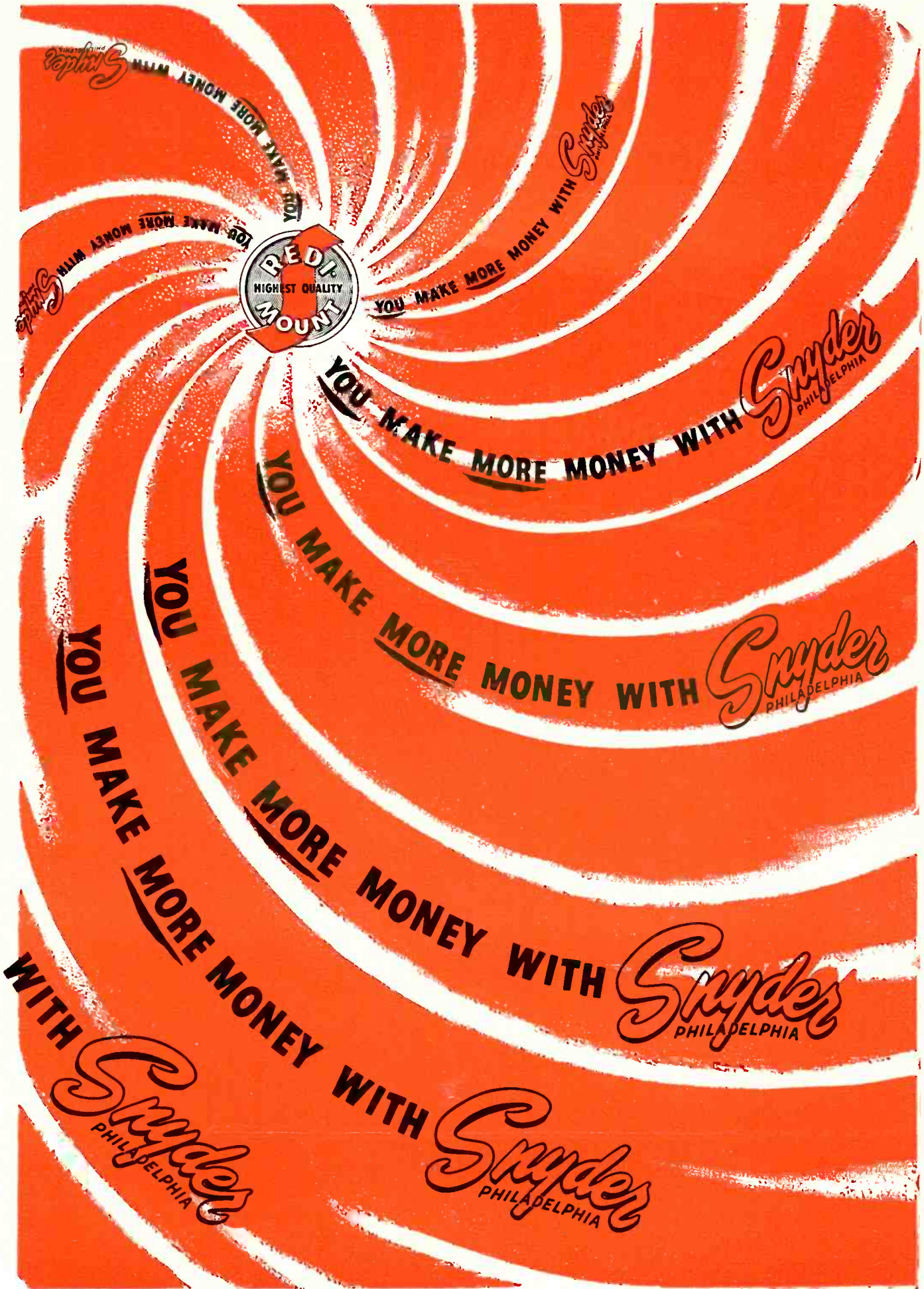

RED MOUNT  
HIGHEST QUALITY

YOU MAKE MORE MONEY WITH Snyder PHILADELPHIA

# CIRCUIT COURT

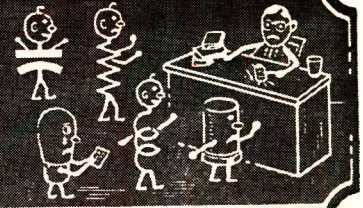

### Capehart 115P2, 413P, 414P

These elaborate AM-FM-SW instruments employ 28 or 29 tubes, the difference being due to a variation in the audio amplifiers. The tuner chassis, common to all models, terminates in ½ of a 6SN7 audio stage. The power chassis contains a 6J5 voltage amplifier, 6J5 phase splitter and a pair of 6J5 tubes. The output stage differs in the two types.

In the 115P2 version, the final stage uses two 6L6 tubes. A special output transformer has a winding which is so connected in the cathode circuits of the last 6J5 stage that sufficient negative feedback is developed to keep distortion at a low level. Reference to the partial schematic will show that self bias is developed by a 250 ohm resistor in each 6L6 cathode. Parasitic suppression is provided by a 2200 ohm resistor in each 6L6 grid lead.

In the models 413P and 414P, the output stage uses four type 2A3 tubes in push-pull-parallel. The use of these low-μ triodes makes feed-back unnecessary. The output transformer has only the usual plate and speaker windings. In order to obtain reasonably high power at low distortion levels, it is advisable to supply fixed bias to

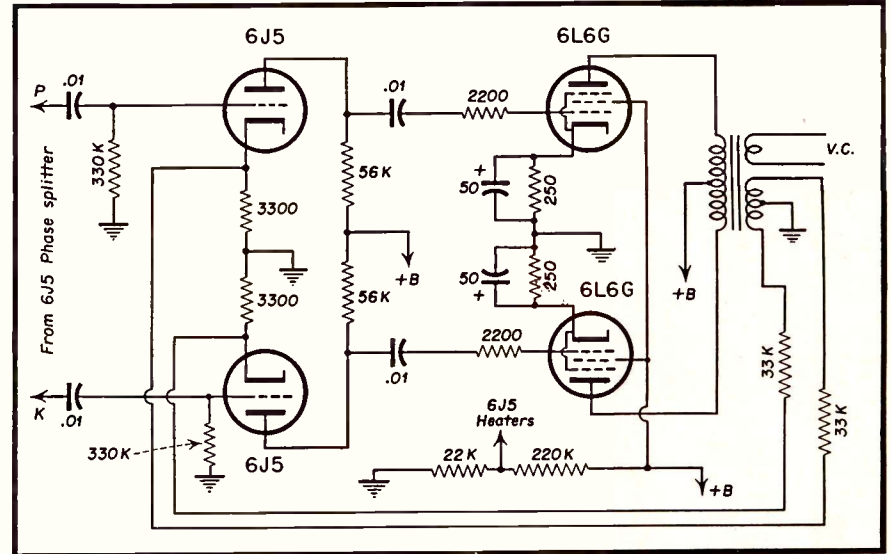

Capehart 115P2. Partial schematic of audio circuit.

these tubes. Optimum balance calls for separately adjustable bias for each pair of tubes.

Reference to the schematic shows how a bias supply consisting of a small power transformer, 5Y3 rectifier and associated filter system makes available the needed voltage. The in-

put transformer to the 2A3 stage has two secondaries, permitting adjustment of the grid voltage for each pair of tubes. The bias required is approximately 70 volts. Resistors of 510 ohms of tubes. The bias required is approximately 70 volts. Resistors of 510 ohms of tubes and prevent parasitic troubles. An adjustable potentiometer across the 2A3 filament winding permits some measure of hum balance.

Note that in both chassis the heater supply to the 6J5 stages is placed at a positive potential above ground by a voltage divider in the plate supply system. This provision is also useful in hum reduction. In both chassis a DC potentials.

### Admiral 6Q1

This a-c/d-c chassis has provision for reception of signals in both AM and FM broadcast bands. Six tubes and a disc-type rectifier are employed. An interesting circuit makes maximum use of the tubes.

A schematic of the circuits from antenna to the dual-frequency i-f stage is shown. The conventional 455 kc and 10 mc i-f values are used.

Reference to the diagram will show that ½ of a 12AT7 tube performs as a tuned mixer on the FM band. A coil and one section of the tuning gang

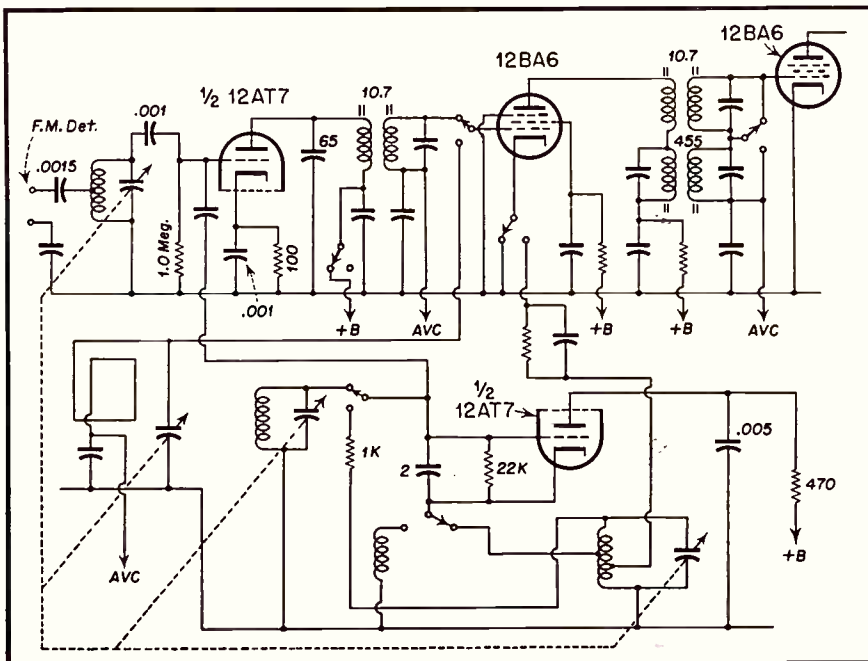

Admiral 6Q1. Partial schematic of r-f and i-f stages.

resonate the antenna circuit, the antenna being connected to a tap on the coil. Cathode bias is developed across a by-passed 100 ohm resistor. Additional bias is built up as a result of rectification of the injected oscillator voltage.

The other half of the 12AT7 is connected as a grounded-slate oscillator. The grid and cathode are switched to appropriate coils for the two ranges. Capacity coupling between oscillator and mixer grids takes place on the FM band.

The next tube in the circuit is a 12BA6 pentode. The grid of this tube is switched to the output of a 10.7 mc transformer in the mixer plate for FM. During AM operation, the grid is switched to the loop antenna. The 12BA6 becomes a mixer, and the cathode returns to ground through a portion of the oscillator coil. Thus, injection is provided. During AM operation the plate voltage is removed from the FM mixer.

## TRADE FLASHES

[from page 6]

A mobile communications market in 1955 approximately double its present size. FCC records today show 320,000 non-broadcast transmitters now in operation, consisting of 100 thousand land or fixed stations and 220 thousand portable or mobile stations, and including police, taxi, utility, aeronautical, industrial, marine, and other types of radio.

Radio amateurs totaling 150,000 by 1955—up from 84,000 in 1950.

Expansion of the broadcast market to 1000 television transmitters on the air by 1955, as against 106 in operation today. Wayne Coy, chairman of the FCC, has estimated, Mr. Bersche said, that there will be more than 1000 TV stations on the air in six or seven years. This is in addition to AM and FM radio stations which today number 3000. The renewal potential of the television broadcast market alone is indicated by the fact that 100 television stations in 1949 spent three million dollars for tubes and parts in that one year. This figure does not include renewal expenditures of the AM-FM broadcasters.

A vast expansion of the industrial electronics market, which, according to Mr. Bersche, offers a potential as great as all other electronics markets combined. Basis for this prediction is the inevitability of a new industrial revolution in which electronic devices

[Continued on page 39]

# Experts choose JACKSON TV instruments for important jobs

IN PRODUCTION WORK AT STEWART-WARNER



Shown in this typical production scene at Stewart-Warner are some of the Jackson Oscilloscopes used in checking television receivers. Used in various stages of production, these Jackson 'scopes are depended

upon to maintain Stewart-Warner's high production standards. This is only one example of how Jackson's outstanding oscilloscope is used for important jobs in industry, too. Also, many other applications.



Provides both wide band width and high sensitivity in one instrument. Band-width relatively flat to 4.5 megacycles, so necessary for accurate TV production and service work. Sensitivity of vertical amplifier is .018 RMS volts-per inch to assure accurate picture on very small test voltages. Has big 5" CR tube, Z-Axis input, many other important features.

IN TEACHING AT DEFOREST'S TRAINING, INCORPORATED

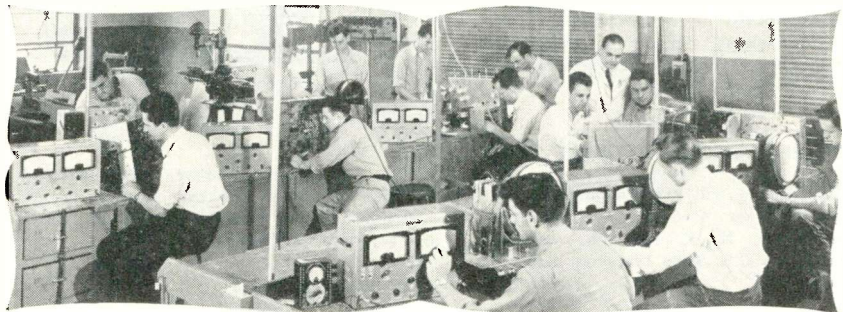

At this famous electronics school, named for the inventor of the vacuum tube, the Jackson Television Sweep Generators are used to instruct future technicians in the proper method of aligning television and other high frequency

equipment. Shown here are some of the generators used by Deforest's in this important work. Jackson equipment was chosen for its ability to provide accurate results, even under the hard usage encountered in teaching.



Includes both Sweep and Marker Generators in one instrument. Electro-mechanical sweep variable from 100KC to over 12 MC. Crystal calibrator circuit provided for external crystal. Generator covers full FM and TV bands. Instrument is same height as oscilloscope for compact service bench installation. Marker Generator has 400 cycle Audio Generator. Scope timing voltage provided.

Trust the Experts' Judgment . . . Choose JACKSON

See your distributor — or write

**JACKSON ELECTRICAL INSTRUMENT COMPANY**  
Dayton 1, Ohio

# NEW PRODUCTS

Three new miniature tubes—5915, 5963, and 5964—have just been made available to industrial equipment designers for reliable performance in “on-off” control applications, such as electronic computers, involving long periods of operation under cutoff conditions.

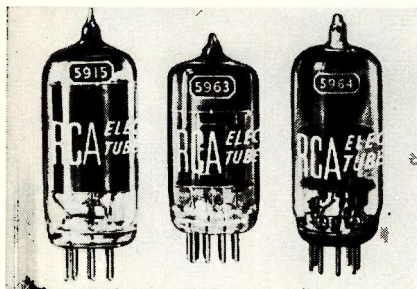

The 5915 is a pentagrid amplifier of the 7-pin miniature type designed especially for gated-amplifier service. Grids No. 1 and No. 3 can each be used as independent control electrodes.

The 5963 is a medium-mu twin triode of the 9-pin miniature type intended particularly for frequency-divider circuits. It has a mid-tapped heater to permit operation from either a 6.3-volt or 12.6-volt supply, and separate terminals for each cathode to provide flexibility of circuit arrangement. The 5963 has a maximum plate dissipation of 2.5 watts.

The 5964 is a medium mu twin triode of the 7-pin miniature type for use in frequency-divider circuits. Its cathode is common to the two triode units. The 5964 has a maximum plate dissipation of 1.5 watts.

These three types are not intended for applications critical as to microphonics, nor are they, in general, superior to other types for conventional amplifier or converter service in which they might be used.

## 17-INCH RECTANGULAR TUBE

General Electric will start making 17-inch rectangular picture tubes at its Buffalo and Syracuse plants, E. F. Peterson, manager of sales for the G.E. Tube Divisions here has announced.



This tube is the third rectangular type to be made by the company. The others are the 14-inch glass and 16-inch glass.

The new tube (17BP4-A) has a neutral-density faceplate and is a magnetic-focus-and-

deflection tube. It features an electron gun designed to be used with an external, single-field ion-trap magnet for the prevention of ion-spot blemish. An external conductive coating serves as a filter capacitor when grounded.

Heater voltage of the 17BP4-A is 6.3 volts and the heater current is 0.6 ampere plus or minus 10 per cent.

Further information on the 17BP4-A may be obtained from the Tube Divisions, General Electric Co., Schenectady, N. Y.

## CAPACITY BRIDGE

The new Bakelite-encased capacity bridge Model 381 which the Simpson Electric Company of Chicago has just released to the market, is entirely new in engineering, design and compactness.

Model 381 measures a mere 3½ x 5½ x 2½ inches. Actual weight of this condenser tester is 1¼ pounds. The small size with its unusually wide range capacity makes it adaptable to all types of service where condensers are tested.

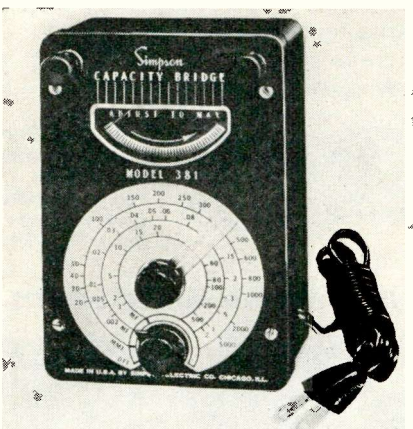

This new condenser tester has a patented circuit which allows for three capacity ranges - 20 mmfd to 500 mmfd, .005 mfd to 2 mfd and 1 mfd to 500 mfd.

## NEW WARD YAGI

The newest Ward TV antenna is a Yagi. Based on the interlinking folded dipole principle, this model is designed to provide exceptional performance in fringe areas. A built-in

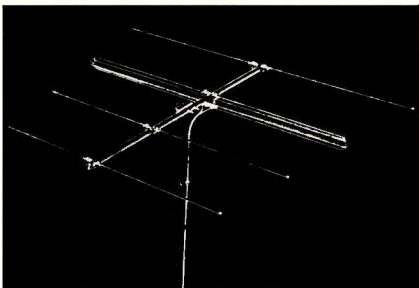

impedance transformer steps up impedance. Its narrow beam width permits maximum energy pickup, and pinpoint directivity with a very high front to back ratio eliminates co-channel interference. Being sharply tuned, a model is

supplied for each TV channel. Stacking kits for stacking either high band or low band arrays are available. Ward Yagis are factory preassembled, ready to unfold and install. For further details write Ward Products Corp., Cleveland, Ohio.

## NEW TV AND FM BOOSTERS

The development of two new television and FM boosters models BT-1 and BT-2 by The Astatic Corporation brings to a total of four the number of models now being produced by this Conneaut, Ohio, company.

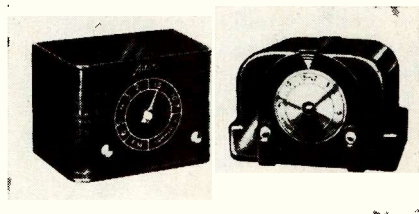

Both of the new units employ the Mallory Inductuner for continuous variable tuning, by a single tuning knob, through both TV and FM bands. Exceptionally high gain is afforded, very uniform through both high and low channels, according to a company spokesman. Band width is declared adequate over the entire range.

The BT-1 (left) is encased in a metal cabinet of the simplest possible design so that it will not clash with any style of TV receiver cabinet. It has a rich mahogany woodgrain finish with gold dial facing and numerals.

The Model BT-2 (right) is distinctly modern in dark brown plastic cabinet. The entire dial face revolves below a fixed pointer in tuning and is extra large for easy visibility. Dial and numerals are harmonizing gold and green. Slightly higher priced than the BT-1, the Model BT-2 has a recessed pilot light to show whether booster is on or off.

## NEW L-PAD

Clarostat Mfg. Co., Inc., Dover, New Hampshire, manufacturers of resistance devices, announce a new addition to their L-Pad line. The new L-Pad has been designed

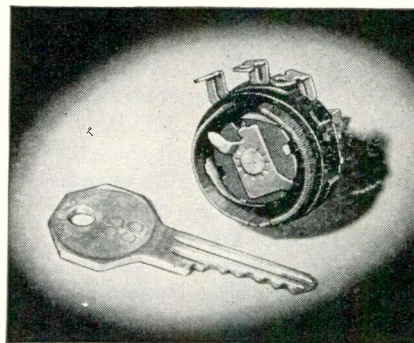

for special application work where dependability and cost are prime requisites.

The new Clarostat Type No. CM8727, 8 ohm L-Pad is a single unit with two separate wire windings for maintaining constant impedance. It was designed primarily for use in outdoor drive-in theatres and other P.A. uses. Its compactness of size, identical to Clarostat's Type 43 control, 1½ dia. by 9/16" deep, its low cost, and its rugged construction are some of the numerous advantages offered in this control. Available upon special order within impedance ranges from 6 to 300 ohms. Rotation of the control is 120°.

### NEW ASTATIC CARDIOID MIKE

Astatic Corporation, Conneaut, Ohio announce the Synabar Model DR-10 unidirectional cardioid crystal type microphone which features use of a special sintered metal to cancel out 15 db front to back, making the unit dead to sound from the rear.



Of rugged construction, advanced design, the unit has a range from 50 to 10,000 cycles per second. A selector switch allows choice of characteristics for crisp voice, general voice or music. Synabar has an output level of — 54 db. Finish is satin chrome. The crystal is sealed against climatic conditions.

### NEW TUNER

Mechanically and electrically designed for ready replacement of switch-type TV tuners, the new DuMont Series T3A Inputuner provides reception of FM as well as TV channels at a new low in cost. This continuous tuner has performance superior to that provided by previous DuMont Inputuners and is available to both jobbers and set manufacturers, from the Electronic Parts Division, Allen B. DuMont Laboratories, Inc., East Paterson, N. J.

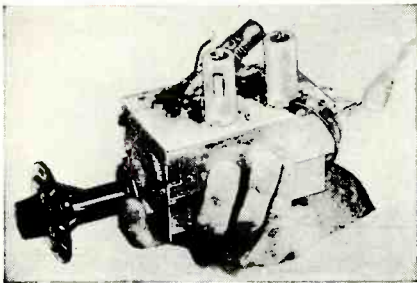

The series T3A Inputuner employs the Mallory-Ware three-section spiral inductuner plus antenna tuning. This combination provides excellent sensitivity and selectivity. The space required is identical with that of most leading switch-type tuners. Standard mounting holes further facilitate interchangeability. Electrically the new Inputuner is designed to work into the i-f system of TV receivers using a separate sound i.f. It is available with variations in the mixer plate network, making it adaptable without alteration to the

# CLEARER PICTURES

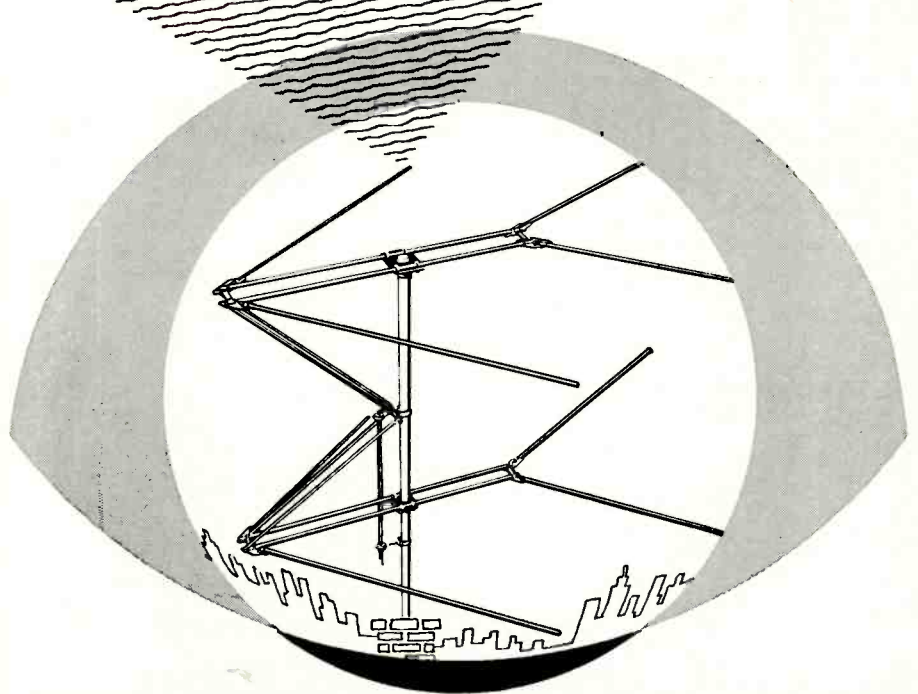

# WORKSHOP

## DUBL - VEE TV ANTENNA

PATENT PENDING

By applying the proven "end-fire" principle to TV antennas the WORKSHOP DUBL-VEE set the pace for 1950. Its quick acceptance — over 80,000 installed in three short months — is a testimonial to WORKSHOP'S acknowledged leadership in antenna design and engineering.

The DUBL-VEE is typical of WORKSHOP antennas in other fields — commercial, amateur and aircraft. In every instance, advanced engineering and outstanding performance have established ready acceptance. You know when you specify the DUBL-VEE, or any other WORKSHOP antenna, that you are getting the best.

Write for Bulletin E



## THE WORKSHOP ASSOCIATES, Inc.

135 CRESCENT ROAD, NEEDHAM 94, MASSACHUSETTS



i-f system of other separate sound i-f television receivers.

The series T3A provides greater gain than any previous DuMont Inputuner, with particular emphasis on improved high band performance. Input impedance is 300 ohms. The inclusion of the sound trap with the tuner is optional as well as the choice of either 21.25 or 21.75 mc sound center i.f. The tuner has low oscillator radiation and low noise figure. It comes complete with tubes (6BC5 r.f. tube and 6J6 mixer-oscillator), TV-FM scales and mixer plate network. The new DuMont Inputuner will be used by many leading manufacturers of separate sound i-f receivers during the coming fall season.

### DUAL-CONCENTRIC CONTROL

To fill the ever increasing TV demand for different control combination Clarostat Mfg. Co., Inc., Dover, New Hampshire, manufacturers of resistors and controls, now offers a combination wire-wound and carbon control.

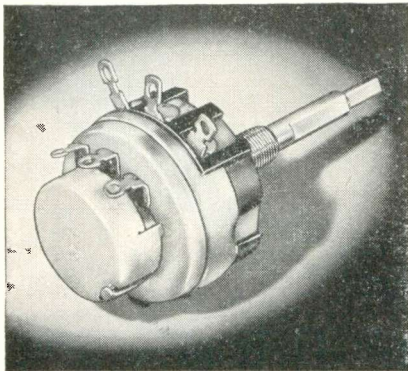

The front control is of the wire-wound type used for focusing circuits and other higher electrical value circuits. The rear control is the carbon control and may be had in practically any value for various circuits controls using this type. The concentric shafts have been so designed as to facilitate easy, independent control in either circuit.

### TV REPLACEMENT BALLASTS

JFD air-cooled TV Ballast Tubes are finding growing use as replacements in hundreds of TV sets, announced the JFD Manufacturing Co., Inc. of Brooklyn, New York.



Seventeen different models help withstand possible overloads in many types of Emerson, Motorola, Telelone, Belmont, Stewart-Warner, Pilot and Electromatic Television receivers. Employed as original components by TV set

manufacturers, the JFD TV ballast has developed into an important and profitable replacement part in the servicing field.

Further information and literature are available direct from the manufacturer, its representatives and distributors.

### HEARING AID

Telex, Inc., Telex Park, Minneapolis 1, Minnesota, announces the new Telex 300 hearing aid. New to the hearing aid industry is



the tube-shaped construction of the 300 which makes the instrument as easy to carry as a pen or pencil. Ultra miniature tubes, tiny printed circuits and miniature batteries are matched resulting in a one-piece hearing aid, a fraction over five inches long and a half inch in diameter, weighing just two and a half ounces.

The 12K gold case of the Telex 300 is silver lined and features a microphone concealed in the clothing clip.

### NEW BENT GUN

Uniform focus over the entire usable screen area is now attained by means of the new DuMont Bent-Gun announced by the Cathode-ray Tube Division of the Allen B. DuMont Laboratories, Inc., 750 Bloomfield Ave., Clifton, N. J.

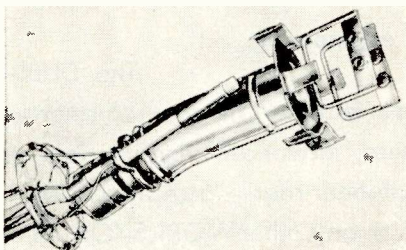

A higher degree of pre-focusing in the new DuMont Bent-Gun passes a smaller diameter beam bundle through the deflection field. This reduces spot distortion and results in uniform focus over the entire usable screen area for pleasingly sharp pictures.

A new grid-cathode assembly makes it possible to obtain this greater pre-focusing without increasing the overall length of the tube. An improved bulb spacer simplifies electron-gun centering and insures proper anode contact. Stray emission at higher voltages is minimized by rounding the corners of pertinent electron-gun components.

These latest developments, which retain the advantage of employing a single beam-bending magnet, are being incorporated in all DuMont Teletrons.

### 3 INCH SPEAKER

A tiny three-inch radio speaker similar to those used in the smallest portable sets, supports a 307 pound man. The manufacturers of



Utah Radio Speakers back up their claims of strong construction with this graphic demonstration. In his hand, the man holds an identical speaker.

### AUTO RADIO ANTENNA

The new "Quick-Mount" Auto Radio Antenna is engineered for simple, easy installation. It is mounted from the top, on cowl or fender, by only one man, in five minutes. There is no need to get under the car. No special tools are required.

The simple installation procedure is as follows:

1. Locate position desired on cowl or fender and mark with center punch.
2. Bore  $\frac{3}{8}$ " hole through sheet metal.
3. Slide antenna lead with attached Base Mount through the hole.
4. Move Base Mount arms to horizontal position so that they both contact undersides of cowl or fender.

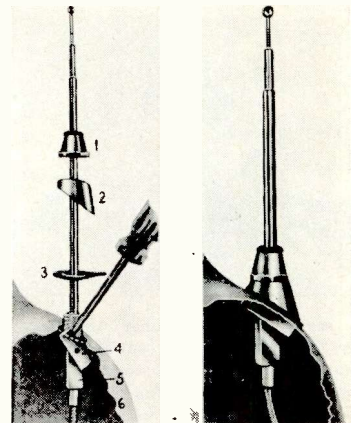

5. Then simply slide Lock Nut all the way down and tighten.

For further information, write to the manufacturer: Belnord And Co., 474 Sterling Place, Brooklyn, N. Y.

## TRADE FLASHES

[from page 35]

will meet the demand for increased efficiency on the production lines of the near future.

Noting that the "common denominator of all electronic progress is the electron tube," the RCA Renewal Sales Manager said that sales of renewal receiving tubes alone will jump from a total of 60 million sold by the end of this year to a sales volume of 150 million by 1955. By 1955, he said, there will be an overall total of 1,700,000,000 active receiving-tube sockets, which, together with associated parts and products, represents a billion dollar market for the renewal products of the electronics distributor.

### Jensen Knighted

Peter L. Jensen, president of Jensen Industries, Inc., Chicago, received the Order of Knight of the Flag from King Frederick on his recent trip to Denmark. Mr. Jensen was recognized for his contribution to the field of radio.

Mr. Jensen, the first person ever to speak over a radio, invented the dynamic loud speaker, the public address system, and the electric phonograph, as well as many other inventions in the electronic field. He is also the founder of the Magnavox Company and the Jensen Manufacturing Company, and is now president of Jensen Industries, Inc., phonograph needle manufacturers.

### Tung-Sol Introduces New Tube

A new beam power amplifier embodying all the important improvements in electron tube design has been announced by the Tung-Sol Lamp works of Newark, N. J. This tube, designated 5881 is designed to operate in circuits for which the 6L6 is specified and is completely interchangeable wherever the 6L6 is now in use.

### Capehart Movies on TV Made Available

Two new Hollywood-type movies, one on TV salesmanship, the other on TV installation, were given their world premier this week by the sponsors, the Capehart-Farnsworth Corporation of Ft. Wayne Indiana, a division of International Telephone And Telegraph Corporation.

According to Stanley A. Morrow, Director of Advertising, the two pictures, produced primarily for use by

**NEW IMPROVED FARM PACK** Offers **MORE VALUE** for **MORE SALES**

FOR ALL POPULAR FARM RADIOS with 4-Hole Socket

BIG SUPER 'A' and BIG SUPER 'B' UNITS

2550

1 1/2 VOLT 'A' 90 VOLT 'B'

# BURGESS GIANT ECONOPAK



### CHECK THESE ADVANTAGES:

- ★ IT'S BIG... 12 x 8 1/2 x 7"
- ★ IT'S HEAVY... 34 pounds.
- ★ IT'S POWERFUL... due to highest quality raw materials.
- ★ IT'S CHROME PROTECTED... for reliable, longer life.
- ★ IT'S QUALITY CONSTRUCTED... husky carton, carefully soldered connections, and only high test cells are used.
- ★ IT'S LONG LASTING... twice the life of ordinary batteries.
- ★ IT'S GUARANTEED... for complete satisfaction.

### Exclusive Construction Doubles Battery Life!!

Increase your farm pack profits with the all-new, giant-sized Burgess Econopak! The only battery of its kind in America gives you seven tremendous sales advantages!

The Burgess Giant Econopak can be used in place of any four-hole "1 1/2A and 90B" pack—and its exclusive new Chrome Protected construction assures double life for steady, repeat sales.

Check—compare—and you'll know why the Burgess Giant Econopak is the undisputed leader in farm pack batteries!

ORDER FROM YOUR BURGESS DISTRIBUTOR



# BURGESS BATTERIES

Capehart distributors and dealers, are designed to stimulate sales and service practices through-out the industry.

Both pictures are available on a loan basis without charge from Capehart-Farnsworth Corporation, Ft. Wayne, Indiana or any Capehart regional manager or distributor. Mr. Morrow emphasized that Capehart is anxious that all retail TV receiver salesmen and dealer's service people are welcome to see and use both pictures for the good of the industry as a whole.

#### Howard E. Anthony Receives Doctorate Degree

The Board of Trustees of the University of Hollywood have awarded an Honorary Doctorate Degree of Doctor of Science in Electronics to Mr. Howard E. Anthony, President of the Heath Manufacturing Company of Benton Harbor, Michigan.

This honor and recognition was conferred upon Mr. Howard E. Anthony in recognition of the valuable contributions that Mr. Howard E. Anthony has made to the industrial electronics field.

#### Cogan Forecasts TV Allocations

D. H. Cogan, President of Air King Products Company, Inc., Brooklyn, New York, manufacturers of television receivers, radios and wire recorders announced that with production at the highest peak in the history of Air King Products, it has become necessary to allocate television receivers and radio. Distributor showings across the country have sold the expanded capacity of Air King Products for the balance of the year.

Mr. Cogan further stated Air King had been so well received nationally because of a new and improved chassis and the excellent design and cabinetry.

#### FRSAP Holds Clambake

Shown below is a picture of the group which attended the 4th annual Clambake and the July meeting of the Federation of Radio Servicemen's Association of Pennsylvania on Sunday July 23rd, 1950 at Lily Lake, Pa.



Delegates were present from Scranton, Wilkes-Barre, Philadelphia, Reading, Harrisburg and Altoona.

Officers of the State Federation are: Dave Krantz, President, Philadelphia, seated fourth from left. John G. Rader, Sec'y Treasurer, Reading, seated fifth from left. Leon Helk, Corresponding Sec'y, Carbondale, rear row, second from left with hat.

#### Rider Announces New Books

Two new books have been announced by John F. Rider, Publisher, Inc., 480 Canal St., N. Y. These are the "Encyclopedia on Cathode-Ray Oscilloscopes and Their Uses", and Rider's TV Manual Volume 5.

The Encyclopedia is divided into four categories: theory and operation of cathode-ray tube and oscilloscopes, which discusses mechanical characteristics, screens, spots displacement, linear time bases, the basic oscilloscope and its modifications, etc.; an applications section which deals with measurements, alignment, transmitter

# TV's T-formation



New smooth action! New thrilling performance! Greater all-round team effectiveness for football gridirons and television receivers with the T-formation — Thomas Tubes.

Banish the galloping ghosts and put your receivers in the clear for consistent gains in popularity and sales. Try television's famous T-formation—and we do mean Thomas! There are no finer television picture tubes.

**THOMAS ELECTRONICS, Inc.**

118 Ninth Street

Passaic, New Jersey



testing, audio and television testing by waveforms, etc.; commercial oscilloscopes and related equipment is the third phase, and in it the schematics and circuit descriptions of the 'scopes produced during the past ten years by such manufacturers as Dumont, RCA, General Electric, Hickok, Philco, Sylvania, Supreme, etc., are described; the final section is a comprehensive compilation of 1600 complex waveform patterns listing the harmonics and the exact phase and amplitude of each waveform—such information has before been published. Three appendixes, the characteristics of cathode-ray tubes, RTMA cathode-ray bases, and photography, round out the contents of the book.

TV Manual Volume 5, taking up where TV 4 leaves off, offers complete factory-authorized servicing data from 74 manufacturers for the period March through July 1950. This big 12 X 15 inches manual has all pages filed in proper place so that it is ready for immediate bench use. The latest volume contains 614 models and 250 chassis in the equivalent of 2,230 pages (8½ x 11). A cumulative index for Rider TV Manual Volumes 1 through 5 is also included, to make any material instantly accessible.

#### New Sylvania Products Intrigue Servicemen

Two new products just announced by Sylvania are arousing considerable interest in the TV servicing field. The first is a new 7-inch 'scope, and the second is a TV picture tube test adapter.

The 'scope characteristics include a vertical deflection amplifier which provides a sensitivity of .1 volt rms for a one inch peak-to-peak deflection; sine wave frequency response at full gain flat within 3 db of 1000 cycles value from 7 to 70,000 cycles free of peaking and useable to much higher frequencies; and an input impedance of 1/2 megohm and 34 mmf.

The horizontal amplifier provides a sensitivity of at least .25 volt rms for one inch peak-to-peak deflection; sine wave frequency response within 4db from 7 to 120,000 cycles; a total deflection of at least 8½ inches with negligible distortion; and input impedance of ½ megohm and 34 mmf.

Horizontal sweep characteristics include: linear (multi-vibrator) saw-tooth sweep, left right, from 10 to 30,000 cycles; non-linearity not exceeding 10% between rated limits at any sweep frequency; and response to positive synchronizing signals.

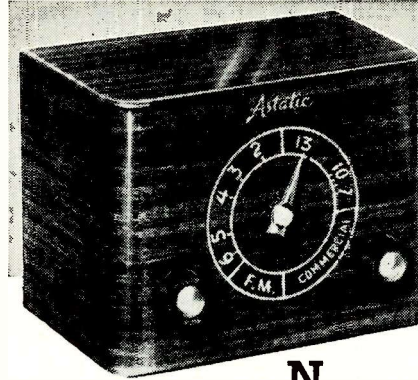

**ASTATIC BOOSTER  
MODEL BT-1  
LIST PRICE \$29.95**

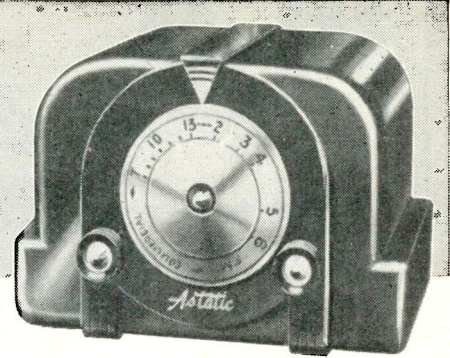

**ASTATIC BOOSTER  
MODEL BT-2  
LIST PRICE \$32.50**

**N**EVER BEFORE such quality features in a low-priced booster. Choice of conventional styling in a metal cabinet with rich mahogany woodgrain finish or modern design in dark brown plastic. Simplified controls—single tuning knob with continuous tuning through both TV and FM bands.

## ASTATIC LEADS



**ASTATIC BOOSTER  
MODEL AT-1  
LIST PRICE \$49.50**

**A**STATIC four-tube deluxe models—no other booster can do so much in improving TV picture contrast and clarity, in improving sound, in eliminating interference. Feature exclusive variable gain control and dual-tuning. Model AT-1 in fine furniture finish mahogany, model AT-1B in blond wood cabinet.

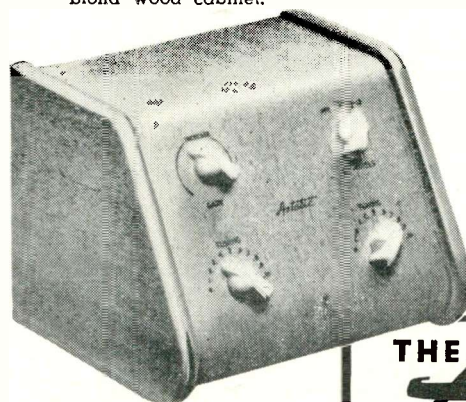

**ASTATIC BOOSTER  
MODEL AT-1B  
LIST PRICE \$51.50**

### THE TV AND FM BOOSTER FIELD IN THESE THREE IMPORTANT WAYS

**1**

**COMPLETE LINE**—Four models from which to choose, with variety of handsome cabinet styling.

**2**

**UNEQUALLED PERFORMANCE**—Astatic engineering leadership assures superior booster performance... unequalled improvement of TV and FM reception.

**3**

**WIDEST PRICE RANGE**—A price to fit every purse, assuring top volume sales.

Write for New, Full-Color Folder giving Complete Details on Astatic Boosters

**THE Astatic CORPORATION**  
 CONNEAUT, OHIO  
 IN CANADA: CANADIAN ASTATIC LTD., TORONTO, ONTARIO

# Hi-Q

## Ceramic Capacitors

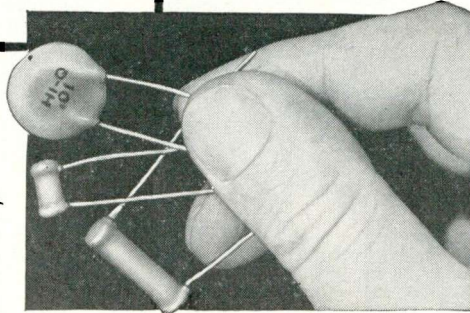

● For the best in ceramic capacitors, it's the well-known Hi-Q line now available through your Aerovox jobber. You can buy one or more units of any kind at any time. Available in several types—disc, tubular, stand-off, feed-thru, high-voltage, and zero temperature coefficient.

Hi-Q components are better four ways: (1) Precision. (2) Uniformity. (3) Reliability. (4) Miniaturization. Widely used in

today's TV receivers.

### See Your Jobber . . .

He now stocks those Hi-Q ceramic capacitors for your convenience. Ask your local Aerovox distributor for latest catalog listing these and other new capacitor types.



CAPACITORS • VIBRATORS • TEST INSTRUMENTS

*For Radio-Electronic and Industrial Applications*

AEROVOX CORPORATION, NEW BEDFORD, MASS., U. S. A. • Sales Offices in All Principal Cities  
Export: 41 E. 42nd St., New York 17, N. Y. • Cable: AEROCAP, N. Y. • In Canada: AEROVOX CANADA LTD., Hamilton, Ont.

Patent Pending



## new! LOW COST DC SOURCE ELECTRO "BJ" JUNIOR

SUPPLIES 1 to 12.5 AMPS. 6 VOLTS CONTINUOUS DUTY  
3 to 9 Volts at Other Ratings

ONLY \$32.40 NET

### Demonstrate and Test from AC Lines . . . Radios • Relays 'Phone Circuits • Instruments • Other Low Voltage Devices

New Model "BJ" Junior Filtered Power Supply utilizes same exclusive application of selenium rectifiers used in the famous Model "B." This application, using conduction cooling, doubles the rectifier power rating, dissipates over 3 times the heat and provides lower cost per ampere output over other types. Supplies ample power, with a peak instantaneous current rating of 25 amperes (from standard 50/60 cycle 115 volt source). Heavy duty components withstand high over-loads. AC ripple less than 0.4 volts at 6 volts DC 8 amperes.

### Unmatched Double Value - Lowest Price, Recognized Top Quality

Voltmeter 0-10 volts 5% accuracy.  
Ammeter 0-20 amperes 5% accuracy.  
Heavy-duty selenium rectifiers, transformer and choke.

8 Heavy-duty power tap adjustments.  
2000 Mfd. filter condenser.  
Readily accessible fuse.  
Steel cabinet, blue hammerloid finish.

Send for New Folder on Complete Line of Battery Eliminators



Pioneer Manufacturers

of Battery Eliminators

ELECTRO PRODUCTS LABORATORIES, Inc. 4495-BJ Ravenswood Ave., Chicago 40, Ill.

With regard to the TV picture tube test adapter, testing of television picture tubes without having to remove them from the television receiver is now possible, using a new cathode ray tube testing adapter in conjunction with any standard Sylvania Tube Tester, according to an announcement by H. H. Rainier, manager of distributor sales for the Radio Tube and Television Picture Tube Divisions of Sylvania Electric Products Inc.

The new Sylvania Cathode Ray Tube Testing Adapter Type 228 is designed to indicate shorts, leakage and open heaters in electromagnetic cathode ray tubes and will also indicate relative emission of types having accelerating anodes. In addition, when used with the Sylvania Tube Testers Type 219 and 220, heater-cathode leakage may be checked.

### A. J. Albano New Tel-O-Tube Exec.

Anthony J. Albano, Chief Engineer of the Tel-O-Tube Corporation of America, East Paterson, New Jersey, has been elected secretary of the corporation, it was announced this week by Mr. Samuel Kagan, head of the company.

### Harry P. Weston Appointed Reeves V. P.

Reeves Soundcraft Corp., Manufacturer of TV Tubes of Long Island City, N. Y. has announced the appointment of Harry P. Weston as Executive Vice President. Mr. Weston was formerly Vice President Treasurer of the Graham-Paige Corp.

### G. E. Announces New Line of TV Components

General Electric has announced a complete new line of television receiver parts, applicable to G. E. and to many other receiver makes.

The new line includes 70 degree deflection yokes for magnetic deflection circuits; horizontal sweep output and high voltage transformers, and other components such as EM-PM focus coils, width and linearity controls, ion trap magnets, etc.

A new catalogue is now available which gives a complete description of the various components and may be obtained from the Parts Section, G. E. Receiver Division, Electronics Park, Syracuse, N. Y.

### Telrex Service News

Telrex Service News—The "Service News" is prepared for the thousands of "Conical-V-Beam" dealers

and servicemen throughout the nation, and its contents written expressly for those who use Telrex products. "Tek-Talk" is a regular feature, made up of excerpts from a book written by M. D. Ercolino, originator of the "Conical-V-Beam" and President of Telrex, Inc. Contact your Telex distributor.

#### New Booklets

*Filter Facts*—Causes of TVI and the procedures necessary to eliminate it, including shielding, filtering, and by-passing. Send 15 cents to Barker & Williamson, Inc., 237 Fairfield Ave., Upper Darby, Pa.

*Time for Sound talk*—A glossary of terms used by tape recording technicians and customers plus details on various sizes and types of sound recording tape, dual-and single-track recording, and different tape recording speeds. Write, Minnesota Mining and Mfg. Co., 900 Fauquier St., St. Paul 6, Minn.

#### Catalogs

A complete new communication equipment vibrator replacement guide is now available on request from the James Vibrapower Company, 3224 W. Armitage Avenue, Chicago 47 Illinois. The guide shows correct type for all equipments nationally installed in the rapidly growing communications maintenance market.

In 40 pages packed with new types, extended listings, code designations, applications and other data, the latest Aerovox General Catalog provides a most practical addition to the reference library of the radio-electronic worker. Capacitors of many different types, many of them new, are cataloged. An entire section is given over to television capacitors for TV servicing. Wire-wound and carbon resistors are listed, as well as Aerovox vibrators and test instruments. A copy of this latest Aerovox catalog may be obtained from your local Aerovox distributor.

New Catalog DC2S giving details on IRC's Concentrikits Stock Assortment has been announced by International Resistance Co. The Stock assortment covered by this Catalog contains all necessary parts for easy assembly of any of 144 different concentric dual controls. A handsome metal four drawer cabinet is supplied at no extra cost. Servicemen desiring a practical answer to their concentric dual control replacement problems may obtain copies of Catalog DC2S by writing International Resistance Co., 401 N. Broad St., Phila. 8, Pa.

## SHOP NOTES

[from page 32]

### Sync Buzz Due to the Transmitting Station:

If the above realignment fails to reduce the buzz, the fault is probably due to the video modulation system used at the transmitter. This type of buzz can usually be identified by its appearance at intervals when there is a large amount of white in the picture. In 20X1, 20Z1 and 20Y1 chassis, the buzz may be eliminated or reduced to a minimum, in many instances, by modifying the first sound tube (V201) circuit as follows:

The conversion may be made using the following procedure:

1. Remove C202 (120mmfd) connected between L201 and pin 1 of V201 (6AU6) and replace it with a short length of wire.
2. Remove R201 (1 meg.) connected between pin 1 of V201 and ground.
3. Remove all connections from pin 7 of V201.
4. Connect an 82 ohm, ½ watt resistor, part number 60B28-31, between pin 7 and ground.
5. Realign the receiver.

### Residual Sync Buzz:

This type of sync buzz rarely reaches an objectionable level; it is

**SPECIALISTS**  
**SPECIALISTS**  
**SPECIALISTS**  
**SPECIALISTS**  
**SPECIALISTS**  
**OXFORD Speakers**  
*are made by*  
**Speaker SPECIALISTS**

**"A jack of all trades is a master of none".**

We, at Oxford, are devoting our efforts solely to making speakers and have been specializing in outstanding speaker production since 1924.

Our highly skilled engineers and technicians, our expansive volume production facilities, and our every effort are for the sole purpose of manufacturing speakers. Because we are **SPEAKER SPECIALISTS**, Oxford has met the most exacting needs, which has resulted in countless satisfied customers. Our sales policies are always fair and workable for your benefit.

The next time you need speakers, specify **OXFORD** . . . the product of men who know the speaker business . . . specialists to serve your every need.

Write for your copy of our new catalog today!

Leading jobbers carry Oxford Speakers for TV, FM, AM, AUTO and PA.



**OXFORD ELECTRIC CORPORATION**

3911 South Michigan Avenue • Chicago 15, Illinois

EXPORT: ROBURN AGENCIES, NEW YORK CITY

due to stray capacitive coupling and may be reduced to a minimum as follows:

1. Tune in a station and disconnect U208 from pin 5 of V204 (6AS5).
2. Connect approximately 1 inch of insulated wire to pin 5 of V204 (6AS5) and approximately 3/8 inches of insulated wire to the terminal connected to pin 6 of V401B (12AU7 sync separator).
3. Twist these leads together, a turn at a time, for a minimum in the buzz and reconnect C208.
4. Connect approximately 1 inch of insulated wire to pin 4 of V203A (6SN7) and approximately 3 inches of insulated wire to the terminal connected to pin 6 of V401B.
5. Twist these leads together, a turn at a time, for a further minimum in the buzz.

The above procedures should be effective in removing all sync buzz complaints. However, should the receiver not respond to these remedies, it is highly possible that the transmitter is at fault.

**ADMIRAL CORPORATION**  
Service Division

## AM-FM

[from page 23]

may be checked for output and balance. A properly adjusted discriminator will result in an "S" curve on the scope screen. Any departure from this screen will result in unbalance and distortion.

### Limiter Stage

The limiter stage in an FM receiver, for proper operation, depends on non-conduction and saturation of plate current, occurring above the positive and negative signal peaks. The most important points regarding correct limiter operation are: plate and screen voltages, about 35 volts, correct values of resistors and condenser in grid return of limiter stage. Note that in *Fig. 11*, the limiter stage is included and therefore the gain of that stage may also be comparatively determined by the total height of the "S" curve. Often a 6SJ7 tube is used, which is of the sharp cut-off type, and functions well as a limiter.

### I-F Amplifiers

The basic functioning of i-f amplifiers whether they be in AM sets or FM sets is about the same. However, there are some different approaches to servicing both types such as might be expected when the i-f frequencies vary so widely. Also the fact that the AM bandwidth need be no greater than 10 kc as compared to the 200 kc bandwidth normally encountered in FM i-f transformers requires a different method in i-f transformer alignment in each case. Some FM receivers lower the "Q" of the i-f coils by shunting resistors across the coils. This reduces the gain of the i-f stage but broadens the tuning, making the necessary 200 kc bandwidth easier to obtain. The majority of AM receivers do not resort to coil damping, but simply peak up the i-f stage or stages. The 10 kc bandwidth may be checked on in the AM receiver, in the same manner as checking for the 200 kc bandwidth in the FM receiver. *Figure 12* shows a typical instrument set-up enabling the serviceman to check the over-all

## Insure BETTER Television Service to Your Customers! . . . Exclusively Designed

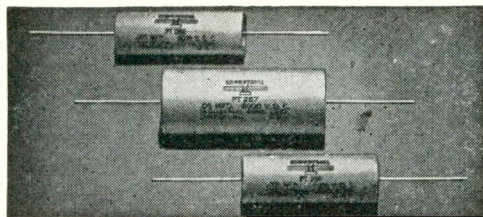

## HIGH VOLTAGE AND ELECTROLYTIC TUBULAR TELEVISION CAPACITORS

### Especially Engineered for Television Circuits by INDUSTRIAL CONDENSER CORP.

The economical quality line for replacement. Industrial Condenser Corp., manufacturers of Capacitors exclusively brings you highest quality for the particular requirements of Television at exceptionally attractive prices! Special Capacitors are Pyroteen impregnated for low power factor, high insulation resistance, high operating temperatures. Oil, Pyroteen, Wax and Electrolytic Capacitors. Finest materials throughout.

**Ask Your Jobber for our Attractive Prices Today!**

Or write for Bulletin 1095. Industrial makes quality Capacitors for Television, Radio, every electronic and industrial application—all types.

Send for Complete Catalog

### INDUSTRIAL CONDENSER CORP.

3243 N. CALIFORNIA AVENUE CHICAGO 18, ILLINOIS  
Sales offices in all principal cities.



Modern plant built by Industrial Condenser Corp., for manufacture of Capacitors only.

### STATEMENT OF THE OWNERSHIP, MANAGEMENT AND CIRCULATION REQUIRED BY THE ACTS OF CONGRESS OF AUGUST 24, 1912, AS AMENDED BY THE ACTS OF MARCH 3, 1933, AND JULY 2, 1946.

of Radio-Television Service-Dealer published monthly at New York, N. Y., for October 1, 1950.

State of New York )  
County of New York ) ss.

Before me, a Notary Public in and for the State and county aforesaid, personally appeared Sanford R. Cowan, who, having been duly sworn according to law, deposes and says that he is the publisher of Radio-Television Service-Dealer, and that the following is, to the best of his knowledge and belief, a true statement of the ownership, management, etc., of the aforesaid publication for the date shown in the above caption, required by the Act of August 24, 1912, as amended by the Act of March 3, 1933 and July 2, 1946 embodied in Sec. 34.38 Postal Laws and Regulations, to wit:

1. That the names and address of the publisher, editor, managing editor and business manager are: Publisher: Sanford R. Cowan, 1620 Ocean Ave., Brooklyn 30, N. Y.; Editor: Sanford R. Cowan, 1620 Ocean Ave., Brooklyn 30, N. Y.; Managing Editor: Samuel L. Marshall, 262 Sullivan Place, Brooklyn 25, N. Y.; Business Manager: Sanford R. Cowan, 1620 Ocean Ave., Brooklyn 30, N. Y.

2. That the owners are: Cowan Publishing Corp., 342 Madison Ave., New York 17, N. Y.; Sanford R. Cowan, 1620 Ocean Ave., Brooklyn 30, N. Y.

3. That the known bondholders, mortgagees, and other security holders owning or holding 1 per cent or more of total amount of bonds, mortgages, or other securities, are: None.

4. That the two paragraphs next above, giving the names of the owners, stockholders and security holders, if any, contain not only the list of stockholders or security holders as they appear upon the books of the company, but also, in cases where the stockholder or security holder appears upon the books of the company as trustee or in any other fiduciary relation, the name of the person or corporation for whom such trustee is acting, is given; also that the said two paragraphs contain statements embracing affiant's full knowledge and belief as to the circumstances and conditions under which stockholders and security holders who do not appear upon the books of the company as trustees, hold stock, and securities in a capacity other than that of a bona fide owner; and this affiant has no reason to believe that any other person, association, or corporation has any interest direct or indirect in the said stock, bonds, or other securities than as so stated by him.

(Signed) SANFORD R. COWAN, Publisher.

Sworn to and subscribed before me, this 28th day of September, 1950.

(Seal). HARRY N. REIZES, Notary Public.

State of New York, No. 24-3249550, Qualified in Kings County, Certs. filed with Kings & N. Y. Co. Clk. Off. & Kings Co. Reg. Off. Commission expires March 30, 1951.

r-f and i-f response of an FM receiver. The same set-up may be used in the checking of the response of an AM receiver, bearing in mind that the sweep width of the sweep generator need not be as great as in the FM set-up. However, sweep alignment of AM receivers may not always be feasible due to the limitations of frequency coverage of the modern sweep generator.

### Mixers

Again comparing *Figs 1* and *2* shows that the AM receiver combines the function of mixer and oscillator in one tube, whereas a separate mixer and oscillator is used in the FM receiver. Electronic coupling exists in the AM converter stage as compared to capacity coupling in the FM mixer-oscillator stage. Injecting a test signal into the AM converter tube would call for a connection onto the control or signal grid. This is usually located at the grid which connects to a tuning condenser that tunes the antenna coil secondary winding, or the following stage. The ability of the converter tube to pass a signal may be determined from the comparative gain in pattern height on the 'scope, as compared to the pattern obtained when injecting a signal onto the first i-f tube grid. If the r-f signal injected onto the signal grid of the converter tube is amplitude modulated, with a variable audio generator (*Fig. 10*) the resultant pattern on the scope screen will now include the ability of the converter stage plus all i-f stages to amplify equally audio frequencies up to 10 kc that are in an amplitude modulated carrier.

The performance of the mixer tube and its associated stage may also be visually observed for gain and bandwidth in FM receivers. The mixer tube as seen in *Fig. 2* will also influence the waveshape as seen on the 'scope when a frequency swept signal is injected onto it. Again, a comparison in performance as the mixer tube is included in the "signal pipeline" will greatly aid in telling the overall story of set performance. Just as a rusted section of pipe in a water conveying system will result in impure water when visually observing the flow from the open end or output, so will a signal be affected when a single stage of amplification adds something undesirable to the signal. This would be distortion, oscillation, insufficient gain, or mis-alignment. The mixer stage should not provide a "frequency bottleneck" but should contribute to the overall bandpass,

necessary for best performance in FM receivers, of 200kc.

### Oscillators

Referring to *Figs. 1* and *2* the method of mixing oscillator and signal frequencies, and obtaining the resultant IF frequency, is different. The converter tube as used in the AM set provides a more compact method of mixing than a separate oscillator and mixer tube as used in the FM receiver. However, separate oscillator and mixer tubes provide a comparatively quieter i-f frequency output than the converter tubes at the higher frequencies. The best aid

in trouble-shooting oscillators is the VTVM. All voltages should be checked in the oscillator stage with particular attention paid to the bias voltage developed across the oscillator grid leak. Zero voltage from oscillator grid to cathode is the best indication of a non-oscillating condition, whereas a weak oscillator or unstable oscillator will indicate low voltage or zero bias voltage over part of the range of the tuning gang. The performance of any receiver, whether AM or FM is no better than the oscillator tracking. Therefore a carefully aligned receiver including i-f

# TV AND RADIO MEN

## Asked Us To Build This Kit



- 1/4" Stub No. A 132
- Heavy Duty Handle No. ZH 2
- Medium Duty Handle No. ZH 1
- 6" Bit Extension No. ZX 56
- 1/4" Regular Bit No. ZB 45
- 3/16" Regular Bit No. ZB 34
- 1/8" Regular Bit No. ZB 24
- #2 Phillips Bit No. ZP 24
- #1 Phillips Bit No. ZP 14
- 3/16" Hex Wrench No. ZS 6
- 1/4" Hex Wrench No. ZS 8
- 3/16" Hex Wrench No. ZS 10
- 1/2" Hex Wrench No. ZS 11
- 3/8" Hex Wrench No. ZS 12
- 7/16" Hex Wrench No. ZS 14
- 1/2" Hex Wrench No. ZS 16
- 3/16" Metal Tip Aligner No. AT 45
- 3/32" Pocket Clip No. A 116-2
- #1 Phillips Thin Blade No. PO 1
- 1/8" Screw Holding No. OK 24
- 1/8" Insulated Blade No. VR 261
- 3/16" Screw Holding No. OK 38
- 3/16" Insulated Blade No. VR 381
- 1/8" x 10" Non-magnetic Adjuster No. VB 210
- 3/32" Fiber Television Aligner No. AT 510



Kit No. TV 27

**27 Different VACO Pieces**  
*Speed Up Television and Radio Work!*

Hundreds of radio and television men in all parts of the business . . . servicing, jobbing, production . . . told us what to put into this kit. It's made to *their* specifications, not ours. And it's complete right down to the extra pockets for your favorite pliers.

That's why *you'll* want one, too! Here in a single package is everything you need for faster TV and radio work . . . for saving valuable time that means money in your pocket. Order yours, today. Your trade price only . . . . . \$16.00

See your jobber, or write for information



**317 E. Ontario Street**  
**Chicago 11, Ill.**

In Canada: Vaco-Lynn Products Co., Ltd.  
1212 Notre Dame St., W., Montreal 3, Que.



**Do a Better Job . . .  
Eliminate Troublesome  
and Costly Complaints  
and Servicing!**

**TV INSTALLATION TECHNIQUES**

by Samuel L. Marshall

What are all the factors of a good TV installation? How can you do a better job, faster and more profitably? The answers to these, and many other questions and problems confronting the installation and servicing technician, are covered fully in TV INSTALLATION TECHNIQUES. This information-packed RIDER book is the ONLY text that gives every installer of an antenna system complete information pertaining to the mechanical considerations of TV antennas—ice loading, wind surface, receiver adjustments, and mounting requirements whether for short chimney-attached mast or an 80-ft. tower, including foundation. It also contains municipal regulations governing the installation of TV antennas and masts for all the major cities and areas of the United States. TV INSTALLATION TECHNIQUES is a book for every person who does or intends to do television installations. It points the way to better and faster workmanship that reflects itself in fewer service calls. This volume is a practical aid that will put dollars in your pocket.

Approx. 336 Pages, 270 Illustrations, 8 3/8" x 5 1/2", Cloth Bound **\$3.60**

**For a Better Understanding  
of FM Systems in All  
Phases of Radio and  
Television . . .**

**FM TRANSMISSION AND RECEPTION**

by John F. Rider and Seymour D. Uslan

With the rapid growth of Television and FM radio, with expansion in the various types of communication systems, the material contained in FM TRANSMISSION AND RECEPTION is increasingly valuable to the experienced technician and beginner as well. The more you know about FM, the more thorough your job can be—the greater your earning power becomes. The entire subject of frequency modulation is covered fully . . . all types of systems employed in television, radio, amateur radio, railroad, aviation, marine, police, point-to-point and mobile receivers. Basic theory, transmission, reception, circuit design and servicing are covered, with mathematics kept to a minimum. Almost all of the presently used FM commercial transmitters are described in detail. A question section follows each of the "meaty" chapters.

416 Pages, Profusely Illustrated **\$3.60**

**10-DAY FREE TRIAL**

Order these books today. Keep them for 10 days . . . if you are not completely satisfied, return them to us and your money will be refunded.

Rush This Coupon Today

JOHN F. RIDER PUBLISHER, Inc.  
480 Canal St., New York 13, N. Y.  
Please send me the following books on your 10-Day Money-Back Offer.

TV INSTALLATION TECHNIQUES \$  
FM TRANSMISSION AND RECEPTION \$

NAME .....  
ADDRESS .....  
CITY ..... ZONE ..... STATE .....

Check for \$ ..... Money-Order for \$ ..... Encl. 3

alignment and oscillator tracking will give assurance that:

(a) the i-f stages will accept and amplify signals occurring at the i-f frequency.

(b) the oscillator stage will always maintain a frequency, that is displaced from the signal frequency by an amount equal to the i-f frequency, regardless of the dial setting.

**CRT**

[from page 19]

very small and the other two are slightly increased in diameter since the electron beam is diverging. The size of these apertures in the first and second anode assists in the focusing action of the electron stream by removing the outer marginal electrons and by reducing the diameter of the screen spot. The aperture on the control grid may have its diameter effectively changed by the varying voltage on the control grid.

**FRONT ENDS**

[from page 29]

nel 13. The second coil in series with the first coil provides the correct line length for Channel 12; This continues until the last set of contacts are shorted out. At this point the complete line length is tuned to channel 12.

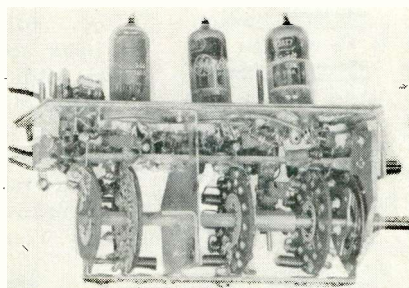
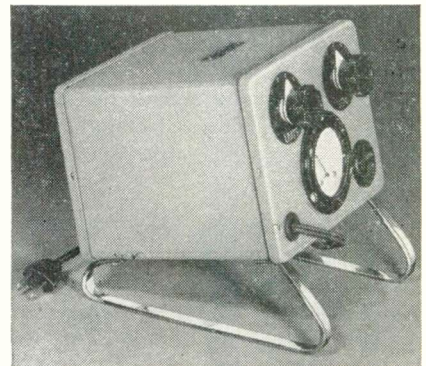

Fig. 3-36: G.E. Model 16T1 tuner.

In order to make the transition between channel 7 and channel 6 a set of adjustable inductors is inserted in each line. The adjustments on these inductors are used for alignment of the r-f circuits and correct shaping of the r-f response curve.

Figure-Eight coils are used for the low frequency channels. Coils of this

**It's NEW  
...and it's NEWS!**



**VARIVOLT MASTER  
Model N-202 Voltage Adjusting  
Isolation Transformer**

A new, larger capacity transformer that provides positive control of your voltage fluctuations—better than ever, and safer because it isolates you from your work. Raises voltage or lowers it—in 1 1/2 volt steps—high for locating weak points, low for testing under minimum conditions. Handles the smallest or largest servicing job, even up to 20' TV Combinations!

Rated capacity at 117 volt output is 500 watts. A marvel of efficiency, Varivolt Master weighs 21 lbs. yet requires less than a square foot of bench space. Steel runners permit easy movement, and slant the instrument for accurate reading. See your Jobber Today!

Write for Catalogue  
Today

It's free. The Halldorson line of Vacuum Sealed Transformers is tops for quality—one of the widest lines in the industry. You're up-to-date with a Halldorson Catalogue. The Halldorson Company, 4500 N. Ravenswood, Chicago 40, Illinois.

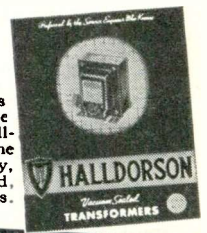

**Halldorson  
Vacuum Sealed Transformers**

**\$1.00 to \$5.00 PAID  
for "SHOP NOTES"**

Write up any "kinks" or "tricks-of-the-trade" in radio servicing that you have discovered. We will pay from \$1 to \$5 for such previously unpublished "SHOP NOTES" found acceptable. Send your data to "Shop Notes Editor," RADIO SERVICE DEALER, 342 Madison Ave., New York 17, N. Y. Unused manuscripts cannot be returned unless accompanied by stamped and addressed return envelope.

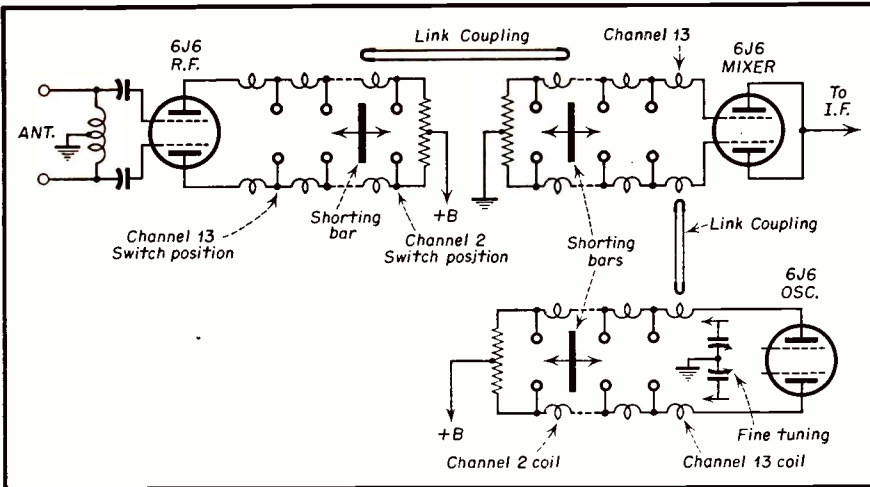

Fig. 3-37: Simplified circuit of tuner used in RCA 630 TS.

type result in a non-critical winding because the coupling between coils is minimized. As a result, the maximum amount of wire is made available for the small size inductors required.

The parallel line tuning circuit is employed in the plate circuit of the r-f tube, the grid circuit of the mixer tube, and in the oscillator. Coupling between circuits is provided primarily by links coils, with additional capac-

tors inserted at certain points (not shown) to effect correct bandpass.

The coils in the oscillator circuit are not wound in figure-eight fashion. Trimmer adjustments are provided in each coil so that accurate alignment of the oscillator at each channel may be made. Fine tuning as shown in the figure provides an oscillator frequency variation of approximately 0.6 mc.

[To Be Continued]

## TRANSMISSION LINES

[from page 21]

put of the booster and the input of the receiver should represent an anti-resonant condition or act as an absorption ( $\frac{1}{4}$  wave line) trap at some one channel frequency, there will be a loss rather than a gain in the use of the booster at that frequency.

If this condition is present it can be determined by running the hand along the connecting wire between the booster and TV receiver. At some point the output will be greater. At this point one of the capacitive 300 ohm line loading clips (antenna stubs) should be inserted. Move it to the point which gives greatest gain. One or more other loading clips should be used on the line from the antenna which is connected to the input of the booster. (See Fig. 2). This will help compensate for the inevitable losses that result from the booster feed through and cut out switch. There is such a switch on all boosters.

Several matching elements may be used at once. In the author's experience with a Hallicrafters, and with

## TWO SETS IN EVERY HOME Made Easy with New Coupler

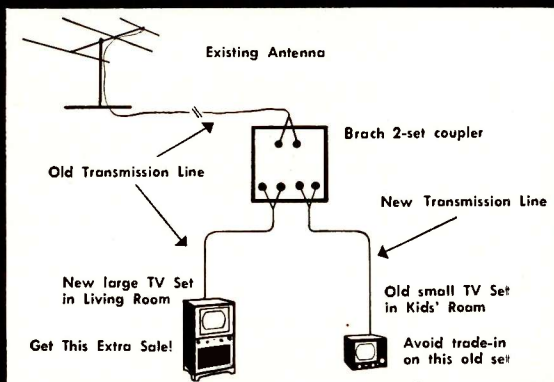

### The Brach 2-Set Coupler

- Eliminates interference
- Matches 300 & 75 ohm lines
- Installs with hand tools
- Low in cost
- Avoids trade-in sales

ORDER  
FROM  
YOUR  
JOBBER  
TODAY

**BRACH MANUFACTURING CORP.** (Div. of General Bronze Corp.)  
200 Central Ave. Newark 4, N. J.



**GUARDIAN CENTERING MAGNETS and FOCUS COILS** Insure Better Positioning of the Pattern in Popular TV Sets...

### GUARDIAN CENTERING MAGNETS

The Guardian Centering Magnet compensates magnetically for any misalignment of the electronic beam of the focus coil assembly. Eliminates manual adjustment of the raster.

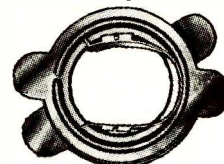

### GUARDIAN FOCUS COILS

Over a million Focus Coils have rolled off Guardian's production lines into TV sets of leading manufacturers. With more than 75 types established as *Guardian standard*, speedy delivery to meet today's replacement needs is a matter of routine. Write.

**GUARDIAN ELECTRIC**  
1606-L W. WALNUT STREET CHICAGO 12, ILLINOIS

A COMPLETE LINE OF RELAYS SERVING AMERICAN INDUSTRY

# TWIN LEAD, TELEVISION LIGHTNING ARRESTER

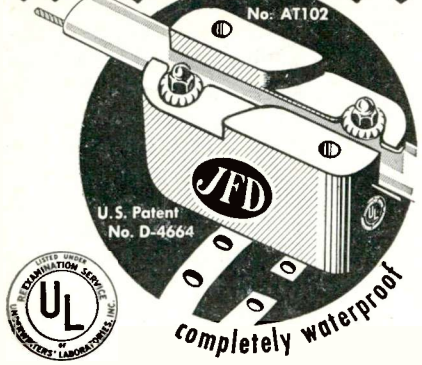

APPROVED for OUTDOOR-INDOOR Use \$2.25  
Protects Television Sets Against Lightning and Static Charges

## JFD SAFE TV GUARD

Simple to install everywhere and anywhere...no stripping, cutting or spreading of wires. More than 300,000 in use today!

SEE YOUR JOBBER OR WRITE TO  
**JFD MANUFACTURING CO., Inc.**  
6127 16th Avenue, Brooklyn 4, N. Y.  
First in Television Antennas & Accessories

**FREE! SEND FOR IT NOW!**

## ALLIED'S NEW 1951 CATALOG

**212 PAGES—EVERYTHING IN RADIO, TV AND ELECTRONICS**

Radio's Leading Buying Guide

Service Technicians and Engineers: ALLIED'S complete 1951 Catalog brings you all the latest equipment and money-saving values—from the world's largest stocks of test instruments, amplifiers, P.A. systems and equipment, tubes, parts, tools, books and accessories—ready for instant expert shipment. Send today for your FREE 12-page ALLIED Catalog.

**ALLIED RADIO**

ALLIED RADIO CORP., Dept. 26-K-O  
833 W. Jackson Blvd., Chicago 7, Ill.

Send FREE Catalog

Name.....  
Address.....  
City.....State.....

a Tele-Tone may be of some interest to the reader: The sets are located in what should be a high signal area in New York City. Low band stations are received very well indeed with a simple dipole cut for the low band. The landlord would permit no further additions to the antenna system so that performance on the high band was poor. Tenastubs attached to the line one each for the four high frequency channels brought in the high band stations with good brilliance. One matching device was placed inside the set between the front end antenna terminals and the rear panel connection terminals along the connecting section of line. This was peaked on Channel 13. Another was peaked on Channel 11 and fell about 10" from the rear terminal connections. The Tenastubs for channel 7 peaked about two feet away from the TV set.

With the arrangement described above excellent reception was enjoyed on all New York Channels with only a single dipole having 47" rods each side of center.

### AD INDEX

Aerovox Corporation.....	42
Alliance Manufacturing Co.....	1
Allied Radio Corp.....	48
American Phenolic Corp.....	4
Astatic Corporation, The.....	41
Belden Manufacturing Co.....	13
Brach, L. S. Mfg. Corp.....	47
Burgess Battery Company.....	39
Clarostat Mfg. Co., Inc.....	7
Commercial Trades Institute.....	48
Electro Products Labs.....	42
Guardian Electric Mfg. Co.....	47
Halldorson Co., The.....	46
Heath Company, The.....	9
Hytron Radio & Electronics Corp.....	16
Industrial Condenser Company.....	44
Jackson Electrical Instrument Co.....	35
JFD Manufacturing Co., Inc.....	48
Littelfuse, Inc.....	3
Mallory & Co., Inc., P. R.....	Cover 2
Oxford Electric Corp.....	43
Radiart Corporation, The.....	14, 15
RCA (Electron Tubes).....	Cover 4
RCA Service Company.....	48
Regency Div., I. D. E. A. Inc.....	Cover 3
Rider Publisher, Inc., John F.....	46
Sangamo Electric Company.....	10
Schott, Walter L. Co.....	12
Snyder Mfg. Co.....	33
Sprague Products Company.....	6
Sylvania Electric Products Co.....	5
Thomas Electronics, Inc.....	40
Triplett Elec. Instrument Co.....	11
Universal TV System.....	48
Vaco Products Company.....	45
Workshop Associates, Inc.....	37

## ELECTRONICS TECHNICIANS WANTED

The RCA Service Company, Inc., a Radio Corporation of America subsidiary, needs qualified electronics technicians for U. S. and overseas assignments. Candidates must be of good character and qualified in the installation or maintenance of RADAR or COMMUNICATIONS equipment or TELEVISION receivers. No age limits, but must have at least three years of practical experience.

RCA Service Company offers comprehensive Company-paid hospitalization, accident and life insurance programs; paid vacations and holidays; periodic review for salary increases; and opportunity to obtain permanent position in our national and international service organization, engaged in the installation and maintenance of AM, FM, and TV transmitters, electronic inspection devices, electron microscopes, theatre and home television, r-f heating equipment, mobile and microwave communications systems, and similar electronic equipment.

Base pay, overseas bonus, payments for actual living and other expenses, and benefits mentioned above add up to \$7,000 per year to start for overseas assignments, with periodic review of base salary thereafter. Openings also available at proportionately higher salaries for specially qualified technicians with supervisory ability.

Qualified technicians seeking an advantageous connection with a well-established company having a broad-based, permanent peacetime and wartime service program, write to:

Mr. G. H. Metz, Personnel Manager,  
RCA Service Company, Inc.,  
Camden 2, New Jersey.

## HAVE YOU A JOB FOR A TRAINED TECHNICIAN?

We have a number of alert young men who have completed intensive training in Radio and Television Repairing. They learned their trades thoroughly by working on actual equipment under personal, expert supervision. If you need a trained man, we invite you to write for an outline of our course, and for a prospectus of the graduate. No fees, of course. Address:

Placement Manager, Dept. P105-10  
**COMMERCIAL TRADES INSTITUTE**  
1400 Greenleaf Chicago 26

## JOB CONDITIONED! ABLE, ALERT MEN—READY FOR WORK!

Thoroughly trained in TV Installation and Service by UNIVERSAL TV SCHOOL (Est. 1938), Pioneer TV Training School. Screened men, willing to work and eager to demonstrate their skill. Expertly guided on modern TV test equipment, these men have completed 9 months intensive training and are fully groomed for industry. When in need of TV installation or bench man please contact us. This service is FREE. Write or wire

**UNIVERSAL TELEVISION SYSTEM**  
Wirthman Bldg. Kansas City 3, Mo.  
G. I. APPROVED

**Regency**  
 Division, I.D.E.A., INC.  
 55 N. New Jersey St., Indianapolis 4, Indiana

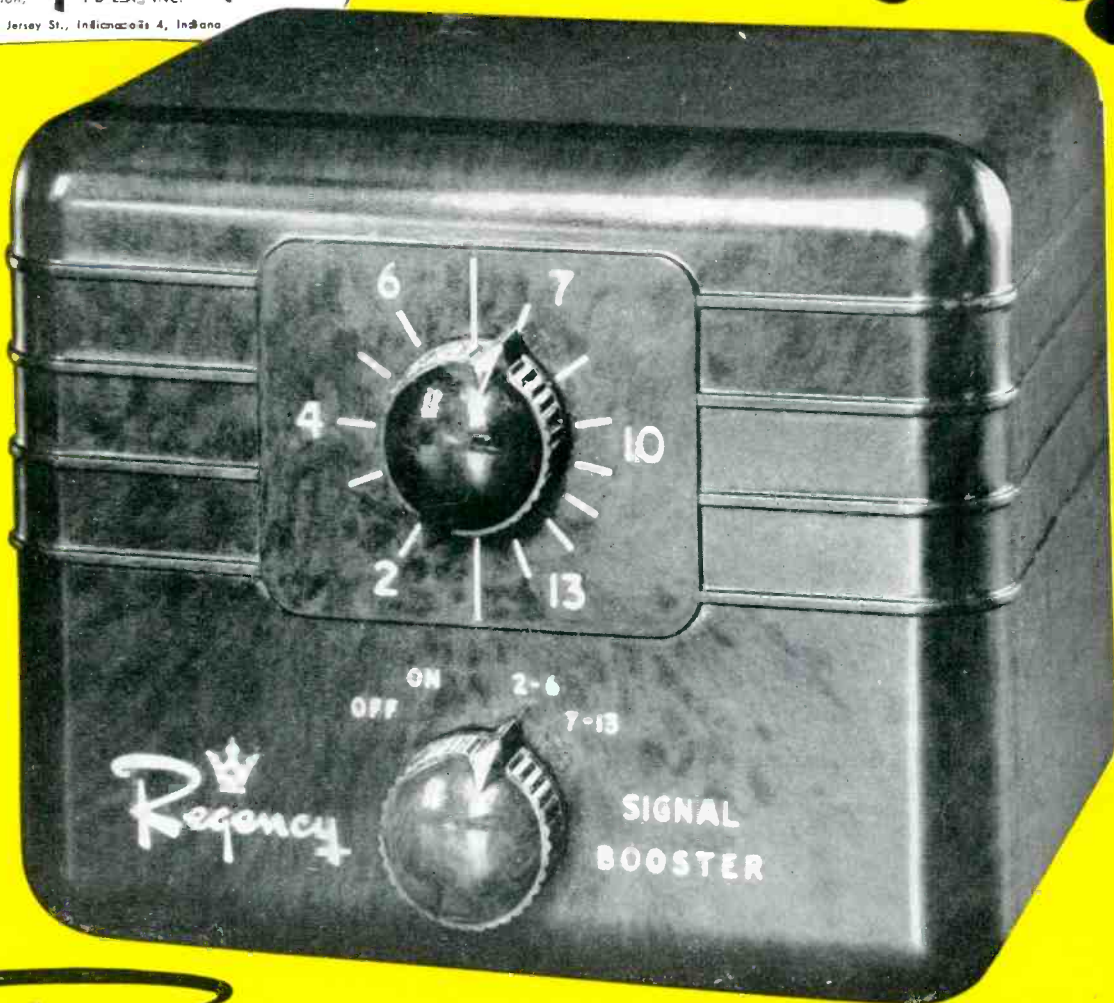

**Regency**

THE DB 400  
 LIST \$32.50  
 IN BLONDE FINISH AT \$37.50

**TV IS THE LARGEST SELLING SIGNAL BOOSTER!**

**BECAUSE . . .** Regency wins all performance tests in nationally-known laboratories . . . Regency is the lowest priced QUALITY Television Signal Booster . . . Regency offers such features as simplified tuning control; easy installation; full coverage on all 12 channels . . . and Regency is UNDERWRITERS'  APPROVED.

**REGENCY** Division, I.D.E.A. INC. • 55 New Jersey Street, Indianapolis 4, Indiana

# Now... the new RC-16

## RCA RECEIVING TUBE MANUAL

- ✓ Up-to-the-minute
- ✓ Over 300 pages
- ✓ Latest TV tube data
- ✓ Over 460 tube types
- ✓ "Lie-flat" binding
- ✓ Expanded circuit section



... you should have these other "RCA firsts" in authoritative technical literature



Receiving Tubes for AM, FM, and Television Broadcast. Bulletin 1275-E. Characteristics and base diagrams on over 450 RCA receiving types. 24 pages. Price 10 cents.



New RCA Triple Pindex at your fingertips... any 3 base diagrams out of over 600 receiving tubes and kinescopes. Price 75 cents.

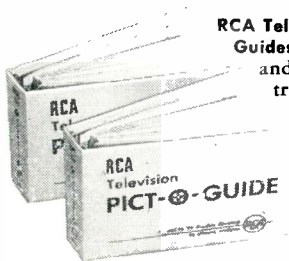

RCA Television Pict-O-Guides. For quick and accurate TV trouble shooting by picture analysis. (See your RCA Tube Distributor for details.)

Months of planning and preparation went into the new RC-16 Receiving Tube Manual to produce what is unquestionably the most complete and authoritative reference guide to receiving-type tubes ever published.

Patterned after the famous RC-15—of which over 600,000 copies were sold—and retaining its proved features, the new and larger RC-16 contains over 300 pages of detailed information on more than 460 RCA receiving tubes and kinescopes.

### Features include

... tube and circuit theory with formulas and examples for calculating power output, load resistance, and distortion for several classes of amplifiers—plus new information on cathode follower design.

... new information on kinescope installation and handling.

... a classification chart which groups types having similar characteristics and the same filament or heater voltages. Also shows miniature types and their GT equivalents.

... expanded circuit section, including many new audio amplifier and receiver designs.

... design data and charts for resistance-coupled amplifiers.

1 1 1

A textbook in itself, the new RC-16 is the most valuable day-to-day tube reference guide in the field... yet it costs only 50 cents! **Get your copy today from your local RCA Tube Distributor.**

For quick action—

-----Mail this coupon to your **RCA TUBE DISTRIBUTOR**\*-----

Mr. RCA Tube Distributor:  
Please rush RCA Technical Literature checked below for which remittance is enclosed—

Name \_\_\_\_\_

Address \_\_\_\_\_

City \_\_\_\_\_ Zone \_\_\_\_\_ State \_\_\_\_\_

- RC-16 RCA Receiving Tube Manual (50 cents)     Receiving Tubes for AM, FM, and TV (10 cents)
- RCA Triple Pindex, New Edition (75 cents)    Tell me how I can obtain Volume I  Volume II  of the RCA Pict-O-Guide



**RADIO CORPORATION**  
**of AMERICA**

ELECTRON TUBES    HARRISON, N. J.

\*If you do not know your RCA Tube Distributor, orders may be sent to RCA, Commercial Engineering, Section J55U, Harrison, N. J.