

September

1940

Radio

SERVICE DEALER

This Month

WHY WIDE-BAND F. M.?

REPAIRING CABINETS

TESTING SHORT CUTS

R-F DEGENERATION

USING SQUARE WAVES

Price

25¢



**No Other
Line Gives You
Such Complete
Coverage**

P. R. MALLORY & CO., Inc.
MALLORY

Replacement CONDENSERS

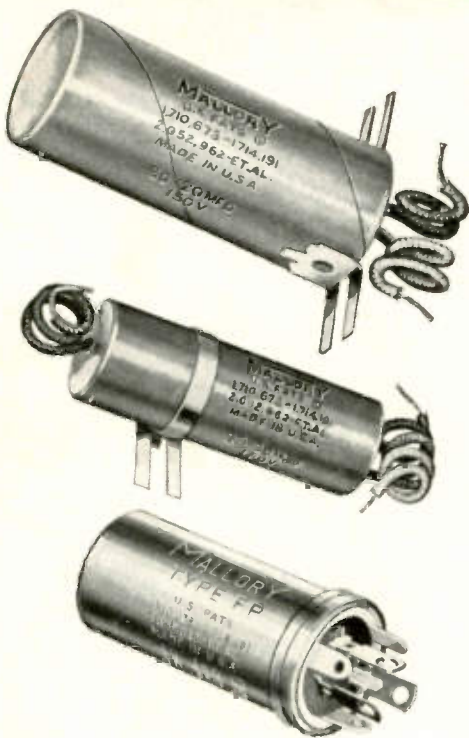

You can be absolutely sure of exact replacements, and thorough coverage of every condenser need because the Mallory line of Replacement Condensers has been specifically developed around an exhaustive study of millions of condensers in *all* makes and models of standard radio receivers.

Mallory Tubular Condensers are available in over 50 ratings with common anode, common cathode and separate sections where sizes permit. All types afford exclusive mounting features that save time and money on every installation.

*FP (Fabricated Plate) Condensers, made by Mallory, have brought about a new high in efficiency and performance. Averaging field returns of only 5/100ths of 1% . . . FP Condensers give you features not duplicated by any other condenser.

Mallory Type BB Condensers likewise afford Fabricated Plate Construction and give all of its advantages in these smaller sizes. Encased in a heavy, one-piece, drawn aluminum can, they are insulated with an attractive cardboard tube well marked for rating identification. Strong internal construction eliminates troublesome open circuits.

See your Mallory distributor today. He can give you complete information on the full Mallory line . . . and you'll find him well stocked to serve you.

P. R. MALLORY & CO., Inc.
INDIANAPOLIS INDIANA

Cable Address — PELMALLO

*TRADE MARK REG. U. S. PAT. OFF.

Use
P. R. MALLORY & CO., Inc.
MALLORY
APPROVED
PRECISION PRODUCTS

Include VIBRATORS • VIBRAPACKS • CONDENSERS • VOLUME
CONTROLS • ROTARY SWITCHES • SINGLE AND
MULTIPLE PUSH BUTTON SWITCHES • RESISTORS
RADIO HARDWARE

Radio

SERVICE-DEALER

SOUNDMAN AND JOBBER

Reg. U. S. Pat. Off.

Ad Index

Allied Radio Corp.	27
New 1941 Catalog	
Amperite Co.	26
AC-DC Regulators	
Audel, Publishers	27
Radiomans Guide	
Centralab	3rd Cover
Sound Projection Controls	
Clarostat Mfg. Co., Inc.	24
Concentric Shaft Dual Controls	
Gamble Hinged Music Co.	23
Techniques of Recording	
General Industries Co., The	27
R70 Home Recording Unit	
Guardian Electric Co.	24
Antenna Relays	
International Resistance Co.	17
Type D All-Purpose Controls	
Jackson Elec. Inst. Co., The	25
Model 636 Dynamic Tube Tester	
Lafayette Radio Corp.	26
New 1941 Catalog No. 82	
Mallory & Co., P. R.	2nd Cover
Replacement Condensers	
Meck Industries, John	23
Audiograph Mobile P-A System	
National Union Radio Corp.	4th Cover
Tube Tester & Tubes	
Oxford-Tartak Radio Corp.	25
Replacement Speakers	
Racon Electric Co.	2
P-A Horn Speakers	
Raytheon Production Corp.	15
Tubes in Industry	
Sprague Products Co.	4
Tel-Ohmike DeLuxe	
Supreme Instrument Corp.	21
Model 589 Tube & Battery Tester	
Triplett Elec. Inst. Co.	26
Model 1213 Tube Tester	
Weston Elec. Inst. Corp.	19
Model 772 Supersensitive Analyzer	

Contents

Transients (Editorial)	3
Make Your Test Oscillator Pay	5
By Billy Parker	
How Wide-Range Frequency Modulation Reduces Noise	6
By John H. Potts	
The Sound System at Elwood	8
Serviceman's Diary	9
By J. P. Hollister	
Horace (Cartoon Strip)	9
Touch Up Those Cabinets	10
Technical Service Portfolio:	
Section V—	
Testing Audio Amplifiers	11
Set of the Month—	
Motorola Model 40-60W	14
Circuit Court:	
R-F Degeneration	16
Loop Feedback	16
Hum Meets Hum	16
Shop Notes:	
Motorola Condenser Symbols	18
New Tubes: 5W4GT, 1LC5, 1LC6, 1LD5	18
RCA 16K, 16T3 Police Band	18
RCA Little Nipper Speaker Adjustment	18
RCA Gain Data	18
RCA Tone Guard	18
RCA 16K to 111K Oscillator Failure ..	18
RCA 1941 Receivers; Reducing Sensitivity	18
RCA 15BP Power Switch Replacement ..	20
RCA VA-21 Wireless Record Player Motor Data	20
Stewart-Warner Loop Alignment	20
Zenith 1941 Wavemagnets	20
Zenith 1941 Receiver Service Notes ..	20
New Products	22
Latest Literature	28

Cover Photo



★ Television goes military at the recent Army maneuvers held in upper New York State, providing an ultra-modern means of scouting and reporting troop movements, etc, to headquarters. This was the first time in history that television had entered the military picture, and credit for the innovation goes to the Allen Du Mont Laboratories.

Published Monthly by

COWAN PUBLISHING CORP.

11 WEST 42nd ST., NEW YORK, N. Y.

Telephone: CHickering 4-3278-9

M. L. MUHLEMAN, EDITOR
S. R. COWAN, ADV. MANAGER

Subscription rate, \$2.00 a year in U. S. and Canada; single copies, 25 cents. In foreign countries, \$4.00 a year. Editorial and advertising offices, 11 West 42nd St., New York, N. Y.

(s) elect RACON for election profits

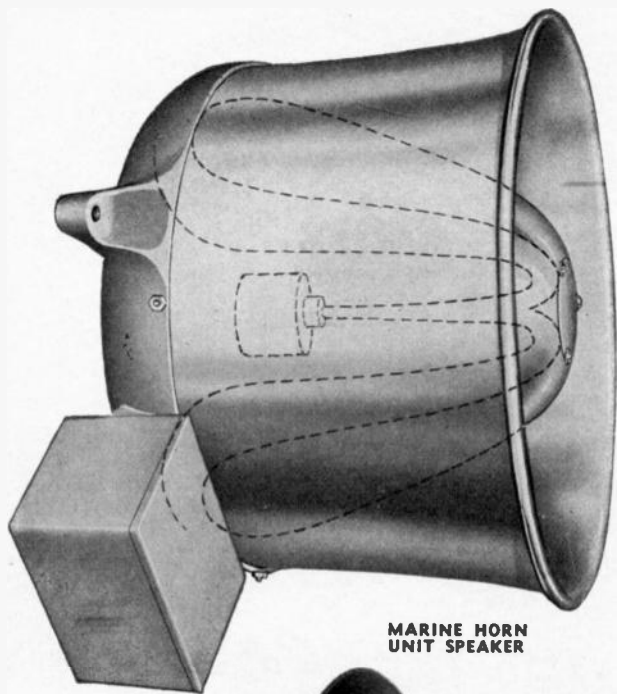

MARINE HORN
UNIT SPEAKER

the biggest season soundmen ever had is just starting

During the next few months thousands of public address systems will be working on election campaigns—in military preparedness maneuvers—and at sporting events—and they'll take a beating from hard usage, inclement weather, overloading and rough handling.

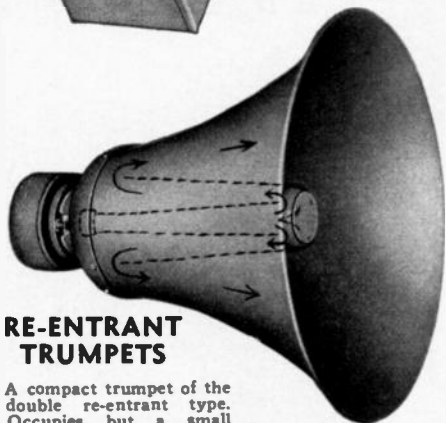

RE-ENTRANT TRUMPETS

A compact trumpet of the double re-entrant type. Occupies but a small space, nevertheless has a long air column enabling it to deliver highly concentrated sound of the greatest efficiency over long distances. Base and inside cone arm made of aluminum castings, outside bell of heavy gauge aluminum spinning, center section of RACON ACOUSTIC material to prevent resonant effects. Available in 6', 4½', 3½', and 3' air column units.

Every sound installation and p-a system employing RACON Products will bring the seller or renter higher fees and better profits because the element of failure has been eliminated and customer satisfaction assured.

RACON alone supplies unbreakable, storm-proof, weather-proof horns, speakers and trumpets. RACON speakers deliver the maximum output and response obtainable for the size of speaker used. There is a RACON reproducer for every purpose—it is the only complete line made. Leading soundmen specify, insist on and use RACON products exclusively—they know it pays.

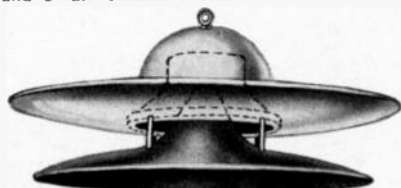

RADIAL CONE SPEAKERS

Types for high fidelity, giving even intensity sound projection over a circumference of 360° radially. Upper deflector made of heavy gauge aluminum, cone covering of steel, and lower deflector of RACON ACOUSTIC material storm-proofed for all weather conditions. Models for 5"—6"—10"—12" cone speakers.

Illustrated here are several RACON PRODUCTS. Complete data and literature sent on request.

RACON ELECTRIC CO.

52 East 19th Street New York, N. Y.



UNBREAKABLE TRUMPETS

The last word in trumpet design and particularly adaptable where high quality and high efficiency is required, with the ability to withstand the roughest handling without breakage. Made of RACON ACOUSTIC STORMPROOF MATERIAL. Demountable. Available in 3½' and 4½' and 6' sizes.

Super Giant P. M. Horn Unit

Operating capacity 12-15 watts, peak 25 watts. Other P.M. Units available, from "baby unit" of 5 watts to "bull unit" with an operating capacity of 50 watts. Efficiencies of the highest order obtainable with the finest magnetic material and steel utilized.



THE OLDEST, LARGEST AND FOREMOST MANUFACTURERS OF AIR COLUMN SPEAKERS IN THE WORLD.

MARINE CONE UNIT SPEAKERS

Re-entrant type speakers of the marine type using cone type driving units for indoor and outdoor applications. Bell made of heavy aluminum cone mounting made of aluminum casting, and center bullet of RACON ACOUSTIC material to prevent resonant effects. Material stormproofed for all weather conditions. Baby size for 2" or 3", miniature for 5", regular for 8", and giant for 12" speakers.

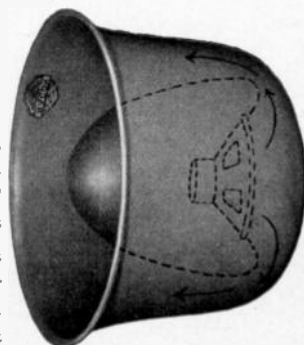

Transients

AERIALS . . . Volume of listening is scheduled to break all records for the next few months. Reasons—election campaigning via radio, war news of ever-increasing tempo, a return to indoor distractions with the coming of cold weather. It is time, therefore, for the serviceman to put on an antenna rehabilitation campaign.

Make October an Aerial Clean-Up Month in your locality. Set your antenna installation and fix-up charges a shade lower for the purpose of stimulating the business. At the same time, advise your customers that such charges are necessarily higher after winter sets in, when work on antennas becomes increasingly difficult. Get them to have the work done now, while charges are low.

Hinge your campaign on noiseless reception. The slogan this year is "Listen Before You Vote". Use it whenever you can, but say to the customer, "Listen before you vote, yes, but why not listen in comfort? A good antenna will insure noiseless reception."

In your efforts to promote better reception conditions in your locality, do not ignore the owners of mediocre receivers equipped with loops or trailing-wire antennae. Many of them have never enjoyed good reception, but it is your job to persuade such listeners that it is worth the investment involved in a top-notch antenna system.

★

PRICE . . . The single-copy price of RADIO SERVICE-DEALER has been upped to 25 cents. The annual subscription price remains the same, however. You'll save a great deal by subscribing now.

★

MIGHTY MIDGETS . . . As pointed out elsewhere in this issue, it is impossible to ignore the engineering advancements that have been made in the ac/dc type of receiver. These sets have already surpassed the overall performance that may be obtained from higher priced re-

ceivers produced no more than a few years ago. There is no question but that further improvements are forthcoming.

Yet it is said that the midget has ruined the radio business, produced a listening public with tin ears, and caused the serviceman no end of trouble. These assertions are all too true. It is the price one has to pay for progress.

But progress, fortunately, does not stand still, and if an ill wind blows no good, it may at least blow itself out. Something of the sort is happening in the case of the mighty midget.

To begin with, the first midgets brought radio receivers within range of everyone's pocketbook, and increased the listening audience tremendously. That much, at least, was good for the industry, and for the nation. The midget brought radio into every home, and by indirection has increased general business, just as directly and indirectly the low-priced auto has benefited the business of the nation.

But there followed a period when it was the aim of practically every radio manufacturer to produce midgets at the lowest possible price, and this *was* ruinous. Because many of these radio makers lost sight of the fundamentals of quantity production, one of which is that the price of any given commodity shall be reduced when a certain increase in production warrants it, *but without disturbing a specified minimum in quality of materials and performance.* The midgets were cheap, but it is a question if many were worth what one paid for them. The radio industry has no occasion to be proud of such a doubtful achievement.

Recently the situation has changed somewhat, due principally to the fact that good engineering has produced means whereby equal or better performance can be obtained at less cost, and in some cases manufacturers have plowed back the gain into materials of better quality.

But of more importance is the growing realization that a real demand exists for a quality midget, even though its price may level off between that of an ordinary midget and a table model.

Knudsen, of General Motors, is credited with the statement that the reason for the rapid growth of the auto industry was because everyone wanted to get from A to B sitting down. One reason, if not the main reason, for the popularity of the midget has been its convenience. It's unobtrusive in any room, can be lugged about, needs no connections other than the power line. People will overlook a slew of faults, including poor tone, just so long as the "convenience factor" is high.

By virtue of this demand, good midgets are reaching the market. They are from \$5 to \$10 more expensive than previous midgets of the same overall dimensions. The dealer can make a reasonable profit on them, the serviceman can charge a reasonable fee for fixing 'em without his customers throwing fits. They're worth pushing because the customer gets his money's worth.

And this is only a beginning. What may be the forerunner of a new trend is a recently introduced high-fidelity receiver not greatly larger than a midget and having all its conveniences. It sells for a nickel under \$60. And on the way are midget f-m sets!

Automotive engineers have learned how to build power, stability, ruggedness and driving comfort into the low-price car. The result is that the market for the large, expensive car has practically vanished, for there is little the larger car can offer that the smaller car cannot also offer.

Our engineers are fast learning how to build sensitivity, power, tone quality and operating ease into the midget. Their efforts may doom the console, but in the long run the radio business will benefit by whatever they accomplish.

EDITOR

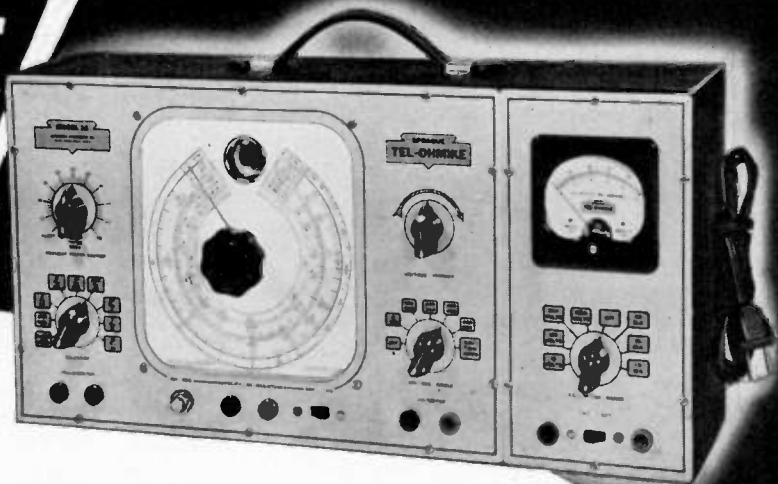

SPRAGUE TEL-OHMIKE *De Luxe*

Time—sold on a profitable basis—is the essence of successful servicing. And when it comes to saving time in checking condenser or resistor troubles or doing a dozen and one other jobs around a service bench, the new De Luxe Tel-Ohmike beats anything you've ever seen. It includes a built-in voltmeter and a milliammeter with switch and pin-jacks provided so that the meters may be used for measurements external to the instrument.

Tel-Ohmike makes it easy to make complete, accurate tests of *all* condenser and resistor characteristics. It indicates "opens" and short-circuits—even the hard-to-find intermittent "opens." It measures leakage current and power

factor; measures insulation resistance up to 10,000 meg.; analyzes all condenser types at their *exact working voltages*; makes capacity measurements from .000010 mfd. to 10,000 meg. and resistance measurements from .5 ohms to 5. meg. Balance indications are given by a "magic eye" tube. Measurements are taken from large, direct-reading scale. See Tel-Ohmike, at your jobbers, or write for folder.

De Luxe Tel-Ohmike **\$39.95 Net**
 Standard Tel-Ohmike (Without voltmeter or milliammeter, but with jack so you can plug in your own meters) **\$29.70 Net**

Save Headaches!

After you've located a bad resistor with Tel-Ohmike—then play safe! Replace it with a Sprague Koolohm — and you know the job is done **RIGHT!** Koolohms cost no more than ordinary resistors, yet are outstandingly different in construction, amazingly superior in performance. Every bit of wire is insulated **BEFORE** it is wound with an exclusive heat-proof, moisture-resistant material. This permits layer-windings to give greater resistance in smaller size, faster heat dissipation, and permits use of larger, sturdier wire for safety. Then, to top off an already tip-top job, Koolohms are insulating from end to end and doubly protected with a peel-proof, crack-proof ceramic shell containing the famous Sprague Automatic Overload Indicator. Catalog free.

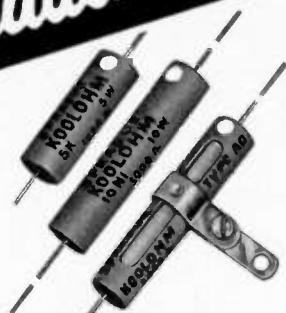

KOOLOHM RESISTORS



Cross-section view of 5-watt Koolohm showing large, durable wire and layer windings.

Cross-section of Koolohm wire with portion of insulation removed.

Save Money!

... and save time and space in the bargain. Follow the lead of hundreds of successful servicemen who use Sprague Atoms for all types of dry electrolytic condenser replacements — large or small. Atoms always fit. They've got more "guts," are more dependable than many of the larger, old-style units they replace. All capacities—voltages—single and dual combinations. Two or more Atoms may be combined by using Sprague ST Mounting Straps to give you countless hard-to-get "special" replacements.



Use Atoms Universally

NEW! Atom Types for Vertical Mounting

Pacing the rapidly growing trend toward condensers with "feet" for vertical soldering to the chassis, or for bending through chassis holes, Sprague now brings you a complete new line of Atom-type dry electrolytic condensers known as Type LM. Don't miss them! Featured by foremost jobbers. Catalog free.



SPRAGUE

SPRAGUE PRODUCTS CO., NORTH ADAMS, MASS.

MAKE YOUR TEST OSCILLATOR PAY

By **BILLY PARKER**

ARE you getting your money's worth out of your test oscillator? Ten to one you aren't. If you'll use it more often, you'll increase your diagnosing and trouble-shooting speed by a percentage that will surprise you.

No claims are made that a test oscillator will take the place of experience, but it will certainly prove a definite aid in supplementing it provided advantage is taken of its wide adaptability.

This article will be primarily of interest to the serviceman who is not so fortunate as to possess one of the new signal tracers or an oscilloscope, but those who do will find some beneficial short-cuts here. The writer is a serviceman for a large Philco distributor and uses these methods himself, despite the fact that he is equipped with an elaborate test panel.

NOISY I-F TRANSFORMERS

Take noisy i-f transformers, for instance; an unmodulated test oscillator will show them up quite readily, as the oscillator signal tends to emphasize the noise.

To track such noise, set the oscillator to the i-f frequency and feed a strong unmodulated signal into the grid of the mixer tube. The oscillator is easily set by first modulating the signal and tuning it for maximum sound output, then flipping the switch to the unmodulated position.

Proceed by feeding the oscillator signal to the first i-f grid and so on, toward the second detector, until the stage is reached where the peculiar scratching noise made by a defective i-f transformer disappears. The transformer preceding this point will prove to be the bad actor.

AUDIO OSCILLATION

If you've ever been perplexed by audio oscillation at high volume levels, you'll appreciate this short-cut:

The condition is most apparent on strong signals, so in this case it is best to turn the attenuator of the test oscillator to the full position—or as near to full as will keep the receiver from blocking.

Again, do not modulate the oscillator. This may cause some to raise an eyebrow, but practice has shown the unmodulated position to be best, since the least tendency toward audio oscillation is quite easily heard above the swish caused by the pure r-f signal from the test oscillator.

With the receiver tuned to the test signal, proceed to push audio grid and

plate leads toward the chassis and away from each other until you come across the guilty lead.

In most cases it will be found that the offending leads are those going to the volume control (audio shunt type) or those of the plate output.

DEAD LOCAL OSCILLATOR

One can quickly and surely determine if the local set oscillator is functioning by the following method:

Tune the receiver to the approximate position of a strong station, preferably a local, and turn the volume control on full. Then tune the test oscillator to a

SHORT CUTS

* In the article on this page, the author covers a group of practical methods for the rapid checking of faulty receivers with nothing more than a good test oscillator. The methods outlined might well come under the heading of "Aural Signal Tracing," for each test is based on the noting of circuit conditions with the receiver in operation. Try 'em out on your own oscillator.

frequency equal to the receiver i.f. plus the frequency of the station—to 1670 kc, for instance, if the i.f. is 460 and the station 1210 kc.

The coupling to the set is accomplished by connecting the output terminals of the test oscillator to a small coil of 40 or 50 turns which is slipped over the mixer tube. The test oscillator should be unmodulated and its full output employed.

The success of this test depends upon the accuracy with which the test oscillator is tuned. A slight variation of not more than 4 or 5 kc in the actual oscillator frequency is permissible. If the adjustment is reasonably accurate, the local station will come pounding in.

R-F OSCILLATION

How often have you wished for a sure-fire method of determining just which stage in the r-f or i-f section of a receiver was generating unwanted oscillations? If you could have ascertained that, you could have found the cause in no time. Well, here's how:

Set the oscillator to any desired frequency in the band and operate it in the unmodulated position. Tune the receiver close to this frequency so that the resulting audio heterodyne is near to zero beat.

The guilty stage is shown up by holding a finger near (but not touching) the grid cap of one r-f or i-f tube after another. This will alter the pitch of the beat note in the event that the particular stage is oscillating. Otherwise the pitch of the beat will remain substantially constant.

If two or more grids give the same results, the chances are that each associated stage is oscillating, or the oscillations are common to all stages in which the pitch of the beat note alters. This is seldom the case; usually only one stage is involved, and oscillation is due to an open condenser, or to grid leads either too long or improperly dressed.

LOOSE CONNECTIONS

Loose connections are more easily located if the receiver is tuned to a strong unmodulated signal from the test oscillator, and all the leads moved or tapped with a non-metallic prod. A poor connection will indicate its presence by a harsh scraping noise from the loudspeaker.

Be sure to have the set volume control full on when making this test.

TRACKING RATTLES

If you don't own an audio oscillator for use in tracking down rattles and vibrations that show up at certain audio frequencies, the test oscillator may be used for this purpose. Here's how:

Tune the receiver to a strong local station at the low-frequency end of the dial and beat the unmodulated signal from the test oscillator against it. The pitch of the beat note may be altered over the entire audio-frequency range by tuning the test oscillator to either side of zero beat. This must be done carefully and slowly since a small variation in the frequency of the test oscillator will cause a correspondingly large variation in the pitch of the beat note (however, this is made less critical by selecting a station signal at the low-frequency end of the receiver dial, as suggested).

Tune the test oscillator slowly over the audio beat range until the mechanical vibration shows up. Then, with the oscillator set at this point, press shields,

(Turn to page 26)

How Wide-Band Frequency

BROADCASTING by the frequency-modulation method has already proved to be the most satisfactory means of reducing noise due to natural or man-made static which has so far been devised. But it is not generally understood that the reduced noise in f-m reception is due in great measure to the wide frequency bands which this method of modulation permits utilizing, rather than to the special attributes of the f-m signal and design features in the f-m receiver. While Major Armstrong emphasized the need for wide-band frequency modulation for noise reduction in his original article on the subject*, most of the subsequent descriptions of the system have paid little attention to this vitally important point. Occasionally, in fact, we are led to believe that noise reduction is accomplished solely by the limiter stage, though this is far from true.

MORE THAN LIMITER INVOLVED

Much of the misunderstanding of the means by which frequency modulation reduces noise arises from our thinking of the effects of noise in terms of amplitude modulation rather than of frequency modulation. It is easy to see that noise can cause amplitude variations in a radio wave and that these variations can result in a signal which is amplitude-modulated by noise and is detected, amplified and reproduced by the speaker, just as in any other amplitude-modulated signal. Consequently, when we note that the f-m receiver has a special limiter stage which is designed to smooth out any amplitude variations in the signal, one may jump to the conclusion that once the noise peaks are thus leveled

*"A Method of Reducing Disturbances in Radio Signaling by a System of Frequency Modulation", by E. H. Armstrong, Proc. I.R.E., May, 1936.

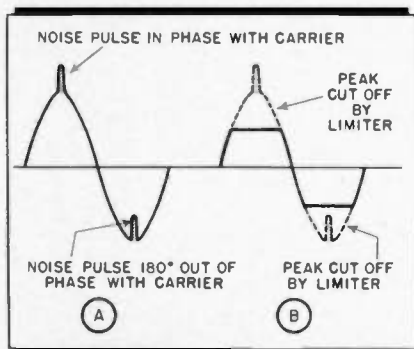

Fig. 1. Noise pulses in phase or 180° out of phase with the carrier, are clipped off by limiter action, as shown.

off, the noise should be completely eliminated.

Actually, this is part of the story, but not the whole story—not by a long shot. For, if the limiter were functioning properly—and noise elimination were its only function—there would be no need for wide-band frequency modulation. So long as the audio range of modulation were encompassed, noise-free reception would be secured.

Over its effective limiting range, the limiter does remove amplitude variations in the signal, whether caused by noise, non-uniform amplification over the frequency deviation range, or any other cause. But, insofar as noise peaks are concerned, the effectiveness of the limiter depends upon the phase of the noise pulse with respect to the signal, as well

WHY WIDE BAND

★ If it were true that the limiter in an f-m receiver completely eliminated noise, there would be no necessity for a frequency deviation at the transmitter greater than that necessary to accommodate the audio range. Actually, frequency-modulated noise is generated in the limiter stage. By employing wide frequency deviations, this f-m noise is reduced to a negligible point in the discriminator circuit, as explained in the accompanying article.

as the amplitude of the noise. And it should be understood that all which follows here is based on the assumption that the signal is stronger than the noise, because neither f-m nor a-m is effective if the noise is stronger, or as strong as, the signal.

NOISE-SIGNAL PHASE

When the noise is exactly in phase or exactly out of phase with the carrier, it adds to or subtracts from the total signal voltage; this is illustrated in Fig. 1-A, in which the shaded area above the positive half-cycle of the carrier represents noise in phase with the carrier, while the similar area over the negative half-cycle represents noise which is 180° out of phase with the carrier. We see here that the noise causes variations in the amplitude of the carrier.

Now if we pass this noise-modulated wave through a limiter stage and thereby reduce the signal amplitude below the minimum signal level shown in Fig. 1-A, the result is a clean signal, free from noise modulation, as illustrated in

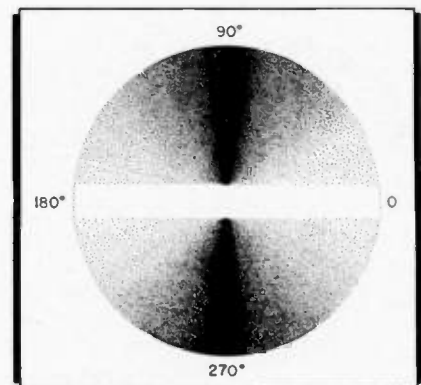

Fig. 3. The variations in shading correspond to variations in noise intensity due to phase differences.

Fig. 1-B. This is substantially the effect which is obtained in practice, but only when the noise is exactly in phase or 180° out of phase with the signal.

Since noise is composed of a large number of frequencies which are irregular in period and whose major frequency components are within the audio range, while the carrier frequencies are extremely high in comparison, it follows that at some instants the noise frequencies will be in phase with the carrier while at all other instants they will be out of phase with the carrier. Some noise pulses will reach a peak when the carrier cycle is just starting, as shown in Fig. 2-A; these are 90° out of phase with the carrier. And, as shown in Fig. 2-B, in the output circuit of the limiter, they are just as strong as before. The same situation exists with respect to noise pulses which reach their negative peaks when the carrier cycle is just starting; these are 270° out of phase with the carrier. At phase differences intermediate to these points, less noise will be passed. Over a carrier cycle, the noise modulation passing the

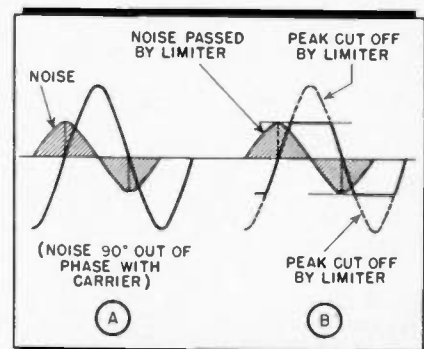

Fig. 2. Noise pulses less than 180° out of phase with the carrier occur in different time intervals than the carrier, and are not clipped by the limiter, as indicated.

MODULATION REDUCES NOISE

By JOHN H. POTTS

limiter may be represented by Fig. 3, in which the variations in shading correspond to the variations in noise intensity due to the differences in phase between the noise pulses and the carrier.

So we find that the output of the limiter contains all components of noise modulation which are not exactly in phase or 180° out of phase with the carrier. Since the presence of these components of noise is due to their phase relationship to the carrier, rather than to their amplitude or frequency, this is caused by phase modulation, which results by reason of limiter action.

The discriminator-detector in an f-m receiver is designed to convert frequency variations in the incoming wave into audio voltages. Phase modulation, such as we have discussed above, also causes frequency variations in the wave. In fact, phase modulation is often considered to be the same as frequency modulation, though this is not precisely correct in that the frequency changes which result from phase modulation vary in extent with the frequency of the audio modulation, while the frequency deviation which results from pure frequency modulation is independent of the modulating frequency, when all other factors remain the same.

PHASE-FREQUENCY MODULATION

To see how phase modulation causes frequency changes, let us consider the carrier wave, shown in Fig. 4-A, to be phase-modulated by a low-frequency sine wave (which may be assumed to represent a noise frequency), shown in Fig. 4-B.

When the carrier wave is phase-modulated by the noise frequency, the output of the limiter may be represented

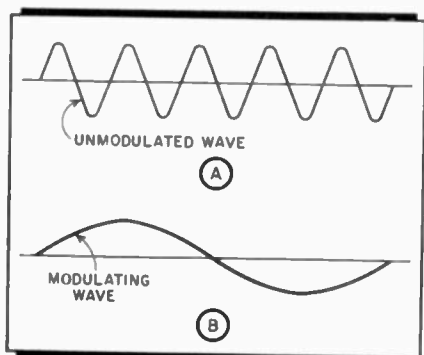

Fig. 4. (A) Unmodulated carrier, equivalent to an f-m wave at its resting frequency. (B) Modulating wave, equivalent to a noise pulse capable of modulating wave (A).

by the dotted wave in Fig. 5. Note that the height of this wave is the same as that of the carrier wave—represented by the solid-line wave in Fig. 5—showing that amplitude variations have been removed. But note also that the peaks of the cycles of the dotted wave, shown as points *b*, *d*, *f*, *g* and *i* do not coincide with the corresponding peaks *a*, *c*, *e*, *h*, *j* in the carrier wave. In other words, they are out of phase with the carrier and represent the results of phase modulation. Over some of the cycles shown, the dotted wave peaks occur after the carrier wave peaks and, over other cycles, they occur before the carrier peaks.

Let us see how this comes about. Since the modulating (noise) frequency shown in Fig. 4-B is much lower in frequency than the carrier frequency, it

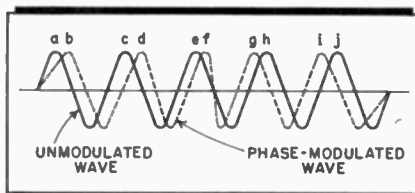

Fig. 5. How noise pulses phase-modulate a carrier.

takes a longer time interval to reach its maximum peak than the carrier. Thus, when a carrier positive half-cycle has already reached its peak, the modulating current in the positive half-cycle of the low-frequency wave is still increasing. As a result of modulation it keeps adding to the carrier after the latter has already passed its peak and has started to decrease. Since any increase in amplitude has been removed by the limiter, the effect is to shift the peak of the modulated wave to a new point, such as *b* in Fig. 5, which occurs a little later than the unmodulated carrier peak, point *a*.

Since it takes a longer time for the modulated wave to reach the peak *b* than for the unmodulated carrier to reach its peak *a*, the result is a slowing down in frequency. That is, for a given period of time, more cycles of the unmodulated signal would be completed than of the phase-modulated signal.

Over the positive half-cycle of the modulating frequency, we note that the effect of phase modulation is to decrease the frequency of the modulated wave because the modulating current is continually adding to the modulated carrier current.

Over the negative half-cycle of the

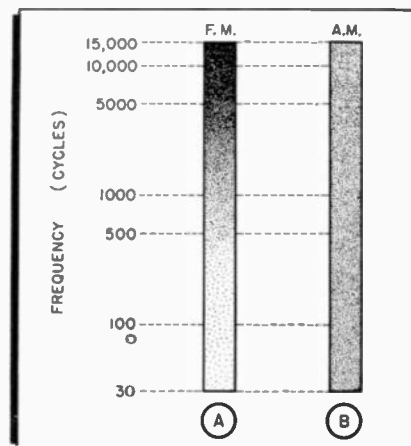

Fig. 6. (A) Noise distribution in the a-f range of an f-m system of broadcasting. (B) Noise distribution in an a-m system.

modulating frequency, the effect is just the opposite. Note that as a result of phase modulation, the peaks *g* and *i* occur earlier than the peaks of the unmodulated carrier *h* and *j*. This results because over this portion of the cycle, the modulating current is continually subtracting from the modulated carrier current. Since more such modulated half-cycles could be completed in a given time period, the frequency is higher.

FREQUENCY-MODULATED NOISE

We see, then, that as a result of phase modulation the frequency of the wave is alternately decreased and increased at a rate corresponding to the modulating (noise) frequency. Thus the effect of phase modulation due to noise is to produce a wave which varies in frequency at a rate determined by the noise frequency. Since the discriminator-detector responds to frequency variations in the signal, no matter how produced, the noise is detected, amplified and reproduced.

In phase modulation, the amount of phase shift which occurs is the same no matter what the frequency of the modulating voltage is. The amount of frequency shift which thus results is, however, dependent upon the frequency of the modulating voltage. For low frequencies, the frequency shift is small and therefore the output voltage of the discriminator-detector is small. As the modulating frequency increases, the frequency deviation due to phase modulation likewise increases and therefore the output of the detector becomes greater. Thus, when the noise frequency is low, which is generally the case, the noise output due to phase modulation is likewise low. Over an audio frequency

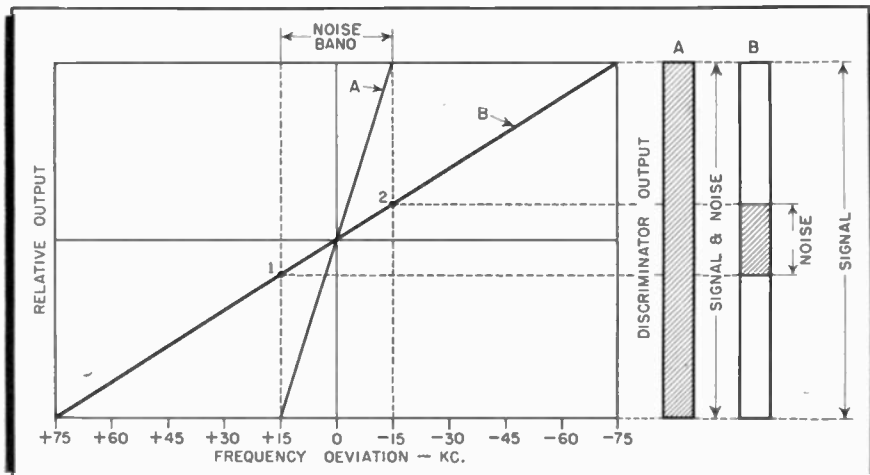

Fig. 7. The frequency deviation due to noise is so small in comparison to the signal deviation, that noise output from the discriminator is negligible.

range of 15,000 cycles, the relative distribution of noise with respect to frequency may be represented by the stippled block in Fig. 6-A, when the noise frequencies over the entire band are considered.

In amplitude modulation, the noise voltage output is independent of the noise frequency and is proportional only to the noise amplitude. Thus, the same noise output will result no matter whether the frequency of the noise is 15,000 cycles or 15 cycles, other conditions remaining equal. Comparing the relative noise output due to phase modulation and amplitude modulation, when the noise frequencies are distributed over the entire band and are of equal amplitude, the stippled block in Fig. 6-B will give an idea of the relative output of noise from each system. Armstrong found that the improvement in the f-m system over the a-m system, due solely to the difference in the distribution of noise voltages over the audio frequency range, was of the order of 1.7 to 1, or 70%.

PART DISCRIMINATOR PLAYS

When other conditions are maintained constant, the output of the discriminator-detector in an f-m receiver is proportional to the frequency deviations in the modulated signal. Since we have seen that noise produces frequency deviations in the signal, it follows that if the audio modulation at the transmitter is made to produce greater frequency deviations than the noise, then the detected signal will be proportionately stronger than the noise, and a better signal-to-noise ratio will be obtained.

This is exactly what is done. The frequency changes which would normally result from a given amount of phase modulation at the transmitter are multiplied many times, and a filter is employed at the transmitter so that the lower frequencies produce a greater phase shift than the higher frequencies in order to compensate for the falling off

in frequency shift which normally occurs in phase modulation when the modulation frequency is low. Complete compensation is not made for this effect; the higher frequencies are purposely broadcast with less attenuation than is required to produce a flat output, giving a rising high-frequency characteristic to the received signal. A filter in the output of the receiver detector circuit serves to reduce this high-frequency emphasis to normal and correspondingly reduce any high-frequency noise components which may be present, thus improving still further the signal-to-noise ratio.

NOISE vs. BANDWIDTH

The improvement in signal-to-noise ratio achieved by wide-band frequency modulation is illustrated in Fig. 7, where both narrow-band and wide-band modulation are plotted against a corresponding receiver discriminator-detector characteristics for the sake of comparison.

If we assume narrow-band modulation, encompassing the complete audio range only, and a discriminator circuit adjusted to provide optimum output within this range of ± 15 kc, then the discriminator characteristic may be represented by line A. Since the noise also occupies this audio band in its entirety, the noise output is distributed over the entire range of modulation. Hence, the ratio of the discriminator output for the noise and the signal is the same, as indicated by block A.

However, as a result of wide-band modulation, the signal is spread over a frequency deviation of ± 75 kc, corresponding to full modulation at present standards. In this case, with the discriminator characteristic represented by line B, the signal-to-noise ratio is proportionately increased, as indicated by block B. Noise deviations in the audible range operate the discriminator only over that portion of characteristic B from 1 to 2, whereas the signal deviations operate the discriminator over the entire linear portion of its characteristic B.

Obviously still wider bands will further improve the signal-to-noise ratio.

It is seen that the increase in signal-to-noise ratio is proportional also to the depth of modulation of the transmitted wave. For low-percentage modulation, the frequency deviation of the wave is less and therefore the signal-to-noise ratio is also less. This, as we all know, corresponds to the results in the case of amplitude modulation. But, in frequency modulation, it is possible to increase the modulation depth for a given carrier level by almost any desired amount, while in amplitude modulation the limit is reached, for a given carrier level, when the modulating current equals that of the unmodulated carrier.

THE SOUND SYSTEM AT ELWOOD

WHEN Wendell L. Willkie stepped under the stone arch of the Elwood, Indiana, High School on August 17th to greet his fellow townfolk as the Republican candidate for president of the United States, his voice was carried to an audience more than twice the capacity of Chicago's Soldier's Field by a Western Electric sound system large enough to blanket an entire world's fair.

This system, installed by the Boom Electric Company of Chicago, is probably the largest ever employed for a one-day event. Through its microphones, amplifiers and loudspeakers the speakers' voices were brought not only to the crowd (estimated at 15,000) at the high school, but to 200,000 more Willkie supporters gathered in 250-acre Calloway Park a mile or so from the school, as

well as an unestimated number of natives and visitors gathered in the streets of down-town Elwood.

THREE-IN-ONE SYSTEM

The huge public-address system was actually three separate systems hooked into a single network through private telephone lines installed by the Indiana Bell Telephone Company. Although Mr. Willkie delivered an informal talk at the high school, he received formal notification of his nomination and delivered his acceptance speech at Calloway Park, necessitating the installation of two separate pick-up stations. Programs from both locations were heard in the streets of the Elwood business section.

In order to eliminate possible feed-
(Turn to page 27)

Serviceman's Diary

By J. P. HOLLISTER

FRIDAY—Got in early this morning. Jerry had told me he was going to stop off at the garage and pick up the truck, in again for repairs.

There is something wrong with the radiator; every hot day it boils over on a long trip and rusty water oozes over the hood. It's about time we traded it in. The old Fargo has gone far; how far I don't know. Sometimes Jerry gets a hunch that the speedometer should be checked, and every time the garage men take it apart they forget to leave the total mileage indication where it was before. Sometimes it reads as much as 10,000 miles less after they get through with it—the dumb clucks!

Usually Jerry hangs around the garage, jawing with the guys down there about politics. This time he got back early. I heard him jam on the brakes as he pulled up sharp in front of the store.

"Mitt me, kid!" he yelled, as he burst into the store.

"What now?" I asked cautiously. He never gets so enthusiastic unless he has put something over on me or wants to cover up something he shouldn't have done.

"I sold two Stromberg combinations last night." He had cooled off a little, but there was still a gleam in his eye which I couldn't understand.

"Yeah?" I said. "Trying out the drug-store stuff, eh?" He had been playing around with the idea of a one-cent sale. You know, you pay list for one item and get another for one cent extra. Since we only got forty and ten on the combinations, this would have given us a net loss. If he sold one console at list and a midget, with it, for one cent extra

—well, it had possibilities. But two combinations. . . .

"Now, listen," he was getting a little sore, "get this straight. I sold two sets. I sold them at a profit. And I wouldn't have sold them if I had listened to you!"

He walked over to his desk, sat down and started to dial the telephone.

"Come on, spill it!" I demanded. "That 'phone call can wait."

"Oh, now, really I'm so sorry," he grinned. "I had no idea you were so interested." He waited a moment, got the busy signal and hung up.

"Chop suey," he murmured, bending over his desk and drawing a lot of triangles on a letterhead. "It's too bad you don't like chop suey."

I didn't answer. I could see he was trying to get my goat. He waited a moment, then continued.

"Remember the Stromberg we sold to the owner of the Chinese restaurant down the street?"

"The Stromberg I sold," I corrected. "Might as well get it straight. After all the trouble I had, it isn't likely I would forget that."

"After all the trouble we had, you mean." It was his turn now. "I wanted to switch him to an automatic record changer and an amplifier, but no, you said never to try and switch an Oriental. And so he got the set and we had no end of trouble getting the noise out. You tried filters on the neon sign and they simply made the noise louder. Then when we shut the juice off the sign it was just as bad. If I hadn't pointed out that the flasher on the tailor's sign next door was causing most of the trouble, we would have had to take back the set."

"Blah," I said. "All you did was to swing your arm every time the sign flashed and I watched you from the window, listening to see if the flashes corresponded with the noise bursts in the set. But let it pass, you thought of trying it. So what?"

It hadn't been hard to fix, though it took two trips and hours of time to find the trouble. An 0.1 bypass across the flasher contacts did the trick.

"Just this," Jerry continued. "After we got the noise out, the Chinaman was tickled pink and he wanted to pay extra for the work. And you said, no, don't take his money, it's good advertising not to. And then he invited both of us to have a dinner on him. And you said, no, that's just as bad as taking money. . . ."

"You ate down there?" I cut in.

"Sure," he replied. "He would have been insulted if I hadn't. I called him up and asked him if I could bring a girl friend along, because you were ill and couldn't come. We had a swell dinner, and afterwards he told me he would have bought two more sets if it hadn't been for the trouble in getting the noise out. Because his other restaurants are in an even worse location. So, I told him about the record-changer combination, brought him down to the store and here's the order." He shoved it over to me.

"You win," I told him. "You know I can't eat chop suey; it repeats on me. Besides, I wouldn't take my girl into such a joint. The bums you run around with would go anywhere."

"Oh, yeah?" he grinned. "Know who I took?" He scribbled a name on a piece of paper and held it up.

"My girl!" I yelled.

HORACE—

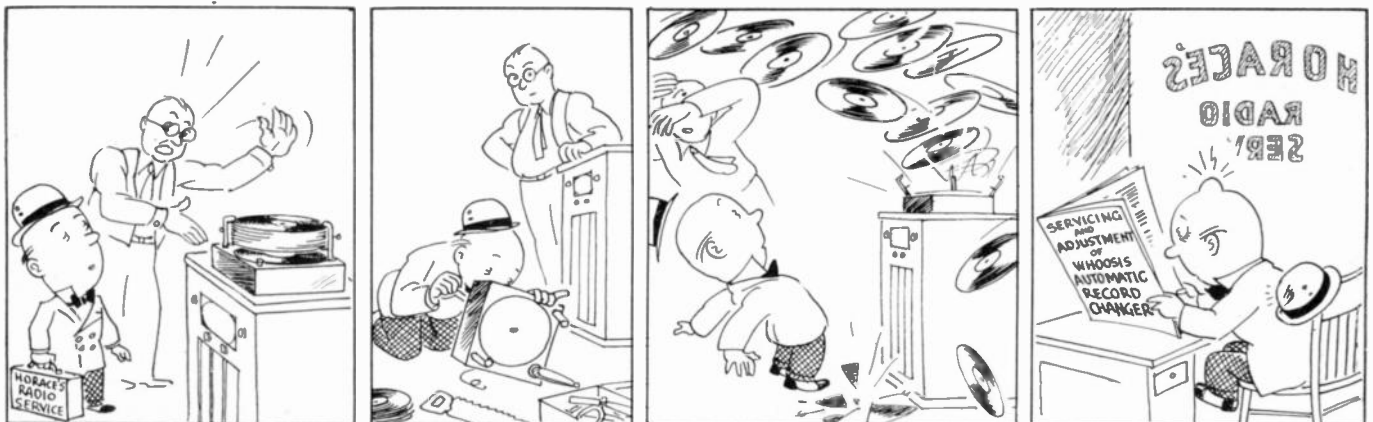

TOUCH UP THOSE CABINETS

There's Money and Good Will in Radio Cabinet Refinishing Work

IF one tries to find out why some service shops make excellent money and others, under similar conditions, do not, he will learn that those who prosper are the ones who give consideration to the many sidelines of radio servicing that help to improve customer relations.

A sideline of no little importance is the repair and refinishing of radio cabinets. This type of work falls within the province of radio servicing, just as fender ironing and body touch-up falls within the province of auto servicing.

The serviceman can use touch-up or polishing jobs as a means of additional profit, or purely for the sake of improving customer relations, which is profitable in the end, anyhow.

Both servicemen and dealers will find in refinishing work a means of moving trade-in sets at a good price.

Dress up the second-hand jobs and watch them go.

FINISHING AND REFINISHING

There is a big difference between new finishing and refinishing. Anyone can paint a cabinet or give it a coat of varnish, but to make an old radio look like new, or to fix a damage, is rather complicated if one does not have just the right material and some experience.

The serviceman who intends to repair damaged cabinets must buy special refinishing materials and should never attempt to do such repairs with ordinary lacquers, enamels or stains, as such materials may cause more damage.

All stains, lacquers, and enamels used for refinishing should be of the spirit type. This has several advantages, the most important being that an unsatisfactory patch can be washed off completely without affecting the surrounding



Typical radio cabinet patching outfit—the Walsco K-10, for dealers and servicemen.

finish of the cabinet. The drying time is also considerably reduced, which is important if a set has to be delivered in a hurry. There will be no special thinners required as thinning, washing out brushes, cleaning the hands, etc., can be done with alcohol which is obtainable anywhere.

The first thing in cabinet repairing is the determination of the kind of injury. There are three different kinds:

RENEWING POLISH

The first, and most easily repaired, is the renewal of the polish on old or stock-worn cabinets when the lacquer or varnish is not damaged. It is remarkable how an old cabinet can be improved just by *proper* polishing.

There are several kinds of polish on the market, the most satisfactory types having a wax base. They will clean the cabinet as well as bring it to a high lustre.

The serviceman should always have two polishing cloths on hand; one with which to apply the polish, and the other to rub the cabinet to a high gloss. All rubbing should be done with the grain, and never across it. It is always recommended to carry a small bottle of polish in the tool case as it makes an excellent impression on a customer if the cabinet is polished when it is delivered, whether it is a repair job brought back or a new radio just set up.

DAMAGED FINISHES

The second kind of injury consists of damage to the finish itself. This finish, in most cases, is a coat of stain covered with lacquer.

To replace a finish if the stain and lacquer have been removed requires some practice. In such cases, the damage should be sanded first, with the grain, with 6-0 or 7-0 Garnet finishing paper. After this sanding, the spot should be carefully cleaned and then the stain applied with a small brush.

It is best to use a spirit aniline stain which is obtainable and ready for use in shades to match radios. The brush should be small and very little stain should be taken to brush over the damage. Overlapping at each stroke, and overlapping the old finish should be avoided as this will form dark stripes or rings. The real color will not show up after this staining but only after the finish has been built up over the stain.

The easiest way of building up the finish is with a spray gun. However,

very few radio shops have this equipment. There is another method which does not require any tools, and which will work very satisfactorily. This method is termed "French Polishing" and consists of the application of special lacquers or varnishes with a "French Polishing Pad." This pad can be made of soft muslin or a similar cloth by folding it several times and placing some cotton or any other soft material in the center. The pad should be about twice the size of a golf ball. A few drops of French Varnish or Patching Lacquer



The Walsco K-9 radio cabinet repair kit, for quick patching of damaged sets.

should be put on the pad and also a couple of drops of oil. The pad has to be patted in the palm of the hand until it becomes sticky, then the surface should be polished immediately. A circular motion should be used and the surface only touched lightly. It is important that the pad is kept in motion all the time and the size of the circles changed. One should never stop or lift the pad until a smooth polish is established.

By repeating this operation at intervals, extremely smooth coats of varnish or lacquer can be produced. This "French Polishing," after once learned, will serve to repair a great number of damages that often occur in radio shops and stores.

DAMAGE TO WOOD

The third kind of injury consists of damage not only to the finish, but also to the wood. Broken edges, holes, and deep indentations fall in this classification.

There are two ways of repairing such damages. One is to fill such holes with plastic wood or similar substances and level it off with sandpaper and finish as explained previously. The finish obtained by doing so is not considered to be the best; however, it is recommended for all those who have had no experience in refinishing work. It is easy to do and gives satisfactory results in most cases.

The better method, commonly used by professional refinishers, is the filling of
(Turn to page 24)

TECHNICAL SERVICE PORTFOLIO

SECTION V

TESTING AUDIO AMPLIFIERS

IN addition to the stage-by-stage tests of receiver audio circuits described in Sections I and II of the Portfolio, there are a number of overall tests of audio systems which will be found invaluable in special servicing. The tests to be described serve not only to provide accurate knowledge of the characteristics of receiver audio systems and p-a amplifiers, but likewise to reveal obscure defects, such as speaker rattles at certain frequencies, cabinet resonance, audio regeneration and other faulty conditions which may not be observed when the testing is done at a single audio frequency. Methods of making overall measurements of electrical sensitivity, calculating db gain and its bearing on the selection of microphones, also described, will be found especially useful to those who go in for p-a work.

The audio amplifier in a receiver does not differ fundamentally from a public-address amplifier, but the latter has about 100 times as much gain and, usually, a far higher power output. And, when the gain and the power output of an amplifier are increased, so also are the woes which may beset it. Insofar as testing is concerned, the increased gain of the p-a amplifier means that greater care must be exercised in shielding the test leads, grounding of the apparatus and placement of leads to avoid feedback. Aside from these precautions, the test methods for both types of audio amplifiers are essentially the same.

AMPLIFIER CHARACTERISTICS

The principal characteristics of an amplifier are its gain, fidelity, power output and hum level. From a servicing standpoint, we may assume that a given amplifier must once have proved satis-

factory on all these counts, otherwise it would not have been purchased and installed. So the purpose of measuring such characteristics, from a servicing angle, is primarily to find out to what extent these characteristics have varied as a result of use or, in the event some essential component has required replacement, to make certain that the original performance has been restored.

Aside from these reasons, it is a matter of much satisfaction to any jobber, dealer or serviceman to be able to make comparative tests of apparatus and to have on hand actual figures showing the performance of equipment. Considerable care should be used to interpret such information correctly, however, since what may be considered ideal performance from a laboratory viewpoint may be far from desirable from a practical viewpoint. Much depends on the nature of the application. For instance, the microphones used in airplanes are designed to cut off frequencies below 700 cycles, thus reducing most of the noise due to the motors. Obviously an amplifier for such microphones in which considerable space and weight was used in order to employ components which would give good response for frequencies which

the microphone was designed to attenuate would be less desirable than a smaller, lighter amplifier which covered the desired frequency range, and no more. The same applies to other sound systems used exclusively for speech. And, above all, we should not forget that such factors as noise, hum, acoustic feedback, mechanical and electrical connections are often more important, from a maintenance angle, than slight deviations from normal characteristics.

ELECTRICAL FIDELITY

To make measurements of electrical fidelity, a variable-frequency audio oscillator will be required. For servicing purposes, the beat-frequency type has a wider range of application than the simple audio oscillator which enables the selection of a few audio frequencies at various portions of the audio range. Since the beat-frequency type supplies a continuously variable frequency, it is possible to tune it to any point in the a-f range. This makes it possible to sweep over the audio range and locate any peaks in the a-f response which may not occur at the particular frequencies covered by a step-by-step a-f oscillator. The beat-frequency oscillator is less stable

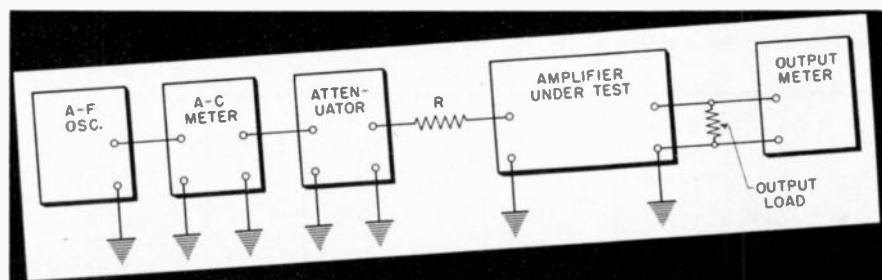

Fig. 1. Test set-up for checking the fidelity, gain and other characteristics of an audio amplifier or sound system.

in frequency, however, and is therefore not as accurate for exacting measurements.

Output meters may be of the copper-oxide rectifier type. Such meters have a frequency error in that their response falls off at the rate of 1/2 to 1 per cent per 1000 cycles over the audio range. By using copper-oxide meters to measure both the output of the test oscillator and the output of the amplifier under test, the error is automatically compensated for since both meter readings will fall off to the same degree and thus will offset each other.

In testing amplifiers used for record reproduction, it is a good idea to supplement the beat-frequency oscillator with frequency records. The latter enable a checkup of the complete system, including the pickup. Often it will be found that a fidelity test made with such records shows a rising low-frequency characteristic and a falling off in response at higher frequencies. It should not be assumed that such a characteristic is objectionable. On the contrary, the rising low-frequency characteristic tends to compensate for the normal attenuation of such frequencies in recording, while the falling high-frequency end similarly corrects for accentuation of such frequencies during recording. In the latter instance, a better signal-to-noise ratio is obtained because, by attenuating the highs in reproduction, surface noise and needle scratch are likewise attenuated, while the frequencies accentuated in recording are simply brought down to normal level. However, this recording practice is confined mostly to high-fidelity recordings.

Presence of objectionable peaks in the output when checking a phonograph amplifier with a frequency record may be due to pickup arm resonance; this may occur when a different pickup assembly is installed in a given system and the resonant frequency may be changed by increasing or decreasing the weight or mass of the assembly. Alternatively, the peak may be reduced by suitable electrical filters, usually specified by manufacturers. Use of frequency records is most convenient and desirable in testing phono combinations in homes, since the records are easily carried around and

enable a complete overall dynamic test of the phono system. Often rattles in speakers, or rattles caused by loose tube shields, chassis mounting screws, etc., may be simply and quickly revealed by such a test.

TEST SET-UP

For checking the fidelity, gain and other characteristics of an amplifier, a set-up similar to that shown in Fig. 1 should be employed. The output of the audio oscillator is fed to an a-c meter which is shunted by an attenuator. In series with the high side of the attenuator and high input terminal of the amplifier is a load resistance *R*, of a value corresponding to that of the microphone or other device to which the amplifier is normally connected. In the output circuit of the amplifier, a resistance load corresponding to the voice coil impedance at 400 cycles is shunted across the output transformer secondary in place of the speaker voice coil. This is done because the impedance of the speaker voice coil varies over the a-f range and may, in some cases, be four times as high at 10,000 cycles as at, say, 100 cycles. This varying impedance causes a similar variation in output voltage which would cause misleading results in the interpretation of the fidelity curve of the amplifier alone. In some cases, it may be found desirable to omit this load resistor and leave the speaker connected. If this is done, it is essential that the speaker be mounted on a baffle because the impedance of the voice coil will be far different at low frequencies when no baffle is used.

For fidelity tests, two methods are available. Either the output may be kept constant and the input signal level varied, or the input signal may be maintained constant and the variations in output level for different frequencies noted. The former method is preferable for amplifiers whose response characteristic varies widely at different frequencies in that there is less chance of erroneous results occurring due to overload distortion on amplifier peaks. However, the attenuator in the input circuit will have to be accurately calibrated for such tests.

It is simpler to maintain the input signal constant and measure the variations in output level. If carefully done,

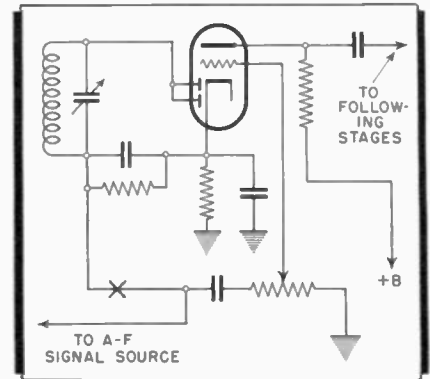

Fig. 3. In checking fidelity of a-f amplifier, break the diode feed circuit at point marked X; otherwise the diode will rectify the positive half-cycles, thus causing distortion.

there should be no difference in the results. It is important to work well within the normal undistorted power output level rating of the amplifier. If the rated output is 20 watts, an output level of 2 or 3 watts at 400 cycles is sufficiently low to enable measurement of peaks at other frequencies in the average p-a or receiver audio amplifier without exceeding the linear range of the amplifier.

Many output meters are calibrated directly in db. This is a great convenience in fidelity measurements, since the variations in db can then be noted directly on the meter without calculation. If a variable input attenuator is employed, it should likewise be calibrated in db for this purpose.

TESTING RANGES

The usual range of frequencies covered is from 30 to 10,000 cycles. Over this range, the output of the beat-frequency oscillator varies least when the impedance of its load matches that of its output transformer. Thus, the combined resistance of the a-c meter and the attenuator which it shunts should be so chosen that they form the proper load for the b-f oscillator. If a 1000-ohms-per-volt meter, on its 5-volt scale, is employed, its resistance is 5000 ohms. If the attenuator has a total resistance of 5000 ohms, the total shunt resistance is then 2500 ohms.

The signal level required will be of the order of 1 millivolt for p-a amplifiers and about .05 to 0.1 volt for receiver audio amplifiers. For the former, it is convenient to use a voltage divider having a total resistance of 5000 ohms, tapped at 5 ohms. This will serve to attenuate to 1 millivolt a voltage across the divider of 1 volt. This latter level may be conveniently measured with the usual service copper-oxide meter. Similarly, a tap at 250 ohms will provide a .05-volt output and at 500 ohms, the output will be 0.1 volt.

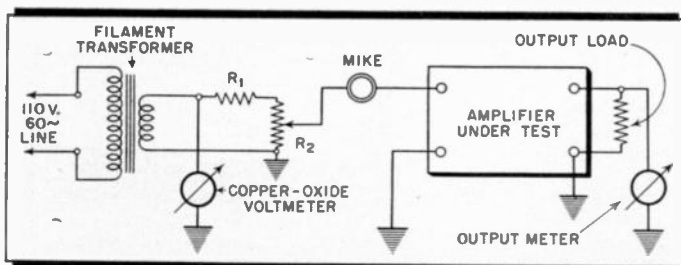

Fig. 2. If noise level in room is low, the mike or pickup may be used in place of R in Fig. 1, for a true dynamic test.

The load resistance R corresponds to the dummy antenna used in receiver testing. It is substituted for the mike, pickup or other load to which the amplifier is normally connected. If the noise level in the test room is reasonably low, the actual mike with which the amplifier is to be used may be employed in place of R , as shown in Fig. 2. This will enable a true dynamic test of the amplifier under conditions approximating normal operation. Similarly, if a phono amplifier is being checked, the actual pickup and its associated network may be substituted for R . Care should be taken, if either the mike or the pickup is a low-impedance type, that the resistance of that portion of the attenuator which is included in the measuring circuit is low in comparison with that of the device being employed. Otherwise, since it is in series with R , its resistance must be considered in determining the total input load resistance.

Fidelity measurements are made on the basis of the relative response of the amplifier at frequencies other than 400 cycles in comparison with the response at 400 cycles. Therefore, the first measurement to be made is the response at 400 cycles. Since fidelity measurements concern only relative levels, the actual gain of the amplifier is not required for this test. These relative output levels may be determined either in voltage or db ratios. If measured in the former terms, they may be converted to db ratios by reference to a db table.

GAIN MEASUREMENTS

The setup of Fig. 1 may also be employed for gain measurements. The gain in db of an amplifier can not be directly determined by the ratio of the output voltage to the input voltage because the db system is essentially a power ratio and the power ratio must take into account the difference in impedance of the input and output circuits of the amplifier. Manifestly, the signal voltage across a 2-ohm winding of an output transformer will not be the same as that across a 500-ohm winding, when both are properly loaded, yet the power in each case may be the same.

To correct for this discrepancy, the gain in db is expressed in the following equation:

$$\text{Gain (in db)} = 20 \log \frac{E_o}{E_i} + 10 \log \frac{R_i}{R_o}$$

In this formula

- E_o = Output signal voltage across load
- E_i = Input signal voltage
- R_i = Input load resistance
- R_o = Output load resistance

For example, if the output signal voltage is found to be 10 volts when the input signal is 1 millivolt, the db ratio is

$$20 \log \frac{E_o/E_i}{10,000} = 20 \log \frac{10,000}{10,000} = 20 \log 1 = 0 \text{ db}$$

If the input and output loads of the amplifier are equal, as, for instance, is the case in an intermediate line amplifier when both input and output lines are 500 ohms, the gain of the amplifier is 80 db.

In most p-a amplifiers, however, these loads are not the same. The output load may be of the order of a few ohms while the input resistance may be several megohms. The latter is of particular interest. It usually matters little whether the input grid leak in a high-impedance circuit is 1 megohm or 10 megohms; either will be high in comparison with the impedance of the average microphone used directly in such circuits. Yet if we are to apply the formula for db gain, taking into consideration only the input resistance of the amplifier, we shall find that the higher the input grid resistance, the

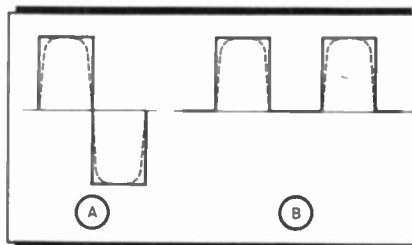

Fig. 4. (A) A typical square wave with fundamental and odd harmonics present. (B) Another type of square wave with negative half-cycles suppressed. Dotted lines indicate distortion in amplifier.

greater the rated db gain, though the actual gain of the amplifier remains the same in that a given signal output voltage from the microphone will produce the same output voltage.

To obtain a certain amount of standardization, many amplifier manufacturers now rate their db gain on the basis of an input resistance of 150,000 ohms. Thus, in the above example, if the output resistance were 4 ohms and the input resistance is considered as 150,000 ohms, the rated gain in db of the amplifier is equal to the measured voltage gain of 80 db, as found above, plus

$$10 \log \frac{R_i/R_o}{37,500} = 10 \log \frac{150,000/4}{37,500} = 10 \log 1 = 0 \text{ db (approx.)}$$

Thus the total gain in db becomes 80 plus 46 or 126 db.

The output level of 10 volts across 4 ohms represents an output power of 25 watts, determined by the formula $W = E^2/R$. If this is the maximum undistorted power output of the amplifier, and we find that this output is produced by a signal input of 1 millivolt, then the output of the microphone with which the amplifier is to be used must also be 1 millivolt, at an average conversational

level at normal distance, to work satisfactorily with the amplifier.

MIKE RATINGS

The usual reference level for microphone ratings is one volt per bar or—which amounts to the same thing—one volt per dyne per sq. cm. If we talk into a microphone at a distance of about 1 foot at an average conversational level and the resulting voltage output of the mike is 1 volt, then its rating would be zero db. Actually the output of a microphone is considerably less than 1 volt; accordingly its db rating is expressed as minus so many db, depending upon its voltage output. Since this is a voltage ratio, the actual rating in db is obtained by multiplying the log of the ratio by 20. If we require an output of 1 millivolt, or .001 volt, since the log of .001 is —3, the db rating becomes —60 db.

This means that a mike rated at —60 db will deliver into an open circuit, corresponding to a very high resistance load, an output of 1 millivolt at the distance mentioned and at an ordinary conversation level. If we require 2 millivolts to produce full output from the amplifier, then the mike must deliver twice the output voltage, or 6 db more, to produce the required input signal level. The microphone rating would accordingly have to be —54 db.

Usually the gain of the amplifier should be somewhat greater than necessary, on the basis of these computations, so that full output may be obtained without working the amplifier wide open and when the speaker moves away farther than one foot from the mike.

60-CYCLE TEST

A simple and convenient setup for checking amplifier gain at a single frequency is shown in Fig. 2. The test is made at 60 cycles, obtained by using the 2.5-volt winding of a filament transformer which is shunted by an attenuator to produce outputs of the order of a few millivolts. The same ratios specified in (Turn to page 21)

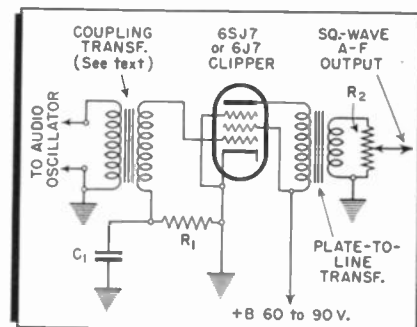

Fig. 5. Schematic of limiter or clipper which will provide a satisfactory square wave for test purposes.

Set of the Month —

MOTOROLA MODEL 40-60W

OVER the past year, so many improvements and simplifications have been made in the so-called "midget" ac/dc receivers that their overall performance under average reception conditions is fast approaching that which we are used to expect from more elaborate sets.

The most recent advancement, and one that does not add materially to the cost of a midget, is the inclusion of an r-f stage, with resistance- or untuned transformer-coupling between the r-f tube and the mixer. The additional gain so obtained is adequate to over-ride two major faults of loop-operated midgets used at any distance from local stations—noise background and oscillator hiss. Naturally, the additional gain also serves to raise the level of weak stations to a point where their programs are serviceable.

Representative of such engineering advancements is the new Galvin *Motorola Model 40-60W*, the circuit of which is shown in Fig. 1. Other notable examples



Galvin's *Motorola Model 40-60W*.

of midgets with r-f stages are the latest *RCA Models 15X and 16X-1*, the *Zenith 6D510*, and the *Stromberg-Carlson Nos. 500H, 500J and 500S*.

MOTOROLA CIRCUIT

The *Motorola Model 40-60W* has a number of interesting features. The loop, for instance, is tapped, with one

section serving as the coupling coil when an external antenna is employed. In this sense, the loop is the equivalent of the usual antenna coil, with the low ends of primary and secondary grounded.

For reception in the Police Band, the inductance of the loop is lowered by placing in shunt with it the coil (2), this being accomplished by grounding the lower end of the coil through switch (14) which also shunts an additional coil across the oscillator tank circuit.

The same switch is used to provide one-step tone control—by grounding the bypass condenser (16) which is tied to the plate of the 12SQ7.

The 12SK7 r-f stage is coupled to the 12SA7 mixer by means of an untuned iron-core r-f transformer (3). The secondary of this transformer is shunted by a resistor which broadens the resonance curve. The gain is appreciably higher than would be the case with resistance coupling.

The receiver also includes inverse (Turn to page 24)

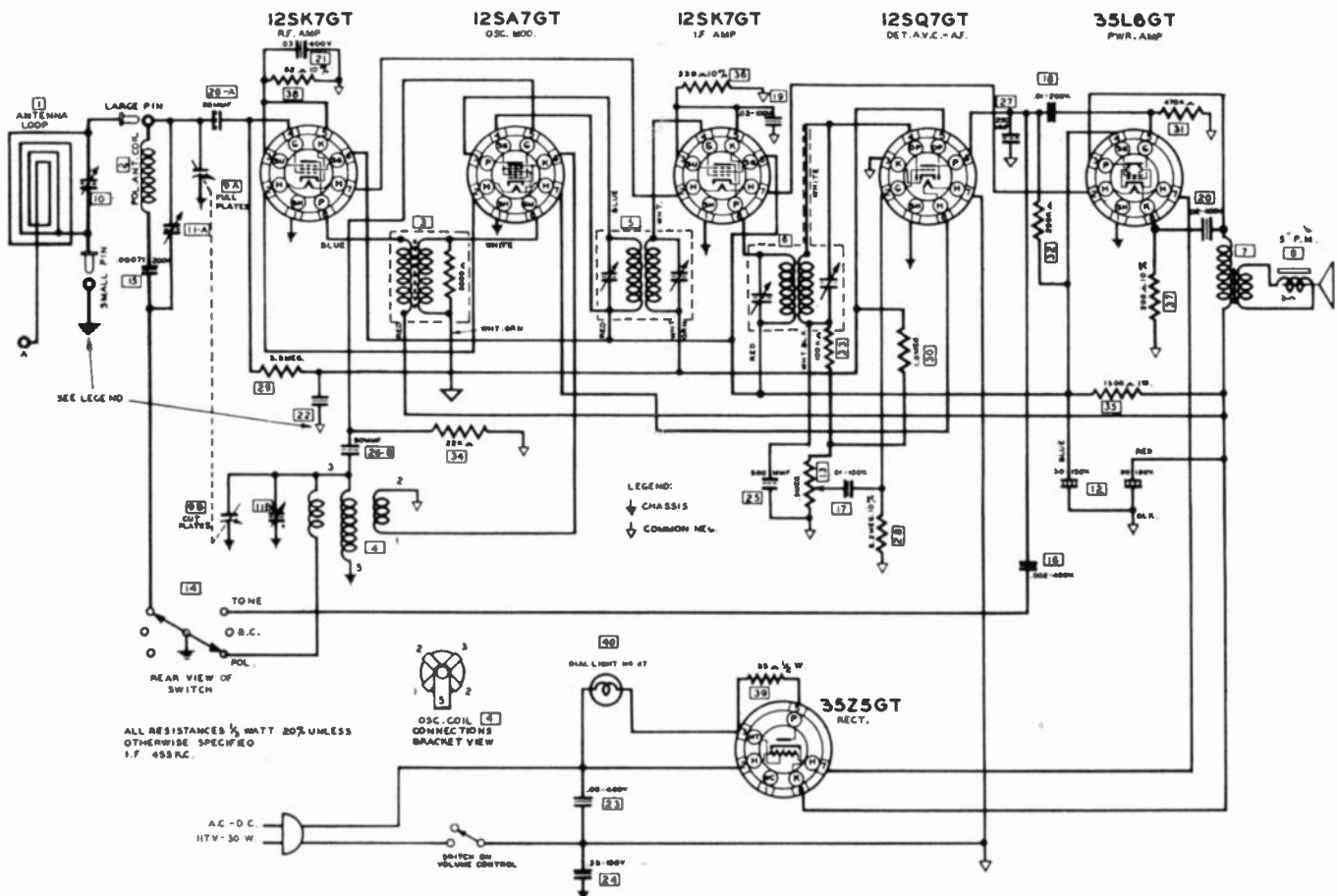
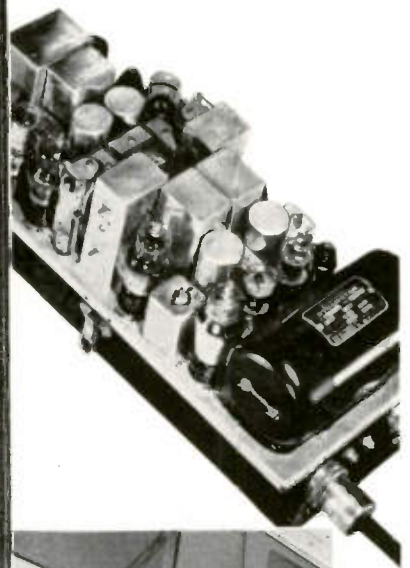

Fig. 1. Schematic of *Motorola Model 40-60W*, analyzed in the accompanying article.

U. S. GOVERNMENT

APPROVED

**AVIATION DIRECTION FINDER
IS RAYTHEON EQUIPPED!**



An acknowledged leader in the field of aircraft radio direction finders, is Learadio. Their equipment bears the official mark of approval of the Civil Aeronautics Authority and is used not only by the United States Government but also by the Governments of Canada, China, England, Japan, Peru, Sweden and many others.

It is not surprising that an independent survey by the Lear engineers of available tubes for these delicate and vital instruments showed RAYTHEONS to be the best for the work and most reliable.

Yet these are the same tubes from the same production that you might be using as replacements in an ordinary home radio receiver! Is it any wonder that the best engineers of Set Manufacturers and most successful Servicemen use RAYTHEONS in their work? Especially since RAYTHEONS actually cost no more!

Raytheon Production Corp., Newton, Mass., New York, Chicago, Atlanta, San Francisco.



RAYTHEON
MAKES THEM ALL

"WORLD'S LARGEST EXCLUSIVE RADIO TUBE MANUFACTURERS"

Circuit Court

R-F DEGENERATION

YOU'VE SEEN LOTS of inverse feedback circuits; sometimes they pick up the signal at the plate of the output tube and dump it back into its input grid-return circuit. Others shoot the signal at the plate of a resistance-coupled stage through a resistor and blocking condenser into the high side of the preceding plate or input grid circuit. Simplest of all was the idea of cutting out the electrolytic across the cathode resistor of the power tube. For a nice, easy modernization job, we can think of nothing we would rather tackle than clipping the red lead from such an electrolytic.

But all these stunts have to do with audio circuits. Now comes a new one; and it's in an i-f stage. That extra 50-ohm resistor *R14* in series with the bypassed 500-ohm one (*R6*) in Fig. 1 is put there to provide inverse feedback; that's why it isn't bypassed. Not for the same purpose as in a-f circuits, of course, but to help keep the sensitivity and selectivity of the i-f stage from shifting all over the lot at different signal levels.

What happens is this: when you align an i-f amplifier with a weak signal, so that the avc does not operate to any extent, the adjustment of the i-f transformer secondary trimmer which gives perfect alignment is not the same as that for a strong signal. The reason is that, with a strong signal, the avc goes into action and increases the grid bias on the i-f tube, and this in turn changes the input conductance, so that a readjustment of the trimmer is necessary to restore correct alignment. The change in trimmer capacity required may amount to 1.5 mmfd for the normal range of signal variation.

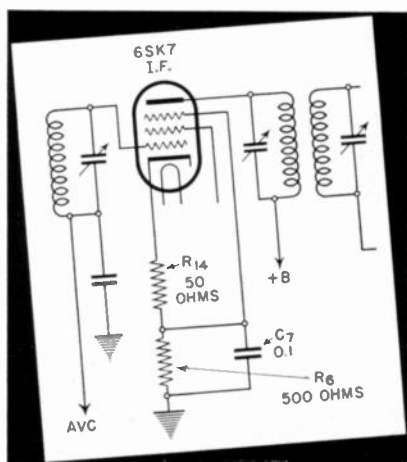

Fig. 1. Inverse feedback in an i-f stage. The out-of-phase voltage is developed across *R14*.

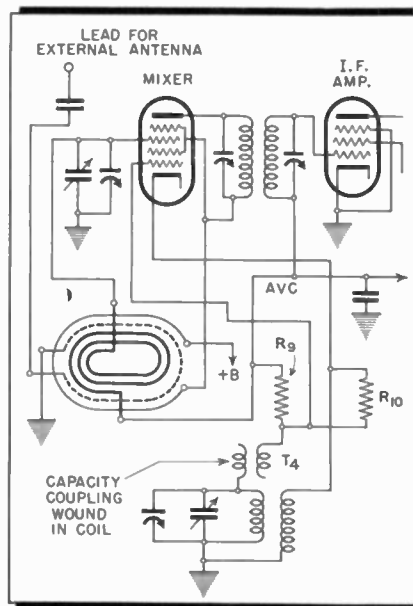

Fig. 2. Regenerative feedback by means of a third loop winding.

This detuning effect by strong signals, when the set is aligned for weak signals, affects mostly the selectivity. It also reduces sensitivity and broadens the tuning, but neither of these results matters on strong signals. In fact, the fidelity of the receiver actually may be better when the i-f. is not sharply aligned. But selectivity is important, particularly in auto radios, such as the *Ward Model 04BR-567A*, from which the circuit of Fig. 1 is derived.

Inverse feedback of the type shown tends to correct this trouble. The cause and cure were discovered by Freeman, of Hazeltine, and were published in the IRE Proceedings for November, 1938. Now it's showing up in production receivers. You'll find that many others have it—*G.E.*, for instance, in their Models J-105, J-805, J-71, and J-64. Align in the usual way anyhow.

LOOP FEEDBACK

EMERSON HAS a whole slew of circuit tricks in chassis *EL* and *EP*. A portion of the circuit is shown in Fig. 2. The loop is a three-winding affair, the outer winding providing regenerative feedback from the mixer plate return which adds a little "hop" to the input circuit. Note that the high "B" juice is on this winding.

They get rid of the oscillator grid condenser by using two dead-end windings, one of which connects to the oscillator tuned circuit. The capacity coupling between the dead-end windings furnishes

all the micromikes needed for the purpose; other models used only a single dead-end coil close to the tuned circuit, previously described in these columns.

A degree of avc delay is obtained by feeding a portion of the negative rectified voltage developed across the oscillator grid leak, *R10*, into the avc resistance network, by means of *R9*. This tends to increase the sensitivity to weak signals, and provides a limiting bias for the mixer and i-f stage so that the cathodes may be grounded.

HUM MEETS HUM

HUM MEETS HUM in the *Emerson ED-354* receiver, and the result is less hum. In the schematic, Fig. 3, the simple and clever stunt which Emerson uses to reduce hum in their ED chassis is shown.

Note that the filter choke, which happens to be the speaker field in this layout, is in the negative leg of the power supply. The resistors *R4*, *R2* and *R1* form a voltage divider from which taps are taken off to provide negative bias for the 6SQ7GT and 6V6GT grids.

The designer apparently was faced with the problem of bypassing these resistors to get the hum out of the audio amplifier in an economical and efficient manner. Yet these resistors are low in value. To bypass *R2* at audio fre-

(Turn to page 23)

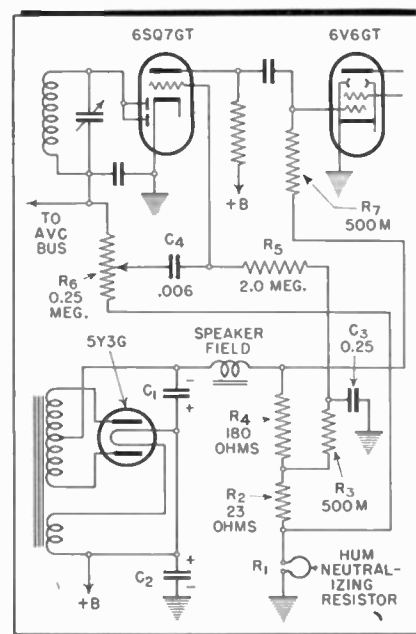

Fig. 3. Hum voltage developed across *R1* is used to cancel hum in audio circuit.



THESE 18



TYPE D ALL-PURPOSE CONTROLS

Handle 60% to 75% of ALL REPLACEMENTS



TAP-IN SHAFTS Stay Put!

...The All-Metal Cabinet is Included - AT NO EXTRA COST!

Now, for the first time, you can purchase a stock of only 18 Controls, 6 switches and 5 special, extra shafts . . . and be prepared for quick, efficient service on more than two-thirds of the radios you are called upon to repair!

You save time, because it is no longer necessary to order a control every time you need one! You simplify installations because IRC Type D All-Purpose Controls with their Tap-in Shafts are easier to install and can be used universally to replace midget size or larger, old-style controls! You save money—and you assure your customer of a first-class job!

Best of all, you pay only the standard price for the controls, switches and shafts. The handy new IRC Master Radiotician's Control Cabinet, as illustrated, is included with your purchase at not one cent of extra cost.

The Cabinet itself is of all-metal construction. Attractively decorated, it is an asset to the appearance of your shop. It is 14½" x 7¼" x 4", weighs approx. 6 lbs. complete. IRC Control numbers are marked underneath each compartment so you can tell at a glance just what values should be reordered to keep your stock complete. Three drawers supply ample space for shafts, switches or other spare parts. Front metal cover snaps securely shut for carrying, or may be removed when Kit is used in your shop. The regular net price of the 18 Controls, 6 switches and 5 special, extra shafts is \$14.97—and the Cabinet is included for not one cent extra!

Type D All-Purpose Controls are exact reproductions of the larger IRC Type CS Controls, with exactly the same design, exactly the same features and with the added convenience of Tap-in Shafts.

Just pick the control you need, select the proper shaft, tap it into position in the cone-shaped control receptacle following simple instructions enclosed with each control, and the job is done. The shaft won't pull or vibrate loose—and you're sure the quality of the control is the highest money can buy.

HERE IS WHAT YOU GET!

The IRC Master Radiotician's Cabinet is factory-packed with the following 18 Type D All-Purpose Controls, switches and special shafts of the most popular types shown by records to be capable of handling the big majority of all control replacements.

IRC Control Type No.	Resistance	Purpose	IRC Control Type No.	Resistance	Purpose
2-D13-133	500,000	A	1-D13-133 X	500,000	F
1-D11-116	10,000	B	1-DC13-133 X	500,000	G
1-D11-123	50,000	C	1-D13-137	1.0	A
1-D11-128	100,000	C	1-D13-137 X	1.0	A
1-D11-133	500,000	C	1-D13-139	2.0	F
1-D13-123	50,000	D	1-D13-139 X	2.0	F
1-D13-128	100,000	A	1-D14-116	10,000	H
1-D13-130	250,000	A	1-D16-119	20,000	B
1-D13-130 X	250,000	E			

A—Tone or Audio Circuit Control
 B—Antenna Grid Bias Control
 C—Potentiometer Voltage Divider
 D—Tone Control
 E—Tapped for A. V. C.
 F—Tapped for Tone Compensation
 G—Friction Clutch Auto Radio Type
 H—Antenna Grid Bias of 2 Tubes

Switches: 5—No. 41 S.P.S.T.; 1—No. 42 D.P.S.T.
 Shafts: 1—Type B Auto Radio; 2—Type C with slotted, knurled terminals; 2—Type D with slotted, unknurled terminals.

Dealer Net on above controls, 6 switches, 5 shafts . . . **\$14.97**
THE CABINET IS INCLUDED FREE!

INTERNATIONAL RESISTANCE CO.

401 N. BROAD ST., PHILADELPHIA, PA.

Attached is \$14.97, check, money order (or send C.O.D.) one IRC Master Radiotician's Control Cabinet complete with the 18 Type D All-Purpose Controls, 6 switches and 5 Tap-in Extra Shafts as described. It is understood that, if this does not meet my full approval, I can return it in good condition for full credit within 5 days.

NAME _____

STREET _____

CITY _____ STATE _____

Name of your regular jobber _____ City _____

(Jobber's name must be given to secure net dealer cost shown) State _____

USE THIS HANDY ORDER FORM

Shop Notes

MOTOROLA CONDENSER SYMBOLS

The latest Motorola schematics carry elaborated symbols for condensers so that one may tell at a glance whether a capacitor is of the air, mica or paper type, or an electrolytic.

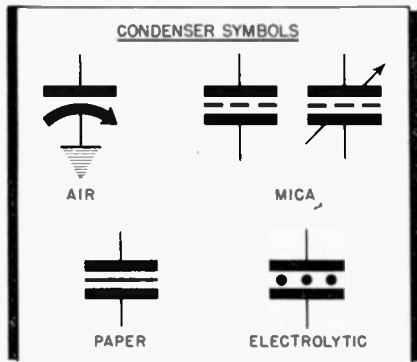

The symbols employed are shown in the accompanying sketch.

NEW TUBES

RCA 5W4-GT

The 5W4-GT is a high-vacuum full-wave rectifier with a T-9 bulb for use in a-c receivers having relatively low current requirements. Filament draws 1.5 amps at 5 volts.

With condenser input filter, maximum a-c rms voltage per plate is 350, d-c output, 100 ma. With choke input filter, maximum a-c rms voltage per plate is 500, d-c output 100 ma.

Sylvania 1LC5

Type 1LC5 is an r-f pentode of loktal construction designed for service in low-drain battery-operated receivers. Functions well at reduced B voltage. May be used in avc circuits since it has a medium cut-off characteristic.

Filament draws .050 amp at 1.4 volts. Plate voltage, 45 to 90. Mutual conductance, 750 to 775.

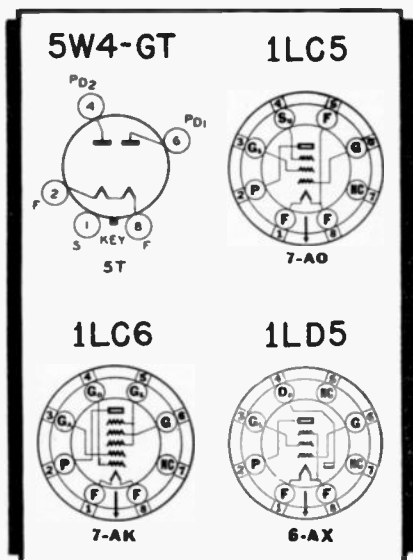

Sylvania 1LC6

The 1LC6 is a pentagrid converter of the loktal type. Feature is its ability to function at reduced B voltage, over the range of 45 to 90 volts.

Filament draws .050 amp at 1.4 volts. Conversion conductance at zero grid voltage, 250 to 275; at -2 volts, 50; at -3 volts, 5.

Sylvania 1LD5

The 1LD5 is a loktal diode-audio pentode for low drain battery sets. The diode plate is located at the negative end of the filament pin No. 8.

Filament draws .050 amp at 1.4 volts. Plate voltage, 45 to 90. Mutual conductance, 550 to 575. Voltage gain of pentode, 70 to 120 in resistance-coupled circuit.

RCA MODELS 16K AND 16T3

2400-kc Police Band

Where desirable, reception of a police station in the 2400 kc band may be obtained by adding a jumper connection from trimmer C₃ to trimmer C₄₀, and lining up push button No. 5 to the desired police station. Realignment of C₃ at 1500 kc will be necessary.

RCA LITTLE NIPPER

Speaker Adjustment

Certain cases of "off center" cones have been attributed to a binding between the speaker housing and chassis base as illustrated.

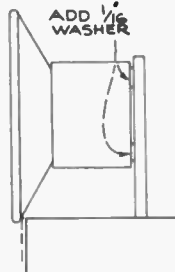

This should be checked wherever rattle is experienced, and washers added as indicated, if required.

RCA GAIN DATA

Using 3-volt Fixed Bias

To provide more definite operating conditions, the r-f and i-f gain data for RCA Victor Service Notes is now obtained with a fixed 3-volt bias on the avc bus.

To duplicate this gain data, it is necessary to connect a 3-volt bias battery temporarily to the set as indicated in the service notes. The negative side of the 3-volt battery should be connected to the avc bus, and the positive side of the battery should be connected to the chassis. (In a.c.-d.c. receivers, the positive side of the battery should be connected to the common negative wiring.)

The battery may consist of two small flashlight cells connected in series.

Use of the fixed bias eliminates necessity for shorting out the avc circuit, and minimizes difficulty due to over-loading with resultant grid current.

RCA TONE GUARD

The RCA Tone Guard is an acoustic network around the opening of the phonograph compartment in some models. It

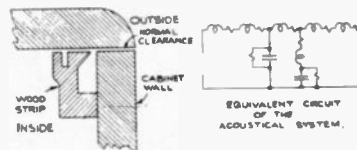

acts as a low-pass filter to reduce passage of the high-frequency sound that is generated and radiated directly into the air by the vibrating parts of the pickup.

A cross-section view of the Tone Guard and the equivalent electrical circuit are shown herewith. The series elements of the filter are formed by the normal slit

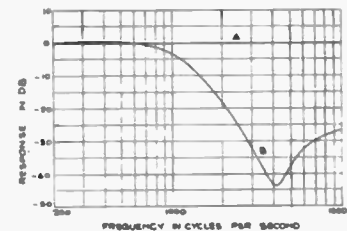

Curve A is response frequency characteristic of conventional door and cabinet, taken as unity. Curve B is characteristic of Tone Guard, showing reduction of high-frequency noise.

between cabinet and lid. The shunt elements are formed by slots in the wood strip. The filtering action is very effective, as indicated in curve B.

RCA MODELS 16K, 16T3, 16T4, 17K, 18T, 19K, 110K, 111K

Failure to Oscillate on Push-Button Tuning

Should a case of non-oscillation on any push-button range be experienced, check the oscillator grid leak to assure that it is 56,000 ohms. Some sets employed a 33,000 ohm leak which was occasionally found troublesome with low line voltage.

Low-Frequency Oscillator Push-Button Coil

To ensure low-frequency coverage on the push-button oscillator coils in these models, a high-inductance coil, Stock No. 37133, is used for the 540-1030 kc push-button oscillator ranges.

RCA 1941 RECEIVERS

Reduction in Sensitivity

It may be found necessary in certain localities to reduce the sensitivity of these receivers in order to reduce the effect of noise pickup in between stations. This can be done by adding larger resistors in the i-f cathode connected between the existing 100 ohms and ground with a 1/10 mfd. in shunt with the added resistor. On the receivers which do not use a 100-ohm resistor in the i-f cathode, the resistor and capacity combination should be added between the cathode and ground. The value of the resistor could be anything between 500 and 3,000 ohms depending upon the reduction in sensitivity required.

(Turn to page 20)

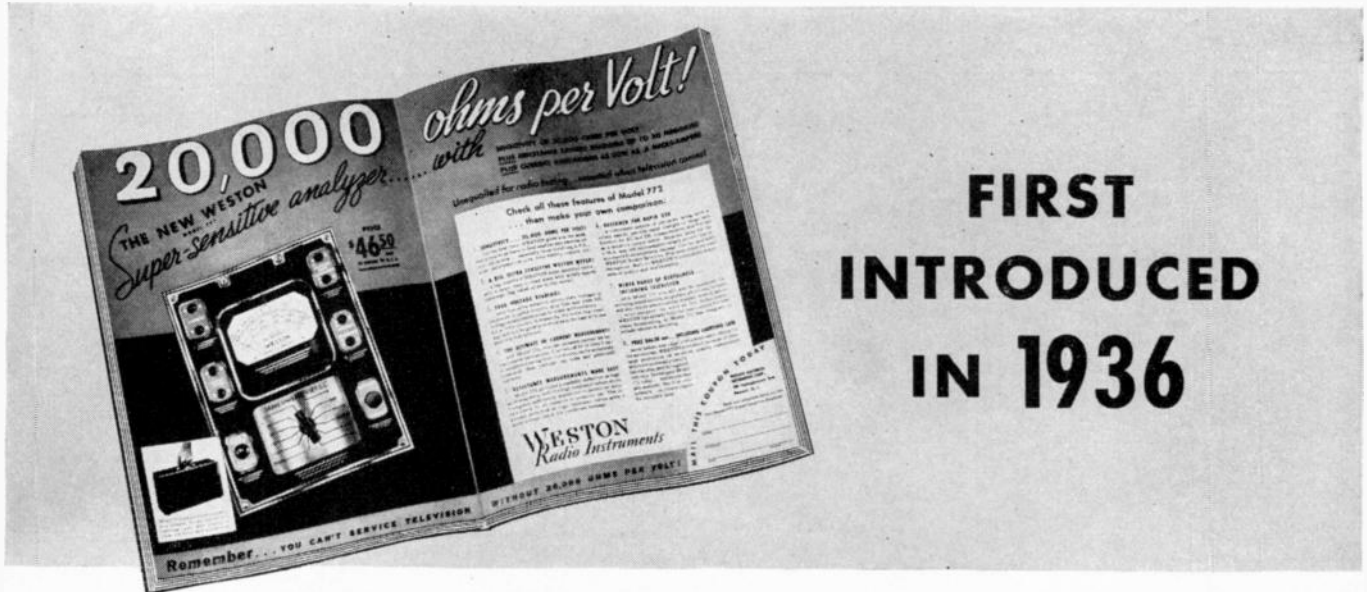

**FIRST
INTRODUCED
IN 1936**

Still Tops for 1941!

Owners of Model 772 have experienced the true economy of buying correctly designed instruments which measure in fundamentals

Servicemen who purchased one of the original Model 772's over four years ago have found this super-sensitive Analyzer "up-to-the-minute" all during this period...and find it still "tops" in the field for today's and tomorrow's measurement needs.

It more than met the test requirements of all A.M. receivers...despite the refinements and circuit changes during these many years. It met the requirements of television, too; and today, it is the outstanding instrument for F.M. servicing...because of its high sensitivity, its sound design and construction, and because it measures in fundamental quantities. There are no trick circuits or gadgets to cause early and costly obsolescence. It is a fundamental instrument that, with usual instrument care, will remain in full service indefinitely.

Be sure to get all the facts on Model 772 and other WESTON fundamental test equipment. Write to Weston Electrical Instrument Corporation, 605 Frelinghuysen Avenue, Newark, New Jersey.

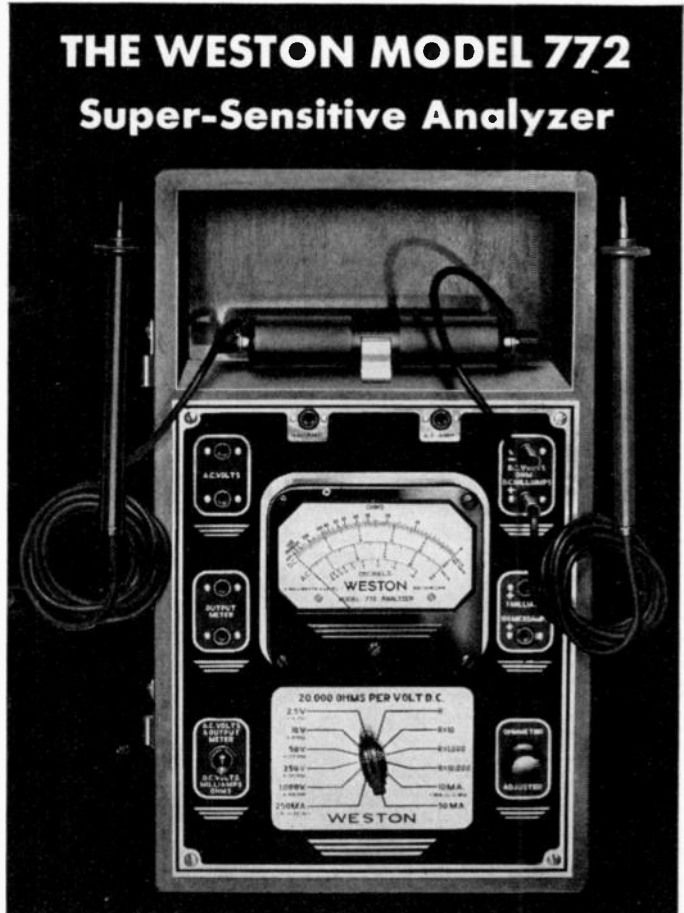

Laboratory Standards... Precision DC and AC Portables... Instrument Transformers... Sensitive Relays... DC, AC, and Thermo Switchboard and Panel Instruments.

WESTON

Specialized Test Equipment... Light Measurement and Control Devices... Exposure Meters... Aircraft Instruments... Electric Tachometers... Dial Thermometers.

FOR OVER 52 YEARS LEADERS IN ELECTRICAL MEASURING INSTRUMENTS

Shop Notes

RCA MODEL 15BP

Replacement Power Switch

Filament burn-outs may be caused by excessive voltage surges occurring when

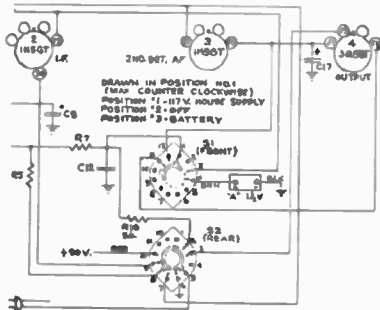

switching from "POWER LINE" to "BATTERY" or vice versa. Whenever servicing receivers for this reason, the power switch should be replaced and wired as shown, using Stock No. 37393 power switch kit.

Note the addition of a 5-ohm resistor, and the necessity for installing a new indicator, both of which are included in the replacement power switch kit, Stock No. 37383. The new indicator is arranged "BATTERY-OFF-POWER LINE," neces-

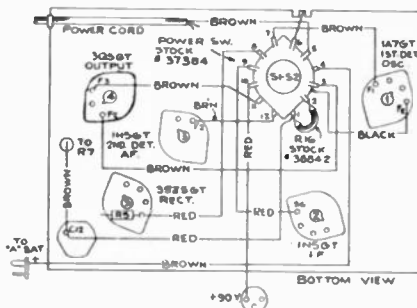

sitating that the switch pass through "OFF" in going from line to battery, thereby discharging all filter capacitors.

Additional Data

The following data should be added to the Service Note for Model 15BP:
Power line consumption, 117 volts . . . 35 watts
Total rectified "B" current, 117 volts, 60 cycles56 mls.

Also, in some production, capacitor C15 on plate of 1H5GT is changed from 390 mmfd. to 100 mmfd., to provide increased high-frequency response.

RCA VA-21 WIRELESS RECORD PLAYER

Motor Data

The motor used in this model is the direct-drive synchronous type, and the following data applies to all other RCA Victor jobs using the same type of motor.

Smooth starting and running will be insured by keeping the bearings well cleaned and oiled.

Hum and Vibration:—A small amount of hum when starting, decreasing to a negligible amount when running, is normal. If excessive vibration occurs, it may be due to:

1. Insufficient lubrication, or any failure that will cause binding.

2. Leather washer not oiled. (Check to make certain that the leather washer is above the steel washer.)

3. Motor not properly supported from motor board.

4. Burrs on poles of rotor or stator. Remove with fine emery cloth.

Important:—The damper spring must fit without binding or chattering in the slot in the stator. The stator must be free to deflect in either direction between the limits of the damper spring. The damper spring must exert approximately equal force in restoring the stator to its mid-position when the stator is deflected manually in either direction.

Removing Rotor:—The rotor and turntable assembly simply rests on the ball

ZENITH 1941 WAVEMAGNETS

The primary winding of the Wavemagnets used on 1941 models is of the high impedance type and the natural period of this winding is within the broadcast band. When an antenna is connected to the primary winding the additional capacity tunes it below broadcast frequencies which is very desirable for energy transfer.

However, this requires that the primary winding be short circuited whenever an external antenna is *not* attached in order to preserve the tuning characteristics of the loop winding. A shorting bar is provided for this purpose, and should *always* be in place when the receiver is operated on the Wavemagnet alone.

Details of direct-drive synchronous motor used in RCA VA-21 Wireless Record Player. The same motor is employed in other inexpensive RCA record players.

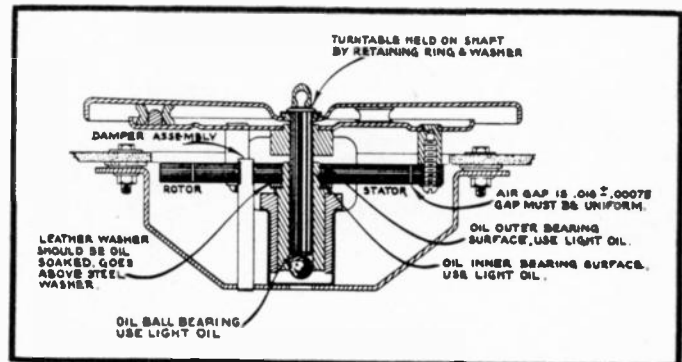

bearing at the bottom of the vertical bearing. Remove by lifting upward.

Rotor Adjustment:—Remove motor from cabinet. Loosen the three screws that hold the rotor to the turntable, insert three 16-mil shims at equal distances around the gap between the rotor and stator, and then carefully tighten the three screws. The top of rotor must be flush with top of stator; add additional steel washers beneath the stator if necessary.

STEWART-WARNER

Loop Alignment

Chassis 03-6J, 01-6K, 03-6L, 01-6M, 03-5R, 07-5R, 03-5S and 01-9A utilizing tapped loops must have the "Intermediate" band aligned before the "Broadcast" trimmers are adjusted. If the "Broadcast" band were aligned first, any efforts to align the "Intermediate" trimmers would result in detuning the "Broadcast" band.

On all these sets, provision is made for aligning the antenna trimmers after the set is installed in the cabinet. The capacity between the loop and the chassis affects the tuning of the loop. Therefore, when making preliminary adjustments of the "Broadcast" antenna and oscillator series padding condenser, it is important that the loop be placed in a position relative to the chassis that is approximately the same as the position it occupies when installed in the cabinet. Otherwise the adjustment of the padding condenser will be incorrect.

Final adjustments of antenna trimmers must be made after the chassis and antenna are mounted in the cabinet.

Although the alignment procedure specifies that the output of the signal generator is to be connected to the external antenna terminal through a resistor or condenser, it is satisfactory to couple the signal to the loop by means of an unshielded wire placed near the receiver loop, the other end of the wire connecting to the output of the signal generator.

ZENITH 1941 SERVICE NOTES

6A02-6A04

Noisy—Right hand pilot light wiring may be pinched by automatic bracket. Check for poor contact on manual push button. Check for loose or poor contacts on pilot lights.

Oscillation on short wave band—Push black lead of automatic away from automatic adjustments. Keep white and green leads of automatic away from 7L7-7H7 socket.

7A02-7A04

Dead—480-mmfd. condenser on automatic may be grounded against automatic frame or latch bar.

Oscillation—Push leads of wave trap close to chassis keeping them away from antenna coil.

12A3

Hum—Change 6J5 in first audio socket.

All Chassis

Weak short wave—Open r-f choke in plate circuit of 1232 tube.

Noisy—Dial rubbing against escutcheon. Stator lugs on braid of gang condenser rubbing against side of opening in chassis. Make sure all loktal type tubes are firmly seated in sockets.

Cannot be aligned—Check for open or rosin connection on primary winding of Wavemagnet.

Overloads—Usually due to open resistor in avc circuit of first detector.

Phono Models

Distortion—Check for broken crystal in pickup.

Low Volume—Check for poor contact in phono switch and plug contacts—check shield on lead from crystal pickup for poor ground.

SERVICE PORTFOLIO

(From page 13)

the discussion of Fig. 1 apply also to this attenuator. The mike is shown in series with the high side of the input circuit.

A routine check of the gain at 60 cycles, from time to time, is of great help. Normally, there is a slight and constant deterioration in amplifier performance which is usually first evident in the low-frequency response. By periodically checking at 60 cycles with this simple setup, any variations in gain are quickly determined.

If the amplifier is fairly flat from 60 cycles up to the voice frequencies, the setup of Fig. 2 may also be employed to check microphone sensitivity. If long, sustained syllables, such as "ah" and "oh" are spoken into the mike and the resulting output meter reading noted when the input attenuator is set for zero input, this reading may be compared with the 60-cycle input voltage required to produce the same output, thus giving the microphone voltage output.

In checking receiver audio amplifiers, distortion may result if the signal is fed into an input circuit in which a diode is present. In the typical circuit shown in Fig. 3, unless the circuit is opened at the point (x), the diode will rectify the positive half of the signal cycle, causing distortion which will be readily apparent on an oscillograph.

In checking the fidelity of an amplifier of which Fig. 3 may represent the input circuit, remember that the input load is the diode load and the resistor *R* in Fig. 1, representing this load, must be inserted in series with the signal source. The diode bypass condenser should be shunted, not across *R*, but across the input circuit of the amplifier, to duplicate actual operating conditions.

Many are coming to realize that feeding pure sine waves into an amplifier which is designed to work from complex waves, such as are secured from speech and music, does not represent a true dynamic test, however useful it may be from other standpoints. Accordingly much experimentation has been devoted to the production of signal sources rich in harmonics. Obviously, if a wave having a fundamental frequency of 30 cycles and strong harmonics up to 10,000 cycles, then a single test of an audio amplifier determines its response characteristics over this frequency range. If the amplifier amplifies one harmonic more than another, then the output wave shape will not be the same as that applied to the amplifier.

SQUARE-WAVE GENERATORS

Square waves are being used for this purpose. In Fig. 4-A, a typical square wave in which only the fundamental and odd harmonics are present is shown. Another type of square wave, in which the

Fig. 6. Test set-up for taking a frequency run on an a-f amplifier with a square-wave generator and cathode-ray oscillograph.

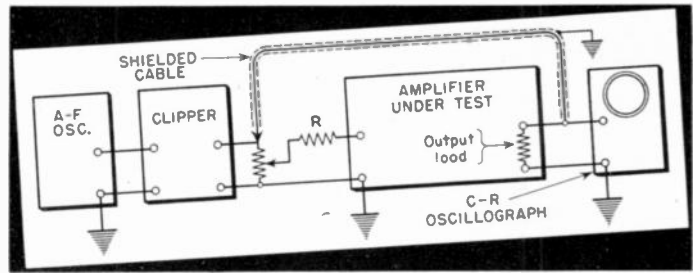

negative half-cycle is suppressed, is shown in Fig. 4-B.

Special square-wave signal generators, suitable for service operations, have not yet appeared on the market though laboratory apparatus of this type is available.

For those who wish to experiment, the typical limiter circuit shown in Fig. 5, employed in f-m receivers, will be found to produce a wave approaching these characteristics when fed by a sine-wave
(Turn to page 23)

A TUBE TESTER.. A BATTERY TESTER

All for Only

\$29.95

Terms: \$1.00 cash and 8 monthly payments of \$3.63

FREE
TUBE SETTING SERVICE FOR ONE YEAR

IN producing Model 589 there has been no compromise in the circuit design or materials. The same manufacturing methods, careful inspection and accurate calibration are incorporated in this instrument as in all other SUPREME testers. It will pay you to investigate and see this tester before you buy. Its price is the lowest at which a GOOD tube tester can be built.

MODEL 589 TUBE AND BATTERY tester has a completely modernized circuit. The tube test sockets are not wired directly to the circuit, but, instead, pass through the patented SUPREME Double Floating Filament Return Selector system which automatically re-connects all tube elements to any possible tube base arrangement. Due to the fact that any or all elements of each socket can be rotated to any desired position, only one socket of each type is necessary. Tests every type of tube from 1.4 volts to full line voltage at its correct anode potential under proper load. Tests separate sections in multi-purpose tubes. Checks all leakages, shorts, open elements and filament continuity with a neon lamp. A circuit insert is provided for checking noise, leakage, loose and bad connections. The battery testing circuit of the Model 589 provides the proper load at which each battery is to operate, plainly marked on the panel, for all 1.5, 4.5, 6.0, 45 and 90 volt portable radio types. The condition of the battery is indicated on an English reading scale.

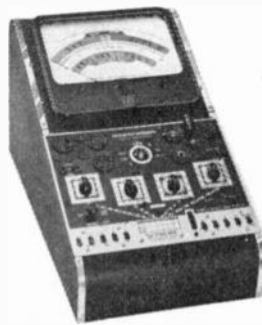

This is the fastest and easiest tester to operate. Just "follow the arrows"—you can't go wrong. Roller type tube chart with brass geared mechanism lists tubes in logical numerical order. Each tester carries a one year free tube setting service. SUPREME engineering and construction PLUS the best materials the market affords, make the 589 your biggest dollar value. You will be proud to own this instrument.

MODEL 599 TUBE AND SET TESTER is very similar in appearance to the Model 589, and includes all the features and advantages of this instrument. In addition, it provides the following ranges:

0.2 TO 1500 D.C. VOLTS—5 carefully selected ranges—0/5/15/150/600/1500 volts. 1000 ohms per volt STANDARD sensitivity.

0.2 TO 600 A.C. VOLTS—4 A.C. ranges—0/5/15/150/600 volts. Rectifier guaranteed with instrument and fully protected from overload damages.

0.2 M.A. TO 600 M.A.—3 direct current ranges 0/5/60/600 allow measurement of screen, plate, "B" supply and D.C. filament loads.

0.2 TO 600 OUTPUT VOLTS—0/5/15/150/600—ideal for alignment. No button to hold down—no external condenser necessary.

0.1 OHM TO 20 MEGOHMS—4 ranges 0/200/20,000 ohms, 0/2/20 megohms. A low range at high current with 3.5 ohms center scale.

ELECTROSTATIC—ELECTROLYTIC LEAKAGE TEST—Sensitive calibrated 20 megohm range provides excellent leakage test of paper and electrolytic condensers.

Just as the 589 is your best value in a tube and battery tester, the 599 is your best value in a combination tube tester, battery tester and set tester. Remember, you have all the features of the 589 PLUS a complete A.C. DC volt, ohm, megohm, milliammeter, at a cost of only 47c per range.

Dealer Net Cash Price
\$39.50

Terms: \$4.50 cash; 9 payments of \$4.33.



Illustrated above is the Model 589 in a counter type metal case. This model is available with option of 7" or 9" illuminated meters. Has two neon lamps for sensitive or super-sensitive tests. Write for prices and information.

SUPREME

SUPREME INSTRUMENTS CORP.
GREENWOOD, MISSISSIPPI, U. S. A.

New Catalog Just Off Press.
Write for your copy Today!

Metal cabinets as illustrated for the Model 589 at left and 599 above are identical—can be used either in a horizontal position or vertical position by merely reversing the instrument panel. Write for prices and information.

Presenting —

NEW PRODUCTS

DACO-DAYRAD

Fluortest Jr. & Sr.—Two new instruments designed for the rapid testing of fluorescent lighting fixtures with ratings up to 100 watts.



Fluortest Senior will analyze in one minute any 110-120, or 220-240 volt, dc or ac, any cycle, fluorescent fixture. Indicates line voltage, lamp voltage, wiring accuracy, condition of reactors, ballasts, compensators, starters, etc. In this respect the Junior and Senior models are alike.

The Senior model also checks all auxiliaries when removed from the wired circuit on 110-120 volts or 220-240 volts ac, 50-60 cycles. Other cycle tests available at slight additional cost. Also checks all lamps separately, up to and including 100 watts.

The Senior is encased in shark-skin grain black leatherette portable carrying case with removable cover. Operating instructions on front panel. Weight 17 pounds. Size 14½" x 14½" x 6".



The Fluortest Junior is for testing wired circuits only. Operating panel of black and silver aluminum. Encased in black cobra grain leatherette portable carrying case. Weight 4 pounds. Size 8½" x 4½" x 6". By The Dayton Acme Co., 2339 Gilbert Ave., Cincinnati, Ohio. RADIO SERVICE-DEALER.

UNIVERSAL MIKE

Weight Scale—Weight scale for servicemen and recordists for rapidly determining the weight on pickups or cutting heads.

Reads in ounces and has a hook to clinch stylus holder screw.

"Minute Blanks"—New 4-inch double-face recording discs for brief, personal messages. Paper base and non-inflammable. Mails in an ordinary envelope.

Scale and Blanks by Universal Microphone Co., Inglewood, Calif. RADIO SERVICE-DEALER.

BRUSH

Xtal Pickup—The PL-25 pickup, illustrated, is virtually identical to the PL-20 and uses the same crystal cartridge. The arm is designed for records not over 12 inches in diameter and measures 10½ inches overall, compared with 14 inches overall for the PL-20.

Frequency response of PL-25 is flat within plus or minus 2.5 db from 50 to 6000, with only a slight rise to 10,000. Has permanent stylus of polished sapphire and low inertia vibratory system. Stylus pressure is 30 grams.

Will reproduce constant-amplitude recordings without any form of equalization; commercial records (constant velocity) by



simple equalization in the reproducing circuit. By The Brush Development Co., 3333 Perkins Ave., Cleveland, Ohio. RADIO SERVICE-DEALER.

MONTGOMERY WARD

Preamplifier—The "Professional Airline". Six channels permit the use of four additional mikes at one time, with two extra phonos, though not both at once. Can be operated up to a mile distant from main amplifier.

Included are two tone boosters to emphasize either the low bass or high treble tones, or both; and four mike input controls for regulating volume of each individual mike. Also one master phono volume control and one master gain control for overall volume control of both phonos and all mikes.



Operates on 105-125-volt 50-60-cycle a.c., and draws 60 watts. Fully described in Montgomery Ward's new catalog, "Simplified Sound Systems", which may be had free by writing Montgomery Ward & Co., Dept. RSD-39, Chicago, Ill. RADIO SERVICE-DEALER.

BELDEN

Line Filter—Type 8100 DeLuxe Power Line Filter, contains two dual condenser sections and two dual high-Q chokes. Ground is provided by 3-wire Belden power cord, eliminating possibility of shock from case. Unit has a rating of 3 amps at 115 volts.



Type 8105 Standard Power Line Filter also available. Same rating as the 8100. By Belden Mfg. Co., 4689 W. Van Buren St., Chicago. RADIO SERVICE-DEALER.

JACKSON

Audio Oscillator—Model 652 operates on a new principle. It provides an audio-frequency voltage developed at its fundamental frequency, setting the basic design of the instrument apart from the beat-frequency type of audio oscillator. For complete information, write The Jackson



Electrical Instrument Co., 121 Wayne Ave., Dayton, Ohio. RADIO SERVICE-DEALER.

PRESTO

Blower System—Type 400, for clearing instantaneous record surfaces. Directs tiny blast of air across disc just behind cutting head which throws the waste thread to the center, clearing it from the cutting stylus. Simultaneously removes lint or grit from disc surface. Will not produce "air noise" in high-fidelity recordings.

Blower can be attached to any Presto recorder without alterations. By Presto Recording Corp., 242 West 55th St., New York, N. Y. RADIO SERVICE-DEALER.

audio signal source. The input voltage should be sufficiently high to produce overloading, thus resulting in clipping of the positive and negative half cycles of the signal voltage. Other circuits using diodes are used commercially, but the signal input requirements are higher.

Using the limiter as a clipper, the set-up of Fig. 6 may be employed. In operation, the cathode-ray oscilloscope is connected first to the clipper output and the wave is observed. Then the output signal across the voice coil is similarly observed and the results compared. The dotted lines shown in the diagram, Fig. 4-A, indicate that distortion is present in the amplifier.

Sufficient data is not available at the moment of writing to take up in detail the results which may be secured from this test method. However, it is coming into use for production testing of amplifiers and, on the basis of information already gathered, promises to offer many advantages in such applications.—*J.H.P.*

CIRCUIT COURT

(From page 16)

quencies, he would need an electrolytic with a reactance low in comparison with 23 ohms (R_2) at audio frequencies. Several hundred mikes would be required if the resistor were directly bypassed.

Alternatively, a series resistance-capacity network could be used and that is what was chosen. R_3 and C_3 form this filter. Since the resistance of R_3 is 500,000 ohms, C_3 —though only 0.25 mfd—is very low in reactance at audio frequencies in comparison with 500,000 ohms, so the hum in the grid-return circuit of the 6SQ7GT is adequately filtered.

The 2-meg resistor R_5 , also in the grid-return circuit of the 6SQ7GT, is used to isolate C_3 from the audio amplifying circuit. Otherwise C_3 would also bypass the signal voltage at the first a-f grid.

With the first a-f grid circuit nicely filtered, a hum-free signal would be amplified and passed on to the grid of the 6V6GT output tube grid. And, if no hum were present in the latter circuit, the result would be hum-free reproduction.

But the 6V6GT grid is operated at a bias derived from the voltage drop across R_4 , R_2 and R_1 , in series. Since this divider is not bypassed directly, some hum is present. This could be filtered out directly, by using a resistance-capacity filter similar to R_3 - C_3 , but such a procedure would increase greatly the resistance in the grid circuit of the 6V6GT . . . far more than is permissible in the grid circuit of a power tube which is likely to have quite some gas.

Now available for DIRECT MAIL—

RADIO SERVICE-DEALER's List of 20,000 Independent Radio Servicemen and Service Organizations — Radio Dealers — Soundmen — Managers of Retailers' Service Departments — Radio Jobbers and their sales personnel.

These 20,000 men account for 90% of the nation's radio service and sound work each year—

for further information—write: **RADIO SERVICE DEALER, 11 W. 42d St., New York, N. Y.**

BE FULLY INFORMED ON RECORDING!

Prepare for the fast growing demand for men who thoroughly understand the mechanics of instantaneous acetate recording.

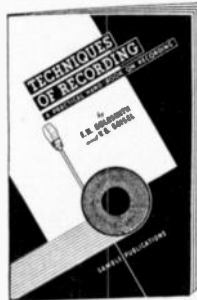

A Gamble Publication

Send today for

"TECHNIQUES OF RECORDING"

by F. H. Goldsmith and V. G. Geisel

A big, fully-illustrated book, packed with all the information you need . . . 44 pages . . . size 7 x 10½ inches. A thoroughly practical handbook of recording which discusses

Advent of "Acetate"
Definition of parts
Stylus setting
Width or Depth of Cut
Equalization for recording at 33-1/3 rpm
Reproducing Needles

Acoustics and Microphone placement
Establishing correct recording level
Monitoring and Mixing
Tone Deformation
Extraneous Noise

Price \$1.00 Postpaid

Send Check or Money Order to

Gamble Hinged Music Co., 218 S. Wabash Ave., Chicago, Ill.

A Money Making Election Special!



AUDIOGRAPH

15 Watt Mobile with Phono-Top

—for 6 volt battery and 110 volt operation

for **\$69.50**

★ 6v Battery—110v A.C.—No external power packs. Changeover by removing battery cable and substituting A-C cord. No chance for misconnection.

★ Full Fifteen Watts Power—Use for mobile truck work. Has power to cover large crowds at indoor and outdoor meetings. Uses Class A output circuit; far superior to amplifiers using less costly Class B output.

★ Phono Motor and Crystal Pickup—Plays 12" records with constant speed phono motor and high quality crystal pick-up. Amplifier is also available without the phono top (Model AM-15C).

★ Tubes Used—One 6SJ7 input amplifier, one 6SC7 electronic mixer, two 6V6G push-pull beam power outputs, and a 6X5G rectifier. All circuits are operated at voltages within standards specified by tube manufacturers, assuring you of long tube life.

★ Output Provisions—Three output sockets are provided, two with 4 ohms for paralleling two 8-ohm speakers, and one with 8 ohms for a single speaker. Screw-on Amphenol connector is provided for microphone.

★ ★

AVAILABLE AT OVER 200 JOBBERS — have a demonstration today.

★ ★

AUDIOGRAPH 25 Watt and 40 Watt. MOBILES also available. Write for complete data—

AUDIOGRAPH Sound Systems

product of JOHN MECK INDUSTRIES

1313 W. Randolph St., Chicago, Ill.

CONCENTRIC-SHAFT Dual Controls

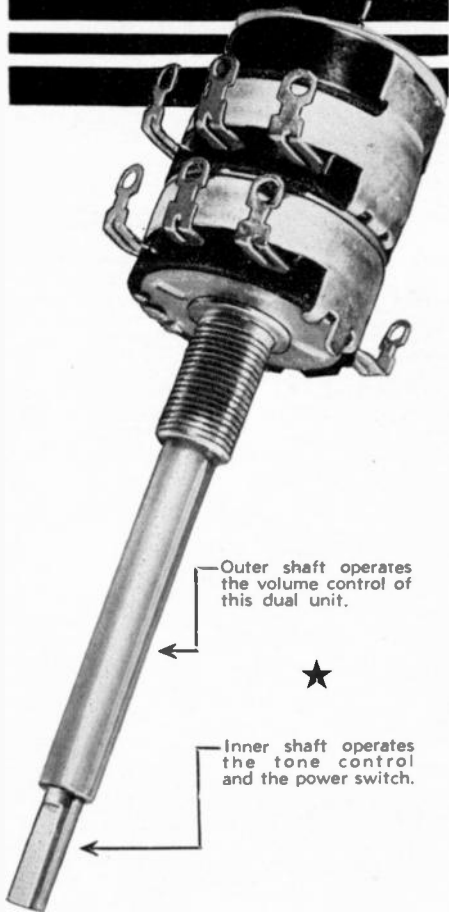

★ Yes, that really complete line of Clarostat Exact-Duplicate Replacements includes Concentric-Shaft Controls for those Philco and RCA sets.

★ You don't have to improvise when you standardize on Clarostat. You get the right data and the right replacement for the best job.

Ask for MANUAL . . .

★ Ask your jobber for copy of latest Clarostat Service Manual, with up-to-the-minute volume-control replacement listings. Or for the Plug-In Resistor Replacement Manual for 15c. Or write direct to . . .

CLAROSTAT MFG. CO., Inc.

Dept. S1, 285 N. 6th St. Brooklyn, N. Y.



The problem is solved by omitting the filter and introducing some hum in the diode circuit of the 6SQ7GT. The hum voltage across *R1* is passed on through *R6* and the coupling condenser *C4* to the 6SQ7GT grid. When amplified by the triode section of this tube, the hum is reversed in phase and is applied to the grid of the 6V6GT. There it meets, in reverse phase, the hum already in the grid circuit of this tube and bucks it. So hum reduction is accomplished.

CABINET REPAIR

(From page 10)

holes with stick shellac. Many radio jobbers who carry refinishing materials also carry a line of stick shellac. The repairing is done by melting the stick shellac on a spatula, which is heated over an alcohol torch (no other fuels than alcohol can be used without discoloring the shellac) and filling the hole gradually with the shellac. Great care has to be taken not to burn the surrounding finish with the hot spatula and not to overfill the patch, as it is difficult to remove the excess shellac. Final leveling can be done by carefully rubbing with very fine sandpaper (7-0 Garnet)—or better, with special liquids such as shellac rubbing fluid. This fluid, rubbed on with felt, will level off the fill without effecting the surrounding finish of the cabinet.

DEVELOP SKILL

Many damages consist of a combination of the above classes. The radio man should always bear in mind that he must have the right materials and he should not start with his experiments on valuable objects or customers' sets. He will always find some old cabinets around on which he can make tests to develop his skill.

Many jobbers carry special refinishing materials for radio sets, and complete kits which contain all essential items. There are, however, some kits on the market which are absolutely unsuitable. One kind is designed for the professional finisher; the other merely consists of an assortment of regular lacquers and paints. Both types should be rejected.

MOTOROLA 40-60W

(From page 14)

feedback in the power stage, and at small cost. This is accomplished by means of fixed condenser (20) connected between plate and cathode of the 35L6G tube. The feedback voltage is developed across the unbypassed cathode resistor (37).

The circuit is also typical of a comparatively recent trend toward the use of resistance-capacity power-supply filters in receivers employing beam-power tubes.

Subscribe Now To RADIO SERVICE-DEALER

while the dollar-saving

½ Regular Price

SUBSCRIPTION RATE

-12 Issues for \$1.00-

is still in effect



YOURS at New

Toboggan Prices . . .

Antenna Relays

by Guardian . . .

★ Modern straight-line production methods . . . and volume sales to thousands of radio amateurs . . . enable GUARDIAN to offer these precision engineered antenna relays at low prices. Buy the best . . . and save money at the same time. These relays are famous for sturdy construction and dependable operation. Easily mounted in any position. Tested under actual operating conditions, will handle any power up to 1 k.w., any frequency up to (and including) 28 MC on A.F. or R.F. circuits.

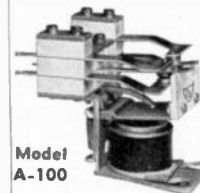

Standard A-100 and A-100-C Antenna Relays AISIMag insulated operate on 110 V. 60 cycle A.C.

LIST PRICES:

Model A-100	A-100 Double Pole Double Throw Relay . . .	\$5.95
	A-100-C Single Pole Double Throw Relay . . .	\$3.30
	R-100-G Triple X Insulated	\$5.00

FREE CIRCUIT DIAGRAMS

SEE YOUR JOBBER TODAY or write for specifications and full details.

Get New Bulletin "S". No Obligation.



GUARDIAN ELECTRIC

1633 W. WALNUT ST., CHICAGO, ILL.

In Fig. 1, the filter is composed of the resistor (35) and the dual electrolytic condenser (12).

Filters of this sort are satisfactory where the current drain through the resistor does not exceed 50 ma or so. In Fig. 1, the plate of the power tube is supplied directly from the output of the line rectifier, the screen from the far side of the filter. Since small changes in plate voltage (ripple) in a beam-power tube do not cause corresponding changes in plate current, the plate supply need not be well filtered. Good filtering of the screen voltage is necessary, and a simple resistance-capacity filter is sufficient for this purpose.

Note that the condenser symbols in Fig. 1 are a bit unconventional. See "Shop Notes" in this issue for key.

VOLTAGE MEASUREMENTS

Voltage measurements are based on a line voltage of 117. All voltages should be measured from the common negative. The following readings should obtain:

Tube	Plate	Screen	Cathode
R.F.	117	86	1
O-M	85	85	0
I.F.	85	85	2.8
Det.	40	—	0
Pwr.	112	82	6
Rect.	AC	—	117

Location of trimmers is shown in the chassis layout of Fig. 2. Note that the loop antenna trimmer is so positioned that it may be adjusted with the chassis in the cabinet.

In aligning, set volume control at maximum and go through the following operations in the order given:

1) Set gang condenser at minimum, band switch in broadcast position, and feed a 455-kc signal from test oscillator to oscillator-modulator grid through a 0.1-mfd condenser. Adjust trimmers 1, 2, 3 and 4.

2) Connect test oscillator to external antenna terminal through a 400-ohm resistor. Set test oscillator to 1600 kc. Adjust trimmer 5.

3) Set gang condenser to 1400 kc, set test oscillator at same frequency. Adjust trimmer 6.

4) Set gang condenser at 3.2 mc, band switch in s-w position. Tune test oscillator to same frequency and adjust trimmer 7.

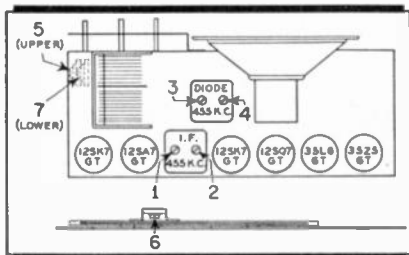

Fig. 2. Showing trimmer locations.

Model 636
\$29.95

Do you believe in Miracles?

Perhaps you don't believe in miracles, but the new Jackson 636 Tube Tester will just about convince you that there are such things. This tube tester is absolutely new, ultra-modern (a 1941 model) and complete in every detail, including ROLL CHART.

There is nothing else like the 636. No other manufacturer can possibly duplicate the Jackson DYNAMIC method of test. This method is patented and "Dynamic" is a registered Jackson trade-mark.

The Jackson Dynamic circuit is less complicated to operate yet makes a more accurate test on every tube. Model 636B \$29.95. Portable style slightly extra. (Prices higher west of Rockies.)

THE JACKSON ELECTRICAL INSTRUMENT COMPANY
121 Wayne Ave., Dayton, Ohio



FREE!

"Learn the Truth About Dynamic Tube Testers" is a vitally important folder just off the press. Write for it today. It's free.



*It Is More **ECONOMICAL** and **Profitable** To Replace a Defective Speaker Than To Repair It!*

Oxford *is the reason*

Model P-M	Size In.	V. C. Imp. ohms	Pow. Cap. w.	Price less trans.
2ZMP	2½	3-4	1	\$1.75
3ZMP	3½	3-4	1½	1.85
4ZMP	4½	3-4	2	1.95
5ZMP	5	3-4	2½	2.00

ELECTRO DYNAMIC

3W1	3	4-5	1.75
3W2	3	4-5	1.75
4W1	4	4-5	1.85
4W2	4	4-5	1.85
J61	6½	5	2.55
J81	8	5	3.40

★ The profit a service-dealer can net on any job depends upon the amount of time he uses doing it. Patching and repairing defective speakers—when new ones are available at Oxford's low prices—is an uneconomical and unsound method to pursue.

★ Your customer will credit you with good business judgment—paying better prices, too—when you REPLACE a defective speaker with an excellent substitute quickly rather than repair old ones AT LESS PROFIT and more time consumed. Try it . . . you'll be convinced as to the soundness of this practice. Servicing is a profitable business when money making methods like this are followed.

Your Jobber stocks an Oxford speaker for every application. See him today.

OXFORD TARTAK RADIO CORP.
915 W. Van Buren Street Chicago, Ill.

Conclusive Testing



\$22.00 Dealer Net

TRIPLETT

Model 1213

- Exclusive Handy Hinged Postcard Reference Tube Chart
- Checks tubes with Filament Voltages from 1.4 to 117
- RED • DOT Lifetime Guaranteed Instrument
- Neon Shorts Test

Model 1213 contains all sockets to test all present day tubes, including Octals, Loctals, Bantam Jr., Miniatures, etc. Also tests Pilot Lamps and Gaseous Rectifiers. Ballast Tube Continuity Test. . . . Has separate line voltage control meter . . . Housed in snappy-appearing metal case with brown suede baked enamel finish. Three-tone panel is brown, tan and red with silver markings . . . Dealer Net Price . . . \$22.00

Model 1270

11 RANGES
TEST ALL
HOUSEHOLD
APPLIANCES

\$29.83

Dealer Net Price



RED • DOT
LIFETIME
GUARAN-
TEED
INSTRU-
MENT

- Five Wattmeter Scale Ranges 0-20-500-1000-2000-4000 (most essential for the modern electric ranges).
- Four Alternating Current Scale Ranges 0-6.5-13-26 Amperes
- Two AC Voltage Scale Ranges 0-130-260
- RED • DOT Lifetime Guaranteed Instrument

Model 1270 is an advanced electrical circuit analyzer that shows the wattage consumption, amperes and line voltage of all household appliances and small motors under actual operating conditions. Power used by the smallest appliances is checked on an extremely low range of 0-20 watts (fused to prevent damage from accidental overload). Other scale ranges make it possible to test electric refrigerators, washers, radios, ironers and other appliances, including ranges operating on 220-volt three-wire system. Readings are shown on a 4-inch square Triplett Electro-dynamometer type instrument, with long easily read scales. Model 1270, complete with leads for two-wire circuits . . . Dealer Net Price . . . \$29.83 (Special leads available for three-wire circuits.)

Write for catalog on complete line of test equipment. Triplett also manufactures electrical measuring instruments in more than 25 case styles.

Section 479 Harmon Drive

THE TRIPLETT ELECTRICAL INSTRUMENT CO.
Bluffton, Ohio

TEST OSCILLATORS

(From page 5)

dial frame, etc., with the hand until the offending part is found.

CHECKING AVC

To check avc action, set the test oscillator for a modulated output, tune it to any desired frequency in the band, and tune the receiver to the same frequency. The receiver volume control should be about half on.

Now slowly increase the output of the test oscillator. There will be a corresponding increase in the volume of the signal from the receiver until the avc voltage reaches its optimum value, after which a further increase in the output of the oscillator will cause no substantial change in the receiver volume, provided the avc is functioning properly.

Though this method lacks accuracy, it has the advantage of being rapid, and usually tells one as much about the avc action as he needs to know. Moreover, it is a handy method of comparing the avc action in receivers of different make and price range, to say nothing of receivers of the same make and model. With a little experience, one gets to know what to expect, without making actual measurements.

DEAD RECEIVERS

It is easy to trouble-shoot dead sets and localize the defect by this simple method:

First, to determine if the audio amplifier is functioning use the common method of placing a finger on the grid terminal of the second detector. If it is functioning, there will be a loud hum, if the set is operating from an a-c source.

Assuming the audio stages are not at fault, tune the modulated test oscillator to the i.f. of the receiver and, working back from the second detector, place the hot lead of the test oscillator on each successive grid cap or terminal. The defective stage will be found where the signal stops or becomes very weak.

This same test serves to determine if a stage is operating as it should. The signal should increase in volume as the hot prod of the test oscillator is progressively moved from the grid of the second detector toward the antenna terminal. If the signal fails to get louder at any point, the particular stage involved is not operating as it should. This, of course, discounts avc action, which must be taken into consideration, either by killing it or by retarding the test oscillator attenuator as the prod is moved along.

CHECKING SENSITIVITY

In extremely noisy locations where man-made interference makes it difficult

Simplest

WAY TO REPLACE
BALLASTS

- 4 STANDARD TYPES of Amperite Regulators replace over 200 types of AC-DC Ballast Tubes now in use.
- Not to be confused with ordinary dropping resistors. Amperite actually regulates.
- Amperite Regulators are equipped with a patented Automatic Starting Resistor which prevents initial surge and saves pilot lights.
- Amperite AC-DC Regulators; List \$1.00. Amperite Replacements for 2V Battery Set ballasts List \$1.25

WRITE FOR REPLACEMENT CHART "S"

AMPERITE Co. 561 Broadway, N. Y. C.

AMPERITE

SAVE MONEY

WITH THIS

Free Book



RADIOS



PARTS



P.A. EQPT.



TEST EQPT.

Lafayette Radio

100 SIXTH AVENUE, NEW YORK, N. Y.
CHICAGO • ATLANTA • BOSTON
NEWARK • BRONX, N. Y. • JAMAICA, L. I.

LAFAYETTE RADIO CORP.
DEPT. 81J — 100 SIXTH AVE., NEW YORK, N. Y.
Rush FREE Catalog No. 82

NAME _____
ADDRESS _____
CITY _____ STATE _____

**HOW HOME RECORDERS
—AT LOW COST—
OFFER GOOD PROFITS**



To cut records, place cutting arm over record blank. To play back, place pickup on record. It's just as simple as that.

WORK up more and more extra sales on ordinary service calls—sell the new, *simplified*, low-cost GI-R70 home recording unit in homes. Sell it to lawyers, musicians, to teachers of music, drama and public speaking, and to their pupils.

GI-R70 assembly includes high-quality tangent-tracking crystal pickup, separate cutting arm, feed-screw mechanism—concealed for better appearance—and rugged, uniform-speed rim-drive motor with weighted turntable. Complete unit mounted, ready for easy installation. Order one for testing.

Write today for catalog and prices

The GENERAL INDUSTRIES CO.

447 Taylor Street

Elyria, Ohio

JUST OUT!

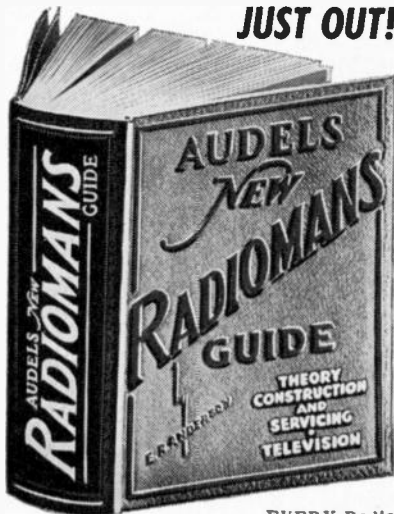

RADIO

The whole subject of Modern Radio—covering the Basic Principles—Construction & Operation—Service—Repairs—Troubles—All Easily Understood. Over 750 Pages. 400 Illustrations. Parts & Diagrams—LATE TELEVISION DATA—Valuable for REFERENCE AND HOME STUDY.

To get this practical information in handy form for yourself **FREE** in and mail coupon today. **COMPLETE • PAY ONLY \$1 A MO.**

AUDEL Publishers, 49 W. 23rd St., N. Y. City
Send AUDEL'S NEW RADIOMANS GUIDE for free examination. If O. K. I will send you \$1 in 7 days; then remit \$1 monthly until price of \$4 is paid. Otherwise, I will return it.

Name.....
Address.....
Occupation.....
Reference..... **SD**

EVERY Radio Mechanic—Service Man & Student Needs "Audeis Radiomans Guide"—Just Out!

to judge the sensitivity of a receiver, a fair estimate can be made with a modulated test oscillator.

Disconnect the antenna and feed the receiver input from the test oscillator, with the attenuator set so that the signal is just audible when the receiver volume control is full on. Note the reading on the attenuator and compare this with readings previously obtained by a similar test on like receivers of known sensitivity.

MICROPHONIC TUBES

Microphonic tubes are so easily shown up with the test oscillator that it makes you feel guilty. It's as simple as this:

Tune the oscillator to any desired frequency in the band, operate it in the unmodulated position, and tune the receiver to the same frequency. The receiver volume control should be full on.

Now increase the setting of the oscillator attenuator to the point where microphonics just begin. Don't over-do this. Then press and move all tubes until the offender is located.

SOUND AT ELWOOD

(From page 8)

back of the loudspeaker output into the microphones, Western Electric's new directional "cardioid" microphones were employed at both pick-up points. Remote control stations near both speakers' platforms enabled operators to adjust volume and quality to meet local conditions. Provision was also made for monitoring the entire system from a headquarters control station, where a microphone was set up to provide facilities for routine and emergency announcements. Private telephone circuits kept remote control operators in constant touch with sound system headquarters.

A KILOWATT OF AUDIO

At Calloway Park, where over 1,000 watts of audio power carried Mr. Willkie's speech to every corner of the 250-acre area, each unit of a huge battery of double-throated horns was individually controlled, each having been connected to a separate 50-watt amplifier. Thus, each horn of the huge system could be adjusted to fit whatever wind conditions arose.

For the long projection throws, three clusters of six-foot Western Electric trumpet loudspeakers were installed, two of these clusters being mounted on 20-foot portable steel towers. These special features were made necessary because two-thirds of Galloway Park is heavily wooded and part of the audience was cut off by a large shelter pavilion. Five multi-cellular speakers were employed for the direct projection. Tests of the park loudspeaker installation were heard

IF

You Are NOT a PAID Subscriber to

Radio
SERVICE DEALER

You May NOT Receive The Next Few Issues

You Can't Afford To Miss A Single Copy

SUBSCRIBE TODAY

JUST OUT! ALLIED'S 1941 RADIO CATALOG



FOR EVERYTHING IN RADIO
Get ALLIED'S FREE, 1941 Catalog—with the biggest ever, 212 PAGES—with special sections for Dealers, Servicemen, and Sound Men. Radio's greatest Buying Guide! Nothing like it for completeness. New P.A. Section—24 new Sound Systems—7 to 75 watts— for all applications, easy Time Payment Plan—15 Day Trial Offer—brand new features—lowest priced! Service men—all the new Test Equipment, new tools and service replacement parts. Now 15,000 quality replacement parts. Brand Bargain Section—real "bays" in brand new merchandise! 83 New Radio Models—wonderful radio "leaders" and profit-builders—all types—for every purse and purpose. It will pay you to keep your 1941 ALLIED Catalog handy for Everything in Radio at Lowest Prices!

FREE

ALLIED RADIO CORP.
833 W. Jackson Blvd.
Chicago, Ill., Dept. 35-J-1

Rush me your FREE new 212 Page 1941 Radio Catalog.

Name.....
Address.....
City.....State.....

Mr. Radio Serviceman:

RSA MEANS BUSINESS!

New business promotion plans and new member-helps spell increased profits for RSA members at the start of the new season. Watch for the RSA Replacement Parts Guide—New Broadcast Promotions—New Member Helps! Don't be the last man in your neighborhood to join RSA. Send the coupon Today!

MAIL THIS COUPON NOW!

RADIO SERVICEMEN OF AMERICA, INC.

304 S. Dearborn St.,

Chicago, Illinois

I am interested in RSA Membership. Tell me about it.

Name

Address

City State

RS-940

Let's Grow Together
in 1940!



**RADIO SERVICEMEN
OF AMERICA, Inc.**

Reliable Service Assured

**JOE MARTY, JR., EXECUTIVE SECRETARY
304 S. DEARBORN STREET, CHICAGO, U.S.A.**

in the Elwood business section, a mile away.

To avoid possible failure of the power supply for this huge sound system network, the Indiana General Service Company provided emergency standby circuits.

Besides the main public-address system installed to carry the notification and acceptance ceremonies, two smaller Western Electric systems were installed at the Pennsylvania Railroad stations to facilitate the direction of the huge throng which descended on Elwood to pay tribute to her favorite son. These systems were designed to cover the area necessary to direct the unloading of two 15-car trains at once. Through microphones designed especially to deliver voice frequencies capable of over-riding crowd noise, announcers called the times of train arrival and departures, gave directions as to the best way to reach the high school and Calloway Park.

LATEST LITERATURE

1941 Calendars—National Union Radio Corp., Newark, N. J., through a cooperative plan, will supply radio service dealers with full color art-mount calendars in a choice of five subjects for the 1941 season.

Political Postcard—To help servicemen and dealers boost their business during the

political campaign, Hygrade Sylvania Corp., Emporium, Pa., has made available a 1-cent government postcard that urges set owners to have their radios tuned up now for perfect reception. "Listen Before You Vote" is the headline which ties in with a limerick bordered by the donkey and the elephant.

Allied Catalog—Allied Radio Corporation, 833 Jackson Blvd., Chicago, Ill., have issued a new 212-page radio catalog for 1941. Direct color photography is used with striking effect.

A 40-page radio section introduces 83 new receivers. There are 35 pages given over to 24 new sound systems. The radio parts section contains 128 pages. Each section is indexed for speedy reference.

Copy may be obtained free on request to Allied.

Meissner Vibrator Guide—A new Vibrator Replacement Guide of 12 pages, and complete up to August 1, 1940, has been issued by the Meissner Manufacturing Co., Mt. Carmel, Ill. Handy easy-to-read reference chart included. Also a Buffer Replacement Chart and data on buffer condensers—something new. Copy free on request to Meissner.

Lafayette Catalog—Lafayette Radio Corp. (formerly Wholesale Radio Service Co., Inc.) have issued their 1941 master catalog containing 196 pages. Has 4-color cover and features 32 pages of radios and radio-phono combinations, in addition to Radiocorders. Also 32 pages devoted to Lafayette's new line of p-a equipment.

Post-card addressed to above company at 100 Sixth Ave., New York, N. Y., or any of its branches, will bring the catalog without charge.

V-T Voltmeters—Supplement No. 10 to the 3rd Edition of the Mallory-Yaxley Radio Service Encyclopedia deals with the vacuum-tube voltmeter and its use in radio servicing.

Various commercial units are described. Subsequent sections detail the use of such equipment in signal tracing, checking distortion, checking avc, qavc, afc circuits, etc.

Supplement contains 22 pages. Issued on subscription basis by P. R. Mallory & Co., Inc., Indianapolis, Ind.

Capacitor Manual—From Cornell-Dubilier comes Edition No. 1 of the Capacitor Manual For Radio Servicing—a 256-page book listing the type numbers, etc., of condensers for replacement in commercial radio receivers. A total of 18 pages of reference diagrams of bypass circuits, filter circuits, etc., are included to simplify the listings and make them more convenient to use in actual practice.

Set manufacturers are listed alphabetically with models of each listed directly under the company name. Capacity, working voltage, location in circuit, etc., of each bypass or filter condenser is given.

Cushing Catalog—T. F. Cushing, 349 Worthington St., Springfield, Mass., distributor, has issued a 250-page catalog of radio, sound and refrigerator parts and equipment. Copies free to dealers and servicemen.

for Every Application

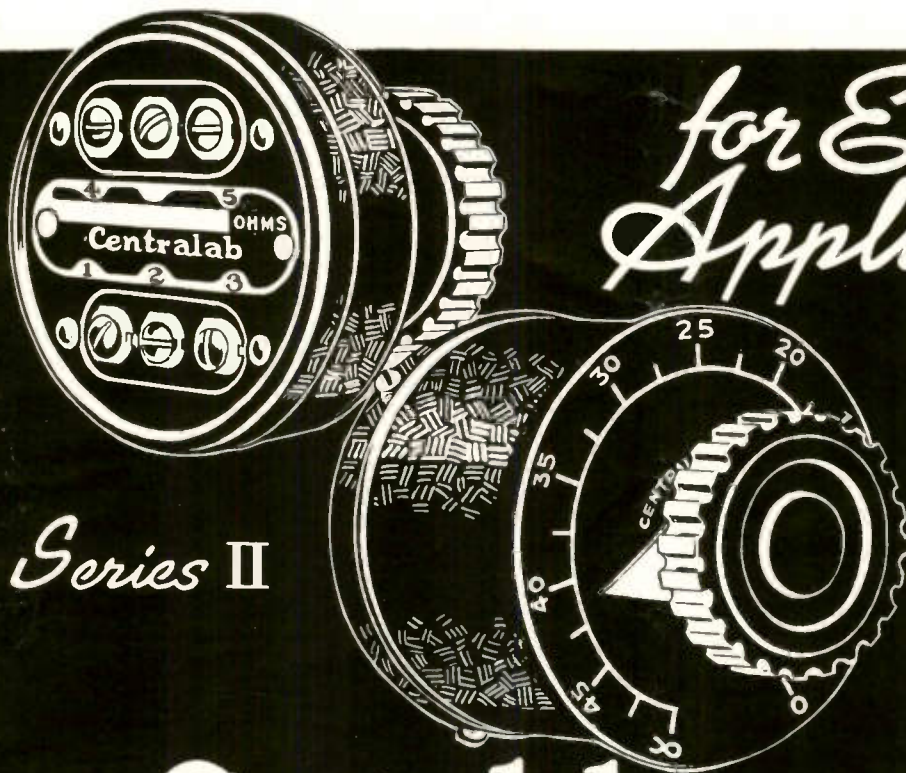

Series II

Centralab SOUND PROJECTION CONTROLS

CENTRALAB SERIES II

Controls are the finest for input circuits in broadcast stations, public address systems, and recording apparatus of new or old design. Will prove faultless in the most critical service.

The curve chart above shows the change in impedance and attenuation plotted against clockwise rotation for a "T" pad attenuator. The impedance characteristic (dotted line) is substantially the same at any setting. The attenuation curve (solid line) varies from infinity at zero rotation to zero Db. at full rotation. No insertion loss.

Electrostatic and electromagnetic shielding provided by a black finished steel case. Bakelite screw type terminal strip on back of case. All resistance elements insulated from shaft and bushing. Single hole mounting. Mounting bushing 3/4" long with 2 locknuts and lockwashers. Case diameter 2 3/4". Depth back of panel "T" Pad — 2 3/8"; Gain Control — 1 3/8". Maximum load dissipation 1 watt.

For detailed information, write for technical booklet.

CENTRALAB: Division of Globe-Union Inc.
MILWAUKEE, WISCONSIN

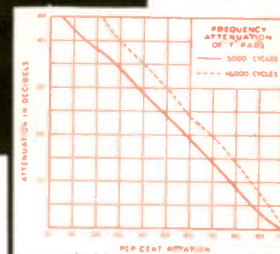
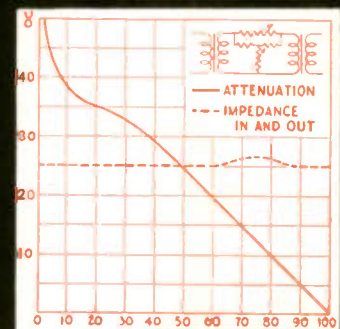

ECONOMY P/A CONTROLS

These controls are intermediate to the series II line and the older series I types. As their name implies, they are economy controls designed primarily for inexpensive sound equipment, where original cost is a limiting factor. They are designed for all types of fading and mixing systems. All units have soft aluminum shaft 2 1/4" from end of 3/8" brass bushing. Small diameter bakelite case same dimension as Standard Radiohm. Non-rubbing contact for smooth, quiet operation. Limited to input applications. Maximum power rating for all units one watt.

Special low deposits on all N. U. Triplett Deals to November 30th

TRIPLETT
TUBE TESTER
Model 1620
\$12.50
DEPOSIT

**TRIPLETT TUBE TESTER
MODEL 1620**

Has new lever-type flexible switching giving individual control for each tube prong . . . Filament voltage switching from 1.1 to 110 takes care of present and future tubes with filament voltages up to 117-volt types . . . Giant 6-inch scale RED•DOT lifetime guaranteed indicating instrument . . . Neon short test . . . Separate line voltage meter . . . Speed Roll Chart can be spun from one end to the other in less than four seconds . . . Housed in wooden case of graceful proportions with sockets, knobs and markings in ivory.



TRIPLETT
MODEL 1620
Regular Dealer
Price \$37.84

and it's Yours
on N.U. DEAL

Over 50,000
completed deals
your guarantee
of complete
Satisfaction



J. E. STAGE, Longview Radio Sales & Service Co., Longview, Wash. Think your Free Equipment Plan great—Have signed 20 N U Equipment Deals—have been using N U program 9 years. N U tubes all check alike—rarely have to make replacements.



MATHEW J. BERLOWITZ, Juncau Radio Shop, Milwaukee, Wisconsin. I find in checking my records I signed 29 contracts. There is no better way for a serviceman to painlessly acquire good service equipment. In my 10 years of exclusive dealing with N U their products have always been satisfactory.



E. J. MAGINOT, Boston, Mass. In my opinion, and in the opinion of many other service engineers with whom I am associated, N U enjoys a prestige which needs no apology. Modern radio sets demand modern testing equipment. N U supplies it the easy way.

YOU TOO CAN HAVE THE
"Best Equipped Shop in Town"

Get it the National Union way . . . you deposit \$12.50, immediate delivery is made on Triplett Model 1620 Tube Tester. You sign agreement to purchase 1275 points over a 2 year period. On completion you receive bill of sale and your deposit is refunded as a merchandise credit.

☆☆☆

National Union purchase points can be taken in Tubes, Condensers or Batteries. All products the finest in quality, thoroughly guaranteed and competitively priced.

☆☆☆

National Union Radio Tubes are known as the radio service dealer's tubes because they are used by more service dealers than any other make.

☆☆☆

You too can have the best equipped shop in town, just get your equipment the easy "N. U. Way" — Remember National Union has the finest sales helps and promotional pieces to help you sell yourself to your community and make more money.

☆☆☆

Special low deposit on all Triplett Testers until Nov. 30th, 1940.

Ask Your Jobber or Write to

NATIONAL UNION RADIO Corp
57 STATE STREET, NEWARK, N. J.

The Best Equipped
Shop in Town
Gets the Business