

*Radio*  
**SERVICE  
DEALER**

MAY, 1949



**IN THIS ISSUE:**

Modern Tape Recorders, Part 1  
New TV Test Equipment, Part 2  
A New TV-FM Sweep Generator  
TV Quiz  
45 RPM Connections to Receivers  
Transistors and the Serviceman

**AM-FM-TV-SOUND**

*The Professional Radioman's Magazine*



# SHOOTING



High output efficiency  
is one reason why  
**MALLORY VIBRATORS**  
are so popular!

High output efficiency! That's one of the vital reasons why more Mallory Vibrators are in use today than all other makes combined.

You get maximum efficiency from a Mallory Vibrator because its related parts are carefully

matched. Every part is carefully balanced with its counterpart by an exclusive Mallory method.

All working parts of Mallory Vibrators are Mallory-designed and Mallory-made. For Mallory focuses on Vibrator design an unusual combination of engineering talent and resources in electronics, electrochemistry and metallurgy.

The result is not only *high output efficiency* from Mallory Vibrators, but *long life* and *dependable starting*. No wonder more Mallory Vibrators are used in original equipment than all other makes combined. No wonder they make the best replacements. See your Mallory Distributor.

## Mallory "2448" Vibrator Deal

This deal gives you a handsome storage and display cabinet for your stock of vibrators, together with a selection of vibrators and buffer capacitors that will answer 75% of your requirements.

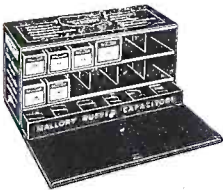

You pay only the service man's net price for the six vibrators and twelve buffer capacitors. There is no charge for the attractive, convenient cabinet. Your Mallory distributor has them in stock for immediate delivery.

*More Mallory Vibrators are used in original equipment than all other makes combined*

P. R. MALLORY & CO. Inc.  
**MALLORY**

CAPACITORS • CONTROLS • VIBRATORS • SWITCHES • RESISTORS  
• RECTIFIERS • VIBRAPACK\* POWER SUPPLIES • FILTERS

\*Reg. U. S. Pat. Off.

**APPROVED PRECISION PRODUCTS**

**P. R. MALLORY & CO., Inc., INDIANAPOLIS 6, INDIANA**



## Rider Manuals turn Servicing Problems into Servicing Profits

"We've been steady users of Rider Manuals ever since we got the first one. The factory-authorized circuits and data on radio servicing have acted as 'true guiding hands', saving us time, enabling us to get at problems quickly, and making sure that every job we handle 'stays sold'."

M. M. HENLEY, Service Mgr., May Electric Appliance,  
61 Fox Street, Aurora, Illinois



20 YEARS OF LEADERSHIP IN  
FACTORY-AUTHORIZED SERVICING INFORMATION  
**Authentic, Official, Reliable!**

**RIDER RADIO MANUALS**

**RIDER TV MANUALS**

**RIDER PUBLIC ADDRESS MANUALS**

### Available Now! VOLUME XVIII



2036 pages PLUS "How It Works" Book and Cumulative Index of VOLUMES XVI, XVII, XVIII. Covers products of 110 manufacturers up to January, 1949... AM-FM Auto Receivers and Record Changers. Complete . . . \$19.80

### Available Now! VOLUME 2 Rider Television Manual



Equivalent of 2300 pages PLUS Cumulative Index Covering TV Volumes 1 and 2. Official, Authentic Service Data on Complete Receivers, Kits and Boosters from the Service Departments of 67 Manufacturers. Complete . . . \$18.00

### Available Now! RIDER PA MANUAL

The first industry-wide public address equipment manual, covering amplifier production of 147 manufacturers from 1938 to 1948. 2024 pages PLUS "How It Works" Book. Complete . . . \$18.00

### Coming Soon! VOLUME XIX RIDER MANUAL

With the issuance of Volume XIX, we will have released to the radio servicing industry the world over approximately 31,000 pages of factory-authorized information. More than 100 manufacturers; more than 2100 pages. Available at your jobber late in May. **WATCH FOR IT!**

Your Jobber Carries **RIDER MANUALS**  
a Full Line of

The world's greatest compilation of radio servicing information — direct from the manufacturers themselves. RIDER MANUALS are a "must" for Servicemen, Schools, Colleges, Public Libraries, Design and Development Laboratories!

#### IMPORTANT NOTE!

Are you receiving your copy of "Successful Servicing"? It's Rider's own publication of interest to every Serviceman. Send your name and address, and we'll put you on our list, FREE of charge.

#### RIDER MANUALS

Television Manual, Volume II	\$18.00
(plus "How It Works" and Index)	
Television Manual, Volume I.	18.00
(plus "How It Works" and Index)	
Volume XVIII	19.80
Volume XVII	16.50
Volume XVI	8.40
Volume XV	19.80
Volume XIV to VII (each volume)	16.50
Volume VI	12.50
Abrided Manuals I to V (one volume)	19.80
Record Changers and Recorders	9.00
Master Index, Covering Manuals, Vols. I to XV	1.50

**RIDER MANUALS mean SUCCESSFUL SERVICING**

**JOHN F. RIDER, PUBLISHER, Inc.,**

480 Canal Street, New York 13, N. Y.  
Export Agent: Rocke International Corp., 13 E. 40th St., N.Y.C.  
Cables, ARLAB.

NOTE: The Mallory Radio Service Encyclopedia, 6th edition, makes reference to only one source of radio receiver schematics — Rider Manuals.  
ANOTHER NOTE: The C-D Capacitor Manual for Radio Servicing, 1948 edition No. 4, makes reference to only one source of receiver schematics—Rider Manuals.



# 2 New



# Radiart

# TV-ANTENNAS

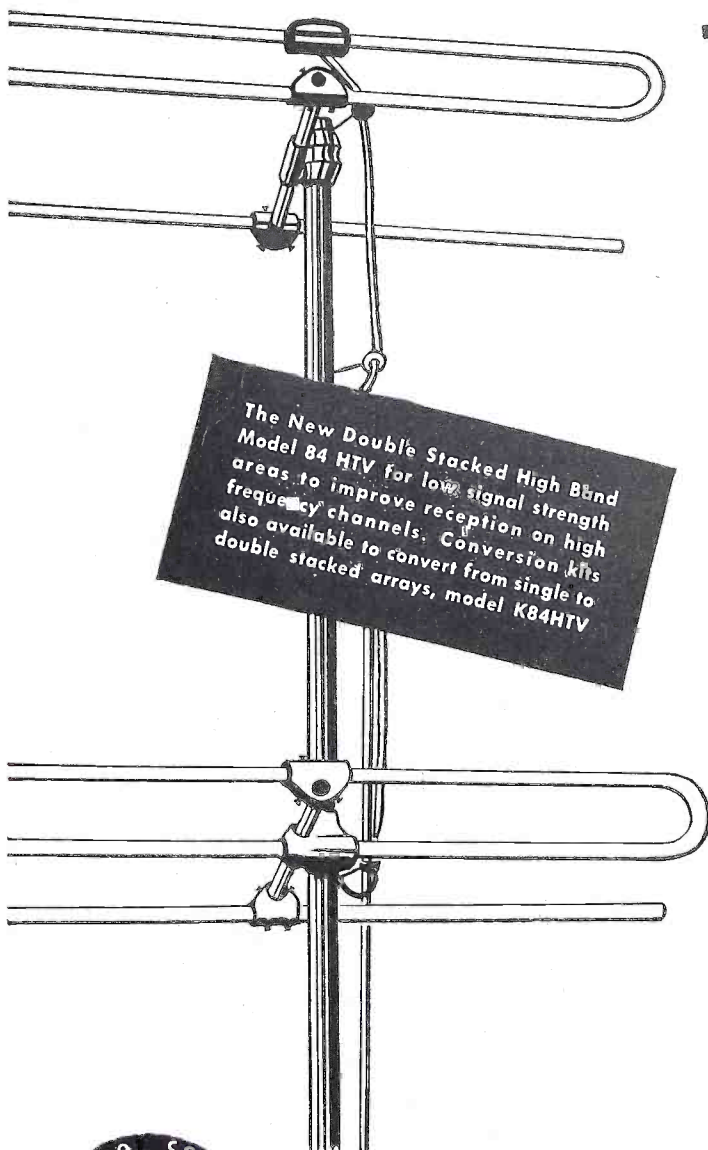
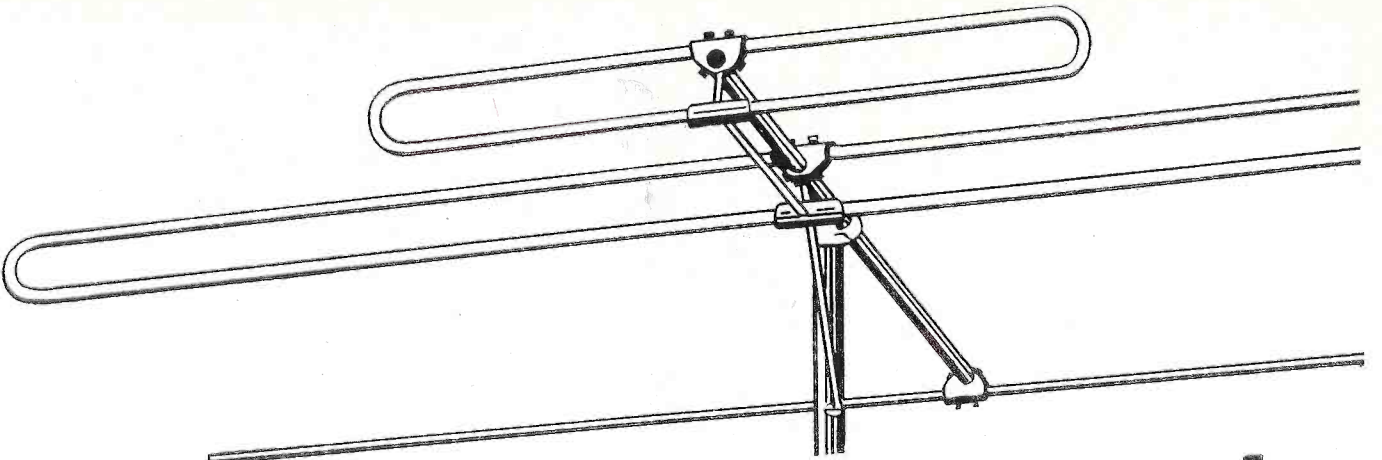

The New Double Stacked High Band Model 84 HTV for low signal strength areas to improve reception on high frequency channels. Conversion kits also available to convert from single to double stacked arrays, model K84HTV

The New Model 85X "in line" Antenna Rotators... especially designed for use with famous quick assembly design and superior electrical performance on all channels.

Here are the two "hottest" developments from the Radiart Laboratories. Skillfully engineered... sturdily constructed... these new types add even greater versatility to the popular Radiart TV and FM antenna line.

The New 1949 Vibrator Guide is off the press... Ask your Radiart jobber for your copy



IT'S RIGHT... WHEN IT'S RADIART



**THE RADIART CORPORATION**  
CLEVELAND 2, OHIO  
MANUFACTURERS OF THE FAMOUS RED SEAL VIBRATORS



PERFORMANCE-ENGINEERED AT ELECTRONICS PARK

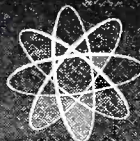

# SMALL-SIZE SPEAKERS

**That Talk in Terms of  
GREATER SERVICE SATISFACTION  
To 65% of Your Trade!  
Because they deliver more—**

**POWER  
SENSITIVITY  
FIDELITY**

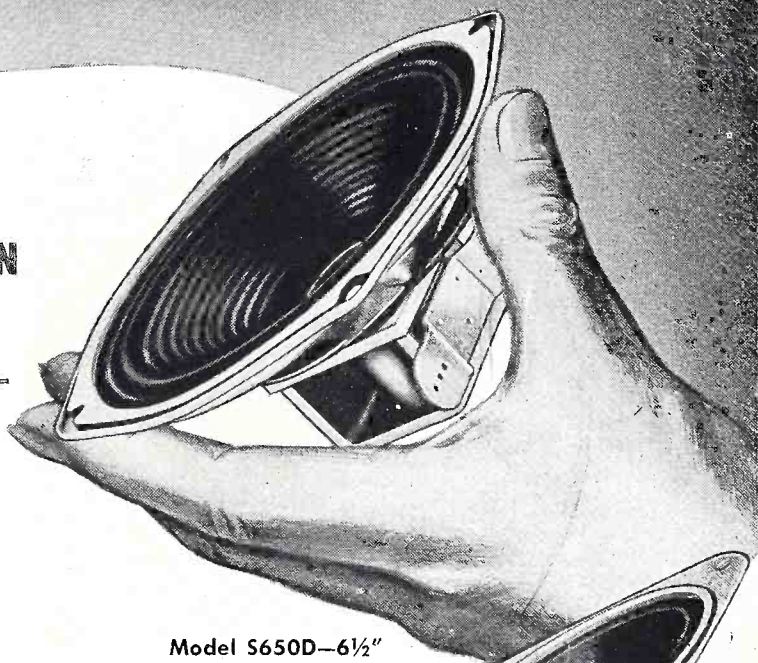

Model S650D-6 1/2"

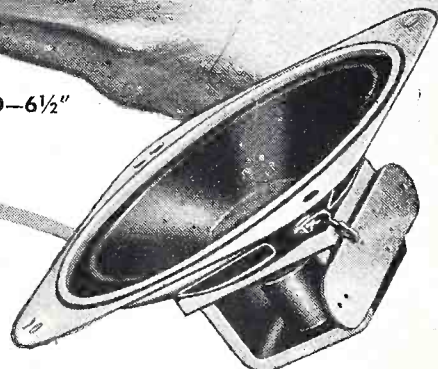

Model S525D-5 1/4"

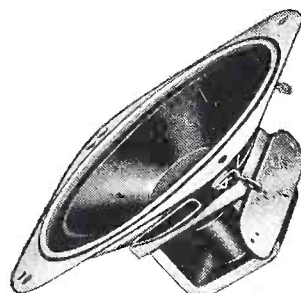

Model S400D-4"

A RECENT SURVEY shows that 65% of all speaker service requirements are on sets using 4 to 6 inch speakers! Remember—even the smallest General Electric speaker is rated at 4 watts... General Electric speakers, with sturdy all-weld construction, give you higher sensitivity because each G-E Alnico 5 magnet is fixed so firmly in the yoke that hundreds of pounds of pressure cannot budge it!

It costs no more to give your customers the finest! The G-E Speaker family is headed by the famous 1201—grand-daddy of 'em all. Build your reputation on the General Electric Value Line! Send for FREE BULLETIN on G-E speakers:

General Electric Company,  
Electronics Park,  
Syracuse, New York.

**Yes—Even the Smallest G-E Speaker  
Uses the Aluminum Foil Base Voice Coil**  
—not subject to warping resulting from high humidity. Provides much higher wattage handling capacity.

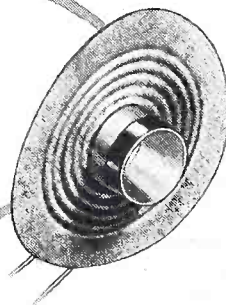

*You can put your confidence in—*

**GENERAL  ELECTRIC**



# EDITORIAL

## The Customers Write

Our proposal of a "National Preventive Maintenance Month" to be co-sponsored by NAB and RMA, (as outlined in "Field Findings" last issue), was well received by the trade. An executive of NAB believes that if RMA supports the idea NAB will too. As yet we have not been favored with RMA's reaction.

Meanwhile, all radio technicians, particularly those residing where there is no servicemen's association, might aid the cause by sending us their suggestions as to how such a Nationwide campaign for a month of radio service checkups might be most effectively handled in their particular community. Servicemen Associations can help too by going on record that they favor a "Preventive Radio Maintenance Month". RMA will act faster if this plan is supported by the servicing profession as a whole.

## Annual Index

In our March editorial we asked whether or not our subscribers want an Annual Index published each December tabulating all text material published during the year. The response was overwhelmingly affirmative. The Index will appear in the December issue.

## TV Installation Technique Changes

For many months it has been the practice of TV installation specialists to send out two-man teams to handle videosect installations. Experience proved this method too costly and unprofitable. Now one man is being sent out alone. Working alone adds complexities to the job, especially in orienting antennas properly.

The test instrument manufacturer who recently marketed a TV Antenna Compass and the TV kit manufacturer who is supplying a type of field strength intensity meter, (which give the installer C-R tube readings while he is working at the antenna itself), both deserve acclaim for having made a fine contribution toward speeding up and simplifying TV antenna installations.

## Here's An Idea!

Few, if any, table model TV sets manufactured to date have circuits with built-in phono jacks which permit videosect owners to play through them phonograph record-players. This fact affords a profitable and tremendous sales potential for Service Dealers.

In this issue, on page 22, we describe how radio technicians can efficiently wire phono-jacks into TV set circuits. Now, all you need do is advise all TV set owners in your locality that for a nominal sum you can sell, and install for them, a 33-1/3-45-78 (or combination of the three) rpm record-player or changer attachment which will utilize the fine audio system that is an inherent part of their TV set.

The public is phonograph player conscious. The public is becoming acutely fidelity and tone-quality conscious. The public would welcome a TV set record-player modernization job such as we advocate. You can get the business if you tell the public that you are ready and able to be of service.

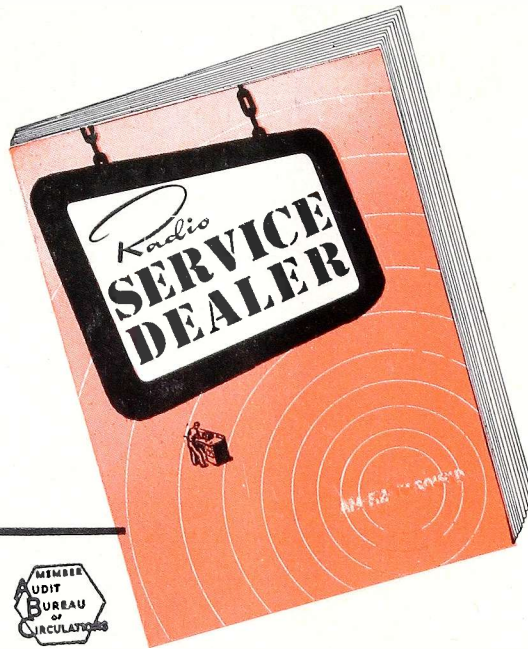

Sanford R. Cowan  
EDITOR & PUBLISHER

Samuel L. Marshall  
MANAGING EDITOR

COWAN PUBLISHING Corp.  
342 MADISON AVENUE  
NEW YORK 17, N. Y.

Vol. 10 No. 5

MAY, 1949

Editorial .....	4
Field Findings .....	6
Trade Flashes .....	12
Modern Tape Recorders, Part 1, by C. A. Tuthill .....	15
Analyzing the mechanical and electronic operation of modern tape recorders.	
New TV Test Equipment, Part 2, by Allan Lytel .....	17
Concluding installment	
A New TV-FM Sweep Generator, by L. S. Rich .....	19
Theory and operation of this device	
New TV Quiz No. 2, by David Gnessin .....	21
Connecting 45 RPM Record Players to Receivers .....	22
Timely circuit data on this new product	
The Transistor and the Serviceman, by Rufus P. Turner .....	25
Explaining the intricacies of this new component	
Shop Notes .....	27
Circuit Court .....	28
New Products .....	39

SANFORD L. CAHN  
National Advertising Sales Manager

HARRY N. REIZES  
Advertising Manager

JEAN M. WHEELER, Circulation Manager  
BRANCH: J. C. GALLOWAY 816 W. 5th St., Los Angeles 13, Calif., Mutual 8335

DAVID SALTMAN, Production Manager

RADIO SERVICE DEALER is published monthly by Cowan Publishing Corp., 342 Madison Ave., N. Y. 17, N.Y. Subscription price: \$2 per year in the United States, U.S. Possessions & Canada; elsewhere \$3. Single copies: 25c. Entered as second class matter Dec. 13, 1948 at the Post Office at New York, N.Y. under the Act of Mar. 3, 1879. Copyright 1949 by Cowan Pub. Corp.



# Belden

## RADIO-ELECTRONIC WIRES AND CABLES



# FOR BETTER SERVICE

## HOOKUP WIRE ASSORTMENTS



**5** display assortments

8858 8859 8860

8864 8865

SMALL — LOW-COST STOCK  
Handles Most Service Requirements

# Belden Radio WIRE



# Field Findings

A resume of Industry happenings here, there and everywhere

I am peeved at Al Jolson. Newspapers recently quoted him as saying that he was giving up his radio program because it only pays him a measly \$5,500 a week, and after he gets through paying taxes he winds up with a mere \$550 net. It must be kinda tough on poor Al. Let's say that he works 10 hours a week rehearsing his show and putting it on the air—and because this is very tiring, he only broadcasts 40 weeks a year, so he only has \$22,000 net to show for his radio work. Ah me! I personally know 6,497 radio servicemen who would swap jobs with Al at the drop of a microvolt.

My criticism of Al Jolson and other big name radio stars is not captious. Those fellows simply make too much money too easily. All they needed was some talent, but no particular amount of genuine intelligence or learning. Take a radio technician in contrast and you'll find that the average radioman has had good schooling with upwards of \$10,000 cash outlay for education, tools, inventory, etc., and all he can hope to make a year is \$10,000 gross, or \$7,500 net (if he's a real top-notch and works an average of 60 hours a week, 52 weeks a year).

The pity of it all is this: the radio-listening public could get along very nicely without Al Jolson but it would be in a hell of a spot if it didn't have radio technicians. And no technicians that I know of are griping if they are earning a measly \$550 a month gross. Someone should get to the ears of the radio advertising sponsors who pay these so-called entertainment potentates and tell 'em that a lot of small fry entertainers who do not earn fabulous salaries are a lot more interesting to listen to than the big-shots. For example, Hooper-ratings or not, I'd prefer to listen to a Quiz or audience participation program at home and take my chances on being able to win \$20,000 or more for answering

by S. R. COWAN

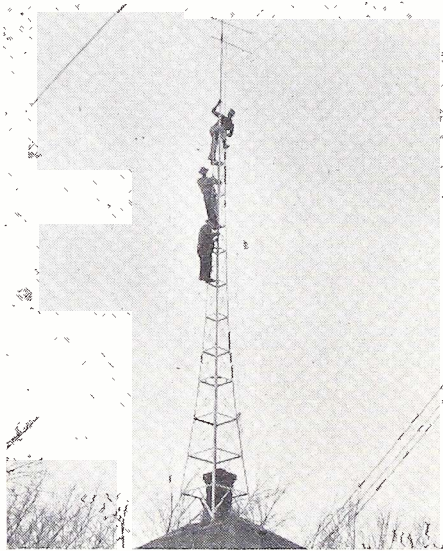

Tower by Western Coil & Electric Co.

TV installers have to be steeple jacks today. Somebody's going to come along and invent a TV set for underwater use—better order your deep-sea diving outfit now.

a question rather than listen to Jack Benny's corny quips, even though he did move from one network to another to save himself plenty bucks of tax money.

## Learning The Hard Way

At TV's outset I was personally enraged to hear that factory-assigned service depots were going to charge \$35 and more for every installation plus guarantee. (Eventually it got so that a \$65 fee was considered nominal). So, being a hard-to-convince heckler, recently I decided to learn for myself how much of such a high fee represents legalized robbery. I decided to make a TV installation, with an assistant, to check time, costs, profits, etc. Did I get my ears pinned back!

First of all, it's bad for lumbago to have to carry a small table model TV set weighing a mere 65 pounds up 3 flights of stairs. (I wonder, what does a big console do to one's spine?) Then one spends 15 minutes unpacking the several cartons, if one works real fast. Then you get the set's C-R tube squared away, stick on a temporary antenna rig to see "wot happens," and from there on you simply sweat bullets. Adjustments here, adjustments there, everywhere adjustments . . . and a raster shows up but no sound. (Sometimes it's the other way around, but, in either case, it's a pain in the lower, nether part of one's shoulders).

Fast workers, like me, can get alignment up to fairly reasonable standards in another 20 minutes . . . and then one starts to fix the permanent antenna. Of course, as is true in a great many cases, my trial installation had to be where outdoor roof antennas are taboo. My assistant and I watched the C-R pix and frantically waved dipoles around like a helicopter for another 20 minutes, and then, with relief, decided where the fastenings should be made. Then, wiring up was started. That our first decision was to drill holes in stone window casements, (which we did in less than half an hour), was wrong didn't become apparent until after the so-called out-the-window installation was completed. Surprise!

It's quite dismaying, (to say the least), to find that those d--n TV signals don't remain constant, and what happened during our arm-waving survey didn't hold true after the holes had been reamed into the stone window sills and the antenna tied in.

Of course this slight problem wasn't too hard to lick. All we had to do was to start "surveying out the window" all over again. Then, dog-gone it, and happy to say, Channels 2 and 4 came in like a house afire, 30 minutes later. But . . . "wot happened" to Channels 5 and 7? Oh sure,



# Test Pointers

## ... ON TV HEAD ENDS

Head-end troubles in the rf stage, mixer, or oscillator of standard TV receivers which use separate picture- and sound-if amplifiers, are usually readily isolated because such defects are common to both the sound and the picture. When the raster is normal but the sound and picture are dead, weak, or intermittent, the trouble is probably in the head end.\*

When this is the case, initial inspection at the customer's home can be confined to a check of the antenna and transmission line, tubes, and low-voltage power supply.

If sound and picture are both dead, the oscillator may be inoperative. The oscillator grid bias should be checked with a suitable electronic voltmeter against the value given in the manufacturer's service data.

A few volts change in oscillator grid voltage from channel to channel is to be expected. The oscillator frequency can be measured quickly with the aid of a heterodyne detector and a signal generator. The signal-generator frequency must, however, be very accurate; it should be either crystal controlled or crystal calibrated.

Some troubles in the head end show up only at the speaker and are not readily discerned in the picture, because the sound channel is more responsive to slight changes in frequency.

In a misaligned receiver, the rf oscillator may be detuned far enough in one direction to kill the sound with little effect on the picture. In any case, when the rf oscillator frequency is readjusted on sets which have a "fine tuning" control, center this control during the adjustment.

Head-end misalignment can also cause poor picture definition. The high video frequencies are usually affected first, in that the vertical wedges on the test pattern get "milky" and cannot be resolved very far "down," (in toward the center of the pattern).

To check the head-end alignment, connect the sweep generator to the antenna terminals, and the oscilloscope to the converter, as specified by the manufacturer of the receiver. An accurate marker oscillator is needed to determine the response curve. The head-end response should look about like Fig. 1A, which shows a good response curve for channel 13. The picture carrier frequency for this channel is 211.25 Mc; the marker pip at this frequency should appear at least 70% up the curve, and preferably on top, as shown. The sound carrier frequency for channel 13 is 215.75 Mc and should likewise appear above 70% on the curve.

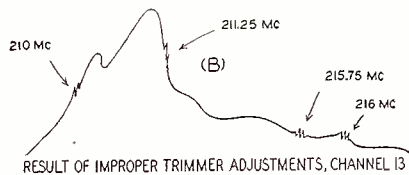
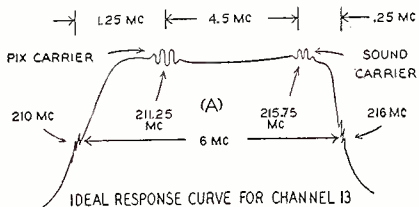
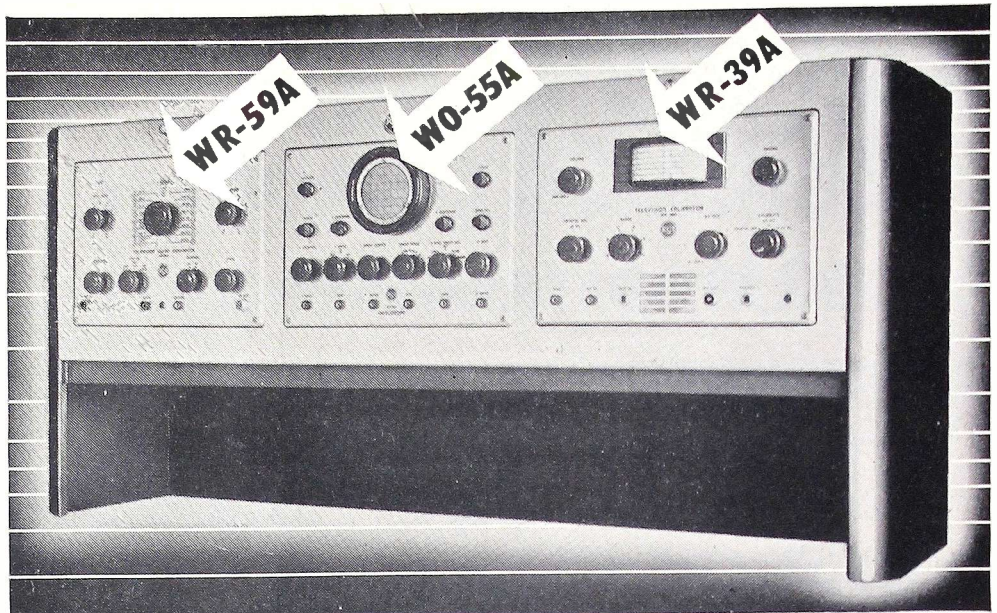

Fig. 1.

The rf response should be essentially flat over each channel. If the response is low at the sound carrier, the sound will be weak compared with the picture response, and vice-versa. Fig. 1B shows channel 13 misaligned. This response curve will produce a poor picture and very weak sound. Since a sharp peak exists on the low-frequency side of the picture carrier, the high frequencies will be attenuated and the picture will lack crisp, sharp definition. The vertical wedge of a typical test pattern would appear weak or "light gray" as compared with the horizontal wedges.

Intermittents and microphonics can be checked very readily by observing the response curves on the scope while the connections, switches, lead dress and slug adjustments are gently prodded and moved.

\*Sets containing age circuits driven from the video amplifier and sets using the intercarrier system may also develop other faults which can cut off the picture without disturbing the raster.



The WR-39A and WR-59A combined with the WO-55A Oscilloscope in RCA's new WS-17A Rack, provide a modern, self-contained set-up for the efficient and profitable alignment of television receivers.

# YOUR ANSWER to accurate television alignment

- ✓ The RCA WR-59A Television Sweep Generator
- ✓ The RCA WO-55A Oscilloscope
- ✓ The RCA WR-39A Television Calibrator

● Designed by RCA engineers at "television headquarters"—these companion units furnish *all basic signals* necessary for the rapid, accurate alignment of television receivers. Flexibility, dependability, and accuracy are outstanding characteristics of these instruments.

For alignment, the WR-59A Television Sweep Generator and WR-39A Television Calibrator can be used with the RCA WO-55A General Purpose Oscilloscope matching unit—as illustrated—or with any good oscilloscope.

The WR-59A Television Sweep Generator covers all television frequencies. All ranges develop 0.1 volt rms or more on *fundamentals* and can be quickly selected by means of a band switch. Excellent shielding plus a piston attenuator allow the output to be re-

duced to the noise level. Unusually flat output is provided with amplitude variation on all ranges of less than 1 db. Phasing and retrace-blanking controls are incorporated.

The RCA WR-39A Television Calibrator is a variable-frequency oscillator, dual-crystal frequency standard, and heterodyne detector with audio amplifier and speaker. The VFO puts markers of fundamental frequency and crystal accuracy on TV-FM traces from 19 to 110 Mc and 170 to 240 Mc. Dual-crystal standard is used to calibrate VFO or other signal generators with 250-kc and 0.25-Mc check points from 250-kc to 240 Mc.

See your RCA Test Equipment Distributor today for further technical details or write RCA, Commercial Engineering, Section 55 EX. Harrison, N.J.

For test equipment you can trust  
always keep in touch with your RCA Distributor



**RADIO CORPORATION of AMERICA**

TEST AND MEASURING EQUIPMENT

HARRISON, N. J.



# CHICAGO

## EXACT REPLACEMENT

### VIBRATOR TRANSFORMERS

#### For Quicker, Easier, Better, More Profitable Servicing

This new CHICAGO stock line fills the serviceman's long-standing need for *exact replacement* Vibrator Transformers designed for application in a wide range of popular makes and models of auto radios. Exact replacement units in the line provide mountings and characteristics identical to those of the original transformers. For many other sets, CHICAGO Vibrator Transformers are available with electrical characteristics equivalent to the original parts, and readily adaptable for quick, easy mounting. The typical units listed below incorporate famous CHICAGO engineering and quality manufacture—your assurance of top performance. Available *now* at leading jobbers.

CAT. NO.	A-C Sec. Volts	D-C Load Current	LIST PRICE
VT-1	250-0-250	50 MA	\$7.00
VT-2	265-0-265	50 MA	7.25
VT-3	270-0-270	60 MA	7.50
VT-4	300-0-300	60 MA	7.75
VT-5	295-0-295	70 MA	8.00
VT-6	280-0-280	80 MA	8.50

Write for descriptive catalog folder

#### You get these exclusive advantages with CHICAGO Exact Replacements . . .

1. Electrical characteristics identical to the original vibrator transformer. Because plate voltages and characteristics are the same as originally specified by the manufacturer, no extra condensers or resistors are required. CHICAGO Exact Replacements save you time and money.
2. Mountings are *exactly the same*—no need to drill new holes, no alteration of chassis required. Customers see an exact size replacement—no need to explain away a transformer either larger or smaller than the original.
3. Your services are easier to sell when you can assure the customer in advance that replacements will be made with exact duplicate parts.
4. The original quality performance you achieve in your finished installation means satisfied customers and repeat business.

Look for CHICAGO Transformers in Sams' Photofacts

## CHICAGO TRANSFORMER

DIVISION OF ESSEX WIRE CORPORATION

3501 ADDISON STREET • CHICAGO 18, ILLINOIS

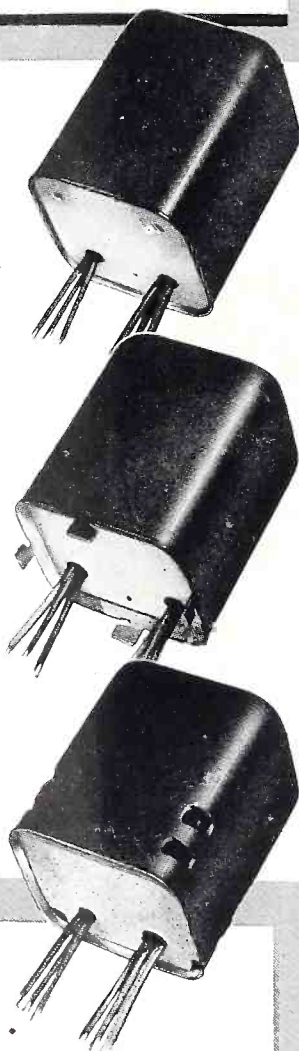

good old 7 need a high freq. (spelled freak) antenna, so, let's rig one up! Channel 5's misbehaviour is still worrisome though, but we'll lick that later. So, half an hour later, after considerably more wig-wagging, we find the proper spot to rig up the short antenna for the upstairs Channels, 7, 11 and 13. Only now we find good old Channel 11 works better on the long antenna than on the short one, mathematics, theory and regulations to the contrary. But still 5 don't come in! *Hell, we'll fix that later!!*

Now, let's see how the installation is. Oooops . . . something slipped! The set's horizontal drive has gone out of whack. So we realign it! But now she's rolling all over, and we're only getting half a picture. In fact, we're almost drunk from watching the vertical sweep roll over scillions of rps . . . and we finally slow her down. Now we have a sweet raster, *but we've lost the sound.* Ah! Shucks! . . . let's not give up, this is a simple installation . . . but we still don't get Channel 5. Let's work on that? Okay! Let's. And we do . . . and two hours later we now have sound coming in on 5 like a symphony . . . *but we lost the picture.* So, we readjust to get the picture, and brother, do we get it? We sure do, with 4 lovely ghosts. And, by the way, we've lost that lovely sound, and instead we get a puddle of mush. But, why worry . . . we've only been on the job 4 hours so far, and now that 5 has been improved (which is debatable), we've completely lost Channel 7. So, back to work on 7. But, it's two hours past dinner-time and the wife isn't at all happy about an over-roasted, high-cost beef steak. All right, time out to eat.

A quick meal, and back to the grind. But, by now Jupe Pluvios is helping and it is pouring cats and dogs, so every time one sticks his neck a wee bit out the window he gets ge-dunked plenty. Let's quit until tomorrow! Shucks . . . no! We'll lick this baby or get out of the radio business. So, two more hours of piddling goes down the drain. Now we are *completely* flabbergasted. Let's get help . . . an expert . . . let's call Sam Marshall. He'll gladly help. But, not until tomorrow. That's fine. It may stop raining by then. It does, for the next day it isn't raining. No Sir, it's snowing. And, with expert Marshall on the job, only two more hours are required. Of course matters were speeded up considerably because Marshall had a bazooka. And, after getting every darn station to come in, with the exception of 5,



# Service Dealers

## Form A Group,

## Subscribe to "RSD"—

## SAVE Up to \$1.00 each.

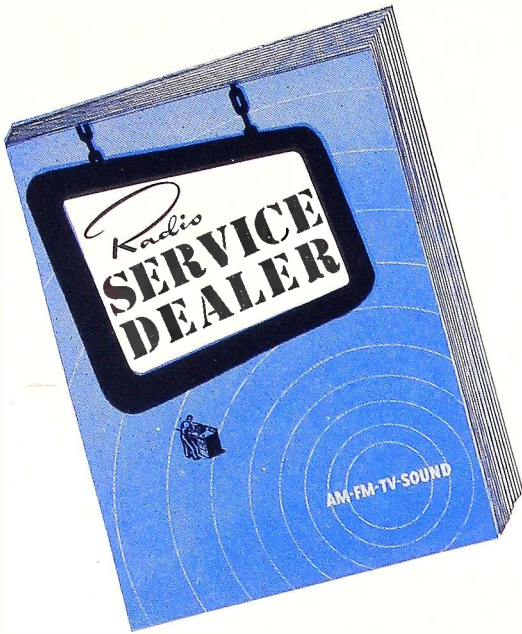

"The Professional Radioman's Magazine"—published monthly. All articles are exclusive and timely. Practically every issue is worth what an entire 1 year subscription costs.

★ The more in a group the bigger the savings. 6 men in a group save \$1.00 each; 4 men groups save \$ .75 per man. Present "RSD" subscribers may participate in or form a group with co-workers, or even competitors. Still active subscriptions are automatically extended 1 year. Start a Group today! The timely and exclusive technical data appearing in future issues of "RSD" will make this the best investment you ever made. The special Group Rate offer may be withdrawn at any time—so hurry.

### Use This Coupon For Convenience

(The coupon below can be used for from 1 to 6 subscription orders. Use it today!)

TEAR OUT—MAIL TODAY



RADIO SERVICE-DEALER MAGAZINE  
342 Madison Ave., New York 17, N. Y.

Please enter 1 year subscription orders for the names given below. Our remittance is enclosed.

NOTE: If you do not wish to tear this order blank out, just print or type the information on a single sheet of paper, following the style given. Each subscriber's occupation must be clearly described.

	In U.S.A. & Canada	Foreign Rates
<input type="checkbox"/> One 1-year subscription	\$2.00	\$3.00
<input type="checkbox"/> Two 1-year subscriptions, each	1.75	2.75
<input type="checkbox"/> Three 1-year subscriptions, "	1.50	2.50
<input type="checkbox"/> Four 1-year subscriptions, "	1.25	2.25
<input type="checkbox"/> Five 1-year subscriptions, "	1.10	2.00
<input type="checkbox"/> Six 1-year subscriptions, "	1.00	1.50

Name.....  
Address.....

Describe Title or Position and Type of Business.....

State whether a New Subscriber  or Renewal Order

Name.....  
Address.....

Describe Title or Position and Type of Business.....

State whether a New Subscriber  or Renewal Order

Name.....  
Address.....

Describe Title or Position and Type of Business.....

State whether a New Subscriber  or Renewal Order

Name.....  
Address.....

Describe Title or Position and Type of Business.....

State whether a New Subscriber  or Renewal Order

Name.....  
Address.....

Describe Title or Position and Type of Business.....

State whether a New Subscriber  or Renewal Order

Name.....  
Address.....

Describe Title or Position and Type of Business.....

State whether a New Subscriber  or Renewal Order



Quality  
Engineered

# TRANSVISION

Precision  
Manufactured

## TELEVISION INSTRUMENTS

### EQUIPMENT AND COMPONENTS

For Better TV Performance and Lower Installation Costs

### Eliminate the Variables in Television Installation with the Transvision FIELD STRENGTH METER

Improves Installations !! Saves 1/2 the Work !!

Has numerous features and advantages, including—(1) Measures actual picture signal strength (2) Permits actual picture signal measurements without the use of a complete television set

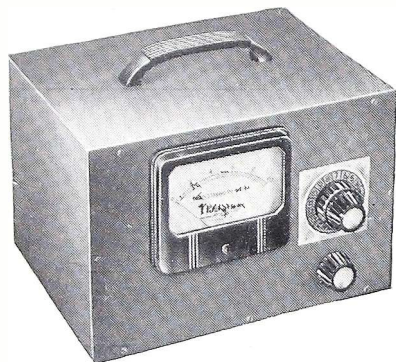

(3) Antenna orientation can be done exactly . . . (4) Measures losses or gain of various antenna and lead-in combinations . . . (5) Useful for checking receiver re-radiation (local oscillator) . . . (6) 12 CHANNEL SELECTOR . . . (7) Amplitudes of interfering signals can be checked . . . (8) Weighs only 5 lbs. . . . (9) Individually calibrated . . . (10) Housed in attractive metal carrying case . . . (11) Initial cost of this unit is covered after only 3 or 4 installations . . . (12) Operates on 110V, 60 Cycles, AC.

Model FSM-1, with tubes .....Net \$99.50

### TRANSVISION ALL-CHANNEL TELEVISION BOOSTER CONTINUOUS TUNING



Model B-1 .....List \$32.50

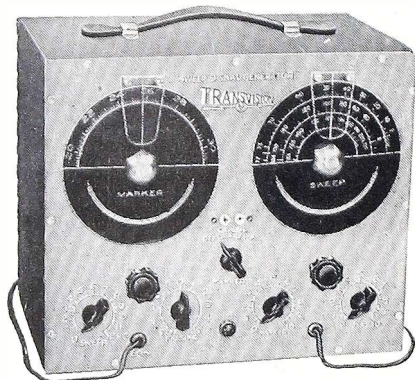

### TRANSVISION TELEVISION and FM SWEEP SIGNAL GENERATOR

Complete frequency coverage from 0-227 MC with no band switching . . . Sweep width from 0-12 MC completely variable . . . Accurately calibrated built-in marker generator.

Model SG .....Net \$79.50

### TRANSVISION IS NOW EXCLUSIVE DISTRIBUTOR OF DU MONT TV/FM INPUTUNER

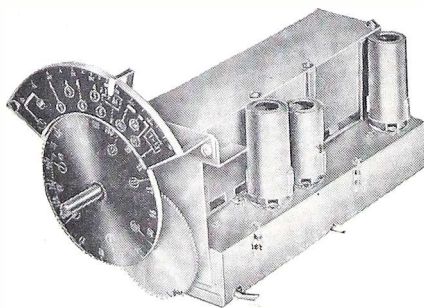

Model IT-1, with tubes .....List \$59.95

All Transvision Prices are fair traded; subject to change without notice. Prices 5% higher west of the Mississippi

TRANSVISION, INC., Dept. RSD NEW ROCHELLE, N. Y.

Please ship the following Transvision Products THROUGH YOUR NEAREST LOCAL OUTLET:—

RSD-5

I am enclosing 10% DEPOSIT in the amount of \$....., balance C.O.D. ( ) I want to get into the Television Business. Send me details of your Dealer Plan.

Name.....City and Zone..... (please print)

Address..... State.....

which is still an elusive little darling, off comes the bazooka, out go the stations, and we start all over. (You know, for experts, this TV antenna installation work is a cinch. All you have to have is the patience of Job, lots of time, a skin impervious to rain and sleet . . . and plenty of luck.) And, to climax it all, then the neighbor upstairs tells you "there must be something wrong with your TV rig because he gets Channel 5 like a house-afire. You look for yourself to see if he's kidding. He's not. That it happens to be true that he can't get Channels 7 or 11 worth a damn gives you some, but not much consolation. Then, in desperation, you, or I should say I, take one more gander at the entire rig to find out "wot happened" to 5, and by Jimminy, the thing's coming in just dandy. Did anyone piddle around with something to make this phenomena happen? No Sir, because an hour later 5 has gone sour again. But, ouce around the dial shows us 4 is rollin' in grand. There's a hockey game on. I hate hockey like I hate sitting on a bee's hive. But . . . if that's what the set wants to show me, by Gosh and by Crimminy, that's what I'll watch. TV can't lick an expert like me! It's just that I'm like 90% of the other guys in this racket . . . I'm not lucky, that's all. And, to end this sermon. I once felt that radiomen were getting rich at the racket of charging \$35 for an installation, plus warranty. Brother, from now on, any TV antenna job I hear of that was billed for less than one hundred bucks convinces me that the serviceman was a sucker and underpaid.

*Moral:* TV antenna installations are the life-blood of this new industry. Radiomen should try to get all the jobs they can. But, they should make sure they make a profit on every job, and you simply can't determine in advance what kind of troubles are gonna mess up your preliminary calculations. So, take my advice and don't quote a flat fee in advance. Submit the bill after you've finished an installation and know how much time you've spent on it.

#### Sarnoff Is Optimistic

Radio Corp. of America's prexy, David Sarnoff, issues annually a most enlightening year-end statement to his stockholders. From the 1948 Report one can glean plenty of prognostication. The General opined that even though more than 2 million video sets are scheduled for production during 1949 the demand

[Continued on page 47]



THEY'RE  
HERE

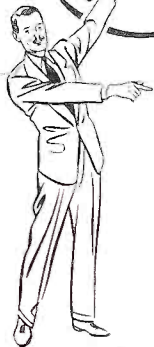

SHORTPROOF



FOR  
FLASHLIGHTS



LONGER  
ACTIVE  
LIFE

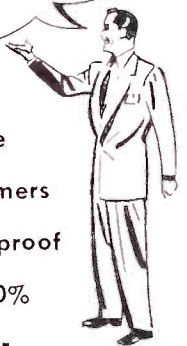

THE NEW "Plastic Clad"  
**PHILCO**  
RADIO "A"  
**BATTERIES**  
INCREASE THE LIFE OF YOUR FLASHLIGHT

Here, from Philco, is the flashlight battery customers will cheer for. It's shortproof . . . and packed with 20% more active material for extra long life that keeps buyers coming back for more.



**NEW COUNTER DISPENSER**  
Turns stock fast! They sell on sight, in this compact eye catching dispenser. Place it up front and cash in on this big news in flashlight batteries. Has testing bulb. Fits in minimum space.

GET READY FOR THE NO. 3  
PHILCO ACCESSORY  
"GOLD RUSH" PROMOTION



SEE YOUR  
PHILCO  
DISTRIBUTOR



## QUESTION

Why do so many television sets use Sprague KOOLOHM Resistors for all 5- and 10-watt wire wound power resistor requirements?

## ANSWER

Because Koolohms far surpass other wire wound resistor types in the essential characteristic of resistance stability. Also because, being doubly insulated, Koolohms can be mounted anywhere—even directly against a metal chassis. Koolohms are highly heat- and moisture-resistant. One type—the *standard* type handles any job. No need to worry about choosing special coatings. Moreover, Koolohms cost no more than ordinary resistors, and are actually cheaper in many cases.

## SERVICE HINT

Play safe by using Sprague Koolohms in all your work—not only in television, but wherever you want a really first class job. And remember: Koolohms can be used safely at their full wattage ratings, even in enclosed places. No need to buy a 10-watt resistor when the circuit only needs 5-watts. A 5-watt Koolohm dissipates a full 5 watts!

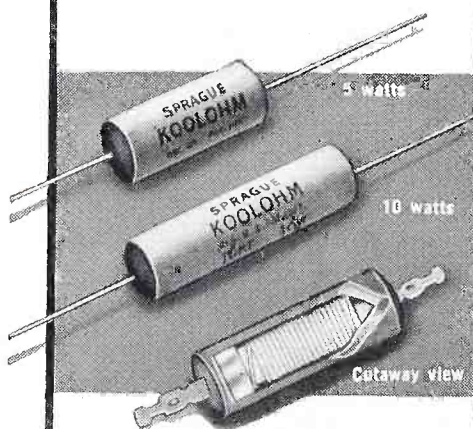

Wound with ceramic-insulated wire. More resistance in less space. Doubly protected, insulated and sealed by outer ceramic jacket. Highly resistant to moisture and heat.

**SPRAGUE  
KOOLOHM**  
(Reg. U. S. Pat. Off.)  
**WIRE WOUND RESISTORS**

SPRAGUE PRODUCTS CO., North Adams, Mass.

(Jobbing distributing organization for products of Sprague Electric Co.)

# TRADES FLASHES

A "press-time" digest of production, distribution & merchandising activities

### Need For Antenna Standards

The television industry is laying up future headaches for itself unless it takes steps to set up adequate standards for antennas, Gardiner G. Greene, president of Workshop Associates, Newton Highlands, Mass., told RADIO SERVICE DEALER recently.

"No television set is any better than its receiving antenna," Greene warned, "and for the industry to spend vast sums in advertising and promoting video without taking steps to assure the purchaser that his set will deliver a satisfactory picture into the home is to pursue a very short-sighted policy that may materially affect set sales in a year or two."

### Town Meeting Attendance

On the eve of the final Town Meeting of Radio Technicians during the current season, Harry A. Ehle, chairman of the Town Meeting Committee of the Radio Manufacturers Association announced that attendance at the first four Meetings was 10,280 technicians, dealers, and distributors.

### 1949 TV Sales

During 1949 television sets will be purchased by at least 1,580,000 families, but as many as 2,710,000 sets may be sold by the industry if it improves its selling techniques, according to a survey on the "Attitudes of Non-Owners of Television" released today by Sylvania Electric Products Inc.

### Transvision Distributes Inputuners

The appointment of Transvision, Inc., of New Rochelle, N.Y., as exclusive national distributors of Du Mont Inputuners through jobbing, amateur supply, and retail channels was announced by Herbert Suesholtz, General Manager of Transvision, Inc.

Transvision has further been granted the exclusive right to use the Du Mont Inputuner in their television kits, and is now restyling its kits in order to make greater use of this high performance TV/FM head-end.

### Parts Store On Wheels

This is the interior of the Philco parts and accessories merchandiser



trucks now being put in operation by Philco distributors throughout the country. More than \$16,000 worth of parts can be stored and displayed in the trays and shelves.

### New Stewart-Warner Receivers

Two new console models—"Contemporary," an AM radio-phonograph, and "Boulevard," an AM radio with phonograph-jack for playing any speed of external record player,—have been announced by Stewart-Warner Electric, a division of Stewart-Warner Corporation. Shipments are now being made to dealers, E. L. Taylor, general sales manager, said.

### Five New Howard W. Sams Books

Howard W. Sams has just announced that Oliver Read's handbook, "The Recording and Reproduction of Sound", is being readied for release in May. The second book announced is Vol. 2 "1948 Record Changer Manual". The third book, "Television Antennas," design, construction, installation and troubleshooting guide, is the fruit of 13 months of study and work on the part of the Sams' organization. Written by Donald A. Nelson, the book covers actual field experience in installing, adjusting and orienting all types of antenna in all sorts of locations.

The fourth book is the Photofact TV Course in book form. Based on a series of sixteen television theory and service orientation lectures originated by A. C. W. Saunders, the Photofact Television Course incorporates a thorough exposition of practical television

[Continued on page 46]



IN RADIO AND TELEVISION TUBE SALES



1949 IS A  
G-E YEAR!

**Biggest news of the year:  
General Electric's TV-service course!  
Jampacked with profit possibilities for  
you and other tube dealers to whom tele-  
vision—the miracle market—offers peak rewards.**

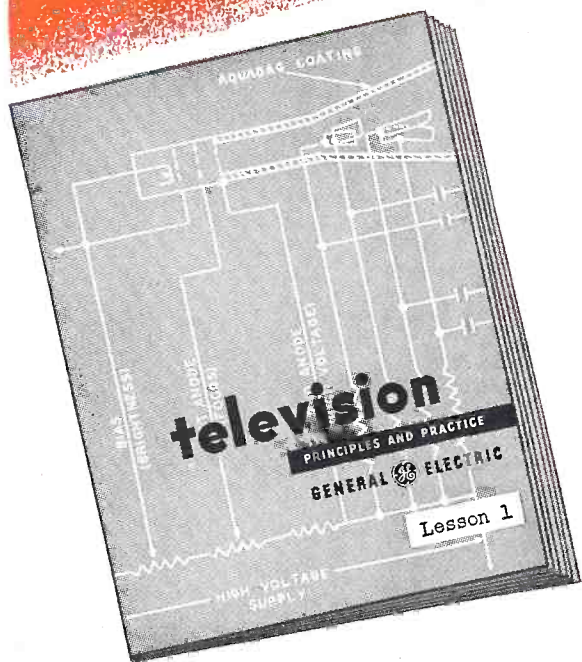

It's all here, in this book and those that follow—the basic theory of television; how TV receivers operate; the tubes and other components; how to install and repair sets of various types to their owners' satisfaction and your profit. Each lesson of the series is a clear, straightforward explanation of some one phase of television . . . *plus* a searching list of questions for you to answer after study.

Mail your answers, and a reply will reach you soon afterwards, grading you on your knowledge of the subject. This is an organized, hard-hitting correspondence course. You'll work hard to learn—but the hours you devote to General Electric's TV-service course will pay off in the sale of tubes, parts, and service to owners with real money to spend.

See your G-E tube distributor for the details! He's ready *now* to start you along this thruway to profits. It's one more step in General Electric's 1949 campaign to help you help yourself to prosperity and an assured business future. *Electronics Department, General Electric Company, Schenectady 5, New York.*

*You can put your confidence in—*

**GENERAL  ELECTRIC**

161-HA4



**SAVE TIME!**

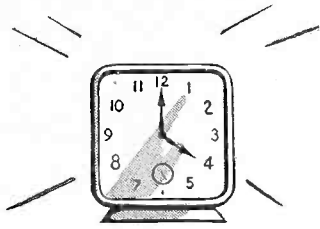

**SAVE MONEY!**

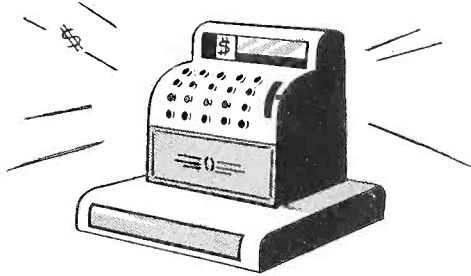

**SAVE SPACE!**

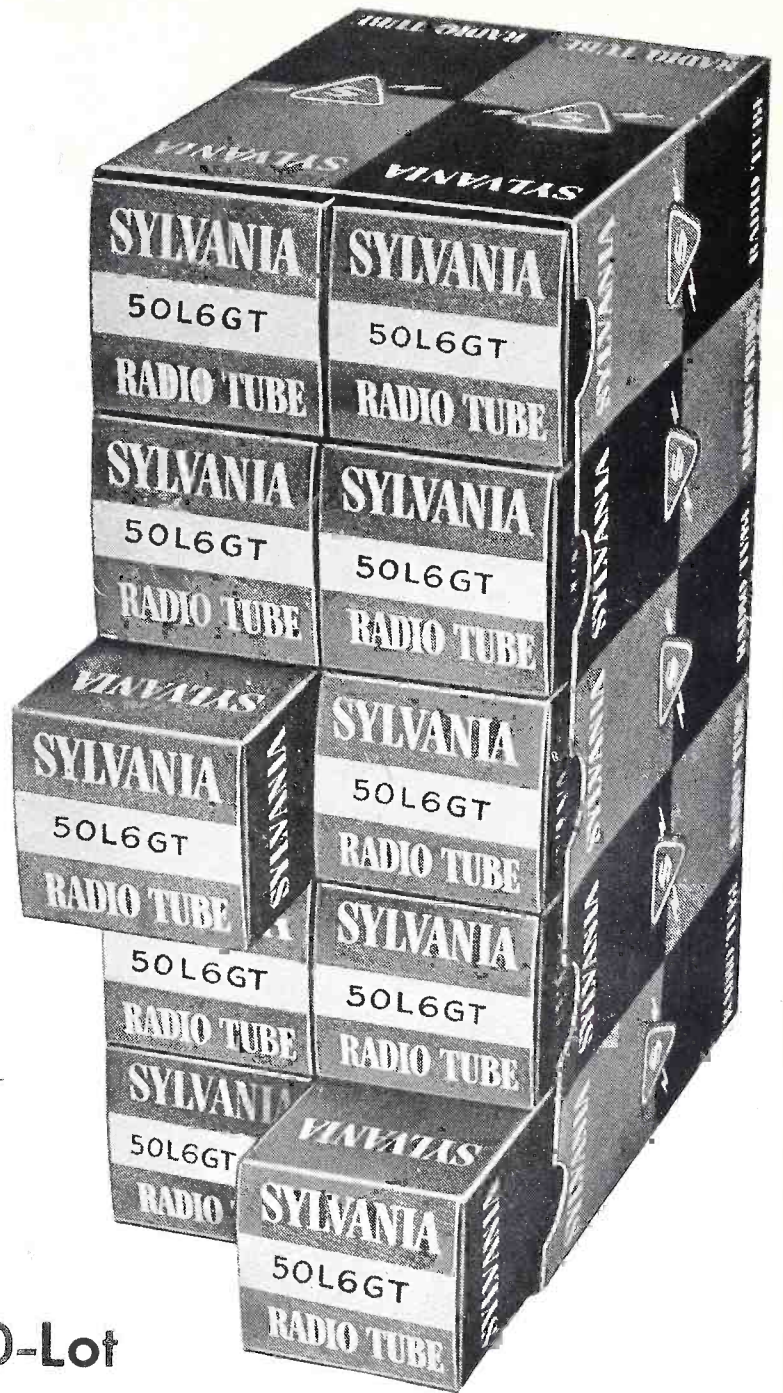
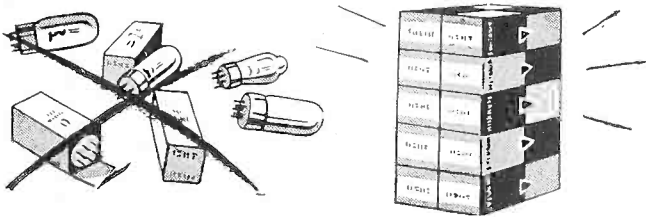

with Sylvania's New 10-Lot  
Cartons of *fastest-moving radio tubes!*

**H**ERE'S the new, handy 10-lot package, developed by Sylvania to make your job easier! You save time, you save money by keeping plenty of fast-moving tube types *on hand*. No need to make numerous trips to your distributor to buy a few tubes at a time—especially when you're just one type short on a service job!

This new package is easy to handle, easy to stock—no more loose tubes and cartons to take

up unnecessary space! Now your shelves will be neatly arranged, making it possible to store more tubes in the same space. Buying Sylvania tubes the 10-Lot Carton way simplifies your inventory and re-ordering job since you can inventory on the basis of 10 and re-order the same way! See your Sylvania Distributor today for any further details! *Sylvania Electric Products Inc., Radio Division, Emporium, Pa.*

**SYLVANIA**  **ELECTRIC**

RADIO TUBES; CATHODE RAY TUBES; ELECTRONIC DEVICES; FLUORESCENT LAMPS, FIXTURES, WIRING DEVICES, SIGN TUBING; LIGHT BULBS; PHOTOLAMPS



# Modern TAPE RECORDERS

by C. A. TUTHILL

## PART I

**B**ECAUSE of the increasing interest in tape recording machines; because that growing interest is justified; because tape recorders are capable of high quality performance, this article is written to better acquaint dealers with a product they may be handling any day now. Of the several tape recorders available the Twin-Trax offering was chosen for discussion since it seems to include most of the features pertaining to contemporary tape recorders. In fact one of their models has even provided for cross-over recording from disc to tape through the inclusion of a disc turntable affixed to the central capstan of its mechanism. This is clearly shown in *Fig. 1*.

Magnetic tape machines run in price from around \$100.00 for the simpler types on up through \$600.00 or more for cabinet models capable of four continuous hours (4) of either recording or playback. Larger sized 13½" reels and parallel records or twin tracks on one single tape make the long playing or recording time possible. (See *Fig. 2*)

Economy is naturally the gain through the use of these double or twin-track tapes. One recording is effected during transit of the tape in one direction while the second track is recorded after an automatic vertical shift and reversal device sends the same tape back into its original reel. Despite this dual construction however, standard single track tape records, recorded at a speed of 7½ inches per second, can be played back through these machines. Portable and battery-operated models are also available.

### Basic Features

Essentially the equipments described herein consist of five basic units, name-

**Beginning a two part article in which the mechanical and electrical characteristics of a commercial tape recorder are discussed with the idea in mind of acquainting the Radio Service Dealer with the mechanisms and circuits.**

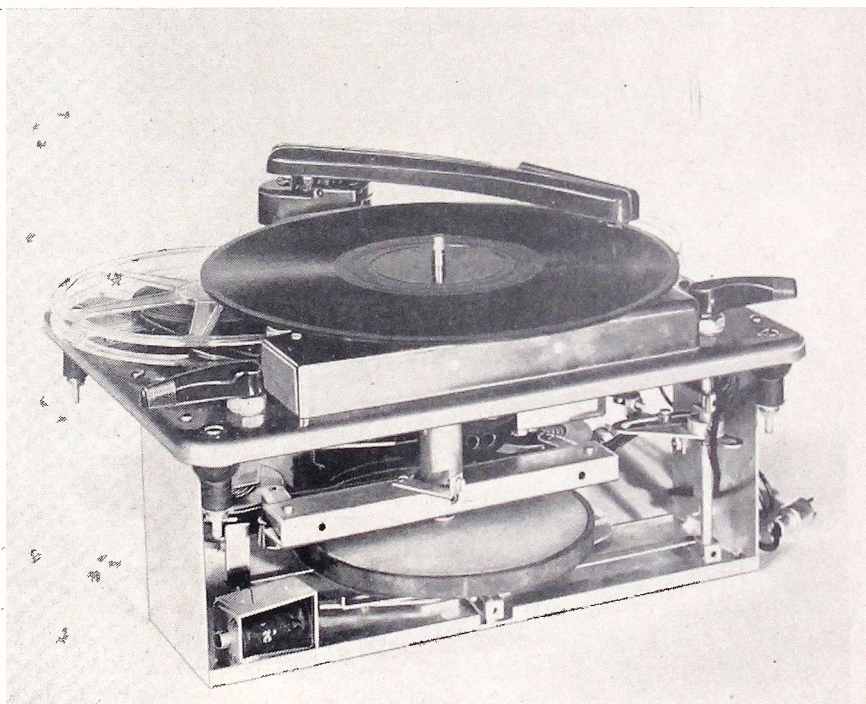

Fig. 1. Open view of Tape Recorder

ly,—Tape Handling Mechanism; Recording-Playback Head; Erasing Head (magnetic erasure); Recording Amplifier, and a Playback Amplifier.

To afford greater freedom in the accomplishment of high quality reproduction, a separate amplifier is used for *playback*. This permits useful flexibility in the design of the record-

ing amplifier. Both are resistance coupled units conducive to a linear response over a wide frequency range. Complete combined schematics appear in *Fig. 3* and will be discussed later in this article. While studying the schematics it should be borne in mind that, in addition to the supersonic oscillator used for erasing circuits, a lower level



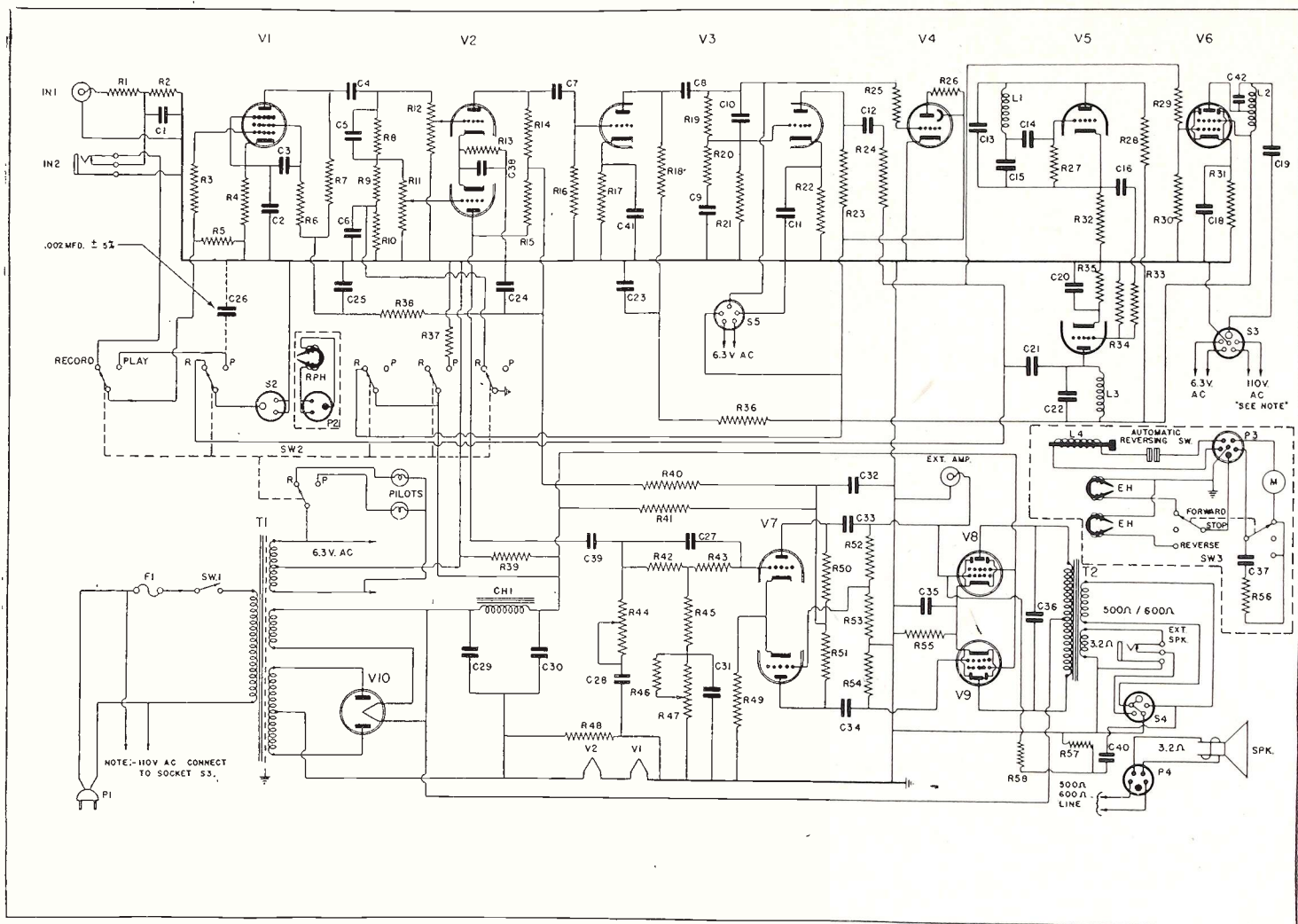

Fig. 3. Tape Recorder schematic

50 kc signal is tapped off at capacitor C-21 from the supersonic oscillator (V-5). A pure sine wave bias source is thus supplied to the recording head of these tape machines. More on that later.

**Tape Handling Mechanism**

Regardless of the nature, design, or method employed, any recording machine depends upon its mechanical achievements, we might even say *mechanical excellence*, for whatever success it enjoys. The designers of this tape recorder have thought twice in

this direction. The simplicity in design attests to the fact. And though the readers of this article may be primarily interested in electronic features, they cannot lightly dismiss the mechanical rudiments of any recording machine which they intend, as dealers or servicemen, to handle. Such comparatively new terms as *spindles*, *shuttles*, *clutches* and *braking mechanisms* must be taken in stride with understanding, for your customers are going to be mechanics as well as megohm dissectors. Because of that, more than

the usual space will be devoted here to mechanical consideration of these recorders.

Fortunately the sketches of *Figs. 4A & 4B* will save the reader considerable time since they are readily understandable. However these sketches only show what is above decks. And we will confine ourselves mostly there since the reader can get details from the manufacturer who claims that, with decent treatment, the mechanism riding in oilite bearings will require little

[Continued on page 44]

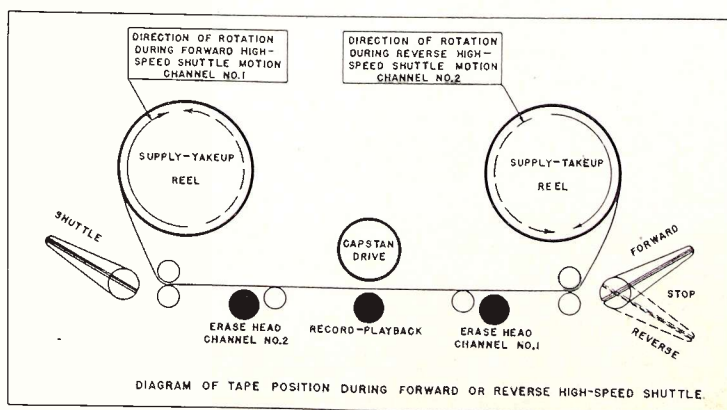
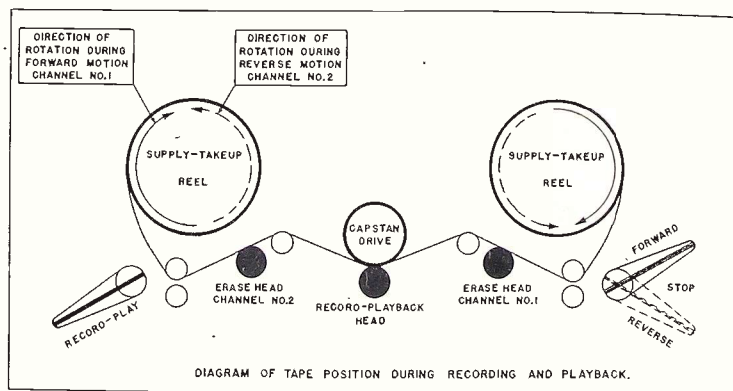

Fig. 4. Threading mechanisms of Tape Recorder



# New TV TEST Equipment

by ALLAN LYTEL

PART 2



Fig. 4—R.C.A. Cathode Ray Oscilloscope Model WO 58A.

**Concluding installment on the theory and operation of various type of TV test equipment. Cathode ray oscilloscope characteristics are discussed in this issue.**

## Cathode Ray Oscilloscope

The RCA Cathode Ray Oscilloscope, Type WO-58A shown in Fig. 4, has been especially designed to be used together with the RCA Television Sweep Frequency Generator and Television Calibrator. Special features have been incorporated to make this device applicable to television alignment and trouble-shooting work although, of course, it may be used for general oscilloscope work. One of the main features is a vertical amplifier designed to have the best possible transient-response characteristics and also amplify a wide band of frequencies without introducing phase distortion. Accordingly, the WO-58 presents a good picture of sync pulses and deflection waveforms. By avoiding a sharp high-frequency cutoff, phase distortion is kept very low. The vertical amplifier response curve is essentially flat to two megacycles and then slopes gradually downward until it is down about 50% at four megacycles. This assures what amounts to a linear phase characteristic which is ideal for television pulse work. This is exceedingly important, for the big question in the serviceman's mind when a distorted picture is seen on the scope, is the

source of this distortion. This amplifier virtually assures that the distorted picture is caused by the circuit being tested. A review of the controls will show the particular applications to television service work.

1. *Intensity.* This controls both the Power Switch and the brightness of the test pattern.

2. *Focus.* Focus controls the sharpness of the image.

3. *Vertical Centering.* Controls the vertical position of the trace.

4. *Horizontal Centering.* Controls the horizontal position of the trace.

5. *Sync Adjust.* Controls the amount of synchronizing voltage fed to the sweep generator.

6. *Horizontal Gain Vernier.* Is used together with the horizontal selector and Gain control to provide the proper width of pattern.

7. *Sync Selector.* This control is used to obtain the proper synchronizing voltage from any one of six positions. Position, Internal (+), takes the sync signal from the vertical amplifier, and trace flyback starts during positive-going portion of the vertical signal. Position, internal (—), takes the sync signal from the vertical amplifier, and the trace flyback starts during the negative-going

portion of the vertical signal. Line (+) takes the sync signal from the power supply and trace flyback starts during the positive-going portion of the voltage output from the Phase Control. Position, Line (—), takes the sync signal from the power supply and the trace flyback starts during the negative-going portion of the voltage output from the Phase Control. External (+) takes the sync signal from the Sync terminal and trace flyback starts during the positive-going portion of the externally supplied sync signal. Position, External (—) takes the sync signal from the Sync terminal and trace flyback starts during the negative-portion of the externally supplied sync signal.

As with the conventional oscilloscope, Internal Position is used to sync the sweep with the vertical amplifier, frequency. Line position is used to sync the sweep with the power line frequency, and External Position used to synchronize the sweep, with the frequency of an external source.

8. *Vertical Range.* Position, 5, takes the signal directly from the probe tip to the input of the vertical deflection amplifier. Position, 1.5, attenuates the input signal 3 to 1. Posi-



	WO 58A	WO 55A
Vertical Amplifier Sensitivity	less than 0.5 volts (peak to peak) per in. direct input probe	less than 1.33 volts (peak to peak) per inch at max. gain
Vertical Deflection Plates Sensitivity	less than 39 volts (peak to peak per inch)	less than 135 volts (peak to peak per inch)
Frequency Response (Sinewave)	flat within $\pm 20\%$ from 5 cps to 2 mc. flat within $\pm 50\%$ from 1 cps to 4 mc.	flat within $\pm 10\%$ from 7 to 40,000 cps. flat within $\pm 20\%$ to 70,000 cps.
Input Impedance (Vertical Amplifier)	1 megohm shunted by 25 $\mu\text{mf}$ .	0.5 megohm shunted by 55 $\mu\text{mf}$ .
(Horizontal Amplifier)	1 megohm shunted by 55 $\mu\text{mf}$ .	0.5 megohm shunted by 37 $\mu\text{mf}$ .
Sweep Circuit (Frequency Range)	10 cps to 100 kc	15 cps. to 50 kc

Fig. 6—Comparison of important characteristics between two cathode ray oscilloscopes, WO 58A and WO 55A.

tion, 5, attenuates the input signal 10 to 1. Position 15 attenuates the input signal 30 to 1. Position, 50, attenuates the input signal 100 to 1. If the attenuating probe is used, each of the above is multiplied by a factor of 10. This Vertical Range Control is used in conjunction with the Vertical Calibration knob in order to calibrate the oscilloscope amplifier for particular use.

9. *Vertical Calibrate.* This is designed to permit continuous adjustment and calibration of the vertical amplifier when used with the Vertical Range Switch.

10. *Sweep Range.* As with the conventional oscilloscope, this is designed to choose the proper range of sweep frequencies. The various positions of this switch indicate the limits of frequency in each position. There are four such positions: from 10 to 100 cps, from 100 to 1000 cps, from 1 to 10 kc, and from 10 to 100 kc.

11. *Sweep Vernier.* This control allows continuous adjustment over any range selected from the Sweep Range Control.

12. *Horizontal Selector and Gain.* With the four positions of this switch, it is possible to provide a sinusoidal sweep, a saw-tooth sweep, or an external sweep. Position, 1, applies the horizontal signal voltage directly to the horizontal amplifier. Position, 1, applies this same voltage to the horizontal amplifier while attenuating the input signal by ratio of 10 to 1. Position, Sweep, applies plate voltage to the sweep oscillator in the oscilloscope and applies the output of this oscillator to the horizontal amplifier. Position, Line, uses a portion of the 115 volts a.c. as a horizontal amplifier input signal.

13. *Phase.* This control adjusts the phase of the input sine wave applied in position, Line, above in number 12. Phase Control also adjusts the phase of the 60 cycle voltage used for synchronization of the sweep oscillator when the Sync Selector Switch is on Line, (+) or (—).

In addition to these controls, the following terminals are found on the bottom of the front panel.



Fig. 5—R.C.A. CRO Model WO 55A

1. *Horizontal Input Terminal* supplies the input signal to the horizontal amplifier through the Horizontal Selector and Gain Switch. All of the terminals marked G are chassis grounds and a connection may be made to any point.

2. *Sync Terminal* connects to the External position of the Sync Selector Switch.

3. *Vertical Input Terminal* is a coaxial connector which supplies the input signal to the vertical amplifier through the Vertical Range Switch. The shielded cable used for this vertical input has three different probe tips. The red probe tip is direct to the Vertical Input Terminal, the black probe is an attenuating probe, with a factor of 10 to 1 with very low capacity and a crystal rectifier is used in the blue probe.

4. *Meter Terminal.* This supplies a calibration voltage of 5 volts peak-to-peak for the vertical amplifier.

5. *Blanking Terminal.* This terminal may be used to apply external blanking voltages in order to intensity modulate the cathode ray tube beam. The purpose of the blanking voltage is to remove the signal from the cathode ray tube and allow a base line to be traced by the electron beam. When a blanking voltage is used, there is alternately a response curve and a straight base line traced on the tube face. This gives the optical illusion of both of these traces appearing at the same time. *Intensity modulation* allows time markers to be placed upon a trace for precise measurement of the duration of a phenomenon.

6. Through a door located on the left side of the oscilloscope, connections may be made to terminals direct to the vertical deflection plates of the cathode-ray oscilloscope. When the switch located in this door is thrown to the external position, connections are made directly from these terminal points to the deflection plates.

#### Calibration for Vert. Amp.

This oscilloscope is designed to be used as a peak-reading voltmeter. Any conventional oscilloscope may be used as such a meter but this model contains special devices and circuits for proper calibration, which is as follows:

1. Connect Vertical Input Cable to the Meter jack using the Direct probe.

2. Set the Vertical Range Switch on the 5 position and adjust the Vertical Calibrate knob until exactly one

[Continued on page 38]



# A New TV-FM SWEEP GENERATOR

by L. S. RICH

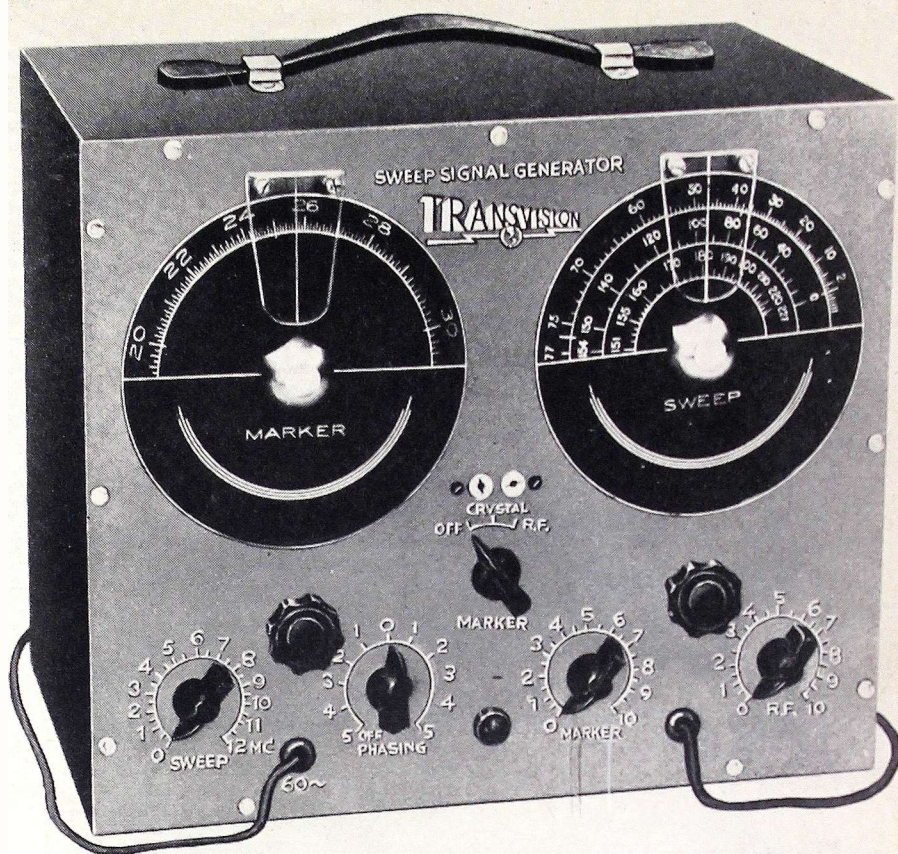

Fig. 1—Front View of Transvision Sweep Generator.

## Description of a TV-FM sweep generator which is both simple in construction and effective in operation.

**T**HE sweep generator and mark is rapidly evolving as a "must" TV servicing equipment. Naturally, the serviceman who has never had the occasion to operate this versatile combination is very much concerned with what to look for in evaluating instruments of this type. Basically, the sweep generator is a signal generator with a sweep wide enough to render the operating characteristics of the i-f and r-f amplifiers of a TV receiver visible on a cathode ray oscilloscope. To this end it must cover the frequency spectrum in which any r-f or i-f frequency falls. This is the *first* requirement.

A *second* requirement is to provide a variable sweep width so that the operation of circuits in which the widths of the frequency characteristics vary may be observed with con-

venience. A *third* requirement is to provide a means of injecting a portion of the sweep voltage into the horizontal sweep circuit of the scope so that exact synchronization takes place in the sweeps of both units. Along with this a means must be provided so that the phase angles in both units

are identical otherwise double traces will appear. A *fourth* requirement is to provide a marker frequency so that points on the CRO trace may readily be identified for whatever purpose this identification may be: linearity, maximum amplitude, minimum amplitude etc. This marker frequency may be generated by a separate unit or may be provided internally with the sweep generator. In any event, the marker must be reasonably accurate, and for this reason provisions should be made for crystals as the controlling or checking devices.

Of course other refinements enter into the design of a sweep generator, such as high stability, smooth operation of controls, and a minimum of interference between circuits. In addition the absence of spurious responses is of great importance, since their presence leads only to confusion.

From the laboratories of Transvision comes a new combination Sweep and Marker generator which seems to meet the requirements outlined above, and at the same time is almost the model of simplicity. This will become apparent if we will refer to the block diagram of this piece of equipment as shown in Fig. 2.

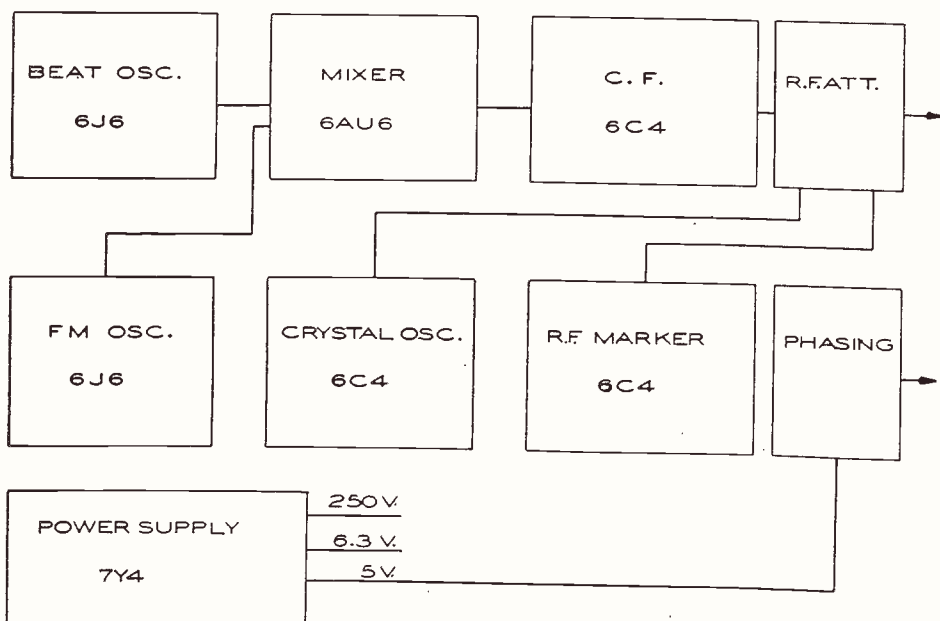

Fig. 2—Block diagram of Sweep Generator.



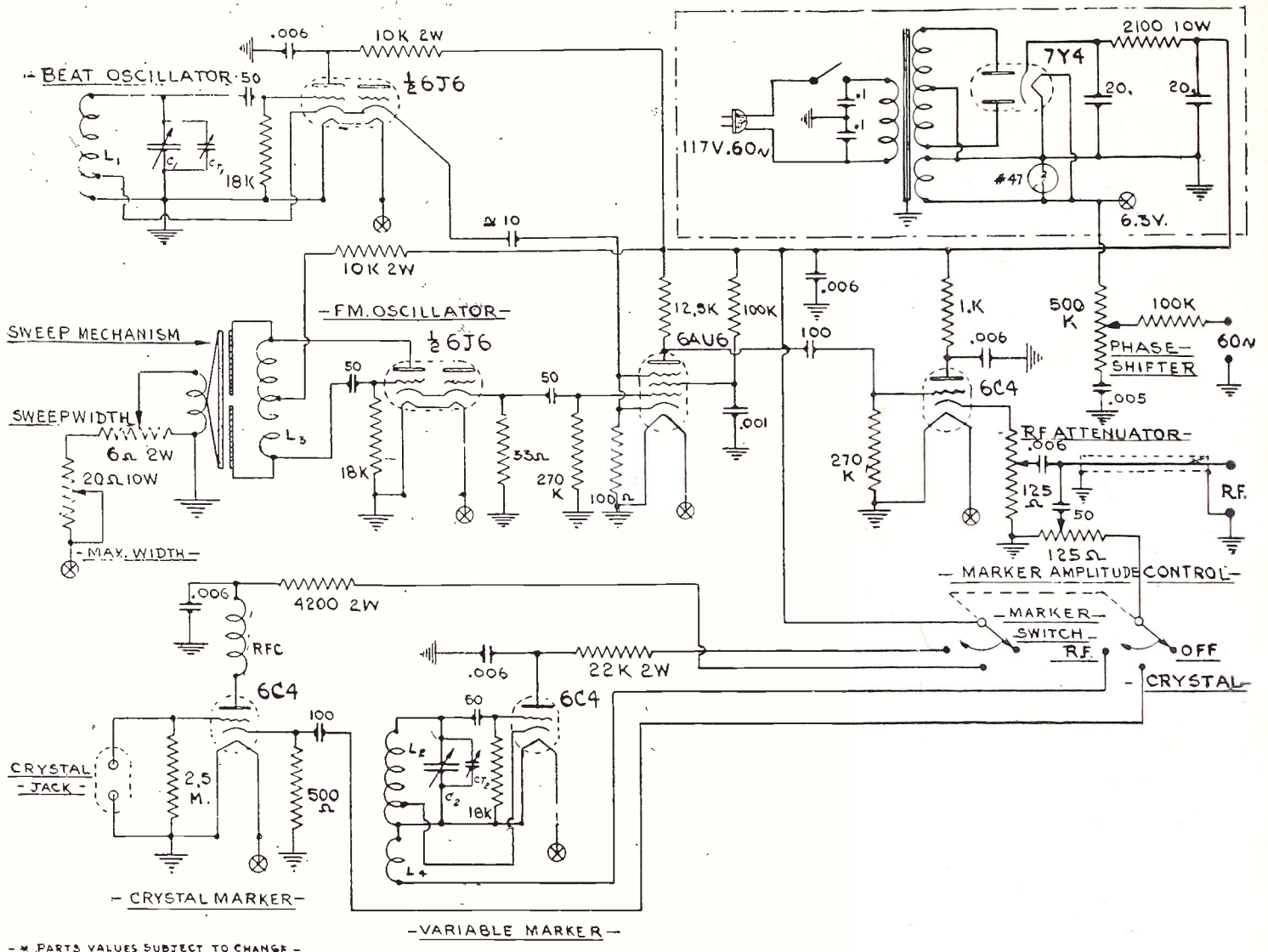

Fig. 3—Circuit diagram of Transvision Sweep Signal Generator.

**Sweep Frequency Generation**

First let us see how the various center frequencies from 2 mc to 227 mc are obtained, without the aid of bandswitching. The block marked, BEAT OSC.-6J6, is a conventional Hartley oscillator circuit (see Fig. 3) to which the sweep dial is attached. This circuit develops center frequencies from 37 to 114 mc. The block below this, marked, FM OSC.-6J6, is a frequency modulated fixed oscillator operating at 114 mc. These two oscillators are cathode coupled into the MIXER 6AU6 tube (so marked on the block diagram) so that the sum and difference frequencies between the two oscillators result in frequencies between 2 and 227 mc.

Calibration of the sweep dial is in three bands, of which the 2 mc to 77 mc band represents the difference frequency between the fixed oscillator (114 mc) and any one frequency setting of the variable oscillator (37 to 114 mc). Band 2, from 40 mc to 154 mc, represents a harmonic calibration

of Band 1 (from 20 mc to 77 mc). Band, 3 from 151 to 227 mc, represents the sum of the fixed oscillator (114 mc) and any one frequency setting of the variable oscillator (37 to 114 mc).

**Variable Sweep Facilities**

The method of obtaining an r-f signal with a frequency modulated sweep up to 12 mc is fairly simple. Reference to the block diagram in Fig. 2 indicates that the f-m signal is obtained from the block marked, FM OSC.-6J6, and reference to Fig. 3 will indicate how the output of this oscillator is frequency modulated. The tank coil is resonated by shunting it with a specially designed split stator capacitor which is varied by means of an electromechanical driving mechanism. Two stator plates are mounted upon a lucite square, fastened to the driving mechanism and so positioned as to form a split stator capacitor in conjunction with a light metal cup attached to the driving mechanism's diaphragm.

The driving mechanism, when excited by a 60 cycle voltage, causes the metal cup to vibrate back and forth with respect to the fixed capacitor plates, thus causing a change of capacitance across the tank circuit, with consequent frequency change. The amount of frequency change is controlled by the control marked, Sweepwidth, shown in Fig. 3, and enables an f-m sweepwidth of the output signal of from 50 kc to 12 mc.

**Sweep Injection**

Since the sweep is controlled from the 60 cycle line a portion of the filament voltage is supplied through the Phase Shifter control to a shielded cable marked 60 cycles (this marking is on front panel at point from which cable emerges). This 60 cycle signal is injected into the horizontal plates of the CRO so that proper synch is obtained between the swept oscillator and the trace on the screen of the CRO. The phase shifter controls the phase angle of this signal so that it

[Continued on page 38]



# TV QUIZ NO. 2

by DAVID GNESSIN

## BEFORE ANSWERING THE QUESTIONS — READ THESE RULES:

This quiz, based upon information made available by courtesy of the Howard W. Sams Photofact Television Course will prove of value to all radiomen interested in reviewing TELEVISION. For those who possess the Sams course a reference to the page involved is given in parenthesis after each question number. Readers should *write* out the answers, *copy* the diagrams for practice, and circle correct answer if multiple choice is given.

After quiz is completed, compare with answers given elsewhere as indicated. *Save these quizzes.* They will cover the entire Sams' course and are applicable to the review of television *regardless of special technical background of reader.*

Another TV quiz is now being prepared for early release. Answers to this quiz on page 37. The series will run indefinitely.

1. (p 5) A definite electrostatic field exists between C-R cathode and control grid. The lines indicating this field are best illustrated in which of the following drawings? Re-draw the correct one. Show polarity.

2. (p 5, 6) Drawn below (Fig. 2) is a longitudinal cross-section of a simple basic C-R electron gun. Copy this drawing, then draw in the electron beam, showing divergence, convergence and *two* cross-over points. (Mark these two points X.)

3. (p 7) Given such a C-R system as shown in Question 2,

(a) Which tube element governs brilliancy of beam?

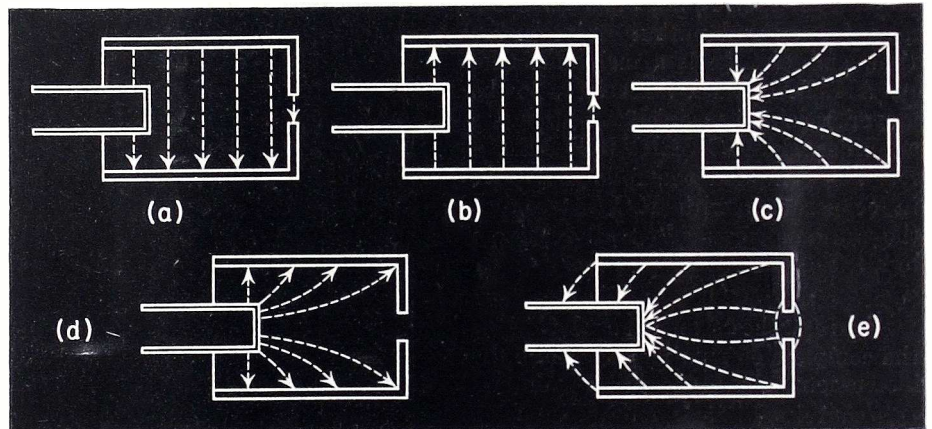

Fig. 1—Refer to Question 1.

#1. (See Fig. 3) This new electrode is electrically connected to anode #2. Its function is to accelerate the electron stream before focusing. *One* of the reasons below is *not* correct to describe the advantage of this most modern C-R construction:

(a) It removes the focus anode from interaction between focus and intensity control adjustment.

[Continued on page 36]

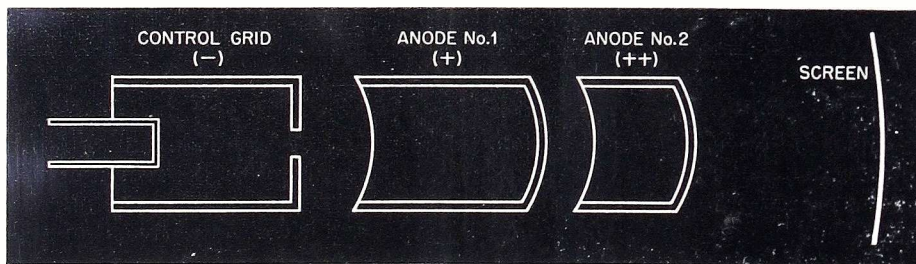

Fig. 2—Refer to Question 2.

(b) Which tube element governs speed of electron beam?  
 (c) Which tube element governs focus of *spot*?  
 (d) One of the tube elements in a to c above is normally set at a fixed value, with no provision made for changing this setting. What is the name of that element?

4. (p 7) An improvement over the simple basic C-R electron gun shown in Question 2 places an extra electrode between control grid and anode

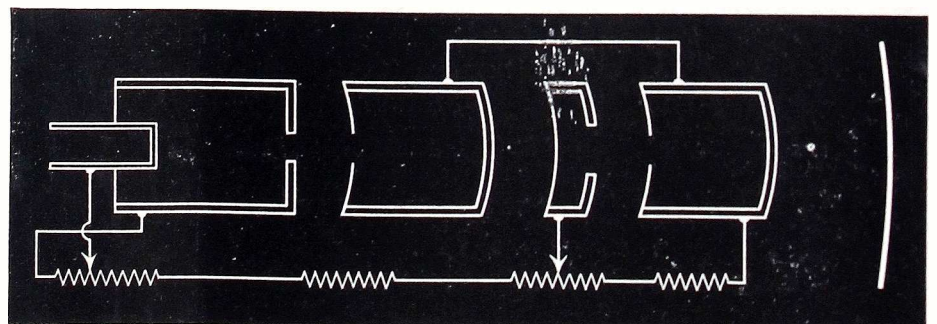

Fig. 3—Refer to Question 4.



# Connecting

## 45 R. P. M.

**T**HE advent of "Madame X", R.C.A.'s new 45 rpm record player has opened up a vast field of record player sales and installations of this popular product. In anticipation of the need for an explanation of its operation, and circuit data on connecting up AM, FM, and TV receivers to the player mechanism itself without the amplifier, RADIO SERVICE DEALER has compiled the following data in cooperation with R.C.A., so that the radioman can adopt all receivers to all types of record players.

### Operation

Figure 1 shows an exposed view of the complete 45 rpm player. While the instrument shown is RCA Victor's self-contained 45 rpm phonograph with built-in amplifier and loudspeaker, the changer unit is identical with those incorporated in all of the company's new 45 rpm instruments.

When the instrument is turned on, the motor drives the turntable through the idler wheel at a speed of 45 rpm. In automatic operation, the trip pawl is actuated by the inward motion of the trip lever which is attached to the tone arm. At the tripping point, a lug on the turntable engages the trip pawl and automatically cams the mechanism

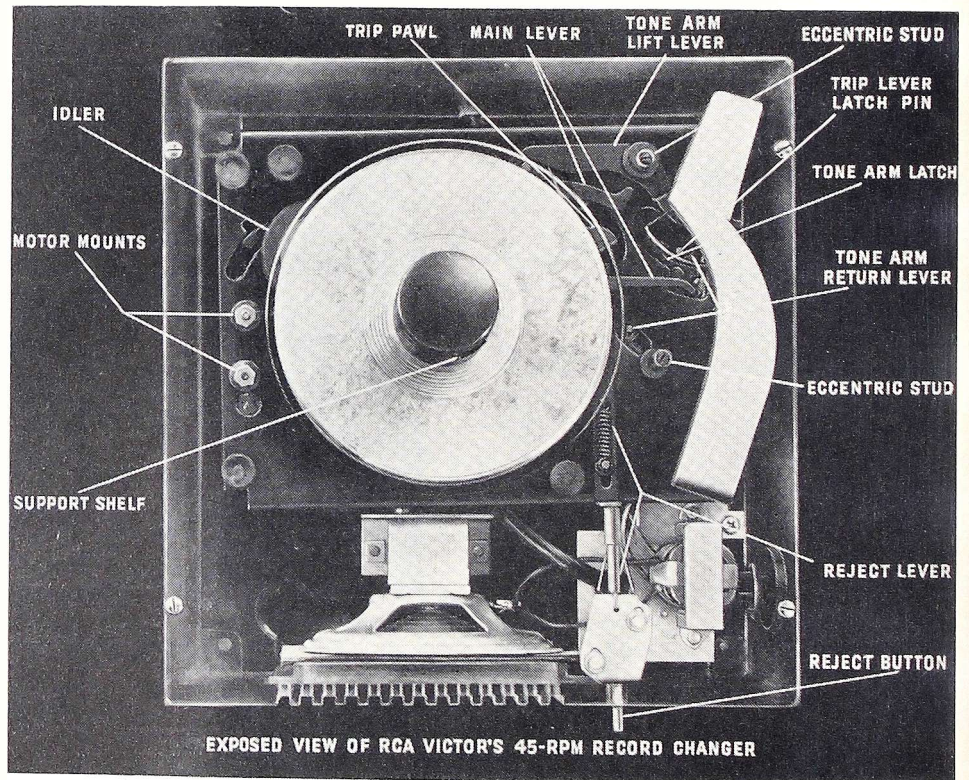

Fig. 1. View showing various mechanisms of player

into its rapid cycle. The reject button, which actuates the reject lever, is for manual operation to produce the same action, and is used to drop the first

record to the turntable and also to reject records when desired. The main lever actuates the entire cycling operation and is controlled by a cam under the turntable. When the trip pawl trips the changer into cycle, the tone which actuates the reject lever, is for arm lift and return levers guide the tone arm up and away from the turntable to permit passage of the dropping record. The tone arm latch, which is engaged by the tone arm latch pin, holds the tone arm in place for a precision landing on the new record.

Figure 2 reveals a cutaway drawing of the new changer. As these cutaway views of the new 45 rpm records show, the label area is thicker than the playing surface and the center rim. This unique design provides the records, when stacked, with protective air spaces between the playing surfaces

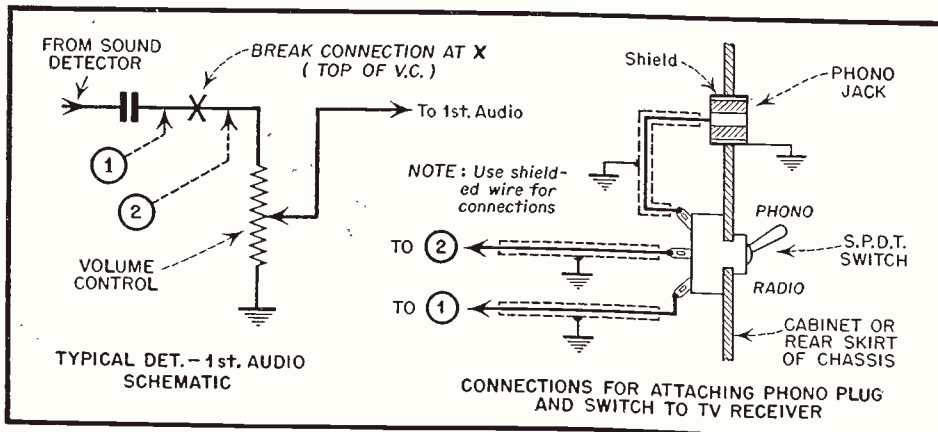

Fig. 3. Basic hookup of any record player to any receiver



# PLAYERS

## To Receivers

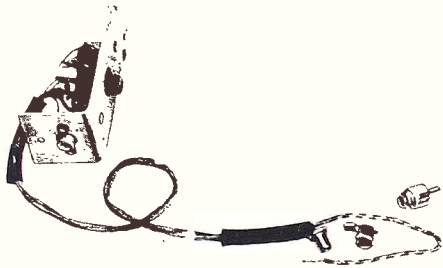

Fig. 4. R.C.A. Switch-Plug unit.

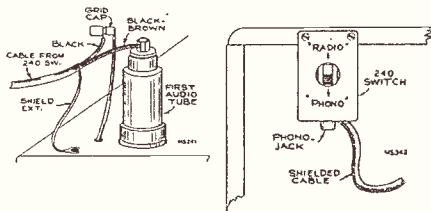

Fig. 5. Hookup for Method No. 1

### Connecting To Receiver

A basic diagram for hooking up any type of record player without an internal amplifier to a receiver is shown in *Fig. 3*. A convenient switch-plug combination manufactured by R.C.A. for this purpose (Stock No. 240) is shown in *Fig. 4*. Instructions for installing this device are as follows:

### Precautions

When connecting the switch to sets that operate on both a.c. and d.c., it is necessary to isolate the cable shield from the chassis. This is best done by connecting the shield to the chassis through a .25  $\mu$ f 300-volt condenser. Care should be taken that the shield braiding and switch bracket do not come in contact with the chassis.

If the common-negative wiring in the a-c/d-c set is isolated from the set chassis, connect the No. 240 cable shield, through a .25  $\mu$ f capacitor, to the common-negative wiring, and not to the chassis.

Interference from radio programs coming through while records are be-

and an air space between the center rims for the passage of the selector blades. With this unprecedented safety feature, the separator blades do not touch the records during the selection operation. In the left sketch, the mechanism is shown in position halfway through the record-changing cycle. The selector blades have emerged into position under the record stack, while the support shelves have receded into the spindle.

In action, the selector blades and the support shelves operate simultaneously. The selector blades move into the air space between the bottom record and the rest of the record stack, while

the support shelves recede, allowing the bottom record to drop to the turntable. The tone arm, as shown in the sketch, has been moved up and away from the turntable to permit passage of the dropping record. In the other sketch, the changer is seen in playing position. The support shelves are supporting the record stack, and the selector blades are recessed within the center spindle. The rotation of the shaft attached to the drive gear causes the drive pinions to move the selector blades and support shelves as described. The rotation of the drive-gear shaft is controlled by the main cam of the mechanism.

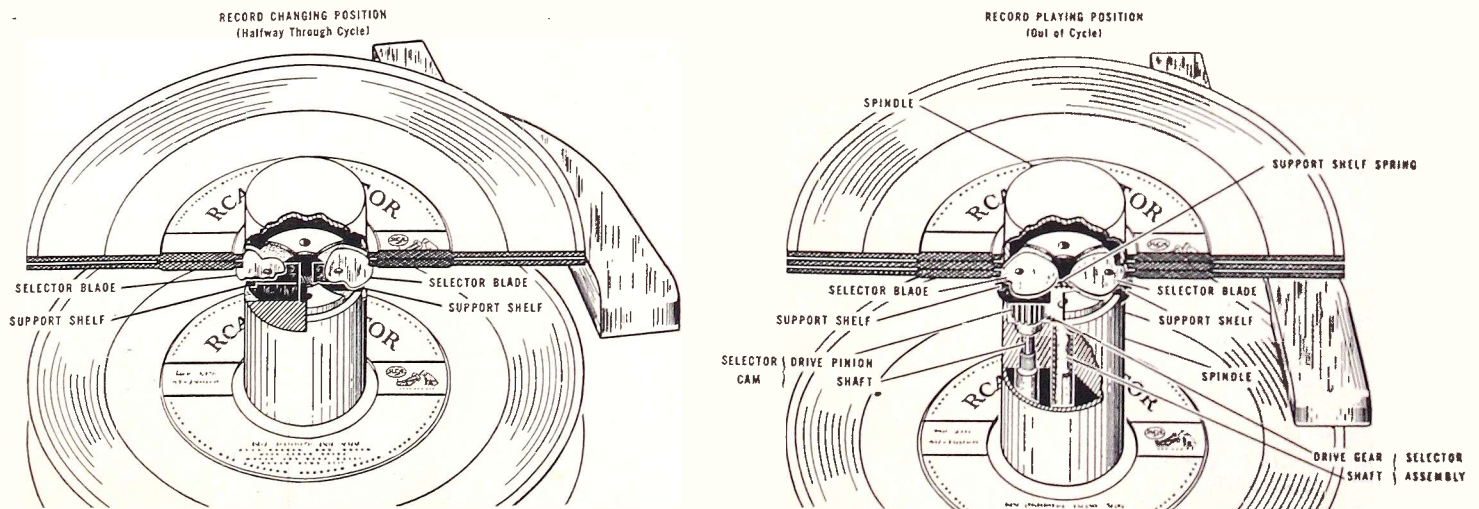

Fig. 2. Left: Position of record player in half way position of changing cycle. Right: Position of record playing mechanism when changer is in playing position. In action, the selector blades and the support shelves operate simultaneously.



ing played may be helped by one or a combination of the following:

- a. Turn the radio volume control off. (Cannot be used for Method No. 2)
- b. Tune the radio to a quiet point on the dial.

### Hook Up Method No. 1

For radio receivers in which the 1st-audio tube has a top grid cap (see Fig. 5) including the following types, quick simple connection can be made, without removing the chassis from the cabinet:

24	75	1D8GT	6B6G	6F7	
32	77	1F7GV	6B7	6J7	5T7G
35	85	1F6	6B8(G)	5K5G	
36		1H5		6Q7	
		(G,GT)		(G,GT)	
55			6C6		12C8
57		2A6	6D6		12Q7GT
58		2A7	6F5	6R7(G)	

1. Fasten the switch to the cabinet or chassis.
2. Connect the braided shield extension to the radio chassis by either soldering or placing the spade lug under a mounting screw. (On a-c/d-c sets, see PRECAUTIONS.)
3. Disconnect the grid lead from the 1st-audio tube.
4. Connect the cap on the black lead to the clip on the grid lead, as shown above.
5. Connect the clip on the black-brown lead to the grid cap at the top of the 1st-audio tube, bending the terminal if necessary to proper size for a metal tube cap.
6. Insert the plug on the end of the record player lead into the jack on the bracket.
7. Secure or position the connection cable assembly so that the cap and clip terminals are well separated from each other and other metal parts.

### REPLACEMENT PARTS

Stock No.	Description
70617	Capacitor
30649	Resistor
35787	Jack
31048	Plug to fit 35787

### Hook Up Method No. 2

For radio receivers in which the vol-

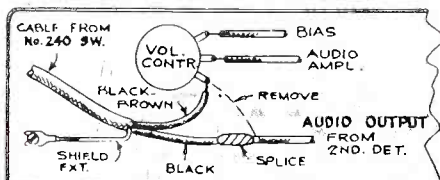

Fig. 6. Hookup for Method No. 2

ume control is in the audio input circuit, (See Fig. 6) and where Hook-up Method "1" is not feasible.

1. Fasten the switch to the cabinet or chassis.
2. Connect the braided shield exten-

sion to the radio chassis by either soldering or placing the spade lug under a mounting screw. (On a-c/d-c sets, see PRECAUTIONS.)

3. Unsolder the lead from the volume control lug indicated in the diagram. It is usually necessary to remove the chassis from the cabinet in order to get at the volume control lugs.
4. Remove "clip" and "cap" terminals from the ends of the switch cable.
5. Solder the black-brown lead to the lug disconnected in Step 3.
6. Solder the lead disconnected in Step 3 to the black lead. Wrap the joint with friction tape.
7. Insert the plug on the end of the record player lead into the jack on the bracket.

### Hook Up Method No. 3

For radio receivers in which the 1st-audio tube does not have a top grid cap. See Fig. 7.

1. Fasten the switch to the cabinet or chassis.
2. Connect the braided shield extension to the radio chassis by either soldering or placing the spade lug under a mounting screw. (On a-c/d-c sets, see PRECAUTIONS.)

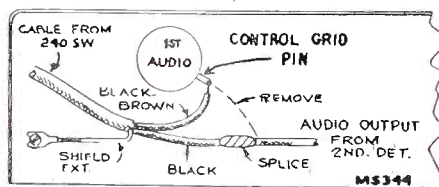

Fig. 7. Hookup for Method No. 3

3. Unsolder the lead from the control grid pin, 1st-audio tube, as indicated in the diagram. It is usually necessary to remove the chassis from the cabinet in order to get at the tube sockets.
4. Remove "clip" and "cap" terminals from the ends of the switch cable.
5. Solder the black-brown lead to the pin disconnected in Step 3.
6. Solder the lead disconnected in Step 3 to the black lead. Wrap the joint with friction tape.
7. Insert the plug on the end of the record player lead into the jack on the bracket.

RCA-202W1 Record-Player Selector (See Fig. 8) provides a convenient means for switching the "phono" input of a radio or phonograph amplifier between two phonograph pick-ups, such as, for example: an internal and an external pickup, or two external pickups. See Fig. 9.

Each of the two input circuits of the Selector is provided with a coaxial jack and a 3-pin receptacle. The out-

put cable terminates in a 3-pin plug. The short adapter cable includes a 3-pin receptacle and a coaxial plug for use with equipments which have coaxial type "phono" jacks. These are the two most popular types of fittings used on record-player devices.

Instructions for mounting this selector in accordance with the PRECAUTIONS outlined previously for use with a-c/d-c equipment is as follows:

1. Remove the phono-plug from the

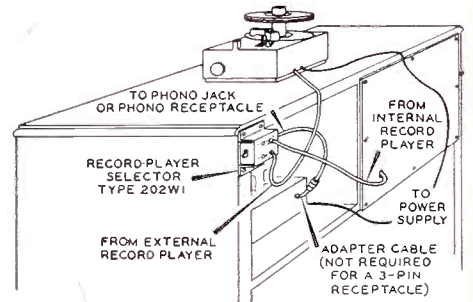

Fig. 8. R. C. A. 202W1 Record Player Switch mounted on cabinet

phono-jack on the amplifier chassis and insert it in the jack marked "INTERNAL" on the Selector.

2. If the amplifier chassis has a 3-pin phono-receptacle, insert the 3-pin plug of the Selector cable into this receptacle. If the amplifier chassis has a coaxial phono-jack, use the adapter cable between the Selector output plug and amplifier jack.
3. Insert the "external" record-player plug into the appropriate jack marked "EXTERNAL" on the Selector.
4. The Selector is now ready for use. Pushing the switch button in either direction selects one of the two pickups which are connected to the Selector. It should be noted that

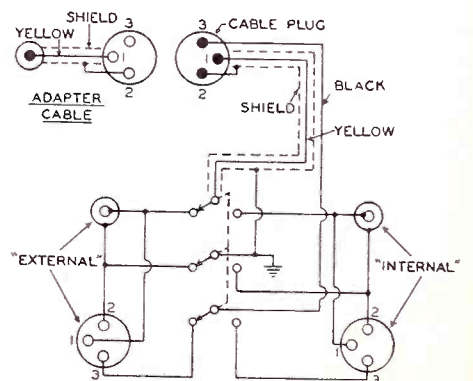

Fig. 9. Wiring diagram of R.C.A. 202W1 Switch

this Selector does not control the record-player motors.

This device is not recommended for use with a-c/d-c equipment which does not meet the requirements of the Underwriters Laboratories.



# TRANSISTORS

and

## The Serviceman

by RUFUS P. TURNER

An elementary explanation of the theory and applications of this new device

A good amount of material has been printed lately about the sensational new Transistor, although not particularly in the language of the serviceman. Since commercial Transistors are expected to be available in the near future, the time is ripe for radio service dealers to begin thinking seriously about these new components and their possible significance in future service problems. This is the proper moment to prepare a mental cradle for the new baby which is on its way.

### Theory

For the benefit of the technician who has been too busy to keep abreast of the latest literature, we might explain that the Transistor is a crystal triode invented a short time ago by Bell Telephone Laboratories scientists. Essentially, it is a germanium crystal device similar to the familiar 1N34 diode except that the Transistor has two catwhiskers instead of one. The points of the two whiskers rest almost upon the same spot on the surface of the germanium crystal, being separated by only a couple of thousandths of an inch. One whisker acts pretty much like the grid of a vacuum tube, while the other acts like the plate. The crystal slug itself is comparable to the cathode of a tube.

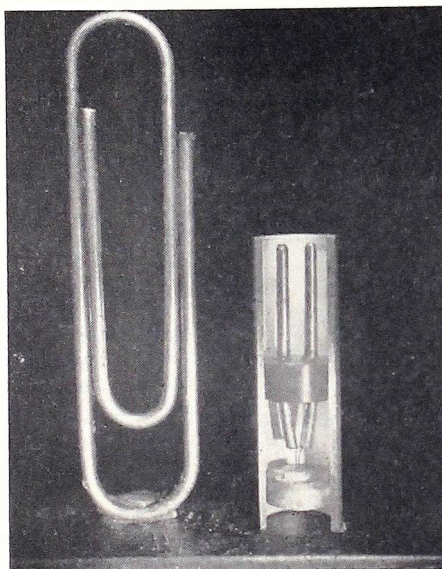

Fig. 1. Comparison of size between a typical transistor and an ordinary paper clip

In Transistor terminology, the "grid whisker" is called the *emitter*, and the "plate whisker" the *collector*.

### Bias Voltages

The emitter is biased positively by a small d-c voltage in the neighborhood of 1 volt, applied between emitter and crystal. A higher negative d-c voltage (for example, 50 volts) is applied to the collector. A low direct current, from several microamperes to several milliamperes, flows in the emitter circuit; a higher current of several milliamperes flows in the collector circuit.

The emitter current is identical with the forward current of an ordinary crystal diode, while the collector current is identical with the reverse current of a crystal diode. If the emitter voltage is raised or lowered by a small amount, the collector current shifts

in the same direction by a larger amount. The device thus exhibits transconductance.

### Amplification and Oscillation

Although the emitter (grid) current may be much larger than the collector (plate) current (a condition which does not occur normally in vacuum tubes), the d-c power in the collector circuit is several times larger than the emitter power. Thus, a large amount of output power is controlled by a small amount of input power, which is a state of amplification.

An a-c signal voltage may be applied in series with the emitter bias, just as a signal ordinarily is applied in series with the grid bias of a tube. The amplified signal then may be taken across a load resistance in the collector circuit in the same manner that an amplified signal is taken across the plate load resistor in a tube amplifier circuit.

Figure 2 shows the simple Transistor amplifier circuit. The Transistor also may be made to oscillate, one such circuit for this purpose being shown in Figure 3.

### Construction

A "cut-open" view of an experimental Transistor, posed beside a paper clip for size comparison, is shown in Figure 1. The two whiskers,

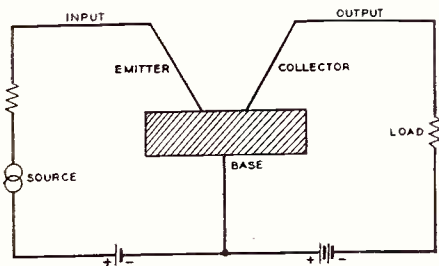

TRANSISTOR USED AS AN AMPLIFIER

Fig. 2. Amplifier circuit

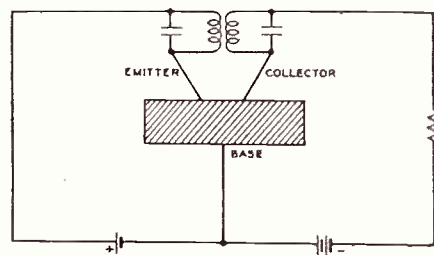

TRANSISTOR USED AS AN OSCILLATOR

Fig. 3. Oscillator circuit



each attached to the end of a wire of about the same diameter as the paper clip wire, can be seen plainly resting on the germanium slab. The enclosing metal cylinder is the "cathode connection" of the device, it being in contact with the metal disc to which the germanium slab is soldered. Emitter and collector connections are made to the two slender plugs formed by the wires which hold the whiskers. This is a plug-in type of construction similar to that employed in radar crystals of the coaxial type. The overall appearance of Transistors of this construction may be seen in *Fig. 4*.

There is no indication that this type of construction, which requires a special tiny socket, will be employed in commercial Transistors. It seems feasible that a molded flat-disc-type unit with three pigtail leads will be one of the final commercial constructions. It is likely also that a third, perpendicular pigtail might be added to the present 1N34 arrangement. Double, triple, and even quadruple triodes probably will be made in a standard metal tube envelope so that all the "tubes" of a multistage amplifier may be plugged into one standard tube socket. Undoubtedly, every effort will be made to exploit fully the small size possible in the Transistor.

#### Applications

Bell Laboratories engineers already have constructed and operated a practical, tubeless broadcast-band super-het receiver employing Transistors in the r-f, i-f, and audio amplifier stages; crystal diodes in the mixer and 2nd detector; and selenium rectifiers in the power supply. This achievement indicates that at least some of the functions now handled by tubes in receivers will be given over to Transistors within a reasonable time after their commercial appearance.

The highest operating frequency of the Transistor, according to the last publicity releases, is 10 megacycles. This relatively low upper-frequency limit does not detract severely from the usefulness of the Transistor, however, since the device will find numerous applications in the audio, i-f, and broadcast regions and at those short waves on this side of 10 megacycles. It is to be expected that further improvements, especially when the device goes into quantity production, will result in a raising of the present high-frequency limit.

We have interviewed a number of radio service dealers in an effort to learn their anticipations and appre-

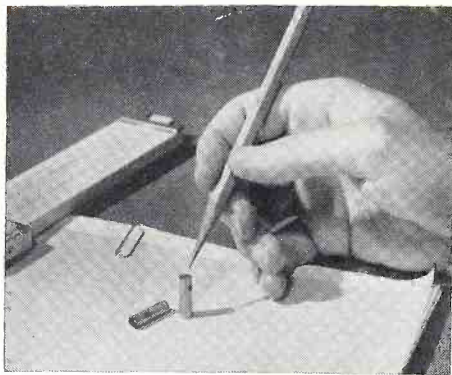

**Fig. 4.** Overall appearance of typical transistor.

hensions regarding the Transistor. One commonplace opinion, freely expressed, is that inasmuch as the Transistor (affording a power gain of 100 in the experimental models) requires two sources of power analogous to the conventional "A" and "B" batteries, it might be more feasible in most cases to employ a 1-volt tube instead. In line with this thought, it should be remembered, however, that the emitter current of the Transistor still is lower than the lowest filament current taken by a dry cell tube; and it has been pointed out by Fink and Rockett (*Electronics*, Sept. 1948) that the overall efficiency of the Transistor amplifier is good. In commercial Transistor circuits, both emitter and collector voltages undoubtedly, will be taken from taps on the voltage divider of a single power supply.

The Transistors already produced are smaller than the smallest subminiature tube. Their small size and light weight will recommend them to applications in which compactness, small physical size, lightness, and instantaneous operation are requisite. Such applications are seen immediately to include hearing aids, pocket receivers, and pocket-size test instruments.

Because the input (emitter) circuit of the Transistor, like its cousin the crystal diode, draws current; the Transistor, like a tube which draws grid current, will load an input circuit more so than a high-input-impedance vacuum tube. There are some applications, however, such as broadcast tuning, in which this feature will be an asset. The same characteristic causes the input circuit to present a variable, low impedance to the input signal source, calling for special matching transformers. But this should cause no greater difficulty than the class-B tube amplifier which shows appreciable grid current under normal conditions of operation. The germanium diode has an average forward re-

sistance of about 100 ohms at 1 volt, and it seems reasonable to suppose that the input resistance of the Transistor will be of the same order of magnitude, since this characteristic evidently is closely associated with the physics of the germanium crystal-tungsten whisker point contact although being subject to some manufacturing variation. The low input resistance of the Transistor will limit its application as a triode voltmeter (since a desirable feature of the v. t. voltmeter is highest practicable input resistance), and at this writing the Transistor accordingly does not appear to be a future supplanter of the VTVM tube.

It is of interest to the serviceman to compare the *apparent* advantages and disadvantages of the Transistor. This we must do in a general way, since both advantages and disadvantages are evident only from an appraisal of information already released on experimental models in advance of commercial fabrication and on opinions drawn from our own experience with germanium crystal devices.

#### Expected Advantages:

1. Small physical size.
2. Light weight.
3. Metal construction.
4. No vacuum.
5. Three terminals only.
6. Instantaneous operation. (No heat-up time required).
7. Low input and output capacitances.
8. Good power gain. (100 reported by Bell Labs.).
9. Good overall efficiency.
10. Long life.
11. No heater or cathode heat.

#### Expected Disadvantages:

1. Low input impedance.
2. 10-megacycle operating limit.
3. Input bias source must supply current.
4. Noise level higher than that of tube-type triode.
5. Low power output. (Bell Labs reports 25 milliwatts for a single-ended Transistor amplifier).
6. Special test circuit required until tube-checker manufacturers have chance to catch up to Transistor.
7. Negative temperature-resistance coefficient.
8. Requires specially-designed circuits for best operation.

The author and the editors are keeping as close as possible to Transistor developments and will release practical working data just as soon as practicable.



R. C. A. 711V1, 711V2,  
711V3-Interference

Certain remote localities have recently reported the presence of interference (generally after dark) at certain frequencies in the broadcast band. This interference, when present, appears in the background of certain stations or between stations, unless unusually severe; and it generally takes the form of code or amateur voice. Accompanying this interference is generally an abnormal quantity of "tweets" or whistles when tuning across the band. External antenna(s) make the condition worse.

To overcome this condition a production change has recently been made in the factory to remove a coil ( $L_3$ ) from the chassis and employ a different loop antenna. Instruments having the above changes incorporated may be identified by a letter "L" following the serial number on the radio chassis.

Referring to Fig. 1 the following instructions are given for changing the antenna loop circuit:

(Leads not shown in illustration require no change).

1. Remove radio chassis.
2. Refer to illustration and remove red lead connecting from  $L_3$  to terminal 8 of  $S_4$ .

3. Unsolder the blue lead from  $L_3$  and connect same end to terminal 8 on  $S_4$ .  $L_3$  may remain in the chassis without leads connected to it.

4. Remove loop cable from loop and from terminal board on rear of cabinet.

5. Remove lug from end of yellow loop lead and solder this lead to terminal 5 on antenna terminal board on radio chassis.

6. Re-install radio chassis.
7. Clip off Pin 5 on chassis end of 5 conductor flexible antenna cable and file remainder of pin smooth with surface of plug.

8. Plug 5 conductor cable into antenna terminal board on chassis (see sketch). Note that with one pin removed the plug can be moved one pin to the right and plugged in, making incorrect contact.

9. Carefully pull the yellow lead downward along the 5 conductor cable far enough to permit taping it to the plug portion of this cable to prevent the yellow lead from breaking at the soldered joint at terminal 5 when flexed by opening of radio door. "Scotch" or other good tape is suitable.

10. Connect the red and black loop leads to the rear terminals 4 and 5 respectively from which they were

# SHOP NOTES

Write up any "tricks-of-the-trade" in radio servicing that you have discovered. We pay from \$1 to \$5 for such previously unpublished "SHOP NOTES" found acceptable. Send your data to "Shop Notes Editor".

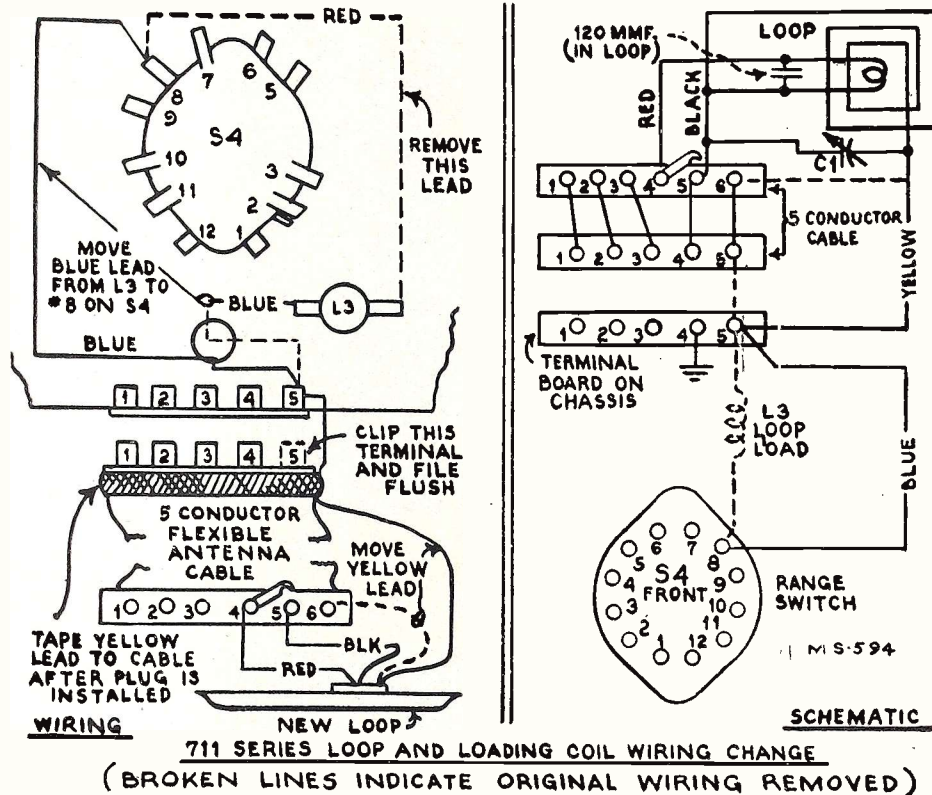

Fig. 1. Changes in R.C.A. 711V1, 711V2 loop circuit

originally removed. Close link from 4 to 5 if no outside antenna is used. If an outside antenna is used consult instruction sheet or service data for correct connections.

11. Remove the screw from terminal 6 in the antenna board on rear of cabinet to avoid improper connection in the future.

12. Remove old loop and install new loop in its place.

13. Plug loop cable into new loop.

14. Peak the loop trimmer on a weak station around 1400 kc.

15. If a test oscillator is available, the low frequency oscillator core ( $L_{12}$ ) adjustment should be made while rocking the gang through 600 kc., to obtain maximum output. Re-peak loop trimmer again at 1400 kc.

16. Grounding one of the FM antenna terminals (connect terminal 1 to 5) on the board on rear of cabinet may prove advantageous to reduce excess signals if an external FM antenna is used.

NOTE: The new loop referred to above, may be identified by a green

paint dot on one metal mounting bracket. Also, the large coil has 20 turns of wire with only a few turns or no turns visible through the holes near the edge of the loop frame. The original loop contains 13 turns all of which are visible through the holes near the edge.

### Insulated Handles On Tools

I have accidentally found out that vinylite or plastic Genflex Tubing swells when it is immersed in General Cement Service Solvent, and when the solvent evaporates the tubing comes back to its natural form.

If you take a piece of tubing about 1/4" to 3/8" diameter and immerse it in solvent for a few minutes then slip the tubing over the handles of pliers or wire cutters you get professional molded and insulated sleeves on the handles. Smaller sizes can be used on screw drivers also. It shrinks on the tool and makes a smooth handle.

Submitted by:  
F. Castree  
Rockford, Ill.

[Continued on page 36]



# CIRCUIT COURT



## RCA Q22

Typical of several models of RCA receivers designed for the export market is the unique output stage of the model Q22A. This particular set is an a-c operated, multi-band, six tube instrument.

The heart of the scheme is a tube, not common domestically, but not new to the trade by any means. The tube is a type 6SD7G. It incorporates two sets of elements within the same envelope; a small triode, and a pentode output section, similar to a 6F6.

A partial circuit of the set in question is shown, illustrating the method of obtaining the push-pull output. The second detector and first audio functions are handled in a 6SQ7. In the plate circuit appear a fixed by-

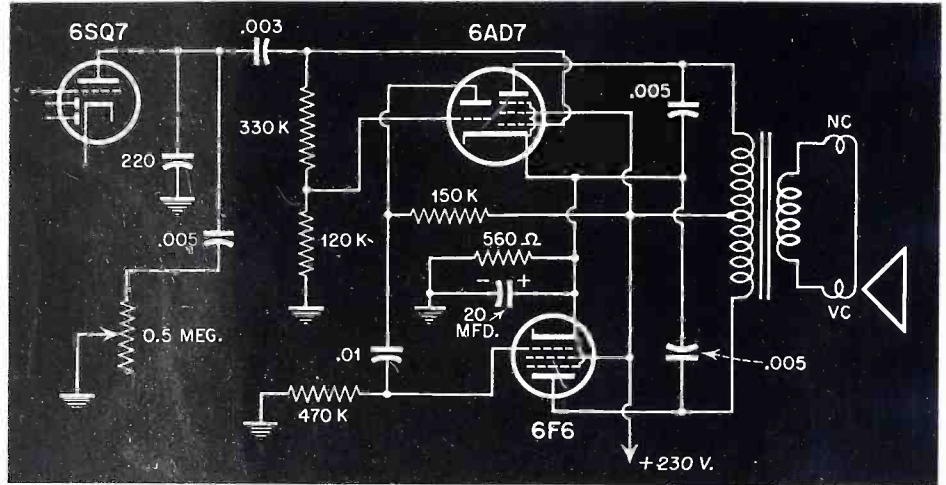

R.C.A. Model Q22—partial schematic of output stage

inversion, and push-pull pentode out-

It will be obvious that the portion of the voltage applied to the triode grid must be calculated to match the gain of the triode and end up with a voltage on the grid of the 6F6 equal to that applied to the pentode grid of the 6AD7, so that equal voltages will appear on the halves of the output transformer.

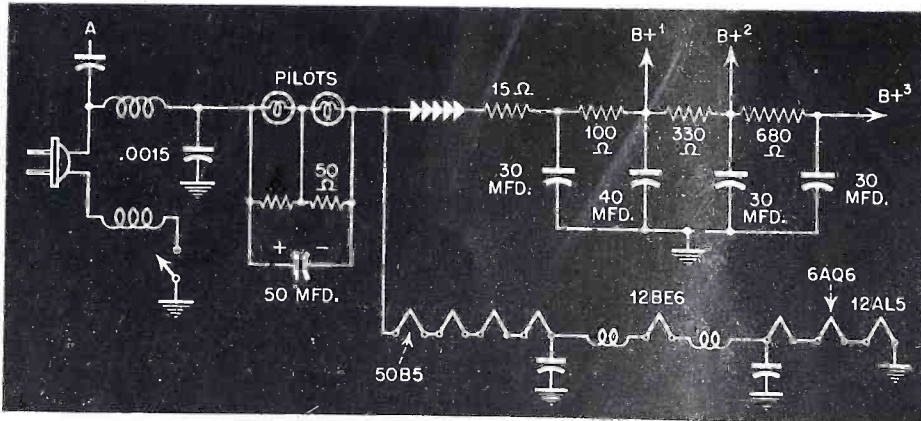

Airadio Model 3100—partial schematic of power supply

pass and a variable tone control. Following the coupling capacitor there is a voltage divider composed of 330K and 120K ohm resistors.

The full audio voltage across this divider is applied to the grid of the pentode section of the 6AD7. It is amplified in this stage and appears across one half of the output transformer.

An appropriate portion of the voltage in the grid circuit is applied to the triode grid of the 6AD7. Inversion takes place and the output of the triode plate is coupled to the grid of the 6F6 tube. Amplification takes place in this stage and the output voltage appears across the other side of the output transformer. Thus, phase

put have been accomplished in an unusual, but effective manner.

## Airadio 3100

The Airadio 3100 is an ac-dc receiver covering only the 88-108 mc. FM band. Eight tubes are employed, including a 50B5 tube feeding the built-in PM speaker. Provision is made to switch the output to a jack, in place of the voice coil, permitting connection to an external amplifier and speaker.

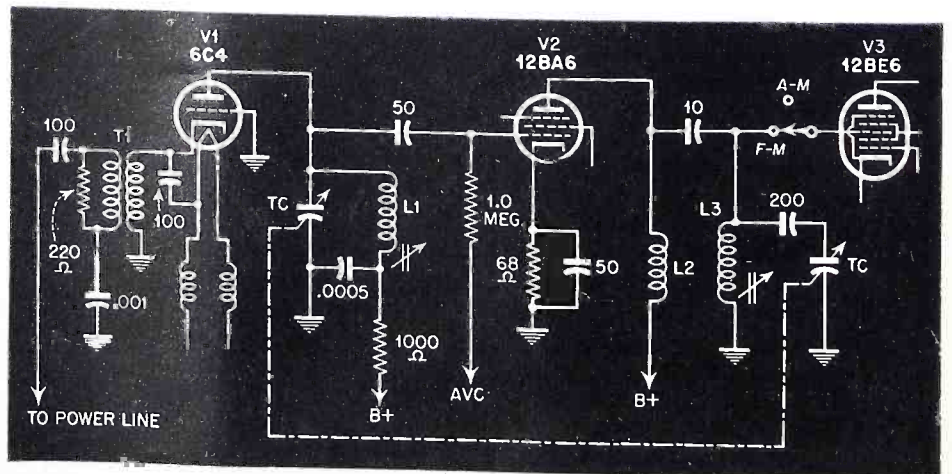

Arvin Model 182 TFM—partial schematic of FM front end





**Built-in antenna**

**12 $\frac{1}{2}$ "  
"Spotlite Brite" TV**

**full-size console  
at \$349.95!**



Air King Products Co., Inc. • 170—53rd St., Brooklyn 32, N.Y.

Wait till your customers see the new Air King A-2001 and A-2002. 12 $\frac{1}{2}$ " "Spotlite Brite" tube for a sharper, clearer, bigger picture... plus the rich tone of a full sized 10" speaker... plus a built-in dipole antenna and every other feature in the book! Air King has everything at this unbelievable low price!

The 12 $\frac{1}{2}$ " A-2001 and A-2002, or the 10" A-1001A and A-2000 available in beautifully hand-rubbed wood—mahogany or blonde mahogany. A-1001A 10" Console priced at \$299.95, A-2000 10" Table model at \$239.95. Order now!



Table 12 $\frac{1}{2}$ "  
\$299.95

**See Air King's Display at  
Chicago Radio Parts Show  
Blackstone Hotel • Ivy Room  
Monday, May 16th through 19th**



# NOW! A \$10 SALE

for every record-player in your area!

LIST PRICE \$7.50



## SELL NEW TITONE PICKUP!

FIRST BASIC PICKUP ADVANCE IN 10 YEARS—the original piezoelectric ceramic pickup!

SELLS ITSELF IN A 2-TO-5-MINUTE CALL! Fits all tone arms. Whenever your service men make any call—let all your customers hear TITONE. They'll say "SOLD!" and you'll profit, because—

TRANSCRIPTION TONE QUALITY! Full frequency to 10,000 cycles! Bell-like supertone makes even old players thrilling!

SURE-FIRE IN HUMID CLIMATES! Utterly unaffected by climate, moisture, fungus! Booms sales, wins back customers.

DOUBLES RECORD LIFE AND PLEASURE! Gives "ordinary" records sparkling quality—revives worn favorites. Will play down to 1/2 normal pressure, NO "needle talk!"

RUGGED! PERMANENT! No crystals, magnets, filaments to fail! No pre-amplifiers. Ceramic TITONE performs perfectly for years!

# NO TONE LIKE TITONE

CALL YOUR JOBBER or write to SONOTONE

Box T-3 Elmsford, N. Y.

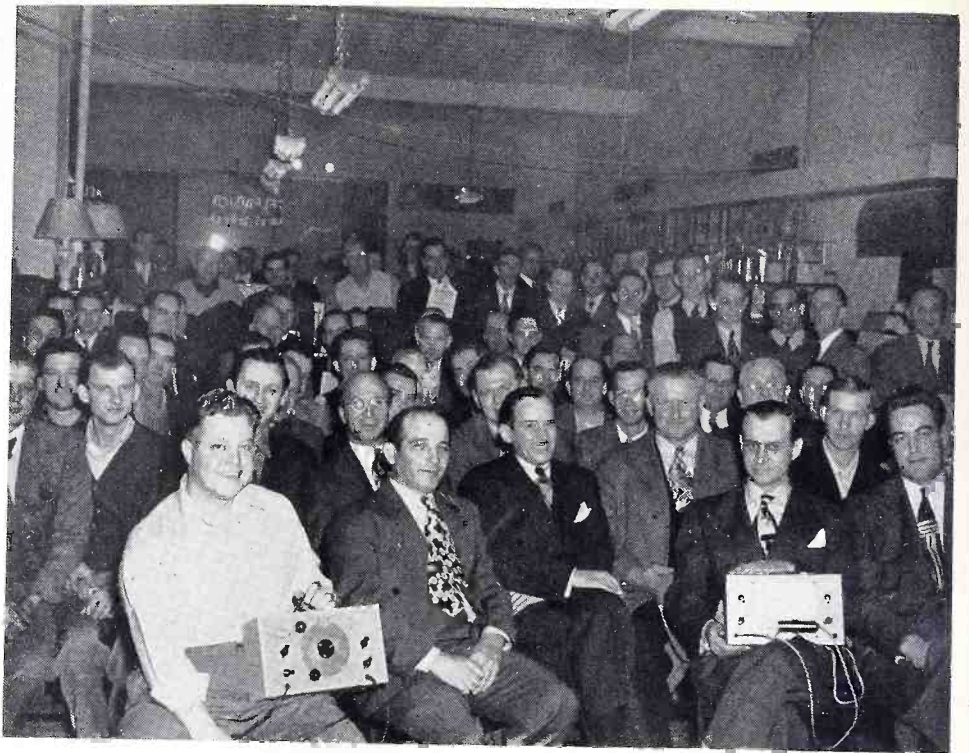

Service Meeting sponsored by L & S Distributors, Watertown, N. Y. Left to right: Earl A. Lounsbury, Dave Sohet, Paul Nief, Roy Schenck, and Douglas Carpenter of McMurdo Silver

The partial schematic shown illustrates details of the power supply circuits. Beginning at the line plug, it will be noted that there is an r-f choke in each side of the line. Ahead of one of these is a 100  $\mu\text{mf}$  capacitor which can be connected by a link on the antenna terminal board to one side of the primary of the r-f coil. This fea-

ture permits pick-up on local stations, in the absence of an external antenna. During the initial surge of current, when power is first applied, lamp burn-out is prevented by the charging current of the large capacitor. In addition, a low impedance path for hum voltages is provided.

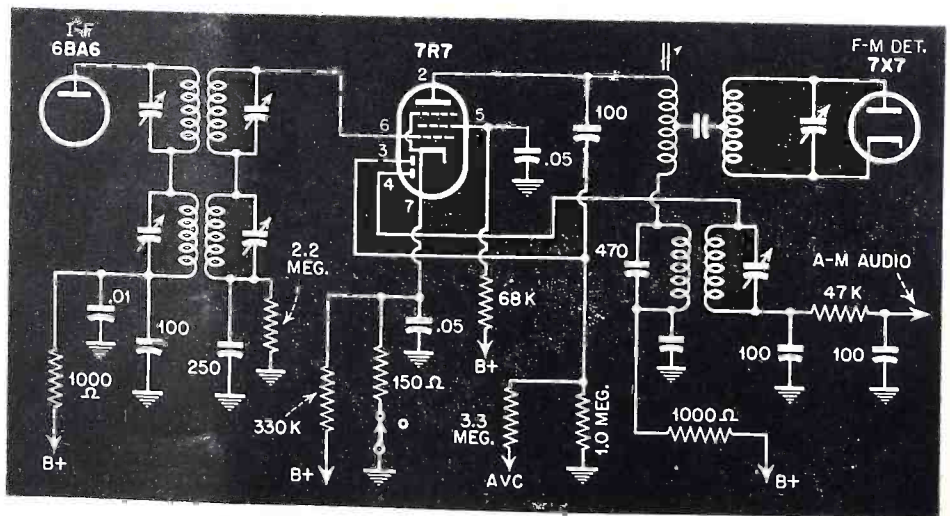

Philco Model 48-1264—partial schematic of AM/FM i.f.

ture permits pick-up on local stations, in the absence of an external antenna.

Next in line, after the usual r-f bypass capacitor, is a network which provides pilot light operation. The lamps are of the 6-8 volt, .15 ampere type. Each is shunted by a 50 ohm resistor, and the whole shunted by a 50  $\mu\text{f}$  elec-

A dry-disc-rectifier, followed by an elaborate R-C filter, provides dc power to the tubes. The plate supply for the output tube is taken off first, to get maximum voltage and because hum in this circuit is no great problem. Next, the r-f and i-f tubes are supplied. Final filtering is given the volt-



# PHOTOFACT Publications

## The Books that Help You

**SAVE TIME**

**EARN MORE**

**SAVE WORK**

**LEARN MORE**

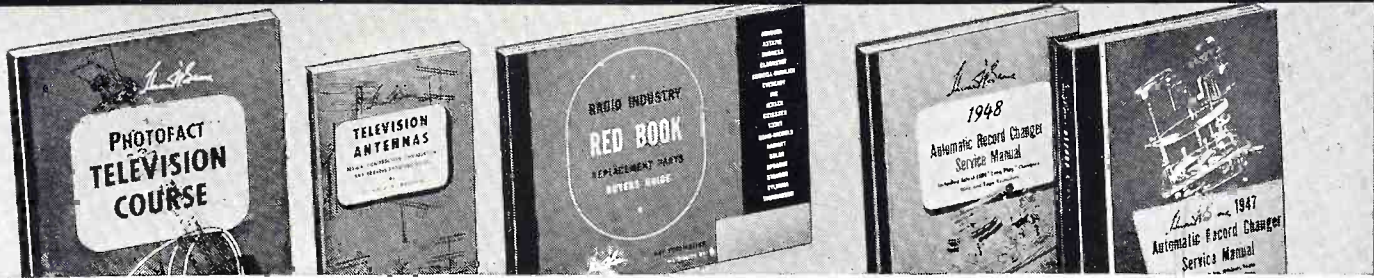

### NEW TELEVISION BOOKS

#### TELEVISION COURSE

Gives you a clear, complete understanding of TV principles, operation and practice. Covers: Beam Formation and Control; Beam Deflection Systems; Beam Modulation and Synchronization. Full analysis of the Cathode Ray tube, voltage supplies, control functions, antenna circuits, RF and IF systems, AGC, video amplification, contrast, etc. 216 pages; 8½ x 11"; profusely illustrated; sturdily bound. **\$3.00** Only.....

#### TELEVISION ANTENNAS

All you need to know about TV antennas. Written by Donald A. Nelson; based on actual field experience. Shows you how to select antenna, how to install it, how to solve troubles. Many short-cuts help you save time and earn more. Chapters cover: antenna principles; construction; analysis of all types of commercial units; installation data; problems and trouble-shooting. 192 pages; 124 illustrations. **\$1.25** Only.....

### THE RED BOOK

Tells you in *one* volume all you need to know about replacement parts for 17,000 receivers made from 1938 to 1948. Eliminates wasteful hunting through dozens of incomplete manuals. Includes full, accurate listings of all 9 major replacement components; lists correct replacement parts made by 17 leading manufacturers. Gives original parts numbers, proper replacements and valuable installation notes on: Capacitors, transformers, controls, I.F.'s, speakers, vibrators, phono-cartridges, tube and dial-light data, battery replacement data. 448 pages; 8½ x 11"; sewed binding. **\$3.95** Only.....

### RECORD CHANGER MANUALS

**Volume 2, 1948.** Covers 45 models made in 1948, including new LP and dual-speed changers, plus leading wire and tape recorders. Complete accurate data—based on actual analysis of the equipment. Gives full change cycle data, adjustment information, needle landing data, hints and kinks, parts lists, exclusive "exploded" diagrams. A time-saving, money-making book. Over 400 pages; 8½ x 11"; deluxe bound. **\$6.75** Only.....

**Volume 1, 1947.** Covers over 40 different post-war models up to 1948. Includes full, hard-to-get data on leading wire, ribbon, tape and paper disc recorders. 400 pages; fully illustrated; 8½ x 11"; hard binding. **\$4.95** Only.....



### SPECIALIZED SERVICE DATA VOLUMES

**Post-War Auto Radios.** Covers everything you need to know on over 100 post-war models (practically every auto radio made since 1946); represents the products of 24 different manufacturers. Makes auto radio servicing easy. Over 360 pages; profusely illustrated; each model treated uniformly, completely, accurately—based on actual study of the equipment. Sturdy binding; 8½ x 11". **\$4.95** Only.....

**Post-War Audio Amplifiers.** Invaluable data for custom-builders, audio men and sound engineers. Covers a wide variety of well-known audio amplifiers and FM and AM tuners, plus data on important wire and tape recorders. Presents a complete analysis of each unit. A "must" for all sound men and custom installers. 352 pages; 8½ x 11"; sturdily binding. **\$3.95** Only.....

**Post-War Communications Receivers.** Complete technical analysis of more than 50 of the most popular communications sets on the market. An invaluable service aid, a perfect buying guide for purchasers of communications receivers. All data is accurate and authoritative, based on actual examination and study of each unit. 264 pages; profusely illustrated; 8½ x 11"; durably bound. **\$3.00** Only.....

### "MUSTS" FOR EVERY SERVICE BENCH

**Radio Receiver Tube Placement Guide.** Shows you exactly where to replace each tube in 5300 radio models, covering 1938 to 1947 receivers. Clear, accurate diagram for each tube layout. Saves time—eliminates risky hit-or-miss methods, especially where tubes have been removed from the set. Indispensable in the shop or on calls. 192 pages. **\$1.25** Only.....

**Dial Cord Stringing Guide.** The book that shows you the *one right way* to string a dial cord. Here, in one handy pocket-sized book, are all available dial cord diagrams covering over 2300 receivers; 1938 through 1946. Makes dial cord restringing jobs quick and easy. Nothing like it. Order copies today for your tool kit and shop bench. **\$1.00** Only.....

### PHOTOFACT SERVICE MANUALS

Here's the radio service data that's invaluable—that saves you time and helps you earn more! Preferred and used daily by thousands of Radio Service Technicians. Complete, accurate—based on analysis of the actual equipment. Uniform treatment for each model: includes Standard Notation Schematics; full chassis photo coverage; alignment, stage gain, voltage and resistance analysis; parts numbers and proper replacements; disassembly notes; oscilloscope wave forms; record changer analysis—everything you need for quick, profitable servicing. Covers all post-war radios; in semi-annual deluxe bound volumes, over 1000 pages each. 7 volumes cover receivers made to Oct. 1, 1949. **\$18.39** Each Volume in Deluxe Binder.....

### "The Recording and Reproduction of Sound"

by Oliver Read

The first complete reference book that gives the right answers on all phases of SOUND. Written by the editor of *Radio News*. Authoritative, complete information on recording and reproduction. Nothing else like it. Order now.

320 Pages **\$5.00** Deluxe Bound



Published by **HOWARD W. SAMS & CO., INC.** • INDIANAPOLIS 1, INDIANA



# MAKE MORE PROFIT

## Replace Phono Pickup Cartridges



- Makes Cartridges Easier to Sell and Install
- Saves Ordering-Time and Servicing-Time
- Improves Record Playing
- Turns Prospects into Satisfied Customers
- Builds Cartridge and Needle Business

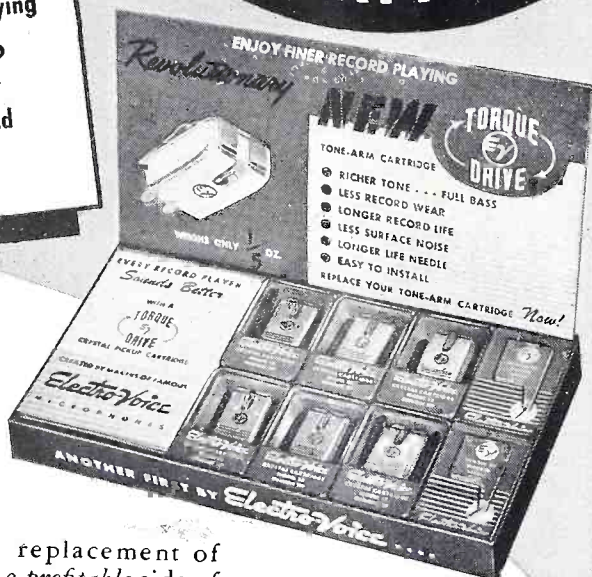

Greatest Merchandising Opportunity in Cartridge History!

**YOU CAN MAKE** the replacement of phono pickup cartridges a *profitable* side of your servicing. No longer is it necessary to order one cartridge for each repair job. With the 3 basic models in the TORQUE DRIVE KIT, you can immediately replace any one of over 150 types in common use. Furthermore, the revolutionary TORQUE DRIVE Crystal Cartridge modernizes your customer's player, greatly improves reproduction, prolongs record life. Has replaceable Osmium-Tip or Sapphire-Tip needle.

### HANDY SALES AND SERVICE KIT

Enables you to make most replacements immediately. Has 6 quick-selling cartridges, 4 extra needles, mounting plates, and replacement guide. Available in Kit "A" (Osmium) and Kit "B" (Sapphire).

Write for Bulletins 141-142, and name of nearest E-V Distributor

**ELECTRO-VOICE, INC., BUCHANAN, MICHIGAN**  
Export: 13 East 40th St., New York 16, U. S. A., Cables: Arlab

E-V Pat. Pend. Licensed under Brush Patents

New Model L14 Microgroove Crystal Cartridge and new Models 20 and 22 Magnetic Cartridge for Regular and Microgroove also available.

IT PAYS TO REPLACE WITH  
**Electro-Voice**

age for the oscillator and first audio plates. It is these circuits which are most susceptible to generation of hum modulation.

The heater string will be seen to come off after the pilot lamp network, but ahead of the rectifier. As is usually the case, the output tube and i-f tubes appear toward the high potential end of the string where hum can be of least bother. The second detector and first audio tubes are as near to ground as possible. The 12BE6 convertor will be seen to be isolated by RF chokes and appropriate by-pass capacitors.

### Arvin Model 182TFM

A separate r-f amplifier section is found in this eight tube a-c d-c table model receiver on the FM band. This precedes the 12BE6 pentagrid convertor, which alone constitutes the head end on AM.

FM pick-up is accomplished by means of chokes in the power line and a 100  $\mu\text{f}$  capacitor from one side to the primary of  $T_1$ . This broad-band unit couples the signal to the cathode of  $V_1$ , a 6C4 triode. It is of interest that the cathode is tied to the heater, for r-f voltages, by a 100  $\mu\text{f}$  capacitor. The heater is isolated from the power line by two r-f chokes. These items will serve to increase the r-f impedance of the cathode-heater circuit and provide maximum signal voltage thereon.

The grid of  $V_1$  is at ground potential, and the amplified signal is developed across the first tuned circuit, the coil for which is  $L_1$ . A 500  $\mu\text{f}$  capacitor completes the tuned circuit, and the coil is trimmed by a variable core.

A 50  $\mu\text{f}$  capacitor couples the signal to the grid of  $V_2$ , a 12BA6 tube, functioning as a conventional tuned r-f amplifier.  $L_2$  in the plate circuit of  $V_3$  confines the signal to its proper course and it continues to the tuned circuit in the grid of the 12BE6 convertor, via the range switch.  $L_3$  is also provided with a variable core.

### Philco Model 48-1264

One of the interesting features of this instrument is the use of a newly developed tube as a combined i-f amplifier and AM detector. The set has 8 tubes plus rectifier, but three of the tubes are used for more than one purpose. A 6AG5 r-f stage, on FM only, is followed by a 7F8 convertor. The first i-f stage, using a 6BA6 tube, operates at 455 kc. on AM and the unusual frequency of 9.1 mc on FM.

Reference to the diagram will indicate details of the circuits following the 6BA6 i-f stage and preceding the 7X7 FM detector. The audio stages



are intentional, employing a 6J5 ph error and push-pull 6K6 output tubes.

The type 7R7 tube used in the stage under discussion combines a pentode and two diode plates, all with a common cathode. In the grid circuit will be found the series-connected i-f transformers for the two bands. These are capacitor tuned. The cathode returns to ground through 150 ohms on radio, but on phono position this return is opened by a section of the function switch. Additional bias is supplied by a 330K ohm resistor from the cathode to *plus B*.

The i-f being amplified appears at the plate of the 7R7 and a portion of it is coupled to one of the diodes, via 100  $\mu\text{f}$ , where a.v.c. is developed across the 1 meg. load resistor. The plate windings of the succeeding i-f transformers are in series, with the FM unit slug tuned and the AM coil resonated by a 470  $\mu\text{f}$  fixed capacitor.

The AM signal appears at the secondary of the appropriate transformer and is applied to the second diode plate of the 7R7 tube. The FM signal proceeds to a 7X7 detector. Of note is the connection of the coupling capacitor from a tap on the transformer primary, rather than from the plate in the usual manner.

**RCA Victor Model 8F43**

This battery-operated receiver, designed for farm use, has provision for eventual connection to a power line. The actual connection is made through a small AC operated supply which mounts within the cabinet in place of the battery pack.

Four tubes of the low-drain filament type are used in the set. The power supply employs a 6X5 rectifier. A schematic of the a-c supply is shown. Jacks are available to provide appropriate circuits for the filament and plate supplies, a well as making it possible to open and close the line source by means of the same switch used to turn the battery power on.

Several unusual features are found in the supply. One is the use of a half-wave connection for the rectifier in the B supply. The filter is conventional, using two 20  $\mu\text{f}$  capacitors and a 4700 ohm resistor. The output is 90 volts, of which 5 volts is utilized as bias on the 3Q5 output tube. This voltage is obtained by returning the grid resistor to the negative of the 90 volt supply and having a 470 ohm resistor to the common return for all other tubes.

The 6.3 volt winding on the power transformer supplies the rectifier tube heater, and by means of taps delivers

# VEE-D-X

*provides everything you need*

**SINGLE SOURCE**

Antennas, Masts, Towers  
Chimney, Vent Pipe and all Angle Mounts  
Guy Cable, Guy Rings and Collars  
Turnbuckles, Thimbles, Cable Clamps  
Lightning Arresters  
Transmission Line

## FOR BETTER TV & FM INSTALLATIONS

### Now VEE-D-X HAS AN ANTENNA FOR EVERY NEED

**SUPER RD-13**—The champion of all antennas. Holds every record for long distance reception. A four bay, full wave, thirty-two element stacked array.

**JUNIOR JR-13** — A fine performer, yet moderately priced. Two bay, full wave, sixteen element stacked array, adequate for most fringe areas.

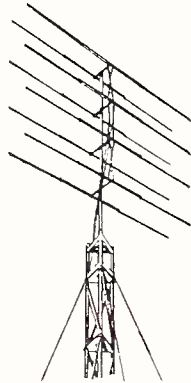

**SECTIONAL TOWER** — .0' and 20' sections for mounting antennas up to 140'. Sections shipped assembled and painted. Fast low cost erection on ground or roof.



**LIGHT WEIGHT MAST** — Nothing finer — or faster to install. Sturdy magnesium mast in 12' or 20' lengths. Rotates with guy cables installed.

**SKY MONITOR DGA-12** — For outstanding results in near fringe and primary areas. Broad band antenna with tunable Q section. Extremely flat response. Low in cost.

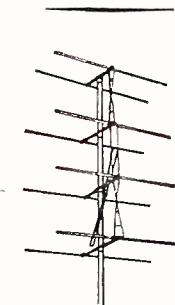
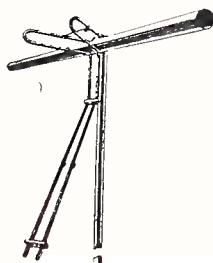

**CHAMPION RDH**—A sixteen element full wave, four bay, stacked array, cut especially for any one of channels 7 to 13. Outperforms any other high channel antenna.

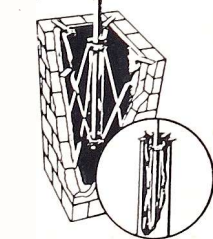

**CHIMNEY MOUNT** — The finest chimney mount available. Fits any opening — round, square or rectangular from 4" to 22" for 1", 1 1/8", and 1 1/4" masts.

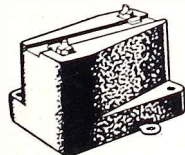

**LIGHTNING ARRESTER** — No need to cut transmission lines. Does not disturb impedance match. High dielectric, low loss.

### Introducing THE NEW YAGI

*sensational low cost, high gain antenna*

The new VEE-D-X, RDY Series, a four element beam cut for each particular channel. Here is an antenna which is the most sensational single channel performer yet to be manufactured. VEE-D-X engineers have attained astonishing results in producing an array combining every desirable characteristic necessary for optimum performance.

**New all angle mount**  
Particularly suited for mounting on side of house near a window for manual rotation of antenna. Designed to clear overhang of eaves. Also excellent for flat or pitched roofs as shown below.

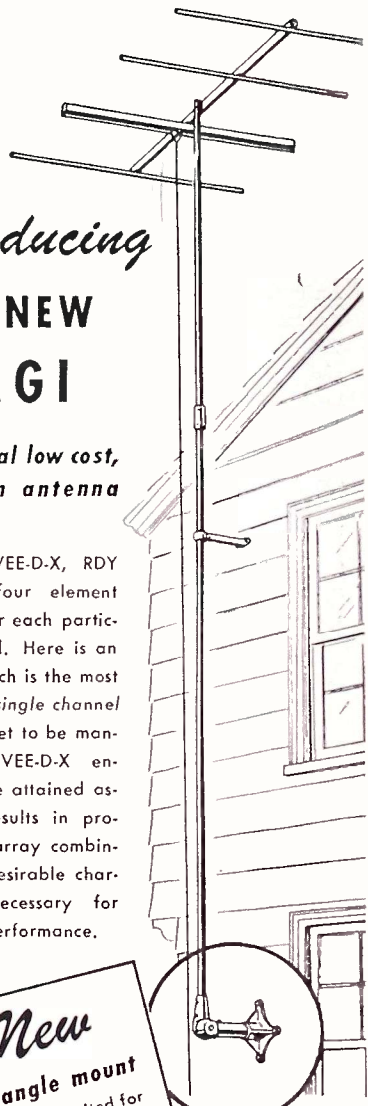

**VEE-D-X means video distance**

LaPOINTE-PLASCOMOLD CORP., Unionville, Conn., 5

Gentlemen: Send me new literature and prices on the complete line of VEE-D-X television accessories.

Name.....  
Company.....  
Street.....  
City..... Zone..... State.....



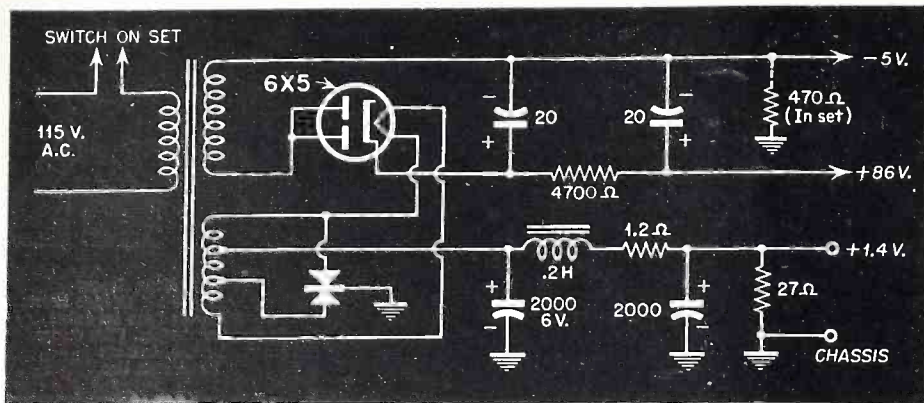

R.C.A. Model 8F43—provisions for connecting to a.c.

# AMPHENOL ANTENNAS

for every  
FM or TV Requirement

An efficient, high-gain antenna is imperative for TV reception, and Amphenol leads with the finest attainable. Highly trained and highly skilled Amphenol engineers have produced the most effective high and low band antennas and are continually making improvements as new ideas are developed. Constructed of aluminum tubing and aluminum alloy castings, Amphenol antennas have high forward gain combined with high front-to-back and front-to-side ratios, insuring maximum pick-up and lasting enjoyment to the user.

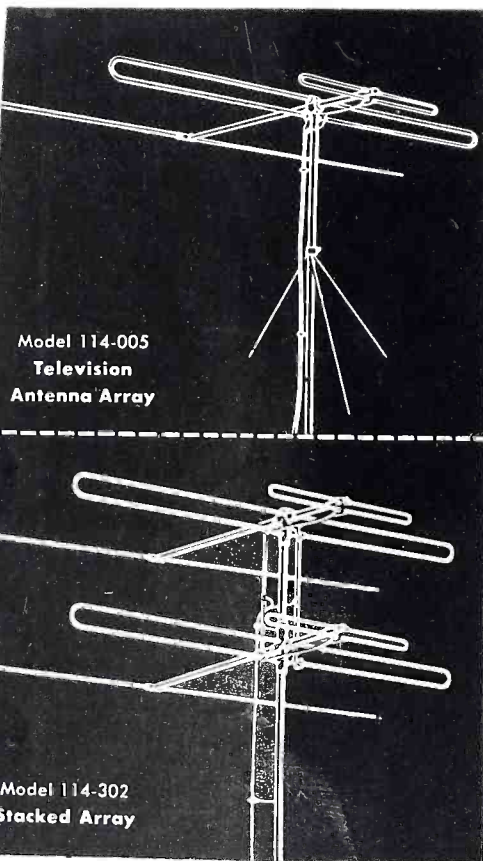

Model 114-005  
Television  
Antenna Array

Model 114-302  
Stacked Array

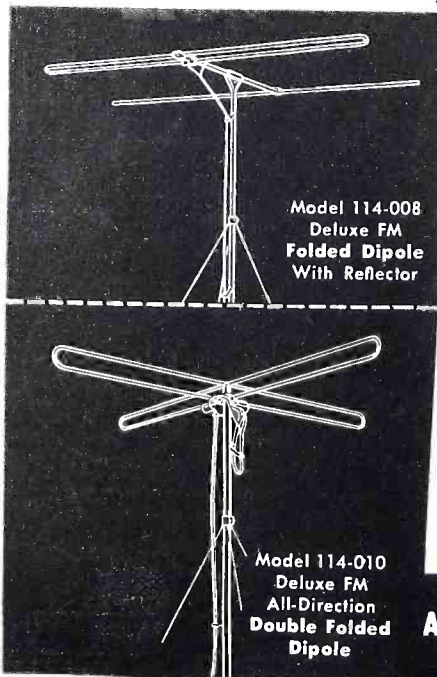

Model 114-008  
Deluxe FM  
Folded Dipole  
With Reflector

Model 114-010  
Deluxe FM  
All-Direction  
Double Folded  
Dipole

Specifically engineered for finest FM performance, Amphenol FM antennas provide interference-free and general long distance reception which is unmatched in the FM antenna field. For rural, suburban or close-in installations, Amphenol FM antennas combine efficient operation with clean-cut, attractive design . . . antennas are entirely constructed of rust-proof aluminum. For consistent, top-quality service, Amphenol FM antennas are chosen again and again.

**AMPHENOL**

**AMERICAN PHENOLIC CORPORATION**

1830 SOUTH 54TH AVENUE  
CHICAGO 50, ILLINOIS

2.85 volts to each side of a full-wave copper oxide rectifier. The 2.3 volt d-c output of this rectifier is filtered by two 2000  $\mu$ f capacitors and a .2 henry choke. Additional drop to the 1.4 volt potential needed for the tubes takes place in the 1.2 ohm resistor and 27 ohm bleeder.

### General Television Model 9B6P

Two items of interest appear in the circuit of this a-c/d-c receiver. Both are shown in the partial circuit indicating components used in the power supply and output stages. The instrument uses five tubes and rectifier and covers the 550-1600 kc band only.

Push-pull audio is used in the output stage and the method of obtaining drive for the second tube, from the single 12SQ7 first stage, is unusual. The first 50L6 is fed in the usual manner from the preceding plate via a coupling capacitor. The grid of the second 50L6, however, is returned to ground directly. A com-

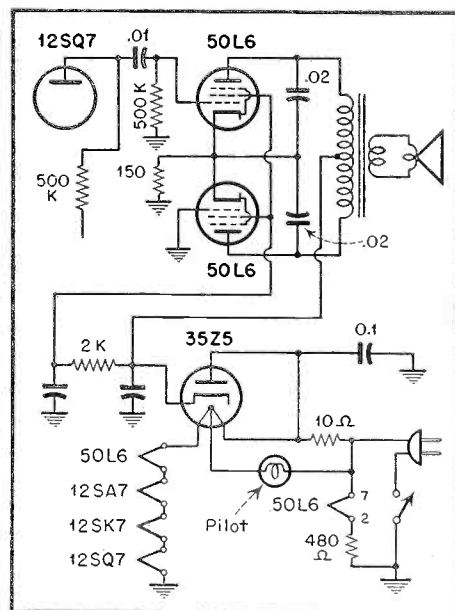

General Television Model 9B6P—partial schematic output stage

mon cathode resistor of 150 ohms is used to provide self-bias, and at the same time to excite the second tube. The plates connect to the opposite ends of the output transformer in the usual manner. Note that the .02  $\mu$ f plate bypass capacitors return to the common cathode point.

With two 50 volt tubes and one 35 volt tube, as well as three twelve volt tubes, it is obviously not possible to heat the entire string across the 115 volt line in the usual manner. The scheme employed is to connect all but one 50L6 in a series string and provide a resistor of 480 ohms to drop the voltage for the other 50L6.



# TRADE LITERATURE

## Crystal Pickup Selector Guide . . .

A handy new Torque Drive Crystal Pickup Cartridge Replacement Selector Guide has been published by Electro-Voice Inc., Buchanan, Mich. This replacement chart (Bulletin No. 146) lists the 3 basic types of E-V Torque Drive cartridges that replace over 150 standard model crystal pickup cartridges in common use.

## RCA Radio Service News Vol. XIV,

No. 1 . . . TV Antennas and Transmission Lines, by John R. Meagher. Discussion of various types of "ghosts" obtained in TV receivers. Also, Television Service, by the same author, showing how picture quality is affected by various troubles in video amplifier stages.

**Amphenol Engineering News**, Vol. 2, No. 2 . . . Discussion on coaxial cable that should interest every serviceman; a historical development of this necessary TV component.

**The Willard Salesman** Vol. XI, No. 1 . . . Willard Storage Battery Co., 246-286 E. 131 ST., Cleveland 1, Ohio. Excellent article on "What You Should Know About Generator Regulators". Especially valuable to auto-radio servicemen.

**Audio Record**, Vol. 5, No. 2 . . . Audio Devices, Inc., 444 Madison Ave., N. Y. C. Microgroove in Your Studio, by C. J. LeBel. Pertinent data on microgroove recordings of interest to sound men.

**TV Fringe Area Installation** . . . Vision Research Labs. P. O. Box No. 52, Kew Gardens 15, N. Y. A sixteen page booklet on helpful suggestions in fringe area TV installations.

**Successful Servicing**, Feb. 1949 . . . John F. Rider, Publishers, 480 Canal St., N. Y. C. "Contract TV Service", an article which analyzes contract problems as related to installations and service charges.

**Lemons Make The Best Lemonade . . .** A new booklet full of useful information for radio and appliance dealers on how to set up and operate a profitable servicing department has just been published by Philco Corporation, it was announced by James M. Skinner, Jr., vice president—service and parts.

**Miniature Electron Tubes** . . . This latest edition—six pages—91 types, 19

of them new. Contains pertinent characteristics, data and basing diagrams for all miniatures announced to date, regardless of make. Lists similar larger prototypes. Now available at Hytron jobbers free of charge, or write us direct.

## New Catalogs

January Flyer, The Heath Company, Benton Harbor, Michigan. . . Radio Surplus Corp., 732 South Sherman St., Chicago 5, Ill. . . The Recordisc Corp., 395 Broadway, New York 13, N. Y. . . The House of Television,

Starrett-Lehigh Building, New York 1, New York. . . Catalog N. 163, Cornell Dubilier Electric Corp., Plainfield, N. J. . . TV Antenna Catalog, Radio Merchandise Sales Inc., 550 Westchester Ave., New York 55, N. Y. . . Catalog N. 438, J.F.D. Mfg. Co. Inc, 4111 Fort Hamilton Parkway, Brooklyn 19, N. Y. . . Catalog No. 48B, Meissner Mfg. Division, Maguire Industries Inc., Mt. Carmel, Ill. . . Chicago TV Transformers, Chicago Transformer Division, Essex Wire Corp., 3501 Addison St., Chicago 18, Ill.



## The MOST COMPLETE Transformer Catalog in the Industry!

The big, new 1949 edition of the Stancor catalog has just come off the press. It's the catalog that every radio technician uses as his transformer "bible" . . . and it's yours for the asking. Complete listings of over 400 stock items, handy reference charts, easy-to-use indexes and diagrams make this Stancor buying guide better than ever. Write for your free copy today!

### ● TRANSFORMERS AND CHOKES

Detailed electrical and physical specifications, including applications, ratings, dimensions and prices, give you all the information you need to select the right Stancor unit for your purpose.

### ● HIGH FIDELITY TRANSFORMERS

A complete listing of the new Stancor HF and WF series. Made for the discriminating audio engineer to meet applications where superior quality is a "must."

### ● AMATEUR TRANSMITTERS

Years of experience in meeting amateur and commercial communication needs are built into the high quality Stancor transmitting equipment listed in this catalog.

### ● HANDY CHARTS

A transmitting and rectifier tube chart, a driver-modulator chart, output transformer-tube chart, and a full page of dimensional drawings of all Stancor mounting types are "plus" features of this new catalog.

### STANCOR TELEVISION CATALOG

Be sure you also have the latest edition of the Stancor television replacement parts catalog. You can depend on Stancor television components . . . built with the same care that goes into Stancor original equipment for TV set manufacturers. Write for Catalog 337 or see your authorized Stancor distributor.



**STANDARD TRANSFORMER CORPORATION**  
ELSTON, KEDZIE & ADDISON • CHICAGO 18, ILLINOIS



(c) It makes electron beam longer so that greater focus action

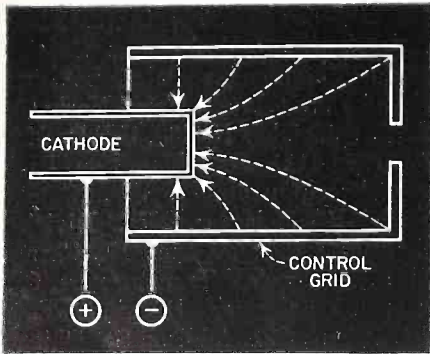

Fig. 4—Answer to 1.

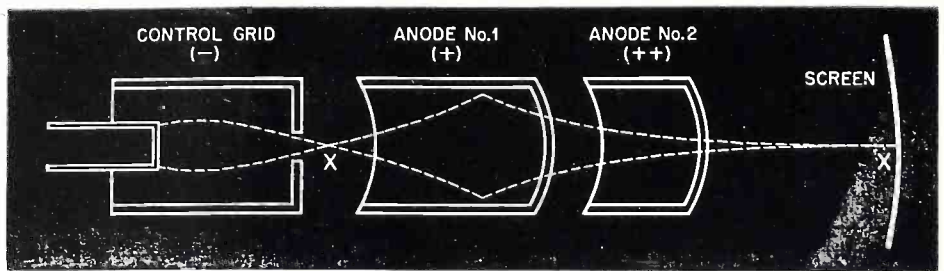

Fig. 5—Answer to 2.

(b) It relocates focus anode so larger aperture still controls focus, but draws less current.

and higher intensity is possible.

(d) It reduces or eliminates focus bleeder, since better regulation is effected.

5. (p 8) Drawn below (Fig. 3) is a cross-section of a modern C-R electron gun, with basic power supply connections. Copy this drawing, then draw in the electron beam, showing divergence, convergence, and two cross-over points. (Mark these points X.) Then, change the simple direct connections where necessary to variable controls, labelling them *Brightness* (also ambiguously known as *Brilliance* or *Intensity*) and *Focus*. Indicate polarity. Name the parts.

## TELEVISION Service Shops ... End 'Fixed' Antenna Troubles!

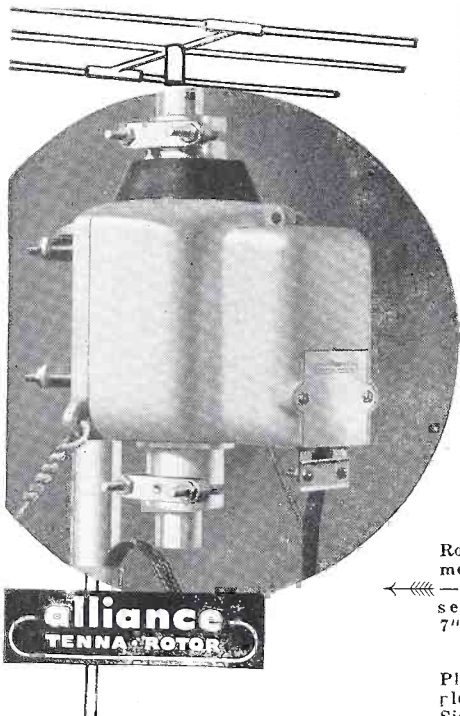

### alliance TENNA-ROTOR

- Fewer Call - Backs !
- Happier Customers !
- Faster Installations !
- Bigger Profits !

Rotator unit—metal enclosed  
← moisture sealed. Size 7" x 8".

Plastic control case  
plugs into 110 volts. →  
Size 5" x 5".



• Tenna-Rotor speeds TV installations—saves man-hours on the job because it eliminates critical antenna orientation! Now, *one man* does all the work—easily and quickly! In fringe or multi-station areas, your customers get "peak" reception, selectivity and wider range! And it overcomes "ghosts" and variable reflection factors! Foolproof, weatherproof, built for long life, Tenna-Rotor comes individually boxed—complete assembly (rotator and control case)—weighs 12 lbs.—retails at \$39.95 (slightly higher west of Rockies). Be sure to ask for genuine Alliance 4-conductor cable with each unit! Join the trend to Tenna-Rotor! It pays off with more sales and faster service! Order from your jobber—NOW!

## alliance motors

Alliance Manufacturing Company • Alliance, Ohio  
Export Department: 401 Broadway, New York, N.Y., U.S.A.

### SHOP NOTES

[from page 27]

#### Philco 37-650-Distortion

Tuneable distortion on a number of these sets, proves to be a short in wafer plate between r-f., 6K7G plate and 6A8G grid return, which are on same rotor and will be noticeable by arcing at times. This short, in bakelite, may be removed with bent ice pick and spot light, using carbon tet to wash charred granules away. Stubborn case, the wafer must be removed, all char thoroughly scraped and be sure to put wafer back in with rotor in same position as when it came out. This can prove most aggravating, especially as arcing isn't always present but grids of AVC may read several volts positive instead of going negative on station.

Submitted by:  
David V. Chambers  
Upper Darby, Pa.

#### Oscillation in Firestone 4-A-62

Oscillation at the low frequency end of the broadcast band in this model was quite a problem until we attempted to align the set. The set seemed to work perfectly after passing out of the oscillation zone yet when attempting to align the I. F. transformers it was found that the primary slug of the first A. M. transformer seemed to have little or no



effect. Shunting the primary with a 47 mmf mica condenser we obtained a peak and the oscillation ceased. The transformer is of the K-Tran type manufactured by the Automatic Manufacturing Co. In this type the lugs are made in such a way as to be folded one on top of the other and a strip of mica between them. It was barely conceivable that the condenser that this forms could be defective as the plates can be plainly seen. The only other possible defect we could imagine would be a shorted turn on the coil. Ohmmeter readings failed to show a marked difference between the primary of the defective and similar transformer primary used in the second A. M. section, however. Replacing the transformer with a new unit eliminated the trouble and a four aspirin headache.

Submitted by:

Wayne E. Lemons  
Buffalo, Missouri

## ANSWERS TO TV QUIZ

1. Drawing (c) is correct. (See Fig. 4.) Note that the control grid is negative with respect to the cathode. Therefore the electrostatic lines of force will extend from grid to cathode, choosing shortest path between points, but somewhat curved at extremes because difference in area between elements.

2. Below is shown Fig. 5. The electron beam is shown by dotted lines. Note first cross-over *X* caused by convergence of beam due to action of control grid. Maximum divergence takes place just before end of Anode #1, then second convergence begins. The second cross-over *X* takes place at screen.

3. (a) Control Grid  
(b) Anode #2  
(c) Anode #1  
(d) Anode #2

4. Ans. (c) is wrong. The only way the electron beam could be made longer is to lengthen the tube, since it already goes from cathode the full length of tube to screen.

5. Fig. 6 shows a modern electrostatic focus electron gun assembly, properly connected, with parts named, polarity shown and variable controls designated. Note that at first glance the Brightness control appears to be a cathode control rather than a control grid variable. Upon study, however, it will be shown the Brightness control varies the cathode reference point. This acts to vary the Control Grid negative voltage, as required.

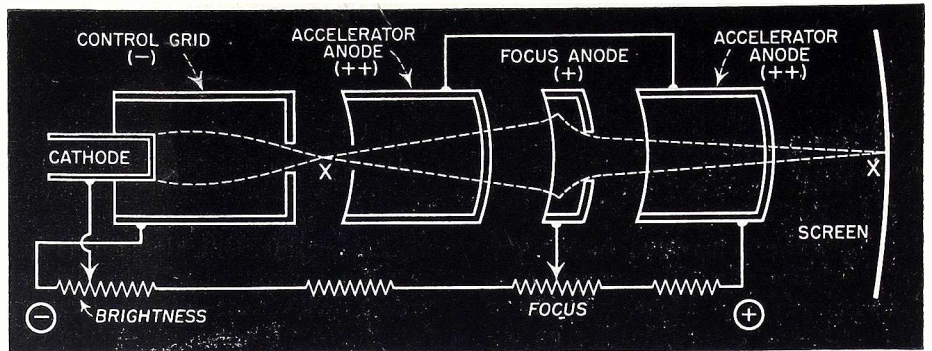

Fig. 6—Answer to 5.

# DEALERS' CHOICE

THREE DUOTONE NEEDLES PUT PEP IN ACCESSORY SALES



**THE "STAR"**—A top-quality sapphire-tipped needle, the Duotone "Star" has rolled up sales records in stores across the country. Entirely hand made, long-wearing, individually tested and inspected. Packed in individual transparent lucite containers. Free display cards and national advertising boost sales. List price \$5.00.

**THE DURPOINT**—The Duotone Durpoint answers the steady demand for a good, permanent needle at low cost. Plays thousands of records without changing. Takes additional polish from record groove, reducing surface noise and record wear. Twelve needles on an eye-catching display, each packed on individual card. List price each needle, \$1.00.

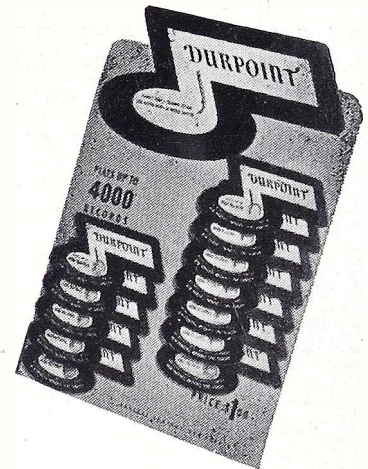

**THE SHOCKPROOF NYLON**—The Duotone Shockproof Nylon needle is really shockproof, will absorb shock when whole tone arm is bounced on record. Twelve needles in individual transparent plastic containers on three-dimensional self-demonstrating display. Free demonstration needle and two counter signs with each card. List price each needle, \$2.50.

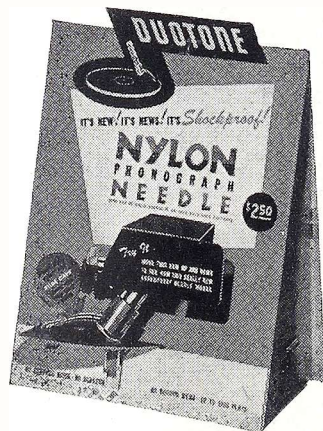

THE **DUOTONE** COMPANY, INC.  
799 Broadway New York 3, N. Y.



## NEW TV-FM SWEEP

[from page 20]

is in exact step with the phase angle of the scope, otherwise two traces will be observed.

### Marker Facilities

Two separate marker circuits are made available in this generator: a crystal controlled Pierce Oscillator with front panel facilities for an external crystal, and an internal variable marker oscillator covering the frequency range between 20 and 30 mc. These are shown in the block diagram, Fig. 2, marked respectively CRYSTAL OSC.-6C4, and R.F. MARKER-6C4. Their overall function in the complete circuit is readily made apparent from the circuit diagram shown in Fig. 3. The selector switch on the front panel marked (see Fig. 1): OFF-CRYSTAL-RF controls the insertion of these marker circuits into the sweep signal. With the selector switch in OFF position, both crystal and variable markers are inoperative. In the CRYSTAL position, with the proper crystal inserted, an accurately crystal controlled frequency is fed through the marker attenuator to the cathode follower output. Attenuation for either marker is obtained by means of a spe-

cial marker amplitude control. See Fig. 3.

### Applications

In all sweep generator applications a most important precaution to observe is to employ a good heavy common ground between sweep generator, receiver, and CRO. Unless this is done, spurious responses will be obtained which will render all measurements meaningless. If the trace on the CRO tends to change when either chassis, cables, or generator is touched, it is a sure indication that the grounding is at fault.

The alignment procedure of all wide band amplifiers follows basically the same pattern. However, TV receiver manufacturers furnish complete and detailed alignment information which should be followed closely for best results. This generator may be used for aligning the video i-f stages, the front end oscillator and r-f stages (if no pattern is available), and the sound i-f stages.

## NEW TV TEST

[from page 18]

inch of vertical deflection is obtained on the tube screen. Next, disconnect the probe from the meter jack and do not again move the Vertical Cali-

brate knob during voltage measurements.

3. The applied voltage to the scope was 5 volts peak-to-peak but in position 5 of the Vertical Range Switch there was an attenuation of 10 to 1. These relations are used so that a peak-to-peak voltage may be measured from its deflection on the scope screen. The vertical probe is placed across a test voltage to be measured and a Vertical Range Switch is turned to a position allowing some convenient vertical deflection on the scope. The peak-to-peak voltage which is being tested at the probe tip is the Vertical Range Switch setting multiplied by the number of inches of vertical deflection. Since a 5 volt peak-to-peak signal was used as a calibration voltage and one inch of deflection was obtained, the rule may be applied of multiplying the one inch of deflection times the marking of 5 on the Vertical Range Switch and obtaining a result of 5 volts peak-to-peak. Any other peak-to-peak voltage can be measured in exactly the same manner. Where the test voltage has a sinusoidal character the figure obtained can be multiplied by 0.354 in order to obtain the r-m-s voltage. Where the attenuating probe is used for voltage measurements, all of the Vertical Range Switch settings are effectively multiplied by a factor of 10.

This oscilloscope type WO 55A shown in Fig. 5, is designed to fit in a rack or to be used with the Television Calibrator WR 39A and the Television Sweep Frequency Generator type WR 59A. This smaller oscilloscope is somewhat similar to the WO 58A but is somewhat different in several important features. These features may be seen from the comparison chart shown in Fig. 6.

This smaller test oscilloscope uses the new 3 MP1 cathode ray oscilloscope which allows a very compact arrangement. The functions of the various controls in this model oscilloscope is so similar to the controls of the type WO 58A that they will not be repeated here. Reference should be made to the description of the various controls and their use under the cathode ray oscilloscope type WO 58A which will apply to the type WO 55A as well.

While this smaller oscilloscope may well be used for ordinary AM and FM visual alignment it is not recommended for nor designed to permit an accurate visual check of the critical wave forms found in the television receiver. This may be seen from the frequency response characteristics of this scope.

## ASK THE MAN ON THE ROOF WHY HE PREFERS SOUTH RIVER MOUNTS

The New South River  
**BUO-MOUNT  
ANTENNA BASE**  
Model No. DM 37  
(Pat. Pending)

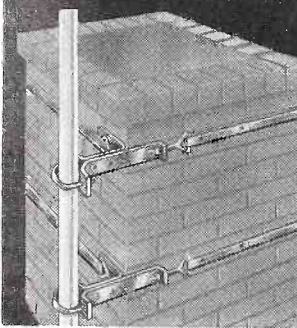

Holds tubing from 5/8" to 1 1/2" O. D. Made of riveted steel in hot dipped, everlasting galvanized finish. Features special "U" bolt.

NEW List Price **\$4.25**  
Individually Boxed

★  
Installation men will always specify South River because on the job their Exclusive, Quality Features save time and work. This means low cost installation. The man on the job knows and cares about quality. That's why he insists on South River Mounts.

The Original South River  
**CHIMNEY MOUNT  
ANTENNA BASE**  
Model No. SR10  
(Pat. Pending)  
The Aristocrat of Antenna Bases

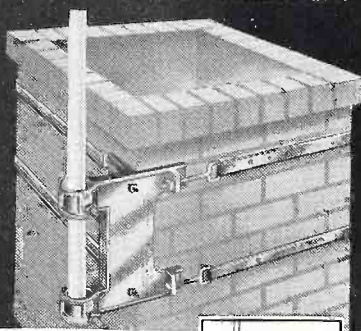

Holds tubing from 1/2" to 1 1/2" O. D., pipe from 1/4" to 1 1/4". Exceptionally durable. The four eye bolts enable straps to be tightened evenly. Also available in two sections if requested.

List Price **\$7.50** Individually Boxed

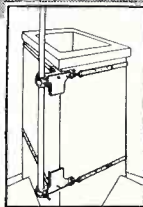

Both mounts can be installed in minutes by one man with no special tools.

Write for full information on our line of wall brackets, vent pipe mounts and accessory supplies.

**SOUTH RIVER  
METAL PRODUCTS COMPANY, INC.**  
SOUTH RIVER, NEW JERSEY



**NEW TV COUPLING DEVICE  
SOLVES MULTIPLE DWELLING  
ANTENNA DILEMMA**

Reeves Soundcraft Corp., 10 East 52nd St., New York, offers as a solution to apartment house TV antenna problems the Soundcraft TV Distribution System consisting simply of "Multivideo Connectors". Deriving signal from any antenna with 300 ohm feedline and capable of operating ONE receiver with some signal reserve, a Multivideo Connector for each additional receiver is simply snapped over the feedline wherever desired. Because cutting, baring, or splicing of feedline is eliminated, service is not interrupted. Tests with thirty receivers on one antenna show a NON-CUMULATIVE insertion loss of 4 db. Each receiver gets the antenna signal less only this small loss.

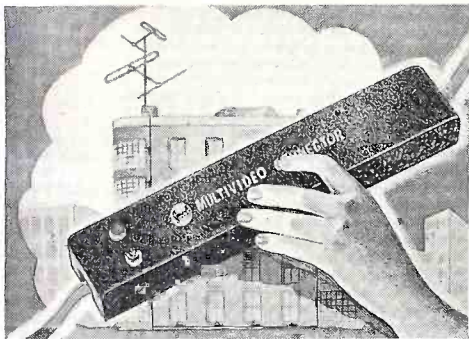

Reradiation interference and tuning surges are absorbed by the Multivideo Connector to the point where receiver performance equals that obtained from receivers connected to adjacent separate antennas. Multivideo Connectors list for \$12.85. Write for illustrated brochure and your discount. (Advertisement)

**HOW TO  
CRACK the IRON CURTAIN**  
OF LANDLORD RESISTANCE TO  
ROOF TOP ANTENNA CHAOS

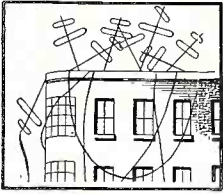
**KILL THIS** → 

**USE THESE** ↓ 

**SOUNDCRAFT  
Multivideo Connectors**

Any good antenna and 300 ohm feedline will operate many TV receivers with the same performance as if using separate antennas. Non-cumulative insertion loss of only 4 db. No cutting or baring of feedlines.

List Price \$12.85

**REEVES Soundcraft CORP.**  
10 EAST 52nd STREET · NEW YORK 22, N. Y.

To REEVES SOUNDCRAFT CORP.  
10 EAST 52nd ST., NEW YORK, N. Y.

PLEASE SEND STORY AND DISCOUNTS . . .

NAME \_\_\_\_\_  
ADDRESS \_\_\_\_\_

INDIVIDUAL  DEALER

# NEW PRODUCTS

## TV ANTENNA COMPASS

Ray Simpson, President of the Simpson Electric Company, 5200-18 W. Kinzie Street, Chicago, Illinois, announces that they are now marketing their new TV antenna compass.

Simpson's new TV Antenna Compass takes the physical form of a ruggedly built pocket size meter which is connected by a simple insulation-piercing alligator clip to the video in-

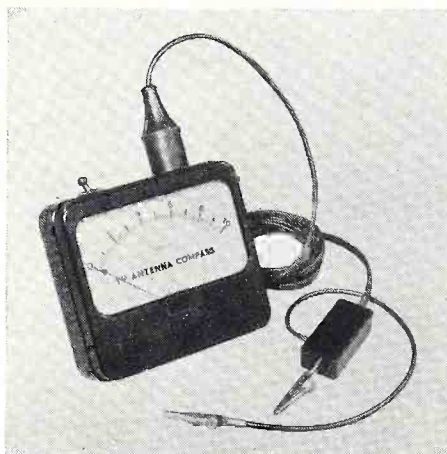

put of the cathode ray tube in the television receiver. By an extension cord, it is carried to the antenna site. With a test pattern tuned in on the area's weakest station, the antenna is then simply rotated for maximum deflection of the TV antenna compass.

## NEW CARTRIDGE AND PICKUP

The Astatic Corporation, Conneaut, Ohio, announces a new pickup cartridge with a ceramic element and a replaceable needle. Also announced is a turnover type pickup which plays 33-1/3 or 45 RPM and standard records at eight grams needle pressure, without necessity of automatically or otherwise altering the needle pressure in switching from one type recording to the other.

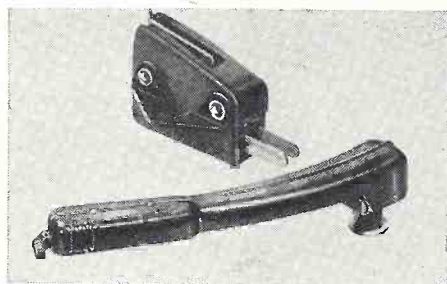

Called the "GC," the new Astatic Ceramic Cartridge features miniature size and light weight and six grams minimum needle pressure.

Astatic's new turnover type pickup is announced as the Model 6D. The 6D's cartridge has two separate, independent needles, the special Astatic "Q" type, which have been on the market for some time and are readily obtainable.

## TUBULAR TWIN-LEAD

A new tubular 300 ohm Twin-Lead for TV and FM antenna lead-ins is now being introduced by the American Phenolic Corporation under the catalog number 14-271. The tubular

design holds moisture or dirt outside the concentrated field between the conductors and, therefore, eliminates any possibility that the transmission line impedance will be varied or the dielectric losses increased by any abnormal condition in weather or collection of soot or other dirt. Since the dielectric between the conductors is principally air, the losses in the new tubular transmission line are low.

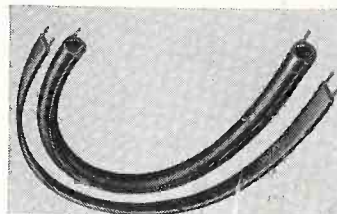

The conductors in the new 14-271 Amphenol Tubular Twin-Lead are seven strands of #28 copper wire. The outside diameter is approximately 5/16". Any of the conventional coaxial cable type insulators may be used to support this new tubular Twin-Lead.

## 45 RPM PORTABLE PLAYER

Allied Radio announces the new Knight electric phonograph with RCA-developed automatic changer for the new 7" 45 rpm records, housed in compact portable case. Contains built-in amplifier and properly baffled 5 1/4" dynamic speaker.



Case is attractively covered in brown rawhide fabric. Contains space for carrying records. Very compact. Weight is only 12 1/2 lbs.; size, 15" x 8 3/4" x 9 1/4". Complete with tubes, crystal cartridge and osmium-tipped .001" needle. For 105-125 volts, 60 cycles AC. Sold by Allied Radio Corporation, 833 West Jackson Blvd., Chicago 7, Ill.

## NEW HYTRON SOLDERING AID

The new Hytron Soldering Aid recently announced by Hytron Radio & Electronics Corp. is the first of the shop tools growing out of the Hytron Contest and is now available to servicemen through Hytron jobbers.

While iron keeps joint hot, fork tip of Hytron Soldering Aid—like two tiny metal fingers—straddles and, with slight twist, grips end of wire. Effortlessly unwraps it. Shifting to other side of lug, it grips and pulls wire free.

Spade-type-reamer tip clears lug hole of solder. Or pushes other wires aside for new



# RAPID ALIGNMENT of FM & Television receivers with NEW SWEEP GENERATOR

Gives true OVERALL picture of  
Television & FM receiver response

You can trouble-shoot and test FM and Television receivers faster with the revolutionary new FERRET MODEL 720 SWEEP GENERATOR. Designed for the busy service man who can profit from faster, easier testing. This model has more sweep width than any other signal generator. You observe, *visually*, sound traps and adjacent channel traps and get a true overall picture of receiver response.

## ALIGNS ANY FM AND TV RECEIVER

The new advanced-design FERRET SWEEP GENERATOR is advance-engineered (see specifications below) to meet every new development in television equipment. This means that your investment is insured against the threat of obsolescence. This generator has a frequency coverage, on fundamentals, from 0 to 260 m.c. on 8 bands and a sweep range from 50 k.c. to 20 m.c. on *all* bands.

## PUSH BUTTON CONTROL

Testing is greatly speeded up by the new push-button FERRET control system. This operates the B+ circuits only and permits individual or simultaneous use of the crystal oscillator, marker oscillator, or sweep F. M. television generator. You lose no time waiting for this instrument to "warm up" because one button is used for stand-by, which cuts off the B+ from various oscillators, but keeps filament voltage on, and the generator ready for instant use.



**FERRET Equipment**  
COASTWISE  
ELECTRONICS CO., Inc.  
130 N. Beaudry Avenue  
Los Angeles 12, Calif.

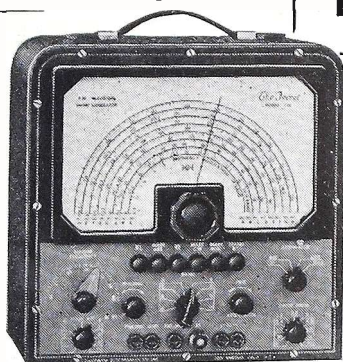

MODEL 720 FERRET FM-TELEVISION SWEEP GENERATOR with push-button control and extended sweep range.

## BUILT-IN VARIABLE MARKER

The FERRET SWEEP GENERATOR is equipped with a built-in variable marker from 19 m.c. to 40 m.c. on fundamentals, and the marker is Pippier, Absorption, and modulated marker type, the latter being desirable for trap alignment. Crystal oscillator allows for any frequency, up to 10 m.c. on fundamentals, by a front panel socket.

## NO EXTERNAL FREQUENCY STANDARDS

The FERRET SWEEP GENERATOR is entirely independent of markers or external frequency standards since *any* marker frequency is obtainable, from 19 m.c. to 40 m.c. on the variable marker. The variable marker oscillator has an accuracy of 1% or better.

## ENTIRELY ELECTRONIC!

## NO MECHANICAL PARTS

This amazing new instrument does not use any mechanical devices such as vibrators or speakers. It is purely electronic. The large 9-inch calibrated dial with a 5 to 1 vernier drive gives unusual accuracy. The FERRET SWEEP GENERATOR has temperature-compensating circuits and is fully shielded, has low output impedance, a 4-step attenuator, built-in phasing control and provision for external modulation.

## REASONABLE PRICE

The FERRET MODEL 720 FM-Television SWEEP GENERATOR costs \$164.95 (slightly higher in Eastern States). This is about the lowest price for a generator of this type. We know of no other generator at *any* price with so many exclusive "extras." You get more for your money when you invest in FERRET equipment. This instrument will not go "out-of-date" and will be in use much longer than ordinary generators now on the market. Many users tell us that the FERRET MODEL 720 is a wise investment because "it pays for itself in the time it saves—in the customer satisfaction it gives."

## FREE - MAIL COUPON TODAY COMPLETE INFORMATION AND PRICES.

COASTWISE ELECTRONICS CO., Inc.  
130 N. Beaudry, Dept. N 549  
Los Angeles 12, California

Please send me without obligation or cost full information about the equipment checked below:

- Ferret FM-TV Sweep Generator No. 720
- Ferret TV Signal Tracer-Electronic Volt Ohm Meter No. 730
- Ferret Sine-Square Wave Generator for Video & Audio No. 710
- Ferret Signal Generator & TV Calibrator No. 701
- Ferret De Luxe TV Test Speaker-Universal Substitutor No. 721
- Ferret Germanium Crystal Probe for TV Trouble Shooting & Alignment

Name \_\_\_\_\_  
Address \_\_\_\_\_  
City \_\_\_\_\_ Zone \_\_\_\_\_ State \_\_\_\_\_

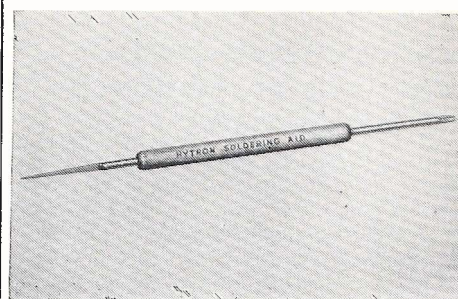

wire. Fork tip next guides new wire through and around lug. Holds it firmly in place while soldering. Other uses? Probing, scraping. Separating and positioning wires, lugs, contacts, parts—etc.

## 45 RPM RECORD CHANGER

Crescent Industries, Inc., is now turning out new 45 RPM record changers in quantity for manufacturers and soon hopes to make them available to distributors, according to J. Wayne

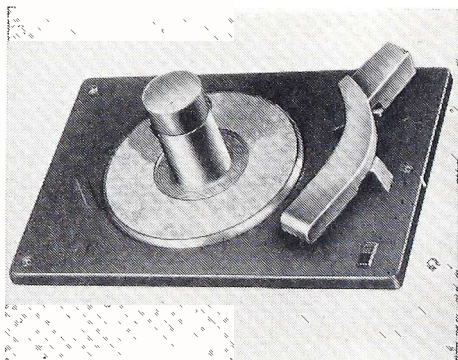

Cargile, Manager, Distributor Division. The new item will be distributed through authorized Crescent distributors on a national basis and, as production permits, an additional variety of Crescent models will be offered to the trade.

## NEW THREE-SPEED PICKUP

The "Twilt"—a new Torque Drive Twin-Tilt Phono Pickup Cartridge for all three speeds—is announced by Electro-Voice, Inc., Buchanan, Michigan. A single "Twilt" cartridge with a single Twin-Tip replaceable needle plays 78, 45 and 33 1/3 rpm records with-

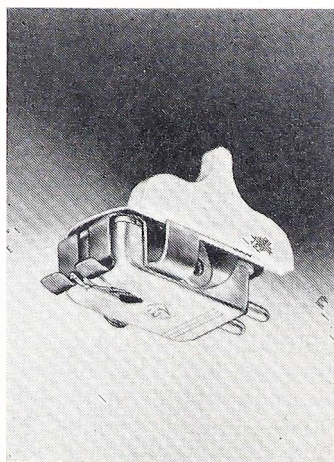

out weight change and with a tracking pressure of only 6 grams on either needle-tip. With easy, positive-tilting, snap-action, you merely tilt the "Twilt" to select the one mil (.001) or the three mil (.003) needle-tip, as you wish—for fast or slow speed records.

Available in Torque Drive Crystal and variable reluctance Magnetic types . . . with replaceable twin-tip .001 sapphire and .003 osmium needle, 18" cable. Dimensions: 1 1/2" wide and 3/4" high including tilt control lever. Length 1 1/2".

For complete information, write for Twilt Bulletin No. 153 to Electro-Voice, Inc., Buchanan, Michigan.



### NEW JFD INDOOR TV ANT.

The JFD Manufacturing Co., Inc., of Brooklyn, New York, has just initiated production on its new Indoor TV-FM antenna named the "Tele-Vee". A feature of this new

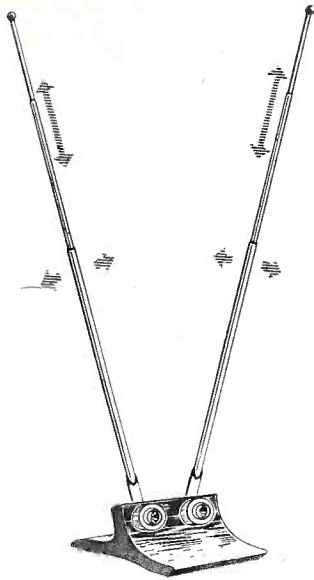

JFD product is the unique base of exclusive design, fashioned so as to harmonize with and add beauty to the home. An illustrated bulletin No. TV130 describing the "Tele-Vee" Indoor Antenna is available upon request from the manufacturer.

### 45 RPM RECORD PLAYER

Alliance Manufacturing Company, Alliance, Ohio, announces their new single-play 45 r.p.m. record player, Model J.P. 45. Expressly designed

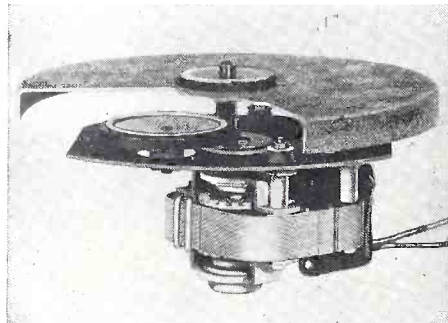

for the new 45 r.p.m. records this unit comprises a complete motor and turntable assembly.

It will be supplied in individual cartons and distributed through the usual jobbing channels to retailers and service repair shops.

### NEW REPLACEMENT TRANSFORMERS

Thordarson Electric Manufacturing Division, Maguire Industries, Inc., 500 West Huron Street, Chicago, has recently announced a new line of high quality replacement transformers at standard replacement prices. Spe-

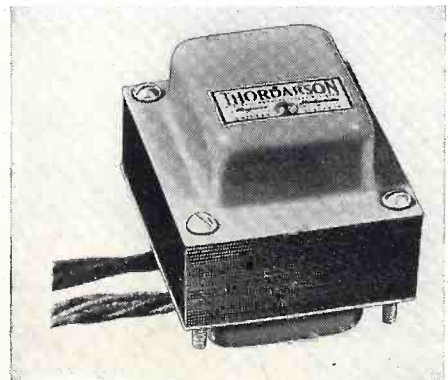

## Best By Comparison!

### THE MEISSNER 8C FM RECEPTOR

**New Ceramic Components Assure  
Even Finer Performance**



This outstanding receptor now offers even finer performance, truer tone, more stability—the result of new design changes and the exclusive use, wherever possible, of ceramic components.

Designed for simple connection to present AM radio receivers, the 8C instantly converts them to standard AM or thrilling, static-free, high fidelity FM reception.

It is also excellent for use with Phono Amplifiers, or with Public Address Systems.

#### Compare These Features:

- **AUDIO FIDELITY:** Flat within plus or minus 2 db. from 50 to 15,000 CPS. output voltages as high as 15 volts R. M. S. obtained without distortion.
- **SENSITIVITY:** 40 microvolts.
- **AUDIO OUTPUT:** 3 volts R. M. S. at minimum usable signal input, 30% modulation. For greater signal inputs, high quality audio power amplifier may be used which has high impedance input and which will produce full output with 10 volts R.M.S. audio input.
- **AMPLIFIER REQUIREMENTS:** Any high quality audio power amplifier may be used which has high impedance input and which will produce full output with 10 volts R.M.S. audio input.

**See and hear the new 8C Receptor at your Meissner Jobber.**

## MEISSNER

MEISSNER MANUFACTURING DIVISION  
Maguire Industries, Inc., Mt. Carmel, Illinois

# Here's Your Summer Replacement Profits!

### SUMMER IS YOUR FUSE SEASON AND FUSE PRO- TECTION IS VITAL

- Millions of motorists on the road need RADIO FUSE REPLACEMENTS.
- Millions of people at picnics, concerts, etc. hear by public address systems—all needing FUSE REPLACEMENTS.
- Millions of TV sets need FUSE REPLACEMENTS.

Littelfuse is the foremost manufacturer of fuses in the world. Protection is Positive.

Stock up right now—call your jobber today.

## LITTELFUSE INC.

4787 NORTH RAVENSWOOD AVENUE  
CHICAGO 40, ILLINOIS

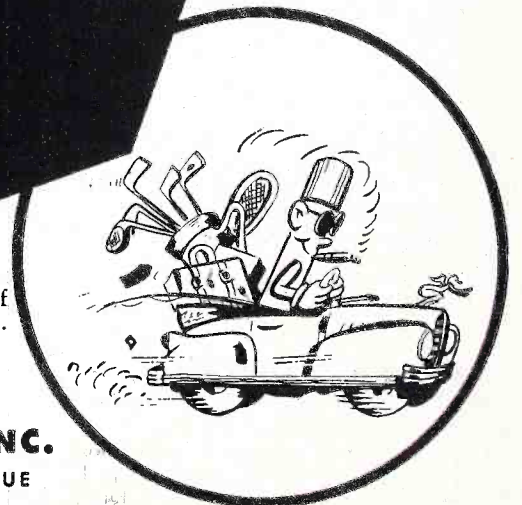



# FOUND!

the "MISSING LINK" to  
GOOD TV ANTENNA  
INSTALLATIONS

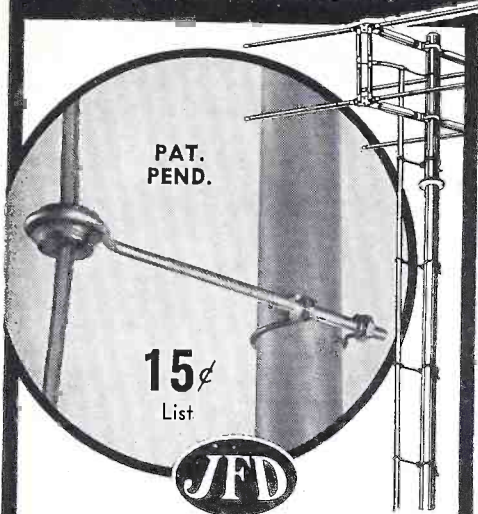

## MAST CLAMP LEAD-IN SUPPORTS

Made with POLYETHYLENE  
(the ultra-low loss insulation material)

Now you can make any old or new TV installation last longer, look neater, perform better with the unique JFD Mast-Clamp Lead-In Supports. These new Screw Eye Insulators are JFD-engineered to anchor lead-ins firmly in place and assure better TV/FM reception.



**TL100-350**  
1" Clamp with 3/2" Screw  
Eye for Twin Lead. **15c**  
List



**RG100-350**  
1" Clamp with 3/2" Screw  
Eye for Coaxial  
Cable. **15c**  
List



**DTL100-350**  
1" Clamp with 3/2" Screw  
Eye for two Twin Leads. **35c** List



**DBR18TL3**  
3/2" Screw Eye with wood-  
screw thread, for two Twin  
Leads. **28c** List

Mast Clamps are made in all sizes for all applications, individually designed to fit masts from 1/2" to 2" O.D. Screw Eyes range from 3/2" to 12" in length.

Visit JFD Booth 117 at Chic. Parts Show

**JFD MANUFACTURING CO., Inc.**

6113 16th Avenue B'klyn 4, N. Y.

WRITE TODAY  
for Valuable 4-page Bulletin #DBR

© Copyright 1949 by JFD Mfg. Co. Inc.

FIRST In Television Antennas and Accessories

All rights reserved. No part of above work may be reproduced in any form except by written permission of the manufacturer.

cifications are: "24" Output Replacements: Specific duty transformers available in four models, 2,000 to 25,000 pri. imp. with 5 watts output.

### TV REPLACEMENT CAPACITORS

A complete line of the most popular television replacement electrolytic capacitors is now available from distributors of the Sprague Products Company, North Adams, Mass.

Engineered especially for tough TV replacement applications, Sprague's new type TVA and TVL "Twistlock" electrolytics are designed to stand up under the extremely high

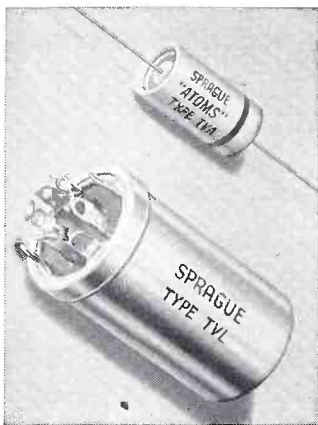

temperatures, high ripple currents, and high surge voltages encountered in television receivers. Included in the listing are 93 separate ratings comprising the units most needed by teleservicemen. Complete description of these capacitors is given in Sprague bulletin M-429, available upon postcard request.

### RCA 8" SPEAKER

R.C.A. announces a new 8-inch PM Speaker RCA-408S3 having a 1-inch voice coil and a 6.8-ounce magnet, is intended for use in television receivers and large table radios. The 408S3 will handle 8 watts.

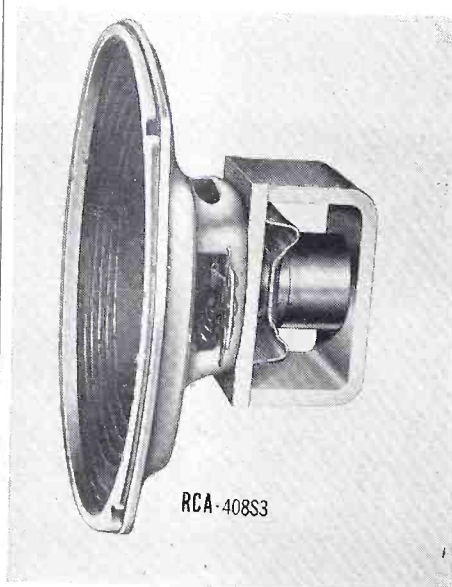

This new speaker utilizes a one-piece stamped steel frame. The Alnico V magnet is held accurately in place without the use of cement by the RCA-developed Magnet Clamping Spring.

The 408S3 is dustproof and rust resistant. Its cone, voice coil, and suspension are moisture resistant. Two sets of holes are provided in the frame for mounting a strap-type output transformer.

### FP CAPACITORS

P. R. Mallory & Co., Inc., announces the newly labelled line of Mallory twist-mount, FP (Fabricated Plate) Capacitors.

The Mallory FP Capacitor has been further improved in a number of ways in recent months.

In 1949 as Before...

# BURGESS

is the *Money-Making*  
Portable Battery Line!

### A COMPLETE LINE

★ ... of quality batteries. All sizes and voltages for all portable radios ... simplifies ordering and stock!

### ★ SUPERIOR QUALITY

... made even better by new engineering principles that increase the service life of dated, fresh Burgess Batteries!

### ★ NATIONAL DEMAND

... stimulated by advertising in nationally famous magazines read by more than 70 million battery buyers every month!

### ★ MORE PROFITS

... through the gaining popularity of this sales-winning, complete line of better dry batteries!

## Get Set for Another BIG Portable Battery Season!



Make your store headquarters for popular Bur-

gess radio batteries. Get new free counter and window displays—enclosures—streamers. Ask your jobber or write to Burgess.

If you're not already enjoying all the sales-winning, profit-making advantages of the Burgess battery line, write or phone your Burgess jobber; or for the name of your nearby Burgess distributor write to

# BURGESS

BATTERY CO., FREEPORT, ILL



These improvements include stronger anode tabs, the ability to withstand higher discharge



currents, new high surge separators, still greater heat resistance, an extra heavy rubber seal, heavier cathode tab and special etched cathode.

#### TV SIGNAL BOOSTER

A Television Signal Booster, which strengthens television signals in "fringe" areas, has been developed by the engineering department of the Philco Corporation and is now available



for shipment to dealers and servicemen, it has been announced. Easy to install and to operate, the new booster works with any television set, except a.c./d.c. (series filaments) models. A single dial brings in sound and picture more clearly.

#### SET SCREW WRENCH

This compact little tool, small enough to carry in the pocket, consists of six sizes of set screw wrenches anchored in a cast holder.

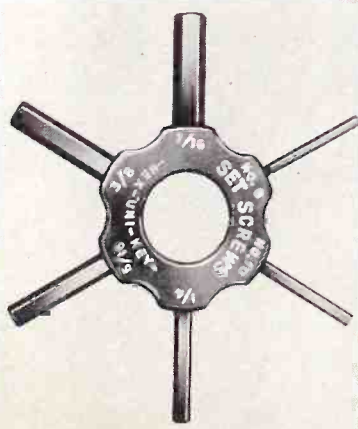

The Hex-Uni-Key is manufactured by the Eklind Tool and Mfg. Co., 2627 North Western Avenue, Chicago 47, Illinois.

## Convert Battery Radios To ALL-ELECTRIC

operate-service  
demonstrate-  
test



with

**Electro**  
ELECTRICAL AND RADIO EQUIPMENT

## ELECTRO BATTERY ELIMINATORS

for only a few cents per hundred hours

Use radio for unlimited time without fading. Completely eliminates fussing with batteries. Easy to install—simple to use. Fits in battery compartment of most radios. Convenient, permanent, on-and-off switch.

Will operate in any position—nothing to spill, get out of order. Hum free, completely filtered, silent in operation. Universal plugs and sockets fit any radio. Durable finished in handsome blue Hammerloid.

**MODEL "S" — WITH SELENIUM RECTIFIER** — Operates any 1.4 volt—4, 5 or 6 tube Battery Radio from 115 volt 60 cycle source.

**MODEL "P" — COMPACT** — Same as Model "S" except has tube rectifier at lower cost. Also available for 220 volt operation.

**MODEL "F"** — Operates 2 volt, 4, 5, 6 or 7 tube radio from 115 volt 60 cycle source. (0.5 amp. filament max.)

WRITE FOR COMPLETE INFORMATION

### ELECTRO PRODUCTS LABORATORIES

Pioneer Manufacturer of Battery Eliminators  
549 W. Randolph St. Chicago 6, Illinois

## ILLINOIS CONDENSER

Presents

### A Greatly Expanded Line



NEW CATALOG  
NOW AVAILABLE

Customer acceptance—proven by 15 years of high quality production—has made Illinois condensers one of the fastest sellers in the field.

They are reliable, even in the most humid climates . . . they are long lived under brutal heat conditions . . . they are manufactured under the strictest quality control methods in the industry . . . they are backed by a one year guarantee!

#### From Radio To Television

There is an Illinois condenser to meet every modern need . . . original application to replacement. An expanded line has been developed to serve the entire electronic field—from radio to television.

A new and greatly expanded Illinois Condenser catalog is now off press. Write for your free copy today!



**ILLINOIS CONDENSER CO.**  
1616 NORTH THROOP STREET • CHICAGO 22, ILL.



## TAPE RECORDERS

[from page 16]

attention and no lubrication. Suffice it to say that below decks (beneath the top of the chassis), where will be found a number of rubber-rimmed discs, slipping clutches, a breaking mechanism, and a heavy duty driving motor. conscientious effort has been invested to insure good service.

All rubber rimmed surfaces are pre-

cision ground to insure absolute concentricity. This alone is tantamount to the elimination of flutter or "wows". All pressure-bearing metal surfaces are automatically removed from any contact with rubber surfaces or rubber rims during idle periods so as to avoid the possible development of flat sectors which could cause flutter during normal operation.

Self adjusting constant-torque dry slipping clutches are employed for takeup in both directions. One is at-

tached to each of the tape reel spindles. These clutches embrace annular ribbed beryllium copper tension plates which hold a highly polished steel flat ring in contact with graphite-packed wool felt discs. It is stated that these clutch components readjust themselves for packing or compression from wear during the life of the mechanism.

The clutch unit is designed with a 4 to 1 overdrive so that adequate tension is applied for head contact and takeup during recording or playback in either direction. When the tape is disengaged for shuttle purposes, either for re-wind or cueing as shown in Fig. 4B, it travels in either direction at four times its normal recording speed of 7½ inches per second. Hardened steel tape guide posts are installed to prevent wear and vertical tape drift during operation.

All shafts are precision centerless ground and ride in oilite bearings which require no lubrication. A special thrust ball bearing is utilized in

# JAMES

## has a brand NEW line!

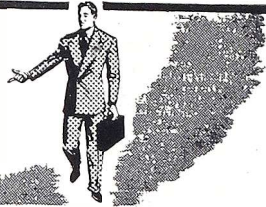

Your jobber will know all about the new James auto-radio vibrators. They were displayed at the Radio Parts Show in Chicago, May 15th, 16th and 17th. Ask him about these important features:

- 1—New design assures dependability with strong H-frame construction, patented reed and oversized dynamic wiping contacts.
- 2—New prices gives you a superior vibrator at a saving you can pass on to your customers.
- 3—New package makes it easy for you to identify and ask for James vibrators when you enter your jobber's store.

When you order replacement vibrators, always be sure you get the extra dependability and long lasting quality of the new JAMES line.

**JAMES VIBRAPOWR CO.**  
3224 W. Armitage Ave. • CHICAGO

**NEW design!**

**NEW price!**

**NEW look!**



Fig. 2—Complete Tape Recorder.

the capstan mechanism which is seen located centrally atop the chassis in Fig. 4A. The capstan serves as the focal point for many procedures. A few examples follow:

(a) A turntable is attached to the capstan when cross-over recording from disc to tape is desired. Here smart engineering evolved a rotational commercial speed of 78.26 rpm.

(b) A torque-balanced drive motor (4 pole induction motor) maintains a constant capstan speed throughout a considerable voltage supply range.

(c) When a reversal of direction of tape travel is desired, an additional rubber-coated idler is engaged between the motor shaft and the main capstan drive.

### Braking Mechanisms

When the "Forward-Reverse" lever is thrown to the "Stop" position, a braking mechanism is actuated. What actually happens is this,—two metal fingers are applied against the rubber-rimmed tires of the supply and takeup spools thus enabling an instantaneous stop. As a direct result there is no spilling or fouling of the tape.

It is notable that pressures developed by these metal fingers in no way affect the capstan drive. The rubber

## Insure BETTER Television Service to Your Customers! . . . Exclusively Designed

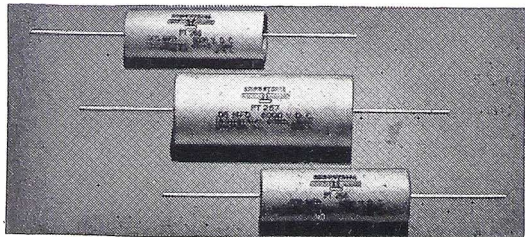

### HIGH VOLTAGE AND ELECTROLYTIC TUBULAR TELEVISION CAPACITORS



### Especially Engineered for Television Circuits by INDUSTRIAL CONDENSER CORP.

The economical quality line for replacement. Industrial Condenser Corp., manufacturers of Capacitors exclusively brings you highest quality for the particular requirements of Television at exceptionally attractive prices! Special Capacitors are Pyroteen impregnated for low power factor, high insulation resistance, high operating temperatures. Oil, Pyroteen, Wax and Electrolytic Capacitors. Finest materials throughout.

Ask Your Jobber for our Attractive Prices Today!

Or write for Bulletin 1095. Industrial makes quality Capacitors for Television, Radio, every electronic and industrial application—all types.

Send for Complete Catalog

**INDUSTRIAL CONDENSER CORP.**

3243 N. CALIFORNIA AVENUE CHICAGO 18, ILLINOIS  
Sales offices in all principal cities



Modern plant built by Industrial Condenser Corp., for manufacture of Capacitors only.



# favorite choice

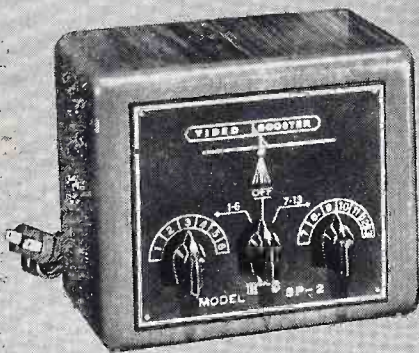

**RMS SP-2**  
**video  
antenna  
booster**

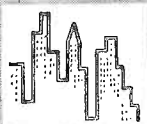

This is the **BOOSTER** that has become an accepted part of every **DEALER** and **SERVICE MAN'S** stock and kit. Tests have proved it the outstanding **BOOSTER** in the business

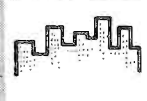
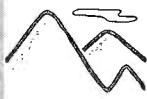

See the **RMS BOOSTER** at the **Parts Show, Stevens Hotel, Chicago, Booth 31.**

Send for 'Data Sheet No. 215-B.'

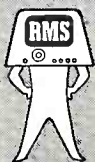

**RADIO MERCHANDISE SALES, INC.**  
550 Westchester Avenue, New York 55

rims used for braking are disassociated with mechanism controlling lineal tape speed. There is only one caution in this regard. While the *red* shipping thumbscrews are still in place, the "Forward-Reverse" control should be in the "Reverse" position. If the lever has been forced forward, excessive stretching of the forward motor positioning spring may subsequently cause speed variations.

### Tape Threading

The simplicity of threading the tape mechanism is brought out in the *A* and *B* sketches of *Fig. 4*. The original threading for recording as seen in *Fig. 4A*, serves also for playback. The simpler threading of *Fig. 4B*, serves for high speed re-wind to the beginning or to any portion of the tape record.

Before attempting to thread, place the lefthand "Play-Record-Shuttle" lever into the "Shuttle" position. This lever actually controls threading. It leaves the tape slot in the hood open for threading when set in the "Shuttle" position. Normally the tape should be reeled with the coated or dark side, (magnetic side) face up or on the outside. However, if delivered otherwise, a reel may be used on this machine without the need for rewinding. It is merely necessary to twist the tape one half turn before it passes the right hand guide post. Of course once it is unwound, it may be used in the other direction without the half twist. Initially the feeder or supply reel is placed upon the right hand spindle with the key side downward.

Normally the righthand reel rotates clockwise and feeds the tape through a forward slit in the assembly from right to left while the clockwise take-up reel receives it. The lever positions, as shown in *Figs. 4A & B*, determine the direction of tape travel.

### Automatic Reversing Mechanism

When a reversing solenoid is energized it kicks the "Forward-Reverse" lever into the "Reverse" position. When this happens the Recording-Playback head is automatically shifted vertically to the second or unused half of the tape and simultaneously the direction of travel of the recording tape is reversed. The manner in which this is accomplished is rather simple. A one inch long piece of one quarter inch wide aluminum foil, adhesive or glued, is affixed to the back of the tape, (contra-magnetic side) somewhat short of the end of the reel. When in contact with the laminated switch serving as the righthand tape guide post, it actuates the solenoid which kicks the conducting aluminum cones in the direction control knob into the "Reverse" position.

[To Be Continued]

# it's new!

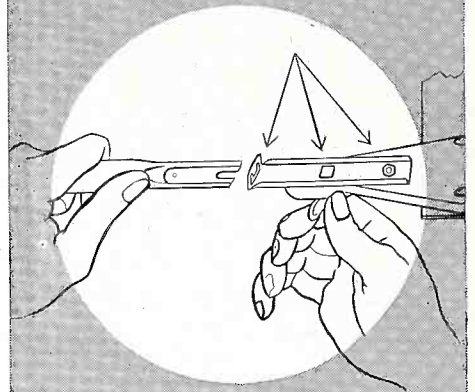

The **RMS TV**  
**ANTENNA LINE** with the  
**New, Exclusive feature**

## SPEE-D-LOK\*

assembly

Dealers and service men across the country recognize these facts about the **RMS Antenna Line**:

1. **GREATER EFFICIENCY — BETTER RESULTS**
2. **SPEEDIER INSTALLATION IN MATTER OF SECONDS**
3. **MODERATELY PRICED**



See the **RMS Antenna Line** at the **Parts Show, Stevens Hotel, Chicago, Booth 31.**

Send for the **NEW Spring 1949 Catalog # 215.**



**RADIO MERCHANDISE SALES, INC.**  
550 Westchester Avenue, New York 55



# NEW! AMCON TWISTED LUG ELECTROLYTICS

FASTER  
CHASSIS  
ASSEMBLY

IMPROVED  
APPEARANCE

TOP-NOTCH  
PERFORMANCE



ON DISPLAY IN BOOTH 155  
(ROOMS 900-01A)

WRITE FOR CATALOG AND PRICES



## AMERICAN CONDENSER CO.

4410 N. Ravenswood Ave., Chicago 40, Illinois

**Ghosts CAN  
be eliminated!**

Use a **HI-GAIN  
UNI-DIRECTIONAL ANTENNA**  
with a very **Narrow Beam Width**

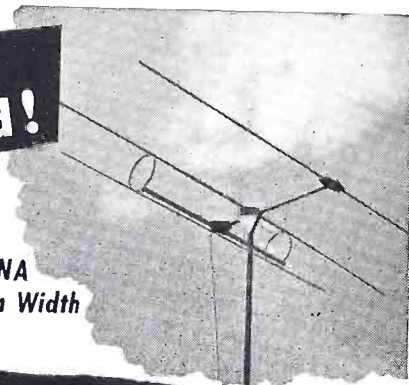

**The TRICRAFT MODEL "1000"  
is just such an ANTENNA!**

Gives over **10 DB** Gain over a  
half wave length dipole in the high band  
and **5½ DB** in the low.

- All wave
- Low standing wave ratio
- Sturdy construction
- Light weight
- Complete, ready to install
- Individually packed

A SPECIAL KIT AVAILABLE TO CONVERT  
MODEL "300" INTO MODEL "1000"

A "TRICRAFT" ANTENNA FOR EVERY NEED.

Visit Booth No. 147 at the May Radio Parts Show, Chicago.



*Tricraft Products Co.*

1539 North Ashland Ave., Chicago 22, Ill.

Manufacturers of complete line of Television, FM and AM antennas and accessories

## TRADE FLASHES

[from page 12]

receiver circuit principles, together with an extensive coverage of television circuitry as applied to present day production line models of television receivers.

The fifth book is the "Photofact Auto Radio Manual". Containing complete service information on more than 100 post-war auto radio receivers, the Manual will prove a welcome addition to every auto radio service shop operator. Practically every auto radio made since 1946 is included. It represents the products of 24 manufacturers.

### Electrovox Moves

Electrovox Company, Inc. announces the removal of their factory and general offices to 60 Franklin Street, East Orange, N. J. (Or. 4-1060-1-2).

### Projection TV

A television picture four feet wide by three feet high, projected on a conventional home movie screen from a small cabinet containing a complete television receiver, was demonstrated



to the press here recently by North American Philips Company, Inc., of 100 East 42nd St., N.Y.C. Both TV pictures shown are obtained from the same type of 2½" projection tube used in conjunction with the Protelgram Optical System.

### Rider Announces Three Books

John F. Rider Publisher, Inc. announces TV Manual Volume 2 is currently available at Rider distributors. Exceeding the original estimate of manufacturers scheduled for inclusion, TV Volume 2 covers the products of 67 manufacturers, including TV boosters.

Announced also is "TV Picture Projection and Enlargement" as a May publication. It will be available at all Rider distributors and book dealers. Approximately 250 pages, it will



sell for \$3.30. The author is Allan Lytel of Temple University Technical Institute.

Containing over 2,100 pages, Volume 19 the 3rd book announced, will be the largest Rider Manual to date. Ready for May publication, it will contain authentic, factory authorized service data on AM, FM, auto and communications receivers made by over 100 manufacturers.

#### Clarostat Holds Open House

So that folks of Dover and surroundings up New Hampshire way might see what it means to be with Clarostat in its new plant, the Clarostat Mfg. Co., Inc., manufacturers of resistors,

controls and resistance devices, held an open-house party on Saturday afternoon, April 9th. Visitors exceeded 3200, and included employees, their families and friends, and local folks at large.

#### Testing TV Antennas

During the last six months, Ward's engineers of Ward Prod. Corp., Cleveland, Ohio, have submitted these antennas to rigorous laboratory and field tests using their new Mobile Antenna Laboratory extensively. Fully equip-



ped with high frequency signal generators, transmitters, cable, etc., the mobile unit has enabled the Ward engineers to test reception patterns under all types of transmitting conditions and all urban and rural topographical situations.

#### FIELD FINDINGS

[from page 10]

will exceed the supply by 3 to 1. By the end of 1953 it is hoped TV production will exceed 5 million units annually, and by then it is expected that over 18 million videosets will be in actual use. If that is to be so, our recent editorial prediction that over 100,000 trained radio-video technicians will be needed is quite conservative.

On January 12th of this year, relay and coaxial lines tied up a network encompassing Boston to Richmond to St. Louis to Chicago and back to New York via Detroit and Cleveland. By 1953 the entire country should have coast-to-coast TV hookups. Today only 47 video stations are on the air while 75 applicants have permits to construct stations. Meanwhile, FCC has 312 additional permits pending.

The prewar year 1940 was a boom radio year. Set sales and service bus-

### COMPARE ACTUAL PERFORMANCE CURVES - - -

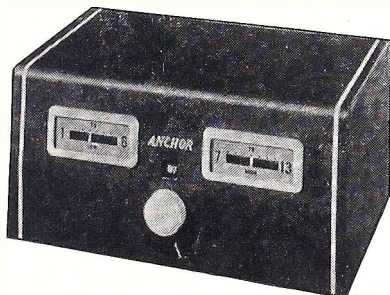

### OF THE ANCHOR TV - PRE - AMPLIFIER

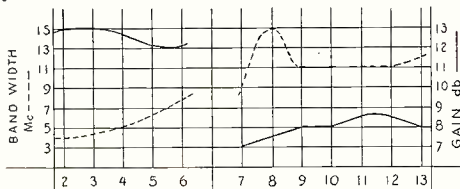

HAZELTEEN REPORT NO 2801-17

The ANCHOR PRE-AMPLIFIER is engineered to amplify the signal only, not the noise. Furthermore, the inherent noise of this unit is not measurable.

The ANCHOR Booster provides maximum gains possible from the 6AK5 tube with excellent band widths.

It increases signal strength without loss of picture detail.

The outstanding acceptance of the ANCHOR TV-PRE-AMPLIFIER by Service Engineers and Dealers is the best testimonial to its quality.

Engineered for modern and the best TV reception. Priced right for profits. Get details now.

See your jobber or write us.



### AUTO RADIO VIBRATORS

have Ceramic Stack Spacers

Visit ATR Booth  
82 Radio Parts  
Show May 16 to  
20 Chicago



#### A COMPLETE LINE OF VIBRATORS...

Designed for Use in Standard Vibrator-Operated Auto Radio Receivers. Built with Precision Construction, featuring Ceramic Stack Spacers for Longer Lasting Life.

Backed by more than 17 years of experience in Vibrator Design, Development, and Manufacturing.

ATR PIONEERED IN THE VIBRATOR FIELD.

NEW VIBRATOR GUIDE  
FREE



### "A" BATTERY ELIMINATORS

for DEMONSTRATING AND TESTING AUTO RADIOS

New Models . . . Designed for testing D. C. Electrical Apparatus on Regular A. C. Lines. Equipped with Full-Wave Dry Disc Type Rectifier, Assuring Noiseless, Interference-Free Operation and Extreme Long Life and Reliability.



AMERICAN TELEVISION & RADIO Co.  
Quality Products Since 1931  
SAINT PAUL 1, MINNESOTA-U.S.A.



Tune out Acoustic Feedback

THE NEW **Bogen**  
**ANTI-FEEDBACK CONTROL**



This revolutionary control actually "tunes out" acoustic feedback in the sound distribution system. One of nine important features of the new Bogen HX50 — fifty watt amplifier. Write for FREE complete literature.

**David Bogen**  
**CO., INC.**  
663 BROADWAY NEW YORK 12, N. Y.  
**BOOTH 44 - RADIO PARTS SHOW!**

*Telrex* INC.  
**CONICAL ANTENNAS**  
*America's Outstanding Television Beam*

- ★ The ONE antenna for ALL channels (no high frequency head needed)
  - ★ Maximum efficiency on ALL channels
  - ★ 4 to 1 front to back ratio on all frequencies
- TELREX Conical Antennas provide the highest possible gain to the receiver—since the full strength of the signal (as received at the antenna) is carried to the set with negligible loss—and with a definite reduction in the strength of ghosts or reflections.

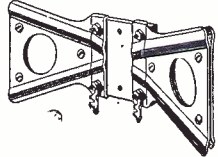

TELREX Conical Antennas are built better. Note this center clamp which provides such a strong grip over bet-

ter than 3" of each rod surface. It is both a mechanical support and electrical contact second to none. And is only one of the features which result in improved and steadier pictures — from a better antenna — o TELREX. © 1949, Telrex, Inc.

AVAILABLE IN A VARIETY OF MODELS TO MEET ANY NEED  
At your distributor or write

**TELREX, INC.**  
ASBURY PARK 6, NEW JERSEY

iness was terrific, compared to previous years, and then we proclaimed with joy that the radio industry was "big stuff—a half-billion dollar a year industry". Look what TV has done to the radio business since the war ended! In a scant 28 months, with TV still in swaddling clothes and production but a trickle compared to what it will be, we find the new radio-TV industry is already a 2½ billion dollar a year business. The only pity of it is that but a mere handful of technicians are getting the cream of the profits as TV is of the country. But be patient! TV still confined to very limited sections will hit your section soon.

**AD INDEX**

Air King Prods. Co., Inc.....	29
Alliance Manufacturing Co.....	36
American Phenolic Corporation.....	34
American Television & Radio Co.....	47
American Condenser Co.....	46
Anchor Radio Corp.....	47
Belden Manufacturing Co.....	5
Bogen Co., Inc., David.....	48
Burgess Battery Co.....	42
Chicago Transformer Corp.....	8
Coastwise Electronics Co.....	40
Duotone Co., Inc., The.....	37
Electro Products Labs.....	43
Electro-Voice, Inc. ....	32
General Electric Co. (Components)	3
General Electric Co. (Tube Div.).....	13
Hytron Radio & Electronics Corp.	Cover 3
Illinois Condenser Co.....	43
Industrial Condenser Co.....	44
James Vibrapowr Co.....	44
J. F. D. Manufacturing Co.....	42
La Pointe Plascomold Corp.....	33
Littlefuse, Inc.....	41
Mallory & Co., Inc., P. R.....	Cover 2
Meissner Mfg. Div. Maguire Industries	41
Philco Radio Corp.....	11
Racon Electric Co., Inc.....	48
Radiart Corporation, The.....	2
Radio Merchandise Sales, Inc.....	45
RCA-Victor (Test Equip. Div.).....	7
RCA-Victor (Tube Div.).....	Cover 4
Reeves Soundcraft Corp.....	39
Rider Publisher, Inc., John F.....	1
Sams & Co., Inc., Howard W.....	31
Sonotone Corp. ....	30
South River Metal Products Co.....	38
Sprague Products Co.....	12
Standard Transformer Corp.....	35
Star Expansion Bolt Co., Inc.....	48
Sylvania Electric Prods., Inc.....	14
Telrex, Inc. ....	48
Transvision, Inc. ....	10
Tricraft Products Co.....	46

**Easier Antenna Installations**

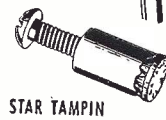

STAR TAMPIN



STAR DRYVIN



STAR STAZIN

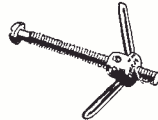

STAR SPRINGIN

Star Expansion Bolts make it easy to fasten TV equipment to brick, stone, concrete or any other type of masonry. Help you to position antenna masts, cables and lines in the best possible manner... assure greater satisfaction; reduce service calls. There's a Star fastening for every masonry job. See your jobber or write for details.

**★ STAR EXPANSION BOLT CO. INC.**

147 Cedar Street, New York 6, N. Y.

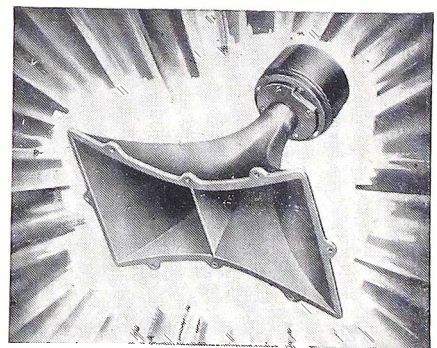

**YOURS FOR THE FIRST TIME Modern Priced Cellular Hornth Aater produces at High Fidelity**

If you've been looking for a high fidelity cellular horn, at a moderate cost, just listen to the clear true-to-life tones reproduced by the new Racon two-cell high frequency horn and you'll agree your search is ended.

Product of Racon advanced engineering, this all cast aluminum high frequency horn is logarithmically expanded as two horns to give the widest distribution angle. Power capacity of unit permits choice of cross-over point which makes best possible use of available cone speakers. Designed for flush mounting in any cabinet. Mounting template supplied without charge.

Tweeter—Model No. CHU2 Aluminum casting  
List price \$37.50  
Tweeter—Model No. CHU1 Standard Acoustic Cloth List price \$30.00

Write today for our catalog

**RACON ELECTRIC CO., Inc.**

52 E. 19th Street

New York, N.Y.



# You CAN'T GO WRONG

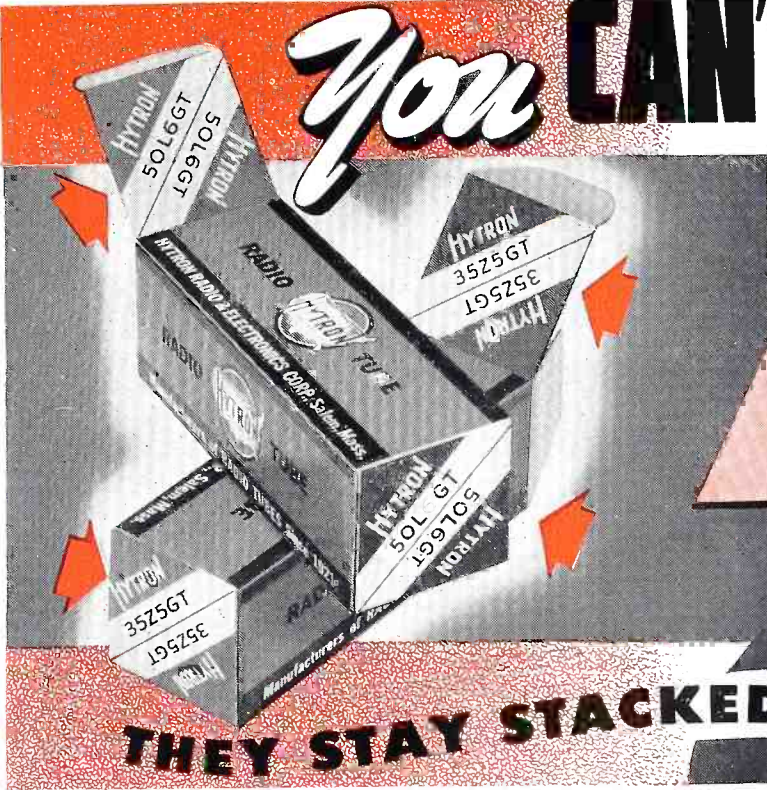

NEW HYTRON ALL-WAYS CARTON  
Has type number of tube imprinted *twice* on *both* ends. Half the dual imprint (generously large, easily read) of the type number is always right side up. Stack the All-Ways carton any way; you can't go wrong.

NEW HYTRON TUBE STACKER Handy way to buy and stack tubes. Holds 10 cartons neatly—safely—compactly. Inventory where you can see it. Choice of horizontal or vertical stacking. Removal of cartons leaves shelves still neat; yet reminds you to re-order. Two Stackers: For miniatures; for GT, metal, lock-in. Free from your Hytron jobber.

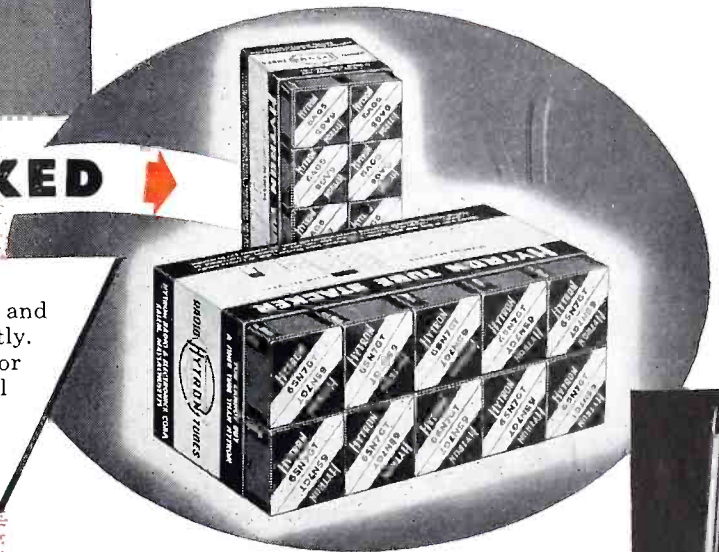

## Now SOLDERING MADE EASY--FAST!

No more battling with bulky long-nose pliers to unsolder those nicely wrapped, "mechanically solid" joints. No more patching leads snipped short. Unique Hytron Soldering Aid (contest winner) makes job a cinch. Servicemen say: "I reach for the Soldering Aid automatically along with my soldering iron. Wouldn't be without it." You will be just as enthusiastic. A time-and-money saver. Only 49¢ from your Hytron jobber.

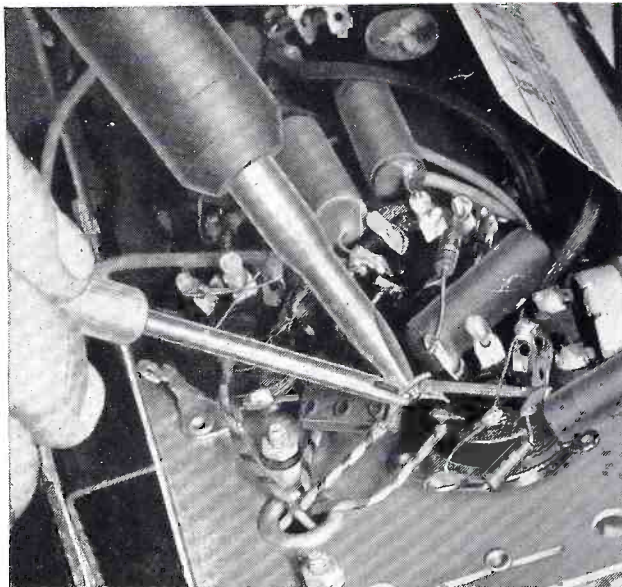

### HERE'S HOW

While iron keeps joint hot, fork tip of Hytron Soldering Aid—like two tiny metal fingers—straddles and, with slight twist, grips end of wire. Effortlessly *unwraps* it. Shifting to other side of lug, it grips and pulls wire free.

Spade-type-reamer tip clears lug hole of solder. Or pushes other wires aside for new wire. Fork tip next guides new wire through and around lug. Holds it firmly in place while soldering. Other uses? Probing, scraping. Separating and positioning wires, lugs, contacts, parts—etc.

The compact Soldering Aid handles like a pencil—leaves work visible. Tips are: twist-proof... insulated from each other to avoid shocks... hard-chrome plated to shed solder.



SPECIALISTS IN RADIO RECEIVING TUBES SINCE 1921



# HYTRON

RADIO AND ELECTRONICS CORP.



MAIN OFFICE: SALEM, MASSACHUSETTS





*The very picture of profit...*

**by the greatest name in radio**

● RCA and *only* RCA, can offer you this preferred line of related products for greater sales volume throughout the year.

You benefit by handling RCA Tubes, Batteries, TV Components, Speakers, Parts and Accessories . . . because you can get them all from *one* dependable source of supply . . . because the RCA monogram on

any product gives it immediate customer acceptance. Also, you'll save time and give greater customer satisfaction with the outstanding new line of RCA Test Equipment in your service shop.

See us at the  
**CHICAGO PARTS SHOW**  
Hotel Stevens, May 15-16

ALWAYS KEEP IN TOUCH WITH YOUR RCA DISTRIBUTOR



**RADIO CORPORATION of AMERICA**

HARRISON, N. J.