

Radio

**SERVICE
DEALER**

SEPTEMBER, 1948



IN THIS ISSUE:

De-emphasis In FM Receiver Circuits
Appliance Repair Techniques for Radiomen
Video Amplifiers, D-C Restorers
Speaker Cone Replacement Repairs
Simple Wattmeter
TV Quiz

AM-FM-TV-SOUND

The Professional Radioman's Magazine

**ALL
NEW**

P. R. MALLORY & CO. Inc.
MALLORY
Midgetrol

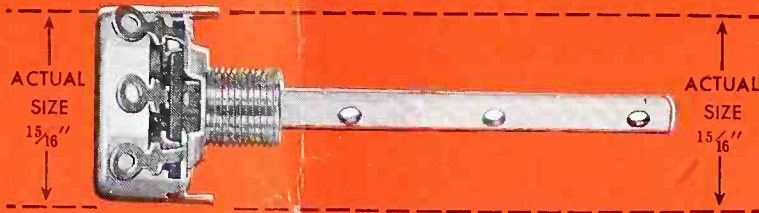

*The Little Volume Control
with BIG Advantages*

**Bigger
Market**

The small size of the Mallory Midgetrol lets you service portables, auto radios and small AC-DC receivers which require $15/16''$ controls.

**Simpler
Installation**

The unique shaft design of the Mallory Midgetrol saves installation time with *all* types of knobs.

**Simpler
Stocking**

Electrical characteristics let you use the Mallory Midgetrol to replace $1/8''$ as well as $15/16''$ controls. Stocks are further reduced because no special shafts are needed.

The Mallory Midgetrol is quietest by actual tests — and tests prove it stays quiet, too. In addition, it has nine big features that are *all new*.

- NEW SIZE
- NEW DESIGN
- NEW SHAFT
- NEW EXTENSION
- NEW SWITCH
- NEW ELEMENT
- NEW CONTACT
- NEW TERMINAL
- NEW TWO-POINT SUSPENSION

It's the NEW Standard in Carbon Controls. See your Mallory Distributor.

P. R. MALLORY & CO. Inc.
MALLORY

CAPACITORS . . . CONTROLS . . . VIBRATORS . . .
SWITCHES . . . RESISTORS . . . RECTIFIERS . . .
VIBRAPACK* POWER SUPPLIES . . . FILTERS

*Reg. U. S. Pat. Off.

APPROVED PRECISION PRODUCTS

P. R. MALLORY & CO., Inc., INDIANAPOLIS 6, INDIANA

CROSLEY *Twice Tested*

★ RADIO PARTS

for general replacement

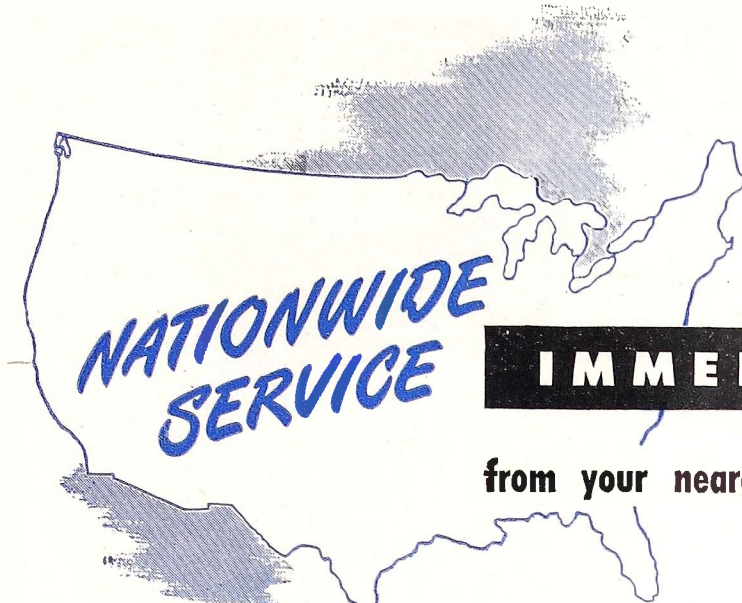

IMMEDIATE DELIVERY!

from your nearest **CROSLEY** Distributor, listed below



LOOK FOR this emblem on the outside of every package of parts you buy. It's your guarantee of quality parts inside.

CROSLEY TELEFLEX
packaged FM & TV antennas



TELEFLEX has all the electrical advantages claimed for other antennas . . . plus exclusive features that save installation time, labor and cost! Comes factory assembled in one carton, ready to install on location in less than three minutes! All external connections factory made to eliminate trouble from water, ice or shorts. Reflector spacer rods adjustable without cutting. Dipole elements adjustable to full FM and TV range without cutting. *Teleflex* straight dipole-type antenna, with 60 feet of 75 ohm transmission line, only \$6.90 from your Crosley Distributor. \$5.40 less transmission line.

CROSLEY
Division—**AVCO** Manufacturing Corporation
Cincinnati 25, Ohio

Albany, New York Roskin Bros.
Amarillo, Texas

Domestic Appliance Dist.
Atlanta, Georgia . . Georgia Appliance
Baltimore, Maryland Legum Distributing
Birmingham, Ala. Alabama Service Co.
Boston, Mass. Wahn Distributors
Buffalo, N. Y. Western Mdse. Distrs.
Bristol, Tenn.-Va. Interstare Hardware Co.
Carrier Mills, Ill. . . . O'Keefe Distributing
Charlotte, N. C. . Carolinas Auto Supply
Chicago, Illinois . . . Harry Alter & Bros.
Cincinnati, Ohio . . . Modern Distributing
Clarksburg, W. Va. . . Utility Co., Inc.
Cleveland, Ohio . . Frankelite Company
Columbus, Ohio Miami Valley Dist. Co.
Dallas, Texas . . . Lone Star Wholesalers
Davenport, Iowa . . . Sieg Home Supply
Dayton, Ohio Miami Valley Dist.
Denver, Colo. . Graybar Electric Co., Inc.
Des Moines, Iowa . . . H. E. Sorenson Co.
Detroit, Mich. Peninsular Dist. Co.
El Paso, Texas Vaughan Appliance
Fargo, N. D. Meyers-Taube Co.
Ft. Smith, Arkansas Eads Bros. Furniture
Ft. Wayne, Indiana . . R. M. Kaough Co.
Ft. Worth, Texas. United Appliance Co.
Grand Rapids, Mich.

Independent Distributors, Inc.
Great Falls, Mont. . . Gt. Falls Paper Co.
Harlan, Ky. Kentucky Mine Supply
Harrisburg, Pa. Jules Alexandre, Inc.
Hastings, Nebraska . . . Dutton-Lainson
Hazleton, Pa. Lehigh Valley Dist.
Houston, Texas

Reader's Wholesale Distributors
Huntington, W. Va. Huntington Wh'e Furn.
Indianapolis, Ind. . . Capital Paper Co.
Jackson, Miss. . . . Southern Wholesalers
Jacksonville, Fla. Graybar Elec. Co., Inc.
Kansas City, Mo. . . . Superior Distr. Co.
Little Rock, Ark. . . . Wright Service Co.
Los Angeles, Calif. . . . J. N. Ceazan Co.
Louisville, Ky. Cooper-Louisville
Manitowoc, Wis. . . J. J. Stangel Hdwe. Co.
Memphis, Tenn. National Rose Co.
Miami, Fla. Graybar Electric Co., Inc.

*Milwaukee, Wis. Greusel Distr. Co.
*Nashville, Tenn. Nashville Chair Co.
*Newark, N. J. Apollo Service, Inc.
New Haven, Conn. H. M. Tower Corp.
*New Orleans, La.

Woodward, Wight & Co.
*New York, N. Y. . . . Crosley Distr. Corp.
*Omaha, Nebr. Electric Fixture & Supply
Orlando, Fla. . . . Graybar Elec. Co., Inc.
*Peoria, Illinois . . . Johnston-Moody Co.
*Philadelphia, Pa. . . Judson C. Burns, Inc.
*Phoenix, Arizona Appliance Distributors
Pittsburgh, Pa. Pittsburgh Products Co.
Portland, Maine Graybar Elec. Co., Inc.
*Portland, Ore. . . Fields Sales Company
Providence, R. I. Graybar Elec. Co., Inc.
Quincy, Illinois . . . Tenk Hardware Co.
Reno, Nev. . . Heat. & Air Cond. Supply
*Richmond, Virginia . Louis O. Bowman
*Roanoke, Va. . . . Richardon-Wayland
Rochester, N. Y. . . . O'Donnell-Dunigan
Saginaw, Mich. J. Geo. Fischer & Sons
*Salt Lake City, Utah Western Supply Co.
*San Antonio, Texas. Alamo Distributing
*San Francisco, Calif. California Electric
Savannah, Georgia Frank Corp.
*Seattle Wash. . . Commercial Appliance
Shreveport, La. . . . Electric Supply Co.
*Sioux Falls, S. D. . . Power City Radio
South Bend, Ind. . . The Ridge Company
*Spokane, Wash. . Standard Sales Co.
*Springfield, Ill. . Central Ill. Wholesalers
Springfield, Mass. . . . Tarbell-Watters
*Springfield, Mo. . . . Rogers & Baldwin
*Sterling, Illinois . . Hardware Products
*St. Louis, Missouri . . . ARA Distributing
*St. Paul, Minn. . Motor Power Equip. Co.
*Syracuse, N. Y. . . O'Donnell Distributors
Tampa, Fla. . . . Graybar Elec. Co., Inc.
*Toledo, Ohio

Walding-Kinnan & Marvin Co.
*Tulsa, Oklahoma Tom P. McDermott, Inc.
Tucson, Arizona Appliance Distributors
*Washington, D. C. American Wholesalers
Watertown, S. D. Lyle Meyers
Wichita, Kansas Loyal Distributors
*Youngstown, Ohio . . . Dorrance Supply

EDITORIAL

by S. R. COWAN

Landlords Oppose TV Antennas

The video industry is becoming acutely aware that many landlords refuse to permit tenants to have TV antennas installed on their roofs. This discourages the sale of videosets. Lawyers have studied the matter thoroughly and report that nothing can be done about it.

Landlords own all rights to the roofs of premises rented to tenants and unless, at the time a lease is drawn, it is definitely stipulated that the tenant may install a TV antenna on the roof, the tenant has no recourse under present laws. Landlords even have the right to rip down a TV antenna put up without their permission and can even charge the tenant for the labor to which they have been put.

Of course, most landlords use roof privileges as a wedge against their tenants, and our landlord is typical, for he blandly proclaims that "only tenants who will sign a lease at increased rentals will be afforded the privilege of putting a TV rig on the roof." The video industry must combat the condition on a nationwide basis. Is RMA or is NAB doing something about it?

Unjustified Gripes

Parts jobbers and set distributors are crying the blues because sales have tapered off recently. They should know better!

Set distributors for months have overloaded dealers with too much "small stuff." Really, set makers are to blame for they overproduced and dumped the load on wholesalers. On what basis are set makers entitled to the opinion that this country can absorb over 20 million sets annually? None! Now, because of overproduction, we're in a Buyer's Market, and if set makers aren't aware of it, it is a pity. Moral—radio dealers, keep in a fluid cash position—don't overstock!

Parts jobbers, right after war's end, did not get enough replacement parts to meet the huge demand needed for the backlog or repair jobs that had accumulated. Also, thousands of ex-GI's jumped into radio servicing, ordered parts from many jobbers, creating a false demand. Actually not much of the total demand for parts was satisfied as the parts makers were too busy filling postwar orders from set makers.

In late 1946 the replacement parts shortage eased (except for certain types of tubes which are still in short supply) and subsequently service dealers were able to build up for themselves what could be called a normal operating inventory. Now that service dealers are operating on a fairly normal basis—using about 32% more replacement parts than ever before, parts jobbers should appreciate the fact. Actually the fall-off in jobber sales is in the industrial classification, not in the true radio replacement sales category.

Finally those service organizations and servicemen in this country who are complacently working along as usual should get wise to the fact that competition is becoming keener. Many retailers are giving up their service departments, farming out their work to service organizations. Are you independents getting your share of this sort of work?



Member of the
Audit Bureau of
Circulations

radio
service
dealer

VOL.
9
NO.
9

SANFORD R. COWAN, Editor & Publisher

SAMUEL L. MARSHALL, Technical Editor

SEPTEMBER, 1948

Editorial	2
Field Findings, by S. R. Cowan Industry happenings here and there	8
Trade Flashes	10
De-emphasis in FM Receiver Circuits, by Charles Chilton Precautions to take when installing FM tuners	13
Installing Speaker Replacement Cones Technicians should have this know-how	16
Appliance Repair Techniques That Radiomen Should Know, by Wm. R. Wellman, Part 2 Basic information regarding many electrical appliances	17
Video Amplifiers, D-C Restorers, by S. L. Marshall, Part 3 Principles of D-C restorers with applications to current circuits	20
Build This Simple Wattmeter, by Rufus P. Turner Constructional details of a handy radio-appliance tester	24
Service Contacts Promote Set Sales, by C. Thomas How a successful Service-Dealer upped service and sales	25
Circuit Court Ranger Model 118; Electronic Labs. Model 3000; Edwards Fideletuner; Meissner 2961 Series; Bendix 84FS Factometer.	26
Shop Notes G.E. TV receivers Models 901 and 910, addition of balanced input antenna transformer; Webster phono-turntables, to correct slow running; R.C.A. 612V1-2-3, oscillator blocking over 1400 kc.	28
New Products	29

SANFORD L. CAHN

National Advertising Sales Manager

HARRY N. REIZES

Advertising Manager

BRANCH: J. C. GALLOWAY, 816 W. 5th St., Los Angeles 13, Calif., Mutual 8335

Jean M. Wheeler
Circulation Manager

David Saltman
Adv. Production Manager

RADIO SERVICE DEALER (title registered U. S. Pat. Off.) is published monthly at 28 Renne Ave., Pittsfield, Mass. by the Cowan Publishing Corp. Executive & Editorial Offices, 342 Madison Avenue, New York City 17, New York. Subscription rates:—United States, U. S. Possessions and Canada, \$2.00 for 1 year, \$3.00 for 2 years; elsewhere \$3.00 per year. Single copies: 25c Printed in U. S. A. Entered as Second Class Matter at the Post Office at Pittsfield, Mass., under the Act of March 3, 1879. All subscribers should allow at least three weeks for change of address. Copyright, 1948, by Cowan Publishing Corp.

ONE Button

... clears every switch setting
 ... ready for the next tube test

Model 335 Plate Conductance Tube Tester

The Simpson Automatic Reser is just another of the practical refinements that make Simpson tube testers serve you better than other testers. When you finish a test, just press the Automatic Reser button and instantly all switches, both push button and rotary, return to normal. This not only saves time but prevents error due to previous settings being left in position at the beginning of the new test. The Reser mechanism, in whose design and tooling many thousands of dollars have been invested, is Simpson patented. No other switch control mechanism is so completely automatic.

Simpson Model 335 adds the Automatic Reser to its many other features. It tests tubes in percentages of rated plate conductance, also indicating that the tube is good, fair, doubtful, or definitely bad. Only a few settings are necessary for the most complicated tube. Sockets for all types of tubes are provided, including the new 9-pin miniature; also the sub-miniature as used in hearing aids, etc.

For 105-130 volts, 50-60 cycle. Size: 15 1/2" x 9 1/2" x 6 1/4"
 Dealer's Net Price, complete with 12-page
 Operator's Manual \$98.50



Model 340 SIGNAL GENERATOR— 75 Kilocycles to 120 Megacycles Fundamentals to 30 MC.

Electron coupled circuit assures extreme stability and output uniformity, throughout the band. Standard 30% modulation at 400 cycles. Coil, attenuator and signal selector individually shielded. Effective shielding throughout. Each coil individually calibrated to close tolerances against crystal standards by means of variable inductance and variable minimum capacitance. For 105-130 volts, 50-60 cycle. Size: 16" x 10" x 6".

Dealer's Net Price, complete with 44-page
 Operator's Manual \$69.85

Simpson





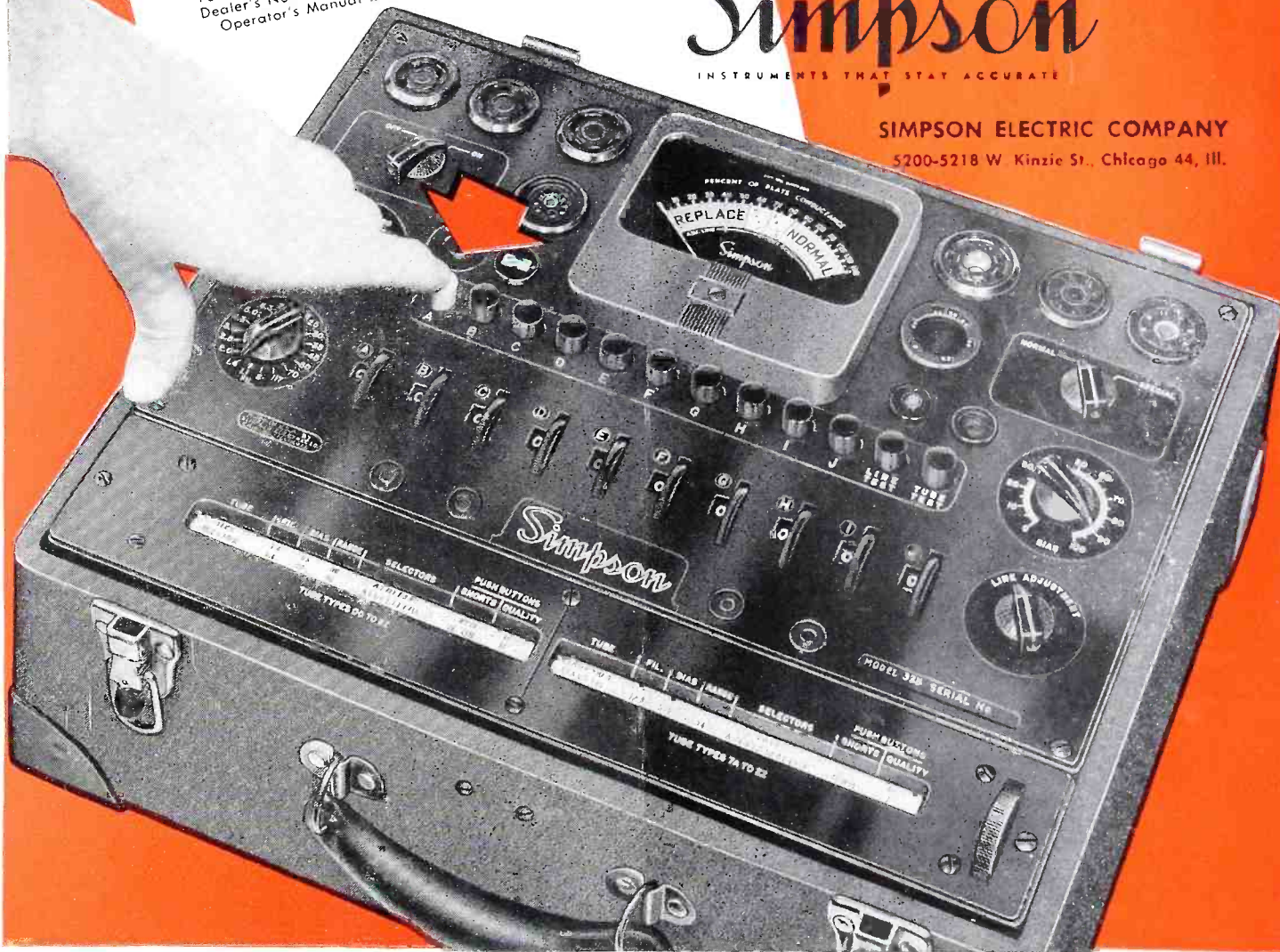

INSTRUMENTS THAT STAY ACCURATE

SIMPSON ELECTRIC COMPANY
 5200-5218 W. Kinzie St., Chicago 44, Ill.





MORE HOURS OF SERVICE

-  **8411**
-  **8401**
-  **8422**
-  **8410**
-  **8412**
-  **8423**

**MICROPHONE
CABLES**

Belden
Radio **WIRE**

ACCLAIMED FROM
COAST TO COAST



GENERAL  **ELECTRIC**

FIRST AND GREATEST NAME IN ELECTRONICS

176-048-8050

**NEW
LOW
PRICES**

On RCA Top



**RCA 15-watt
DE LUXE AMPLIFIER MI-12295**

**NOW
ONLY
\$87⁵⁰**

List price
complete with tubes

• You've never seen a value like this distinctively styled RCA 15-watt All-Purpose Amplifier. You can't beat it for high quality performance, compactness, beauty, and simplicity of operation under all sorts of operating conditions.

Electronically engineered to give top performance. Frequency response (30 to 15,000 cycles). Two high impedance microphone input channels 116 db. gain (RMA), each with individual volume control. Two hi-impedance phono channels, one for hi-level and one for low-level pickups. Can be used with popu-

lar low output magnetic pickups. Phase inversion and inverse feedback used to obtain low distortion and uniform frequency response for various load conditions. Unique balanced tandem tone control circuit. Choke filtered power supply for minimum hum and uniform regulation. Large functionally designed control knobs. Accessible output terminal board and replaceable cartridge type fuse conveniently located in rear. Set of locking-type 3 pin Cannon plugs and receptacles for each microphone input. Also available with 2 low impedance inputs (250 ohms).

15 watt push-pull Output—
Noise-free electronic mixing—
Switch for high-low power
output requirements — Under-
writers-approved.

Additional Unparalleled
Amplifier Values

RCA 50-watt De Luxe Hi-Impedance Amplifier MI-12293 \$197⁵⁰
Complete with RCA Tubes Now only

RCA 30-watt De Luxe Hi-Impedance Amplifier MI-12296 \$115⁰⁰
Complete with RCA Tubes Now only



SOUND PRODUCTS
RADIO CORPORATION of AMERICA
ENGINEERING PRODUCTS DEPARTMENT, CAMDEN, N.J.

In Canada: RCA VICTOR Company Limited, Montreal

Quality Sound Equipment

COMPARE...BE CONVINCED!

**More business for you because it's RCA...
More profit because of these new values**

RCA SPEAKER

MI-12422

12-inch high efficiency, Alnico V, Cone Type Mechanism. Special cone provides a selected listening characteristic—a result of thousands of listeners' reactions over the past 10 years. 10-watt capacity. 15 ohm voice coil.

\$12⁵⁰

Also available with matched 10-watt multi-tap line transformer as MI-12421.

\$18⁰⁰

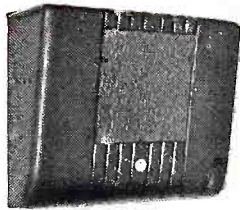

RCA MOLDED SPEAKER BAFFLES

Molded Plasticized Fibre Baffle with attractive gray hammeroid finish and contrasting grille cloth, 12" x 15" x 5 1/2", sloping front, strong, moisture-resistant, and non-warping. Available for 5", 6 1/2" and 8" mechanisms as MI-6378, MI-6379, and MI-6380, respectively.

\$3⁷⁵

Similar baffles for 5", 6 1/2", 8", 10" and 12" mechanisms also available in molded Bakelite and wood.

All prices shown are suggested list prices subject to normal dealer discounts.

RCA VARACOUSTIC MICROPHONE

MI-6204-C

Three microphones in one. Here you have the popular cardioid microphone (uni-directional) *plus* standard velocity microphone (bi-directional) *plus* standard pressure microphone (non-directional) all in one general purpose unit. Variable characteristic obtained by ingenious slider mechanism on rear of housing. Quality and performance found heretofore only in more expensive polydirectional Broadcast Microphones. High sensitivity, shock mounted, high impedance. 30 feet of cable.

\$67⁵⁰

These and many other profitable items of sound equipment are available through your RCA Sound Products Distributor.

NEW BANTAM VELOCITY MICROPHONE

MI-12080-B

Smaller than a pack of cigarettes. First used at all 1948 political conventions. Broadcast quality. Built-in voice-music switch. 15 feet of cable.

\$60⁰⁰



MAIL THIS COUPON FOR FREE CATALOG

RCA SOUND PRODUCTS (Dept. 112-I)
Radio Corporation of America
Camden, N. J.

Please send me free copy of RCA's new Catalog on complete line of matched sound products *and price list*.

Name _____

Company _____

Type of Business _____

Address _____

City _____ State _____



BUY THE BEST FOR LESS

es of sound products—micro-amplifiers, speakers, record-ercoms, portable P.A. and us other profitable items. Send FREE copy today.

FIELD FINDINGS

A resume of Industry happenings here, there and everywhere

I NEVER had a "Lost Weekend" like Ray Milland's but, to me the entire month of July was a "Lost Month" as I was required to serve on the Grand Jury and consequently could devote no time to routine business affairs. For that reason the department "Field Findings" did not appear in our August issue. This, then, is the first opportunity in which to report about the coast-to-coast lecture tour I propose to make, with speaking dates scheduled from Sept. 8th through Oct. 8th.

My Cleveland, O., speech originally scheduled for Sept. 2nd is being postponed until Oct. 7th or 8th to avoid conflict with Al. Saunders, who on behalf of Howard W. Sams Co., will give a technical talk in Cleveland on Sept. 8th.

Instead of speaking in Denver, Col. on Sept. 16th I may on that date speak in Kansas City, Mo. Contact K. C. jobbers for particulars, for at this writing, the arrangements are only in the tentative stage. Now, regarding Denver being dropped from the schedule, jobbers there suggested this on the premise that "Denver's servicing business is too competitive and vindictive at present and the participants have no desire to fraternize." Ordinarily that reason alone would cause me to want to meet at Denver to try to effect more harmony amongst those in the servicing profession. But, if the jobbers there say the time is not appropriate now for such a mission I must abide by their judgment. To Denver dealer and service organizations may I suggest that steps be taken towards correcting the present disharmony. In unity there is strength, and with the advent of TV out there soon, you'll need plenty of coordination to avoid the pitfalls sure to confront you.

You Are All Invited

At every meeting in every city on my speaking tour there will be refreshments of some kind. In some cases the jobbers are providing beer and pretzels, in some cases I am, in other cases jobbers or the host serviceman's association are providing buffet snacks before or after the technical program, and in some cases the jobbers are going

by S. R. COWAN

all-out to the extent of providing a free, complete dinner before the session opens. See the "Speech Schedule" in the box on this page.

All meetings will be "open meetings" to which all radio dealers, servicemen and students in radio training schools are cordially invited. The point of the meetings is to provide at least one, and in most cases two or three, technical lecture of extreme timeliness. In every case my own talk will be: "Checking Video & Synch Waveforms by CRO." I am told by several authorities who have read the manuscript that it is exceptionally fine. (A deep bow to Sam Marshall for his cooperation in its preparation, and to the many test equipment and TV equipment manufacturers who collaborated by lending our laboratory the necessary apparatus

from which tests were made, waveforms were studied and data compiled).

At most meetings, through the courtesy of leading manufacturers, in addition to my own lecture, other speakers will deliver talks on such subjects as: "Vibrators & Vibrator Power Supplies," "Television Antennas," "Characteristics of Cables and Transmission Lines," "Microphones & Phono Pickup Cartridges—Their Construction and Theory of Operation." Where time permits, in addition to the customary Question & Answer session, we may also get in a discussion of practical methods of "Determining the price to charge for services rendered."

Effective this issue Radio Service Dealer goes to press 10 days ahead of its regular schedule and some of the

(Continued on page 54)

Cowan's Speech Schedule

Milwaukee, Wis.—Sept. 8th.

Meeting 7 p.m. at Juneau Hall of the Milwaukee Auditorium, Co-sponsored jointly by Electro-Pliance Distributors, Inc., Marsh Radio Supply Co., and Radio Parts Company, Inc.

Evansville, Ind.—Sept. 9th.

Meeting in Knights of Columbus Hall, 302 Market St. at 6:30 p.m. with free complete dinner being served with compliments of Ohio Valley Sound Service (distributors.).

Minneapolis, Minn.—Sept. 13th.

Meeting at 8 p.m. at the Andrews Hotel, Minneapolis, under auspices of Radio Servicemen of America, Inc., co-sponsored by Bauman Co., F. C. Hayer Co., Lew Bonn Co., Stark Radio Supply Co.

St. Paul, Minn.—Sept. 14th.

Meeting 8 p.m. at the Northwest Vocational Institute, Grand Ave., under joint co-sponsorship of St. Paul Assn. of Radio Servicemen, Lew Bonn Co., and Electronic Distributing Co.

Omaha, Nebr.—Sept. 15th.

Meeting 8 p.m. at Rome Hotel, Omaha. Jointly co-sponsored by Radio Equipment Co., Omaha Appliance Co., and J. B. Distributing Co. of Omaha, World Radio

Laboratories, Inc. of Council Bluffs, Iowa, and Leuck Supply Co., Lincoln, Neb.

Kansas City, Mo.—Sept. 16th.

Meeting place and time not yet designated.

Salt Lake City, Utah—Sept.

17th. Meeting 8 p.m. at Central Radio Supply Co., 47 E. 5th South, under that firm's sponsorship.

San Francisco, Cal.—Sept. 22nd.

Arrangements with Radio Service Dealer's Assn. still pending.

San Diego, Cal.—Sept. 27th.

Meeting at 7:30 p.m. at the Electric Building under sponsorship of the Bureau of Radio & Electrical Appliances.

Burbank, Cal.—Sept. 28th.

Dinner meeting to start 7:30 p.m. at Skylane Cafe (opposite Burbank Airport). Co-sponsored by Radio Technician's Association of Burbank.

Long Beach, Cal.—Sept. 29th.

Meeting time and place not yet designated by co-sponsor, the Radio Technician's Assn. of Long Beach.

Des Moines, Iowa—Oct. 6th.

Meeting time and place not yet designated by Radio Trade Supply Co., the co-sponsor.

**Lightest
Most Efficient
Crystal Pickup
Cartridge
Ever Conceived!**

NEW
SERIES 12

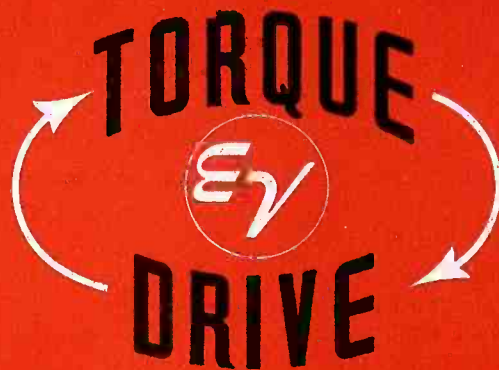

ACTUAL SIZE →

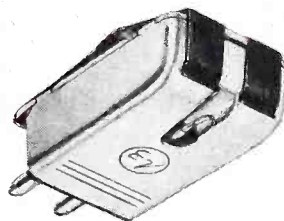

← WEIGHS ONLY $\frac{1}{5}$ OZ.



HANDY NEW KIT MAKES SALES AND SERVICE EASY!

Enables you to service most replacements immediately—helps you sell more replacement jobs to old and new customers—cuts overhead and inventory—increases turnover and profit! Contains 6 cartridges, 4 needles, mounting plates, literature, replacement chart and full instructions. Available in KIT "A" (Osmium) or KIT "B" (Sapphire).

New Model L-14 for MICROGROOVE

New Microgroove Torque Drive Crystal Cartridge now available—at same price. Model L-14 has smooth, peak-free, wide range response to 12,000 c.p.s. No filter necessary. Replaceable Osmium-tip or Sapphire-tip needle.

New Model 20 MAGNETIC CARTRIDGE

Now available for REGULAR or MICROGROOVE records. Uses Model 503 Matching Transfilter.

BETTER COUPLING OF RECORD GROOVE TO CRYSTAL

Exclusive Electro-Voice development now brings amazing improvement in record playing . . . outmodes existing crystal pickup cartridges . . . opens up vast new replacement opportunities. Fully tested and proved . . . the new Series 12 TORQUE DRIVE provides a more rugged cartridge for everyday use in home phonographs, booth demonstrators, and coin-operated machines. Assures finer reproduction, less surface noise, less needle talk, less record wear, longer record life, more needle plays!

3 BASIC MODELS REPLACE OVER 100 STANDARD TYPES

Comes in low, medium and high voltage outputs to provide universal replacement. Speeds servicing, steps up your profit. Installation is simple. Each cartridge is furnished with replaceable Osmium-tip or Sapphire-tip long-life whisker needle. It is available individually or in kits.

- Series 12 with Osmium-tip needle. List price, \$7.50
- Series 12 with Sapphire-tip needle. List price, \$8.50

It's the talk of the industry! Ask your E-V Distributor, or send now for Bulletins 141 and 142.

ELECTRO-VOICE, INC., BUCHANAN, MICH.

Export: 13 East 40th St., New York 16, U.S.A.
Cables: Arlab



ANOTHER FIRST BY

Electro-Voice

TRADE FLASHES

A "press-time" digest of production, distribution & merchandising activities

TV for Cinn. Hotel

Cincinnati's new, ultra-modern 400-room Terrace Plaza Hotel utilizes television to the utmost.

Telesets were furnished by the Crosley Division, of the Avco Manufacturing Corporation.

Four telesets have been provided for the eighth floor Terrace Garden cocktail bar and restaurant. Three of the sets have 10-inch picture tubes and are movable, while the other set, having a 12-inch picture tube, is built into the wall of the back bar.

Another receiver with 12-inch picture tube has been installed in the mirrored wall above the bar of the Gourmet Restaurant located on the 20th floor.

Sets with the larger viewing tube are also located in the private dining rooms on the eighth floor.

All rooms in the new hotel are equipped with television antennas and guests can be provided Crosley table sets with 10-inch picture tubes as a room service.

Statistics show that room service revenues in New York hotels increased from \$35.00 to \$175.00 per room per month following the installation of television in hotel rooms.

Signal Corps Needs Radiomen

Positions are being offered by the Signal Corps in the following areas: Hawaii, Japan, Guam, Saipan, Tinian, Iwo-Jima, Okinawa, and Alaska. For further information write: Civilian Recruitment Office, Signal Corps Photographic Center, 35-11 35th Avenue, Long Island City 1, New York. Capt. Allyn W. Greene, Chief, Post Operations Division.

Motorolas In Forest Service

In their modernized emergency communications system the U. S. Forest Service will use 88 Motorola "Handie-Talkie" units. These portable FM 2-way radio communications units, weighing less than nine pounds, will be used in patrolling four national forests in California—Shasta, Six Rivers, Angeles and Tahoe. In addition, the Forest Service has ordered eleven central stations and seventy-two mobile units for installation in forestry trucks and cars. In its entirety the new equipment will establish constant inter-communications between foresters heretofore operating in semi-isolation.



RCA's new life-size projection TV model.

Life-size TV Projector

Providing life-size television pictures for large audiences is easy by means of this RCA Schmidt-type reflective optical projection system. The projector (Model TLS-86) is as simple to operate as a conventional home television set. Employing the RCA all-electronic tuning system, the circuit automatically locks the set in step with the incoming television program, insuring well-framed, steady pictures. A simple focusing system permits clear pictures on the face of a reflective-surfaced opaque screen or, by rear projection, on a translucent screen up to 63 square feet in area.

RCA TV Trans. for Small Cities

A new 500-watt television transmitter, facilitating the extension of television to cities of 50,000 and enabling smaller stations to act as network outlets or to originate their own programs, is now in production and will be ready for delivery in the Fall, it was announced by the RCA Engineering Products Department. Used with this transmitter (Type TT-500A, a three-section RCA Super Turnstile Antenna, which has a gain of approximately four, can radiate an effective output of about 2,000 watts. This will provide adequate coverage over a television service area of 1400 square miles.

Du Mont Moves

The Television Receiver Sales Di-

vision of Allen B. Du Mont Laboratories, Inc., has completed moving to new and enlarged quarters at Du Mont's 515 Madison Avenue, New York City.

Sylvania Ups 2—Lays Cornerstone

R. J. Hartung was promoted to Controller of the Radio Tube Division of Sylvania Electric Products Inc., it was announced by J. C. Farley, General Manager of the Radio Division, and William A. Browne was appointed Merchandising Supervisor for the same division, according to R. W. Andrews, Merchandising Manager.

At Bayside, N. Y., on July 12, the cornerstone for the first of a group of modern research laboratories for Sylvania Center was laid today by Walter E. Poor, chairman of the board of Sylvania Electric Products Inc. The initial laboratory building, which with equipment will represent an investment of approximately a million dollars, will be dedicated late this fall. It will be one of a group of laboratories which will comprise the Sylvania Research Center covering 28½ acres.



"King" Makes Debut

To exemplify the friendly relationship between factory and user, the Air "King," a congenial, informal and good natured caricature will appear in all advertisements; it was announced today by A. D. Adams, Advertising Manager for Air King Products Co., Inc., Brooklyn, N. Y. manufacturers of radios, combinations, wire recorders and television receivers.

New Radiomen

Heading for jobs in the radio and electronics field hundreds of students in the Electrical department at Dunwoody Industrial Institute in Minneapolis, Minnesota, are part of the 5,790 who have been receiving trade training there during the past year. In the day

(Continued on Page 38)

Howard W. Sams

presents the amazing
**RADIO INDUSTRY
 RED BOOK**
 REPLACEMENT PARTS
 BUYER'S GUIDE

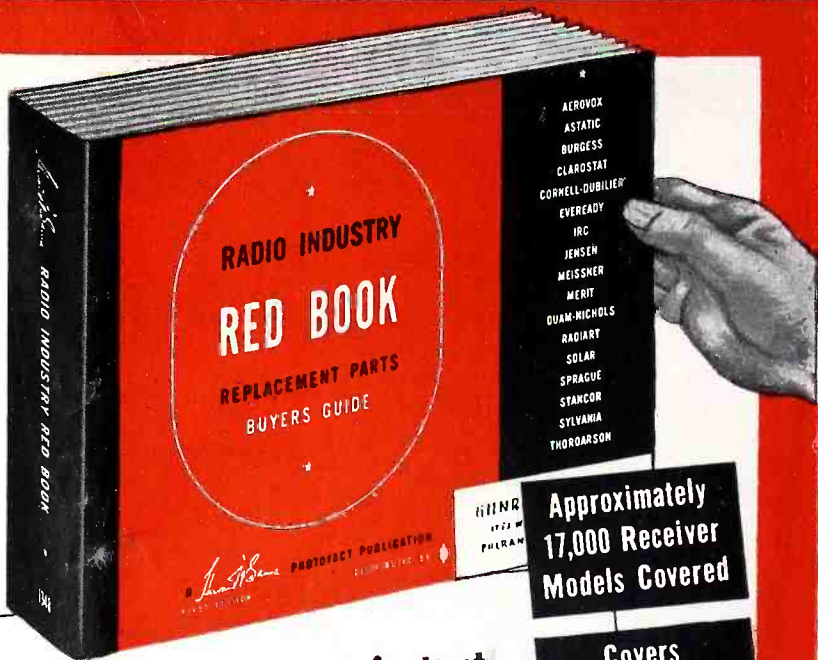

Approximately
 17,000 Receiver
 Models Covered

Covers
 Ten Years:
 1938 to 1948

Easy to Use:
 All Data
 Quick to Find

440 Pages
 Smythe-bound
 Opens Flat

NOW—a SINGLE authoritative volume that gives you instant reliable data on ALL replacement parts for thousands of popular radio receivers... more useful data than in all other replacement parts guides and manuals **COMBINED**...

COMPLETE!

The First Cooperative Industry Effort in Behalf of the Radio Service Technician

FOR THE FIRST TIME IN RADIO HISTORY!

All 9 Major Replacement Components Listed
(not just 1 or 2 components)

17 Leading Parts Manufacturers Represented
(not just 1 manufacturer)

COMPLETE DATA ON ALL RECEIVER REPLACEMENT PARTS—ALL IN THIS ONE GREAT BOOK!

Save time! Stop wasteful hunting! Get ALL the parts data you need—quickly—from this single book. NOW—for the first time—have all the replacement parts data you need—ALL in one single, authoritative volume. No more waste of valuable time searching through dozens of incomplete manuals and catalogs. The RED BOOK, first and only complete parts guide ever produced, covers approximately 17,000 radio models made from 1938 through 1947—10 full years. Lists parts made by 17 leading manufacturers—not just one! Gives you complete, accurate data on all 9 major replacement components—not just one or two! Clear, concise, easy-to-use—over 440 pages (8½" x 11") bound in a sturdy sewed cover, arranged alphabetically by manufacturer and model number for quick reference. Does away with confused collections of separate books and manuals—gives you complete information—PLUS data that cannot be found in any other source—at a fraction of the price you'd pay for the books it replaces. There's never been anything like it—absolutely indispensable for every service shop!

Only the RED BOOK gives you ALL this invaluable data. Here's everything you need to know about the replacement parts for the receivers you service daily. The RED BOOK gives you original manufacturers' parts numbers, proper replacement parts numbers and valuable installation notes on *Capacitors, Transformers, Controls, IF Coils* (including Peak Frequencies), *Speakers, Vibrators and Phono Cartridges, Tube and Dial Light* data includes number of tubes in each chassis, with type number for each tube, plus dial light numbers. *Battery* data includes replacement numbers on A, B, and AB packs. The following leading replacement parts manufacturers are represented in the RED BOOK:

- | | |
|------------------|-----------|
| AEROVOX | ASTATIC |
| BURGESS | CLAROSTAT |
| CORNELL-DUBILIER | IRC |
| EVEREADY | JENSEN |
| MEISSNER | MERIT |
| QUAM-NICHOLS | RADIART |
| SOLAR | SPRAGUE |
| STANCOR | SYLVANIA |
| THORDARSON | |

18 months in preparation—over \$90,000 to produce. The RED BOOK is the product of thousands of man-hours spent in laboratory research and in cooperation with 17 participating manufacturers to produce the most complete, accurate, authoritative parts replacement guide ever published. Every bit of information in this amazing book has been painstakingly checked to insure maximum accuracy and usefulness. Over \$90,000 was spent to prepare the RED BOOK—the only book that brings you everything you need to know—every bit of replacement parts data you want to make your work easier and more profitable. You can't afford to be without the RED BOOK. It's the indispensable guide you'll use profitably every single day. Stop hunting for the right answers now—order your copy today.

**THE INDISPENSABLE
 RED BOOK... ONLY... \$3.95**

BE SURE TO ORDER YOUR RED BOOK TODAY →

HOWARD W. **SAMS** & CO., INC.
 INDIANAPOLIS 7, INDIANA

Mail This Order Form to Your Parts Jobber Today or send directly to HOWARD W. SAMS & CO., INC., 2924 E. Washington St., Indianapolis 7, Ind.
 My (check) (money order) for \$..... enclosed.
 Send..... RED BOOK(S) at \$3.95 per copy. (I understand that delivery will be made to me in September.)

Name.....
 Address.....
 City..... State.....

Your HYTRON SERVICEMEN'S Contest

A REPORT TO YOU

THE EDITOR-JUDGES COMMENT

"Judging the contest is fun, and I'm learning something from it... am impressed with both quantity and quality of the entries... contributors took genuine interest in a challenge to their American ingenuity... hard to make a choice... it is evident that servicemen have found it necessary to devise for themselves special tools... no designer sitting off at a distance can possibly anticipate their needs so well... basis of a fine exhibit... would like to print... will result in valuable additions to serviceman's tool kit."

FIRST PRIZE WINNERS

May

Harry L. Smith, Long Island City, N. Y., was picked by the judges as the lucky winner of the DuMont Type 274 Five-Inch Oscillograph.

June

To lucky Gerard P. Diaz, Parkville, Missouri, went the RCP Model 665-A "Billionaire" vtvm and Model 705-A Signal Generator.

Heartiest congratulations to them both, as well as to the other winners.



**FIRST PRIZE
SEPT.**
Jackson 641
Universal
Signal Generator

Second prize — each month, \$50 U. S. Savings Bond.
Third Prize — each month, \$25 U. S. Savings Bond.
Grand Prize, \$200 U. S. Savings Bond — to contestant whose idea is judged to be best of the 6 winning monthly first prizes.

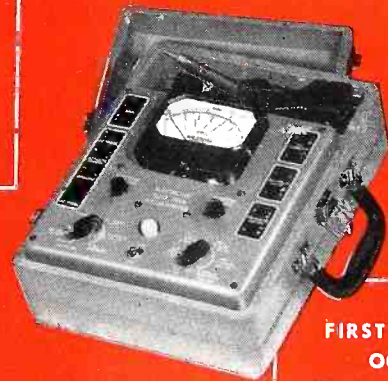

**FIRST PRIZE
OCT.**
Weston 769 H-F
Electronic Analyzer

AN INVITATION TO YOU

Come on in, servicemen! The contest's fun — and easy, too. Many prizes left. Only one thing to worry about — time's a-wasting. Pick up an entry blank today at your Hytron jobber's. Or drop us a penny postal. The easy-to-follow entry blank will help you do the rest.

Just describe briefly your proposal for a simple, economical shop tool like the Hytron Tube Tapper or Miniature Pin Straighteners. Enter in any or all monthly contests. Mail to Hytron Contest Editor. Then make room on your bench for one of those deluxe first prizes.

SPECIALISTS IN RADIO RECEIVING TUBES SINCE 1921.

HYTRON

RADIO AND ELECTRONICS CORP.

MAIN OFFICE: SALEM, MASSACHUSETTS



DE-EMPHASIS IN FM RECEIVER CIRCUITS

by CHARLES CHILTON

Improved FM performance is obtained when proper precautions are taken in installation of FM tuners, several of which are discussed in this article.

UNDER ideal conditions, FM receivers provide finer radio reception than can be obtained from commercial AM receivers. That much is quite well understood by any service dealer who has installed FM receivers or tuners. However, not all FM tuners are operating under truly ideal conditions because of one requirement of FM receiving systems—de-emphasis.

Pre-Emphasis

A thorough understanding of the reasons for de-emphasis—and for its complement, pre-emphasis—is necessary before attempting to evaluate its importance to the FM listener. Simply stated, *pre-emphasis* is a specific form of equalization applied to the audio signal before it modulates the FM carrier. Although reduction of noise is obtained from frequency modulation, this advantage is increased by pre-emphasis. In practically any program—music or dialogue—the majority of the sound energy is in the lower frequency ranges, while the most objectionable noise is contained in the higher frequency ranges. Therefore, if the high frequencies of the audio signal comprising the program are boosted before modulating the carrier, and then compensated for by a corresponding droop in the receiver, an additional reduction of noise results. A proper choice of the equalization curve effectively precludes overmodulation, and since the power content at various frequencies is well established, it is a simple matter to determine a safe value for the curve.

Pre-emphasis—the correct term for

the equalization applied at the transmitter—is measured in microseconds, and a value of 75 μ sec is specified by the FCC. Presumably all stations are operating under these standards. This pre-emphasis provides a response curve which rises gradually from the middle range up to a boost of 10 db at 6,700 cps, and of 15 db at 12,000 cps, as shown at (A) in *Fig. 1*.

De-Emphasis

In order for the program to be reproduced correctly, a corresponding amount of *de-emphasis* must be applied at the receiver, with a response curve which is the exact opposite of that at the transmitter. This is usually done

by employing a series resistor and a shunt capacitor between the output of the discriminator or ratio detector and the audio amplifier. The de-emphasis curve is shown at (B), with the resulting overall curve being flat, as at (C). Thus the program is reproduced as close to the original signal as possible. A similar reduction in noise could have been obtained with AM receivers if the standards had been set at the start of broadcasting, but they were not so set. There are, however, a number of reasons why pre-emphasis is not practicable for AM broadcasting, and in addition, the entire system of FM also reduces noise still further. If pre-emphasis had been used in AM broad-

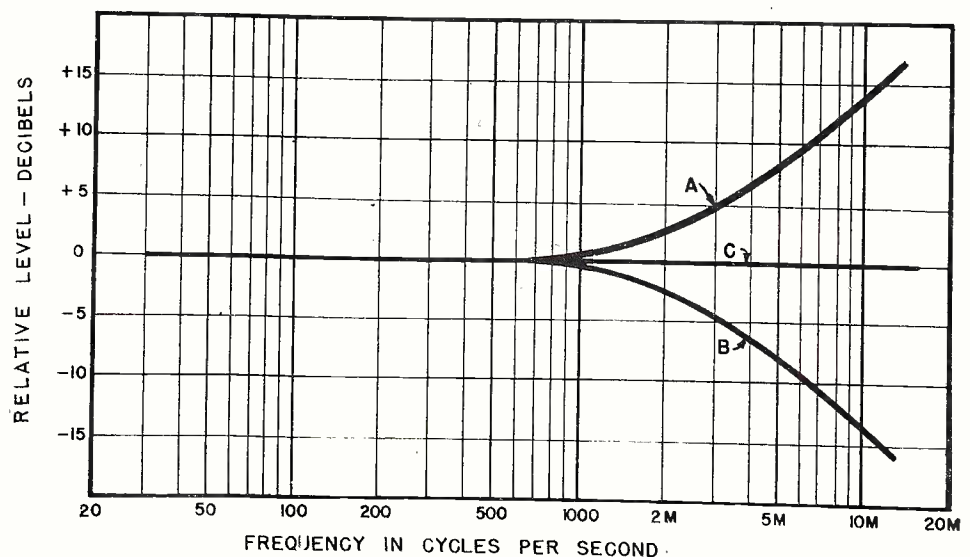

Fig. 1—Frequency response of FM transmitter at (A), showing pre-emphasis; of FM tuner at (B) showing de-emphasis; and sum of two curves giving flat response, (C).

casting, it is certain that there would have been a slight improvement.

Now, you may well ask, how is de-emphasis related to FM tuners and their performance when connected to an amplifier and speaker, or to the audio section of a radio receiver? The answer is simple—not all tuners are designed to have the correct amount of de-emphasis. The manufacturers should not necessarily be blamed for this, because there are extenuating circumstances. One of the most important reasons is that most FM tuners will be connected to the audio amplifier and speaker of a conventional AM receiver. Many such receivers are deficient in high-frequency response in either amplifier or speaker, or both, and in order to have anything like normal FM reception, some compensation should be made for this deficiency, or there would be no great advantage in having the FM tuner. This accounts for the prevalence of tuners having less de-emphasis than the standard value of 75 usec.

The discriminator or ratio detector circuits of several common FM tuners are shown in *Fig. 2*, with the de-emphasis circuit shown in heavy lines. The amount of de-emphasis is measured by the product of the series resistor and the shunt capacitance, the values being in ohms and farads, and giving a result in seconds. Since values in farads are unwieldy and never encountered in actual practice, it is simpler to use ohms and microfarads, the result then being in microseconds. Thus a series resistance of 75,000 ohms and a shunt capacitance of .001 μf will give a de-emphasis of $75,000 \times .001$, or 75 μsec .

Commercial Applications

Referring to (A) in *Fig. 2*, the circuit of one popular model, the Pilotuner, it is seen that the de-emphasis is $15,000 \times .0015$, or 22.5 μsec . While this is lower than normal, it must be remembered that about six feet of shielded cable is used for the output, with an average capacitance of 25 $\mu\mu\text{f}$ per foot, or a total of 150 $\mu\mu\text{f}$. This

only increases the de-emphasis to approximately 25 μsec , however. Thus, when this tuner is connected to the average receiver, considerable compensation is provided for poor high frequency response. If it is connected to a good amplifier and speaker, it will not be completely satisfactory because of the overabundance of highs. From the figures given above, it is seen that while the transmitter boost at 12,000 cps is 15 db, the de-emphasis at the same frequency is only 6.5 db, resulting in a response 8.5 db above normal at 12,000 cps. This is bound to be unpleasant, for a good amplifier and speaker installation will definitely "spit" at you with a boost of this magnitude. This effect is increased if the connecting cable is shortened so that only a few inches of shielded wire is used between the tuner and the amplifier input.

Another well-known model is the Edwards Fidelotuner, with the de-emphasis circuit shown at (B). Here the de-emphasis is seen to be 50 μsec . In the Fada Model 795, (C), it is again

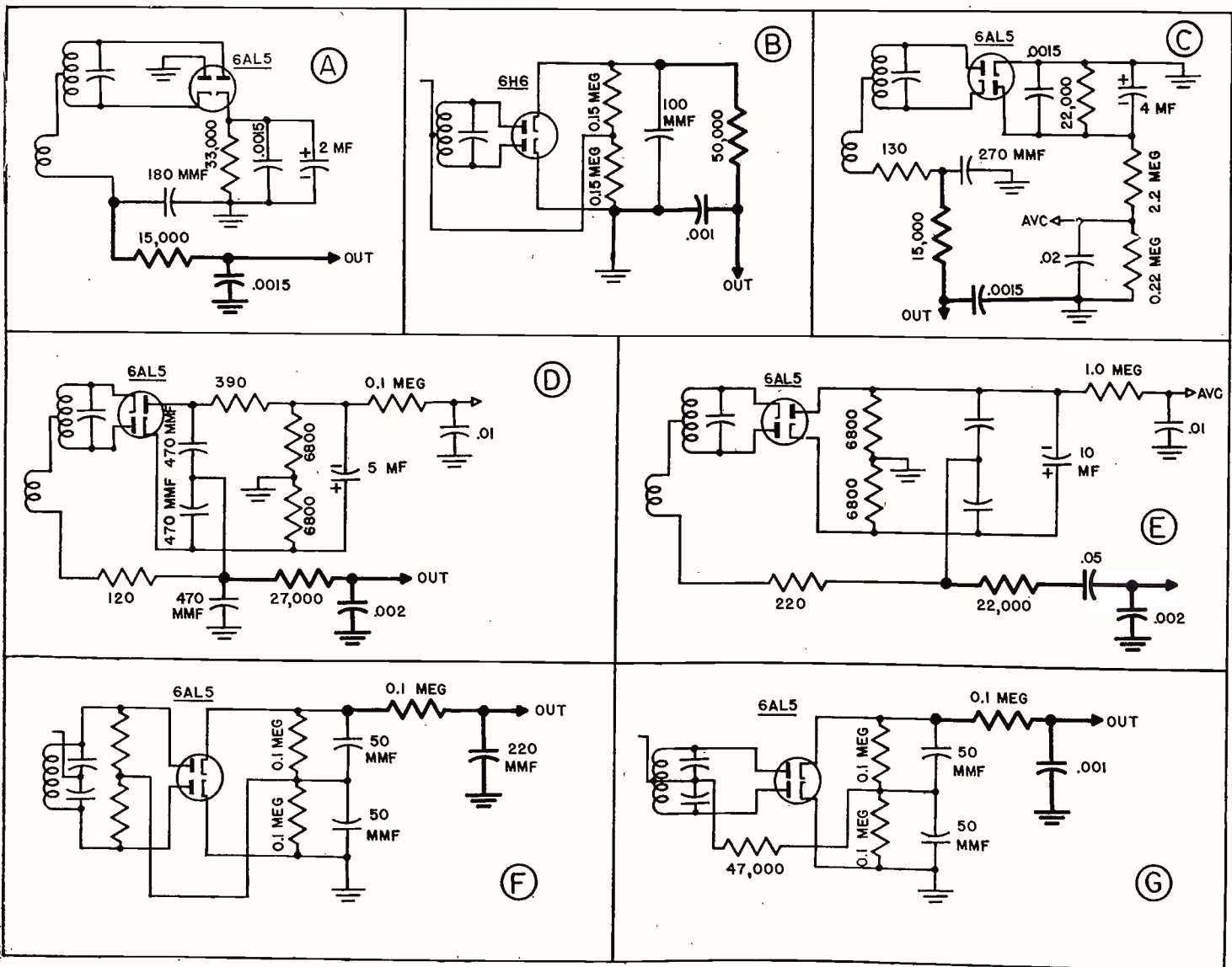

Fig. 2.—Discriminator or ratio detector circuits of a number of representative FM tuners, showing de-emphasis components in heavy lines. (A) Pilotuner; (B) Edwards Fidelotuner; (C) Fada 795; (D) Packard Bell 872; (E) Meissner 8C; (F) Meissner 9-1091; (G) Approved Electronic. Note that (A), (C), (D), and (E) are ratio detectors; others are discriminators.

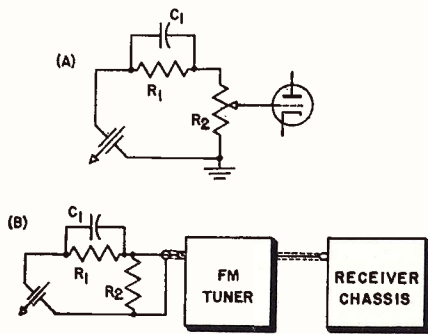

Fig. 3.—(A) Usual method of equalizing crystal pickup to compensate for drooping high-frequency characteristic. R_2 may be a fixed resistor, followed by the volume control. (B) Recommended method of connection to receiver when phonograph jack is used for FM tuner, with pickup being connected through the tuner when it is switched off.

22.5 μsec . The Packard Bell Model 872, (D), shows a value of 54 μsec . There are two Meissner models, the smaller being solely an FM tuner, Model 8C, shown at (E). The de-emphasis circuit for the combination AM-FM tuner Model 9-1091 is shown at (F). In the 8C, the de-emphasis is 44 μsec , while in the combination tuner it is only 22 μsec . In the latter instrument, however, this is of little importance because of the variable bass and treble controls. The Approved Electronic FM tuner, (G), is at the other extreme, with a 100 μsec de-emphasis. One other model of importance, not shown, is the General Electric XFM-1, which has a value of 27 μsec .

This variation does not necessarily mean that one tuner is better or worse than another. But it does mean that the service dealer must exercise some care in connecting a tuner to a customer's receiver or other amplifier. If a tuner is to be used with a conventional receiver, good results may possibly be obtained because the insufficient de-emphasis will help to compensate for the shortcomings of the set itself. But if the radio receiver is a high-fidelity model, some changes should be made to reduce the high frequency response. This may be done simply by connecting additional capacitance across the output of the tuner. If insufficient highs are present when the Approved model is used, the .001- μf capacitor may be changed to one of a lower capacitance, 500 or 750 μf being suggested for a trial.

Many FM tuners are equipped with a jack into which a phonograph pickup is plugged, with the output lead being plugged into the phono jack on the receiver chassis. Combined with the a-c switch is a SPDT switch which connects the tuner to the output lead when the power is on, and connects

the pickup to the output lead when the power is off. This arrangement has certain advantages, since few receivers are provided with double inputs to accommodate both phonograph and FM. However, this often brings up another problem.

As is well known, all crystal cartridges require equalization of the high-frequency end of the spectrum to reproduce records properly. If the FM tuner does not have sufficient de-emphasis, and in addition, some high-frequency boost is built into the receiver for the pickup, it is obvious that FM programs will be equalized far too much. The usual circuit for equalizing a crystal pickup is shown at (A) in Fig. 3. The values for R_1 and R_2 , and for the capacitor C_1 vary considerably, but R_1 is generally of the order of 1.0 megohm, R_2 about 0.27 megohm, and C_1 from 50 to 250 μf . To obtain best results, therefore, the pickup equalization should be removed from the receiver chassis and installed between the crystal and the jack on the tuner, as shown at (B). With this change, both FM and phonograph should be operating under optimum conditions, and the owner should be better pleased with the results. If the phonograph should happen to employ one of the newer types of magnetic pickups, it is absolutely essential that an extra input be provided so that the output from the tuner does not go through the equalized preamplifier required for the low-level pickup. Such a connection would result in too much bass response, and too much overall gain. The proper place to connect the output of the FM tuner is just ahead of the volume control, in a manner similar to that shown in Fig. 4.

One other type of FM tuner is available which employs the FreModyne circuit. It is easily recognized by its tube complement, since it uses but one dual triode and a rectifier. A similar

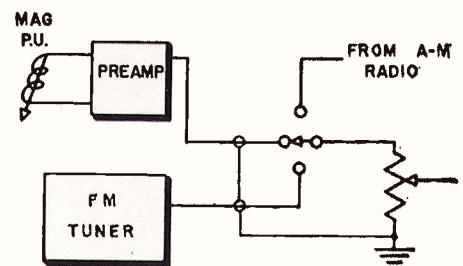
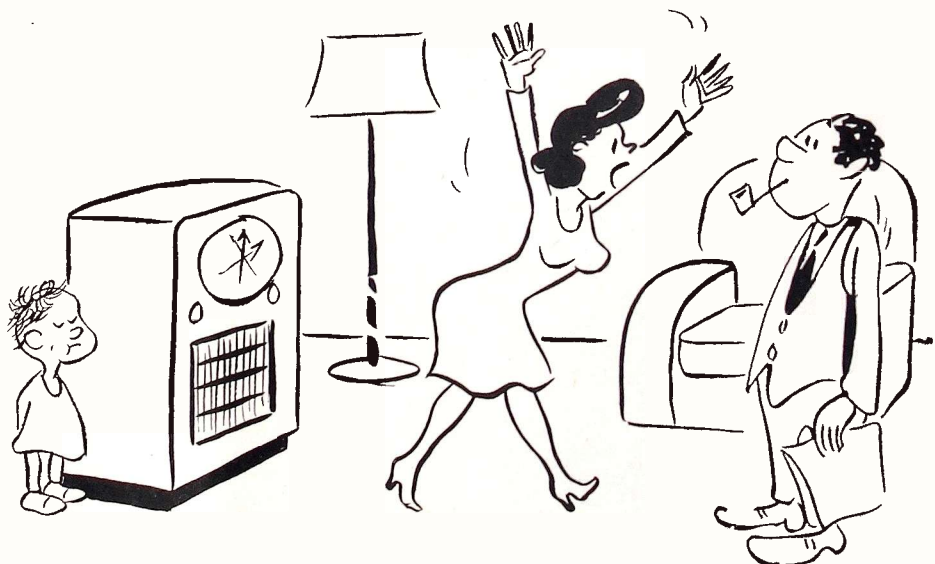

Fig. 4.—Connections necessary when magnetic pickup is used with preamplifier, either as a separate unit or when built into the receiver chassis.

de-emphasis circuit may be encountered, but in one model—the Audar or Telvar—an output transformer is used. The turns ratio is approximately 1.6 to 1, with the lower impedance winding toward the output. In this model, the de-emphasis is obtained simply by connecting a capacitor directly across the output terminals. If a change is deemed necessary, this capacitance value may be increased or decreased, as required.

None of these suggestions outlined for improvement of FM tuner performance entails any great amount of work, and the results more than justify the effort expended. If the service dealer knows the causes of unsatisfactory reproduction and the methods used to correct the trouble, he can make a satisfactory installation, with the probability of making more sales. Regardless of how a tuner is built, or of the various elements of its design, the final test is how it sounds, and to make sure of satisfaction, these adjustments should be made to suit the customer. Too many FM installations are made without this important consideration, with the result that FM reception—while more noise-free than that from conventional AM receivers—is often overbalanced toward the high frequencies and not a true reproduction of the studio program. The correction of this condition rests with the service dealer.



"Help! The baby just swallowed a radio tube and two condensers, get a repair man quick!"

Installing

SPEAKER REPLACEMENT CONES

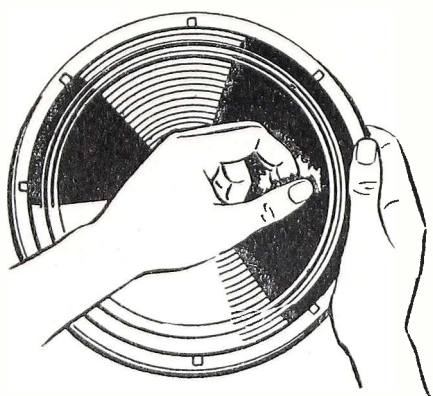

Fig. 1—Remove old cone and voice coil assembly.

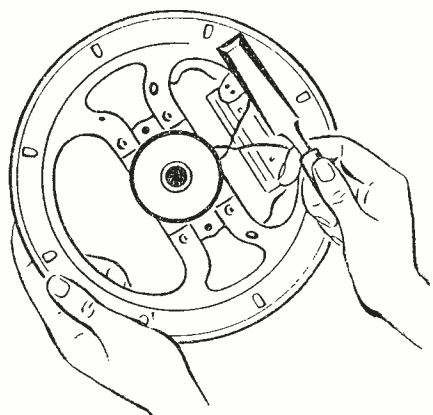

Fig. 2—Scrape and glue or cement from cone and speaker mounting surfaces. (Soaking rim of speaker in warm water helps break down cement at that point. Be careful not to immerse speaker too deeply in water. Do not let water steam).

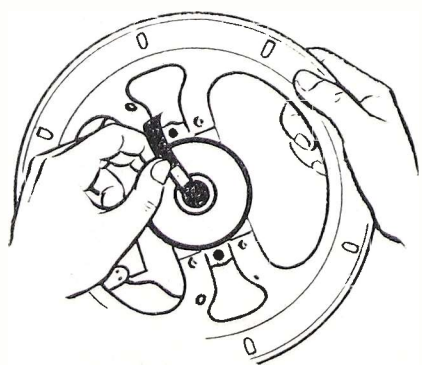

Fig. 3—Clean pole piece of dirt and filings. Put Scotch Tape with sticky side out on shim stock, and push into gap. Hold shim steady and move speaker in rotary motion until all dirt and filings are removed. If available, use air-blower to blow out dirt and filings.

All speakers manufactured since 1940 use corrugated spiders made of cloth. To simplify installation of replacement cones for that type of speaker, there are available cones with the voice coil and spider separated from the cone. Instructions which follow are given in sequence, and are published with permission from Waldom Electronics, Inc.

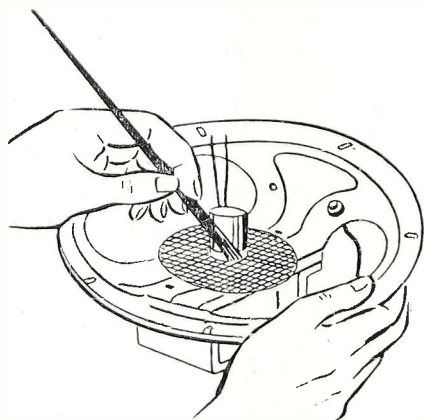

Fig. 4—Put spacer or shim on inside of voice coil. Be sure voice coil leads are in vertical position. Apply cement to spider mounting surface and put voice coil and shim over pole piece. Be sure spider is level.

On inside spider cone types, follow above instructions, but use shim stock, about 1/4" wide in strips, and insert in gap, leaving these in place until cement is dry.

On outside spider types, such as 2 point and 3 point cone types, follow instructions given except that you do not cement the spider, as directed in Fig. 4. Screw spider down and center as directed above.

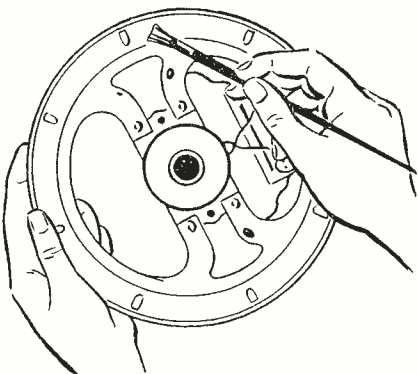

Fig. 5—Apply cement to cone mounting surface and apply cement around neck of voice coil where cone and voice coil join.



Fig. 6—Cement paper ring and place in position, making sure mounting holes are lined up. Turn speaker on face and allow to dry thoroughly, at least 2 hours.

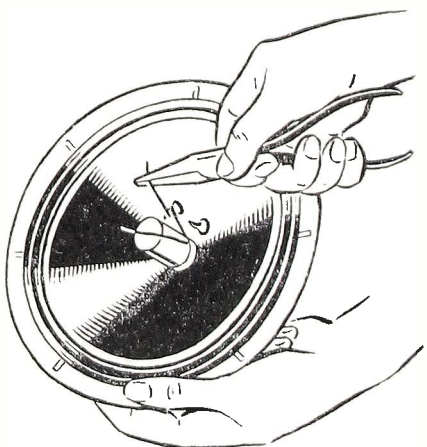

Fig. 7—Bring voice coil leads to eyelets, loop around and solder. Solder voice coil leads from cone to eyelets of mounting, or lugs of terminal. Leave enough slack to allow free movement of the cone.

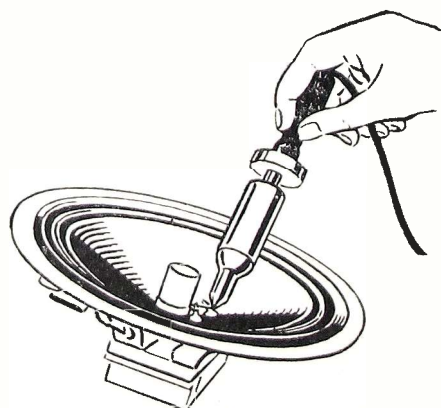

Fig. 8—Remove shim and place cement around voice coil where it meets cone. Put cement on eyelets where voice coil leads are soldered. Allow to dry and speaker will be ready for operation.

APPLIANCE REPAIR TECHNIQUES

that Radiomen Should Know

by WILLIAM R. WELLMAN

PART 2

THE subject of electric refrigeration is included here for the sake of completeness, but the topic is approached with a number of reservations. No attempt will be made to cover even a small portion of the field, nor is it advocated that the radio service man enter into this work unless he has had previous preparation by way of experience or training and has the required equipment. However, there are localities, as stated previously, in which specialists in certain fields are lacking and the service man in such situations should be familiar with at least the electrical portion of an installation.

Refrigerators

The average household refrigerator uses a capacitor-start induction motor of $\frac{1}{8}$ to $\frac{1}{4}$ h.p.; larger boxes may use a repulsion-start motor. In the usual case, the compressor is driven through the medium of a V belt, and automatic starting and stopping of the machine is effected by some type of "cold control" which may be adjusted by the owner through a moderate range. Ordinarily, the cold control actuates a switch to close the motor circuit whenever the temperature in the box rises above the limit for which the control is adjusted, and opens the circuit when the temperature falls to this point.

Failure of the machine to start at all may indicate any one of a number of faults. First of all, it is possible that

In this 2nd and final installment on "Electrical Appliance Repairs," the author discusses the basic principles and repair techniques of refrigerators, heating devices, fluorescent lamps, and electric clocks.

the cold control does not function properly, or perhaps, does not function at all, and therefore does not trip the motor switch. If you can locate the wires which run from the power line and the motor to the automatic switch, you may be able to connect a jumper across the switch. If the motor starts normally, you have established the fact that the trouble is in the control. The difficulty may lie either in the temperature-actuated device or in the switch itself, although the latter is not likely, since such switches are usually very ruggedly constructed. Another possibility, of course, is that the control has been set for a temperature which is too high, a condition which may be checked by moving the control knob.

If you have decided that the trouble definitely is in the temperature control device, replacement will depend upon the type used. Many systems are in use, but the most popular one is illustrated in *Fig. 7*. It consists of a small bulb or a coil of thin tubing which is filled with a very volatile liquid. This bulb or coil is connected to the bellows, shown in the sketch, by a capillary tube. Heating of the liquid in the bulb results in expansion; this expansion forces the bellows to expand, tripping the motor switch. Cooling the bulb has the reverse effect. The bulb is clamped to the evaporator or cooling coil in the refrigerator, and the bellows will be found mounted at the back of the temperature control knob or dial. Such controls cannot be repaired; replacement is the only remedy. The cost of a new unit in most cases is two dollars or less. To remove the unit, loosen the clamp screw or screws holding the bulb, then remove the screws which hold the bellows to the back of the switch. The entire assembly may then be taken out. Be sure that

you install an exact duplicate or a satisfactory replacement unit. After a new control has been installed, some adjustment will be needed in order to obtain the desired temperature with maximum economy. This can best be accomplished by trial and error, and the use of a thermometer. Naturally, conditions such as the temperature to be maintained, the size of the refrigerator and the amount of food stored and the room temperature will determine the length of the operating cycle, but under average conditions, a machine should not run more than a total of twenty minutes out of each hour.

If you discover that the motor still does not start with the automatic switch short-circuited, there is the possibility of a broken or loose connection, probably at the motor terminal board. This is usually accessible through an inspection plate located on the front end plate of the motor. See *Fig. 8* for a drawing of a typical terminal board. While inspecting the condition of the connections, note the condition of the rubber insulation on the leads. Very often, excessive oiling will cause deterioration of the rubber. This will call for cutting away the defective portion of the wire, with consequent shortening of the leads but there is generally enough slack to provide for this.

Some motors are equipped with a thermal overload cutout, shown in *Fig. 8*. This is usually mounted on the end plate; in the example given in the drawing, it is located on the inspection plate. The function of this device is to protect the motor in the event of an overload or failure of the motor to start, by opening the motor circuit. It consists of a bimetallic strip which expands when heated and breaks a pair of contacts which are in series with the

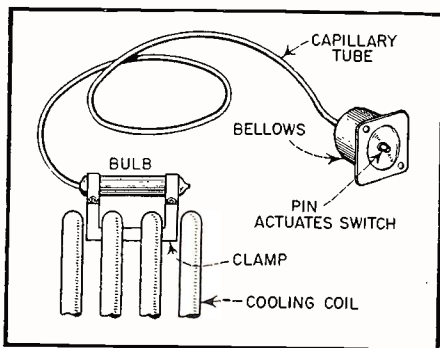

Fig. 7—Refrigerator temperature control device.

machine. If you find that the motor does not start because the thermal protective device has operated, look for the cause of the overload or stalling of the machine. Never attempt to start the motor under such conditions by short circuiting the thermal overload contacts.

If the motor fails to start, but a humming sound is heard, the fault probably lies somewhere in the starting winding circuit. If a thermal cutout is not used, the humming noise will persist, but if the motor is equipped with such a device, the hum will stop after a short time. The most likely cause of the difficulty is failure of the centrifugal switch to close the circuit to the starting winding. As a result, the motor cannot start, but current flowing through the running winding sets up a hum. The switch may fail to operate as a result of burned or dirty contacts which will occur after a long period of service. Overoiling is another cause. The excess oil drips into the switch, dust collects and a greasy mass is formed. Washing the switch and the inside of the motor end plates with benzine or carbon tetrachloride will remove the oil or grease. Under some conditions the centrifugal switch will stick and will not open. This means that the starting winding will carry current at all times, and may burn out as it is not intended for continuous duty. Rewinding is not a particularly difficult job, but the gauge of the wire must be known and the correct number of turns should be used.

In any repair job which entails removing the motor end plates, be sure to notice whether spacing washers are used. These are slipped over the shaft to prevent excessive end thrust. If such washers are used, be sure to count the number used on each end of the shaft and to replace that number when reassembling the machine. If too few are used, considerable end thrust will result; if too many are inserted, the rotor or armature will not turn freely.

Appliances Using a Heating Element

Electrically, almost all heating appliances are extremely simple, consisting of a coil or grid of resistance wire or strip and, perhaps, a thermostatic control. There is, therefore, no need to discuss operating principles or circuits. But from a mechanical standpoint, such appliances might present some minor mechanical problems that might result in loss of time in taking apart or reassembling the appliance.

The simple or non-automatic toaster consists of a single or double resistance unit, usually consisting of resistance ribbon wound upon a mica form. Such units become brittle after a long period of use and may break; rough handling is often a contributing cause. Replace-

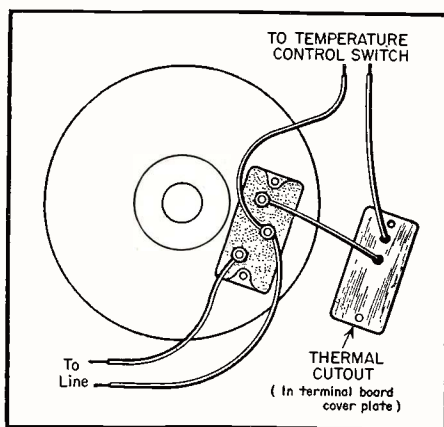

Fig. 8—Typical refrigerator terminal board.

ment is a simple matter and new elements are obtainable at very low cost. The principal things to know are the physical dimensions of the element and the amount of power consumed by the appliance. The procedure of removing the old element and installing a new one will vary, and depends upon the construction of the individual appliance. The ends of the resistance unit are generally connected to a pair of pins to which the heater cord is to be attached. Since these pins must pass through the metal shell or case of the toaster, insulation must be provided at these points. Such insulation usually consists of mica washers or bushings, or in some cases both bushings and washers. The inner ends of the pins are threaded and the ends of the resistance winding are secured to the pins by means of hexagon nuts. When removing or loosening these nuts in order to disconnect the element, care must be used not to break the mica insulation. When the new element is in place and connected, it is a good idea to test continuity from each pin to the case to be sure that neither pin is "grounded".

Broilers and similar appliances using a round type element often use a wire-type element, rather than strip or ribbon, and the element is usually wound on a ceramic base. Needless to say, such bases are fragile. The terminal pins may pass through holes in the ceramic and may be fitted with nuts on the inside ends for making connection to the ends of the resistance unit. Excessive tightening at these points will almost certainly crack the ceramic material. Sometimes the element is fastened to the broiler cover by means of a screw and nut, with the screw passing through holes in the ceramic and the cover of the appliance. The same caution applies here regarding the use of too much force in tightening the nut. You will find that many broilers have three terminal pins instead of two. This is because a dual heating element is used, providing a low and a high heat. The terminal pins must

be clean, and this applies also to the contact springs inside the attachment plug. Heating appliances consume considerable power, and even a small amount of contact resistance is undesirable. The resistance may easily be great enough as to cause the appliance to fail to heat up and in some cases arcing and heating inside the attachment may occur. If you encounter a complaint of this kind and you note also that the cord is worn or frayed, it is always best to replace the entire cord set. If the cord is in good condition, it may be possible to restore the cord set to satisfactory condition by taking the plug apart and cleaning the contacts and perhaps increasing the spring tension by bending slightly. Many such connectors are held together by small screws and nuts and sometimes the nuts and perhaps the screw heads as well will be covered with a sealing compound which must be chipped away. While on the subject of cords, it may be well to mention that some appliances do not use a detachable cord. In such cases, the cord ends and the resistance element terminals are joined together at some type of terminal strip often located inside the appliance. This is particularly true of laundry irons. A few irons have a special type cord with a rubber reinforcement moulded around the cord at the point where it enters the iron, which of course, is the point where maximum flexing of the cord takes place. Generally a special type of cord must be obtained for replacement in such cases.

Laundry iron elements are fairly well standardized and are easy to replace. Taking an iron apart in order to remove the element or to make other repairs may not be such a simple job unless you have had some previous experience or spend a little time in studying the method of assembly. This is because of the tendency toward "streamlining" such appliances which leads to the concealment of screws. For instance, in one popular type of iron there are no visible screws or other fastenings. The shell presents a smooth, unbroken appearance. In order to take the iron apart, the handle must first be removed. Then the heat control knob is taken off. Under this knob there is a small index plate which lifts out, and immediately under the plate will be found the single screw which fastens the one piece shell to the lower part of the iron. Removing this screw permits the shell to be lifted off, exposing the interior of the appliance. This is cited merely as an example of the type of construction to be expected.

Thermostats

All appliances which have automatic control of temperature use the same

asic principle—a simple thermostat. In some appliances, such as irons, the thermostat serves to keep the temperature constant at or near the desired level. In an automatic toaster the thermostat is used to release a device which expels the toast. Almost all such controls are adjustable and carry calibrations of some type. In the “dial the fabric” type of laundry iron, various types of fabrics are marked on the control knob or dial. Turning the knob increases or decreases the tension on one of the thermostat contacts and in this way raises or lowers the temperature at which the contacts will open. Fig. 9 illustrates the basic idea of one such control. With the iron not connected to the supply line, the contacts are closed. When current begins to flow, heating of the thermostat causes expansion of the movable contact, and when the temperature rises sufficiently, the contacts separate, breaking the flow of current. Of course, the iron then cools slightly, allowing the thermostat contacts to again close. This process is repeated continually, keeping the temperature of the iron nearly constant. Sometimes it is found that the range of the thermostat must be shifted. In the type shown in Fig. 9, this is done by first removing the screw which holds the control knob. This will permit removal of the knob and you will find it is fitted over a collar having two flats, much like those used on radio control shafts. The collar is also removable. The iron is now plugged into an outlet, and the collar turned until the desired maximum temperature is obtained. The collar is then lifted off the shaft and turned to such a position that when the knob is replaced it will give the correct indication of heat. Knob and setscrew are then replaced.

Situations will always arise in which a heating appliance must be repaired, if possible, without installing the new element needed. This is usually because

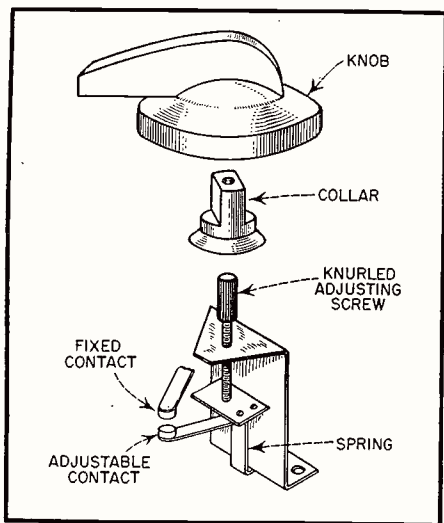

Fig. 9—Basic construction of thermostat control.

a new element is not obtainable. While the practice is not recommended, such repairs are possible by repairing the break in the resistance winding. Of course, this will mean that the resistance is reduced and the appliance will consume slightly more power. An alternative procedure is the use of one of the preparations marketed especially for repairing breaks in heating elements. These are obtainable under various trade names.

Fluorescent Lighting

Fluorescent lamp circuits are somewhat more complicated than ordinary lighting fixtures, of course, but compared to radio equipment the principles and circuits are extremely simple.

Before discussing the usual troubles and their correction, suppose we consider the basic principles involved in a simple circuit using a single tube. In this circuit, illustrated in Fig. 10, we find five major components: the lamp, *A*; the lamp holders (not illustrated); the starter, *B*; the ballast, *C*; and the line switch, *D*.

The lamp consists of a glass tube, varying in length from about eight to approximately sixty inches, depending upon the wattage. The inside wall of the tube is coated with a chemical compound which glows, or fluoresces, when under the action of ultra-violet light. The chemical composition of this material, which is called a phosphor, determines the color of the light emitted by the lamp. The principle is quite similar to that used in cathode-ray tubes, except that in fluorescent lamps the phosphor is acted upon by invisible light rather than by an electron beam.

At each end of the tube there is a filament, the ends of which are connected to the terminal pins. Most ordinary types of lamps are so constructed, and have a pair of terminal pins at each end of the tube; in a few special types, a single pin is used at each end. The filaments are coated with a material which emits electrons when heated. During manufacture, a small quantity of mercury is placed in the tube. After the air has been pumped out, argon gas is injected, and the tube is then sealed.

The ballast, *C* in the drawing, is merely an iron-core inductance. Its function in the circuit is two-fold: to supply a high voltage for starting the lamp, and to limit the amount of current flowing through the lamp after starting.

The starter *B*, is a small glass bulb enclosed in a protective aluminum case. This case also holds a small condenser which is connected in parallel with the starter and is designed to reduce radio interference. Inside the starter bulb there are two contacts, one fixed, the

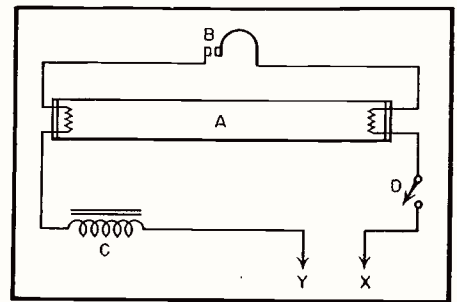

Fig. 10—Basic fluorescent circuit.

other movable. The movable contact is made up of two dissimilar metals which do not expand or contract at the same rate during temperature changes. In other words, these two contacts are really a type of thermostat. The bulb which encloses the contacts is filled with neon gas.

When the components just described are connected as shown in Fig. 10 we have the simplest type of fluorescent circuit. When the line switch *D* is closed, we have a complete circuit from the point *X* on the supply line, through the line switch and one lamp filament to one of the starter contacts. At the same time we also have a complete circuit from *Y*, the opposite terminal of the supply line through the ballast and the other lamp filament to the second starter contact. Since the resistance of the circuit (ballast and filaments) is fairly low, almost full line voltage is applied to the starter contacts, which are open at the moment. Just as in the case of the familiar neon glow lamp, we get a glow discharge in the starter bulb. This glow discharge generates a certain amount of heat, which causes the movable contact to expand and touch the fixed contact. If you will trace the circuit, you will see that we now have a complete path from one side of the supply line, through one filament, through the now closed starter contacts, through the second filament and the ballast and back to the supply line. Current now flows in this circuit, causing the filaments to glow and to emit electrons. Of course, it is apparent that as soon as the starter contacts close the glow discharge stops and the line voltage is then divided between the ballast and the lamp filaments.

At this point it will be well to keep two points in mind: current is flowing through the filaments and the ballast and this flow will magnetize the core of the ballast; second, stopping of the glow discharge in the starter bulb will allow the movable contact to contract and open the circuit again. This sudden breaking of the circuit causes several things to happen. First of all, the lamp filaments are extinguished. They

(Continued on Page 38)

VIDEO AMPLIFIERS

In this, the final installment of the series on "Video Amplifiers," the basic principles of d-c restoration are discussed, with applications to current circuits employing this principle.

IN OUR previous article on this series (D-C Component, RSD July, 1948) we explained the reason for the d-c component in the transmitted video signal. These facts were pointed out: 1) The blanking level amplitude, barring fading, etc., is constant. 2) The position of the video signal axis varies with respect to the blanking level, depending on the background brightness or, d-c component of the scene transmitted. Dark backgrounds move this axis up towards the blanking level, and bright backgrounds move this axis down towards the zero axis which represents the bright region. See Fig. 1.

Progress of D-C Component

We are now ready to trace, with some knowledge of its origin and purpose, the d-c component of the signal in the TV receiver itself. The waveform appearing in Fig. 2a occurs in the detector

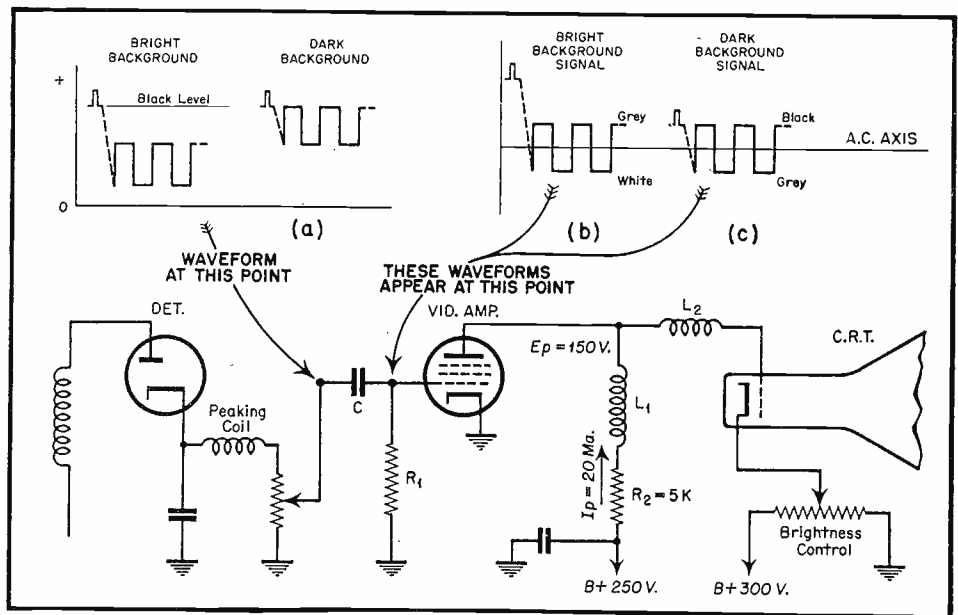

Fig. 2—Typical video amplifier circuit and waveform at detector output.

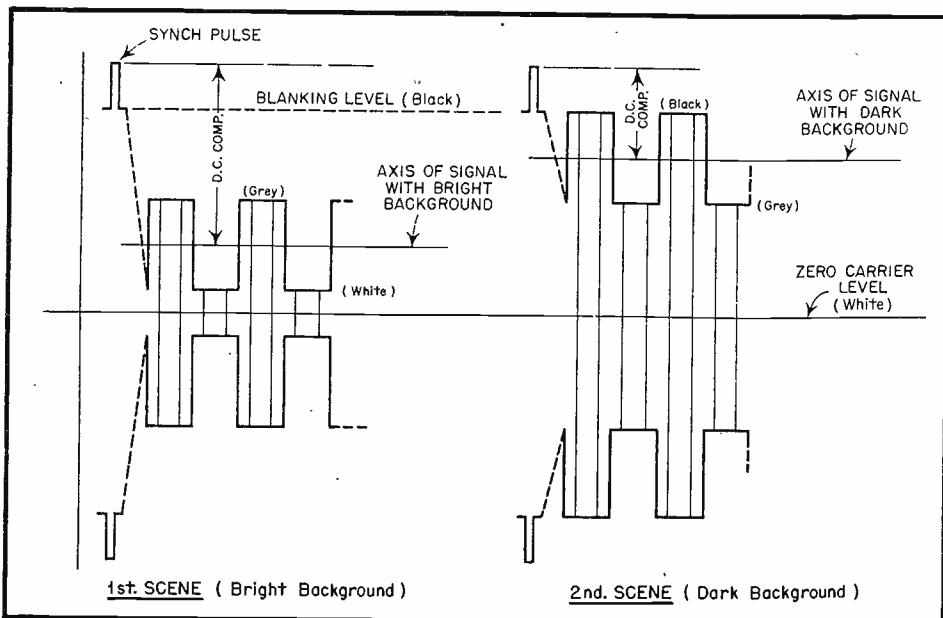

Fig. 1—Modulated video signal showing relative axes of signals produced by same scene, but with different background brightness levels.

output as the demodulated video signal. The circuit shown in this figure represents a typical detector and video amplifier found in many TV receivers.

In this circuit the signal developed at the cathode of the detector has a negative picture polarity so that the waveform across the load resistor appears as in Fig. 2a. This is essentially a pulsating d.c. On passing through the coupling condenser, C, the signal becomes a.c. with its axis taking a position midway between equal positive and negative areas, as shown in Figs. 2b and 2c.

Now at this point in our explanation we are going to assume that the signal appearing at the grid side of the coupling condenser is amplified through a conventional class "A" amplifier and in this form sent on to the grid of the CRT. We are going to show that this system will not work for all values of background brightness. However, our time will not be wasted, for by this

D-C RESTORERS

by SAMUEL L. MARSHALL

PART 3

analysis we will begin to understand what is needed in order to make use of the d-c component present in the original composite video signal.

The output of the video amplifier tube is 180° out of phase with the input. Therefore the signal appearing at the plate of this tube now has a positive picture signal phase. This means that the synch pulses drive the signal in a negative direction. Observing that the plate of the output tube is directly coupled to the grid of the CRT, we may rightfully conclude that the synch pulses drive the grid of the CRT in a negative direction. This is shown graphically in *Fig. 3*, where we have assumed a signal which varies in contrast between absolute black and absolute white.

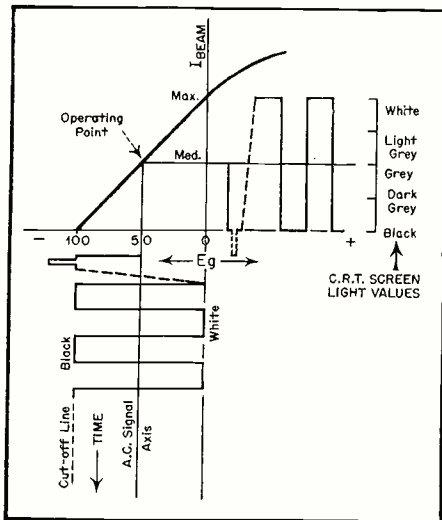

Fig. 3—Incoming video signal corresponding to black and white produces black and white light values on the CRT screen if contrast and intensity controls are adjusted correctly.

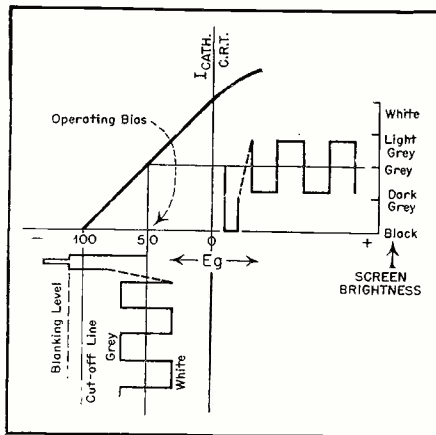

Fig. 4—CRT characteristic, showing how video signal varying between white and grey appears on screen of CRT as varying between bright grey and dark grey. Blanking level and cut-off line do not coincide.

CRT Requirements

It must be borne in mind that the amplitude of an incoming black & white signal must be able to vary the light on the screen of the CRT between black and white. Now, in order to do this the beam current must be able to swing from zero, or black, to maximum, or white. According to the I_{BEAM} vs. E_g characteristic of the CRT in *Fig. 3* the grid voltage required to produce this swing is (in this particular case) 100 volts peak to peak. By merely advancing the contrast or gain control until full contrast (black and white) is obtained, we are able to get this swing.

From the figure, the operating "C" bias coincides with the a-c signal axis. We observe that this axis falls on the -50 volt "C" bias point. For the signal shown the grid swing is made to vary between zero and -100 volts, causing the light on the screen to vary between white and black.

Now, a basic operating principle of the CRT is that the blanking level of the incoming signal should fall on the cut-off line of the CRT characteristic. In this manner the synch pulses above the blanking level can cut the beam current off, and the trace and retrace lines become invisible. Referring again to *Fig. 3* we find that the blanking level falls exactly on this line.

Notice that the "C" bias in this

case is -50 volts. A higher value of "C" bias would result in a shifting of the axis of the incoming signal to the left, causing the blanking level of the signal to fall beyond the cut-off line. Blanking would therefore occur before the blanking level were reached, and part of the picture would be made invisible. In addition, the light values would be incorrect.

A lower value of "C" bias would shift the axis of the incoming signal to the right, causing the blanking level of the signal to fall short of the cut-off line. This would result in part of the synch pulse being made visible, in addition to which the light values again would be incorrect.

The correct "C" bias is easily and visibly adjusted by merely manipulating the CRT "C" bias or intensity control until the trace and retrace lines fade into invisibility. This automatically lines up the blanking level of the incoming signal with the cut-off line.

All this is fine for the one signal and its particular background brightness illustrated in *Fig. 3*. Now let's see what happens when a signal with a different background brightness level enters the picture, such as the one illustrated in *Fig. 4*. This corresponds to the incoming signal shown in *Fig. 2b*, and represents a checkerboard pattern varying between white and grey.

It is obvious that the operating

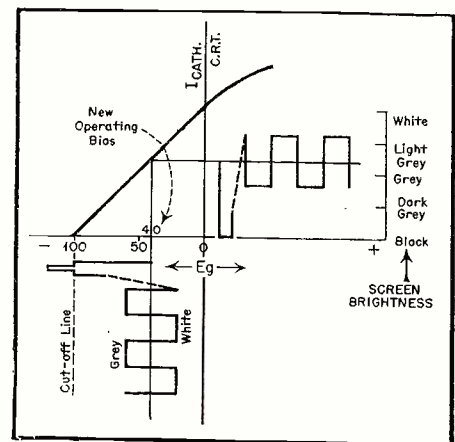

Fig. 5—New operating bias lines up blanking level with cut-off line. Greys and whites of screen now correspond to greys and whites of signal.

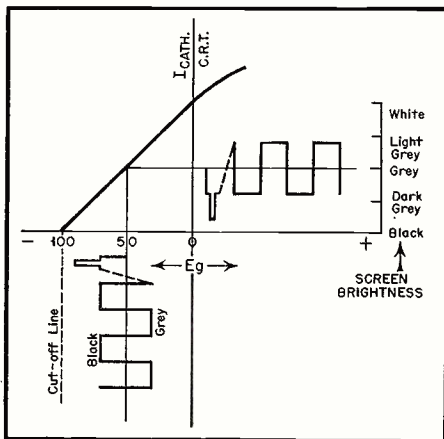

Fig. 6—Incoming signal which varies between black and grey appears dark grey and light grey on screen. Synch pulses now visible.

conditions shown are incorrect for two reasons: 1) the synch pulse blanking level falls *beyond* the cut-off line, and, 2) the total brightness of the reproduced scene is reduced, producing a signal which varies between light grey and dark grey.

It should be pointed out that this condition can be temporarily remedied by merely adjusting the brightness control until an operating bias is obtained which lines the blanking level up with the cut-off line. See Fig. 5. However, this would require adjustment of the brightness control every time the background brightness of the scene changes—evidently an impossible requirement.

By the same analysis it can be shown that the signal of Fig. 2c would cause the synch pulses to fall far short of their mark in the cut-off region, thereby rendering them visible. At the same time the original scene, which varies between black and grey, would appear on the face of the CRT as one which varies between dark grey and light grey. See Fig. 6.

It is because of the fact that the blanking levels of the incoming signals *do not always* line up with the cut-off line that this system is inadequate.

Automatic "C" Bias Operation

It is evident that some means must be employed whereby the blanking levels of the incoming signals *automatically* line up with the cut-off line for any value of background brightness, without recourse to readjustment of the brightness control. This means that the operating "C" bias of the CRT would automatically have to change for each scene whenever the background brightness of the scene changes. This is depicted in Fig. 7. Notice that for the two scenes, corresponding to Figs. 2b and 2c, the "C" bias has been shifted so that the blanking levels of the respective signals both fall on the cut-off line. Notice also that the re-

produced scenes on the face of the CRT are now correct interpretations of the original signals.

Exactly how the operating "C" bias on the CRT tube is automatically varied with signals of different background brightnesses or the d-c component contained in the signal will now be discussed.

Study of the "C" bias circuit of the CRT, as shown in Fig. 2, should reveal that for no signal control grid of the CRT which has the same potential as the plate of the video amplifier is 150 volts (approximate) positive with respect to ground. This is due to the assumed voltage drop of 100 volts in the video amplifier plate load resistor, R_2 . L_1 and L_2 are peaking coils, and can therefore be neglected in the voltage considerations we are about to take up. If the brightness control is set at 250 volts, it should be evident that the "C" bias on the CRT will be $250 - 100 = 150$ volts negative. We can therefore see that the "C" bias on the CRT is dependent on two factors: 1) the voltage setting of the brightness control, and 2) the voltage drop across R_2 . Increasing the voltage drop across R_2 increases the bias and vice versa.

Since we cannot change the setting of the brightness control continually, our only recourse to automatic variation of the operating "C" bias is to make the d-c voltage drop across R_2 vary automatically with the d-c component contained in the signal. Making the d-c voltage drop across R_2 vary in this manner requires that the d-c plate current, which flows through R_2 , likewise vary with the d-c component. Now, the only way we can vary the d-c plate current in this tube is to vary the grid bias.

The d-c component contained in the signal determines the amplitude of the synch pulse above the signal axis (see Fig. 7). Therefore, if we can employ a circuit in which the grid bias depends on the amplitude of the synch pulses we will have accomplished our purpose of automatically varying the grid bias with the d-c component. A simple circuit in which the d-c grid bias varies with the amplitude of the incoming signal is a grid-leak biased amplifier, applications of which are found in

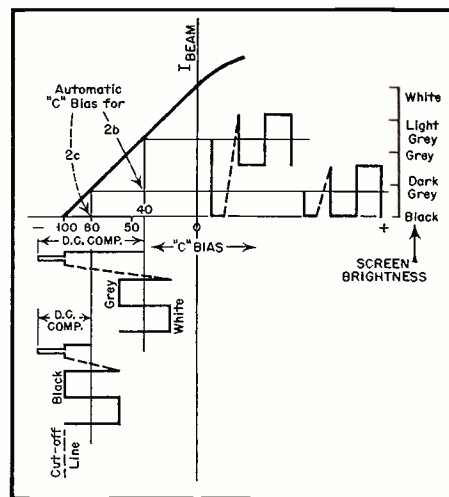

Fig. 7—Automatic "C" bias lines up blanking levels of any signal with cut-off line. Signals are now reproduced with correct contrast.

almost every oscillator circuit.

Grid-Leak Biased D-C Restorer

The principle of operation of this circuit (refer to Fig. 2, C and R_1) is that a signal appearing at the grid causes grid current to flow during the positive halves of the cycles. The direction of current flow makes the grid side of the resistor negative and the ground side positive. The greater the signal strength the greater is this current flow. The resultant voltage drop across R_1 charges condenser C , and this charge is maintained as a "C" bias on the tube during a period of time corresponding to the time constant of C and R_1 . In TV receivers the value of C is approximately $.1 \mu\text{f}$, and $R_1 = 500,000$ ohms, making the time constant equal to $1/20$ sec. This keeps the "C" bias on the tube constant during a period of time greater than a frame ($1/30$ sec.).

At this point let us consider the three signals shown in Fig. 8 which are applied separately to the grid of the video amplifier. The signal in Fig. 8a has a maximum swing of about 2 volts between the signal axis and the top of the synch pulse. This 2 volt signal biases the video amplifier grid two volts negative, causing a plate current flow of 10 ma. The drop across R_2 is $.01 \times 5,000 = 50$ volts, making the plate voltage 200 volts. To accomo-

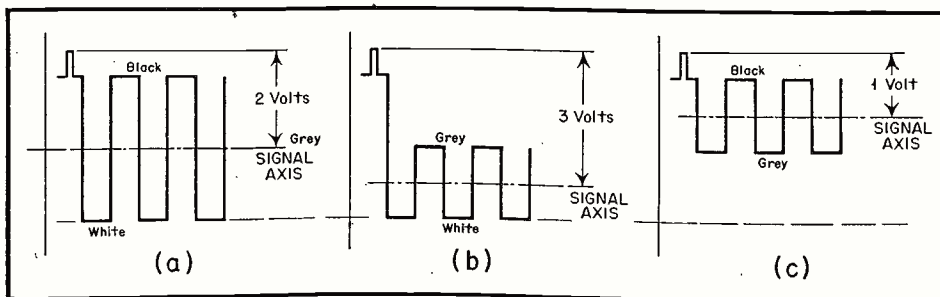

Fig. 8—D-C component values for different signals.

ate this black and white signal we adjust the brightness control as explained previously, so that the net "C" bias on the CRT is -50 volts.

Now the grey and white signal of Fig. 8b is applied. Although the video portion of the signal is smaller than the previous signal, the d-c component is greater, that is, 3 volts. The "C" bias on the video amplifier tube is now increased, causing the plate current to go down. The voltage drop across R2 is now smaller, and the net "C" bias on the CRT grid is reduced. This automatically shifts the operating point of the CRT characteristic to the right as shown in Fig. 7, thereby lining up the cut-off line with the blanking level.

Proceeding to signal 8c, which is black and grey, we observe that the d-c component is now 1 volt. This brings the voltage on the grid of the video amplifier down to 1 volt, causing the plate current to increase. The voltage drop across R2 and hence the "C" bias on the CRT, is likewise increased, shifting the operating point to the left as shown in Fig. 7. Again the cut-off line is lined up with the blanking level.

We have therefore succeeded in obtaining a circuit which automatically lines up the blanking levels of different signals with the cut-off line. Notice that the bias shifts are automatic. Notice also that the degree of bias shift is directly proportional to the d-c component contained in the signal. Inasmuch as this d-c component actually raises or lowers the d-c bias on the tube on which it is applied, we refer to this circuit as a "d-c restorer".

Once we establish the reference levels of black and white by proper adjustment of the contrast and intensity controls, further adjustment of these controls is unnecessary, unless the station undergoes a decided loss or gain of signal strength during the course of a broadcast. It must be remembered, though, that in tuning in another station we are dealing with a new blanking level, so that readjustment of these controls will be necessary.

Diode D-C Restorers

Many commercial receivers employ a separate diode tube or a IN34 crystal for d-c restoration. The principle of operation is the same as just described, that is, a d-c voltage must be developed which depends on the amplitude of the d-c component contained in the signal.

In the upper part of Fig. 9 we show the video signal as it is developed across the plate load resistor, R2, in the video amplifier. During the synch pulses the plate side A of this load resistor is negative, and the B+ or ground side positive, because the video signal has a negative synch polarity. If we trace the circuit carefully we will observe

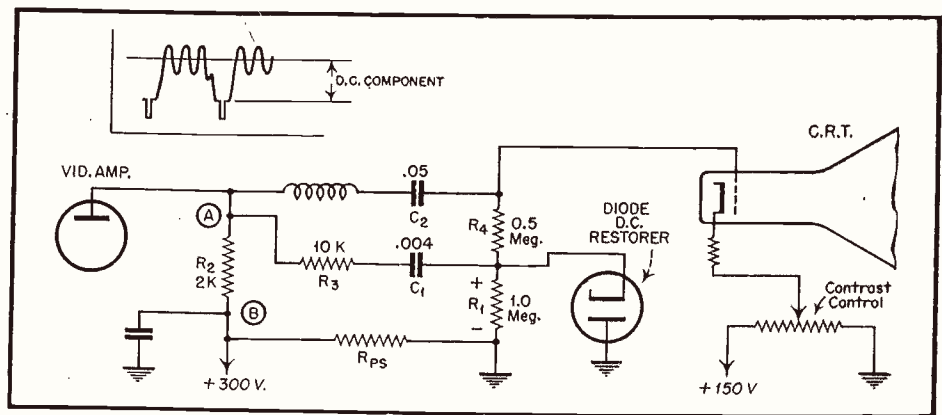

Fig. 9—Typical d-c restorer using diode.

that the diode tube is connected across R2 through R3, C1, and Rps, the equivalent resistance of the power supply. The voltage across R2 during the time the synch pulse is effective is the d-c component contained in the signal.

Since the plate of the diode is connected to the positive side, B, of the load resistor, it will conduct during synch pulses and charge condenser, C1, to a value proportional to amplitude of the d-c component. During the rest of the signal time the diode is inoperative, and C1 discharges slowly through R1. However, the time constant of C1 and R1 is high enough to permit the voltage drop across R1 to remain substantially constant over a number of horizontal lines.

Notice that R1 is in series with R4, the grid load resistor of the CRT. The voltage drop across R1 establishes, therefore, a d-c voltage on the grid which is proportional to the d-c component contained in the signal; which

is what we set out to do originally.

Because the cathode side of the diode is positive, the upper side of R1 is also positive, so that, the polarity of the voltage which is impressed on the grid of the CRT is positive.

A little reflection will serve to clarify this point. Reference to the upper part of Fig. 9 will reveal that the d-c component increases as the signal gets brighter. This means that the positive voltage drop across R1 increases, and the grid goes more positive. But if the CRT grid goes more positive the screen becomes brighter. Inasmuch as this is exactly what the signal wanted to convey, the operation is correct.

The initial setting of the contrast control determines the operating bias of the CRT grid. This bias is made more or less positive by the action of the d-c restorer circuit. Notice that the video signal is resistance-coupled to the grid of the CRT through condenser C2. The advantage of this system is that the CRT grid is not at a high B+ potential, as is the case with grid leak d-c restorers.

Summary

To summarize the complete process of d-c insertion and restoration as it takes place in the transmitter and in the receiver, we enumerate the following steps:

1. Background brightness is added to the video signal and the synch pulses in the transmitter so that its effect raises or lowers the distance between the a-c video signal axis and the blanking level which represents black. This distance is the d-c component.

2. In the receiver a certain value of "C" bias on the grid of the CRT determines the black level of the tube. This bias corresponds to the cut-off point.

3. The d-c component contained in the incoming signal is made to vary the d-c "C" bias on the grid of the CRT, directly or indirectly, thereby shifting the operating bias so that the blanking levels of all signals fall on the cut-off line.



"Now you have the tubes, condenser, transmitter, capacitors, transformer, speaker, resistors, wires and switches laid out on the floor. We'll continue from here next week at this same time!"

Build this

SIMPLE WATTMETER

by RUFUS P. TURNER

POWER drain is an important characteristic of radio receivers, electronic devices, and all types of electrical appliances handled by radio service dealers. Knowing how much power is required for operation gives the dealer, serviceman, and customer a concrete idea of operating cost and, in some cases, is a final point in establishing the superiority of one appliance over another. Moreover, a wattage reading often calls attention to trouble in the device under test.

The serviceman should own a wattmeter and should use it frequently. The need if this instrument often arises in radio and appliance shops but falls short of realization mainly because of the relatively high price of suitable wattmeters. The serviceman who feels that a wattmeter is outside his budget limits therefore will welcome the data this article gives for building a good wattmeter from inexpensive parts.

Constructional details of a simple wattmeter, a device which the serviceman is occasionally called upon to use both in radio and appliance work.

Instrument Requirements

A wattmeter which is to be used for checking the power drain of radios and appliances need not be complicated, since it is to be operated only at the power-line frequency. For greatest simplicity of operation, the instrument must be direct-reading, and it should so be designed that it may be plugged into the a-c power line and the radio or appliance plugged into the meter output circuit. The wattmeter described in this article meets the foregoing requirements and may be assembled in a few minutes from parts usually found in the service shop.

Operating Principle

The operating principle of a simple

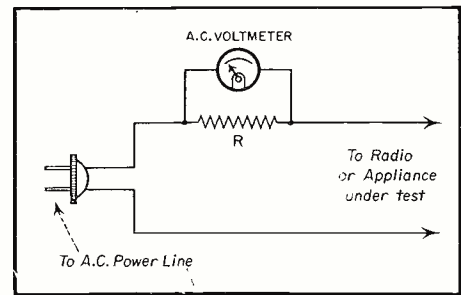

Fig. 2—Basic circuit of simple wattmeter.

wattmeter is illustrated by the basic circuit in *Fig. 2*. The method of operation is explained in the following manner: A resistor, R , is connected in series with the a-c power line and the radio or appliance under test. The full operating current of the device therefore must pass through this resistor. In order to keep the voltage drop across this resistor small, R is made 1 ohm or less. An a-c voltmeter or millivoltmeter is connected in parallel with resistor R so as to read the voltage drop across this resistor. The meter-resistor combination thus comprises an ammeter in series with the power line and the device under test. A straight a-c ammeter might also be employed without the resistor, but this instrument is less common than the a-c voltmeter in radio shops.

Simple Wattmeter

Since the meter deflection is proportional to the current flowing through the resistor and into the radio or appliance, it is proportional also to the power (line voltage \times current drawn) taken by the appliance. The meter scale accordingly may be graduated directly in watts on the basis of a certain line voltage (say, 115 volts). The wattage readings then will be correct for that line voltage, and a simple correction factor may be applied for other line voltage values. This explanation, of course, neglects the effect of power factor such as might be encountered in a radio power transformer. However, the circuit action gives sufficient accuracy for the usual run of radio and appliance testing.

(Continued on page 44)

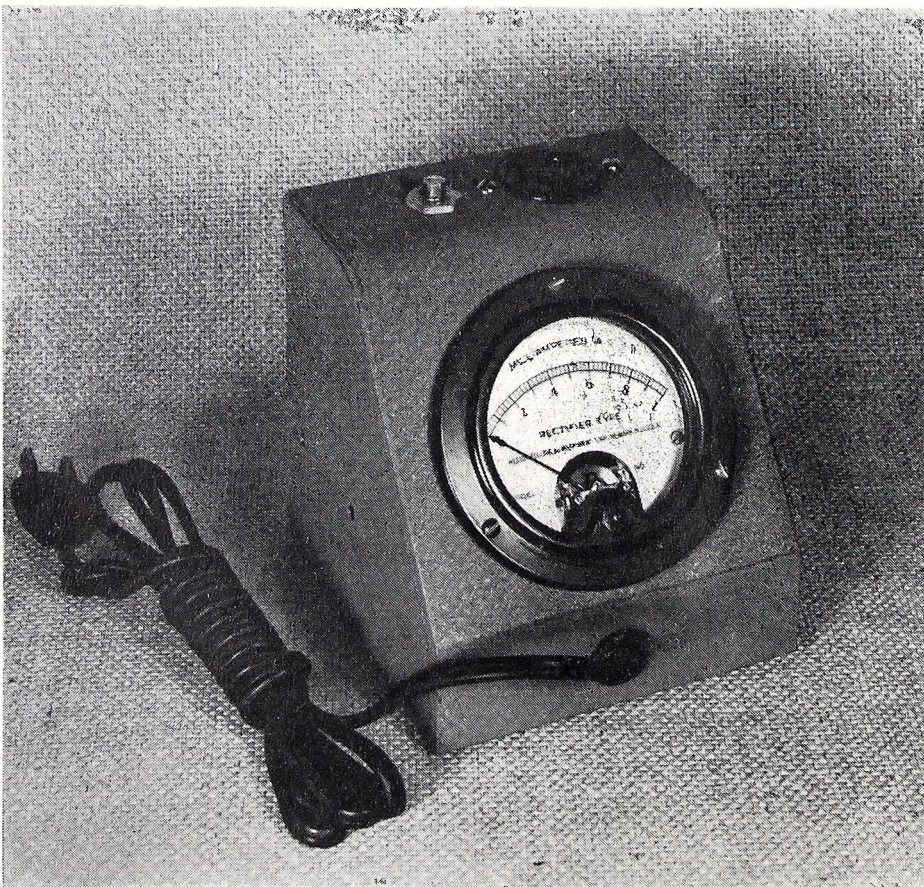

Fig. 1—Front view of simple wattmeter.

SERVICE CONTACTS PROMOTE SET SALES

by C. THOMAS

CRISTOBAL Echavarria, owner of the Cris Radio Shop, located in lower Rio Grande Valley in Texas, has found that service is the best sales builder of new radios. Cris has tried all types of advertising.

"I figure," says Cris, "that when the average person wants a new radio, they just about know where they intend to buy it. The exceptions are those who must have a certain trade name. And, if we do not happen to have that particular make, we have gained nothing by drawing people's attention to the makes we do stock.

"Invariably, our new radio sets are sold to our old service customers. So we try to build as large a following in this line as we can.

"First, I would say from my own experience that store location is most important. We moved into the center of town . . . into the high rent district, after learning that it cost too much time, money and effort to get people to go out of their way in order to patronize us when we were out on the outskirts of town. Frankly, too many flatly refused to consider us when it meant extra steps for them.

"The old saying *"We are as near as your telephone"* meant little, even when we moved into town. A few customers call us up, but the majority prefer to

Many radiomen are in enviable positions as far as sales are concerned because of their personal contacts and reputations. This enterprising service dealer is making the best of these opportunities.

bring their sets into the shop and have us look them over and quote an estimate before they give us the go ahead.

"More cautious ones came in first to inquire . . . and to look us over . . . to see if we have the equipment to do a good job, and to determine if we look as though we have the skill to use the equipment. Also, I believe some look to see if we were doing any volume of business, figuring that if a good number of others had confidence in us, they too, can take a chance. And our shop is so arranged as to make the right impression, or what we think is the right impression.

"We sell very few new sets to strange walk-in customers. Our new radio sales are in the main made to our service customers. The average radio owner

sours on a set after he has had to spend money repairing it a couple of times.

"This is true here, there, and everywhere; I have found out by talking with radio men in other cities. So, we sell sets in order to not lose any potential business profits. If we can't service a set, we don't hesitate to sell one.

"The impressiveness of service shop . . . that is: in full view of the customer, I believe, has built for us our following of service and sales customers. We use newspaper advertising and although we are unable to trace enough business to the advertisements to pay for the space, yet, we continue to advertise. We hope, at least, to make people come in to get to know us.

"The second time a customer visits us,
(Continued on page 46)



Above—What customer fails to be impressed by this arrangement?

Right—Chris demonstrates a P.A. outfit to a prospective purchaser.

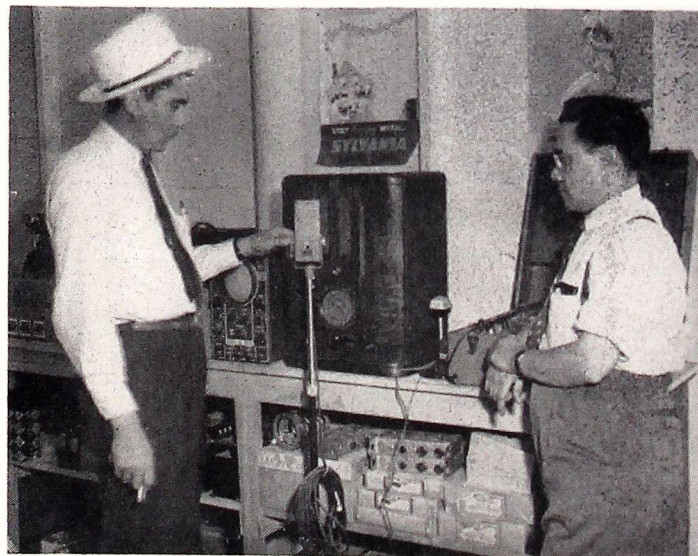

CIRCUIT COURT

Ranger Model 118

This two-band portable has provision for headphone reception in addition to the more usual speaker performance. More than adequate volume from the weaker short wave stations is assured by this feature. A jack appears on the front panel of the set for the insertion of the headphones.

A partial schematic is shown illustrating the manner of connection to accomplish the application. The output transformer has the usual high impedance primary to match the pentode output tube. The secondary, of a few ohms, matches the voice coil of the PM speaker.

The additional items supplied to incorporate the headphone feature include two fixed capacitors and a jack. The jack has a pair of contacts, normally closed, which complete the voice coil circuit. When phones, either crystal or

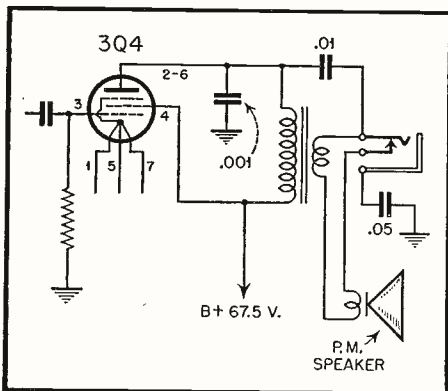

Partial schematic of Ranger Model 118

magnetic, are plugged in the jack the circuit between the transformer secondary and the voice coil is broken. At the same time, the tip of the jack connects one side of the phones to the plate of the 3Q4, through a .01 μf condenser. The sleeve of the jack returns the other side of the phones to ground through a .05 μf condenser. The output of the set will then actuate only the phones.

Having the two condensers in the circuit isolates both sides of the phone circuit from the d-c portions of the set and prevents any danger of shock to the user. Since the plate impedance of a 3Q4 is quite high, best results would be obtained with phones of several thousand ohms impedance.

Electronic Labs. Model 3000

A variation of the trend to simple circuits for small a-c/d-c receivers is found in this instrument. Unlike most sets, a t-r-f circuit is employed. A length of wire serves to pick up broad-

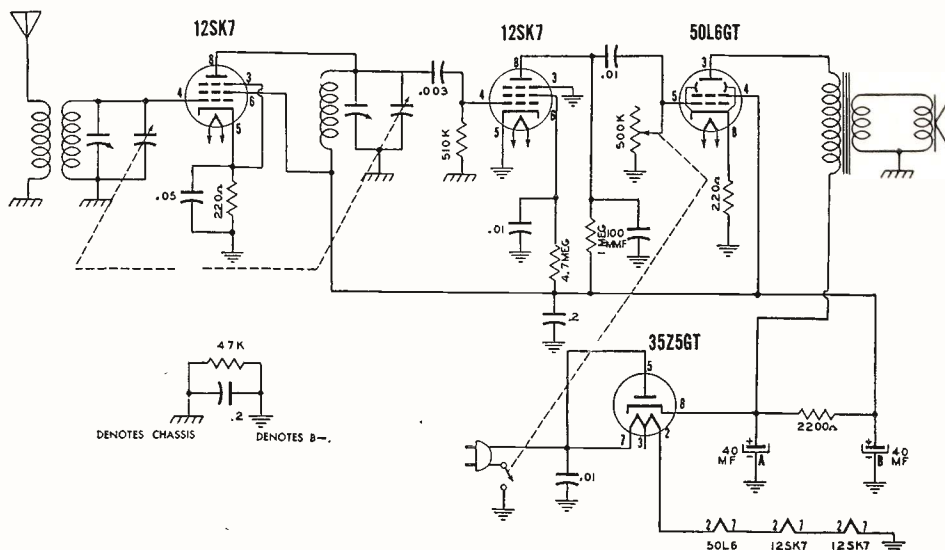

Circuit of Electronic Labs. Model 3000.

cast band signals. The r-f coil has a fairly high impedance primary closely coupled to the tuned secondary. A 12SK7 tube, with 2.6V bias developed across the 220-ohm cathode resistor, amplifies the signal 100 times at 600 kc.

The plate circuit of the r-f tube is tuned by a coil and second section of the gang. The r-f voltage is then coupled through a .003 μf capacitor to the control grid of the 12SK7 detector. Grid detection, across a 510K-ohm leak, ensues. The gain through the detector for the audio component is 25.

A 50L6 output stage, with volume control in the grid circuit, and a 35Z5 rectifier complete the layout.

characteristics and is well adapted to this service. Only one cathode appears in the tube, both triode sections being common to it.

The cathode returns to ground via a 1000-ohm resistor to establish the mixer bias at a suitable amount for good rectification. Since this bias would be undesirable on the oscillator, the grid leak of the latter portion of the circuit is returned to the cathode rather than to ground.

Tuning is accomplished in a pair of rods, one set for each tube section. Trimmers are provided (marked A9 and A10) to bring the circuits into proper alignment to generate the 10.7 mc i-f signal. Small coils provide means of initially adjusting the inductance arms of the circuits to the proper relationship. The coil in the mixer stage will be seen to be in the ground side of the tuned circuit. This permits tapping the antenna lead up on it to the appropriate point for proper impedance match.

Plate voltage is applied to the mixer through an RC filter and to the oscillator on the grid side of the tuned lines. This point is at a lower impedance

Edwards Fidelotuner

A unique convertor circuit and tuning arrangement appears in the Edwards Fidelotuner. The pertinent portion of the schematic is shown. This instrument is intended for connection to the audio portion of a receiver not incorporating FM. The tuner employs five tubes and a disc rectifier.

The oscillator and mixer functions are performed by a 6J6 dual-triode. This tube has excellent high frequency

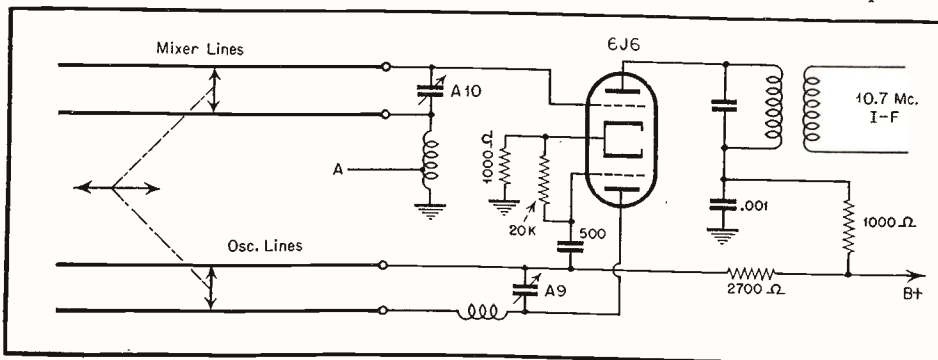

Convertor circuit and tuning arrangement of Edwards Fidelotuner

than the plate side. Sliders, moving with the indicator, vary the frequency by changing the length of the lines.

Meissner 2961 series

A block diagram is shown of the several details of this rather complicated instrument. Twenty-nine tubes are incorporated to cover AM and FM reception, including two short-wave bands. The audio and rectifier tubes with their associated components, are on a chassis apart from the r-f and i-f channels. Electrical push-button tuning is provided on the broadcast band.

For the sake of simplicity, the extensive tube component has been divided into three sections. Miniature tubes are employed in most of the stages where appropriate.

In the AM position the line-up begins with a type 9003 tuned r-f amplifier. Mixing takes place in a 6BE6, the oscillator voltage being derived from a 6C4. Two 9003 tubes are used in the 455 kc i-f stages. Detection takes place in a 9002 triode used as an infinite impedance circuit. A portion of the i-f signal is taken off between the i-f stages and applied to a 6AG7 a-v-c amplifier. Rectification takes place in one half of a 6AL5 tube. Further amplification of the signal takes place in a 9003 stage. This output is rectified in the second half of the 6AL5 and serves to actuate the 6U5/6G5 tuning eye.

In the FM position the first tube is a 6AG5 r-f amplifier, followed by a similar tube as a mixer. The oscillator uses a 6C4 tube. Three i-f stages at 10.7 mc are followed by cascade limiters in which 9001 tubes are used. A 6AL5 serves as a discriminator.

Input to the audio channel can be obtained from either detector or a phono pick-up. A 9002 triode acts only on phono signals. It is followed

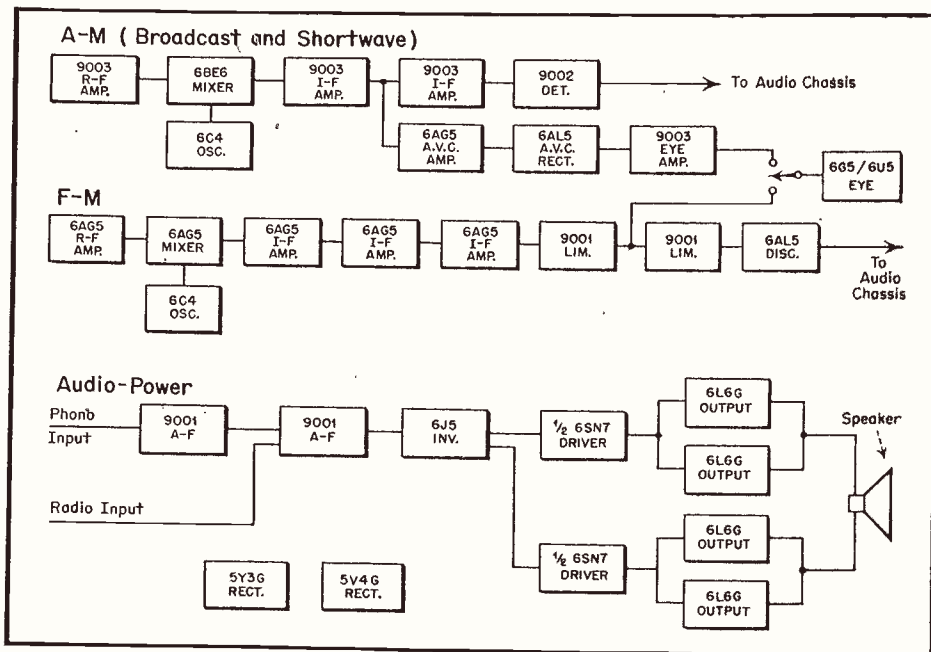

Block diagram of Meissner Model 2961 Series.

by another 9002 which can also derive its input from the radio chassis. The next stage generates out-of-phase voltages in a 6J5 cathode follower. A 6SN7 dual-triode drives the push-pull parallel 6L6G output tubes. An elaborate, push-button operated tone selection system is incorporated in the audio circuits.

Bendix 84 FS Factometer

A partial schematic of the Bendix 84FS Factometer, showing the signal frequency and oscillator circuits, discloses interesting features. The instrument is a portable AM-FM receiver designed to demonstrate, or measure, the presence of usable signals. The switches are shown in the AM position. An extendable rod antenna mounts on the set. Provision is made to attach feeders from external antennae. A

meter indicates the strength of FM signals.

In the AM position, the antenna is connected to the primary of an iron core transformer. The secondary is tuned by one section of the dual two gang tuning condenser. The developed signal is applied to the grid of the mixer section of a 7F8. D-C bias is developed across the cathode resistor. The plate is shunt-fed via a 47K-ohm resistor.

The oscillator section of the 7F8 utilizes a Hartley circuit in which the coil is grounded at one end, the cathode tapped up on the coil and the plate connected to the other end (via a 220 $\mu\mu\text{f}$ capacitor). The grid is returned to ground via the grid leak. The plate is shunt fed, and the r-f energy coupled into the mixer section through the common cathode connection.

In the FM position the oscillator circuit remains the same, except for the switching in of appropriate tuning elements. The mixer grid is switched to a tap on the plate load of a 6AG5 tube, which is used as a tuned r-f amplifier for FM. The grid circuit is also tuned to the signal frequency.

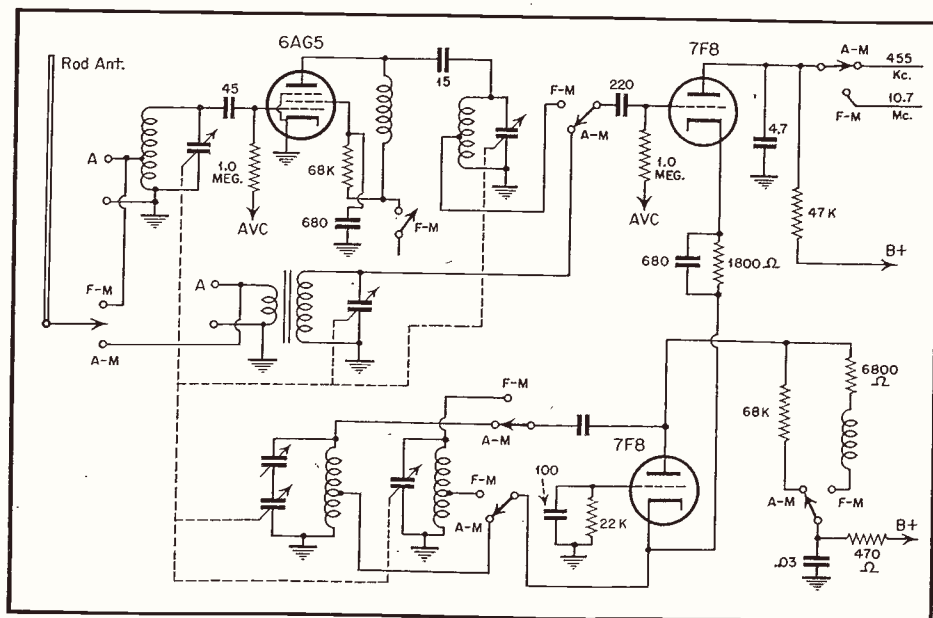

Signal frequency and oscillator circuit of Bendix Model 84FS Factometer.

R.C.A. Q103 Series, RC104 and RC1044B. Reducing Microphonic Howl

R.C.A. suggests the following remedy for reducing microphonic howl in the above receiver. A cement felt pad is cemented to the side of the 1st i-f transformer next to the 12SA7 1st Det.-Osc. tube. A rubber band around the tube and transformer holds the tube against the felt, and reduces the tendency to howl on high volume.

G.E. TV Receivers, Models 901 and 910. Addition of Balanced Input Ant. Transformer.

From the G.E. Service Dept. comes this note on connecting a balanced input transformer to the above receivers.

The input transformer, Stock No. RLA-033 is made available for addition to the Models 901 and 910 television receiver to provide a balanced input to ground for the transmission line. This eliminates direct pickup on the transmission line, of noise pulses and also video i-f harmonics radiated from the receiver.

1. Unsolder $C1$, 300-ohm transmission line and green lead from terminal board on top-rear of r-f head-end unit.

2. Remove two screws holding terminal board. Save two brass grounding straps, discard terminal board along with $L2$ and $C2$.

3. Remove green wire and 1.0 meg-ohm resistor $C175$ (see Fig. 2) from BC and SW external antenna terminal board, and discard parts. The green lead is end of lead removed in step (1).

4. Remove two screws holding the terminal board mounting plate to the r-f head-end unit. Remove the screw and two spacers which support this plate to main chassis. Discard mounting plate.

5. Assemble transformer (1) (see Fig. 1), Stock No. RLA-033 to mount-

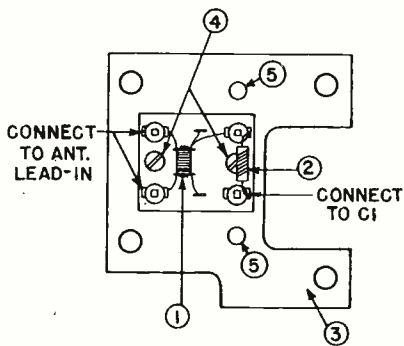

Figure 1

ing plate (3), Stock No. RAP-008, using two No. 4-40 x 5/16" screws, nuts, and lockwashers. Solder choke (2), Stock No. RLI-037, as shown in schematic, Fig. 3, and mechanically mount as shown in Fig. 1. Also, fasten the two brass ground straps, removed in step (2), to the holes (5) shown in Fig. 1, using two No. 4-40 x 5/16" screws, nuts, and lockwashers.

6. Re-assemble mounting plate and transformer assembly to the head-end unit, using the same self-tapping screws removed from original mounting plate.

7. Solder C_1 to choke as shown in Figs. 1 and 2.

8. Re-connect antenna input transmission line to terminals as shown in Fig. 1.

9. Label on the cabinet back under the hole through which connections are

SHOP NOTES

Write up any "tricks-of-the-trade" in radio servicing that you have discovered. We pay from \$1 to \$5 for such previously unpublished "SHOP NOTES" found acceptable. Send your data to "Shop Notes Editor".

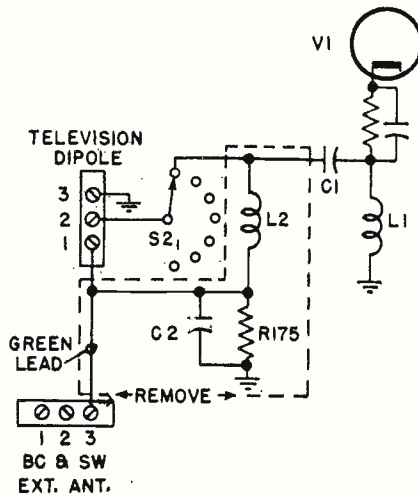

Figure 2

made to the terminal board for "external antenna for broadcast and short wave" must be changed. The change consists of blocking out with black ink, the link connection shown for dipole antenna. Provision is still provided for using an external antenna on BC and SW, but it must be independent of the television dipole and transmission line.

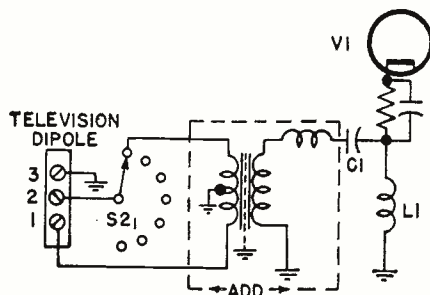

Figure 3

When searching for the cause of the trouble an alignment tool having a high di-electric constant and without a metal tip can be used to probe in the circuit. It is important that the position of the wires and components be changed as little as possible or the receiver may require realignment. During such probing the air column of the speaker in relation to the chassis be as near as possible to normal operation position. Failure to maintain such relation may result in false indications of either excessive howl or no howl.

Webster Phono Turntables, Models 50, 55, etc. Running Slow

Here is a tip to service men who are experiencing trouble with phono turn-

tables which are not turning up fast enough to the required speed. This is especially true with the Webster type 50 and 55 etc.

In a great many cases the small bearing which is directly under the turntable has one or two of the balls which are slightly worn and do not show any superficial wear under casual examination. This is partially due to improper lubrication in assembly and partially to the fact that some of them are of too soft a composition. We have found it a good practice to grease the bearings of new tables before placing in operation, and if the balls themselves appear dark in color, replacing them with new bearings. On some turntables which have only a set of fiber washers to turn on, the addition of one of the bearings will make for longer wear. The latter can be done only if it does not raise the turntable too high so that the drive wheel slips out from under the rim.

Submitted by J. H. Larry, *Some Electronics Store, St. Albans, Vt.*

R.C.A. 612V1, 612V3, 612V4

R.C.A. offers the following service information on the above receivers:

Oscillator Blocking: 1400kc.—1600 kc.

Under certain conditions the receiver may fail to operate between 1400kc and 1600kc. This has been caused by spurious frequencies causing oscillator blocking. All receivers above serial No. 25,000 have a 10 ohm series resistor ($R54$) connected in the oscillator grid circuit. It is recommended that this resistor be added to any receivers which fail to operate between 1400kc. and 1600kc. Referring to Fig. 4, this resistor is connected between $C16$ and terminal No. 1

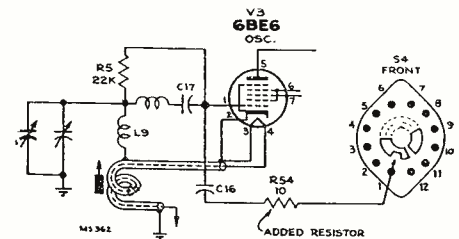

Figure 4

of switch $S4$ (front) r.f. shelf assembly. In chassis below serial No. 25,000, $C16$ is connected between No. 1 of $S4$ front to terminal No. 1 of $V3$ oscillator socket. It is recommended that $C16$ be disconnected from $S4$ and the resistor added

(Continued on page 36)

NEW PRODUCTS

New Roto-Ranger

The Simpson Model 221, something new in test instruments—is actually the equivalent of 25 individual instruments. Designed as a high sensitivity a-c/d-c volt-ohm-milliammeter and equipped with rotating dials, it is ideal for television, radio, and industrial testing.

Its operation is simple—as the selector switch is moved to the range desired, the proper scale for that range is brought into place behind the meter

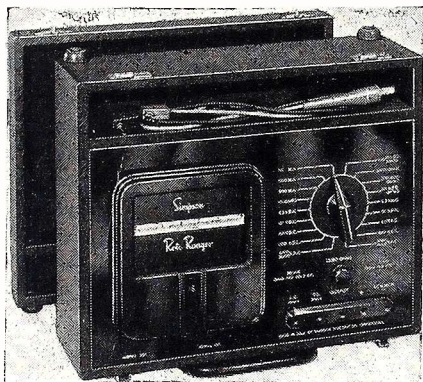

window. Each scale is large and full-sized as it would be for a separate instrument.

The Roto-Ranger will measure automatic frequency control diode balancing circuits, grid currents of oscillator tubes and power tubes, bias of power detectors, automatic volume control diode currents, rectified radio frequency current, high-mu triode plate voltage, and a wide range of unusual conditions which cannot be checked by ordinary servicing instruments. Direct current sensitivity is 20,000 ohms per volt.

Floor-Stand TV Lens

Walco Sales Company, 66 Franklin St., East Orange, N. J., producer of liquid-filled plastic television magni-

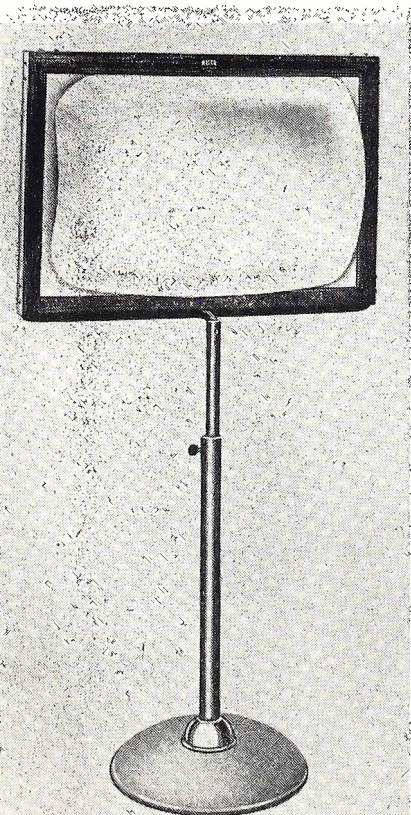

fying lenses, announces a new, improved model lens attached to a floor stand for use in front of console television receivers. Features include a round metal base, similar to the type used on floor lamps, with an adjustable vertical bar which supports the Walco magnifier. This model permits quick and easy adjustment of the lens to the proper height when used in front of all television receivers, particularly console models. When not in use, the unit may be stored away in a closet, inasmuch as the lens is not secured to the television set.

TV Antenna Installation Aid

The Raytheon-Belmont antenna alignment communicator allows the Service engineer who is adjusting the antenna to talk over the intercom

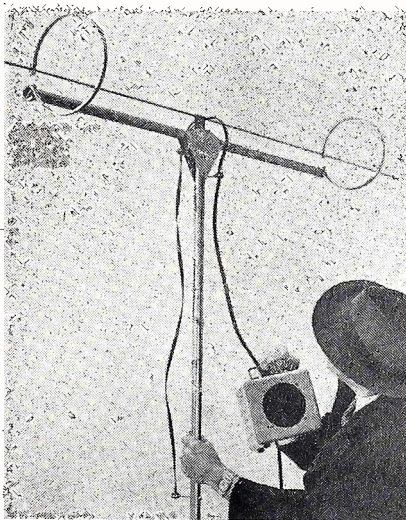

system to his co-worker making adjustments on television receiver. For details write: Raytheon-Belmont Co., attention, Ray Rice, 60 East 42nd Street, New York 17, N. Y.

Automatic Stapling Gun

The Heller Stapling gun will automatically staple braided, rubber coated, single and double strand wire and hollow tube lines to baseboards, plaster walls, window frames, door jams, rafters and around difficult angles or corners.

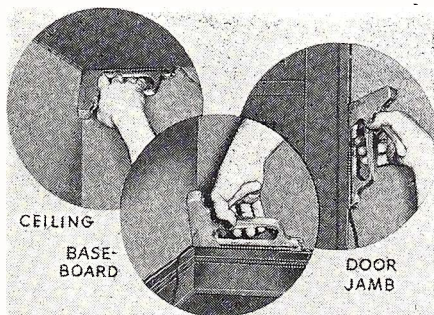

The unit, which uses a new type of staple with a better holding and easier driving point, is excellent for use in Television Radio Installation, intercommunication system and similar wiring operations. For details write The Heller Company, 2153-E Superior Avenue, Cleveland 14, Ohio.

New Espey Tuner

Espey Manufacturing Company has added the model 512 custom-built chassis AM/FM tuner.

Designed to provide a high quality radio channel for industrial and

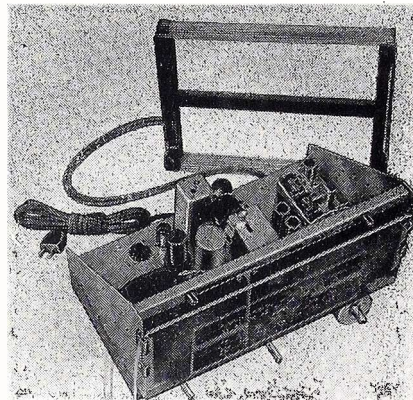

school public address systems as well as to serve as the tuning unit in a high fidelity custom-built installation. Model 512 is a super-het employing nine tubes plus an electron ray tuning tube and a rectifier. The tuning range is 535 kc to 1750 kc on the standard broadcast band, and from 88 mc to 108 mc on FM. The tuner contains its own power supply. AVC is used on both AM and FM. For details, write Espey, 528 E. 72nd St., New York 21, N. Y.

Smaller Volume Control

A smaller 15/16" diameter carbon volume control of entirely new design is announced by Clarostat Mfg. Co., Inc., 130 Clinton St., Brooklyn, N. Y. Despite its compactness, nothing has been sacrificed in electrical and mechanical sturdiness.

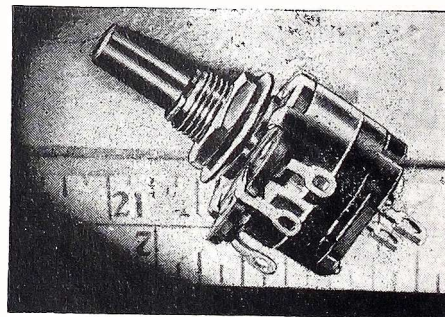

The new control is available with or without switch. However, the switch is factory-equipped or built integral with the control proper. Dimensions are 15/16" diameter by 29/64" deep without switch, or 49/64" deep with switch. Standard units have a 1/4" long 3/8-32 threaded bushing, together with a 1" long knurled shaft, and are available in 250,000, 500,000, 1,000,000 and 2,000,000 ohm values, with the Z audio taper.

New G. E. Tone Arms

A new tone arm, equipped with the G-E variable reluctance cartridge, for playback of 10 and 12 inch records, and a new transcription arm for

professional use, are now available from the Receiver Division of the General Electric Company's Electronics Department.

Designed specifically as a companion unit for the G-E variable reluctance cartridge, the new tone arm is balanced at the factory, giving 1-ounce stylus pressure, yet may be adjusted to any stylus pressure.



The new arm may be used with any record player without an automatic changer. Each is supplied with a tone arm rest, mounting template and a 24-inch special cotton-covered shielded lead.

The new transcription arm is designed for use by broadcasters, sound laboratories, recording studios and wired music services. It features simple installation on popular turntables, no arm resonances in audio range, low mass and low friction arm. It is completely adjustable for stylus pressure, and has an easy-to-read scale, calibrated in grams and ounces.

For further information on the new tone arm, No. UPA-002 and transcription arm Type FA-21-A, write the Component Parts Section, G-E Receiver Division at Electronics Park, Syracuse, N. Y.

New AC/DC TV Set

New Raytheon-Belmont universal table model television receiver which operates on AC or DC. Has 17 tubes plus rectifier with 7" direct view video screen. Covers 13 station channels.

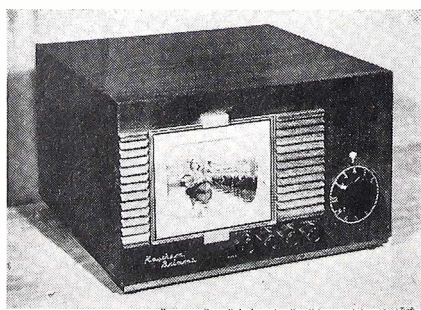

Genuine mahogany cabinet measuring 17" x 16 1/2" x 10 1/2" and weighing 30 pounds. For details write Raytheon-Belmont Co., attention Ray Rice, 60 East 42nd Street, New York 17, N. Y.

Lifetime Plug

A new type Lifetime Automatic Attachment Plug Cap which requires

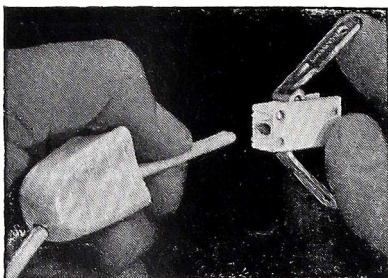

no stripping or slitting is being manufactured by Academy Electrical Products Corp., 4849 Broadway, New York 34, N. Y.

The plug is molded of durable Plaskon and comes in a wide variety of modern pastel colors. No screws, soldering or crimping is used to attach plug. Connection is automatically accomplished by metal points incorporated in swingable blades. These points pierce insulation of individual conductors and make electrical contact.

Projection TV Custom Set

The new Projection Television Assembly by Television Assembly Company, 540 Bushwick Avenue, Brooklyn 6, New York, projects a full 520 square-inch flat picture onto an Eastman Kodak Projection Screen that concentrates light, by means of an optical-electronic system consisting of: the Bausch & Lomb F/1.9 Projection Lens, the RCA 5TP4 Projection C.R. Tube, a pre-wired 30 KV Tripler Flyback Supply, and an aluminum-top coated mirror. This System projects a brilliant, soft picture that is comfortably seen from close or distant range.



The 30 KV Power Supply is pre-wired, ready for operation.

The entire Projection Assembly consists of 36 tubes (including the C.R. Tube) and features:

1. The perfected 13-tube pre-wired, pre-tuned I-F Picture & Sound Strip having 5 1/2 stages of I-F picture amplification, with a 4.25 mc bandwidth, all on one chassis.

2. Dumont Inputuner, having 3 continuously tunable circuits, from 44 to 216 mc—covering all TV Channels plus FM, amateur, and aviation, with no band-switching.

3. Three-stage audio amplifier, with two type 6F6's in push-pull, Class AB,

delivering approximately 12 watts undistorted output.

4. RCA 12" Heavy Duty PM Speaker.

5. 30 KV Power Supply consists of 3 Type 1B3GT as a Tripler, using fly-back deflection, maintaining a 3" x 4" picture of incandescent brilliance on the face of the projection tube, at a minimum of 27 kv.

6. Single Dipole & Reflector, plus 60 ft. lead-in.

7. Two Low Voltage Power Supplies, to insure greater stability and regulation, producing a minimum of heat.

This Projection Television Assembly is the first of its kind. With each is supplied Manual of Instructions and Schematic data prepared by John F. Rider.

New ATR Inverters

American Television & Radio Co., 300 East Fourth St., St. Paul 1, Minnesota, announces a complete new line of DC-AC Inverters, operating on DC input voltages ranging from 6 volts



DC to 220 volts DC, delivering an output of 110 volts, 60 cycles, AC at output capacities ranging from 75 watts to 500 watts. These inverters are specially designed for operating AC radios, public address systems, television sets, amplifiers, small AC motors, and electrical appliances, from DC voltage sources. Being featured in the line is an automatic switching unit for use as an auxiliary unit with 32 volt and 110 volt DC input inverters, permitting the automatic start and stop of these units as the load is turned on and off. The ATR Inverter Line includes more than 33 different standard types. Complete descriptive literature is available free by writing the factory.

Battery Tester

The new Chicago Model 471 Battery Merchandiser shows at a glance the condition of any dry "A" or "B" battery. It may be used on the counter or hung on a wall because of



its dual position design. The 5½ inch meter tells whether a battery is fresh or should be replaced.

Two ranges provide for both low and high voltage batteries. The 1½ to 10 volt range accommodates flashlight cells and "A" batteries. "B" batteries are tested on the 10 to 150 volt range merely by flicking the toggle switch and setting the selector dial to the rated voltage of the battery. All tests are made under load according to the battery manufacturer's specifications.

For further details write Chicago Industrial Instru. Co., 536 W. Elm St., Chicago 10, Ill.

New Solder In Tube

The L & R Manufacturing Company of 577 Elm St., Arlington, N. J., offers Solderzit, packed in a convenient



tube, an all-purpose, high-strength metal solder that contains its own flux. To use, merely clean the surfaces to be joined, apply Solderzit and heat with soldering iron, torch or match flame.

Custom Cabinets

The Jensen Mfg. Co., 6601 S. Laramie Ave., Chicago 38, Ill., realized the need for a quality loudspeaker as the heart of our modern home or office entertainment center and commissioned leading furniture stylists and electronics engineers to create their Customode, unified matching enclosures for all electronic equipment.

Jensen offers four basic Customode units: a medium utility cabinet for large equipment, small television sets, etc.; a small utility cabinet, for tuner, amplifier, recorder, record changer, etc.; a reproducer cabinet,

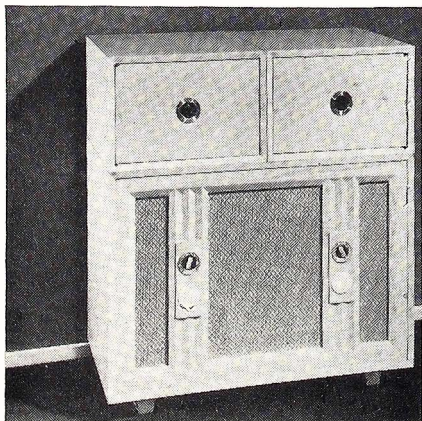

bass reflex design for a 15-inch coaxial speaker, the last word in acoustical correctness; and a record cabinet, holding more than 200 records. For literature, write Jensen direct.

Cathode-Ray Stethoscope

Feiler Engineering Co., announces the Cathode-Ray Stethoscope.

The Cathode-Ray Stethoscope is really two instruments in one: a fine, precision-engineered five inch cathode-ray oscilloscope combined with the

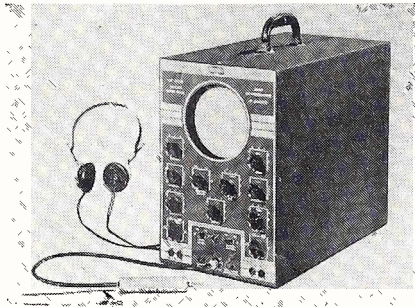

unique Feiler Stethoscope. It is primarily designed for FM and television servicing and is also ideal for AM and audio work.

It can be used in conjunction with a Stethoscope probe and earphones, enabling the operator to see and hear the signal simultaneously.

For full details on all Feiler instruments, write Feiler Engineering Co., 947 George Street, Chicago, Illinois.

VTVM Kit

A high-frequency vacuum tube voltmeter in kit form is now available at the Radio Kits Company, 120 Cedar Street, New York City.

This low-cost VTVM kit features a linear diode AC rectifier and 1% precision resistance for improved high-

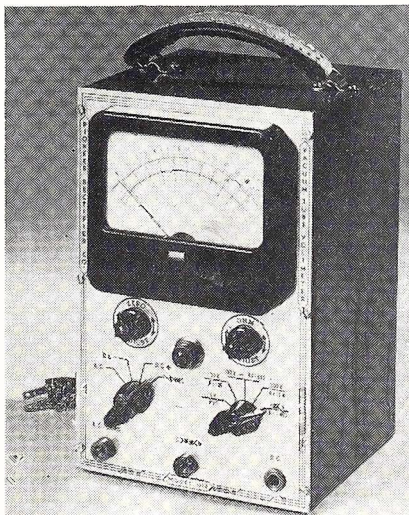

frequency measurements. The output meter scale is calibrated for a 600-ohm circuit based on a reference level of 1 milliwatt. This VTVM measures up to 1000 volts AC or DC on a 5-range linear scale and up to 1000 megohms in 5 ranges. This kit is complete with tubes and instructions for assembly.

New Ward Dipole

Ward Products Corp., 1523 E. 45th St., Cleveland 3, Ohio, announces their new Model TV S-6 stacked array, said to be exceptionally powerful for

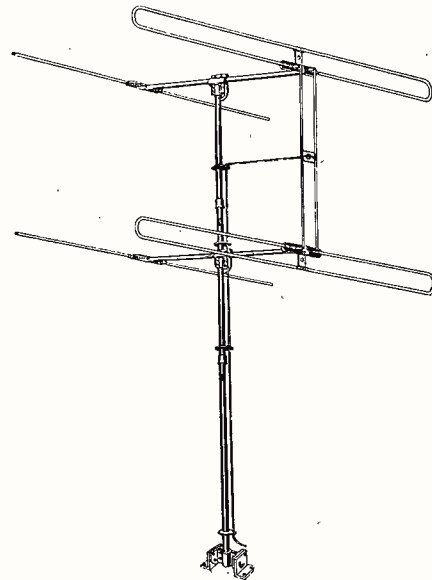

T.V. reception in remote installations and poor signal locations.

The strong signal pick-up is accomplished by stacking two antennas, one above the other with correct ½ wave spacing. An ingenious method of allowing complete adjustability for orienting even though bays are stacked has also been engineered. Pre-assembly of component parts have been designed to save installation time and expense.

9-Pin Miniature Pin Straightener

Hytron Radio & Electronics Corp., Salem, Mass., announces the Hytron 9-Pin Miniature Pin Straightener, third in a series of shop tools specially designed for servicemen's use.



This precision tool is built of special stainless steel and aluminum. It is timely, too, just when noval tubes are becoming common in f-m and t-v receivers. Each serviceman should be equipped with three—one for the bench, one for the tool kit and one for the counter near the tube tester. You can get your 9-Pin Miniature Pin Straighteners from your Hytron Jobber.

Universal Television Alignment Generator

With the new Hickok Model 610 Television Generator now announced

(Continued on page 36)

Your new CRL parts catalog

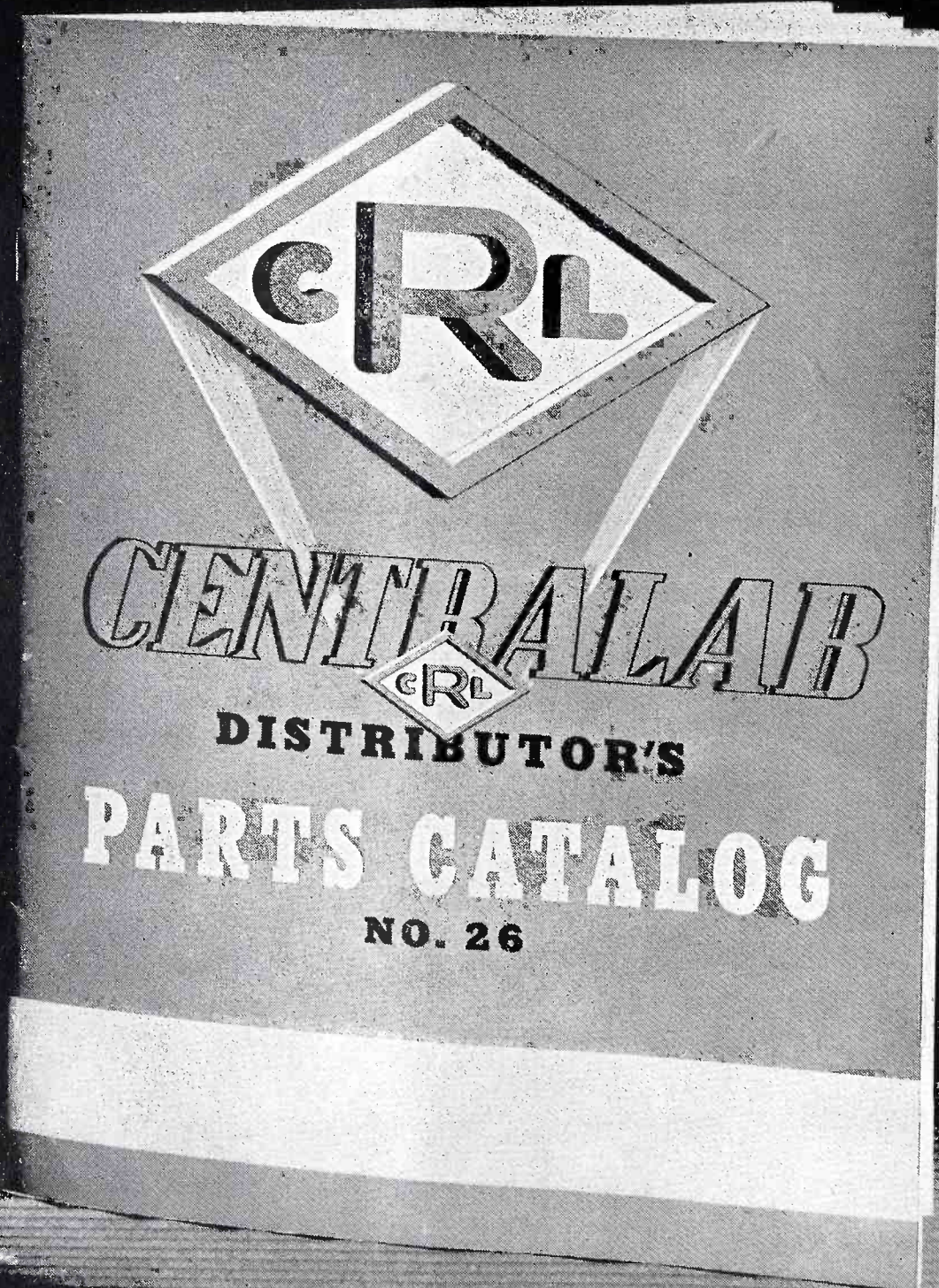

20 pages of up-to-the-minute information

- NOW READY!

HERE IT IS — Centralab's complete new Distributor's Parts Catalog! 20 pages jam-packed with valuable technical information about Centralab's electronic components, including new prices and all new additions to the

Centralab line. Below are some of the new items which help make the CRL line one of the most complete in the service field. Ask your Centralab Distributor for your copy of this new Catalog — or write direct to us.

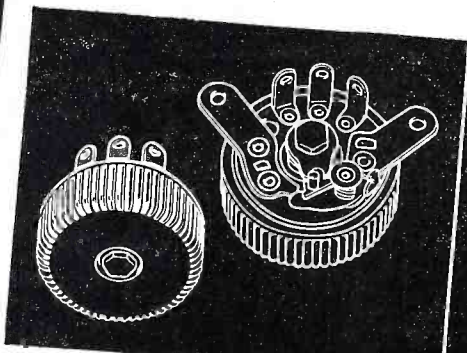

MODEL "1" RADIOHMS: No larger than a dime, specially designed for hearing aids, miniature receivers. With switch (right) or without. Rating 1/10 watt. 500 ohms — 5 megohms resistance.

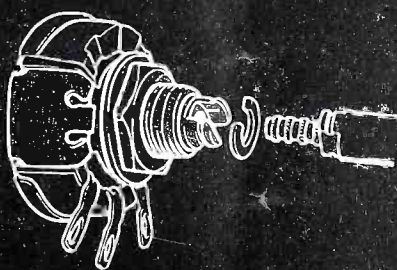

"ADASHAFT" RADIOHMS: Available in all sizes for all Model "M" volume control applications. Six types of shafts. Permits small stock to handle almost any kind of control replacement.

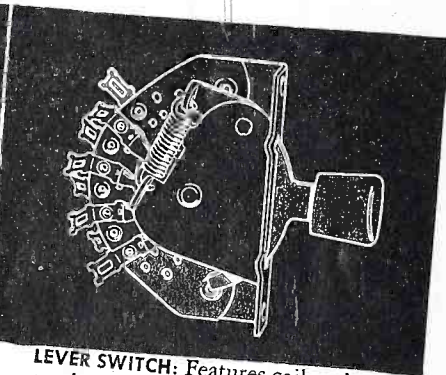

LEVER SWITCH: Features coil spring mechanism with index spring, replaceable without removal of switch from chassis. Life test — 150,000 cycles. 8 indexing combinations. Silver-plated clips and contacts.



AUXILIARY SPEAKER SWITCH: Three position switch to provide remote control for auxiliary speaker installations. Life test — 10,000 cycles. Rating 6 watts.

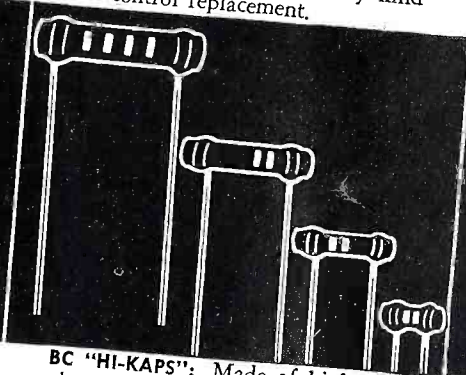

BC "HI-KAPS": Made of high dielectric Ceramic-X. Four basic tube sizes with capacity range from .000010 to .01 mfd. 500 WVDC. 1000 VDC flash test.

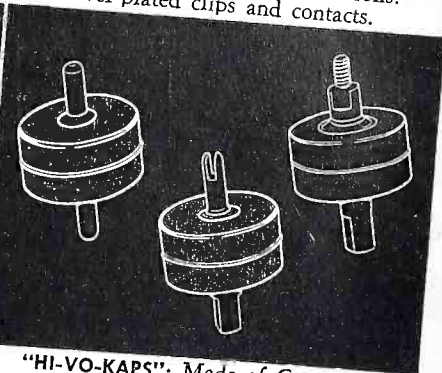

"HI-VO-KAPS": Made of Ceramic-X. Combine high voltage and small size for television and high voltage applications. 10,000 WVDC. 20,000 VDC. Capacity—500 mmf.

Centralab

Division of GLOBE-UNION INC., Milwaukee

— at your CRL Distributor!

TECHNICAL QUIZ NO. 7

Subject: Television Patterns

BEFORE ANSWERING THE QUESTIONS—READ THESE RULES:

Illustrated below are 10 TV test patterns. One is a correct pattern and 9 are faulty due to one of 3 causes, such as: 1) faulty receiver operation, 2) misadjustment of controls, 3) faulty reception due to some outside interference. Listed at the bottom of the next page are various pattern descriptions. Alongside of each is a space reserved for your answer.

Examine each pattern carefully. Identify it with one of the pattern descriptions given, and jot down the corresponding number given under each pattern in the space allotted. For each correct answer you are credited with 10 percentage points. Correct answers to the questions are given on Page 46.

RATINGS FOLLOW: 100% = Perfect, 90% = Excellent, 80% = Good, 70% = Fair, 60% = Passing
Any score below 60% is failure. Tests must be completed within 20 minutes.

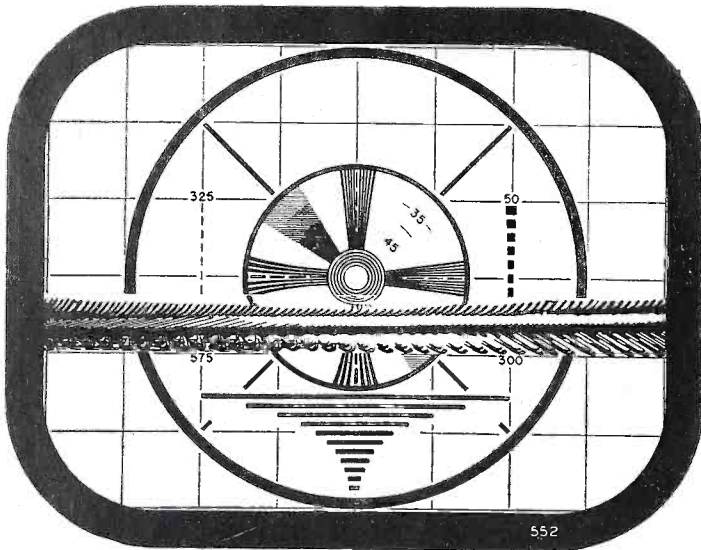

1

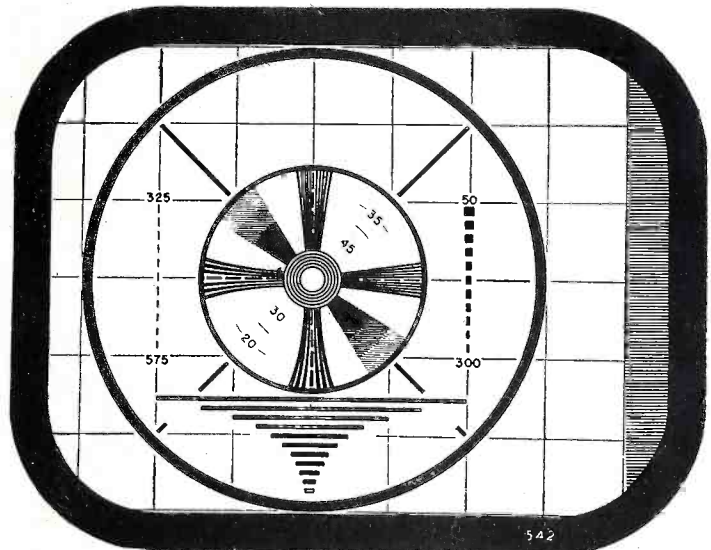

3

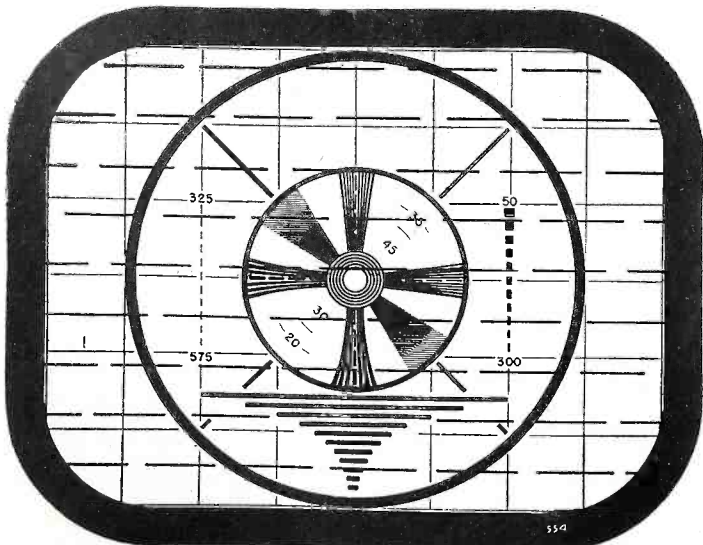

2

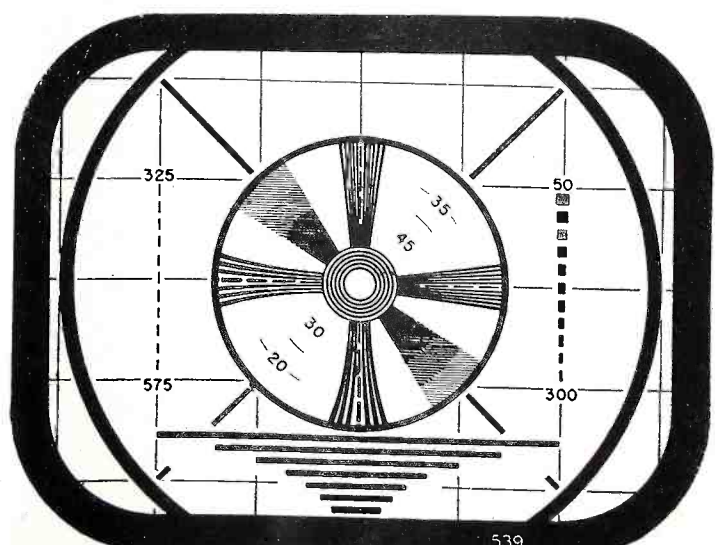

4

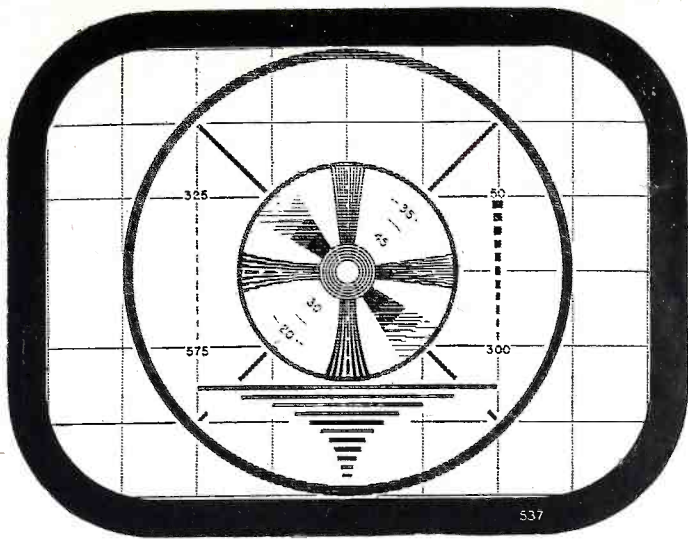

5

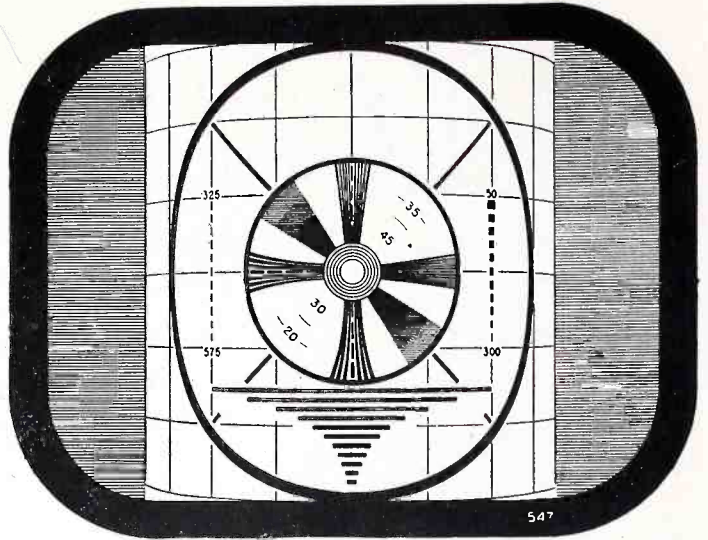

8

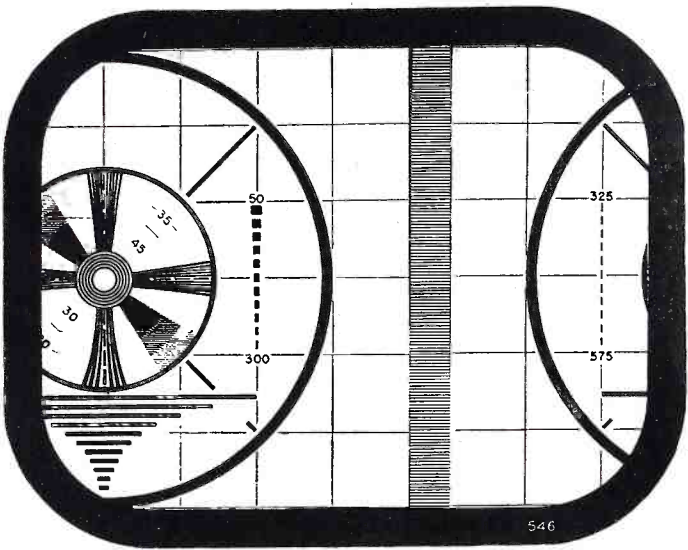

6

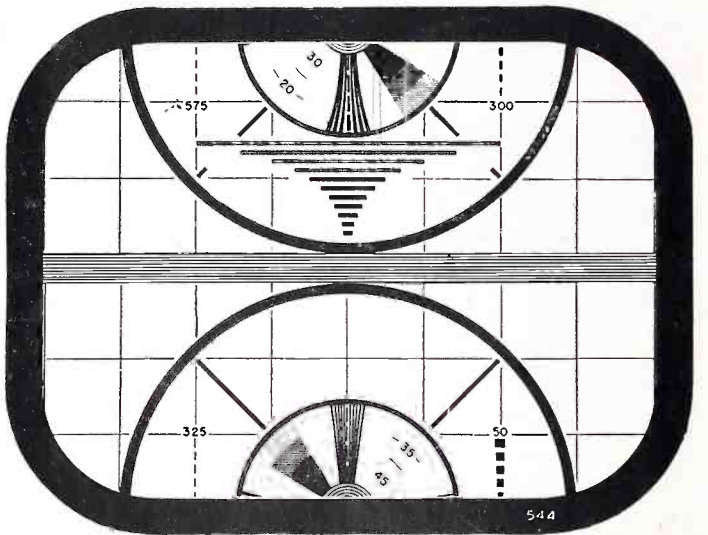

9

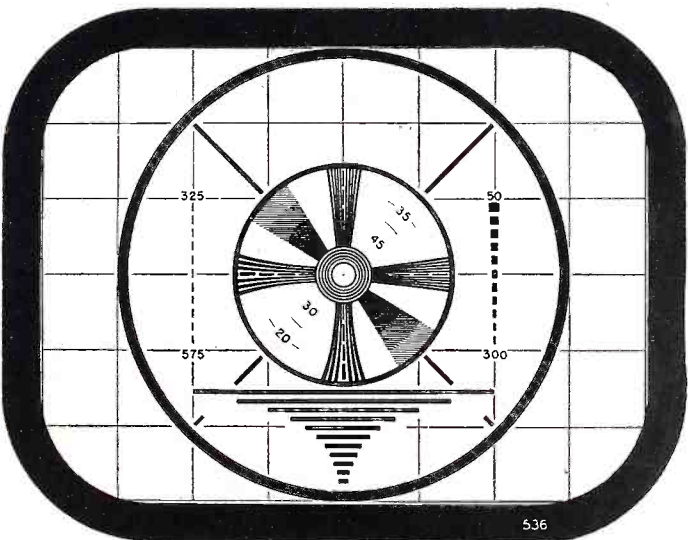

7

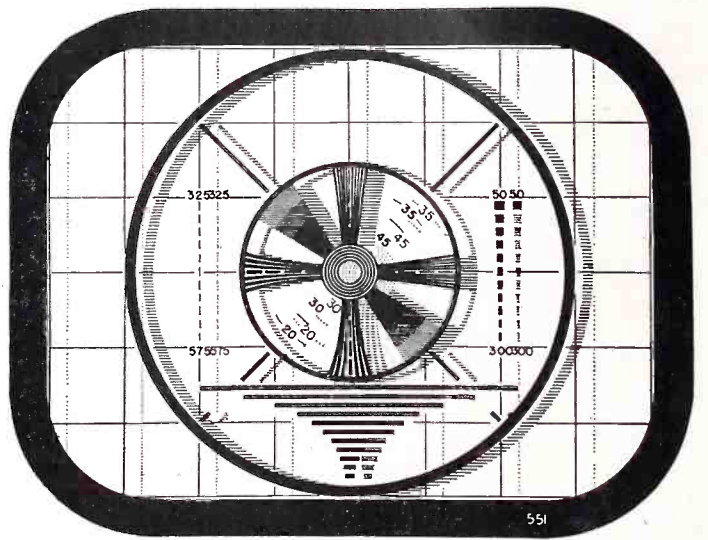

10

Answer Column

Pattern Description	Pattern No.	Pattern Description	Pattern No.
Correct Pattern	7	Too large horizontally and vertically	4
Too small horizontally, and correct vertically	8	Multiple images (ghosts)	10
Too light	5	Vertical tearing	6
Off center horizontally	6	Diathermy interference	1
Ignition interference	2	Horizontal tearing	9

TRANSVISION

BIGGEST VALUES in TELEVISION!

Large-Image, Direct-View TV Kits at Low Cost!

Kits Engineered for EASE of ASSEMBLY and Top Performance.
Cabinets designed and built for Beauty, Utility, Durability.

NO TECHNICAL KNOWLEDGE REQUIRED for ASSEMBLY.

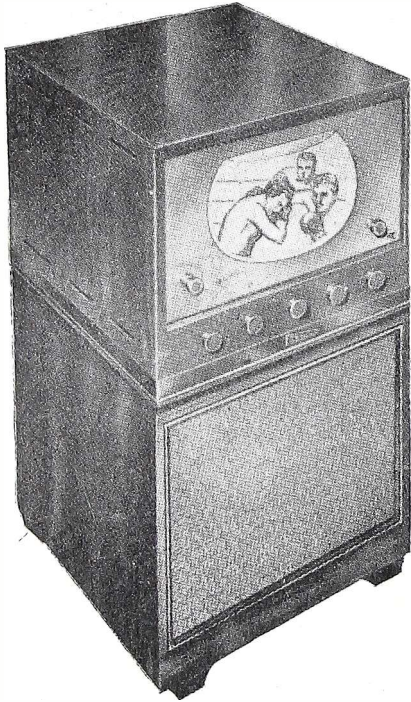

Console Model 7CL

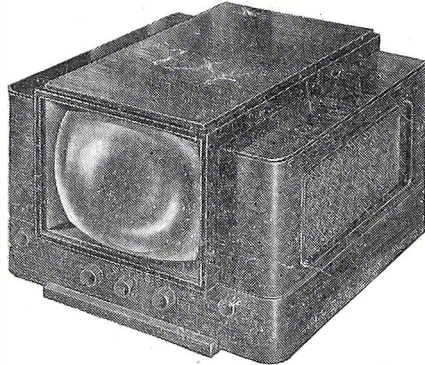

MODEL 10BL Gives 115 Sq. In. Picture

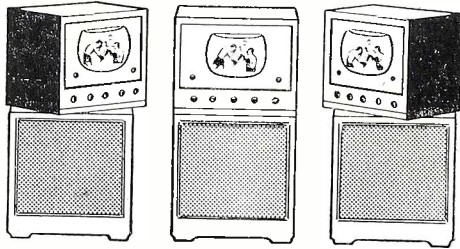

Roto-Table for full 180° Visibility

TRANSVISION manufactures the most extensive line of high quality Television Kits, Cabinets, and Components. Models illustrated and listed here are only representative of Transvision's leading values. See your distributor.

MODEL 10BL, TV/FM Kit, gives 115 sq. in. picture, complete FM Radio; receives all channels; streamlined cabinet. . . . NET \$299.00

Roto-Table for Model 10BL, gives full 180° visibility. . . . Net \$24.95

MODEL 7CL, TV Kit, gives 60 sq. in. picture; console cabinet complete with Roto-Table; streamlined design. . . . Net \$199.00

MODEL 7BL, same as 7CL except that it is a table model. . . . Net \$189.00

All prices include cabinets, tubes, antenna, and 60 ft. of lead-in wire. (Models 7CL and 7BL can be supplied with complete FM Radio for small additional cost.)

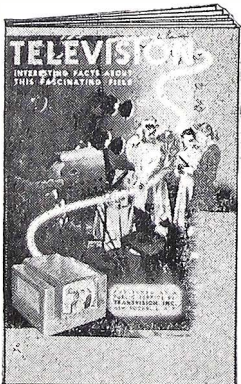

FREE Fascinating BOOKLET On Television

Illustrated 20-page 2-color booklet gives you excellent basic information on television. Call at your distributor's for a FREE COPY; or write to us for names of distributors.

"SERVICE NOTES"

by Transvision . . . the Key to Successful Television Servicing . . . Confidential Television Notes and Information, product of experience with over 20,000 television sets. Complete with photos, diagrams. Worth a small fortune. Cost is only \$1.95 NET



All prices 5% higher west of Mississippi; all prices fair traded. For further information see your distributor, or write to:

TRANSVISION, INC. Dept. R.S.D., NEW ROCHELLE, N. Y.
In Calif.: Transvision of California, 8572 Santa Monica Blvd., Hollywood 46

For TELEVISION, it's TRANSVISION—the complete line of High Quality Kits, Cabinets, Antennas, Lenses, Filters, Boosters, Components—Ask your distributor!

NEW PRODUCTS

(from page 31)

the operator can visually align television receivers to any of the 13 present TV channels from 44 mc to 216 mc., visually align IF stages of an TV receiver including old and current



bands, align all traps with a calibrated signal—modulated or unmodulated, and insert an accurate marker at any point along the IF response curve. Self contained marker frequencies are directly calibrated on a large 9½" dial.

Write The Hickok Electrical Instrument Company, 10533 Dupont Avenue, Cleveland 8, Ohio, for complete and detailed information.

SHOP NOTES

(from page 28)

in series thus holding the over-all length of C16 and R54 to that originally required for C16.

Microphonic Howl—FM Operation:

Some of these receivers have developed howl when operating on FM.

Howl of this nature is generally a result of vibration from the speaker being transmitted to some component or series of components in the oscillator circuit. The vibration of these components causes the oscillator frequency to become modulated, resulting in a howl being emitted from the speaker.

The following are possible causes:

1. Loose elements in the oscillator tube.
2. Loose plates or unequal spacing of rotor and stator plates in the FM oscillator section.
3. Capacitor C88 should be placed adjacent to the side wall of the r-f shelf and be firmly held in place. This may be accomplished by melting wax against the capacitor and the chassis.
4. All oscillator r-f and ant. leads should be well separated and arranged to produce the least capacity change if set into vibration.

Specify the



1201

**DELUXE ALNICO 5
LOUDSPEAKER**

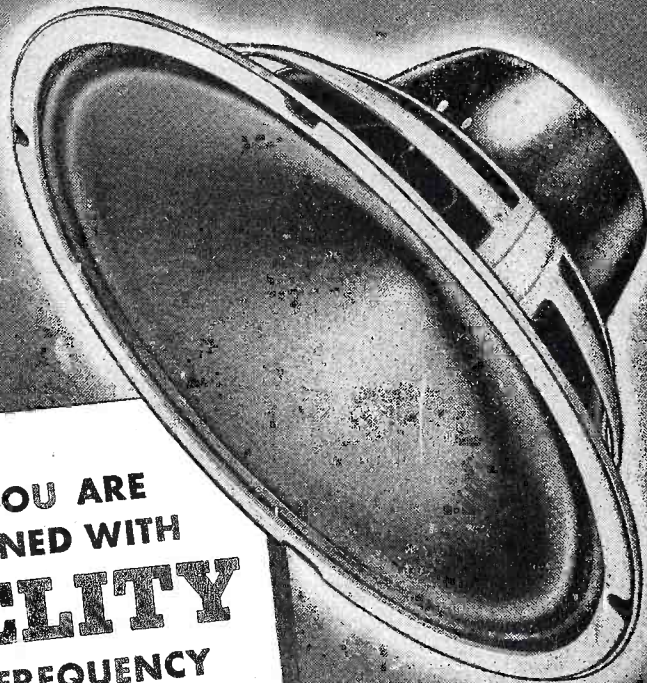

WHEN YOUR
JOB DEMANDS
POWER
25 WATTS
POWER HANDLING
CAPACITY

WHEN YOU ARE
CONCERNED WITH
FIDELITY
BROAD FREQUENCY
CHARACTERISTIC
50—13,000 CYCLES

EQUIPPED WITH
THE FAMOUS
GENERAL ELECTRIC
ALUMINUM FOIL BASE
VOICE COIL

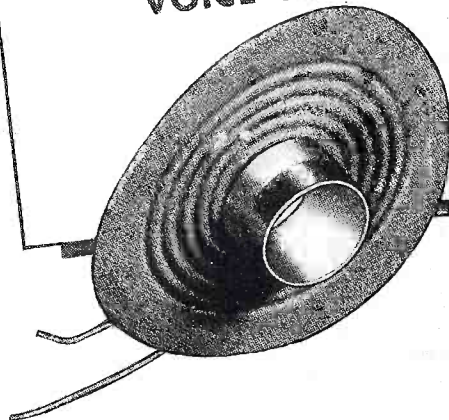

POWER, fidelity and a price that will amaze you for a speaker of this exceptionally high quality—it's the G-E 1201.

It's a wide range speaker with the frequency response stretched out at both ends of the curve to give intense realism, smooth, full lows and "high fidelity." A curvilinear cone is employed to provide this extended frequency response. Alnico 5, 14½ ounces of it, gives high sensitivity and smooth response.

The moving parts in the speaker assembly are ruggedly designed to take high power without damage to the speaker in any way.

Note: Frequency response 50—13,000 cycles.

For complete information on this outstanding speaker write: *General Electric Company, Electronics Park, Syracuse, New York.*

GENERAL  **ELECTRIC**

169-G8

TRADE FLASHES

(from page 10)

school regular pre-employment training, 3,022 attended, and in the evening school extension training, 2,768.

In their quest for job knowledge, students at Dunwoody put in 1,949,847 hours of training. They came from

(Continued on page 48)

APPLIANCE REPAIRS

(from page 19)

will continue to emit electrons for a short time, however, because they do not cool immediately. With the breaking of the circuit, current ceases to flow in the ballast, also. The magnetic field which was built up now collapses. The sudden collapse sets up a voltage surge with the result that about 200 volts is applied between the ends of the lamp. Electron flow throughout the length of the tube takes place, and the electrons cause ionization of the argon gas. In a very short time the mercury vaporizes and it too becomes ionized. We now have what amounts to an arc, traversing the length of the tube, from one filament to the opposite one. Due to ionization, the resistance of the lamp drops to allow value and the line voltage is then high enough to maintain the arc. The ballast serves to keep the current from rising too high. The light emitted by this arc contains a high percentage of ultra-violet and near-ultra-violet; this light strikes the phosphor crystals on the tube wall and the crystals then fluoresce, generating most of the visible light. One more point should be noted: once the lamp is in operation, the heat of the arc keeps the filaments in emitting condition. The flow of current through the filaments is necessary only during a short time while the lamp is being started.

Fluorescent lamp troubles are confined to a few types, and are easily diagnosed provided that the basic principles are understood. If, on closing the line switch, the filaments fall to glow, any one of the following may be the cause: defective lamp (one or both filaments open); defective starter (contacts do not close); open ballast; a broken connection, or a poor contact at one of the lamp holders. Remove the lamp from the holders and test continuity of the filaments with an ohmmeter or by connecting an incandescent lamp in series and plugging into an outlet. Never connect a fluorescent lamp filament directly to the supply line. For 15 watt lamps use a 25 watt incandescent lamp in series, for 15 to 40 watt lamps use a 60 watt incandescent; for lamps over 40 watts use a 100 watt bulb. If the filaments



Back of every
Racon product

ADVANCED ENGINEERING

WHEN you invest in a Racon Horn or Speaker you get all-around super-efficiency—qualities that can not be duplicated by units of conventional type. Such units may resemble Racon units externally but only a Racon has the internal features that bring you top performance.

Racon superiority is the result of Advanced Engineering—improvements developed in the Racon Laboratories by Racon Engineers through tireless research and testing.

For unmatched performance, long life and economy install a Racon.

RACON DOUBLE RE-ENTRANT TRUMPET

(Illustrated above)

An excellent example of Racon scientific engineering. Designed to deliver highly concentrated sound over long ranges with maximum efficiency. Seven models, ranging in length from 6-5/8" to 28". All with aluminum casting inside tone arm and bell of heavy gauge aluminum spinning. Large sizes built with center reflecting section of Racon Acoustic material for preventing resonant effects. Smaller sizes have heavy gauge aluminum spinning for center section.

Strong construction, practically abuse proof. Fitted with swivel mounting ratchet wall bracket. For large sizes U-bracket mounting supplied on request, no extra cost.

Write for Catalog of complete Racon line.

RACON ELECTRIC CO., INC.

52 E. 19TH STREET, NEW YORK, N. Y.

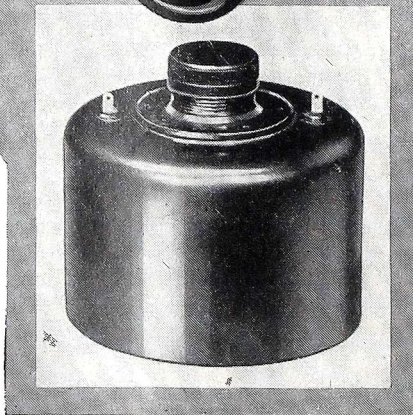

PERMANENT MAGNET HORN UNITS

These units, highly popular in all types of service, embody many improvements. Two groups with Alnico V Magnets and Alnico Blue Dot Magnets. All steel parts plated to prevent corrosion. Also fitted with corrosion proof metal or plastic diaphragms. Voice coil impedance on all units: 15 ohms, except dwarf size—which is 8 ohms. Special ohmages on request.

NOW FURNISHED WITH WATERPROOF CASING

All units, from junior to giant size, may now be had with heavy spun aluminum case, forming a close fitting hermetically sealed, watertight housing for outdoor use. Waterproof type at slight extra cost.

RACON

Speakers
Horn Units
Horns



For the first time . . .
RIM DRIVE DUAL SPEED PHONOMOTORS!

For the **NEW 33 $\frac{1}{3}$ R. P. M. RECORDS**

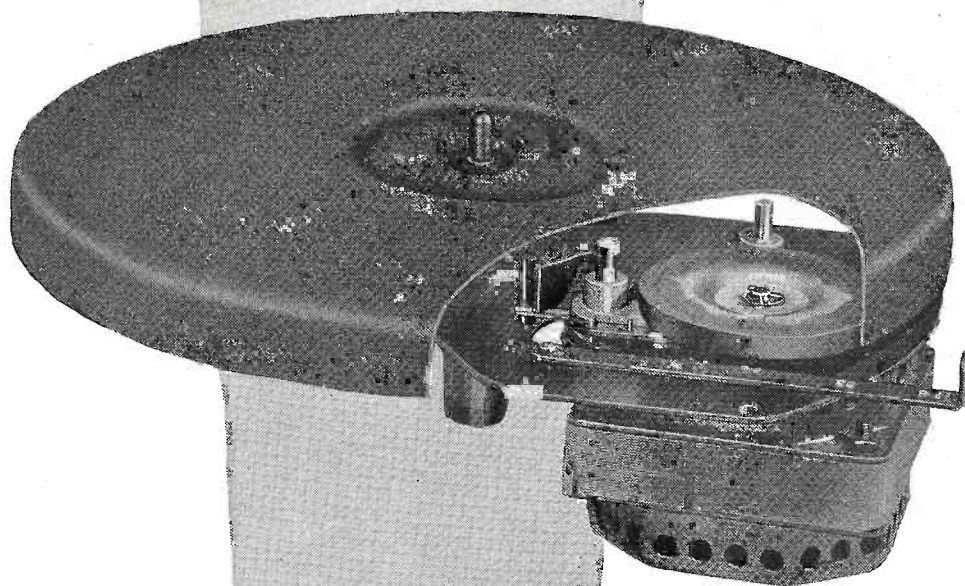

MODEL DR—Deluxe model 4 pole, shaded pole motor designed for use in all high-grade instruments in which the ultimate in performance is desired. Novel speed change mechanism is both simple and positive in operation.

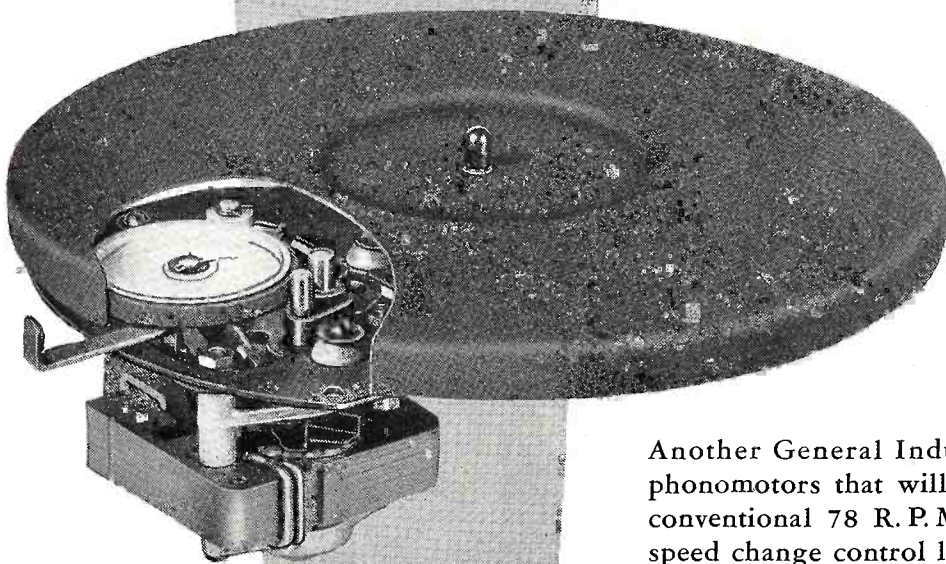

MODEL DM — Compact low cost 2 pole, shaded pole motor designed for portables, table models, and other instruments in which space is an important factor. Ingenious speed change mechanism incorporates highest quality molded rubber belt.

Another General Industries' *first . . .* low cost, dual speed phonomotors that will play both the new 33 $\frac{1}{3}$ R. P. M. and conventional 78 R. P. M. records. Both motors have external speed change control levers . . . both are engineered and built to the same high quality standards which distinguish all phonomotors, recorders and record changer-recorders in the famous *GI Smooth Power* line.

Complete information about this newest development in the phonomotor industry is available on request. Write or wire today to:



The GENERAL INDUSTRIES Co.

DEPT. K • ELYRIA, OHIO

are not open, inspect the lamp holders to be sure that the contacts are clean and have sufficient tension. Likewise inspect, and clean if necessary, the terminal pins of the lamp. Look for broken or loose connections and check the ballast for continuity. If no trouble is found up to this point, you have, in all probability, a defective starter. Remove it and insert a new one. If a new starter is not at hand, remove the original one from its socket and connect a jumper across the starter socket contacts. When the line switch is closed, the lamp filaments should light. Removing the jumper quickly should then start the arc discharge.

If you encounter a situation in which

the filaments light but the arc discharge does not begin, the most likely trouble is a defective starter. A defective ballast is also a possibility, but not too likely. The starter may be checked readily by twisting it out of its socket after the filaments have lighted. The lamp should then start. If it does not, try replacing the lamp. If this still does not produce results, the ballast may be at fault.

Repeated blinking of a lamp during starting generally indicates a defective starter. This should be corrected immediately, otherwise the lamp, and possibly the ballast as well, may be damaged. Defective starters account for many of the premature failures of

lamps. The life of a lamp is based upon the number of starts; more frequent starting reduces lamp life greatly. The usefulness of a lamp is ended when one of the filaments opens or when the filaments lose their active material. The latter condition is often preceded by blackening of the ends of the lamp.

Single-lamp fluorescent fixtures are used mainly as bed lamps, desk lamps and in small installations, such as over kitchen sinks. Occasionally a customer will complain that such a fixture causes an objectionable stroboscopic effect. This cannot be overcome except by the use of a multi-lamp installation. Fixtures having two or more lamps may often be treated as separate circuits each having one lamp. Ordinary two-lamp circuits, which, by the way, afford greatly reduced stroboscopic effect, consist merely of two lamps, two starters and two ballasts. The individual circuits are identical with the one just described and illustrated in *Fig. 10*. In some cases, the ballasts are not independent, but are contained in a single case, but in the majority of such cases a connection diagram showing the coloring of the leads is pasted on the ballast case, which greatly simplifies trouble shooting. More complicated circuits, with provision for power factor correction, have a condenser connected in series with one lamp. Still others use an autotransformer for obtaining the high voltage for starting the lamp.

Radio interference may be set up by fluorescent lamps and usually can be traced to one of two causes. Opening and closing of the starter contacts is one cause, although this should not occur if the starter is in good condition, on account of the interference condenser mentioned previously. It is possible that this condenser may become defective, in which case the most economical procedure would be to replace the starter, rather than to attempt to install a new condenser. The second source of interference is within the tube itself. The arc discharge will radiate a certain amount of interference, and very little can be done about it. Usually, however, it is not radiated more than a very few feet from the lamp. Occasionally you will find a lamp that functions normally, insofar as light output is concerned, but which generates more than the usual amount of noise. It is best to replace such lamps, because experience has shown that their life is usually very short.

Electric Clocks

Electric clocks utilize the principle of the synchronous motor—the same principle employed in some phonograph motors on the market a few years ago.

(Continued on page 42)

ATTENTION . . . SERVICEMEN!

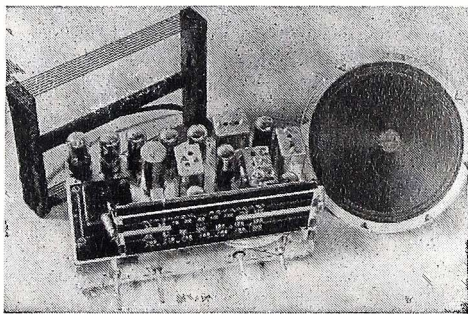

ESPEY Model 7-B-1

Mr. Serviceman!

Are you reaping the full advantage of the tremendous replacement market that exists today? Most of your customers are in need of a modern AM-FM radio receiver chassis. They will select ESPEY because the ESPEY chassis are the finest available on the market today—at the lowest price.

Head and shoulders above the crowd, from an engineering, design, manufacturing and quality standpoint. All features that are needed in a modern receiver are included, together with all hardware, speakers, and antennas required to make your installation job quick and easy.

This replacement market, Mr. Serviceman, is a "natural" for you, because YOU have entry into the home; your customers have confidence in YOU, and they will follow YOUR recommendation. There are millions of console sets in existence today whose owners desire to keep their cabinets, and are now aware how easy it is to install a modern AM-FM ESPEY chassis. This large market is growing bigger every day, as more and more owners decide they want FM. And this opportunity is reserved for YOU.

For further information about this terrific potential, drop a line today to Dept. M-9

ESPEY MANUFACTURING CO., INC.

528 EAST 72nd ST., NEW YORK 21, N. Y.

"Established 1928"

added sales punch for the



FASTEST SELLING AUTO AERIAL LINE



● The NEW Radiart Auto Aerial line is the talk of the country! NOW . . . here is ADDED sales appeal for these fast sellers! This colorful counter display card will draw attention of your customers to these top quality aerials . . . and that means ADDED profitable sales for you! The Radiart Aerial line has everything! Finest quality chrome plating . . . easy speedy one man installation . . . they replace almost all factory equipped Aerials . . . give unequalled performance . . . and they all have the finest interchangeable lead ins of any auto radio aerial.

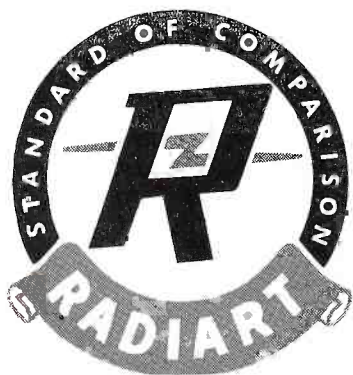

The Radiart Corp.

CLEVELAND 2, OHIO

EXPORT: SCHEEL INTERNATIONAL, INC. • 4237 N. LINCOLN AVE., CHICAGO, ILL.

MANUFACTURERS OF THE FAMOUS RADIART "RED SEA" VIBRATORS

Such phonograph motors required hand starting, as did early electric clocks. Reduced to fundamentals, an electric clock consists of an iron rotor revolving on a shaft placed between the poles of a field coil. Just so long as the supply line frequency is constant, the clock will keep accurate time, and most public utilities maintain frequencies constant within a half cycle or perhaps less. The revolving rotor drives a gear train which moves the clock hands. In older clocks, which require hand starting, all of the gearing is visible when the back of the clock is removed. In more modern clocks, some of the gearing is contained in a brass case which you will find between the field

poles. The protruding shaft of this gear unit makes one revolution per second.

Clocks give remarkably little trouble, and such defects as do occur are fairly easy to locate. A modern, self-starting clock which does not run at all may have developed an open field winding. Another symptom of this trouble is lack of any hum when the ear is placed close to the case. Of course, it is assumed that the attachment plug, the cord and all connections are in good condition. If no humming is heard, disconnect the clock from the line and check continuity of the winding. If it is open, it will probably have to be replaced, although you may be lucky

enough to find the break near the outer end. If there is evidence of current passing through the winding and the hands do not revolve, inspect the mechanism to determine whether the clock has the enclosed gear unit described above. If so, it is quite likely that the gears are prevented from turning by gummed lubricant inside the case. Replacement is the most satisfactory procedure, although repairs may sometimes be effected by proceeding as follows: remove the entire gear case, noting the position in which it is mounted inside the field coil. Now drill two very small holes in the case. One of these should be so located that it will be uppermost with the clock in normal position. With a small squirt can inject a small quantity of benzine into the case. Allow the benzine to remain at least a half hour, shaking the unit every few minutes. At the end of this time, remove all of the benzine that you can by shaking, let the rest evaporate. When you are sure that the inside of the case has had time to dry out, squirt a little high grade very light oil in through one of the holes. Now solder up one of the holes (the one that is uppermost need not be soldered) and replace the unit. While this type of repair is usually effective, you may find that the reconditioned gear unit is a little noisier than usual.

Old type clocks which are started by hand often will run well when started, but are difficult to start. In one such clock, the starting mechanism consists of a ratchet lever which is pushed across the edge of a small rubber wheel. This causes the wheel to twirl and starts the clock. Wear or excessive lubrication may cause deterioration of the rubber. As a replacement, you might try a grommet of the same size, having a center hole small enough so that the grommet will be a tight fit on the shaft.

Clocks that have been in service a very long time often develop humming or grinding noises that are difficult to clear up, because generally the noise is caused by wear of parts. Actually, of course, such a clock should be replaced, but if necessary you can often help matters by the judicious use of rubber pads placed under the base of the clock. Wall type clocks seem to give much more trouble in this respect, probably because the noise is transmitted to the wall and thus intensified. Many such cases have been relieved by placing small pads of sponge rubber (taken from an old vibrator) between the back of the clock and the wall.

New JFD Catalog

The JFD Co., Inc., Brooklyn, N. Y. offers a new 16 page Television and FM Antenna brochure, covering Television and FM Antenna equipment.

★ PHOTOFACT Publications HELP YOU TO SUCCESS!

These are the indispensable service data books you'll use profitably every single working day...

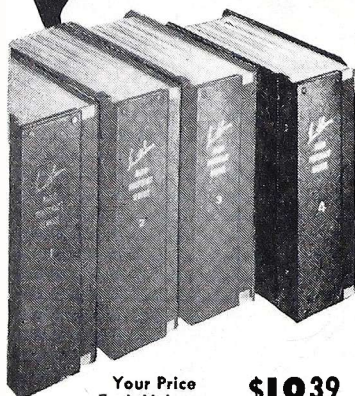

Your Price
Each Volume,
In Deluxe Binder

\$18³⁹

NOW! PHOTOFACT VOLUME 4 Includes First Three TV Course Installments

Bring your file of post-war receiver Service Data right up to July, 1948! Here's the most accurate and complete radio data ever compiled—preferred and used daily by thousands of Radio Service Technicians. Includes: Exclusive Standard Notation Schematics; photo views keyed to parts lists and alignment data; complete parts listings and proper replacements; alignment, stage gain, circuit voltage and resistance analysis; coil resistances; record changer service data, etc. Order Volume 4 today—keep your Photofact library up-to-date—it's the *only* Radio Service Data that meets your *actual* needs!

- Vol. 4.** Covers models from Jan. 1, 1948 to July 1, 1948
- Vol. 3.** Covers models from July 1, 1947 to Jan. 1, 1948
- Vol. 2.** Covers models from Jan. 1, 1947 to July 1, 1947
- Vol. 1.** Covers all post-war models up to Jan. 1, 1947

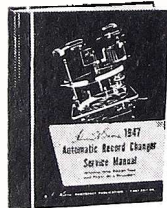

1947 Record Changer Manual

Nothing like it! Complete, accurate data on over 40 post-war models. Exclusive exploded views, photos from all angles. Gives full change cycle data, information on adjustments, service hints and kinks, complete parts lists. PLUS—for the first time—complete data on leading Wire, Ribbon, Tape and Paper Disc Recorders! 400 pages; hard cover; opens flat. Order now! **ONLY.....\$4⁹⁵**

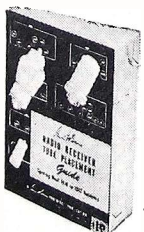

Receiver Tube Placement Guide

Shows you exactly where to replace each tube in 5500 radio models, covering 1938 to 1947 receivers. Each tube layout is illustrated by a clear, accurate diagram. Saves time—eliminates risky hit-and-miss methods. 192 pages, completely indexed. **ONLY.....\$1²⁵**



Dial Cord Stringing Guide

The book that shows you the *one right* way to string a dial cord. Here, in one handy pocket-sized book, are all available dial cord diagrams covering over 2300 receivers, 1938 through 1946. Makes dial cord restringing jobs quick and simple. **ONLY..\$1⁰⁰**

THE FIRST TELEVISION FOLDER APPEARS IN PHOTOFACT SET NO. 46 DON'T MISS IT!

Now—PHOTOFACT brings you a new kind of Television Service Data—a complete, accurate analysis of a popular Television receiver—based on actual examination of the set in the Sams' laboratories. This is the beginning of a series of uniform, accurate, authoritative Television Folders, exclusively PHOTOFACT—plus the \$500 Television Course—at no extra cost to you! Don't miss Set No. 46—at your local jobber now!

**STAY AHEAD OF THE GAME —
SUBSCRIBE REGULARLY TO
PHOTOFACT FOLDER SETS**

HOWARD W. **SAMS** & CO., INC.
INDIANAPOLIS 7, INDIANA

Here's that Triplett F.M.-A.M.

Sig. Gen.

Frequency Ranges: Fundamentals—from 100 K.C. to 120 M.C. in ten bands. Added Frequency—(provided by built-in fixed 50 M.C. oscillator) from 120 M.C. to 170 M.C. Second harmonics can also be used to double the A.M. fundamental ranges.
Dealer Net... \$173.25

MODEL 3433

**F.M. SWEEP FROM 0 TO 300 K.C.
 MODULATION FREQUENCY 60 OR
 400 CYCLES PER SECOND**

Stable frequency modulated signals give undistorted wave form. This permits easy and more precise alignment over all frequency ranges thus insuring maximum performance in a radio set that can in every way be comparable with original factory adjustments.

Other features include: constant deviation by using a fixed frequency reactance modulated oscillator, 110 Volt A.C. line filter to prevent leakage thru power supply, horizontal synchronized sweep voltage available thru jack on front panel.



For Ranges from 165 K.C. to 120 M.C. Select the Signal Generator with the Illuminated Dial

- Seven long scaled 330° arc.
- A big open, illuminated scale—easily read.
- 5 Fundamental Ranges 165 K.C. to 40 M.C.
- 2 Harmonic Ranges directly calibrated 36 M.C. to 120 M.C.
- 10 to 1 vernier tuning.

RANGES

A-165-525 KC	E-18-40 MC
B-500-1750 KC	Harmonics to 120 MC
C-1700-6200 KC	E2-36-80 MC
D-6-18.5 MC	E3-54-120 MC

Here is a very popular unit since everyone needs a stand by signal generator.

MODEL 3432 with its uniformly illuminated dial is the top value in signal generators for ranges to 120 MC. All R.F. and audio circuits are double shielded with copper plated steel... transformer is electrostatically shielded... the circuit selector provides for internally modulated signal (variable 0 to 100% at 400 cycles). Variable amplitude of external modulation 40 to 15,000 cycles, unmodulated signal or variable audio 0-10 volts at 400 cycles. The output attenuator provides fine control of R.F. Output to Co-axial output cable connector... Housed in Metal case, tan enamel finish. Leather strap handle for carrying.

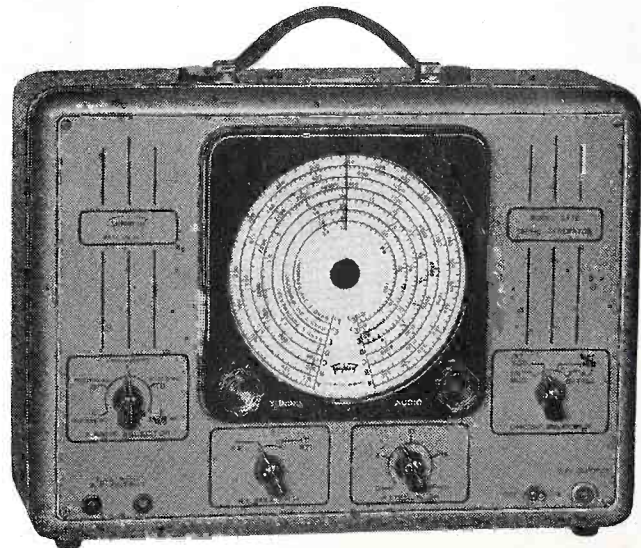

MODEL 3432
 Illuminated Dial
\$69.50 Dealer Net

Precision first... to Last

SEE AT YOUR RADIO PARTS DISTRIBUTOR OR FOR MORE INFORMATION... WRITE

TRIPLETT ELECTRICAL INSTRUMENT COMPANY • BLUFFTON, OHIO, U.S.A.

In Canada: Triplett Instruments of Canada, Georgetown, Ontario



WATTMETER

(from page 24)

From this description, the reader can see that the only components required for building a simple wattmeter is an a-c voltmeter (or millivoltmeter), a resistor, and the necessary hardware. In lieu of a conventional a-c voltmeter, an a-c milliammeter with series multiplier resistor may be employed.

Complete Wattmeter

The circuit schematic of the complete instrument making use of the principle just described is given in *Fig. 3*.

Meter *M* is a rectifier-type 0-1 a-c

milliammeter. If the reader does not have an a-c meter available, he may employ a 0-1 d-c milliammeter in series with a Sylvania *1N34* crystal diode. *R₂* is a 1-ohm, 50-watt wirewound resistor selected to have the exact resistance value. *R₁* is a 20,000-ohm wirewound rheostat set to give the meter a full scale deflection of 5 volts a.c. The plug is inserted into an a-c power outlet, and the device under test is plugged into the female output socket. The completed wattmeter is shown in *Fig. 1*. (This photograph was made before the special watts scale was added to the milliammeter).

Fig. 4 shows how the scale of the

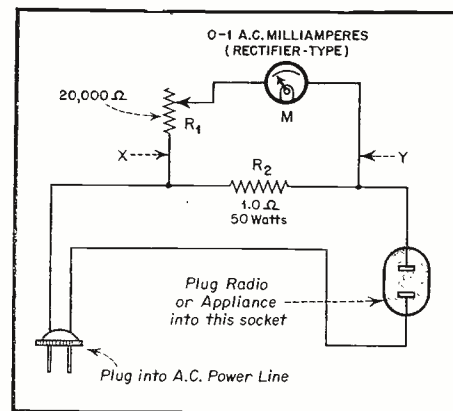

Fig. 3—Complete circuit of simple wattmeter.

milliammeter compares with a direct-reading wattage scale. If the reader desires, he may prepare a special scale to replace the regular milliammeter card. Or he may letter-in a watts scale above the milliamperere scale of the meter, as shown in *Fig. 4*.

The watts scale given in *Fig. 4* is based on a line voltage of 115 and presupposes that rheostat *R₁* (see *Fig. 3*) has been adjusted so that 5 volts deflect the meter exactly to full scale. Thus, a deflection of 1 milliamperere indicates 5 volts across resistor *R₂*. This voltage drop (current drain *X* resistor *R₁*) indicates that a current of 5 ampereres flows through *R₁*. 5 ampereres X 115 volts = 575 watts, the full-scale power value shown in *Fig. 4*.

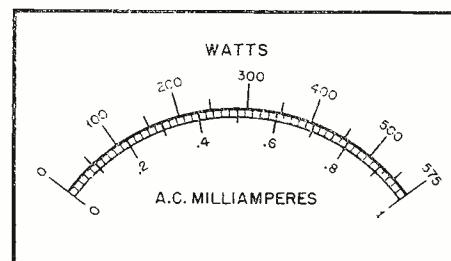

Fig. 4—Scale reading of simple wattmeter.

The wattage readings therefore are correct only when the line voltage is 115. If the line voltage is higher than 115, add to the meter reading 5 watts for each volt higher than 115. If the line voltage is lower than 115, subtract 5 watts for each volt lower than 115.

Construction

The wattmeter (see *Fig. 1*) is built in a sloping-front metal meter box, 4½" high, 4¼" wide, and 4¼" deep (at bottom). This is a convenient and handy mounting for the instrument. However, an individual builder may use any suitable box or case which is available.

Rheostat *R₁* is mounted through the top of the case and may be seen in the left-hand position in *Fig. 1*. The rheostat shaft is sawed short and slotted for screwdriver adjustment, since this component ordinarily needs no readjustment once it has been set. The output socket also is mounted through the top

NOW! UTAH TRANSFORMERS

Tested PERFORMANCE

UTAH announces a new group of replacement transformers designed especially for use with Utah Speakers. They're engineered and built for peak performance under severe climatic conditions . . . each transformer must pass moisture and operational tests. Utah construction assures complete vacuum impregnation, the use of cellulose acetate insulation, and other fine materials. Three types . . . Universal Output, Universal Line, and Single Output . . . in eight sizes, are available for immediate delivery.



UTAH RADIO PRODUCTS
 HUNTINGTON, INDIANA
 DIVISION OF INTERNATIONAL DETROLA CORPORATION
 EXPORT DIVISION: MORHAN EXPORTING CORP., N.Y.C.

UTAH QUALITY RADIO PRODUCTS

*Curtain
Going Up-*

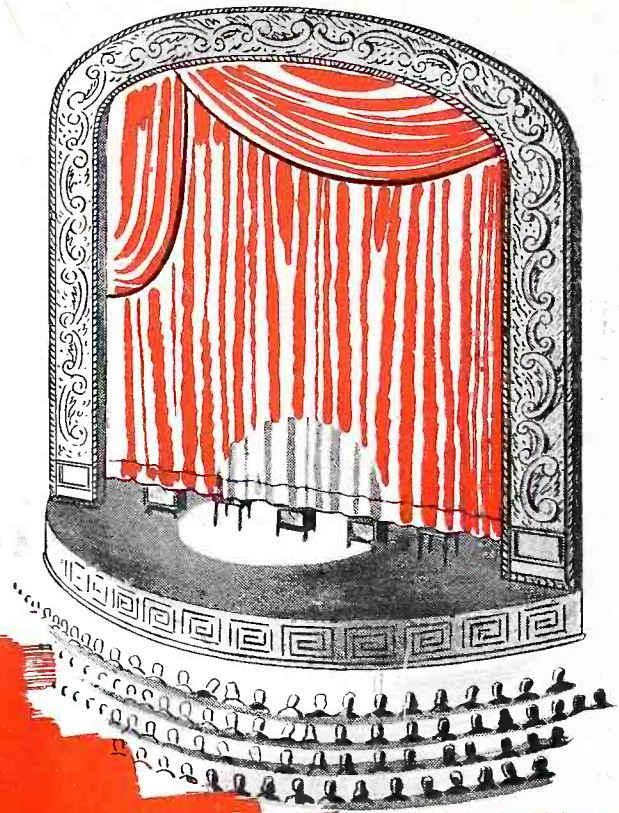

on an eye-filling
new line of advanced

Wonder-Window Television

by Stewart-Warner

New faster tuning! New picture realism . . . more of the scene on the viewing screen! New home-size styling! New Stewart-Warner Wonder-Window Television will give every Stewart-Warner dealer in telecast areas a better, clearer picture of profitable television sales.

Stewart - Warner

FM RADIOS AM • RADIO-PHONOGRAPHS • TELEVISION

CHICAGO 14  ILLINOIS

of the case and is directly to the right of the rheostat. The line cord passes through a grommet-lined hole directly under the milliammeter.

Wiring is simple and straightforward. No special precautions are necessary, since the instrument will be used only at power-line frequencies.

Adjustment

After construction of the instrument is completed, the only adjustment required is the setting of rheostat R_1 . Proceed as follows:

(1) Temporarily disconnect the meter circuit (M and R_1) from resistor R_2 .

(2) Feed an accurately-measured 5-

volt a-c signal (power-line frequency) to points X and Y (see *Fig. 3*).

(3) Adjust rheostat R_1 for exact full-scale deflection of the a-c milliammeter. Response of the meter is linear. That is, half the meter scale indicates half of 5 volts, or $2\frac{1}{2}$ volts. 0.25 milliamperes corresponds to and indicates $1\frac{1}{4}$ volt, etc.

(4) Reconnect meter circuit to resistor R_2 .

Use of Instrument

Use of the wattmeter in measuring power drain is extremely simple:

(1) Insert wattmeter line plug into a-c power outlet.

(2) Plug radio or appliance into wattmeter output socket.

(3) Read watts from meter deflection. Watts scale of meter is correct when line voltage is exactly 115. If line voltage is higher than 115, add to meter reading 5 watts for each volt higher than 115. If line voltage is lower than 115, subtract 5 watts for each volt lower than 115. When operating in the line-voltage range of 110 to 120 volts, these correction calculations can be omitted altogether if the operator can put up with an 8% error.

TECHNICAL QUIZ No. 7 ANSWERS

Do NOT read or study these answers until you have finished marking down your answers to the "Quiz" given on page 35 of this issue. When that is done, compare your answers to these correct ones.

- 1—Diathermy interference
- 2—Ignition interference
- 3—Off center horizontally
- 4—Too large horizontally and vertically
- 5—Too light
- 6—Horizontal tearing
- 7—Correct pattern
- 8—Too small horizontally, correct vertically
- 9—Vertical tearing
- 10—Multiple images (ghosts)

SERVICE CONTACTS PROMOTE SET SALES

(from page 25)

he is no longer a stranger. On the first call we get down to his level regarding radios. This we can determine easily by the way he talks. The words he uses to tell us what is wrong with his set. We do not try to impress the man or woman that we know all there is to know about radios by conversing with them in technical language. Usually we just sum up the cost mentally as close as we can . . . and relay the amount to the customer. That is what he wants to know, anyway. Why attempt to give him a course in radio technique in one easy lesson?

"If the estimated repair price seems too high, we try to sell them a new set.

"Oddly enough, our console sales far exceed our table models. We are unable to keep enough console models in stock at any time.

"Oh, yes. We do a fairly large volume with P. A. systems. These we sell, service, and rent.

"So far I have not gotten into the appliance business. Just have not had the time to devote to it. Our radio sales and service keeps me and one man busy. We do no outside solicitation. Both of us work off the floor or at the bench. And until we locate a couple of good outside men looking for a job, we will continue as we are."

520 Sq. In. 20" x 26" PICTURE PROJECTION TELEVISION

IN ASSEMBLY FORM FOR CUSTOM INSTALLATIONS



36 RCA TUBES • EASTMAN KODAK PROJECTION SCREEN • f 1.9 BAUSCH & LOMB PROJECTION LENS • 30 KV FLY-BACK POWER SUPPLY • ANTENNA • PICTURE & SOUND I.F. FACTORY WIRED AND TUNED • DUMONT INPUTUNER

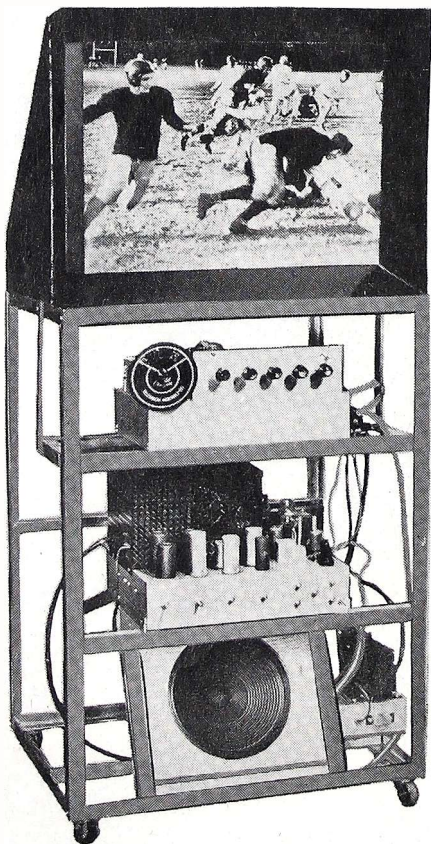

For realism, clarity, definition and BIG SCREEN Televiewing, the pictures produced by this unit have no equal!

This screen is absolutely flat, precluding curvature distortion anywhere in the picture. Picture tones are true black, grey and white—high in brilliance, yet absolutely glare-free!

Easy to assemble! Everything is supplied, including prewired high voltage power supply, Dumont Inputuner, wired and pretuned 13 tube I.F. strip for picture and sound, precision Bausch and Lomb f 1.9 projection lens, Eastman Kodak projection screen, Mirror, 36 RCA tubes including 5TP4 projection tube, special dipole with reflector and 60 ft. coaxial lead-in, 12" heavy duty RCA PM speaker, push-pull 12 watts audio, rack, hood and picture frame as illustrated, all parts, hardware, etc. (Big easy-to-follow manual of instructions and schematic data prepared and edited by renowned John F. Rider, Publisher.)

GUARANTEE • • •

All Television Assemblies are guaranteed to operate to your satisfaction when simple directions are followed.

DISTRIBUTED THROUGH NATIONAL PARTS DISTRIBUTORS

TELEVISION ASSEMBLY CO. 540 BUSHWICK AVE. BROOKLYN 6, N. Y.

Form A Group, Servicemen-

Subscribe to "RSD"-

SAVE Up to 50%

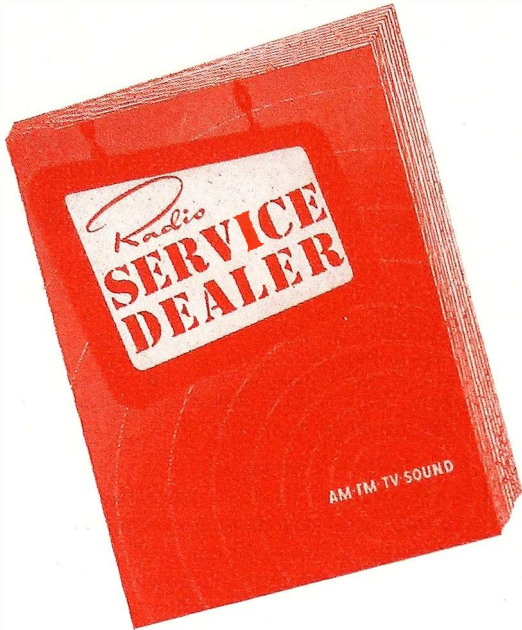

★ The more in a group the bigger the savings. 6 men in a group save \$1.00 each; 4 men groups save \$.75 per man. Present "RSD" subscribers may participate in or form a group with co-workers, or even competitors. Still active subscriptions are automatically extended 1 year. Start a Group today! The timely and exclusive technical data appearing in future issues of "RSD" will make this the best investment you ever made. The special Group Rate offer may be withdrawn at any time—so hurry.

Use This Coupon For Convenience

(The coupon below can be used for from 1 to 6 subscription orders. Use it today!)

YEAR OUT—MAIL TODAY

RADIO SERVICE-DEALER MAGAZINE 342 Madison Ave., New York 17, N. Y.	In U.S.A. & Canada	Foreign Rates
<input type="checkbox"/> One 1-year subscription	\$2.00	\$3.00
<input type="checkbox"/> Two 1-year subscriptions, each	1.75	2.75
<input type="checkbox"/> Three 1-year subscriptions, "	1.50	2.50
<input type="checkbox"/> Four 1-year subscriptions, "	1.25	2.25
<input type="checkbox"/> Five 1-year subscriptions, "	1.10	2.00
<input type="checkbox"/> Six 1-year subscriptions, "	1.00	1.50

NOTE: If you do not wish to tear this order blank out, just print or type the information on a single sheet of paper, following the style given. Each subscriber's occupation must be clearly described.

Name..... Address..... Describe Title or Position and Type of Business..... State whether a New Subscriber <input type="checkbox"/> or Renewal Order <input type="checkbox"/>	Name..... Address..... Describe Title or Position and Type of Business..... State whether a New Subscriber <input type="checkbox"/> or Renewal Order <input type="checkbox"/>
Name..... Address..... Describe Title or Position and Type of Business..... State whether a New Subscriber <input type="checkbox"/> or Renewal Order <input type="checkbox"/>	Name..... Address..... Describe Title or Position and Type of Business..... State whether a New Subscriber <input type="checkbox"/> or Renewal Order <input type="checkbox"/>
Name..... Address..... Describe Title or Position and Type of Business..... State whether a New Subscriber <input type="checkbox"/> or Renewal Order <input type="checkbox"/>	Name..... Address..... Describe Title or Position and Type of Business..... State whether a New Subscriber <input type="checkbox"/> or Renewal Order <input type="checkbox"/>



NEW

IMPROVED

**PATENTED
SOLDERING IRON TIP**

NOTE: No damage can result to the transformer as long as these electrodes are used with same care exercised with the use of any other wire or electrode.

Heating Time 9 Seconds • Guaranteed 6 Months

● Now better than ever, with newly designed longer neck to reach more tight spots. Amazing variety of uses for long period of time without breaking or "eating through". Sufficient heat generated to handle average soldering needs... eliminates need for heavier irons. Each electrode guaranteed for six months, except against misuse or breakage caused by carelessness.

Soldering iron tip (chrome plated to prevent heat loss) **65¢ each**

At dealers and jobbers from coast to coast

CAL-PERRY CORPORATION
62 Franklin Street
East Orange, N. J.

TRADE FLASHES

(Continued from page 38)

Minnesota and 38 other states, and these foreign countries: Canada, Hawaii, British West Indies, Venezuela, Brazil, Porto Rico, Panama, Iceland, France, Alaska, Mexico, Costa Rica, Columbia, and the Philippine Islands.

Dunwoody will begin its 35th year of training men for trade work with the re-opening of school in August.



New officers of Sightmaster Corp., (left to right) F. Wakefield Minor, Vice Pres. and Gen. Mgr., Michael Kaplan, President, and Arthur Ard, Sales Manager. New factory and executive offices are located at 385 North Avenue, New Rochelle, N. Y. New York Office and Show Room: 220 Fifth Avenue, New York 1, N. Y.

Association News

The latest we hear from the Associated Radio Servicemen of New York is that its membership is well over 450. This number will be more than doubled when the boys around town learn of the tie-up ARSNY has effected with radio station WNEW where this station publicizes, in spot announcements, the advantages of dealing with ARSNY members. And if we are any judge of values, this number will be tripled when the news spreads of the comprehensive TV Course which is planned for its members in the Fall and Spring of 1948-49.

The Mid-State Radio Servicemen's Association of Pennsylvania will hold an election of officers on Aug. 10, 1948. Mr. Robert Miller of D & H Distributing Co., of Harrisburg will speak on "Oscilloscopes and Their Use to the Service Man." On Sept. 14, 1948 they will install their officers. The invited speaker for that evening is Mr. Russell Knerr of Knerr's Inc., who will speak on "Multi-vibrators and Their Use In Television."

From Philadelphia, we hear that boys of PRSMA held their last Spring meeting on June 3, 1948, at the Franklin Institute. It was jointly sponsored by the Howard W. Sams Distributors of Philadelphia. Mr. Al Saunders of Newton, Mass., author of Howard W. Sams Photofact Television Course, spoke on the "Need of Educating Servicemen in the New Field of Television."

TV Master Antenna

Solving the solution to the perplexing television antenna dilemma. Eight television receivers supplied by leading manufacturers hooked on to the intra-video and FM antenna system. This new master antenna can serve any number of sets in apartment houses,



PROTECTION IS VITAL

DESIGNERS of radio, communication, electronic and electrical apparatus protect their products against electrical damage by incorporating the proper type of Littelfuse made for the purpose. Engineers call this **Product Insurance**. Technicians and maintenance men responsible for keeping radio-electrical devices in peak operating condition also rely upon Littelfuse—knowing that when they use our dependable products, they provide their customers and themselves with maximum protection. We call this **Service Insurance**. Ask your Jobber for the Littelfuses you require.

LITTELFUSE  *Incorporated*

4787, N. RAVENSWOOD AVE. CHICAGO 40, U. S. A.

NITE-T-LITE • SWITCH-LITE • IGNITION-FRITZ • NEON INDICATORS
SWITCHES • CIRCUIT BREAKERS • FUSES, MOUNTINGS AND ACCESSORIES

schools, hospitals, etc., requiring but one master aerial for each television station. Insures ghost-free, trouble-free, interference-free reception.

International Buys Minerva

John B. Milliken, president of the International Television Corp. announced that the company had purchased the complete facilities, equipment and furnishings of the Minerva Radio Corporation at 238 Williams Street, New York City. The acquisition of these facilities will enable International to realize full-scale production of their complete line of television receivers.

Crossin Heads UST Sales

The appointment of J. F. Crossin as Director of National Sales for the United States Television Mfg. Corp. has been announced by Hamilton Hoge, UST president.

Emerson Previews 1949 Line

More than two hundred Emerson distributors from the United States and foreign countries attended the New York meetings to view the new 1948-49 models and to learn about the coming advertising and sales promotion programs of the company. The exhibit of new sets to be offered to the public constitutes 30 radio models of all types and 6 television receivers.

Admiral's New Combo

A radio-phonograph combination that will render four hours of continuous music, and that will play records at 33-1/3 revolutions per minute as well as at the standard speed and that will retail for as little as \$169.95, was recently announced by Admiral. Also announced was the formation of the Admiral Corporation Milwaukee Distributing Division, Inc., and the appointment of R. O. Hebernstreit as manager, as well as the appointment of George H. Deacon as regional manager. Mr. Deacon will represent the Admiral Corporation in southern Ohio, Indiana, West Virginia and Kentucky.

Garod's New TV Sets

Three new television receivers including the 12" direct view table model with AM and FM reception, a 10" direct view table model with AM and FM, and a five-in-one console combination with a 12" direct view tube were announced by Garod Electronics Corporation at a dealer showing in their New York City showrooms.

GE Ups 2—Ships TV to Don Lee

Creation of a new position on the Vice President's staff, with the title of Manager of Marketing, and the establishment of the General Sales Division as one of seven operating divisions in the Electronics Department of the General

Sharp, Clear Television Reception at 100 MILES AND OVER

You can be assured of the finest television reception at more than double the normal range with a Workshop 6-element Super High-Gain Antenna. Weak, remote "signals" come in strong and steady to produce pictures sharp in detail and contrast. This antenna is *actually* opening up new television areas.

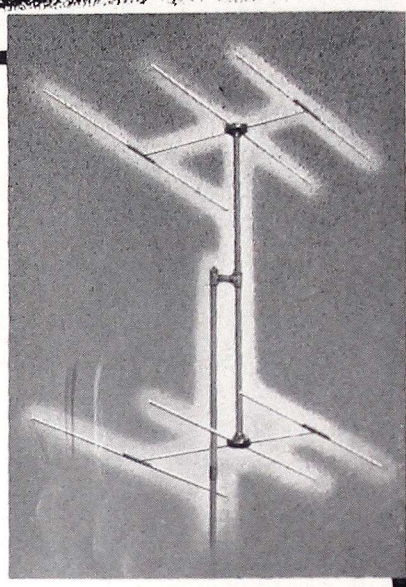

List Price \$45.00
Write for
Television Antenna Catalog

THE WORKSHOP ASSOCIATES INCORPORATED
69 Needham Street, Newton Highlands 61, Mass.

Announcing—

"TELEVISION INTERFERENCE— Its Causes and Cures"

A new Handbook by Radio Magazines, Inc., covering in detail the important facts of TVI. The TVI Handbook is edited to fill the pressing requirements of amateurs and other technicians confronted with the problems of TV interference, or otherwise unsatisfactory television reception. Included in its thorough treatment of causes and cures are a comprehensive set of TV screen photos depicting all types of reception, many case histories, preventative design data, and other equally pertinent facts. It is a vital publication for radiomans wherever TV is on, or about to go on the air.

Price 50c postpaid, or order from your local jobber.

CQ—Radio Magazines, Inc.
342 MADISON AVE., New York 17, N. Y.

Enclosed find \$.....for....copies of the TVI Handbook

Name.....

Address.....

City.....Zone...State.....

NEW

IMPROVED

PATENTED SOLDERING IRON TIP

NOTE: No damage can result to the transformer as long as these electrodes are used with same care exercised with the use of any other wire or electrode.

Heating Time 9 Seconds • Guaranteed 6 Months

● Now better than ever, with newly designed longer neck, to reach more tight spots. Amazing variety of uses for long period of time without breaking or "eating through". Sufficient heat generated to handle average soldering needs... eliminates need for heavier irons. Each electrode guaranteed for six months, except against misuse or breakage caused by carelessness.

Soldering iron tip (chrome plated to prevent heat loss) **65¢ each**

At dealers and jobbers from coast to coast

CAL-PERRY CORPORATION

62 Franklin Street East Orange, N. J.

TRADE FLASHES

(Continued from page 38)

Minnesota and 38 other states, and these foreign countries: Canada, Hawaii, British West Indies, Venezuela, Brazil, Porto Rico, Panama, Iceland, France, Alaska, Mexico, Costa Rica, Columbia, and the Philippine Islands.

Dunwoody will begin its 35th year of training men for trade work with the re-opening of school in August.



New officers of Sightmaster Corp., (left to right) F. Wakefield Minor, Vice Pres. and Gen. Mgr., Michael Kaplan, President, and Arthur Ard, Sales Manager. New factory and executive offices are located at 385 North Avenue, New Rochelle, N. Y. New York Office and Show Room: 220 Fifth Avenue, New York 1, N. Y.

Association News

The latest we hear from the Associated Radio Servicemen of New York is that its membership is well over 450. This number will be more than doubled when the boys around town learn of the tie-up ARSNY has effected with radio station WNEW where this station publicizes, in spot announcements, the advantages of dealing with ARSNY members. And if we are any judge of values, this number will be tripled when the news spreads of the comprehensive TV Course which is planned for its members in the Fall and Spring of 1948-49.

The Mid-State Radio Servicemen's Association of Pennsylvania will hold an election of officers on Aug. 10, 1948. Mr. Robert Miller of D & H Distributing Co., of Harrisburg will speak on "Oscilloscopes and Their Use to the Service Man." On Sept. 14, 1948 they will install their officers. The invited speaker for that evening is Mr. Russell Knerr of Knerr's Inc., who will speak on "Multi-vibrators and Their Use In Television."

From Philadelphia, we hear that boys of PRSMA held their last Spring meeting on June 3, 1948, at the Franklin Institute. It was jointly sponsored by the Howard W. Sams Distributors of Philadelphia. Mr. Al Saunders of Newton, Mass., author of Howard W. Sams Photofact Television Course, spoke on the "Need of Educating Servicemen in the New Field of Television."

TV Master Antenna

Solving the solution to the perplexing television antenna dilemma. Eight television receivers supplied by leading manufacturers hooked on to the intra-video and FM antenna system. This new master antenna can serve any number of sets in apartment houses,

PROTECTION IS VITAL

DESIGNERS of radio, communication, electronic and electrical apparatus protect their products against electrical damage by incorporating the proper type of Littelfuse made for the purpose. Engineers call this **Product Insurance**. Technicians and maintenance men responsible for keeping radio-electrical devices in peak operating condition also rely upon Littelfuse—knowing that when they use our dependable products, they provide their customers and themselves with maximum protection. We call this **Service Insurance**. Ask your Jobber for the Littelfuses you require.

LITTELFUSE **Incorporated**

4787, N. RAVENSWOOD AVE. CHICAGO 40, U. S. A.

NITE-T-LITE • SWITCH-LITE • IGNITION-FRITZ • NEON INDICATORS
SWITCHES • CIRCUIT BREAKERS • FUSES, MOUNTINGS AND ACCESSORIES

schools, hospitals, etc., requiring but one master aerial for each television station. Insures ghost-free, trouble-free, interference-free reception.

International Buys Minerva

John B. Milliken, president of the International Television Corp. announced that the company had purchased the complete facilities, equipment and furnishings of the Minerva Radio Corporation at 238 Williams Street, New York City. The acquisition of these facilities will enable International to realize full-scale production of their complete line of television receivers.

Crossin Heads UST Sales

The appointment of J. F. Crossin as Director of National Sales for the United States Television Mfg. Corp. has been announced by Hamilton Hoge, UST president.

Emerson Previews 1949 Line

More than two hundred Emerson distributors from the United States and foreign countries attended the New York meetings to view the new 1948-49 models and to learn about the coming advertising and sales promotion programs of the company. The exhibit of new sets to be offered to the public constitutes 30 radio models of all types and 6 television receivers.

Admiral's New Combo

A radio-phonograph combination that will render four hours of continuous music, and that will play records at 33-1/3 revolutions per minute as well as at the standard speed and that will retail for as little as \$169.95, was recently announced by Admiral. Also announced was the formation of the Admiral Corporation Milwaukee Distributing Division, Inc., and the appointment of R. O. Hebernstreit as manager, as well as the appointment of George H. Deacon as regional manager. Mr. Deacon will represent the Admiral Corporation in southern Ohio, Indiana, West Virginia and Kentucky.

Garod's New TV Sets

Three new television receivers including the 12" direct view table model with AM and FM reception, a 10" direct view table model with AM and FM, and a five-in-one console combination with a 12" direct view tube were announced by Garod Electronics Corporation at a dealer showing in their New York City showrooms.

GE Ups 2—Ships TV to Don Lee

Creation of a new position on the Vice President's staff, with the title of Manager of Marketing, and the establishment of the General Sales Division as one of seven operating divisions in the Electronics Department of the General

Sharp, Clear Television Reception at 100 MILES AND OVER

You can be assured of the finest television reception at more than double the normal range with a Workshop 6-element Super High-Gain Antenna. Weak, remote "signals" come in strong and steady to produce pictures sharp in detail and contrast. This antenna is *actually* opening up new television areas.

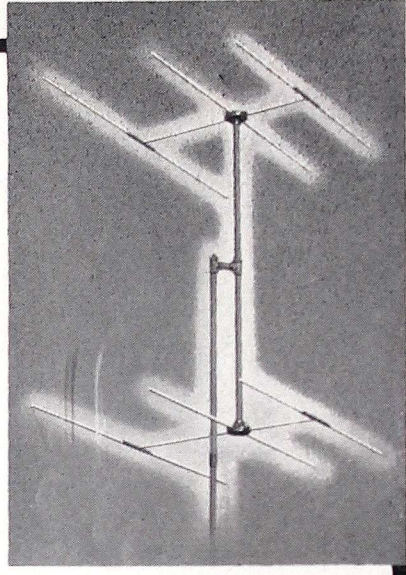

List Price \$45.00
Write for
Television Antenna Catalog

THE WORKSHOP ASSOCIATES INCORPORATED
69 Needham Street, Newton Highlands 61, Mass.

Announcing—

"TELEVISION INTERFERENCE— Its Causes and Cures"

A new Handbook by Radio Magazines, Inc., covering in detail the important facts of TVI. The TVI Handbook is edited to fill the pressing requirements of amateurs and other technicians confronted with the problems of TV interference, or otherwise unsatisfactory television reception. Included in its thorough treatment of causes and cures are a comprehensive set of TV screen photos depicting all types of reception, many case histories, preventative design data, and other equally pertinent facts. It is a vital publication for radiomen wherever TV is on, or about to go on the air.

Price 50c postpaid, or order from your local jobber.

CQ—Radio Magazines, Inc.
342 MADISON AVE., New York 17, N. Y.

Enclosed find \$.....for....copies of the TVI Handbook

Name.....

Address.....

City.....Zone...State.....

THE MOST DESIRABLE ANTENNA MOUNT EVER MADE!

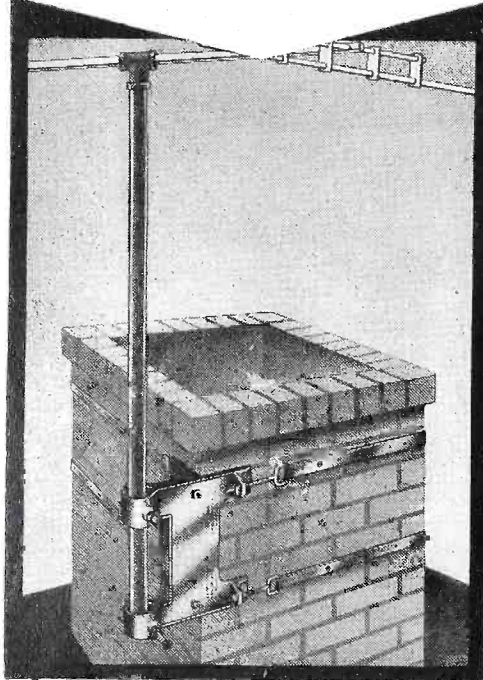

Pat. Pending

Chimney Mount Antenna Base

- for TELEVISION
- FM • AMATEURS

List Price: **\$7.50**

Cost to Retailer: \$4.50

**Installed in 10 minutes • Permits Use
of Several Mounts on One Chimney**

Chimney Mount is by far the fastest selling product of its type in the radio and television fields. It can be installed in ten minutes without the use of special tools or drilling of holes. Several mounts can be strapped to one chimney—to pole, 2 x 4, side of house or to any rectangular roof extension. Fastens aerial to highest point with galvanized steel bands having a combined tensile strength of more than 3,000 lbs. Made of corrosion-resistant aircraft-type aluminum alloy. Weight: 3 lbs.

Available Through All Leading
Jobbers and Dealers or Write to:

South River Metal Products Co.
South River, New Jersey

Electric Company were announced today by Dr. W. R. G. Baker, Vice President and General Manager of the department. E. H. Vogel has been appointed to the new Manager of Marketing position. A. A. Brandt, the department's General Sales Manager since 1943, will manage the General Sales Division.

General Electric Company has shipped television equipment for Don Lee Broadcasting Corp. at Los Angeles, Cal. The station, which serves the metropolitan Los Angeles area, will change its call letters from W6XAO to KTSL. The television equipment has been designed to operate on television channel 2.

Metzner Obit

Russell W. Metzner, sales manager of replacement tubes for General Electric's Tube Division, died suddenly at Syracuse.

He had been in the lamp and radio merchandising field since 1928, first with Hygrade Sylvania Lamp Company in Chicago and later with the Ken-Rad Tube and Lamp Corp. at Owensboro, Ky. He had been employed by G. E. since January 1945, when the company purchased the Ken-Rad interests.

Rep. & Distributor Appointments

Appointment of Pittsburgh Products Company, Pittsburgh, Pa., and Utility Company, Inc., Clarksburg, W. Va., was announced today by Crosley Division, Avco Manufacturing Corporation.

The appointment of Western Appliance Corporation, Denver, as the Zenith Radio distributor for the state of Colorado and portions of Nebraska and Wyoming, was announced today by H. C. Bonfig, vice president of Zenith Radio Corporation.

Appointment of The Frank Corporation, of Savannah, Georgia, to serve Georgia and South Carolina was announced today by Crosley Division, Avco Manufacturing Corporation.

George F. Ryan, Vice President, Wire Recording Corporation of America, announces the appointment of the following WIREWAY representatives and their respective territories: The Brnum Co., Dallas, Texas—covering Texas, Oklahoma, Arkansas and Louisiana. Don H. Burcham Co., Portland, Oregon—covering Washington and Oregon. Norman B. Neely Enterprises, Los Angeles and San Francisco—covering California, Nevada and Arizona. The Neimann Co., Minneapolis, Minnesota—covering Minnesota, North and South Dakota, Nebraska and Iowa. Ray Hutchmacher & Associates, Chicago, Ill.—covering Wisconsin, northern Illinois & Indiana. Land-C-Air Sales, Inc., New York—covering New York State, Eastern Pennsylvania, Southern New Jersey and Virginia. W. H. Connors Co.,

which of these 6 HANDICAPS slows up your soldering?

Retinning and redressing tip?

Delayed heating? • Clumsy, rigid tip?

Obsolete source of heat?

Blind spots? • Awkwardly shaped iron?

NEW WELLER SOLDERING GUNS Eliminate Them All!

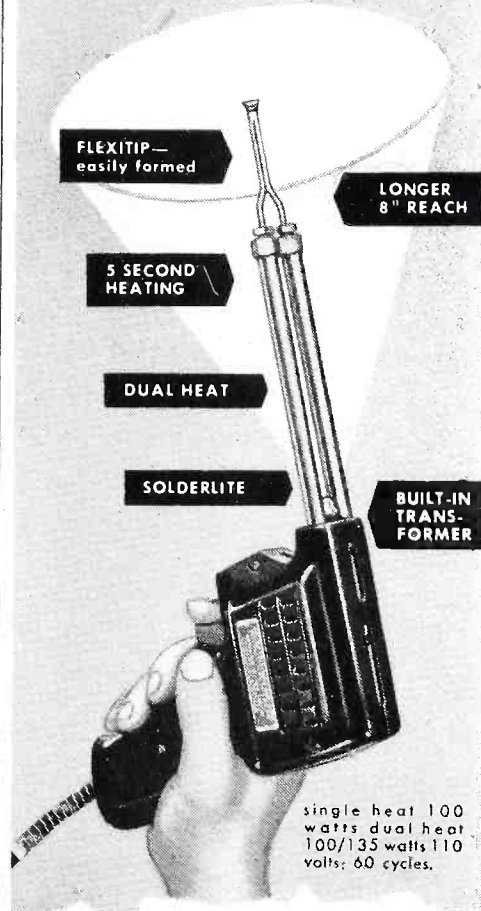

Designed especially for radio, television and appliance service men, Weller Guns provide longer reach (4", 8" or 12") for getting through wiring deep into chassis. Also, the transformer is not separate from the gun, but is built in for convenience and safety. No need to unplug gun when not in use; heat comes "on" only when you pull the trigger—no retinning or redressing necessary when properly used with genuine Weller Tips.

For all service work, we recommend the efficient 8" model DX-8 with dual heat; or the 4" types—S-107 single heat and D-207 dual heat. See your distributor or write for bulletin direct.

WELLER
MANUFACTURING COMPANY

804 Packer Street • Easton, Pa.

Denver, Colorado—covering New Mexico, Colorado, Utah, Wyoming, Idaho and Montana. J. W. Weaver, Atlanta, Georgia—covering North and South Carolina, Georgia, Alabama and Florida. John R. Tilton, Waterloo, Ontario—covering Eastern Canada.

Frank Wedel was appointed Northwest Rep., and Al Gates, New England Rep., it was announced by the Air King Products Co., Inc., recently. New Distributors added to their list are: Schwabacher Hardware Company, Seattle 14, Washington; Seattle Radio Supply Inc., Seattle 1. Washington; Offenhauer Company, Lansing, Michigan; Davis Radio Distributing Company, Mount Vernon, N. Y.; Radio Supply Company, Wichita 7, Kansas; Southern Radio Supply Co., New Orleans 19, La; Ace Hardware Corp., Chicago, Illinois; John A. Costelow Company, Topeka, Kansas; Illinois Fluorescent Company, DeKalb, Illinois; Merkel Bros. Hardware Co., Quincy, Illinois; Master Appliance Mfg. Corp., Racine, Wisconsin; Kiefer Electrical Supply Co., Peoria, Illinois; Johnson Radio & Electronic Equipt., Jamestown, N. Y.

Announcement has been made by Emerson Radio of the appointment of the Merchants Wholesale Co. as Emerson's Detroit Distributor.

The Charles F. Schwartz Company, Buffalo, N. Y., has been appointed to distribute Arvin radios and electrical appliances in the Buffalo and western New York area, it was announced by Noblitt-Sparks Industries of Columbus, Indiana.

The Koehler-Pasmore Company, Detroit, Michigan, has been appointed sales representative for Alpha Solder in Michigan.

The appointment of Buhl Sons Co. as the Detroit, Mich., distributor, has been announced by United States Television Mfg. Corp.

Marvin H. Kirkeby has been appointed a sales representative of Alpha Metals, Inc. Mr. Kirkeby will represent the Alpha line of solders in the territory of Minnesota and North and South Dakota.

Karet Rep For Astra-Sonic

The Pentron Corporation of 611 W. Division St., Chicago, has appointed R. M. Karet Associates as exclusive national sales representatives for the Astra-Sonic portable Wire Recorder-Radio-Phonograph combination.

New Weston Reps

Weston Electrical Instrument Corp. of Newark, N. J., has appointed three new representatives to cover Texas and Oklahoma.

The new representatives and their territories are: Butler and Land, 3405

AMPERITE

Studio Microphones at P.A. Prices

Ideal for BROADCASTING
• RECORDING
• PUBLIC ADDRESS

"The ultimate in microphone quality," says Evan Rushing, sound engineer of the Hotel New Yorker.

- Shout right into the new Amperite Microphone—or stand 2 feet away—reproduction is always perfect.
- The only type microphone that is not affected by any climatic conditions.
- Guaranteed to withstand more "knocking around" than any other type mike.

Special Offer: Write for Special Introductory Offer, and 4-page illustrated folder.



Models
RBLG—200 ohms
RBHG—Hi-imp.
List \$42.00



"Kontak" Mikes
Model SKH, list \$12.00
Model KKH, list \$18.00

AMPERITE Company, Inc.
561 BROADWAY • NEW YORK 12, N. Y.

In Canada: Atlas Radio Corp., Ltd., 560 King St. W., Toronto

FULL 13 CHANNEL TV-FM COVERAGE!

It's Here...
NEW JFD
Super-Beam HI-LO
Duo-Orienting Array

it's
DIFFERENT

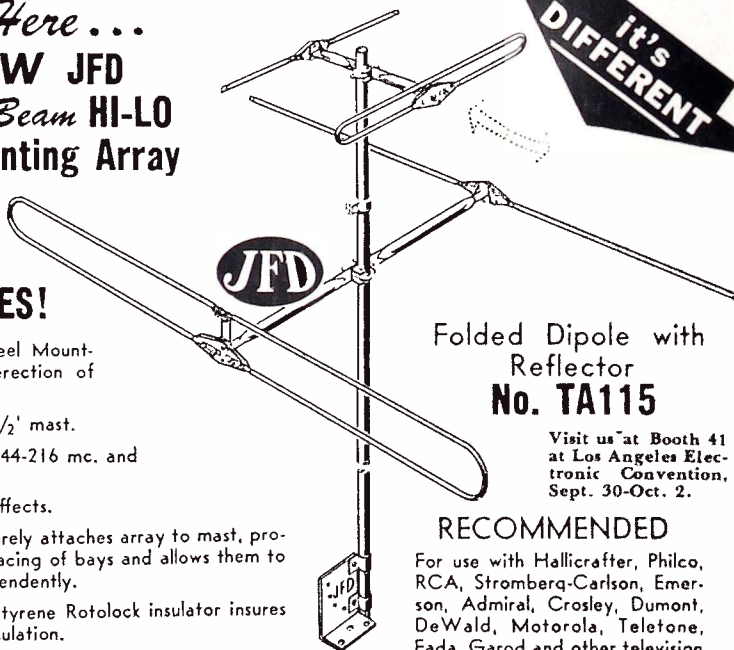

FEATURES!

- ✓ JFD All-Angle Steel Mounting Bracket for erection of masts anywhere.
- ✓ Corrosion-proof 7½' mast.
- ✓ Frequency Range 44-216 mc. and + 4.2 DB gain.
- ✓ Minimized ghost effects.
- ✓ U-Bolt Clamp securely attaches array to mast, provides unlimited spacing of bays and allows them to be oriented independently.
- ✓ Unbreakable polystyrene Rotolock insulator insures high frequency insulation.
- ✓ Lightning-fast assembly time — no hardware bag.

Folded Dipole with Reflector
No. TA115

Visit us at Booth 41
at Los Angeles Electronic Convention,
Sept. 30-Oct. 2.

RECOMMENDED

For use with Hallicrafter, Philco, RCA, Stromberg-Carlson, Emerson, Admiral, Crosley, Dumont, DeWald, Motorola, Teletone, Fada, Garod and other television sets.

Write for the New JFD 16-page Super-Beam Catalog, No. 78105.



MANUFACTURING CO. Inc.

4113 Ft. Hamilton Pkway, Brooklyn 19, N. Y.

New Book makes AUTO RADIO REPAIR twice as easy!

Covers all auto
Radio types from
mid-1930's to
present, includ-
ing mobile FM.



Just Out!

SERVICING THE MODERN CAR RADIO by A. L. Hurlbut

Second edition, 702 pages, 8 1/2 x 11, 222 illus., over
500 circuit diagrams \$7.50.

Here—written by a practical auto radio expert of 20 years' standing—is everything to help the beginner or experienced serviceman gain profitable skill in the fast-growing field of car radio servicing. A complete guide to the work. Book not only describes installation, testing, and repair methods fully, but also gives needed special facts of car radio circuits, differences between car and home radio servicing problems, shop setup and business-getting ideas, etc. And invaluable for all jobs, is the big gallery of circuit diagrams on hundreds of models, old and new.

Practical facts and methods on:

- | | |
|--|--------------------------|
| Getting into the car radio business | Antenna installation |
| Differences between mobile and home radios | Loudspeaker installation |
| Antennas and input circuits | Remedying interference |
| Power supplies | Servicing procedure |
| Circuit features | Vibrator maintenance |
| Auto electrical systems | Loudspeaker servicing |
| Setting up shop | Car-radio alignment |
| Car set installations | Push-button tuning, etc. |

OPPORTUNITY OF A LIFETIME
for alert servicemen, says A. A. Ghirardi
author of famous radio servicing
books and articles



ALFRED A. GHIRARDI
Good auto radio men are scarce, and this book gives you a gold mine of information you need to cash in on this profitable, fast-growing business.

"I believe **SERVICING THE MODERN CAR RADIO** represents an opportunity no wide awake serviceman can afford to miss. There are over 9,000,000 car radios—approximately 16 out of every 100 radio receivers in use today—a wonderful field for increasing servicing business; increasing profits, stepping ahead of competition!

Good auto radio men are scarce, and this book gives you a gold mine of information you need to cash in on this profitable, fast-growing business.

10 DAYS' FREE EXAMINATION

Murray Hill Books, Inc. (Division of Rinehart & Co.) Dept. RSD-98, 232 Madison Ave., New York 16, N. Y.
Send me Hurlbut's *Servicing the Modern Car Radio* for 10 days' examination on approval. In 10 days I will send \$7.50, plus few cents postage, or return book postpaid. Postage paid on cash orders; same return privilege. (Books sent on approval in U. S. only. Price outside U. S., \$8.00, postpaid.)

Name.....
Address.....
City (Zone) & State.....
Occupation.....

Milton Ave., Dallas, North Texas; The Lynn Elliott Company, 322 M. & M. Building, Houston, South Texas; Riddle and Hubbell, 302 South Cheyenne Ave., Tulsa, all of Oklahoma.

Warner Handles Clarostat

A. J. Warner Co. of 5022—29th Ave., Minneapolis 6, Minn., will now service both industrial and jobber sales, it is announced by Clarostat Mfg. Co., Inc., manufacturers of resistors, controls and resistance devices, Brooklyn, N. Y. the Warner organization will cover Minnesota, North and South Dakota, Iowa and Northern Wisconsin with the exception of Milwaukee and Madison.

Remco Handles S-W

Appointment of Remco, Inc., recently formed distributing organization, as exclusive distributor in the Chicago area for Stewart-Warner radio and television equipment was announced by Floyd D. Masters, sales manager of the radio division of Stewart-Warner Corporation.

Utah Appointments

Morhan Exporting Corp., New York, has been granted exclusive export sales rights for Utah Radio Products Division of International Detrola Corp., in every country throughout the world, except Canada and Mexico, Mr. Philip Heckendorn, Utah's general manager announced recently.

Another appointment in the Distributor Sales Department was announced. The firm of Garstang and May, Indianapolis, now represents Utah throughout Indiana, Western Kentucky and Southern Illinois.

Bendix Appoints

Moving swiftly to close all territories for coverage of the Bendix Radio direct-to-dealer merchandising plan, E. C. Bonia, general sales manager for radio and television, today announced three new appointments.

New England was closed with the exception of the Boston area in two appointments: George Bartlett and his Bartlett Radio Company, 8 Longfellow Street, Portland, Maine, will cover that state as district merchandiser. Vermont and New Hampshire will be covered by Tom Farley of 3 Ninth Avenue, Haverhill, Massachusetts.

The Pittsburgh and Western Pennsylvania area are represented by the J. E. Miller Company, Inc., 80 Twenty-sixth Street, Pittsburgh 22, Pennsylvania.

Manuals & Catalogs

Rider Television Manual Volume 1.
Published 1948 by John F. Rider,
Publisher, 404 Fourth Avenue, N. Y. 16.

CHECK!

DISTORTIONLESS SOUND-SYSTEM CONTROLS!

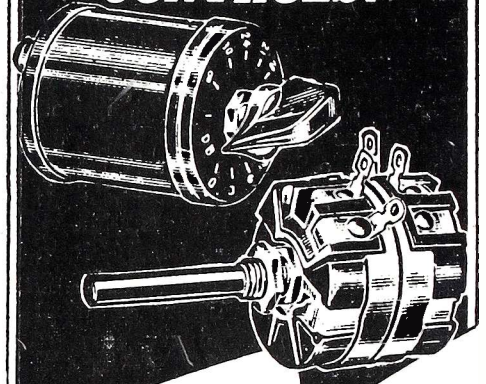

OUTPUT ATTENUATOR

Constant-impedance volume control handling up to 10 watts at any dial setting. Used as output level control for power amplifiers. Or as input attenuator for individual speakers in P-A systems.

L-PADS AND T-PADS

Constant-impedance attenuators. These self-compensating volume controls eliminate distortion arising from mismatching of impedances.

PLUS THE "KNOW-HOW"

Clarostat can tell you how to eliminate distortion in sound-system volume control. Clarostat has made the bulk of the L- and T-pads, attenuators and faders, now in general use!

CLAROSTAT



Ask your
Clarostat
jobber for
latest cat-
alog. Or
write us.

Controls and Resistors

CLAROSTAT MFG. CO., Inc. · 285-7 N. 6th St., Brooklyn, N. Y.

In Canada: CANADIAN MARCONI CO., Ltd
Montreal, P.Q., and branches

N. Y. 1400 pages including 39 giant pages + 13 page separate index + 203 page "How It Works" text, Price \$15.00.

This manual represents an excellent job of compiling circuit diagrams, chassis layouts, and other pertinent service information of the 1946-1947 television receivers (both complete and kit) produced by the industry's leading manufacturers. In keeping with the pattern established by their previous manuals the Rider organization has spared no effort in making the reference material as complete as possible, and the contents readily available.

Giant pages (the size of six regular pages) are a feature of this manual. Their purpose is to keep huge schematics clear and legible. They are folded in such a manner that when unfolded the schematics unfold beyond the edges of the other pages thereby making the diagram readily available.

Cathode Ray Equipment. Information regarding the tools of present-day oscillography—cathode-ray tubes, oscillographs, allied equipment and accessories—is now available in the new catalog just issued by the Instrument Division of Allen B. Du Mont Labs., 1000 Main Avenue, Clifton, N. J. It features a wide selection of standard tubes and instruments. A copy may be had by writing to the above address on your business letterhead.

Television. "Interesting facts about this fascinating field." Published 1948 by Transvision Inc., New Rochelle, N. Y. The purpose of this booklet is to make available an introduction to television on a very elementary level. Principles and terminology are simply explained. Questions that are likely to arise in the minds of beginners are voiced and answered. Concepts that are difficult to explain verbally are illustrated graphically. A 20-page publication everyone interested in television should read.

Glassmikes. "Plasticon ASG silicone-filled capacitors for higher voltages." Condenser Products Company 1375 North Branch St., Chicago 22, Ill. A 16-page illustrated booklet on the applications of this new product. Very informative and interesting, and should be read by engineer and technician alike.

Television Trouble Shooting Lessons 9 & 10 by Philco Radio Corp., Phila., Pa. Lesson 9 discusses the physical and electrical considerations underlying TV antennas. Lesson 10 delves into problems encountered in choosing the proper type of aerial system for a given installation. The content is well presented in clear language and excellently illustrated. 21 pages.

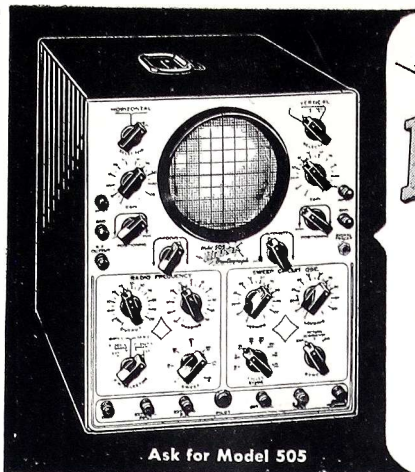

THE HICKOK World Famous CATHODE RAY OSCILLOGRAPH

Sensitive and accurate—for stage by stage alignment A modern 5" Cathode Ray 'Scope with outstanding HICKOK exclusive features:

Phasing Control; Self-contained Mixer Circuits; Return Eliminator; Demodulator; Wide and Narrow Band FM Oscillator; Wide Band Amplifiers—Sinusoidal and Linear Sweep.

SEE YOUR JOBBER OR WRITE FOR ILLUSTRATED LITERATURE.

THE HICKOK ELECTRICAL INSTRUMENT CO.
10533 Dupont Avenue • Cleveland 8, Ohio

Permoflux SPEAKERS



YOUR JOBBER CAN SUPPLY YOU!

Permoflux quality and dependability—the same as supplied to the major set manufacturers—is your assurance of complete customer satisfaction. You'll find Permoflux Speakers easy to install and readily available in both PM and Electro-dynamic types. You'll find too, that it pays to give your customers "tops in tone" with a Permoflux Replacement Speaker.

TWO COMPLETE FACTORIES TO SERVE YOU **PERMOFLUX** WRITE FOR FREE BULLETIN
PIONEER MANUFACTURERS OF PERMANENT MAGNET DYNAMIC TRANSDUCERS

PERMOFLUX CORPORATION
4900 WEST GRAND AVE., CHICAGO 39, ILLINOIS
236 SOUTH VERDUGO ROAD, GLENDALE 5, CALIFORNIA

JUST TWO OF THE FINE, COMPLETE LINE OF TV ANTENNAS TO BE FOUND IN OUR NEW CATALOG

GET YOURS NOW
LOW CHANNEL • HI-CHANNEL
STACKED ARRAYS • STRAIGHT OR
FOLDED DIPOLE • REFLECTORS • THE
NEW WINDOW ANTENNA FOR ALL
CHANNELS • AND MANY OTHERS
JOBBER: Many CHOICE sections open
WRITE FOR DETAILS NOW

HY-LITE Antennae INC.
Makers of Fine Antennas for AMATEUR • FM • TELEVISION
528 TIFFANY ST., BRONX 59, N.Y.

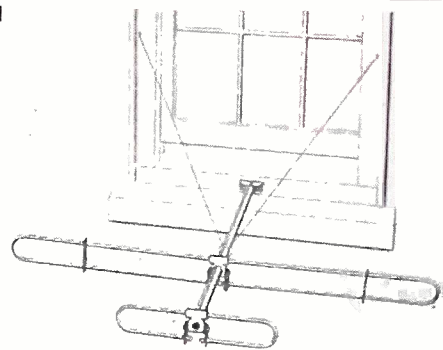

HY 80 W ALL CHANNEL WINDOW ANT.

\$23⁰⁰ COMPLETE  \$15⁹⁵ COMPLETE 
HY 30 S ALL PURPOSE • ALL CHANNEL

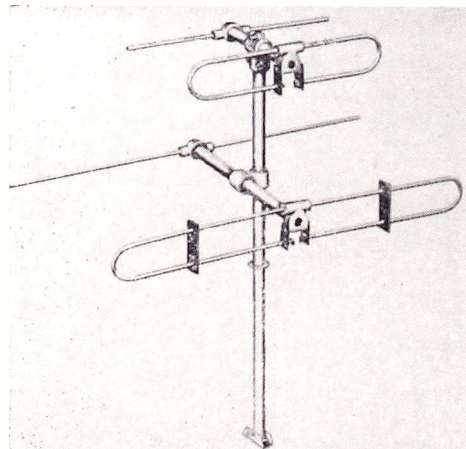

3 steps to

GREATER DISTANCE

BETTER VIDEO

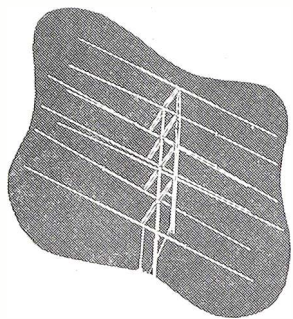

VEE-D-X,
the long range,
high gain
TV antenna

Two or three stage
TV Pre-Selectors for
higher antenna gain
and isolating
interference.

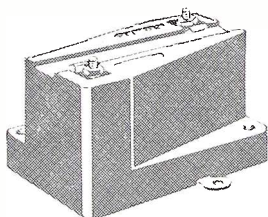
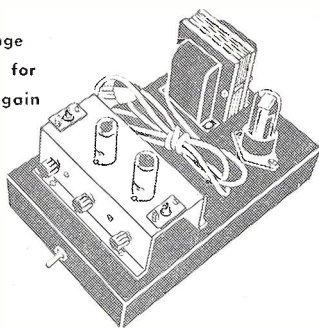

VEE-D-X
lightning arrester,
protection to
TV receiver
and equipment.

Three important steps to take to get the most out of every TV receiver. VEE-D-X developed this high quality, engineered TV equipment after extensive research and development to provide an adequate and safe antenna system for every type of installation. There is no substitute for a high gain antenna in TV, but with the addition of a VEE-D-X Pre-Selector, higher gain is achieved along with the suppression of unwanted signals. Protected with a VEE-D-X lightning arrester, you can have the finest TV antenna system available with a VEE-D-X installation. See your favorite radio jobber or write to: LaPointe Plascomold, Unionville, Connecticut.

VEE-D-X

Adds more vision to television

FIELD FINDINGS

(from page 8)

sponsoring groups are not yet able to inform me definitely where their meeting is to be held. Ample space will be provided for large audiences. Contact your Jobber if the meeting for your city is not posted as being definite in the adjoining box, and remember that we will try to keep you informed by direct-mail of latest developments. For example, we still don't know whether our Cleveland date is for Oct. 7th or the 8th, and we're still awaiting confirmation about where we will meet at Des Moines on the evening of Oct. 6th. The Los Angeles meeting is also pending. What a job it is to get these things lined up during the summer-time vacation!

TV May Go "Upstairs"

FCC is seriously considering adding the 475-500 mc band to TV in the anticipation it will result in less TVI (television interference). FCC has already abolished Channel 1, and there are rumors to the effect that Channels 2, 3 and 4 are in jeopardy. Talks about the "upstairs band" —480-960 mc are in progress but nothing much can develop until after the big pow-wow scheduled for Sept. 20th. Naturally, big factors in TV want to leave the present frequency assignments alone fearing a drop-off in TV set sales if the public "gets wise" that present-day models might become obsolete in a short while. Actually, no immediate FCC move can be expected regarding the higher bands, but if they are opened, it is likely that dual telecasting would be effected for a 5 to 7 year period with the eventual dropping of the lower frequencies. Incidentally, radio firms have already designed units that permit operating present style video sets on the higher frequencies. Any good technician can handle the change-over.

Records Of The Month

A firm has been established in Chicago to sell to the public phonograph record albums on a regular monthly basis similar to the Book Of The Month plan. They even plan to give a bonus album free to everyone who has purchased five albums.

Radio and music dealers who retail records and albums will find this Club a serious competitor if it succeeds. Every album the Club sells takes that much potential business away from a legitimate dealer.

Service Tips From ARSDN

The Columbus, Ohio association (As-



Easier Antenna Installations



STAR TAMPIN



STAR DRYVIN



STAR STAZIN



STAR SPRINGIN

Star Expansion Bolts make it easy to fasten TV equipment to brick, stone, concrete or any other type of masonry. Help you to position antenna masts, cables and lines in the best possible manner... assure greater satisfaction; reduce service calls. There's a Star fastening for every masonry job. See your jobber or write for details.

★ STAR EXPANSION BOLT CO. INC.

147 Cedar Street, New York 6, N. Y.

Vital Aids

IN SERVICING
MINIATURE TUBE RADIOS
AND EQUIPMENT



★ Star Miniature Socket Wiring Plugs for accurate alignment of miniature socket contacts during wiring. Precision cast of zinc base alloy—pins of stainless steel. #JE-9 (9 pin); #JE-10 (7 pin).

★ Star Miniature Tube Pin Straighteners (with stainless steel insert) to obtain a perfect fit when the tube is placed in the equipment. #JE-15 (9 pin); #JE-13 (7 pin).



Scientifically designed — Precision made
Immediate Delivery in Any Quantities

★ STAR EXPANSION PRODUCTS CO., INC.

147 CEDAR STREET, NEW YORK 6, N. Y.

For added sales
(and profits!)



demonstrate

the amazing Shockproof

nylon needle*

by

DUOTONE

Actually b-o-u-n-c-e the whole
tone arm on a record without
effect. A spring steel shaft and
nylon elbow—that is the secret!

\$2.50
LIST

*pat. pending

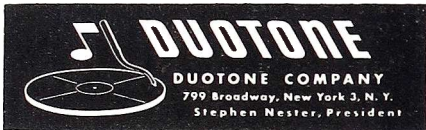

Mueller

(THE CLIPPER)
**ANNOUNCES THE NEW
No. 22 "TWIN-CLIP"**

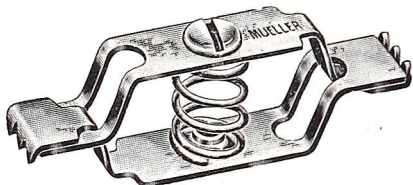

**HAS JAWS ON BOTH ENDS
Something New and Different!**

Both jaws may be opened at the same time by pressing the center of the clip, or either jaw may be opened separately without disturbing the grip of the other.

Two inches long, made of cadmium plated steel. Has screw connection.

The Twin-Clip is a real time-saver in many electrical and mechanical applications. May be used to make a quick splice, temporary repair hookup, hanging and racking various articles for display or industrial processing, holding identification and record cards, etc.

Send for Free Samples and
Complete Catalog 1905

Mueller Electric Co.

1605 E. 31st St. Cleveland 14, Ohio

sociated Radio Service Dealers of Columbus) periodically issues an inexpensive yet highly informative bulletin for its membership. The current number has some service hints worth mentioning; for example: 1) When installing TV antennas, the best leadin for a weak signal, if not in a noisy location, is a standard twin lead, well waxed to prevent moisture; 2) the best lead if you have noise is co-axial line, using two leadins, using the center of each and grounding the shield of each to the set.

Judging Contests

It has been my fortune, (good or bad, I'm not sure yet), to be asked by several radio manufacturers to act as Judge in contests they are running. The contests range in scope from: "Which Is The Best Window Display" to "What Handy Gadget Should Be Made Available To Servicemen."

I've recently reviewed many hundreds of servicemen's ideas in regards to gadgets and must confess that the experience has been most gratifying. It is really amazing to see "ideas" submitted by men in all parts of the country which are absolutely identical, despite the fact that the men themselves are separated by thousands of miles, and of course, have never been in contact with each other. Here is proof positive that necessity is the mother of invention. It's too bad that all the contest entrants can't be adjudged winners. The least we can do is give them a great big Bow of Recognition for Ingeniousness.

Gripe About Franchises

Several "RSD" subscribers have written recently griping that radio set manufacturers are making it too difficult for Service Dealers in small cities to handle their franchises. Most Service Dealers want to handle nationally advertised brands, but naturally cannot afford to put many thousands of dollars into inventory for each and every line. On the other hand, Distributors for set lines are dollar and volume hungry, and consequently many will give their lines to any Tom, Dick and Harry who has ready bucks, regardless of their background or experience in radio merchandising.

If it weren't for average-type Service Dealer establishments in average-size cities, and if it weren't for the sacrifice and industriousness of average-type radio servicemen, radio set manufacturers would be retarded twenty years. They seem to fail to appreciate how much their progress has depended upon the servicing end of the business. Now, to correct a bad situation, the better known set makers should review the dealings of their distributors and see to it that the old standbys get a break.

**How BURGESS
Makes Flashlight
Battery Sales
EASY FOR YOU!**

NEW ADVERTISING
STIMULATES SALES

Yes! You profit by this new Burgess advertising campaign! New, full-column ads . . . new 70-line ads . . . new 35-line ads every month sell Burgess Batteries to over 70 million readers of 9 nationally famous magazines — SATURDAY EVENING POST . . . BETTER HOMES AND GARDENS . . . COLLIER'S . . . COUNTRY GENTLEMAN . . . AMERICAN MAGAZINE . . . PROGRESSIVE FARMER . . . SOUTHERN AGRICULTURIST . . . PATHFINDER and FARM JOURNAL!



Burgess Flashlight Batteries are manufactured under laboratory controlled conditions from only the highest grade raw materials. Yes! Burgess quality is recognized by millions! Order Burgess Flashlight Batteries today from your distributor in attractive counter vendors of 12 or 48 batteries!

SALES PROMOTIONAL
HELPS

Counter and window cards, streamers, enclosures, and newspaper ads, are offered FREE to dealers to help build Burgess Flashlight Battery Sales. Ask your Burgess distributor.

**BURGESS
BATTERY COMPANY**

FREEMONT ILLINOIS

GET INTO THE TELEVISION BUSINESS IN A BIG WAY NOW WITH THE NEW **TRANSVISION** DEALER PLAN

It brings you a sure-fire means of doing a BIG and PROFITABLE business in Television Receivers.

It's simple . . . but it's great!

- NO FORCED PURCHASES
- NO "TIE-IN" DEALS
- NO CAPITAL PROBLEM
- NO INVENTORY PROBLEM

Get the **FACTS** about this amazing new Transvision Dealer Plan which will give you a big stake and big future in television.

FILL OUT AND MAIL THIS COUPON NOW!

Transvision, Inc., New Rochelle, N. Y.
 Rush all the information on your special new Dealer Plan.
 I want to attend your Special Dealer Television Meeting.
 Name
 Address
 My distributor is

Selected Group of Men, desire employment in Radio Field. Will travel anywhere. Qualified radio servicing, installation, test instruments, circuit operation, etc.

EASTERN TECHNICAL SCHOOL
888 Purchase Street, New Bedford, Mass.

ANTENNAS TELEVISION - FM

Highest Quality-Lowest Prices

WRITE FOR FREE CATALOG, TECHNICAL INFORMATION AND DEALER NET PRICE LIST.

THE NATIONAL TELEVISION COMPANY
1155 NEILSON AVE., FAR ROCKAWAY, N. Y.

Ad Index

Air King Prods. Co., Inc.	Cover 3
Amperite Co., Inc.	51
Belden Mfg. Co.	4
Burgess Battery Co.	55
Cal-Perry Corp.	48
Centralab Div. of Globe-Union	32, 33
Clarostat Mfg. Co.	52
Clippard Instru. Lab., Inc.	56
Crosley Div., Avco Mfg. Corp.	1
Duotone Company	55
Eastern Technical School	56
Electro-Voice, Inc.	9
Espey Mfg. Co., Inc.	40
General Elec. Co. (Speaker Div.)	37
General Electric Co. (Tube Div.)	5
General Industries Co., The	39
Hickok Elec. Instru. Co.	53
Hy-Lite Antennae, Inc.	53
Hytron Radio & Electronics Corp.	12
J. F. D. Mfg. Co., Inc.	51
La Pointe Plascomold Corp.	54
Littelfuse, Inc.	48
Mallory, & Co., Inc., P. R.	Cover 2
Mueller Electric Co.	55
Murray Hill Books, Inc.	52
National TV Co.	36
Permoflux Corp.	53
Racon Electric Co., Inc.	38
Radiart Corp, The	41
Radio Magazines, Inc.	49
R C A (Tube Div.)	Cover 4
R C A (Sound Div.)	6, 7
Sams & Co., Inc., Howard W.	11, 42
Simpson Electric Co.	3
South River Metal Prods. Co.	50
Star Expansion Bolt Co., Inc.	54
Star Expansion Prods. Co., Inc.	54
Television Assembly Co.	46
Transvision, Inc.	36, 56
Stewart-Warner Corp.	45
Triplett Elec. Instru. Co.	43
Utah Radio Products	44
U. S. Treas. Dept.	45
Weller Mfg. Co.	50
Workshop Associates, Inc., The	49
Wright, Inc.	56

YOU DON'T HAVE TO GRUNT & SWEAR & SWEAT

when installing Wright Verified Speakers with the new Adjustable Mounting Bracket

They fit on like an old shoe

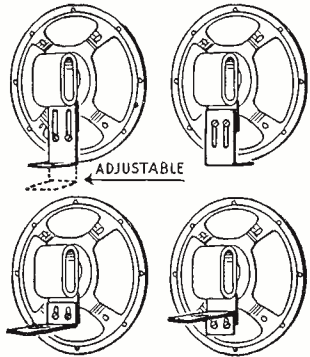

Write for literature and name of nearest distributor

WRIGHT
Inc.

2231 University Ave., St. Paul 4, Minn.

SHOOTS TROUBLE FASTER!

MAKES MORE MONEY FOR YOU ON JOB OR AT SERVICE BENCH!

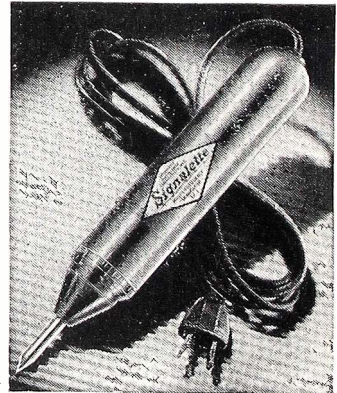

PRICE \$9.95 at distributor or postpaid, direct Sorry, no COD's. Ohioan's add 3% State Sales Tax

Signalette

MULTI-FREQUENCY GENERATOR

In radio service work, time means money. Locate trouble faster, handle a much greater volume of work with the SIGNALETTE. As a trouble shooting tool, SIGNALETTE has no equal. Merely plug in any 110 V. AC-DC line, start at speaker end of circuit and trace back, stage by stage, listening in set's speaker. Generates RF, IF and AUDIO Frequencies, 2500 cycles to 20 Megacycles. Also used for checks on Sensitivity, Gain, Peaking, Shielding, Tube testing. Wt. 13 oz. Fits pocket or tool kit. See at your dist. or order direct.

CLIPPARD INSTRUMENT LABORATORY, INC.

Dept. D 1125 Bank Street
Cincinnati 14, Ohio

Qualified Jobbers write, wire for details.

Only **AIR KING** Experience

could Build this Matchless

WIRE RECORDER

PHONO-COMBINATION



**AIR KING Portable
WIRE RECORDER
Model A-750-1**

\$139⁵⁰

*Includes federal excise tax
Slightly higher in Zone 2*

AIR KING has the "know-how"!

BUILDERS OF FINE RADIOS for 28 years, AIR KING likewise pioneered the Wire Recorder. From the time of its drawing-board inception, AIR KING engineers laboriously strived for that perfect, popular-priced Wire Recorder . . . the recorder that guarantees vivid reproduction . . . and versatility to meet all uses. As a result of these years of concentrated effort toward perfection and the thousands upon thousands of AIR KING Wire Recorders still giving matchless service, the AIR KING is your best Wire Recorder buy.

AIR KING has the experience!

AIR KING PRODUCTS CO., INC., 174 53rd ST., BROOKLYN 32, N. Y. • Export Address: Air King International, 75 West St., New York 6, N. Y.

Compare these exclusive

AIR KING features —

- RECORDS DIRECT FROM RADIO
- RECORD PLAYER. Plays 10" & 12" records
- RECORDS DIRECT FROM PHONOGRAPH
- 5-TUBE AMPLIFIER (including rectifier)
- Automatic shut-off at end of play or rewind of wire
- Crystal mike for hand, table or stand
- Rewind speed: 6 times forward speed
- Erases automatically when recording over used wire
- Safety lock prevents accidental erasure
- Covered in leatherette. Luggage-type carrying case
- Weighs 30 lbs. • 5" Alnico V P.M. speaker
- Complete with these extras: Two spools of 15-minute wire and cable for radio attachment

AIR KING RADIO

Division of HYTRON RADIO & ELECTRONICS CORP.

The Royalty of Radio Since 1920





Push RCA Tubes and Watch Your Business Grow!



A few of RCA's outstanding sales aids for servicemen and dealers.

Get the lead . . . Hold the lead . . . with RCA's new line of sales aids

• Lead the field in sales and service with these new, compelling RCA sales aids! They'll give you the powerful point-of-sale support you need to help bring more business your way . . . because they associate your business with the greatest name in radio and television.

See the complete line of RCA sales and business aids . . . and learn how they can be used to promote business for you. The new booklet, "RCA Schematic for Bigger Profits and Better Service," presents the whole story. Get your copy today from your RCA Distributor.

Greatest array of sales and business aids in the industry! The materials you need to sell more service, sell more RCA tubes, and speed up your work, are illustrated and described in this new RCA Sales Aid Catalog. Your RCA Tube Distributor has a copy for you.



SEE YOUR RCA TUBE DISTRIBUTOR TODAY FOR FULL DETAILS



TUBE DEPARTMENT

RADIO CORPORATION of AMERICA

HARRISON, N. J.