



radio dealer

ALL OUT FOR
THE MIGHTY
7th
WAR LOAN

In
This
Issue:

RADIO SERVICE SURVEY
Franchise Selection
Wire Recorder

FM Sets Saved

May, 1945
25c



**A
Complete
Repair Job
Rings
the Bell**

**... and Here's What MALLORY
Offers To Make It Complete**

HALF-FINISHED repair work, held up for want of the right part—or because the part is defective—means trouble for you. That's why the Mallory line is built with two important things in mind:

First, to insure quality (Mallory precision standards, plus an impressive list of engineering "firsts," have long demonstrated their effectiveness on *that* score). Second, to meet the maximum number of replacements needs with the minimum number of items. (The Mallory program of interchangeable parts and streamlined stock is the brilliant answer to *that*.)

But Mallory products, however carefully and intelligently made, would be of little use if they were not available when and

where you needed them. So Mallory gives you Selective Distribution—an outstanding distributor, in the right place, with the right help, when you need it.

What kind of help? Technical information, unsurpassed in its field . . . tried and tested business formulas . . . data on new developments . . . plans for the future . . . promotion materials to keep your name before your prospects . . . consistent Mallory advertising, maintaining public acceptance.

Yes, Mallory offers outstanding products—precision-made, widely accepted by the industry—and *it makes it as easy as possible to get them and use them*. It's that over-all picture that counts . . . the important "extras" that make your repair work complete.

P. R. MALLORY & CO., Inc., INDIANAPOLIS 6, INDIANA



*More than ever—
ALWAYS
INSIST ON*

P. R. MALLORY & CO. Inc.
MALLORY
APPROVED
PRECISION PRODUCTS

VIBRATORS • VIBRAPACKS* • CONDENSERS
VOLUME CONTROLS • SWITCHES • RESISTORS
FILTERS • RECTIFIERS • POWER SUPPLIES

ALSO MALLORY "TROPICAL"® DRY BATTERIES, ORIGINALLY DEVELOPED BY MALLORY FOR THE U. S. ARMY SIGNAL CORPS, NOT PRESENTLY AVAILABLE FOR CIVILIAN USE.

® Trademark

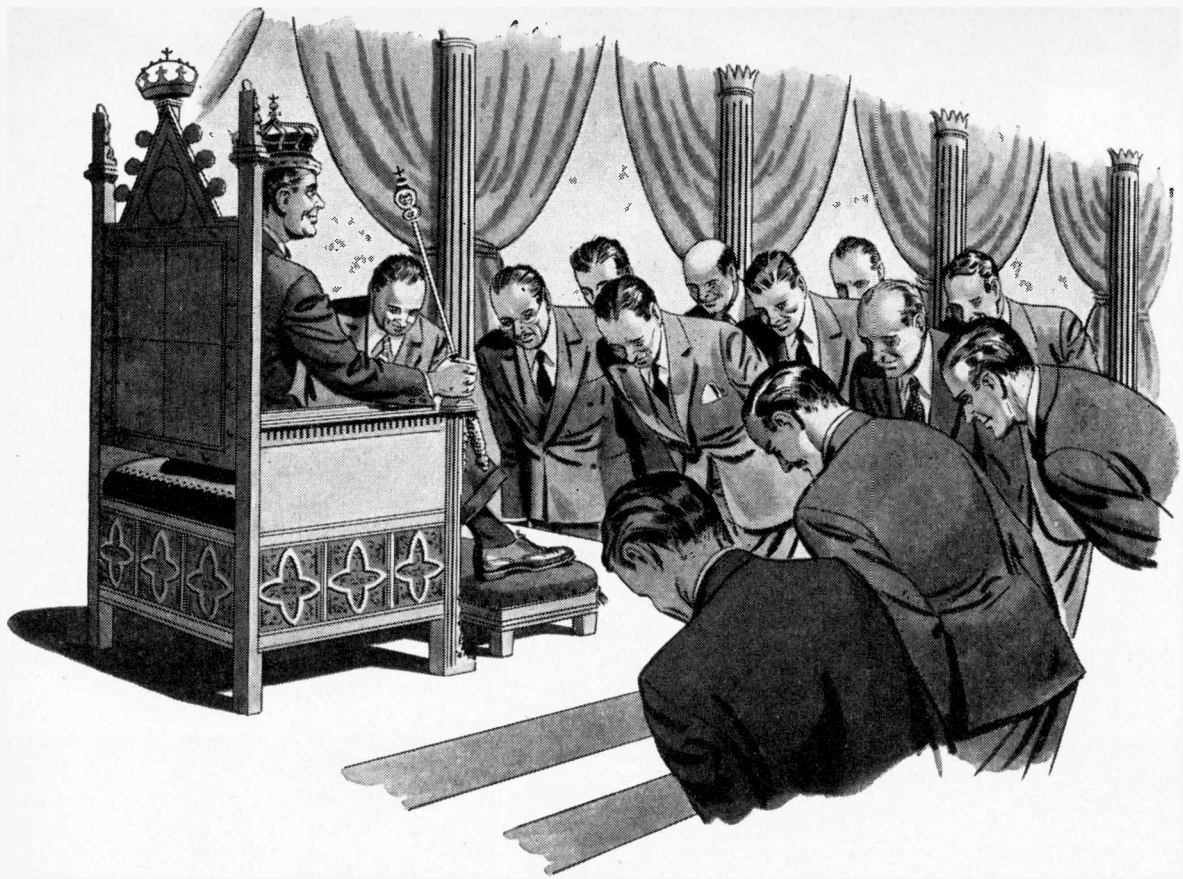

LONG LIVE KING DEALER!

YES, MR. DEALER, YOU'RE KING. And will be until "The System" makes you the GOAT again!

What "System"?

Why, the system of distribution that made a battle ground of dealers' stores in the last radio war.

THE SYSTEM filled with bad trade practices, inflated discounts, "Co-op" allowances, "Spiffs," high-pressure promotions, dumping and all the other evils that ate up dealer profits.

Will it happen again?

Sure! It can't miss IF old practices are followed.

If they are, dealer mortality may be even higher—with 125 manufacturers instead of 57 slugging it out for postwar leadership.

This kind of trade war will make the Chains happy.

It drove business to them before and it will again.

SOME OF THE BEST dealers in the U. S. know from experience that the *S.C.M.P. avoids all the pitfalls of the old distribution system—

*S.C.M.P. enables dealers to meet any and all competition and still make a profit.

Sparton—"Radio's Richest Voice"—since 1926, has established many firsts in the industry.

After Victory is won, there will be new Spartons—radios and combinations with FM of unsurpassed performance. All in beautiful cabinets and created by America's leading designers.

YOU can be the Exclusive Sparton Dealer (if you qualify) in your Community. Appointments are being made now.

If you are interested may we suggest that you do not delay requesting a copy of the *S.C.M.P. book which explains the plans in detail.



The coveted Army-Navy "E" awarded all five plants of Sparks-Withington Co.

ONE SPARTON DEALER IN EACH COMMUNITY

Check These Profit-Increasing Features

- One exclusive dealer in each area
- Direct factory-to-dealer shipment
- Landed dealer cost prices
- Low consumer prices
- National advertising
- Factory prepared and distributed promotion helps
- Seasonal promotions
- Uniform retail prices
- Products styled by outstanding designers

Radio and Appliance Division—Plant 5

THE SPARKS-WITHINGTON CO., JACKSON, MICH.

***S.C.M.P.**

Sparton Co-operative Merchandising Plan. An exclusive method of profitably retailing radios and home appliances that has been and is being advertised regularly to consumers in leading magazines as The Sparton Way.

There's no let down in MT. CARMEL

Though the war news is good . . . and getting better every day . . . the men and women of Meissner's famed "precision-el" haven't let down. As you can see, in the photographs on this page, they devote the same concentration to their work now as they did when the going was tough. This stick-to-it-iveness is one more reason for Mt. Carmel's rapid rise to prominence as one of the centers of an exacting industry, electronics.



They Listen to a news broadcast during their lunch hour. Then it's back to work with a determination to equal military victories with new production records on the home front . . . without loss of Meissner quality.



"Precision-el" at Work. They're building Meissner quality into this vital electronic war material. After victory that same pride in a job well done will give new meaning to Meissner's slogan, "Precision-built by Precision-el."



His Skilled Fingers have mastered many of the secrets of electronics. After victory, he and many of Meissner's "precision-el" like him will pass this knowledge and tradition of precision to a new generation.



His Smile is a Reflection of the hundreds of smiles he sees each day as the men and women of Meissner pass through the gates he guards. If you ask him, he'll tell you it's the smile that helps put precision into "precision-el."

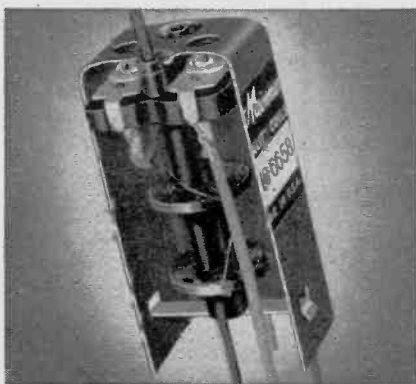

"Step Up" Old Receivers!

These Meissner Ferrocart I. F. input and output transformers are getting top results in stepping up performance of old worn receivers. Special powdered iron core permits higher "Q" with a resultant increase in selectivity and gain, now available for frequency range 127-206. Ask for numbers 16-5728 input, 16-5730 output. List \$2.20 each.



MEISSNER

MANUFACTURING COMPANY • MT. CARMEL, ILL.

ADVANCED ELECTRONIC RESEARCH AND MANUFACTURE

Export Division: 25 Warren St., New York; Cable: Simontrice

RADIO SERVICE DEALER

radio service dealer

Member Audit Bureau of Circulations

Covers all phases of radio,
phonograph, sound and elec-
trical appliance mer-
chandising and servicing

VOLUME 6 NUMBER 5

MAY, 1945

CONTENTS

With The Editor	8
In & Around The Trade	10
Pointers on Franchise Selection	17
Pre-test Radio "Buy-appeal"	18
"Home Front" Eisenhower is Radio Dealer	19
Radio Service Opportunity	20
How to Recalibrate Test Equipment Part 2	23
Working P-A	25
FM Sets Saved	26
Wire Recorder Development	28
Waiting for "Sales Day"	31
Technical Service Portfolio XLIX	32
Radio Service Dealer Survey	38
Trade Products	42
Shop Notes	47

Cover: 7th War Loan

RADIO SERVICE DEALER (title registered U. S. Pat. Off.) is published monthly at Boston Post Road, Orange, Connecticut, by the Cowan Publishing Corp. Executive & Editorial Offices, 342 Madison Avenue, New York City 17, New York. Publication Office, Boston Post Road, Orange, Conn. Subscription rates:—United States and Possessions \$2.00 for 1 year, \$3.00 for 2 years; elsewhere \$3.00 per year. Single copies: 25c. Printed in U. S. A. Entered as Second Class Matter October 3, 1941 at the Post Office at East Stroudsburg, Pa., under the Act of March 3, 1879. Permit for Second Class Entry pending at Orange, Connecticut. All subscribers should allow at least three weeks for change of address.

Copyright, 1945

COWAN PUBLISHING CORP.

SANFORD R. COWAN,
Editor and Publisher

LEWIS C. STONE
Managing Editor

CHARLES H. FARRELL, Advertising Manager

HAROLD J. SUGARMAN, Eastern Adv. Mgr.

RENIE ARMSPACH, Circulation Manager

ELAINE WILSON, Advertising Prod. Mgr.

10,000 PARTS

Ten thousand different radio and electronic parts
immediately available on priorities

EAST SERVICE

Trained expeditors select and ship same day
your order is received

SINCE 1922

Known since 1922 as reliable jobbers, wholesalers and
manufacturers of radio and electronic equipment

Radio Wire Television Inc.

World's Largest Radio Supply House
100 Sixth Ave. (Dept. S-5) New York 13, N. Y.
Boston, Mass. Newark, N. J.

Originators and Peacetime Marketers of the Celebrated

Lafayette Radio

Write today for our bargain flyers and special bulletins



MODEL
204-TC

DYNAMIC HANDI-MIKE

TECHNICAL DATA MODEL 204-TC

IMPEDANCE: 35-50 Ohms.

FREQUENCY RESPONSE: 200-7500 Cps.

OUTPUT LEVEL: Into 50 ohm input; 44 db below 6 milliwatts for 100 bar signal.

SWITCH: Type "T." Press-to-talk. Vertical toggle with snap action.

CORD: 6 feet long. Rubber jacketed. 2 Conductor and shield.

CIRCUIT: Two wires direct to microphone. Switch "makes" independent circuit. For use in connection with control circuit of transmitter or other relay operated device.

DIMENSIONS: Length overall 8 inches, head diameter 2 1/4 inches.

SHIPPING WEIGHT: 2 pounds.

There are seven other dynamic handi-mike models from which to make a selection.

Universal Handi-Mikes have been, through these years of progress in Radio-Electronics, as common a part to specialized sound equipment as the vacuum tube is to your home radio. The same microphone restyled and redesigned progressively has met the wanted need of a rugged hand held microphone. The Handi-Mikes are now available in both carbon and dynamic microphones with a variety of switches and circuits from which to choose.

UNIVERSAL MICROPHONE COMPANY
INGLEWOOD, CALIFORNIA



REPRESENTATIVES: *New York, Chicago, Kansas City, Cleveland, Boston, Tampa, Houston, Philadelphia, Detroit, Seattle, St. Paul, Salt Lake, Los Angeles, San Francisco, and Asheville.*

RADIO SERVICE DEALER

Depend on
ARVIN
for Quality

Top Flight Craftsmen — with years of radio experience before and during the war — will build the ARVIN Radios you've ordered from your distributor, just as soon as possible, as explained to your customers in the magazine page reproduced below, from a current issue of The Saturday Evening Post . . .

Top Flight Craftsmen

WILL BUILD YOUR ARVIN RADIOS—LATER

WHEN THE SIGN SAYS "GO"



These are the skilled hands of an Arvin Top Flight Radio Craftsman. All the radios they are producing now go to war—precision-built fighting-radios like the one you see here. But some fine day they'll make Arvin Top Flight Radios for your home.

- ▶ For many years before the war, Arvin craftsmen made good, dependable home radios—more than 500,000 the last peacetime year. In days to come, they'll use their skill and long experience to build even better radios—and a broader line of models for you to choose from.
- ▶ Your new Arvin Top Flight Radios are ready for production when the sign says "GO." There'll be tiny ones, middle-size ones, big ones, radio-phonograph combinations with AM and FM—table models, floor models, portables and rural battery sets—beautiful, dependable values from an old reliable manufacturer.
- ▶ The day is coming when you can radio-furnish your home completely and economically with Arvin Top Flight Radios—upstairs, downstairs, all through the house and outdoors, too. You'll hasten the day by buying more War Bonds.

READY FOR THE "GO" SIGN



Products to come from NOBLITT-SPARKS INDUSTRIES, INC., Columbus, Indiana
Then war work ends . . . ARVIN Radios, Metal-Chrome Dinette Sets, Metal Outdoor Furniture, Electric Heaters, Electric Irons and Appliances, Laundry Tubs, Car Heaters and Other Equipment for Homes and Cars.



UPSTAIRS



DOWNSTAIRS



ALL THROUGH THE HOUSE



OUTDOORS, TOO

Trade Winds...



hallicrafters

hallicrafters

Trade winds in the radio industry are blowing in all directions. Promises of miracles and magic in FM and television are becoming more than commonplace. And more than likely (and in due time) these promises will be fulfilled. Hallicrafters will have equipment very profitable and practical to offer distributors. Hallicrafters highly advanced

developments in the field of high frequency receivers and transmitters for use on land, at sea and in the air, will assume a very important place in the total radio picture. Radio distributors now testing the trade winds will keep a weather eye on Hallicrafters — for exclusive developments ready to fit into the widely expanding markets.

hallicrafters RADIO

THE HALLICRAFTERS CO., MANUFACTURERS OF RADIO AND ELECTRONIC EQUIPMENT, CHICAGO 16, U.S.A.



Buy a
War Bond
Today!



**SERVICE
WITH
METALS**



**FOR
MORE
PROFIT**

RCA was first to market and manufacture metal tubes back in 1935. Since then, RCA has made more than 150,000,000 metal tubes...more than all other manufacturers put together. After the war, RCA Preferred-Type metal tubes will offer both the stock-saving advantages of the RCA Preferred-Type Program, and the high performance assured by the greatest experience in producing metal types.

**RCA PREFERRED-TYPE Metal Tubes
make your servicing easier and quicker**

DURING the war it's been hard to get metal types...you have had to substitute glass types for metals. Result? We all realize, more than ever, how much easier metal tubes make servicing! And for good reason...

How many times have you had to add shields to sets...how many hours have you spent realigning...when self-shielding metal tubes would have done the trick pronto! How much time have you spent in grounding shields...when easy-to-work-with metal tubes are self-grounding?

Yes, metal tubes save trouble from the word "go." Even when you're just testing tubes, metal types are easier to take out and put in...without fooling with clumsy shield cans.

We hope it won't be long until plenty of RCA

Preferred-Type metal tubes are available again. And they'll be welcome as replacements for unshielded glass types. For, the time metal tubes save in servicing means more money to you...bigger, better profits and more satisfied customers.



When *new* sets start rolling, look for RCA metal tubes in them. Sell your customers the sets you *know* are easier to service.

Listen to
"THE MUSIC AMERICA
LOVES BEST,"
Sundays, 4:30 P. M.
EWT, NBC Network



62-6636-02

**THE FOUNTAINHEAD OF MODERN TUBE
DEVELOPMENT IS RCA**



**BUY
WAR
BONDS AND KEEP'EM!**

RADIO CORPORATION OF AMERICA
RCA VICTOR DIVISION, CAMDEN, N. J.
LEADS THE WAY . . . In Radio . . . Television . . . Tubes . . .
Phonographs . . . Records . . . Electronics

with the editor.....

Paging Horace Greeley

RADIOMEN will note with interest the U.S. Census Bureau's recent report on wartime civilian and military population shifts. Between April 1940 and July 1944 nearly 4,000,000 people entered the South and West zones, 3,000,000 having shifted from the North trading area. Specifically, California's population increased 1,839,602, (a 26.6% rise), while New York State lost 846,252 and Pennsylvania 653,092.

Retailers of commodities and technical services are affected by population shifts. Those who are located where population has dropped nat-

urally have lost a certain amount of potential. And dealers located where big population gains are recorded may assume that they will have more prospects for their wares.

Experts have studied the matter to ascertain whether the shifts, many of which are due to wartime exigencies, will affect markets postwar. It is agreed that a vast number of migrators, having seen new spots, have come to like 'em well enough to stay put. Big cities in America will lose. Re-phrasing that World War I song hit, "It'll be easy to keep 'em down on the farm after they've seen Broadway and the many gruesome battlefields".

The Customers Always Write

IN a recent issue of "RSD" we ran an article describing how radio service dealers could easily and profitably modernize auto radios belonging to law enforcement officers so the sets would bring in police signals as well as broadcast band programs. That the suggestion "clicked" is proven by the heavy volume of mail saying, "Thanks".

Our mail also indicates that many honorably discharged war vets, who prior to induction were

not engaged in radio, now plan to or have already come into the field either as dealers or technicians. So, while the replacement parts and tube shortage remains acute — perhaps the trained technician manpower shortage will ease up a bit. Set owners may soon have to wait only three weeks to get a set repaired. You can tell your customers, if they gripe, that despite priorities over 10% of New York City's police cars now roost idly in depots because their radios are on the blink and can't be made to operate because of some sort of shortage.

The "BIG DAY" Approaches

DURING February and March we traveled 14,000 miles, covered 41 States, much of Mexico and South America to learn what's going to happen when war pressure eases up sufficiently to allow resumed production of civilian commodities such as radios and electrical appliances. That big day is fast approaching.

We find that the public is avidly anxious to buy all types of radios and appliances. Besides wanting new items the public wants to have its defective units repaired, too. All manufacturers know, from their field representatives, how terrific the potential market is. And manufacturers expect to be able to meet the demand for tubes, parts, sets and appliances without great diffi-

culty. Many set makers are confident that they will be able to reconvert so quickly, they will be able to have civilian items on the production line before war orders are finished. Some even expect to make deliveries to distributors within 60 days after being given the green light.

Radio-appliance manufacturers are skilled merchandisers. They make mistakes on occasion but they seldom miss opportunities like that which lie ahead. If service dealers plan as soundly as manufacturers, sailing will be smoother for all.



MARION INSTRUMENTS



**GEARED TO
EVER-CHANGING
NEEDS OF
INDUSTRY**

War requirements, plus our own design and construction refinements, now provide industry with instruments of heretofore unknown qualities. As new needs arise, we are geared to use our highly specialized, yet diversified, knowledge in solving any measurement problem.

Solid Alnico magnets
Serrillium copper frames
Sintered soft iron pole pieces
Very high torque movements

Our engineering department welcomes inquiries — especially those demanding extra-critical instruments for special applications.

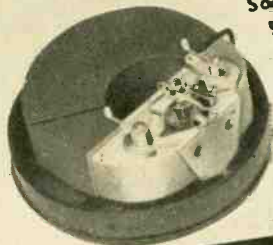

MARION ELECTRICAL INSTRUMENT CO.
MANCHESTER, NEW HAMPSHIRE

Distributed by **ELECTRICAL INSTRUMENT DISTRIBUTING CO.**
452 BROADWAY • NEW YORK, N. Y.

In & Around the Trade

Being a condensed digest of production, distribution and merchandising activities in the radio and appliance trade.



Two-way Motorola FM radio employing a wavelength of 118.65 mc. is now in use by Cleveland's Yellow Cab Company, to direct and control operations of fleet. One hundred additional cabs will be equipped pending permission by the FCC. Remote control station in dispatcher's office transmits messages to cabbies on the go. Power of 15 watts is used for both mobile and fixed transmitters.

Short-Cut Service Methods

Service dealers and industrial engineers who attended the meeting held recently in the newly opened Jamaica, L. I., branch of Harrison Radio Co., witnessed a number of demonstrations of modern test equipment operation.

RCA's L. A. Goodwin, Jr., gave a talk on present day problems of test equipment procurement and availability to servicemen. A. Liebscher spoke on

modern radio service testing technique. He showed for the first time in public a new meter made with a one piece plastic front and designed for use with the RCA VoltOhmyst.

Another "first" was the exhibition of the new Type 170-A Audio Chanalyst, a complete sound system portable test bench. Employing the Dynamic Demonstrator and the Radio Chanalyst, a new method of bridging a test signal around defective components was demonstrated. Short-cut methods of dynamic testing were discussed. This, in keeping with the theme of the meeting, illustrated the possibilities of speeding trouble shooting with modern test equipment.

West Coast EMA

At its recent meeting, Mr. L. W. Howard was elected vice-chairman of the Los Angeles Council of the West Coast Electronic Manufacturers Association. Mr. Howard is vice-president in charge of engineering and sales, Peerless Electrical Products Co., 6920 McKinley Avenue, Los Angeles 1, California. Other officers elected were Mr. Howard Thomas of Packard Bell Co., chairman, and Mr. James L. Fouch, Jr., of Universal Microphone Co., treasurer.



James L. Fouch, Jr., president Universal Microphone Co., makes his annual report at San Francisco meeting of the executive council of the West Coast Electronic Manufacturers Association.

Meck Anticipates

John Meck Industries, Inc., of Plymouth, Indiana, announce that they have now reached 100% occupancy of the buildings which they own there. Up to the present, manufacture of electronic war materiel has only occupied 60% of the floor space. By continuing in war production and occupying the remaining 40%, the company expects to be able to set up production lines which can be converted within 60 days of the resumption of unlimited civilian production and will be able to turn out 2000 home radio sets per day.

The Chicago expediting office is now located at 35 East Wacker Drive under the direction of Fred Arnold. At the end of the war, this office will become the firm's Chicago sales office and showroom.



Five Sparks-Withington plants receive Army-Navy "E". Presentation by Maj. Gen. W. H. Harrison, Chief Signal Corps Procurement, to Harry G. Sparks, president of the company.

New Guide Book Features "Must" Parts

Concord Radio Corporation of Chicago and Atlanta (formerly Lafayette Radio Corporation) has just published a comprehensive 68-page Guide Book of special interest to every user of radio parts and electronic equipment. Issued in a period when new products and improvements on old products are born almost every day, and when availabilities are never the same from hour to hour, the Concord Guide Book is exceptionally valuable in bringing the parts and equipment buyer up to date on what is new and on what is obtainable quickly.

This book features hundreds of "must" items available immediately in single units or in large quantities. It lists and offers standard lines of condensers, resistors, transformers, tools, testers, tubes, and other essential com-

[Continued on page 12]

ONE TO GO!



V-E DAY

To All Hytron Employees:

Put yourself in the shoes of that friend of yours who is now a combat infantryman fighting Japs. How is he going to feel on V-E Day?

Sure, he is going to be pleased and proud that the Nazis have got the thrashing they asked for -- but his joy in that Victory is going to be overshadowed by the grim realization that he has a long, hard fight ahead.

All of us at Hytron will have a tough job ahead, too, after Victory in Europe. The production demands of the Navy alone for the Jap war are staggering. The tubes we are producing will go far toward making possible the bombing raids, the bold fleet actions, the many invasion thrusts that will bring Japan to her knees.

GI Joe will have no time out for celebrations. He doesn't want that now. He wants to finish the job, so that he may come home and join with us all in a real celebration.

The management feels that we, too, have no time to spare -- will have none to spare until final Victory is won. Hytron plants will not close down on V-E Day.

Those boys overseas expect us to keep on backing them up; the management believes you want to do just that. On V-E Day -- and until V-J Day -- let us all give vent to our enthusiasm by redoubling our production efforts for final Victory.

Bruce A. Coffin
Bruce A. Coffin
General Manager

Post: 3-31-45
Remove: After V-E Day

OLDEST EXCLUSIVE MANUFACTURER OF RADIO RECEIVING TUBES



HYTRON

RADIO AND ELECTRONICS CORP.

MAIN OFFICE: SALEM, MASSACHUSETTS
PLANTS: SALEM, NEWBURYPORT, BEVERLY & LAWRENCE



FORMERLY HYTRON CORPORATION

HOMER G. SNOOPSHAW says:

"Customers won't need a 'detector' to find the war battery story in this Burgess ad! These ads in 45 magazines and 1,629 weekly newspapers show homefolks how batteries serve Americans overseas!"



HE HAS YOUR BATTERY



Beyond the front lines high-explosive land mines lie hidden in the earth—waiting for the unwary foot soldier! Portable, battery-powered Mine Detectors locate danger and help clear the way for tanks and infantry. War-winning weapons and instruments use thousands of dry batteries every day—that's why we're short of them on the homefront. Burgess Battery Company.

Support the 7th! Buy Your Share Today!



BURGESS BATTERIES

IN THE NATION'S SERVICE

BURGESS BATTERY COMPANY, FREEPORT, ILLINOIS

In Trade

[from page 10]

ponents and equipment. A special feature is the 16-page "Special Values" Section.

Radio dealers and technicians can get copies by writing to either of the company's two shipping points—901 W. Jackson Boulevard, Chicago 7, Illinois; or 265 Peachtree Street, Atlanta 3, Georgia.



Thomas F. Joyce Joins

Raymond Rosen of Raymond Rosen & Company, specialty wholesale distributors of Philadelphia, Pa., announces that Thomas F. Joyce has acquired an interest in the company and will act as general manager. He was formerly general manager of the radio, phonograph and television department of the RCA Victor Division of the Radio Corporation of America.

In making the announcement, Mr. Rosen said: "We are particularly pleased that Tom Joyce has become a member of our firm. With the unfortunate death of Albert Slap, one of the founders of the business, it became necessary to have someone to take over Mr. Slap's responsibilities. That is what Tom Joyce is to do. He has had a long and extremely successful experience in all phases of the industry's merchandising activities. He played an important part in the comeback of the record business and the return of the phonograph to public favor. His activities in laying the groundwork for the early postwar large scale commercial development of television have received national recognition.

In commenting on his new association, Mr. Joyce said: "I am happy with my new business association, with Raymond Rosen and Joseph Wurzel, whom I have known for the

[Continued on page 14]

SERVICE TO SERVICEMEN... THAT'S STANCOR'S RECORD

Standardize
ON

STANCOR

Transformers

Call your nearest Stancor Jobber...
or write us for his address

STANDARD TRANSFORMER
1300 N. HALSTED STREET · CHICAGO



CORPORATION

SYLVANIA NEWS

RADIO SERVICE EDITION

MAY Published by SYLVANIA ELECTRIC PRODUCTS INC., Emporium, Pa.

1945

SYLVANIA SERVICEMAN SERVICE

by
FRANK FAX



In various sections of the country, servicemen have been active in a movement to have legislation passed for the licensing of radio servicemen. This, they feel, will tend to preserve their prestige in the eyes of the public, and keep radio repairing standards high by assuring that only those servicemen who are qualified be permitted to set up shop.

Many servicemen maintain that such legislation will be of even greater necessity as we approach the postwar years. (Sylvania's survey shows that within 5 or 6 years after the war, the number of radio sets in America will reach 100 million. All of these millions of units are expected to be more complex in construction and will require more of the expert service radio servicemen have been rendering.)

As reports are received referring to impending or passed legislation, this column will carry the information. Meanwhile Sylvania Electric will welcome additional information regarding this movement from radio servicemen or organizations.

Address Sylvania Electric Products Inc., Emporium, Pa.

SURVEY SHOWS PUBLIC CONFIDENCE IN SERVICEMEN

Future Bright Because of This Widespread Trust and Postwar Increase In Sets

"Does the radio serviceman do a good job?" He most certainly does!

This is one of the outstanding facts revealed by the nation-wide, impartial survey conducted by one of America's leading market research organizations, at the request of Sylvania Electric's Sales Research Department.

PUBLIC IS SATISFIED

92.5% of the thousands of set owners questioned expressed full satisfaction in the jobs radio servicemen are doing—a highly significant fact when it is considered that repair men are responsible for approximately 30,000,000 repair jobs per year. In addition, of these thousands interviewed, 89.3% said that the serviceman's charge for work is entirely equitable.

These facts show that (1) servicemen have the confidence of the American public; (2) servicemen have obviously exhibited good business sense, have charged "fair" prices—resulting in further establishing a nation-wide feeling of assurance in their work.

POSTWAR OUTLOOK GOOD

There is every evidence, then, that the future of the radio serviceman is bright. After the war there will be more radios to repair (5 to 6 years after—75 million home radios; 25 million auto sets). More shops and more men will be needed (perhaps 30,000 shops in all, employing 90,000 men)—to handle 50 million repair jobs per year!

(Future issues of SYLVANIA NEWS will report further on this survey.)

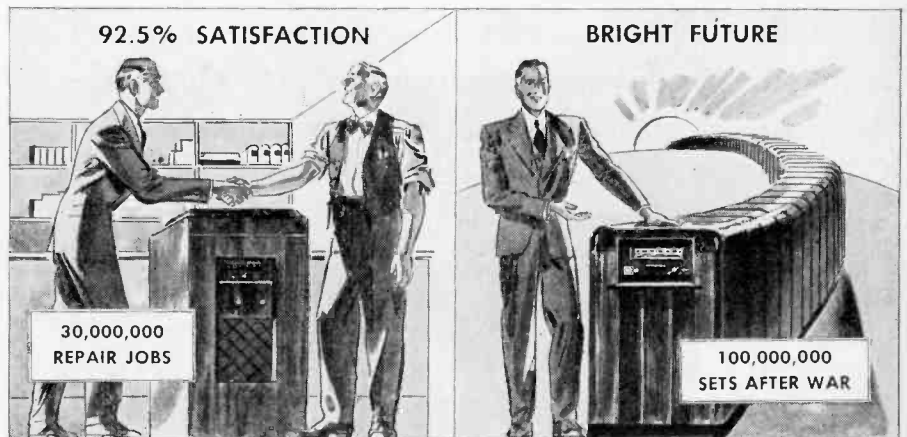

SYLVANIA ELECTRIC

MAKERS OF RADIO TUBES; CATHODE RAY TUBES; ELECTRONIC DEVICES; FLUORESCENT LAMPS, FIXTURES, ACCESSORIES; INCANDESCENT LAMPS

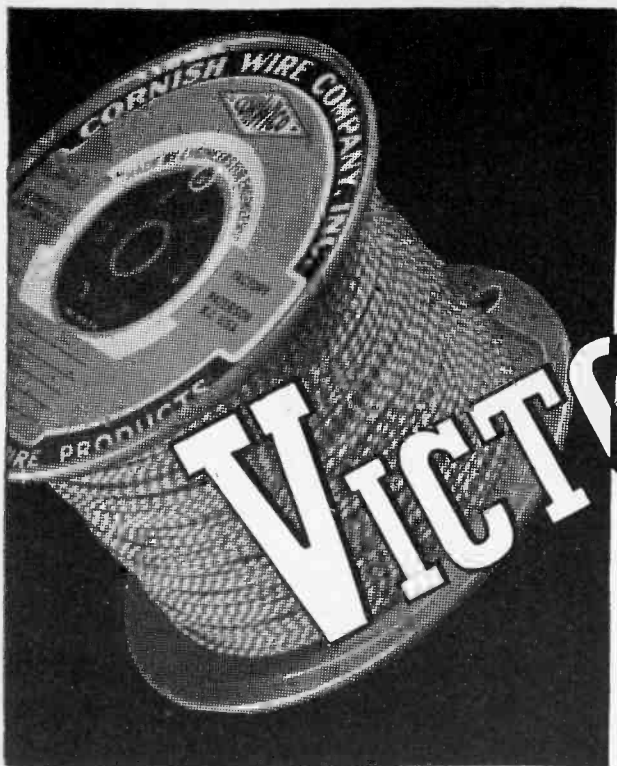

is so

Exacting

AFTER the last enemy lays down his arms . . . then must follow the fabulous changeover whereby industry diverts production for War into production for Peace.

A critical and an exacting phase!

We at CORWICO are already planning for the transition. Soon millions of tons of basic materials formerly required by our armed forces can be diverted to peacetime uses . . . including, you may be sure, the fine CORWICO Wires that civilians have so patiently gone without for so long.

cornish

WIRE COMPANY, INC.

15 Park Row, New York City, New York



"Made by Engineers for Engineers"

In Trade

[from page 12]

past 15 years. While I have had several offers from manufacturers to join their organizations in an executive capacity, all of which I deeply appreciate, the offer made to me by Raymond Rosen & Company makes possible an ambition which I have always had—to be in business for myself.

"Raymond Rosen & Company has played a vital role in building up independent dealerships in Eastern Pennsylvania, Delaware and Southern New Jersey. It has ambitious plans for strengthening these independent dealerships during the postwar period and in helping qualified ex-service men to establish themselves in territories where dealerships are open. In my new work I will feel that I have been successful if I make a contribution to the success of a program which is so vital to our country—the success of the independent dealer."

From a modest beginning in 1926, the organization grew to the point where, before the war, it was the largest wholesale specialty distributing company in Pennsylvania, and one of the largest in the United States. Among the nationally known lines handled by the company are: Kelvinator and Leonard Refrigerators; RCA Victor Radios, Phonographs and Television Receivers; Victor Records and RCA Sound Systems; Bendix Home Laundry; Eureka Vacuum Cleaners; and American Kitchens.

Railroad Radio

Recent frequency allocations announced by the Federal Communications Commission have paved the way for widespread use of radio communications by the nation's railroads, according to John W. Hammond, communications sales manager of the Bendix Radio division of Bendix Aviation Corporation.

"In allocating wide bands of frequencies for use in end to end train communications," Mr. Hammond said, "the FCC has recognized the successful results of tests conducted for the past year or more with the Baltimore and Ohio, Burlington, Santa Fe and other railroads throughout the nation."

Present indications point to future use of radio communications by 40 or more railroads representing more than 60 per cent of the nation's total mileage. Tests have shown that radio in train operations and terminals can contribute substantially to efficiency and lower costs in transportation.

[Continued on page 37]

THESE 10 CONTROLS REPLACE 95%

All controls
complete with switch



5M-A



10M-B



25M-A



50M-B



100M-B



250M-TX



500M-TX



1 MEG-TX



2 MEG-TX



500M-CB

N. U. *Save-a-Shaft* VOLUME CONTROLS

If you haven't already put in a stock of N.U. Save-a-shaft Volume Controls . . . order yours today from your N.U. Distributor. Here's a real time-saver he can deliver fast! Minimum investment in stock of only 10 types is all you need to get going. NATIONAL UNION RADIO CORPORATION, Newark 2, N. J.

7 REASONS WHY

1. 10 types handle over 95% of your volume control replacement needs.
2. Eliminates shaft sizing and knob fitting.
3. Adaptable to any standard shaft.
4. Controls are complete with switch.
5. If no switch is needed, use same control but don't pull switch lug.
6. Individually packaged with instructions.
7. All sizes \$1.00 list price.

NATIONAL UNION RADIO TUBES AND PARTS

Transmitting, Cathode Ray, Receiving, Special Purpose Tubes • Condensers • Volume Controls • Photo Electric Cells • Panel Lamps • Flashlight Bulbs



PERFECT REPLACEMENT

for Nearly Every Control

... Large or Small!



TYPE MR

SET SCREW AND SPRING KNOBS
INSTALL EASILY, FIT PERFECTLY!

MALLORY Replacement VOLUME CONTROLS

HERE is only one of the complete and simplified line of Mallory Controls—a line that replaces and *duplicates*, practically every volume control now in service! This particular replacement control is designed to match large originals that use set screw or spring type knobs. In common with the rest of the Mallory line, it has precisely the features that assure satisfaction: quiet, smooth operation . . . gradual attenuation and long life . . . not least of all, easy installation! See your nearest Mallory distributor. Have him show you how only 16 Mallory controls meet approximately 85% of all replacement needs!

P. R. MALLORY & CO., Inc., INDIANAPOLIS 6, INDIANA



An A-C switch that snaps on and stays on!



The perfect size for every application!



Precision-built like a fine watch!



Rugged strength for years of service!



More than ever—
ALWAYS
INSIST ON

P. R. MALLORY & CO. Inc.
MALLORY
APPROVED
PRECISION PRODUCTS

VIBRATORS • VIBRAPACKS* • CONDENSERS
VOLUME CONTROLS • SWITCHES • RESISTORS
FILTERS • RECTIFIERS • POWER SUPPLIES

ALSO MALLORY "TROPICAL" DRY BATTERIES, ORIGINALLY
DEVELOPED BY MALLORY FOR THE U. S. ARMY SIGNAL
CORPS, NOT PRESENTLY AVAILABLE FOR CIVILIAN USE.

*Trademarks

Ability to produce and merchandise a line successfully calls for wide range of models of all types of radio receivers at fair prices—with delivery timed for best peak selling by dealers.



Joseph Gerl (left) with Ralph Walker at dealer conference called by Sonora distributor Walker-Jimieson in Chicago. Article is based on speech there.

Pointers on Franchise Selection

by **JOSEPH GERL, President**
Sonora Radio & Television Corp.

IT appears that the public will want to buy about 20 million sets as soon as they are available. This figure is based upon nationwide surveys which indicated that within the four years civilian radio production has been stopped, approximately 20 million sets have become obsolete.

It will take a little over two years from the day civilian production is resumed, to meet that vast demand. In that two year period however a new demand for current replacements for another 10 million sets will arise. In the next three years therefore, it appears as if you will be able to sell at least 30 million sets. That means 3 out of 5 radio sets in use will have to be replaced. With such demand for 30 million new sets over the next three years, a sellers market will be created—the like of which has never been seen in the radio industry.

The fact that there will be a demand for millions of radios in the early post war years does not necessarily insure any company or any distributor or any retailer that any

particular brand of radio set will be a leader in the market. Competition will still be an important factor, and quality of merchandise at a reasonable price will still be the guides which the consumer will undoubtedly follow.

Styling and Engineering

The radio business is as style conscious as the ladies' hat business. Every year we must design from 50 to 75 different cabinets with an immense variety of dials. The long-term radio manufacturer must be wary of the many so-called novelty cabinets that have been the graveyard for many radio manufacturers, and have been the source of considerable loss to many dealers. There are few radio manufacturers with sufficient background and experience to enable them to avoid the production of such monstrosities.

Technologically, the radio business is more complex and subject to more changes than the automobile, refrigeration or aviation industries. From

the crystal and cat's whiskers set, to the battery, to the regenerative, to the tuned radio frequency, to the neutrodyne, to the superhetrodyne, to the electric set, to the dynamic speaker, to foreign bands, to phonograph combinations, to record changers, to frequency modulation sets, to wire recording, and now to television marks the rapid shifts in the radio industry.

The radio manufacturer must keep

A SELLERS MARKET

We will not only be called upon to replace old sets with news sets, but advertising has created a tremendous demand for frequency modulation and television. New advertising will create another yearning for recording on wire. All this will swell and augment the desire of the American public for products of our industry.

pace with all these new developments. One false step, one wrong turn, one mistaken delay, and his loss is great while the merchandise becomes a drug on the dealers' shelves. Here again an alert engineering organization is of great importance.

Delivery and Timing

The third factor in the radio business is its seasonability. The manufacturer must design his new sets in January, introduce them in June, build and ship in July, August, September and October, and must have passed on to the trade the bulk of his production by November. He begins production of his spring line again in January. Between these seasons he must lay off a number of personnel, and then must recall them in time to produce the new models.

Any false move in this complicated timing means a loss. Delivering the merchandise too late in the season may mean the liquidation of a good share of the radios at a loss, perhaps of millions of dollars at the end of the season. It is vital therefore that a radio manufacturer must have an intimate sense of "know-how" and understanding of the seasonal characteristics of the industry, to design and produce and deliver his production at the right time and at the right place.



A "point-of-sale" franchise certificate is presented by Crosley distributor Harry Alter to radio and appliance dealer Art Mellich, owner of the General Radio Service Company, Chicago. Looking on: salesman Jim Brandt (left), and sales manager H. C. Huebner (right), both of the distributor's staff.

Advertising and Merchandising

Finally, one of the most essential secrets of success of the radio industry lies in a manufacturer's general merchandising policies—how to present and advertise his products to the general public. A manufacturer may be adept at production, he may be a wizard at timing, but if he falls short in merchandising he will soon be a

hasbeen. And experience to build a successful merchandising policy in the radio industry is not acquired in the washing machine business, nor in the electric stove business, or the refrigerator business, or the airplane business. The ability to produce and sell radios successfully come only from long painstaking experience in the radio business.

PRE-TEST RADIO

"BUY-APPEAL"

By "lending their ears" to continuous tests being conducted here by Bendix Radio division of Bendix Aviation Corporation, hundreds of typical radio listeners, ranging from farm workers and business executives, to bobbysock swingsters and symphony patrons, are helping to point the way to new postwar improvements in radio receiver tonal quality.

The tests now being conducted with the carefully selected groups indicate that all types of radio listeners readily recognize differences between new wider range musical reproduction and the former limited range radio reception, according to Leonard C. Truesdell, general sales manager for home radio. Here's the way it is done:

1. Using two instruments, one a pre-war type of receiver and the other a new wide-range receiver, five selections are played for each test group, alternating between the two receivers.

2. A vote is taken after each selection for tonal range preference.
3. Following the playing of all five selections a vote is taken on tonal range preference for the entire program.
4. Both instruments are set at peak bass and treble range for the first part of the test and at equal volume levels.
5. In the second part of the test one selection is played with both volume controls set at low volume markings.

Voting is done on forms which are marked by each individual participating in the tests. Truesdell explained that the tests were being conducted to determine listening reaction to new reception developments which will incorporate greatly improved tone quality and a wider range of musical notes in postwar radio sets, in connection with the company's forthcoming line of AM and FM radios and radio-

phonograph combinations.

The tone tests are being conducted by Bendix engineers and marketing and survey specialists as part of a nation-wide program to determine public preferences in radio receivers as well as radio cabinet designs, Truesdell said. "Scientific pre-testing" of all product design and performance features will continue to be a major activity at Bendix Radio. "In styling all of our cabinet designs," Truesdell said, "we will take into careful consideration the likes and dislikes of consumers, by learning from them just what their style preferences are.

"In order to leave nothing to chance, or to the dictum of a few we have retained the expert staff of Opinion Research, Inc., to conduct radio cabinet style clinics throughout the nation. Simulating actual retail show room buying conditions, the style clinics pre-test overall cabinet styling and a variety of detail features. The clinics also tabulate and relate preferences as they are affected by costs, thus providing both the manufacturer and the dealer with extremely valuable advance information concerning 'Buy Appeal.'"



Sam "Red" Eisenhower at far end of long bench. Woman doubles in office and on light repairs; full-time man in front. Below: Detailed job-ticket.

"Home Front" Eisenhower IS RADIO DEALER

General "Ike" Eisenhower's 6th cousin makes his service bench longer, stretches profits.

by **W. SCHWARTZ**

TWO ideas have helped Sam Eisenhower, owner of Radio Hospital, Rockford, Ill., solve his service problems during a difficult period.

The first of these is the setting aside of one day a week for pickup of heavy radios and one day for their delivery. The second was to enlarge his radio work bench to provide more working room. This resulted in practically doubling the repair work output.

"When I realized that we would have to get along during the war period with the profits we could make from service work," said Mr. Eisenhower. "I decided to limit pickup and delivery of radios for servicing."

Monday is "pickup-day"; and deliveries are made on Saturday. There is neither pickup nor delivery on smaller

models, except in case of invalidism, etc.

"We have been very pleased the way this definite policy worked out," says Mr. Eisenhower. "Everybody knows about it, and it saves us much explanation and arguing with customers who try to get special consideration. It is a fair policy, too, and our customers have cooperated very well."

Mr. Eisenhower studied his service facilities and came to the conclusion that he needed more room in the service department. He observed that with many radios lying about during wartime for lack of tubes and parts, and with the greater volume of business, he and his full-time service man and part-time service man spent too much time looking for extra space or looking for tools.

Today he has a new bench, 20-feet long, along one wall at which four people can work without crowding, and he also has an auxiliary bench along another wall. At the end of this bench he has facilities for repairing auto radios and has a drive-in right at that spot as well. The service bench is lighted with long strips of fluorescent lighting which has also helped to increase work output.

"We have been able to turn out twice as many radio repairs since we've had the new arrangement," says Mr. Eisenhower. "We can all work longer hours and more efficiently when we aren't crowded or irritable. This arrangement permits one service man to work on two or three chassis at one time without too much lost motion."

Mr. Eisenhower is, by the way, a sixth cousin of General Ike Eisenhower.

No 5841		DATE _____	
PROMISED			
ESTIMATE <input type="checkbox"/> REPAIR <input type="checkbox"/> REMOVAL <input type="checkbox"/> BROUGHT IN <input type="checkbox"/>	COMPLAINT		NAME _____ ADDRESS _____ MODEL _____ SERIAL NO. _____ INVOICE NO. _____ No 5811
	LABOR AND MATERIALS		
	REMARKS		
REPAIRS RECOMMENDED		DATE _____	
A MINIMUM CHARGE OF \$1.00 IS MADE ON ALL ESTIMATES WHICH IS CREDITED TO LABOR CHARGE WHEN WORK IS COMPLETED.			
No 5841		CLAIM CHECK	
NO GOODS DELIVERED WITHOUT THIS CHECK NOT RESPONSIBLE FOR FIRE OR THEFT			
ALL GOODS LEFT OVER 30 DAYS WILL BE SOLD FOR CASH. WORK GUARANTEED FOR 90 DAYS ONLY WHEN PAID IN FULL AND COVERS ONLY PARTS INSTALLED BY US.			
RADIO HOSPITAL			
112 N. CUMMIS ST.		ROCKFORD ILL. MAIN 1550	

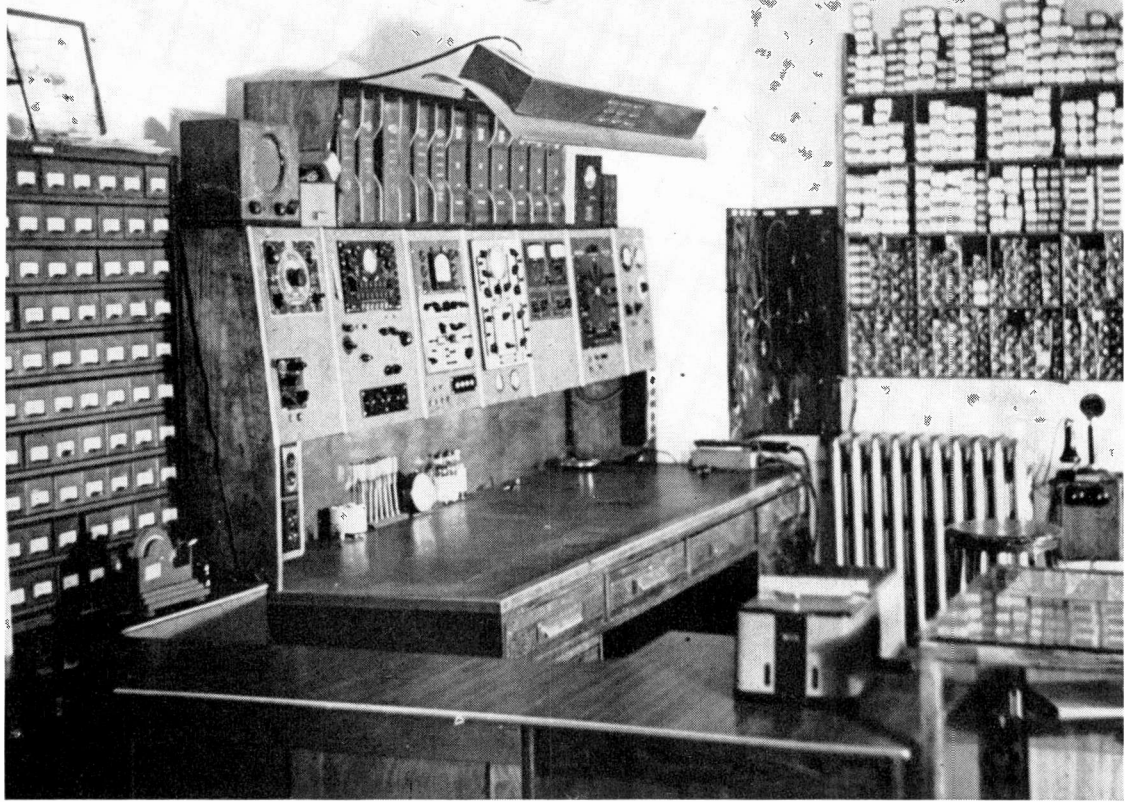

Survey below is recall of 1941 conditions: over half of service dealers stocked 250 tube types, averaging almost 3 brands per shop. Photo above is 1941 recall of "normal" local service shop tube stock, for resale and service. (Precision Radio Service, North Dakota). In letter to RSD, owner stated: ". . . In front of shop are plenty of new radios for the customer to inspect while the old set is being repaired . . ." (!) Added to service equipment shown are portable units: vibrator tester, battery tester, station setter, tube tester and analyzer, etc.

Radio Servicing —

THROUGH widespread acceptance of record players, FM and television a sound past and an extremely bright future for the radio service industry which in postwar years will sell 60 million tubes through 30 thousand shops, employing 90 thousand men, were revealed as a result of a national survey of set owners and repair men by Sylvania Electric Products Inc., as announced by Frank Mansfield, director of sales research. Among the other findings of the survey were that the public is almost unanimous in its high opinion of the radio serviceman; that before the war servicemen completed some 30 million repair jobs per year, selling 30 million tubes in the process.

There are approximately 24,700 radio service establishments in the United States today, employing 60

TECHNICAL FACTS OF RADIO SERVICE AND REPAIR

1. 40% of all radio repairs can be made with either tubes alone, with mechanical or electrical parts alone, or labor alone, in the following proportions:

- 52% of all repair jobs require tubes
- 63% require electrical parts (see text)
- 31% require mechanical parts
- 44% involve labor only

2. Radio service and repair outlets in prewar sold 30,000,000 tubes annually, but tube inventory poses a difficult problem for them. Many feel that too many types have been required in the past and they blame the set manufacturers.

While 54% of all service dealers stock 250 tube types, 38% stock 300 and 20% stock at least 400—fully 94% of those interviewed said there should be fewer. 89% thought there should be less than 200; 79%, less than 150; and 65% thought 100 types enough.

Despite this feeling the study indicated that the average outlet stocks about 3 brands of tubes. Distribution of these brands by service outlets, and in order of importance, are: RCA, Sylvania, Phileo, Tungsol, National Union, Raytheon.

Brand preference was not attributed to price or consignment consideration except by 9% of the outlets interviewed. 58% stated that quality and performance were the prime reason for brand preference.

RADIO SERVICE KEY TO NEW SET SALES POSTWAR

IN the opinion of Harold W. Schaefer, assistant manager, Westinghouse home radio division, postwar radio service business will offer a challenging combination of expanded opportunities and new responsibilities. There is the all important job of installing new FM and television sets. In these installations, more than in any other postwar activity, the radio service dealer can be of lasting benefit to the radio industry.

Such installations, properly made, will contribute much to the general and rapid acceptance of these newer radio developments, while unsatisfactory installations will retard acceptance by fostering doubt as to their worth and reliability.

Postwar, FM and television will make more exacting demands on both the manufacturers and the radio service men. Because they operate at much higher frequencies than AM radio, the technical problems of each are greatly increased. This is particularly true of television, since the definitions

of sight are greater than those of hearing.

Manufacturers will have to use higher quality materials and employ cleaner production techniques if they are to build the kind of receivers required by these scientifically-stepped-up services. Radio dealers and their service men, on the other hand, will have to keep abreast of improving installation and maintenance methods. This will require additional investments of time and money to acquire the necessary "know-how" and equipment. But despite costlier operations, both will profit because of vastly expanded demand and opportunities.

Proper antenna installation is the one greatest contributing factor to good FM and television reception. Strict attention to these installations will save the postwar service man a great many headaches, and they should be of little trouble even in view of the contemplated shift from 42-50 mc band to the 84-102 mc band.

In many locations the regularly

built-in set antenna will provide excellent reception. However, in less favorable places it will be necessary to go to outside dipole antennas and, in particularly unfavorable spots, to beam antennas. Every television receiver must have a good antenna system. Often this will require special filters to eliminate electrical interference, or particular placement to cut down reflections.

In the past, because of the relatively few television receivers in use, each antenna became a custom installation. In the future, as postwar production places millions of new television receivers in use, this special treatment will be impossible—and antenna installation will become the everyday job of the radio dealer's service men.

Other jobs facing the postwar television service man will include handling as high as 30,000 volts used on projection cathode ray tubes and the larger diameter kinescopes, and testing and checking the complex optical system employed with projection tubes.

a Growing Opportunity

Latest survey shows postwar radio service business potential 60 per cent greater, through widespread public acceptance of record players, FM, television.

thousand people with specialized skills unknown twenty-five years ago. The survey indicates not only that the public is well satisfied with wartime radio service but that over 90% of all repair men today frequently have to modify circuits due to wartime scarcities. In spite of the complexity of the modern radio receiver, nine out of every ten changes made by servicemen are successful.

Better Service Equipment

Servicemen generally attribute the

need for service to the failure of seven specific components, in the following order of importance: tubes, condensers, power supplies, tuning systems, IF coils, RF coils, and filters. But while tubes are most frequently needed for radio servicing they are not affected by humidity, which was cited as a major cause for radio servicing in an average of 44% of the sets serviced throughout the nation. Humidity as a cause of trouble varies in importance in different parts of the country. Measured in terms of sets

serviced, it has been reported as follows: Pacific States 22%; East North Central States 28%; South Atlantic States 61%; and Gulf States 87%.

Mr. Mansfield predicted that there will be 75 million home radios and 25 million automobile radios in use 5 to 6 years after the end of the war. (See "100,000,000 Radio Receivers Wanted", in April issue.) This will mean that there will be an increase of about 5,500 radio service establishments and an increase in employment of about 50%. Stressing the need for more and better equipment for radio servicing he also predicted that this trend will become more urgent with the widespread acceptance of record players, FM and television. To meet these future tube replacement needs he estimated that 60 million tubes annually will be required as compared with 34 million in 1941.

RADIO SERVICE SURVEY CHART

WHAT IS THE SIZE OF THE RADIO SERVICE FIELD?

There are about 24,700 Radio Service Establishments in the U. S.

They employ a total of about 60,000 radio experts. In less than 25 years this great industry has grown from nothing.

These technicians, found today in nearly every town and village of our country, have mastered the intricacies of one of the most complex developments of modern times—Radio.

WHAT VOLUME DO THEY SELL?

30,000,000 Repair jobs per year.

30,000,000 Tubes—of which 20 million are sold as a part of service.

Millions of condensers, transformers, resistors, vibrators and countless other parts—sold as a part of service.

DOES THE RADIO TECHNICIAN DO A GOOD JOB?

HE MOST CERTAINLY DOES!

92.5% of set owners say he does a good job.

89.3% say charges for work are "fair."

90.4% of radio technicians are making repairs by changing circuits. And these changes are successful in 90.6% of these cases.

THESE MEN KNOW THEIR BUSINESS.

HIS JOB IS COMPLEX

40.5% of the repairs can be made with one of the following: Tubes, Labor, Mechanical Parts or Electrical Parts:

35.6% require two of these factors.

17.2% require three.

6.7% require all four.

MANY REPLACEMENT PARTS ARE REQUIRED

52.2% of the jobs require tubes.

62.9% require electrical parts.

31.1% require mechanical parts.

43.9% involve labor time.

AND THE INVENTORY PROBLEM IS DIFFICULT

IN TUBES ALONE—

54% of radio technicians carry 250 types in stock.

38% carry 300 types.

20% carry over 400 types.

THEY FEEL THAT THERE ARE TOO MANY TUBE TYPES

93.6% say "There should be fewer."

89% say "There should be less than 200."

79% say "Less than 150."

65% say "Less than 100."

And they lay the blame for the complexity on set manufacturers.

THEY STOCK AN AVERAGE OF 2.8 BRANDS

61.6% stock RCA

47.2% stock Sylvania

45.6% stock Philco

27.7% stock Tung-Sol

17.4% stock National Union

14.8% stock Raytheon

WHY DO SETS FAIL?

The most frequent causes mentioned were—(in order):

Tubes

Condensers

Power Supply

Tuning System

I. F. Coils

R. F. Coils

Filters

THE AVERAGE SHOP IS WELL EQUIPPED NOW

But the need for more and better instruments is recognized by servicemen everywhere. More and better training will be required to handle:

RECORD PLAYERS

F. M.

TELEVISION

SIXTY MILLION TUBES WILL BE NEEDED ANNUALLY

(Against 34,000,000 in 1941)

More and more of these tubes will be sold as a part of service. Less of them will move through cut-rate outlets.

The distributor can look forward to double his 1941 business in the post-war period.

AFTER THE WAR . . .

There will be more radio receivers to repair. 60 million sets now in use. Five to six years after the war — an estimated 75 million home radio receivers and 25 million auto radio sets. They will be more complex — require more service. More shops and more men will be needed. Perhaps 30 thousand shops in all, employing 90 thousand men, to handle some 50 million servicing and repair jobs per year.

HOW TO RECALIBRATE SERVICE TEST EQUIPMENT

PART 2

Burden of repairing and recalibrating privately owned test equipment rests with radio service dealers themselves as manufacturers engage in full-time war work.

by **ENGINEERING DEPARTMENT,**
Aerovox Corporation

Wien Bridge. A simple Wien bridge set up as an audio frequency meter (see Figure 6) may be used to measure audio frequencies in terms of known values of resistance and capacitance.

For its useful operation, this circuit depends upon the fact that the bridge may be balanced for only one input frequency at a time. When R_1 is made equal to twice R_2 and C_1 equal to C_2 , R_4 and R_5 will always be equal at null and the input frequency will equal:

$$(1) \quad f_r = \frac{1}{6.28RC}$$

Where R is in Ohms
and C in Farads

If it is desired to make the bridge continuously variable and to have it cover the entire audio range, R_4 and R_5 should be the two halves of a dual rheostat. The entire range 20-15,000 c.p.s. may be covered if R_4 and R_5 are each 500,000 ohms and C_1 and C_2 each 0.0133 mfd.

In operation, the unknown frequency is presented to the bridge through the input transformer, T, and the R_4 - R_5 combination adjusted for null in the headphones. A sharper null is obtained

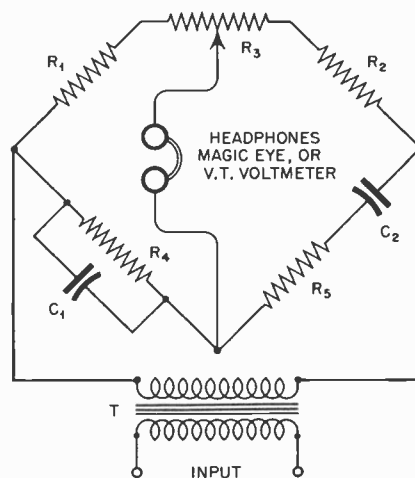

Figure 6

by then adjusting the potentiometer, R_3 . A dial attached to R_4 - R_5 may be graduated directly in cycles per second. This calibration may be performed by accurately measuring the resistance of each setting of R_4 and R_5 , accurately measuring the capacitance of C_1 and C_2 , and making computations as indicated by Equation (1). The best calibration of the bridge will be

one made against a good, freshly-calibrated oscillator, however. Increased accuracy of adjustment may be realized by using a high-impedance ac vacuum-tube voltmeter in place of the headphones.

Piano. Audio oscillator dial frequencies may be referred aurally also to notes struck on a critically tuned piano. Notes are chosen whose frequencies correspond to easily-read points on the oscillator dial. Examples are middle C with a frequency of 256, the next highest A at 440, etc., etc.

The oscillator is tuned to the piano note by adjusting the former to "zero beat". This consists of making a final setting to eliminate all waxing and waning between the two tones until they reinforce each other cleanly.

Multivibrators. If the experimenter owns a reliable secondary frequency standard, such as a 100-kc. crystal oscillator, multivibrators may be provided to yield audio calibration frequencies which are subharmonics of 100 kc. The multivibrator output is delivered to one set of oscilloscope plates (see Figure 5), while the audio oscillator output is presented to the other set; and calibration is carried out by means of Lissajou's figures, as explained earlier in this article.

For working data on practical multivibrator circuits, the reader is referred to the article *Theory and Operation*

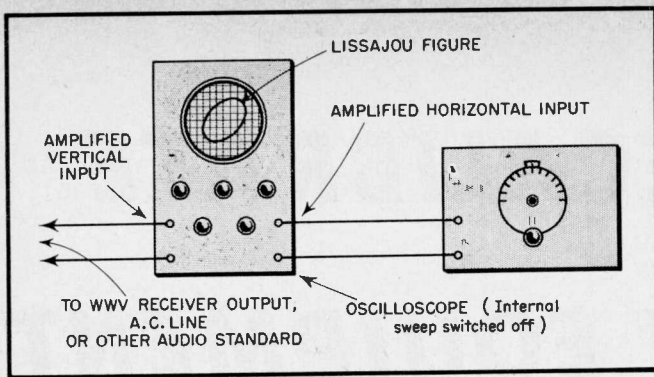

Figure 5

of *Multivibrators* in the November 1940 issue of the *Aerovox Research Worker*.

DC Voltage

Drop Across Precision Resistor. When a reliable current-indicating meter (ammeter or milliammeter) is available, together with an accurately known resistor, standard voltages for meter calibration may be produced as voltage drops set up across this resistor by known values of current through it.

A simple circuit for the production of standard voltages is shown in Figure 7. The precision resistor, R_2 , is connected to a battery in series with a rheostat, R_1 , and the current meter M_1 . The voltmeter to be calibrated (M_2) is connected across the precision resistor.

As R_1 is adjusted, various values of current flow through the precision resistor and are indicated by the current meter. These currents produce voltage drops, equal to the current meter reading multiplied by the ohmage of the precision resistor.

$$(2) \quad E = IR_2$$

Cells. Various cells and batteries, when new, may be employed as practical dc voltage standards. A dry cell from *fresh stock* may be depended upon to deliver 1.4 to 1.5 volts. A storage cell or battery is much more dependable, however, since 2.06 volts per cell will be delivered by the common lead-acid type as long as the specific gravity of the electrolyte, as tested with a hydrometer, is between 1.300 and 1.200 for most makes.

Bias Cells. Where there will be no practical current drain, as in testing a high-impedance-input dc vacuum-tube voltmeter (like the VoltOhmyst), bias cells, singly or connected in series, may be used to supply calibrating voltage. However, it must be borne in mind that the manufacturer's tolerance on these units is plus or minus 10%

and the 1-volt cell therefore will deliver between 0.9 and 1.1 v.

AC Voltage

AC Line. The ac power line is readily available for use as a calibrating voltage source. By means of a calibrated potentiometer, lower voltages than that of the line may be secured.

Nearly every shop has some means of measuring line voltage with fair accuracy. But in cases where even this is lacking, the line voltage may be assumed to be of the average value common to the community (i.e., 110, 112, 115, etc.) and calibrations made on this basis.

Variac Dial. Experimenters possessing a Variac will find that the direct-reading voltage dial on that device is sufficiently accurate for most practical calibrations of service ac voltmeters where the line voltage is 115.

On the dials of the smaller-model Variacs, RMS voltages between 10 and 130 may be read directly at intervals of 5 volts and may be estimated closely at intermediate $2\frac{1}{2}$ -volt intervals.

If higher voltages than the Variac dial-limit are required, a step-up transformer of known turns-ratio should be connected to the Variac. Dial voltage readings will then have to be multi-

plied by the turns ratio to indicate the volages delivered by the transformer secondary.

Direct or Alternating Current

Precision Resistor. Calibrating currents of known value may be obtained for checking ammeters, milliammeters, and microammeters by applying a series of known voltages across a series circuit embracing the meter under test and a single precision resistor. The circuit is shown in Figure 8.

The source of voltage, P , is a battery for dc calibrations and is a transformer winding for ac testing. The test circuit includes precision resistor R_2 and the current meter under test, M_1 . The precision resistor must be non-inductive if ac calibrations are made. Voltage applied to this circuit is obtained through potentiometer, R_1 , and its various levels are indicated by voltmeter M_2 . The calibrating current values are then determined by dividing the reading of the voltmeter by the value of the precision resistor:

$$(3) \quad I = \frac{E}{R_2}$$

Resistance

Standard Resistors. Ohmmeters and resistance bridges are calibrated best by means of resistors of known value. There is no alternative. The serviceman or experimenter should keep on hand several closely-rated resistors which will allow him to check a number of points on his ohmmeters or resistance bridges. In some localities, one individual keeps the standards which may be borrowed, when needed, by any of several other technicians.

Calibrating resistors should be carefully stored, preferably in a cool dry place and in a topped jar containing a sprinkling of calcium chloride, Silica Gel, or similar dessicating agent. The resistors need not be expensive precision units if these cannot be afforded, but may be service-type resistors carefully selected at the supply house and carefully stored between calibrations.

Capacitance

Standard Fixed Capacitors. Standard capacitors will be required for checking microfarad meters, capacitance bridges, capacitance-testing oscillators, and similar instruments. Unfortunately, no substitution is possible in this case.

A sufficient number of calibrating capacitors should be provided to allow checking of several points in each range of the instrument. It is not im-

COMMUNITY STANDARDS

It is suggested that, whenever possible, all of the servicemen and experimenters in one locality share the expense, labor, and skill necessary to acquiring standards and making calibrations. The calibrating equipment thus becomes group property available to any member desiring to calibrate his equipment. In this way, we believe each individual may benefit by the immediate availability of good standards and that strain on equipment manufacturer and customer alike may materially be reduced.

perative that these capacitances be integral values, as long as their true values are known. It is also not necessary that the units be expensive precision standards. Accurately-measured silvered mica capacitors will suffice for all service equipment testing. Larger values may be supplied by oil and electrolytic types.

Several test capacitors of suitable value may be connected around a rotary selector switch to provide an easily switched decade type capacitance standard. For ruggedness, the assembly may be enclosed in a small metal box.

Standard Variable Capacitor. A good adjustable standard for small capacitance values is a case-mounted variable capacitor with a maximum setting of 1000 mmfd., having a dial direct reading in micro-microfarads.

The variable unit may be of the ordinary experimental and radio instrument type, having a total of 43 or so plates. But for best stability, it should have rigid mechanical construction and ceramic insulation.

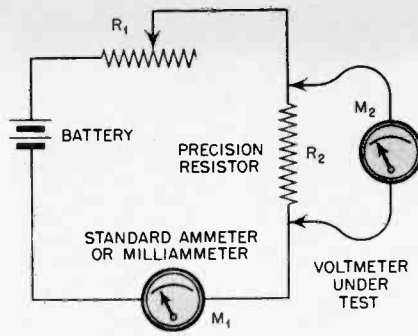

VOLTAGE DELIVERED TO M_2 = READING OF M_1 MULTIPLIED BY VALUE OF R_2

Figure 7

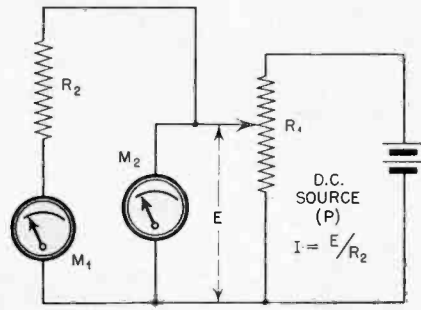

Figure 8

The capacitor must be calibrated beforehand at as many dial points as practicable. If the experimenter does not have access to a bridge or other source for calibrating this variable standard, a reasonably accurate capacitance calibration may be made in terms of frequency in the following manner:

A single-layer coil is connected in parallel with the capacitor to provide a resonant circuit, and this coil is coupled to the output of a freshly calibrated oscillator or signal generator. At any capacitor dial setting, the resonant frequency of the coil-capacitor combination is located with the oscillator. The capacitance at that setting may then be calculated from the equation:

$$(4) \quad C = \frac{I}{39.4f^2L} \text{ FARADS}$$

Where f is the resonant frequency in megacycles and L is the inductance of the coil in microhenries

The operation is repeated at a number of dial settings until an adequate direct-reading dial is obtained.

WORKING P-A

The "Radio Bulletin Board", a special program of world-news, war-news and plant-news, sponsored by the Operadio Manufacturing Co., St. Charles, Ill., and broadcast twice daily over radio station WMRO, Aurora, has proven to be an effective method of creating better employee and community relations. The broadcasts are scheduled for Operadio's morning and afternoon rest periods, six days a week. Picked up by radio, the programs are immediately relayed to workers in the two Operadio St. Charles plants through the Plant-Broadcasting system, manufactured by the company.

The popular newscasts, which have been a part of Operadio's personnel program for two years, are made up of late press releases, employee items, news of former workers now with the Armed Forces, and general company information. Each broadcast runs a total of 10 minutes. The "personal mention" feature has proven popular and a steady flow of news items are regularly received from "reporters" in all departments. Entirely new broadcasts are presented each morning and afternoon.

At scheduled intervals throughout the day, the Operadio Plant-Broadcast-

ing system also carries scientifically planned work music programs. Careful time-studies of workers' reactions have shown that work music relieves fatigue, reduces accidents, and mini-

mizes absenteeism. Both Operadio plants also use the Plant-Broadcasting system extensively for "voice-paging" executives and officials.

The programs can be credited with establishing better public relations, since listeners in all communities serviced by WMRO regularly listen to the Operadio-sponsored news reviews.



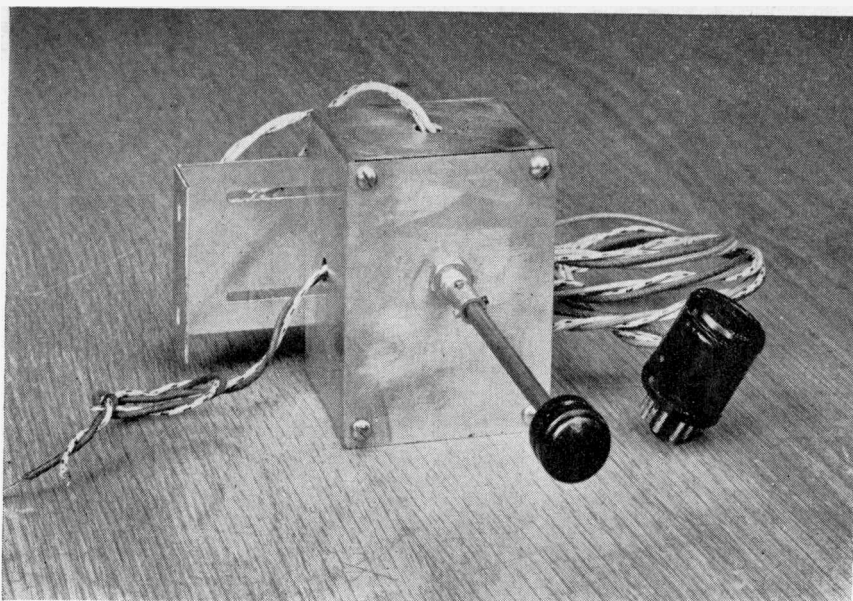

Figure 1

Fig. 1: The one-tube converter with mounting bracket, power take-off plug, etc.

Fig. 2: Experimental three-tube unit demonstrated before FCC.

Fig. 3: 1-tube unit installed in typical prewar FM receiver.

Fig. 4: Inside view, with type 7S7 tube, band pass inductances, adjustable condensers.

Fig. 5: Control switch of 1-tube unit fitted into prewar FM set.

FM SETS Saved from

Potential business for service dealers of 7 to 10 million dollars in sale and installation of inexpensive converters to present FM set owners.

WHEN the Federal Communications Commission first announced its intention of moving FM from the pre-war position between 42 and 50 megacycles to the higher band where it would be free from long distance interference and would have adequate room for expansion, opponents of the move argued that all existing FM receivers would be made obsolete as it would be impractical or impossible to adapt them to the new frequencies.

The Hallicrafters Company of Chicago, manufacturers of high frequency

radio and electronic equipment, now reveal details of two FM converters which were the subject of much discussion at the recent FCC hearings in Washington. These converters, one a three-tube model which includes a power supply and the other a one-tube device, will enable pre-war FM sets, to receive stations in the proposed new FM band from 84 to 102 megacycles.

The three-tube model which was demonstrated by the FCC in Washington uses a type 7V7 mixer, a type 7A4 oscillator, and a type 6X5GT/G rectifier. The output of the converter is fed into the antenna connections of the FM receiver which is tuned to 42 megacycles. The converter oscillator is arranged to track 42 megacycles below the mixer frequency and the entire device simply acts as the front end of a superheterodyne, using the FM receiver as an IF amplifier. Devices similar to this have long been used by the amateurs to

USE OF CONVERTERS

No claim is made by Hallicrafters that the use of the converter is the best way to receive on the proposed new FM band. A converter provides a simple, inexpensive way to keep prewar sets in use when FM frequencies are changed. Statements to the effect that the public will suffer great financial loss because of obsolescence of some 500,000 or so present receivers are not accurate, it is explained.

The single-tube converter is designed for use in primary service areas where signal strength is high and the principal considerations are appearance and convenience. The three-tube converter includes its own power supply and is intended for use where signal strength is low and high performance is the prime necessity.

Figure 2

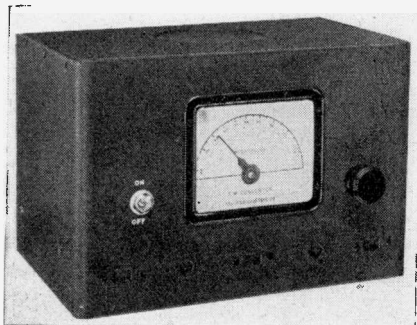

receive VHF signals on standard communications receiver.

The experimental three-tube model is far larger than necessary as it was built into a chassis and cabinet that happened to be available in the laboratory and is in no sense a finished product. This model could be built for an estimated \$11 f.o.b. Chicago, whenever the priority situation permits. This price assumes quantity sales to a single customer and does not include any Federal or State excise taxes.

Of far greater appeal to the present FM set owner, however, and holding more promise for dealers, is the new one-tube model which can be placed inside the cabinet of practically any FM set. This new development makes use of a single type 7S7 tube and all tuning is done with the

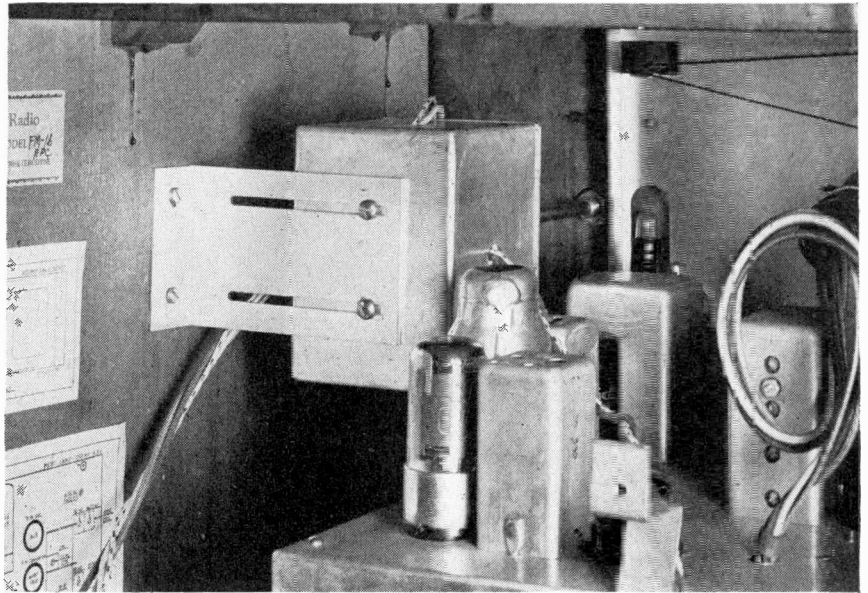

Figure 3

Figure 4

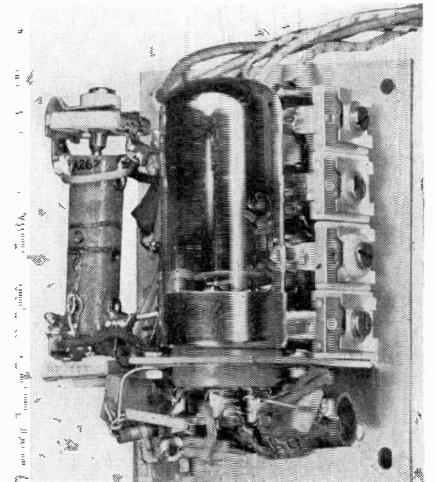
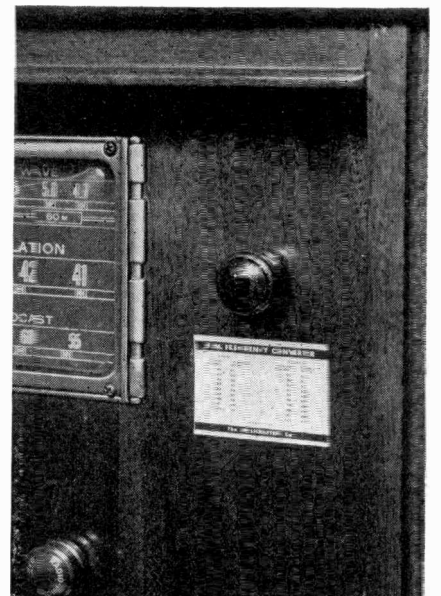

Figure 5



Obsolescence

regular receiver dial. It can easily be installed by any service man and only requires that one hole be drilled in the front of the receiver to accommodate the control switch. A universal mounting bracket is provided and power is taken from an adapter plug which is placed under one of the receiver's output tubes.

With this one-tube model the RF input goes to a band-pass filter instead of the usual tuned circuit and the oscillator section is operated at a fixed frequency. The panel switch has three positions, one connects the antenna directly to the receiver to permit normal operation while the other two connect different values of capacity in the band-pass and oscillator circuits of the converter. The FM receiver is used as a *variable* IF and with two fixed frequencies of the oscillator selected by means of the control switch covers the new range of 84 to 102 megacycles in two bands.

Hallicrafters' experimental FM station, W9XHB, is now in operation on 100 megacycles and it is planned to demonstrate the new converter to the public in the near future. The price of this one tube model, f.o.b. Chicago, based on quantity sales is \$5.60. This will permit retail sales at well below \$10, which was the figure originally given in the company's testimony.

New Antennas

Among many comments and opinions expressed in the trade are the following, by W. R. Jones, manager of general engineering for radio receiver tubes with Sylvania.

According to Mr. Jones, another "in" for the service dealer is the possibility that antenna installations in many instances will have to be altered to a considerable extent in order that satisfactory signal strength may be obtained. It is quite probable that if antenna installations become hand-tailored jobs, dealers may find themselves in great demand for this sort of work.

It is also possible that the manufacturers who originally marketed the receivers for the present FM band will supply converters to their customers. Moreover, service dealers who are willing to learn the necessary "know-how" can provide custom-built converters to meet specific requirements. If this is done it should net the service dealers an additional source of income. Should the customer purchase a converter offered by receiver manufacturers, the dealer who sets himself up to become an expert in the FM field can probably obtain the contract for installing this converter and seeing that it operates properly.

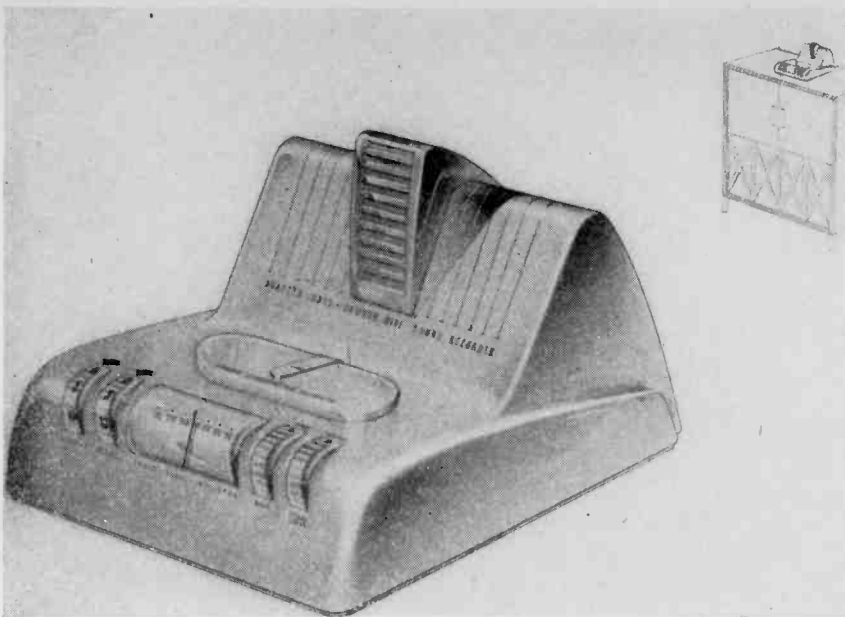

At left: Possible post-war wire recorder adapter would fit on top of existing radio receivers. Microphone has integral base for use outside the adapter unit.

Below: Possible post-war radio-television combination console with integral wire recorder (insert shows the control panel). Speaker and magazine storage are in bottom of cabinet. Both drawings are conceptions by Product Designers, Chicago, and are not actual production models.

Wire Recorder Development

Home radio recording units anticipated within a year after war's end; industrial machines sooner

by **LEWIS C. STONE**
Managing Editor

THE Armour Magnetic Wire Sound Recorder and Reproducer records sound magnetically on a spool of wire nearly as fine as a human hair, and having rewound the wire, can play it back with high fidelity immediately. The recorded wire requires no processing before playback. The record is permanent, not deteriorating with age or use so far as can be determined. Vibration, motion, or position of the recorder or reproducer do not affect the performance.

Authorities in electronics say that the Armour method will revolutionize sound recording and reproduction. Modifications of this basic principle result in recording instruments of various kinds, some of which record only, some of which reproduce only, and others of which both record and play back.

Recordings may be made for any one of a number of purposes including entertainment and education, communication, dictation and transcription, signal controls, and as a record of proceedings or interviews, or the taking of testimony.

Applications for licenses to manufacture the wire recorder have been received from manufacturers in the

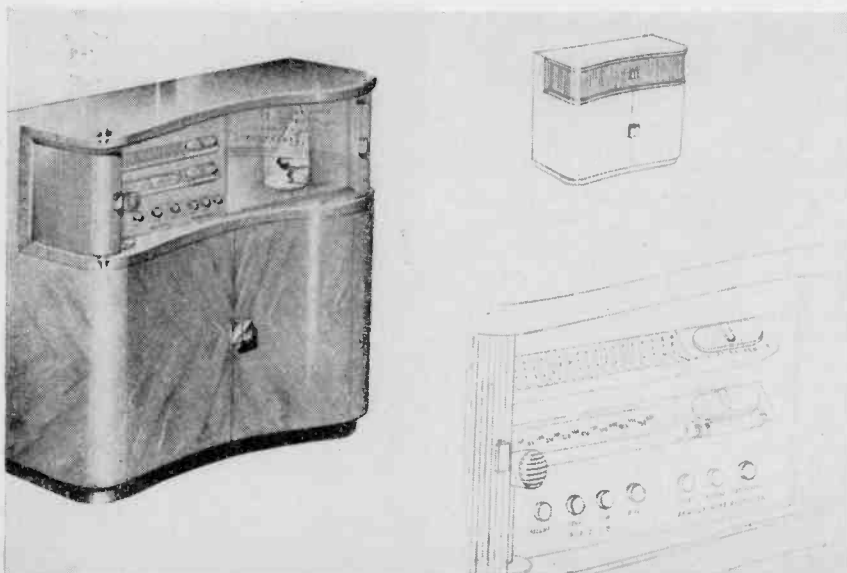

United States and in many foreign countries. New licenses are being granted with increasing frequency as the development progresses sufficiently to warrant it. Following are licenses in this country, as of February of this year:

- Automatic Electric Company, Chicago
- C. G. Conn, Ltd., Elkhart, Ind.
- E. H. Scott Radio Laboratories, Inc., Chicago
- General Electric Co., Bridgeport, Conn.
- Lewyt Corp., Brooklyn, N. Y.
- J. P. Seeburg Corp., Chicago
- Radiotechnic Laboratory, Evanston, Ill.
- Raytheon Manufacturing Co., Newton, Mass.
- Stromberg-Carlson Co., Rochester, N. Y.
- Utah Radio Products Corp., Chicago
- WiRecorder Corp., Detroit

A number of companies operating under the license will, in the post war period, concentrate in four fields. One model will take down all programs aired by radio stations, providing a 24-hour day library broadcast. Another model for home recording for non-commercial entertainment will enable owners to record any home activity or transcribe a radio program for immediate playback. Third, a self-contained battery operated recorder will be offered for the street interview type of program and other field work. The fourth type will be in transportation communication. These machines will all start and stop automatically, and require no attention while operating.

Will Supplement Discs

In a statement announcing the Stromberg-Carlson model, Frederick C. Young, vice-president in charge of engineering and research, declared that his company "looked upon the wire recorder as a supplement to records rather than a substitute. Although wire recording is itself not entirely new, having been used to a limited extent since the beginning of the century, the work of the Armour Research Foundation gave research in the medium a new and added impetus."

How It Works

The wire recorder employs a .004 inch diameter magnetic steel wire, which is sent from one reel to another through a series of guide pulleys, pass-

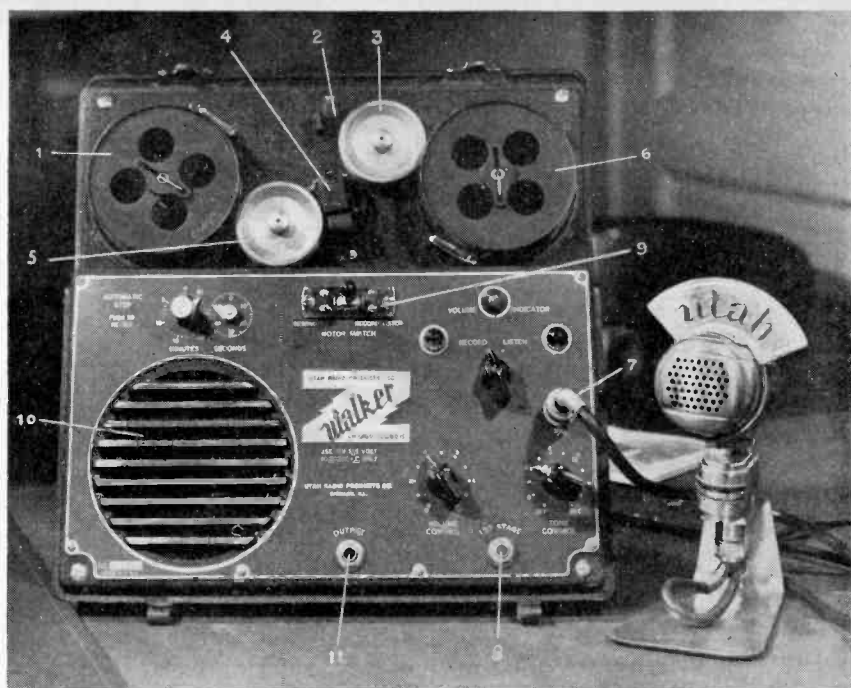

For both recording and reproducing, the wire travels from spool (1), through a demagnetizing coil (2), around the pulley (3), through the recording or sound head (4), around the lower pulley (5) and finally winds up on the right hand spool (6). The microphone may be attached to the connection at (7) or a radio receiver plugged into the jack (8). The motor switch (9) controls the direction of wire travel so that the wire either passes from spool (1) to spool (6) in recording or reproducing, or reverses to wind up on spool (1) preparatory to recording or reproducing. (10) is a five-inch speaker built into the recorder; however, a large speaker may be used by connecting it to the jack (11). Volume, tone controls and automatic timing and stop device also included.

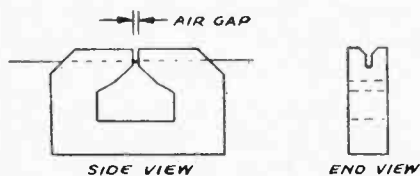

Figure 1

ing through a magnetic recording head which charges the wire and sound waves are transformed into electronic impulses which pass through a magnetic field. As the wire is moved it receives a series of magnetic impressions which correspond to the original sound vibrations. When the magnets are connected through amplifiers to a speaker and the wire passes through the magnetic poles, the sound is reproduced.

Although the inside mechanism of the machine is composed of hundreds of scientific gadgets, the working part is merely two spools each about three inches in diameter and resembling the reel spools of a small movie projector. Over 11,000 feet of wire finer than a human hair are wrapped around these spools and one spool will record a sixty-minute program. When the desired recording is to be made, all that

is necessary is to press a button and set the timing arrangement. The rest is automatic.

In the recording head the wire passes through a small slot cut along the side of a laminated core (Fig. 1). A .002-inch gap is cut in the core in a plane at right angles to the axis of the slot. The magnetic flux traverses the wire longitudinally at this gap.

Electrical compensation to correct for frequency response is incorporated in the amplifier preceding the recording head and is used during the recording process.

When the recording operation is finished, the record can be played back immediately without processing. The wire is simply rewound on the first reel by reversing the motor.

To play back, the wire is run through the recording head in the same direction as when recording the sound. The recording head acts as a pickup and reproduces the sound.

Sound can be removed from the wire as easily as it was recorded. A demagnetizing coil, also in the path of the wire and placed so that the wire reaches that point before entering the recording head, can be energized by throwing a switch. As the wire

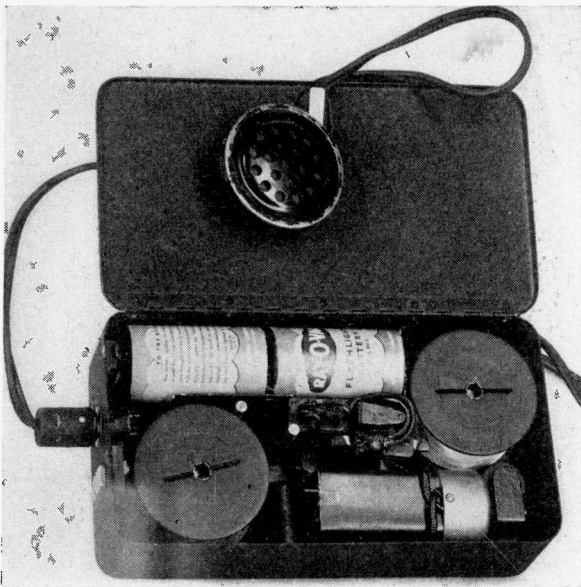

"Handbag model" self-contained battery operated wire recorder fits into lady's purse.

SPECIFICATIONS

Standard Model 50 Record, Playback, and Erase Unit. This is the original model now being manufactured exclusively for the Armed Services.

Dimensions: 13 inches wide, 12½ inches high, 9½ inches deep.

Weight: 35 pounds, complete with accessories.

Type of Case: Cast aluminum, with carrying handle.

Finish: Black crackle paint.

Dimensions of Spool: 3¾ inches in diameter and 1¼ inches wide.

Wire on Spool: Approximately ½ pound, 11,500 feet, .004-inch recording wire.

Recording Time per Spool: 66 minutes at a wire speed of 2½ feet per second or 33 minutes at a wire speed of 5 feet per second. Can be adapted for spools containing three times these lengths of recording.

Input A: High impedance dynamic, ribbon, or crystal microphone.

Input B: AM or FM tuners, phono-pickup, 500 ohm line zero level.

Output: 10 ohm for speaker voice coil or headphones.

Monitoring speaker: 5" P.M., self contained. (Automatically cut out by inserting phones or external speaker).

Tubes: Five receiver-type tubes.

Dynamic Range: In dynamic range (soft to loud) the background noise is 40 db below maximum signal strength.

Frequency Response: The Armour Magnetic Wire Sound Recorder, Model 50, as built for the Navy, has a flat frequency response from 200 cycles per second to 3000 cycles per second, considered adequate for speech only. For music, this model could be changed to give a flat frequency response from 75 cps to 10,000 cps. Wire recording can give flat frequency response as high as wanted—even beyond 15,000 cps, considered the limit of human hearing. Frequencies, as high as 80,000 cycles (supersonic), have been recorded.

Power supply: 115 volts, 60 cycles a-c. Can be used on 50 cycles at slight reduction in speed; on 220 a-c with a transformer; on 110 d-c with a converter; or on a storage battery with converter.

Power consumed: 40 to 60 watts.

passes, any message already on it is blanked out by a high-frequency electro-magnetic field which leaves the wire in a magnetically neutral state. Simultaneously, as the wire enters the recording head, a new message can be recorded.

Possible Uses

Here are some of the important applications projected for postwar industrial, educational, commercial, and entertainment uses:

1. Home and field recording in radio receiving sets;
2. Recording and playing professional records in radio-phonograph combinations or automatic phonographs;
3. Speech training, lectures, language and other courses; commercial and vocational training, and music training and appreciation, wire books and reviews for schools, colleges, institutions, industries, homes, blind, and illiterate world populations;
4. Office and remote dictation; and transcription;
5. Police calls and reports;
6. Transportation communication—land, sea and air;
7. Sound with slide pictures or motion pictures;
8. Broadcasting and remote pickup;
9. Court reporting;
10. Signal Systems;
11. Transmission of graphics;
12. Advertising;
13. Church and industrial music;
14. Organs and organ music.

The development of the magnetic wire sound recorder is one of the more recent of the many projects undertaken by the Armour Research Foundation of Illinois Institute of Technology. Since its establishment in September 1936, the Foundation has served more than 1,500 companies, governmental agencies and associations of manufacturers on a not-for-profit basis in scientific fact-finding and development. It is supported through payments, gifts and appropriations by the industries, agencies, and individuals for whom its services are performed.

The Armour magnetic wire sound recorder and reproducer was invented by Marvin Camras while a student in electrical engineering at Illinois Institute of Technology. It was developed and perfected at the Foundation, where Camras is now on the staff as associate physicist.

BEFORE the war many a radio dealer carried on a thriving business in "Trade-ins"—old time sets taken in as part payment on new ones. A little re-touching and the trade-in could be disposed of with comparative ease. True, such trade-ins might remain on the dealer's floor for a spell, but what of that? Eventually all could be disposed of.

Today the picture is different. Radio dealers wish to pick up real old time chassis with but one thought in mind—to wit, cannibalizing them clean and salvaging all usable repair parts. If comparatively modern sets can be located they can be sold—almost on the spot to patrons whose original radio has gone sour and who must await a needed tube or other replacement. These are potential customers for a "used" set which can serve as a downstairs radio until their original set is fully repaired. The set can later be relegated to a position in the household as a "secondary" receiver.

But how to acquire a reservoir of old and semi-modern radios—that's the \$64 question!

Bernards, of Syracuse, has a system. They run advertisements in local newspapers—on the sport page or adjacent to it—directed at men or women about to leave for the service. Ads point out to such prospective servicees that their present radio has a cash value—cash they may find useful to them to last until the final payday. After the war they can purchase a new radio. And at present they haven't any valid use for their set.

Many of these individuals are "family men" who will not market their radio since the family will use it for the duration. But in a majority of such cases a second radio is usually on the premises—perhaps a real old-timer, of which they are happy to rid themselves.

The company does not confine its efforts to oral presentations, but uses a window which is a mixture of war photos and of radios revamped and ready for sale—radios taken in during the past few weeks. The theme is, "Take part in a brand new salvage drive—bring in a radio you aren't using—so that someone else may be able to hear the latest war communique concerning their loved ones."

Bernard's makes a cash offer upon inspection, the sum fluctuating, depending upon model number, condition of set and all other valid circumstances, and makes it a rule *not* to require the customer to leave a radio for appraisal. It's "spot cash" and that ruling has brought unusually favorable results.

Many times, if the customer is asked

WAITING FOR "SALES DAY"

Wartime shortages brought out best "merchandising" efforts of dealers, demonstrating their readiness and ability to swing into new set sales at once.

by CHARLES BECK

to leave a set for inspection he changes his mind about its sale and the entire proceedings strike an almost unsurmountable snag. The firm does not bargain, however—its original price is its "top figure." It feels that "bargaining" is a time-consumer and, incidentally, reduces the reputation and dignity.

It is reported that the time and funds spent in executing a campaign such as this in the acquisition of "old radios" is worthwhile not only from the "parts" standpoint but from the "goodwill" generated by having available radios to sell in an emergency when a store customer is badly in need of them.

Baum's, Rochester, N. Y., advises that electric clocks make an excellent sideline for repairing—the radioman can put two hours a day on 'em and relax from his strictly radio-repairing chores. There's the same labor charge and, of course, no home calls or deliveries are needed for this line of war service.

Granger, Rochester, N. Y., reports that many cases of "noise due to electrical interference" turn up. This type of activity (checking source of electrical interference) requires a tremendous amount of time on the serviceman's part. Women can be trained exclusively for "noise-checking"; but gas cannot be obtained to do all the home-calling since nothing can be accomplished at the shop. At present noise-checkers take the bus to the customer's house and patiently analyze the neighborhood on foot.

Sound Equipment, St. Paul Street, Rochester, N. Y., covers the p.a. field

and specializes in servicing of theatre and commercial sound installations. They advise that tubes are especially hard for them to handle because when a commercial client needs a tube he needs it in a hurry. And replacements for amplifiers are no cinch. Labor presents little problems in p.a. because high-schoolers like to cover dances and public events—handling the installations, etc. It also advises that many commercial sound systems break down because inexperienced help do not handle such systems properly—overloading it or otherwise damaging it.

Agdelburgh Radio Service, of Ogdensburg, N. Y., uses a bicycle to make home calls with every day from 8:00 to 11:00 A.M. His shop opens from 11:00 A.M. through 6:00 P.M. Using a bicycle does not require tire or gasoline consumption—the speed is approximately as great as the car in crowded city streets—but of course no sets can be transported from home to serveshop. However, the majority of sets can be serviced in the home.

Rexall Radio, of Utica, N. Y., has had to cut out tube checking as a separate function except on one day—Monday. All tubes are checked free on Monday—on all other days a charge of 25c is made. This is to encourage all patrons wanting tube once-overs to bring 'em in the first of the week.

La Corte, of Schenectady, N. Y., has a local theatre announce over its p.a. system the days of the week the serveshop is open. In return for this announcement between every show the serviceman repairs the theatre p.a. unit whenever same needs attention.



Just a Kid... BUT DEEP IN ELECTRONICS

NOW he's a Major in the U.S. Army Air Forces. A few short years ago he was a freshman in high school, just a kid "fooling around with radio." Today "the kid" knows every inch of his giant bomber.

He knows each link in the vast chain of Superfortress performance. And that includes the important electronic details of amplification.

After the war, thousands like him are going to tell you what can be done in sound reinforcement, and how! Because "the kid" has used Eastern-built equipment in war, he'll buy Eastern-built equipment in peace — or maybe he'll sell it! In either case, his generation will have a great influence on the selection, installation and operation of sound and electronic equipment. And

we believe that Eastern products will rate high with these young men.

* * *

To aid the war effort, our engineers are available for consultation on any amplification problem. Until Victory, Eastern will continue to devote its resources to the design and manufacture of vital war equipment. Meanwhile, let us send you the next of a series of useful articles prepared by our engineering staff on the newest developments in amplification related to both sound systems and industrial instruments. Ask for Brochure E-C.



Buy MORE War Bonds



EASTERN AMPLIFIER

CORPORATION

U. S. Reg'n. Applied For

794 EAST 140th STREET • NEW YORK 54, N. Y.

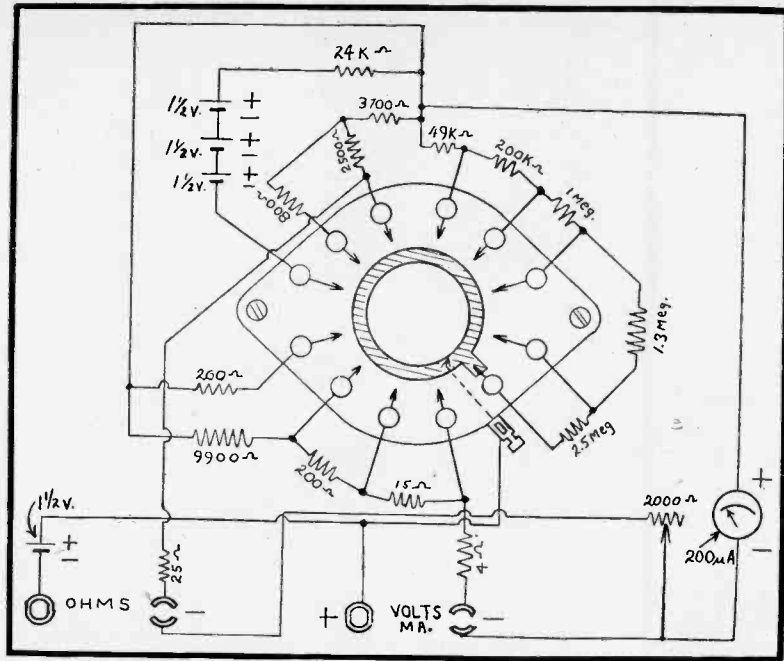

Philco Corp. Volt-Ohm-Milliammeter
(Model 023)

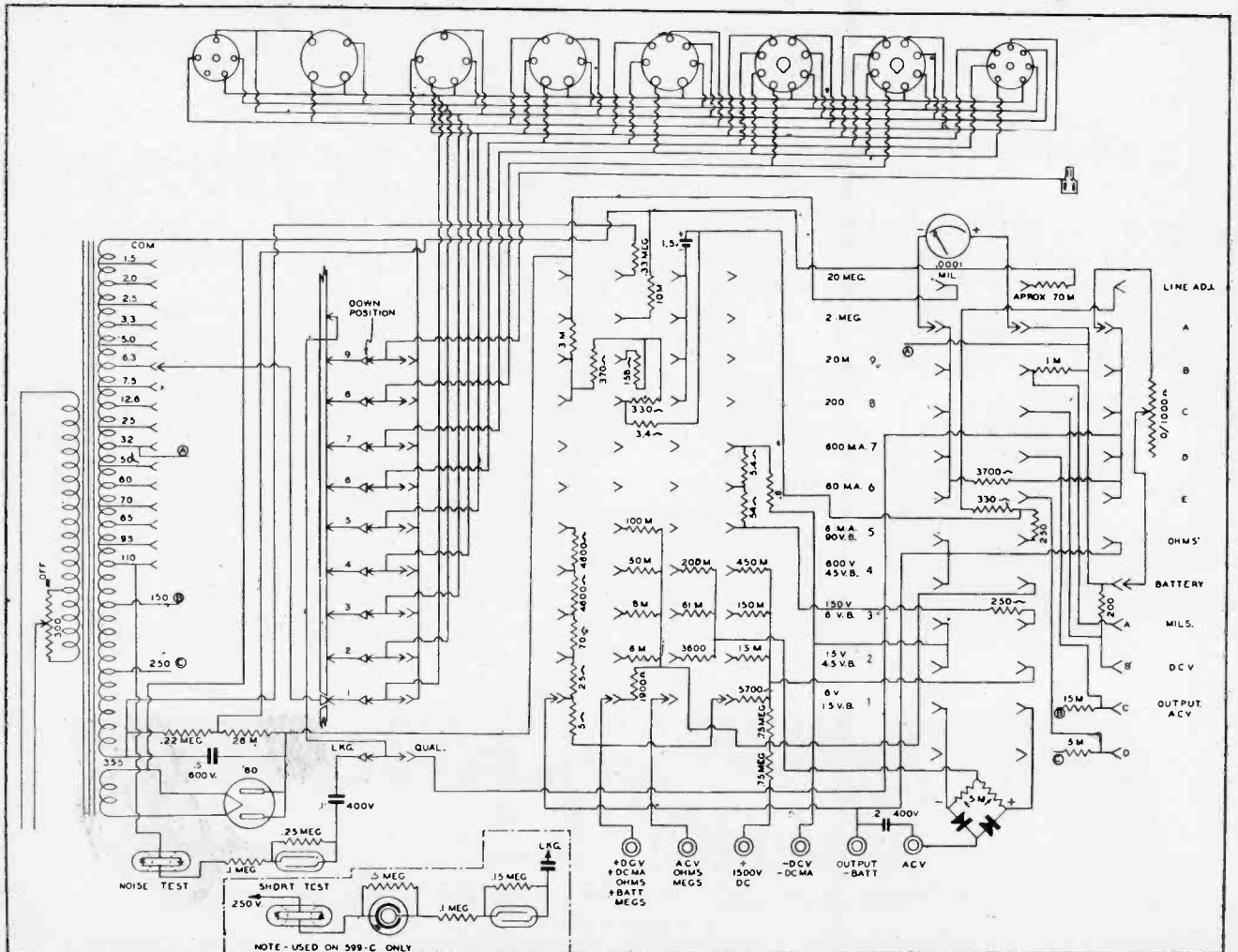

Supreme Instru. Corp. Tube-Set-Battery Tester (Model 599)

SPRAGUE TRADING POST

A FREE Buy-Exchange-Sell Service for Radio Men



CONDENSER-RESISTOR TESTER de luxe!

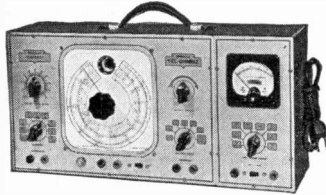

EVERY basic characteristic of EVERY type of condenser and resistor can be read quickly and accurately on direct reading scales on the Sprague de luxe Tel-Ohmike. Measures capacitance from .000010 to 2000 mfd.; d-c resistance from .5 to 5,000,000 ohms; and insulation resistance to 10,000 megohms. Contains built-in d-c volt milliammeter. Power factor and leakage current of electrolytic condensers are read directly. Built-in power supply permits all characteristic measurements under actual working conditions up to 1,000 volts DC. A "magic eye" indicator shows bridge circuit balance.

Sprague de luxe Tel-Ohmikes are NOW AVAILABLE to Sprague distributors under W.P.B. Form 3243 or AA-5MRO.

FOR SALE — RCP #411 supertester, A-1 Condition, \$25. Norman A. Paggeot, 100 Washington, Apt. 8, Grand Haven, Mich.

FOR SALE — 10 adapters converting 1R5 to 1A7; also 12 ditto for converting 1T4 to 1N5. Adapter unit less tube only, \$1.25. Want one 12A7 tube. Pfc. Earl Daniel, ASN 14170184, Squadron 0, Box 52, Will Rogers Field, Oklahoma.

FOR SALE — 954 and 955 tubes, \$1.50 ea.; 832 transmitting tubes, \$5 ea. C. W. Lanam, 2320 Shattuck Ave., Berkeley, Calif.

FOR SALE OR TRADE — Bosch 6-tube car radio, perfect condition, or will swap for a comm. receiver either Howard 430 or 435 or Echophone EC-1 or Sky Buddy. Chas. H. Doolittle, 415 Irving Ave., Syracuse 10, N. Y.

FOR SALE — Four 2A3 and four 56 RCA tubes; Thordarson trans. pp to pp #T58A70; ditto single to pp #T74A31; ditto choke 150 mills. #T17C00; ditto power trans. #56R05, 350v @ 110 mills. C. J. Murphy, Chief Mus., U.S.N., Bldg. #3, % Band, U.S. Naval Training Station, Great Lakes, Ill.

FOR SALE OR SWAP — Meissner FM radio tuner for Meissner all wave tuning assembly complete. Frank P. Dane, 3852 Eagle St., San Diego 3, Calif.

WANTED — One 0-1 d-c milliammeter. Must be A-1. Cash. All letters answered. Stewart C. Allen, 2505 Pacific Dr., Bakersfield, Calif.

WANTED — Small tube checker, up to 50 volts. L. Drouman, 315 — 9th Ave., New York, N. Y.

WANTED — Complete set or single vols. Rider manuals, also used late model test eqpt. Emil J. Patrick, Ridge Rd., Ambridge, Pa.

FOR SALE — RCP #423 V-0-M, neatly new; Triplett 678 Ohmmeter, 0-1 meg. in 5 ranges; also Triplett 321 0-1 ma. in good condition. R. H. Ott, Box 21, Glen Mills, Pa.

WANTED — Gernsback service manuals 1936, 37 and 38. Also want 117Z6; 12SK7 tubes. Sell or swap 117L7; 25L6; 35L6; 25Z6. Riley Parsons, Raquette Lake, N. Y.

WANTED — Tube tester, must handle Loekalt and bantam tubes; also Rider's manuals, any or all, Louis Cardillo, % Radio Lab, Box 125, East Canaan, Conn.

FOR SALE — Triplett tube tester #1310, \$12. W. H. Elkins, 389 Cambridge Ave., Memphis 5, Tenn.

WANTED — Polished globular carbon as used in carbon microphones and will pay well for same or information as to where it can be bought. E. B. Overshiner, 25 S. Dearborn St., Chicago 3, Ill.

FOR SALE — Complete radio shop, manuals, meter, tube tester, oscillator, power supplies, cabinets, speakers, welder, drills, parts, tubes, etc. Complete list on request. Retail value over \$2250, price \$1250. Vick Radio Service, Box 216, Kershaw, S. C.

WANTED — Echophone EC1 or Hallcraft Sky Buddy or similar. M. L. Beiner S 2/c, Becks. 68, N.A.C., Norman, Okla.

WANTED — All types test eqpt. and Rider's manuals for new business. A. F. Kawell, 309 Locust St., Mankato, Minn.

FOR SALE OR TRADE — 6v 10 amp. transformer, used about 2 hrs. Want 117Z6, 12SA7, 80, 6E5, 6F6 and other tubes. Thomas Lamb, 689 Arlington Ave., Mansfield, Ohio.

WANTED — Small electric radio, any make, also test eqpt. of all types. E. L. Breeden, Box 348, Manassas, Va.

FOR SALE — Philco 1941 8-tube auto radio AR-75 and RCP multimeter, #446. H. R. Ringold, 132 N. Dolney Dr., Beverly Hills, Calif.

WANTED — Tube tester & signal generator for FM-AM, late model. John Vaich, 86 Harvard St., Brockton 24, Mass.

WANTED — Superior channel analyzer; QCA condenser tester; Superior 1230 sig. generator; Rider's manuals; small metal lab. A. Mayfield, 3330 Lawrence, Denver 5, Colo.

FOR SALE — Rider channel; Jaeson oscillator; Stancor master pack; Rider manuals; Racon units; radio parts; amplifiers; microphones. Natl. Sound Eqpt. Co., 625 Main St., Worcester, Mass.

WANTED — Phono pickup (prefer Astatic CL 407) and 78 r.p.m. motor or record changer; type 913 or 902 tube; and crystal mike such as Turner BX and CX or Shure 717B or 707A. Richard Rauppach, Box 906, Bly, Ore.

WANTED — Used phono-recorder, radio-recorder, or recording attachment ready to use. All letters answered. Paul Aunited, 1669 North Dorgenois St., New Orleans 19, La.

WANTED — EC-1 or Sky Buddy, new or used; also one 25Z6 or 25Z5 and one 25L6. Cpl. Sid Gorenstein, 597 AAF Band, Turner Field, Albany, Ga.

WANTED — All types test eqpt.; small pocket AC-DC multimeter; also small panel meters. Cash. S. W. Iss. 3451 Giles Place, New York 63, N. Y.

WANTED — 3" oscilloscope, preferably Supreme, but others will do. Cash. Walt's Radio Service, 911 Shawnee St., Pittsburgh 19, Pa.

WANTED — Tube tester and signal generator. Have brand new electric steel guitar complete to trade. G. D. Squires, 3122 Lebanon St., El Paso, Texas.

WANTED — Tube tester for cash. Describe fully. C. W. Carson, 855 Jenevein, San Bruno, Calif.

WANTED for cash or trade: Zenith cabinet for chassis 6D 315 port. 5 tube. Have set short wave Aero plug-in coils with base, strafe line freq. condens., two audio transformers, two Natl. Vern. dials m.d. on panel, 200 ohm carbon hand mike. Ralph E. Turner, 9 Lawrence Rd., Melford, Mass.

WANTED — Old style Colin B. Kennedy long wave receiver 175 to 25,000 meters, with 2-stage amplifier. Will trade radio mdse. or pay cash. Cardin Radio Lab., 112 E. Moses St., Cushing, Okla.

WANTED — Rider manuals nos. 2 and 7, also two 117Z6 tubes. V. R. Majors, Heber, Calif.

WANTED — Phono recorder for 1940 Philco combination. Rev. Earl C. Gross, 125 Steuben St., Painted Post, N. Y.

FOR SALE — Brand new RCP vac. tube voltmeter #665, 8" meter, latest model, \$79.50. M. A. Porter, 1713 Larrabee St., Chicago, Ill.

FOR SALE — New uncrated Capehart-Jensen auditorium dyn. speaker 14". \$35; also FM tuner, \$32.50; Jensen heavy 10" dynamic, \$7.50. J. Cooper, 445 E. Grand Blvd., Detroit 7, Mich.

WANTED 110v 60 cy. phono motors in good condition, also turntables & parts. Cash or trade for radio books. T. Whalen, 2622 S. Park Ave., Lackawanna 18, N. Y.

FOR SALE — C-D model BX capacitor bridge with tubes & instructions, \$20, new condition. Want Philco 030 signal tracer, also late model tube tester and any or all Rider manuals. Louis Fladkoff, 143-48 41st Ave., Flushing, N. Y.

WANTED — One 117Z6 tube for Zenith portable. Cash. Pfc. A. J. Stellberg, ASN, 16116672, 876 B.S. 383 B.G., Walker A.A.F., Victoria, Kans.

FOR SALE OR TRADE: 2 oscillators; 2 voltammeters; 2 tube checkers; Riders 1-14; 15 JCA amplifier chassis with covers; about 400 tubes or other parts. Will consider SX-28 or equivalent on trade. Elihu Widener, 133 Orkney Rd., Oak Ridge, Tenn.

FOR SALE OR TRADE — Two new 5X1 tubes. Will trade for 50L6 or 12SA7. Ghirardi's Radio Physics Course, \$3.50. M. Francis, 1232 E. 75th St., Chicago 19, Ill.

YOUR OWN AD RUN FREE!

This is Sprague's special wartime advertising service to help radio men get needed parts and equipment, or dispose of radio materials they do not need. Send your ad today. Write PLAINLY or PRINT — hold it to 40 words or less. Due to the large number received, ads may be delayed a month or two, but will be published as rapidly as possible. Sprague reserves the right to reject ads which do not fit in with the spirit of this service.

HARRY KALKER, Sales Manager

Dept. RSD-55, SPRAGUE PRODUCTS CO., North Adams, Mass.

Jobbing Sales Organization for Products of Sprague Electric Company

SPRAGUE CONDENSERS KOOLOHM RESISTORS

T.M. REGISTERED U. S. PATENT OFFICE

Obviously, Sprague cannot assume any responsibility, or guarantee goods, services, etc., which might be exchanged through the above advertisements

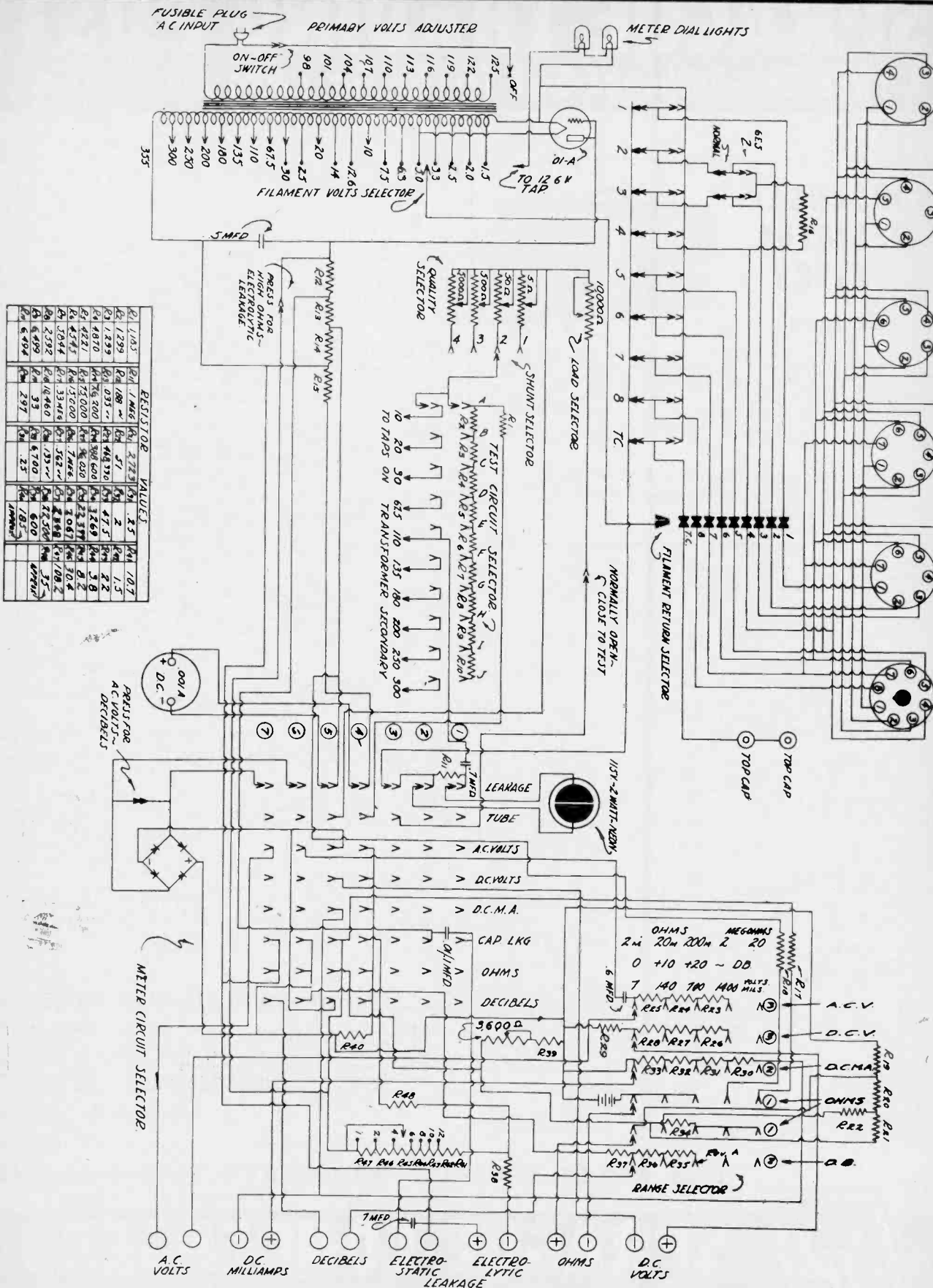

Supreme Instru. Corp. De-Luxe Tube Tester (Model 500)

In Trade

[from page 14]

Bendix Dealer Plans

With its nation-wide distributor roster nearly 100 per cent complete, Bendix Radio during April and May will present merchandising and dealer organization plans to distributors at a series of district meetings, according to Leonard C. Truesdell, general sales manager for the company's forthcoming line of home radios and radio-phonograph combinations.

Truesdell will outline to distributors the company's program and policies for distribution, dealer selection, territorial sales objectives, advertising and merchandising. W. P. Hilliard, general manager of Bendix Radio, will describe the engineering and manufacturing background of the company to distributors. Other speakers will include H. W. Royer, product manager for the radio and radio-phonograph line; Earl I. Hadley, new appointed advertising and sales promotion manager; and Paul J. Reed, assistant advertising manager.

[Continued on page 48]

HANDLE MORE JOBS IN A LOT LESS TIME!

THE GREATEST TIME SAVER IN SERVICING HISTORY

Radio servicemen everywhere say that A. A. Ghirardi's **RADIO TROUBLESHOOTER'S HANDBOOK** (3rd Edition) helps them **TURN OUT TWICE AS MUCH WORK IN A GIVEN TIME!** Four times out of five, it tells exactly how to repair a set — *without any elaborate testing whatever!* Actually, this big 4-pound, 744-page manual-size Handbook is a complete guide to quick, easy repairs on **PRACTICALLY EVERY RADIO RECEIVER NOW IN USE.**

4,800 DIFFERENT RADIO MODELS

Its 404-page Case History Section gives full details on common trouble symptoms, their causes and remedies for **OVER 4,800 DIFFERENT RADIO MODELS.** It describes the trouble exactly, tells exactly what to do to repair it. It eliminates much testing — helps you do **TWO OR MORE** jobs in the time normally required for one — repair cheap sets profitably — train new helpers, etc. Equally important are hundreds of other pages specifically geared to today's needs — dozens of hints on the proper substitution of tubes and parts; if alignment peaks for over 20,000 superhets; transformer troubles, etc. and hundreds of graphs, tube charts, data, etc. — all carefully indexed so you can find what you need in a hurry. Price only \$5 complete (\$5.50 foreign) on our **UNRESERVED 5-DAY MONEY-BACK GUARANTEE!**

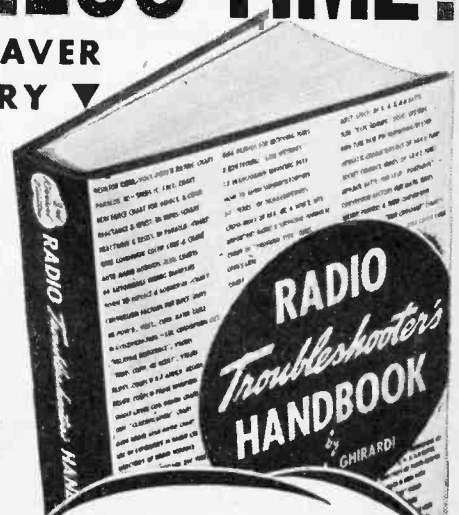

NOT A STUDY BOOK!
You don't study this Handbook! Simply look up the radio's Make, Model, and the Trouble Symptom — and go to work! Eliminates useless testing on 4 JOBS OUT OF 5!
ONLY \$5 COMPLETE

ALL THE FACTS ON A LITTLE KNOWN SUBJECT!

JUST! OUT!

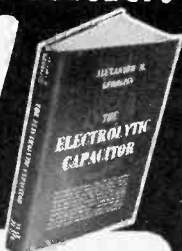

"The ELECTROLYTIC CAPACITOR"

Don't buy, specify, use, or replace Capacitors blindfolded! Save time, save money, and increase your service efficiency by really knowing all about this vital subject! Actually, no Radio-Electronic component is more important or less understood than the Electrolytic Capacitor. Postwar equipment will employ more of them — and in new, improved types. This new book by Alexander M. Georgiev for more than 15 years a leader in Capacitor research and development, at last explains the entire subject. Answers all the many questions servicemen, engineers, and designers have been asking about capacitors for years.

ENDORSED BY A. A. GHIRARDI

"I heartily recommend The Electrolytic Capacitor as 'must' reading for the man who really wants to forge ahead in post-war Radio-Electronics", states A. A. Ghirardi, internationally famous technical author. "It tells what types to use and where, and how to use them to best advantage — explains the advantages and disadvantages of each — how to make emergency repairs and a host of other subjects invaluable to the man who KNOWS it pays to KNOW." Contains over 200 pages and eighty illustrations. Price only \$3 (\$3.25 foreign).

USE COUPON in adjoining advertisement. Mail today!

Ghirardi's Complete Guide to Modern Professional RADIO SERVICE WORK

Test Instruments, Troubleshooting, Repair



Once in a blue moon a technical book is written that is so important, so complete, and so easy to understand that it is used and recommended universally by members of a profession! A. A. Ghirardi's **MODERN RADIO SERVICING** is that kind of a book — **AND MORE!**

Actually, it is the only single, inexpensive book giving a complete course in modern Radio Repair work in all its branches. Explains all necessary test instruments . . . even how to build your own; how to troubleshoot **ALL** makes of receivers, analyze their circuits, test components; make adjustments; repairs, etc. — all step-by-step. Used for reference, it serves as a beautifully cross-indexed volume for "brushing up" on any type of work that may puzzle you. 1300 pages, 720 self-testing review questions, 706 illustrations and diagrams. \$5 complete (\$5.50 foreign) **5-DAY MONEY-BACK GUARANTEE.**

EVERY CONCEIVABLE SERVICE SUBJECT!

Milliameters, ammeters & voltmeters; Methods and instruments for measuring resistance; ohmmeters; How to build your own instruments; Tube checkers; Set analyzers; Point-to-point testing; Test oscillators; Preliminary trouble checks; AVC and QAVC circuits; Troubleshooting; Testing components; Obscure radio troubles; Aligning and neutralizing; Auto radios; All-wave radio servicing; Marine radio; Interference reduction; How to start and operate a Radio-Electronic service business, etc. etc.

See Money-Saving Offer in Coupon!

5-DAY MONEY BACK GUARANTEE

Dept. RSD-55, Technical Division, MURRAY HILL BOOKS, Inc., 232 Madison Ave., New York 16, N. Y.

Enclosed find \$ for books checked (send postpaid) or [] send C.O.D. (in U.S.A. only) for this amount plus postage. If not fully satisfied, I may return the books in 5 days for full refund.

[] RADIO TROUBLESHOOTER'S HANDBOOK \$5 (\$5.50 foreign)

[] MODERN RADIO SERVICING \$5 (\$5.50 foreign)

[] MONEY-SAVING COMBINATION—Both books (over 2040 pages of invaluable service data) for only \$9.50 (\$10.50 foreign).

[] THE ELECTROLYTIC CAPACITOR (see adjoining adv.) \$3 (\$3.25 foreign).

Name

Address

City & Dist. No. State

Please print or write plainly.

RADIO service DEALER Survey

MORE LETTERS FROM READERS give views on the questions:

1. Shall Radio Servicemen and Technicians be required to undergo examinations as to their technical ability?
2. Shall Radio Servicemen and Technicians be licensed or not?

We would like to publish in full all of the many letters received from subscribers all over the country in response to our editorials on the subject. But space permits printing portions of only a few examples which indicate a wide variety of viewpoints, and reveal again the will to eradicate many abuses in the field of radio servicing.

Numerous questionnaire returns are received daily. The returns will be tabulated and analyzed and the results published in one or more issues of RADIO service DEALER. Watch for future announcements.

PREFERS ASSOCIATION

Why should we be licensed? All radio establishments are required to have a city license to do business. The so-called screw-driver man has already seen his day—radio receivers are becoming too complicated and will be more so in the future.

Let us forget him, and concentrate on having a strong association or organization to bind the radio servicemen together and to work toward the upbuilding of the trade, for in that way and that way only, will they ever be recognized as professional men and receive the remuneration due them.

How many times have you fellows wished you could show the manufacturers how to build their radios? How many times have you cursed and worried over a two by four midget, that should have never been built? How many times have you searched for an outlaw schematic in vain? And how many times have you known of distributors selling critical tubes and batteries to non-service establishments, such as auto-parts dealers? And why do we have to keep in stock a thousand tubes, to have one of a kind?

I would like to hear from those interested in forming an association . . .

G. E. Renfro, Ga.

LICENSE NO PROTECTION

I am a licensed electrical contractor, doing radio business. All this license stuff is bunk—it has proven to me to be a political football, involving graft for someone . . . Nature eliminates the unfit, and licenses do not protect

[Continued on page 40]

GET THE LATEST DATA

On U.H.F. Cables and Connectors!

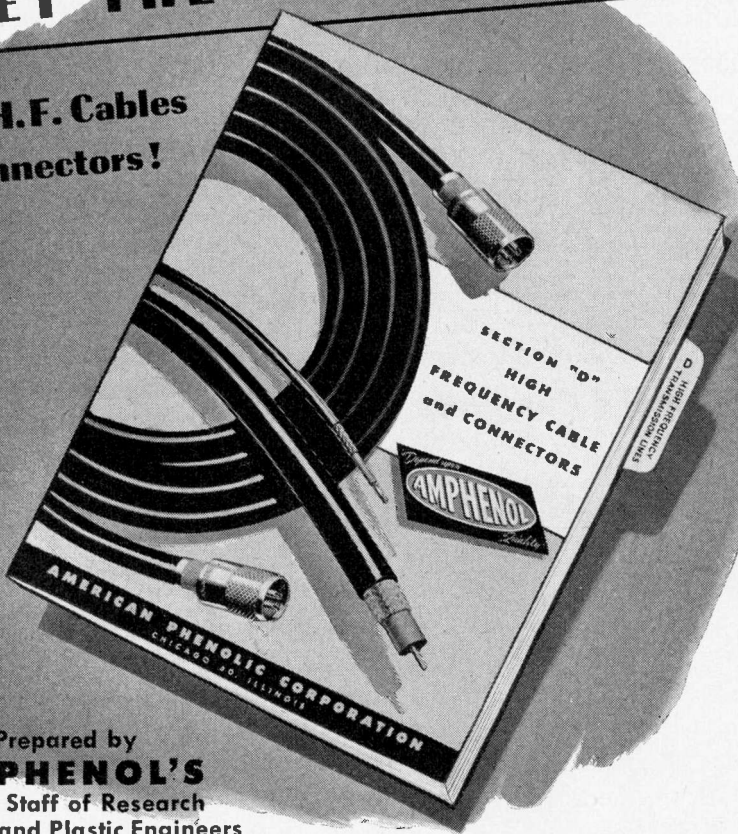

Prepared by
AMPHENOL'S
Expert Staff of Research
Electrical and Plastic Engineers

Complete data is available on Amphenol's cables for the latest requirements —incorporating the solid, flexible, low-loss, mechanically stable, thermoplastic polyethylene.

Explanatory charts and technical information given on Amphenol precision-engineered manufacturing methods. The information contained in the new catalog Section "D" has been compiled thru the close cooperation of Amphenol Engineers and Army-Navy Engineers

as well as large industrial concerns.

This explains why Amphenol U.H.F. Cables embody the same built-in quality, perfection and performance that typify every Amphenol-Engineered product.

For quick reference there is also included a complete chart listing Amphenol cable sizes, characteristics and dimensions as approved by Government Agencies.

Send today for your copy of Section "D" High Frequency Cables and Connectors. Use the coupon!

AMPHENOL CORPORATION
Chicago 50, Illinois
In Canada: Amphenol Limited • Toronto
U. H. F. Cables and Connectors—Radio
Parts—Plastics for Electronics and Industry
—Conduit—Connectors (A-N and British)
—Fittings—Cable Assemblies
Please send a copy of the new
catalog Section "D"

Name _____ (RD)

Company _____

Address _____

Also send information on _____



Wondering about tube testers?

*...Here's what Simpson has ready
and waiting for your postwar needs*

Sensational? Yes . . .

1. This new Simpson Mutual Conductance Tube Tester tests tubes with greater accuracy than any commercial tube tester ever designed.
2. Provides greater flexibility for future tubes than any other tester.
3. Tests tubes with voltage applied automatically over the entire operating range.
4. Simplifies as never before the interpretation of tube condition from mutual conductance readings.

SIMPSON ELECTRIC COMPANY
5200-18 Kinzie Street, Chicago 44, Ill.

Simpson

INSTRUMENTS THAT STAY ACCURATE

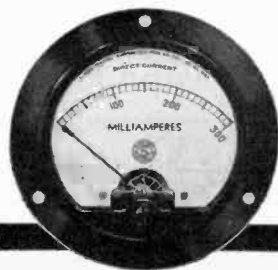

SURVEY

[from page 38]

the sucker from the sharpster . . . A person with good manners and common horse sense is to be preferred to a sarcastic math. and theory wizard . . .
A. Fiess, N. Y.

NO REGIMENTATION

I was a licensed master painter for years and I know now what a racket that was. I've done radio work for many years, sold radios and do all my own service work. But I didn't

have a technical education. I learned through practical work and self-study. We have enough regimentation. A license is just another tax on business.
Schmutzler, Wis.

INCREASE PUBLIC CONFIDENCE

I am greatly in favor of licensing, for these reasons: Since many other technicians or professionals must show their capability why not the radio technicians? Also it would increase the confidence of the general public, since it would be assured of the service technician's competency to undertake

the job of repairing radio or television sets.

With radio, television and other electronic equipment and services becoming more complicated every day, licensing will become a must for the safety of all concerned.

Let us hope that licensing will win out.

H. G. Quade, Texas

NO GUARANTEE OF GOOD WORK

I am voting against licensing. Certain trademen such as plumbers are licensed because the public health or safety is involved. Does anyone suggest that public health and safety are involved in radio repair and servicing? If so, we had better license kerosene lamp trimmers and cigarette smokers.

As for the idea that licensing will stop the "gyps"—well, look around. We have recently seen a large percentage of doctors involved in an insurance kick-back scheme; the Readers Digest survey on opticians, auto repair shops, etc. These professional men are the men with high ethical standards, held up as a shining example. Phooey!

No; whether a man "gypts" or not depends on the man and the opportunity, not on a license or skill. Did you ever see plumbing and electrical work installed by licensed men that was so slipshod it was dangerous and in contravention of the building and sanitary codes—in spite of the fact that there was supposedly an inspection after installation.

One of your recent correspondents had the right idea when he said that a lot of the present radio service men started with a screw driver, and if the young ones coming up have the ability to start that way—why more power to 'em!
G. Chappel, New Jersey.

LEAVE IT TO CUSTOMERS

We need no licensing laws or commission. If a man can repair a radio let him work at it. If he cannot do it well, the customers will soon find it out and he will vanish from the industry . . .

V. V. Keasler, Jr., Texas.

SHOP LICENSE ENOUGH

If one had not first been an amateur how in the world would one have become experienced enough to be classed as a professional radio technician?

I have found that no amount of study, without practical experience, is worth much . . . The only licensing required for the radio service trade is the shop license, the same as any other store.

J. R. Houston, Pa.

RADIO SERVICE DEALER

RIDER VOLUME XIV COVERS 1941-42 RECEIVERS

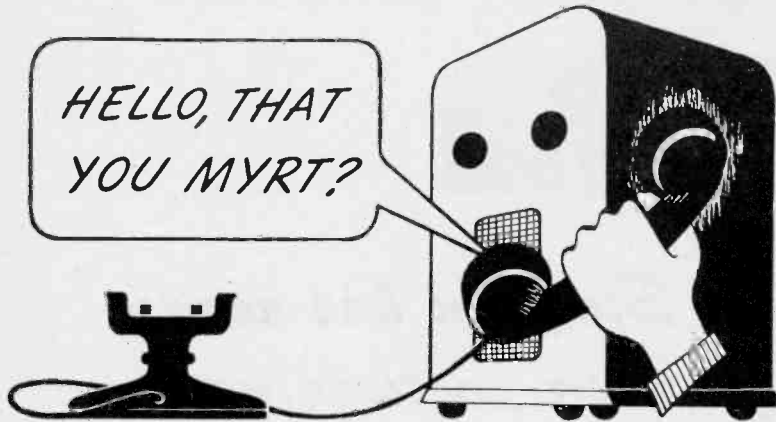

One of the first programs I carried as a new radio, four long years ago, was that of "Fibber McGee" saying "How's every little thing?" Of course he was talking to "Myrt" and not to me, though I felt fine at that time.

But if he asked me now! After the way I've been worked since 1941 I'd lay down and quit if it weren't that I have my war job to do. And there are no newer receivers to take my place. But I'm not the only one—most of my

contemporaries are wheezy, or lying quiet in repair shops right now.

It's a good thing Rider Manual Vol. XIV came out recently. It enables radio servicemen to diagnose the ills of our 1941-42 receivers quickly, easily and accurately. That gets us out of shops and back into homes where we're needed.

If you can't get immediate delivery on Volume XIV from your jobber please be patient—paper restrictions, you know.

RIDER MANUALS (14 VOLUMES)
Volumes XIV to VII . . . 12.50 each volume
Volume VI . . . 9.50
Abridged Manuals I to V (1 vol.) 15.00
Automatic Record Changers and Recorders . . . 7.50
OTHER RIDER BOOKS YOU NEED
The Cathode Ray Tube at Work
 Accepted authority on subject . . . 4.00
Frequency Modulation
 Gives principles of FM radio . . . 2.00
Servicing by Signal Tracing
 Basic Method of radio servicing . . . 4.00
Servicing Superheterodynes . . . 2.00

The Meter at Work
 An elementary text on meters . . . 2.00
The Oscillator at Work
 How to use, test and repair . . . 2.50
Vacuum Tube Voltmeters
 Both theory and practice . . . 2.50
Automatic Frequency Control Systems
 —also automatic tuning systems . . . 1.75
A-C Calculation Charts
 Two to five times as fast as slide rule . . . 7.50
Hour-A-Day-with-Rider Series—
 On "Alternating Currents in Radio Receivers"—
 On "Resonance & Alignment"—
 On "Automatic Volume Control"—
 On "D-C Voltage Distribution" . . . 1.25 each

JOHN F. RIDER PUBLISHER, INC. 404 FOURTH AVE., N.Y. 16, N.Y.
 Export Division: Rocke-International Corp. 13 E. 40th Street New York City Cable: ARLAB

RIDER MANUALS are complete **IN 14 VOLUMES**

SYLVANIA NEWS

RADIO SERVICE EDITION

MAY

Published in the Interests of Better Sight and Sound

1945

**SYLVANIA
SERVICEMAN
SERVICE**

by
FRANK FAX

Newest of Sylvania Electric's technical bulletins on Tube Substitutions is the 20 page "Aids To War-Time Servicing" that servicemen throughout the country are finding most helpful in these days of radio tube shortages.

The manual is another Sylvania contribution to assist servicemen in meeting the present acute shortage of many tube types. In addition, it contains several charts of diagrams showing adaptor circuits commonly required.

This bulletin is available free on request from your Sylvania distributor, or from Sylvania Electric Products Inc., Emporium, Pa.

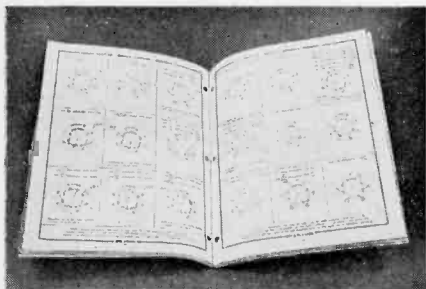

Sylvania Expands Service Aid with New Radio Tube Substitution Manual

Full Data Contained in New 20-page Bulletin Superseding Earlier Guides



Recognizing, early in the war, the difficulties that would result from tube shortages, Sylvania Electric immediately took steps to aid servicemen in tube substitution problems. Early in 1942, Sylvania published—and distributed free to servicemen—a 4-page bulletin, "Correlation of Tube Types for Substitution."

MORE EXTENSIVE DATA

This bulletin proved so helpful to servicemen that Sylvania continued this service in the Technical Section of Sylvania News, and then decided to re-issue the information in more comprehensive form. An enlarged, more fully developed "Radio Tube Substitution Charts for War-Time Servicing" appeared in 1943. This was a

6-page bulletin containing information based in part upon the WPB civilian radio tube program, permitting complete presentation in one convenient folder.

Now, newest and largest of these Serviceman Service charts is a 20-page manual entitled "Aids to War-Time Servicing" presenting the latest in Sylvania Tube Substitution Charts and containing 4 full-page charts of 9 diagrams each describing adaptor circuits.

CONSISTENT POLICY

Publication of this book is the latest step in Sylvania Electric's consistent policy of assisting radio servicemen to carry on their business efficiently and profitably.

SYLVANIA ELECTRIC

SYLVANIA ELECTRIC PRODUCTS INC., Emporium, Pa.

MAKERS OF RADIO TUBES; CATHODE RAY TUBES; ELECTRONIC DEVICES; FLUORESCENT LAMPS, FIXTURES, ACCESSORIES; INCANDESCENT LAMPS

TRADE PRODUCTS

Jensen's New Speaker

A new and important addition to the Jensen family of Speech Master speakers—Type NF-300 Reproducer—announced to the trade by Jensen Radio Manufacturing Company, Chicago, promises to become a popular and valuable postwar speaker for specialized applications.

Type NF-300 Reproducer was origi-

nally developed by Jensen engineers for use as a loud speaker and microphone (talk back) in ship intercommunicating systems so it has all of the physical and audio features of reliability and performance required of sea going, battle-tested equipment.

Unusual compactness is achieved by a uniquely designed reflex horn, the rim of which provides for panel mount-

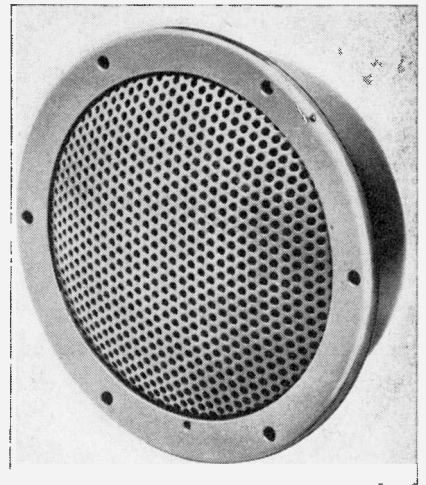

ONE OF A SERIES OF ELECTRO-VOICE ADVERTISEMENTS EXPLAINING IN DETAIL THE APPLICATIONS AND SPECIFICATIONS OF ELECTRO-VOICE MICROPHONES

INDOOR OUTDOOR

IN ALL KINDS OF WEATHER

HIGHER ARTICULATION WITH LESS FATIGUE

Electro-Voice MODEL 600-D

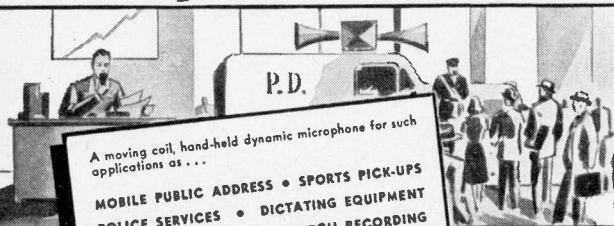
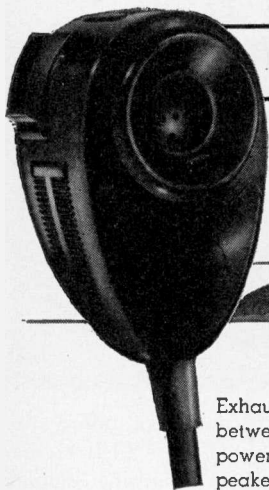

A moving coil, hand-held dynamic microphone for such applications as . . .

MOBILE PUBLIC ADDRESS • SPORTS PICK-UPS
POLICE SERVICES • DICTATING EQUIPMENT
MARINE SERVICES • SPEECH RECORDING

Exhaustive tests have proved that a uniform response to all frequencies between 200-4000 c.p.s. will give higher articulation, provide more usable power level, and be less fatiguing to the listener than one which is peaked. These advantages are assured in the Electro-Voice Model 600-D because the frequency response is unweighted and substantially flat. Where ambient noise does not interfere or distract, high fidelity speech transmission is provided, indoors or outdoors . . . in any kind of weather.

OUTPUT LEVEL RATING: Power: 56 db below 6 milliwatts for 10 dynes/cm pressure. Voltage (high impedance): 5 db above .001 volt/dyne/cm², open circuit. Voltage developed by normal speech (100 dynes/cm²): .177 volt.

FREQUENCY RESPONSE: 100-6000 c.p.s.

WEIGHT: 9 ounces.

HARMONIC CONTENT: Less than 2% at all frequencies.

DIAPHRAGM: Made of heat-treated duralumin, corrosion inhibited.

VOICE COIL: Made of pure aluminum, high-Q design.

CASE: Constructed of finest quality, high impact phenolic.

PRESS-TO-TALK SWITCH: Sliding contact, self cleaning type; standard circuit opens microphone and closes relay simultaneously. Other combinations optional.

TRANSFORMER CORE: Made of nickel alloy, hydrogen annealed metal; low capacity windings.

MAGNETIC CIRCUIT: Employs Alnico V and Armco magnetic iron.

IMPEDANCES: Hi-Z (Direct-to-Grid), 50, 200, 250, or 500 ohms.

Equipped with 6 feet of two conductor and shielded synthetic rubber jacketed cable.

Model 600-D, List Price \$27.50

Model 600-DL, with switch lock, List Price \$29.00

See your nearest radio parts distributor today. His knowledge of Electro-Voice microphones may aid you in selecting the appropriate type for your specific needs. He may also be an important factor in speeding your order.



ing, while carrying the protective screen assembly. The Alnico 5 permanent magnet material is used, giving exceptional field strength in minimum space. The diaphragm is of moulded phenolic and the sound chamber is a combination of moulded bakelite and metal castings. The voice coil impedance is 12 ohms, nominal value. Maximum power handling capacity for speech is 10 watts. The unit is available on properly rated priority orders showing suitable end use.

Tube Adapters

The tube adapters of Adaptol Company, Brooklyn, N. Y., are now presented to the trade in a handsome full-colored carton container which, according to the manufacturer, assists in selling them and helps to preserve



them in stored spots. Included in a line of almost 200 numbers are several adapters with built-in resistors which save a lot of time and trouble.

A feature of the line, it is pointed out, is the convenience of being able to read on the stem of the adapter what tube it converts to-and-from. Further information may be had by writing the company at 260 Utica Ave.

[Continued on page 44]

RADIO SERVICE DEALER

KEN-RAD

METAL TUBES



Better than Ever

Better because great new resources, facilities and experience have been added . . . strengthening Ken-Rad's leadership . . . enabling Ken-Rad Metal Tubes to serve even more successfully today's radio-owners and those who will buy the finer new instruments soon to appear . . . increasing substantially the value of the Ken-Rad franchise!

✍
● Write for your copy of "Essential Characteristics" the most complete digest of tube information available.

KEN-RAD

OWENSBORO, KENTUCKY

878-D1-8850



AN AMERICAN SOLUTION TO
YOUR CAPACITOR PROBLEMS

ALL TYPES • BY-PASS
AND ELECTROLYTIC

DATA SHEETS
ON REQUEST

AMERICAN CONDENSER CO.

4410 No. Ravenswood Ave.

Chicago 40, Ill.

TOUGH!

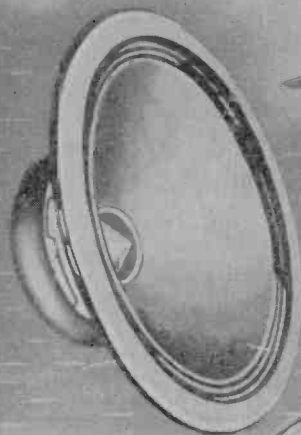
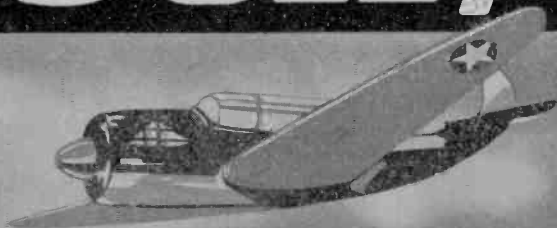

Cinaudagraph Speakers are made to take the tough raps. This is the built-in result of better manufacturing experience. Look at the record of achievement and you'll put Cinaudagraph Speakers at the top of your list.

Watch Cinaudagraph
Speakers After Victory!



Cinaudagraph Speakers, Inc.

3911 S. Michigan Ave., Chicago
Export Div., 13 E. 40th St., New York 16, N. Y.

"No Finer Speaker in all the World"

PRODUCTS

[from page 42]

Improved Ballasts

Adjustable, air-cooled, improved AC-DC ballasts are ready for delivery, announces the J.F.D. Manufacturing Company. The new A, B and C ballasts are housed in perforated metal containers to dissipate heat; thus the title "air-cooled". In addition, they are provided with a longer mica form so that long and finer lengths of resistance wire can be used, making for more precise adjustments. The ballasts can take the place of some 2,500 exact duplicates and list for \$1.50 each, OPA-approved price. Inquiries should be addressed to the company at 4111 Fort Hamilton Parkway, Brooklyn, N. Y.

Beat Frequency Audio Oscillator

A new beat frequency audio oscillator, Type AO2, is announced by the Specialty Division of the General Electric Company's Electronics Department. The unit has been designed to simplify the measurements of audio amplifiers and radio receiver fidelity, according to E. E. Williams, sales manager. It may be used also for the testing of loud-speakers and for frequency measurements or calibration.

Using full vision and making possible direct calibration, the unit provides a stable sine wave, continuous variable frequency from 25 to 15,000 cycles per second. The panel control knob regulates the output level from zero to full power output.

A Type 6E5 Electron-ray Tube is



used to indicate zero beat while adjusting the panel control knob to obtain the proper relationship between the two high frequency oscillators. The maximum output of the device is 120 milliwatts on the "cathode follower" type output impedance coupling circuit. A specifications sheet on the unit is available on request to the G-E Specialty Division, Schenectady, N. Y.

[Continued on page 46]

RADIO SERVICE DEALER

There's **RACON** — the finest

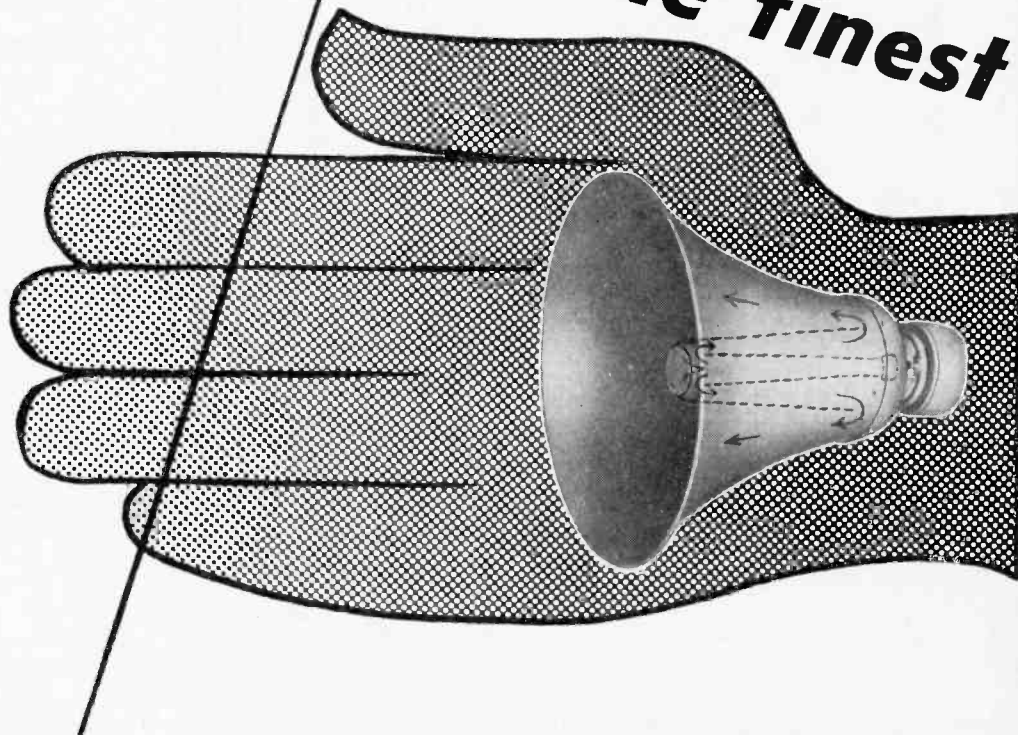

A properly planned sound installation is a good investment and soon pays for itself. Practically all industrial firms use, or plan to buy, some type of P-A or paging installations.

The majority want RACON speakers and driving units because they have proven to be the finest that money can buy.

RACON receiver units are supplied with either metal or plastic diaphragms. RACONS outperform higher power-rated speakers of other manufacture, yet cost no more and afford peak efficient, dependable service over a longer period of time. Specify RACONS!

There's a speaker, horn or driving unit for every purpose. Literature will be sent upon request. Hand prospective P-A buyers our catalog — they'll "OK" RACONS.



RACON ELECTRIC CO. 52 EAST 19th ST. NEW YORK, N. Y.

JFD "sockette" RADIO TUBE ADAPTERS



Now Over 400 TYPES
covering over
1300 SUBSTITUTIONS

THE REPLACEMENT FUNCTION OF EACH
SOCKETTE CLEARLY MARKED ON ITS BASE.

JFD presents the most complete line of tube adapters in the radio field. Now it is no longer necessary to rewire radios to accommodate tubes that are not available . . . because JFD has an adapter that permits the use of tube substitutes.

Each Sockette is proven by test to answer the purpose for which it was designed. Slow-moving, shelf tubes can now be converted to popular types by the use of a JFD Sockette.

Every conceivable type of adapter is incorporated, such as resistor type, loktal type, loktal metal base type, octal type, miniature type, &c.

JFD SOCKETTES must be good, for over a 1,000,000 of them are in use today . . . AND THE NUMBER KEEPS GROWING DAILY.



Write for our newest
JFD SOCKETTE 3-
WAY TUBE ADAP-
TER MANUAL No.
340. 16 pages with
thousands of listings
that ANSWER
YOUR SUBSTITU-
TION PROBLEMS
AT A GLANCE!

J. F. D. Manufacturing Co.
4111 Ft. Hamilton P'kway, B'klyn 19, N.Y.

PRODUCTS

[from page 44]

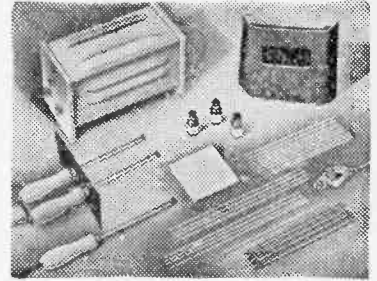

Electric Welder Set

The new portable "Weldprod" unit, announced by Welder Products Company, develops a heat up to 7000 degrees F. Electric arc welding is done by means of a metallic arc attachment, in conjunction with fluxed rods. Flame welding can be handled with the electric flame torch which operates by means of a carbon arc. It can be used for repairing iron, steel, cast iron, brass, bronze, copper, aluminum, etc. Also for melting, burning, cutting (on the lighter metals), case hardening, hard surfacing and tempering. Will handle metals up to one-quarter inch in thickness.

To operate, the welder is plugged into any 110-volt a-c or d-c outlet. It can be taken from job to job, inside or outside of the shop. Current is only consumed while working—lifting the torch from work shuts off the power. For further details, address the company at 321 Broadway, New York 17, N. Y.

Stromberg-Carlson Wire Recorder

An improved model of the wire recorder, one of the wonder developments of wartime communications research, was demonstrated recently by engineers of the Stromberg-Carlson Company's research laboratories. The recorder is produced under license of the Armour Research Foundation.

Frederick C. Young, vice-president in charge of engineering and research of the Rochester, N. Y., radio-telephone firm, declared that "the laboratory model's ability to record and play back music with so markedly high a fidelity has removed one of the chief obstacles to the instrument's early future application to the home radio receiver." It was the first time that the device had been coupled with ultra-high quality amplifiers and loudspeakers.

A magazine containing recordings

[Continued on page 50]



Bombs Away!

From pilot to bombardier . . . "target sighted" . . . from bombardier to pilot . . . "target hit" . . . and communications scored again. Halldorson Transformers are helping to maintain communication lines on all battle fronts, in air, on land or on the sea.

We are aiding in home communications by providing a full line of victory type transformers . . . quantity is limited . . . but not quality. Like their fighting brothers, our victory transformers are capable of operating under the severest conditions.

JOBBERS, write for complete information on our Halldorson Victory Type Transformers.

THE HALLDORSON COMPANY

4500 Ravenswood Avenue

Chicago 40, Illinois

HALLDORSON
Vacuum Sealed
TRANSFORMERS

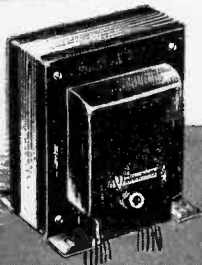

SHOP NOTES

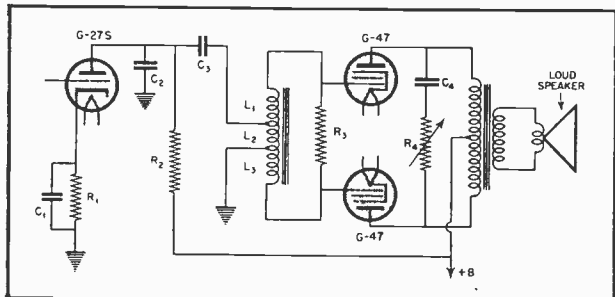

Figure 1

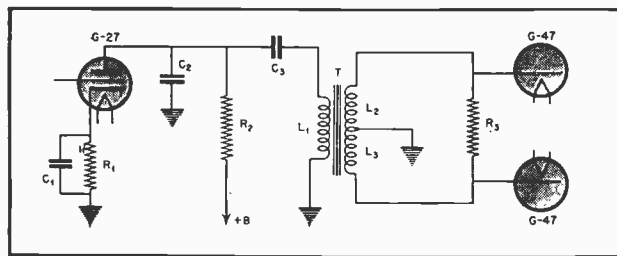

Figure 2

MAJESTIC 210 CIRCUIT REVISION

Under present conditions many parts which are unobtainable must be replaced with equivalent parts, or the circuit must be so modified that a substitute part can be used. The original audio circuit of the set is shown in Fig. 1 and the revised Majestic 210 circuit in Fig. 2. The advantage of using the blocking condenser C3 is that d.c. is kept out of the primary winding of T, preventing core saturation due to a high plate current of d.c. and permitting better frequency response accordingly. Also, a better balance is possible with respect to the signal voltages applied to each output tube grid, using the replacement transformer. The plate load resistor R2 and bias resistor R1 need not be changed since the d-c voltage is the same on G-27 as it was originally. The capacity of C3 may be .25 mfd. at 400 volts.

Submitted by Willard Moody

ZENITH AC-DC TABLE MODELS

Sets show terrific distortion and hum which is checked *not* to come from blown filter pack nor from defective tubes. Remedy: Check RF by-pass condenser, between rotor of tuning condenser which will be found to be open and is also the "B" load. Replace the condenser.

—From Zenith Service Hints

AIRLINE 62-376, 6-VOLT

A difficulty to which these sets are sometimes subject is that the reception seems to be chopped up or stuttering. At other times it seems to be a genuine case of "motor boating." The trouble is not in the filter condensers, as may sometimes be assumed, but in the vibrator. The points wear and make contact unevenly, giving the effects described above.

Submitted by Jim's Radio Shop.

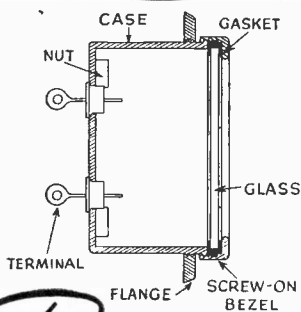
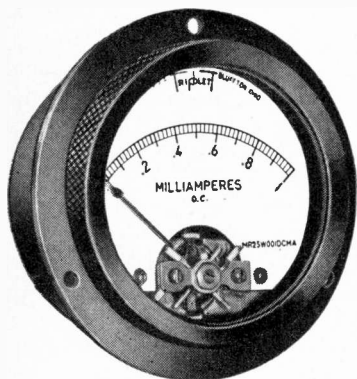

Introducing the
NEW TRIPLETT LINE
of
HERMETICALLY SEALED INSTRUMENTS

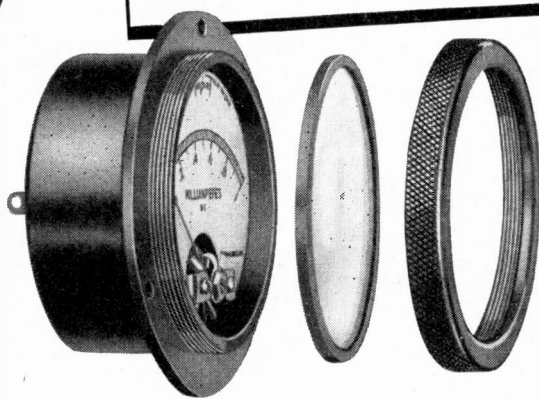

All the features of standard instruments retained. Withstand submersion tests at 30 feet. Comply with thermal shock, pressure and vibration tests. Resistant to corrosion. Conform to S. C. No. 71-3159 and A.W.S. C-39.2-1944 specifications. 1½", 2½" and 3½" metal cases with 1/16" thick walls, in standard ranges. D.C. moving coil, A.C. moving iron and thermocouple types. Write for circular.

Precision first
...to last

Triplet

ELECTRICAL INSTRUMENT CO. BLUFFTON, OHIO

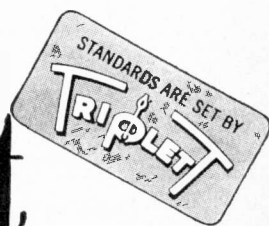

Radio Club Officers

At a recent meeting of its directors, The Radio Club of America, Inc., announced the reelection for the 1945 term of the same officers who served the previous year: President, F. A.

Klingenschmitt; Vice-President, O. James Morelock; Treasurer, Joseph Stantley; Corresponding Secretary, M. B. Sleeper; Recording Secretary, John H. Bose; Publicity Chairman, Austin C. Lescaboura.

In Trade

[from page 37]

Tubes and Parts

The Electronics Distributors Industry Advisory Committee convened with officials of the Radar-Radio Division of the WPB in Washington recently. The many problems that have confronted the parts jobber in recent months were placed on the agenda and through the efforts of the committee, were submitted for immediate and thorough consideration.

Tubes

In view of the continued shortage of radio receiving tubes, the WPB is making every effort to get all existing tubes into service and obtain the maximum volume of new tube production. To this end, the WPB with the cooperation of other bureaus of the government, is seeing to it that information as to surplus radio receiving tubes is made available to the manufacturers and distributors so that any actual surplus supplies may reach dealers and service men for civilian supply. There is no immediate prospect, however, that the civilian tube supply situation will improve materially; rather it is expected to remain about the same as in late 1944, approximately one and a half million tubes a month.

Regarding the availability of tubes and electronic equipment following the end of the European War, it was said that although certain military requirements may fall off, much of the electronic equipment used in Europe would either have to be tropicalized—made moisture and fungus proof—or replaced by new equipment for use in the Pacific theater. In either event, it would appear a continued burden will remain upon the manufacturers of military equipment.

Transformers

Transformers were reported as becoming critical again, due largely to increasing military demands, closer control by WPB is anticipated, although available production capacity is believed greater than military needs.

Most applications submitted to WPB for scheduling of transformers for civilian use have been approved, giving the delivery a fixed date. Methods were discussed for simplifying this scheduling procedure, such as a small order exemption on rated orders.

This latter suggestion, as presented by the Advisory Committee, seems to have found favor with the WPB offi-

[Continued on page 49]

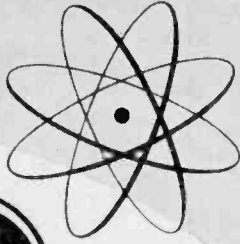

OSCILLOSCOPE CRO-3A

EVERY service man needs this portable oscilloscope for accurate and rapid service work on AM, FM and Television receivers. We list only a few of the many uses that make it indispensable in the modern service shop: study wave shapes and transients; measure modulation adjustment of transmitters; check receiver alignment; determine peak voltages; trace electronic tube characteristics. The CRO-3A gives a sharp, clear picture and is equipped with a screen for easy daylight viewing. Write today: *Electronics Department, General Electric, Schenectady 5, New York.*

Electronic Measuring Instruments

GENERAL ELECTRIC

177-D4

SPEED UP REPAIRS WITH THESE G-C AIDS!



FREE
STEEL
CABINET

G-C Dial Belt Kits

Exact replacement woven fabric belts. Easy to install — no stretching — no adjustments — a perfect fit every time. Kits come with 25, 50, 100, 200 or 300 belts.

Get This New FREE Dial Belt-Drive Cable and Cabinet Repair Guide!

Pocket size 68 page book contains thousands of listings, specifications — time saving service instructions. Invaluable to every radio man. Get a copy from your jobber. If he cannot supply you, write us.

Immediate delivery on G-C Belts and Cables



Order From Your Radio Parts Jobber
ALWAYS ASK FOR G-C PRODUCTS

GENERAL CEMENT MFG. CO.
ROCKFORD, ILLINOIS



Our G.I.'s

are more important
than our G's, our I's,
our GL's-or anything
else!

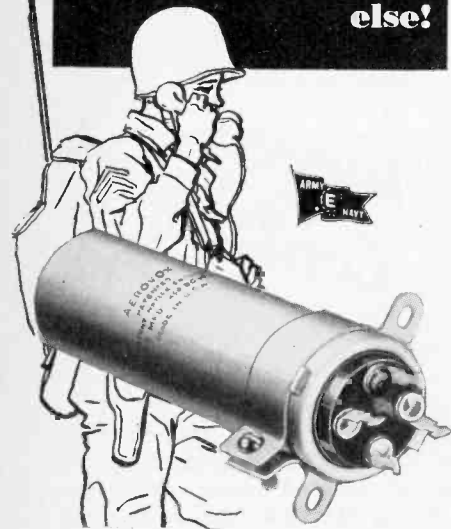

● You'll agree that's the best policy — when we say that "Our G.I.'s come first". Of course we'd like to supply you with those metal-can electrolytics you prefer for servicing and initial-equipment needs. But so long as our armed forces require every metal-can electrolytic we can produce, we'll just have to keep supplying our trade with cardboard-tube types which will at least see us through on the home radio front until victory is achieved.

● See our jobber . . .



AEROVOX CORP., NEW BEDFORD, MASS., U. S. A.

In Canada: AEROVOX CANADA LTD., HAMILTON, ONT.

Export: 13 E. 40 St., New York 16, N. Y. Cable: 'ARLAB'

FOR SALE Wholesale Radio Business

Established distributor representing major radio, parts, equipment & tube manufacturers. Trade area 100 mile radius. Virgin territory. Considerable mail order trade. Location: California.

Refer Radio Service Dealer. Box 94.

In Trade

[from page 48]

cial and if the Committee proposal is adopted, the obstacles arising from form 1682 will have been done away with.

Surplus

Lists of available excess or surplus electronic materials may be obtained at all WPB regional offices immediately upon publication each month. WPB, through its Component Recovery Section, desires to aid dealers and distributors in need of parts to fill rated orders. Materials in inventory after the expiration of a 45 day period become available for civilian supply. Any distributor may request release of excess material, and if not taken on rated orders in the 45 day period, release is usually approved.



Hot Jazz Albums

With the announcement that it will release at once a series of educational record albums in the field of hot jazz, Victor now takes a long-needed step forward in a movement to give jazz the stature which it deserves, helping

[Continued on page 51]

ADDRESS CHANGES—

Subscribers to RSD should notify our Circulation Dep't. at least 3 weeks in advance regarding any change in address. The Post Office Dep't. does not forward magazines sent to a wrong address unless you pay additional postage. We cannot duplicate copies of RSD sent to your old address.

RSD Circulation Dep't.

Cowan Publishing Co.

342 Madison Ave., New York 17, N. Y.

GET THIS CATALOG!



Mail Coupon for New CONCORD Radio Parts BUYING-GUIDE

Immediate shipment of radio parts and electronic equipment from CHICAGO or ATLANTA. Save time by ordering all your needs from ONE source. Many parts available without priorities.

CONCORD'S great, new 68-page Buying-Guide includes 1945 Revised Listings of standard lines of Condensers, Transformers, Resistors, Tubes, Test Equipment, Repair and Replacement Parts, Tools, and hundreds of other essential items. Page after page of top-quality radio and electronic parts, and a special 16 page Bargain Section offering hundreds of hard-to-get parts at important savings. Mail coupon now for your FREE copy.

ORDER FROM CHICAGO OR ATLANTA
CONCORD carries vast stocks. CONCORD ships to you at once from the nearest shipping warehouse, CHICAGO or ATLANTA. CONCORD invites you to consult our technical experts on special requirements. CONCORD can expedite any "essential" order and speed action. CONCORD now serves the United States Government, Institutions, Industry—and can serve YOU, whether you want one part or a hundred. Telephone, wire, or write your needs.

CONCORD RADIO CORPORATION

Lafayette Radio Corporation

CHICAGO 7, ILL. ATLANTA 3, GA.
901 W. Jackson Blvd. 265 Peachtree Street

CONCORD RADIO CORPORATION
901 W. Jackson Blvd., Dept. K-55
Chicago 7, Illinois
Please RUSH FREE copy of CONCORD'S new 68-page Buying-Guide and Revised Listings.

Name.....
Address.....
City..... State.....

PRODUCTS

[from page 46]

of fine music up to two hours in length can be played back with as high fidelity as that possible with present-day phonograph records, Mr. Young said, pointing out that his company looked upon the recorder as a supplement to records rather than a substitute.

Hard Solder Flux

The Special Chemicals Co. announces a flux suitable for all types of hard soldering, brazing and welding of a wide variety of ferrous and non-ferrous metals and alloys. Known as "Kwikflux", it can be worked with direct flame gas, hydrogen, acetylene and muffle (direct and indirect) and induction heating. This fluxing agent cleans and floats away from the metal surface any oxides and other foreign matter present during the soldering operation; acts as a solvent for the metal oxides formed by the action of the air; covers the brightened metal surface with a protective film to exclude air. The film washes off quickly and easily in hot water. For more information address the company at 30 Irving Place, New York 3, N. Y.

Low Cost Multitester

Announced for ready delivery by Omaha Radio Products Co., subject to priority rating certificate with order, Model MT-100 multitester is offered on a money back guarantee. It can be operated at either a 25 or 65 degree angle. Case is metal; it comes complete with internal battery, and with or without test leads. Range is up to 1000 volts d-c; 2000 volts a-c. Shunts and multipliers held to tolerances of plus or minus 2 per cent. For more information, address the company at 368 Saunders-Kennedy Bldg., Omaha 2, Nebr.



Tapped Controls

★ Clarostat standard tapped controls, Series TCP, permit replacement of tapped units with the assurance that the total resistance value and tap satisfactorily match the original.

Twelve selected values, in resistance ranges from 250,000 ohms to 2 megohms. One or two taps. These standard units are listed in the Clarostat Interim Line (essential wartime servicing items). These controls are equipped with the original Ad-A-Switch feature. List price \$1.50.

★ See Our Jobber!



CLAROSTAT MFG. CO., Inc. • 285-7 N. 6th St., Brooklyn, N. Y.

DESIGN

Counts

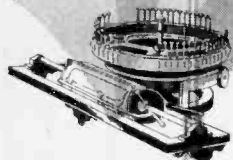

One of the first typewriters developed was that of Thurber in 1843. Then clumsy and slow, it has been brought to its present high level of efficiency and speed by careful application of design.

Here at THE WARD PRODUCTS CORPORATION Design Counts, also; because, it is only through superior design that the benefits of experience and the finest production facilities can best be brought to the user. For the finest antennas for all applications . . . for home and automobile use . . . look to WARD.

WARD

Antennas

BUY WAR BONDS

BACK AGAIN . . . SOON
WARD AERIALS

"World's Finest for Car & Home"

THE WARD PRODUCTS CORPORATION
1523 EAST 45TH STREET • CLEVELAND 3, OHIO

**YOUR NEW FREE CATALOG
IS READY FOR YOU!**

Radionic's Catalog No. 26 lists hard-to-get radio parts! • Helps you fill your radio and electronic needs. • All parts are available for immediate shipment • All are highest quality. • All are exceptional values.

SEND TODAY FOR YOUR
FREE COPY TO RSD 5

**RADIONIC EQUIPMENT CO.,
"CHANCELLOR" PRODUCTS
170 NASSAU STREET, NEW YORK 7, N. Y.**

\$1.00 PAID FOR SHOP NOTES

Write up any "kinks" or "tricks-of-the-trade" in radio servicing that you have discovered. We will pay \$1 in War Stamps for such previously unpublished "SHOP NOTES" found acceptable. Send your data to "Shop Notes Editor," RADIO SERVICE DEALER, 342 Madison Ave., New York 17, N. Y. Unused manuscripts cannot be returned unless accompanied by stamped and addressed return envelope.

DEALERS

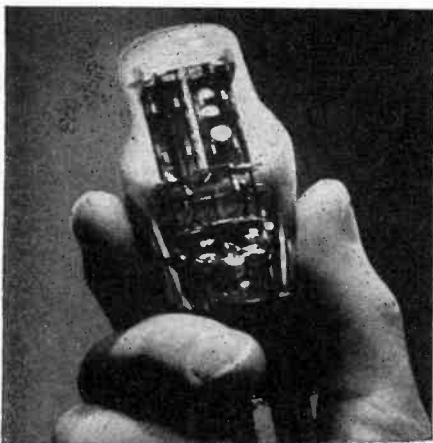

STOP! don't
throw it away!

Let **RTS** reprocess
your dead

RADIO TUBES

NEW Scientific Process

**REACTIVATES THORIUM
CONNECTS OPEN FILAMENTS
CLEARS SHORTS and
MICROPHONICS**

(NOT the old "flash" trick)

MINIMUM ORDER 6 TUBES

SEND NO
CASH **50¢**
C. O. D. ONLY

Prices approved
by O.P.A.
1 volt & 3-Q5
\$1.00

30-Day Guarantee

Every tube fully tested in
checkers & sets before playing

Send itemized list with order

Make sure glass, base & prongs are intact... flashed, exploded or open cathodes **REJECTED** and **NOT RETURNED**

RTS RADIO TUBE SERVICE CO. INC.

6805 20th Avenue, Brooklyn 4, N.Y.

In Trade

[from page 49]

to increase dealer sales. Starting with six albums, Victor is presenting prominent jazz exponents in outstanding recordings of their work which represent the better qualities of the art form, as interpreted by each.

The first six album sets, each of which has a striking, colorful picture cover, are devoted to work by Louis Armstrong's Orchestra, McKenney's Cotton Pickers, Jelly Roll Morton's piano and orchestra, Benny Goodman's trio and quartet, Lionel Hampton's orchestra, and the Quintet of the Hot Club of France, six groups which represent probably as many different phases of jazz.

Stromberg-Carlson Changes

In a program of company-wide expansion, Wesley M. Angle, president of the Stromberg-Carlson Company from 1934 through the war years, is chairman of the board of directors. Dr. Ray H. Manson, former executive vice-president and general manager, is president, succeeding Mr. Angle. Lee McCanne, previously secretary and assistant general manager, is vice-president and general manager.

Universal Appoints

Cecil L. Sly, vice president and sales manager for Universal Microphone Co., becomes Director of Sales, a newly created post.

Dee Breen resigns as western division sales manager of the El Monte, Cal., plant of Littlefuse, Inc., to become sales manager for Universal.

United Transformer

Under the major expansion program at the United Transformer Corporation, 150 Varick St., New York 13, N. Y., Samuel L. Baraf has taken over the merchandising activities as director of sales and merchandising. Simultaneously, Ben Miller joined as general sales manager.

G.E. Appoints

D. C. Spooner, manager of the automatic blanket and sunlamp division, announces appointment of E. H. Norling as sales manager of the sunlamp and heater section of General Electric.

Norling joined G.E. in 1927 in the advertising and sales promotion division of the electrical refrigeration department. He prepared the first retail sales training courses for domestic, apartment house and commercial refrigerator salesmen with a total enrollment of about 25,000.

THE SPEED TESTER

SUPREME

MODEL 592

★ 25,000 OHMS PER VOLT



★ PUSH BUTTON OPERATED

- ★ Design proven by over 5 years production
- ★ Dual D.C. Sensitivity—25,000 ohms per volt and 1000 ohms per volt
- ★ Matched resistors of 1% accuracy
- ★ Push button operated—no roaming test leads
- ★ Open face—wide scale 4 1/4" meter. 40 microamperes sensitivity
- ★ 1 Microampere first scale division

SPECIFICATIONS

D.C. MICROAMPERES:
0-70-700 microamperes
D.C. MILLIAMMETER:
0-7-35-140-350 milliamperes
D.C. AMMETER
0-1-14 amperes
D.C. VOLTS, 25,000 OHMS PER VOLT:
0-3-5-7-35-140-350-700-1400 volts
D.C. VOLTS, 1000 OHMS PER VOLT:
0-3-5-7-35-140-350-700-1400 volts
A.C. VOLTS, 1000 OHMS PER VOLT:
0-7-35-140-350-700-1400 volts
OUTPUT VOLTMETER:
0-7-35-140-350-700-1400 volts
DECIBEL METER:
0 db to plus 46 db
OHMMETER:
0-500-5000-50 000-500,000 OHMS
0-5-50 MEGOHMS
POWER SUPPLY
Battery Operated

With the above specifications the Supreme Model 592 Speed Tester meets today's requirements for general laboratory use, assembly line tests and inspection, radio and other electronic repair and maintenance.

SUPREME

SUPREME INSTRUMENTS CORP.
Greenwood, Miss., U.S.A.

RADOLEK

Radio-Electronic Service Parts

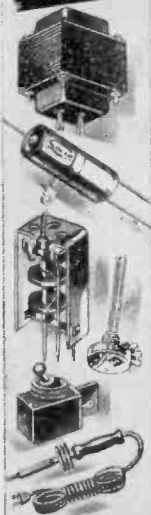

Large stocks assure the finest and most complete selections of all available items at lowest prevailing prices. Thousands of active buyers depend on us for their entire Radio repair and replacement requirements. Because we understand service problems, every order is expedited for delivery in double quick time. Everything we do is planned for convenience and satisfaction to our customers. You will find it profitable to make Radolek your buying headquarters.

FREE BUYING GUIDES

Because of existing conditions we keep our customers right up to the minute on available merchandise by releasing supplements frequently instead of sending our regular Big Profit Guide once a year. Send the coupon now to get these Free Buying Guide Supplements as they are issued.



FAST SERVICE!

RADOLEK CO., Dept. R-102
601 W. Randolph St., Chicago 6, Ill.
Please send FREE Buying Guide Supplements

NAME.....
ADDRESS.....

ORDER FROM RADOLEK

Ad Index

Aerovox Corporation	49
Agency: Austin Lescaboura & Staff	
American Condenser Co.	44
Agency: Michael F. Mayger	
American Phenolic Corp.	38
Agency: Evans Associates, Inc.	
Bakersfield Radio Supply	49
Burgess Battery Company	12
Agency: Howard H. Monk and Associates	
Burstein-Applebee Co.	52
Agency: Frank E. Whalen Co.	
Cinaudograph Speakers, Inc.	44
Agency: Michael F. Mayger	
Clarostat Mfg. Co.	50
Agency: Austin Lescaboura & Staff	
Concord Radio Corp.	49
Agency: E. H. Brown Adv.	
Cornish Wire Company	14
Agency: Hart Lehman Advtg.	
Eastern Amplifier Corp.	33
Agency: Roberts & Reimers, Inc.	
Electro-Voice Mfg. Co.	42
Agency: Shappe-Wilkes, Inc.	
General Cement Mfg. Co.	48
Agency: Turner Advertising Agency	
General Electric Co.	48
Agency: Maxon, Inc.	
Halldorson Co., The	46
Agency: Sander Rodkin Adv. Agency	
Halicrafters Co., The	6
Agency: Burton Browne, Adv.	
Hytron Corp.	11
Agency: Henry A. London Adv.	
J. F. D. Manufacturing Co.	46
Agency: Mitchell Advertising Agency	
Ken-Rad	43
Agency: Maxon, Inc.	
Mallory & Co., Inc., P. R.	2nd Cover, 16
Agency: Aitkin-Kynett Co.	
Marion Electrical Instrument Co.	9
Agency: Shappe-Wilkes, Inc.	
McElroy Mfg. Corp.	52
Agency: Shappe-Wilkes, Inc.	
Meissner Mfg. Co.	2
Agency: Gardner Advertising Co.	
Murray Hill Books, Inc.	37
Agency: The Harry P. Bridge Co.	
National Union Radio Corp.	15
Agency: Hutchins Adv. Co.	
Noblitt-Sparks Industries, Inc.	5
Agency: Sidener & Van Riper	
Olson Radio Warehouse	52
Agency: Jessop Advertising Co.	
Racon Electric Co.	45
Agency: Leon Allen Advertising	
Radio Corporation of America	7
Agency: Kenyon & Eckhardt, Inc.	
Radio Tube Service Co.	51
Agency: Daniel de Koven Advtg.	
Radio Wire Television, Inc.	3
Agency: Diamond Seidman Company	
Radionic Equipment Co.	50
Agency: Hirshon-Garfield, Inc.	
Radolek Company	52
Agency: Turner Advertising Agency	
Raytheon Manufacturing Corp.	4th Cover
Agency: Burton Browne Adv.	
Rider, John F.	40
Agency: Lansford F. King Advtg.	
Sheffield Radio Co.	52
Agency: Sander Rodkin Adv. Agency	
Simpson Electric Co.	39
Agency: Kreicker & Meloan, Inc.	
Spainhower, Frank	52
Sparks-Withington Co., The	1
Agency: Brooke, Smith, French & Dorrance, Inc.	
Sprague Products Co.	35
Agency: The Harry P. Bridge Co.	
Standard Transformer Corp.	12
Agency: Burnet-Kuhn Adv. Co.	
Stromberg-Carlson Co.	3rd Cover
Agency: McCann-Erickson, Inc.	
Supreme Instruments Corp.	51
Agency: O'Callaghan Adv. Agency, Inc.	
Sylvania Electric Products, Inc.	13, 41
Agency: Newell-Emmett Co.	
Triplett Electrical Instru. Co.	47
Agency: Western Adv. Agency, Inc.	
Universal Microphone Co.	4
Agency: Ralph L. Power, Advtg.	
Valley Radio	52
Ward Products Corp.	50
Agency: Burton Browne Adv.	

NATION-WIDE
MAIL ORDER
DISTRIBUTORS
SINCE 1928



**RADIO AND
ELECTRONIC
DEVICES**

For...
**TRADE... INDUSTRY...
COMMUNICATION...
PUBLIC UTILITY...
VOCATIONAL AND
EXPERIMENTAL
APPLICATIONS**

BURSTEIN-APPLEBEE CO.
1012-14 MCGEE ST.
KANSAS CITY 6, MISSOURI

**RADIO
Wholesale
REPAIR**

THIS IS THE ANSWER
TO YOUR RADIO REPAIR TROUBLES!

Just SEND us the SET via Railway Express.
We REPAIR and RETURN. You ADD MARK-
UP AND DELIVER. That's all there is to it.

- Complete Stocks—We can fix 'em all
- 90 day guarantee
- Prompt service
- OUR LOW PRICES mean more Markup for you.

Send that set to
SHEFFIELD RADIO CO.
914 Belmont Ave. Chicago 14, Ill.

RECORDING DISCS
Aluminum, Cardboard & Glass Discs,
All Sizes. Professional Quality.
Immediate Delivery
Send For Price List
VALLEY RADIO
867 Broad St.
Central Falls, R. I.

● **Ted McElroy**
World's Largest Manufacturer of
Wireless Telegraphic Apparatus
COMPLETE CENTRAL OFFICE EQUIPMENT
McElroy Manufacturing Corp.
82 Brookline Avenue • Boston, Massachusetts

FOR SALE

1 — RCA Signal Generator, Model No. 150.
\$40.00 and
1 — RCA 2" Scope, Model No. 151-2
\$45.00 or
Both \$80.00. Both in A-1 Condition.
FRANK SPAINHOWER — Box 1239
843 E. Heidt St., Sheridan, Wyo.

OLSON Radio Warehouse
CABINET CHART



Showing 47 popular models

A big Wall Chart of
radio and phonograph cabinets,
to hang in your shop for reference. Forty-
seven clear photos of high
quality cabinets that are
quickly available from
Olson Radio Warehouse.
Handy order blanks
included with Chart.

10¢
MAIL
TODAY

Olson Radio Warehouse
73-B Mill St., Akron, Ohio

I enclose ten cents in coin. Please send me the
Wall Chart of radio and phonograph cabinets.

NAME.....
ADDRESS.....

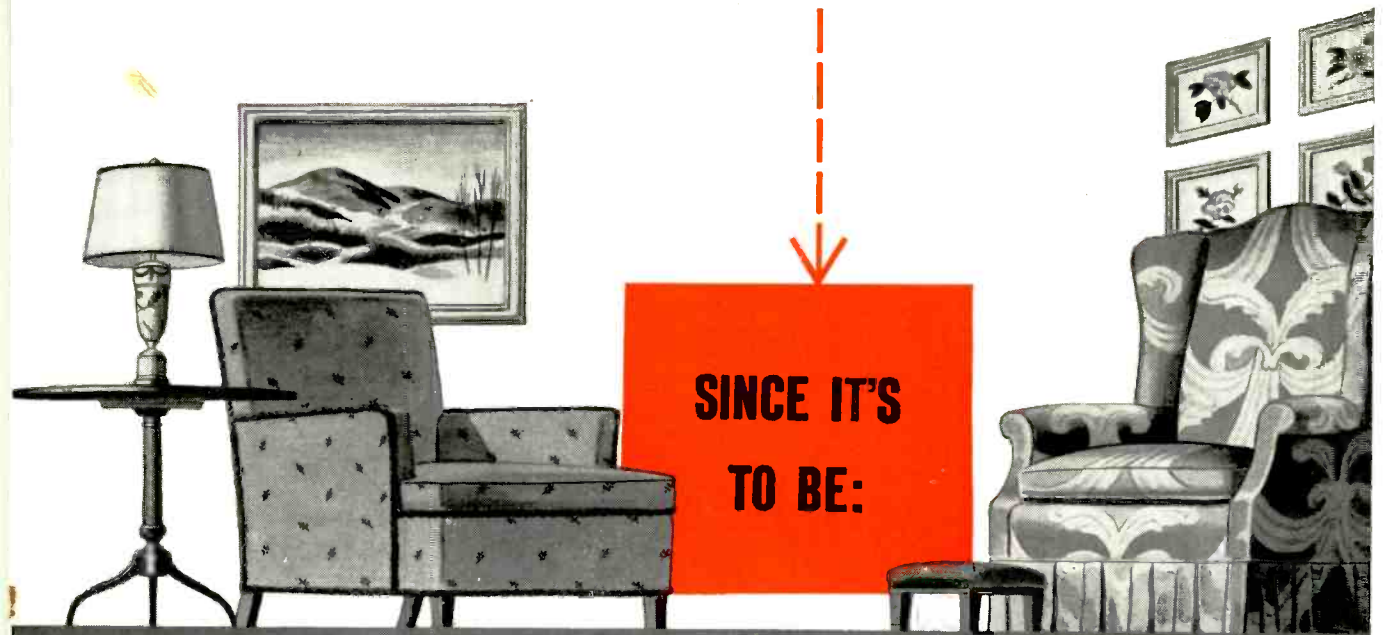

**SINCE IT'S
TO BE:**

“STROMBERG-CARLSON FOR THE MAIN RADIO IN
YOUR CUSTOMER'S HOME”

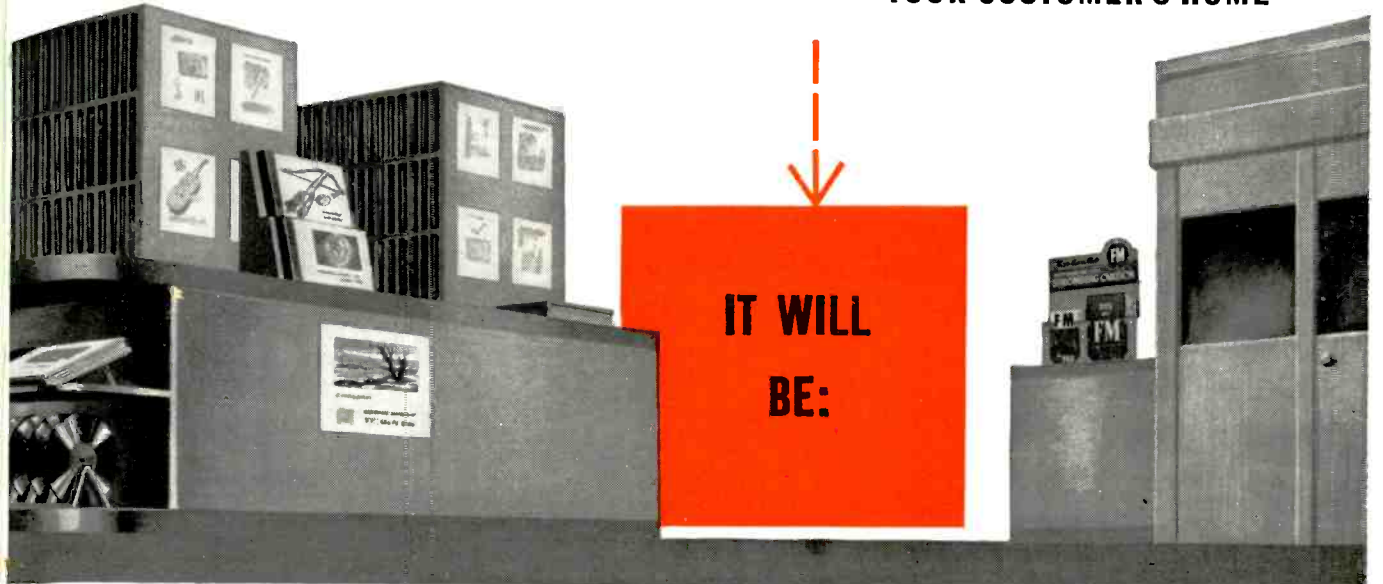

**IT WILL
BE:**

“STROMBERG-CARLSON FOR THE MAIN RADIO LINE
IN YOUR SHOWROOM”

The thought that the main radio in any home should be as fine a radio as its purchaser can buy — a Stromberg-Carlson — is being carried to the radio-purchasing public by over 475,000,000 impressions in thirteen leading magazines. Turn this potent merchandising effort to your own direct service by becoming an authorized Stromberg-Carlson dealer under the very favorable Franchise Agreements now being offered. Get in touch with your local distributor or write us at once. For Stromberg-Carlson is:

— *the important radio unit — the radio unit carrying real profit opportunity — the radio unit with easy-selling public acceptance.*

By becoming an Authorized Dealer now, you can organize your post-war business around the Stromberg-Carlson “main radio,” a consistent profit maker — whether in an outstanding table model, console, or radio-phonograph combination.

STROMBERG-CARLSON ... ROCHESTER 3, NEW YORK
RADIOS... TELEVISION... TELEPHONES
AND SOUND EQUIPMENT

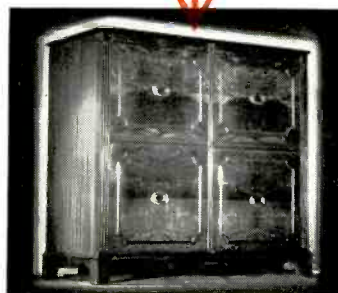



Feast your eyes on this mighty, 100-passenger airliner! When peace comes, a giant fleet of its sister ships will girdle the globe for Pan American World Airways. And in each of them will be the best electronic devices to come out of the war, equipped with famous Raytheon high-fidelity tubes!

Raytheon tubes have been used for years by Pan American, and it is because of their proven performance, fine reception and complete dependability that they were selected to play such a vital role in this great company's future operations. The assignment is but one of hundreds of postwar applications for which Raytheon tubes have been specified by America's radio and electronic industries.

When tubes are more readily available for civilian use, Raytheon will offer radio service dealers the *finest* tubes in its history . . . tubes combining long prewar experience with outstanding wartime development. And that's not all. They'll be backed by a Raytheon merchandising program that will be the most *beneficial* ever offered you. Keep your eye on Raytheon . . . for greater postwar profits!

Increased turnover and profits . . . easier stock control . . . better tubes at lower inventory cost . . . these are benefits which you may enjoy as a result of the Raytheon standardized tube program, which is part of our continued planning for the future.



Raytheon Manufacturing Company

RADIO RECEIVING TUBE DIVISION

Newton, Mass. • Los Angeles • New York • Chicago • Atlanta

RAYTHEON

High Fidelity

ELECTRONIC AND RADIO TUBES



All Four Divisions Have Been Awarded Army-Navy "E" With Stars

