

Radio
**SERVICE
DEALER**



Official U. S. Signal Corps Photo. See Page 1

\$2 PER YEAR

JUNE 1943

RADIO-ELECTRONIC MAINTENANCE

Will You Pinch Hit

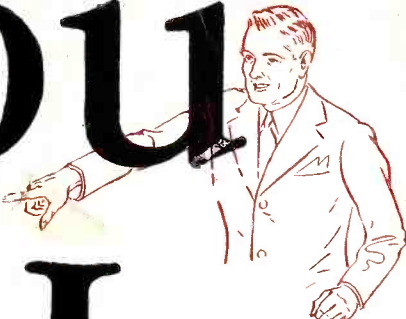

It is getting hard in many communities to service home radio sets properly in order to "keep 'em listening."

The shortage of radio service engineers is acute—the military forces have priority on radio technical skill.

But, those of you who remain on the home front have the chance of a lifetime to render important service to your community. Make a list of the names of all the "old timers" you can remember. See and talk to each one. Chances are they're still radio "bugs" and will be willing and anxious to help if told of the need that exists.

Organize a service club in your community . . . see to it that every bit of existing knowledge is put to work. We will help you. Now is the time to pinch hit to "keep 'em listening." Will you do your part?

P. R. MALLORY & CO., Inc., INDIANAPOLIS, INDIANA

P. R. MALLORY & CO. Inc.
MALLORY



Approved Precision Products

Radio SERVICE-DEALER

SOUNDMAN AND JOBBER

Reg. U. S. Pat. Off.

Vol. 4, No. 6 ★ June, 1943



Editor & Publisher
SANFORD R. COWAN

Advisory Editor
M. L. MUHLEMAN

Contributing Editors

JOHN H. POTTS **JOHN F. RIDER**
"On Leave" Major
U. S. Sig. Corps

Circulation Manager
R. ALAN



Executive & Editorial Offices
132 West 43rd St., New York

Ad Index

Aerovox Corporation	30
Paper Tubular Condensers	
Anchor Radio Distrib. Service Co.	30
Radio Parts—Accessories	
Centralab	25
Parts	
Clarostat Mfg. Co., Inc.	31
Controls & Resistors	
General Electric Co.	3
Consumer Acceptance	
International Resistance Co.	9
Potential New Markets	
Ken-Rad Tube & Lamp Corp.	27
Radio Tubes	
Lafayette Radio Corp.	25
Replacement Parts, Kits & Books	
Mallory & Co., Inc., P. R., 2nd Cover	
Service Club Plan	
Meissner Mfg. Co.	12
Radio Training Kits	
Ohmite Mfg. Co.	28
Resistors	
Racon Electric Co.	4
Horns, Trumpets & Speakers	
Radio & Technical Pub. Co.	11
New Troubleshooters Handbook	
Raytheon Production Corp.	4th Cover
In Fever Machines	
RCA Mfg. Co., Inc.	3rd Cover
Cathode Ray Tubes	
Sprague Products Co.	7
"Trading-Post" & Condensers	
Standard Transformer Corp.	31
Replacement Transformers	
Sylvania Electric Products, Inc.	26
Technical Manual on Tubes	
Triplett Elec. Co.	31
Combat Line Instruments	
Universal Microphone Co., Ltd.	30
Plugs & Jacks	
U. S. Treasury Dep't.	24
This Year's Bonds	

Contents

Editorial	2
To Be Or Not To Be—"Susfu"— "Victory" Lines OK'd	
Trouble-Shooting Short-Cuts	5
By John H. Potts	
Superheterodyne Receivers, Part 2	8
By Oscar E. Carlson	
Technical Service Portfolio—XXXI	13
Electrolytic Condensers	
Battery Production & "MR" Tubes	18
By San D'Arcy	
Signal Corps Training Kits	19
By J. P. Hollister	
Servicing Facilitated By L-265 Order	25
By Charles Golenpaul	
A Hint About Your Signal Tracer	25
By Robert Boudreaux	

Cover Picture

(OFFICIAL U. S. SIGNAL CORPS
PHOTO)

At Signal Radio Repair Shops all types of radio and radar (meaning "radio detection and ranging") apparatus is serviced by especially trained men, many of whom were recently civilian radio servicemen.

Military restrictions prohibit describing the circuits of radar and communications equipment. Suffice to say, such units are totally unlike commercial radio sets or transmitters in design, type of component, etc.

Any trained radioman seeking a commission in the Signal Service should apply at his nearest induction center or write to his Selective Service Board for particulars.

Entire Contents Copyright 1943 by Cowan Publishing Corp.

All rights reserved—no part of this magazine may be reproduced in any form, by any means, or translated into foreign languages without permission in writing from the publisher.

RADIO SERVICE DEALER, published monthly at 34 N. Crystal Street, East Stroudsburg, Pa., by the Cowan Publishing Corp., Executive and Editorial Offices at 132 W. 43rd Street, New York, N. Y. Subscription rates—United States and Possessions, \$2.00 for 1 year, \$3.00 for 2 years; elsewhere \$3.00 per year. Single copies 25c. Printed in U.S.A. Entered as Second Class Matter October 3, 1941, at the Post Office at East Stroudsburg, Pa., under the Act of March 3, 1879.

editorial

FLASH—VICTORY LINES OK'D—

● We can't give you details as the presses are rolling. This much we do know—that WPB has amended its order L-63 and now a line of "Victory" Transformers and Condensers should start in production. More next month.

TO BE OR NOT TO BE—

● Leading radio-electronic-radionic manufacturers are working on war orders to capacity yet each is giving much thought to the Postwar Era. The wide divergence of opinion amongst top manufacturers, regarding radio's future, warrants much consideration on the part of jobbers and service-dealers, for their destinies are positively controlled by the policies of manufacturers.

One faction in radio now feels that immediately following cessation of hostilities manufacturers will revert to pre-war merchandising policies. Under this setup, sets at first will resemble small 1941 models in style, price and production volume. Then will come the deluge of F-M and Television receivers, along with consoles and record-players. We'll be back in the old groove, feels this faction, and the life of service-dealers will be complacent, because at first they'll be dealers primarily engaged in selling sets to a set-starved market. Later, service-dealers will be busy keeping 'em perking.

Another faction believes that after the war some top manufacturers will want to control their products and markets right down the line—having their own exclusive Distributors, Dealers and Super-Service Stations. Under such a setup, believes this particular faction, the independent parts jobber and servicing organization will be frozen out of existence.

Still another faction believes that after the war the radio industry will be split into two or three semi-interlocking competitive groups whereby certain top manufacturers will set their caps for the ultra-swank radio console—F-M—Television market, leaving the dregs of midgets and portables to the small-fry set producers to whom large volume and low price means everything. And at the same time, this particular faction feels that the big-shots will go after the industrial-control fields with vengeance to skim the cream off the while lush profits may be had. On this basis, feels this group, we are headed into an age of industrial-control—an era in which radio servicemen will be forced to sell and service cheap sets only or else get on the payroll of a plant that uses many electronic devices, in the capacity of electrical-electronic maintenancemen.

We believe that a happy combination of all factional opinions will eventuate. We feel that indus-

trial-control by means of radio frequency apparatus is a certainty of the future—and such equipment will need maintenance staffs. We disagree with a manufacturer who believes that television has been oversold and the public bilked. Progress cannot be stopped. Television represents a form of progress in the art of entertainment and communications. It must come, and will come, unless something better is born to take its place. We believe that the Super-Service Station and exclusive distribution planning system must fail. It didn't work for the automotive industry. Even Ford broadcasts daily, "bring any make of car to our shops and we'll help you keep 'em rolling." Besides, no one will buy a set if he knows that he is entirely dependent upon one source of supply for its future continuance in operation.

The jobber has his work cut out for him. He must refrain from competing with his customers. If forced to add to his income during the emergency it is logical that he should service sets, on a wholesale basis, for service-dealers who are swamped. In the Postwar Era let the jobber look to allied-to-radio markets and go into selling public address or electronic control systems. He's a natural for the coming industrial markets. Lastly, we feel that a deluge of trained radiomen will come from the armed services prepared to take their old place in the scheme of things. Then there will be competitive scrambles in which ability above all will be the decisive factor. The coming industrial era will see countless radio-electronic-radionic installations requiring constant adjustments and repairs. As we see it, there will be no period of depression or recession for competent, technically trained service-dealers in our time.

SUSFU

● A very polite definition of this old radio term is "*Situation Unchanged, Still Fouled Up.*" And Susfu eloquently describes the present state of the radio-electronic maintenance field.

Our May issue editorial "Misleading Statements By WPB" brought many comments from retailers, servicemen and jobbers. Without exception it was the consensus that if WPB cannot find a way to get replacement tubes into civilian radios at least WPB should not becloud the issue by releasing dual-meaning blurbs.

Addressing the R.M.A. Service Managers Committee on June 10th in Chicago, Mr. Frank H. McIntosh of WPB explained that Order L-265 had been amended and that after July 1st all tubes made from materials allocated to civilian production will be stamped "MR"—meaning *Maintenance and Repair*, not *Military Reject*. Such "MR" tubes delivered to jobbers are restricted and can only be sold to civilians, radio service-dealers or others who do not possess a military or high priority rating. WPB deserves commendation for taking this step on behalf of "ordinary guys" like servicemen and set owners. But, don't get too optimistic, for there is a dark side to the picture. There is no assurance that tube manufacturers will ever produce any "MR" tubes. The story is covered elsewhere in this issue under the caption, "*Battery Production & MR Tubes.*" By all means read it.

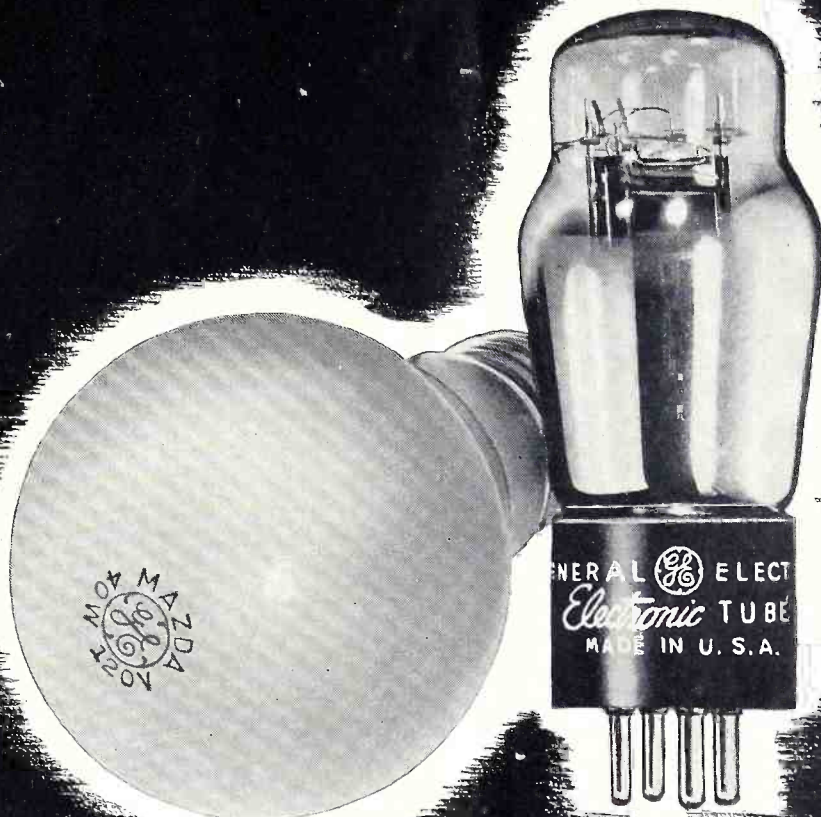

G-E Mazda Lamp . . . G-E Electronic Tube ON EACH THE G-E SYMBOL MEANS CONSUMER ACCEPTANCE

An "old friend" in practically every electrified home in the land is the G-E Mazda Lamp. People rely on it as they do on their telephones, and for much the same reason. It is dependable and efficient.

General Electric's aim is to make G-E Electronic Tubes for home receivers — FM, AM, television — just as widely relied upon by America as the lamp bulbs that bear the famous G-E symbol.

To bring this about and to pre-sell the vast replacement market that will be waiting for your tube service after the war, G.E. is conducting a powerful four-color advertising campaign in the nation's big-circulation magazines.

A current advertisement of this campaign is illustrated at the right. Like all

of the series, it draws special attention to G-E Electronic Tubes. General Electric leadership in electronics, built up through years of experiments with and improvements upon electronic products, is your assurance of the engineering excellence of these tubes, outstanding products of the famous G-E Electronic Research Laboratory.

When peace is restored, G-E Electronic Tubes will be your fast-moving stock, thanks to constant forceful advertising and promotion aids that are pre-selling your peacetime customers right now! . . . *Electronics Department, General Electric, Schenectady, N. Y.*

• On Sunday night listen to the General Electric Mazda Lamp program over N. B. C. See local newspapers for time and station.



This advertisement appears in:

Collier's	May 22, 1943
The Saturday Evening Post	May 29, 1943
Fortune	June, 1943
Country Gentleman	June, 1943
Look	June 1, 1943
Life	June 14, 1943

GENERAL ELECTRIC



Official Photo by U. S. Signal Corps;
courtesy of Douglas Aircraft Co.

On The B-19

★ A RACON Marine Horn Speaker is used in the cabin of the world's largest bomber, the B-19. Approved by the Bureau of Marine Inspection and Navigation, Department of Commerce, these units are also to be found aboard U. S. Navy and Army Vessels. Weatherproof and Stormproof RACON Acoustic Material, plus superior engineering design, are reasons why many types of RACON Horns are used by all branches of the Military Services. Shipyards, war factories, air bases and training camps that use public-address systems can select just the type of speaker needed from the complete line made by RACON.

The quality, efficiency and dependability of RACONs have long been recognized. There's nothing finer. RACONs deliver more energy per watt input. Because of RACON's exclusive Stormproof, Weatherproof, Acoustic Material the elements cannot affect RACON's efficient operation. Use RACONs when planning your next installation. Inquiries are invited—perhaps we can help you in some phase of the war effort. Ask for our free catalog, too.

RACON ELECTRIC CO., 52 East 19th St., New York, N. Y.

RACON

RACON Speakers Used By The U. S. Military



P-M
HORN
UNIT

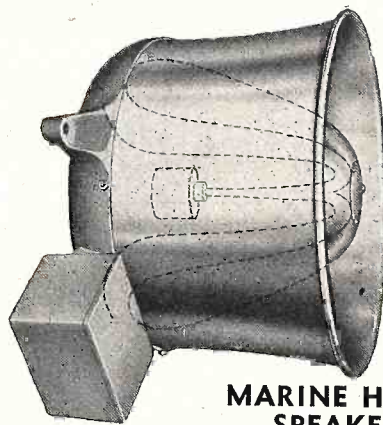

MARINE HORN
SPEAKER

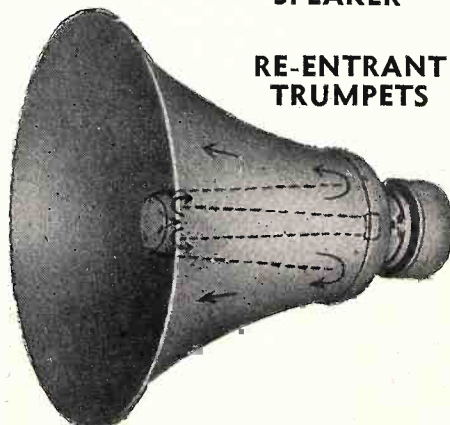

RE-ENTRANT
TRUMPETS

Here are but two of the many RACON Speakers and one of the many P-M Horn Units. The Marine Horn Speaker is of the re-entrant type, for marine and general p-a applications. Available in several sizes, from 5 to 50 watts, they may be used as loudspeaker or as microphone. (Approved by the Bur. of Marine Inspection, Dep't of Commerce.) RACON Re-entrant Trumpets occupy small space but afford a long horn that carries highly concentrated sound efficiently over long distances. Several sizes available.

TROUBLE-SHOOTING SHORT-CUTS

by

John H. Potts

THE speed with which an experienced radio serviceman can often localize receiver defects is frequently a source of wonderment, not only to beginners in the field but also to trained radio engineers. Often the latter do not think of possible causes which are encountered in the field because such troubles are seldom experienced in laboratory work. Speed in trouble-shooting is not secured by sticking to any particular system of localizing defects, but rather to a combination of all systems, aided and abetted by a plentiful supply of common sense. As in everything else, the method to follow is that which gives the desired results with the least possible expenditure of time and effort, and through experience, a good serviceman almost intuitively follows the proper procedure. In this article we want to show how it is often possible to accomplish a lot in a very short time by taking advantage of short-cuts. No doubt you are already using many such ideas in your own work, but some, we feel certain, will be new to most of us and all will help those who more recently entered the service field.

The first step in trouble-shooting should invariably be an analysis of possible causes based on the complaint. Manifestly it requires no truckload of equipment to determine what's wrong with a radio when the customer complains that the "part which makes it loud and soft" makes a noise when turned, or when we learn that an odor "like burning tar" emanates from the receiver. We know, even before we see the set, that in one case a new volume control is going to be required and in the other, that there is something very, very wrong with the power transformer. And we find out that the customer who insists that all the tubes are burned out because they don't light when the set is switched on is almost never right. If it's an a-c/d-c set, we'll check first the linecord resistor, if one is used, and the power switch. In every case, we check first the most likely cause, based on analysis or experience, then we proceed to look for other possible causes in the order of their probability.

Inoperative Sets

Let's suppose that the set is inoperative. Usually the customer will tell us whether or not the tubes get warm when the power switch is turned on. If they don't, then the first steps necessary are to determine whether or not power is getting to the set. Many servicemen save time

at this point by plugging a tube checker—using a double plug—into the same wall receptacle in which the receiver was plugged, inserting the receiver plug into the double plug. Snapping on the switch of the tube checker tells us immediately whether or not power is available at the receptacle and at the same time we are all set to check the tubes, a necessary operation no matter what the cause of receiver failure if we are to be able to give an intelligent estimate regarding the cost of the repairs.

Short-circuits usually cause heat, especially, in circuits where power is normally carried. Thus a touch of the finger on the case of a power

transformer will often tell whether lack of operation is due to a short or an open circuit. There is usually a slight trace of hum present in all receivers; listening for this hum gives a quick indication of the presence or lack of power in the receiver, when the speaker is OK.

If power is present and there is no quick, obvious indication of the cause of the trouble, it's a good idea to check the rectifier tube with the tube checker. Before replacing the tube in its socket, check the resistance from the cathode or filament socket terminal in the set to ground. If a short circuit or abnormally low resistance to ground is indicated, the

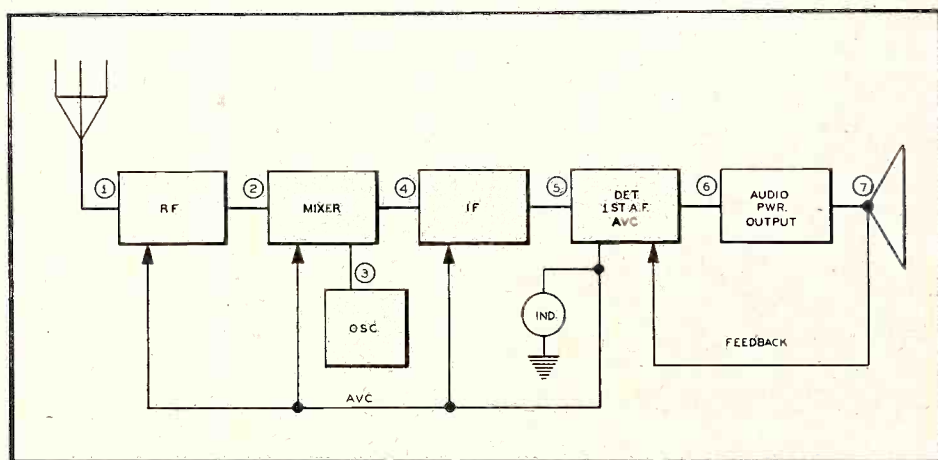

Fig. 1. Trouble-shooting is simplified by first localizing the trouble in a major section of the receiver. Such sections are shown numbered in the order of test by the signal tracing method.

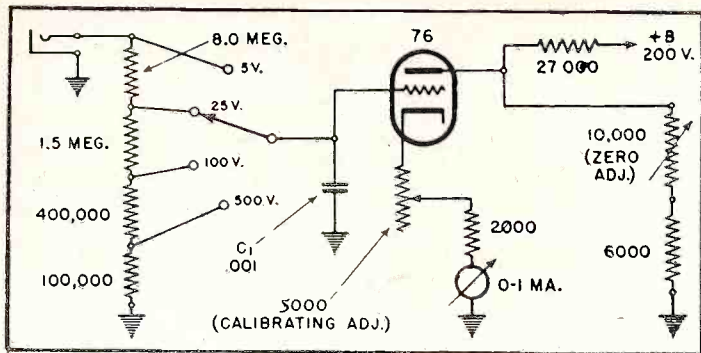

Fig. 2. Diagram of a typical electronic voltmeter such as used in conjunction with signal-tracing equipment.

rectifier tube should not be replaced and further trouble-shooting should follow without attempting to operate the receiver. If an open circuit is indicated—which would be normal if there were no bleeder or voltage divider circuits across the B supply—the tube may be replaced and tests continued. *Never replace a blown 25Z5 without making this test.*

If accessible, the grid cap may be momentarily disconnected from the detector-first a-f tube; this should result in a loud hum in the speaker, which will serve to show that the audio section of the receiver is operative. With the volume control set to maximum, thereby increasing the background noise level, touching the finger to the mixer grid should cause an increase in noise if the i-f and mixer sections are working. If there is still no evidence of a signal, we would first suspect the oscillator—or the oscillator section of a converter, if no separate oscillator is used.

Checking Oscillation

To check the oscillator, we measure the voltage from the oscillator grid to ground. If the oscillator is functioning, a negative voltage will be developed across the oscillator grid leak; if not, then the circuit is dead.

What is the most likely cause of failure to oscillate? Generally a defective tube, and as our tube checker is already hooked up, we can check the tube first. If the tube checks OK, and proper voltages are present in the set, we will want to take a look at the oscillator tuning condenser, particularly if we are dealing with a midget receiver—often the rotor plates become shorted to the stator, especially if the set is dropped or knocked over. Then we'd check to see if the padder or trimmer were shorted. If the weather had been damp for a prolonged period, we'd be inclined to suspect poor impregnation in the coil. Next, we would look into the corrections at the coil terminals, at the socket, etc. We would reserve for the last checking of fixed mica condensers—seldom does anything happen to them.

In many instances troubles may be accurately diagnosed with no test apparatus whatsoever. In a good many receivers, particularly where tuned r-f stages are employed, squeals and howls occur when the tuning dial is rotated while the receiver is operating. The volume is normal. Such troubles are caused by defective rotor contacts to the gang sections of the tuning condenser. Normally all that is necessary to correct the trouble is simply to remove the contact clips, bend them so as to increase the tension, and replace. If the receiver is operated in a section where dampness is prevalent, a film of corrosion may have formed over the contacting area of the clip; this may be cleaned off with sandpaper—never use emery cloth on any receiver. Emery gets into parts and causes grounds or noise.

AVC Trouble Source

The foregoing is a simple and frequently encountered trouble. Not so simple nor so often found is the condition apparent when tuning whereby it becomes difficult to tune from a strong station to a weak one without having to wait momentarily for

the weak station to build up to normal volume. As a result such weak stations may be passed over. This trouble is caused by too long a time constant in the avc circuit. It may result when an 0.1 mfd condenser has been substituted for a .01 mfd one as an avc bypass. Often such receivers have a previous history of intermittent operation and many servicemen make a practice of replacing all small bypasses in such receivers, without bothering to test them, assuming that the cause is a defective bypass and it takes less time to replace the condenser than to undertake to test each one. The assumption is made that an excess of capacity can cause no difficulties in bypassing, therefore the common 0.1 size is frequently substituted for smaller values which may not immediately be at hand. The time taken to charge and discharge such condensers is appreciable, and the high voltage charge which these condensers accumulate when the set is tuned to a strong station holds over when quickly tuning to a weak signal. As a result, the high avc bias from the strong signal lowers the sensitivity of the set to a point where the weak signal becomes inaudible and is passed over.

Another trouble resulting from this cause occurs when tuning from a weak station to a strong one. In this case it takes a noticeable period for the avc bypasses to charge. During this period the strong signal comes in with a bang tapering off rapidly in signal strength as the avc takes hold. The remedy in such cases is obviously to reduce the capacity in the circuit. While the same effect

(Continued on page 26)

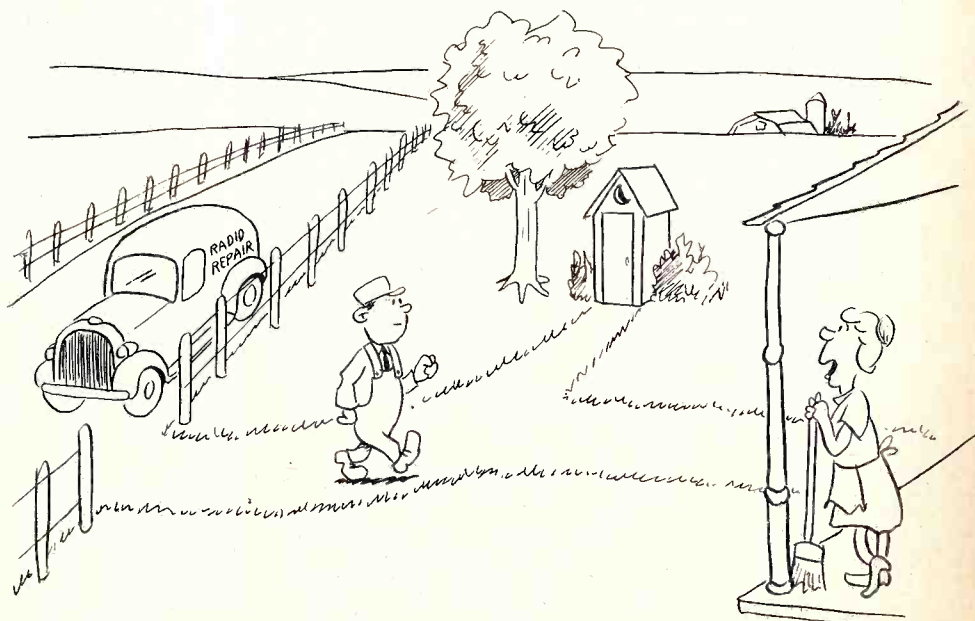

"Young man—is this a business or social call?"

The SPRAGUE TRADING POST

EXCHANGE — BUY — SELL

Your own ad run FREE!

The "Trading Post" is Sprague's way of helping radio servicemen obtain the parts and equipment they need, or dispose of the things they do not need during this period of wartime shortages. Send in your own ad today—to appear free of charge in this or one of the several other leading radio magazines on our list. Keep it short—WRITE CLEARLY—and confine it to radio items. "Emergency" ads will receive first attention. Address it to:

SPRAGUE PRODUCTS CO., Dept. RSD36
North Adams, Mass.

FOR SALE—Emerson 6 volt "B" power eliminator. Make offer. John Kujan, 735 Horne St., Bronx, New York, N. Y.

IN THE MARKET—for 3" Oscilloscope. Describe fully, and name price. Wimberley Radio Service, Hayti, Mo.

WANTED—Cathode ray tube, any size, new or used; or used oscilloscope, preferably Hickok, RCA, or Du Mont. H. Kelley, 5915 Helen Ave., Detroit, Mich.

meter or volt-ohm-meter, factory built, at a reasonable price. Sound Service, Inc., 11th & Quaker, Tulsa, Oklahoma.

WILL BUY OR TRADE—Want pre-selector, analyzer, 8 M.M. projector; have tubes, cameras, meters, speakers, new filter blocks. G. Samkofsky, 110 Wilson St., Brooklyn, N. Y.

FOR SALE—Supreme, model 500 automatic tube and set tester; 100% working order except for copper oxide rectifier—\$35 cash. Leon D. Markham, St. Louis, Michigan.

WANTED—Supreme audolyzer, model No. 562, Supreme signal generator model No. 561, Sprague Tel-Ohmike, Volt-Ohmyst, or similar instruments; also good tube tester for testing latest tubes. Must be in good condition. Give complete description and price. R. Flockhart, Mt. Vernon, New York.

FOR SALE—Keuffel & Esser 18-piece Drafting set in wooden case. First \$25 takes it. M. Cimorelli, Catskill, N. Y.

URGENTLY WANTED—Will pay cash for radio test equipment, VOM, tube tester and other parts; Hickok preferred but any make considered; also Rider's Manuals from No. 6 to 13 incl. What have you for cash? Edw. J. Danaher, 134 Merrimac St., Buffalo, N. Y., c/o University Radio Service.

RIDER'S MANUALS WANTED—Volumes 10-11-12 and 13. State condition and price. Fred Hartmann, 32-26 - 54th St., Woodside, L. I., New York.

URGENTLY NEEDED—Volt-ohm-meter and tube tester, also parts. Cash promptly. Sgt. Lawrence A. Steinberg, 316 East 15th St., Sioux Falls, So. Dak.

FOR SALE—Metal rack for Precision E-200 and 954, \$17; misc. radio parts; Radio News and Radio-Craft Magazines; Ranger free point tester with space for v.o.m. in metal cabinet, \$5. T. Wojciechowski, 2837 Fulton St., Brooklyn, N. Y.

NEEDED IMMEDIATELY—All types of test equipment, in good condition, for cash. Will sell or trade precision 5840 K.C. crystals; also 12SA7, 12SQ7, 35L6, 80 Tubes. L. C. Woodard, Signal Section, 328th Sub-Depot, Ft. Sumner, N. M.

WANTED—Condenser, analyzer and O-1 ma. milliammeter. Give full description, condition and price. Charles Morehead, Box 22, Flat Lick, Ky.

OSCILLOSCOPE WANTED—State model, condition, price. G. Boles, 315 - 51st Street, Brooklyn, 20, N. Y.

WANTED AT ONCE—Urgently need 1/100 ampere meter fuses. Will pay cash. Daniel L. Schacher, 4608 Forbes St., Pittsburgh, Pa.

WANTED—Meters, test eqpt. precision resistors, copper-oxide rectifiers, switches, receivers, neon bulbs, tools, manuals, motors, pick-ups, calcimine paint, brushes, etc. Describe fully. Roby's Swapmart, 3569 Cottage Grove Ave., Chicago, Ill.

HOME RECORDER FOR SALE—G-E portable JM-7 connected for two mikes. One 7-tube 6L6 output. 30-watt amplifier, open case. Priced, both for \$65. R. R. Reid, Parkersburg, Iowa.

FOR SALE—Abbott TR-4; 2-810 tubes; 2-809 tubes; 1-815 tube; 26 albums popular records; 3-954's; 1-9002 and socket, also meters and parts. Write for list. G. V. Sawyer, 37 Cleveland Ave., Devon, Conn.

WANTED—Jewell 199 set analyzer; ditto No. 444; Jewell 57 D-C volt-meter, 0-50 volts and 0-50 amps.; Test-O-Phone test unit; RCA service tip file and supplemental cards; RCA 156A tube checker, counter or portable type 156; Rider-Chanalyst; RCP tube checker model 309S or 309SC; Triumph A & B battery tester, model 630; GTC porta-power unit for 1½ volt radios, Model U or G; pair 7" Klein's pliers No. 201-7NE; back copies of Radio News, Radio Craft, Radio Today. Describe fully and name best cash price. Howell's Radio Service, Anna, Texas.

FOR SOUTH PACIFIC USE—Anxious to buy Echo-phone EC-1 Receiver. Urgently needed. Must be in good condition. Have you one to sell for a boy "over there"? Write T.Sgt. J. E. Grimes, M.C.S. Det., Quantico, Va.

TEST EQUIPMENT WANTED—"Jumbo" panel meter with 5" or 6" vane; communications receiver such as National FBXA. Will trade other equipment, auto radios, or what do you need? A. H. Mekeel, 9 Marple Road, Poughkeepsie, N. Y.

FOR QUICK SALE—Clough Brengle Type VE unimeter, portable type; AC volts 0 to 750; DC volts, 1 to 1000, DC mils., 1 to 1000, ohmmeter, 1 ohm to 3 meg., first-class condition—\$25; also small 5c to \$1 National cash register just reconditioned—\$35; and Rider's Manuals 1 to 13, complete, regular price. Act promptly. Nick Shuler Radio Service, Gonzales, Texas.

WANTED FOR CASH—Power supplies or component parts for same at from 1500 to 3000 volts and about 300 ma.; also 2 HK-254 or similar tubes and RCA 954, 955, 956. William R. Kennedy, Physics Dept., Montana State College, Bozeman, Montana.

WILL BUY—Good used sound equipment, amplifiers, microphones, P.M. speakers; also vacuum tube ohm-

HERE'S THE PATRIOTIC WAY TO REPLACE A DEFECTIVE CONDENSER SECTION



When you find one bad section in a multi-section dry electrolytic condenser, don't replace the entire unit! Most defective sections can be replaced by using a Sprague Atom of the proper capacity and voltage, as illustrated here. The Atom can either be fastened by tape to the multi-section unit, or simply held in place by means of its sturdy wire leads. You'll save time and money—and you help conserve essential war materials as well!

Atoms are made in a complete line of capacities and voltages, as well as in many combinations.

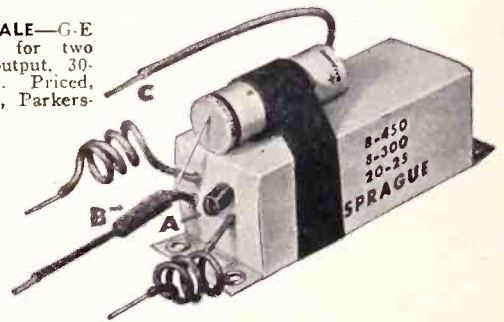

Illustrating how a Sprague Atom Type UT-8 (8 mfd. 450 volt) replaces the 8 mfd. 450-volt section of a 3-section condenser rated at 8 mfd. 450 V.; 8 mfd. 300 V., and 20 mfd. 25 V.:

- Cut lead to defective section and tape end.
- Connect cut circuit lead to positive (+) side of Atom.
- Connect Cathode (-) side of Atom to common minus lead of multi-section condenser.

SPRAGUE
PRODUCTS CO.
North Adams, Mass.

SPRAGUE CONDENSERS AND KOOLOHM RESISTORS

Obviously, Sprague cannot assume any responsibility for, or guarantee goods etc. which might be sold or exchanged through the above advertisements.

THE SUPERHETERODYNE RECEIVER

PART 2

Converters

A converter serves to combine the incoming r-f signal with that of the local oscillator signal and to supply a third frequency lower than the r-f signal but still retaining the modulation form that was present in the r-f. The simplest converter is the triode. In this type converter we depend on the non-linear detector action of the triode when biased to cut-off. The tube is normally biased to nearly cut-off and enough local oscillator voltage is impressed to increase the plate current above the value with no excitation present. The tube then operates on the non-linear portion of the characteristic curve and has maximum conversion efficiency. A simple triode converter circuit is shown in Fig. 9.

Besides the triode converter, modern superheterodyne receivers very often employ such converters as the Pentagrid Converter Tube. This is a five grid tube combining the function of the local oscillator and detector in one tube. The schematic of such a tube, either a 6A7 or a 6A8 is shown in Fig. 10. *Grid 1* acts as an oscillator control grid. *Grid 2* acts as the oscillator plate. These two grids are connected as in any tuned grid plate feedback amplifier. The bias is obtained by grid leak and

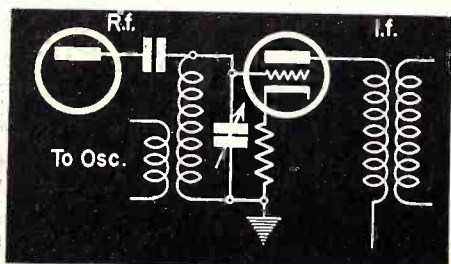

Fig. 9. Triode Converter

by Oscar E. Carlson

blocking condenser. *Grid 2* is normally supplied with about a 200 volt positive potential with respect to cathode.

The oscillator action is similar to the conventional triode but the action within the tube is not completed. *Grid 2* is not a solid plate and electrons pass through it. The electrons passing *grid 2* vary in accordance with the oscillator anode current and therefore we may think of the space around *grid 2* as being a virtual cathode, or varying source of electrons. *Grid 4* then becomes the control grid of a screen grid tube upon which the signal voltage is impressed. *Grids 3* and *5* are connected together, one on each side of this control grid. This accomplishes two purposes. *Grid 3* acts as an accelerating grid to draw electrons beyond *grid 2* and under the influence of *grid 4*. *Grid 5* acts to shield the control *grid 4* from the effect of the plate just as in any screen grid tube. *Grids 3* and *5* are maintained positive with respect to cathode by about 100 volts. The plate is made positive by 250 volts and connects to the output circuit just as in any amplifier. The desired mixing action is accomplished in the electron stream instead of in the tuned grid circuit as in the conventional first detector and oscillator. The plate circuit is tuned to the i-f frequency and amplified by the i-f amplifier stage, or stages.

Fig. 10. Pentagrid Converter

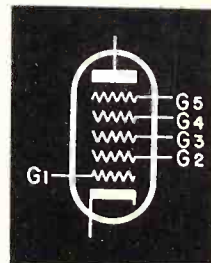

Detection

Diode detection is the nearly universal type of detector in use today. Detection is simply the rectification of the r-f signal so that only the modulation component will remain. An *RC* combination in the cathode circuit is the load across which the output voltage is developed. The proper combination of *R* and *C* is very important as for a given modulation frequency and large value of *R*, if *C* is small the filtering action is inadequate and a large r-f component will be present and the effective signal amplitude will be decreased. If *C* is too large it will not discharge rapidly enough and at higher modulation frequencies the output voltage will not follow the decrease of the modulation envelope to the lower limits thus flattening out the lower alternation of the signal voltage and resulting in distortion. *C* and *R* must be sufficiently



IRC Research Points to

BIG JOB AHEAD FOR SERVICEMEN

In tomorrow's "after victory" world the servicing of radio sets will be only part of the responsibilities of Servicemen.

Shown above are a few of the new industrial and scientific electronic applications which, though now confined to war uses, will be commonplace in the days ahead.

Because IRC research has kept in step with *every important electronic development*, you will find IRC resistance units installed in much of the original equipment in these

fields. With IRC engineers and executives keenly aware not only of your increased opportunities but of their obligations to you, wherever resistors are required it will be more than ever to your advantage to specify:



INTERNATIONAL RESISTANCE COMPANY

Dept. R • 401 N. BROAD STREET • PHILADELPHIA

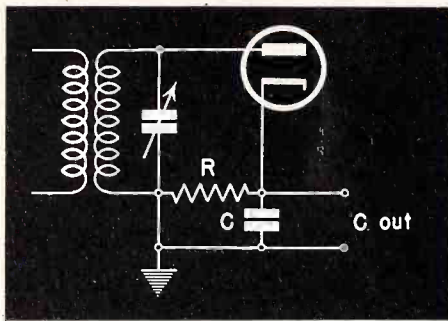

Fig. 11. Diode detector.

small so that the discharge of C through R is at least as rapid as the modulation amplitude decreases during a cycle. Fig. 11 illustrates a simple diode detector. To determine the proper value of either C or R to use with the circuit we pick some arbitrary value of either. In that case, for proper operation:

$$\omega_s \left(\frac{R \times R_o}{R + R_o} \right) C \cong \sqrt{\left[\frac{R_o}{(R + R_o) K} \right]^2 - 1}$$

where

ω_s is $2\pi \times$ the modulation frequency in c.p.s.

R_o is the grid load resistor of following tube.

R is the diode load resistor.

C is the filter capacity.

K is the percentage of modulation expressed as a decimal.

In practice X_c/R should not be less than 3. R may be 250,000 ohms and C from 50 to 100 micro-micro-farads.

Another type of detector that was once very popular but is now seldom used is the Plate Detector, or Linear Detector. A linear detector develops a rectified output proportional to the amplitude of the input voltage and detection is accomplished by working the tube with such plate and bias voltages that the $Eg-Ip$ characteristic curve is essentially linear and the entire half of the cycle is cut off without altering the shape of the upper half.

This detector is illustrated in Fig. 12. It is nothing more than a class

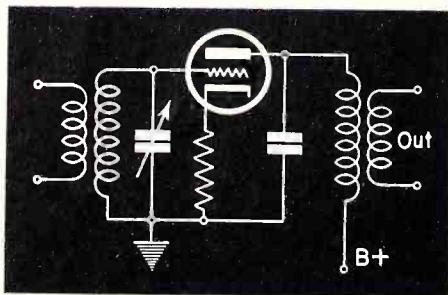

Fig. 12. Plate or linear detection.

B amplifier with the plate circuit so arranged as to suppress the carrier frequency while accepting and passing on to the next tube the modulation frequency component. As such the tube must be biased to almost cut-off and a large plate voltage must be used to give an essentially straight characteristic curve.

When the tube is biased to near cut-off and a large alternating voltage is applied to the grid, there will be a pulse of plate current during each positive half cycle of the applied voltage and no plate current during the negative half cycles. Due to this high bias no grid current flows during the signal and there is no loss of selectivity in the preceding r-f or i-f circuit as with grid leak or diode detection.

Audio Amplifiers

The two general types of audio amplifiers in use for radio receivers are the class A and the class B amplifiers. The class A amplifier operates in such a manner that the form of the power supplied to the plate load circuit is essentially a reproduction of the grid excitation voltage, that is, the plate current varies directly with the grid voltage. Thus, since the tube is operated well within the linear limits of the characteristic curve, the plate voltage also varies in the same form as the grid voltage. Usually, the tube is operated in the center of the straight portion of the $Eg-Ip$ curve and the grid is not permitted to swing either positive or into the lower bend of the characteristic curve.

Plate current for the class A amplifier flows at all times and the voltages are such that the tube operates as a linear amplifier. The amount of second harmonic distortion that is present in the output that was not present in the input is taken as a measure of the distortion and is usually limited to less than five percent (5%).

Whenever the plate current, due to excessive excitation extending beyond the straight portion of the characteristic curve or to a flow of grid current, is distorted out of the form of the input voltage variations, harmonics result in the output. The amplifier characteristics are low efficiency and low output with a large ratio of power amplification. The low efficiency is due to the fact that plate current flows during the full 360 degrees of the excitation cycle thus causing a continuous expenditure of power within the tube. Fig. 13 illustrates the action of a normally operated class A amplifier tube. Low output is due to the fact that

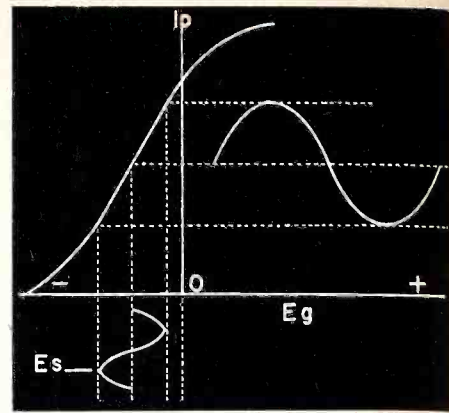

Fig. 13. Graphical analysis of a class A amplifier tube.

high excitation cannot be used, as explained above. The theoretical limit of efficiency is 50%.

Due to the low operating efficiency the plate power input must be kept comparatively low due to the large proportion of the input being dissipated within the tube itself. The high ratio of power amplification is due to the fact that high excitation voltages cannot be used and consequently the power requirements for excitation are very low.

Class A audio amplifiers may be used as first audio driver stages for a succeeding class A power amplifier or class B power amplifier. If class B output tubes are employed an interstage coupling transformer is required to couple the driver stage to the power amplifier. A phase inverter can be used for such coupling. We shall not, however, cover such an arrangement in this article.

If the class A driver stage is followed by a class A power stage, resistance capacitive coupling is usually used. Such an arrangement is shown in Fig. 14. The function of such a coupling arrangement between stages is merely to allow the transfer of the signal component of the plate voltage from the driver tube to the grid circuit of the succeeding stage. The dc plate voltage

(Continued on page 22)

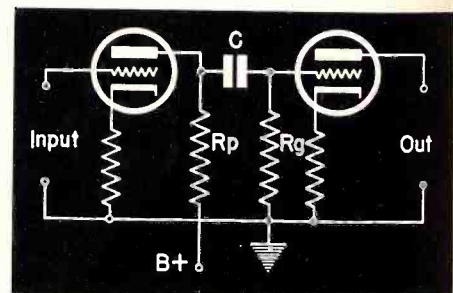

Fig. 14. Resistance capacitive coupled class A amplifiers.

JUST OUT!

Alfred A. Ghirardi's BIG, NEW WARTIME SERVICE HANDBOOK

(3rd Edition of the famous RADIO TROUBLESHOOTER'S HANDBOOK)

The NEW book that helps you repair more radios — easier, and twice as fast!

NEW 3rd EDITION

9 Additional Sections—
Completely Revised—Now
Contains 744 big, manual-
size Pages

RADIO Troubleshooter's HANDBOOK

- RESISTOR CURR.-VOLTS
- PARALLEL (R) —
- REACTANCE CHART
- REACTANCE & RESIST.
- REACTANCE & RESIST.
- RMA CONDENSER COLOR CODE & C
- AUTO-RADIO INTERFERE. ELEM. CHARTS
- 88 AUTOMOBILE WIRING DIAGRAMS
- WHEN TO REPLACE A CONDENSER (CHART)
- CONVERSION FACTORS FOR ELECT. UNITS
- DB-POW'R., VOLT., CURR., RADIO TABLE
- WAVELENGTH-FREQ. — LCX CONVERSION CHT
- "RELATIVE RESISTANCE", VALUES
- "TEMP. COEFF. OF RESIST.", VALUES
- RESIST.-COUPL'D A-F AMPLIF. DESIGN
- RESIST.-COUPL'D PHASE INVERTERS
- SINGLE-LAYER COIL DESIGN CHART
- TUBE "CLASSIFICATION" CHART
- AUTO-RADIO GEAR-RATIO CHART
- USE OF EXPONENTS IN RADIO CAL
- DIRECTORY OF RADIO SCHOOLS
- GRID-BIAS RESISTORS FOR 297 TUBES
- DIRECTORY OF P. A. EMP'T. AMPLIFRS.
- DIRECTORY OF TEST EQUIP. MANFRS.
- DIRECTORY OF RADIO BOOK PUBLISHERS
- DIRECTORY OF RADIO RECEIVER MANFRS.
- DIRECTORY OF RADIO ACCESSORIES MANFRS.
- DIRECTORY OF RADIO MAGAZINES
- DECIMAL & METRIC EQUIV. OF FRACTIONS
- "PHONE-RADIO" TROUBLE SHOOT'G. CHART
- "AUTO-RADIO" TROUBLE SHOOT'G. CHART
- "LITE" WIRE SIZE, WEIGHT & DATA CHART
- LOW-PASS ("PI") FILTER DESIGN CHART
- HOW TO RECONSTRUCT OLD RECEIVERS
- VOLUME & TONE CONTROL CIRCUITS
- VOLUME & TONE CONTROL RESIST. TAPING

RADIO Troubleshooter's HANDBOOK

By
ALFRED A. GHIRARDI



**CUTS TESTING
TIME IN HALF!**

**The Book That Tells You What to Do . . .
... AND HOW TO DO IT!**

The 3rd Edition of Ghirardi's famous RADIO TROUBLESHOOTER'S MANUAL is NOT a book of theory. Every one of its 744 big, manual-size pages is literally loaded with practical, every-day, factual data that will help you do almost every job, quicker and easier—and at a greater profit! Eliminates guesswork. Saves time. **Pays for itself the first time you use it!**

In short, it is the most valuable collection of servicing information ever assembled between two covers—and, even though it is larger than the previous edition, it is sold at the same old price of **ONLY \$5** postpaid anywhere in the U. S. A. (\$5.50 foreign).

**STOP GUESSING ON
RADIO SERVICE JOBS!**
Every Wasted Minute Costs YOU Money!

The most important book any service shop or individual can own during these critical times—bar none! Enables you to cut corners—save valuable troubleshooting and repair time—train new technicians in your shop—repair cheap sets at a real profit—handle tough jobs in half the time normally required—and much more. Now in its 3rd Edition—completely revised—bigger than ever—and containing **NINE ADDITIONAL SECTIONS OF VITAL NEW MATERIAL**. In short, this new 3rd Edition of Ghirardi's RADIO TROUBLESHOOTER'S HANDBOOK is the most valuable collection of servicing information ever assembled between two covers! Its 404-page Case History Compilation now gives common trouble symptoms, their causes and remedies, for over 4800 models of the 202 most popular makes of receivers. Often, these eliminate the need for any elaborate testing. **ALMOST ALWAYS**, they save from 25% to 50% of the time you would normally require to repair a set.

NOW COVERS 75 IMPORTANT SUBJECTS

This feature, however, is **ONLY ONE OF 75 IMPORTANT SUBJECTS** covered in this brand new HANDBOOK—subjects which make the volume absolutely indispensable to busy servicemen at a time when both parts and test equipment are scarce, and when you've got to have plenty of "Know How" in order to substitute existing tubes, etc., properly.

THE HELP YOU NEED . . . WHEN YOU NEED IT!

There are scores of time-saving charts, graphs, tables and data compilations—all designed to **HELP YOU REPAIR MORE RADIOS—REPAIR THEM EASIER—AND DO IT IN LESS TIME!** There are I-F alignment peaks for over 20,000 super-hets; a big section of data on those pesky I-F transformer troubles—**AND THE MOST UP-TO-THE-MINUTE TUBE CHART** you've ever seen, with complete information on **EVERY** tube type and with dozens of practical tips on how the types may be interchanged. Other features include plug-in and ballast resistor replacement charts; condenser and resistor charts; coil and transformer data; wire tables—and a wealth of other material that saves your time every day!

PLAY SAFE . . . ORDER NOW!

Send your order today! Make sure you get your copy while the supply lasts. (Paper shortages, etc., may make it impossible to reprint!) Your money will be cheerfully refunded if you don't agree within 5 days that it is the finest business investment you can possibly make!

5-DAY MONEY-BACK GUARANTEE

RADIO & TECHNICAL PUBLISHING CO., Dept. RSD-53
45 Astor Place, New York, 3, N. Y.

Enclosed find payment for books checked below. Check here also, if desired sent C.O.D. for the amounts indicated, plus postage. In either case, if I am not fully satisfied, I may return books within 5 days of receipt for refund.

- Ghirardi's new 3d Edition RADIO TROUBLESHOOTER'S HANDBOOK \$5. (\$5.50 foreign.)
- Ghirardi's MODERN RADIO SERVICING \$5. (\$5.50 foreign.)

SPECIAL MONEY-SAVING COMBINATION OFFER

The new HANDBOOK and MODERN RADIO SERVICING at special price of only \$9.50 for the two. (\$10.50 foreign.)

Name

Address

City State



Another Ghirardi "Must" for Busy Servicemen

Written so you can easily understand it!

These are days when it pays big to have a complete line-up of modern servicing information at your fingertips—and Ghirardi's MODERN RADIO SERVICING is the only single book that gives a complete course in modern radio testing instruments, troubleshooting, and repair procedure. Everything explained simply, clearly. Unexcelled for helping train new men quickly in your shop—for brushing-up on short-cuts and kinks which may be hazy in your mind—for every-day reference. The famous 1300-page home-study course on the entire art of radio repair, with 706 illustrations, and 720 review questions. Only \$5 complete (\$5.50 foreign).

See **MONEY-SAVING COMBINATION OFFER** in coupon!

Meissner Radio Kits are designed for Quick Training!

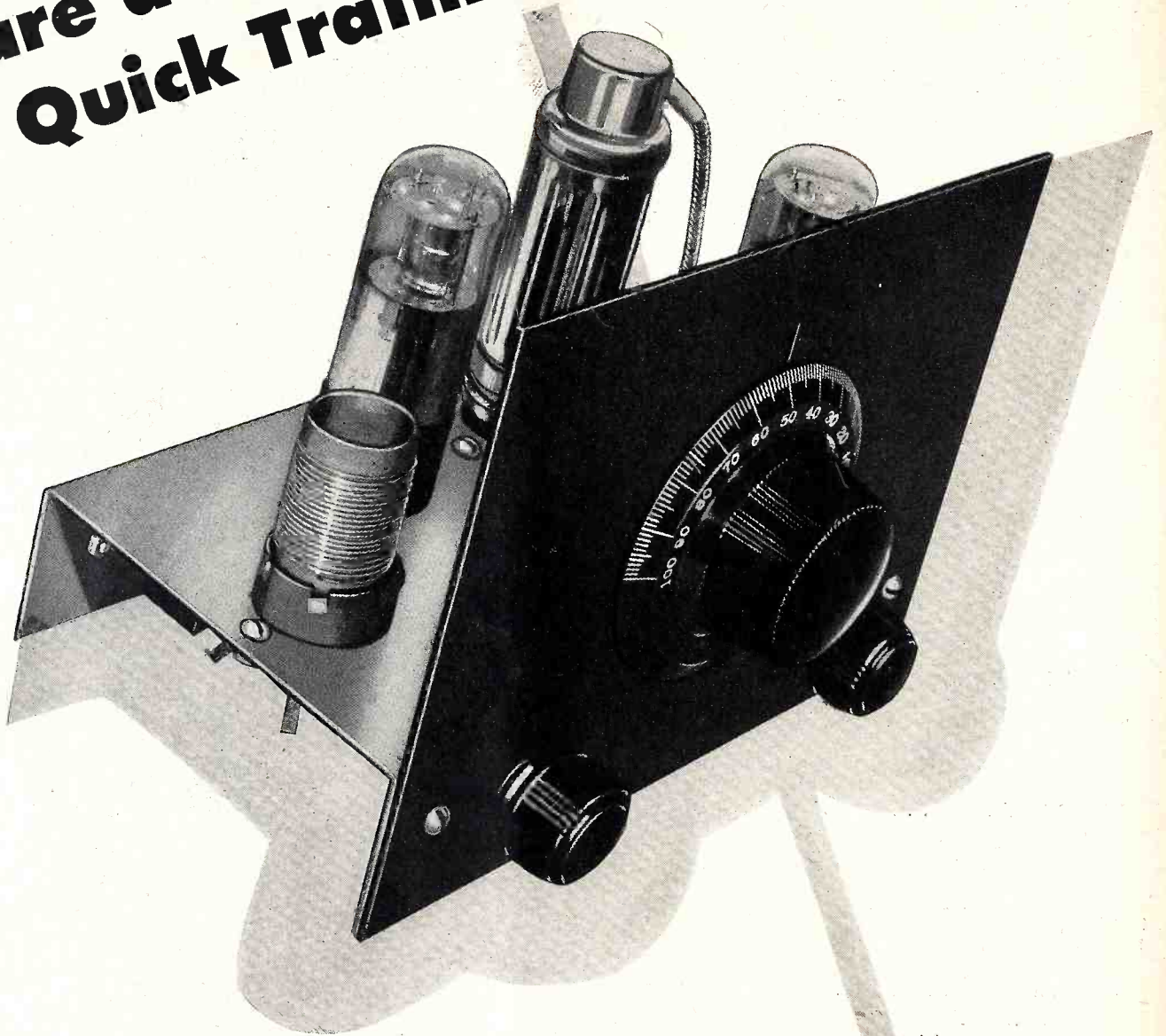

Meissner one, two and three tube Student "Midget" Kits solve the problem of quicker radio training. The Kits are especially designed for classroom use. The "add-on" feature permits the conversion of the one tube to a two tube and the two tube to a three tube receiver. Meissner Student "Midget" Kits are being widely used in schools for defense radio training.

SIMPLIFIED CONSTRUCTION! Meissner wiring diagrams enable the beginner to quickly assemble the Kit and give better results in basic radio instruction. See your Meissner distributor or write

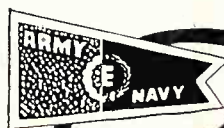

Meissner

MT. CARMEL, ILLINOIS

"PRECISION-BUILT ELECTRONIC PRODUCTS"

TECHNICAL

SERVICE PORTFOLIO

SECTION XXXI

ELECTROLYTIC CONDENSERS

DESPITE the fact that failure of electrolytic condensers is one of the most common causes of radio trouble, it is also true that this type of condenser represents one of the greatest improvements in radio component parts design to have occurred in the past fifteen years. It is due principally to electrolytics that radios are now substantially hum-free, yet are compact and light in weight. Better hum filtration has resulted in better audio systems and consequently, improved fidelity. Higher gain p.a. apparatus, resulting from the improved filtering efficiency of electrolytics, enables better microphones to be used and therefore more natural reproduction is achieved. In industrial applications, high-capacity electrolytics are used to start capacitor motors, which are quite generally used in theater and other installations because of their quietness in operation. The electrolytic has given us, for better or for worse, the a-c/d-c midget.

In a great many cases, the electrolytic is more sinned against than sinning, insofar as troubles in service are concerned. Extremes of heat and cold affect any units containing a liquid or moist component. Electrolytics are no exceptions. Yet we find such condensers jammed in close to hot rectifier tubes or pressed in near or even against the scorching

heat of a line voltage-dropping resistor, so frequently located along the back of small midget a-c/d-c receivers. In the early days of electrolytics, when electrolytes were not so well understood, the combination of poor set design and excessive heating of the electrolytic occasionally caused so much gas pressure within the condenser that explosions resulted. This was particularly the case with the older wet electrolytics, which were fitted with a vent from which the gas could normally escape. When this vent became clogged up, there was no other release for the pent-up gas, except to "pop." Improvements in condenser design have overcome this trouble, but the need for avoiding abuse of the con-

denser in order to obtain maximum life and operating efficiency is just as essential as heretofore.

Electrolytic Advantages— Limitations

To get a better idea of the problems involved in the design of electrolytics, and of their advantages and limitations, let us first consider *Fig. 1*, which shows essentially how such condensers are made. The positive electrode is aluminum, and the negative electrode is generally, but not always, of the same metal. In between these electrodes is placed an electrolyte, which is either in liquid or paste form. In most modern condensers, the paste form electrolyte is used. When a voltage is applied to the electrodes, an electro-chemical action takes place, much like that which occurs in an electro-plating bath. However, instead of a plating being formed, a thin film of insulation is deposited on the positive electrode. This film serves as the dielectric for the condenser in the same manner as mica and wax-impregnated paper serve in other types of condensers. Principally because this film dielectric is so microscopically thin, the capacity obtained for a given area of electrode is very large—much larger proportionately than for the same area when mica or paper are used.

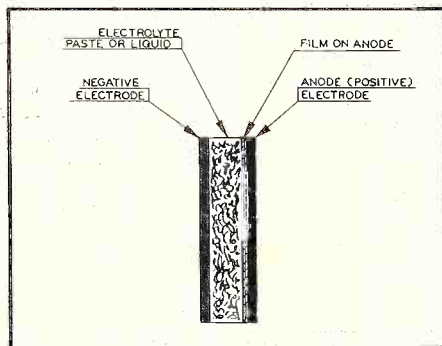

Fig. 1. In an electrolytic condenser, an insulating film is formed on the anode, as shown.

The resultant capacity after forming is dependent not only upon the area of the electrodes but also upon the forming voltage and the type of electrolyte employed. The lower the forming voltage, the thinner the film and the higher the capacity. That is why low-voltage electrolytics of very high capacity can be made in such small sizes.

There are other methods of increasing the capacity of the condenser, without reducing the forming voltage. One such is by etching the surface of the anode. This is done either chemically or mechanically and produces minute corrugations in the aluminum foil and thereby increases the effective area of the condenser surface. It is necessary to use a high forming voltage if the condenser is to be subjected to high voltages in service, since the thinner films which result at lower forming voltages will not withstand high operating voltages. Then there is the fabricated plate method by which means an exceptionally high plate surface is obtained mechanically to greatly increase capacity in small units.

The types of electrolytes used are to a certain extent trade secrets, and vary with the forming voltage, ultimate capacity desired and type of construction. In many condensers, the electrolyte is, or used to be, sodium or ammonium borate dissolved, with boric acid, in water; or a dilute solution of sulphuric acid. Sometimes the condenser is partly formed with one type of electrolyte and the forming process is completed with another type.

Note that the film thus formed appears only around the positive foil. If the polarity is reversed, the film will be destroyed and the condenser will be ruined. In alternating current circuits, where the current

continually reverses, electrolytics are unsuitable, as ordinarily constructed. You may wonder why they are able to operate in power supply filter circuits because of the hum which is normally there. However, we should remember that this hum is not an alternating current, but a pulsating one. And there is no objection to using electrolytics in circuits where a pulsating current exists. Also, in testing, it is necessary to use an alternating current as a current supply source for a bridge; in such cases a polarizing voltage which is sufficiently high to make certain the anode foil of the condenser is never negative is used. When the supply voltage for the bridge is very low—less than 2 or 3 volts—it is possible to omit the polarizing voltage without causing breakdown of the anode film, but measurements made under these conditions do not yield the same results which are obtained when the proper polarizing voltage—equal to the normal d-c working voltage of the condenser—is employed.

Effect of Varying Temperature

We have stated that the capacity of an electrolytic condenser is affected by the operating temperature. An idea of the magnitude of the change with temperature may be obtained from a consideration of the graph, Fig. 2. This represents the change in capacity of representative 10 mfd condensers of the plain and etched foil varieties over a wide temperature range. Note that a plain foil condenser which has a capacity of 10 mfd at normal room temperature drops to nearly 1 mfd at 40 degrees below zero. And the etched foil type, of similar capacity at normal room temperature, loses half its capacity at minus 40 degrees Fahrenheit. While most of us don't

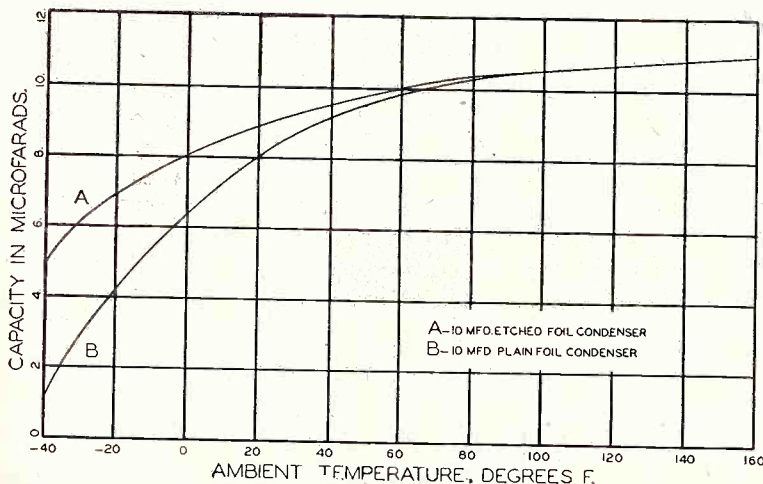

Fig. 2. The capacity of electrolytic condensers decreases at low temperatures, as shown.

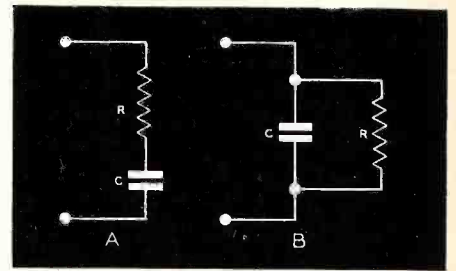

Fig. 3. The power factor creates losses in a condenser equivalent to those resulting from series resistance (as in A above), or shunt resistance (as in B).

feel like sitting around, listening to the radio, when the temperature in the room is anywhere near 40 degrees below zero, even lower temperatures are frequently encountered in high-altitude bombing planes, and in field operations in Arctic regions. When electrolytics are used under such conditions it is necessary to select a condenser with sufficient excess capacity to make up for the loss which occurs at low temperatures.

Although the capacity increases at higher temperatures, it is not to be assumed that operation at temperatures above normal is favorable to the performance of electrolytics. Quite the reverse. As we have mentioned before, every electrolytic contains a certain amount of moisture, regardless of the type of electrolyte employed. At high temperatures this moisture evaporates more rapidly—the condenser “drys out”—the capacity eventually decreases and poor filtration results. Further, the average life of the condenser is greatly reduced, more frequent breakdowns occur, the power factor is considerably increased. In general, the performance as a whole is considerably worse than at low temperatures. The same drawbacks are likewise experienced, though not to so great an extent, with all types of wax or oil impregnated paper condensers.

Power Factor

The effect of an increase in power factor in a condenser is similar to an increase in the series resistance of the condenser, as represented by R in Fig. 3A, or to a decrease in the shunt resistance, shown in Fig. 3B. Both these factors represent losses in filtering efficiency; in series resistance, because the impedance of the condenser is increased so that more of the current to be bypassed passes along through the external circuit to which the condenser is connected rather than being applied to the condenser. And, insofar as

the shunt resistance is concerned. this serves to limit the amount of charge which the condenser can receive and hold in a given time and thus reduces its ability to store energy, which is a measure of condenser efficiency.

In general, electrolytic condensers are not as efficient as paper condensers insofar as bypassing is concerned, assuming that we are comparing two condensers of equal capacity, because the power factor of electrolytics is normally far greater than that of paper condensers—usually about 10 or more times as great. But if we compare these two types of condensers on the basis of physical size, we find that an electrolytic can be made in a small fraction of the space required for a standard paper condenser of equivalent capacity or filtering efficiency.

Filtering Efficiency

When we speak of filtering efficiency, we refer of course to low-frequency filtration, such as is required in power supply circuits normally found in home radios. The electrolytic is not efficient as a filter of radio frequencies, and occasionally circuits are encountered in which poor operation results because of the attempt to use an electrolytic both as an r-f and a-f filter.

Such a circuit is shown in *Fig. 4*. Here the filter condenser C_F acts not only as a bypass for hum frequencies in the power supply, but also for radio frequencies present in the plate circuit of the i-f amplifier stage shown. When the electrolytic is fresh, it may serve both these functions satisfactorily; but long before it has reached the end of its useful life as a hum filter for the power supply it has become useless as an r-f filter. The result is frequently oscillation or low volume of output in receivers so afflicted. Now that electrolytics are so scarce, it is worthwhile to prolong their life by shunting them with paper condensers—0.1 mfd or thereabouts, when they are still sufficiently good to serve as hum filters. The paper condenser will take care of r-f bypassing. C_{RF} demonstrates this application.

Electrolytics are characterized by high leakage, up to about 1 ma per microfarad of capacity, which is not present in paper or mica condensers. As a result, electrolytics cannot be used as coupling condensers in resistance-coupled amplifier stages. Further, electrolytics should not be,

but often are, used as screen bypasses in a-f stages. An example is shown in *Fig. 4*, where the screen bypass condenser C_B is an electrolytic. Here the effectiveness of the condenser, and in fact the performance of the entire circuit, is dependent upon the amount of leakage present in the condenser C_B . When the leakage is high, it serves as a resistance which forms a voltage divider with the screen series resistor. As a result, only a portion of the normal screen voltage reaches the screen; the gain of the tube and circuit is reduced, overload and distortion occur. There is no simple remedy other than replacing the electrolytic with a suitable paper condenser. If the screen resistor is high in value—it is usually 0.1 megohms or more—a paper bypass of 0.25 mfd is normally adequate.

Condenser Testing

Nowadays when test equipment is hard to get, it is often necessary to improvise some simple method of testing electrolytics which will tell us just how bad they are. One method, adaptable to power supply filter condensers of the commonly used 8 mfd type, is shown in *Fig. 5*. This is a perfectly ordinary power supply, which is normally connected to a working radio receiver, but to which has been added a means of comparing the electrolytic condenser C_2 , already in the power supply, with another which we want to test, designated as C_x . By manipulating the switch S_1 , either C_2 or C_x (both

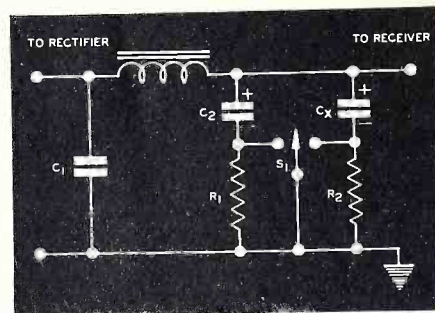

Fig. 5. The performance of an electrolytic condenser can be quite simply checked by comparison with another, as shown above.

nominally the same) serves as the final section filter of the power supply, and we can judge by listening to the result in the speaker as to how well the condenser C_x performs with respect to C_2 . In this circuit, R_1 and R_2 are the same value—about 10,000 ohms or more. When the switch S_1 is turned to short out R_1 , C_2 serves as the filter condenser and the power supply functions normally. When S_1 is turned to short out R_2 , then C_x replaces C_2 as the filter and the performance of C_x can be compared with that of C_2 . R_1 and R_2 , when in series with the condensers with which they are associated, serve so to limit their effectiveness as bypasses that the condensers may be considered to be completely out of the circuit. It is necessary to use these resistors because, if we simply switched from one condenser to the other, a heavy discharge would take place through

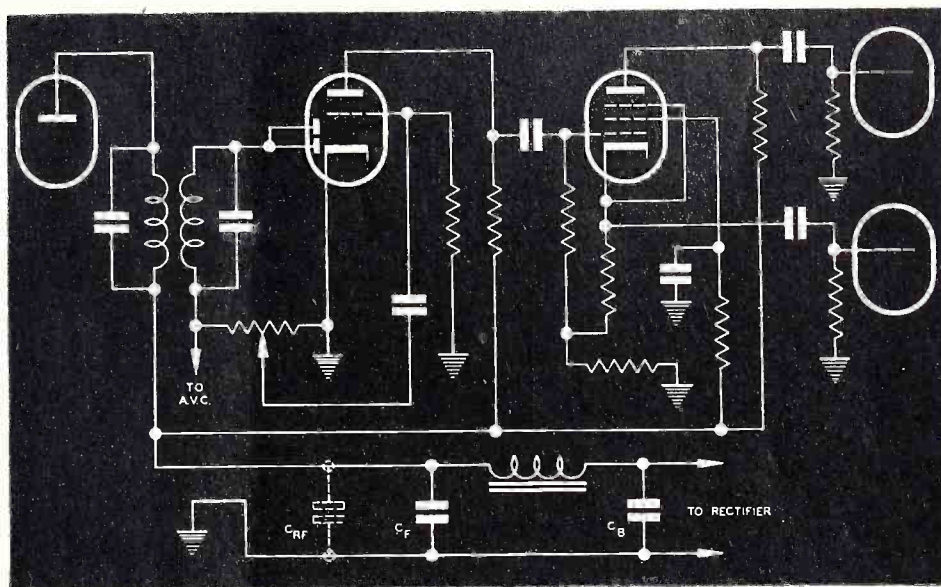

Fig. 4. An electrolytic may be required to bypass radio-frequency, as well as audio-frequency, currents. Better results are obtained by using an auxiliary condenser, C_{RF} , to handle the r-f currents.

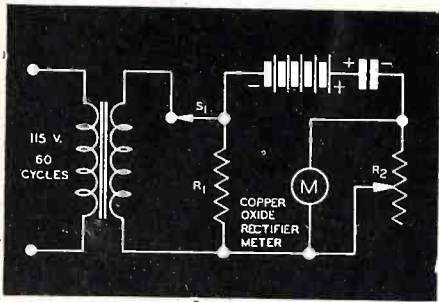

Fig. 6. Both capacity and leakage can be checked with this simple circuit.

the switch contacts which would ruin them in a short time.

A simple method of checking capacity and leakage, assuming that a copper-oxide rectifier type of meter is available, is shown in Fig. 6. The transformer shown in a type designed for heating tube filaments, with a secondary of 6.3 or more volts. The battery voltage—a power supply with filtered d-c output can replace the battery—serves to polarize the condenser and thus enables accurate capacity readings. Further, it enables us to determine the leakage present in the condenser under test.

In operation, the switch *S1* is opened so that no a-c voltage is applied to the circuit. *R1*—which may be 1000 or more ohms—serves to limit the current in the circuit should the condenser under test be shorted. The reading on the meter indicates the leakage current in the condenser. This should not exceed approximately 1 ma plus .05 ma per microfarad of capacitance (1.40 ma for 8 mfd). After the leakage has been noted, *S6* is switched to apply

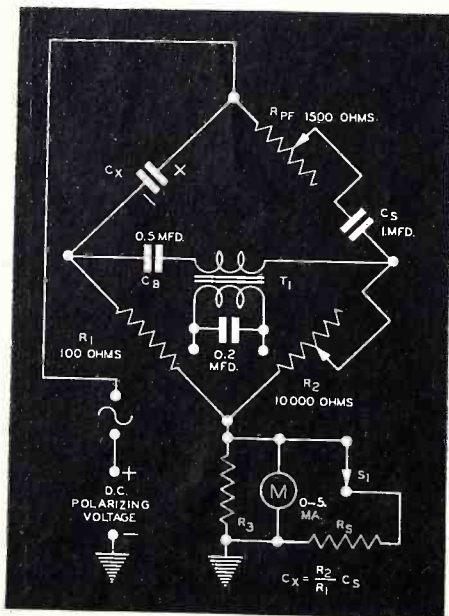

Fig. 7. For accurate measurements of capacity and leakage, this bridge circuit has come into general use.

the a-c test voltage to the circuit. *R2* is adjusted until the proper reading, predetermined by calibration with other condensers of known capacity, has been obtained. The value of *R2* depends upon the meter used—if from an analyzer, *R2* may represent the a-c current range shunts.

Bridge Circuits

A standard bridge circuit for measuring capacity and leakage of electrolytic condensers is shown in Fig. 7. In this schematic, *Cx* is the unknown condenser under test, *Cs* is the standard condenser, *Rpf* is the series resistance which enables power factor determination and *R2* and *R1* are balancing arms of the bridge. The resistor *R3* is not a part of the bridge circuit, but has been added in order to enable measurement of the leakage current. Actually this resistance may be omitted if we are careful to make certain that the meter is shunted by *Rs* when the d-c polarizing voltage is applied to the condenser under test. If the condenser has not been recently in use, adequate time for forming (up to one-half hour at full polarizing voltage) should be allowed before testing.

The formula

$$C_x = \frac{R_2}{R_1} C_s$$

shows the condition under which the bridge is balanced. When *Cs* is equal to 1 mfd, *Cx* in microfarads is equal to *R2/R1*. Thus when *R2* is 10,000 ohms and *R1* 100 ohms, *R2/R1* equals 100 and the capacitance of the condenser under test would then be 100 mfd, which represents the maximum range of the bridge. This range may be increased to 1000 mfd either by increasing *R2* to 100,000 ohms, or decreasing *R1* to 10 ohms; the latter is preferable. Except for very special applications, such as the measurement of starter condensers and others used in industrial applications, it is not likely that any need for a range greater than 100 mfd will be required. If *R2* is calibrated down to 10 ohms, the minimum value of the capacitance which can be measured will be 10/100 times 1 mfd or 0.1 mfd. Smaller values can be checked by increasing the resistance of *R1* so that the fractional capacity is greater. For example, if *R1* is 1000 ohms, then under the same conditions capacitances of .01 mfd can be checked. For still lower values, *Cs* can be re-

duced to 0.1 or less and the minimum value of capacitance measurable will be proportionately less. The bridge is adaptable to all types of condensers.

The power factor range can be determined from the formula (approximate)

$$\text{Power Factor (per cent)} = 100 \times 2 \times 6.28 \times 60 \times R_{pf} \times C_s$$

when the test frequency is 60 cycles and the power factor is such that the resistance is small in comparison with the reactance of the condenser. When *Rpf* is 1500 and *Cs* is 1 mfd the power factor is equal to $100 \times 2 \times 6.28 \times 60 \times 1500 \times .000001$, or about 56%. (In this formula *Cs* is in farads and 1 mfd therefore equals .000001 farads). It is assumed that the resistance of *Cs* is negligible, which will be the case of a high-grade paper type condenser is employed. Other values of power factor will be proportionate to the value of *Rpf* used.

Another type of bridge which may also be used for capacity, power factor and leakage measurements is shown in Fig. 8. This is quite similar to Fig. 7 in its manner of functioning and the bridge arm and condenser standard values should be the same as in the circuit of Fig. 7. Care must be taken that the signal source does not have capacity to ground, as would be the case if a filament transformer were used, otherwise inaccuracies in measurement will occur and difficulties in

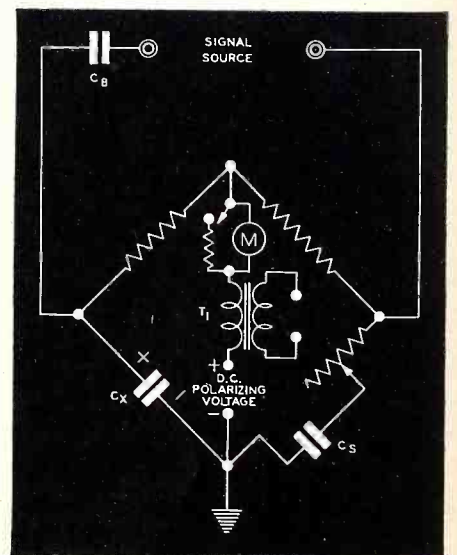

Fig. 8. This bridge circuit is somewhat similar to that of Fig. 7, but the d-c polarizing voltage is located differently in the circuit. Constants for the resistors and condensers are the same as in Fig. 7.

balancing will be encountered.

With reference to the signal source, a filament transformer, the secondary of which feeds the bridge, will serve nicely in connection with any power supply source, consisting of a conventional rectifier and filter circuit, to supply the d-c polarizing voltage. Alternatively a special power supply, which combines both a-c and d-c in a single unit may be used. This is accomplished by using a partly filtered half-wave power supply, as shown in Fig. 9. As shown, the d-c polarizing voltage is taken off the high side of a 50,000-ohm resistor, which serves as a load circuit for the power supply. This resistor is bypassed by a single 1-mfd paper condenser, scarcely sufficient bypassing to remove more than the higher harmonics of the rectified voltage. As a result, considerable 60-cycle ripple is present in the output voltage, and this ripple is put to work by serving as the signal source for the bridge.

A further advantage of this type of power supply is that the current is limited by the grid potential of the type 45 half-wave rectifier. When the grid is at ground potential, little rectified current is available for the load, 50,000 ohms, and for the bridge, so the voltage is low. At maximum setting, when S1 is joined to point 1 through the tap switch, the grid is at the same potential as the plate and maximum rectified current flows. Consequently the voltage across the load is high. By this means it is possible to secure a wide range of polarizing voltages without using a tapped transformer. Also, the need for a tapped voltage divider is avoided. And the fact that the same load resistance is always present means that a definite ratio of hum to polarizing voltage is maintained. An arrangement of this type is used in the Aerovox capacitor bridge.

Some means of detecting bridge balance will also be required. Since the signal frequency is 60 cycles, phones are not desirable because they are relatively insensitive at this frequency. By using an amplifier which tends to amplify the 60-cycle frequency and attenuate high frequencies, a sharper balance is obtained. Such an amplifier is illustrated in Fig. 10. If the choke L and the condenser C in the input circuit are chosen to resonate at 60 cycles (a 10-henry choke and an 0.5 mfd condenser will do the trick) a high voltage at 60 cycles will be developed

across C, which will be fed to the grid of the 6J5. There will be relatively little signal response at higher frequencies and what does get through may be further reduced by the bypass condenser (.01 mfd) across the grid circuit of the 6K6. A loudspeaker or copper-oxide meter will then serve well as a detector. The bridge is balanced when the signal heard or indicated is at a minimum. The bridge transformer may be any audio type for inter-stage use—a 1:3 step-up ratio is satisfactory.

Since the purpose of this testing is to determine whether or not the condenser in question is satisfactory for use, the problem of setting limits beyond which a condenser should be rejected arises. And this depends upon a number of factors. Some idea of what to expect in new condensers may be gathered from the specifications which have been set up for the Victory line of electrolytics, which will be standard for the duration. These are listed below:

Leakage—1 ma, plus .05 ma per mfd
Power Factor

25 V. and 50 V., DCW25%
150 V. to 250 V., DCW20%
450 V. DCW15%

Capacity Tolerance

Minus 15% to plus 200%

The higher power factors are encountered, as indicated, in the lower voltage bypass electrolytics. Since these are normally used as cathode bypasses and therefore shunt resistors of low value, neither the leakage nor the power factor considerations are as important as in the higher impedance circuits. The average run of new condensers will be well within the above limits in every respect. For use in power supply circuits where only low frequency hum is a consideration, a power factor has high as 50% will cause a loss in filtering efficiency in a standard

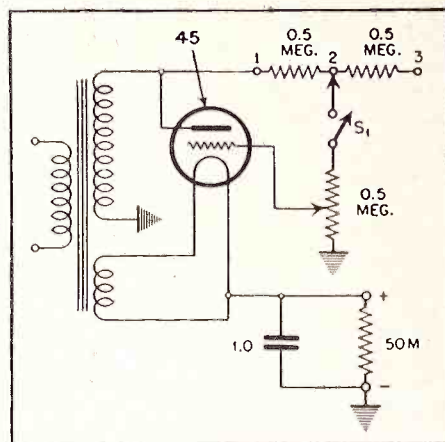

Fig. 9. This unique power supply furnishes both d-c for polarizing purposes and a-c for bridge tests.

power supply circuit of only around 15%, as compared with that provided by a perfect condenser. Usually, however, high power factor is accompanied other deficiencies, such as high leakage and low capacity, which combine to render the condenser unsatisfactory. Naturally, a certain amount of judgment must be exercised; if a condenser still performs acceptably in the circuit in which it is employed, but shows high leakage, power factor and low capacity on test, one may be certain that it is likely to require replacement in the very near future. Consequently it had better be done immediately rather than to wait for what is likely to be a "no-charge" call-back.

In testing condensers for industrial use, such as the motor-starting variety, severe heating will result if the power factor test shows above 20% power factor. Such condensers should measure close to their rated capacity—within 20%, at least, for satisfactory service. In radio receivers, we really don't care how high the capacity is (for filter circuits). The higher the capacity, the better the filtration.

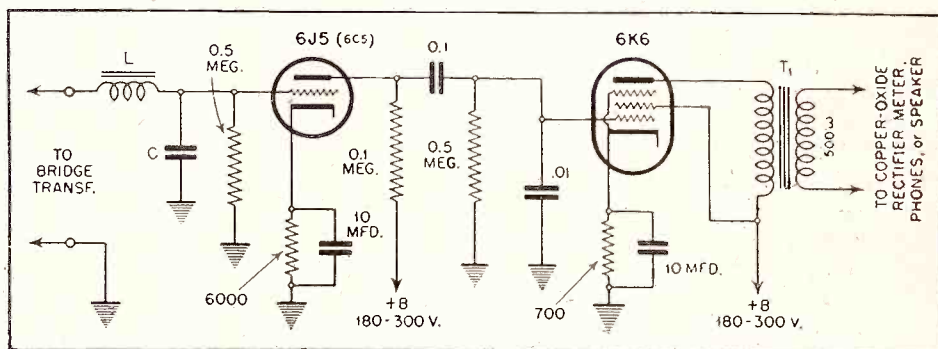

Fig. 10. This bridge amplifier is especially suited for use with capacitance bridges employing a 60-cycle signal source.

BATTERY PRODUCTION.

AND "MR" TUBES

By San D'Arcy

THAT there is a shortage of replacement tubes is well known. That farm radios are becoming inoperative in droves because there are no batteries is likewise common knowledge. That radio is daily becoming a most important factor in disseminating vital news events, crop control news, changes in rationing and other governmental regulations is likewise factual.

Many radio service-dealers and jobbers have wondered how long it would be before there would be a resumption of deliveries of batteries for farm radios. The answer came, like a bombshell, from War Production Board on May 17th. So the record may be clear, here is the complete release:

WPB Release 3570

"Production of radio batteries has been boosted to a rate of 425,000 a month, the Consumers Durable Goods Division of the War Production Board announced May 17th. This exceeds the pre-war volume, the Division said in reporting on WPB's program to bring relief to farmers in non-electrified areas of the nation who have felt the battery shortage most severely. These rural dwellers depend upon battery radios for daily war and food program news, as well as for entertainment.

"Initiated in mid-March, the battery program, at the present rate of production, and if continued over a twelve-month period would easily cover normal requirements for the 3,200,000 radios that are estimated to be on farms. The present monthly rate—more than double the mid-March output—is 50,000 more than the 1941 average monthly output of 375,000 radio batteries for the 2,700,000 sets estimated on farms that year. It is impossible to state now whether the present rate of production can be continued indefinitely.

"Breaking down these comparative figures reveals that in 1941 the production allowed an annual use of 1.4 batteries per radio per year. The current rate if continued, would exceed this allowance, and permit 1.62 battery sets per radio.

"This indicates one of the purposes in WPB's program—to accommodate increased daily use of radios. Reports indicate that farm radio listening-in time has increased about two hours a day. The goal of the supply program is not only to meet normal requirements, but to satisfy an abnormal anticipated need for 2.0 batteries per radio per year.

"Two factors in this supply problem dim the brightness of today's picture. One is the abnormal back-

log of radio battery requirements which has accumulated in the last nine months of curtailed production. It will take some time to balance supply and demand with such an initial handicap.

"The other is the uncertainty of maintaining present revived production. Facilities, manpower, and the critical materials that are involved in the production of radio batteries, are subject to prior claimants including the Army and Navy. The present reversion to civilian production is possible through a temporary lag in prior claims. For this reason it is not possible to predict how long production will continue at the present rate, whether it will be increased, or cut back again."

It is unnecessary to spend much energy analyzing the WPB announcement. Batteries are now being made and delivered to jobbers.

It is possible that deliveries of batteries may continue without serious interruption—or the materials shortage may again become acute.

"MR" Tubes

If it could work the WPB L-265 order would clean up a messy situation insofar as replacement tubes are concerned. There simply are no tubes for civilian radio sets now, but under L-265, as amended, there could be, *IF* tube makers can find the facilities for producing the "MR" tubes. There is the catch! We understand that government agencies plan to purchase about 120,000,000 tubes for the military services within the next year. Tube production facilities, as now established and working at peak capacity, are limited to a maximum output of only 110,000,000 tubes annually. If Uncle Sam needs for himself 10% more tubes than tube makers can produce, how can there be a surplus of

(Continued on page 32)

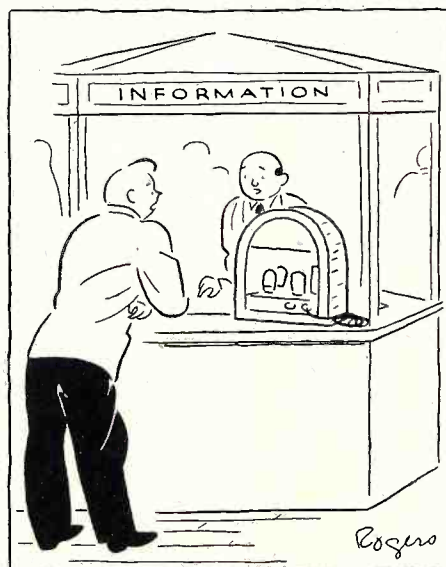

"No service shop in town will tell me how long it will be before I can get this set repaired. Can you tell me?"

SIGNAL CORPS TRAINING KITS

Part 2.

By J. P. Hollister

THE thrill which all of us have experienced in building our first radio is something we never forget. The magic in being able to connect together a few simple components and convert unseen, intangible waves into familiar voices and music is ever fascinating, the more so when we do the work ourselves. Because of this, thousands of radio trainees in the Armed Forces are finding that the long hours in the training schools often pass all too quickly, though each man looks forward eagerly to the time when the last connection has been made and the radio he has been assembling is "perking." Because no two radios are ever precisely the same, each man knows his is an individual, custom-built job, even though he uses the same hook-up as others. And there is always the possibility that a little added care in shortening a connection, or making a better soldered joint, or in rearranging the wiring, will make his radio work a little better than the best of the others.

In the Signal Corps training groups many radio kits are employed, ranging from the simplest one-tube types for beginners to a highly efficient five-tube broadcast super-heterodyne. Some of the simpler kits are ideal for experimental purposes around the shop and for teaching undergraduates in high schools. Many servicemen are utilizing their spare time in instructing junior classes in such work. The more complicated kits serve as perfectly good receivers, when assembled, which will equal or surpass the results obtained from many commercial models. Now that standard commercial types are practically extinct, these kits look to be a way out for those who have no receivers now.

Single Tube Models

The single tube receiver kit uses a 1E4G tube in a simple regenerative circuit, and will be found re-

markably efficient in pulling in distant stations. It is assembled on a steel chassis, which fastens to a steel panel. Both parts are available already punched for assembly of the parts.

The schematic of the 1-tube kit is shown in Fig. 1. A tickler-feedback

circuit is employed, the coil plugging into a specially designed, 5-prong socket. A 10,000-ohm potentiometer serves as regeneration control. The 1E4G filament is heated directly by a 1.5 volt dry cell. Although the filament of this tube is rated to operate at 1.4 volts, it is so designed that it

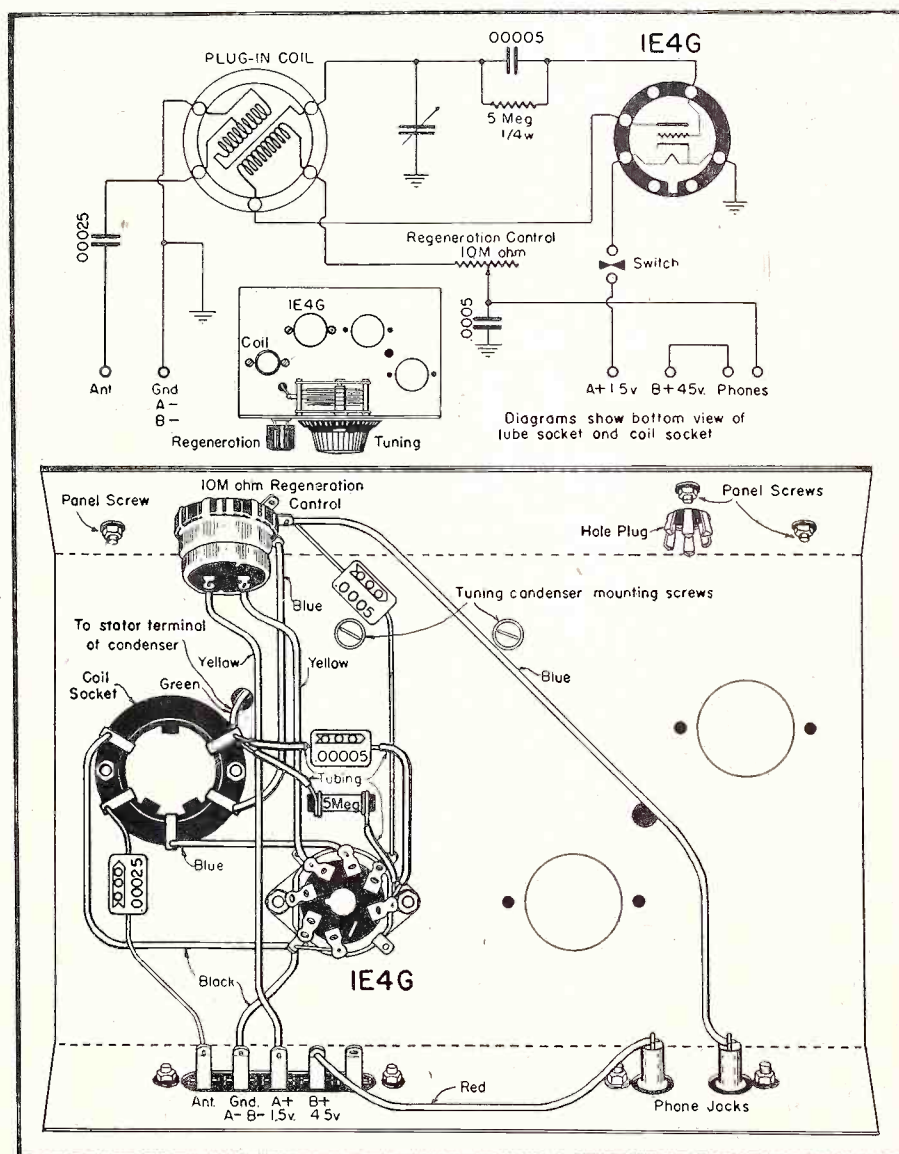

Fig. 1 (above) . . . Schematic of the 1-tube receiver kit and below (Fig. 2), the chassis layout.

of the driver tube must be isolated from the grid circuit of the succeeding tube so that grid may be negative with respect to its cathode and consequently not draw grid current.

The coupling condenser, or dc blocking condenser, is the controlling factor of the low frequency response of the audio amplifier. The larger the value of this condenser, the lower will be the impedance offered to the passage of low frequency audio voltages. This condenser is usually so chosen that the lowest frequency passed by the circuit will be on the flat portion of the amplifier response curve which would include the highest frequency that we wish to amplify.

The class B amplifier operates in such a manner that the power output is proportional to the square of the grid excitation voltage. The grid is biased to the cut-off point. Little or no plate current flows during periods of no excitation. Plate current flows only during the positive alternation of the excitation cycle. In order to increase the power output the grid may be allowed to swing positive on excitation peaks. If this is done, suitable filters must be used to remove harmonics from the output circuit. With the use of high plate voltage and bias the dynamic characteristic of the tube is fairly straight nearly to the cut-off value and the slight amount of distortion due to this curvature is not objectionable.

Fig. 15 shows the typical operation of one class B amplifier tube. To utilize such tube circuits in audio frequency work it is necessary to operate two tubes in a so-called "push-pull" circuit. This is necessitated to achieve a reproduction of the input voltage, since each tube reproduces only half an excitation cycle. The tube grids are connected to the extreme ends of a center tapped secondary on the input, or interstage, transformer. This allows the two tubes to be alternately ex-

Fig. 15. (a) Graphical analysis of a class B amplifier tube. (B) Push-pull circuit.

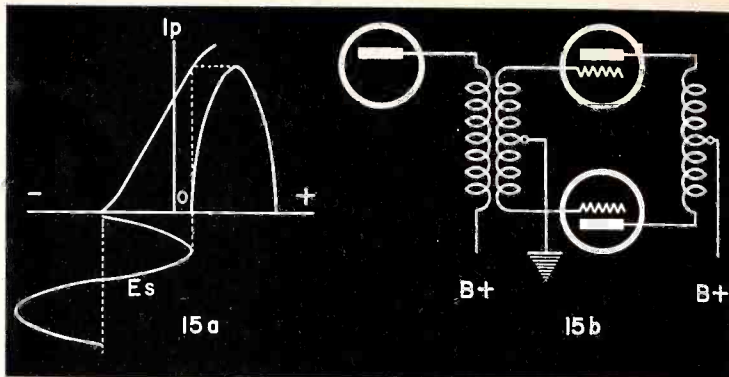

cited so that we achieve in the output circuit a reproduction of the input voltage.

The characteristic of such an amplifier is fairly high efficiency and output with a relatively low ratio of power amplification. This is due to the power required to produce the large excitation necessary. The minimum efficiency of such an amplifier is about 32% and the maximum efficiency attainable is about 78%.

Automatic Volume Control

To keep the receiver gain constant with varying signal intensities a system known as automatic volume control (AVC) has been in use for several years. The principle is very simple. A portion of the amplified i-f signal supplied to the second detector is rectified, passed through a resistor of proper value and the dc voltage drop across this resistor is applied as additional bias for the r-f and i-f tubes. As the signal voltage increases the rectified current through the resistor increases. This increases the bias on the controlled tubes and thus decreases the gain. To accomplish this it is necessary that the second detector, if to be used to provide both audio voltage to the audio amplifier and negative voltage to the controlled tubes, be hooked up as a negative rectifier. That is, we must connect the cathode to ground so that is the positive side of the circuit and our negative volt-

ages will then be taken off the high end of the voltage divider. The audio voltage is fed from the variable tap of this resistor to the audio stages and the rectified voltage that is to be used as AVC voltage is filtered by an RC combination and passed on to the controlled tubes. Such an arrangement is shown in Fig. 16.

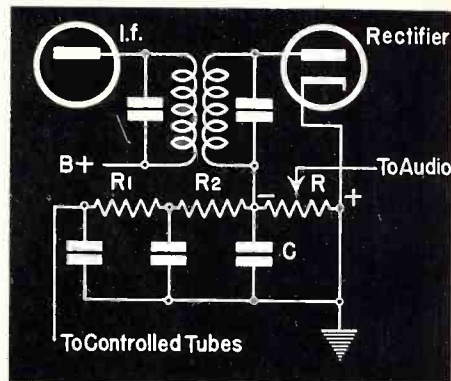

Fig. 16. Automatic Volume Control.

The output of the last audio stage may be fed through a suitable output transformer to a loud speaker of either the Dynamic or Permanent Magnet Type.

We have covered briefly so far the various components of a superheterodyne receiver. The omission, you may have noticed, is the power supply for the receiver. Since this is usually well understood by most students and technicians it will not be included in this article. For those who do not feel sure of power supply operation a bibliography will be found at the end of this article. This bibliography covers texts dealing with pertinent subjects related to radio receiver and other theory.

Bibliography:

- Fundamental of Radio—*Terman*
- Practical Radio Communications—*Nilson and Hornung*
- Elements of Radio—*Marcus and Marcus*
- Automatic Volume Control—*Rider*
- Radiotron Designers' Handbook—*Distributed by RCA.*



"Can you fix this by Oct. 8th?"

\$1.00 PAID FOR SHOP NOTES

Write up any "kinks" or "tricks-of-the-trade" in radio servicing that you have discovered. We will pay \$1 in Defense Stamps for such previously unpublished "SHOP NOTES" found acceptable. Send your data to "Shop Notes Editor," RADIO SERVICE-DEALER, 132 W. 43rd St., New York City. Unused manuscripts cannot be returned unless accompanied by stamped and addressed return envelope.

Answering Your Problems!

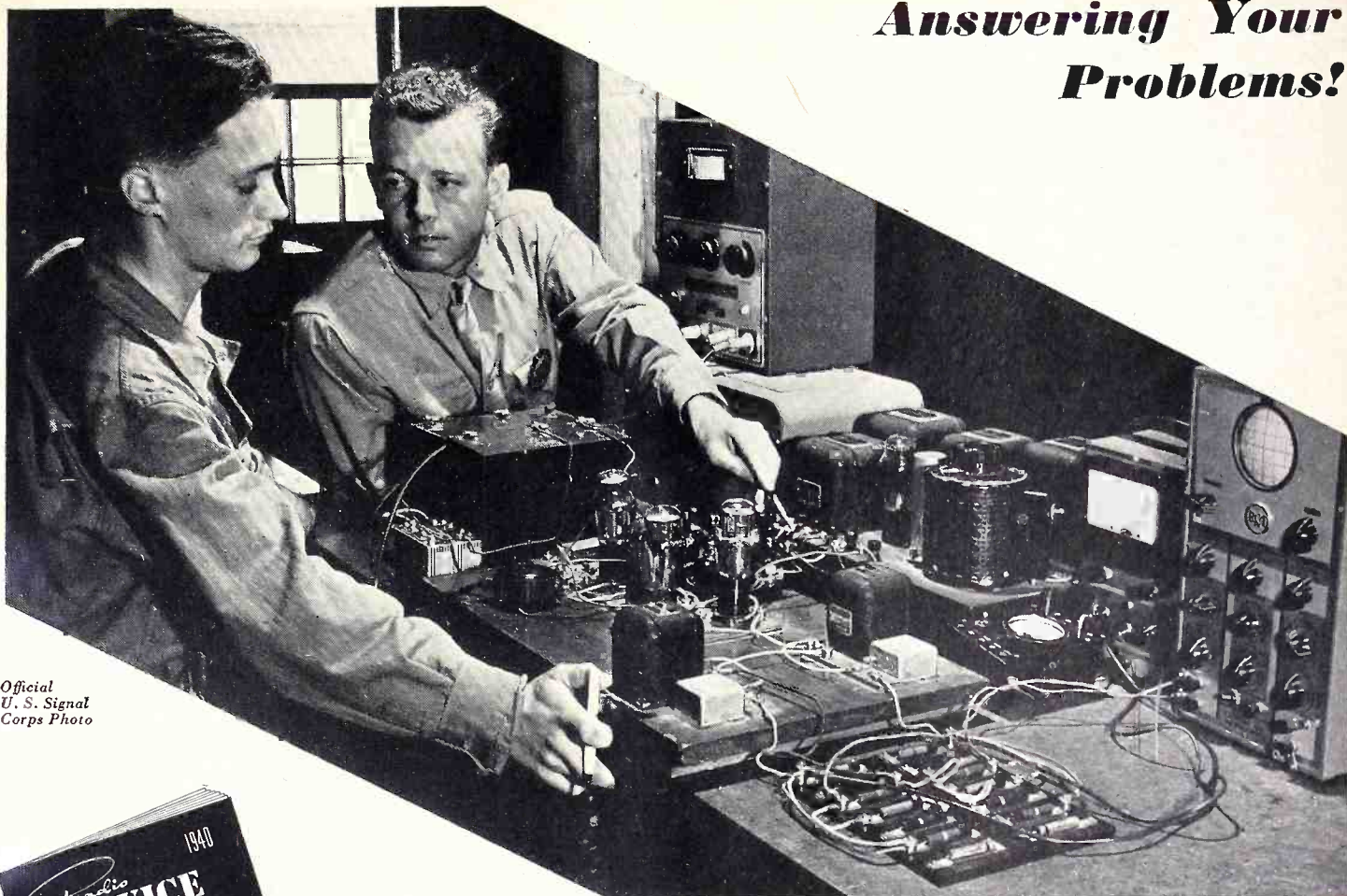

Official
U. S. Signal
Corps Photo

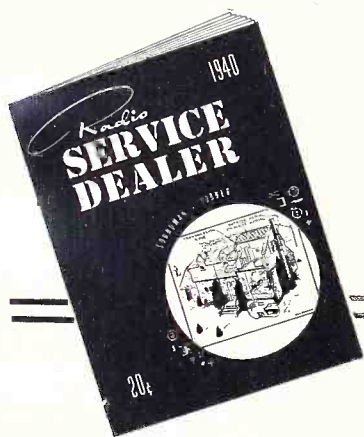

"MORE FOR YOUR MONEY"

*"Several magazines claim they are doing a terrific publishing job for radio servicemen and dealers. One even claims that it alone is responsible for helping to keep the radio service business alive during these trying times. That's baloney! I've found only one radio magazine that really knows what our problems are and is trying to do something to help us. Yes, it's 'Radio Service-Dealer' that delivers what we want—so please keep it up! "RSD" gives me much more for my money so I gladly pay you \$2 for a year's subscription rather than subscribe to other magazines that charge less, claim too much and deliver too little." (Signed L.H.R.)

*Mr. L. H. R., a Service-Dealer in Detroit, Mich., wrote this.

We have hundreds of cordial letters like it in our files.

Richard Alan,
Circulation Mgr. of "RSD."

TEAR OUT AND MAIL TODAY.

RADIO SERVICE-DEALER
132 West 43rd Street, New York City, N. Y.

Sirs: Here is my check (or money order) for \$..... Enter my subscription order to RSD for the next issues. (12 issues cost \$2.—24 issues cost \$3.) (Canadian and Foreign subscriptions are \$3 annually.)

Name (print carefully)

ADDRESS

CITY STATE I am

OWNER
 SERVICE MGR.
 SERVICEMAN

FIRM NAME

IS YOUR FIRM A: SERVICE-DEALER JOBBER MANUFACTURER

IF IN SOME OTHER BUSINESS, TELL WHAT IT IS:

LAST YEAR'S BONDS GOT US STARTED

THIS YEAR'S BONDS



ARE TO WIN!

★ Last year saw nearly 30,000,000 workers voluntarily buying War Bonds through some 175,000 Pay-Roll Savings Plans. And buying these War Bonds at an average rate of practically 10% of their gross pay!

This year we've got to top *all* these figures—and top them handsomely! For the swiftly accelerated purchase of War Bonds is one of the greatest services we can render to our country . . . and to our own sons . . . and our neighbors' sons. Through the mounting purchase of War Bonds we forge a more potent weapon of victory, and build stronger bulwarks for the preservation of the American way of life.

"But there's a Pay-Roll Savings

Plan already running in my plant."

Sure, there is—but how long is it since *you've* done anything about it? These plans won't run without winding, any more than your watch! Check up on it today. If it doesn't show substantially more than 10% of your plant's pay-roll going into War Bonds, it needs winding!

And you're the man to wind it! Organize a vigorous drive. In just 6 days, a large airplane manufacturer increased his plant's showing from 35% of employees and 2½% of pay-roll, to 98% of employees and 12% of pay-roll. A large West Coast shipyard keeps participation jacked up to 14% of pay-roll! You can do as well, or better.

By so doing, you help your na-

tion, you help your workers, and you also help yourself. In plant after plant, the successful working out of a Pay-Roll Savings Plan has given labor and management a common interest and a common goal. Company spirit soars. Minor misunderstandings and disputes head downward, and production swings up.

War Bonds will help us win the war, and help close the inflationary gap. And they won't stop working when victory comes! On the contrary—they will furnish a reservoir of purchasing power to help American business re-establish itself in the markets of peace. *Remember, the bond charts of today are the sales curves of tomorrow!*

You've done your bit  Now do your best!

THIS SPACE IS A CONTRIBUTION TO AMERICA'S ALL-OUT WAR EFFORT BY
RADIO SERVICE-DEALER

Servicing Facilitated By L-265

Order

By Charles Golenpaul*

THE first constructive legislation released by the War Production Board that actually benefits consumer, serviceman, and jobber, while cutting red tape to the bone is the recent WPB Limitation Order L-265.

Now for the first time the serviceman can really buy those replacements he needs in his work. Previous restrictions are swept aside. By submitting the defective part he has removed from radio or similar assembly, or certifying that he needs the replacement, he can walk into his jobber and get that requirement part. Meanwhile, the jobber in turn should have no hesitancy in giving that part to the serviceman since the jobber can replace his stock on this same part-for-part basis.

I like this new Limitation Order L-265. It's simple. It reduces paper work to a minimum. And yet it safeguards the use of our strategic materials as it should. The serviceman merely collects that part which he is replacing—or gets a certificate when he sells the customer. He does not have to pass the defective part on to the jobber. He must simply certify that he has collected the components in kind, or corresponding certificates. He must keep a record of the parts or certificates, and this record must balance with his purchases. The junked parts are turned in at scrap or salvage stations within 60 days of their collection.

This new order should work wonders in wartime servicing. Until now, unfortunately, many jobbers have held up on the release of their merchandise. They have held out for better odds, working under the false impression that they could not replace their stock, although they could have replaced whatever they sold by filing the PD-1X form. However, the present part-for-part routine now clears up all doubts as to stock replenishment *within the production scope of the manufacturers.* (Italics ours, ED.)

The serviceman did not have to flash a priority in order to buy replacement parts prior to L-265. The jobber did have to furnish a priority which he obtained through the PD-1X. The difference now with

L-265 is that the jobber can display his merchandise and make every effort to sell it, whereas before he doled out his precious stock only to pet accounts. The result was that some servicemen were out of luck. And millions of receivers were silent for want of proper repairs.

The WPB is certainly proving its intention of keeping American radio sets functioning, to the end that the American people can be kept informed and guided and encouraged at every stage in the winning of the war.

A Hint About Your Signal Tracer

By Robert Boudreaux

The Signal Analyzer or Signal Tracer, (whichever you prefer to call it) is more or less misunderstood by some servicemen. For that reason the writer undertakes giving some light on its adaptabilities to the modern service shop.

Many hours can be saved with the Tracer once the serviceman has learned to use it. I remember the time I bought mine—a friend told me that I would like it for three or four months and then I would stop using it. That was two years ago and I am not thinking of putting it aside.

The Atwater-Kent Model 487 whose gain data was published as Card 4, page 29, May 1943 RADIO SERVICE-DEALER, had a funny trouble in it. The RF gain was normal up to the diode detector, but past that it was extremely weak. By applying one volt on the control grid with the audio signal generator tuned for 400 cycles per second, there was a gain of only about 1 to 3 from the grid to the plate of the 2A6 tube. By placing an 8 mfd. condenser across from cathode to ground the gain would jump up to normal on the meter with its probe on the 2A6 tube. Seeing the voltage go up to normal for that type tube would encourage a serviceman, but the trouble was not found at that point.

Moving the probe to the 2A5 output tube's plate, a gain of about 1 to 2 was obtained which was far from being right. The solution was found by placing an 8 mfd. condenser from screen grid to ground (chassis) of the 2A5 which caused the voltage gain to go up to normal.

Now, you may think that it would have been easier to try the condenser across the screen grid in the first place, and such would be correct had there been any hum coming from the speaker; but in this set there was no hum, and a stage-to-stage gain test was the quickest way in which to isolate the fault.

This is a typical example of how this wonderful instrument, a Signal Tracer, can save hours for you.

OPA On Overtime

WHEN an appliance repair shop specifically offers to do a repair job in overtime hours, the customer requesting such a special service, and the work is actually done during overtime hours by mechanics who are paid time and a half, the shop may in most cases charge one and one-half times its regular customers' hourly rate, the Office of Price Administration announced.

This interpretation applies where the seller in March, 1942, the base period under the services regulation (Maximum Price Regulation No. 165), actually made an extra charge for overtime labor or where he did not regularly supply any overtime labor as such in March. In the first case, the repair shop has its overtime charge in March as a ceiling price. In the second case, where no overtime was regularly supplied in March, the special overtime service now becomes a new or different service, and the maximum price for it is determined either by the nearest competitor's charges or by the use of the regular percentage margin mark-up formula provided by the regulation.

The only case in which the special charge cannot be made is where the repair shop regularly worked overtime in March without making any distinction in its charges for regular hours and overtime hours.

In all cases, overtime work at an extra charge must be specifically authorized by the customer, and the extra charge cannot be made merely because employees are worked overtime to finish a job which the customer intended to have completed within regular shop hours.

*Sales Manager, Aerovox Corp.

FOR THAT
MARCH
HEADACHE

SYLVANIA SERVICEMAN SERVICE

by
FRANK FAX



Is the memory of income tax day still painfully fresh? Was the preparation of the form almost as hard as digging up the scratch to pay?

Well, this is just the time to tell you about the new Sylvania Business Record Book. It's a simple week-by-week bookkeeping system, specially designed for your business. Layout was directed by Rodman L. Modra, who was formerly Chief Deputy Collector of U. S. Internal Revenue. This tax expert tells how to use it.

Use it in conjunction with Sylvania's 3-in-1 daily Service Forms, and you have a complete record of daily business dealings for the year.

And it's useful not only for tax purposes. These are days of reports, questionnaires and affidavits that must be filled out. The Sylvania Business Record Book enables you to answer any quiz the experts give.

Buy your own bookkeeping service for only \$1. If your jobber is unable to supply you, write to Frank Fax, Dept. RS-6, Sylvania Electric Products Inc., Emporium, Penna.

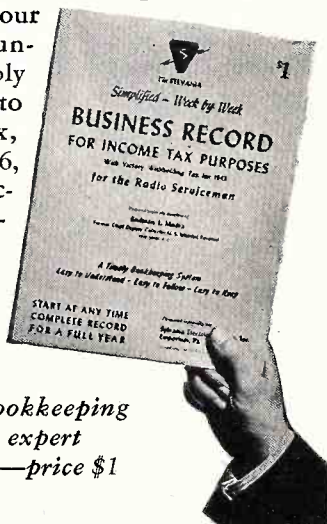

Complete bookkeeping system with expert instructions—price \$1

SYLVANIA

ELECTRIC PRODUCTS INC.
RADIO DIVISION

Trouble-Shooting Short-Cuts

(Continued from page 6)

could be secured by reducing the avc filter resistor values proportionately, this is likely to lead to other difficulties.

Occasionally troubles are present in receivers when the chassis is installed in its cabinet but the set functions satisfactorily when removed from the console. Many such cases are due to warping of the wood, which places the chassis under strain and sometimes bends it so that closely adjacent parts are shorted; or intermittent action becomes evident when the vibrations of the speaker, coupled with the warping, causes intermittent shorts. Sometimes, too, longer mounting bolts are substituted for those normally supplied to hold the chassis in place and a short results due to the excess length of the bolt grounding some portion of the receiver circuit.

In many of the smaller receivers using a single i-f stage and no r-f pre-selection, strong stations at the low frequency end of the dial can be heard even when the oscillator section of the pentagrid converter is inoperative. In such cases the i-f trimmers are usually somewhat mis-tuned so that the circuit is even broader than usual. Then, when the set is tuned to the low frequency end of the dial, it functions as a tuned r-f receiver rather than as a super-heterodyne and the low-frequency broadcast signal rides through. When the gang condenser is tuned to higher frequencies, the signal becomes progressively weaker, but no other stations are brought in.

Occasionally, too, only a single station can be tuned in no matter where the receiver dial is turned, but for an entirely different reason. If there is no change in output volume as the dial is rotated, we can be pretty certain that the trouble is merely a loose set screw connecting the dial and condenser shaft. Variants on this theme are conditions where the dial bushing is not concentric with the condenser shaft so that the condenser is turned, while the set screw is loose, but only over a portion of the range. In such cases we shall find that one or more stations tune very broadly while others seem to tune normally. Once experienced, it is easy to identify such troubles when they recur.

Bench Test Method

When the set is on the shop bench, it is convenient to keep in mind the

major sections of the receiver, as shown in Fig. 1. If we break it up into these sections as has been done in this block diagram, it is simpler to isolate the section in which the fault is present. Once we have established this, it requires merely a check of the components in the particular section affected rather than a test of the entire receiver.

In either signal tracing or signal injection, the usual practice is to check each circuit or stage in the numerical order (or the reverse) given in the diagram. Thus, in signal tracing, we would start at the antenna, feeding a signal to the receiver at this point, and check with the signal tracer the presence or absence of the signal at each succeeding point in the order marked. For signal injection, we would connect an output meter across the voice coil and feed the signal to each stage, starting at the grid of the power output tube and working back to the antenna stage. Each time the signal was injected, we would check to note the response in the output meter.

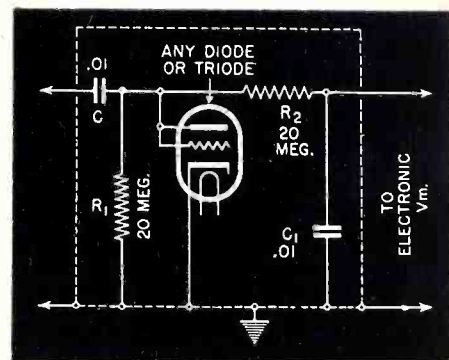

Fig. 3. Used in conjunction with the electronic voltmeter of Fig. 2, this rectifying circuit enables a-c tests to be made.

Instead of this step-by-step method, we can of course take in broader sections of the receiver in much the same manner as we discussed earlier in this article. That is, we can feed a signal—in the case of the signal injection method—to the input of the audio section and note the resulting output. If there isn't any—fine, the trouble's in the a-f section. If there is output—equally fine, we know we should look elsewhere for the trouble.

In the case of signal tracing, we do just the reverse. We feed the signal to the antenna and check at the second detector to see if the signal has progressed through the r-f and i-f stages. If so, then we know the trouble's in the a-f section.

Of course, again, much can be done without instruments. For instance, if there is a tuning indicator on the set, we need not hook up a signal

tracer to find if there is any response up to the second detector. If there is no signal, we will get no indication on the magic eye or other indicator, when we feed a signal to the antenna. Naturally, this isn't the whole story; perhaps the indicator isn't working, perhaps there's something wrong in the a-c system. Maybe, too the power supply isn't delivering any juice. But if we do get a healthy closure of the eye when we apply a normal broadcast signal to the antenna input, we can be pretty certain that we'll save time by looking in the audio system for the trouble.

The above is based on the assumption that the receiver under test is inoperative or, at least, almost so. If the trouble is noise, or hum, or oscillation, or any of the other annoying manifestations peculiar to radios, then we still follow substantially the same method, but instead of looking for a replica of a signal fed to a point in the receiver, we look for the presence or absence of the noise or other abnormal sound in the section under test.

A circuit diagram of an electronic voltmeter similar to that used in the Rider Chanalyst is shown in *Fig. 2*. This covers from 0.2 to 500 volts in four ranges. A special scale is required, so calibrated that the zero is in the center. The principle of operation has been described before, but for the benefit of newcomers let us go over it again. A milliammeter in the cathode circuit of a type 76 triode is adjusted to read half scale (0.5 ma) by means of the 10,000 ohm zero adjusting rheostat and the 6000 ohm calibrating adjustment, the latter being adjusted only when tubes are changed. If we now apply a positive voltage to the grid of the type 76 tube, the cathode current will increase and consequently the meter reading will be higher; if we apply a negative voltage to the input the cathode current will decrease and the meter pointer will accordingly swing toward zero. Thus in measuring positive voltages, with respect to ground, the meter reading increases and for negative voltages it decreases. At full sensitivity, 5 volts positive swings the pointer to full scale and 5 volts negative swings it to zero. The voltage divider in the input circuit enables the four ranges to be covered.

This meter is automatically protected against excessive overload or damage. If a high negative voltage is applied to the input, the meter pointer swings to zero; it cannot read less, because the negative voltage simply drives the cathode current to zero. If an excessive positive

voltage is applied, the meter pointer may swing off scale, but the current is limited by the voltage drop through the 27,000-ohm plate resistor, and cannot become sufficiently great to burn out the coil.

The electronic voltmeter is adapted only to checking d-c voltages. It is used with a shielded cable and probe point. In series with the probe is a 1-megohm resistor. In combination with the 10-megohm input, this gives a total input impedance of 11 megohms, so the loading on the circuit under test is very small.

This instrument is most useful for checking d-c voltages in high impedance circuits, such as the plate and

grid circuits of resistance-coupled amplifiers, the oscillator grid voltage resulting from rectification, screen voltages, etc. It may be adapted to a-c tests by using a diode or triode in a circuit illustrated in *Fig. 3*. The circuit under test is then coupled to the diode input and the output of this rectifying unit is coupled directly to the electronic voltmeter. The input voltage divider of the electronic voltmeter had best be removed to increase the sensitivity. The calibration for a-c will not be the same as that for d-c.

These two units will come in handy for a multitude of tests in signal and other circuits.



In plane-to-plane-to-base communication as demonstrated in the Aleutians Ken-Rad Electronic Tubes guide and guard our forces in the air on the land and sea In all allied maneuvers everywhere instant communication knits together our combat units "Coordination through communication" — that's the success story now being recorded in every global quarter Knowing this Ken-Rad's army of service men dealers and distributors are glad to wait for their full quota of Ken-Rad tubes None of us — ever! — will keep Victory waiting one needless second

KEN-RAD

RADIO TUBES • INCANDESCENT LAMPS • TRANSMITTING TUBES

OWENSBORO • KENTUCKY

for Permanent
Resistance
Today and
Tomorrow...

OHMITE Resistors

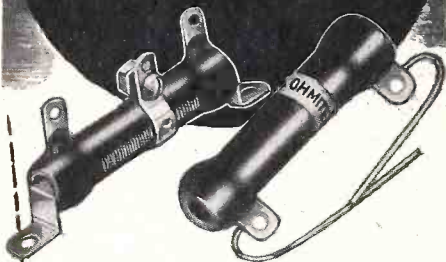

Consistent performance day-after-day under a wide range of operating conditions has proved the dependability of Ohmite Resistors. This rugged quality has enabled Ohmite Brown Devils and Dividohms to keep existing installations going longer. It has also made them especially well fit for today's wartime applications... and tomorrow's peacetime needs.

Handy Ohm's Law Calculator

Figures ohms, watts, volts, amperes—quickly, accurately. Solves any Ohm's Law problem with one setting of the slide. Send only 10c in coin for handling and mailing. (Also available in quantities.)



10c



OHMITE MANUFACTURING CO.
4847 Flourney St. • Chicago, U. S. A.

Signal Corps Training Kits

(Continued from page 21)

Coils are available to cover the following short-wave ranges:

- 70 to 200 meters
- 35 to 70 meters
- 15 to 35 meters

as well as the standard broadcast band of 545 to 1500 kc.

AC-DC Models

There are many who prefer to do away with batteries, and for such ac-dc kits are available. These function similarly to the battery models, although different tubes, components and more care in layout and operation are required. The circuit is the same as for the battery types, insofar as the detector is concerned, and

the same coils may be employed to cover the ranges given for the battery models.

A schematic of the two-tube ac-dc kit is shown in Fig. 7 and the corresponding wiring diagram in Fig. 8. The first type 76 tube is employed as a regenerative detector in the same type of circuit used for the battery-operated kit. The second type 76 tube has its grid and plate joined, and serves as a diode half-wave rectifier. The 20,000-ohm resistor in its cathode circuits acts as a filter resistor and is bypassed by the two 8-mike electrolytics, which serve to remove most of the hum.

The three-tube ac-dc kit, shown in Figs. 9 and 10, is similar to that just described, but has a single-stage resistance-coupled audio amplifier added. The type 76 tube has greater

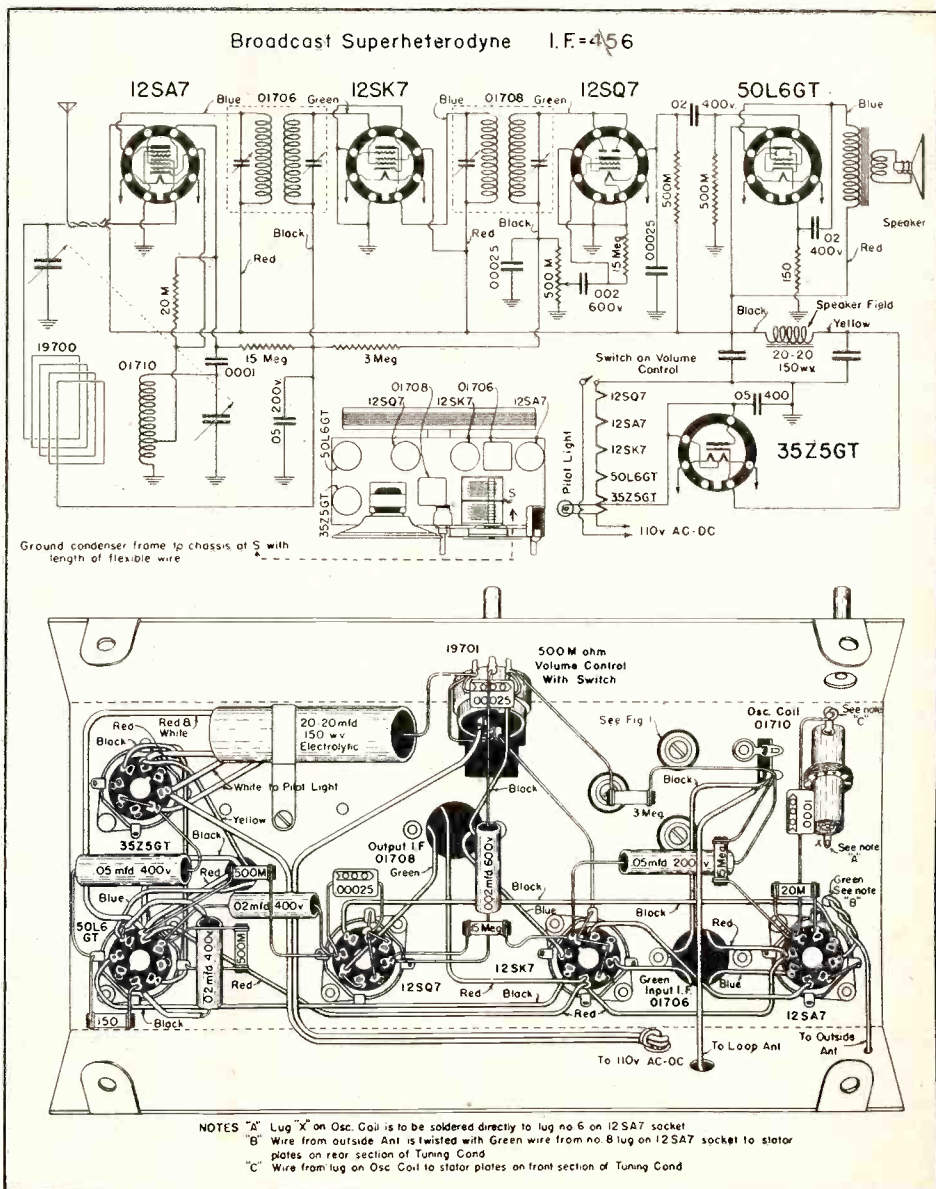

Fig. 11. (above)—This 5-tube a-c/d-c receiver meets the need not only for an advanced training kit but also as a home receiver for custom-built installations. Fig. 12 (below)—shows how easy it is to follow the wiring.

power output than the small battery tubes used in the battery-operated kit, and adequate power will be found available to operate a midget speaker, preferably of the magnetic type, on strong signals.

Because one side of the a-c line is grounded, particular care must be taken in operating these ac-dc models. If the metal chassis is placed where it may touch other metal, such as a radiator, pipe, etc., there is a possibility of crossed grounds resulting which will damage the apparatus or blow out the line fuse. Do not touch any of the metal parts when the set is in use without making certain that no grounds may result. These kits should be reserved for the use of more advanced students who will understand the need for such precautions, which are not peculiar to these particular kits but apply also to an ac-dc chassis.

The 5-tube ac-dc broadcast superheterodyne circuit shown in Fig. 11 follows along the design lines of the better commercial receivers. It will therefore serve not only for training advanced students but also as an excellent item for dealers and servicemen who need a chassis for custom-built installations. The tube lineup assures adequate sensitivity and power output, and its adaptability to modern apartment house use in large metropolitan centers is obtained through the use of a built-in loop antenna. The sensitivity is high enough so that the average field strength of local stations will produce full power output, and, for weak, distant stations, an external antenna may be employed, coupled to the loop by twisting around one of the loop leads.

In this receiver, the 12SA7 pentagrid converter is coupled to a single 12SK7 i-f stage operating at 456 kc, thence to a 12SQ7 detector, avc and 1st a-f amplifier. The powerful 50L6GT beam power output tube feeds a dynamic speaker, the speaker field of which serving as a filter choke. The 25Z5GT rectifier has its heater tapped to provide the proper voltage for the pilot light. The negative voltage developed at the oscillator grid, when oscillating, is coupled to a voltage divider circuit formed by a 15-megohm 3-megohm and 500,000-ohm resistor (the volume control) in series, and the voltage resulting at the junction of the 15- and 3-meg. resistors is employed as a bias for the 12SA7 and 12SK7, in addition to that provided by the avc system.

By this unique feature, the normal increase in oscillator voltage which occurs at the high-frequency portion of the tuning range and which re-

INSTRUCTORS!

Send for this **NEW**
FREE BROCHURE



RADIO TRAINING KITS

Lafayette's Special Department for handling the needs of instructors and school management has just prepared this new brochure to aid schools in their government training courses. We are helping Uncle Sam to teach radio and we can help you too.

Lafayette Radio is headquarters for all radio and electronic parts and equipment of every nationally known manufacturer in the field. A single order, no matter how large or how small, will bring prompt delivery on all your requirements.

Send for your free copy of "Radio Training Kits" brochure today.



write now - address:

School Sales Division
901 West Jackson Boulevard
Chicago, Illinois

Dept. 6K3

**"Quick Deliveries
on Radio and Electronic
Parts and Equipment"**



*Parts
by*
Centralab

- Steatite Insulators
- Ceramic Trimmers
- High Frequency Circuit Switches
- Volume Controls
- Ceramic Capacitors
- Wire Wound Controls
- Sound Projection Controls

Div. of Globe-Union Inc., Milwaukee, Wis.

for Permanent
Resistance
Today and
Tomorrow...

OHMITE Resistors

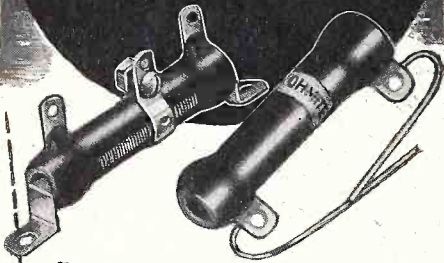

Consistent performance day-after-day under a wide range of operating conditions has proved the dependability of Ohmite Resistors. This rugged quality has enabled Ohmite Brown Devils and Dividohms to keep existing installations going longer. It has also made them especially well fit for today's wartime applications... and tomorrow's peacetime needs.

Handy Ohm's Law Calculator

Figures ohms, watts, volts, amperes—quickly, accurately. Solves any Ohm's Law problem with one setting of the slide. Send only 10c in coin for handling and mailing. (Also available in quantities.)



10c



OHMITE MANUFACTURING CO.
4847 Flourney St. • Chicago, U. S. A.

Signal Corps Training Kits

(Continued from page 21)

Coils are available to cover the following short-wave ranges:

- 70 to 200 meters
- 35 to 70 meters
- 15 to 35 meters

as well as the standard broadcast band of 545 to 1500 kc.

AC-DC Models

There are many who prefer to do away with batteries, and for such ac-dc kits are available. These function similarly to the battery models, although different tubes, components and more care in layout and operation are required. The circuit is the same as for the battery types, insofar as the detector is concerned, and

the same coils may be employed to cover the ranges given for the battery models.

A schematic of the two-tube ac-dc kit is shown in Fig. 7 and the corresponding wiring diagram in Fig. 8. The first type 76 tube is employed as a regenerative detector in the same type of circuit used for the battery-operated kit. The second type 76 tube has its grid and plate joined, and serves as a diode half-wave rectifier. The 20,000-ohm resistor in its cathode circuits acts as a filter resistor and is bypassed by the two 8-mike electrolytics, which serve to remove most of the hum.

The three-tube ac-dc kit, shown in Figs. 9 and 10, is similar to that just described, but has a single-stage resistance-coupled audio amplifier added. The type 76 tube has greater

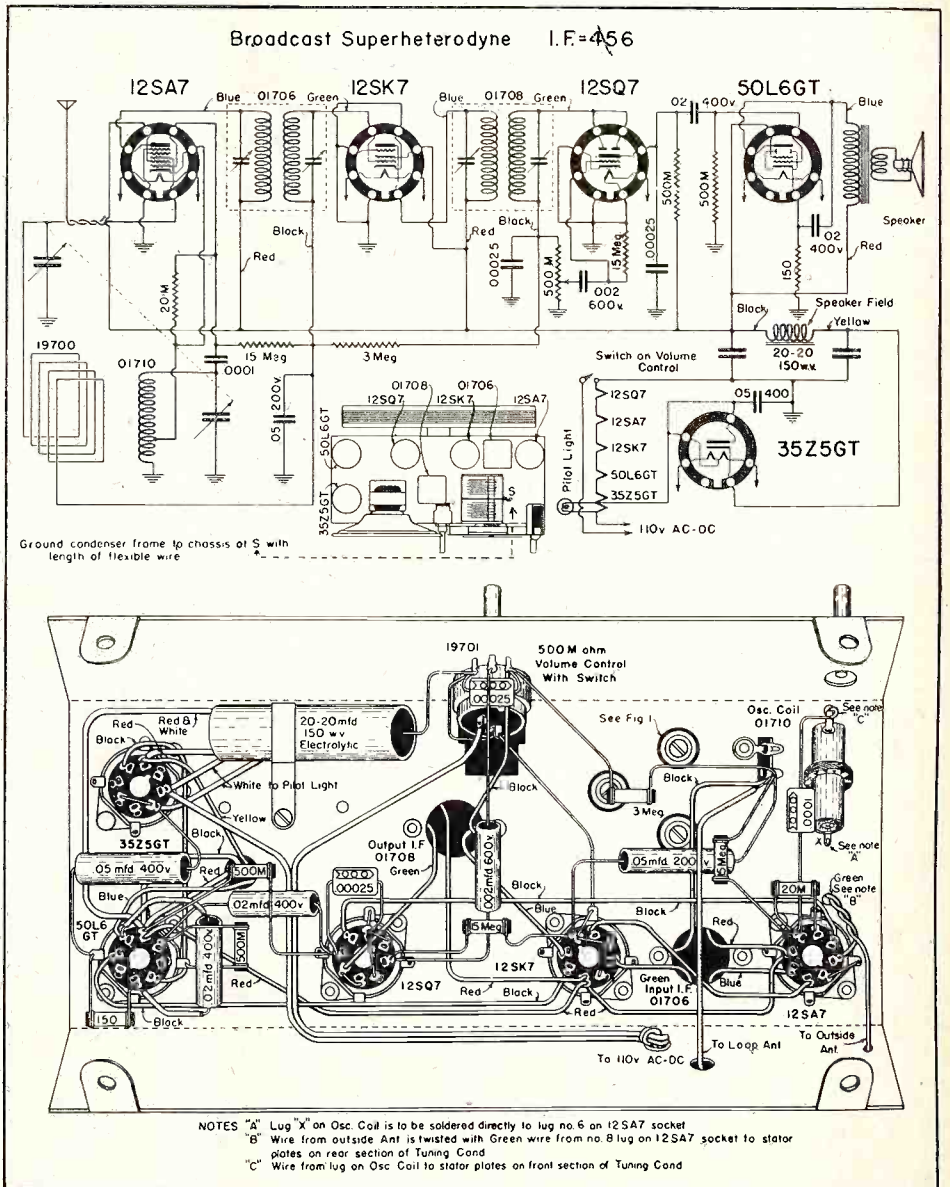

Fig. 11. (above)—This 5-tube a-c/d-c receiver meets the need not only for an advanced training kit but also as a home receiver for custom-built installations. Fig. 12 (below)—shows how easy it is to follow the wiring.

power output than the small battery tubes used in the battery-operated kit, and adequate power will be found available to operate a midget speaker, preferably of the magnetic type, on strong signals.

Because one side of the a-c line is grounded, particular care must be taken in operating these ac-dc models. If the metal chassis is placed where it may touch other metal, such as a radiator, pipe, etc., there is a possibility of crossed grounds resulting which will damage the apparatus or blow out the line fuse. Do not touch any of the metal parts when the set is in use without making certain that no grounds may result. These kits should be reserved for the use of more advanced students who will understand the need for such precautions, which are not peculiar to these particular kits but apply also to an ac-dc chassis.

The 5-tube ac-dc broadcast superheterodyne circuit shown in *Fig. 11* follows along the design lines of the better commercial receivers. It will therefore serve not only for training advanced students but also as an excellent item for dealers and servicemen who need a chassis for custom-built installations. The tube lineup assures adequate sensitivity and power output, and its adaptability to modern apartment house use in large metropolitan centers is obtained through the use of a built-in loop antenna. The sensitivity is high enough so that the average field strength of local stations will produce full power output, and, for weak, distant stations, an external antenna may be employed, coupled to the loop by twisting around one of the loop leads.

In this receiver, the 12SA7 pentagrid converter is coupled to a single 12SK7 i-f stage operating at 456 kc, thence to a 12SQ7 detector, avc and 1st a-f amplifier. The powerful 50L6GT beam power output tube feeds a dynamic speaker, the speaker field of which serving as a filter choke. The 25Z5GT rectifier has its heater tapped to provide the proper voltage for the pilot light. The negative voltage developed at the oscillator grid, when oscillating, is coupled to a voltage divider circuit formed by a 15-megohm 3-megohm and 500,000-ohm resistor (the volume control) in series, and the voltage resulting at the junction of the 15- and 3-meg. resistors is employed as a bias for the 12SA7 and 12SK7, in addition to that provided by the avc system.

By this unique feature, the normal increase in oscillator voltage which occurs at the high-frequency portion of the tuning range and which re-

INSTRUCTORS!

Send for this **NEW FREE BROCHURE**



RADIO TRAINING KITS

Lafayette's Special Department for handling the needs of instructors and school management has just prepared this new brochure to aid schools in their government training courses. We are helping Uncle Sam to teach radio and we can help you too.

Lafayette Radio is headquarters for all radio and electronic parts and equipment of every nationally known manufacturer in the field. A single order, no matter how large or how small, will bring prompt delivery on all your requirements.

Send for your free copy of "Radio Training Kits" brochure today.



write now - address:

School Sales Division
901 West Jackson Boulevard
Chicago, Illinois

Dept. 6K3

"Quick Deliveries on Radio and Electronic Parts and Equipment"

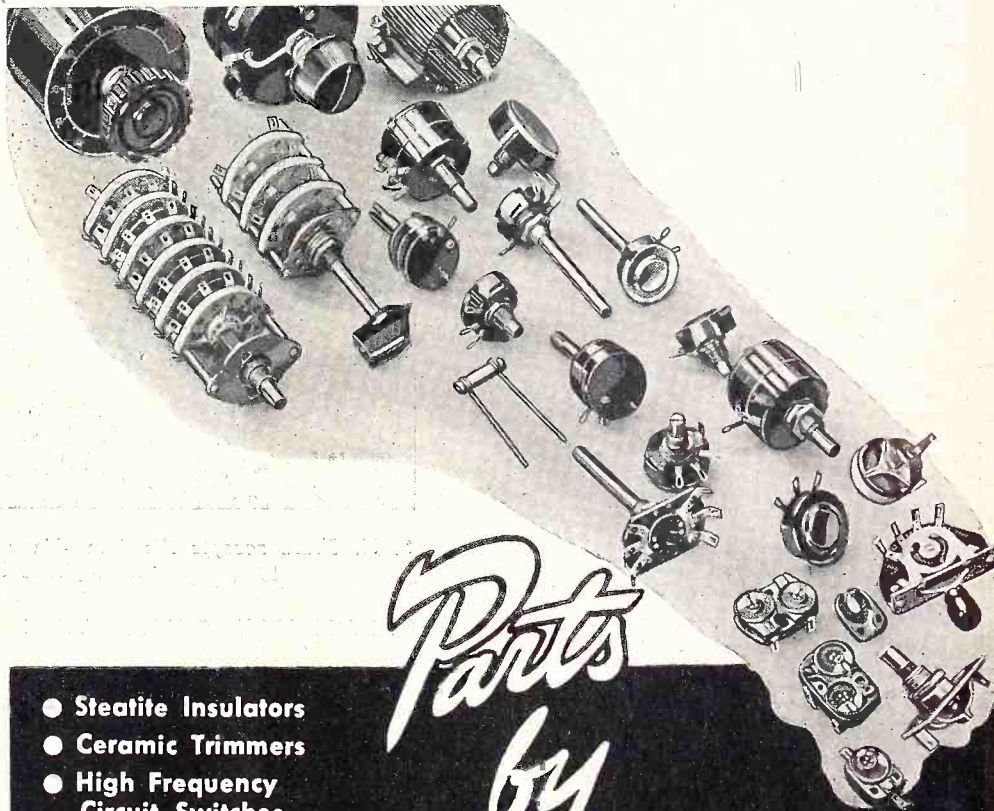

Parts by
Centralab

- Steatite Insulators
- Ceramic Trimmers
- High Frequency Circuit Switches
- Volume Controls
- Ceramic Capacitors
- Wire Wound Controls
- Sound Projection Controls

Div. of Globe-Union Inc., Milwaukee, Wis.

Super-Sealed PAPER TUBULARS



• Those super-sealed Aerovox paper tubulars are just as good as they look. Beneath that colorful yellow-black-and-red label jacket, you'll find an extra-generously-waxed cartridge for maximum protection against moisture penetration. Likewise the extra-generously-waxed ends neatly milled and with pigtail leads that won't work loose. In all climes—from frigid Arctic to torrid tropics, these paper tubulars are establishing new performance records. 400, 600, 1000 and 1600 v. D.C.W. Popular capacities.

• Ask Our Jobber . . .

Ask for these Aerovox paper tubulars. Ask for other wartime capacitors you need. Ask for our latest "Victory" catalog—or write us direct.



AERVOX CORP., NEW BEDFORD, MASS., U. S. A.
In Canada: AERVOX CANADA LTD., HAMILTON, ONT.
Export: 100 VARICK ST., N. Y. C. • Cable: 'ARLAB'

VICTORY LINE

Aerovox Condensers, Consolidated Resistors, Ductone Recording Blanks, Ken-Rad Radio Tubes, Leotone Pickup Needle Screws, Mueller Battery Clips, Wright, Inc. Speakers, Walsco Knob Springs, Dial Drive Springs, Radio Set Screws, Radio Cement, Snap-in Trimouts, Scratch Removing Polish, Radio Troubleshooters Handbook 3rd Edition, \$5.00 Postpaid.

Established 10 Years
Price List Free To Dealers
Advance Deposits On Tube Orders Accepted
Interested in Sub-Contracts

Anchor Radio Distributing Service Co.
Box 21 Ithaca New York

sults in a greater negative potential at the oscillator grid, due to rectification, is put to work to increase the bias on the 12SA7 and 12SK7 tubes. This reduces slightly the sensitivity at this end of the range (where it would normally be higher) and thus produces a more uniform degree of sensitivity throughout the tuning range. On strong signals, this biasing of the grids is further augmented by the avc action, which is accomplished in the usual manner through the medium of the 12SQ7 diodes. And, for weak signals, the avc action is rendered less effective due to the decreased gain resulting from the oscillator biasing, so that the net result is a slight increase in sensitivity over and above that which would normally result from the application of this system, were the avc to act with the same effectiveness as with stronger signals. Which is just what we want.

The tuning range is from 540 kc to 1600 kc. The oscillator section of the two-gang tuning condenser is specially shaped to provide the proper frequency difference without the use of padding condensers, thus simplifying the aligning problems, which

simmer down to a matter of adjusting the oscillator trimmer at 1400 kc, the test signal being fed to the loop by means of a small auxiliary loop connected to the test oscillator output and placed several inches away from the receiver loop, to avoid interaction between the two.

Because the power line is connected directly to the chassis, a non-metallic cabinet and non-metallic knobs must be employed to avoid any possibility of a person making contact with any metallic portion of the set. The back of the set should also be protected against inquisitive fingers, yet ventilation should be provided. Take care that the mounting screws are insulated and, in servicing, do not attempt to remove the chassis from the cabinet before disconnecting the power plug from the wall receptacle. These precautions are standard with all ac-dc receivers.

All of these kits described in this article are available from the Miessner Manufacturing Company, through whose courtesy, plus that of the Signal Corps, we have been permitted to reproduce the schematics and layouts.



S. N. Shure accepts the Army-Navy "E" Burgee awarded to Shure Bros., "Microphone Headquarters."

WESTERN S-M GROUP CHANGES TITLE

» » The Sales Managers Club, Western Group, a trade association of radio parts manufacturers which has been in existence for over ten years, has changed its name to the Association of Electronic Parts and Equipment Manufacturers, to be known in the trade as "E. P. & E. M." The Association, which now has over fifty members, has made this change so as to be readily identified with the industry which it represents. There will be no change in the functions of the organization. The group meets on the second Thursday of each month in Chicago, and has

been a potent factor in radio industry matters. It is currently rendering a service to its members on priorities problems, price controls, government contracts and regulations, and manpower problems. It is also giving earnest consideration now to post war planning. The present chairman of E. P. & E. M. is Mr. Jerome J. Kahn. The Sales Managers Club, Eastern Group, has not changed its name but will continue its identity and affiliation with the Western Group as heretofore.

★

BUY MORE WAR BONDS

NEW TRAINING KITS BROCHURE

Lafayette Radio Corporation's Special Department for handling the needs of instructors and school management has just prepared this new brochure to aid schools in their government training courses.

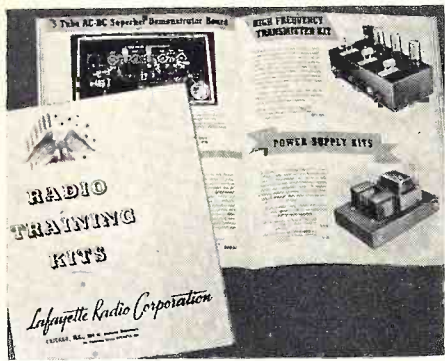

Lafayette's engineers have expressly designed the kits mentioned in this folder to fit present training programs. Starting with fundamentals and progressing to basic receiver and transmitter operation, a progressive training program may be built up around these kits. Lafayette Radio Corporation, 901 W. Jackson Blvd., Chicago, Illinois.

★

BOOK THAT "SELLS" SOUND

A 24-page book on "Music and Manpower," has just been released by Operadio Manufacturing Company, of St. Charles, Illinois.



Treating the subject of industrial music as a production factor both historically and currently, the book represents important reading to any executive concerned with the problem of maintaining or increasing war production in the face of a dwindling manpower supply.

Although only a limited edition has been printed, a copy of "Music and Manpower" will be sent gladly to any executive addressing Operadio Manufacturing Company, St. Charles, Illinois.

G. E. EXPANDS ITS NEWS PROGRAM

The General Electric Company expanded its radio news service to the public from three to six nights a week, and increased the number of stations on the Columbia Broadcasting System carrying this news program from 60 to 117, when it began sponsoring the

10-minute news program, "The World Today" 6:45-6:55 P.M., EWT, on May 31. This was announced by Dr. W. R. G. Baker, Vice President of the company in charge of G.E.'s Electronics Dept. The new program supplants the former news program sponsored by General Electric, carried at 6 P.M., EWT, for over a year on CBS.

Look for those GREEN cartons

★ Although Clarostat is now 100% on war work, Clarostat jobbers still have a stock of essential Clarostat replacements. And those civilian Clarostats fully reflect the performance, dependability and reputation demanded by our armed forces.

★ So look for the green Clarostat carton. It is your guarantee of getting "tops" in controls and resistors.

Are You Moving?

Notify RSD's circulation department at 132 West 43rd Street, New York City of your new address 2 or 3 weeks before you move. The Post Office Department does not forward magazines sent to a wrong address unless you pay additional postage. We cannot duplicate copies mailed to your old address. Thank You!

STANCOR
TRANSFORMERS
First Choice of Servicemen!



STANDARD TRANSFORMER
 • CORPORATION •
 1500 NORTH HALSTED STREET . . . CHICAGO

PLUGS JACKS

U. S. ARMY
SIGNAL CORPS
U. S. NAVY
APPROVED



NAF-1136-1
PL-68, PL-54
PL-55, JK-26
JK-48, PL-291
NAF-212938-1

Prompt Deliveries

UNIVERSAL MICROPHONE CO., LTD.
424 WARREN LANE
INGLEWOOD, CALIFORNIA

TRIPLETT *Combat Line* TESTERS

Pocket
Size
MODEL
666H



 VOLT-OHM-MILLIAMMETER

Although some older designs are no longer obtainable, several alternate models are available to you under Government requirements.

TRIPLETT ELECTRICAL INSTRUMENT CO., BLUFFTON, OHIO

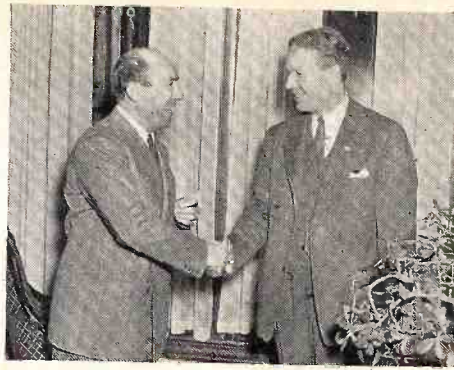

R. C. Sprague (right) president of Sprague Specialties Co. and Sales Manager Harry Kalker of Sprague Products Co. extend mutual felicitations occasioned by the Army-Navy "E" award to Sprague.

"MR" Tubes

(Continued from page 18)

tubes for civilians? We are old-fashioned in one respect—we still believe that two plus two equals four. WPB don't add that way.

The obvious solution rests with the military agencies. If they need more tubes than can be produced, some means of expanding tube production facilities should be tried. If WPB is convinced that the Armed Services will require 110% of the potential output, and that no expansion of tube facilities is to be made, WPB should bluntly state the facts and not evade the issue by putting out some bait in the form of orders about "MR" tubes—tubes that will never be made.

To actually get badly needed batteries (and replacement tubes) into the sets of civilians only one manner of procedure is necessary, to our way of thinking. WPB should determine what minimum limits of replacements can be made for civilian's exclusive use, and then WPB should endeavor to obtain allocations of needed materials and production facilities so the units in question can be produced. Then the manufactured items should be ear-marked for distribution to jobbers in equitable manner—and the latter should endeavor to get the components into use in civilian radios as quickly as possible. Let's try to keep one radio in every home in working order. With wisely determined allocations and WPB cooperation it might be achieved.

★

CRYSTALS WANTED!

The government needs more quartz crystals. And so the WPB has sent out a call to all citizens who may own property on which such material may be located, or who know where any

can be found, to get in touch with the Miscellaneous Minerals Division, War Production Board, Temporary "R" Building, Washington, D. C. If samples can be provided at the same time, they will be welcome. There should be several samples of the best crystals obtainable from the location.

These crystals are needed for the manufacture of quartz oscillator plates used in radio equipment for the armed forces. At present practically all of the quartz used for this purpose comes from Brazil.

The Miscellaneous Minerals Division wants only separate individual crystals—clusters, groups or grainy masses won't do. And each crystal must weigh at least half a pound, be at least an inch thick and three inches long. It must be clear and colorless on the inside, although light smoky quartz can be used. But milky quartz, rose quartz and purple quartz (amethyst) are useless.

★

FOLDER ON GHIRARDI'S NEW HANDBOOK

Ghirardi's newly revised and expanded 3rd Edition "Radio Troubleshooter's Handbook" containing 744 manual-size pages of valuable time-saving data covering all phases of radio service work is described and a detailed listing of its 75 topic section titles is given in an attractive new 4-page folder in color just issued by the Radio & Technical Publishing Co., 45 Astor Place, New York City.

This colorful folder points out the specific advantages this new 744-page Handbook offers the busy technician working under present "wartime" serving conditions—not as a "study book" but as a reference volume which contains a gold mine of vital, profitable time-saving troubleshooting and repair information and data that will enable him to cut corners, save troubleshooting and repair time, train new technicians; repair cheap sets at a profit; handle tough jobs in half the usual time.

Copies of this new folder are available from local radio supply houses, radio dealers and bookshops, or direct from the publishers.

★

G. E. POINTS AHEAD

Two consumer markets that are due for phenomenal post-war expansion are F.M. radio and recorded music, in the belief of the General Electric Company.

Aimed at both is the current G-E four-color full-page magazine advertisement entitled "First step in your child's musical education . . . an F.M. radio-phonograph," which features General Electric F.M. radio-phonograph combination sets.

Copy is based upon child appeal and children's records, which, together with "grown-up" music, are a valuable and necessary adjunct to getting the child's taste and education off to the right start.

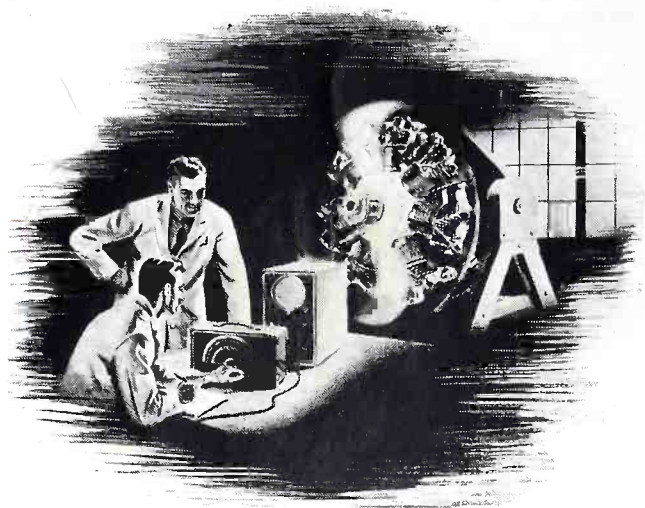

MODERN MEASUREMENTS

*without mechanical movement
or its limitations*

No type better illustrates the indispensable nature of the Electron Tube throughout science and industry than the famous RCA Cathode-Ray Tube. No type better emphasizes the steadily growing business opportunities for RCA servicemen, dealers, and distributors who make a point of keeping abreast of the far-reaching developments in applying basic electronic principles to new jobs.

Used in oscillographs, RCA Cathode-Ray Tubes are paving the way to higher standards in measuring any phenomena that can be transformed into electrical impulses—and *doing it without mechanical movement and its inherent limitations.*

In addition to their better-known applications in radio and communications, C-R Tubes are used regularly in such diverse fields as ignition, timing, and adjustment work; acoustics and vibration studies; studies of magnetic phenomena; medical and biological research; aeronautical engine synchronization; engine-pressure indications, and a host of others.

Such things as these are what we're talking about when we say "*The Developments of Today Are but a Promise of the Future*"—and this means for servicemen and distributors, as well as for RCA itself.

RCA ELECTRON TUBES

RADIO CORPORATION OF AMERICA
RCA Victor Division • Camden, N. J.

RAYTHEON TUBES AID MEDICAL SCIENCE!

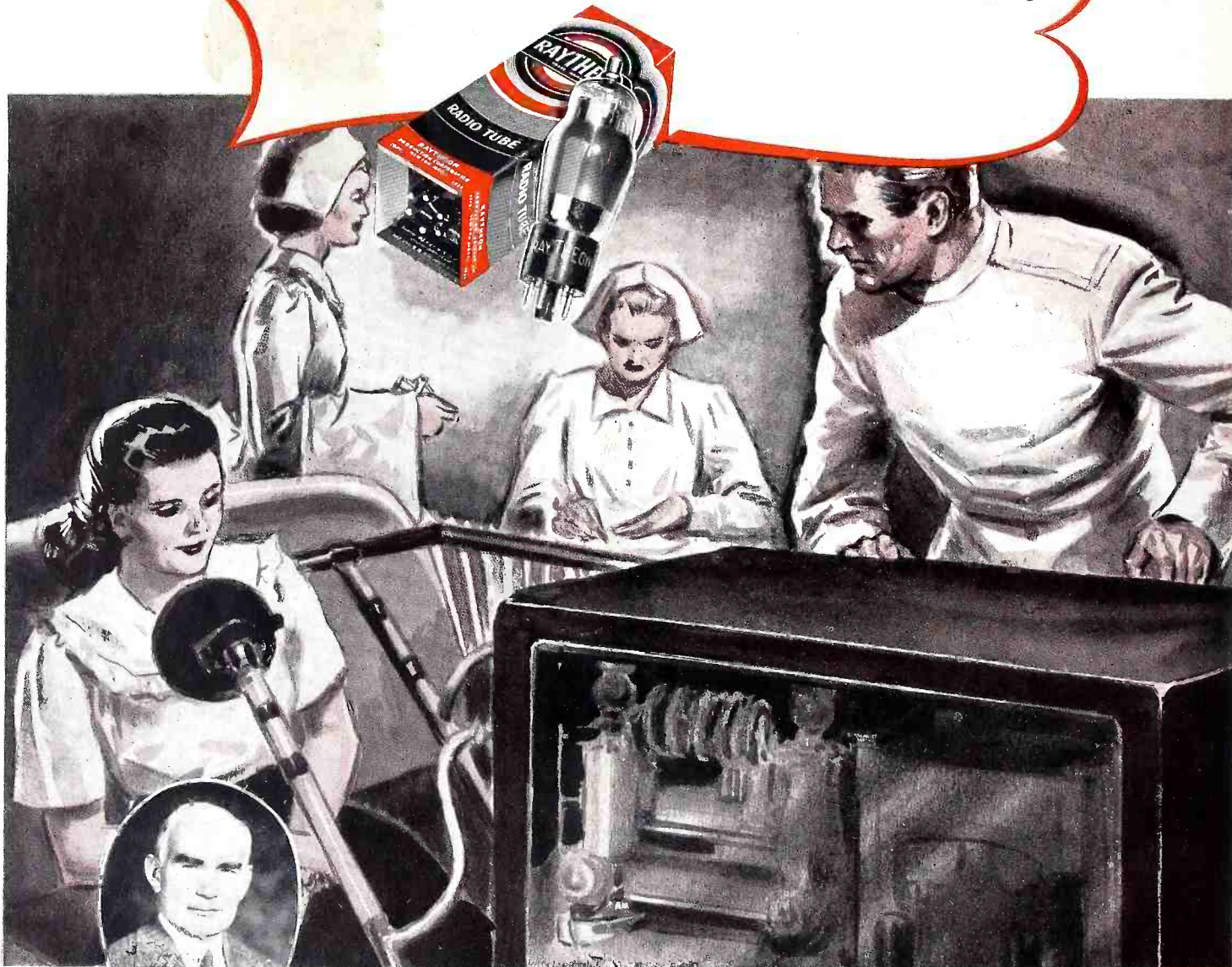

Dr. Lee de Forest, Inventor of the Radio "Fever" Machine

As the annals of modern medical science part company with the past, new ideas supplant pre-war practices... the radio "fever" machine is a modern example... developed by Dr. Lee de Forest for treatment of colds and respiratory organs... another advance

in the new electronic era... made possible by the use of tubes. Raytheons are daily doing their duty in new electronic developments... a part that Raytheons have so successfully played in civilian life. There is a qualified dependence in Raytheon tubes.

RAYTHEON PRODUCTION CORPORATION

Newton, Mass. • Los Angeles
New York • Chicago • Atlanta



Devoted to Research and the Manufacture of Tubes for the New Era of Electronics