

Radio
**SERVICE
DEALER**

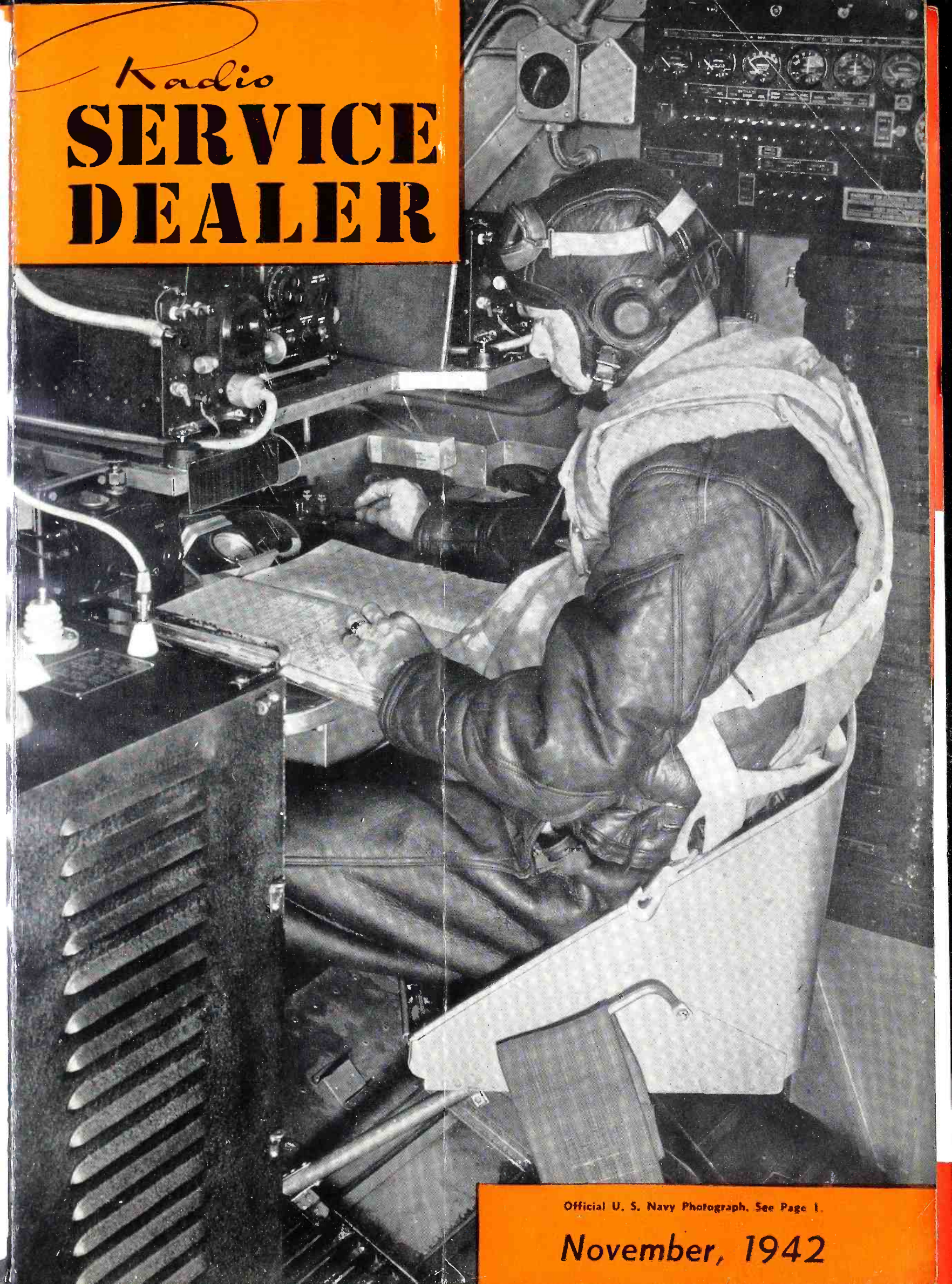

Official U. S. Navy Photograph. See Page 1.

November, 1942

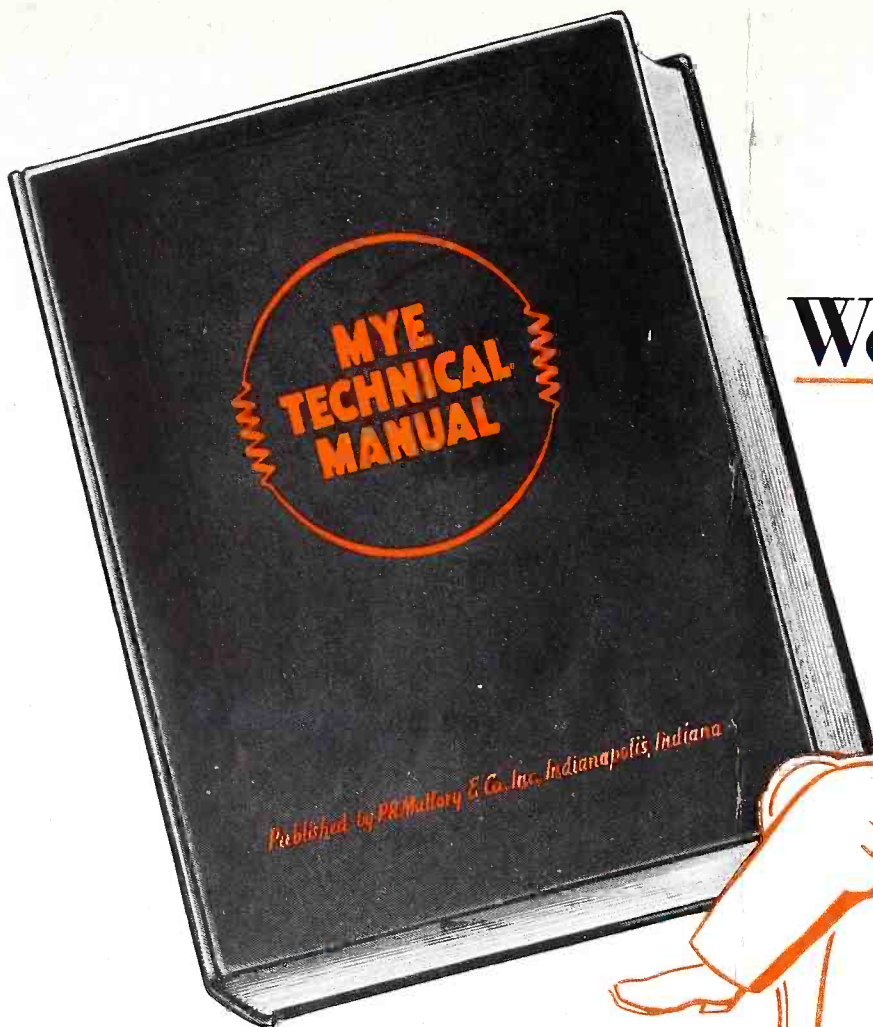

A Book Worth Owning...



Have you a few well-read and well-beloved books in your library that you wouldn't part with at any price? We suggest you add another . . . because once you've read even a few chapters, you'll agree with hundreds of radio servicemen, engineers, amateurs . . . the new MYE TECHNICAL MANUAL is a book worth owning.

Many hundreds of copies of this book are being distributed to military radio instructors . . . in training centers of the Army, Navy and Marine Corps, including the Air Forces. Once you glance through this list of chapter headings, you'll understand why.

- 1 Loud Speakers and Their Use
- 2 Superheterodyne First Detectors and Oscillators
- 3 Half-Wave and Voltage Doubler Power Supplies
- 4 Vibrator and Vibrator Power Supplies
- 5 Phono-Radio Service Data
- 6 Automatic Tuning—operation and adjustment
- 7 Frequency Modulation
- 8 Television—suggestions for the postwar boom
- 9 Capacitors—how to overcome wartime shortages
- 10 Practical Radio Noise Suppression
- 11 Vacuum Tube Voltmeters
- 12 Useful Servicing Information
- 13 Receiving Tube Characteristics—of all American tube types

Just one suggestion. We know you'll want a copy of this manual eventually. It contains 392 pages of information as down-to-earth as a soldering iron, as indispensable as a voltmeter. It's beautifully bound,

with hard cloth covers. It's worth far more than its price, \$2.00 net to servicemen.

But the supply for civilian use is limited. It will pay you, in the time, effort and money this book can save you *now*, to waste no time in going to your Mallory Distributor to reserve a copy. Order your MYE TECHNICAL MANUAL today!

P. R. MALLORY & CO., Inc., INDIANAPOLIS, INDIANA
Cable—PELMALLO

P. R. MALLORY & CO. Inc.

MALLORY

Approved Precision Products

Radio SERVICE-DEALER

SOUNDMAN AND JOBBER

Reg. U. S. Pat. Off.

Vol. 3, No. 11 ★ November 1942

★
PUBLISHER
SANFORD R. COWAN

Managing Editor
M. L. MUHLEMAN

Contributing Editors
JOHN H. POTTS **JOHN F. RIDER**
"On Leave"

News Analyst
A. N. BELKNAP

Circulation Manager
R. ALAN

Special Representative
LEE ROBINSON

★
Executive & Editorial Offices
132 West 43rd St., New York

Ad Index

Aerovox Corporation	31
High-voltage Capacitors	
Aircraft Radio Labs	32
Instruments Wanted	
Army, U. S. Signal Corps	3
Enlistments	
Brach Mfg. Corp., L. S.	25
Antennas	
Burt, W. R.	32
Tubes Wanted	
Centralab	31
Resistors, Controls, Switches	
Clarostat Mfg. Co., Inc.	28
P.A. Controls	
Electro-Voice Mfg. Co., Inc.	27
Microphones	
General Industries Co., The	28
Phonograph Motors	
Guardian Electric Co.	29
Relays	
International Resistance Co.	11
Fixed and Variable Resistors	
Lafayette Radio Corp.	27
Replacement Parts and Kits	
Mallory & Co., Inc., P. R. .. 2nd Cover	
New MYE Technical Manual	
Meck Industries, John	31
Audiograph Sound Equipment	
Meissner Mfg. Co.	21
Radio Training Kits	
Racon Electric Co.	4
Horns, Trumpets, Speakers	
Radio Servicemen of America, Inc. ..	32
Brandex and Service Notes	
Raytheon Production Corp. .. 4th Cover	
Raytheons Have Enlisted	
Rider, John F.	22
Rider Books & Manuals	
Signal Corps, U. S. Army	3
Enlistments	
Standard Transformer Corp.	25
Transformers	
Triplett Elec. Instru. Co. .. 3rd Cover	
Thin Line Instruments	
U. S. Treasury Dept.	24
Pay-Roll Savings Plan	
Vaco Products Co.	29
Screw Drivers	
Ward Leonard Elec. Co.	31
Relays, Resistors, Rheostats	

Contents

Editorial:	
Tube Shortage—Selective Service ..	2
Noise Generators	5
By John H. Potts	
CIRCUIT COURT—	
RCA—Phono radio frequency compensation circuits	8
Silvertone 7072—8 tube, 2 band a-c phono recorder	9
RCA-Radiola 522—Superhet ..	10
Silvertone 7167—8 tube, 2 band Super with pre-selector	10
Thinking Ahead	13
By J. J. Kahn	
Shop Notes	14
Philco PT-15; Modulation hum 934; Vacuum phototube characteristics 2AP1; High-vacuum Cathode-ray tube 935; Vacuum phototube, ultraviolet type	
5R4-GY; Full-wave rectifier tube 6J6; Twin triode, miniature type 6AG5; R-F amplifier pentode, miniature	
1C21; Cold-cathode Gas-triode	
Technical Service Portfolio—XXIV ..	15
Resistors and Volume Controls	
My Log	20
By San D'Arcy	
Help Wanted	26
Tube Substitution Chart	30
Suitable for framing, this chart makes the replacement of discontinued tubes simple.	

Cover Picture

(Official U. S. Navy Photograph)

RADIO OPERATOR

The radio operator aboard a U. S. Navy Bomber plays a most vital part. He gets an invaluable training that will serve him well in the post-war era. The Navy needs radiomen. See "Help Wanted", page 26.

Entire Contents Copyright 1942 by Cowan Publishing Corp.

All rights reserved—no part of this magazine may be reproduced in any form, by any means, or translated into foreign languages without permission in writing from the publisher.

RADIO SERVICE DEALER, published monthly at 34 N. Crystal Street, East Stroudsburg, Pa., by the Cowan Publishing Corp., Executive and Editorial Offices at 132 W. 43rd Street, New York, N. Y. Subscription rates—United States and Possessions, \$2.00 for 1 year, \$3.00 for 2 years; elsewhere \$3.00 per year. Single copies 25c. Printed in U.S.A. Entered as Second Class Matter October 3, 1941, at the Post Office at East Stroudsburg, Pa., under the Act of March 3, 1879.

editorial....

Critical Tube Shortage

● A recent W.P.B. survey indicated that nearly 50 million tubes were on jobbers' shelves or in service-dealers' stocks. Normally such a volume of tubes would serve civilian requirements for a year. Now it is evident that actually less than 15 million tubes are "in inventory"—the bulk of these are slow-movers, worthless for replacement use.

Meanwhile the entire output of all tube manufacturers is going into the war effort. No civilian use replacement tube production is scheduled for an indefinite time. The 10 thousand radio service-dealers, who still function as such, face trying days indeed. Between 2 and 3 million sets are becoming inoperative monthly, even if circuit revisions are resorted to, due to the tube shortage alone. Sets to be repaired are piling up on service benches.

The general public has no idea of the situation's acuteness—that a "radio black-out" impends. Broadcast stations realize how close to disaster they are; audiences falling away as though struck by a plague. Being "organized" the broadcasters may yet salvage a critical situation. But while price ceilings are in effect tube manufacturers will leave well enough alone. Even if they had facilities and could make tubes for civilian use now these would have to be sold for less than their cost price. Present tube prices were based upon huge production run economies no longer possible. We hope O.P.A. will realize this and afford the relief needed. Some one, somewhere had better do something in a hurry because the general public simply will not stand for a curtailment of radio. Hell is about to break loose, and don't say no warning was given.

Inviting the Undertaker

● One of radio's leading "dealer" publications has just published the most fantastic suggestion ever made for service-dealers' consideration. Says our contemporary, in effect, "go after juke box repair work!" Say we, "LAY OFF or you'll risk a busted head." Juke box servicing is "organized," in no uncertain manner, and any outsider who butts in becomes a prospect for a roughing up. Well, it just goes to show you how little those "merchandising-minded" editors, sitting behind polished desks in New York City, know about the real workings of radio from a technical and practical side. (In addition, the Petrillo ban has stopped delivery of new recordings. Jukes rely upon new, popular tunes, and without them jukes are doomed to hasty obsolescence.)

"Dealer, be alert to the profits of servicing" says the retailing-minded editors who are grasping for a floating straw, trying to get dealers service-work minded—and they climax the entire nonsensical article with this classic observation: "get after juke box servicing—even gas ration boards consider jukes necessary for public morale." What utter tripe! If anything, gas rationers will refuse a "C" card to servicers who diddle away gasoline trying to get to jukes while thousands of taxpayers' receivers are piling up awaiting pickup and the parts needed for their repair.

Favoritism Again

● Selective Service Headquarters issued a list of 92 essential occupations recommended for deferment. Photo-radio operators (facsimile), recording engineers and broadcast station repairmen are included in the list, but not mere radio servicemen—the chaps who are striving to keep civilian sets playing and war-plant or ship-yard public address and paging systems operating to speed-up production. Discrimination or oversight?

Tabloid newspapers and wire services, the prime users of radio relayed photos, employ automatic equipment so simple and fool-proof that even children can be quickly trained to operate them efficiently. Why defer wire servicemen and not radio repairmen?

Skilled technicians are required for broadcast station maintenance work. But what good will it be to keep BC repairmen on their jobs so their stations can broadcast beautifully modulated signals to millions of dead receivers lying idle in homes—dead sets because radio servicing manpower is being drained to the home-front danger point. Not enough servicemen are left to carry on the volume of work!

A transmitter without sets to receive its signal is like a car without wheels—worthless. Why the Selective Service deferment favoritism to broadcast station servicers and none for civilian maintenance men?

Solder Can Be Had

● For months many radio parts and materials have been hard to get. Solder, the most vital of all materials for a radio maintenance man, has been the scarcest item on the list, and for a peculiar reason. Radio jobbers formerly didn't bother much about solder as a stock item. Servicemen usually bought it from 5 & 10's or hardware stores. (Generally they bought the wrong alloy or type and made their work doubly difficult). Freezing of jobber inventories complicated the situation because jobbers couldn't buy what they formerly didn't stock. PD-1X now comes to the rescue. We are advised by a solder manufacturer that jobbers using PD-1X forms can obtain enough solder to meet emergency requirements. We learn the hard way, don't we? Jobbers—get busy! Servicemen, buy solder from radio jobbers exclusively henceforth!

SRC

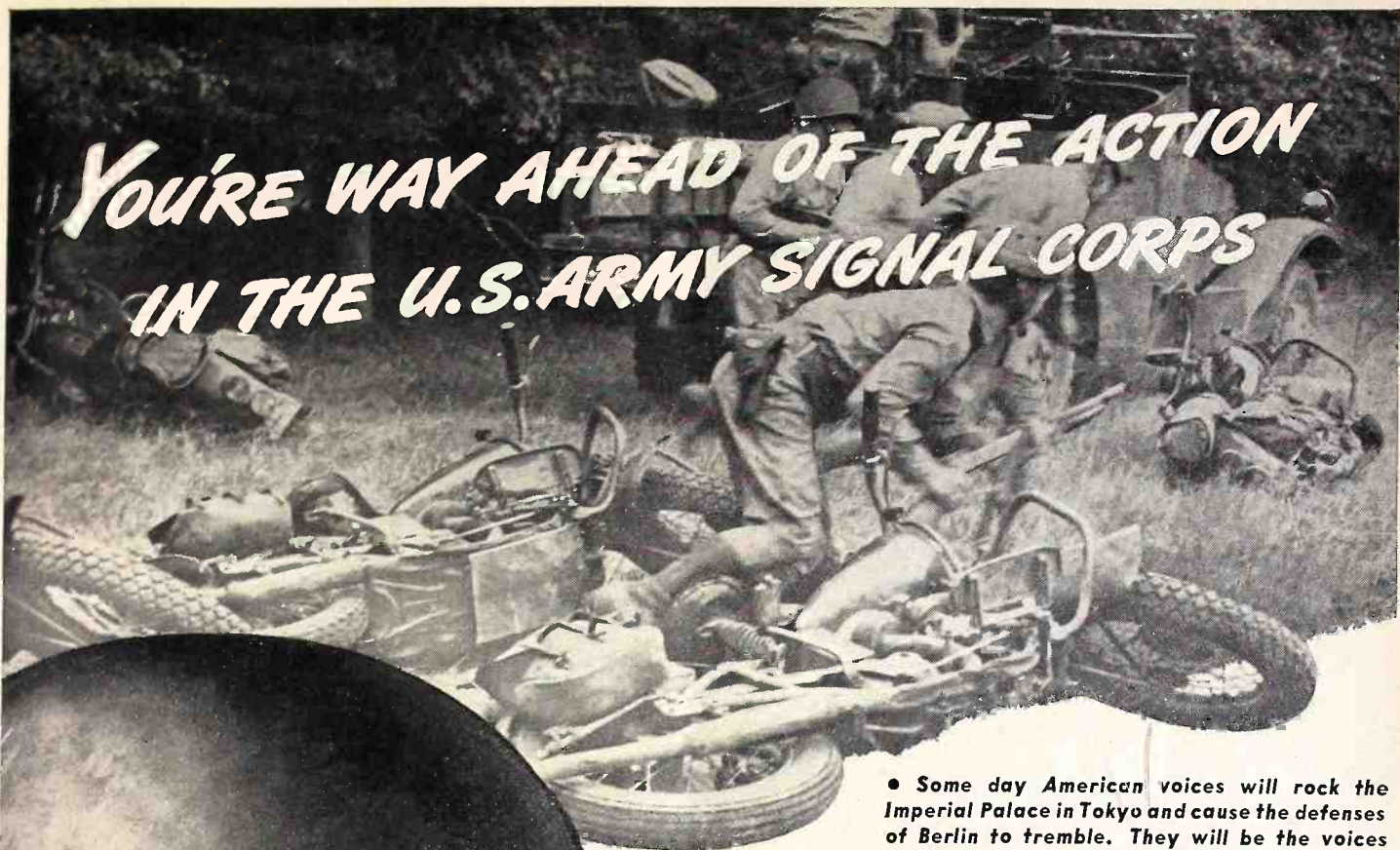

YOU'RE WAY AHEAD OF THE ACTION IN THE U.S. ARMY SIGNAL CORPS

• Some day American voices will rock the Imperial Palace in Tokyo and cause the defenses of Berlin to tremble. They will be the voices of U. S. Army radio men, relaying commands for the final attack. Will yours be one of them?

IN THIS fast-moving war, words are weapons. Split-second communications are vital to the timing and teamwork that win battles. As one of Uncle Sam's radio soldiers, you not only see action—you help to guide and direct it!

In Army communications, your opportunities for heroic service are limitless. At the same time, you receive training and experience that will be invaluable for a successful after-the-war career. You learn how to assemble, install and operate the most modern radio transmitters, receivers, "Walkie-Talkies," "Electronic Sentries" and scores of other closely guarded secret devices—pioneers of future industries—which combine today to knit the whole Army into one hard-fighting unit.

Any man, physically fit, from 18 to 44, inclusive, may enlist. Licensed radio operators and radio, telegraph and telephone workers may enlist for active duty at once. They may advance rapidly up to \$138 a month, plus board, shelter and uniforms, as they earn higher technical ratings.

Men of 18 and 19 may choose enlistment in the Signal Corps without any previous training or experience.

Those without qualifying experience, who enroll full time, may enter the Signal Corps Enlisted Reserve for training with pay. Graduate Electrical Engineers may apply for immediate commissions in the Signal Corps.

Civilians over 16 years of age may attend a Signal Corps School, and will be paid not less than \$1020 per year for full-time training and future service with the Signal Corps. Apply U. S. Employment Bureau or U. S. Civil Service.

"KEEP 'EM FLYING!"



U.S. ARMY RECRUITING AND INDUCTION SERVICE

Visit or write the nearest U. S. Army Recruiting and Induction Station or write to: "The Commanding General," of the Service Command nearest you, or Procurement Branch, AH-2, A.G.O., Washington, D. C.



RACON keeps 'em smiling

... on Land ... at Sea ... and in the Air

Dependable communications, regardless of climatic conditions, hard use or other circumstance, are vital to the war effort.

ON LAND RACON trumpets and speakers carry orders to men training at army camps or in maneuvers. They are used in Shipyards and Ordnance plants. RACON Paging Horns and loud speakers are employed in the finest industrial p-a installations. Police departments and OCD use RACONS.

AT SEA RACONS dependably serve Steamship Lines., the Maritime Commission, Coast Guard and Navy ships.

IN THE AIR RACONS fly on bombers and blimps. At air bases RACONS carry orders over the din of roaring motors. RACON Aeroplane Horns are world famous, as is the rest of the line, because they are most efficient and dependable. They deliver more energy per watt input.

Only RACON offers Stormproof, Weatherproof, Acoustic Material. Only RACON offers a complete line—a speaker, horn or driving unit for every purpose.

Specify RACONS when bidding on your next p-a installations.

A catalog describing the complete RACON line is available on request.

MARINE HORN SPEAKERS

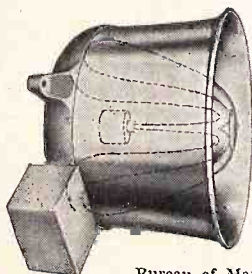

Re-entrant type speakers using horn type units for marine and general P-A applications — may be used as loud-speaker or as a microphone. Miniature and regular sizes approved by the Bureau of Marine Inspection and Navigation, Department of Commerce, for marine work. In all sizes, miniature, midget, regular and bull, handling from 5 to 50 watts.



RACON P. M. HORN UNITS

Operating capacity 12-15 watts, peak 25 watts. Other P.M. units available from "baby unit" of 5 watts to "bull unit" with an operating capacity of 50 watts. Efficiencies of the highest order obtainable with the finest magnetic material and steel utilized.



PAGING HORN

A small, extremely efficient 2-foot trumpet for use where highly concentrated sound is required to override high noise levels, as in factories, outdoors, etc. Uses very small, very efficient P.M. unit. Ideal for sound trucks, hotel lobbies and paging systems.

RE-ENTRANT TRUMPETS



A compact trumpet of the double re-entrant type. Occupies but a small space, nevertheless has a long air column enabling it to deliver highly concentrated sound of the greatest efficiency over long distances. Base and inside cone arm made of aluminum castings, outside bell of heavy gauge aluminum spinning, centre section of RACON ACOUSTIC material to prevent resonant effects. Available in 6', 4½', 3½', and 3' air column units.

RACON ELECTRIC CO. 52 EAST 19th ST. NEW YORK, N. Y.

NOISE GENERATORS

in radio servicing

by John H. Potts

TO many it may seem at first a little difficult to realize that noise in any form can be of any value in radio servicing. But, after a moment's consideration, it will become evident that many operations and tests are now being made in the field in which noise alone provides the signal source. This noise may be atmospheric or man-made static, for which no service apparatus is required. This we utilize when we adjust the regeneration control of a midget receiver. Or it may be pickup noise resulting when we touch the grid of a tube in a high-gain, high-impedance circuit, such as we find in a-f amplifiers of most sets. In each case the noise gives us information regarding the performance of the circuit or circuits involved. Such tests are often the easiest and quickest methods to use, and are therefore the most efficient.

Apparatus designed to produce electrical noise has been in use for test and adjustment purposes in radio factories for some years, but little information regarding its application in the service field has been published. At the present time, when the demand for service is at its greatest, it seems particularly advisable to discuss any methods or devices which promise to increase

our efficiency. Because noise generators are simple to design and construct, and have very definite advantages in many service applications, we believe that many will be interested in hearing about them. But, first, a word about their applications.

All-Band Noise Generator

In general, a noise generator is of greatest value in providing a test signal which extends over a very wide band of frequencies so that tuned circuits may be quickly tested

for operation without the need for tuning to a specific frequency, as is the case when a test oscillator or signal generator of the conventional type is employed. Since the type of noise generator in which we are interested produces a signal which covers not only the r-f band, but also the i-f and audio ranges, it becomes possible to inject such a signal in any circuit in any receiver and thus discover, from the response in the speaker (or the lack of it) whether or not the circuit under test is operating. It becomes possible to feed such a signal to the antenna circuit of a multi-band receiver and get a quick check of the relative sensitivity of each band by simply noting the strength of the output signal as the tuning condenser is rotated over each of its tuning ranges. "Dead spots" are revealed immediately, which might ordinarily be overlooked. In i-f circuits, preliminary tuning adjustments may be made of circuits badly out of line; this will be of especial value when a replacement, not accurately pre-tuned, is being used. The padding condenser in an oscillator circuit may be adjusted properly without rocking the gang condenser.

The simplest device for such test purposes is a small buzzer. One was

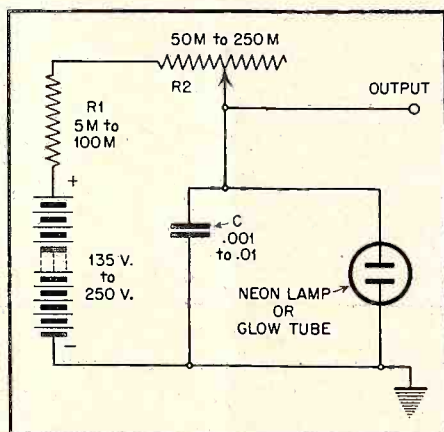

Fig. 1. A simple relaxation oscillator. R1 is a limiting resistor.

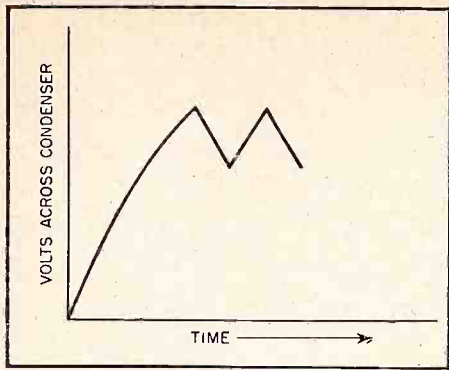

Fig. 2. The wave shape obtained from an oscillator of the type shown in Fig. 1.

on the market a few years ago but its power output limited its usefulness. A circuit such as that shown in Fig. 1 is adaptable to a wider range of application. This consists of a so-called relaxation oscillator and operated on the following principle: When the condenser C is charged to a voltage sufficient to cause the gas in the neon lamp or glow tube to ionize, the lamp lights. The lamp then forms a very low resistance path for the condenser to discharge and the condenser voltage drops until the extinction point of the lamp is reached. Then the lamp no longer forms a conducting shunt for the condenser, so the condenser starts to charge again. This cycle of charge and discharge is repeated at a rate determined primarily by the resistance and capacity in the circuit. The resulting wave form is illustrated in Fig. 2.

Vacuum-Tube Circuits

A method of accomplishing substantially the same result with a vacuum tube is shown in Fig. 3. This is a negative-conductance circuit in which oscillation is produced due to

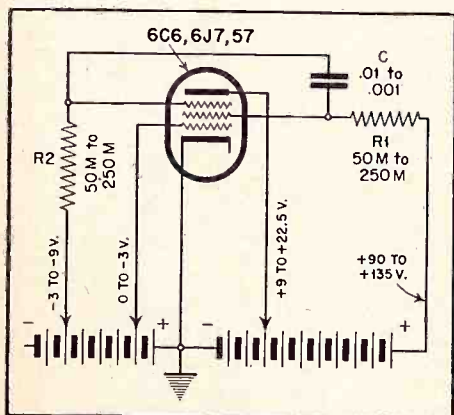

Fig. 3. A single-tube relaxation oscillator of the negative conductance type.

the negative resistance characteristics resulting when the screen grid of a pentode is operated at a higher voltage than the plate. Actually the active tube elements of this oscillator are the screen and suppressor. The control-grid potential governs the strength of oscillation, as does the bias on the suppressor. The plate voltage is not critical, but is always less than the screen voltage. In this circuit, as in the preceding one, the oscillation frequency is mainly dependent upon the values of C and R —in this case, of $R1$ and $R2$. The waveform of the output is likewise somewhat dependent upon the constants used, as well as upon the tube voltages. When experimenting with this circuit, it will be found that the poorest waveform (and we want a poor waveform for this purpose) will be obtained when the tube oscillates violently. This is secured by operating the control grid at zero bias and by adjusting the screen and suppressor voltages for maximum depth of oscillation.

A better method of obtaining the type of waveform most suitable for testing over a broad band of frequencies is shown in Fig. 4. This is a typical multivibrator circuit which consists of two resistance-coupled triode amplifiers, in which the output of one feeds into the input of the other. As in the other circuits, the waveform and the frequency depend upon the constants employed. For our purposes, a square wave is most desired, since this wave shape indicates a signal with harmonics of maximum strength over a very wide band. The fundamental frequency should preferably be somewhere between 400 and 1000 cycles.

Coupling System

To get the most value out of any of these circuits in this application, we need some means of coupling the resulting test signal to the receiver. If we connect to one of the grid circuits, we can, to be sure, feed the signal to any high-impedance circuit

in a receiver, but the loading effect which results when we connect to a low-resistance circuit is often sufficient to stop oscillation in the test apparatus. To avoid this, it is advisable to use a sort of buffer tube between the multivibrator and the test apparatus. This may take the form of an amplifier, such as is shown in Fig. 5. The audio choke in the output circuit forms a high-impedance load for the audio frequency fundamental, generated by the multivibrator. The r-f choke in series provides a high impedance for the higher harmonics of the multivibrator signal. Any tube may be used for the purpose; a type 45 is shown simply because it is readily available and is low in cost. In one commercial instrument, the buffer tube consists of a 955 acorn, chosen because its low inter-electrode capacitances make it possible to get the most output from the higher harmonics, which are weak in any event.

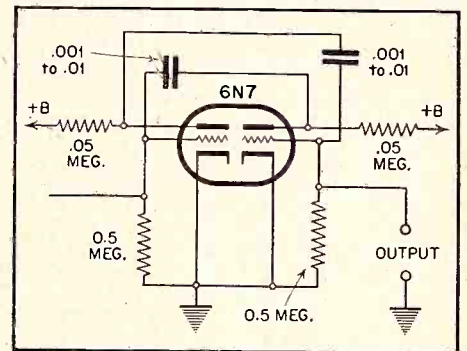

Fig. 4. A typical single-tube multivibrator circuit. Two triodes, type 76 or equivalent, may be substituted.

The buffer amplifier just described may be used with any other multivibrator circuits described. Connection is made to the "high" side of the input circuit through the blocking condenser, as shown.

To apply this test method, let us consider the block diagram, Fig. 6. This is assumed to represent a radio receiver which is inoperative, or which gives weak response. Before servicing a receiver with such symptoms, we shall take it for granted that the power-supply voltages have been checked, and that a check of the wattage consumption of the entire receiver indicates that no serious overload exists.

Testing Procedure

To proceed, then, the multivibrator signal is fed first to the grid of the output tube in the receiver, point 1 in the diagram. If no signal is heard,

\$1.00 PAID FOR SHOP NOTES

Write up any "kinks" or "tricks-of-the-trade" in radio servicing that you have discovered. We will pay \$1 in Defense Stamps for such previously unpublished "SHOP NOTES" found acceptable. Send your data to "Shop Notes Editor," RADIO SERVICE-DEALER, 132 W. 43rd St., New York City. Unused manuscripts cannot be returned unless accompanied with stamped and addressed return envelope.

the fault is immediately isolated to some component in this stage. Or, if the signal is weaker than it should be, then in the case of a receiver which is merely weak but not inoperative, we should stop and check the speaker, output tube and other components in the output stage.

However, if a normal signal is heard in the speaker when we feed to the output tube grid—and we can determine what is normal by tests on a few normal receivers—we continue with our tests by feeding the signal to the second test point, which is designated as point 2 and is located at the input to the first a-f stage. The signal should be much stronger when fed to this point, because of the gain which is obtained in the first a-f stage. If no signal, or a weaker signal, is obtained then we know that some component in this stage is at fault. Note that we have eliminated the last stage as a source of trouble as the result of our first test, so we need confine our investigations solely to this stage.

Our next step, assuming that the signal strength obtained by feeding to point 2 was normal, is to check the last i-f and detector stages. This is done by feeding the signal to point 3. No adjustment of trimmers should be made; the signal is "broad" enough so as to ride through, even though the trimmers in a single transformer are badly out of adjustment. If the signal is weak—and the complaint is weak reception—the natural tendency to try readjusting the trimmers to increase the signal output should be resisted until the completion of the test routine.

The next test point, number 4, is at the input of the preceding i-f stage. This is tested in the same manner as just described. There should be considerable gain in signal strength between these stages, but this will be offset by AVC action, assuming the receiver is so equipped. If a "magic" eye or other indicator of signal strength is used in the receiver, the increase in signal strength should be apparent.

The signal is next fed to point 5, the input to the mixer or converter. Since this circuit is normally operating at radio frequencies, it is well to tune the gang condenser to the low-frequency end of the dial, so maximum signal strength will be obtained. Some gain should be obtained, though it will not be large. It is interesting to note that the signal will ride through when fed to point 5, whether or not the oscillator section of the receiver is operating. In the latter case, the mixer simply functions as an i-f amplifier tube. In

the case of a converter tube, this should be kept in mind, because it frequently happens that only the oscillator section is inoperative.

Our last test calls for feeding the signal to the antenna circuit. This embraces a test of the complete receiver. If the response is normal at this point, we should concentrate our attention on the set oscillator circuit, checking the voltage across the oscillator grid leak with an electronic voltmeter, or connecting a milliammeter in either the plate, grid or cathode circuit of the oscillator and noting whether touching the grid causes a change in the meter reading. If it doesn't, the oscillator is not functioning.

Use In Alignment

These are the general tests and routine in trouble shooting with the noise generator. In alignment work, the noise generator has been found useful when called into service for adjusting the r-f trimmers and padders. The procedure is to align the i-f sections in the customary fashion with a signal generator. After this is done, the multi-vibrator signal is fed to a point corresponding to point 5 in Fig. 6, at the input to the converter tube, and the receiver dial is turned to the high-frequency trimmer adjustment point, as specified in the manufacturer's service notes. The oscillator trimmer is then adjusted until maximum output is obtained. Then the dial is turned to the low-frequency padding point and the padder is similarly peaked. The oscillator trimmer should be rechecked, but reports from the field indicate that this is seldom more than slightly out of adjustment. No recheck of the padder should be required.

The feature of this method is that the rocking of the gang condenser, formerly essential in adjusting the

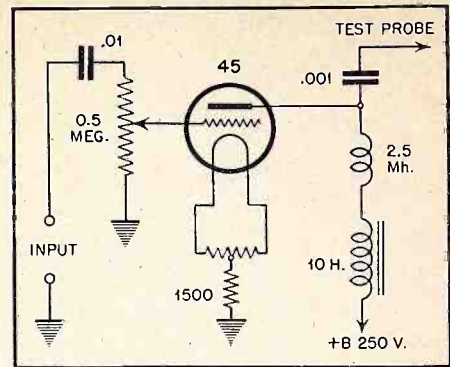

Fig. 5. This amplifier acts as a buffer tube and may be used with any of the relaxation oscillators described in this article.

padder, becomes unnecessary. The r-f stages are adjusted as usual, with a signal from the customary test oscillator or signal generator.

Note that the multivibrator does not supersede the signal generator. It will always be necessary to have a signal source which provides accurately known frequencies. But it does simplify testing by the signal-tracing or signal-substitution methods by eliminating the need for retuning each time we enter a circuit adjusted for a different frequency.

While we have described only the adaptability of the noise generator to trouble shooting without a signal-tracing instrument, it should be understood that the noise generator is likewise suitable as a signal source in conjunction with such instruments as well.

As with any other new method, it must be realized that a certain amount of time will be required before the maximum in results will be secured. But those who have persevered with such devices as we have here outlined, have found the time well spent.

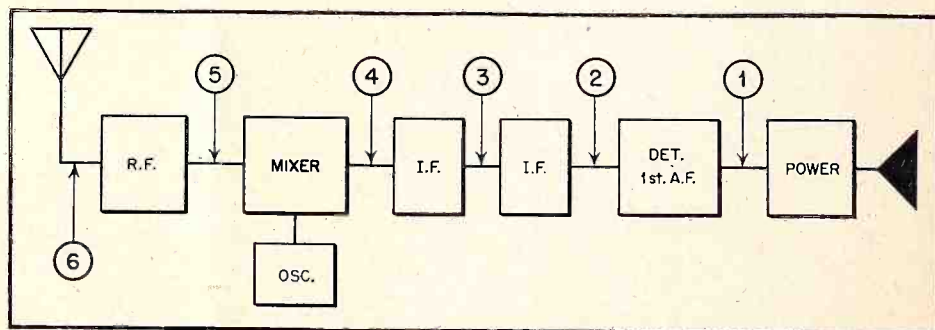

Fig. 6. A block diagram of a representative superheterodyne receiver. The numbered points represent equivalent test points in an actual receiver.

Circuit Court

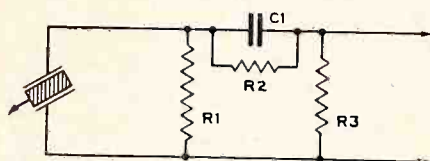

Fig. 1. Phono compensation circuit with series equalizer

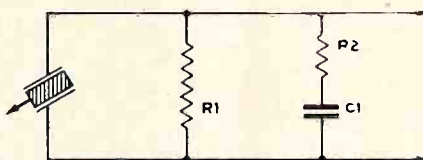

Fig. 2. Phono compensation circuit with shunt equalizer

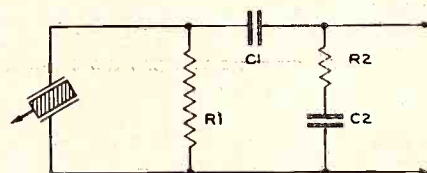

Fig. 3. Another form of phono compensator with shunt equalizer

THE day is fast approaching—if it is not already here—when a large part of radio service work is going to fall into the class of “hay-wire” repairs. We mean by this that the serviceman will have to redesign parts of receiver circuits on his own hook, if the receivers are to continue in operation at all.

In many respects, the job is going to be easier in the larger receivers. If an i-f tube goes west, and cannot be replaced, the entire stage can be by-passed, if the receiver has more than one i-f stage; and the receiver will still be satisfactory for local reception. Likewise, one side of a push-pull power amplifier can be put up in moth balls for the duration, if a replacement tube is not available, providing the serviceman does a bit of redesigning in the stage involved.

The job will not be so easy in the smaller receiver, for the less expensive set has practically nothing in its makeup that could be classed as non-essential. Here it is necessary to redesign the circuit to fit a tube type foreign to the set, where an exact duplicate cannot be obtained.

But, on the whole, there are many stunts that can be pulled, even in the smaller sets, to “keep people on the air.” Study circuits and make use of your tube manual, and you’ll be surprised what you can get away with.

Tone Compensation

Because of the widely varying frequency characteristics of various types of audio amplifiers with which crystal pickups may be used, it may be desirable in some cases to make refinements in the pickup circuit to compensate for the characteristics of the amplifier. In *Figs. 1, 2* and *3* are shown three methods, worked out by RCA, by which varying degrees of compensation are obtainable.

In the circuit of *Fig. 1*, the low-frequency response may be increased by increasing the value of the pickup load resistor *R1*. On the other hand, high-frequency response may be increased by increasing the value of condenser *C1*. Thirdly, the voltage output may be increased by increasing the value of *R3* with respect to the total value of *R2* plus *R3*. The resistor *R2* and condenser *C1* constitute a series equalizer.

In *Fig. 2*, the low-frequency response may be increased by increasing the value of *R1*. The high-frequency response may be increased by increasing the value of *R2*. The out-

put may be increased by decreasing the value of *C1* which, in conjunction with *R2*, constitutes a shunt-type equalizer.

In *Fig. 3*, increasing *R1* increases the low-frequency response. Increasing *R2* increases the high-frequency response. Increasing the value of *C1* with respect to the total value of *C1* plus *C2* increases the output.

The “center” values for the condensers and resistors in all three circuits correspond to the values normally employed in such compensation networks. Arbitrary values can be selected from phono-radio schematics, and thereafter altered to suit the ear and the pickup voltage output required.

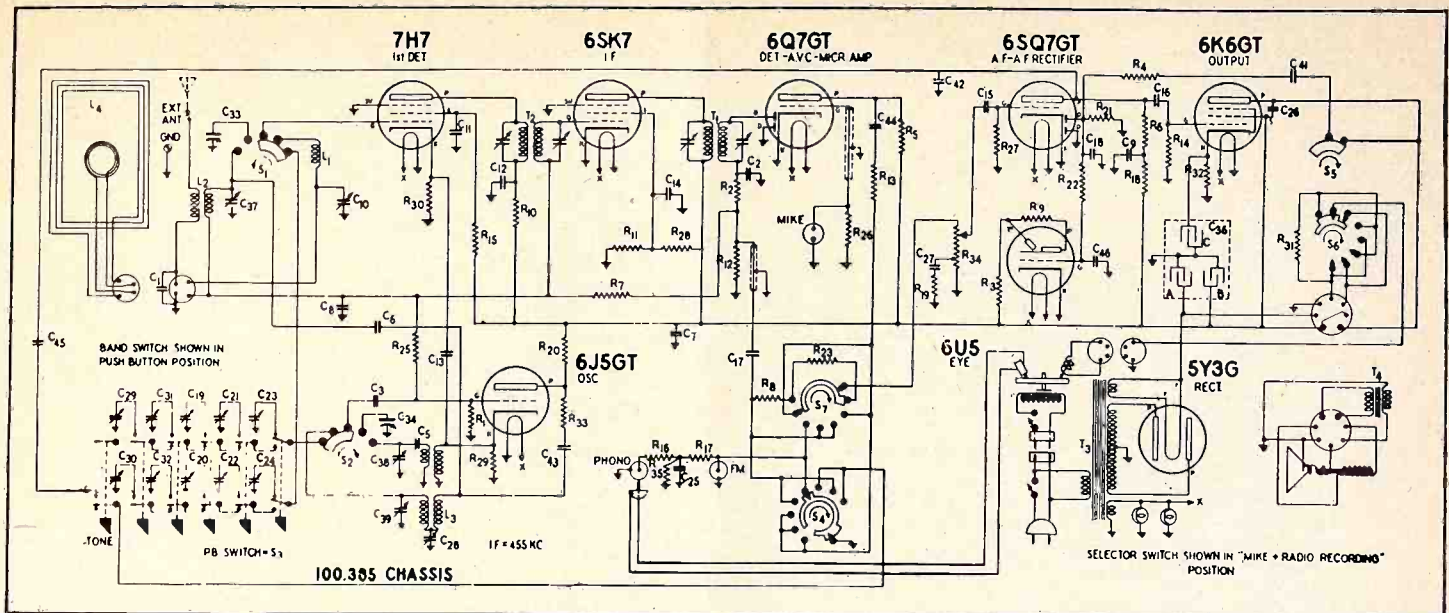

Fig. 4. Schematic diagram of Silvertone Model 7072 receiver

Silvertone 7072

This late *Silvertone* model is an 8-tube, 2-band a-c super with push-button tuning and record-changing recorder. The complete diagram is shown in *Fig. 4*.

The loop, L_4 , is designed for standard-band "loop" reception only. Its primary is in series with the primary of the short-wave antenna transformer L_2 , and is shunted by condenser C_1 so that it is not effective in the short-wave range. The secondary or loop proper is in series with the loading coil L_1 , the total additive inductance having the proper value for standard-band coverage in conjunction with the tuning condenser C_{33} . The loop may be used as a pickup in the short-wave band, in lieu of an external antenna, but in this case is not tuned, the loop turns functioning as a capacitive antenna.

The 6J5GT converter oscillator is cathode coupled. The oscillator signal is fed to the cathode of the 7H7 first detector through condenser C_{13} , with the voltage build-up across the 7H7 cathode resistor R_{30} . Voltage from the grid circuit of the oscillator tube is introduced into the avc circuit, and therefore on the detector diode, through the 10-meg. resistor R_{25} . The resultant rectified voltage provides an initial bias on the first detector and i-f tubes.

The 6Q7GT is used as second detector and mike amplifier. Since the triode of this tube feeds into the volume-control circuit when switch S_7 is in the recording position, the volume control R_{34} is used to adjust mike input gain.

The phono pickup circuit is equalized, and the volume control is of the usual compensated type.

The triode of the 6SQ7GT is used as the a-f voltage amplifier, and is resistance-coupled to the 6K6GT output tube. One diode in this tube is employed as an a-f rectifier, to provide control voltage for the grid of the 6U5. Voltage is picked off the plate of the 6K6GT and fed to the 6SQ7 diode through C_{41} and R_4 . The resultant rectified voltage appearing across R_{21} operates the eye tube which functions as a volume-level indicator.

One push-button switch is employed for tone control in the plate circuit of the 6SQ7GT a-f voltage amplifier.

Radiola 522

The circuit of this late RCA job, shown in *Fig. 5*, applies to 1st production Chassis No. RC-1001C and 2nd production Chassis No. RC-1022-

A. Slight changes were made in the 2nd production run, and these are shown in *Fig. 6*.

The circuit is conventional, incorporating such tricks of the trade as an open-ended winding on the oscillator coil instead of a grid condenser, and a stop on the volume control so that the resistance of the control beyond the stop may be used as the "resistor" in the i-f filter, the remainder of which is made up of the condensers C_{11} and C_{12} . And the stunt of improving frequency response and reducing distortion by the simple expedient of leaving off the power-tube cathode by-pass condenser and using another of much lower value, connected from plate to cathode, to provide additional inverse feedback.

This receiver employs an iron-core i-f transformer between mixer and i-f tubes, and an air-core unit coupling the i-f tube to the 2nd detector. But both transformers are adjusted by means of trimmer condensers.

Note that with an electrodynamic speaker, the power-tube plate supply is also filtered. It has long been the practice in small receivers using p-m dynamics, to connect the power-tube plate supply lead directly to the cathode of the rectifier. This wasn't bad, but neither was it particularly good.

We've always liked the simple phono-connection arrangement in these receivers. With the exception that there is some possibility of signal break-through in the 12SQ7 tube, the method is neat. The pickup voltage output is applied directly across the grid resistor R_3 , and volume con-

Address Change?

Notify RSD's circulation department at 132 West 43rd Street, New York City of your new address 2 or 3 weeks before you move. The Post Office Department does not forward magazines sent to a wrong address unless you pay additional postage. We cannot duplicate copies mailed to your old address. Thank You!

trolled from the record player. The receiver volume control is turned all the way down which precludes signal pickup from the diode output circuit, and also grounds C_3 . This reduces the pickup output somewhat, but there is always more than enough output available.

Silvertone 7167

Though this 8-tube, 2-band a-c super has no r-f stage, it does have, 1) a rotatable loop, which provides a form of selectivity, and 2) a pre-selector circuit in the broadcast-band range. The complete circuit is shown in Fig. 7.

The pre-selector is composed of two sections of the three-gang condenser, VC , the loop antenna, the loading coil L_4 , the pre-selector coupling coil L_3 , and the translator coil L_1 . This arrangement provides adequate selectivity without the use of a tuned r-f stage.

In the short-wave band, a separate short-wave antenna transformer, L_2 is employed. The frequency range of

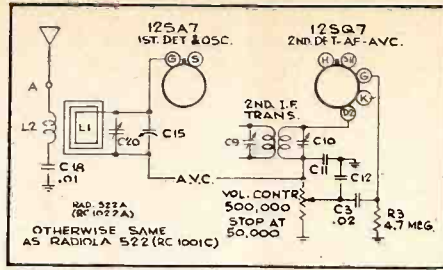

Fig. 6. Circuit changes made in 2nd production of RCA Radiola 552 receiver

the oscillator coil, L_5 , is shifted to a higher band by means of a tap on the grid coil, controlled by the waveband switch.

The triode section of the 7E6 functions as a tickler-feedback oscillator. Coupling to the grid circuit of the 7H7 translator is by means of a gimmick wound around the lead to the plate of the oscillator tube.

One diode of the 7E6 is used as a bias control. Oscillator voltage appears on the diode plate by cathode emission, and the resultant rectified

voltage appears across resistor R_3 . This negative voltage is applied to the avc line through resistor R_4 , and constitutes an initial bias for the translator and i-f tubes. When a signal is tuned in, avc voltage is developed in the load circuit of the second-detector diode. This comparatively high negative voltage also appears on the 7E6 bias control diode, thus repelling the flow of electrons to the diode and removing the initial bias. The condenser C_8 across the bias control diode load resistor R_3 functions as a radio-frequency bypass.

Regeneration is introduced in the i-f stage by means of a third winding on the second i-f transformer. The regeneration takes place in the screen circuit.

Grid bias for the triode section of the 6SQ7GT is provided by means of a bias cell connected in series with the grid resistor R_{25} . A continuously variable tone control appears in the plate circuit of this same tube, and additional, push-button tone control is provided in the circuit of the

(Continued on page 12)

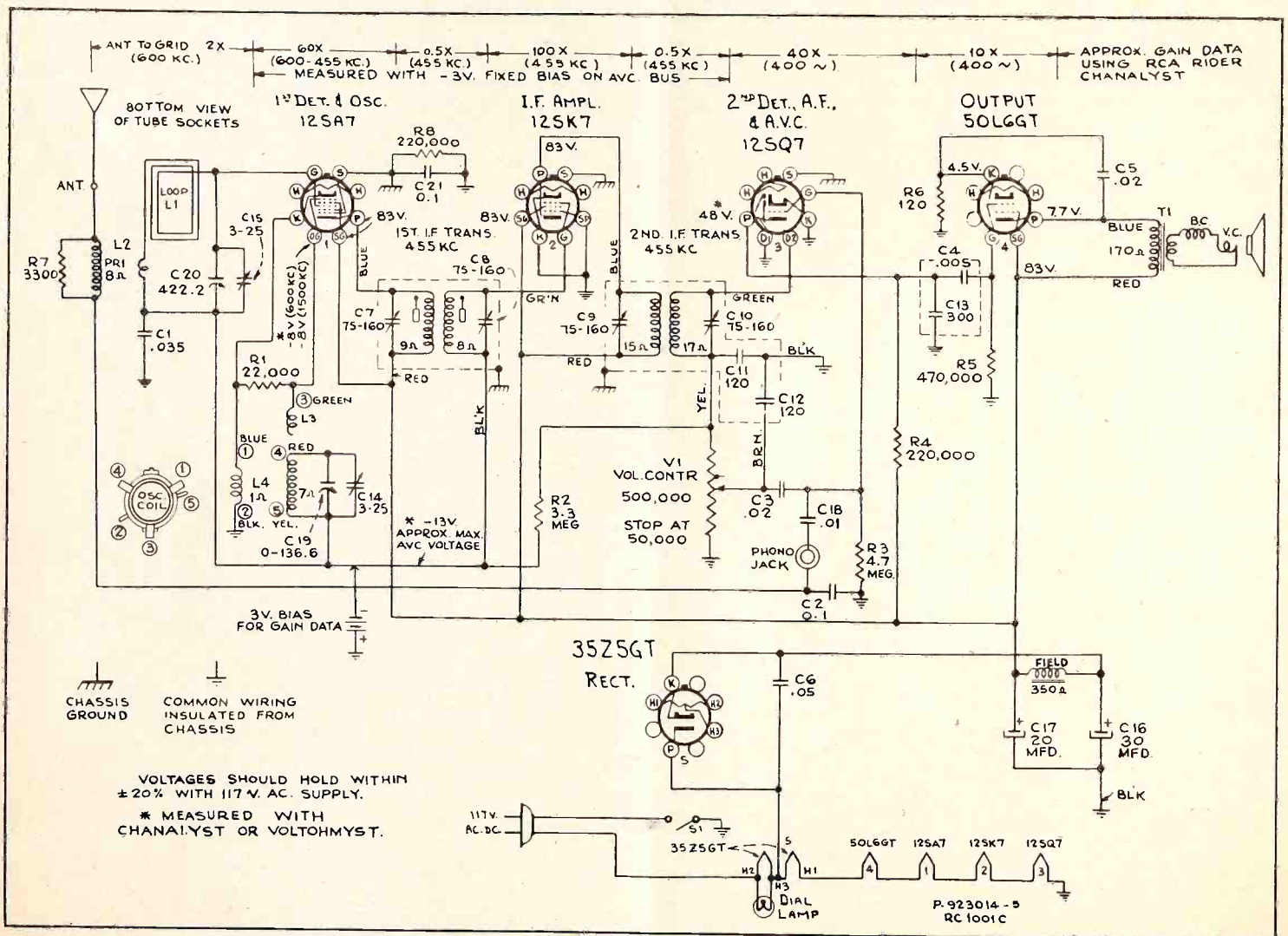

Fig. 5. Schematic diagram of RCA Radiola 552 receiver. See Fig. 6 for production change



PREFERRED
for
PERFORMANCE



RESISTORS

WHY? . . . Results of a nation-wide survey conducted by a wholly independent research organization disclosed that Executives and Engineers in the electronic industries *overwhelmingly prefer* IRC resistors. In voting them "superior" by a plurality of more than two to one, these specific reasons were cited—

BECAUSE . . . IRC offers "best product" and "most complete line."



IRC flies the flag of the
Army-Navy Production Award
for "High Achievement"

INTERNATIONAL RESISTANCE COMPANY

401 N. BROAD STREET • PHILADELPHIA

CIRCUIT COURT

(Continued from page 10)

compensated volume control *R18*. One 2-position switch provides high-frequency boost, and a second 2-posi-

tion switch provides bass boost. Both switches control resistance and capacity voltage dividers common to the volume-control circuit.

A second 6SQ7 is employed as a phase inverter in a purely conven-

tional circuit. The push-pull power stage incorporates inverse feedback, the common cathode resistor being unbypassed. Additional feedback is provided by voltage feed from plates to cathodes via condensers *C33-C34*.

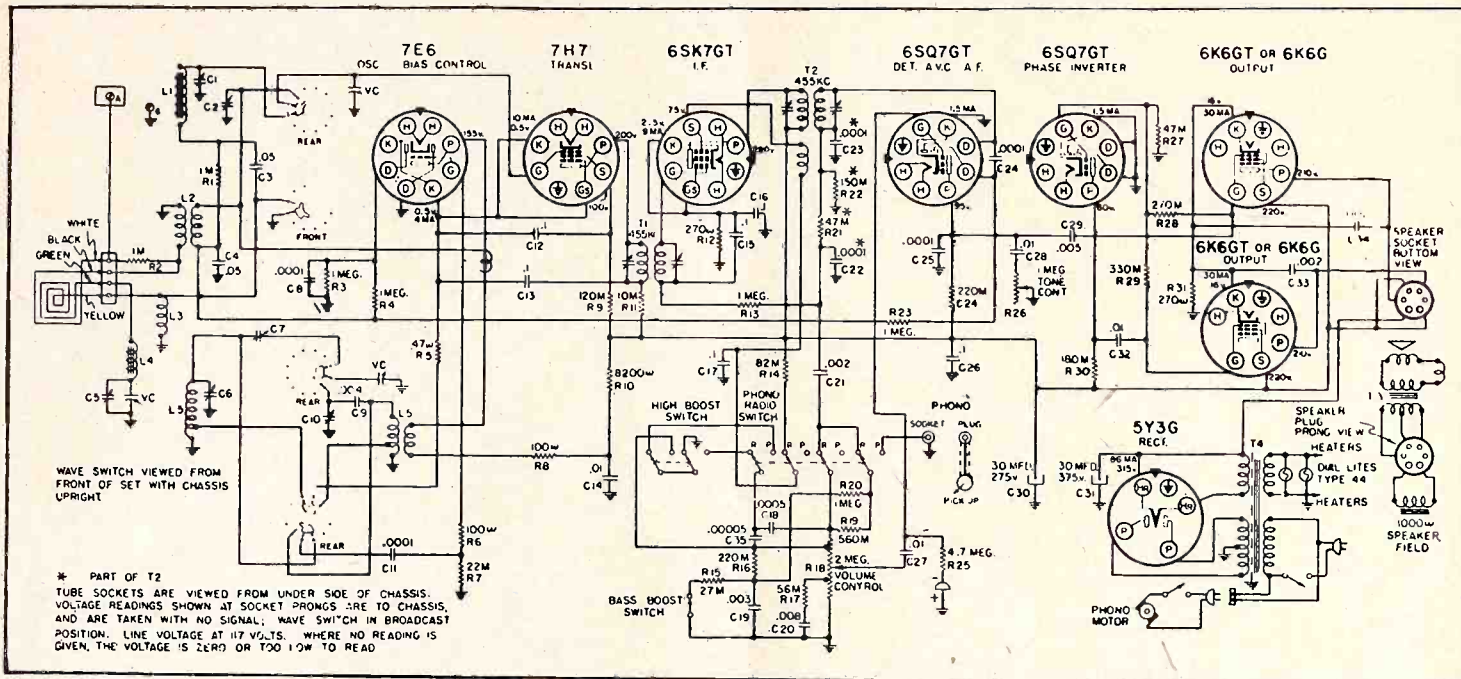

Fig. 7. Schematic diagram of Silvertone Model 7167 receiver



TARGET FOR TONIGHT

... Your Business?

Maybe they won't actually come and drop a *bomb* on your business, but the Axis war lords have their eye on it, just the same. They want to wipe it out as a competitive force—or take it over lock, stock, and barrel. Here is a threat that you can reply to *now*, today, and in no uncertain terms—by buying War Bonds to the very limit of your powers, that our armed forces may have the guns, tanks, and planes they need to crush the Axis *once and for all*.

THE GOAL: 10% OF EVERYONE'S INCOME IN WAR BONDS

Every American wants the chance to help win this war. When you install the Pay-Roll War Savings Plan (approved by organized labor), you give your employees that chance. For details of the plan, which provides for the systematic purchase of War Bonds by voluntary pay-roll allotments, write: Treasury Department, Section S, 709 12th St. NW., Washington, D. C.



Buy War Savings Bonds

This space is a contribution to America's All-Out War Program by
RADIO SERVICE-DEALER

THINKING AHEAD

on servicing radio sets

by Jerome J. Kahn



OUR Administration and the various divisions of the government consider home radio receiving sets an essential part of the war program. Efforts have been constantly made to clarify the problems relative to the procurement of materials for the further maintenance of those radio sets.

The present program, the PD1X forms filled in by jobbers, will serve to acquaint the War Production Board with the exact status of the inventories of replacement parts, and will provide the vehicle upon which the radio section of WPB may present to the various material sections and requests for allocations of materials to produce the much talked about 'Victory Lines' of replacement parts or components.

Suppose that as of today or tomorrow this allocation program was approved by the various departments within WPB! What next? When I ask what next, I am pondering over the problem of man power to properly utilize these replacement parts and get them into the inoperative home receiving sets to provide the proper types of reception the Administration is anxious to see the radio industry provide 'John Q. Public' from broadcasting station down to serviceman.

Servicemen's Ranks Depleted

Very bluntly, the continued requests of the Army Air Force for radio men, the Signal Corps cam-

The author of this article is president of Standard Transformer Corp., a director of RMA, Chairman of the RMA Priorities Committee and a member of the Radio Replacement Parts Industry Committee working with WPB. Much of his time and energy is now devoted towards obtaining a steady flow of replacement parts for service-dealers' use.

Here he outlines a Plan of Operations that merits consideration, especially in those territories where servicing man-power has been depleted; or where jobbers, having but little priority-rated business, are "considering" entering the servicing business.

The prime object of the Priorities Committee is to assure the utilization of every bit of man-power, conserve materials to the maximum degree and spread servicing and parts so that they will be uniformly available to all set owners.

paigns to enlist radio servicemen, the Navy's enlistments of qualified radio men, as well as the draft have fallen short of their quotas and as well have left our radio serviceman's market badly depleted of qualified men, competently equipped to properly service a receiver. If these parts were available, where would the serviceman come from that could properly use them? This presents the problem of correlating all the facts, material, and man power into one unified program so that the proper servicing may be accomplished. There are several ways in which this could be done. One would be to have the public service or utility companies handle the servicing of home receivers. My thought, however, is that for the duration of the war a mobilization of servicemen, dealers, and radio parts jobbers, might answer our problem and keep the serv-

icing of radio receiving sets in the field where it belongs.

The writer is of the opinion that time saving primarily is the essence of defeating this difficulty we are now facing in the servicing problem. We know the average radio set can be repaired in a few moments. The greater portion of time is spent in making the call, analyzing the trouble, and toting back and forth of that particular receiver to the shop to permit the efficient installation of whatever part or parts may be required.

Our first problem, then, is to save that time devoted in making the service calls, picking up and delivering the defective units. My plan would call for the set user to bring his radio set into the dealer or serviceman's place of business and after it has been repaired to pick it up.

(Continued on page 21)

Shop Notes

Card 1

PHILCO PT-15

(Constant or Bad Modulation Hum)

Hum in these models is usually caused by high resistance shorts due to faulty insulation in the bakelite, as between tube sockets and chassis, and leakage between windings of antenna coil. To remedy, alter antenna circuits as shown. Bond one side of a-c line direct to chassis. Dry moisture out by heating set several hours after covering it with a heavy cloth. Several bondings may be re-employs a magnal 11-pin *Gulliver*.

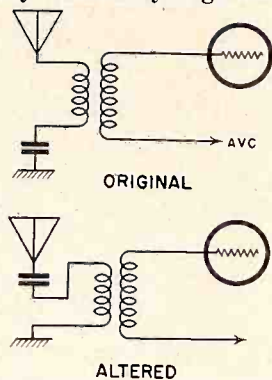

Card 2

934

Vacuum Phototube

The RCA-934 is a small high-vacuum phototube intended primarily for use in sound and facsimile equipment but it is also suitable for light-operated relays and light-measuring equipment. Its S4 photo-surface has exceptionally high response to blue and blue-green radiation and negligible response to red radiation. Dimensions: 2 15/32" long x 23/32" diameter.

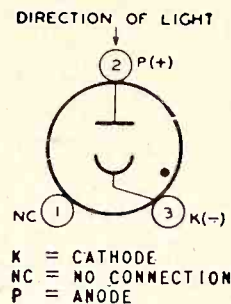

Card 3

2AP1

High Vacuum Cathode-Ray Tube

The RCA-2AP1 is a high-vacuum, cathode-ray tube 902 except that it has separate leads to all deflecting electrodes and the cathode, employs a magnal 11-pin base, and can be operated with higher anode voltages.

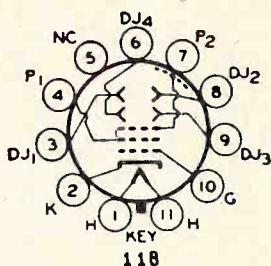

Card 4

935

Vacuum Phototube—(Ultraviolet-Sensitive Type)

The RCA-935 is a high-vacuum phototube possessing extraordinarily high sensitivity to radiant energy rich in blue and near ultraviolet and will respond in the region down to about 2000 Angstrom units. Because of its excellent stability, consistency of spectral response, and extremely high sensitivity, the 935 is particularly suited for use in measuring ultraviolet absorption of gases and liquids.

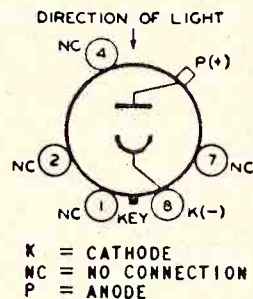

Card 5

5R4-GY

Full-Wave High-Vacuum Rectifier

The RCA-5R4-GY is a coated-filament type of full-wave, high-vacuum rectifier having a maximum peak inverse voltage rating of 2800 volts, a peak plate current rating of 650 milliamperes, and a maximum d-c output current rating of 175 milliamperes when a choke-input type of filter is used. The 5R4-GY has a micanol base.

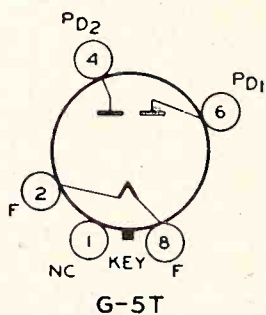

Card 6

6J6

Twin Triode (Miniature Type)

The RCA-6J6 is a Miniature twin triode having two grids and two plates with a common cathode indirectly heated. The twin units may be operated in parallel or in push-pull. With push-pull arrangement of the grids, and with the plates in parallel, the 6J6 is particularly useful as a mixer at frequencies as high as 600 megacycles. It is also useful as an oscillator.

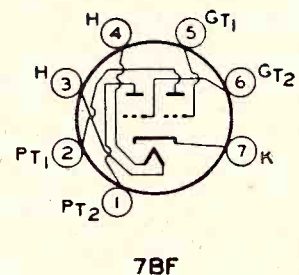

Card 7

6AG5

R-F Amplifier Pentode (Miniature Type)

The RCA-6AG5 is a heater-cathode type of r-f pentode with a sharp cut-off characteristic and a high value of transconductance. Having miniature construction, the 6AG5 is useful in compact, light-weight equipment as an r-f amplifier up to about 400 megacycles, and as a high-frequency intermediate amplifier. It has low input and low output capacitance.

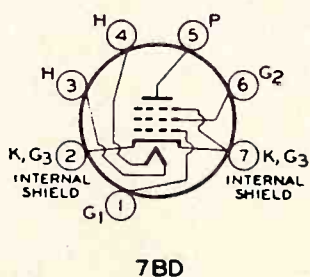

Card 8

1C21

Gas-Triode

The RCA-1C21 is a cold-cathode, glow-discharge triode designed for use primarily as a relay tube. The discharge can be initiated with a very small amount of energy applied in the grid circuit. It is similar to the type OA4-G but is more sensitive.

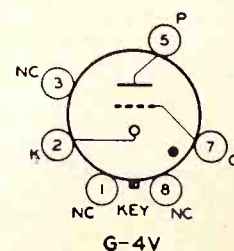

TECHNICAL SERVICE PORTFOLIO

SECTION XXIV

Resistors and Volume Controls

IN PEACETIME the matter of replacing defective resistors or volume controls is simple; you just find out what is called for in the schematic and make a replacement with an exact duplicate chosen from your own stock or at your jobber's. But nowadays things are different; we can't always pick out just what we need for a given job because parts are scarce and are becoming scarcer. And, to make it still harder, there seems to be a greater demand for radio servicing now than at any time in the past fifteen years.

In some respects these difficulties are helpful rather than otherwise. All of us are going to have to do a lot more thinking than we did before. And that means we are bound to learn a lot more about radio servicing than we would have if we followed the same old routine.

We are going to ask ourselves if this business of replacing a defective part with another of precisely the same characteristics is necessarily the proper thing to do. For, we are likely to conclude, if the original part wouldn't stand up in the circuit, how do we know that an exact duplicate will be any better? Maybe—if we are servicing without a schematic—the part we are replacing is not the proper value due to some error on the part of another serviceman. Maybe the schematic itself is in error, or the designer may not have allowed a sufficiently good safety factor in his wattage rating.

To answer these doubts we must be able to sit down and work out some of these design problems ourselves. We will find the time well spent, because as time goes on and

parts become scarcer, we are going to be obliged to do a lot of things which aren't immediately necessary. We are going to have to redesign circuits to use parts and tubes which are obtainable to replace those gone for the duration, to reduce set operating voltages to reduce strain on weakening components, to change over from avc to manual volume control and lots of other things which would be unthinkable under normal conditions.

Molded Resistors

Because we cannot handle any design problems intelligently without definite knowledge of the characteristics of the components we have to work with, let us first consider the data given in *Table I* on fixed molded composition resistors, what we generally call carbon resistors. We believe this is the first time these important characteristics have been given in any service literature, yet familiarity with them is vitally important in many aspects of radio servicing, as well as in design work.

The wattage ratings are familiar enough, of course. But we wonder

how many servicemen know that the wattage rating is definitely tied in with other characteristics which must be simultaneously considered in choosing the proper rating. For example, note that a 1/2-watt resistor is designed to operate at a temperature not to exceed 90° C. (194° F.). The temperature rise at rated load is given as 40° C. (104° F.). This means that, under rated load, the temperature of the resistor will be 40° C. hotter than the ambient, or surrounding, temperature. Thus, if the air temperature around the resistor is 20° C. (68° F.) the actual temperature of the resistor under rated load will be 40 plus 20 or 60° C. This is all very well, since the maximum operating temperature is not reached. But if the resistor happened to be mounted on the terminals of a power transformer, where the temperature of the winding under load frequently rises to 90° C. or even higher, it is possible for the maximum operating temperature of the resistor to be reached even higher, it is possible for the maximum operating temperature of the resistor to be reached even though it isn't being subjected to any load at

TABLE I

TYPICAL CHARACTERISTICS FIXED MOLDED COMPOSITION RESISTORS			
Wattage Rating	1/2 watt	1 watt	2 watts
Maximum Operating Temperature	90°C	90°C	90°C
Temperature Rise at Rated Load	40°C	50°C	62°C
Temperature Coefficient per °C.	0.12%	0.12%	0.12%
Voltage Coefficient (% change per volt)	0.03%	0.03%	0.03%
Resistance Variation with Age	2 1/2% (av.)	2 1/2% (av.)	2 1/2% (av.)
Maximum D-C Voltage	350	350	350
Resistance Variation due to Humidity	5% (av.)	5% (av.)	5% (av.)
Noise (microvolts per volt)	2 to 10	2 to 5	1 to 3
Tolerances	5%-10%-20%	5%-10%-20%	5%-10%-20%

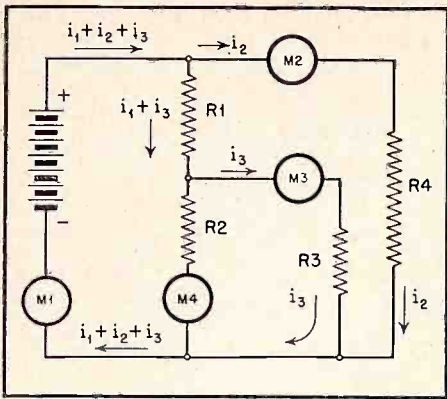

Fig. 1. Illustrating distribution of currents in an electric circuit; it's practically the counterpart of Fig. 2.

all. These considerations are particularly important in the tropics, but should be kept in mind even in our climate—*don't let a resistor get too hot*. Along these lines, it is a good idea not to hold a hot iron against a small resistor when soldering—many have been damaged in this manner.

The temperature coefficient of the resistor is important when it is used as a voltage divider or multiplier in test instruments. The coefficient 0.12% per degree C. means that for each degree centigrade change in temperature the resistance value will change by a factor of 0.12%. Thus a 40-degree change means a 4.8% change in resistance. If all resistors changed in the same degree and in the same direction—that is, positive or negative—this wouldn't matter much, since the proportionate resistance of a divider would remain the same. This, unfortunately, is not always the case. In the higher resistance values a different "mix" is employed than for low values of resistors, so the characteristics likewise are subject to change. In some cases it has been found that higher values of composition resistors increase in

resistance with an increase in temperature, while low values decrease in resistance under the same conditions.

Voltage Coefficient

The voltage coefficient is the percentage change in resistance which results when a voltage is applied to the resistor. If the voltage drop across a 1/2-watt resistor is 100 volts, we may expect a change in resistance of the order of 3.0% since the change per volt is .03%. This applies to high resistances, of the order of 0.5 megohm or more. The voltage coefficient, in any event, is usually negligible in comparison with the temperature coefficient.

The resistance variation with age is a sort of settling of the composition which occurs while the resistor is resting in stock as well as after installation in a set. This may result in an increase in resistance or a decrease; generally the former for high resistance values and the latter for low values, as with temperature variations, but this varies with resistors of different makes.

The d-c voltage rating is the maximum voltage which should be applied to a given resistor, regardless of its wattage rating. We might figure that a 10-megohm, 1/2-watt resistor could well be used with 1000 volts across it because the resulting wattage dissipation would be only 0.1 watt—well within its rating. But actually we should not apply more than 350 volts to its terminals if we want to keep out of trouble.

Noise results when a voltage is applied across a resistor or when the resistor is used as a plate load. This noise is small in comparison with tube noises, in most cases, but nevertheless it is a limiting factor in high gain p.a. amplifiers. The noise is caused by imperfect cohesion of the mixture used in making resistors and is more prominent in small resistors than in larger ones. Thus, for low noise, it is always best to use a resistor of high wattage rating. This type of noise is not present in wire-wound resistors, which are accordingly preferable for high-quality amplifiers where low noise is imperative. It must always be remembered, though, that as stated, tube noises are generally greater unless special precautions are taken, such as operating at sub-normal operating voltages.

Dampness causes a change in resistance in any molded composition

resistor. However, it must be remembered that in normal operation the interior of a radio receiver tends to get pretty warm, and this increase in temperature lowers the relative humidity so that the parts dry out rapidly. In most cases, resistors then regain their normal rating so this effect is not of much consequence in practical work. It is a good idea to keep this point in mind when checking resistance values in damp weather when the set has been inoperative for an appreciable period—it may save your finding that resistors which appear to be of the wrong value are perfectly all right under operating conditions.

Tolerances

Tolerances are frequently misinterpreted. Many people have the idea that such-and-such resistors are better than some other make because the values of resistance are sometimes closer to their ratings than others. This is purely a matter of selection and has nothing whatsoever to do with the quality of the resistor. If you must have, and are willing to pay for, resistors having a close tolerance, you need merely specify this when buying. For a 5% tolerance rating, a resistor nominally rated at 100 ohms may be of any value from 95 to 105 ohms; for a 20% tolerance, from 80 to 120 ohms. In most receiver applications, a tolerance of 20% is close enough for plate, cathode or grid resistors, avc circuits, diode loads, and volume controls. For fixed biases applied to control-grid circuits, a closer tolerance is sometimes required. When tolerances closer than 5% are required, it is advisable to use wire-wound resistors because the latter are far more stable than composition types. This is apparent from a study of the variables shown in Table I. However, for high

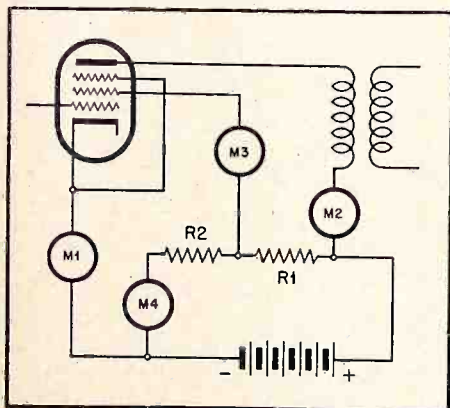

Fig. 2. Current distribution in vacuum-tube circuit. Compare this with Fig. 1.

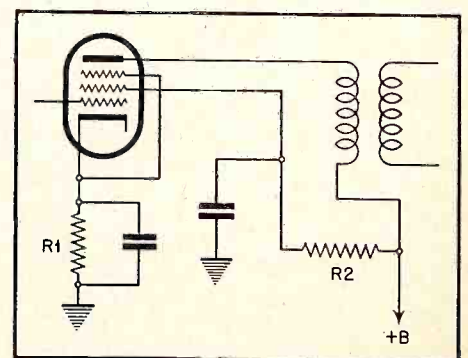

Fig. 3. Text explains fully the method for determining values of cathode resistor R1 and screen resistor R2.

resistances, it will often be found that the cost of wire-wound types is prohibitive. Except in laboratory test equipment, wire-wound resistors are usually chosen because they are available in greater wattage ratings for a given size rather than for their greater stability.

In every circuit using resistors and potentiometers we are concerned with voltages and currents, either a-c or d-c, or both. Therefore, in making replacements, our problem is to restore the original voltages and currents. Insofar as tube operating voltages are concerned, in the absence of a schematic or service notes we may determine the required voltages from any tube manual or chart. The a-c voltages in which we are interested are usually signal voltages; those we shall take up later on. Once we know what voltages are required, the resistance value need for replacement can be determined by substitution or by calculation.

Often it is quicker to find the proper resistance value by substitution, using a calibrated wire-wound potentiometer for this purpose and adjusting it until the proper voltages are restored. But this method is open to criticism because often when this adjustment is being made other components in the receiver, such as the tubes, may not be up to normal rating with the result that we adjust the voltages for a condition which does not represent those present when everything is as it should be. Further, this method does not work out well with low-current, high-resistance circuits, such as plate and screen resistors, where voltages are hard to measure accurately. In any event, it is important to be able to calculate the required values, and a knowledge of the proper way to tackle such problems will be of value not only in service work, but in any technical work along radio lines which one may want to enter.

Current Distribution

Most servicemen understand the simpler applications of Ohm's law, but many do not realize that these simple fundamental principles may be applied to the most complex circuits. In Fig. 1, which is a rather academic presentation of a problem in the distribution of currents in a typical electric circuit, we may not at first realize that this represents very closely the distribution of currents in a vacuum tube amplifying circuit. Meters are shown in each

Fig. 4. Typical receiver power-supply filter circuit. R1 is a voltage-dropping resistor which serves to reduce effective tube voltages.

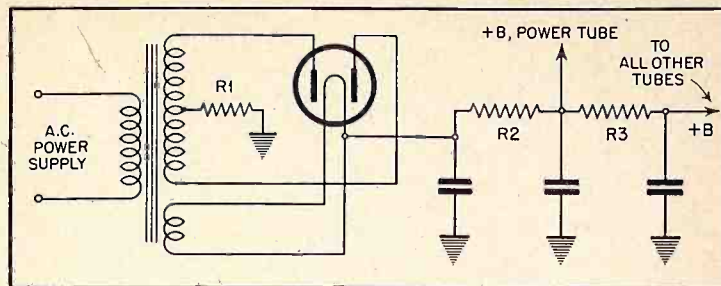

circuit for clarity. Three currents are designated— i_1 , i_2 and i_3 . All are supplied from a single voltage source as indicated. The current through $R1$ and $R2$ is shown as i_1 , and is indicated on the meter $M4$. No portion of this current passes through $R4$, therefore the current i_2 indicated on $M2$ may be considered as an entirely separate circuit from that of $R1$ and $R2$ and the current may be calculated without considering $R1$ or $R2$. But, as the current for $R3$, indicated on $M3$, must pass through $R1$ in order to reach $R3$, the voltage across $R1$ will be dependent upon both currents, i_2 and i_3 . Again, however, each current may be calculated separately. Thus we can determine how much current is represented by i_3 if we know the values of $R1$ and $R3$, and the voltage. And we can find out the same for i_1 if we know what $R1$ and $R2$ are. To find the voltage drop across $R1$, we add the currents i_1 and i_3 . Then the voltage drop is obtained by Ohm's law.

Let's take an example. The battery voltage is 300, $R4$ is 30,000 ohms, $R2$ is 100,000 ohms and $R3$ is 100,000 ohms. We will assume that we have to select a resistor for $R1$ which will provide 100 volts across $R2$. This same voltage will of course appear across $R3$, since the two are in parallel. When the voltage across $R2$ is 100, the current i_1 through $R2$ will be equal to $100/100,000$ (corresponding to E/R) or .001 ampere, which is 1 milliampere. The current i_3 through $R3$ will likewise be 1 ma because the resistance of $R3$ is the same as that of $R2$. The currents i_1 plus i_3 which pass through $R1$ are thus equal to 2 ma. In order to reduce the 300 volts to 100, the resistor $R1$ must cause a 200-volt drop when 2 ma are flowing through it. Applying Ohm's law ($R = E/I$) $200/.002 = 100,000$ ohms.

Note that $R4$ doesn't enter the picture at all in these calculations. And if any number of additional circuits were added we would have no need to consider them either in determining what is required for any circuit where no portion of the current in

another circuit passes through it. If we want to find the current in $R4$, we can ignore the currents in $R1$, $R2$ and $R3$, because none of the currents in these circuits pass through $R4$. Thus i_2 would be equal simply to $300/30,000 = .010$ ampere = 10 ma. The total current drawn from the battery, $i_1 + i_2 + i_3$ would thus be equal to $1 + 1 + 10$, or 12 ma.

Tube Circuits

In Fig. 2, the same circuits shown in Fig. 1 are represented, but we are now showing tube circuits as portions of the load, rather than the resistors $R3$ and $R4$. Thus we see that the current i_2 in Fig. 1 may be considered to represent plate current and the current i_3 screen current. Because the total current in any tube must return to the cathode, the sum of the screen and plate currents, i_2 and i_3 , represents the cathode current. The only current which does not pass through the cathode circuit is i_1 , which represents the current in the voltage-divider circuit. It is important to realize this, because it means that a voltage divider across a battery will draw current at all times, whether or not the tube, in the circuit shown, is operating.

We see from Fig. 2 that the screen and plate circuits of an operating tube can be considered as resistors similar to $R3$ and $R4$ in Fig. 1. Often, in modern circuits, the voltage divider is eliminated and we need to calculate the value of resistor neces-

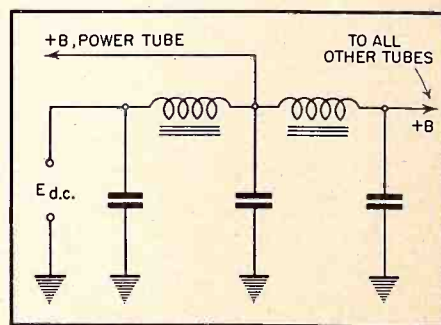

Fig. 5. With a choke filter only the d.c. resistance of chokes need be considered in determining output voltages.

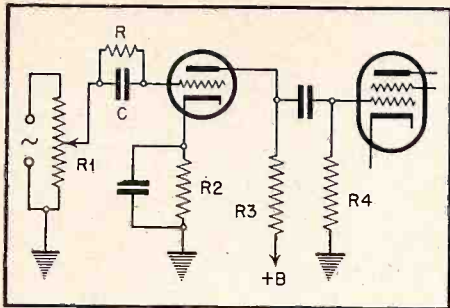

Fig. 6. Audio circuit in which a.c. voltages must be considered; across R1, R3 and R4, for instance.

sary to supply a given screen voltage. For example, in Fig. 3, we might be required to determine what value R2 should be. Let's assume the tube to be a 6K7. The plate voltage is 250 and the screen voltage, according to the tube manual, should be 100. The screen current, as listed in the manual, is 1.7 ma. To find the value of R2, then, we must calculate what resistance is required to reduce 250 to 100 volts at a current of 1.7 ma, or .0017 amp. This means that a 150-volt drop is required. Since R equals E/I , R would be equal to $150/.0017$ or 88,000 ohms (approximately). This value is not critical because screen currents vary among tubes, and other compensating factors will tend to keep the performance normal when the voltage varies.

The cathode resistor R1 is calculated similarly, except that both screen and plate currents enter into the picture. For the 6K7, the plate current would be 7 ma and the screen current, as we have seen, 1.7 ma. The sum thus equals 8.7 ma. Since the cathode bias determines the grid voltage, which should be in this case -3 volts, we find R1 by dividing 3 by .0087. This equals 345 ohms (approximately). Thus 350 ohms has become a common value in many designs.

In Fig. 4 and Fig. 5 are shown

typical power - supply filter circuits. In Fig. 4, R1 serves as a voltage-dropping resistor through which all the current in the supply circuit must pass, as it acts as a return circuit for all rectified current. Through R2 will also flow the current for all circuits, with the exception of the small leakage current which passes through the first section filter condenser. Through R3 flows all current except that for the power stage, which we see is taken off at the junction of R2 and R3.

The analysis of Fig. 5 may be carried out the same as for Fig. 4, except that for d-c voltages we need consider only the d-c resistances of the chokes in the filter circuit.

Wattage Calculations

In the preceding examples we have considered only voltages and currents. From these we have been able to calculate resistance values. For wattage ratings, we can determine the wattage dissipation by the formula $E^2/R = W$. Thus when the voltage is 300 and the resistance is 30,000 ohms, the wattage dissipation is $300^2/30,000$, or $90,000/30,000$, which equal 3 watts. Or, if we are basing our calculations on currents, it is equal to $I^2 \times R$. Thus, for a 10-ma current in a 30,000-ohm resistor, the wattage dissipation would be $.010^2 \times 30,000$ or $.00010 \times 30,000$, which also equals 3 watts.

The mathematical method of determining wattage dissipation just described is of course well known to most of our readers. However, what is not generally appreciated is that some safety factor must be allowed. We must reckon that the unforeseen failure of some related component may seriously increase the current in a circuit so that resistors will be subjected to considerable overload. Further, as we have seen, temperature and other factors limit the cur-

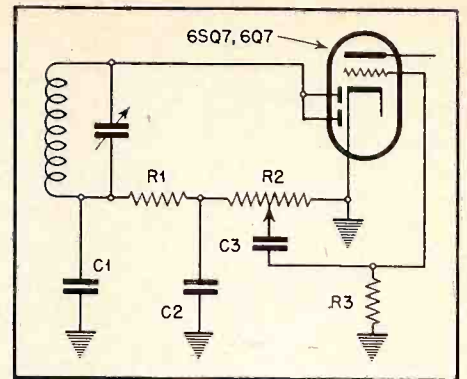

Fig. 8. In this circuit the volume control R2 also carries d.c., and is therefore subject to early breakdown.

rent which may be accommodated regardless of the wattage rating. A good rule is to choose a 1/2-watt resistor for all wattages of 1/4 or less; 1 watt resistors for 1/2 watt to 1/4 watt and 2-watt resistors for any values between 1/2 and 1 watt. Some designers always choose a resistor having at least four times the wattage rating which would be theoretically required.

A-C Voltage Considerations

So far, too, we have considered only d-c voltages. We must remember that, in many circuits, the a-c voltage across a resistor may far exceed the d-c potential. In Fig. 6, for instance, we may apply a much larger signal voltage to the input control R1 than we would think of using were d-c voltages involved. An ordinary carbon-type volume control, of the small varieties used in radios, has a rated wattage dissipation of but 1/2 watt; it is quite easy for this value to be exceeded when a low-resistance control is being used. We should always consider the signal voltage which will appear across any resistor or control. Thus, signal voltages will appear across R1, R3 and R4 in Fig. 6. Of course, there will also be a slight signal voltage across R and R2, but in these circuits it will be small because, in the case of R, the grid input circuit is of such extremely high input resistance that the current through R is limited to purely a capacitive current, and is further reduced by the bypassing action of C. This circuit, of course, is used to increase the high-frequency output. In the case of R2, its associated bypass condenser reduces the signal voltage to a negligible value. The signal voltage developed across the plate load, R3, causes a variation in the effective voltage in the circuit derived from the supply circuit. This

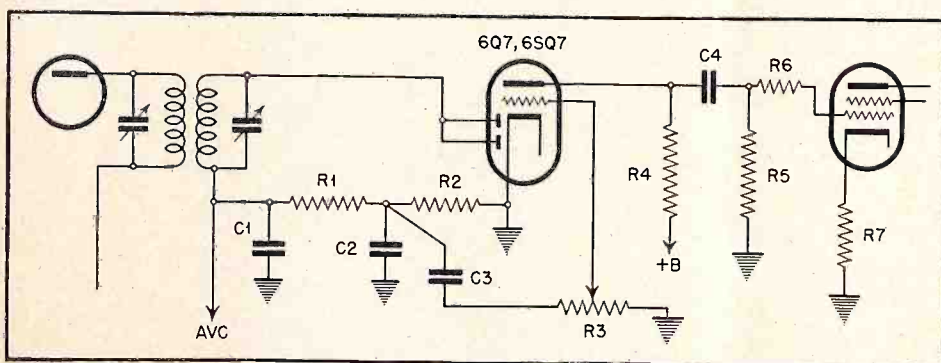

Fig. 7. Typical detector-amplifier circuit. The d-c across R1 and R2 must be considered, as these resistors form the diode load circuit.

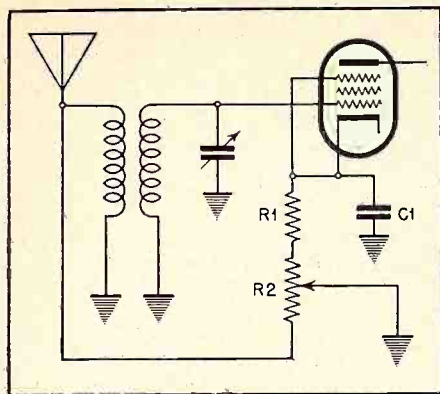

Fig. 9. Alternate volume-control circuit to replace avc and diode detector when the latter type of tube is unavailable.

signal voltage will be substantially the same as that across R_4 .

Fig. 7 represents a typical radio receiver detector-amplifier circuit. R_1 and R_2 are subject to applied d-c voltages resulting from rectification of signal voltages. The value seldom exceeds 50 volts and, because the resistances used are ordinarily high, the rectified current is small and the wattage dissipation correspondingly low. Such a circuit usually causes little trouble. However, it must be remembered that the volume control must be of 2 to 10 megohms resistance to avoid appreciable distortion.

Fig. 8 represents a modification of Fig. 7 which is quite often found in low-priced receivers. The volume control appears in the diode circuit rather than in the grid circuit. It is possible, with this form of connection, to use a lower resistance volume control, usually $\frac{1}{4}$ megohm, while R_3 may be 10 or 15 megohms. However, the rectified d-c across the control, absent in the circuit of Fig. 7, tends to create noise so that more frequent replacement may be required than with the preceding circuit. All volume controls are likely to become noisy quicker if they are used in circuits in which d-c is present.

There are times when it will be found difficult to obtain the proper control replacements for one or the other of the two circuits shown (Figs. 7 and 8). When a control for one is available, it may be useful to know that the other circuit may be modified so it may be used.

Alternate Controls

There are occasions when it may become necessary to eliminate the avc circuit in a receiver being repaired because no combination diode-triode or diode-pentode tube can be

obtained for replacement purposes. In such cases, volume control may be effected by using the circuit of Fig. 9. The control resistance may be 15,000 ohms or thereabouts. R_1 is the usual cathode resistor.

Combination volume and tone controls, formed by using filter circuits in conjunction with tapped volume controls, as illustrated in Fig. 10, provide an excellent method of improving the performance of receivers with unsatisfactory tone quality in that the low-frequency response may automatically be increased as the volume control setting is reduced. Representative values may be found in set manuals. This makes up for the apparent falling off in lows at low volume. This effect is purely psychological, so the compensation introduced by the special control and its associated circuits is not subject to the criticism which has so often been brought against the older, conventional type of tone control.

In choosing replacement controls it is well to keep in mind that tapered controls which show abrupt changes in resistance at any point are likely to become noisy at that point. A taper which will last in service should have a curve which slopes smoothly into the steep portion required for proper audio grid control. Such a control may not initially seem quite as good in operating qualities as one with a more abrupt slope, in that the increase in volume as the control knob is rotated is not quite so uniform, but a control of this type will usually outlast the other.

It is well to avoid, at all times, using a carbon-type control if any current is to be taken off the moving arm. Most controls are designed to work into circuits which require no appreciable current; consequently

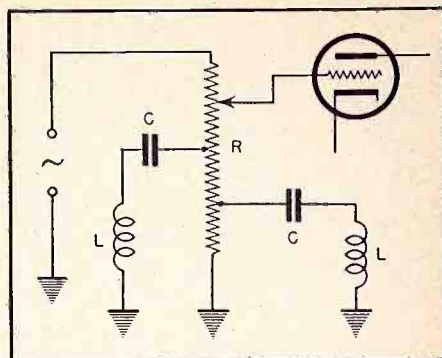

Fig. 10. Combination volume- and tone-control circuit for improving bass response at very low volume levels.

the contact to the control element is often simply a very small surface, which quickly develops poor contact when subjected to excessive current. This is especially true of high-resistance controls. In any applications where current must be taken from the moving arm, it is best to use wire-wound controls.

Volume controls of the carbon types are subject to humidity troubles just as are resistors of the same composition. Care should be taken not to store them in damp places. But do not try to seal them up completely. If this is done, then moisture inside the case may condense on the composition element and cause serious trouble.

Checking Noise

A circuit for checking noise in either controls or fixed composition resistors is shown in Fig. 11. Noise is expressed as "equivalent noise voltage" in engineering terms. Just what this means is apparent from a study of the test circuit. Thus, when we apply a d-c voltage across R_x , in Fig. 11, a certain amount of noise is

(Continued on page 29)

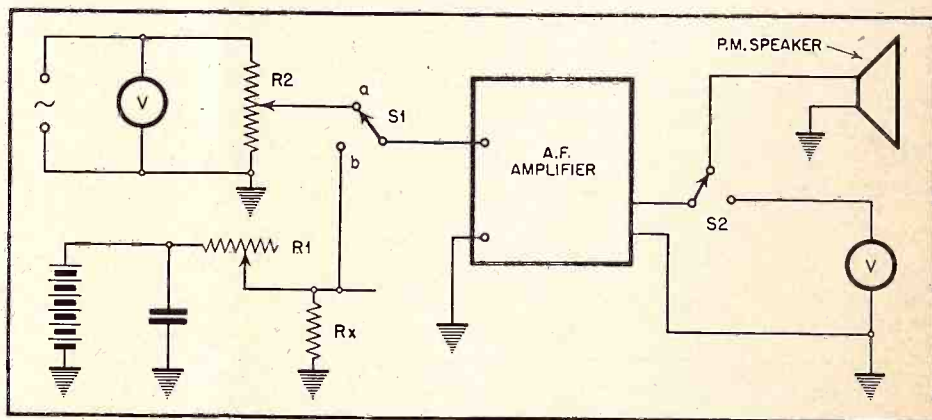

Fig. 11. Test setup for checking noise in composition fixed resistors or potentiometers. It operates on the substitution method, where the noise in one circuit is compared with that in another.

MY LOG

by San D'Arcy

IT'S midnight. My head and feet hurt. For a long time I've owed myself a little rest, and this is it! I feel like reminiscing, so, as Red Skelton would say, "I'll dood it!" Yes I will, if my nerves will just quiet down.

Gosh, in the good old days my pard Jerry and I used to do a lot of reminiscing. We'd sit here in the shop for hours, after knocking off, talking about the gals we knew and the things we did. Most of 'em were foolish things, but fun. You know what I mean! But tonight it's different. I'm so dag nabbed tired and groggy from Girls, Girls, Girls that I don't even want to think of 'em.

Not so many months ago Jerry and I would jump in Liz and take a ride around town picking up four or five chassis. That was a day's work for us. If there was a real rush on one of us would stick to the bench and the other would do the hot-footing. Those were seven sets-to-repair days. Big days they were, too, for on seven repair jobs a day Jerry and I could make nice sugar. That is, we thought we were making good dough then.

I remember the Saturday night, not long ago, when Jerry and I checked the till and figured the week's take. We found ourselves eighty bucks to the good. That meant forty apiece, and boy, were we rolling in clover! We were big-shots, so out for a bottle of two-fifty Rye we went. That bottle only lasted

two hours, but as I remember it, the hang-over lasted two days. And as I sadly recall the situation, half a dozen of our repair jobs came back because in our misery we had forgotten to solder connections, or had delivered the wrong sets to the wrong people.

Jerry and I don't have time for such nonsense now-a-days. But confidentially speaking, our big job now is to make sure that our bench workers keep their minds on their jobs so that the customers get a square shake. Since I hired Elaine two weeks ago, it's been quite a problem. She is a problem and so are our two new benchmen. If it gets much worse I'll have to make up my mind and try to find new mechanics. Elaine is so cute I don't think I'd have the nerve to fire her. But she does the darndest things! You'd think a girl like that would know, by this time, how to solder leads together.

When I opened the shop at seven o'clock this morning I felt pretty good. There were only seventy or eighty chassis laying around, and if you stepped carefully you wouldn't get snagged very badly. The other day we had over one hundred and fifty jalopies in work and then we really had a mess on our hands. But the boys, Jerry, Elaine and I got down to business and we cleaned up a lot of easy jobs in order to make room for the pile of stuff that is accumulating around town. Our hook looks like it needs an assistant, and I'd buy another if I could, but there ain't another in town, and I'm too busy to put up a long nail.

But that gal Elaine sort of gums up the works. In some respects she speeds up production, and in others she ties us up in knots. I could al-

(Continued on page 28)



Thinking Ahead On Servicing Radio Sets

(Continued from page 13)

This might even mean that 'Mr. John Q Public' might have to take his chassis out of a console cabinet, unless it were in large combination installations, but during war times, I don't think that they could object to this.

Today, if a person wants a receiver to play he *must* be made to realize that some discomfort and some effort must be experienced on his part to provide sufficient time-saving on the part of the serviceman to permit him to devote his valuable time to the technical aspects of servicing the receiver itself and not merely to that of being a delivery boy.

Consolidating Technical Work

The second problem would be the establishing of these collection agencies wherein the public might bring their receiving sets for service. The average service-dealer is so busy these days that it may take some time to get around to actually perform some operations on the receiver. These servicemen or individual shops should effect a mobilization and concentration of the remaining technical skill into an organization such as the local parts jobber wherein all service work could be done by these consolidated servicemen. The service-dealer's store would then act as the media through which the receiver was delivered by the public and then turned over in quantities to this master servicing organization operating over the local parts jobber's guidance. By having the actual servicing done within the parts jobber's establishment, it would salvage the time generally required by the average serviceman to run down and pick up one specific type of tube or one or two other miscellaneous parts that would go into the service work for that particular day. Bear in mind that in order to expedite man power, time is the one element that can be saved.

When one of these sets is delivered to the master service organization or the parts jobber, as we have established him, it would then be turned over to a master diagnostician who by experience could in most instances tell within a few minutes just what is the difficulty, and in many in-

ARE

Coils

YOUR PROBLEM?

For many years Meissner Coils have been the accepted standard by engineers who insist upon high quality performance . . . Meissner precision coil construction never varies . . . they are the best that engineering research and modern production methods can make.

When you specify a Meissner Coil you have the assurance of long, trouble-free operating life backed by a name that is synonymous with precision-built products.

Coils illustrated and described represent only a few of the complete Meissner Coil line.

See your nearest Meissner distributor today.

Meissner

MT. CARMEL, ILLINOIS

"PRECISION-BUILT PRODUCTS"

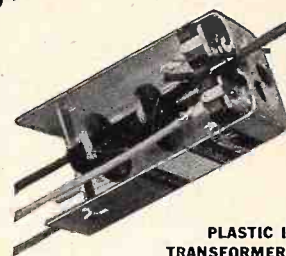

PLASTIC IF TRANSFORMERS

The most popular replacement types. Compact in size, 1 1/4" square, 2 1/4" high. Available in all frequencies from 175 kc. to 455 kc. List price \$1.10 each.



UNIVERSAL ADJUSTABLE COILS

Adjustable - Inductance Ferrocart (Iron Core) coils will replace the broadcast band coils in practically any receiver. 3 types available, Antenna, RF, Oscillator. List price \$1.38

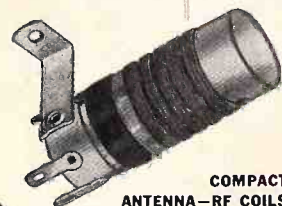

COMPACT ANTENNA-RF COILS

Ideal units for replacement in compact midget or auto Radio sets. Coils wound on form 3/8" in diameter, 1 1/4" long. List price, either type, Antenna or RF, 50c each.

stances could repair it in making the diagnosis. If difficulty in diagnosis is met, the set could then be turned over to one man that would be termed in the vernacular as a 'piddler', the kind of an individual who has enough patience and knowledge to sit down and trace out the circuit and find out just what is wrong. Thus, service work would be expedited to a large degree. Upon completion of the job, the radio service-dealer would then pick up the sets to be taken back to his store or the owner could pick up his at the master servicing establishment. Thus, much time would be

saved and this plan may tend to keep radio service available to the public.

Salvage A Factor

The above suggested plan would also facilitate the reclamation or salvaging of used and defective parts. The Radio Section of WPB has asked that some plan be presented to effect the most general salvaging of such defective units, and it would appear most logical that were a procedure of this type accepted as a standard practice for the duration, by having the units serviced by the jobbers or



★ "Sure, I'd Rather Have Roast Beef" ★

... but if it's a question of who it goes to—me or a boy at the front—Brother, I'll eat fish and like it."

★ People are accepting with ever-increasing good-grace each days new war-born inconvenience—WHEN they know the reason for it.

★ If you explain to your customers how war needs are taking all new radio parts—how you have licked a tough situation to get their sets into operation *without* those parts—they'll be satisfied with performance that's a "little less than perfect."

★ Improving repairs, however, *may* require your eliminating certain stages, substituting for specific resistors, condensers, sockets, etc. It *may* require that you transfer certain materials from one part of a set to another. But one thing it is always *certain* to require is a knowledge of exactly what is *inside* the set.

★ That's where Rider Manuals help you out—quickly. They save you hours otherwise wasted "guessing out" defects and experimenting with "possible" methods of improvising repairs. They lead you right to the cause of the trouble and furnish the facts that enable you to turn out a big volume of work in spite of material and labor shortages.

★ So, reach for one of your thirteen Rider Manuals when you begin *every* job. Today, it's good sense and good citizenship to work with the greatest possible efficiency.

★ YOU NEED ALL THIRTEEN RIDER MANUALS TO "CARRY ON" ★

master servicing organization set-up under the jobber's surveillance, the salvaging of materials would be thus effected in the most important link in the chain of returning those strategic materials to the melting pot. The question of salvaging is to develop directly in proportion to the proximity of our receiving material allocations and must, therefore, be considered as one of the salient elements of the above plan.

Many jobbers throughout the country have already been affected by the shortages reviewed in this article. Many jobbers have already

RIDER MANUALS	
Volumes XIII to VII.....	\$11.00 each
Volumes VI to III.....	8.25 each
Volumes I to V Abridged.....	\$12.50
Automatic Record Changers and Recorders..	6.00

OTHER RIDER BOOKS YOU NEED

The Cathode Ray Tube at Work.....	\$3.00
Frequency Modulation.....	1.50
Servicing by Signal Tracing.....	3.00
Meter at Work.....	1.50
Oscillator at Work.....	2.00
Vacuum Tube Voltmeters.....	2.00
AFC Systems.....	1.25
HOOR-A-DAY-WITH-RIDER SERIES—on "Alternating Currents in Radio Receivers"—on "Resonance & Alignment"—on "Automatic Volume Control"—on "D-C Voltage Distribution."	
	90c each

JUST OUT!

A-C CALCULATION CHARTS—Two to five times as fast as a slide rule—and more fool-proof. All direct reading—operative over a frequency range of from 10 cycles to 1000 megacycles. 160 Pages—2 colors—9½x12 inches—\$7.50.

FOR EARLY PUBLICATION

Inside the Vacuum Tube—complete elementary explanation of fundamentals of vacuum tubes.

John F. Rider, Publisher, Inc.

404 Fourth Avenue, - New York City

Export Division: Roche-International Electric Corp.
100 Varick St., New York City Cable: ARLAB

lem is going to become increasingly acute and if we expect materials to be freed by the cooperation of WPB, we must also find some way of "un-freezing" the man power so that these materials may be used advantageously.

Let us try to think ahead of the man power problem in radio service and have our own program well established so that when we receive the materials we expect we will have a place to use them!

★ INSULATED FLEXIBLE ELEMENT FOR TIGHT SPOTS

»» Available in any length, by the inch, foot or yard, a low-power flexible heating element finds many uses where space is limited. Known as the Glasohm, and also widely used as a flexible power resistor, this product is made by Clarostat Mfg. Co., Inc., 285-7 N. 6th St., Brooklyn, N. Y.

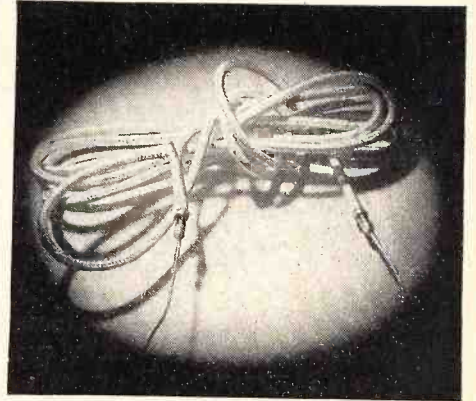

In the Glasohm construction the resistance wire is wound on a fibre-glass core and is protected by a fibre-glass braided covering. The fibre-glass is virtually indestructible glass, almost as flexible as silk. The unit can be bent and compacted to fit snugly about parts to be heated, or jammed into very tight spots, in either case providing an efficient heating means. Glasohm heating elements can be made to any required length and provided with any type terminals. Wattage ratings are from 1 to 4 watts per body inch depending on the application. Operating temperatures up to 750° F.

★ JOB COST CALCULATOR

»» Pay rolls and job costs can be figured in a fraction of the usual time through the use of a new calculator, according to the manufacturers, the Berger-Bricker Company of 433 South Spring Street, Los Angeles, California.

Operating on a simple new principle, this device includes all hourly rates of pay from \$0.50 to \$1.75 with a half-cent spread between rates. It covers all time periods up to 104 hours with divisions of one-tenth of an hour. It is handsomely made of lacquered wood and easily fits into a desk drawer. Selling price of the new pay roll calculator is \$7.50.

converted to a plan coinciding in principle with the above-mentioned outline in cities such as Pittsburgh, Pa.; Moline, Ill.; Denver, Col.; Oakland and Long Beach, Cal. In the Middle West, two other distributors have written their servicemen accounts obtaining their reactions to a plan very similar in nature and outlining to them the necessity of action being taken promptly. It would be well, therefore, that the parts distributing groups consider this phase as an industry problem to perpetuate their own organizations.

As time goes on our service prob-

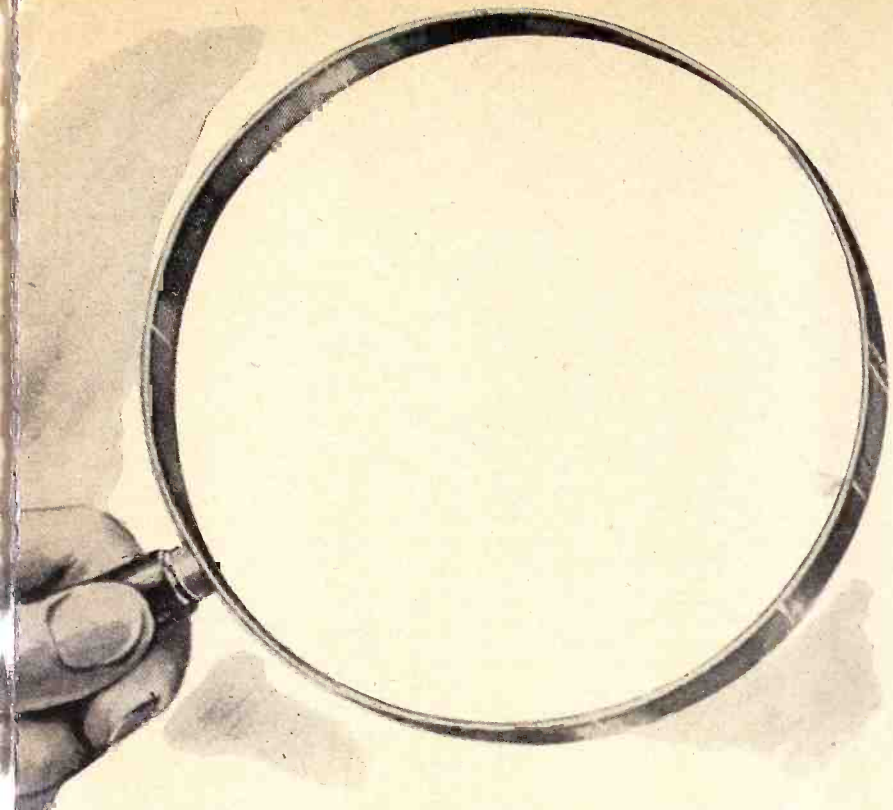

What do you see?

The answer, obviously, is *nothing*. Not one of us in the radio servicing field can put our future prospects under a glass and examine them with a real degree of accuracy.

We know there is a serious shortage of replacement parts and tubes; a condition that will get worse, not better. We know that many of our competitors have entered some branch of the Signal Corps; that many more of us will soon join them. We know we have more work in our shops than we can comfortably handle; that a bigger backlog will pile up, despite our efforts.

We service-dealers have a vital job to do—buying War

Stamps—and keeping as many civilian sets in repair as possible. How best can we do this job? By keeping thoroughly informed on the latest technical servicing procedure—methods that help save time and materials—learning tricks that will speed up work without impairing efficiency. What source gives you that type of technical data, and information on the latest government “cellings,” restrictions, rulings, etc.? The answer is RADIO SERVICE-DEALER—the technical monthly that practically every radio servicing organization in the country now subscribes to or reads regularly . . . yes, RSD, that publication knows the problems of service-dealers and tries to help solve them.

TEAR OUT AND MAIL TODAY

RADIO SERVICE-DEALER

132 West 43rd Street, New York City, N. Y.

Sirs: Here is my check (or money order) for \$..... Enter my subscription order to RSD for the next issues. (12 issues cost \$2.—24 issues cost \$3.) Canadian and Foreign subscriptions are \$3 annually.

Name (print carefully)

ADDRESS FIRM NAME Est. 19.....

CITY STATE My Position Is: Owner Service Mgr. Serviceman

(If any other, state what it is)

Please check whether firm is

- An independent servicing organization, we do not sell sets.
- An independent service-dealer (engaged primarily in service work)
- A service-dealer (does servicing, but is primarily interested in retailing)
- Selling, renting or servicing Sound Equipment
- Jobber
- Manufacturer (State it).....
- Any other classification

I belong to a serviceman's organization Yes No

We stock the following checked items:

- TUBES
- PARTS
- RECEIVERS
- BATTERIES, etc.
- SOUND EQUIP.
- ELEC. APP'L'S.

We own the following instruments:

- V-T Voltmeter
- Tube Checker
- Analyzer
- Oscillator
- Signal Generator
- Volt-Ohm Meter
- Others
- MANUALS

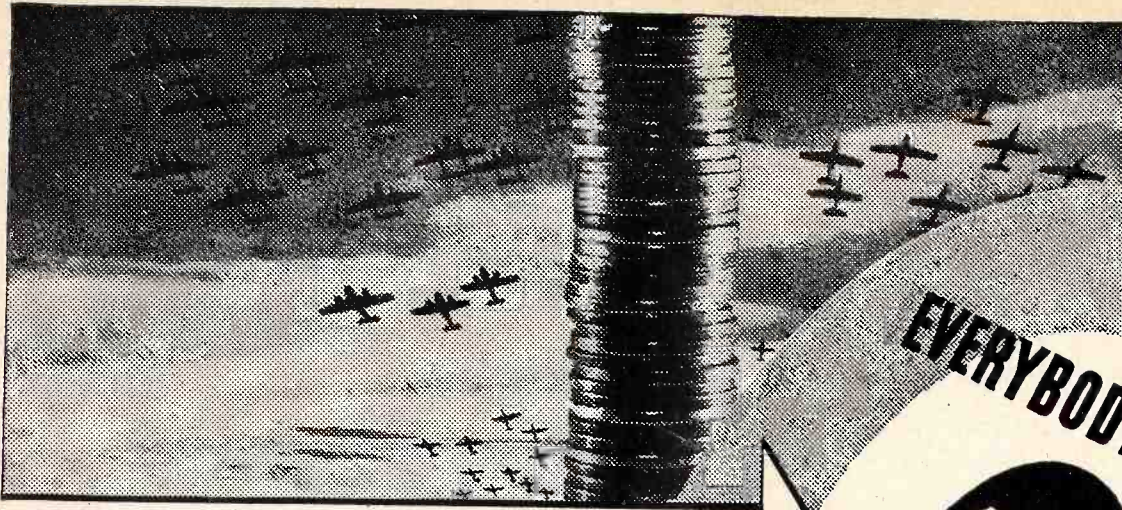

New Target for Industry:
**More Dollars Per Man Per Month in the
 PAY-ROLL WAR SAVINGS PLAN**

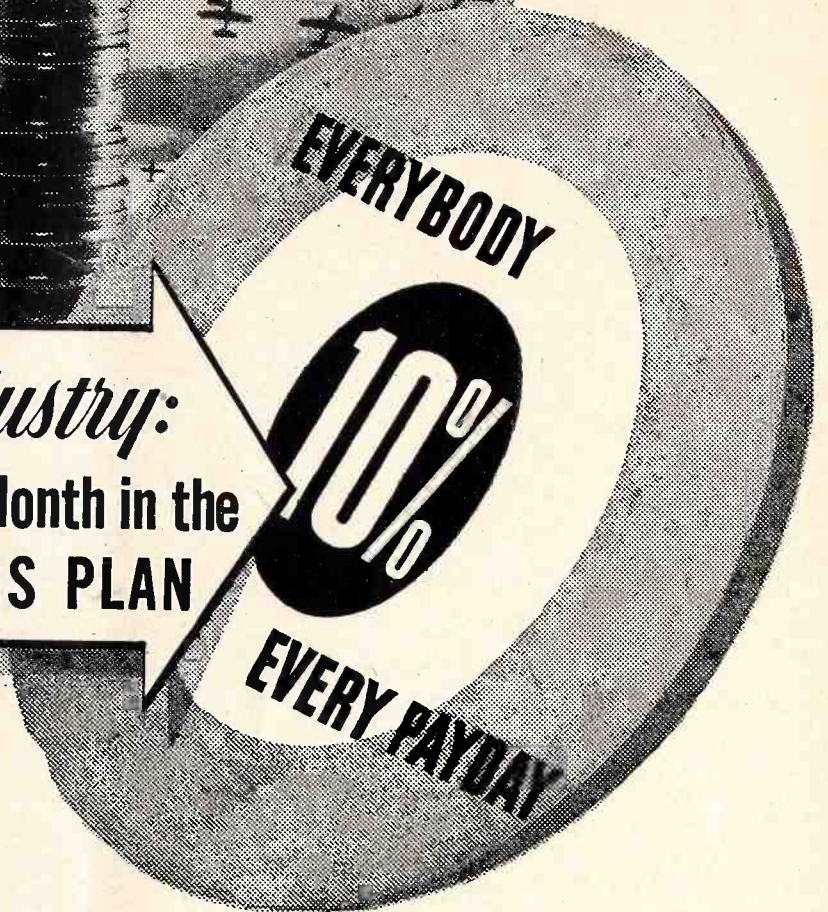

TO WIN THIS WAR, more and more billions are needed and needed fast—AT LEAST A BILLION DOLLARS A MONTH IN WAR BOND SALES ALONE!

This means a *minimum* of 10 percent of the gross pay roll invested in War Bonds in every plant, office, firm, and factory in the land.

Best and quickest way to raise this money—and at the same time to “brake” inflation—is by stepping up the Pay-Roll War Savings Plan, having every company offer every worker the chance to buy MORE BONDS.

Truly, in this War of Survival, VICTORY BEGINS AT THE PAY WINDOW.

If your firm has already installed the

Pay-Roll War Savings Plan, *now is the time—*

1. To secure wider employee participation.
2. To encourage employees to increase the amount of their allotments for Bonds, to an average of at least 10 percent of earnings—because “token” payments will not win this war any more than “token” resistance will keep the enemy from our shores, our homes.

If your firm has not already installed the Pay-Roll War Savings Plan, *now is the time to do so.* For full details, plus samples of result-getting literature and promotional helps, write, wire, or phone: War Savings Staff, Section E, Treasury Department, 709 Twelfth Street NW., Washington, D. C.

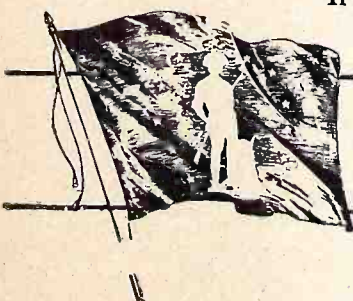

U. S. War Savings Bonds

This space is a contribution to America's all-out war program by

RADIO SERVICE-DEALER

Radio Service-Dealer, November, 1942

NEW DISPLAY FOR NEEDLES

»» Jensen Industries, Inc., 737 North Michigan Avenue, Chicago, offer a new, uniquely designed counter needle merchandising display which occupies a counter space of 4½" x 11½", by 13½" in height. It contains a "Baker's Doz-



en" of Jensen Long-Life Phonograph Needles, each needle being attached to a two color round package which is inserted in individual compartments. A window banner depicting the superior performance of Jensen needles is also included.

★

CLAROSTAT CONTROL EARNS "A"

»» The inspection routine or quality control practiced in the Clarostat plant has won the rare recognition of an "A" classification granted by the Eastern Procurement District, Army Air Force. This means that Clarostat's own inspectors, having demonstrated a high degree of quality control to the satisfaction of the Air Force, are now entrusted with full responsibility of meeting all requirements as established. Duplication of inspection during fabrication by Air Corps inspectors can thus be eliminated, and the latter can now confine their activities to general supervision of the inspection system and the final approval and stamping of completed assemblies.

★

WINDOW TRIM ATTRACTS CUSTOMERS

»» First of a series of suggested window trims to utilize display material to best advantage, the Ken-Rad Radio Tube window trim illustrated is being offered to dealers as a model handling of available material. The display set consists of a large 19" x 24" eased card "Selected for Service," three window streamers illustrating the same theme, one cutout "Ken-Rad on Parade" and two twin-tube cutouts.

Tube cartons and crepe paper trim are added to make a pleasing display high in attention value, yet easy for any service-dealer to construct with a minimum of effort or expense. For further particulars write Ken Rad, Owensboro, Ky.

"ALL-OUT"
TO HELP WIN THE WAR

Today, the 36-years of skill and experience that pioneered and developed the "QUANTITY-plus-QUALITY" manufacture of BRACH products, are directed exclusively toward serving our armed forces on their road to Victory.

ANTENNAS & RADIO PARTS
BRACH
 100% WAR PRODUCTION

L. S. BRACH MFG. CORP.
 World's Oldest and Largest Manufacturers of Radio Aerial Systems
 55-65 DICKERSON STREET • NEWARK, N. J.

Safeguard your
"GUARANTEE"
 USE **STANCOR**

STANDARD TRANSFORMER
 CORPORATION •
 1500 NORTH HALSTED STREET . . . CHICAGO

STANCOR



"HELP WANTED"

VITAL need to enlist approximately 100,000 skilled technicians immediately in the Army Air Forces, Signal Corps and Ordnance Department was announced by the War Department on August 9.

These specialists are needed *now* to keep equipment in operating order. So great is the present emergency that a special recruiting campaign has been launched to find men who can step immediately into important maintenance jobs.

Opportunities for Promotion

To be eligible, men must be between 18 and 44 inclusive, citizens of the U. S. and physically qualified according to general standards of military service. They will enlist as privates, but non-commissioned officer or technician ratings are often given men doing jobs of this sort. Skilled men are needed, and promotion should be rapid with commensurate increases in pay. Whereas a private receives \$50 a month, a master sergeant, the highest non-commissioned grade, receives \$138 to which certain allowances may be added. The Army pays all a man's expenses—food, clothing, shelter and medical care.

To make sure that industry's production program is not upset, all men who wish to enlist as mechanics and technicians now must be cleared by their local Selective Service Board before acceptance by the Army.

For a limited period this Recruiting Program offers trained men an opportunity to choose any one of the three branches, Air Forces, Signal Corps or Ordnance Department, for which their experience and skill qualifies them. These men are expected, after a minimum of on-the-job instruction to familiarize them with Army machines and Army ways, to qualify as maintenance experts.

Jobs to be Filled

The Army Air Forces want men to serve as radio operators and radio mechanics.

The Signal Corps wants men whose experience qualifies them as telephone and telegraph cable splicers, telephone and telegraph installer-repairmen, radio operators, telegraphic printer operators, telegraphic printer installer-repairmen, and telephone and telegraph wire chiefs.

Best in Training and Equipment

While the type of work these men will do should be familiar to them already, the machines and equipment used by the Army offer new opportunities for valuable experience. All three of these branches of the Army are equipped with the most modern, most highly developed machines and devices in the world. Some of the equipment is secret. The man who qualifies as an expert in any of these jobs will have learned much that will be helpful in postwar industry.

Jobs in the Air Forces

Here is a picture of the type of work which technicians in the Air Forces perform:

Aircraft Radio Mechanics adjust and repair various types of transmitting and receiving radio equipment as members of the Ground Crew.

Aircraft Radio Operators operate transmitting and receiving radio equipment (partly in code), and make adjustments and minor repairs. Some can become aerial radio operators—part of the Air Crew, with a 50% pay increase.

Jobs in the Signal Corps

The Signal Corps operates the Army's highly specialized communications system. But it does more than that. It furnishes equipment to other branches of the Army and it is constantly pioneering in its field.

Signal Corps men have the satisfaction of knowing that they are furnishing Army staffs with the spot news of battle to guide important and split-second tactical decisions. The list of jobs given above offers a broad picture of the type of work the men do. Because much of the equipment is secret,

however, it is impossible to give details.

Field Staff of Recruiters

Because of the importance which the Army attaches to finding these needed specialists quickly, a special staff of recruiters will be at work throughout the United States, equipped to answer all questions. Men who are interested should visit their local recruiting stations. Postmasters can direct them to the nearest station where full information is available.

Enlistment Plan

All men who apply for enlistment will be examined carefully upon their experience and qualifications. Air Forces men must pass a special intelligence test as well as an oral trade test given by an office of the United States Employment Service.

The Signal Corps will accept a recognized radio or telegraph license or membership in either the RMS or RSA from applicants who desire to become radio operators or mechanics. The Corps will also approve men who are actively engaged in radio service work or who are graduates of a recognized radio school.

Once the qualifications of an applicant are satisfactorily determined, he will be given a thorough physical examination. If no disability is discovered, he will be sworn in immediately as a private in the Army of the United States.

All recruits will be sent to a Reception Center for the same kind of "processing" which every man receives when he enters the Army. This is a matter of a few days at most. From the Reception Center, Air Forces men will go to an Air Forces station, Signal Corps men will be sent to the nearest Signal Corps Replacement Training Center and Ordnance men will proceed to the Ordnance Department Training Center.

Here they will begin their real military training and also learn the maintenance jobs for which the Army so sorely needs them. By putting their civilian skills in uniform these men will fight with the tools they've always worked with.

KAHN HEADS SALESMANAGERS CLUB

»» Jerome J. Kahn, President of Standard Transformer Corporation, has been elected Chairman of the Sales Managers Club, Western Group, for the ensuing year. Mr. Kahn succeeds Mr. S. N. Shure of Shure Brothers, who has served for the past twelve months. Mr. Shure piloted the club through practically all of the initial priorities period, and during his administration the group prospered and expanded in educating jobbers and manufacturers on priorities developments. Mr. Kahn will take up the task from this point on and carry on with the policies which he has helped to establish. For the past several years he has been one of the most active manufacturers in the radio replacement parts field. He was a member of the original Priorities Committee of the Radio Parts and Associated Industries, he was Chairman of the Radio Victory Dinner held at the Stevens Hotel last June and did an excellent job in making that affair a huge success.

Mr. Kahn was the original sponsor of the "Keep 'em Playing" campaign designed to bring pressure on the proper groups in Washington to make an allocation of critical materials for replacement parts for home receivers. He is now a member of the Radio Replacement Parts Industry Advisory Committee working with WPB, a director of the Radio Manufacturers Association, and Chairman of the RMA Priorities Committee.

Paul H. Tartak, President of the Oxford Tartak Radio Corporation, was elected Vice-Chairman of the Group, while Miss H. A. Staniland of Quam-Nichols Company and Kenneth C. Prince, Chicago attorney, continue as Treasurer and Secretary respectively.

★

FIRST AID INDEX

»» A First Aid Index in handy pocket size form is being issued by Sylvania for servicemen to use with local war emergency volunteer groups. It measures 6½ x 3 inches folded, and fits into pocket, purse or auto compartment. They are available at 5c each, minimum quantity for imprinting by Sylvania is one hundred.

The Sylvania First Aid Index bears the approval of the Commander-in-Chief of the U. S. Volunteer Life Saving Corps. With the war increasing in fury and hitting closer to home, Americans by the hundreds of thousands will be answering the home defense call to become Air Raid Wardens and First Aiders. Servicemen will find this item gratefully appreciated by the valiant home front war workers.

★

New Ohmite Catalog—now available, catalog 18 will be rather helpful to users of rheostats, resistors, "T" pads and attenuators. Special chokes, switches and mountings are described for users of radio and electronic equipment. Write Ohmite Mfg. Co., 4846 Flournoy St., Chicago, Ill.



Lafayette has complete stocks—ready for immediate delivery! Nationally known radio, electronic and sound parts and equipment available for all Military training courses. Lafayette parts and equipment are in daily use by technical schools handling Military training courses including Signal Corps Schools. Write for FREE technical advice—our engineers are at your service.

INSTRUCTORS—Write Dept. 11K2 at 901 W. Jackson Blvd., Chicago, Ill., for FREE 130-page general catalog and Instructive Public Address Catalog listing all P. A. Units.

A number of kits in one are provided by our 7-tube demonstration kit (illustrated). It can be built in stages, each stage interconnected with tip jacks. When completed, there are 2 stages of R. F., a detector stage, an audio driver stage, a beam power push-pull audio and a power supply. The circuit diagram will suggest many interesting uses.



LAFAYETTE RADIO CORP.

901 W. Jackson Blvd., Chicago, Ill.

265 Peachtree St., Atlanta, Ga.

Camera Fans: Photographic equipment at lowest prices.

Write for FREE PHOTOGRAPHIC CATALOG!



Coming through . . .

Clear . . . intelligible . . . in the heat and noise of battle . . . orders are coming through

Electro-Voice MICROPHONES

While we cannot discuss the actual developments embodied in many of our new models, we can say that they have been designed specifically to limit background noises and to allow speech to come through the bedlam of battle.

ELECTRO-VOICE MFG. CO., Inc.

1239 SOUTH BEND AVENUE

SOUTH BEND, INDIANA

Export Office: 100 VARICK STREET, NEW YORK, N. Y.

GENERAL INDUSTRIES *Smooth Power* MOTORS

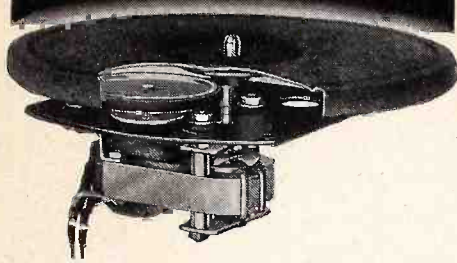

Ask Your Jobber— He May Have Some

When we engaged in all out production for Victory, very fortunately we had on hand a number of G. I. Motors for domestic uses. We are glad to make these available to the trade through our regular jobbers as long as they last.



THE GENERAL INDUSTRIES CO.
Dept. 17 • Elyria, Ohio

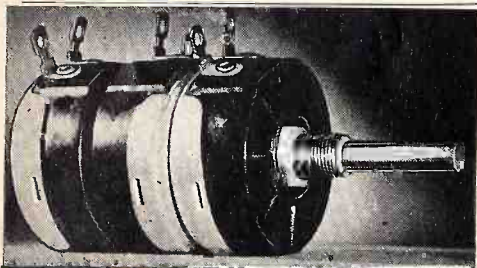

P - A Controls

★ In servicing P-A and theatre sound installations, don't overlook that wide selection of sound-system controls offered by Clarostat. The wire-wound T-Pad constant-impedance series CIT-58 control here shown is typical. Also L-pads, mixers, faders, constant-impedance attenuators, etc. All are included in the Clarostat COMPLETE line of controls.

★ Likewise in servicing radio receivers, don't forget those Clarostat replacement controls, plug-in tube-type resistors, voltage-dropping power cords, etc.

★ Ask your local Clarostat jobber about these aids in your servicing. He's well equipped to take care of your usual and unusual needs.



My Log

(Continued from page 20)

most call her a demoralizing influence. She don't mean to cause any trouble, but she does, just because she's the kind of girl Elaine is. (Jerry says I'm getting sweet on her, but that's a lot of bunk).

Now when we lost Pete and Hector to the draft boards two weeks ago and I decided to train a gal to take their place, I had an idea that a girl could be taught to follow-up specific instructions without too much trouble. It don't work out that way. Tippy, who does most of my signal chasing, thought the gal would be of most help to us if she learned to work under him. Hank, who makes most of the actual repairs, had another idea. He wanted Elaine to learn the "rudiments of servicing" first—how to solder connections, how to find broken leads or how to discern burned out condensers. Jerry, on the other hand, figured that Elaine should work out in the front of the store with him, talking to customers, explaining why we'd need a month to do a job that usually took two hours. Hell, you simply can't get parts now-a-days, but customers don't give a hang about your troubles. They know their set is dead, and they want it fixed pronto—and they don't care how you do it, as long as you do it in a hurry.

Well, this morning I managed to get the pile of finished work off into one corner and I found Doc Parson's old Philco half under the bench. I knew that chassis was around somewhere and I'd been looking for it for a week. Kept stalling Doc by telling him we couldn't locate the trouble, and to some extent, that wasn't exactly a lie. We couldn't even find the set. So I put the Philco up on the bench and let her heat up. In a few seconds I located the trouble. The avc line was grounded, but otherwise she was okay. I put a tag on it "float avc off ground and replace 3-megger for luck" and shoved it over to Hank's shelf. Just as I was doing that Elaine walked in, gave me a cheery "Good morning," took off her coat and said, "What'll I do now Boss?" I figured this was as good a time as any, so I started to explain to her what was wrong with Doc's set, and how the repairs should be made. She's quick, Elaine is, and in a few minutes she gave me the whole spiel as to what should be done, so I let her start in on her own. I still think everything would have been fine if

Jerry hadn't come in just then with a load of chasses that he'd picked up.

I helped my pard lay the new business down in neat piles and then we both loaded Liz up with the finished jobs in order to make more room. Hank came in about then and he got the job tickets all sorted out for Jerry while I tallied the prices to make sure we hadn't gone "over the ceiling" anywhere. And, as we three had plenty to keep us occupied, we just forgot that Elaine was hard at work in the shop. She'd still be soldering things, I guess, if Tippy hadn't come in just then. I sort of noticed that he went into the shop without paying any attention to him, and I was just coming back for another load of sets to pile into Liz when a roar burst forth that had too many decibels behind it for comfort. I barged into the back, and there was Tip, ashen around the lips and shaking at the knees. He was incoherent, to say the least, for his first roar gave out all he had . . . and over on the other side of the bench was Elaine, holding on to the soldering iron, waving it in front of her as though she were one of the Three Musketeers, fighting a duel for her life.

"What happened?", I asked, but Tippy couldn't answer. He just pointed to the chassis on the bench, and to the galaxy of parts that had spilled out of it. I knew at a glance then what happened. Elaine had started to work on Doc's set with the soldering iron. She knew what points had to be touched with the iron, but she didn't care much about the other points that shouldn't have been. Consequence—more parts had been unsoldered and had fallen out of the set than the average small-time jobber carries in stock. Well, from now on Elaine will work out front, away from the bench. And I'm going to have to sound-proof the shop because the noise that Hank makes every time he finds another part to solder into Doc's set ain't fit for a nice young lady's ears.

★

SYLANIA GETS "E"

» Rear Admiral Charles W. Fisher, Director of Shore Establishments, U. S. N. presented the Army-Navy "E" Burgee to the Emporium, Pa. employees and plant of the Sylvania Electric Products, Inc., on November 5th.

Sylvania's president, B. G. Erskine received the plant flag from Admiral Fisher; an employee accepted the token "E" pin on behalf of all employees from Colonel W. S. Diener, Commanding Officer, Central Office Pennsylvania District, Internal Security Board.

Technical Service Portfolio

RESISTORS & VOLUME CONTROLS

(Continued from page 19)

generated. If the battery voltage is 100 and R_1 is adjusted to equal R_x , then 50 volts d-c will appear across this noise voltage resulting from the R_x . When switch S_1 is on point b , 50 volts d-c passing through R_x will be impressed on the input circuit of the amplifier. When S_2 , in the output circuit, is connected to the output voltmeter, an indication will be obtained proportional to the noise voltage being applied to the input circuit. This indication is noted and S_1 is switched to point a . R_2 is connected across a signal source, usually a 1000-cycle audio oscillator, and is calibrated. When R_2 is so adjusted that the indication obtained with the switch S_1 on point a is the same as that with the switch on point b , then the audio signal voltage is considered equivalent to the noise voltage in the resistor. Thus, with 50 volts across R_x , if the noise is 100 microvolts, the rating is 2 microvolts per volt.

In this circuit, all controls other than the resistor under test are wire-wound and are free from noise from causes which affect composition resistors. Other methods are available. Low noise levels are very difficult to measure because of inherent noise in the test apparatus.

★

MICA CAPACITORS NEEDED BY UNCLE SAM

» It is no military secret that planes and tanks, desperately needed by our armed forces, are being held up at production centers for want of radio equipment, which equipment in turn cannot be completed because of the mica capacitor shortage. The main bottleneck in radio production is mica capacitors.

Responding to the appeal of our Government, the Aerovox Corporation of New Bedford, Mass., with its mica production capacity already stepped up several dozen fold over pre-war levels, has sent out an urgent appeal to jobbers asking them to make existing mica capacitor stock available to Uncle Sam. Special inventory forms have been provided so that jobbers can simply, quickly and explicitly tabulate their available stock and send the information to the Army-Navy Communications Production Expediting Agency, Pentagon Building, Arlington, Va.



RELAYS BY GUARDIAN SERVE ALL FRONTS!

★ Yuletide joys of '42 will not include the many electrical gifts which brought us cheer, and ease, and comfort in other years. Relays by Guardian have marched on from peacetime industry to the firing lines of war. Doing war jobs in many ways . . . in planes . . . in tanks . . . in communications . . . in bomb releases and gun controls. Wartime jobs which Guardian anticipated and planned long before "Pearl Harbor".

But, while thinking, building, and engineering the tools of war today, Guardian again is looking ahead to peacetime applications of Relays, Solenoids, Electrical Controls of all kinds. Write. Our wartime experience can help you build better products for the future.



Controls for Any Purpose
ranging from 150 watts to
1000 cmps . . . from tiny
relays weighing less than
an ounce . . . to big, rug-
ged two-pounders.

GUARDIAN ELECTRIC
1637 WEST WALNUT STREET CHICAGO, ILLINOIS
A COMPLETE LINE OF RELAYS SERVING AMERICAN WAR INDUSTRY

Are You Moving?

Notify RSD's circulation department at 132 West 43rd Street, New York City of your new address 2 or 3 weeks before you move. The Post Office Department does not forward magazines sent to a wrong address unless you pay additional postage. We cannot duplicate copies mailed to your old address. Thank You!



"Just what the Signal Corps Ordered"
—and to prove it, signal corps men are
using these 3 specially selected "Vaco"
drivers every day.

Thousands of sets of the numbers shown below are already in use, performing an important task and helping signal corps trainees to do faster, better work.

"Vaco" Drivers are preferred because they fit the hand properly and have shock-proof, break-proof, chip-proof Amberyl handles and narrow straight bits.

Other famous "Vaco" Drivers specially suited for radio work include G2 Grip-point Screw-holding and Spin-hex nut drivers.

JOBBER: Order your "Vaco" signal corps Drivers immediately . . . carry high priority rating.



VACO PRODUCTS CO. 1123 W. Washington Blvd.
CHICAGO ILLINOIS

TUBE SUBSTITUTION CHART

3rd REVISION

COPYRIGHT 1942
COWAN PUB. CORP.

Discontinued Type	Replace With	Changes
00A	30	Use 2-volt filament supply
0Z3	0Z4	Use adapter or change socket
01A	30	Use 2-volt filament supply
01AA	30	Use 2-volt filament supply
1A1	Resistor	See text June RSD
1A1/5E1	Resistor	See text June RSD
1A5G	1A5GT/G	None
1A7G	1A7GT	None
1B1	Resistor	See text June RSD
1B4	32	Bulb is larger
1B4P	32	Bulb is larger
1B4P/951	32	Bulb is larger
1B7G	1B7GT	None
1C1	Resistor	See text June RSD
1C5G	1C5GT/G	None
1D1	Resistor	See text June RSD
1D7G	1C7G	Requires higher filament current
1E1	Resistor	See text June RSD
1E2	Resistor	See text June RSD
1E5GP		See text June RSD
1E5GT		See text June RSD
1E7G	None	See text June RSD
1F1	Resistor	See text June RSD
1F7GH	1F7G	None
1F7GV	1F7G	None
1G1	Resistor	See text June RSD
1G4G	1G4GT/G	None
1G5GT/G	1F5G, 33	See text June RSD
1G6G	1G6GT/G	None
1H5G	1H5GT	None
1J1	Resistor	See text June RSD
1J5G	1F4, 1F5G	Socket (see text June RSD)
1K1	Resistor	See text June RSD
1L1	Resistor	See text June RSD
1N1	Resistor	See text June RSD
1N5G	1N5GT	None
1P1	Resistor	None
1P5G	1P5GT	None
1Q1	Resistor	See text June RSD
1Q5G	1Q5GT/G	None
1R1G	Resistor	See text June RSD
1S1G	Resistor	See text June RSD
1T1G	Resistor	See text June RSD
1U1	Resistor	See text June RSD
1W1	Resistor	See text June RSD
1Z1	Resistor	See text June RSD
2A3H	2A3	See text June RSD
2A7S	2A7	See text June and Aug.
2B6	6B5	See text June RSD
2B7	6B7	See text June RSD
2B7S	6B7	See text June RSD
2E5	6E5	See text June RSD
2G5	6U5/6G5	See text June RSD
2S/4S	6H6	See text June RSD
2Z2		See text June RSD
2Z2/G84		See text June RSD
3Q5G	3Q5GT/G	None
5W4	5W4GT/G	None
5W4G	5W4GT/G	None
5Y3G	5Y3GT/G	None
5Z4G	5Z4	None
5Z4MG	5Z4	None
6A4	47, 6F6	See text June and Aug.
6A4/LA	47, 6F6	See text June and Aug.
6A5G	6A3, 2A3	See text June and Aug.
6A6X	6A6	6A6X has ceramic base
6A7S	6A7	See text June and Aug.
6A8MG	6A8GT, 6A8	None, see text Aug. RSD
6AB5	6AB5/6N5	None, see text Aug. RSD
6AB6G	6B5	Socket (see text June RSD)
6AC5G	6AC5GT/G	None
6AC6G	6B5	See text June RSD
6AE5G	6AE5GT/G	None
6AE5GT	6AE5GT/G	None, see text July RSD
6AF6GT	6N5	See text June RSD
6B6G	75/65Q7	Socket (see text June RSD)
6B7S	6B7, 6B7G	See text June RSD
6B8GT	6B7, 6B7G	Socket
6C5G	6C5GT/G	None see text July RSD
6C5MG	6C5GT/G	None
6C7	85	Socket (see text June RSD)
6D7	6J7	Socket (see text June RSD)
6E6	No replacement	
6E7	6K7	Socket (see text June RSD)
6F5MG	6F5/6F5G/6F5GT	Socket, see text July RSD
6F7S	None	
6G5	6U5/6G5	None, see text Aug. RSD
6H5	6U5/6G5	None, see text Aug. RSD
6H6G	6H6GT/G	None
6H6MG	6H6GT/G	None
6J5G	6J5GT/G, 6C5	See text July and Aug.
6J5GX	6J5G	Only differ. is ceramic base
6J7MG	6J7GT, 6K7G	None
6K6G	6K6GT/G	None, see text Aug. RSD
6K6MG	6K6GT/G	None, see text Aug. RSD
6K7MG	6K7GT, 6K7G	See text July RSD
6L6GX	6L6G	Only differ. is ceramic base
6N5	6AB5/6N5	None, see text Aug. RSD
6N6	6B5	Socket (see text June RSD)
6N6MG	6B5	Socket (see text June RSD)

Discontinued Type	Replace With	Changes
6N7G	6N7	None
6P5G	6P5GT/G, 76	Socket, see text July RSD
6P7G	6F7	Socket (see text June RSD)
6Q6G	6T7G	None
6Q7MG	6T7G	None
6T5	6U5/6G5	None, see text Aug. RSD
6T7G/6Q6G	6T7G	None
6U5	6U5/6G5	None, see text Aug. RSD
6V6G	6V6GT/G	None, see text Aug. RSD
6V6GX	6V6GT/G	Only differ. is ceramic base
6W7G	85	Socket (see text June RSD)
6W5G	6X5GT/G	See text June RSD
6X5	6X5GT/G	None
6Y5	6X5GT/G	Socket (see text June RSD)
6Y7G	79	Socket (see text June RSD)
6Z3	1-V	None
6Z4	6Z4/84	None
6Z5	6X5GT/G	Socket (see text June RSD)
6Z5/12Z5	6X5GT/G	Socket (see text June RSD)
6Z6MG		See text July RSD
6Z7G	6N7	See text June RSD
7A7LM	7A7	See text June RSD
7B5LT	7B5	None, see text July RSD
7B6LM	7B6	None
7B8LM	7B8	None
7C5LT	7C5	None, see text Aug. RSD
7G7	7G7/1232	None, see text Aug. RSD
WD11	No replacement (obsolete)	
WD12	No replacement (obsolete)	
WX12	No replacement (obsolete)	
12A	6J5GT	Socket, fil. voltage
12A5	None	See text June RSD
12A8G	12A8GT	None
12B7	14A7/12A7	None
12J7G	12J7GT	None
12K7G	12K7GT	None
12K8GT	12K8	None
12Q7G	12Q7GT	None, see text Oct. RSD
12SA7G	12SA7GT/G	None
12SK7G	12SK7GT/G	None
12Z5	6Z5	None
14A4	7A4	Fil. voltage
14A7	14A7/12B7	None
14B6	7B6	Fil. voltage
14B8	7B8	Fil. voltage
14C5	7C5	Fil. voltage
14E6	7E6	Fil. voltage
14E7	7E7	Fil. voltage
14F7	7F7	Fil. voltage
14N7	7N7	Fil. voltage
15	No equivalent	See text June RSD
24	24A	None
24S	24A	Socket (see text June RSD)
25A6	25A6GT/G	None
25A6G	25A6GT/G	None
25A7G	25A7GT/G	None
25AC5G	25AC5GT/G	None
25B5	6B5	Fil. voltage—Socket
25B6G	43	Socket (see text June RSD)
25B8GT	12B8GT	Fil. volt., see text Oct. RSD
25D8GT	No equivalent	None, see text Oct. RSD
25L6	25L6GT/G	None
25L6G	25L6GT/G	None
25N6G	6B5	Socket—Fil. voltage
25S	1B5/25S	None
25Z5MG	25Z5	None
25Z6G	25Z6GT/G	See text Oct. RCD.
27S	27	Socket (see text June RSD)
31	No equivalent	
35A5LT	35A5	None
35L6G	35L6GT/G	None
35S/51S	35	Socket (see text June RSD)
39/44	7B7, 78	Socket, see text July RSD
45A	45	None, see text Aug. RSD
46A1	Resistor	See text June RSD
46B1	Resistor	See text June RSD
48	No equivalent	
49	No equivalent	
50Y6G	50Y6GT/G	None
51	35	None
55	85	Filament voltage
55S	85	Socket—Fil. voltage
56S	56	See text June RSD
57S	57	See text June RSD
58S	58	See text June RSD
70A7GT	70L7GT	See text June and Oct.
70L6GT	25L6GT	Fil. voltage
75S	75	Socket
79	No equivalent	See text June RSD
89	No equivalent	See text June and Aug.
117L7GT	117L7/M7GT	None
117M7GT	117L7/M7GT	None
117Z6G	117Z6GT/G	None
117Z6GC	117Z6GT/G	None
182B/482B	No equivalent	See text June RSD
183/483	No equivalent	See text June RSD
485	No equivalent	See text June RSD
950	No equivalent	
1232	7G7/1232	None
1852	6AC7/1852	None, see text Aug. RSD
1853	6AB7/1853	None



Something new has been added to this space-saver oil-filled high-voltage capacitor. Note the two terminals—spaced on the stepped terminal post. This means the can of this handy inverted-screw-mounting capacitor is now insulated or “floating.” No longer is an insulator washer required when non-grounded mounting on a metal chassis is desired. • 600 to 1500 v. D.C.W. .5 to 4 mfd. • Ask your Aerovox jobber for new “Victory” catalog.

AEROVOX CORPORATION
 NEW BEDFORD, MASS., U. S. A.
 In Canada: AEROVOX CANADA LTD., Hamilton, Ont.
 EXPORT: 100 Varick St., N. Y., Cable 'ARLAB'

NEW CATALOG
OF SOUND AMPLIFYING SYSTEMS
 AUDIOGRAPH Sound Systems represent the latest in Public Address equipment—a complete line plus pre-tested accessories.
NEW LOWER PRICES
 Outstanding quality and performance at prices that help you meet any competition.
WRITE FOR YOUR FREE COPY
AUDIOGRAPH
 THE FIRST NAME IN SOUND
 John Meck Industries—Liberty at Pennsylvania Ave., Plymouth, Ind.

COLOR CODE RESISTOR CARD

» Sylvania announces a Color Code Resistor card for radio technicians issued as a help in Wartime radio servicing.

In handy pocket size form, the Sylvania Color Code Resistor Card should prove to be a valuable aid in circuit revision work. It clearly shows the A, B, C, and D color denotations of a resistor, explains the resistor color code and gives examples. On the reverse side of the card is Ohm's Law, one of the basic radio circuit formulas. Its definition and explanation is a helpful reference for radio men.

OHM'S LAW
 When a continuous current is flowing thru a given conductor, the ratio of the voltage across the conductor to the current flowing through it is a constant. This ratio is called the resistance of the conductor. The potential difference or voltage across the conductor may be expressed in terms of the current and the resistance of the conductor. Ohm's Law may be expressed in the following manner: $E = IR$

COLOR CODE CHART—RMA STANDARD

AXIAL TYPE LEADS		RADIAL TYPE LEADS		
A	B	C	D	
Black 0	Black 0	Brown 1	Black 0	No Color ± 20%
Brown 1	Brown 1	Red 2	Red 00	
Red 2	Red 2	Orange 3	Orange 000	Silver ± 10%
Orange 3	Orange 3	Yellow 4	Yellow 0000	
Yellow 4	Yellow 4	Green 5	Green 00000	Gold ± 5%
Green 5	Green 5	Blue 6	Blue 000000	
Blue 6	Blue 6	Purple 7	Purple 0000000	
Purple 7	Purple 7	Gray 8	Gray 00000000	
Gray 8	Gray 8	White 9	White 000000000	

Resistor Color Code. The A color of a resistor denotes the first significant figure, the B color the second significant figure and the C color indicates the number of ciphers after the first two significant figures. The D color denotes the tolerance value of the resistor.
 Example: Band A (Axial Type) or Body (Radial Type) = Red
 Band B (Axial Type) or Dot (Radial Type) = Green
 Band C (Axial Type) or End (Radial Type) = Orange
 Value of Resistor = 25000 Ohms

Servicemen are running into an increasing number of circuit revisions, and technical helps such as this one give servicemen a lift in the very tough job of keeping America's Radio working with a limited amount of materials.

Resistor cards are available through Sylvania jobbers or can be secured by writing directly to Sylvania News, Emporium, Pa.



WALSCO GETS TREASURY FLAG

» The “Star Spangled Banner” is being sung every pay day by the employees of the Walter L. Schott Company, makers of Walsco Products, 9306 Santa Monica Boulevard, Beverly Hills, California, in honor of the “Bulls Eye” flag now waving over their plant. It was awarded to them by the U. S. Treasury Department because all employees are buying War Bonds through the Payroll Allotment Plan.



FORTUNE KILLED IN CRASH

» J. Douglas Fortune, Industrial Sales Engineer of Thordarson Electric Mfg. Co., was fatally injured while piloting a plane near Chicago on Saturday, October 17th. Mr. Fortune was internationally known for his development work in radio and electronic equipment; was a regular contributor to many leading radio publications and authored “Amateur Radio” a book widely read by Amateur Radio operators. Mr. Fortune's untimely death is a great loss to the radio industry which he so faithfully served.

Old Man Centralab
 reminds you to always “specify Centralab” when ordering parts.

- FIXED RESISTORS
- CERAMIC CAPACITORS
- VOLUME CONTROLS
- WAVE CHANGE SWITCHES
- TOGGLE SWITCHES

Centralab
 DIVISION OF GLOBE UNION INC.
 MILWAUKEE, WIS.

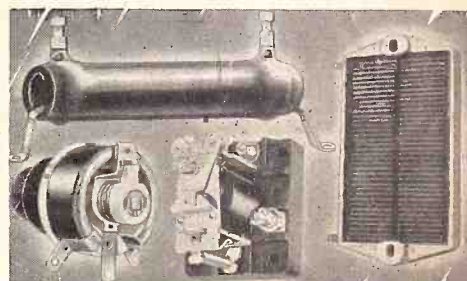

RELAYS RESISTORS RHEOSTATS

The oldest and most complete line for use in commercial, police, fire department and government radio and signal work. Proven dependability and conservative ratings. You are not experimenting when you install Ward Leonard items . . . you know they are right.

WARD LEONARD RADIO SPECIALTIES

WARD LEONARD ELECTRIC COMPANY
 46 South St., Mount Vernon, N. Y.

Please send me Circular 507 covering Relays, Resistors and Rheostats.

Name

Street

City and State

Call Signal

Attention Tube Distributors

We will pay list less 50% for the following tube types, of standard manufacture, individually cartoned. We cannot supply priority rating. Would consider buying your complete stocks at slightly better discount. WIRE us collect if you can furnish over 100 tubes. WRITE us if you have less than 100 for sale. Deposit wired or mailed with each of our orders, balance COD.

1B5/25S	6J5 C or CT
2A3	6K7 C or CT
2A4G	6L6 C or CT
5U4C	6SC7 or CT
5V4C	6SQ7 C or CT
5Y3C or CT	30
5Z3	45
6B5	70L7CT
6C6	76
6H6 C or CT	80
	2051

W. R. BURTT

308 Orpheum Bldg. Wichita, Kansas

Production Designer

Want competent man capable of supervising drafting or layout job, able to recommend modification of a complete design to facilitate production by modern methods. Man with experience in manufacture of light equipment of a structural nature for limited production; requires broad experience with knowledge of relative merits of all well-known production methods such as bending, forming, drawing, punching and forging.

Man of these talents not now in 100% war work will be highly compensated with unusual opportunity and permanency in important war assignment with large manufacturer located in Boston.

Give complete particulars for interview in Chicago. Applications held strictly confidential.

Write Box A-11 Radio Service Dealer

Instruments Wanted!

The Signal Corps, Aircraft Radio Laboratory, Wright Field, Dayton, Ohio, has need of or can place in critical war industries meters and test equipment for training purposes.

Write stating type, condition of equipment, and price desired to

Director, Aircraft Radio
Laboratory,
Wright Field, Dayton, Ohio

We have available a supply of RCA Victor service notes for 1938, 1939, and 1940. If you would like a set—over 200 pages of detailed service data—send 45c in cash to cover postage and handling.

"BRANDEX"—a guide to concealed service data on "private brand" sets can be had for 25c per copy. It is cross-indexed for Brand-name, Manufacturer outlet, Identification marks, etc. Hurry before the supply is exhausted. Once they are gone there won't be any more.

RADIO SERVICEMEN OF AMERICA, Inc.
RSA Press & Supply Service
414 Dickens Ave., Chicago, Illinois

RSAMAN in Far East Writes—

"Radio servicing here in Bombay and Ceylon is 'very different.' We find receivers of all makes, from A to Z; American, British, Australian and Japanese. The American brands are easiest to service because the manufacturers gave consideration to the servicing factors while Continental makes show no standardization and on these we have no manuals from which to gain help. It's a tedious task! In Ceylon there are but few dealers and each repairs his own sets. There are no up-to-date servicing organizations and the average so-called Manager or Radio Engineer in charge of dealers' shops don't know the difference between a rectifier and detector valve." Signed, Sam Shroff, Ceylon, India. (This letter, dated Dec. 2, 1941, was mailed before the Jap's attack on Pearl Harbor and attempt to conquer India.)

★

Fraenckel To G-E Electronics Dept.—V. H. Fraenckel will have charge of the coordination of commercial engineering of all product lines of the General Electric Radio, Television and Electronics Department, according to a recent announcement by Dr. W. R. G. Baker, Vice-President. G. F. Metcalf, formerly in charge of this work, has entered the U. S. Army with the rank of Lieutenant Colonel, Signal Corps. Mr. Fraenckel will report to G. W. Henyan, Manager of the Transmitter and Tube Divisions of the Department.

A native of Illinois, Mr. Fraenckel attended L'Ecole Polytechnique from which he received the equivalent of a Master's degree in Science in 1925. Later he took graduate work in physics at the University of Chicago and the University of Michigan, where he was a member of the staff of the Physics Department and the Department of Engineering Research respectively.

He was employed by the General Electric Company in October, 1937, working in the Vacuum Tube Engineering Department. In October 1939 he was transferred to the Research Laboratory where he was engaged in research on electronics and television problems until his recent appointment.

★

Multiple Station InterComm—The W-105 is an interesting new low-cost communicating system for office and industrial application announced by Rauland. Warehouses, service stations, small factories, wholesale distributors, professional and business offices will find this system saves time and money far beyond its cost.

This system consists of a Master, or central control unit, the only amplifier in the entire system. Up to five Re-

mote, or outlying sub-stations can be used. The Master or central unit can call and converse with any one of the five Remote stations as selected.

A new and special feature of this system is that the Master unit can call and "listen-in" or converse with all five Remote stations at one time. This is done by means of the sixth, or "all" position on the selector switch. Further particulars, write "Rauland," care of RADIO SERVICE-DEALER, 132 W. 43 St., New York City.

★

100% In Bond Buying Plans—Allied Radio Chicago, Illinois, distributor of radio and electronic equipment, is proudly displaying a huge MinuteMan flag, symbolic of a 100% voluntary enrollment by its employees in the Payroll Savings Plan for the purchase of War Bonds.

Under this plan, sponsored by the U. S. Treasury, regular deductions are made from each paycheck, and War Bonds are delivered to employees as soon as sufficient credits have accumulated.

Two days after A. D. Davis, President, had appealed for cooperation with the plan, all departments reported a 100% enthusiastic response.

★

Hutchins Enters Service—Ever since Pearl Harbor, Henry Hutchins, General Sales Manager of National Union has felt the urge to return to the Naval Service to do his bit. He did it, and is now Lieutenant Commander Hutchins, U. S. Naval Reserve on active duty. When this war is over he will be back with National Union again.

★

N-U Announces Volume Control—The new "Sav-a-Shaft" Control introduces a new development in replacement control design by utilizing the shaft from the defective control. Not only does this "Sav-a-Shaft" for vital war material requirements, but for the service-dealer it guarantees that the shaft will be of correct diameter and length and that the knob will fit the control perfectly. No cutting, filing or special knob is necessary regardless of whether the knob requires a flat, split knurl or other special shaft-end.

Every control has a switch—comes completely assembled so that the switch mechanism is inoperative. However a simple operation places the switch in action when necessary. The new National Union controls are available at N-U jobbers in various resistance values, tapers and taps to satisfactorily handle about 95% of usual replacements encountered in radio service work.

TRIPLETT

NEW *Combat Line* INSTRUMENTS

THESE PHOTOGRAPHIC REPRODUCTIONS ARE THREE-QUARTER SIZE

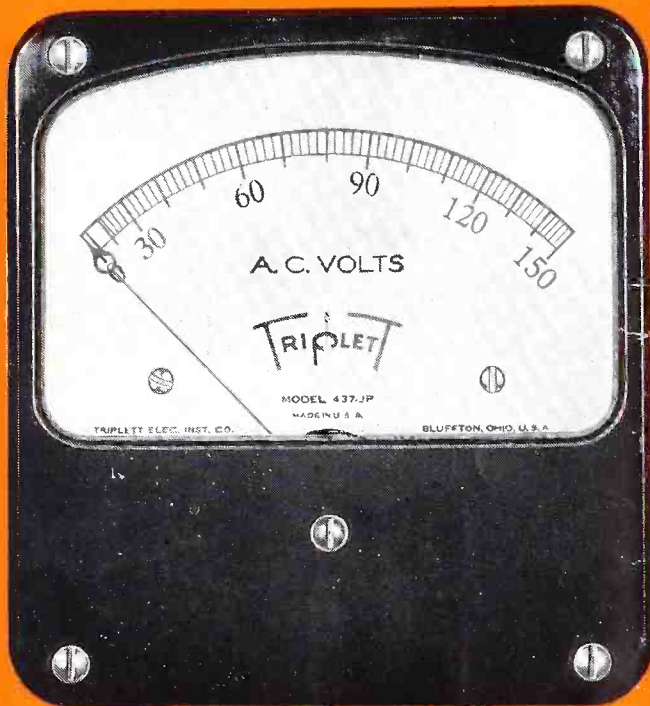

MODEL 437-JP

MODEL 372

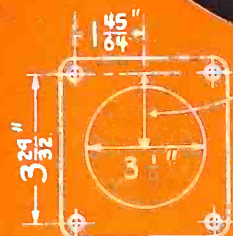
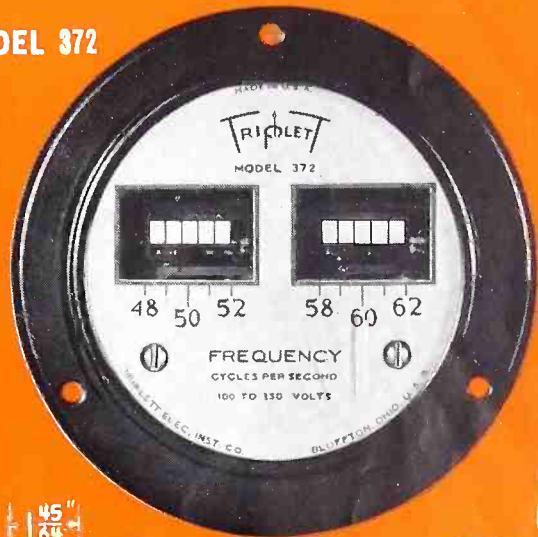

Model 437 - J P



Model 372

2 1/8" SIMPLE INSTALLATION DIAGRAMS

Maximum Service in Minimum Space

TRIPLETT *Thin Line* INSTRUMENTS

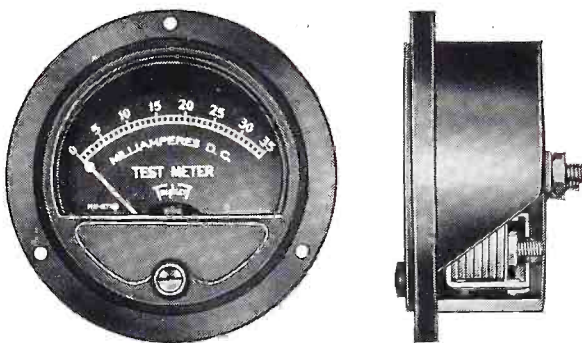

Precision performance by new *thin* instrument with *standard* Triplett movement housed in either metal or molded case. No projecting base; wider shroud to strengthen face; simplified zero adjustment; balanced bridge support; metal bridges at both ends; doubly supported core. For "Precision in limited space" write for Triplett Thin Line Bulletin.

The Triplett Combat Line

New Answers to specialized needs of War: Production Speed-up and Standardization; Performance under the Stress and Vibrations of Combat Service.

Model 437 J P—A rectangular line of meters to meet dimensions shown (see diagram). Wide-open scale for maximum readability. Complete coverage AC-DC Voltmeters, Ammeters and Wattmeters. Magnetic or static shielding provided on order. Molded Plastic Case for maximum protection in high voltage circuits. Pivots, Jewels and other component parts designed to meet severe vibration requirements.

Model 372—Frequency Meter—"All-American make" Vibrating Reed Frequency Meter. Maximum readability by grouping of Reeds. Range-Frequency-Voltage to meet specific requirements. Protected against excessive panel vibration. In standard 3 inch mounting or on special order in any cataloged Triplett Case.

A WORD ABOUT DELIVERIES

Naturally deliveries are subject to necessary priority regulations. We urge prompt filing of orders for delivery as may be consistent with America's War effort.

TRIPLETT ELECTRICAL INSTRUMENT CO.
BLUFFTON, OHIO



Raytheon Tubes

CAN TAKE IT!

The same Raytheon radio tubes that gave you top quality performance are now giving unfailing performance with the Signal Corps despite field conditions and the rigors of every climate.

Raytheons are now on 24-hour-day watches in the jungles and in the Arctic—duty that means freedom to the world! They must not fail and they do not fail. Thanks to thousands of Americans working to make it so—RAYTHEONS CAN TAKE IT!

RAYTHEON PRODUCTION CORPORATION
Newton, Mass. • New York • Chicago • Los Angeles • Atlanta

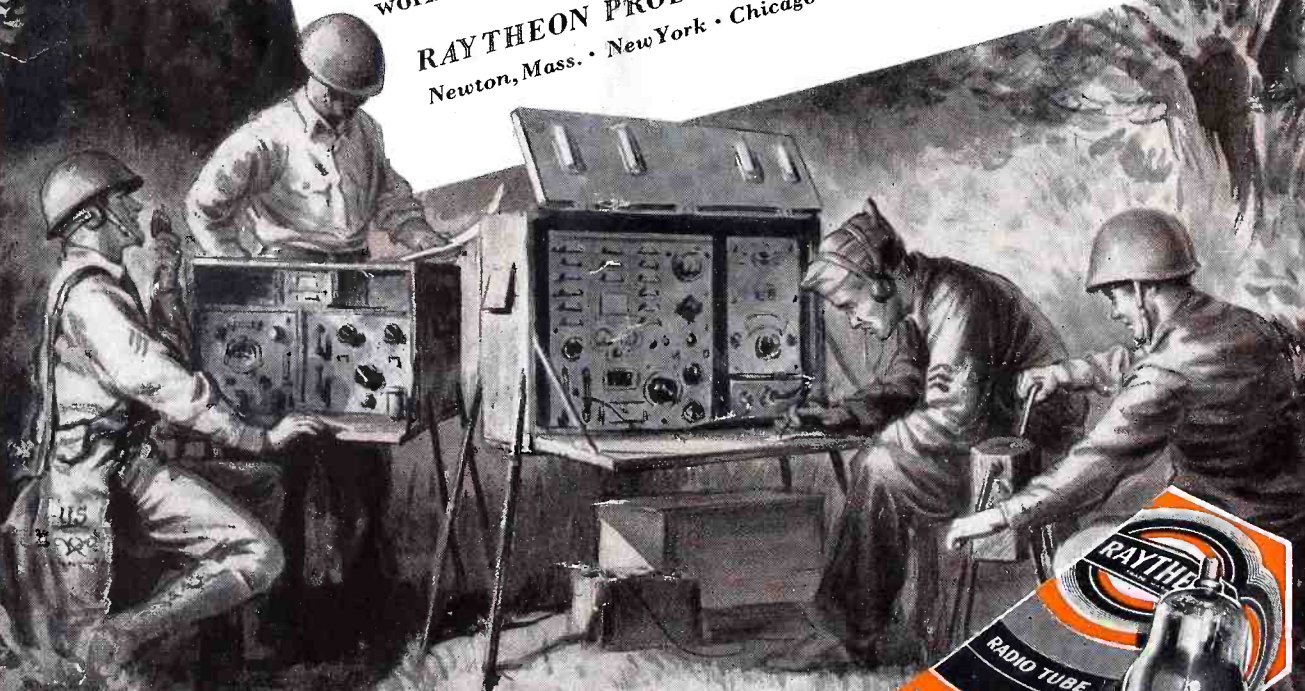

RAYTHEON RADIO TUBES



DEVOTED TO RESEARCH AND THE MANUFACTURE OF TUBES FOR THE NEW ERA OF ELECTRONICS