

# ET/D

FEBRUARY 1982 • \$1.50

ELECTRONIC TECHNICIAN / DEALER  
LEADING THE ELECTRONIC  
SERVICE MARKETS

**Microcomputer service**

**Satellite TV**

**Vans**

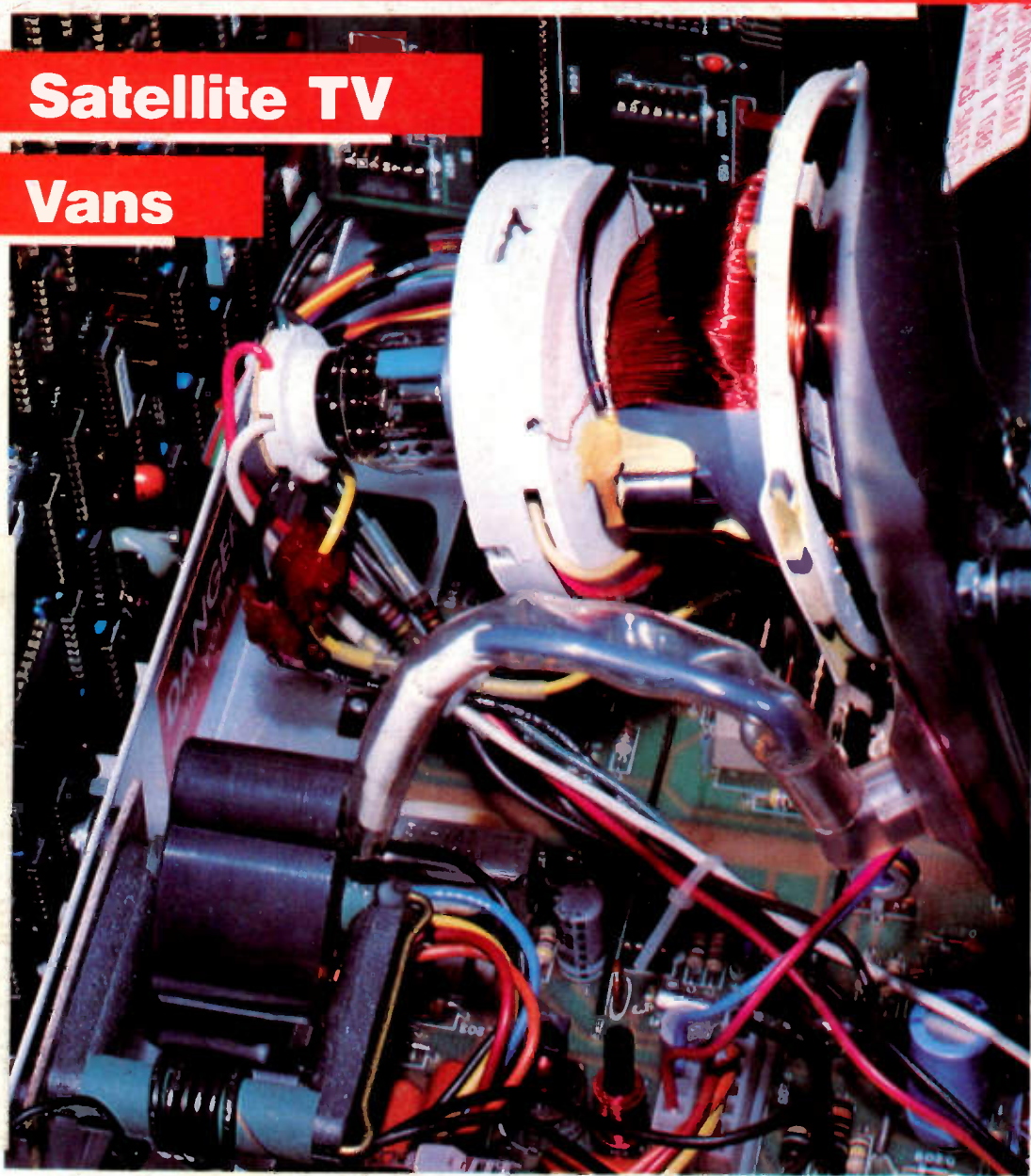

KQWR 4038013 P 2 AS APR82  
RAY KOWECK  
27734 DENMAR  
WARREN MI 48093 CTR

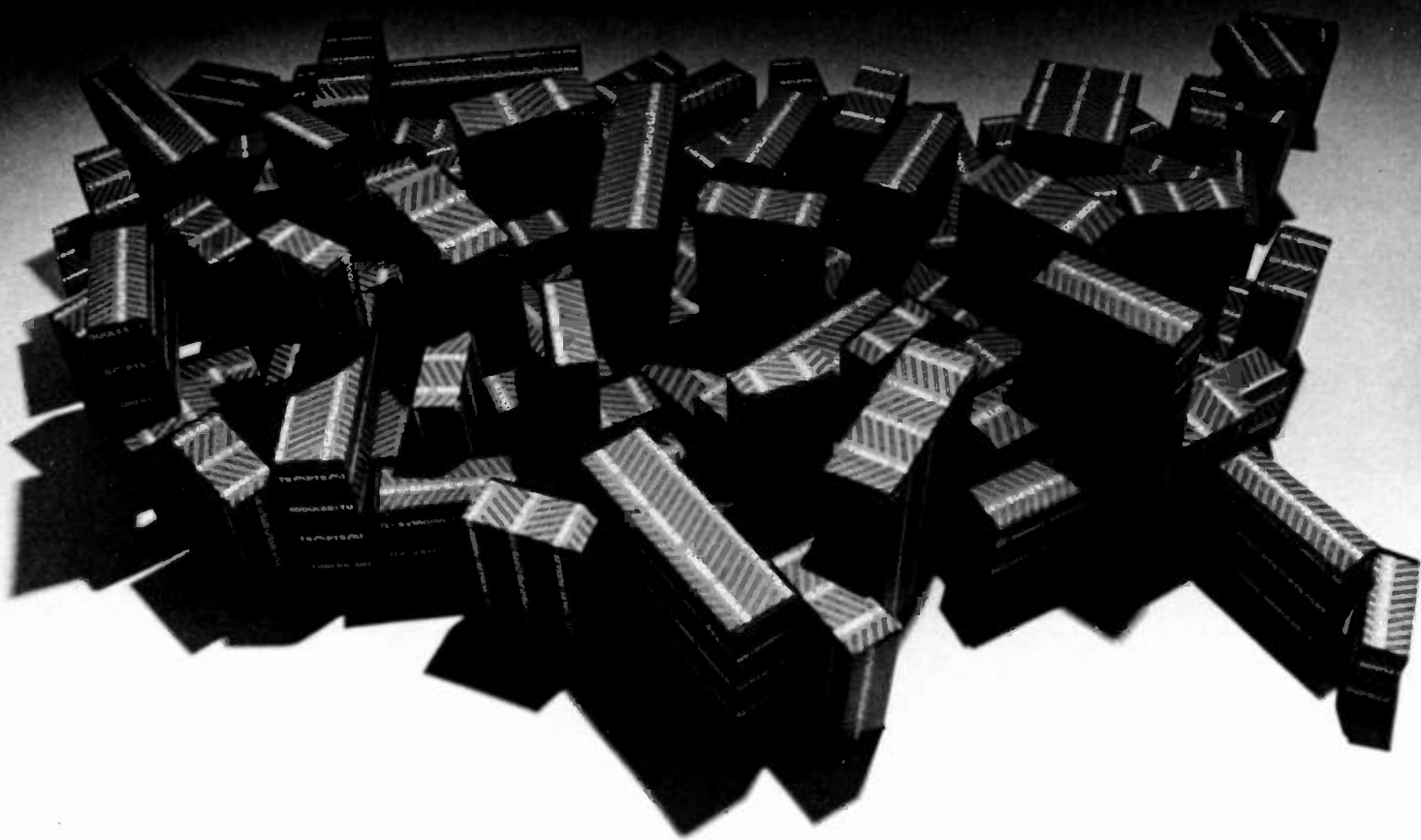

## Coast to coast, one box stands out at over 1400 locations.

In the past five years PTS has grown from 40 to over 1400 locations nationwide. That means there's a PTS Distributor or Servicenter near you, where you'll find quality rebuilt tuners and modules.

Why so much growth? Because thousands of professional TV service dealers have come to depend on PTS for quality rebuilt tuners and modules everyday.

And they like the convenience of picking up all the brands they need in one stop.

How many electronics rebuilders make modules and tuners available at over 1400 locations?

### Only One.



**PTS CORPORATION**

For the name of the PTS Distributor or Servicenter nearest you write PTS Corporation, P.O. Box 272, Bloomington, IN 47402  
Circle No. 113 on Reader Inquiry Card

# INDUSTRY REPORT

## NAB Testimony on DBS

National Association of Broadcasters President Vincent T. Wasilewski said recently that the "dramatic impact" of direct broadcast satellite service (DBS) on the future of America's communications system requires Congressional review of the Federal Communications Commission's proposed authorization of DBS.

Testifying before the Subcommittee on Telecommunications, Consumer Protection, and Finance of the House Committee on Energy and Commerce, Wasilewski said that DBS "involves the last available chunk of usable spectrum space. It affects the United States' relations with other Western hemisphere countries, the future of fixed microwave service and high definition television, and impacts on local broadcasting."

The FCC appears "to be engaged in an unprecedented rush to judgment to get DBS applicants through the regulatory turnstile before any national DBS policy has been determined," Wasilewski said. Predicting that interim authorizations will become permanent, he stated that "the FCC simply won't pull the plug on a DBS operation which risks a commitment of one-half to a billion dollars once it has been given the go-ahead."

If the Commission proceeds with its plans for interim authorization of DBS, Wasilewski said, it would not only ignore its responsibility to locally-responsive programming and hinder the development of HDTV—"a truly dramatic innovation in television service,"—but it would displace the terrestrial microwave operators serving high demand uses for business, educational systems, and municipal public safety services from the 12 GHz band. "... The issue is not marketplace, free competition philosophy," he said. "It is the FCC's duty to allocate spectrum among various uses ... on the basis of spectrum efficiency and public benefit. This it has not done."

Appearing with Wasilewski before the Subcommittee was Paul Bortz of the consulting firm of Browne, Bortz & Codrington, Denver, Colo., who elaborated on the spectrum management issues. "In a service as potentially important and as voracious a user of spectrum as DBS, an ad-hoc, incremental approach denies the totally appropriate roles of legislation and regulation in achieving efficient spectrum use," he said.

Bortz pointed out the major issues and tasks that need to be addressed to assure effective and efficient use of the spec-

trum, including the establishment of policy guidelines to direct the allocation of 12 GHz spectrum among many competing uses; the determination of rural service needs, considering the growth of various technologies; the future of fixed satellite service demand and the cost to the Federal government and users of relocating frequencies; the displacement of terrestrial private microwave users in the existing band; balancing the demands of competing services within direct broadcast satellite service, and the development of HDTV in this country.

Bortz concluded that the "development of DBS service provides an important opportunity to apply sound spectrum policy analysis to a complex set of issues," yet, he said ... "there seems to be an unfortunate trend among some at the Commission to confuse speed of service initiation with innovation. Impulsive decision making can slow, not speed, innovation."

## STC Challenges NAB Petition

Satellite Television Corporation has opposed a National Association of Broadcasters (NAB) petition urging the FCC to institute a sweeping investigation into the effects of STC's application for authority to construct a direct broadcast satellite (DBS) system to provide subscription television service.

"Plainly," STC said, "there is only one purpose to be served by the NAB petition: delay."

The statement went on to say that all of the issues raised by the NAB petition have been the subject of an exhaustive two-year FCC study and have also been addressed by a number of very comprehensive FCC proceedings.

In its opposition statement, STC described the NAB petition as a move to ask the "Commission to institute a totally duplicative proceeding without identifying a single public interest benefit to be achieved by its initiation."

On December 17, 1981—just one year ago—STC, a wholly owned subsidiary of COMSAT (Communications Satellite Corporation), asked FCC approval to build DBS satellites to provide three channels of premium programming, without advertising, to American consumers. Individual subscribers would receive the scrambled signals using 2½ foot dish-shaped antennas.

## \$5 Billion Market by 1990

The market for videotex/teletext services alone will be \$1 billion by 1985, reaching \$5 billion in 1990, according to a report from Strategic Incorporated entitled *U.S. Impact of Videotex/Teletext Information & Communications for the Home Market, #3C6*. Equipment includes interactive terminals and specially-equipped TV sets; computer and peripherals for use in CATV headends or in information databases; and pos-

sibly low-cost printers and transaction terminals. Services include telephone and cable-TV communications facilities used in accessing specific databases provided by information providers, as well as home security, electronic banking and tele-shopping.

A summary of market forecasts shows: the larger number of TV households which reaches a high of 93.8 million in 1990 from 77.7 million today, and the growth in number of households equipped with cable from 16.4 million today to 29.4 million by decade's end. Teletext services, which will be advertising-supported and free to the customer, are already beginning; test services by CBS, NBC, PBS, Westinghouse, and Field Communications are operational or nearly operational.

Nearly 3.5 million TV households would, by the most optimistic predictions, have teletext of some kind by mid-decade, while 20 million television households would have the service by 1990. Moreover, with 77.7 million households having a television presently, teletext service, information presented on the TV screen like closed captioning for the deaf, can be added easily by purchasing an adaptor or buying a set with a built-in adaptor.

Videotex, on the other hand, offers a greater opportunity and impact to consumers and suppliers of home and business products and services, the study points out. Consumers will be offered a wide assortment of interactive services such as home shopping, home banking, and others that can be addressed via a combination of personal computers and public telephone networks and/or television systems and cable TV networks. The report predicts that average household expenditures for pay-as-you-are services will be from \$10 to \$30 per month.

To get the service into the home, the report suggests that advertisers and programming sponsors will save the day by subsidizing or absorbing the cost sufficiently to get the consumer's attention. The existing services—newspaper, book, magazine publishers as well as broadcast television companies—which stand to lose from the migration of advertising to this new medium are not standing by idly. They are moving to protect themselves against loss by buying up cable companies, developing teleservices, and looking at hardware and services to support the TV set and its full range of peripherals: videodiscs, home computers, etc.

Large companies banking big money on the market include Knight Ridder newspapers in conjunction with AT&T. Cox Cable, Warner Amex with Qube, Dow Jones, Reader's Digest with Source Telecomputing, among others. Most current U.S. videotex/teletext projects are covered in detail in the study.

# ET/D

ELECTRONIC TECHNICIAN/DEALER  
LEADING THE ELECTRONIC  
SERVICE MARKETS

February 1982 Vol. 104, No. 2

WALTER H. SCHWARTZ  
Editor

THEODORE L. DECKER  
Assistant Editor

RAY ALLEGREZZA  
Contributing Editor

TOM GRENEY  
Publishing Director

TAIRE LIND  
Production Manager

LILLIE PEARSON  
Circulation Fulfillment

DAVE PETERSON  
Reader Service

JULIE LAITIN  
Promotion Director

DAWN ANDERSON  
Classified Ad Mgr.

## FEATURES

### Microcomputer Troubleshooting

*Simpler Than you think* ..... 12

### Service Vans

*Large and Small* ..... 16

### Computer Programming, II

*More Basic* ..... 27

### Satellite TV

*An Introduction* ..... 32

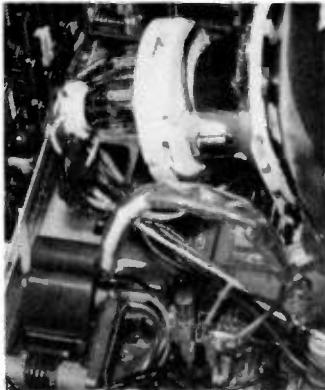

**On the Cover:** That the microcomputer has some very familiar looking aspects is made evident by this close up of the Heath/Zenith, H-89/Z-89. For more examples see page 12.

## DEPARTMENTS

Industry Report	3
From the Editors Desk	5
Letters	6
At the Bench	8
Security Viewpoint	10
The Business Side of Things	11
TEKFAX	19
Bulletin Board	34
Test Instrument Report	35
Dealers Showcase	36
New Products	38
Classified Advertising	40
Calendar	41
Advertising Index	42



A HARCOURT BRACE JOVANOVIĆ PUBLICATION



ELECTRONIC TECHNICIAN/DEALER (ISSN 0192-7175) is published monthly by Harcourt Brace Jovanovich Publications. Corporate offices: 757 Third Avenue, New York, New York 10017. Advertising offices: 757 Third Avenue, New York, New York 10017 and 111 East Wacker Drive, Chicago, Illinois 60601. Accounting, Advertising Production and Circulation offices: 1 East First Street, Duluth, Minnesota 55802. Subscription rates: one year \$12, two years \$20, three years \$26 in the United States; one year \$15, two years \$24, three years \$32 in Canada. All other countries: one year \$40, two years \$70. Single copies: \$1.50 in the United States and Canada; all other countries: \$4.50. Second class postage paid at Duluth, Minnesota 55806 and additional mailing offices. Copyright © 1982 by Harcourt Brace Jovanovich, Inc. All rights reserved. No part of this publication may be reproduced or transmitted in any form or by any means, electronic or mechanical, including photocopy, recording, or any information storage and retrieval system, without permission in writing from the publisher. ELECTRONIC TECHNICIAN/DEALER is a registered trademark of Harcourt Brace Jovanovich, Inc.

POSTMASTER: Send address changes to ELECTRONIC TECHNICIAN/DEALER, P.O. Box 6016, Duluth, Minnesota 55806.



Walter H. Schwartz, *Editor (Duluth)*

Theodore L. Decker,  
*Assistant Editor (Duluth)*

Tom Greney, *Group Vice President  
Publishing Director (Chicago)*

Taire Lind, *Production Manager*

Penny Haugsand, *Production Supervisor*

Lillie Pearson, *Circulation Supervisor*

Dave Peterson, *Reader Service*

Julie Laitin, *Promotion Director*

Dawn Anderson, *Classified Ad Mgr.*

Please submit editorial  
manuscripts to:  
Editor ET/D, 1 East First Street,  
Duluth, Minn., 55802.

### ADVERTISING SALES

Please send all advertising material to:  
ET/D, Production Mgr.  
120 West Second Street  
Duluth, Minn. 55802  
(218) 727-8511

#### EAST REGION

Mark Eder  
757 Third Avenue  
New York, N.Y. 10017  
(212) 888-4382

#### MIDWEST REGION

Keith Lewis  
111 East Wacker Drive  
Chicago, Ill. 60601  
(312) 938-2325

#### SOUTHERN REGION

Chuck Cummings  
A. M. Mosher  
613 N. O'Connor  
Irving, TX 75061  
(214) 253-8678

#### WESTERN REGION

Joyce Amiri  
10741 Moorpark St., Suite #21  
North Hollywood, CA 91602  
(213) 980-7750 or (213) 760-1684



### HARCOURT BRACE JOVANOVIH PUBLICATIONS

Robert L. Edgell, *Chairman*  
Richard Moeller, *President*  
Lars Fladmark, *Executive Vice President*  
Arland Hirman, *Treasurer*  
Thomas Greney, *Group Vice President*  
Ezra Pincus, *Group Vice President*  
Lawrence Witchel, *Group Vice President*  
Joe Bilderbach, *Vice President*  
James T. Gherna, *Vice President*  
George A. Glenn, *Vice President*  
Harry D. Ramaley, *Vice President*

# FROM THE EDITOR'S DESK

*Don't let the microcomputer pass you by!* In the beginning, there were radios and radio servicemen. And one has to have a great deal of respect for the problems these (to us) pioneers had to contend with, considering the quality of the test equipment and components they worked with. Intermittents and unusual circuits plagued them; they had their fly-by-nite radio merchandisers and sets with dummy tubes . . . all sorts of problems comparable to those we have today. Then, shortly after World War II, television became a commercial reality and a tremendous readjustment had to take place for those who wished to stay in business. There are more radios now in use than ever before, but who cares?—they are basically a throw-away item. Most did weather the storm, and then came color TV—something new to learn about. Again, most of us readjusted. In the '50's, high-fi audio began but did not really take off until stereo and finally stereo-FM broadcasting caused it to boom. When the dust had settled, however, a new generation of specialized audio sales—and service—stores had sprung up to a great extent in competition with the existing consumer electronics sales and service operations.

More recently, these audio stores and new video stores began to aggressively merchandise VCR's, again leaving the more traditional, now really TV only operations, behind. Television is becoming a smaller and smaller part of consumer electronics as a whole. Television service can never return to the level of the '60's. By the best estimates I can find, the TV service business will be at a level of about twenty-five percent of that of the '60's throughout the '80's. Locally, I notice some of these relatively new entrepreneurs are getting into the satellite TV business—two-way radio shops, etc.—and they are also getting into microcomputers!

The opportunities appear to be excellent: totally discounting home computer sales, there are as many as 10 million small businesses, each of which can use a microcomputer—may almost *have* to use a microcomputer—in the next few years. Reportedly, microcomputers require service; certainly all of our computer equipment does, as does our computer-based typesetting equipment.

ET/D is going to give you an orientation in microcomputers. Programming, troubleshooting, opportunities that we may become aware of—whatever we can do to impress you with the potential of the microcomputer business.

Sincerely,

# LETTERS

## HELP!

Your magazine still great after all these years—your reader's survey is a good idea.

I need a schematic for an old GE radio chassis G-99 I am restoring. Maybe your readers will help—it's old, but I don't know how old. Big console, push button and multi-band and electro-mag speakers. I would write GE, but don't really know where or what GE location to write. Tube diagram says manufactured in Bridgeport, Conn. Don't know if that address would still be good. Thanks.

J. Eddie Johnson  
1916 West Maple Ave.  
Orange, TX 77630

Needed: Pincushion X former (79A143-2) for Emerson TV Model 25EC24S/Ch. 30K2091-2.

Ricky J. Blackwell CET  
410 Homewood Ave.  
Burlington, NC 27215

We have been unable to obtain a sche-

matic for a Westinghouse TV No. CP78Mh1. We have tried, RCA, West, etc., here in Canada. Is there anyone that you know of who will send a schematic for this COD to us. Thanks.

Dorothy Barkhouse  
Office Manager  
Shore TV  
Box 74½ Seaforth  
Hfx. Co., N.S.  
Canada B0J 1N0  
P.S. This was an American West. set. We tried West, New York, no answer.

## BOUQUETS:

Thank you for your help in publishing my letter regarding schematics for the Farfisa electronic organ. I received a letter from Mark Electronics, 3 School St., West Chelmsford, MA 01863, informing me where I could get the schematics. I was directed to write to DIVERSIFIED KEYBOARDS, INC., P.O. Box 193, Lakeview, Ohio 43331. I was able to buy the schematics from them. George Olsen  
Olsen TV 384-1861  
13519 Westwind Drive  
Silver Spring, MD 20904

## AND BRICKBATS?

Have a few comments and requests. I

missed 1 year of ET/D during 80-81 and was a bit surprised to see the drastic changes in staff which have taken place. I thought Richard Lay was doing a fine job as editor. The magazine, while still quite informative, seems to lack some of the old color and dynamics—just doesn't seem as interesting. Sitting here looking at the May 1978 issue, and it seems to deal more directly with the concerns of TV and stereo repair shops than the recent issues I've received. They've been loaded with ads and articles relating to "security systems". This field, I feel, is a separate entity, and one deserving of it's own publication rather than weakening the original strengths of ET/D, i.e. pertinent information on use of test equipment, shop management, TV theory, etc.

In the plus column I'd say you've done a fine job preparing techs for tomorrow's economy (satellite TV and Rental TV esp.). The Reader Surveys were most welcome.

Thanks for your help and continued success with ET/D.

Bill Putney  
Box 263

Litchfield, CT 06759

P.S. A regular "troubleshooting" column (article) dealing with one section (video,

# Reach for reliability.

Solve over 178,000 solid state replacement problems using 1800 SK and KH types. RCA's new Replacement Guide puts the reliable answers at your fingertips.

From foreign to domestic components, RCA simplifies just about any replacement application, including integrated circuits, high-voltage triplers, rectifiers, thyristors and transistors. The guide uses a convenient dual numbering system, which

matches the right SK replacement to your consumer or MRO/Industrial needs. For example: SK3444/123A.

Pick up your copy of the 1982 RCA SK Replacement Guide. Nothing puts reliability within easier reach. See your RCA SK Distributor, or send a check or money order for \$2.25 to: RCA Distributor and Special Products Division, P.O. Box 597, Woodbury, N.J. 08096.

chroma, and so on) in each issue would be most helpful. There are many out here who don't know how to do a ringing test on a flyback. Other servicing shortcuts would really save us time and trouble.

Neither ET/D nor you (collectively; there are individual exceptions) can survive on TV and audio service alone. All of us must diversify. Security is one of the most profitable of such options open to us. However, since we have thoroughly introduced you to it by now, in 1982 we will not be emphasizing security as we did in 1981. We will put some emphasis on satellite TV and on microcomputers, and we hope to have a regular trouble-shooting column. Editor.

Your November editorial is starting to recognize reality in this business.

Not only do nonservicing dealers not deserve to be subsidized by competent servicemen, import brands and private label brands do not deserve to be subsidized in their service obligations by your fine magazine. I'm referring to your Tekfax concentration on Jap and other foreign schematics.

The total market share of all these "Mickey-Mouse" brands is under 10%—and that is primarily concentrated in the

large metropolitan areas—if these people do not supply service information. Timely facts supply and proper reimbursement for in-warranty repair labor, then they do not deserve even the small market share they presently enjoy.

Get your editorial policies back into the mainstream and you might attract enough advertising that you could increase the editorial pages back to what it was in the grand old days before solid state.

Bob Baker—CET  
Bob's TV Service  
2542 Yellowstone  
Billings, MT 59102

P.S. How about a little concentration on Satellite TV reception problems?

The "Mickey Mouse" brands do make up more than 10% of the market and—those sets we regarded as "Mickey Mouse" 10 or 12 years ago—Panasonic, Sony, Sharp, etc. are firmly established. Nevertheless, we are considering carefully the direction TEKFAK should take. Editor.

#### OPEN LETTER TO NATIONAL SERVICE MANAGERS

Our study of problems afflicting all servicers, thus adding to cost and frustrations of set owners, servicers and set

producer/marketers, reveals several simple solutions.

(1) Costly multiplicity of forms required by warrantors to authenticate compensation claims could be better served were each company to authorize use of the enclosed NATESA Service Order form. Please advise if you will accept it, or indicate changes you would need to authenticate it for acceptance.

(2) Parts procurement policies and procedures by various companies often cause serious delays in completing service and add to costs and time delays to servicers and set owners. Obviously, this damages your and servicer's image. Study indicates that installing "800" phones can eliminate misunderstandings. Won't you please advise us of your "800" numbers on parts and your conditions for parts procurement? We will get this information to members, and help them and you.

(3) Service problem back-up "800" numbers can reduce cost of service to purchasers of your brand, and servicers, resulting in better acceptance for your products. Please advise use of your "800" service back-up number and conditions for use of that number.

Your response to these three subjects

Continued on page 42



**The new  
1982 RCA SK  
Replacement Guide.**

**RCA SK Replacement  
Solid State**

**RCA SK Series  
1982**  
Guide to Reliable Replacements  
• Consumer • Industrial/MRO  
Over 178,000 Solid State Replacement Recommendations  
Available from your local RCA SK Distributor  
SK 8-7174

# AT THE BENCH

with Barry D'Iott

If your shop is like a lot of the shops I've seen, your lighting isn't as good as it should be. Like a customer who gets used to watching a dim picture tube, you can get used to weak shop lighting. "So what," you might ask, "if the lighting doesn't bother me, why should I worry about it?" Two reasons.

1. With plenty of light you might spot something you might otherwise not have noticed. For example, I was working on a General Electric EC chassis with horizontal shrinkage. Turned out the B+ going to the horizontal output circuit was a little low . . . caused by a high resistance short. Where was the short? In a wire that had gotten crimped under the flyback. How did I find it? I saw a slightly pinkish spot on the red B+ wire caused by overheating at the point it was crimped.

2. Having to constantly adjust to weak lighting is a physical exertion even if you're not conscious of it. This exertion tends to erode your concentration. I think you'll agree with me that a troubleshooter is only as good as his or her concentration.

"OK" you ask, "How do I determine if I have good lighting?" I'll give you a specific answer. **THE BEST LIGHT IS LIGHT THAT SHINES OVER YOUR SHOULDERS AND ON TO THE CHASSIS YOU ARE WORKING ON.** The best place for a lighting fixture is hanging from the ceiling about 2 feet from the bench and angled at about 45° to shine towards the bench. Lights that are mounted directly over the bench aren't as good because they shine the light onto the top of the set. (If you think about it, most of the time the circuitry you are working on is parallel to your chest . . . that's why you need the light shining over your shoulders.)

What about clamp-on movable bench lamps? If you have good overall illumination, in my opinion, they are not necessary. Wouldn't it be nice to have them out of the way? (Occasionally, you have to peer deep into the innards of a set in a cabinet. I find a flashlight the handiest thing for this.)

Specifically, what light fixtures are needed?

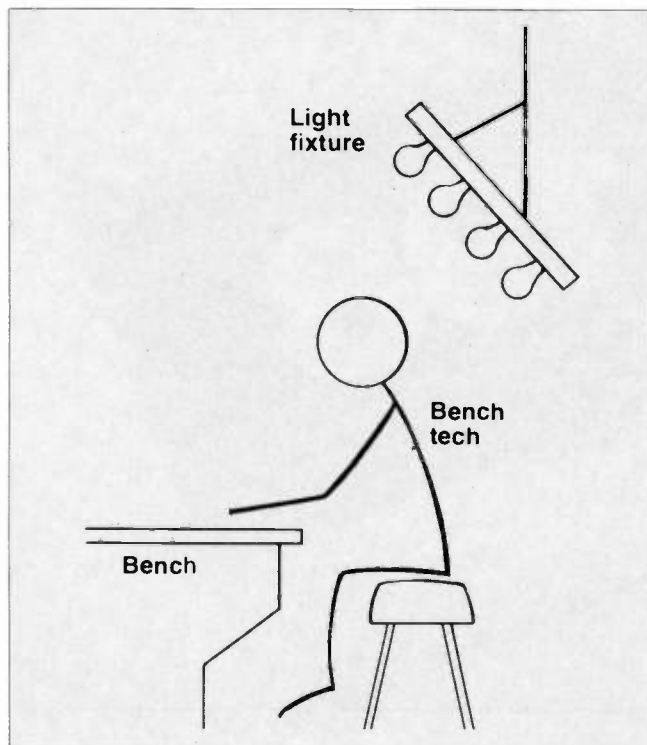

I personally prefer a 4-bulb fluorescent fixture hung by chains from the ceiling. Since the amount of light that's optimum is somewhat subjective, you can adjust the brightness (to coin a phrase) by raising or lowering the fixture. If you are one of those people that doesn't like the illumination from regular fluorescent bulbs, you might try what are called "full spectrum" types.\* They give off illumination that is very close to natural light. If you object to fluorescents because they cause interference to your AM radio which is tuned to the ball game, then simply put a .22mf at 600 volt mylar capacitor across the ac line *inside* the fixture. There are more elaborate filters available, but it has been my experience that the .22 works fine.

If you just don't like fluorescents for some reason I can't think of, then put up track lighting. The kind you can add or subtract lighting elements are best. (They call the lighting elements bullets.)

Let me warn you of one drawback to nice bright lighting. You may notice that the bench area needs a little cleaning and straightening out. Do it. You'll be glad you did. There is a correlation between having an orderly work environment and sustaining the orderly thinking processes needed for effective troubleshooting. A neat bench and good lighting will make a difference.

\*The "full spectrum" bulbs I know about first hand are available from Luxor Lighting Products, Inc., headquartered in the Empire State Building, New York, NY 10118. They are available nationally through distributors in major population centers.

I'm told that GE makes a similar bulb, but I haven't actually seen it.

## SERVICE SEMINAR

### MAGNAVOX

#### 800 Parts Telephone Numbers

Chicago-800/323-7566  
Chicago only-800/942-9633  
Los Angeles-800/421-1221  
CA only-800-262-1317  
Cleveland-800/321-0840  
Ohio only-800/362-2935  
Atlanta-800/241-7790  
Georgia only-800/282-7022  
New York-800/631-4134  
New Jersey only-800/562-3797  
Maine: Call collect 201/935-1212

### QUASAR

**TS-977—horizontal oscillator off frequency.** Possible causes: 1. IC401 and related components. 2. Overvoltage protection circuit Q553/Q554 and associated circuitry.

Overvoltage protection circuit: Diode D513 rectifies the horizontal retrace pulse flyback winding at pin 1. The resultant DC (+) voltage at the cathode of D513, directly proportional to high voltage variations, is applied to the base of Q553 thru R531 and R532. The emitter voltage of Q553 is clamped by zener diode D512 to establish the operating level so base voltage changes above a given level will effect conduction of Q553. Under normal conditions, Q553 is in a cut off state, thus its collector voltage is + 12.5V (source) which also keeps Q554 non-conductive. If the horizontal retrace pulse amplitude



To isolate:

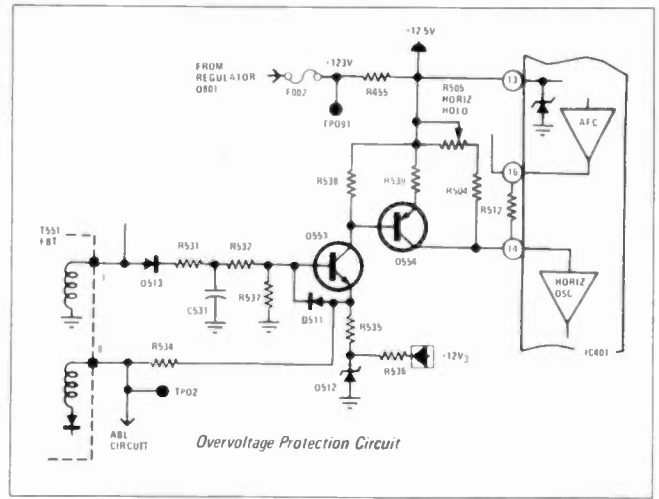
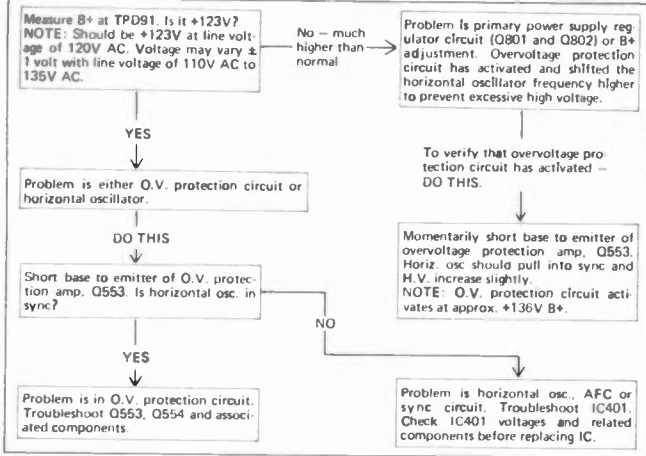

(representative of H.V.) increases beyond a specified limit, the positive dc voltage at the cathode of D513 also increases, thus Q553 conducts and its collector voltage decreases. With the lowering of Q554 (PNP) base voltage it goes into conduction and now represents a lower resistance in parallel with resistor R504 and horizontal hold control R505. This produces an increase in the horizontal oscillator frequency and a lowering of high voltage. Increased CRT beam current produces more ABL (negative) voltage, at pin 8 of T551, which opposes the positive voltage at Q553 emitter, thus it drops slightly, bringing the transistor closer to conduction. Excessive levels of high voltage (base) and/or beam current (emitter) produces current through both transistors to assure operation within safe limits.

977 overvoltage circuit operation is easily checked "in-home" by measuring high voltage while B+ is raised and observing the point at which the horizontal oscillator goes out of sync.

1. Tune in a station to make sure horizontal osc is in sync.
2. Set brightness and picture controls so picture is just visible.
3. Connect high voltage meter to high voltage anode button on CRT.
4. Temporarily connect a 500k (or larger) potentiometer from the junction of R811 and R812 (B+ adj control) to ground.
5. Slowly vary potentiometer to increase B-plus and resulting high voltage. Picture should go out of horizontal sync at approximately 32kv (approximately 136 volts B+).

Overvoltage protection circuit check out procedure: The TS-

NOTE: Procedure using a variac is given in service manual.

# OMNITRON: The Source for Quality at Low Cost

<b>Silicon H.V. Triplers</b> <b>HIGH VOLTAGE MULTIPLIERS</b>		<b>SYLVANIA Triplers</b>			<b>REMEMBER!</b> Sylvania Tubes 70% + 10% OFF LIST	<b>Sylvania ECG Replacement Semiconductors and Components</b> Full line in stock. The best quality semiconductor.
		<b>ECG-500A</b> 212-139 212-139-01 212-139-02 <b>\$12<sup>95</sup> ea.</b>	<b>ECG-523</b> 212-141 212-141-01 <b>\$15<sup>00</sup> ea.</b>	<b>ECG-526A</b> 212-141-02 212-141-03 212-141-04 <b>\$16<sup>99</sup> ea.</b>		
<b>FULL SIZE, DELUXE, CUEING STEREO CERAMIC CARTRIDGE</b> BSR Turntable #1C <b>\$24<sup>99</sup></b> <small>\$24.99 ea. std. carton of 4 \$26.99 ea. less than std. carton</small>		<b>CABLE TV CONVERTER</b> <b>\$23<sup>95</sup></b> CUV-2 Converts Mid & Superband Cable Channels to UHF 23.95 ea. std. carton of 10 29.95 ea. less than std. carton		<b>TUNER SHAFT INSULATOR</b> <b>28¢</b> each #114800 min. 10 pieces		<b>POPULAR FOCUS DIVIDER ECG Hi Div-1</b> <b>SPECIAL 50% OFF \$4<sup>15</sup></b> <small>Replaces Admiral 750C871 1 thru 8, 610C66 1 thru 10, Curtis Mathes 08A161 001 thru 003, Magnavox 230199-1, 2 and 4 and others.</small>
<b>PICKERING CARTRIDGE — P/AC</b> <b>\$4<sup>99</sup></b> <small>(original box)</small>		<b>PICKERING V15 SERIES (replica)</b> <b>\$2<sup>99</sup></b>		<b>POPULAR ZENITH TUNER GEAR</b> <b>\$3<sup>99</sup></b> #834-22		<b>ZENITH TUNER WISHBONE</b> <b>\$1<sup>77</sup></b> #S-75830
<b>YOKE &amp; BLUE LATERAL CLAMP</b> <b>89¢</b> #141171 RCA min 5 pieces		<b>ZENITH 4 LEAD CAPACITOR</b> <b>\$4<sup>19</sup></b> #800-866 (orange color)		<b>HEAVY DUTY CLIP LEAD SET</b> <b>\$1<sup>79</sup></b> HDC-1		<b>TUN O WASH</b> Heavy duty tuner degreaser/solvent Lg. 24 oz. <b>\$2<sup>99</sup></b> TW-2400
	<b>TUNER CLEANER</b> Lg. 16 oz. <b>\$1<sup>89</sup></b> TC-16		<b>BLUE STUFF</b> <b>\$1<sup>99</sup></b> 1639-8S		<b>FREEZ-IT</b> Lg. 15 oz. <b>\$1<sup>89</sup></b> FR-16	<b>UNIVERSAL 15 MEG FOCUS CONTROL</b> <b>\$1<sup>74</sup></b> FC-1
	<b>RCA THERMAL FUSE</b> <b>\$1<sup>39</sup></b> #135930		<b>PUSH-PULL SWITCH</b> <b>\$1<sup>78</sup></b> KR8W			

## OMNITRON

ELECTRONICS  
 770 Amsterdam Ave., New York, NY 10025

► Also ask for Free 100 Page Catalog ◀

Send Purchase Order, Check or Money Order  
 or Call Toll Free 800-223-0826

in NY STATE (212) 865-5580

ORDERS SHIPPED UPS/COD F.O.B., N.Y.C.

MASTER CARD • VISA

## OPTIMA VALUE SALE

TO ORDER CALL TOLL FREE 1-800-327-0224

G.E. SYLVANIA, ZENITH 75% OFF LIST NEW-BOXED

<input type="checkbox"/> 3A3	5 for \$13.69	<input type="checkbox"/> 6JE6	5 for \$28.44
<input type="checkbox"/> 6BK4	5 for \$25.38	<input type="checkbox"/> 6LB6	5 for \$27.38
<input type="checkbox"/> 6CK3	5 for \$12.75	<input type="checkbox"/> 6LF6	5 for \$29.94
<input type="checkbox"/> 6FO7	5 for \$10.56	<input type="checkbox"/> 17JZ8	5 for \$14.88
<input type="checkbox"/> 6GH8	5 for \$10.81	<input type="checkbox"/> 38HE7	5 for \$26.13

All Tubes Not Advertised, Write In at 75% off list. Sleeves Only. Singles 72% off list.

TRANSISTORS & I.C.'s...MIN 5 2 Year Guarantee

<input type="checkbox"/> 2SC867A Sony	\$3.95	<input type="checkbox"/> 2SC1172B	\$2.00
<input type="checkbox"/> SG613 Sony	\$6.95	<input type="checkbox"/> 2SC1308K	\$2.00
<input type="checkbox"/> TA7222 Toshiba	\$1.50	<input type="checkbox"/> 2SC1358A	\$2.00
<input type="checkbox"/> TA7204P Toshiba	\$1.00	<input type="checkbox"/> 165	\$2.00
<input type="checkbox"/> 116BA521	\$1.25	<input type="checkbox"/> 238	\$2.00

### REPLACEMENT FOR EEG

<input type="checkbox"/> 123A	\$ .40	<input type="checkbox"/> 195A	\$ .95	<input type="checkbox"/> 791	\$1.85
<input type="checkbox"/> 130	\$ .95	<input type="checkbox"/> 196	\$ .79	<input type="checkbox"/> 792	\$1.85
<input type="checkbox"/> 152	\$ .79	<input type="checkbox"/> 197	\$ .79	<input type="checkbox"/> 793	\$2.35
<input type="checkbox"/> 153	\$ .79	<input type="checkbox"/> 230	\$3.05	<input type="checkbox"/> 808	\$1.50
<input type="checkbox"/> 171	\$ .79	<input type="checkbox"/> 291	\$ .65	<input type="checkbox"/> 819	\$1.50
<input type="checkbox"/> 182	\$1.95	<input type="checkbox"/> 329	\$1.06	<input type="checkbox"/> 822	\$2.10
<input type="checkbox"/> 183	\$1.95	<input type="checkbox"/> 712	\$1.35	<input type="checkbox"/> 820	\$2.10
<input type="checkbox"/> 186	\$ .65	<input type="checkbox"/> 731	\$1.35	<input type="checkbox"/> 1167	\$1.95

### ZENITH, RCA & SYLVANIA MODULES

<input type="checkbox"/> 9-79	\$ 2.95	<input type="checkbox"/> 145260	\$22.49
<input type="checkbox"/> 9-147	\$18.01	<input type="checkbox"/> 145261	\$27.94
<input type="checkbox"/> 150-190	\$12.95	<input type="checkbox"/> Rep. ECG500A	\$11.95
<input type="checkbox"/> 138697	\$20.79	<input type="checkbox"/> Rep. ECG523	\$13.95
<input type="checkbox"/> 139546	\$27.28	<input type="checkbox"/> Rep. ECG526	\$15.95
<input type="checkbox"/> 141417	\$36.57	<input type="checkbox"/> 32-39202-3	\$14.95
<input type="checkbox"/> 141427	\$30.69	<input type="checkbox"/> 32-43068-1	\$14.95
<input type="checkbox"/> 145259	\$19.63	<input type="checkbox"/> 32-41658-3	\$14.95

### GENERAL

<input type="checkbox"/> Columbia Wire 59U Spools	.....	4.9¢/foot
<input type="checkbox"/> 2 1/2 Amp 1000 PIV	.....	100 for \$ 8.95
<input type="checkbox"/> 3 Amp 1000 PIV	.....	100 for \$15.00
<input type="checkbox"/> 12 & 6 Volt Sub-Minature Bulbs	.....	
With Long Leads	.....	10 for \$ 2.40
<input type="checkbox"/> 9 ft. 59U F-F 99c		<input type="checkbox"/> 12 Ft 59U F-F \$ 1.10

### Quantity Prices Available

Letters of credit and all checks placed on deposit with Bank of Hallandale, FL. VISA/Bank Americard & Master Charge accepted. Min. order \$75. FOB Dania, FL. Catalog \$3, refundable upon order.

SEND CHECK OR MONEY ORDER TO:

## OPTIMA ELECTRONICS

2022 Tigertail Blvd., Dania, FL 33004

Phone (305) 920-3550

TOLL FREE 1-800-327-0224

Circle No. 112 on Reader Inquiry Card

Now, more than ever  
...Men who KNOW say...



## IS THE ANSWER

HELP NATESA HELP YOU  
BY DOING YOUR PART

Are YOU the operator of an ethical, professional caliber tv-radio-home electronics service business?

Write for details on how you can gain great benefits and participate in the destinies of this great industry.

**NATESA**  
5930 S. Pulaski Road  
Chicago, Illinois 60629

# SECURITY VIEWPOINT

By John Sanger

The question of whether to sell or lease alarm systems is one that has been discussed in the alarm industry for quite some time. And, there are good arguments for both methods.

Leasing provides a monthly income and, since the title to the equipment stays with the dealer, increases assets. It also carries with it the responsibility to perform routine preventative maintenance as well as emergency service. Depending on the number of customers, additional service personnel may be required, which will add to overhead. Moreover, if a service crew spends, on an average, more than two hours per month servicing a customer's system, there will be no profit from the monthly lease fees.

Personally, I believe that selling the system to the customer makes more sense for a small dealer. Selling systems means cash at the time of sale; it means a good cash flow for the business. The dealer can charge for service calls—based on the actual amount of time spent—after the warranty period has expired. There will be a profit on the sale and installation as well as service calls without the worry that service call expenses will exceed monthly lease fees.

With an inflationary economy, many shoppers are reluctant to commit themselves to long-term lease agreements. If a leased system is all that is offered, the customer may go elsewhere to purchase an alarm.

To capture some of the best of both methods, leasing and selling, the dealer might consider selling all of the alarm equipment except the digital dialer in a monitored system. The sale assures a good cash flow; leasing the digital dialer and charging a monthly fee for monitoring provides a monthly income.

The monthly income aspect of leasing the digital dialer is really secondary. Primarily, the dialer is leased as a benefit to the customer. If the home is sold and the homeowner wants to move the alarm, it can be removed and taken to the new residence. The digital dialer, because it is connected to a monitoring service, will be useless to the homeowner in his new residence—depending on where the new residence is located there may or may not be an alarm dealer to reprogram the PROM in the dialer.

A digital dialer costing, say, \$75.00, could be leased for \$5.00 per month—giving a payback period of fifteen months. (Hopefully, most customers will not move frequently, and the \$5.00 per month will add to profit after fifteen months.) The monthly fee for monitoring two channels could be \$15.00 per month. (Cost to the dealer: about \$8.00 per month.) The customer would be paying \$20.00 per month for a two-channel monitored system—which would be less than what most large alarm companies charge, especially if they operate their own central station, giving the small dealer a slight competitive edge. During the first fifteen months, the dealer would gross \$7.00 per month per customer; after fifteen months, \$12.00. That may not seem like much at first, but it will seem much better when the 100th customer is signed up.

# THE BUSINESS SIDE OF THINGS

By William Joseph

Do you remember the first time you were ever ripped off?  
I do. And it was a bad check.

Even though it happened many years ago, I can still remember the sinking feeling when that check bounced. It was, in a sense, like being violated in some way—almost like having been mugged or deprived of my civil rights. If you've been in business for any length of time, you almost surely know exactly what I mean.

I had done my part (repaired a television set), but my customer had chosen to cheat me. As a young man just getting started, I needed the money. I didn't get it because I didn't know the basics that every businessman should know about handling bad checks.

I do now.

To begin with, it takes a while to learn how bad is "bad". Fortunately, most checks that are returned by the bank are "bad" only because of an honest error or oversight on the part of the customer. Some, though, are clearly fraudulent and in violation of the law. The first step in improving the odds that you will eventually collect the money due you is to learn to tell the difference.

A check that has been forged, or one that has been drawn against an account that doesn't even exist, is obviously the work of a person with criminal intent. Under those conditions, you will probably need to seek legal redress and may want to consult with your attorney or local police department.

The best defense against this unkind assault on your pocketbook is a policy that sets strict rules for identification, such as recording driver's license numbers. No service dealer need ever feel embarrassment in asking for this courtesy, even while in the customer's home. Consumers who are in the habit of tendering personal checks are used to being asked for identification.

The great majority of "bad" checks returned by your bank, however, are not going to be due to intentional fraud. They will be stamped NSF (not sufficient funds). Most will be due to your customer's carelessness rather than criminal intent. It is for this reason that your first step when your bank returns an NSF check should always be to simply deposit it a second time. This procedure allows time for the writer to become aware of his error and to make the necessary deposit to his account. That second trip will often strike paydirt.

Most banks will allow you to deposit an NSF check for a second try. However, there are some banks that themselves tender NSF checks to the bank on which they were drawn a second time before returning them to the depositor. You should check with your bank so that you will know their exact policy. If they have already tendered the check a second time, they probably won't accept it from you a second time.

Once a check has been returned to you twice, it's time for a direct contact with the customer to make him aware of the problem. A goodly percentage of those customers will be genuinely embarrassed and will offer to make immediate settlement. Accept the offer—at once. The more time that passes, the more likely it is that human nature will take over—and human nature can be remarkably inventive when it comes to reasons for putting off unpleasant obligations.

At this point, some service dealers prefer to go directly to the customer's home or business (or send a technician) to give the customer an immediate opportunity to pay up. Don't be bashful here. After all, it's *your* money.

*continued on page 39*

ARE YOU HAVING PROBLEMS WITH AUTOMATIC

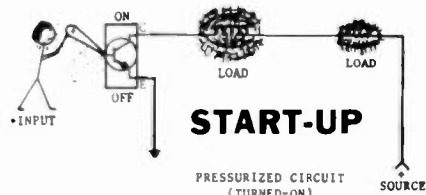

**START-UP**

PRESSURIZED CIRCUIT (TURNED-ON)

and

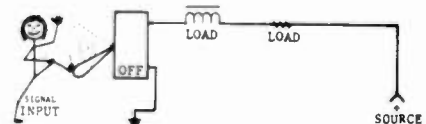

**SHUT-DOWN**  
circuits?

**TELE-TECK**  
has the  
**SOLUTION**

Tele-Teck Schematics give you  
**EVERYTHING YOU NEED**

- (1) How the circuit works (in pictorial sequence)
- (2) A quick checklist for known symptoms/parts failures
- (3) An oversize **easy to read** schematic (one that makes sense)
- (4) An easy to follow (instant) parts location pictorial
- (5) An easy to follow step-by-step troubleshooting procedure
- (6) A parts list with original manufacturers' part numbers and most known substitutes
- (7) An on-going course in electronics (practical application)

ALL IN ONE 16 PAGE MANUAL  
TELE-TECK DOES EVERYTHING  
BUT FIX THE SET FOR YOU

**SOUND TOO GOOD TO BE TRUE?**

For only \$10<sup>00</sup> we will send you a sample schematic for these start-up/shut-down/HV circuits:

RCA CTC 85    Magnavox T987  
GE MB 25      RCA CTC 72

After we prove to you that **you** can fix **any** auto start-up/shut-down/HV circuit in less than 30 minutes by using Tele-Teck Schematics, we will tell you how you can buy a T-T Schematic for almost any S-U/S-D/HV circuit at a reduced rate.

Enclosed is my \$10<sup>00</sup>. Please send all four of the above samples to:

Name \_\_\_\_\_

Address \_\_\_\_\_

City & State \_\_\_\_\_ Zip \_\_\_\_\_

Our address is:  
TELE-TECK, Box 15108, Amarillo, TX 79105

Circle No. 117 on Reader Inquiry Card

# Microcomputer Troubleshooting

## Impressions of the Z-89

I recently spent a week with Zenith Data Systems at its training facilities in suburban Chicago. Zenith is currently and successfully teaching TV technicians to troubleshoot its computer products. And it is *not* an alien world!

By Walter H. Schwartz

When the people at Zenith Data Systems began to consider the implications of rapidly expanding sales of their microcomputer systems, they concluded that an adequate service network would quickly be necessary. And, they decided, what would be more logical than to call on Zenith's existing base of authorized servicers to supply the necessary computer technicians. Zenith Data Systems, therefore, offered training and a microcomputer to those television technicians interested—at an attractive package price. Zenith has trained several hundred technicians and has authorized over two hundred Zenith Data Systems warranty service centers in the last year or so. They feel the program has been successful; good TV technicians adapt very easily to basic microcomputer troubleshooting, and with their previous knowledge of basic electronics, video systems, and power supplies, have a head start in becoming effective microcomputer technicians.

### The training

How does Zenith go about this? What sort of a training program do they offer?

The Zenith computer classes are small—never more than fourteen people; mine had seven. Each of us had a Z-89 computer in front of us from the time we first sat down. Alongside the Z-89

was a stack of printed materials; service manuals for the Z-89 computer and the Z-19 terminal, study materials on the Z-80 microprocessor (used in the Z-89 and Z-19), a diagnostic workbook, material on number systems and binary math, information on BASIC, and service notes and material on the Z-89.

On Monday after a brief introduction to the instructors and the objectives of the course, we took a pretest to show ourselves just how far we had to go by the end of the week. After the test we spent the rest of the morning examining just how the Z-89 broke down into its various job assemblies. In the afternoon we briefly examined decimal, binary octal, and hex number systems and their conversions one to another—and then turned on the Z-89 and went through its power supply, theory, and operation.

Tuesday we tore down the Z-89 and reassembled it in a test stand (it only takes a few minutes and it makes the various sub-assemblies quite accessible). With the rest of the boards out of the way, the video board is easy to work on (and to remove entirely if necessary), and at this time we examined it quite thoroughly (more about this later).

The third day of training was devoted to an introduction to the CPU board, to floppy disc drives, and other auxiliary memory devices—and to troubleshooting a bugged Z-89. The next day we worked with a systematic troubleshooting procedure, which by the nature of a computer allows trouble to be isolated quite readily. Following this, Thursday afternoon and a short day Friday were spent using various operating systems and doing some elementary programming. The business implications of computer service were discussed at dinner Thursday evening. It was a busy week.

I came away convinced that there was nothing either magic or awesome about microcomputers—just enough new to be

quite confusing. Troubleshooting can follow very logical steps; a great deal of built-in diagnostics and diagnostic programs make fault analysis and isolation in a microcomputer much easier than in a television receiver.

### Familiar circuits

Much of the circuitry of a microcomputer will appear quite straightforward to any good technician; some areas will look very familiar. Let's look at the power supply since it is so basic to any electronic device. As you can see from the schematic, the Z-89 power supply is quite conventional. (Fig. 1) The outputs are +65 volts and + and - 18 volts unregulated, 12 volts regulated, and + and - 5 volts regulated. The Z-89 service data points out convenient test points for checking all of these. So suddenly you are well into the computer and still on familiar ground! The unregulated + and - 18 volts are widely distributed throughout the CPU and terminal logic boards to supply a number of 5 and 12 volt, both + and -, regulators. In troubleshooting, especially since cables and plugs can cause problems, verifying the presence of proper supply distribution and/or board regulator operation would be an early step (on-board regulators can fail and since they are current limiting, they are protected against external shorts; a short on a supply line remains a local failure).

### Video

Take a look at the video/sweep board and CRT circuitry—no great mysteries here. A few points are a little confusing; the inputs labeled vertical sync and horizontal sync are really drive inputs. Input pulses from the terminal logic circuit board arrive here (via the CPU logic board) to be shaped into suitable wave-shapes to drive the deflection yoke. The video amplifier is also quite simple—no

shades of gray and no colors to worry about. The input is nice square pulses, little gain is required, and the only confusing thing is that the brightness control is what we would call a TV contrast control (the TV-style brightness control is the circuit-board-mounted G1 control). You should have no problems.

The Z-89 diagnostic test disc provides set-up instructions and patterns for video board adjustment under the title, CRTADJ.

### Keyboard

The keyboard is merely a matrix of normally open switches. It can be checked with an ohmmeter. The service data indicates which plug pins correspond to which letter or function. The individual switches can go bad and can be replaced fairly easily.

### Into the wilderness

When approaching troubleshooting the logic areas of the Z-89, it is important to realize that by the very nature of a computer it can be sectionalized for fault diagnosis and also, diagnostic programs will help pinpoint problems.

The first step in diagnosing Z-89 problems, assuming the power supplies

allow the computer to be turned on, is to switch to the "off line" mode of operation. This makes the computer into a soft-copy video typewriter; whatever is typed on the keyboard appears on the CRT, but goes no further. Successfully being able to enter every letter, number, and symbol and fill the CRT screen top to bottom verifies keyboard operation and terminal logic board operation, since the only logic link between the terminal logic board and the CPU board is via the IC Zenith calls an ACE (Asynchronous Communications Element)—perhaps more familiar as a UART (Universal Asynchronous Receiver-Transmitter), which converts the parallel data output and required input of either the CPU board or the terminal logic board to serial data in the interconnecting cable (or to interfacing boards for peripherals). In other words, if the "off line" function works OK, almost the only possible problem area on the terminal logic board is the ACE.

### The test disk

The major aid in diagnosing a malfunctioning Z-89 (not a dead machine) is the diagnostic test disk. The tests available are truly impressive to a technician who

is accustomed to diagnosing TV or audio defects. Here, in abbreviated form, are some of the test files contained on the disk. Each can be entered by simply typing its title, (assuming no malfunction prevents it). CRTADJ; this was mentioned in connection with the video board. Next, it requires assistance from the user to verify proper operation of the terminal logic board. The user is asked YES/NO questions about the display. The user responds with either a Y or N. If the test detects an error, it will be identified at the bottom of the screen. If all tests check OK, the program exits and returns to HDOS, the standard mode of operation.

KEYBRD; this program checks the operation of the keyboard. A simulated keyboard will be displayed on the screen. The user should depress the keys shown in reverse video. The CAPS LOCK key must be in the up position at the start of this test. The terminal bell will sound if an incorrect key is struck. When the CAPS LOCK key is highlighted in reverse video, the user should depress it and leave it in its locked position. The program ends after checking the operation of the OFF LINE and BREAK keys. The program exits and returns to HDOS when a (CR) is struck at the end of the test.

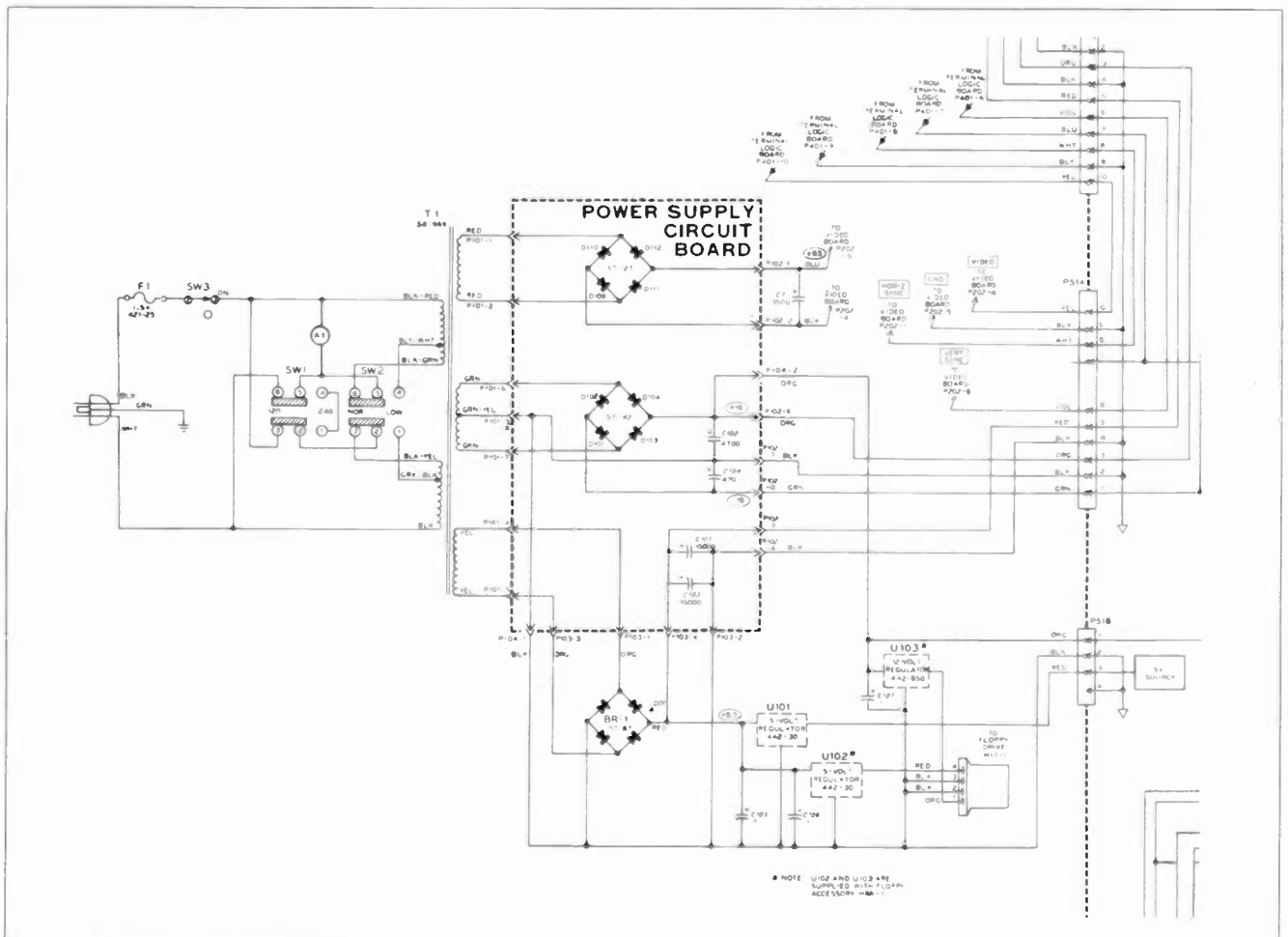
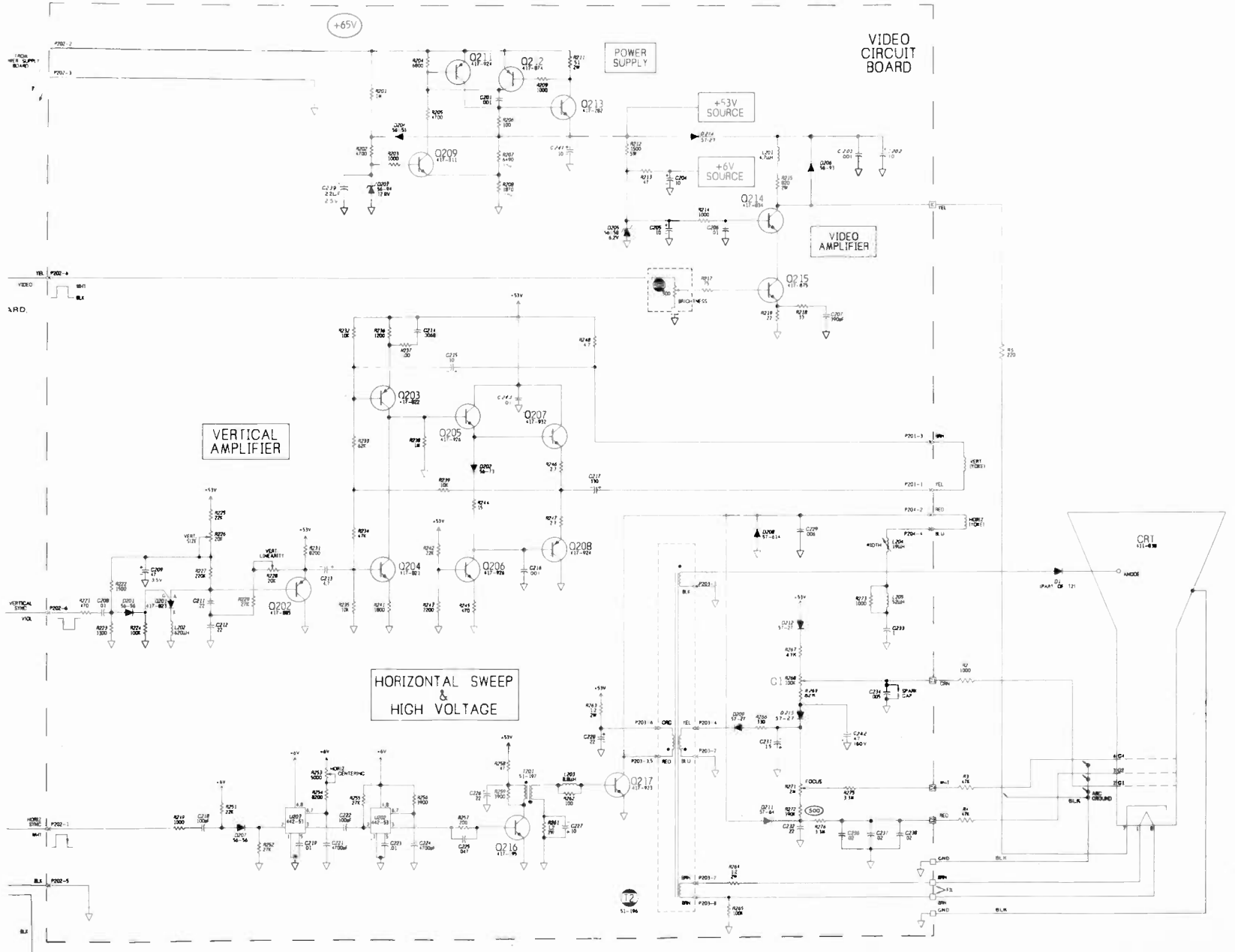

Fig. 1. Zenith Data Systems' Z-89 power supply.

Fig. 2: The Z-89's sweep/video board.



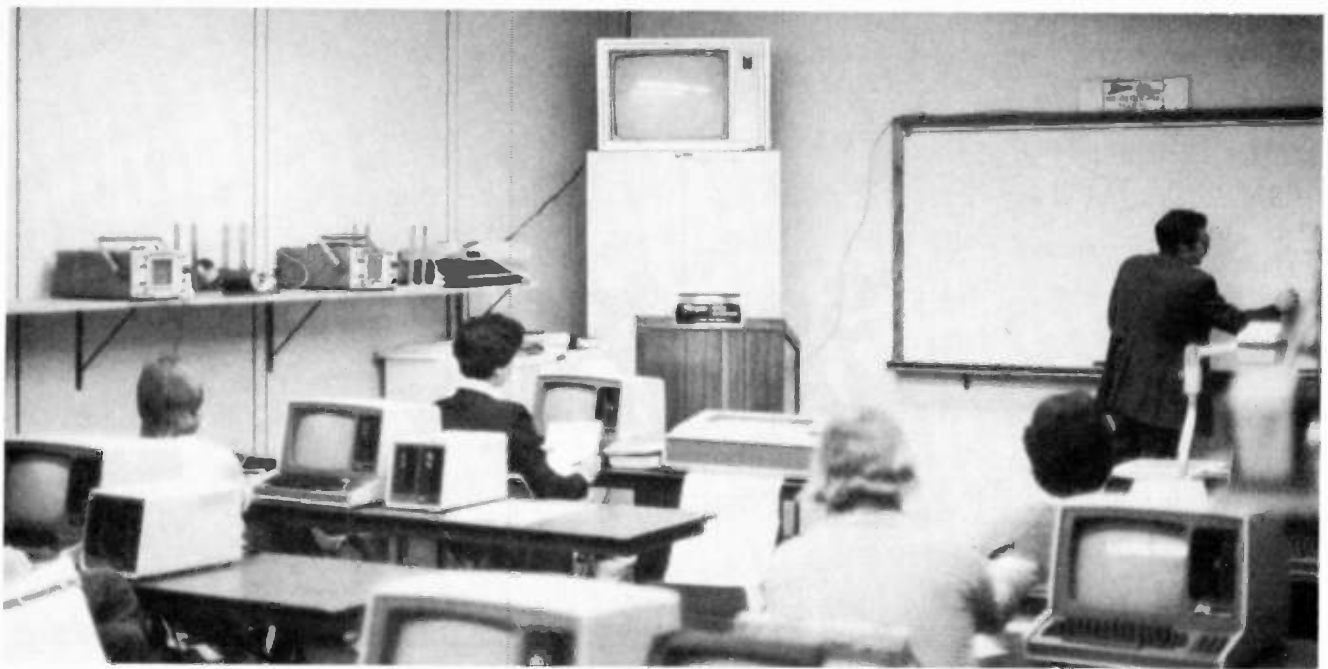

Fig. 3. A Z-89 training class in session, conducted by Training Director Mark Groeger.

Z89CPU; this program is a series of nine tests checking the functions of the CPU and two-port serial I/O boards. The program automatically runs all nine tests and, if there are no errors, returns to HDOS.

The first three of the tests following check the operation of the two 8250 ACE chips on the serial I/O board:

**Test 1: Serial Reset Values.** Checks the condition of certain registers after power-up or reset.

**Test 2: Serial I/O Registers.** Checks the operation of certain registers by first writing data to them and then reading back the same data.

**Test 3: Serial Loopback Modes.** Sets the two ACE chips to a loopback mode, transmits a string of data, and expects to receive the same data.

**Test 4: Single-Step Interrupt.** Checks the single-step detection circuitry of the CPU board by forcing the circuitry to become active. While the circuitry is active, the test looks for a level 2 interrupt after the execution of every op code.

**Test 5: 2 ms Clock Interrupts.** Checks that the 2 ms second clock is no slower than 2 ms by entering a 50 ms loop and counting at least 25 clock pulses. Then it turns off the clock for 50 ms and expects to see no clock pulses.

**Test 6: CPU/TLB Baud Rates.** Checks that the CPU and TLB boards are synchronizing their baud rates from 110 to 9600 baud. Failure of this test could be caused by either the CPU or TLB boards.

**Test 7: Drive Configuration.** Checks the configuration of the internal Z89 disk drive (SY0:).

**Test 8: Disk Rotational Speed.** Checks the rotational speed of the internal Z89

disk drive (SY0:) by checking the timing of the index pulse.

**Test 9: Disk Drive Read/Write.** Checks the ability of the internal disk drive to write and read a file to ten track/sectors.

**RAMTST1;** this program checks the floppy disk RAMS and the second 16K bank of RAM on the CPU board. This test writes a series of data patterns to address locations in the RAM chips and reads these locations to verify that the write/read operation was successful. There is a total of 36 patterns used. If an error is detected, the test will stop and display the location, the data written, and the data that was actually read back. If no errors are found, the program links to RAMTST2.

**RAMTST2;** this program is similar to RAMTST1, but tests the first, third, and (if the Z89 being tested has 64K of RAM) fourth 16K banks of RAM. As in RAMTST1, any errors found will be displayed. It is possible to pinpoint a defective memory IC with these tests.

**SERIAL1;** this program is a duplication of the first three tests of Z89CPU and is used to check the serial I/O board.

**LCPU;** this program is the first of a series of five programs that make up the life test for the dynamic memory (RAM) of the CPU board. These five programs are: LCPU, LRAM1, LRAM2, RESULTS, ERROR. LCPU resets the error file and pass counter to zero, then links to LRAM1 which is similar to RAMTST1. LRAM1 checks the floppy disk RAMS and the second bank of 16K RAM. Next, it links to LRAM2, which is similar to RAMTST2. LRAM2 checks the first, third, and (if available) the fourth banks of 16K RAM. If an error is detected during either LRAM

1 or LRAM 2, the location address, data written, and data read will be stored on the ERROR file. The file RESULTS is the program that writes the information to ERROR. If no errors are detected during LRAM1 or LRAM2, the pass counter is incremented and the next pass is started. These programs run in an infinite loop. The only way to exit this life test is to reset the Z89.

There are several other tests and programs on the test disk including one for binary, decimal, hex, and octal ASCII conversion. The amount of information available through the use of these tests is impressive, as is the ability of the Z-89 to diagnose its own problems.

## Opportunities

I have tried here not to teach you to fix the Z-89—and I'm sure I have been successful in not doing so—but to show you that the microcomputer is not an awesome device, and has similarities to familiar equipment. Plus: the manufacturers can be of tremendous assistance in training...and the computer itself does a great deal of its own troubleshooting for you!

Zenith Data Systems opened opportunities in microcomputers (including sales, to those interested) to consumer electronics service shops. They offer training, good service data, parts, and advice. It would be very worthwhile for you to look into other possibilities as well. Don't let 'em scare you!

Zenith still is looking for authorized servicers. If you are interested, contact: Charles Vollmer, National Service Manager, Zenith Data Systems, 11000 Seymour Ave., Franklin Park, IL 60131. **ETD**

# Service Vans for Today

Large, small,—?

The costs of operating a service vehicle have soared. When considering a new van, what are the factors to consider? And, what's new? What are the options? Here we consider some of the available vans and pickup conversions.

By William Joseph

Choosing the right service van has become more important than ever before. Trucks that are pleasing to the eye and economical to operate are an unbeatable assist on the road to better profits. The trouble is that economy of operation is becoming an elusive goal for most service dealers.

There was a time, of course, when the cost of getting the service technician around to his calls was a relatively minor consideration on the P&L statement. Not so today.

One of the largest service companies in the country reports a current cost of 39¢ per mile for its service fleet. For the small dealer who does not enjoy the economies of scale, the cost is almost surely a good bit higher. To get an idea of what that expense might mean to you, multiply the average miles per call traveled by your trucks by about 40¢. The result is your average direct mileage cost for every call you run. For many dealers, truck costs are now running 10% or more of total operating expenses—and growing daily.

In deference to the old maxim that "the best way to make an extra dollar is not to spend it in the first place", many dealers are taking a look at alternatives



Fig. 1 A Chevrolet S10 compact pickup with a commercial van body.

that may reduce mileage expenses. They're finding out that there is some good news and some bad news.

First, the good news: There are several alternatives to the old standby Ford, Chevy, or Dodge half-ton panel trucks. Electric vehicles, propane fuel conversions, and foreign minis are all being used in one form or another in various service operations around the country.

Now the bad news: There is no solid evidence yet that any of them can be considered viable choices for most service dealers. While some seem to hold more promise than others, the jury is still out on all of them.

Least promising, at least at the current level of technology, are the electric vehicles. Despite the ubiquitous announcements of "breakthroughs" in battery technology, the fact is that electric vehicles just can't measure up to the demands of most service operations. Batteries are very heavy, very expensive, and, in commercial use, have to be replaced about every two years. Most electrics now on the road will travel no

more than about 40 or 50 miles between rechargings. When all the costs for batteries and recharging are added together, "fuel" for an electric costs about the same as gasoline. Since the initial price of electric vehicles is much higher than their conventional counterparts, they're clearly no bargain.

While it may be true that the space-age battery capable of pulling electric vehicles into the mainstream of commercial usage is just around the corner, it hasn't arrived yet.

One alternative that does seem to be drawing interest lately, especially among operators of larger fleets, is the conversion of standard gasoline engines for operation on LP gas (propane). According to the National LP Gas Association, about one million engines are now operating on propane (including generators and irrigation pumps). According to the association, about 200,000 more engine conversions are forecast for this year.

Although the conversion is expensive (an average of perhaps \$1200 for a typical service van), propane burns more





Fig. 2 A Toyota mini-pickup with a Handy Mandy MV-90 body mounted.

efficiently and is considerably less expensive than gasoline.

Figuring the payback on propane conversions is relatively easy. Since propane and gasoline will usually deliver about the same number of miles per gallon, it's necessary only to multiply the number of gallons of fuel now being used by the vehicle for one year by the difference in price per gallon between gasoline and propane in your area. Example: A truck uses 2,000 gallons of gasoline per year in an area where propane costs 50¢ per gallon less than gasoline. Fifty cents times two thousand gallons equals a savings of about \$1,000 per year. A 14 month payback in the case of a \$1200 dollar conversion.

It sounds worthwhile, and it can be. But, alas, propane also has its share of disadvantages. Refueling stations are still mighty scarce in some areas, and installing your own storage tanks will be too expensive if you operate a small fleet.

Then, there is that nagging question: If conversions to propane continue to grow, will the increased demand give birth to large price increases and/or shortages?

And not everyone who has made the conversion is happy. The chief of one small Pennsylvania police department that converted 15 patrol cars says, "We should have stayed with gas. The cost of propane is cheaper and it burns cleaner, but there are a lot of other problems."

He reports frequent breakdowns, stalling while idling, and an odor that is offensive to some officers.

How about the foreign minis? Do they hold the key to lower transportation costs for the average service dealer? Well, nothing much has changed in this area since we reported to you in these pages last year (ET/D Feb. 1981). While there

are some dealers who report satisfaction with the likes of such imports as the Luv, Courier, Datsun, and Toyota, the consensus is not favorable.

High sticker prices that include stiff import tariffs and reports of high maintenance costs are frequent complaints against the minis. Some fleet operators report that the actual cost per mile is higher with the foreign minis than with standard vans. At least for now, most operators of large fleets of service vehicles seem to have abandoned the foreign imports.

Whether your own preference is for the domestic product or an import from foreign shores, there is one caveat that seems to be almost universal: While you may opt for a manual transmission as an economy measure for your personal vehicle, *don't buy manual transmissions for your service vans.*

Stan Weiss, president of Minute Men, Inc., an electronic service dealer near Pittsburgh, PA, echoes the feelings of most dealers we surveyed on the subject of manual transmissions when he says, "We will never again buy manual transmissions. The technicians inevitably ride the clutches to death. The cost of frequent clutch replacements and the resulting downtime more than wipe out any savings in original cost."

So, how about Detroit? Have they heeded the clarion call of distressed service dealers throughout the land? Well, yes and no.

1982 is not a major model changeover year for the big three as far as light trucks are concerned, but there are some bright spots here and there.

As reported last year, Detroit is keenly aware of the demand for an economical but sturdy vehicle of the type used by service dealers. Although the pace may be slower than some would like, it's clear

that American manufacturers are putting in a valid bid for your continued business.

## Dodge

The lineup at Dodge for this year is generally unchanged. What Dodge describes as their time-tested, fuel-slingy 225 CID slant six engine continues as the basic power plant for most of the light-duty domestic truck models for 1982.

Optional engines for heavier duty work are the 318 CID V8, available with either the two-barrel or four-barrel carburetor. Once again, Dodge vans will offer a choice of 109" or 127" wheelbase and a wide range of transmission and axle ratio combinations.

Items previously sold as options now made standard on Dodge vans include dual electric horns, cigar lighter, and rear door check arms. As with Ford and Chevrolet, one thing that is definitely different this year at Dodge is price. You guessed it—up again.

## Chevrolet

For now, at least, the hottest news comes from General Motors' Chevrolet Division. Robert Lund, Chevy general manager and vice president, reports two brand new developments for 1982. First, that long-rumored diesel engine for Chevy light duty trucks has arrived at last. And, to put the icing on the cake, the new Chevrolet S-10 Fleetside for 1982 is here—the first domestically built compact truck.

The new diesel engine is a 6.2 liter, 130 horsepower model designed and built by Chevrolet. Estimated mileage is about 22 in the city, 27 highway.

"This is a heavy-duty diesel engine," says Lund. "It will give our customers the power and load-hauling capacity of Chevrolet's gasoline-powered trucks with the diesel's traditional fuel economy advantage."

At least for now, however, the new diesel will be available only on the pickup truck configuration. Says Chevy public relations manager Ed Breslin, "We know there's an interest in this engine among standard van users, but we won't be able to offer it right away." Breslin explains that the diesel engine is larger than the current gasoline model and just won't fit in the standard van until design changes can be made, probably next model year.

Also new from Chevrolet this year is America's first domestically built small truck. Dubbed the S-10, it comes with a 1.9 liter, 82 horsepower, four cylinder gasoline engine. A 2.8 liter engine is available as an option. The larger engine is the same one that made its debut in

the Chevy Citation.

Slightly larger than the Chevy Luv (an import), the S-10 has a 108.3" wheelbase, with a stretched version available at 117.9". Payload is rated 1000 and 1500 pounds. The heavier payload requires a package that includes power brakes, front stabilizer bar, heavy-duty rear springs, radial tires, and V-6 engine. Fuel economy is expected to range from 22 MPG in the city to 39 highway, depending on the model, engine, and transmission.

Unfortunately, cargo van users will have to purchase the S-10 as a chassis/

cab base—or in the pickup configuration, relying on one of a number of outside companies specializing in furnishing closed bodies for this type of vehicle. This, of course, is one of the same disadvantages associated with the foreign minis which also are manufactured in the pickup style.

### Ford

The ubiquitous Econoline series from Ford remains relatively unchanged from last year. All models, including the Super Van with 347 cubic feet of cargo space, will again be offered.

Ford will also continue to import the compact Courier in basic pickup configuration. The 1982 version will have a new steering column featuring stalk controls and an AM radio standard. Choices will still include two engines, automatic or manual transmission, and two wheelbases with two pickup box sizes and payload ratings.

Not to be outdone by rival GM, Ford, too, has announced plans for its own domestic compact truck. Ford's version will be called "Ranger" and, like its counterpart at Chevrolet, will be available at first only as a pickup.

The Ranger, which is scheduled for introduction about mid-year, will include as standard equipment a 2.0 liter in-line four cylinder engine, four-speed manual transmission, and Ford's first computer-designed instrument panel. Options include a 2.3 liter in-line four and automatic transmission. Payload ratings are 1200 pounds for the standard version and 1600 pounds for the heavy-duty model. Wheelbase on the short version will be 108", with a stretched version at 114".

### Minis

Clearly, the auto manufacturers up to now have limited mini trucks to the pickup configuration. Does this mean that all is lost for the service dealer who needs the economy of a mini with the security of a closed body?

Not at all, according to H. L. Mandeville Jr., president of Handy Mandy Trailer Manufacturing Company. His firm, as well as a number of others, specializes in outfitting pickup trucks with closed van bodies to make them suitable for service work. Says Mandeville, "The Handy Mandy model MV-90 will fit onto all mini pickups except the Volkswagen."

According to Mandeville, his firm will supply the truck with fiberglass body mounted or will custom-fit a body to the customer's truck. Special interiors designed for electronic service work are also available. Additional information can be obtained from the company at P.O. Box 269, Perry, OK, 73077.

Zubrick Industries, P.O. Box 494, Garden Grove, CA, 92642, is another of the firms providing service van bodies for mini pickups. According to the company, there is more useable storage space area in a Zubrick body than in a long wheelbase van.

Choosing the service van best suited to the needs of your business may be getting more complicated, but the increasing number of alternatives is making the job more interesting. As the competition for your business heats up, the ultimate service van draws closer. **ETD**

## "Your customers will come out ahead with a Satellite Video Receiver from Comtech Data."

Richard Desman, SATMAR Satellite TV, Phoenix, Arizona



**MODEL 650**  
FOR SINGLE RECEIVER SYSTEMS WITH DOWN CONVERTER ANTENNA MOUNTED FOR MOST ECONOMICAL INSTALLATION

**MODEL 550** FOR MULTI-RECEIVER COMMERCIAL SYSTEMS

**Ahead in Dependability** - Comtech's track record for excellence in satellite communications technology spans over ten years. This expertise is designed into every video receiver.

**Ahead in Quality** - Twenty four channel broadcast quality video with 6.2/6.8 MHz program demods plus a full year's warranty.

**Ahead in Technology** - Digital channel select with LED display. Remote control capability. Self-contained LNA power supply.

**Ahead in Customer Satisfaction** - Add it all up and Comtech comes out ahead for those who desire the finest in a "no compromises" modular video receiver that will provide years of trouble-free service.

We are currently expanding our dealer base and your inquiry is invited. Call or write Jeannine Hillier at (602) 949-1155 for immediate delivery from stock.



**COMTECH Data Corporation**  
A SUBSIDIARY OF COMTECH TELECOMMUNICATIONS CORP.  
350 NORTH HAYDEN ROAD • SCOTTSDALE, ARIZONA 85257  
(602) 949-1155/TWX: 910-950-0085

Circle No. 102 on Reader Inquiry Card

# Microcomputer Programming, II

## Basic BASIC

This second article of Bernard Daien's series on programming will show you how to make a microcomputer actually *do* something. ET/D's editors are carefully following all instructions on a borrowed Z-89. It is really necessary to be able to try even this elementary programming for things to make sense and to stay with you. So beg, borrow, or even buy a microcomputer and learn. A suggestion: you may find a computer available through an evening class at a neighborhood school. Editor.

By Bernard B. Daien

In part I we discussed the need for programming in higher languages than machine language or assembly language and began to lay the foundation for programming in BASIC. In this article we continue with programming procedures for BASIC.

We previously mentioned that each program line in BASIC format consists of 72 characters or spaces, but the last two spaces in each line are not used . . . a margin of sorts. This business of spacing is very important, and spacing is rigidly dictated in BASIC. This should not bother you, since when you write a letter, each paragraph is indented and there is a left and right hand margin, etc.

You accept this and have accommodated to it. Now you will be doing the same thing in BASIC programming.

As a matter of fact, in the previous article it was noted that there are different BASIC dialects (variations). This, too, is no different than common English usage, where several different words can be used to describe the same thing. For example, when you talk about something "small", you often use the word "little" or "tiny", etc. And, we understand our British cousins quite well, although they often use different expressions. We figure it out very quickly by the context . . . the way the words are used and their relationship to the words preceding and following. So it is with BASIC. As you grow familiar with BASIC, these things, which are so simple in common English, will become equally easy in BASIC. As in other things, "practice makes perfect" . . . (and it also makes things easier). Now . . .

### Don't forget the spaces ...

First, to be more specific, each line of a program is called a "program statement". As we mentioned earlier, there are a variety of statements . . . some are "system commands", for example. Most lines in the program are preceded by a line number, but system commands do *not* have a line number preceding them. Also, you will notice that system commands usually stand alone; seldom does anything follow them on the line. *After you have typed the line number and the desired statement, you must always press the return key* (carriage return key) *in order to complete the statement.*

We earlier stated that we do not use

the last two spaces in each line. In regard to spacing, we *must* also leave a space between the line number at the beginning of the line and the following statement. These are not just niceties, they are requirements!

We use four symbols to indicate addition, subtraction, multiplication, and division. These are, respectively, +, -, \*, and /.

Notice that we use the asterisk for the multiplication symbol. It is forbidden to use the X for the "times" symbol, as X is reserved for use as a variable quantity. Similarly, we do not use the ÷ symbol for division, using instead the slant bar, /. But, when we use these symbols mixed with numbers, as in  $5 + 3 - 2$ ,  $9 * 6$ , or  $8 / 2$ , there is no space used between the numbers and the symbols. As you will see later, the comma and the semicolon are also used as BASIC symbols for computing purposes (not for punctuation), and when used, there is no space between the numbers and these symbols. For example: 7,15,23,1 or 16;4;7.

The symbols for addition, subtraction, multiplication, and division are called "operators". There is an additional operator for exponentiation (powers and roots), and it is either a double asterisk, \*\*, or an arrow symbol pointing upwards,  $\blacktriangle$ . The use of the comma and the semicolon is to denote spacing in the computer's answer . . . the way the parts of the answer are spaced out. We call these two symbols "delimiters" . . . and there will be more about the use of operators and delimiters later—but for now, we are merely trying to impress upon you the fact that the way we use these symbols involves spaces, or the lack of them.

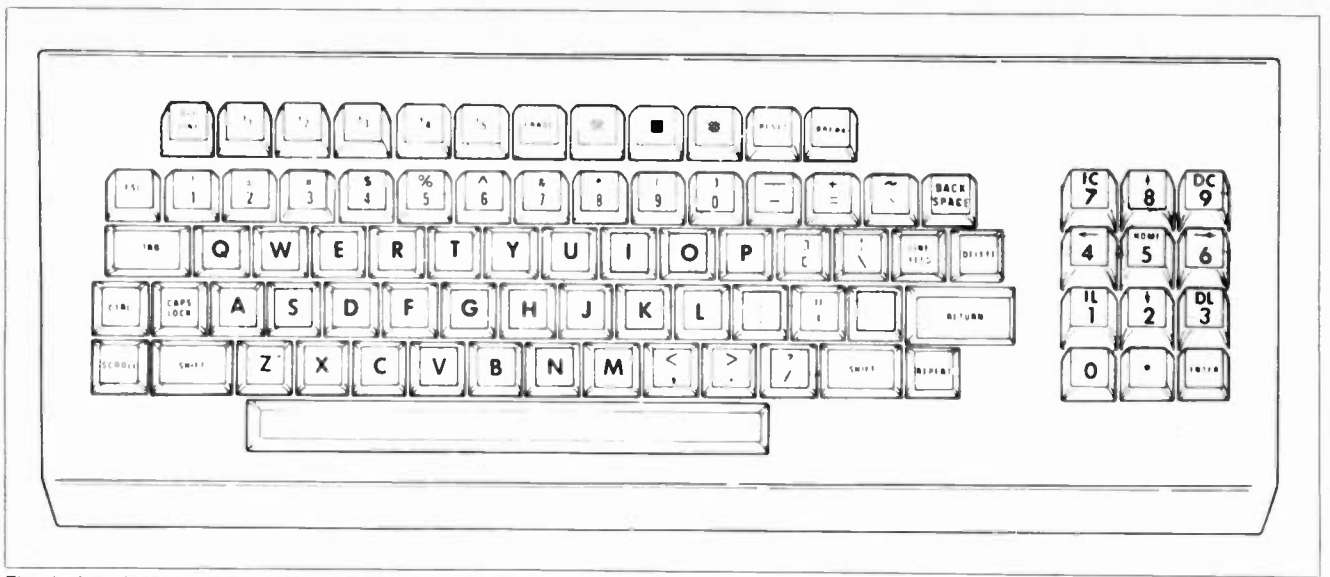

Fig. 1. A typical computer keyboard (Courtesy Zenith Data Systems)

The computer has a very limited ability to recognize things . . . therefore we must learn to write them exactly as the interpreter program knows them.

### Using some simple BASIC

Now we are going to put together some of the pieces we have already learned, but first, in order to do this, we must add a few more words that are needed to make a program work . . . We can do this best by example, using the following program:

```
10 PRINT "LEARN THIS"
20 END
RUN
```

Notice that there is no period used at the end of each line. You simply press the carriage return key, as if you were using a typewriter, and the terminal is ready for the next line. The carriage return key also causes the line you have already typed to be executed. Since RUN is a system command, there is no line number preceding it. The computer now replies:

```
LEARN THIS

DONE
```

Notice that the computer merely printed *exactly what we included between the quotation marks*. Stated simply, the PRINT command followed by a space, then by characters in quotation marks, causes the computer to reproduce exactly the material you included between the quotation marks. The material is not confined to the computer's vocabulary, and therefore can be a title for your program—or anything else desired. (Often, the programmer titles the program and

adds some remarks to assist other persons who may later use the program.)

Let's look at that little program a second time and see what else we can discover. Not only is there a line number preceding the statement PRINT, but there is something following it, in order to make a complete statement . . . but when the system command RUN is used, no line number precedes it and nothing follows it! (Many commands are "stand alone" commands.) Most dialects of BASIC require the use of the END statement in program line 20 (the last line). (You see, we have found a use for the program line numbers already . . . identifying a particular line in the program . . . and we do the same thing when we talk to the computer . . . we identify a line, or lines, by line number.)

A note of caution: It is understood that you have already typed the command, SCR (for "scratch") before beginning your programming session, in order to clear the computer's memory for the new program being entered. This is merely a reminder of what we covered in Part I.

Absolutely nothing will happen on most machines until you type the command RUN at the bottom of your program. RUN causes the computer to execute the program, and *the program is run in the order in which the lines are numbered*, not the order in which they are entered. If you add program lines at the bottom of an original program, out of numerical sequence, the computer will arrange them in correct sequence as it executes the program!

We can look at this by writing a program that will enable us to see what the computer is doing, by ordering it to make a number of PRINT commands instead of doing a calculation. That way we can

see what the computer does in rearranging lines. Try this:

```
10 PRINT "THIS"
20 PRINT "IS"
40 PRINT "PROGRAM"
30 PRINT "A"
50 END
RUN
```

The computer then executes the commands and prints the material, but *in the proper numerical sequence*:

```
THIS
IS
A
PROGRAM

DONE
```

We can do more with the command RUN, however . . . If you have a long program, you might want to look at only part of it. Let's say you have already worked on the first half of a long program and are satisfied that it's ok, but now you have added some more programming and you want to look at only the portion added—without repeating the entire program. In that case, you can start running the program at some point after the beginning by typing the command RUN followed by the line at which you wish to begin, as follows:

```
RUN 30
```

In the case of the program we just ran, the computer would reply:

```
A
PROGRAM

DONE
```

This is a worksaver when you are checking your program for errors. Errors?? Of course. You will make quite a few errors, and much of your time will be spent correcting them by running and rerunning programs till they are finally error free. The computer will help you by pointing out many of the errors, and you will find certain errors yourself.

Logically, this brings us to some simple error-correcting aids, because you are going to be making errors in these practice programs and will be terribly frustrated if you cannot get them straightened out! So we will make a little detour to examine some simple ways to get "bugs" out of our program. The buzz word for the process is "debugging". So, on to . . . . .

## Debugging

The trouble with using the word RUN to see what has happened to our program, is that RUN causes the program *results* to be printed . . . i.e., the program is executed. Suppose we want to see if the computer has the program in its memory as *we typed it*. If the program is not in memory exactly as we typed it, then the *results* of running a program with an error in it must be erroneous also. Besides checking the execution of the program, we must check to see if the program has been entered correctly . . . the basic first step in debugging. To do this we use the command:

### LIST

(Remember that you must press the carriage return key after each line in order to execute the line statement or command!)

The computer will now reply by printing everything programmed . . .

```
10 PRINT "THIS"  
20 PRINT "IS"  
30 PRINT "A"  
40 PRINT "PROGRAM"  
50 END
```

DONE

Notice the difference between this result and the result of typing RUN. The LIST command execution provides the program line numbers, the quotation mark symbols, and the rest exactly as written by the programmer . . . with one exception. You can see that it has put the statements in proper numerical order even though they were typed in improper order. This is because the computer enters the program's statements in the order

numbered, not in the order typed . . . but that is exactly what we want to see in our first step in debugging the program . . . we want to see WHAT HAS BEEN ENTERED INTO THE COMPUTER'S MEMORY, because that is what the computer will execute later on.

By now, you are beginning to get the idea that the *program is executed from the program stored in memory*, and when we type a program, *we are entering it into the computer's memory only*. It is not executed until we hit the commands END and RUN. Until we execute the program, *it is merely held in memory*. We are now examining exactly what it is that is being held in memory. And now that we know what is held in memory, we can make corrections, if needed.

To delete a program line, merely type the line number and then depress the carriage return key. What you have done is retyped that particular program line, but put nothing into it, therefore it is empty. This is done simply, as below:

```
40 (and press return key)  
Line 40 is now erased.
```

Of course, if you wish to correct an error, you can do that by typing the line number, followed by whatever statement is correct. The incorrect statement will be deleted and the new statement placed into the program in memory. This happens because we cannot put two different pieces of information into the same memory storage location. Whenever we write new information into a memory location, we automatically wipe out the old contents of the memory. Therefore, THE LAST STATEMENT WRITTEN INTO A MEMORY LOCATION IS THE ONE THAT IS STORED, and of course, is the one that remains in the program.

Now that you know that pressing the return key at the right moment (after the program line number) can delete a line, you also know that depressing the return key inadvertently can erase something by error! And that's one of the ways errors creep into programming!

Now here is where we get just a little bit more complicated, but not much. As long as we are talking about the return key, let's go a step further . . . . . What happens if we are halfway done typing a program line and discover we have made an error? Just stop as soon as you can after the error and press the return key. (Some computers will indicate to you that you have made an error at that point.) Now press the return key AGAIN and retype the whole program line over as if it had never been typed before. The computer will put it in the

correct place in the program, as retyped.

But what if you have made a real mess of things and need to delete many lines? It gets to be work, eliminating one line at a time, and there is always the possibility of introducing another error if you are doing a lot of correcting . . . so here's an easy way to eliminate a group of lines *with one statement* . . . Just print DELETE 50-90 and presto, lines 50 through 90 are gone, forever. Again, be careful that you do not delete more than you intend to. Some mistakes are disastrous, and you can wipe out an entire program without intending to do so. IT IS GOOD PRACTICE TO WRITE YOUR PROGRAM LINE BY LINE ON A PIECE OF PAPER AS YOU GO, SO THAT YOU HAVE A RECORD OF WORK PERFORMED IN THE EVENT OF ACCIDENTAL ERASURE OF THE PROGRAM! If you have a printing machine, the record is on the paper tape, but if you have a terminal which reads out on a cathode ray tube, you have no written record to fall back on if the program is erased.

(Again, note that there is no number before the word DELETE.)

## Back to BASIC

We have learned quite a bit, but at this point it is easy to add a few more facts . . . building upon what we already know. So we are going back to where we left off when we started this little side trip on error correction. Now that we can correct errors, we can proceed with programming, secure in the knowledge that we will not be halted by an error and our inability to do anything about it. So, let's go back to our old friend . . . BASIC.

We sort of got into BASIC at the deep water end of the pool . . . on the theory that the best way to get into a cold pool is to dive in . . . fast. Now we are going to go back and give you a little more background that will help you to understand how we arrived at the BASIC language in the first place; then we are going to do a little more programming.

It is generally accepted that BASIC had its inception at Dartmouth College, as an easily learned language with great flexibility. It is particularly used in education . . . a good starting language for persons considering branching out into other languages later. There are now many variations of it because of several factors. One factor is the limitations of the particular computer being used. Each computer manufacturer uses a variation of BASIC that avoids the limitations of his machine. Therefore, the BASIC that works on one make of machine may need to be revised, or translated, if it is

to be run on another make of machine. Usually you can get an interpreter program to do this between the more popular brands of computers. Another reason for dialects in BASIC is the *end use* of a computer. Computers intended for different main-end use applications may have slightly different variations to facilitate programming for that use. Along these lines, BASIC has become popular for many business uses, entertainment uses, educational uses, and specialty applications like graphics.

Now that your mind has had a momentary respite from programming while we discussed BASIC's history and variations, we can go back to programming afresh . . .

### PRINT ...

Remember that we used the word PRINT, with the following characters in quotation marks. Used in that manner, the computer merely prints out exactly what we enclosed in quotes when it executes the program. But, if we leave the quotes off, the computer behaves in a very different manner. Let's look at a short program to illustrate this . . .

```
10 PRINT 8 + 2
20 END
```

RUN

The computer executes the program, and answers . . . . .

```
10
DONE
```

Without the quotation marks, *the computer performs calculations requested* . . . you have now stated a problem, and the computer provides the answer. Therefore, you must have some kind of math expression after PRINT when used in this way. Of course, we can combine both kinds of uses of the word PRINT when it is useful to do so, as in the following: Look at this program . . .

```
10 PRINT "8 + 2 EQUALS"
20 PRINT 8 + 2
30 END
RUN
```

To which the computer replies . . .

```
8 + 2 EQUALS
10
DONE
```

The computer has printed out exactly

what we included between the quotation marks on line 10, then did the CALCULATION which was indicated after the word PRINT on line 20 without quotes.

As you can see, the carriage return key has several uses, the word PRINT has several uses, etc. We are thus able to squeeze a great deal of flexibility out of the characters on the terminal keyboard. Figure 1 shows a typical keyboard pattern, for the benefit of those who have never seen one.

In the next article we will continue with programming, now that we have laid the groundwork for it. So far, we have been discussing programming as if the computer were right in front of us . . . but in many cases the computer is remotely located and we have several problems as a result . . .

First, we may have to communicate with the computer via the telephone lines, and we need to learn the procedures for establishing contact with the computer and for avoiding conflict with others who may also be using the computer on a time-sharing basis. We will also need to establish some kind of security to prevent unauthorized persons from interfering with our use of the computer. We will cover such basics in the next article. **ETD**

## INDUSTRIAL INTERCOMS FOR HIGH NOISE AREAS



For many years ADCO intercoms have been a leading choice of U.S. industry to deliver clear, penetrating voice communication under the most severe conditions. Thousands are performing efficiently in areas of high noise . . . many where conventional intercom systems failed totally. Typical installations are in factory production zones, on loading docks, and in other outdoor areas—in saw mills, steel mills and foundries—on construction jobs and oil rigs. Regardless of weather, temperature or operating conditions.

Each individual intercom unit is self-contained, transmitting an amplified signal to permit an unlimited number of stations over any distance. Installation is simple, practical: plug each unit into a power source and connect units together by ordinary 2-wire cable.

Full range of AC and DC models available, as well as extreme temperature models and units compatible with existing sound-power systems.

**ATKINSON DYNAMICS**

A Division of Guy F. Atkinson Company  
Section B  
10 West Orange Avenue  
South San Francisco, CA 94080  
Phone (415) 583-9845

Circle No. 101 on Reader Inquiry Card

## PUBLIC NOTICE

Do you understand the new

### RCA

Start-up and shut-down circuits?

We at METS are willing to bet that you haven't even seen a schematic that shows how this circuit is wired . . . much less how it works! \*†‡\* (Yet you will soon be required to work on them)!

**FURTHERMORE,**

unless you are using METS literature you will **never** know just how easy it is to troubleshoot the start-up/shut-down circuits in RCAs CTC 85-86-88-89-90-91-92-93-96-97-99-107-108-109.

**PROVE IT TO YOURSELF**

Send us \$3.95 and we will send you the above procedures. Then you will know once and for all who writes the best service literature.

Our exclusive Time-Lapse® Schematic Pictorials all but eliminate reading (just follow the pictures) — We explain in detail how it works, how it is wired, and how to fix it —

**METS, Box 8228, Amarillo, TX 79109**

(Don't forget to include your name, address, city, state & zip)

Circle No. 109 on Reader Inquiry Card

# MICROPROCESSORS from A to Z

by Bernard B. Daien

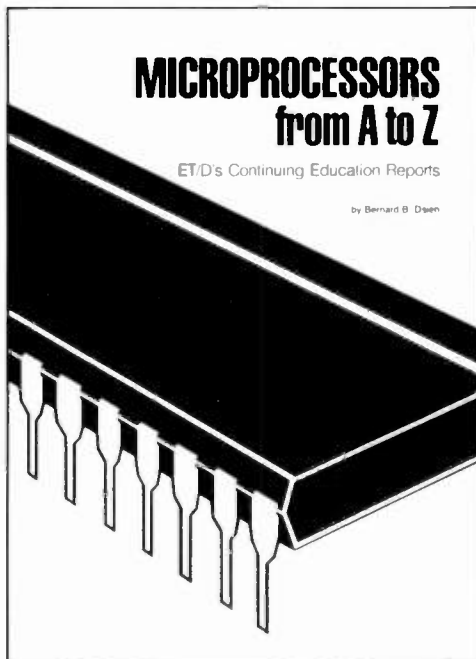

An introduction to the conceptual world of microprocessors-brought to you by the publishers of **ELECTRONIC TECHNICIAN/DEALER**

only **\$9.95** per copy

## YOU LEARN:

- What a microprocessor is
- How it works
- How to use it

## AND . . .

- How to apply this knowledge when you're dealing with the installation, use, troubleshooting and programming of microprocessors

The optimum time to enter the world of digital electronics is now! Technicians who understand the microprocessor can literally take their pick of jobs in this expanding field. The demand is great for trained personnel. Let MICROPROCESSORS FROM A TO Z help you adapt to this evolving new industry.

*A whole new world can open to you for only \$9.95. Order your copy of MICROPROCESSORS FROM A TO Z today!*

Microprocessors • Book Dept., One East First St., Duluth, MN 55802

**YES! Please send me \_\_\_\_\_ copies of ET/D's MICROPROCESSORS FROM A TO Z at \$9.95\* each. My payment is enclosed.**

\*Please add \$2.50 per order and, if ordering multiple copies, also add 25c per additional copy to cover postage and handling costs.

NAME \_\_\_\_\_

FIRM NAME \_\_\_\_\_

STREET ADDRESS \_\_\_\_\_

CITY \_\_\_\_\_ STATE \_\_\_\_\_ ZIP \_\_\_\_\_

PHONE NUMBER \_\_\_\_\_

SIGNATURE \_\_\_\_\_ DATE \_\_\_\_\_

Orders will be fulfilled within 60 days of the date of order.

**COPIES  
LIMITED—  
DON'T  
DELAY!**



# Understanding Satellite TV, part I

## Introduction

ET/D, in the last two months, has introduced you to satellite TV reception with a talk given by Rick Towers of Towers TV in Florida. Now we begin a series of articles which should enable you to select, buy, sell, and install TVRO equipment successfully.

### By Jesse Delgado

During the early part of the year 1975, the only TV viewing on local TV, on a Sunday, might typically consist of some regional pro-football games, an old movie, and a PBS program about home remodeling.

This type of programming, needless

to say, often did not satisfy the typical U.S. TV viewer.

This lack of local TV variety brought about questions of alternative TV programming from electronics-oriented individuals, who felt there must be better viewing available from the communications satellites stationed in orbit above the U.S.

The next question asked by these individuals was how to receive the signals from the communications satellites at a reasonable cost to the individual viewer.

At this particular time, satellite reception manufacturers had what they considered low-priced systems available to large corporations and cable companies for a base price range of \$50,000 to \$70,000, which, needless to say, left the individual out of the market—unless he was unusually affluent.

There were certain electronics hobbyists who felt that if manufacturers could make *commercial* satellite reception systems, they could also just as well make less expensive *home* satellite reception systems. So the home satellite reception system was born.

Certain individuals such as Taylor Howard, Stephen Gibson, and Robert Cooper Jr. (and others) have helped spread the word of home satellite reception systems to others throughout the U.S. and the world.

The next question that may be asked is: why are home satellite reception systems important to me—an electronics technician?

You, as electronics technicians and dealers, must realize the home satellite reception system is more than just an expensive toy for the idle rich, but is actually the beginning of a communi-

cations expansion that will eventually affect everyone throughout the world.

Satellite reception systems will bring educational, cultural, and entertainment programming to the masses, keeping the general public better informed and leaving more options open to them in everyday business and social communications. Satellite communications reception systems will bring a great change in all fields of communications as we know them today.

Obviously, as electronics technicians and dealers you will probably be involved in the selling, servicing, and the maintenance of the electronic equipment that will support the satellite reception systems. Keep in mind that satellite communications reception systems will affect you directly and indirectly . . . throughout your career.

To understand satellite TV reception, we have to start with the very beginning of the communications satellite. Satellite technology began in 1957 with the launching of the Russian satellite "Sputnik", which broadcast a recorded message back to the earth's surface. This type of satellite was quite crude in comparison with satellites now in orbit.

In 1962, the "Telstar" communications satellite was launched and put into operation to facilitate communications between different points on the earth's surface. The "Telstar" satellite was orbiting the earth only a few hundred miles above its surface. The low orbit altitude of the satellite created a communications gap. Because of the satellite's high speed relative to the earth's rotation, "Telstar" was completing one orbit of the earth in roughly 97 minutes, thus preventing continuous satellite communications with





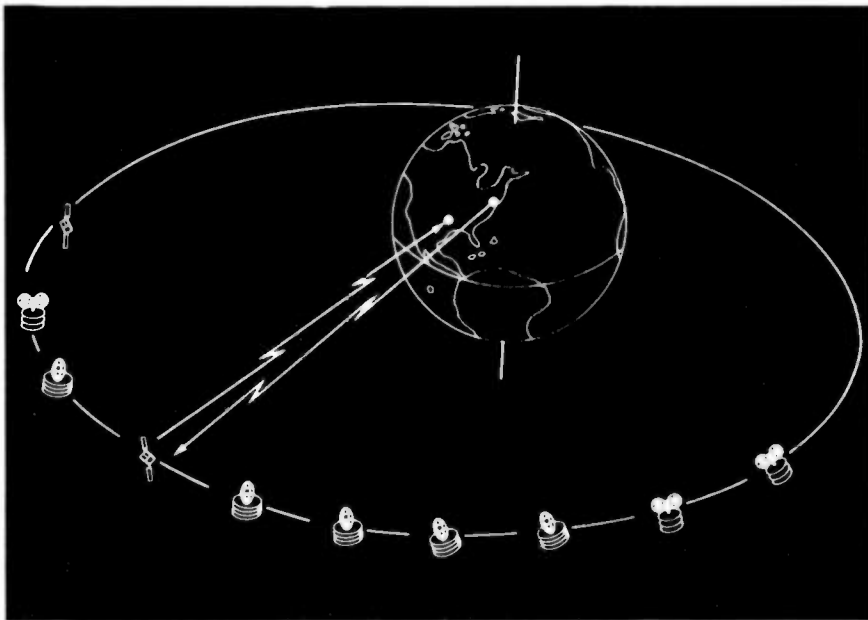

Some distinct advantages of satellite communications are: the time of day or sunspot activity and weather conditions have a negligible effect on the signal; the satellite microwave frequencies allow sufficient bandwidth capacity to transmit TV and other broadband signals that won't fade, as HF radio signals will.

The cost and efficiency of satellites versus long-range ground communications far outweighs the high launching cost of satellites. Communications by ground microwave relay stations involve literally thousands of microwave relay stations to make up a vast nationwide microwave network completely covering the entire U.S. with its signal. A single microwave relay station orbiting in space can completely cover the continental U.S. with its signal—thus showing a significant difference in cost and efficiency as opposed to a ground microwave network costing hundreds of millions of dollars. Plus, the microwave network will require continual maintenance throughout the system's life expectancy.

In the next article we will dwell on the operations of the satellite's inner workings and the frequencies involved in the transmission of space signals. **ETD**

*\*Based on the proposal, in 1946, of Arthur C. Clarke, the science-fiction writer.*

any single point on the earth's surface.

So scientists hit upon the idea of launching higher altitude, lower speed satellites\*. This idea brought about a new generation of satellites called geosynchronous satellites. Basically, a geosynchronous satellite can best be explained by a simple example. The farther away an object is from the earth, the slower its necessary speed relative to

the rotation of the earth. The satellite then can orbit the earth once each twenty-four hours. Thus, the satellite gives the impression of being fixed or stationary in relation to a point on the earth's surface. It is also important to note that for a satellite to be in a geosynchronous orbit, that satellite must maintain a distance approximately 23,500 miles from the earth's surface.

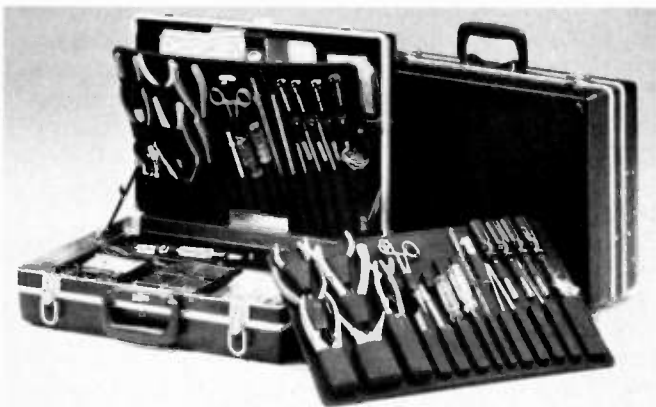

## A Platt tool case won't fall apart at the seams because there are no seams.

Unlike other tool cases, the pockets on a Platt pallet\* are molded. There are no seams, stitches or rivets to tear loose. It's a one-piece unit that's practically indestructible.

The case itself comes in tough, lightweight ABS Thermoplastic or rich looking vinyl reinforced by ABS Thermoplastic. Platt also has rugged hardware. Like an aluminum rim for extra strength. Steel core handles. And tough brass locks.

Inside there are compartments for larger tools, parts boxes and testing equipment. And multiple lid pockets for papers and order book.

Both the case and pallet are guaranteed for one year.

Contact us for complete information on Platt's full line of tool cases and your nearest distributor.

**platt**

\*Pat. No. 3,880,285 Cases for business and industry.  
2301 S. Prairie Ave., Chicago, Ill. 60616 (312) 225-6670

Circle No. 114 on Reader Inquiry Card

## TV MODULES and TUNERS

### WORKMAN & UTR

ARE NOW COMBINED TO GIVE YOU THE EXCELLENT QUALITY AND SERVICE YOU DESERVE. WITH OUR COMBINED EFFORTS, YOU DON'T NEED TO KNOW ANY OTHER NAME IN MODULE AND TUNER REBUILDING.



UTR is one of the largest rebuilders of modules and tuners in the world.

FAMOUS FOR:

- Quality Parts ● Quality Workmanship
- Same Day Service ● 1 Year Warranty

### UTR Electronics

Division Of: WORKMAN ELECTRONIC PRODUCTS, INC.  
575 University Ave. S.W. ● Atlanta, Ga. 30310  
Phone 404 753-5311

Circle No. 119 on Reader Inquiry Card

# BULLETIN BOARD

Tektronix has recently published an **oscilloscope primer**, a 36 page introduction to scope theory and application, applying specifically to its new low cost 2213 and 2215 oscilloscopes. *The XYZ's of Using a Scope* explains the basics of oscilloscopes and some accessories, basic theory of the display, amplifiers, sweep and trigger, the selection and use of probes, and how to evaluate scope specifications. The primer also includes a chapter on measurement techniques and explains the basics of amplitude and time measurements, X-Y measurements, and the uses of delayed sweep. A series of actual exercises is described for hands-on experience.

*The XYZ's of Using a Scope* is available from Tektronix new direct sales National Marketing Center (1-800-547-1845) in Beaverton, OR, where sales engineers will also answer questions about all of Tektronix lower priced scopes and accessories.

Circle No. 140 on Reader Inquiry Card

*Communications Electronics*, reportedly the world's largest distributor of radio scanners **introduces its new catalog**. It has a variety of radio scanner receivers used by professional law en-

## SATELLITE TV SYSTEMS

**MECHANICAL  
AND  
ELECTRICAL  
ACCESSORIES**

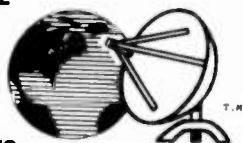

**"COMPARE OUR QUALITY,  
PRICES AND SERVICE!"**

**CALL, OR WRITE FOR OUR  
LATEST BROCHURE AND  
PRICES.**

901-795-4504

**TENNESSEE ELECTRONICS  
P.O. BOX 181108  
MEMPHIS, TENNESSEE 38118**

Circle No. 118 on Reader Inquiry Card

forcement agencies, firemen, marine, government and ham radio operators. This free catalog also features computer products, cordless telephones, wireless intercoms and scanner receiving antennas. To receive your free consumer catalog, write to: Communications Electronics, Box 1002 Dept. A17, Ann Arbor, Michigan 48106.

Circle No. 141 on Reader Inquiry Card

A 12 page catalog describing **prototype printed circuit board manufacturing equipment** is available from *Electronic Trend Products*. The catalog includes data on bench top etchers, electrolysis tin plate units, ultra violet light source, small drill systems, gold plate edge card units, bubble etchers, guillotines, and single and double sided positive photoresist 1 oz. copper boards designed for low volume high quality PCB manufacture.

Circle No. 142 on Reader Inquiry Card

**Logic test equipment** from *Global Specialties Corp.* is highlighted in their new brochure, which details the company's full line of logic probes, pulsers, monitors, and complete logic analysis kits. Full product descriptions and specifications are included in this latest publication, along with important information on the company's new LM-4 Logic Monitor and LP-4 ECL Logic Probe.

Circle No. 143 on Reader Inquiry Card

A new twelve-page, four-color brochure from the *John Fluke Mfg. Co., Inc.*, features the company's entire line of seven **handheld and bench/portable DMM's**. Included is the new "8020B-Series"—improved versions of the firm's handheld DMM family. New to these instruments are high-speed continuity beepers on three models, as well as easier-to-read front panel nomenclature, a heavy-duty 600v back-up fuse on the current input, and a two-year specifications warranty. The brochure describes each of these capabilities in detail. Fluke also is adding four new DMM probes to their line of voltmeter accessories. The literature features specifications and ordering information on these, also.

Circle No. 144 on Reader Inquiry Card

To help security system dealers and installers build customer confidence and to allay fears of magnetic switch unknowns, *Sentrol, Inc.*, has just published a useful question-and-answer information bulletin. In handy pocket size (6" x 9"), it answers in non-technical language the most commonly asked questions about **magnetically actuated switches**.

Such queries as "How do magnetic contacts work?" "Can a magnetic switch be defeated?" "When installed will magnetic contacts show?" and "How long will magnetic contacts last and give protection?" are answered in this folder. Designed to be used by individual security supply firms, ample room is provided in the folder for individual identification and personalization, including identifying special problem solver recommendations for specific installations. The new sales aid is available in packets of 100 and 500 for \$10 and \$50 per packet.

Circle No. 145 on Reader Inquiry Card

*Stanford Applied Engineering* announces the release of a new, condensed catalog that describes their complete line of **electronic packaging hardware**, components, and systems. Included in the catalog are particulars on edgeboard/PC connectors, connector hood assemblies, Multi-Term<sup>®</sup> IDC connectors and cable, switches, cylindrical connectors, IC sockets, component mounting boards, EMI filters, card files, logic panels, and backpanels.

Circle No. 146 on Reader Inquiry Card

A full-line **catalog of Sturdilite electronic and industrial work stations** has been published by *Angle Steel*. The catalog details features, sizes, and colors to meet a wide variety of functions and working environments. Various components can be assembled to meet special needs utilizing the modular "building-block" design.

Circle No. 147 on Reader Inquiry Card

A new **mail order electronic products catalog** from *Etco* includes a great variety of products such as telephones, speakers, recording tape, quad amplifiers, and many others which will prove interesting to technicians and hobbyists. The catalog also includes a microcomputer kit and numerous video and cable TV products—converters, recording accessories, microwave downconverters, to name a few. The 96-page catalog also includes a list of hard-to-find tubes.

Circle No. 148 on Reader Inquiry Card

A new **magnetic replacement needles catalog** is now available from *Astatic*. The company offers both the original manufacturer's genuine needle and a high quality replacement for the original. The Astatic NMR catalog covers the most popular magnetic replacement needles for leading manufacturers including Audio Dynamics, Audio Technica, Empire, Ortofon, Pickering, Shure, and Stanton.

Circle No. 149 on Reader Inquiry Card

# TEST INSTRUMENT REPORT



The Scopex 14D-10V oscilloscope.  
For more information check 150 on the Reader Service Card.

## The Scopex 14D-10V

A TV scope

By Walter H. Schwartz

It's nice to see an occasional import come from across the Atlantic instead of the Pacific. (The last we featured was the German-built Hameg HM312 oscilloscope, in December 1980.) Scopex is a British company apparently specializing in low-cost oscilloscopes and, I am told, involving some people formerly of Tel-equipment.

The Scopex 14D-10 and the 14D-10V are 10 MHz, dual trace, triggered oscilloscopes designed specifically as economical yet adequate instruments for the day-to-day troubleshooting and maintenance of video equipment. The Scopex people recognize the scope specmanship that is going on at present, but feel that a 10 MHz oscilloscope is quite adequate for TV work. (This more easily makes the instrument price competitive. Wider rated bandwidths require faster sweep speeds, which mean faster writing speed, which means less brightness unless the CRT anode voltage is increased, which means more gain is necessary. All of these mean higher cost.)

Features of the 14D-10 and 14D-10V include, of course, the dual trace mode (trigger is always from Channel A, which is the channel available for single trace use). ADD and INVERT modes are also available. ADD instantaneously adds A to B (equal signals in phase would result in twice the deflection, etc) and INVERT allows the 14D-10 to be used as a differential instrument. Input attenuators are switchable for deflection sensitivity of from 2mv to 10v/cm. There is no continuously variable control. X-Y (vector)

mode is also available.

Sweep times range from 1 microsecond/cm to 100 milliseconds/cm and a X5 magnifier is available. Trigger modes are normal and TV. At slow sweep speeds, trigger is optimized at a vertical rate; at higher speeds it is optimized for a horizontal rate. In the 14D-10V, when the FRAME (vertical) mode is selected and the sweep speed is set to 2 ms/cm, a marker on the display above shows the starting position of the line selecting DELAY control. Selecting DELAY causes the timebase to start at this point (no earlier than line 17). Increasing the sweep speed to 200  $\mu$ sec/cm causes the display to show just three lines of horizontal sweep. The DELAY control can now be used to look at any three lines. This makes viewing VITS and VIR (lines 17 and 18) rather easy—though if earlier lines than 17 are ever used, they would not be viewable. In the U.S. VITS is present in two forms on alternate lines 17. Field 1 displays the multiburst, Field 2 color bars. These appear superimposed on the 14D-10V and it was necessary to switch to dual trace, wherein each appeared on a separate trace. This unfortunately resulted in a marginally dim trace. A viewing hood was necessary for close examination of the traces. This is apparently not a problem in Britain.

We found the 14D-10V to be a quite satisfactory TV scope. Our performance checks showed the various calibrations to be accurate, and the vertical amplifier bandwidth turned out to be about 18 MHz, far beyond specs. Plus: the price is very competitive.

# DEALER'S SHOWCASE

## Satellite Receiver

Circle No. 125 on Reader Inquiry Card  
*Automation Techniques, Inc.*, recently presented the GLR-500 imageless satellite receiver. The company provides automated video equipment to the cable, industrial, and broadcast television industries. The two-piece design of the GLR-500 gives the flexibility of having the tuning module either at the receiver or at the LNA, reportedly simplifying installation and operation. The design of

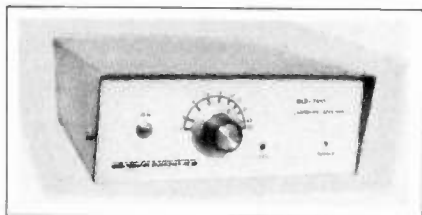

the imageless mixer effectively eliminates image frequency noise or interference and eliminates the need for expensive in-line components such as special digital filters and resonant cavities, according to the manufacturer. A new digital deviation detection system is said to provide a very linear "textbook" FM demodulation curve that gives outstanding video quality.

## FREE CATALOG OF Burglar/Fire Alarms



With over 1600 hard to get security products for home, business and industry, Mountain West is a one-stop supermarket for professional alarm installers as well as do-it-yourselfers. Systems and parts range from simple, quickly installed units to the most sophisticated electronic equipment. 68 pages are filled with pictures, diagrams and instructions.

Mail to: **Mountain West**  
4215 N. 16th St.  
Box 10780 Dept. ETD-2  
Phoenix, AZ. 85064

Circle No. 110 on Reader Inquiry Card

## Earth Station System

Circle No. 126 on Reader Inquiry Card  
*Winegard's* recently introduced TVRO earth station packages are complete systems for receiving satellite TV signals. Each Winegard package includes either a 10-foot or 12-foot dish, comprised of eight fiberglass petal sections, reportedly being able to withstand wind loads of 125 mph and up to one inch of radial ice. The antennas feature a textured front surface which is said to diffuse solar heating, and the petal segments are designed to automatically self-align. Included with the antenna is a prime-focus feed and polar (hour angle) mount which allows realignment with any satellite located between 70° and 140°W without any foundation changes. Other components of the package are either of two LNA's (Low Noise Amplifiers). The LNA's are 3.7 thru 4.2 GHz GaAs FET amplifiers. Maximum gain is 50dB, noise figure options from 85°K (1.12dB N.F.) to 120°K (1.5dB N.F.). The Winegard LNA's also feature low input VSWR, case grounded

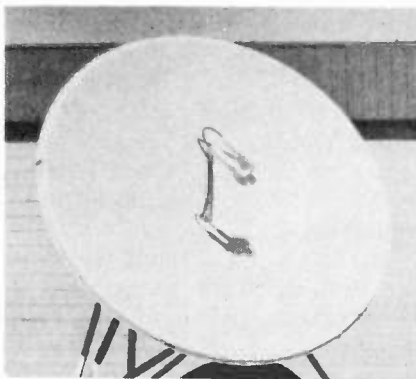

input coupling to resist destruction due to lightning, and power conditioning circuits for wide dc input range and surge suppression. The amplifiers are housed in a rugged, low profile, weatherproof enclosure with waveguide pressurization capability. Winegard's satellite video receiver features remote control capability, digital channel select, and a self-contained LNA power supply. The manual gain control/automatic gain control switch control and test point permit alignment of the antenna to insure optimum antenna positioning. Included as a standard feature is the 6.2/6.8MHz program demod and optional demods permit expansion. If the antenna installation utilized a dual polarization antenna, the receiver will switch power between the vertical polarization and horizontal polarization automatically. A convenient disable permits the polarization to be locked in one position for use with a single polarization or rotator system. A complete hardware and cable kit is included with the package.

## Satellite Receiver

Circle No. 127 on Reader Inquiry Card  
The STS Receiver recently introduced by *National Microtech, Inc.*, downconverts to 70MHz at the antenna. The unit is designed for cable runs of up to 1000 feet from the hermetically sealed down-converter. The receiver features 6.2 MHz and 6.8 MHz audio subcarriers, inverted and normal video polarity, scan tuning, and temperature stability from -25° to +150°F, the manufacturer claims. Na-

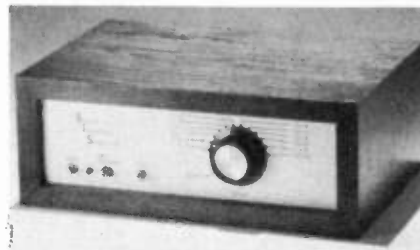

tional Microtech also offers complete TVRO packages designed around its X9 antenna.

## TVRO Antenna

Circle No. 128 on Reader Inquiry Card  
*Hastings Antenna Company, Inc.*, recently introduced its 12-foot, 24-section



aluminum dish with a reported 41dB gain. The unit features a F/D ratio of .375, offset polar mount, scalar horn, rotor, and rotor LNA mounts.

## TVRO Receiver

Circle No. 129 on Reader Inquiry Card  
The *Comtech Model 650* is an antenna-mount receiver with remote control capability, digital channel select, and a self-contained LNA power supply. The chan-



nel select allows setting the channel and confirming it on the LED readout. The MGC/AGC switch, control, and test point permit alignment of the antenna to insure optimum positioning. Included as a standard feature is the 6.2/6.8 MHz PGM demod. Optional demods permit expansion. Also included as a standard feature is a dc block for operation of a cable-powered LNA, and if the requirement is for an LNA with a standard power cable, the 650 has an external voltage for that need.

### TVRO Equipment

Circle No. 130 on Reader Inquiry Card  
The Skyview IV home satellite TV antenna is an 11-foot fiberglass dish designed to be expanded to 13 feet by bolting on optional panels. The unit, manufactured by *Interglobal Satellite Systems, Inc.*, is constructed in four pieces. The 1/4"-thick fiberglass antenna features a full-screen mesh and is designed to withstand winds up to 125 mph. The unit weighs 600 pounds and includes crank-operated Az/EI mount, rotor, and scaler feedhorn. Gain of the antennas is reportedly 40.1 dB for the 11-foot and 41.7 dB for the 13-foot. Frequency coverage is 3.7 to 4.2 GHz and the F/D ratio is .44. Interglobal, which recently acquired the Downlink™ and Skyview™ home satellite business, also offers the Skyview I, an 8-, 10-, or 12-foot spherical antenna constructed of angle iron, mahogany, and woven hardware cloth. These sphericals come with feedhorn, LNA mount, rotor, and bracket mounting assembly. The company also offers the D-2X receiver—consisting of a sealed weatherproof unit designed to mount close to the LNA. The D-2X utilizes phase lock loop circuitry and also incorporates "dual conversion" circuitry, reportedly allowing multiple receivers to share one antenna/LNA combination. This would enable viewers in different rooms to tune in different channels.

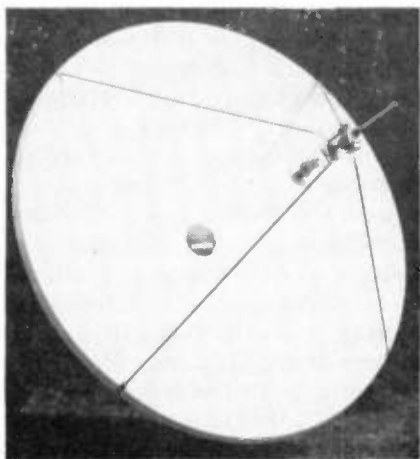

### VCR Cleaning Cassette

Circle No. 131 on Reader Inquiry Card  
*Nortronics* VHS format VCR 130 and Beta format VCR 135 drop-in video head cleaners are said to be non-abrasive. The units, which use a wet system of cleaning, reportedly clean the entire tape path of any video cassette recorder, including all video heads, tape guides, pinch roller, capstan, erase head, audio head, and control track. The system provides a fresh, moving cleaning surface with each application; harmful residue is never left behind to damage the recorder, the manufacturer claims. **ET/D**



# INTER-TEC

INTERNATIONAL TRANSISTORS AND ELECTRONIC COMPONENTS
P.O. Box 1483 Union, N.J. 07083

<p>2-Way Mini Splitter</p>  <p style="text-align: right;">SPL-2WM</p> <p style="text-align: right;">\$1.50</p>	<h2 style="text-align: center; margin: 0;">SEMICONDUCTOR SPECIALS</h2> <table style="width: 100%; border-collapse: collapse;"> <tr><td>2SC867A.....</td><td style="text-align: right;">\$3.40</td></tr> <tr><td>2SC1114.....</td><td style="text-align: right;">3.85</td></tr> <tr><td>2SC1172B.....</td><td style="text-align: right;">3.50</td></tr> <tr><td>2SC1308K.....</td><td style="text-align: right;">2.40</td></tr> <tr><td>2SD313.....</td><td style="text-align: right;">.45</td></tr> <tr><td>2SD386A.....</td><td style="text-align: right;">.90</td></tr> <tr><td>AN214.....</td><td style="text-align: right;">1.65</td></tr> <tr><td>AN247.....</td><td style="text-align: right;">3.25</td></tr> <tr><td>HA1156.....</td><td style="text-align: right;">1.50</td></tr> <tr><td>HA1342.....</td><td style="text-align: right;">2.15</td></tr> <tr><td>HA1377.....</td><td style="text-align: right;">3.45</td></tr> <tr><td>M51513L.....</td><td style="text-align: right;">1.80</td></tr> <tr><td>M51515L.....</td><td style="text-align: right;">3.75</td></tr> <tr><td>LA4430.....</td><td style="text-align: right;">1.75</td></tr> <tr><td>TA7205.....</td><td style="text-align: right;">1.40</td></tr> <tr><td>STK435.....</td><td style="text-align: right;">4.10</td></tr> <tr><td>STK0029.....</td><td style="text-align: right;">3.95</td></tr> <tr><td>UPC1181.....</td><td style="text-align: right;">2.25</td></tr> <tr><td>UPC1182.....</td><td style="text-align: right;">2.25</td></tr> <tr><td>SG613.....</td><td style="text-align: right;">6.90</td></tr> </table>	2SC867A.....	\$3.40	2SC1114.....	3.85	2SC1172B.....	3.50	2SC1308K.....	2.40	2SD313.....	.45	2SD386A.....	.90	AN214.....	1.65	AN247.....	3.25	HA1156.....	1.50	HA1342.....	2.15	HA1377.....	3.45	M51513L.....	1.80	M51515L.....	3.75	LA4430.....	1.75	TA7205.....	1.40	STK435.....	4.10	STK0029.....	3.95	UPC1181.....	2.25	UPC1182.....	2.25	SG613.....	6.90	<p>300 Ohm Splitter</p>  <p style="text-align: right;">UVF-300</p> <p style="text-align: right;">\$1.05</p>
2SC867A.....	\$3.40																																									
2SC1114.....	3.85																																									
2SC1172B.....	3.50																																									
2SC1308K.....	2.40																																									
2SD313.....	.45																																									
2SD386A.....	.90																																									
AN214.....	1.65																																									
AN247.....	3.25																																									
HA1156.....	1.50																																									
HA1342.....	2.15																																									
HA1377.....	3.45																																									
M51513L.....	1.80																																									
M51515L.....	3.75																																									
LA4430.....	1.75																																									
TA7205.....	1.40																																									
STK435.....	4.10																																									
STK0029.....	3.95																																									
UPC1181.....	2.25																																									
UPC1182.....	2.25																																									
SG613.....	6.90																																									
<p>High Voltage Tripler</p>  <p style="text-align: right;">HVT-523</p> <p style="text-align: right;">\$12.75</p>	<p>5 Asst. Alignment Tools</p>  <p style="text-align: right;">AAT-5</p> <p style="text-align: right;">\$1.10</p>	<p>Pickering Cartridge</p>  <p style="text-align: right;">V-15/AT-2</p> <p style="text-align: right;">\$9.90</p>																																								
<p>Matching Transformer</p>  <p style="text-align: right;">TMT-300</p> <p style="text-align: right;">50¢</p>	<p>Piezo Tweeter</p>  <p style="text-align: right;">PZT-35</p> <p style="text-align: right;">\$5.75</p>	<p>Universal "Piggy-Back" Antenna</p>  <p style="text-align: right;">ATU-538</p> <p style="text-align: right;">\$2.99</p>																																								

PHONE OR WRITE FOR OUR NEW CATALOGUE TODAY!



**NATIONWIDE: 800-526-4958**  
**NEW JERSEY: 201-688-0300**



# NEW PRODUCTS

## Lightning protector

Circle No. 160 on Reader Inquiry Card  
An Impulse Suppressor offering protection from multiple surges has recently been added to the *PolyPhaser Corporation's* product line. The unit, designed for MATV/CATV users, is installed outdoors, directly in the coax line, at a good ground point. According to the manufacturer, microsecond response to lightning or static build-up impulses . . . plus multiple impulse suppression . . . is afforded by the unit. The unit is said to handle 10,000 amps of current, time after time, with no oxidation or vaporization of the contacts after an arc. The IS-75F model is designed for MATV/CATV 75 ohm F connector applications and is constructed of weatherized aluminum

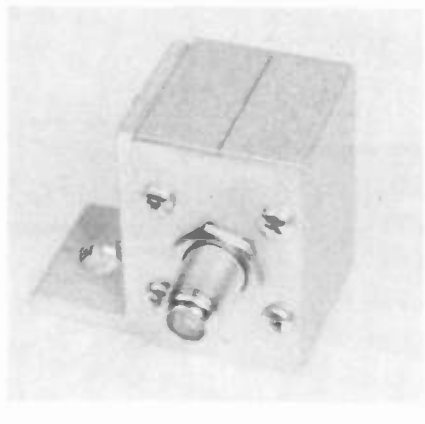

## ATTENTION Satellite Dealers

### ✓ These Prices

- 5" Sony B&W TV—\$40<sup>00</sup>
- Amplica 120° LNA—\$495<sup>00</sup>
- Type N Connectors—\$2.75
- Chaparral Super Feed Horn—\$39.80

Call or Write For Our  
Catalog & Prices

**TEI Electronics, Inc.**  
P.O. Box 181108  
Memphis, Tennessee 38118  
901-795-4504

Circle No. 108 on Reader Inquiry Card

38 / ET/D - February 1982

capable of withstanding marine environments. Model IS-300T is designed for 300 ohm ribbon line installations and has screw terminals for in-line insertion. The design, reportedly similar to that used in the telephone industry, does not rely upon an air-gap. PolyPhaser offers many other impedances and connector configurations in addition to these two units.

## Multimeter

Circle No. 161 on Reader Inquiry Card  
A new 12-range pocket size multimeter was introduced recently by *Etcon Corp.* The unit comes complete with case,

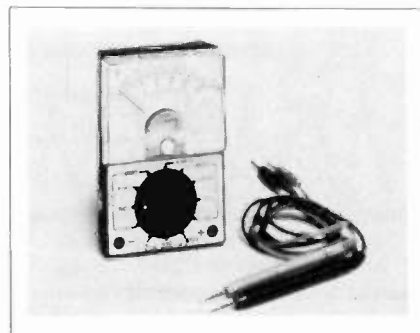

probes, battery, and owner's manual. The VOM910 Mini Multi-Meter offers ac voltage ranges of 0-10v, 50v, 250v, and 1000v; dc ranges of 0-10v, 50v, 250v, and 1000v; dc current ranges of 0-1 ma, 100 ma, and 250 ma; and resistance readings of 0-200 k ohms. The unit weighs 3.5 oz and measures 3-9/16 in. x 2 3/8 in. x 1 1/4 in. The VOM910 reportedly features diode overload protection, a fuse protected ohms circuit, color coded meter scales for easier reading, and a core magnet movement. Accuracy as specified is within 3% of full scale for dc voltage, current, and resistance—and within 4% of full scale for ac voltage.

## Truck Body

Circle No. 162 on Reader Inquiry Card  
A new, economical, fiberglass service truck body designed to eliminate extra weight and improve handling is currently available from *Kindwall Corporation*. The new, modular-styled, "Series '81 Fleet-master" truck body is totally rust-free. It's built with a solid, reinforced fiberglass shell and finished with a glossy gel coating. The "Series '81" unit is available with a wide variety of low-cost "flexible interiors" that can be tailored to match specific service body requirements...and altered as service needs change. Every unit in the series is aerodynamically designed and features a tight seal construction that allow full use of tailgate



and interior. Heavyduty, die-cast, easy-to-lock hardware is standard on all side and rear doors. All doors are available with or without windows. Aluminum roof ribs reinforce the solid, lightweight fiberglass shell and prevent drumming. The units are available to fit short and long-bed pickups as well as full-sized models.

## DMM/Computer Interface

Circle No. 163 on Reader Inquiry Card  
*Sabtronics* recently announced its new Model 2020 digital multimeter with microprocessor interfaces to adapt to all popular home/personal computers. Combining its multimeters with a micro-



processor interface expands *Sabtronics* product line to provide solutions to data acquisition problems. The Model 2020 DMM has 0.1% basic dc accuracy with 3 1/2 digit LED display for normal bench use. The new DMM is capable of directly measuring ac and dc volts up to 1000 v, ohms to 20 megohms and ac and dc current to 10 amps. Optical coupling between the DMM and the computer reportedly protects the computer from damage and also serves to isolate ground noises that can affect sensitive measurements. The Model 2020 DMM is equipped with all cabling and I/O support necessary for use with either TRS-80®, Apple®, Pet® or Atari® computers, as per customers choice.

## THE BUSINESS SIDE OF THINGS

continued from page 11

It's important, though, that you do not permit yourself to cross the bounds of discretion. Recent changes in the law have made conduct that could be considered as "harassment" of debtors possible grounds for criminal action.

By the way . . . I am not a lawyer, nor have I received any special training that would qualify me to render legal advice. (My lawyer made me put that in!)

If you still haven't collected your money, there is a little-known procedure that may offer you a successful last resort. Some banks upon which NSF checks have been drawn will permit the payee (you) to leave the check in their care. When the customer makes a deposit sufficient to cover the amount of the check, the bank will certify it and forward it to you.

This can be done, of course, only by the bank upon which the check was originally drawn, and not every bank has such a policy. But it's worth looking into.

Contrary to what some people believe, post-dated checks are perfectly legal in all states—as are checks dated on Sunday. Post-dating a check (putting a future date on it) can be a perfectly legitimate means for allowing the check writer a little time to make the necessary deposit to his account before you present the check for payment. Whether you accept post-dated checks is up to you. Your own experience and your instincts will help you to formulate your policy on the matter.

One thing you should *never* do, however, is return a bad check to the writer before the debt has been fully settled. Once you hand that rubber check over to the person who wrote it, you have relinquished your best evidence as well as your strongest ammunition in your fight to collect.

As long as you're in business, it's unlikely that you will be able to completely avoid any losses from bad checks. By following these suggestions, though, you should be able to keep those losses to an absolute minimum. **ET/D**

### Next Month in ET/D

- Alarm Installation Techniques
- CCTV
- Satellite TV, II

# Star View Systems

**H&R COMMUNICATIONS, INC.**  
Route 3, Box 103G - Pocahontas, Arkansas 72455



### KIT CONTAINS

- 12' Antenna
- AZ/EL Mount
- 24 Channel Receiver
- 120° LNA
- Feed Horn
- All Miscellaneous Cable and Connectors Needed
- Everything You Need
- No Special Tools Needed
- Complete Antenna Weight Only 125 Pounds

Offers the all aluminum.

## MODEL 12K SYSTEM . . .

A complete home satellite receiving system that will satisfy your low-end needs.

With Star View, you can sell installed systems at \$3995.00 with reception comparable to systems at twice that price.

**ONLY \$2,400.00**

UPS SHIPPABLE



**VOLUME DISCOUNT: One free with each order for ten!**  
**800-643-0102 or 501-647-2291**

Circle No. 105 on Reader Inquiry Card

## GLASS BREAKAGE BREAKTHROUGH!

Sentrol's new 5101 Glass Breakage Sensor responds to the sounds and/or shock waves of a wide range of breaking materials. Yet it won't false alarm when a truck goes by or a wind gust rattles



a window. A patented filtering method gives positive protection. Simple to install. A breeze to adjust. Send for Catalog Sheet with the full story or call TOLL FREE 1-800-547-2556.

10831 S.W. Cascade Blvd. Portland, OR 97223 Phone 503/620-8540

BUILDING THROUGH EXCELLENCE

Circle No. 116 on Reader Inquiry Card

# CLASSIFIED

**RATES:** 60 cents per word (minimum charge, \$20). Bold face word or words in all capital letters charged at 85 cents per word. Boxed or display ads charged at \$75 per column inch (one inch minimum). Agency commissions will be given only when camera-ready art is provided by agency. For ads using blind box number, add \$5 to total cost of ad. Send ad copy with payment to Dawn Anderson, ELECTRONIC TECHNICIAN/DEALER, 1 East First Street, Duluth, MN 55802.

**BOX NUMBER REPLIES:** Mail box number replies to: ELECTRONIC TECHNICIAN/DEALER, Classified Ad Department, 120 W. 2nd St., Duluth, MN 55802. Please include box number in address.

## BUSINESS OPPORTUNITIES

**SATELLITE TV DEALERS** Min. Investment, high profits. Market expanding 24% year. 80 channel home earth station, commercial, apartments, motels. **EASTRIDGE SATELLITE** (collect) 601/647-3406, Box 0, Charleston, MS 38921. 3/82

**RAMPART SECURITY SYSTEMS DEALERS'** sales are booming. The Rampart Dealer Program offers **ENORMOUS PROFIT POTENTIAL PLUS EXCITING RESIDUAL INCOME.** Our success and reputation are a result of a total business format approach for the residential, small commercial market. Product, marketing and management training with complete backup has made success a reality for over 50 dealers. No experience necessary just a strong desire to succeed. **NOW IS THE TIME TO DIVERSIFY.** Investment only \$12,500 backed by inventory. Call Franchise Director collect (215) 752-2210 or write **RAMPART INDUSTRIES, INC.,** 1 Oxford Valley, Suite 317, Langhorne, PA 19047. TF

**MECHANICALLY INCLINED INDIVIDUALS** Assemble electronic devices in your home. Knowledge or experience not necessary. Get started in spare time. Turn your spare or full time into cash. No investment—Write for free details. **ELECTRONIC DEVELOPMENT LAB,** Box 1560B, Pinellas Park, FL 33565. TF

## FOR SALE

**WINTER SPECIALS - 2SC 1172B-20 lot \$1.79; 2SC 1308K-20 lot \$1.79; SGG13 SONY-10 lot \$5.90; 5 FT SOLDER WICK-79c. MINIMUM ORDER \$50. REDCOAT ELECTRONICS, 66 - 15 Thornton Place, Forest Hills, NY 11374, (212) 261-9479. 3/82**

**SUPREME Television - Radio Diagram manuals discounted 60%. Free information. SASE. Beitman, 1760 Balsam, Highland Park, IL 60035.**

**Sencore VA 48 TV - VTR - Matv and video analyzer. Like new. Used very little. \$695.00. Voights' Radio & TV, Route 6 Box 84, Brainerd, MN 56401.**

**EPROM programming. Reasonable rates, quality work. Free details. ADTRONICS, 663 Branch Drive, Port Orange, FL 32019. 2/82**

**PICTURE TUBE REBUILDING EQUIPMENT** capable of producing four high quality tubes per day (**WILL TRAIN TO OPERATE**) Call or Write Atoll Television, 6425 Irving Park, Chicago, Illinois 60634, ph. 312-545-6667.

**Automobile radio and tape replacement parts:** Delco, Chrysler, Philco-Ford, Motorola, Panasonic and many others. Large inventory. **Laran Electronics Inc.** 3768 Boston Road, Bronx, NY 10469 (212) 881-9600 out of New York state (800) 223-8314 TF

**TV AND RADIO TUBES 49¢ EA!** Send for free color parts catalog. Your order free if not shipped in 24 hours. **Cornell Electronics** 4215-17 University San Diego California 92105 TF

**SCRAMBLED-TV WHAT IT IS-HOW IT WORKS.** New publication explains how the two encoding/decoding systems used today work. Theory, circuits, etc. Send \$9.95 to: **Workshop, Box 393ETS Bethpage NY 11714.** TF

**SONY-PANASONIC-RCA-ZENITH-EXACT REPLACEMENT PARTS-LARGE INVENTORIES-SEND PART OR MODEL NUMBERS-WILL UPS OR COD-GREEN TELE RADIO DISTRIBUTORS, 172 SUNRISE HIGHWAY, ROCKVILLE CENTRE, N.Y. 11570.** TF

**TUBES—**Receiving, Industrial and Semiconductors, factory boxed. Free price list. Low, low prices. **TRANSLETERONIC INC.,** 1365-39th Street, Brooklyn, N.Y. 11218E 800-221-5802, 212-633-2800.

**Burglar Alarms - Cassette tape programs on How To Expand Or Start Your Alarm Business - Send for FREE tape and lists to: Alarm Data, Dept. ET 1825 George Ave., Annapolis, MD, 21401, or call (301) 269-6000.** 3/82

**SATELLITE super-mixer; DBM-4150A. Clean up your TRVO receiver! Near-theoretical performance; flat response. DC-1500IF, SMA connectors; \$69.50—CK MO/ COD. RIGEL SYSTEMS, 2974E Scott Blvd., Santa Clara, CA 95050 (408) 727-3628. 2/82**

**FOR SALE TV TROUBLE ANALYSIS TIPS.** Over 300 symptoms/remedies by circuit area. Tough ones I found in years of servicing. e.g. Poor sync-C66 shorted-Wards-GEN-12349A-SAMS 995-2. Save time and money. Due to demand, send only \$12.50 to **CHAN TV, 8151 Grandview Rd., Chanhassen, MN 55317.**

**SATELLITE TELEVISION:** Information on building or buying your own earth station. Six pages of what's needed, where to get it, costs, etc. \$4.00 to **Satellite Television, RD #3, Box 140, Oxford, NY 13830.** TF

## HELP WANTED

Highest earnings available to top-notch TV technicians. Must be totally honest, non-smoker, non-drinker. Low crime area. Excellent for families. Superior camping, hunting, boating, fishing, and skiing area. Send resume and recent snapshot to **American Television Service, 1032 South State St., Orem, UT 84057, (801) 226-1776.**

## WANTED

**WANTED: PICTURE TUBE REBUILDING EQUIPMENT** working or not. Write or call Atoll Television, 6425 Irving Park, Chicago, Illinois 60634. Phone 312-545-6667.

**MIRROR IN-THE-LID, SPINNING DISK, AND OTHER PRE-1946 TELEVISION SETS,** parts, literature wanted for substantial cash. Also need 12AP4, 9AP4, MW-31-3 picture tubes, and any information on projection sets made by **TELICON CORP.** of N.Y. in 1947. **Arnold Chase, 9 Rushleigh Rd., West Hartford, CT 06117. (203) 521-5280.** 3/82

**Classifieds get  
you  
the results you  
want!**

send a classified advertising message ● ● ●

● ● ● write here.

\_\_\_\_\_

\_\_\_\_\_

\_\_\_\_\_

1. Number of insertions (circle) 1 2 3 6 12
2. Start with (month) \_\_\_\_\_ issue (Copy must be in by 1st of month preceding)
3. Amount enclosed: \$ \_\_\_\_\_

PAYMENT MUST ACCOMPANY ORDER WE'LL BILL RATED FIRMS

NAME \_\_\_\_\_ COMPANY \_\_\_\_\_

STREET \_\_\_\_\_

CITY \_\_\_\_\_ STATE \_\_\_\_\_ ZIP \_\_\_\_\_

MAIL AD COPY TO: DAWN ANDERSON, ELECTRONIC TECHNICIAN/DEALER, 1 EAST FIRST STREET, DULUTH, MN. 55802.

**RATES:** 60 cents per word (minimum charge, \$20). Bold face words or words in all capital letters charged at 85 cents per word. Boxed or display ads charged at \$75 per column inch (one inch minimum). For ads using blind box number, add \$5 to total cost of ad.



# CALENDAR

**NARDA SCHOOL OF SERVICE MANAGEMENT**  
 March 28-31, 1982  
 Notre Dame University, South Bend, IN  
 John Gooley: (312) 454-0944

**PROFESSIONAL AUDIO RETAILERS ASSN. ANNUAL CONC ANNUAL CONFERENCE**  
 April 17-20, 1982  
 Scottsdale, AZ  
 Jerry Fogel: (816) 444-3500

**ELECTRONICS DISTRIBUTION SHOW AND CONFERENCES**  
 April 29, 30 and May 1, 1982  
 New Orleans Hilton  
 David Fisher: (312) 648-1140

**NATIONAL SOUND AND COMMUNICATIONS CONFERENCE**  
 April 29, 30 and May 1, 1982  
 New Orleans Marriott Hotel  
 Gerald Newman: (312) 648-1140

**TELSA (CT) STATE CONVENTION**  
 May 1-2, 1982  
 Quality Inn, Vernon, CT  
 Vincent Lanter: (203) 766-4931

**WESA STATE CONVENTION**  
 June 4-6, 1982  
 Lake Lawn Lodge, Delavan, Wis.

**ASEA (AZ) STATE CONVENTION**  
 June 4-6, 1982  
 Tucson Marriott, Tucson, AZ  
 Martin Gleaming: (602) 888-0707

**MESDA/ISCET/ETA-GNO(LA)/TSA(AR)/T-E-A (TX) ANNUAL NATIONAL ELECTRONICS SERVICE CONVENTION AND TRADE SHOW**  
 August 2-7 1982  
 New Orleans, LA  
 J.W. Williams: (817) 921-9061

**NATESA ANNUAL CONVENTION**  
 August 11-15, 1982  
 Indian Lakes Resort, Bloomingdale, Franc  
 Moch: (312) 582-6350

ET/D welcomes announcements of state and regional annual conventions, meetings and conferences of interest to the consumer electronics service industry.

**SHARE THE COST OF LIVING.**

**GIVE TO THE AMERICAN CANCER SOCIETY.**

This space contributed as a public service

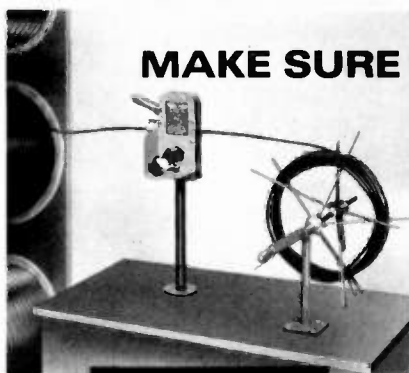

**MAKE SURE you get paid for every inch of wire sold**

**EXACT MEASURING** is a must when you retail coaxial cables, audio cables, and electronic/electrical wires. You can work confidently and quickly . . . yet keep close control . . . with **HYKON WIRE METERS** and **REELS** set up on a counter or as a portable combo. Wire up to 1" diameter pulls from stock through the meter onto take-up reel for neater delivery. Write for details or call us at  
 AREA 216 821-2320

**Hykon**

**MANUFACTURING CO.**  
 ET-161 East State Street ALLIANCE, OH 44601

Circle No. 106 on Reader Inquiry Card



**E.S.I., Inc.**  
 800-645-4720 (for 4 buses) 516-785-7714 (collect)  
ASK For JOEL or ROSE  
 3171 Hempstead Turnpike  
 Levittown, New York 11756

WITH FIRST ORDER YOU WILL RECEIVE 27 PAGES OF PARTS

24 HOUR PHONE SERVICE  
7 DAYS A WEEK

**WE WARRANTEE EVERYTHING WE SELL - FAST SERVICE - OPEN ACCOUNT PLUS YOU PAY DISTRIBUTOR PRICES THESE ARE OUR REGULAR PRICES**

**A-20 FREE—SG613—FREE ORIGINAL SONY TRANSISTOR WHEN YOU BUY FIVE AT 8.50 EACH. RECEIVE THE SIXTH AT NO CHARGE!**

—6GH8 - 89c—

Buy 25 tubes at our **REGULAR LOW PRICE** of 70 + 10% off our list on Zenith / GE / RCA / SYL and buy up to 100 6GH8 at 89c each

OR

Buy 20 A-15 2SC1172B for \$2.60 and get 6GH8 for 89c  
**HAVE IT YOUR WAY!! Joel**

A-10	8kv Color Focus Rectifier	.59	A-15	Replacement for ECG 238	
C-39	80 @ 450 Axial Lead 10/12.50	1.35	2SC1172B	\$2.60	
C-37	47 @ 160 Axial Lead	.30			
T-35	Polarized Cheater Cord C-Clip	.59			
T-38	Non-Polarized Cheater Cord C-Clip	.59			
T-66	120 OHM Cold Glow Bar	.70			
T-50	Tuner Cleaner 16 oz. Can	2.10			
T-51	Freeze Mist 15 oz. Can	2.10			

**CALL FOR OUR FREE CATALOGUE**

**TRIPLERS**

STOCK #	ECG EQUIVALENT	PRICE
T-45	500A	10.50
T-1B4	523	14.95
T-53	526	14.75

**ANTENNA ACCESSORIES**

T-85	300 ohm 2 set coupler	1.50	T-31	75 to 300 ohm matching transformer	.59
T-321	300 ohm 4 set coupler	2.75	R-199	6' F59 to F59	2.89
T-166	75 ohm 2 set coupler	1.75	R-200	12' F59 to F59	2.99
T-167	75 ohm 4 set coupler	2.25	R-201	25' F59 to F59	4.75
T-84	300 ohm UHF/VHF/FM splitter	1.50	T-97	8 Section (Sony Replacement)	2.99
T-300	75 ohm UHF/VHF/FM splitter	1.69	T-98	10 Section (Sony Replacement)	3.29

OUR TERMS: 1% within 10 days of billing or 20 days net. We do not have longer terms past due charge of 10% will be added after 20 days. We warrantee everything we sell except sony transistors.

Circle No. 104 on Reader Inquiry Card

**Help wanted. Every day of the year.**



**The American Red Cross. The Good Neighbor.**

A Public Service of This Magazine & The Advertising Council 

## AD INDEX

Circle No.	Page No.
101 Atkinson Dynamics	30
102 Comtech Data Corp	18
103 Digitron Electronic Corp	42
104 E.S.I. Corp	41
105 H & R Communications	39
106 Hykon Mfg Co	41
107 Inter-Tech	37
108 Lewis Construction	38
109 Mets Systems	30
110 Mountain West	36
N.A.P. Co Electronics	Cover 3
111 Omnitron Electronics	9
112 Optima Electronics	10
113 PTS Corp	Cover 2
114 Platt Luggage	33
RCA	6-7
116 Sentrol Inc	39
117 Tele-Teck Corp	11
118 Tennessee Electronics	34
119 Workman Electronics	33
120 Zenith Radio Corp	Cover 4

## BULLETIN BOARD

Circle No.	Page No.
140 Tektronix	34
141 Communications Electronics	34
142 Electronic Trend Products	34

143 Global Specialties Corp	34
144 John Fluke Mfg Co	34
145 Sentrol Inc	34
146 Stanford Applied Engineering	34
147 Angle Steel	34
148 Etco	34
149 Astatic	34

## TEST INSTR. RPT.

Circle No.	Page No.
150 Scopex	35

## DEALER'S SHOWCASE

Circle No.	Page No.
125 Automation Techniques	36
126 Wingard	36
127 National Microtech Inc	36
128 Hastings Antenna Co	36
129 Comtech	36
130 Interglobal Satellite Systems	37
131 Nortronics	37

## NEW PRODUCTS

Circle No.	Page No.
160 PolyPhasor Corp	38
161 Etcon Corp	38
162 Kindwall Corp	38
163 Sabtronic	38

## LETTERS

Continued from page 7  
will be cataloged and made available to all members. Without doubt, servicers are in the business of protecting the brand image. This will prove very beneficial to all concerned, and will prove your interest in the post sale period.

Frank J. Moch

Executive Director

NATESA

5930 So. Pulaski Road

Chicago, IL 60629

## HELP NEEDED

I need a transistor heat sink kit for a Zenith 25DC57 color TV. It is the vertical output transistor socket #S-87064 said by my distributor to be no longer available. A used one is O.K. You may remove the socket assembly by removing a part of the chassis, about 8 x 4 1/2 in. held in place with 4 screws. If any one can locate a used 25DC57 chassis, I would appreciate it if you removed this section, and will pay any reasonable price for it.

Mac

Mac's Radio & TV Repairs

Star Route, Box 607

Pettus, W. VA. 25153

## COMPARE OUR LOW PRICES

(EXR) SAME EXACT PARTS AS SYLVANIA ECG\* LINE.

AT 50% TO 80% OFF SYLVANIA PRICES.

SYLVANIA ECG* TYPE NO.	SYLVANIA SUGG. RESALE	OUR PRICE
ECG 123A	1.32	.30
ECG 165	13.50	2.95
ECG 238	15.75	2.95
HI-DIV #1	5.00	3.30
HI-DIV #3	5.90	3.75

### SPECIAL MULTIPLIERS, TRIPLERS (Min. 10 pcs.)

ECG 500A	10.50
ECG 523	12.60
ECG 526	12.80

### SPECIAL (Min. 5 pcs.)

2SC867A	3.95
2SC1034	7.85
2SC1308K	2.40
AN214Q	1.95
STK0050	7.95

COD ORDERS WELCOME (Min. Order \$25)

CALL TOLL FREE 800-526-4928

3 YEARS WARRANTY ON ALL PARTS.

## DIGITRON ELECTRONIC Corporation

110 Hillside Ave. • Springfield, N.J. 07081

OFFER EXPIRES FEB. 28, 1982

\*ECG IS A TRADE MARK OF PHILIPS ECG, INC.



**Dr. Robert Smithdas is blind, nonhearing, and nonverbal. He is a published poet.**

President's Committee on  
Employment of the Handicapped  
Washington, D.C. 20210

Produced by The School of Visual Arts Public Advertising System

Circle No. 103 on Reader Inquiry Card



**It's not the bible,  
but a lot of service technicians  
swear by it.**

Behold! The Sylvania ECG® Master Replacement Guide, the most comprehensive publication of its kind used by the industry.

Inside you will find more than 170,000 industry part numbers cross referenced to over 2,500 ECG numbers, including most of the hard-to-find foreign parts that are plaguing more and more repairmen every day.

If the part number is illegible, there are also easy to use comprehensive selection tables to help you identify and replace

transistors and linear IC's by application. You will find clear, concise descriptions and illustrations on each type from diodes to IC's with specifications, applications and package dimensions.

What's more, you also have Philips ECG technical resources ready to help you with any questions you might have regarding particular situations or applications; and as always, all ECG parts you will receive come with the knowledge that they've met specifications which are equal to

and usually exceed those of the original parts and that they've been tested using stringent procedures established by the U. S. Military.

To find out more, seek your nearest authorized Philips ECG distributor.

If you are not already a believer, one look at our catalog should convert you.

**Philips ECG**

*A North American Philips Company*

# Don't touch that connection!

**New Zenith push-button VIDEO ORGANIZER permits switching from one program source to another without changing cable connectors. Lets you select up to six different program sources for viewing. Up to three different sources for recording. Even lets you view one program source while simultaneously recording another. All this without changing cable connections!**



Model S10W

At last the nuisance of manually changing cable connections is a thing of the past!

With Zenith's new Video Organizer, separate input and output jacks enable you to make a complete connection of TV and VHF antenna or cable TV antenna, subscription TV decoder, video disc player, video cassette recorder, video game and home computer or other auxiliary video equipment.

So you switch from one program

source to another with pushbutton ease - without changing connections.

Equally important, the Video Organizer's advanced engineering design by Zenith results in low insertion loss and high isolation. Eliminates electromagnetic interference for maximum picture quality. And permits greater flexibility in use and ease of operation for more hours of uninterrupted home video enjoyment.

Write now for more information!

**ZENITH**  
The quality goes in before the name goes on.

Zenith Radio Corporation/Service, Parts & Accessories Division/11000 Seymour Avenue/Franklin Park, Illinois 60131

Circle No. 120 on Reader Inquiry Card