

ET/D

MARCH 1980 • \$1.50

ELECTRONIC TECHNICIAN/DEALER
LEADING THE CONSUMER AND
INDUSTRIAL SERVICE MARKETS

NiCads from A to Z

Consumer
electronics and
the 80s

Servicing PLL

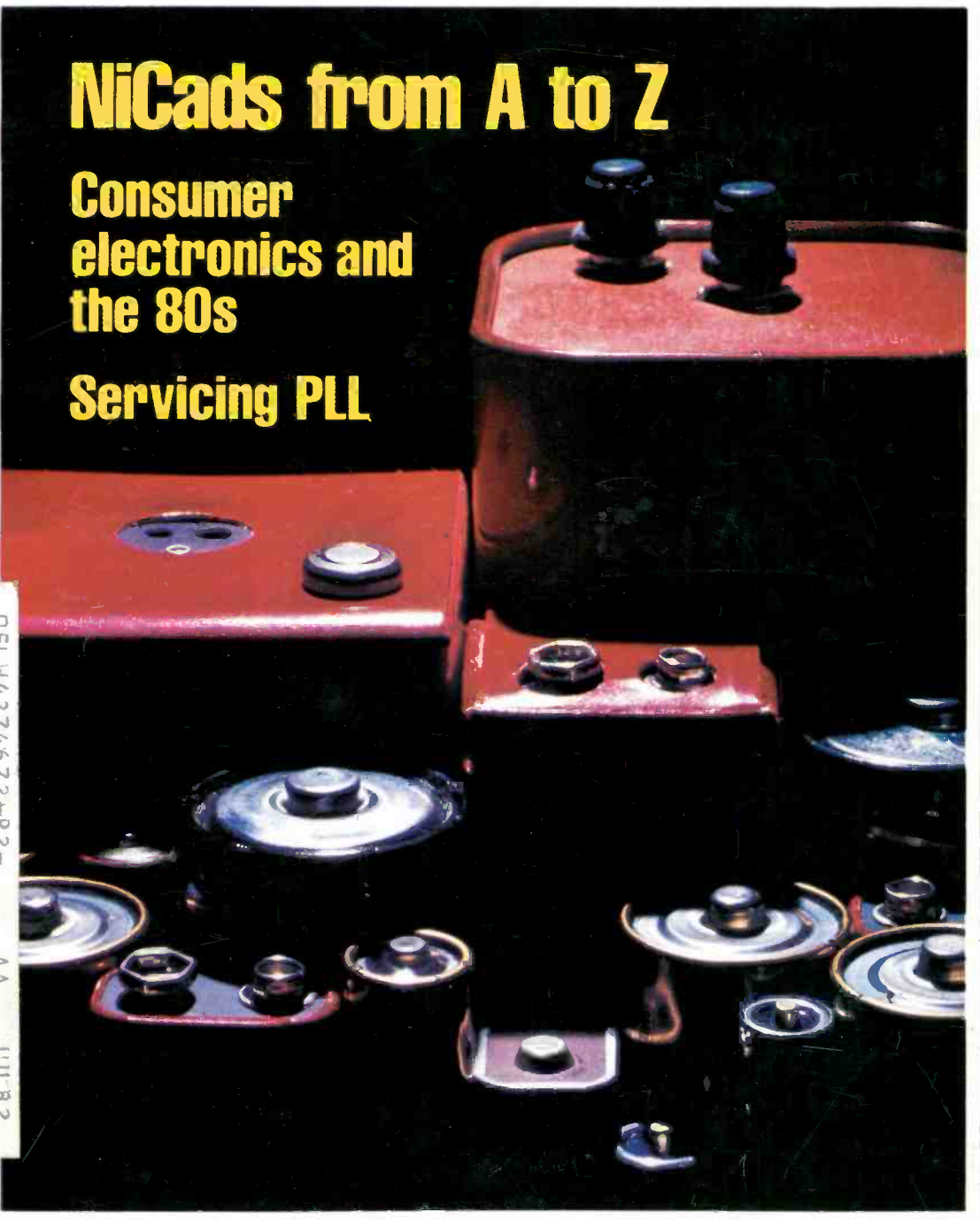

DELW4274672-PP2-
7823ADIR -679-
W H DELSCHLAGER JR
21 LOCUST LANE
NEW EGYPT
AA JUL82
-AS

NJ

Ahoy there!

We've dropped anchor just long enough to prepare TV servicing dealers/technicians for the most exciting news from PTS Electronics since the creation of same day TV tuner rebuilding. If you don't want to miss the boat then make sure you watch for our upcoming announcement.

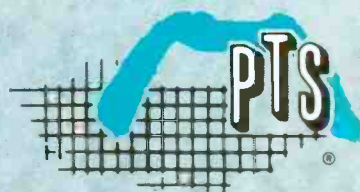

PTS ELECTRONICS, INC.
The Only Name You Need To Know

For the location nearest you,
see servicer center guide on next page.

PTS SERVICENTER GUIDE

MIDWEST

Home Office
BLOOMINGTON, IN 47401
5233 S. Hwy. 37, P.O. 272
812-824-9331

CLEVELAND
Parma, OH 44134
5682 State Road
216-845-4480

KANSAS CITY, KS 66106
3119 A. Merriam Lane,
P.O. 6149
913-831-1222

MINNEAPOLIS, MN 55408
815 W. Lake St.,
P.O. 8458
612-824-2333

ST. LOUIS, MO 63130
8456 Page Blvd.,
P.O. 24256
314-428-1299

DETROIT, MI 48235
14745 W. 8 Mile Rd.
313-962-1783

GRAND RAPIDS, MI 49501
1134 Walker N.W.
P.O. 1435
616-454-2754

CINCINNATI, OH 45216
8172 Vine St., P.O. 18057
513-821-2298

MILWAUKEE, WI 53218
7211 W. Fond du Lac
414-464-0789

COLUMBUS, OH 43227
4005A E. Livingston
614-237-3820

INDIANAPOLIS, IN 46202
1406 N. Pennsylvania Ave.
317-631-1551

DAVENPORT, IA 52803
2024 E. River Dr.
319-323-3975

OMAHA, NE 68104
6918 Maple St.
402-571-4800

CHICAGO, IL 60659
5744 N. Western Ave.
312-728-1800

SOUTH
CHARLESTON, SC 29411
3839 Rivers Ave.
P.O. 10203
803-554-8434

JACKSONVILLE, FL 32210
1918 Blanding Blvd.
P.O. 7923
904-389-9952

WASHINGTON, DC
Silver Spring, MD 20910
8950 Brookville Rd.
301-565-0075

CHARLOTTE, NC 28225
2542 Lucena St., P.O. 5512
704-332-6007

BIRMINGHAM, AL 35201
210 N. 9th St., P.O. 1801
205-323-2657

MEMPHIS, TN 38104
1289 Madison Ave.,
P.O. 41043
901-726-1260

NORFOLK, VA 23504
3118 E. Princess Anne Rd.
804-625-2030

NEW ORLEANS
Metairie, LA 70004
3920A Airline Hwy.,
P.O. 303
504-837-7569

TAMPA, FL 33690
2703 S. MacDill, P.O. 14301
813-839-5521

NASHVILLE, TN 37214
2426A Lebanon Rd.
615-885-0688

PACIFIC

SACRAMENTO
North Highlands, CA 95660
8131 Walt Ave., P.O. Box X
916-334-2012

SAN DIEGO, CA 92105
5111 University Ave.,
P.O. 5794
714-280-7070

LOS ANGELES
Paramount, CA 90723
7259 E. Aiondra Blvd.
213-834-0111

PORTLAND, OR 97213
5220 N.E. Sandy Blvd.
P.O. 13098
503-282-9636

SEATTLE, WA 98188
988 Industry Dr., Bldg. 28
P.O. 88831, Tukwila Branch
206-575-3060

NORTHEAST

SPRINGFIELD
Westfield, MA 01085
300 Union St., P.O. 238
413-562-5205

PHILADELPHIA
Yeadon, PA 19050
548 Penn St., P.O. 129
215-622-0450

PITTSBURGH, PA 15202
257 Riverview Ave. W.,
P.O. 4130
412-761-7648

ELMWOOD PARK, NJ 07407
158 Market St., P.O. 421
201-791-6390

BALTIMORE, MD 21215
5505 Reisterstown Rd.,
P.O. 2581
301-358-1186

BOSTON
Arlington, MA 02174
1167 Massachusetts Ave.,
P.O. 371
617-648-7110

BUFFALO, NY 14214
299 Parkside Ave.
716-837-1656

MOUNTAIN

DENVER
Arvada, CO 80002
4958 Allison St.
303-423-7080

SALT LAKE CITY, UT 84105
1233 Wilmington Ave.,
P.O. 6218
801-484-1451

PHOENIX, AZ 85009
2916 W. McDowell Rd.,
602-278-1218

TUCSON, AZ 85719
801 E. Broadway
602-624-6493

SOUTHWEST

LONGVIEW, TX 75601
110 Mopac Rd., P.O. 7332
214-753-4334

OKLAHOMA CITY, OK 73147
4509 N.W. 10th, P.O. 74917
405-947-2013

HOUSTON, TX 77207
4326 Telephone Rd.,
P.O. 26616
713-644-6793

INDUSTRY REPORT

New Chairman for NRSC Group

Wallace Johnson, executive director of the Association for Broadcast Engineering Standards, has been elected chairman of the National Radio Systems Committee. NRSC has been formed to investigate methods for improving AM and FM transmission and reception.

According to a statement from EIA, the NRSC will review performance and compatibility of all components of the radio transmission system from program sources to receiving environment and will, when appropriate, recommend practices and guidelines.

The next NRSC meeting is April 15 during the National Association of Broadcasters convention in Las Vegas.

CBS, RCA Announce Video Disc Pact

RCA's intention to market a reasonably priced video disc system on a mass market basis received a significant boost with the announcement recently that CBS would make and distribute discs for the "SelectaVision" system.

"SelectaVision," one of two competing video disc technologies currently on the market in the U.S., is the cheaper of the two, a fact which RCA chiefs feel will make it more competitive in the U.S. market than the contending "Magnavision" system offered by Magnavox.

From a technological standpoint "Magnavision," plus another system soon to be introduced by U.S. Pioneer, use laser beam pickup of information from the "platter," a definite advantage when compared with RCA's capacitance/stylus pickup system which is more prone to wear on the disc itself.

In announcing the CBS/RCA pact, RCA Chairman Edgar Griffiths said he anticipates selling 200,000 players the first year—which will be 1981. The video disc player, he predicted, will achieve 30 to 50 per cent penetration of all U.S. color television households within 10 years.

According to CBS President John Backe, his firm is committed to participation "in all the new audio/visual technologies which hold great promise in the 1980s . . ."

Stereo is King on Campus

According to figures released by *Amper sand*, a magazine for college students, 97.7 per cent of the nation's college students have home stereo systems and 72.8 per cent want to upgrade.

The magazine reported that 2,569 men and 1,341 women in the 18 to 24 age group completed their survey.

—73 per cent of students owning home stereo systems own components, 25 per cent own compacts.

—59 per cent of the students said they owned car stereo units.

—20 per cent of the respondents plan to purchase a car stereo system

The magazine added that over 45 per cent of the respondents lived in dormitories, 27 per cent rented their own apartments, about 12 per cent rented a home or owned one, and 11 per cent lived with their parents.

Color Sales in '79 Reached Second Highest Level

Electronic Industries Association (EIA) statistics say 1979 ended up as the second best year ever for color television sales in the U.S.—down only 3.8 per cent from the 10.2 million sold in 1978.

According to EIA's figures, 1979 produced 9,846,487 in color sales.

Meanwhile, EIA said black and white TV sales in 1979 reached 6,254,601, up 3.1 per cent over 1978's total. That figure made 1979 the best year for black and white since 1973, EIA reported.

Other statistic reported by EIA:

—VCR sales total 475,396, up 18.3 per cent over 1979.

—Radio sales fell 12.1 percent to 39,659,529.

—And, unit sales of AM/FM or FM only radios totaled 21,772,045, a decline of 11.3 per cent over 1978's sales.

ETA-I Plans Technical/Management Workshops

Electronics Technicians Association-International plans another of its regional workshops for April 18-19 at the Hilton Airport Hotel, Indianapolis.

Simultaneous technical and management programs are planned for the 18th and the morning of the 19th with a trade show/bazaar/swap-meet scheduled for the afternoon of the 19th.

Workshop subjects (at least 17 technical and 11 management) include satellite ground station receivers, op-amps, VTR alignment by eye and ear alone, scanner repair and micro-computer servicing, P and L statements, advertising, SBA loans, setting service changes and many others.

Registration for either program is \$20.00. Write ETA, 7046 Doris Dr., Indianapolis, IN 46224 for information.

Korean Firm Steps Up U.S. Marketing Effort

Gold Star, entering its second year of selling television sets in the U.S., has announced it is expanding its U.S. marketing effort to include a whole range of home entertainment products.

According to a company spokesman, Gold Star, a subsidiary of a South Korean conglomerate known as The Lucky Group, is aiming at \$150 million in sales during 1980—its second full year of dis-



Circle No. 102 on Reader Inquiry Card

RICHARD W. LAY
Editor

WALTER H. SCHWARTZ
Managing Editor

DAVE NEIMAN
Associate Publisher

TOM GRENEY
Publishing Director

JOHN PASZAK
Graphic Design

KATHY TARNOWSKI
Production Manager

LILLIE PEARSON
Circulation Fulfillment

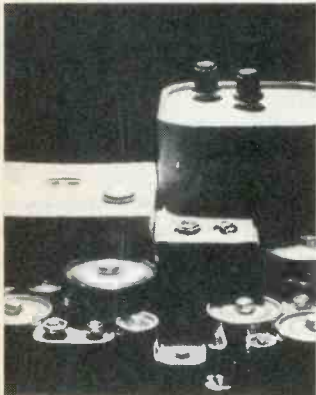

On the cover: Nickel cadmium batteries. These rechargeable devices are now available in virtually every size and shape to meet the burgeoning demand by consumers for portable instruments ranging from television sets to electronic watches. For a report on their proper care and feeding see page 20.

FEATURES

A new decade in consumer electronics

Glitter from Vegas at CES 15

The care and feeding of NiCads

Proper handling is essential 20

Servicing phase locked loop and divider circuits

Useful do's and don'ts for the practicing technician 24

A look at Motorola's 6800 microprocessor

What goes on inside 30

Microprocessors part V

All about registers and buses 36

DEPARTMENTS

INDUSTRY REPORT	1
FROM THE EDITOR'S DESK	6
CONTINUING EDUCATION REPORT	8
LETTERS	9
NEWSLINE	10
SERVICE SEMINAR	12
TEST INSTRUMENT REPORT	38
BULLETIN BOARD	40
NEW PRODUCTS	41
DEALERS SHOWCASE	46
CLASSIFIED ADS	48
AD INDEX	50
READERS SERVICE	57
TEKFAX	59



A HARCOURT BRACE JOVANOVICH PUBLICATION



ELECTRONIC TECHNICIAN/DEALER (ISSN 0192-7175) is published monthly by Harcourt Brace Jovanovich Publications. Corporate offices: 757 Third Avenue, New York, New York 10017. Advertising offices: 757 Third Avenue, New York, New York 10017 and 111 East Wacker Drive, Chicago, Illinois 60601. Editorial offices: 111 East Wacker Drive, Chicago, Illinois 60601. Accounting, Advertising Production and Circulation offices: 1 East First Street, Duluth, Minnesota 55802. Subscription rates: one year, \$11; two years, \$18; three years, \$24 in the United States and Canada; all other countries: \$30. Single copies: \$1.50 in the United States and Canada; all other countries: \$3.50. Controlled Circulation postage paid at Dansville, New York 14437. Copyright © 1980 by Harcourt Brace Jovanovich, Inc. All rights reserved. No part of this publication may be reproduced or transmitted in any form or by any means, electronic or mechanical, including photocopy, recording or any information storage and retrieval system, without permission in writing from the publisher. ELECTRONIC TECHNICIAN/DEALER is a registered trademark of Harcourt Brace Jovanovich, Inc.

POSTMASTER: Send Form 3579 to ELECTRONIC TECHNICIAN/DEALER, P.O. Box 6016, Duluth, MN 55806.

Special

Stock Up & Save on Replacements for ECG Horizontal Deflection and Horizontal Output Transistors.

Minimum order 10 of each.

ECG is a registered trade name of the ECG Sylvania Corporation.

Equivalent to ECG 163A



\$390
Horizontal Deflection
TO-3 CASE

Equivalent to ECG 165

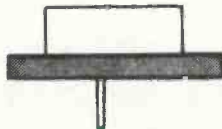

\$240
Horizontal Deflection
TO-3 CASE

Equivalent to ECG 238



\$245
Horizontal Output
TO-3 CASE

Now in Stock at MCM! Test Equipment from Leader.

30 MHz Dual-Trace Oscilloscope with Delay Model LBO-520

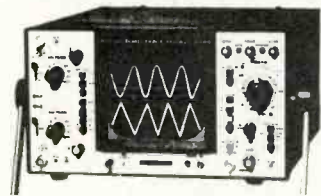

MFGR. LIST

\$1,050

Call the toll-free hot line for the low, low MCM Audio price.

- 5mv sensitivity
- Built-in delay line
- (CH-1, CH-2) Single shot trigger
- 5" PDA CRT for crisp, bright trace

Video Color Signal Source Model LCG-395A



MFGR. LIST

\$300

Call the toll-free hot line for the low, low MCM Audio price.

- Rainbow gated simultaneously displayed (3 bars, 10 bars)
- 5-step staircase 20% segments, from 0 to 100%
- Window and noiseless white raster position

FET Multi-Function Multi-Meter Model LEM-73A



MFGR. LIST

\$179

Call the toll-free hot line for the low, low MCM Audio price.

- 8 AC/DC Voltage Ranges
- 8 AC/DC Current Ranges
- Hi-low Ohms/7 resistor ranges. 10 meg impedance
- Battery or AC. Adapter included

Prices subject to change without notice.

Easy-Reading Frequency Counter Model 1LDC-824S



MFGR. LIST

\$320

Call the toll-free hot line for the low, low MCM Audio price.

- 80 MHz, 250 MHz, 520 MHz
- Large, bright fluorescent display
- Frequency Range 10 Hz to 520 Mhz
- Period Measurement 100mS to 1uS

Call This Toll-Free 24 Hour Hot Line

1-800-543-3528

(In Ohio call 1-800-762-3418) TLX 288349



mcm audio, inc.

Your original Japanese semiconductor supplier
639 Watervliet Avenue, Dayton, Ohio 45420

tributing its own brand in this country.

In addition to color, black and white television, and TV-radio combos, Gold Star is about to introduce a line of stereo components, including mini components, compact stereos, and front loading cassette tape decks. Announcing additions to its color TV line at the Winter CES, Gold Star said a 19-inch programmable receiver with infrared remote control comprised the firm's "top of the line."

Additionally, four new black and white models were introduced, three matched stereo component systems, three cassette tape decks, two mini component systems, and two compact stereo systems.

RCA Satcom III Loss Jolts Cable Industry.

RCA's multi-million dollar Satcom III, an artist's rendition of which appeared on ET/D's November cover, is either lost or destroyed in space and hopes are virtually nonexistent for its recovery.

The \$77-million satellite, fortunately covered by insurance, seriously damages industry plans for major expansion of cable systems, industry sources report. It is possible some slack can be taken up by using available transponders on Telesat Canada, Western Union, and AT&T satellites, but the next Satcom launch is not scheduled until mid 1981 and it's unlikely that launch date can be moved up appreciably. **ET/D**

ET/D

Richard W. Lay, *Editor*
(Chicago)

Walter H. Schwartz, *Managing Editor*
(Duluth)

Dave Neiman, *Associate Publisher*
(Chicago)

Tom Greney, *Group Vice President*
(Chicago)

John Paszak, *Graphic Design*

Kathy Tarnowski, *Production Manager*

Debi Harmer, *Production Supervisor*

Lillie Pearson, *Circulation Supervisor*

Gene Bailey, *Reader Service*

Julie Laitin, *Promotion Director*

Dawn Anderson, *Classified Ad Mgr.*

Please submit editorial manuscripts to:
Editor, ET/D, 111 East Wacker Drive
Chicago, Ill., 60601

ADVERTISING SALES

Please send all advertising material to:
ET/D, Production Mgr.
120 West Second Street
Duluth, Minn. 55802
(218) 727-8511

East Region
Thomas Palmisano
757 Third Avenue
New York, N.Y. 10017
(212) 888-4382

Midwest Region
Dave Neiman
111 East Wacker Drive
Chicago, Ill. 60601
(312) 938-2325

Southern & Western Region
Chuck Cummings
613 N. O'Connor
Irving, TX 75061
(214) 253-8678

Sheila Connolly
10741 Moorpark St., Suite #21
North Hollywood, CA 91602
(213) 980-7750 or (213) 760-1684

HRJ

HARCOURT BRACE JOVANOVIICH PUBLICATIONS

Robert L. Edgell, *Chairman*
Richard Moeller, *President*
Lars Fladmark, *Senior Vice President*
Arland Hirman, *Treasurer*
Thomas Greney, *Group Vice President*
Ezra Pincus, *Group Vice President*
Lois Sanders, *Group Vice President*
Joe Bilderbach, *Vice President*
James T. Gherna, *Vice President*
George A. Glenn, *Vice President*
Harry D. Ramaley, *Vice President*

Only VIZ bench DMM's tell so much for so little



Sheer magic from the Wizard of VIZ

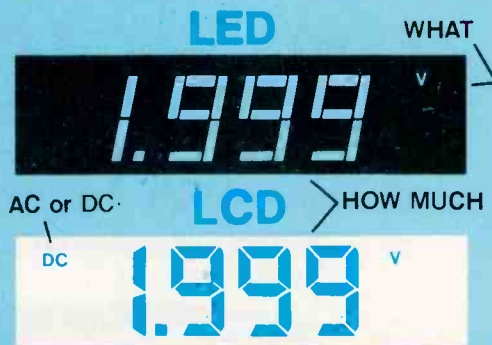

Manual ranging



WD-762 LCD display \$210



WD-760 LED display \$199.95

Autoranging



WD-763 LCD display \$265



WD-761 LED display \$255

These are all laboratory quality instruments for bench or battery use. Supplied with AC adapter, spare fuse and deluxe probes. Features include:

- Accuracy 0.1% DCV
- Full range hi or lo power ohms, pushbutton selectable
- 10 amp AC or DC
- Fully shielded against RFI
- Voltage ranges from 0.1mV to 1000V AC & DC.

See your local VIZ distributor.

VIZ

VIZ Mfg. Co., 335 E. Price St., Philadelphia, PA 19144
Over 70 test instruments in the line

Replace three power supplies with the one that tracks

Almost anyone can build three power supplies in one box, but B&K-PRECISION has built one power supply capable of *outperforming* three separate supplies. An exclusive automatic tracking circuit is the reason.

The B&K-PRECISION 1650 multiple-output power supply was designed for use with both linear and digital circuitry. For digital requirements, the unit offers a 5 volt DC, 5 amp output; and two separate A & B 0-25 volt DC outputs at 0.5 amps for analog circuits. The exclusive automatic tracking circuit allows the B output to precisely track voltage changes of the A supply, while maintaining complete electrical output isolation. As a result, any combination of outputs

may be connected in series or parallel, or be totally isolated.

The heart of B&K-PRECISION's automatic tracking circuit is a tiny LED opto-isolator. A pulse-width modulated light beam is transmitted through this device, providing a control signal which directs proportional control of the B supply when the A supply

output is varied. For example, if the B control is set at 100%, the same voltage level will appear at both the A and B outputs. If the B control is instead set to a 50% position and the A output is set for 10 volts, the B output will deliver 5 volts.

Auto-tracking makes the 1650 the ideal power source for breadboard and prototype digital circuits. It can provide two simultaneously varying test voltages, or positive and negative voltages for operational amplifiers. The 1650 is a money-saving alternative to separate power supplies with features that can't be met by separate supplies. For immediate delivery, a ten-day free trial or in-plant demonstration, contact your local B&K-PRECISION distributor.

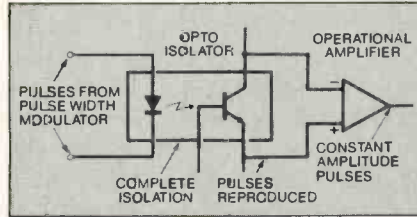

BK PRECISION DYNASCAN CORPORATION

6460 W. Cortland Street • Chicago, IL 60635 • 312/889-9087

International Sales, 6460 W. Cortland Street, Chicago, IL 60635 USA: TELEX: 25-3475

Canadian Sales, Atlas Electronics, Ontario

B&K-PRECISION
Model 1650 \$300
Other power supplies
from \$125



Circle No. 105 on Reader Inquiry Card

ET/D - March 1980 / 5

FROM THE EDITOR'S DESK



News Item: Color television sales currently run at a 10-million set per year clip.

News Item: Black and White Sales are moving along at 6-million sets a year.

News Item: By 1985, 7-million video cassette recorders are expected to be "in place" in American homes with annual sales by that time reaching 1.3 million per year.

News Item: By 1985, another 7-million video disc players will be located in American households (to say nothing of their penetration of industry) and annual sales will total between 3 and 5 million.

News Item: *Ampersand*, a national publication for college students, says a survey it conducted indicated that 95.7 per cent of all college students from 18 to 24 own home stereo systems and 73 per cent want to "upgrade." Realize this encompasses tuners, amplifiers, speakers, tape decks, and turntables.

If you want to disregard the impact of "personal" or "home" computers, do so. But, be aware that within the next two to three years you will not be able to find a profitable business that *does not* rely on computer supported records keeping. Think how many businesses there are in your hometown!

The list could go on and on. Microwave ovens, the tremendous growth in satellite cable TV systems across the nation; auto sound; the coming improvement in television sound; AM stereo—all are developments that will spawn new product introductions into the American home, not at a trickle, but by millions upon millions of units.

Yet, in the face of this virtually inconceivable avalanche of electronic productry, plus the expanding opportunity for those currently within the independent consumer service industry, I personally have been told by "industry experts" that consumer service is dead.

"The incidence of failure is dropping," I am told. Our product doesn't break down, says a manufacturer. Things will last almost forever, says another. The consumer service industry is no more, says a competitor of ET/D's.

I think we should classify such statements as what they are: marketing phrases designed to impress a non-sophisticated public. I have no quarrel that all of you in the television service business have felt the dropoff in service business attributable to the improved reliability of solid state electronics.

Still, can any mature, thinking human being conceivably question the existence of a viable, profitable consumer service market in the face of such overwhelming production?

The only real question is: Who will do the servicing? You, or the manufacturers?

Why do you think RCA and Zenith sell more TV's than anyone else? Is it because they make "better" TVs? Of course not! The sets which Magnovox, Sony, Sylvania, G.E. Panasonic, etc., etc., etc., are every bit as good. After all, they do the same thing that RCA's and Zenith's comparably priced sets do.

No, the real reason goes beyond quality. The real reason for the success of the former is their marketing stance, i.e., advertising and promotion—in short, their identity in the public eye. They are better known for television than anybody else, period.

I believe there is a critical message here for the independent consumer electronics service industry. The creation of a professional identity, recognized and known by your customers, in your service area, is critical to your survival. The time is already here when, I feel, the industry can no longer survive without a strong, and effective marketing approach to doing business. It is now time for the professionally run serveshop in this country to begin to aggressively seek other markets, other outlets for their service talents.

It will not be any "lack" of service that will kill the independent consumer electronics service industry if it dies. The only thing that can kill it is a lethargic independent service industry itself.

Sincerely

Richard M. Lay

TRI-COLOR

WIRE CUTTING AND STRIPPING DISPENSER



- 3 Rolls of wire in one convenient dispenser
- 3 Colors, Blue/White/Red, 50 ft. (15m) of each color
- AWG 30 (0,25mm) KYNAR® insulated wire
- Built-in cutting plunger cuts wire to desired length
- Built-in stripper strips 1" of insulation
- Easily refillable
- For wire-wrapping and other applications.

Model No. **WD-30-TRI**
Patent Pending

WD-30-TRI	DISPENSER WITH WIRE	\$5.95
R-30-TRI	TRI-COLOR REPLACEMENT SPOOLS	\$3.95

Kynar® Pennwalt

MINIMUM BILLING \$25.00/ ADD SHIPPING CHARGE \$1.00/ NEW YORK STATE-RESIDENT ADD APPLICABLE TAX



MACHINE & TOOL CORPORATION 3455 CONNER ST. BRONX, N.Y. 10475 (212) 994-6600/Telex 125091

Circle No. 114 on Reader Inquiry Card

CONTINUING EDUCATION REPORT

Two programs of the Heath Company's Continuing Education Series that should be of interest to electronic technicians, consumer, industrial, and medical all, are entitled *Operational Amplifiers*, and, what is in a considerable sense an extension of it, *Active Filters*. The operational amplifier, so named because it was used to perform analog mathemat-

accessories for the experiments, the Heath ET-3300 breadboard or its equivalent—a breadboard, plus and minus 12 volt, (preferably variable 0-12 volt) power supplies—a function generator, an oscilloscope, and a multimeter. Each program has test questions at the end of each lesson unit and offers an optional final exam (in a sealed envelope). Passing the final examination with a score of 70% or better entitles the student to 3.0 Continuing Education Units (CEU's).

The op-amp program describes the ideal operational amplifier, the limitations of real, practical op-amps, various applications including linear amplifiers, differentiators, integrators, constant current converters, various non-linear applications, wave form generators, active filters and two special kinds of operational amplifiers, the Norton Op-Amp and the instrumentation amplifier.

When you finish the program, particularly if you do the thirty-six experiments, which is highly recommended, (some eighty-eight parts including 7 op-amp IC's are included) you will thoroughly understand what makes an op-amp behave as it does in each of its applications (and be able to design circuits for these applications) and be able to troubleshoot op-amps, however applied.

The active filters chapter of *Operational Amplifiers* is about thirty pages long. The *Active Filter* program is a complete course in the design and application of basic active filters. After a review of op-amps (all the active filters considered are based on op-amps) and filter basics the program covers first-order low-pass and high-pass active filters, second-order VCVS (voltage-controlled-voltage-source) low-pass and high-pass filters, higher order filters, bandpass and notch filters, and variable state filters.

Seventy-six components including three op-amps are included as part of the program. Here again, the experiments are highly recommended—nothing replaces hands on experience to make something stick in memory. Eighteen experiments are suggested; some include design problems. Again, you should come away with a thorough understanding, of basic active filters, design and troubleshooting.

Operational Amplifiers' price is \$39.95; *Active Filters* costs \$29.95. Both come with all the components for the experiments. Heath's ET-3300 Circuit Breadboard costs \$89.95 in kit form or 149.95 fully assembled; it is useful for all sorts of other analog or digital circuit experimentation. **ETD**

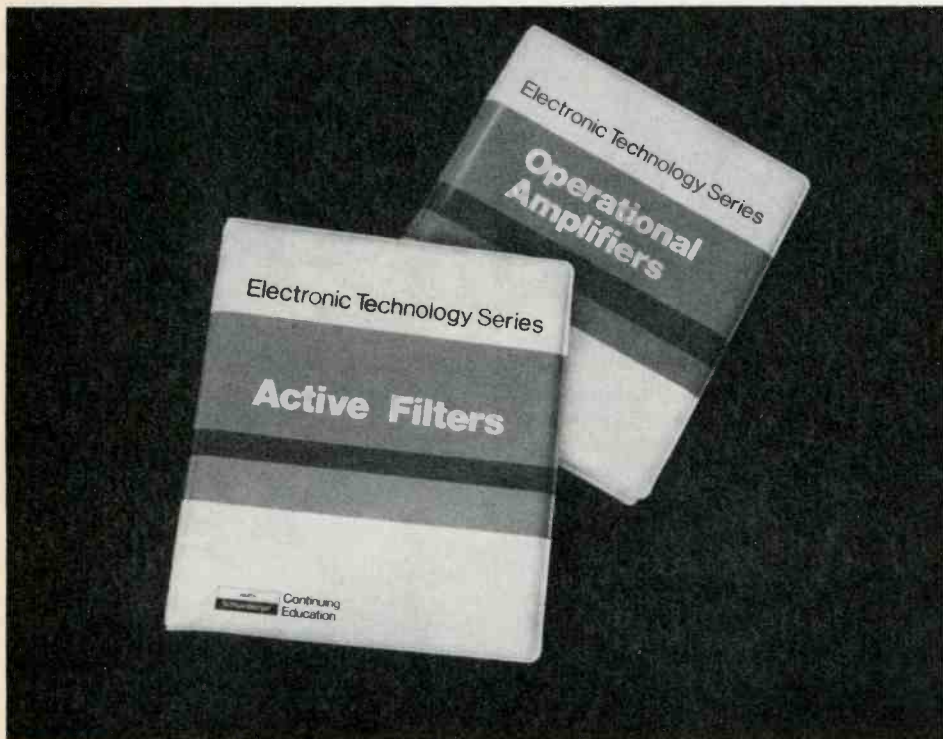

For more information circle No. 160 this issue

Op Amps and Active Filters

The easy way

By Walter H. Schwartz

ical operations in analog computers as far back as the '40s, is a high gain, hopefully wide band, differential input dc amplifier, the characteristics of which are determined by the feed back elements associated with it. In the case of the theoretically perfect op-amp the feed back would entirely determine its operation.

With the advent of very successful IC op-amps we are seeing them used as instrumentation amplifiers, voltage regulators in power supplies, active filters, oscillators to generate sine waves and many other waveforms, as amplifiers and audio preamplifiers (in fact if analyzed some of even the highest power audio amplifiers appear as large, operational amplifiers. You will find them in the equipment you troubleshoot as well as in the troubleshooting instruments you use.

Operational Amplifiers consists of 385 pages of step-by-step self-instructional text and a package of components for experiments. *Active Filters* is 300 pages and it too has the parts for hands-on experiments. Both require as

LETTERS

CATV:

This is to advise you of my change of address. Thank you for such a fine publication. Do you plan on any articles on community cable systems?

Thanks again.

Joe Box, Jr.

PO Box 143

Fisher, AR 72429

Editor: We hope to have features on CATV, on both the business and legal, and technical aspects, this spring or early summer.

COMMENTS AND REQUEST:

Refer to ET/D, Jan., 1980 (Letters)

The irate independent has a fan, "Hats Off" to Nick Grasso. It looks like some manufacturer would get smart and make a brand of TV's and equipment and sell only to TV independents shops. It would cut out service to these discount houses. If people cannot get service, they will stop buying the junk.

I need the same thing "Jim's Radio & TV" needs—a power transformer for a "Carole" tape player. Model #19860,

Trans. #TP17425B. Schematic for this model (this is some of that discount junk that Nick Grasso was speaking of).

I agree with Richard Sanderford. I make my living repairing TV's. I also would like to see more TV repair articles in your magazine (Service Seminars).

Do me a favor and stop putting "Service Seminar" on both sides of page (I cut these out and paste them in my "case history" book).

Thanks

Bill Barnett

Barnett TV Service

Rt. 3-Box 352

Magnolia, AR 71753

Editor: We try to keep Service Seminar at about a page each issue. As for other TV service articles we must balance them against other areas of service, new developments, etc. Also, unfortunately we cannot keep Service Seminar on one side of the page. All I can suggest is that you photo copy it. I've never liked to cut up my magazines anyway.

TEKFAX:

As a subscriber since 1968, I want to thank everyone involved in the publication of ET/D for the fine job of helping all of us in field. I would appreciate your

putting the following in the letters column. I want to obtain TEKFAK 100 thru 108 and 111.

E. A. Brocke

223 S. Church St.

Grass Valley, CA 95945

HELP NEEDED:

Please assist me in locating a source for the purchase of tips for a ZEVA soldering iron and a PLATO PLUS soldering iron.

Tony Radthe

R&R Electronics

Box 376

Zachow, WI 54182

Editor: We do not know the brand—anyone who does please tell Mr. Radthe.

For Heathkit audio oscillator AO1 and Lafayette VOM Model 99-5073; operating instructions and schematic or any information. Also for a Channel Master stereo radio cassette 8 track, need cabinet complete with radio dial, knobs, hardware, etc. Help!

Joe Martinez

Martinez Electronics

1324 Dover St.

Caparra Terrace, PR 00920 **ET/D**



THE NEW performer.

Model 30 "GRABBER" Clamp-On AC Volt/Ammeter takes tough line service right on the jaw.

The GRABBER's jaws get around lines to 1" diameter fast. Its MEMO-LOC™ dial pointer and single range switch make measurements easier... its SURE-VU large dial face makes reading more exact... diode overload protection for the meter movement and newly designed 48" safety leads make it all more dependable.

Nine ranges (300AC Amps in six ranges and 0-600 VAC in three ranges) with extra-rated components makes the drop-resistant, hand-held Model 30 GRABBER a must for line maintenance. Optional accessories include Model 32 plug-in Ohmmeter adapter with 10 ohm center scale and man-made leather holster type carrying case.

For a demonstration, contact your Triplett Distributor, Mod Center or Representative. Triplett Corporation, Bluffton, Ohio 45817. (419) 358-5015. TWX (810) 490-2400.

\$65
MODEL 30



CARRYING CASE

See this man-made leather, holster type carrying case for the Model 30 at your local distributor. Heavy duty case only \$9.00.

Triplett performance... a tough act to follow

TTT TRIPLETT

...Circle No. 121 for information

...Circle No. 122 for FREE demonstration

NEWSLINE

MICROWAVE TUBE SALES UP. The sale of electron tubes for microwave ovens are expected to total \$220 million during 1979, according to the Electronic Industries Association. That would be a record level but, ironically, it would amount to little growth compared to 1978's total of \$91 million due to inflation.

NEW ANTI-JAP SUIT OVER OVENS? Is a new anti-import suit--similar in nature to the squabble over Japanese television imports into the U.S. -- brewing? Possibly so. The reason: The U.S. International Trade Commission has just ruled that imports of microwave ovens and industrial electrical motors from Japan to the U.S. have injured U.S. producers. The next step? An investigation by the U.S. Commerce Department.

CONTROL DATA TO MAKE FLAT SCREENS. Control Data Corporation has announced it will make flat screen neon gas plasma displays for computers and other alphanumeric uses. Viewed as eventual replacements for CRT terminals, they will be brighter, use less energy, but cost about four times as much.

ELECTRO/80 SLATES 34 SESSIONS. Electro/80, the high technology gathering of industry leaders slated for Boston May 13-15, has scheduled a total of 34 technical conferences for attendees. If anyone doubts the state of the art of the industry, it might be well to note virtually every seminar of a technical nature deals with some phase of the microcomputer, microprocessor, peripheral industry.

GTE PROFITS UP 3.7 PERCENT. General Telephone and Electronics Corporation says its profits rose 3.7 per cent to \$645.1 million in 1979 on revenues of \$9.96 billion. Revenue, GTE said, rose 14 per cent over the previous year. However, its consumer electronics operations reported a \$9.3 million loss in 1979, resulting GTE said, from severe price competition in Europe on television and stereo products.

\$3,145 HOME VIDEO CAMERA? Yep! At least that's the info we receive from Sharp. The professional products department at Sharp says it is making available to consumers "who require better quality and more sophisticated features" its 3-tube vidicon at a suggested retail of \$3,145.

BRIEFS. The Winter Consumer Electronics Conference held last January in Las Vegas set an attendance record of 58,626--up 9.6 per cent over the 1979 CES...MIDCON, THE IEEE-sponsored electronics show that alternates between Chicago and Dallas, has announced November 4-6 as the dates for its next event, this time in Dallas ...Yet another industry meeting--the Electronic Business Communications Show, has been announced by the Electronics Industries Association. It's scheduled September 3-5 in Las Vegas -- and its backers say it will -- "will define the emergence of a synergism" in telecommunications.

Facts from Fluke on low-cost DMM's

Three good reasons to buy your handheld DMM from Fluke.

Ask yourself what you're really looking for in a handheld DMM, and then take a good long look at ours.

CHOICES? The Fluke line of handheld DMM's now offers three clear performance choices. There's the 8022A Troubleshooter, a solid value for basic voltage/current/resistance measurements that offers 0.25% basic dc accuracy. The 8020A Analyst is the world's best-selling DMM and first to offer conductance for high-resistance measurements to 10,000 Megohms — now with accuracy improved to 0.1%. And the new 8024A Investigator, a powerful instrument also with 0.1% accuracy that boasts three unique capabilities: *logic level/continuity detection* with an audible "beeper" for

instant continuity testing, and slow-speed logic checking, *peak hold* to lock onto elusive transient signals, and *direct temperature readings* to 1265°C via K-type thermocouples.

CONVENIENCE? Pick one up and you'll know what *true* one-hand operation means — tough, lightweight, palm-size packages designed with in-line push buttons for quick range and function changes.

RELIABILITY? Count on it. A substantial number of components are used exclusively to insure reliability and to guard against overloads.

Calibration is traceable directly to the National Bureau of Standards.

LOW COST? Compare these U.S. prices: \$139 for the 8022A, \$179 for the 8020A and \$219 for the powerful 8024A.

Fluke standards of quality and customer service, of course, are uncompromising — for our line of handheld DMM's and all our products. For more facts call toll free **800-426-0361**; use the coupon below; or contact your Fluke stocking distributor, sales office or representative.



IN THE U.S. AND NON-EUROPEAN COUNTRIES:

John Fluke Mfg. Co., Inc.
P.O. Box 43210 MS #2B
Mountlake Terrace, WA 98043
(206) 774-2481
Telex: 152662

IN EUROPE:

Fluke (Holland) B.V.
P.O. Box 5063,
5004 EB Tilburg,
The Netherlands
(013) 673 973 Tlx: 52237

- Please send all the facts on Fluke low-cost DMM's.
- Please have a salesman call.

Name _____

Title _____ Mail Stop _____

Company _____

Address _____

City _____ State _____ Zip _____

Telephone () _____ Ext. _____

For technical data circle no. 111.

ETD 3/80

SERVICE SEMINAR

GE

CHASSIS MC-2/MB-2 CIRCUIT BREAKER NUISANCE TRIPPING. Possible repair—reset HV adjust pot.

1. Turn the set on and allow a few minutes for warm-up.
2. Turn brightness and contrast controls to *minimum* and set the HV adjust pot to *minimum*.
3. Set your VOM to the proper scale to measure up to 150 volts DC.
4. Place the VOM + probe on pin 2 of the HV Regulator Module and the ground probe to the chassis ground.
5. Slowly turn the HV adjust pot up while watching your voltmeter and note the voltage level at which the circuit breaker trips.
6. Turn the HV adjust pot down and reset the circuit breaker.
7. a. If the trip voltage exceeded 145VDC, set the voltage to 140 volts. Check HV per chart.
b. If the circuit breaker trip voltage was lower than 145 volts, set the B+ voltage 5 volts lower than the trip level.

CHASSIS	HIGH VOLTAGE
MA	26.5KV
MB	28.5KV
MB-75	28.5KV
MB-2	28.5KV

8. Check High Voltage. If it exceeds the value in the table, reduce it to the proper value with the HV Adjust Control. NOTE: These are maximum values. They must not be exceeded.

9. Change Zener, Y1302, if sufficient high voltage cannot be obtained to produce a normally good raster. High voltage must never be allowed to exceed the value specified in the chart. If Y1302 is replaced, repeat steps 1 to 8.

CAUTION: If it is necessary to cause the circuit breaker to trip more than once, allow three minutes between successive trips to let parts cool.

NOTE: Further adjustment of the brightness limit control may also be necessary. Refer to the service manual for correct procedure.

RCA

Chassis CTC 62, 72, 74, 78, 81—ITR replacement.

Replacement ITR's are listed in the following cross reference; all replacements are metal can types.

Chassis	Trace ITR				Commutator (Retrace) ITR			
	Original		Latest Replacement		Original		Latest Replacement	
	Number on ITR case	Stock Number	Number on ITR case	Stock Number	Number on ITR case	Stock Number	Number on ITR case	Stock Number
CTC 62	8564-1	138032	8564-3	145783	8564-2	138033	8564-4	145784
CTC 72 (early)	8564-1	138032	8564-3	145783	8564-2	138033	8564-4	145784
CTC 72 (late)	8564-7	141255	8564-3	145783	8564-8	141256	8564-4	145784
CTC 74 (early)	8564-3	141255	8564-3	145783	8564-4	141256	8564-4	145784
CTC 74 (late)	8564-5	141255	8564-3	145783	8564-6	141256	8564-4	145784
CTC 78	8564-7	141255	8564-11	146302	8564-8	141256	8564-12	146303
CTC 81	8564-5	141255	8564-11	146302	8564-6	141256	8564-12	146303

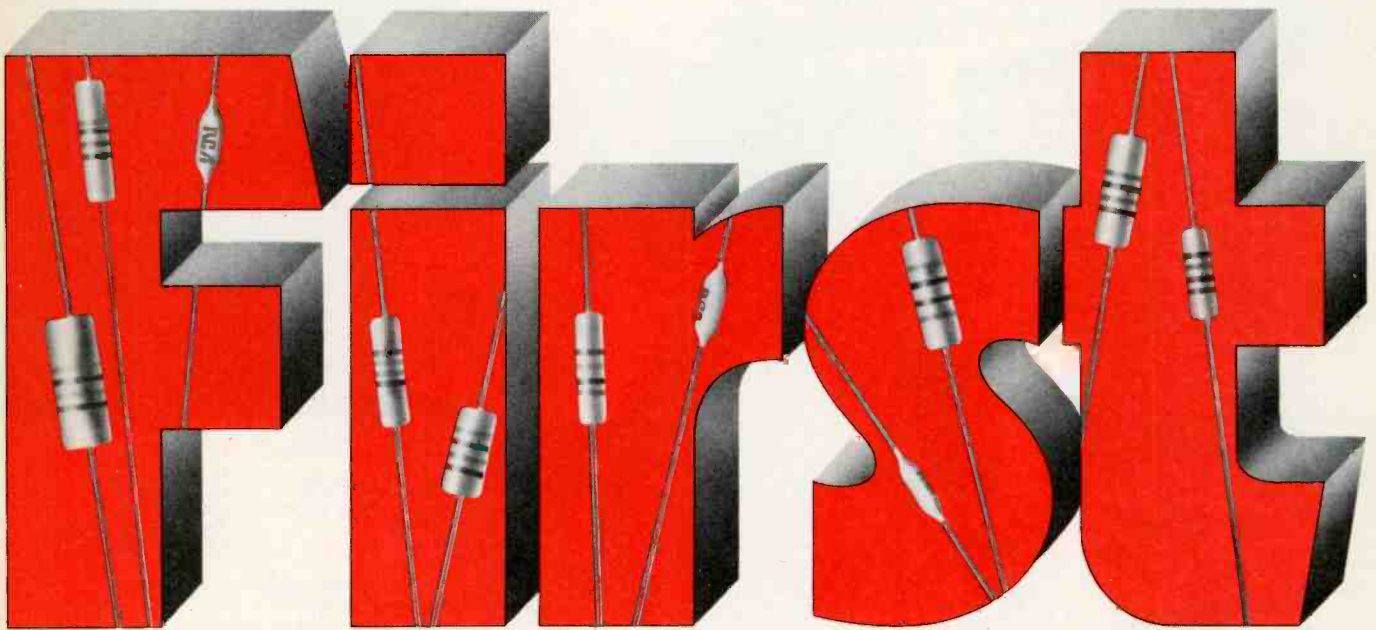

RCA's broad line of flameproof resistors.

SYLVANIA

GT-MATICS—Intermittent Sweep. The following sequence of steps should repair the intermittent on the first try;

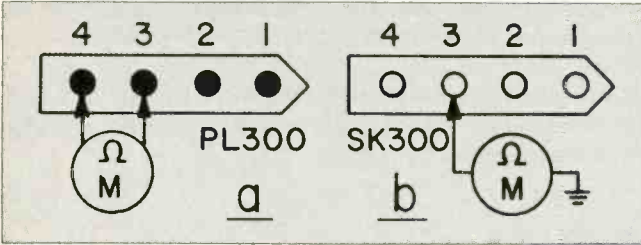

1. Replace the deflection board.
2. Check the service switch for open.
3. Check deflection and convergence wiring for opens.
4. Check vertical B+ for open.

Check as follows:

1. Replace the deflection board. If you wish to repair it, here are the most likely problems.

- a. Check vertical output transistors and their socket seating.
- b. Check vertical drivers and their socket seating.
- c. Replace vertical IC302 and IC400.
- d. Check for break in board (less likely cause).

Check for intermittent service switch.

a. Use a p-p ac voltmeter or a V.O.M. on ac scale with .05 cap. in series with +lead.

1. All GT-Matics—TE-9 on deflection board has 23V p-p when set is normal or service switch is in normal.
2. TE-9 goes to 0V ac if service switch is in service position or is open and cause of trouble.
3. 23V p-p pulse is also present at

- a. TE-6 on all 26KV chassis.
- b. TE-4 on all 30 KV chassis and only drops slightly when switch is moved to service.

3. Check for bad crimped connection to convergence or deflection yoke plugs.

a. Unplug yoke and connect ohmmeter as shown and flex the leads to locate an open at the plug.

b. To check the convergence board for continuity, leave the deflection yoke unplugged and connect the ohmmeter between pin 3 and the chassis ground where it should read 0.5 ohms. Then, flex the wires and watch for an open reading.

4. Check for loose connection on deflection module mounting rail (underside of chassis). 36VB + lead is the only chassis lead likely to be the cause.

a. Connect a 50V range meter to T.P. TE-10 on all deflection modules to monitor for loss of 30V B+. If just "no vertical sweep," here's the quick way to isolate.

Check voltage at TE-10 or heat sink of Q308. Is it +30V?

Yes. Sweep board is likely ok, so, no. 3, yoke or convergence checks should provide the answer.

Reads 36V. Output transistors are not being turned on, so, check no. 1, deflection board and no. 2, service switch.

Reads less than 30V. Check I.F. board TA22 for +36V to confirm power supply or deflection board trouble.

Audio amplifier repair—Here are repair procedures for direct coupled audio stages such as those in the Sylvania CR2743, RQ3747 and RQ3748 component receivers. (In general, these tips apply to similar direct coupled amplifiers).

1. Note the complaint and take special note of channel and trouble description.

a) DON'T TURN UNIT ON IF DEAD OR SHORTED

And still your best source for replacement use.

Since RCA's flameproof resistor line was first announced in 1974, the line has included the values and ratings most needed in modern electronics circuitry. Available in $\frac{1}{4}$, $\frac{1}{2}$, 1 watt and 2 watt ratings from 0.1 ohm to 1.5 megohms, these high-quality metal-film resistors can be used in nearly all applications calling for 2, 5, or 10 percent tolerances.

RCA flameproof resistors are attractively packaged in easy-to-spot blister packages, color coded by wattage ratings.

RCA's line is still first in its field and is still your best choice for the flameproof resistors you need most. For full information, contact your RCA distributor. Or write to RCA Distributor and Special Products Division, 2000 Clements Bridge Road, Deptford, N.J. 08096.

RCA Flameproof
Film Resistors

CHANNEL IS NOTED.

2. Closely, visually inspect for overheat clues: resistors and other components.

a) Note that flame proof emitter resistors do not change appearance when overheated, so, check them carefully.

3. Make comparison resistance checks from key points to ground, comparing readings on the defective channel and good channel.

4. Testing Methods.

a) Every junction, diode, and transistor in the bad channel should be checked for short or open.

b) One end of every diode can be unsoldered in a few minutes with a "solder-sucker" iron and F/B ratio test made. Transistor junctions can be checked, similarly, with the ohmmeter. After replacement of open or shorted components, again, take a few ohmmeter to ground, channel comparison checks.

5. Do not connect speakers.

a) Connect voltmeter to the zero buss of the trouble channel and turn unit on.

1) There should be zero voltage present.

b) If the meter starts to swing + or -, quickly switch the unit off and locate the open or shorted element you missed.

c) Connect speakers only when checks of all zero busses indicate proper repair by no voltage present.

1) Meter will be deflected at instant of turn on and turn off, but, no voltage remains.

d) All power supply voltages should be verified.

6. Other repair ideas:

a) The output transistors on the RQ's can be checked by unsoldering the base wire (blue) on the P.C. board. This opens the circuitry enough for accurate testing.

b) Diodes and resistors can be checked for opens and shorts with the "Wiggle" method. If the solder on one end of the part is thoroughly removed, this gives the wire room to be wiggled free of connection. It is useful if the ohmmeter lead is clipped to the free lead. With a little practice, you will soon see you can rely on this method and save a lot of time.

SUMMARY

Virtually any open or shorted component junction can cause massive failure. All components should be checked before power is applied.

SONY

17 inch and larger sets using GCS—damper replacement.

When replacing damper diodes S1D30-15 or TH-15 a new type GH3F should be used. The original heat sink can be discarded. Full length leads should be left on the GH3F to act as a heat sink: for optimum reliability two GH3F diodes can be used in parallel. ET/D

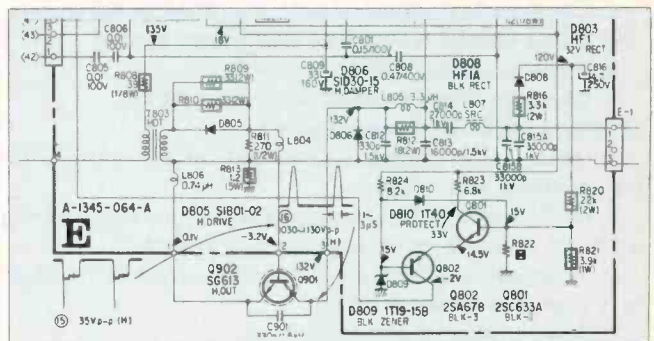

INTRODUCING...

THE ROAD RUNNER ADMM™

FROM WESTON



AUDIO RESPONSE™ PLUS DIGITAL DISPLAY

- 5 RANGE AUDIBLE SIGNALING FUNCTION
- RUGGED FIELD SERVICE DESIGN
- 0.5" LCD DISPLAY
- 6 FUNCTIONS
- 29 RANGES

WESTON INSTRUMENTS
THE MEASUREMENT PEOPLE®
614 Frelinghuysen Ave.,
Newark, NJ 07114

SANGAMO WESTON
Schlumberger

A new decade in consumer electronics

Glitter from Vegas at the CES

They came from around the world to market the products retail outlets will be selling in just a few short months. In audio, in TV/video, software, from every conceivable corner of the industry. When the dust had settled and all the votes were in, it suddenly became clear that the consumer had become king in the highly competitive world of consumer electronics.

By Richard W. Lay

The 1980 Winter Consumer Electronics Show (CES) staged this past January in Las Vegas underscores the consumer as king in the fast changing world of home entertainment electronics.

Placed at his fingertips through the literally tons of electronic products displayed in dizzying arrays at this winter's show were the means by which the consumer gained control of his own "entertainment" environment—free for the first time of the programming dictates of the three major television networks.

If the 1980 CES is to be characterized it should be called the beginning of a decade of independence and freedom for the consuming public. There is no question now—after viewing this event—that the thoughtful and serious consumer finally has at his command all of the elements necessary to shed the



Fig 1 Record crowds jammed the aisles at the 1980 Consumer Electronics Show Jan. 5 to 8 in Las Vegas.

restrictive and boring programming spewed forth for so long by the major commercial broadcasters in their stampede to garner "ratings" from the lowest echelons of America's television viewing public.

Television or video?

Perhaps the difference between "television" and "video" was only a semantic difference in the past. However, the latest CES served to underscore the fact that television—as we knew it—is indeed dead and "video"—with all the ramifications—is the new byword of the 80s.

The most singularly striking feature of this year's CES was indeed the emphasis on the consumer's ability to

program and control his own entertainment environment—totally without regard for broadcast schedules or restrictions as to program content. This "non-restriction" included everything from X-rated VCR tapes to TV games, to pre-recorded classics and movies on both VCR tapes and laser beam decoded optical video discs. Color and black and white "home" video cameras were displayed by the dozens for the VCR enthusiast who wants to replace his film library with a personal VCR tape library. Or, for those without the desire for the more exotic, you could still just slap in a tape and record whatever the "commercials" might be broadcasting.

This year's CES also held forth the

Fig 3 Toshiba's Mark II Pulse Code Modulator, may be used with either the Beta or VHS systems, provides dynamic range of more than 85 dB and frequency of response from DC to 20KHz.

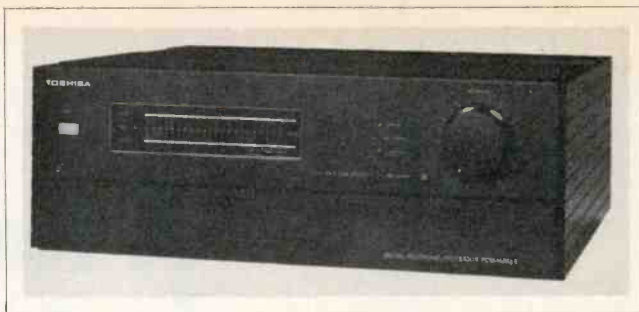

Fig 2 Small screen black and whites are among the hottest items in TV sales these days. This one inch, VHF/UHF/AM/FM combo from Panasonic—the TR1000P—is one of the smallest.



Fig 4 Sony's new SL-5600 Betamax, suggested retail of \$1,350, was one of a whole multitude of new VCRs flowing into the consumer market at CES.

promise of a "new sound," (see ET/D, February, 1980) whether that consumer be audiophile or not. The next significant move in consumer electronics appears to be the move to enhance television sound to a level more nearly approaching true stereo and of the upgrading of traditional stereo systems through the technologies of digital pulse code modulation.

This phenomena is underscored by two video oriented projects now underway with Sony's pulse code modulator which develops high quality stereo in conjunction with its Betamax VCR; and through Magnavox's video disc machine—Magnavision. Both products provide excellent quality stereo sound reproduction when used in conjunction with already existing playback systems.

The next logical step here seems the enhancement of the sound strips in the television receiver itself...a move already underway in Japan...and begun here three years ago by Quasar and since joined by other manufacturers of console color receivers.

For a quick look at this year's show—and a slant on the future from the so-called experts, read on.

Home video

Magnavox's Ken Ingram—VP in charge

of marketing for the astoundingly popular Magnavision—perhaps said it best when he noted the television set will become the "anchor" for a family of video components. Such would include disc and cassette machines, video games and cameras—"all of which will offer the consumer a home video system that can be compared to the audio systems in American homes today.

"There has developed a growing disenchantment with the quality of material available on commercial television, more video options in the home mean that control over the television set is now—for the first time—firmly in the hands of the viewer."

Ingram further noted as far as Magnavox is concerned there is no conflict between the VCR and video disc. "Our experience shows that the two systems are entirely compatible—not competitive—and they will soon complement each other in the same way record players and tape recorders complement each other today," he said.

In fact, the combined market for VCR/VDP in 1985 will be \$4.2 billion, he predicted, with the VDP comprising \$2.9 billion of that total.

Getting back to the basics of what started this whole thing, the television set, industry execs are predicting that 85

per cent of all units sold in 1980 will be equipped with microprocessor controlled electronic tuners. Additionally, up to 25 per cent of the portables will carry remote controls and 30 per cent of consoles will be so equipped.

Overall, the 1980 sales outlook for color TVs is expected to be off from three to five per cent with a year end result of about 9.3 million sets. Black and white sales should total some 5.8 million.

Audio

From the audio end of the industry at CES came the prediction that the decade of the 80s will be anything but orthodox as people continue to upgrade hi-fi systems—but not in traditional ways.

For example, market consultant Ray Boggs of Venture Development Corp., says the use of video disc and tape systems to supply high quality audio signals to present hi-fi systems is a probability. Magnavox, he claims is eyeing a special \$400 version of their disc machine for audio purposes only. "The use of video disc equipment for audio applications will complicate the lives of turntable and tape deck manufacturers but amplifier and speaker people" should be overjoyed.

Additionally, Boggs notes, the intro of



Fig 5 Severe angle shot of Projection Systems' large screen display at the Winter CES shows high brightness level despite the off center viewing location.

"stereo" television to the U.S. will have a major impact—but mostly on TV manufacturers who most probably will meet the challenge with console TV/music systems. Consumers indeed are interested in improved TV sound, he said, according to the results of a recent VDC report. "Television and Home Information Display: A strategic analysis for viewdata/teletex industry participants."

Personal computers

The 1979 consumer market for computers was disappointing, according to Arthur D. Little consultant Bill Meserve, not so much from a demand standpoint—but from the supply end of the industry.

With shortages in semiconductor chips forestalling shipments, the industry sales for 1979 totaled a disappointing \$500 million. This figure should double in 1980, Meserve said, but the most striking aspect of the industry will be the pent up growth of the "consumer" segment, rising from \$30 million to \$120 million in 1980.

While Meserve was extolling his figures at CES, a University of California researcher predicted personal computers would be the next major electronic phenomenon in the American home. Its progress will rival that of the television set, according to Jack Nilles, who says that by the 1990s you can expect to see well over 40 million small, personal computers in the American households. Generally prices of these "home" units would range from game oriented devices selling for \$500 to

sophisticated management systems going for up to \$15,000.

New products

Typical of the major companies present among the more than 800 exhibitors at the show and the types of efforts they are putting forth are the following:

—Toshiba unveiled two new video tape recorders; an experimental voice activated television system based on voice analyzing microprocessor circuitry that responds to the users commands; its Pulse Code Modulator—the Mark II—for use with either Beta or VHS format VCRs; and yet another experimental model of its endless loop, fixed head video tape recorder first shown at last summer's CES show in

—Quasar showed its hand-held language translator; two new video cameras, smaller, lighter, portable video cassette recorders, four new color TVs; and a "talking" microwave oven which, among other statements, keeps the user informed as to the food temperature.

—Sony showed its newest Betamax, the SL-5600 which contains the 14-day/multi-event programmer, plus BetaScan. Several innovative features are an electronic indexing system to permit the viewer to find the program he desires when there is more than one on a tape and the special memory backup system which preserves programming instructions in case of power failure.

—The VHS systems were in prominence also, with Magnavox being one of the many companies showing Matsushita's new 6-hour programmable VCR which includes still frame, frame-by-frame advance, slow motion, plus fast forward and reverse.

Despite the endless glitter and the parade of professional models employed to hype the marketing efforts of the large and powerful exhibitors at this show, perhaps one of the most noteworthy exhibitors was a small company out of New Jersey—Projection Systems, Inc.—which showed its own version of a large screen projection TV, with a flat screen providing the widest viewing angle of any large screen television system I've seen.

The company says the unit contains a 160 degree viewing angle, and personal observation at the show confirmed this to be true. In fact, it won't "go dead" when viewed from the side. The video projector for this screen system is comprised of three 6-inch high resolution CRTs, with special high voltage focus circuitry. It's compatible with the US NTSC or European PAL video systems. **ET/D**

high quality without high cost



**IN A CONTROLLED
OUTPUT
SOLDERING IRON**

BY Weller®

Model W-60. Versatile 60-watt, pencil-type tool with automatically controlled temperature and output. Only 7 1/4" long. Weighs but 2 1/2 oz. Quick-change, anti-oxidation-coated 1/4" screwdriver tip. Several other sizes available with choice of temperature outputs. Use with or without optional, mounted or free-standing bench stand PH-60.

Ask your local distributor or write...



**The Cooper Group
Electronics Division**

WELLER® · WISS® · XCELITE®
P.O. BOX 728, APEX, NORTH CAROLINA 27502, 919/362-7511

Circle No. 107 on Reader Inquiry Card

Nickel cadmium batteries

Their Care and Feeding

Batteries of virtually every variety have gained in popularity dramatically in recent years as the proliferation of smaller, more efficient, portable test instruments and consumer products became a fact. Many of the expenses associated with nonrechargeable batteries can be overcome with the use of NiCads, however, to gain the most benefit you must know how to handle these portable power sources.

By Bernard B. Daien

With the adoption of semiconductors, battery power became practical. With battery power, portability became common. Thus today's calculators, frequency counters, portable radios, and a host of other devices, are "pocket" items.

Unfortunately, battery power is probably the most expensive of the conventional forms of electrical power. And replacing batteries is inconvenient. To eliminate these problems, some form of rechargeable battery is indicated. As a result, the nickel-cadmium (NiCad) battery is rapidly increasing in popularity. Despite a relatively high initial cost, the NiCad is extremely economical because of its long useful life.

Too often NiCad batteries never reach their full life expectancy because of misuse. And many "dead" NiCads can

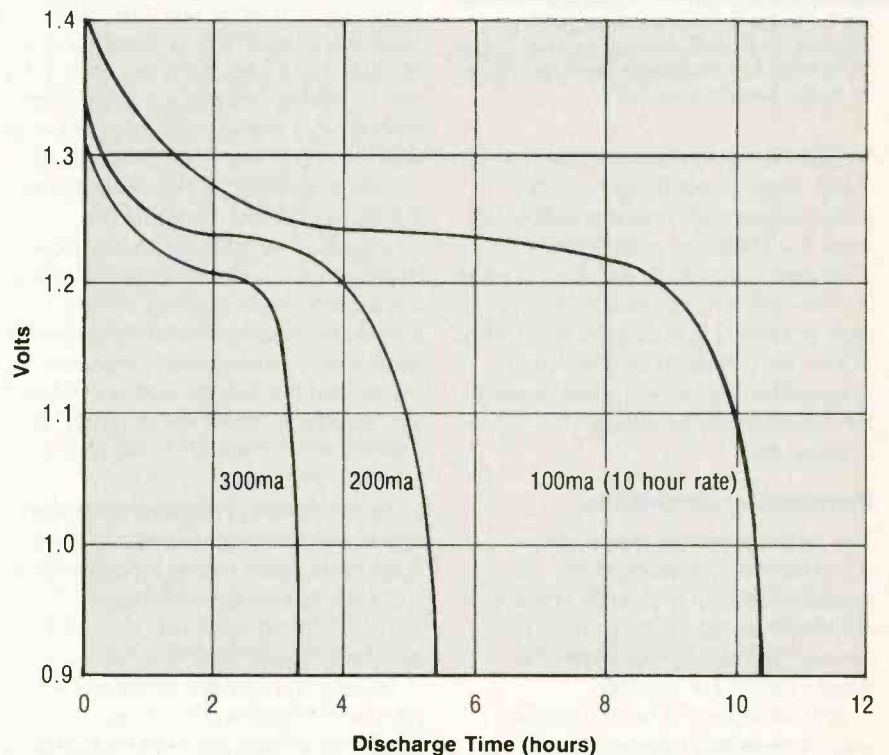

Fig. 1 The graph of the output voltage and time relationships for various discharge rates for a button type NiCad cell with a 1 ampere hour rating (Taken at 20° C ambient).

be put back into useful life by reconditioning, or rejuvenation.

This article confines itself to the practical application of NiCad batteries. Much of the literature on this subject discusses the history of batteries in general, primary and secondary batteries, construction of batteries, etc., which is of little concern to the user. By contrast, the reader will find this discussion is "user oriented," and correspondingly brief, considering the content.

Meet the NiCad

As a good way to start, it should be mentioned that nickel-cadmium

batteries are usually shipped partially charged. Even when shipped fully charged, some loss of charge can be anticipated in shipment, and on the shelf. Before putting the battery into use it is advisable to completely discharge it, using a load resistor which limits the discharge current to the manufacturer's recommended value. (More about this later.) When the voltage has dropped below one volt per cell, discharge should be stopped. The battery should then be fully charged, per manufacturer's recommendations. This discharge/charge cycle conditions the battery for use.

As a matter of fact, such conditioning

is recommended periodically, in order to keep the NiCad in top condition, and several discharge/charge cycles are usually employed. The principles of charging and discharging will be covered later in this article.

NiCads will self discharge depending upon the ambient temperature, losing half their charge in 60 days at 25 degrees Centigrade. At the temperatures encountered in an automobile on a hot summer day it takes only 20 days to lose half charge, but if kept in the refrigerator (not freezer!), half charge can be kept for at least a year.

NiCads can operate over the range of -20 to +45°C and can be stored without harm from -40 to +60°C., but charged only over the range of 0 to 45 C! This is

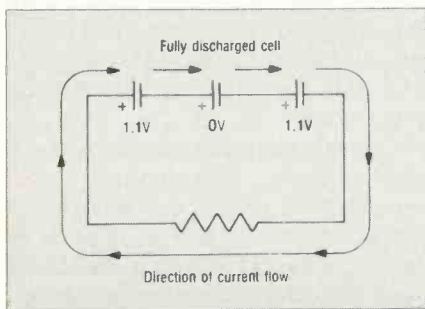

Fig. 2 The reverse charging of a discharged cell by the remaining, partly charged cells in series connected multicell batteries does produce a damaging effect.

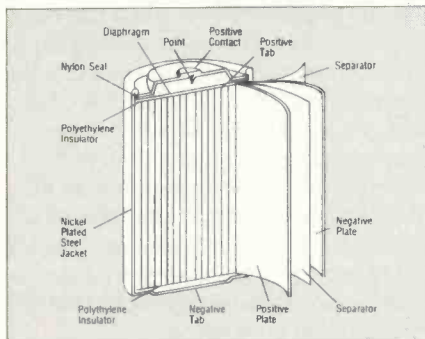

Fig. 3 The cross sectional constructional details of a NiCad cylindrical cell.

due to the fact that attempting to charge a cold battery results in gassing, which will also be discussed in detail in the section on "Charging," later.

Temperature dependent

By now you are aware of the fact that the NiCad is a temperature dependent device, something you may not have considered before. To make up for this however, the NiCad withstands shock, vibration, and most other environmental conditions well, and is not fussy about mounting upside down, or in any other position. It should be mounted so that heat generated during charge, and discharge, can be dissipated, and

ventilation should be provided to take care of gases vented. NiCads generate hydrogen and oxygen, when subjected to overcharge, and certain other stress conditions. Since hydrogen and oxygen explode when ignited, this should be a consideration in mounting the battery.

The battery electrolyte is alkali, and can cause damage to skin, eyes, clothes, and metallic connections. Spilled electrolyte can be neutralized with vinegar, or any other mildly acid solution, and the residue rinsed with water. Nickel plated connectors resist electrolyte corrosion well, and are recommended.

NiCads come in a variety of sizes, shapes, and types. For this discussion we will consider the two most common types used in electronic equipment; the button type and the cylindrical type.

Other types are made, some with special temperature, or charge/discharge characteristics, etc. The rectangular type is often made with provision for adding water as needed, in industrial use, but we cannot consider them in an article of this length.

Since NiCads have a very low internal impedance, they are capable of very high short circuit current output, which can destroy the battery, therefore precaution should be taken to prevent the dangers involved in such short circuiting.

Vented batteries

Most NiCads are vented to permit the escape of gasses. Two types of vents are in use, one type acts as a "safety valve" only. Once blown, the seal is permanently ruptured, the cell soon dries out and becomes useless. The other type of vent is termed "resealable" because the vent is spring pressure loaded, and recloses when the internal gas pressure drops. This type of seal permits the cell to vent, but upon resealing the battery continues to be useful. Of course, continuous venting eventually destroys the cell. Cells without vents are capable of exploding when subject to overstress conditions, and should be used only within their recommended operating and environmental conditions. They can be dangerous!

Now that we have looked at some of the general facts about NiCads, we will be a little more specific. The normal range of output voltage per cell is between 1.2 and 1.4 volts, but depends upon several factors. At temperatures much below normal room ambient (70° F.), voltage drops about a tenth of a volt. And, the heavier the drain during

discharge, the lower the voltage delivered.

Past history of the cell also affects the voltage in a variety of ways. The faster the cell is charged (high charging rate), the higher the output voltage will be when removed from charge, approaching 1.5 volts for the higher charging rates . . . however, this voltage will drop back into the normal range after a short period of time on the shelf, and very quickly after being put into service. When the cell is charged at normal rates, the voltage does not exhibit so much rise.

Discharge rates

Most NiCad specifications use the "ten hour rate" as standard, and, unless otherwise stated, it will be assumed that the following refers to the ten hour rate. If a fully charged NiCad cell is fully discharged in ten hours by a given load current, we are using the ten hour rate. Cells are rated in "ampere hours" . . . a "1 ampere hour cell" would deliver 1 ampere for one hour. It is usually assumed that such a cell would also deliver 0.1 amperes for ten hours, for a total of 1 ampere hour. (This is not strictly correct, since cells tend to have more efficiency at low discharge rates.) Thus it is possible to calculate the ten hour rate from the manufacturer's ampere hour rating of the cell, which is usually included in the cell's type number.

Figure 1 shows the output voltage, versus time, for a typical 1 ampere hour button type NiCad cell, at several different discharge rates. Notice that at the ten hour rate (100 milliamperes discharge current), the voltage falls to 1.1 volts, and that at 1.0 volts the voltage is dropping very rapidly, clearly indicating imminent total discharge. This is why 1.0 volts should be considered the end point for discharge at room temperature. **DO NOT DISCHARGE NICADS BELOW 1.0 VOLT PER CELL!**

There are several good reasons for this warning. First, the number of charge/discharge cycles a cell can take in its lifetime depends upon how deeply it is discharged. If the cell is normally recharged at the 1.0 volt point, it will accept more recharges than if it is permitted to run all the way down. Perhaps more important, in multi cell batteries, the phenomenon of "reversed polarity" can lead to shortened life, or failure of one or more cells.

This occurs when a cell becomes completely discharged before the rest of the cells in the series connected battery, due to the fact that all cells are not

exactly alike in charge capacity. The cell with the lowest charge capability simply discharged before the others. As shown in Figure 2, the current from the rest of the cells actually reverse charges the discharged cell, producing gas generation, venting, and reduced life.

Let's assume that the middle cell has discharged to zero potential, while the end cells still have some remaining charge. The charged cells continue to push current through the battery-load closed circuit. This current must therefore flow through the discharged cell in the direction shown by the arrows. Note that this current produces a reverse charge in the center cell, since current flows from negative to positive, which is opposite in polarity to the cell's indicated polarity.

Polarity reversal

When a NiCad battery is made of several series cells, the manufacturer tests, and matches cells, to minimize the possibility of polarity reversal. If the user assembles several cells in battery holders, to form a battery pack (supply), he normally does not attempt to match cells, and the possibility of reversal of polarity greatly increases. The way to minimize this is to insure that the total voltage does not drop to less than 1.0 volt per cell, in discharge. Recharging the battery before it "bottoms out" is the easiest way to avoid this problem.

A battery voltage indicator is a very worth-while item, and it need not be a meter, which is relatively expensive. There are several electronic voltage sensing circuits, using zener diode references and op amps, which do the job, using LED warning lights. Commercially available ICs are also inexpensive and well suited for the purpose. But, regardless of the means used, polarity reversal should be avoided.

Referring back to Figure 1, for a moment, look at the 100 ma discharge curve. Between the first hour, and the tenth hour of use, the output voltage per cell is 1.2 V plus or minus 0.1 V. Thus the nicad cell holds its output voltage quite constant compared to most other types of battery power sources. The output is also relatively constant with regard to time in stand-by use.

This characteristic is useful in certain power supply applications, when apparatus must be operated continuously . . . by operating the nicad battery on a charger, and using the battery as the source of power, several advantages are obtained. First, in the event of power failure, the NiCads will

continue to supply the load as a non-interruptible source . . . and, secondly, the NiCads act as a very effective filter capacitor, eliminating the need for bulky filter caps.

NiCads have a low internal impedance, and a high apparent capacitance. Since conventional capacitors become poor filters at the lower frequencies, the NiCad offers very considerable advantage at the low frequencies used on utility lines, and particularly so when half wave rectification is employed.

Internal shorts

If a battery exhibits zero voltage after some reasonable charging period, it should be tested for internal shorts. Batteries which are sitting discharged are particularly prone to internal shorts, since there is no current flow to "burn out" minor shorts.

A large percentage of such cells can be restored to usefulness by using an external current source to burn out the short. One method is to charge an electrolytic capacitor to 1.5 volts, and then apply it across the NiCad's terminals, *PLUS TO PLUS, AND MINUS TO MINUS*, as if charging the battery. The high pulse of current does an effective job . . . if some precautions are observed. 1. The capacitor should be charged to 1.5 volts. Higher voltage can damage the cell. Less will not achieve the desired results. 2. The duration of the pulse, and the current amplitude can be controlled by the size of the capacitor used.

Generally a starting value of 1000 mfd can be tried. If results are not obtained after *two or three pulses*, the capacitor can be increased to 10,000 then on up to 100,000 or so mfd. The reason for several pulses is that there may be multiple shorts, and all must be removed.

Normal charging is current limited, usually to the ten hour rate, and therefore is not sufficient to burn out shorts, once established. The high pulses delivered by a large capacitor are not current limited. Some experimenters have reported success in clearing shorts with a low voltage, high current supply, using a momentary connection to avoid damaging the cell, but unfortunately, most of us do not have access to high current 1.5 volt supplies.

No voltage taps

NiCad battery strings should not be "tapped" for multi-voltage supply purposes. This leads to unequal discharge of cells, and invites reversal of

polarity, as previously explained. Separate batteries should be used for multi-voltage supplies. Along similar lines, it is generally advantageous to use a larger battery, with a higher ampere hour rating, in order to achieve a discharge rating at the 10 hour (or longer) rate. High discharge rates dissipate more heat, due to internal battery resistance, and lead to shorter battery life.

The NiCad is capable of delivering high currents, and occasionally is used to provide high current short duration pulses, but this application should be undertaken after examining the manufacturers recommendations. Small batteries, pushed hard, do not give full life, and have problems with venting. When small size and weight are essential, the manufacturer can often provide batteries designed for high rates of charge and discharge, as part of the product line.

Internal overheating due to high discharge rates, high ambient temperatures, or both, causes boiling of the electrolyte and can be detected by heating of the cell exterior. Cells should never be operated in a well insulated (thermally) container, since heat build-up can readily occur.

Charging

As you probably know, there are many ways to charge batteries; constant current, constant voltage, taper charge, slow charge, trickle charge, float, fast charge, etc. NiCads should not be charged constant voltage, nor should attempts be made to charge cells in parallel. The usual method of charging is constant current, at the ten hour rate, for 13 hours. Thus a one ampere-hour battery would have a ten hour rate of one-tenth of an ampere.

However, in order to allow for the fact that no device is 100% efficient, we must charge for more than ten hours. Thirteen hours represents a total efficiency of just over 75%, which is pretty good! Most small devices with built in NiCads have a recommended 16 hour charge to insure 100% charge, and the slight overcharge does no harm to the nicad, at *this 10 hour rate*.

When it is necessary to keep a battery on charge for fairly long periods, the 30 hour rate is recommended. In order to charge continuously, the 100 hour rate should be used (10 ma in this case). This is also known as trickle charging, and cells in this use should be discharged to 1.0 volt every 6 months, and recharged at the 10 hour rate for 13 hours to reform the cell and insure reliability.

As mentioned early in this article, temperature must be a consideration. Charging is not effective, and can be harmful, at high or low temperatures. Overcharging, or incorrect charging, shortens life and reduces capacity (the amount of useable charge).

Overcharging at a high rate leads to venting, and venting also reduces cell life. Recharge efficiency may be important to some persons who use a great deal of battery power, or for portable or other uses where the available recharge power comes from a very limited source, which must be conserved. In such cases it is advisable to charge at room temperature at the 20 hour rate, in which case recharge efficiencies as high as 90% can be achieved, with a cell capacity of 100% of rating.

Using a DC meter

When charging from a transformer-rectifier set up, without the use of any filtering, the charging current is a series of pulses (pulsating dc current) directly out of the rectifier. There has been some confusion as to whether the charging current is the rms, average, etc. This is easily resolved by using a conventional moving-coil, direct current type meter with proper current range, (or shunted as required). Such a meter has an *average current response* and is what is required for direct reading of the charging current, regardless whether half wave, full wave, or multiphase rectification is used.

It should be noted that when only one (or a few) cells are to be charged, the voltage drop across silicon rectifiers in a full wave bridge can be greater than the voltage required by the NiCads . . . which is very inefficient, and with high current cells represents a heavy loss of power. In such cases it is wise to consider the use of Schottky type (low voltage drop) rectifiers, such as are used in automotive applications.

As with all devices, there is an end-of-life point for NiCad cells which do not fail catastrophically. This occurs when the cell capacity decreases to 60% of its rating, at which time there is a rapid acceleration of loss of capacity. But a word of caution is in order here. Some capacity losses are temporary, and can be restored by several full discharge/charge cycles. Other capacity losses are permanent. Thus, when a cell reaches 60% of its original capacity, and cannot be restored by repeated charge/discharge cycling, it should be taken out of service.

Cell capacity can only be measured

by going through a full charge/discharge cycle, at normal ambient temperature. Age reduces capacity, high charge/discharge rates reduce capacity, low temperatures also reduce cell capacity. Some cells now made have internal control devices which permit fast charging, and are so specified by the manufacturer. As with all NiCads, the manufacturers' recommendations should be closely followed.

There is no "quick check" for determining the state of charge of a NiCad cell! The only reliable method is to completely discharge the cell, and then completely charge it. A discharged cell, below 1.0 volt can be detected, but that's about it.

Points to remember

- A properly maintained NiCad battery will operate for *hundreds* of charge/discharge cycles.
- There is an observable rise in the voltage of a battery on charge, when the 100% charge point is exceeded, but it too varies with the rate of charge (increases as rate of charge increases), and with temperature (increases if temperature is decreased).
- Charging at temperatures below 0° C (freezing) results in excessive venting. Recharging efficiency becomes markedly lowered when temperatures rise. Again, room temperature is the optimum.
- The restoration of cell capacity by the full discharge/charge cycling method is often referred to as "conditioning" or, "reconditioning."

With certain types of construction, a nonsealable vent that blows is visible and accessible. Some success has been achieved by resealing these with a dab of silicone rubber, providing the sealing is accomplished soon after the venting occurs, and that there has been no appreciable loss of electrolyte. The silicone rubber plug will form a new safety vent. Solder, epoxy, or other durable materials must *never* be used for resealing a vent, as the cell will explode under stress. Some NiCads have metal tabs for soldering to the cell. When a cell has no such tab, do not attempt to solder to it. Damage to the cell seal, which is plastic, will probably occur.

Salvage batteries

A good source of NiCads for experimental use is the salvage of discarded NiCad multicell batteries. Usually only one of the cells is bad, and if

continued on page 4

Quietrole

The Original...

A First in the industry, with over thirty years of use by satisfied customers.



Spray Pack Mark II gets into places of close tolerance and washes out the dirt, leaving a thin film of lubricant which lasts indefinitely, with zero effect upon current capacity and resistance.

Spray Pack Mark II has been tested and proven in the Space Age and is still the finest lubri-cleaner available. It is quick, safe, effective - a MUST for every tool caddy.

Available from LEADING jobbers.



Circle No. 117 on Reader Inquiry Card

BELTRON OWNERS

Edtron Instruments, Inc., manufacturer of the Beltron System,

is now offering a Dealer Direct Up-date Program for the Beltron Set-up Chart. For \$7.95 per year, Edtron will send out at least two updates plus items of interest we think you can use. Our latest update (as of June 1, 1979) has adaptors through the AE-27 in it.

Please send your address and Beltron serial number along with the first year subscription amount of \$7.95 to:

Attn: Set-up Chart

EDTRON INSTRUMENTS

1190-X Miraloma Way
Sunnyvale, Calif. 94086

Countdown and divider circuits in modern TVs

New techniques for new systems

Zenith's System 3 master scan and divider networks are typical of the "new wave" of PLL controlled sync. Here's a state-of-the-art look at what's going on.

By Robert L. Goodman, CET

This article begins with some basic phase-lock-loop (PLL) divider circuit and program-able divider operations. These will include VCO, phase detectors and flip-flops. We will then delve into PLL stability, master scan oscillators and VCO problems.

Various scope and frequency counter testing techniques will be discussed next. Oscilloscope versus frequency counter testing for PLL faults will then be considered.

The last section is devoted to understanding and troubleshooting PLL circuits used in modern-day color TV sweep systems. This will include "in-depth" coverage of the Master scan oscillator and the Vertical/Horizontal divide chip techniques.

The information contained in this horizontal system must have three main functional blocks or sections. These blocks are as follows: 1- A single or pulse reference source. 2- A voltage controlled oscillator (VCO) whose output frequency is controlled by the amount of DC applied to its control input. 3- A phase example of a basic phase locked-loop operation. Like any PLL, the TV

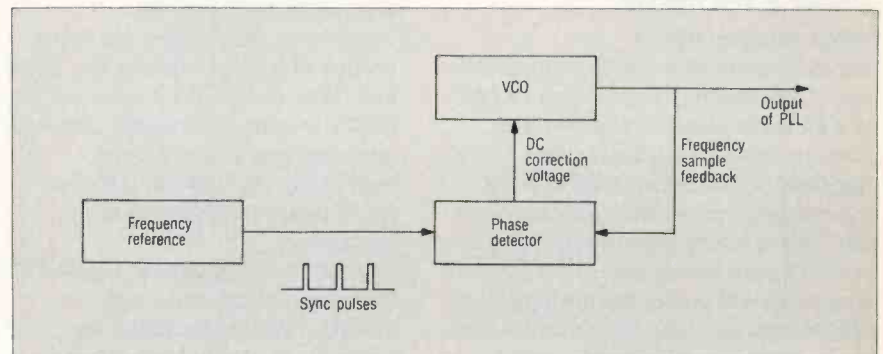

Fig. 1 A block diagram of a PLL system.

horizontal system must have three main functional blocks or sections. These blocks are as follows: 1-A single or pulse reference source. 2-A voltage controlled oscillator (VCO) whose output frequency is controlled by the amount of DC applied to its control input. 3-A phase detector that produces a DC output voltage proportional to the difference in frequency of the two signals fed to its two inputs. The horizontal sync pulses from the TV station provides the reference signal for this system.

The block diagram in Fig. 1 shows how these three blocks are connected together. The VCO will operate at some frequency close to the desired frequency when there are no sync pulses present at the sync input of the phase detector. Let's now look at the sequence of operation for a PLL to lock in a TV receiver's horizontal sweep.

- 1 - The sync pulses and the signal coming from the VCO are compared in the phase detector. There will be a DC correction voltage produced if they are not the same frequency.
- 2 - The DC voltage from the phase detector is fed to the VCO input which

causes it to change frequencies. The direction the frequency changes depends on the polarity of the correction voltage.

- 3 - When the VCO output is exactly the same frequency as the reference input, the correction voltage is zero or at its designed value. Under these conditions the PLL is now "locked."
- 4 - Any frequency drift in the VCO causes a DC output change away from the phase detector which starts the above process again.

All phase-locked loops operate with this same feed-back action. As we will see a little later, additional circuits are required to allow the output frequency of the PLL to deliver frequencies other than the reference oscillator frequency.

PLLs and divider circuits

The two inputs to the phase detector of any PLL must be the same frequency in order for the PLL to lock-in. Let's now look at the results of a flip-flop (divide-by-two) stage placed between the VCO output and phase detector input (Fig. 2). Now the frequency at the phase-detector input will be exactly

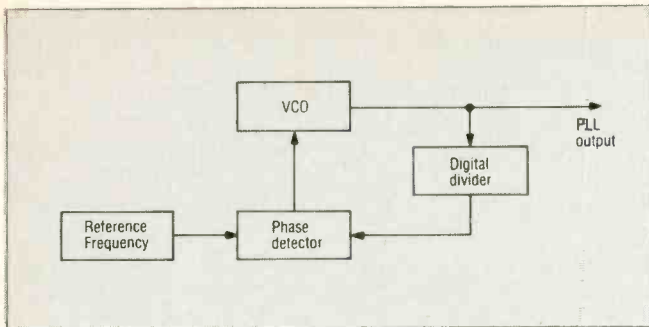

Fig. 2 PLL system with a divider chip.

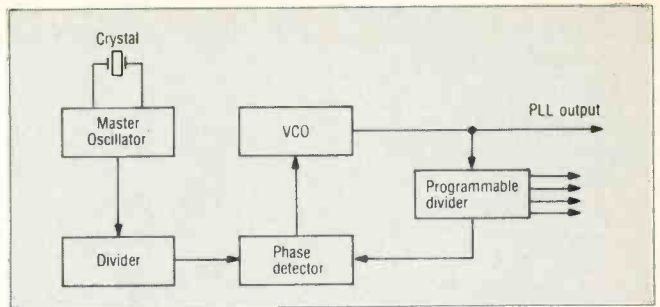

Fig. 3 In some systems a crystal is used in conjunction with the PLL circuitry.

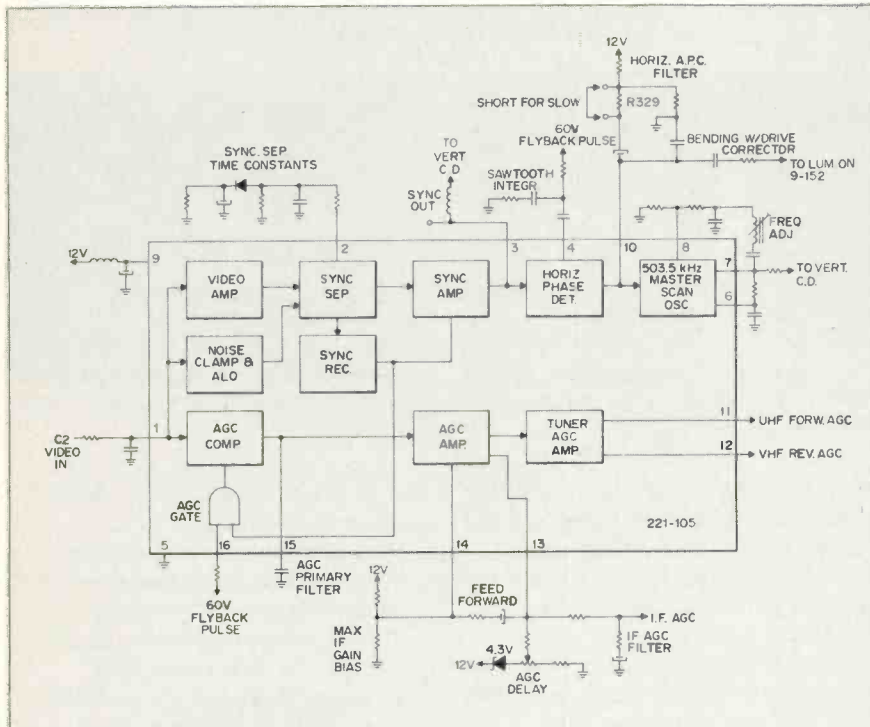

Fig. 4 Zenith's M1 module with AGC, sync separator and master scan functions.

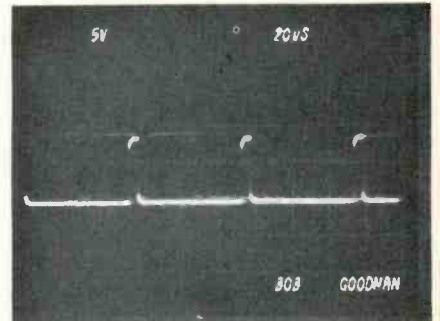
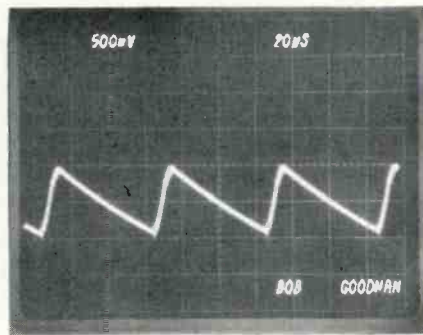
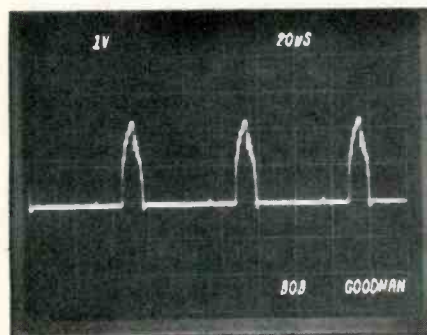

Fig. 7 The output of Pin 3 of the IC.



one-half of the VCO frequency. The feedback action of the phase detector will change the VCO frequency until the signal coming from the flip-flop output is exactly the same as the reference signal. This occurs because the VCO operates at twice the reference oscillator frequency because only half of the signal is going to the phase detector. Actually a divider stage is used to multiply the VCO's output frequency. If the divider were a divide-by-four stage,

the VCO would have to operate at four times the reference frequency in order for the PLL to lock. Special IC's have been designed with many flip-flop stages within one device for use in PLL design. The PLL that uses only fixed dividers, however, will only develop a single frequency that is a multiple of the reference signal's frequency.

Programmable divider IC's

A special type of IC called a

"programmable divider" allows the frequency of the PLL to be changed by using DC control voltages. A programmable divider is similar to a fixed divider IC except that it has extra "programming" or "JAM" pins. Tying these pins to B+ in different combinations will cause some of the flip-flop stages to be bypassed which results in a different divide-by number. As an example, one programmable IC allows any divide-by number from 3 to 15,999 to be selected by switching voltages to the correct combination of 16 programming pins. This IC allows a PLL to be programmed for up to 15,996 (15,999 minus 3) different frequencies, which are all referenced to the same master oscillator via the phase detector.

Either a programmable or fixed divider IC is easily tested with a frequency counter connected to the input and then to the output. The ratio of these two frequencies indicates the divide-by number of the stages. These divider IC's often divide by the wrong number, when defective, resulting in the wrong PLL output frequency. The divide-by number of a programmable divider is determined by the combination of programming pins tied to Vcc. Check the service data for these chips to find out which pins are tied to B+ for key PLL output frequencies that you can check out with a frequency counter.

Troubleshooting

Either fixed or programmable divider IC's may divide by the wrong number when defective. Use a frequency



Fig. 8 An accurate counter is needed to check frequencies in any digital circuit, including this check of the master scan oscillator frequency.

counter, with adequate input bandwidth, to test for proper IC division. For this test you need only measure the input and then the output of the IC to confirm the correct division of frequency. Now compare the measured division to the programming instructions on the programmable divider data tables.

Many PLL circuits have a few additional stages that are included to provide more stability of the output frequency. The phase detector operates best with input frequencies in the audio range. One kHz would be a typical operating frequency. The reference oscillator, however, will usually be crystal controlled for extra stability over a long period of time. These crystal oscillators perform best in the frequency range of one to ten MHz. Note the block diagram of a crystal controlled oscillator and a phase detector where the best characteristics of both types of circuits are utilized (Fig. 3). A one MHz oscillator, for example, may be divided by 1000 to produce a phase detector frequency of 1 kHz. The programmable divider between the VCO and phase detector must also produce an output frequency of one kHz when the VCO is operating at the correct frequency. Be sure that the frequency counter you are using to troubleshoot these PLL circuits gives accurate readings at these audio frequencies.

Oscillator and VCO problems

The frequency counter is used to check the output frequency of the master or reference oscillator. All of the PLL output frequencies will be incorrect if the master oscillator is not operating at the proper frequency. The counter used for this test must have high accuracy and be very stable.

Problems in the voltage-controlled-oscillator (VCO) can also develop an improper output frequency. The VCO can only be controlled over a certain range of frequencies known as the "VCO lock-in-range." The lock-in

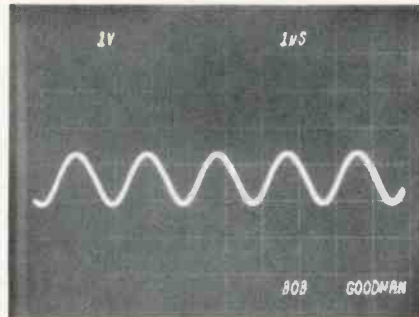

Fig. 10 Pin 9 shows the 32H master scan sinewave.

range is determined by the VCO tuning circuit made up of coils, capacitors and varicap diodes. The varicap diodes receive the DC voltage from the phase detector to change the operating frequency of the PLL.

Some VCO's use at least one adjustment to set the upper and lower limits of the lock-in range. This adjustment is set to center the lock-in range frequencies over the normal operating frequency range of the PLL. The VCO may lock-in at either the highest or lowest frequency but not lock at the other extreme. If this occurs it usually indicates that one of the frequency determining components has changed value. The frequency counter will help you locate this type of problem.

Connect the counter to the VCO output to check for proper lock-in range. Select the highest and then the lowest PLL frequency with the channel selector or PLL frequency control. The frequency counter should show a solid, stable reading at both of these frequency extremes. You should try to adjust the lock-in range adjustment if either of the frequencies are either unstable or off-frequency. There is a problem in the VCO tuning circuits if this adjustment does not allow you to lock both the highest and lowest frequency.

Scope versus counter in PLL

An oscilloscope can be used to trace some of the signals around these PLL

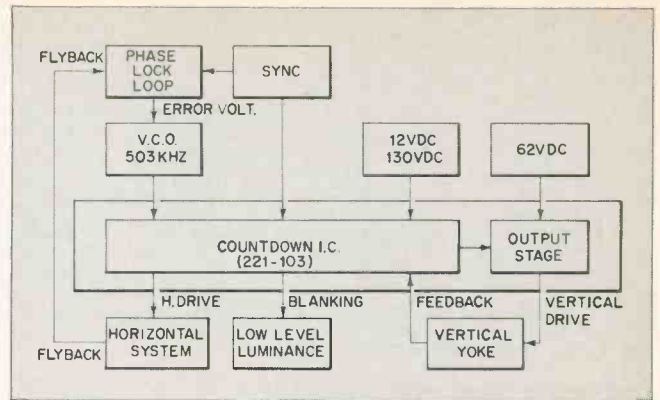

Fig. 9 Block diagram of the vertical countdown chip.

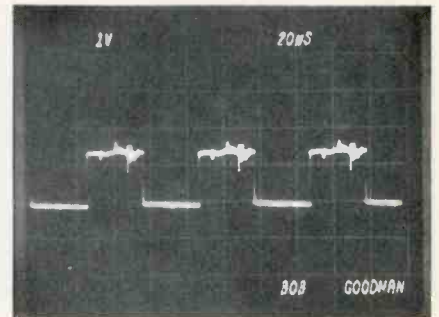

Fig. 11 A normal drive signal at pin 11 of IC 221-103.

circuits but is limited to only certain portions of the PLL.

Scope limitations are as follows:

- 1 - Scope frequency response will usually not be great enough.
- 2 - Frequency measurements are usually very time consuming.
- 3 - Scope frequency measurement accuracy is not adequate for proper PLL testing.

You should be able to measure the VCO output frequency to determine if it is correct. This measurement will tell you if the PLL is operating at the correct frequency and is also necessary when testing a divider stage connected directly to the VCO output. Keep in mind that the VCO output can be several hundred MHz for many PLL applications. This is well above the frequency bandwidths of most scopes.

It takes a good bit more time to measure a frequency with a scope than with a frequency counter. After scope warm-up the first step is to switch the horizontal sweep vernier control into the calibrate mode. If this is not done the frequency count results will be meaningless. Next, determine the amount of time for one cycle of the waveform by counting the number of divisions on the CRT and multiply this by the setting of the scope's timebase switch. Finally, you must convert the time measurement to frequency by dividing it into one. After all of these steps are taken the scope measurement

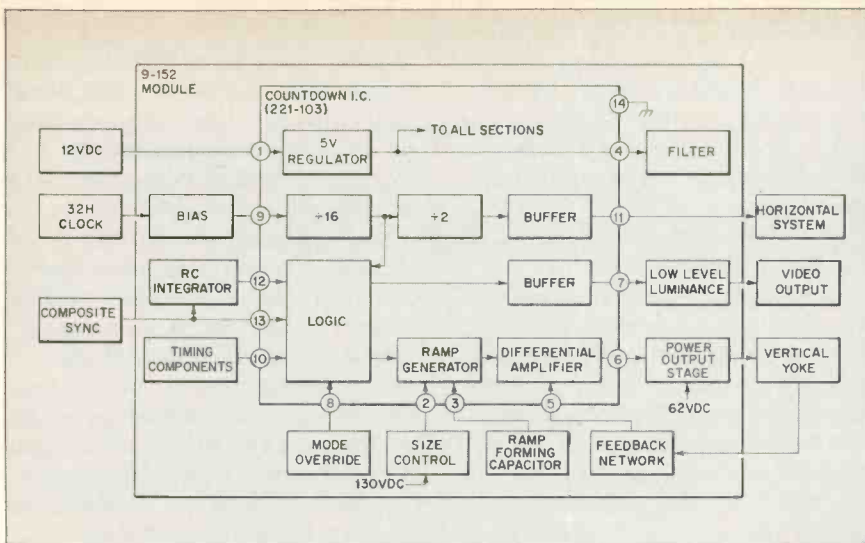

Fig. 12 Detailed block diagram of the vertical countdown chip.

will probably be off by 5-or-10 per cent. This is too great an error for accurate PLL troubleshooting.

Scope measurement errors can occur in many ways. The calibration of the scope's sweep speeds will usually have about a 5% error. Then you must add interpretation errors such as determining exactly where the waveform starts and stops, estimating the distance between the divisions on the CRT screen and even the width of the trace itself. All of these scope interpretation errors are, of course, eliminated by using a frequency counter.

Modern TV sweep systems

Digital IC's, count-down chips, and PLL systems are now common in TV receivers. This was unheard of only a few years ago. We will look at one of the systems now being used in several color TV brands being sold today. A lone IC now replaces both the vertical and horizontal sweep circuit oscillators. No vertical or horizontal hold controls are used because of this new system design.

Briefly, the heart of the system is a phase-locked-loop that is referenced to the horizontal sync pulses. The PLL oscillator runs at 503.5 KHz which is 32 times the horizontal sync frequency. This frequency is much more stable than the horizontal frequency because in some sets a "ceramic resonator" component is used to keep the PLL stable between horizontal sync pulses. You could look on this as some type of a "flywheel effect." A ceramic resonator is similar to a crystal but is much lower in cost and only a little less accurate. Note block diagram of the master scan oscillator on Zenith's MI module (Fig. 4).

The 503.5 kHz signal is first divided by 16 with digital dividers. This frequency is needed to provide precise interlace

scanning during vertical trace. The resulting 31.468 kHz occurs within the "chip" and cannot be measured by the outside world.

The 31.468 kHz signal is now divided by two to provide the horizontal frequency of 15.734 kHz which is fed to the horizontal output stage. The 31.468 kHz signal is also divided by 525 in other count-down stages to produce the vertical frequency of 59.94 Hz which is then fed to the vertical output via special shaping circuits. Additional digital circuits reset the internal counter stages at the proper time to maintain vertical and horizontal sync.

The master scan "Chip"

Referring to the block diagram in (Fig. 4) of IC 221-105 again, note that video enters the IC at pin 1. Video is then fed to the video amplifier within the chip and goes on to the sync separator. The normal dual-time constant sync separator network circuit is connected to pin 2.

A sync recovery circuit senses a loss in separated sync, as might happen with a sudden drop in signal strength, and applies an output which again turns on the AGC system to help it recover quickly. An AGC keying or gating pulse is fed to pin 16 of this chip from the horizontal sweep section. The correct pulse that should be found at pin 16 is shown in the (Fig. 5) scope waveform.

The sync amplifier provides an input for the AGC gate, horizontal phase detector and a composite sync output which is then fed to the 221-103 vertical count-down chip.

The horizontal phase detector, in addition to receiving the sync pulses, also receives a sawtooth voltage at pin 4, which is developed by integrating the 60 volt positive horizontal sweep pulse. Note the correct saw waveform in Fig.

6. This is the feedback or comparison pulse required to lock-in the master scan oscillator. The phase detector output is filtered at pin 10. The phase detector in turn controls the master scan oscillator in order to lock in the picture. More details on this later in the vertical countdown section. At this point you may also check for sync out pulses at pin 3 of the chip as shown in the Fig. 7 scope waveform.

Checking the MSO

The important frequency to measure as we start these checks is the 503.5 kHz master scan output to make sure that the PLL is working properly. Note the frequency counter shown in Fig. 8 being used to make this measurement. Another check is to make sure there are horizontal sync pulses fed to the IC input (from either a TV station or video signal generator) or the PLL will not be locked to an incoming signal. If you have a trouble symptom where the picture will not lock in, a scope check of the horizontal sweep feedback pulse at the phase detector would now be in order. This comparison pulse is at the horizontal sweep rate and should be present at pin 4 of the 221-105 IC. Another symptom that may occur is an AGC overload where the picture bends or weaves. In this case make a scope check for the 60 volt P-P horizontal pulse that should appear at pin 16 of the same IC. This is the gating pulse that must be present at the AGC gate in order for proper AGC system operation to take place.

The frequency of the Master Scan Oscillator is adjusted by shorting a stake at pin 3 to ground and adjusting the core of the FREQ. ADJ. coil for a zero beat of the horizontal and vertical by looking at the TV set's screen. Adjust the coil for slowest roll and/or slide of the picture. These systems do not have a horizontal oscillator as such and thus no horizontal hold control is used.

Count-down circuitry

The block diagram for the Zenith System Three vertical count-down IC that will now be reviewed is shown in Fig. 9. This count-down system utilizes a 221-103 IC which is fed by the 503.5 kHz Master Scan Oscillator. The scan signal at pin 9 of this IC should appear on the scope as shown in Fig. 10. This IC also provides vertical deflection, horizontal drive to the predriver, and a blanking output to the low level luminance circuits. The vertical system accepts a clock signal from the master scan oscillator which operates at 32

times the horizontal frequency (32 H). The IC divides this down to H before being amplified by the buffer to provide a drive signal to the horizontal pre-driver. With normal circuit operation the drive pulse shown in (Fig. 11) will appear at pin 11 of the 221-103 IC. A sample of the horizontal sweep pulse is then compared to the incoming sync pulses by an internal phase-lock-loop contained in the 221-105 IC. The output of the phase locked loop is used to regulate the master scan oscillator.

A frequency counter should be used to check the 15.734 kHz horizontal output signal at pin 11 of the 221-103 chip. This check will confirm that the internal digital counting stages are dividing the PLL output by the correct number. Note that because of interfering signals that may be riding along with the drive pulses the frequency count could be wrong. To eliminate this problem use a counter with an input attenuator that lets you decrease its sensitivity until it displays only 15 kHz drive pulses.

The vertical sweep system consists of an 221-103 IC, two power transistors, and the peripheral circuit elements. The vertical hold has been eliminated with this system. A block diagram of the system is shown in Fig. 12.

To divide by 32, the frequency is first divided by 16 (down to 2H) for use in the logic circuitry of the IC. The signal is then further divided by 2 (down to H) before being buffered to drive the horizontal sweep stage.

Vertical divider

To produce the vertical sweep a logic circuit provides a pulse to trigger a Ramp generator. Associated with the Ramp generator, is a size control and a Ramp forming capacitor. The voltage ramp from the Ramp generator is DC coupled inside the IC to one side of a differential amplifier. The differential amplifier drives a transistor output stage which in turn feeds the yoke's vertical windings. The yoke current is sensed and wavelshaped in the feedback network and a sample of the yoke current is coupled to the feedback side of the differential amplifier. The differential amplifier and output stages make the sample of yoke current look just like the voltage ramp at its input.

To measure the vertical divider frequency, reduce the counter's attenuator for less noise pick-up, because noise on this ramped shaped signal could give you a false reading.

Should the vertical or horizontal divide

frequencies not be correct, the prime suspect would be the IC. I guess the beauty of these divider chips is that there are no outboard components that could cause the output frequencies to be incorrect. Also, check chip B +.

The logic circuitry within the countdown IC has some other inputs. One input receives integrated vertical pulses to make sure that the vertical retrace interval coincides with the vertical interval of the composite sync. Also, the logic circuit receives composite sync because it must decide if the signal being sampled has 525 lines per frame, then the ramp generator is triggered by the count-down chain in the IC. This assures good interlace and solid-lock picture. If the signal does not have 525 lines per frame, then the Ramp generator is triggered on and interlace and noise immunity may be lost. Thus the logic circuit must determine if the incoming signal is standard or non-standard.

The 221-103 vertical count-down chip is supplied by 12 volts DC from the color chassis power supply. Included within this chip is a 5 volt regulator circuit. Most of the circuitry inside this IC uses this regulated 5 volts. This 5 volts is filtered at pin 4 and is used for bias networks at pins 12 and 9. **ET/D**

Price Without Sacrifice.



HITACHI V-302 & V-152

Put a proven Hitachi dual-trace oscilloscope on your bench for as little as \$695. Our V-152 15MHz model includes unprecedented sensitivity (1 mV/div)...10X sweep magnification...front panel XY operation...trace rotation...Z-axis input...and more. Need greater bandwidth? Our V-302 model is the only 30MHz dual-trace scope with signal delay line priced under \$1000, with all the above features, to make your testing operations fast, easy, and accurate. Reliability is exceptional, too. (As you'd expect from a manufacturer with over 20 years of experience "outscoping" the competition.) So exceptional, in fact, that Hitachi quality is backed by a 2-year warranty...the longest in the industry. Whether you use it for teaching or repairs, for video, audio, or computer testing, you can't find more scope for your dollar than at Hitachi. Write for more details.

Hitachi...The measure of quality.

- V-152 15 MHz Dual Trace . . . \$695*
- V-302 30 MHz Dual Trace . . . \$945*

*Probes included.

HITACHI
Hitachi Denshi America, Ltd.
175 Crossways Park West
Woodbury, NY 11797
(516) 921-7200

Circle No. 112 on Reader Inquiry Card

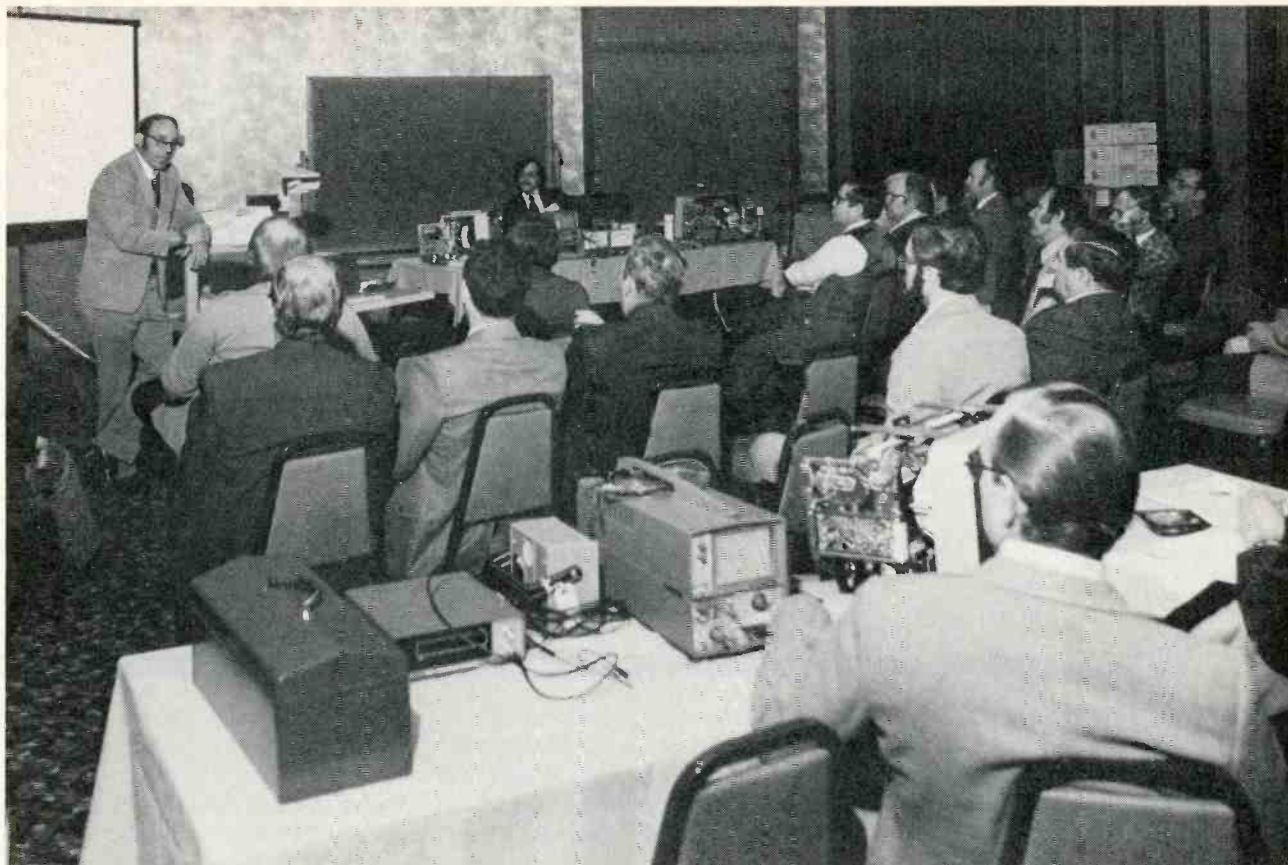

Educators and Technicians discuss continuing education and industry trends with RCA.

Are you ready to service the products of today and the future?

Then you're probably ready to work on more reliable television sets.

Many manufacturers are moving toward single board chassis design. This design can mean higher quality and reliability with fewer connectors—a possible source of trouble.

Single board design poses a challenge to service technicians. It requires increased skill and updated training.

For efficiency reasons technicians need to be able to troubleshoot accurately and to repair single board circuits in the home.

Service organizations can do several things to increase their in-home repair competence and efficiency.

(1) Consider test equipment. Even the best technician is inefficient without adequate and reliable tools.

(2) Make use of new technical data. The right information can save service hours.

(3) Learn everything you can about single board circuitry. Many manufacturers, including RCA, will be publishing information and sponsoring workshops on troubleshooting and repairing single board design with integrated circuits.

If you're ready, we're ready to help.

For a FREE subscription to the RCA COMMUNICATOR, the periodical with practical ideas for TV service people, write to RCA Consumer Electronics 1-455, 600 N. Sherman Dr., Indianapolis, IN 46201.

RCA

Consumer Electronics Division
600 N. Sherman Drive
Indianapolis, IN 46201

Better Service Through Better Communications

Understanding microprocessor operations

A look inside Motorola's 6800 MPU

(Editors Note: The following article has been reprinted from the recent publication: *Basic Microprocessors and the 6800*, by Hayden Book Company, Rochelle Park, N.J.)

By Ron Bishop*

Computers are not new. The abacus, which originated many centuries ago, is a form of digital computer. This calculating device, illustrated in Fig. 1, can be used to add, subtract, multiply, and divide. Each column contains two beads above the cross bar and five beads below it. Each bead above the cross bar represents five units, and each bead below it represents one unit. Notice the value of each column as shown below the abacus. The number depicted is 10201. If the number 60201 were to be illustrated, a bead above the cross bar in the 10,000 column would also be raised. Details of "abacus arithmetic" will not be shown here. However, with a little imagination one can understand how the abacus is a form of computer.

The first mechanical adding machine was developed in the 1600s. Several other types of adding machines and various rudimentary forms of digital computers were invented over the next 350 years. In the late 1940s, the first real "electronic" computers were

introduced, but they used vacuum tubes. Such tubes were not really the answer, since they are quite large (1 to 3 in. high), require large amounts of power as well as space, and generate tremendous amounts of heat.

With the invention of the transistor, a semiconductor device, in the late 1940s and early 1950s, many of the problems associated with tubes were solved. Transistors are small compared to tubes (1/4 in. high) and require relatively little power. They made it possible to design and build digital computers which could be housed in cabinets and racks that would easily fit in a modestly sized room.

Then in the late 1960s and early 1970s, the microprocessor was born. With this new technology, we were able to replace a module containing 5 to 10,000 transistors with a small piece of semiconductor material less than 1/4-inch square; thus, the term microprocessor. Although the basic principles of digital computing changed very little, this small chip of semiconductor material, often referred to as an "integrated circuit," opened the door to a whole new era of microelectronics. New computer-controlled applications that were beyond our wildest dreams several years earlier now started to emerge. Hand-held electronic calculators - a luxury item for the average person only several years ago are now available to everyone. Electronic TV games, such as ping-pong, are also a by-product of the microprocessor. The list is endless.

Even though the microprocessor has already affected our lives, its full impact is yet to come. By 1985, a large number

of homes in the U.S. will have some kind of computer-based system containing, in all probability, a microprocessor. These microprocessor-based systems will control lights, pool motors, monitor a security system, keep tax records, store recipes, and so forth. The only limitation is one's own imagination. Functions previously performed by computers costing thousands of dollars in the 1960s can now be handled by a micro-processor-based system costing less than \$1,000 and occupying much, much less space. A microcomputer kit, which can be assembled in less than 10 hours, can be purchased for less than \$200 today.

We are indeed entering a new era.

A computer model

Before the microcomputer system is studied in detail, let us first develop a computer model to illustrate its basics.

Picture yourself sitting at a large desk. The shirt you are wearing has a pocket on each side. To your left is a stack of cards, face down, each with an instruction printed on its face. To your right is a small blackboard, a piece of chalk, and an eraser. Directly in front of you are two trays, an input tray and an output tray. On the wall is a large clock.

We have now created a situation which is analogous to a microcomputer system. You will act as the MPU. You will pick a card off the deck of cards once each minute and execute the instruction printed on its face. The deck of cards can be referred to as a "Read Only Memory" (ROM), since its contents cannot be changed. Each card in this ROM represents an "instruction" in memory.

*Mgr., Technical Operations, Motorola, Inc.

The blackboard, chalk, and eraser to your right may also be referred to as a type of memory. However, in this memory, you can write things down and erase them later on. Such a memory can be referred to as a "Random Access Memory" (RAM), since it may be written on or changed at random. It can be used for storing data (writing information).

Time (each minute) will be determined by the clock on the wall. Any operation performed by you (the MPU) must be done in an orderly, timed sequence.

The two trays in front of you are the "input" and "output" trays. Information to you (the MPU) must come through the input tray. Likewise, output from the MPU must go through the output tray. The input tray, in this system, is filled with cards containing random numbers from 1 to 10.

The pockets in your shirt each contain a sheet of paper large enough to write

cards 3, 4, and 5.

Card 3: Read a number from the input basket and write this number on the paper in your right pocket (B accumulator).

Card 4: Add the numbers from your right and left pocket and put the result on the paper in your left pocket.

Card 5: Is the number odd? If not, go back to card 3.

Card 6: Is the number greater than 100? If not, return to card 3.

Card 7: Write the number located in your left pocket on your blackboard.

Card 8: Are there five numbers on your blackboard? If not, return to card 1.

Just as an instruction from your deck of cards — the program in memory (ROM) — is read and executed by you in sequence (unless you the MPU are told

computers respond only to a binary (1's and 0's) language. Therefore, each instruction in our analogous system must be represented by a binary number. For example, card 4 might contain the binary number 00011011 ($1B_{16}$)*, which would be interpreted by the MPU as "add the contents of the A accumulator to the contents of the B accumulator and put the results in the A accumulator."

As you probably have concluded by this time, a microcomputer system consists of five elements: (1) a microprocessor (MPU), (2) a random access memory (RAM), (3) a read only memory (ROM), (4) a clock, and (5) some technique for getting data in and out of the system (input and output).

The microprocessor (MPU)

The role of a microprocessor chip is analogous to the role you played in the

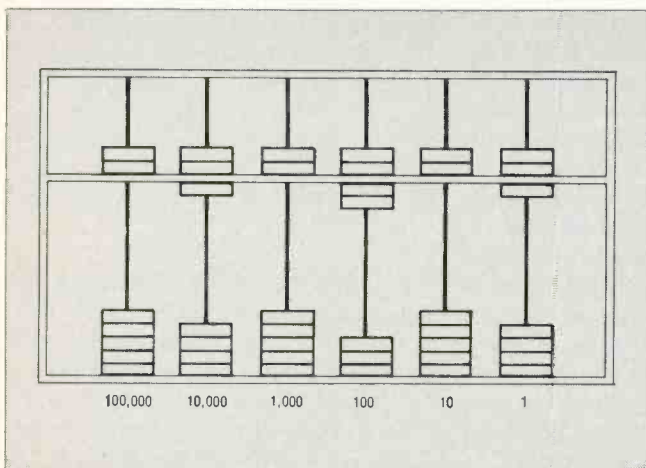

Fig. 1 An artist's representation of the Abacus

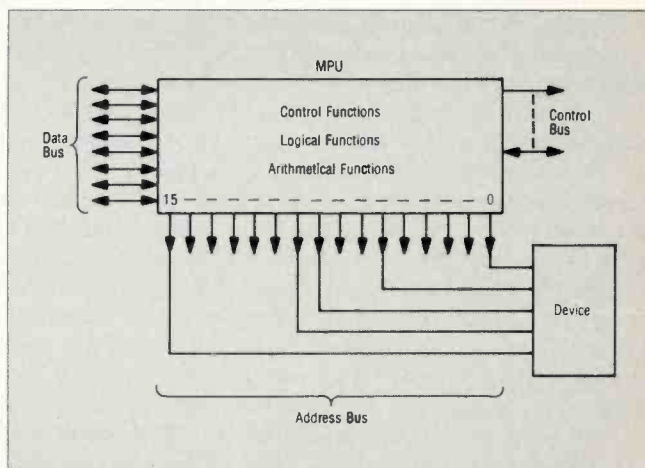

Fig. 2 Partial diagram of an MPU showing the Data, Control, and address busses.

one number on and a pencil with an eraser. Your left pocket may be referred to as an "A accumulator." An accumulator is similar to the RAM (Random Access Memory) except that it can hold only one number whereas the RAM can store several numbers. Your right pocket may be referred to as your "B accumulator." Both accumulators are identical and perform identical functions, that is, providing temporary locations for the storage of numbers.

The instructions in your program (ROM) will direct you (the MPU) to accumulate, by the addition of numbers from the input tray, five odd numbers greater than 100 on your blackboard (RAM). The instructions on the first eight cards read as follows:

Card 1: Read a number from the input basket and write this number on the paper in your left pocket (A accumulator).

Card 2: Is the number odd? If yes, skip

to branch to some other instruction) during some time interval, so does a microcomputer system execute its instructions. In our analogous system, data is stored in temporary locations (pockets and blackboard). A microcomputer system also contains temporary storage locations, called accumulators and RAMS, that function in much the same way. Microcomputer systems also have a clock to control the sequence of events, and the input and output trays of our model system are similar in function to those of a microcomputer system.

Notice that as each instruction is read, you must either make a logical decision based on the contents of the instruction or perform some calculation. These actions are the function of the microprocessor in a microcomputer system. However, in the latter, the instructions have to be coded in some manner. Remember that digital

computer model just discussed. It is so small that it can be held in your hand, yet it contains all the electronics necessary to perform arithmetic, control, and logical functions. Since the MPU must communicate with other devices in the system, it must have some way to decide which one of them RAM, ROM, input, output it wishes to "address." This problem is solved by attaching several wires, called lines, to each device in the system. Since these lines "address" the device the MPU wishes to communicate with, they are referred to as an "address bus." Most MPUs today contain 16 address lines. By charging some of them at a high voltage (logical 1's) and some at a low voltage (logical 0's) an address is generated. The device with that address will then communicate with the MPU. For example, consider the 16 lines (wires) that make up the address bus in Fig. 2. Assume that we wish to communicate with a device whose

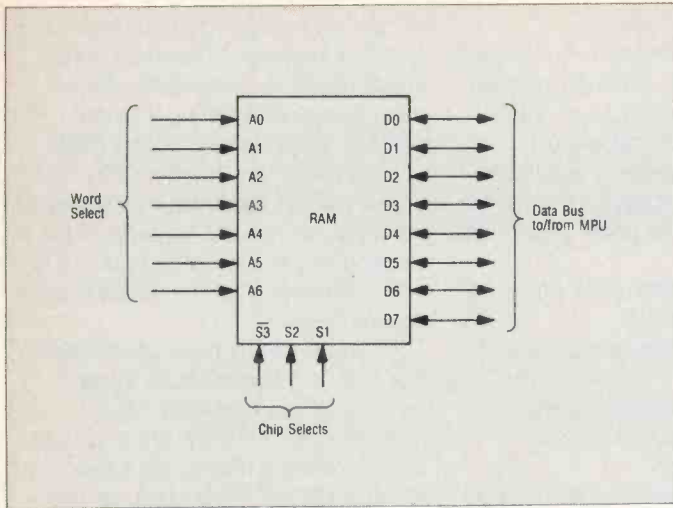

Fig. 3 Representation of a RAM showing word and chip select ports.

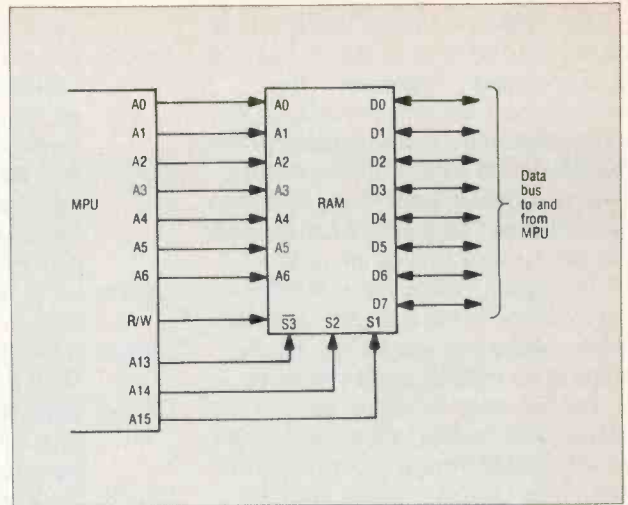

Fig. 4 MPU connections to the RAM

address is 8321_{16} . The binary pattern of 8321_{16} is 1000 0011 0010 0001. If each line that represents a "1" in this binary number were charged at 5V and each line that represents a "0" were charged at 0V, only one device at the other end of these wires bus would answer to that address and communicate with the MPU. Notice that the arrows of the address bus in Fig. 2 all lead from the MPU in the direction of the devices, thereby indicating that all addresses are generated by the MPU. Notice also that the individual lines are numbered 0 through 15. Since each line will have either a high or low voltage to represent a binary "1" or "0", the lines will be collectively referred to as "bits," a term derived from the words binary digits. The 16 lines, then, are referred to as "16 bits." Standard practice is to refer to the first line (the least significant bit when treated as a binary number) as bit 0, the second line as bit 1, and so on to the sixteenth line (the most significant bit when treated as a binary number), which is referred to as bit 15. It is also common practice to refer to a group of eight bits as one "byte." Therefore, the address bus of 16 bits wide would be two bytes wide. Bits 0 through 7 make up the least significant byte, and bits 8 through 15 make up the most significant byte.

Just as the MPU must address the device that it wishes to communicate with, it must also have some channel through which it can send data to, or receive data from, the device after it has been addressed. Similarly, when you dial an address (number) on your phone, there must be some way of sending and receiving data (talking and listening). In a computer, this transaction takes place on a series of wires (lines) referred to as "data bus." Most MPUs today use a data bus consisting of eight data lines (bits) although there are some MPUs with 16

data lines. Notice the doubly directed arrows of the data lines in Fig. 2, indicating that data can be sent or received by the MPU. Again, a high voltage on a data line indicates a binary "1", and a low voltage indicates a "0."

The third type of microcomputer "bus" is the "control bus." Its lines control the sequence of events for the total system. For example, when there is data on the data bus, it is the job of the control bus to inform a device whether the MPU is just trying to get data from it or whether the device should store the data on the data bus, that is, whether it should "read" or "write." Several separate functions are performed by the control bus of any microcomputer system, varying from one type of microprocessor to the next.

As was shown in our model, the MPU must provide areas for temporary storage of data. Some MPUs have one accumulator, but many have two or more. Accumulators are often referred to as "registers," for example, the A register or the B register.

Other registers also found in MPUs are the program counter, the index register, the stack pointer register, and the condition code register. Their characteristics are often a function of the individual type of MPU.

Random access memory

As was illustrated in the computer model presented earlier, a RAM is an area where data may be stored; this data may be erased at any time and new data stored in its place.

The data bus in Fig. 3 is the same as that shown in Fig. 2 for the MPU. In this simplified example, notice the three "chip selects" marked S1, S2, and S3. Also notice the "word select" lines marked A0 through A6. It is through these sets of lines that a RAM memory location is addressed. The function of

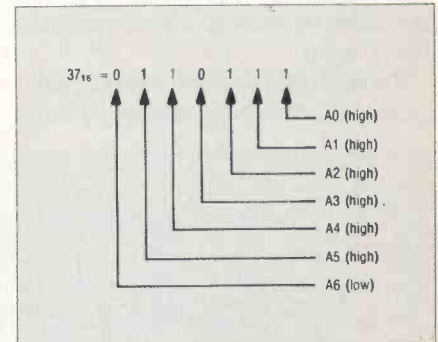

Fig. 5 Memory location 37_{16}

the "chip select" might be compared to selecting a page in a book whereas that of the "word select" might be compared to selecting a line on that page. Both "chip selects" and "word selects" are means of specifying an address on the RAM. These lines will therefore be connected to the address bus from the MPU, but a set of rules must be observed to achieve the desired address.

When a high signal ("1") is applied to S1 and S2 of Fig. 3 and a low signal ("0") is applied to S3, this particular RAM will be addressed. As you can see, then, the address of a RAM is determined by the way S1, S2, and S3 are connected to the address bus. For example, if S1 and S2 were connected to bit 14 and bit 15 of the address bus, respectively, and S3 were connected to bit 13, the address of this RAM would be 1100 0000 0XXX XXXX. (The assumption is made that this address is for one device only.) The X's shown in the address will be connected to the word select lines to address an individual word in this RAM.

Since there are seven word select lines, the number of words that may be addressed on this particular RAM range from 000 0000 (all lines with 0 volts) to 111 1111 (all lines to a high voltage). This binary range is equivalent to 00-7F

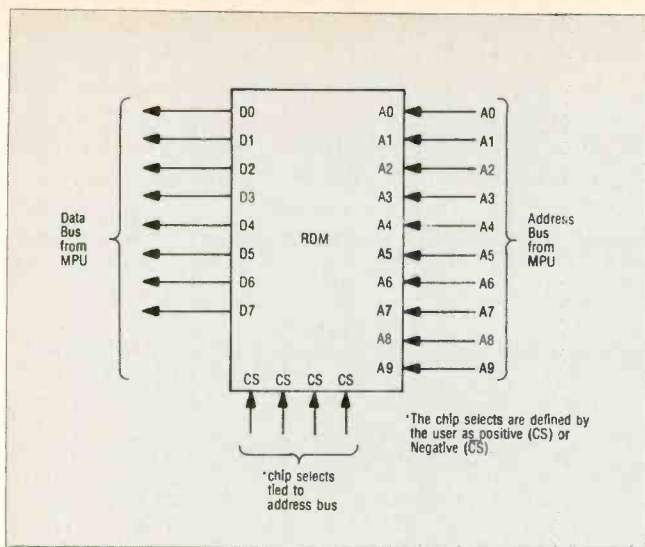

Fig. 6 MPU connections to the ROM

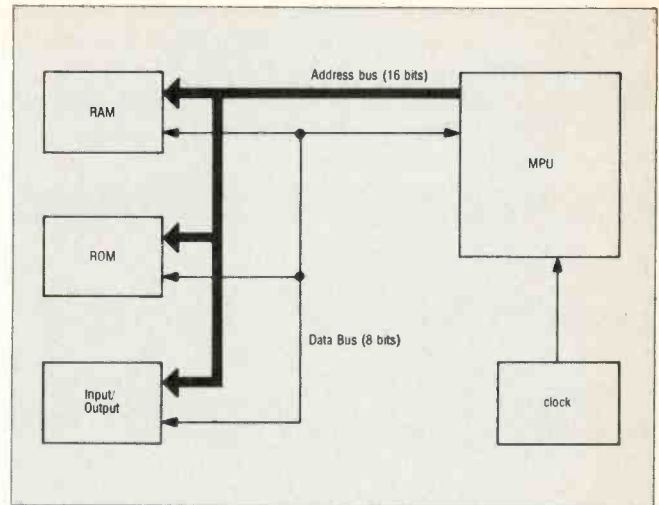

Fig. 7 A complete microcomputer system

(base 16), which is the same as 128 locations. As you probably have realized by now, the data word length acceptable to the RAM is eight bits (one byte), which can be put directly on the data bus.

The relationship between the MPU and the RAM is illustrated in Fig. 4. The R/W line shown is a signal line from the MPU to inform external devices that the MPU wants (1) to read data, if this line is high, or (2) send (write) data, if it is low.

To expand on the word selection process of a RAM, let's assume that the chip selects and word selects are tied to the MPU address bus as shown in Fig. 4. If A14 and A15 are put in a high state and A13 in a low state while A0-A6 are in a low state, the contents of memory location 000 0000 will be gated to the data bus if the MPU requests the contents of that location (the R/W line will be high). If the MPU desires to read the contents of location 0011 0111 (37₁₆), the R/W line will be in the high state address lines A14 and A15 will be high and A13 will be low; and address lines A0, A1, A2, A4, and A5 will be high (see Fig. 5). The contents of this location would then be placed on the data bus to be transferred to the MPU.

The range of addresses for this RAM, as it is presently connected to the address bus, is from 1100 0000 0000 0000 (location 000 0000 of this RAM), to 1100 0000 0111 1111 (location 111 1111 of this RAM), or from C000₁₆ to C07F₁₆.

It should be obvious by now that all A0's through A6's would be tied to A0 through A6 of the address bus if there were more than one RAM in the system. However, chip select lines S1, S2, and S3 would be tied to different address lines to provide each RAM with its own unique address.

The RAM we have just considered has 128 memory locations, each eight

bits wide. Other types of RAMs vary from 1024 bits each to 16,384 bits each. However, the principles discussed are still applicable.

RAMs come in two basic types, referred to as static and dynamic. Dynamic RAMs usually have more storage capability than static RAMs since their storage cells are smaller. However, what is known as a "refresh signal" must be applied to their cells as frequently as once every millisecond, or the data will be lost. This signal often comes from the MPU clock, which causes the MPU to run at a slightly slower rate. Static RAMs do not need this refresh signal. As long as the main power source is applied, the static RAM will retain its data.

Read only memory

Read only memories (ROMs) have an address scheme much the same as that of the RAM. The program to tell the MPU what to do is stored in consecutive locations in the ROM, but the MPU cannot change the contents of ROM locations as it can RAM locations.

Programs are fixed in ROM memories by several different techniques. One is called "mask programmable." After a user has written his program, he supplies it to a ROM manufacturer. The manufacturer will then produce the ROM, usually in large quantities, with the program built in. ROMs obviously do not need to have power continually applied or to be refreshed to hold their program. This state is referred to as "nonvolatile." A typical ROM containing 1024 separate locations, each eight bits wide (1024 × 8), is shown in Fig. 6. ROMs vary in size just like RAMs.

Notice that the data lines are directed toward the MPU. Data can flow only from the ROM to the MPU. As one can see, the required ROM must be selected by

the proper signal on the chip selects from the address bus, after which the individual memory location must be addressed through A0-A9 of the address bus.

Input/output

All microcomputer systems must provide a way of getting data loaded into and out of the system, usually by means of one or two chips called I/O ports or peripheral interface chips. The program can then direct the MPU to their output lines.

The clock

Just as the computer model developed earlier depended on the clock on the wall to determine when events were to happen, all microcomputer systems are also regulated by clock signals. These signals are routed through the MPU to allow it to execute instructions from the ROM in a timely, orderly manner.

The system

It is now time to consider all the computer elements previously discussed in this chapter as they relate to the overall system. This interrelationship is shown in Fig. 7.

Remember that the MPU does only what the program in the ROM directs it to do. A common misconception many people have is that computers are superbeings, that they have brains and can "think." That belief, of course, is false, as you already know. They do exactly what they are told to do and only that, although they do it very fast. The contents of two accumulators can typically be added in 2 or 3 microseconds (.000002 sec.). That's fast!

Interrupts

In the control bus to and from the MPU

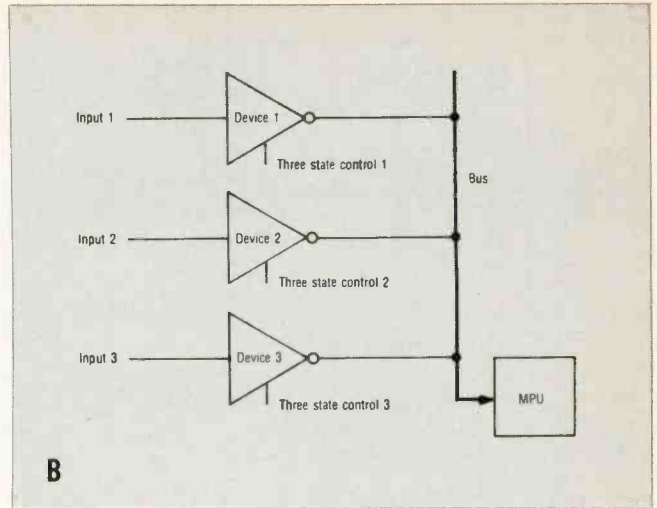
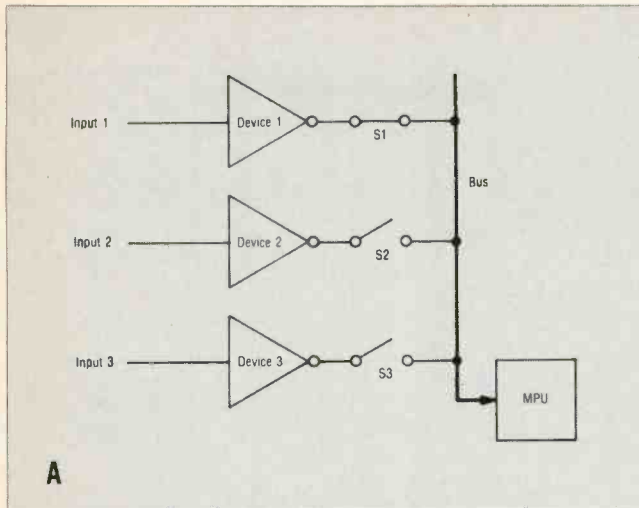

Fig. 8A 8B Two methods of obtaining three-state control

shown in Fig. 2, one of the lines is called an "interrupt line." This section will illustrate the purpose of "interrupts."

Interrupts, as the term indicates, refer to a technique in which the microprocessor is interrupted from doing its primary duties so that it may perform a task much more important. The MPU may be monitoring some rather routine input lines, doing calculations, storing data, and the like, when an emergency type situation occurs. When the MPU is made aware of this emergency situation by an interrupt, it finishes the instruction it is presently executing, stores the contents of its internal registers, and goes to an internal program to solve the difficulty.

Before we can obtain a thorough understanding of interrupts, it is essential to understand what a "real time computer system" is. We're all familiar with the many hand calculators available. These calculators just sit around until you need them, at which time you punch in some numbers, perform some arithmetical calculations, and read the results in the display. A "real time operating system" is similar to the calculator, except that data is continually being fed into the MPU and compared against known data so that output decisions can be made.

To extend the illustration, let us create a "real time situation." The automobile that you have just purchased has a microprocessor system that controls and monitors the following functions:

1. Sounding an alarm if water temperature rises above a certain predetermined limit.
2. Maintaining speed at a value you select.
3. Maintaining the interior temperature at a value you select.

In reality, it could, and would, perform many more functions, but for the sake of

simplicity, these will be enough to illustrate a "real time operating system."

An indicator on the dash of your car allows you to select the speed and inside temperature desired, and a button on the dash, when pressed, places the above functions under microprocessor control.

Let's assume that you are driving down the highway and elect to place these three functions under computer control. You press the button that turns the computer on. The microprocessor will branch to a program in its memory that tells the MPU to read the speed selector. The program will next direct the MPU to check the actual speed; it does so by reading a sensor that generates a signal proportional to the speed. If the actual speed has not yet reached the selected speed, a signal will be generated and transmitted to an electromechanical device that will effectively "push on the gas." The program then directs the MPU to "read in" the temperature selected. The MPU will check the actual temperature inside the automobile through another sensor. If the temperature needs to be raised or lowered, the MPU will send a signal to the appropriate device (either the heater or the air conditioner). The above events will have occurred in much less than a second. The program will now alternately check the speed and temperature, making sure that they reach the desired values. After the desired values are reached, the MPU will continually monitor them to keep both at the desired values.

This is a very simplified example of a real time computer system. Now, you may ask, what about the third function? The alarm that will sound if the water temperature rises above some predetermined value? This is where the need for an interrupt arises. As we have seen, the MPU has a separate input data

line to serve as an interrupt line. The voltage on this line, in a normal situation, may be +5 V. However, when the water temperature exceeds the predetermined limit, a sensor will cause the voltage on the interrupt line to drop to zero. When this happens, the MPU will finish the instruction it is executing very quickly, store the contents of its internal registers in memory so that they will be available at a later time if needed, and branch to another program in memory that has been specifically written for situations in which the interrupt line goes low. This program may sound an alarm, put speed and temperature under manual control, or perform any other function desired. Such reactions are often described as "servicing the interrupt." The water temperature rising above limits is much more important than maintaining a constant speed or temperature.

In reality, a real time computer system may have several input functions that may cause an interrupt, even though there is only one interrupt line.

Three-state control

"Three-state control" is a term used frequently, although often not clearly understood. Three state control is a technique that allows more than one device to share a common bus, but not at the same time.

In Fig. 8A, device No. 1 is normally tied to the bus that serves as an input to the MPU. Now assume that the output status of devices Nos. 2 and 3 are needed by the MPU. If S1 is opened and S2 closed, the status of device No. 2 can be fed into the MPU. Likewise, if S1 and S2 are open and S3 closed, the status of S3 can be read by the MPU. As far as the MPU is concerned then, each device has three states, "1", "0", and an open
continued on page 47

1097-192 p.—All About Telephones (\$7.95)



An Extraordinary Offer to introduce you to the benefits of Membership in

ELECTRONICS BOOK CLUB

take any **6** (up to 9 books) of these 24 unique electronics selections **\$1.99** for **ALL SIX** (values to \$111⁵⁵) for only

with a Trial Membership in the Book Club that guarantees to save you 25% to 75% on a wide selection of electronics books



Facts About Club Membership

- The 6 introductory book selections of your choice carry publisher's retail prices of up to \$111.55. They are yours for only \$1.99 for all 6 (plus postage/handling) with your Trial Membership.
- You will receive the Club News, describing the current Selections, Alternates, and other books, every 4 weeks (13x a year).
- If you want the Selection, do nothing, it will be sent to you automatically. If you do not wish to receive the Selection, or if you want to order one of the many Alternates offered, you simply give instructions on the reply form (and in the envelope) provided, and return it to us by the date specified. This date allows you at least 10 days in which to return the form. If, because of late mail delivery, you do not have 10 days to make a decision and so receive an unwanted Selection, you may return it at Club expense.
- To complete your Trial Membership, you need buy only four additional monthly Selections or Alternates during the next 12 months. You may cancel your Membership any time after you purchase these four books.
- All books—including the Introductory Offer—are fully returnable after 10 days if you're not completely satisfied.
- All books are offered at low Member prices, plus a small postage and handling charge.
- Continuing Bonus: If you continue after this Trial Membership, you will earn a Dividend Certificate for every book you purchase. Three Certificates plus payment of the nominal sum of \$1.99 will entitle you to a valuable Book Dividend of your choice which you may choose from a list provided Members.

May we send you your choice of 6 of these practical time-and-money-saving book selections as part of an unusual offer of a Trial Membership in Electronics Book Club?

Here are quality hardbound volumes, each specially designed to help you increase your know-how, earning power, and enjoyment of electronics. Whatever your interest in electronics, you'll find Electronics Book Club offers practical, quality books that you can put to immediate use and benefit.

This extraordinary offer is intended to prove to you through your own experience, that these very real advantages can be yours...that it is possible to keep up with the literature published in your areas of interest, and to save substantially while so doing. As part of your Trial Membership, you need purchase as few as four books during the coming 12 months. You would probably buy at least this many anyway, without the substantial savings offered through Club Membership.

To start your Membership on these attractive terms, simply fill out and mail the coupon today. You will receive the 6 selections (up to 9 books) of your choice for 10-day inspection. YOU NEED SEND NO MONEY. If you're not delighted, return the books within 10 days and your Trial Membership will be cancelled without cost or obligation.

ELECTRONICS BOOK CLUB, Blue Ridge Summit, Pa. 17214

Circle No. 109 on Reader Inquiry Card

ELECTRONICS BOOK CLUB

Blue Ridge Summit, Pa. 17214

Please open my Trial Membership in ELECTRONICS BOOK CLUB and send me the 6 selections circled below. I understand the cost of the books I have selected is only \$1.99 for all 6, plus a small shipping charge. If not delighted, I may return the books within 10 days and owe nothing, and have my Trial Membership cancelled. I agree to purchase at least four additional books during the next 12 months, after which I may cancel my membership at any time.

604/882 637/628 678 714 730
861/905 952 1053 1085 1097 1101
1119 1123 1120 1128 1138 1152
1168 1169 1174 1176 1201 1241 6277

Name _____ Phone _____
Address _____
City _____
State _____ Zip _____

(Valid for new Members only. Foreign and Canada add 15%.) T-300

Microprocessor the easy way, part V

Inside the microprocessor, continued

Although it is possible to treat the microprocessor as a black box, it is helpful to know how its internal functions operate and interact. Here's more of what goes on inside that forty (or more) legged beast

By Bernard Daleh

This article is a continuation of article IV, covering registers and memory. Since MPUs utilize several registers, and memories; it takes more than one short article to cover the subject. Article III did not include the "stack", "stack pointer", or "memory data register", which are discussed now. Memory addressing is continued. Since programming requires memory addressing, we are now touching on the very beginnings of programming. A later article will include an introduction to programming.

More registers

There are two registers that are hardly ever shown in diagrams of the MPU (architecture, organization). In fact, they are seldom mentioned in the texts, and for this reason they are often labeled "invisible" registers. Nevertheless they are there, in one form or another. One of these registers you have already encountered in Article IV in this series the "memory address register" (MAR), now we will encounter the "memory data register", sometimes referred to as the "memory buffer register" (MDR).

(Some MPUs use other registers to perform this function ... and once more,

the lesson is driven home that a register is named for the function it performs a most confusing situation for the student of MPUs, since the register, like a chameleon, may change, depending upon what it is doing, who is describing it, or at the whim of the manufacturer and his technical writers. Once this fact is accepted by the reader, a major cause of frustration is eliminated!) The MDR is used as a short term storage for data being transferred into or out of memory. The word stored is held long enough for desired operations to be performed. Meanwhile the memory is freed for the writing, or reading of other memory words.

Remember, the bidirectional bus system in an MPU can only accommodate one signal at a time, and with much traffic into and out of the memory, registers hold information until the bus is able to handle it, in turn, in accordance with the micro and macro instructions. This is like the railroad analogy again, where short sidings are used to temporarily store cars, and keep the main line free, while the express traffic roars by. When needed, the cars are put back on the main line, during lulls in traffic, in an orderly sequence, on a scheduled basis, with all traffic accommodated, by the use of short term storage of various cars, at various times.

The Stack

Before we can consider the next registers, we must define the "stack", since these registers exist because of the stack. The stack is a very unique concept, in several ways, First, it is different because it is really a **part of the external random access memory**

(RAM), which is reserved for stack operations i.e., the stack portion of the RAM is not used to store the usual instructions or data words.

Second, the stack is not limited to a specific size. Depending upon the use to which the stack is put, the number of addresses reserved in the RAM for stack use may be less than ten, or up to several hundred.

Third, the stack is a "last in, first out" (LIFO) memory. This means that the last word stored, will be the first word retrieved, like putting a stack of books into a box. The last book put into the box is on top, and will be the first book taken out of the box. This implies that the first book into the box, will therefore be the last book out of the box, and so it is with the stack. However this is no problem, since the stack always has information written into it, and read out of it, in sequence. The rest of the RAM, which is not used as the stack, operates just the way it's name implies random access memory, which means that any location can be addressed, at any time, in any sequence. Only the stack portion of the RAM is a LIFO memory.

Remember, the stack is not a separate memory or register. It is merely a part of the RAM reserved for a special use, as needed, and used in a special way.

Now we can go on, to the other registers associated with the use of the stack.....

The stack pointer

At this point you may have begun to wonder about how we define the limits of the stack within the host RAM. This is taken care of by the "stack pointer",

which is another register which normally stores the first, or starting address (memory location), of the stack. As words are written into the memory, the stack pointer increments (increases by one) the address held in the stack pointer. Thus the stack pointer stays in step with the stack..... Remember, the entries into the stack **are made in sequence**, which greatly simplifies things. As each word is entered into the stack, during the write process, the pointer merely has to increase the address location it is holding, by one number.

During readout, the stack decreases the address held by one, (decrements). Since we are dealing with a last-in, first-out memory, everything stays coordinated, and the stack pointer always points to the top address in the stack.

The process of writing into the stack is commonly called "pushing", similarly reading out of the stack is referred to as "popping" ... think of it as pushing information down into the stack, then popping it back off later. (These terms are used only with the stack.)

(The words "decrement" and "increment" are used commonly with sequential addressing of memory, whether it be stack, ROM, or RAM, and will be encountered frequently.) It was stated earlier that the stack pointer normally starts with the first address in the stack. This doesn't just happen. The programmer loads this first step into the stack in a process called "initializing". Initializing consists of first clearing out any previous address in the stack, which may be left over from a previous programming, or have just been a random number which was generated by transients when the computer was switched on. This process of initializing is not confined to the stack, but is used in other registers as well. As a matter of fact, if you use a pocket electronic calculator, you will notice that the instructions say, "Turn on the calculator, then press the CLEAR key to clear the calculator. Now make your first entry." The process of clearing, etc., on the first entry is really initializing. Now, back to the stack.

Uses of the stack

Briefly stated, the **status** of the MPU is preserved in the stack when interruptions are required in the operation of the MPU. The word "status" as used here means the condition of all the registers, etc. (It is similar to the use of a "status board" to indicate the condition of a military operation, in which

the "status quo", or present condition, is shown.) When some situation arises which requires interrupting the normal routine of the MPU, each of the several registers which contain the essential information in the operation of the MPU, have their contents transferred, in an orderly sequence, to the various addresses in the stack. The information is held in the stack, while the MPU is diverted to accomplish whatever was directed by the interrupting source. Later, when the MPU goes back to its previous operations, the contents of the stack are transferred back into the various registers, in orderly sequence. Everything goes right back to where it came from, and the MPU is restored to the "status" it had prior to the interruption. You can readily see how handy the LIFO stack is, because by its nature, we know just how it will handle the register contents, insuring everything is done to preserve the status of the various registers, for a later time, when needed. Note that it was indicated earlier that the portion of the RAM used for the stack was "reserved" for that purpose ... and therefore always held available for use at any time.

Now what circumstances would interrupt the normal operation of the MPU? Let's assume the MPU is connected to a teletype line, which inputs information from time to time. When the teletype line is not inputting information, the MPU may be assigned a task, by means of a program. Suddenly the teletype line becomes active. If the MPU ignores it, the information is lost, perhaps forever. What actually happens is that the teletype has been assigned a priority, and is therefore able to interrupt the operation of the MPU. The various registers transfer their contents to the stack. The MPU proceeds to handle the teletype input. The teletype stops. The MPU transfers the contents of the stack back into the registers, thus restoring the "status" the MPU had at the moment it stopped to handle the interrupt. The MPU then commences operations again at the precise point where it left off, as if nothing had ever happened.

Sometimes a program is written in such a way that the programmer wishes to interrupt one set of operations, go on to something else, then go back to the original operation. This too is a form of interrupt which can be handled by the stack. In short, there are several situations in which the stack is very useful.

Op Codes and Operands

Two words will be encountered quite

often, but not explained in most MPU texts "Op code" and "operand". Op code is short for "operational code", which is that part of an instruction (used by computer programmers in programming an MPU) indicating which operation is to be performed. The op code is sometimes referred to as the "instruction code", which means the same thing. The other part of an instruction word is labeled the "operand" and denotes the quantity that is operated on.

Stated another way, the programmer enters instructions, step by step, in his programming. Each instruction has two parts, the instruction part (op code) which tells what the programmer **wants done**, and the other part, which tells what he wants it **done to**. Since each instruction held in the computers memory has a code number assigned it, in the instruction set for the MPU, the words "instruction **code**" or "op **code**" make sense.

Frequently the operand is data, which has been stored in RAM memory, in which case the operand will consist of **the address** of the data in memory. When the data at that memory address is read out, it is transferred into a register, and then manipulated in accordance with the instruction in the op code. If this seems a bit confusing, be advised that each step in a program is called an "instruction" in many texts. In addition, when we manipulate data, what happens is an operation in accordance with an "instruction", as differentiated from "data". So we really are dealing with two different meanings for the word "INSTRUCTION"! Now this is not really unusual, since the common word "bank" has several different meanings a financial institution, the slope of earth on the edge of a river, or, to aviators, the tilting turn of an aircraft. Which meaning is intended is denoted by the text, and the reader perceives this instantly. So it is with the word "instruction". Now go back and read the two preceding paragraphs, and see if they make sense to you!

Many MPUs are set up so that data is normally entered into memory, and then, when used in the program, is called up from memory by merely entering the address at which it is stored. It is rather uncommon, on many MPUs to enter data directly into the computation. Although this may seem rather a roundabout way to do things, there are reasons for doing so. First, many MPUs do not have an easy way to enter directly into the desired register ... but, the

continued on page 47

TEST INSTRUMENT REPORT

Some twenty years ago, in the early days of color television, NTSC color bar generators were available. Most notably, Hickok produced its suitcase full of tubes, the Model 656XC, which in 1956 cost \$495.00. In the interim, the gated rainbow generator took over because of its much lower cost; the only NTSC generator I can recall being available a

These levels vary greatly from color to color (Fig. 2).

For maximum utility however, the B&K-Precision 1250 produces many other patterns for troubleshooting and adjustment of all types of video equipment—not just color receivers. Available patterns include NTSC Color Bars [defined as white (75%), black (7.5% set-up level), 75% saturated pure colors red, green and blue and 75% saturated hues of yellow, cyan and magenta (mixtures of two colors in 1:1 ratio without the third color)]; -IWQ signal [defined as a special pattern consisting of equal parts of -I (40 units chroma at 303°), W (100% white), Q (40 units chroma at 33°) and black.] It occupies the bottom one-fourth of the screen; Top Burst Off, (color is unsynchronized in the top fourth of the screen); Full Burst Off (to check the color killer); Chroma Off; Dots, Cross hatch, Dot hatch, and Center Cross (patterns to check convergence); Linear Staircase (five equal steps of increasing luminance with constant Chroma; with Chroma Off, luminance only); Raster (solid raster of black, red, blue, green, yellow, cyan, magenta, and white. All of these signals are offered on Channel 3 or 4 or at IF or as video. Sound is available; a 4.5MHz subcarrier is modulated by 1 or 3kHz or an external audio source. All output jacks can be used simultaneously; RF output, video, sync and audio (at the back panel) can be used simultaneously and independently (to service or test more than one unit).

An NTSC color bar pattern is specified for troubleshooting and adjustment by most VCR manufacturers. The waveforms shown on the manufacturers service data usually require NTSC color bar input. Recording and playing back the color bar pattern provides an overall performance check.

The NTSC color bars can be used as you would use the gated rainbow generator's pattern in troubleshooting all video and chroma problems. The NTSC pattern also is used with a vectorscope. An NTSC vectorscope would be recommended but any good X-Y scope can be used (B&K-Precision furnishes a NTSC vectorscope graticule for your scope with the 1250). It is simply set up with the Y input to the red gun of the picture tube and the X input to the blue gun as is normal vector scope practice. The resulting pattern is shown in Fig. 3. These NTSC color bar patterns require some getting used to after years of gated rainbow patterns. Considering the variety of patterns available and their versatility this might be well worth while.

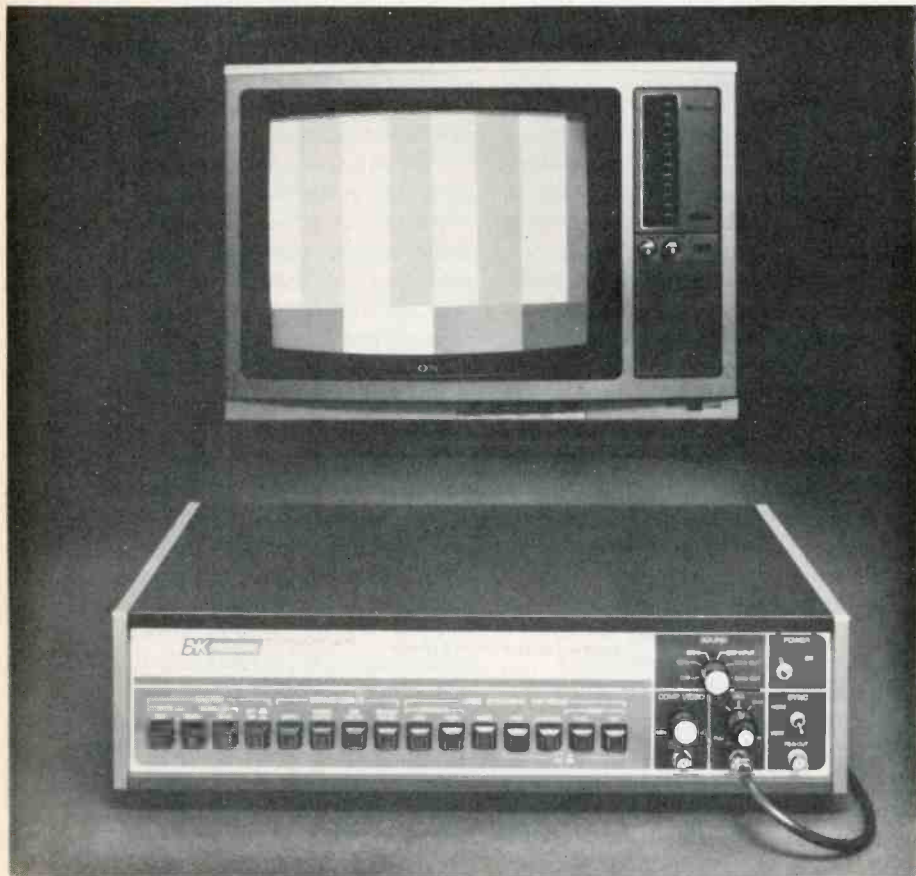

Fig. 1 B&K-Precision's Model 1250 and an NTSC color bar pattern (in black and white) with the -IWQ in the lower one-fourth of the screen. For more information Circle Number 150 on the Reader Service Card.

An NTSC Color Bar Generator

B&K-Precision's 1250

By Walter H. Schwartz

few years ago was offered by EICO. Now because of the requirements of some of the VCR manufacturers the NTSC generator is again available.

There are some very significant differences between the patterns produced by a gated rainbow and a NTSC generator. The gated rainbow generator produces all hues at the same chroma and luminance levels—they do not necessarily correspond to typical transmitted levels. That is why some colors are bright and some are rather washed out. It also produces a continuous spectrum of color across the screen—the colors are divided by black level vertical bars which cover the worst of the transitions between colors. The NTSC generator supplies signals to NTSC standard luminance, hue and saturation levels, which appear of uniform brightness to the eye.

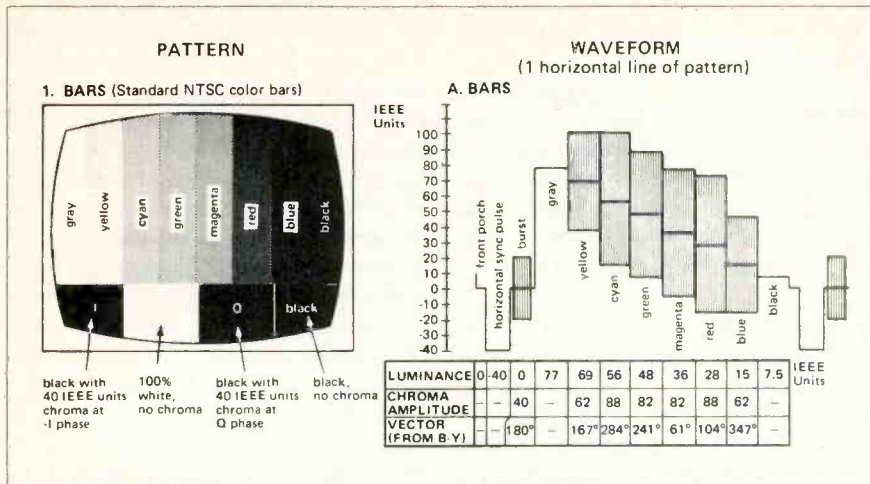

Fig. 2 An NTSC color bar pattern and the corresponding video waveforms.

For instance, a single color screen will produce a single color vector on the scope; this is something you can't do with a gated rainbow generator.

Cost and size are the trade offs—the Model 1250 sells for \$795 and although light (11 lbs) it measures 4½ inches high by 18 inches wide by 12 inches deep—it is a bench instrument; it would be hard to pack all those features into a very portable unit. The 1250 comes with an output cable with a matching pad, a vector-scope graticule and a good instruction-maintenance manual. **ETD**

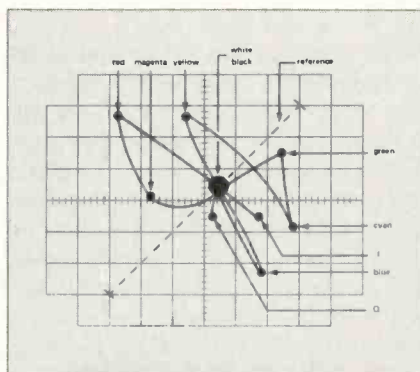
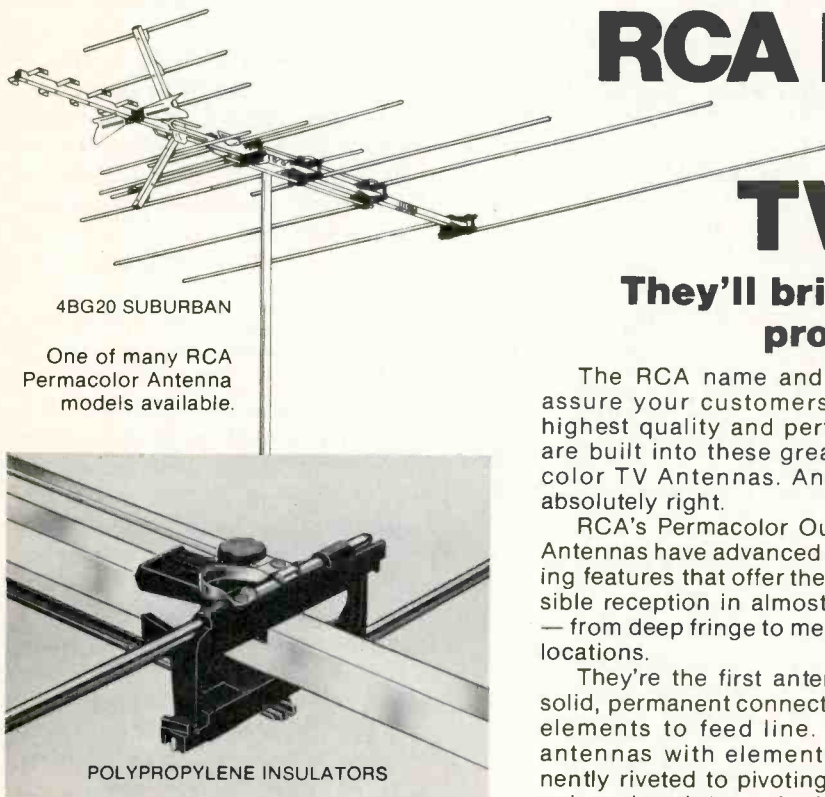

Fig. 3 An NTSC vectorscope presentation.



Insulator design locks elements for top performance and long life.

RCA Permacolor Outdoor TV Antennas.

They'll bring in a better sales and profit picture for you.

The RCA name and tradition assure your customers that the highest quality and performance are built into these great Permacolor TV Antennas. And they're absolutely right.

RCA's Permacolor Outdoor TV Antennas have advanced engineering features that offer the best possible reception in almost any area — from deep fringe to metropolitan locations.

They're the first antennas with solid, permanent connections from elements to feed line. The first antennas with elements permanently riveted to pivoting polypropylene insulators. And, the first with a weather-resistant blue and gold vinyl finish.

RCA's Permacolor line is a complete line consisting of: 10 UHF-VHF/FM all band combo models, 7

OPTIMA VALUE SALE

TO ORDER CALL COLLECT (212) 439-7434

G. E., SYLVANIA, ZENITH 75% OFF LIST NEW-BOXED

- 3A3 5 for \$ 8.63
- 6BK4 5 for \$15.94
- 6CJ3 5 for \$ 8.06
- 6FQ7 5 for \$ 6.50
- 6GF7 5 for \$11.38
- 6GH8 5 for \$ 6.75
- 6HV5 5 for \$19.00
- 6JE6 5 for \$17.94
- 6LB6 5 for \$17.25
- 6LF6 5 for \$17.13
- 17JZ8 5 for \$ 9.18
- 38HE7 5 for \$15.75

All Tubes Not Advertised, Write in at 75% off list. Sleeves Only. Singles 72% off list.

TRANSISTORS

- Minimum 10 of a Number
- TA7204P ea. \$.89
 - TA7205P ea. \$.89
 - 2SC1172B ea. \$1.95
 - 2SC1308K ea. \$1.95
 - 2SC1358A ea. \$1.95
- Rep. ECG
- 731 (221-45) ea. \$.49
 - 713/790 (221-48) ea. \$.49

ZENITH & RCA MODULES

- 9-92 \$ 5.95
- 9-103-04 \$ 5.95
- 9-121-01 \$ 7.95
- 9-147 \$ 8.95
- 150-190 \$12.95
- 132581 \$ 6.20
- 133455 \$ 6.20
- 133563 \$ 6.00
- 136691 \$11.78
- 138697 \$14.40
- 139685 \$ 6.48
- 141154 \$22.40
- 142706 \$15.88
- 145256 \$11.58
- 145280 \$16.36
- Rep.ECG500A \$8.95

- DIAMOND NEEDLES, Min. 10 ea. \$.79
- ZENITH 142 166,8
- ZENITH 142 167
- PANASONIC EPS 25 (EPC42)

GENERAL

- 2½ Amp 1000 PIV 100 for \$6.00
- CB Lighting Arrestor, min. 100 ea. \$.49
- Y88 Yokes ea. \$3.95
- DY99AC Color Yoke \$3.95
- Y107 Yoke \$3.95
- G.E. Color 76X10 76X11 \$3.95
- Blue Lateral Magnet \$.89

Quantity Prices Available.

Wanted: Electronic Merchandise & Will Pay Cash Letters of credit and all checks placed on deposit with Manufacturers Hanover Trust Bank, N.Y.C. VISA/Bank Americard & Master Charge accepted. Min. order \$75 FOB Brooklyn, N.Y. Catalogue \$3, refundable upon order.

SEND CHECK OR MONEY ORDER TO:

OPTIMA ELECTRONICS

Box 372 Ryder Street Station
Brooklyn, New York 11234
Phone (212) 439-7434

Circle No. 115 on Reader Inquiry Card

Circle No. 118 on Reader Inquiry Card



BULLETIN BOARD

Weekend Projects for the Radio Amateur is a recent publication of the *American Radio Relay League*. While the projects are intended to be quick, easy and useful to hams, a number of them have service shop application. Among those of possible interest to technicians are an oscilloscope calibrator, a capacitance substitution box, a motor speed control, an expanded-scale line monitor, a husky 12 volt, 10 ampere, power supply and possible a Ni-Cad battery charger. The other projects are also interesting to anyone interested in radio communications, ham or not. *Weekend Projects* is \$3.00 from local distributors or from the ARRL, 225 Main St., Newington, CT 06111.

If you want to know what goes on inside integrated circuits, how they are made and why they are made that way, the compromises, trade-offs, the designer must make, all the details involved in the design and internal opera-

tion of IC's *Check Handbook of Micro-circuit Design and Application* by Stout and Kaufman. There is as could be expected an emphasis on microprocessors and other digital devices but op-amps, active filters, and various linear and non-linear analog circuits are treated also. Most IC applications are considered quite thoroughly. 499 pages, 303 illustrations, hardbound, \$32.50, McGraw-Hill.

Wire wrapping and other tools are featured in a new 20-page catalog from *O.K. Machine and Tool*. It covers a broad range of products including the new PRB-1 10ns logic probe. Catalog 62H-1979 is free from O.K. Machine and Tool Corp., 3455 Conner St., Bronx, NY 10475.

An **automatic distortion measurement system** is presented in a brochure from *Radiometer Electronics U.S., Inc.* It describes an automatic distortion meter and an automatic sweep oscillator (the basic instrument) and options which permit automatic plotting of continuous distortion or frequency response curves and automatic measurement of individual harmonics. Write: Jerry Bush, Radiometer Electronics U.S., Inc., 811 Sharon Drive Cleveland, OH 44145.

Audio and Video Interference Cures by Larry Kahaner explains the causes of most types of interference to radio or television reception and a number of basic cures for them. Various types of interference to television, radios, PA systems, Hi-Fi stereo equipment and even telephones are considered as caused by both various types of transmitters and by lights, motors and other electrical devices. Aside from an occasional bad definition—the information presented is very useful. From Hayden Book Company, Inc., 50 Essex St., Rochelle Park, NJ 07662.

Minicomputer regulators are the subject of a new brochure from *Sola*. Sola's Micro/Minis are reportedly designed to protect equipment from any common ac power problem short of total blackout. It is stated that they eliminate noise, transients, and low voltage, and short term disruptions that can cause errors or memory loss. Specifications for 50 and 60Hz portable models and 60Hz hard wired models is included. Contact Pam Samson, Sola, 1717 Brusse Rd., Elk Grove Village, IL 60007.

A Security System Merchandising Portfolio is now available from *Chamberlain Manufacturing Corporation*. It includes information on selling, to the home security market, Chamberlain's radio-controlled Dual Alarm Home Security System. It also includes a collection of sales literature, brochures, envelope stuffers, direct mail pieces, ad mats, sample radio commercials and other material. Contact: Michael Schatz, Chamberlain Manufacturing Corp., 845 Larch Ave., Elmhurst, IL 60126.

Semiconductors, service aids and test instruments are featured in *Catalog 20* from *ORA Electronics*. Included in *Catalog 20* are an extensive listing of Japanese integrated circuits and semiconductors, both individually and in kits (at a cost savings), capacitors, tape heads, test cassette, chemicals, metric hardware and test equipment by Leader and Hitachi. For a copy write: ORA Electronics, 7241 Canby Ave., Reseda, CA 91335.

A tool catalog reportedly listing more than 10,000 items has just been published by *Contact East*. It contains 144 pages of photos, diagrams and descriptions of hand tools, soldering supplies and assembly and test devices. The catalog is free upon request from: Contact East, Inc., 7 Cypress Drive, Burlington, MA 01803. **ET/D**

When you price by "The Book"... everyone benefits!

Eliminates undercharging...controls overpricing...treats both customer and shop owner fairly!

The Parts Pricing Book

Lists over 160 pages of current parts prices for instant reference. Computerized with automatic up-dating...\$24.50 + up-dating.

The Labor Pricing Book

The new 4th Edition will expand your business mind as never before! Greatly simplified while being expanded to include all the new products, as well as the traditional...\$29.50

CALL TOLL FREE: 800-228-4338

8/5 C.S.T. MONDAY/FRIDAY

sperry tech inc. P.O. Box 5234 Lincoln, Nebraska 68505

tv & radio tech's guide to pricing



Each book is a great time saver! Pricing parts and labor from **ONE BOOK**...together they're fantastic!

NEW PRODUCTS

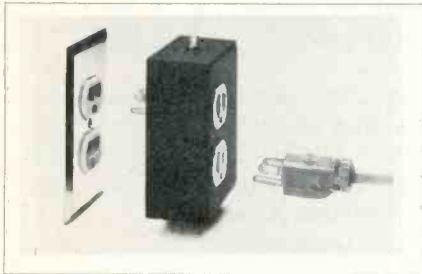

Line Surge Protection

Circle No. 130 on Reader Inquiry Card

A power surge control device that protects small computers, communications, medical and other electronic equipment from voltage transients, has been introduced by *R&K Enterprises*. Called Surge Sentry 120, it plugs into any standard, 120V wall outlet to provide immediate protection from transients. Reportedly, in operation the SS-120 detects short duration voltage surges, and immediately shunts all unwanted or potentially dangerous voltages.

Features of the new device are a stated response time of less one nsec, and power dissipation capacity of 600,000 watts. Because the device is parallel with the power line, the SS-120 will not interrupt equipment operation in the event it malfunctions.

Oscilloscope With DMM

Circle No. 131 on Reader Inquiry Card

A new 100MHz oscilloscope with a variety of features and options for lab or field use has just been introduced by *Gould*. The OS3600 is a dual trace 100MHz instrument with 5mv/cm sensitivity to 85MHz. Display modes are Channel 1, Channel 2, Ch 1 and Ch 2 alternate or chopped, Ch 1 and Ch 2 added algebraically, and XY display. It reportedly uses a 16Kv accelerating potential for bright presentation of fast pulses with

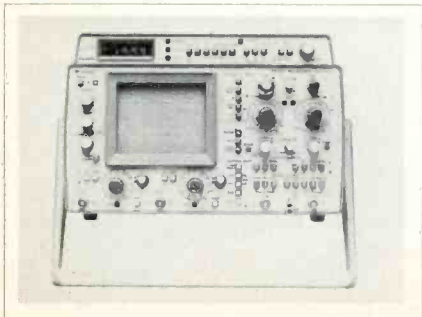

sweep speeds in 22 steps from 50ns/cm to 0.5 s/cm and a X10 expander.

Several delayed sweep modes are available as is trigger holdoff. A significant option is the Gould DM3010 DMM which can measure signal amplitude to $\pm 2\%$, ± 2 digits and time $\pm 1\%$, ± 1 digits, or frequency as the reciprocal of period. It can also be operated independently. Price of the OS3600 is \$2699; with the DM3010 option the price is \$3299.

Audio Analyzer

Circle No. 132 on Reader Inquiry Card

The *BPI 7000A* audio analyzer combines seven functions in one instrument to effect a considerable savings in cost when compared to individual instruments. Contained in its single package are a low distortion audio oscillator, an auto-nulling distortion analyzer, an ac voltmeter, a wow and flutter meter, a speed and drift meter, and an output power meter, and, optionally, a 100 and 250W, 8 ohm load.

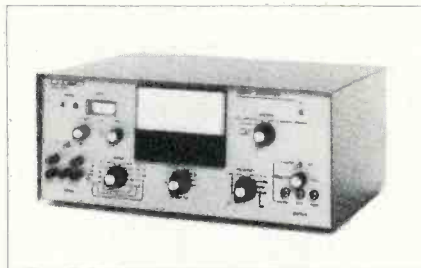

The audio oscillator offers five fixed frequencies, 50Hz, 400Hz, 1KHz, 3KHz and 15KHz, all at less than .015% THD; the distortion analyzer reportedly measures THD at the oscillator frequencies (except 3KHz) with a minimum full scale range of .03%; the 7000A measures power output to 1KW, ac voltage from 10 mv full scale to 300v full scale, wow and flutter reportedly as low as .03% full scale, and offers a scope output to visually observe the signals being measured. The price of the BPI Model 7000A is \$1295.00. BPI also offers several other items of audio test instrumentation.

IC Extractor

Circle No. 133 on Reader Inquiry Card

New Model EX-2 from *O.K. Machine and Tool Corp.* extracts all 28/40 pin D.I.P. IC's having standard .600 in. body widths, including MOS and CMOS devices. Its mechanism is self-adjusting and lifts the IC from socket or board using uniform pressure applied simultaneously at both ends of the IC. Designed for one-hand operation, the EX-2 features heavy chrome plating for

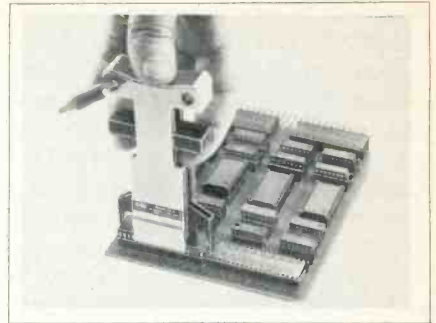

reliable static dissipation, as well as a terminal lug for attaching a ground strap (strap not included). The EX-2 is priced at \$7.95.

Distortion and Noise Measuring Set

Circle No. 134 on Reader Inquiry Card

The *Amber Model 3500* is a high performance distortion and noise measuring system incorporating a low distortion sine wave oscillator, a total harmonic distortion (plus noise) analyzer, a wide band and weighted true rms level meter and a tuneable band pass filter. It will measure signal level, frequency response, wide band noise, weighted noise, narrow band noise, crosstalk and total harmonic distortion. With an option,

**NO ONE,
BUT NO ONE
SELLS TEST
EQUIPMENT
FOR LESS**

**B & K, EICO, HICKOK,
LEADER, NLS, SENCORE,
SIMPSON, VIZ**

**plus a complete line
of tubes, tools and
electronic supplies**

For pricing ...

**CALL TOLL FREE
800 845-9518**

N.Y. State call (516) 752-0050

FORDHAM

RADIO SUPPLY CO. INC.
855R Conklin St. Farmingdale, N.Y. 11735

it can also measure intermodulation distortion. Effort was made to simplify operation and reduce operator error and measurement time. The number of controls has been reduced; automatic features included are auto-set-level and automatic nulling. Tuning has been simplified with a single continuously variable control covering a frequency decade and four range push buttons to select one of four decades. LED's guide the operator to the correct setting of controls and automatic electronic servos handle the delicate adjustments usually associated with distortion analyzers. Measurement time has been improved

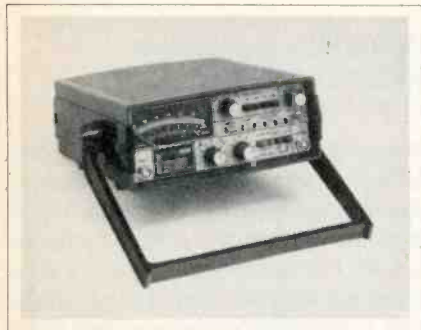

by reducing the settling time of the oscillator and the nulling circuits. Final measurement, after selection of any parameter, is extremely fast. The ganged continuous oscillator/analyzer tuning control provides the ability to manually sweep over a decade to rapidly characterize the distortion of the device under test. Total harmonic distortion measurements can be made to below 0.001%. Harmonics of the oscillator at midband frequencies are reportedly lower than 110 dB down and fundamental rejection in the analyzer exceeds 120dB. At 100kHz, the upper frequency limit of the system, measurements can be made to below 0.1%. The meter detection circuitry is reportedly true RMS for accurate noise and distortion measurements. It handles a crest factor of 3 on level measurements and 10 on distortion measurements. The log volts, linear dB scale improves reading accuracy and provides equal dB resolution over the full scale. Narrow band measurements can be made down to -120dBV using the tuneable band pass filter. Since the filter tracks the oscillator, crosstalk measurements and frequency measurements in noisy environments can be made. Alternatively, this band pass filter can be internally modified to be a low pass filter to permit flat, band-limited (20kHz for example) noise measurements to extremely low levels. A switching power supply allows a single rechargeable internal battery or external 12V wall-plug transformer to provide two

dual polarity, isolated power rails to operate the oscillator and analyzer. The entire instrument requires less than 10 watts. The price is \$1600; availability is 4 to 6 weeks.

RF Shielded DMM

Circle No. 135 on Reader Inquiry Card

B&K-Precision's new Model 2815 DMM is reportedly shielded adequately to retain its accuracy near two-way radio or broadcast transmitters up to 450MHz. The 2815's stated accuracy is 0.1% of reading on dc volts, and 0.75% on dc current. High and low voltage ohms ranges are available with a maximum resolution of 0.01 ohm in the lowest range. Ohms ranges are protected to +1000 and -450Vdc and 450Vac except the ten ohm range which will momentarily sink up to 3 amps without damage. The price is \$150 complete with test leads, tilt stand, manual and spare fuses.

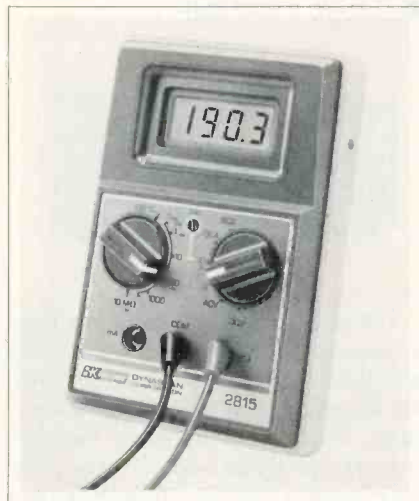

Portable Surveillance Kit

Circle No. 136 on Reader Inquiry Card

The Model VT101 by *Visual Methods, Inc.*, consists of two compact cases capable of transmitting and receiving high quality television pictures and sensing intrusions along a 2/3 mile path via an FCC certified (no license required) microwave beam. The transmitter (target) case includes the lenses, camera and transmitter needed to establish a wireless video and alarm observation post. The battery operated camera and transmitter/intrusion equipment, right angle pinhole lenses, and 75/150 mm telephoto lens provide versatile viewing capability. For extended surveillance, a 117 VAC/220 power supply is included. The receiver case at the monitoring location contains the microwave re-

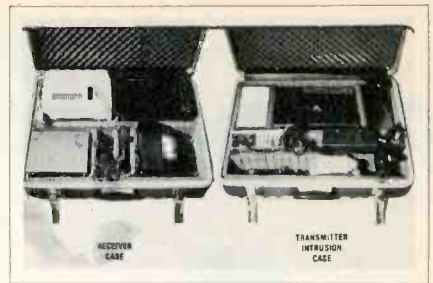

ceiver, intrusion detection console, a 5 in. black and white television monitor and a 12VDC/110VAC power inverter for mobile remote monitoring. Priced at less than \$6000.

Digital RF Wattmeter

Circle No. 137 on Reader Inquiry Card



A new digital multi-function RF wattmeter, Model 4381, has recently been introduced by *Bird*. Using standard Bird plug-in elements, the 4381 measures powers from one-tenth to ten thousand watts from 0.5 to 2300MHz. Forward and reflected power can be displayed; VSWR and dB return loss are calculated continuously and can be displayed at the push of a button.

Ladder Rack

Circle No. 138 on Reader Inquiry Card

JM Marketing Corp. recently introduced a new carry-all ladder rack designed and built specifically for vans and intended for transporting multiple ladders, scaffolding and pipes. Constructed of aluminum castings and 1/4-gauge steel tubing, the ladder rack is reportedly capable of supporting loads weighing up to 1500 pounds without bending. The ladder rack is designed to attach to the drip rails of any van. The basic ladder rack is furnished with two ladder rack supports; a third support is available.



DVOM

Circle No. 139 on Reader Inquiry Card

Hickok has just introduced a new addition to their LX series of DVOMs. The LX304 offers a one-half inch high, 3½ digit liquid crystal display, automatic polarity, zero and over-range indication; reportedly one-half year battery life is typical. Self-contained with a protective cover the LX304 also has automatic decimal, a diode and transistor test capability and is stated to offer 0.5% accuracy.



Adjustable Circuit Breaker

Circle No. 140 on Reader Inquiry Card

A circuit breaker with an adjustable current range of from 250ma. to 7.75 amps in 250ma. steps is available from *The Long Range Company*. The Model 101



Breaker Box is intended to protect bread board or other test set-ups at initial turn-on. The 101 will operate on ac or dc (either polarity) in, reportedly, about 10 milliseconds and indicate tripped status by a red LED. A push button resets the unit.

Distortion Analyzer

Circle No. 141 on Reader Inquiry Card

A new digital readout automatic distortion analyzer Model 6801, has just been introduced by *Krohn-Hite*. The 6801 can

\$140 Gets It All.

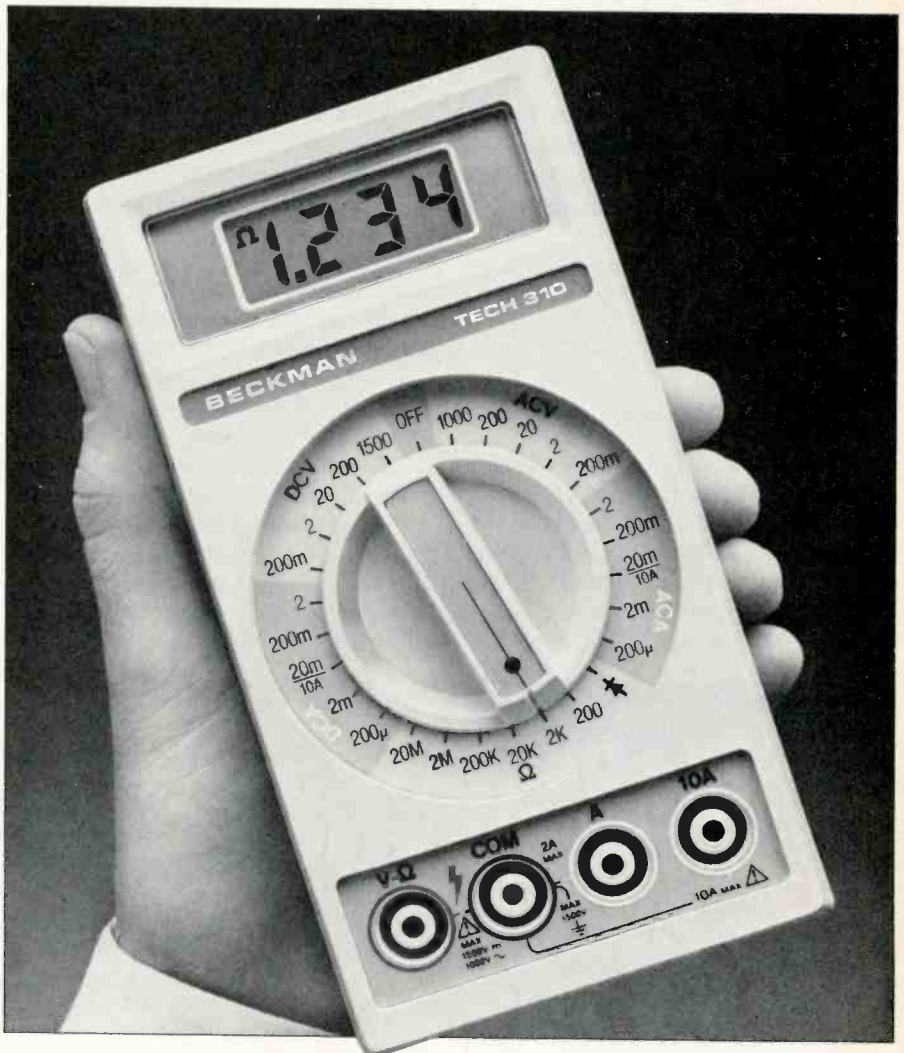

We just knocked down the last reasons for not going digital in a multimeter. Fast continuity measurement. And price.

Beckman's exclusive Insta-Ohms™ feature lets you do continuity checks as fast as the analogs. And Beckman's superior technology and experience let you own this beauty for such a reasonable price.

Of course you get a lot more. Like 7 functions and 29 ranges including 10 amp ac/dc current capability. 0.25% Vdc accuracy. In-circuit resistance measurements and diode/transistor test function. Two years' typical operation from a common 9-volt battery. In other words, all the features you want in one hand-held unit of exceptional good looks and design.

With 1500 Vdc overload protection, 100% instrument burn-in, plus rugged, impact-resistant case, you're assured of the utmost in dependability and long-term accuracy. You get a tough meter that keeps on going, no matter how tough the going gets.

So visit your dealer today and get your hands on the DMM that does it all. Or call (714) 871-4848, ext. 3651 for your nearest distributor.

BECKMAN

Circle No. 106 on Reader Inquiry Card

measure total harmonic distortion to 0.003% with .001 resolution and ac voltage over a frequency range of from 10Hz to 110kHz. Four decade push-button range selectors reportedly allow fast auto-nulling of fundamental frequency over 10:1 frequency ranges: 10-100, 100-1k, 1k-10k, and 10k-110kHz. An analog output is provided. The price is \$1600; delivery is 60 days.



35MHz Scope

Circle No. 142 on Reader Inquiry Card

A new 35MHz, dual channel, portable scope with chop frequency of 500kHz and an alternate sweep capability has been introduced by *Kikusui International Corp.* Called the Model 5630, this new scope reportedly offers improved performance characteristics and specifica-

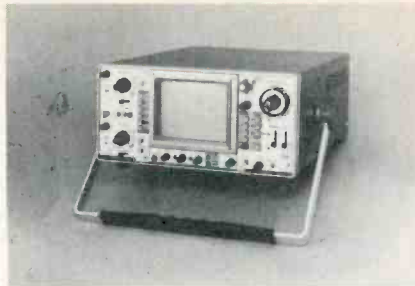

tions. An alternate sweep and calibrated delay are features of the 5680 not normally found on scopes of this class. The horizontal axis (sweep time) for Channel A (main sweep) and Channel B (delayed sweep) is 0.1 μ sec/div to 0.5 sec/div in 21 steps. A 10 X magnification can accelerate the sweep time to 10nsec/div to 50msec/div. The vertical axis will accommodate signals from DC to 35MHz (-3dB). Normal sensitivity (deflection factor) is 5mV/div to 5V/div in 10 steps. A 5 X magnification capability can increase this sensitivity to 1mV/div to 1V/div. Operational modes are Channel 1, Channel 2, Alternate and Chop, complemented with an Add mode and an X-Y mode. There are four trigger modes for Source A signals (Internal, External, External \pm 10 and Line) plus two trigger modes for Signal Source B (internal and external). Trigger coupling includes

AC, HF rejection, and DC. For video waveforms, a synchronization circuit linked to the time/div switch lets the user view signals associated with TV servicing.

Price of the model 5630 is \$1595.

4 1/2-Digit DMM

Circle No. 143 on Reader Inquiry Card

A new DMM from *Fluke*, the Model 8050A, is a 4 1/2-digit bench instrument with true RMS, microprocessor control,



and large LCD readout. In addition to the accuracy and resolution provided by 4 1/2-digit DMM's, the 8050A reportedly has features previously found only in higher priced voltmeters, i.e., offset mode and dBm measurement. The 8050A provides 38 ranges and 7 functions in ac and dc volts and current, dBm, resistance and conductance. **ETD**



SOLID STATE DEVICES

AVAILABLE FOR IMMEDIATE SHIPMENT AT PROFIT SAVING PRICES!

WE FEATURE A QUALITY LINE OF SEMI-CONDUCTOR REPLACEMENTS FROM PROJECTOR BELT & RAYTHEON.

- ✓ Guaranteed Quality
- ✓ Same Day Shipment
- ✓ Toll Free Ordering

CALL TOLL FREE

1-800-558-9572

Ask for our Dealer Proven Catalog today!



**PROJECTOR
RECORDER
Belt Corporation**

200 Clay Street, P.O. Box 176
Whitewater, WI 53190

Circle No. 116 on Reader Inquiry Card



Thordarson replacement flybacks & yokes fit exactly

Thordarson flybacks and yokes are exact replacements . . . from mounting holes to wiring color code. Engineered and built better than the original you replace. Satisfy more customers with superior Thordarson performance. Buy from your Thordarson distributor.

THORDARSON

Thordarson Meissner, Inc.
Electronic Center
Mt. Carmel, Illinois 62863

Circle No. 120 on Reader Inquiry Card

WE REACH THE PEOPLE YOU NEED TO REACH!

Place a recruitment ad in any of these HARCOURT BRACE JOVANOVIICH PUBLICATIONS - and you know your ad dollar is wisely spent.

HBJ PUBLICATIONS does a better job of reaching those who count (*your potential employees*) than any other business publisher.

Magazine	Circulation	Magazine	Circulation
Body Fashions/Intimate Apparel	10,226	Housewares	14,500
Dental Industry News	6,000	LP Gas	14,112
Dental Laboratory Review	11,800	Neurology	13,100
Dental Management	103,000	Paper Sales	11,600
Drug & Cosmetic Industry	9,200	Professional Remodeling	32,478
Electronic Technician/Dealer	50,000	Quick Frozen Foods	24,000
Fast Service	53,026	Rent All	11,150
Flooring	20,223	Roofing/Siding/Insulation	18,343
Food Management	53,078	Snack Food	10,113
Hearing Instruments	16,119	Tobacco Reporter	5,000
Home & Auto	22,353	Toys, Hobbies & Crafts	14,262
Hotel & Motel Management	38,200		

Don't forget that classified advertising works just as effectively in locating employees as it does if you are looking for a position, have a line, machinery or a business to sell, are seeking representatives or wish to buy a specific item. Let it go to work for you!

HBJ PUBLICATIONS - COUNT ON US TO REACH THOSE WHO COUNT!



Harcourt Brace Jovanovich Publications
One East First Street
Duluth, Minnesota 55802

Call Dawn Anderson at 218-727-8511

DEALER'S SHOWCASE



Computer-Controlled Speaker System

Circle No. 151 on Reader Inquiry Card

The Analog Base Computer (patent applied for) is the heart of *KLH Research and Development Corporation's* new line of speakers. The computer repor-

tedly allows reproduction of bass with the fidelity of speakers four times as large. It controls the speaker cone excursion by constantly reading the output of the power amplifier, anticipating cone motion. Other features are cast aluminum speaker baskets, polypropylene cones, and cabinets finished in walnut. The suggested retail prices range from \$420 to \$1000 per pair complete with the Analog Bass Computer.

Burglar Alarm

Circle No. 152 on Reader Inquiry Card

Guardian Electronics offers an audio discrimination alarm system which electronically discriminates between normal sounds and those produced by breaking glass, prying, and other break-in sounds to which the Guardex Alarm System responds by turning on the lights or other equipment. If nothing further happens it resets and shuts off the lights, etc. If another sound does occur a siren sounds for 90 seconds after which it listens again. If a further sound is heard the siren sounds again. If nothing is heard the system resets after five minutes and the cycle can repeat as necessary. The



diverse moisture on power cords. When a fault occurs, the GFCI cuts the current flow at a point below (as low as 5 milliamps) the serious shock threshold for healthy adults. The kit (No. TGTR II5 FCP) contains: GFCI receptacle, spacer, wall plate, wire connectors, mounting screws, ground clip and complete installation instructions.

Stereo Headphones

Circle No. 154 on Reader Inquiry Card

A new series of stereo headphones with variable density earcushions has recently been introduced by *Koss*. The new HV/X series earcushions retain low frequencies but allow mid and high frequencies to vent for what is described as a "more transparent high velocity type sound." Frequency response is reportedly 15 to 35,000Hz. Weighing 7.8 ounces, the HV/X retails for \$69.95 and the HV/XLC with volume-balance controls is \$79.95.



Home Entertainment Center

Circle No. 155 on Reader Inquiry Card

A new home entertainment center from *Gusdorf's Status Pro Collection* has room for everything in audio and video. One section, the entire height of the unit,

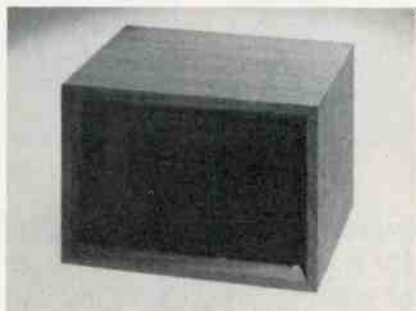

system looks like a stereo speaker; battery backup power can be used. The Guardex 8000 can cover up to 2000 sq ft in a home and 10,000 in an open commercial building and has a list price of \$199.95. The Model 9300 has wireless remote sensor capability and lists for \$239.95. Remote sensors are priced at \$59.95.

Ground Fault Interrupter

Circle No. 153 on Reader Inquiry Card

General Electric has introduced a new ground fault circuit interrupter receptacle kit for the do-it-yourself market. This kit, which is designed to replace a standard 15 amp, 125 volt duplex receptacle, is packaged for point-of-sale rack display. It reportedly protects against dangerous electrical "leaks" to ground which can occur in appliances and tools with frayed wiring, damaged insulation, faulty electrical connections or conduc-



endeco soldering & desoldering equipment

SOLDERING IRONS

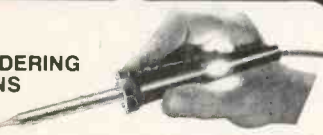

Pencil style. Safety light. Two heats — 20w and 40w. 6 tips. Unbreakable handle. 2 and 3 wire neoprene cords.

DESOLDERING IRONS



Pencil style. Safety light. Some operate at 40w, idle at 20w. 8 tip sizes. 2 and 3 wire neoprene cords.



SOLDERING & DESOLDERING KITS

Everything needed to solder or desolder or both. All in a handy lifetime metal box with hasp.

See your distributor or write...

Enterprise Development Corp.

5127 E. 55th St. • Indianapolis IN 46220
PHONE (317) 251-1231

Circle No. 110 on Reader Inquiry Card

is covered with bronze toned tempered safety glass doors. Behind these are four adjustable shelves for audio components and record storage. A slip-in section for television has back panels to conceal the wall. Below, double-doored cabinet space reveals the Gusdorf VCR slide-out shelf for a video cassette recorder. Separations in the back allow heat emission. Available in a walnut tone finish with Rendura coating, the Model 1930 retails for about \$300.



Tuned Port Speakers

Circle No. 156 on Reader Inquiry Card

An eight member family of efficient tuned port speakers was introduced at The Winter Consumer Electronics Show by American Acoustics Labs. The new



Equation Series is reportedly efficient enough that they can be driven by as little as five watts per channel to compliment modestly powered receivers and amplifiers. Specifications indicate excellent bass response for all of the series and to as low as 18Hz in the case of the Equation 25 subwoofer. All AAL speakers carry a 10-year limited warranty against defects in materials or workmanship.

BATTERIES

continued from page 23

shorted, even that cell may be restored by the means described earlier. In other cases, the plastic wrap around the battery can be removed, and the faulty cell discarded. The remaining cells, after conditioning, will usually be found to be

serviceable, since NiCads, unlike storage batteries, do not go bad if left uncharged for indefinite periods of time.

Considering the present cost of NiCads, a considerable savings can be made by using salvaged cells for lower voltage battery use. They can be rewrapped with ordinary plastic electrical tape, duct tape, or any other suitable material.

In many cases, discarded NiCads require only a few conditioning cycles for restoration to full use, especially where they have been on trickle charge for a year or more! Now that you know about the care and feeding of NiCads, you will find many money saving uses for them.

Your bench and auto flashlights eat a lot of dollars worth of batteries. NiCads could save their cost many times over, even in that ordinary use. And in portable tape recorders there is even a bigger savings. Recently a nine volt transistor type battery has been marketed, for use in radios, calculators, etc. It should be very useful, considering the short life of those nine volt batteries . . . (and very economical). **ETD**

6800

continued from page 34

circuit. By controlling S1, S2, and S3, the device tied to the bus can be controlled. Fortunately, three-state gates (Fig. 8B) are available on the market today. The device will appear as an open circuit to the bus when the three-state input is low ("0"). However, if the three-state input goes high ("1"), the output of that device ("1" or "0") can then be tied to the bus. Figure 8B shows only one line. Device No. 1, for example, could represent a piece of equipment (such as a typewriter) that in reality has eight output lines tied to the eight lines of the data bus. In this situation, there could be eight identical gates for each line of device No. 1, of which the three-state control lines of each gate would be controlled by the same source so that the output of all eight lines would be gated to the data bus simultaneously.

Most microprocessors on the market today have an input pin available on the MPU for this very purpose. The M6800 has a pin called the "TSC" (Three-State Control). When this pin is in the low state, the address bus and the read/write line are in their normal state. However, when a high signal is applied to this pin, the address bus and the read/write line are floating (open). **Number represented in hexadecimal. For explanation see ET/D, Dec., 1979, p. 15. ETD*

MICRO-PROCESSORS

continued from page 37

memory has easy access to most registers, therefore we enter the data into memory, and transfer it wherever we want it to go, by proper programming. And, entered into memory, the data is stored for future repeat use, and preserved, in case errors require another try at programming. The few preceding paragraphs give you a peek, through a crack in the door, at programming. The programmer needs to know the various "Op codes", or their equivalent English language words in higher languages ... and he also needs to know where he wants the operand to wind up (which register), and how to get it there, in the particular brand and model of the MPU he is using. Since brands and models vary somewhat in their internal organization and microinstructions, the programmer needs to be familiar with the particular machine being used. As you can readily understand, this leads to difficulties when the student is struggling to enter the MPU field therefore we are going to take still another crack at op-codes and operands to make sure that the basic concept is crystal clear.....

Op codes and operands....again!

Computer programming instructions are comprised of two parts named "fields"; the op code, and the operand. Operands are data, or the memory address of data. The op code is not data, it is an instruction, which indicates what operations are to be performed upon the data. In most 8 bit MPUs the op code takes one 8 bit byte, and the operand takes one, or two, additional 8 bit bytes. The reason the operand may take two 8 bit bytes is that the address bus is a 16 bit bus, and, as pointed out previously, the data may be in the form of a memory address, the memory location addressed will hold the desired data in this case.

The last article in this series will lay the foundation for programming. Other articles in ETD will cover programming separately.

Summary

This article covered the memory data register, the stack, stack pointer, op code, and operand. Buzz words, "status", "initialize", "field", "push", "pop", "decrement", "increment", "LIFO", and others, were defined in terms of their computer use. The first steps towards computer programming were taken. **ETD**

CLASSIFIED

RATES: 45 cents per word (minimum charge, \$15). Bold face words or words in all capital letters charged at 60 cents per word. Boxed or display ads charged at \$55 per column inch (one inch minimum). Agency commissions will be given only when camera-ready art is provided by agency. For ads using blind box number, add \$5 to total cost of ad. Send ad copy with payment to Dawn Anderson, ELECTRONIC TECHNICIAN/DEALER, 1 East First Street, Duluth, MN 55802.

BOX NUMBER REPLIES: Mail box number replies to: ELECTRONIC TECHNICIAN/DEALER, Classified Ad Department, One East First Street, Duluth, MN 55802. Please include box number in address.

FOR SALE

PICTURE TUBE MACHINE

We buy and sell NEW AND USED CRT rebuilding machinery. COMPLETE TRAINING. Buy with CONFIDENCE from the ORIGINAL MFR. For complete details, send name, address and zip code to:

LAKESIDE INDUSTRIES

4069-71 N. Elstone Ave., Chicago, IL 60618
Phone: 312-583-6565

UNIQUE 1" DIGITAL ALARM CLOCK, in your favorite 12 oz. beer or beverage can. Send \$5.00 for plans. R. Sanderford, 6400 Andy Drive, Raleigh, NC 27610.

Automobile radio and tape replacement parts: Delco, Chrysler, Philco-Ford, Motorola, Panasonic and many others. Large inventory. **Laran Electronics Inc.** 3768 Boston Road, Bronx, NY 10469 (212) 881-9600 out of New York state (800) 223-8314. TF

CB Modification Manual The Bootleggers Bible Now with 77 different PLL chips explained \$14.95. **CB Radio Repair Manual** \$12.95, 20, 140, and 300 watt **Linear Amplifier Plans** all for \$8.00. A.P. Systems, Dept ETD, Box 488, Milford PA 18337. MC/VISA 717-686-5900. 3/80

SONY-PANASONIC-RCA-ZENITH-EXACT REPLACEMENT PARTS-LARGE INVENTORIES-SEND PART OR MODEL NUMBERS-WILL UPS OR COD-GREEN TELE RADIO DISTRIBUTORS, 172 SUNRISE HIGHWAY, ROCKVILLE CENTRE, N.Y. 11570. TF

REPLACEMENT COLOR YOKES-DEALERS ONLY. Zenith 95-2501-2532-2638-2667-S89633 etc. \$19.95. Magnavox 361380-1 \$21.95 etc. Sylvania, G.E. etc. \$17.95 to \$22.95. Request for price list on your letterhead. David Sims Enterprises, Inc., 665 Jericho Turnpike, Huntington Station, N.Y. 11746. 516-549-3925 800-645-5030

HAMs, CBers, SWLs—eight character **MORSE-A-WORD** morse code reader with built-in code practice oscillator; **RTTY READER**. Decodes signals off the air. Send for details. **MICROCRAFT CORPORATION**, Box 513E, Thiensville, WI 53092, 1-414-241-8144. 4/80

CLOSED CIRCUIT TV SYSTEMS. Whether you're a one man operation or a large shop, you can increase your business sharply by selling, installing, & renting CCTV systems for schools, hotels, business, etc. For information on the many uses and a free catalog, for the best prices anywhere on these ALL AMERICAN made units, write or call Columbia Video Systems, Box 676, Beltsville, MD 20705, 301-587-3355.

TUBES—Receiving, Industrial and Semiconductors, factory boxed. Free price list. Low, low prices. **TRANSELETRONIC INC.** 1365-39th Street, Brooklyn, N.Y. 11218E 800-221-5802, 212-633-2800.

ELECTRONIC organ kits. The ultimate design. Sounds like a pipe organ. Build it to sell or build it to keep. Models for churches, homes, clubs, pizza parlors. Send \$2 for demo record and catalog. **DEVTRONIX**, Dept. 75, 6101 Warehouse Way, Sacramento, CA 95826.

Super saver specials Full line Sylvania tubes 70% discount full warranty. Full line original ECG Sylvania semiconductors. Specials-AN 16 Sony Trinitron \$5.99/mfd-50v, 10mfd-50v, 47mfd-160v, 10 lot \$3.99, 80mfd, 100-450v, 99¢ Redcoat Electronics, 66-15 Thornton Pl., Forest Hills, NY 11374, (212) 261-9479.

TV & RADIO, SERVICING CAN BE A SNAP, WITH NEW CHECKER, TEST'S FLY-BACK-VERT-AUDIO-DRIVER & POWER TRANSFORMER'S CHOKE'S. ONLY \$9.95. BATT INCLUDED. TO: JACK ROSS, 6206 N. FRANCISCO, CHICAGO, IL 60659.

send a message...

...write here.

1. Number of insertions: (circle) 1 2 3 6 12
 2. Start with (month) _____ issue (Copy must be in by 1st of month preceding)
 3. Amount enclosed: \$ _____

PAYMENT MUST ACCOMPANY ORDER. WE'LL BILL RATED FIRMS

NAME _____ COMPANY _____

STREET _____

CITY _____ STATE _____ ZIP _____

MAIL AD COPY TO: DAWN ANDERSON, ELECTRONIC TECHNICIAN/DEALER, 1 EAST FIRST STREET, DULUTH, MN. 55802.

RATES: 45 cents per word (minimum charge, \$15). Bold face words or words in all capital letters charged at 60 cents per word. Boxed or display ads charged at \$55 per column inch (one inch minimum). For ads using blind box number, add \$5 to total cost of ad.

ELECTRONIC BARGAINS, CLOSEOUTS, SURPLUS! Parts, equipment, stereo, industrial, educational. Amazing values! Fascinating items unavailable in stores or catalogs anywhere. Unusual FREE catalog. ETCO-013, box 762, Plattsburgh, NY 12901. TF

OSCILLOSCOPES

Discount prices from \$212.00.
BECKMAN METERS in stock.

Call (213) 786-6890
TESTEK, 6910 Hayvenhurst Ave.
Van Nuys, CA 91406

LINEAR AMPLIFIER, 2-30 MHz, 100 or 200 watt solid state. 300 MHz COUNTER. Modulation BOOSTER. Omnidirectional BASE ANTENNA. Plans \$3.00 each. \$10.00/all. Catalog of others. Panaxis Box 130 ET3 Paradise, CA 95969

TV AND RADIO TUBES 49¢ EA!! Send for free color parts catalog. Your order free if not shipped in 24 hours. Cornell Electronics 4215-17 University San Diego California 92105 TF

CARBIDE CIRCUIT BOARD DRILLS-Stock sizes shipped immediately. NEW. Numbers 68 (.031"), 65 (.035"), 62 (.038"), 60 (.040"), and 58 (.042"). All 1/8 inch shank. One for \$4.25-each additional drill, \$3.25. CM CIRCUITS, 22 Maple Avenue, Lackawanna, NY 14218. 4/80

ANALOG MM SWAP DIGITAL MM Send me your old, beat up, used Analog Multimeter and a check for \$180.00 and I will send you a new 3 1/2 Digital DMM 3020 Digital Multimeter the same day. Kontron Electronic, Inc., 700 So. Claremont St., San Mateo CA 94402, Jack Frye, (415) 348-7291 11/80

Build your own speaker system. Write for free catalogue. MCGEE RADIO, 1901 McGee St., Kansas City, MO 64108.

PICTURE TUBE REBUILDING EQUIPMENT capable of producing four high quality tubes per day (WILL TRAIN TO OPERATE) \$3400. Call or write Atoll Television, 6425 Irving Park, Chicago, Illinois 60634, ph. 312-545-6667. 3/80

KEYBOARDS for synthesizers and organs. Available in 37 and 61 notes, completely assembled with single/or dual contacts. Send for information: DEVTRONIX Organs Dept. 75, 6101 Warehouse Way, Sacramento, CA 95826. 4/80

Satellite Television-Movies, Sports, etc. Build or buy your own Earth Station. Article gives alot of hard-to-find, necessary information. Send \$3.00 for article to: Satellite Television, R.D.3, Box 140, Oxford, NY 13830. TF

Supplement your TEKFAK file with early Sams' Photofacts, Supreme Publications, Rider's manuals. Bargain list of available material free. Beitman, Box 46, Highland Park, IL 60035.

HEWLETT-PACKARD 'SCOPES 22 mhz Dual Trace \$350. 50 mhz Dual Trace \$650. Calibrated & Guaranteed, Free Catalog. 1445 N.W. 9th St., Homestead, FL 33030. (305)247-6349 4/80

CATALOG OF ELECTRONIC PLANS. Pre-amps, speakers, crossovers, transmitters, linears, and more. Send \$1.00 to: Peter-Schmitt Enterprises, Dept. ED, P.O. Box 07071, Milwaukee, WI 53207 3/80

Reconditioned test equipment. \$1.00 for catalog. JAMES WALTER TEST EQUIPMENT, 2697 Nickel, San Pablo, CA 94806.

B & K 1077B Television Analyst, like new, \$395.00. Sencore 143 CRT Tester, \$50.00. Harley Jansen, 1600 1st Ave., Marion, IA 52302. 319-377-3141.

FOR RENT

TV RENTAL SYSTEMS! COMPLETE & GUARANTEED. MANUAL OR COMPUTERIZED, SEND \$2.00 FOR COMPLETE DETAILS. PERRY'S RENTAL SYSTEMS, BOX 1407, SANTA MARIA, CA 93456 TF

HELP WANTED

ELECTRONICS/AVIONICS EMPLOYMENT OPPORTUNITIES. Report on jobs now open. Details FREE. Aviation Employment Information Service, Box 240Y, Northport, New York 11768

T.V. Technician-sharp, management capable. Relocate to suburb of San Francisco in sunny California. Excellent opportunity for ambitious, self confident person. Send resume to American T.V., 3309 Vincent Dr. Pleasant Hill, CA 94523. 2/80

Experienced tuner technicians needed. Start at \$4.00 per tuner, call toll free 1-800-433-7124.

BUSINESS OPPORTUNITIES

BROADCAST STATION. Start your own any type! Unique Cable FM station operation-investments/experience unnecessary! Receive free tapes, records. Get your FCC license! Much more. Free details. "Broadcasting:", Box 180 ET3, Paradise, CA 95969

MECHANICALLY INCLINED INDIVIDUALS Assemble electronic devices in your home. Knowledge or experience not necessary. Get started in spare time. Above average profits. \$300-#600/wk. possible. Sales handled by others. No investment-Write for free details. ELECTRONIC DEVELOPMENT LAB, Box 1560B, Pinellas Park, FL 33565. TF

SUCCESSFUL TV SALES AND SERVICE. Exclusive business in West Wisconsin community, \$70,000 and better gross! Commercial building, 2 bedroom apartment, small house, fixtures, repair inventory and equipment, popular retail franchise, \$48,000. Details: Amity Real Estate Company, Box 156, Arcadia, WI 54612. 608-323-7705.

ST. PETERSBURG, FLA: T.V. Sales and Service attached to modern 2 bedroom home. Separate rental house. Includes inventory, equipment, truck and furniture. Newly remodeled. Excellent area for home and business. \$140,000. Phone owner 1-813-541-2039. TF

NEW JERSEY. T.V. Sales and Service. Business and Building. Located in prime commercial location. Established 7 years. Terms available. Pete Hayes, 280 Kingston Road, Parsippany New Jersey. 201-386-9794 5/80

Established TV-Stereo business. RCA-Pioneer-Kenwood. Excellent return. Farming community, good area to raise family. 1700 square ft. building with two apartments available. Southeast Nebraska (402) 645-8122 between 9 and 5. 4/80

WANTED

TUNER SERVICE serving over 400 dealers in the Chicago area wants additional lines. Write or call: Economy Tuner Service., 4901 N. Elston, Chicago, IL 60630. Phone 312-282-3939. 4/80

Wanted for Cash: 53, 7N7, 7F7, 6L6 metal, 6AF6, 6HU8, 304TL, all transmitting and special purpose tubes. DCO Inc., 10 Schuyler Avenue, North Arlington, N.J. 07032, Toll Free (800) 526-1270. 3/80

Wanted: Hotel-Motel TV's Any quantity. Call or write C.C.T.V. (714) 891-1776, 12081 Beach Blvd., Stanton Calif. 92680. 4/80

Stop excusing your life away.

Everyone has an excuse for not seeing their doctor about colorectal cancer. However, 52,000 people die of colorectal cancer every year. Two out of three of these people might be saved by early detection and treatment.

What's your excuse? Today you have a new, simple, practical way of providing your doctor with a stool specimen on which he can perform the guaiac test. This can detect signs of possible colorectal cancer in its early stages before symptoms appear. Ask your doctor about a guaiac test, and stop excusing your life away.

 American Cancer Society

THIS SPACE CONTRIBUTED AS A PUBLIC SERVICE.

Energy Book

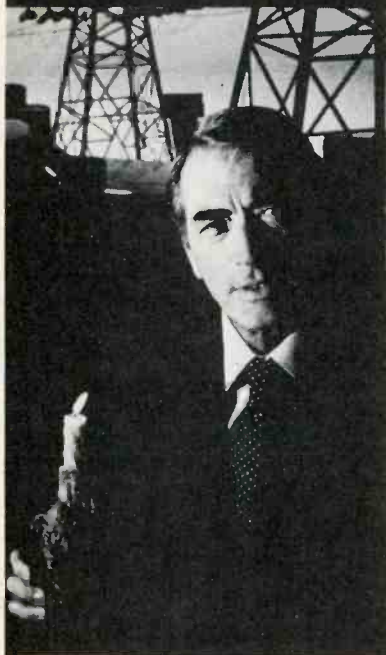

for your employees!



Compelling articles on conservation explain how to save energy, and money, now—on the job and at home.

Coal, solar heating, windpower and other reserve sources all fit into the energy puzzle.

It is crucial that America act now to stretch its resources. You, and everyone who works for you, should have a copy of "The Energy Puzzle." For information on how to get bulk copies, write The Alliance to Save Energy.

A ALLIANCE TO SAVE ENERGY
Box 57200, Washington, D.C. 20006

I want to help save energy. Send me your book.

Name _____

Address _____

City _____ State _____ Zip _____

Ad Council A public service message from this magazine and the Advertising Council

AD INDEX

Circle No.	Page No.
105 B & K Precision/Dynascan Corp.	.5
106 Beckman Instruments	.43
103 Channel Master	Cov 3
107 Cooper Group, The	.19
Edtron Instruments	.23
109 Electronic Book Club	.35
110 Enterprise Dev. Corp.	.46
111 Fluke Mfg., John	.11
Fordham Radio Supply Co.	.41
GTE Sylvania, EGC Consumer Renewal	Cov 4
112 Hitachi Denshi America Ltd.	.28
113 MCM Audio Inc.	.3
114 OK Machine And Tool	.7
115 Optima Electronics	.39
102 PTS Electronics Inc.	Cov 2, 1
116 Projector-Recorder Belt Corp.	.44
117 Quietrole Co.	.23
118 RCA Corp./Antenna Div.	.39
RCA Corp./Consumer Electronics	.29
RCA Corp./Resistors Div.	.12-13
119 Sperry Tech Inc.	.40
120 Thordarson Meissner Inc.	.44
121 Triplett Corp. (for info)	.9
122 Triplett Corp. (for demo)	.9
Viz Mfg. Co.	.4
123 Weston Instruments	.14

This index is furnished for the readers' convenience. However, the publisher can not guarantee its accuracy due to circumstances beyond our control.



You cannot spend tomorrow what you have not saved today.

So the wise save for tomorrow by joining the Payroll Savings Plan today.

Because mighty U.S. Savings Bonds from little paycheck allotments grow.

And a Bond every payday could keep your doctor-to-be away. At medical school. Or take you away. On vacation.

So do put off for tomorrow what you can save today. Join the Payroll Savings Plan.

For, remember, a rolling Bond gathers no moss. But it does gather interest.

Which is why a Bond in time saves.

Take stock in America.

Ad Council A public service of this publication and The Advertising Council.

MIDLAND		CORONADO		PANASONIC	
Model	Schematic No.	Model	Schematic No.	Model	Schematic No.
B&W TV Model 15-D31033	1832	Color TV Model 6-20502A/20486A	1833	Color TV Chassis NMX-L2A	1834
Color TV Chassis NMX-K81A	1835				

PRODUCT SAFETY COMPONENTS
THE DESIGN OF THIS RECEIVER CONTAINS MANY CIRCUITS AND COMPONENTS INCLUDED SPECIFICALLY FOR SAFETY PURPOSES. FOR CONTINUED PROTECTION NO CHANGES SHOULD BE MADE TO THE ORIGINAL DESIGN AND COMPONENTS SHOWN IN SHADDED AREAS ON THE SCHEMATIC SHOULD BE REPLACED WITH EXACT FACTORY REPLACEMENT PARTS. THE USE OF UNAUTHORIZED SUBSTITUTE PARTS MAY CREATE A SHOCK, FIRE, X-RADIATION, OR OTHER HAZARD. SERVICE SHOULD BE PERFORMED BY QUALIFIED PERSONNEL ONLY.

RELIABILITY AND PERFORMANCE
FOR CONTINUED RELIABILITY AND PERFORMANCE, EXACT FACTORY REPLACEMENTS ARE RECOMMENDED FOR ALL OTHER PARTS. IF A SUBSTITUTE MUST BE USED, BE SURE ITS QUALITY AND SPECIFICATIONS ARE IDENTICAL TO THE ORIGINAL PART.

- NOTES:**
- Resistors are shown in ohms: K - 1,000, M - 1,000,000
 - Capacitors are shown in μ F otherwise noted; P - μ F
 - All resistors are $\pm 5\%$ tolerance
 - All waveforms measured with strong signal input; contrast set to give normal picture.
 - Voltage reading taken with "VTVM" from point indicated to chassis ground.
 - Voltage reading may vary $\pm 20\%$.
 - May choose anyone, since listed following transistors have same characteristics.

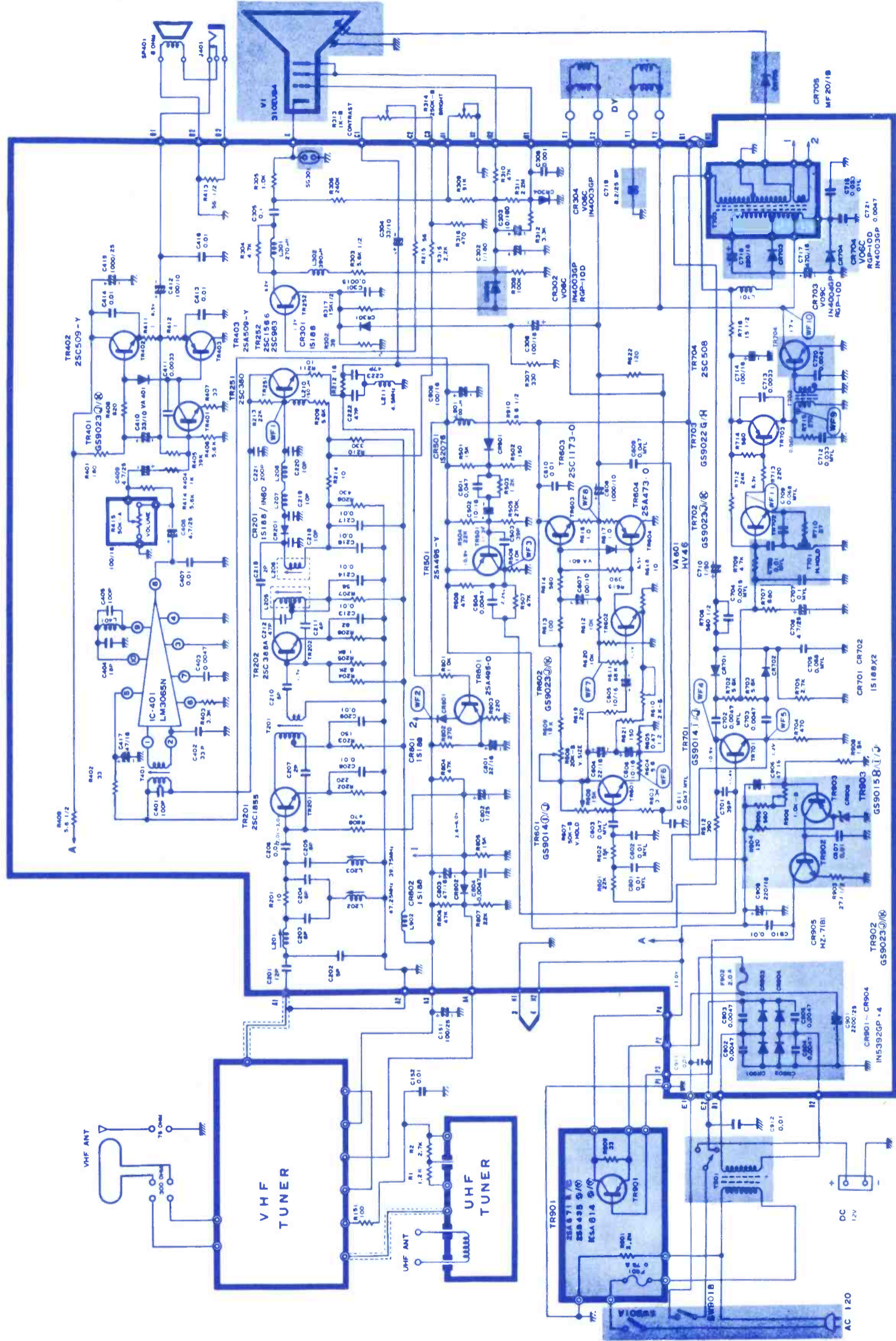

1834

PANASONIC
Color TV Chassis
Section NMX-L2A

MARCH • 1980

ET/P
TEKTRAX

COMPLETE MANUFACTURER'S CIRCUIT DIAGRAMS

	29A564A 25C1473NC 25C16856 25C1573	COLLECTOR EMITTER BOTTOM VIEW
	25C1905 25C1819M 25C1683	COLLECTOR EMITTER BOTTOM VIEW
	25D537 25C1829A 25D643 25D692	COLLECTOR EMITTER BOTTOM VIEW
	25C1226 25C1520	COLLECTOR EMITTER BOTTOM VIEW
	25C1941	COLLECTOR EMITTER BOTTOM VIEW
	25B642	COLLECTOR EMITTER BOTTOM VIEW

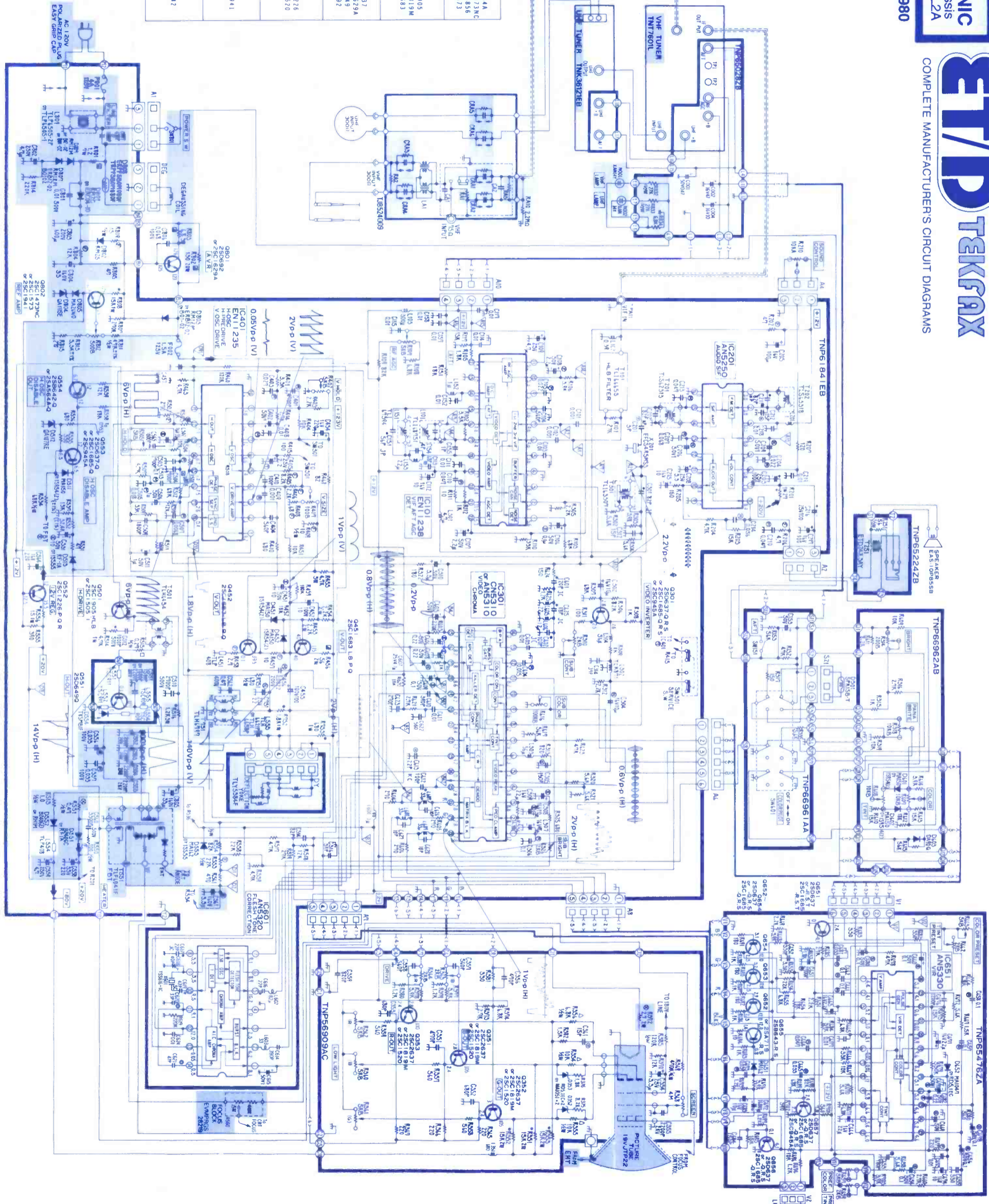

IMPORTANT SAFETY NOTICE

THE SHADED AREA ON THIS SCHEMATIC DIAGRAM INCORPORATES SPECIAL FEATURES IMPORTANT FOR PROTECTION FROM X-RADIATION, FIRE AND ELECTRICAL SHOCK HAZARDS. WHEN SERVICING IT IS ESSENTIAL THAT ONLY MANUFACTURER'S SPECIFIED PARTS BE USED FOR THE CRITICAL COMPONENTS IN THE SHADED AREAS OF THE SCHEMATIC.

- RESISTOR**
All resistors are carbon 1/4W resistor, unless otherwise noted the following marks:
Unit of resistance is OHM (Ω), K = 1,000, M = 1,000,000.
① Solid
② Wire Wound
③ Non-Flammable
④ Cement
- CAPACITOR**
All capacitors are ceramic 50V capacitor, unless otherwise noted the following marks:
Unit of capacitance is μF, unless otherwise noted:
① Electrolytic
② Bipolar
③ Z Type
④ Dipped Tantalum
⑤ Polyester
- COIL**
Unit of inductance is μH
- TEST POINT**
V Test point position
- VOLTAGE MEASUREMENT**
Voltage is measured by a VTVM receiving color bar signal, when all customer's controls are set to the maximum position.
- When arrow mark (→) is found, connection is easily found along with the direction of an arrow.
- When schematic diagram of a board is described in more than two places, they are encircled with dotted line.
- This schematic diagram is the latest at the time of printing and subject to change without notice.
- Indicates the route of the +B voltage supply.

SCHEMATIC DIAGRAM

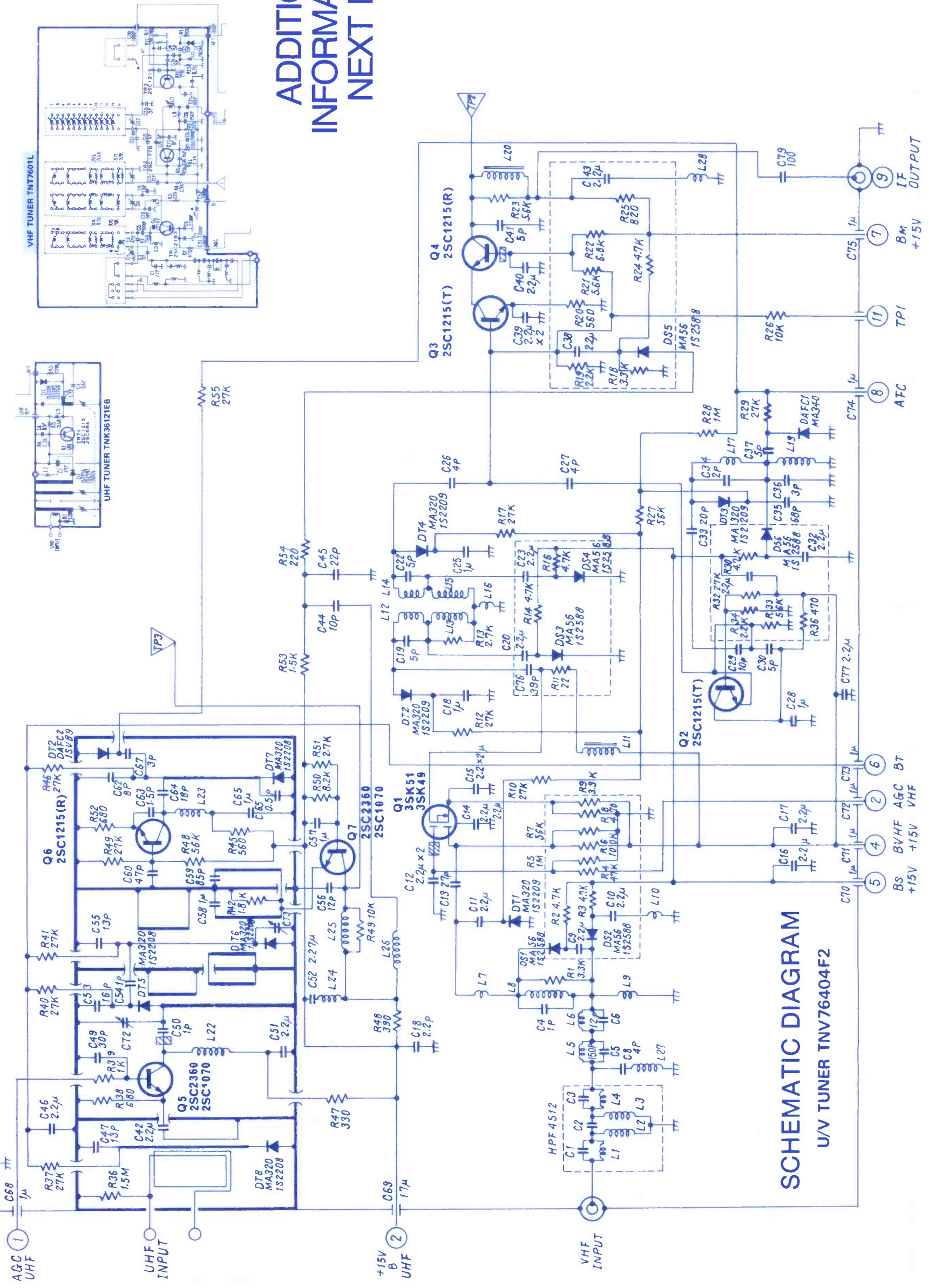

SCHEMATIC DIAGRAM
U/V TUNER TNV76404F2

**ADDITIONAL
INFORMATION
NEXT PAGE**

Channel Master gives you 3 ways to insure CRT sales...

Safety

Implosion protection techniques used by Channel Master to produce **All** of their certified replacement tubes are recognized under the Component Program of Underwriters Laboratories Inc.



Channel Master has been meeting or exceeding industry implosion protection standards for over eighteen years by continually developing sophisticated new equipment and techniques. Local "rebuilders" just don't have these same resources and often try to cut costs by skimping on implosion protection. Tubes from these outfits are not only dangerous but can also cost you dissatisfied customers and lost sales.

Industry surveys indicate that there are some 30 million color receivers that are at least 7 years old, still in use in American homes today. Since the average life span of a color picture tube is 6 to 8 years, 30 million 7 year old sets represent an enormous continuing growth potential for CRT sales.

Superior Quality

During production, Channel Master examines every CRT by putting it through twenty separate and distinct tests. The tubes are even taken for a bumpy 65 mile ride and then tested again for focus convergence, emission and gas

ratio, high voltage leakage, inter-electrode leakage and peak cathode emission—just to make sure each tube delivered lives up to its guarantee.

Warranty

Whether it's a two year Monarch, three year Color Lux or a lifetime Opti-Chrome "LT," the warranty that comes with every Channel Master CRT is your assurance that you're giving your customers the best CRT available. They will appreciate the value you've given them, and you will appreciate their return sales!

Channel Master...We work harder to make you look better.

Channel Master

Division of Avnet, Inc.,
ETD380, Ellenville, New York 12428

SYLVANIA ECG[®] SEMICONDUCTOR GUIDE HELPS SOLVE GE AND RCA'S PROBLEMS.



No one knows better than Sylvania that the show must go on. So when a faulty semiconductor in any brand of home entertainment product turns into a showstopper, it's Sylvania to the rescue. Our ECG[®] semiconductor guide is the most used, and useful, guide in the industry. It makes it easy to replace any ailing performer with an ECG semiconductor that will get the show back on the road.

When it comes to replacement parts the right place to come is Sylvania. Your Sylvania distributor carries a complete line of ECG[®] semiconductors, picture tubes, receiving tubes, and test equipment designed to make any brand work like it's brand new.

Sylvania. The easy way to get even the hardest part.

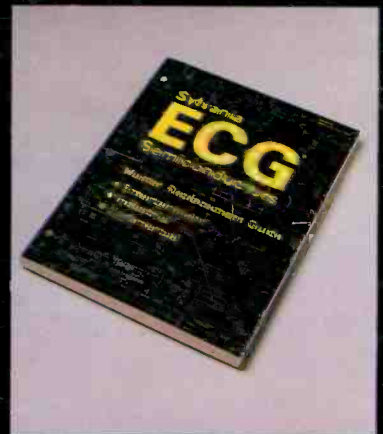

SYLVANIA

