

JUNE 1973 • 75 CENTS  A HARDCOURT BFACE JOVANOVICH PUBLICATION

# ELECTRONIC TECHNICIAN/DEALER

WORLD'S LARGEST TV-RADIO SERVICE & SALES CIRCULATION

Talk Back  
to Your TV Set

Troubleshooting  
—When There's No  
Voltage Test Data!

Productivity:  
Foundation for  
Success

FRIM5593349-P2-  
1 WILLIAM W FRISE  
7176 GALE RD  
ATLAS  
MI 48411  
-AM -8753AL  
# AS

# Announcing a new line of indoor antennas with the name your customers know. Zenith.



## 5 models meet every customer's need and cover the fastest-selling price points.

The new Chromatenna line lets you offer a full range of 5 different models and price brackets to satisfy every customer. Strong sales appeal, too, because every model features the same Zenith name that stands for quality in both color and B&W TV. The sales clincher is the handsome Chromatenna package.

Your Zenith Distributor has all five new models. Stock, show and sell them all for top profits!

At Zenith, the quality goes in before the name goes on.®



Model 973-804



Model 973-803



Model 973-802



Model 973-801



Model 973-800



For quality you can depend on, in replacement parts and accessories — all in one convenient place

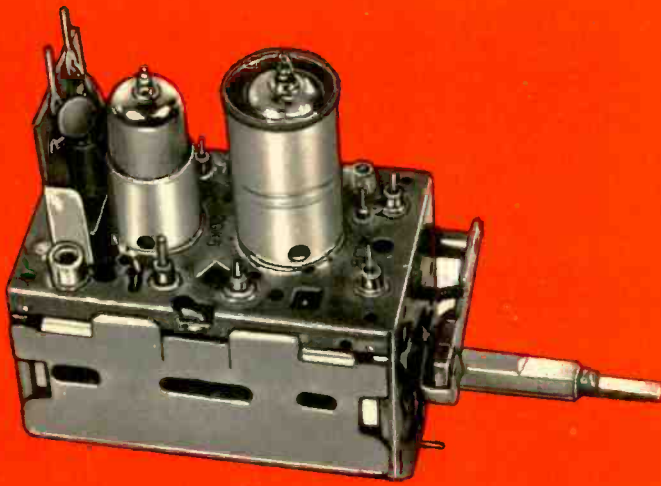

# \$9.75

ALL PARTS INCLUDED

EXCEPT TUBES & TRANSISTORS

ONE YEAR GUARANTEE

## TUNER SERVICE CORPORATION

**PROVIDES YOU WITH A COMPLETE SERVICE FOR ALL YOUR TELEVISION TUNER REQUIREMENTS.**

**REPLACE**

Universal Replacement Tuner \$9.75  
This price buys you a complete new tuner built specifically by **SARKES TARZIAN INC.** for this purpose.

All shafts have a maximum length of 10½" which can be cut to 1½".

Specify heater type parallel and series 450mA or 600mA.

**CUSTOMIZE**

Customized tuners are available at a cost of only \$15.95; (with trade-in \$12.95)

Send in your original tuner for comparison purposes.

**REPAIR**

VHF Or UHF Any Type \$9.75.  
UHF/VHF Combo \$15.00.

In this price all parts are included, tubes, transistors, diodes, and nuvistors are charged extra. This price does not cover mutilated tuners.

Fast efficient service at our conveniently located service centers.

All tuners ultrasonically cleaned, repaired, realigned and air tested.

## TUNER SERVICE CORPORATION

### FACTORY SUPERVISED TUNER SERVICE

Backed by the largest tuner manufacturer in the U.S. — Sarkes Tarizan, Inc.

<b>HEADQUARTERS</b>	537 S. Walnut, Bloomington, Indiana 47401	Tel: 812-332-7251
<b>ARIZONA</b>	2629 North 1st Ave., Tucson, Arizona 85717	Tel: 602-791-9243
<b>CALIFORNIA</b>	Sarkes Tarzian, Inc., Tuner Service Division 10654 Magnolia Blvd., North Hollywood, Calif. 91601	Tel: 213-769-2720
<b>CALIFORNIA</b>	1324 Marsten Rd., Burlingame, California 94010	Tel: 415-347-5728
<b>CALIFORNIA</b>	123 Phoenix Avenue, Modesto, California 95351	Tel: 209-521-8051
<b>FLORIDA</b>	1505 Cypress St., Tampa, Florida 33606	Tel: 813-253-0324
<b>GEORGIA</b>	938 Gordon St., S.W., Atlanta, Georgia 30310	Tel: 404-758-2232
<b>INDIANA</b>	6833 Grand Ave., Hammond, Indiana 46323	Tel: 219-845-2676
<b>INDIANA</b>	817 N. Pennsylvania St., Indianapolis, Indiana 46204	Tel: 317-632-3493
<b>KENTUCKY</b>	2920 Taylor Blvd., Louisville, Kentucky 40208	Tel: 502-634-3334
<b>NEW JERSEY</b>	547-49 Tonnele Ave., Jersey City, New Jersey 07307	Tel: 201-792-3730
<b>OHIO</b>	4597 Pearl Road, Cleveland, Ohio 44109	Tel: 216-741-2314
<b>OREGON</b>	1732 N.W. 25th Avenue, Portland, Oregon 97210	Tel: 503-222-9059
<b>TENNESSEE</b>	1215 Snapps Ferry Rd., Greeneville, Tennessee 37743	Tel: 615-639-8451
<b>TENNESSEE</b>	1703 Lamar Avenue, Memphis, Tennessee 38114	Tel: 901-278-4484
<b>TEXAS</b>	11540 Garland Road, Dallas, Texas 75228	Tel: 214-327-8413
<b>VIRGINIA</b>	4538 E. Princess Anne Rd., Norfolk, Virginia 23502	Tel: 703-855-2518



WATCH US GROW

... for more details circle 134 on Reader Service Card

# ELECTRONIC TECHNICIAN/DEALER

JUNE 1973 • VOLUME 95 NUMBER 6

## PHILLIP DAHLEN, CET

Editor  
1 East First Street  
Duluth, Minn. 55802  
(218) 727-8511

## ALFRED A. MENEGUS

Publisher  
757 Third Avenue  
New York, N.Y. 10017  
(212) 572-4839

## TOM GRENEY

Publishing Director

## JOSEPH ZAUHAR

Managing Editor

## NANCY HOYUM

Production Manager

## JOHN PASZAK

Graphic Design

## LILLIE PEARSON

Circulation Fulfillment

## GENE BAILEY

Manager, Reader Services

## MANAGERS

### BERNARD H. PYGON

43 East Ohio Street  
Chicago, Ill. 60611  
(312) 467-0670

### CHUCK CUMMINGS

Ad Space South/West  
613 North O'Connor  
Irving, Texas 75060  
(214) 253-8678

### KEN JORDAN

### DONALD D. HOUSTON

1901 West 8th Street  
Los Angeles, Calif. 90057  
(213) 483-8530

### CHARLES S. HARRISON

### CY JOBSON

57 Post Street  
San Francisco, Calif. 94104  
(415) 392-6794

### ROBERT UPTON

Tokyo, Japan  
C.P.O., Box 1717

This month's cover shows a close-up photo by your editor of one of the circuit boards described in the TEKLAB Report beginning on page 27.

- 
- 7 EDITORIAL: We Service Junk!
  - 8 LETTERS: Pertinent comments concerning past issues.
  - 16 READER'S AID: What you need or have for sale.
  - 18 NEW AND NOTEWORTHY: Merchandise of special interest.
  - 20 NEWS: Events of interest to our industry.
- 

## FEATURES

### 27 TEKLAB REPORT

Some interesting circuitry observed in Magnavox's Color-TV Chassis T979.

### 31 TALKING BACK TO YOUR TV SET . . . THROUGH THE NEW TWO-WAY CATV SYSTEMS

Edward Lacy tells how some of the newer CATV systems are being designed to monitor the TV viewer.

### 38 FLYING SAUCERS FOR BETTER TV RECEPTION

Our first-hand evaluation of RCA's new Mini-State TV Antenna System.

### 40 PRODUCTIVITY: FOUNDATION FOR SUCCESS

William Joseph offers some good advice on how to make better use of one's time for greater profits.

### 43 TROUBLESHOOTING—WHEN THERE'S NO VOLTAGE TEST DATA!

Raymond Herzog tells how one can approximate proper circuit voltages in order to determine malfunctions with present readings.

### 45 TAXES AND FUTURE RETIREMENT

Some helpful hints on how to hold off paying some of your taxes until you reach retirement when your income is lower.

### 46 IS YOUR WIFE WELL INFORMED ABOUT YOUR BUSINESS?

Ernest Fair offers some suggestions concerning the facts that your wife should know just in case you become ill or have an accident.

### 47 TEST INSTRUMENT REPORT

Reviewing specifications for hm electronics' Model HM-310 VOM/Transistor Tester.

---

48 TECHNICAL DIGEST: Hints and shortcuts for more effective servicing.

50 COLORFAX: Tips for easier color-TV set repair.

53 NEW PRODUCTS: Instruments and components to make your job easier.

56 DEALER SHOWCASE: These items may increase your sales revenue.

60 ADVERTISERS INDEX: Manufacturers concerned about you.

61 READER SERVICE: A source of additional information.

63 TEKFAQ: Up-to-date schematics for easier servicing.



A HARCOURT BRACE JOVANOVIICH PUBLICATION



HARCOURT BRACE JOVANOVIICH PUBLICATIONS: James Milholland, Jr., Chairman; Robert L. Edgell, President; Lars Fladmark, Senior Vice President; Richard Moeller, Treasurer; John G. Reynolds, Vice President; Thomas Greney, Vice President; Ezra Pincus, Vice President; Bruce B. Howat, Vice President; James Gherna, Vice President.

ELECTRONIC TECHNICIAN/DEALER is published monthly by Harcourt Brace Jovanovich Publications. Corporate Offices: 757 Third Avenue, New York, New York 10017. Advertising Offices: 43 East Ohio Street, Chicago, Illinois 60611 and 757 Third Avenue, New York, New York 10017. Editorial, Accounting, Ad Production and Circulation Offices: 1 East First Street, Duluth, Minnesota 55802. Subscription rates: One year \$6, two years \$10, three years \$13, in the United States and Canada. Other countries: one year \$15, two years \$24, three years \$30. Single copies: 75¢ in the U.S. and Canada; all other countries \$2. Second class postage paid at Duluth, Minnesota 55806 and at additional mailing offices. Copyright © 1973 by Harcourt Brace Jovanovich, Inc. All rights reserved. No part of this publication may be reproduced or transmitted in any form or by any means, electronic or mechanical, including photocopy, recording, or any information storage and retrieval system, without permission in writing from the editor or publisher.

POSTMASTER: Send form 3579 to ELECTRONIC TECHNICIAN/DEALER, P.O. Box 6016, Duluth, Minnesota 55806.



## As you can see, your Sylvania distributor has 200 picture tubes in stock.

And they're all in just five Sylvania cartons.

Because our line of five color bright 85XR® OEM-quality tubes gives maximum coverage of 19V, 21V, and 25V diagonal sets with a minimum of stock.\*

It also means faster service because these Sylvania picture tubes are direct replacements. You replace a kimcode with a kimcode, a bonded with a bonded.

And then, there is the biggest advantage of all: You can count all your large-screen color tube needs on the fingers of one hand.

See your local GTE Sylvania distributor for a complete replacement list. With needs that you

can count on one hand, you can bet he has the tube you want in his hands.

Sylvania Electronic Components, 100 First Ave., Waltham, Mass. 02154.

- \*XR23VANP22/
- SRE25BGP22 . . . . . Replaces 53 types
- XR23VAQP22/
- SRE25BHP22 . . . . . Replaces 27 types
- XR19VABP22 . . . . . Replaces 22 types
- XR18VAHP22 . . . . . Replaces 82 types
- XR18VADP22 . . . . . Replaces 16 types

**GTE SYLVANIA**

# Here's everything you'd expect from a high-priced portable multimeter.

## Except a high price.

The B & K Solid-State Electronic Multimeter (Model 277) has 8 important features that you can get on most other quality-made units, but not at prices like ours.

You'd expect to pay quite a lot for a multimeter featuring both high and low power ohms ranges. Both are critically necessary. The B & K 277, with its .068 V power source on low power ohms, will always read the true value of a resistor shunted by a semi-conductor without concern for the semi-conductor's presence. A con-

ventional ohmmeter with a 1.5 volt supply could cause a shunt semi-conductor to conduct, giving a false resistance reading.

The 277's high-power resistance ranges are useful in determining whether transistors are good or bad simply by first forward biasing them to make them conduct and then reversing the leads to qualify the front-to-back ratio.

The B & K 277 has so many features you wouldn't expect at the price: like a .1 V low-voltage scale for both AC and DC; a DC current range of

$1 \mu A$  full-scale for testing sensitive semi-conductor leakage; the unit is fully protected from overloads by fuse; input impedance of  $15 M \Omega$  on DC; 1% precision resistors; a  $4 \frac{1}{2}$  inch,  $50 \mu A$  mirrored scale meter; frequency response to 150 KHz and 59 individual ranges.

Our price alone doesn't make it a value, but our features at our price make it a fantastic value.

# \$99<sup>95</sup>



**B&K** Very good equipment at a very good price.

Product of Dynascan Corporation/1801 W. Belle Plaine Ave., Chicago, Ill. 60613

... for more details circle 103 on Reader Service Card

## We Service Junk!

How many of us are so proud of our abilities to service anything electronic that we will openly boast to our customers with large window displays that: "We Service Junk!"?



Preposterous! is the immediate reaction to such a suggestion. Such claims would merely lower the professional image of our shop. What would our customers think of us if we openly dealt with junk? And although they represent superior brands, what would our customers then think of any merchandise that we might have for sale?

Besides our public image, we must also consider the rates that we charge for the professional service performed. If like most shops, we charge the highest rate for work done on color-TV sets, an intermediate rate for B/W-TV sets, and a lower rate for those audio products that we service. Why? It has been generally assumed that since the basic function of a color-TV set is much more complex than that of a B/W-TV set, and since the function of a B/W-TV set, in turn, is more complicated than audio equipment (if we ignore the associated need for exceptional mechanical skills), then we must scale our hourly rates accordingly. Many of us believe this to be true, others merely accept it as the explanation that best satisfies the public.

Another reason, too commonly accepted in alternate logic, is that the more expensive the product, the more it is worth the customer to have it repaired. Thus a customer paying \$750 for a color-TV set is willing to pay \$35 an hour for repair work, a customer

paying \$210 for a B/W-TV set is willing to pay \$15 an hour, and a customer paying \$65 for an AM/FM radio is willing to pay \$2.25 an hour for repairs. This makes sense, doesn't it?

During this current era of Consumerism, many manufacturers of consumer electronic products have spent a great deal of time and money working toward better "serviceability" of their products. So great has been the demand for better "serviceability" that some manufacturers have become very concerned with their ratings—as either carried out independently or through some professional association(s).

We have had in our lab some of the products of this effort—color-TV sets with plug-in panels and plug-in transistors arranged in configurations that so simplify servicing that the customer could almost do it.

Some of these same manufacturers, however, have completely ignored the serviceability of their other product lines—either with the philosophy that the hardest job should be done first, or that people don't care that much about the less-expensive products. And as a result, we have seen some beautiful B/W-TV sets with circuitry that is nearly beyond belief—layered together with no thought of future servicing. But that isn't anything compared to some of the audio products—for which there is no parts list, no **partial** schematic, no components that can be unsoldered without damaging neighboring components, no parts availability, etc., etc.

No! Let's look at our rates again! Do we charge more for the easy jobs and less for the hard ones? Do we allow an electronic technician (who may earn the same basic salary whether servicing one product or another) to spend three hours to fix a \$65 radio for a customer fee of \$2.50 per hour, when instead he

might be completing the repair of seven \$400 color-TV sets, earning \$35 an hour?

Some of us are just too kind. A customer comes in, "cries" a little about the kid's radio that just went dead, and out of human concern we accept the job—hoping it's just the batteries. Maybe this is a good customer that has had considerable color-TV set work done recently or an extensive antenna job. Maybe this is a new customer that can be satisfied and will later return with something we can make a little money on. Yes, good customer relations are **important**, but will we lose our shirts making the customer happy—only to have the customer move out of town next week?

Do we service all the junk circuitry that comes our way, or do we just service the junk that we sell, or do we sell and service only quality electronic products designed for serviceability?

It is far better to tell the customer **No** than it is to risk losing our money or reputation on products that we are simply unable to stand behind—for lack of service revenue, lack of service information, or just lack of parts.

We cannot afford to keep this problem secret any longer. Let's clean out our sales inventory of all products that we are not prepared to service (even if this does leave a few holes in our product line that must be handled by the discount houses down the street) and let's charge what our professional service is worth—even if occasionally it means \$10 an hour on color-TV sets and \$45 an hour on \$15 portable radios! Yes, some of our customers will get mad. But if we take a moment to explain things, they'll be mad at that discount house, not us.

*Phillip Dahlen, C&T*

## LETTERS

Reader comments concerning past feature articles, Editor's Memos, previous reader responses or other subjects of interest to the industry.

### About the Customer Relations Problem

I am writing you in regard to the article you put in the April 1973 issue of *ELECTRONIC TECHNICIAN/DEALER* about the technician in Pennsylvania who installed a picture tube and then had trouble with the customer. Here are my thoughts concerning the situation:

I think before he proceeded he should have told the customer the type (name) of picture tube he was going to install. I personally stick to . . . about 90 percent of the time. Almost always I tell the customer what brand tube I will install and why.

I think his bill was too high, but I didn't do the work and don't know the circumstances.

I don't understand the tear in the shadow mask but assuming the customer saw it, he should have also.

I would go even further than this Pennsylvania reader and, if I felt it necessary, put in the tube make that the customer might accept better—if this were possible.

Much of TV work is customer relations, as well as technical skill. I think he may have lacked the first.

Of course I realize that a reputation has to be earned and that no one can satisfy some people.

Surely if this dealer has sold many new TV sets, he should have had even worse problems with customers either wanting their money back or a new TV set. I have! I think he has partly dug his own grave and is now running scared.

I know there can be many customer-relations problems in this business. I am 47 years old and have been in my own business for 10 years. I worked for three other TV stores for 16 years before that. I hope this will somewhat qualify what I have said.

EARL HINES

### How We Solved the Customer Problem

In your editorial in the April issue you mentioned a dealer who found himself in trouble with a customer for replacing the picture tube with a well-known brand (in the trade) which failed in service, resulting in a complaint by the customer.

In the Northern Nevada Electron-

ics Assn. we have affiliated with the Better Business Bureau of Reno and established an arbitration panel. In the event of a complaint, we convene a panel consisting of three members of the trade, three members of the public, one member from the University of Nevada who is an electronics teacher, and the local BBB manager, who acts as chairman.

Our most recent case concerned a table radio that had distorted sound. After repair, the customer complained that the sound was still distorted and gradually getting worse. But the panel found that the radio was okay unless played at an excessive level. If this same case had been taken to Small Claims Court by either the customer or the dealer, the judge would not have been technically competent to resolve the issue and would probably have ordered the dealer to make further repairs or refund the money to the customer.

I would advise your correspondent to join his local association and establish an arbitration procedure ahead of time.

MONTY HUCKLE, CET

### Comments about Theory

One of the letters in your April issue appears to have been written by a man who thinks certification is all-right for those who learned electronics in a practical manner. I think so too, but only if in doing so he has learned both the practical and the theoretical. The writer of the passage did not suggest theoretical. His suggestion was—at least I assumed it to be—merely concerned with doing the "practical" thing.

His reference to accredited education from institutions is 100 percent wrong, and I will prove it to him. (I am one who learned both the theoretical and practical).

I have seen it over and over, and it is still going on! The man who only knows the practical way is always going by a special system that we call "Hit or Miss." And why does he have to do this? Can you say? I can! He obtained a job that had already been butchered by someone like himself. There may be quite a few parts missing from the set that he cannot locate. He may locate all defective tubes or transistors but the set still doesn't work. What then? Something may be there that he knows nothing about.

Can a transistor or tube amplifier work without bias, and what bias conditions are correct? Some technicians who graduate from school know nothing about calculations for finding the proper bias resistor for a circuit. If he

doesn't know, then how does a man without any theoretical knowledge know? Answer: "Hit or Miss." But it may take him a few months, and finally he may end up with a distorted set—and a curse to every electronic technician that is alive.

Does the author of that letter know that some radio/TV repair men call the characteristic curve in the tube manual # % \$ \* foolishness! Why? Because they don't understand it, at least not the men that know only the practical way. The theoretical man knows about these curves because in many applications they lead him to success.

A. C. ANDERSON

### An Expert is a Common Man Away from Home

Before I became involved in electronics, I was sent along with an expert sent out from Chicago (175 miles) by Sears to correct an intermittent trouble in a heating system. Practically all local area servicemen had failed to locate the problem. I was a sales clerk at the time, but in holding the light for him I observed a bent part in a control that he did not recognize. A few weeks later I corrected the trouble with the twist of a wrist, use of a pliers and a little common sense.

In reading the letter in the March issue, "Every Coin Has Two Sides," I thought of the above. Mr. Jones seems certainly to have missed the point regarding CETs. Everyone should know that being a CET does not make one better or worse, but every CET has improved his knowledge considerably before earning the use of these letters. Incidentally, many good TV repairmen have passed the CET Test with no special preparation at all.

The letters CET indicate two things—four years of experience and a minimum level of electronic servicing knowledge, as measured by a recognized standard nationwide test. No more—no less. It has nothing to do with being union or not, operating or working in an independent shop, company owned service, an electronic instructor, a college graduate or strictly self-made. I have reached the point that when some one tells me some TV man or instructor is so good, my reply is, if applicable, do you know why he is not a CET? Did he fail the test or does he question his own competence? He has had years to prepare and is concealing information about his electronic knowledge that may be useful to others, including customers, employers, or possibly students.

*continued on page 10*



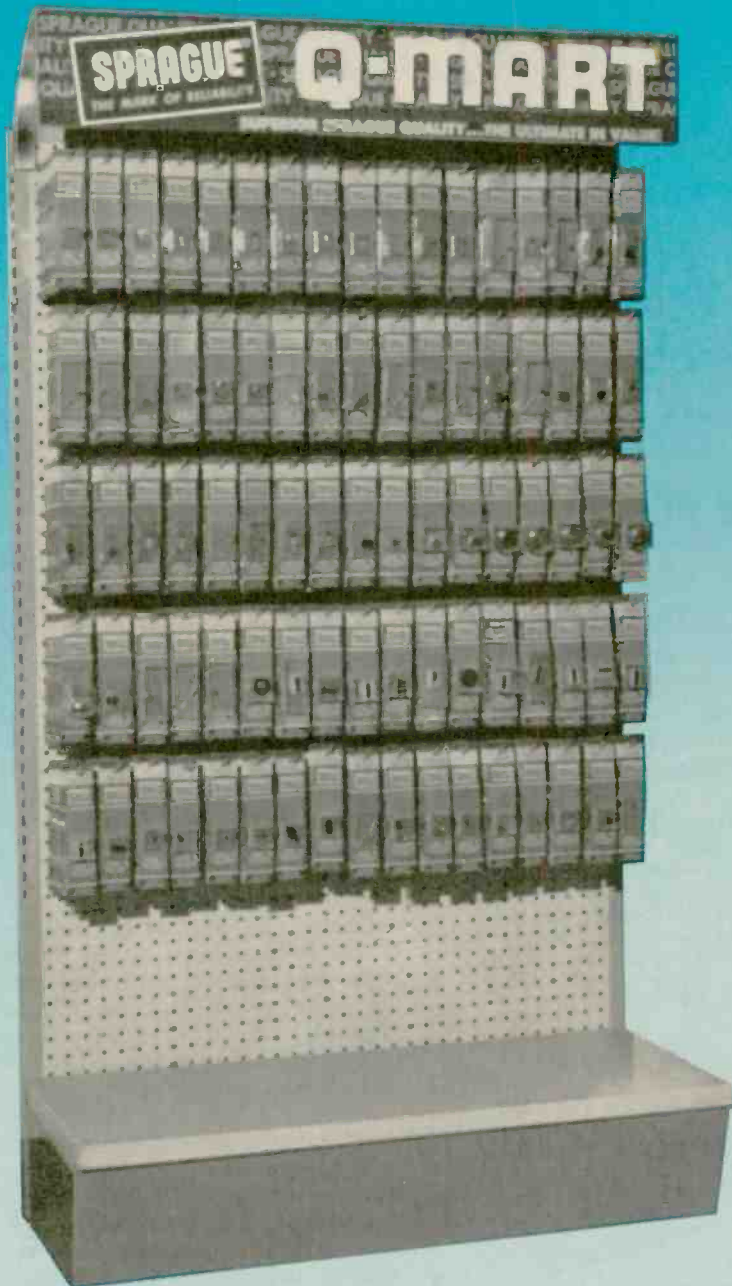

*Don't delay . . . Stop at your Sprague distributor's Q-MART today! And while you're there, don't forget to pick up your free copy of Sprague's 48-page Semiconductor Replacement Manual K-500. Or . . . write to Sprague Products Co., 65 Marshall St., North Adams, Mass. 01247.*



MEMBER

**THE BROAD-LINE PRODUCER OF ELECTRONIC PARTS**

*New*

## SPRAGUE SEMICONDUCTOR Q-MART READY TO SERVE YOU!

**Replacement Semiconductors for  
Service Technicians, Laboratories,  
Hobbyists, Experimenters**

Sprague's "Total-Capability" Replacement Semiconductor Q-MART, being installed in more distributors' stores with each passing day, simplifies the selection and purchase of small-signal transistors, power transistors, field effect transistors, silicon rectifiers, linear integrated circuits, and LED devices, with a product variety that cannot be obtained from any other single source.

Designed with the service technician/hobbyist/experimenter in mind, it gives you ready replacements for over 30,000 original manufacturers' part numbers which are frequently found in home/mobile entertainment and communications equipment.

You'll enjoy the ease with which you can serve yourself right from your Sprague distributor's Q-MART. Every semiconductor is individually packaged in a handy, reusable Kleer-Pak® plastic box (no hard-to-open bubble packs or blister packs) mounted on a card that gives you a good description of the device, complete with pinning diagram, electrical parameters, and important cross-reference replacement information.

What's more, every device is a popular device. There are no dogs to waste time with or cause confusion. Your distributor's Q-MART contains only the hottest, fastest-selling semiconductors based on frequency-of-use. With this kind of movement, you can be sure you're always getting factory-fresh stock.

65-211E



. . . for more details circle 129 on Reader Service Card

# NEW Heathkit Solid-State DC-15 MHz Scope

Add versatility and performance to your bench

- DC to 15 MHz bandwidth with 24 nsec rise time
- 10 mV input sensitivity
- 22 sweep rates from 2 s/cm to 0.2  $\mu$ s/cm (40 ns/cm with X5 magnifier)

The new Heathkit IO-104 is a versatile, solid-state service bench oscilloscope designed to meet the needs of contemporary electronics. Vertical sensitivity of 10 mV/cm and 12 calibrated attenuator positions accommodate a broad range of input signals. Time bases from 2 s/cm to 0.2  $\mu$ s/cm can be selected. The horizontal amplifier accepts external inputs from DC to 1 MHz. Complete triggering controls are provided. The IO-104 offers one of the best price/performance ratios available. For the maximum in sensitivity, stability and trouble-free operation, put the IO-104 on your bench. Kit IO-104, 44 lbs.



**329<sup>95</sup>\***

## Heathkit "Profit-Makers" pay off in price and performance



**IM-102 3½-Digit Multimeter 229<sup>95</sup>\***

Measures AC and DC voltage, current and resistance, with automatic switching for DC polarity. 5 overlapping ranges show DC voltage from 100  $\mu$ V to 1000 V; 5 AC ranges cover 100  $\mu$ V to 500 V; 10 ranges measure 100 nA to 2 A, AC or DC; 6 resistance ranges cover 0.1 ohm to 20 megohms. Kit IM-102, 9 lbs. Kit ID-1041, high-voltage probe accessory, 2 lb., 6.95\*



**IB-1102 120 MHz Frequency Counter 299<sup>95</sup>\***

An 8-digit counter with illuminated over-range, gating, kHz and MHz indicators. High-impedance, low-capacitance (FET) input circuit for minimum loading. 1 Hz resolution without switching time base. Sensitivity is 50 mV to 100 MHz, 125 mV above 100 MHz. Kit IB-1102, 12 lbs.

**IM-104 Portable FET VOM**



only **79<sup>95</sup>\***

A portable lab-grade FET VOM combining accuracy, versatility and ruggedness. Dual FET meter amplifier circuitry for 10 megohm input impedance. And there are 53 ranges on 4 scales for all servicing applications. Kit IM-104, 4 lbs.

**IT-121 FET/Transistor Tester**

**49<sup>95</sup>\***

Designed for quick, accurate in or out of circuit testing of conventional (bipolar) transistors, diodes, FETs, SCRs, triacs, and unijunction transistors. Gain (DC Beta), transconductance (GM), and leakage values are read directly. Kit IT-121, 6 lbs.



Free — Your 1973 Heathkit Catalog with the world's largest selection of instrument kits.

HEATH  
Schlumberger

HEATH COMPANY, Dept. 24-6  
Benton Harbor, Michigan 49022

Enclosed is \$ \_\_\_\_\_, plus shipping.

Please send model(s) \_\_\_\_\_

Please send FREE Heathkit Catalog.

Name \_\_\_\_\_

Address \_\_\_\_\_

City \_\_\_\_\_ State \_\_\_\_\_ Zip \_\_\_\_\_

\*Mail order prices; F.O.B. factory.      TE-281

... for more details circle 115 on Reader Service Card

## LETTERS...

*continued from page 8*

The letters M.D. after a man's name does not make him a doctor, but it helps identify one. Some people seek medical quacks and some will seek TV-service quacks also, but that does not mean that I should leave them uninformed. I shall do my best to inform consumers and shall not hesitate to say that a TV man who is not a CET has not passed the test. If the listener assumes he failed, okay. The other side of the coin is the technician wanting to downgrade a CET by implying he is as competent, even though he has not earned the privilege of using the letters, or implies to the consumer that CET is meaningless as the manager of one company owned service did in a letter which included this statement: "A C.E.T. or Certified Electronic Technician is only a fraternal organization. . ."

Yes, a coin has two sides.

SAM DANES, CET

## Hit Nail on Head

You hit the nail on the head when you said in your editorial of this month's issue [March 1973] of ELECTRONIC TECHNICIAN/DEALER that the unconcerned that allow themselves to be directed like sheep are the people that make a Hitler possible.

I think those who allow themselves to become members of electronic associations belong in that group. They make it possible for such associations to become dictators. The members must obey the rules and regulations of the associations and pay their dues or they are "kicked out."

When the majority of electronic technicians let themselves be enticed into joining such associations, they will make them so powerful that no technician will be able to get a job in electronics unless he becomes a member and pays his dues punctually.

I also believe it is better for the electronic industry if the two leading national electronic associations do not merge, because of the same reason. There will be nobody to oppose them. They will be able to impose their will on everything they want.

Just as it is good for the country to have two major national political parties, I believe the two major electronic associations should remain divided so that they compete against each other and try to do better for the good of their members and the electronics industry.

*continued on page 12*

# We're making it our business to make your business easier.

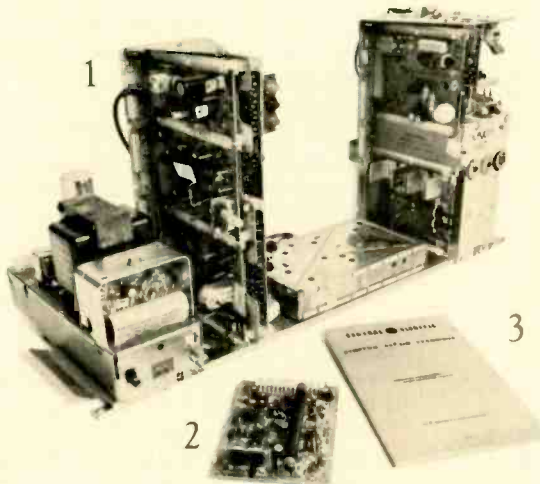

We've made the commitment to make General Electric the most serviceable TV in the industry. We began by bringing in panels of independent service experts to tell us how. And we listened. These are some of the results:

**1. A CHASSIS STANDARDIZATION PROGRAM.** The more standard chassis we make, the fewer you have to familiarize yourself with. So we're building more standard chassis. For example, our J chassis can be found in 19, 16 and 10-inch diagonal screen sizes.

**2. GE's MODULAR SOLID-STATE SETS SERVICE LIKE TUBE SETS.** They're designed for one-call service in the home; and, believe it or not, are easier to service than a tube set. Also like a tube set, you can actually trouble shoot the problem while the set is operating. Then you have a choice. Either change the module or repair it.

**3. AN STC PROGRAM DESIGNED TO TAKE THE "TOUGH" OUT OF "TOUGH DOG" SERVICE.** The "S" stands for Symptom Repair Manual. It lists 60% of all faults and how to find them. The "T" stands for Trouble Shooting Flow Charts. These charts will take you through the next logical sequence of checks to find unlisted faults. These two service aids are designed to cope with 95% of all GE television problems. They were created to keep you from getting to "C" — time consuming Circuit Analysis.

**4. A SERVICEABILITY DESIGN AWARD COVERING THREE CHASSIS.** All three received a 90%+ NEA serviceability rating. And all three have special design features. Like modules, plug-in transistors and replaceable main circuit boards. The compact portables can be opened like a book for servicing.

There's a lot more. For additional information about the STC Program or any GE service question, call collect or write: "Dutch" Meyer, General Electric, Portsmouth, Va. (703) 484-3521.



GENERAL  ELECTRIC

Wading through reams of manufacturers' references is the hard way to find transistor replacements. We know, because we checked over 45,000 types to find just 66 universal transistors that cover 99% of your functional needs.

Now we've put them on our new Transistor Application Slide-Rule so that you can locate a replacement every time — in seconds. All you have to know is the transistor's function and polarity.

You'll spend more time on profitable servicing, less time tracking down replacement numbers, special sources

and waiting for deliveries.

You'll save money, too. You stock fewer types to do more jobs. And when you buy ten IR premium quality transistors, you get 20% off net, not the usual 10% other brands allow.

GET OUR LATEST SLIDE-RULE FREE, plus our current "Semiconductor Cross Reference and Transistor Data Book", by redeeming the coupon below at your nearest IR distributor. And, with the addition of 14 new types, IR's "universal transistor line" now offers broader coverage of your application requirements than ever before.

# Can't find the right transistor in your references?

## Try IR's New Application Slide-Rule, Free!



GOOD FOR NEW

## FREE SLIDE RULE

REDEEMABLE FOR ONE IR TRANSISTOR APPLICATION SLIDE-RULE (Value \$1.00)

**14 NEW TRANSISTORS ADDED**

AND FREE IR SEMICONDUCTOR CROSS REFERENCE AND TRANSISTOR DATA BOOK (Value \$1.00)

**INTERNATIONAL RECTIFIER**

Semiconductor Div.: 233 Kansas St., El Segundo, California 90245 • (213) 678-6281

... for more details circle 116 on Reader Service Card

## LETTERS...

*continued from page 10*

I think every citizen of this democratic country has the constitutional right to earn a living without having to pay dues to some organization. We, ourselves, have permitted such conditions to exist because of our jealousies and greediness. We are making this world a much harder place to live in than it already is.

Subscribers to electronic magazines are not interested in the personal opinions of the editors, but in being informed about the latest developments in electronics and in plenty of good electronic articles that will help them in their daily work.

I must admit that the March issue of ELECTRONIC TECHNICIAN/DEALER contains some very interesting and instructive electronic articles, although I miss Mr. Zauhar's TEKLAB Report.

I hope to see more of these articles in your magazine in the future. I sincerely think that if you do include many instructive electronic articles, your subscribers will look forward with anticipation and anxiety to each month's issue and feel proud to be a subscriber to ELECTRONIC TECHNICIAN/DEALER.

LOUIS MONTOYA

*There must always be those who criticize what we are doing—either on a personal or a group basis, as in the case of our professional associations. To prohibit the voicing of such criticism is to close our ears to the possibility that we may be wrong—thus reducing our chances of improvement. Some criticism may be justified, some may not, but all must continue to be allowed as long as we wish to remain in a democracy. Ed.*

### Sad Problems with Dealer

I fully agree with your editorial in the March issue. I have had very sad problems with one dealer and I would like you to comment on it. A letter in reference to this has been sent to the manufacturer in question.

In 1969 I asked the vice-president of a large piano and organ dealership to send me to an organ service school in Chicago. His reply was, "I will make arrangements for you to be allowed to attend." I wound up paying the air fare, two meals a day, and also lost a week's pay. I was told that after I went to this school I would service this brand of organ full time. Upon my return, I was given the work. However, I was then expected to do the work at a reduced rate, as I was now privileged to be able to service

this brand. Mind you, I was not allowed to purchase parts or do work on my own, and as an independent that is where I make my money.

I let the problems slide, however, and gradually figured out ways to get a fair price without hurting the customers. I was then faced with a new problem.

When the manufacturer came out with a new line of L.S.I. organs, I said that I had to go to the service school in upstate New York. Again, I was told that I would have to fit the school into my schedule and pay for it myself. I was lucky that I met a technician who lived near the meeting who let me stay at his place, fed me, and even picked me up at the airport. I stayed two days and then left, knowing I was the only man working for this dealer who would know anything about this organ. I was never given the chance to prove this as the dealer's other technician borrowed my notes, tapes and prints, and gave himself the clinic.

This week was the last straw. I received notice from the manufacturer of a coming school. I called the dealer to ask who he was sending and got this reply: "We can't waste time or money to send you to schools. If you can't service these organs, you shouldn't be doing our work. If you want to go to the school, go, but, we will start looking for someone else in your absence."

Now, I am faced with the problem of whether to go to the school and lose the dealer, or service the organs with no knowledge, as I have been for three months now—costing the dealer two sales by unsatisfied customers. I hate getting involved with equipment I know nothing about, but I do like to eat.

This same dealer refused to allow me to carry needed parts with me. A parts kit for this manufacturer costs \$135.00. It contains transistors, diodes, IC's, and photocells. With it, I could do half my repairs on the spot, but if I want it, I have to pay for it. The dealer will not pay for me to go to a customer more than once for one repair. That is, if I have to order parts, I have to go back free. If I leave this dealer, I must give up more than half my income. I do owe him for "getting into" this brand of organ.

Thank you for your time and interest.

[Although this was a signed letter, carrying the name of the dealer on the stationery, we decided that it would be best not to publish this information. Ed.]

No technician should continue to accept this type of working relationship. This dealer is not only unfair to

you, but is obviously using bad business principles that are hurting his own income. I suggest that you go to the school and continue to service the organs that he sells—biling the customers directly for your services. By now your own reputation should have grown to the point that it can be counted on for future business. How do our other readers feel concerning this matter? Ed.

### Need Far More than Tests

In the January issue of ET/D Mr. Matt Rusk makes the point that there is already a standard of excellence in

the electronics field—the FCC License.

I would like to take this opportunity to agree with Mr. Rusk, but to also point out that what we need far more than mere tests is more organization—and some kind of a quality control system to assure that those persons that do take the existing examinations are, at least, partially qualified to be electronics technicians. I cite, for example, the "paper mills" that exist in several of our large cities where a man can obtain a First Class FCC license by attending a four- to six-week school. He is obviously not a qualified

*continued on page 14*

# Leader...

## We Make Audio Service A Lot Easier For You!

### Now, the First Low-Cost Portable Audio Lab that puts Time & Labor Charges on Your Side!

#### LBO-310 NEW 3" SOLID STATE OSCILLOSCOPE

A compact, light-weight general purpose scope that delivers the highest sensitivity and stability for the money. What's more, it'll probably pay for itself in weeks! Features unusually bright display and extra-sharp focus; FET's in the input circuits; automatic synchronization; and Z axis modulation. Also monitors waveforms to 100MHz on direct connection & has a DC to 1MHz v't'l bandwidth. Sensitivity is 20mV p-p/div with 10Hz to 100KHz sweep, 4 ranges cont. adjustable between steps. **\$199.95**



#### LT-70 VOLT/OHM METER

This rugged, all-around, low-cost tester delivers the accuracy and sensitivity of more expensive units... and adds lots of important extras, such as: full protection against overload and polarity reversal; dB scales for measuring audio output; LI scales for checking leakage of transistors and diodes; readings as low as 0.25V and 75  $\mu$ A full scale; a shielded metal case with sloped, non-glare plastic window for easy viewing; and a large 4" meter. Complete with accessories. **\$34.95**

"Put us to the test"

## Leader

INSTRUMENTS CORP.

37 · 27 Twenty-Seventh Street,

Long Island City, N.Y. 11101 (212) 729-7410

... for more details circle 121 on Reader Service Card

# MATV PRODUCTS?

## Consider telstrom

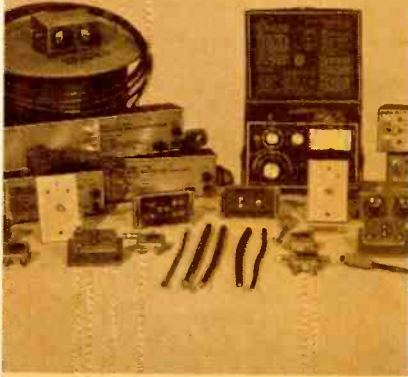

Start with a full line of antennas, add hardware, broadband amplifiers, line reducers, tap-offs, low-loss (trunk and distribution) cables plus additional products required for MATV installations.

It adds up to one of the most complete lines of MATV products on the market. Best of all, they're priced to sell—priced for you to make a profit.

Consider a moment—shouldn't you check out Telstrom? For complete information see your local distributor or write:

**telstrom MATV products**

 **antennacraft**

P. O. Box 1005 Burlington, Iowa 52601

... for more details circle 101 on Reader Service Card

## LETTERS...

*continued from page 13*

technician, but he does hold a license.

I would recommend that technicians establish levels of competence similar to carpenters or plumbers with apprentice, journeyman and master technician classifications that would correspond to tests at each level—CET, Second Class FCC and First Class FCC—or better still have specific tests developed for each level that would be the same test nationwide so that a man in Oregon could move to Florida and not jeopardize his advancement chances because he had been studying for an advancement test in Oregon.

Until a strong national organization comes along for everyone to unite behind, we are going to hear more of the "poor underpaid technician" with all of his certificates hanging on the wall. I, for one, feel we should be paid more.

I have not taken the CET test (I intend to) but I do have a First Class FCC License.

FRED S. DART

*Your editor is of the opinion that we do have a strong national organization concerned with standards of achievement—that being the International Society of Certified Electronic Technicians—your editor being Chairman of that association. The CET Exam is the state licensing exam in Oregon, and there are service dealers in Florida that currently use the same exam for evaluating new employees. ISCET also has an industrial exam, and is preparing to give exams in other areas of electronic specialization. Ed.*

### Disturbed after Reading Teklab Report

I was very disturbed after reading the April Teklab report. The modular "throw away" program is not only an insult to technicians but also the customer. The customer in need of repairs to his TV set is getting it stuck to him by the manufacturer, but the technician will be absorbing all the abuse. My position was most appropriately explained in the article by Mr. Gerald L. Quint on page 59 of the same issue. Everyone should make it a point to read this article and think about it. Then alert your customers and friends who are thinking of purchasing this product. Remember, we are here to fix, not to throw away.

STEPHEN N. TOCZYLOWSKI

*Wouldn't it seem that the decision whether to repair or replace a module*

*should be made by either the electronic technician or customer, on the basis of which will cost less for the repair of the TV set? No one benefits if needless hours (of our valuable time) are spent to repair a module that can be economically replaced. But why replace an expensive module if it is obvious that the problem is merely a shorted common capacitor? Ed.*

### Congratulations for Editorials

I want to congratulate you for the fine editorial in this February edition on the merger of the two national associations—NEA and NATESA. Also, for printing the letter from W. S. (Bob) Harrison, Secretary General of the Virginia Electronics Assn., with their Resolution which says it the way I would have said it.

Arthur Crabb isn't the only one who liked your November editorial about the Canadian satellite vs. CATV. Enclosed is a copy of our association's booklet on Cable TV compiled by Michael R. De Feo for TELSAs (Television Service Association, Inc. of Connecticut).

WILLIAM O. GRANVILLE

## MOVING?

Send Change of  
Address to:

**ELECTRONIC  
TECHNICIAN/DEALER**

1 East First St.  
Duluth, Minn. 55802



Come, let us work  
together to achieve greater success in our  
professional endeavors.

**NATESA / NEA / ISCET**

**Joint Conventions**

August 24-26, 1973

Crown Center Hotel,  
Kansas City, Mo.



George Loomis, Division Manager in Tucson, personally supervises a shipment of Griffiths parts to Japan.

# Griffiths Electronics is exporting hand assembled CRT electron guns to Japan. Let's hear it for our side!

That's bigger news than "Man Bites Dog," but it really isn't a surprise. For a long time, we've been doing our thing better, faster, and more efficiently than our competition.

When you're the best, you get noticed. When your price is right, you get orders—even from Japan.

Griffiths gives distributors the best deal on replacement CRTs: protected profit margins, fast delivery from warehouses all over the country, a complete line covering every set made, and strong promotions that keep dealer demand high.

The Japanese know a good thing when they see it. Why don't you get in on the action?

**GRIFFITHS**  
electronics, inc.

2875 Westside Boulevard/P. O. Box 12007, Jacksonville, Florida 32209

Jacksonville, Florida/ Dallas, Texas/ Chicago, Illinois/ Danville, Virginia/ Atlanta, Georgia/ San Francisco, California  
(904)355-9006 (214)333-0357 (312)379-7600 (703)792-3872 (404)938-2080 (415)467-2375

... for more details circle 114 on Reader Service Card

# Profits grow faster with SK 3016.

It's all you need to put top-of-the-line quality in nearly 2,600 replacements. With it, you can offer more on-the-spot service and build better business efficiency all down the line. It's just one of RCA's 156 SK devices that can replace over 51,000 different foreign and domestic types.

See your RCA Distributor today. He'll give you the full story on SKs and your copy of the new RCA SK Replacement Guide SPG-202N. RCA Electronic Components Harrison, N.J. 07029

**RCA** Electronic Components



## READERS' AID

Space contributed to help serve the personal needs of you, our readers.

### For Sale

I have for sale 113 sets of Tekfax dated back to March 1963. Please make offer.

M. J. VILHOSKY

2744 Brier SE.  
Warren, Ohio 44484

Antique radio and TV tubes at less than dealer price. I also have Riders Radio and TV manuals for sale.

G. C. GOODWIN

Rankin, Ill. 60960

I have Riders Troubleshooters Manuals, Volumes 3 to 16 for sale.

ELMER RHODE

1044 Birchview Rd.  
La Crosse, Wisc. 54601

I have available back copies of Tekfax No. 107 and 110.

NIX-FIX-IT

Rt. 1, Box 225  
Franklin, N.C. 28734

### Business for Sale

I have for sale a TV Sales and Repair Shop located in northern Catskills New York. Included are equipment, truck, stock and house on 1½ acres. Make an offer.

FRANZ ZENKER

Cor. E. Redmill Rd. & RT. 32  
Greenville, N.Y. 12083

### Schematic Needed

I need the schematic and service information for an old Philco radio, Chassis Type 17, Code 121.

LOUIS SCHUITEMA

627 Deerfield Drive  
Streamwood, Ill. 60103

I would like to obtain a schematic and/or operating instructions for a Jackson 600 Lab Scope; plus the 3 probes which originally were sold with the instrument, part numbers LC2-1P, LC10-1P and DEM-P.

BILL HENNER

324 Forest Ave.  
Aurora, Ill. 60505

### Information Wanted

I would like to rebuild my fire-damaged, Supreme, Model 688, Audolyzer. I would like to obtain the data and service sheets.

ALEX RALSTON

P.O. Box 366  
Unity, Saskatchewan S0K 4L0

I need the Assembly-Operating Manual for the Paco Model MX-100 Multiplex Adapter.

C. W. LINDEN

4268 No. Carruth Ave.  
Fresno, Calif. 93705

I need the base diagram and all information for a 5AWP2 tube.

R. CARDONA

Apeninos 633  
Puerto Nuevo, Puerto Rico 00920

### Part Wanted

I would like to obtain a motor for an AKAI Roberts Tape Recorder. It is a two-speed four-wire unit used in Models X-100, X-150 and 1710-W. Will buy used motor even with bad bearings as long as the field coil is good.

M. R. DAVIS

Davis Electronics  
2655 West Park Dr.  
Baltimore, Md. 21207

I would like to know how I could obtain parts for a Decca Solid State Stereo, Model DP169. I wrote to Decca Distributing Corp., New York, N.Y. 10022 and got no reply.

AVENUE RADIO & TV SERVICE  
313 Mankato Ave.  
Winona, Minn. 55987

I have a Precise Model 909 Vacuum Tube Volt Meter with a bad transformer. I would like to know where I could obtain the part.

FRED O. WALZ

Bowdle, S.D. 57428

### Service Business Wanted

I wish to buy all or part of a profitable TV service business. Licensed with 20 years of experience. Prefer shop in the smaller town. Please send details.

LOUIS ZARAFONETIS

P.O. Box 437  
Vincennes, Ind. 47591



# NEW LOW PRICES ON WINEGARD® QUALITY ACCESSORIES!

set couplers—2-way splitters—band separators—matching transformers <sup>reduced up to</sup> **31%**

Why buy "second line" TV components when you can buy the best . . . Winegard engineered-and-built for less and get the same high quality and performance?

Check with your distributor for new low pricing on these items.

**Reduced 14%**

**CS-285 300 OHM V-U BAND SEPARATOR**—High quality, low loss Band Separator for adapting single 300 ohm download to separate 300 ohm VHF and UHF antenna connections of TV set. Perfect match insures perfect color and black and white reception.



**Reduced 31%**

**CC-482 82 CH. 4-SET COUPLER**—Deluxe low loss coupler connects four TV-FM sets to a single 300 ohm download. Efficient coupler circuit provides a maximum amount of signal to each receiver. Specially designed for color, black and white and stereo.



**Reduced 31%**

**CS-387 75 OHM V-U-FM BAND SEPARATOR**—Band Separator for making connection between 75 ohm coaxial download and separate 300 ohm antenna terminals of TV set and FM receiver. Features latest printed circuit design for low loss, high isolation and perfect match. Excellent for quality color and FM stereo reception. Connector included.



**Reduced 28%**

**CC-33 82 CH. 2-SET COUPLER**—Inexpensive coupler for connecting two TV or FM sets to a single 300 ohm download. Features handy no-strip terminals for easy connection.



**Reduced 18%**

**CS-380 300 OHM V-U-FM BAND SEPARATOR**—Latest Band Separator design adapts 300 ohm download to separate VHF and UHF antenna terminals of TV set and provides FM stereo thru handy no-strip screw terminals. Unique printed circuit design has extremely low loss, excellent match and high isolation for perfect color and FM stereo.



**Reduced 22%**

**CS-175 75 OHM V-U BAND SEPARATOR**—Quality 75 ohm Band Separator for attaching coaxial cable to separate 300 ohm antenna terminals of TV set. Features printed circuit and latest circuitry for low insertion loss and perfect color transmission. Connector included.



**Reduced 26%**

**CC-282 82 CH. 2-SET COUPLER**—Efficient 300 ohm coupler connects two TV-FM sets to a single 300 ohm download. Input and output connections are handy no-strip type for easy installation. Quality circuitry insures perfect color and black and white reception.



**Low Price!**

**LS-27 82 CH. LINE SPLITTER**—High quality line splitter for dividing a single 75 ohm coaxial cable into two trunk lines. Indoor type with transformer network features excellent match. Connectors included.

**NEW**



**Low Price!**

**T-12BLK 82 CH. MATCHING TRANSFORMER**—Compact indoor Matching Transformer for attaching coaxial cable to 300 ohm antenna terminals of TV or FM receiver. Packed 6 per poly bag, 8 bags per master carton. Connectors included.

**NEW**



**WINEGARD**  
ANTENNA SYSTEMS  
3000 KIRKWOOD ST. • BURLINGTON, IOWA 52601

... for more details circle 135 on Reader Service Card

## NEW AND NOTEWORTHY

For additional information on products described in this section, circle the numbers on Reader Service Card. Requests will be handled promptly.



### TRANSISTOR NOISE AND FREQUENCY TESTER 700

*Checks two characteristics of a transistor*

The Model NF-1 Transistor Noise and Frequency Tester has been developed to check the relative noise of transistors and zeners, and to indicate the relative frequency response of transistors and signal diodes. Operation of the instrument is easy and merely requires that the operator select the desired mode of operation, depress a test button and read the characteristic that is being tested on a large color-coded meter. An attenuator switch adjusts the noise level to the proper null point on the meter to get a noise reading. The instrument measures 8 in. by 6 in. by 4½ in. and weighs 4 lb. Jud Williams Co. Inc.

### CARTRIDGE ALIGNMENT TAPE 701

*Permits rapid test and adjustment of functions*

A Model AT-820 Alignment Tape has been developed to permit rapid test and adjustment of most important functions on the popular eight-track cartridge players used in homes and automobiles. The cycle playing time is said to be approximately eight minutes with the recorded tests including: Program and channel identification by voice; track height; azimuth; frequency response and speaker phasing and tape speed; wow and flutter; switching and crosstalk; plus four programs of stereo music for testing overall machine performance. Each tape is supplied with detailed instructions for proper use and identification of all test tracks and frequencies. Nortronics Co.



**FOR MORE  
NEW PRODUCTS  
SEE PAGE 53**

### DIGITAL MULTIMETER 702

*Instant auto-ranging with triple-slope conversion*

An instant auto-ranging four-digit portable multimeter, Model 4444, is said to include the following features: setting of the decimal point, polarity sign, proper units annunciator, over-ranging, blanking of redundant zeros and overload protection. The operator selects the type of measurement required and connects the leads. Then with instant automatic ranging, the unit reportedly provides a clear four-digit readout, displaying polarity, units, decimal point and optimum reading, automatically. Any input from 10 $\mu$ v to 1kv can reportedly be applied at any time without fear of damage to the instrument. The 4½ digit LED display is said to be formed on a single chip for maximum reliability and minimum interconnections. Its common-mode rejection is reportedly over 130dB for dc voltage measurements and greater than 70dB for ac voltage measurements at 50/60Hz  $\pm$ 1%. Other manufacturer specifications include dc accuracy of  $\pm$ 0.02%  $\pm$ 1 digit  $\pm$ 10 $\mu$ v (over 90 days) and an input resistance of 1000M plus 10 $\mu$ v sensitivity and bias current of 0.2na. The unit is housed in a lightweight case which is small enough to be carried in a standard attache case. Weston Instruments Div.



# We've expanded our replacement guide to over 75,000 listings.

That's 34,000 more than our last ECG™ Semiconductor Replacement Guide. And more replacements than you'll find in any other guide.

We've also made our new ECG 212E guide more useful by including our industrial replacement types so you can locate commercial components with the same ease as consumer components.

You'll also find more imported types listed and the proper ECG replacement cross referenced.

Both the ECG 212E guide and the ECG replacement semiconductors are available at your local Sylvania distributor.

And we've made sure that the parts are just as available as the guide.

After all, when you work hard to produce the biggest and the best replacement guide, you also work hard to make sure the parts are available when needed.

*Sylvania Electronic Components, 100 First Ave., Waltham, Mass. 02154*

## **GTE SYLVANIA**

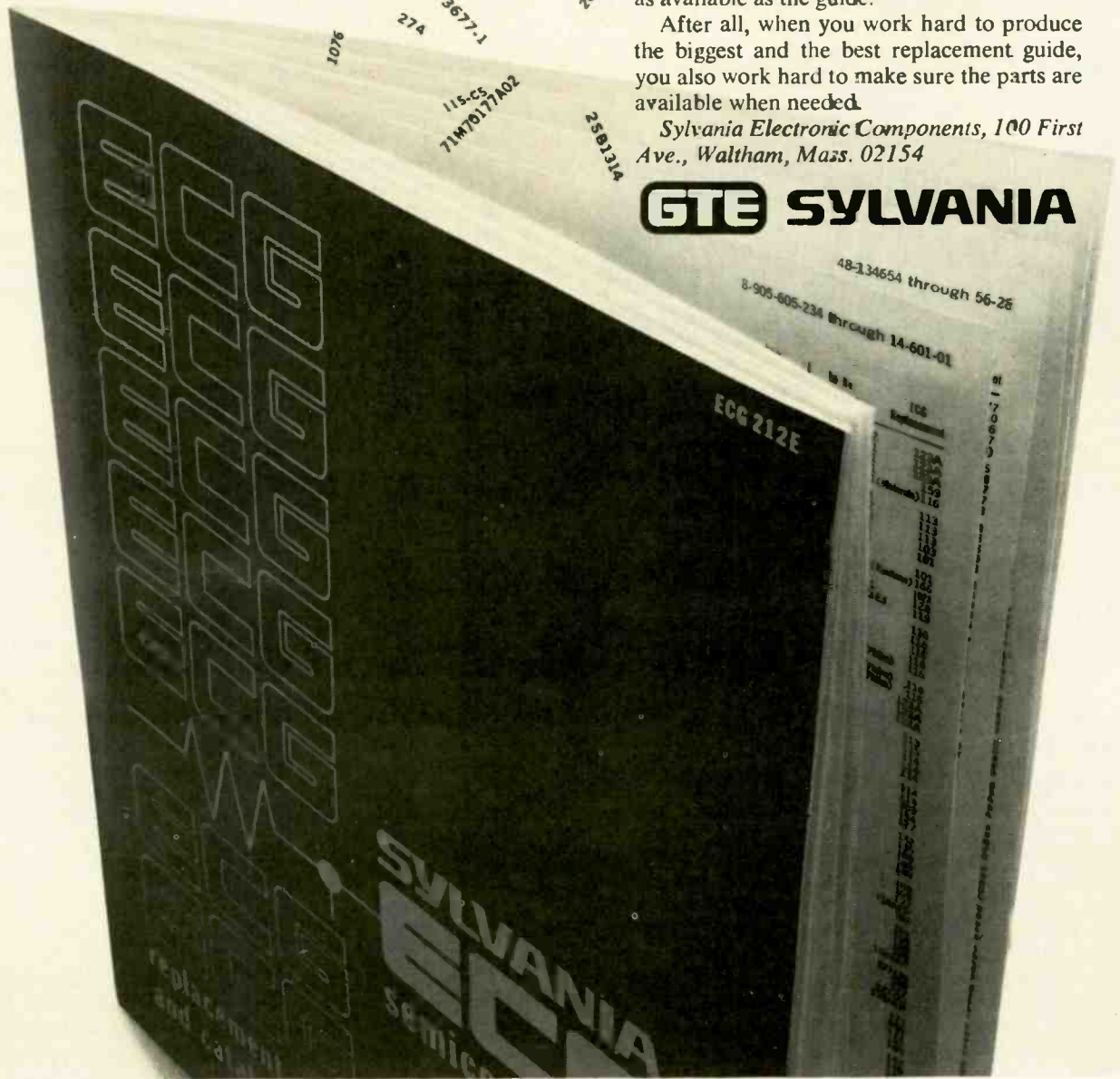

## Virginia Electronics Association Announces Plans for June Convention

Local representatives of the Virginia Electronics Assn. are now distributing tickets for their annual convention, to be held June 22-24, 1973 at the Holiday Inn at Tysons Corner, Va., which is located near Washington, D.C. Convention registration is \$25.00 per person and \$15.00 per person for the Saturday night banquet.

Convention speakers and programs are in the process of being lined up to coincide with the theme "Progress Through Education," and the Ladies Auxiliary has reported plans to conduct a shopping tour of the fabulous Tysons Corner Center Mall. Phillip Dahlen, your editor, will be the keynote speaker at the Saturday night banquet.

## Two-Way Cable TV to Soon Become Accepted Part of Canadian Life

Two-way TV is expected to be an accepted part of Canadian life within two years. So reported John Sie, Division Manager of Jerrold Electronics in addresses to



the major cable TV companies recently in Canada.

"We expect major field testing installations involving five cable operators with 2000 home subscribers each before the end of 1973," he stated. "We have all the technology and are now producing thousands of units for pilot testing in homes."

He also stated that two-way TV will be an advertiser's dream. For the very first time, it will be possible to determine immediately how many homes are watching the commercial and to gauge both group and individual responses. Suddenly, an advertiser knows how many prospects he has and where they live!

## Sample CET Questions Generate Much Interest

We have received considerable correspondence as a result of our printing questions and answers representative of the material included in the CET Exam. Some of our readers have even found an occasional error in what we have printed. We wish to apologize for any such occurrence, but wish to also stress the fact that these are *not* the questions used in the CET Exam.

Actually, many people studying these questions or the CET Exam Study Guide are pleasantly surprised upon taking the exam to discover that it is actually much easier than they expected. Although it is true that nearly 50 percent of those taking the exam fail it, these generally are the individuals who have not taken enough time to pre-

pare for it—should they be lacking this information when performing their jobs.

Although all of the questions that we have printed—this is the 12th and last in a series—have appeared as essay-type questions, there are *no* essay questions in the CET Exam. They are all multiple-choice questions, which means that the correct answer is printed right there in front of you. All you have to do is recognize it and check the answer sheet accordingly!

### Section XII

#### Troubleshooting

1. What is a ringing test used for?
2. Poor alignment can cause poor color sync. (True/False)
3. What is a detector probe used for?
4. Why is a low-capacitance or attenuator probe used?
5. If a modulated 41.25MHz frequency is applied to the mixer test point in a TV set, the waveform observed at the video detector output should be adjusted for (minimum/maximum) with the 41.25MHz coils?

#### Explanations

1. The ringing test commonly refers to a test performed on coils, specifically the horizontal-output transformer and yoke. The coil is pulsed with a voltage and the scope is used to watch the ability of the coil to resonate or "ring" with distributed capacitance. Shorted or open coils drastically effect the ringing.
2. True. Since the color information is about 3.58MHz away from the picture carrier, a set with a narrow bandwidth (poor alignment) could have color-sync problems.
3. A detector probe is used to check for quality of modulated RF signals beyond the frequency spectrum measurable with the scope directly.
4. A low-capacitance probe is used to reduce the loading effects of the test instrument.
5. Minimum. The 41.25MHz frequency is the sound-carrier frequency in the IF's. This frequency is minimized in the IF's to reduce sound bars in the picture and to reduce beat frequencies.

## Canadian Spacecraft to Inaugurate Full-Time U.S. Domestic Communications

With timely FCC approval, two RCA companies—RCA Global Communications, Inc., and RCA Alaska Communications, Inc.—plan to use Canada's most recent communications satellite, Anik II, to initiate U.S. domestic service in August 1973. This will usher in a new era of lower cost and more innovative communications for the nation, according to Howard R. Hawkins, RCA Executive Vice President and Chairman of the RCA companies.

Although Anik II is primarily for Canadian communications, two of its transponders have been leased at \$2.7 million annually by RCA to carry communications traffic between the U.S. East and West Coasts, and between both coasts and Alaska. Initially earth stations will be installed in the New York-Washington Corridor, near San Francisco and at Anchorage, Alaska. An earth station already exists at Juneau, Alaska; and a fifth station near Los Angeles will be planned later.

## Please Help Us Trace This Stolen Merchandise

On February 19, 1973, the audio visual department of Mount Vernon Junior College [2100 Foxhall Road, Washington, D.C. 20007] was broken into, and over five thousand dollars worth of equipment taken. The major loss was

*continued on page 22*

# TV TUNER SERVICE



ELECTRONICS, INC. is proud to announce  
the **GRAND OPENINGS**  
of our new  
**SERVICE CENTERS** in . . .

**CLEVELAND, OHIO**

**SAN DIEGO, CA.**

**HOUSTON, TEX.**

**OKLAHOMA CITY, OK.**

**PHILADELPHIA, PA.**

**PITTSBURGH, PA.**

**PORTLAND, OR.**

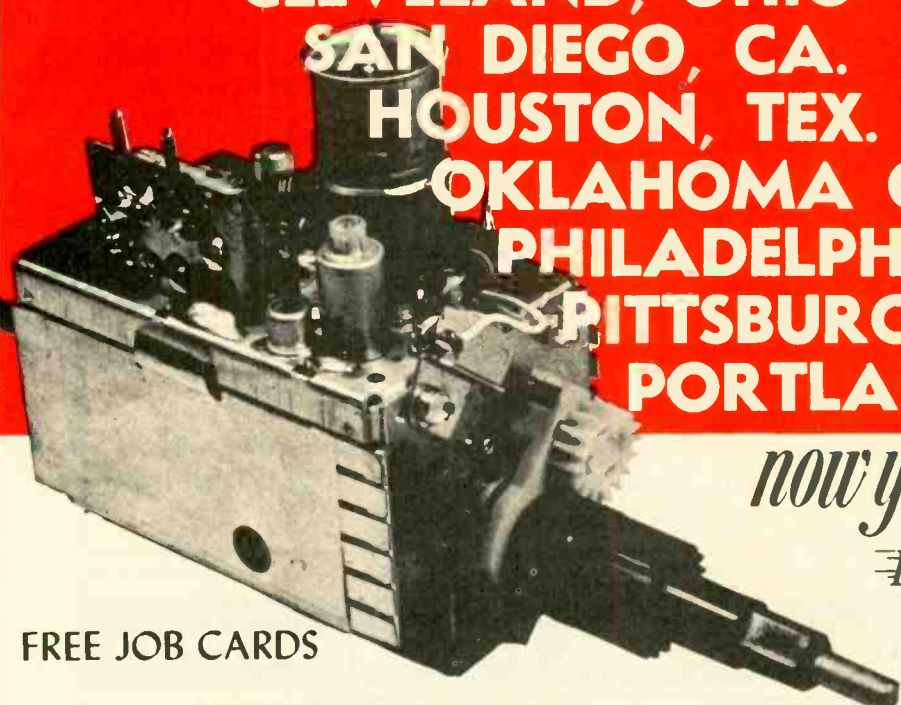

*now you too... get*

*Fast 8 hr. Service!*

**\$9.95**

**1 YEAR GUARANTEE**

FREE JOB CARDS

FREE SHIPPING LABELS

Come and see us. PTS Branches are all company owned—No Franchises—we care for our customers. For a TUNER PART or COMPLETE TUNER REBUILT, come to us, we will take care of your tuner problems like no one else can. WE'RE PROFESSIONALS—18 years experience made us what we are!

## You owe it to yourself

to try P.T.S. We are the fastest growing, oldest and now the largest tuner service company in the world. Here is what you get:

1. **Fastest Service**—8 hour—in and out the same day. Overnight transit to one of our plants.
2. **Fine Quality!** Your customers are satisfied and you are not bothered with returning tuners for rework!
3. **Lower Cost!** Up to \$5.50 less than other tuners for rework!
4. **Friendly, helpful service!** We help you do more business—that way we will do more, too. We want your business and we try to deserve it!

Color—Black & White—Transistor—Tubes  
—Varactor—Detent UHF

VHF or UHF..... \$9.95  
UV-Comb..... \$16.95

Major parts, tubes, transistors, shipping  
charged at net cost  
(Dealer net!)

HOME OFFICE—INDIANA:  
 ELECTRONICS, INC.  
P.O. BOX 272  
BLOOMINGTON, IND. 47401  
TEL. 812, 824-9331

OKLAHOMA:  
PTS ELECTRONICS, INC.  
P.O. BOX 60566  
OKLAHOMA CITY, OKLA. 73106  
TEL. 405, 947-2013

MASSACHUSETTS:  
PTS ELECTRONICS, INC.  
P.O. BOX 3189  
SPRINGFIELD, MASS. 01103  
TEL. 413, 734-2737

SOUTHERN CALIFORNIA:  
PTS ELECTRONICS, INC.  
P.O. BOX 5794  
SAN DIEGO, CALIF. 92105  
TEL. 714, 280-7070

NORTHERN CALIFORNIA:  
PTS ELECTRONICS, INC.  
P.O. BOX 41354  
SACRAMENTO, CALIF. 95841  
TEL. 916, 482-6220

OHIO:  
PTS ELECTRONICS, INC.  
5682 STATE RD.  
CLEVELAND, OHIO 44134  
TEL. 216, 845-4480

COLORADO:  
PTS ELECTRONICS, INC.  
P.O. BOX 4245  
DENVER COLO. 80204  
TEL. 303, 244-2818

TEXAS:  
PTS ELECTRONICS, INC.  
P.O. BOX 26616  
HOUSTON, TEX. 77032  
TEL. 713, 644-6793

TEXAS:  
PTS ELECTRONICS, INC.  
P.O. BOX 7332  
LONGVIEW, TEX. 75601  
TEL. 214, 753-4334

PENNSYLVANIA:  
PTS ELECTRONICS, INC.  
P.O. BOX 16856  
PHILADELPHIA, PA. 19142  
TEL. 215, 724-0999

PENNSYLVANIA:  
PTS ELECTRONICS, INC.  
257 RIVERVIEW AVE. W.  
P.O. BOX 4130  
PITTSBURGH, PA. 15202  
TEL. 412-761-7648

FLORIDA:  
PTS ELECTRONICS, INC.  
P.O. BOX 6881  
JACKSONVILLE, FLA. 32205  
TEL. 904, 389-9952

OREGON:  
PTS ELECTRONICS, INC.  
P.O. BOX 13096  
PORTLAND, OR. 97213  
TEL. 503-282-9636

for finer, faster,

... **Precision**

**Tuner Service**



send faulty unit with tubes, shields and all broken parts to:

PTS ELECTRONICS, INC.  
5682 STATE RD.  
CLEVELAND, OHIO 44134  
TEL. 216, 845-4480

PTS ELECTRONICS, INC.  
5111 UNIVERSITY AVE.  
SAN DIEGO, CALIF. 92105  
TEL. 714, 280-7070

PTS ELECTRONICS, INC.  
4324 TELEPHONE RD.  
HOUSTON, TEX. 77032  
TEL. 713, 644-6793

PTS ELECTRONICS, INC.  
307 N. MAY  
OKLAHOMA CITY, OKLA. 73106  
TEL. 405, 947-2013

or to any of our strategically located Service Centers

... for more details circle 125 on Reader Service Card

continued from page 20

in our Sony audio and video equipment.

I am sending you a list of the stolen merchandise in the hope that you will keep an eye out for it.

I cannot tell you how much I would appreciate your cooperation in this matter, as we cannot afford new equipment for some time.

John Gensor  
A.V. Coordinator  
(202) 331-3544

Sony Video Equipment		
cameras	Model AVC 3200	Serial # 27415, 27002
viewfinders	Model AVF 3200	Serial # 14401, 17948
vtr's	Model 3650	Serial # 32554
	Model CV 2200A	Serial # 10248
Sony Audio Equipment		
amplifier	Model 6050	Serial # 82730
tape decks	Model 355	Serial # 132256
	Model TC-650	Serial # 18158

**Northern Virginia Group Meets to Discuss Licensing**

The Northern Virginia Electronics Services Assn. converted its regular January meeting into a forum to discuss the pros and cons of the proposed state dealer registration bill. Cliff Sheffield, President of the Northern Virginia Affiliate of the Virginia Electronics Assn., called the meeting to order and then turned it over to various guests for brief

statements, plus questions and answers.

Senator Charles Waddell from Sterling, Va., expressed surprise that a trade association was actually in favor of industry regulation, much less being one of the principal promoters of a completely drafted bill. Senator Waddell indicated an intense interest in sponsoring the bill in the Senate at this year's session of the General Assembly.

A record turnout of more than 40 persons participated in a thoroughly searching probe and, upon conclusion, an overwhelming majority appeared to be heartily in favor of the proposed legislation, as written.

**ETA Toledo Announces Installation of Officers**

The Electronic Technician Association of Toledo, Ohio has announced the election and installation of new officers. These include the following: Paul Kurth, CET, President; Larry Taylor, CET, Vice President; Dave Zawodny, CET, Secretary/Treasurer; Dave Garwacki, CET, Chairman of the Board; and as board members, Lavan Helm, CET; Russ Method, CET; Art Sattler, CET; and Bob Schladetsch, CET. Bob Schladetsch is also editor of the ETAT monthly paper.

**M O V I N G ?**

Be sure to let us know your new address. Please enclose a complete address label from one of your recent issues.

**KAY-TOWNES *Again* LEADS THE INDUSTRY!**

WITH THE REVOLUTIONARY

ALL-NEW

**ICA**  
ANTENNA

with ZOOM-CONTROL  
\*(Patent Pending)

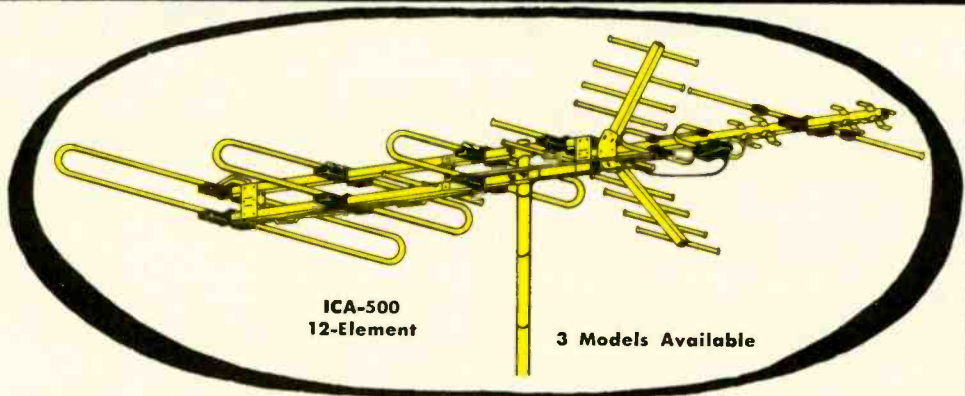

ICA-500  
12-Element

3 Models Available

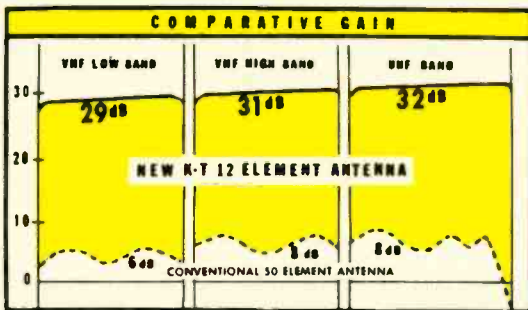

**40 TIMES THE SIGNAL — 1/2 THE SIZE!**

FOR THE FIRST TIME! Kay-Townes has engineered an integrated antenna providing a flat 32dB gain across the entire TV spectrum. (Channels 2 through 83) Half the size of conventional 50 element antennas and more, the ICA produces more than 40 times the signal. The ICA antenna incorporates a special ZOOM-CONTROL permitting the signal level to be adjusted for specific reception areas.

Utilizing an entirely new design principle\*, this compact antenna is built with commercial quality throughout employing two heavy gauge square cross-arms and rugged commercial construction. The First Commercial Quality Antenna at Consumer Prices!

Write for information on the Sensational KT ICA  
"THE NEW STANDARD OF THE INDUSTRY"



**KAY-TOWNES, INC.**

P.O. Box 593 Turner Chapel Road  
Rome, Ga. 30161 (404) 235-0141  
AN ALCO STANDARD PARTNERSHIP



... for more details circle 118 on Reader Service Card

# Delta Answers Four Big Questions About Security Systems With Their Problem Solver, The All New Centrally Controlled System.



**Will it detect intrusion, fire, gas, sound alarms; determine power failure, trigger dialers and sound internal and external alarms?**

Yes, the system protects anything you want protected.

**Can it be installed easily with minimum wiring?**

Yes, the system uses existing AC wiring in the building?

**Is it flexible to use with existing systems?**

Yes, the system is completely flexible and can be used with other existing systems.

**Is it affordable? Can you add on to meet new demands?**

Yes, the system is priced to sell. Completely expandable, it can be used with any other components to fit customer needs.

## 8 NO-PROBLEM COMPONENTS THAT WORK FOR YOU!

**(1) Fire Detector:** Detects dangerous gases and fire. Activation puts computer system in immediate alarm condition by overriding any other signal. **(2) Phase Lock Loop Alarm Transmitter:** Used to connect existing N/O or N/C circuits

to computer with minimum wiring. **(3) Phase Lock Loop Emergency Transmitter:** Panic/emergency signal device puts system into instant alarm. **(4) Computer:** Central control unit receives signals from Delta's alarm transmitter via existing AC power lines, thus activating self-contained horn, Delta's telephone dialer (when attached) or other alarm devices. Equipped with time exit and entrance delay. The system will sound an alarm condition should AC power fail for more than 45 seconds. **(5) Disable Transmitter:** Allows the complete system to be turned on and off from some remote area. **(6) Phase Lock Loop Receiver:** Accessory to activate 110V light, bells or other alarm device. **(7) DeltAlert Ultrasonic Detector:** Senses movement of intruder in protected area causing activation of alarm system. **(8) Projector:** All-weather type speaker creating loud 100db noise.

The complete system uses existing AC wiring as a signal carrier. This advantage is made possible by Delta's breakthrough in fool-proof electronic circuitry. Modern technology and Delta Products now present you with the **No Problem Security System.**

If you want a security system that solves problems instead of creating them, write or call today, for complete information on Delta's Problem Solver, the Total Security System with Central Control.

100% American Made



## DELTA PRODUCTS, INC.

P.O. BOX 1147 • GRAND JUNCTION, COLORADO 81501  
PHONE (303) 242-9000

*Superior Security at Sensible Prices*

Dept. ETD

... for more details circle 108 on Reader Service Card

# Introd



See the complete line of 1974 Zenith Components and Accessories at your Zenith Distributor's Open House. Call now for exact dates.



# ucing

Now your Zenith Distributor has the parts and accessories you need in one convenient place — your Zenith One-Stop Shopping Center.

You'll find the complete Zenith line there... bigger and broader than ever... including:

## REPLACEMENT PICTURE TUBES

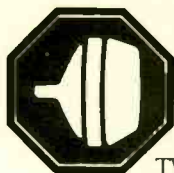

Famous Super Chromacolor® picture tubes in a range of sizes to replace a total of 80 industry types. Plus Sunshine® and Cinebeam picture tubes to fit almost any brand of color TV. And Zenith black & white picture tubes to replace 401 other types of B & W tubes.

## ZENITH QUALITY PARTS



All the parts you need, from bel fuses to TV knobs. The star is the Zenith Instant Parts Program (ZIP). It puts the 100 most used replacement parts at your fingertips, in a specially designed, compact rack. ZIP makes

inventory and re-ordering fast and easy for you. Also, Zenith now offers a line of capacitors, resistors, integrated circuits and universal semi-conductors.

## REPLACEMENT RECEIVING TUBES



A complete line of more than 1,000 Zenith quality tubes... the same tubes as used in Zenith original equipment. Built to operate with great reliability—to cut your callbacks. And they have the long life needed to increase the satisfaction of your customers.

## ZENITH QUALITY ACCESSORIES



Here are just a few! Quad, stereo and monaural headphones. Broadened line of outdoor antennas featuring 13 all-new Super Chromatenna models. Complete new Chromatenna indoor antenna line. Antenna rotors. Three grades of batteries in a wide range of sizes. Electronic chemicals, including tuner degreaser, tuner cleaner, circuit cooler and tape head cleaner. "Cabinet Care" furniture polishes. Cassette and 8-track recording tape cartridges.

Beside parts and accessories, your Zenith Distributor has the specialized "know how" to help solve tough service problems. Come in or phone today.

**ZENITH**  
®  
For quality you can depend on,  
in replacement parts and accessories —  
all in one convenient place

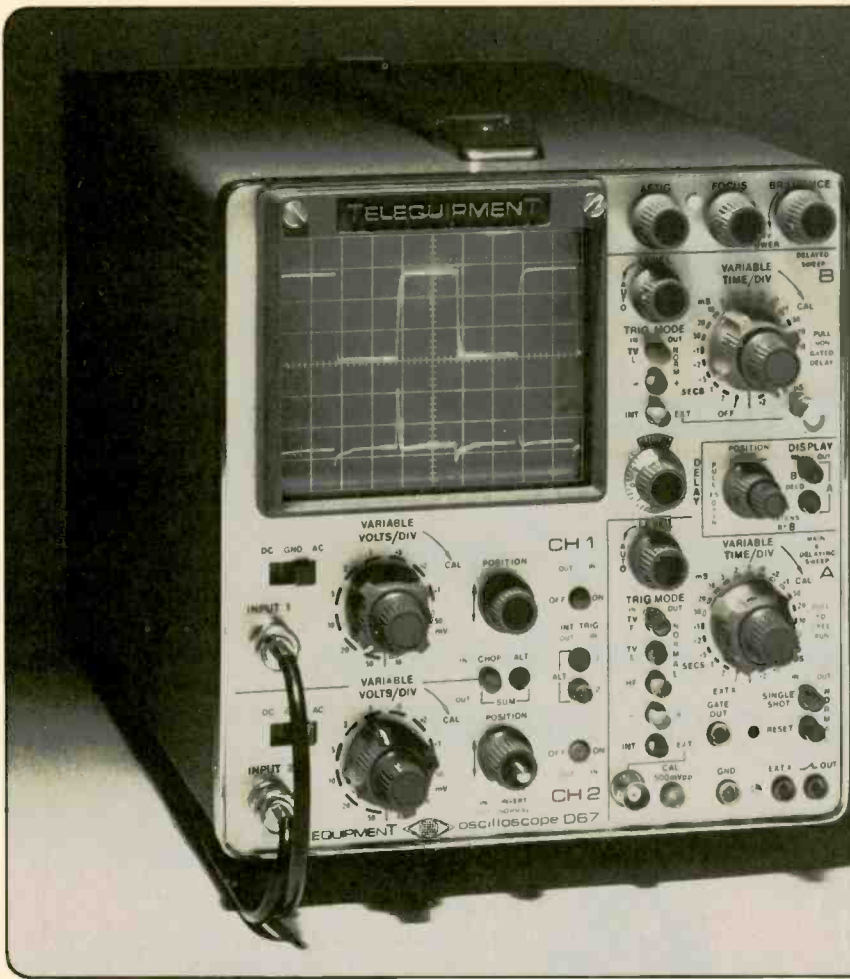

**MORE  
VALUE  
IN**

**TELEQUIPMENT** 

**DUAL-TRACE  
OSCILLOSCOPES**

**\$975**

**D67 25 MHz, 10 mV/cm, 200 ns/cm**



**D66 25 MHz, 10 mV/cm, 100 ns/cm \$795**



**\$595 D54 10 MHz, 10 mV/cm, 200 ns/cm**

**Part of the Telequipment line from Tektronix, Inc.**

The Telequipment line is growing . . . and offers you a greater selection for your next dual-trace scope. Take the new **D66** . . . it offers a choice of alternate or chopped dual-trace display and convenient single-button X-Y operation. The **D67** offers laboratory performance with delayed sweep, regulated power supplies, and 3% accuracy. The **D54** offers dual-trace convenience at lowest cost. All have triggered sweeps.

All are backed with the same warranty as other **TEKTRONIX** products, and are marketed and supported in the U.S. through the Tektronix network of 58 Field Offices and 34 Service Centers. Call your nearest office or write Tektronix, Inc., P.O. Box 500, Beaverton, Oregon 97005.

U.S. Sales Prices FOB Beaverton, Oregon

. . . for more details circle 131 on Reader Service Card

**TEKLAB REPORT**

# Magnavox's Solid-State Modular Color-TV Chassis T979

by Joseph Zauhar

This chassis incorporates a special circuit that automatically adjusts the picture for changes in room lighting

■ As we review the latest color-TV sets, it is becoming increasingly evident that they are including features to make servicing easier and allowing for more of the service work to be done in the home. The manufacturer of the TV set featured this month promotes the fact that it has received a National Electronic Associations (NEA) chassis serviceability design award.

We received for lab purposes the Magnavox Model IC7582 color-TV set employing the new modular all solid-state chassis T979. This chassis incorporates a number of new serviceability features as well as being designed for high performance and reliability. The chassis design and layout is arranged to minimize the amount of time required to service the chassis.

Although all of the circuits are solid-state, the chassis maintains the familiar configuration of tube-type chassis. The service adjustments that the technician is familiar with remain essentially the same.

The modern styled walnut cabinet is of Neo-classic design and employs a pull-open panel door which completely conceals all of the customer controls. The secondary controls, which include the CONTRAST, BRIGHTNESS, TONE, TINT, VERTICAL and AUTO FINE TUNE switch, are located under a second panel door which is spring loaded and remains in the closed position when not held open. The cabinet is also provided with a metal bottom screen which is hinged to provide access to the bottom of the chassis. Wing type

fasteners are used on the back cover to shorten removal time.

Most of the circuitry employed is located on five circuit panels which plug into the main chassis pan. And most of transistors and circuit modules located on these panels plug into sockets for easy removal. All circuit panels are screened on both top and bottom to provide component identification, indicate printed-circuit wiring, test points and adjustment identification. The screening also provides identification of the signal inputs and supply-voltage points to aid in troubleshooting.

**Burst, ACC and Color Killer Circuits**

The color circuits employed in this chassis are contained on plug-

in circuit panels "B" (part two in TEKFAK Schematic No. 1476), "C" and "E." The 3.58MHz output, color demodulators and color difference amplifiers are on the "B" panel. The "C" panel contains the chroma amplifiers and videomatic module. This panel also contains the burst, ACC and color killer circuits. The SCREEN and DRIVE controls are located on the "E" panel.

The burst, automatic chroma control (ACC) and color killer circuits control the operation of the color circuits. When a color program is received, these circuits turn ON the color circuits, provide a phase reference for demodulation and control the gain of the chroma amplifier. When a received program is not in color, the color killer turns OFF the

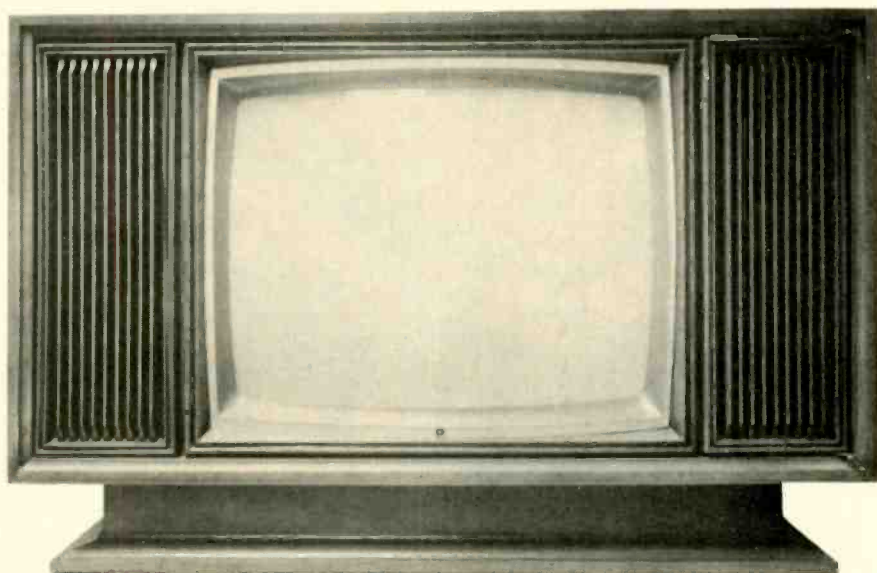

The Magnavox Model IC7582 Color-TV set employs the new modular solid-state chassis T979.

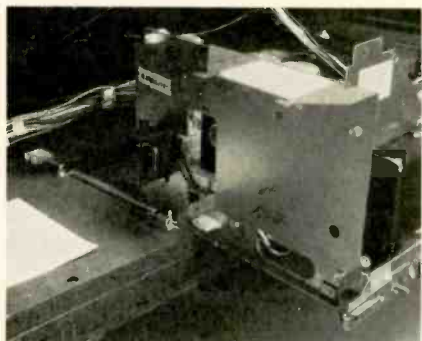

The chassis slides out on rails to make all components even more accessible if replacement is required or to make voltage checks and adjustments.

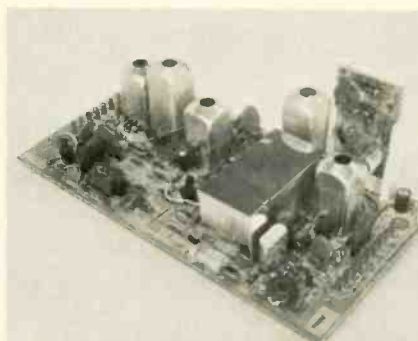

The "C" panel contains the burst, ACC, color killer, chroma amplifiers and the edge connected plug-in Videomatic module located on the rear right of the panel.

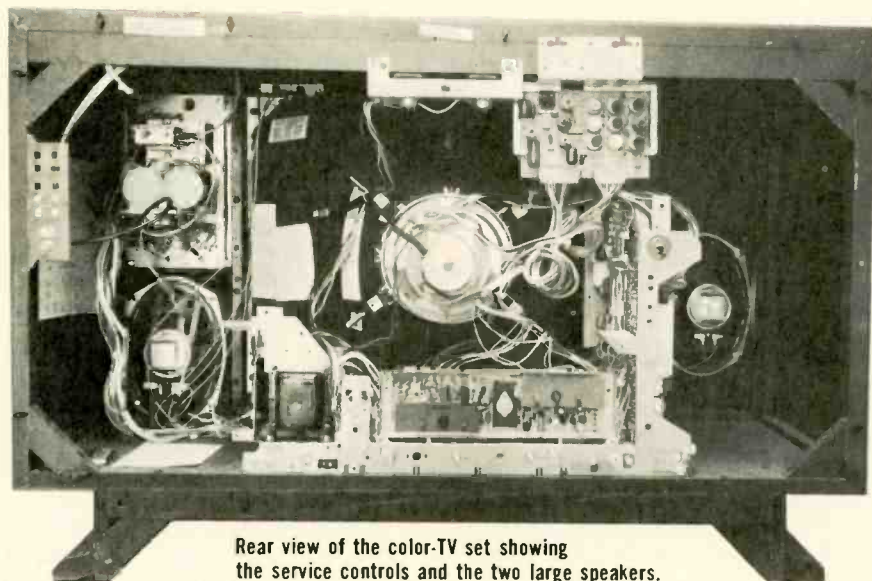

Rear view of the color-TV set showing the service controls and the two large speakers.

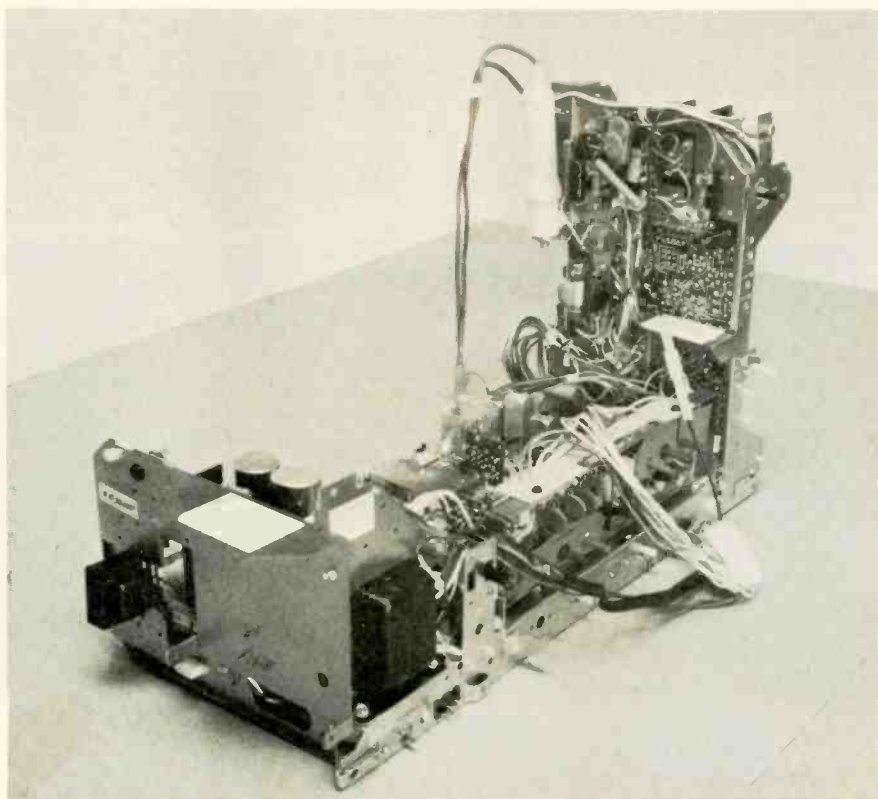

Although all of the circuits are solid-state, the T979 chassis maintains the familiar configuration of the tube type chassis.

chroma amplifier so that only B/W information is observed in the picture.

The chroma signal taken from the secondary winding of the band-pass transformer is coupled to the base of the burst amplifier. The burst amplifier transistor, Q7, operates as a Class C amplifier and is held reverse biased by a charge on capacitor C25. So that just the burst signal is amplified, a pulse from the flyback is applied to the base of Q7 to turn it ON only when burst is present. The burst amplifier then conducts only during the interval when the base is driven positive by the horizontal pulse. The timing of the pulse coincides with the burst signal, so burst is amplified and chroma is blocked. The amplified burst is then coupled through burst transformer T3 to the two detectors, bridge diodes D2 and D3. T3 is tuned to 3.58MHz and supplies outputs of equal amplitude but opposite phase to the two detectors.

The burst phase detector compares the phase of the burst signal with the phase of the 3.58MHz oscillator, and if a difference exists, a dc correction voltage is applied to the varicap diode, VC1, in the oscillator circuit. This causes the frequency of the oscillator to become phase locked with the burst signal.

The ACC circuit provides an automatic gain control for the chroma amplifier stage. The killer/ACC detector (transistor Q4) receives the same two signals from the burst transformer as does the phase detector, but the reference signal from the 3.58MHz oscillator is shifted 90° by coil L3 and capacitor C42. The detector produces a positive dc output proportional to the amplitude of the burst signal, which keeps the killer/ACC amplifier transistor, Q6, forward biased. The level of Q6 conduction is determined by the output from bridge diode D2. As the burst signal increases, the output of the detector becomes more positive, increasing the conduction of transistor Q6 and the ACC driver transistor, Q5. Then, through dc coupling, the conduction of chroma amplifier Q1 is increased. If no burst is present, conduction decreases in Q6, and the outputs of Q5 and Q1 are minimal.

The 100N1 transistor (Q1) used in the chroma amplifier stage decreases in gain as its collector cur-

rent increases. Therefore, a higher positive base voltage at the chroma amplifier causes the transistor to conduct more, which decreases its gain. Should the burst amplitude decrease, the opposite action occurs so that a relatively constant chroma output level is maintained.

In the T979 chassis the chroma output stage (transistor Q3) is cut OFF when no color burst signal is present. When a color program is being received, the killer/ACC amplifier is forward biased and the transistor Q6 emitter goes more positive because of the emitter follower action. The emitter of color killer transistor Q4 is connected to the emitter of Q6, and since its base voltage is fixed by the KILLER ADJUSTMENT control, transistor Q4 is reverse biased and cut OFF. And the chroma output stage amplifies the chroma signal as long as Q4 is cut OFF. If no burst is present, as in a monochrome broadcast or off station reception, the emitters of Q6 and Q4 become less positive and color killer Q4 becomes forward biased and saturates. The base of the chroma output transistor Q3 is then shunted to near ground potential and the stage is cut OFF.

### Videomatic Circuit

One of the most interesting features employed on this chassis is the Videomatic System. This circuit monitors the light intensity in the room and automatically adjusts the picture CONTRAST, BRIGHTNESS, and COLOR LEVEL when changes in lighting occur.

The Videomatic circuitry is located on an edge-connected plug-in module found on the right rear edge of the "C" panel. One of the first things noticed was an LDR (Light Dependent Resistor) mounted in the lower center edge of the picture tube mask, which is connected to the circuitry through a Molex connector. At the rear top edge of the TV set cabinet is the sensor "range adjust" potentiometer.

The circuit operates at a high gain level, increasing the contrast, brightness and color to facilitate daylight viewing. As the lighting decreases, the gain in both the video and chroma circuits is lowered, keeping the picture at a comfortable viewing level.

As we review the Videomatic circuit, it can be followed in both this

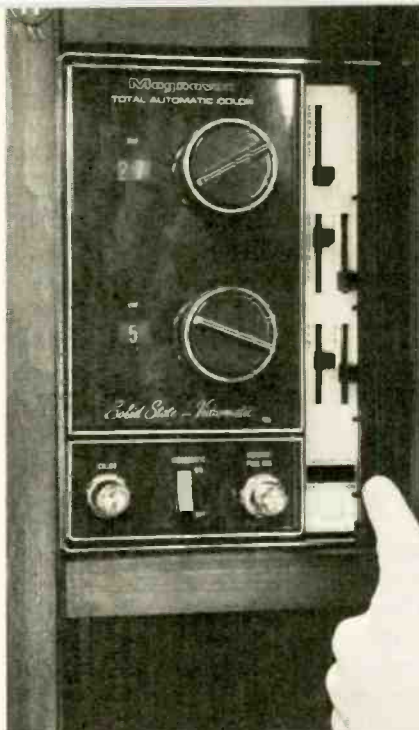

All customer controls are concealed with panel doors. The new Videomatic switch is located at the bottom center of the control panel.



The "A" panel contains the following circuits: AFC, video IF, video detector, video driver, 45.75MHz detector, sound IF and quadrature detector module.

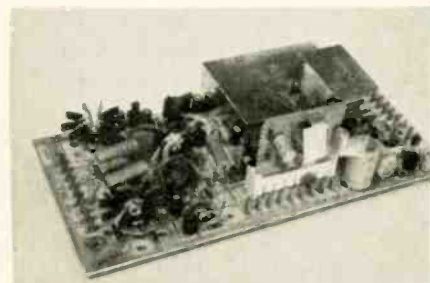

The "B" panel contains the AGC, noise canceller, audio module, 3.58MHz output, color demodulators and the color difference amplifiers.



The "D" panel contains circuits employed in the sync keyer, sync separator, vertical sweep and horizontal sweep stages.

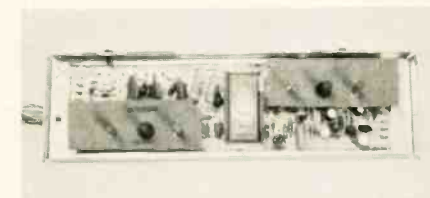

The luminance amplifier, blanker, beam limiter and picture tube screen and cathode circuits are found on the "E" panel.

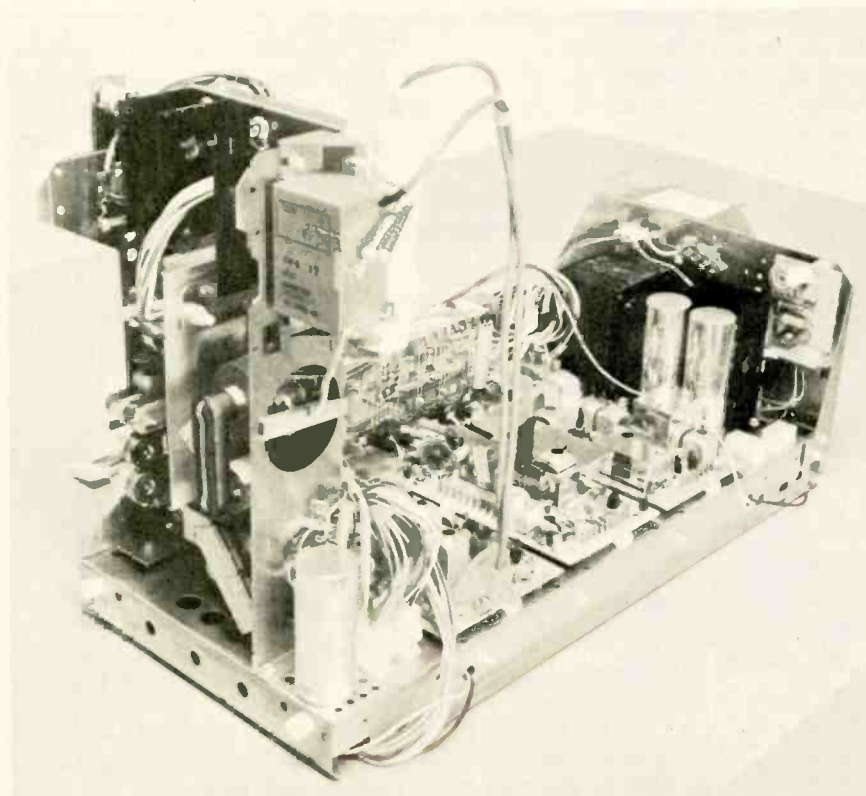

Front view of the compact "L" shaped modular solid-state chassis employing five circuit panels, which plug into the main chassis pan.

month's TEKFAK Schematic No. 1476 and the simplified schematic below. In the simplified schematic, the Videomatic module circuit is contained within the dashed lines. The ON/OFF switch, sensor and RANGE adjust are shown at the lower left and the controlled video and chroma stages to the right.

Operation of the circuit is controlled by the voltage present at TP1. This voltage becomes the source of bias for the PNP driver transistor, Q1, and a current source for the LED (Light Emitting Diode) contained in a photocoupler circuit to the right of Q1. The photocoupler is a self-contained, non-repairable unit. The LDR's resistance in the unit is dependent upon the light emitted by the LED.

A parallel resistance path is formed from TP1 to ground. With the VIDEOMATIC switch in the ON position, the LDR becomes the controlling element in the network, since its resistance can vary from approximately 100Ω to several thousand ohms. At high light levels, the resistance to ground at TP1 and the resulting voltage at this point are very low.

At this low voltage, the resulting current flow through the LED is minimal and no significant light strikes the LDR in the photocoupler. The high resistance of the LDR in series with Capacitor C1 offers a high impedance to the video signal at the base of the luminance driver. It is at this time that the

BRIGHTNESS, CONTRAST and COLOR controls are adjusted.

The low voltage at TP1 also places the base of the videomatic driver, Q1, near ground potential. The resulting base voltage forward biases the driver to the point of saturation, lowering its emitter (pin 1 on the edge connector) to near ground potential. At this time, the videomatic circuit produces maximum brightness, contrast and color.

Covering the sensor LDR drastically increases its resistance. This in turn raises the voltage at TP1 to a level where more current flows in the coupler LED, illuminating it. The resulting resistance of the LDR in the photocoupler is lowered, and the impedance at the base of the luminance driver is reduced. This change noticeably reduces the amplitude of the video contrast but with less effect on the dc level (brightness).

Concurrently, the larger voltage at TP1 increases the base voltage of driver transistor Q1, decreasing its conduction. The emitter voltage moves in a positive direction and increases the forward bias on bridge diode D2A, transistors Q6 and Q5, and finally Q1, the chroma amplifier. Transistor Q1 is unique in that its gain decreases as the forward bias increases, resulting in less gain through the chroma channel.

The adjustment of this circuit in the home should be made with the room lighting high—during daylight hours or with the artificial room

lighting at its maximum. The BRIGHTNESS, CONTRAST and COLOR levels should be adjusted to the most pleasing picture with the VIDEOMATIC switch ON. The room should then be darkened to the lowest anticipated viewing level and the SENSOR RANGE adjusted to the most pleasing picture. Covering the LDR would simulate viewing in a totally dark room.

### Color Demodulators

The R-Y and B-Y demodulator circuits have the same basic balanced dual-diode configuration and the operation is quite similar to that of the burst phase detector circuit, producing outputs which are proportional to both the amplitude and the phase of the applied signals. Two signals are applied to each demodulator. First, the 3.58MHz reference signal which is amplified by the 3.58MHz output transistor, Q1, having equal but opposite polarity CW signals coupled to both ends of the demodulators. The second signal is the chroma information, which for the R-Y demodulator has been shifted in phase by coil L4, and capacitors C45 and C16.

The chroma signal is applied directly to diode D1 and a lagging phase shift has delayed the information applied to diode D2, resulting in a phase difference of 90° between the two demodulators. The output from each demodulator is a resultant of the CW reference signal and the shifted chroma signal. Each output circuit incorporates a small choke (L2 and L3) to remove the 3.58MHz carrier signal.

### Horizontal-Output and High-Voltage Circuits

The horizontal-output stage has three main functions: it supplies the

*continued on page 59*

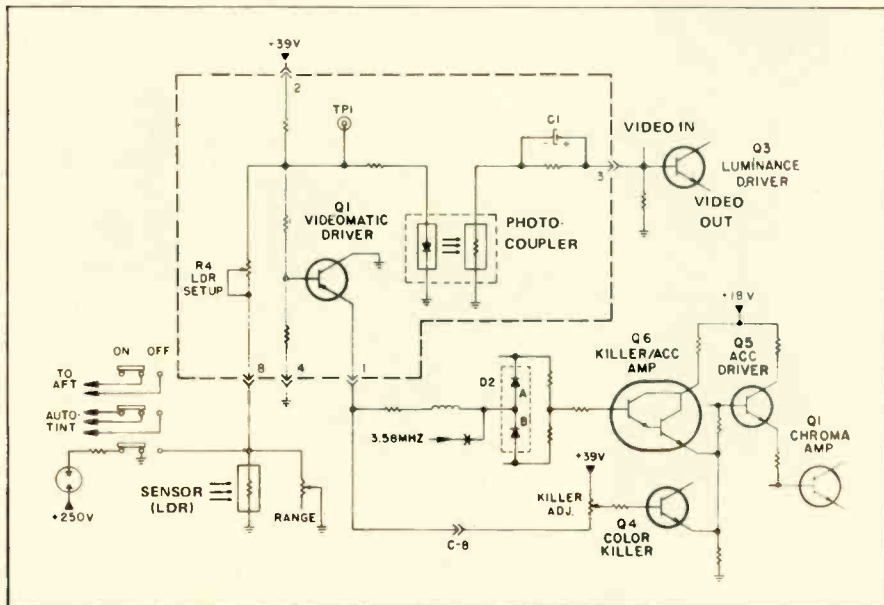

This simplified schematic shows the Videomatic module, contained within the dashed lines. The switch, sensor and RANGE adjust are shown at the lower left. The controlled video and chroma stages are shown at the right. Courtesy of Magnavox.

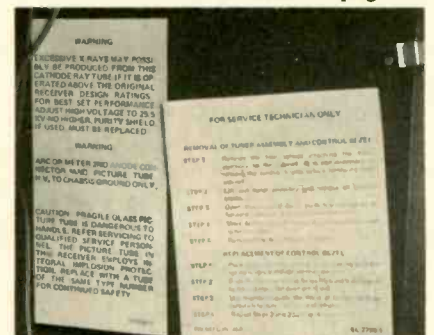

Service instructions, panel location guides and safety precaution sheets are cemented to the inside of the cabinet and picture tube shield for quick reference.

# Talking Back to Your TV Set . . . through the new two-way CATV systems

by Edward A. Lacy

■ For years, the signals on the nation's CATV systems have flowed in only one direction—*downstream*, from the antenna headend to the subscribers' TV sets. But now, after years of prediction, in scattered systems throughout the country the signals are also going upstream, from the homes to the headend. In effect, this exciting development is giving subscribers the ability to talk back to their TV sets, express opinions and even make requests!

Opinion polling, audience counting (or channel monitoring), simple home shopping, alarm monitoring, utility meter reading, TV classrooms, and premium (pay!) TV are just some of the features now being tested.

In less than a second, the cable TV's central computer will ask each subscriber, in turn, such questions as:

- Do you need police or firemen?
- Which channel is your TV set tuned to?

- Do you agree with Congressman Jones' proposal?
- Which contestant do you like best in the beauty contest?
- Would you like to order this new gadget shown on your screen?
- What is the reading on your electric utility meter?
- What answer is correct on this safe drivers' examination?
- Which premium movie would you like to watch?

For some of these questions, you would have to push a button or turn a switch to indicate your response, but in other cases, including burglar and fire alarms and channel monitoring, your terminal would respond automatically for you, without your intervention.

Offhand, such services seem to simply offer additional conveniences and entertainment to the average TV viewer. However, the Electronic Industries Assn. (EIA) has predict-

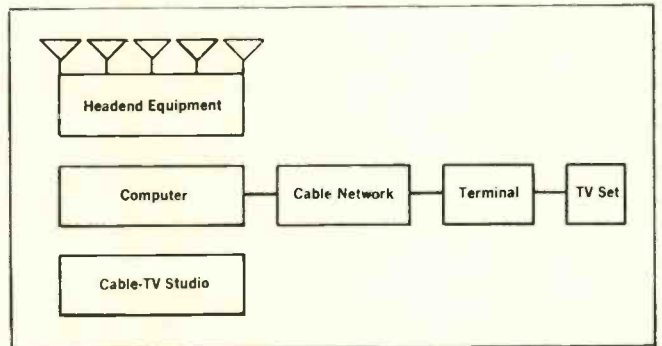

Fig. 1—Simplified block diagram of two-way cable-TV system.

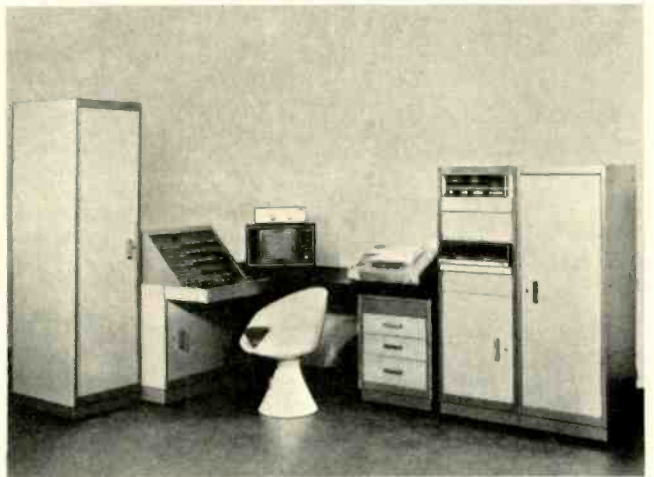

Fig. 2—TOCOM's headend equipment for two-way CATV.



Fig. 3—Community Information System's headend for two-way CATV.

ed that broad-band communications networks, such as two-way cable TV systems, will eventually allow us to live in rural areas yet have the conveniences of the big city!

With such enormous entertainment, social and economic potentials, it is no wonder that everybody, it seems, is trying to get into the stream. Government agencies, manufacturers, major cable system operators, consultants, and non-profit research and development firms have all been conducting all sorts of tests and studies, and are now installing these two-way systems.

American Television and Communications Corp., the nation's second largest cable TV operator, is now installing its "Polycom" two-way cable-TV system in Orlando, Fla.

Other major companies, including TOCOM, Inc. at Irving, Texas, Theta-Com of California at El Segundo, Calif., and Community Information Systems at Jonathan, Minn., are busily installing hundreds of test terminals to determine subscriber preferences.

Even though these installations are interim, test-type systems, they are, nevertheless, a definite indication of the systems that are sure to come, sooner perhaps than you may think.

"Two-way cable TV is now a technical reality," says E. D. McCormick, president of Community Information Systems. "Not all technical problems have been identified and solved, but no further fundamental physical inventions are required."

Now that the FCC has lifted the construction freeze on cable-TV sys-

tems in the largest 100 TV viewing areas, new systems will almost be compelled to offer two-way services since marginally better TV reception alone may not be sufficiently attractive to recruit subscribers.

Whether the cable operators favor two-way services or not, they are being given a big push in that direction by the government. The FCC has specified that the new systems must have a two-way capability even though they are not required to install terminals at this time.

When these systems are installed in your community, sometime probably within the next five years, you may see them described by such terms as *bidirectional systems*, *interactive programming*, *wired city*, *wide spectrum services*, *broadband*, and *auxiliary services*.

They are *bidirectional* of course because the signals go in both directions on some of the cables. Because the subscribers can take part in some of the programming, the systems are called *interactive*. With a whopping 300MHz bandwidth on each cable, they are quite naturally called wide spectrum or broadband. It is no problem then, with such bandwidth, to offer auxiliary services in addition to conventional TV signals. Which explains why some experts recommend that all homes be wired with coaxial cable (giving a *wired city*) and that over-the-air TV broadcasting be *abolished!*

Regardless of the name, a basic two-way cable-TV system (Fig. 1) uses a conventional CATV an-

tenna headend, a single- or dual-cable distribution network, a central computer (Fig. 2 and 3), and a terminal (Fig. 4 through 7) in each subscriber's home, in addition to his regular TV set.

Ultimately, according to Walter S. Baer of the Rand Corp., two-way terminals may include such features as frame-grabbing devices for still picture viewing, a video recorder for feature films, a facsimile receiver and printer, a complete keyboard for message entry, a TV camera and microphone for video and voice communi-

cations, connections to utility meters, and a control unit.

But for the present, at least, a basic subscriber terminal includes only a wideband receiver and demodulator tuned to accept downstream polling signals, a decoder to compare addresses received with its own address, and a simple keyboard. If the addresses match, the subsequent message is sent on to the control logic unit—otherwise the message is ignored.

The terminals are connected to the cable network through isolation de-



Fig. 4—TOCOM's subscriber terminal.



Fig. 5—Community Information System's subscriber terminal.



vices which minimize the amount of RF noise the subscriber can accidentally put on the upstream.

Two-way cable TV signals are transmitted by either of two methods: on the same cable (using different frequencies for upstream and downstream traffic) or on two cables, with one of the two cables dedicated to downstream traffic only and the other cable reserved for upstream (or a combination of upstream and downstream) traffic.

Most of the cable TV systems now in operation are single cable systems.

To provide two-way services on these systems without adding an additional cable, it is necessary to go back and replace the amplifiers on the line with two-way amplifiers and cross-over filters for separating the upstream and downstream signals.

This approach, however, is far from ideal, for any device added to a cable-TV amplifier cascade will deteriorate to some degree the performance of the downstream system.

For this reason, many of the major companies, including TelePrompter, Cox and TOCOM, are in-

stalling dual cables, at least for the main trunk lines, in all of their new construction.

Whether one or two cables are used, TV cable signals are generally distributed over a party-line type network, also called a "tree" network. Like other party lines, this network transmits the same signal at the same time to all subscribers. Unlike the telephone party line, the TV cable in a two-way system carries digital and video signals as well as audio.

Technically, many of the major problems associated with the simpler two-way cable-TV services have been eliminated. Even small computers can interrogate all the subscribers in a reasonable time.

Still, there are enough minor problems left to keep the engineers busy. For instance, in some parts of the country, the security systems have generated so many false alarms that the police no longer respond to such calls. Another problem is interference on the upstream channels. New types of RFI-proof cable and cable connectors must be used, or else the cumulation of noise going upstream, including reception of high-power shortwave stations such as the Voice of America and local hams, can knock out the system.

Entirely apart from these technical problems, there is a potential danger that a lot of data could be accumulated by two-way cable systems about individual subscribers, without their knowledge.

With automatic polling and recording equipment connected to the subscri-

er response services, notes Mr. Baer, a cable operator *could* amass a substantial data file on each subscriber, including his viewing habits, his buying patterns, and his political preferences. The cumulation and correlation of such data could pose potential threats to individual privacy. Should the cable operator be allowed to keep this data at all? Should he be able to sell it to advertisers or allow government officials to see it?

Undoubtedly, regulations will be adopted to require full disclosure and consent before information can be legally received from subscribers' premises. As a preliminary protection, the FCC has specified that upstream signals must be at the subscribers' option.

Long before this problem becomes major, the cable-TV industry must face the more immediate problem of money.

Like many other new services, no one is sure what the public wants in the way of two-way cable TV or how much they will be willing to pay. But even the minimum services will require a tremendous investment by cable system owners, who may bill it, directly or indirectly, back to the subscribers. At a cost of \$200 per household, Mr. Baer predicts that it would take over a \$3 billion investment to equip just 25 percent of today's TV households for two-way services!

Aside from this equipment investment, it is generally agreed within the industry that it will cost you, the individual subscriber, \$5 to \$25 additional per month, to talk back to your TV set. ■



Fig. 6—Vicom Terminal, showing home-bound student.



Fig. 7—Theta-Com's SRS Model 102 console. Photo courtesy of Theta-Com of California.

# An Extraordinary Offer

to introduce you to the benefits of Membership in

## ELECTRONICS BOOK CLUB

for a limited time only you can obtain

**ANY 3** OF THESE UNIQUE BOOKS . . . yours for only **99¢** each  
...with Trial Club Membership  
(Combined List Price \$40.85)

May we send you your choice of any three books on the facing page as part of an unusual offer of a Trial Membership in Electronics Book Club?

Here are quality hardbound volumes, each especially designed to help you increase your know-how, earning power, and enjoyment of electronics.

These handsome, hardbound books are indicative of the many other fine offerings made to Members . . . important books to read and keep . . . volumes with your specialized interests in mind.

Whatever your interest in electronics—radio and TV servicing, audio and hi-fi, industrial electronics, communications, engineering—you will find that Electronics Book Club will help you.

With the Club providing you with top quality books, you may broaden your knowledge and skills to build your income and increase your understanding of electronics, too.

### How You Profit From Club Membership

This special offer is just a sample of the help and generous savings the Club offers you. For here is a Club devoted exclusively to seeking out only those titles of direct interest to you. Membership in the Club offers you several advantages.

- 1. Charter Bonus:** Take any three of the books shown (combined values up to \$40.85) for only 99¢ each with your Trial Membership.
- 2. Guaranteed Savings:** The Club guarantees to save you 15% to 75% on all books offered.
- 3. Continuing Bonus:** If you continue after this trial Membership, you will earn a Dividend Certificate for every book you purchase. Three Certificates, plus payment of the nominal sum of \$1.99, will entitle you to a valuable Book Dividend which you may choose from a special list provided members.
- 4. Wide Selection:** Members are annually offered over 50 authoritative books on all phases of electronics.
- 5. Bonus Books:** If you continue in the Club after fulfilling your Trial Membership, you will receive a Bonus Dividend Certificate with each addi-

### SPECIAL FREE BONUS

. . . if you act now!

Yes, if you fill in and mail the membership application card today, you'll also get this Bonus Book, FREE!

#### UNDERSTANDING SOLID-STATE CIRCUITS

Thoroughly explains semiconductor circuit operation without physics or high-level math; covers linear and digital circuitry.

Regular List Price \$7.95

tional Club Selection you purchase. For the small charge of only \$1.99, plus three (3) Certificates, you may select a book of your choice from a special list of quality books periodically sent to Members.

**6. Prevents You From Missing New Books:** The Club's FREE monthly *News* gives you advance notice of important new books . . . books vital to your continued advancement.

This extraordinary offer is intended to prove to you, through your own experience, that these very real advantages can be yours . . . that it is possible to keep up with the literature published in your areas of interest . . . and to save substantially while so doing.

### How the Club Works

Forthcoming selections are described in the FREE monthly *Club News*. Thus, you are among the first to know about, and to own if you desire, significant new books. You choose only the main or alternate selection you want (or advise if you wish no book at all) by means of a handy form and return envelope enclosed with the *News*. As part of your Trial Membership, you need purchase as few as four books during the coming 12 months. You would probably buy at least this many anyway . . . without the substantial savings offered through Club Membership.

### Limited Time Offer!

Here, then, is an interesting opportunity to enroll on a trial basis . . . to prove to yourself, in a short time, the advantages of belonging to Electronics Book Club. We urge you, if this unique offer is appealing, to act

promptly, for we've reserved only a limited number of books for new Members.

To start your Membership on these attractive terms, simply fill out and mail the postage-paid airmail card today. You will receive the three books of your choice for 10-day inspection. **SEND NO MONEY!** If you are not delighted, return them within 10 days and your Trial Membership will be cancelled without cost or obligation. Electronics Book Club, Blue Ridge Summit, Pa. 17214.

### Typical Savings Offered Club Members on Recent Selections

Simplified TV Trouble Diagnosis	List Price \$8.95; Club Price \$5.95
Servicing the New Modular Color TV Receivers (Two Giant Volumes)	List Price \$15.95; Club Price \$7.95
Citizens Band Radio Service Manual	List Price \$7.95; Club Price \$4.95
4-Channel Stereo—From Source to Sound	List Price \$6.95; Club Price \$3.95
Complete Minibike Handbook	List Price \$8.95; Club Price \$5.95
125 Typical Electronic Circuits Analyzed & Repaired	List Price \$7.95; Club Price \$4.95
Understanding & Using the Oscilloscope	List Price \$7.95; Club Price \$4.95
Introduction to Medical Electronics	List Price \$9.95; Club Price \$6.95
Handbook of IC Circuit Projects	List Price \$7.95; Club Price \$4.95
Passive Equalizer Design Data	List Price \$19.95; Club Price \$12.95
Basic Audio Systems	List Price \$7.95; Club Price \$4.95
Elements of Tape Recorder Circuits	List Price \$7.95; Club Price \$4.95
How to Repair Music Instrument Amplifiers	List Price \$8.95; Club Price \$5.95
How to Repair Small Gas Engines	List Price \$8.95; Club Price \$4.95
Hi-Fi Stereo/Quad Principles & Projects	List Price \$7.95; Club Price \$4.95
Refrigeration	List Price \$7.95; Club Price \$3.95
Using Electronic Testers for Automotive Tune-Up	List Price \$7.95; Club Price \$4.95
Kwik-Fix TV Service Manual	List Price \$8.95; Club Price \$5.95
Basic Electronics Course	List Price \$8.95; Club Price \$5.95
Marine Electronics Handbook	List Price \$7.95; Club Price \$4.95
Pictorial Guide to Tape Recorder Repairs	List Price \$7.95; Club Price \$4.95

**SEND NO MONEY!** Simply fill in and mail postage-paid Airmail card today!

### Solid-State Circuit Troubleshooting Guide

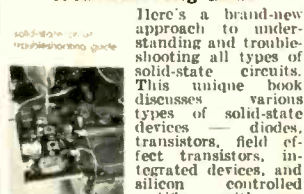

Here's a brand-new approach to understanding and troubleshooting all types of solid-state circuits. This unique book discusses various types of solid-state devices—diodes, transistors, field-effect transistors, integrated devices, and silicon-controlled rectifiers—with emphasis on how these devices work in circuits you're counter, and how to pinpoint a faulty component in minutes. The book is loaded with schematic diagrams of typical circuits and practical suggestions on how to troubleshoot and repair them. Many "service thinking" charts are included. 224 pps., over 150 illus. Hardbound. **List Price \$7.95 • Order No. 607**

### How to Use Modern Oscilloscopes, Sweep-Marker Generators



How to use modern TV test instruments. Scope types and specifications are covered, including DC dual-trace amps, and probes. Thoroughly explains vectorscopes, with details on vector timing charts, demodulated patterns, phase and frequency measurements; practical oscilloscope applications, encompassing how to make peak-to-peak and DC measurements, time-base measurements, video and sync waveform analyses; sine, square, and triangular wave testing; using the new push-button signal & sweep-marker generators; vectorscope troubleshooting and alignment techniques. 256 pps., over 225 illus. **List Price \$7.95 • Order No. 550**

### Handbook of Electronic Circuits



Contains 124 examples of standard transistor circuits, complete with operational data for amplifiers, oscillators, logic and switching circuits, power supplies, and various nonlinear circuits. The broad range of circuits included were selected on the basis of application and practicality. A design philosophy section is included with each group of circuits, thereby providing a basis for understanding circuits other than those selected as examples. This is a collection of practical circuits which have wide application. Each circuit description includes data concerning any unique design or operational data. Hundreds of illustrations and diagrams. 448 pps., 6" x 9". Hardbound. **List Price \$8.95 • Order No. G-30**

### Handbook of Electronic Tables: 2nd Edition

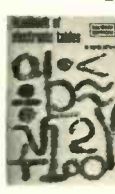

Here is the Second Edition of a book that has proved to be one of the most popular electronics texts ever published. It offers fast and accurate solutions to all the common and uncommon electronics and related math problems. All you have to do is bring your values to the right table—and that's almost as easy as looking up a word in the dictionary. But you get more than just answers: Preceding each table is an explanation of the formula from which the tabular data was derived—along with examples that show you explicitly how to set up your problem. This book can be used for daily reference. 224 pps., 73 tables. Hardbound. **List Price \$7.95 • Order No. 125**

### Major Appliance Repair Guide



Everything you need to know to fix any major electrical appliance is contained in this comprehensive, up-to-date volume. The authors explain every step in great detail, and practical suggestions on how to troubleshoot and repair them. Many "service thinking" charts are included. Numerous troubleshooting charts help you pinpoint the cause of virtually any problem in a matter of minutes. Repair procedures are included for dishwashers, clothes washers, dryers, water heaters, garbage disposers, and ranges, using typical models and case-history data drawn from actual experience. In every case, the material is based on practical, down-to-earth reasoning and techniques. 288 pps., over 260 illus. Hardbound. **List Price \$8.95 • Order No. 555**

### CATV System Maintenance



A practical guide on all phases of maintaining a CATV system, with adequate technical data on system design to enable run-of-the-mill engineering work required in planning and installing additions and extensions. The major emphasis is on maintenance—providing a wealth of information on how to locate and correct equipment failures, including tips on how to eliminate various types of interference at the head-end. Step-by-step maintenance charts help to isolate and correct the more common head-end problems. Sections on plant construction and maintenance provide valuable "how-to" information on pole-line mechanics and distribution techniques. 192 pps. Leatherette cover. **List Price \$12.95 • Order No. 82**

### Audio Systems Handbook



Complete reference guide to audio system design, encompassing home entertainment, commercial sound and studio installations. Chapter 1, covering amplifiers and amplification, explains db and impedances, level limitations, insertion gain, plus a host of other basics necessary for practical system design. The author goes to great lengths to impart an understanding of these vital ingredients as they apply to over-all operation. The same may be said of the treatment in succeeding chapters on equalizers, mixers, filters, distribution systems, program sources, commercial systems, studios, and loudspeaker systems. 192 pps., 125 illus. Hardbound. **List Price \$7.95 • Order No. 494**

### Dictionary of Electronics



You'll find this huge volume extremely useful in whatever connection you have with electronics. This dictionary of electronics defines most all of the electronic terms you will run across in your everyday reading... from alpha particles through zoom lens terms you need and use most often, including those found in radio, TV, communications, radar, electronic instrumentation, broadcasting, industrial electronics, etc. It provides full, complete and easily-understandable explanations of thousands of specific electronics terms (such as transistors, acoustic feedback, alpha particles, beat oscillator, final audio, electrostatic lens, nonlinear resistance, etc.). 420 pps., 487 illustrations. Hardbound. **List Price \$8.95 • Order No. 300**

### Circuit Consultant's Casebook



A practical guide of value to anyone involved in any phase of circuit design work from theory to actual breadboard performance. Written for the circuit designer who encounters difficulties either in conceiving a suitable circuit configuration to meet a required specification or in obtaining optimum performance from a newly designed circuit. Part 1 is devoted to basic design problems, and includes a wealth of actual examples. Part 2 deals with ways of meeting specific requirements not readily achieved by standard circuit. In certain cases a simple modification to a standard circuit configuration is shown to be sufficient; in others a novel approach is given. 224 pps., 114 illus. Hardbound. **List Price \$9.95 • Order No. 288**

### 199 TV Tough-Dog Problems Solved



Here is a master collection of actual case-history solutions—answers to many of the most challenging tough-dog TV problems on both color and B & W sets—covering all popular makes. From Admiral to Zenith. This book is organized so that you can quickly find the solution to particular problems. To enable you to find information relative to a particular problem in a specific set, a cross-reference of troubles by brand name and chassis is included. The content is organized into trouble symptom sections. Several different circuits are included so the information provided will apply to similar circuits in other models. 256 pps., 199 illus. Hardbound. **List Price \$7.95 • Order No. 559**

### Electronic Circuit Design Handbook



New Fourth Edition—A brand-new, enlarged edition of the ever popular circuit designer's "cookbook," now containing over 600 proven circuits, for all types of functions, selected from thousands on the basis of originality and practical application. Now you can have, at your fingertips, this carefully planned reference source of tried and tested circuits. Selected on the basis of their usefulness, this detailed compilation of practical design data is the answer to the need for an organized gathering of proved circuits, both basic and advanced designs that can easily serve as stepping stones to almost any kind of circuit you might want to build. 416 pps., 19 big sections, over 600 illus. 8 1/2" x 11". **List Price \$17.95 • Order No. T-101**

### Installing & Servicing Electronic Protective Systems

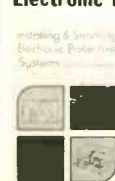

Here's everything you need to know to break into this challenging field! Covers the installation and servicing of virtually every electronic fire and theft security system, tells how to estimate costs, and contains data on how to build your business. Over 160 photos and illustrations, including complete schematic diagrams of many protective devices. Discusses sensing and detecting methods, then covers specific types—electromechanical, photoelectric, ultrasonic, microwave, proximity, audio and visual, seismic, vibration and stress, intrusion systems, night viewing devices, vehicular, etc. Federal Crime Insurance regulations, glossary, and list of manufacturers and suppliers. 256 pps. Hardbound. **List Price \$7.95 • Order No. 605**

### Electronics Self-Taught With Experiments & Projects



Tired of project books that simply tell you how to build one gadget, then leave you wondering why you bothered? Looking for a greater challenge and worthwhile knowledge as a result of your effort? You'll find it in this unique new book, written especially for serious experimenters, hobbyists and students—a book that shows why you do certain things, tells how devices and circuits work, and suggests innovations that should spur you forward to more important work in electronics. There are circuits and projects using integrated circuits, plus communications devices, logic circuits, "industrial" devices, and lab-type equipment. 288 pps. Hardbound. **List Price \$7.95 • Order No. 553**

### 104 Easy Projects For The Electronics Gadgeteer



A varied assortment of TO BELESS and TRANSISTORLESS devices that are useful in the home and car—and fun to build! These specially-designed one-evening projects require no tubes, transistors, or IC's, yet frequently outperform more sophisticated designs. There's an anemometer, a hygrometer, a light meter, flashgun tester, darkroom timer, automatic slide projector, an electric combination lock, dry-cell rejuvenator, tape recorder tone compensator, tone generator, telephone intercom adapter, an electronic coin toss, a "worn timer" and many, many more. Any project in the book can be built for under \$5.00. 160 pps. Hardbound. **List Price \$6.95 • Order No. 524**

### Model Car Racing By Radio Control



A complete handbook on one of today's most fascinating hobbies—encompassing everything you need to know to get started and advance to competition status. Written by one of model racing's pioneers, it explains the basic concepts of model cars and the means used to control them remotely. Also included are detailed chapters on the engine, power train, suspension system, and chassis. You'll learn how to put a car together, either from "scratch" or from one of the many kit types available. Next, you'll learn how to prepare for a race, how to "drive" a model racer, and the etiquette of the sport. 224 pps., over 250 illus. Hardbound. **List Price \$6.95 • Order No. 592**

### Philco Monochrome TV Service Manual



This all-in-one schematic servicing manual contains all the data you need to repair all Philco black and white TV sets, from 15G20 to TV-35 ("N" through "T" line). Covers 42 different chassis designs! In this one compact volume, you have all the basic information needed. Included are full-size schematic diagrams, PC board layout drawings and photos, adjustment and alignment instructions, and parts lists. The foldout section has 24 full-size schematic diagrams. 196 pps., including 36-page fold-out section. 8 1/2" x 11". **List Price \$7.95 • Order No. 564**

**AN EXTRAORDINARY OFFER.**

... for more details circle 105 on Reader Service Card



RCA's Model 5MS440 Mini-State Antenna System mounted 10 ft above the roof of your editor's home. Note the trees, which can be a source of reflected TV signals.

# Flying Saucers for Better TV Reception

by Phillip Dahlen

Although a number of solid-state antennas are now on the market, this is the first one that we have encountered that is directional enough to warrant its construction with a built-in rotator.

■ We have in the past received for examination quite a number of antenna systems designed around a pre-amplifier circuit. However, the RCA 5MS440 is the first such system we have encountered that contains within its own housing—a 21-in. "Radome"—additional elements for directional reception. And, of the outdoor-type antennas received, this is the first one that we have felt free to open for first-hand observation of active circuitry.

Cemented on top of a large lightweight polystyrene disk are the dipole, reflector and five directors that form the UHF antenna, plus a solid-state pre-amplifier; while secured around its perimeter are two metal bands designed for VHF re-

ception. At one end, these bands are connected to the pre-amplifier; while at the other end, they are terminated with a resistor. This traveling-wave ring contains special slots for tuning in the VHF channels.

Beneath the plastic disk is a motor housing for rotating the entire mechanism within the plastic antenna enclosure. Although we did not wish to remove the antenna elements from the disk or try experimenting with other "unknowns" in order to obtain access to the motor assembly, it could be easily studied in the photograph supplied us by RCA Corp., and we did observe it rotating the antenna elements.

This antenna is the nearest thing to a flying saucer that your editor

has yet seen. Attractively enclosed in plastic, it comes with accessory feet for installing in a closet or on an attic floor, plus an accessory bracket for mounting to a mast in either the attic or on the roof.

Also included in the package sent us for evaluation was a power supply, a length of cable for feeding the TV-set coupler, a coupler for providing 300Ω impedance signals to the TV set's VHF and UHF antenna terminals, and a rotator control that also plugs into the power supply. Of particular interest was the 50 ft of lead-in wire also supplied—though not normally included in the price of the system. It contains within a single outer jacket both the 75Ω coaxial cable and the



Top view of the 21-in. "Radome" housing the antenna.

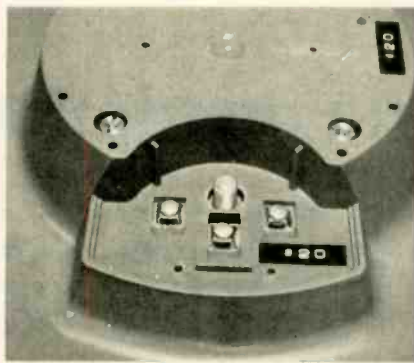

Close-up view of bottom of antenna showing the three rotator terminals and the coax terminal, which are normally enclosed for greater protection against the elements.

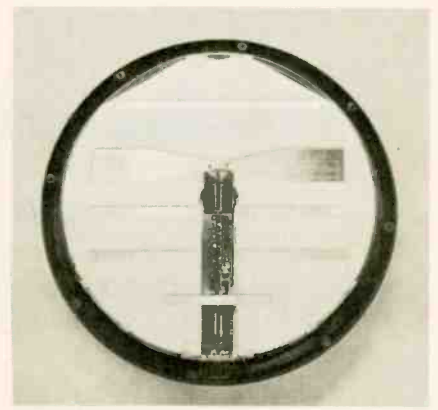

Top view of antenna with cover removed to expose the electronic elements. Filters are included in the amplifier for a reduction of FM-station sensitivity and the interference that it can generate.

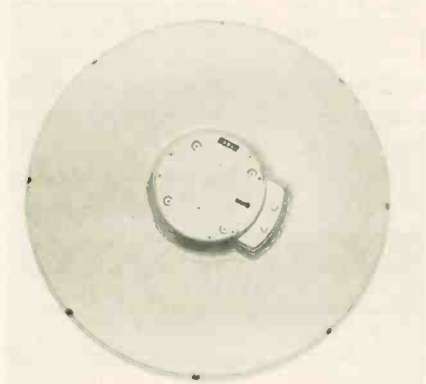

Bottom view of RCA's Mini-State Antenna, designed for use within 35 miles of TV transmitting stations.

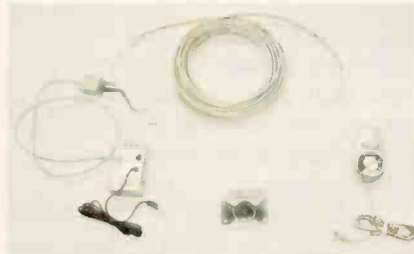

Accessories received with the antenna system include a bracket for most mounting the antenna, the rotator control, lead-in cable, power supply, coupler, and cable for connecting the coupler to the power-supply module.



Two angular views of the antenna showing the VHF elements around the perimeter and the UHF elements in the middle.



Three accessory legs may be attached to this 6-lb antenna for more convenient indoor use.

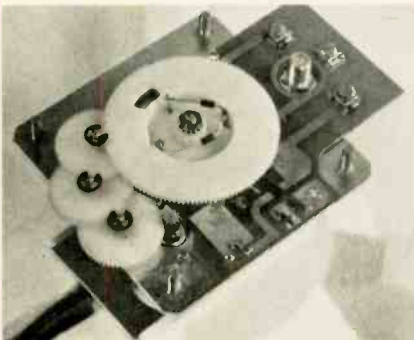

Close-up view of antenna rotator. Photo courtesy of RCA Corp.

three color-coded wires for use with the antenna rotator—thus simplifying our task of connecting the antenna (mounted 10 ft above your editor's home roof) to the power supply by the TV set in the living room.

Prior to the installation of this antenna, your editor had been using the antenna that came with the house. It was of modified log-periodic design with foam 300Ω twin-lead wire from the antenna to the TV set. This wire had been carefully spaced away from the outside of the house with the frequent use of standoffs and was brought into the basement through a wooden window casing. In the basement it was neatly wrapped around a metal

hot-air duct before passing through the floor to the TV set. Despite this one major flaw, the signal that had been received contained but minor ghosts (just a few insignificant reflections off the hot-air duct), though there was some interference on Channel 6—possibly from other stations on the FM Band.

Upon installing the solid-state antenna, we noted that all channels received were virtually ghost free and that there was no longer any sign of interference patterns in the TV picture. When rotating the antenna, we noted that a very slight ghost could be seen when the antenna was faced in the wrong direction, but the TV set's AGC circuit tended to compensate a great

deal for the resulting change in signal strength—color being lost only on some channels when the antenna was pointed well away from the direction of the TV transmitters. (It should be noted that your editor's home is located about eight air miles south west of the Duluth TV transmitters, out in the country where there are no large buildings or hills to produce ghosts—only the trees. The only locally available TV stations are on Channels 3, 6, 8 and 10, there being no UHF stations within about 60 miles. Those UHF stations are translators for local VHF stations unable to penetrate the forest-covered iron range.)

In order to make a more critical  
*continued on page 58*

# Productivity: Foundation for Success

Whether you are a self-employed technician or a service dealer with a dozen or more employees, productivity plays a bigger part in your business success than you may realize. If individual productivity is high, you should be able to enjoy a financially healthy business. If it is poor, economic health will be all but impossible. by William Joseph

■ In spite of the vital importance of technical productivity, many service dealers seldom give any organized thought to the problem of how to improve it. In the smaller service operations, the failure to keep adequate statistical information often means that management has no meaningful idea of the productivity of the individual employees. Such a circumstance almost certainly precludes optimum financial performance.

This point can be illustrated by thinking of a service department as a factory. In this case, the finished product is a completed repair job; either in the customer's home or in the shop. Just like the product being manufactured in a factory, every completed job in your service department is being produced at a specific cost. Not only must that exact cost be known, but each item of expense making up that cost must be known. This is a positive requirement if you are to control the expense of operating your business.

Bear in mind, though, that there is one very important difference between a factory and your service department. Your raw material is not steel or wood or plastic, it is labor. That labor—your own as well as that of your employees—constitutes, by far, the largest share of expense going into your finished product. All items of expense are important, of course, but your labor expense is the most important of all because it probably exceeds all others combined.

The service dealer should think of himself as a merchant. His product is skilled labor which he buys at one price and sells at another; hopefully at a profit. Thus, the cost of labor is a nucleus around which all other factors revolve. Despite what you may think, your absolute cost of labor is determined less by

the basic rate of wages you pay than by the amount of work being performed each day by your technicians.

Consider this:

The Hi-Voltage Service Co. employs four outside technicians. The records indicate that their average productivity is six completed calls, per man, per day.

On the other side of town is the Lo-Voltage Co. They also have four technicians, and the wages paid are

just about the same. Lo-Voltage's productivity, though, averages only four completed calls, per man, per day. Because of that difference in productivity, the cost of labor at Lo-Voltage is *50 percent higher than his competitor's*. And yet, both companies are paying the same basic wage rates.

To put it another way, the service manager at Lo-Voltage could, in effect, add two men to his force. These men would be fully trained,

TECHNICIAN _____		MONTH _____		19__		
DATE	HOURS WORKED #1	CALLS TAKEN OUT #2	NOT HOME #3	GO BACK—PARTS #4	TO SHOP #5	CALLS COMPLETED #6
1						
2						
3						
4						
5						
6						
7						
8						
9						
10						
11						
12						
13						
14						
15						
16						
17						
18						
19						
20						
21						
22						
23						
24						
25						
26						
27						
28						
29						
30						
31						
TOTAL						

COMPLETED CALLS PER DAY  
(#6 ÷ DAYS WORKED)

% GO BACK PARTS  
(#4 ÷ #2)

% NOT HOME  
(#3 ÷ #2)

% TO SHOP  
(#5 ÷ #2)

SUMMARY

NUMBER OF EIGHT-HOUR DAYS WORKED  
(#1 ÷ 8) = \_\_\_\_\_

would work for no salary at all, would require no benefits, would never get sick, and would need no additional tools or test equipment.

How does he accomplish this awesome feat? By raising his present productivity of four calls per man, per day to the six now being done by his competitor's men. The chances are that he can do it, too, because experience clearly shows that productivity, like any other area of management responsibility, will respond to skilled management attention. Left unattended, though, it can be depended upon to deteriorate even further.

Adequate records provide the foundation for all good programs to improve productivity. There is no practical way to by-pass this requirement. Many service dealers do an excellent job of maintaining various kinds of records relating to their business, while at the same time not making any effort to analyze the performance of individual employees on a scientific basis. Some dealers interviewed confess that their failure to keep productivity records is largely due to the fear that they will become too complex or cumbersome. Others indicate the feeling that little can be done by the small dealer to increase productivity. Both fears are groundless.

Productivity records not only do not have to be complicated, it is best if they are kept simple and basic. A chart similar to the sample in the illustration should be kept on a monthly basis for each man. The vital statistics for outside technicians are:

- number of 8-hr days worked
- number of calls taken out
- percentage of "not homes"
- percentage of "to shop"
- percentage of "go back for parts"
- number of calls completed daily

Using this information, recorded daily, it is simple to compute the monthly statistics including the most important, average completed calls per day. In order to arrive at this figure, simply divide the number of 8-hr days worked during the month into the total completed calls. For the sake of uniformity, it is essential that all calculations be based on an 8-hr day. Otherwise, a man who works 10 hr on a given day

might appear to have better productivity than another man who worked only 8 hr on the same day. This variation is easily compensated for by charging the man's daily entry with 1¼ days on the day he worked 10 hr. A 12 hr day would be recorded as 1½ days, etc.

The records for bench men, of course, can be even less elaborate since entries for such things as mileage and "not home" are not required.

For those who object to even this much record keeping, the payroll cost-per-call method may be used. This method requires only that the total number of completed jobs by each technician be recorded each month. This figure is divided into the total salary paid to the technician. The result is the average payroll cost for him to complete one job.

The cost-per-call method provides a valid basis for comparison between technicians when basic wage rates are equal. It does not, however, highlight the causes for individual variations in performance, such as will be shown by the productivity chart. Either system, of course, is subject to countless variations and modifications to suit the requirements of the user. When productivity charts are used, they will sometimes help to pinpoint the reason for poor performance. For example, one man may be running too high a percentage of "not homes," while another may have too many "go back for parts" calls.

Once a system for furnishing accurate figures is in operation, it then becomes necessary to establish standards of performance. Unfortunately, there are no universally accepted standards of production for electronic technicians. This is primarily due to the many variables involved. Such things as distances traveled, traffic conditions, types of merchandise serviced, and variations in the methods used to compute productivity, all combine to make it impractical to attempt to establish norms acceptable in all cases. It is a relatively simple matter, though, to establish local objectives that are pertinent to local conditions.

You can almost be certain that any shop employing more than two

technicians will show sharp differences in productivity, even though all men are doing similar work. By setting the performance of your top producer as the objective for all other technicians, you establish a target that perpetuates itself. Almost always, as the productivity of the group improves, at least one man will maintain a significant lead over the others. By always setting the performance of your best producer as the objective, your standards are kept both reasonable and up-to-date.

Before any attempt is made to work with individuals on their productivity, you should take an objective look at the conditions under which your men are working. More often than you may think, circumstances under the direct control of management serve to frustrate capable men who would genuinely like to be more productive.

Systems that waste the time of technicians at the beginning or the end of the day are common problems in service operations. It must be remembered that 30 unnecessary minutes spent in the shop by each man in the morning or evening will add up to a devastating expense at the end of the month.

The stage for good productivity must be set by streamlining all activities that tend to use up the precious time of your technicians. A few minutes a day saved on such things as drawing parts, checking in or out, or picking up the new day's work can result in important improvements in overall productivity. You cannot expect your technicians to respect the value of their time if you do not demonstrate your own interest.

Truck inventories vitally affect productivity, and they must not be overlooked. Obviously, a technician cannot complete his call if he does not have the part he needs in his truck. If he has to write a "go back" more than two or three times a year for the same part, you are wasting time and money until you get that part added to his truck stock. Such an attitude is indicative of shortsightedness on the part of management. If your total cost-per-call is \$10.00 (all items of expense including payroll and overhead) you can

afford to carry that part in a truck for a very long time before the cost of the inventory approaches the cost of an extra trip back to the customer's home.

It goes without saying that truck inventories cannot be allowed to grow needlessly; but neglecting them, or practicing false economy is always a much more costly error. A simple system for analyzing usage should be considered a necessity. One easy way to do this is to maintain a written tally of every part ordered by outside technicians. Whenever a given part appears on the list at the rate of say four or five times per year per truck, the chances are that you will save money by adding it to your truck inventories. On the other hand, parts that are moving slowly, or not at all, must constantly be culled to make room for active parts.

Repairs in the home, as opposed to repairs in the shop, make a lot more sense than some dealers realize. The tendency to encourage technicians to bring chassis in for shop repairs without a reasonable effort to do the job in the home can be poor business for several reasons:

1. Most customers are willing to pay a fair price, provided they receive *good* service. A repair job done properly in the customer's home on one trip is good service.

2. By removing a chassis to the shop for repairs, you can usually justify a higher charge to the customer. But don't overlook the fact that your expense is increased by the cost of an additional round trip to the customer's home, plus the time of the bench man. Today, this may add a lot more expense than you realize. A job done quickly and properly in the customer's home can be done at less expense to both you and the customer; and you have cultivated a satisfied customer.

3. Failure to encourage your men to complete repairs in the home makes your position inconsistent. It then becomes difficult to motivate them to improve productivity . . . and

improved productivity is your most certain road to improved profits.

Tools and test equipment are every bit as essential to good productivity as are parts. The more progressive service dealers are coming to realize the wisdom in supplying special equipment that the technician cannot or will not supply himself. It is axiomatic that the proper tool will reduce the time necessary to do a repair job. The time saved through the use of proper tools accrues to the direct benefit of the employer; still, too many service dealers are reluctant to make the investment necessary to permit themselves the benefit of this potential increase in productivity.

Years ago, it was expected that a technician keep himself technically qualified to do his job. In today's age of dizzying changes in design and manufacturing technology, it is simply unrealistic for an employer to take this position. Today, even the most determined technician will find it extremely difficult to keep himself up-to-date on new servicing techniques and design changes, solely through his own efforts. Small service dealers obviously cannot afford the costly internal training programs enjoyed by the giants in the industry. Nevertheless, continual training for electronic technicians is a practical necessity. Most small dealers find that the best way to meet this requirement is to participate in the service clinics and training seminars conducted by manufacturers, distributors and trade associations. This requires an investment, of course, but every dollar spent for effective training is a step toward better productivity. In short, take advantage of training for your technicians wherever and whenever you can get it.

Once an organized effort to provide a climate conducive to good productivity has been established, attention can be given to improving individual performance. The continuing difficulty in finding skilled and experienced technicians has provided a handy excuse for many service dealers to avoid facing up to the problem of dealing with the poor performer. This is a grave mistake, since avoiding such a prob-

lem can surely be counted on to make it worse. Poor productivity in a service organization is a cancer that feeds on itself. Left without attention, it is certain to deteriorate even further.

One thing that makes this problem somewhat easier to deal with than might be imagined is the simple fact that the overwhelming majority of people want and need the personal satisfaction of knowing that they are doing well in their chosen profession. This is basic in human nature, and the service dealer should learn how to develop this instinct to a fruitful end.

Personal counseling designed to appeal to the technician's professional pride and his inherent need for recognition can be very effective. Don't be afraid to let a man know that his time is valuable, that neither of you can afford to waste it, and that you are anxious to provide him with any help that will enable him to use his time more productively.

Make sure that any interviews on the subject of his productivity allow the technician to communicate his views. Give him the opportunity to comment on your present systems and how they might be improved. Ask him if his tools and truck stock are adequate to do the job and, most important, be prepared to give honest consideration to his answers. Two-way communication is a must if you are to earn the full support and cooperation of your employees.

Your discussions with an employee about his work should always be explicit. Every employee is entitled to know in specific terms just what you expect of him. Provided that your standards are reasonable, the chances are that he will do his best to fulfill them.

If you want to enjoy the satisfaction and profitability that results from top efficiency, start now with a planned program to improve productivity. Make certain that your technicians have a clear idea of what you expect of them; maintain working conditions that will encourage the efficient use of time; and keep your records accurate and up-to-date. Then, see for yourself how better productivity means better profit. ■



# Troubleshooting— When There's No Voltage Test Data!

by Raymond E. Herzog

Don't let the lack of dc voltage test data dead-end your troubleshooting. Here's how to determine dc voltages with a simple circuit analysis technique.

■ When troubleshooting circuits, how often do you make use of dc voltages given in a manufacturer's service manual?

To this not too uncommon question, most service technicians would readily say, "Just about all the time."

For indeed, dc voltages serve as a convenient indicator of a circuit's operation. And they are quick and easy to measure, requiring only a dc voltmeter (contrasted with the elaborate test set up needed for some ac measurements).

Unfortunately, however, some of

these important dc voltages that you'd like to measure are not always given in service literature. Or, there may be no service literature at all!

If this lack-of-information problem is keeping you from productive troubleshooting, then you'll want to read on—you'll learn how to use a simple dc circuit analysis technique to determine what a given dc voltage should be.

This technique, it should be noted, gives only approximate answers. But the manufacturer's specified test voltages have a 10 percent

tolerance anyway, so this approximate answer generally is close enough. Having determined the voltage, you can then continue your troubleshooting, whereas with no voltage information, you'd be dead-ended.

Although it can be used with many circuits in TV, radio, audio equipment, and so forth, the technique does have two small limitations:

- The dc voltage to be determined is for a "no signal" condition.
- The circuit must be a type that is operating (conducting) all the time in the absence of an input signal.

The first item is no problem since a "no signal" condition is easy to get. And because most circuits are normally biased ON, the analysis will find many applications.

These limitations are needed because a circuit's tube or transistor forward bias is used in the analysis. This bias is a known value for a given device, but only for a steady ON state and with no detracting signal.

Some circuits for which the technique cannot be used are: oscillators (including sinewave, vertical blocking and horizontal sawtooth), TV deflection amplifiers, sync separators, and some AGC circuits. You can experiment with various circuits to get to know which ones can or cannot be analyzed. For instance, because a TV deflection amplifier is driven with a sawtooth input, its operating bias is affected by this input; thus, there's no resemblance to a

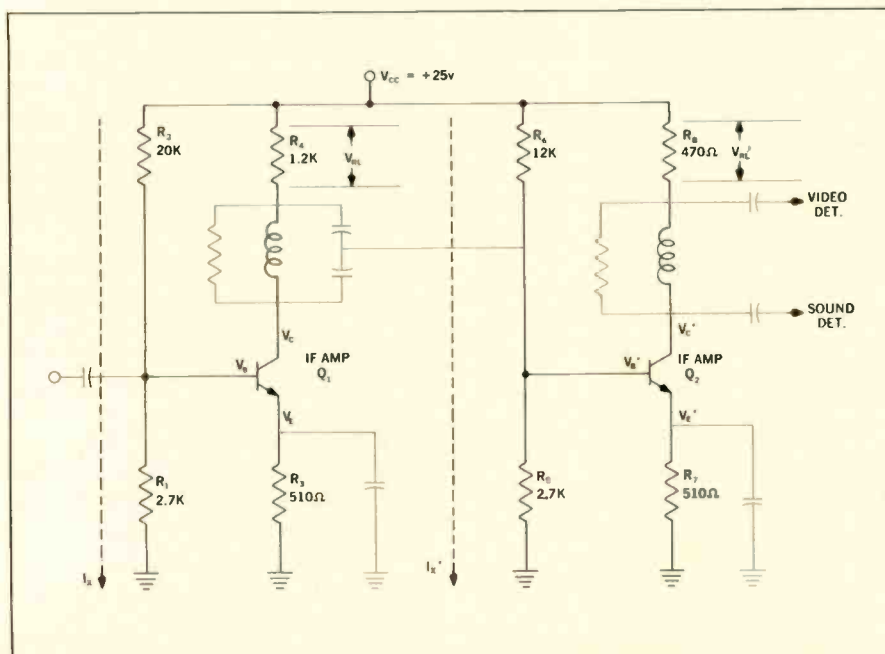

Fig. 1—Two IF stages of an Airline color-TV set—shown in more detail in the August 1971 TEK-FAX Schematic No. 1371—which are used in the explanation of a simplified dc analysis for determining voltages  $V_{be}$ ,  $V_{be}'$  and  $V_{ce}$ .

steady ON condition.

*One interesting aspect of the analysis is that it's ideal for circuits with transistors.* And you don't even have to know the type of transistor! (Although such information would give a more accurate answer.) In exemplifying the technique, this article will use transistor circuits.

Concerning transistors, you should remember that:

- Transistor forward base-to-emitter voltage ( $V_{BE}$ ) generally is 0.2v to 0.3v for a germanium device, and 0.6v to 0.7v for a silicon device.
- Transistor base current is much less than the collector and emitter current.
- Transistor emitter current is the sum of its base and collector currents.

And a final note of introduction before we get into the technique: For the product under test, the B+ power supply voltage feeding the circuit to be analyzed must be known. If service literature is at hand, you're in luck since it always gives power supply voltages (although not all other voltages—but then, that's where we came in). If there's no service literature, you can measure the power supply voltage. This, of course, presupposes that the trouble is not in the power supply itself.

So then, after this lengthy introduction . . . on with the technique.

### Simplified DC Circuit Analysis

Five easy steps are involved in this analysis for determining dc voltages. We'll list them here, and then go through an example:

1. Draw the circuit, showing only those components affecting dc operation.
2. Calculate the base-to-ground voltage,  $V_B$ :
  - (a) First, determine the current through the base resistor network, ignoring the base current itself (base current has little effect on the answer).
  - (b) Then, multiply this current times the base-to-ground resistor to get  $V_B$ .
3. Calculate the emitter-to-ground voltage,  $V_E$ :
  - (a) First, write down the  $V_{BE}$

voltage, using the typical values previously given.

- (b) Then, for a PNP transistor, add  $V_{BE}$  and the  $V_B$  from step (2) to get  $V_E$ ; or, for an NPN transistor, subtract  $V_{BE}$  from  $V_B$  to get  $V_E$ .
4. Calculate collector current,  $I_C$ :
    - (a) First, calculate the emitter current,  $I_E$ , by dividing the emitter-to-ground resistance into voltage  $V_E$ .
    - (b) Since the emitter current and collector current are about equal, this calculated value for  $I_E$  becomes the value of  $I_C$ .
  5. Calculate collector-to-ground voltage,  $V_C$ :
    - (a) First, multiply the collector current,  $I_C$ , times the value of the collector load resistor.
    - (b) Then subtract this voltage drop from the collector power supply voltage,  $V_{CC}$ , to get  $V_C$ .

With the dc voltages  $V_B$ ,  $V_E$  and  $V_C$ , you can then proceed to make meaningful measurements.

### Example: Determining DC Voltages in a Video IF Stage

Let us see how these five steps work out for determining some dc voltages in a TV receiver. The two video IF stages shown in Fig. 1 will illustrate the technique quite well. We'll go through the first stage step by step, and then let you work out the second stage.

*Step 1:* The first step has already been done in our diagram. Components affecting dc operation are shown in heavy lines; some of the other circuitry is lightly drawn in to let you see what the circuit is.

*Step 2a:* Current through the base resistor network,  $I_x$ , is simply the B+ voltage,  $V_{CC}$ , divided by the total resistance:

$$I_x = \frac{V_{CC}}{R_1 + R_2} = \frac{25v}{2,700\Omega + 20,000\Omega} = 1.1ma.$$

*Step 2b:* The voltage to the base,  $V_B$ , is the voltage drop across the 2.7K resistor,  $R_1$ :

$$V_B = (I_x)(R_1) = (1.1ma)(2.7K) = 2.97v.$$

*Step 3a:* If the type of transistor is known (germanium or silicon), write down the normal base-to-emitter voltage,  $V_{BE}$ . In our example we

have a silicon device which has a  $V_{BE} = 0.6v$ . If it is not known whether the transistor is germanium or silicon, you might make an intelligent assumption concerning which type it is. Or you could use a value of  $V_{BE} = 0.4v$  (0.4v being the average of the two possible values of 0.2v and 0.6v). [Using  $V_{BE} = 0.4v$ , the calculations are still within 10% of the manufacturer's values:  $V_B = 2.97v$  (no change);  $V_E = 2.57v$ ; and  $V_C = 18.9v$ .]

*Step 3b:* Since we have an NPN transistor, its emitter voltage,  $V_E$ , is less positive than its base voltage. This difference is the  $V_{BE}$  voltage from the preceding step. Thus:  $V_E = V_B - 0.6v = 2.97v - 0.6v = 2.37v$ .

*Step 4a:* The emitter current,  $I_E$ , can then be found:

$$I_E = \frac{V_E}{R_3} = \frac{2.37v}{510\Omega} = 4.65ma.$$

*Step 4b:* Recalling that the collector current,  $I_C$ , is about the same as the emitter current, we'll put down:

$$I_C \approx I_E = 4.65ma.$$

*Step 5a:* The voltage drop across the collector load resistance (assuming the coil resistance to be 0 $\Omega$ ) is  $V_{RL}$ :

$$V_{RL} = (I_C)(R_{load}) = (I_C)(R_4) = (4.65ma)(1.2K) = 5.6v.$$

*Step 5b:* This last step gives us the collector voltage,  $V_C$ :  $V_C = V_{CC} - V_{RL} = 25v - 5.6v = 19.4v$ .

There, you have all three transistor voltages:  $V_B$ ,  $V_E$  and  $V_C$ . Approximate, of course, but more often than not, within the manufacturer's 10% tolerance.

To assure that you understand these steps, you may work out the values for  $V_B$ ,  $V_E$ , and  $V_C$  for the second stage. Just follow the procedures given in the above example. Use  $V_{BE} = 0.6v$ .

Voltages and currents for the second stage will be identified with a prime sign (') to distinguish them from those of the first stage.

Your answers should be:

$$I_{E'} = 1.70ma$$

$$V_{B'} = 4.59v$$

$$V_{E'} = 3.99v$$

$$I_{E'} \approx I_{C'} = 7.82ma$$

$$V_{RL}' = 3.7v.$$

$$V_{C'} = 21.3v$$

# Taxes and Future Retirement

by William Joseph

November 13, 1966, was an important day for small businessmen. That was the day that the President signed into law the Self-Employed Individuals Tax Retirement Act of 1962, and its amendments.

■ In past years, comfortable retirement was something that many small businessmen could only think of wistfully. The economic pressures in keeping the business going, plus the constant need of working capital prevented many owner/managers from accumulating enough savings to provide for their retirement years. Now, with the help of Uncle Sam, the forward-looking businessman may create a retirement fund that can provide a lot of gold for those "golden years."

Basically, the law provides that self-employed persons may set aside a portion of their earnings into a retirement fund for themselves. All such contributions to the fund are entirely tax deductible for federal income tax purposes. Of course, taxes must then be paid when you begin to draw benefits from the fund at your retirement. Presumably, though, at a much lower rate than you now pay for current income. In the meantime, all earnings of the fund are retained for additional growth with complete immunity from income taxes.

As you might imagine, such important tax savings are available only to those who observe the specific requirements involved. The rules are simple, though, and should present no problem to those who are interested.

If you have employees, certain of them must be included in order to qualify yourself. Your plan must cover all full-time employees with three or more years of service. You do not have to include part-timers or seasonal employees who work

less than five months a year.

Each year, you may contribute up to 10 percent of your income, to a maximum of \$2500. The contributions that you put into the fund for your employees, if any, do not have to be in the same amounts as your own, but they must be the same on a percentage-of-income basis.

The law allows you two broad choices for determining the financing of your plan. You may set up either a profit-sharing plan or a pension plan. The choice permits you to devise a formula that should be suitable to your needs and not cause a financial hardship to the business.

In a pension plan, you commit your business to make definite contributions to the fund, including contributions for eligible employees, without regard to the ups and downs of business profits over the years. Under this arrangement, your contributions become part of the cost of doing business and must be paid regardless of profits.

In the profit-sharing program, you may limit your obligation to a fixed percentage of profits or a fixed percentage of profits with a specific maximum. Thus, in a year where there is no profit, you do not incur any obligation. The obvious disadvantage of this plan is your inability to offer your employees any certain estimate of the retirement benefits they may expect.

The law also permits you several choices for investing the money in your fund: You may set up a trust to be administered by a bank; you may purchase annuities or life in-

surance contracts directly from a life insurance company; or you may purchase special retirement bonds from the United States Treasury. These bonds provide safety, a fixed return, and they eliminate administrative costs.

Once you have established your retirement fund, it becomes subject to very specific restrictions. There are penalties for making contributions to the fund in excess of the 10 percent or \$2500 annual limit. Also, unless you are disabled, you may not draw benefits from the fund until you reach the specified retirement age. Your plan must specify a "normal retirement age" which can be 62, 65, or any age above 59½. If you should die before reaching retirement age, all benefits are payable to your beneficiary.

Information for setting up a plan is contained in Document 5592 (10-66). It can be obtained at no cost from your District Director of Internal Revenue. In addition, you will want counsel from your accountant, lawyer, or other financial advisor. Once a plan has been established, its operation is simple and requires very little effort on your part.

The advantages of setting up a retirement plan are obvious. For most businesses, the tax benefits can be quite significant. Also important is the enforced savings habit that results from such a formal arrangement. If employees are involved, the plan will certainly raise their morale and should serve to reduce costly turnover.

There is a principal disadvantage in starting a retirement plan under this law. You must remember that once you make contributions to the fund, that money is no longer available to you until you reach retirement age. No matter how dire the emergency or how badly you are in need of operating capital, you may not withdraw, or even borrow, any part of it. The law was written specifically to permit self-employed individuals to enjoy the security of a certain retirement income. Once you have invested money in your fund, the law does not permit you to change your mind. ■

# Is Your Wife Well Informed About Your Business?

Should you become ill, disabled or even die, will your wife be able to save your business from immediate disaster?

by Ernest W. Fair

■ Perhaps your wife lacks the knack for business and no one knows it better than yourself. Just the same, for your own welfare, as well as hers, there are a number of things she should know about just in case something should happen to you.

Who she can call on to take over for a short duration if you are suddenly incapacitated and cannot make necessary basic decisions and who is to take care of service work in process.

Where the vital book-keeping records are kept and how to read the basic information therein she may need to handle some important problem.

The name of your lawyer and exactly how he is to help her during any type of emergency.

The entire picture of your banking relations with respect to the business and the name of the bank officer therein she can call upon for assistance.

Where the safe combi-

nation can be found, the keys to locked drawers and cabinets are kept, and which ones do the job in each specific place.

The names, addresses and telephone numbers of members of your staff and the specific responsibilities each has in the business, salaries paid to them, etc.

Any future programs regarding the business to which you have been committed and what she or someone else is to do about each of them.

The nature of your basic tax records, where they are kept, and to whom she is to refer for information concerning any such matters.

What promises you have made to specific staff members for the immediate future and what is to be done about them should you be absent.

A list of the insurance policies covering the business, their kind and nature, where they are kept and whom she is to contact with respect to them.

Her legal rights to the

business, not just should you pass away, but while you may be totally incapacitated for a time, and how she can protect them.

The nature of any binding contracts or agreements that you may have made for the immediate future, even those unwritten, and what she is to do about them.

What she is *not* to do as well as what should be done and why you so specify each such restriction.

The market value of the business just in case you should suddenly pass away.

Your own immediate plans for the business just in case she may want to carry them through; particularly those on which some work has already been done.

Your favorite sources of supply and which are of preferred rating. It could save a lot of headaches.

Any and all promises you have made to staff personnel with respect to future promotions, pay raises, bonuses, etc. ■

# hm electronics' Model HM-310 VOM/Transistor Tester

by Phillip Dahlen

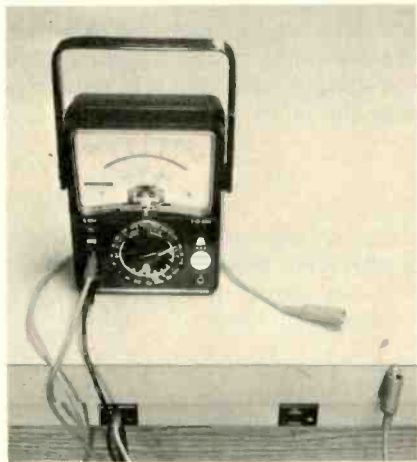

hm electronics' Model HM-310 VOM/Transistor Tester being used for transistor testing (above) and measuring capacitance (below). For more details, circle 900 on the Reader Service Card.

In addition to measuring resistance, ac voltage, dc voltage and dc current, this instrument can be used for measuring capacitance and transistor dc characteristics

■ Past articles and letters in our publication have offered hints on how any VOM can be used to test forward- and reverse-bias resistances in a transistor, and with a battery even dc gain. The results are not as specific as when checking ac gain characteristics with a curve tracer, but generally it does provide at least an adequate "go, no go" evaluation when testing transistors.

This instrument is designed to permit such measurements without the need for external circuitry, thus offering far greater simplicity. A standard transistor socket is provided

on the front of the instrument, which is designed to directly read alpha (0 to 0.9965), beta (0 to 285) and  $I_{c0}$  (0 to  $12\mu a$  and 0 to  $48\mu a$ ). [To refresh the memories of some of our readers, alpha ( $\alpha$ ) is determined by the equation  $\alpha = \frac{I_c}{I_E}$  and beta ( $\beta$ ) is determined by the equation  $\beta = \frac{I_c}{I_B}$ ;  $I_E$  being the emitter current,  $I_B$  being the base current, and  $I_c$  being the collector current.  $I_{c0}$  is collector leakage current.]

Its ability to measure capacitance is another feature not found in too many other VOM's. When checking out this feature, we connected the common lead of the VOM directly to one side of a 112v ac outlet and the VOM lead to a  $.003\mu f$  capacitor—the other side of the 112v ac outlet being connected to the other side of the capacitor. Sure enough, the needle registered  $.003\mu f$  on the capacitance scale—a convenient feature should somehow the markings be missing from some capacitor. The use of any external 30v ac source permits multiplying the capacitance scale by 20.

Other manufacturer specifications for this interesting instrument include those shown at the left.

DC Millivolts:	0 to 120mv, 600mv (100K/v)
DC Volts:	0 to 3v, 12v, 30v, 120v, 600v, *3kv, *30kv (100K/v)
AC Volts:	0 to 6v, 30v, 120v, 600v, *6kv (10K/v)
Resistance:	R×10, R×1000, R×100,000
DC Current:	0 to $12\mu a$ , $600\mu a$ , 12ma, 300ma, 12a (all at 250mv voltage drop)
Decibels:	-20 to + 58dB (0dB = 1mw, 600Ω line)
Capacitance:	0 to $0.01\mu f$ , $0.2\mu f$
Transistor Tester:	NPN and PNP
Accuracy:	±3% all ranges except ac, ±4% ac
Scale length:	3 in.
Meter:	Mirrored scale, diode overload protected band sus- pension movement
Dimensions:	2½ in. by 5 1/16 in. by 6½ in.
Weight:	3 lb.
*Probe Option	

# TECHNICAL DIGEST

The material used in this section is selected from information supplied through the cooperation of the respective manufacturers or their agencies.

## MAGNAVOX

Speaker System Models 1S8757 through 1S8759, and 1S8762 through 1S8766—Fusible Resistors

Speaker systems such as the Models 1S8757 through 1S8759 and 1S8762 through 1S8766, employ a fusible resistor in series with the positive lead to the speakers. This device is intended to protect against excessive current flow in the event of a shorted speaker voice coil. This fusible resistor is rated a  $.225\Omega$ , 2w and is identified by Part No. 240104-3. Because of the protective characteristics of this resistor, you are cautioned to use only the exact replacement. When replacing one of these fusible resistors, use the full length of the resistor leads and heat sink the leads while soldering them in place.

## RCA

Easy FM Alignment Markers

Many stereo FM receivers use double-tuned IF stages to achieve the wide-band response required for low-distortion reception of FM multiplex. Because alignment is critical for lowest distortion, sweep alignment of the IF stages and ratio detector is often specified in service data. Sweep alignment requires the use of 10.6MHz and 10.8MHz marker frequencies, which are sometimes difficult to obtain. This article describes an easy way to obtain the required markers.

The test equipment required for proper FM sweep alignment includes a sweep generator providing a 1MHz wide sweep centered at 10.7MHz and a marker generator to obtain 10.6MHz and 10.8MHz markers. The RCA WR-514 Chanalyst or WR-69 sweep generator (used with WR-70 Marker Adder) are well suited for the marker insertion technique to be described. The RCA WR-50 RF Signal Generator is used to supply the 10.6 and 10.8MHz markers.

The sweep generator (WR-514 is illustrated) is connected to the IF input through a dc blocking capacitor—

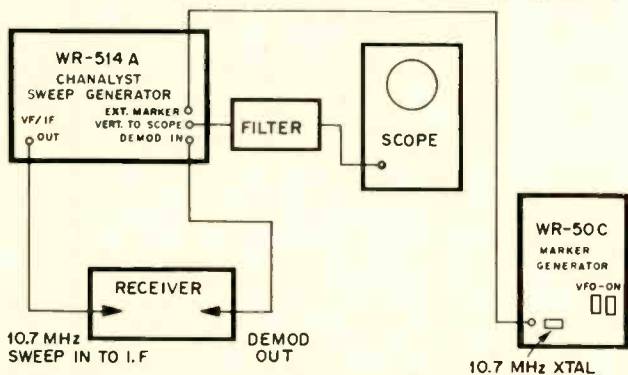

as described in the service data for the receiver—and adjusted to obtain a sweep response curve of correct amplitude. The WR-50, serving as a marker generator, is setup to furnish the 10.6MHz and 10.8MHz markers in the following manner:

Connect the marker generator to the Chanalyst sweep generator (or marker adder) as shown in the illustration. Install a 10.7MHz crystal in the front panel crystal socket

of WR-50. Set WR-50 generator's V.F.O. dial and range switch to obtain a 100kHz signal. Set an RF Output and Xtal-Osc switches of WR-50 to HIGH and V.F.O. switch to ON. Adjust the RF attenuator on WR-50 to obtain markers of correct amplitude.

With the conditions described, the WR-50 is actually feeding two signals (100kHz and 10.7MHz) to the Ext-Marker input of the WR-514 sweep generator. These signals enter the marker-adder section of the generator, where

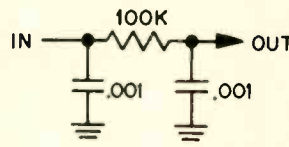

because of the relatively high signal levels, cross-modulation produces 10.6MHz (10.7MHz - 100kHz) and 10.8MHz (10.7MHz + 100kHz) products plus the original 100kHz

and 10.7MHz inputs. The output signal of the marker adder is the normal sweep response curve, plus prominent 10.6MHz and 10.8MHz marks and a residual 100kHz component which is filtered out by the pi-section filter in series with the scope input—as shown in the illustration.

With practice this test instrument combination will provide the electronic technician with a straight-forward alignment technique.

## SYLVANIA

FM Tuner Specification Terms and Their Meaning

FM Sensitivity

The Institute of High Fidelity (I.H.F.) has set a standard defining the tuner's ability to provide sound on an extremely weak signal—FM sensitivity ranges anywhere from  $10\mu\text{v}$  down to  $1.2\mu\text{v}$  or thereabouts. Obviously the lower the microvolts the better the unit's weak signal performance.

Quieting

Quieting and sensitivity, or vice-versa, are interrelated. A tuner's capability to produce a useable output signal at a certain dB level above noise is its quieting ability. Remember, sensitivity is measured in microvolts and quieting in dB.

A receiver having an input sensitivity of  $1.3\mu\text{v}$  that produces 20dB quieting is a top flight tuner. A tuner with a lower number is the better FM tuner.

Full Limiting

Before an FM receiver's IF system can begin to limit, the RF signal level must be a certain minimum strength. Full limiting is the tuner's ability to reject signal amplitude variations that cause audio output changes. A tuner having full limiting capability with a  $2\mu\text{v}$  to  $4\mu\text{v}$  signal input has fine performance. Here again, the full limiting capability to signal level input is measured by the amount of microvolts. The smaller the input signal, the better the unit.

Signal to Noise

This is usually referred to as the S/N ratio. Random noise is ever present in the FM reception world where signals from weak stations permit background noise to be present. This noisy background is not a desired addition to FM sound. Unlike full limiting, quieting and FM sensitivity, the desired numerical result of this ratio should be high instead of low. The higher the number, the better the FM receiver. Receivers measuring 60dB are real performers.

Capture Ratio

Many areas are blanketed with FM stations. With co-

and adjacent FM channels being present, one station can and may interfere with another.

The number of this ratio is measured in dB, and tells the engineer that if two stations share the same frequency, the tuner's capture ratio indicates that the station which is interfering will be rejected as long as the interfering signal is weaker by 1.5dB or more. Here again, the higher the number, the better the performer.

#### Image Rejection

An FM antenna receives all broadcast signals. Being constantly bombarded by them, a pre-selector stage is required to select and reject all but the desired signal. This stage is an RF amplifier and amplifies the selected signal. Another part of the FM front end is the mixer with an output in the IF (Intermediate Frequency). In FM this frequency is generally 10.7MHz and in AM it is generally

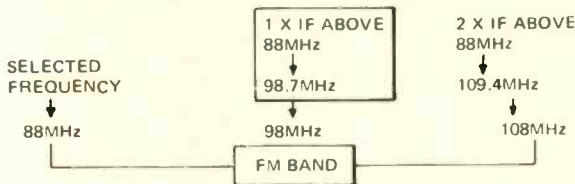

455kHz. These frequencies are generated by the pre-selected RF signal and the local oscillator signal beating together in the mixer.

The ability of the tuner to reject an unwanted signal that occurs at twice the IF frequency, as long as it is not more than 60dB stronger than the selected signal, is ideal. The larger the number the better the unit.

#### Half IF Rejection

This performance specification is somewhat like  $2 \times$  IF rejection and is expressed in dB. Half IF rejection is also called Spurious Response Rejection and shows the tuner's ability to reject unwanted signals occurring at  $\frac{1}{2}$  IF above

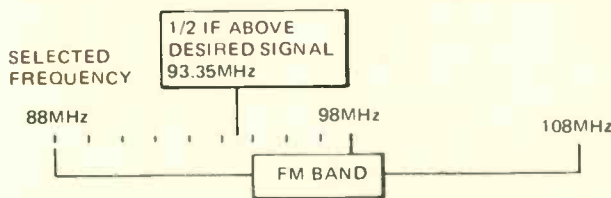

the wanted signal. Here again, the dB number indicates performance. The larger, the better. A high quality receiver usually has a rejection capability of 70 to 90dB.

#### Alternate Channel Rejection

The FCC assigns all FM channels in geographic areas to eliminate adjacent channel interference and an alternate channel assignment takes place. The test of a receiver's ACR (Alternate Channel Rejection) is determined by

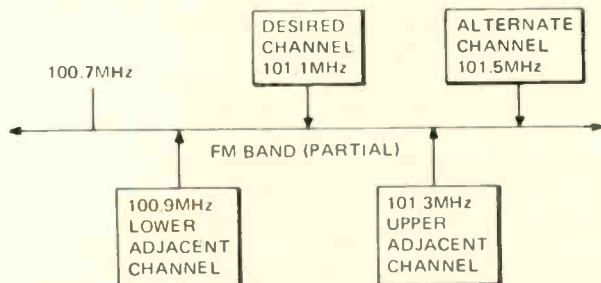

how well the alternate channel is rejected when receiving the desired station. Here again, the dB is used to express

the receiver's ACR ability. The larger the number, the better the receiver. A dB ratio of 50 or more makes the unit a good performer.

#### FM Muting

Many FM tuners do not use this function and spew interstation noise from the speaker system when tuning from one end of the dial to the other. The ability to cut out background noise, while tuning from one FM station to another, is an expression of top design in a tuner and usually is qualified by a figure measured in microvolts. Signals under  $5\mu\text{v}$  are not useable but will set the muting circuits into operation provided the muting function is operational.



"Send over your TV repairman that always brags he can fix anything!"

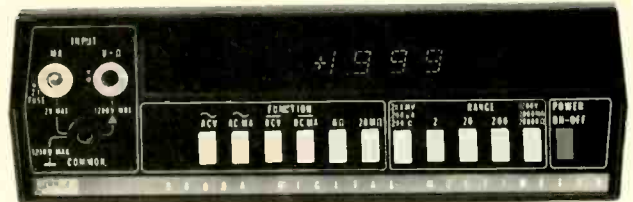

## Think of it as the best tester in your bag. Only \$299

Now you can get a high performance Model 8000A Digital V.O.M. from Fluke, America's foremost maker of quality digital multimeters, especially designed for TV, radio, stereo and audio service. No other digital V.O.M. gives you the resistance range to check breakers and switches, the high resolution voltage to look at emitter base and other transistor voltages, excellent ac accuracy and full accuracy with a 30 second warm-up.

Measures in 26 ranges 100  $\mu\text{V}$  to 1200 V, 0.1  $\mu\text{A}$  to 2A, and 100 milli $\Omega$  to 20 meg $\Omega$  with a basic dc accuracy of 0.1%. Full year guarantee. Low cost options include rechargeable battery pack, printer output, deluxe test leads, HV, RF & 600-amp ac current probes, carrying case, and rack mount. Unique self zero eliminates offset uncertainty. Electronics securely mounted in high-impact case. Service centers throughout U.S., Canada, Europe and Far East for 48-hour turnaround repair.



P. O. Box 7428,  
Seattle, Washington 98133.

Get all the details from your nearest Fluke sales office. Dial toll-free 800-426-0361 for address of office nearest you.

... for more details circle 112 on Reader Service Card

# COLORFAX

The material used in this section is selected from information supplied through the cooperation of the respective manufacturers or their agencies.

## EMERSON

Color-TV Chassis K17/K18 Run 17 and Higher—Sound Circuit Modification

A 4.5MHz transistorized limiter stage, transistor Q200, has been added to the sound IF circuitry as shown in the schematic. The limiter stage increases sound performance

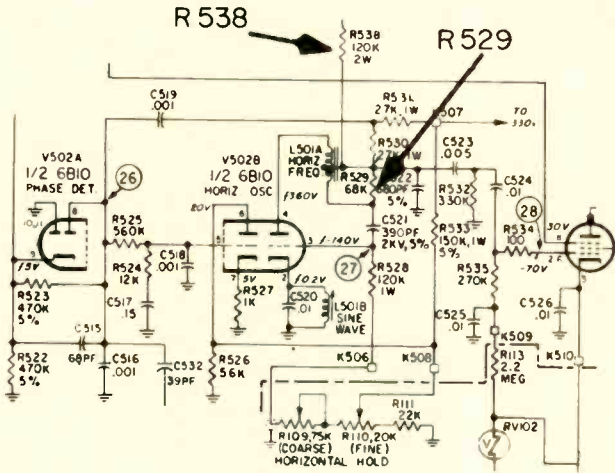

and eliminates the possibility of buzz when the TV set is operating in deep fringe areas, or from a cable system which is transmitting a relatively low amplitude of sound barrier.

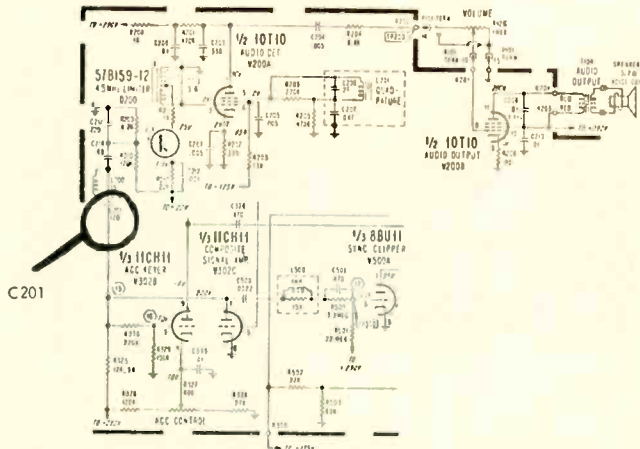

If snaking appears in the picture (video bend) with changes in contrast level, dress the orange lead (lead between resistors R538 and R529) away from the delay line. Also change capacitor C201 from 120pf to 47pf.

## MAGNAVOX

Color-TV Chassis T974/T936/T956/T957—ACC Servicing Tip

The ACC (Automatic Chroma Control) circuitry used in the T974, T936, T956 and T957 chassis are designed to monitor the station burst signal and compensate for

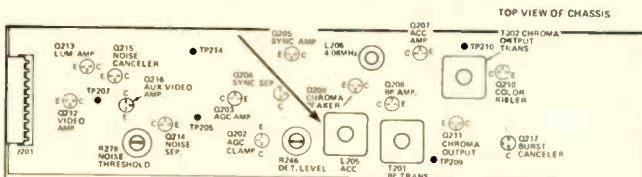

changes in chroma levels which in theory should proportionately accompany burst level changes. In practice, all stations do not maintain specified burst-chroma level relationships.

If a station transmits too high a burst, too much bias will be placed on the chroma amplifier. This could result in a no color condition on a model utilizing one of the above chassis. Initially, the indication would be saturated reds. When this condition is corrected by use of the COLOR control, the other colors drop out.

The condition can be alleviated by detuning the ACC coil, L205, on the T974 chassis or L23 on the T936, T956 or T957 chassis. The effect of the ACC action is reduced by the amount of detuning. Best performance was ob-

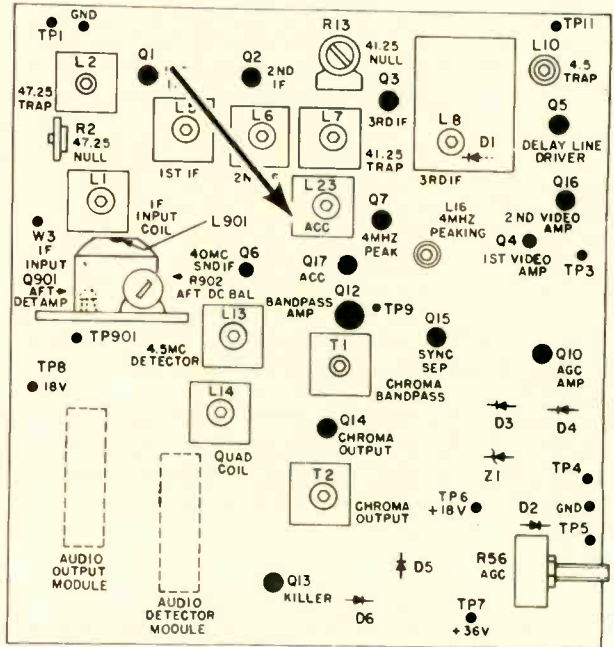

tained by turning the slug 5 to 6 complete turns clockwise (toward the board).

## Color-TV Chassis T979—Vertical Jitter

There have been reports of vertical jitter, particularly during scene changes. Engineering evaluation of the problem determined that capacitor C8 on the "D" panel was

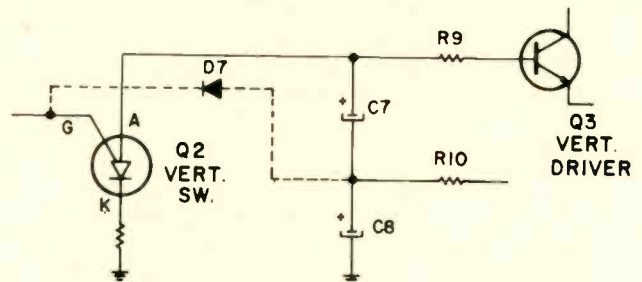

not completely discharging during the conduction time of the Vertical Switch transistor, Q2.

To eliminate the problem, a Silicon Diode, D7, was incorporated in production on all chassis after December 18, 1972. The diode is forward biased by the lowering of the gate potential when the switch conducts. This provides a low-impedance discharge path for capacitor C8 and insures the removal of any residual charge on the capacitor.

The diode, Part No. 530116-3, is available at the Magnavox Parts Centers and only this silicon device should be used in modifying early production "D" Panels.

This diode has been added on the second issue of the Magnavox factory schematic dated December, 1972.



However, the cathode of the diode is erroneously shown connected to the anode of the switch. The schematic should be corrected to show the D7 cathode connected to the gate.

#### Color-TV Chassis T979—Brightness Change

A condition of brightness change may be experienced in the T979 chassis during the first few minutes of operation. The problem occurs because Z101, an 18v zener diode, is located adjacent to high-wattage resistors. A thermal action takes place which changes the zener voltage and causes the brightness change. The problem may be eliminated by relocating Z101 to the underside of one of the "C" panel connectors. Connect the cathode of the diode to Pin 10 and the anode to the chassis ground. If the brightness continues to change over a long period of time (up to 15 minutes or so), the problem may be caused by a faulty luminance output transistor, Q4, on the "E" panel.

#### Color-TV Chassis T952—Flyback Removal

Several field reports have indicated that flyback removal is difficult in the T952 chassis because of the screws which hold the flyback in place. These two screws are driven through the flyback bracket into the PC board, necessitating removal of the screws from inside the flyback cage. Removal can be simplified by removing the high-voltage rectifier tube socket before attempting to remove the screws. The high-voltage cage does not have to be removed to change a flyback if the above procedure is used. Removal of the high-voltage socket simply requires removing two "wing nuts."

#### Color-TV Chassis T979—Failure of C12 on "C" Panel

A condition of weak or no chroma has been traced to leakage in capacitor C12, located on the "C" panel. This

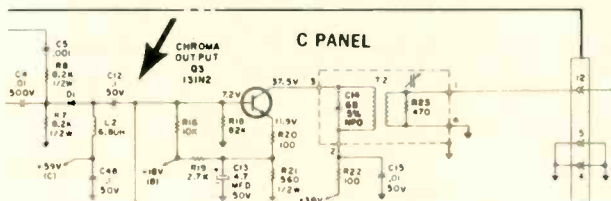

capacitor is used in the input circuit of the chroma output stage to couple the chroma signals from the COLOR control to the base of transistor Q3, while blocking the 39v dc applied to the anode of diode D1.

The suspect capacitor is a .1 $\mu$ f/50v unit manufactured by Dielectron and can be readily identified by a letter D on its body. Replacement with a .1 $\mu$ f/100v should precede any additional troubleshooting as any leakage will alter the operating voltages of transistor Q3.

#### Test Fixture Yoke Matching Transformer Kit 171266-1

A possibility exists that the 6800pf/600v capacitor, located between pins 6 and 9 on the transformer, could be damaged by heat from the 18K, 7w resistor tied between these same terminals.

To prevent possible damage, the capacitor should be relocated. This can be accomplished very quickly and easily

*continued on page 52*

# DO-IT-YOURSELF grabber



**NEW**

- Simplified Assembly
- Versatile
- Comfortable Finger Grip Action
- Completely Field Serviceable
- Molded of Tough Lexan\*

Model 3925  
Mini Test Clip  
Shown Actual Size

This test clip with gold plated hook is excellent for rapid testing of components and Wire Wrap† pins. Clip is completely insulated to point of connection. Build any combination of test leads with wire up to .090 dia. Easy and comfortable to operate. Molded of rugged Lexan to resist melting when soldering. Write for literature and prices.

#### SIMPLIFIED ASSEMBLY



Rapid assembly or replacement of damaged lead.

#### MODEL 3925

hooks onto components or slips over square Wire-Wrap pins

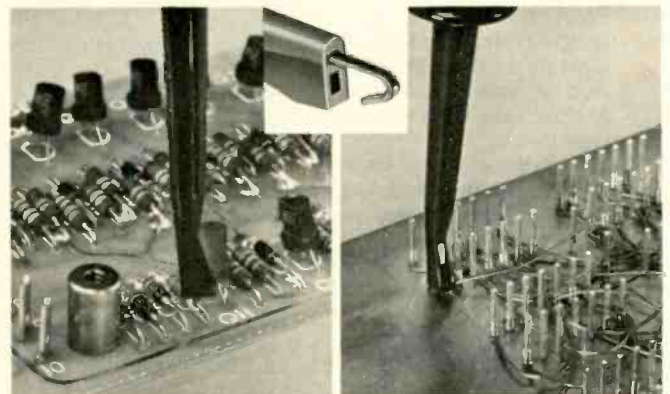

\*Lexan is a General Electric trade-mark. †Registered trade-mark of Gardner-Denver Co.



**POMONA ELECTRONICS**

A Subsidiary of ITT

1500 East Ninth St., Pomona, Calif. 91766  
Telephone (714) 623-3463

... for more details circle 124 on Reader Service Card

**NEW!**

# INSTANT CONTACT CLEANER



NO RESIDUE • NON-FLAMMABLE  
NON-TOXIC • NON-CONDUCTOR

A CHEMICALLY PURE CLEANING AGENT  
WITH:

- 1. SELECTIVE CLEANING POWER** — removes greases, oils, dirt and organic soils with no effect on the article being cleaned.
- 2. EXCELLENT PENETRATING AND WETTING ACTION** — its high density and low surface tension permits maximum penetration of most minute crevices where its superior wetting action then cleans even most difficult materials.
- 3. PURITY** — evaporates completely — leaves **NO** residue.
- 4. SAFETY** — Non-explosive, non-flammable, non-toxic.
- 5. STABILITY** — does not react chemically with other materials.

SEND FOR  
FREE SAMPLE

Available in 7 & 16 oz. aerosols  
with "Snorkel Tubes"

**LPS RESEARCH LABORATORIES, INC.**

2050 COTNER AVENUE, LOS ANGELES, CALIFORNIA 90025  
PHONE: (213) 478-0095

... for more details circle 119 on Reader Service Card

## AT LAST! PROFESSIONAL HOME PROTECTION EVERYONE CAN INSTALL AND AFFORD.

Model FC-100

WIRED **\$69.95**

- Start your custom Burglar/Hold-up/Fire Alarm System with the FC-100. Add on Sensors, Alarms and Accessories to suit your own needs.
- "Do-it-Yourself" Installers Handbook included. No technical knowledge needed — No soldering.
- 100% Professional in Design, Reliability, Performance.



**'Fail Safe'-SYSTEM BY EICO**

A New Concept in "Do-it-Yourself" Home Protection

### FREE 32 PAGE EICO CATALOG

For latest catalog on EICO Test Instruments, Stereo, EICOCRAFT Projects, Environmental Lighting, Burglar/Fire Alarm Systems, and name of nearest EICO Distributor, check Reader Service Card or send 25¢ for First Class mail service.

EICO, 283 Malta Street, Brooklyn, N.Y. 11207



... for more details circle 109 on Reader Service Card

## COLORFAX...

*continued from page 51*

by unsoldering the leads of the capacitor and mounting it behind the board. The leads can be passed through the existing terminal holes and reconnected. Kits in current production are incorporating this change.

In the event the capacitor has already been damaged, a replacement can be ordered under part number 250590-6820.

### RCA SALES CORP.

UHF Traps

In areas where one or more of the lower UHF channels are received at an exceptionally high level resulting in AGC overload or interference, a UHF trap may be helpful in attenuating the signal. A trap cut for a particular chan-

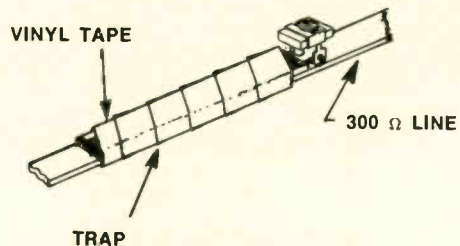
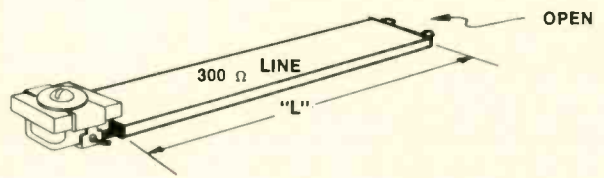

nel can be positioned on the 300Ω lead-in near the antenn terminals. This trap should be moved and retuned until the optimum position along the lead-in is found. Secure the trap by taping along its entire length with vinyl tape.

UHF traps can be easily made by cutting the Stock No. 78818 FM Trap to a specific length as noted below:

UHF Channel	"L" Inches	UHF Channel	"L" Inches
14-15	4 $\frac{3}{8}$ in.	25-26	3 $\frac{5}{8}$ in.
16-17	4 $\frac{1}{4}$ in.	27-28	3 $\frac{1}{2}$ in.
18	4 $\frac{1}{8}$ in.	29-30	3 $\frac{3}{8}$ in.
19-20	4 in.	31	3 $\frac{1}{4}$ in.
21-22	3 $\frac{7}{8}$ in.	32-33	3 $\frac{1}{8}$ in.
23-24	3 $\frac{3}{4}$ in.		

### Picture Tube 21VAKP22 Grounding Clip

Some versions of the 21VAKP22 picture tube utilize a metalized tape which completely surrounds the tube in the area just behind the screen. TV sets built with this version of the 21VAKP22 have a special spring clip installed between the metalized tape and one of the picture tube mounting hooks.

Whenever this version of the 21VAKP22 is used in a TV set, whether original equipment or a replacement, this spring clip must be installed in order to ensure a positive ground return path for the tape, thus preventing the possibility of symptoms such as corona or high-voltage leakage in the area of the face plate.

The spring clip is the same as the chassis-to-rear cover retaining clip used on RCA color-TV sets for several years. The clip Stock No. is 78324, Drawing No. 938283-1.

## NEW PRODUCTS

For additional information on products described in this section, circle the numbers on Reader Service Card. Requests will be handled promptly.

### SUB-CHANNEL MODULATOR

*Ideal for CCTV origination in MATV systems* **703**

A new sub-channel version of their recently developed Uni-Mod TV modulator is completely solid state and said to be notable for reliability and low cost. It reportedly accepts audio and video inputs and uses them to produce a complete 6MHz TV channel at

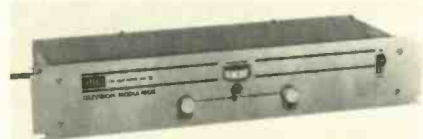

any of six sub-channel frequencies. Said to be capable of handling color or monochrome, the new units employ crystal controlled visual carriers. Adjacent channel operation is reportedly made possible by unique helical resonator bandpass filters. Flat video response, together with low differential gain and phase are said to provide excellent picture and sound quality. A front panel meter, which can be switched to read audio or video, makes it easy to adjust for the proper modulation percentage. A backlighted ON/OFF switch indicates the operational status of the unit at a glance. Sub-channel units can be mounted on any desk top cart or shelf. They occupy only 3½ in. of 19 in. rack space. Jerrold Electronics Corp.

### SPEAKER

*Phasing rings smooth frequency responses* **704**

A 15-in., two-element, coaxial speaker, Model 5A445, includes phasing rings that are designed to smooth out its frequency responses. These



rings reportedly correct for a phase difference caused by the positioning of the low- and high-frequency cones at two locations along the speaker axis.

They also reportedly improve dispersion, extending coverage without sacrificing proper sound distribution. The speaker is rated at 50w and is said to be equipped with a 3-in. diameter low-frequency voice coil operating in an intense magnetic field created by a 100-oz magnet to handle peaks several times greater than the unit's normal power rating. The speaker also reportedly features built-in crossover networks and roll-damped, curvilinear cones treated to resist moisture. Dukane Corp.

### EMERGENCY DIALER

*Used in conjunction with burglar and/or fire-alarm systems* **705**

An automatic dual-track emergency dialer is said to include an integrated circuit audio amplifier and a new multi-purpose switching relay. Called "AcroLarm" the basic L700D Model is used in conjunction with burglar and/or fire alarm systems to offer technical advances to supply every modern



emergency dialing system advantage, plus add-on capabilities. Features reportedly include an exclusive tape deck cartridge with a 3M tape that never needs threading or installer handling, along with an option list that describes a supervised "burg" loop control module, a power supply, a rechargeable battery, a U.L. approved transformer, and an entrance delay module and "listen-in" verifier. Acron Corp.

### SECURITY SYSTEM

*Single sensor can cover approximately 100 sq ft* **706**

A security system has been designed to employ solid-state sensors which are attached to any floor beam, joist or riser. A very slight amount of flexure is detected by the solid-state transduc-

er, and the resulting signal is fed back to an amplifier signal processor, which trips an alarm relay. The sensors are epoxied to the structural member



and are reportedly unaffected by temperature or moisture and will not trigger on vibrations caused by outside noises and traffic. The associated signal processing amplifier has a sensitivity control which can be adjusted so that the sensors will trip only if a predetermined weight is exerted. Delectron Security Systems, Incorp.

### TELESCOPING ANTENNA MAST

*Stronger than high-carbon masting of the same gauge* **707**

A new telescoping antenna mast is reportedly constructed of a special-strength "Golden Duratube" process steel. Also featured are new contour guy rings to eliminate sharp, wire-fraying edges. Previously available only in straight 5- and 10-ft lengths, it now is available in 20-, 30-, 40- and 50-ft telescoping lengths. The special process steel is said to be bonded inside and out with oxide primer and is then over-coated with a tough, golden acrylic finish. The contour guy rings, resembling inverted saucers, are

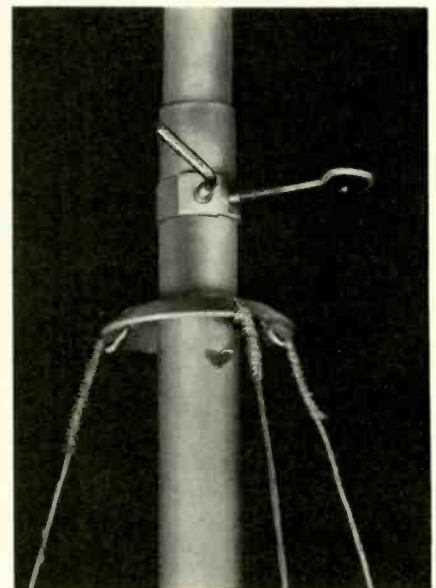

made of aluminum. They rest on the swaged shoulder of the mast and reportedly cannot ride up or bind the adjacent telescoping sections. Channel Master.

*continued on page 54*

## NEW PRODUCTS...

continued from page 53

### NIGHT VIEWING DEVICE 708

*Ideal for undetectable night observation*

Introduced is a night viewing device which reportedly allows an observer to see at night as if it were daylight by amplifying light to generate a clear bright picture with minimal illumination. The device is reportedly so sensitive that starlight alone supplies sufficient illumination for effective operation. Even the light the image

produces is trapped by a proprietary eyepiece design that will not allow

light to leak out onto the face of the observer. Accessory adapters allow the device to be attached to ITV cameras,



and they can also be attached to 16mm and 35mm motion picture cameras. Apollo Lasers, Inc.

### MINIATURE HAND TOOLS 709

*Low-cost tools for miniature work*

A Tinitool Kit, No. 030, is introduced containing three different miniature hand tools—a straight scribe, triangular scraper and a bent prober.

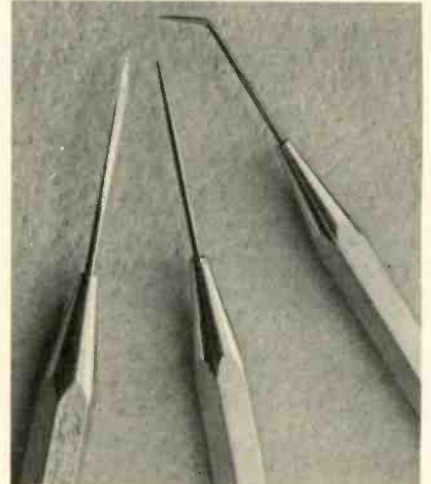

The tools are reportedly made from 1/32 in. diameter oiled hardened tool steel and nickel plated. The handles are 4-in. long non-rolling hexagonal aluminum. minitool.

### WELDING TORCH 710

*Produces a flame temperature of 5000°F*

A miniature self-contained welding torch has been introduced which is said to produce a flame temperature of 5000°F. It is reportedly designed for welding, brazing, or soldering small items made of copper, steel, stainless steel, brass, bronze, aluminum and zinc base alloy as well as noble and rare metals. Said to be held easily



and comfortably in the hand, the Microflame torch produces the high-temperature flame using miniature cylinders of LP gas and Micronox. The size and heat of the flame can be adjusted with the needle valves. Gas consumption is also controlled by valve opening and tip size. The cylin-

## As fast as you get 'em we help you fix 'em

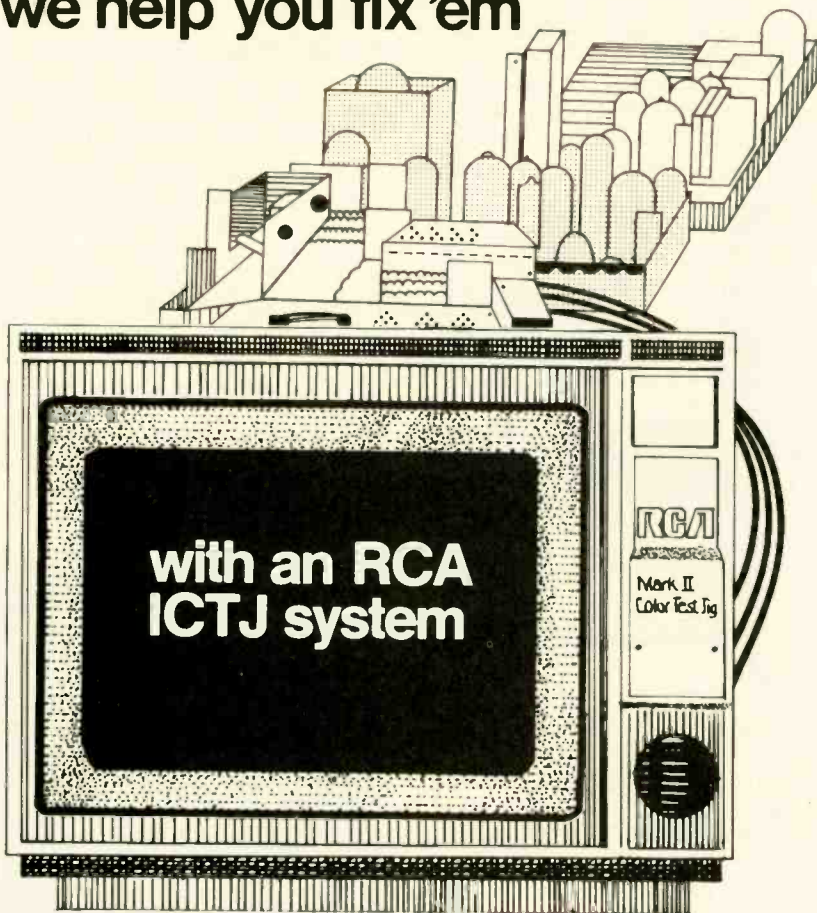

Sound like the TV serviceman's dream? It is. RCA's Industry Compatible Test Jig is a complete testing system that lets you service almost all color TV console chassis on the market—and updates you as new ones come along.

Here's how: The RCA ICTJ system includes the test jig itself (in bench or portable models), plus a handy cross-reference manual that specifies the right adaptors for each set. Choose from more than 100 adaptors and cables available (optional extra) to meet your needs. But most important, as the new models need service, you'll be kept up to date with new inserts for the manual and any necessary new adaptors will be made available. So whatever's coming, you'll be ready.

See your RCA Parts and Accessories distributor today for full information.

Parts and Accessories, Deptford, New Jersey 08096

# RCA

... for more details circle 127 on Reader Service Card

ders can be individually shut off and replaced independently of each other. The miniature gas welding torch reportedly comes complete with torch, flame tips, torch tube, gaskets, gas supply and instructions. Microflame, Inc.

## SHOP ORGANIZER 711

*Designed with the technician in mind*

The Kole Shop Organizer is said to contain 24 popular No. 4 bins. The complete outer shell and every shelf is reportedly constructed of double-layered 200-lb test corrugated fiberboard. In addition, there are two

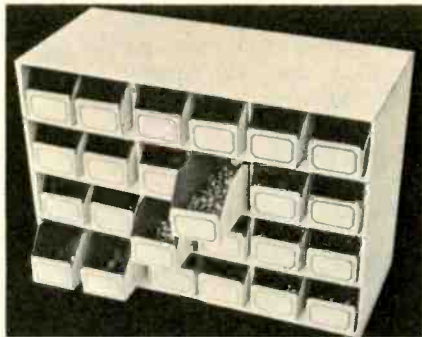

double layered vertical supports on each level of shelves. The unit is designed for stocking on top and along side one another and is available in mottled white only. Kole Enterprises, Inc.

## SINGLE-CHANNEL UHF PREAMPLIFIER 712

*Designed for CATV use*

A complete line of UHF preamplifiers, designated as the SCMA-U series, are available for use on Channels 14 through 70. Typical noise figures for the preamplifiers are reportedly 3.5dB for all channels from 14 through 50 with a guaranteed maximum not exceeding 4.0dB; and

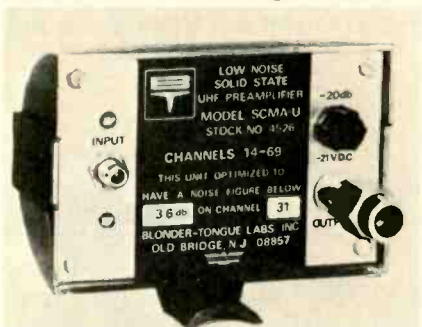

4.5dB for channels 51 through 70, with maximum guaranteed not to exceed 5.0dB. Minimum gain of each preamplifier is rated at 22dB for any of the available channels. They will reportedly operate within rated speci-

fications over a temperature range from  $-40^{\circ}\text{F}$  to  $+140^{\circ}\text{F}$  and total current requirement is only 60ma. The entire solid-state circuit is powered by  $-21\text{v}$ , which can be readily duplexed on the signal cable. The unit is housed in an aluminum casting measuring 3 in. by 5 in. by 2 in. Blonder-Tongue Laboratories.

## INTRUSION ALARM 713

*Operates with open-switch and closed-loop circuits*

Introduced is an intrusion alarm called "Protection Pal" that includes trigger action with both open-switch and closed-loop circuits. Phone jacks

are used for circuit outlets and a lantern-size 6v battery will reportedly operate the unit for a year. This system has a built-in panic button, or this button can be wired to any location in the home with a nearly invisible flat adhesive wire available in colors to match your decor. The unit incorporates a built-in siren, but it will also blow a horn, or turn on lights or other devices powered by house current. The unit measures  $1\frac{3}{4}$  in. by  $2\frac{3}{4}$  in. by 4 in. Noel's Electronics.

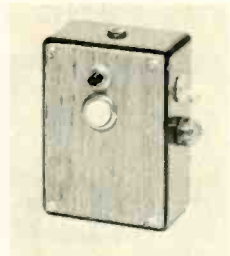

RCA's XL-100 Components Kit....

# The portable repair shop expander

that improves your in-home service capabilities.

It's especially designed with 27 necessary components to be a perfect companion to RCA's Color TV Module Caddy. In fact, it fits right into a special compartment provided in the caddy.

The components kit contains resistors, transistors, diodes, fuses, a circuit-breaker and a tube of heat sink compound. And when you carry them with the RCA Module Caddy's 11 modules, it's like bringing

your shop right to your customer's set. It also helps minimize reschedules and call-backs. No matter how you look at it, the components kit is a must for every professional TV technician. For more information, see your local RCA Distributor or fill out the coupon and mail it today. RCA Parts and Accessories will send you complete details on these essential kits, with no obligation.

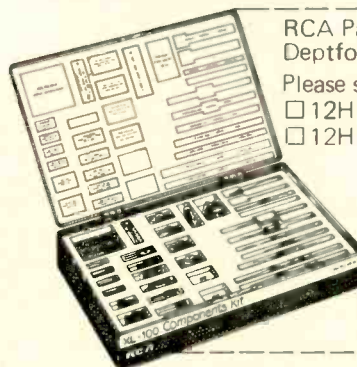

RCA Parts and Accessories, P.O. Box 100  
Deptford, N.J. 08096

Please send information on: (check one or both)

- 12H190 Module Caddy
- 12H195 Components Kit

Name \_\_\_\_\_

Address \_\_\_\_\_

City \_\_\_\_\_ State \_\_\_\_\_

Zip \_\_\_\_\_

**RCA**

... for more details circle 128 on Reader Service Card

## REBUILD YOUR OWN PICTURE TUBES?

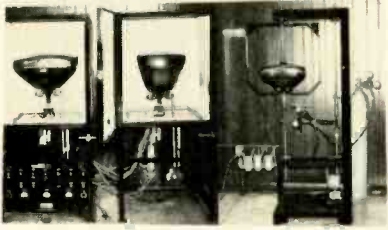

With the Lakeside Industries, Inc. picture tube rebuilding unit, you can rebuild any picture tube, be it black and white or color or 20mm or etc. We offer you the most revolutionized equipment of our modern times. This unit is easy to operate and requires only 4 x 8 ft. of space. You can rebuild the finest tube available. The picture will be clear and sharp. Your cost to rebuild a color tube is approx. \$6.60. Your cost to rebuild a black and white tube is approx. \$1.85.

Profit? Imagine building four color tubes per day and if you sold these tubes for \$60.00 each. Total income \$240.00. Total cost \$26.40. Net profit \$213.60. Multiply this figure by five days per week. Your profit \$1,068.00 per week. Cut this figure in half! Build and sell only two color tubes per day. Your profit \$534.00 per week. Facts are facts, figures do not lie.

For further information, please send your name and address to Lakeside Industries, Inc., 3520 West Fullerton, Chicago, Ill. 60647. Phone: (312) 342-3399.

P.S. No salesman will call.

... for more details circle 120 on Reader Service Card

## ANTUL ANTENNA PRODUCTS

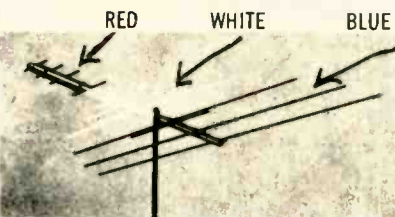

Model 3240-P—\$19.00

### Featuring OVER 20 COLORS

- Exclusive ANTUL —Antulized Antennas
- T.V. Antennas—custom colored in many colors Antulized
- Antenna Mounting Hardware
- Pre-assembled Chimney Mounts
- Tools
- Staple Gun
- Tars and Caulking
- Anchor Bolts for Towers
- Signs
- Fishing Wires
- Clamps, Mounts, Nails
- Drill Bits, etc.

**NEW** Metropolitan area antenna in "camouflage" three shades of green to blend with trees. Model 3230-C—\$19.00

FM stereo all-directional antenna in patriotic red, white and blue. Model 3400-P—\$7.50

**SEND FOR OUR FREE CATALOG**

3549 N. ELSTON AVE., CHICAGO, ILL. 60618  
312-463-4428

... for more details circle 102 on Reader Service Card

## DEALER SHOWCASE

For additional information on products described in this section, circle the numbers on Reader Service Card. Requests will be handled promptly.

### FOUR-CHANNEL CONVERSION SYSTEM 714

Can be used to select four different sonic effects

A Quasi-Quad four-channel conversion system is designed with a passive matrix enhancer and packaged with two rear-channel speakers. Reportedly designed to be connected to

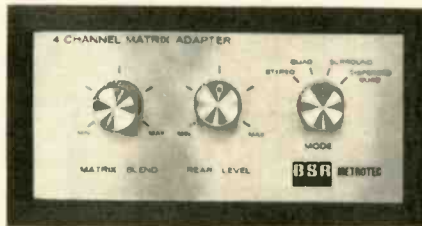

the speaker terminals of any stereo system, the adapter has controls to adjust matrix blend and rear speaker loudness, and to select four different sonic effects to suit different kinds of music and personal taste. The system will reportedly play any four-channel matrix sound source, and also enhance normal stereo records, tapes and FM broadcasts by synthesizing a four-channel effect. BSR.

### TURNTABLE 715

Designed to exceed broadcast specifications

The Connoisseur BD/2 transcription turntable reportedly provides performance abilities exceeding broadcast specifications for hum, rumble, wow



and flutter. The unit has the following manufacturers specifications: Hum Level: -80dB; Rumble: -60dB and less than 0.1% wow and flutter. The SAU2-type arm is said to be a sleek yet strong pick-up arm that features a damped hydraulic lifting and lowering device to provide maximum protection for the stylus and record. Other features include: Bias Compensator which corrects for possible skating ef-

fect, Gimbals set at 45/45° and a 60Hz synchronous constant speed 450 rpm drive motor. Hervic Electronics, Inc.

### PORTABLE TV SET 716

Weights 5.3 lb and will operate on nine "D" cell batteries

A new lightweight, portable TV set is designed to play virtually anywhere, utilizing three choices of power. Indoors, it runs off regular ac current. Outdoors, it runs on nine "D" cell batteries or the car battery. Outstanding design features of the TV set reportedly include: electric contactless tuning AGC, plus a sensitive extra long built-in rod antenna for VHF reception and an equally sensitive UHF loop antenna, both supplied as



standard equipment. The TV set is said to weigh 5.3 lb without batteries and measures 8 21/32 in. high by 8 21/32 in. wide by 10 7/16 in. deep. It is available in two color combinations: red and white or blue and white. JVC America, Inc.

### EIGHT-TRACK TAPE PLAYER 717

Self-contained unit for minimum space

A completely self-contained stereo eight-track tape player, Model 717K, is designed to provide the car owner with the maximum in stereo sound while using the smallest amount of space. The unit can reportedly be in-



stalled in any make of car. It is said to be small enough to fit in the glove

compartment and has 16w output for maximum stereo sound, plus ITL and OTL circuits for minimized distortion and stable sound. The Weltron Co.

## ALIGNMENT TAPE 718

Designed for all 1/4-in. reel-to-reel systems

The AT-120 alignment tape is designed for all 1/4-in., reel-to-reel recorder/players. It is said to be a professional quality, 7.5 ips, full-track master recording with equalization and levels in accordance with NAB standards. The tape reportedly features all the tones necessary to maintain optimum recorder performance

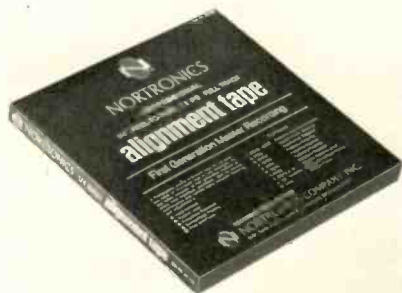

by verifying essential operating parameters including head azimuth, recording level, frequency response, tape speed and drive flutter. Nortronics Co., Inc.

## STEREO HEADPHONES 719

Full high- and low-end high-fidelity sound

A set of lightweight stereo headphones, Model SH-850, is said to feature full high- and low-end high-fidelity stereo sound, fully adjustable dual



crown band, soft sound chamber cushioner and a tangle-proof expander cord. Lear Jet Stereo Inc.

# DISCOUNT PRICES

## RAYTHEON TUBES

5 6BA11	\$4.95
5 12GE5	4.95
5 6HB7 (Admiral)	4.50
25 I.R. 2.5 AMP.—1000 Plv.	3.95
10 I.R. DD04 Diodes	2.98
10 I.R. DD05 Diodes	2.98
Zenith voltage triplers 212-109	6.95
Zenith color demods 221-45	2.95
5 Color CRT Harness	1.00
10 HV Anode Leads B/W	1.00
20 Assorted Astatic Needles	3.29
100 Assorted By-Pass Cond.	4.98
Blue Lateral Magnets—2 for	2.98
20 Assorted Mallory Controls	2.00
5 1 Meg. Vol. Contr.—on/off SW	1.19
100 MFD. 150 Volts—Axial—12 for	1.98
500 MFD. 25 Volts (P.C.)—5 for	1.00

### COLOR YOKES

Motorola 24D68592B01	5.95
Silvertone 80-56-46	4.95
Magnavox 361395	5.95

### COLOR FLYBACKS

Emerson 738229A	6.95
Emerson 738223	6.95
RCA 143536-501	7.95
RCA 14353637-501	7.95

MINIMUM ORDER \$15.00  
SEND FOR FREE CATALOG  
TUBES UP TO 80% OFF

SEND CHECK OR MONEY ORDER

## TV TECH SPECIALS

P.O. BOX 603

Kings Park, L.I., New York 11754

... for more details circle 130 on Reader Service Card

# SPRAY AWAY THE RACKET.



Squeak. Whine. Whirr. Psss! Silence. Quietrole did it again. Silenced those moving T.V. parts, with one squirt from the handy spray pack. Cleaned away dirt, dust, and crud. Without damaging anything... in any black and white or color set. Silence is golden. So is Quietrole.

Also available in bottles, and the new Silicone—"Silitron."



Product of **QUIETROLE**

COMPANY

Spartanburg, South Carolina

... for more details circle 126 on Reader Service Card

# Pix-Mate™

## the crt tester

### you can afford to take along

only ... \$34.95

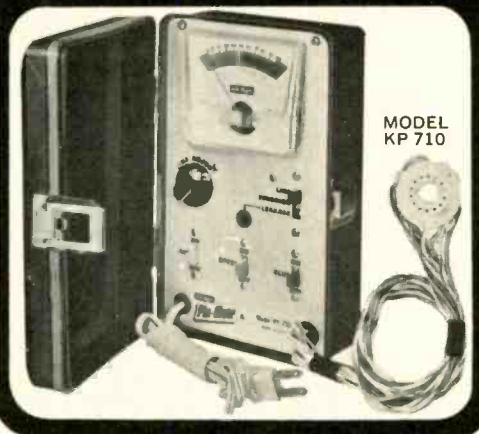

- A quality CRT tester with individual test for each gun.
- Compare guns for emission.
  - Test for leakage and shorts.
  - Legible 3 color scale.
  - Compact, portable, rugged.
  - Avoid recalls, check the CRT on every call.

WRITE US!

# TeleMatic

take along the time savers

- PIX-MATE • CRY-S-MATE • GEN-MATE
- SOUND-MATE • TRACE-MATE

The Caddy-Mate Line.

2245 PITKIN AVE., BROOKLYN, N. Y. 11207

... for more details circle 132 on Reader Service Card

# FLYING SAUCERS...

continued from page 38

evaluation of this antenna system, we disconnected the 75Ω cable from the coupler and connected it to a battery-powered field-strength meter. This meter was then tuned for a maximum video-signal and then maximum audio-signal readings for each of the four channels, holding it at each frequency as the antenna was rotated. The resulting readings were then logged against the direction of the antenna, as indicated by the rotator control. Al-

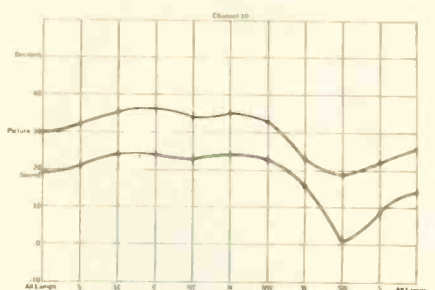
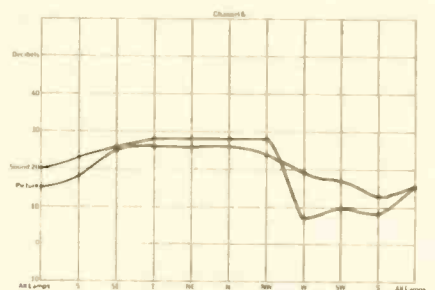
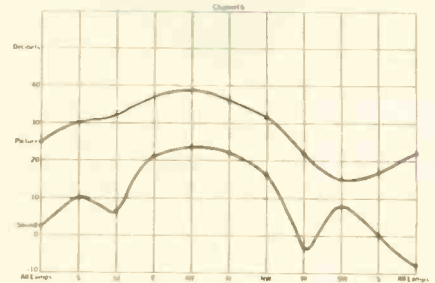
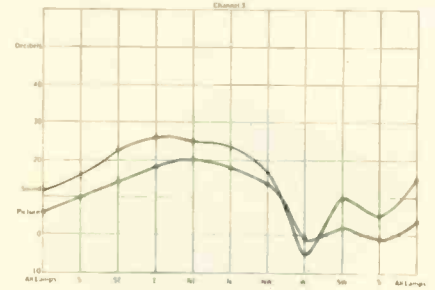

Graphs indicating the relative sensitivity of the antenna system to various VHF frequency transmitters as it is rotated. Although the antenna is designed for a sensitivity that is within 2dB of being flat, plus a 34dB null depth, these characteristics appear distorted as direct-reception TV signals inter-react with reflected signals. (The rotator-control lamps would seem to indicate that the antenna rotates more than 360°, while actually it is slightly less.)

# HOW DOES GEORGE DO IT?

\* 3 IN A SERIES

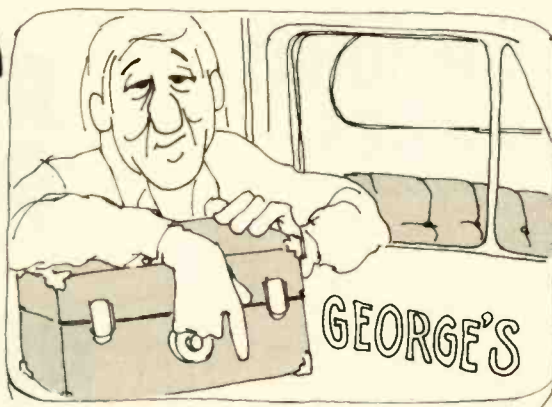

IN EVERY GROUP OF TECHNICIANS, THERE'S A "GEORGE" WHO ALWAYS SEEMS TO EARN A LITTLE MORE THAN THE REST OF US--SOMETIMES EVEN WITH SHORTER HOURS TO HELP EVERY TECHNICIAN MAKE THE MOST OF HIS TIME, HERE'S "HOW GEORGE DOES IT!"

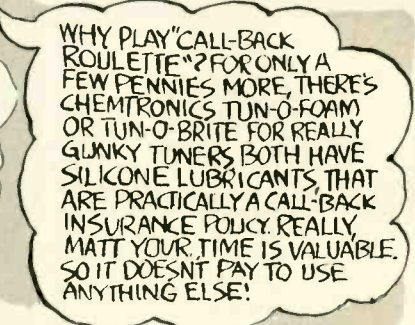
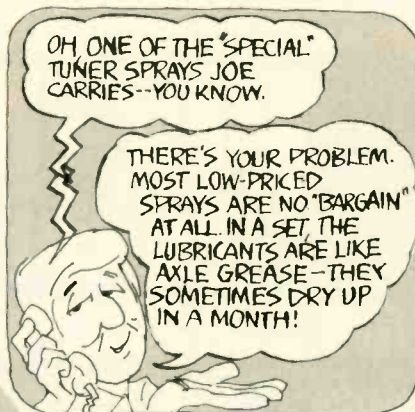
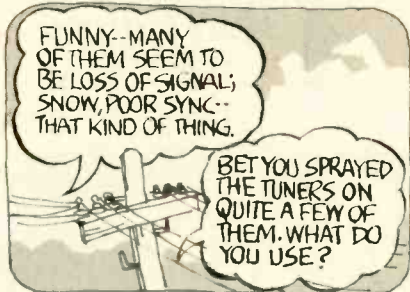

WHY LET GEORGE DO IT? DO IT YOURSELF WITH TUN-O-FOAM TUN-O-BRITE TWO CHEMTRONICS CHEMICAL PROBLEM-SOLVERS THAT SAVE YOU TIME AND MONEY.

SEND FOR OUR FREE PROBLEM-SOLVING BROCHURE AND CATALOG.

# CHEMTRONICS INCORPORATED

1260 RALPH AVENUE, BROOKLYN, NEW YORK, 11236, OUR BUSINESS IS IMPROVING YOURS

... for more details circle 106 on Reader Service Card



though it is readily admitted that the resulting data was taken under anything but laboratory conditions and is extremely rough, at least it does provide a graphical illustration of the relatively high directivity of this antenna system. ■

## TEKLAB...

*continued from page 30*

deflection yoke with horizontal scanning currents, develops the high voltage for the second anode of the picture tube, and develops an 800v boost voltage for use with the screen controls to establish the proper voltages on the picture tube screen grids. The auxiliary windings supply pulses to the AGC, AFC, chroma search and convergence circuits.

The horizontal output transistor, Q302, acts as a switch which is turned ON and OFF by the rectangular waveform applied to its base. When the transistor is turned ON, the beam is moved from near the center of the screen to the right side. The transistor is turned OFF during retrace time and during the time the left side of the screen is scanned.

The positive pulse developed during retrace is stepped up by the horizontal output transformer and coupled to the high-voltage tripler/rectifier. The output of this module is 25.5kv, which is applied to the second anode of the picture tube. This tripler/rectifier also produces 5.6kv which is used as a focus voltage. The high-voltage adjustment is accomplished by adjusting the regulated 115v supply voltage while taking a measurement at the picture tube with a high-voltage probe.

The 800v positive pulse appearing at the collector of transistor

Q302 is rectified by diode D303 to produce the boost voltage necessary for the picture tube screen grids.

### Power Supply

The transformer driven power supply provides six dc voltages, one of which is regulated, plus a 6.3v ac supply for the picture tube filament. This filament winding is elevated to 130v dc above ground to reduce the voltage difference between cathode and filament in the picture tube, minimizing the possibility of arc-over. A negative temperature coefficient thermistor, RV201, limits surge current in the 115v and 130v supplies during initial turn-on.

Two special features are incorporated into the power supply. They are the Color Purifier (automatic degaussing system) and Quick-On circuits. A line tap switch is not used in this chassis, which will reportedly operate without line voltage compensation at any extremes normally encountered.

### Summary

We feel that the design and layout of this chassis will not only shorten service time but will allow more of the service work to be done in the home. The panels are easily removed and most of the transistors are placed in sockets, allowing for troubleshooting by substitution of the panel or individual components.

A transistor/diode module kit is available and includes a service booklet for use with the T979 chassis. The information contained in the booklet includes in-home service adjustments, panel layouts and signal flow diagrams. Also included are troubleshooting charts which are of great help in locating faulty transistors, modules and diodes. ■

# FINCO

## Handy-Helper DOLLY

For MOVING and LIFTING

• TV • APPLIANCES • FURNITURE • LARGE CARTONS

Model TC-1 DEALER NET **\$89.50**  
WRITE FOR CATALOG 20-621

### The FINNEY Co.

34 West Interstate Street  
Bedford, Ohio 44146

... for more details circle 111 on Reader Service Card

RADIOMETER COPENHAGEN

# stereo generator

Exceptionally stable and complete stereo signals with push button selection of all combinations.

- World famous Model SMG1
- Both composite and RF outputs.
- Extremely low distortion.
- Excellent channel separation throughout audio range.

Price \$ 1195

**THE LONDON COMPANY**  
811 SHARON DRIVE  
CLEVELAND, OHIO 44145  
Tel. (216) 871-8900

221D

# CORNELL ELECTRONICS COMPANY

4213 N. UNIVERSITY AVE. SAN DIEGO CALIF. 92105

THE ORIGINAL HOME OF

# 36¢

PER TUBE  
UNLESS OTHERWISE PRICED  
100 TUBES OR MORE  
33¢ PER TUBE

ONE YEAR GUARANTEE  
INDIVIDUALLY BOXED  
5 DAY MONEY BACK OFFER  
LAB TESTED USED

Same Low Price East or West Coast!

- ★ Bargain Tools
- ★ Transistor Tester
- ★ Technician's Library

SEND FOR FREE NEW 48 PAGE COLOR CATALOG

- ★ Dumont Picture Tubes
- ★ Diodes—Transistors—Kits
- ★ Tube Cartons

**SPECIAL OFFER**  
ON ALL ORDERS OVER \$10.00

# 25¢

PER TUBE (NO LIMIT)  
FROM THIS LIST

6AG5	6CB6
6AU6	6J6
6AX4	6SN7

**Your Order FREE if Not Shipped in 24 Hours**

... for more details circle 107 on Reader Service Card

# MOLDED PLASTIC COLOR CODED AMP FUSES

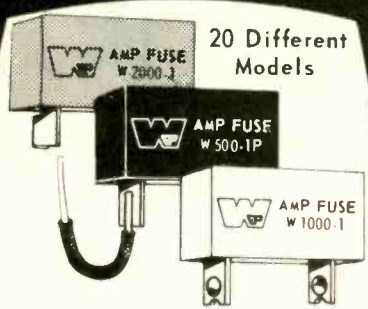

Reliable protective fusing device for replacement of original manufacturer's part numbers.

Listed in Howard Sams' Photo-facts and Counterfacts.

FREE vest pocket cross reference booklet indicating correct Workman part numbers to manufacturer's part numbers. No. X58

MANUFACTURED BY  
**WORKMAN** Electronic  
Subsidiary of IPM TECHNOLOGY INC.  
BOX 3828 SARASOTA, FLA. 33578

... for more details circle 136 on Reader Service Card

# TUNE-IN

on these TOP-RATED  
"NO-NOISE" PRODUCTS

PROVEN PERFORMANCE FOR COLOR AND B/W

**FIRST**, simply spray parts with  
**SUPER SPRAY BATH**.  
Dissolve and flush away grease, dirt,  
oil and oxidation—penetrative action  
cleans and restores all component  
parts.



**THEN**, follow with  
**VOLUME CONTROL AND  
CONTACT RESTORER**

for special attention to volume controls,  
push button assemblies, band  
switches, relays and other electrical  
contacts.



"NO-NOISE"  
products are  
guaranteed non-  
flammable, no  
carbon tet, non-  
toxic -- safe for  
plastics.

For Tuners  
(Incl. wafer type) use  
**TUNER TONIC**  
With Perma Film  
**OR SUPER LUBE**  
for further  
cleaning and lubrication -  
economical, a little does a lot.



Other Famous "NO-NOISE" Products  
• EC-44 • Frigid-Air  
• Tape-Recd Head Cleaner

Often imitated but never duplicated  
**ELECTRONIC CHEMICAL CORP.**  
813 Communipaw Avenue Jersey City, N. J. 07304

... for more details circle 110 on Reader Service Card

## READERS SERVICE INDEX

### ADVERTISER'S INDEX

101	Antennacraft	14
102	Antul Antenna	56
103	B & K Division, Dynascan Corp.	6
104	Bele Electronics	60
105	Book Club—Tab Books	34-37
106	Chemtronics	58
107	Cornell Electronics	59
108	Delta Products, Inc.	23
109	Eico Electronic Instruments Co., Inc.	52
110	Electronic Chemical Corp.	60
111	The Finney Company	59
112	John Fluke Manufacturing	49
113	Fordham Radio Supply Co., Inc.	60
	GTE Sylvania, Consumer Renewal	5, 19
	General Electric Company	11
114	Griffith's Electronic	15
115	Heath Company, The	10
116	International Rectifier Corp.	12
117	Jensen Tools & Alloys	60
118	Kay-Townes, Inc.	22
119	LPS Research Labs	52
120	Lakeside Industries	56
121	Leader Instruments Corporation	13
122	London Co., The	59
123	Mountain West Alarm Supply Co.	60
	Panasonic	3rd Cover
124	Pomona Electronics	51
125	Precision Tuner Service	21
126	Quietrole Company	57
127	RCA Parts & Accessories	54
128	RCA Parts & Accessories	55
	RCA Electronic Components	16
129	Sprague Products Company	9
130	TV Tech Aid	57
131	Telextronix, Inc.	26
132	Telematic Div., UXL Corp.	57
133	Triplet Corporation	4th Cover
134	Tuner Service Corporation	3
135	Winegard Company	17
136	Workman Electronic Products, Inc.	60
137	Yeats Appliance Dolly Sales Co.	60
	Zenith Radio Corporation	2nd Cover
	Zenith Radio Corporation	24-25

### NEW PRODUCTS

700	Transistor Noise and Frequency Tester	18
701	Cartridge Alignment Tape	18
702	Digital Multimeter	18
703	Sub-Channel Modulator	53
704	Speaker	53
705	Emergency Dialer	53
706	Security System	53
707	Telescoping Antenna Mast	53
708	Night Viewing Device	54
709	Miniature Hand Tools	54
710	Welding Torch	54
711	Shop Organizer	55
712	Single-Channel UHF Preamplifier	55
713	Intrusion Alarm	55
714	Four-Channel Conversion System	56
715	Turntable	56
716	Portable TV Set	56
717	Stereo Headphones	56

### TEST INSTRUMENT

900	hm electronics' Model HM-310 VOM/Transistor Tester	47
-----	---	----

## DISCOUNT PRICES

## TEST EQUIPMENT



**Mullard Tubes Specials  
Catalog & Prices on Request**

**FORDHAM** Radio Supply  
Company, Inc.



558 Morris Avenue, Bronx, N.Y.  
Tel: (212) 585-0330

**RCA**

**DISTRIBUTORS OF ELECTRONIC SUPPLIES**

... for more details circle 113 on Reader Service Card

## COLOR CONVERTER FOR BLACK AND WHITE TELEVISION

Also television projector system. Both will be sold on a kit form. Completely electronic. Good opportunity to join electronics and research laboratory. Applicants may enjoy future distributor privileges. Write for free brochure. Bele Electronics Corp., P.O. Box 416, Dept. 17, Hialeah, Florida 33010.

... for more details circle 104 on Reader Service Card

## FREE ALARM CATALOG

Full line of professional burglar and fire alarm systems and supplies. 80 pages, 400 items. Off-the shelf delivery, quantity prices.



**mountain west alarm**  
4215 n. 16th st., phoenix, az. 85016

... for more details circle 123 on Reader Service Card

## FREE CATALOG

**HARD-TO-FIND PRECISION TOOLS**

Lists more than 1700 items—pliers, tweezers, wire strippers, vacuum systems, relay tools, optical equipment, tool kits and cases. Also includes four pages of useful "Tool Tips" to aid in tool selection.



**JENSEN TOOLS**  
4117 N. 44th Street, Phoenix, Ariz. 85018

... for more details circle 117 on Reader Service Card

## YEATS dollies

**FURNITURE PADS** \$6.00 EACH

**YEATS PLATFORM DOLLY** \$24.95

**ROLLS UP & DOWN STAIRS**

**YEATS dollies**  
1307 W. FOND DU LAC AVE.  
MILWAUKEE, WIS. 53205

YEATS Model No. 5 \$78.50

... for more details circle 137 on Reader Service Card

# ELECTRONIC TECHNICIAN/DEALER TEKFAX

COMPLETE MANUFACTURER'S CIRCUIT DIAGRAMS  
AND TECHNICAL INFORMATION FOR 5 NEW SETS

# 1473 GENERAL ELECTRIC TV Chassis 12SE/15SE/S3

JUNE • 1973

GROUP  
**250**

	SCHEMATIC NO.		SCHEMATIC NO.
AIRLINE	1477	MAGNAVOX	1476
TV Model GA1-11253A/B		Color TV Chassis T979	
GENERAL ELECTRIC	1473	PHILCO-FORD	1475
TV Chassis 12SE/15SE/S3		Color-TV Chassis 3CR40/41	
GENERAL ELECTRIC	1474		
Color-TV Chassis KE-11/EB			

SYMBOL	DESCRIPTION	GENERAL ELECTRIC PART NO.	
R401	5, 5w, 5%, fuse resistor	ES14X28	
	triple control	ES49X2	
R205	1.2M, vert hold		
R206	500K, height		
R209	2M, vert lin.		
	triple control	ES49X10	
R164	25K, contrast	(Short Shafts)	
R167	200K, brightness	(Long Shafts)	
R309	1.5M, volume w/S401		
	triple control	ES49X4	
R164	25K, contrast	(Long Shafts)	
R167	200K, brightness	(Short Shafts)	
R309	1.5M, volume w/S401		
C402A	300 μf, 175v	ES31X254	
C402B	200 μf, 150v		
C402C	10 μf, 150v		
C402D	100 μf, 150v		
L151	coil, 47.25MHz trap	ES36X3	
L153	coil, video detector (Primary)	ES36X757	
L154	coil, video detector (secondary)	ET36X587	
L165	coil, 4.5MHz trap, sound takeoff	ES36X4	
L201A, B	yoke deflection 21 mm, toroidal	ES76X48	
L251	coil, horiz osc	EU35X1	
L301	coil, 4.5MHz, audio interstage	ES61X1	
L302	coil, quad	ES36X665	
T201	xformer, vert output	ES64X6	
T251	xformer, horiz output	ES77X10	
T301	xformer, audio output	ES64X1	
	fuse, 4a, fast-blo, W101	EP10X52	
	fuse, 1a, slow-blo, F403	ES10X7	

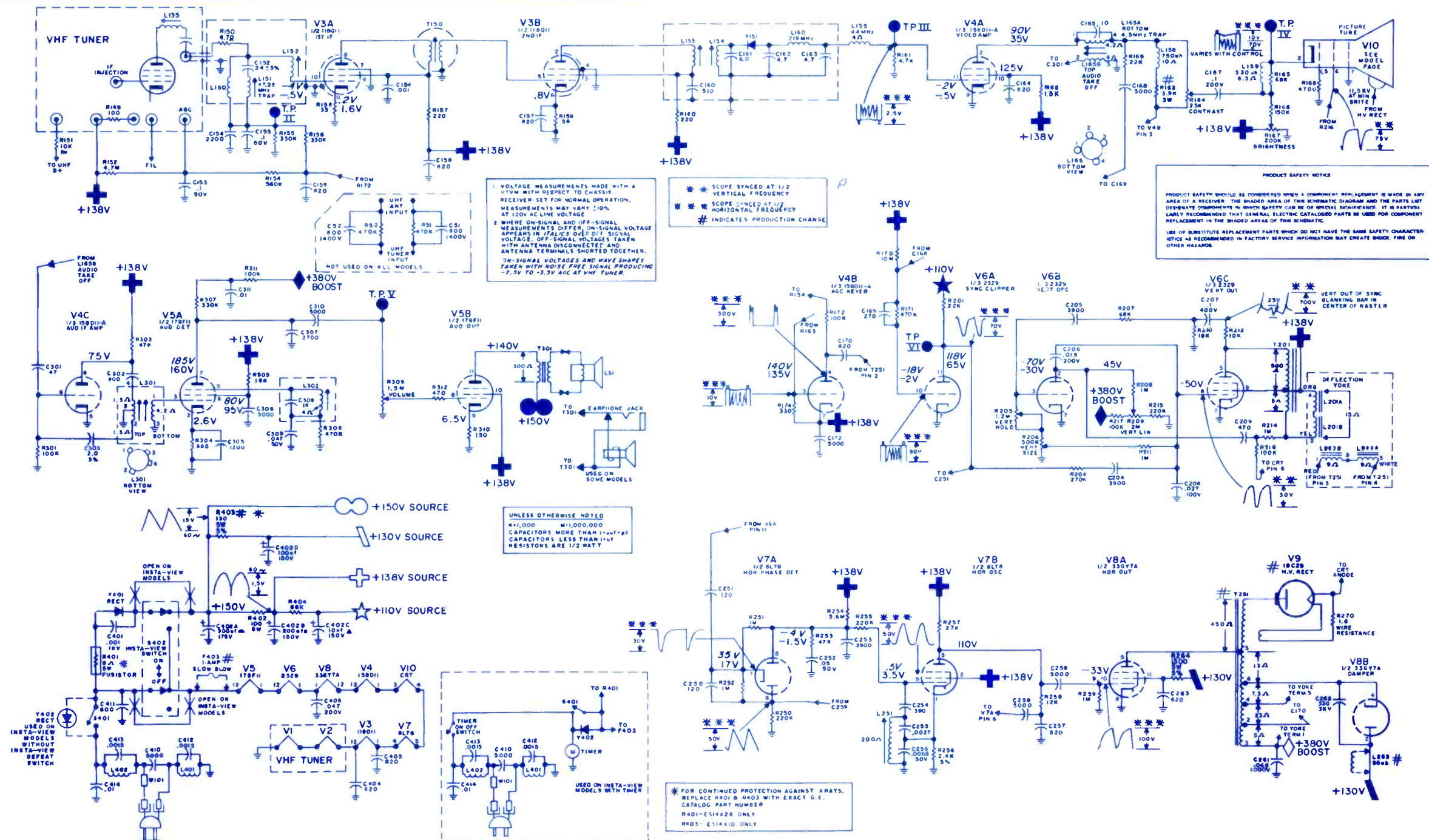

1474

GENERAL ELECTRIC

Color-TV Chassis KE-II/EB

JUNE • 1973

ELECTRONIC TECHNICIAN/DEALER **TEKFAK**

COMPLETE MANUFACTURERS' CIRCUIT DIAGRAMS AND TECHNICAL INFORMATION FOR 5 NEW SETS

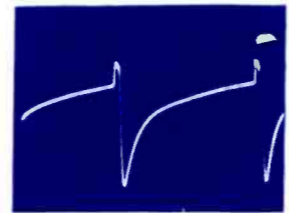

7 1/2 VERT. RATE 80 VPP V11, PIN 10 OFF-THE-AIR SIGNAL

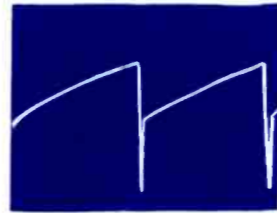

8 1/2 VERT. RATE 210 VPP V11, PIN 11 OFF-THE-AIR SIGNAL

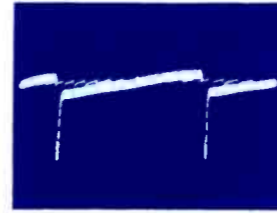

9 1/2 VERT. RATE 85 VPP P102, PIN 1 OFF-THE-AIR SIGNAL

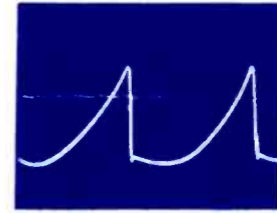

10 1/2 VERT. RATE 18 VPP V11, PIN 7 OFF-THE-AIR SIGNAL

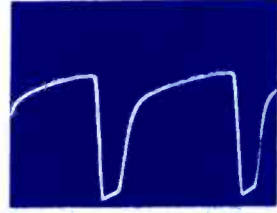

11 1/2 HORIZ. RATE 220 VPP V11, PIN 5 OFF-THE-AIR SIGNAL

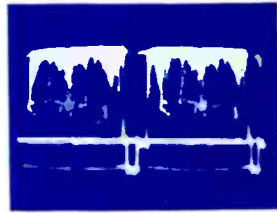

1 1/2 HORIZ. RATE 3.5 VPP TP 111 OFF-THE-AIR SIGNAL

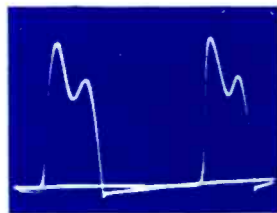

2 1/2 HORIZ. RATE 180 VPP V6, PIN 7 OFF-THE-AIR SIGNAL

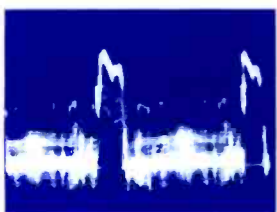

3 1/2 HORIZ. RATE 12 VPP V6, PIN 5 OFF-THE-AIR SIGNAL

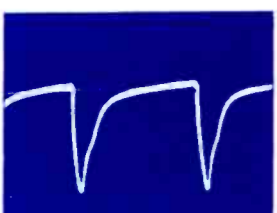

4 1/2 HORIZ. RATE 75 VPP V8, PIN 7 OFF-THE-AIR SIGNAL

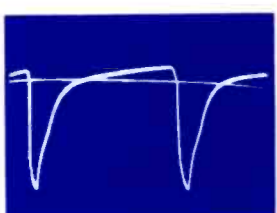

5 1/2 HORIZ. RATE 34 VPP V10, PIN 7 OFF-THE-AIR SIGNAL

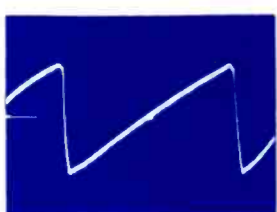

6 1/2 HORIZ. RATE 8 VPP V10, PIN 8 OFF-THE-AIR SIGNAL

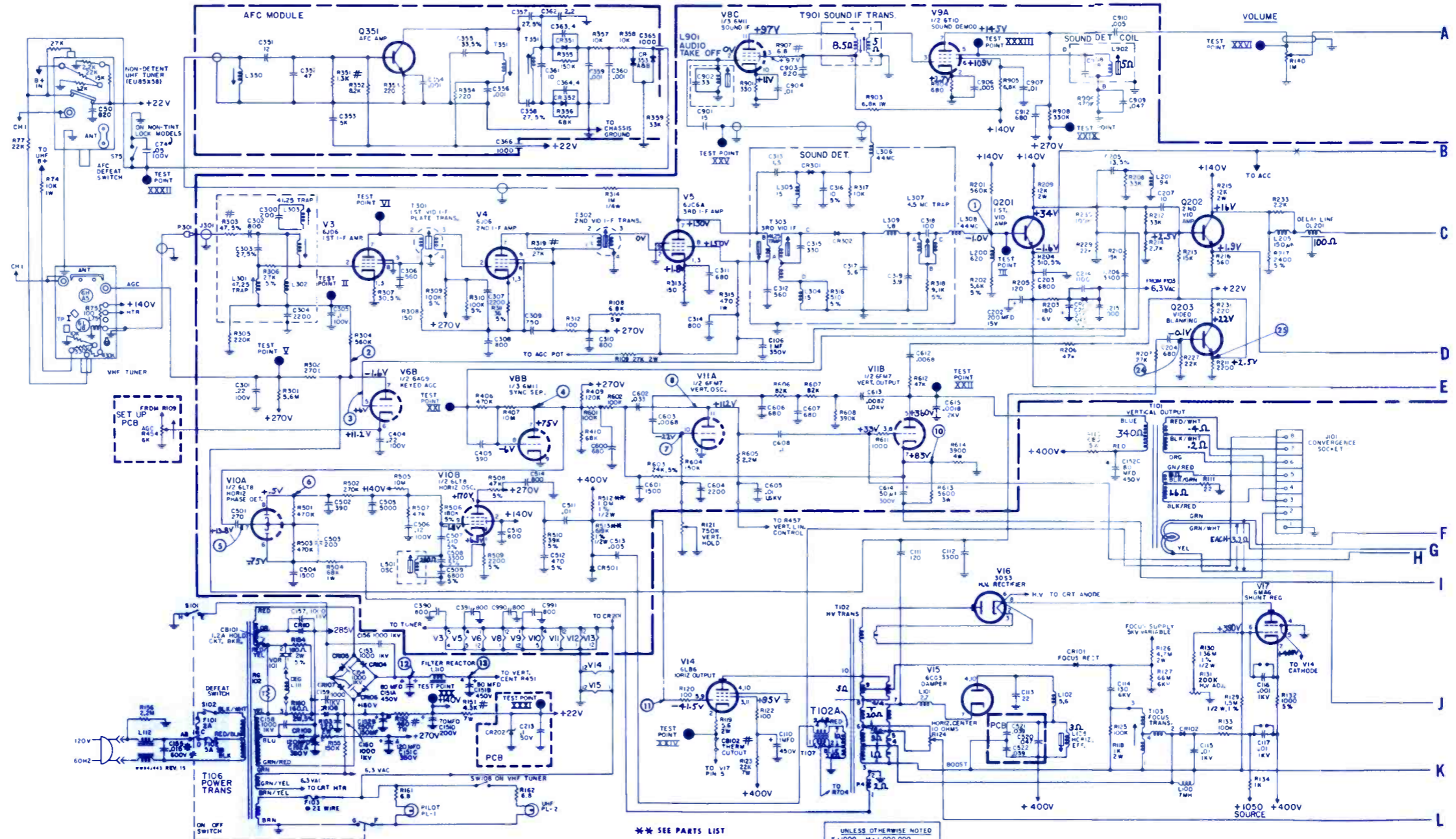

\*\* SEE PARTS LIST

UNLESS OTHERWISE NOTED  
R = 1000 M = 1,000,000  
CAPACITORS MORE THAN 1 µF  
CAPACITORS LESS THAN 1 µF  
RESISTORS ARE 1/2 WATT  
COILS IN µH

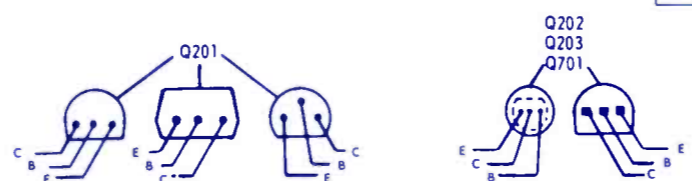

TRANSISTORS--BOTTOM VIEWS

**GENERAL ELECTRIC**  
Color-TV  
Chassis KE-II/EB

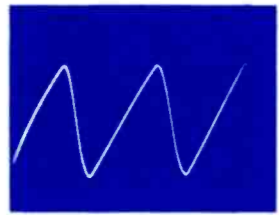

1/2 VERT. RATE  
22 VPP

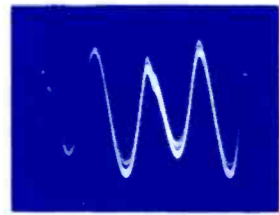

1/2 VERT. RATE  
1.5 VPP

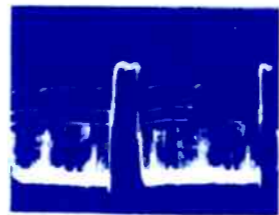

1/2 HORIZ. RATE  
120 VPP

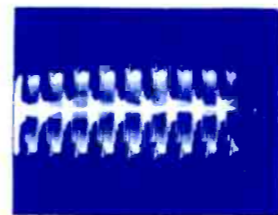

1/2 HORIZ. RATE  
110 VPP

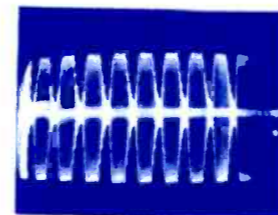

1/2 HORIZ. RATE  
6 VPP

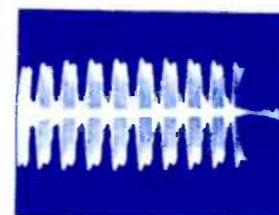

1/2 HORIZ. RATE  
46 VPP

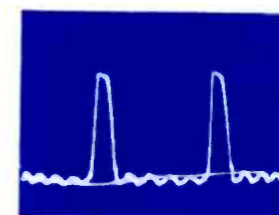

1/2 HORIZ. RATE  
120 VPP

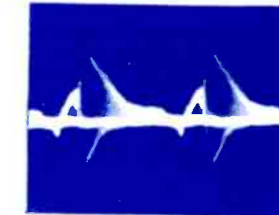

1/2 HORIZ. RATE  
200 VPP

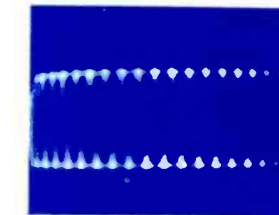

1/2 HORIZ. RATE  
100 VPP

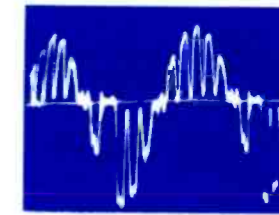

1/2 HORIZ. RATE  
270 VPP

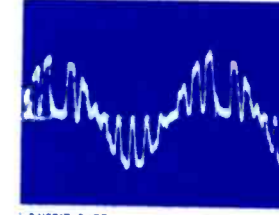

1/2 HORIZ. RATE  
70 VPP

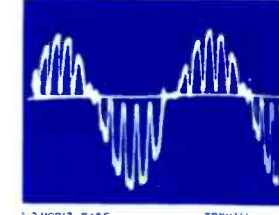

1/2 HORIZ. RATE  
260 VPP

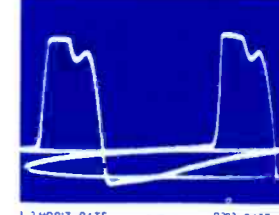

1/2 HORIZ. RATE  
28 VPP

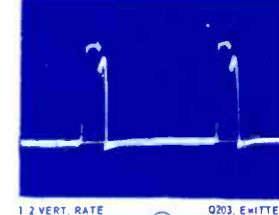

1/2 VERT. RATE  
20 VPP

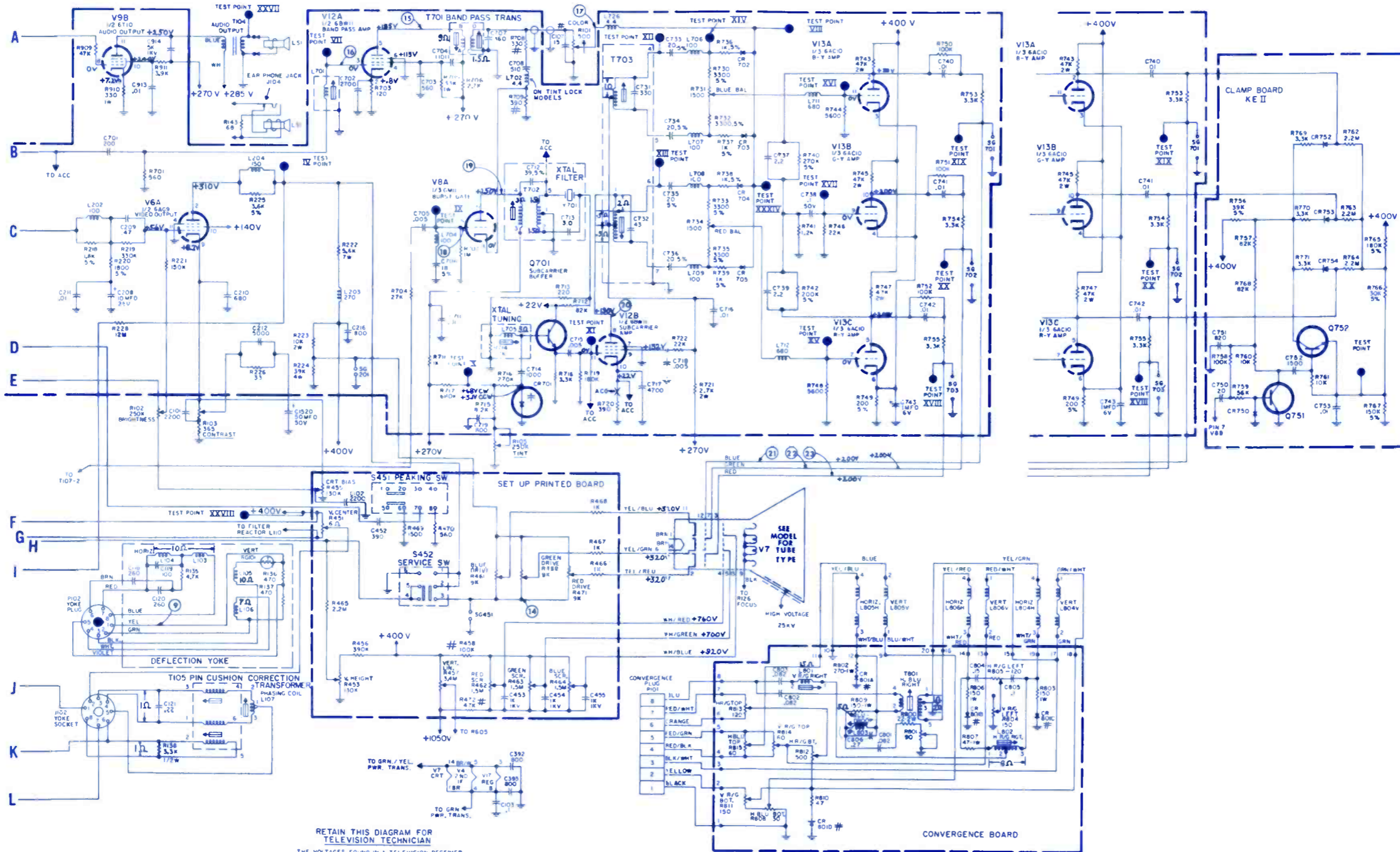

**RETAIN THIS DIAGRAM FOR TELEVISION TECHNICIAN**

THE VOLTAGES FOUND IN A TELEVISION RECEIVER ARE DANGEROUS AND CAUTION SHOULD BE EXERCISED WHEN THE CHASSIS IS EXPOSED. ALWAYS COMPLETELY REMOVE THE BACK WHEN SERVICING THE RECEIVER. THE HIGH-VOLTAGE SUPPLY FOR THE PICTURE TUBE ANODE WILL GIVE AN UNPLEASANT SHOCK. ALWAYS DISCHARGE THE PICTURE TUBE ANODE TO THE CHASSIS ON NON-ENERGIZED RECEIVER BEFORE HANDLING THE TUBE. SECONDARY HUMAN REACTIONS TO OTHERWISE HARMLESS SHOCKS HAVE BEEN KNOWN TO CAUSE INJURY. SINCE THE HIGH VOLTAGE IS PRODUCED FROM THE B+ VOLTAGE, CERTAIN PORTIONS OF THE HIGH VOLTAGE GENERATING CIRCUIT ARE DANGEROUS AND EXTREME CAUTION SHOULD BE OBSERVED.

THE PICTURE TUBE IS HIGHLY EVACUATED AND IF BROKEN, GLASS FRAGMENTS WILL BE VIOLENTLY EXPELLED. WHEN HANDLING THE PICTURE TUBE ALWAYS WEAR GOGGLES AND PROTECTIVE CLOTHING.

\* SPECIAL FOR 120V AC POWER LINE  
DO NOT SUBSTITUTE  
\*\* MATCHED PAIR

1475

PHILCO-FORD

Color-TV  
Chassis 3CR40/41

ELECTRONIC TECHNICIAN/DEALER **TEKFAKX**

COMPLETE MANUFACTURERS' CIRCUIT DIAGRAMS  
AND TECHNICAL INFORMATION FOR 5 NEW SETS

JUNE • 1973

SYMBOL DESCRIPTION PHILCO-FORD PART NO.

C204-200 μf/200v, 150 μf/350v, 20 μf/200v	
50 μf/200v, B+ filter	30 2625 3
IC1-act amp & det. (3CR41)	46 5002 6
IC91-ICB, 4.5MHz amp/demod	46 5002 8
IC92-IC21 color osc/react/demod	46 5002 21
L41-horiz hold	32 4891 2
L 92-quad	32 4876 1
L93-sound take-off	32 4936 3
L94-burst trans	32 4931 1

L 95-chroma take-off	32 4878 3
L100-3.58MHz osc	32 4932 2
L101-chroma bandpass	32 4929 1
R224-6.8M, focus control	33 1385 1
RT200-degaussing	33 1376 6
RV55-horiz bias	33 1379 2
RV200-degaussing coil	33 1379 1
T1-xformer, audio output	32 10156 1
T2-xformer, filter choke	32 10155 3
T3-vert output, xformer	32 10167 1

T4-xformer, horiz output	32 10111 7
VR1-3K AGC adjust	33 5628 14
VR93-CRT bias	33 5628 12
VR201-tint	33 5649 25
VR202-color	33 5648 14
VR203-brightness	33 5631 18
VR204-contrast	33 5631 19
VR205-vert hold	33 5631 16
VR206-on-off/volume	33 5646 14
VR207-12M, focus adj	33 5631 24

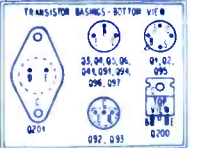
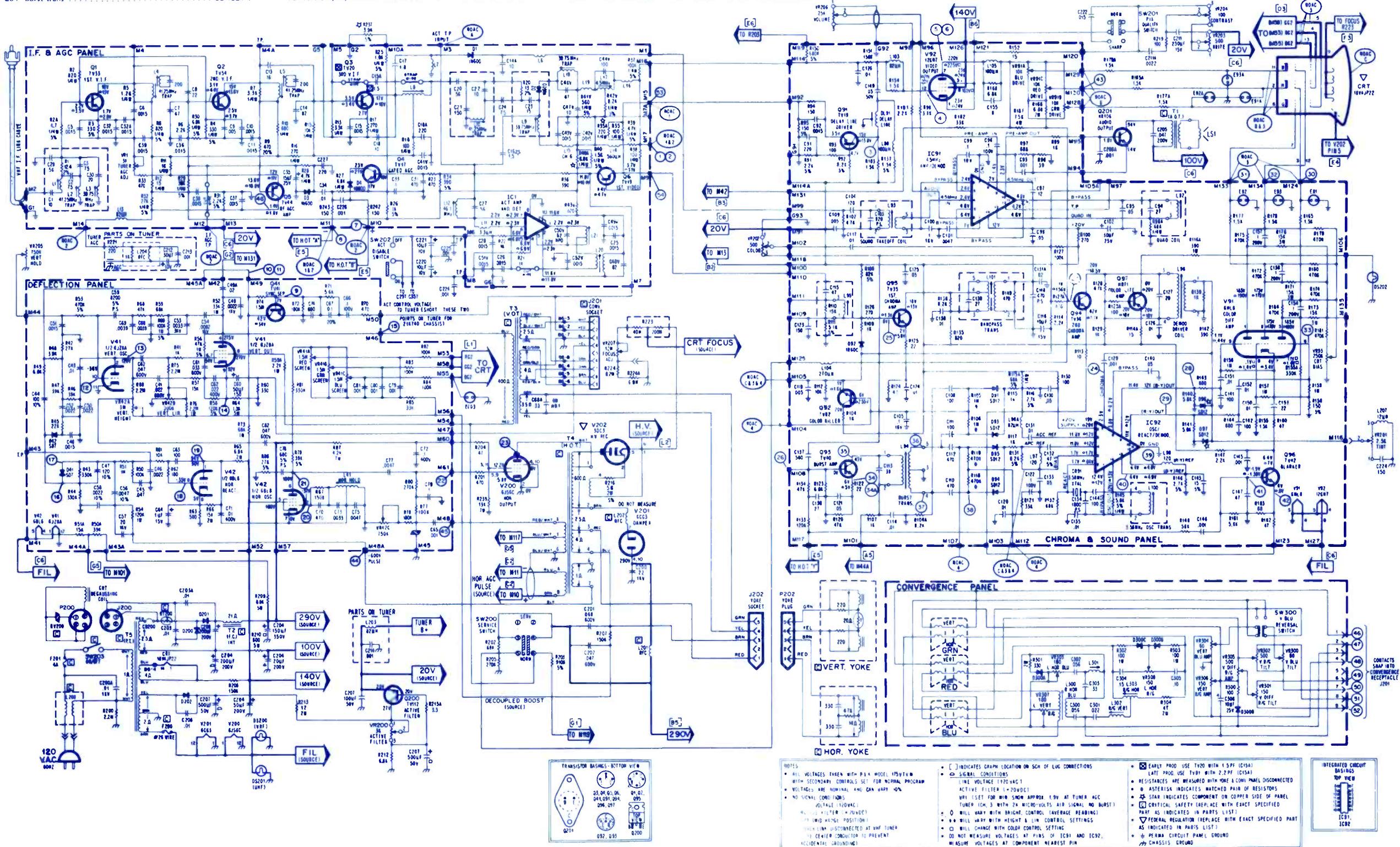

- NOTES:**
- ALL VOLTAGES TAKEN WITH R14 MODEL 1959FM WITH SECONDARY CONTROLS SET FOR NORMAL PROGRAM
  - VOLTAGES ARE NOMINAL AND CAN VARY 40%
  - NO SIGNAL CONDITIONS UNLESS OTHERWISE SPECIFIED
  - VOLTAGE (120VAC) UNLESS OTHERWISE SPECIFIED
  - RESISTANCE MEASURED WITH 100Ω COIL
  - RESISTANCES ARE MEASURED WITH 100Ω COIL UNLESS OTHERWISE SPECIFIED
  - STAR INDICATES COMPONENT ON COPPER SIDE OF PANEL
  - CRITICAL SAFETY (REPLACE WITH EXACT SPECIFIED PART AS INDICATED IN PARTS LIST)
  - FEDERAL REGULATION (REPLACE WITH EXACT SPECIFIED PART AS INDICATED IN PARTS LIST)
  - PEAKS CIRCUIT PANEL GROUND
  - CHASSIS GROUND

**PHILCO-FORD  
Color-TV  
Chassis 3CR40/41**

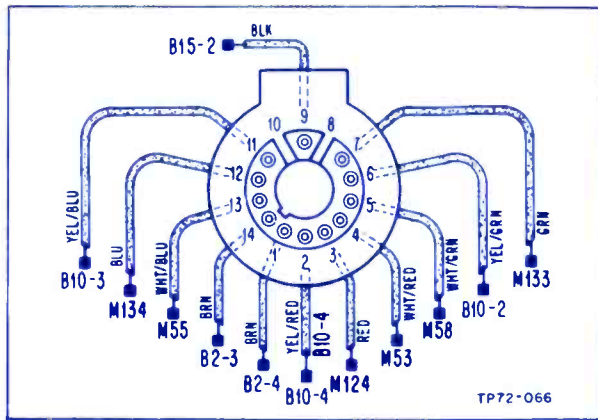

**CRT SOCKET WIRING, 3CR40/41**

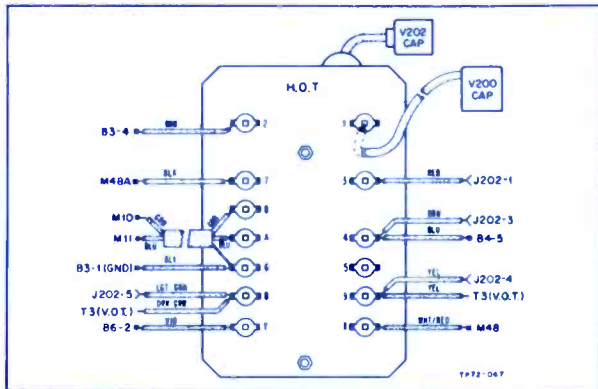

**H.O.T. WIRING, 3CR40/41**

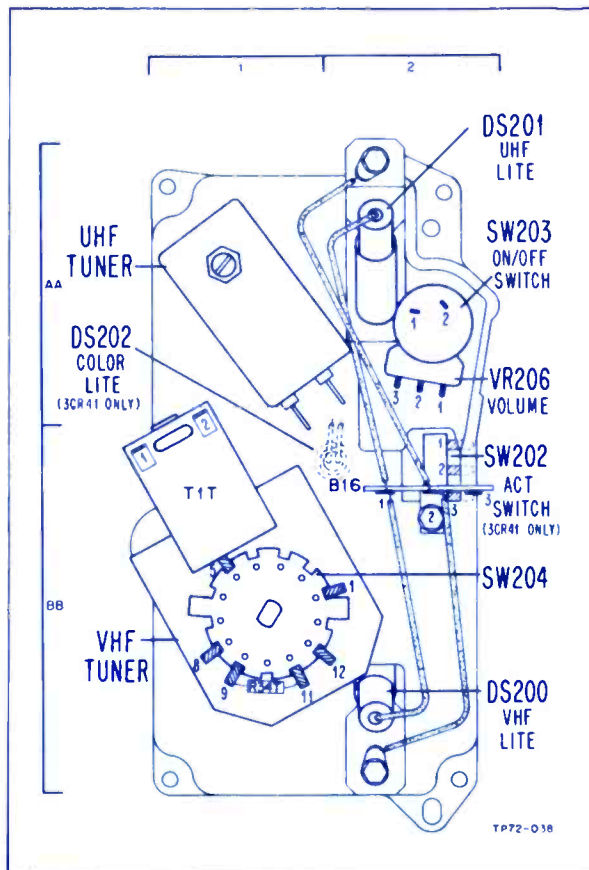

**REAR VIEW INSTRUMENT PANEL, 3CR40/41**

CRT		
PIN	VOLTAGE	
2	R.K	+270
3	R.G1	-90
4	R.G2	440 TO 660
5	G.G2	440 TO 660
6	G.A	270
7	G.G1	84
11	B.K	272
12	B.G1	90
13	B.G2	440 TO 660

**NGT45**  
CRT BIAS MIN FULL COB  
BRIGHTNESS FULL COB  
CONTRAST FULL COB  
CHROMA FULL COB  
SERVICE SW NORMAL  
LINE VOLTAGE 120 VAC

5M18	
PIN	VOLTAGE
1	120
2	180
3	185
4	3.5
5	3.5
6	10.7
7	10.7
8	10.7
9	10.7
10	10.7
11	10.7
12	10.7
13	10.7
14	10.7
15	10.7
16	10.7
17	10.7
18	10.7
19	10.7
20	10.7
21	10.7
22	10.7
23	10.7
24	10.7
25	10.7
26	10.7
27	10.7
28	10.7
29	10.7
30	10.7
31	10.7
32	10.7
33	10.7
34	10.7
35	10.7
36	10.7
37	10.7
38	10.7
39	10.7
40	10.7
41	10.7
42	10.7
43	10.7
44	10.7
45	10.7
46	10.7
47	10.7
48	10.7
49	10.7
50	10.7
51	10.7
52	10.7
53	10.7
54	10.7
55	10.7
56	10.7
57	10.7
58	10.7
59	10.7
60	10.7
61	10.7
62	10.7
63	10.7
64	10.7
65	10.7
66	10.7
67	10.7
68	10.7
69	10.7
70	10.7
71	10.7
72	10.7
73	10.7
74	10.7
75	10.7
76	10.7
77	10.7
78	10.7
79	10.7
80	10.7
81	10.7
82	10.7
83	10.7
84	10.7
85	10.7
86	10.7
87	10.7
88	10.7
89	10.7
90	10.7
91	10.7
92	10.7
93	10.7
94	10.7
95	10.7
96	10.7
97	10.7
98	10.7
99	10.7
100	10.7

MEASURED TO GROUND  
PINS AS INDICATED

12GN7	
PIN	VOLTAGE
1	26
2	23
7	270
8	165

**BOTTOM VIEW WITH PW PANELS-3CR40/41 CHASSIS**

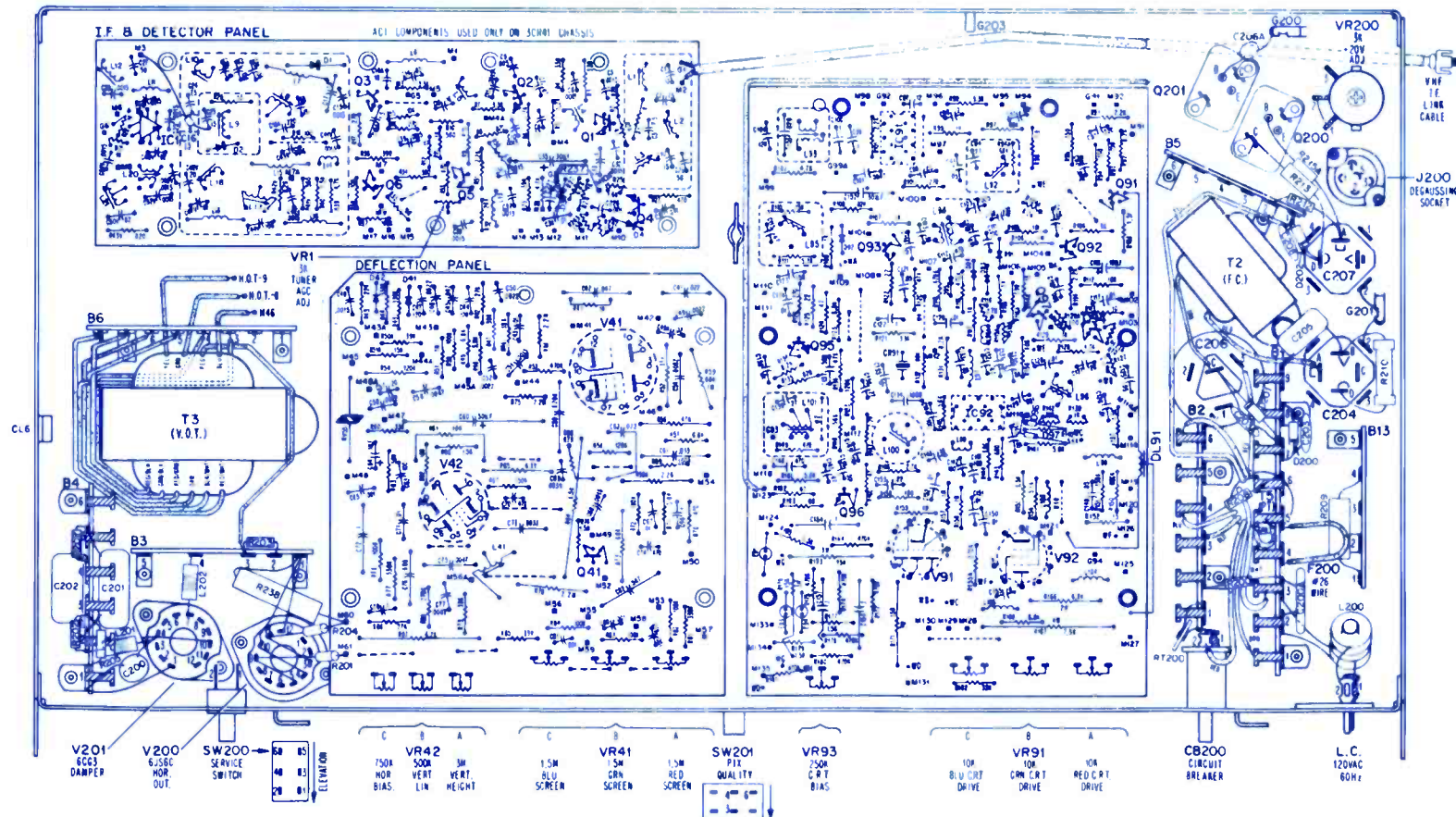

1 1.5 VOLTS P/P. 60 HZ (MAX. CONTRAST) M17

2 1.5 VOLTS P/P. 15,750 HZ (MAX. CONTRAST) M17

3 4.2 VOLTS P/P. 15,750 HZ Q91 COLL

4 3.8 VOLTS P/P. 15,750 HZ PIN 2 V92

5 80V. P/P. (cont. at point of start of sync compression) 15,750 HZ Pin 7 V92

6 65V. P/P. (MIN. CON.) 15,750 HZ PIN 7 V92

7 40 VOLTS P/P. 15,750 HZ M10

8 13 VOLTS P/P. 15,750 HZ M10

9 6.6 VOLTS P/P. 15,750 HZ BASE OF Q41

10 50 VOLTS P/P. 15,750 HZ M49

11 50 VOLTS P/P. 60 HZ M49

12 85 VOLTS P/P. 60 HZ PIN 10 V41

13 150 VOLTS P/P. 80 HZ PIN 2 V41

14 15 VOLTS P/P. 80 HZ PIN 9 V41

15 1KV VOLTS P/P. 60 HZ (SPIKE) 200 VOLTS P/P. 60 HZ (SAWTOOTH) M46. OR PIN 4 V41

16 12 VOLTS P/P. 15,750 HZ D41, D42

17 16 VOLTS P/P. 15,750 HZ D41 TOP END

18 8 VOLTS P/P. 15,750 HZ PIN 9 V42

19 45 VOLTS P/P. 15,750 HZ PIN 1 V42

20 150 VOLTS P/P. 15,750 HZ PIN 2 V42

21 200 VOLTS P/P. 15,750 HZ PIN 6 V42

22 200 VOLTS P/P. 15,750 HZ M61

23 15,750 HZ LOOSE COUPLED V200 PLATE

24 6 VOLTS P/P. 3.58 MHZ PIN 7 IC92

25 1 VOLTS P/P. 1.05 15,750 HZ Q95 BASE

26 5.5 VOLTS P/P. 15,750 HZ M108

27 3 VOLTS P/P. 15,750 HZ Q94 BASE

28 8 VOLTS P/P. 3.58 MHZ Q101 COLL PIN 9 IC92

29 8.0 VOLTS P/P. 3.58 MHZ Q101 COLL PIN 10 IC92

30 45 VOLTS P/P. (CHROMA) 70V. P/P. (SYNC) 15,750 HZ M124

31 17 VOLTS P/P. (CHROMA) 70V. P/P. (SYNC) M133

32 50 VOLTS P/P. (CHROMA) 70V. P/P. (SYNC) M134

33 2 VOLTS P/P. (CHROMA) 25V. P/P. (SYNC) R159 PIN 6 V91

34 0.4 VOLTS P/P. 15,750 HZ Q93 EMIT.

34A EXPLODED VIEW OF BURST OF VIEW 34

35 70 VOLTS P/P. 15,750 HZ Q93 COLL.

36 12 VOLTS P/P. 15,750 HZ PIN 5 L94

37 12 VOLTS P/P. 15,750 HZ PIN 4 L94

38 6 VOLTS P/P. 3.58 MHZ D94, R118

39 3.0 VOLTS P/P. 3.58 MHZ PIN 12 IC92

40 2.0 VOLTS P/P. 3.58 MHZ PIN 13 IC92

41 9 VOLTS P/P. 15,750 HZ Q96 BASE

42 3.5 VOLTS P/P. 17,500 HZ Q96 EMIT.

43 90 VOLTS P/P. 15,750 HZ CONT SET JUST BELOW POINT OF SYNC COMPRESSION M130, M129, M128

44 550 VOLTS P/P. 15,750 HZ M48A

45 1KV VOLTS P/P. 15,750 HZ M48

46 45 VOLTS P/P. MAX. SLOPE 1.4 VOLTS P/P. MIN. SLOPE 15,750 HZ PIN 1 J201

47 260 VOLTS P/P. 15,750 HZ PIN 2 J201

48 12 VOLTS P/P. PIN 4 J201

49 12 VOLTS P/P. MAX. SLOPE 8 VOLTS P/P. MIN. SLOPE 15,750 HZ PIN 6 J201

50 5 VOLTS P/P. 1.2 VOLTS P/P. SAWTOOTH 15,750 HZ PIN 7 J201

51 20 VOLTS P/P. MAX. SLOPE 15 VOLTS P/P. MIN. SLOPE 15,750 HZ PIN 8 J201

52 6 VOLTS P/P. 15,750 HZ PIN 9 J201

53 6 VOLTS P/P. 15,750 HZ M15

54 1.4 VOLTS P/P. 15,750 HZ M6

55 12 VOLTS P/P. PINS 3 & 4 IC92 3.58 MHZ

56 9 VOLTS P/P. PIN 5 IC92 3.58 MHZ

LINE VOLTAGE - 120 VAC  
AIR SIGNAL - FOR MONOCHROME SIGNALS  
COLOR BAR GEN. - B&K 1245 - FOR COLOR SIGNALS  
ACTIVE FILTER AT 20 VDC

◆WILL VARY WITH COLOR CONTROL SETTING

1476

MAGNAVOX

Color-TV  
Chassis T979

ELECTRONIC TECHNICIAN/DEALER **TEKFAKX**

JUNE • 1973

COMPLETE MANUFACTURERS' CIRCUIT DIAGRAMS  
AND TECHNICAL INFORMATION FOR 5 NEW SETS

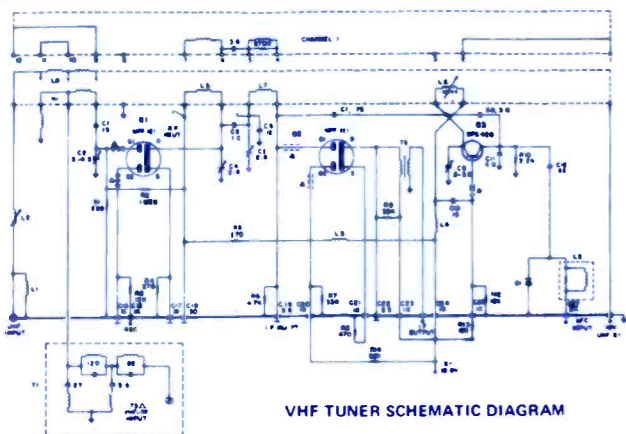

VHF TUNER SCHEMATIC DIAGRAM

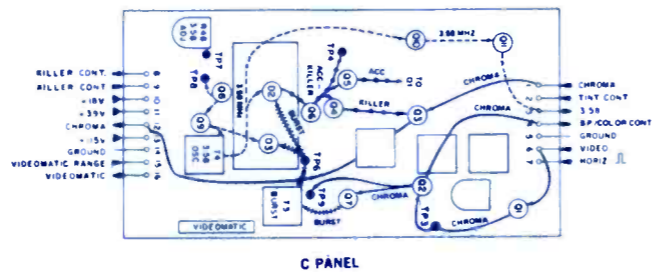

C PANEL

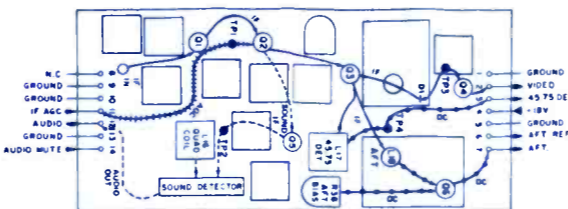

A PANEL

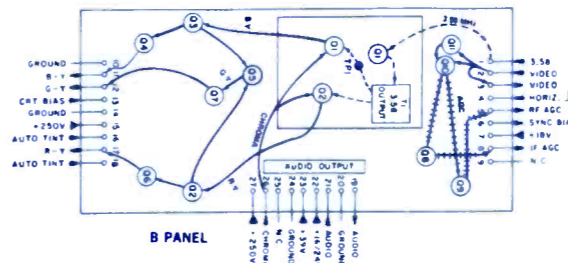

B PANEL

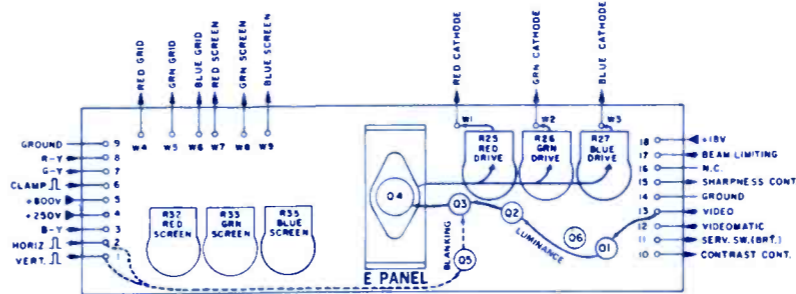

E PANEL

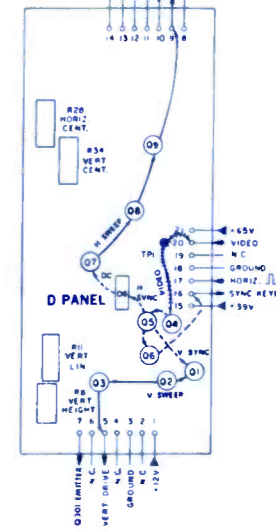

D PANEL

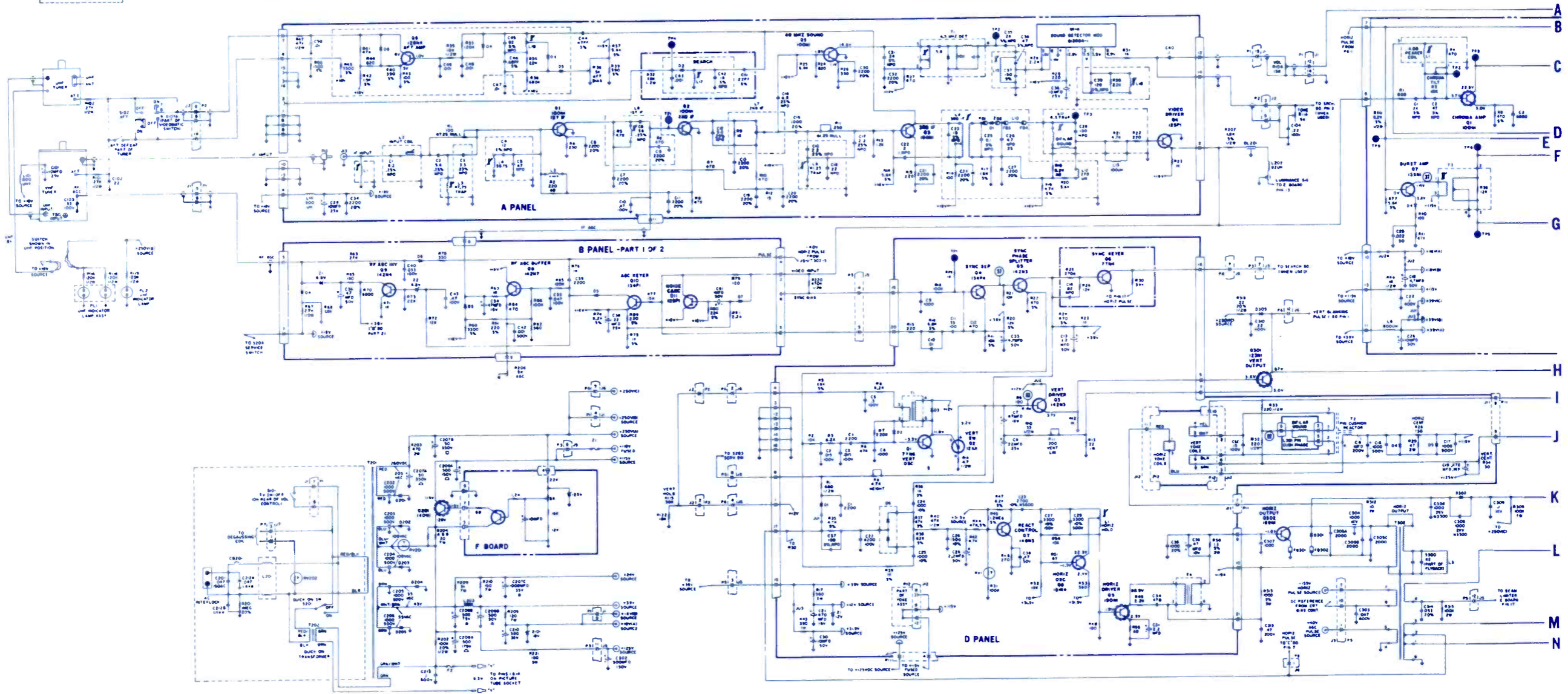



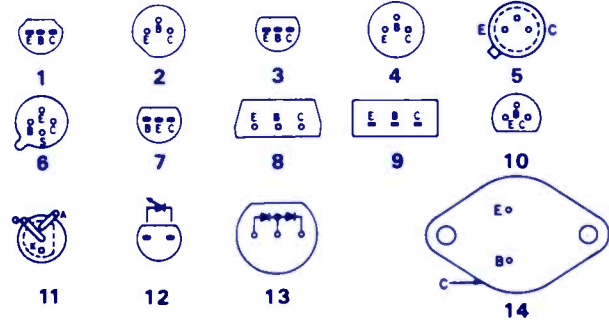
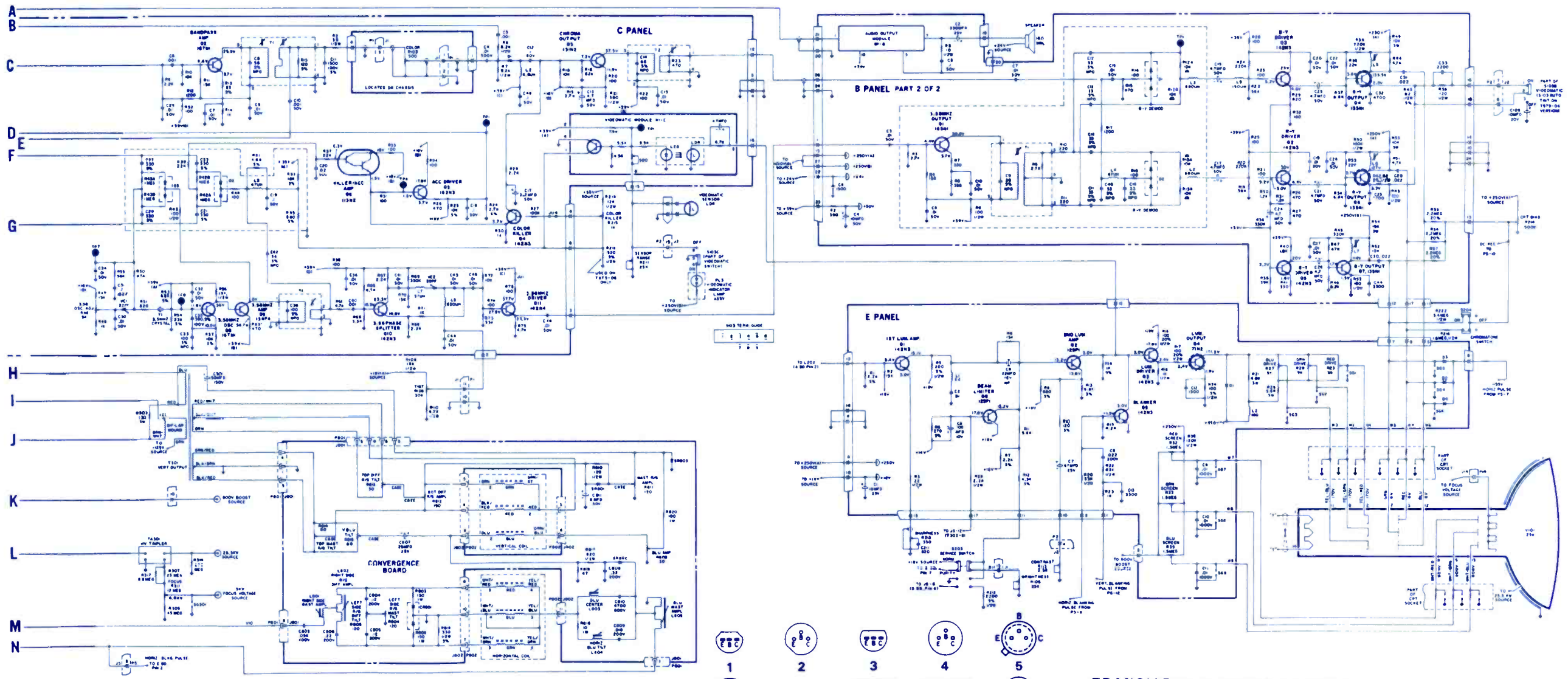
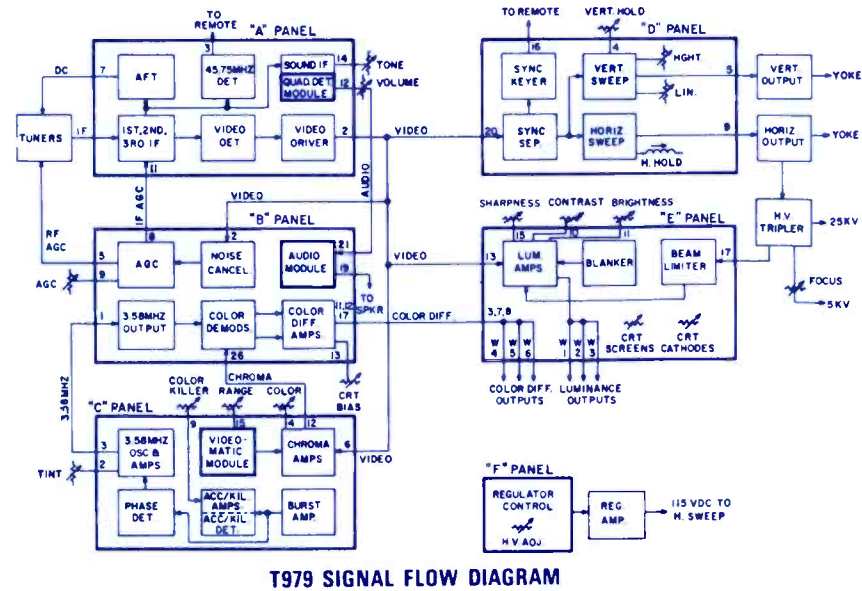
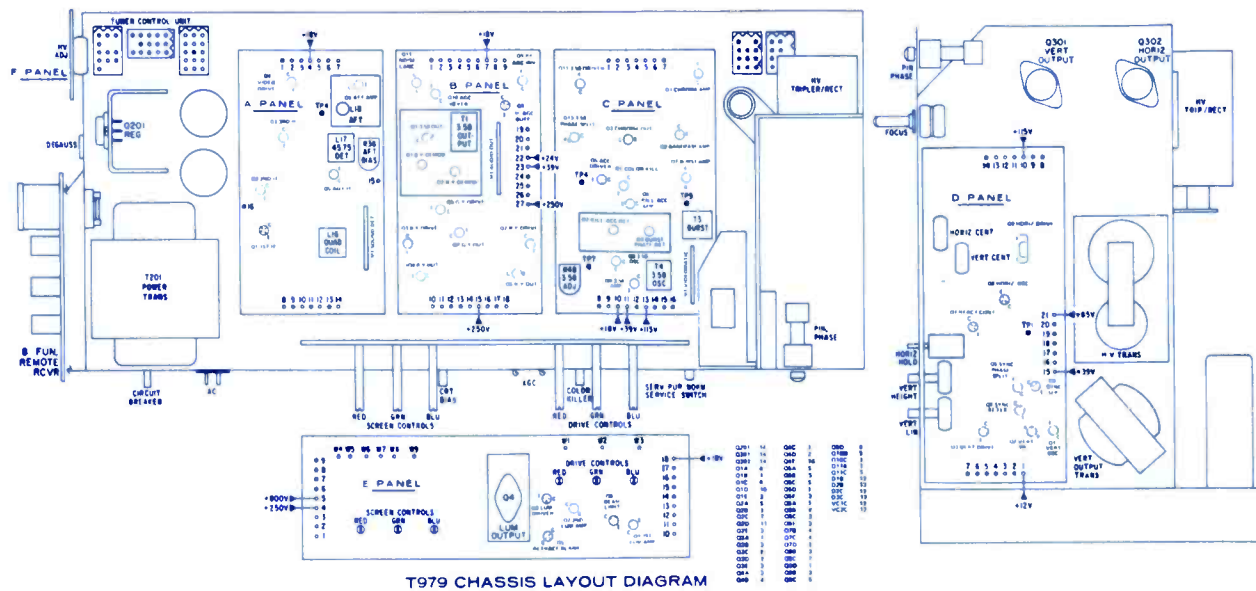

**TRANSISTOR & DIODE BASINGS**

Q201	14	Q4C	3	Q2C	7	Q6C	3	Q9D	9
Q301	14	Q4D	2	Q2D	11	Q6E	3	Q10B	5
Q302	14	Q4E	14	Q2E	3	Q7B	4	Q10C	3
Q1A	6	Q5A	6	Q3A	1	Q7C	4	Q11B	2
Q1B	1	Q5B	3	Q3B	3	Q7D	2	D1B	13
Q1C	6	Q5C	3	Q3C	8	Q7E	3	D2B	13
Q1D	10	Q5D	3	Q3D	3	Q8C	7	D3C	13
Q1E	3	Q5E	3	Q3E	3	Q8D	1	D3C	13
Q2A	6	Q5A	1	Q4A	3	Q8E	3	VC1C	12
Q2B	3	Q5B	4	Q4B	4	Q8C	5	VC2C	12

SYMBOL	DESCRIPTION	AIRLINE PART NO.
C504A, B, C	250 $\mu$ / 165v 150 $\mu$ / 150v 200 $\mu$ / 150v electrolytic	67A30 11
R208	500K on/off volume	75A1-185
R320	30K video	75A112-13
R418	5M, height	75A101-16
R422	1.2M, vert hold	75A100-8
R466	500K, vert lin	75A101-17
L201A, B	coil, sound IF	72A301-2
L202	coil, quad (includes C207)	72A132-77
L301	coil, 47.25MHz trap	72A296-4
L401	coil, horiz hold	94A17-19
T201	x-former, audio output	79A124-5
T303	x-former, sound take off, 4.5MHz	72A185-5
T401	x-former, vert output	79A139-4
T402	deflection yoke	94A372-2
T403	x-former, horiz output	79A138-15
CR301	diode, video detector, 1N60	93A-8
CR401	diode, horiz phase detector	93A-9
F501	fuse, 2 a (pigtail)	84A7-8

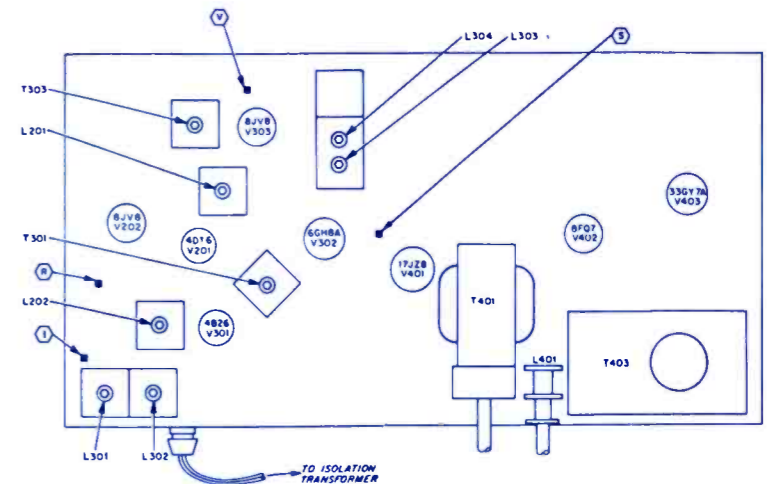
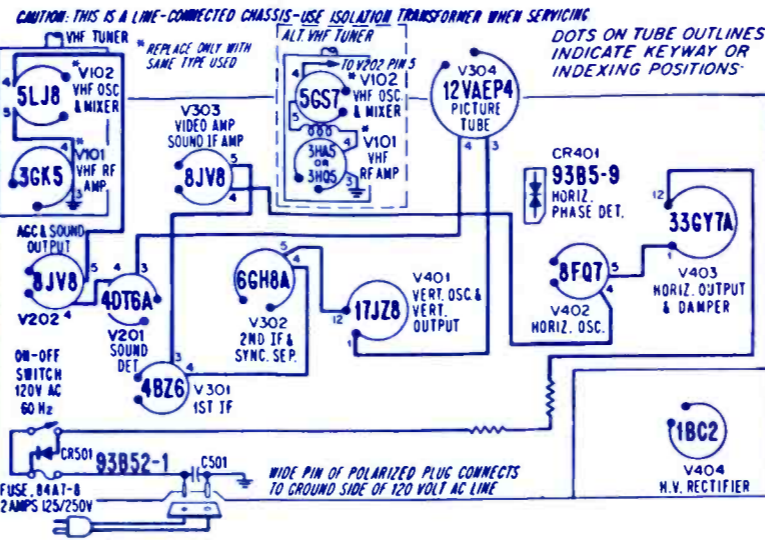

Top View of Chassis Showing Alignment Locations and Test Points

Tube Location Chart

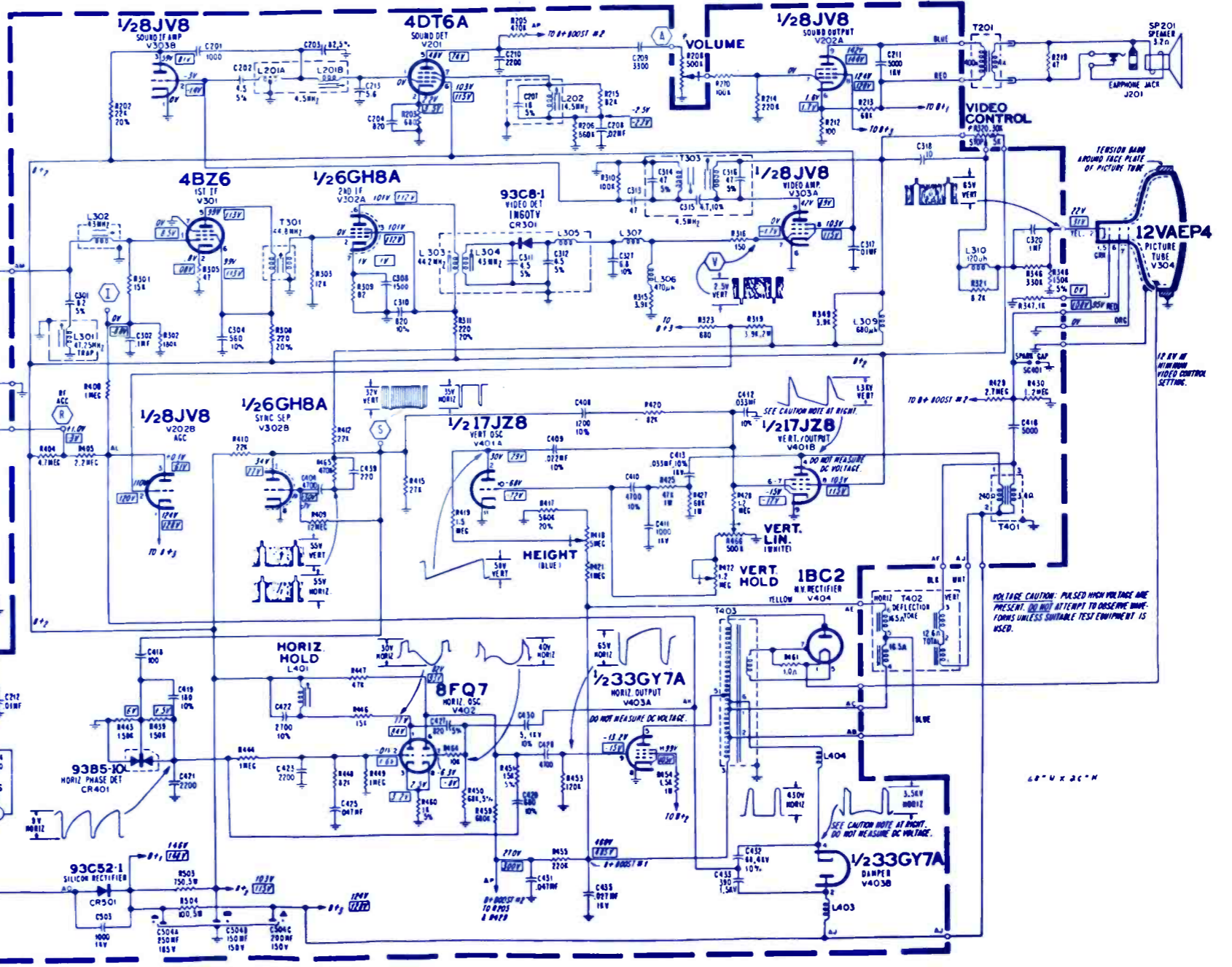
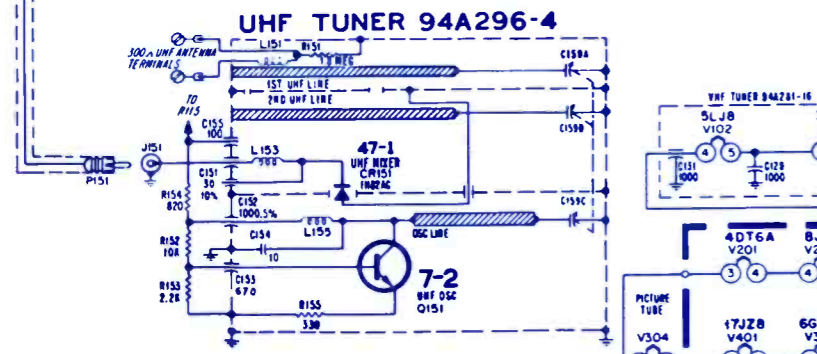
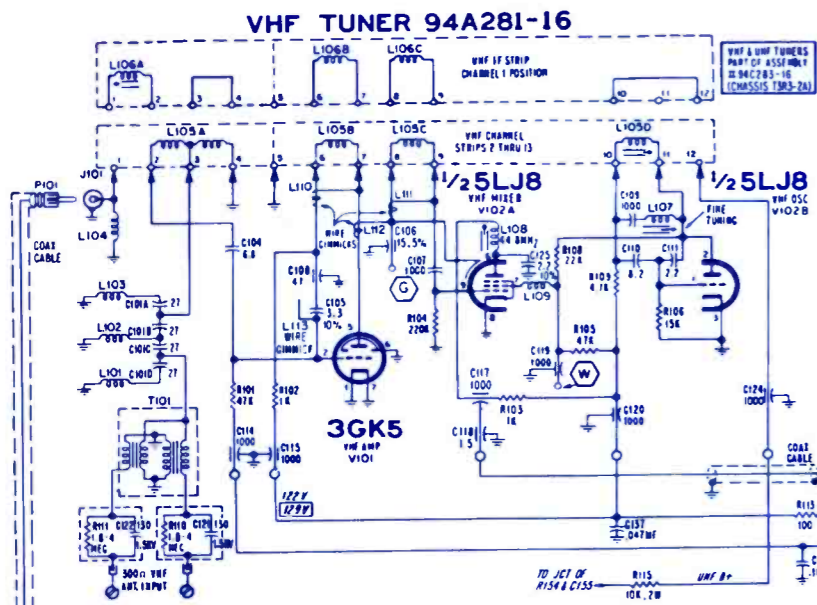

**SCHEMATIC NOTES:**  
 1. PART NOT MOUNTED ON PRECISION WIRED SYSTEM.  
 2. VOLTAGE WILL VARY WITH SETTING OF CONTROLS.  
 3. RESISTOR VALUES 1/2 WATT 10%. CAPACITOR VALUES IN MICROFARADS 20%, UNLESS OTHERWISE INDICATED. DC VOLTAGES MEASURED WITH VTVM AT 120V AC LINE. HAZ. CONTRAST & BRIGHTNESS AND MIN. VOLUME. DC VOLTAGES IN BUSH BEAS-USED WITH SIGNAL OF MEDIUM SIGNAL. STRONGER VOLTAGES NOT IN BUSH MEASURED WITH AN SIGNAL. CHASSIS GROUND.  
 4. WARNING: USE ISOLATION TRANSFORMER WHEN SERVICING WITH CABINET BACK REMOVED.

**NOTE:** PLUG A SOCKET OF LINE CORD ARE POLARIZED SMALLER PIN CONNECTS TO HOT SIDE OF 120V AC LINE.

# Announcing the Panasonic Parts Hot Line.

In 48 hours we can ship you anything we've got.

The New Panasonic Parts Hot Line is a performance promise: 24-hour-a-day, 7-day-a-week service. Now, if you have a problem getting the part you need, just call one central number.

Then things start happening fast: we'll ask our computer to locate your part (or parts) by searching all five regional Panasonic parts depots. In just seconds. Electronically. Then we'll telex an order to the depot which has the part you need and within

48 hours, your order is on its way.\*

And we can make this promise with confidence, because our warehouses are now fully automated. We've got the 2,000 fastest moving parts on electronic order pickers. At the touch of a button any of these high traffic parts is at our fingertips.

To become a member of the Panasonic Parts Hot Line, call the toll-free number below. We'll send you a bright red emblem imprinted with the hot line num-

ber for your particular region. We'll also send you an easy-reference booklet that gives you the names of authorized Panasonic parts distributors in your area, and information on other Parts Division services.

We know that your business depends upon having the right parts at the right time — when your customer needs them. Our business is standing right behind your business, with quality parts for over 1,000 products.



**Panasonic  
Parts  
Hot Line  
3-4712**

**Panasonic**  
just slightly ahead of our time

Call toll-free anywhere in the U.S. 800-523-5336. (In Pa. 800-562-5395)

\*Of course we cannot ship on weekends and hot days.

If your problem is **measuring  $\mu V$ ,  
 $\mu A$  and milliohms**  
 in transistorized  
 and integrated  
 circuits . . .  
 Solve it with  
**Triplett's 801**



Model 801  
 \$ 231

1. Lower power ohms — 8 ranges with 35 mV power source and 1 ohm center scale.
2. High sensitivity — 5 mV AC full scale at 10 megohm input impedance; 50 mV DC at 11 megohm input resistance.
3. Simplified scale — 8" meter with only 4 arcs for all 73 ranges.

It offers 73 measurement ranges including 8 low-power resistance ranges that apply only 35 mV to the device under test . . . does not activate or damage solid-state components. With full-scale readings as low as 50 mV DC and 5 mV AC, 5  $\mu A$  DC and 100 Ohms (1 Ohm center-scale) — plus a 10 megohm input impedance on the AC scales and 11 megohm input resistance on DC — Triplett's Model 801

V-O-M is ideally suited to in-circuit testing. When you add 2% DC and 3% AC accuracy on the voltage ranges (current: 3% DC and 4% AC) and a 25  $\mu A$  suspension-type meter with a nearly 7 1/2" scale length, there's no doubt that the Model 801 has no equal among analog V-O-M's in terms of sensitivity and versatility. And there's an optional **Leakage Adapter (\$33)** that measures leakage currents

as low as 1  $\mu A$ .

See the remarkable **Model 801** V-O-M — priced at **\$231** — at your Triplett distributor. For more information—or for a free demonstration—call him or your Triplett sales representative right away. Triplett Corporation, Bluffton, Ohio 45817.

**TRIPLETT**

The World's most complete line of V-O-M's . . .  
 choose the one that's just right for you

For full details . . . . . Dial Toll-Free 800-645-9200 for nearest Triplett  
 Representative. . . . . New York State . . . . . Call Collect 516-294-0990

. . . for more details circle 133 on Reader Service Card