

ELECTRONIC TECHNICIAN

WORLD'S LARGEST ELECTRONIC TRADE CIRCULATION

APRIL 1966



SERVICING COLOR TV
GARAGE DOOR OPERATORS
CALL-BACKS CAN BREAK YOU
CITIZENS BAND — A NEW LOOK

LIBRARY OF THE
UNIVERSITY OF CALIFORNIA
LIBRARY

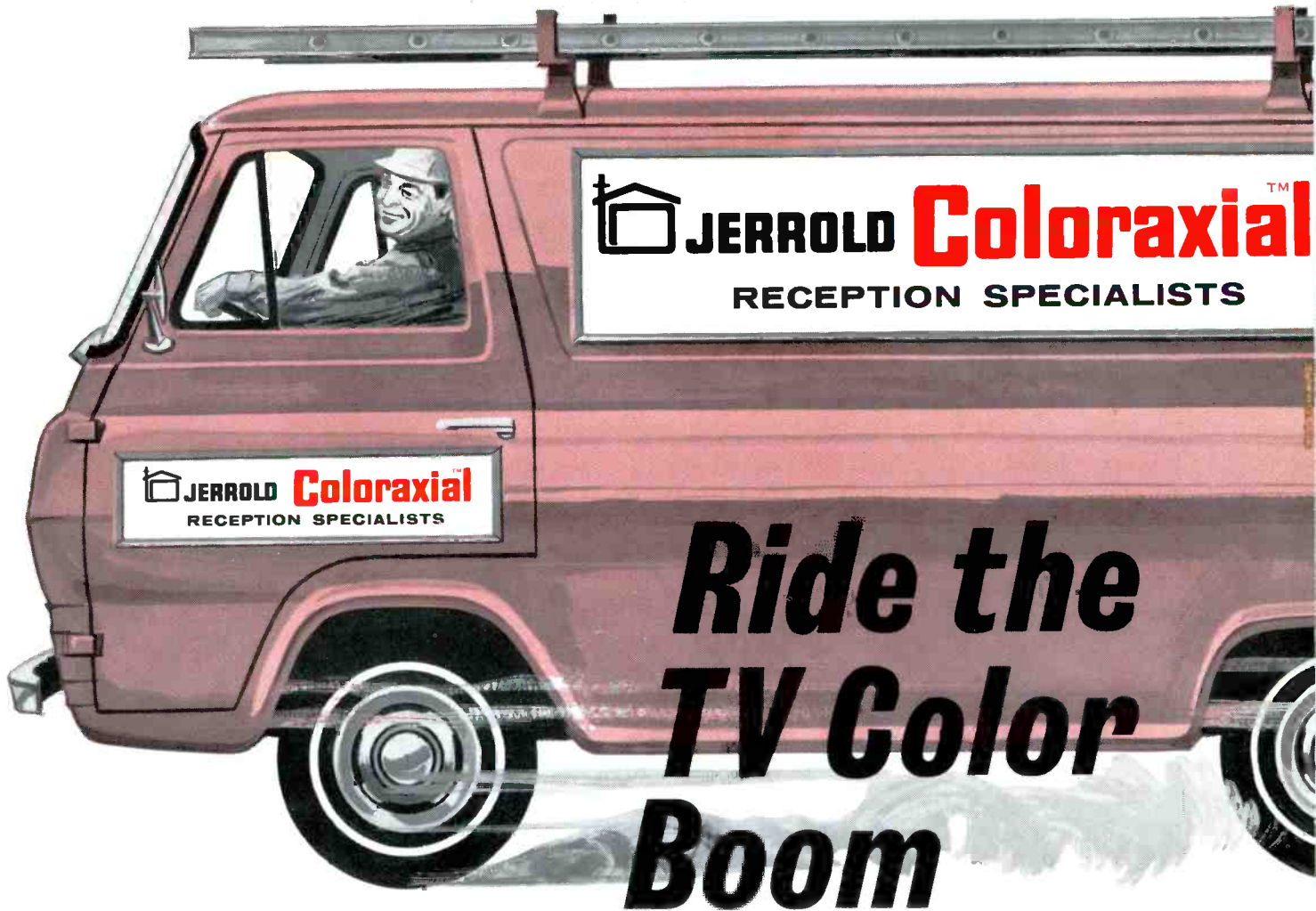

 **JERROLD Coloraxial™**
RECEPTION SPECIALISTS

 **JERROLD Coloraxial™**
RECEPTION SPECIALISTS

***Ride the
TV Color
Boom***

ALL THE WAY TO THE BANK

with Jerrold's New Show 'n Sell Program

'65 was a banner year for antenna sales. In '66 you'll double and triple antenna profits—when you tie in with Jerrold's money-making Show 'n Sell program!

PROMOTION POWER! Jerrold furnishes everything you need to mass merchandise antenna systems. Eye-catching window and floor displays, antenna danglers and mast wrap arounds, knob danglers for TV sets, bulletin board displays, colorful banners, plus hard-selling door hangers to give you leads . . . arm patches and truck signs; window banners to identify you as an "Accredited Reception Specialist"—issued by the American Institute for Better Television Reception.

ADVERTISING! Jerrold's automatic co-op ad program means business. Sales-building ads are easily adapted to give you an individualized ad program that tells everyone to see you for expert antenna services.

HOW TO! Jerrold and your distributor will invite you to dramatic meetings to show you how to take advantage of the booming color TV, second set, UHF and FM stereo antenna markets. You ring up the profits.

SALES! Jerrold packages consumer-accepted antenna systems and reception aids that are right for the specific needs of your area. Consumer acceptance means high sales volume.

PROFITS! You'll profit as never before with Jerrold's Show 'n Sell program. Talk to your Jerrold Distributor fast—he'll show you how to set new profit records this spring.

JERROLD ELECTRONICS CORPORATION
Distributor Sales Division
401 Walnut St., Philadelphia, Pa. 19106

JERROLD

... for more details circle 102 on postcard

APRIL 1966
VOL. 83 NO. 4

ELECTRONIC TECHNICIAN

WORLD'S LARGEST ELECTRONIC TRADE CIRCULATION

RON KIPP Publisher
JACK HOBBS Managing Editor
QUINTO BOCCHI Technical Editor
DOUGLAS HEDIN Industrial Editor
RICHARD CLAYTON Field Editor
DONALD GRANT Assistant Editor
JUDITH BERINI Editorial Production
MAGGIE KANE Advertising Production
GEORGE LIPPISCH Artist
RUTH GELINEAU Circulation Fulfillment



AN OJIBWAY
PUBLICATION

OJIBWAY PRESS, Inc.

Ojibway Building, Duluth, Minn. 55802
AREA CODE 218 727-8511

PUBLICATIONS DIVISION:

ROBERT EDGELL President
ANGUS STONE Marketing Manager
BEN MARSH Editorial Director
HARRY RAMALEY Production Director
JIM GHERNA Art Director
JOE WOLKING Circulation Director
WARREN BODIN Ad Production Supervisor

Sales Offices:

NEW YORK: Ron Kipp, 25 W. 45 St.
New York, N.Y. 10036
AREA CODE 212 581-4200

CHICAGO: Jack Daniels, 221 N. LaSalle
St., Chicago, Ill. 60601
AREA CODE 312 CE 6-1600



Copyright 1966 by Ojibway Press, Inc., Duluth, Minn. 55802. Reproduction and reprinting prohibited except by written authorization of the publication. Subscription price: \$5 for 1 year, \$8 for 2 years, \$10 for 3 years. Pan American and Foreign, \$9 for 1 year, \$14 for 2 years, and \$18 for 3 years.

If you have a change of address or a question about your subscription, write: ELECTRONIC TECHNICIAN, Circulation Department, Ojibway Building, Duluth, Minnesota 55802. BE SURE TO SEND ALONG THE ADDRESS LABEL FROM YOUR MOST RECENT ISSUE. Second class postage paid at Waseca, Minnesota and at additional mailing offices.

POSTMASTER: Send notification form 3579 to ELECTRONIC TECHNICIAN, Ojibway Building, Duluth, Minnesota 55802.

Cover

Eleven seconds past 5:16 p.m. on November 9, 1965, a backup protective relay in a Canadian hydro electric plant tripped out a power line which set off a chain-reaction power failure and black-out in most of the Northeastern section of the United States. Millions of battery operated solid-state radios have been credited with the possible prevention of serious and widespread public reaction during the candle-light hours that followed.

FEATURES

- Making Money With Garage Door Operators** 43
Tells you how to service a remote control item that becomes more popular every year
- What About CATV?** 48
The first in a series of articles giving the history of community antenna TV systems
- You and Color TV** 53
How to use a scope and color generator to troubleshoot chroma circuits
- 'Call-Backs' Can Break You!** 56
How to cut your call-backs below the ulcer-giving level
- The Future Looks Bright For Two Home-Audio Specialists** 58
Two partners tell how they are operating their Hi Fi business
- The New Look In Citizens Band Radio** 60
The status of CB up to date
- Selecting the Best Antenna For A Given Job** 62
Antenna specifications are not as confusing as they may appear

DEPARTMENTS

- | | | | |
|-----------------------|----|------------------------|-----|
| Editor's Memo | 24 | New Products | 70 |
| Letters to the Editor | 26 | Book Reviews | 90 |
| Sync on Business | 32 | News of the Industry | 93 |
| Technical Digest | 36 | Catalogs and Bulletins | 98 |
| Colorfax | 64 | Advertisers Index | 100 |

TEKFAK ----- 16 PAGES OF THE LATEST SCHEMATICS

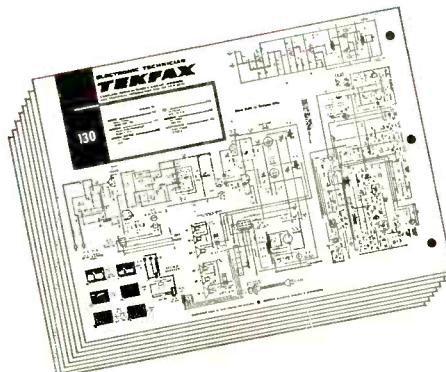

- ADMIRAL: Color TV Chassis G13 Series
RCA VICTOR: TV Chassis KCS144E
SEARS-SILVERTONE: Color TV Model 6164
SYLVANIA: TV Chassis A02-1, -2
WESTINGHOUSE: TV Chassis V-2486 Series
ZENITH: TV Chassis 14N22

Hard-Sell vs Soft-Sell

Inertia is one major human characteristic. It no doubt accounts for the reason why most humans, long accustomed to soft-seated jobs, usually struggle hard to keep their down-bottomed chairs even though others are frequently better qualified to sit in those chairs.

And this probably explains why new ideas and better ways of doing things are frequently difficult to sell and why old ideas die hard.

The modern philosophy of selling has come a long way during the past decade. The foot-in-the-door salesman is dead — or at least in a state of obsolescence. But some people don't know that — yet. One reason is, they were long ago kicked upstairs to soft seats and now direct others who do the selling. And, in some cases, they're doing a poor job of directing. Their selling ideas have gone the way of last autumn's leaves.

It's time to inform these "directors" that the man in the street doesn't fit Barnum's concept any more. The man in the street is now much better informed — primarily because of the knowledge-explosion through communications technology.

That brings us to a point we've had hammered into our head recently. It concerns technicians who attend manufacturers' "service meetings," "seminars," etc., ostensibly designed to inform technicians about up-to-date techniques for servicing color and solid-state equipment. Some technicians feel that these meetings frequently turn out to be just old-fashioned snake-oil and horse-liniment bally-hoo sessions on particular products the manufacturer sells.

No one can blame a manufacturer for thumping his tub or tooting his horn. If he has anything worth selling it's worth advertising. But the meeting that's promoted as a "service seminar" is not the proper place, is it? If you're ever the subject of this brand of captive-audience opportunism, let your objection be heard.

We believe those manufacturers who do more "service-seminar" informing will, in the long run, promote a public image that will be remembered longer in the years ahead — a "service-rendered" image that will soft-sell itself throughout the countryside.



Look what's happened to the RCA WR-51A FM Stereo Signal Simulator

...it got to be the WR-52A...

NEW, REDESIGNED AND IMPROVED

Last year we decided to make a few improvements in our WR-51A Stereo FM Signal Simulator...for two years THE established test instrument for multiplex stereo servicing. We intended to call it the WR-51B. But one thing led to another and we made so many extensive improvements that we virtually had a new instrument on our hands. You're looking at it: the NEW RCA WR-52A STEREO FM SIGNAL SIMULATOR.

We've added an RF Deviation Meter to measure the modulation level of both stereo and monaural FM signals. The meter is also used to accurately establish the level of the 19 Kc subcarrier.

We've included provisions for modulating left or right stereo signals with an external monaural source.

We've added a switch to disable the 19 Kc oscillator to provide a low-distortion monaural FM output.

We've added a new frequency (72 Kc)...required, along with the 67 Kc frequency, for trap alignment in some sets.

These features, together with numerous internal circuit design changes have resulted in a vastly improved, almost completely new instrument. And, the RCA WR-52A includes all those features that made its predecessor such a valuable servicing tool.

□ COMPOSITE STEREO OUTPUT—for direct connection to multiplex circuit

Choice of left stereo and right stereo signals

□ RF OUTPUT—for connection to receiver antenna terminals

100 Mc carrier, tuneable
Choice of FM signals—left stereo, right stereo, monaural FM, internal test and 60 cycle FM sweep
FM stereo deviation adjustable from 0-100%
100 Mc sweep signal adjustable from 0 to more than 750 Kc at a 60 cps rate

RF output attenuator

□ CRYSTAL-CONTROLLED 19 Kc SUBCARRIER ($\pm 0.1\%$)

□ SINE WAVE FREQUENCIES

Three low-distortion frequencies—400 cps, 1 Kc, 5 Kc

Two crystal-controlled frequencies—19 and 38 Kc
Additional frequencies—67 and 72 Kc for trap alignment

□ READILY PORTABLE—weighs only 12¾ pounds, measures 13½" by 10" by 8"

□ COMPLETE WITH WIRED-IN CONNECTING CABLES

We also raised the price...just 50 cents. The WR-52A is now \$250.00.* Ask to see it at your Authorized RCA Test Equipment Distributor.

*Optional distributor resale price, subject to change without notice. May be slightly higher in Hawaii and the West.

RCA ELECTRONIC COMPONENTS & DEVICES, HARRISON, N.J.



The Most Trusted Name in Electronics

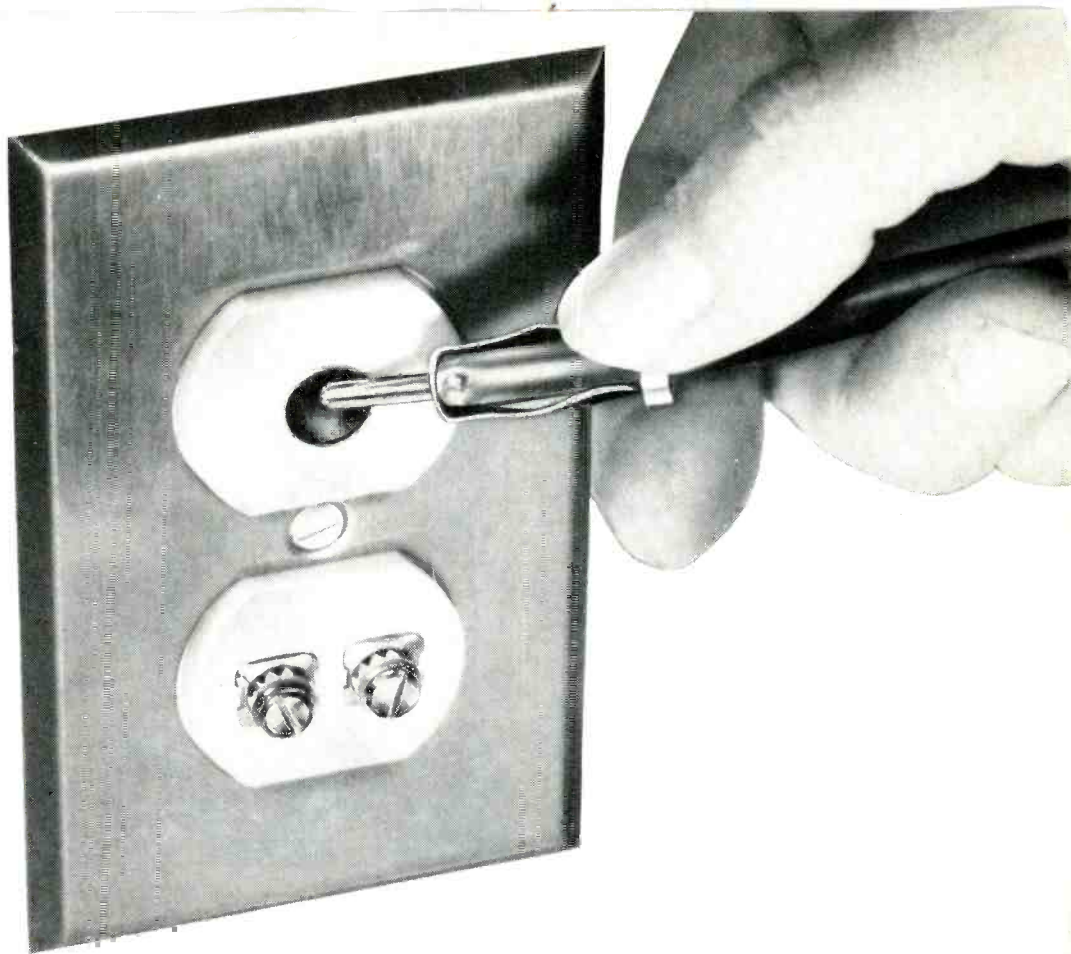

The most important connection you can make for FULL PROFITS from FULL-HOUSE TV!

The demand for multiple outlet, Master Antenna TV installations has entered a totally new phase . . . one which goes far beyond the already big market for commercial applications and reaches to millions of newly created multiple set homes.

Color TV. . . as well as increasing FM multiplex popularity is the big reason why. Every homeowner who buys a color set instantly becomes a prospect for a residential MATV installation to operate two, three, or more receivers with maximum quality reception from one antenna.

New Channel Master mass production techniques on the same precision-quality, commercial-grade MATV components designed for big building applications have resulted in equipment price reductions that average 25% and more per installation. For MATV installing companies

this means more volume and profit from highly competitive commercial jobs. For radio-TV service dealers it means an opportunity to get started in a totally new, high-income business meeting the booming demand for residential master antenna systems. The market is here now. And, it represents business that only you . . . a qualified service technician . . . can get.

NEW . . . for the age of COLOR

Channel Master announces a new 15 db commercial-grade amplifier, Model 7035, with dual 75 or 300 ohm inputs and outputs that make it ideal for private home MATV systems. Call your distributor or write Channel Master for details.

IMPORTANT . . . Contact your Channel Master distributor now for details on a complete MATV system design and installation course.

CHANNEL MASTER

ELLENVILLE, N.Y.

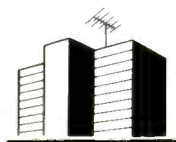

. . . for more details circle 109 on postcard

SEE YOUR ELECTRONICS PARTS DISTRIBUTOR:

Weller® for every soldering job

Pencil Soldering Irons by Weller



"Marksman" Kit with pencil soldering iron; screwdriver, cone and chisel tips; handy soldering aid and a supply of solder. **\$444** list Model SP-23K.



"Marksman" Iron at popular price. Stainless-steel long-reach barrel. 1/8" replaceable tip. Maximum tip temperature, 750°F. **\$298** list Model SP-23.



Weller Iron is industrial rated, highly efficient. Does work of bigger irons. Only 7 7/8" long including the tip. 25 watts. 115 volts. **\$520** list Model WP-S.

Temperature Controlled Soldering Unit

For universal hobby soldering, including heavy-duty metal work. Temperature control is in the tip. Interchangeable tips give a choice of 500°F, 600°F, 700°F and 800°F controlled temperatures. Operates on 24 volts. Complete with 3/16" 700°F tip and 60 watt, 120 volt, 50/60 cycle power unit with soldering pencil stand and tip cleaning sponge attached. Model W-TCP. **\$260** list



Dual Heat Soldering Guns

100/140 Watts. Two trigger positions let you switch instantly to high or low heat to suit the job. Tip heats instantly and spotlight comes on when trigger is pulled. Tip has exceptionally long reach. Model 8200. **\$695** list

145/210 Watts. A professional model with all Weller gun features: instant heat, dual heat, spotlights. Model D-440. **\$995** list

240/325 Watts. Heavy-duty model with all Weller gun features: instant heat, dual heat, spotlights. Model D-550. **\$1095** list



Dual Heat Soldering Gun Kit

Includes Weller 100/140 watt dual heat gun, 3 soldering tips, tip-changing wrench, soldering aid, flux brush, supply of solder . . . all in a colorful utility case of break-proof plastic. Model 8200PK. **\$895** list



Heavy-Duty Soldering Gun Kit

Features Weller 240/325 watt dual heat gun; tips for soldering, cutting and smoothing; tip-changing wrench; solder; metal-tone utility case of break-proof plastic. Model D-550PK. **\$1295** list



Utility Grade Solder On Hang Cards 5 feet of 40/60 alloy solder in each pack. Acid core, AC-40. **39¢** list. Rosin core, RC-40.



Superior Grade Solder In Dispenser Tubes 10 feet of 60/40 alloy rosin-core solder in each tube. Number RC-60. **59¢** list

WELLER ELECTRIC CORPORATION, Easton, Pa.
WORLD LEADER IN SOLDERING TECHNOLOGY

. . . for more details circle 146 on postcard

LETTERS TO THE EDITOR

Swap Schematics

I'm trying to build my collection of transistor radio, tape recorder, etc. schematics, plus foreign models using tubes. Would anyone be interested in exchanging extra copies? I have a copying machine and for those with only one schematic of a kind I'll be glad to make an extra copy in exchange for a loan of their copy. . . .

LEO TONELLI

Toronto, Ontario, Canada

Likes ET

I have enjoyed every issue of ELECTRONIC TECHNICIAN and every article in it and I know that thousands of other readers agree . . . Keep up the good work.

ALLEN JOHNETTE

San Antonio, Tex.

Needs Roll Chart

I need an up-to-date roll chart for a Model TV-11 tube tester. Can any one help me?

FRAN CARCIA

Columbus, Ga.

Specializing

I gain much useful information from your timely articles. I am primarily concerned with articles on TV sales and service as I am planning on gradually "phasing out" my other servicing activities. During the last few years I have found it increasingly difficult for a small shop to be very diversified as far as servicing is concerned. It is no longer practical to carry the necessary stock and have the required service information, both of which are essential to good, fast servicing . . . I am also concerned with UHF reception. I need literature on UHF field strength meters. As you well know, it is very difficult to find a signal in some areas and a battery operated field strength meter would certainly be a valuable instrument. I have never seen such an instrument advertised . . .

S. CROTEAU

Redwood Valley, Calif.

• The concept of 'specializing' ('thinking small') by smaller service operations is generally considered a sound approach. Only the larger operations have what is necessary to diversify ('think big').—Ed.

WHY

bother with makeshift twist-prong capacitor replacements?

When you substitute capacitor sizes and ratings, you leave yourself wide open for criticism of your work . . . you risk your reputation . . . you stand to lose customers. It just doesn't pay to use makeshifts when it's so easy to get the exact replacement from your Sprague distributor!

Get the right SIZE,
right RATING every time
with improved



SPRAGUE TWIST-LOK® CAPACITORS!

1,863 different capacitors to choose from!

The industry's most complete selection of twist-prong capacitors, bar none. Greater reliability, too. Exclusive Sprague cover design provides a leak-proof seal which permits capacitors to withstand higher ripple currents.

GET YOUR COPY of Sprague's comprehensive Electrolytic Capacitor Replacement Manual K-107 from your Sprague Distributor, or write Sprague Products Co., 65 Marshall St., North Adams, Massachusetts.



WORLD'S LARGEST MANUFACTURER OF CAPACITORS

65-122-63 RT

APRIL 1966

. . . for more details circle 142 on postcard

27

LETTERS TO THE EDITOR

Updates Us

In general your article on "Solving UHF Reception Problems" in the February issue was well designed to alert service-dealers to the special precautions necessary when dealing with UHF signals. However, we feel that there are several recent technical developments in UHF which were not covered in the article and should be brought to the attention of your read-

ers. First, the problems of locating a UHF antenna with respect to a VHF antenna on the same mast are solved by using one of the new properly engineered combination UHF/VHF antennas with a rotator. By designing the antenna so that both VHF and UHF sections are integrated in a single unit so that each can be used to enhance the performance of the other, the prevalent dangers of upsetting VHF performance by installing a UHF antenna on the same mast have been largely overcome. With one of these units only one download need be run from antenna to set.

Efficient filter networks are now

available which will split VHF and UHF signals arriving at the set on a single download. These networks can also be used to combine the signals from separate VHF and UHF antennas into a single lead-in. Insertion loss on the best of these units is negligible except in the most marginal of situations.

Also newly available are 300-ohm shielded encapsulated lead-ins which combine the low-loss, good match characteristics of twin-lead with the interference rejecting properties of coaxial cables. The case of installing this shielded lead without regard to avoiding obstacles so that stand offs are not required largely compensate for the additional cost.

PAUL E. MAYES
Technical Consultant
JFD Electronics Corp.

Champaign, Ill.



NEW BANNER 85! 8 channel CB and AM broadcast combined in one radio for only \$99.50

Once again, you get more from Hallmark technology. Unexcelled top performance from the 8-channel, crystal-controlled CB operation, plus full-fidelity AM broadcast — two radios in one, at one amazing low price!

With rugged hand-wired reliability, the Banner 85 CB fea-

tures 0.3 μ v for 6 db S+N/N ratio, 45 db selectivity, full 4 watts power output, and high level modulation. A switch-controlled on-off automatic noise limiter improves reception in congested regions, extends range in quiet areas. The AM broadcast outperforms most car radios.



New T/C/I Ranger! All solid-state CB with unique pre-aligned modular plug-in circuits. Push-button channel selectors. Noise immune squelch, compression amplifier for high modulation, optional fully-regulated DC power supply.

Part 95, FCC Rules, applicable to operation.

Write today for complete information!

HALLMARK INSTRUMENTS

Sales Office: P. O. Box 502, Richardson, Texas 75080 (AC 214) AD 1-3453
Plant: 1601 W. Broadway, Lubbock, Texas 79401



A DIVISION OF The Nova Corporation

... for more details circle 119 on postcard

Scope Isolates Trouble

Here's one that had me going for a while and it may help some other technician. This Zenith 19L26 had poor horizontal hold. It would hold for hours and then lose horizontal sync. About 3 turns of the horizontal hold would bring it back — but the picture would be very touchy . . . In

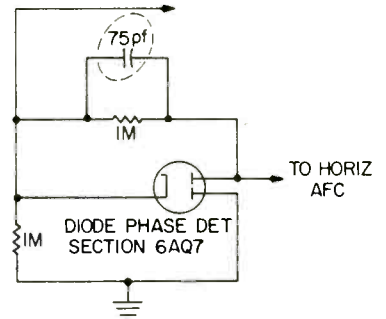

scoping the horizontal oscillator we discovered that it *did not change* frequency when the sync went bad. This indicated the trouble was in either the AFC or sync circuits. The 75pf capacitor shown in the simplified schematic checked good with a VTVM — but in the capacitor checker it would break down on any voltage above 150v. When the voltage was reduced it would heal up again. A new one solved the problem, of course.

ORVILLE CONARD
Green Forest, Ark.

Needs Speaker Parts

Never see anyone run an ad on speaker cones, spiders, voice coils, etc. I'd like to know where to get a supply.

FRANK'S AUTO RADIO
El Monte, Calif.

• We have not been able to locate a small-lot supplier.—Ed.

First UHF/VHF/FM 2-83 antenna that really works in fringe areas

New Winegard Chroma-Tel CT-100

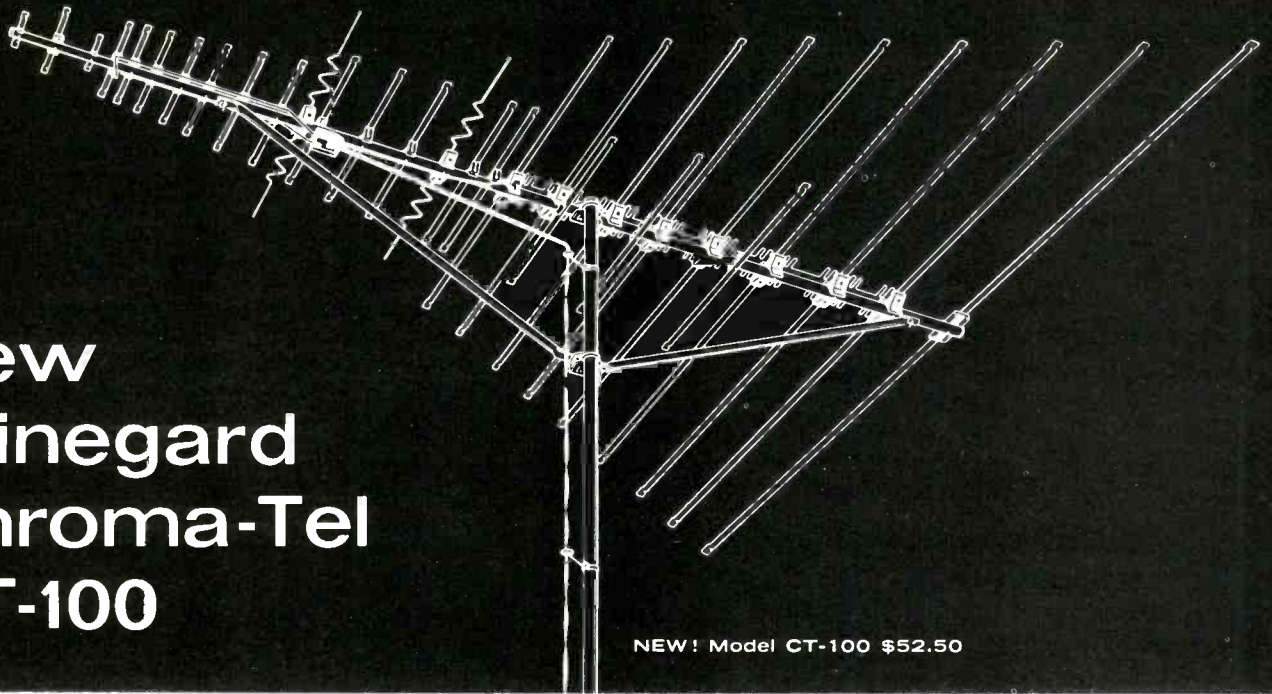

NEW! Model CT-100 \$52.50

Winegard's sensational new CT-100 Chroma-Tel has 29 elements in all. And they're all working to provide the finest all-band reception (UHF-VHF-FM) even in difficult fringe areas.

In addition to those 29 elements, the CT-100 incorporates a unique matching network that guarantees maximum signal transfer to the downlead—and on all channels 2-83 plus FM. Gives sharpest color and black & white reception.

And like all Chroma-Tels, it has Winegard's exclusive Chroma-Lens Director System (intermixes both VHF and UHF directors on the same linear plane without sacrificing

performance) . . . and our Impedance Correlators (special phasing wires that automatically increase the impedance of Chroma-Tel's elements to 300 ohms).

That's Winegard's new CT-100 Chroma-Tel. Bigger and better. But not too big. The full-line of Winegard Chroma-Tels still offers half the bulk; half the wind loading; half the truck space; and half the weight of all other all-band antennas—and at much lower prices. No wonder Winegard Chroma-Tels (now 4 models) are the hottest performing, hottest selling all-band antennas on the market! Better call your Winegard distributor or write for Chroma-Tel Fact Finder 242.

Model CT-40 \$17.50



Model CT-80 \$27.50

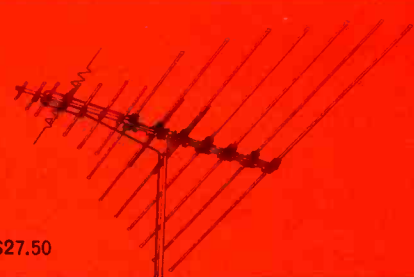

Model CT-90 \$37.50

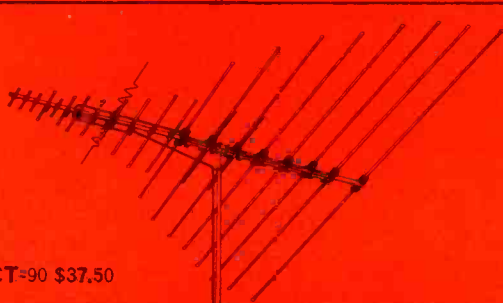

FREE!

Every Winegard Chroma-Tel, including the new CT-100, comes complete with free CS-283 UHF-VHF Signal Splitter. Hangs behind set and separates UHF and VHF signals coming from antenna to the two pairs of set terminals.



LETTERS TO THE EDITOR

Eagle Eyes

As you undoubtedly realize by this time, the Log of 6 is incorrectly given in Chart 3 on page 84 in the February 1966 issue. It is 0.778 — not 0.802. Furthermore, the logarithms of 5 and 6 do have relations to the others in a manner easy to recall once one knows the intent of logarithms. For years I have used a method of remembering the loga-

rithms of the number from 1 to 10 which entails little rote memorization. It is most easily explained in steps: 1) Rote memorize the logarithms of 1, 2, 3, 7 and 10; 2) obtain the logarithms of 4 and 8 from the logarithm of 2 as given in the article; 3) obtain the logarithm of 9 as given in the article; 4) obtain the logarithm of 5 by subtracting the logarithm of 2 (0.301) from logarithm 10 (1), or 0.699; 5) obtain the logarithm of 6 by adding the logarithms of 2 (301) and 3 (0.477), or 0.778. It sounds complicated, but is basically easy, especially if one uses memory aids. The logarithm of 10 to the base 10 is

1 by definition. The logarithm of 1 to any base is zero. The value for the logarithm of 2 can be remembered by relating it to the common knowledge that 3db up represents a power gain of double (2). Moreover, if one forgets the logarithm of 3, the logarithm of 9 can be obtained with only small error by merely taking it to be midway between the logarithm of 8 and the logarithm of 10.

CHARLES BAKER

Indianapolis, Ind.

Dial Stringing Aids

Regarding your article "Dial 'B' For Broke," I have always found dental picks an invaluable aid in restringing dial cords. They cannot be matched when making the last loop around the pulley and when placing the end of the tension spring in place. A second aid is powdered resin rather than the liquid mentioned in your article. I carry it in an empty "Polaroid" coating wiper-tube which fits inside the spool of dial cord.

DICK CALKINS

Akron, Ohio

Help

Can any ET reader help me? I need a schematic, data and parts list for a Hickok tube tester Model 540? Write via ET.

ROBERT ULSCHMID

Glendale, N.Y.

More on Le Coq

"A Toast To The Designers" was very consoling. I sometimes wonder why I get up some days . . . I think it's about time these designers get on the wagon.

JOHN DAVIS

Longview, Tex.

. . . In all my 47 years of servicing I have never read as good an article as "A Toast to the Designers." May God have mercy on their souls—for all the swearing they have made technicians do . . . I'm not usually a letter writer but let me take this opportunity to tell you that ET is the best magazine in the business. . . .

CARL WAGNER

Washington, Pa.

Needs Info On Old Color Set

I need a book "Principles of Color TV and Technical Features of the RCA Victor Model CT100 Color TV Receiver." Can anyone help me?

C. NAVARRO

Los Angeles, Calif.



...IT'S THE FINEST

Model CRO-3 5-inch

Wide-Band, High Sensitivity Oscilloscope

essential for booming
COLOR TV
servicing . . .

basic for
BLACK/WHITE TV
servicing . . .

... also widely used
in the laboratory
and in industry

The Jackson CRO oscilloscope was designed as a wide band scope when color TV first made its entry into the field. It is widely used by professionals who laud its stable circuitry, accuracy and extraordinary laboratory quality. It has constantly been improved upon by Jackson engineers, making the present Model CRO-3 the finest instrument of its type.

ACCESSORY PROBE FOR THE JACKSON CRO-3

LC2-1P Low Capacity Probe . . . \$19.95

Size: 10 1/8" W x 16 3/4" D x 13 1/8" H.
Wt.: 18 lbs. 6 oz.



SPECIFICATIONS

- Wide band amplifier, flat within 1 DB from 20 cycles to 5 MC
- Two range vertical deflection sensitivity from 0.018 RMS volts per inch
- Highly stable amplifier circuits...no balancing required
- Positive or negative internal horizontal sync
- Linear sawtooth sweep oscillator, 20 cycles through 50 KC
- Input calibrating voltage, 10 volts peak-to-peak
- Vertical polarity reversal
- Horizontal sweep expansion
- Return trace blanking
- Z-axis modulation...external or internal 60 cycle
- Direct connections to deflection plates when required
- Includes LC10-P High Voltage Low Capacity Probe and DEM-P Demodulation Probe

Dealer Net \$254⁹⁵

See your Jackson distributor, or write for catalog

JACKSON ELECTRICAL INSTRUMENT COMPANY

35 Windsor Avenue, Mineola, New York 11501

In Canada: William Cohen Corp. Export: Morhan Exporting Corporation
458 Broadway, New York 13, N.Y.

IF IT'S A JACKSON...IT'S THE FINEST

... for more details circle 124 on postcard

Join our profit-sharing plan for color TV repair.

Here's how the plan works. First, Sylvania advertises you in TV Guide as the right TV serviceman for color repair—Mister Right. We make you a big name in a booming business.

We have all kinds of tie-in display pieces.

We supply you with our color bright 85™ picture tube and color receiving tubes that you can push or ignore, since you're independent.

And the payoff: you get the profits from all the new color TV repair business we send you. We get more profit because we make more replacement parts. No one else offers

you a profit-sharing plan like this because no other major tube manufacturer deals exclusively with the

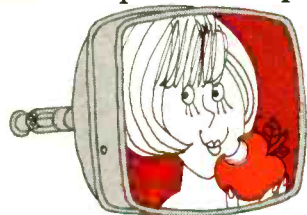

Independent Service Dealer.



In the Mister Right part of the plan, your Independent Sylvania Distributor puts your name, town and phone number in up to four TV Guide ads this year. You're listed right next to our big, full-color ads that talk about you.

He also gives you up to nine Mister Right display pieces. Free banners, displays to spark up your windows, decals and cards. And, an illuminated Color TV Service sign for a slight charge.

So join our profit-sharing plan. There'll be a lot to share. See your Independent Sylvania Distributor.

Sylvania Electronic Tube Division, Electronic Components Group, Seneca Falls, New York 13148.

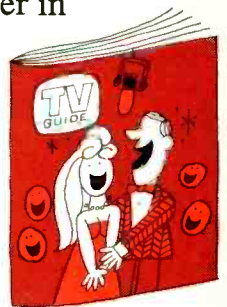

SYLVANIA
SUBSIDIARY OF
GENERAL TELEPHONE & ELECTRONICS GTE

**"TAKING THE
COUNTRY BY
STORM!"**

**THE ALL NEW
IMPROVED
SENCORE
TC136 MIGHTY MITE IV**



Now Americas Number ONE Tube Checker . . .

Checks compactrons, novars, nivistors, 10 pins and the latest 10 pin used in many new color TV sets, plus over 1200 foreign tubes. The Mighty Mite is so popular because it checks each tube for:

- **GRID LEAKAGE** of as little as 1/2 microamp or 100 megohms
- **EMISSION** at tubes full rated cathode current
- **SHORTS** of 180K or less between elements

With These New Exclusive Mechanical Features . . .

- New third hand set-up book holder.
- New removable hinged cover
- New taut band meter

Get your Mighty Mite from your distributor now, and join the more than 30,000 Mighty Mite users the world over. **\$74.50**

SENCORE

426 SOUTH WESTGATE DRIVE • ADDISON, ILLINOIS

. . . for more details circle 140 on postcard

SYNC ON BUSINESS



A close-up mike, claimed by the manufacturer to cancel all sound originating more than one-quarter inch from the unit, is a dynamic handheld type, model 602F. Designed for audio and radio communications, it has a response from 200Hz to 5kHz. Noise cancellation is achieved by a balanced port opening which directs unwanted sound to the rear of the diaphragm, out of phase with the same sound arriving at the front. Also recommended for commercial and industrial paging and public address where severe feedback is caused by speaker and microphone locations. By Electro-Voice, Buchanan, Mich.

• • •

"Snap-together" TV and audio controls are described in a new 4-page brochure from Clarostat Mfg. Co., Dover, N.H. The line of field-assembled controls is said to permit electronic parts distributors to snap together standard and non-standard controls to fill more than 95 percent of all possible servicing requirements. A quick-reference replacement guide references manufacturers model numbers to assembly number, control function and control component parts.

• • •

A complete 8-hour "music library on tape" which dealers can give to purchasers of a Norelco continental 201 tape recorder, free listings in TV guide and local newspaper ads, plus a bonus advertising allowance, are highlights of a spring promotion announced by North American Philips Co. Dealers will also receive 50 copies of a popular 192 page paperback, "Family Fun In Tape Recording," with counter dispenser.

• • •

Communications crystals for marine and CB equipment are available from R. S. Puleo, 5 Whittier St., Lynbrook, L.I., N.Y. 11563. Crystals are shipped air mail special delivery and stocks are on hand for railroad, petroleum, power, public safety, business, aviation and other radio services, the manufacturer says. Prices and lists of selections are available on request.

• • •

A cartridge replacement manual for 1966, covering a total of 5700 cross-referenced listings, is now available from Sonotone, Elmsford, N.Y. 10523.

• • •

Magnetic tape tracks can be viewed by using two non-toxic, non-flammable chemical solutions which permit users to view the magnetic track on video, instrumentation and sound recording tape. At your jobber or write direct to Reeves Soundcraft, Great Pasture Road, Danbury, Conn., for full information.

Complete TUNER REPAIR for only

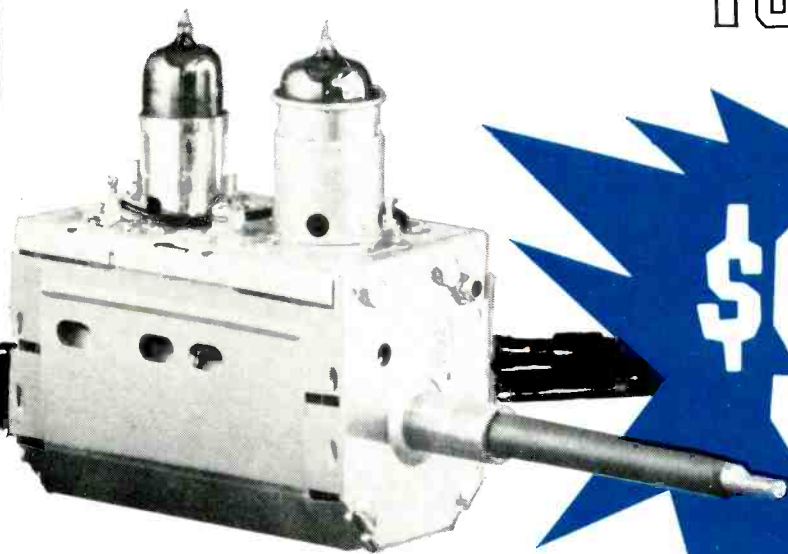

\$9.50

Sarkes Tarzian, Inc., largest manufacturer of TV and FM tuners, offers unexcelled tuner overhaul and factory-supervised repair service. Completely-equipped and conveniently-located Service Centers offer fast, dependable and factory-supervised repair service on all makes and models. Centers are staffed by well-trained technicians, assisted by engineering personnel.

Tarzian-made tuners received one day will be repaired and shipped out the next. More time may be required on other makes. Every channel—not just the channels existing in any given area—is checked and re-aligned per orig-

inal specifications. Exclusive cleaning method makes the tuner look—as well as operate—like new.

Cost, including ALL labor and parts (except tubes) is only \$9.50 and \$15 for UV combinations. No additional charge. No hidden costs. Too, you get a full, 12-month warranty against defective workmanship and parts failure due to normal usage.

Always send TV make, chassis and Model number with faulty tuner. Check with your local distributor for Sarkes Tarzian replacement tuners, parts or repair service. Or, use the address nearest you for fast, factory-supervised repair service.

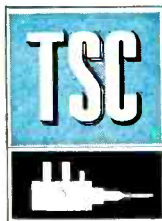

TUNER SERVICE CORPORATION

(Factory-supervised tuner service authorized by Sarkes Tarzian)

MIDWEST—817 N. Pennsylvania St.,
Indianapolis, Ind. Box 1642
Tel: 317-632-3493

EAST — 547-49 Tonnele Ave., Jersey City, N. J.
Tel: 201-792-3730

WEST—

SARKES TARZIAN, Inc.

Tuner Service Division

10654 Magnolia Blvd.,
N. Hollywood, Calif.
Tel: 213-769-2720



MANUFACTURERS OF TUNERS, SEMICONDUCTORS, AIR TRIMMERS, FM RADIOS, AM-FM RADIOS, AUDIO TAPE and BROADCAST EQUIPMENT

Gain to spare at the toughest location

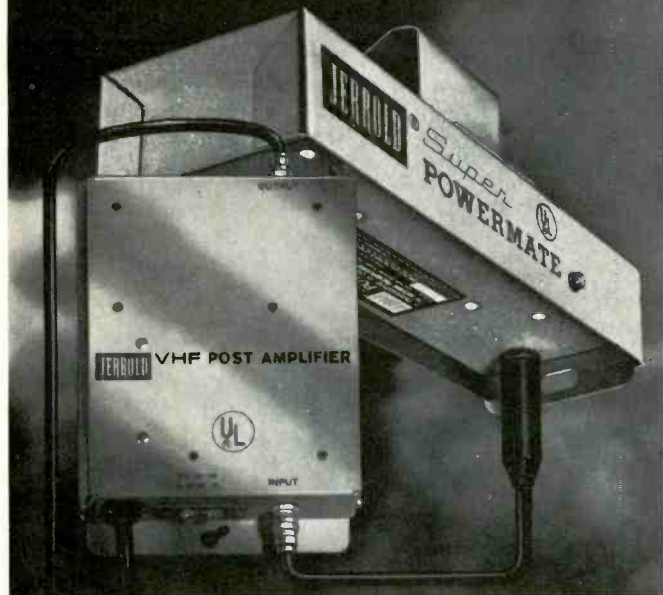

JERROLD SOLID-STATE "DE-SNOWER" AMPLIFIERS MODELS SPC-132, SPC-103

The famous Jerrold 5-transistor Powermate "De-Snowder," Model SPC-132, shown above, and its 2-transistor companion model, SPC-103, give you a choice of antenna-mounting coaxial VHF amplifiers that can't be equalled for bringing bright, snow-free pictures to master-antenna systems.

Their high gain (SPC-132 up to 29 db, SPC-103 up to 16 db) and extremely low noise figure make these preamps ideal for the really tough system installation from custom home to motel or apartment house. Coaxial downlead is a *must* for good color reception, and belongs in any quality system for longtime interference-free reception.

Examine the "De-Snowder" at your Jerrold distributor's, or write for complete information. *Jerrold Electronics, Distributor Sales Division, 4th & Walnut Sts., Philadelphia, Pa. 19105.*

JERROLD

... the most experienced name
in TV signal distribution



... for more details circle 126 on postcard

SYNC ON BUSINESS

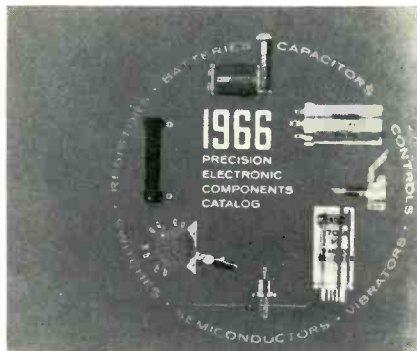
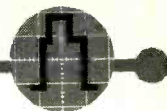

A general parts catalog covering batteries, capacitors, circuit breakers, controls, flashlights, jacks, plugs, rectifiers, resistors, semiconductors, timers and vibrators is a must for your service bench. At your distributor

or write Mallory Distributor Products Co., P.O. Box 1558, Indianapolis, Ind. 46206.

Selecting transistors for substitution in home entertainment products appears to be a problem at times. A complete transistor replacement guide for domestic and foreign original types is furnished by Semitronics Corp., New York, N.Y. 10013.

A UHF/VHF signal splitter made by Winegard fits on the back of TV sets. Known as CS283, it is a PC job and designed to separate UHF and VHF signals coming from a combination UHF/VHF antenna or antenna coupler. Pre-attached 300 Ω wires connect to the UHF and VHF antenna terminals on back of set or on UHF converter. VHF bandpass is 0-235MHz. UHF bandpass is 400-1000-MHz. It is said to have 15db minimum isolation to prevent interaction. At your jobber.

You may never get a call for a tuning fork but here's one that gives the classic "A" electronically. You may even be asked to repair or adjust one with WWV signals. It is called the Symphonic-Tuner and derives its "A" tone from a high-frequency tuning fork controlled oscillator. The frequency is divided within the unit to produce a 440Hz tone. It is already being used by many symphony orchestras and probably all the music schools will have them soon. They are made by Electronic Research Products, 951 Commercial Street, Palo Alto, Calif.

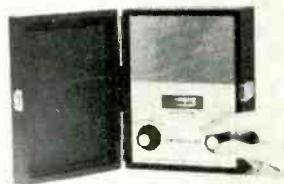

Transistor radio sales spurted during the 'black-out' power failure in the east. Transistor radio sales always spurt during the autumn months when hurricanes and twisters rush up the east coast, across the southern coast or inland in various areas. Now the National Association of Broadcasters (NAB) has endorsed a drive to encourage portable transistor receivers in every home. The FM Committee of NAB has approved a resolution requesting NAB to call on manufacturers, civil defense and broadcasters to encourage personal ownership of an AM/FM portable transistor radio. The Committee's action was based on results of a study of the 1965 Northeast U.S. power failure.

*the instrument with
endless uses...the all new
improved completely solid state
SENCORE FS134 FIELD STRENGTH METER*

HERE ARE JUST A FEW OF THE MANY USES...



A. Distribution Systems

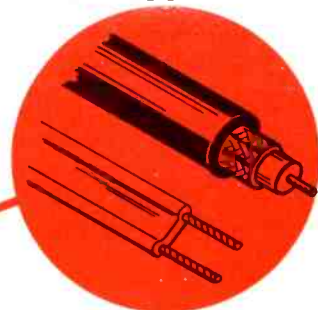

D. Transmission Lines



B. Antenna Installations

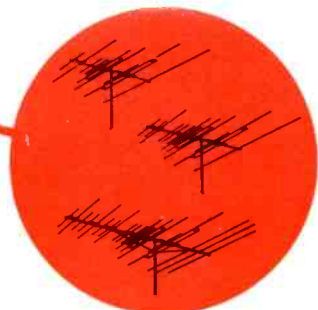

E. Antenna Comparisons

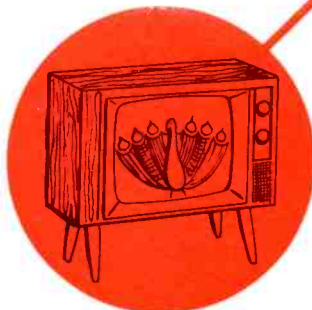

C. Color Insurance



F. Checking Generators

only
199.50
lowest price going

A. INSTALLING AND CHECKING OUT DISTRIBUTION SYSTEMS

Qualify for this multimillion dollar business in hotel, motel, and hospital installations.

B. INSTALLING UHF, VHF, AND FM ANTENNAS

Cut down installation time and pay for the FS134 in a short time on critical UHF as well as VHF and FM antennas.

C. COLOR INSURANCE

Be sure the signal is adequate on each channel for proper color TV operation.

D. CHECK TRANSMISSION LINES

For the first time read actual db loss in either 75 or 300 ohm transmission lines.

E. COMPARE ANTENNAS

For actual db gain; see which is best for each location, both VHF and UHF. Also excellent for

orienting "dishpans" for translator use at the high end of UHF band.

F. CHECK ANY GENERATOR OUTPUT

For correct frequency and output all the way up to a tenth of a volt RMS. What a time saver when you want to know if your generator is putting out.

PLUS: LOCALIZE NOISE AND INTERFERENCE

Find noise source fast; pick quiet locations for antenna installations or orient antenna away from noise when possible.

These are only a few uses of this UHF-FM-VHF accurately microvolt calibrated field strength meter. You can start paying for the FS134 tomorrow in the time saved today — if you see your Sencore distributor now. Why not pick up the phone and ask him to show you the new FS134?

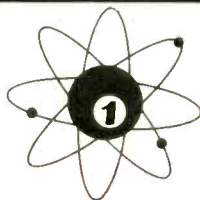

SENCORE

NO. 1 MANUFACTURER OF ELECTRONIC MAINTENANCE EQUIPMENT

426 SOUTH WESTGATE DRIVE, ADDISON, ILLINOIS 60101

... for more details circle 139 on postcard

TECHNICAL DIGEST

MAGNAVOX

TV Chassis T908—Power Supply and Tuner—Circuit Descriptions

Power Supply. The dc supply voltages in the T908 chassis are developed by two secondary windings on the power transformer. Five separate dc voltages are developed. A low voltage winding connected in a full wave rectifier circuit develops the +12v and +14.5v supplies. The +12v supply is regulated by a zener diode and operates most of the small signal type transistors. The

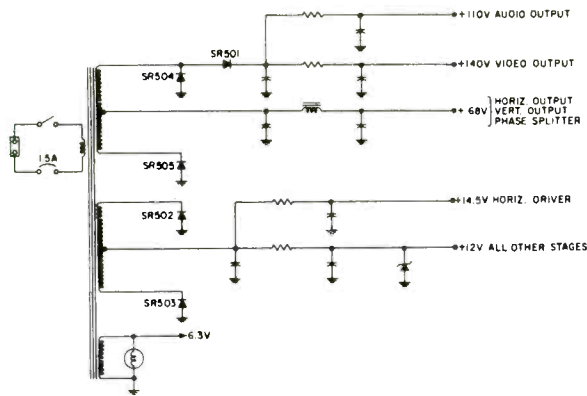

+14.5v supply is used only with the horizontal driver stage and is separated from the +12v supply to provide better decoupling of the horizontal sweep pulses.

The second winding is also connected as a full wave rectifier to provide a +68v output. This supply is used to power the horizontal and vertical output stages along with the phase splitter. SR501 operates as a half wave rectifier to produce two higher dc voltages. The +140v supply is used by the video output stage and the +110v supply is used by the audio output stage. A 6.93vac winding supplies the pilot lamps and the filament of the CRT.

Tuners. An incremental inductance VHF tuner is used with the T908. In this type of tuner, small amounts of inductance are switched in or out as the channel selector is rotated from one station to another. The tuner in-

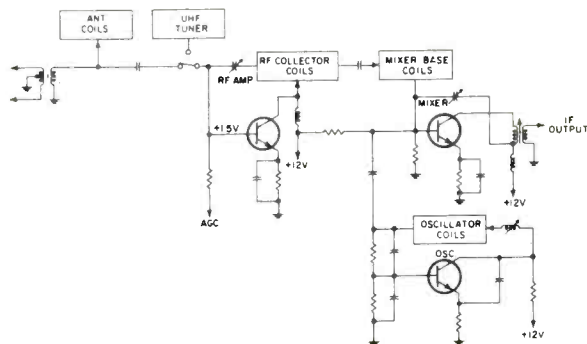

corporates NPN silicon transistors in the RF, mixer and oscillator stages. The RF amplifier is neutralized for stability and is controlled by a delayed RF AGC voltage. A nominal +1.5v is applied to the base of the amplifier so that the stage operates at maximum gain. When the received signal becomes strong enough an RF AGC voltage is developed which reduces the gain of this stage. The RF amplifier also functions as a 40 MHz IF

amplifier when the tuner is set to the UHF position.

Signals from the collector of the RF stage are coupled to the base of the mixer stage where they combine with the oscillator signal. The mixer output signal is then developed across the IF transformer in the collector circuit and link-coupled through coaxial cable to the first IF amplifier. The mixer is neutralized by coupling a portion of the output signal back to the base.

The oscillator uses the modified colpitts configuration. Feedback voltage for maintaining oscillation is developed across a capacitance voltage divider network in the base circuit. The resistors across the capacitors connect back through the oscillator coils to the 12v supply and provide the initial forward bias on the base to start oscillation.

The tuner features pre-set fine tuning. This is accomplished by switching in individual oscillator coils for each TV channel. When the fine-tuning control is pushed in, a gear train engages a gear on the oscillator coil slug. The gear-train disengages when the fine-tuning control is released. This pre-set tuning arrangement is the same as used on tube-type tuners.

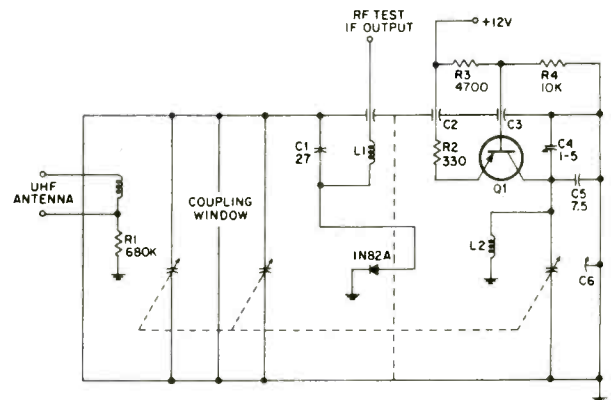

The UHF tuner is quite similar to the ones used with our tube-type models. It incorporates two passive RF preselector circuits, a PNP UHF local oscillator, and a 1N82A diode mixer. The tuner box is divided into three compartments: the RF preselector circuit, the mixer pre-selector stage and the mixer diode, and the third contains the oscillator circuit.

The antenna is terminated by two turns of wire which inductively couple the signal to the RF preselector circuit. This section consists of a solid metal bar with a variable capacitor attached to the one end to form a resonant circuit tuned to the incoming frequency. The signal is next coupled to a similar resonant circuit in the mixer compartment. Coupling is achieved through an opening in the partition which separates the two.

The signal is then coupled from the mixer preselector circuit to one end of the mixer diode by a short length of wire. The opposite end of the diode extends through a partition into the oscillator compartment. The oscillator signal is coupled into the mixer lead to combine with the received signal. The difference frequencies produced by beating the oscillator signal with the received signal are coupled through a low pass filter. This filter allows the 40MHz IF to pass through without attenuation but filters out the high frequency oscillator signal and the RF signal

Steve Lovitch is too busy to wait a week for any part to arrive.

Steve Lovitch keeps on the go. He gets a lot of business because he is running a Philco Qualified Service Center. And the attention he gets from his Philco Parts Distributor helps to keep things moving.

99 out of 100 times that Steve needs a part, he finds that his Philco Distributor has it right on hand. That hundredth time, Philco's Lifeline Emergency Service swings into action, and Steve's part is on its way to him — by air — in 24 hours or less.

That's not all Steve likes about being teamed up with Philco. He's his own boss, but he still gets all the training, attention and benefits he could want.

Philco Tech Data Service helps him keep posted on how to service new Philco products. Steve knows that he gets the facts faster, fuller and at lower cost through Philco. And Steve's other Philco benefits include a complete accident insurance program for himself and his men and valuable advice on how to make his business more profitable.

Steve Lovitch has a good deal. And he knows it. Shouldn't you find out what Philco can do for you? Talk to your Philco Parts Distributor, or contact Parts & Service Department, Philco Corporation, Tioga & "C" Streets, Philadelphia, Pa. 19134.

PHILCO
A SUBSIDIARY OF *Ford Motor Company*



... for more details circle 133 on postcard

PINPOINT COLOR TV TROUBLES IN SECONDS...



WITH THE NEW IMPROVED SENCORE CA122(A) COLOR CIRCUIT ANALYZER

It's a standard ten color bar generator; produces vertical lines, horizontal lines, crosshatch, and adjustable dots, PLUS a complete TV analyzer for color and B&W—at less money than color generators only. Here is what the CA122(A) will do for you by tried and proven signal injection into these stages.

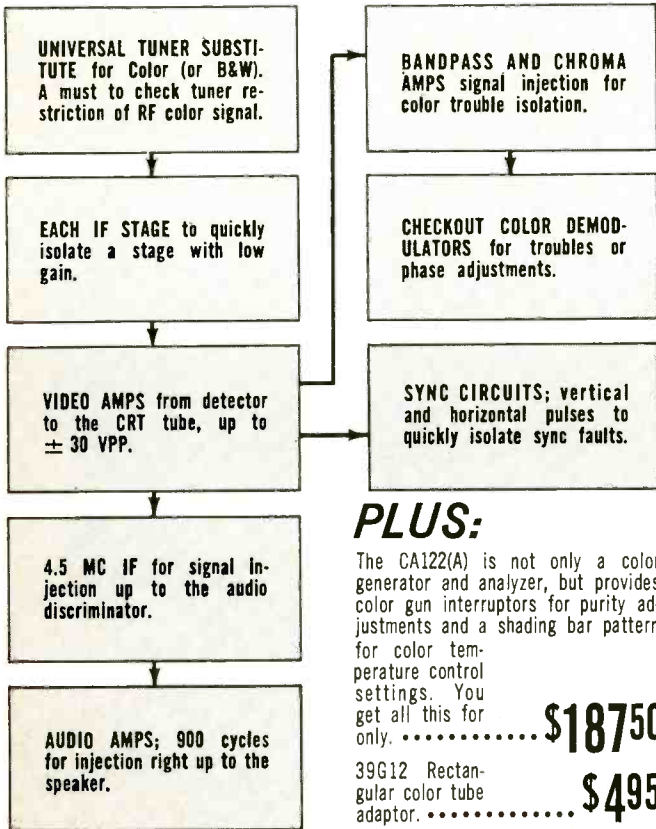

See your distributor today. He has the CA122(A) in stock now.

SENCORE

426 SOUTH WESTGATE DRIVE • ADDISON, ILLINOIS

... for more details circle 141 on postcard

TECHNICAL DIGEST

from the antenna. The output signal is cabled to the input of the RF amplifier in the VHF tuner. You will recall that this amplifier converts to a 40MHz stage when the tuner is switched to the UHF position.

A PNP transistor is used in the grounded-base oscillator circuit. Another tuned line is used to control the frequency of oscillation. Positive feedback from collector to emitter through the transistor's internal capacitance sustains oscillation. Forward bias is obtained from the voltage divider resistors in the base circuit.

GENERAL ELECTRIC

5B Chassis—High Voltage Rectifier Failures

A few cases of 1BC2 rectifier failure are attributable to the socket connections used in early production receivers. The internal construction of the 1BC2 includes

EARLY PRODUCTION

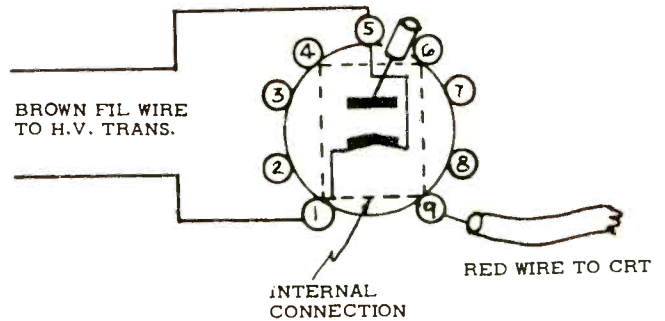

LATE PRODUCTION

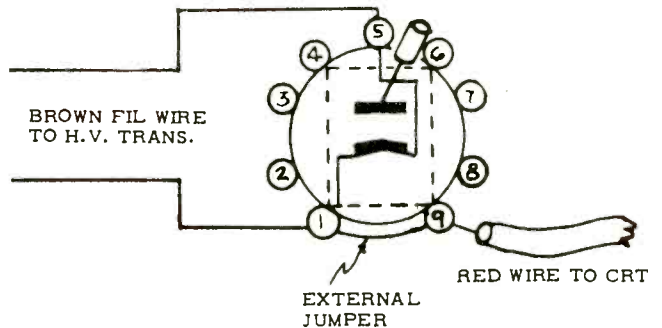

a corona shield which is supported by welding to the inner ends of pins 1, 4, 6 and 9. For convenience in assembly, early production sets were connected as shown in Fig. 1. It is apparent that the HV connections must pass through the internal connections in the tube and may not be opened in the event of a weld failure in the tube. Late production receivers are connected as in Fig. 2, which provides a positive HV connection to the tube filament and increases reliability. If you encounter any 1BC2 failures, you should install a jumper between lugs 1 and 9 of the tube socket. If the tube has failed because of an open weld, it may then operate without replacement. This jumper will also eliminate any possibility of subsequent tube failure from this cause.

Hayden Book Company and Electronic Technician solve a problem:

**How to break the expensive schematics habit
before it gets completely out of hand...**



MAKE IT A **LOW-COST
ANNUAL AFFAIR!**

starting now...

Invest in this 2-volume manual once a year....

Replacement Parts List

Less than 15¢
per schematic!

as easy to use
comprehensive
and indispensable as
the telephone book!

Complete Circuit Schematics

Actual page size — large 14¾ x 11 inches

ANNOUNCING... **TV TECH/MATICS '65**

- *What it is.* The first in an annual series of permanently bound information "packages" for the active television technician. It provides complete schematics and vital servicing data for every 1965 TV receiver produced by the leading American manufacturers. (See this year's list of 23 makers.) As an extra bonus, this first TV Tech/matics also covers all color sets made from 1960 to 1965.
- *What about depth of coverage?* First of all, you get a clearly detailed and annotated circuit diagram of the specific model. You also get the following: a replacement parts list, alignment instructions, tube and critical parts locations, and important voltage readings and waveforms. In other words — you get all the information you really need.
- *Is it a reliable source?* All of the Tech/matics diagrams and service data are based on the original manufacturer's specifications — compiled and organized by the expert editorial staff of *Electronic Technician* magazine.
- *Is TV Tech/matics easy to use?* Extremely. Each volume is organized alphabetically -by-maker and then numerically-by-model number. Or you can use the comprehensive Chassis/Model Finder that is bound in every volume!

Insure over 90% of your future schematic needs!*

Alignment Information

**A full year's
information
always on hand!**

**GENERAL ELECTRIC
TV Chassis DA**

Important Waveforms

**You get
TV data only!
(No "odds & ends")**

Actual page size — large 14 3/4 x 11 inches.

**TV TECH/MATICS '65
COVERS ALL OF THESE MAJOR
MANUFACTURERS:**

VOLUME 1 —

Admiral, Airline, Andrea, Coronado, Curtis Mathes, Dumont, Electrohome, Emerson, Firestone, General Electric, Magnavox, Motorola, Muntz, Olympic, Packard Bell.

VOLUME 2 —

Philco, RCA Victor, Sears - Silvertone, Setchell - Carlson, Sylvania, Truetone, Westinghouse, Zenith.

**Beginning with TV Tech/matics '65 and forthcoming yearly editions:*

*TV Tech/matics '66out this Fall
TV Tech/matics '67out this Winter*

YOUR ONCE-A-YEAR SCHEMATICS EXPENSE:

\$19.90 — Complete, 2-Volume Set

AT YOUR ELECTRONICS DISTRIBUTOR, OR . . .

Get TV Tech/matics '65 on Free Approval

HAYDEN BOOK COMPANY, INC.:

Send me the complete (2 vol.) TV Tech/matics '65 for 10 days' free use. At the end of that time, I will either remit \$19.90 (plus a few cents postage) or return the set without further obligation.

Send only Volume _____ @ \$9.95 and on same terms as above.
(See important note regarding separate volumes on back page.)

Name _____

Address _____

City _____ State _____ Zip _____

Payment enclosed. Hayden pays postage; same return privilege.

Tear out and use today — No postage needed!

Don't miss...

the complete television schematics service

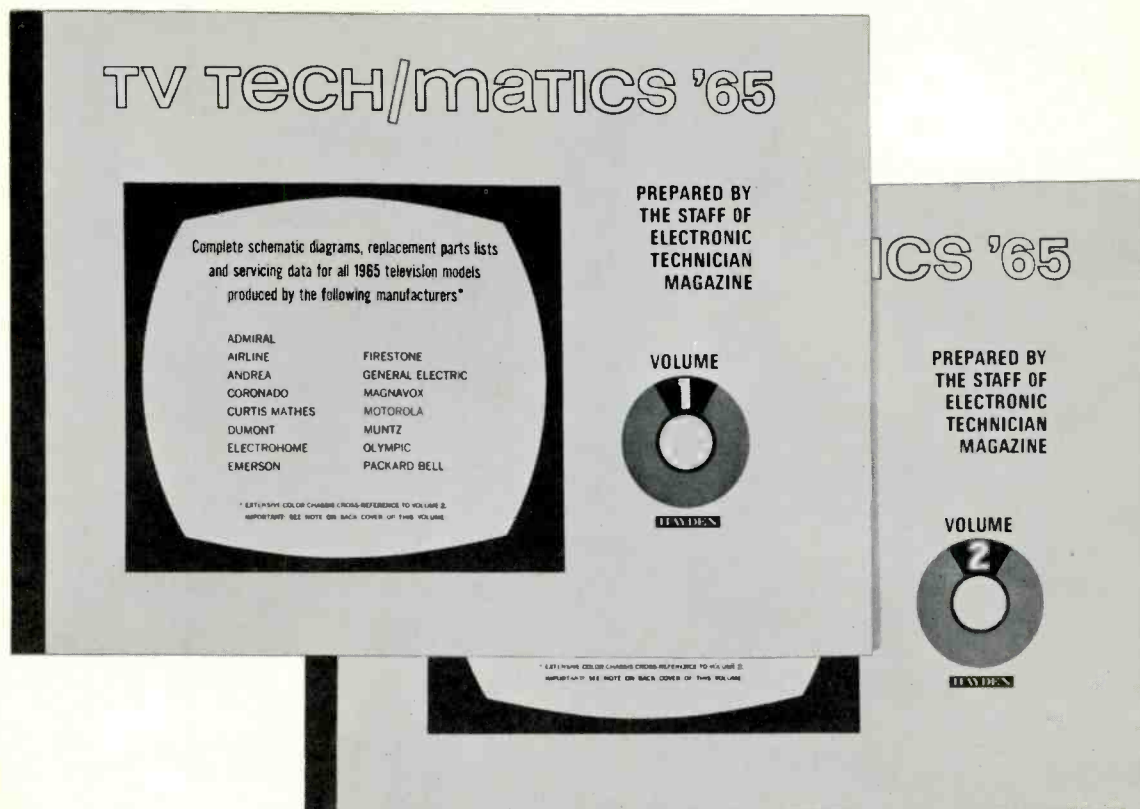

for all the key schematics of the model year in a single, low-cost purchase!

TAKE OUR NO-RISK INTRODUCTORY OFFER NOW!

BUSINESS REPLY MAIL
NO POSTAGE STAMP NECESSARY IF MAILED IN THE UNITED STATES

postage will be paid by
HAYDEN BOOK COMPANY, INC.
116 West 14th Street
New York, N. Y. 10011

FIRST CLASS
Permit No. 7665
New York, N. Y.



note:

TV Tech/matics '65 — including all color sets since 1960 — is divided into two volumes for easier handling (see alphabetical list of makers). Because TV manufacturers may share an identical chassis in certain color sets, these are cross-indexed to avoid duplication. Sometimes this may require reference from one volume to the other. For this reason, we recommend the volumes be bought as a set.

Making Money With Garage Door Operators

Sell, install and service a remote control item that enjoys a rapidly growing demand

■ Thousands of service-dealers and technicians are now making money selling, installing and servicing automatic garage door operators. It is a profitable business if handled correctly. And a steadily increasing population — with more new homes needed every year — guarantees continued expansion of business.

Present garage door operators may be divided roughly into two general systems. In one, the garage door is automatically opened or closed by depressing a button on the *dash board* when the car approaches or leaves the garage. In this system the transmitter is mounted under the car's hood. The transmitter may contain electron tubes or solid-state components. The vibrator in the transmitter is switched on when the dash-board transmitter button is pushed. Tubes are activated when the car ignition key is turned to the ON position.

The other system uses a small transistorized hand-held transmitter which may be placed in the glove compartment, the front seat or attached to the sun visor with clips.

The older under-the-hood transmitter radiates a signal from a short stiff-wire antenna mounted on glazed insulators. The portable unit uses a built-in ferrite antenna. Signals are picked up by a receiver mounted in the roof of the garage which actuates a relay and turns on the motor that controls the door.

Operating frequencies of garage door transmitters and receivers may be from 5kHz upward to 465 MHz —from VLF to UHF.

Transmitters

Some older type transmitters use a 12AT7 tube as RF output and tone oscillator. A 6 or 12v vibrator, in the power supply, provides power to the transmitting circuit. These vibrators are regular car radio types. They function the same way in the garage door operator transmitter as in the car radio.

A 27MHz tube transmitter is shown in Fig. 1. This transmitter uses a 12AU7 tube. One half of the triode section is the crystal controlled oscillator. The other half is a tone oscillator. The frequencies of this type transmitter seldom drift or change, hence frequency adjustment is unnecessary and the plug-in tone channel selector coil should not be tampered with.

The crystal controlled RF oscillator is plate modulated by the tone oscillator. A tone channel selector is "plug-in" so two different installations will not operate next to each other. This prevents a car-owner from opening up his neighbor's garage door as he comes up his own driveway. The tank coil has a small neon bulb to indicate RF voltage. When the neon bulb is not lit, the transmitter isn't operating.

A vibrator furnishes the higher B+ voltage for the 12AU7. Two

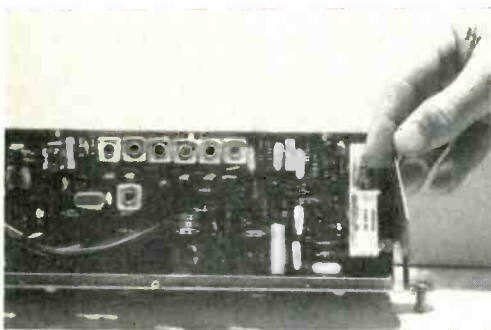

Finger points to plug-in selector coil in Perma-Power G270 receiver.

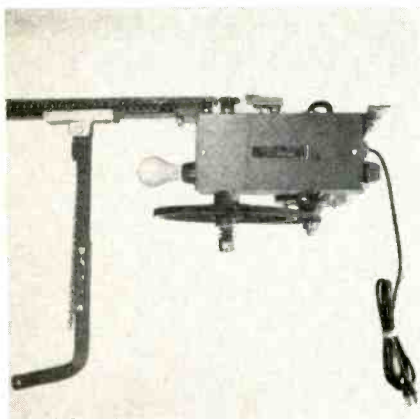

Allister garage door operator.

Garage Doors...

small selenium rectifiers work in a voltage doubler circuit. The voltage from the power supply ties to the plug-in channel coil assembly and to pin 6 of the 12AU7. This plate potential should be near 200v. A 4.7K resistor ties the B+ voltage and modulated tone to the crystal RF oscillator tank coil.

A typical transistorized transmitter is shown in Fig. 2. The 9v battery powers four transistors and the oscillator is crystal controlled. The unit also uses an RF amplifier, a modulator and a plug-in transistorized channel selector.

This particular transistorized unit operates in the 26.97 to 27.27-MHz frequency range. Neighboring installations will not be interfered with because the transmitted signal is code-pulsed by the audio frequency. Pulsed audio comes from a plug-in unit that modulates the transmitted signal. Most of these portable units will transmit from 35 to 60 ft or more when aimed through the windshield. Some will transmit beyond this distance when held outside of the car and the antenna is aimed at the garage properly.

Some transistorized units mounted under the hood use the auto's radio antenna as transmitting

antenna. These units may have a range of 100 to 200 ft.

Receivers

A receiver must pick up the small transmitted signal, amplify it and close a relay. Consequently, they are considerably more elaborate than transmitters.

Several different receiver types to match the frequencies of various transmitters are used. Whether the receiver is tube or transistor type, they perform the same jobs.

A typical tone modulated tube receiver is shown in Fig. 3. The received signal is amplified in the RF amplifier tube, V201. The RF amplifier output, tuned by L202, is detected by the diode, CR201. R205 functions as a "distance control."

The audio signal is fed back to the grid of V201, which also functions as the first AF amplifier stage. The output signal is taken from the screen grid, which acts as a triode plate for audio amplification.

V202A is the 2nd AF amplifier. This 12AU7 triode is resistance coupled to the balanced audio detector — diodes CR202 and CR203. Their respective load resistors are R211 and R212.

If the audio signal frequency is different from the desired channel frequency, the signal voltages produced to each diode are approximately equal. The diodes are connected so the dc output voltages

are in series but of opposite polarity. Thus all frequencies, other than the desired channel frequency, will cause no dc output. When the audio signal is at the same channel frequency, however, voltage is blocked from diode CR203 by the filter action of the channel selector network and zero dc is indicated across R212. The resulting dc output is then positive and causes the thyatron, V203 to fire — closing relay, K201. V203 is normally kept non-conducting by ac bias applied to its cathode. The capacitor, C214, protects the relay from working on transient voltage conditions. The power supply is transformer operated by using a selenium half-wave rectifier. The schematic of a transistorized receiver is shown in Fig. 4.

Transmitter Troubleshooting

Most of the troubles in tube transmitters will be caused by tubes and vibrators. And after a unit ages a few years, the small filter capacitor and selenium rectifiers should be checked. If rectifiers are bad, replace them with silicon units. This will usually raise the power supply output voltage, increasing the RF output.

If the vibrator is weak and erratic in operation, replace it. You may have to tap on it before it comes on. And it may fail to come on until the motor is reved up. In any event, don't take a chance with

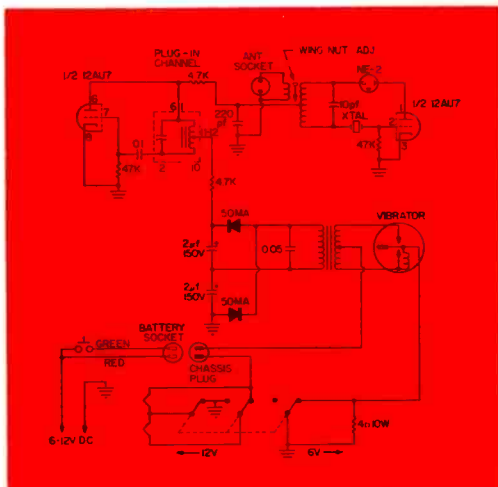

Fig. 1—Schematic of typical door operator tube transmitter.

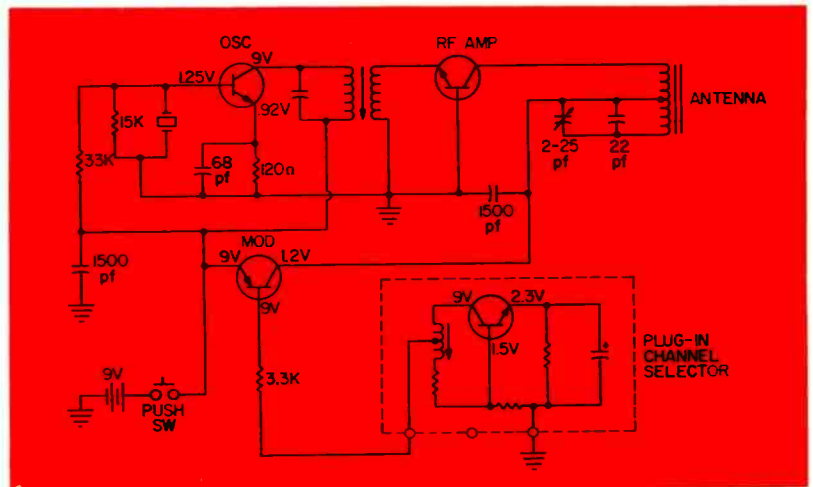

Fig. 2—Perma-Power G370 series transistorized door operator transmitter.

this type vibrator — replace it.

Most garage door transmitters can be checked out with a neon lamp. On some of the higher RF output transmitters the neon lamp can be held close to the tank coil. This coil, at 27MHz, has only a few turns. On other units one side of the neon lamp may have to touch the coil to give an RF indication. You can also check a 27MHz unit with a CB walkie-talkie. Just hold the walkie-talkie close to the weak transmitter and listen for beep or RF "rush" when the transmitter is on. Do not hold the button down on a transmitter too long. They are all designed to operate intermittently. Approximately 60sec is long enough.

Another method of checking a transmitter uses a few turns of insulated wire wound into a loop, with a crystal diode in series with it and a VOM. The VOM should be on the lowest dc voltage scale. This method works very well with the small transistorized hand-held transmitters. You can also check these transmitters with a sensitive grid-dip meter (switched to detect RF) when held close to the transmitter tank coil.

Unusual Transmitter Problems

You may also run into some unusual and unexpected cases, too. A farmer, for example, reported trouble with his door operator to a local TV-radio shop. He said he's turned

the wing nut adjustment on the transmitter tank coil. His car operated on a 6v battery. When he complained that the car had to be within a few feet of the garage door before it opened or closed, the technician checked the transmitter under the hood.

The NE2 RF indicator lamp showed no RF. It was then discovered that the farmer had also placed the slide switch to 12v instead of 6v. When placed on 6v, the vibrator "perked up." The tank coil wing nut was then adjusted until the neon lamp peaked at its brightest — indicating maximum transmitter output.

A local dentist, who liked to hunt pheasant, brought his car in to have the transmitter checked. He said his garage door would not operate unless he was within 10 ft of it. This meant a weak transmitter signal or weak receiver. The transmitter was adjusted to maximum neon lamp brightness. This indicated the transmitter was operating. Next, the transmitter antenna wire was checked. One of the insulators was broken off. The dentist admitted he "just wrapped the wire around a metal brace to keep it from dragging on the ground." He "guessed" it broke loose when he drove through a corn field. . ."

A new insulator was installed and the wire tied at the end. The dentist took the car home but the repair didn't help. Then the technician



Heathkit garage door operator.

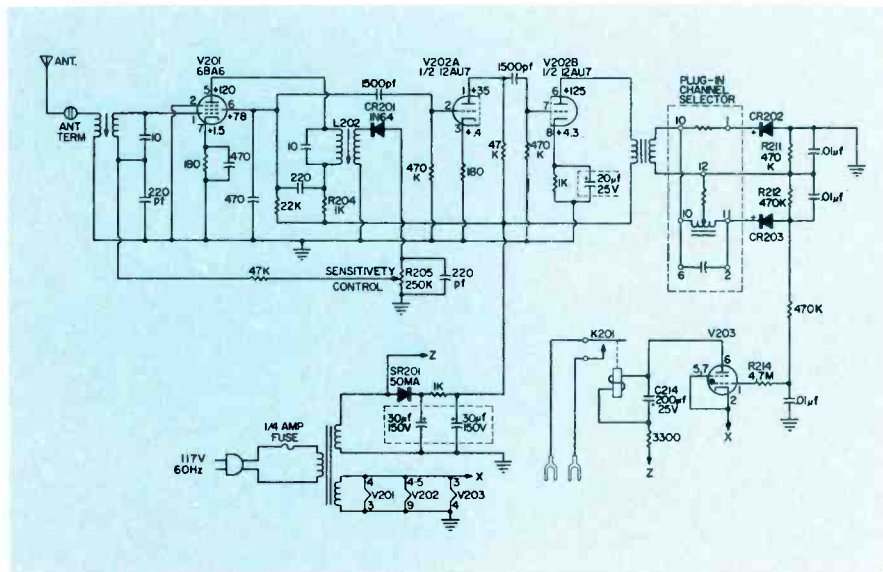

Fig. 3—Schematic of door operator tube receiver.



Car-owner closes door when backing out of garage. Photo courtesy Alliance Mfg.

Garage Doors...

went to his house to check the receiver. Everything checked good, but still no distance.

The transmitting unit was checked within 20 ft of the door, but wouldn't work the receiver. At 10 or 12 ft the door operated properly. Again the receiving antenna wire and insulators were checked. The wire looked too short. Sure enough, the antenna wire was 4½ ft long and the correct length, after checking manufacturer's specs, was discovered to be 8 ft. Readjusting the wing nut on the tank coil compensated for the shorter antenna and the set worked OK.

Another unusual difficulty frequently arises because of transmitter mounting. One customer, for example, came in with a new Mercedes Benz which had the transmitter already mounted. A local garage had mounted the unit on its side, tight against the fender wall. You couldn't get the lid off the transmitter to test a tube. And the transmitting antenna was practically jammed against the radiator. The whole thing had to be moved and remounted.

One big trouble arises with hand held portable transmitters: The car

owner drops it, cracks the case and the PC board. And make sure you check the battery *under load*. Put the VOM across the battery (while it's still in the set), press the button and read the voltage. If the 9v battery reads 8v or less, replace it. On the smaller transmitters which use mercury cells, when the battery drops 0.25v, some units become inoperative.

For intermittent transmitter operation, check for trouble in the ON/OFF switch contacts, loose or cracked resistors or for a bad PC board. Also check battery connections for corroding and poor contacts.

Receiver Problems

Most troubles that develop in tube receivers will be tubes (including thyratrons in older receivers), rectifiers and relay contacts. Bad relay contacts can be intermittent and if too dirty they will not make proper contact. A poor selenium rectifier will increase its resistance and lower the output voltage. This alters the voltage on the receiver's tubes, reducing the distance the transmitted signal will key it.

Open or dried filter capacitors will cause the receiver to oscillate

and close the relay without a transmitted signal. This is called "phantom" keying of the receiver and can result from a number of other causes, including: gassy or shorted tubes, open ground connection on rectifiers, relay pulls in because of too low voltage or distant signal interference. And be sure you check the electrolytic across the relay field coil for the same "phantom" symptoms.

Never adjust the receiver's tuned coils. They do not get out of adjustment by themselves. Of course, if the owner or other inexperienced person turns these cores, then a complete alignment is necessary.

Most receivers can be aligned with a signal generator and VT-VM. The signal generator can also be used to signal-trace the receiver. Loosely couple the signal generator output to the antenna. Use a signal tracer with RF probe and check from stage to stage.

To test the receiver relay operation on the test bench (on sets using thyratrons), place a 117v lamp in series with the relay contacts. When the button is pressed on the transmitter, the thyratron fires and the lamp will light — if the thyratron and relay are good. On modern receivers using a triode relay keyer,



Multi-Elmac hand-held transmitter.

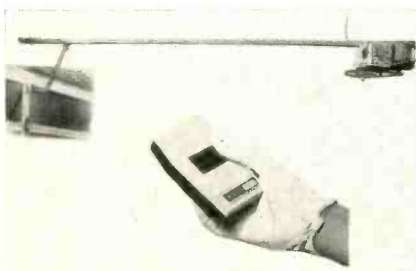

Eico garage door operator equipment.

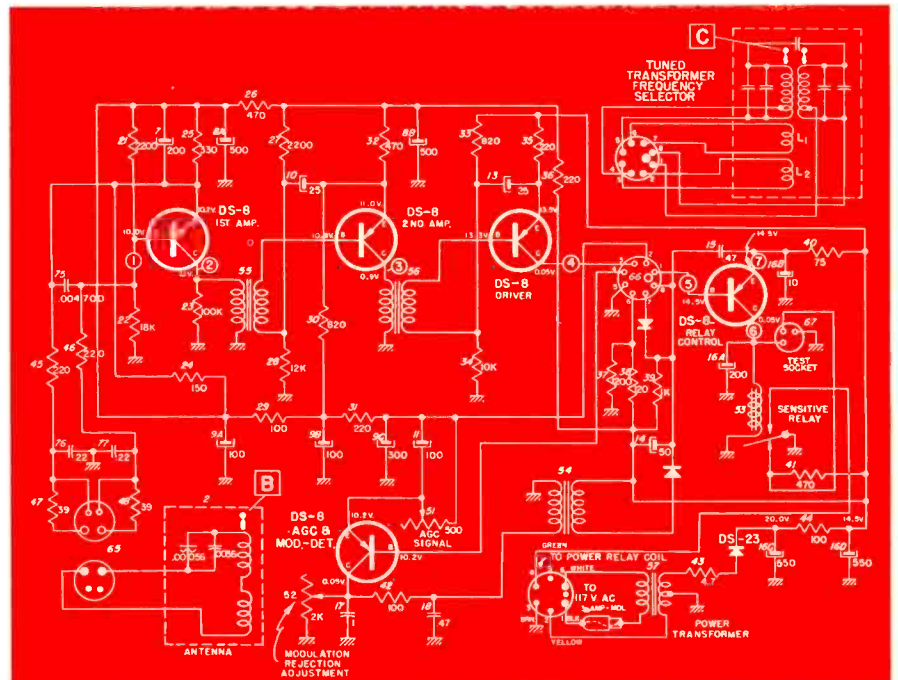

Fig. 4—Delco transistorized door operator receiver schematic.

follow manufacturers' instructions for checking relay pull-in voltage.

Shorted and weak transistors will prevent the receiver from triggering the relay until the auto is within a few ft of the receiver. The techniques for testing transistors are the same as used in servicing transistorized TV and radio circuitry.

Carefully measure the voltage on each transistor element. Remember, only a small variation in voltages here can upset the unit. In most cases, if a higher than-normal voltage appears on two elements, the transistor is shorted. And, in most cases, the transistor must be unsoldered from the PC board before it can be properly tested.

Large electrolytics should also be checked carefully. And, finally, don't forget to check the fuse before you begin taking the receiver apart.

A schematic and service specifications of garage door operator receivers and transmitters are necessary for proper maintenance.

A list of manufacturers who belong to the Door Operator & Remote Controls Manufacturers Association (DORCMA) is shown here. If you service this equipment and require specific technical information, write to the equipment manufacturer involved. ☐

Membership Roster of Door Operator and Remote Controls Manufacturers Assn. as of January 13, 1966

A. E. Moore Co.
10 Holbeck St.
Waupaca, Wis.

Advance Industries
2002 French Rd.
Appleton, Wis. 54910

Alliance Mfg. Co.
Alliance, Ohio

Allister Mfg. Co.
Exton, Pa.

Berry Doors
2400 East Lincoln Rd.
Birmingham, Mich.

Berry Electronics
3941 Research Park Dr.
Ann Arbor, Mich. 48104

Edwards Power Door Co.
630 S. Columbus Ave.
Mount Vernon, N.Y.

Linear Corp.
8621 Bellanca Ave.
Los Angeles, Calif. 90045

Multi-Elmac Co.
21470 Coolidge Hwy
Oak Park 37, Mich.

Overhead Door Corp.
First National Bank Bldg.
Dallas, Tex. 75202

Perma-Power Co.
5740 N. Tripp Ave.
Chicago, Ill. 60646

Ray-Dor Mfg. Co.
5400 Brookpark Rd.
Cleveland 29, Ohio

Scientific Products
550 E. Congress
Detroit, Mich 48226

Teletron Co.
4050 S.W. 14th Ave.
Fort Lauderdale, Fla.

Vemco Products
5740 E. Nevada
Detroit, Mich. 48234

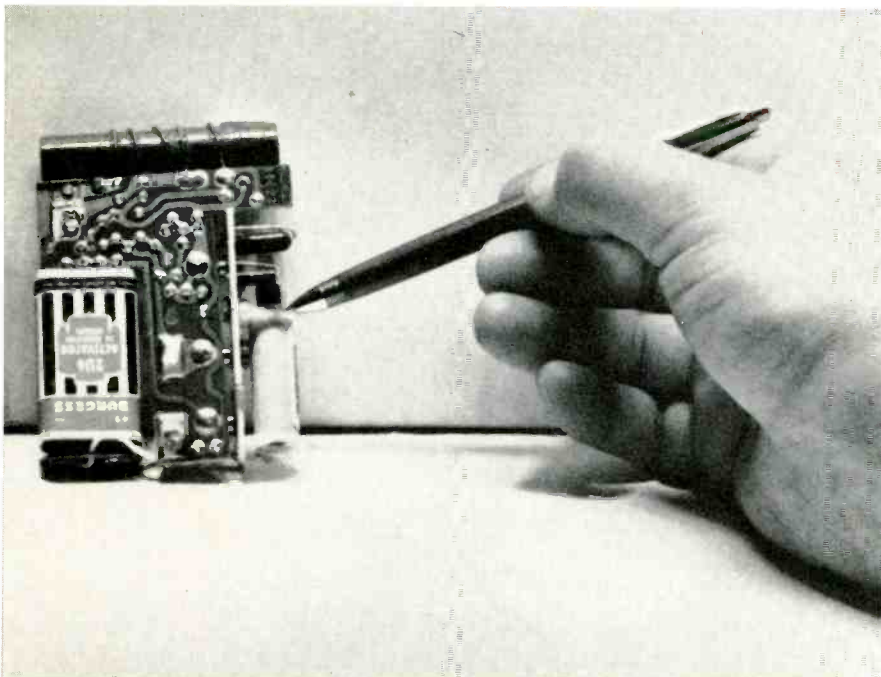

Pen points to channel selector coil in typical transistorized garage door operator transmitter.



Tamar transmitters and receiver.

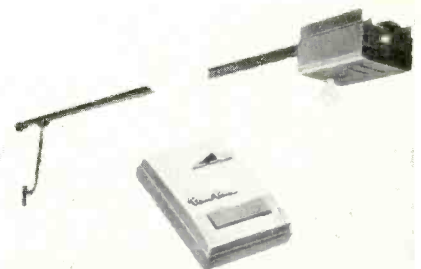

Perma-power hand-held transmitter and garage door operator with receiver.

What About CATV?

A Report on a Growing Industry

■ After two long years and a ceiling-high stack of press releases, magazine and newspaper articles, editorials and speeches, some direction has finally been given to the subject of Community Antenna TV (CATV). After going over each piece of this verbal mountain, ET estimates that more words have been written and spoken — pro and con — on CATV than about color TV, solid-state electronics, how to make a living in this business and all other bread-and-butter problems of service-dealers and technicians put together. And until recently, out of this mountain of alternately confused and confusing verbiage— little intelligence or clarity has emerged.

It has been said: "If anyone can remain calm when emotional confusion rages round him — he just doesn't know what's going on." To this, indeed, we plead guilty. And since we did not know what was going on, we sat waiting to learn something — waiting for one single, important, tangible event to take place. We preferred to leave the propagandizing to the professional "opinion-molders."

Now, there is a glimmer of light shining through the dust, the smog, the fuss and feathers. The Federal Communications Commission (FCC) has taken a firm, though belated, grasp on the bull's horns. And congressmen can no longer toss the hot potato. Many points are not yet clear, but one thing is certain: The CATV industry will be controlled — one way or another — and its future progress and the extent of its expansion will be

determined primarily by public demand.

Many words have been printed and spoken both condemning and praising CATV. And, as it appears now, many service-dealers and technicians throughout the country were drawn into supporting one side or another. And it also appears clear now: All have been *used* in a political-economic struggle. This will become more obvious when the thermo-nuclear fall-out has cleared.

What is CATV?

For the benefit of those who do not know — and many do not — a CATV system uses tall, high gain antenna systems to pick up distant TV signals so they may be fed throughout a neighborhood or town on cables that extend directly into a subscribers home. Sometimes the signals are brought into an area via microwave facilities. The subscriber pays on the average about \$4.50 a month for this service. CATV usually provides clearer reception and a greater selection of channels than could be obtained otherwise. Let's dig a little deeper into the subject.

CATV had its beginnings in the hills of Pennsylvania and Oregon back in 1950. The first commercially successful CATV system was installed in Lansford, Pa., late that year. Many of the initial installations were owned and operated by local TV technicians. Only a few channels could be carried over the first systems, and the equipment had limitations. The operator usually had a limited amount of capital — much of his finances were

derived from charging a high installation fee. The system would be installed in sections, wiring one section of a town at a time. It would then be expanded with funds received from subscribers until, eventually, the whole town would be wired.

(Contrast this with a "turnkey" installation of today. A "turnkey" installation means that a contractor is hired to do the complete job and when completed he turns over the "keys" for a properly operating system.)

Over a period of time, the original installation fees were reduced. Many systems would make no installation charge in return for the subscriber's antenna, as the initial charges were often based on the cost of an outdoor antenna installation. As the industry grew, patterns changed and the operators felt that with little or no installation charge more customers would sign up and a very profitable business could be conducted on the increased monthly returns.

In the late 1950s, although FM signals were added, the growth of CATV was limited because only five channels could be carried. The early 1960s saw the advent of the 12-channel system. This opened up whole new horizons for the industry. It enabled operators to cover all stations which could be picked up from the air plus distant stations brought in via microwave. Additionally, free channels are allotted to local schools and most systems provide a time and weather channel. Some systems originate a limited amount of programing such as local

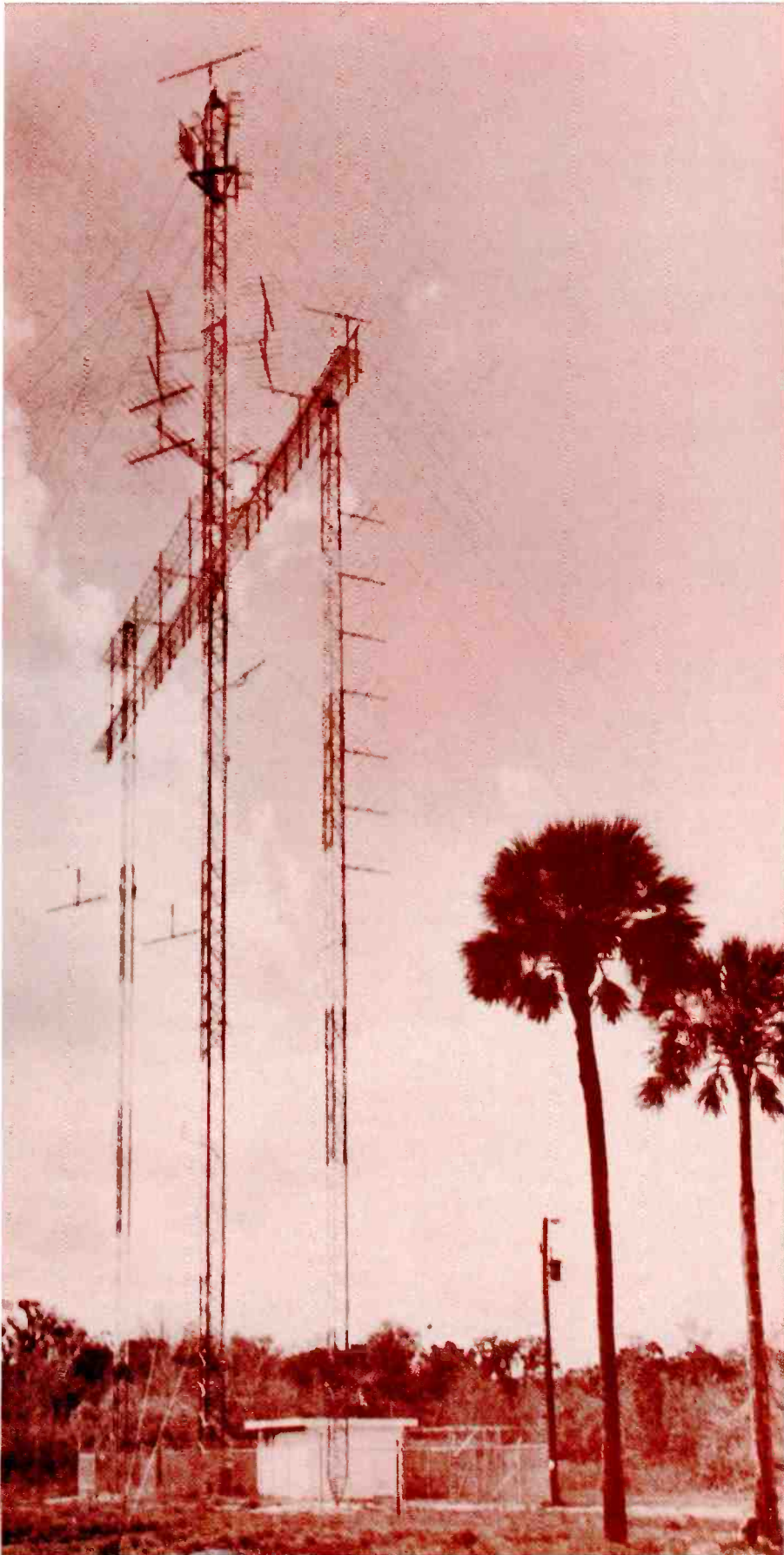

Typical CATV antenna array.

news, town council meetings, etc.

CATV will be used extensively to provide educational TV service; programs originating in schools, colleges or programs from a central point transmitted via cable to all schools within a district or even an entire state. The state of Delaware has a cable system servicing schools throughout the state.

CATV equipment manufacturers are constantly improving amplifiers, cable installation methods and other hardware; as a result, larger and more trouble-free systems are possible. A giant step forward has been the application of solid state amplifiers to CATV. This type of equipment simplifies power requirements and the gear is much more reliable.

These improvements have made large-city CATV feasible. Most cities offer all three networks with local channels, so CATV must offer improved reception, time and weather services and many of the other features offered in the smaller systems. A fairly new service introduced recently is a direct wire news service in which the subscriber is able to read news directly from the leading news services on his TV screen.

An example of CATV in a large city is Harrisburg, Pa. Before CATV, Harrisburg was served by three UHF stations and one VHF station. Now a CATV subscriber receives these four stations plus seven more stations from Washington, Baltimore, Philadelphia, York and Hershey. In addition, a locally originated time and weather channel plus six FM channels are

What About CATV?

also received. The system has a potential of 50,000 homes in Harrisburg and the 17 surrounding communities.

The suburbs of Cleveland are another proving ground for big city CATV. Cleveland has all three networks but lacks an independent station, so two companies are gambling that the addition of more TV channels and the other CATV services will entice subscribers to sign up.

The city of New York recently granted franchises for CATV to three different firms to operate in different sections of Manhattan. The systems will be limited to carrying local channels only and are prevented from offering pay-TV.

Franchise applications have been made in scores of large cities, but many of these proposed systems will encounter delays in receiving permits because of a recent FCC ruling. (More information on FCC regulations are given later in this article.)

The improvement in equipment and the movement of CATV to the larger population areas has attracted a great amount of investment capital. The smaller systems are being bought by group owners of systems, modernized and converted to 12 channel systems with a profitable return to the group owner. Many large corporations are getting into the CATV business, including G-E, CBS and NBC.

The CATV industry, through its national organization, National Community Television Assn., (NCTA) maintains that CATV is an auxiliary service; in effect, it says, the customer rents the system's antenna for a monthly fee. On the other hand some broadcasters, some TV service organizations and some antenna manufacturers cite CATV as a parasite which "steals" the signals of the TV stations and sells them for a profit. The broadcasters are represented by the National Association of Broadcasters (NAB); the service industry by the National Alliance of Television and Electronic Service Assoc-

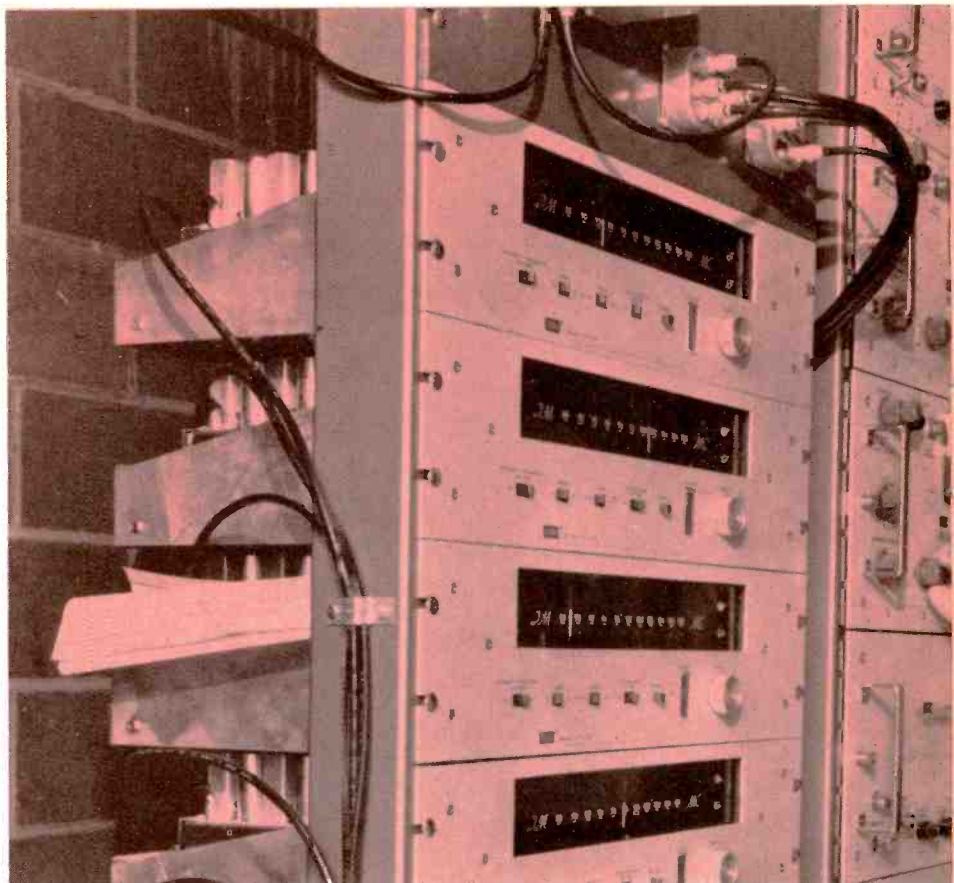

All signals are processed at the head end.

ations (NATESA) and the National Electronics Associations (NEA); the antenna manufacturers by Television Accessory Manufacturers Institute (TAME).

Although the views of these organizations may vary somewhat, the all oppose the uncontrolled expansion of CATV. There are exceptions, especially in the broadcast field where many broadcasters are CATV system owners. (Also, some antenna manufacturers and TV service people have money invested in systems.) It is felt by many that CATV and the broadcasting industry, with governmental regulation, will learn to live together. In the final analysis, the public will decide. If the public is willing to pay for the services offered by CATV, then the system will grow; if the system has nothing to offer, it will fail.

Franchising

In most states, a prospective CATV operator must obtain permission from the local city council to operate a CATV system. Fran-

chises for up to twenty years are awarded; in some cases the franchise is exclusive, in some it is not. Many times the city is paid a small percentage of the gross income. In many communities the franchise contains clauses that prevent the operator from selling or servicing television receivers.

In some cities there have been ten or more applicants, and this has presented problems for the councils. Because of lack of pole space, the granting of more than one franchise for a given community is an uncommon occurrence.

The next step is to secure pole space from the phone company or the utility company. A monthly or yearly rental is charged for using the poles, and the operator must install his equipment in accordance with specifications set by the utilities. The Bell System and other phone companies also make facilities available that an operator may lease; the phone company installs and maintains the equipment and the operator pays a monthly rental fee based on system mileage. Many

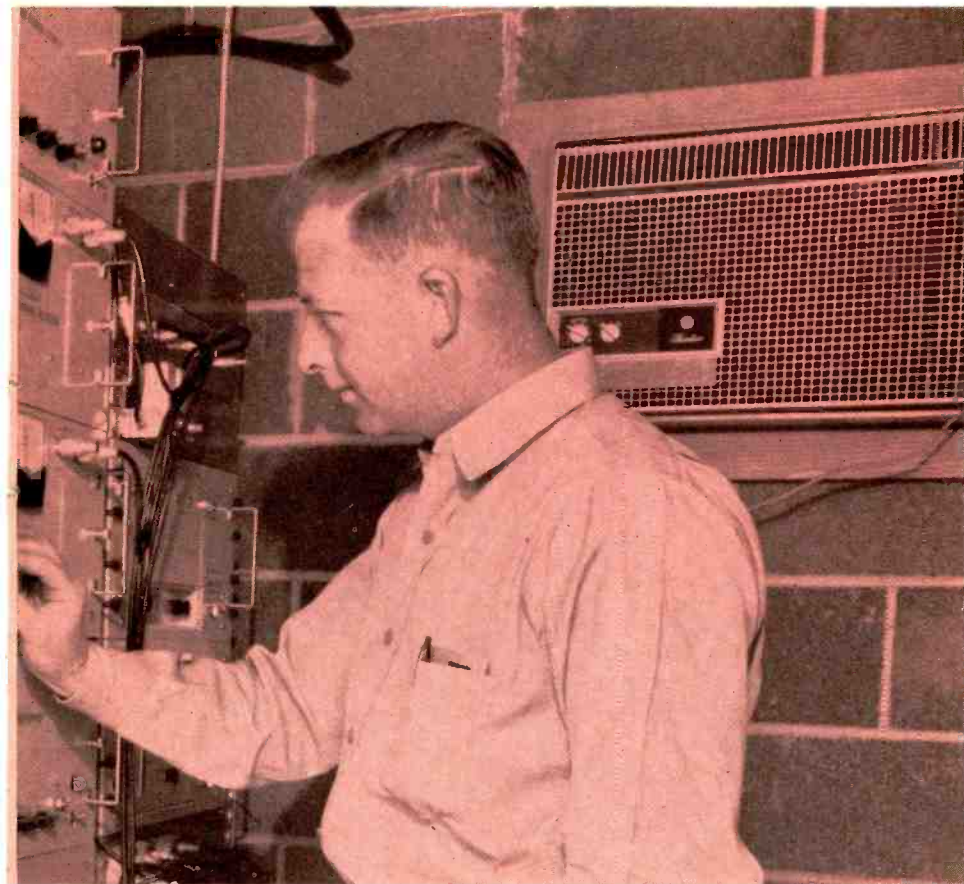

smaller phone companies are actually becoming CATV operators, installing the system and operating it in the course of their business. One major advantage gained in using the lease-back services is that the operator's initial investment can be much smaller.

In the state of Connecticut, CATVs are considered a public utility and their operation is regulated by the state Public Utilities Commission. Laws of a similar nature are also before numerous other state legislatures. Here again there are both proponents and opponents to the question whether or not CATV should be considered a utility. Other states may follow Connecticut's lead in regulating systems. In Connecticut, operators are limited to a 6 percent return on their investment and are not allowed to originate news, weather or other programs. Recently, delegates to the annual convention of the National Assn. of Railroad and Utilities Commissioners adapted a resolution calling on states to treat CATV as a public utility. The association also

recommended drafting a model law to bring CATVs under state control.

There are some cities where the CATV system is owned and operated by the municipality. In one case, Asheville, N.C., the city council accepted a bid from a private operator who offered the city 16 percent of the first \$600,000 gross and 50 percent of all additional gross, with the city assuming full ownership after 20 years. Other cities whose councils are besieged with franchise requests may follow the lead of Asheville. In most cases, a substantial income to the city could result.

Pay-TV?

Will CATV become pay-TV? Here again, only time will tell. If CATV does move into the major markets, it could be considered a natural for pay-TV. To survive, pay-TV needs a large number of subscribers. (Settlement of the subscription TV muddle in California will determine to a large extent how much pay-TV will grow.) Pay-TV could conceivably become an auxil-

iary service to CATV, carrying programs which are economically unfeasible for regular broadcasting stations to transmit. CATV in the future will have 20, 40 or 60 channels; systems will have plenty of space to carry a number of special programs.

The TV Technician and CATV

How has CATV affected the TV technician? If you live in a CATV area, you know how it has affected you. In some instances, CATV has helped sell more TV sets by furnishing more and better programs. With more sets sold, it follows that service will increase, but antenna sales may decrease.

A threat to the independent TV technician, however, is posed by the CATV company that sells and services TV receivers. A cable company is in an excellent position to service sets; it will receive a great number of calls in which the customer attributes the outage to the cable system. In most cases, the fault is in the set — but once the cable technician is in the home, it is a simple matter to sell the customer on his repairing the defective set, perhaps at a reduced rate. This problem — existing in CATV areas — has been lessened to a great extent by the action of city councils in wording their franchises to prevent it. If CATV is being discussed or applications being made in your community, you should work with the city council on the matter.

Study how CATV will affect you. You may find that greater program variety will result in an increase in your business. Just being against CATV because someone urged you to is not enough. If you ever have an opportunity to visit and inspect an operating system, by all means do so and discuss CATV with the manager and technicians. It will enable you to obtain first hand information concerning the industry.

The CATV field has opened a wide new area for working electronic technicians. It has created many new jobs as system managers, technicians and engineers. Many former TV technicians are now gainfully em-

ployed by CATV systems. The industry is relatively new and is growing rapidly, so the opportunities for advancement are numerous. Many TV technicians, as noted, have even invested in CATV systems.

The CATV manufacturing industry also needs qualified help, especially in their sales engineering and field engineering forces. With the installation of many new systems and quite a few being modernized, there is a real demand for trained technical help.

The two national TV service organizations (NEA and NATESA) have both gone on record as being firmly opposed to CATV. They have advocated, along with many others, that CATV should be controlled by the FCC. Now that the FCC has assumed jurisdiction, maybe all concerned can benefit by the orderly growth of the industry under governmental control.

During April of 1965, the FCC asserted jurisdiction over all CATV systems using microwave facilities. Recently the commission assumed regulation of all CATV systems, whether or not microwave is used. In taking this step, FCC rescinded

the rule that CATV feared most, the 15-day-before-and-after non-duplication rule. This rule, instituted at the time the FCC first assumed control of the microwave-fed systems, prevented a CATV operator from duplicating programs of local stations (with a signal from a distant station) for 15 days before and after the program was shown locally.

In asserting jurisdiction over all CATV systems, the FCC moved toward tighter control of the industry in the larger cities. Any system seeking to serve in the top 100 television markets must now obtain FCC approval and an evidentiary hearing will be conducted. The main concern of the FCC is CATV's effect on the television stations in the area, especially the UHF outlets.

Prior approval is not required by systems in smaller communities. However, the commission will conduct hearings on petition of interested parties on an individual basis. These hearings will be primarily concerned with the importation of distant signals.

Although it assumed regulation of CATV, the FCC will recommend to Congress that a national

CATV policy be established. The Commission would like confirmation of its regulatory powers over the industry. It wants Congress to consider whether or not CATV should be deemed a public utility. The federal government's role in rate regulation, jurisdiction over franchising and extension of service, should be determined.

Another issue is whether CATV is pay-TV. In this area, a congressional decision on CATV program origination is desired. Some broadcasters and others believe that CATV should not be allowed to receive and distribute TV signals at will. Several copyright suits are now pending in the courts, but the FCC is recommending that Congress act in solving the problem.

A recap of the recent FCC action shows that the CATV industry in smaller communities is left virtually free. In fact, with the abolishment of the 15-day-before-and-after rule, the industry is in a stronger position than it was. A study of big city CATV will give the FCC a chance to further analyze UHF's role and help determine the relationship between CATV and pay-TV. ■

What About CATV?

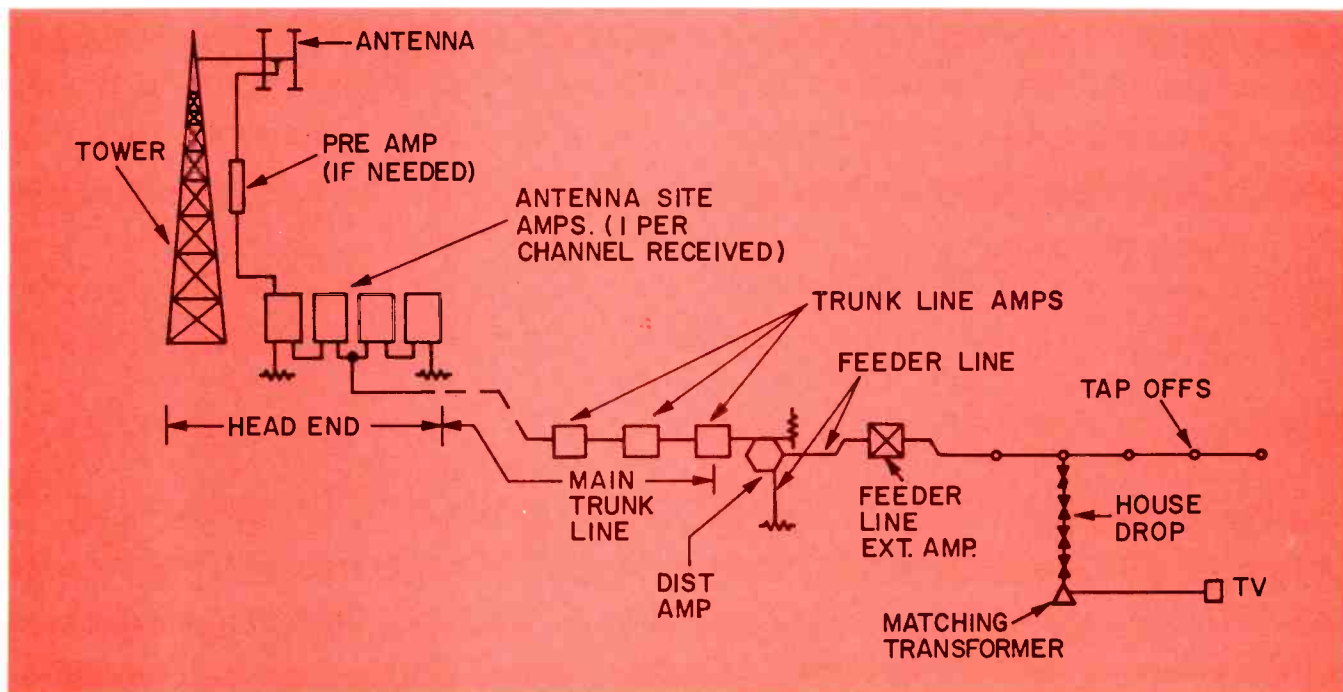

Block diagram of a CATV system.

YOU & COLOR TV



Use a wideband scope and a keyed rainbow generator to effectively troubleshoot chroma circuits

■ Many TV sets have been repaired by using a VTVM, a screwdriver, a "wet finger" and parts substitutions — the sawed-off-shotgun approach.

Then along came an enterprising young distributor one day who convinced us to attend a seminar dealing with oscilloscopes. The most important thing we learned at the seminar was how to use a scope to speed our work and make it easier. After this, we were able to spend more time with our families in the evening.

Modern Approach to Chroma Troubleshooting

You need proper test instruments to successfully troubleshoot the chroma section of color TV receivers. This includes a wideband scope and a keyed rainbow generator. The rainbow generator is recommended because most waveforms furnished by manufacturers are taken with this type generator.

Besides being wideband, the

scope should have a low capacity probe and preferably built-in calibration facilities.

To properly analyze the chroma signal, the scope must be able to pass the color subcarrier without attenuation. If the scope has more than 3db attenuation at 4MHz, it is not generally acceptable for chroma servicing.

The keyed rainbow generator should have, in addition to an RF output (for feeding the signal into the antenna), a separate video output which is used to directly check the chroma signal. Also, as an important asset to any color signal source, a 4.5MHz sound carrier signal is desirable for proper adjustment of fine tuning.

As in any TV, logical troubleshooting procedures should be established for servicing the chroma section. The first thing we must do is localize the trouble. Some symptoms of chroma section trouble are: no color picture, absence of one or more colors, incorrect hue as indicated by inability to tune correct flesh tones, washed out color and poor color sync.

A fairly sure method of isolating chroma section troubles is to inject a color-modulated video signal into the video amplifier. If a normal color pattern cannot be obtained, you can almost be certain that the trouble exists in the chroma section.

Then, of course, the problem is to further isolate the trouble to a specific stage. Now we bring the scope into play, together with the color generator. The scope and the CRT screen, of course, is used together to give you a *visual* indication of the location of the fault. The secret of efficient servicing with a scope lies in your ability to analyze improper waveforms and recognize that a certain stage is not functioning properly.

The Troubleshooting Procedure

It is easy to introduce typical troubles into the chroma section. Let's use a Motorola TS914 chassis to illustrate how to apply a scope and VTVM to properly solve a problem. In all cases, the monochrome and sound sections are operating normally and all the chroma section tubes check OK. (The complete schematic of a Motorola TS-914 chassis appeared in the September 1965 issue of TEKFAH.)

A short description of the circuitry will help you better understand the waveforms involved.

The first color IF stage is the triode section of a 6DX8 tube (Fig. 1). The chroma signal is fed from the first video amplifier to the grid of this stage. The triode acts as a cathode follower with the bias provided by the 180Ω cathode resistor (R901) and the ac load appears across L900, an RF choke which is self-resonant at 3.58MHz.

The chroma signal feeds through the color intensity control to the 2nd color IF stage grid. Transformer assembly, T900, in the output of the 2nd color IF, is the plate tuning transformer. Also included in this assembly are the phase shift networks feeding the color demodulator. When the 2nd color IF tube conducts, the voltage drop across R910 is large enough to light a color indicator neon lamp.

When a monochrome signal is received, a negative voltage develops at the free running oscillator grid. This voltage also appears at the color killer grid. The killer control is set so the tube will barely conduct on a monochrome signal. A 600v horizontal pulse is fed to the killer and when the tube conducts, C924 accumulates a negative charge. This charge is applied to the 2nd color IF grid — cutting the stage off.

When a color signal is received, a greater negative voltage appears at the oscillator's grid. This increased negative voltage cuts off the killer stage — removing the negative voltage from the color IF grid and allows the stage to operate normally. A voltage divider (R908, 909 and 925) between plate load resistor, R910 and the color killer grid, gives a more positive action to the killer stage. When the 2nd color IF tube begins conducting its plate voltage is reduced. This reflects a lower voltage into the killer grid and reinforces the negative voltage received from the oscillator — resulting in a more positive killer stage action. By the same token, when the color stage is cut off, the opposite action takes place, resulting in more voltage to the killer grid. This allows the killer stage to conduct more positively.

The chroma signal from the top of L900 is also coupled to the cathode of V18A (Fig. 2). This color sync stage is keyed by a positive horizontal pulse so the tube only conducts during the horizontal blanking interval, allowing only the burst pulses to pass. The tube is cut off otherwise, so the chroma information does not appear at the plate. These burst pulses are coupled by T901 to the grid of V18B (2nd color sync stage), further amplified and coupled into the oscillator stage by color sync filter, T902. When properly tuned this transformer feeds the burst in the proper phase for correct demodulator action.

First we will establish a number of normal test waveforms that can be expected with a color signal fed in at the antenna, with 2v P-P appearing at pin 8 of the first video amplifier (Fig. 3). Normal waveforms of the color IF section are shown in Fig. 1 and color sync waveforms are shown in Fig. 2.

The problems we introduce will make it easy for you to associate the loss of certain waveforms with

the pattern appearing on the CRT screen.

All waveforms are taken with a keyed rainbow generator output fed into the antenna terminals with a 2v P-P chroma signal appearing at the grid of the first video amplifier. With C928 (Fig. 2) open, color sync is lost. A scope check of pin 8 (V18A) reveals a normal waveform and the horizontal gating pulse appears at pin 9 of the same tube.

A normal waveform also appears at pin 2, the grid of the 2nd color sync stage. No pulse appears at pin 3 of V18B, the loss of this gating pulse, caused by opening C928, prevents this stage from being keyed, causing loss of sync.

Next we will open L900 (Fig.1), a choke in the cathode circuit of the 1st color IF stage. The color pattern is somewhat washed out and color sync is OK. In this case we

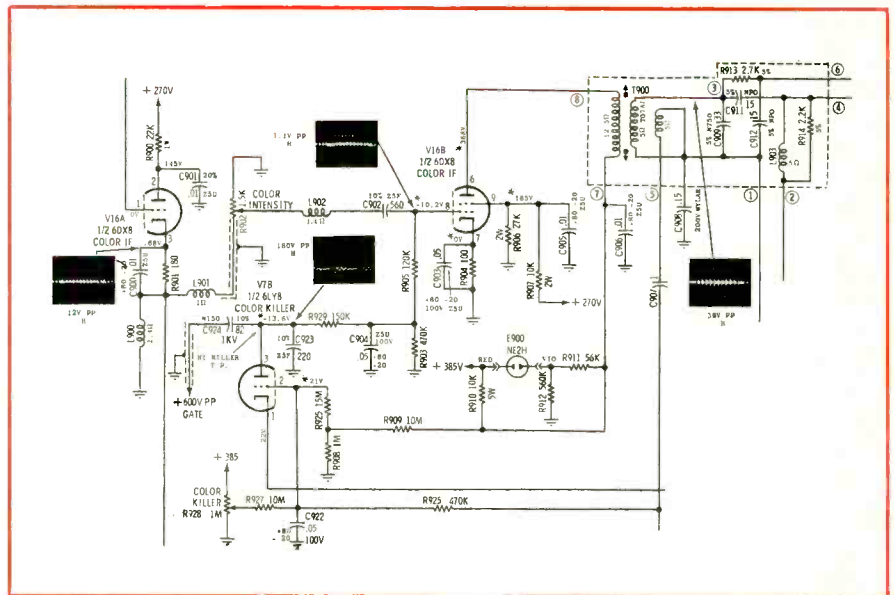
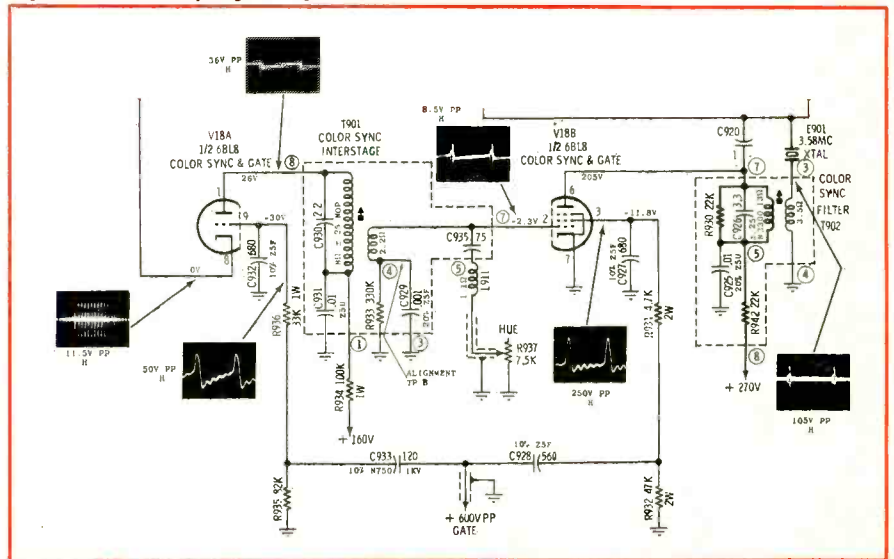

Fig. 1—Color IF section of Motorola TS914

Fig. 2—TS914 color sync gate stages



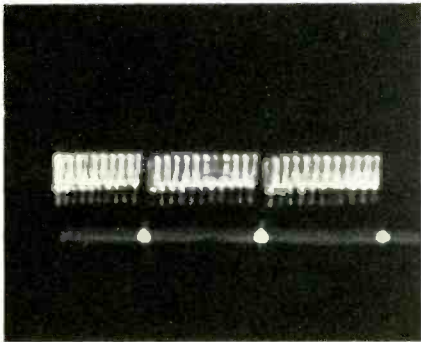

Fig. 3—Single at grid of 1st video amplifier, Chroma 2v P-P, Horiz 4 v P-P.

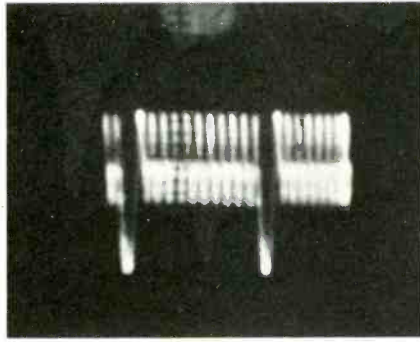

Fig. 4—Waveform at pin 3, V16A, with L902 open.

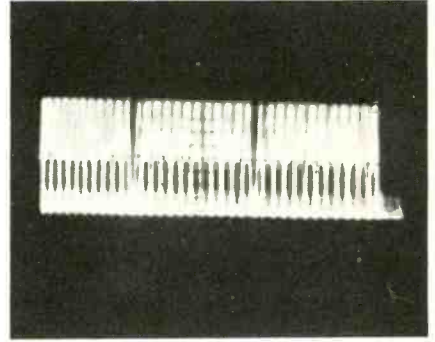

Fig. 5—Horizontal pulse is not present with V18 removed from socket.

first check the chroma signal at the grid of the first video amplifier and find it normal. This tells us that the RF and IF stages are operating normally and that the problem lies in the chroma section.

The abnormal waveform appearing at pin 3, the cathode of the 1st color IF, is shown in Fig. 4. Notice the pulse appearing during the horizontal blanking period. This indicates the horizontal pulse is somehow getting into the 1st color IF stage. A similar waveform also appears at pin 8 of V18A (Fig. 2). If we remove V18, the chroma portion of the waveform at pin 3 V16 (Fig. 5) does not return to normal but the keying pulse disappears. The cathodes of the two tubes are tied together, so when you pull V18 it removes the keying pulse from Pin 3 of V16. This isolates the problem to the first sync stage, and when voltage and resistance checks are made we can easily locate the open choke. Opening this choke disrupts the bias on V18A and causes the horizontal pulse to appear at the cathode. The fault also reduces the amount of chroma information that reaches the demodulators, thereby causing the washed out picture.

When L902 (Fig. 1) opens, this causes a no-color condition. The first point to check is the grid of the video amplifier and the chroma voltage is OK here. Next we find normal chroma voltage at pin 3 of V16A and our third checkpoint, pin 8 of V16B, reveals the loss of color information here. This may appear

to be an over-simplification of the problem, but actually, we are doing very important spade-work by establishing convenient chroma test-points which will help you solve the difficult problems more easily.

Many times the chroma signal amplitude is significant. To show this, R904, the cathode resistor of V16B, (Fig. 1) increases to 1000 Ω . This results in color bars appearing as pastel hues instead of fully saturated colors. We again make our initial waveform check at pin 3, V16A, and find normal chroma here. The 1.1v P-P chroma signal is present at pin 8 of V16B. A 17.5v P-P reading instead of the normal 39v P-P reading at terminal 3 of T900 (Fig. 1) points to the problem in the 2nd color IF stage.

Color Killer Problems

Improper color killer action can also cause washed out colors or a complete absence of color. If we bridged R909 (Fig. 1) with a 1M resistor the color disappears. Scope checks again show that normal chroma signals are at pin 3, and pin 8 of V16A (Fig. 1). No chroma information appears at terminal 3 of T900 (Fig. 1). This again isolates the problem to the 2nd color IF stage. A VTVM voltage check at pin 8 reveals an abnormally high negative voltage. This leads us to an improperly operating killer stage.

In summarizing the application of a scope and keyed rainbow generator to the chroma section of the Motorola TS914 chassis, we find

three important types of waveforms.

One is the chroma signal which measures 2v P-P at the grid of the 1st video amplifier tube and appears in varying amplitudes at a number of points in the chroma section. A substantial reduction in amplitude of this waveform at any of these key points gives you a definite clue as to where the problem exists.

The 2nd waveform is a positive horizontal pulse which is used to key the two sync stages and the color killer. Without a scope it would be very difficult to determine the presence of/or the amplitude of this pulse.

The third scope presentation is the burst pulse at the plate of the 1st color sync gate. These pulses are amplified by the 2nd color sync stage and coupled into the oscillator stage. Here again the scope is indispensable in tracing this waveform.

We have more or less limited our discussion to the presence or absence of waveforms. This was done to establish some quick test points for isolating various general chroma troubles. Forthcoming articles will analyze variations in shape and other important aspects of the waveforms in this and other color chassis.

An earlier article dealt with the demodulator section of this receiver (ELECTRONIC TECHNICIAN March 1966) and demodulator troubleshooting procedures will be further developed in a forthcoming issue. ■



A skilled technician and self-

cept on order. Antennas are also installed.

"There's no way to eliminate every call back," he declared, "but you *can* reduce them to a point where they won't eat deeply into your profits. The trouble is, most service-dealers and shop operators never take the time to investigate the nature of call-backs, find out what really causes them, so intelligent and practical measures can be instituted to reduce them."

The Nature Of Call-Backs

"Call-backs," he resumed, "have been blamed on almost everything, including lack of technical experience, equipment design, sub-standard components, inefficient servic-

'Call-Backs' Can Break You!

■ "TV-radio service-dealers who have a high call-back ratio today had better do something about it. Call-backs can put you out of business quicker than you think — especially if you're a smaller operator."

The shop owner said he'd been in the TV-radio business for 15 years.

We had heard about him and his very low call-back ratio. He agreed to tell how he did it, but he wanted no publicity.

He owns and manages a modern TV-radio shop, employs two good technicians and a full time girl who answers the phone, keeps records and handles correspondence. He sells TV sets, including color sets, transistor radios and Hi Fi components. The shop gives full and complete service on all equipment it sells — plus service on record changers and tape recorders — which it does not normally sell ex-

ing procedures, etc. But call-backs are not caused by any one or even all of these things taken together."

We had learned that call-backs were not an isolated problem in managing a TV-radio business. They arise because of weaknesses throughout the entire organization.

"Call-backs," he said, "cannot be reduced to a safe level without considering them in relation to the over-all quality and efficiency of your operation — and this includes your business know-how, service techniques, your public 'image' and your customer relations standards.

"If you want to reduce call-backs significantly, stop thinking of them as an isolated 'thorn in your side,' an irritation you must live with, a fact of life — like death and taxes. Call-backs are an undesired effect of multiple causes, *one* tell-tale reflection from a flawed-diamond — a danger signal that should warn

educated business man tells how to reduce profit-gouging 'come-backs' below the ulcer-giving level

you that your over-all technical and business operation is not what it should be.

"For example," he continued, "the average cost of making a service call today is around \$5. This does not include a profit on your business investment. This cost will, of course, vary a little from operation to operation, from locality to locality — but not much. If you make 10 calls on a given day, at a charge of \$6.95 just for service, and one call is unpaid, you've cut your profit margin for that day more than 33 percent! That doesn't make any sense. But it does illustrate a vicious characteristic concerning the nature of call-backs."

Eliminating Call-Backs

"How do we go about eliminating call-backs?," he asked. "I'll tell you. You train every customer to expect rapid, expert service at reasonable cost — and hence, they expect to pay for each service call made — except under unusual circumstances. This is part of your customer relations policy."

His shop offers and gives fast service, but as a result of carrying out an intelligent long-range customer-relations policy, a large number of long-time regular customers are willing and frequently do wait a day or two or longer for repairs or on antenna installations. The management uses this condition to its advantage and profit. Time and effort spent on customer relations has become a profitable investment for this operation.

"Ten years ago," the owner said, "call-backs were gouging deep into our profits. I had one technician and a girl. I made house calls, helped with antennas and did most of the bench work. We were all working hard to keep up with the business. But we were knocking our brains out — and losing our shirt. So then I took a week off and evaluated the situation. When I returned I hired another technician — the best one I could find —

and I've been in the shop ever since.

The owner of this modest business paid himself a salary of approximately \$9500 last year. Both technicians were paid \$7680. They receive time-and-one-half for hours worked over 40 hours a week. Each man receives a day off during the week (Monday through Thursday) and both work on Saturday. The shop is closed on Sundays. When overtime is required beyond normal hours, customers are given the choice of waiting until the work can be done on a regular-time basis or pay the bill at the additional overtime rate.

"That was the most profitable week off I've ever had in my life," our man said. "I drafted up a program — a technical, business and employee relations program. At night, I started studying business administration and public relations fundamentals. I studied to be a better technician. And I organized this shop."

After looking around the establishment we could see the results of his efforts. The work area is highly organized and arranged for efficiency. It is a time-and-motion-study expert's dream. The benchman can sit on a comfortable easy-backed stool and reach anything required to begin and finish a troubleshooting and repair job after a chassis has been set up. He can even reach tubes and most parts required for repair. He can call the girl on an intercom for additional parts he may need.

"When a set is repaired here," the manager pointed out, "it is gone over thoroughly according to a strict previously planned routine which varies only when we discover a better way to do something.

"We only accept complete repair jobs and refuse to do 'minimum repair' or 'patch-up' jobs which frequently result in call-backs.

"When it becomes necessary to replace a rather large number of tubes in an old set, either at the shop or in the home, the customer

receives a brief explanation that a certain percentage of new tubes sometimes fail within a 90 day period and no charge will be made to replace the tube — *but \$5, a break-even service charge, will be made.*

"This policy holds true for parts replacements, too. The customer knows in advance what to expect. Tubes are not replaced indiscriminately, however, just because emission is low. Only shorting, leaking or gassy tubes are replaced or a tube that's required to improve reception, sync stability, etc.

"Replacing older tubes that have stood up through a long 'burn-in' period just because the tube tester indicates low emission, is one of the best ways to maneuver yourself into a non-profit call-back. It doesn't pay and it doesn't do the customer any favors, according to our records. In other words, if a tube is good except for low emission and a new tube does not improve some function of the set, the old tube remains."

Approximately 80 percent of all calls for service result in sets being repaired in the home, according to the owner. About 20 percent go to the shop. A little more than 100 calls are made each week. The charge for a service call is \$6.95 — which pays for up to a half hour in the home.

"On shop repairs I give a detailed estimate to every customer over the phone *after* parts have been 'tacked' in and the set has been checked out as normal after it has 'cooked' for 4 hours at normal in-cabinet temperatures. If a customer decides he does not want the set repaired, a total charge of \$15.95 is made for the service call and bench time required to provide an honest and accurate estimate for the repair. This is always explained to the customer before a set is removed from the house. We've had very few customers turn down an estimate.

continued on page 84

The Future Looks Bright

High quality merchandise, two young partners and tested

■ "More people are interested in good music today than ever before," says James Dotson, one of the two partners who owns the Audio Center Sales Co. in San Antonio, Tex. His partner, Robert Peavy, agrees.

Mr. Dotson and Mr. Peavy, both trained audio specialists, were being interviewed by an ELECTRONIC TECHNICIAN field reporter. Mr. Dotson had just returned from a late-afternoon-into-the-evening rehearsal of the San Antonio Symphony Orchestra, where he is the principal percussionist.

"My experience with the real live product — music —" he continued, "has given me a stronger drive for developing better home Hi Fi systems. Good Hi Fi equipment should remove every obstacle between recording and playback. People who buy Hi Fi equipment should be given a chance to listen to music that sounds like an actual live performance. We try hard to give our customers the kind of equipment we personally believe in, equipment best suited to their particular needs — the same kind of equipment we want in our own homes. We want our customers to be entirely satisfied."

These words sum up a business philosophy that pre-dates the "hard-sell" era; this older "golden-rule" approach is fast being revived. It is being revived by pressures from a better educated and more discriminating public that constantly demands higher quality products and services.

Audio Center Sales Co. is less than two years old, but Mr. Dotson had spent a number of years in the audio business, including time in the management area, before establishing his own business.

The business did \$60,000 gross the first year. In January of this year it pulled in a sum which leads the partners to believe that 1966

gross returns will soar far beyond 1965.

Their typical home Hi Fi installation runs from \$600 to \$800, but some complete installations have been made in the \$3000 area. The partnership has franchises for nationally advertised Hi Fi component lines, carrying amplifiers, tape recorders, speakers, record changers and AM/FM tuners.

Not Always Easy

The partnership's road to success has not, however, been strewn with rose petals. Difficulties, sometimes serious problems, will come up in the business of providing high quality audio components.

"Most everything in the Hi Fi component line is franchised," Mr. Peavy said. "This means you're dealing with the factory, rather than with distributors.

"And then the market changes fast sometimes — you have difficulty keeping up with trends. You have to read a lot to know what is going on in the field so you can advise your customers properly and stock the merchandise they want.

"Since all ordering must be done from out-of-town manufacturers, it's difficult to get equipment promptly when its needed.

"It takes at least two weeks to get merchandise in here. This, of course, is not true if you're buying from local distributors. If you have local distributors you can get the equipment fast. Moreover, the distributor can keep you advised of trends. In this way, you know when a new product is coming out. He can also tell you what is hard to get. That way you can be prepared for delays and be able to notify your customers," Mr. Peavy concluded.

Getting Customers

Mr. Dotson cut in: "We ran into trouble getting customers at the very beginning. The local phone



The Audio Center's store front.

Mr. Dotson demonstrates turntable to customer.

Mr. Dotson setting up displays.

For Home-Audio Specialists

business ideas add up to successful Hi Fi business

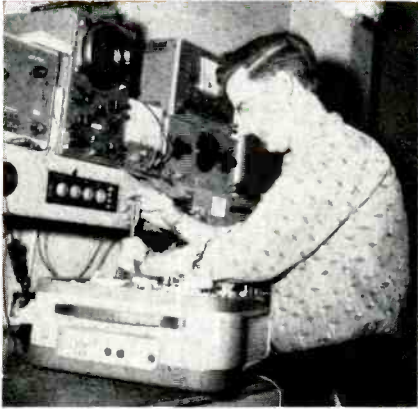

A section of the audio service shop.

Mr. Dotson works with technician on section of service bench.

Mr. Dotson is principal percussionist with the San Antonio Symphony Orchestra.

company had closed its advertising pages just before we decided to open." We had to advertise on FM radio. But then a customer would write down our name and forget the phone number. When he couldn't find us in the Yellow Pages, that was the end of that customer."

Despite this major problem and the difficulty of getting merchandise quickly, the partnership prospered.

"We soon began to get good results from spots on the FM station," Mr. Dotson continued. "Most FM station listeners enjoy good music, and they're anxious to get good music into their homes.

"We've found that a good display ad in the Yellow Pages, which we now have, is very important as a supplement to FM advertising. We've experimented with various types of advertising but found FM spots, display ads and phone-book listings are the best for us.

"There's just one other point I'd like to mention," Mr. Dotson added. "The best advertising in the world is word of mouth recommendations from satisfied customers."

The success of each installation is what makes the success of any Hi Fi business, the partners affirm. "Each audio man who installs a good Hi Fi system creates his own market," Mr. Peavy commented.

"That's true," Mr. Dotson interjected. "Furthermore, the market is constantly expanding because every customer who now has any kind of Hi Fi system is anxious to up-grade it with a better one."

The customer relations policy of the partnership is highlighted by the individualized interest taken in every customer. Counseling and advice predominate over hard-sell. Both partners strive for "frankness and honesty" in their relations with customers.

"This policy holds in our service department, too," Mr. Peavy said.

Service and Technical Considerations

"We are specialists," he continued. "We concentrate on specific lines."

The service department includes two men. The service charge for home calls is \$6.

"Six dollars an hour is our minimum charge for house calls or for work done on our work benches," Mr. Peavy explained.

Store hours begin at nine in the morning and end at half past five in the afternoon. Service calls are given evenings and on Sundays if prior arrangements have been made.

"Every job we do is a custom job," Mr. Peavy said. "We prescribe what is needed for each customer, remembering that the customer wants the best music reproduction he can get within his price range. As every audio specialist knows, this involves many considerations besides the price tag on the installation — room acoustics, size of the room, decor (draperies and carpeting) and sound preferences of the customer."

Mr. Dotson believes that the weakest link in most systems, other than the listening room acoustics, is the speaker." He added, "More experimenting and development is needed in this area than in any other part of the playback system. At the present state of the art, the finer electro-static speakers offer the most natural sound for the home listeners, — in my opinion."

Looking To The Future

Both Mr. Dotson and Mr. Peavy are very optimistic about the future of their Hi Fi business and the opportunities it presents.

"The market has great possibilities for today and tomorrow," Mr. Peavy said.

"More and more people are be-

continued on page 88

The New Look in

FCC opens way to expand this 'common man'

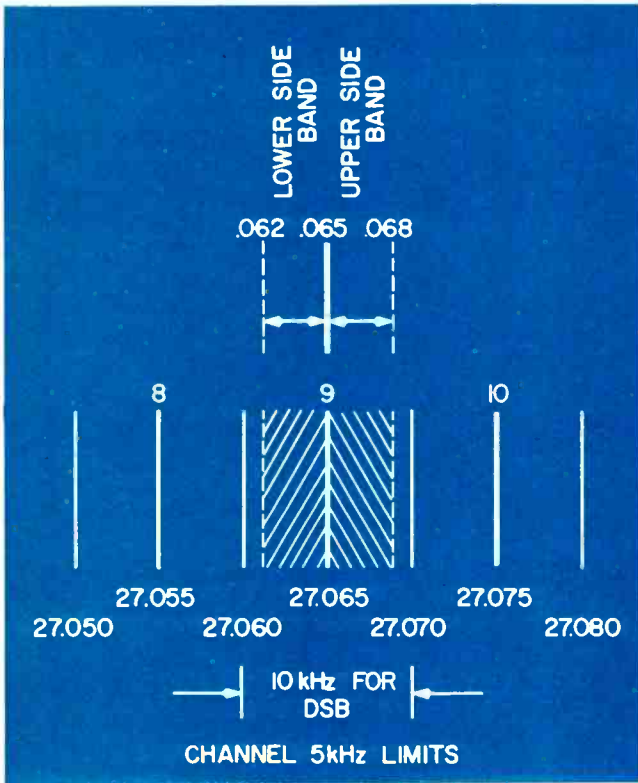

■ Citizens band radio has grown and progressed beyond anyone's dreams. More than 2 million transceivers are now in use. Late in 1964 the Federal Communications Commission (FCC) prepared a new interpretation of the rules governing Citizens Radio Service. This was not put into immediate effect. The new rules became effective April 26, 1965.

Rule Changes

The changes have certain significant items related to the widespread use of Citizens Radio Service. The commission emphasized, for example, that the primary purpose of the Class D Citizens Authorization was and is a means of the communicating between units of a single licensee. Interstation transmission or communicating between units of different stations is permitted under certain conditions and restricted to seven individual channels. These interstation communications are limited to five consecutive minutes with a five minute silent period and call sign identification. The rule changes also prohibit loaning of call signs by equipment distributors. These changes to Part 95 (formerly Part 19) of the FCC rules, are discussed in greater detail herewith.

Antennas. A considerable amount of attention

is given to the rules relating to antennas. CB antennas may be mounted on a man-made or natural formation whose height is not above 40 ft. But under this rule a man-made structure is not a tower, pole or mast. This means, apparently, this structure cannot be erected exclusively for a CB antenna mounting point. An existing receiving tower may be used to mount a CB antenna but the tower itself must not be higher than 20-ft over a natural formation or man-made structure.

It is important to note that the Federal Aviation Commission (FAA), charged with enforcing Aeronautical regulations, is concerned with the 20ft antenna-height rule. It does not consider 20ft over any natural or man-made structure a potential hazard to aircraft. Because of the tremendous number of applications it is not possible to make individual rulings to decide which of these may be a potential source of danger to aircraft and so the FAA recommendations remain in force, as a general over-all rule.

Band splitting. One significant change restricts certain channels in the band under a band-splitting rule. The FCC ruled that 5 channels could be used for interstation communications and the 5 channels were expanded to 7 channels; these were 9 through 14 and 32.

This does not prohibit these 7 channels being used to communicate with one base and several mobile stations all on the same frequency. Also, since these channels are about mid-band, it seems this was done to favor communications among similar stations. Communications between different stations has been the cause of citizens band congestion. Thus, in effect, channels 1 through 8 and 15 through 23 should be used for same-station operation.

Silent periods. In earlier rulings, the FCC decided that a station should observe a two-minute radio silence after each 5 minute transmission. The silent period has been extended to 5 minutes. Stations operating under the same license, however, are not included under this tightened regulation. Stations under the same license may communicate up to 15 minutes without even a station identification. But it is possible for different stations to transmit a short acknowledgement, when an incoming call is received, to tell the calling station that a silent period is being observed at a particular time.

Distant operation. The FCC redefined the terms "ground-wave" and "skip". The rule now says that communications are not allowed between stations beyond 150 miles apart. The limitation of 150 miles is actually far beyond the normal ground wave range of the CB band.

Selective calling and remote control. Several changes were also made regarding selective calling

Citizens Band Radio

communications medium into a thriving business

and remote control. The rule provides for 15sec limits on the period of selective signaling. This does not appear to affect any selective calling systems now in use, including the 3-tone sequential systems, and these do take up to several seconds to complete a calling cycle. It is possible under the new rules to have sub-audible calling tones which are defined as frequencies below 150Hz.

The new rule does not allow remote control of CB equipment but it does allow control between separate points on a vehicle or on a boat. Thus, the various control heads which have been developed for CB service to provide remote control between buildings of a multi-plant structure or between floors of the same building may be used.

In phone patching, no specific new rule was made but the FCC says that interconnections between CB radios and a public telephone might possibly violate certain other laws.

Power output. One significant change has been made regarding RF power output measurements. Under the original law a 5w maximum was measured as the product of final plate voltage and current (power input). A new definition is the 4w maximum RF power output—which is somewhat less than the output from the average CB transmitter.

This may have been done to provide the FCC with a more convenient method of measuring power output. We know, of course, that a 5w transmitter must have 80 percent efficiency to produce 4w power output and probably very few, if any, CB transmitters attain this efficiency in the final stage. We have measured a few and their actual outputs ranged from 3 to 3.5w.

Single sideband. New rules also recognize CB single sideband (SSB) and authorize "amplitude voice modulation including single sideband and/or suppressed carrier." The power input is defined in terms of "average watts" and quite obviously it is possible to have much larger peak powers using SSB transmission.

To measure average power, a meter with two percent accuracy and maximum time constant of 0.25sec is suggested but there's no limitation on peak power. According to the FCC "for single sideband operation peak envelope power will exceed the average power by an amount which is dependent on the peak to average characteristics of each station operator's voice."

What SSB Can Do For CB

The major technical consideration in reducing congestion and expanding the CB market, is SSB. Essentially, a transmitter operated at 27MHz has two sidebands — depending on the audio frequency. If an audio frequency of up to 10kHz is used for modulation,

as an example, the entire double sideband (normal AM operation) would extend from 26.090 to 27.010MHz, as shown on previous page.

The upper sideband is from 27 to 27.010MHz and the lower sideband is from 26.090 to 27MHz. In effect, since the upper and lower sidebands contain exactly the same information (as produced by standard AM methods), it is possible to remove either sideband and still maintain all necessary audio information.

SSB transmission suggests transmission of one sideband while suppressing the other. Effectively, this does two things: it doubles the number of possible channels and increases effective transmitted power.

The increase in effective power occurs for two reasons: first, all the available transmitter power can now be concentrated in the single sideband, and second, because only one sideband is to be received, it is possible to have a more selective receiver which will naturally have higher gain.

It is possible, by transmitting all the available power in either an upper or a lower sideband — and by eliminating the carrier — to provide an improvement over ordinary AM of about 5db. And receiver performance would be increased approximately the same. From another viewpoint, this amounts to a 10db increase in system performance by using SSB instead of AM.

The actual bandwidth required to transmit intelligence in the Citizens Radio Service, is 3kHz. How SSB works can be demonstrated easily. Suppose we operate on channel 9. Channel 9 is 27.065MHz. Channel 8 is 27.055MHz and channel 10 is 27.075MHz. Considering an audio passband of 3kHz, the proposed SSB channel 9 operation would take place on the upper sideband between 27.065 and 27.07MHz, as shown in Chart I. The lower sideband would appear between 27.060 and 27.065MHz. Thus channel 9 would allow two of these 3kHz channels to operate without interference — in the existing space allocated to channel 9.

Since each of these SSB systems require only 3kHz for ordinary operation, there would still be 2kHz to spare because they would use 3kHz within a 5kHz space. Note, however, that the 0.005 percent frequency tolerance would allow a center frequency shift from the center frequency of channel 9 (27.065) of 1.35kHz. Thus subtracting 1.35kHz from the unused 2kHz, it can be seen that an unused guard band would be provided. This would mean a 0.65kHz band at either side of each of the two single sideband operations. In effect, this means splitting the 23 present CB channels into 46 channels, each with a 3kHz bandwidth within a 5kHz space.

A forthcoming article will look into SSB circuits, selective calling, encoding and decoding circuits. ■

Selecting the Best Antenna For A

Don't let specifications confuse you

■ Many technicians still ask "Which antenna should I use to get best results when my customer is 42 miles, as the 'crow flies,' from the nearest TV transmitting station?"

No one can give a precise answer to that question; many factors enter into giving even an approximate answer. But, with the help of manufacturers antenna data; with some experimenting and experience — plus a good portable field strength meter — you can answer the question yourself and select antennas that will do the job properly.

One important consideration, as stated here many times before, is the effective radiated power (ERP) of the transmitting station. You should know the ERP of every station in your vicinity. Then, of course, come other important considerations: 1) height of the transmitting antenna and 2) height of the receiving antenna. Other factors include TV or FM receiver sensitivity and the type of terrain separating the transmitting antenna from the receiving antenna. Lastly, the antenna gain needed for the particular location.

Antenna Gain

Gain is the most important consideration of the receiving antenna (all other factors being normal) in relation to reception distance. Hence, on the long-haul fringe installation, if your customer has only one direction to receive from, look for the highest gain antenna you can find. This holds true for VHF, FM and particularly for UHF reception. Of course, there are exceptions which we will mention shortly.

Chart I shows the approximate amount of antenna gain required to

obtain reasonably good reception at various distances from a station's transmitting antenna. This assumes a flat terrain between the receiving point and the transmitting antenna.

Although, in general, the length of the antenna's forward lobe sharpens as the antenna's inherent gain increases, this is not necessarily true. Some antenna designs give a sharper, more narrow lobe than others having the same gain. This is also an important consideration if high hills, buildings or other structures are to the right or left of the receiving location. As you know, the sharpest lobed antenna will pick up fewer "ghost" signals. Additionally, the size and length of the back and side lobes of high gain antennas are also important. This is especially true of high gain UHF antennas. This is one point to watch carefully in selecting UHF antennas — especially if more than one channel is to be received on a single broadbanded antenna. Check the polar patterns for each channel to be received. The gain may be fine for one channel, with few side or rear lobes, but on another channel the situation may be different. Also the voltage standing wave ratio (VSWR) for a given channel is also important. Ghosts can be caused by lead-in reflections, too.

Selecting UHF Antennas

Chart II shows a series of antennas numbered from 1 to 12. Because of the many variations in antenna types made by different manufacturers, some antenna types listed here are designated in general terms. They represent all antennas manufactured today. Also, if you use a field-strength meter with a half-wave dipole, db gain listing will be about 2db less than

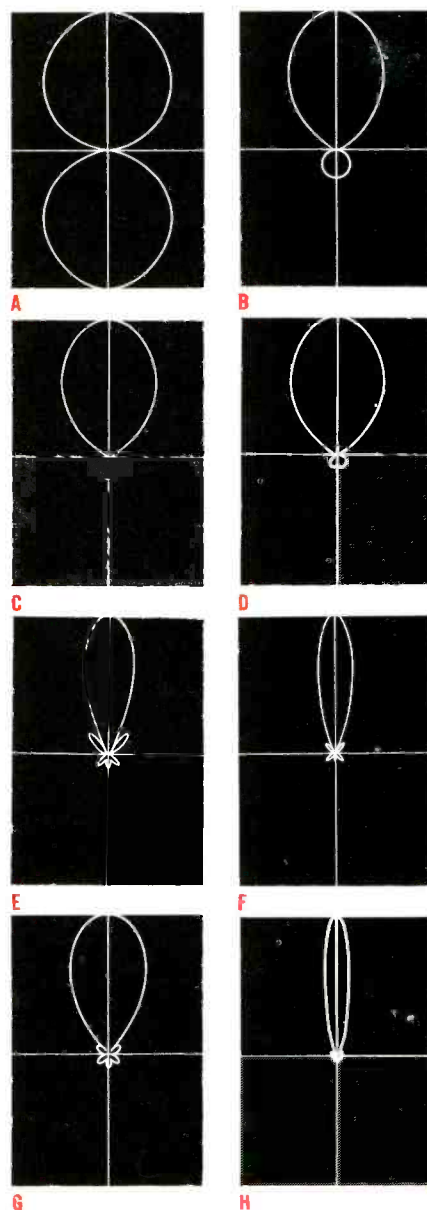

the gains shown for a theoretical isotropic antenna.

Antennas 2, 4, 5, 6 and 8 would normally be the choice for Area "A" shown in Chart 1.

Area "B," the semi-local area, would call for either antenna 4, 5, 6, 7 or 8.

Given Job



CHART I

Area "C," the fringe area, would require antenna 7, 8, 9 or 10.

The deep fringe area "D," would normally require either antenna 9, 10, 11 or 12. And if two antennas stacked do not provide sufficient gain, it may be necessary to use a good mast-mounted preamplifier here. If orientation becomes critical or additional stations are to be received from different directions, a rotor may also be required.

The general approach to selecting a proper gain antenna, either UHF or VHF, requires a knowledge of the TV receiver's gain. That is, in microvolts (μv), what is the minimum voltage required by that receiver to give a snow-free picture? Suppose this is $100\mu v$. If we use an adjustable half-wave dipole on the field-strength meter we have to figure the loss in the particular lead-in we are using to the dipole (similar to the lead-in we plan to use on the antenna).

Suppose we have 100ft of this lead-in and it has a loss of 1.5db in wet weather. If we run up the dipole to the height at which we want the regular antenna and measure $50\mu v$ on the field-strength

continued on page 86

CHART II UHF ANTENNAS

ANTENNA NUMBER	ANTENNA TYPE	GAIN OVER ISOTROPIC (AVERAGE)	FRONT TO BACK RATIO (AVERAGE)	TYPICAL LOBE	COMMENTS
1	Dipole (half Wave length)	2.14 db	0	A	Good for narrow frequency coverage. No front to back ratio. No rejection for back path reflections.
2	Dipole With Screen Reflector	6.24 db	Under 20 db	B	Good for narrow frequency coverage. Improved front to back ratio.
3	Single Bow-Tie With Screen Reflector	6.24 db	Under 20 db	C	Frequency range increased slightly over dipole with screen.
4	Two Bow-Ties Stacked With Screen Reflector	9 db	Under 20 db	C	Improvement in gain over single bow-tie.
5	Corner Reflector	11 db	20 db	D	Limited frequency range.
6	Periodic or Similar type Antennas	10-11 db	Over 25 db		Generally uniform gain and VSWR over the entire UHF range. Very good front to back ratio. Clean Pattern.
7	Two Periodic type Antennas Stacked	13-14 db	Over 25 db		Same as single periodic type antenna, but 3 db increase in gain.
8	Log Periodic type Antenna (3/2 wave-length elements)	10-15 db	Over 20 db	E	Generally uniform gain and VSWR over the entire UHF range. The slightly narrow beam makes installation critical (especially for color). Undesired side lobes.
9	Yagi	7-17 db	Over 20 db	F	Narrow frequency coverage. Not recommended for TV except when broad banded.
10	Bow-Tie Arrays	10-17	20 db	G	Limited to narrow frequency coverage.
11	Parabolic Dish Reflector Dipole Feed	16-21 db	Over 20 db	H	Narrow frequency coverage very narrow beam. Critical Installation.
12	Parabolic Dish Reflector Broad b and Antenna Feed	16-21 db	Over 20 db	H	Broad frequency coverage. Narrow beam. Installation critical. Some degradation in performance because some elements are not in focus.



COLORFAX

Luminance Channel of Magnavox 45 and T904 Series

At the plate of the last IF stage the 41.25MHz sound carrier and the 45.75MHz video carrier couple through a capacitor to the sound detector diode. The two signals combine to form a 45MHz difference frequency which is then coupled to the sound IF amplifier and the following circuits.

The IF output also couples through the IF transformer to the video detector. The 41.25MHz sound carrier is present at this point and is filtered out by the sound reject trap. In prac-

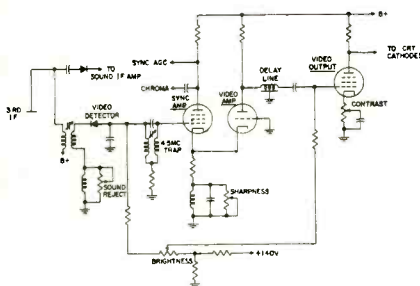

tical circuitry it is not possible to completely eliminate the sound carrier and as a result a portion of this signal mixes with the 45.75MHz video carrier in the video detector and produces a low amplitude 4.5MHz output signal. This 4.5MHz signal, if not eliminated, will beat with the 3.58MHz chrominance signal to produce a 920kHz signal. This beat signal would be amplified and appear as narrow diagonal lines across the picture tube screen. To prevent this beat signal from being produced a bifilar wound trap is used to attenuate 4.5MHz signal in the output of the video detector.

The video IF carrier is applied to the cathode of the video detector diode. The detector output is a video signal in which the sync tips are negative. The signal is then coupled to the grid of the sync amplifier where it is amplified and inverted in the plate circuit. At this point the video signal is coupled to the AGC amplifier grid and the sync separator grid. Also at this point, the chrominance information is separated from the luminance signal by coupling it through an 18pf capacitor to the bandpass

amplifier grid and the burst amplifier grid.

The sync amplifier also acts as a cathode follower for the luminance signal. The signal is developed across a small, unbypassed cathode resistor and drives the cathode of the video amplifier. This stage exhibits low gain and low output impedance and achieves an excellent impedance match to the delay line in the plate circuit. You will recall that the purpose of the delay line is to retard the luminance signal a small amount so that it arrives at the picture tube in unison with the color information. The delay line retards the luminance signal about one Msec.

A sharpness control is located in the cathode circuit of the sync amplifier to provide varying amounts of amplification for the high frequency components of the video signal. The control is connected across a resonant circuit tuned to about 2MHz. The tuned circuit looks like a high impedance to the frequencies around 2MHz when the control arm is grounded. These frequencies are then reduced in amplitude by degeneration. As the control arm is moved toward the cathode, more and more of the high frequencies are shunted around the tank circuit and amplified. This control has its usefulness in weak-signal areas. Background noise can be reduced with this control so that it becomes less noticeable.

The signal is coupled from the delay line to the grid of the video output stage through a capacitor. The dc component is not lost, however, because a parallel path is provided by the Brightness control. A negative dc voltage is developed at the anode of the video detector diode, and this voltage is applied to one end of the brightness control. A small positive voltage is applied to the opposite end of the control by the two voltage dividing resistors. With this arrangement, the bias on the grid of the video output tube can be varied from a negative value to a positive value. This causes the dc plate voltage of the output stage to vary.

As the cathodes of the CRT become more positive the beam currents decrease and the brightness is reduced. Conversely, decreasing the cathode voltage increases the beam currents

and brightness level. The dc component of the video signal adds or subtracts from the grid voltage on the video output tube so the brightness varies with the low frequency components of the video signal.

The video signal is inverted so that sync tips are in a positive direction. This is the proper polarity for driving the picture tube cathodes. A positive vertical blanking pulse from the plate of the vertical output tube is coupled to the CRT cathodes and provides blanking of the three guns during the vertical retrace period.

The luminance signal is coupled directly to the cathode of the red gun, and through the video drive controls to the green and blue guns. The light emitting qualities of the three phosphors are unequal. Since the red phosphor is usually the least efficient of the three it receives the full value of the luminance signal. The drive controls reduce the luminance signal reaching the green and blue guns so all three guns are equalized.

In conjunction with the drive con-

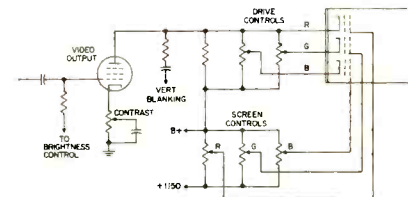

controls there are three screen voltage potentiometers, one for each gun. These also compensate for differences in phosphor efficiencies and cut-off characteristics in the individual guns. The contrast control is located in the cathode circuit. A 50μf capacitor connects from the center arm to ground. This circuit operates on the degeneration principle. Minimum contrast occurs when the center arm is moved to the ground end of the control. At this setting the video voltage developed across the control opposes the video signal on the grid. This is negative feedback or degeneration. As the control arm is moved toward the cathode more and more of the control resistance producing less degeneration and more amplification of the video signal and, therefore, more contrast.

continued on page 68

Compare Color Generators

look at the rest... and you'll buy the best, new B&K model 1245

The all solid-state B&K Model 1245 Color Generator duplicates the waveforms transmitted by a color TV station.

Adherence to these waveforms makes it easy to converge the color tube, check sync and make other raster adjustments . . . and the color generator with station quality signal will be able to sync next year's sets. Generators with compromise waveforms do not give you this obsolescence protection.

Here are oscilloscope photographs from the outputs of two typical competitive color generators, one transistorized and one tube type, and the B&K Model 1245. The detailed analysis with each photograph shows a few of the reasons why you'll save time and effort with B&K.

COLOR

CROSSHATCH

STANDARD STATION SIGNAL

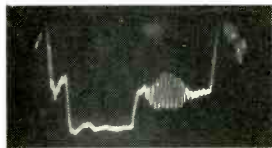

One horizontal sync pulse with its color burst.



Two lines showing horizontal sync pulse with black and white signal.

TRANSISTORIZED B&K MODEL 1245



Good duplication of station signal including back porch. If the set won't sync, the set is defective.

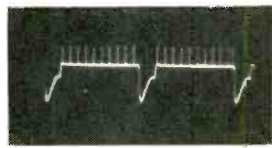

Well defined back porch on horizontal sync pulse permits accurately setting color killer and almost eliminates need to adjust brightness and contrast.

TRANSISTORIZED GENERATOR A

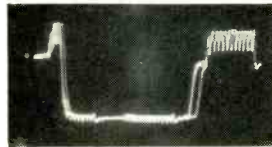

No back porch causes unstable color sync. Burst amplitude compression may permit sync on wrong color bar.

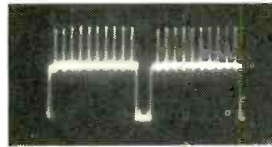

Square wave horizontal sync pulse with no back porch and poor dc coupling forces adjustments of brightness, contrast & fine tuning to obtain usable pattern.

GENERATOR B



No back porch; color information on top of sync-pulse makes sync difficult on some sets.



Complete absence of any back porch necessitates readjustment of brightness, contrast and fine tuning to obtain a usable pattern.

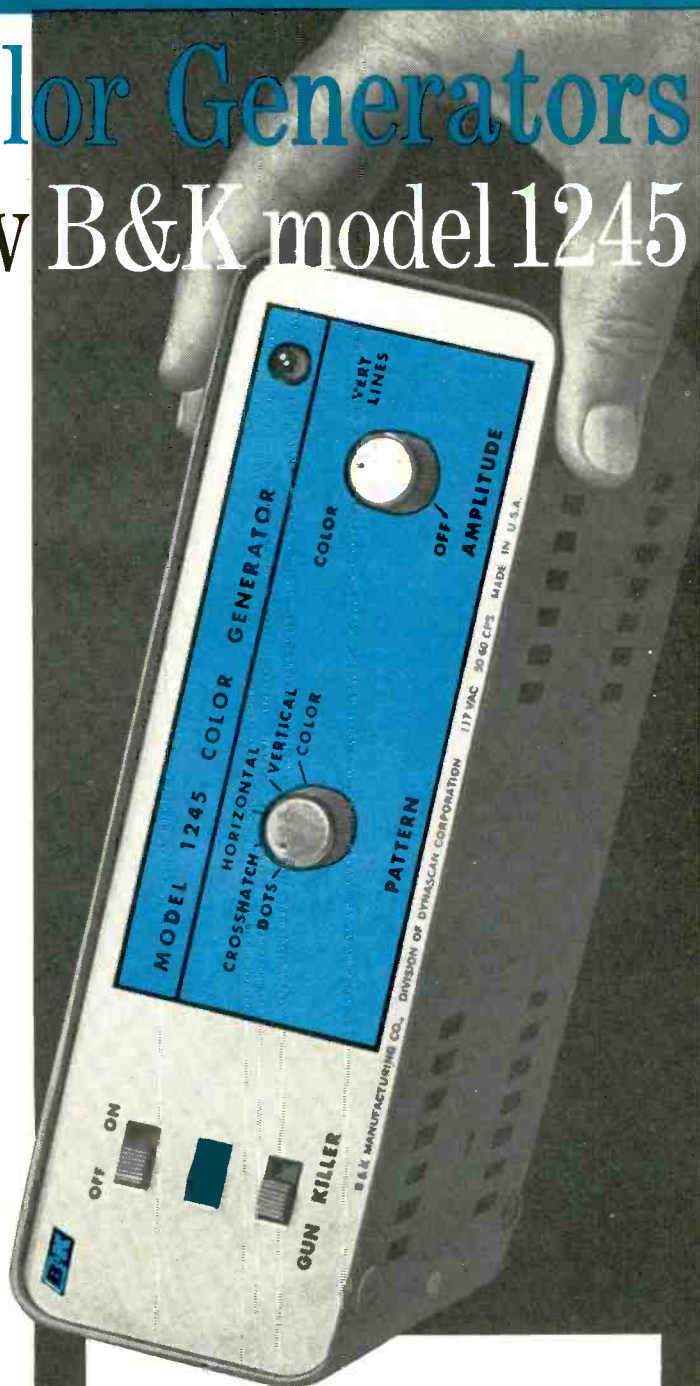

For the first time, with the no-compromise waveforms from the B&K Model 1245, it is possible to accurately set the color killer threshold control with a color generator.

The miniature size and convenience of the Model 1245 match its performance. It provides crystal-controlled keyed rainbow color bar display, and dot, crosshatch, horizontal line and vertical line patterns as well as gun killer controls that will work with any picture tube. Size only 2 7/8 x 8 1/2 x 8 7/8". Net \$134⁹⁵.

See your B&K Distributor for a demonstration or write for Catalog AP22.



B & K MANUFACTURING CO.
DIVISION OF **DYNASCAN CORPORATION**
1801 W. BELLE PLAINE AVE. • CHICAGO, ILL. 60613
Canada: Atlas Radio Corp., 50 Wingold, Toronto 19, Ont.
Export: Empire Exporters, 123 Grand St., New York 13, U.S.A.

With this tiny chip, RCA launches the biggest



(Solid Integrated Circuit shown actual size.
So small it cannot be manipulated by
human fingers—yet it is a complete elec-
tronic circuit containing 24 transistors
and diodes and all interconnecting wiring.)

revolution in TV circuits since the coming of color.

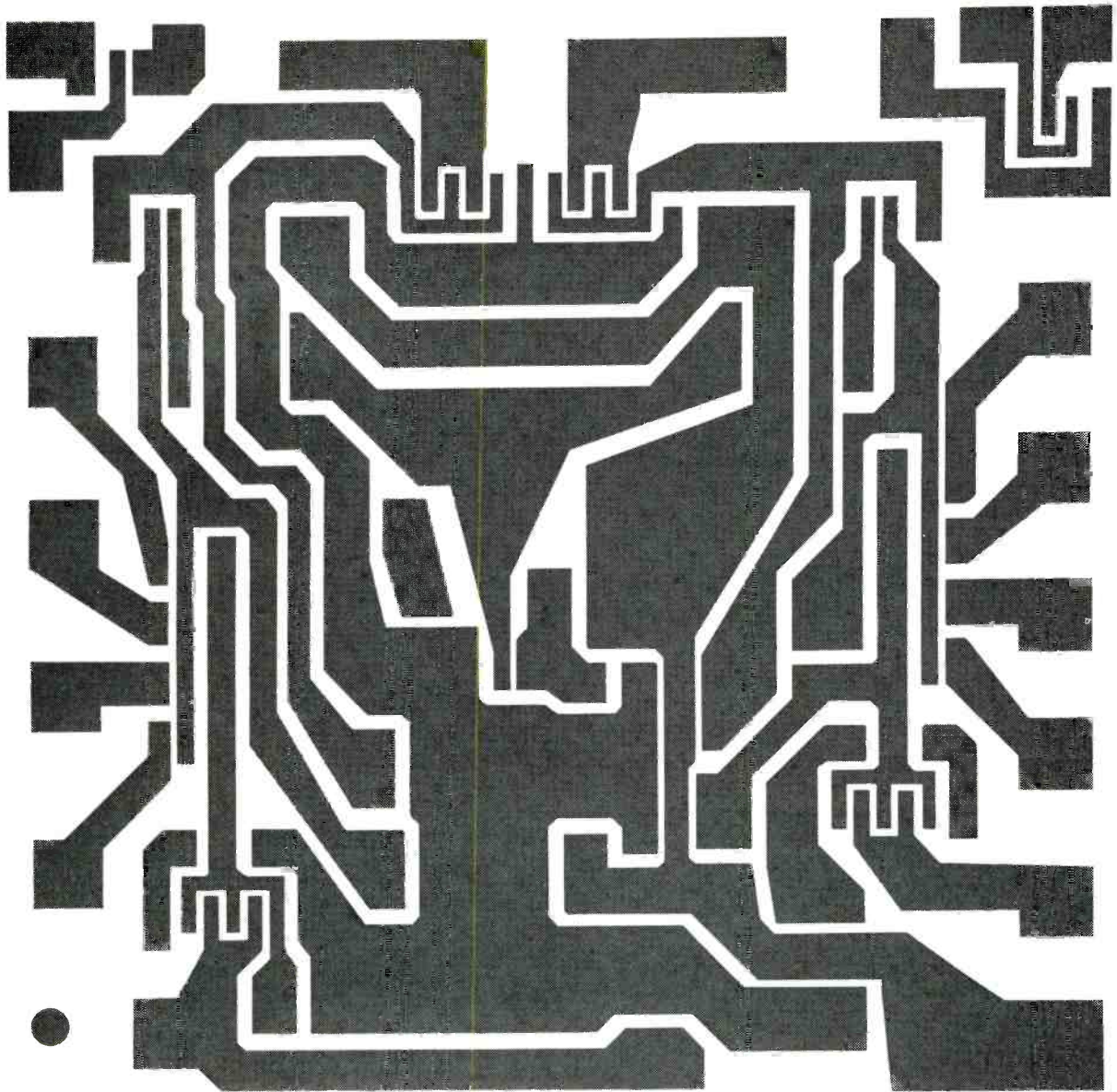

{ Solid Integrated Circuit used in RCA Spectra 70 computer shown 10,000 times actual size—actual size shown on opposite page. }

RCA uses Solid Integrated Circuits in space vehicles... in Spectra 70 Computers ... and is now building them into the sound systems of some RCA Victor Color TV and black and white TV sets. Solid Integrated Circuits are the latest in a series of space age advances over old-fashioned handwiring.

What's an RCA Solid Integrated Circuit? It is a tiny block of silicon incorporating matched transistors, resistors and diodes. Formed at 2000 degrees F. and hermetically sealed against the elements, these virtually indestructible circuits are mounted on RCA Solid Copper Circuits of proven dependability. RCA Solid Integrated Circuits are such a giant step toward the future that they

will ultimately prove more meaningful than the big leap from vacuum tubes to transistors. It was the reliability of integrated circuits that caused them to be designed for use in the electronic systems of space vehicles where size, weight and reliable performance are absolutely critical. The use of these new circuits in RCA Victor TV is but one of the early steps in this electronic

revolution—a step that was vital to approach the perfection we seek in circuit function performance. RCA engineers and scientists are now engaged in the task of broadening the application of this new space age marvel. Out of their efforts will come a new and even higher standard of reliability for all RCA Victor home entertainment and other RCA products.

COME INTO THE SPACE AGE WITH



THE MOST TRUSTED NAME IN ELECTRONICS



COLORFAX

RCA CTC17X Vertical Blanking

In modern TV design it is common practice to supply, from within the receiver circuits, blanking pulses in addition to those transmitted by the station. Most receivers supplement vertical blanking; some also include horizontal blanking. Usually, pulses obtained via fixed-value components perform this function. In RCA's CTC17X color chassis, however, active vertical blanking is realized by inclusion of a separate transistorized stage. The solid state circuit permits precise timing and shaping of a pulse to be used for elimination of vertical retrace lines.

An NPN transistor functioning in a grounded base configuration is used. In this circuit, the emitter is the signal input element — that is, a pulse obtained from the vertical output transformer is coupled to the emitter. The transistor is so biased that during active scanning time the transistor is

conducting. During the time that the positive vertical pulse is applied to the emitter (during vertical retract time) the transistor is forced into cutoff. Now, recall that in a common base circuit, with the signal takeoff in the

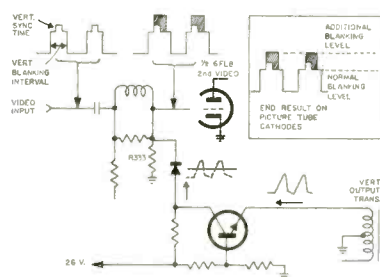

collector circuit, the input signal to the emitter has no phase reversal. Therefore, a selected portion of the positive input pulse is developed in the collector output circuit. The positive signal, shaped by the transistor circuit, is coupled via the diode to the grid of the second video tube; this added positive signal increase at the grid causes more tube conduction during the time indicated by the shaped portion of the waveform. (The waveform illustrated at the input to the video stage is indicating the vertical blanking interval and the vertical sync pulse). R333 (27K) is a bias resistor

to limit the positive excursion on the grid, thus protecting the tube. The output signal available at the plate is, of course, a negative going signal, modified to include the additional blanking level. The transistor actually acts as a switch — during scanning time the transistor is conducting; during vertical retrace time, the transistor is driven into cutoff. The block diagram shows the end result on the picture tube cathodes — after inversion and amplification in the third video amplifier. The additional level appears during vertical retrace time; the increased positive signal impressed on the cathodes of the picture tube is sufficient to insure complete blanking of vertical retrace lines.

MOVING?

Be sure to let us know your new address. Please enclose a complete address label from one of your recent issues.

PRECISION FREQUENCY STANDARDS AT BUDGET PRICES



MODEL FS 400



MODEL VSF 700

RANGE — 30 Mc to 174 Mc

Most useful instrument in its class — use it as a precision RF Frequency Standard, a 5 KC FM Deviation Standard or an accurate, stable Signal Source. Pinpoint all Allocated Frequencies 30 - 50 Mc and the common Allocated Frequencies 150 - 174 Mc without mathematics or interpolation. Calibration Charts furnished with each instrument cover all frequencies in its range. Accuracy of $\pm .0002\%$ in the field or $\pm .00003\%$ in the Shop or Lab while simultaneously beating WWV.

FS 400 \$395.00
F.O.B. EAST HADDAM, CONN.

RANGE — 30 Mc to 470 Mc

This fine instrument includes all the above features PLUS, extended UHF coverage up to 470 Mc, plus over 50% greater flexibility, plus the extra operating conveniences of a precision Turn-Counting Dial plus the reliability of precision Hand-Wired Circuitry. The VSF 700 is a "wise" investment for any Serviceman or Technician working in the Mobile Radio Service Field.

VSF 700 \$695.00
F.O.B. EAST HADDAM, CONN.

VIKING INSTRUMENTS, INC.

EAST HADDAM, CONN. 06423
TEL. (203) 873-8643

Quality Control Instrumentation ■ RF Frequency Standards ■ AM and FM Monitor-Receivers ■ Audio Frequency Tone Generators ■ Special Devices — Electronic and Electro-Mechanical ■ Electrical and Electronic Harnesses and Cable Assemblies ■ Intruder Detection Equipment ■ Alarm and Control Systems — Pressure, Temperature, Flow, Level, Speed.



WRITE TODAY TO DEPT. ET FOR COMPLETE DETAILS

... for more details circle 145 on postcard
ELECTRONIC TECHNICIAN

Gold Brand tubes live so long they hurt our business.



They can last 10,000 hours. They survive 10-g's vibration or 500-g's impact shock. And withstand extreme temperatures, high altitudes.

Every Gold Brand tube in Sylvania's complete line is this dependable. So even though customers don't reorder them frequently, they always reorder.

We use our new gold-plating process to make grids for these tubes. It forms a strong bond and eliminates flaking and peeling. Eliminates shorts from these causes.

Rhenium-tungsten heater wire increases ductility and mechanical strength, thus improving heater life.

A heavy insulating coating guards against heater-to-cathode leakage. Bends are coated individually to prevent hot spots and shorts.

Cathodes are formed from powdered metals. This way we can control properties and minimize contaminants.

In fact, we sometimes wonder if we've done too much to our Gold Brand tubes. Sylvania Electronic Tube Division, Electronic Components Group, Seneca Falls, N. Y. 13148.

SYLVANIA
SUBSIDIARY OF
GENERAL TELEPHONE & ELECTRONICS **GTE**

NEW PRODUCTS

FOR MORE INFORMATION CIRCLE NEW PRODUCT NUMBERS ON POSTCARD INSIDE LAST COVER.

Desoldering/Resoldering Iron 700

A pencil-style iron for removing and replacing miniature components in printed circuit boards and conven-



tional wiring is announced. Known as the Model 300, it is only 8in. long and weighs 3½ oz. Rated at 40w and 115vac, it delivers a 720° F tip temperature, according to the announcement. List \$13.49. Enterprise.

Tapped Resistors 701

Two commercial resistor styles — adjustable and tapped power wirewounds — are introduced. Designated as the HLA (adjustable) series and the HLT (tapped) series, the models are a direct replacement for vitreous enamel tapped and adjustable resistors. The HLT series contains 13 models in sizes ranging from 11 to 225w with a resistance range of from 1Ω to 1.1M. Depending on size, HLT

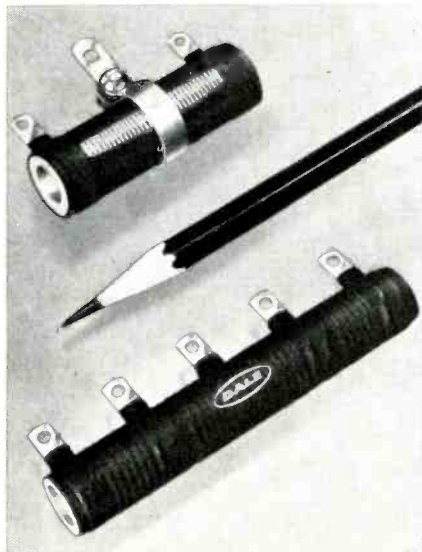

models can be furnished with taps which divide them into from 2 to 14 sections with the resistance and power rating of each section according to customer specifications. Dale.

Transceiver 702



with batteries. It is designed for one-hand operation and includes a 51 in. whip antenna. The unit is less than seven in. high and measures 7x3x1½ in. G-E.

A transceiver with a sending-receiving range of up to two miles is announced. The model Y700 uses six 1½v penlight batteries and weighs 1¼ lb

Propeller Fans 703

These filter box propeller fans are designed to cool or exhaust in a wide variety of applications. For instance, they can be used in military field ve-

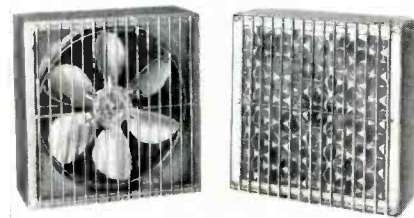

hicles, ground control vans or other mobile military enclosures. They are also used in stationary enclosures for electronic systems or for commercial or industrial uses. Four models deliver 275, 450, 725 and 1200 cfm. McLean.

Graphite Lubricant 704

A graphite powder suspended in an evaporating penetrant is intro-

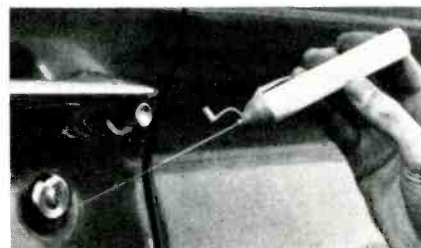

duced. This product consists of extremely fine particles of lubricating

graphite permanently mixed in a penetrant carrier. The penetrant loosens rusty locks, hinges, etc. The lubricant is packaged in a pen oiler with a needle thin 0.035 in. stainless steel tube. Armitte.

Nut and Screwdriver Set 705

Announced is a hip pocket size nut and screwdriver set consisting of a 4⅞ in. amber plastic handle and 12 interchangeable blades as follows: 7

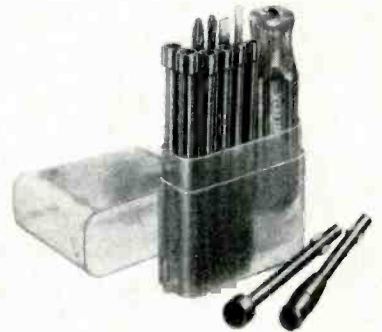

nutdrivers (3/16in. hex through 3/8in. hex), 2 Phillips screwdrivers (no. 1 and no. 2), 2 slotted screwdrivers (3/16in. and 9/32in.) and an extension blade that provides an added 4in. reach. Xcelite.

Ham and CB Test Set 706

A portable instrument that indicates the status of all the vital RF characteristics of CB equipment to



check it for optimum operation is announced. The 715 gives you fast, accurate reading/checking of: standing wave ratio true RF power modulation percentage, modulation distortion and relative field strength, according to the maker. Eico.



LOOK WHAT'S HATCHING IN **COLOR TV**



Assortment #094074
10 BULK BREAKERS



**A COMPLETE ASSORTMENT
OF CIRCUIT BREAKERS FOR
COLOR TV APPLICATIONS**

Ten breakers, seven ratings in one handy box for 100% replacement needs. Assortment available consisting of breakers on individual display cards or in bulk.

Included with each assortment: Pocket size cross-reference on color and black/white TV circuit breaker applications. Form No. CBCRP865H.



Assortment #094073
10 CARDED BREAKERS

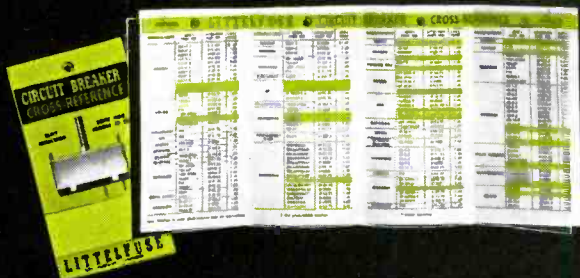

LITTELFUSE

DES PLAINES, ILLINOIS

NEW PRODUCTS

Speaker



MO2 speaker is designed to fit be-

707

A weather-proofed speaker for mobile two-way radio transceivers and medium power, mobile public address amplifiers is introduced. The

tween automobile grille and radiator, in engine compartment, under dashboard — anywhere concealed installation or minimum obstruction is necessary. Specifications are: Power, 25w. Impedance, 8Ω. Frequency response, 300Hz to 13KHz. Sound level, 122db measured 4ft on axis at rated power. Dispersion, 130°. Dimensions, 6 $\frac{3}{8}$ x 8 x 4 $\frac{3}{16}$ in. Weight, 5lb. List price, \$44.00. Atlas.

Color TV Rectifier **708**

A universal color TV rectifier replacement kit is announced. The rectifier replacement kit contains 1 focus

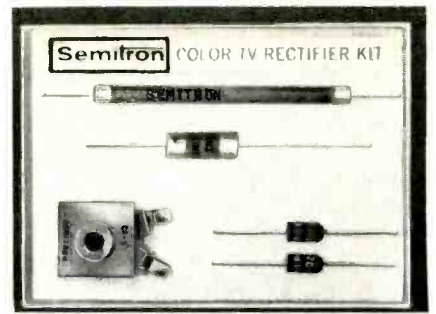

rectifier, 1 booster rectifier, 1 convergence rectifier and 2 power-supply rectifiers. Included with the kit is a semiconductor replacement and interchangeability guide. This guide supplies replacement information for over 5000 semiconductors. Semitron.

Mica Capacitors **709**

A line of molded mica capacitors designed for operation at 1250 C and 1500 C per the requirements of the

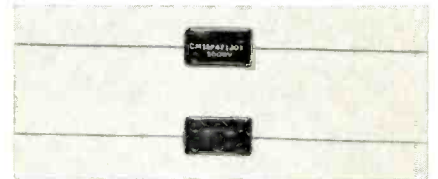

MILC5 specification is introduced. The HTCM line includes case size 15. Electro Motive.

Ladder Jacks **710**

A set of ladder jacks for mounting on the upright of a ladder for erect-



ing scaffolding are introduced. Jacks are adjustable to the pitch or angle of the ladder. Master.

CB Radiotelephone **711**

An all solid-state citizens band mobile two-way radio is introduced. The 6-channel set designated Pace I, is ideal for the H-E-L-P (Highway



Emergency Locating Plan). Under this plan, motorists in distress may use their CB radios to make contact with emergency aid units or other motorists, and secure quick assistance. Pace.

Fills a void...

Hy-gain's new
CITIZENS BAND
"Magna-Topper"



- Magnetic base installs instantly on any vehicle
- "Topper" design provides uncompromised total performance

Every CBER who has seen the new "Magna-Topper" says it's sensational...the only Citizens Band antenna designed for temporary installations that delivers uncompromised total performance on all 23 channels. As a matter of fact, it's so good, many will be installed permanently. It features superior "Topper" design...a magnetic base that permits instant installation on any vehicle...a unique base plate that forms a capacity connection to the vehicle body creating an undistorted groundplane for uncompromised performance.

Backed by an extensive promotional program...selling for \$14.95...the "Magna-Topper" is bound to be a real favorite of H.E.L.P. groups, React Teams, and all CBERs wanting maximum performance and versatility from a mobile antenna. Don't get caught with a void in your merchandising picture. Attractively skin-packed for instant display.

For complete details, see your Hy-Gain representative or write...

HY-GAIN ELECTRONICS CORPORATION

8469 N.E. Highway 6 — Lincoln, Nebraska 68501

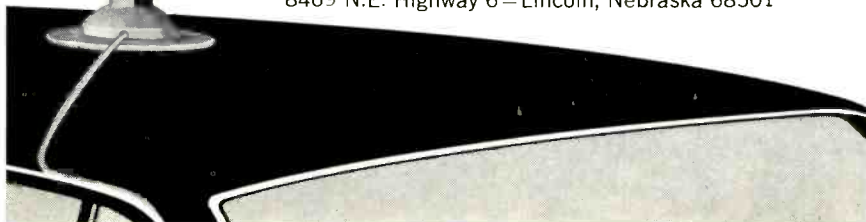

... for more details circle 122 on postcard

The cover gives you the whole story.



The United Delco box tells you for sure you're getting a replacement radio part of the same high quality as the original.

And it tells you who authored it, too. Namely, Delco Radio.

So, if you'd like to hang on to your reputation and customer goodwill, just ask yourself this next time you order transistors:

Do they come individually packed in a distinctive box? (Bushel buying is for potatoes, not transistors.)

Do they carry an easy-to-read, can't-make-a-goof number?

Are the numbers—and the transistors—grouped in such a way that you can service more car radios with fewer parts?

Is there a good chance that the parts are original equipment on nearly half of the car radios on the road?

Delco Radio transistors are all of these, and you can get them from your United Delco supplier. He handles the most widely advertised, merchandised and recognized

name in the parts business—United Delco.

That's how your customers know a good part when they see it.



DELCO RADIO, Div. of General Motors, Kokomo, Ind.

... for more details circle 111 on postcard

**MOST
VERSATILE**

TRIPLET

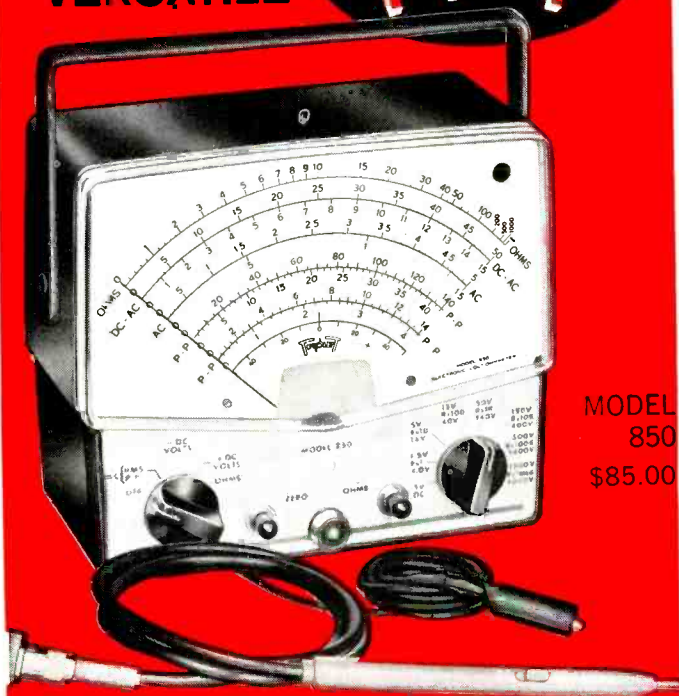

**MODEL
850
\$85.00**

**MODEL 850
ELECTRONIC VOLT-OHMMETER
IS BEST FOR YOU**

FACTS MAKE FEATURES:

- 1** Long 7" easy-to-read scale.
- 2** .5 D.C. volt range for transistor circuits.
- 3** HIGH STABILITY. Meter connected in cathode circuit of 12AU7.

High Input Impedance (11 MEGOHMS) and wide Frequency Ranges give this extremely versatile Electronic Volt-Ohmmeter considerable advantage in the measurement of DC voltages, AC RMS and Peak-to-Peak voltages. It measures directly the Peak-to-Peak values of high-frequency complex wave forms and RMS values of sine waves on separate scales.

ADDED PROTECTION. Meter is shorted out in OFF position for greater damping, meter safety during transit, electrically protected against accidental overload. ZERO CENTER mark for FM discriminator alignment, plus other galvanometer measurements.

New pencil thin test probe used for all functions: DC, AC, and ohms. No need to change cables. Beautifully styled case for professional appearance and functional utility, 7⁵/₈" x 6¹/₁₆" x 3³/₄".

Carrying handle can be used as a tester stand to place the tester at 25° angle for ease in reading.

Frequencies to 250 MC may be measured with auxiliary Diode Probe, \$8.00 extra. DC voltages to 50 KV may be measured with auxiliary High Voltage Probe. \$23.00 extra.

TRIPLET ELECTRICAL INSTRUMENT COMPANY, BLUFFTON, OHIO

... for more details circle 143 on postcard

NEW PRODUCTS

Portable Radio

712

A six-band portable receiver is introduced. The WR4000 has solid-state circuitry and is powered by regular size "D" flashlight batteries, and approximately 300hr of operating time can be expected from a set. Each of the six bands is displayed individually on a drum-type dial. Band No. 1 covers 185 to 400kHz and includes the Consolan (long range radio navigation) frequencies. Band no. 2 is 535 to 1650kHz, covering the standard AM broadcast frequencies. Bands no. 3, no. 4, and no. 5 cover the international short wave frequencies, 2 to 4MHz; 5.85 to 10.3MHz; and 11.4 to 18.2MHz. Band no. 6 covers the entertainment FM frequencies from 86.5 to 108.0MHz. Hallicrafters.

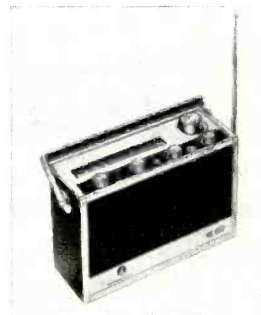

Stock Cart

713



This stock cart offers a choice of either two or three 16 gage steel shelves with 2¹/₂ in. deep retaining sides. Shelves can be mounted with edges up or down. Corner posts on the two-shelf models are pre-punched to accommodate a third shelf if desired. All stock carts are equipped with a push handle and are finished in a gray coating. Running gear consists of four double ball bearing raceway swivel casters with 5in. rubber wheels. All models are 34-1/32 x 36in. Two shelf sizes are available: 18 x 36in. and 24 x 36in. Colson.

Fuse Extractor Posts

714

Two waterproof RF shielded fuse extractor posts that eliminate possible transmission or receiving of stray RF signals through the hole in the chassis used for the fuse post mounting, are introduced. They are designed to take 3AG and 8AG size fuses and for military ground support test equipment and commercial and industrial computer applications. Littelfuse.



For more information on these

NEW PRODUCTS

See pages 101 and 102

READERS SERVICE

FINCO[®]-AXIAL

COLOR-KIT



FINCO-AXIAL COLOR-KIT, Model 7512 AB

High performance Indoor and Outdoor Matching Transformers convert old-fashioned and inefficient 300 ohm hook-ups to the new Finco-Axial 75 ohm color reception system.

List price for complete kit . . .
7512AB \$8.95

7512-A Mast mounted matching transformer . . . list \$5.40

7512-B TV Set mounted matching transformer . . . list \$4.15

FINCO-AXIAL SHIELDED COLOR CABLE, CX Series

Highest quality, 75 ohm swept coaxial cable (RG 59/U) complete with Type F fittings, weather boot ready for installation.

Available in 25, 50, 75 and 100 foot lengths. List price . . . \$5.55, \$8.65, \$11.50 and \$14.20.

Write for Color Brochure # 20-349



**the
complete
color TV
reception
system**

For the best color TV picture

*eliminates color-fade, ghosting and smearing!
Improves FM and Stereo, too!*

QUICK, EASY INSTALLATION

ENJOY brilliant "TV-Studio" color reception today by changing over to the new Finco-Axial Color Reception System. NOW, color fade, ghosts and smears are a thing of the past. Finco-Axial shields color sets against signal loss . . . eliminates outside interference and mismatch problems.

THE FINNEY COMPANY 34 WEST INTERSTATE STREET, DEPT. 110, BEDFORD, OHIO

NEW PRODUCTS

Headset-Microphone 715

A line of lightweight headset-microphone assemblies is introduced. Miniature dynamic earphone elements



are supplied in impedances of 20 Ω , 150 Ω , or 300 Ω . Sensitivity is 105db at kHz ref. 0db .0002 dynes/cm² with input of 1mw. Frequency range is 100Hz to 4.5kHz. Roanwell.

Semiconductor Tester 716

A semiconductor tester that checks



diodes, rectifiers, transistors, and field-effect transistors in, or out-of-circuit is announced. The Model 259 in-circuit semiconductor tester measures both transistors and diodes, in-circuit, for reverse leakage down to 500 Ω of loading. It also measures field effect transistors for leakage and transconductance, and both low and high power transistors for kHz Beta (h_{fe}) within a range of 1 to 1000. Other measurements include the resistance across the emitter-to-base, collector-to-base and collector-to-emitter electrodes of transistors. An optional feature available is an automatic Beta calibration circuit which sets the collector current of each transistor under test at one milli-ampere. American Electronic.

Cord Switch 717

A pendant (cord) switch, particu-

larly suited to applications remote projector and camera control, and a wide variety of industrial instrumentation and control devices, including call services in hospitals and rest homes, is introduced. Called the "Cor-dette" switch, this component offers a choice of contact styles, cable terminations and color variations. Four momentary-action contact arrangements NO SPST, NC SPST, SPDT, or an (NO and NC SPST switch pair)

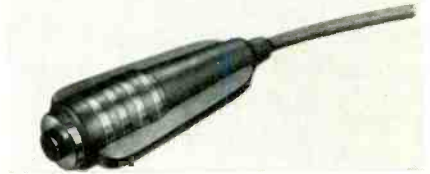

with gold plating carry up to 500ma, 50w, ac, non-inductive loads. Switchcraft.

Small Capacitor 718

This subminiature electrolytic capacitor is rated at 3 μ f-10v and meas-

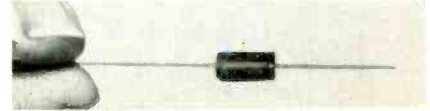

ures 5 x 8.5mm. International Electronics.

The most complete line sells best!



That's one reason why the Johnson CB line outsells all other brands.

Only Johnson's engineering superiority can bring you so many units to cover virtually all applications. Five different 5-watt units, three of them all solid state . . . Hand-held units with 100 milliwatt and 1 1/2 watt power inputs . . . A single sideband transceiver for greater range . . . Rechargeable battery packs for portable operation . . . Antenna matching systems . . . Voltage converters for any DC power source . . . Selective calling systems . . . AC power supplies . . . Antennas . . . and many others.

Sell the leader . . . sell Johnson!



E. F. JOHNSON COMPANY

2726 TENTH AVE. S.W. / WASECA, MINN. 56093

. . . for more details circle 127 on postcard
ELECTRONIC TECHNICIAN

for the traffic outlet
that doesn't want to lose a sale...
RCA's NEW LAZY SUSAN FULL-LINE BATTERY CENTER



15" wide, 15" deep, 23" high, plus header.



Radios



Toys



Flashlights

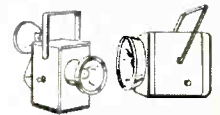

Lanterns



Hearing Aids



Cameras



Industrial and Commercial Applications

The base section
can also be used as
a showcase for
transistor radios and
other battery-operated
devices.

Now display and sell up to 40 different battery types for radios, toys, flashlights, hearing aids, cameras and industrial and commercial applications. Batteries can be grouped by application for faster service, easier inventory control. RCA's Lazy Susan Full Line Battery Center (1P1214) is a clear extruded vinyl plastic showcase with revolving shelves of high impact styrene. Solid brass trim adds strength to the unit. It's attractive, durable and convenient. Latched half doors in the rear allow easy access to battery stock. Don't let those potential sales walk by... contact your RCA Battery Distributor... and start making your battery business that much better.

RCA ELECTRONIC COMPONENTS AND DEVICES, HARRISON, N. J.



The Most Trusted Name in Electronics

NEW PRODUCTS

Compact Stereo

719

A music system with AM/FM stereo and a Garrard AT60 automatic



turntable is introduced. The SC430 speakers contain 8in. woofers with air-suspension design. Harman-Kardon.

Headphones

720

Stereo head phones with a single headband made of plastic covered un-



breakable steel are introduced. The model MBK64S have oval earpads of foam rubber. The standard stereo model has an 8ft cable with metal telephone plug, 17Ω, with full frequency range of 20Hz to 17kHz. Stanford.

Stereo Tuner

721

A solid-state tuner using silicon transistors is announced. The S3300 incorporates a stereo noise filter which reduces high-frequency background



noise without affecting the frequency response of the program being received. A dual automatic-gain-control system maintains proper selectivity under the strongest signal conditions, the manufacturer claims. Sherwood.

Vertical Antenna

722

A citizens band ½ wavelength vertical antenna is introduced. It is con-



structed of heavy wall aluminum tubing with a phenolic base insulator. Cush Craft.

tests all tubes!

Popular low cost tester—complete with adapter for more than 400 Cathode Ray Picture Tubes!

MODEL 88—Tests receiving tubes including novars, nuvistors, newest 10-pin types, compactrons and magnovals. PLUS: Picture tube adaptor with 12-pin socket fits more than 400 cathode ray picture tubes including 110° deflection types. Grid Circuit Test, Tube Merit Test and Filament Test . . . quickly find cathode emission leaks, shorts, grid emission, gas error, filament continuity and cathode-to-heater emission. Stationary receiving tube chassis. Complete with speed-indexed setup data, pin straighteners and 12-pin picture tube socket on 2-foot cable.

Complete picture tube test—accommodates new 10-pin sockets!

Model 98—Spots same tube faults as Model 88 above—PLUS unit features a replaceable plug-in chassis to customize or update instrument for newest tube types; built-in 12-pin picture tube socket; dial controls that isolate or transpose tube circuits and select test current. Grid Circuit; Cathode Emission; Tube Merit; and Heater Current tests for over 2500 types of receiving and picture tubes.

\$99⁵⁰
Dealer Net

Features "no-set-up" testing . . . always up to date!

Model 107B—40 prewired sockets accommodate 63 basic pin arrangements for testing all modern TV, radio, industrial and foreign tubes. Has plug-in chassis wired to test tubes, circuit by circuit. Performs Grid Circuit Test, Dynamic Mutual Conductance Test and Cathode Emission Test. Data book pages covering new tubes mailed periodically to all registered owners.

\$189⁵⁰
Dealer Net

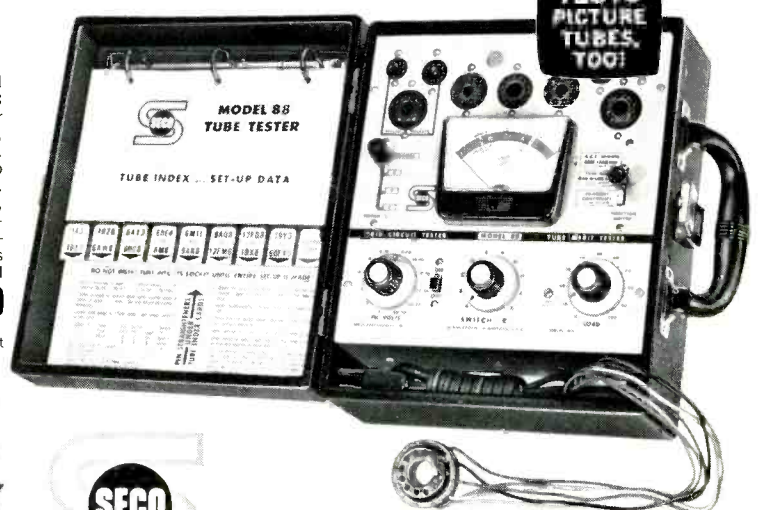
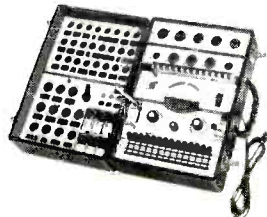
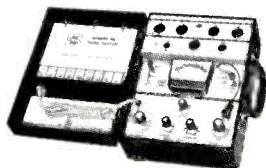

\$74⁵⁰

Dealer Net

SECO

SECO ELECTRONICS CORP.

1205-D So. Clover Dr., Minneapolis, Minn. 55420

. . . for more details circle 138 on postcard

ELECTRONIC TECHNICIAN

This is **RECORD-O-FONE**[®]

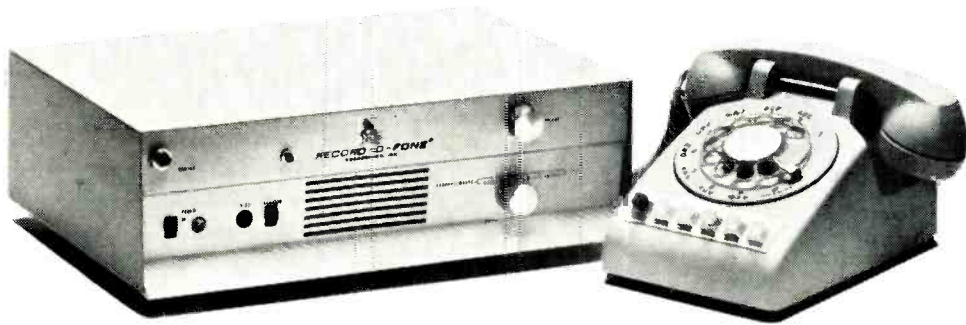

Who else do you know who'll answer your phone 24 hours a day, never get sick, cranky, take a vacation, or come in late and who keeps her ears open and her mouth shut? (Except to you)

When you step away from the office, what do you do... cross your fingers and hope there are no urgent calls; or do you flick a switch and *know* that your phone will be answered quickly on the very first ring... courteously and in your own voice... *everytime*?

Many thousands of business and professional people who bought a Record-O-Fone *last year alone*, know the second way is a good deal safer. They have found it to be far less costly than missing one important phone call because no one answered their phone.



WHY RECORD-O-FONE?

Because only Record-O-Fone combines crystal clear reproduction with the remarkable electronic key ("TELE-KEY"); which lets you *and you alone* collect your messages from anywhere in the world—by any telephone.

Want to know why busy people claim that Record-O-Fone is the next best thing to carrying your office phone in your pocket? Just drop the coupon in the mail.

ROBOSONICS, INC., 408 Concord Ave., New York, N.Y. 10454
ET-1 (212) LU 5-5300

Please send FREE literature Would like FREE demonstration

name _____

address _____

city _____ state _____ zip _____



© 1965 Robosonics, Inc. †T.M. Reg.
® Manufactured under one or more U. S. & Foreign pats.,
issued & pending.

NEW PRODUCTS

Punches and Chisels 723

A line of punches and cold chisels is introduced. The tools are hammer

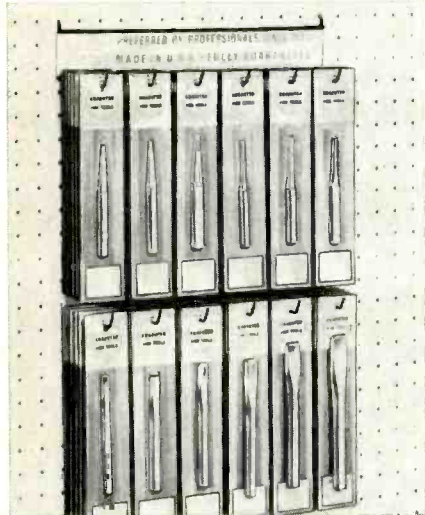

forged, heat-treated, nickel-chrome plated and polished. Krauter.

Ignition Shielding 724

A commercial ignition shielding system which suppresses radio fre-

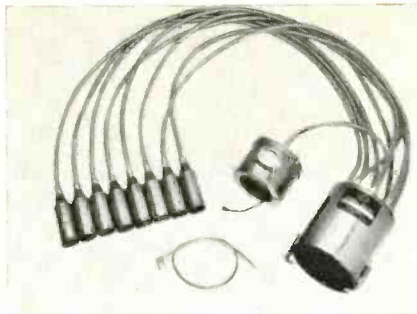

quency interference created by the electrical systems of internal combustion engines is introduced. The unit is approved by the military to satisfy the requirements of specifications MILSTD826-ground support equipment. Hallett.

Single Sideband CB Unit 725

A single sideband CB transceiver is announced. The Messenger 350 weighs 6lb for 12v operation and comes in a cabinet 8 x 2½ x 9½ in. An optional ac power supply for base sta-



tion is available. The ac supply mounts beneath the unit. For hand-carried field operation a small power pack battery module is also available as an option. The power pack uses a rechargeable nickel-cadmium battery and furnishes enough power for eight hours operation. The unit can also be used as a self-contained 3w public address amplifier with an accessory weather-proof outdoor speaker. E. F. Johnson.

Tape Recorder 726

A three-speed solid-state monophonic tape recorder is introduced.



The model 122 is a compact recorder which offers up to 12 hours of record/replay time. It has a VU meter and a variable tone control. It measures 14 x 6½ x 11 in. and weighs 17lb. Concord.

ZENITH LOG PERIODIC ANTENNAS

offer high
signal gain and
ghost rejection

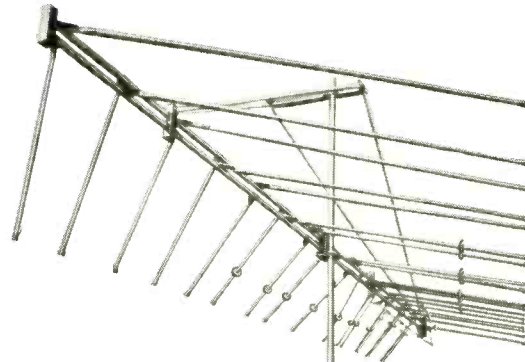

All-channel VHF/UHF/FM and FM Stereo

Developed by the University of Illinois antenna research laboratories, each Zenith log periodic antenna works like a powerful multi-element Yagi . . . not on just one or a few channels, but across the entire band it's designed for.

Order Zenith antennas and all genuine Zenith replacement parts and accessories from your Zenith distributor.

BUILT TO THE QUALITY STANDARDS OF ZENITH ORIGINAL PARTS

Also Zenith periodic antennas for

- UHF • VHF
- FM AND FM STEREO
- PLANAR HELICAL UHF

ZENITH

The quality goes in
before the name goes on

. . . for more details circle 149 on postcard
ELECTRONIC TECHNICIAN

Inventory on wheels!

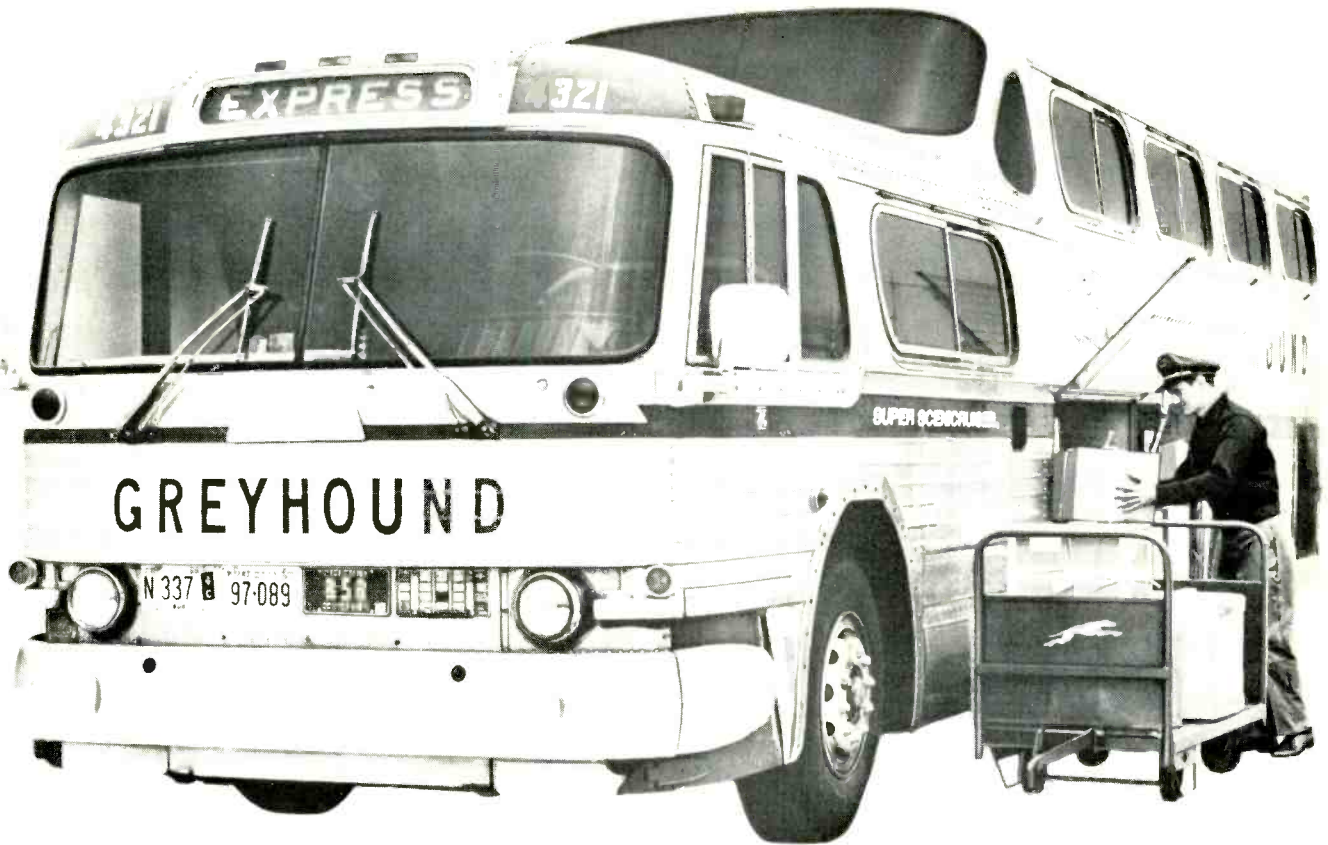

Your inventory is as big as a catalog, and as close as a Greyhound bus, when you specify Greyhound Package Express.

Greyhound Package Express makes a catalog come alive. Using this fast, efficient, low cost shipping service, you could see an item in a catalog before noon today, and have it on your shelf tomorrow morning. Or very often, in just a matter of hours. That means you can order exactly what your customers

need. And have it for them exactly when they want it. You save space, time and money. No premium rates to pay. Your shipments travel aboard regular Greyhound buses on fast, frequent schedules. Ship anytime. Greyhound Package Express serves you 365 days a year, 24 hours a day, weekends and holi-

days. Choice of C.O.D., Collect, Prepaid ... or open a Greyhound Package Express Charge Account.

For additional information about service, rates, schedules and routes, call Greyhound, or write: Greyhound Package Express, Dept. 53-D, 140 South Dearborn Street, Chicago, Illinois 60603.

It's there in hours and costs you less

For Example	Buses Daily	Running Time	20 lbs.	30 lbs.	40 lbs.*
LOS ANGELES— SAN FRANCISCO	25	9 hrs. 15 mins.	\$2.10	\$2.45	\$2.80
DALLAS— SAN ANTONIO	10	7 hrs. mins.	1.90	2.15	2.45
CINCINNATI— LOUISVILLE	14	2 hrs. 20 mins.	1.65	1.90	2.15
CLEVELAND— COLUMBUS	10	2 hrs. 55 mins.	1.80	2.05	2.40

*Other low rates up to 100 lbs. Lot shipments, too.



One of a series of messages depicting another growing service of The Greyhound Corporation.

... for more details circle 118 on postcard

brand new
...and very important...
**QUAM COLOR TV
REPLACEMENT
SPEAKERS PREVENT
COLOR PICTURE
DISTORTION**

OFTEN CAUSED BY STRAY
MAGNETIC FIELDS FROM
ORDINARY LOUSPEAKERS

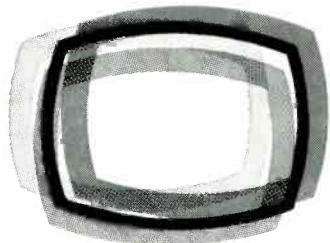

When you use an ordinary loudspeaker in a color TV set, you're looking for trouble... picture trouble. The external magnetic fields from standard loudspeakers will deflect the primary color beams, causing poor registration and distorted pictures.



**QUAM RESEARCH SOLVES
THIS PROBLEM**

An entirely new construction technique, developed in the Quam laboratories, encases the magnet in steel, eliminating the possibility of stray magnetic fields and the problems they cause! These new Quam speakers have been eagerly adopted by leading color TV set manufacturers. Quam now takes pride in making them available for your replacement use. Five sizes (3" x 5", 4", 4" x 6", 5 1/4", 8")... in stock at your distributor.

QUAM
QUAM-NICHOLS COMPANY

234 E. Marquette Rd. • Chicago, Ill. 60637

... for more details circle 134 on postcard

NEW PRODUCTS

Panel Meters 727

An addition to a panel instrument line is announced. The Model 120G

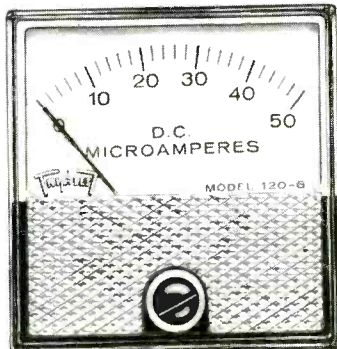

measures 1 3/4 in. sq and extends 1 1/2 in. behind the panel. The panel instrument movements range from 10µadc up. Triplett.

Fluorescent Safety Lamp 728

A portable fluorescent extension light is introduced. The unit is said to outmode breakable incandescent work



lights by reducing explosion and fire hazards, eliminating shocks and contact burns and cutting operating and replacement expense. K&H Industries.

Power Amplifier 729

A 200w solid state power amplifier, designed for industrial and commercial plant paging and music systems and auditorium sound systems is announced. The 1590A normally operates on a 120vac, 50/60Hz power supply (240v is available for foreign operation). The amplifier also operates from a 28vdc battery and will

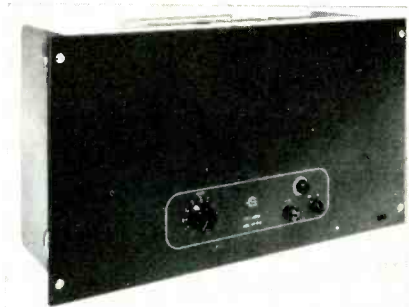

automatically switch to this power source in the event of an ac power failure and will automatically transfer back when ac power is restored. The standby battery is maintained by trickle charge when the amplifier is on ac power. Altec-Lansing.

Amplifier 730

An amplifier designed for a background music/paging system or portable PA application is introduced.



The model "twenty three" has three microphone inputs with separate gain controls, phono input and auxiliary input for tuner, tape recorder preamp or radio output, 70v line output and convenient ac outlet. A paging switch automatically mutes other microphone, phono and auxiliary inputs. A five-step tone control and master power switch are also provided. Bell.

Crystals 731

A line containing the complete range of CB crystals individually blister-packed, coded and identified by channel number is introduced. The

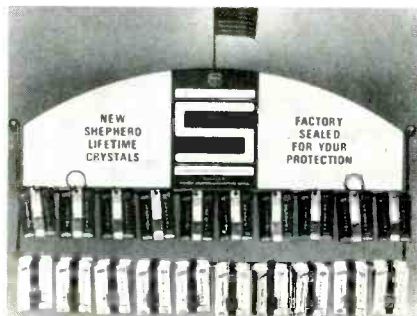

blister package is printed with blue-on-white for transmit crystals and white-on-blue for receive crystals. All of the blister-packs are punched for self-selling display on a rack designed for wall or pegboard. Regency.

"I'm British, you know."



New VIDOR batteries are such a spectacular No. 2 line you'll work your tail off to make them your No. 1

Because now you can sell *fine British quality* at discount-outlet...or precedent-shattering profits

Britain... quality. They're the same. Garrard, Rolls-Royce, Wilkinson, to name a few.

Long enough, you've heard the same old song on battery deals and markups. Listen to something new and exciting now.

IRC's VIDOR. With an introductory deal to knock your hat off. And it's just the beginning.

You can sell VIDOR for class, which it is, to the carriage trade. At your usual prices or even more. VIDOR matches or exceeds the quality of any battery you've ever handled. This way, you can make a bloomin' fortune.

Or you can sell VIDOR for mass, discount-priced...and still get a bigger markup than you're getting now! That's a pretty good way to get rich, too.

Either way, you've got to win. VIDOR has the kind of quality-profit story you haven't heard before. And VIDOR is here to stay.

Hop in now, right at the start. The quicker you do, the more money you'll make. Call your IRC representative for all the profitable details today.

Consumer & Distributor Products Div.,
IRC, Inc., Philadelphia, Pa. 19108.





... for more details circle 123 on postcard

COMPLETE TUNER OVERHAUL

995

ALL LABOR AND PARTS (EXCEPT TUBES & TRANSISTORS)*

COLOR TUNERS GUARANTEED ALIGNMENT ADDITIONAL COLOR NO CHARGE

Simply send us the defective tuner complete; include tubes, shield cover and any damaged parts with model number and complaint. Your tuner will be expertly overhauled and returned promptly, performance restored, aligned to original standards and warranted for 90 days.

UV combination tuner must be single chassis type; dismantle tandem UHF and VHF tuners and send in the defective unit only.

Exact Replacements are available for tuners unfit for overhaul. As low as \$12.95 exchange. (Replacements are new or rebuilt.)

And remember—for over a decade Castle has been the leader in this specialized field... your assurance of the best in TV tuner overhauling.

CASTLE
TV TUNER SERVICE, INC.

5713 N. Western Ave., Chicago 45, Illinois
41-92 Vernon Blvd., Long Island City 1, N. Y.

For service in Canada write to Chicago or use reader service card in this magazine.
*Major parts are charged extra in Canada.

... for more details circle 108 on postcard



ON MAY 1, 1966

Gavin

CAPTURES COLOR

... for more details circle 114 on postcard

NEW PRODUCTS

Tying Device 232

A plastic wire bundle and harness tying device which can be disassembled and reused is introduced. A part of a line of harness fabrication ties and accessories, the device can be permanently installed when temporary tying is no longer required. Thomas and Betts.

Variable Transformers 233

Variable transformers for single or three phase, 120 or 240v service that provides single unit constant current ratings to 4.2kva, ganged unit ratings to 14.5kva are introduced. For 120v service, single type 146 has a rated output of 0-140v, 30amp. For 240v duty, single type 246 has a rated output of 0-280v, 15amp. Superior.

Rear Seat Speaker 734

A rear seat speaker kit packed in a display carton which will stand on the counter or can be hung from peg-



board is announced. In addition, this package has all parts on display and is sealed in a heavy skin-pack to eliminate pilferage and damage. Oaktron.

Cardioid Microphone 735

A cardioid microphone with the acoustical advantages of an adjustable



bass response dynamic microphone is announced.

Adjustable bass response is achieved by a rotary switch marked, "normal" and "less bass." It switches in a ferrite core inductor to modify the low frequency response. Frequency response is 40Hz, to 15kHz when the switch is in the "normal" position. By switching to "less bass" you modify the response to 100Hz to 15kHz. Turner.

'CALL BACKS' . . .

continued from page 57

"Three days after a repaired set is returned to a customer, I personally call on the phone and ask if the set is operating satisfactorily. If a complaint arises which I cannot handle over the phone, I make a *personal* visit to the customer's home, at a time convenient to me and the customer — after shop closing hours. I make very few such visits."

He picked up a sheet of paper from his desk and continued:

"Every bench repair job is *personally* inspected by me before it is returned to the customer. No unsatisfactory job is ever delivered to a customer.

"We keep complete records on every repair and a checkout list is filled out by the benchman. Sets are checked out like a jet pilot checks his plane before he takes off.

"A complete list of manufacturers production changes are filed for reference and files are up-dated immediately when the production change information is received.

"Every chassis is cleaned dust free with compressed air. And every chassis is handled very carefully from the beginning to the time it is returned to the customer.

"All safety glasses and CRT screens are cleaned when the set is reinstalled in the cabinet.

"We use only quality parts when making replacements and no 'job-lot' low-priced components are ever used.

"The tuner and all controls are cleaned on every TV set repaired in the shop.

"These are some of the precautions — all taken together — which help to prevent call-backs," he concluded.

The owner meets one evening

Listen!

Now Jensen brings you 9 auto rear seat speaker kits



They're designed for all popular makes of cars on the road today. New connectors make them faster and easier to install than any other kit.

Oversize air gap clearance, dust drain holes, and solid domes eliminate call-backs.

Jensen's nine new models are available in two lines—deluxe and economy. And they're both packaged in Jensen visual Show Pack for display mounting and in standard cartons for off-the-shelf sales.

Don't pass up profits! Ask your Jensen representative for complete details. Or write Jensen Manufacturing Division, The Muter Company, 6601 S. Laramie Ave., Chicago, Ill. 60638

jensen

Over
10 million
cars
need one
here!

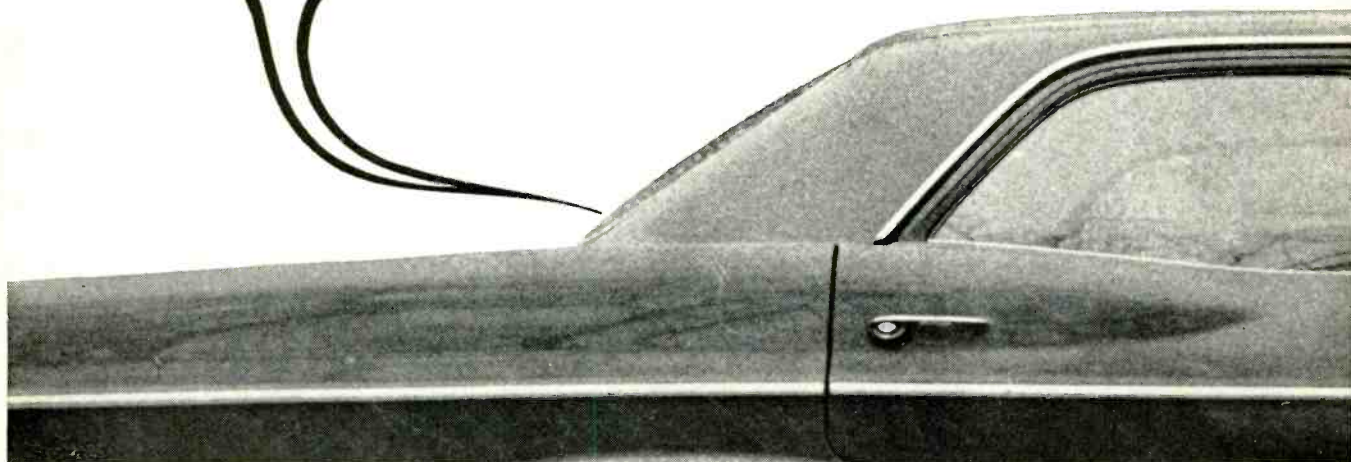

See the new auto rear seat speaker kits and the other new Jensen speakers at the NEW Show in San Francisco.

... for more details circle 125 on postcard

If you think all vidicon replacement tubes are alike, you've got a surprise coming...



Amperex Vidicons are pre-tested and pre-selected as direct plug-in replacements for all these popular types: 7735A, 7038, 7697, 7325, 7336, 7291

Manufactured according to traditional Amperex custom quality standards (each tube comes with its own test data; is packed and shipped in an individual, gimbal-stabilized container), these are off-the-shelf replacements at off-the-shelf prices. Yet each tube provides unparalleled sensitivity and resolution, outstanding lag characteristics and amazingly uniform operation throughout its life. All vidicon replacement tubes are not alike; a replacement is an improvement with an Amperex tube.

Three types are available to most economically match the application—the 55850AM for low cost applications; the 8483 for most conventional applications; and the 55850S for the exacting commercial, professional, medical and broadcast applications.

For complete information, write: Amperex Electronic Corporation, Tube Division, Hicksville, Long Island, New York 11802.

Amperex®

... for more details circle 103 on postcard

each month with his technicians in a "bull session" at his house and discusses any gripes they may have. He asks for their opinions about improving the business. He gives the men substantial raises every year — the amount is dependent primarily on the productivity of the men. He makes it plain that he wants the best they can give and makes no bones about not keeping them if they don't function at the peak of their respective abilities.

"I have learned to constantly think in 'self-development' terms and I urge my technicians to do likewise," he says.

He believes that management and technical ability are like Siamese twins that cannot be separated.

"A successful TV-radio service business depends on both," he said, "and now we constantly search for new ways to improve the quality of our service. It's the only way you can cut your call-back ratio to a low level."

An accountant visits the shop once a month and checks books and records. The accountant calls the manager's attention to any unusual

conditions that may be reflected in the records. This includes a report on the call-back ratio chart, too. But this seldom varies more than a small fraction — and it stands around 0.99 month after month. This represents about 4 non-profit call-backs a month!

ANTENNA . . .

continued from page 63

meter, we can now figure what db gain our antenna should have:

$$\text{Antenna Gain} + 20 \log \frac{100}{50} = 20 \log 2 = 20 \times 0.301 = 6.02\text{db} + 1.5\text{db} = 7.7\text{db.}$$

The antenna we select then must have at least a 7.07db gain to give us 100 μ v at the antenna terminals of the set.

FM/Multiplex Reception

Again, in general terms, we use the same techniques for selecting antennas for FM/stereo reception. But, as in color TV reception, we have additional considerations. Be-

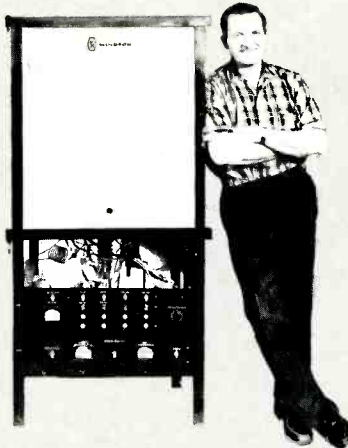

**fat, ugly machine that can
make you a lot* of money.**

Just so you'll be sure . . . it's an oven. Not for pies. Nor cakes. Not even for pizzas. It's for television picture tubes. and performs chores like tube evacuation, cathode bombarding, induction heating, and more. Most important, it is part of the exclusive Windsor System of picture tube rebuilding — your key to a business you can run (right along with what you're doing right now), and make extra money with in amounts you might not have thought possible (*like \$4,000, \$5,000, \$10,000 a year and more!).

Sound good? Then send for the full story. Write direct, or circle our number right away. Who knows, that happy guy in the picture could be you.



WINDSOR ELECTRONICS, INC.
999 North Main Street
Glen Ellyn, Illinois 60137

... for more details circle 147 on postcard

If this year's phono cartridges look new...and just a bit revolutionary...

they are!

In 1965 Admiral, Motorola, Philco, V-M and Zenith all introduced superb new phonographs using a unique new series of ceramic phono cartridges.

With these ingenious designs, the Tetrads Corporation takes its place as one of the brightest innovators in the phono cartridge field. And it's a testimonial to their creative design that already hundreds of thousands of Tetrads cartridges have been installed by many of America's leading phonograph manufacturers.

There's just one problem: Tetrads sells only to manufacturers. So how can you get replacements for your customers?

Well, you might place separate small orders with all the phonograph distributors — but this is time consuming and costly. So Tetrads made it possible for you to buy all 24 new cartridge models — every needle, too — from just one source. Your E-V distributor.

Why were we chosen to handle Tetrads replacements? It's a natural. We're the aggressive new leader in needles and cartridges, with a deep involvement in modern cartridge design (and many significant innovations of our own)! Most significant to you, E-V is determined to be first with the cartridges and needles you need to keep in step with a fast-changing market.

Come to your Electro-Voice distributor for Tetrads cartridges, of course. But don't stop there. We didn't!

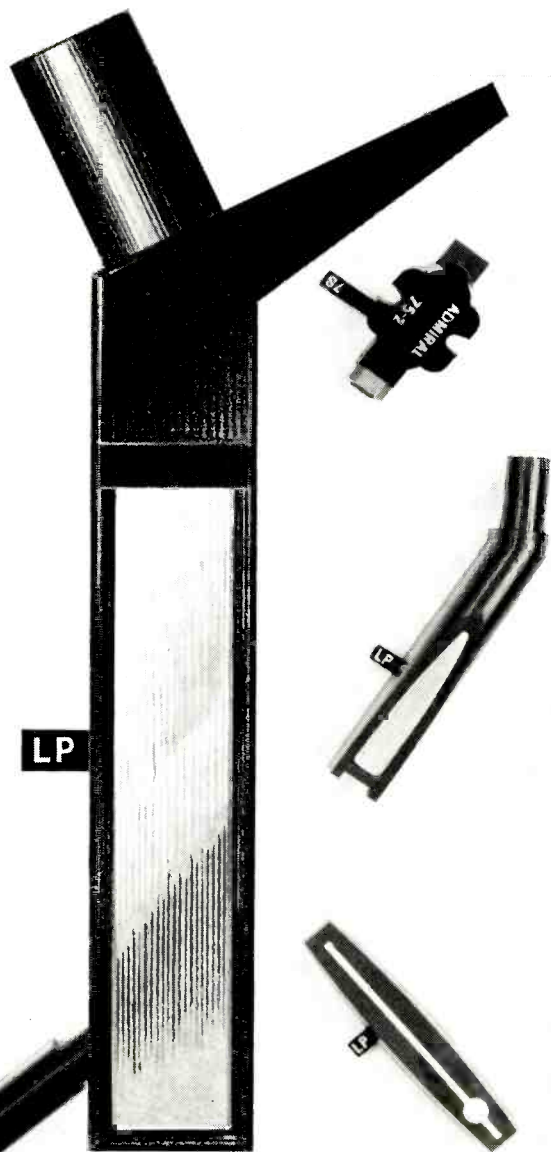

Electro-Voice®

The modern complete line of replacement phono cartridges

ELECTRO-VOICE, INC., Dept. 467T, 663 Cecil Street, Buchanan, Michigan 49107

... for more details circle 112 on postcard

NEW AKTRON INDUSTRIES, INC. REAR SEAT SPEAKER KIT

COMPLETE NOTHING ELSE TO BUY
ALUMINUM VOICE COIL SPEAKER
SOLDERLESS HOOK-UP
FADER CONTROL GIVES COMPLETE
SPEAKER BALANCE
MULTI-IMPEDENCE SPEAKER
LOUVERED, CHROME PLATED GRILL
COMPLETE INSTALLATION BROCHURE
EYE CATCHING
PROTECTIVE DISPLAY PACKAGING



STANDS
BY ITSELF

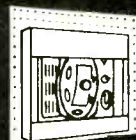

HANGS
FROM PEGBOARD



cause the modulation percentage of the FM/stereo main carrier is less than that of monophonic signals, less information is available. Because of this, we need higher gain antennas for FM/stereo reception. The response of the antenna should also be as flat as possible across the entire FM band from 88 to 108MHz. Here again, because reflected signals can seriously distort FM/stereo reception, the antenna should have a sharp frontal lobe.

Selecting the proper antenna for a particular job is admittedly a little difficult. But today's conditions make it necessary for technicians to take the time necessary to learn how to do it quickly and accurately. ■

THE FUTURE . . .

continued from page 59

coming interested in good music. That's because TV has brought a lot of good music to viewers. Not only has TV exposed the public to *more* music, it has provided *better* music." ■

Warming up to the subject with obvious enthusiasm, Mr. Dotson developed this further.

"There have been discussions before and after symphony performances on TV, and talks on music before and after operatic performances. This has made for a better informed public.

"Once curiosity is whetted, people usually visit the symphony themselves. After that, symphonic or operatic music may be brought into their homes via Hi Fi equipment.

"This trend will increase as people have more leisure time. This gives them more time to become aware of music. This will bring about constantly increasing sales and more service in the area of quality components."

When you look at the quality equipment displayed in the Audio Center Sales Co., the attractive "spotlight" type lighting — you feel that Jim Dotson and his partner Robert Peavy are well on their way to building a highly successful Hi Fi business.

"Word of mouth" is contagious! ■

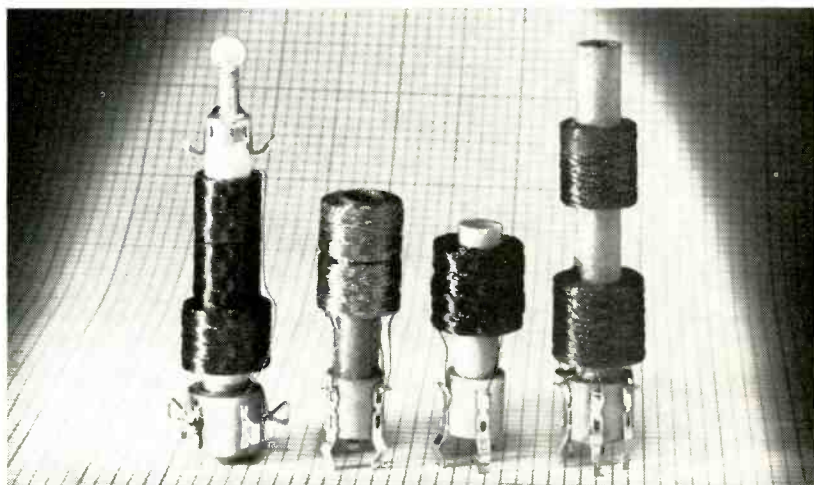

Exact Replacement Linearity Coils for More than 25 Color TV Manufacturers

Exact replacement Models 6347 and 6348 Red/Green Convergence . . . Model 6349 Horizontal Oscillator and Waveform . . . and Model 6350 Focus coils are for Color TV sets by manufacturers such as RCA • Admiral • GE • Silvertone • Emerson.



Write today for your Linearity Coil Cross Reference Guide.

J. W. MILLER COMPANY

5917 SO. MAIN STREET • LOS ANGELES, CALIFORNIA 90003

SEE YOUR LOCAL DISTRIBUTOR FOR FULL LINE OF RF & IF COILS, CHOKES, FILTERS & TRANSFORMERS.

. . . for more details circle 132 on postcard

. . . for more details circle 130 on postcard

ELECTRONIC TECHNICIAN

New Professional DC 'Scope Heathkit® IO-14

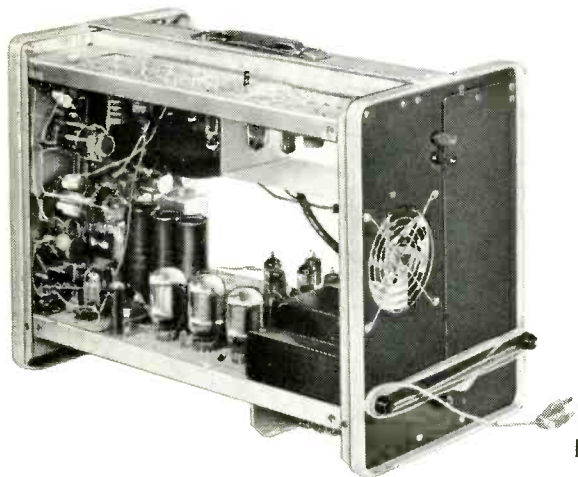

Kit **\$299**
Factory Assembled **\$399**

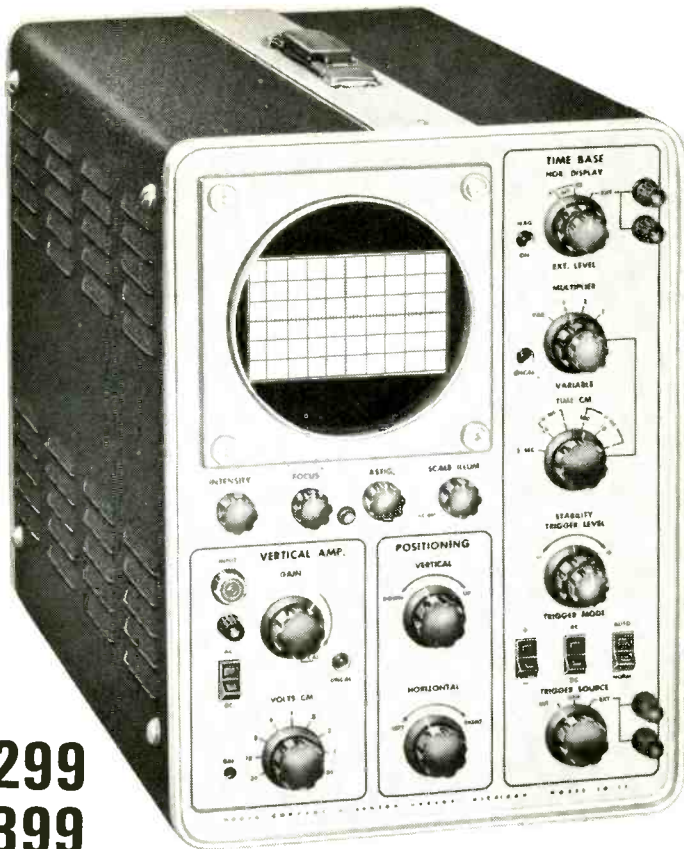

Eighteen Years Ago Heath Broke The Price Barrier On Oscilloscopes With A Low-Cost Scope For Hams, Hobbyists, And Service Technicians. Now Heath Breaks The Price Barrier Again! . . . With A Precision, Fast-Response, Triggered Sweep, Delay Line Oscilloscope For The Serious Experimenter, Industrial Or Academic Laboratory, And Medical Or Physiology Research Laboratory.

- A high stability 5" DC oscilloscope with triggered sweep • DC to 8 mc bandwidth and 40 nanosecond rise time • Vertical signal delay through high linearity delay lines—capable of faithful reproduction of signal waveforms far beyond the bandwidth of the additional circuitry • Calibrated vertical attenuation—from 0.05 v/cm to 600 volts P-P maximum input • Calibrated time base • 5X sweep magnifier • Forced air cooling • Input for Z axis modulation • Input for direct access to vertical deflection plates • Easy circuit-board construction & wiring harness assembly • Components are packaged separately for each phase of construction • Easy to align • Fulfills many production and laboratory requirements at far less cost than comparable equipment—particularly scopes capable of fast-rise waveform analysis • No special order for export version required—wiring options enable 115/230 volt, 50-60 cycle operation

Here Is A Truly Sophisticated Instrument . . . designed with modern circuitry, engineered with high quality, precision-tolerance components, and capable of satisfying the most critical demands for performance. The IO-14 features precision delay-line circuitry to allow the horizontal sweep to trigger "ahead" of the incoming vertical signal. This allows the leading edge of the signal waveform to be accurately displayed after the sweep is initiated.

The IO-14 Provides Features You Expect Only In High Priced Oscilloscopes. For example, switches are quality, ball-detent type; all major control potentiometers are precision, high-quality sealed components; all critical resistors are 1% precision; and circuit boards are low-loss fiber glass laminate. The IO-14's cabinet is heavy gauge aluminum. Its CR tube is shielded against stray magnetic fields, and forced air ventilation allows the IO-14 to be operated under the continuous demands of industrial and laboratory use.

Kit IO-14, 45 lbs. \$299.00
Assembled IO-14, 45 lbs. \$399.00

IO-14 SPECIFICATIONS—(Vertical) Sensitivity: 0.05 v/cm AC or DC. Frequency response: DC to 5 mc, -1 db or less; DC to 8 mc, -3 db or less. Rise time: 40 nsec [0.04 microseconds] or less. Input impedance: 1 megohm shunted by 15 uuf. Signal delay: 0.25 microsecond. Attenuator: 9-position, compensated, calibrated in 1, 2, 5 sequence from 0.05 v/cm. Accuracy: ±3% on each step with continuously variable control (uncalibrated) between each step. Maximum input voltage: 600 volts peak-to-peak; 120 volts provides full 6 cm pattern in least sensitive position. (Horizontal) Time base: Triggered with 18 calibrated rates in 1, 2, 5 sequence from 0.5 sec/cm to 1 microsecond/cm with ±3% accuracy or continuously variable control position (uncalibrated). Sweep magnifier: X5, so that fastest sweep rate becomes 0.2 microseconds/cm with magnifier on. (Overall time base accuracy ±5% when magnifier is on.) Triggering capability: Internal, external, or line signals may be switch selected. Switch selection of + or - slope. Variable control on slope level. Either AC or DC coupling. "Auto" position. Triggering requirements: Internal; ½ cm to 6 cm display. External; 0.5 volts to 120 volts peak-to-peak. Horizontal input: 1.0 v/cm sensitivity (uncalibrated) continuous gain control. Bandwidth: DC to 200 kc ±3 db. General 5ADP31 or 5ADP2 Flat Face C.R.T. interchangeable with any 5AD or 5AB series tube for different phosphor characteristics. 4250 V. accelerating potential. 6 x 10 cm edge lighted graticule with 1 cm major divisions & 2 mm minor divisions. Power supply: All voltages electronically regulated over range of 105-125 VAC or 210-250 VAC 50/60 cycle input. (Z Axis) Input provided. DC coupled CRT unblinking for complete retrace suppression. Power requirements: 285 watts, 115 or 230 VAC 50-60 cps. Cabinet dimensions: 15" H x 10 ½" W x 22" D includes clearance for handle and knobs. Net weight: 40 lbs.

FREE! 1966 Heathkit Catalog

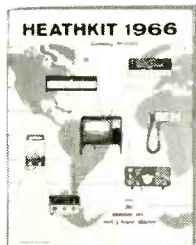

108 pages . . . many in full color . . . describe over 250 Heathkits for the lab, hobbyist, and industry.

Heath Company, Dept. 24-4
Benton Harbor, Michigan 49022

Enclosed is \$ _____, plus shipping for model (s) _____
 Please send FREE Heathkit Catalog & full IO-14 specifications.

Name _____

Address _____

City _____ State _____ Zip _____

Prices & specifications subject to change without notice.

TE-142

. . . for more details circle 120 on postcard

ON MAY 1, 1966

Gavin

**CONQUERS
COLOR**

... for more details circle 115 on postcard

BOOK REVIEWS

TRANSISTORS: PRINCIPLES AND APPLICATIONS. By R. G. Hibberd. Published by Hart Publishing Co., 304 pages, soft cover, \$2.45, hard cover, \$5.95.

This volume is a comprehensive guide to transistor characteristics and uses of various types that have been developed in recent years. The book fully describes the junction transistor, the epitaxial planar, field effect, metal-oxide silicon and thin film types. The author describes principles of operation, transistor characteristics, equivalent circuits, parameters and how to establish suitable dc operating conditions. A chapter is included on the manufacture of transistors. The operation and characteristics of associated semiconductor components used in conjunction with transistors: the junction rectifier, the silicon controlled rectifier, the zener diode, the tunnel diode, the varactor diode and the phototransistor are also described. Low level, high power and high frequency amplification; oscillator, switch and dc amplifier circuits; ra-

dio receivers and power supply arrangements are all covered in separate chapters. Practical circuits, complete with transistor types and component values for various applications are included. The book also includes notes on handling and testing transistors and a chapter on solid state circuit techniques.

COLOR TV TRAINING MANUAL. By C. P. Oliphant & Verne M. Ray. Published by Howard W. Sams & Co., 224 pages, soft cover. \$5.95.

This revised and updated edition covers all the basic fundamentals of color TV. Additionally, it explains color TV principles and all types of color receiver circuits. Included, also, is a section on troubleshooting plus an important chapter on color receiver alignment. Various convergence procedures are thoroughly covered in another section. The book uses an easy-to-understand approach and the numerous illustrations show the reader how to effectively use his test equipment to properly service color TV sets. A number of color trouble symptoms are discussed and explanations for the symptoms are given. The book may prove valuable to both apprentice and experienced technician.

What are you doing about car stereo?

The 4-Track Market Is Here!



Craig Car-Stereo is your answer. Lots of consumer electronics people are picking up extra profits with the Craig line.

It's the best line on the market. Loaded with quality you can sell. Quality electronics you and your customers can count on.

Along with the 4-track, dual-head Car-Stereo line, you've got a huge tape cartridge music library that keeps the profits coming in.

Craig Car-Stereo is your answer. Drop us a line for the name of your nearest distributor.

The 4-track market is here and it's yours for the selling!

CRAIG PANORAMA, INC.

2302 East 15th Street • Los Angeles, Calif. 90021 • (213) 623-2421 • TLX 76-4116

... for more details circle 110 on postcard

MOVING?

Be sure to let us know your new address at least 30 days in advance.

And please enclose a complete address label from one of your recent issues.

ELECTRONIC TECHNICIAN

Ojibway Building

Duluth, Minn. 55802

727-8511

NEWS OF THE INDUSTRY

Raytheon Expands

Raytheon Co. will expand integrated circuit production at Mountain View, Calif., establish a new integrated circuit production facility at Santa Ana, Calif., and move a transistor assembly activity to Paso Robles, Calif. Fred Wills, manager of the semiconductor operation, said the new integrated circuit facility at Santa Ana will be in a 20,000-sq-ft area of the computer operation plant. This facility is expected to be operational early this summer.

To make room for expanded microcircuit production at Mountain View, transistor assembly will be moved to a new facility in a 10,000-sq-ft leased plant at Paso Robles, about half way between San Francisco and Los Angeles.

Some 200 persons now working on transistor assembly at Mountain View are being trained for integrated circuit work. Wills said an equal number will be hired at the new plant in Paso Robles where production is expected to start in April.

Jerrold Moving Offices

The Jerrold Corp. announces plans for further expansion of its facilities. The plant at 15th and Lehigh Ave., Philadelphia, which has housed offices for the parent company and offices and main manufacturing facilities for the company's subsidiary, will now be devoted exclusively to manufacturing. All sales and administrative offices will move to 401 Walnut St., where seven floors, totaling 63,000 sq ft, have been leased.

The manufacturing facilities at 15th and Lehigh will expand into the vacated office space to substantially increase that building's production space. A second shift, started in January, will be expanded to include the new area. The company recently purchased 60,000 sq ft of space to add to its TACO manufacturing facility and has instituted other programs at all of its manufacturing plants to increase production. This comprehensive program will double the production capability of the company. The corporation employs over 2000 people and will now occupy more than 420,000 sq ft throughout its nine locations.

Kaiser Broadcasting Corp. Granted Pay TV Option

Kaiser Broadcasting Corp. announces a major move toward bringing over-the-air subscription television service to the Los Angeles area with the signing of an option agreement for the Los Angeles franchise for Zenith's systems of subscription TV.

The announcement was made jointly by Richard C. Block vice president and general manager of Kaiser Broadcasting Corp. (a subsidiary of Kaiser Industries), and Pieter E. van Beek, president of Teco, Inc., the Chicago company which granted the option. Teco, Inc., is licensed by Zenith Radio Corp. to develop its Phonevision systems of subscription TV in North America.

Future development by Kaiser of the Los Angeles Phonevision franchise under this option is contingent on the FCC's decision on a Zenith-Teco petition now pending before the FCC. The petition to the FCC, based on three years of successful test operation in Hartford, Conn., seeks authorization of subscription TV on a nationwide basis.

Communications, mobile radio... A First Class FCC License ...or Your Money Back!



Your key to future success in electronics is a First-Class FCC License. It will permit you to operate and maintain transmitting equipment used in aviation, broadcasting, marine, microwave, mobile communications, or Citizens-Band. Cleveland Institute home study is the ideal way to get your FCC License. Here's why:

Our training programs will quickly prepare you for a First-Class Commercial Radio Telephone License with a Radar Endorsement. Should you fail to pass the FCC examination after completing your course, you will get a full refund of all tuition payments. You get an FCC License... or your money back!

You owe it to yourself, your family, your future to get the complete details on our "proven effective" Cleveland Institute home study. Just send the coupon below TODAY. There's no obligation. Cleveland Institute of Electronics, 1776 E. 17th St., Dept. ET-22 Cleveland, Ohio 44114.

NEW in 1966

Only CIE offers new, up-to-the-minute lessons in all of these subjects:

- Logical Troubleshooting
- Laser Theory and Application
- Microminiaturization
- Single Sideband Techniques
- Pulse Theory and Application
- Boolean Algebra

Mail Coupon TODAY For FREE Catalog

Cleveland Institute of Electronics

1776 E. 17th St., Dept. ET-22
Cleveland, Ohio 44114

Please send FREE Booklet "HOW TO GET A COMMERCIAL FCC LICENSE," without obligation.



Your present occupation _____

Name _____ Age _____
(please print)

Address _____

City _____ State _____ Zip _____

A leader in Electronics Training... since 1934

*before you buy any
color generator...
get all the facts*

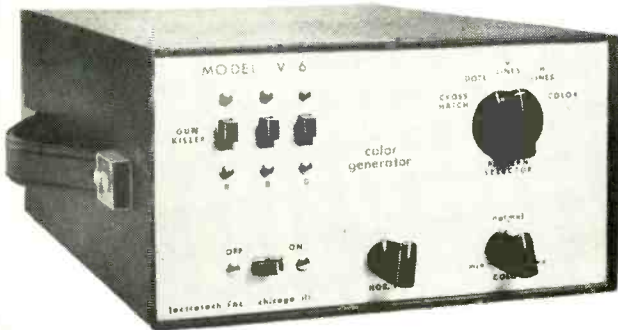

only one has all
these features and
it's only 99⁵⁰*

LECTROTECH V6

Any comparison will prove that the Lectrotech V6 truly stands alone. Provides all of the time-tested standard features plus many Lectrotech exclusives for the fastest, most reliable color installation and servicing. The V6 gives you: Crystal-controlled keyed rainbow color display • All cross hatch, dots, vertical lines only, horizontal lines only • Red-blue-green gun killer (usually extra or not available on other color bar generators) • Exclusive Dial-A-Line feature (Horizontal adjustable 1 to 4 lines wide) • Exclusive solid state reliability • Exclusive voltage-regulated transistor and timer circuits • Exclusive simplified rapid calibration • Off-On Standby Switch • Adjustable dot size • Color level control • Connects to antenna terminals (no connections needed inside of set) • Power transformer-line isolated, to prevent shock hazard • Lightweight and portable, only 4½" H. x 7¾" W. x 10¾" D. Weight, 7½ lbs.

*Except our own V7



V7 Sensational new Lectrotech V7 — the only complete Color TV Test Instrument.

Has all the features and performance of the V6 PLUS Lectrotech's exclusive built-in Color Vectorscope for simplified visual color servicing.

Complete.....only **189⁵⁰**



ONE YEAR WARRANTY

See your distributor or write for details before you buy any color generator.

LECTROTECH, INC.

Dept. ET-4, 1221 Devon Avenue • Chicago, Illinois 60626

... for more details circle 128 on postcard

NEWS OF THE INDUSTRY

Snyder Plant in Israel

Snyder Mfg. Co. is considering the possibility of building a plant in Israel to produce its housewares, TV antenna and sporting goods lines, it was announced by Ben Snyder, president. He and Mrs. Snyder recently toured Israel as part of a study tour of European and Middle East markets.

The Snyder firm president said he "was greatly impressed by the industry of the Israeli citizens and the tremendous progress they made in the past decade."

He said he spoke at length to representatives of the government there on prospects for a Snyder production plant and found "the government highly receptive." A production plant in Israel, Mr. Snyder explained, would produce goods for use in Israel and for export to African nations, the Far East and Europe. He said the climate in Israel is conducive to high productive capacities, and new immigrants still pouring into this tiny democracy could easily be trained. "Our engineering and marketing staffs are now taking this matter under consideration," he stated.

"We are considering all phases, including the economics of such a move. We may send top management personnel to Israel to make further studies if it warrants such a step to assist in making a decision."

HERE IT IS--

THE

LEADER!

NEW

Brach

UHF/VHF

TV ANTENNAS

FOR

Black/White & Color



6651 Chromate
6652 Chrome

- Ultimate in Design!
- Unequaled in Performance!
- Outstanding in Value!

BRACH MANUFACTURING CORP.

DIVISION OF GENERAL BRONZE CORPORATION
899 Main Street, Sayreville, N.J. 08872

... for more details circle 107 on postcard

ELECTRONIC TECHNICIAN



The best reason for using Motorola's HEP semiconductors . . .

is usually put in the bank!



Because HEP, from Motorola, offers you quality solid-state devices at substantial savings.

It's money in the bank when you select Motorola's HEP semiconductor devices to fill your replacement needs. These devices help you in four ways to build your business, to stock fewer parts and lower your costs. (1) Motorola HEP devices cost you less than competitive devices so you can give high quality work and quality devices at lower customer costs. This means more business for you but your profit margin and labor costs remain the same. (2) Motorola HEP's Value Insured Parameters (VIP) assure you of reliability and top performance. Each device is individually tested to printed ratings — that means when the job is sold it stays sold. (3) Motorola HEP's pocket cross-reference covers almost 5,000 JEDEC and manufacturers devices that you use. (You can count 'em.) You stock only a few to cover all of them! (4) Each Motorola HEP device is backed by the leader in the lively art of solid-state electronics —

and bears a name your customers recognize and accept.

See your local HEP distributor today. Reduce your parts investment and lower your costs. You can bank on the fact that you will be first with the latest, best and most dependable semiconductors. Get HEP. Use HEP.



To get your copy of the handy pocket semiconductor cross-reference guide see your HEP distributor or send a card with your name and address to Motorola HEP, Box 955, Phoenix, Arizona 85001.



MOTOROLA
Semiconductors

... for more details circle 131 on postcard

New G-E MASTR PROGRESS LINE Executive two-way radio gives you complete control of your business

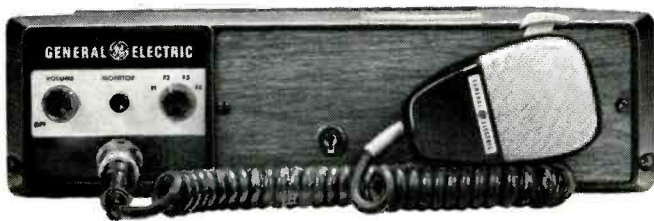

**Only value-priced two-way radio
with professional features:**

- Silicon transistors throughout receiver and transmitter for high and low temperature reliability
- Built-in electronic voltage regulation for longer component life and "stay-stable" performance
- Station and mobile modules quickly interchangeable for rapid maintenance and minimum spare parts requirements
- Ruggedized 5G construction virtually eliminates costly mechanical failures.
- High IF Selectivity up front... achieves new dimensions in adjacent channel performance
- Complete mounting versatility - under dash, in trunk or externally in a weatherproof case
- Ovenless plug-in crystals for instant on-frequency stability
- Flutter-lock squelch circuit... eliminates message chopping

A General Electric two-way radio is the efficient way to reach men on the road. With it, you save on man-hours, gas and telephone charges. And now there are two mobile radios in the G-E MASTR Progress Line: The Professional Series for greater system flexibility. And the new Executive Series for many professional features in a lower priced radio.

Look into a MASTR now. Contact your G-E Communications Consultant listed in the Yellow Pages under Radio Communications. Or write to General Electric Company, Communication Products Department, Section 11546, Lynchburg, Virginia.

First in Two-Way Radio

GENERAL  ELECTRIC

... for more details circle 117 on postcard

NEWS OF THE INDUSTRY

Admiral Adds Portable TV

A 19-in. portable TV receiver has been added to Admiral's 1966 line, announces William S. Lowry, sales manager.

The Corsair has 17,000v picture power, gated automatic gain control, transistorized two speed UHF tuner, monopole antenna, unitized UHF/VHF channel selector, retractable handle and polarized power plug.

Service Dealers Welcome At 1966 NEW Week

Service dealers and industrial purchasing agents will be eligible to attend National Electronics Week in 1966 in a departure from past practice, announces Mario Chirone, Elmar Electronics, chairman of the Credentials and Registration Committee for Electronics Industry Show Corp.

Admission to NEW exhibits (and to exhibits at the predecessor Electronics Parts Distributors Shows) was formerly limited to members of those trade categories who normally buy directly from the exhibiting companies. At the 1966 show, to be held in San Francisco in June, customers of the exhibitors' customers will be permitted to attend.

This special attendance privilege will be available only on Sunday, June 5, Mr. Chirone said. Service dealers, industrial purchasing agents, and others who normally deal with any of the parts distributing, audio and sound, or specialty houses for whose primary benefit National Electronics Week is held will be able to secure a "Sunday Guest" badge for only \$2.00. To purchase these "Sunday Guest" badges such individuals will need a special registration form from their supplier, qualifying them as members of the trade. (It is not intended that the general public be invited or permitted to attend and distract from the business environment of NEW.

Registration forms for the "Sunday Guest" badge will be available from companies in the direct customer category in Mid-April.

Direct customers of the exhibiting companies will again be admitted free, Mr. Chirone said, if they register for badges in advance. Badge application forms are available from Electronic Industry Show Corp. 100 S. Wacker Dr., Chicago, Ill. 60606.

Those individuals wishing to attend the trade show who have not registered in advance and who are not eligible for the special "Sunday Guest" badges will be able to purchase an unrestricted guest badge at the door. The unrestricted guest badge may be used all three exhibit days but costs \$5.00. "This fee is designed," Mr. Chirone said, "not to produce revenue, but to eliminate the merely curious casual visitor who has no business reason for attending."

The trade exhibits at 1966 NEW are merely one facet of the week-long conclave (May 30 through June 5) which is considered the major marketing event in electronics. NEW also incorporates conventions and meetings, and a one-day educational program, The Profit Forum. It is the industry's only national trade show oriented towards the marketing and merchandising of electronic products. Exhibits will be held in San Francisco's Civic Auditorium Friday, Saturday, and Sunday, June 3, 4 and 5. Headquarters hotels are the San Francisco Hilton and the St. Francis, the Sir Francis Drake and Del Webb's Towne House.

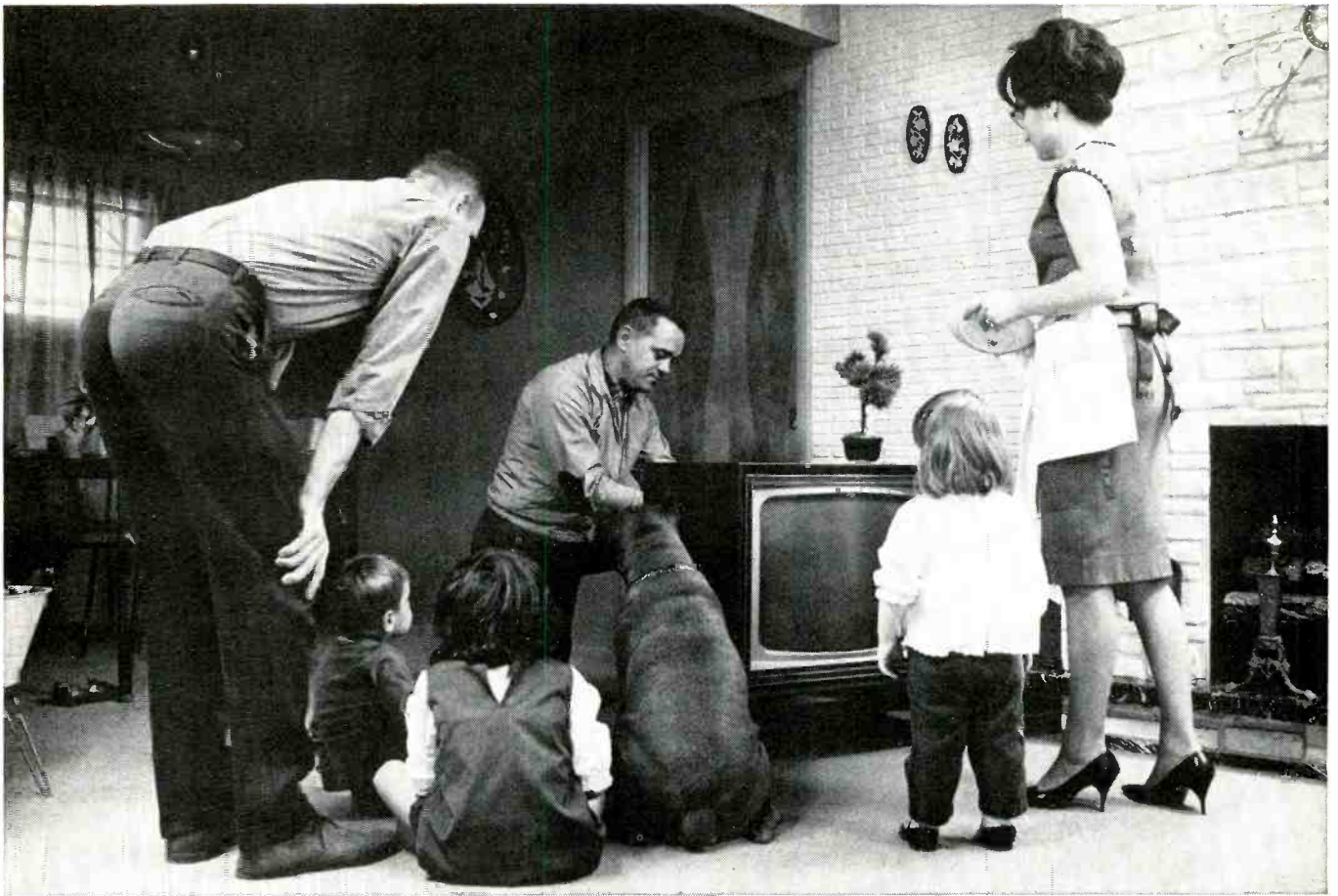

When you use your CRT Commander, everyone wants to watch



Compact and only 7½ lbs, the CRT Commander has a built-in high impedance voltmeter (so you don't have to carry a VTVM). Price: \$89.95.

Sometimes that's the price you pay for using a professional-looking piece of equipment. And there's something about Amphenol's new tester-rejuvenator that attracts attention.

We think the CRT Commander deserves your attention, too. Here are three reasons why:

1. **It tests more tubes than other models.** The CRT Commander has 11 steps of filament voltage plus extra taps for future releases. There's not much chance of its becoming obsolete.
2. **It tests both b/w and color**—and does it the way NCTA recommends. Testing with the CRT Commander is fast and easy. Five permanently-fixed adaptors do the work of seven.
3. **If a tube will rejuvenate**, the CRT Commander will do it—even where others fail. As recommended, it treats each gun separately in color CRT.

Compare Amphenol's CRT Commander to any other tester-rejuvenator on the market. If you want more information, see your Amphenol salesman. Or write to Dan O'Connell, Market Manager for Service Products, 2875 South 25th Avenue, Broadview, Illinois 60153.



AMPHENOL

... for more details circle 104 on postcard

Why break your back !



Let the Ungar HOT-VAC De-Soldering Tool do the tough jobs

Trouble melts away. The new Ungar Hot-Vac gives you finger tip control for printed board rework and repair. Hot-Vac makes it possible to remove components 50% faster than any other method. One hand operation frees the other for component handling. A special ungargized white coating on the



inner surface of the Hot-Vac tip and solder collector prevents sticking and clogging. A piffit-squeeze of the bulb discharges molten solder. Your local Ungar distributor will be happy to give a Hot-Vac demonstration and complete information, or send coupon below for detailed literature.

SEND FOR COMPLETE INFORMATION ON HOT-VAC TODAY!

Ungar Electric Tools, 2701 W. El Segundo Blvd.
Hawthorne, California 90252 • Dept. E. T. - 4

Name (Please Print) _____ Title _____
Company _____
Address _____
City _____ State _____ Zip _____



... for more details circle 144 on postcard

CATALOGS AND BULLETINS

- Flat Cable** 400
This 10-page booklet contains illustrations and detailed instructions for installing a brand of flat cable. Instructions are also included for splicing the cable and hooking up accessories. 3M.
- Portable Handles** 401
A line of handles are described in this eight page brochure. The handles are used for luggage, instrument cases, radio and TV sets and other portable hand carried equipment. Sherwood Plastics.
- Crimping Tools** 402
Specifications and uses of a variety of crimping tools are contained in this 20-page bulletin. Buchanan.
- Soldering Tools** 403
This 8-page catalog contains electrical and mechanical specifications for a line of soldering tools. A description of some soldering accessories is also included. Weller.
- Magnetic Tape Heads** 404
Physical configurations and electrical specifications are given for a line of tape heads in this 10-page catalog. Michigan Magnetics.
- CRT Tester** 405
This bulletin gives electrical and mechanical specifications for a portable picture tube tester. The unit will check both black and white and color tubes. Lectrotech.
- Electronic Parts** 406
Numerous items of interest to both the TV-radio service-dealer and the industrial technician are contained in this 300-page illustrated catalog. GC Electronics.
- Alkaline Batteries** 407
The brochure lists full specifications and ordering information for a line of alkaline batteries. Gulton.
- Antenna** 408
A sector-phased, omni-beam antenna is described in this 4-page brochure. Physical, mechanical and electrical specifications are included. Antenna Specialists.
- Antenna** 409
Prices and discounts on a line of TV and communications antennas are contained in this brochure. S & A Electronics.

Brand **NEW** FROM **HICKOK**

MODEL 209C 9-INCH VTVM

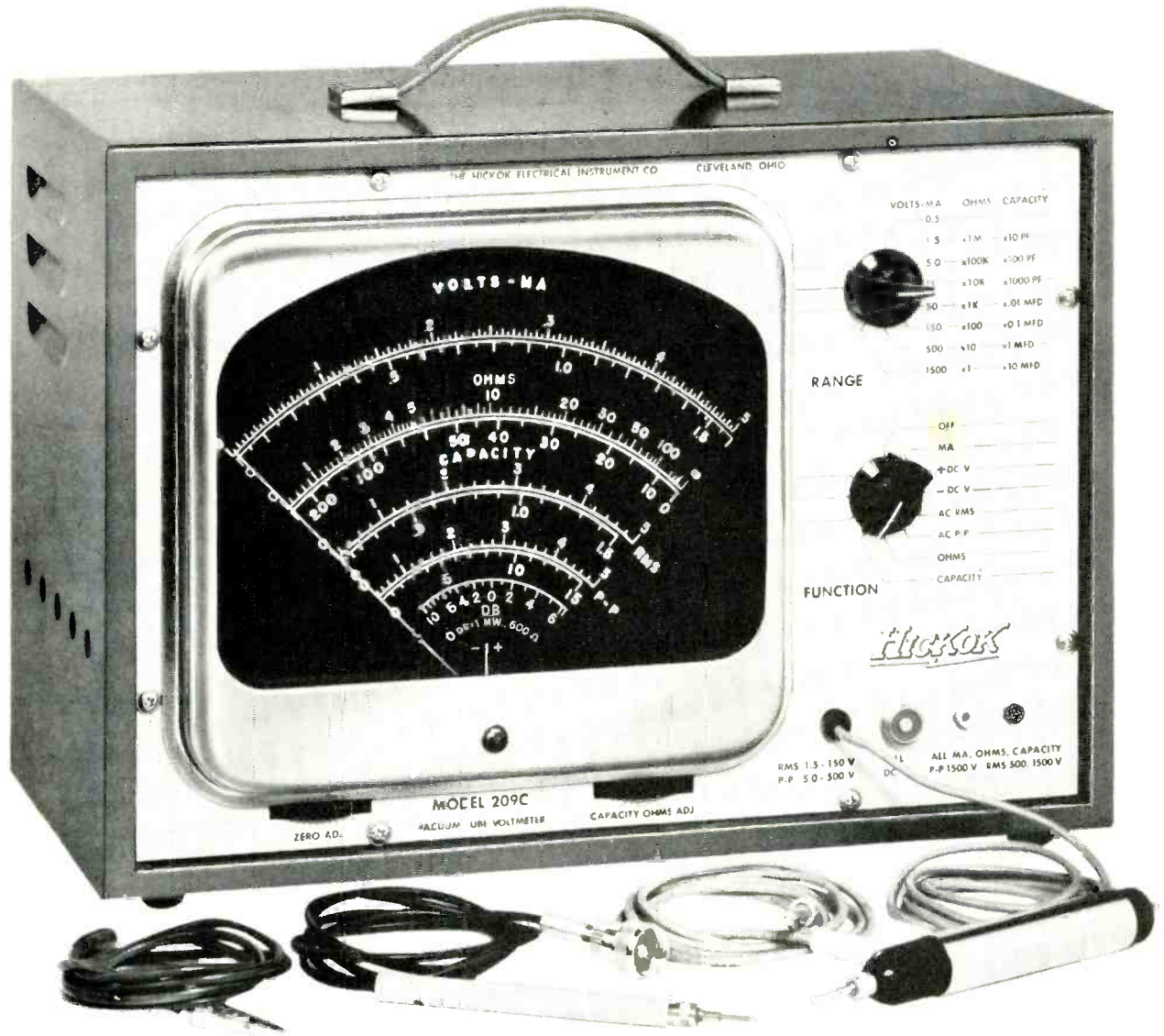

HIGHLIGHT FEATURES

- ... Large 9" Display
- ... Ultra Stable Circuitry
- ... High Input Impedance
 - DC—11 megohms
 - AC—10 megohms, 11pf
- ... AC Measurements Up To 200mc
- ... High Accuracy
 - DCV, ACV— $\pm 3\%$ FS
 - Ohms, Capacity— $\pm 3\%$ ARC
- ... Lightweight—15 lbs.
- ... Fully Field Tested
- ... Measurement Ranges
 - DC Voltage—0-1500v
 - DC Current—0-1500ma
 - AC Voltage (RMS)—0-1500v
 - AC Voltage (P-P)—0-1500v
 - Decibels—-10db to +66db
 - Resistance—0.2 ohm to 1000 meg.
 - Capacity—50pf to 2000Mfd
 - Inductance—obtainable mathematically from scale readings

Price \$184.50

THE HICKOK ELECTRICAL INSTRUMENT CO. • 10523 Dupont Avenue • Cleveland, Ohio 44108

... for more details circle 121 on postcard

ON MAY 1, 1966

Gavin

CHARGES INTO COLOR

... for more details circle 116 on postcard

FREE!

**NEW MERCHANDISING AIDS
BIG PROFITS WITH ROBINS^M_M
RECORDING HEADS**

FREE!

- ✓ LARGE RECORDING HEAD REFERENCE WALL CHART
- ✓ HEAD SPEC. CHART
- ✓ WINDOW BANNERS
- ✓ INFO... WHERE TO GET ROBINS EXACT REPLACEMENT RECORDING HEADS!

TAPE RECORDER SALES—REPAIRS are BOOMING! Repairs are profitable when you use ROBINS HEADS! Write for FREE Merchandising Aids and info...

ROBINS INDUSTRIES CORP.
15-58 127th STREET, FLUSHING, N. Y. 11356

... for more details circle 136 on postcard

ADVERTISERS INDEX

Amperex Electronic Corp.	3rd Cover, 86
Amphenol Distributor Div.	97
Arrow Fastener Co.	100
B&K Manufacturing Co.	65
Brach Manufacturing Corp.	94
Castle TV Tuner Service, Inc.	84
Channel Master Corp.	25
Cleveland Institute of Electronics	93
Craig Panorama	90
Delco Radio Div.	73
Electro-Voice, Inc.	87
Finney Co., The	75
Gavin Instruments, Inc.	84, 90, 100
General Electric Co., Communication Products Dept.	96
General Electric Co., Distributor Sales Dept.	19-22
Greyhound Corp.	81
Hallmark Instruments	28
Hayden Book Cos.	39-42
Heath Co.	89
Hickok Electrical Instrument Co.	99
Hy-Gain Electronics, Inc.	72
IRC, Inc.	83
Jackson Electrical Instrument Co.	30
Jensen Manufacturing Co.	85
Jerrold Electronics Corp.	2nd Cover, 34
Johnson Co., E. F.	76
Lectrotech, Inc.	94
Littelfuse, Inc.	71
Miller Co., J. W.	88
Motorola Semiconductor Products, Inc.	95
Oaktron Industries	88
Philco Corp.	37
Quam-Nichols Co.	82
Quietrol Co.	100
Radio Corp. of America RCA Electronic Components & Devices	4th Cover, 24, 77
RCA Sales Corp.	66-67
Robins Industries Corp.	100
Robosonics, Inc.	79
Sarkes Tarzian Tuner Service Dept.	33
Seco Electronics Corp.	78
Sencore, Inc.	32, 35, 38
Sprague Products Co.	27
Sylvania Electric Products, Inc.	31, 69
Triplett Electrical Instrument Co.	74
Ungar Electric Tools	98
Viking Instruments, Inc.	68
Weller Electric Corp.	26
Windsor Electronics, Inc.	86
Winegard Co.	29
Zenith Sales Corp.	80



**EFFICIENT!
SAFE!
FAST!**

**AUTOMATIC
STAPLE GUNS**



**For Fastening Any
Inside or Outside**

Wire Up to 1/2" in Diameter

- UP TO 3/16"
No. T-18
- UP TO 1/4"
No. T-25
- UP TO 1/2"
No. T-75

- Telephone wire
 - Intercom wire
 - Bell wire
 - Thermostat wire
 - Radiant heating wire
 - Hi-Fi, Radio & TV wires
- Tapered striking edge gets into close corners!

Available in:
**Brown, Ivory, Beige,
Monel, Bronze, Natural**

ARROW FASTENER COMPANY, INC.

1 JUNIUS STREET • BROOKLYN 12, N. Y.

... for more details circle 105 on postcard

SNAP
CRACKLE
POP

is a pleasant sound in a bowl of Breakfast Food
BUT
it's a malfunction in TV and radio that can be eliminated quickly and profitably with **QUIETROLE**

NOW! QUIETROLE

Offers 3 New Aerosols
To save time . . .
make added income

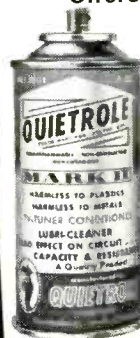

- 1 **QUIETROLE MARK-II**
For Tuners
- 2 **QUIETROLE SPRAY-PACK**
For Controls & Switches
- 3 **QUIETROLE SILITRON**
For General Use

All with extenders
HARMLESS TO PLASTICS
... non-conductive, non-inflammable and non-corrosive. Zero effect on capacity and resistance.

Harmless to metal
YES! Quietrole is still available in bottles with an eye dropper!



manufactured by

QUIETROLE Company
Spartanburg, South Carolina

... for more details circle 135 on postcard

ELECTRONIC TECHNICIAN

If you think
all replacement tubes are alike,
you've got a surprise coming

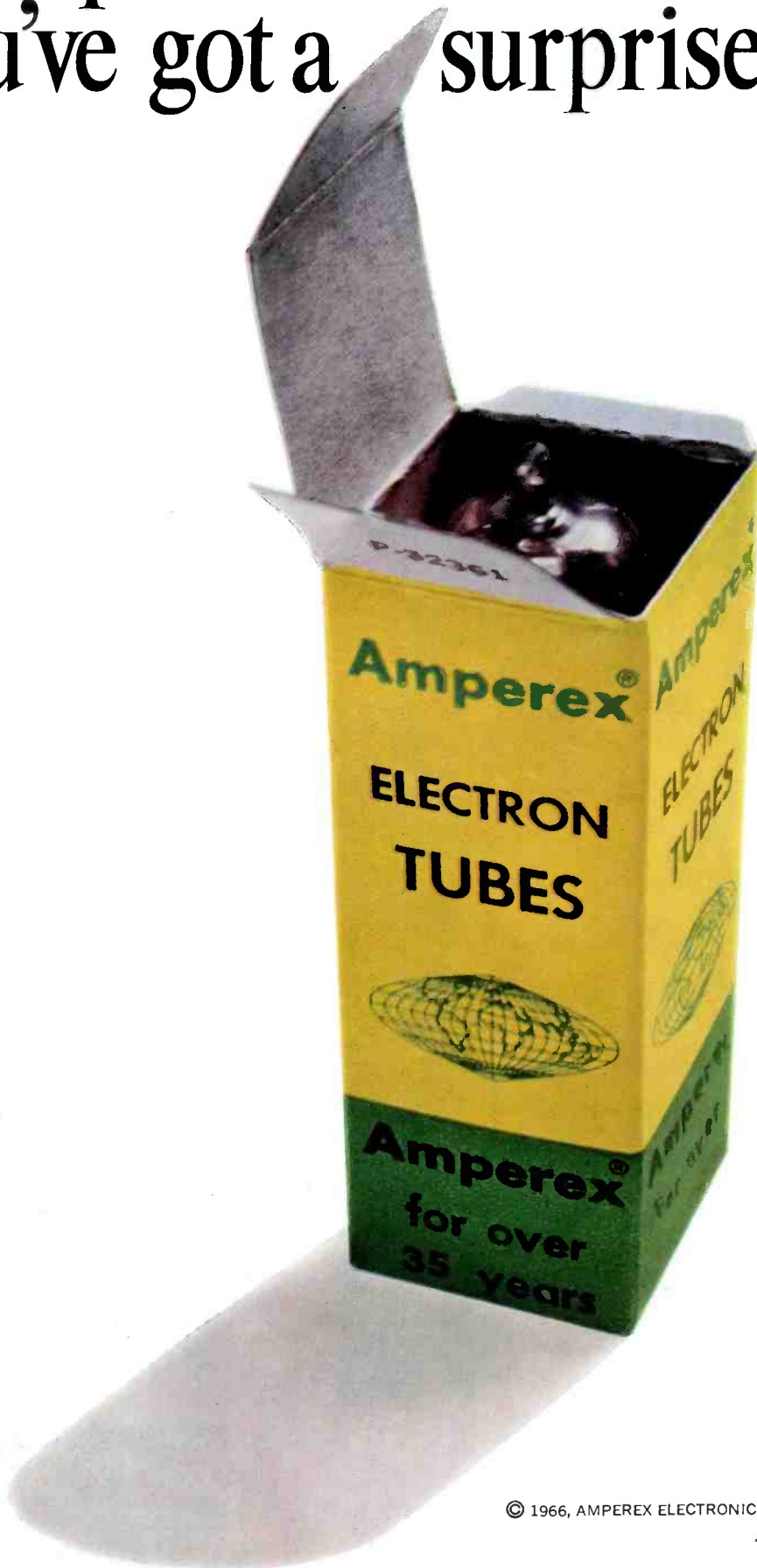

Now in one handbook...the service information you need for 12 makes of color TV sets



TABLE OF CONTENTS

- INTRODUCTION
 HOW TO USE THIS HANDBOOK
 ABBREVIATIONS USED IN THIS HANDBOOK
- Section 1. CHASSIS INDEX
 - CHASSIS LAYOUTS
 - Section 2. PURITY ADJUSTMENTS
 - Section 3. CONVERGENCE ADJUSTMENTS
 - STATIC CONVERGENCE (general)
 - DYNAMIC CONVERGENCE (specific)
 - Section 4. BLACK AND WHITE SETUP ADJUSTMENTS
 - Section 5. PHASE AND MATRIX ADJUSTMENTS
 - Section 6. COLOR AFPC FIELD ADJUSTMENTS
 - Section 7. MISCELLANEOUS ADJUSTMENTS
 - Section 8. FUSES AND CIRCUIT BREAKERS
 - Section 9. TEST EQUIPMENT FOR COLOR TV SERVICING
 - Section 10. RECEIVING TUBES FOR COLOR TV

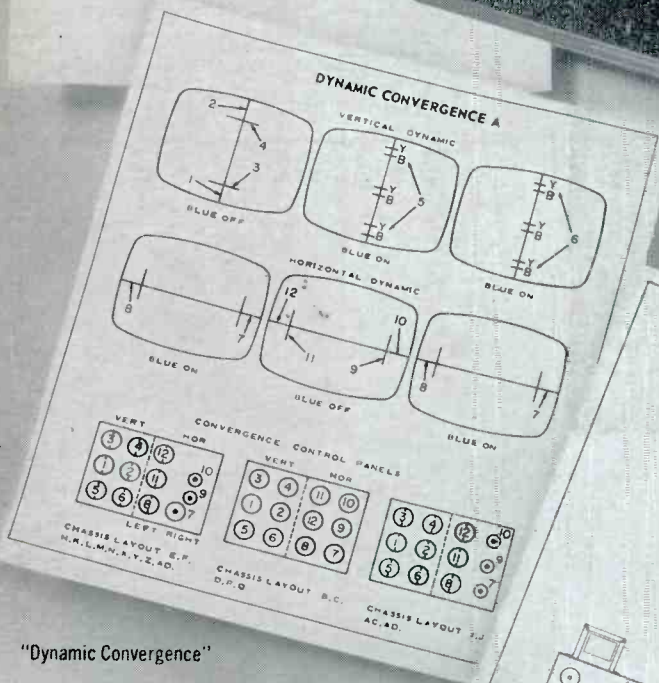

"Dynamic Convergence"

Just look up the chassis number of the set you are working on in the CHASSIS INDEX and you will be guided to the proper sections of the 140-page RCA Color TV Service Handbook. All the information is based on the manufacturer's own service notes. You'll want to carry a copy in your tube caddy on every color TV service call.

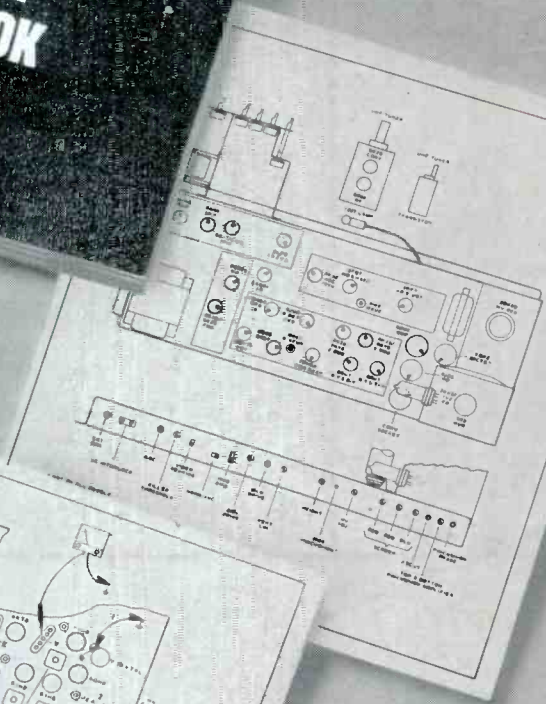

"Chassis Layouts"

"Color AFPC Field Adjustments"

TO KEEP UP WITH COLOR, SEE YOUR RCA DISTRIBUTOR ABOUT GETTING THE RCA COLOR TV SERVICE HANDBOOK (1A1553).

RCA ELECTRONIC COMPONENTS AND DEVICES, HARRISON, N. J.



The Most Trusted Name in Electronics

RCA's personal quality performance program aims for missile-type reliability in commercial receiving tubes. Under this program thousands of RCA people have pledged to strive for error-free performance so that when you replace with RCA receiving tubes you're sure of a satisfied customer.