

TECHNICIAN

& Circuit Digests

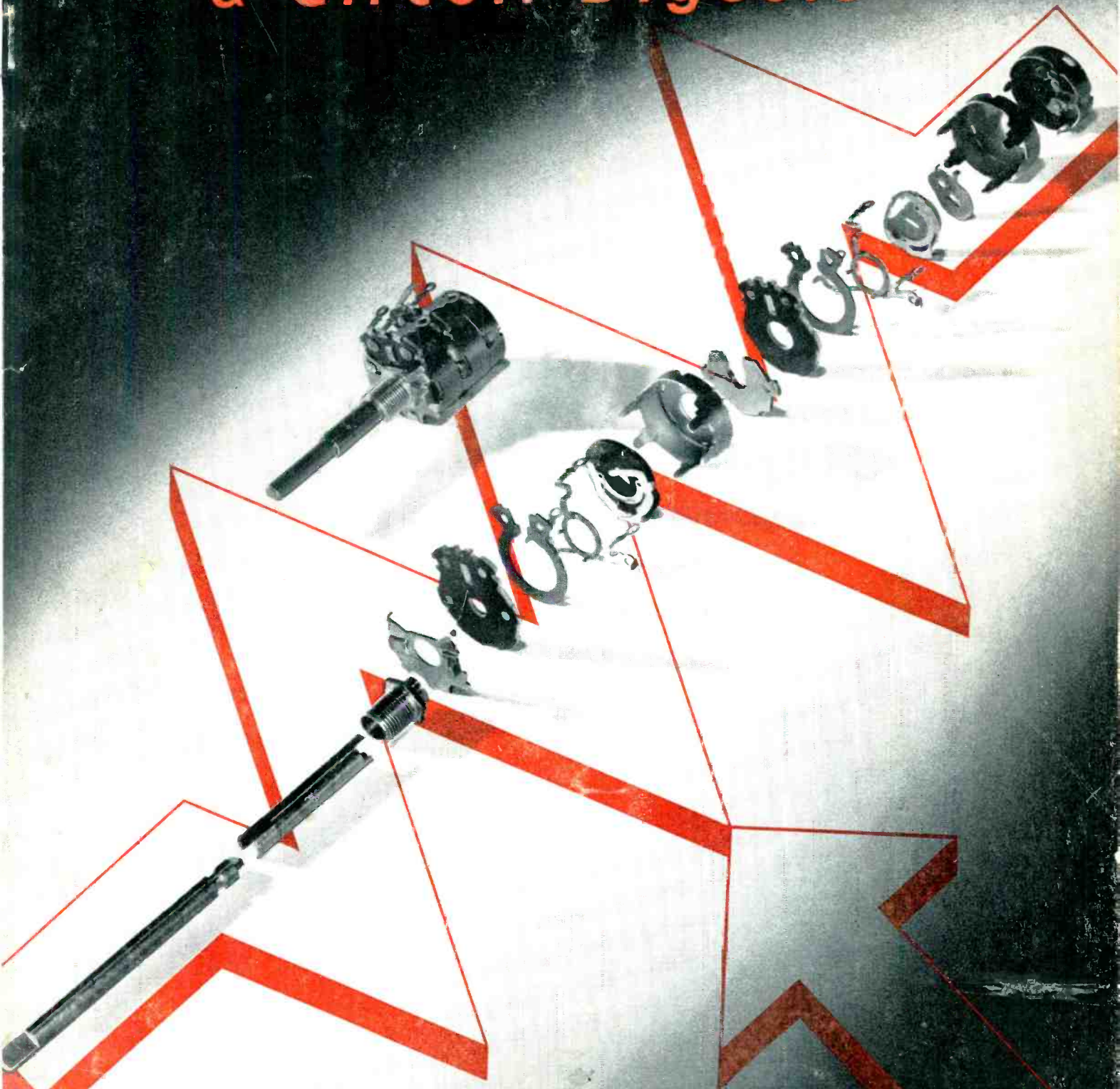

RESISTIVE CONTROLS

Over 400 million in regular use

Special Feature! Color-TV Terminology—Systems Chart

In 2 Sections • Section 1

October • 1954

HERE'S WHY IRC EXACT DUPLICATES ARE DOUBLE-MONEY-BACK GUARANTEED

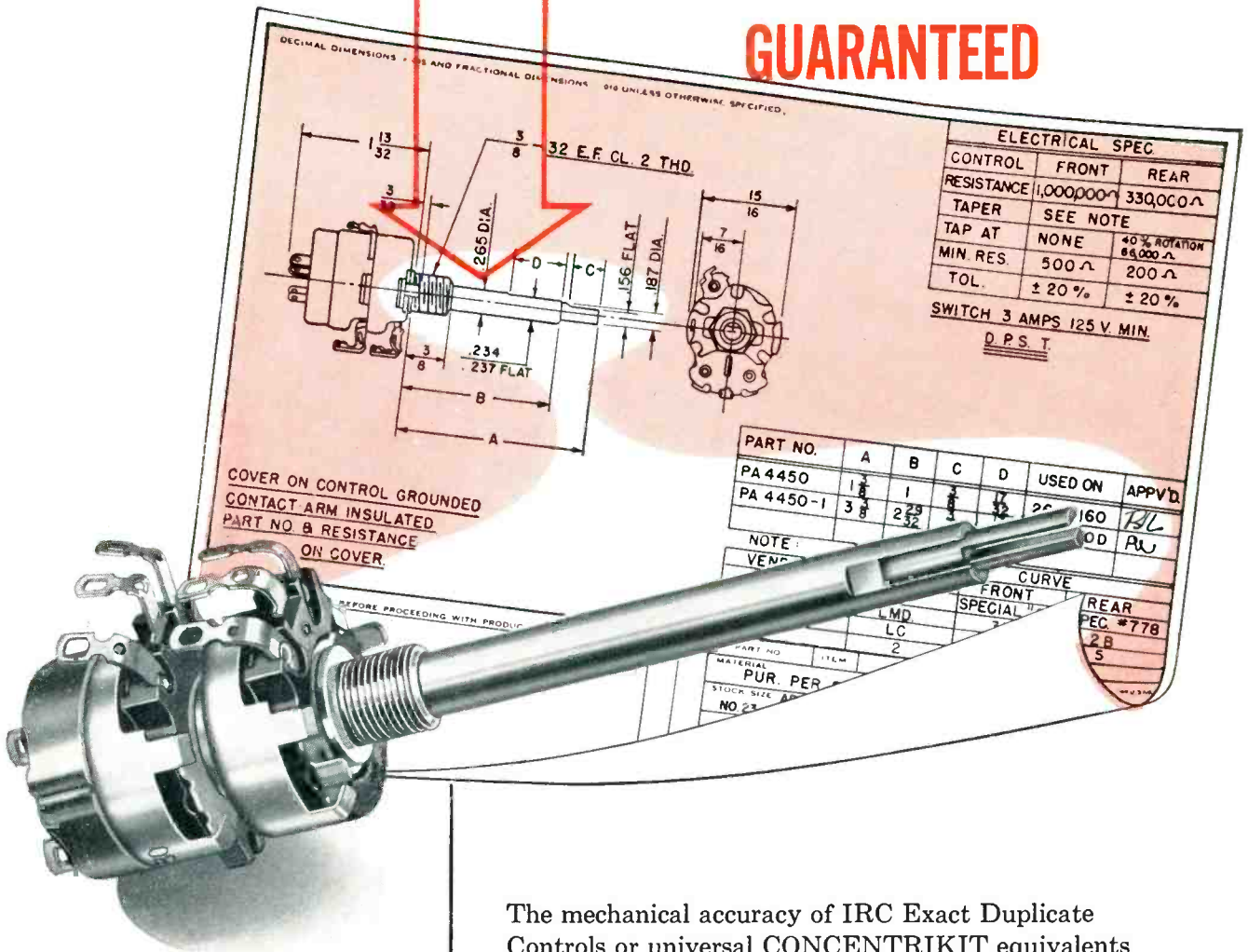

**ONLY IRC GUARANTEES
SATISFACTORY MECHANICAL FIT
AND ELECTRICAL OPERATION
OR DOUBLE-YOUR-MONEY-BACK**

The typical manufacturer's specifications shown here are exactly duplicated by IRC QJ-180 control. CONCENTRIKIT assembly includes P1-229 and R1-312 shafts with B11-137 and B18-132X Base Elements, and 76-2 Switch.



Wherever the Circuit Says 

The mechanical accuracy of IRC Exact Duplicate Controls or universal CONCENTRIKIT equivalents is based on set manufacturers' procurement prints. Specifications on those prints are closely followed.

Shaft lengths are *never less* than the set manufacturer's nominal length—*never more* than $\frac{3}{32}$ " longer.

Shaft ends are precisely tooled for solid fit.

Inner shaft protrusion is accurately duplicated for perfect knob fit.

Alterations are never needed.

For Exact Duplicate Controls, specify IRC. Most Service Technicians do.

INTERNATIONAL RESISTANCE CO.

425 N. Broad Street, Philadelphia 8, Pa.

In Canada: International Resistance Co., Ltd., Toronto, Licensee

TECHNICIAN & Circuit Digests

TELEVISION • ELECTRONIC • RADIO • AUDIO • SERVICE

OCTOBER, 1954

M. CLEMENTS O. H. CALDWELL
Publisher Editorial Consultant

SIDNEY C. SILVER, *Managing Editor*

CREIGHTON M. MARCOTT, *Assistant Editor*

ANN O'ROURKE, *Assistant Editor*

ALBERT J. FORMAN, *Consulting Editor*

J. L. STOUTENBURGH, *Consulting Editor*

DR. A. F. MURRAY, *Contributing Editor*

CHARLES F. DREYER, *Art Director*

ELMER KETTERER, *Circuit-Digest Production*

GEORGE PUGLICI, *Circuit Diagrams*

BUSINESS DEPARTMENT

M. H. NEWTON, *Business Manager*

H. A. REED, *General Sales Manager*

LEE GRAVES, *Eastern Sales Manager*

CHARLES S. ROEVER, *District Manager*

P. J. CARNESE, *Sales Promotion Manager*

N. McALLISTER, *Asst. Business Manager*

ELMER DALTON, *Circulation Manager*

MARTHA USDIN, *Production Manager*

KATHLEEN CAFARO, *Reader Service*

JOHN J. BORGHI, *Controller*

W. W. SWIGERT, *Credit Manager*

480 Lexington Ave., New York 17, N. Y.
 Telephone Plaza 9-7880

S. M. GASKINS, *Western Manager*

JOHN D. LUPTON, *District Manager*

201 N. Wells St., Chicago 6, Ill.
 Telephone RAndolph 6-9225

CHRIS DUNKLE & ASSOCIATES
California Representative

3257 W. 6th Street, Los Angeles 5, Calif.
 Telephone DUnkirk 7-6149

1651 Market Street, San Francisco 3
 Telephone UNderhill 3-5282

CIRCULATION

This issue 50,000, which includes 45,114 professional servicemen and service managers of retail stores, 2,006 parts distributors, plus manufacturers and miscellaneous.

TECHNICIAN & CIRCUIT DIGESTS, October 1954, Vol. 60, No. 4. \$50 a copy. Published monthly by Caldwell-Clements Inc., Publication Office, Emmett St., Bristol, Conn. Editorial, Advertising and Executive Offices, 480 Lexington Ave., New York 17, N. Y. Entered as second class matter at the Post Office at Bristol, Conn. June 10, 1954. M. Clements, President; M. H. Newton, Assistant to President; John J. Borghi, Vice President and Secretary; M. B. Clements, Treasurer. Subscription rates: United States and Canada, \$4.00 for one year; \$6.00 for two years; \$8.00 for three years. Pan-American and foreign countries, \$7.00 for one year; \$10.00 for two years; \$14.00 for three years. Printed in U.S.A.

Copyright by
 Caldwell-Clements, Inc., 1954

FRONT COVER: Exploded view of concentric tandem resistive control with SPST switch shows large number of precision-made parts which constitute the standard "pot" found in radio and TV receivers. Unit is made by Chicago Telephone Supply Corp., Elkhart, Ind. For details on understanding and servicing resistive controls, see article on page 28.

Associations—Who's Left Out?, Technician to You!	13
"Tuning in the Picture"	14
Troubleshooting Video I-F Stages in the TV Receiver .. Philip Thier	16
Hum-Bugging Audio Amplifiers	18
Understanding Your Vacuum-Tube Voltmeter .. James A. McRoberts	20
Test Equipment "Spec" Chart	22
Servicing Color TV Now	26
Inside Resistive Controls	28
You and the Law	30
Selenium Rectifiers: Interchangeability, Applications	32
"Tough Dog" Corner	34
Shop Hints	36
New Tools & Service Aids	42
New Antennas & Accessories	44
Broadband Yagi Design	46

SECTION TWO

ANOTHER COLOR TV FIRST!

- Color TV Terminology Chart
- Schematic of RCA's New 21-in. Color TV Receiver

Circuit Digests*	57
-------------------------------	-----------

Arvin: Chassis "D" 379-UHF, "D" 382-VHF	Emerson: Chassis 120220-D, 120239-D	RCA: Chassis KCS87, KCS87A
Capehart-Farnsworth: Chassis CX-37, CX-37-1	Hallicrafters: Chassis B1600D	Zenith: Chassis 19R20, 19R21

DEPARTMENTS

Letters to the Editors	6	Service Association Reports	38
Calendar of Coming Events	15	New Products	40, Section Two
Industry Keyhole	30	News of the Industry	48
News of the Reps	38	Manufacturers' Catalogs & Bulletins 53	
New Books	53		

CALDWELL-CLEMENTS, INC.

Publication Office, Bristol, Conn.

Editorial/Business Offices 480 Lexington Ave., New York 17, N. Y., Tel. Plaza 9-7880

Publishers also of MART and TELE-TECH & ELECTRONIC INDUSTRIES

*Reg. U. S. Patent Office

Experience



tells me...

to build my Electronics Business on **DELCO and UNITED MOTORS SERVICE**

DIVISIONS OF GENERAL MOTORS CORPORATION

There is no substitute for experience. Especially in a business as changing and fast-growing as the electronics business. Through experience, electronic parts distributors have learned that it pays to deal with names you know—solid names like Delco and United Motors Service that have long been respected for dependability and business integrity.

Follow the lead of successful electronic parts distributors, build your business on a firm foundation that offers these exclusive advantages to the industry:

ONE SOURCE—Delco offers special application parts as well as complete coverage of the most important universal parts groups.

ONE POLICY—A single sales policy for all electronics parts eliminates the confusion of dealing with many manufacturers.

ONE BILLING OPERATION—Means fewer records to keep, fewer purchase orders; cuts bookkeeping time and costs to a minimum.

READY-MADE MARKET—In addition to universal replacement parts, Delco is the sole source for original equipment replacement parts on all Delco radios.

TECHNICAL ASSISTANCE—Current bulletins and field schools play an important part in keeping the industry well posted on new developments.

DISTRIBUTION—United Motors Service maintains 21 strategically located warehouses to assure ample supply of all parts.

QUALITY—You are assured of uniformity of parts, built to high standards of production and to exacting specifications.

A GENERAL MOTORS PRODUCT   A UNITED MOTORS LINE



SPEAKERS

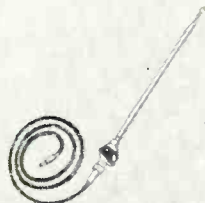

AUTO RADIO AERIALS



VIBRATORS



CONTROLS

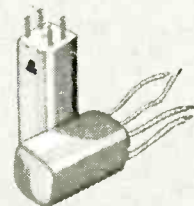

COILS



CAPACITORS



RECEIVING TUBES

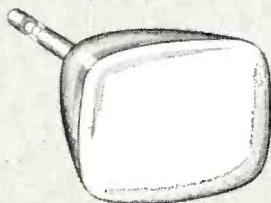

PICTURE TUBES



SUPPRESSION PARTS

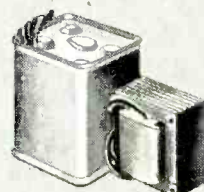

TRANSFORMERS

ACHIEVEMENT OF A

Quarter Century

For those who pursue the ultimate—the rediscovery of perspective in music...

Imperial

PR-100



The stimulation and pleasure gained by listening to a live performance is the result of much more than frequency range considerations.

Here is a revolution—the use of true proportions of sound in authentic reproduction including smooth coverage of the complete useful frequency range and thus recreating the fine performance with the greatest possible degree of accuracy.

Voices come to life and there's a new almost geometrical separation of instruments. A three-way system with 1-f unit loaded by a new-design reactance-annuling trilateral-mouth horn for bass; selected compression-driver horn-loaded mid channel with intrarange equalizer for a final touch to precise balance and coloration elimination; and superlatively smooth, space-blended supertweeter top. Each instrument is individually serial numbered and accompanied with a signed certificate certifying that the reproducer fully meets the exacting performance standards set for it. (Components and performance are the same as for RS-100 Laboratory Reference Standard Reproducer.)

PR-100 "IMPERIAL" REPRODUCER

ST-919. Selected Mahogany. Net Price..... \$525.00
ST-918. Satin Korina. Net Price..... 335.00

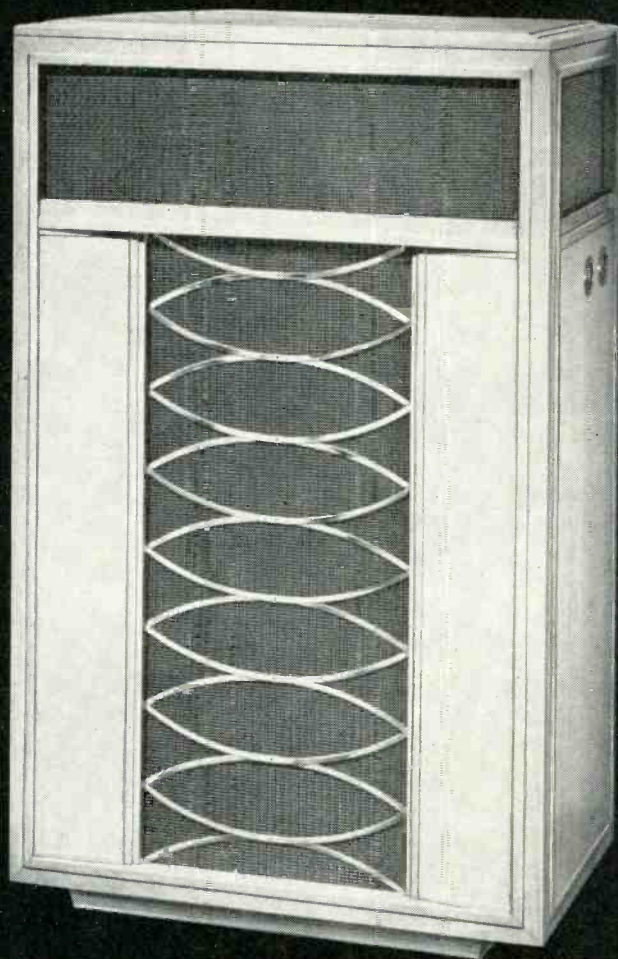

LABORATORY STANDARD

RS-100



Built for research comparison.

The Imperial was designed by the Jensen engineering staff for their own use as a reference standard of the highest quality of high-fidelity reproduction. In this original laboratory version the RS-100 Laboratory Reference Standard Reproducer is a new and important tool for sound, recording and broadcast engineers, workers in psychoacoustics and music critics who require an unusually high quality of reproduction. Some music lovers and audiophiles will undoubtedly want to own an RS-100. Cabinet is plywood attractively two-toned in blue gray.

RS-100 LABORATORY REFERENCE STANDARD REPRODUCER

ST-920. Net Price..... \$468.00

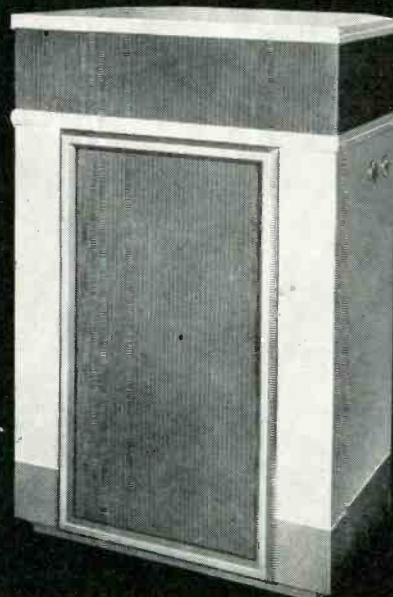

Durbin Luwina Advertising

Jensen

MANUFACTURING COMPANY

Jensen—world's quality standard for more than a quarter century.

Division of the Muter Co.
6601 S. Laramie, Chicago 38, Illinois

Now, TV set owners can understand benefits of Aluminized Tubes!

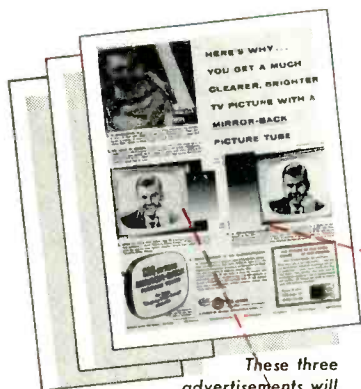

These three advertisements will appear in **POST** this fall.

THESE ADVERTISEMENTS IN **POST** EXPLAIN THAT:

1. IN **MAGAZINES**, the pictures you see (when magnified) are made by a series of tiny dots applied to the paper *mechanically*.

ON YOUR TV SCREEN, the pictures are also made by a series of dots (which appear as lines) applied *electronically*. These dots, in both cases, create a variety of tones including black, a range of grays, and white. BUT, it is the **LENGTH** of this "Black-to-White Range" (the gray scale) that makes the picture excellent, good, fair, or poor.



ARTHUR GODFREY famous CBS star

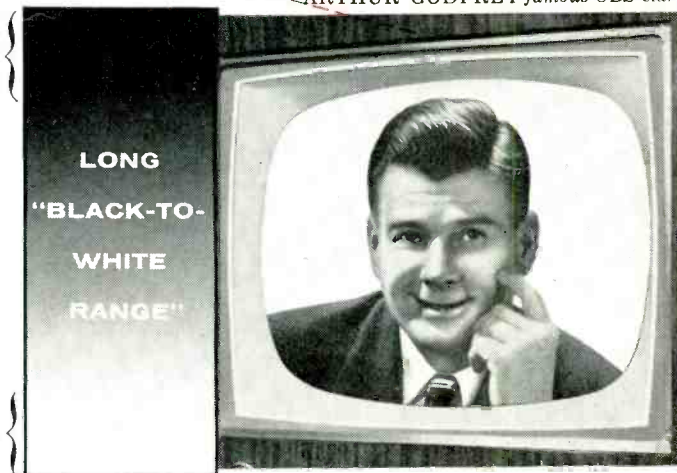

2. **ORDINARY PICTURE TUBES** used in most TV sets made before 1953 produce a *short* "Black-to-White Range." While the picture is good, the picture tube cannot develop enough *light output* for a *long* "Black-to-White Range."

3. **CBS-HYTRON MIRROR-BACK TUBES** produce up to *twice the light output* of ordinary picture tubes. Like the silver backing on a mirror, the *shiny* aluminum backing on a Mirror-Back tube reflects to the viewer *all the light* on the screen. The resulting increased brightness and reduced halation (unwanted spreading of light from one dot to another) is *essential* to give you a *long* "Black-to-White Range." The full range you *must* have for the clearest, sharpest, brightest pictures that are a joy to watch.

TALK LONG "BLACK-TO-WHITE RANGE" PICTURES
...SELL BIGGER-PROFIT

CBS-HYTRON MIRROR-BACK PICTURE TUBES

Talk . . . demonstrate . . . and sell "Long-Black-to-White-Range" clearer, sharper, brighter pictures. It's easier to sell premium-grade, brand-new CBS-Hytron Mirror-Backs . . . with their controlled quality and dependable full-year guarantee. Profit more. Tie in with POST. Get this Mirror-Back Promotion Kit . . . from your CBS-Hytron distributor, or mail coupon.



CBS-HYTRON, Danvers, Mass.

I want all the material to identify me as a *Certified Quality Service* dealer who sells Mirror-Back tubes. Please rush me CBS-Hytron Mirror-Back Promotion Kit containing:

1. 22 x 28-inch Advertised-in-POST window poster.
 2. 25 consumer self-mailers. "How You Can Have Clearer, Sharper, Brighter TV Pictures."
 3. *Certified Quality Service* decalcomania.
- I enclose 25¢ for postage and handling.
I want . . . more consumer self-mailers at 1¢ each, for which I enclose an additional \$

Name (please print)
Street
City State



CBS-HYTRON Main Office: Danvers, Massachusetts

A Division of Columbia Broadcasting System, Inc.

A member of the CBS family: CBS Radio
CBS Television • Columbia Records, Inc.

CBS Laboratories • CBS-Columbo • CBS International • and CBS-Hytron

Introducing

THE BEAUTIFUL NEW

CROWN

Tenn-A-Liner®

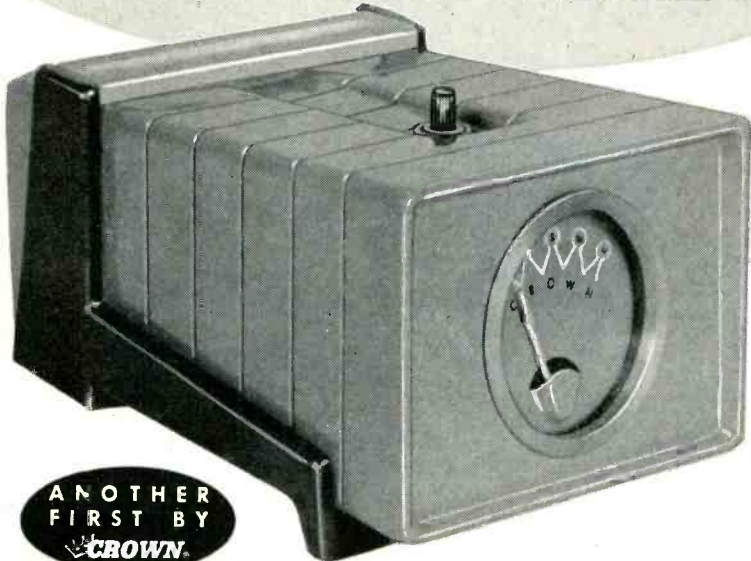

ANOTHER FIRST BY CROWN

the antenna rotator that's color styled with feminine buy-appeal.



It's another first by Crown . . . the beautiful, new, two-tone Tenn-A-Liner . . . a deluxe model so attractively styled it literally sells on sight.

Functional as well as attractive, it incorporates all the famous proved and exclusive features that have made Crown one of the best buys on the TV accessory market. Ease of operation . . . immediate and constant directional indication . . . dependable performance under the most severe load and weather conditions . . . a remarkably low call back service record . . . plus competitive pricing and an unusually high dealer profit margin. Yes, the Crown Tenn-A-Liner has everything it takes to make a hit with the dealer and customer alike. Now is the time to get set for a big fall business with the new Crown Tenn-A-Liner—Write for complete information today!

Remember . . . Crown's "points for profit" plan applies to the sale of each Crown Tenn-A-Liner. Ask your distributor how you can live like a King on Crown's exclusive "P.F.P." plan!

PFP PLAN APPLIES

SELL with confidence
sell CROWN®

CROWN® CONTROLS Co., Inc. NEW BREMEN, OHIO

SUBSIDIARY—CROWN CONTROLS MFG., LTD., 1166 LAKESHORE RD., LONG BRANCH, ONT.

LETTERS To the Editors

Need for Standards

EDITORS, TECHNICIAN:

Your editorials in the April and August issues are very much to the point—as far as they go. . . . (Reference is to pleas for standards in antenna and test-equipment specs.—Ed.) . . . Yet a simple statement of a pretty well known fact about the exaggeration in advertising is not likely to cure the situation. Isn't the real need for some sort of research (organization) which will assemble the facts on each item and report them in comparison with the claimed figures? . . . Some manufacturers would probably howl, but I believe the reliable ones would welcome proof of their reliability.

We are presently in need of new service equipment, and have deferred the purchase from month to month just because we lack any means of determining which instruments will give us the service we desire.

FRANCIS G. MCCOLLISTER
Clarksburg, Ohio

•The suggestion for a committee on standards and/or testing has its merits. Possible starting points: The Radio-Electronic - Television Manufacturers Association; separate committees set up by mfrs. of antennas, test instruments, Hi-Fi equipment, etc.; or research, on the national level, by service associations. Have any other ideas? Let's hear from you.—Ed.

EDITORS, TECHNICIAN:

I have just completed reading your "Open Letter to Test Equipment Manufacturers" in the August issue of TECHNICIAN. I think the letter is a great one. I am sure that all of us in our own field are guilty of many of the things you mentioned in your letter. We here at RCP have tried to be as honest and conservative in our literature as we possibly could.

Your letter will certainly help in making literature of all manufacturers more direct and accurate. Keep up the good work!

BURT U. LEVY, SALES MGR.
Radio City Products Co.
Easton, Penna.

Likes Shop Hints

EDITORS, TECHNICIAN:

It goes without saying our preference in radio mags is TECHNICIAN . . . There are only two men in our shop, but we both agree we would like to see more Shop Hints.

L. T. LANGENESS, Mgr
Radio-TV Sales & Service
Moorhead, Minn.

You'll be getting your wish in forthcoming issues.—Ed.

**Fabulous..Revolutionary
..Completely New..**

MIGHTY MO*

*Pat. No. 2680196, others pending.

**the most powerful antenna
ever built, featuring TESCON'S
NEW exclusive DDP (Double Diamond Phasing)**

Tescon's miraculous Mighty Mo will make prime signal areas out of even the deepest fringe sections of the country.

Mighty Mo... complete with DDP, an entirely new and revolutionary concept of phasing, will trap even the weakest signal and perk it up to a clear, brilliantly sharp, deep-toned picture. Tescon absolutely guarantees that each and every Mighty Mo will perform where other antennas have actually failed!

Unshakeable proof, substantiated by exhaustive field tests, definitely shows that Mighty Mo does more than any other antenna manufacturer loudly claims his product will do. Theoretical ratings will never pay off. Rely on tested results... that's your real proof, that's your money in the bank.

**Here's Mighty Mo's proof
...the results of ACTUAL
FIELD TESTS.**

- On channels 2 to 13, Mighty Mo outperforms every other antenna manufactured today.
- Higher uniform gain over all channels. Does not vary more than 1½ D.B. on any channel across band. Perfect on color TV.
- Clearer, sharper, deeper pictures on all channels.
- Higher average gain than 6 of the most advertised antennas.

STOCK

**this red-hot, fast moving,
money-making antenna...right now!**

MIGHTY MO'S FEATURES

- DDP (Double Diamond Phasing) precision-timed phasing regulator enables the weakest of signals to be trapped and then boosted to a clear, magnificently sharp, photo-like picture.
- Flat response... a must for color reception.
- Largest screen area... over 70 sq. ft. Screen elements spaced less than 1/10 wave length apart for maximum reflector efficiency.
- Highest front to back ratio ever achieved.
- Absolutely no rear pick up or co-channel interference... no "venetian blinds."
- ½ wave element spacing on all channels for super-gain.
- Completely preassembled... not an erector set type antenna.
- Uniform gain response... no erratic audio and video patterns.
- Thoroughly tested for mechanical stress and strain... exceptionally rugged.
- Guaranteed to perform where other antennas fail.

Designed for VHF - UHF

Style no. } Stacked MM200
 } Single MM100

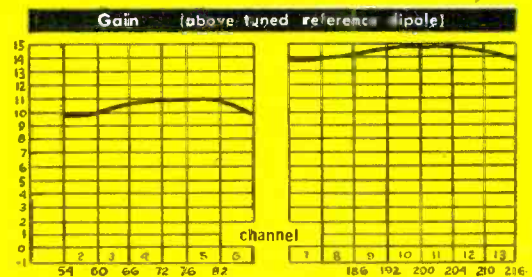

**Most uniform gain response ever recorded.
Does not vary more than 1½ D.B. on any channel.
Extremely important for quality color reception.**

TESCON TV PRODUCTS COMPANY
SPRINGFIELD GARDENS 13, NEW YORK



Ever since Daddy got his
Jensen 1-A-DAY SALES PLAN
(and the cute little Needle Caddy Kit)
he's been selling needles like hot-cakes!

P.S. *This could be a sweet deal for you, too—
sellin' needles on every service call!*

HERE'S THE RIGHT ANSWER...

... RIGHT AWAY!



NEW Picture Tube Selector

Instantly Gives Information On Picture Tube Interchangeability!

The New Du Mont Picture Tube Selector lists all picture tubes and gives complete information on the most popular types. In one quick setting of the slide, you get complete electrical values, important physical information, and basing . . . plus a complete table of interchangeable types. Sturdy construction and convenient pocket size make this newest Du Mont Teletron service aid ideal for field or shop use. It's available from your Du Mont Teletron Distributor.



Replacement Sales: Cathode-ray Tube Division • ALLEN B. DUMONT LABORATORIES Inc. • 750 Bloomfield Avenue, Clifton, New Jersey

FINCO* introduces

3 SENSATIONAL New Antennas

Patent No's. 2,566,287 2,630,531 2,655,599 other patents applied for.

FINCO 400-SA

FEATURING "FRO-BAC"* FULL DIMENSIONAL SCREEN

The engineering masterpiece of the antenna industry! The sensational, new Finco 400-SA eliminates rear signal interference (adjacent and co-channel), ghosts and electronic noise—delivers famous Finco high gain for clear, sharp pictures in the SUPER fringe area on all channels, UHF and VHF. The special electronic FRO-BAC screen has 80 sq. ft. of highest efficiency, FULL LENGTH reflector surface. Pre-assembled for quick installation.

FINCO 200-A

The ideal antenna for "in-between areas" . . . (too far out to use "Local" type antenna, too close to warrant use of a super-fringe antenna). The new Finco 200-A combines basic, double CO-LATERAL* design with exclusive Finco electronic patents to deliver unbeatable gain and performance in the Semi-Fringe area on all channels, UHF and VHF. Completely pre-assembled.

FINCO 200-SA

The Finco 200-SA was engineered specifically for the "in-between", semi-fringe areas where a FRONT-TO-BACK problem exists. The special FRO-BAC full dimensional screen eliminates rear signal interference, ghosts and electronic noise. This antenna delivers reception power that cannot be matched by ordinary antennas. Completely pre-assembled.

*Trade marks of the Finney Company.
Registration No's. 559,104 575,345

Copyright 1954, The Finney Co.

**The FINNEY
Company**

4612 ST. CLAIR AVENUE • CLEVELAND 3, OHIO

MODEL 14-S CONVERSION KIT

**FRONT-TO-BACK PROBLEM IN
YOUR AREA??? MANY FINCO
400-A INSTALLATIONS???**

This kit contains special electronic FRO-BAC screen and stainless steel hardware for quick conversion of models 400-A and 400 to model 400-SA.

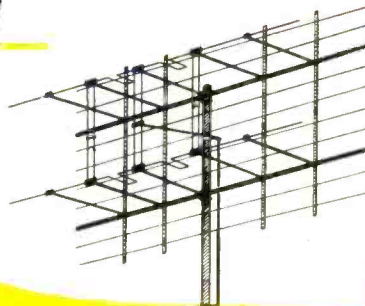
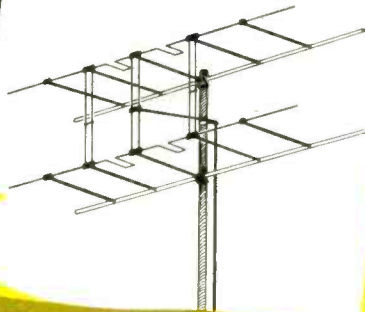
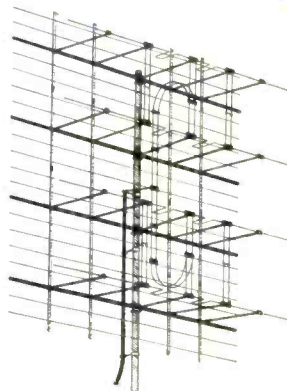

THE 980 LINE



Model 985 Calibrator—\$199.50



Model 983 Oscilloscope—\$329.50



Model 984 Sweep Generator—\$199.50



Model 982 Vacuum Tube Voltmeter—\$69.50

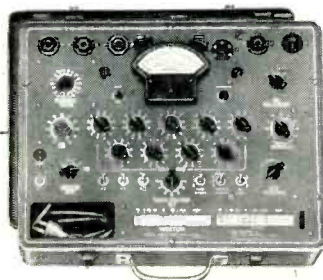

Model 981 Tubechecker—\$199.50



Model 980 Analyzer—\$52.50

Representing an entirely new approach in test equipment design and operation, the 980 Line instruments have brought new *simplicity* and new *time-saving facility* to TV receiver alignment and servicing. Now available to TV technicians through leading distributors. Literature giving complete information on request. WESTON Electrical Instrument Corporation, 614 Frelinghuysen Avenue, Newark 5, N. J.

8420



TEST EQUIPMENT

ANOTHER RAYTHEON FIRST!



RAYTHEON 17AVP4

Raytheon leads the way to smaller, light weight, more compact, television receivers with the amazing new 17AVP4 monochrome picture tube. It is $3\frac{5}{8}$ inches shorter in overall length and approximately 4 pounds lighter than present 17 inch tubes. The type 17AVP4 incorporates a new 90° deflection angle bulb, a 1 inch shorter neck length and achieves maximum compactness with conventional viewing area. The 17AVP4 has electrostatic focus, magnetic deflection and features the same crisp, clean picture that makes all Raytheon Picture Tubes outstanding for quality.

This important new Raytheon tube, developed and produced at Raytheon's new modern picture tube plant at Quincy, Massachusetts is one more reason why you can standardize on Raytheon Picture Tubes with complete confidence that you are giving your customers the very latest and best.

Remember, Raytheon Picture Tubes are Right for Sight, Right for You, and always New. Buy them through your nearest Raytheon Tube Distributor.

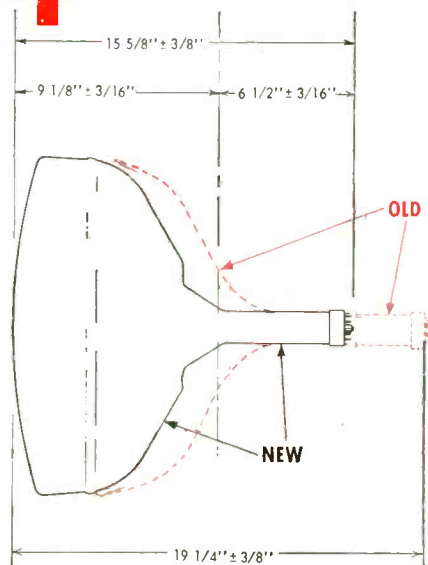

Excellence in Electronics

RAYTHEON MANUFACTURING COMPANY

Receiving and Cathode Ray Tube Operations
 Newton, Mass., Chicago, Ill., Atlanta, Ga., Los Angeles, Calif.

RAYTHEON MAKES ALL THESE:

RECEIVING AND PICTURE TUBES • RELIABLE SUBMINIATURE AND MINIATURE TUBES • SEMICONDUCTOR DIODES AND TRANSISTORS • NUCLEONIC TUBES • MICROWAVE TUBES

TECHNICIAN & Circuit Digests

CALDWELL-CLEMENTS, INC., 480 LEXINGTON AVENUE, NEW YORK 17, N. Y.

Associations—Who's Left Out?

A friend of ours who has been in the service business for years—way back before TV, for that matter—reports being upset by a recent experience. A lone wolf during most of his career, he had finally yielded to the argument that men can do things better when they get together. Since honest ethics, earning a living and upgrading his profession are as much his concern as anyone else's, he decided it was time to join an association. It was quite a shock to learn that his local group wouldn't accept him.

Why? Although it's one of the smaller outfits, pushing hard to get more members, it's only interested in people who are in business for themselves.

Our friend's history in the profession is one of which he may well be proud. There are thousands like him in this country. Can the service industry afford to split its strength? Where do employed technicians fit into the picture?

Room must be made for them somewhere. As we see it, there are two ways of dealing with the problem:

1. It can be considered that, since most independent service organizations scarcely fall into the big business class, there is little difference of interest between the shop owner and his bench man. In this case, only one type of organization is necessary, the basis for which

can be the existing association.

2. If shop owners feel, as a group, that they must deal with important problems that are no concern of the employed worker, or that there is a basic conflict of interest, an additional type of organization may be needed. It may be modeled after the professional societies common to other engineering and technical fields, or it could use the guild as its basic pattern. Exactly what form is to be chosen is, in the long run, up to the technician.

If the latter pattern is the one that develops, there is as much room for coordinated activity between the two types of groups as there is common interest in the service industry. In this way, at least, there can be a united show of strength where needed.

In any case, it is time most of our present associations took a good look at themselves. Reports of their activities indicate that they sometimes function as organizations of business men, other times as strictly technical groups, in some cases as purchasing cooperatives, and sometimes strictly as social clubs.

This sort of indecision is not unusual for an infant industry—and the service business surely falls into that class. But, in the interests of healthy growth and long-range stability, we must decide where we are going.

Technician to You!

In an open note to publishers, the editor of one association monthly (*Associated Radio-Television Service Dealers' News*, Columbus, Ohio) has this to say: "Please stop referring to the TV Technician as a serviceman. It reminds me of the grease monkey. . . . After all, aren't we TECHNICIANS?"

As a matter of fact, just giving ourselves a name isn't the final answer to the problem of professional standing and community respect. As a part of the answer, however, it ought not to be overlooked.

Many associations, along with several far-sighted receiver manufacturers who appreciate their own dependence on the technician, have invested time, effort and money in getting his story across to the public. Set owners are being told about the high level of skill and training required, about heavy investments that must be made in specialized equipment and in parts, and about the complex nature of service work. We tend to

defeat this continuing campaign when we settle for being called repairmen or mechanics.

Our opposite numbers in England, we understand, run into a lot less trouble with the set-owning public than we do. Their decisions as to what has to be done with defective sets—and their quoted fees—are respected more than they are disputed. The British TV technician has good community standing, is seldom regarded as a gyp. Also, he calls himself a *service engineer*.

While that title is entirely legitimate, we are realistic enough to ask for only a little progress at a time. Since we cannot expect anyone to have more respect for us than we have for ourselves, it's up to us to use and insist on the preferred term. *That means we also have to act and look like technicians.* What attitude do you take toward yourself, especially when dealing with customers? Are you a tinkerer with a screwdriver in his back pocket, or a skilled specialist?

Tuning In the

TRADED-IN TV SETS can be real income producers in some areas, especially in resort and vacation regions. One dealer in Sarasota, Florida, stuck with a sizeable inventory of old dogs taken in trade, is now doing nicely renting them out to vacationers and other transient residents. Last we heard, all available sets were on rental and the dealer had a waiting list of prospects in addition.

THE USED-SET MARKET gets another approach by Motorola. Using the technique of the used-car dealer as a starting point, this mfr. has issued a "Trade-In Sales Manual" that goes into detail about the 4 basic steps: appraisal, reconditioning, pricing and resale. Don't try to make a fat profit or unload a lemon on this deal, the manual warns, since used-set buyers are eventual prospects for new sets. Try to recover the amount you lost on the trade-in (plus cost of reconditioning) and give customer satisfaction. The manual suggests types of prospective customers for used sets.

HI-FI SWITCH: Time was when American audio bugs used to incorporate highly regarded foreign equipment in their home systems. Fast growth of this field over the last few years in this country may result in a trend reversal. Espey's low-cost speaker-amplifier unit, the Overture, will be marketed in America, Europe and the Far East.

SOME BIG-CITY NEWSPAPERS REFUSING ads from servicing organizations in cases where the papers have received a number of complaints from readers charging misrepresentation.

THOUGH 10 YEARS OR MORE AWAY, that picture-frame TV set we talked about last month is more than just a gleam in the eyes of GE engineers. They've gone to the trouble of building a dummy model, shown on this page. The thin screen, which replaces the pix tube, is suitable for wall mounting. Miniaturized and printed circuit components will be built into the frame. Controls will be incorporated in a remote unit located at chairside or elsewhere in the room.

The picture-frame TV set of the future, as GE engineers see it.



BETTER BRUSH UP ON PHONOGRAPH servicing because it could be big business next year. Reasons: Increased interest in Hi-Fi, and better merchandising practices, plus the fact that there could be a trend toward bringing out more TV-radio-phono combinations.

ALL TECHNICIANS SHOULD BE INTERESTED in the drive for adequate home wiring. "Octopus outlets," common in many homes where there are not enough wall receptacles, provide plenty of grief for servicers. Where customers "gang up" facilities through use of several cube-taps, noise in receivers frequently occurs, fuses are blown and current supplies are often cut off.

PORTABLE RADIO SALES went well this year, and a lively Xmas market for the carry-about sets is expected. Too few shops cash in on the big potential in battery sales. An adequate supply of batteries, plus constant use of manufacturer-supplied displays, will pay off in additional profits.

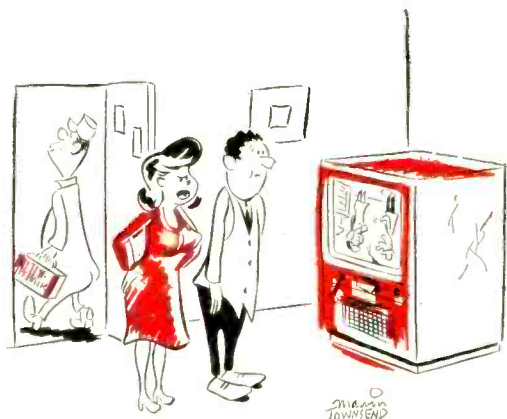

"Well! Are you still proud of yourself for finding a TV serviceman who only charges 50¢ per visit?"

INCREASE IN "FIX-IT-YOURSELF" activities by consumers noted in many industrial centers, and seen cutting shop revenue. Lowest rate of repairing in the home by customers prevails in those residential sections where the majority of men are white-collar workers. Highest rate is in localities where the majority are skilled mechanics, including employees in electronic factories.

HOME-SERVICE SERMON: Solder on the rug makes the housewife say "Ugh!" . . . Bits of insulation from wires annoys, irks and ires . . . The sloppy mechanic puts the home in a panic . . . But the welcome mat's out to greet the guy skillful and neat.

TECHNICIAN EDITORS estimate that almost 80,000 motor vehicles are in use today in servicing home TV and radio sets, with some of the larger service and installation organizations using as many as 50 vehicles during some of the busiest days.

Picture

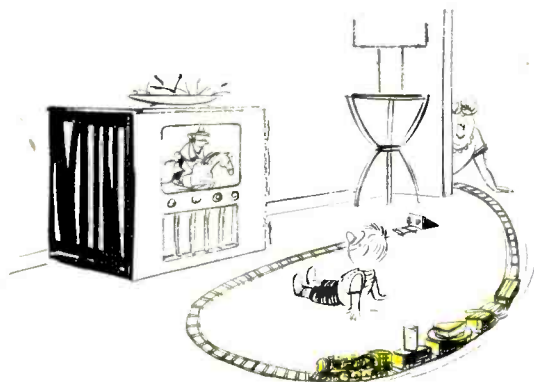
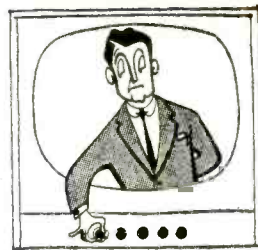

POWER OF PRAYER: This one just missed our "Tough Dog" department. It actually happened to an Oklahoma servicer. "My set's acting peculiar," a woman complained to him over the phone. "It's gone off the air, and the only way we can get it to come back on is for my mother to get down on her knees beside it and pray. It goes off again the minute she gets up." The baffled technician came to the house and replaced a defective tube.

HERE'S WHAT HAPPENS TO TRADED-IN PRODUCTS: 68% of TV sets are offered for resale; 27% of TV receivers taken in on trades are cannibalized for parts, and 5% are junked. 30% of radios are offered for resale; 40% are stripped for parts, and 30% are thrown in the junk-pile.

IT'S AN ILL WIND—Technicians in the hurricane-whipped northeastern corner of the country ought to be checking around for antennas that failed to last out the big blow.

SERVICE MANAGER WE KNOW checked up on some customers who were no longer on the firm's active list. Though a number of those who'd left the fold "rigged" answers, still others were frank in giving reasons. Results: largest number left because of "poor service," which included failure to keep appointments properly, and a seemingly large number of call-backs. Disputes over bills was next, with a "too-expensive" reason last.

HI-FI IN THE HOME—in the new home, that is. A builder of suburban homes near Dayton, Ohio is using high fidelity to sell his houses. Each home has a complete built-in custom system using GE components, with the units integrated on either side of the fireplace. These houses are really built around the Hi-Fi set-up. The attached garage is against the outside wall of the living room. Back panels for component housings are accessible from the garage, allowing plenty of room for servicing.

COLOR-TV SET CONTRACTS BY MANUFACTURERS expected to average between \$100 and \$150 per year in 1955. Estimated color receiver production for '55—200,000 sets at prices ranging down to \$695 for "big-screen" jobs.

MAKE A BUCK WITH YOUR TRUCK. You can help write off some of the overhead on your service truck if you're wise to the fact that it's a shop on wheels. Alert technicians and dealers stock their trucks with such replacement items as phono pickup cartridges, needles and batteries, other items that the customer may think of or the outside man can suggest once he's in the home. Cards suggesting antenna repairs are also worth using, to be slipped under the door of homes where the outside servicer spots an antenna that looks as though it's just been through a hurricane.

THE REPLACEMENT BIZ IS BOOMING, with antennas, tubes, and receiver components accounting for \$650 million in turnover in 1953, according to the sales mgr. of one set manufacturer. A look at this year's figures thus far indicates the 1954 total will rise to \$800 million. With more sets in existence, and getting more use, over the years, the service industry may be considered in its infancy right now.

THE GRAVY IS THERE, but you won't get any if you don't bother to ladle it up. Department stores in big metropolitan areas, also aware of the big future in repair work, are putting on the big push to land service contracts. If you want your share, be ready to compete.

HEALTHY TV SALES in 1953 surpassed those of the preceding year, matched the levels set in '50 and '51. Increased buying occurred all over the country, but the largest gains were in the West and North Central regions. Another interesting trend: every year, more people use credit to buy sets.

THAT TECHNICIAN'S DUMB GIRL FRIEND is still in circulation. She thinks a horizontal drive is something a patient gets while riding in an ambulance, that a square wave is a Navy dame from the sticks, and she's dead certain that a corner speaker is a soapbox orator. She's sure a chassis support is a girdle. The other day, her technician friend said he was going over to Mrs. Jones' home to install an interference trap, and this dame actually said she'd bet anything that that horrible nosy neighbor next door to the Joneses would be the first one to get caught in it.

CALENDAR OF COMING EVENTS

- Oct. 4-6: Tenth Annual National Electronics Conference, Hotel Sherman, Chicago, Ill.
- Oct. 8-20: Radio-Electronics-Television Mfrs. Assoc. Radio Fall Meeting, Hotel Syracuse, Syracuse, N.Y.
- Oct. 13-16: The Audio Fair, Sponsored by Audio Engineering Society, Hotel New Yorker, New York.
- Oct. 22-23: Electronic Parts Distributors' Seminar, sponsored by National Electronic Distributors Assoc. and Radio Parts & Electronic Equipment Shows, Inc., Baker Hotel, Dallas, Texas.
- Oct. 22-24: New England High-Fidelity Music Show, Hotel Touraine, Boston, Mass.
- Feb. 10-12: Audio Fair—Los Angeles, sponsored by Audio Engineering Society. Alexandria Hotel, Los Angeles, Calif.

Troubleshooting Video I-F

Transients, Improper Frequency Response, Oscillation, Microphonics,

BY PHILIP THIER

• Many symptoms that appear to be caused by defects in other sections of the TV receiver are actually due to faults in the video i-f system. One important symptom that falls into this category is poor transient response. Misalignment of the video i-f strip is a common cause of this symptom. Let's consider the trouble in detail.

I-f Transients. *Transient response* refers to the ability of an amplifier to pass a sharply-changing signal without introducing oscillation. An i-f amplifier with a poor transient response will break into oscillation when steeply-sloping video signals are applied to it. Oscillatory signals that closely duplicate the original signal that started them going will be produced in such a case. These oscillations are coupled from the tuned output circuit back into the i-f amplifier tube by radiation, then amplified and passed on to the succeeding stage as an echo of the original signal.

At the picture tube, a "transient" image arrives later than the true image. Since the horizontal sweep "paints out" the viewed picture from left to right, the transient appears to the right of the true image as a "halo" effect. Viewed on a test pattern, transients cause the vertical wedges and the various shadings

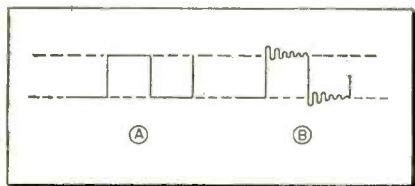

Fig. 1A—Ideal square-wave pattern. B—Oscillations in square wave due to transients.

present at the center bull's eye to blur into a cloudy grey-white, the central black area losing its definition.

The transient effect may be mistaken for a ghost. To determine whether the double image is a ghost or a transient, rotate the antenna while observing the picture. If the reflected image changes position with

respect to the original, it is a ghost. A ghost condition will show up differently or be non-existent on different channels, while the transient just sits there, stubbornly misbehaving in the same way, no matter what channel is tuned in, or in spite of what is done to the antenna.

To test an i-f amplifier's transient response, apply a symmetrical square wave of appropriate frequency to it and observe the output on an oscilloscope. (Some signal generators provide internal square-wave modulation; in other cases, square-wave modulation will have to be applied externally, by means of a square-wave generator.—Ed) If the response curve appears as shown in Fig. 1A, the amplifier is operating properly. Should the am-

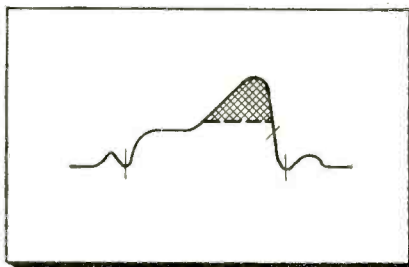

Fig. 2—Peak in response. Signals in the frequency range represented by the shaded area tend to cause spurious oscillation.

plifier have a poor transient response, the square wave will be distorted, as shown in Fig 1B. This type of distortion, incidentally, can occur in the video amplifier, as well as in the video i-f stages. Both these receiver sections should be square-wave tested, to determine where the fault lies.

If the i-f amplifiers are at fault, realignment may be attempted, to correct the response. When the correct response cannot be obtained by alignment, circuit components should be carefully checked.

Try replacing the i-f tube of the stage in which trouble is encountered, and then attempt realignment. At times, due to mechanical shock or faulty construction, the physical placement of the internal elements of a tube may change. This will change the internal capacitances of the tube. Since the tube capacitances

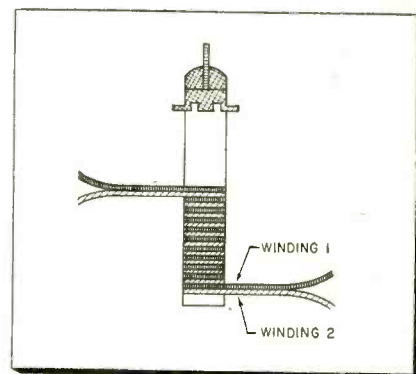

Fig. 3—Bifilar type of i-f transformer. Either winding may be used as primary or secondary. Powdered-iron slug tunes coils.

are effectively in parallel with the i-f transformer, the change that has occurred may be just enough to shift the circuit response to a point where transients are generated.

Poor L-F Response. When video i-f trouble reduces the bandpass of this section, the presence of certain associated symptoms will generally provide clues to the nature of the trouble. Distortion caused by poor low-frequency response will cause large black areas to trail off and smudge, rather than come to an end sharply. In a test pattern, the horizontal wedges will be blurred, while large objects and letters are smeared to the right. The smearing in this case is due to the non-uniform phase shift to which the low-frequency black signals are subjected. The low-frequency distortion may take place in the r-f or video amplifier stages, as well as in the video i-f section. A quick response check with a signal or sweep generator and an oscilloscope should localize the trouble.

Inadequate H-F Response. Poor high-frequency response (in the video i-f section, as elsewhere) results in the loss of fine detail in the picture. White areas overlap into black, producing an image that appears to be out of focus. In a test pattern, the vertical wedges will "wash out" before reaching the center bull's-eye.

Often tubes which check good in ordinary tube testers will not operate efficiently as broadband ampli-

Stages in the TV Receiver

Trap Troubles. Sync Pulse Clipping; Undesired Sync Separation

fiers. Tubes which have a low emission due to aging may not be capable of maintaining broadband amplification. The video i-f transformer coils may be affected by high humidity or severe temperature changes that produce corrosion, shorted turns or a displacement of the coil windings. Any of these can shift a coil's tunable frequency range beyond usable limits. The faults just cited may not be noted in some cases until a careful realignment procedure has failed to correct the limited band-width condition.

Oscillation and Microphonics. Oscillation and microphonics in video i-f stages raise considerable havoc with TV reception. Damped oscillations or "ringing" will produce horizontal streaking or tearing over a limited area of the picture. An over-peaked i-f amplifier circuit (see Fig. 2) will tend to break into oscillation, when excited by particular frequencies within the pass-band. A properly-adjusted circuit will not usually fall into spurious oscillation. When realignment does not correct the ringing present, a tube replacement or change of bypass condenser may be in order.

Effects on reception similar to those just described are caused by

microphonics. Tubes with loose, vibrating elements tend to modulate the signal being amplified, causing black or white blotches to appear in the picture. When such symptoms are noted, or vibrations of picture elements or howls in the sound occur, it is time to tap away at tubes and condensers, to find the microphonic component.

Trap Considerations. In split-sound pix i-f systems, the maximum video bandwidth is 4 mc, with the adjacent-channel and associated sound carriers attenuated greatly by absorption traps. If the traps are not tuned to properly eliminate the unwanted frequencies, the bandwidth of the associated i-f amplifier is apt to be excessively broad. The picture may, besides suffering a loss of gain, be marred by sound bars and adjacent-channel noise in such a case.

Due to planned station allocation, adjacent-channel interference is not very likely to occur in major television service areas. In fringe areas between large cities, however, adjacent-channel reception is a definite possibility.

Other Band-Width Troubles. Generally, band-width and gain can be properly adjusted by following

closely the alignment procedures recommended by the set manufacturer. Where excessive bandwidth cannot be corrected by alignment, and it has been determined that the sound and adjacent-channel traps are functioning properly, the grid-to-ground resistance of the stage involved should be measured. A resistance lower than the design value can be the cause of a loss of gain, with a broadening of the circuit bandwidth characteristic.

Aging of components may drive the grid resistance above the correct design value. This will increase the stage gain, but reduce the bandwidth.

I-f Transformer Troubles. Humidity and extremes of temperature can seriously affect an i-f transformer. In some cases, the insulating coating on the coils is not complete. Minute cracks in this insulating material allow moisture to come into contact with the wires. The resultant corrosion can cause circuit defects ranging from an open winding to a short between turns. The open-circuit condition may result in complete loss of signal or, at best, very weak signal.

Shorted turns, and their very
(Continued on page 54)

Mild transients. Note slight reflections in lettering.

Severe antenna-produced ghost. (courtesy RCA)

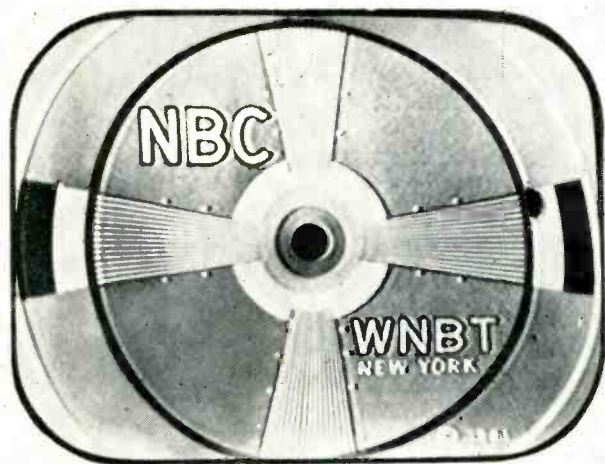

Hum-Bugging Audio Amplifiers

• Sixty-cycle ac is fine in audio amplifiers as long as it's kept in its place. For power supplies and filaments, it's ok; but you have to keep that old hum bug out of the grid circuits.

Hum is a very exasperating and often difficult thing to track down. Everyone has his pet rules and precautions for shutting out the bug, but sometimes it takes a little extra doing. The points outlined in this article are worthy of consideration, since they will extend your de-bugging fire power by providing a varied choice of weapons.

Chassis-Conducted Hum. The old saw about keeping leads as short as possible doesn't always apply to circuit grounds. Often, a hum complaint stems from ground returns having been indiscriminately tied to chassis. When this is the case, there's no telling what complicated current path may exist in the chassis and become part of the input circuit. If the input signal is returned along three or four inches of chassis having a circulating hum current, this chassis voltage drop is, in effect, inserted in series with the signal, and amplified along with the set owner's favorite overture. When the serviceman suspects that an improper ground in the input stage is responsible for hum, the simplest localization test (which also serves as a remedy) is to return the grounds of the first stage directly to the input jack ground.

To eliminate chassis-conducted hum in general, run a no. 14 bare copper ground bus wire (that is not permitted to touch chassis) along the path of your tube line-up, going from the input tube, through the output tubes, to the rectifier (see Fig. 1). Connect this bus wire to the chassis at the input jack, and *only* at this point. Connect all circuit grounds to this wire physically *in the order of the tube line-up*, ending at

Fig. 1—Connecting filament grounds to chassis in order of tube line-up. "Hot" filament wiring is not indicated in the sketch.

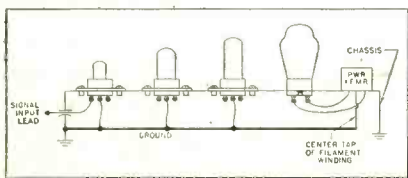

BY KARL GRIEF

the power supply.

Usually, rewiring the first stage ground as previously described should in itself be sufficient to eliminate most cases of chassis-conducted hum.

Pickup in Line-to-Grid Input Transformers. In an intercom or similar system using an input transformer, such as a voice-coil to grid transformer (loudspeaker employed as a mike input, for example), the input transformer must be remote from the chassis, if the latter uses a power transformer. The field surrounding a large power transformer can affect a shielded input transformer from a distance as great as four or five feet. Therefore, note whether the input transformer is mounted five to ten feet from the chassis and even then, oriented for minimum hum pickup. The lead to the amplifier must be shielded, and the (input) transformer case and one side of the primary grounded. Also check if the transformer is located near fluorescent lights or building wiring—both are capable of inducing hum into the windings.

Floating Chassis. Ancient as it seems, grounding the chassis by connecting a wire (no. 14 or larger) to the building water system will serve to "tie down" the chassis and the entire audio system. Either the regular plumbing pipes or a nearby radiator will provide a good ground, and prevent pick-up from an otherwise floating system. The wire used to ground the chassis should be as short as possible, for best results.

Improperly-Insulated Input. Although wood is considered an insulator, it can cause an awful lot of hum to be introduced, if the input signal wire is allowed to touch it. Look for any type of feed-through connector or terminal strip whose "hot" side might be contacting wood, or some similar "insulator," when you are making your quick preliminary inspection for visible causes of hum. This source of hum is apt to be discounted without testing because it seems downright fantastic.

Discontinuities in Shielded Input Leads. Look for a spliced input line. Unless a really bang-up job is done, you can be fairly sure of hum problems with a spliced shielded line. Always buy enough wire when making an installation to use a continuous line from pickup to input plug.

Input Lines Running Near Power Wires. In no instance should signal input leads be allowed to run parallel or significantly near 115 v 60-cycle power line wiring or line cords. Regardless of shielding, some hum will be picked up at normal input

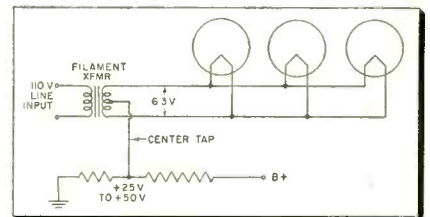

Fig. 2—Biasing the filament line to minimize cathode-to-heater emission in audio amplifier.

impedances, if this recommendation is ignored.

Improper Power Supply Filtering. Although often replaced by a resistor for economy, a B-plus filter choke is still a very efficient and sure guard against hum. It is obvious why manufacturers don't use them, in all cases (cost factor); when you want a job to be as perfect as possible, however, insert such a choke (when one is not present in the set, of course). Keep a couple of sizes in stock to test with.

Further Hum Tests. The tests we have described, if properly made, will take care of most "hum-bugs." If the bug, however, is elusive, or if

Common and Uncommon Sources of a Universal Trouble in Hi-Fi Installations

there are two or three bugs, as is often the case, make the following additional tests to locate the source of trouble. Incidentally, for hum to be at an acceptable level, you should, to hear it, have to place your ear directly at the center of, and as close as possible to, the speaker; the hum should be no more audible than the little "frying" and rushing sounds known as tube noise.

Determining Whether Hum Is Internal or External to Set. Ground the signal input either by shorting the input leads together, or by turning the input potentiometer so that no signal is fed in. If the hum *decreases only slightly*, it is due to internal or external causes, or a combination of both. If the hum *disappears entirely* with the input grounded, forget the amplifier and look for trouble in the shielded leads that are often present at the input. If the hum *persists*, it is originating in the amplifier. I leave the input grounded and make the checks described in the paragraphs following, in such a case.

Power Supply Filtering Tests. The first place to check in tracking down hum is, commonly, the power supply. If a substantial amount of ripple is measured (with a scope) at the dc supply feeding the tubes, improper filtering is indicated. To test the filter condensers present, bridge them with known good ones of at least the same or twice as much capacitance (check polarity and voltage ratings carefully). If the hum drops substantially, replace the old capacitor(s); if the original condenser turns out to be good, indicating that a huge capacitance is necessary, add another filter stage, using a filter choke. This last measure is recommended primarily for cases where the manufacturer has used a resistor instead of a choke in the "B" supply, or instances when an ac-dc amplifier whose filtering is not too adequate to begin with, is used in an installation demanding a very low level of hum.

Other checks (at the B+ point) for hum can be made by using earphones, with a 0.1 mfd condenser placed in series to block the dc (hum should be imperceptible); and with an ac voltmeter applied between B+ and ground (0.01 volts is excellent).

Do not overlook the possibility of

a poor rectifier tube. If it has developed a low back resistance, its rectifying efficiency will be reduced; not only is a sizable ripple likely under the circumstances—ac may also be applied to the filters.

Stage by Stage Localization. Beginning at the second tube in your lineup, ground the grid of each successive tube with a screwdriver. When grounding a certain grid eliminates the hum, this usually indicates that the hum is originating in the *preceding* stage. Pull the previous tube and note effect on hum, to make certain.

If it is not the fault of the preceding tube, but the hum did decrease when grounding the tube grid referred to, the tube whose grid you are grounding is at fault. The trouble in this case is usually caused by the collection of filament-emitted electrons at the grid, with a hum voltage consequently developing across the grid resistor. Grounding the grid removes the hum, because the grid resistance becomes zero.

To remedy the condition, try another tube. This trouble sometimes is inherent in a particular tube. Another remedy (when the condition persists in spite of tube replace-

ment) is to connect the filament transformer center tap to a positive dc voltage of 25 to 50 volts (see Fig. 2). The filament is then made more positive than the grid, eliminating or minimizing the filament emission previously described.

Other Remedies. When hum has been localized to a particular stage, and neither replacement of the tube nor biasing of its filament satisfactorily reduces the hum, try bucking the hum out with an oppositely-phased hum voltage (design limitations in the amplifier being serviced are assumed).

Say a series input resistor is utilized, and shorting it eliminates the hum. Connect one side of a lead to a filament pin, and bring the other end of the lead near the resistor. Then connect the lead to the *other* filament pin, and repeat. In one case, the hum will be heard to null out at a fixed distance, and then increase as the lead is brought still closer to the resistor. When the lead is connected to the other, or wrong side, the hum will continually increase. When the nulling side has been determined, wrap the wire on the resistor in such a way that minimum hum level is obtained (Fig. 3).

Fig. 3—Hum reduction in circuits (A) and (B) by means of a bucking voltage is illustrated in (C) and (D). Which side of the heater lead to use, other details, are discussed in the text.

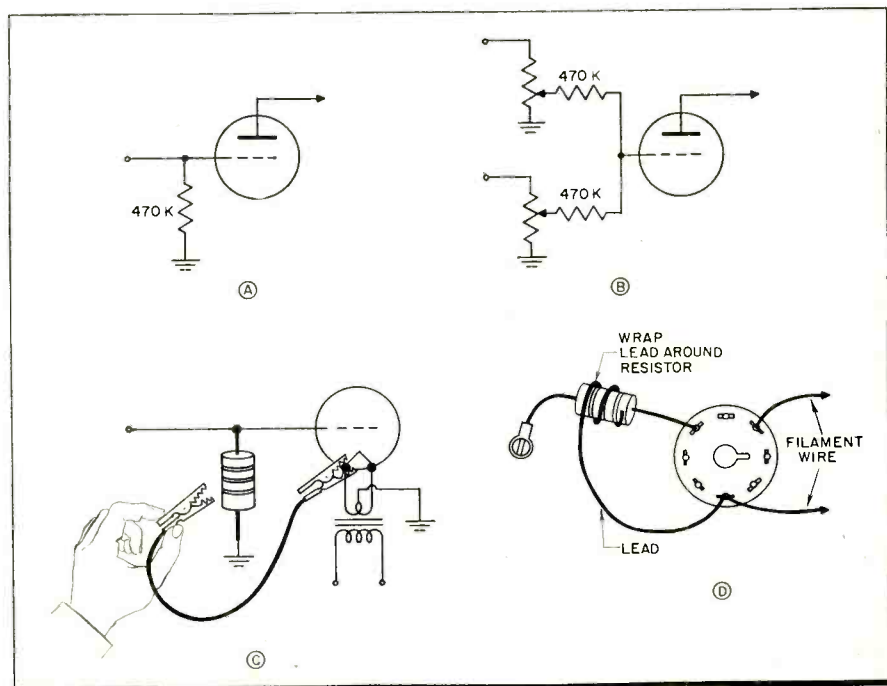

Understanding Your

Data on the Theory of VTVM Operation, to Help You

BY JAMES A. McROBERTS

The technician should understand the basic principles underlying the operation of his vtvm, if he wishes to use, maintain and troubleshoot his own instrument intelligently. This article will describe how a vtvm works; the one to follow will discuss the servicing of a vtvm.

Electronic voltmeters are used because their reading more closely approximates the voltage actually present in the circuit under test. The vtvm, because of its high input resistance and isolating probe, loads down the circuit to be tested much less than a non-electronic meter, providing considerably more accurate voltage readings.

Electron Tube Considered as a Variable Resistor. Let's consider a triode with 20 volts applied between its grid and its cathode. Now, the amount of current which flows in the plate-cathode circuit of this tube depends primarily on the plate voltage (20 v) and the grid voltage. Varying the grid voltage could easily produce three cases such that the plate current is 0.25, 0.50, and 1.00 ma, respectively. Dividing the voltage applied (20 v) by the currents, we can see that the plate-cathode circuit acts as a resistance—a variable resistance—of 80k, 40k and 20k respectively. We have made the tube

act as a variable resistor or rheostat, with the grid voltage as the control, instead of the rheostat shaft.

A Simple Electronic Voltmeter.

Now we can put the tube to work, hooking it up as shown in Fig. 1. A schematic is shown in Fig. 1A; the variable-resistance feature of the circuit is more clearly illustrated in Fig. 1B. The dotted line at the control is used to indicate that the variation in resistance is achieved by the tube's grid action.

Now, if the device shown is connected to the power supply (indicated by B+ and B-), current will flow through the simple circuit, and the meter will indicate the amplitude of this current. This value of current is, of course, the applied voltage divided by the sum of the resistances in the circuit. Note that the calibration resistance remains fixed, while the tube resistance varies.

The amount of the current indicated can just as easily be marked on the meter in volts, instead of in units of current. If a grid voltage of 1 v causes 0.25 ma of current to flow, we could mark the point indicated on the meter 1 v; if 2 v causes a flow of 0.50 ma, we could mark the line to which the meter needle points 2 v, and so on.

The calibration resistor is adjustable, to permit the resting current of the tube (current with no grid volt-

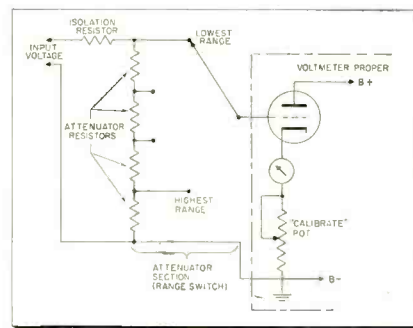

Fig. 2—Adding a range switch and a step attenuator to the vtvm will extend its range.

age applied) to deflect the meter needle to some predetermined mark, usually zero on the meter scale. The calibration could be made such that zero is read at the center of the meter scale; a negative grid voltage would then cause the meter to deflect in one direction, while a positive voltage would produce a deflection going the other way.

Now, the range of voltages that can be measured by the simple instrument just described is limited by the permissible grid voltage which may be applied to the tube's control grid. This voltage, or voltage range, is called the *grid base*. The grid base is ordinarily about 5 volts or less. To extend the voltage range that the meter can measure, a resistive step attenuator is employed. Through the action of this attenuator, the voltage applied to the grid of the voltmeter tube is less than the total voltage input. The attenuator ranges are controlled by a *range switch*, which selects an appropriate fraction of the total input voltage (see Fig. 2). The voltage drop across the isolation resistor in the probe is allowed for in the design of the instrument.

Differential-Amplifier Type Instruments. Most modern instruments use a circuit that employs what is known as a *differential amplifier* or *bridge circuit*. The most elementary form of such a circuit is shown in Fig. 3. It contains two tubes or tube sections that behave like resistances. The plate-cathode circuit of one tube is varied by its grid bias, causing its plate resistance, R_{p1} , to vary also.

The plate resistance of the second

Fig. 1A—One-tube vtvm schematic. B—Equivalent circuit, tube shown as variable resistance.

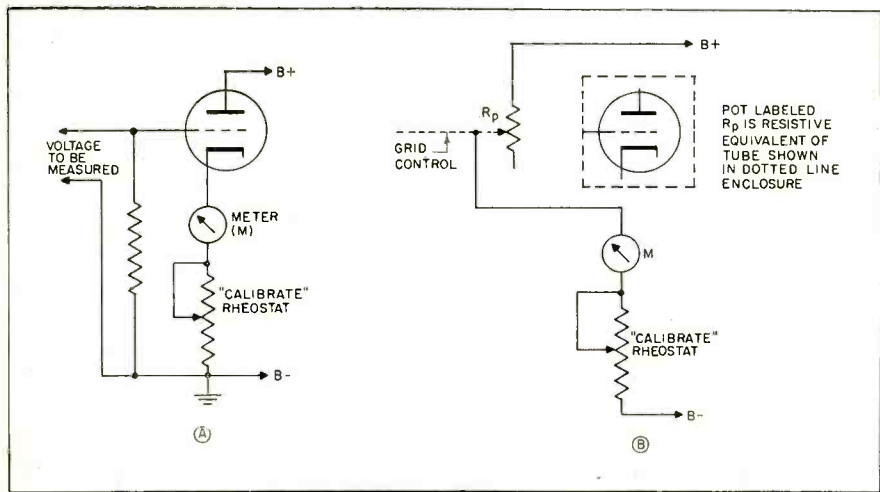

Vacuum-Tube Voltmeter

Use, Maintain and Troubleshoot Your Instrument

tube or tube section— R_{p5} —remains fixed, since its grid is returned to a fixed voltage point (usually the chassis ground). Plate load resistances R_{L1} and R_{L2} are fixed, and approximately equal to each other. The reader can now see that if the plate resistance of tube 1 (R_{p1}) equals the plate resistance of the second tube (R_{p5}), then the voltage drops across the load resistors will be equal as well. The potential difference across the meter (M) will be zero under such conditions, and its needle will not deflect.

The more complete circuit of Fig. 4 shows a *zero adjust* potentiometer which can be adjusted to make the voltage at the left-hand side of the bridge equal to that at the right-

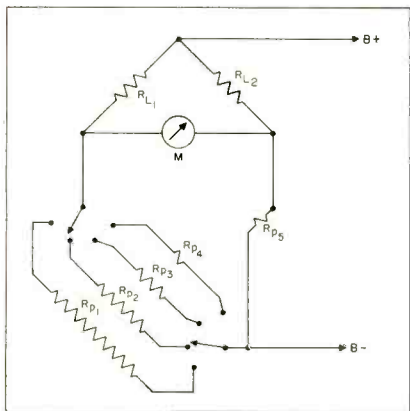

Fig. 3—Elementary bridge circuit. R_{p1} , R_{p2} , R_{p3} and R_{p4} form part of the bridge.

hand side, producing this condition of null or balance (no current through meter) with no voltage applied to the input.

Now, if the grid bias of tube 1 is altered, a corresponding change in its plate resistance will be produced. Four values of plate resistance for tube 1 are assumed in Fig. 3. For any value of R_p for tube 1 which does not equal R_{p5} (the plate resistance of tube 2—the tube with the fixed or zero voltage input) the meter will indicate, and the indication will be proportional to the variation in the plate resistance of tube.

In other words, the difference in the plate voltages of the tubes will produce a potential difference across the meter, causing a current to flow

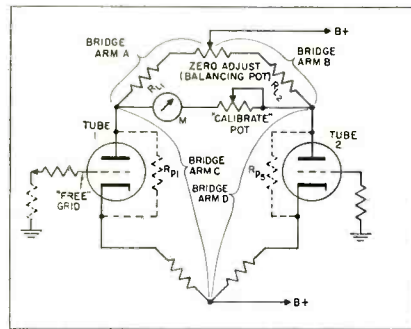

Fig. 4—Bridge circuit of Fig. 3 shown in more detail. R_{p1} and R_{p5} are tube plate resistances.

through it; the amplitude of this current will be proportional to the amplitude of the voltage applied to the grid of tube 1.

As in the case of the simple vtvm previously described, the meter (M) does not read the current through it, but measures rather the input voltage that is causing that particular current to flow. For example, a 200 microampere meter movement, with the range switch of the instrument set at 5 v, will have 100 microamperes flowing through it if 2.5 v is applied; the meter will accordingly read 2.5 v. With 25 v applied on the switch set to the 50 v range, the meter will again draw 100 microamperes; the reading now is 25 v, or 2.5×10 , the step attenuator delivering $\frac{1}{10}$ of the input to the "free grid."

Provision is made in commercial instruments for reversing the free and grounded grids of the two tubes (or tube sections) of the differential amplifier, so that either tube may act as the variable resistor. The switch that does this is part of the function switch; the action permits negative voltages to be read up-scale on the meter. The function switch also inserts the separate calibration resistor needed (in series with the meter) for each range.

Fig. 5 shows a modification of the circuit of Fig. 4; the meter in this case is inserted in the cathode circuit of the tube sections. The cathode resistors become arms of the bridge. The *zero adjust* is now in the cathode circuit, and balances the bridge (with no input voltage present) by adding resistance to one arm

while subtracting resistance from the other. The voltage drops across each cathode arm are thus made equal.

The range of the differential-type of instrument is increased in the same way as in the case of the simple single-tube instrument.

Ohmmeter Function. The basic voltmeter section just described may be used as an ohmmeter, with the meter scale calibrated in ohms. A portion of the circuit involved in a typical meter is shown in Fig. 6. On the division of voltages across the unknown and ohms range resistances depends the input voltage applied to the "free" voltmeter tube grid. The input voltage, in turn, causes a current (inversely) proportional to the unknown resistance to flow through the meter. This current causes the needle to deflect across a scale calibrated in ohms.

The voltage drop across the fixed resistor is produced by current forced through it via the range resistor. The value of this resistor varies in accordance with the different ohms ranges selected by the

(Continued on page 52)

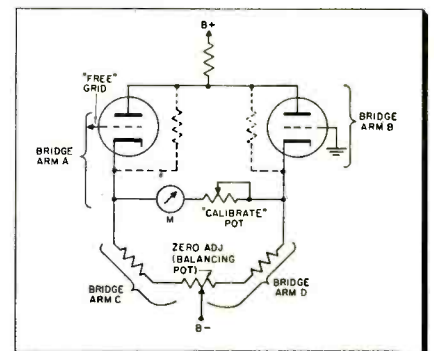
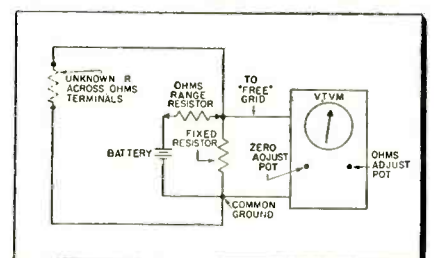

Fig. 5—Bridge with meter in cathode circuit.

Fig. 6—Typical ohmmeter section of vtvm using battery power supply and bridge circuit.



Test Equipment "Spec" Chart

27 Popular V-O-M's and Multimeters

(Specifications are based on data supplied by manufacturers)

MANUFACTURER	MODEL NO.	METER SIZE	SENSITIVITY (OHMS/VOLT)	VOLTAGE RANGES	RESISTANCE RANGES †	DC CURRENT RANGES †	DB RANGES	REMARKS	PRICE
CHICAGO INDUSTRIAL INSTRUMENT CO., 536 W. ELM ST. CHICAGO 10, ILL.	431A		AC/DC: 1,000	AC/DC: 0-15-30-150-300-1500-3000 V.	3 RANGES— 10 K TO 1 MEG	3 RANGES— 1.5 MA TO 7.5 A.			\$19.50
	421D		AC/DC: 5,000	AC/DC: 0-4-10-40-100-400-1000 V.	3 RANGES— 10 K TO 1 MEG	4 RANGES— 4 TO 400 MA			\$24.50
	458A		AC/DC: 1,000	AC/DC: 0-2.5-10-50-250-1000-5000 V.	3 RANGES— 1 K TO 2 MEGS	5 RANGES— 1 MA TO 10 A.	-5 TO +55 DB		\$29.50
ELECTRONIC INSTRUMENT CO., INC. 84 WITHERS ST., BROOKLYN 11, N. Y.	536	3-IN.	AC/DC: 1,000	AC/DC: 0-1-5-10-50-100-500-5000 V.	3 RANGES— 5 K TO 1 MEG	4 RANGES— 1 MA TO 1 A.	6 RANGES— -20 TO +69 DB	WITH 1% PRECISION RESISTORS AS MODEL 526 — \$13.90*	\$12.90*
	565-K	4.5-IN.	AC: 1,000 DC: 20,000	AC/DC: 0-2.5-10-50-250-1000-5000 V.	3 RANGES— 2 K TO 20 MEGS	4 RANGES— 100 μA TO 500 MA.	5 RANGES— -12 TO +55 DB	WITH 1% PRECISION RESISTORS — MODEL 555 — \$29.95	\$24.95*
	566-K	4.5-IN.	AC/DC: 1,000	AC/DC: 0-1.5-10-50-100-500-5000 V.	3 RANGES— 500 OHMS TO 1 MEG	4 RANGES— 1 MA TO 1 A.	6 RANGES— -20 TO +69	WITH 1% PRECISION RESISTORS — MODEL 556 — \$16.90	\$14.90
ELECTRONIC MEASUREMENTS CORP., 280 LAFAYETTE ST. NEW YORK, N. Y.	102	3-IN.	AC/DC: 1,000	AC: 0-12-120-600-1200-3000 V. DC: 0-6-60-300-600-3000 V.	2 RANGES— 1 K TO 1 MEG	4 RANGES— 6 MA TO 1200 MA			\$14.90
	104	4.5-IN.	AC: 1,000 DC: 20,000	AC/DC: 0-6-60-300-600-3000 V.	3 RANGES— 20 K TO 20 MEGS	3 RANGES— 6 MA TO 600 MA	5 RANGES— -4 TO +67 DB		\$26.95
HEATH CO., BENTON HARBOR, MICH.	M-1			AC/DC: 0-10-30-300-1000-5000 V.	2 RANGES— 3 K AND 300 K	2 RANGES— 10 MA AND 100 MA		KIT.	\$14.50*
	MM-1	4.5-IN.	AC: 5,000 DC: 20,000	AC/DC: 0-1.5-5-50-150-500-1500-5000 V.	3 RANGES— 0.2 OHMS TO 20 MEGS	5 RANGES— 150 μA TO 15 A.	-10 TO +65 DB	KIT.	\$26.50*
HICKOK ELECTRICAL INSTRUMENT CO., 10514 DUPONT AVE., CLEVELAND, OHIO	450	5-IN.	AC: 5,000 DC: 20,000	AC/DC: 0-2.5-10-50-250-1000-5000 V.	4 RANGES— 1 K TO 100 MEGS	7 RANGES— 50 μA TO 10 A.	5 RANGES— -30 TO +55 DB		\$46.50
	120	5.25-IN.	AC: 5,000 DC: 20,000	AC/DC: 0-1.2-3-12-60-300-600-1200-6000 V.	5 RANGES— 200 OHMS TO 20 MEGS	7 RANGES— 60 μA TO 12 A.	8 RANGES— -20 TO +77 DB		\$39.95
PRECISION APPARATUS CO., INC., 92-27 HORACE HARDING BLVD., ELMHURST 6, N. Y.	40	3-IN.	AC/DC: 1,000	AC/DC: 0-3-12-60-300-1200-6000 V.	3 RANGES— 5 K TO 5 MEGS	4 RANGES— 600 μA TO 600 MA	6 RANGES— -22 TO +70 DB		\$26.95
	858-P	4½-IN.	AC: 1,000 DC: 20,000	AC/DC: 0-3-6-12-60-300-600-1200-6000 V.	6 RANGES— 6 K TO 600 MEGS	8 RANGES— 60 μA TO 12 A.	8 RANGES— -26 TO 70 DB	MOUNTED IN WOOD-EN CARRYING CASE	\$61.50

(Continued on page 24)

Boost your converter sales



The Mallory Concealed Converter—first on the market

Give Your Customers their choice

...with two Mallory converter styles

Mallory . . . and only Mallory . . . offers you both types of ALL-CHANNEL UHF CONVERTERS—one designed to fit inside any TV set and the other to be used on or beside any set.

The New Mallory '188' Concealed Converter is mounted inside the TV set . . . out of sight! All that shows is a clear plastic selector dial and switch. Installation is easy. A bracket and four screws are supplied to mount the unit on either side or at the top in wood cabinets. For plastic or metal cabinets, the converter may be mounted on the fiber-board rear enclosure.

Both the Mallory '188' and the Mallory '88' Cabinet Model give the same trouble-free performance that has made Mallory the leading converter in every area since the start of UHF telecasting.



The Mallory Cabinet Converter—first on the market

No radiation problem! Mallory Converters contain specially designed components to prevent troublesome interference from radiation—a problem common to low quality converters which can ruin TV reception over a wide area.

Give yourself greater Converter Sales . . . By giving your Customers Their Choice of Mallory Converters.

P. R. MALLORY & CO. INC.
MALLORY

CAPACITORS • CONTROLS • VIBRATORS • SWITCHES • RESISTORS
RECTIFIERS • POWER SUPPLIES • CONVERTERS • MERCURY BATTERIES

APPROVED PRECISION PRODUCTS

P. R. MALLORY & CO. Inc., INDIANAPOLIS 6, INDIANA

MANUFACTURER	MODEL NO.	METER SIZE	SENSITIVITY (OHMS/VOLT)	VOLTAGE RANGES	RESISTANCE RANGES †	DC CURRENT RANGES †	DB RANGES	REMARKS	PRICE
RADIO CITY PRODUCTS, INC., 152 W. 25TH ST. NEW YORK, N. Y.	453 C		AC: 1,000 DC: 20,000	AC: 0-2.5-10-50-250-500- 1000 V. DC: 0-2.5-10-50-250-500- 1000-5000 V.	4 RANGES— 2 K TO 20 MEGS	4 RANGES— 100 μ A TO 500 MA	5 RANGES— -12 TO +55 DB		\$36.50
	463		AC: 1,000 DC: 20,000	AC: 0-10-100-500-1000 V. DC: 0-5-50-250-1000 V.	4 RANGES— 10 K TO 10 MEGS	3 RANGES— 1 MA TO 1 A.	-8 TO +55 DB		\$26.95
	480	3-IN.	AC/DC: 1,000	AC: 0-10-100-500-1000 V. DC: 0-5-50-250-500- 1000 V.	4 RANGES— 10 K TO 10 MEGS	4 RANGES— 1 MA TO 1 A.	-8 TO +55 DB		\$14.85
SIMPSON ELECTRIC CO., 5200 W. KINZIE ST. CHICAGO 44, ILL.	260	4 1/2-IN.	AC: 1,000 DC: 20,000	AC/DC: 0-2.5-10-50-250- 1000-5000 V.	3 RANGES— 2 K TO 20 MEGS	5 RANGES— 100 μ A TO 10 A.	5 RANGES— -12 TO +55 DB		\$38.95
	262		AC: 5,000 DC: 20,000	AC: 0-3-8-40-160-800 V. DC: 0-1.6-8-40-160-400- 1600-4000 V.	6 RANGES— 500 OHMS TO 50 MEGS	7 RANGES— 80 μ A TO 16 A.	4 RANGES— -12 TO +45.5 DB		\$59.50
	269		AC: 5,000 DC: 100,000	AC: 0-3-8-40-160-800 V. DC: 0-1.6-8-40-160-400- 1600-4000 V.	6 RANGES— 2 K TO 200 MEGS	7 RANGES— 16 μ A TO 16 A.	4 RANGES— -12 TO +45.5 DB		\$88.00
SUPERIOR INSTRUMENTS CO., 2435-41 WHITE PLAINS RD., NEW YORK 67, N. Y.	770-A	2 1/2-IN.	AC/DC: 1,000	AC: 0-15-30-150-300- 1500-3000 V. DC: 0-7.5-15-75-150-750- 1500 V.	2 RANGES— 10 K AND 1 MEG	3 RANGES— 15 MA TO 15 A.	3 RANGES— -6 TO +58 DB		\$15.85
	542	3-IN.	AC/DC: 5,000	AC: 0-6-30-150-600 V. DC: 0-6-150-300-1500 V.	4 RANGES— 2 K TO 2 MEGS	4 RANGES— 0.3 TO 150 MA	4 RANGES— -6 TO +50 DB		\$27.70
	543	3-IN.	AC/DC: 1,000	AC/DC: 0-15-150-600- 3000 V.	2 RANGES— 2 K AND 200 K	3 RANGES— 6 TO 600 MA			\$24.60
TRIPLITT ELECTRICAL INSTRU- MENT CO., BLUFFTON, OHIO	630	5 1/2-IN.	AC: 5,000 DC: 20,000	AC/DC: 0-3-12-60-300- 1200-6000 V.	4 RANGES— 1 K TO 100 MEGS	5 RANGES— 60 μ A TO 12 A.	7 RANGES— -30 TO +70 DB		\$39.50
	666-R	3-IN.	AC/DC: 1,000	AC/DC: 0-10-50-250- 1000-5000 V.	3 RANGES— 3 K TO 3 MEGS	3 RANGES— 10 MA TO 1 A.			\$26.50
	625-NA	5-IN.	AC: 10,000 DC: 20,000 AND 10,000	AC/DC: 0-2.5-10-50-250- 1000-5000 V. (ALSO) DC: 0-1.25-5-25-125-500- 2500 (20 K/V)	3 RANGES— 2 K TO 40 MEGS	6 RANGES— 50 μ A TO 10 A.	7 RANGES— -30 TO +69 DB		\$49.50
WESTON ELECTRICAL INSTRUMENT CORP., 614 FRELINGHUYSEN AVE. NEWARK 5, N. J.	980	5-IN.	AC: 1,000 DC: 20,000	AC/DC: 0-1.6-8-40-160- 400-1600 V.	5 RANGES— 1 K TO 10 MEGS	5 RANGES— 80 μ A TO 8 A.	6 RANGES— -15 TO +54 DB		\$52.50

† FIGURES DENOTE MAXIMUM READINGS ON LOWEST AND HIGHEST SCALES.

* PRICES APPLY TO KITS. ALSO AVAILABLE WIRED AT EXTRA CHARGE.

A new standard in
 electrical and mechanical
 perfection in all **32**
 new YAGI antennas

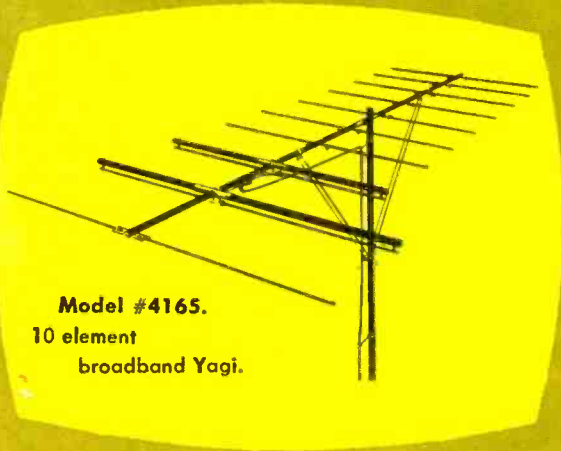

Model #4165.
 10 element
 broadband Yagi.



Featuring the new
WALSCO "Octopus"
Model #4110.
 A combination
 Yagi-conical for
 superlative all-channel
 reception.

Walsco's exclusive
 "umbrella" snap-out
 design provides perfect
 element alignment
 instantly.

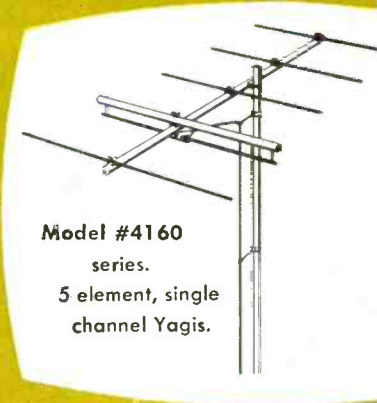
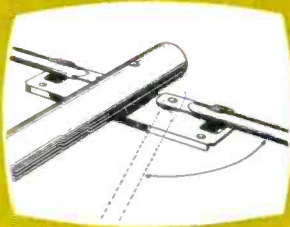

Model #4160
 series.
 5 element, single
 channel Yagis.

WALSCO "futurized" YAGIS reach everywhere

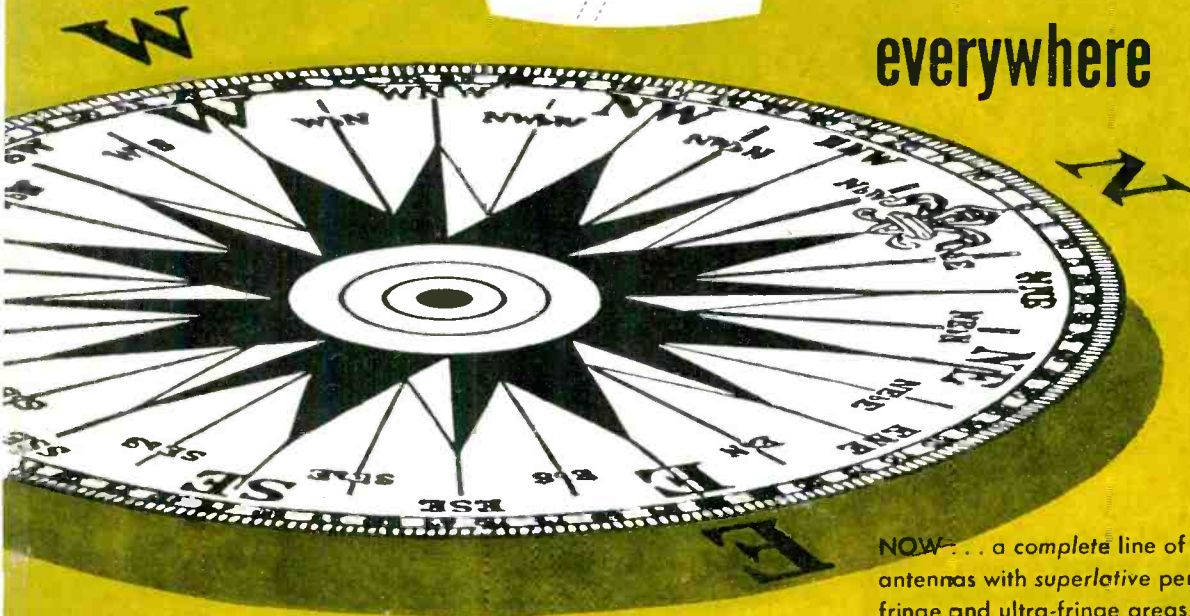

NOW . . . a complete line of 32 "futurized" Yagi antennas with *superlative* performance . . . for fringe and ultra-fringe areas; for black and white and color on all present and future channels. No loose hardware . . . completely pre-assembled using Walsco's exclusive "umbrella" snap-out design. Nothing compares at any price!

Write for complete information
 on all 32 "futurized" Yagi models

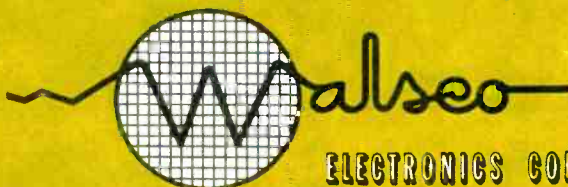

ELECTRONICS CORPORATION

3602 Crenshaw Blvd. • Los Angeles 16, California

Overseas Distributor:

Ad Auriema, Inc. • 89 Broad St., New York 4, N.Y.

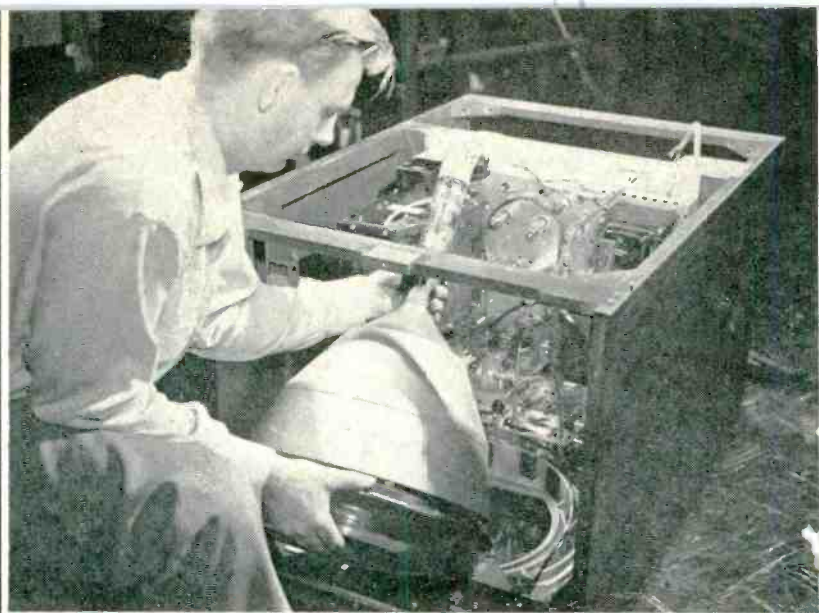

▲ Tri-color tube is easily installed by laying cabinet face down on floor, with top removed. μ -metal shield shown around CRT prevents stray magnetic fields from affecting convergence, smearing colors

◀ Setting up the receiver in the home is a big operation. Servicemen are using Scope, Color Simulator and Dot-Bar Generator. Complete job takes minimum of 2-3 hrs not including installation of antenna



Servicing Color TV NOW

Here's how RCA technicians are handling color TV troubles

Photos taken at Midtown (NYC) branch of RCA Svc. Co. Techs are G. Monaghan, A. Martin

◀ Quick check on whether set will pass color is made by injecting signal from Color Simulator at antenna terminals. Good color eliminates set, points to faulty antenna

Convergence is seriously impaired by ▶ variations of the 2nd Anode voltage. RCA CT-100 shown employs 19.5 kv, regulated. Hi-voltage probe is a must for home servicing

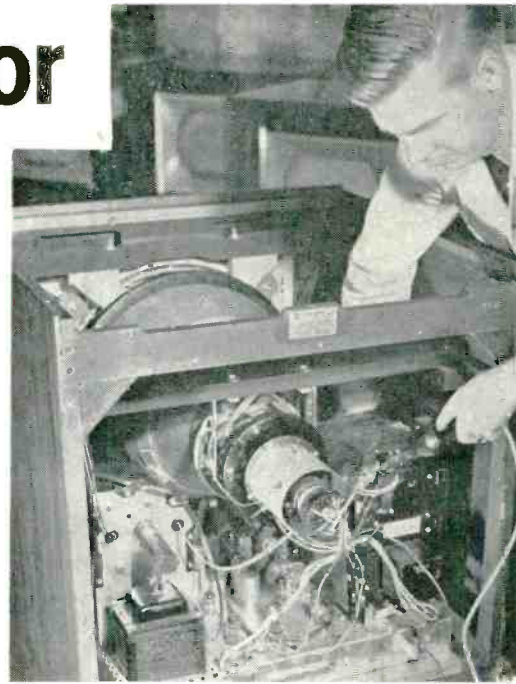

▼ After four months of servicing these sets, shop techs have a word of cheer—the standard troubles, sync and supply voltages, are still most common. Color circuits give little trouble

▼ Aligning the color receiver for the full 4 MC bandwidth requires careful adjustments—and top-notch equipment. Run-down sweep generators and marker generators will need re-calibration

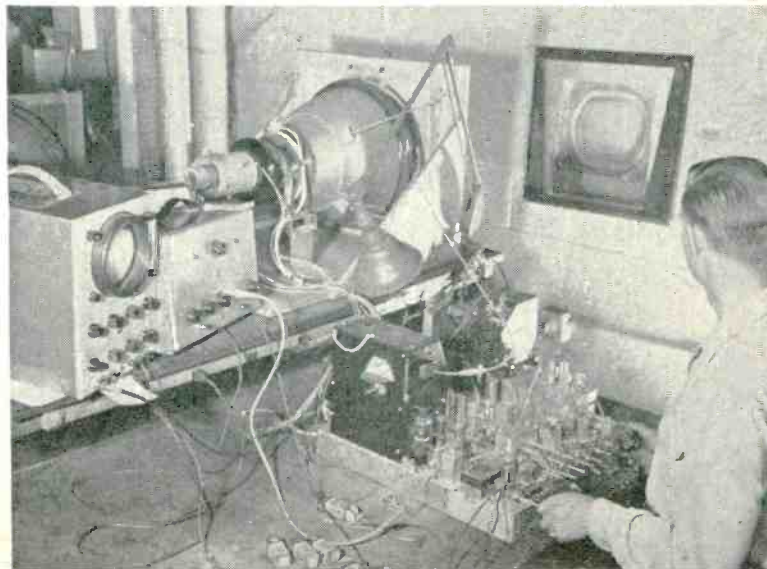
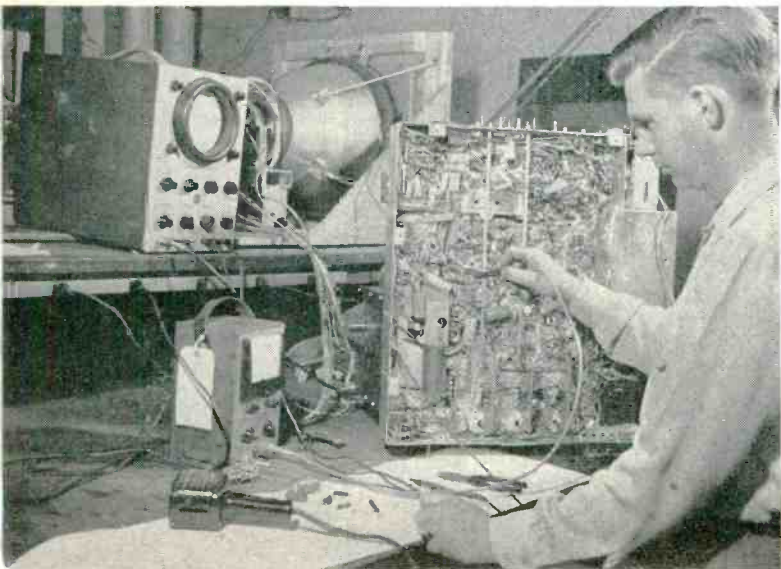

WAR DECLARED ON DEALER CALL-BACKS!



NEW TUBE TYPES FROM SYLVANIA SPEARHEAD ATTACK!

The most important step in a concentrated campaign to eliminate dealer call-backs has been taken by Sylvania with the release of a group of new tube types. Sylvania's new 5U4GB leads the group.

The 5U4GB attacks the call-back enemy on many different fronts:

1. The tube has been re-designed. Now, plates are longer and heavier with twin wings for better heat dissipation, Sylvania's 5U4GB carries increased ratings of 275 ma at 44 volts drop with 1.0 amp peak plate current.
2. Wafer Stem Construction—originally developed by Sylvania for the lock-in tube—has been adapted to the 5U4GB. The wafer stem eliminates electrolysis, provides stronger mount construction, permits better spacing.
3. A new T-12 bulb provides greater heat dissipation, gives added strength, more rigidity because of its straight construction.
4. Bottom mica has been added to make the tube stronger, improve filament alignment and eliminate arcing.

Other Sylvania types are vastly improved, too! All have Sylvania's famous wafer stem construction, plus these additional design features:

- Better Lead Spacing
- Stronger Mount Supports
- Stronger Micas
- Firmer Filament and Plates
- Greater Protection Against Shock and Vibration
- Better Heat Dissipation
- No Glass Electrolysis
- Fewer Burnouts
- Stronger, More Rugged Overall Construction

NO MINOR SKIRMISH

The Sylvania war on dealer call-backs is not a minor skirmish. It will continue until dealer call-backs on these and other receiving tube types are completely eliminated. The dealer's

biggest profit-robbing enemy can look forward only to an incessant, continuing effort on the part of Sylvania to make his existence a thing of the past. These quality tubes are now at your Sylvania distributor's.

TO IDENTIFY SYLVANIA'S NEW RECEIVING TUBES LOOK FOR THE NEW CARTON!



This new tube carton identifies Sylvania's new high quality, improved receiving tubes. It's assurance to dealers of the finest receiving tubes made—unsurpassed for quality and performance. For further information write to Dept. 4R-4210 at Sylvania.

SYLVANIA

Sylvania Electric Products Inc. 1740 Broadway, New York 19, N. Y.

In Canada: Sylvania Electric (Canada) Ltd., University Tower Bldg., St. Catherine Street, Montreal, P. Q.

LIGHTING • RADIO • ELECTRONICS • TELEVISION

Inside Resistive Controls

Variable Resistors: Tips on Repairing Them in the Home

• Variable resistors—or, as we know them, controls—fall into two categories, wire-wound and carbon. Depending on the make of monochrome TV set, there will be from five to thirteen of these controls and, as a general rule of thumb, the quality of the set can be judged from the number of controls and from how much effect they have on their respective circuits.

For reasons of economy, wire-wound resistors are disappearing as original components. The difference in price between wire-wound and carbon units, though negligible to the serviceman, adds up to thousands of dollars to the TV manufacturer.

As a circuit component, the variable resistor finds application both as a potentiometer, in which the wiper arm taps off a portion of the voltage developed across the complete resistor, and as a rheostat, where connection is made only to an end terminal and the middle wiper arm, permitting variation of the series resistance. A classic example of the potentiometer-connected variable resistor is the volume control. Rheostat-connected units are frequently found as vertical and horizontal hold controls, among others. To a large extent, the kind of repairs that can be made on the control will be determined by the way the unit is being used.

Tapers

Electrically, resistive controls may be further sub-divided according to their tapers, as shown in Fig. 1. Taper No. 1 is a right-hand logarithmic taper for a carbon composition variable resistor; No. 2 is the so-called "linear" taper, which is actually no taper at all, but simply denotes a control which varies in re-

BY CREIGHTON M. MARCOTT
ASSISTANT EDITOR, TECHNICIAN

sistance, hence in voltage in proportion to the amount of rotation, as in height and vertical linearity controls. Taper No. 3 is a modified logarithmic

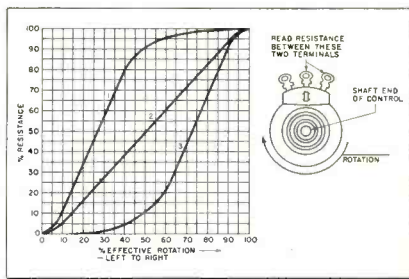

Fig. 1—Typical right- and left-hand taper curves for variable composition resistors

left-hand taper similar to that found in volume controls. The reason for a logarithmic taper here becomes obvious when we recall that the effect of increased volume on our hearing varies *not* in proportion to the power output, but as a logarithmic or exponential function. Thus, with a logarithmic taper, a 10% increase in shaft rotation will result in an apparent 10% increase in the sound output over any portion of the control.

Control Defects

Troubles with resistive controls will generally fall into three categories. First—and a problem with which we are all familiar—they become dirty; a combination of particles loosened by the action of the wiper arm and actual dust from the air. Second, they burn, or open, due to excessive current, and third, they

short to the shell, or ground out. These are the problems with which we will deal here.

Cleaning the Control

A few years ago, it was excusable for the technician to use carbon tet in treating dirty controls. However, today there are a number of cleaners on the market which do a far superior job. Carbon tet evaporates very rapidly, tending to leave condensation on the surface; also, it dissolves the lubricant in the control, leading to premature wear. Cleaners now available contain a lubricant, a corrosion preventative, a slow-evaporating solvent and a conductor. The latter counteracts any contact resistance introduced by the lubricant.

The solution is best applied to the control through the spaces around the terminals, being injected by a dropper. However, adequate treatment is usually possible by simply tilting the set back and dropping the solution on the shafts, allowing the liquid to run down into the controls.

Open Controls

Whether we can do anything for the "open" control will depend on whether it is operating as a potentiometer or rheostat, and the extent of the damage. Despite their substantial appearance, many of the rear apron controls are rated at 1/2-watt or less, and this should be taken into consideration when attempting a repair. They are not high-current devices.

For the "open" potentiometer-connected control; that is, where leads are connected to all three terminals, a visual check is the first step. On most controls, the back can be easily removed by bending the tabs which hold it in place. Then,

(Continued on page 50)

terminal; E—movable wiper arm; F—on-off switch lever; G—on-off switch.

Elements of the concentric controls are; A—rear control shaft; B—front control shaft; C—carbon composition element; D—wiper

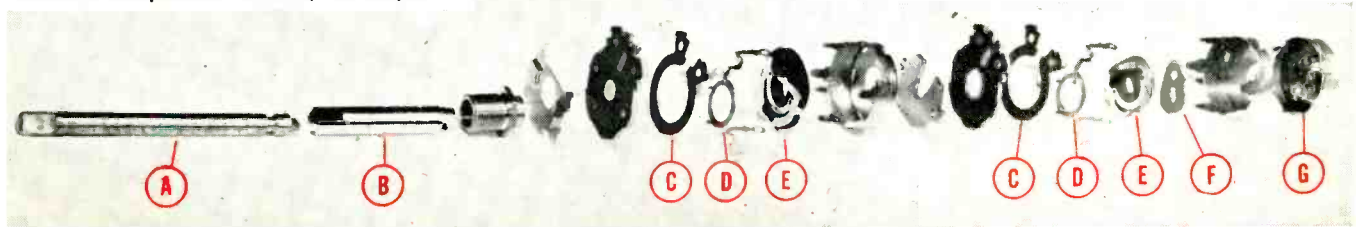

21-IN. COLOR SET



Going into production is a complete large-screen RCA-Victor color TV receiver using 28 tubes, including RCA's new 21-in. crt. The picture tube provides 250 sq. in. of viewing area, is lighter than the earlier 15-in. tube with the 12½-in. viewing diameter, and uses a shadow mask with a metal cone. A new feature is a color equalizer, which eliminates the former magnetic shield and rim coil. Improved design of the 3 electron guns permit a wider deflection angle. Brightness comparable to that of a monochrome tube is said to be provided right up to the rim.

TSG Service Warning

Watch your step on service calls from customers who have just installed their own indoor antennas, says Television Service Guild, 333 W. Monument Ave., Dayton, Ohio. One TSG member, out on a call to such a customer, reached for the antenna only to be greeted by 115 volts. The set owner had made the "slight" error of connecting the antenna to the ac line instead of to the receiver's antenna input terminals.

SERVICING MADE EASY



1955 line of Setchell Carlson receivers should make a big hit with TV techs. Chassis—all plug-in units—is mounted under hinged lid. Units are individually removed for servicing. Tube replacements are made from standing position

Sales-builders

by **TACO**



MAGI-MIX ANTENNA Couplers

An extremely efficient band pass filter permitting the use of a single transmission line with the following antenna combinations:

Cat. No. 1425A High-band and low-band VHF antennas

Cat. No. 1460 UHF and VHF antennas

Cat. No. 1465 Two UHF antennas

Cat. No. 1433 VHF high-band, VHF low-band and UHF antennas

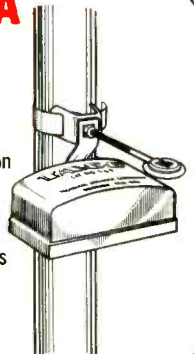

MULTI-SET Couplers

Three models—Cat Nos. 820-2; 820-3; and 820-4 permit two, three, or four set operation respectively from a single antenna installation. Units split signal equally between receivers and provides necessary isolation to

eliminate interaction between sets. Eliminate those trade-in headaches—sell a second set — not a second-hand set.

SELECTRONIC Switch

A multi-purpose, 300-ohm impedance switch with high-efficiency contacts for minimum loss. Used for manual switching from antenna to antenna, switching signal from one receiver to another, and ideal for use in high-fidelity signal switching.

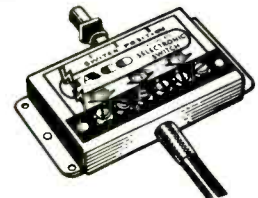

Taco, the oldest and most respected name in antennas, offers you real SALES-BUILDERS in the line of antennas, accessories and promotional backing. You can't lose with Taco as your brand. Stop in and see your Taco distributor. Pick up your copy of the Taco catalog and see for yourself why Taco has been the STEADY LINE since 1932 . . .

TECHNICAL APPLIANCE CORPORATION
SHERBURNE, NEW YORK

In Canada: Hackbusch Electronics, Ltd., Toronto 4, Ont.

You and the Law

Know Your Rights, Avoid Pitfalls, When Customers Welsh on Bills

By BERNARD BRESSLER
MEMBER, NEW YORK BAR

Often it is impossible for a technician to make repairs at the price of his initial estimate in the home. If he is not careful to clearly state that the amount he is quoting is not a final price, he may find that he has made a binding contract to repair the set at the price quoted. If he takes the set to his shop with the owner's understanding that the figure quoted was not a final charge, he should fix the price with the owner before starting to work.

Approval of the price by a son or wife answering the phone at a later date will not usually bind the objecting owner to pay that price. This is true even though the answering party says that the owner told him that he could approve the price. If there is no price agreed upon, the technician is not stuck; but he will be entitled only to "reasonable" charges for services and materials.

"Reasonable" charges are an amount which a jury would find and are not necessarily related to what the technician honestly believes are "reasonable" charges. The question can reach the courts either as a result of a suit by the technician to

get paid if he has not kept the set or, if he has kept the set (and is entitled to continue to keep the set until he has received either the contract price or reasonable charges, under lien laws of which New York's is an example), the issue is raised when the owner tries to recover the set by having the lien vacated.

Resale of Set

The rights given by the lien law are very important and protect the technician in dealing with his customers. If the customer does not pay the agreed price, the technician can sell the property at a public sale, after giving proper notice and advertising the sale. Of the proceeds of the sale, the technician retains the amount owing to him and an amount sufficient to cover the expenses of advertising and of the sale.

The lien law gives a right against the television set which was repaired only so long as the technician keeps possession of the set. Once the set is returned to the owner, the lien no longer exists. If possession of the set was obtained from the owner or with the owner's consent, the technician need not return it to the owner until he is paid. However, this

rule does not hold if an agreement has been reached to the effect that payment is to be made at some time after the set is returned. If payment is to be made at a future date, for example one week after the set is returned, no lien can be created.

Thus the law protects the technician—if he is careful in making arrangements with his customer. If he obtains the owner's understanding that the original estimate is not a final price at the time he receives the set, and then gets the owner's consent to the final price which is to be paid upon delivery, he will have the law on his side in attempting to get paid for his services.

The New York lien law, on which this article has been based, is itself based upon common lien laws, and therefore similar to the lien law of most states. Hence, the precautions advised here are generally applicable across the United States, although local rules may make additional procedures necessary.

The author has provided TECHNICIAN with thoroughly documented references to actual statutes and precedents concerning all points covered in his article. These references are available on request.

Industry Keyhole

J. H. SPARKS INC. of Philadelphia, Pa. has been appointed a distributor for *Magnecord* background music service for the Phila. area, Delaware and nine counties in N. J. **TAPE TUNES INC.** of Madison, Wis. was named for southern Wisconsin and **MOSES RADIO-ELECTRONICS CO.** of Hartford for the state of Connecticut. **WOOD-ALEXANDER AND CO.**, Locust St., Hartford, Conn., has signed to handle the *Stromberg-Carlson* radio-TV and hi-fi line. Similar distributorship went to **INLAND EMPIRE WHOLESALERS**, South 110 Wall St., Spokane 4, Wash. for Idaho, Mont., Ore., and Wash.

Sylvania Electric Products Inc. has named three new distributors for its radio and TV tube products: **T. V. RADIO DISTRIBUTING**, 812 Main St.,

Peru, Ind.; **SERVEX ELECTRONIC DISTRIBUTING CO.**, 215 Jefferson St., Tiffin, Ohio and **WHOLESALE ELECTRONIC SUPPLY CO.**, 906 Franklin St., Waco, Tex. . . . The **JENSEN-BYRD CO.** of Spokane, Wash. and **EMPIRE STATE WHOLESALERS INC.**, Troy, N. Y. have signed up as distributors for *Sylvania's* radio-TV products. . . . **PARKER METAL GOODS CO.**, 161 Summer St., Worcester 8, Mass., mfr. of standoffs, insulators, chimney mounts, and related items is now servicing the radio-TV distributing trade directly.

E. T. DONOHUE INC., 13 Canal St., Rochester, N. Y., has been appointed a distributor for *Du Mont* TV receivers. . . . **THE GAS ENGINE AND ELECTRIC CO. INC.** of Charleston, S. C. is now a distributor for *Motorola*. . . . **PERMOFLUX CORP.** distributor division has completed moving into its new quarters at 2835 N. Kedzie Ave., Chicago. . . . *Espey's* "Overture" speaker-amplifier unit will be handled in the Phila. area by **RAYMOND ROSEN**. . . .

JOHN D. VAN DER VEER was promoted to asst. general sales mgr. of *Tung Sol Electric Inc.* after serving since 1950 as manager of initial equipment electron tube sales. . . . **THE ELECTRONIC PARTS DISTRIBUTORS'** 3rd regional seminar will be held at the Baker Hotel, Dallas, Tex. October 22-23. . . . **JULIAN K. SPRAGUE**, pres. of the *Sprague Electric Co.*, North Adams, Mass., was named chairman of the Advisory Gp. on Electronic Parts of the Dept. of Defense. **CHAS. W. HOSTERMAN** has been appointed asst. general mgr., Electronics Div., *Sylvania Electric Products, Inc.*, with offices in the Woburn, Mass. plant. . . . **ROBERT LEON** of *Brush Development Co.* heads the Standards and Engineering Committee of the Magnetic Recording Industry Association. . . . **IMPROVED ANTENNA DESIGN** is the goal of the new research lab opened in Ashtabula, Ohio, by *Ward Products Corp.* of Cleveland.

NOW

any selenium rectifier
can be replaced with a

Federal

Federal's

COMPACTED · EYELET TYPE

UNIVERSAL LINE

meets all replacement needs
where size is a factor

ONE SOURCE OF SUPPLY

... Federal's Universal and Regular Lines
provide complete coverage of today's
selenium rectifier requirements!

SERVICEMEN! Now you can buy all the selenium rectifier
types you'll ever need ... from *Federal!*

Whatever the make or rating of the rectifier being re-
placed, Federal's new, smaller-size *Universal Line*—or Federal's
Regular Line—will meet all requirements!

The Universal Line's smaller "H" dimension does the
job where space is a factor. The five types are listed below.
All are eyelet construction, with 6/32" mounting screw
enclosed. They are designed to handle approximately 70%
of all replacements.

Make *your* servicing job easier ... more profitable ... by
simplifying rectifier procurement. Get *uniform* quality, de-
pendability and performance—plus *long, long life*—by re-
placing with Federal's *Universal* and *Regular* Lines ... in
the easy-to-identify "Rectifier Red." Ask your distributor,
or write to Dept. F354.

UNIVERSAL LINE RATINGS AND DIMENSIONS:

Type	Max. DC Ma.	"H" Dim. Max.	Plate Size
1263A	65	21/32" ± 1/32"	11/16" Sq.
1236A	300	1-3/8" ± 1/32"	1-5/8" Sq.
1238A	350	1-3/8" ± 1/32"	1-3/4" Sq.
1241A	400	1-1/4" ± 1/32"	2" Sq.
1237A	500	1-3/8" ± 1/32"	2" Sq.

Federal has available a new type bolt and nut for mounting rectifiers
in tandem. Order bolts by Part No. IDR-6131; nuts by Part No. IDR-6015.

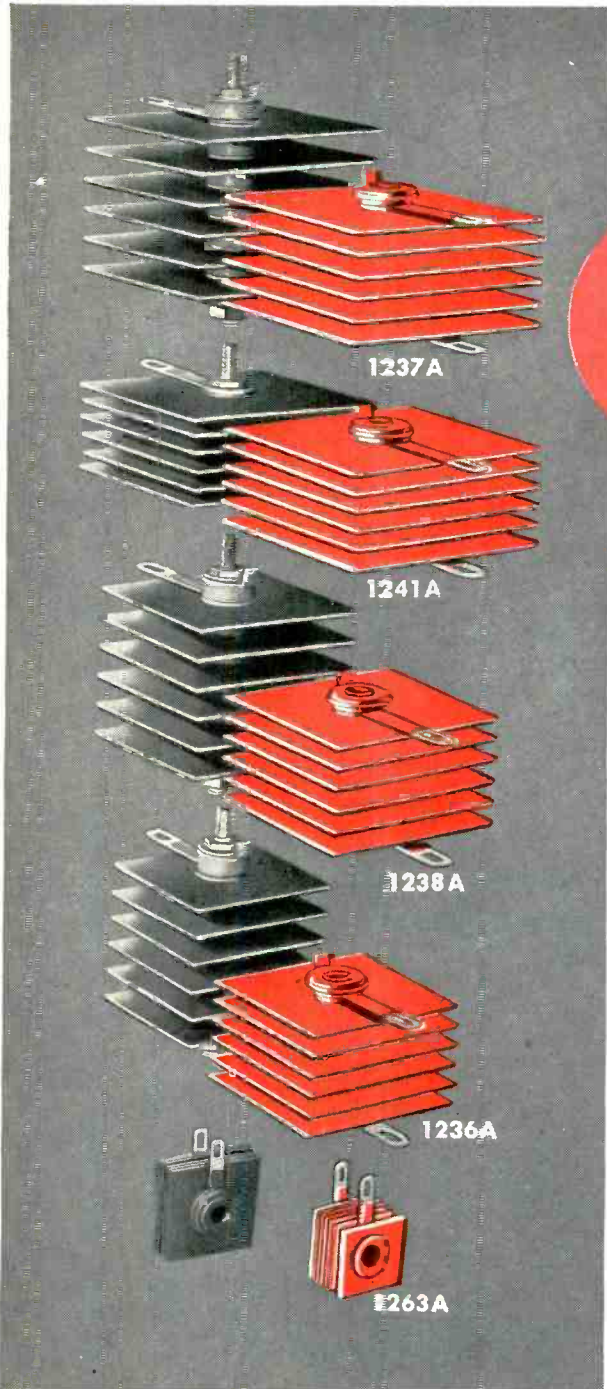

Federal Selenium Rectifiers are listed in
Howard W. Sam's Counter-Facts and Photo Facts

America's first and largest manufacturer of selenium rectifiers

Federal Telephone and Radio Company

A Division of INTERNATIONAL TELEPHONE AND TELEGRAPH CORPORATION

COMPONENTS DIVISION

100 KINGSLAND ROAD

CLIFTON, N. J.

In Canada: Federal Electric Manufacturing Company, Ltd., Montreal, P. Q.
Export Distributors: International Standard Electric Corp., 67 Broad St., N. Y.



**Federal
"S-C-S"
GERMANIUM
DIODES!**

—in the industry's
most useful
PACKAGE LINE!
Ask your
Distributor!

Selenium Rectifiers

Interchangeability and Common Applications

After almost eight years of knocking at the door, the selenium rectifier is now coming into its own as the answer to compact, low-cost power supply design. This year they are being found in more TV sets than ever, in the higher priced quality receivers as well as the cheaper models.

Construction

Briefly, the selenium rectifier consists of a base plate—usually of aluminum—on which is applied a layer of selenium. Heat treatment crystallizes the selenium and increases its conductivity. An artificial barrier layer is next applied over the selenium and this forms the base for the front electrode, which is usually applied by a spraying process. This front electrode is an alloy which may be composed of a number of elements. The selection will be determined chiefly by the ability of the alloy to offer a low resistance path to current emanating from the base material and a high resistance to current going toward the base. A tin, cadmium and bismuth compound is frequently used.

Groups of individual cells are assembled into stacks, the number of cells to depend on the uses of the rectifier. It is of interest to note here that kits now available from one of the major manufacturers allows the serviceman to design and build his own rectifying equipment. The kit comprises a number of individual cells and stacking hardware.

Polarity

Confusion often arises over the polarity marking of selenium rectifiers. To avoid a mistake, consider the rectifier as a battery supplying the circuit in question. The positive side of the rectifier will then go—in the case of a power supply—to B+, or the input filter condenser. In any other circuit, the positive side goes to that point which, measured with a voltmeter, shows the positive potential.

Applications

Fig. 1 shows a typical operation of a selenium rectifier—a 100 ma, 117 v. unit—in a 3-way portable power supply. The higher efficiency and

greater power output of a B+ supply using seleniums provides increased sensitivity and, in portables having directly heated cathodes, the attractive instant starting feature.

Fig. 2 is an ac-dc half-wave power supply, with series-connected filaments, of a typical table model radio.

Fig. 3 is a less familiar circuit arrangement for a separate TV power supply providing the voltages shown in the illustration. Where a moderately large negative potential to ground is desired, use of this separate supply eliminates the need for an involved voltage divider circuit which when defective, affects all parts of the receiver. The rectifier used here is the low-current type, with output of 10–20 ma.

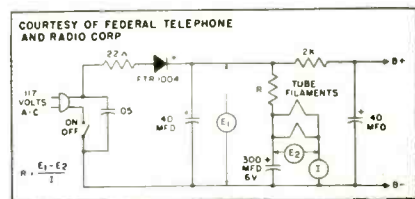

Fig. 1: Power supply of 3-way portable radio

INTERCHANGEABILITY GUIDE

Based on similar charts prepared by International Rectifier Corp. and Sarkes Tarzian, Inc.

Max. DC Current Output (MA)	Max Input Voltage (RMS)	Federal Type	Int'l Rectifier Type	Radio Receptor (Seletron) Type	Sarkes Tarzian Type
20	130	1159	CR20		
30	130		CR30	8Y1	35
50	130	1214	CR50-RS65Q		50
65	130	1263-1002	RS65	8J1	65
75	130	1003	RS75	5M4	75
100	130	1004	RS100	5M1	100-100A
150	130	1005	RS150	5P1	150
200	130	1006	RS200	5R1	200
250	130	1028-1010	RS250	5Q1	250-250A
300	130	1236-1090	RS300	6Q4	300
350	130	1238-1023	RS350	5QS1	350A
400	130	1241-1130	RS400	5S2	400
450	130	1021	RS450		450
500	130	1237-1179	RS500	6S1	500
75	156-160	1007A			78-78D
100	156-160	1014A		6M1	108
150	156-160	1009	RS156	6P2	
200	156-160			6H1	208
250	156-160		RS256	6Q1	
350	156-160		RS356	6QS2	

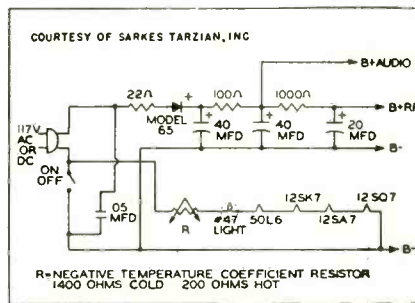

Fig. 2: Selenium use in typical ac-dc receiver

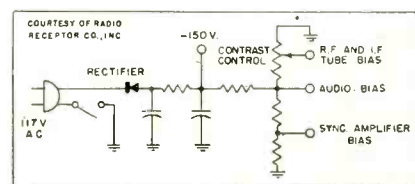

Fig. 3: An independent TV bias supply

truly UNIVERSAL

Replacement Selenium Rectifiers

1. Use the through bolt or machine screw that previously held the replaced rectifier.

2. Use the special locating lug and mounting stud supplied with every Sarkes Tarzian rectifier.

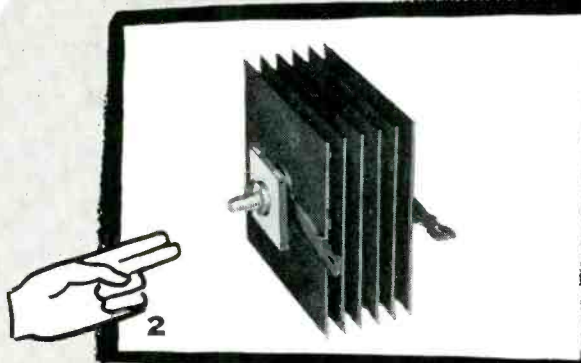
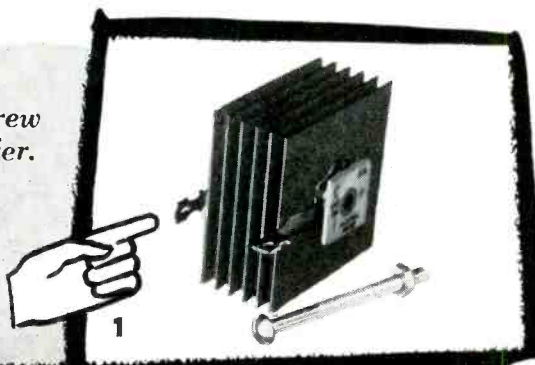

3. Sarkes Tarzian rectifiers are equipped with "plug-in" type lugs to accommodate even the most modern sets.

A Sarkes Tarzian exclusive on the replacement market.

plus small, small size

COMPARE

THESE DIMENSIONS* WITH THOSE OF ANY OTHER RECTIFIER ON THE MARKET:

S.T. MODEL	RATING MA DC	LENGTH (MAX.)	PLATE SIZE (MAX.)
300X	300	1 1/8"	1 5/8" SQ.
350X	350	1 11/32"	1 5/8" SQ.
400X	400	1 1/8"	2" SQ.
500X	500	1 11/32"	2" SQ.

*SMALLEST OVERALL SIZE FOR FULL RATING

SEE YOUR DISTRIBUTOR FOR TRULY UNIVERSAL REPLACEMENT RECTIFIERS.

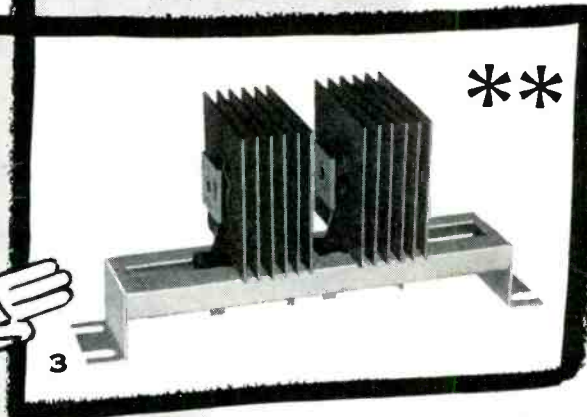

**MODERNIZE OLD TV SETS WITH THE NEW CONVERSION CHASSIS NOW AVAILABLE AT YOUR DISTRIBUTOR'S.

Sarkes
Tarzian, INC.

Rectifier Division

DEPT. CC, 415 NORTH COLLEGE AVE. BLOOMINGTON, IND.

In Canada: 700 Weston Rd., Toronto 9, Tel. Murray 7535 • Export—Ad. Auriema, Inc., N. Y. C.

"Tough Dog" Corner

Difficult Service Jobs Described by Readers

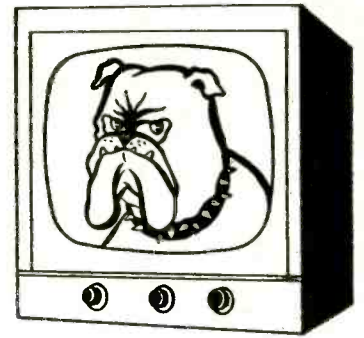

Yoke Was On Him

Next to intermittents, some of the toughest dogs that I've had have been caused by defective parts that were in stages that were *apparently* unrelated to the symptom indicated. This dog was one of those.

It was a 21-inch Hoffman, chassis 191. The symptoms were insufficient width, and a blank raster and no audio when the set was tuned to a strong station. A new 5U4 and 6BG-6G, plus a width control adjustment, just about cured the width problem. This was a clue that I muffed. Next I set about finding my other troubles. Detuning the set or taking off the antenna lead-in to weaken the signal brought in sound and a snowy picture. This was obviously agc trouble, I thought.

I connected a variable bias box into the agc bus to see if increasing the negative agc voltage would provide a normal picture. It did. I measured the negative voltage that the bias box had to supply to produce this normal picture. I then disconnected the bias box and measured the voltage developed by the agc keyer to compare what was available with what was needed. About -6 v was needed; the keyer developed only about -3 v.

Replacing the 6AU6 agc keyer, and C405 (the coupling condenser from the flyback transformer to the keyer plate) didn't help. I checked the pulse on the plate of the agc keyer with a scope, and found that its amplitude was far less than 460 v peak-to-peak indicated on the schematic. Ungrounding the shield of the shielded lead that connects C405 to the flyback (to see if the flyback pulse was breaking down the insulation to the shield) led me nowhere.

I remembered the lack of width encountered at the beginning of the service job. Perhaps a defective flyback transformer was causing poor scan and developing a small pulse for application to the agc system. I replaced the transformer with one from stock, and started to pull hair out when I saw no improvement.

I took a deep breath and prepared myself for a long battle with the horizontal scan system. I started out by pulling off the cover of the deflection yoke, so that I could meas-

ure the resistance of the horizontal windings. Oh, was this a piece of luck! There was the trouble staring me in the face. The 100k resistor across one of the horizontal windings of the deflection yoke—R719—was burnt to a crisp.

The resistance of R719 had dropped to a very low value, shorting out one horizontal winding of the yoke. This certainly was enough to load down the horizontal scan system, causing the picture to be narrow, and also reducing the size of the flyback pulse supplied to the agc circuit.

Who would have thought that you could solve an agc problem by looking inside a deflection yoke?—E. R. Nelson, Tonawanda, N. Y.

Hot Rolls (Vertical)

The original complaint on this Air King 16C1 was no picture. Before this symptom set in, I was told, the set "hadn't been working right" for some time. The loss of raster, traced back to the horizontal sync circuit,

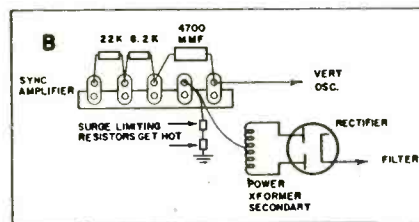
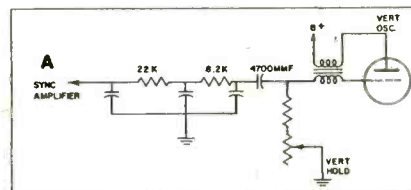

was corrected when a new 6AL5 horizontal phase detector was installed. After that, I discovered the set would start rolling vertically when it had been playing for a few minutes.

An adjustment of the vertical hold locked the picture in easily, but after 15 minutes it began to roll again, this time very slowly. I turned the set off to let it cool, then turned it on again without adjusting the hold. This time the roll was very rapid. After checking all components that could be at fault to no avail, I replaced everything from the integra-

tor to the grid of the vertical output tube. Still no improvement.

By a lucky chance, I happened to feel the 4700-mmfd condenser connected to the grid winding of the vertical blocking oscillator, and realized that it was quite warm. Then I noticed that the power supply's surge limiting resistors, which were hot during operation, were connected to a binding post located between two other posts on the board across which the 4700-mmfd capacitor was connected. I unsoldered the two resistors, for test purposes, and then tried the set. It worked perfectly. Binding the resistors to another point cleared up the symptom.

Apparently heat had caused leakage between the binding posts. In this circuit very little leakage, say in the order of 25 meg, would be enough to shift frequency in the grid circuit.—R. Abel, Pittsburgh, Penna.

● Another possibility: Even without leakage, heat reaching the condenser might change its value enough to detune the grid.—Ed.

Whistling in the Dark

A steady high-pitched tone, not always evident, when recording from the AM tuner to tape was the trouble we were asked to clear up. Since the AM tuner worked well independently of the recorder, and a quick check in the home showed nothing out of order in the tuner, the recorder was taken to the shop. The only sign of trouble seemed to be a microphonic tube, which was replaced. However, when the tape recorder was returned to its owner,

(Continued on page 50)

\$ For Your "Tough Dog Story"

Have you tangled with a difficult or obscure service problem recently? Write it up, telling us how you licked it, and send it to "Tough Dog" Editor, TECHNICIAN, Caldwell-Clements, Inc., 480 Lexington Ave., New York 17, N.Y. \$10 will be paid for usable material. Unacceptable items will be returned to the contributor.

PRECISION

Announces a **NEW**
BASIC TEST INSTRUMENT

...for Laboratory and Test Bench
...for Engineer and Technician

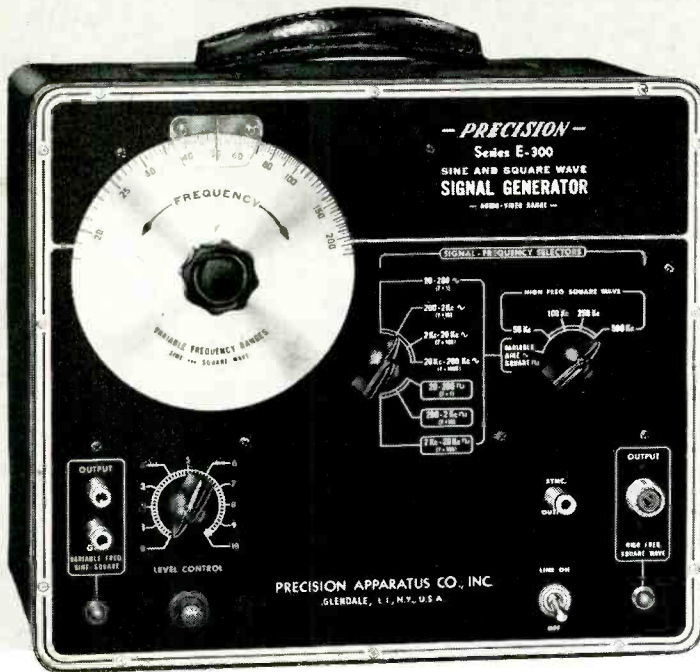

THE MODEL

E-300

SINE-SQUARE WAVE SIGNAL GENERATOR

(AUDIO-VIDEO RANGE)

GENERAL SPECIFICATIONS:

VARIABLE-FREQUENCY SINE-WAVE RANGES:

for testing audio amplifiers, low frequency RF amplifiers, etc.:
Continuous Coverage from 20 Cycles to 200 Kilocycles in Four Bands.

VARIABLE FREQUENCY SQUARE-WAVE RANGES:

for analyzing audio amplifiers, wide-range amplifiers, etc.:
20 Cycles through 20,000 Cycles in Three Bands.

FOUR FIXED, HIGH-FREQUENCY SQUARE WAVES:

for analysis of video and other wide-band amplifiers up to 20MC band-width:
50 KC - 100 KC - 250 KC - 500 KC steps.

OUTPUT CHARACTERISTICS:

Variable Frequency Ranges: 0-2000 ohms, 0-10 volts RMS, flat within ± 1 db.
Accuracy: $\pm 2\%$ from 50 cps. to 200 KC. ± 1 cps. from 20 cps. to 50 cps.
Distortion: Less than 1% from 20 cycles through 200 KC.
20 KC Square-Wave Rise Time: .5 microseconds.

FIXED HIGH FREQUENCY SQUARE-WAVES: 0-250 ohms, 0-5 volts P-P

Rise Time: .05 microsecond • Overshoot: Negligible

TUBE COMPLEMENT: 1-5879, 1-6CL6, 1-6J6, 2-6AU6, 1-6BL7, 1-6AH6, 1-6X4.

SEPARATE OUTPUT CIRCUITS: for the variable and fixed frequency ranges. Dual pilot lamps automatically indicate the active output jacks.

TERMINATED, LOW-LOSS, HIGH FREQUENCY COAXIAL OUTPUT CABLE:

transmits the H.F. square waves to circuits under test, without distortion.

EXTERNAL 'SYNC' TERMINAL POST:

for synchronizing oscillograph horizontal sweep to H.F. square-wave.

ETCHED-ANODIZED TUNING DIAL and PANEL: NO-glare, engine-turned dial finish and soft-black panel field afford utmost visibility and ease of reading.

MODEL E-300: in black, ripple finished, portable steel case - $10\frac{1}{2} \times 12 \times 6$ ". Complete with tubes, coaxial output cable and operating manual.

Net Price **\$175⁰⁰**

THE NEW SERIES E-300 has been especially developed to answer many modern electronic amplifier testing problems which cannot be handled with just the usual complement of test instruments.

The Series E-300 provides accurate sine and square wave signals for direct performance testing of:

High Fidelity Audio Amplifiers
TV Video Amplifiers
Carrier Current Systems
... and other wide range devices, etc.

Sine-Square Wave Analysis, with the Series E-300, streamlines amplifier test procedure and assures more uniformly high standards of apparatus performance, because sine-square wave testing is a most reliable indicator of:

Frequency Response
Phase Shift
Amplitude Distortion, etc.

The operating Manual for the Series E-300 has been especially prepared to describe the basic techniques of sine-square wave testing. The information establishes a foundation that will permit the operator to interpret sine-square wave-forms in terms of frequency response, distortion, etc.

You may obtain this comprehensive Manual, at only 25¢ per copy, to cover cost of printing and handling. Write directly to factory.

EXPORT DIVISION: MORHAN EXPORTING CORP.
458 Broadway, New York 13, U.S.A.
IN CANADA: ATLAS RADIO CORP.
560 King Street W., Toronto 2B



PRECISION Apparatus Company, Inc.

92-27 Horace Harding Blvd., Elmhurst, L. I., N. Y.

Shop Hints to Speed Servicing

Tips for Home and Bench Service Contributed by Readers

Phono Hint

In replacing phono cartridges, or often when replacing needles, it is necessary to remove the cartridge from the tone arm. When the time comes to replace the cartridge in the arm, the little screws are often hard to handle, especially when working from the underside of the tone arm. A dial cord stick can be used for such situations. Scrape the head of the screws across the stick, filling the slot with the compound. It is then a simple matter to make the screw stick to the end of the little screwdriver employed, permitting this screwdriver to be inserted from any position.—*Fred L. Davis, Jr., Clayton, Mo.*

Economy Pilot Bulbs

Instead of using 6-watt 115-volt bulbs as pilot lamps in set-ups of shop or test equipment, as in panel set-ups, use a 200,000-ohm resistor in series with a NE-2T pigtail-type neon lamp. Put this combination across the 115-volt line. This cuts current consumption from 6 watts for each bulb down to about 1/25 of a watt. Space is also saved by mounting the little bulbs in grommets with 1/4-in. inside diameter, for a perfect fit. These neon bulbs can also be used to replace the regular 6-watt lamps in dial lighting and indicator applications.—*Harvey Muller, Danboro, Penna.*

Antenna Connector Gimmick

Clothespin type antenna clips are very convenient to use around the shop to allow quick connection to and disconnection from the antenna posts of TV receivers on the bench. However, any other technician will bear me out on this: so many times, in turning the chassis over for service or in mounting it on its side, the

antenna lead gets caught on something, or else turns out to be too short, and the terminal strip is broken away from its mounting before one realizes it. After having this happen to several sets in the shop, I finally ended up with the idea of cutting the 300-ohm lead a foot or so behind the clothespin connector and inserting a pair of Mosley connectors (see illustration). Now, if there is any undue strain, it is the line itself that pulls apart, and no damage is done.—*M. G. Goldberg, St. Paul, Minn.*

Allen Wrench Assist

We keep some very thin automobile shim stock around the shop, for use in removing Allen set screws that have become rusted or otherwise so firmly seated, that removing them may require a major job (particularly when the Allen wrench cannot grip the screws). Clean out the set screw head with a piece of stiff wire, then place a small piece of the shim stock over the head of the Allen wrench. Now tap the wrench into the opening in the screw head. This provides a firm grip for the wrench and often eliminates a time-consuming and irksome chore.—*Stanley Clark, East Bradenton, Florida*

Eliminating Wiper-Motor Noise

The radios of P-24 Plymouth cars often develop a definite windshield-wiper motor noise that can be cured by re-routing the antenna lead-in wire. To remedy the trouble, operate the radio and the windshield wiper at the same time. Then move the lead-in around until the static-free position is located, generally at some point far removed from the windshield-wiper motor and its wir-

ing. When this optimum position has been located, tape the lead-in wire into place.—*Harry Mayover, The Little Radio Shop, Phila, Pa.*

Upper Channel Reception

In many areas, when a new channel starts operation in the high VHF band, many set owners complain of very weak or snowy reception despite the fact that signal is expected to be good; i.e., their neighbors may be getting excellent pictures. If the tuner of the receiver in question is not of the type that uses a separate set of coils for each channel, the answer may be near at hand, with the TV technician being the cause of the trouble, as well as the cure.

To illustrate, consider what happened in New York City a few months ago when Channel 13 switched its transmitter to a better position (the Empire State Building) after being unreceivable at many points in the city. After the switch reception was just as poor as ever on thousands of sets! This is what had happened to these sets, since reception on some other high-band channel (Channel 11, in most cases) had not been too good in all cases: In certain tuners, alignment begins by peaking on the highest channel available in the area, and then peaking down to channels lower in frequency in descending order. Channel 13, which wasn't available anyhow, was sacrificed in favor of 11; that is, when the tuner was in position for Channels 13 and 12, r-f peaking was performed on Channel 11. Thus, when 13 became receivable, the tuner was not aligned to pick it up. With front ends of this type when a new high-band VHF channel comes on the air, the safest procedure is to realign according to the manufacturer's instructions where reception is not up to par.—*Clifford H. Goldstein, New York, N. Y.*

Pull-apart antenna connector for bench use prevents damage to receivers during servicing.

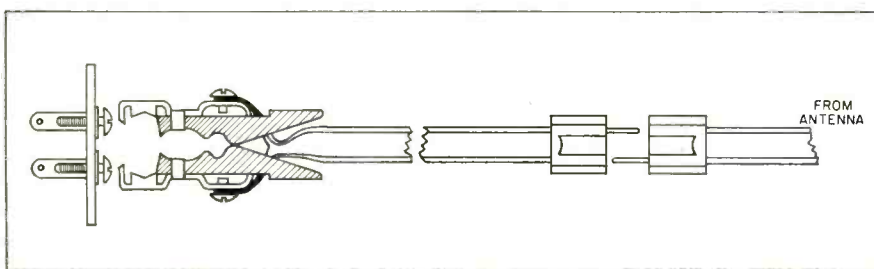

SHOP HINTS WANTED

TECHNICIAN will pay \$5 for acceptable shop hints. We are particularly interested in hints on the following subjects: Hi-Fi servicing, TV and radio interference, industrial electronics, TV antennas, test equipment and UHF. Unacceptable items will be returned. Send your hints to "Shop Hints" Editor, TECHNICIAN, Caldwell-Clements, Inc., 480 Lexington Ave., N. Y. 17, N. Y.

NEW!

PHILCO

... SUPER PERFORMANCE

TV

ANTENNAS

GUARANTEED TO OUTPERFORM

ANY equivalent type antenna or

YOUR MONEY

and

LABOR COSTS

BACK!

Enough words have been written about TV antenna performance. *Now, see the facts for yourself!* Compare any of the new PHILCO Super Performance TV Antennas with any equivalent type on the market. If the new PHILCO does not give you the finest picture possible, your money back for the antenna *plus* your labor costs up to \$10.00. Here at last is *real* guaranteed performance! PHILCO TV Antennas provide gains up to 15 db in some models... strong signal pickup... high front to back ratio. Powerful Conical... all-aluminum VHF Yagis, engineered for quick rigging... light weight. Stacked versions provide top-quality fringe area reception. Six UHF Yagis cover the entire UHF spectrum.

GET YOUR "FREE RIDE" WITH PHILCO • SEE YOUR PHILCO DISTRIBUTOR !

PHILCO CORPORATION

ACCESSORY DIVISION

"A" and Allegheny Ave. • Philadelphia 34, Pa.

SERVICE ASS'N REPORTS

Teeth in Licensing Law (RTSA, Minn.)

Although the city of St. Paul, Minn. has an ordinance requiring a license for any shop doing TV repairs no effort was made until recently to track down the free-lance and basement operators carrying on business without a license. Positive action by members of the Radio-TV Service Assoc. of St. Paul, Inc., has brought a swift change. In the past 4 months, the association has turned in the names of 70 non-licensed repairmen to the City License Inspector. Notification was also made to the phone company and the Internal Revenue Bureau that these individuals were in business.

The organization is also getting support from jobbers. The Lew Bonn Co., parts distributor, announced that technicians must identify themselves in order to purchase replacement parts.

Election of Officers (NETSDA, East)

The National Electronic Technicians and Service Dealers Associations, representing servicemen's organizations in Pennsylvania, New Jersey and New York, held its elections recently in New York. Max Liebowitz of N.Y. was elected president; Dave Van Nest, of Trenton, N.J., vice-president; John A. Wheaton of Mineola, L.I., secretary, and T. L. Clarkson, of Harrisburg, Pa. treasurer. Steps were also taken to incorporate as a non-profit corporation. Arrangements are being made to rotate meetings in the different states.

First Chapter Organized (CETA, N.Y.)

The first graduates of the Advanced TV training Course held in New York City under the auspices of the Radio-Electronic-Television-Manufacturers Assn. have formed their own organization, the Certified Electronic Technicians Association.

Function of CETA is to operate in close harmony with the local RETMA Service Committee and the RETMA instructional staffs to make sure that members receive advanced instruction in new industry developments and, through their grievance committee, to review consumers' accusations of malpractice.

Plans have been formulated to establish chapters of CETA in all localities where the RETMA Advanced TV Training Course is to be given.

Secretary of CETA is E. D. Tilin, 755 Ocean Ave., Brooklyn 26, N.Y.

Standard Service Fees (FRSMAP, Penna.)

The Federation of Radio Servicemen's Associations of Pennsylvania (FRSMAP) is gathering reports from its member organizations throughout Pennsylvania on the pricing of service in their respective areas. When all the reports are submitted, a questionnaire will be sent to the member chapters to establish a standard price rate.

Public-Relations Drives (RTGLI, N.Y.; TELSA, Conn.)

Two servicemen's organizations, one in the New York area, the other in Connecticut, are taking concrete steps to improve relations with their customers.

The Radio-Television Guild of Long Island, (RTGLI), with headquarters in Bethpage, N.Y., is planning a full-fledged public relations drive through a professional PR specialist. High points of the program are co-operation with the local Better Business Bureau, "licensing" of the guild members, setting up of a group health insurance plan, guaranteeing work of guild members and setting up a service clinic on a weekly basis for "tough dogs."

At New Britain, Conn. the Technical Service Assn, Inc. (TELSA) arranged air time on WNHC-TV, New Haven, to bring their problems to the public.

News of the Reps

"THE REPRESENTATIVES" total membership now stands at 649, including 12 foreign members. The 1954 national membership roster is now available on request. Write to "The Reps" at 600 S. Michigan Ave., Chicago 5, Ill.

GORDON DOUGHERTY, formerly with the Hagerty-Scott rep organization of Detroit, now has his own company, located at 2339 1/4 S. Cedar St., Lansing, Mich.

THE PAUL KURTZ CO. of Detroit is regional sales rep for the Insuline Corp. of America of Manchester, New Hampshire. Kurtz will contact distributor accounts throughout Michigan.

HALLCRAFTERS has named 2 new reps to handle its line. McPherson-Thomas, Inc. of Ft. Wayne will cover Indiana, Kentucky and 2 cities in Ohio (Dayton and Cincinnati). The rest of Ohio will be handled by James H. Todolny of Pittsburgh, Penna.

THE JACK GOSS CO. of Cambridge, Mass., will contact distributors through New England for the Allen D. Cardwell Electronics Productions Corp. of Connecticut.

MARTY BETTAN SALES, 167-16 73rd Ave., Flushing 65, N. Y., was established following Bettan's resignation as sales manager for Radio Merchandise Sales, Inc. of N. Y. The new NYC rep outfit will continue to represent RMS, as well as Ames, Eicor and other lines.

CHARLES M. FURMAN, JR. and Associates, 1228 Harding Pl., Charlotte 3, N. Carolina will cover that state and Virginia for Hi-Lo TV Antennas. The antenna mfr. is located at 3450 N. Ravenswood, Chicago 13, Ill.

ADOLPH I. GROSS Associates in N. Y. will represent the AudioGersh Corp. nationally for their line of ELAC record players.

UNICORN TV ANTENNAS, made by American Screen Products of Miami, Fla., have national sales representation as a result of a recent trip by Ralph C. Powell, product mgr. At the end of the trip, rep appointments had been made to Floyd Fausett & Son, Atlanta, Ga.; James Gordon, Detroit, Mich.; Arthur H. Baier Co., Cleveland, Ohio; Ed Schulz, Indianapolis, Ind.; and Charles Kettering, Aspen, Colo. Earlier appointments include J. R. Hughes, Buffalo, N. Y.; Kay Sales Co., Kansas City, Mo.; and Al J. Rissi, Monrovia, Calif.

DR. BURTON BROWNE, head of the ad agency that bears his name, was scheduled to address the Rocky Mountain Chapter of "The Reps" at their conference on Aug. 31.

WALTER J. BRAUER and Associates, 15631 Lakewood Hts. Blvd., Cleveland 7, Ohio, have added Thomas O. Miles to their staff.

WILL YOU HELP US?

... By giving us the name of the technical association to which you belong? We'd like this information as part of an editorial survey which we're conducting.

Service Association:
Address
Manager or Recording Secretary's Name:
Phone:
Your Name:
Your Address:

Mail to: Associations Editor, TECHNICIAN,
480 Lexington Avenue, N.Y.C. 17, N.Y.

A service record unmatched
in the history of television!

CROSLEY SUPER-V

is a service man's dream!

"No more groping and twisting"

"Entire chassis accessible for service"

*Just look at what
service men say!*

"By removing the cabinet back, every tube is right in front of one's eyes. No more groping and twisting to relocate tube-socket pins. The separate diagram showing the actual filament wiring makes the search for an open filament a matter of seconds."
L. B. Hallberg, Hardware Products Co., Sterling, Ill.

"The Crosley Super-V is a service man's dream; the new vertical chassis allows the changing of tubes in a few minutes. When service of a more complicated nature is required, the cabinet can be removed by loosening 6 screws; this leaves the entire chassis accessible for service."
Roy R. Thompson, Saginaw Distributors, Inc., Saginaw, Mich.

*Just look inside
a Super-V!*

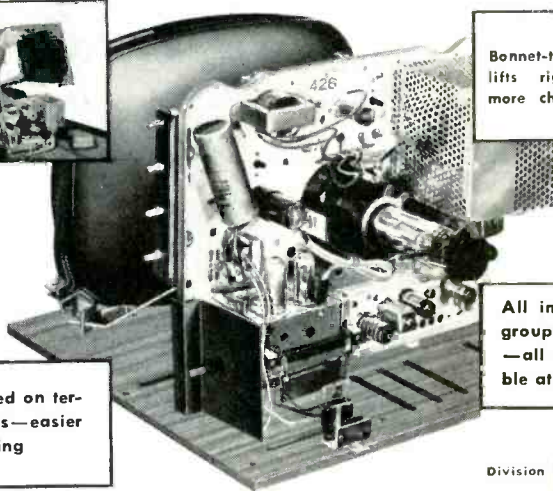

Bonnet-type cabinet lifts right off — no more chassis tugging

All important parts grouped in one plane — all tubes accessible at rear

Points wired on terminal strips — easier circuit tracing

Division **AVCO** Cincinnati 25, Ohio

Crosley gives you more for your money!

a NEW standard!

The ELMENCO STEATITE-CASED PAPER TUBULAR CAPACITOR has provided the electronics industry with a new standard of performance. The combination of superb quality and dependability coupled with low cost has enabled manufacturers to upgrade their specifications. The ELMENCO PAPER TUBULAR now is the standard to which others must be compared.



The steatite tube and baked synthetic resin end-fill provide a seal which rivals that of hermetically sealed construction, resulting in a dependability and longevity previously unequalled. Whether in operation or on the shelf, this paper tubular capacitor will maintain its excellent characteristics for years.

- Non-inductive winding
- Mineral oil vacuum impregnation
- Tight moisture-proof seal
- Safe operation at 85° C
- Long life on the shelf or under extreme operating conditions
- Low cost

The steatite-tubed capacitor is the only ELMENCO PAPER TUBULAR made because it is of a design superior to others. Whether mica, paper, or ceramic dielectric, a capacitor bearing the ELMENCO name represents the finest product in its field. For those who appreciate quality, it is well to remember that "ELMENCO replaces but is never replaced."

Send For
Information
And Free
Catalog

ARCO ELECTRONICS INC. 103 LAFAYETTE ST.
NEW YORK 13, N. Y.

West Coast Branch

ARCO CAPACITORS INC. 5281 West Pico Blvd., Los Angeles 19, Calif.

Brach COLOR TV ANTENNA

Colorcon is a conical type TV antenna adapted for both b & w and color TV reception. The antenna is distinguished by the red center elements which are engineered to stop spikes on the color TV subcarriers. Special color correction feature is made possible by the adjustable reflectors, which may act as a corrective peaking filter on many of the TV channels. Brach Mfg. Co., 200 Central Ave., Newark, N.J.

CDR ROTOR

Completely automatic, Models AR-1 and AR-2 antenna rotators feature a mechanical brake which is released magnetically, quick-mounting antenna mast collet and self-

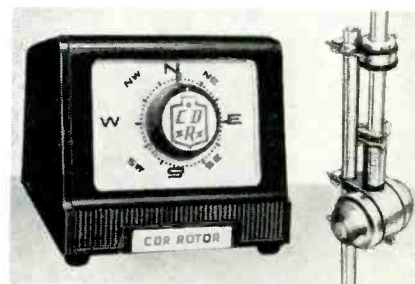

centering sawtooth clamps. Control unit is housed in modern-design plastic cabinet and uses 4-wire cable. Model AR-2 includes a thrust bearing for heavy loads. Radiart Corp., subsidiary of Cornell-Dubilier Corp., 3455 Vega St., Cleveland 13, Ohio—TECHNICIAN

Alliance ANTENNA

First antenna in the Alliance line, the broad-band VHF-UHF Monolober is available in single or double-bay. Features pre-assembled, snap-out design, with the UHF portion and VHF reflectors secured to the boom. Aluminum with rust resistant or plated hardware. Price, for single bay, is \$22.95. The Alliance Mfg. Co., 100 Lake Pk. Blvd., Alliance, Ohio.—TECHNICIAN

Jordan TOWERS

Zinc-plated tubular steel construction of the new Morrice self-supporting tower is claimed to make it impervious to rust and resistant to cracks or chipping. The tower is self-supporting up to 50 ft. and can be erected by two men in one hour. Added height above 50 ft. may be obtained by guying the upper units. Adaptable to TV antennas, floodlights, loudspeaker systems etc. Available in units up to 120 ft. Jordan Mfg. Co., Morrice, Mich.—TECHNICIAN

(New Products continued on p. 42)

Your Best Buy

for BLACK-and-WHITE ...and COLOR TV!

In color receivers, all of the color information is contained in the region from about 2 Mc to 4.1 Mc on the over-all rf-if response curve, as shown in Fig. 1. Any loss of gain in this region will weaken the color signals. If the loss is appreciable, it may result in such effects as poor color sync, poor color "fit" (incorrect registration of color and brightness information on the kinescope), or cross-talk or color contamination between I and Q channels.

The rf-if amplifiers must be aligned correctly to provide flat response for modulating frequencies up to 4.1 Mc. The RCA WR-59C Sweep Generator and WR-89A Marker Generator provide the flatness of sweep output and crystal accuracy essential for aligning color circuits.

In color receivers, there are a number of video-frequency sections, including the video amplifier, the bandpass amplifier, the demodulator channels (see Figures 2, 3, 4), and the green, red, and blue matrix networks—including the adders and output stages. A flat video sweep extending down to 50 Kc is a necessity in checking or aligning the tunable bandpass filter and the I and Q filters. Late model RCA WR-59C Sweep Generators provide a flat video sweep extending down to 50 Kc. They also cover all rf and if ranges required for both color and black-and-white receivers.

Get full details today from your RCA Distributor.



RCA WR-59C
Television Sweep Generator



RCA WR-89A
Crystal-Calibrated Marker Generator

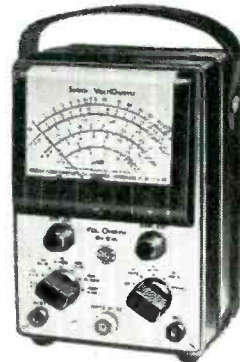

RCA WV-97A
Senior VoltOhmyst®

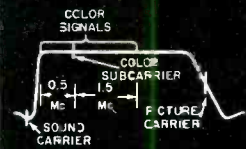

Fig. 1.
RF-IF Response



Fig. 2.
Bandpass Filter Response



Fig. 3.
I Channel Response



Fig. 4.
R-Y, B-Y, or Q Channel Response

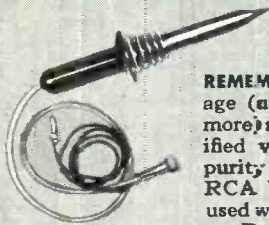

RCA WG-289
High Voltage Probe

REMEMBER that the high voltage (up to 30,000 volts and more) must be set to the specified value before adjusting purity and convergence. The RCA VoltOhmysts can be used with the RCA High Voltage Probe (WG-289 and WG-206 Multiplier Resistor) to measure dc voltages up to 50,000 volts.



Now off the press — RCA's new enlarged, 2nd edition of "Practical Color Television for the Service Industry." Price: \$2.00 — from your RCA distributor.



RADIO CORPORATION of AMERICA
TEST EQUIPMENT
HARRISON, N. J.

New Tools And Service Aids

Trico TEST CLAMPS

Heavy duty "Kliplok" clamps make particularly good connection due to pressure grip. A twist of the insulated knob applies jack screw pressure for solid mechanical grip and free flow of current. Available in a number of types, for testing, grounding, clamping knife switches or fuse holders and setting up portable equipment. With solder or solderless lugs. Trico Fuse Mfg. Co., 2948 N. 5th St., Milwaukee 12, Wis.—TECHNICIAN

Alpert WIRE CUTTER

Designed for cutting and trimming wires in hard to reach places, the Roto-Cutter utilizes a rotary shearing action, cuts copper wire sizes up

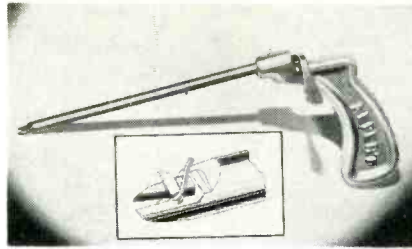

to #14 gauge. Slim design—6-in. long and 1/4-in. in diameter—makes it useful in reaching points inaccessible to ordinary diagonal cutters. \$3.95. Alpert Mfg. Co., 2950 N. Holton St., Milwaukee, Wis.—TECHNICIAN

Champ 4-WAY TOOL

This hand tool does several jobs. It shears bolts and screws, crimps solderless terminals and connectors, cuts and strips wire, and provides an easy-to-see gauge for judging stud,

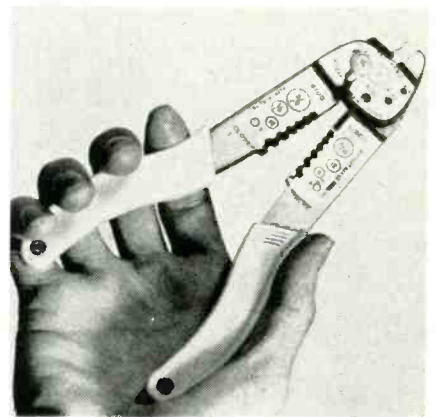

bolt, and screw sizes. The Champ is made of heat-treated steel and equipped with insulated handles. Wire and screw sizes, as well as the stud gauge and a stripping gauge, are etched on permanently. Aircraft-Marine Products, Inc., 2100 Paxton St., Harrisburg, Pa.—TECHNICIAN

Lindgren SCREEN ROOM

Pre-fabricated, fully assembled, table model screen room, the Portascreen, is 35 1/2 x 35 1/2 x 35 1/2 in. An efficient portable shielded

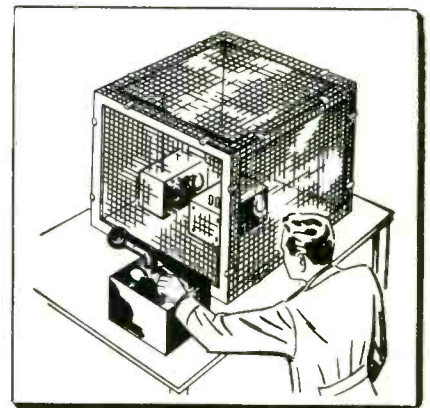

enclosure for use on table or work bench, for testing smaller equipment and screening out r-f interference. True double shielded screening provides an attenuation of over 100 db from 5 mc to 10,000 mc. \$175.00. Erik A. Lidgren & Assoc., 4515 N. Ravenswood Ave., Chicago 40—TECHNICIAN

(New Products continued on p. 44)

Your Ideal SECOND Soldering Tool

NEW
Weller Junior

for your service truck . . .
service kit . . .
extra bench tool

MODEL 8100
ONLY \$795 LIST
over 100 watts

This newest Weller Soldering Gun fills your need for an extra soldering tool. Its new, compact design includes all regular Weller Gun features, at a rating of over 100 watts. Its new, low price makes it as convenient to buy as it is to own!

SEE THE WELLER *Junior* AT YOUR DISTRIBUTOR NOW

Weller Junior SOLDERING GUN

805 Packer Street, Easton, Pa.

40% Sharper Tuning

than any other **AUTOMATIC ROTOR**

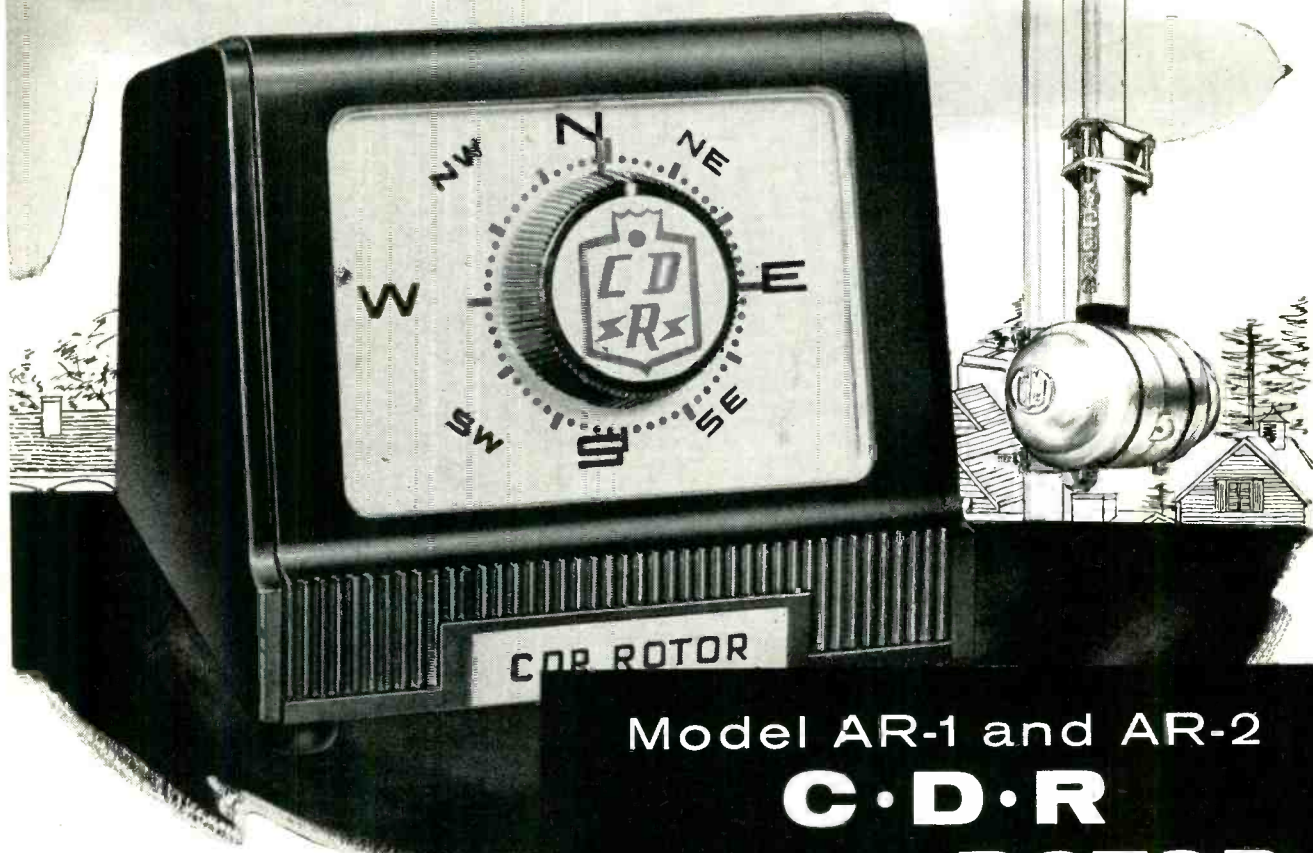

Model AR-1 and AR-2

C·D·R

automatic ROTOR

★ Here is EVERYTHING that ANYONE could ask for in a rotor! Powerful enough to turn any TV antenna... sturdy construction... and a handsome modern design plastic cabinet that AUTOMATICALLY turns the antenna to any position... AND ACCURACY that presents 40% SHARPER TUNING than any other automatic rotor!

...AND THEY ARE PRE-SOLD to consumers in every leading rotor market area with saturation TV SPOT ANNOUNCEMENTS!

Model AR-2... complete AUTOMATIC rotor with thrust bearing... and handsome modern design cabinet, uses 4 wire cable

Model AR-1... same as AR-2 without thrust bearing

Field Tested
For Years

& Tried
& Tested
& Proven



CORNELL-DUBILIER
SOUTH PLAINFIELD, N. J.



THE RADIART CORP.
CLEVELAND 13, OHIO

New Antennas and Accessories

TV LAMP ANTENNAS

A line of indoor TV antennas built into attractive lamps suitable for the top of TV cabinets combines utility with decoration. The antenna element is of quadruple-loop construction. Available in a choice of modern styles with red, white or chartreuse fibreglass shades. TV Lamp Antenna Mfg. Co., 3124 Lawrence Ave., Chicago 25, Ill.—TECHNICIAN

Rohn ANTENNA TOWERS

A new No. 6 tower, suitable for home TV installation and other communication requirements is designed to fill 75% of all tower needs. This tower is self-supporting up to 50 ft., or guyed up to 150 ft. It features a 12½ in. triangular design with heavy-duty corrugated cross bracing. Rohn Mfg. Co., 116 Limestone, Bellevue, Peoria, Ill.—TECHNICIAN

JFD VHF ANTENNAS

Designed to blank out co-channel and adjacent channel interference, the new Shut Out antenna is said to employ a unique configuration, and a new principle of electronic phase

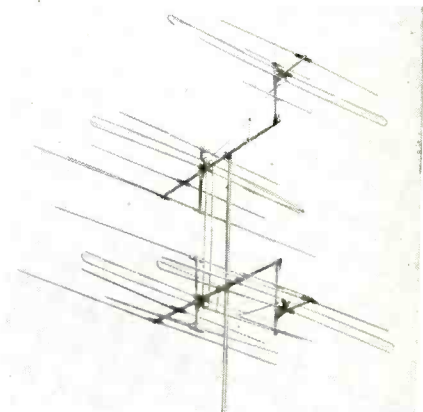

cancellation. According to field tests, the antenna, operated in a stacked array, has a measured front-to-back voltage ratio of 400-to-1. Aluminum construction, pre-assembled for quick installation. JFD Mfg. Co., Inc., 6101-16th Ave., Brooklyn 4, N.Y.—TECHNICIAN

Ward TV ANTENNA

Scout Conical 10 is the latest in the Scout series. It is all aluminum and priced for the metropolitan market. Also available in the 10-element

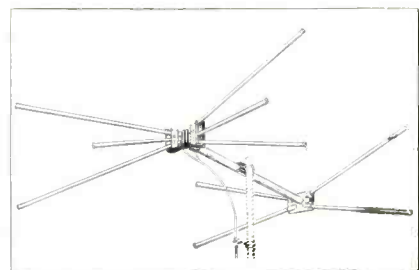

Economy Conical Kit, model TV-280, Ward Products Corp., 1148 Euclid Ave., Cleveland 15, Ohio.—TECHNICIAN

Davis DISTRIB. AMPLIFIERS

A new line of distribution amplifiers providing outputs for 2, 4, or 8 TV receivers provides complete electronic isolation for each output. This is accomplished by using separate triode amplifiers, giving 40 db isolation. No isolation resistors are used. Individual r-f amplifier stages for both high and low channels permit boosting any particular channel or portion of the band. Individual gain controls for each r-f amplifier prevent cross-modulation by permitting optimum separate adjustments. Davis Electronics, 4002 Burbank Blvd., Burbank, Calif.—TECHNICIAN

Put Your Microphone Dollar on the

Gold Standard

NEW GOLD-FINISHED ASTATIC MICROPHONE WITH SELF-SUPPORTING STANDARD RECESSED IN BACK

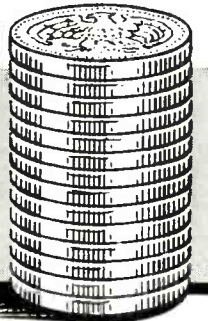

CRYSTAL
Model 302
List Price \$10.50
—47 db with 8' cable

CERAMIC
Model 301
List Price \$10.00
—54 db with 8' cable

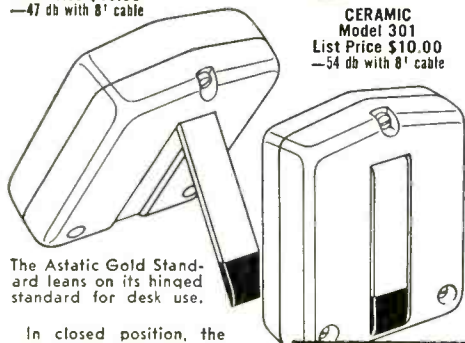

The Astatic Gold Standard leans on its hinged standard for desk use.

In closed position, the metal standard with protective plastic foot is recessed. fits flush with the microphone housing for maximum convenience in hand use.

This exclusive, new Astatic microphone design—with metal standard which hinges in and out of its recess in back—sets a new standard for convenience of use as well as for performance quality. You will be amazed at the rich, full trueness of tone . . . actually unprecedented in the Gold Standard's price range. Only Astatic engineering and Astatic precision mass production could make possible so much quality of microphone design and construction for so little. By any comparison, you can't do better than to put your microphone dollar on Astatic's new Gold Standard. Write for complete performance data, Catalog S-430.

EXPORT REPRESENTATIVE
401 Broadway, New York, N. Y.
Cable: Astatic, New York.

THE
Astatic
CORPORATION
CONNEAUT, OHIO
IN CANADA: CANADIAN ASTATIC
LIMITED, TORONTO, ONT.

FKB UHF ANTENNA

New light weight Model F550 UHF parabolic Opticon is claimed to have perfect front-to-back ratio

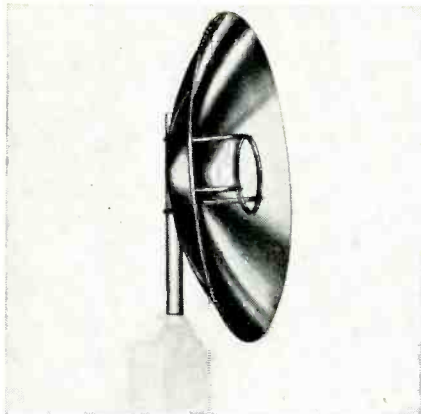

with no side pick-up. It is constructed of spun aluminum, weighs 2¼ lbs., and matches 300 ohm line. \$19.95. The FKB Opticon Co., 1738 E. Calvert St., South Bend 14, Ind.—TECHNICIAN

Walsco FEED-THRU BUSHING

An improved universal feed-thru bushing, designed for use with all standard TV lead-in wires, is made of Tenite butyrate plastic. Ivory or brown butyrate end plates, with rubber grommet centers are attached at the end of the bushing with set screws. Installed in the wall through a ¾ in. drilled hole. It is adaptable to walls up to 16 in. thick. Walter L. Schott Co., 3225 Exposition St., Los Angeles 18, Calif.—TECHNICIAN

Dynamic INDOOR ANTENNA

The Tentenna is equipped with 10 switch-selected tuned circuits for VHF and UHF TV, as well as AM-FM radio. Manufacturer says no

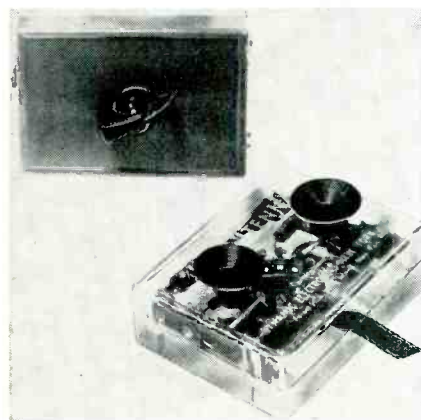

orientation is needed. Suction cups permit concealed mounting without special tools. Comes in choice of colors. List price, \$4.95. Dynamic Electronics-New York, Inc., Forest Hills, Long Island, N. Y.—TECHNICIAN

Adelco WAVE TRAP



Designed especially to eliminate adjacent channel interference, the Hi-Q wave trap is available in four models to cover the VHF band. Advance Electronics Co., Oak Park, Mich.—TECHNICIAN

INDOOR TV ANTENNA

The Picture Clear antenna is a UHF-VHF indoor antenna built into a polished mahogany picture frame. Two completely separate antennas, each with its own set of leads, allow coverage of both TV bands. Price \$9.95. Abbey-Graham Electronics, 1754 State St., East St. Louis, Ill.—TECHNICIAN

HOTTEST IN THE FRINGES.. NATION-WIDE! CLEAR BEAM'S BIG

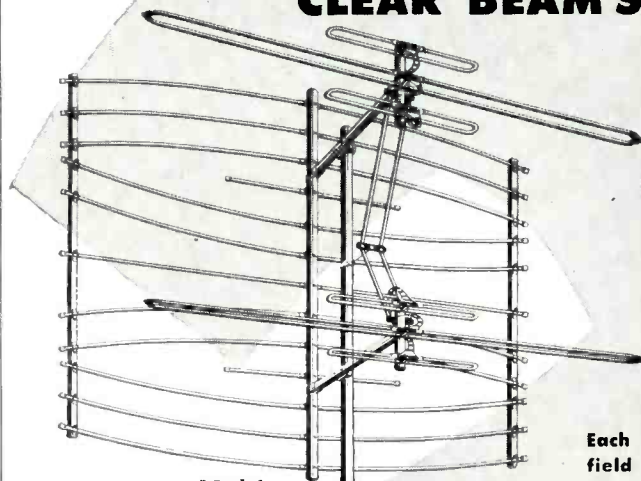

Model TK1500

TRI-KING

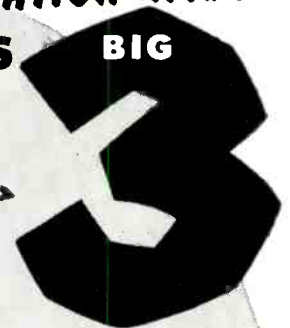

ALL-BAND FRINGE ANTENNAS

Each a peak performer in its field . . . a triple threat to any fringe problem . . . with more dollar-for-dollar construction value!

The Tri-King TK1500 offers super fringe performance through better design features. Half wave electrical spacing between dipoles for higher gain on every channel. Positive "back up action" through the use of a full radar screen . . . acclaimed industry-wide as the finest reflector ever designed for ghost rejection and elimination of co-channel

interference! Fully wind tunnel tested. Available in single bay (Model TK1000) and Super, wide spaced array (Model TK1800).

Clear Beam
BIG CHIEF
2 Bay Model BC 12-2

An advanced conical-Yagi with element diameters varied for precision tuning, matched sensitivity and peak performance on high and low band!

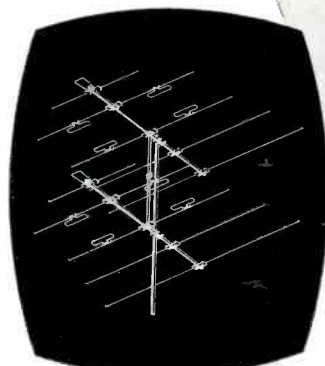

Clear Beam
HUNTER

2 Bay Model MYH 50-2

New wave trap principle gives extremely high gain, sharp directivity, in-phase tuning on all channels. New, flat design for low wind resistance!

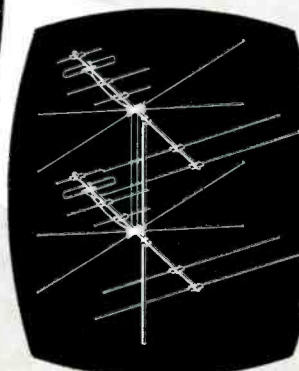

B CLEAR ANTENNA CORP. **BEAM**

Canoga Park, Calif. • Chicago, Ill.
affiliated with TEMPO TV products

Warehouses in Seattle, Portland, San Francisco, Honolulu, Dallas, Kansas City, Chicago, Detroit, Baltimore

I'D RATHER USE TUNG-SOL TUBES



There's every reason why servicemen feel this way. Tubes they need they can get. Quality is always uniform—always up to set manufacturers' specs. Callbacks are rare. It's more profitable for servicemen to use Tung-Sol Tubes.

TUNG-SOL®

dependable

PICTURE TUBES



TUNG-SOL ELECTRIC INC., Newark 4, N. J.
Sales Offices: Atlanta, Chicago, Columbus,
Culver City (Los Angeles), Dallas, Denver,
Detroit, Newark, Seattle.

Broadband Yagi Design

By HAROLD HARRIS
Channel Master Corp.

In launching a development project on a new antenna, the stringent requirements of color TV had to be taken into account: very high gain, uniform response, narrow polar patterns and high front-to-back ratios. A review of existing designs revealed that the yagi meets all of these requirements but one, that of flat broad-band response. In addition to its sharp directivity and high gain, it permits compact, economical construction and results in a straight in-line design. The latter factor provides ease of assembly, clean appearance and a physically convenient installation. The fundamental problem, then,

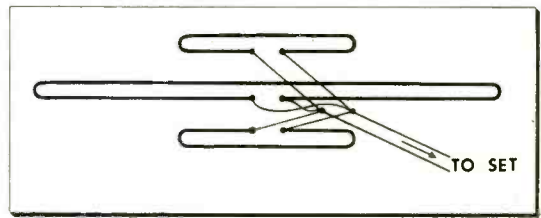

Fig. 1—Physical configuration of the basic broad-band VHF tripole.

was to combine all-channel coverage with yagi principles, while avoiding deterioration of yagi performance that takes place when compromise designs are attempted.

The first step was the selection of a broad-band driven element. For this the tripole, introduced last year, was chosen. Illustrated in Fig. 1, the tripole combines a folded dipole tuned to the low band, channels 2—6, with two dipoles tuned to channels 7—13. This configuration takes advantage of the fact that the third harmonic of the low VHF band (channels 2—6, 54—88 mc; 3rd harmonic, 162—264 mc) more than covers the high band (channels 7—13, 174—216 mc). As connected by the special phasing and matching harness, this assembly gives efficient dipole operation on the low band and functions as three dipoles in phase, with increased gain, on the high band.

The next step was a reconsideration of the choice of reflectors and directors, together with their spacing, as used in yagi systems. In attempting to broaden the band-

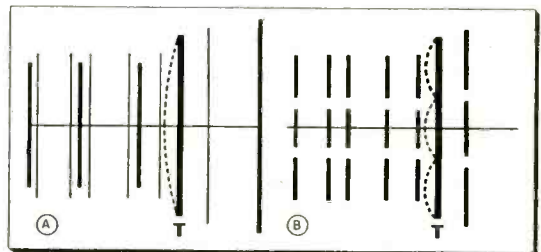

Fig. 2A—Yagi using a tripole, T, as the driven element. Low-band parasitic system is shown by heavy lines, high-band system in light outline. B—High-band operation. Low-band elements are not shown.

width of the yagi, many antenna engineers in the past had started out with conventional spacing formulas, then compromised the optimum single-channel spacings thus arrived at. In this case, an attempt was made to develop new spacing relationships. The somewhat unorthodox disposition of parasitic elements, as compared to conventional yagis, may be seen in Fig. 2A.

One interesting result of the configuration is that two

High Gain and Sharp Directivity Can Be Combined with All-VHF Coverage

parasitic systems, instead of one, are used. Those elements appearing in heavy outline act as reflectors and directors on the low band in conjunction with the driven element, tripole T. The parasitic system for the high band is shown in lighter outline. Actually, the high-band elements are not single, continuous conductors. Each one is a series of three segments connected in a straight line. Operation on the high band is illustrated in Fig. 2B, where the low-band elements have been removed for the sake of clarity. Since the tripole itself acts as three in-phase dipoles, the effect achieved is that of three high-band yagis, mounted side by side.

No Cross-Band Interaction

The development of new element-spacing relationships, while important in producing the desired broadband characteristics, was significant in another direction. With two parasitic systems intermixed on the single crossarm, it was important to prevent any interaction between these systems that might reduce efficiency on either or both bands. The problem was not serious on the low band, since the shorter high-band elements had no significant effect on the low-band system. However, the opposite was not the case. High-band directors were therefore placed quite close to low-band directors, as

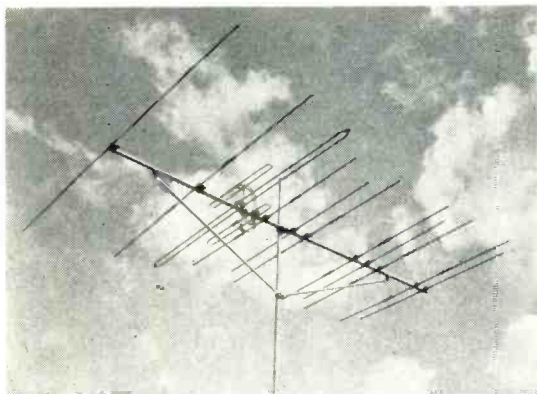

Fig. 3—Commercial example of the tripole-yagi VHF combination.

may be seen in Figs. 2A and 3. When operating on channels 7—13, the former system thus “robbed” current from the latter.

In its final form, the combination tripole-yagi antenna provides several desirable characteristics. The use of new dimensions and spacing relationships permit the incorporation on a single crossarm of separate systems for each of the two VHF bands; and use of the tripole as the driven element results in uniform yagi performance broad-banded through channels 2 to 13. Sharp narrow-lobe directivity with high gain are retained. As compared to earlier tripole antennas, the new design shows an improvement. In preceding designs, the tripole is backed up by a screen reflector. Although such screens are relatively non-sensitive with respect to frequency, optimum spacing between the driven element and the screen itself varies from channel to channel. Placement of the screen therefore necessitates a compromise, which has been avoided in the development under discussion.

Commercial versions of the triple-powered yagis now reaching the market are being called Rainbow antennas. One version is illustrated in Fig. 3.

I'D RATHER YOU WOULD



Customer confidence in local servicemen is due in large measure to the dependability of the products they use. Tung-Sol maintains quality standards that build up the local serviceman in his community.

TUNG-SOL[®]

dependable

TUBES—DIAL LAMPS

TUNG-SOL makes All-Glass Sealed Beam Lamps, Miniature Lamps, Signal Flashers, Picture Tubes, Radio, TV and Special Purpose Electron Tubes and Semiconductor Products.



Look to



...the only full line of phonomotors!

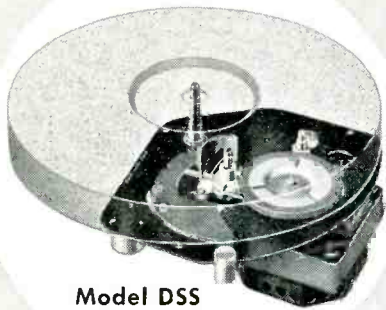

Model DSS
33 1/3-45-78 r. p. m.

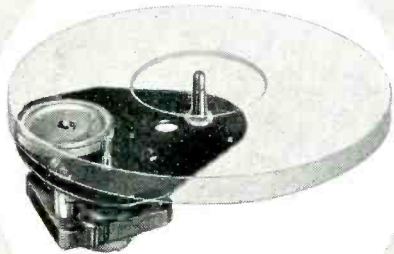

Model AX
78 r. p. m.

There's no problem in selecting the phonomotor that *best* meets your requirements when you choose from the GI Smooth Power line. It's the most complete line in the industry...backed by the fifty-one-year-old reputation of America's leading manufacturer of phonomotors, recording motors, tape-disc recording assemblies and disc recording assemblies.

HIGHEST QUALITY—Model DSS

4-pole motor, 115 volts a. c., 60 cycles
For three-speed applications in which compactness is secondary to need for absolute minimum of stray field radiation. Ideally suited for all types of pickups, including magnetic.

Features include precision construction throughout, oilless motor and turntable bearings, dynamically balanced rotor. Moving lever to "OFF" position automatically disengages idler wheel from motor shaft, and cuts off current.

LOWEST COST—Model AX

2-pole motor, 115 volts a. c., 60 cycles
Low-priced, single-speed, rim-drive motor suitable for installations where size and cost are prime factors. Incorporates features found in more expensive motors.

OTHER MODELS

A complete line of 78 r. p. m., two-speed and three-speed motors. The popular Model SS (not shown) is a compact 3-speed phonomotor incorporating the vertical idler shift principle and shift lever which disengages idler wheel from motor shaft during non-operating periods.



Write for catalog containing dimensions and specifications of these and many other single-speed, dual-speed and 3-speed models in the Smooth Power phonomotor line.

THE GENERAL INDUSTRIES CO.
DEPARTMENT MD • ELYRIA, OHIO

News of the Industry

Ungar to Head Parts Show

Leon B. Ungar, of Ungar Electric Tools Inc., Venice, Calif., was elected president of the Radio Parts & Electronic Equipment Shows Inc., at the annual meeting of the Board



of Directors in Carmel, Calif. Ungar succeeds Harry A. Ehle of International Resistance Co.

The association sponsors the annual Electronic Parts Show, the 1955 version of which will be held May 16-19 in Chicago.

CBS-Columbia Names Kaplan

Sidney Kaplan, former Electronics Service manager for Gerald O. Kaye & Associates, has taken over as service manager for CBS-Columbia Distributors Inc., the factory distributing branch for CBS-Columbia television and radio receivers.

B-T Expands Facilities

Blonder-Tongue Labs Inc., manufacturers of master TV systems and UHF converters, have expanded the capacity of their Westfield, N. J. plant to 50,000 sq. ft., with the opening of a second plant nearby.

At the same time, it was announced that a Sales-Engineering Div. has been created to provide field service for master installations. The company is also planning regular technical meetings to acquaint dealers and servicemen with the sales potential of such systems.

RCA Opens 3 West Coast Antenaplex Sales Offices

The RCA Service Co. has opened three offices in the West Coast area to handle sales of RCA Antenaplex TV distribution systems.

For the Pacific Northwest, an office has been located in Seattle, at

Faster, Easier, more PROFITABLE Operation

Get into the MASTER habit!

Brings you the product data of the industry in one handy book—all products vital to your daily sales and service operations. In the customer's home, across the counter or on the bench, you'll value the MASTER'S thoroughly complete descriptions, specs, illustrations and prices...all systematically organized in 18 big sections. Over 1300 pages of unabridged catalog data direct from the manufacturers. Keeps you abreast of all latest electronic products. Increase your sales and speed-up your buying—the MASTER way.

As **\$1.95** at your parts distributor. Publisher's price **\$6.50**.

OFFICIAL BUYING GUIDE OF ELECTRONICS-TV-RADIO-INDUSTRY

- 1370 pages
- 8" x 11"—5 lbs.
- Over 8,000 illus.

Just a few of the more than 85,000 items included:

- Tubes—Transmitters
- Test Equip.—Receivers
- Transformers
- Capacitors—Antennas
- Resistors—Wire & Cable
- Coils & Relays
- Recording & PA Hardware & Tools

Get your MASTER now from leading parts distributors or write to:
United Catalog Publishers, Inc., 110 Lafayette St., N. Y. 13

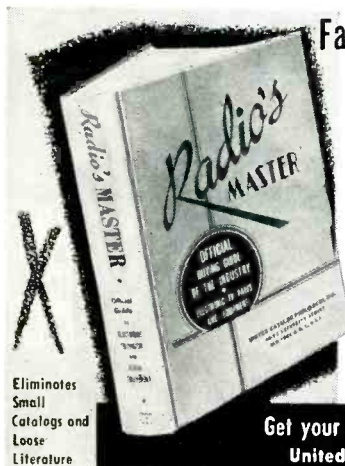

Eliminates Small Catalogs and Loose Literature

718 Dearborn St. under Edward Long, former Antenaplex rep in Southern California.

Another office is located in Hollywood, at 911 N. Orange Drive, managed by Warren Burr. This office serves Southern California.

The third office, covering Northern California, has been located at 2640 Bayshore Blvd., San Francisco. Edward Norton is Antenaplex rep in this area.

New Hi-Fi Tweeters

The development of new designs in efficient high-frequency transducers that can be mass-produced have been announced by Philco and Columbia Records. Both sources are incorporating their recently developed tweeters in their latest lines of home phonographs.

The kilosphere speaker, incorporated in the latest Columbia "360" phonographs, is a perforated metal oblong with hundreds of tiny apertures, encased in a plastic foil. When applied audio signal sets the membrane in motion, each opening acts as a separate speaker. This eliminates the point-source effect common to conventional speakers, and permits wide-angle dispersion of undistorted high-frequency tones.

Philco's electrostatic speaker employs 16 vertical columns arranged to form a half cylinder. When excited, all 16 columns vibrate uniformly and in the same phase, dispersing clean upper-range sound over an angle of 180 degrees.

Millionth Transistor

A milestone was heralded at the Raytheon plant in Newton, Mass., with the production of its millionth germanium junction transistor. Despite this large number now in use, company officials pointed out, the field failure rate is running less than 2 percent per year. A Raytheon spokesman foresaw production of power output and radio-frequency transistors late this year, with the first transistorized portable and pocket radios appearing in 1955.

READERS! We Want Your Side of the Story.

In December, **TECHNICIAN** will review developments during the past year in the field of parts and components. The things manufacturers have been doing to make your job easier will be highlighted.

We also want your side of the story to be heard. Let us know which new product features you have liked, which design changes have helped you, which ones haven't. If you have any gripes, we want to hear those too. This is your chance to sound off to manufacturers with suggestions for improvements. But don't delay! If you want to be in on the December round-up, let us hear from you right away!

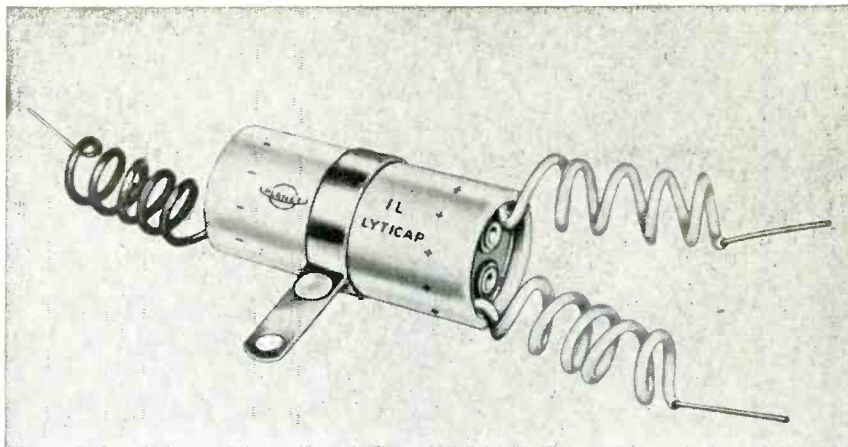

NEW DUAL SECTION ELECTROLYTIC CAPACITORS HERMETICALLY SEALED IN ALUMINUM TUBES WITH COMPLETELY FLEXIBLE INSULATED LEADS. By riveting the leads directly to the condenser end disc, Planet has eliminated the use of rigid terminal risers ordinarily used on this type construction. This allows Planet Type IL capacitors to fit into a smaller space and eliminates the possibility of lead breakage.

"ENGINEERED FOR QUALITY"
GUARANTEED FOR ONE YEAR

PLANET MANUFACTURING CORPORATION
225 BELLEVILLE AVENUE
BLOOMFIELD, N. J.

Write for Catalog 200—Lists Specifications on Stock Items

THE NEW MODEL TV-11

TUBE TESTER



- Uses the new self-cleaning Lever Action Switches for individual element testing.
- Because all elements are numbered according to pin number in the RMA base numbering system, the user can instantly identify which element is under test. Tubes having tapped filaments and tubes with filaments terminating in more than one pin are truly tested with the Model TV-11 as any of the pins may be placed in the neutral position when necessary.
- Uses no combination type sockets. Instead individual sockets are used for each type of tube. Thus it is impossible to damage a tube by inserting it in the wrong socket.
- Free-moving built-in roll chart provides complete data for all tubes.
- Phono jack on front panel for plugging in either phones or external amplifier detects microphonic tubes or noise due to faulty elements and loose external connections.

EXTRA SERVICE—The Model TV-11 may be used as an extremely sensitive Condenser Leakage Checker. A relaxation type oscillator incorporated in this model will detect leakages even when the frequency is one per minute.

Operates on 105-130 Volt 60 Cycles A.C. Hand rubbed oak cabinet complete with portable cover **\$47⁵⁰**

SHIPPED ON APPROVAL
NO MONEY WITH ORDER — NO C. O. D.

Try it for 10 days before you buy. If completely satisfied send \$11.50 and pay balance at rate of \$6.00 per month for 6 months.—No Interest or Carrying Charges Added. If not completely satisfied, return to us, no explanation necessary.

MOSS ELECTRONIC DISTRIBUTING CO., INC.
Dept. D-71, 3849 Tenth Ave., New York 34, N. Y.
Please rush one Model TV-11. I agree to pay \$11.50 within 10 days after receipt and \$6.00 per month thereafter.

NAME
ADDRESS
CITY ZONE STATE

5
CORES
OF
ERSIN
FLUX

in **ERSIN**
Multicore
**WORLD'S FINEST
CORED SOLDER
ON WOODEN SPOOL**

Ready Now
ON YOUR
JOBBER'S
COUNTER

ASK FOR
NEW
50c
**SERVICE
PAK**

EXTRA VALUE! Unlike other low cost, haphazard solder packages, the MULTICORE SERVICE PAK features a convenient wooden spool, and—important to you—length of wire, alloy and gauge is clearly marked on every 50c SERVICE PAK!

Also available in 1 lb. cartons and 7 lb. reels:

MULTICORE SALES CORPORATION, 164 Duane St., New York 13, N. Y.

FREE 

**1955
308-PAGE
ALLIED
ELECTRONIC
SUPPLY
CATALOG**

Send for it

*Everything in Electronics
For Service Technicians and Engineers*

Get the complete, up-to-date 1955 ALLIED Catalog. It's packed with the world's largest selection of TV and radio parts and accessories, test instruments, Hi-Fi systems and components, P. A. systems, tubes, tools—everything for service work and industrial electronic application. Depend on ALLIED for fast shipment from the world's largest stocks—save time and money. Send today for your FREE 308-page ALLIED Catalog.

ALLIED RADIO CORP., Dept. 25-K-4
100 N. Western Ave., Chicago 80, Ill.

Send FREE 1955 ALLIED Catalog

Name _____
Address _____
City _____ Zone _____ State _____

The
ASD
Model TV-20

**TELEVISION
Tube Tester**

- no roll chart
- practically no set-up
- 20 connected sockets

write for details or
see your distributor

AMERICAN SCIENTIFIC DEVELOPMENT CO.
374-376 S. MAIN ST.
FT. ATKINSON WISCONSIN

Tough Dogs

(Continued from page 34)

the whistle re-appeared on the first try.

The recorder was taken back to the shop and thoroughly checked for two days. Since nothing wrong could be found, it was returned to its owner again. The first check in the home was made with the tuner connected to the recorder, but before the latter was put back into its normal mounting. No note was heard. When the recorder was returned to its mounting, the note was heard again. This suggested some sort of interaction between the two units, although each one by itself was operating normally. The whistle was finally eliminated when the recorder's high-frequency bias oscillator was adjusted to shift its frequency slightly. It seems that, on certain stations, the bias oscillator was beating with the tuner oscillator to produce a tone in the audible range that was being passed through the system.—George S. Lehsten, Teaneck, N. J.

Inside Resistive Controls

(Continued from page 28)

after removing the C-washer around the neck of the shaft, the complete control is disassembled.

Open controls occasionally result from poor wiper action or grit between the arm and composition. These two possibilities should be checked. For an actual open in the composition, it is far wiser in this case, to replace the unit, since proper operation depends on utilization of the complete resistor. The use of graphite, as found in soft pencils, to fill in the burned sections is a common practice but can be recommended only for temporary repairs.

For the rheostat-connected control, however, there is a very good chance of returning the old device to full efficiency. Once the condition which caused the excessive current is repaired, we need only check to see whether the undamaged part of the control provides sufficient range for operation. If not in one direction, try it with the control electrically turned around—that is, with the end terminals reversed.

Shorted Controls

Centering, focus, height and brightness controls are most likely to short, due to the high potentials

a bear for punishment



C-D does it again with its new Cub

Outperforms any other molded tubular



- * A better-looking tubular with
- * A better humidity seal.

Get more for your money by insisting on C-D's new "CUB-KIT".

For your nearest C-D authorized jobber see the Yellow Pages of your Classified Phone Book. Write for Catalog to: Dept. RT104 Cornell-Dubilier Electric Corporation, South Plainfield, New Jersey.

CONSISTENTLY DEPENDABLE

CORNELL-DUBILIER CAPACITORS



There are more C-D capacitors in use today than any other make.

PLANTS IN SO. PLAINFIELD, N. J.; NEW BEDFORD, WORCESTER AND CAMBRIDGE, MASS.; PROVIDENCE AND HOPE VALLEY, R. I.; INDIANAPOLIS, IND.; SANFORD AND FUGUAY SPRINGS, N. C. SUBSIDIARY: RADIART CORP., CLEVELAND, OHIO

applied between their terminals and the shaft. When we consider that the control is originally designed to withstand a difference of 1,000 v between the shaft, or ground, and the wiper arm, the futility of trying to repair these units becomes apparent. It would be very difficult to duplicate the original insulation. In this case, replacement is by far the wisest course.

A quick check on whether the control is shorted is made by simply unscrewing the collar around the bushing and removing the control from the chassis.

Even as an emergency measure, do not try to insulate the control from the chassis. The voltage that caused the breakdown is still on the shaft, which means a nasty shock for you or the next serviceman.

Other Tips

If you are up against a persistently noisy volume control and even replacement does not seem to help too much, check to see whether any dc is being developed across the pot. On some older sets, the design engineers goofed, and as much as 4 or 5 v may be read across the control. Putting a .01 in series with the pot should clear it up.

Saving old controls can get you off the hook with some difficult customers. This applies particularly to those dual controls incorporating a switch. It is very easy to replace the defective section. This is also the basis for the line of replaceable sections and switches now available from some of the top manufacturers from which you can make any combination of concentric controls, including an on-off switch. The latter is a must for any home-servicing kit.

In replacing vertical lin pots, use a wire-wound control where possible. It costs only a few cents more and guards against the day when some tech in search of more height replaces the vertical output tube with a "hot" version (such as a 6W6 for a 6K6) causing excessive current to flow in the linearity pot.

For home servicing, these four controls should take care of the most common troubles: a 5-meg height control; a 5,000-ohm vertical lin pot; a 4-watt wire-wound focus pot of 1,500 or 2,500 ohms and a 1-meg volume control, with on-off switch.

BOB MILLER SALES CO., 805 Eldorado, Clearwater Beach, Fla., and Dave M. Lee Co., 2517 2nd Ave., Seattle, Wash., have been appointed to represent Condenser Products Co. In addition to covering Washington, Lee will also rep in Idaho, Montana and Oregon.

There are more C-D capacitors in use today than any other make.

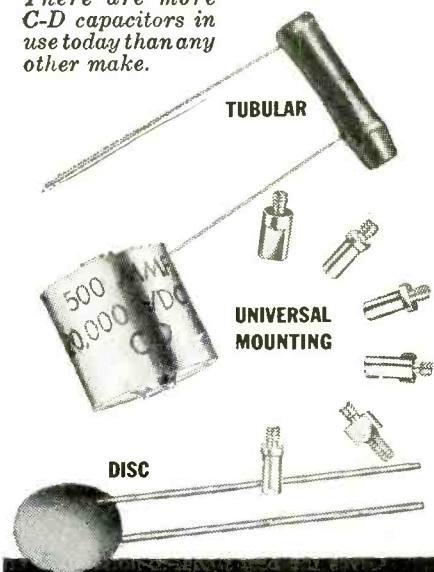

There's a C-D ceramic with the "Million Dollar Body" for every requirement

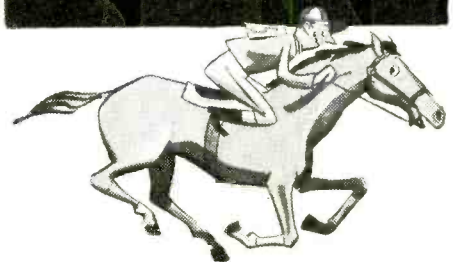

Every one a winner

A line of the most popular, fast-moving sizes, in both general purposes and temperature compensating types. Ask your C-D jobber about them today! He's listed in your local Classified Telephone Directory. For catalog write to Dept. RT104, Cornell-Dubilier Electric Corp., South Plainfield, New Jersey

CONSISTENTLY DEPENDABLE

CORNELL-DUBILIER CAPACITORS



PLANTS IN SO. PLAINFIELD, N. J.; NEW BEDFORD, WORCESTER AND CAMBRIDGE, MASS.; PROVIDENCE AND HOPE VALLEY, R. I.; INDIANAPOLIS, IND.; SANFORD AND FUGUAY SPRINGS, N. C. SUBSIDIARY: RADIART CORP., CLEVELAND, OHIO

Never before such
CLEAR TV RECEPTION
 for fringe areas
The "DE-SNOWER"
PREAMPLIFIER

Get beautifully clear TV reception where boosters have failed. Mounted at the antenna, the "De-Snower" amplifies the signal—not the snow . . . lets you locate antenna for best reception . . . use long, low-noise coax lead-ins or thousands of feet of open-wire or ribbon line.

The "De-Snower" is the heart of Jerrold's famous community TV systems which serve as many as 5,000 TV receivers from a single antenna. Sensitive, maintenance-free cascode circuit using 6BQ7-A's, 6AK5, & 6CB6 tubes combines a whopping 25 db gain with extremely low noise—only 6 db. Gives the best signal-to-noise ratio attainable in any fringe area.

Leading parts distributors stock the "De-Snower" in two models—Channels 2-6 or 2-13. Flat response for color.

There's PROFIT in MULTIPLE INSTALLATIONS

. . . for apartments, clubs, motels sell the "De-Snower" Distribution Amplifier. 8-outlets, extremely low noise cascode circuit. 15 db gain—like having a pre-amplifier at each outlet. 72 or 300 ohm inputs from 1 all-band antenna or separate high-low arrays or from "De-Snower" Preamplifier.



JERROLD ELECTRONICS CORP.
 26th & Dickinson Sts. • Philadelphia 46, Pa.

JERROLD

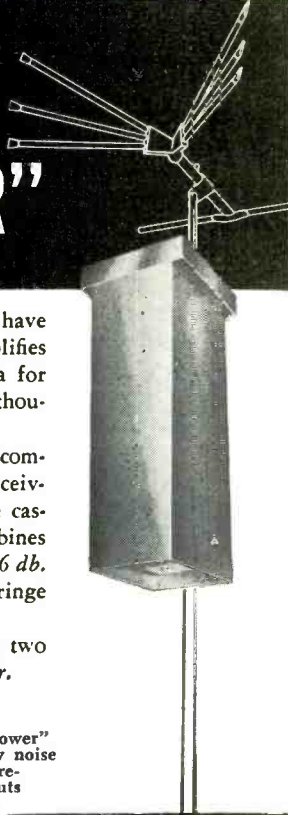

Vacuum-Tube Voltmeter

(Continued from page 21)

range switch. An internal battery (in some cases, an internal power supply) is used as a supply voltage for the ohms circuit. The amount of voltage developed across the fixed resistor—i.e., the input voltage—depends on the value of the unknown resistance in the external circuit. A short-circuit will reduce this voltage (and consequently the meter reading) to zero. Such a short-circuit is introduced deliberately (by shorting the ohms leads together) to balance the bridge, with the zero *adjust* on the *ohms* function.

A calibration resistor of ohms is switched into the meter circuit exactly as it is for volts (refer back to Figs. 4 and 5). This calibration resistor is a front panel adjustment, and is usually marked *ohms adjust*. It is used to set the meter needle to the end of the scale, with no external resistance present across the input terminals.

AC Volts Function. The ac volts function utilizes the basic dc voltmeter circuit more completely than the ohmmeter function does. Basically, the input ac voltage is converted to a dc voltage by rectifier action; the range section serves as the load resistor for the rectifier; it also provides a voltage-divider action, permitting voltages in excess of the grid base to be measured. On the lowest scale(s), the range switch may incorporate compensating resistors, to counteract the non-linearity of the rectifier; or a special low-voltage scale may be inscribed on the meter face, for readings on these lower ranges.

A simple single diode rectifier is not used in voltmeters, because such a circuit would cause a change in reading when the input leads (carrying the ac voltage to be measured) were reversed. This effect is known as "turnover." A balanced type of double rectifier is used instead. A balancing control (factory adjustment) is incorporated. The control is adjusted to minimize "turnover." A blocking condenser at the input terminal permits only ac to be applied to the diode rectifier. A calibration resistor is used to calibrate the ac function.

FREDERICK I. KANTOR has given up his own reps firm to become national sales manager of the Electro-Magnetic Products Div., Technical Tape Corp, Morris Heights, N. Y., manufacturers of Encore magnetic recording tapes.

KESTER

Since the most important single step in Radio-Television Servicing is soldering . . . it's just plain good sense to use the best — KESTER SOLDER . . . Key Name in Solder for More Than 50 Years.

KESTER SOLDER COMPANY
 4264 Wrightwood Avenue • Chicago 39, Illinois
 Newark 5, New Jersey • Brantford, Canada

SOLDER

**INTERNATIONAL
RECTIFIER
CORPORATION**

EL SEGUNDO
CALIFORNIA

**RADIO TV
TYPE
SELENIUM
RECTIFIERS**

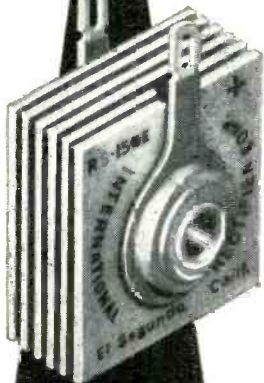

**NOW
AVAILABLE
AT
YOUR
FAVORITE
JOBBER**

**Widest Range
in the Industry**

Ask for Bulletin JRP-2

**INTERNATIONAL RECTIFIER
CORPORATION**

1521 E. Grand Ave., El Segundo, Calif. • Phone: URagon 8-6281
CHICAGO: 205 W. Wacker Drive • Phone: Franklin 2-3889
NEW YORK: 50 Madison Avenue • Phone: Plaza 5-8665

**MFRS' Catalogs &
Bulletins**

ARKAY RADIO KITS: Catalog RK-55 describes a line of educational and hobby kits ranging from a single-band T.R.F. to a six-band receiver covering 550 kc to 22 mc. Also included are vtvm's, signal generators and multi-testers in kit form. For free copy, write Radio Kits Inc., 120 Cedar St., New York 6, N. Y.

RCA RECEIVING TUBE MANUAL: Basic technical data on more than 500 entertainment-type electron tubes, including 67 new tube types introduced since 1950, are contained in this new 1954 edition, No. RC-17. New features include: a tube classification chart, by application as well as by tube number, and expanded text material. Available at 60¢ from RCA tube distributors or from Commercial Engineering, R.C.A. Tube Division, Harrison, N. J.

INTERNATIONAL RECTIFIER DIODES: Bulletin GD-1A, 4 pages, lists ratings and specifications on a line of germanium diodes. Includes a complete replacement guide for replacing RETMA type diodes, and characteristics for new "Red Dot" diodes for 100° applications. Write to: International Rectifier Corp., 1521 E. Grand Ave., El Segundo, Calif.

ASTATIC CATALOG: A full line of phonograph pickups and needles, cartridges, recording heads, microphone stands, UHF-TV converters and boosters is described in a new catalog released by The Astatic Corp., Conneaut, Ohio.

NEW BOOKS

AUTO RADIO MANUAL—5A. Published by John F. Rider Publisher Inc., 480 Canal St., N. Y. 13, N. Y. 208 pages; \$3.00, paperbound.

Fifth in the specialized series of Rider Manuals dealing with auto radios, this volume contains servicing information on automobile radio receivers produced over the period 1950-54 for Henry J, Hudson, Kaiser-Frazer, Nash, Packard, Studebaker, and Willys.

TV FIELD SERVICE MANUAL. By H. A. Alsborg. Published by John F. Rider Publisher, Inc., 480 Canal St., N. Y. 13, N. Y. 147 pages; \$2.40, paperbound.

Second in the series of TV field service manuals, this edition covers the receivers manufactured by Bendix, Capehart, CBS-Columbia, Crosley and Dumont, from 1947 to 1953. Emphasis is placed on information necessary to make repairs on these sets in the home. Tube layout charts, information on adjustments and data on key voltage and resistance readings are stressed for that reason. A list is also provided of stock troubles which may be encountered with each set.

**INTERNATIONAL
RECTIFIER
CORP.**

Brings You A Chance to Win A
FREE FORD V-8
Plus 49 Other Big Prizes

Selenium Diode

Application Contest

INTERNATIONAL RECTIFIER CORPORATION'S Selenium Diode Application Contest is open to you. Here is a chance to cash in on your ability and ingenuity.

Just illustrate and explain a new application for International Rectifier Corporation's SELENIUM DIODES.

Pick up an official entry blank from your Parts Distributor. He has one or will be glad to get one for you. Have the entry blank countersigned by your Distributor's Salesman and send it to us before January 1, 1955. The entry blank will give you all the rules and information.

Our Judges

DR. LEE de FOREST
United Engineering Labs, L. A.

J. T. CATALDO
Int'l. Rectifier Corp, El Segundo

F. W. PARRISH
Int'l. Rectifier Corp, El Segundo

For Entry Blanks

See Your

PARTS DISTRIBUTOR

Your Ability and "Know-How"
Can Win A

FREE FORD FOR YOU!

**GET YOUR ENTRY BLANK
TODAY!**

**CONTEST ENDS
JANUARY 1, 1955**

INTERNATIONAL RECTIFIER

C O R P O R A T I O N

EL SEGUNDO

CALIFORNIA

Video I-F Stages

(Continued from page 17)

elusive partner in crime, the resistive oxide path between turns, often give trouble. A permanently-shortened turn will shift the transformer frequency range, but the intermittent short, the arcing case, whether in the grid or plate circuit, produces noise streaks in the picture resembling auto ignition interference. In the sound channel, the trouble manifests itself by "static" noise. A resistive path between adjacent turns will generally result in sound bars in the picture, since the effective parallel resistance broadens the over-all frequency response characteristic of the transformer.

The bifilar i-f transformer shown in Fig. 3 has the advantage of a high degree of coupling between coils, but the desired proximity of windings introduces a serious disadvantage. Unless the coils are insulated before winding, and the entire assembly well impregnated, there is a great tendency for shorts to occur between the coils.

Video I-F Hum. A cathode-to-

heater leak in any video i-f tube will produce effects ranging from one or two black bars on the screen, to a very dark image, with complete loss of synchronization. The hum appears in the sound as a harsh rasping buzz. Hum in agc, r-f and video stages will often produce the same symptoms.

Clipping Troubles. An amplifier that is operating too high up on its characteristic curve will be saturated when fairly large input signals are applied at its input. This means that signal information present at the top of the input waveform is limited or chopped off, and is absent from the output waveform. Video i-f signals are amplitude-modulated, with the sync signals riding the top of the waveform. Should any video i-f tube act as a limiter, the synchronizing pulses will be lost. Amplifier saturation resulting in limiting may be caused by low plate voltage, a leaky coupling capacitor, primary-to-secondary leakage in transformer-coupled circuits, or loss of grid bias due to an open dc return between grid and ground.

Sync Separation in Video I-F Stages. There is a (desired) form of clipping which destroys the low-

level portion of the signal, permitting only the high positive signal peaks to be reproduced. This type of limiting takes place, of course, in the sync separator circuit. The tube is biased close to cut-off, necessitating the presence of a large positive-going signal at the grid to produce any output at the plate.

Sync separation ordinarily takes place after the composite video signal has passed the video detector stage. Suppose, however, that one of the video i-f amplifiers is acting as a "sync separator?" Only the sync pulses and some of the black-level video information will appear in the output under such circumstances; the rest of the signal will be dissipated in the grid circuit. At best, a very dark picture will be seen, with all the white and most of the grey areas reproducing as black. Such cut-off limiting in intercarrier systems will destroy the sound as well as the video signal.

An increase in grid-to-ground resistance, reduction in plate voltage or increased cathode resistance, any condition, in fact, which will increase the grid bias to a point approaching cut-off, can result in the clipping of all but positive composite signal peaks.

Miller

ADJUSTABLE

ION TRAP

Efficiency

PLUS!



The Miller #6295 Adjustable Ion Trap is made to replace any single ion trap with gausses from 32 to 55. Most old picture tubes would give better pictures if the old ion traps were replaced and adjusted to proper gauss.

This Miller #6295 Adjustable Ion Trap, like all 850 Miller television and radio replacement parts, is unconditionally guaranteed. These adjustable ion traps may be bought singly or in an attractive counter display carton of 24 units.

Catalog No.	Description	Net Price
6295	Adjustable Ion Trap	.75

SOLD BY ALL LEADING RADIO AND TELEVISION PARTS DISTRIBUTORS
Write for General Catalog 55

J. W. MILLER COMPANY
5917 South Main Street • Los Angeles 3, California

Canadian Representative: Atlas Radio Corporation, Ltd. 560 King Street, W. Toronto 28, Canada

new Bogen UHF Design
traditional Bogen efficiency

NEW 'UCT-1' UHF CONVERTER

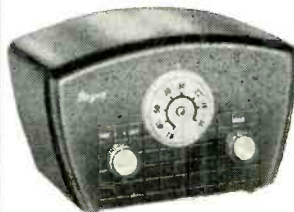

- better than competitive converters by a 6 db signal-to-noise ratio
- 6 db reduction in noise level means corresponding 6 db increase in signal level from antenna—clearer viewing
- maximum performance in all signal areas—often permits simpler antenna
- connects to any VHF set
- single-knob tuning runs entire UHF range, channels 14 to 83 inclusive
- complete with tubes, 4' of 300-ohm twin lead, instruction sheet... list \$42.50



"UHB,"
UHF
Booster,
list \$41.00



"G-Line," UHF Transmission line, list \$43.75 (kit includes: 2 launchers, 150 feet of special insulated wire, 2 stand-off brackets)

Bogen

See your distributor or write
DAVID BOGEN CO., INC.
29 Ninth Avenue, New York 14, N. Y.

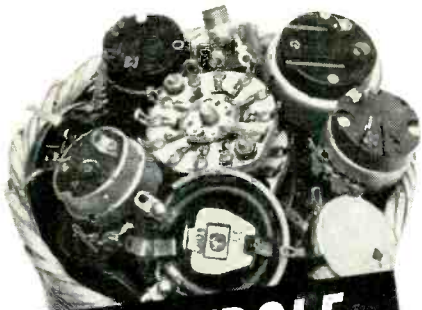

QUIETROLE
 Reg. U. S. Pat. Off.
The ORIGINAL
NON-INFLAMMABLE
NON-CONDUCTIVE
LUBRICANT CLEANER



CONTROLS & SWITCHES like new by the BASKETFUL for only a few PENNIES . . . that's what QUIETROLE can do for you, and only QUIETROLE will give that long lasting smooth, quiet operation . . . even new controls last longer and operate quieter when treated with QUIETROLE . . . the original and most reliable product of its kind.

THE CHOICE OF BETTER SERVICEMEN "EVERYWHERE"
 Supplied in 2, 4, and 8 oz. sizes. Ask for it at your distributor.



manufactured by
QUIETROLE
COMPANY
 Spartanburg, South Carolina



the one and only
"LITTLE GIANT"

LIGHTNING ARRESTER

Exclusive patented strain relief lips plus saw tooth contact design for fool-proof installation of all flat, tubular, oval and open-wire twin lead.

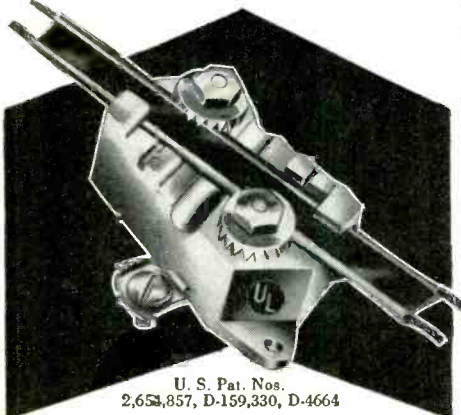

U. S. Pat. Nos.
 2,652,857, D-159,330, D-4664

No. **AT105** (for wall or window sill mounting) **\$1.25** list

No. **AT105S** (with stainless steel strap for universal mounting) **\$1.50** list

Look to JFD for Engineering Leadership
JFD MFG. CO., Inc., Brooklyn 4, N. Y.
 EXPORT DIVISION: 15 MOORE ST., N. Y. C.

ADVERTISERS INDEX
OCTOBER, 1954

Allied Radio Corp.	50
American Scientific Development Co.	50
Arco Electronics Inc.	40
Astatic Corp.	44
Bogen Co., Inc. David	54
CBS-Hytron Div., Columbia Broadcasting System, Inc.	5
Clear Beam Antenna Corp.	45
Cornell Dubilier Electric Corp.	51
Crosley Div., Avco Manufacturing Corp.	39
Crown Controls Co., Inc.	6
Du Mont Laboratories, Inc., Allen B.	9
Federal Telephone & Radio Co.	31
Finney Co.	10
General Industries Co.	48
International Rectifier Corp.	53
International Resistance Co.	Cover 2
Jensen Industries, Inc.	8
Jensen Manufacturing Co.	4
Jerrold Electronics Corp.	52
JFD Manufacturing Co., Inc.	55
Kester Solder Co.	52
Mallory & Co., Inc., P. R.	23
Miller Co., J. W.	54
Moss Electronic Distributing Co., Inc.	49
Multicore Sales Corp.	50
Philco Corp.	37
Planet Manufacturing Corp.	49
Precision Apparatus Co., Inc.	35
Quietrole Co.	55
Radiart Corp.	43
Radio Corporation of America	41, Cover 4
Raytheon Manufacturing Co.	12
Sarkes Tarzian, Inc.	33
Skyline Manufacturing Co.	56
Sola Electric Co.	55
Sprague Electric Co.	Cover 3
Sylvania Electric Products, Inc.	27
Technical Appliance Corp.	29
Tescon TV Products Co.	7
Tung-Sol Electric Inc.	46, 47
United Catalog Publishers, Inc.	48
United Motors Service Div., General Motors Corp.	2, 3
Walsco Electronics Corp.	25
Weller Electric Corp.	42
Weston Electrical Instrument Corp.	11

TV Voltage Trouble?

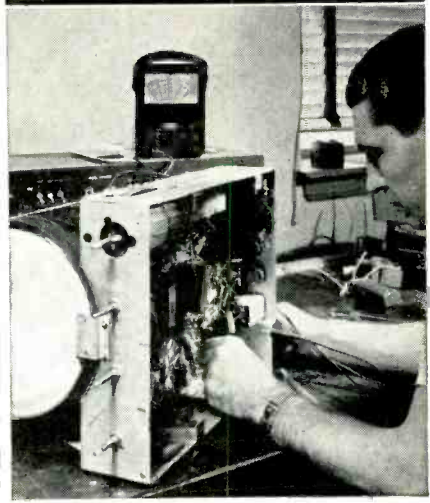

TeleVolt
AUTOMATICALLY
corrects fluctuating
line voltage

Low voltage causes poor television reception. If your customers' line voltage is bad, supply the television manufacturers' specified voltage by plugging in a SOLA TeleVolt Constant Voltage Transformer between the set and wall outlet. It will also protect costly components against damaging high voltage surges. The TeleVolt is a patented voltage regulator that automatically stabilizes voltage within $\pm 3\%$ with line fluctuations as great as $\pm 15\%$; it is not a voltage booster.

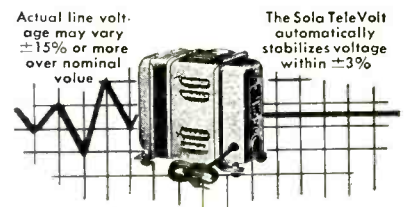

Actual line voltage may vary $\pm 15\%$ or more over nominal value

The Sola TeleVolt automatically stabilizes voltage within $\pm 3\%$

Write today for Bulletin 8J-CV-175 or see your electronic distributor

SOLA Tele Volt
Automatic Constant Voltage
TRANSFORMERS

SOLA ELECTRIC CO.
 4633 W. 16th St. Chicago 50, Ill.

While every precaution is taken to insure accuracy, we cannot guarantee against the possibility of an occasional change or omission in the preparation of this index.

CO-TRAP gives highest FRONT TO BACK RATIO of 5 major competitors!

introducing the all channel **SKYLINE IMPERIAL** with Co-Trap

AMAZING FRONT TO BACK RATIO TEST DATA

(DB)

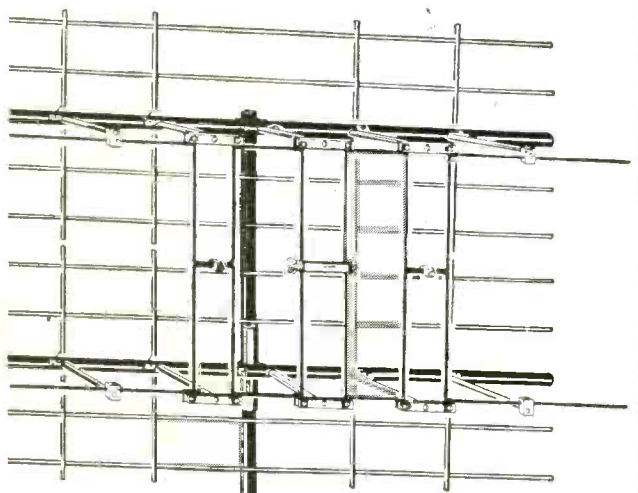

Patented

FREQUENCY (Megacycles)	RELATIVE VOLTAGE	
	2-bay Model 701 (Without "Co-Trap" Screen)	Skyline Imperial Model 701-CT (With "Co-Trap" Screen)
50	9.12	10.1
60	9.4	18.1
70	9.4	14.
80	6.8	14.8
90	7.4	14.8
170	3.5	12.9
180	5.1	14.
190	6.4	21.9
200	4.1	16.9
210	4.1	14.
216	3.5	20.

Independently tested by the Research Division of Mark Products Co. of Chicago, Edward F. Harris, Chief Engineer.

CHARACTERISTIC VHF BAND PATTERNS with "Co-Trap"

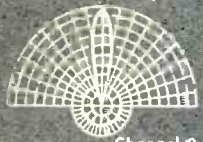

Channel 9



Channel 4

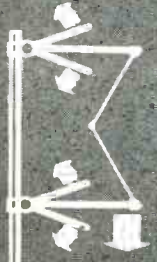

UNFOLD—
TIGHTEN

3000 WITNESSES AT GRAND DEBUT WATCH THE "IMPERIAL" OUTPERFORM 4 MAJOR COMPETITORS!

Side-by-side comparison test proves "Imperial" far superior at rejecting co-channel interference!

Two competitors failed completely—pictures entirely blotted out.

Another two showed inferior pictures and much interference.

Coming through with flying colors, the "Imperial" gave a clear picture free of interference.

Full size 5000 square inch screen.
All aluminum—extra heavy throughout.
Completely pre-assembled.

MODEL No. 701-CT (2-bay, with "Co-Trap" screen) → **\$27.50**

MODEL No. 700-CT (4-bay, with "Co-Trap" screen) also available—\$57 list

SKYLINE MFG. CO. 1652 Rockwell Ave., Cleveland 14, Ohio

capacitor replacements

FOR SETS OF THE MONTH

ARVIN CHASSIS "D"

Symbol No.	Rating MF @ WVDC	Arvin Part No.	Sprague Replacement
C1	80+60+20+10@300	22422-24	*TVL-4641 TVA-1608
C3	60+40@300/100@50	22422-25	TVL-2770 TVA-1310
C4	150@150	22422-26	TVL-1430
C5	150@150	22422-26	TVL-1430
C6	10@50	42008	TVA-1304

Note

*Parallel sections to obtain desired capacity.

CAPEHART CHASSIS CX-37 SERIES

Symbol No.	Rating MF @ WVDC	Capehart Part No.	Sprague Replacement
C238	25@25	650228A-7	TVA-1205
C403	2@150	650228A-11	TVA-1701
C603	50+40@400/100 @50/100@25	750090B-38	R-1304
C604	50+20@400/20 @350/25@25	750090B-39	R-1305

EMERSON CHASSIS 120220-D, 120239-D

Symbol No.	Rating MF @ WVDC	Emerson Part No.	Sprague Replacement
*C62	250@150	925258	TVA-1430
C71	(Includes C58, C69) 120@300/40@250/100@50	925256	TVA-3560
C72	(Includes C21, C32, C70) 120+40+40@300/10@250	925259	TVL-3585 TVA-1504

Note

*Alternate part 925279 rated 120@150. Sprague replacement TVA-1422.

HALLICRAFTERS CHASSIS B1600D

Symbol No.	Rating MF @ WVDC	Hallcrafters Part No.	Sprague Replacement
C132	200+5@150	45B260	TVL-2444
C138-1	10@450	45B266	TVA-1705
C139-1	200@150	45B265	TVL-1431
C140	140+5@300/200+30@150	45B263	R-1553
C101, 102	470 MMF 2000 VDC	47A472	20GA-T47

Sprague makes more capacitors . . . in more types . . . in more ratings . . . than any other capacitor manufacturer. Send 10c for 48-page TV Replacement Capacitor Manual to Sprague Products Co., 65 Marshall St., North Adams, Mass., or get it FREE from your Sprague distributor.

RCA CHASSIS KCS87, KCS87A

Symbol No.	Rating MF @ WVDC	RCA Part No.	Sprague Replacement
C114	100@250	79314	TVL-1535
C132	80@400/80@200	79147	¹ TVL-3764
C134	100@400	79700	² TVL-2673

Notes

¹Parallel 40mf sections.

²Parallel sections.

ZENITH CHASSIS 19R20, 19R21

Symbol No.	Rating MF @ WVDC	Zenith Part No.	Sprague Replacement
C31	10@475/4@350/100@50	22-2546	*TVL-4805
C38	80+40+10@400/20@25	22-2547	TVL-3792 TVA-1205

Note

*Omit 40 mf section.

SPRAGUE "T-C" RULE



Use this handy pocket-size Sprague Temperature Coefficient Rule to find quickly the values of stock N750 and NPO type ceramic capacitors to connect in parallel to equal a capacitor of desired intermediate temperature coefficient of the required capacitance.

COLOR CODE CHARTS

Complete charts for color codes on all types of ceramic capacitors are on the back face of this rule.

Get your Sprague "T-C" Rules now from your Sprague distributor, or directly from Sprague Products Company, 65 Marshall Street, North Adams, Massachusetts. Only 15c each.

DON'T BE VAGUE...INSIST ON

SPRAGUE

(Distributors' Div. of the Sprague Electric Co.)

You see it once . . .



They view it day after day!



**BE SMART . . . install an RCA picture tube . . .
and be certain of a satisfied customer**

RCA takes no chances with its reputation for quality — its picture tubes are quality-controlled throughout production. And you take no chances when you install RCA picture tubes. Your customers will recognize the familiar RCA emblem — what it stands for: Top materials, top workmanship . . . top product! Build your reputation for fine service with the finest picture tubes made — RCA. See your local RCA Tube Distributor for your RCA Picture Tube needs — sizes from 3" to 27". There's an RCA Picture Tube for virtually every set, regardless of make, in RCA's "Balanced Line."



RADIO CORPORATION of AMERICA
ELECTRON TUBES

HARRISON, N.J.