

TV • AM • FM • Appliances • Records • Servicing

# RADIO & TELEVISION RETAILING



*The 1951 TV music show*

*sparks the march toward*

**MORE BUSINESS—BETTER BUSINESS**

*Straight Ahead!*

July • 1951

CALDWELL-CLEMENTS, INC.

The most talked about name in Television today

**AIR KING—CBS COLUMBIA**

destined to be America's

# Leading Line



◀ **17 C5** 17" screen. Smartly styled console. Hand rubbed dark mahogany or blonde finish. Adaptable for color converter or UHF.



▲ **17 M3** 17" screen. Ebony black metal cabinet. Gold knobs and mask. Adaptable for color converter and UHF.



▲ **17 T1** Fine mahogany table model. 17" screen. Built-in Ultra Dynamic Antenna. Adaptable for color converter and UHF.

▶ **20 C2** Exquisite mahogany console. 3/4 doors. 20" screen. Adaptable for color converter and UHF.

Prices from \$199.95 to \$499.95. Slightly higher South and West.

## Air King Television by CBS COLUMBIA

The most exciting new name in television! You've read about it, in the newspapers and in the trade papers. Now *hear* about it and *see* the AIR KING—CBS Columbia line at the MUSIC SHOW in Chicago, July 16th through 20th. Complete display in Suite 649-650 at the Palmer House. Applications for distributor franchises will be considered during the show.

See America's *leading line* in television!



Custom-tuned for

**AIR KING**  
TELEVISION

your neighborhood.

TRADE MARK

AIR KING PRODUCTS CO., INC., 170-53rd STREET, BROOKLYN 32, NEW YORK

# RADIO & TELEVISION RETAILING

IN THIS ISSUE

JULY, 1951

## ★ *AM, FM, Television*

Cover—More Business, Better Business—Straight Ahead!	
Editorial—Auctions, Price Wars—on the Way Out.....	25
What's Ahead—In Radio, Appliances, Records and Television.....	26, 27
Color Television Facts for Your Customers.....	32, 33
How One Dealer Meets Color TV Competition.....	36, 37
Profitable Trade-Ins on TV Sets.....	34, 35
Home Trials to Sell Fine Television Sets.....	30, 31
1951 Music Show—to Help Dealers Sell More.....	38, 39
Selling More Phono Needles.....	44
Demonstrations Will Sell Recorders.....	48
Latest Radio, Television and Phono Models.....	62, 64
More Sales of Portable Radios.....	68
Seen at the Parts Show.....	71

## ★ *Records, Phonographs, Accessories*

Bright Future for the Disc Department.....	40, 41
Directory of Phono Record Makers.....	42
Selling More Phono Needles.....	44
News of the Disc Industry.....	Begins on page 46

## ★ *Electrical Appliances*

Latest Model Electrical Appliances.....	72
Current Model Vacuum Cleaner Specifications.....	67
New Products for Summer Selling.....	74

## ★ *Servicing and Sound*

Money in Auto Radio Servicing.....	77
TV Horizontal Troubleshooting.....	78, 79
FM Detectors—Part VI of a Series.....	80, 81
Repairing Phono Record Players.....	82, 83
New Aids for the Servicer.....	84

Photo credits: Galloway, p. 68; Devaney, p. 31; Gendreau, p. 39.

**Latest Product Specifications, Directories, etc.,**  
that have appeared in RADIO & TELEVISION RETAILING:

### Specifications:

Recorders.....	Apr. '51, p. 62
Room Air Conditioners.....	Mar. '51, p. 60
Home Radios.....	Apr. '51, p. 58
Portable and Auto Radios.....	Apr. '51, p. 56
Washing Machines.....	May '51, p. 84
Television Receivers.....	May '51, p. 60
Test Instruments.....	May '51, p. 100
Vacuum Cleaners.....	July '51, p. 67

### Directories:

Distributors.....	Jan. '51, p. 115
TV & FM Antenna Mfrs.....	Mar. '51, p. 36
Custom Component Mfrs.....	Apr. '51, p. 34
Electric Housewares.....	June '51, p. 36
Phono Record Mfrs.....	July '51, p. 42

### Reference Charts:

FM Coverage Areas.....	July '50, part II
Battery Replacement Chart.....	Apr. '51, p. 73
Four Field Statistics.....	Jan. '51, p. 38

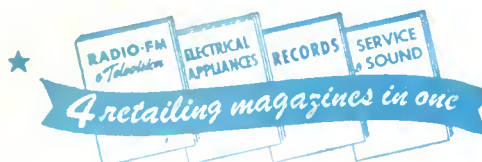

Including "RADIO & TELEVISION"  
"RADIO & TELEVISION TODAY"  
and "ELECTRICAL RETAILING"

ORESTES H. CALDWELL  
Editorial Director

M. CLEMENTS  
Publisher

JOHN L. STOUTENBURGH  
Executive Editor

EDWARD A. CAMPBELL  
Technical Editor

JOHN G. MCGEOY  
Assistant Editor

CHARLES F. DREYER  
Art Director

### BUSINESS DEPARTMENT

M. H. NEWTON  
Sales Manager

HOWARD A. REED  
Assistant Sales Manager

A. O'ROURKE  
Production Supervisor

N. McALLISTER  
Director, Reader Service

### BRANCH OFFICE CHICAGO 6

S. M. GASKINS, Western Manager

JOHN D. LUPTON, District Manager  
201 N. Wells St., Randolph 6-9225

### LOS ANGELES 5

CHRIS DUNKLE & ASSOCIATES  
Southern California Representative  
2506 W. 8th Street, Dunkirk 7-6149

### CIRCULATION DEPARTMENT

B. V. SPINETTA  
Circulation Director

W. W. SWIGERT  
Credit Manager

### RADIO & TELEVISION RETAILING\*

July, 1951, Vol. 54, No. 1, 35 cents a copy. Published monthly by Caldwell-Clements, Inc., 480 Lexington Ave., New York 17, N. Y. PL 9-7880. M. Clements President; Orestes H. Caldwell, Treasurer. Subscription rates United States and U. S. Possessions \$2.00 for one year, \$3.00 for two years, \$4.00 for three years. Canada \$3.00 for one year, \$4.00 for two years, \$5.00 for three years. Pan American Countries \$4.00 for one year, \$5.00 for two years, \$6.00 for three years. All other countries \$5.00 for one year, \$7.50 for two years, \$10.00 for three years. Printed in U.S.A. Entered as second class matter, November 16, 1950, at the Post Office at New York, N. Y., under the act of March 3, 1879.

\*Trade-Mark Reg. U. S. Pat. Off.

Copyright 1951 by

CALDWELL-CLEMENTS, Inc.

Publishers also of TELE-TECH

Caldwell-Clements, Inc., 480 Lexington Ave., New York 17, N. Y.

# Be Sure of Your Installations Get the *Aptitude-Tested* RG/U TRANSMISSION LINE CABLES

● You know what you are doing when you use Belden RG/U Transmission Line Cables—they're aptitude rated. They are designed to provide desirable electrical characteristics, and rigid control assures constant quality.

Specify Belden Radio Wires.

Belden Manufacturing Co.  
4697 W. Van Buren Street  
Chicago 44, Illinois

#### APTITUDE RATING No. 8236

Frequency (Mc)	Attenuation per 100 ft
100.	2.65
200.	3.85
300.	4.80
400.	5.60

#### APTITUDE RATING No. 8237

Frequency (Mc)	Attenuation per 100 ft
100.	2.10
200.	3.30
300.	4.10
400.	4.50

#### APTITUDE RATING No. 8238

Frequency (Mc)	Attenuation per 100 ft
100.	1.90
200.	2.85
300.	3.60
400.	4.35

#### APTITUDE RATING No. 8239

Frequency (Mc)	Attenuation per 100 ft
100.	2.90
200.	4.20
300.	5.50
400.	6.70

#### APTITUDE RATING No. 8241

Frequency (Mc)	Attenuation per 100 ft
100.	3.75
200.	5.60
300.	7.10
400.	8.30

#### APTITUDE RATING No. 8240

Frequency (Mc)	Attenuation per 100 ft
100.	4.10
200.	6.20
300.	8.00
400.	9.50



**Belden**  
*Radio* WIRE

The  
*Aptitude-Tested* **LINE**

**You've got a**  
**Protected Market**  
**with Magnavox**

• Before awarding a franchise, Magnavox carefully examines a market in terms of the prospective dealer's ability to serve it and to build a profitable business there,

without interfering with existing dealers in the area. Once the dealership is granted, Magnavox protects this market for the dealer by awarding no conflicting franchises. A protected market free from unfair competition is one of seven specific benefits the Magnavox dealer derives from his Partnership through Selective Distribution. Others are long discounts, Fair Traded prices wherever permitted by law, staunch user loyalty, direct-with-factory dealing, consistently effective advertising and helpful merchandising support.

The Magnavox Company,  
Fort Wayne 4, Indiana.

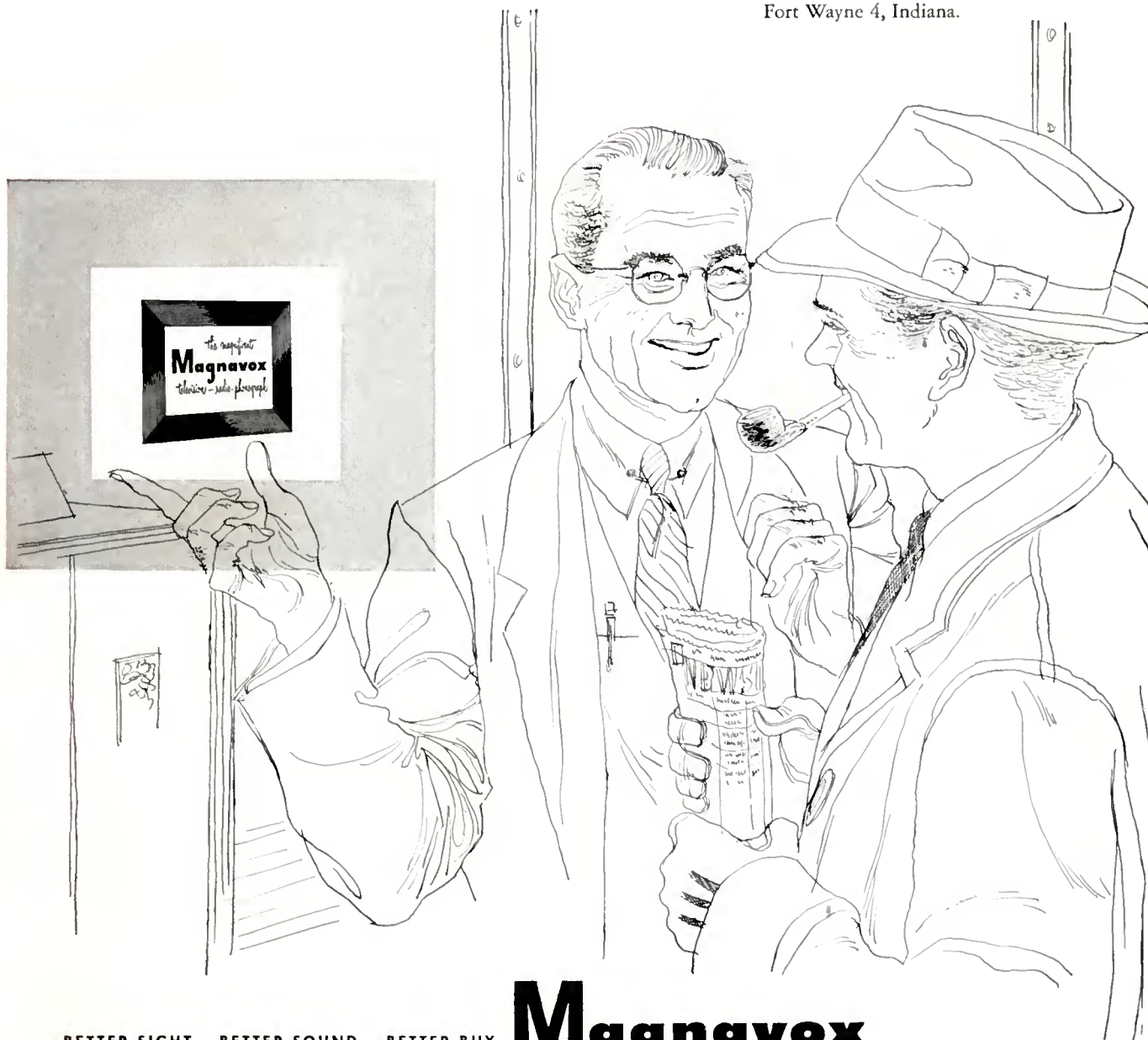

BETTER SIGHT...BETTER SOUND...BETTER BUY

**Magnavox**

*One of a series of advertisements in business papers on "Why Magnavox Is Your Best Profit Opportunity."*

# Duke Ellington's first choice ...

IS THE OVERWHELMING CONSUMER CHOICE, TOO!

Duke Ellington, the modern music master, wouldn't think of rehearsing without his new Model 288 Electronic Memory Wire Recorder.

The newly-designed *natural voice* play-back sound chamber lets the Duke hear his own music *exactly* as it's played. And he likes the reliability of the new non-spill recording head.

Those two new features—plus countless others—make the 288 the top magnetic wire recorder for performance, quality—and *price!*

That's why the Webster-Chicago Electronic Memory Wire Recorder is the top choice of consumers, too!



## WEBSTER-CHICAGO

5610 Bloomingdale, Chicago, Ill.

Electronic Memory  the  
Ultimate in Magnetic Recording



Dictation Machines



Diskchangers



Tape Recorders

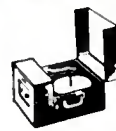

Portable Fonographs



Home Fonographs

# QUALITY FIRST... A PHILCO POLICY

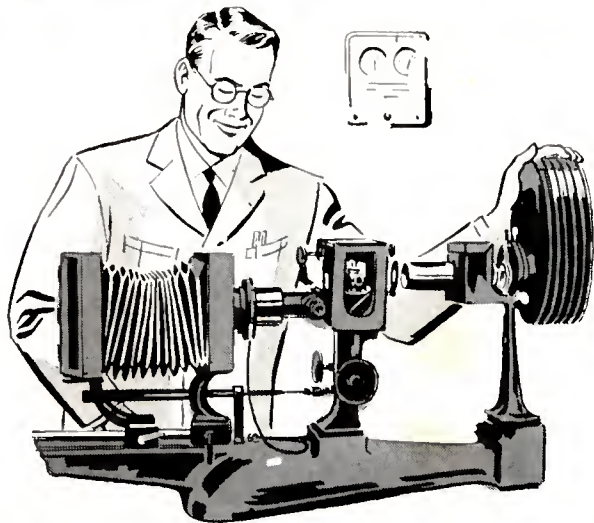

## MICRO CAMERA ENLARGES PHOTOS HUNDREDS OF TIMES

The micro photographs in the circles at the right show clearly why Philco chrome finish outwears other cheaper finishes as illustrated. Here the various coats of plating are magnified to reveal their relative thickness and the type of bonding used to join each finish to the base metal. NOTE the differences in Philco—a difference that can be measured in years of satisfied service to Philco owners.

The work being done every day in the Philco refrigerator engineering laboratories, proves that the hardest people to please are not your customers, but Philco engineers, *themselves*. Here are typical tests which show the searching analysis concentrated on every detail of quality and performance. Yes, you sell **QUALITY** that's tested and proved to give satisfaction, when you sell a Philco.

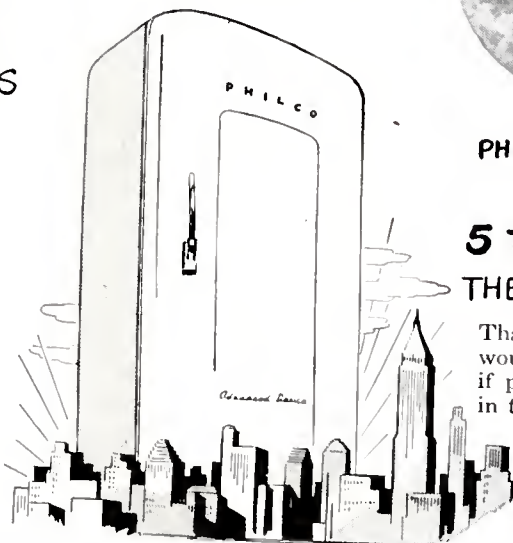
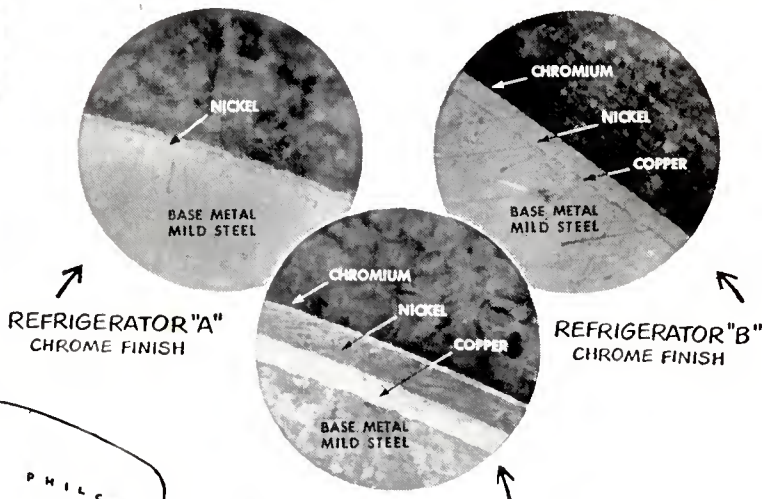

## 5 TIMES LARGER THAN THE EMPIRE STATE BUILDING

That's how much a Philco refrigerator would be enlarged by the micro camera—if photographed at the same setting used in the chrome finish photos.

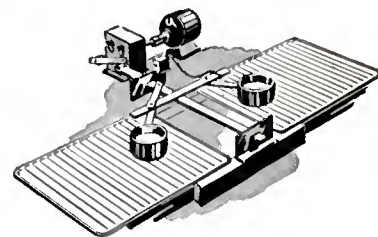

## RUB...RUB...RUB 2 MILLION TIMES

Weighted metal discs simulating the effect of milk bottles, test durability of chrome finish on shelves. Every rub is counted on a test meter, recording wear-resistance for comparison with other similar tests.

## BATTERING RAM OPENS AND CLOSSES DOOR, EQUIVALENT TO 20 YEARS OF USE

Every 2 seconds, hour after hour, day after day, this Philco test machine opens and closes the refrigerator door... giving a full 20-year life test to gasket, hinges, etc., etc., in a period of days.

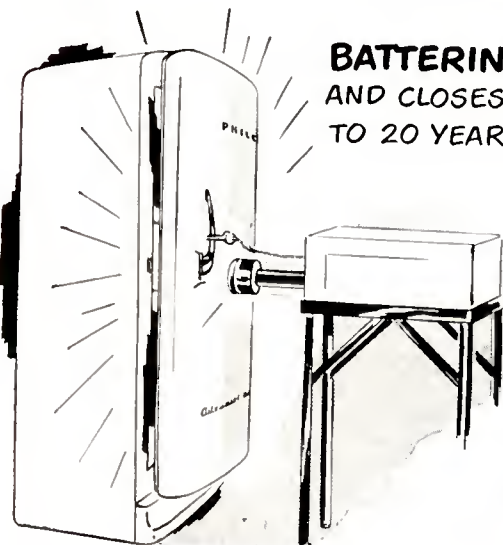

**PHILCO** *Famous for Quality the World Over*

# TOPS THEM ALL FOR PRESTIGE AND PROFITS



The Incomparable

## Caphart TELEVISION

Hundreds of Caphart franchise holders agree—the name “Caphart” draws the kind of trade that means easier, more profitable selling! That’s because the Caphart is a quality instrument in every sense of the word . . . backed by a reputation that was years in the making.

No other line can match the renowned CX-33 chassis that provides the Caphart Crystal-Clear picture. No other possesses the world-famous Symphonic-Tone System. And of course, Caphart cabinetry stands alone . . . appeals to the discriminating of all income groups everywhere.

Perhaps you, too, can join the fortunate group of dealers who make Caphart their banner line . . . learn why the Caphart franchise is called the most valuable in the industry. See your dealer or write to E. Patrick Toal, Director of Sales at Fort Wayne.

★ **WHEN IN CHICAGO** . . . be sure to visit the Caphart Salon, Room 1118, at the Merchandise Mart.



\*Includes Federal Excise Tax. Warranty extra. All prices for Zone 1.

### The Caphart “BOSTONIAN”

Luxury television at a realistic price. 20-inch Crystal-Clear picture. Mahogany veneer cabinet. Caphart Symphonic-Tone. The set of the year for sales and profits!

ONLY  
**\$359<sup>95</sup>\***

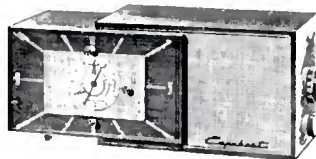

#### The best looking Clock-Radio on the market

The Caphart Clock-Radio is not only an accurate timepiece, it serves as a tireless servant . . . reminds of appointments, turns on appliances. Really beautifully styled in a choice of colors. A sure sales winner!

**\$49<sup>95</sup>**

*Slightly higher in the West.*



#### The Caphart table model Radio

True Caphart quality in miniature. Handsomely designed in dark green plastic . . . unbelievably beautiful tone. It’s set to make a big splash in the table-radio market . . . boost profits for you!

**\$32<sup>95</sup>**

*Slightly higher in the West.*



**CAPEHART-FARNSWORTH CORPORATION, Fort Wayne 1, Indiana**

*An Associate of International Telephone and Telegraph Corporation*



# YOU'RE ALWAYS WITH G-E PICTURE TUBES! **1<sup>ST</sup>**

**FIRST** with a long-term user warranty. G.E. pioneered the customer warranty on picture tubes . . . commencing with date of retail purchase . . . safeguarding your customers and you, as tube dealer, for six months after installation. By this BIG step forward, G.E. removed any worry that its picture tubes on your shelves might run beyond the manufacturer's warranty period. Now you can stock a full line with confidence. And no matter when the tubes are installed, your customers will get full-term, registered G-E warranties in every case!

**FIRST** to benefit from full-page tube consumer advertising. General Electric made tube history when it launched full-page tube advertising in LIFE and the POST—a continuing campaign that is reaching regularly more than 24,000,000 readers from coast to coast. As a G-E dealer, you profit directly from the tremendous G-E tube acceptance which this advertising creates.

**FIRST** in wide range of G-E tube types and sizes available. Round tubes and rectangular—glass, metal—small, medium, large-screen—General Electric builds virtually all types and sizes, giving you *the biggest picture-tube line*. You can service any TV set with assurance that a G-E tube will meet your needs! Conversions to larger screens often are practical—and profitable. With G-E tubes, you can give set owners the larger, easier-to-view pictures they want. And G-E Aluminized Tubes enable you to give them *brighter TV pictures!*

**FIRST** in proved tube quality. You can't beat G-E picture-tube performance! Quality features (example: all-glass electron-gun beading) typify the care G.E. gives to design details that make for superiority. Afterwards comes precision manufacture by ultra-modern equipment in new, well-lighted premises . . . followed by final tests which relentlessly reject any tubes with faulty screen or other characteristics. G-E picture tubes uniformly are *good tubes!* They give top owner satisfaction—build profits and prestige for you!

**CASH IN NOW ON THESE G-E "FIRSTS"!  
SEE YOUR G-E TUBE DISTRIBUTOR!**

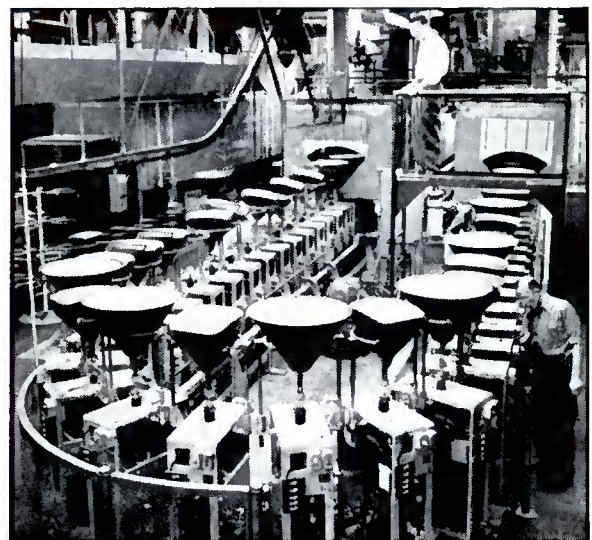
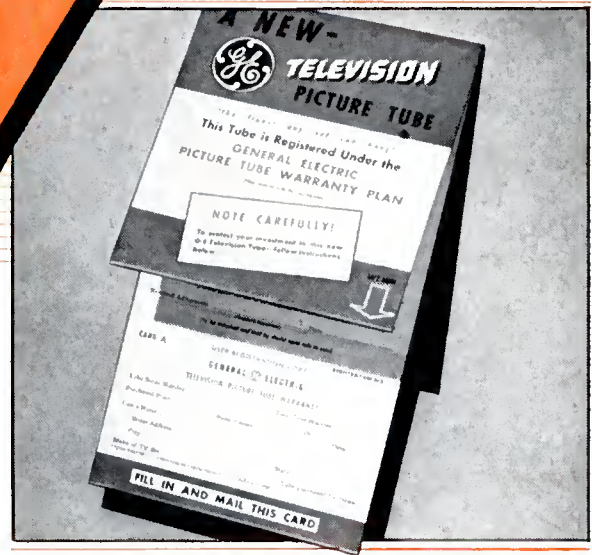

**GENERAL  ELECTRIC**

181-KA7

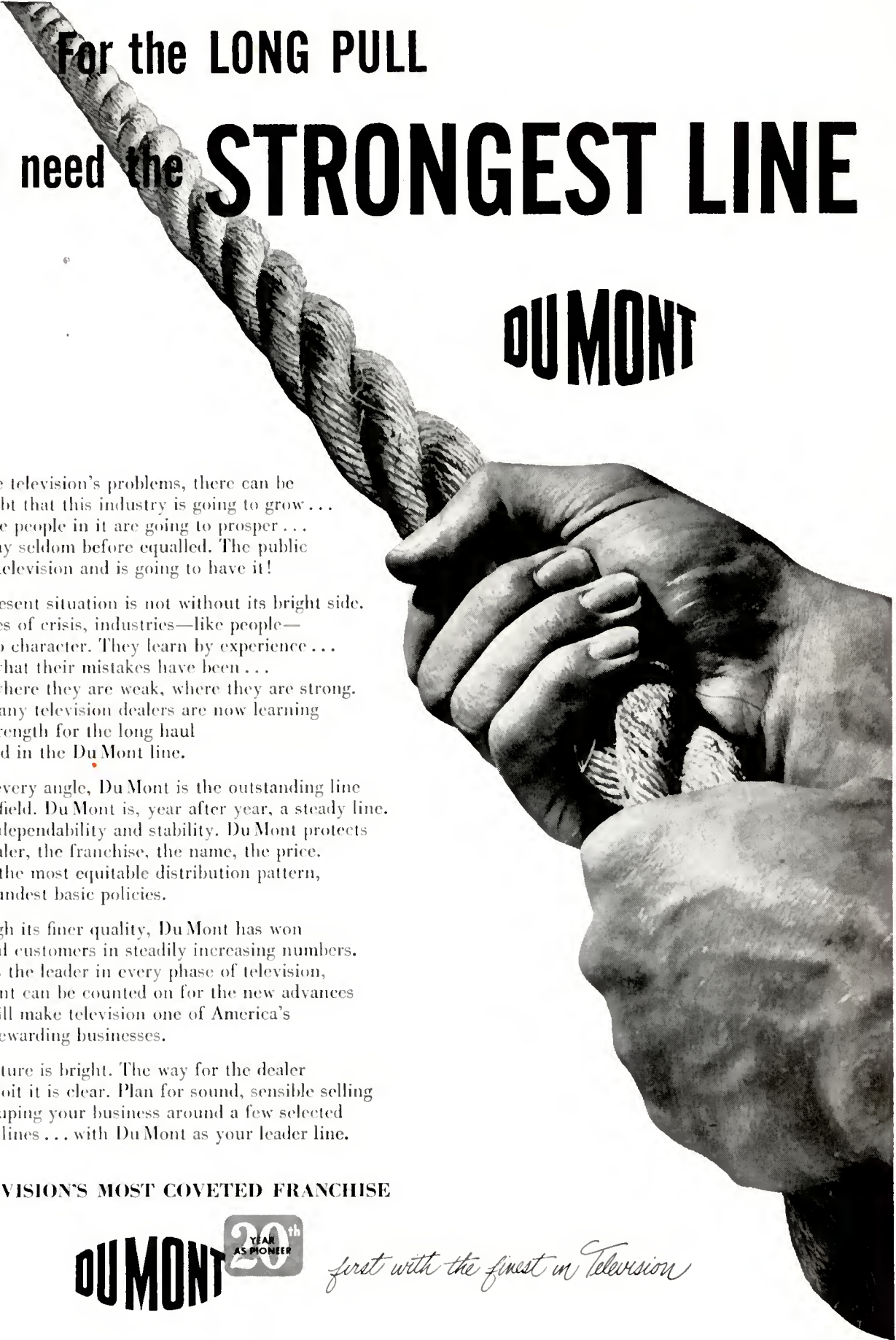

For the **LONG PULL**  
you need the **STRONGEST LINE**

**DUMONT**

Despite television's problems, there can be no doubt that this industry is going to grow . . . that the people in it are going to prosper . . . in a way seldom before equalled. The public wants television and is going to have it!

The present situation is not without its bright side. In times of crisis, industries—like people—develop character. They learn by experience . . . learn what their mistakes have been . . . learn where they are weak, where they are strong. And many television dealers are now learning that strength for the long haul is found in the DuMont line.

From every angle, DuMont is the outstanding line in the field. DuMont is, year after year, a steady line. It has dependability and stability. DuMont protects the dealer, the franchise, the name, the price. It has the most equitable distribution pattern, the soundest basic policies.

Through its finer quality, DuMont has won satisfied customers in steadily increasing numbers. Always the leader in every phase of television, DuMont can be counted on for the new advances that will make television one of America's most rewarding businesses.

The future is bright. The way for the dealer to exploit it is clear. Plan for sound, sensible selling by grouping your business around a few selected strong lines . . . with DuMont as your leader line.

**TELEVISION'S MOST COVETED FRANCHISE**

**DUMONT** 

*first with the finest in Television*

# You get all five ...with RCA Batteries

## 1. Completely rounded line

(one source for both fast-moving and hard-to-get types!)



2. Radio trade distribution

3. Radio-engineered quality

4. Greatest array of selling aids

5. Top brand acceptance

 No other radio battery line offers you as much as RCA! You get a *complete* line . . . *one source* for both fast-moving and hard-to-get types. Seven batteries are designed to minimize your stock requirements . . . meet most of today's demand. The complete line provides a type for almost every portable and farm radio need!

You get radio trade distribution, too, which builds your volume through greater repeat sales. Remember, *RCA Battery distribution always steers customers back to radio dealers and servicemen . . . away from the non-radio outlets!*

You get radio-engineered quality . . . top performance and long-lasting power. Every sale means a satisfied customer for you!

You get the greatest array of selling aids in battery sales history! Signs, displays, merchandisers, and servicing aids . . . all designed to make your selling easier.

And, you get top brand acceptance with "the greatest name in radio . . . RCA" . . . for faster, more profitable sales.

Call your local RCA Battery Distributor *today* for complete details on how you can join the radio trade switch to RCA Batteries . . . and greater battery sales!



**RADIO CORPORATION of AMERICA**

**RADIO BATTERIES**

**HARRISON, N. J.**

# POSITIVE RESULTS IN

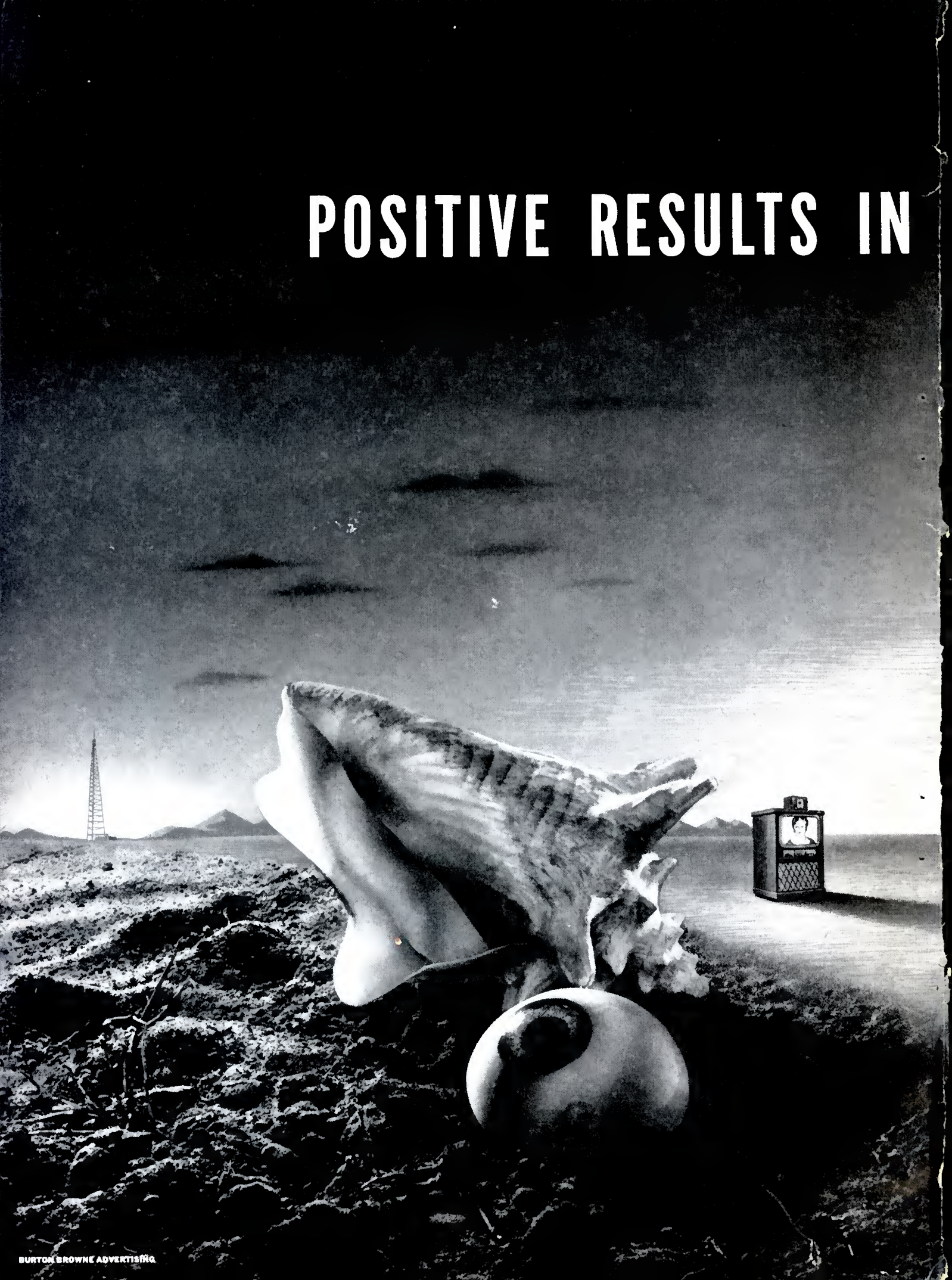

# NEGATIVE AREAS

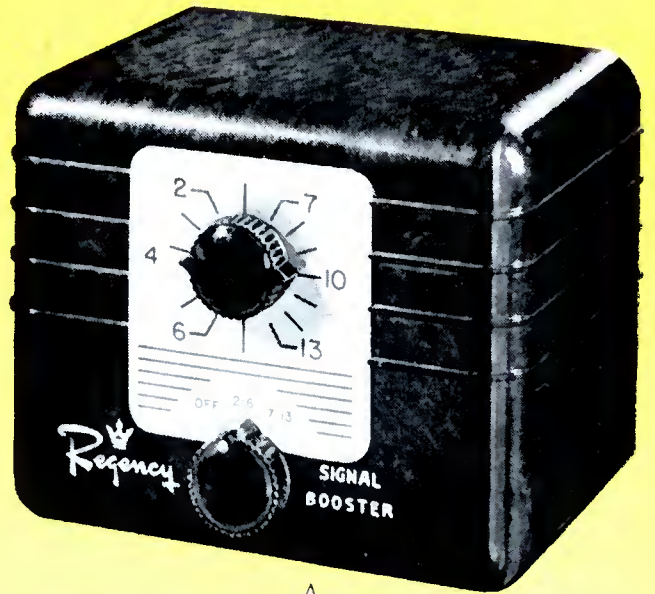

  
*Regency*

**LARGEST SELLING BOOSTER  
AT ANY PRICE!**

*In negative receiving areas where sound signals are reduced to the meaningless murmur of a sea shell, where picture signals diminish into dissolving views —the Regency booster activates these dormant signals, producing strong, clear, lifelike sound and images. No other booster gives such positive results as Regency. That is why Regency is the largest selling booster at any price!*

REGENCY • DIVISION OF I. D. E. A. Indianapolis 4

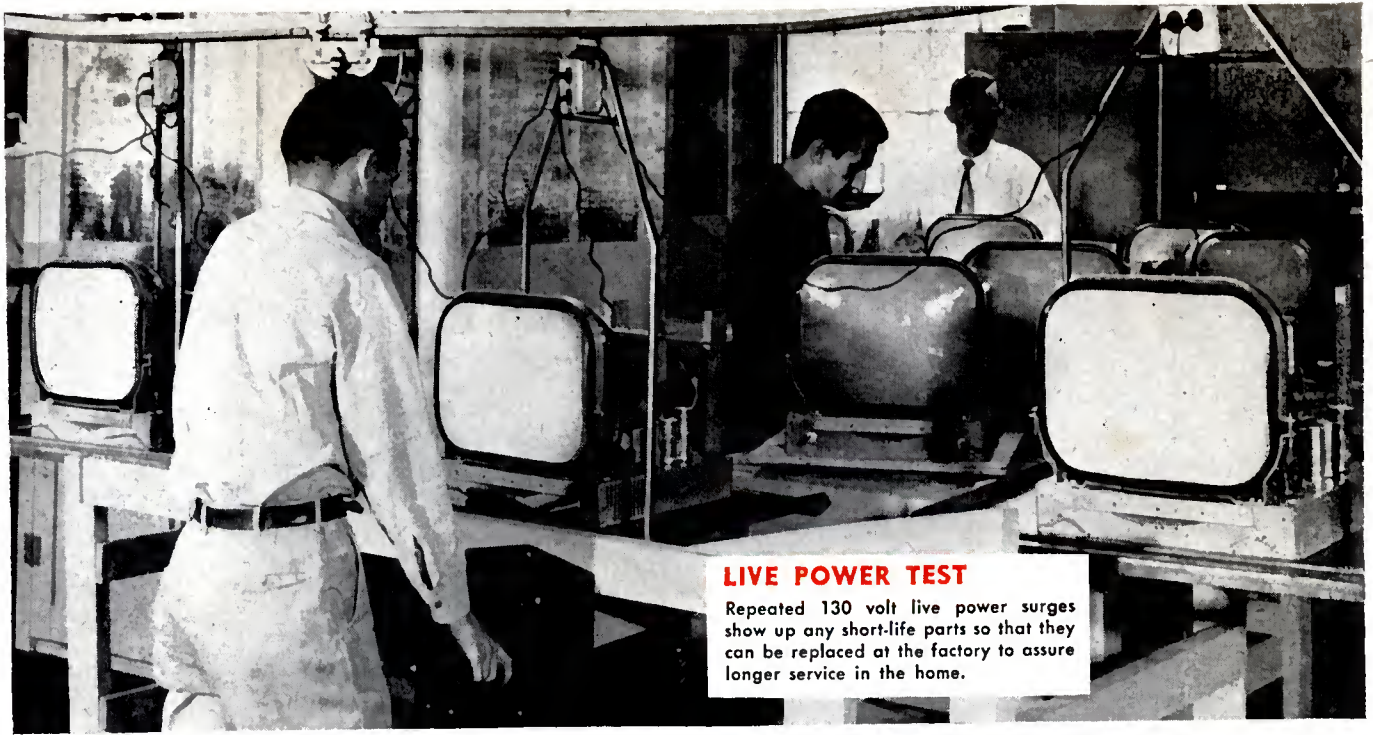

#### LIVE POWER TEST

Repeated 130 volt live power surges show up any short-life parts so that they can be replaced at the factory to assure longer service in the home.

QUALITY CONTROL and step-by-step performance testing make

# Motorola TV

## most dependable!



#### SHAKE TABLE TEST

Checks the stability and security of wiring connections with a rough "ride" on vibrations more violent than in normal usage.

Carefully controlled during assembly, checked and tested through every step of production, Motorola TV must MEET and PASS the most rigid specification tests for top quality performance. This means you can be assured that every Motorola TV you sell will give longer, better, more continuous performance in your customer's home with less "time out" for service. This reputation for dependability is the result of ownership approval and dealer enthusiasm.

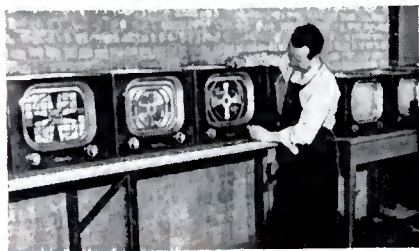

#### SPOT CHECK TEST

Pull sets off the final "line" at random and submits the chassis to a special inspection of every important operational function.



#### FINAL CHECK TEST

Highly skilled technicians spot any possible weakness which may have been undetected in previous individual chassis section tests.

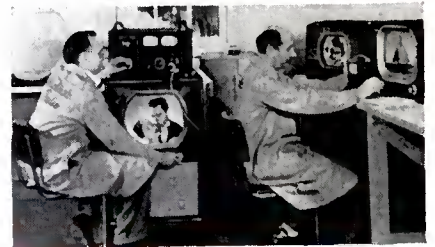

#### SIGNAL RECEPTION TEST

Engineering laboratories test the supersensitive power "pull" for "Fringe area" signals and signals within a 60-mile radius.

SEE YOUR DISTRIBUTOR TODAY! MOTOROLA INC., 4545 Augusta Blvd., Chicago 51, Ill.

# To our Customers:

## your **Standard Register** system now means **MORE POWER TO YOU** in business!

**IT'S THE "POWER" OF INFORMATION.** Today, because of greater complexities in business . . . price and wage regulations . . . merchandise shortages . . . increased taxation . . . you must have better-than-ever information on your sales, inventories and operations.

With your Standard Register system, you have complete, dependable information in the vital *source records* of all cash or charge transactions. Are you taking every advantage of the possibilities in your system?

For instance, are you using your continuous-strip, locked-in copies for speedier and more accurate ledger posting? Have you considered using these copies for "blanket billing" (the simplified procedure widely used by department stores and others)? Does your system adequately serve inventory purposes—to control your stock and purchases, identify profitable items, spot hard-to-get ones? Are you using the best Form Flow Register *model* to fit your particular needs completely?

Your Standard Register representative will be glad to review your present forms system and assist you to revise it to meet today's new requirements. He's in position to furnish accessory equipment, forms and supplies to make your system serve you better.

### Standard Registers and Forms provide . . .

- Fast, easy, accurate record writing.
- Useful copies for all purposes.
- Security from loss or alteration: consecutive numbering, locked-in copy.

## Standard Register

Kant-Slip, the original marginally punched

## Continuous Forms

Simplify record writing

FORM-FLOW REGISTERS • THE REGISTRATOR PLATEN

Offices in all principal cities

### CUSTOMER COUPON

The Standard Register Company  
1307 Campbell Street, Dayton 1, Ohio

I'd like to see Business Aids—giving system ideas I can use in my business. No obligation, of course.

Name \_\_\_\_\_

Company \_\_\_\_\_

St. Address \_\_\_\_\_

City \_\_\_\_\_ Zone \_\_\_\_\_ State \_\_\_\_\_

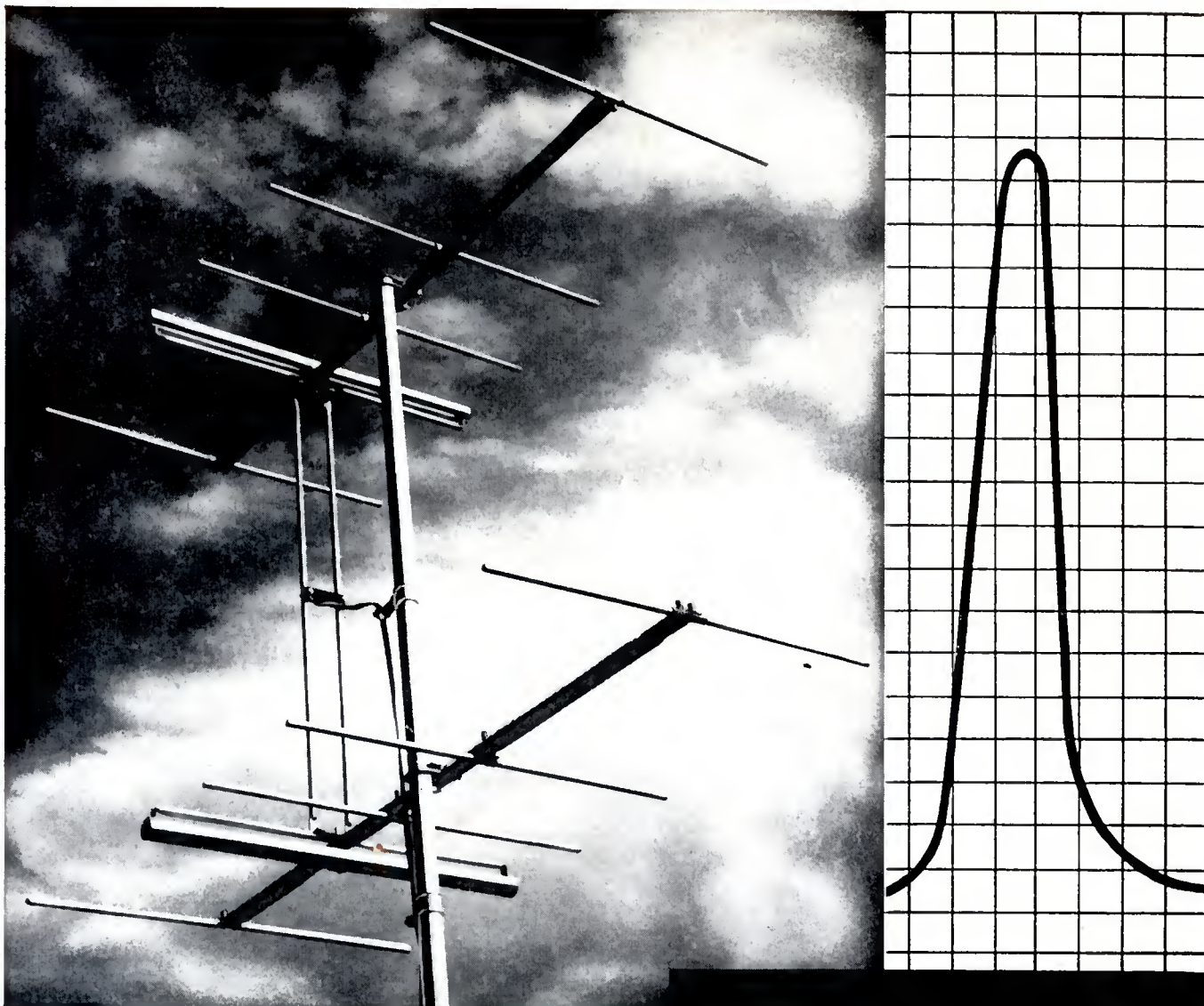

Clear, strong signals with a minimum of noise pickup — that's the **BEAMED POWER** you get with a Taco Yagi. Unwanted signals and interference are rejected through the sharp directivity of these antennas.

High gain assures a better picture in the weakest fringe-area installations. High front-to-back ratio eliminates co-channel interference. Proved in thousands of installations for durability under the most adverse weather conditions.

For more fringe-area sales and more satisfied customers install the finest — Taco Yagis.

**ASK YOUR TACO DISTRIBUTOR FOR THE NEW TACO CATALOG No. 35**

**BEAMED  
POWER**

**RADIO & ELECTRONIC EQUIPMENT**

**TACO**

**TECHNICAL APPLIANCE CORP.**

SHERBURNE, N. Y. • IN CANADA: STROMBERG-CARLSON CO. LTD.  
TORONTO 4, ONTARIO





**DON'T MISS**

# The most interesting display at the NAMM show

## The World's Finest Private Collection of Antique Musical Instruments

from the collection of Melville Clark, world famous harpist and patron of the arts, director and past president of NAMM. Mr. Clark will personally demonstrate his collection and invite you to play some of these fabulous instruments, yourself.

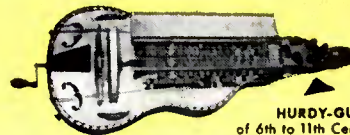

**HURDY-GURDY** of 6th to 11th Century. Forerunner of the violin.



**MUSICAL BIRDS.** Very rare. Over 200 years old, and one of only two known in America with 3 mechanical singing birds.



**MUSICAL SEWING BOX.** Walnut inlaid with gold and ebony. Exquisite grand opera stage. Serbian dancing figure.



**THOMAS MOORE HARP.** The instrument on which the famed minstrel composed "The Last Rose of Summer."

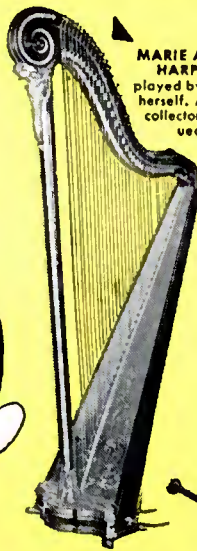

**MARIE ANTOINETTE HARP.** Owned and played by the Empress, herself. A magnificent collector's item. Valued at \$14,000.

**CONCERT ROLL ORGAN** used 100 years ago for Chautauques and Camp Meetings.



**RARE AND UNUSUAL MUSIC BOXES . . .** and the World's Smallest perfect violin. Identical 64th scale model of a Stradivarius.

**AND DON'T MISS**

Advance News of a Revolutionary New Electronic Development That Puts the Forthcoming Westinghouse Television Line — Years Ahead!



VISIT THE **WESTINGHOUSE SUITE** ROOMS 633-635, AT THE PALMER HOUSE, JULY 16th THROUGH 19th.

YOU CAN BE SURE...IF IT'S

# Westinghouse

WESTINGHOUSE ELECTRIC CORPORATION • TELEVISION-RADIO DIVISION • SUNBURY, PA.

# CROSLEY...

## THE TV WITH A FUTURE!

- ★ *Ready now for UHF with the Crosley Unituner ... built-in connections for color converter*
- ★ *Engineered with reserve sensitivity for fringe area, clear picture reception*
- ★ *Housed in beautiful cabinets to enrich home decoration*

Visit the display of Crosley Television and Radio sets at the Music Merchants Show, Chicago, Illinois, July 16-19, at the Palmer House, Room 652.



*Better Products  
for  
Happier Living*



Steel Kitchen Cabinets



Freezers

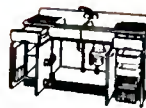

Sinks



Shelvador® Refrigerators

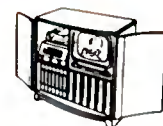

Television

★ **Right from the start** Crosley engineered and built TV with the Unituner which provides a clear channel band to receive UHF signals. With the simple addition of the Ultratuner (a UHF converter) your Crosley customers will receive all the UHF stations without sacrificing any VHF channels. When UHF comes to your town, you'll be able to give Crosley customers full reception by the simple addition of the inexpensive Ultratuner. And Crosley Television sets are so designed—with built-in color connections—that they can be simply converted for color reception when FCC authorized color is available. You can sell Crosley, confident that new developments like UHF and color do not obsolete Crosley sets.

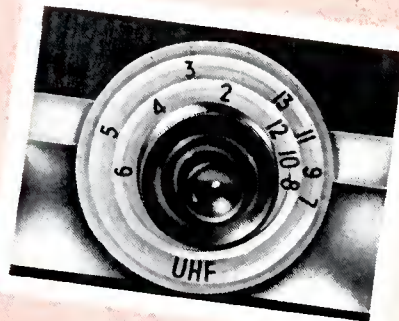

★ **In those difficult suburban areas** where weak TV signals make poor reception the rule, Crosley Reserve Sensitivity Receivers give the kind of good performances that reward your selling effort with a happy customer. And whether in weak or strong signal areas, the Crosley Super-Powered Chassis delivers the extra power needed to assure you of a clearer, brighter picture under all operating conditions.



★ **Crosley cabinets are distinctively and tastefully styled** to blend handsomely with traditional or modern furnishings. Select wood veneers, hand-rubbed to satiny lustres, are cut and joined with craftsman care to give you an elegant piece of furniture to sell. Your customers will be pleased to see how these decorator-styled pieces of furniture add new beauty to the home.

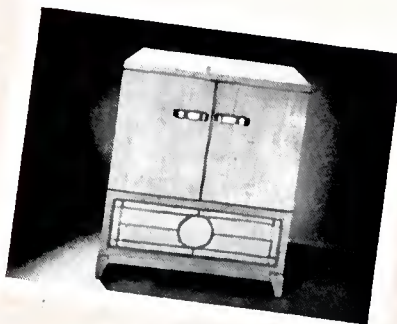

These are but a few of the many reasons why you can count on Crosley—the TV with a future—to help you win satisfied customers. See your local distributor today for full details, or write Crosley Division, Avco Manufacturing Corporation, 1329 Arlington Street, Cincinnati 25, Ohio.

Crosley Division



Cincinnati 25, Ohio

# CROSLEY *Family Theatre* TELEVISION



Garbage Disposers



Electric Ranges



Electric Water Heaters

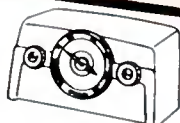

Radios

# This Tag

Appears on every  
Stewart-Warner  
TV set manufactured  
since November 1950



**STEWART-WARNER** dealers are ready for color TV. Because of farsighted engineering, all **STEWART-WARNER** sets built since November 1950 have provision for an adapter for CBS color TV. Here's what this means to **STEWART-WARNER** dealers:

1. With plug-in socket provided at rear of chassis, color adapter can be connected quickly and easily—no chassis rewiring—no factory rebuilding required.
2. The value of their **STEWART-WARNER** inventory is not only protected against obsolescence but is actually enhanced as a result of this advanced design.
3. They can close sales to customers concerned about color TV merely by demonstrating the plug-in socket at the back of each set. This gives **STEWART-WARNER** dealers a real merchandising opportunity.

AND DON'T OVERLOOK STEWART-WARNER'S BUILT-IN PROVISION FOR U.H.F. RECEPTION WITH THE MIRACLE TURRET TUNER—NO CONVERTER NEEDED

*You're Out in Front with*  
**Stewart-Warner**

Call or wire your **STEWART-WARNER** distributor **TODAY!**

STEWART-WARNER ELECTRIC • Division of Stewart-Warner Corporation • 1300 N. Kostner Ave., Chicago 51, Illinois



Commercial Credit Offers More Advantages to Dealers and Customers—Because of the broad protection and benefits offered both buyer and seller, *more* dealers finance *more* home appliances through COMMERCIAL CREDIT than under any other national financing plan. Customers return to buy again because they like features such as Property Insurance Protection in event of damage to, or loss of, the merchandise . . . and Life Insurance Protection, which cancels the unpaid balance in event of purchaser's death.

## Dealers profit by Commercial Credit's fast credit approval

COMMERCIAL CREDIT, through its more than 300 offices in the United States and Canada, quickly and efficiently checks buyers' credit standings and relays the information back to dealers . . . speeds deliveries, payments and profits . . . eliminates lost sales due to delays. But that's only part of the picture. COMMERCIAL CREDIT offers dealers a *complete* financing package . . . from a wholesale plan that enables them to keep floor stocks at most profitable levels . . . down to the last detail of property insurance, credit investigation, collection, adjustment and prospect follow-up. Buyers, too, prefer COMMERCIAL CREDIT financing, because of its broad customer protection and benefits . . . and their good will pays off in repeat sales and profits.

Find out *now* how COMMERCIAL CREDIT's attractive financing plan can help you move more appliances from floor to customer. Write, wire or phone your nearest COMMERCIAL CREDIT office. Our local representative will be glad to call at your convenience and give you full details.

### EIGHT WAYS BETTER!

1. Wholesale Financing
2. Fast Credit Approval
3. Life Insurance Protection
4. Property Insurance Protection
5. Automatic Sales Follow-up
6. Tested Collection Service
7. Builds Customer Good Will
8. Nationwide Facilities



## COMMERCIAL CREDIT CORPORATION

A subsidiary of Commercial Credit Company, Baltimore...  
Capital and Surplus over \$100,000,000...more than 300  
offices in principal cities of the United States and Canada.

Make Your First Stop at the NAMM Show



**RED LACQUER ROOM**



**4TH FLOOR · SPACE C**

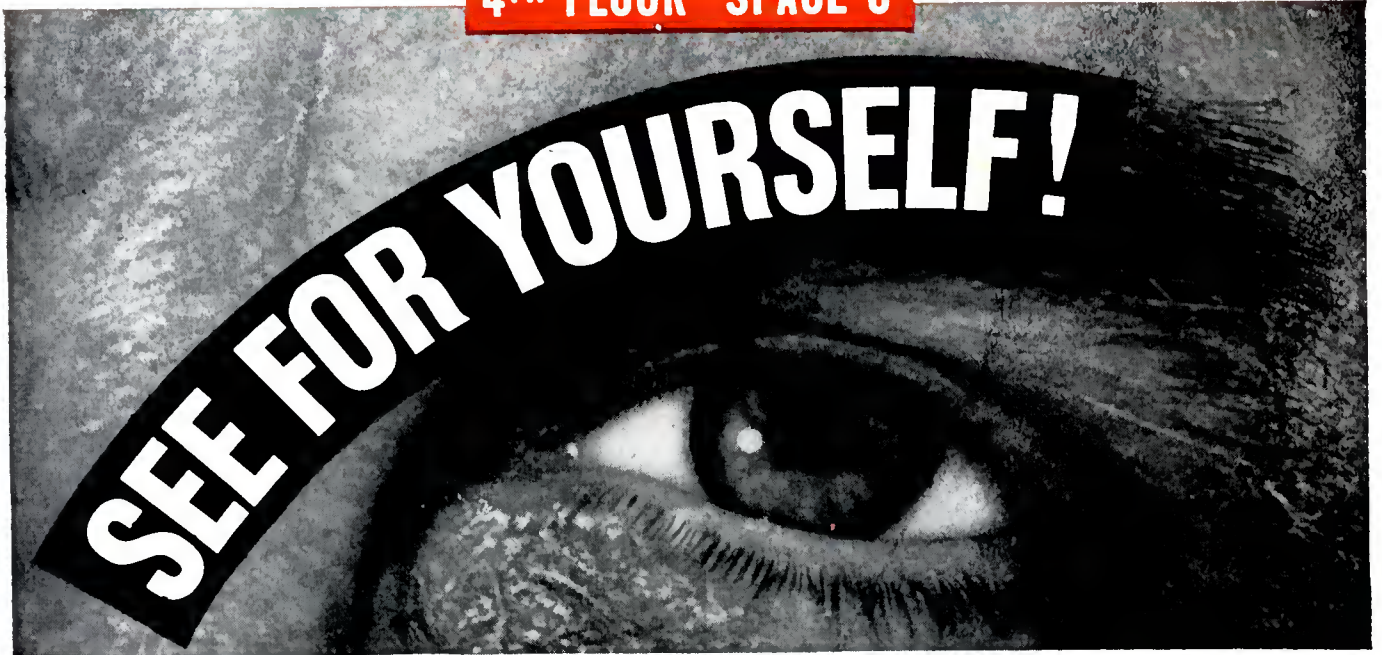

## The First Major Improvement in Television Viewing Comfort

### GREATEST SALES FEATURE EVER OFFERED IN TELEVISION

Here is the feature every T-V prospect has been waiting for. Now, the first line ever developed with a deluxe feature that really sells on "sight."

**Production Will Be Limited.  
The Time To Order Is at the Show.**

And See for Yourself  
All the Other Great Features  
in the COMPLETE

### NEW SYLVANIA LINE

Every model from your price leaders to deluxe is a superb T-V receiver. And every model has Movie-Clear\* pictures, Studio-Clear\* sound, "Triple-Lock" that eliminates interference. Wide Angle Viewing, Black Tube, Big Cool, Long-Life Chassis and Best "Fringe Area" Reception.

\*Sylvania Trademark



# SYLVANIA T-V

SYLVANIA ELECTRIC PRODUCTS INC., RADIO AND TELEVISION DIVISION, 254 RANO STREET, BUFFALO 7, N. Y.

# To Employers who need qualified TV technicians

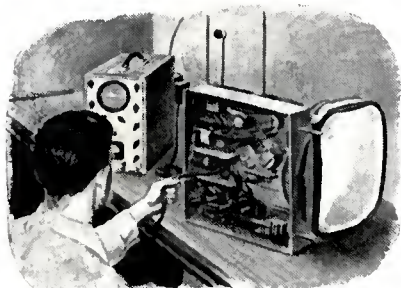

...here's a quick and easy way to train them

Manufacturers... service organizations... dealers... distributors... and other employers of skilled TV technicians who feel the manpower pinch should be interested in this advertisement.

#### A VALUABLE TRAINING TOOL TO MAKE BEST USE OF MANPOWER RESOURCES

Because of the critical shortage of TRAINED and EXPERIENCED TV SERVICEMEN, RCA Institutes offers a highly specialized and practical Home Study Course in TV Servicing, to the working members of the radio-electronics industry.

The object of the RCA Institutes home study course is to train more *good* servicemen and to help make good servicemen *better*. Also to help expand the supply of qualified TV technicians for industry requirements in face of a manpower shortage. The RCA Institutes Home Study Course in TV Servicing provides an effective way to train men now in your employ to use their latent talents to fill positions that require technical training in television.

#### STUDENTS KEEP JOBS WHILE TRAINING ... STUDY LESSONS AT HOME

Employed men supplement the practical experience they get while actually working on their regular jobs with pre-tested technical knowledge learned from a study of the course at home in their spare time. They become more valuable to you as employees with each lesson studied. You quickly train men on the job to utilize their highest skills and capacities. Reduces the need to go outside in the rapidly shrinking manpower market for hard-to-find qualified men. Several thousands of RCA Service Company's own people have taken this course.

#### LOW RATES FOR EMPLOYER GROUPS

The cost of the RCA Institutes Home Study Course in Television Servicing has been cut to a minimum. It covers only the cost of preparation, grading and administration. It is offered by RCA Institutes as an economical and beneficial service to the radio-electronics industry at a time when the need for this kind of help is acute.

Employers may enroll any number of their employees. Reduced tuition rates for groups of six or more. Act now to get full benefits of this practical way to improve the over-all efficiency of your organization.

Send for **FREE BOOKLET**

Mail the coupon—today. Get complete information on the RCA INSTITUTES Home Study Course in Television Servicing. Booklet gives you a general outline of the course by units. See how this practical home study course trains men quickly, easily. Mail coupon in envelope or paste on postal card.



**RCA INSTITUTES, INC.**  
A SERVICE OF RADIO CORPORATION OF AMERICA  
350 WEST FOURTH STREET, NEW YORK 14, N.Y.

**MAIL COUPON NOW!**

RCA INSTITUTES, INC.  
Home Study Department, RT-751  
350 West Fourth Street, New York 14, N.Y.

Without obligation on my part, please send me copy of booklet "RCA INSTITUTES Home Study Course in TELEVISION SERVICING." (No salesman will call.)

Name \_\_\_\_\_ Title \_\_\_\_\_  
(Please Print)

Company \_\_\_\_\_

Address \_\_\_\_\_

City \_\_\_\_\_ Zone \_\_\_\_\_ State \_\_\_\_\_

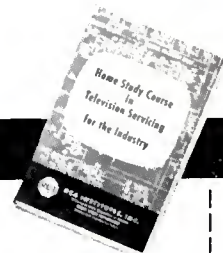

# 2 New Trio Products

## TRIO TV ROTATOR AND DIRECTION INDICATOR

### TWO HEAVY DUTY MOTORS For Trouble-free • Two Direction Rotation

Here's the rotator that provides the ultimate in trouble-free dependable operation. Designed to support the heaviest TV arrays — even in 80 M.P.H. winds! This outstanding rotator has undergone extensive tests for three years, standing up under every abuse and temperature extremes.

Here, indeed, is the rotator that abolishes TV callback problems!

#### Two Heavy Duty Motors

Two 24 volt motors are used — one for clockwise and one for counter-clockwise rotation. Even if children play with the unit and leave it on continuously, a motor cannot burn out since load on a single motor is never on more than 50% of the time!

Positive acting electrical stops at both ends of 360° turn eliminates lead damage.

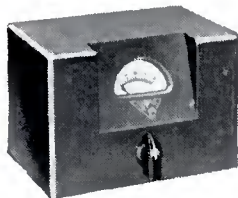

Indicator always shows exact antenna position.

#### Compare These Features

- Cast TENSALLOY aluminum mast holder withstands 4500 lbs. bending movement.
- 1 1/16 steel shaft withstands 4500 lbs. bending movement
- Automatic Electro-Mechanical Brake — reduces coasting to minimum
- Can be fastened to any pipe up to 2" OD
- Two direction rotation
- All-aluminum case — no cast zinc!
- Numbered terminal boards on rotator and indicator
- Turns 1 RPM, lifetime lubricated
- Ball-bearing end thrusts on shafts
- Ideal for 10, 6 and 2 meter amateur use

## NEW TRIO *All Aluminum* TOWER

Weighing less than a pound per foot, this sturdy, extremely handsome, all weather-proof triangular tower represents a great refinement in streamlined appearance and installation ease over all others. Its all-aluminum components permit the most flexible arrangements for construction of the exact tower needed for any installation.

Tower may be raised from horizontal position in heights up to 40 feet. For additional height, sections may be added from bottom.

Comes in 5 foot sections, a bottom section, a top section and as many center sections as desired.

#### FEATURES

- Sturdy, Yet Light In Weight — Less Than A Pound Per Foot
- Forever Rust Proof
- High Quality Extruded Aluminum
- Interchangeable Sections
- Preferred Riveted Construction . . . No Welded Joints
- Dual Swivel Base — 180° and 360° permits vertical or horizontal plane mounting
- Low Installation Cost
- Completely Cartoned For Protection In Shipping — Compact Storage

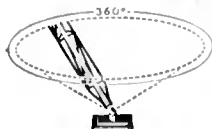

Dual Swivel Base  
180° and 360°

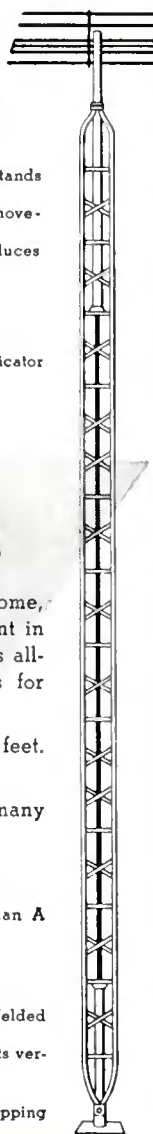

## TRIO YAGIS

*Lead the Field . . .*

### TRIO DOUBLE FOLDED DIPOLE

(Model 304)



Here is the popular TRIO Double Dipole TV Antenna. With 10 db forward gain and a front-to-back ratio of 25 db, it is unexcelled for extreme fringe areas. Available for each of 12 TV channels. Easily stacked for additional gain. Reinforced fittings for extra strength — extra rigidity!

- Exact Impedance Match To 300 ohm Line!
- Sturdy Construction — Light Weight!
- Partially Assembled!

### TRIO 2-CHANNEL YAGIS

(Models 445 & 479)

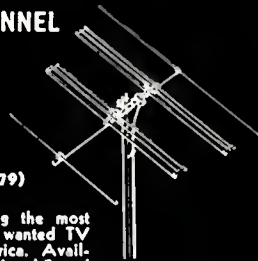

Rapidly becoming the most popular — most wanted TV antenna in America. Available for channels 4 and 5, and channels 7 and 9. Provides gain on two channels equal to any two conventional 4-element yagis!

- Full 10 db Gain On 2 Channels!
- Less Weight Per Gain Than Any Other TV Antenna!

### TRIO PHASITRON Now available separately

(Model No. PC-600)



The TRIO PHASITRON, originally sold only as part of the TRIO Controlled Pattern TV Antenna System, is now available separately for TV set owners who want to get the very best results from their sets and antennas, or to hams and other experimenters.

PHASITRON acts as a continuously variable tuning stub and will provide an exact impedance match between line and booster and helpful in matching output impedance of booster to set input impedance. Due to exact matching, losses in line become negligible and set performance greatly improved.

May also be used to coordinate input from two or more antennas to provide added balanced output to set. Write for full details.

### NEW TRIO TV ACCESSORY CONTROL UNIT

(Model No. RY-1)



A handy control unit that hides away inside or in back of the TV set and provides an automatic line switch for booster, rotator, TV lamp or other accessories. By plugging the line cords from these accessories into the TRIO Control Relay Unit, all accessories are turned on with the one switch controlling the TV set. Quickly installed without making any wiring changes in set.

# THOMPSON CORPORATION

AFFILIATED WITH TRIO MANUFACTURING CO.  
GRIGGSVILLE, ILLINOIS



*Trio* MFG. CO.  
GRIGGSVILLE, ILLINOIS



# THERE'S NOTHING WRONG WITH TV SALES that *UHF* won't cure—and Zenith has provision for it!

Simply place this strip into this Turret Tuner

This Turret Tuner is built into all Zenith TV sets

...and tune in the new UHF station!

**remember...**

with UHF on the way, the goodwill of your customers is at stake.

The sets you sell today, they'll expect to use tomorrow.

More TV stations... more TV programs... and better-than-ever television entertainment! With all this on the way—and TV inventories at an all-time high—you've plenty of reason to put UHF to work making sales for you.

And Zenith alone guarantees that every television set it has ever built and sold to the public has built-in provision for tuner strips to receive the new UHF channels without a converter.

Tie-in with this sales-making bonus! And start boosting this coming new era of television entertainment today... using Zenith's provision for UHF to build more sales, greater profits for you—now, and in the days ahead!

Learn the facts on UHF by writing today, *now*, for your free copy of Zenith's easy-to-read booklet titled "UHF Television—What It Is—What It Means To You." Mail this coupon now!

**ZENITH**  
ALL-WE PAY OFF  
 "LONG DISTANCE" RADIO  
 and TELEVISION

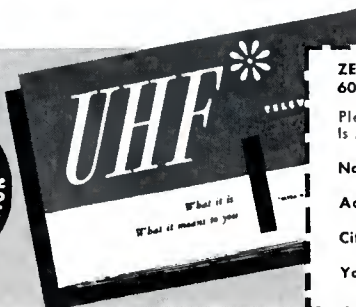

ZENITH RADIO CORPORATION  
 6001 West Dickens Avenue, Chicago 39, Illinois

Please send your free booklet "UHF Television... What It Is... What It Means To You."

Name of Dealer.....

Address.....

City & State.....

Your Name.....

ZI

*Radio Buy Word since 1924*

There is nothing finer than a  
**STROMBERG-CARLSON®**

And here in the new Woodstock and the new MusiClock  
are the two latest models in a radio line that always

has sold on performance, styling and value.

Two more important reasons why—in radio as in television—  
people readily agree,

“There is nothing finer than a Stromberg-Carlson.”

Get the complete facts about these exciting new models  
from your distributor now—or write us:



**THE WOODSTOCK** (Model 1608 PFM) AM radio . . .  
3-speed, fully-automatic phonograph. Separate treble  
and bass tone controls. 12" speaker. Push-pull ampli-  
fication. Beautiful tone. Built-in antenna. Exquisite  
Chippendale cabinet. Generous album space.  
33" high, 32" wide, 17 1/2" deep. \$289.95°

**THE MUSICLOCK** (Model C-1) Table radio-clock-timer that  
combines every desired clock-radio feature in a single unit. Radio  
switches on or off automatically—Wakes you up . . . Lulls you  
to sleep . . . Times electric appliances.  
Beautiful tone. Smart, compact cabinet—  
ebony and red with silver-gray dials.  
10 1/2" wide, 6 1/16" high, 5 11/32" deep.  
Built-in antenna. AC only.

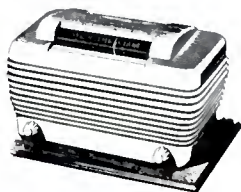
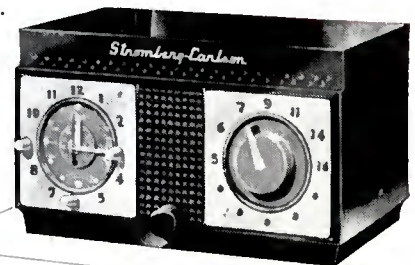

**THE DYNATOMIC** (Model 1500 HB) Ultra-  
smart table radio. All-louvered plastic cabinet.  
Built-in antenna. Brown. \$34.95°. Also avail-  
able in ivory or red.

STROMBERG-CARLSON COMPANY, ROCHESTER 3, N. Y.—IN CANADA, STROMBERG-CARLSON CO., LTD., TORONTO

# RADIO & TELEVISION RETAILING

Including "RADIO & TELEVISION,"  
"RADIO & TELEVISION TODAY,"  
and "ELECTRICAL RETAILING"

O. H. CALDWELL, Editorial Director



M. CLEMENTS, Publisher

## **Auctions, Price-Wars—on the Way Out!**

TV-radio-record-appliance dealers all over the country have been feeling the effects of gimmicked merchandising campaigns, such as auctions and price-wars.

Some merchants have been directly affected, losing numbers of sales to nearby competitors, as the "war" spread to their trading areas.

In big cities throughout the country, numbers of consumers have been waiting to see what the big stores in their areas will do in the way of slashing products—particularly the Fair-Traded ones. Even in sections far removed from the centers of feverish activity, a great many customers are asking for "something off" as a result of what they have read about auctions and price-wars.

### **Price-Cutting Waves Are Old Stuff**

There's nothing new about the use of drastic measures to move merchandise when business slows down. During the Depression, we had those utility-sponsored "package deals", profitless trade-in deals, and price-cutting in 57 varieties of styles. Yet all through such hectic times the majority of astute independent dealers *who didn't cut prices or participate in mad-house sales tactics survived*. And such merchants will survive the present epidemic of frenzied merchandising, which, fortunately, *is already dying down in intensity*.

### **Supply of Big-Demand Products Drying Up?**

The auction technique is practically dead at this writing, and it seems more than likely that the price-war between the big fellows will end before long because of lack of "ammunition." (One maker of items active in N. Y. "war" almost out of steel.)

Following on the heels of the Supreme Court decision, some stores, long at odds with Fair Trade, slashed the prices on a number of products which consumers *had always experienced difficulty in buying at "something off,"* hence, were willing to grab. Now this "ammunition" may soon be depleted. In many of the stores, all of the most wanted brands are being gobbled up, and buying has slowed down since people are not going for the off-brands available even at stiff cuts.

It isn't going to be easy to keep on replenishing stocks of some items before the public clamor dies down. In the first place, some of the products are, and have been in short supply. In the second place, certain manufacturers will do all they can to keep their merchandise away from the price-cutters. And third, how long can the big stores afford to sell big-demand items at a loss?

With the return of good business in the Fall, distress-selling will be a forgotten issue until another seasonal slump comes along.

In the meantime, the smart dealer will do his utmost to make every sale a profitable one, and will lean heavily upon his service department to carry him through this problem-laden period.

# What's Ahead!—in Radio,

NEWSPAPERS AND NEWSCASTERS did a much better job in explaining the color TV situation to the public this time. During the previous excitement which followed FCC's approval of CBS color, sales were seriously affected, but this time the public has been given a pretty clear picture of the whole thing.

THAT THERE ARE INSUFFICIENT FM-AM table model radios to meet the public demand is indicated by the results of a survey made by the nation's FM broadcasters. Thirty-six of the 41 distribution areas queried, or 88%, reported manufacturers' shipments inadequate.

COLOR DECISION HAS ONE PROMINENT ENGINEER predicting that Christmas will see a number of new TV sets with switch for receiving both present and new standard (color) frequencies. Today the sweeps are at 60 and 425 per second. New ones will be 144 and 405. The 15,750 cps squeal which some sharp ears can hear will be changed to 29,160 per second, which nobody can hear.

VOTE TO INCREASE EXCISE TAX on TV, radios, phonos and records. The House Ways & Means Committee voted to up tax on before-mentioned products from present 10% to 15%, at manufacturing level. No increase on electrical appliances, which are left at 10%.

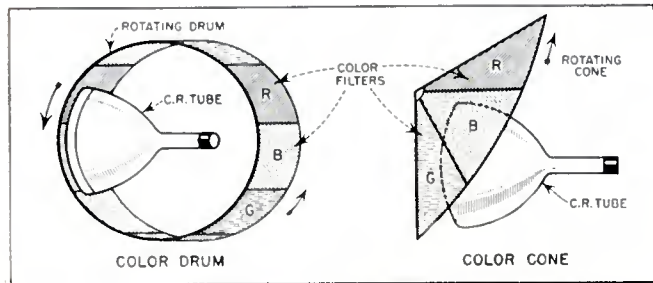

Sketches courtesy of Aerovox Corp.

GREEN LIGHT TO FCC-CBS color system has produced announcements of several converters and adapters in planning stages. Shown above are two suggested ways of saving space in CBS-type color sets. Color pictures up to 17" have been shown on the drum in demonstrations. See following pages in this issue for a complete discussion of the color-TV situation and some answers to customer's questions about color.

SOME DISTRIBUTORS HAVING A TOUGH JOB trying to keep good salesmen because of slow business. A New Jersey wholesaler says that the minute their income starts falling down, a great many salesmen start looking for other jobs. Incidentally, this distributor now has a force working on straight commission.

SEE SHORTAGES DEAD AHEAD. Big manufacturer of laundry equipment, who up until very recently had been telling dealers to buy carefully, keep inventories low, now advocating stocking up in anticipation of shortages before year's end.

SLIGHT UPSWING IN BUSINESS BEING NOTED in spite of the season. Look for marked activity to start in September with strong comeback for TV, refrigerators and other white goods. Room air conditioners selling well in many markets. Maintenance service in radio-TV, and in appliances continuing at a healthy rate.

TEMPORARY SLOW-UP OF SALES OF PHONO RECORDS not viewed with alarm by certain leading dealers in some of the "Music Cities" of the Midwest, Fort Wayne, Indiana, for example, where merchants look for a big increase in the Fall. "They're not buying anything but food right now," said one merchant. "It's a psychological proposition brought about by rising costs of necessities, high taxes, and so forth," explains this retailer, who says the consumer "will get over his reluctance to buy as soon as he gets 'used to the situation.'"

NUMBERS OF FRINGE DEALERS DOING GOOD TV business in spite of sales slow-down. Typical example: Southern Illinois merchant, in town of 4,000, surprised his suppliers recently with an order for 95 TV sets, amounting to nearly \$23,000. His sales are almost all cash, with most installations costing more than the sets themselves.

ONE PARTS SHOW IN 1952! Manufacturers and distributors are pretty well agreed that one national radio parts show a year is enough—in place of the two present get-togethers, one in May and one in September. As pointed out in a previous issue, the extra cost to the industry, of the present duplication, exceeds a million dollars a year—with manufacturers' outlays estimated at \$500,000, distributors' expenses at \$400,000, and Reps \$100,000. Thoughtful leaders are urging the trade to concentrate on one big show for '52. While each show has its own loyal defenders with proper pride of accomplishment, the present National Emergency points the need for combining forces in the public interest.

CONSUMERS ARE SPENDING A BIGGER AMOUNT of their incomes today on radio and TV than they did three years ago, according to Frank Mansfield, Sylvania director of research, who also predicts that the replacement tube market will rise to 154 million dollars in 1952 and to 286 million dollars for the following year.

SMALL SIZE COMBINATION ELECTRIC REFRIGERATOR and gas range being manufactured by General Air Conditioning Corporation, Los Angeles, Calif., designed for small apartments, vacation lodges, etc. The unit is now in dealer stores.

"WE LISTENED TO OPINIONS ON BAD SHORTAGES in the Fall. Most guess yes. But Melville will stay out on the limb. We guess no. (But don't get mad if we're wrong.)"—Bulletin to dealers sent out by Frank Melville, Melville Radio Corp., Flushing, N. Y. distributor.

# Appliances, Records and Television

**BIG CROWD EXPECTED TO ATTEND** the Radio Parts Distributors' Convention, at the Cleveland Auditorium, September 11-13. Special programs have been arranged, and a great many interesting exhibits will be arranged by manufacturers.

*MACY'S IN NEW YORK ADVERTISED* a 17-inch table model TV set at \$129. Asterisk called attention to fact that there was a \$20 additional charge for tax and warranty.

**SERVICE DEPARTMENTS ARE COVERED BY OPS** in Ceiling Price Regulation 34. They should have filed their prices by Friday, June 15. Their price lists must be posted for public inspection where customers can see them plainly. They must give customers sales slips, if they did this during base period, Dec. 19, 1950 to Jan. 25, 1951. Further, they must give itemized bills for service work stating labor and parts charges whenever requested, regardless of past practice.

*"DEALER IS TOPS"*—says Seymour Mintz, Admiral's advertising manager. "Of the three links of distribution—manufacturer, distributor, and dealer—we recognize the dealer as the biggest and most important link in the chain. I think that you will agree with this conclusion when you realize that by this means of distribution we at Admiral raised our yearly sales from \$240,000 in 1934, to \$230,000,000 in 1950! Again I say, the retailer is the key man in our way of doing business!"

**FREQUENCY MODULATION** is once more coming to the front, having registered for the first quarter of 1951 the largest receiver output in FM history. Beginning a year ago, there had been a distinct shortage of AM-FM models, but with recent expanded output, the industry is once more in an inventory position, and sets are available. FM has some geographical advantages which must not be overlooked, for there are specific areas in the country where AM reception is far from satisfactory, particularly such areas as North and South Carolina, where the AM signals from Cuba cause disturbing interference and make AM reception practically impossible at certain times. The acceptance of FM in an area such as this has been excellent and very substantial numbers of AM-FM units are being purchased and used.

**"RURAL ELECTRIFICATION WEEK"** set to begin August 26. Electricity will be available to 95% of the nation's farms at the end of this year. There are about 5,200,000 occupied farms and about 15,500,000 occupied rural dwellings. About 80% of the power used by farmers is supplied by taxpaying companies.

*"BOTH UHF AND VHF WILL soon be incorporated in all TV sets manufactured."* So stated a leader in the TV set manufacturing field at a recent meeting in New York.

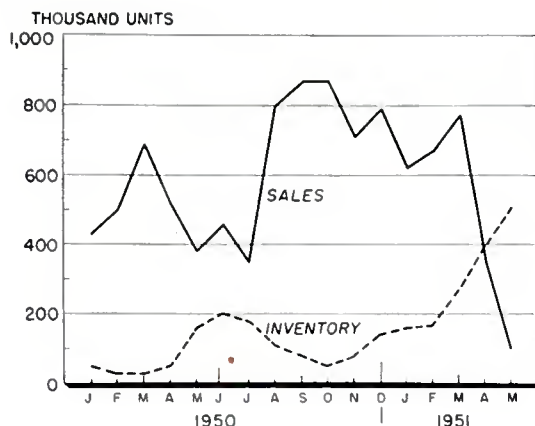

**RATIO OF INVENTORY TO TV SALES.** Data is for period from January, 1950, through May, 1951. During 1950, what may be described as a normal pattern prevailed, with the inventory ratio showing a slight seasonal rise in the summer. In March, 1951, the curve rises, showing the comparatively high ratio of sets in inventory to sets sold. Chart prepared by RTMA.

*HEARD AT A RECENT CHICAGO CONVENTION.* "Business is nearly normal, therefore it's lousy." . . . "Cadillacs may be hard to buy, but they're easy to get for free if you buy enough merchandise."

**LATIN AMERICA** has six TV stations already—two in Havana, two in Mexico City, and one each in Rio and Sao Paulo. Eighteen more are projected in major cities in seven countries and Puerto Rico. Total wired homes within a 60-mile radius of these 24 stations is 3,258,612, according to Philco International's R. L. Romeyn.

## FUTURE EVENTS OF INTEREST TO READERS

- |   |  |  |
|---|--|--|
| July 1-6: New York Lamp Show, Hotel New Yorker, N. Y.   | July 30-Aug. 10: Chicago Gift Show, La-Salle Hotel and Palmer House, Chicago, Ill. | Sept. 11-13: Radio Parts Distributors' Convention (NEDA), Cleveland Auditorium, Cleveland, Ohio.   |
| July 9-13: 15th National Housewares and Home Appliance Manufacturers Exhibit, Auditorium, Atlantic City, N. J.    | Aug. 19-22: 4th Western Housewares Show, Biltmore Hotel, Los Angeles, Cal.         | Sept. 16-20: Philadelphia Gift Show, Hotel Benjamin Franklin, Philadelphia, Pa.                    |
| July 16-19: National Assoc. of Music Merchants 50th Annual Convention and Trade Show, Palmer House, Chicago, Ill. | Aug. 20-24: New York Gift Show, Hotels Statler and New Yorker, N. Y.               | Sept. 23-27: Washington Gift Show, Hotel Willard, Wash., D. C.                                     |
| July 16-20: Western Summer Market, Western Merchandise Mart, San Francisco, Cal.                                  | Aug. 22-24: Pacific Electronic Exhibit, Civic Auditorium, San Francisco, Calif.    | Oct. 8-12: National Hardware Show, Grand Central Palace, N. Y.                                     |
| July 28-31: National Audio-Visual Association Convention and Trade Show, Hotel Sherman, Chicago, Ill.             | Aug. 26-31: Rural Electrification Week.  | Oct. 31-Nov. 1: Fifth National Home Laundry Conference, Commodore Hotel, N. Y.                     |
|   | Sept. 3-7: Boston Gift Show, Hotel Statler, Boston, Mass.                          | Nov. 5-8: 7th All-Industry Refrigeration and Air Conditioning Exposition, Navy Pier, Chicago, Ill. |

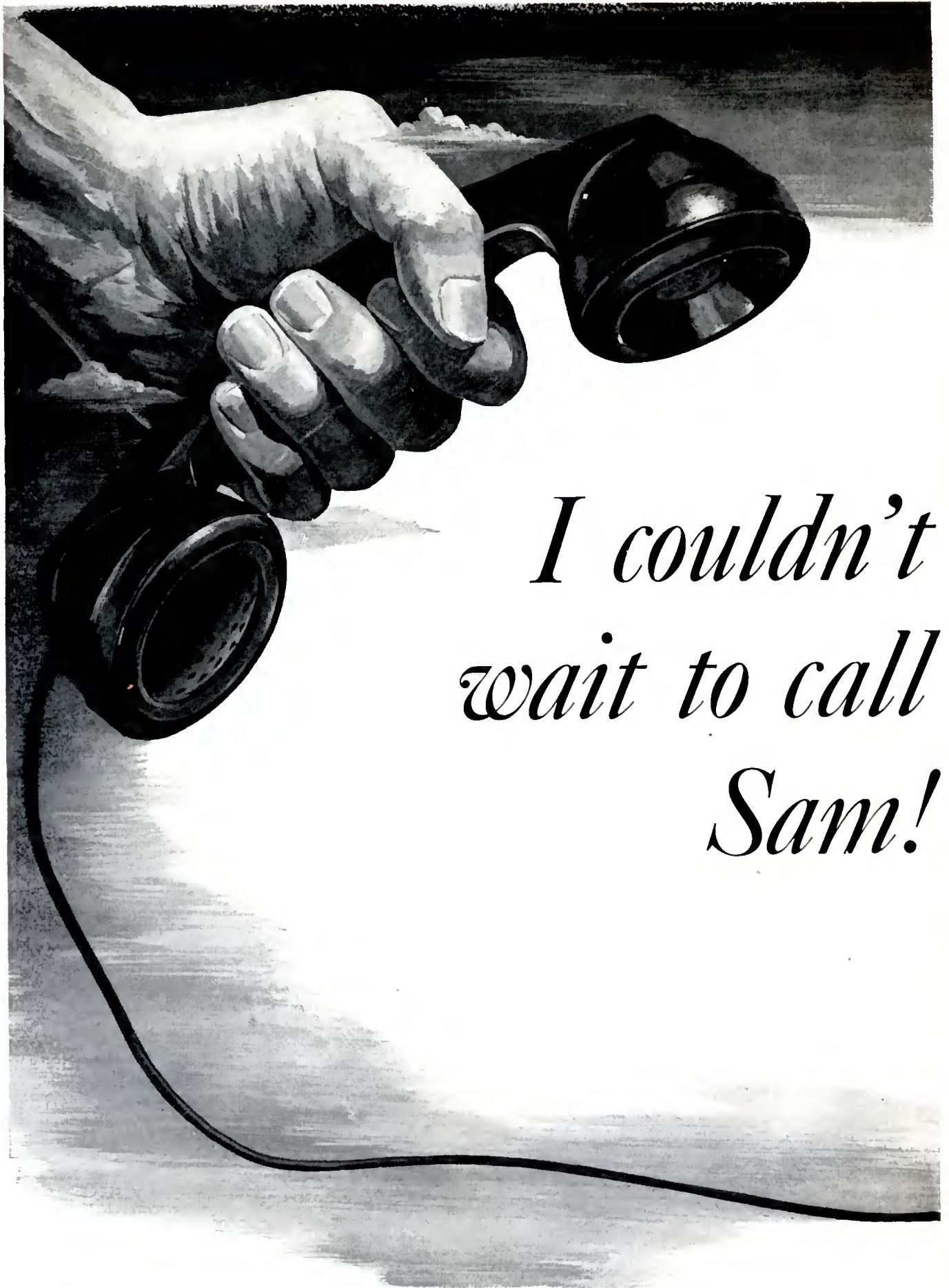

*I couldn't  
wait to call  
Sam!*

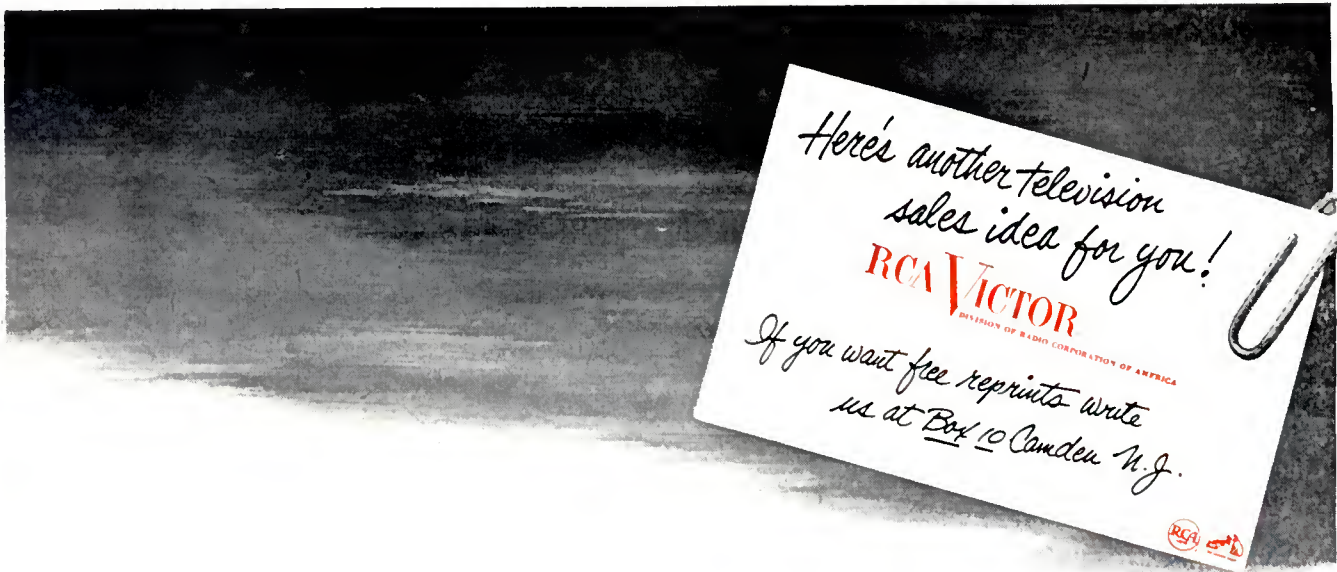

## You see, today I waited more than an hour at the showroom of the Sam Peters Motor Company...

... while the service manager adjusted my carburetor. And brother, was I annoyed when I left! All that time shot! Then I got an idea! It was so good, I couldn't wait to call Sam.

"Sam," I said, "your service is great, but that hour I had to wait seemed like half the day. Why not let your customers actually *enjoy* waiting?"

Sam exploded. "What am I supposed to do, Mr. Genius, hire dancing girls?"

"Nope... install a big-screen television set—the RCA Victor Hillsdale would be perfect."

"What, a TV set in my place?"

"Sure, your customers will have fun waiting and watching big-picture television! And you'll be a mile ahead of Bill Small's outfit."

"That's true, but suppose the kids..."

Then I beat him to the punch. "Lots of sets come with cabinet doors you can close when you don't want the set used... I'll even have my cabinet man put a lock on—free."

The whole thing only took four or five minutes. And before we had hung up I had a big profit sale on another RCA Victor set.

You know I've found dozens of prospects just like Sam here in town... anywhere people have to wait. It's no wonder RCA Victor television is the easiest to sell... plenty of outstanding features and exclusives, it's America's most wanted television.

Hope you'll excuse me, but I think I can sell a set to George, my barber.

*You are cordially invited to visit the RCA Victor exhibit in Private Dining Room #14, Palmer House, Chicago, at the N.A.M.M. Show, July 16 to 19.*



This is one of a series of advertisements published in the interest of television merchandisers by RCA Victor... World Leader in Radio... First in Recorded Music... First in Television

# Sell More TV Sets

**Strict Attention to Every Detail from "Start to Finish"**

• Dealers who offer free home trials of TV sets should have two objects in view. First, of course, they need to make every endeavor to get the prospect to keep the receiver. And second, they should try to sell the customer *the best set he can afford to buy*.

A high average of sales closings as a result of trials in the home can only come about when the dealer prepares the way in advance. In order to do this he needs to take a number of definite steps, *starting with the time the customer inquires about the home trial offer, and ending with the time the salesman calls at the home to try to close the sale.*

Since home trials which result in sales are profitable, and because those which do not click represent dead loss, great care must be exercised every step of the way in using the on-trial technique.

## **Have Definite Understanding**

To begin with, the customer should understand clearly *all of the terms of the trial offer*. He should know in advance just how much the set, and the installation will cost, as well as having a clear understanding about credit terms. The prospective purchaser should know how long he can keep the set (two days is long enough), and he should agree to see the salesman at a pre-determined time after delivery of the receiver.

Dealers who are vague about

terms in advertising or in talks with customers, or who attempt to hide anything from the would-be purchaser will find that they're just making tough-sledding for the salesman when he calls to try to get the name on the dotted line.

Having made all points in the agreement clear to the customer, the dealer should obtain some sort of signed order. A conditional bill of sale is frequently used. This document sets forth the terms under which the dealer delivers the set and under which the customer accepts it. (The prospective purchaser should also be required to sign a receipt when the set is delivered.)

## **The Profitable Procedure**

Before delivering any receiver on a trial basis, the merchant should check very carefully as to the customer's ability to pay for it. Before agreeing to send any receiver out on trial, the dealer should try to get the customer to choose a certain model, a certain price. Such pre-trial qualification will, in most cases, eliminate the necessity for switching sets after the customer has been sold. *It goes without saying that the dealer saves money if he gets a more or less firm decision on any model before sending it out for trial, and doesn't have to make two or more deliveries to get one sale.*

In all cases, the dealer should try to sell the customer the best

set he can afford to purchase. Too few dealers offering home trials do any *advance selling*. Those who neglect to try to *sell up* customers who want home trials usually end up with a flock of small-ticket sales. This has been particularly true during the sales slump, and a great deal of the underselling was due to the feverish desire to make a sale—any sale, during the doldrums. Under such conditions, a great many wealthy people bought sets under \$200, which is poor business for the dealer and for the customer as well.

The salesman who spends a little time *selling up* with home trial customers can get results. He hasn't anything to lose, at all events. If, after the trial period has ended, the customer decides that the price is too high, the salesman is still in a good position to sell a cheaper set. As pointed out before, skillful qualification will pay.

Another good reason for getting the customer to agree to take for trial the best set he can afford to purchase is because of the good psychological effect a fine instrument will have upon members of the family. *The finest instrument on display in the store always looks a hundred per cent better in the home.*

## **Helping the Sale Along**

A great many dealers believe that the on-trial receiver should be delivered in the original carton, and they also believe in telling the customer that if he decides to buy, *he will keep that particular receiver.*

Some merchants send "trial sets" to customers' homes, but this practice has a number of drawbacks. In the first place, the "trial set" is often a battered-up looking affair, and while it may perform well, it certainly doesn't sell itself on appearance. Furthermore, some customers upon being advised that they will get a different set if they decide to buy, will be likely to believe that the "trial set" is "souped up"—and that the one they get won't work as well. Then, too, the use of a "trial set" delays

## **Money-Making ON-TRIAL Techniques**

Try to sell them the best they can afford

Make all terms clear to the customer before delivery

Try to "pre-sell" a certain model on showroom floor

Be sure set operates at peak performance in the home

Hand-pick a number of good TV programs for the customer

Pave the way for a smooth sales-closing after trial ends



# via Home-Trial Method

**Will Avoid Pitfalls, Produce High Sales Average**

the sale process, involves extra deliveries, and reselling techniques.

Before delivery, the set should be thoroughly checked so that only a minimum of adjustments need be made in the home. In fringe areas, dealers usually take along some sort of "portable" outdoor antenna. One successful TV dealer who has done a good job in a locality far removed from television stations, uses a tower on a trailer. He leaves the entire rig at the home of the person getting the trial.

In high signal neighborhoods, servicers should take along a good indoor antenna, and should spend a little time placing and orienting the aerial in order to get the best results possible.

## **Start Selling Right Away**

An effort to satisfy and sell the customer should start the minute the set is delivered. Sales-minded servicers who know how to meet the public can make the delivery without a salesman, but in cases where such men are not available, it is very important that a salesman call at the time the receiver is delivered. After the unit has

been put in operation, the salesman or the servicer should show the customer how to work the controls. In all cases, the customer should operate the controls himself in the presence of the store's representative.

## **Stress TV Programming**

A great many salesmen fail to sell *programming* to prospective purchasers, leaving the latter to grope about for some time in efforts to find programs they like. Since almost all of those who accept on-trial sets are unfamiliar with what's on the air, and because they can't tell too much about shows by newspaper listings, they may go from station to station without finding anything to please them. Once a customer decides that a great many of the programs are not to his liking, he may hesitate to buy on such grounds alone. The smart salesman will jot down a number of shows, forums or what-have-you the customer should be interested in, and leave such list with the prospect. Skillful questioning will reveal the various tastes of the members of the family, and because of the great

variety of programs now on the air, the salesman will have no difficulty in picking out a few, "made to order."

## **Good Reception a Must**

Where an indoor antenna is used, most dealers think it's a good idea to show the customer how to adjust and orient it. A number of factors make this practice advisable, including the possibility that intermittent interference may occur which could be taken out by re-orientation. Furthermore, in showing the customer how to handle the antenna, fear of the aerial equipment is removed from the customer's mind. In cases where the installation will be finally made with an indoor antenna, familiarity with the aerial can eliminate unnecessary service calls. With sets having built-in antennas, proper placement of the unit is, of course, very important.

Where an indoor antenna is being used temporarily during the trial, the salesman or technician should be sure to point out that *better reception* will be enjoyed when the permanent outdoor in-  
(Continued on page 99)



Let  
"ONE WAY"  
Be Your  
AIM!



**Pre-Sell the Home-Trial TV Sets. Make it Easy for the Customer to Say "Yes." The Receivers You Have to Take Back Represent Dead Loss to the Store**

# Profitable Television

**Effective Advertising, Good Selling Methods,**

• Trading-in has always been a great sales stimulator, and its importance as a merchandising practice was never greater than it is at this time when business has slowed up in a great many stores.

In television areas, the drive to get in those small-screen sets is having a real impact on the public. Large amounts of money are being spent in trade-in advertising, and the dealer who hasn't a trade-in policy of some sort is quite likely to lose a lot of business to his competitors who have. Here, we examine the trade-in proposition from the angle of advertising, customer relationships, estimating, and reselling the traded-in units.

For the merchant who wants to retain his customers, get repeat business and satisfied-user leads, the trading-in technique must be handled with kid gloves, and without kidding the public.

Misleading ads, offering fantastic prices for old sets will result in a lot of antagonism toward the store in cases where the customer gets to the point of talking business with the dealer. Furthermore, the average of sales made as a result of "colossal" offers which are purely fictional, will be low, *making the cost of such sales promotional*

*effort high in relation to sales.*

Hard-hitting trade-in advertising copy can be employed successfully by any dealer who makes honest statements, and offers he intends to live up to. Modern folk are smart—much smarter than they ever were before. They know brands, and they know values. And they dislike being fooled.

## Sales-Pulling Ad Ideas

While *many customers* will respond to "bait" ads, *most* will walk out in a huff when they find that the sky-high offer they read about is nothing more than a come-on, and that the offer they receive for their old receiver is pitifully low. Since *the prime purpose in spending money on trade-in advertising, and other forms of sales activities is to get sales*, it just isn't good business to *pre-condition* a prospective customer to *disappointment*. It's an old-fashioned practice which is definitely out of step with modern times.

The dealer who uses strong, yet honest copy in his trade-in advertising can close a satisfactory number of sales with those who respond, which is what he certainly hopes to accomplish through the advertis-

ing he spends his money for.

An effective method is to use a coupon ad, either in newspaper space or in direct-mail pieces. The coupon provides a place for the set owner's name and address, the make of receiver owned, and the age of the unit. The ad offers a free estimate for the purpose of making an allowance on the purchase of a new set.

With the present all-out renewal of the trade-in technique, dealers must have some way of getting in on such activities, making it known to their customers and prospects that they are willing to trade-in sets. In addition to newspaper advertising, signs should be used in show-windows and in the store. Radio and TV spots are employed by a great many successful merchants in stimulating trade-in business.

## Good Selling Methods

Trading-in is a merchandising art. When it comes time to make an offer for an old set, there are a number of pitfalls to avoid. First, no salesman should ever "beat down" the customer's old receiver.

As pointed out in previous articles, the owner usually has a very warm spot in his heart for the ra-

## Suggested Trade-In Allowances on TV Sets

Size Screen	Age 6-mo-1 yr.	1-2 yrs.	2-3 yrs.	Pix tube needs replacing	Add for radio	Add if space for changer
7"	.....	\$25	\$15	—\$15	.....	.....
10" average	.....	35	25	—20	\$5	\$5
10" de luxe	.....	50	40	—20	5	5
12" average	\$65	55	40	—30	7.50	5
12" de luxe	85	75	60	—30	7.50	5
17-16" average	80	70	62	—40	7.50	7.50
17-16" de luxe	110	100	90	—40	7.50	7.50
19-20" average	130	120	.....	—60	7.50	7.50
19-20" de luxe	175	150	.....	—60	7.50	7.50

Above are suggested prices for table models; **add \$10 for consoles**, consoles with doors add \$15.

Subtract for cabinet refinishing—\$25-35. **Or reconditioning, \$10.**

Subtract for other repairs in addition to picture tube—this is COST, whether it's in your shop or the customer's home.

Typical example: Receiver shown in heavy type—**12" set one year old, console with radio**, needs pix tube and needs slight reconditioning work on cabinet. \$65 base price, less \$30 for new pix tube—\$35. Add \$10 for console—\$45. Subtract \$10 for cabinet work—\$35. Add \$7.50 for radio. \$42.50 allowance. This set should sell, with mark-up, for \$100 or more, after reconditioning.

# Trade-In Selling

## Cautious Bidding, and Prompt Resale Are Musts

dio or television set which has given him years of satisfactory service. He will heartily dislike having the unit described as a "piece of junk" in or some such other term. *Such technique is old-fashioned, and, in addition, is not effective any more.* Salesmen who practice these customer-antagonizing techniques do so because they believe this method will prepare the customer for acceptance of a very low offer. This is a wrong premise. It is far better to make the customer feel that he was wise in the beginning to choose the product, and to go on then to justify what the prospect may think is a low offer, on sound business grounds.

### Don't Go Overboard

When business is bad there always exists the very strong temptation to get the sale regardless of the consequences. Under such conditions it is easy to go overboard on allowances. Because of this fact it is vitally important to view all trade-in transactions two ways. First, if the trade-in cannot be sold or used, any allowance made comes directly out of the profit in the new unit. Second, if the used receiver has value, the salesman should have a fairly accurate idea of how much it can bring in a resale. Use of a table, such as the allowance one accompanying this article, will help. First, it can be shown to the customer, adding authenticity to the statements the salesman makes about the value of the old set, and second, it helps greatly in preventing overboard bidding where otherwise the salesman's memory is the sole means of checking.

### Selling the Used Sets

A trade-in transaction doesn't actually end profitably until the used product involved has been disposed of. A great many dealers allow traded-in sets to pile up, be cannibalized, or just "fade away." Since the dealer's good money is tied up in the used products, he should make every effort to put them in shape for resale as promptly as he possibly can.

Every dealer should set up an orderly method for handling the

### Don't Let Used Sets Pile Up

- "Process" Them Immediately
- Price Them Realistically
- Promote Them Actively
- Recondition Them Thoroughly
- And Stand Back of Them

trade-ins. Sets which cannot be resold, should be dismantled, and the parts should be put into special bins or boxes. The sets having resale possibilities should be checked, repaired, and offered for sale.

Used, small-screen television sets sell well in all markets in the country, and the merchant who doesn't move them out quickly is losing a real opportunity to make more money. In many markets, used radios sell well, too, and they should be handled the same way as the TV sets. Some dealers set aside certain portions of their stores for the display of traded-in products, while some of the larger merchants have separate sections for this pur-

pose, where used items are shown.

At all events, the traded-in units *should be promptly processed, realistically priced for resale, and should be promoted.*

Some merchants have a long "waiting" list of customers who want to buy used TV sets. One Philadelphia dealer gets telephone calls every day from people who want to spend \$60 or so for a ten-inch set. This retailer built up a following by using classified ads, and has found that he's been able to swing a lot of used-set prospects over to new big-screen jobs, in addition to moving out the used sets as fast as they come in.

Summing up, there are some very definite things the dealer must do to conduct a successful trade-in campaign. First, he must ferret out the owners of small-screen sets by advertising, and by contacting his old customers. Second, he must use strong ad copy, that pulls without antagonizing. Third, he must use extreme caution in trade-in transactions in order to keep his customers happy. Fourth he shouldn't go overboard in making allowances on old sets, and fourth, he should make sure that the sets he takes in are disposed of promptly and profitably.

## Suggested Resale Prices

### on Traded-In TV Sets

Size Screen	1947	1948	1949	1950
7" table	\$40-50	\$45-55		
10" table	\$50-60	\$55-65	\$60-70	
10" combo	\$60-70	\$70-80	\$80-90	
12" table	\$70-80	\$80-90	\$90-100	\$100-120
12" console	\$80-90	\$90-100	\$100-110	\$115-125
12" combo	\$90-110	\$105-125	\$115-135	\$130-150
15-16" console		\$120-140	\$130-150	\$150-170
15-16" combo		\$130-150	\$140-165	\$160-195

Notes: Sets listed above should be in good operating condition; pix tube & parts (not labor) guaranteed for 90 days.

Large-screen sets, though in demand, have been included because it has been found that some people would rather trade in than continue to pay for repairs on receivers they consider to be "lemons."

Suggested prices on this table should apply during periods **when new sets are being sold at or near list prices**, and should be adjusted up or down according to general market conditions.

# What to Tell Your Customer

## About COLOR

**1** Does the recent Supreme Court decision on color-TV mean that all TV will now be in color?

No. TV as we now know it, will *not* be changed in any way. The decision merely *permits* broadcasts of the FCC-authorized color—doesn't make it mandatory.

**2** Can this new FCC type of color-broadcast be received on the 13 million sets now in U.S. homes?

No. It is an "incompatible" system, which means that it will not work with FCC's own present standards. That is, existing receivers will not be able to "see" a picture of any sort. Therefore color broadcasts will be sent out only a few hours a week, in "off" hours when no regular programs are on.

**3** Will sets now available for sale on your floor receive these color broadcasts?

No, they will not.

**4** Does this mean that these receivers will be made obsolete by color TV as broadcasting increases?

No. Such sets can be *adapted* to receive color broadcasts in black-and-white, and *converted* to receive them in color, at such time in the future that it should become desirable. *Adaptation* involves circuit changes necessary to receive the incompatible color broadcasts, and *conversion* involves the addition of the revolving color disc.

**5** Can any sets be adapted and converted to this type of color?

Yes. But under the present system involving a revolving color-disc, *conversion* would be limited (due to physical size of the disc and motor) to 10 or 12-inch tubes.

**6** Does that mean that future color sets will be limited to 12-inch screens?

Yes, as long as the present system involving mechanical conversion is in use. Other methods (like color-drums) are also being developed, though not yet available.

**7** Is it likely that this system involving mechanical conversion will be replaced by something better?

Yes, definitely. We already have experimental systems which are completely electronic and compatible. The

commercial perfection of such systems will mean the abandonment of the mechanical receivers.

**8** Then, if there were any color sets available now, they are likely to become obsolete?

Yes. They are likely to be made obsolete sooner than present black-and-white receivers, since owners of present black-and-white sets can go on enjoying all existing top-notch sponsored shows during the period in which color-TV is being experimented on and improved.

**9** Are there any color sets now available?

No. Some models have been shown by manufacturers, and some deliveries will be made in the last quarter of this year; but by comparison with present production and sale of TV (500,000 to 600,000 a month), deliveries of color sets will be only a trickle. These will be small-screen sets, and comparatively high-priced (one receiver with a 10-inch picture tube has been quoted at \$400).

**10** When do you think color-TV will predominate?

Not for several years (until a majority of owners have sets capable of receiving it) and possibly never. Technicolor movies have never completely supplanted black and whites; as a matter of fact, less than half of present movies are produced in Technicolor.

The adoption of color-TV would be speeded if a "compatible" system were approved, for then every set owner could receive color broadcasts without any changes to his receiver. This may yet come to pass, as the FCC has "left the door open" for any system which can be proven to be superior to the one presently authorized.

In the last analysis, however, whether or not we have color-TV, what type it will be, and when we will get it, will be decided NOT by the FCC or by the Supreme Court, but by the American public, who will buy what it wants and reject what it doesn't.

Up to now, the American public has not shown any overwhelming desire for color-TV. Their reaction last Fall to the FCC authorization of color was to go out to the stores and buy present type black-and-white sets in greater numbers than ever.

# TELEVISION *and* UHF

*So if I wait for a color set, I will have to get a small-screen set with a mechanical color disc at a relatively high price?*

Right!

*And if I get such a color receiver I will only be able to receive color programs of an experimental nature in a few "off hours"?*

Right!

*But if I buy a regular black-and-white set right now I can expect to enjoy top-notch sponsored network shows immediately and for years to come?*

Right!

*But if this presently authorized incompatible color system should prevail I could have my black-and-white receiver adapted to it?*

Right!

*And there is a likelihood that we will eventually get a compatible color system on which my set would receive programs (in black-and-white) without adaptation, but on which currently planned color sets would not work?*

Right!

*So that there is less chance of a current black-and-white receiver becoming obsolete than the currently planned color sets?*

Right!

Please show me some 20-inch sets . . . I'm going to buy now!

**And here's the way to explain UHF:**

**1** *If I buy a set today, will I be able to receive UHF when it arrives in my community?*

Yes. The set you buy today can be readily adapted to receive UHF when it comes to your locality. Some receivers now on hand have provisions for changing tuner strips, other receivers can be made to get UHF signals through the use of an adapter.

**2** *How soon will UHF broadcasting be here?*

UHF broadcasting on any wide scale is a year or more away. First, FCC hasn't made final allocations yet. Second, there's a scarcity of materials needed to build transmitting stations. Third, there are a number of engineering problems in UHF broadcasting which have not yet been resolved.

## **Let's Get This Straight Regarding Color TV**

To begin with, the editors of RADIO & TELEVISION RETAILING are for color television—provided it's a system that will bring pictures to the present 13 million set owners. The industry as a whole is in favor of color television, as well. The majority of industry leaders want color, but they want it to be compatible and electronic.

The prospects of color television are exciting. The profit picture of color TV is one of unlimited scope. The benefits to the consumer will be tremendous.

Yet the television industry wants the best it can get in the way of color TV. It doesn't want to make obsolete the millions of black-and-white sets it has sold. It doesn't want any color system to halt the sale of black-and-white sets when black-and-white broadcasting will be the dominant programming medium for a long time to come.

The editors of RADIO & TELEVISION RETAILING respectfully urge that the FCC *invite* those having compatible, electronic systems to demonstrate them at once . . . and after seeing such systems, they can choose the one or ones they like best, and authorize experimental broadcasting by such systems, including of course, a continuation of the one the FCC approved last October. If the FCC will do this then the public can judge the merits of the respective systems. This would be a fair arrangement, particularly in view of the fact that the public has not had an opportunity to judge TV color systems by comparison.

# How One Dealer Overcomes

*Stresses Point That Folk Who "Wait" Will Miss Big Shows Now on Air; Tells*



Attractive show-room of Sneed's Radio & Television Company, Tulsa, Oklahoma.

• "The toughest job we're going to have in selling right now is to undo the harm created by the Supreme Court decision on color TV and get our customers to realizing that color TV is a long, long way off rather than just around the corner," declares Clarence Sneed, owner and operator of Sneed's Radio and Television Company in Tulsa, Oklahoma.

Sneed, since establishing his business in 1936 has built it from a small repair shop to a sales and service organization housed in a new \$30,000 building at the edge of the Tulsa business district with some unusual approaches to radio and television set selling. But first, how is he handling the current color TV problem which has affected sales of black and white sets in many parts of the country?

"It's the toughest sales resistance to TV set sales I've ever encountered," he answers, "but I'm solving it by sitting the prospective customer down and explaining the technical difficulties that stand in the way of immediate color TV for everyone. I've pushed news stories in the paper from the local TV station explaining it won't be with us tomorrow and I've used my small ads to keep bucking the idea.

"Any dealer can tell his customers with absolute truth that it may be as much as three years before they will have color TV.

### **Overcoming Sales Resistance**

"Explain to them how the speed-up of the war effort and resulting shortages are making color television even more uncertain.

"Since we've started talking to customers that way they've started to listen and we've overcome the big resistance to a great extent, and we believe it will be forgotten in a comparatively short time. But unless the radio man himself does the telling folks are going to keep right on putting off buying TV to wait for color.

"We point out to such prospects that they are going to miss many thousands of hours of good television programs if they wait around for color. You can also point out that color movies were developed more than 25 years ago but aside from the big musicals and outdoor extravaganzas, most are still shot in black and white and it's going to be that way on TV."

Sneed has developed a plan to aid in boosting TV set sales and with it he was doing business even during the recent slow market.

"My customers get free service," he explains. "It's been a wonderful good-will builder for me and has helped us make sales when our competitors were standing still. I simply tell my customers, 'I don't make you buy a guarantee, I give it to you'.

"We're against some very tough competition here too in big-operator stores who offer television sets at some mighty low and tempting prices. A dealer has to have a competitive selling weapon under such circumstances and the free service method is exactly the weapon he can use.

"A radio and television dealer generally has service facilities such as we have here; the cut-price boys in drug stores and filling stations do not. If you'll check back on your records you'll find costs of servicing a top-make television receiver for the first year are very, very small. It's so little you just can't afford not to use it as a selling weapon.

"People are scared to death of the costs of servicing television receivers because of wild tales they've heard about high prices of picture tube replacements. It's something they start to think about when they set out to buy a receiver. We remove this sales block right off the bat by explaining that we never sell our customers a service guarantee—we give it to them."

### **Custom Work Profitable**

Sneed does a great deal of custom installation business in the Tulsa area and he believes this offers every dealer everywhere an unexplored gold mine of potential profits. The average custom installation charge is around \$400, and as he puts it, "half of that is pure profit." Standard TV chassis are used on all such installations. Each is tailored to fit the individual room into which the customer wishes the set placed. An accompanying illustration shows one such installation by a fireplace in a Tulsa home.

"Besides the profit you can make from such an installation," he points out, "It's the very best advertising you can ever get that will lead to big set sales for you.

# the Color TV Sales Bogey

**Customers Facts in Talks, in Advertising. Effective Selling Methods Outlined.**

"Almost without exception the person for whom you will make such an installation never fails to point it out to everyone they can get into their homes and exclaim 'Look what Sneed's did for us!'"

"It's not a big volume business but it's a highly profitable one. The average installation can be made by any service man you have on your payroll for it entails no more work than installing an ordinary set in a home.

Such installations are powerful sales builders for the Sneed firm even in helping secure prospects for noncustom receivers as well.

Sneed has found newspaper space his most effective means of advertising. He uses small single-column advertisements consistently in local newspapers pushing the name brands of the sets he sells.

## **Ads Bring New Business**

"With these ads I'm not only trying to keep reminding folks that we have the top-quality name brand radio and television sets," he explains, "but I'm after the newcomer to Tulsa. That individual is primarily interested in finding out who is the dealer of the radio or TV set he already has and I want him to know about me."

Sneed also believes that it is of the utmost importance for the dealer to cultivate the friendship of the editors of local newspapers, who will frequently open editorial columns to the merchant for newsworthy articles.

Oklahoma City's TV station was the first in the state to come on the air. Tulsa is about 85 air miles from Oklahoma City. The first day WKY-TV at Oklahoma City came on the air, Sneed, who already had erected an antenna, set up two big-screen receivers for the public to view. Through his acquaintanceship with local newspapers the stunt rated a story and a picture and put him in a front-running spot for TV set sales in Tulsa, particularly when KOTV, the local station, later went on the air. This friendship also enables him to secure newspaper picture space on the big custom installations he makes in the Tulsa area.



One of the custom TV installations made by Sneed, who points out profits in such activity.

Another stunt he uses is a telescoping 40-foot tower with a TV antenna on top which he carries on his truck to all demonstrations. Almost everyone knows it is not needed for local reception, but its advertising effect well justifies its use.

Demonstrations, by the way, are never left in a customer's home. Sneed maintains that if the set cannot be sold during an evening's sales demonstrations the sale had better be forgotten. The risk of

damage is too great with the type of individual who makes a specialty of "demonstrations" in television sets, he believes, to leave them out for any longer period of time.

Instead of leaving sets he demonstrates them during an evening at the customer's house, and if he fails to make the sale he has the receiver returned to the store. This, he claims, eliminates the risk of damage to the sets, and helps people make quicker decisions.

Clarence Sneed, left, works on a TV set with a technician employe. A separate service section is maintained by the firm for the repairs of radio.

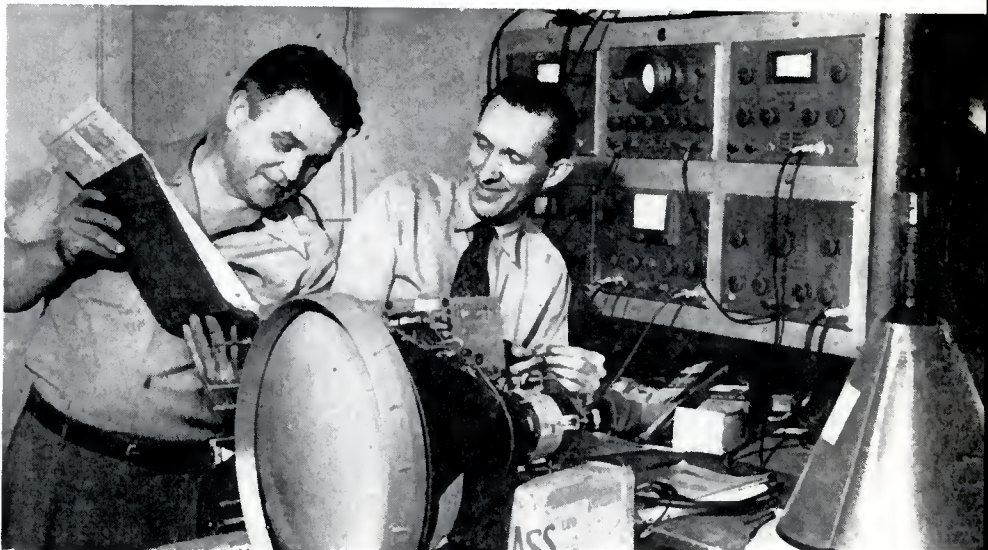

# The Music Show—

Sessions on Store Management, Promotion and Salesmanship.

• With "Golden Years of Music" as a theme, the 1951 Music Industry Trade Show and Convention at the Palmer House, Chicago, July 16-19, will be an appropriate climax to fifty years of National Association of Music Merchants history.

The anniversary event will occupy about 10% more exhibit space than the show last year, with a great many television manufacturers showing lines.

An outstanding convention program has been planned, giving fitting recognition to music merchants and their progress during the past half-century, and including more than the usual amount of practical help for dealers. The opening luncheon on Monday, July 16, and the banquet in the Stevens Hotel grand ballroom Wednesday evening will be in special observance of the Golden Anniversary.

Sessions on store management, business and production prospects, promotion and salesmanship will give those attending something solid to take back with them for better store operation.

The Blackstone, Stevens, Congress and Morrison hotels have allotted sleeping room accommodations to the vast numbers of dealers' and exhibitors' representatives who will overflow the Palmer House.

Ray S. Erlanson, president of the NAMM, has named Ted Korten of Korten's, Longview, Washington, as chairman of the 1951 Nominating Committee. Serving with him will be Arthur B. Birge, The Hollenberg Company, Memphis, Tenn.; L. A. Chenoweth, Chenoweth & Green Music Company, Enid, Okla.; L. E. Fontron, Southern California Music Company, Los Angeles; Robert P. Isbell, Jordan Piano Company, Washington, D. C.; Rollin Mettler, Jr., Mettler Piano Showrooms, New Haven, Conn., and James A. Terry, Terry's Music Store, La Cross, Wisc. The committee will present a slate of sixteen nominees for Directors at the annual meeting, Tuesday, July 17, from which NAMM members will elect eight to replace those retiring this year.

The program schedule for the convention and show is as follows:

*Sunday, July 15:* 10:00 A.M.—5:00 P.M.—Registration, fourth floor foyer; 2:00 P.M.—NAMM board of directors—private dining room 11; 3:00 P.M.—National Association of Music Merchandise Wholesalers executive committee—private dining room 2; 4:00 P.M.—National Piano Travelers Association board of directors—private dining room 6; 6:00 P.M.—National Association of Musical Merchandise Wholesalers annual meeting—Crystal Room.

*Monday, July 16:* 10:30 A.M.—NAMM press conference—private dining room 9; 12:00 Noon—Golden Anniversary luncheon—Grand Ballroom; 3:30 P.M.—Ladies' Tea and Entertainment—Crystal Room; 8:00 P.M.—National Piano Travelers annual jamboree—Grand Ballroom.

*Tuesday, July 17:* 8:00 A.M.—Salesmen's breakfast—National Association of Musical Merchandise Wholesalers—Crystal Room; 10:00 A.M.—NAMM annual business meeting—Grand Ballroom; 2:00 P.M.—Merchandising record forum—Grand Ballroom; 5:00 P.M.—Magnavox Company reception—Grand Ballroom.

*Wednesday, July 18:* 10:00 A.M.—Top management session—Grand session—Grand Ballroom; 10:00 A.M.—Merchandising accessories forum—Crystal Room; 11:30 A.M.—Operating a Sheet Music Department—Crystal Room; 12:00 Noon—NAMM board of directors meeting—private dining room 11; 2:00 P.M.—Selling instrument repairs forum—Crystal Room; 7:00 P.M.—Golden Anniversary banquet—Grand Ballroom, Stevens Hotel.

*Thursday, July 19:* 10:00 A.M.—Retail salesmanship forum—Grand Ballroom.

## Music Show Exhibitors

Accordion Cooperative of U. S., 1697 Broadway, New York 19—Room 906  
Admiral Corp., Chicago 47. Red Lacquer Rm.  
—Sec. "B"  
Aeolian American Corp., E. Rochester, N. Y.—Rooms 833, 834, 835  
Air King Products Co., Inc., Brooklyn 32, N. Y.—Rooms 649, 650  
All State Piano Co., 2320 S. Western Ave., Chicago—Room 865  
Allen Organ Co., Inc., Allentown, Pa.—Room 893  
Aluminum Co. of America, Pittsburgh 19, Pa.—Room 806

American Music Conference, 332 S. Michigan Ave., Chicago—Room 801  
American Plating & Mfg. Co., Inc., Chicago 16—Room 775  
American Rawhide Mfg. Co., Chicago 22—Room 799  
American Society of Piano Technicians, 2200 N. 11th St., Milwaukee 5, Wis.—Room 855  
The Ampeg Bassamp Co., 214 W. 42nd St., New York 18—Room 957  
Arthur Ansley Mfg. Co., Doylestown, Pa.—Room 645  
W. T. Armstrong Co., Elkhart, Ind.—Room 759  
Artistic Products Co., 191 Chrystle St., New York 2—Room 719  
Atlas Accordions, Inc., 117 W. 48th St., New York 19—Room 903  
Atlas Piano Co., 2934 Milwaukee Ave., Chicago 18—Room 809  
A-V Tape Libraries, 1650 Broadway, New York 19—Booth 51  
Vincent Bach Corp., 621 E. 216th St., New York 67—Room 730  
Baldwin Piano Co., 1801 Gilbert Ave., Cincinnati 2, Ohio—Room 816  
Herb C. Barger Mfg. Co., Inc., 2770 W. Colfax Ave., Denver 4, Colo.—Room 707  
Barth-Feinberg, Inc., 17 Union Sq. W., New York 3—Room 724  
Beach Instrument Corp., 165 Oraton St., Newark 4, N. J.—Room 837  
Bomar Musical Instruments, Inc., 141 Park Row, New York 38—Booth 46—Room 904  
Bonvicini Accordions, 617 15th St., Denver 2, Colo.—Room 960  
Boosey & Hawkes, Inc., Lynbrook, L. I., N. Y.—Room 713  
Brason Associates, Inc., 945-47 W. George St., Chicago 14—Booths 95, 96  
Bremen Piano Corp., 3047 W. Carroll Ave., Chicago 12—Rooms 817, 818  
Buegeleisen & Jacobson, Inc., 5-7-9 Union Sq., New York 3—Rooms 760, 761  
Buescher Band Instr. Co., 225 E. Jackson Blvd., Elkhart, Ind.—Room 744  
Capitol Records, Inc., 1507 N. Vine St., Hollywood 28, Cal.—Booths 54, 55  
Carbonari Bros., 1047 S. Highland Ave., Oak Park, Ill.—Room 961  
Central Commercial Industries, Inc., 332 S. Michigan Ave., Chicago 4—Rooms 876, 877, 878  
Chart Music Publishing House, Inc., 506 S. Wabash Ave., Chicago 5—Room 708  
E. Chiassarini, 1595 Broadway, New York 19—Room 701  
Chicago Album & Specialty Co., 426 S. Clinton St., Chicago 7—Booth 21  
Chicago Musical Instr. Co., 30 E. Adams St., Chicago 3—Rooms 728, 729  
Chris-Kratt Instr. Co., Inc., and C. Meisel Music Co., Union, N. J.—Room 747  
Cole Corp., 823 S. Wabash Ave., Chicago 5—Booths 93, 94  
Columbia Records, Inc., Bridgeport, Conn.—Booths 10, 11, 12  
Conn Band Instr. Div., Elkhart, Ind.—Room 732  
Consonata, Elkhart, Ind.—Rooms 889, 890  
Conover-Cable Piano Co., Oregon, Ill.—Room 839  
Continental Music, Elkhart, Ind.—Rooms 740, 741, 820  
Coral Records, Inc., sub. of Decca Records, Inc., 50 W. 57th St., New York 19—Booth 84  
Crosley Div., Avco Mfg., 1329 Arlington St., Cincinnati 25—Room 652  
Damp-Chaser, Inc., Hendersonville, N. C.—Booth 44  
The Danelectro Corp., Red Bank, N. J.—Room 745  
J. C. Deagan, Inc., 1770 W. Berteau Ave., Chicago 13—Rooms 706, 888  
Dean Electronic Co., 35 5th Ave., Brooklyn 17, N. Y.—Room 635  
Decca Records, Inc., 50 W. 57th St., New York 19—Booths 85, 86  
Pietro Deira Accordion Hdqtrs., 46 Greenwich Ave., New York 11—Room 971  
Duotone Co., Inc., Keyport, N. J.—Booth 78  
Dynavox Corp., 40-05 21st St., L. Is. City 1, N. Y.—Room 662



# to Help Dealers Sell More

**Features of Big Chicago Event. Many New TV Models will be Shown**

Eden Toys, Inc., 153 W. 23rd St., New York 11  
—Booth 61

Electro-Music Accessories Co., 321 S. Fair Oaks Ave.,  
Pasadena 1, Cal.—Room 891

Electronic Creations Co., Inc., 363 Greenwich St.,  
New York 13—Room 605

Electrovox Co., Inc., East Orange, N. J.—Booth 77

L. A. Elkington, 323 E. 34th St., New York 16  
—Room 756

Epiphone, Inc., 142 W. 14th St., New York 13  
—Room 778

Estey Organ Corp., Brattleboro, Vt.—Rooms 894, 895

Estey Piano Corp., Bluffton, Ind.—Room 805

Everett Piano Co., S. Haven, Mich.—Rooms 831, 832

Excelsior Accordions, Inc., 333 6th Ave., New York  
14—Rooms 742, 743

Fidelity Amplifier Co., 703 Willow St., Chicago 14—  
Room 663

Carl Fischer Musical Instr. Co., Inc., 105 E. 16th St.,  
New York 3—Rooms 702, 703

Fisher Radio Corp., 45-41 Van Dam St., L. Is. City,  
N. Y.—Room 636

Folkways Records & Service Corp., 117 W. 46th St.,  
New York 19—Booth 48

Franich & Bach, 849 E. 141 St., N.Y. 54—  
Room 842

French American Reed Mfg. Co., Inc., 3040 Webster  
Ave., Bronx 67, N. Y.—Rooms 720, 721

Jesse French & Son Piano Div. H. & A. Selmer, Inc.,  
Elkhart, Ind.—Room 844

R. Galanti & Bros., Inc., 783 Broadway, New York 3  
—Room 718

General Electric Co., Syracuse, N. Y.—Red Lacquer  
Room—Sec. "A"

Fred Gretsch Mfg. Co., 218 S. Wabash Ave., Chicago  
4—Rooms 781, 782, 783

Grossman Music Corp., 740 Bollvar Rd., Cleveland  
15, Ohio—Room 705

Gulbrandsen Co., 816 N. Kedzie Ave., Chicago 1  
—Rooms 847, 848, 849, 850

Haddorff Pianos, 1810 Ridge Ave., Evanston, Ill.  
—Rooms 820, 825, 826

Hall Drum Co., 723 Ursulines St., New Orleans 16,  
La.—Room 700

Hammond Instr. Co., 4200 W. Diversey Ave., Chi-  
cago 39—Rooms 882, 883, 884

Hardman Peck & Co., 33 W. 57th St., New York 19  
—Room 864

Harmony Co., 3633 S. Racine Ave., Chicago 9  
—Room 736

Hershman Musical Instr. Co., Inc., 242-250 4th Ave.,  
New York 3—Rooms 785, 786

Guy Hobbs, Inc., Dallastown, York County, Pa.  
—Booth 83

Hoffman Radio Corp., 3761 S. Hill St., Los Angeles  
7, Cal.—Rooms 681, 682, 683

Frank Holton & Co., Elkhorn, Wis.—Rooms 750, 751

Hudson Electronics Corp., Mt. Vernon, N. Y.  
—Room 604

Imperial Accordion Mfg. Co., 2618 W. 59th St., Chi-  
cago—Room 965

International Accordion Mfg. Co., 21330 Gratiot Ave.,  
E. Detroit, Mich.—Rooms 973, 974

Ivers & Pond Piano Co., 530 Main St., Cambridge,  
Mass.—Room 840

Jackson Ind., Inc., 500 E. 40 St., Chicago 15—Booth 80

Janssen Piano Co., Inc., 237 E. 23rd St., New York  
10—Rooms 810, 811

G. C. Jenkins Co., Decatur, Ill.—Room 796,  
Booth 60

Jenkins Music Co., 1217-23 Walnut St., Kansas City  
13, Mo.—Room 758

Jensen Industries, Inc., 329 S. Wood St., Chicago 12  
—Booth 73

Jewel Radio Corp., 10-40 45th Ave., Long Island  
City, N. Y.—Room 644

Kay Musical Instr. Co., 1640 W. Walnut, Chicago 12  
—Room 722

I. W. Kimbal Co., 31 E. Jackson Blvd., Chicago 4  
—Room 836

Kohler & Campbell, Inc., 401-425 E. 163rd St.,  
New York—Rooms 802, 803

Kraft Bros., 1027 Flinday Ave., New York 56  
—Room 657

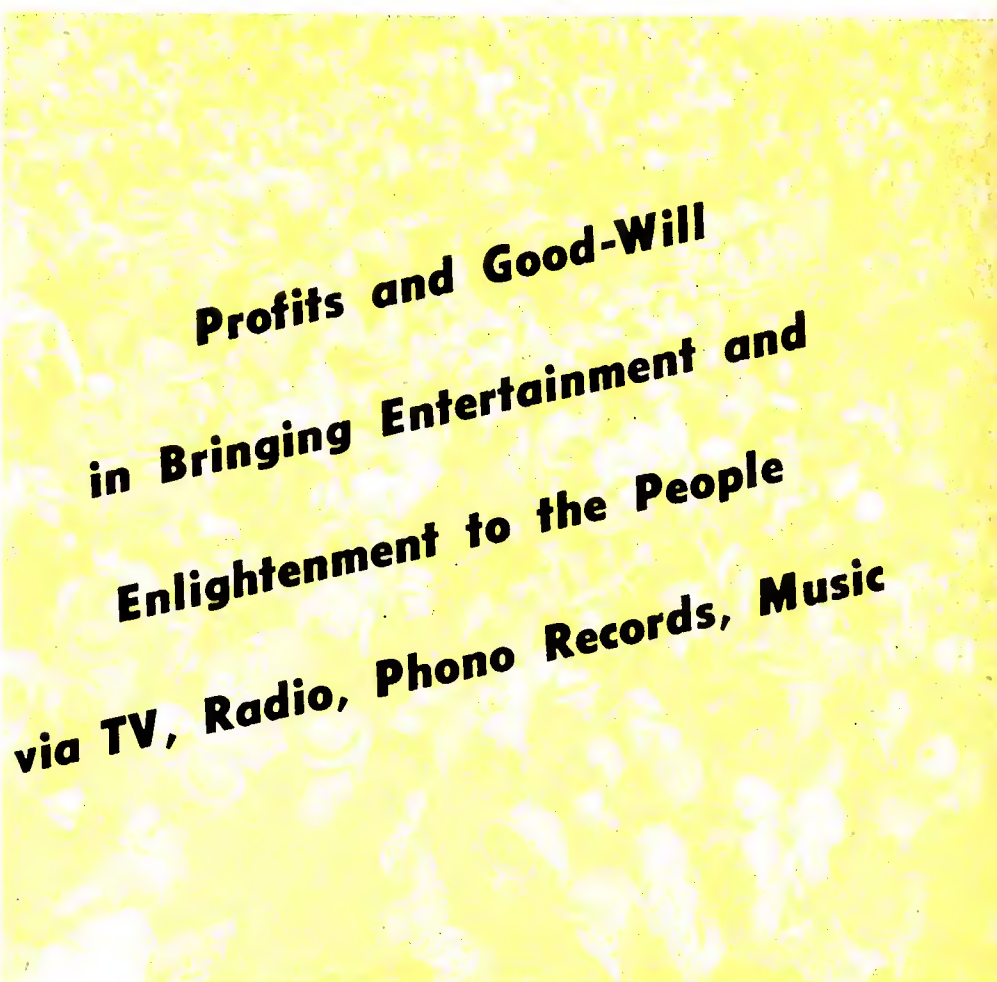

Krakauer Bros., 401 W. 124th St., New York 27  
—Rooms 827, 828

Wm. Kratt Co., Union, N. J.—Room 791

Krauth & Benninghofen, Hamilton, Ohio—Room 739

G. LeBlanc Co., Kenosha, Wis.—Rooms 725, 726

Leedy & Ludwig Drums, Elkhart, Ind.—Room 731

Lester Piano Mfg. Co., Inc., 1533 Chestnut St.,  
Philadelphia 2, Pa.—Rooms 812, 813, 814, 815

Wm. Lewis & Son, 30 E. Adams St., Chicago 3  
—Room 701

Lincoln Records, Inc., 1420 Walnut St., Philadelphia  
2, Pa.—Booth 76

Linton Mfg. Co., Inc., Elkhart, Ind.—Room 793

Maurice Lipsky Music Co., 116 E. 16th St., New  
York 3—Room 765

Lo Duca Bros. Accordion Co., 2451 W. North Ave.,  
Milwaukee 5, Wis.—Room 959

London Gramophone Corp., 539 W. 25th St., New  
York 1—Booth 1

MGM Records, 701 7th Ave., New York 19  
—Booth 91

Maas Organ Co., 3015 Casitas Ave., Los Angeles 39,  
Cal.—Rooms 897, 898

Magnatone Distributors, Inc., 3709 W. Jefferson Blvd.,  
Los Angeles 16, Cal.—Room 717

The Magnavox Co., Ft. Wayne 4, Ind.—P.D.R. 18

Majestic Radio & Television, 70 Washington St.,  
Brooklyn 1, N. Y.—Rooms 684, 685

Major Accordion Co., 3114 E. Davison, Detroit 12,  
Mich.—Room 975

Manual Arts Furniture Co., 1015 Hulbert Ave., Cin-  
cinnati 14, Ohio—Room 819

E. & O. Mari, Inc., 38-01 23rd Ave., L. Is. City 5,  
N. Y.—Room 797

Martin Band Instr. Co., Elkhart, Ind.—Room 789

C. F. Martin & Co., Inc., Nazareth, Pa.—Room 757

Mehlin, Paul G. & Sons, 863 E. 141 St., N.Y. 54  
—Room 841

Melody Record Supply, 693 10th Ave., New York 19  
—Booths 69, 70

Merchandising Displays, Inc., 10 E. Colorado Ave.,  
Colorado Springs, Colo.—Booth 81

Mercury Records, 839 S. Wabash Ave., Chicago 5  
—Booths 78, 88

Maxwell Meyers, Inc., 628 S. St. Marys, San Antonio,  
Tex.—Room 765

M. A. Miller Mfg. Co., 1169 E. 43 St., Chicago—  
Booth 52

Miller Music Table, Inc., 115 S. Wabash, Chicago  
—Room 830

Mills Music, Inc., 1619 Broadway, New York 1  
—Booth 58

Minshall-Estey Organ, Inc., Brattleboro, Vt.  
—Rooms 885, 886

Musette, 863 E. 141 St., New York 54—Room 838

Music Educators National Conference, 64 E. Jackson  
Blvd., Chicago 4—Room 857

Music Publishers Association of U. S., 159 E. 48th  
St., New York 17—Booth 50

National Piano Corp., 54 Canal St., New York 2  
—Rooms 807, 808

National Sales Co., 101 Hopkins Pl., Baltimore, Md.  
—Room 762

Oahu Publishing Co., 1701 Payne Ave., Cleveland 14,  
Ohio—Room 905

(Continued on page 90)

# There's a Bright Outlook

## Market Expansion, Available Money, Views of

• A look at the advance signposts of business in the phono record field indicates a high level of activity for the coming Fall and Winter months. Indications from manufacturers and from the public show that the market for phono records is still widening, release material and its promotional backing is aimed at creating greater demand, and the public has available money now, and most likely will have more in the months ahead.

There are unmistakable signs of these trends, and all that's needed to complete the picture is a concerted effort on the part of disc departments in every section of the country, to make 1951 another banner year in the history of the industry.

There is no question about the fact that people have ready cash, and the dealer who uses clever merchandising and promotion will move his merchandise without resorting to price wars—a policy which results in "cutting off one's nose to spite one's face."

With the power to buy in the hands of the public, the stage is set for a good season. The first four months of 1951 showed an increase over the same period last year. Perhaps this caused a general laxity which helped to bring on the slower "summer season" early. But a good second half can well offset the sum-

mer season and bring the year's total up to the level of the past few years.

The confusion created for the public by the three speed situation has been pretty well resolved by now. Folk now feel reasonably secure in buying different speed records. They understand more about the new speeds and vinylite, and their advantages. In phonograph sales, three speed instruments have predominated for some time now. This means there are many more record customers now owning equipment to play all speeds. Also, of those folk who owned one or two speed equipment, most have either switched to three speed players or have acquired player attachments to accommodate the speeds they were missing. All in all, the market for records of all speeds has been widening right along, and is continuing to do so.

The trend in released material toward show and movie albums, and albums catering to the fans of many personalities and fans of specific types of music or style of performance, is also adding greatly to widening the market for phono records. More and more the new releases are being directed toward definite interests displayed by the public. This helps to "drive home" the enjoyment available in records to a wider audience and continually

## Columbia Head Says TV Helps Sell Records

By James B. Conkling, president, Columbia Records, Inc.

Aggressive and alert record dealers, in my opinion, may look forward to increas-



ingly profitable operations during the next twelve months:

1. Television is helping, not retarding, record purchases. Record industry sales continue upward since mid-1949 despite heavy television buying in the period. Our surveys show proportionately better record business today in television areas than in non-television areas.
2. Record manufacturers are now releasing less but stronger new material permitting better concentration on fewer items with less inventory building.
3. Solidification in the three speed picture permits more realistic ordering; thereby lessening overburden in inventorying.
4. Substantial sales of new speed equipment in the last eighteen months suggest dealer merchandising plans to build entire new libraries for these active record buyers.

## RCA Victor Confident of Dealers' Support

A statement by Paul A. Barkmeier, vice-president, RCA Victor Record Department.



On the basis of recent meetings with RCA Victor distributors, and meetings of distributors with their dealer organizations, we find a very healthy, optimistic outlook for the record business in the third and fourth quarters of this year.

So far as RCA Victor merchandise itself is concerned, our plans are based primarily on offering a desirable, saleable product which includes the right type of quality recorded material, pre-eminent talent and attractive packaging.

Our merchandising and advertising plans are geared to stimulate greatest possible interest in phonograph records and to increase store traffic. The consumer appeal of the product to be offered provides the dealer with unlimited merchandise opportunities. Confident that the right kind of support will be forthcoming from our distributor and dealer organizations, we look forward to a profitable season ahead.

creates new record fans.

Promotion of this new material by manufacturers has intensified too. Individual releases are being more heavily promoted, with continually better, more effective promotion. And cooperative and packaged promotions for the dealer are more common and more extensive.

Material cutbacks thus far for the phonograph, TV, radio and appliance industries have not had a serious effect on the market, due to large inventories on hand. Defense demands have, however, been steadily increasing, and may bring about a considerable cut in production by the end of this year. This will

# for the Disc Department

## Company Heads, All Point to Higher Phono Record Sales

### Expanded Markets Planned by Capitol

A statement from Glenn Wallichs, president, Capitol Records, Inc.

The outlook for the record dealer is good for many reasons. We feel that the intro-



duction of the "Optional Center" for 45 RPM records expands the market for single records of superior quality, which can now be played on the many million three speed changers which have been sold during the past few years. As for Capitol's contribution, we feel this will help dealers in making a mass market for these new single 45 RPM records.

Capitol as a company is expanding into New York Shows. "Flahoolley," a new musical, has been recorded, and two other shows are being negotiated for. This will also add greatly to the market for Capitol records. In addition, we are recording major motion picture musicals in album form.

Additional emphasis will be centered on New York and the eastern area in the near future. It is my intention to strengthen this area with top executive personnel constantly traveling from Hollywood to New York.

Obviously our children's records market will continue to expand with the introduction of a new display rack and a dozen low priced name-performed records at the coming music show.

probably not affect the disc industry to any serious extent. During the last war disc production and sales managed to reach new peaks despite curtailment of supplies. It may, however, affect the

set and appliance manufacturers. But as far as the record dealer is concerned, such an event would only serve to boost his disc sales even higher. There's a certain amount of money folk will spend

### MGM Sees Record Industry in Good Position

By Frank B. Walker, president, MGM Records.

Summer is now with us, also the usual summer slump in record business. In varying degrees it has always been that way, but slightly more noticeable this year, following an unusually busy Spring.

We all know that we are in the midst of a war-time economy, and that conversion from an expanded civilian production to a limited defense production is now un-



derway. This brings about many changes, some unemployment and considerable confusion, but the end is in sight. Plans are made, government contracts have been placed, and the line between civilian and war-time goods has been carefully drawn.

In this division of war-time and civilian goods where do we place the record industry? Definitely in a category of its own, for we are something more than a commercial enterprise, something less than manufacturers of war material. Those of us who are engaged in the manufacture, distribution and customer sale of phonograph records are indeed fortunate in that we are providing relaxation and entertainment to members of the Armed Forces throughout the world, to millions of workers, to the folks at home, to the old, the young, to all who naturally turn to music during periods of emotional stress.

Some remember the war years 1917-1919; all of us recall the years 1941-1945. During those years it was impossible to furnish the buyer with a sufficient number of phonograph records to satisfy his desire for musical relaxation. The balance of 1951 and the year to follow will not be different, and we may, therefore, look forward to an expanded record business, and with the natural pride which goes with association in a business which does so much good for everybody.

on comfort and pleasures. If some of the existing channels for this money are cut off or narrowed down, more money will be spent on those remaining outlets. The record industry, less affected than most peacetime industries by war-time curtailments, will be one of these remaining outlets.

Get busy now to cash in on the new customer markets created by new releases and by new equip-

### Decca President Predicts Sales Upswing

Statement from Milton R. Rackmil, president, Decca Records, Inc.

Coming to the halfway mark of 1951, we at Decca can look back on the first six months with a great deal of satisfaction,



since our volume has topped that of the comparable period of 1950. We feel certain that the last six months will also show a greater volume than the last half of 1950.

What does this mean to the dealer? Simply that the business is there for the aggressive record merchant. It also means that we at Decca will continue our policy of bringing you the fastest selling records in America made by America's top artists.

ment. Map out some definite promotional activity and don't depend only on using an occasional packaged deal. Let the special packages come in addition to your own activity. Don't put it off by saying "I'll do it before Fall;" do it *now*. Set your sales goal and plan out the promotional activity you'll need to attain it. A well organized sales and promotional plan can be your magic wand for turning discs into dollars.

# Phono Record Makers

Up-to-Date Listing Including Labels, Speeds and Types

The following codes are used throughout this directory:

C	Classical
P	Pops
K	Children's
B	Rhythm & Blues
W	Western & Hillbilly
(s)	Single records
(a)	Albums

Following each type are the speeds in which that type is made.

- Adventure Record Co., 1674 Broadway, N. Y. 10—K(s) 78, 45, 33, (a) 78
- Allegro Records, 2 Columbus Circle, N. Y. 19—(C(s) (a) 33, K(s) 78, 33
- Apollo Records Mfg. Co., 457 W. 45th St., N. Y.—P(s) 78, 45, K(a) 78, B(s) 78, 45, (a) 78, 33, Spiritual (s) 78, (Symphonette) C(a) 33, P(s) 78, 45
- Artists Records, Inc., 1653 N. Argyle Ave., Hollywood 28—C(a) 33, P(s) 78
- Atlantic Recording Corp., 301 W. 54th St., N. Y. 19—C(s) (a) 33, K(s) (a) 78, B(s) (a) 78, 45, 33, W(a) 78
- Avis Records, 4016 Alla Rd., Venice, Cal.—K(a) 78, (Clover) P(s) (a) 78
- Banner Records, Inc., 33 Union Sq. W., N. Y. 3—Language (s) 78, 45, 33, (Carnival) P(s) 78
- Blue Note Records, 767 Lexington Ave., N. Y. 21—B(s) 78, (a) 78, 33
- Bornand Record Co., 139 Fourth Ave., Pelham 65, N. Y.—C(s) (a) 78
- Brattle Theatre Co., 40 Brattle St., Cambridge, Mass.—C(s) 33
- Capitol Records, Inc., Hollywood 28—All types, all speeds
- Castle Records, Inc., 5821 Sunset Blvd., Los Angeles 28—P(s) 78, B(s) 78, W(s) 78
- Century Record Co., 737 Fox St., Bronx 55, N. Y.—B(s) 78, 33
- Chandler, Gloria, Recordings, Inc., 422 1/2 W. 46th St., N. Y. 19—K(s) 78, 33
- Children's Record Guild, 27 Thompson St., N. Y.—K(s) 78, 45
- Circle Records, 778 Tenth Ave., N. Y. 19—Folk Music(s) 78, 33
- Clark Phonograph Record Co., Inc., 718 Wilhelm St., Harrison, N. J.—Private label mfrs.
- Classic Editions, 27 Norfolk St., N. Y.—C(s) (a) 33, (Relax) P(s) 78, (a) 33
- Colosseum Record Co., 27 William St., N. Y. 5—C(s) (a) 33
- Columbia Records, Inc., Bridgeport, Conn.—C.P.K.W. in all speeds, (Okeh) B(s) 78, 45, 33
- Concert Hall Society, 250 W. 57th St., N. Y. 19—C(s) 33
- Continental Record Co., Inc., 263 W. 54th St., N. Y. 19—P(s) 78, 45, 33 (a) 33 W(s) 78, 45, 33 W(a) 45, 33
- Coral Records, Inc., 48 W. 57th St., N. Y. 19—P(s) (a) 78, 45, 33, B(s) 78, 45, W(s) (a) 78, 45, 33, (Brunswick) Collectors Items(s) (a) 78, 33, 45
- Cormac Records, Inc., 1653 N. Argyle Ave., Hollywood 28 P(s) 78, W(s) 78
- Cornell Alumni Assoc., 18 East Ave., Ithaca, N. Y.—Cornell music(s) 78, 33(a) 78
- Damon Recording Studios, Inc., 117 W. 14th St., Kansas City, Mo.—C(a) 33, P(s) 78, K(s) 78
- Decca Records, Inc., 50 W. 57th St., N. Y. 19—C(a) All types, all speeds, Inc. Sacred
- Dial Records, Inc., 520 W. 50th St., N. Y. 19—C(a) 33, B(a) 78, 33
- Diamond Record Co., P. O. Box 221, Jackson, Miss.—P(s) 78, B(s) 78, W(s) 78
- Discovery Records, Inc., 708 N. Irving Blvd., Los Angeles, Cal.—C(s) 78, 45, 33, (a) 33, P(s) (a) 78, 45, 33, K(s) 78, 45, 33, (a) 33, B(s) 78, 45, 33 (a) 33
- Dome, 20 E. Jackson Blvd., Chicago 4—BW(s) 78, 45
- Dot Records, Inc., Gallatin, Tenn.—BW(s) 78
- Educational Services, 1702 K St. NW, Washington 6, DC—Languages and historical 78, 33
- Empire Record Corp., 2060 First Ave., N. Y. 29—K(s) 78, B(s) 78, 33
- Esoteric Records, Inc., 75 Greenwich Ave., N. Y. 14—C(a) 33
- Fantasy Record Co., 489 Fifth Ave., N. Y. 17—C(s) 78, K(s) 78
- Folkways Records, 117 W. 46th St., N. Y. 19—K(s) 78, 45 (a) 78, 45, 33, (Ethnic) B(a) 78, 33
- Fortune Records, 11629 Linwood, Detroit, Mich.—PW(s) 78, 45, B(s) 78
- Four Star Record Co., 305 S. Fair Oaks, Pasadena, Cal.—B(s) 78, 45, 33, W(s) 78, 45, 33 (a) 78 (Also Glitledge)
- Fox Records, 1558 N. Vine St., Hollywood 28—K(s) (a) 78
- Globe Record Co., 2561 W. Pico Blvd., Los Angeles 6—Spanish only
- Good Time Jazz Record Co., 707 N. Irving Blvd., Los Angeles 38—P(s) 78, 45, 33, (a) 45, 33
- Gotham Record Corp., 1416 Wood St., Phila. 2—BW(s) 78, 45
- Hart-Van Recording Co., 109 W. Calendar Ave., La Grange, Ill.—P(s) 78 W(s) 78, Religious (s) 78
- Harvard University Baud, Paine Music Bldg., Cambridge 38, Mass.—(Trans-Radio) College music (s) 78 (a) 78, 33
- Harvard Vocarium Records, Cambridge 38, Mass.—Educational (s) 78, 33
- Hayden Society, Inc., 30 Huntington Ave., Boston 15, Mass.—C(s) (a) 33 K(s) (a) 33
- High Time Records, 1514 1/2 Seventh St., Santa Monica, Cal.—PKW&Sacred(s) 78
- Hollywood Rhythms Recording Co., Box 162, Culver City, Calif.—CP(s) (a) 78, B(s) 78
- Imperial Record Co., 6425 Hollywood Blvd., Hollywood 28 B(s) 78, W(s) (a) 78, 45, 33
- Israel Music Foundation, 1650 Broadway, N. Y.—C, Folk(s) (a) 78, 33
- Jansen Electric Co., 86 Sherman Ave., Teaneck, N. J.—P(s) 33
- Jazz Man Records, 6420 Santa Monica Blvd., Hollywood, Cal.—B(s) 78
- Key Records, 1457 Broadway, N. Y.—C(a) 33
- Keystone Records, 1415 Locust St., Philadelphia 2 P(s) 78, 33, B(s) 78, 33, W(s) 78, 33 (Tune-Disc) P(s) 78, 33
- Life Record Co., 64 W. Randolph St., Chicago—P(s) 78, 45, (a) 78, B(s) (a) 78, W(s) 78
- London Gramophone Corp., 539 W. 25th St., N. Y.—C(s) (a) 78, 45, 33, P(s) (a) 78, 45, 33 K(s) (a) 78, 45, B(s) 78, 45, W(s) 78, 45
- Lyricon Discs, Inc., 464 W. 51st St., N. Y. 19—C(s) (a) 33, Folk(s) 33
- Magnolia Record Co., Box 472, Van Nuys, Cal.—C(s) (a) 78, 45, P(s) (a) 78, 45, 33, W(s) 78
- Mercury Record Corp., 830 S. Wabash Ave., Chicago 5—C(s) (a) 33, P, K, B, W(s) (a) 78, 45, 33
- Melody Records, Inc., 693 Tenth Ave., N. Y.—K(s) 78, 45
- MGM Records, 701 Seventh Ave., N. Y.—All types, all speeds
- Mondi's Records, 1619 Jericho Turnpike, New Hyde Park, L. I., N. Y.—PKB&W(s) 78
- Musart Record Co., 8373 Melrose Ave., Los Angeles 46—(Aleo) C(s) 78, 33(a) 78
- Music You Enjoy, Inc., 96 Warren St., N. Y.—K(s) 78
- Mutual Recording Co., 1039 Beech St., Lancaster, Cal.—B&W(s) 78, 45
- New Records, Inc., 141 E. 44th St., N. Y. 17—C(s) 33
- Oceanic Records, Inc., 15 Park Row, N. Y. 7—C(a) 33
- Old Timer Record Co., 3703 N. 7th St., Phoenix, Ariz.—W(s) 78, 45
- Paradox Industries, Inc., 55 W. 42nd St., N. Y. 18—C(a) 33 B(s) 78, 45, (a) 45, 33 (Jolly Roger) B(s) 78, 45 (a) 45, 33
- Paramount, 1637 N. Ashland Ave., Chicago 22—B(s) (a) 33, 78 (S.D.) (American Music) (s) (a) 33
- Perfection Plastic Products, 33 W. Union St., Pasadena, Cal.—(Vita) C(s) (a) 78, 45, 33, P(s) (a) 78, 45, 33 (Belda) K(s) (a) 78, 45
- Peter Pan Records, 461 8th Ave., N. Y. 1—K(s) 78, 45 (a) 78
- Polymusic Records, 66 W. 88th St., N. Y.—C(s) 33
- RCA Victor, N. Y.—CP&K(s) 78, 45 (a) 78, 45, 33, B&W(s) (a) 78, 45
- Record Corp. of America, 510 22nd St., Union City, N. J.—(Royale) CPK&W(s) (a) 78, 45, 33
- Record Pressing Co., Private label mfrs.
- Record Guild of America, Inc., 882 Third Ave., Brooklyn 32, K(s) 78, 45, 33 (a) 78, 45
- Red Bird Records, Lincoln Highway East, Ft. Wayne 8, Ind.—W(s) 78
- Reena Record Corp., 130 W. 42nd St., N. Y. 18—K(s) 78, 45, 33 (a) 78, 33 Folk (also Zimra, Zamir, Makout (s) (a) 78, 45, 33
- Regal Record Co., Linden, N. J.—(Regal, Roost, RFD, Merit) P, BW(s) 78, 45, B(a) 33
- Remington Records, Inc., 263 W. 54th St., N. Y. 19—C(s) (a) 45, 33, K(s) 78, 45, B(s) (a) 45, 33 W(s) 78, 45, 33, (a) 45, 33
- Rich-R-Tone Recording Co., 113 W. Main St., Johnson City, Tenn.—BW(s) 78, 45 (Folk Star) W and Sacred(s) 78, 45
- Regent Record Co., Inc., 58 Market St., Newark, N. J.—CPK(s) (a) 78, 45, 33
- Sacred Records, Inc., 342 N. La Brea, Los Angeles—K(s) 78 Religious (s) 78, 45, 33 (a) 78, 33
- Savoy Records, Inc., 58 Market St., Newark, N. J.—BW&Foreign(s) (a) 78, 45, 33
- Seeco Records, Inc., 1393 Fifth Ave., N. Y. 29—Latin (s) 78, 45, 33 (a) 45, 33
- Seva Record Corp., 45 E. 49th St., N. Y. 17—C(s) (a) 78, P(s) (a) 78, Religious (s) (a) 78
- Skating Rhythms Recording Co., P. O. Box 1838, Santa Ana, Cal.—Skating records(s) (a) 78 (Organ Rhythms) CP(s) 78
- Sounds of Our Times, Ridgeway Station, Stamford, Conn.—Specialty (s) 33
- Spanish Music Center, 1291 6th Ave., N. Y. 19—(SMC) (Coda) Latin 78, 33
- Specialty Records, 8508 Sunset Blvd., Hollywood—BW(s) 78, 45
- Square Dance Associates, 102 N. Columbus Ave., Freeport, N. Y.—W(a) 78
- Standard Phono Corp., 163 W. 23rd St., N. Y. 11—Foreign(s) 78, 45
- Star Songs, 34 Hillside Ave., N. Y. 34—(Clipper) P(s) 78, 45, Latin (s) 78
- Swing Time Record Co., 3427 S. San Pedro St., Los Angeles 11—B(s) 78, 45
- Tara Irish Records, 4903 Girard Ave., Phila. 31—Irish (s) (a) 78
- Tempo Record Co. of America, 8540 Sunset Blvd., Hollywood 46—C(a) 33, P(s) (a) 78, 45, 33 (also Theme)
- Tico Recording Co., Inc., 143 W. 41st St., N. Y.—Latin (s) 78, 45, 33
- Urania Records, Inc., 667 Madison Ave., N. Y. 21—C(s) (a) 33
- Thomas J. Valentino, Inc., 150 W. 46th St., N. Y. 19—Sound effects (s) 78
- Vanguard Recording Society, 799 Broadway, N. Y. 3—C(s) (a) 33
- Vega Record Co., 146 W. 37th Pl., Los Angeles 8—W(s) 78, 45, 33
- Verne Recording Corp. of America, 1724 Madison Ave., N. Y. 29—P(s) 78
- Voco, Inc., 33-34 St., Brooklyn 32—K(s) 78, 45 (a) 78
- WCFM Recording Corp., 1120 Connecticut Ave., N.W., Washington 6, D. C.—C(s) 33
- Westminster Recording Co., Inc., 233 W. 42nd St., N. Y. 18—C(s) (a) 33
- World Wide Records Corp., 315 W. 47th St., N. Y. 19—C(s) 33
- Young People's Records, Inc., 920 Broadway, New York 10—K(s) 78

**Hot as—Blazes**

Two new Columbia Record releases  
topping the classic and popular  
categories for mid-summer  
profit-taking!

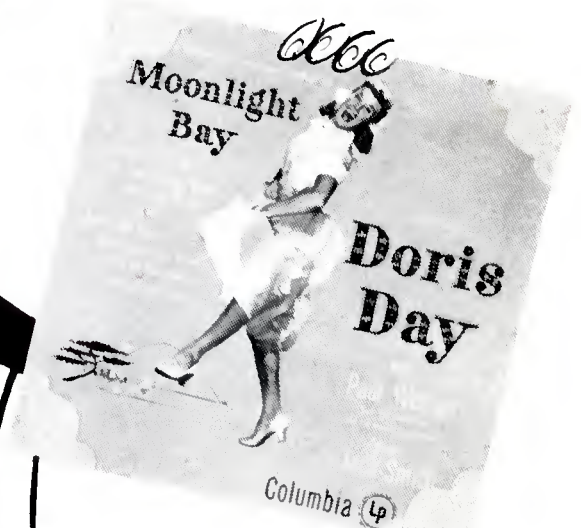

GOUNOD

# FAUST

A METROPOLITAN OPERA  
PRODUCTION

Eleanor Steber, Cesare Siepi, Eugene Conley,  
Frank Guarrera and others. With Fausto Cleva  
conducting the Chorus of the Metropolitan  
Opera Association.

LP Set SL 112

DORIS

# DAY

Star of Warner Bros. technicolor production

## “ON MOONLIGHT BAY”

Singing

Love Ya, Love Ya, Honey :: I'm Forever Blowing  
Bubbles :: Every Little Movement :: Tell Me ::  
On Moonlight Bay :: Cuddle Up A Little Closer ::  
Till We Meet Again :: The Christmas Story.

33 1/3 rpm CL 6186    78 rpm Set C-267

45 rpm Set B-267

**COLUMBIA**

Celebrating 3rd  
Anniversary of 

**RECORDS**

Visit Us At The N.A.M.M.  
Convention—Booths 10, 11 and 12

“Columbia,” “Masterworks,”   Reg. U. S. Pat. Off. Marcas Registradas

# Boost Your Profits with More Sales of Phonograph Needles

Here's the Way to Merchandise This High Markup Item—Plus a Mail Campaign to Find Out What Equipment Your Customers Now Own

• Increasing sales of phonograph needles not only means added profit for the dealer, but a list of better satisfied customers as well.

Improved technical developments in phonographs and in records have given a new importance to this small bulk, high markup item. It matters a great deal more today than it did five years ago whether the needle is new or worn. And the customer who understands this, and knows why, will buy a new needle, and will be better satisfied.

There are two main factors involved in the needle sales pitch: thrift and sound. An old, worn needle will literally tear the records to shreds. Sketch out a simple diagram like the one accompanying this article to show the customer how a needle follows the grooves of

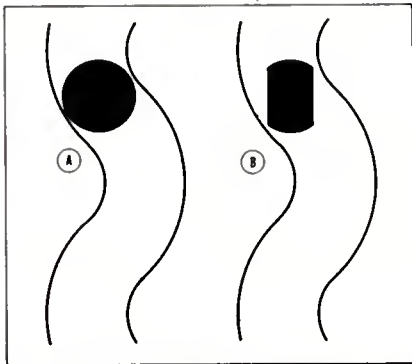

Simple diagram above shows A) a new needle riding the record groove, and B) a worn needle. It's obvious what damage a worn needle can do.

a record. It's plain to see how a worn needle loses its roundness, develops sharp edges which bite into the grooves and soon makes the record useless. If the customer places any value at all on his phono records, he'll readily see the thriftiness of using a needle that has its proper shape.

Any statement of the life of a needle depends on many variable factors: the equipment on which it's being used, the condition of the records, how critical the listener, etc. But one fact can be stressed

along these lines. As the needle wears it reproduces the sound more poorly—and it does this gradually, so that the listener becomes accustomed to it and doesn't notice a change. The only real way for him to tell whether or not he's satisfied with his present needle is to try a new one in his phonograph and compare. Chances are his needle is in much worse shape than he would have been willing to believe without actually making the test.

One way to help sell more phono needles is to keep the cartridge numbers of your customer's players on file. So many times folks walk

into a store to buy a new needle. No sales talk needed—they actually want to buy a needle. "What kind of a phono have you?" asks the salesman. The customer tells him it's an "X" brand, 1948 model. "You'll have to get the cartridge number for me," says the salesman—and there usually follows a dead silence or a profound "the what?" from the customer. So the salesman explains where the cartridge number is and sends the would-be customer home to get it. The customer might do it tonight, or next week, or he might not get around

(Continued on page 94)

Name \_\_\_\_\_  
 Address \_\_\_\_\_  
 Phono Make \_\_\_\_\_  
 Phono Model Number \_\_\_\_\_  
 Cartridge Make \_\_\_\_\_  
 Cartridge Number \_\_\_\_\_

*What Type of Needle Does Your Phonograph Use?*

Save time and trouble when you decide to get a new phono needle—by registering your phonograph NOW. There's NO OBLIGATION....Just fill out and mail us the enclosed card. We'll keep it on file, and whenever you need a new phono needle, visit or phone our store, and we'll know exactly what type of needle your phonograph uses.

The cartridge is built-in to the underside of the pickup arm on your phonograph. Raise the pickup arm as high as it will go and look at the underside (at the needle end of the arm) to get the cartridge brand and number.

REMEMBER....You cannot buy a proper replacement needle without knowing the cartridge number of your phonograph. So look it up NOW... and send it in to us. Chances are you won't think of it when you actually set out to buy a needle.

Apex Company 48 Main Street Hometown, U.S.A. Main 1234  
 RADIO-TV-PHONOGRAPHS-RECORDS-APPLIANCES

Suggested mailing piece a dealer might use to gather valuable information from his customers. With the return card information of phonographs the dealer can also compile an accurate list of prospective phonograph and record customers as well.

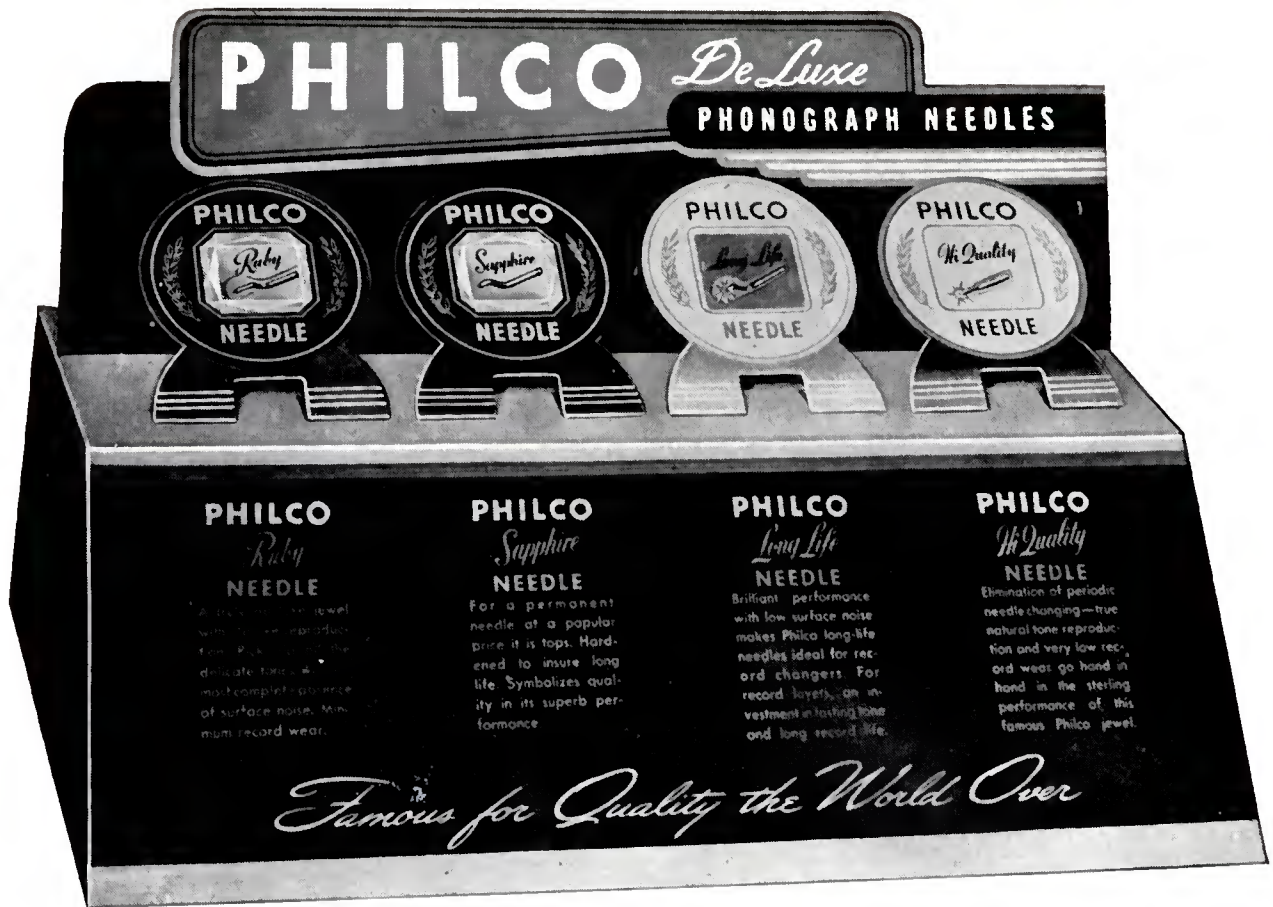

**PHILCO**  
*Ruby*  
**NEEDLE**

A precious jewel with the reputation for Philco's delicate tone and most complete absence of surface noise. Minimum record wear.

**PHILCO**  
*Sapphire*  
**NEEDLE**

For a permanent needle at a popular price it is tops. Hardened to insure long life. Symbolizes quality in its superb performance.

**PHILCO**  
*Long Life*  
**NEEDLE**

Brilliant performance with low surface noise makes Philco long-life needles ideal for record changers. For record lovers, an investment in lasting tone and long record life.

**PHILCO**  
*Hi Quality*  
**NEEDLE**

Elimination of periodic needle changing—true natural tone reproduction and very low record wear go hand in hand in the sterling performance of this famous Philco jewel.

*Famous for Quality the World Over*

**COMPLETE NEEDLE DEPARTMENT**



Here's the hottest Needle Merchandiser ever designed! Compact, colorful, eye-catching... displays, stocks and *sells* a complete line of Philco Deluxe Phonograph Needles, with each needle individually packaged in a tamper-proof, clear-view container. Order now... use it to sell the finest and *only* balanced line of jewel and precious metal needles priced for easy SELL-UP!

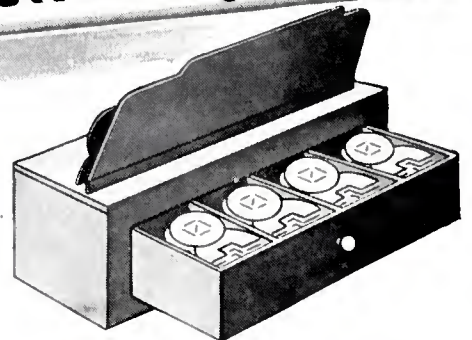

Handy Drawer at rear holds 48 Needles

**PHILCO NEEDLE  
REPLACEMENT GUIDE**

Everything you need to know about Philco Phonograph Replacement Needles and pick-up cartridges... describes and prices each item... tells which phonograph each needle fits. Size 18 1/4" high, 28 1/2" wide.



**See the PHILCO Exhibit**

at the Music Industry Trade Show, Palmer House, Chicago  
—July 16 through 19

**SPACES 3-4-5-6-7**

**Order Now from Your PHILCO Distributor**

## RCA Victor Show Album



Attractive cover design of the new RCA Victor show album, "Make A Wish."

## Color TV Activity

The Supreme Court decision upholding the FCC's approval of the CBS color television system has set off a series of announcements and activity within the industry.

CBS gave special demonstrations of color TV at the semi-annual Home Furnishing Merchandise Market at Chicago, June 18, 19 and 20. The CBS-Columbia dual receiver was developed and field-tested in cooperation with engineers of CBS Engineering and Research Development. Its tuning is simple, incorporating the standard 4-knob type of control, with only one knob added for switching from color to black-and-white reception. The set measures 32 inches wide by 22 11/16 inches deep, and is 36 1/8

inches high. CBS-Columbia, Inc. is the new name of Air King Products Co., Inc., set manufacturer which has become a division of CBS. David H. Cogan, president of CBS-Columbia says that deliveries of the dual receiver are expected to start in late Summer.

Regular color broadcasts beginning June 25th by CBS will become seven-day-a-week schedules after July 2, with programs at 10:30-11:00 A.M. and 4:30-5:00 P.M. Monday through Friday, and afternoon programs Saturday and Sunday.

Also announced by CBS was the final approval by stockholders, of the transaction whereby CBS acquired Hytron Radio & Electronics Corp., which owns Air King Products Co., Inc.

Philco Corporation issued a statement to its distributors and dealers reminding them that all Philco 16, 17 and 20-inch sets now being made by the company, and those which have been purchased since June 1, 1950, can be adapted to receive the CBS color broadcasts. The statement also reaffirmed faith in the present black and white system as continuing to be the public's source of TV entertainment for years to come.

Stewart-Warner Corp. announced that all of its sets shipped since Nov. 1, 1950 are equipped with an adapter jack. On sets shipped before that date, the jack can be added by a serviceman.

John Meek Industries, Inc., also announced that its sets made since Jan. 1 contain adapter circuits for connection to color adapters. The company will begin production of the auxiliary color units as soon as possible.

Slave "Tele-Color" units, announced Tele-Radio Corp., will be available before August 1. They will retail for under \$100. The unit, which contains its own screen, plugs into the video output tube socket of present set to produce its own picture in color.

An adapter was announced by Colortone Television Co., Inc., New York, which retails for \$14.95. Can be used on most makes now on the market.

Meanwhile, General Electric Company announced that it is continuing tests of other color TV systems and will soon begin experimental broadcasts on a composite system which combines the best elements of the existing systems.

## New Rider Book

On September 1, the John F. Rider Publishing Company will introduce a comprehensive and practical guide, directed to everyone interested in television, titled "Television and Electronics as a Career." Ira Kamen, director of television, L. S. Brach Corporation, and Richard H. Dorf, television consultant, are the editors. Each of the six chapters was written by individuals with extensive practical experience in the field they cover.

## Walsco Celebrates 12th Anniversary



Walter L. Schott, president of Walsco, and Milicent Deming, TV star, cut cake to celebrate launching Walsco's 12th anniversary gift offer to the industry. Looking on: Lawrence Des Jardin, vice-president; Frank Hurd, vice-president; and Jack Carter, sales manager. Gift package, worth \$2, includes five new items in Walsco line: No-Ox, Tunerlub, Lubricator, Contactene Injector, and New Radio Cement. Free with \$2 purchase of Walsco hardware or \$10 of Walsco antennas. Offer is good till the end of July.

## Symphonic Phonos Presented at Israel Week

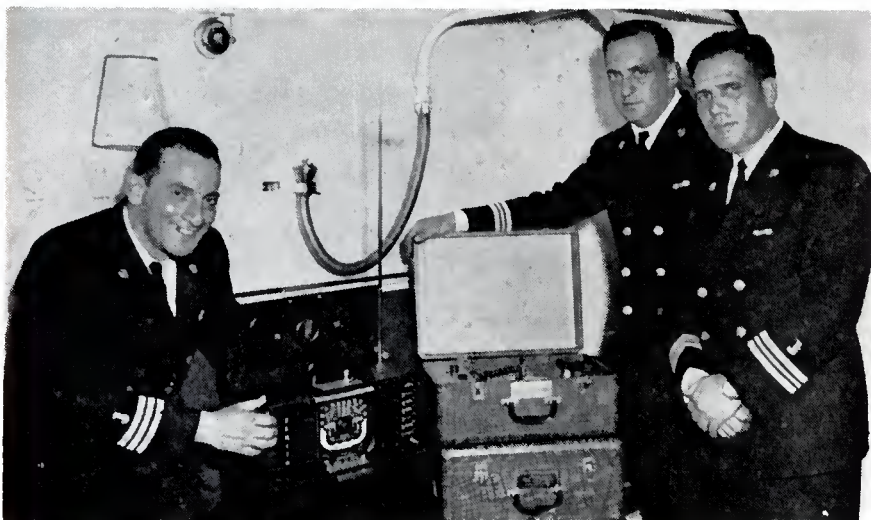

Crews of two Israeli warships, visiting Boston during the recent Israel Week program at Jordan Marsh, were presented two short-wave portable radios and two Symphonic three-speed automatic record players. With the radios and Symphonic players aboard one of the ships are (left to right): Shlomo Erel, commander of the flotilla; Lt. Commander Naftali Rozen, commanding the "Misgav" and Lt. Commander Arie Shaanon, commanding the "Haganah."





# The Line of Distinction

**Awarded to Hudson for consistent Quality, Performance, Value . . . by such leading retailers as:**

- |                           |                        |                            |
|---------------------------|------------------------|----------------------------|
| B. Altman                 | Higbee's               | Sibley, Lindsay & Curr     |
| L. S. Ayres               | D. H. Holmes           | Maison Blanche             |
| Abraham & Straus          | J. L. Hudson           | La Salle & Koch            |
| Bloomingdales             | Lacy's                 | Strouss-Hirshberg          |
| Ludwig Baumann            | Lansburgh & Bro.       | Ed Schuster's              |
| Bullock's Pasadena        | F. & R. Lazarus        | Wolf & Dessauer            |
| Bullock's Los Angeles     | Hutzler's              | Rike-Kumler                |
| Burdine's                 | R. H. Macy's New York  | R. H. White                |
| L. Bamberger              | R. H. Macy's           | John Shillito              |
| Broadway Department Store | Kansas City            | Scruggs-Vandervoort-Barney |
| H. C. Capwell             | R. H. Macy's           | Stewart's                  |
| Carson, Pirie Scott       | San Francisco          | Stewart Dry Goods          |
| Davison-Paxton            | Michaels Bros.         | Thalheimer's               |
| Dayton Co.                | May Co.                | The Emporium               |
| Denver Dry Goods          | Montgomery Ward        | Rich's                     |
| Elder & Johnson           | I. Magnin              | Joseph Horne               |
| Emery, Bird, Thayer       | Loveman, Joseph & Loeb | Zermansky & Fass           |
| G. Fox                    | Kaufmann's             | and many others            |
| Foley Bros.               | M. O'Neill             | Wieboldt Stores, Inc.      |
| Hecht's                   | Famous & Barr          | Hudson Ross                |
| William Hengerer          | Miller & Rhodes        | Marshall Field & Co.       |

**Hudson ELECTRONICS CORP.**  
**MOUNT VERNON, N. Y.**



Model 324



Model 347



Model 360

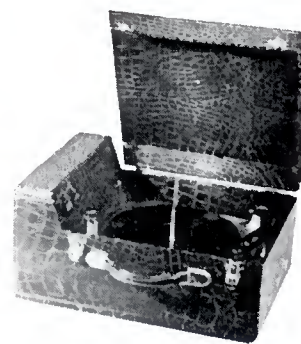

Model 350

*N. A. M. M. Convention — Space 604 — Palmer House*

# How to Get Orders For Recorders

• There's a big market for magnetic recorders all over the country. This market is ripe for the progressive merchant who is willing to do a lot of missionary work in educating the people in his trading area to the advantages and various uses of the recorder.

Following are just a few of the prospects to be found in almost all localities: *offices*, for dictating and record-keeping; *banks*; *municipal departments*, such as for use in police interrogation work; *recording studios*, *broadcast stations*, *factories and plants*, *hospitals*, *doctors*, for recording clinical data; *music schools*, *public schools*, *colleges*, *newspaper offices*. And for the home, recorders will appeal to music students, hobbyists, authors. They can be used as "sound" for home movies, to record favorite broadcasts, for fun at parties, and for scores of other purposes.

The first step to take in the successful merchandising of recorders is an elementary one, meaning that

the salesman should start from scratch in demonstrating the instruments. He shouldn't take it for granted that the prospective purchaser knows anything at all about recorders. Before demonstrating a unit, the salesman should explain simply, clearly and briefly exactly how a recorder operates. Next, he should show the customer how easy it is to run the recorder, and how many valuable uses he can find for it.

## Tell the Customer

Since the recorder, so far as the general public is concerned, is a brand new device which a great many people haven't even seen yet, desire to buy will only follow a skilful, complete sales exposition on the part of the salesman. The writer knows an author who uses a tape recorder which has enabled him to double his writing output. Here's what he told us: "I'd have bought one a long time ago, but I never

had a clear understanding about how recorders worked. *I didn't know, for instance, that one could use the tape over and over again.*" Imagine that! Re-use of the tape was the sales-clincher in this case of a man who, admittedly, had made several inquiries about recorders before some smart salesman finally stressed this feature. Economy of operation is one of the biggest selling angles of the recorder, but people won't know unless the salesman tells them.

So far as in-store selling is concerned, the dealer must do several things. First, he needs to display recorders properly, identifying them clearly through the use of manufacturer - supplied display pieces or by hand-lettered cards. Second, he should offer a demonstration to every customer, paying particular attention to the youngsters who invariably get a big kick out of hearing their voices played back. Since a great many people are reluctant to make a sample recording, smart dealers help such folk feel at ease by inviting the customer to occupy a booth; then leaving him alone to read portions of a circular aloud. It isn't wise to ask prospective buyers to make long recordings. A minute is about right.

## Practice the Operation

The salesperson who is to demonstrate the unit should be able to operate the recorder with the utmost ease. A fumbling demonstration will make the instrument appear "complicated" to the prospect. Such customer may then fear to buy because he feels that he must become an expert in order to operate it, the more so since the salesman is unable to work it smoothly. Familiarity with the recorder is a must for every salesman. He can only become familiar with it through constant practice. In addition to reading the instruction manual, the salesman must acquire a considerable degree of deftness, and he can only obtain this through repeated operation.

Salesmen can cash in on the magic sales appeal of the recorder if they will take it out with them

(Continued on page 92)

## MAGNETIC RECORDERS

Offer "ground-floor" opportunities for dealers

They are not highly competitive, and there are no trade-ins

Since there's no widespread price-cutting on recorders, merchants can make profitable sales

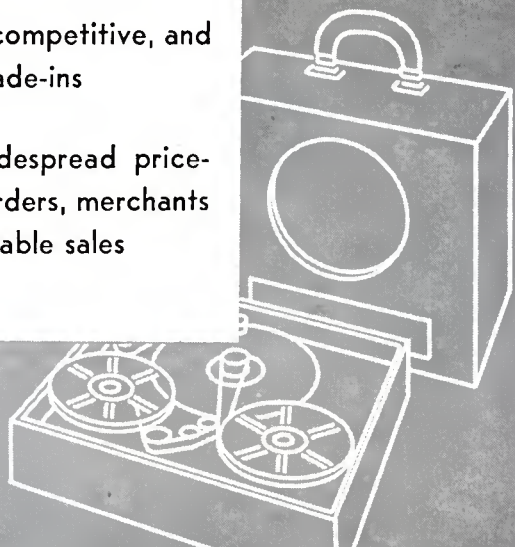

it's a

# LITTLE WIZARD

The New  
**WILCOX-GAY**

Tape Recordio 2A10

**CLICK!**  
it's recording

**CLICK!**  
it's on playback

... **AUTOMATICALLY!**



(2A10) **\$149.95**

Slightly higher west of the Rockies

## A NEW LEVEL OF PERFORMANCE

at your finger tips!

Wilcox-Gay . . . the name that stands for the finest in recording . . . sets a new trend in performance with the introduction of the sensational new Recordio 2A10. This new finger tip control tape recorder—about the size of a portable typewriter—brings tape recording to a new level of quality and performance. Wilcox-Gay's new feature-studded 2A10 is years ahead!

**N A M M TRADE SHOW — CHICAGO**  
Rooms 684-685 Palmer House

We will also exhibit a new line of T.V. and Radio Chassis  
for Private Brand Manufacture

## • WILCOX-GAY CORPORATION •

Sales & General Offices  
743 N. LaSalle St., Chicago, Illinois

IN CANADA: Canadian Marconi

Factory & Service  
Charlotte, Michigan

### RECORDIO 2A10 SPECIFICATIONS

- Two-tone Leatherette carrying case
- Size: 12 x 14 x 7. Weight: Under 20 pounds
- Uses 5" or 7" reels
- Records 4 hours at 1 7/8 speed on 7" reel
- No separate amplifier switch
- . . . pressing record button shifts amplifier and erase head
- No clutches to cause trouble
- Records from mike, external amplifier or other external source
- Tape may be erased and reused many times
- High speed wind—forward or reverse
- Neon recording volume indicator
- Jack for plug-in external speaker
- High fidelity-brilliant reproduction
- 5 x 7 Elliptical speaker
- Model 2A10 Speeds 3 3/4-7 1/2
- Model 2A11 Speeds 3 3/4-1 7/8

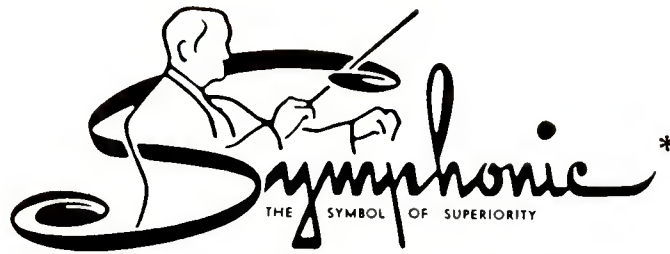

# RECORD PLAYERS

*lead the nation in*

## QUALITY . . . PERFORMANCE . . . REPEAT SALES

Yes . . . in today's market, you need a prominent, nationally-advertised and nationally-accepted brand name. Symphonic is the largest manufacturer of record players exclusively in America . . . approved everywhere by distributors, dealers, schools and homes.

Symphonic provides more quality and more value for each consumer dollar, too! So, be sure that Symphonic is included with your better brand-name merchandise!

Here are the Symphonic representatives from coast to coast. Contact the one nearest you now! You'll see for yourself why it's to your advantage to sell trouble-free Symphonic Record Players and to deal with representatives who give you prompt attention and service, backed up by guaranteed factory cooperation.

MAINE, NEW HAMPSHIRE, VERMONT,  
MASSACHUSETTS, RHODE ISLAND,  
CONNECTICUT

**MICHAEL SCOTT COMPANY**  
Boston, Mass.  
Phone: Wellesley 5-0102

NEW YORK, NEW JERSEY, DELAWARE,  
MARYLAND, WASHINGTON, D.C.,  
EASTERN PENNSYLVANIA

**BLAIR-STEINBERG COMPANY**  
395 Broadway  
New York 13, New York  
Phone: WO 4-7321

NEBRASKA, KANSAS, OKLAHOMA,  
ARKANSAS, MISSOURI, IOWA

**KAY SALES COMPANY**  
3760 Broadway  
Kansas City 2, Missouri  
Phone: Logan 7640

LOWER CALIFORNIA, ARIZONA  
**WEDGE WEBER COMPANY**

1206 Long Beach Avenue  
Los Angeles 21, Cal.  
Phone: Vandike 2009

NORTHERN CALIFORNIA, NEVADA

**E. L. BERMAN COMPANY**  
1355 Market Street  
San Francisco, Cal.  
Phone: Klondike 2-2311  
Ext: 673

OHIO

**EARL S. DIETRICH COMPANY**  
320 Hanna Building  
Cleveland, Ohio  
Phone: Cherry 1-7770

MICHIGAN  
MARKET OPEN

WASHINGTON, OREGON

**RON MERRITT**  
217 Ninth Avenue, N.  
Seattle 9, Washington  
Phone: Seneca 4948

TEXAS, LOUISIANA

**JACK F. McKINNEY SALES COMPANY**  
1330 N. Industrial Blvd.  
Dallas, Texas  
Phone: Sterling 1997

WESTERN PENNSYLVANIA

**EMMET J. TYDINGS**  
903 Plaza Building  
Pittsburgh 19, Pennsylvania  
Phone: Court 1-6821

ILLINOIS

**WILLIAM M. LINZ**  
1335 1/2 Touhy Avenue  
Chicago 26, Illinois  
Phone: Ambassador 2-2067

VIRGINIA, WEST VIRGINIA,  
NORTH CAROLINA, SOUTH CAROLINA

**GOODMAN BROTHERS**  
823 W. 21st Street  
Norfolk, Virginia

MONTANA, WYOMING, COLORADO,  
UTAH, NEW MEXICO,  
TEXAS PANHANDLE

**W. H. CONNORS COMPANY**  
1590 Eudora  
Denver 7, Colorado  
Phone: FR-0566

TENNESSEE, GEORGIA, FLORIDA,  
ALABAMA, MISSISSIPPI

**MAILAND K. SMITH COMPANY**  
315-17 Forrest Avenue, N.E.  
Atlanta 3, Georgia  
Phone: Walnut 6094

WISCONSIN, MINNESOTA,  
NORTH DAKOTA, SOUTH DAKOTA

**D. L. DALE COMPANY**  
910 East Ivy Street  
St. Paul 6, Minnesota  
Phone: Van Buren 4740

INDIANA, KENTUCKY

**HOEMIG SALES COMPANY**  
1730 Clover Lane  
Fort Wayne 7, Indiana  
Phone: Anthony 2083

**SYMPHONIC RADIO  
& ELECTRONIC CORP.**

160 Washington St., N., Boston 14, Mass.

*New Plans, New Models, New Sales  
Material to help you do a Bigger Job!*

See SYMPHONIC at the 1951 MUSIC INDUSTRY TRADES SHOW

BOOTH  
No. 2

**Palmer House, Chicago**

July 16-17-18-19  
EXHIBITION HALL

ROOM  
603

\*U.S. Reg.  
Trade  
Mark

## Cutting New Hit Album



Ezio Pinza and Fran Warren sing "Songs From Mr. Imperium," in Pinza's new RCA Victor album release. The album, released nationally this month, includes the popular "Andiamo," and three other ballads from the MGM movie, "Mr. Imperium," as well as "September Song" and "Yesterdays". Miss Warren collaborates with Mr. Pinza on "Andiamo," "My Love and My Mule" and "Let Me Look At You."

## Kiddie Record Contest

Synthetic Plastic Sales Co., 461 Eighth Ave., N. Y. 1, N. Y., makers of Peter Pan children's records, has announced a national distributor and dealer sales and promotion contest. Starting at the Chicago music show, the contest will run until Dec. 15. First prize for winning distributor and dealer is a 2 week cruise to Central America. Each distributor to enter the contest will receive a prize.

## Walco Diamond Needles

Electrovox Co., Inc., East Orange, N. J., manufacturers of Walco phono needles has announced the availability

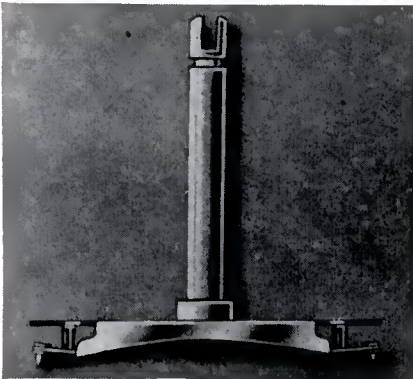

of Walco diamond tipped replacement needles to fit most phonographs and cartridges. Walco diamond needles are now available for Astatic, GE variable reluctance, Shure, RCA, Philco and Webster - Electric cartridges. The needle shown is the model W-66 TP D for GE variable reluctance cartridge RPX-050.

## DuMont Distributor

Thomson-Diggs Company, Inc., 1355 Market St., San Francisco, Cal., has been appointed distributor for Du Mont television receivers, it was announced by Ernest A. Marx, general manager, receiver sales division, Allen B. DuMont Laboratories, Inc.

# This is NO BULL!



Radio-Phono  
Combination  
Model 573  
manufactured by  
Symphonic Radio  
& Electronic Corp.,  
Boston, Mass.

The "ox" is the established trademark of  
**OXFORD SPEAKERS . . . this is no bull!**

AND, it's no "bull" that recognized manufacturers, like  
"Symphonic", select **OXFORD SPEAKERS** to meet the  
highest demands for the finest fidelity.

The next time you need speakers for replacement use,  
choose from the most complete line  
available . . . **OXFORD**, producers of quality  
speakers for over twenty-five years.

Leading jobbers carry  
**OXFORD SPEAKERS** for  
TV, AM, FM, Auto, PA and  
outdoor applications.  
A copy of our latest  
catalog is available  
upon request.

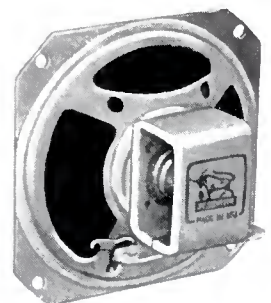

**OXFORD ELECTRIC CORPORATION**

3911 South Michigan Avenue • Chicago 15, Illinois  
EXPORT: ROBURN AGENCIES, NEW YORK CITY

## New Kiddie Record

Pacific Record Co., Pasadena, Cal., is planning national magazine advertising for this fall on a new kind of children's record album. Featuring Hollywood radio personalities, the discs are aimed at teaching children how to talk.

## RCA Victor Names Letts

The appointment of Howard L. Letts to the newly created post of assistant manager of the RCA Victor Record Department has been announced by Paul A. Barkmeier, vice-

president in charge of the department. Letts has been controller of the Record Department since 1945. He will assist in the administration of all RCA Victor Record Department sales, recording and production activities.

## Capehart Distributor

Coffin & Wimple, Inc., of 142 Broad St., Bangor, Maine, has been appointed distributor for Capehart television and phonograph-radios, E. Patrick Toal, director of sales of the Capehart-Farnsworth Corp. announced.

## Young People's Releases

Recent children's record releases by Young People's Records, Inc., 920 Broadway, New York 10, include "I'm Dressing Myself" backed by "Little Old Car" by the Gene Lowell Chorus. Aimed at the 2-5 year old group, the disc helps "stimulate creative activ-



ity." Another 2-5 special is "Let's Play Zoo" (cover shown here) sung by Tom Glazer. It features various zoo animals and the sounds they make. Also by Tom Glazer, for the 6-10 group is "Let's Go To the Rodeo."

## Peter Pan Racks

New display racks for Peter Pan children's records include some with built-in record players (shown). Racks are available, together with records, in a package deal from the manufacturer, Synthetic Plastics Sales Co., 461 Eighth Ave., New York



1, N. Y. Also announced was a "portfolio" of 2 records: Terrytoons and Mighty Mouse; and a new Royalty series featuring Rudolph the Reindeer, Frosty the Snowman, and others. The single 7" discs list for \$.25, the 10" at \$.49 and story book albums at \$1.05.

## J. T. Dalton Appointed

J. T. Dalton has been appointed manager of Zenith's North Jersey distributing organization, which is located in Orange, New Jersey, it was announced by W. W. Boyne, vice-president of Zenith Radio Corporation of New York.

# A DUOTONE EXCLUSIVE



- ✓ THE SIMPLEST NEEDLE INVENTORY EVER DEvised
- ✓ NO COUNTING BOXES OR SEARCHING SHELVES
- ✓ NO NEED TO KEEP CUSTOMERS WAITING
- ✓ FINGERTIP CONTROL

### Use one of DUOTONE'S

**Time Saving Inventory Metal Files or Beautiful Lucite Cases Designed for You**

Duotone has the answer for its many users. Your time is precious — your customer's valued — prompt service to your consumer a "must". We have come to your assistance with the simplest inventory control ever devised. Either our metal inventory file or our clear lucite control cases give you the opportunity to keep your needles in order. Each File or Case has its own inventory chart — you see your stock — are able to inventory them at a glance and your packaged needles are always ready for the customer — no dust — no spots to mar the perfection of Duotone's superior styling.

**Now Available — all replacement needles with diamond points!**

### 12 Compartment NEEDLE ASSORTMENT

The complete needle inventory for record and phonograph dealers. Includes replacements for all types of players in quality built, compartmented cabinets.

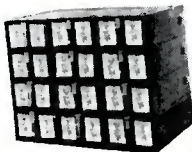

List Price \$528.50  
Your Cost 272.30\*  
Your Profit \$256.20

\*NO CHARGE FOR HANDSOME CABINETS, NEEDLE REPLACEMENT GUIDE AND INVENTORY CONTROL CHART.

**Remember** It's DUOTONE NEEDLES in their specially designed packages that need no "high pressure sales". DISPLAY THEM — SEE THEM DISAPPEAR and you benefit by higher sales — more profit — better consumer relationship.

### 701 SERVICEMAN'S SPECIAL

The perfect kit for the serviceman. A compact kit to take on the job. Every TV and radio call-back is a needle sale possibility. Kit includes compact lucite case, control chart and replacement guide.



List Price \$40.25  
Your Cost 20.53\*  
Your Profit \$19.72

\*CASE AND REPLACEMENT GUIDE SUPPLIED AT NO EXTRA COST.

### 703 NEEDLE DEPARTMENT

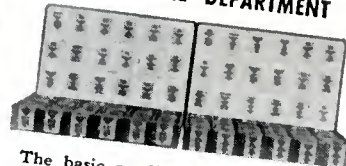

The basic needle stock every dealer needs. Contains 105 needles of 36 different types (constitutes 92% of all needle business). Two beautiful lucite cases include inventory control charts.

\*CASES, CONTROL CHARTS AND REPLACEMENT WALL GUIDE FREE!

List Price \$193.00  
Your Cost 102.00\*  
Your Profit \$ 91.00

— for greater PROFITS — promote DUOTONE needles!

Place your needle department on a high-profit basis with no time lost searching for stocks, trying to figure out orders. Make needle business — big business — by stocking and selling Duotone. The most progressive needle line ever offered the trade! Phone, wire or write for details, today!



Canadian Representative: CHARLES W. POINTON, TORONTO. Export Division: AD. AURIEMA, INC., NEW YORK, N.Y.

**RING UP MORE SALES,  
BIGGER PROFITS WITH**

**V-M  
tri-o-matic®  
PHONOGRAPHS**

45 rpm  
33 1/3 rpm  
78 rpm

**patented spindle design!**



**Model 920  
Plug-in Record Changer**

**positive record protection!**

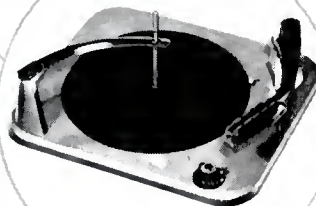

**Model 950  
Replacement Unit**



**Model 955  
on "Plug-in" Base**

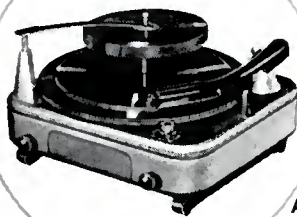

**Model 970  
Amplified Record Player**

**iam-proof!**

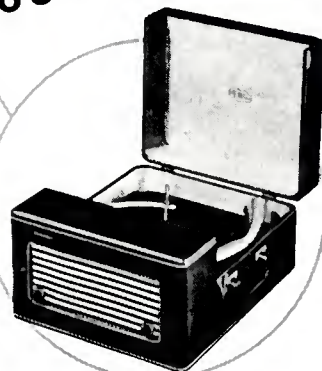

**Model 975  
or 980 Portable**

**automatic intermix!**



**Model 150  
Phonograph (Manual)**



**BOOTH 68  
NAMM SHOW  
Palmer House, Chicago  
July 16-17-18-19  
Room  
648**

**nationally advertised in:**  
Collier's  
Better Homes and Gardens  
House Beautiful  
Esquire  
Holiday

**V-M CORPORATION**  
Benton Harbor, Michigan

## PMA at Music Show

Attending their first National Association of Music Merchants Convention as a group, the Phonograph Manufacturers Association, Inc., have made elaborate preparations for the huge four-day event to be held in Chicago starting July 16th, it was announced by Roland J. Kalb, president of PMA and vice-president of Steelman Phono & Radio Co., Inc. The program includes use of a double booth, numbers 71 and 72, on the main exhibition floor of the Palmer House while member manufacturers will hold their merchandise exhibits on the

sixth floor. A banquet in Chicago and air travel accommodations have also been arranged.

Jerry L. Herold, chairman of the show committee and president of Herold Radio & Television Mfg. Co., said that a very attractive display has been designed especially for the occasion and all those who stop by the PMA booths will receive a cold Coca-Cola, gratis, from a "vivacious" model. He added that the PMA annual banquet for members as well as those in the industry will be held on Tuesday, July 17th, 8 P.M., also in the Palmer House.

Two new manufacturers recently

joined PMA, it was revealed by Alfred H. Suekoff, chairman of the membership committee and of Portofonic Sales Corp. The newcomers are: Edu-Craft Sales Corp., White-stone, N. Y., represented by Larry Lewin, president, and Kraft Bros., Bronx, N. Y., represented by Jack and Harold Kraft.

## New Recoton Guide

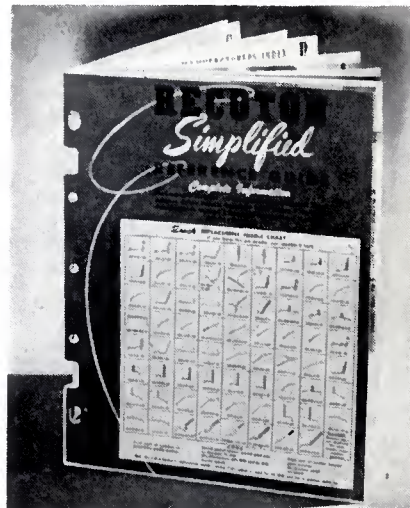

Recoton Corp., 251 4th Ave., New York, N. Y. is offering the Simplified Reference Guide (shown above). The guide contains cross check lists for identifying phono needle type. Also contains listing and prices on Recoton's needle line.

**ANOTHER  
BOZO  
BUSINESS  
BOOSTER!**

**IT'S  
NEW**

the **BOZO** 78 RPM phonograph

**GRAND  
TONE**

**STURDY**

**WASHABLE  
COVERING**

**BOZO'S FACE  
LIGHTS UP**  
as the  
record plays

**RED, WHITE  
AND BLUE  
LEATHERETTE**

Bozo, that super salesman, comes through again — with a real children's phonograph.

A "grown-up" player that sells at a

"kiddie" price. Handsome, sturdy, leatherette covered; waterproof, plus tricky features kids will love. Your Capitol salesman will show you the new Bozo electronic phonograph.



## V-M Plans New Factory

V-M Corporation of Benton Harbor, Michigan, recently announced the acquisition of a 105 acre site just outside of Benton Harbor for the erection of a new factory. The new factory will represent an investment of more than a million and a half dollars and provides expanded facilities for further increasing production.

## New Scott Circuit

Development of an exclusive new highlight control, which enables the user to sharpen or subdue the highlights of the picture on his TV screen has been announced by Scott Radio Laboratories, Chicago. John S. Meek, president of Scott, said the new feature, which is now being incorporated in all Scott television chassis, operates in addition to the normal contrast control used on all TV sets.

## Variety Electric Moves

Variety Electric Co., distributing firm, recently moved to its own three-story building in Newark, N. J., located at 468 Broad St. The sales-room features modern appointments, is fluorescent lighted and is equipped with about 100 feet of counter space. The Company also maintains a large bargain basement, and provisions are being made for "Ham" and Sound rooms to increase the value of the company's services, so that it can handle the requirements of every phase of the industry.



**In response to  
overwhelming  
DEMAND!**

# Walco DIAMOND- tipped replacement needles!

Now available in most popular types of Microgroove, All groove and 78 R.P.M. replacement needles!



**These and many other replacement needles now obtainable under the famous Walco C-I (Controlled Inventory) Plan with diamond points. Remember, no kits, no deals, no minimum orders. You buy only what you sell, with full exchange privilege!**

To meet the ever growing demand of quality-conscious record lovers and professional sound equipment users, WALCO now makes available the more popular types of replacement needles (as well as conventional 78 RPM needles) set with genuine diamond tips. These needles are literally custom-made from South African diamonds, whole stones, and are hand-polished to the exacting specifications set up by the RMA Committee on needle standards.

It has long been an accepted fact among prominent Audio engineers (names on request) that genuine diamond, as a needle material, is without equal for this purpose. Extensive tests and thorough investigations conducted by these engineers confirm the fact that, from an economy standpoint alone, the diamond needle is a sound investment. The almost

Like the "gems" they are, Walco diamond-tipped needles are packaged like fine jewelry, with written guarantee.

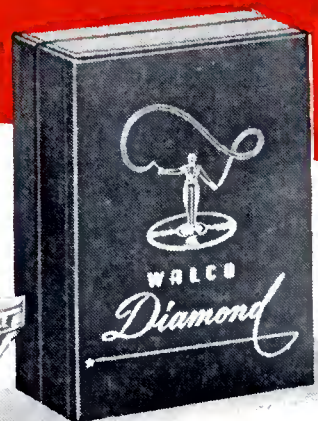

universal adoption of the diamond needle by broadcasting stations, professional transcription outlets, and the armed services bears ample proof of the ever-growing shift to diamonds where quality reproduction is the primary consideration.

Write today for full information and prices of WALCO DIAMOND NEEDLES.

**NOTE:**

Registered owners of the WALCO MASTER CONTROL INDEX will receive mailing containing Walco Diamond Replacement Needle listings.

**Walco** TRADE NAME OF **ELECTROVOX CO.,** 60 Franklin Street  
INC. East Orange, N. J.

## New Address for Garod

Garod International Corporation has moved its office to 385 Fourth Ave., New York 17, N. Y. Garod International Corporation is a subsidiary of The Wilcox-Gay Corp., Majestic Radio & Television, and Garod Radio Corp., handling all their foreign activities under the management of Ernest Nigaglioni.

## Deaf Enjoy TV Set

A 19-inch TV console is bringing the outside world closer to students at Detroit's Evangelical Lutheran Institute for the Deaf. J. A. Klein, super-

intendent of the Institute, recently purchased a Stromberg-Carlson Empire model, equipped with a 19-inch picture tube large and clear enough for the children to interpret dialogue through lip reading.

## Steelman Distributors

Morris J. Steelman, president of Steelman Phonograph & Radio Co., Inc., Mt. Vernon, N. Y., has announced the appointment of two new distributors: Wolfe Distributors, 710 Northwest Second St., Oklahoma City, Okla., and 321 Southwest Blvd., Kansas City, Mo.; and Dunkelman-Pace, 1417 Louisiana Ave., Shreveport, La.

## Adopts 45RPM System



Philadelphia Radio Station WFIL, a key ABC affiliate, has become the first station in the nation to adopt the 45-rpm record playing system as standard broadcast equipment. Here, Roger W. Clipp (center), general manager of the station, discusses the new 45-rpm turntable equipment with J. B. Elliott (right), vice-president in charge of RCA Victor consumer products, and T. F. Joyce (left), vice-president and general manager of the Raymond Rosen Company, RCA Victor distributor in the Philadelphia area.

## Columbia Revives Okeh

The famous "Okeh" label, at one time the hallmark of stellar jazz performances on discs, has been revived by Columbia Records, Inc. Reserved exclusively for Rhythm and Blues waxings, the purple "Okeh" label will feature selections from outstanding releases of the past as well as new artists and material. They will be available on all three speeds.

## Praise Raytheon Ads

The attempt to help dealers sell all makes of television through its advertising of Raytheon TV won industry-wide praise for Belmont Distributor, Inc., Chicago, distributor of Raytheon television. The first of this series of ads said: "When you buy—buy from a reliable dealer, and look at such well-known sets as Admiral, DuMont, General Electric, Motorola, Philco, RCA, Zenith and Raytheon." Both manufacturers and dealers expressed their approval of a united effort to assist all television dealers, announced W. K. Trukenbrod, vice-president and regional sales manager of Belmont Distributor, Inc.

## To Distribute Stromberg

The Nash-Kelvinator Sales Corporation, 1600 St. Charles Ave., New Orleans 13, has been appointed to distribute Stromberg-Carlson radio and television products, according to C. J. Hunt, radio and television sales manager for the Stromberg-Carlson Company. E. S. Kerr is zone manager for Nash-Kelvinator at New Orleans, and concluded the arrangements with Mr. Hunt. Sales manager for radio and television is S. M. Fucich. W. A. Thompson is the Birmingham branch manager.

# Another JENSEN NEEDLE



## The JENSELECTOR

FOR FAST, EASY, REPLACEMENT  
NEEDLE SELLING



### PICKS THE PROPER NEEDLE

This new Jensen Needle Guide will give the exact replacement needle number for any type record player without knowing the model or cartridge number. See your distributor for your new "Jenselector."

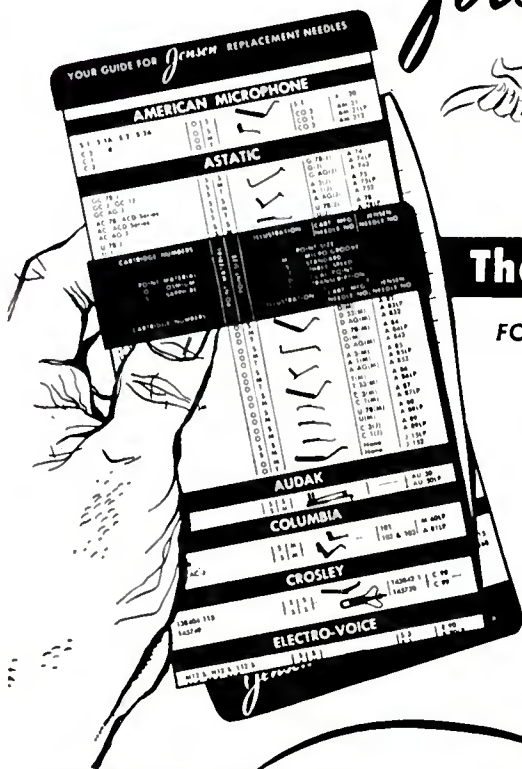

PARTY FUN



MUSIC STUDY



HOME MOVIES



CONFERENCES



# FLEXIBILITY

## OF THE EICOR TAPE RECORDER GIVES YOU A SOUND SELLING PICTURE



Conversion Kit which changes the Eicor Model 115 from standard 7½ in. per sec. to 3¼ in. per sec.

No matter what variations in customer needs you must fulfill, the Eicor offers you the dependability and adaptability which assures you of trouble free, repeat sales. By selective and exacting engineering, Eicor has developed the ultimate in quality of sound fidelity and mechanical efficiency in the low priced magnetic recording field. Such features as two-speed recording and play-back, volume control and tone control, have been incorporated into a chassis built for exacting and rugged long life. It will pay you to handle Eicor.

LANGUAGE STUDY



DOCTORS



MINISTERS



DRAMA



LAWYERS

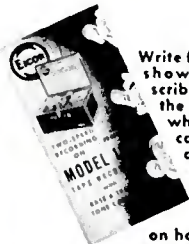

Write for this folder showing and describing some of the many uses to which the Eicor can be put. Address your inquiry ATTN: RTR Dept. 24 for information on how to become an Eicor dealer.



PIONEERING IN MAGNETIC RECORDING

**EICOR, INC.**  
1501 WEST CONGRESS STREET  
CHICAGO 7, ILLINOIS  
DEPARTMENT 24

SPOT INTERVIEWS



RECORD LIBRARY

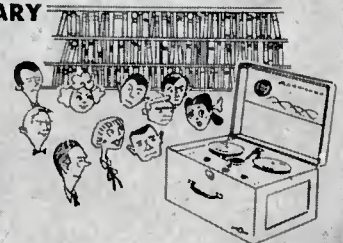

PUBLIC SPEAKING



## Standard Wood Rep.

George Entin, jobber sales manager of Standard Wood Products Corp., Long Island City 4, N.Y., makers of a complete line of cabinets, has announced the appointment of James H. Podolny as its representative in western Pennsylvania, Ohio and West Virginia. Podolny is located at 4716 Coleridge St., Pittsburgh 1, Pa.

## Freed-Eisemann Appointee

Appointment of Gerald Ganly as director of purchases for Freed Radio Corporation, New York, was announced by Arthur Freed, president.

## Capitol Offer O-C Disc

Capitol Records has announced that it will make data on its optional center 45 RPM disc available to other record manufacturers at no royalty charge. Engineering drawings and technical specifications will be loaned by Capitol upon written request. Capitol's "O.C. 45" is the standard "45" disc with a triangular insert molded into the record. Triangle may be easily pushed out with the thumb for playing on large spindle "45" changers. With the triangular center left in, disc may be played on any three speed small spindle changer.

## New Coral Album

"Over the Rainbow" is the appropriate title for the latest Les Brown album released by Coral Records.



The album features eight songs in an assortment of colors: Deep Purple, Red Wing, Blue Moon, Green Eyes, etc. The popular Les Brown style prevails throughout.

## Majestic Vice-President

Henry T. Roberts has been appointed vice-president of Majestic Radio and Television, Division of The Wilcox-Gay Corp., according to an announcement from Leonard Ashbach, president. Roberts will be in charge of the private-brand contract sales department for Majestic and will also act as sales manager for Wilcox-Gay recording products. He will have headquarters at Majestic's Chicago offices, 743 N. La Salle St., and at the Charlotte, Michigan plant.

## To Distributor Posts

Louis J. Chaseman has been appointed sales manager of the northern division and Richard J. Behrens, sales manager of the southern division of Zenith Radio Distributing Corp., Chicago, it was announced by C. F. Parsons, vice-president and general manager.

## RCA Victor Plan Guarantees List Prices

The market stabilization plan recently announced by RCA Victor points up the fact that the television industry's greatest strength is its own merchandising inventiveness. The plan was born out of the current slow-down in television receiver sales at the retail level. Essentially, RCA Victor's plan guarantees to its distributors for a specified period of time the current factory list prices of its present television receivers. Equally important, the company also gives assurance that there will be no new RCA Victor television receivers added to the line in this period. In effect, the market stabilization plan now enables the dealer to assure his customers that there is no need to hold back in anticipation of lower prices, and thus lose many months of exciting television entertainment.

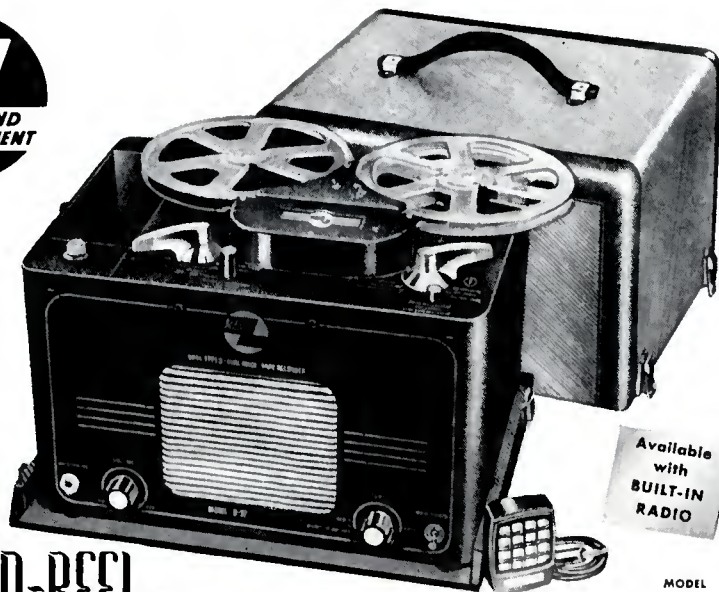

Available with BUILT-IN RADIO

MODEL D-37

SOUND-REEL

Dual Speed—Dual Track  
MAGNETIC TAPE RECORDERS

All 5 Points of Superiority Plus Many More

- Instantaneous push button speed selection, 7.50 in./sec. or 3.75 in./sec., with Automatic Tone-Equalization for each speed
- Full frequency range—professional tone quality
- Up to 2 hours recording and playback time
- Proved Performance, thoroughly field tested and acclaimed everywhere
- Amazingly light weight, yet rugged. Cast zinc & aluminum components

### AVAILABLE IN 6 MODELS

### LIST PRICES

D-37 (illustrated) Complete portable recorder with carrying case	\$243.00
D-37R Complete portable recorder with carrying case, with AM tuner	\$286.20
DC-37 Complete portable recorder with metal cover and lock	\$243.00
DC-37R Same as above but with self-contained AM tuner	\$286.20
LD-37 Complete recorder less carrying case	\$221.40
LD-37R Complete recorder, less carrying case, with AM tuner	\$264.40

\*Plus Federal Excise Tax  
West of Rockies add 5%

Write for your copy of Tape Recorder Catalog #TR-51



MARK SIMPSON MANUFACTURING CO., Inc.  
32-28 49th Street, Long Island City 3, N. Y.

SOUND SYSTEMS and ACCESSORIES

RAvenwood 8-5810-1-2-3-4

### Additional Features

- Capstan driven—negligible wow and flutter.
- Volume level indicator.
- Monitor speaker built-in.
- Record pushbutton prevents accidental tape erasure.
- Inputs... for microphone, for external radio or phonograph.
- Outputs... for earphone monitoring, external speaker or for existing audio system.
- Finish... beautiful spruce green hammer-tone.



... the brand name that assures you high quality, big value, and steady profits in ...

- **RADIOS**
- **PHONO-RADIOS**
- **PHONOGRAPHS**



#515—Portable, Deluxe, 3-speed Radio-Phono combination.

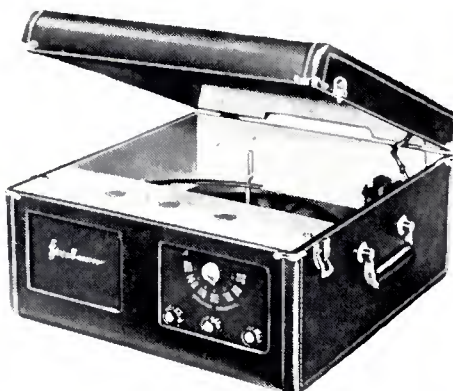

#595—3-speed Radio-Phono combination with Automatic changer.

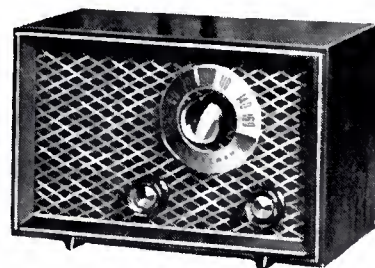

#5101—Compact, super-powered AC-DC Table Radio, at a low price.

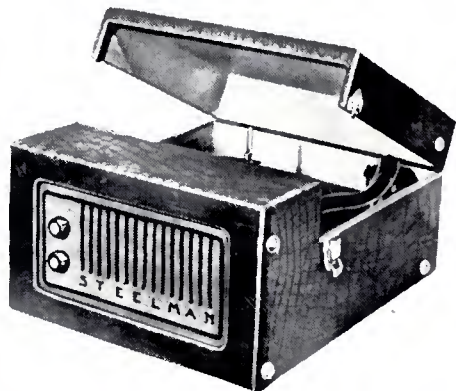

#487—Automatic, 3-speed phono-graph, smart portable style.



#AF-1100—FM-AM table radio, as handsome as it is efficient.



#215 — 3-speed portable, at an exceptional low price.



#327 — Outstanding value in a 3-speed portable phono-graph.

SEE and HEAR the STEELMAN line at the NAMM show  
**PALMER HOUSE—SUITE 659**

Write for complete illustrated catalog ...

**STEELMAN PHONOGRAPH & RADIO CO., Inc.**  
 12-30 Anderson Place, Mt. Vernon, N. Y.

## Permo Needle Facts

Permo, Inc., makers of Fidelitone phonograph needle, is distributing its "Fidelitone Phonograph and Needle Facts," which lists, by manufacturers, the set model numbers and corresponding changer, cartridge, and needle numbers. Sections have so far been announced covering the sets of Admiral, Columbia and Philco. Copies of the "Facts" will be distributed at the Music Show.

## New Walco Wall Chart

An attractive, colorful, 11" x 17" chart, showing not only all of the phonograph needles in use by leading record-player manufacturers, but cartridge makers as well, has been announced by Electrovox Co., Inc. Jobbers and dealers may obtain a copy free by writing Electrovox Co., Inc., 60 Franklin St., E. Orange, N. J.

## Miller Needle Manual

New catalog of the M. A. Miller Mfg. Co., 1169 E. 43rd St., Chicago 15, called the "Miller Manual" contains in addition to a listing of the various types of Miller replacement phono needles, directions for installation of each type. Also offered is a cross-reference chart giving the equivalent Miller needle for each cartridge number, together with the needle equivalent used by four other needle makers.

## Zenith Test Results

"A preliminary analysis of our 90-day Phonevision test shows that it was successful far beyond our expectations," Commander E. F. McDonald, Jr., Zenith Radio Corporation president, said recently. "Our 300 families who participated in the experiment," McDonald said, "saw movies in their homes at an attendance rate 3½ times greater than the .47 times per week which is considered as the average for American movie attendance in the theatres." McDonald said that the total phonevision box-office for the test period was \$6,750, an average of \$22.50 per family for three months, or \$1.73 per week.

## Steelman Distributor

Morris J. Steelman, president, Steelman Phonograph & Radio Co., Inc., Mt. Vernon, N. Y., has announced the appointment of Duizend, Fain and Levin, New Orleans, La., as distributor for the Steelman line.

## Delaware Store Expands

The Robelén Piano Company, 710 Market St., Wilmington, Del., has been acquired by Braunstein's, as part of its expansion program. Robelen's has been established in Wilmington for over 80 years; carried pianos, records, sheet music, radios and television.

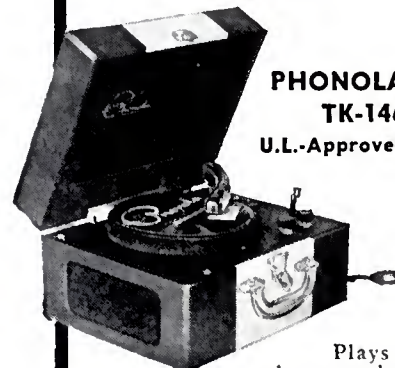

**PHONOLA  
TK-146**  
U.L.-Approved

Plays all three speeds. 3-tube (including rectifier) amplifier . . . 5" speaker. Volume and tone controls. Smartly styled . . . priced to meet competition.

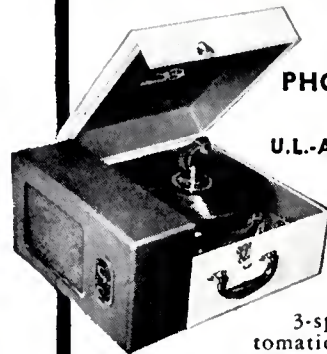

**PHONOLA  
TK-236**  
U.L.-Approved

3-speed, automatic record changer. 3-tube (including rectifier) precision built high fidelity amplifier. Volume and tone controls. 6" Alnico V speaker.



**THE**  
*Crestwood*

**MAGIC TAPE RECORDER**

THE FINEST OF TAPE RECORDERS

No other tape recorder in its price field approaches the Crestwood for *Perfect Reproduction—Unparalleled Fidelity—Frequency Response—Dependability—Power Output—Fast Forward—Fast Rewind—Consumer Satisfaction—Sensible Price.*

The Crestwood offers unlimited sales opportunities.

See the Crestwood on display at Rooms 752-754, The Palmer House, during The Music Trades Show, July 16-19.

Write for complete information.

**CRESTWOOD RECORDER CORPORATION**  
221 N. LaSalle Street  
Chicago 1, Illinois

## VISIT BOOTHS

**63-64**

at the

## MUSIC SHOW

See Phonola's complete new line of electronic and acoustic models—Palmer House, Chicago, July 16, 17, 18, 19, or write for details.

**WATERS CONLEY COMPANY**  
ROCHESTER MINNESOTA

## New Wilcox-Gay Plant

The Wilcox-Gay Corp., of Charlotte, Michigan, has leased a new manufacturing plant in Burbank, Cal., to be used for the manufacture of Majestic TV sets and radios and Wilcox-Gay Recordios for West Coast distribution. The new plant has floor space amounting to 85,000 sq. ft. with provisions to expand facilities when needed.

## Scott Guarantees Price

Prices of radio-phonographs, television sets and television-radio-phonograph combinations made by Scott Radio Laboratories, Chicago, have been guaranteed against decline until September 15th, 1951, John S. Meek, president of the firm disclosed.

## New Commercial Credit Field Promotions

Clayton S. Clark, formerly manager for Commercial Credit Corp. at Fresno, Cal., has been appointed vice-president, division manager for Commercial Credit Corp. in the Salt Lake City area. Sixteen other appointments within the company were also announced.

## Raytheon Radio Show

Nationwide network radio sponsorship of John Cameron Swayze, NBC newscaster, spearheads Raytheon television's merchandising program, W. L. Dunn, vice-president of Belmont Radio Corporation, manufacturer of Raytheon TV has announced. Swayze speaks for Raytheon each Sunday afternoon over 133 NBC outlets.

## Sheldon Honors Kefauver

Sen. Estes Kefauver, who as chairman of the Senate Crime Investigation Committee put on the "show of the year" on TV, received the "Bouquet of the Month" award from Television Mis-Information, publication of Sheldon Electric Co., Irvington, N. J. With the "bouquet" went a formal award certificate and a contribution of \$100 to the Damon Runyon Cancer Fund in the Senator's name.

## Motorola Promotion

A new promotional feature called "G. I. Bonus" is being used by C. L. Lannin, sales manager of Carolina Appliance Company, Motorola distributor in Charlotte, N. C. The distributor is co-sponsoring the radio-merchandising plan with dealers. Based on a giveaway offer of \$7,500 in War Bonds every week, "G. I. Bonus" adds a new twist to radio advertising. Dealer sponsors are supplied with complete promotional material free of charge. This includes window streamers and "pay-off" point-of-sale pieces which make it possible for traffic in the store to participate in the weekly prize offers.

# HERE'S EXACTLY WHERE ASTATIC'S NEW "CAC" CARTRIDGES CAN BE INSTALLED

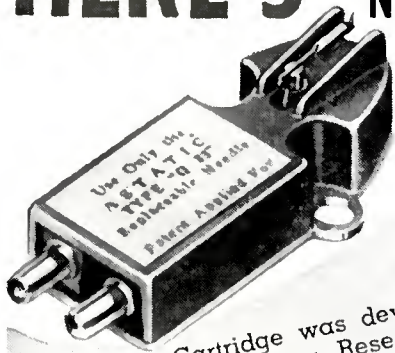

ASTATIC'S CAC-J Crystal Cartridge was developed in conjunction with the Engineering Research and Development Department of CBS to match the recording characteristics of LP records. It is internally equalized to follow Columbia Records, Inc., ideal frequency response for the recording characteristics of LP records. Other models in the "CAC" Series were developed on the same engineering principles, and have proved capable of the same new, high level of performance.

## ASTATIC "CAC" MODELS AND THE CARTRIDGES THEY REPLACE

CAC-J REPLACES*	CAC-AG-J REPLACES	CAC-78-J REPLACES
RCA 74067 74625 75476	ELECTRO-VOICE 33 33S	ELECTRO-VOICE 32 32S
ELECTRO-VOICE 14 14S 34 34S	SHURE P71 P81AD P71A P81C P71B P81CA P71C P81D P71CA P81E P81 W26A P81A W26B	SHURE P70 W23A P70A W23B P85
SHURE P73 P93MG P73A P95MG P73AR W21A P73R W21AR W53MG	WEBSTER A91 A9MI	WEBSTER A3 A3M
WEBSTER A2 A2M F12 F13M		

\*FITS ALL RCA 45 RPM CHANGERS AND IS STANDARD FOR COLUMBIA 102 AND 103 PLAYERS.

SPECIAL MODELS FOR PLUG-IN HEADS. Models CAC-W-J (1-mil needle) and CAC-78W-J (3-mil needle) are furnished with special terminals and fittings for quick, easy installation in record changer tone arms with plug-in heads.

LIST PRICE—All Models  
Sapphire Stylus . \$ 7.50  
Diamond Stylus . 31.00

THE  
*Astatic*  
ASTATIC CORPORATION  
CONNEAUT, OHIO

IN CANADA: CANADIAN ASTATIC LTD., TORONTO, ONTARIO

Astatic Crystal Devices manufactured under Brush Development Co. patents.

# New Radio and TV Sets

This and following pages describing manufacturers' new merchandise are compiled by our editors. This information is presented as a news service to our readers entirely without any advertising consideration whatsoever.

## S-W NEW TV RECEIVERS

Four new television sets have been announced. Model 9125-A is a TV-radio-phono combination with a total of 41 tubes. List price is \$1,250. Features a 17-inch screen and 15-tube FM-AM radio. Model 9200-C, 16-inch TV



console is available, in mahogany (\$369.95) or in blond (\$379.95). Another 17-inch console, model 9202-E, is \$399.95. A 17-inch table model, 9202 (shown here) is available in finishes of brown and green, blond and beige, or mahogany at \$269.95, \$279.95 and \$269.95 respectively. Stewart-Warner Corp., 1826 Diversey Pkwy., Chicago 14, Ill.—RADIO & TELEVISION RETAILING.

## Kaye-Halbert 1952 TV LINE

The new Kaye-Halbert TV line includes the Cambridge, model 074-M, at \$369.95 and model 074-B at \$379.95; the Provincial, model 076 at \$369.95; the Early American Planter in knotty pine, model 077 at \$369.95; model 424, open face 24" console, \$459.95 in walnut, \$469.95 in mahogany, and \$479.95 in blond; three "Hideaway" models, the Modern, \$359.95, \$369.95 and \$379.95 in walnut, mahogany and blond respectively; the Windsor, \$399.95; and the Provincial, \$389.95 (these three models are 20"). The "Harry K" models include a 17" open face console, \$219.95, \$239.95 and \$259.95 in walnut, mahogany and blond respectively; a 20" open face console at \$299.95, \$319.95 and \$339.95 in walnut, mahogany and blond; and a 20" table model at \$249.95, \$259.95 and \$269.95. Kaye-Halbert Distributors, Inc., 5729 W. Jefferson Blvd., Los Angeles 16, Calif.—RADIO & TELEVISION RETAILING.

## Mitchell PORTABLES

New entry into the portable radio field is the model 1256, Caravan. This 3-way personal portable retails for \$39.95. Available in maroon plastic case measuring 9 $\frac{3}{4}$ " wide, 6 $\frac{1}{2}$ " high, and 4 $\frac{1}{4}$ " deep. Mitchell Mfg. Co., 2525 Clybourn, Chicago, Ill.—RADIO & TELEVISION RETAILING.

## Bendix TABLE TV SET

Model T171, latest addition to the television line, is a 17-inch table model. Screen is rectangular, dark-face type; cabinet is hand-rubbed mahogany veneer. List price of this new model, including warranty and Federal tax, is \$299.95. Bendix Radio Div., Bendix Aviation Corp., Baltimore 4, Md.—RADIO & TELEVISION RETAILING.

## Steelman RADIOS

Three new additions to the line have been announced. The "Pacemaker" #6000, is a 3-way portable radio. Case is two-tone simulated leather available in three different color combinations.

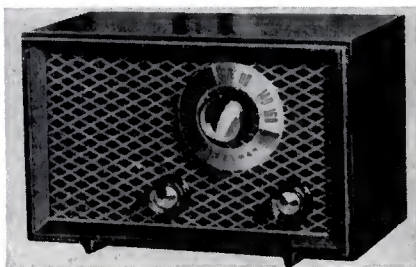

Model 5101, shown here, the "Intermezzo," is a table radio with grid-panel front. Cabinet is mahogany. Set measures 7 $\frac{1}{2}$ " high x 11" long x 5 $\frac{3}{4}$ " deep. The "Triumph," model 5102, is another table radio. Case is hand rubbed mahogany with wood-panel front. Steelman Phonograph & Radio Co., Inc., Mount Vernon, N. Y.—RADIO & TELEVISION RETAILING.

## Mattison NEW TV CHASSIS

The new Silver Rocket Super Rural Chassis, shown here, has been announced. The 28 tube chassis features a built-in booster for longer range re-

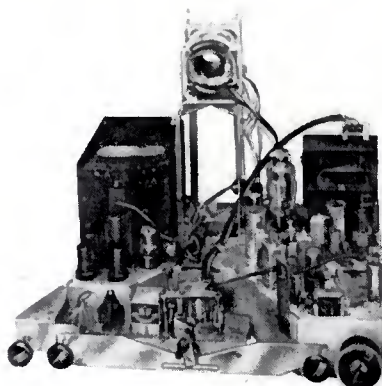

ception. It is available as a separate unit or in any of the Mattison custom cabinets. Mattison Television and Radio Corp., 893 Broadway, New York 3, N. Y.—RADIO & TELEVISION RETAILING.

## Arvin RADIO

The Arvin Hopalong Cassidy model, shown here, housed in red or black steel case features knobs of shatter-



proof black Tenite plastic. Set contains four tubes, operates on AC or DC. Arvin Industries, Inc., Columbus, Ohio.—RADIO & TELEVISION RETAILING.

## GE 24-INCH TV SET

The newest Black-Daylite console television receiver, model 24C101, features a 24-inch picture tube. Eastern list price on this model is \$775. Chassis features many GE improvements for operation with the large size picture tubes. Speaker is twelve-inch. Cabinet is mahogany veneer with full-length doors. General Electric Co., Electronics Park, Syracuse, N. Y.—RADIO & TELEVISION RETAILING.

## Meck "RED-HEAD" TV

New addition to the recently introduced "Red-Head" line of television re-



ceivers is this 20-inch table model. Known as the model JM-720T, it carries a suggested retail price of \$295.80, plus excise tax and warranty. Cabinet is hand-rubbed mahogany. Plastic mask and bevel are removable from the front. John Meck Industries, Inc., Liberty St., Plymouth, Ind.—RADIO & TELEVISION RETAILING.



Announcing the new

**LONG PLAY**

**Revere**

*De Luxe* **TAPE RECORDER**

SEE IT  
DEMONSTRATED  
BOOTHS 14-16  
1951 MUSIC  
INDUSTRY  
TRADE SHOW  
PALMER HOUSE  
CHICAGO  
JULY 16-19

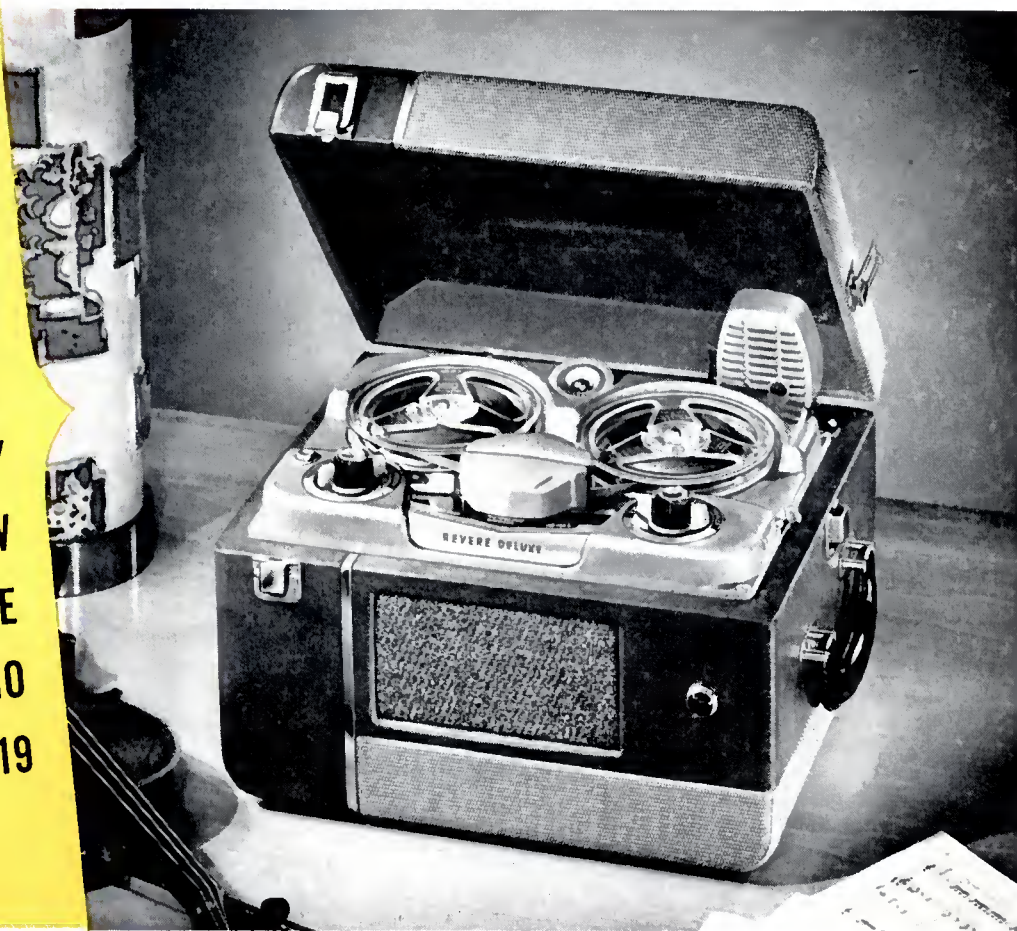

**FULL 2-HOUR RECORDING ON 5-INCH REEL!**

Here it is! The *long play* tape recorder with the finest fidelity, lightest weight and greatest economy on the market today. The sensational new long-play Revere DeLuxe tape recorder records with incomparable fidelity two full hours of voice and music on a small five-inch reel. Its superb tonal quality, particularly on difficult musical passages, has won the praise of leading musicians, opera singers and critics. Handsomely designed, ultra compact and lightweight, it operates anywhere—as easily as a radio. Extra economical, too, as it

uses one half the ordinary amount of tape, which can be automatically erased and reused.

In addition, all of Revere's sales-clinching "extras" are incorporated in the new DeLuxe model—simplified controls . . . powerful, constant speed motor . . . fast forward and rewind speeds . . . quick starting and stopping . . . and beautifully styled carrying case. Write today for complete information about the phenomenal new Revere!

REVERE CAMERA COMPANY • CHICAGO 16



*Model T-500*—Revere DeLuxe 2-hour play Tape Recorder with microphone, radio attachment cord, 2 reels (one with tape), and case, \$179.50

*Model TR-600*—same with built-in radio, \$219.50 • *Model T-100*, Standard 1-hour play, \$169.50  
*Model TR-200*, same with built-in radio, \$209.50

**REVERE—AMERICA'S LARGEST SELLING TAPE RECORDER**

# New Radio, Phono, TV Sets

This and following pages describing manufacturers' new merchandise are compiled by our editors. This information is presented as a news service to our readers entirely without any advertising consideration whatsoever.

## Hoffman NEW TV MODELS

Four open face console television models have been added to the line. These models mark the first time Hoffman has used the open face style. Numbered 886-7 and 896-7, the new models are available in blond, oak and mahogany. The 886, 17-inch console in blond, is shown here. New prices were announced in the 14" table model.



Three new console half-door models, six new full-door consoles, and five new combinations have also been added to the line. The new models use 17 and 20-inch tubes. New models will be shown at the coming music show. Hoffman Radio Corp., 3761 S. Hill St., Los Angeles, Calif.—RADIO & TELEVISION RETAILING.

## Symphonic R-P COMBO

A new radio-phono combination, the Symphony model 573, has been introduced. The new set, shown here, includes a three-speed record player.



Cabinet is covered with leatherette, handle is plastic. List price on this model, \$69.95. Symphonic Radio & Phonograph Co., 160 Washington St., N., Boston, Mass.—RADIO & TELEVISION RETAILING.

## Capehart RADIO-PHONO

Latest addition to the Capehart line is the French Provincial, model 1009-



AF phonograph-radio. Shown here, the set has a cherry cabinet with fruitwood finish. Has a ten-tube plus rectifier chassis, twelve-inch speaker and 3-speed record changer. Retail price is \$425. Capehart-Farnsworth Corp., Fort Wayne 1, Ind.—RADIO & TELEVISION RETAILING.

## Precision "SNOOPER"

The "Snooper" is a new Geiger Counter for use as a civilian defense instrument as well as for prospecting and school use. Powered by flashlight battery, the instrument fits in the palm of the hand. Measures 1½" x 3" x 5". Weighs 1¼ lbs. List price is \$24.95. Precision Radiation Instruments, Inc., 4113 W. Jefferson Blvd., Los Angeles 16, Calif.—RADIO & TELEVISION RETAILING.

## Dean PORTABLE PHONO

A new portable phono will be introduced by Dean Electronics at the Music Show. Designated as model #1798, it is a 3-speed amplified portable with 5-inch speaker and 2-watt amplifier. List price is \$36.95. Other new models to be introduced at the show include a 3-speed automatic, radio-phono combos, and kiddie phonos. Dean Electronics, 35 Fifth Ave., Brooklyn 17, N. Y.—RADIO & TELEVISION RETAILING.

## Mohawk TAPE RECORDER

A midget-sized automatic tape recording machine capable of repeating a sales, advertising or safety message endlessly, or at predetermined intervals, has been announced. Known as the Message Repeater, it measures 6" high, 5½" wide and 5" deep. Retail price is about \$149.50. Handles up to a two-minute message. Mohawk business Machines Corp., 47 West St., New York 6, N. Y.—RADIO & TELEVISION RETAILING.

## Philco 1952 TV LINE

Eleven new television receivers have been introduced. Prices range, including tax, from \$199.95 to \$329.95 for the seven table models and \$299.95 to \$369.95 for the four consoles. Two are 16-inch table models: model 1610 at \$199.95 and model 1612 at \$229.95. Five table models feature 17-inch screens in mahogany and blond cabinets. The four consoles feature 17-inch screens. These are available in regular and blond mahogany and in blond oak cabinets. Philco Corp., C & Tioga Sts., Philadelphia 34, Pa.—RADIO & TELEVISION RETAILING.

## Meck 16-INCH TV SET

Priced at less than \$200, the new 16-inch model shown here is being added to the Meck line. It includes the standard Meck chassis and continuously vari-



able tuner. The exterior is in brown leatherette. Set is called model MM-616T. John Meck Industries, Inc., Liberty St., Plymouth, Inc.—RADIO & TELEVISION RETAILING.

## Mitchell MADRIGAL

This new table radio, available in two models, 1254 in walnut, \$34.95 and 1255 in ivory at \$39.95, has been added

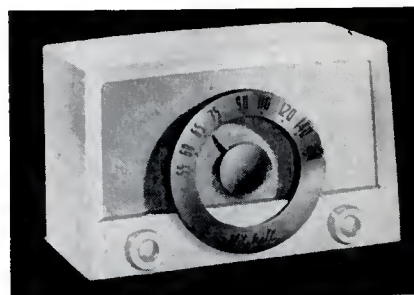

to the line. Features a six-tube chassis and molded plastic cabinet. Mitchell Mfg. Co., 2525 Clybourn, Chicago, Ill.—RADIO & TELEVISION RETAILING.

# See Your Emerson Distributor NOW for the NEW 1952

## Emerson

### 17 and 20 Inch TELEVISION



20-Inch Console  
Model 692  
**ONLY \$399.95**



20-Inch Console  
Full Doors. Model 694  
**ONLY \$459.95**

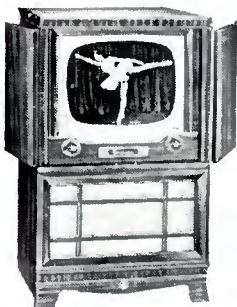

17-Inch Console  
with Doors. Model 687  
**ONLY \$329.95**



20-Inch Ensemble  
Model 697  
**ONLY \$349.95**  
Including swivel table

17-Inch Console with  
3-Speed Phono. Model 699  
**ONLY \$349.95**



17-Inch Console  
Model 686  
**ONLY \$299.95**



20-Inch Console  
with Doors  
Model 693  
**ONLY \$429.95**

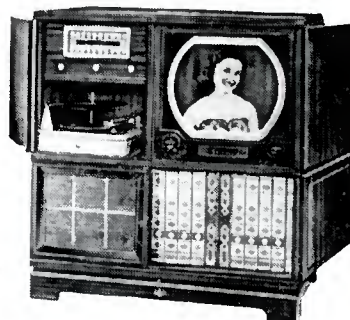

16-Inch TV  
with FM-AM  
3-Speed Phono  
Model 666  
**ONLY \$429.95**



17-Inch Picture  
Model 696  
**ONLY \$249.95**

For Greater Store Traffic,  
Turnover and Profits Feature

**Emerson LIFE-TESTED** Television and Radio



EMERSON RADIO AND PHONOGRAPH CORPORATION, NEW YORK 11, N. Y.

Prices slightly higher in South and West. Excise tax and warranty extra.

# Raytheon pulls 'em in

the pictures!



"... Tujunga is not . . . in a fringe area . . . we are in the IMPOSSIBLE AREA . . . Raytheon Television is the only set that homeowners in Tujunga, Sunland and Verdugo Hills have ever been able to 'really' get a picture on."

*David Myron*

VERDUGO HILLS MUSIC CO.  
Tujunga, California



the prospects!



"Our prospects are immediately impressed by Raytheon's beautiful cabinet design and after a demonstration of its performance, especially on distance, the salesmen soon turn the prospect into a customer."

*Frank Huttinger*

B & H ELECTRIC COMPANY  
Toledo, Ohio

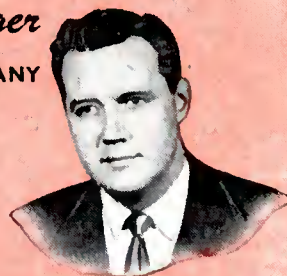

You're sure of **DEPENDABILITY** when you sell

# Raytheon *tv*

Statements like these are almost standard at the Raytheon plant. Dealers are impressed with the way Raytheon TV pulls in the pictures . . . and, consequently, pulls in the customers, too. And with the beautiful additions to its 1951 line, Raytheon really has something that can be told and sold.

For information on how you, too, can profit with Raytheon, contact your Raytheon distributor or write us.

**BELMONT RADIO CORPORATION**  
5921 W. Dickens Ave., Chicago 39, Ill.  
Subsidiary of Raytheon Manufacturing Co.

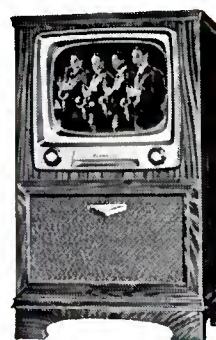

THE STARLIGHT  
Model RC-1720



**RAYTHEON**  
TELEVISION

List prices range from \$279.95 to \$750.00  
INCLUDING FEDERAL EXCISE TAX  
AND 1-YEAR WARRANTY

RADIO & TELEVISION RETAILING • July, 1951

# Specifications of Current Vacuum Cleaners

BEE-VAC, Birtman Electric Co., Chicago 39

## Tank Types

Model T12E at \$65.95 features  $\frac{5}{8}$  HP motor, 2-stage fan, 12 accessories. Cleaner weighs 13 pounds. Model T18E at \$76.95 has  $\frac{3}{4}$  HP motor, 12 accessories, weighs 14 lbs. T14E at \$54.95 has  $\frac{3}{8}$  HP motor, 8 attachments; weighs 12 lbs. Prices include accessories.

## Upright Type

Model 500E, at \$65.95 motor-driven brush cleaner is self-adjusting, fully automatic. Has 3-position handle, built-in spotlight. Cleaner weighs 15 $\frac{1}{4}$  lbs. 9 accessories (model 45) available at extra cost.

## Hand Type

Model J50 is a motor-driven unit, weighing 5 $\frac{1}{2}$  lbs. Sells for \$27.28.

CADILLAC, Clements Mfg. Co., Chicago.

## Tank Type

Model 800 lists at \$74.95, including the attachments. Cleaner with attachments weighs 30 lbs. Motor draws 500 watts.

## Upright Type

Model 143A lists at \$64.95, and weighs 25 lbs. Motor draws 330 watts.

EUREKA, Eureka Williams Corp., Bloomington, Ill.

## Tank Types

Model 700 retails at \$84.95, including 10 attachments. Features a 3-stage fan, and new #60 rug nozzle. A  $\frac{3}{4}$  HP motor is used. The cleaner weighs 16 lbs.

Model 600 retails at \$64.95, including the 9 accessories. It features a 3-stage fan, and the new #60 rug nozzle. A  $\frac{1}{2}$  HP motor is used. Cleaner weighs 14 lbs.

## Upright Type

Model S-250, motor-driven, sells at \$84.95, 8 attachments at \$21.95 additional. The vertical motor is  $\frac{1}{2}$  HP, 2-speed. Toe-latch controls three positions of handle. Has headlight. Only 6" high.

FILTER QUEEN, Health-Mor, Inc., 203 N. Wabash Ave., Chicago.

## Cannister Type

Model 350 lists at \$99.50 with attachments. Cleaner weighs 18 lbs., has  $\frac{3}{4}$  HP motor. No bag, it uses cellulose filter cone. Optional extra equipment follows: Demother attachment, \$14.95; attachment holder, \$3.75; caster set, \$7.95; hair dryer, \$2.95; power polisher, \$34.50.

GENERAL ELECTRIC CO., Bridgeport 2, Conn.

## Upright Type

Model AVF-807 retails at \$89.95, with sets of attachments selling at \$14.95 and \$24.95, respectively. This motor-driven brush cleaner is powered by a 340 watt motor.

## Tank Types

Model AVT-173A sells at \$89.95, including attachments. Model AVT-811 lists at \$79.95, both foregoing prices include attachments. Motors on these models draw 600 watts. Model AVT-160 retails at \$44.95, including accessories. Motor size, 310 watts.

HAMILTON BEACH Div. of Scovill Mfg. Co., Racine, Wis.

## Upright Type

Model 14 lists at \$54.95. #120 deluxe attachment set, \$17.95 extra. Motor 1/5 HP.

## Tank Type

Model 26 lists at \$74.95, including 11-piece accessory set, and is powered by a  $\frac{3}{4}$  HP motor.

HOOVER Company, North Canton, Ohio.

## Upright Types

Model 62 lists at \$99.95. 9 attachments available at \$19.95 extra. This triple-action, rug vibrator cleaner is equipped with a  $\frac{1}{4}$  HP motor, and weighs 19 lbs., 8 ounces.

Model 29 lists at \$87.95. 9 attachments at \$19.95 extra. This triple-action cleaner also features the exclusive rug vibrator. The 29 is powered by a  $\frac{1}{4}$  HP motor. Weight, 18 lbs., 13 ounces.

Model 115 lists at \$59.95. 5 attachments available at \$12.50 extra. Same cleaning action as in models 62 and 29. Cleaner weighs 13 $\frac{3}{4}$  lbs. and has a  $\frac{1}{8}$  HP motor.

## Tank Types

Model 51 sells at \$84.95, including 8 accessories. Weighing 15 lbs., 7 ounces, the Hoover 51 has a 1/3 HP motor, and features the exclusive dirt ejector.

Model 41 retails at \$69.95, including 6 accessories. It weighs 14 lbs. 7 ounces, is equipped with a 1/3 HP motor, and features a disposable dirt bag.

## Hand Type

Dustette, model 1015 lists at \$26.95, weighs 5 lbs. 2 ounces, and has a 1/12 HP motor.

LEWYT Corporation, Brooklyn 11, N.Y.

## Cannister Type

Model 55-80 lists at \$89.95, including 7 attachments. Weighs 14 lbs. Motor draws 575 watts. Features: No dust bag to empty, 3-way filtered air; no radio or TV interference. Available with the model 101 rug nozzle for \$9.95 extra. This nozzle operates like a carpet sweeper when detached from the cleaner. It need not be emptied when so used, for it empties itself when again attached to the tank for use as vacuum.

INTERSTATE Engineering Co., El Segundo, Calif.

## Tank Types

"Compact" C-2 lists at \$119.95, including 11 accessories; weighs 14 $\frac{1}{2}$  lbs., and is powered by a  $\frac{3}{4}$  HP motor.

"Revelation" R-2 lists at \$119.95, including attachments. Same specifications as C-2. Features of both cleaners: All aluminum; vertical dust bag, "cyclonic" suction. Has novel floor polisher attachment.

REGINA Corp., Rahway 1, N. J.

## Upright Type

Model K Elektrikbroom lists at \$39.95. Six-piece accessory set costs \$14.50 extra. Cleaner weighs 6 $\frac{1}{2}$  lbs.; has 1/6 HP motor. Plastic dirt cup empties like an ash tray. Rubber nozzle will not mar furniture. Easy storage.

ROYAL Vacuum Cleaner Co., Cleveland 8.

## Tank Types

Model 290-A lists at \$89.95, including 16-piece accessory set. Weighs 13 lbs., and

packages the dirt in disposable paper bags. Motor draws 550 watts.

Model 280 lists at \$74.95, including 12 accessories. Weight and motor size same as 290-A; has disposable paper bag feature.

Model 250 lists as \$49.95, including 6 accessories. Cleaner weighs 12 $\frac{1}{2}$  lbs. Motor draws 550 watts.

## Upright Types

Model 279, motor-driven brush type retails at \$74.95. 10 attachments are available at \$21.95 extra. Weighs 15 $\frac{1}{2}$  lbs. Motor draws 300 watts.

Model 235C lists at \$54.95. Cleaner weighs 12 $\frac{5}{8}$  lbs. 10 accessories at \$21.95 extra. Motor—300 watts.

## Hand Types

Model 297 lists at \$27.95, weighs 5 lbs. and features a motor-driven brush. The motor draws 175 watts.

SWEEPER-VAC, Hollend-Riegler Div. of Apex Rotarex Corp., Cleveland 10. Tank model 5103 lists at \$59.95, including 10-piece accessory set. Has a 2-stage fan, 1/3 HP motor, and weighs 15 $\frac{1}{2}$  lbs. Disposable paper throw-away bag.

UNIVERSAL, Landers, Frary & Clark, New Britain, Conn.

## Tank Types

VC6702 at \$84.95 comes with 13 attachments; Tattle-Tale light signals when bag needs emptying. Cleaner weighs 33 lbs. Model VC6700 retails at \$74.95, incl. 13 attachments; weighs 31 lbs. Also features Tattle-Tale light. VC6026 lists at \$59.95, incl. 6 attachments; weighs 25 lbs. Deluxe accessory set for VC6026, \$10 extra.

## Upright Types

VC5708, motor-driven brush model, sells at \$69.95; model VC5706, at \$59.95. Both models feature suction regulators and automatic rug-adjusting nozzles. Deluxe attachments for both models, \$19.95; standard attachments for both models, \$13.95 extra. Both models weigh 20 lbs.

## Hand Type

VC7746 is motor-driven brush model selling at \$24.95. It is powered by a 1/5 HP motor; weighs 9 lbs.

WESTINGHOUSE Elect. Corp., Mansfield, O.

## Upright Type

Model F11 lists at \$69.95. 12-piece accessory set available at \$22.95 extra. This motor-driven brush cleaner weighs 17 lbs., and is equipped with a  $\frac{1}{4}$  HP motor. Features "Toss Away" disposable bag.

## Tank Type

Model T4 lists at \$74.95, including 12 accessories. It is equipped with a  $\frac{1}{2}$  HP motor, and weighs 14 lbs. Also features "Toss Away" disposable bag.

## Hand Types

Model H9 lists at \$24.95, weighs 5 lbs. and is powered by a 1/10 HP motor.

Model HC9 Hand vac convertible lists at \$32.90, weighs 7 lbs., and is powered by a 1/10 HP motor.

# It Pays to Promote Sales of Portables

**Carry-About Receivers Move Rapidly in Live-Wire Stores.**

**Here's a Checklist to Help You Get Your Share of This Profitable Business**

• There are many profitable angles to selling portable radios. To begin with, the discounts are satisfactorily long. Next, there is very little price-cutting on carry-about receivers; few trade-in deals.

Previous articles in this magazine have offered numerous suggestions for increasing sales of portables, stressing the need for consistent, attractive display, advertising and demonstration. Such articles have urged dealers to demonstrate sets to each store visitor, and to have salesmen take portables with them on all calls. The necessity for tying in servicers with portable sales activities is strongly advocated as well.

Right now is the time to jump into the peak season with both feet. Numbers of people are going on vacations, and all of them are prospects. Those who own sets will need batteries and service, so advertising and display of batteries and service facilities should be stepped up. Those who have never owned portables should be shown the advantages of taking carry-about sets with them on their vacation. All in all, the alert merchant will get them coming and going. Those who are leaving for vacation trips are his prospects, as well as



Jump into the peak season on portables by promoting them actively. Sell carry-about sets as year round products, but right now sell 'em to the folk going on vacations, and sell service and batteries to portable owners who have returned from vacations and trips. It will pay any dealer to make his store known as headquarters for portable radios.

those who have returned, bringing with them portables needing repair.

The accompanying checklist is designed to bring additional business to the dealer.

Those who answer "yes" to all

of the questions on this list are making lots of sales. Others who are not making full use of the opportunities should decide to do so in order to get a healthy sales volume in portable radios.

## CHECKLIST TO SELL MORE PORTABLES

**Are you displaying portables in your show-windows?..... In your store?.....**

**Are you advertising carry-about sets, stressing their year round use?.....**

**Do your servicers solicit portable repair work on each and every call?.....**

**Do you use ads and lettered signs offering service, batteries, etc.?.....**

**Do you demonstrate a portable receiver to everyone who visits the store?.....**

**Do your salesmen carry a portable with them on all the calls they make?....**

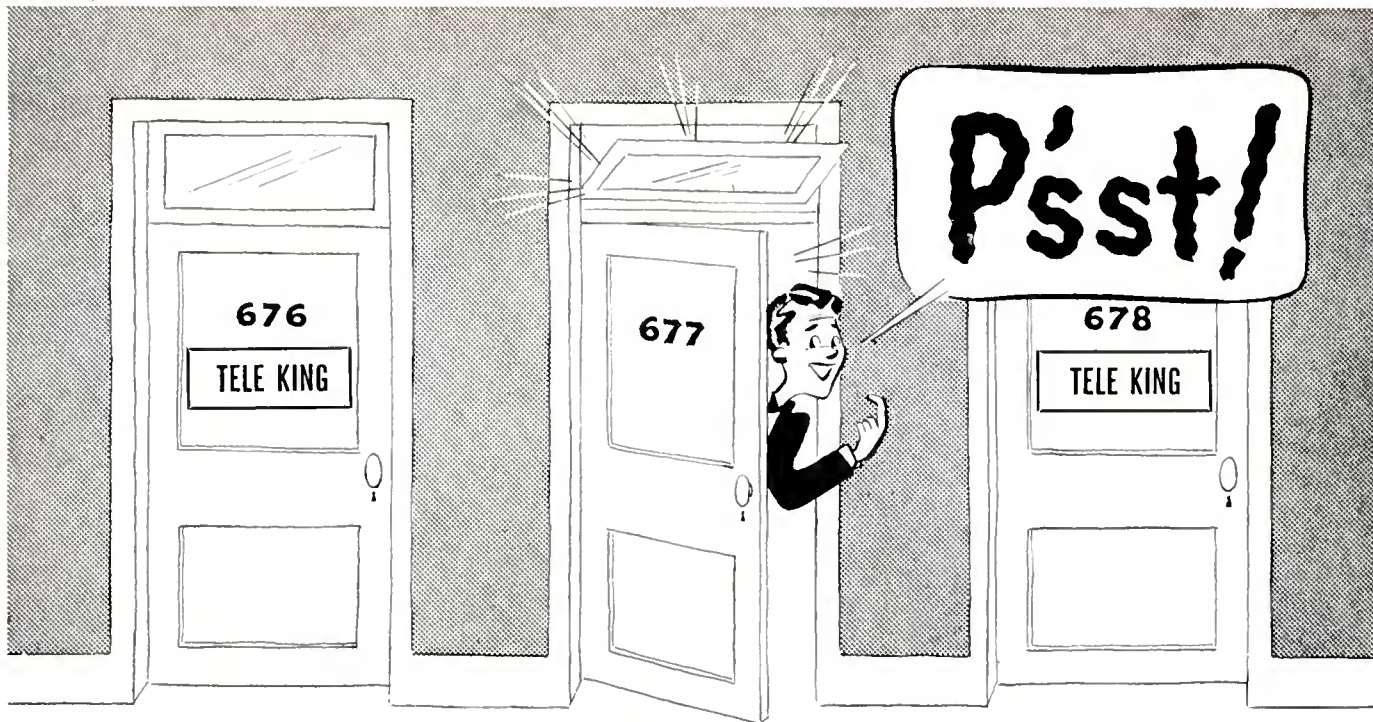

***Behind these Doors  
at the Palmer House***  
**Will Be the Hottest TV News  
of the Chicago Music Show**

**The Line of  
Least Sales  
Resistance!**



**Make a Date  
Now to Pay  
Us a Visit!**

***"The Great TV Independent Serving the Independent Dealer"***  
**TELE KING CORPORATION, 601 West 26th St., New York 1, N. Y.**

# "G-E TELEVISION COSTS LESS TO SERVICE

than any of the other brands we handle!"



*Says* **NORM LIBERMAN**  
**Tele-Care Television and Radio Co.**  
**San Fernando, California**

"Our company installs and services television for 9 dealers who sell 14 different brands. Our records show that G-E television requires less service and has the lowest service cost of them all. For that reason we charge 12½% less on all G-E installation and service contracts."



**17Y2.** 17-inch rectangular black tube. Handsome mahogany veneered cabinet. A price leader.

★ Yes! G-E requires less service—and here's why! G-E is **BUILT TO OVERPOWER INTERFERENCE.** Actual showdown comparisons are made with other best known brands in areas where TV meets its toughest tests. Whether far from the transmitter . . . or in areas of electrical disturbance—G-E **GIVES OUTSTANDING PERFORMANCE.** So it's no wonder that G-E gives such dependable service . . . so much customer satisfaction. See the G-E line at your General Electric TV distributor, now!



**17-INCH**  
**BLACK-DAYLITE**  
**TELEVISION**



**17C109.** Powerful 17-inch set in luxurious 18th century style cabinet veneered in genuine mahogany. Finely-figured doors. Concealed casters for easy moving.



**17C103.** 17-inch console at low price. Rectangular black tube. Smart mahogany veneered cabinet.

**17C110.** 17-inch rectangular black tube. 18th-century styling. Genuine mahogany veneers. Luxurious half-doors. Concealed casters.

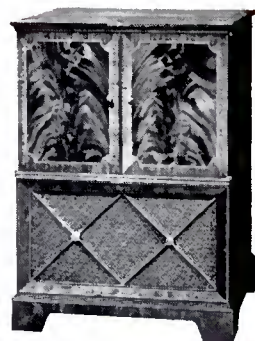

*You can put your confidence in—*

**GENERAL**  **ELECTRIC**



# Seen at Chicago Show



Above: Board of Directors of the Show Corporation. Left to right, seated, John H. Cashman, Radio Craftsmen, Inc.; Arthur Stallman, NEDA; S. I. Neiman, publicity; Charles A. Hansen, Jensen Mfg. Co.; Lew Howard, Triad Mfg. Co.; W. D. Jenkins, NEDA; L. B. Calamaras, NEDA; Herbert C. Clough, Belden Mfg. Co.; J. M. Kirshbaum, Precision Apparatus Co. Standing, Sam J. Spector, Insuline Corp. of America, and Kenneth C. Prince, Show manager.

Photographs were taken during the very successful Parts Distributors Show held at the Hotel Stevens, Chicago. A total of 193 manufacturers exhibited products, and 8,498 persons attended the event.

Robert C. Sprague (below), board chairman, RTMA, and president of Sprague Electric Co., addresses a gathering.



Above: Jerome J. Kahn, Show president, opens the event. With him are Chicago models.



Below, (left): Guests picking up their badges at registration desk. (Right): Typical audience at distributor's seminar.



Below: Aisle of Trade Names. This "who's who" in the parts industry attracted a lot of attention. Visitors came from every state and territory.



# Appliances For Summer

This and following pages describing manufacturers' new merchandise are compiled by our editors. This information is presented as a news service to our readers entirely without any advertising consideration whatsoever.

## Duchess AIR DRYER

The portable Duchess air dryer shown here has been announced. Under high humidity conditions it will remove ap-

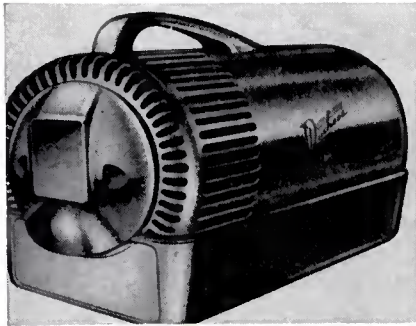

proximately 10 quarts of water from the air in 24 hours. Unit lists for \$129.95. Appliance Mfg. Co., Alliance, Ohio.—RADIO & TELEVISION RETAILING.

## Rumsey MOWER

A new model of electric lawnmower has been introduced. Weighing only 45 pounds, the mower will retail for \$79.50. The motor and alloy steel cutting blade



are enclosed by a reinforced, corrosion and rust proof Laminac plastic housing which is permanently colored. Motor is 1/3 HP. 75-ft. length of rubber covered cable, switch and plug are provided. Rumsey Distributors, Seneca Falls, N. Y.—RADIO & TELEVISION RETAILING.

## Gale Dorothea TURNTABLE

A small turntable, called the "Turn-More" has been announced. Made in



five basic models for horizontal, vertical or upside-down rotation. Operates on AC only. Gale Dorothea Mechanisms, Elmhurst, Long Island, N. Y.—RADIO & TELEVISION RETAILING.

## IH REFRIGERATORS

Seven models are announced for the IH refrigerator line. 9.2 cu.ft. model HA-92, has 50 lb. freezer storage, chill tray, 4 ice cube trays; 8.4 cu.ft. model HA-84, has 50 lb. freezer storage, chill tray, and also 4 ice cube trays; 9.5 cu.ft. model UA-95 has 35 lb. freezer and 4 ice cube trays; 8.4 cu.ft. model HA-83 has 50 lb. freezer capacity and 3 ice cube trays, also chill tray; 8.7 cu.ft. model UA-87 has 35 lb. freezer storage and 3 ice cube trays; 8.2 cu.ft. model HA-82 has 35 lb. freezer capacity and 2 ice cube trays; and 7.4 cu.ft. model HA-74 has 35 lb. freezer capacity and 2 ice cube trays. International Harvester Co., 180 N. Michigan Ave., Chicago 1, Ill.—RADIO & TELEVISION RETAILING.

## Broil-Quik BROILER

A new electric broiler has been introduced. Called the Broil-Quik Trio, it fea-

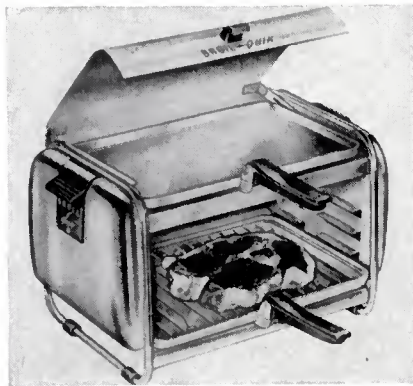

tures a top which lifts up to permit frying. Frying pan is removable by means of a detachable handle. Has four broiling levels. List price is \$39.95. Broil-Quik Co., 2330 Fifth Ave., New York, N. Y.—RADIO & TELEVISION RETAILING.

## Sealine HEAT SEALER

The new Sealine 50 hand sealer, recently announced, offers a variety of wheel shapes for different purposes. Makes use of special fluid which is fed into the heated wheel. Temperature is adjustable from 200° to 450° F. Heat-



ing element uses 50 watts. Seals polyethylene, plicofilm and other thermoplastic films. List: \$18.75. Sealing Mfg. Corp., 170 N. Peoria St., Chicago 7, Ill.—RADIO & TELEVISION RETAILING.

## Chicago HANDYFREEZE

Handybreeze Dial-Aire cabinet circulator permits dialing the degree of air flow desired. Built to windowsill height. List price is \$59.59, including Federal excise tax. Also offered is the 1 quart elec-



tric ice cream freezer shown here. Listing at \$18.95, the freezer will freeze 1 quart of ice cream in about 10 minutes. This is model 2201. Also available are models 2204, four quart capacity, and model 2206, six quart size. These list for \$24.75 and \$28.75 respectively, in zone 1. Chicago Electric Mfg. Co., Chicago 38, Ill.—RADIO & TELEVISION RETAILING.

## Presto FRYER

The Presto automatic Dixie-Fryer, shown here, lists at \$37.95. Features include a jumbo frying basket, cast-in heating element, automatic temperature

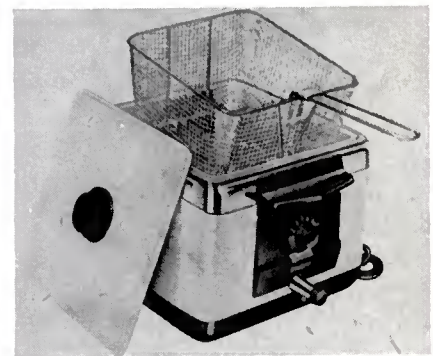

control knob, signal light which goes out when proper frying temperature is reached, heat resistant base, flo-rite drain spout, and stor-away cover. Operates on 115 volts, AC only. 1350 watts. National Pressure Cooker Co., Eau Claire, Wisc.—RADIO & TELEVISION, RETAILING.

**More New Appliances  
On Page 74**

# money isn't everything...

... but you can put your hands on a pile of it if you  
latch on to a history-making campaign breaking soon.

**P.S.** *The campaign pushes clock radios ... all brands. Watch for news of this exciting promotion!*

# New Electrical Appliances

This and following pages describing manufacturers' new merchandise are compiled by our editors. This information is presented as a news service to our readers entirely without any advertising consideration whatsoever.

## Hotpoint DISPOSAL UNIT

An automatic non-clogging food waste disposal, is offered by Hotpoint, Inc. Embodying the first operating changes in this appliance in 15 years, this machine has a shredding mechanism to rotate in either direction, thereby extending the life of the grinding parts. Called model MW-6, it has a three-way sink cover that can be turned to start the mechanism, or used as a sink stopper or strainer. The new model is shorter and more compact than former types, and leaves more under sink storage space. Hotpoint, Inc., 5600 W. Taylor St., Chicago 44, Ill. RADIO & TELEVISION RETAILING.

## Westinghouse MIXER

The Food Crafter, shown here, is called model FM-511, operates by only a thumb movement. Comes equipped

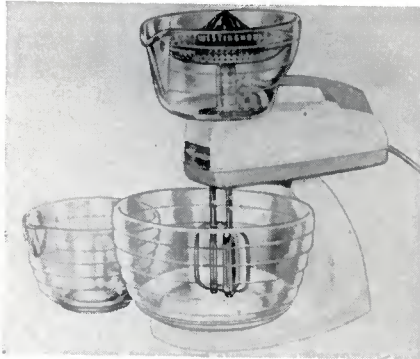

with two merry-go-round bowls. Juicer is available as an accessory. Retail price is \$39.50. Juicer is \$4.45. Power stand for food grinder, \$9.75, and food grinder, \$7.50. Westinghouse Electric Corp., Mansfield, Ohio.—RADIO & TELEVISION RETAILING.

## Arvin TABLE OVEN

A new electric table oven is offered. Used in conjunction with the Arvin Llectric Cook (grille), the oven snaps onto the top. Operates on 110-120 volts AC. Will take a pan up to 9½ inches square. Has two shelves. Unit is designated model 3600, and may be used with models 3400 or 3500 Llectric Cook. Arvin Industries, Inc., Columbus, Ind.—RADIO & TELEVISION RETAILING.

## Iona FOOD MIXER

A new mixer which may be used in its stand or detached for hand use has been announced. Operates on AC or DC, guaranteed for one year. List price is \$17.95, tax included. Iona Mfg. Co., 24 Clark St., East Hartford, Conn.—RADIO & TELEVISION RETAILING.

## Coolerator FREEZER

A new freezer model, F-1130, which fits a 13 cu. ft. capacity in a 55 inch cabinet is shown here. Will store over 450 lbs. of frozen foods in the regular

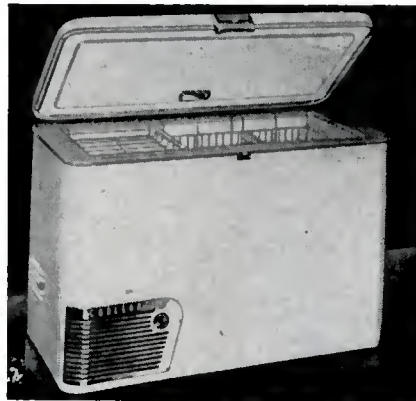

storage compartment and the special quick-freeze section. Illuminated by a lid-mounted light. ¼ HP compressor is fan cooled. List price is \$439.95. The Coolerator Company, Duluth 1, Minn.—RADIO & TELEVISION RETAILING.

## Filter Queen VACUUM

Cannister type vacuum model 350 has no dust bag to empty. Metal pan collects dust and is lined with a paper filter. 10 available attachments include sprayer, etc. Floor nozzle features a floating brush for picking up dog hairs, etc. ¾ HP motor. Health-Mor, Inc., 203 N. Wabash Ave., Chicago 1, Ill.—RADIO & TELEVISION RETAILING.

## Marion DEEP FRYER

The "400" deep fryer, automatic domestic unit, is offered. Variable thermostatic control provides two heats. Pilot lamp lights when turned on, goes out when proper temperature has been reached. Operates on 110 volts, AC. Frying basket is wire mesh, fat container is porcelain. Rutenber Electric Company, Marion, Ind.—RADIO & TELEVISION RETAILING.

## Fryrite DEEP FRYER

A new deep fryer with thermostatic control calibrated 250 to 450 degrees, is announced. The one piece cast aluminum well is 40% larger than on previous model. Capacity is 4 lbs. of shortening. Operates on 110-120 volts, AC only. 1320 watts. List price is \$28.95. Dulane, Inc., 8550 W. Grand Ave., River Grove, Ill.—RADIO & TELEVISION RETAILING.

## IH FREEZERS

Three freezer models are offered. Model 70 has 245 lbs. capacity; model 111 has 389 lbs. capacity; and model 158 holds over 550 lbs. of food. All feature welded steel construction, quiet operation, new styling. International Harvester Co., 180 N. Michigan Ave., Chicago 1, Ill.—RADIO & TELEVISION RETAILING.

## General "CHEF"

A combination refrigerator and gas range is offered. Range has four full size burners. Refrigeration is 4 cu. ft. size. Also available with 3 burner electric range section, two 1000 watt units and one 2150 watts. Designed for small apartments, motels, offices, cabins, etc. Each unit carries a five year warranty applying to the refrigerator. Fits into a 21½ x 27½ inch floor space. General Air Conditioning Corp., 4542 East Dunham St., Los Angeles 23, Calif.—RADIO & TELEVISION RETAILING.

## Fleck BROILER

A new open front broiler is now offered. This new broiler incorporates a new development known as the Pyro-

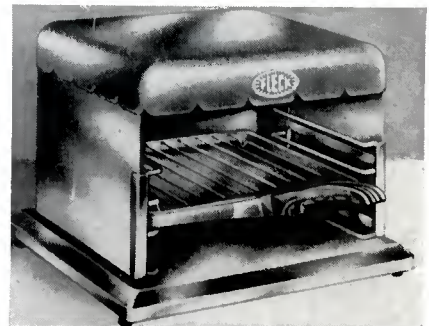

Fleck-Tor unit, which is a parabolic channel heat intensifier. The retail price of this broiler is \$38.50, and the present broiler will be continued at the regular retail price of \$34.95. Romar Corporation, Asbury Park, N. J.—RADIO & TELEVISION RETAILING.

## Hobart KITCHEN AID

Kitchen Aid mixers available in three models: model 3-C, with 3-quart mixing bowl, has two special attachments available; model K5-A, with 5-quart mixing bowl, has seven special attachments available; and model K4-B, with 4-quart mixing bowl, has four special attachments available. Eleven other attachments are made to fit any of the three models. The Hobart Mfg. Co., Troy, Ohio.—RADIO & TELEVISION RETAILING.

ANNOUNCING...THE ULTRA-NEW

# Admiral

## Tele-bar

...WORLD'S MOST LUXURIOUS  
20" TV COMBINATION



321K49... Modern Silver Fox

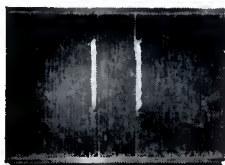

321K46... Period Mahogany



321K47... Modern Blonde

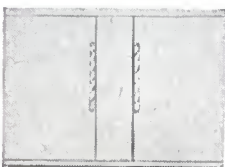

For those who entertain regularly . . . the Tele-bar! This exclusive Admiral creation is an indispensable aid to gracious living . . . combining 20" television, Dynamagic Radio, and 3-speed record playing . . . plus a luxurious built-in bar.

Tele-bar is both beautiful and practical. Its exquisite, hand-rubbed, liquor-proof cabinet provides a place for everything. There's a stainless steel mixing tray, liquor-proof serving shelf, "empties" compartment, racks for 32 glasses, and room for over 30 bottles. Custom quality construction throughout.

Available now in period mahogany, modern blonde, and the new ultra-modern Silver Fox styling. Production is limited, so we suggest immediate contact with your Admiral distributor.

\*Ask your distributor to show you how "Smart Set," Admiral's colorful new home service magazine, can build sales for you!

ON TELEVISION—"Stop the Music," ABC, Thurs., 8 PM, EST . . . "Lights Out," NBC, Mon., 9 PM, EST

Here's a "BOND"  
That Money  
Can't Buy...  
**THE**  
**RAYTHEON**  
**BOND**  
for *ELECTRONIC*  
*TECHNICIANS*



It's a bond of integrity—a bond of ability—a bond of confidence between customer and service dealer. It's a bond resulting from Raytheon's desire to improve relationships between customers and service dealers. It's a bond of great value—yet it's yours *at no cost* if you can qualify. It's a bond that's Raytheon's investment in your future.

For more than five years the Raytheon Bond, which cash protects service dealers' 90-day guarantee on TV and Radio Repairs, has helped radio and television shops throughout the country to increase volume, build customer good will and has shielded them against attacks on their integrity. *It can do the same for you!*

Better ask your *Raytheon Tube Distributor* if you can qualify for this outstanding business asset.



RIGHT...FOR SOUND AND SIGHT



**RAYTHEON MANUFACTURING COMPANY**

Receiving Tube Division

Newton, Mass., Chicago, Ill., Atlanta, Ga., Los Angeles, Calif.

*Excellence in Electronics*

RADIO AND TELEVISION RECEIVING TUBES, CATHODE RAY TUBES, SPECIAL PURPOSE TUBES, SUBMINIATURE TUBES, MICROWAVE TUBES

© 1951 RAYTHEON

# SERVICE & SOUND

Section of RADIO & TELEVISION RETAILING

## Profits From Auto Radio Servicing

Get Your Share in an Uncrowded Field Today

• One way a dealer can offset a slump in sales with a permanent business-builder is to increase activity in service. Yet today many shops are turning down auto radio work even though they are not operating at full capacity during these summer months.

In many cases these establishments could handle not only the business which they now turn away (or at best fail to encourage); they could become the radio service centers for large numbers of garages. When a car owner has trouble with his automobile radio he first asks his garage mechanic, "Do you fix car radios?" If the answer is, "No," he asks the mechanic to recommend someone. Thus the best sources of car set business for the alert radio serviceman

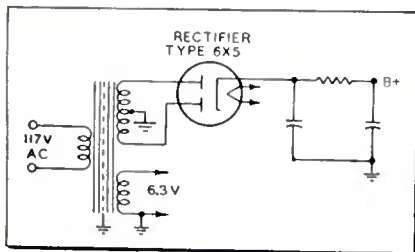

Conventional AC Radio Power Supply

are the garages and service stations near him, where hundreds of cars are serviced every day.

There are over 15 million auto radio sets in the U. S. today. This is about one car radio for every ten people. Those same ten people have about six other sets, so it is apparent that your car repair potential is (very roughly) one sixth the size of your other radio repair business. An increase in business of up to 15% is not to be passed by lightly.

Yet despite this easy-to-get business the field of automobile radio maintenance is all too often ignored. There seem to be three major reasons for this. First, we encounter in many shops a lack of proper equipment. Second, many technicians dislike re-

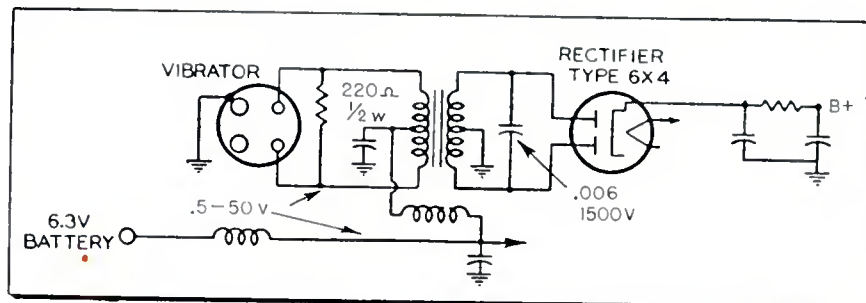

Auto Radio Power Supply. Note addition of .006 1500 V buffer condenser

moval and installation in cars. Third, many operators feel that there is no profit in it.

The idea that auto radio work requires much extra equipment is not a sound one. The only additional parts needed are a few vibrators and buffer condensers, and a supply of 6 volts DC.

The power supply for 6 volts can be provided for as little as \$20 for a kit. Or use may be made of a regular auto battery and a small charger. However, the most satisfactory way is to use a supply which runs off the regular AC line, eliminating the need for charging and maintaining the battery.

There are (at your jobber's) vibrator kits costing between \$15 and \$20, which will service 90% to 95% of all car radios in use today. One of these kits, coupled with \$2 or \$3 worth of buffer condensers represents the total investment in new parts inventory. A final helpful piece of equipment is a manual which lists all car radios, with their complements of tubes, vibrators, buffers, and volume controls.

In the case of sets brought in for service by another concern there is no problem of removal or reinstallation. Too, the construction of cars and car radios today is such that this work is much easier physically than it was five to ten years ago. Once a few installations have been done it will be seen that the mechanical part of car radio service is much simpler than it at first appears.

As for auto radio maintenance being unprofitable—that just isn't so! It can be and is profitable if the work is well done and properly charged for. The shop which charges too little hurts itself just as surely as the shop which turns out poor work. In either case the operator is doomed. It is true here, just as in any other service work—you must do a top grade job, and you must charge enough for it to allow you to pay all expenses and make a profit! Doing the best job in town will be of little help if you go out of business due to insufficient charging.

### Circuits Not Difficult

There are very few differences in the circuitry of automobile and home radios. The greatest variation is found in the power supply. Since there is a supply of 6 V DC readily available, car sets use 6 volt filaments. The low DC is also used to make high voltage DC for the plate supply by interrupting the 6 V DC with a vibrator, running this through a step-up transformer, and then rectifying the several hundred AC volts in a conventional full wave rectifier.

Additional slight variations include the use generally of a tuned RF stage to increase the gain. The small antenna and its low placement tend to bring in weaker signals than are present at the 1st grid of most home sets. The antenna tuning trimmer is a critical adjustment in most car radios, and should be checked whenever

(Continued on page 94)





# Circuits in TV Sets

## Is Examined. Common Troubles Analyzed

ated by the collapse of the field at the end of each cycle. Being a diode, the 5V4(V<sub>s</sub>) is not effective in the circuit when the current (and consequently the voltage) are going in one direction. That is, the diode has no effect when the current is sweeping the electron beam from left to right. But in the reverse direction the voltage on the diode plate causes it to conduct heavily the current produced by the collapsing field. This current is added to the regular low voltage B supply at point X, and it boosts the applied B voltage.

The reason a sawtooth current is required is so that the beam will be pulled across the screen evenly (in a linear fashion) and then returned (in effect) very rapidly to its initial position, ready to be swept again. A sine wave, which could be produced in the oscillator, eliminating the need for a discharge tube (V<sub>2</sub>), could not be used to excite the deflecting coil.

One major change from this type of circuit which is being incorporated in most new sets today is the use of direct drive of the horizontal deflecting coil. In this method the transformer coupling between the output tube and the yoke is eliminated and there is an autotransformer step-down action at the lower end of the horizontal output primary.

The presence of high voltage at the picture tube can be verified by drawing an arc from the anode cap with a well insulated screwdriver. If there is no high voltage at that point, proceed back to the high voltage rectifier cap, where an arc may be drawn if there is a high voltage AC pulse being supplied to the rectifier. (Remember that presence of HV here does not prove that the rectifier is working.) If no high voltage is shown at the HV rectifier cap, one more quick check can be made with the screwdriver by attempting to draw an arc from the cap of the horizontal output tube (point Y in the diagram). If there is no HV arc at point Y then the trouble is known to lie either in the output circuit or preceeding it. Many servicemen employ this method because it is extremely fast in localizing the general area of trouble, despite the fact that doing this has *very occasionally* caused a failure of the high voltage filter resistor or the 1B3 tube. This sort of failure is unlikely in most circuits if care is exercised to draw only a momentary arc, and never to draw it to a ground point. This happens so infrequently that the

time saved is more than worth the extremely few failures possibly involved.

As with other circuits in TV, the most common trouble-causers in the horizontal system are the tubes. A very common cause of insufficient deflection is a horizontal output tube (usually 6BG6, 6BQ6, 6CD6, etc.) whose emission has become low. This normally results in both a lack of enough width and some loss of horizontal linearity. A similar effect is sometimes had when the discharge tube or the oscillator gets weak. A table for rapid trouble-shooting is shown which lists a number of the most common failures and their symptoms.

If the trouble is not due to a faulty tube the suspected component must be tracked down with a scope and then a VTVM, or if the scope is not handy, a meter can be used to measure the AC signal at each grid. Manufacturers' diagrams and voltage/resistance charts are invaluable here, as elsewhere in repair. Today, most trouble-shooting data contains drawing of the waveforms to be expected at input and output of each

stage in the deflecting sections. This practice has made the use of the oscilloscope much easier than ever before. Along with the waveforms are shown the voltage values, for checking with the voltage calibrator, which should be hooked onto the vertical input of the oscilloscope. These voltages can be read with a VTVM, if no scope is used, but remember that the drawings usually show peak-to-peak voltages, and that your meter probably reads RMS values, so keep the relationship of these two in mind and multiply mentally by 1½ the VTVM RMS reading, to approximate the peak-to-peak value you are expecting.

It is possible to have a set in which high voltage is present at the picture tube and yet no raster is observable. This could be caused by improper bias or other voltage on the CRT, or by a defective CRT.

A bright white vertical line on the screen would show that the horizontal sweep and high voltage were working, of course. (Since the electrons were reaching the screen.) So the horizontal deflecting coil would probably be the culprit.

---

## Frequent Horizontal Troubles

No raster—Absence of high voltage.

- A) 1B3 bad; HV filter resistor open. HV filter C shorted.
- B) Output tube (6BG6, 6CD6, 19BG6, etc.).
- C) Oscillator or discharge tube.
- D) Any other component—use scope to find right stage.

"Blooming"—low high voltage.

- A) 1B3 bad. Also check for defective R or C in HV filter.
- B) Output tube weak; low emission.
- C) Some other fault in output stage.

Intermittent high voltage.

- A) 1B3 frequently becomes intermittent.
- B) Output tube intermittent.
- C) Other tubes or any other components.

Loss of width.

- A) Low emission low voltage rectifier (*if loss of height also—although there is extra reserve height on most sets*).
- B) Low emission output tube.

Loss of horizontal linearity.

- A) Wrong adjustment of linearity, width or drive controls.
- B) Failure in discharge or output stage—check faulty waveforms with scope then locate component with meter.
- C) Other tubes or components weak or wrong value.

Note: A, B, C indicate causes in most common order of occurrence.

# Operation of the

Sixth in a Series of Articles on Frequency Modulation Detectors.

by Solomon Heller

• We were saying last month that one of the voltages applied to the discriminator plates was  $E_2$ , or  $E_2$  and  $E_3$ . The second of the voltages that appears at the discriminator plates is  $E_1$ .  $E_1$  is applied to the center tap of  $L_2$  (see fig. 1) and is in series with  $E_2$  and  $E_3$ . We have represented  $E_1$  as being the same at both sides of  $C_5$  (with respect to ground). This is practically true, because  $C_5$  offers a very small reactance to  $E_1$ , and causes it to lose no appreciable voltage in passing through.

Voltage  $E_1$  will have the same effect on  $V_1$  as it has on  $V_2$ . This is true because: a)  $E_1$ 's polarity at the plate of  $V_1$  will be the same as its polarity at the plate of  $V_2$ . When  $E_1$  is negative with respect to ground, the plates of both  $V_1$  and  $V_2$  will be negative to ground. When  $E_1$  is positive with respect to ground, the plates of  $V_1$  and  $V_2$  will also be positive to ground (see fig. 1B). b)  $E_1$ 's phase at the plates of  $V_1$  and  $V_2$  will be the same, since  $E_1$  reaches both plates through an equal number of  $L_2$  windings. Therefore,  $E_1$  will have the same effect on the conduction of  $V_1$  as it has on that of  $V_2$ , and can be represented by a fixed, unchanging vector (see fig. 2E).

## Diode Action

$E_2$  and  $E_3$ , on the other hand, will have opposing effects on the conduction of  $V_1$  and  $V_2$ . When  $E_2$  becomes positive, and causes  $V_1$  to conduct, it will produce a current flow through  $R_1$  that will tend to make the discriminator output *positive*. When  $E_3$  causes  $V_2$  to conduct, it will produce a current flow through  $R_2$  that will tend to make the discriminator output *negative*. Since  $E_2$  and  $E_3$  cause opposing currents in the output circuit, they may be considered as opposing voltages (as far as  $V_1$  and  $V_2$  are concerned), and represented as shown in fig. 2F.

Now, a glance at fig. 2F will show that  $I_2$  lags  $E_3$  by  $90^\circ$ , which is what we would expect (current in coil always lags the voltage across it by  $90^\circ$ ).  $I_2$  seems to *lead*  $E_2$ , however, which is what we would *not* expect. Since  $I_2$  lags  $E_3$  (see fig. 2D), it should also lag both  $E_2$  and  $E_3$ , the voltages which make up  $E_1$ .

Well,  $I_2$  really lags  $E_2$  and  $E_3$  by  $90^\circ$ , as is apparent in vector diagram 2E. But when we take  $E_2$  from the

place where it belongs (above  $E_3$ ), and put it in opposition to  $E_3$ , because that is, in practice, the effect it has on  $V_1$  and  $V_2$ ,  $I_2$ 's phase with respect to  $E_2$  is misrepresented.

Well, let's get on to that long-deferred vectorial addition of the voltages on the plates of  $V_1$  and  $V_2$ , respectively. The voltage applied to the plate of  $V_1$  is  $E_1 + E_2$ . We can refer to the vectorial sum of  $E_1 + E_2$  as  $E_{v_1}$ . The voltage applied to the plate of  $V_2$  is  $E_1 + E_3$ . Its vectorial sum is  $E_{v_2}$  (see fig. 2).

$E_{v_1}$  and  $E_{v_2}$  will reverse in polarity, since  $E_2$  and  $E_3$  are continually reversing in polarity. When the sum of  $E_1$  and  $E_2$  is a positive voltage,  $E_{v_1}$  will be positive, and  $V_1$  will conduct.  $E_{v_2}$  will, at this same time, be negative, and  $V_2$  will be non-conducting. When the sum of  $E_1$  and  $E_3$  is a positive voltage,  $E_{v_2}$  will be positive and  $V_2$  will conduct.  $E_{v_1}$  will be negative at this instant, and  $V_1$  will not conduct. The resultant currents that flow through  $V_1$  and  $V_2$  will cause opposing voltages to develop across  $R_1$  and  $R_2$ .

## Audio Time Constant

"Hold on," you say at this point. "Since voltages  $E_{v_1}$  and  $E_{v_2}$  are not present simultaneously at  $V_1$  and  $V_2$ , why should the voltages they produce buck each other? Why doesn't  $V_1$ 's conduction produce a voltage drop across  $R_1$  that disappears before  $V_2$ 's conduction produces a voltage drop across  $R_2$ ? In other words, since  $V_1$  and  $V_2$  don't conduct at the same time, why should the voltages they produce across  $R_1$  and  $R_2$  be present at the same time, rather than at successive intervals of time?"

The answer is, that condensers  $C_3$  and  $C_4$  (fig. 1A) have a time constant

long enough to keep one voltage present at the output, until the other voltage comes along to argue with it.

Now then: When the incoming frequency is the one to which  $L_1 C_1$  and  $L_2 C_2$  are resonant,  $L_1 C_1$  and  $L_2 C_2$  will be resistive to the applied voltage.  $E_{1a}$ , the voltage applied to  $L_2 C_2$ , will be in phase with  $I_2$ , the current flowing through  $L_2 C_2$  (fig. 2A), since current and voltage are in phase in a resistive circuit. The phase of  $E_2$  and  $E_3$  with respect to  $E_1$  will therefore be the same— $90^\circ$ —and consequently,  $E_{v_1}$  and  $E_{v_2}$  will be equal, and opposite in their effects. The net voltage at the discriminator output will therefore be zero. This is what is desired at this time, because the resonant frequency is the frequency of the carrier when it contains no modulation, and therefore has no audio information associated with it.

When the incoming i-f signal goes above resonance,  $L_2$ 's inductive reactance will oppose the relatively high incoming frequency more than  $C_2$ 's capacitive reactance will. Therefore the  $L_2 C_2$  circuit will act predominantly inductive, and current will lag the applied voltage—i.e.,  $I_2$  will lag  $E_{1a}$  (see fig. 2B). The higher the incoming frequency, the greater will be the angle of lag, since the inductive reactance of the circuit will increase with respect to the capacitive reactance and resistance present.

Now, although  $I_2$  goes out of phase with  $E_{1a}$ ,  $E_2$  and  $E_3$  remain at the same  $90^\circ$  phase with respect to  $I_2$  (since current and voltage in an inductance *always* remain exactly  $90^\circ$  out of phase). The result is that  $E_2$ 's phase angle with respect to  $E_1$  becomes less, causing  $E_2 + E_3$ , or  $E_{v_1}$ , to become greater (see fig. 2B).  $E_3$ 's

Fig. 1.—A) Voltage  $E_1$  is applied to each discriminator diode plate through  $C_5$ . B) Voltage  $E_1$  is in series with  $E_2$  and  $E_3$ .  $E_1$ 's polarity at diode plates will be the same, whether  $E_1$  goes negative or positive.

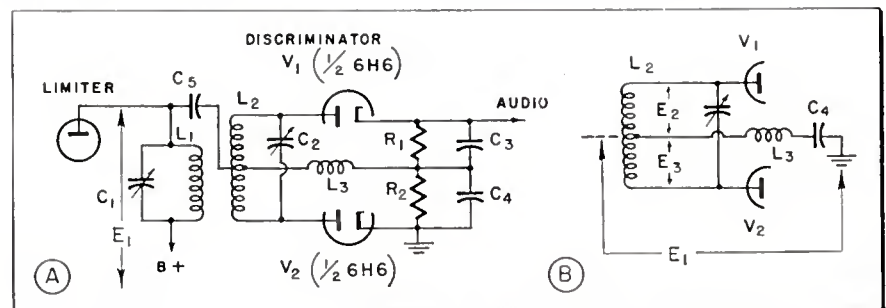

# FM Discriminator

## Explaining Voltages with Vectors

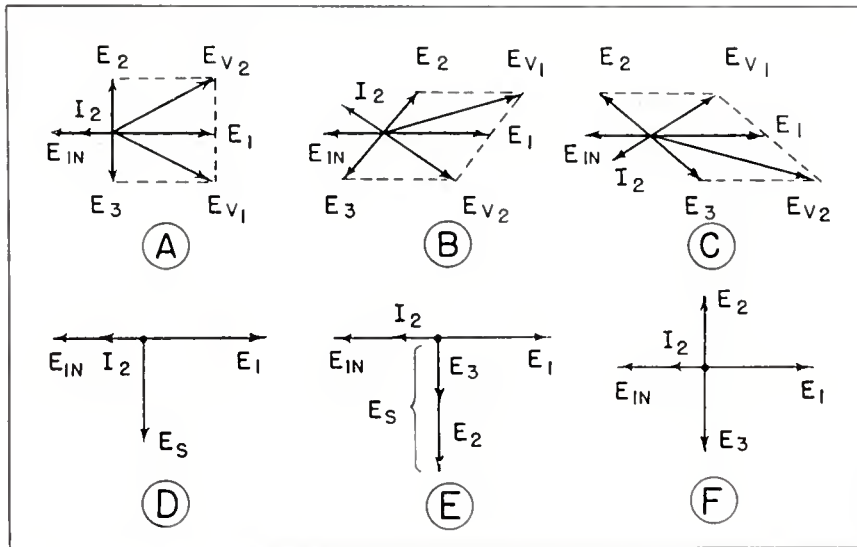

Fig. 2—Magnitude and phase relations of the various voltages impressed on the discriminator are shown vectorially to indicate the way in which they add or oppose to produce the resultant at the output of the discriminator.

phase angle with respect to  $E_1$  simultaneously becomes greater, causing  $E_3 + E_1$ , or  $E_{V_2}$  to become less.  $V_1$  will now conduct more heavily than  $V_3$ , since the voltage applied to it is greater, and the positive voltage developed across  $R_1$  (fig. 1A) will become larger than the negative voltage developed across  $R_2$ . The residual or remaining voltage appearing at the discriminator will therefore be positive.

When the incoming frequency is below resonance, the capacitive reactance to this relatively low frequency offered by the  $L_2 C_2$  tuned circuit will be greater than the inductive reactance. The circuit will therefore act capacitive, and current will lead the applied voltage—that is,  $I_2$  will lead  $E_{IN}$  (see fig. 2C).  $E_3$  now swings closer in phase to  $E_1$ , making  $E_{V_2}$  larger;  $E_2$  swings further away in phase from  $E_1$ , making  $E_{V_1}$  less.  $V_2$  will conduct more than  $V_1$  at this time, and the negative voltage developed across  $R_2$  will exceed the positive voltage across  $R_1$ . The residual voltage at the discriminator output will therefore be negative.

In this way, then, the frequency deviations of the carrier are converted into positive and negative voltages, or amplitude variations, that correspond to the amplitude variations of the original audio signal.

Note that as the audio signal rises in amplitude at the transmitter, the carrier frequency rises. As the audio

signal decreases in amplitude, the carrier frequency becomes correspondingly less. The reverse of this process occurs at the discriminator. As the (i-f) carrier rises above the center frequency, the voltage output of the discriminator increases. As the carrier frequency drops below the center frequency, the discriminator voltage output decreases. In this way, the amplitude variations of the original audio signal are reproduced.

The frequency characteristic of the audio signal is also retained, because the frequency, or rate of change, of the audio signal, is the same as the rate of change of the carrier, which is the same as the rate of change of the discriminator voltage output. To put it in other words: When we say that the frequency of an audio signal is 30 cycles per second, we mean that the duration of one cycle is 1/30 sec. This audio signal will cause one back-and-forth deviation, or swing, of the FM carrier about its center frequency that will also last 1/30 sec. Correspondingly, the voltage variation produced at the discriminator output by the carrier deviation will last 1/30 sec. Since the reproduced audio signal has the same duration as the original audio signal, its frequency is the same as that of the latter.

For readers who have been wondering about  $L_2$  (fig. 1)—its function is to keep voltage  $E_1$  from being shorted to ground by  $C_1$ , which has a low re-

actance to the intermediate-frequency  $E_1$  voltage.

$C_3$  and  $C_1$  (fig. 1A) filter the i-f signal out of the discriminator load, which is in the audio amplifier input circuit.

The discriminator acts as a (double) half-wave rectifier. It rectifies the incoming i-f signal for the same reason that an AM detector rectifies the signal applied to it—i.e., to obtain a uni-directional output.

Now, if we used an FM detection system that didn't rectify, when the positive half-cycle of the FM carrier tended to increase the conduction in the system, the negative half-cycle would tend to decrease it. These equal increase-and-decrease effects would both occur during the time that the system's output should be increasing (since the audio signal is increasing). Zero output would result, inasmuch as the increase effect would cancel the decrease one.

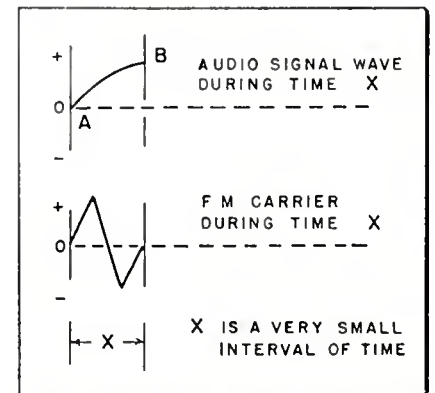

Fig. 3—While the audio signal is going in one direction only (positive) during a small interval of time (X), the FM carrier is going in two directions (positive and negative) in that same time interval.

By eliminating the negative halves of the FM carrier, the uni-directional character of the audio signal at any given instant is correctly represented by the FM carrier, resulting in the accurate reproduction of the audio signal's amplitude characteristic.

Next Month's theoretical analysis of the Ratio Detector, another widely used FM demodulator, will conclude Mr. Heller's seven article series on FM detectors. It will be followed by a practical treatment of FM shop procedures.

# Servicing and Maintaining

## Key to Profitable Phonograph Maintenance Is

• The step-child of many service departments is the handling of record-changer repairs, and allied phonograph problems. Yet today there is renewed interest in phonograph records as an entertainment medium, due at least in part to the advent of microgroove. With the upsurge in sales of records has come a stepup in the number of phonograph service calls. In addition, the use of fine-groove records has made the listener more readily aware of minor flaws in the operation of the changing mechanism. This is because here the output of the needle is smaller in relation to machine-noise than it is in the case of regular groove records. A further complication is the introduction of better quality sound into present-day combinations, resulting also in "better" reproduction of rumble, scratch and distortion.

In the past, many shops have regarded changer service as such an unimportant part of the work that they have not even had a rack to mount the changer on when it came in. A recent informal survey by the writer found racks in less than one out of four radio repair departments. Yet all the shops stated that they did changer repairs and further, that such repairs were increasing in volume.

Most phonograph repair jobs start with an outside service call. It is important that the outside technician know his own limitations; that he be able to correctly and quickly recognize when a changer repair is not the kind to be done in the home. Many jobs that should have been done in the shop have become needlessly complicated by having been first attempted in the customer's house without proper equipment.

Take the case of Jim Doakes, serviceman. After putting a new needle in Mrs. Jones' changer (an old single-speed one which had a lot of cast white metal parts) he showed her how well the new needle sounded. Jim was about to leave when Mrs. Jones asked him if there was anything he could do about the fact that sometimes the arm did not drop just right. He figured it couldn't be very difficult, even though he was unfamiliar with the adjustments on this model changer. After looking in vain for a positioning adjustment he lifted up the changer and, seeing what he thought was a small nut on the arm spindle, tried to loosen it with a spintite. Of course it wasn't a nut, but just a piece of casting and it broke off, disabling the machine. Jim tried to fix it, but with no success. (It happened there was no such adjustment at all on this early-type machine.) Finally, he had to leave a very irate Mrs. Jones and promise to come back the next day with a new part. It took three weeks to get a replacement part for this old model changer, and even then the changer had to be picked up and brought into the shop for the replacement. The dealer lost a lot of good-will and money in this case because (a) the technician was so anxious to please that he attempted a job he was unfamiliar with, and (b) he attempted a job in the home which should have been done in the shop.

The outside man must be able to tell when the job cannot properly be accomplished in the home, and he must be sufficiently self-assured to tell the customer, firmly where necessary, that the job cannot be done correctly on the spot.

He must not use this means to

cover up a lack of proper equipment being carried on the outside call. This equipment should be contained in a kit kept separately for just the times when needed and should include at least the following:

A *stroboscopic disc*, for use under an AC light source—for checking speed of turntable.

A *phono test cartridge*, with shielded lead 3 ft. to 4 ft. long and clips at its end. (Removable-needle type).

*Carbon tet* and/or alcohol, and cloth.

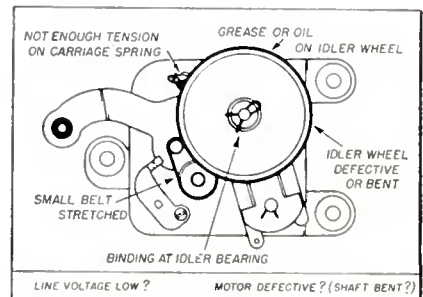

Above: Mechanism is part of V-M changer, used in many combinations today.

*Pressure gauge* for measuring weight of needle on groove.

*Lubricating grease* and *light machine oil*.

*Small kit of replacement needles*, both sapphire and metal.

With the kit of phonograph adjustment equipment listed above, the serviceman should be able to correct most minor troubles and make most adjustments. It is assumed that in addition he will have the usual complete radioman's set of tools with him.

Repair jobs which cannot be handled outside will also require, beyond the things listed for the outside phono kit, *manufacturer's factory data*, *universal AC (fused) test leads* for checking motors, *rack* for mounting the changer and turning it upside down when necessary.

For testing the operation of mechanisms after they have been completely repaired and adjusted, a stack of records, both 10" and 12", some 12" 33 RPM, and a few 45 RPM discs should be kept in the service department.

There are also available *test records* which will rapidly check the *changing cycle* of record changers. These records have only about one groove per inch, so that they run in to the center in four or five revolutions.

Below, in a typical factory service photo is shown a side view of Webster-Chicago's model 106.

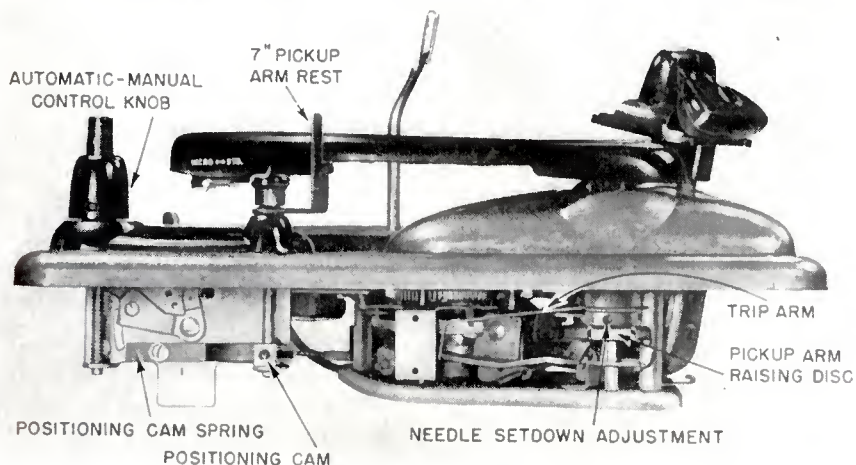

# Phono Record Changers

## Use of Proper Equipment, Including Manufacturers' Data

In shops where high-quality machines are sold or repaired, a *test record* for checking the *frequency response* of the entire system will prove helpful. These records are made by major record companies, and carry grooves modulated with frequencies from 50 cycles to 10,000 cycles, thus providing a check not only of the needle and cartridge, but of the amplifier and speaker also. In cases where rumble is the complaint, it is helpful to have an amplifier and speaker with very good bass response available for checking this point.

### Do It in the Shop

Whenever the trouble is not merely an adjustment which could have been made with a screwdriver, or by replacing the cartridge or needle, the changer should be brought into the shop. The technician who attempts to repair Mrs. Jones' changer in her home beyond the aforementioned repairs is asking for trouble. Involved changer repairs cannot and should not be attempted without a proper rack and the benefit either of manufacturer's diagrams, or years of experience.

Caution! See that no one in your shop ever puts a changer, regardless of make, directly on the floor. It takes only a very slight bump to bend or break the parts of many changers. See that pieces of cardboard are available at all times where changers may be set down.

After the changer is in the shop, it should be set in the rack and, if in operating condition at all, started running. Put one or more records on it and observe its action and see what it fails to do.

If the complaint is "rumble", "squeaking", "thumping", etc., that is, if it is mechanical trouble, but not a failure, then the section of this article dealing with *Maintenance* should be referred to.

If the trouble is a failure to properly accomplish some part of its dropping, changing, or playing cycle, usually the manufacturer's service information will list the common failures and the points to check for eliminating them.

To check mechanical operations, move the turntable by hand on the rack. Move it in the reverse direction if it is jammed. But be careful. A light hand and several years of experience are helpful here. Be certain what you're doing, particularly if it involves *bending* or *twisting* any part of a mechanism. There are al-

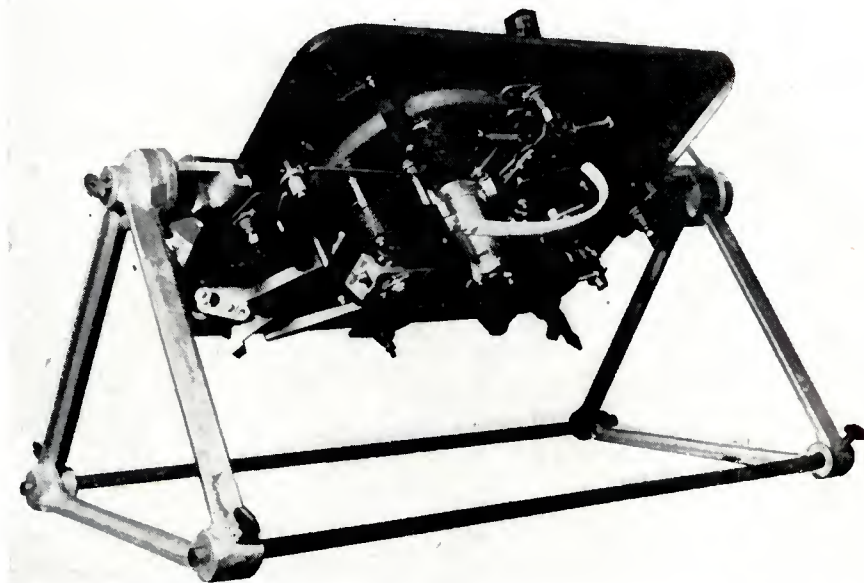

Mounted on adjustable changer rack for easier, faster repair is a Garrard 3 speed changer.

most no repairs that call for this, so stay away from it unless the manufacturer's literature specifically recommends it.

Bridging the test cartridge across the leads of the old head will show at once whether the trouble is in the cartridge or in the set. Most crystals will read high resistance if weak, distorted or dead, and will therefore not materially affect the input impedance of the test head. (Normal resistance of crystal heads is about 2, 3, or up to 10 megs. Variable reluctance heads read much lower—200 to 500 ohms being typical.)

Bad tone which affects only the high notes will usually be caused by a worn or chipped needle, if the fault is present only on phono (not on radio). Particularly with microgroove records the problem of worn needles will be more prevalent than it was with 78s. This is true because (a) the wearing pressure is much greater on the tip of the needle than with 78, despite much lighter total weight, (b) "Permanent" needles are in much greater demand and wider usage than ever before, (c) Present day equipment is capable of much better fidelity and high frequency response, showing up needle wear much more readily than did earlier, poorer equipment.

If the distortion is severe, and is accompanied by a loss in volume, the crystal should be suspected. A quick easy check for crystal failure of this sort is to press the crystal light-

ly to one side of the groove. If this restores most of the proper tone, then one of the two elements of the crystal is dead. Replacement of the unit is the only remedy.

When the motor fails to turn and the servicer has determined that there is no simple failure of contact in one of the interconnecting cables or plugs between the main AC line and the motor, then it is reasonable to suspect the motor itself. Most phono motors for 110 V, 60 cycles, read about 10-20 ohms, a reading much lower than this or considerably higher will indicate shorted turns, or if high resistance, an open in the motor. It usually does not pay to rewind such motors, so a replacement motor must be installed.

More and more changers, particularly in the three-speed category, and in the expensive sets with extended frequency response, will give rumble troubles or speed variation troubles. There are three speed variation difficulties which can occur.

The most common, and easiest to recognize, is "wow." So-called, because of the sound of the word, it is caused by periodic changes in the speed at which the turntable goes around. These changes are very slow (from about 1/2 change per second on 33 RPM, at the slowest, to a few per second).

They are usually due to defects or foreign material in turntable, turntable bearing, main idler, or some other fairly slow

(Continued on page 96)

# New Aids for Technicians

## Gonset FM TUNERS

A very compact FM receiver may be installed in any car which has an AM radio, in a sound truck, or added to an existent indoor radio or sound system

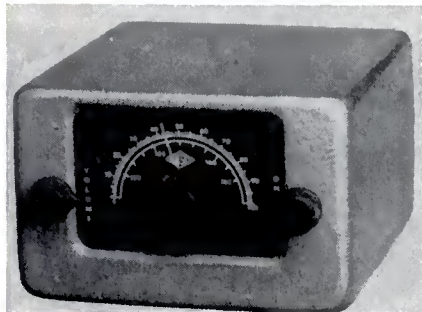

by use of this communications-type tuner. Made not only for the 88-108 (regular broadcast) FM band, but for 30-40, 40-50, 152-162, and 162-174 mc bands, it employs five tubes, measures 5 1/4" by 5 1/4" by 3 1/2", and costs \$59.50. Information, including installation and operating data, is to be had by writing to the Gonset Co., Burbank, California.—RADIO & TELEVISION RETAILING.

## Dumont AUTO-FOCUS TUBE

Now being produced as a replacement for all types of 17" rectangular glass picture tubes, the new automatic focus type incorporates, the maker states, entirely new principles of construction and design. Dumont auto-focus picture tubes require neither the focus coil of the electromagnetic focus types nor the additional focus anode voltage which the recently-developed electrostatic focus types employ. The new tube is simply plugged in, and no focus adjustment of any kind is made, according to the manufacturer, Allen B. Dumont Labs., Inc., Clifton, N. J.—RADIO & TELEVISION RETAILING.

## Mosley 3-WAY SWITCH

This antenna lead-in switch for TV gives a choice of three leads (of 300



ohms), may be mounted on most surfaces. The switch is no. F-20 and is especially recommended by the manufacturer where a flush switch cannot be used. For complete information write to Mosley Electronics, Overland, Mo.—RADIO & TELEVISION RETAILING.

## C-D CONDENSERS

An improved, completely metallized paper tubular line of condensers of the self-healing type are being manufactured in three sizes by the Cornell-Dubilier Electric Corp. Supplied from .01 up in 200, 400 and 600 V DC sizes, they are designated "Pup," "Sealpup," and "Metapup," to indicate the general purpose, extra-dependable, and the very small types, respectively. Cornell-Dubilier Electric Corp., South Plainfield, N. J.—RADIO & TELEVISION RETAILING.

## Radion TV ANTENNA

Featuring quick and easy installation, and universal mounting for window, roof or attic, the Suburban antenna, model 2G10 is designed for reception up to 25 miles from the transmitter. It is steel with baked enamel finish, and complete with mounting hardware and 300 ohm lead, lists at \$12.50. The Radion Corp., 1137 N. Milwaukee Ave., Chicago 22.—RADIO & TELEVISION RETAILING.

## Vee-D-X BOOSTER

A factory pre-set booster which may be mounted on the rear of a TV set, and has no controls, is now being supplied by LaPointe-Plascomold Corp. Stated gain on specific channels is 18

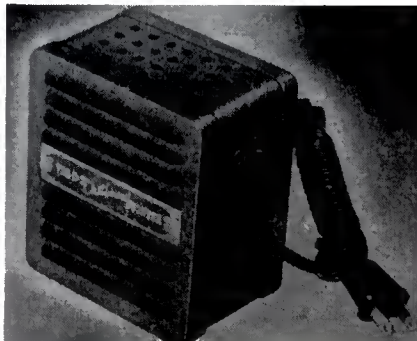

db with 5 mc. bandwidth. The booster uses a twin-triode in push-pull, measures about 4" by 4 1/2" by 2 3/8", and lists for \$19.95. LaPointe-Plascomold Corp., Windsor Locks, Conn.—RADIO & TELEVISION RETAILING.

## Oelrich SERVICE REPORT

This is a 3-copy business form for making the TV service job more business-like. Including copies for office, customer and service department, it lists all pertinent service information including minor and major service charges, claim check and space for dealer imprint. Forms are numbered already, with space for dealer's number also. Three different colors are used and carbons are already inserted. Cost is \$3.95 per 100 sets from Oelrich Publications, 4135 N. Lawler Ave., Chicago 41.—RADIO & TELEVISION RETAILING.

## JFD ROTATOR ARRESTOR

The Model AT104 lightning arrestor has been engineered to protect TV antenna rotator installations from lightning hazards. It accepts the regular 4 conductor rotator control lead with no tools, using the contacts made by 8 sharp points properly spaced. Lead is slipped into place and secured by means of two wing nuts. List price is \$1.50, or, with a mounting strap, \$1.75. JFD Mfg. Co., Inc., 6101 16th Ave., Brooklyn 4, N. Y.—RADIO & TELEVISION RETAILING.

## RCA WRENCH SET

This fingertip wrench set solves the problem of holding, placing, and adjusting nuts in hard-to-reach corners of radio and television sets. These wrenches are worn on the finger and are used to steady the nut or bolt as the screw is driven into position. Each set consists



of five wrenches for the most commonly used nut and bolt sizes. Tube Department, RCA, Harrison, N. J.—RADIO & TELEVISION RETAILING.

## Trio CONTROL UNIT

One of the new items in the Trio line is an automatic accessory control unit designed for turning on and off accessories to the TV set when it is switched. Easy to install, the unit is plugged into the wall in place of the set, and then



the set, TV lamp, booster, rotator, etc., may be plugged into the unit. Thereafter only one switch need be used—the one on the set. For additional information on this unit, which lists at \$7.95, or a new heavy duty antenna rotator, or an aluminum tower, write to Trio Mfg. Co., Griggsville, Ill.—RADIO & TELEVISION RETAILING.

**A STAR PERFORMANCE!**



**EUREKA  
TELEVISION  
and TUBE  
CORPORATION**

What makes a star performance? Concentrated effort of all concerned to give you superior quality . . . careful attention to the smallest details of construction and assembly . . . that's the story at Eureka . . . that's what makes every Eureka Picture Tube a really star performer!

**Write today!**

*for full information on all round and rectangular tubes!*



**Manufacturers of Cathode-Ray Tubes and Electronic Products**  
69 Fifth Avenue, Hawthorne, New Jersey.....Telephone Hawthorne 7-3907

COMPETENT

# Service

starts with **RIDER**

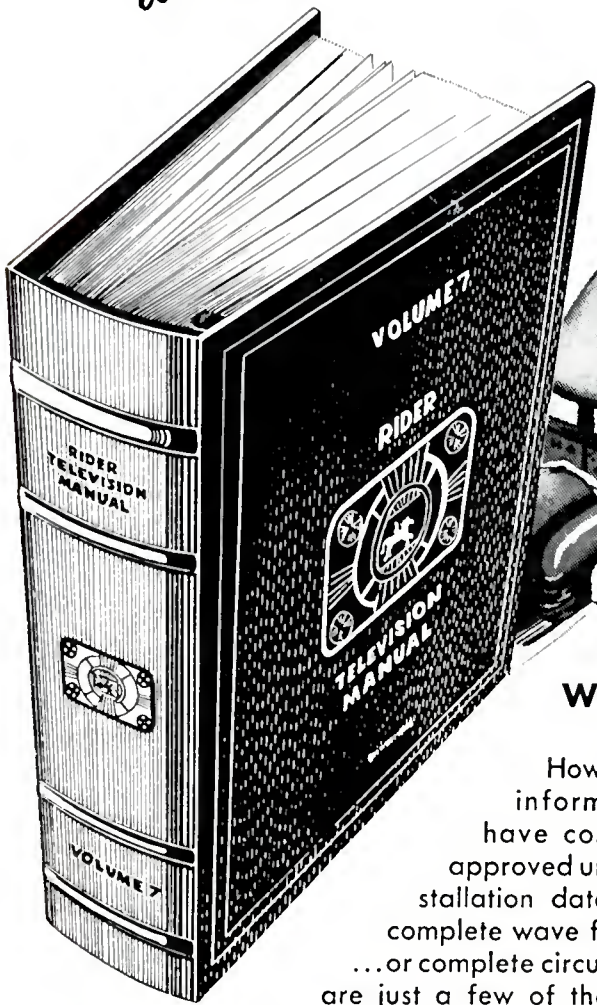

## AND ENDS WITH PROFIT!

How's your servicing information? Do you have complete factory approved unpacking and installation data? What about complete wave form information ...or complete circuit tracing? These are just a few of the questions you can't answer "yes" to unless you have the Rider TV manuals! For Rider is the only source that gives you *all* the information about *all* the sets in all manufacturers' lines, including automatic record changers. Ask your jobber to show you the latest Rider TV manual today.



**JOHN F. RIDER Publisher, Inc.**  
480 Canal Street, New York 13, N. Y.

## New Books

### Color Television Notebook

By Edward M. Noll, published by the Paul Wendel Publishing Co., Indianapolis, Ind. 45 pages, 8 1/2" x 11". Price \$1.00.

The fundamentals of the various proposed color systems are discussed and the details of the CBS system are explained and diagrammed. It includes adaptation of some standard receiver circuits, considerable data on a color wheel, and circuits for motor control and motor phasing. Also shown is a tabular presentation of the advantages and disadvantages of the various competing color systems.

### Elements of Television Systems

By George Anner. Published June 1951 by Prentice-Hall, Inc., 70 Fifth Ave., N.Y. 11, N.Y. 804 pages. Price \$10.35.

The book begins with a study of *closed systems*. Thus basic problems of *any* TV systems can be more readily understood without being concerned about broadcasting. In the second part of the book the viewpoint is expanded to include the problems arising from the addition of a *radio link*. In the last part of this extremely comprehensive text the author adds color to the picture.

### Television Manual

By Hershel L. Stark, published by Authentic Publications, 145 West 57th St., New York. 48 pages, 8 1/2" x 11. Price 50 cents.

This manual is not intended as an aid for the experienced radioman, but should prove helpful to the beginning servicer or to the radioman who has no experience in TV and wishes to prepare for it. It covers the basic adjustments which may be made to the TV set, antenna installation and some common troubles. Easy to understand, it is illustrated fully with clear diagrams.

### Sylvania Names Andrews



Raymond W. Andrews (above) formerly merchandising manager of the Radio Tube and Television Picture Tube Divisions of Sylvania Electric Products Inc., has been promoted to manager of factory sales, according to an announcement by George R. Sommers, general sales manager.



# New Products

## RCA ELECTROSTATIC TUBES

Adding the 14GP4, 17GP4 and 20GP4, all electrostatic-focus picture tubes, the Radio Corp. of America provides metal-saving tubes for replacement use and in new sets. They are all rectangular tubes, and all have glass shells except the 17" size, which has a metal shell. Ratings are typical for large electrostatic picture tubes. Tube Dept., RCA, Harrison, N. J.—RADIO & TELEVISION RETAILING.

## Shure MICROPHONE

The new small Unidyne, model 558, is a cardioid type one-half as large as the Unidyne model 55. This smaller version retains all the important directional qualities of the model 55 and is said to be the only small-size unidirectional moving-coil dynamic microphone. Further information and prices are available from the manufacturer, Shure Bros., Inc., 225 W. Huron St., Chicago 10.—RADIO & TELEVISION RETAILING.

## Standard CUSTOM CABINETS

A new cabinet, designed for the custom installer of radio-phonograph systems, and matching the Standard Wood model RX bass reflex speaker cabinets is now being made in both period and



modern styles. Shown is the period model. Wood choice is mahogany, cordovan mahogany, walnut, ebony, and blond. Also available unfinished. Size is 36" high, 16" deep and 24" wide. Standard Wood Products Corp., 43-02 38th St., Long Island City, N. Y.—RADIO & TELEVISION RETAILING.

## Newcomb PORTABLE PLAYER

A portable transcription and phonograph record player which handles all three speeds, and discs up to 17" in diameter is now being produced. An AC amplifier, 10" Alnico V speaker and a tone control are among its additional features. Weighing 22 lbs., it measures 14" by 15" by 8½". Newcomb Audio Products Co., 6824 Lexington Ave., Hollywood, Cal.—RADIO & TELEVISION RETAILING.

## Speak at NARDA Meeting

Featured speakers at the recent Mid-Year Meeting of the National Appliance & Radio Dealers Association in Chicago included: Carl V. Haacker, RCA Victor merchandise display manager; Benjamin Gross, president of Gross Distributors, Inc.; W. W. Cone, vice-president, Krich-New Jersey; A. L. Scaife, manager of merchandising, traffic appliance department, General Electric Company; W. A. Brees, vice-president in charge of sales, Crosley Division, Avco Manufacturing Corp.; and Anthony Wright, vice-president in charge of engineering, Capehart-Farnsworth Corp.

## Hotpoint Promotion

In a series of meetings recently held with distributors, marketing officials of Hotpoint, Inc., outlined its retail sales strategy for the balance of 1951. The program includes a builder-dealer activity of constructing 100 model all-electric houses, a dealer "open house" campaign, supported by new display materials and demonstrations, a kitchen and laundry planning training program for distributors and dealers, a kitchen modernization merchandising activity, based on a new planning manual for consumers, and a magazine digest of homemaking topics to be mailed to dealer customers.

SEE THE INDUSTRY'S NEWEST TV DEVELOPMENT AT OUR EXHIBIT AT THE CHICAGO MUSIC SHOW IN THE PALMER HOUSE

up to... **200 MILE RECEPTION**

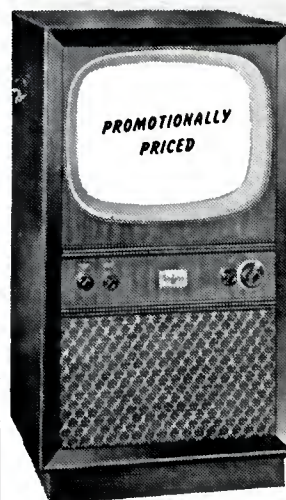

**DX TELEVISION**

**SUPER VIDEO DX**  
TEN TIMES THE SENSITIVITY OF STANDARD SETS

**Sheraton**  
TELEVISION CORPORATION

The Country's Most Powerful TV Receiver  
(Four Microvolt Sensitivity)

**SUPER VIDEO DX**  
20" CONSOLE

The Super Video DX Receiver has opened up profitable new markets in problem Fringe Areas across the nation . . . This set will give superior reception up to 200 miles without the use of boosters. And the reason for this amazing performance is the 4 MICROVOLT SENSITIVITY of this chassis . . . TEN TIMES THE SENSITIVITY OF ANY STANDARD SET ON THE MARKET!

Check These  
High Quality Features . . .

- Four Microvolt Sensitivity
- Four Stages of Video IF
- Keyed Automatic Gain Control
- Syrcoloc—Automatic Frequency Control
- Limiter-Discriminator FM Sound Circuit
- Standard Coil Turret Tuner
- Separate Circuits for Sound and Video

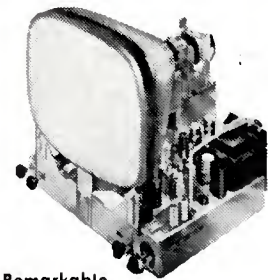

The Remarkable  
**SUPER VIDEO DX 26-Tube Chassis**  
(Incl. 2 Rect.)

# SHERATON TELEVISION CORP.

Red Bank, N. J. • Affiliate of Video Products Corp.

**DISTRIBUTORS - REPRESENTATIVES Choice Territories Now Available!**

CONTACT OUR NEW YORK SALES OFFICE, 2061 B'WAY, N. Y. C. DEPT. R

## Capehart TV-Sports Window Display

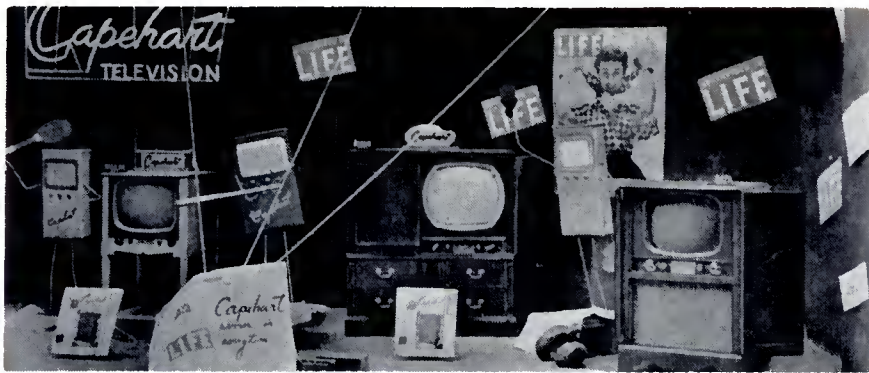

A window display featuring television receivers that box and play baseball and tennis, along with a trio of Capehart television instruments, won first prize for the Loomis Temple of Music in New Haven in a competition conducted by Cardee Distributing Corp.

## E-V CORNER ENCLOSURE

Employing the folded horn principle to reach extra-low bass range, the Electro-Voice new "Aristocrat" loudspeaker enclosure is said to considerably increase air-loading of the 12" driving cone unit. It uses the Klipsch idea, em-

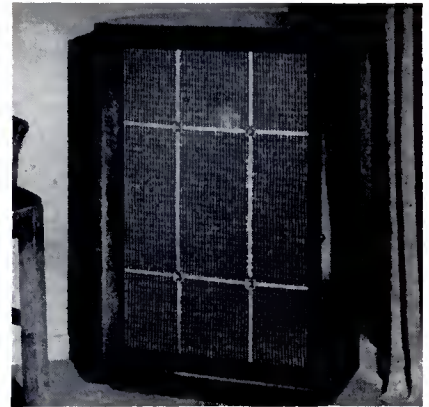

ploying the corner of the room as the final flare of the horn. Made in mahogany (list \$99.50) and blond (\$106) (both less speaker) this cabinet is 29 1/2" high and 19" wide across the corner of the room. Full details and operating information will be sent upon request by Electro-Voice, Inc., Buchanan, Michigan.—RADIO & TELEVISION RETAILING.

## Collins AM-FM TUNER

A deluxe tuner made for the finest grade of sound installations is being offered by the Collins Audio Prod. Co. Using 21 tubes, and complete with its own power supply, this tuner is said to be as high-quality a unit as can be

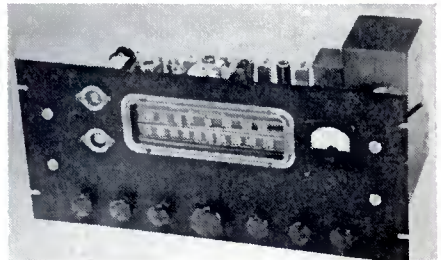

built. It includes a pre-amp for low level magnetic phono, a voltage-regulator tube, and separate bass and treble controls. Both tuning-eye and meter are built-in for tuning accuracy. Collins Audio Products Co., Inc., P. O. Box 368, Westfield, N. J.—RADIO & TELEVISION RETAILING.

## Tested UHF Reception

UHF reception with a regular commercial set converted in less than three minutes was shown to members of the press at Bridgeport, Conn., by the Standard Coil Co., makers of TV tuners. Regular VHF strips were lifted out of the VHF tuner by hand, new UHF strips (two per station) were snapped in place, and the set received UHF signals from a transmitter located five miles distant. Compared to regular VHF reception on same set the UHF was much better. However, VHF was coming from New York, considerably farther away than UHF station.



## TV INTERFERENCE

WITH A **TELE-MATIC** FULL-RANGE FILTER KIT

SIMPLE! • SPEEDY! • EFFICIENT!

- 1 Eliminates antenna-fed interference
- 2 Covers full-range—both I.F. and R.F.
- 3 No more guess-work regarding "interference source"
- 4 No loss of signal
- 5 Sharper steadier pictures
- 6 No service recalls
- 7 Any filter in kit replaceable separately

Send for free technical bulletin RT on antenna installation.

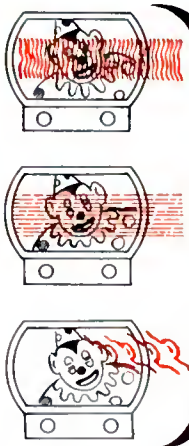

ONE JORALEMON ST. • BROOKLYN 2, N. Y.

**Rauland** Now Offers The First

# LOW FOCUS VOLTAGE ELECTROSTATIC TUBE

*Rauland's new low potential electrostatic-focus picture tube is not just a "defense period" substitute but a permanent and major advance in television cathode ray tube development*

**FOCUSES** with D.C. voltage already available from the receiver's power supply.

**ELIMINATES** focusing coils and magnets—saves critically scarce copper and cobalt.

**REQUIRES NO** re-engineering of present television chassis . . . **NO** added high voltage focus circuit . . . **NO** added receiver tubes—**NO** additional components except an inexpensive potentiometer.

**BETTER** in all ways! Not only saves materials but also gives an actual improvement in picture quality because the over-all focus is better . . . and because it is completely stable in focus under considerable variations in voltage.

*This new Rauland development is now available in substantial quantities in 17 and 20 inch rectangular tubes. For further information, address . . .*

**THE RAULAND CORPORATION**



*Perfection Through Research*

4245 N. KNOX AVENUE • CHICAGO 41, ILLINOIS



# Music Show

(Continued from page 39)

O. Pagani & Bros., Inc., 289 Blecker St., New York 14—Room 970  
 Pan-American Band Instr., Elkhart, Ind.—Room 746  
 Pathe TV Corp., 250 W. 57th St., New York 19—Booths 39, 40, 41  
 Pedler Co., Elkhart, Ind.—Room 790  
 Peerless Album Co., Inc., 800 Union St., Brooklyn 15, N. Y.—Booth 53  
 Pentron Corp., 221 E. Cullerton St., Chicago 16.—Room 640  
 Penzel, Mueller & Co., Inc., 36-11 33rd St., Long Island City 6, N. Y.—Room 787  
 Peripole Products, Inc., 2917 Ave. R, Brooklyn 29, N. Y.—Room 749  
 Permo, Inc., 6415 N. Ravenswood Ave., Chicago 26—Booth 43

Philco Corp., C & Tioga Sts., Phila. 34, Pa.—Booths 3, 4, 5, 6, 7  
 Phonograph Mfrs. Ass'n, Inc., 40-05 21st St., L. Is. City, N. Y.—Booths 71, 72  
 Piedmont Importing Co., Box 6115, Apex Station, Wash., D.C.—Room 954  
 Pollina Accordion Mfg. Co., 6921 Gratiot Ave., Detroit 7, Mich.—Room 700½  
 Pratt, Read & Co., Inc., Ivoryton, Conn.—Rooms 860, 861  
 RCA Victor Div., Radio Corp. of America, Camden, N. J.—P.D.R. 14—Booths 89, 90  
 Radio & TV Equip. Co., 207 Oak St., Santa Ana, Cal.—Room 795  
 Recoton Corp., 251 4th Ave., New York 10—Booth 74  
 Regal Electronics Corp., 605 W. 130 St., N. Y.—Room 641  
 Regal Musical Instr. Co., 3211-15 Grand Ave., Chicago 51—Room 792  
 Revere Camera Co., 320 E. 21st St., Chicago—Booths 14, 15, 16  
 Rexford Record Corp., 1440 Broadway, New York 18—Booth 9

F. A. Reynolds, Inc., 2815 Prospect Ave., Cleveland 15, Ohio—Room 780  
 Rowe Industries, 1702 Wayne St., Toledo 9, Ohio—Room 755  
 Russi Musical Instr., Inc., 61 4th Ave., New York 3—Room 958  
 St. Louis Musical Supply Co., Inc., 4400 Delmar Blvd., St. Louis 8, Mo.—Rooms 715, 716  
 Scherl & Roth, Inc., 2845 Prospect Ave., Cleveland 15, Ohio—Room 779  
 Scott Radio Labs., Inc., 1020 Rush St., Chicago 11—Rooms 660, 661  
 H. & A. Selmer, Inc., Elkhart, Ind.—Rooms 752, 754  
 Joseph Shale, 140 East Ave., Rochester 4, N. Y.—Room 845  
 Sheraton Television Corp., Affiliate of Video Products Corp., 42 West St., Red Bank, N. J.—Room 655  
 Simon & Schuster, Inc., 200 5th Ave., New York 10—Booth 66  
 Slingerland Drum Co., 1325 Belden Ave., Chicago 14—Room 784  
 H. Royer Smith, 10th & Walnut Sts., Philadelphia 7, Pa.—Room 646  
 Sohmer & Co., 31 W. 57th St., New York 19—Room 824  
 Sonic Industries, Inc., 221 W. 17th St., New York 11—Room 601  
 Sonola Accordion Co., 220 4th Ave., New York 3—Room 727  
 Sorkin Music Co., Inc., 559 Ave. of Americas, New York 11—Rooms 735, 776, 777  
 Southern Music Co., 1100 Broadway, San Antonio, Tex.—Room 712  
 Sparton Radio-TV, Jackson, Mich.—Rooms 679, 680  
 Steelman Phonograph & Radio Co., Inc., Mt. Vernon, N. Y.—Room 659  
 Steinway & Sons, 109 W. 57th St., New York 19—Rooms 821, 822  
 Story & Clark Piano Co., 64 E. Jackson Blvd., Chicago 4—Rooms 851, 852, 854  
 Stromberg-Carlson Co., Rochester 3, N. Y.—P.D.R. 17  
 Swiderski Music Co., 859 E. Allegheny Ave., Philadelphia 34, Pa.—Room 968  
 Sylvania Electric Products, Inc., 254 Rano St., Buffalo 7, N. Y.—Red Lacquer Rm.—Sec. "C"  
 Symphonic Radio & Electronic Corp., 160 Washington St., Boston 14, Mass.—Room 603, Booth 2  
 Synthetic Plastics Sales Co., 461 8th Ave., New York 1—Booth 79  
 Targ & Dinner, Inc., 425 S. Wabash Ave., Chicago 5—Rooms 733, 734  
 Tele King Corp., 601 W. 26th St., New York 1—Rooms 676, 677, 678  
 Henry Teller & Son, 5490 Dorchester Ave., Chicago 15—Room 798  
 The Tilben Co., 340 Monroe Ave., Detroit 26, Mich.—Room 748  
 Time Magazine, 9 Rockefeller Plaza, New York 20—Room 658  
 Tonk Mfg. Co., 1912 N. Magnolia St., Chicago 14, Ill.—Room 859  
 Trad Television Corp., 1001 First Ave., Asbury Park, N. J.—Room 651  
 Traficante, 41 S. 8th St., Minneapolis 2, Minn.—Room 907  
 U. S. Musical Mds. Corp., 1658 Broadway, New York 19—Room 709  
 Universal Co., High Point, N. C.—Rooms 642, 643  
 V-M Corp., Benton Harbor, Mich.—Rm. 648, Booth 68  
 Valco Mfg. Co., 4700 W. Walton St., Chicago 51—Room 764  
 The Vanity Fair Co., 61 E. 11th St., New York 3—Booth 67  
 The Vega Co., 155 Columbus Ave., Boston 16, Mass.—Room 714  
 Voco, Inc., 33 34th St., Brooklyn 32, N. Y.—Booth 59  
 W. F. L. Drum Co., 1728 N. Damen Ave., Chicago 47—Room 738  
 Waters Conley Co., Rochester, Minn.—Booths 63, 64  
 Weaver Piano Co., Inc., York, Pa.—Room 843  
 Webster-Chicago Corp., 5610 W. Bloomingdale Ave., Chicago 39—Rooms 638, 639  
 Webster Electric Co., Racine, Wis.—Booths 56, 57  
 Westinghouse Electric Corp., Television-Radio Div., Sunbury, Pa.—Rooms 632, 633, 634; Booth 75  
 David Wexler & Co., 1243 S. Wabash Ave., Chicago 5—Rooms 710, 711  
 Winter & Co., 863 E. 141st St., New York 54—Rm. 838  
 Wolfe's Sales Promotion, 986 Sanford Ave., Irvington 11, N. J.—Room 846  
 World-Wide Record Corp., Jay-Gee Record Co., Inc., 315 W. 41st St., New York 19—Booth 65  
 The Rudolph Wurlitzer Co., DeKalb Div., DeKalb, Ill.—Room 862  
 W. R. Yerke, Inc., Mitchell, Ind.—Booth 17  
 Zenith Radio Corp., 6001 W. Dickens Ave., Chicago 39—P.D.R. 15, 16  
 Avedis Zildjian Co., 39 Fayette St., N. Quincy 71, Mass.—Room 788

## MOSLEY Low Loss TV Accessories . . .



provide BETTER TV PICTURES  
 through more efficient installation!

### ROTATOR CONTROL CABLE PLUGS AND SOCKETS

MOSLEY multi-wire plugs and sockets provide efficient and neat connections for 4 and 5-wire antenna rotator cables. Their precision design and rugged construction make them suitable for many other applications in ham shack, experimental lab, etc. Made of high quality acrylic resin plastic with non-rusting metal parts, these plugs and sockets provide excellent electrical and mechanical connections and are easily installed without the use of solder.

MOSLEY 4 Conductor Plug and Base Socket Combination. Polarized connection for up to four wires. Plug is acrylic plastic. Four extra large non-ferrous set screws hold cable wires firmly. Will also fit MOSLEY F-14 Flush Socket. Base Socket is made of same material and mounts to wall or base-board with three wood screws furnished. Solderless connections to strip type terminal. Catalog No. C-124 (Plug and Base Socket). **List \$2.00**

MOSLEY 4 Conductor Polarized Plug only. Cat. No. C-104. **List \$3.84**

MOSLEY 4 Conductor Base Socket only. Cat. No. C-114. **List \$1.16**

MOSLEY 5 Conductor Plug and Base Socket Combination. Same as C-124 illustrated right but designed for 5-wire cable connections. Cat. No. C-125 (Plug and Base Socket). **List \$2.50**

MOSLEY 5 Conductor Polarized Plug only. Cat. C-105. **List \$1.09**

MOSLEY 5 Conductor Base Socket only. Cat. C-115. **List \$1.42**

MOSLEY 4 Conductor Line Socket. Use with C-104 plug above to extend 4-wire cable. May be used in place of C-114 if base mounting is impractical. Cat. No. C-134. **List \$3.84**

MOSLEY 5 Conductor Line Socket. Same as C-134 but for 5-wire cable connections. Cat. No. C-135. **List \$1.09**



C-124



C-134

**MOSLEY**  
 W O F Q Y

*Electronics*

2126 LACKLAND OVERLAND, MISSOURI

#### A SINGLE SOURCE OF SUPPLY

MOSLEY ELECTRONICS manufactures the only complete line of antenna transmission line connectors, plugs, sockets and other accessories. MOSLEY products are solderless and designed for maximum electrical efficiency. Install MOSLEY accessories with complete confidence. Write for new Catalog No. 50-51.

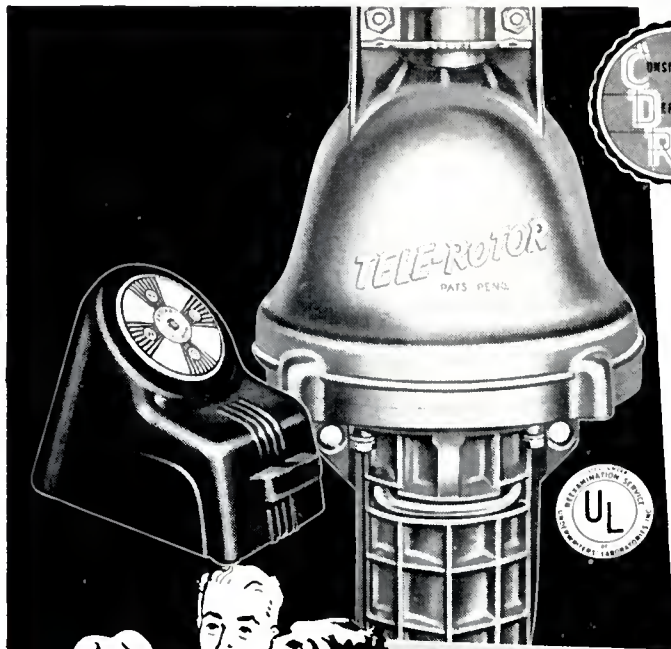

# TELE-ROTOR

This heavy-duty TELE-ROTOR has no match! It's more powerful . . . will turn any TV antenna array under any weather conditions. Easily installed . . . it is trouble-free in performance. Easiest of all to operate!

**MODEL TR-2** . . . rotator with "compass control" cabinet having illuminated "perfect pattern" dial . . . (uses 8 wire cable) . . . . . \$49.95



*Gives your Customers the Best*

## You Can't Beat A

# TELE-ROTOR



## TELE-ROTOR CUB

The new TELE-ROTOR "CUB" is ideal for average installations. The same husky motor as the Heavy-Duty model . . . the "CUB" is the fastest and easiest of all rotators to install. All-In-Line design . . . with true in-line thrust between antenna and mast. The 3/4" STEEL shaft rotates on a case hardened steel ball . . . with in-line reamed oilless bearings.

**MODEL 502A** . . . . . Rotator with plastic control cabinet having indicating meter for "hairline" tuning. (Uses 5 wire cable) . . . \$44.95

**MODEL 501A** . . . . . rotator with control cabinet having end-of-rotation signal. Light flashes every 7.2° showing antenna is turning. (Uses 5 wire cable) . . . . . \$34.95

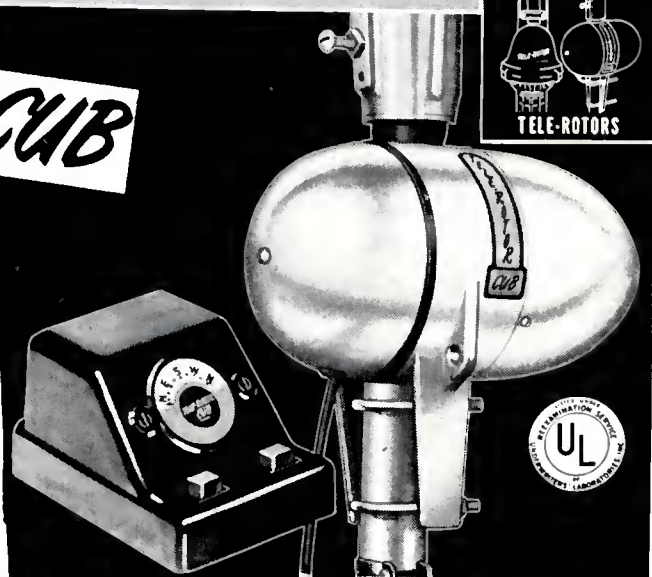

**THE RADIART CORPORATION CLEVELAND 2, OHIO**

**CORNELL-DUBILIER SOUTH PLAINFIELD, N. J.**



## New Astron Sales Rep.

Astron Corporation, 255 Grant Ave., East Newark, N.J., makers of a complete line of capacitors and noise suppressors, announce the appointment of William F. Swinke, 541 Diversey Parkway, Chicago, Ill., as territorial representative for the state of Illinois.

## Stromberg Branch Office

The Stromberg-Carlson Company's Chicago branch office, television division, recently moved to remodeled and redecorated quarters in the building at 315 East Grand Ave., occupying

the fifth floor. James Ward, who was formerly in charge of Stromberg-Carlson service at Los Angeles, has come to Chicago to take charge of this part of the business; Harold Cunningham is service manager, and Jack Schleh is supervisor of the order department.

## Centralab Sales Reps.

W. S. Parsons, vice-president Centralab Division of Globe-Union Inc., has announced the appointment of Earl T. Champion, Skokie, Illinois and Jerry Vrbik as Centralab sales representatives for several midwestern states.

# Recorders

(Continued from page 48)

in calls on commercial and private prospects. People in all walks of life respond actively to demonstrations of recorders, since this device, like the movie camera, for instance, has a terrific personal appeal. Truly, the recorder is *glamour merchandise with great utility value as well*. The salesman who will go out in the field, carrying a recorder with him will be agreeably surprised to find that almost every call will result in a demonstration . . . and a great many in sales.

Dealers who want to get some of the plus-profits recorders offer, need to advertise this product consistently, in order to make their store known as headquarters. In advertising recorders, considerable thought needs to be given to the sort of copy. The ads should tell the reader *just what the product is, how simple it is to operate, how little it costs to run, and how economically it's priced*.

Free trial techniques can be used to close many sales, and here are some tips on in-home, in-office trial selling:

1. Be sure to send a skilled demonstrator with the unit, and be sure that he stays long enough with the prospect to thoroughly familiarize the latter with the recorder.
2. Qualify all persons requesting free trial in order to weed out those who are just curious, as well as those you don't consider able to buy.
3. Don't leave the instrument on trial more than a couple of days. Follow up by personal call.
4. Make sure that the tape or wire you send is in perfect condition.

Profit-wise, recorders are most attractive. No trade-ins are involved, and there is no widespread price-cutting. Competition is not acute, since the recorder is still a "ground-floor" proposition.

The merchant who makes a determined, consistent effort to sell a substantial number of recorders will always be the man who reports that recorders are good sellers, good money-makers. The man who stocks a couple of units and permits them to become dust-covered stepchildren, will never make a dime out of this merchandise.

Missionary work in selling recorders will pay good returns to any dealer anywhere in the United States.

JUST AS GOOD IS A FABLE!



\*Registered Trademark

Don't be sold an imitation  
OF THE  
**"CONICAL-V-BEAM"\***

**BE BRAND CONSCIOUS — DEMAND** a genuine TELREX for the ultimate in TV reception. Many imitations short cut and cheapen the product so that results are often disappointing.

The genuine TELREX "CONICAL-V-BEAM" is manufactured in 24 models—one to meet every TV reception problem, whether in a primary, secondary, fringe, or extreme fringe area.

The TELREX "CONICAL-V-BEAM" is the only antenna devised supplying FULL AUDIO and VIDEO BANDWIDTH and highest Signal to Noise Ratio!

The TELREX "CONICAL-V-BEAM" gives longer lasting customer satisfaction than any other antenna, irrespective of price.

Millions of installations all over the Americas' attest to the Telrex claim that NO OTHER antenna can perform as well as a "Conical-V-Beam."

Get a genuine TELREX "CONICAL-V-BEAM" —

**SEE AND HEAR THE DIFFERENCE.**

**UNIVERSAL Series**  
**U2X-TV**  
\$10.33 List  
Designed to be used as a standard "Conical-V-Beam" or as a modified "Conical-V-Beam" permitting Selective Channel Emphasis.

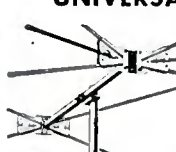

**DEALERS — SERVICEMEN —**  
"TELREX NEWS" can be mailed direct to your place of business. This timely service periodical contains the most authentic antenna technical data available. It's FREE — Write on your Company letterhead or post card with Company stamp.

"CONICAL-V-BEAMS" are produced under Re-issue Patent No. 23,346



**THE SKILL TO DESIGN...  
THE FACILITIES TO PRODUCE...  
THE ABILITY TO DELIVER**

Telrex INC.

AMERICA'S STANDARD OF COMPARISON



ASBURY PARK 2, NEW JERSEY



Here's how YOU  
 can sell more  
 Picture Tubes  
 WITH  
 HYTRON'S NEW  
 EASY BUDGET PLAN!

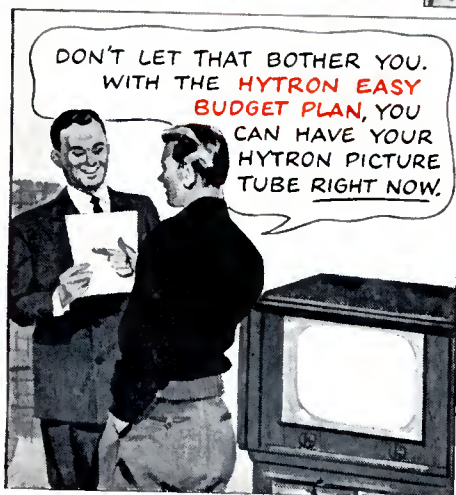

**ANOTHER HYTRON FIRST FOR YOU!**

No need to miss that profitable picture-tube sale — just because the customer doesn't have the cash. The original Hytron Easy Budget Plan saves the sale. Gives you a competitive edge. Hytron has arranged the details for you. A national credit organization, with facilities in all TV areas, stands ready to serve you.

Find out how you can put this wonderful, timely Hytron plan to work right now! Write for complete information today.

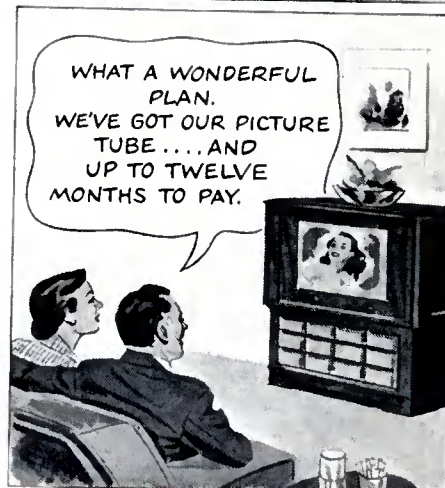

**ANOTHER  
 HELPFUL SERVICE  
 FOR YOU FROM . . .**



MAIN OFFICE: SALEM, MASSACHUSETTS

## Air King Window Contest

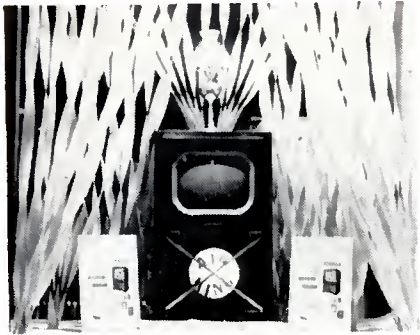

Show window above won first prize in recent Air King window display contest. Store is Jouret's, in Jeanette, Pennsylvania.

## Mul-TV Wins Approval

Recent meetings with FCC officials in Washington attended by Milton J. Shapp, president, and Sydney J. Mass, director of advertising and sales promotion. Jerrold Electronics Corporation, Philadelphia, brought comments that the Jerrold Mul-TV community antenna system offers a useful addition to the 25 year long-range plan of the FCC for providing television service to the greatest number of people throughout the nation. The Mul-TV community system makes it possible for entire towns in "hidden" valleys as well as areas 75 to 125 miles from the nearest TV station to get good television reception from a single master antenna.

## Arvin 1952 Line

More than a hundred distributors of Arvin radios and TV sets will come from all parts of the U. S. to attend a special Arvin convention at the Moraine Hotel, Highland Park, Illinois, on July 29th and 30th, Harlan B. Foulke, vice-president of Arvin Industries, Inc., has announced. Highlight of the two-day meeting will be the unveiling of the complete 1952 line of Arvin TV receivers, radios and radio-phono-TV combinations.

## Auto Radio

(Continued from page 77)

a car set is examined.

One final important technical precaution. Whenever a vibrator replacement is made (and these are the most frequent failures in auto radios) make certain that the buffer condenser(s) is (are) changed. Failure to do this will result in a greatly increased call-back rate!

During any period when repair volume drops, the dealer can put in the little new equipment needed, and help the technician(s) get familiar with the few additional twists that will convert auto radio servicing into a profitable part of your business.

## Phono Needles

(Continued from page 44)

to it at all—and a sale is lost.

Mailing pieces similar to the one accompanying this article as an illustration can be prepared and sent out with return postcards. The cards should have spaces for the name and address of the customer and the cartridge number and number from their phonograph. The make and model of the phonograph should be requested as well, since this will provide leads for future set and record sales as well as giving the dealer a list of customers who need phono player conversion or modernization jobs. The mailing piece should explain how the customer should go about finding the cartridge number.

A general mailing such as this will accomplish many things. Primarily, it will create interest in needles and get folk to look at the needles in their phonographs, resulting in more sales. Also, the people who fill in the cards and return them will keep the store in mind as the place to go when they do want to buy a needle. The data from the cards will also supply a good "special" mailing list of active prospects. And finally, having the cartridge number on file will make sales so much easier.

**more power, more quality**  
**more "sell" in**

**Rauland**  
**MOBILE**  
**SOUND**

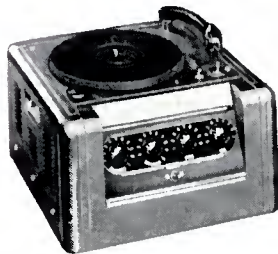
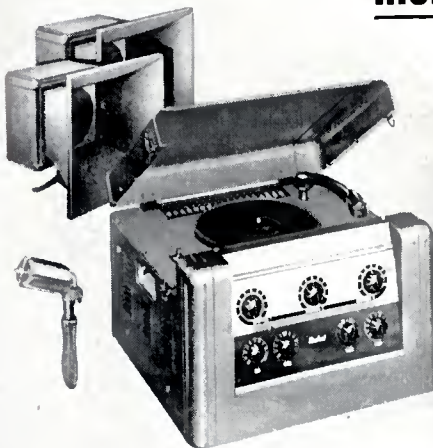

RAULAND Mobile Sound is available also in the 20 watt size illustrated immediately above. Covers 5,000 people indoors, 25,000 square feet outdoors. Has 2 microphone inputs, 1 phone input; electronic mixing and fading on all 3 inputs; tone control. With built-in phono motor and crystal pickup. For 6 volt D.C. or 117 volt A.C. Available in a variety of complete systems for universal operation.

Meet the demand for Mobile Sound with RAULAND equipment—the finest on the market. It's competitive *price-wise*. It's tops *quality-wise*—tops for power, universal application, completeness and rugged dependability.

The 30 watt Mobile System illustrated above covers 10,000 people indoors or 35,000 square feet outdoors. Features: 3 microphone inputs; 2 phono inputs; true electronic mixing on all 5 inputs; separate bass and treble tone controls; remote mixing on all 3 microphones. With built-in phono motor and crystal pickup. Housed in deluxe steel cabinet finished in dark green hammerloid; illuminated panel. Operates anywhere—from 117 volt A.C. or 6 volt D.C.—instant changeover accomplished by merely changing plug-in power cable.

RAULAND 30 Watt Mobile equipment is available in a choice of *complete* systems (including reproducers and microphones) for every conceivable universal sound application. Unsurpassed for versatility, power and tonal excellence. For bigger Mobile Sound sales and profits, get the RAULAND selling details today.

See your RAULAND-BORG Distributor now for full information on the complete RAULAND Public Address Line . . . the line that builds Sound profits.

Electroneering is our business

SOUND  
EQUIPMENT

**Rauland**

INTER-  
COMMUNICATION

RAULAND-BORG CORPORATION • 3523-L Addison St., Chicago 18, Ill.



# 2,000,000

# Radion

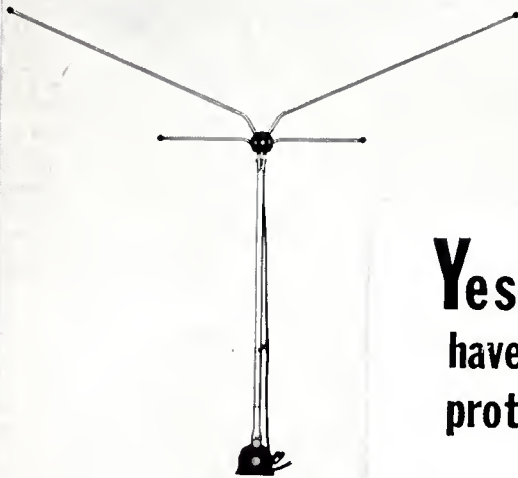

Lowest cost outdoor installation  
The SUBURBAN—2-G-10

Gull-wing conical, for up to 25 miles from transmitter. Factory assembled, with lead-in and necessary hardware for fast installation on wall, roof, window or in attic; only pliers and screwdriver needed. Individually packaged. Packed 6 to a master carton. Shipping weight, 28 1/4 lbs. List, \$12.50.



Aristocrat of indoor antennae  
COSMOPOLITAN TA-55

Uniquely beautiful FOTO-TENNA specifically designed to blend with the finest interior decorating scheme. Beautiful brown leatherette, 11" x 14" closed, opens to approx. 22 1/2" x 14". Complete with lead-in wire. Individually packaged. Packed 12 to a master carton. Shipping weight, 22 lbs. LIST PRICE, \$7.50.

**Yes! 2,000,000 Radion units have speeded up slow sales . . . protected your profits!**

Dealers who believe in never overlooking an opportunity *always* stock *Radion*, in or out of TV sales seasons. When sales are brisk, *Radion* saves countless man-hours' demonstration, installation and service time—permits maximum volume with minimum manpower. When sales are slow, *Radion* makes practical such offers as "free installation up to 20 miles" because of its splendid reception and bedrock low cost installation.

Proof? If that 2,000,000 figure doesn't convince you, call your jobber or mail coupon for additional, money-making facts. We'll show you!

**THE RADION CORPORATION**  
1137 Milwaukee Ave., Chicago 22, Illinois



METROPOLITAN TA-49

The industry standard, Model TA-49 indoor TV Antenna, complete with lead-in. 3-section telescoping tubular steel dipoles. Fully assembled. Individually packaged. Shipped 12 to master carton. Shipping weight, 22 pounds. LIST PRICE, \$6.95.

MAIL THIS  
FOR **PROOF!**

The Radion Corporation  
1137 Milwaukee Ave., Chicago 22, Illinois

Please send complete details on Radion products and dealership.

Metropolitan No. TA-49     Cosmopolitan No. TA-55  
 Suburban No. 2-G-10

Name \_\_\_\_\_

Company \_\_\_\_\_

Address \_\_\_\_\_

City \_\_\_\_\_ Zone \_\_\_\_\_ State \_\_\_\_\_

The New Leader!

*Yagi*

By Clear Beam

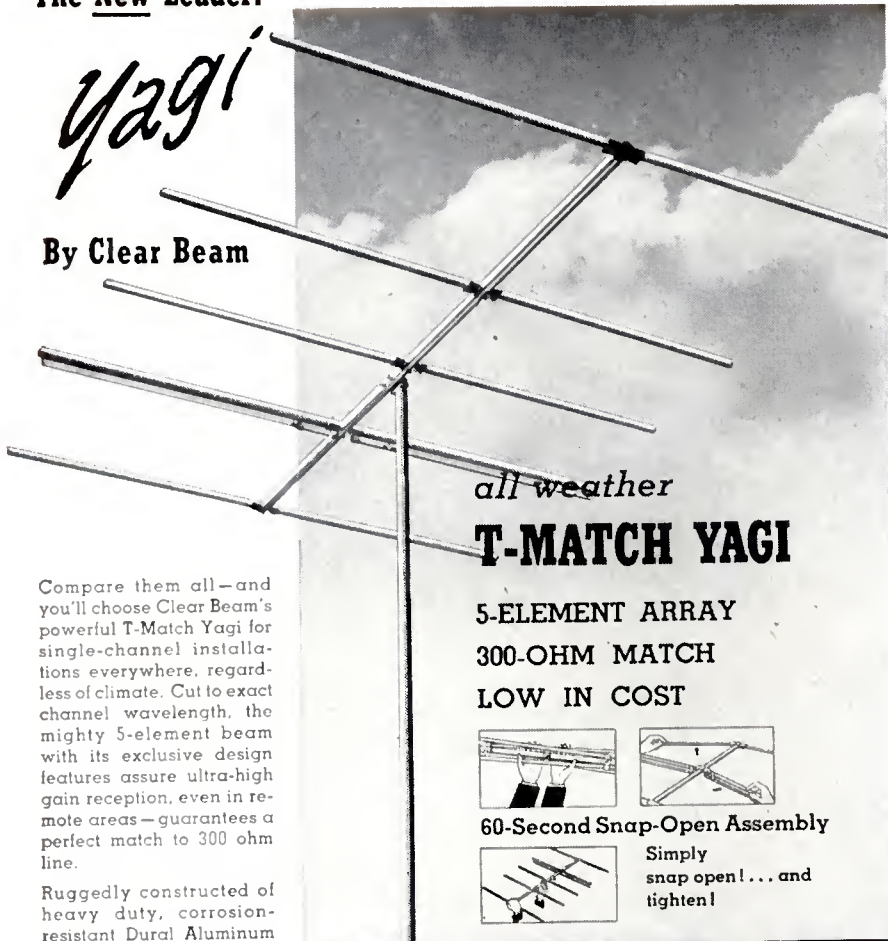

*all weather*  
**T-MATCH YAGI**

**5-ELEMENT ARRAY**  
**300-OHM MATCH**  
**LOW IN COST**

Compare them all—and you'll choose Clear Beam's powerful T-Match Yagi for single-channel installations everywhere, regardless of climate. Cut to exact channel wavelength, the mighty 5-element beam with its exclusive design features assure ultra-high gain reception, even in remote areas—guarantees a perfect match to 300 ohm line.

Ruggedly constructed of heavy duty, corrosion-resistant Dural Aluminum for dependable, all-weather performance, the Clear Beam T-Match Yagi assembles in one-minute flat... slashes installation time... insures customer satisfaction now and for the years ahead.

Compare them all... compare the features and the surprisingly low price... and you'll choose "Clear Pictures... Clear Profits... with CLEAR BEAM!"



**60-Second Snap-Open Assembly**



Simply snap open!... and tighten!

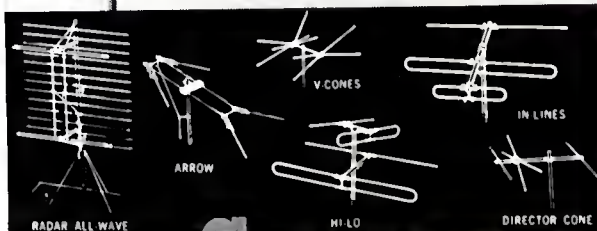

A COMPLETE LINE OF QUALITY

ANTENNAS TO MEET EVERY TV RECEPTION REQUIREMENT

**Clear Beam**

*Antennas*

CLEAR BEAM ANTENNAS 618 No. La Brea Ave. Los Angeles 36, Calif. YOrk 1682

**Record Changers**

(Continued from page 83)

turning part.

The second common variation in the speed at which the turntable revolves is "flutter." This is a more rapid periodic change in the speed of rotation. It may be roughly said to go from about 15 times a second up to the point where it is no longer noticeable. Most people will react to flutter by saying, "the phonograph is going too slow", or "it sounds slow, or sick." This is, of course, partly true since variations of this sort will usually be accompanied by some slowing down. But the slowing down is not what they hear. Contrary to the opinion of most people, they cannot tell when a record is going very slightly slow or very slightly fast unless they are extremely familiar with the particular record. When they say it's going slow, the odds are ten to one it has flutter.

The third trouble is actual slowing down of the turntable. On governor-controlled phonographs, which are almost out of existence as new equipment, the cause is usually a lack of lubrication, or an accumulation of dirt and grease in the governor. In synchronous motors, which most phonographs today have, the trouble may be too heavy a pickup arm, a broken needle point, cold motor (grease thick—gets back to normal after warmup), dirt on any moving part, or lubricant dried up. The rubber idlers or belts should also be checked.

Maintenance on record changers consists of checking for proper operation, cleaning, and lubricating. The proper cleaning agents are carbon tetrachloride (alcohol is usually OK, but be careful of the material it is used on) and a cloth, with a small brush for getting into tight places. All surfaces such as the working surfaces of the motor pulleys, idler pulleys, idler wheels, inside turntable wheels, and friction surfaces in governors, should be carefully cleaned, allowed to dry, and then run for a while. At the same time, before test-running, the bearing surfaces (or inside), of these parts should be cleaned of oil and dirt, and then covered very lightly with a light grade of machine oil. (It cannot be said too often that much of the trouble in new or recently-repaired changers comes from over-generous lubrication. What may not seem like excess oil when the parts are at rest quickly gets distributed to other parts of the machine as soon as the changer starts operating.) Be careful not to lubricate brake surfaces or certain parts of governors. Manufacturers' literature always shows a

(Continued on page 97)

**Be Happy-Buy DEAN**  
**The Dependable PHONO Line**

For Quality At PROMOTION Prices

- Rigid Inspection
- High in Value
- Guaranteed
- Quality Controlled
- Low in Price
- Available in UL



Welcome to Room 635

★ SEE OUR PROFIT LINE

Write for Catalog!



Sold only thru jobbers.

**DEAN** 35 Fifth Avenue Brooklyn 17, N. Y.

## Record Changers

(Continued from page 96)

pictorial diagram of the places for lubrication. In addition to these places, many changers require a couple of drops at each end of the motor every few months. In a large percentage of these motors, there are small pieces of felt near the bearing ends of the motor axle which are intended to hold the lubricating oil. (Do not saturate these—use just two drops in most cases.

Often a flat on the main idler wheel can be eliminated by taking the rubber wheel off and reversing it; that is, turning it inside out.

After the repair has been made, a stock of records should be placed on the changer and allowed to play through two or three times before the changer is marked "ready" and put aside for delivery.

### GE Appointments

Several key appointments in the newly established Traffic Appliance Department of the General Electric Company have been announced by R. E. Boian, manager of marketing for the department. C. R. Thorson, formerly sales manager of the clock division, becomes manager of special accounts. R. C. Walton, formerly with the Appliance & Merchandise Department, becomes manager of marketing services. D. L. McFarland, previously in the appearance design division, has been named manager of product planning. J. D. Phillips, manager of traffic appliance service in the Appliance & Merchandise Department, becomes product service manager. P. A. Wassmanskopf and A. L. Scaife will continue as advertising manager and merchandising manager respectively.

### Honor RCA Sound Jobbers

Seven RCA sound products distributors were honored at an award luncheon in the English Room of the Blackstone Hotel, Chicago, recently, for setting outstanding sales records during the year. They were: Jack C. Arbuckle Co., Fresno, Cal.; Sound Photo Equipment Co., Lubbock, Texas; Endresen Sound Co., Duluth, Minn.; Theodore G. Brice Co., Flint, Mich.; Grice Radio & Electronics Supplies, Pensacola, Fla.; Industrial Electronics Inc., Baltimore, Md.; and Fort Orange Radio Distributing Co., Inc., Albany, N.Y.

### Farr on Fair Trade Ruling

"The effect of the Supreme Court's ruling on Fair Trade will be, to retailing, what the sudden elimination of years of social progress could be to civilization," Mort Farr, president of the National Appliance & Radio Dealers Association, said recently, referring to the Court's ruling that dealers who don't sign fair trade agreements are not bound by them.

# Stimulate More Sales for BURGESS BATTERIES

USE THESE NEW BURGESS PROFIT AIDS IN YOUR STORE!



### EYE-CATCHING WINDOW BANNER MAKES CUSTOMERS OUT OF PASSERS-BY!

This attractive new Burgess window streamer gets immediate customer attention—ties in with Burgess advertising in big national magazines and newspaper supplements with national circulation—reminds customers to buy fresh Burgess portable radio batteries for summer fun. Colorful red, black, yellow on durable stock.

### ATTENTION-GETTING COUNTER CARD REMINDS TO BUY!

Folks just browsing through your store, and customers for other purchases, are reminded to buy Burgess when they spot this colorful red, black, yellow counter card. Printed on heavy cardboard stock with sturdy easel.



### COUNTER MERCHANDISER SELLS THE PRODUCT!

This handsome little counter display takes up little space and displays portable radio battery XX45. This model is most used in the popular smaller portable radios. Consumer benefit printed at top prompts sales. Red, yellow and black.

Contact your jobber now for this material.



# BURGESS BATTERIES

BURGESS BATTERY COMPANY • FREEPORT • ILLINOIS

**NOW!**  
 another great VEE-D-X  
*Single Channel*  
 sensation

AND ONLY  
**\$1995**  
 LIST

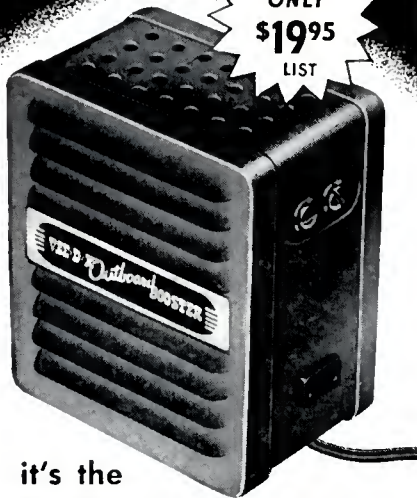

it's the

**VEE-D-X**  
*Outboard*  
**BOOSTER**

Here is the greatest development to improved single channel TV reception since the VEE-D-X "J" Series Yagi. Pre-set for any desired channel, the VEE-D-X Outboard costs much less than any tuned booster, yet delivers 18 db gain with full 5 megacycle band width. Individual slug tuned grid and plate coils assure perfect alignment — 6J6 push-pull cross-neutralized amplifier will not oscillate — unique RF assembly is compact and precision engineered — plus many more outstanding features that revolutionize single channel reception. For complete information contact your local supply source or write direct to The LaPointe-Plascomold Corporation, Windsor Locks, Connecticut.

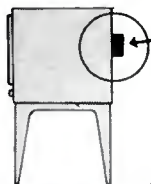

**OUT OF SIGHT!  
 OUT OF THE WAY!**

Fits snugly against back panel of any TV set. No wires, no knobs exposed to TV viewers.

**INSTALL IT!—FORGET IT!**

Bothersome tuning completely eliminated. Turns on and off with set automatically.



**Magnavox Sales Meeting in St. Paul Dealer's Store**



The key features of Magnavox television were the subject of a sales promotion meeting at McGowan's Grand Avenue music store in St. Paul, Minn., with Jack Sharpless, Magnavox district sales manager, telling the story. Standing (l to r): John S. Markoe, Robert F. Smith, Arvid Edblom, Donald Davis, John Vokoun, Sharpless. Seated: W. R. Graves, store manager, and John D. McGowan, president.

**GE's Travelling Service Display in Toledo, Ohio**



Here is General Electric's "travelling" service store as it appeared at the two-day "trade show" sponsored recently by the Warren Radio Company of Toledo, Ohio. The display, operated by GE's Tube Divisions, Receiver Division, and Commercial Equipment Division, is complete with three work benches, exhaust fans, and fluorescent lighting.

**Sprague Electric Celebrates 25th Anniversary**



Marking the 25th anniversary of the founding of the Sprague Electric Company, North Adams, Mass., Robert C. Sprague, president of the company and chairman of the board of the Radio Television Manufacturers' Association cuts the cake presented to him by employees. The first slice goes to the third generation, Robert C. Sprague III, while father Robert C. Sprague, Jr., steadies his son's hand. Participating in the ceremonies are vice-president Julian K. Sprague (second from left) and Miss Mollie Avery, now assistant secretary of the company, and its first employe when the business was founded in Quincy, Mass. a quarter of a century ago.

# Home Trials

(Continued from page 31)

stallation has been made. This is a very important point *since it promises the prospect some "extra" after the sale has been made.* Also, the outdoor antenna system, where needed, will bring in the weaker signals better. In connection with on-trial selling in multi-station areas, accurate statements about "poor" reception from certain hard-to-get stations should be made. It's much easier to tell a prospect right at the start that he can't expect to receive a good picture on station so-and-so than it is to soft-pedal the situation, and run into a lot of trouble later on.

On-trial selling of TV sets requires strict attention to every minute detail of the transaction from inception to sales closing time. There are many pitfalls in the home-trial method which can be avoided by adherence to a pattern designed for profitable operation.

## New Raytheon Warranty

A new register six-month picture tube warranty, which eliminates code dating and cuts down dealer and distributor "paper work," has been announced by the Replacement Tube Department of the Raytheon Manufacturing Company. Under this newly established picture tube warranty, which became effective June 1, Raytheon picture tubes are guaranteed for six months' service from time of purchase by the customer.

## Commercial Credit Corp. Opens New Office

Commercial Credit Corp. has opened a new office at Mt. Vernon, Illinois, located at 1116 Main St. F. P. Rohlman is manager and R. P. Gehring, assistant manager.

## Vee-D-X Elects Two

Jerome E. Respass, Vee-D-X president, announces the election of Henry G. Booker and John M. Berkowitz to the board of directors of The La-Pointe-Plascomold Corporation. These two men, Respass stated, have already proved invaluable as advisers to the company.

## New Sylvania Distributor

Sylvania Electric Products, Inc., announces the appointment of Spiller's, Kennebunk, Maine, as sole distributors of Sylvania television and radio sets in the southern Maine area. Spiller's franchised area is covered regularly by three salesmen: G. Hollis Truscott, southern Maine area; L. Pitt Warren, central Maine area; and Clarence Kilton, northern Maine area.

more and more it's...

# PHILHARMONIC

a **CLOCK-RADIO** worthy of the name

**DEALERS-DISTRIBUTORS** are invited to inquire about available territories

Suggested list starts at

**\$26<sup>95</sup>**

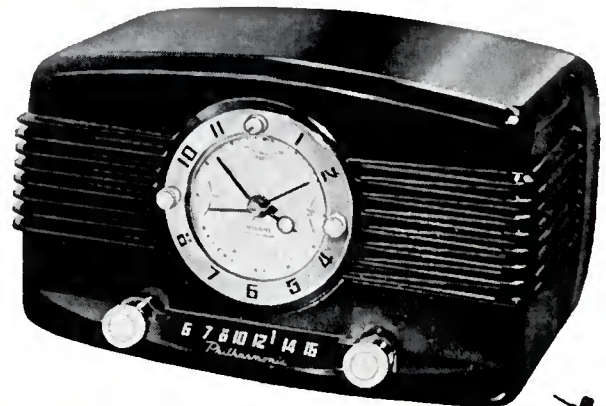

Philharmonic Radio and Television Corp.

General Offices and Plant: New Brunswick, N. J.

# Superior's *new* TELEVISION BAR GENERATOR



**THROWS AN ACTUAL BAR PATTERN ON ANY TV RECEIVER SCREEN!!**

**TWO SIMPLE STEPS**

1. Connect Bar Generator to Antenna Post of Any TV Receiver.

2. Plug Line Cord into A.C. Outlet and Throw Switch.

**RESULTS**—A stable never-shifting vertical or horizontal pattern projected on the screen of the TV receiver under test.

**AT YOUR RADIO PARTS JOBBER**

**DEALERS NET PRICE**

only **39<sup>95</sup>**



Manufactured and Guaranteed by  
**SUPERIOR INSTRUMENTS CO.**  
227 Fulton Street • New York 7, N. Y.

## New Hotpoint Warehouse

Hotpoint, Inc., announced that it has leased approximately 50,000 sq. ft. of warehouse space at 12100 S. Peoria St., Chicago, near its Chicago Heights manufacturing facilities. Production of commercial electric cooking equipment is to be expanded to meet orders related to the nation's defense activity.

## RCA Tube Campaign



"Serving the Community", theme of the new RCA tube promotional campaign, is expressed in six-color three dimensional window display. The retail dealer is shown with his co-workers in community welfare.

## To Distribute Arvin

Appointment of the Peoria Electric Appliance Company, 631 Franklin St., Peoria, Ill., as an exclusive Arvin television and radio distributor in that city and surrounding towns, has been announced by Raymond P. Spellman, sales manager of the television and radio division of Arvin Industries, Inc.

## Aerovox Acquires Wilkor

Aerovox Corporation of New Bedford, Mass., has announced through its president, W. Myron Owen, its acquisition of Wilkor Products, Inc., of Cleveland, Ohio. The latter company manufactures precision resistors. For the first time the company is entering the radio-electronic parts jobbing trade, with sales to be handled by the Distributor Division of Aerovox.

## Mitchell Distributors

E. A. Tracey, vice-president of the air-conditioning division of the Mitchell Mfg. Co., Chicago, has announced the appointment of several new distributors: F. M. Connelly, 905 N. W. 12th St., Portland, Ore.; F. B. Connelly, 1015 Republican St., Seattle, Wash.; Prudential Distributors, Inc., South 151 Stevens St., Spokane, Wash.; and Glenn Earl, Inc., 245 South First West, Salt Lake City, Utah.

## Crosley Names Conley

W. A. Blee, vice-president and general sales manager of the Crosley Division of Avco Mfg. Corp., announced the appointment of W. C. Conley, Jr., as vice-president and manager of branches of the Crosley Distributing Corp., which is a fully-owned subsidiary of the Crosley Division of Avco Mfg. Corp.

## Win W-G Recordette



Mr. and Mrs. Nelson Mammel, of Warren, Michigan, winners of the nationwide "What Welcome Travelers Means To Me" contest, are awarded a Wilcox-Gay Recordette-3 during festivities over the coast-to-coast NBC "Welcome Travelers" broadcast at the Hotel Sherman in Chicago.

## HOFFMAN RADIO CORP.

*of California*



announces the showing of the new Hoffman Easy-Vision Television

the Palmer House  
Rooms 681-683

Music Industry Trade Show  
July 16th-19th

**Tight Copper Supply Seen Through 1952**  
Defense Plant Drain, Slow Scrap Return Cited as Reasons

**Free Market Steel Supply May Drop 25%**  
Iron Age Reports Only 2 Million Tons May Be Available to Trade

**TODAY'S HEADLINES FORECAST TOMORROW'S Sales HEADACHES**  
*Shortages Predicted...Buy Phoenix Now!*

Producers Instructed To Set Aside Increased Percentages Of Steel

**DON'T GET CAUGHT!**

In 9 out of 10 cases, the present overloaded inventories won't last more than a few weeks when Fall business booms! Smart jobbers and dealers are preparing now to lick the coming squeeze on materials. Protect yourself by ordering today...and don't get caught!

TO DO BUSINESS TOMORROW, ORDER PHOENIX Speed-Tennas AND Speed-Mounts TODAY!

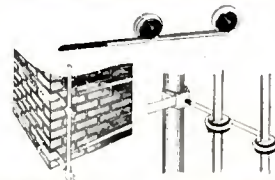

**PHOENIX ELECTRONICS, Inc.** LAWRENCE MASS.

## FOR HIGH EFFICIENCY SOUND REPRODUCTION



MODEL VH-91



MODEL VH-15



MODEL VH-20



MODEL VH-24

# Jensen

*Hypex*

## PROJECTORS

Jensen Hypex Projectors for indoor and outdoor PA and sound reinforcement are highly efficient, sturdy, weather-proof, corrosion resistant loudspeakers with many exclusive advanced features. For example, the Hypex (hyperbolic exponential) flare formula—patent 2,338,262—provides the most effective acoustic loading right down to 1. f. cut-off. Special plastic diaphragm driver unit gives powerful reproduction with a "punch"—yet free from unpleasant harshness. And soundly engineered adjustable mounting facilities make installation a pleasure.

**JENSEN MANUFACTURING COMPANY**  
Division of The Muter Company  
6601 S. Laramie Ave., Chicago 38, Illinois  
Phone: POrtsmouth 7-7600.

### McMurdo Silver Award



Above (left to right), Dr. Burton Browne, Burton Browne Advertising, Dick Graver, vice-president in charge of sales for the Admiral Corp., and Bill Halligan, president of Hallcrafters Co. Occasion: Silver-Marshall Alumni Association awards Graver the first annual McMurdo Silver Memorial Award for the outstanding merchandising job in the electronics industry during 1950.

### New CBS-Columbia Set



Left to right, R. D. Payne, sales manager; I. Melman, development engineer, and D. H. Cogan, president of CBS-Columbia, Inc. (formerly Air King) are shown at the demonstration of the new "Colorvision" color TV receiver.

### Show Westinghouse UHF Set and Converter

A TV set equipped with a new tuner capable of receiving all UHF channel telecasts in addition to the standard VHF was demonstrated at Bridgeport, Conn., by the Westinghouse Television-Radio Division. J. F. Walsh, Division sales manager, also demonstrated a new UHF converter to make possible reception of this service on standard Westinghouse TV models.

Both the installed tuner and the converter were used to receive signals from the experimental ultra-high frequency station KC2XAK near Bridgeport for comparison with signals transmitted directly from New York on standard channels.

### New Eicor Sales Aid

Eicor, Inc., 1501 W. Congress St., Chicago, has a booklet valuable to dealers as an aid in the selling of tape recorders. It lists 12 common uses for recorders with a picture and description of each. Also covered is the Eicor tape recorder model 115.

# FREE!



## New 3<sup>rd</sup> Edition SPRAGUE TV CAPACITOR REPLACEMENT MANUAL

Here—just off press—is the new Sprague Manual that tells you in a jiffy just what capacitor to use on practically any television replacement job. Includes complete electrolytic capacitor replacement data on 964 TV receivers—saves you time, paves the way to better work on practically every job!

### GET YOURS... TODAY!

Ask your Sprague distributor for a FREE copy of this new Manual M-473. Or, write your name on the attached coupon and enclose 10c to cover handling and mailing and we will rush your copy directly to you!

Mail to:

**SPRAGUE PRODUCTS COMPANY**  
65 Marshall Street, North Adams, Mass.  
Enclosed is 10 cents for your M-473 TV Manual.

Name \_\_\_\_\_

Street \_\_\_\_\_

City \_\_\_\_\_ Zone \_\_\_\_\_

State \_\_\_\_\_

## Raytheon Names Hobby



Jack L. Hobby, above, was recently appointed as assistant on public relations on the staff of the president, Charles F. Adams, of the Raytheon Manufacturing Company, Waltham, Mass.

## Rauland Offers Prizes

Rauland Corporation, Chicago, has initiated a new prize incentive promotion to help boost the sale of TV picture tubes at the radio serviceman level. Each Rauland TV picture tube will contain a warranty card containing three copies. When the dealer returns his copy of this warranty to Rauland, he is entitled to from \$1.50 to \$4.50 in prize merchandise.

## Westinghouse Executives

Gwilym A. Price, president of the Westinghouse Electric Corp., has announced the election of two executives to new positions: E. W. Ritter, manager of the company's new Electronic Tube Division, has been named a vice-president, and E. V. Huggins has been elected to the newly created position of executive vice-president of the Westinghouse Electric International Company. Also announced was the retirement of William G. Marshall, who had been vice-president in charge of industrial relations at Westinghouse for 17 years.

## Name Belden Executive

R. A. Mattson, credit manager of the Belden Mfg. Co., Chicago, has been elected to the board of directors of the Chicago Association of Credit Men for a term of three years.

## Majestic TV Award



Kate Smith accepts the "Mighty Monarch of the Air Television Award" from Leonard Ashbach, president of Majestic Radio & Television, in an impressive ceremony on her NBC-TV network show. Each month, the "Mighty Monarch of the Air" Awards Committee, headed by Harry Hershfield, noted writer-humorist, polls TV editors from coast to coast to determine the outstanding TV performer for the month.

## Zenith Phonevision Test

Bills for the motion pictures seen by the 300 test families during Zenith's 90-day test of Phonevision are 99.2% paid, it was announced by Commander E. F. McDonald, Jr., president. The entire sum of \$6,694. paid in by Phonevision subscribers was presented by Zenith to Henrotin Hospital in Chicago.

## Workshop Representative

K. W. Brock, commercial sales manager of The Workshop Associates, Division of The Gabriel Company, announced the appointment of Felix Simon to represent the Workshop line of antennas and accessories in Colorado, Utah, Wyoming, eastern Montana, and eastern Idaho.

### New TRAV-ELECTRIC Model

**STURDY  
MINIATURE  
CONVERTER**  
2 1/2" x 2 1/2" x 3 1/2"  
60 CYCLE AC.  
40 WATTS  
110 VOLTS

Just  
plug into  
**CIGAR  
LIGHTER**

Model  
6-1160

operates  
**Radios, Shavers**

**Turn-  
Tables  
Small  
Dictating  
Machines**  
etc.

**\$15.95**  
List Price

 <b>IN BOATS</b>	 <b>IN THE CAR-IN THE TRUCK</b>
 <b>AT PICNICS-OUTINGS</b>	 <b>ELECTRIC SHAVER</b>
 <b>PORTABLE PHONOGRAPH</b>	 <b>Dictating Machine</b>

Terado Company-1068 Raymond, St. Paul 8, Minn.

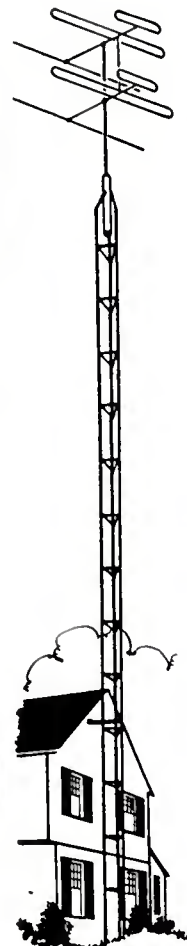

DO IT RIGHT THE FIRST TIME  
... AT ONE LOW COST

Save money . . . eliminate call-backs  
. . . get higher elevation . . . and  
better reception . . . by using the new

## TRIPOD-TYPE, SELF-SUPPORTING STEEL TOWERS

Solve the problem once and for all by bracketing a TRIPOD tower to the side of house, garage, barn, silo, etc., and get rid of the guy wire nuisance for good. These towers have withstood gales of 80 MPH.

You can easily see why these towers are far superior. Lower sections are built of large size, extra heavy material to assure longer life and safety. The top sections are heavy gauge, but material is of smaller diameter, reducing wind resistance. A 50' tower has a center of gravity only 17' from the ground and will support many stacked arrays and accessories.

No holes and bolts to be lined up. Sections slide together and lock in position by setscrew. Finished in high quality hard enamel paint, baked in an infra-red oven.

For extremely low  
factory-to-dealer prices  
and further details, write

**STEEL TOWER DIVISION  
Chicago Stoker Corporation**

4711 W. North Ave., Chicago 39, Ill.  
Telephone CApitol 7-2000





**P  
M  
A**

is  
for  
you

**Booths 71 & 72**

## CLOSING DATES FOR

**RADIO-TELEVISION  
RETAILING**

**5th** of preceding month for all ads requiring proofs, composition, foundry work, key changes, etc.

**10th** of preceding month for complete plates only—no setting

**1st** of month—Publication Date.

Cancellations not accepted after 5th of preceding month..

**Caldwell-Clements, Inc.**  
480 LEXINGTON AVENUE  
NEW YORK 17

## INDEX TO ADVERTISERS

JULY, 1951

Admiral Corp. ....	75
Air King Products Co., Inc. ....	Cover 2
American Television & Radio Co. ....	103
Anchor Radio Corp. ....	Cover 3
Astatic Corp. ....	61
Belden Mfg. Co. ....	2
Burgess Batteries ....	97
Caldwell-Clements, Inc. ....	103
Capehart-Farnsworth Corp. ....	6
Capitol Records ....	54
Chicago Stoker Corp. ....	102
Clear Beam Antennas ....	96
Color Sales Co. ....	104
Columbia Records ....	43
Commercial Credit Corp. ....	19
Crestwood Recorder Corp. ....	60
Crosley Div., Avco Mfg. Corp. ....	16, 17
Dean ....	96
DuMont Labs., Inc., Allen B. ....	8
Duotone Co., Inc. ....	52
Eicor, Inc. ....	57
Electrovox Co., Inc. ....	55
Emerson Radio & Phonograph Corp. ....	65
Eureka Television & Tube Corp. ....	85
General Electric Co. ....	7, 70
Heppner Mfg. Co. ....	104
Hoffman Radio Corp. ....	100
Hudson Electronics Corp. ....	47
Hytron Radio & Electronics Corp. ....	93
Jensen Industries, Inc. ....	56
Jensen Mfg. Co. ....	101
JFD Mfg. Co., Inc. ....	104
LaPointe-Plascomold Corp. ....	98
Magnavox Co. ....	3
Mattison Television & Radio Corp. ....	104
Mosley Electronics ....	90
Motorola, Inc. ....	12
Oxford Electric Corp. ....	51
Philco Corp. ....	5, 45
Philharmonic Radio & Television Corp. ....	99
Phoenix Electronics, Inc. ....	100
Phonograph Mfrs. Assoc., Inc. ....	103
Radiart Corp. ....	91
Radio Corp. of America ...	9, 21, 28, 29, Cover 4
Radion Corp. ....	95
Rauland Corp. ....	89
Rauland-Borg Corp. ....	94
Raytheon Mfg. Co. ....	76
Raytheon Television Corp. ....	66
Regency Div. of I.D.E.A. ....	10, 11
Revere Camera Co. ....	63
Rider Publisher, Inc., John F. ....	86
Simpson Mfg. Co., Inc. Mark. ....	58
Sprague Products Co. ....	101
Standard Register Co. ....	13
Steelman Phonograph & Radio Co., Inc. ....	59
Stewart-Warner Corp. ....	18
Stromberg-Carlson Co. ....	24
Sylvania Electric Products, Inc. ....	20
Superior Instruments Co. ....	99
Symphonic Radio & Electronic Corp. ....	50
Technical Appliance Corp. ....	14
Telechron Dept., General Electric Co. ....	73
Tele King Corp. ....	69
Tele-Matic ....	88
Telrex, Inc. ....	92
Terado Co. ....	102
Trio Mfg. Co. ....	22
Video Prods. Corp. ....	87
V-M Corp. ....	53
Waters Conley Co. ....	60
Webster-Chicago ....	4
Wilcox Gay Corp. ....	49
Westinghouse Electric Corp. ....	15
Zenith Radio Corp. ....	23

While every precaution is taken to insure accuracy, we cannot guarantee against the possibility of an occasional change or omission in the preparation of this index.



## "A" BATTERY ELIMINATORS

*Makes it easy  
to DEMONSTRATE  
AND TEST  
D.C. APPARATUS  
FROM A.C. LINES*



## for DEMONSTRATING AND TESTING AUTO RADIOS

New Models . . . Designed for testing D. C. Electrical Apparatus on Regular A. C. Lines. Equipped with Full-Wave Dry Disc Type Rectifier, Assuring Noise-less, Interference-Free Operation and Extreme Long Life and Reliability.

NEW MODELS NEW DESIGNS  
NEW LITERATURE

"A" Battery Eliminator, DC-AC Inverters  
Auto Radio Vibrators

See your jobber or write factory

**ATR**

**AMERICAN TELEVISION & RADIO CO.**

Quality Products Since 1931

SAINT PAUL 1, MINNESOTA-U. S. A.

# JFD TWIN LEAD LIGHTNING ARRESTER

Protects TV Sets Against Lightning and Static Charges

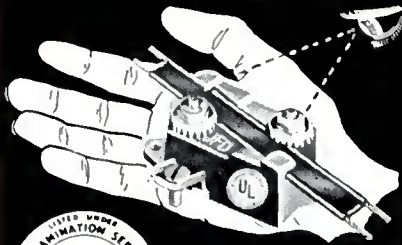

SEEING IS BELIEVING!

ONLY JFD Lightning Arresters offer you these exclusive patented features...

1. Patented strain-relief Retaining Lip which prevents pulling or straining against contact points.
2. You actually see positive contact made with lead-in wire.
3. Lead-in contact remains fully visible at all times.
4. No wire stripping. No Arrester Cover to Hide Poor Contacts!

No. AT105  
**\$7.25**  
List

For Regular Twin Lead

At Your Jobber or Write Direct



MANUFACTURING CO., Inc.  
6103G 14th AVENUE, BROOKLYN 4, N. Y.  
FIRST in Television Antennas and Accessories

BUY FROM  
**HEPPNER**  
THE LEADER

WORLD'S LARGEST  
PRODUCER OF ION TRAPS

NEW  
Universal  
ION TRAP

for  
Replacement  
use with 90%  
of the TV  
picture tubes

Features

- Clip varies magnetic strength
- Speeds up service work
- Eliminates multiple stocking
- Single magnet, snap-on type
- Competitively priced

If jobber doesn't stock, mail coupon



HEPPNER MFG. Co., Round Lake, Ill.

Send data and prices on ION TRAPS

Name .....

Address .....

City ..... State .....

## Burgess Battery Campaign

Colorful window streamers, counter and window display cards and envelope enclosures to tie the dealer in with a national advertising campaign are the center of attention for the 1951 Burgess Battery Company portable radio battery promotion. Dealers can obtain the promotional material without cost from their distributor or by writing direct to Burgess Battery Company, Freeport, Illinois.

## New Manuals, Catalogs, Pamphlets & Booklets

John F. Rider Publisher, Inc. announces that the Rider TV Vol. 7 will be available in July. This 12" x 15" book of 2,352 pages will cover TV sets from fall 1950 to summer 1951. It is priced at \$24.00. Rider also has an 8 page catalog listing all their service publications which is supplied free of charge on request.

The General Electric Co., Syracuse, N.Y. now has a Stylus and Cartridge Replacement Guide for dealers' use in maintaining GE magnetic phono heads and replacing styli correctly. It will be given away free by distributors.

Industrial Television, Inc., has published a technical bulletin "Multivision Antenna System" which describes a multiple antenna system suitable for fringe area installations both large and small, and even for community systems. Write to the company at 359 Lexington Ave., Clifton, N.J.

JFD Manufacturing Co., Inc., of Brooklyn announces the availability of a new brochure, no. 92, describing and illustrating two new types of all-channel television window antennas; the JFD conical model no. C119 and the JFD hi-lo model no. C120.

The Astatic Corp., Conneaut, Ohio has published a catalog which covers all its products for civilian markets. These products include TV and FM boosters, microphones, phono cartridges and arms, needles, recording heads, etc. Catalog will be mailed upon request to the sales department.

The Simpson Electric Co., now has available for prospective purchasers of test equipment a booklet illustrating their various products and giving the specifications and features of each. These include the Simpson Model 480 Genescope, for TV-FM servicing, a complete instrument which has both a scope and two oscillators built in, allowing alignment of sets with no other equipment. This booklet may be had from distributors or from the company at 5200 W. Kinzie St., Chicago 44.

Amphenol has a set of 13 pages 8 1/2" x 11" entitled "Informative Data for TV Installation & Servicemen" concerned with antenna characteristics and radiation patterns which is designed to aid TV installation and servicemen. The discussion goes into considerable detail and employs many diagrams. The set may be had by writing to the company, American Phenolic Corp., Chicago 50, Ill.

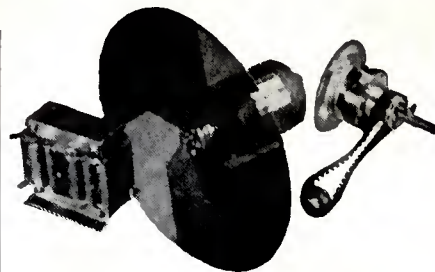

# COLOR CONVERTER-ADAPTER KITS

Convert TV set to receive CBS Color

Kit Includes:  
• MOTOR DRIVE • COLOR WHEEL  
• AUTOMATIC MOTOR SYNCH.  
Complete instructions for converting 630 TS receiver.

Write today for complete data  
COLOR SALES CO.  
295 West Shore Drive, Massapequa, Long Island

# MATTISON

630 CHASSIS WITH

• TUNEABLE •

BUILT-IN BOOSTER!

ONLY THE MATTISON 630 CHASSIS HAS AN ALL CHANNEL TUNEABLE BUILT-IN BOOSTER THAT INCREASES SIGNAL STRENGTH UP TO 10 TIMES. THIS CHASSIS WILL OUT-PERFORM ANY CHASSIS MADE. IT IS AVAILABLE AS A SEPARATE UNIT OR IN THE COMPLETE MATTISON CUSTOM-BUILT LINE OF TELEVISION RECEIVERS.



Manufactured with integrity

See it in operation at your local radio parts distributor or write to

Mattison Television & Radio Corp.  
893 Broadway, New York 3, N. Y.

# PERFORMANCE IS WHAT COUNTS!

## ANCHOR'S

superiority of performance  
*remains unchallenged!*



### THE ANCHOR *Suburbanite*

Single-Stage Booster—for low signal areas in or near cities. Assures consistently good reception up to 75 miles.

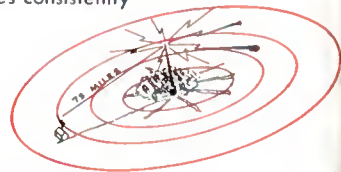

### THE ANCHOR *Granger*

Two-Stage Booster—recommended for distant rural areas. Assures consistently good reception for over 100 miles.

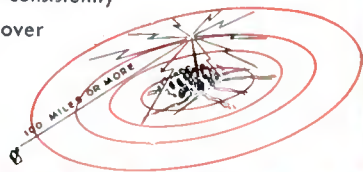

Despite critical material shortages, Anchor not only is offering the same high quality standards so widely hailed by the TV set industry, itself, but it is still making as many boosters as a year ago. To meet the current unprecedented demand, however, Anchor would have to expand, which is naturally not possible now! Therefore they have had to institute a very strict allocating system. No preference on deliveries to anyone has been or ever will be practiced.

When a booster is needed to complete a perfect installation, Anchor's outstanding performance under all conditions has made it the first choice of those who buy and sell. So always buy the *best*—first!



ANCHOR ENGINEERING ALWAYS A YEAR AHEAD!

## ANCHOR RADIO CORP.

2215 SOUTH ST. LOUIS AVENUE • CHICAGO 23, ILLINOIS

THE QUALITY OF RCA TUBES IS UNQUESTIONED



4,500,000



1946

1952

Best Sellers!

*Life expectancy... plus!*

RCA kinescopes incorporate  
the experience of the  
oldest mass-producer of  
picture tubes in the industry



It is a well-established fact that more RCA kinescopes are now in active service than any other brand . . . over 4½ million since the advent of commercial television, when RCA pioneered the first large-scale production of kinescopes.

Significantly, many RCA kinescopes installed *four and five years ago* are still giving good performance today, providing continuous reliable service year after year. Yes, RCA picture tubes of all types have consistently given outstanding performance.

RCA's kinescope quality means substantial savings to dealers and servicemen, in fewer call-backs and "out-of-pocket" replacements. In the long run, it amounts simply to this . . . stocking RCA picture tubes is good business . . . as any long-term user of RCA kinescopes will tell you.

Your local RCA Tube Distributor carries a complete line of RCA picture tubes. See him the next time you buy kinescopes for replacement.

*Keep informed . . . keep in touch with your RCA Tube Distributor*



**RADIO CORPORATION of AMERICA**  
ELECTRON TUBES

HARRISON, N. J.