

# ELECTRONIC TECHNICIAN

Now Including  
**SERVICE**  
Magazine

A J D  
94 SLEEPING GIANT DR  
HAMDEN 18 CONN  
TNS-59N A1 7E458



**CLOSED  
CIRCUIT  
TV**

50¢

November • 1958

# HOW TO BUILD BUSINESS

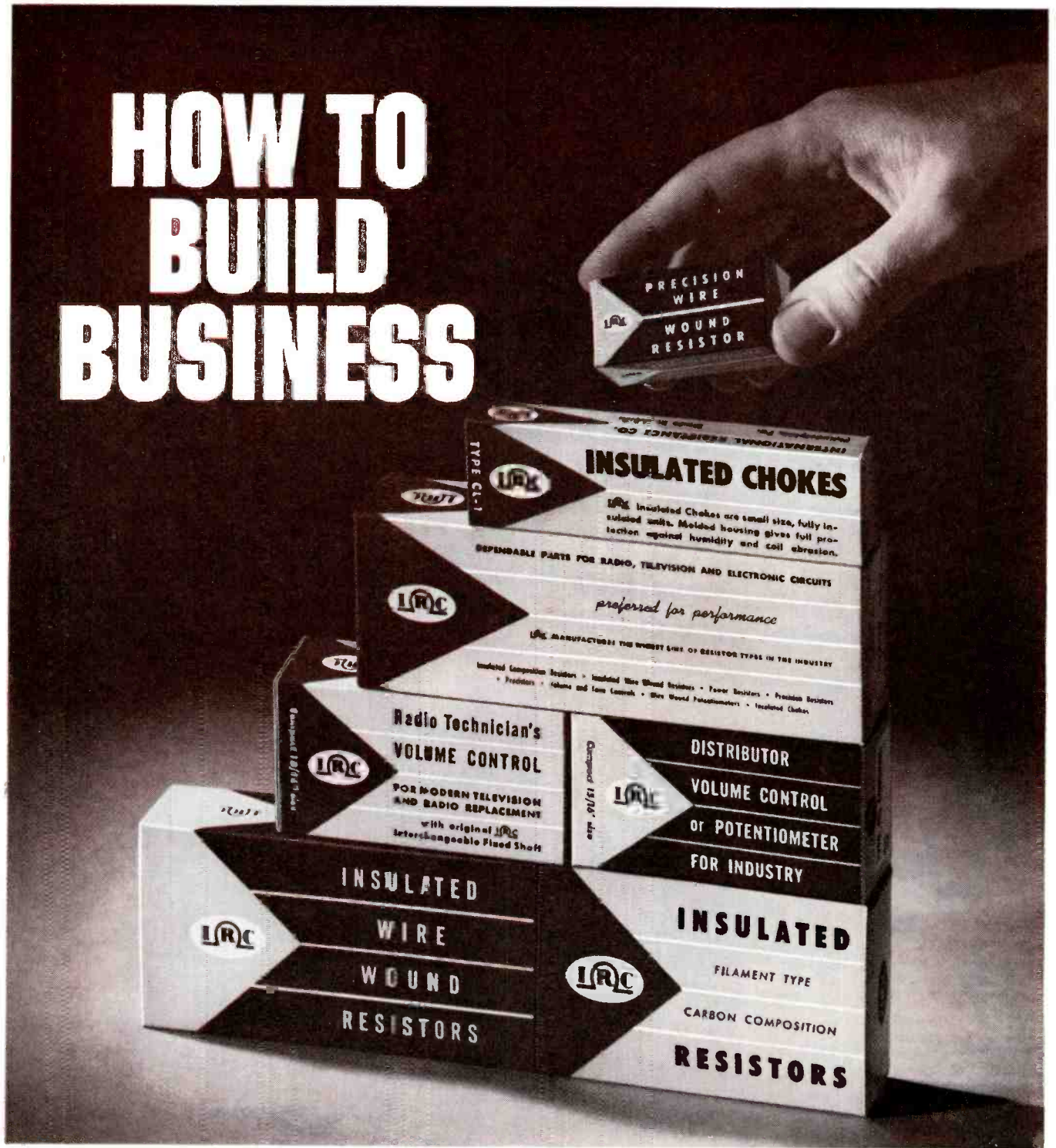

Your service business is a lot of things—promptness, know-how, speed, attitude, personality, reliability. It isn't easy to achieve and you can't do it overnight but you *can* build it more easily, quickly, and solidly by using IRC replacement parts. IRC stands for quality without question, proved in thousands of critical circuits.

Ask yourself how many times you've had to waste time returning defective parts to your distributor and you'll switch to and stick to IRC.



# ELECTRONIC TECHNICIAN

Now Including  
**SERVICE**  
Magazine

TELEVISION • ELECTRONIC • RADIO • INDUSTRIAL AUDIO

ALBERT J. FORMAN *Editor*  
ROBERT CORNELL *Technical Editor*  
B. V. SPINETTA *Assistant Editor*  
C. F. DREYER *Consultant Art Director*  
PAT DRUMM *Editorial Assistant*

Address all mail to  
480 Lexington Ave., New York 17, N. Y.  
Telephone YUkon 6-4242

HOWARD A. REED *Publisher*  
BRYAN S. DAVIS *Publishing Consultant*

## BUSINESS DEPARTMENT

W. ZURKAN *Eastern Sales Manager*  
N. McALLISTER *Production Manager*  
I. HUTCHINS *Accounting Supervisor*  
M. RUBIN *Circulation Manager*  
P. H. DEMPERS *Regional Manager*

5010 Howard St., Skokie, Ill.  
Telephone ORchard 5-1355

CHRIS DUNKLE & ASSOCIATES  
California Representative  
740 S. Western Ave., Los Angeles 5, Calif.  
Telephone DUnkirk 7-6149

420 Market St., San Francisco 11, Calif.  
Telephone SUtter 1-8854

BERNIE EDSTROM *Regional Manager*  
2169 Eldred Ave., Cleveland 7, Ohio  
Telephone LAkewood 1-7900



ELECTRONIC TECHNICIAN & Circuit Digests, including Service, November, 1958. Vol. 68, No. 5. \$5.00 a copy. Published monthly by Electronic Technician, Inc. Publication office, Emmett St., Bristol, Conn. Editorial, advertising and executive offices, 480 Lexington Avenue, New York 17. Telephone YUkon 6-4242.

Entered as second class matter at the Post Office at Bristol, Conn., June 10, 1954. Subscription rates: United States and Canada, \$4.00 for one year; \$6.00 for two years; \$8.00 for three years. Pan-American and foreign countries: \$7.00 for one year; \$10.00 for two years; \$14.00 for three years. Copyright 1958 by Electronic Technician, Inc., New York. H. Reed, President; A. Forman, Executive Vice-President. Title registered in U. S. Patent Office. Reproduction or reprinting prohibited except by written authorization of publisher. Printed in U.S.A. by Hildreth Press.

November, 1958

**FRONT COVER** Improving factory production is just one of the many industrial uses of closed-circuit TV. This non-broadcast application of TV covers banks, stores, prisons, plant security systems and many other places . . . all opening new opportunities for electronic service technicians. See article starting on page 32.

## FEATURES and ARTICLES

<i>Fighting Mad over Captive Service (Editorial)</i> . . . . .	29
<i>"Tuning in the Picture"</i> . . . . .	30
<i>Understanding Industrial Closed-Circuit TV Systems</i> . . . . . E. M. Noll	32
<i>"Tough Dog" Corner</i> . . . . . Paul Boller, D. E. Tucker	35
<i>Troubleshooting Non-Linear Waveforms in Oscilloscopes</i> . . . . . R. G. Middleton	36
<i>Detecting Pulsed Damaged Components in TV Receivers</i> . . . . . Allan Kinckiner	38
<i>Shop Hints</i> . . . . . M. G. Goldberg, C. R. Williams	40
<i>Hi-Fi Product Rating Organizations</i> . . . . . A. J. Farman	41
<i>Building a Technical Library</i> . . . . .	42
<i>Free Literature</i> . . . . .	45
<i>New Products for Technicians</i> . . . . .	54
<i>Latest Test Equipment</i> . . . . .	58
<i>New Products</i> . . . . .	62
<i>New Standards Capacitance</i> . . . . .	74
<i>What's New About Stereo?</i> . . . . . Norman Crowhurst	77
<i>New Audio Products</i> . . . . .	78
<i>Do You Want a Partner?</i> . . . . . E. W. Fair	89
<i>Self-Service Tube Merchandiser</i> . . . . .	94

## DEPARTMENTS

Editor's Memo . . . . .	8	Audio News Letter . . . . .	26
Letters to the Editor . . . . .	12	Calendar of Coming Events . . . . .	31
News of the Industry . . . . .	18	New Books . . . . .	72
Reps. & Dists. . . . .	26	Association News . . . . .	82
Catalogs & Bulletins . . . . .	86		

## CIRCUIT DIGESTS . . . . . 97

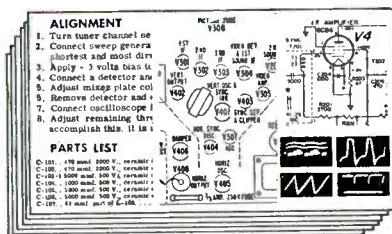

Mr. TV-Radio Service Dealer: MEET THE CHALLENGE

with this **REVOLUTIONARY,**

**RAYTHEON**

**TUBE**

**MART**



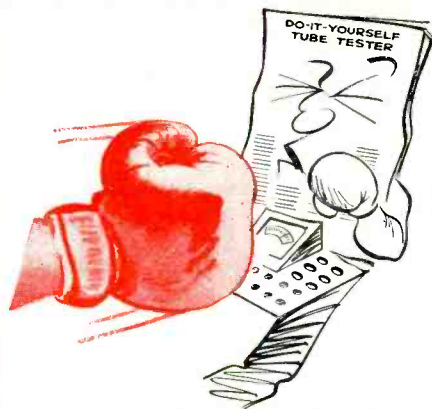

## of the Corner Store Tube Tester

# NEW, PROFIT-MAKING

The new RAYTHEON TUBE MART puts the profits where they belong – in the pockets of Service Dealers like yourself....

As a RAYTHEON TUBE MART AGENT *you* gain:



**TOP PROFITS FROM TUBE SALES**



**CREDIT FOR HELPING SET OWNERS**



**EXTRA SERVICE BUSINESS**



**NEIGHBORHOOD ADVERTISING**

Here's all you do. Place these handsome Raytheon Tube Marts in your neighborhood stores. Keep them stocked and earn a continuous flow of profits. You'll increase your servicing business, too, because each Tube Mart holds your imprinted leaflets — that direct customers to you for TV-Radio service.

It's easy to place Raytheon Tube Marts in profitable locations because you offer the shop owners a new source of extra profit.

For the complete story on how to become the money-making Raytheon Tube Mart Agent in your neighborhood, call your Raytheon Tube Distributor today.



*Excellence in Electronics*

### DISTRIBUTOR PRODUCTS DIVISION RAYTHEON MANUFACTURING COMPANY

Newton 58, Mass., 55 Chapel Street • Chicago, Ill., 9501 Grand Ave. (Franklin Park)  
Atlanta 6, Ga., 1202 Zonolite Rd. N.E. • Los Angeles 16, Calif., 5057 W. Washington Blvd.



# **CHANNEL MASTER**

## **Sells Antenna**

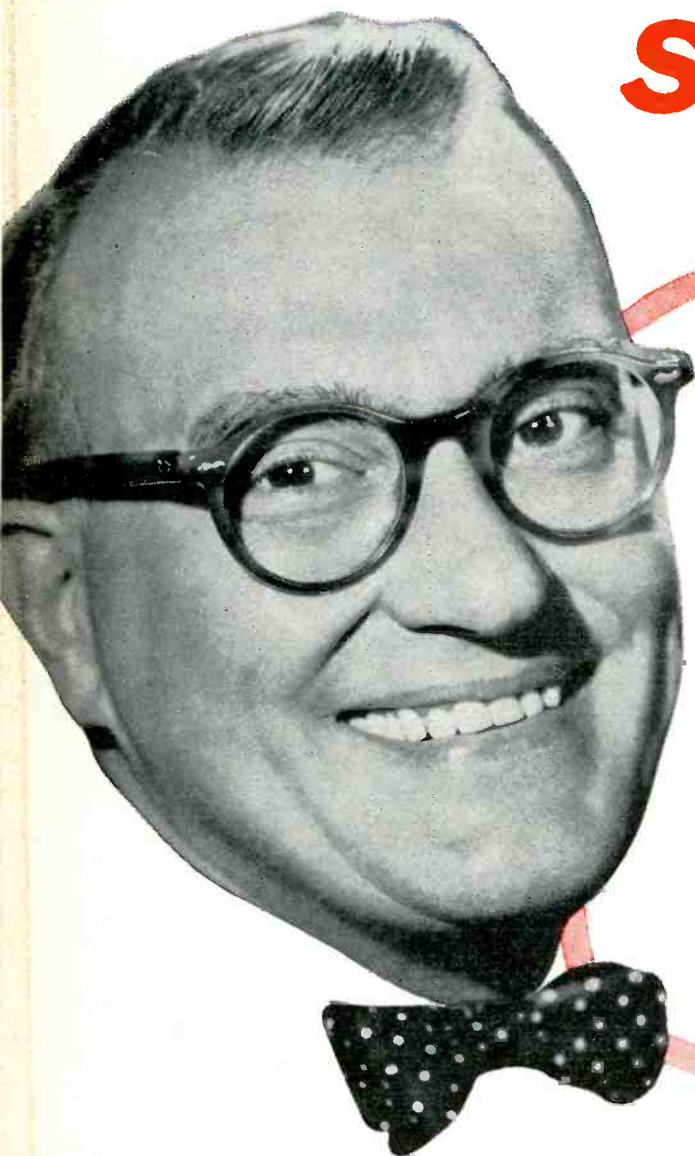

**Dave  
Garroway**

TEAMS UP WITH THE

**T-W**

ON NETWORK TV

**One of America's  
most persuasive  
TV personalities  
is now telling his  
tremendous audience—  
from coast to coast—  
all about the world's most  
powerful television antenna**

on the **"TODAY"** show  
over the entire **NBC-TV** Network

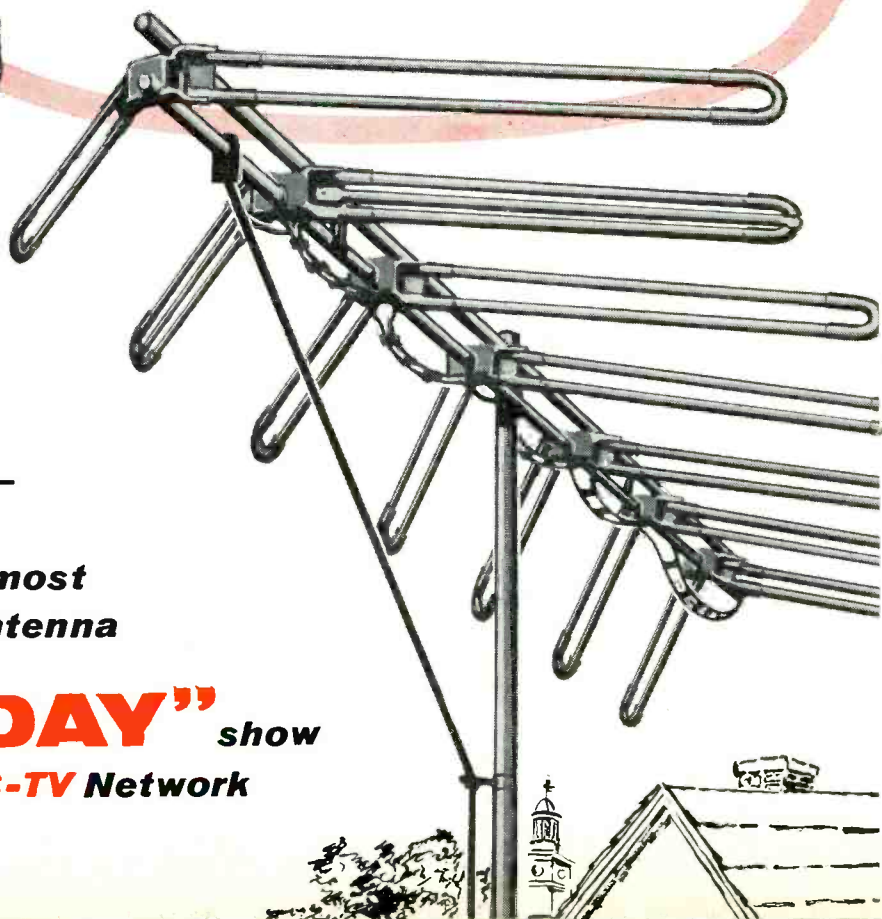

# AD BLITZ

## Replacements

New  
**CHANNEL MASTER Campaign**  
in America's Largest  
Circulation Magazines...

Puts new **LIFE** into your antenna business

**POSTS** your customers on the need  
for antenna replacements

Gives set owners a **LOOK** at better  
reception with the T-W antenna

**GUIDES** prospects to your door  
for an antenna check-up

Helps you **FARM** fertile new  
fields of antenna profits

and now

## **CHANNEL MASTER** TRANSISTOR RADIOS

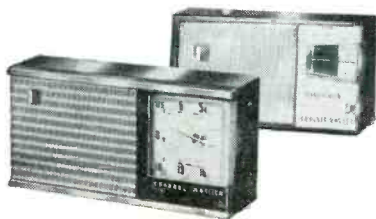

America's #1  
RADIO Value



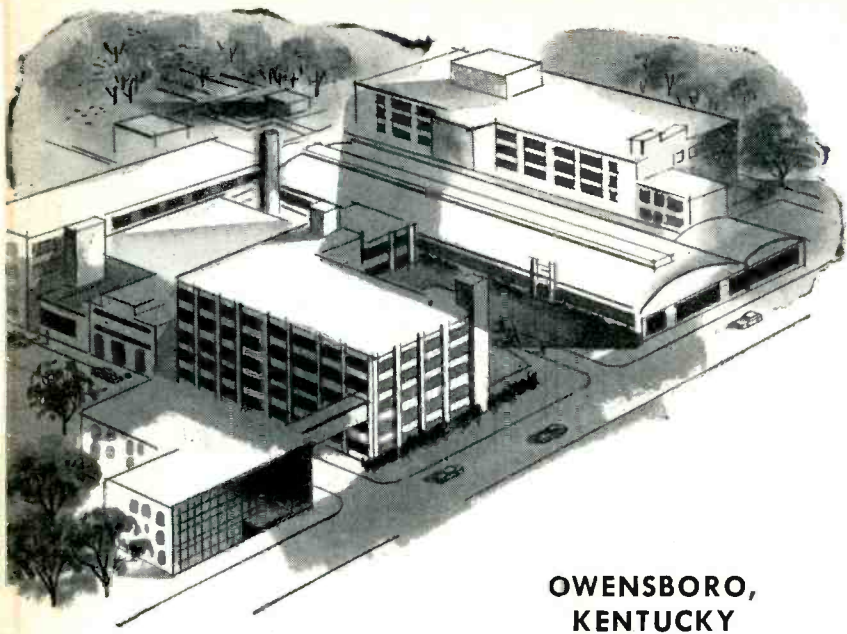

OWENSBORO,  
KENTUCKY

# BROAD NEW CUTS

## FIRST IN TUBE MANUFACTURING FACILITIES!

General Electric's four large and ultra-modern receiving-tube plants back up your replacement sales with a product that is uniform in high quality.

Pace-setting General Electric tube research and design go hand in hand with manufacturing and test facilities that are the most advanced in the industry.

"Snow White" cleanliness is found throughout. Lint-free workers' garments; filtered and conditioned air; floors cleaned many times daily—these help to make G-E Service-Designed Tubes the best, most dependable you can install.

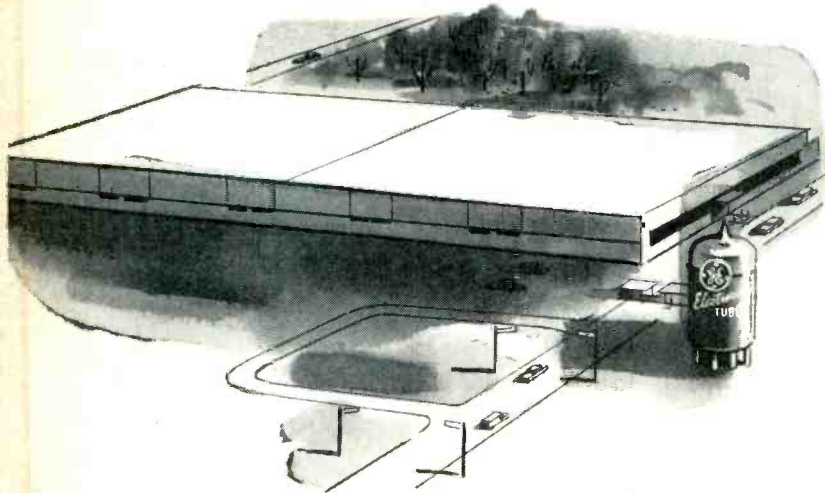

ANNISTON, ALABAMA

TELL CITY, INDIANA

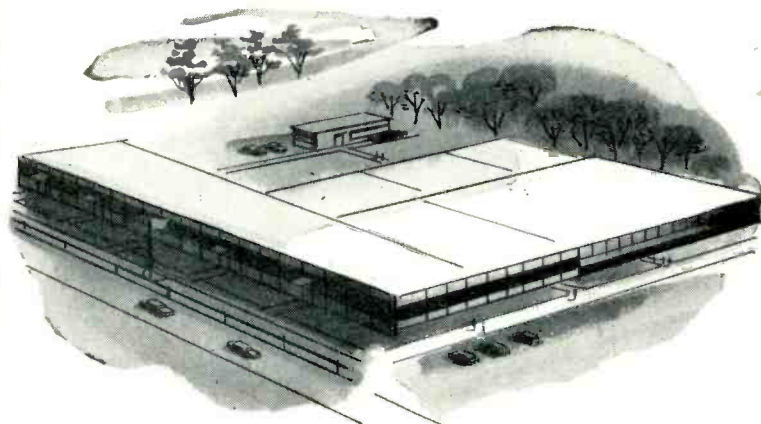
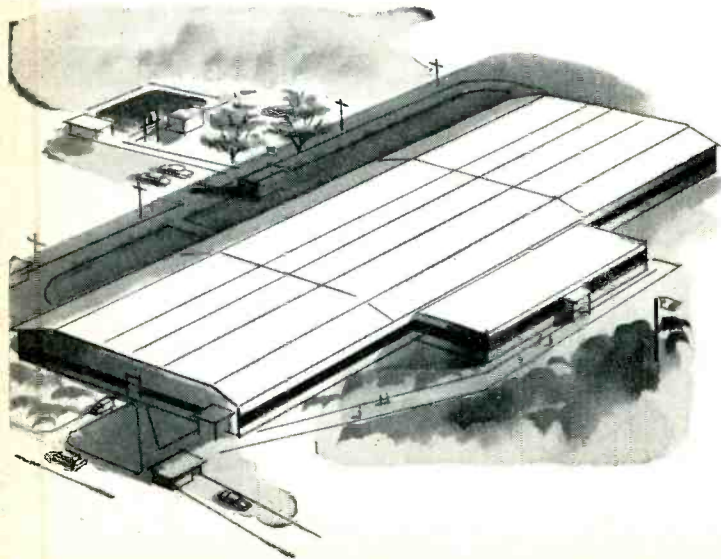



# **G-E SERVICE-DESIGNED TUBE PROGRAM YOUR CALLBACK TIME AND COSTS!**

Over 1000 design, manufacturing, and test improvements add to the reliability of 70 General Electric types!

So that you will have fewer complaints and callbacks—so that your customers can enjoy still finer set performance—General Electric has increased the number of Service-Designed Tubes to 70. More than 1000 improvements have been made in these 70 G-E types. Their quality is outstanding. They are the most reliable tubes you can install in television receivers, regardless of make.

Yet they cost no more! They're completely interchangeable with other tubes. For no extra investment you can have their benefits—less complaint calls, your working time saved for profitable repair jobs, pleased customers. Check the list below! Then phone your G-E tube distributor! *Distributor Sales, Electronic Components Division, General Electric Company, Owensboro, Kentucky.*

\*

\*

\*

The needs of both today's and tomorrow's TV sets are met by these  
70 G-E Service-Designed Tubes. They outperform all others!

1B3-GT	3CB6	5EU8	6AU6-A	6CD6-GA	6EU8	12AT7
1H2	3DT6	5U4-GB	6AX4-GT	6CG7	6EW6	12AU7-A
1J3	4BN6	5U8	6BK7-B	6CG8-A	6J6	12AX4-GTA
1K3	4BU8	5V3/5AU4	6BN6	6CL8-A	6SN7-GTB	12BY7-A
1X2-B	4BZ6	5Y3-GT	6BQ6-GA	6CX8	6T8-A	12BQ6-GA
2AF4-A	5AQ5	6AF4	6BQ7-A	6CY5	6U8-A	12DQ6-A
2CY5	5BK7-A	6AF4-A	6BU8	6DN7	6V6-GT	12SN7-GTA
3BN6	5CG8	6AL5	6BZ6	6DQ6-A	7EY6	17AX4-GT
3BU8	5CL8-A	6AQ5-A	6BZ7	6DT6	8CG7	17DQ6-A
3BZ6	5EA8	6AU4-GTA	6CB6-A	6E:A8	8CX8	19AU4-GTA

*Progress Is Our Most Important Product*

**GENERAL**  **ELECTRIC**

# Focus on Profits

with  
**Centralab**  
**Model B**  
**Controls**

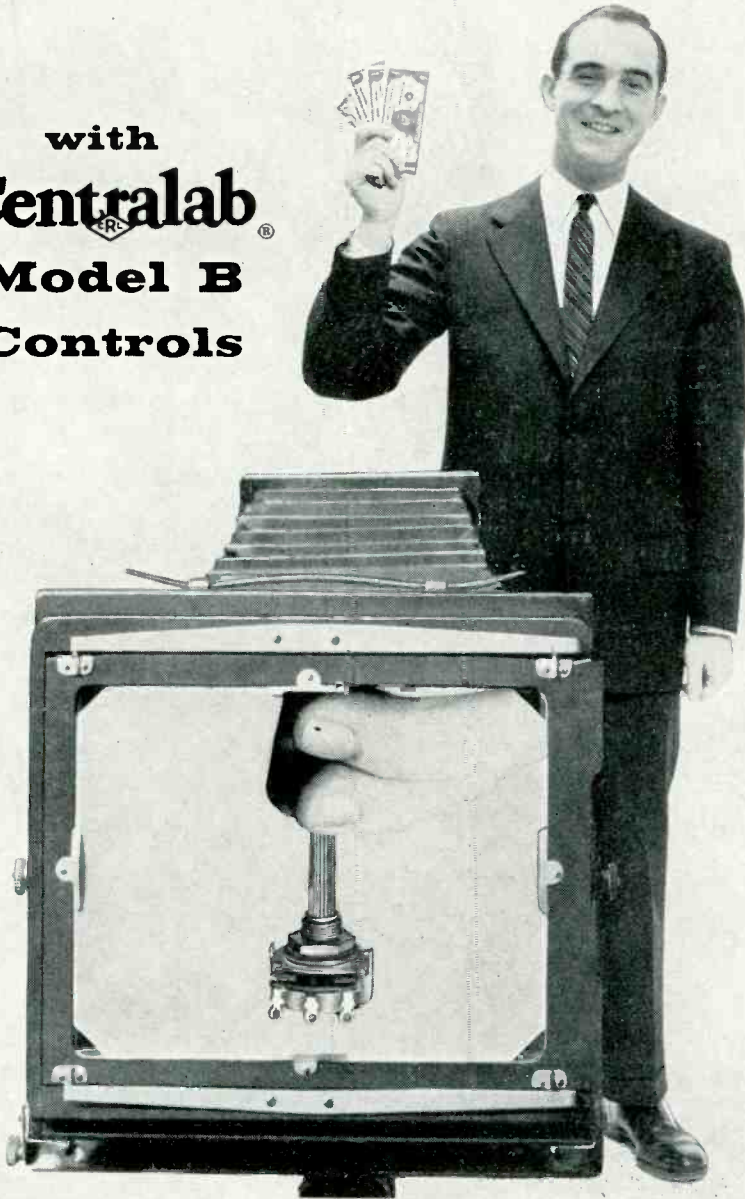

Enlarge your income and develop a long list of satisfied customers. It's easy with Centralab Model B Radiohms in the picture.

This is a replacement carbon control that adapts readily to virtually any application. Universal, fluted, knurled-type shaft fits all knobs—split knurl, shallow flat, deep flat, half-round, round, etc.

AC Line switches snap on, to convert control to switch-type unit.

There's nothing negative about Model B's . . . and you'll get a double exposure of profits. Order today from your Centralab distributor.

Centralab products are listed in COUNTERFACTS and PHOTOFACTS.

# Centralab

B-5806

A DIVISION OF GLOBE-UNION, INC.  
902L E. KEEFE AVE. • MILWAUKEE 1, WIS.  
In Canada: 804 Mt. Pleasant Rd. • Toronto, Ontario

**CONTROLS • SWITCHES • PACKAGED ELECTRONIC CIRCUITS**  
**CERAMIC CAPACITORS • SEMI-CONDUCTOR PRODUCTS**

## Editor's Memo



You don't have to be an aviculturist to recognize the odd birds that flit around our industry. They come in all shapes and sizes, in a wide variety of habits and personalities.

For the benefit of service technician birdwatchers everywhere, we will list some of the interesting specimens one may encounter.

*Brown-headed Cowbird:* This fellow has his profits milked regularly. Munches on jobs here and there irregularly. May be identified by his dumb look when he sees his financial statement.

*Common Snipe:* Good number of these around. Likes to criticize everybody, particularly those trying to do a sincere job. Very defensive about his own actions.

*Crow:* If this type has accomplished anything, important or not, you'll hear about it. If you don't believe he's really top-notch, just ask him.

*Cuckoo:* Prefers to do everything wrong, backwards or in his own weird fashion. Pops up regular as clockwork to tell the world what a nut he is.

*Hermit Thrush:* Here's a lone wolf. He doesn't join in activities with others for the common good. He likes to go it alone with no associations, and he suffers for it.

*Hummingbird:* This fellow gives off his characteristic sound when you're working on a 60-cycle problem.

*Lark:* Happiest bird around. Doesn't worry about responsibilities. Laughs when someone drops a pix tube. Also *Horned Lark*, more devilish variety. Open season on these species.

*Loon:* Closely related to the *Cuckoo*. By word and deed upholds the "crazy as a" description.

*Mourning Dove:* Sad and serious. Natural enemy of the *Lark*. Things could be worse, but he doesn't think so.

*Poor-will:* This variety is a first cousin of the *Cowbird*, and second cousin of the *Mourning Dove*. Oh, if only as much money came in as went out.

*Ruffed Grouse:* Loves to complain. Flies about with chip on his shoulder. Frequently angry. Avoided most of the time by friends, relatives, coworkers and customers.

*Yellow-bellied Sapsucker:* Most pitiable bird of all. Everyone takes him for a ride, and he's afraid to stand up for his rights.

My apologies to the real birds that bear these names. Do you know many of these varieties?

*Al Forman*

**Sylvania consumer advertising points out—**

# The big difference in Picture Tubes!



Take it from Bill Shipley: "Silver Screen 85' consumer advertising makes it easy to *sell-up* to 'first line' picture tubes."

**New TV Campaign dramatizes test results . . . sells consumers up to "first line" picture tubes . . . builds more profitable sales and satisfied customers for dealers everywhere.**

Sylvania's fabulous new family, "The Real McCoys," is one of the top new television shows of the season. Critics label it the "Sleeper of the Year." Week after week, on the "Real McCoys" Sylvania is making millions of set owners aware of the big difference in picture tubes as revealed by direct comparisons of a nationwide sample of cut-rate off-brand picture tubes against Silver Screen 85 standards.

New commercials like the "Brightness Test" are pre-selling consumers on the "first line" performance of Silver Screen 85.

For dealers everywhere it means more and more customers asking for "Silver Screen 85"—Pre-sold customers make satisfied customers—strengthening your business reputation and building long-range profitable growth.

Sylvania has designed this powerful new selling tool for you. Get behind it and *sell-up* to "first line" Silver Screen 85 picture tubes.

HighLight: o<sup>2</sup> Sylvania's "TV  
"Brightness Test."



"Don't be fooled by picture tubes that look alike — they don't act alike."



Sylvania's Silver Screen 85 is over twice as bright as this "off-brand" tube.



"Insist on a nationally known Silver Screen 85—there's one to fit every make TV."

 **SYLVANIA**

SYLVANIA ELECTRIC PRODUCTS INC.  
1740 Broadway, New York 19, N. Y.  
In Canada: Sylvania Electric (Canada) Ltd.  
University Tower Bldg., Montreal

LIGHTING • TELEVISION • RADIO • ELECTRONICS • PHOTOGRAPHY • ATOMIC ENERGY • CHEMISTRY-METALLURGY

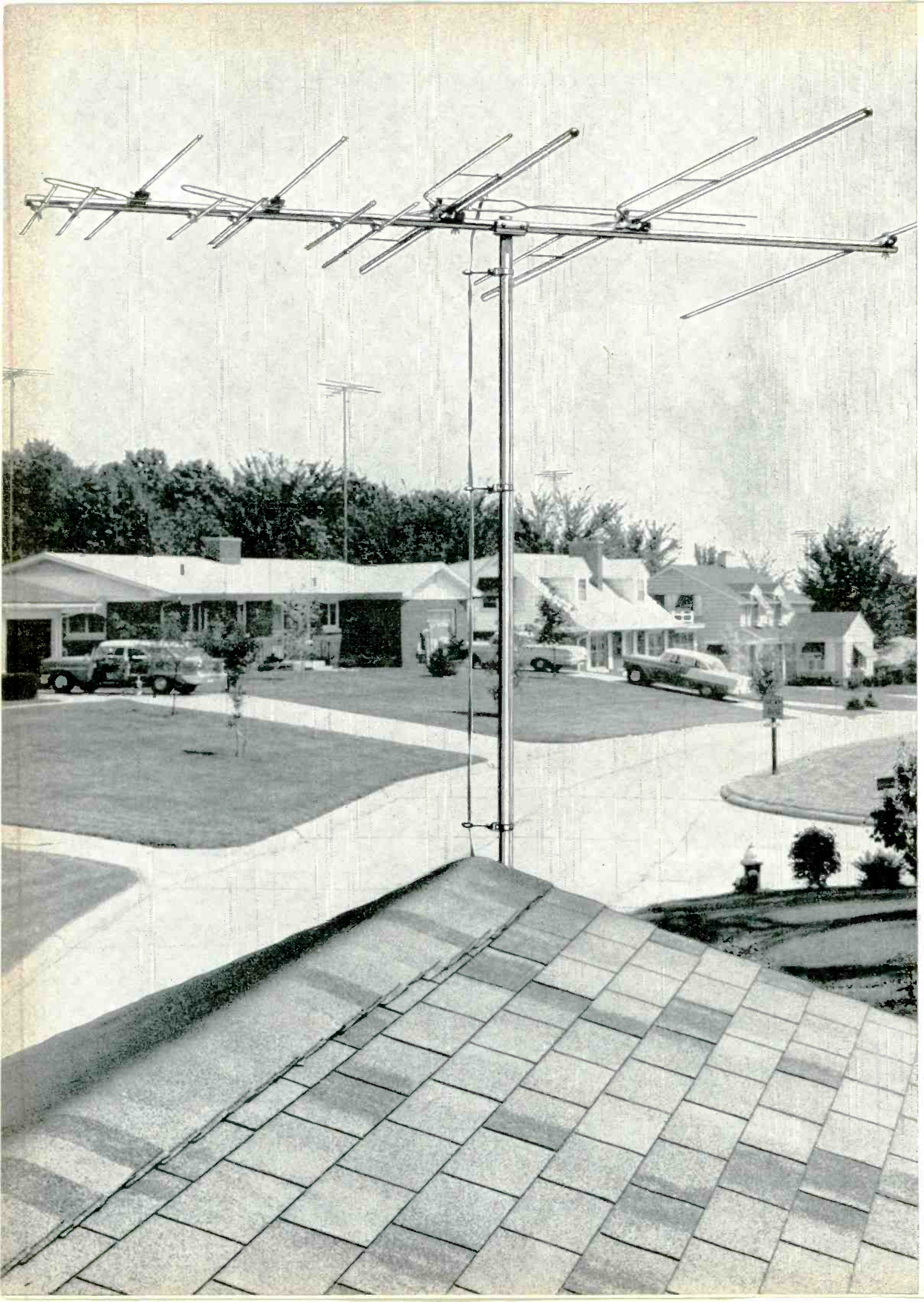

# Why Technicians, Like Yourself, Find Winegard Gold Antennas Easiest to Sell!

*Superior performance and appearance of Winegard Color'Ceptor—backed by unique factory sales helps—speed up your replacement business*

Discover for yourself the profit and personal satisfaction that come from selling the very finest antenna that can be installed on your customers home. You can solve your reception problems with the gold anodized Color'Ceptor. Here's how:

If you live near strong stations, install Color'Ceptor, not for its power but because of its ghost-cutting, unilobe directivity. Get clear, high definition pictures, free of fuzz.

If you live a great distance from stations, your installations need the tremendous all channel gain of the Color'Ceptor that knocks the snow out of those weak signals. Color'Ceptor has highest, all channel gain of any antenna made, is the most efficient antenna you can install.

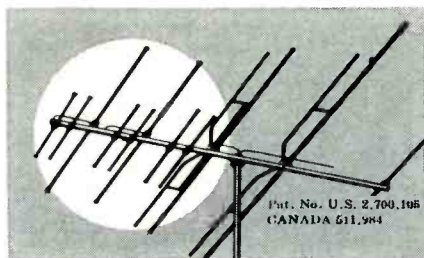

The patented Electro-Lens director design builds up weak signals then concentrates these signals on the driven elements—works the same way a powerful magnifying glass focuses light.

For maximum power, try a pair of Color'Ceptors with Power Packs stacked. Power Pack is a plug-in unit that adds 7 extra elements to the 11 element Color'Ceptor, makes it a super-powerful 18 element all channel yagi.

If you want to solve your co-channel problems, use a Color'Ceptor with Power Pack. This gives you one regular reflector plus two additional reflectors (total 3), really blocks out signals from the back and sides. It gives you a smooth yagi type response lobe on every channel—completely free of minor lobes. Unlike antennas composed of mostly driven elements, Color'Ceptor has

zero side pick-up. If needed, the back two reflectors can be tuned to give a rear null on any one low band channel without affecting the gain on the other channels.

If you are selling and installing color sets, the Color'Ceptor meets all the rigid requirements for a perfect color antenna. It has high gain, sharp directivity, low VSWR (less than 1.5 to 1 any channel), high immunity from off angle signals and flat frequency response. It has no suckouts or resonance peaks and does not have the usual all channel antenna frequency fall-off on end channels 2, 6, 7 or 13.

If you want the best looking, strongest installations, Color'Ceptor is loaded with appeal, built to last and made as precisely as a fine watch. All the elements are perfectly aligned, made from reinforced high tensile aluminum. The hardware is an exclusive Winegard design, for fast easy assembly, keeps your installation straight, neat and streamlined

## Winegard Exclusive *Bright* Gold Anodizing Process

Color'Ceptor's distinctive *Bright Gold Anodized Finish* is more than a beauty treatment. Plain aluminum won't rust but does corrode and corrosion not only ruins an antenna's performance but weakens an antenna so that elements droop and eventually break. ANODIZING won't corrode, chip or peel like plastic coatings or paint. ANODIZING is actually part of the metal itself, stays new many times longer than raw metal antennas.

Winegard bright gold anodizes the Color'Ceptor elements and boom, inside and out—not a quick dull dip process. This is the most expensive weather protection that can be given aluminum but it is worth every penny of manufacturing cost. The Color'Ceptor goes through 7 electro-chemical baths, takes 42 minutes for a complete cycle. It's the only antenna made that is *bright* gold anodized, won't fade or rub off.

... no droop or sag on any element. Color'Ceptor is engineered to be lightweight, yet super-strong. Wind tested to 100 m.p.h. Not bulky, easy to install. Perfect balancing at the mast clamp puts no strain on rotor when used.

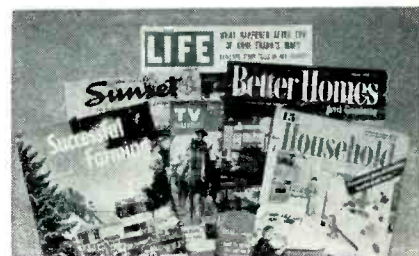

To help you sell Winegard Color'Ceptors, you can have full color displays with a miniature 1/3 scale model of the Color'Ceptor, silk wall banners, giant full color posters, hang tags, counter cards, decals, newspaper mats, radio commercials, spec sheets, full color stuffers, and postcards—plus unlimited co-op advertising to tie-in with Winegard's big national magazine program... ads in LIFE... BETTER HOMES AND GARDENS... HOUSEHOLD... TV GUIDE... SUCCESSFUL FARMING... SUNSET. More national advertising than all other antenna manufacturers combined... more dealers sales helps.

Only Winegard gives a written guarantee of 100% satisfaction on every Color'Ceptor you sell. If your customer isn't happy. Winegard will satisfy his complaint or return list price. You still get your full profit from the sale.

If you want to make money—and who doesn't—switch to Color'Ceptor. Get your fair share of the big antenna market... have satisfied customers who will sell for you by word of mouth. This fall, join Winegard's Dealer Double Profit program. Ask your jobber or write for full details, today.

Down with the old! Up with the Gold!

Copyright 1958—Winegard Co., 3019-11 Scotten Blvd., Burlington, Iowa. Cable address JRWCO.

# YOU CAN'T HEAR A 'SPEC' SHEET!

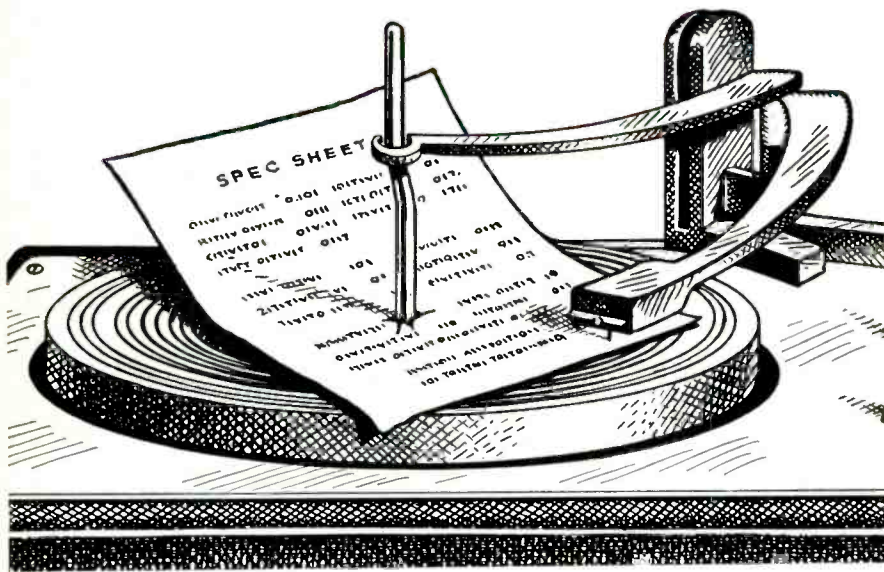

*Sonotone's stereo cartridge has more than just good specs... it gives brilliant performance! More phono makers specify Sonotone for the top of their line—here's why:*

Only Sonotone gives true sound *without* distortion... high frequency response *without* record cutting! Sonotone stereo gives a performance so superior you can truly *hear* the difference. The secret? Sonotone's four exclusive *operating* features:

1. Extremely high compliance.
2. Amazingly clean wide range frequency response.
3. Wide channel separation, due to Sonotone's pantagraph yoke.
4. Rumble filter to screen out vertical turntable noise.

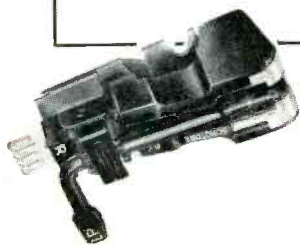

SPECIFY... STOCK... SELL...  
**Sonotone**®  
 Electronic Applications Division, Dept. CT-118  
 ELMSFORD, NEW YORK

## LETTERS

To the Editors

### World Almanac

EDITOR, ELECTRONIC TECHNICIAN:

Many thanks for the extensive work in bringing up to date your article on Television Highlights and industry statistics. They will be published in the 1959 edition of the World Almanac, as in previous years.

ROBERT T. MARTIN

The World Almanac  
 New York, N.Y.

### Granulated Safety Glass

EDITOR, ELECTRONIC TECHNICIAN:

A few days ago I received a call from one of my customers telling me that her living room was covered with glass. So expecting to find the picture tube had imploded, I went there. But the set and tube were OK. In front of the TV set was a pile of glass which had once been



the safety glass. It was in a million pieces, none over a half-inch in size. The customer told me he had turned off the set about midnight in perfect order, and found it in this condition (see photo) in the morning. What happened?

ALFRED RICCIARDI

Wrentham Radio & TV Service  
 Wrentham, Mass.

• Safety glass is specially made so that if shattered by implosion it will "granulate" instead of fly apart in large jagged—and possibly lethal—pieces. Probably the glass was mounted under too much stress due to tight screws, warpage, etc.—Ed.

(Continued on Page 18)

# Use Delco Radio Service Parts!

DS501—Highest power transistor used in auto radios.

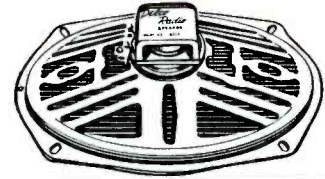
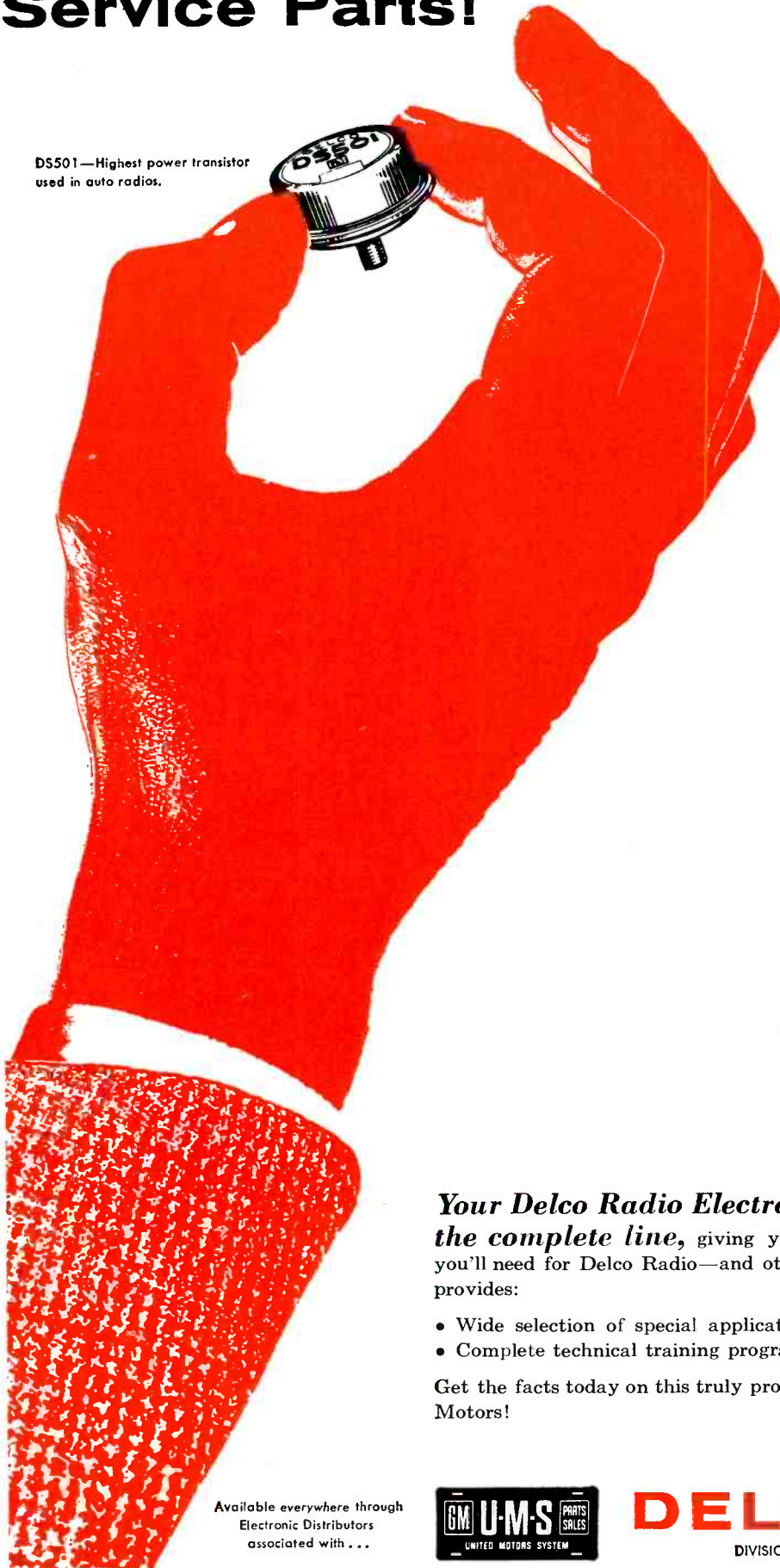

SPEAKERS



IRON CORES



RESISTORS



CAPACITORS



CONTROLS



TUBES



COILS



VIBRATORS

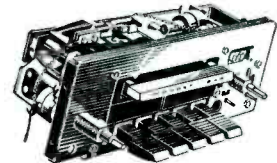

TUNER PARTS

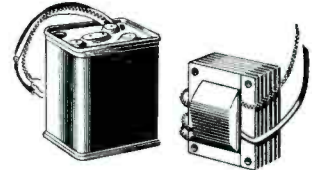

TRANSFORMERS

*Your Delco Radio Electronic Parts Distributor carries the complete line,* giving you fast, dependable service on the items you'll need for Delco Radio—and other radio—service work. Delco Radio also provides:

- Wide selection of special application parts
- Complete technical training program
- Effective warranty program
- Dealer identification signs

Get the facts today on this truly profitable dealer setup, and grow with General Motors!

Available everywhere through  
Electronic Distributors  
associated with . . .



## DELCO RADIO

DIVISION OF GENERAL MOTORS, KOKOMO, INDIANA



## **BUSS FUSES** *can help you maintain customer good-will!*

Your customers stay satisfied with BUSS fuses because . . . BUSS fuses provide, dependable, 'trouble-free' electrical protection under all service conditions.

Every BUSS fuse you sell or install is tested in a sensitive electronic device. Any fuse not correctly calibrated, properly constructed and right in all physical dimensions is automatically rejected.

BUSS fuse dependability helps you gain satisfied customers — and BUSS fuses help you avoid adjustments or call-backs that cut into your profits.

BUSS fuses can further help you maintain your reputation for quality and service because BUSS is the KNOWN brand of fuses. The universal acceptance of BUSS fuses as the finest available is built on the millions upon millions of BUSS

fuses used in home, on farm and in industry over the past 43 years.

*For more information on the complete line of BUSS and FUSETRON Small Dimension Fuses and Fuseholders, write for bulletin SFB.*

Bussmann Mfg. Division McGraw-Edison Co. University at Jefferson, St. Louis 7, Mo.

*BUSS fuses are made to protect — not to blow, needlessly*



A COMPLETE LINE OF FUSES FOR HOME, FARM, COMMERCIAL, ELECTRONIC, AUTOMOTIVE AND INDUSTRIAL USE.

1158



# NEW WESTINGHOUSE GOLD STAR PICTURE TUBES...

*Built 3 ways better  
to put  
customer confidence  
in your  
selling picture!*

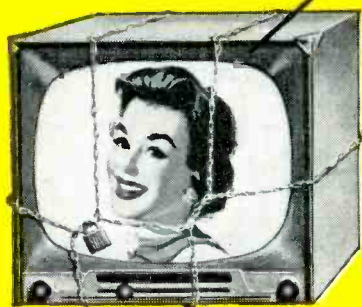
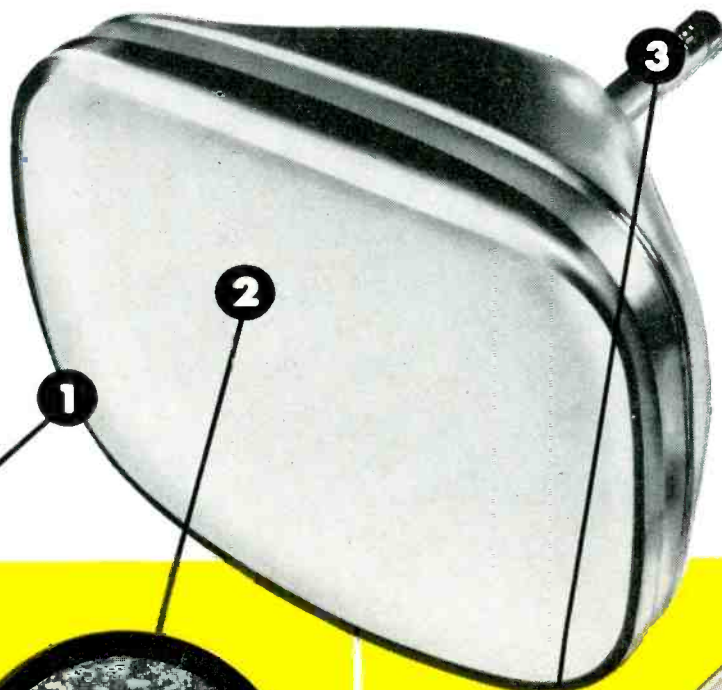

**More Rigid Testing.** Before this amazing new design was approved for distribution, a stock model Gold Star tube actually underwent 25,000 hours of continuous operation in the famous locked TV "Torture Test." It was still 80% as good as new when checked!



**New Aluminizing Method** provides a far smoother coating—not uneven "hill-and-valley" coating found in other tubes. This gives absolute maximum reflection . . . more usable light from the screen . . . a 20% brighter, sharper picture with greatly improved contrast.

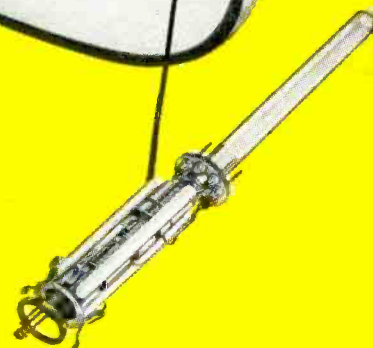

**40% More "Getter" in Electron Gun.** Revolutionary design distributes 40% more protective material over inside of tube. Greatly reduces aging . . . keeps picture brighter longer. And all elements of the Gun are cleaned ultrasonically for superior performance.

*Put customer confidence in your service business. Call your Westinghouse Distributor about new Gold Star Tubes today.*

**YOU CAN BE SURE...IF IT'S Westinghouse**

Electronic Tube Division • Elmira, New York

**FOR ANY HIGH FIDELITY YOU OWN . . .**

**STEREO  
IS ONLY  
60  
SECONDS  
AWAY**



**WHEN YOU CONVERT WITH THE HARMAN-KARDON AX20**

**60 seconds.** That's all it takes to create a complete stereo electronic center with the new Harman-Kardon Nocturne, Model AX20. To convert your present system—component or console—to stereo, simply plug the AX20 into your present amplifier.\* *This one connection does it all.*

With the AX20 there's no shuttling back and forth between two different instruments (you can even tuck your present amplifier out of sight); no adapter box to complicate matters. This one unit—the AX20—controls the power to both amplifiers. It also controls treble, bass, volume, contour, balancing and equalization for both.

The AX20, in brushed copper and black, is strikingly handsome in appearance and outstanding in its performance characteristics. The amplifier delivers 20 watts of hum-free, distortion-free power (40 watt peaks). An exclusive new high gain phase inverter utilizing both positive and negative feedback drives the output tubes with minimum phase shift and excellent stability. As a result, the power amplifier has instantaneous recovery time resulting in uniquely clean and faithful transient response. The AX20 actually produces more clean useful power than conventional 30 watt amplifiers.

The preamplifier is a dual stereo device incorporating ganged bass and treble tone controls, loudness control, contour control,

\*To round out your stereo system—add an appropriate second speaker and stereo cartridge or tape deck—or both.

rumble filter, balance control, mode switch, speaker selector and function switches. Selectable equalization is provided for records and tape (7½ and 3¼ IPS). The second preamplifier delivers ½-volt output at low impedance.

**The Nocturne, Model AX20 (less enclosure) \$99.95**  
**Model AC20 enclosure (optional) \$8.95**

*Prices slightly higher in the West*

For complete information on the AX20 and other fine Harman-Kardon stereo and monaural high fidelity instruments write to Dept. ET-11, Harman-Kardon, Westbury, New York.

**THE AX20 IS PERFECT FOR  
MONAURAL NOW—STEREO LATER**

The AX20 is the perfect unit for those who desire monaural high fidelity today with the assurance of simple conversion to stereo later. Because it incorporates dual stereo preamplifiers plus a powerful 20 watt amplifier—just add a basic amplifier (the new Harman-Kardon HK20 is ideal) at any time and your system is complete. The remarkable AX20 costs no more than conventional monaural 20 watt amplifiers. The HK20 price, with cage, \$59.95.

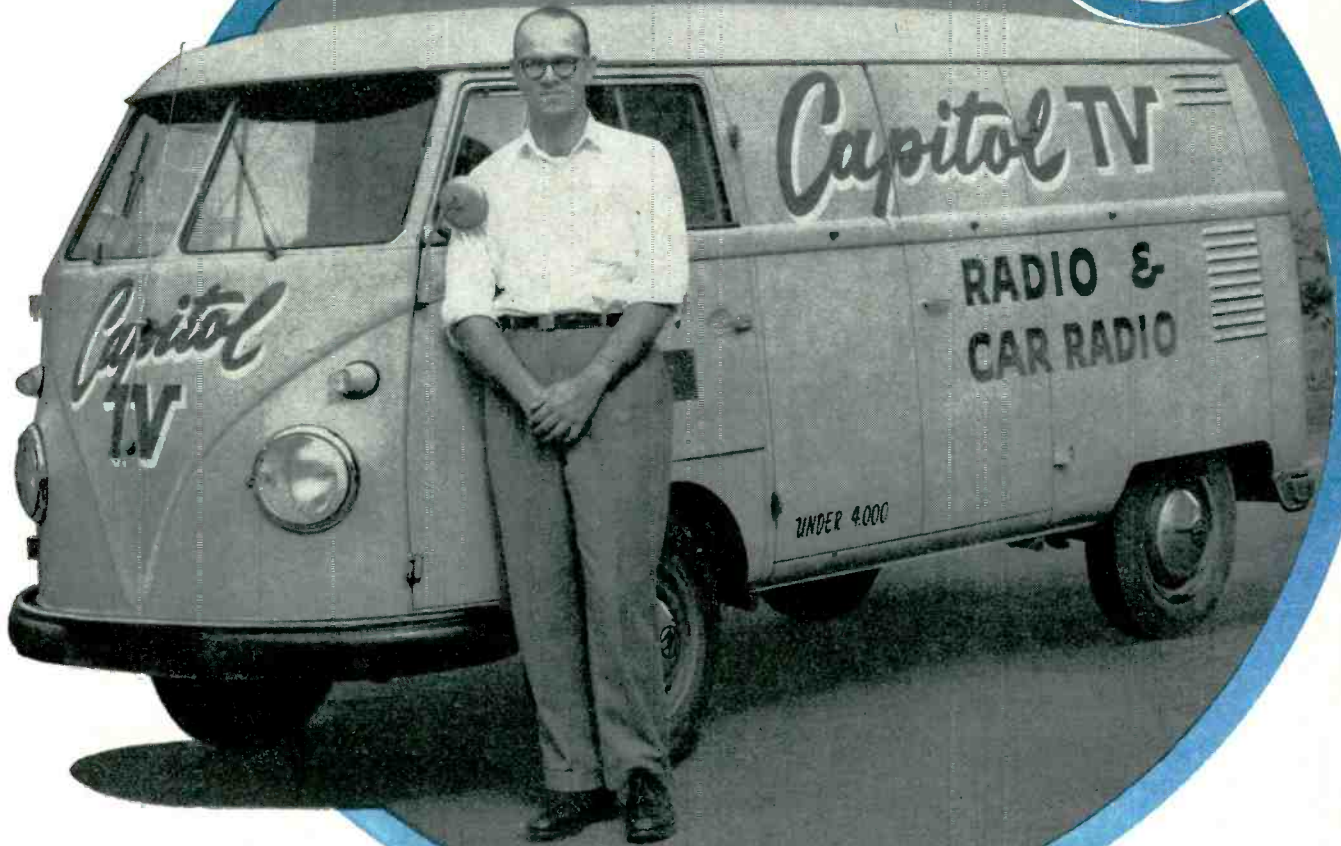

**harman**

**kardon**



## “We like the Volkswagen...”

“for the roomy interior for transporting TV cabinets. Doors on both sides are handy for one-way street unloading. We like it for advertising our store.” Wayne C. Hardwick, owner of Capitol TV, Seattle, Wash., has summed it up briefly and to the point. His Volkswagen Panel Delivery has 170 cu. ft. of space, carries 1830 lbs., turns, parks on a dime and literally runs on pennies.

*The engineered dependability of every Volkswagen is backed up by famous  Service and Genuine  Spare Parts in all 49 states.*



# VOLKSWAGEN

VOLKSWAGEN DELIVERS THE GOODS...FOR LESS!

# "No doubt about it—the Yellow Pages brings in the hi-fi business for us!"

says Joseph B. Schocken, Manager, Lafayette Radio Co., Newark, N. J.

"Hi-fi customers are shoppers—constantly looking for sources of components and equipment. We can think of no better way to tell them what we have—and where we are—than by advertising in the Yellow Pages. It's the best way to reach prospects in the broad area we serve. We *know* it pays off, since many customers actually mention our Yellow Pages ads when they come in to see us here at Lafayette."

24 hours a day, seven days a week, the Yellow Pages puts your selling message right at your prospects' fingertips—reminds them of your products and services when they are ready to buy. Follow the lead of the thousands of dealers who have built more traffic, more sales, more profits through Yellow Pages advertising.

Call the Yellow Pages man at your telephone business office. He'll plan a profitable Yellow Pages program for you!



**LAFAYETTE RADIO CO.**

One of New Jersey's Largest Distributors of

**HI-FI EQUIPMENT  
PUBLIC ADDRESS SYSTEMS**

Amplifiers - Mikes - Speakers & Intercoms for  
Homes - Industry - Schools Etc.

**Market 2-1660**

24 CENTRAL AV., NEWARK

DISPLA~~T~~ AD shown here, in addition to listings under many other headings, builds business for Lafayette over a very broad trading area.

(Letters. Continued from page 12)

## Where to Get ET

EDITOR, ELECTRONIC TECHNICIAN:

I received a copy of your September STEREO 1959 at the New York High Fidelity Music Show. A fine job, and thank you. Where may I obtain copies of your monthly magazine? Do parts distributors handle it on a rack display?

PRESTON HERBERT, JR.

Herbert Sound Systems  
Briarcliff Manor, N.Y.

• We allow some parts jobbers to sell ET, but not too many since we want to make sure that the magazine goes to professional dealers, not hobbyists. Almost all subscriptions are obtained by the field sales staff or direct mail.—Ed.

## News of the Industry

**MOTOROLA INC.** has appointed F. J. POPPELEN as sales manager of their semiconductor division.

**PHILCO CORP.** appoints ROGER S. DREW as assistant manager—merchandising of the Consumer Products Div.

**CBS LABORATORIES**, originally at 485 Madison Ave., N. Y. C., is now located at the new Research Center in Stamford, Conn., which was formally dedicated Oct. 7.

**B&K MFG. CO.** has set up a special plan for converting the model 1,000 Dyna-Scan into a point-to-point signal-injection, direct-viewing TV Analyst for \$89.95.

**GENERAL ELECTRIC's** second annual All-American Awards for public service by TV repairmen, which includes \$500 of trophies and prizes, will be presented to the winners at a ceremony in Washington this month.

**CHANNEL MASTER CORP.** has entered the transistor radio field with radios being made for them by SANYO ELECTRIC CO., LTD., one of Japan's largest consumer products manufacturers. Two 6-transistor models offered initially are listed at \$49.95, including carrying and private listening accessories; and \$34.95, without accessories.

**INT'L TELEPHONE & TELEGRAPH CORP.** announced the consolidation of two of its divisions, FARNSWORTH ELECTRONICS CO., Ft. Wayne, Ind., and FEDERAL TELEPHONE & RADIO CO., Clifton, N. J. whose former president DELBERT L. MILLS now heads the combined divisions. ITT also announced the appointment of CORBIN A. MC NEILL as director of industrial relations.

(Continued on page 22)

*Mr. Service Dealer...*

# YOUR PHILCO DISTRIBUTOR IS HEADQUARTERS FOR A COMPLETE SELECTION OF GENUINE PARTS

**Bendix**

Automatic Electric Washers • Automatic Electric Dryers • Duomatic Washer-Dryer Combinations • Automatic Gas Washers • Automatic Gas Dryers • Gas Duomatics, Washer-Dryer Combinations.

**CROSLEY**

Radio • Television • Refrigerators • Ranges • Freezers • Air Conditioners • Automatic Dishwashers.

**PHILCO-  
Bendix**

Automatic Electric Washers • Automatic Electric Dryers • Duomatic Washer-Dryer Combinations • Automatic Gas Washers • Automatic Gas Dryers • Gas Duomatic Washer-Dryer Combinations.

**PHILCO**

Radio • High Fidelity • Stereophonic High Fidelity • Television • Refrigerators • Electric Ranges • Freezers • Air Conditioners • Automatic Electric Washers • Automatic Electric Dryers • Duomatic Washer-Dryer Combinations • Automatic Gas Washers • Automatic Gas Dryers • Gas Duomatic Washer-Dryer Combinations.

*Don't Settle for Less than Genuine Replacement Parts*

Don't risk your valuable reputation with cheap imitations. Use genuine factory-tested parts that assure dependability and long life. All models of the products listed above are covered in the Philco Home Laundry, Electronics and Appliance catalogs. See your Philco distributor for this important information!

**PHILCO**<sup>®</sup>  
*Accessory Division*

**WORLD WIDE DISTRIBUTION**

Service Parts • Power-Packed Batteries • Universal Components • Long-Life Tubes • Heavy Duty Rotors • Star Bright 20/20 Picture Tubes • Long Distance Antennas • Appliance Parts • Laundry Parts • Universal Parts and Accessories

**PHILCO** . . . Famous for Quality the World Over

*Would you go back to  
the old 12 cylinder Auto.?*

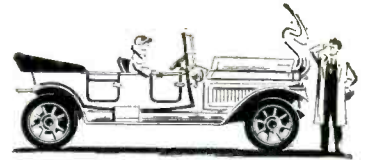

**1959 SPORTS COUPÉ**



The engine in one of today's new 1959 sports cars delivers 300 horsepower and weighs only 660 lbs.!! More than four times as efficient!

**1915 AUTOMOBILE**

In 1915, the 12-cylinder engine in this automotive wonder was hailed as a great advance because it produced 95 horsepower and only weighed 800 lbs.!

Thanks to the miracle of automation, automotive engineers have been able to pack a modern passenger car chassis with power never before thought possible for the size

and weight. Sylvania has been a pioneer in applying automation to the manufacture of TV chassis, bringing more compact, better performing components.

# SYLVANIA **S-110 CHASSIS**

**the chassis modern manufacturing methods built**

- **Better performance under the extremes of line voltage variation.** The advanced high-voltage design of the SYLVANIA S-110 Chassis adjusts automatically for maximum performance at both high- and low-voltage extremes.
- **Better performance under heat, humidity and freezing conditions.** The rigid specifications of reliability of components in the SYLVANIA S-110 Chassis assures better performance and longer trouble-free life under extremes of humidity and temperature conditions.  
Alkyd Resin used in the high-voltage socket of the S-110 Chassis withstands moisture, dirt and even frost accumulations without any permanent damage, even if these conditions are severe enough to cause arcing. Top performance is assured regardless of warehouse locations.
- **Cuts repair time by 60%.** The orderly arrangement of components in the SYLVANIA S-110 Chassis means that most defects can be located in seconds. Circuit can be traced easily from either side by shadow graph method over your bench light.
- **Designed for maximum strength and minimum weight.** The SYLVANIA S-110 Chassis has all-around girder frame construction which gives it the most favorable strength to weight ratio in the industry. This means easier handling and faster servicing because of its light weight. Yet the S-110 is sturdy and rigid when mounted in the cabinet.

**Advanced printed circuitry and components** of the type used in the performance-proved SYLVANIA S-110 Chassis are required and specified in the design and production of guided missiles and space equipment where absolute reliability and ruggedness are demanded.

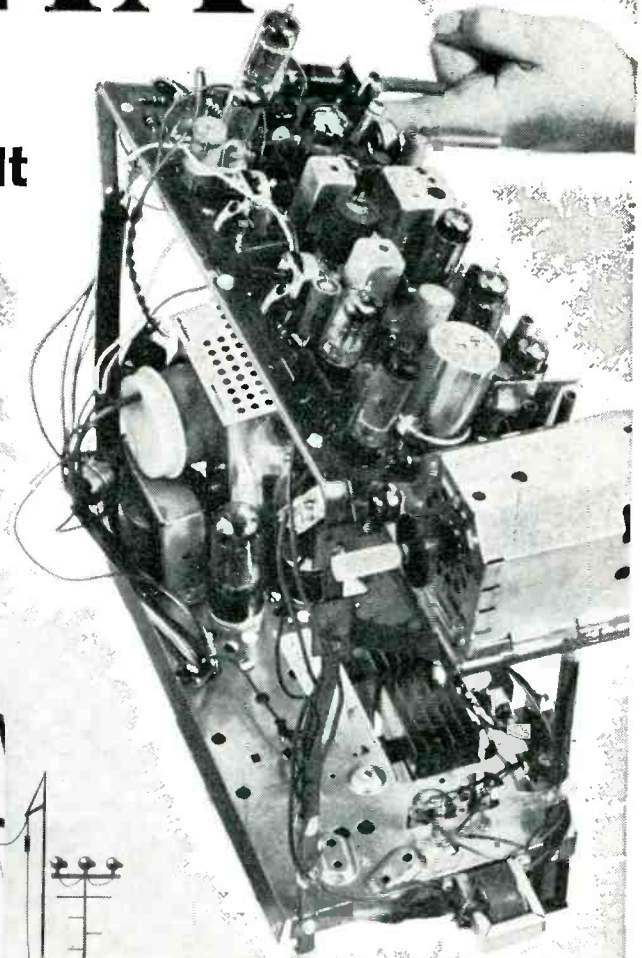

\*Only 10 1/2 lbs. without yoke

**SYLVANIA**  *Pioneers in modern manufacturing methods*

# BLONDER-TONGUE ENTERS HI-FI FIELD

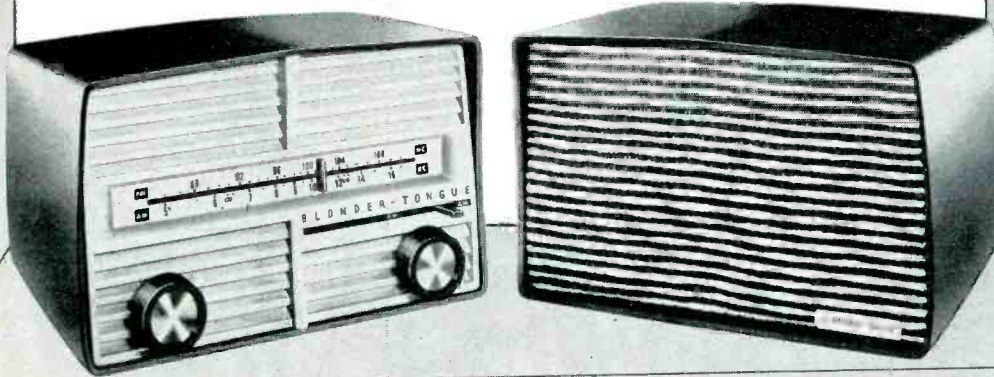

## WITH SALES AND MARKETING PLAN



## TAILORED FOR SERVICE-DEALERS

### FOUR EXCITING NEW B-T HIGH FIDELITY COMPONENTS

Blonder-Tongue high fidelity is engineered and built by a company whose name you have learned to respect for quality, and whose TV products have proved their worth and reliability over many years. Styling is modern, crisp, compact. Pricing realistically-keyed for volume sales—a complete system, tuner, amplifier and speaker—can be sold for about the price of a portable TV set...at a bigger profit for you.

**Model T-88 FM-AM TUNER**—Sensitivity of higher priced tuners; drift compensated circuit for frequency stability; super sensitive AM section for all areas. **64.50**

**Model A-1 DELUXE HIGH FIDELITY AMPLIFIER**—4 unique frequency controls cover entire audio range. Full function selection. **77.50**

**Model SS-2 TWIN SPEAKERS IN ENCLOSURE**—Ideal as auxiliary or second stereo speaker. **15.95**

**Model R-98 DELUXE FM-AM RADIO**—Quality radio—high sensitivity on FM & AM. **64.50**

### BOLD NEW MARKETING PLAN BUILDS PROFITS FOR YOU

There's an authorized B-T high fidelity distributor in your territory who will stock and help you sell B-T high fidelity components. A powerful advertising and promotion program

will build traffic and focus attention on your operation, setting you up as the expert to whom the consumer can turn for advice and assistance in high fidelity and stereo conversion.

*For full hi-fi profits, contact your B-T high fidelity distributor today, or write direct. Dept. ET-11*



**BLONDER-TONGUE LABORATORIES, INC.**

9 ALLING STREET, NEWARK 2, NEW JERSEY

*Master TV Systems  
Industrial TV Systems  
UHF Converters • Amplifiers*

*Mr. Service Dealer*

# PHILCO

## OFFERS YOU A COMPLETE LINE OF UNIVERSAL SERVICE PARTS



Your Philco Distributor has available for you a complete new line of universal parts that fit not only all Philco receivers but every competitive make and model. Eliminate your inventory problems and stock the one line of completeness . . . Philco.

### PHILCO UNIVERSAL SERVICE PARTS

- Sweep Components
- Coils
- Capacitors
- Vibrators
- Condensers
- Rectifiers

All Philco universal parts are precision engineered and quality tested to insure superior operation and longer life. Don't settle for inferior copies . . . insist on genuine Philco universal parts.

**For a program of completeness . . .  
See Your Philco Distributor Today!**



(News. Continued from page 18)

**TRANS-SIL CORP.** has appointed IRWIN WEINSTEIN as sales manager.

**CENTRALAB** has appointed JAMES A. HANNAN as manager of the International Div.

**CBS-HYTRON** has promoted GEORGE TALLENT to manager of quality control-semiconductors.

**THE GABRIEL CO.** of Cleveland has announced the election of PAT LEONE as a director.

"SIDCO" will be the trade name for the pencil-type soldering tips for industrial use being manufactured by the SID UNGAR CO. in Venice, Calif., and will shortly have nation wide jobber outlets.

RCA's appointment of DONALD H. KUNSMAN as President of the RCA Service Co. was announced by CHARLES M. ODORIZZI, who has just been appointed Group Executive VP, Consumer Products and Service.

**GENERAL ELECTRIC** has appointed FRED S. DE WITT as district distributor sales manager in N. Y. C.; DONALD H. HANGEN, district sales manager for Cincinnati, and WILLIAM H. KAISER, JR., district equipment sales manager in Milwaukee.

**HEROLD RADIO & ELECTRONICS CORP.** has appointed ARTHUR GOTTLIEB, formerly with GRANCO PRODUCTS, as national service manager of STEELMAN PHONOGRAPH & RADIO CO., and ROLAND RADIO CORP., divisions of HEROLD.

**RAYTHEON MFG CO.** has announced the staff appointment of seven key people to its new Distributor Products Div. Two new appointments to the Receiving Tube Div. are Joseph J. GRABIEC, marketing manager, and GEORGE LOOMIS, manufacturing manager.

**GENERAL MOTORS' United Motors Service division** has rotated regional managers so that GEORGE C. FALLER will become Eastern Regional Manager; JEFF GRAY, Pacific Coast Regional Manager; CLEVE WEBB, Central Regional Manager; and ROGER W. LUNDBERG, Southern Regional Manager.

**JERROLD ELECTRONICS CORP.** made its first installation of their new TV, FM and AM antenna outlet system in each of the 200 homes built by Pinebrook Development in Upper Dublin Township, a Philadelphia suburb. The antenna system permits use of a hidden attic antenna.

**ASSN. OF ELECTRONIC PARTS & EQUIPMENT MFRS.** announced that ROBERT E. SVOBODA, distributor sales manager of AMPHENOL ELECTRONICS CORP., will succeed COL. GAIL S. CARTER as First VP. Col. Carter has resigned to become executive officer of the NATIONAL ELECTRONIC DISTRIBUTORS ASSN.

### World-Wide Distribution

Service Parts • Power-Packed Batteries •  
Universal Components • Long-Life Tubes  
• Heavy-Duty Rotors • Star-Bright 20/20  
Picture Tubes • Long-Distance Antennas •  
Appliance Parts • Laundry Parts • Univer-  
sal Parts and Accessories

**PHILCO**  
*Accessory Division*



# STEREO'S STANDARD



stereo's standard!

- Model 505 Stereo Control with dual-channel magnetic adapter Price \$11.50 Net
- Model 504 single magnetic Adapter only Price \$3.60 Net
- Model 21D Stereo Cartridge with Diamond Stylus Price \$19.50 Net
- Model 21S Stereo Cartridge with Sapphire Stylus Price \$9.90 Net
- Model 26DST Stereo Turnover to 78 Monaural, Diamond and Sapphire Price \$22.50 Net
- Model 26ST Stereo Turnover to 78 Monaural, Two Sapphires Price \$12.90 Net

Good stereo depends on these vital features: Range Response: 20-16,000 cps  $\pm$  2 1/2 db to RIAA; Distortion: Less than 2%; Channel Isolation: 20 db; Vertical Rumble Rejection: 15 db with 5 meg input; Elements: dual ceramic, (lead-zirconium titanate); Weight: 21D 2.4 grams, 26DST 2.6 grams; Tracking Force: 6 grams; Stylus: 21D—standard .7 mil diamond; 26DST—standard 3 mil sapphire; Vertical Compliance: 2 x 10<sup>-6</sup> cm/dyne; Lateral Compliance: 2 x 10<sup>-6</sup> cm/dyne; Output: .5 Volt RMS from Westrex standard RIAA Test Record; Capacity: 500 mmfd per element for stereo; 1000 mmfd paralleled for monaural; Mounting: EIA (RETMA) standard 1/2" and 7/16" centers; Recommended Amplifier Input Impedance: 5 megohms or higher.

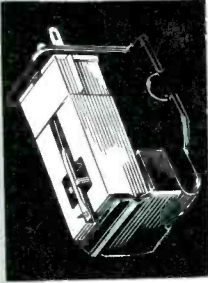

the Electro-Voice totally compatible stereo cartridge

Thousands being installed as original equipment attest to industry acceptance; thousands in use prove its unquestioned superiority for monaural as well as stereo. The E-V Stereo Cartridge uses a .7 mil replaceable stylus and dual high fidelity ceramic elements so essential to the exacting demands of stereo reproduction. Pickup from stray magnetic fields is non-existent, hum and rumble are far below the level of even the most expensive magnetic cartridges, and PZT ceramic elements deliver a precise RIAA curve. The E-V Stereo Cartridges exclusive Rumble Suppressor (pat. pend.) virtually eliminates vertical turntable rumble without degrading full frequency response range of the cartridge... allows you to use it with any turntable or record changer. Totally Compatible... for stereo, it's superb; for monaural... it's superior to even your present cartridge.

**THE FIRST STEP TO STEREO.** Many fine monaural cartridges are too "stiff" to play stereo records without seriously damaging them; therefore, if you replace your present cartridge with the new E-V Compatible Stereo Cartridge, you may continue playing your present library of LP's plus all the new stereo records monaurally.

**THE SECOND STEP TO STEREO.** Connect the E-V Stereo Cartridge leads to the 505 Stereo Control Center (net \$11.50). You can then select from "monaural," "stereo," or "channel reverse" for easy balancing. The 505 also converts your magnetic input to high impedance ceramic input, if required. Run one lead to your present high fidelity system, run the second channel lead to a second amplifier (and speaker). NOTE: The E-V Stereo Cartridge is corrected for RIAA curve, doesn't need the equalization of a second preamplifier.

If you do not plan to purchase a second amplifier and speaker now, you can still get stereo by running the second channel lead through the 505 to your radio or TV set phono input. You can improve your system later by simply adding a second amplifier and speaker. Stereo records are available now. Why wait? Enjoy the vivid reality of stereophonic sound today. Whether you're purchasing your first system or converting now, use the Electro-Voice Compatible Stereo Cartridge. See your high fidelity dealer, or write Electro-Voice for free booklet on choosing stereo equipment, and a special Stereo Demonstration Record (\$1.50 prepaid).

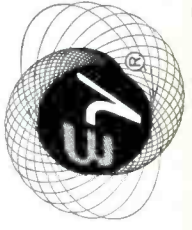

**Electro-Voice**

**ELECTRO-VOICE, INC.**  
BUCHANAN, MICHIGAN

FOREMOST IN ELECTRO-ACOUSTICS—High Fidelity Loudspeakers and Enclosures for STEREO, Phono-Cartridges, Microphones and Public Address Speakers, Marine Instruments, EVI Professional Electronic Instruments and Military Material.

ADD-ON STEREO—THE UNIQUE ELECTRO-VOICE CONCEPT THAT ELIMINATES THE NEED FOR A SECOND FULL-RANGE SPEAKER.

# HOW TO CREATE MORE CONFIDENCE IN YOUR SERVICE BUSINESS



**FREE!** Colorful comic books, window streamers, window display to help tell your customers all that goes into servicing TV sets!

It takes a lot of work, costly equipment and know-how to be a radio and TV serviceman. No one knows this better than you. But, chances are, your customers *don't!*

But now you can give them an insight into your work with this free "The Story Behind TV Service" kit that tells how complicated your job is . . .

how much study it required to learn . . . and how expensive it was getting started. Told in interesting cartoon technique, the booklets are something everyone will read—and understand!

So put these good-will ambassadors to work building consumer confidence for you.

## CALL YOUR WESTINGHOUSE DISTRIBUTOR

YOU CAN BE SURE...IF IT'S **Westinghouse**

Electronic Tube Division • Elmira, New York



*Sell the  
Stereo Changer  
that Means  
Business...*



V-M/'Stere-O-Matic' 4-Speed Automatic Stereo Record Changer—Model 1201

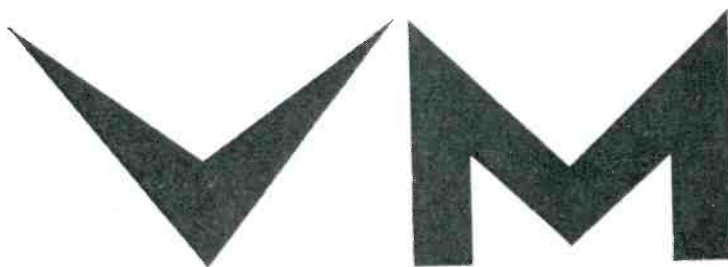

## *V-M's Sensational New 'Stere-o-matic'® Record Changer!*

- **Completely Wired For Stereo With Stereo Cartridge Installed!**
- **Complete With Dual Output Jacks and Stereo/Monaural Switch!**

Once your customers see and hear this incomparable record changer, they'll want it immediately! Sell stereophonic music with "transcription turntable" performance, newest V-M engineering development. **COMPARE IT!** The very finest changer you can sell is *V-M!*

**Here's Why The 'Stere-O-Matic' Is So Completely Superior To All Other Changers In The Same Price Range:**

**RUMBLE:** —48 db for 120 cycle rumble when tested on XLP414 test record (recorded velocity approximately 3.4 cm/sec. at 1,000 cycles.)  
**WOW AND FLUTTER:** ¼ RMS.

**TURNTABLE:** Balanced to assure constant speed. Spindle bearing area centerless ground to reduce frictional drag.

**MOTOR SPEED:** Constant, positive for permanent true pitch.

**tone ARM:** Resonance-free. Easily adjustable for any cartridge weight. Compensated to eliminate variation from bottom-to-top of record stack. Jewel-type anti-friction pivot bearings. Stereo Cartridge installed.

**TRACKING ANGLE:** Variation reduced to a maximum of 2°.  
**AUTOMATIC SHUT-OFF:** Unit shuts off automatically after last record plays.

**RECORD INTERMIX:** Will intermix 10" and 12" records of same speed. V-M "45" spindle fits easily over Tri-O-Matic® spindle for 45 rpm records.

**ELECTRICAL SPECIFICATIONS:** 110-120V; 60 cycles A.C. Special voltages and frequencies upon request.

**ALSO AVAILABLE:** Model 1202 with four-pole motor and plug-in head for GE and other magnetic stereo and monaural cartridges. All V-M models available with matching metal base-pan or pre-cut mounting board.

Model 1201—\$40.00 Audiophile Net. Model 1202—\$40.00 Audiophile Net. (Slightly higher in the West.)

**CALL YOUR V-M REP. TODAY!**

V-M CORPORATION • BENTON HARBOR, MICHIGAN

WORLD FAMOUS FOR THE FINEST IN PHONOGRAPHS, TAPE RECORDERS AND RECORD CHANGERS

the **VOICE** of **MUSIC**

SPECIAL  
ANNOUNCEMENT  
TO THE USERS

OF THE **B&K**

MODEL 1000  
DYNA-SCAN

Now for only \$89<sup>95</sup>

YOU CAN HAVE YOUR  
Model 1000 Dyna-Scan

CONVERTED  
BY THE FACTORY

to the latest  
SIGNAL INJECTION  
DIRECT VIEWING



MODEL 1075

TELEVISION  
ANALYST

(described on opposite page)



This unique plan has been set up, through the cooperation of B&K Distributors, to make it easy for you to obtain all the features and benefits of the sensational new B&K "1075" TELEVISION ANALYST at lowest possible cost!

Your converted unit will have the regular guarantee like a brand new instrument.

It proves again how we work to improve but not to obsolete your B&K equipment.

This conversion service is available through your B&K Distributor—or write to us.



**B&K MANUFACTURING CO.**  
3726 N. Southport Ave. • Chicago 13

## Reps & Distributors

**COLMAN TOOL & MACHINE CO.** appoints **KEENE SALES CO.**, Boston, Mass., as sales rep for the New England states.

**FERGUSON ELECTRONIC SUPPLY CO.** has appointed **ROBERT K. GORHAM**, Hastings, Mich., as sales rep for southern Mich.

**WESTBURY ELECTRONICS** has appointed **GRAYBAR ELECTRIC CO.**, as national distributor of TV distribution equipment and community antenna systems.

**BRUCE INDUSTRIES** of Gardena, Calif., has announced the appointment of 10 distributors for the newly-formed **ATOHM Electronics Div.**

**AMPEREX** appoints as reps in the Ark., La., Okla., and Tex. sales area the firms of **CROCKETT-LUND & Co.**, and **NORVELL ASSOCIATES**, both of Dallas, Tex.

**PYRAMID ELECTRIC CO.** has announced the appointment of **HYDE SALES CO.**, Denver, Colo., as industrial and jobber sales rep for the Rocky Mountain territory.

**BULOVA WATCH CO.** announces the appointment of two new firms to represent the Electronic Div.'s product line of crystal filters, package oscillators, etc. They are: **COMTRONIC ASSOCIATES**, Plainview, L. I., N. Y., for the N. Y. C. metropolitan area, and **KELLEY ENTERPRISES**, Loveland, Colo., for four Western states.

**ELECTRONIC INDUSTRY SHOW CORP.** adopted rules for eligibility requirements for the 1959 Show, May 18-20, which are the same as those of 1958 with one exception. Sales reps badges will now go to applicants who are either members of **THE REPRESENTATIVES of Electronic Products Mfrs.**, or affiliated with an independent contractor sales agency representing at least one exhibitor.

**HOFFMAN ELECTRONICS CORP.** names new distributors for two divisions. For the Semiconductor Div: **SPECIALTY DISTRIBUTING CO.**, Atlanta, Ga.; **STANDARD ELECTRONICS INC.**, Buffalo, N. Y.; **S. STERLING CO.**, Detroit Mich.; and **GEOPHYSICAL SUPPLY CO.**, Houston, Tex. For the Consumer Products Div. in the Mass.-N. H. area, **RADIO ELECTRONICS SALES**, Worcester, Mass.



**MOTOROLA** appoints **W. E. Laswell** sales manager for radio and phonos.

**VIDAIRE JL-8** and **JL-16 L-pads** for adding extra speakers have been released.

**ISOPHON Speaker div.**, Arnhold Ceramics, announces the **Isophon III**, with bass, midrange folded horn and two tweeters.

**SHURE BROTHERS** names **Harold J. Adler** vice president of operations, responsible for all engineering and manufacturing.

**FRAZIER speaker systems** by **International Electronics**, Dallas, has published literature showing its line from \$57 to \$995.

**BOZAK** introduces the **Urban infinite baffle enclosures** in modern design for its **B-302A one-woofer** and **B-305 two-woofer systems**.

**NORTHEAST RADIO**, 11-station FM broadcast net, has filed comments with FCC opposing the "dangerous trend and major problem of compatibility in the proposed 'wide swing' stereo use of the multiplex subchannel." Northeast favors the **Halstead system**; other stations favor **Crosby multiplex**.

**UNIVERSITY LOUDSPEAKER** has demonstrated the moderately priced **TMS-1 Trimensional Stereo Speaker system** in one 30" x 25" x 12 1/2" 3-section cabinet. It has a rear-facing woofer with dual voice coils in the center section, midrange and tweeter facing to the side at each end section. Mid and high frequency bounce from side walls are utilized. End-hinged front doors are positioned to control mixing of the two channels.

(Continued on page 90)

**NEW  
COMPLETE**

**DIRECT  
VIEWING**





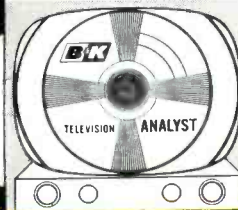
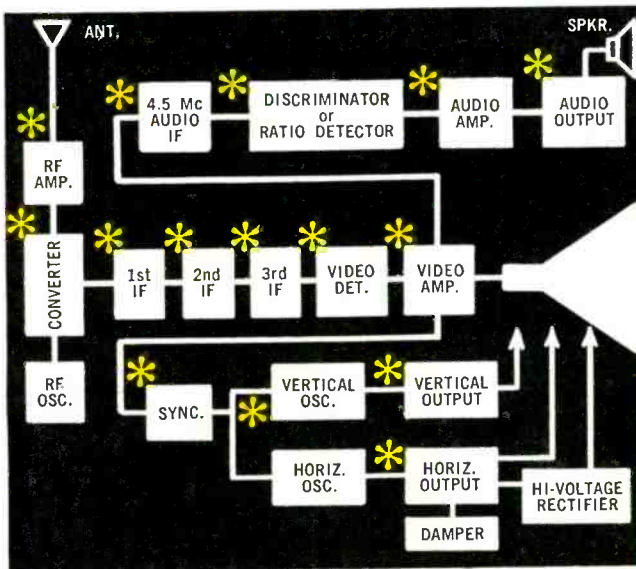

# TELEVISION ANALYST

**test each stage  
SEPARATELY**



← and watch the  
result on the  
TV set itself

**UNIQUE NEW SIGNAL-INJECTION TECHNIQUE  
Saves TV Trouble-Shooting Time and Work**

-  **R.F.** Supplies complete r.f. and i.f. signals with video and audio modulation to quickly trouble-shoot each stage in each of the sections of the TV receiver. Enables you to check the r.f. sensitivity and AGC settings of TV receivers.
-  **VVIDEO** Reproduces a complete test pattern on the screen of the TV picture tube and injects signals into each video stage of the TV receiver for fast, visual trouble-shooting and correction—anywhere, anytime. Makes it easy to check bandwidth, resolution, shading and contrast capabilities of the TV set.
-  **SYNC** Provides composite signal, sync positive and negative.
- SWEEP CIRCUIT DRIVING PULSES** Provides separate vertical and horizontal driving pulses for trouble-shooting deflection circuits.
- INTERMITTENTS** Test signal injection also aids in locating intermittent troubles.
-  **AUDIO** Provides a 4.5 mc sound channel, FM modulated with approximately 25 kc deviation. (This audio carrier is modulated either from a built-in 400 cycle tone generator, or from your own external audio source.) Injection of the 400 cycle tone signal simplifies trouble-shooting of the audio section.
-  **COLOR** Enables you to trouble-shoot and signal trace color circuits in color TV sets.
  -  Generates white dot and crosshatch patterns on the TV screen for color TV convergence adjustments.
  - Generates full color rainbow pattern of orange, red, magenta, blue, cyan, green to test color sync circuits, check range of hue control, align color demodulators, etc.
-  **SET ADJUSTMENT** Enables you to check and adjust the vertical and horizontal linearity, size and aspect ratio of television receivers.

**NEW**



**MODEL  
1075**

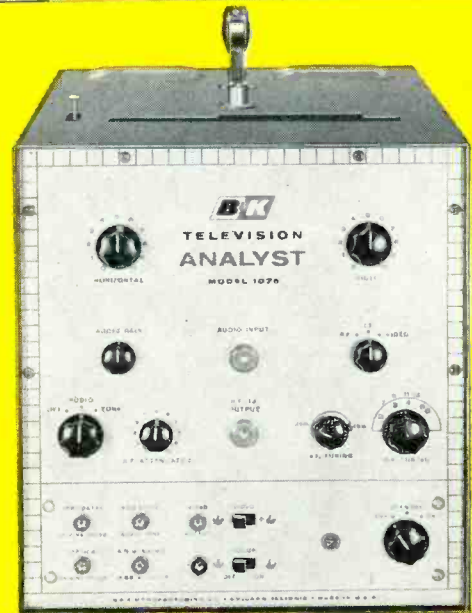

**QUICK, DIRECT, COMPLETE TV TROUBLE-SHOOTING**

Now, by point-to-point signal injection and test pattern reproduction, you can easily trouble-shoot and signal trace *any stage throughout the video, audio and sweep sections* of black & white and color TV receivers. With the remarkable new Model 1075 B&K TELEVISION ANALYST, you can quickly isolate and diagnose TV troubles (including intermittents). By use of the generated test pattern, you can *actually see* the condition directly on the picture tube of the television set itself. No external scope is needed. The TELEVISION ANALYST is practically a *complete TV service shop in one instrument!* **Net, \$259<sup>95</sup>**



See your B&K Distributor or write for Bulletin AP12-T

**B & K MANUFACTURING CO.**  
3726 N. Southport Ave. • Chicago 13, Illinois

Canada: Atlas Radio Corp., 50 Wingold, Toronto 10, Ont.

Export: Empire Exporters, 458 Broadway, New York 13, U. S. A.

here's your convenient,  
 economical way to buy dependable  
 crystal diodes...  
 at your CBS-Hytron  
 distributor's now



*More reliable products through Advanced-Engineering*

**CBS-HYTRON**, Danvers, Massachusetts • A Division of Columbia Broadcasting System, Inc.

# ELECTRONIC TECHNICIAN

Now Including  
**SERVICE**  
Magazine

## *Fighting Mad Over Captive Service*

Electronic-TV service technicians are mad . . . fighting mad over the efforts of some set manufacturers to set up captive service operations.

As an added inducement for buying their TV receivers, these companies are offering "free" parts and labor for an extended period of time. In point of fact it is not free. The consumer pays for the service (usually without knowing it) because it is built into the receiver's price. There is no something-for-nothing.

The independent technician is not afraid of ordinary factory service competition by manufacturers and their set distributors. It's good competition, and the independent can match his local contacts and personal interest against the giants.

However, when the factory service cost is "inboard," when the consumer has to take it with the set, when the manufacturer captures the customer with the first contact for additional future business, then the independent is justifiably up in arms. Then it's captive service.

The independent has his hands full repairing the "dogs" designed with price instead of serviceability in mind. The least he can expect is for the consumer to have an open choice of factory or independent service. Yes, just a fair chance of getting the business . . . which independents never get with captive service.

A manufacturer's captive service policy is shortsighted for four reasons. First, other producers copy the idea, so the sales advantage is lost. Second, it incorrectly leads the customer to believe it's a free deal. Third, it takes away business and alienates technicians who are prime component customers. Fourth, the technician's influential goodwill toward the manufacturer is lost.

A captive service manufacturer places a low inboard service charge on all sets covered, so the average set requiring repair is in effect paid for by the one or two not needing maintenance. Supposedly, the regional set distributor has the option of having inboard-priced service or not. And if he does take it, either the factory service or distributor's own service can be used on the one hand, or independents can be another choice. In actual practice with some companies, it's questionable that many distributors will appoint independents to

carry out the parts and labor warranty.

Thus by the overpowering influence of TV receiver sales departments, one management group is induced to carry out a captive program. Ironically, this undermines the sincere and helpful efforts on behalf of independents that are carried out by the component sales people in the same company.

### ***It's Everyone's Battle***

Independent service associations are in the vanguard of the fight to preserve locally owned and operated electronic maintenance businesses. But they are fighting more than their own battle. Where will jobbers be if all replacement parts go directly from the set producer to the captive service technician? And how broad a market could independent component manufacturers, those without receiver production, expect?

In the face of such potential danger to service technicians, jobbers and parts manufacturers, only the technicians have shown the Unite to Fight vitality. Even electronic publications which purport to represent the servicing industry have kept mum, either unaware or too frightened to sound off.

Captive service will fail . . . not because we wish it so, but because technicians are doing something about it. Here is what *you* can do: 1) Find the TV brands in your community that are being promoted with "free" 90-day service. There is no one national answer; it varies from area to area. Watch newspaper and broadcast media. 2) Call the local dealers and write to the regional distributors and manufacturers. Tell them that consumers value your opinion of set brands, and regularly ask for your advice. Tell them what you think of a captive service brand. 3) Call two friends in the service business, asking each to follow the same procedure . . . and to call two of their friends.

Service associations in every corner of the country are girding to fight captive service. Let's get the support of every individual technician—association member or not—to block this harmful practice.

Your future is linked to the success of independent service. It's worth fighting for!

*As an industry service, reprints of this editorial are available for 1¢ per copy.*

# Tuning In the

**REBUILT CRT's:** may not be completely remanufactured. Purchasers of rebuilt tubes normally expect to receive all new parts and a new phosphor screen with the exception of the glass or metal bottle. However, it is alleged that a few producers in southern California are not equipped to install a new neck and provide a new screen. Unusually lower prices for these products may be the tip-off. The Better Business Bureau has been informed.

**TEXAS JEWELER USES CLOSED-CIRCUIT TV:** to boost customer confidence. Harry Levit and his customers see a different kind of picture on the TV screen on his counter. They observe skilled watch repairers manipulate delicate parts which finally mesh together into a balanced movement. They observe experts polish diamonds, twist, bend, and weld gold and silver to form fine jewelry. A Blonder-Tongue "Observer" TV camera, mounted against a wall in the second floor workshop is helping overcome some of the common problems facing jewelers. Customers cautious about turning over their expensive jewelry to be repaired for fear that, once out of sight, something might happen to it, can now watch every operation first-hand.

**TWIN PANEL CRT:** is shatterproof, dustfree, contoured tube consists of a second contoured glass face panel permanently laminated to the original bulb. Two new laminating materials were developed—one by Rohm & Haas Co., the other by Dow Chemical Co.—to make possible the new process. Each of the two new substances has the same refractive index as the tube glass and panel glass. The process consists of casting a liquid plastic between the surfaces to be laminated. No pressure is required, and only moderate heat. The CRT is set on four flexible spacers inside the twin panel. The intermediate space between glass faces is filled with fluid plastic and then given a brief cure. The spacers are made of a material whose index of refraction matches the plastic.

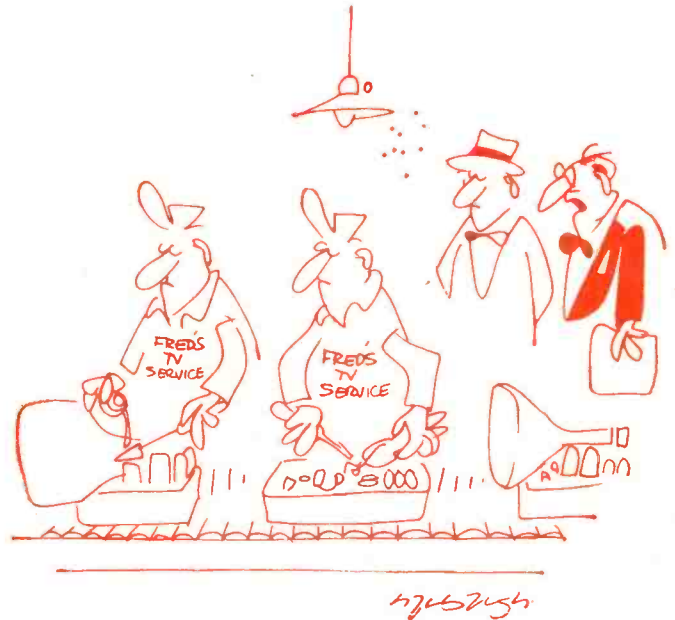
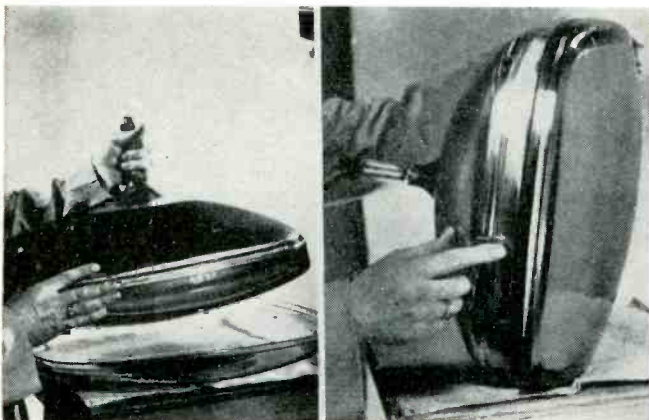

"How's business? Oh, making a living".

**CARRIER TELEPHONE:** A major breakthrough in telephone engineering—development of an electronic system expands two-voice channels to as many as 24 without laying additional cable between exchanges. The carrier is now being tested on actual telephone lines and will be in production next summer in ITT's communication division, Kellogg Switchboard and Supply Co. Carrier frequency is not actually sent over the cable. Only the modulation signal is transmitted, and its frequencies constitute a sort of electronic identification tag. At the receiving end this tagged signal goes to a synchronous detector which recreates the carrier called for by the tag and then sends it on in the proper channel. The new carrier system will find its greatest application in rapidly growing suburbs and metropolitan areas where it will be installed to expand the capacity of exchanges located 3 to 20 miles from each other.

**A STRATOSPHERE CHAMBER:** which gets colder than any place on earth or in the upper atmosphere, will test radars and other electronic devices—made by Raytheon Manufacturing Co., for the Air Force's B-58 Hustler bomber. Temperatures inside the chamber can vary from  $-100^{\circ}$  to  $300^{\circ}$ ; pressures, up to about 100,000 feet in space; and humidity, from 20 to 98%. Vibration tests can be run under any of the chamber's climatic conditions. The chamber is specially reinforced and is mounted on a 56-ton concrete base resting on thick rubber pads to prevent vibration damage to the rest of the building.



# Picture .....

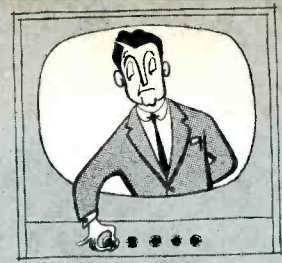

**FEDERAL TRADE COMMISSION:** issues 9-point guide aimed at fictitious pricing. In issuing to its staff this guide on where the law halts fictitious pricing, the Commission served notice on all advertisers and sellers that intensified enforcement has been ordered. It also signals a campaign to acquaint the public with price tricks that have enabled unscrupulous merchants to pass off regularly priced merchandise as bargains.

**UNDERWATER TV:** can be operated by remote control to depths exceeding 1,000 feet. The unit can be worked either by a diver or a remotely controlled propulsion unit from the surface. Navy tests will encompass many uses, one of which is the inspection of a ship's hull while underway. Fishing fleets may eventually employ underwater TV to seek out fishing areas. Offshore oil rigs and piers can also be surveyed with maximum ease from the surface, and underwater construction work can be materially aided. Sunken treasures and the mineral wealth under the sea may also be sought out.

**AUTOMATED RADIO PROGRAM SERVICE:** will be available to U. S. radio stations early in 1959. "Push-button broadcasting service" is based on the novel idea that the American adult prefers to listen to pleasant music rather than rock and roll and endless repetition of the "top 40" tunes. Orchestral and vocal treatments of standard favorites and new tunes with emphasis on the melody will be featured. It consists of an electrically-controlled, time-synchronized tape playback device and a supply of eight-hour tapes delivered regularly to subscribing broadcasters.

## CALENDAR OF COMING EVENTS

- Nov. 20-22: 56th Meeting Acoustical Society of America, Chicago, Ill.
- Dec. 3-5: Eastern Joint Computer Conference, Bellevue Stratford Hotel, Philadelphia, Pa.
- Dec. 3-5: 2nd Natl. Symposium on Global Communications, Colonial Inn Desert Ranch, St. Petersburg Beach, Fla.
- Dec. 9-11: Mid-American Electronics Convention, Municipal Auditorium, Kansas City, Mo.
- Jan. 12-14: 5th Natl. Symposium on Reliability & Quality Control, Bellevue-Stratford Hotel, Philadelphia, Pa.
- Mar. 3-5: Western Joint Computer Conference, Fairmont Hotel, San Francisco, Calif.
- Mar. 23-26: IRE National Convention, Coliseum & Waldorf-Astoria Hotel, New York, N. Y.
- May 6-8: Electronic Components Conference, Ben Franklin Hotel, Philadelphia, Pa.
- May 11-13: Joint Conference on Automatic Techniques, Pick-Congress Hotel, Chicago, Ill.  
Rigo Enterprises Hi-Fi Shows
- Nov. 14-16, Kansas City, Mo.; Nov. 21-23, Seattle.

**ELECTRONIC INDUSTRY ASSOCIATION:** directors adopt 5-point plan for fighting tube counterfeiting practices. The code proposes that manufacturers adhere to the following "principles": 1) Cooperation with law enforcement authorities; 2) Education of interested segments of the industry; 3) Follow recommendations of law-enforcing agencies; 4) Drying up of counterfeit tube sources, and 5) Establish and administer own warranty policies.

**RANDOM NOISE**

35 MEGA MILES

MARS CAN YOU READ ME?

TRANSLATION: WHAT ARE THOSE EARTHLINGS UP TO NOW?

**CATHODE METAL SPUTTERING TECHNIQUE PRODUCES PRECISION PRINTED CIRCUITS INCLUDING RESISTORS, CAPACITORS AND LEADS. TANTALUM AND TITANIUM (MELTING POINT 3000° AND 1,670°C RESPECTIVELY) CAN BE LAID DOWN IN ANY DESIRED SHAPE & SIZE RANGING IN WIDTH DOWN TO A FEW MILS AND IN THE THICKNESS BETWEEN A FEW HUNDRED AND A FEW THOUSAND ANGSTROMS-NO ORGANIC ADHESIVES ARE REQUIRED**

TOM HIGGINS JR.

AIRBORNE TV SHOWS NAVY ICEBREAKER PATH OF LEAST RESISTANCE-ICE RECONNAISSANCE AREA IS EXTENDED FROM 10 MILES TO 35 MILES, AND INFORMATION IS AVAILABLE IMMEDIATELY

# Understanding Industrial

## Closed-Circuit TV Presents Money-Making Opportunities To

CLOSED-CIRCUIT TV	
<b>Equipment</b>	
Camera	
Camera Control	
Master Monitor	
Remote Viewers	
<b>Transmission</b>	
Straight Video	
Video Modulated RF	
<b>Remote Control</b>	
<b>Audio Systems</b>	
Paging	
Intercom	

EDWARD M. NOLL

• A working knowledge of closed-circuit TV cameras, switchers, viewers, and other controllers is important to the technician interested in industrial and other commercial applications of TV. Opportunities for sales and service are growing. Widespread use and a large potential growth of closed-circuit TV can be conservatively predicted. The industrial TV camera is a much simpler and smaller version of the broadcast studio type. In commercial studio broadcasting, camera positioning, fo-

cusings and other operating conditions are controlled by a man at each camera. In most closed-circuit systems the camera is remotely controlled. If the camera is used in a permanent fixed position, the remote control activity is considerably reduced. The viewer from which the camera is controlled is referred to as the master monitor or master viewer. Other viewers, driven by the same camera signal, are called slave or remote viewers. If desired, cameras could be manually operated; but in installations where they are mounted in a tight spot or hazardous location, it is impossible to man them. Remote control also makes it possible for one man, stationed at the master monitor, to control the entire system.

A typical lay-out for an industrial TV system (ITV) is shown in Fig. 1. This particular system includes TV cameras, remote operating controls, video switcher, master monitor, and remote viewers. The operating controls for both cameras are located near the master monitor. The video switcher acts as a camera selector. The operator at the master monitor can choose and adjust the appropriate set of controls for the camera selected.

Fig. 1—Industrial closed-circuit TV system. Remote control and camera switcher enable one-man operation. Video frequency or R-F carrier type transmission may be employed.

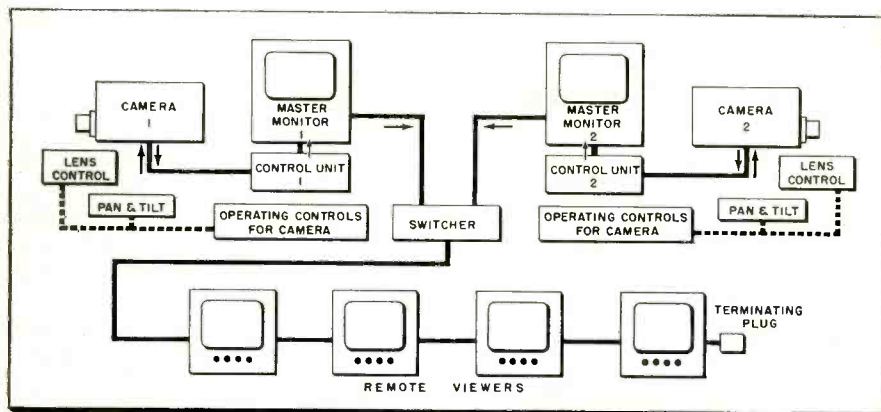

Fig. 2—Camera contains a vidicon CRT, video preamplifier and a blanking amplifier.

Viewers are fed from the master monitor in what seems to be a series hookup. Most viewers have two parallel jacks. To one jack is attached the cable from the master monitor or from the preceding viewer. A second cable is plugged into the second jack and carries the signal on to the next viewer. As in master antenna work, each set is across the transmission line, and the line must be terminated in its characteristic impedance. A dummy plug arrangement, including the terminating resistor, is inserted into one of the jacks on the viewer at the end of the line. No termination or an improper termination on a video cable can lead to a number of disturbances in much the same manner as standing waves on an antenna transmission line, such as: poor picture quality because of frequency or phase distortion; ghosts due to reflections and other transients; interference; and hum troubles. Cables exposed to foot traffic, jarring, or vibration usually are a source of trouble. They should be carefully installed, and frequently checked.

Various types of signal make-up may be employed. Simpler sync pulse formations are generally used. Horizontal and vertical pulses can

# Closed-Circuit TV Systems

*Electronic Technicians Interested In New Related Fields Of Endeavor*

accomplish both sync and blanking in their respective sections. Slotted vertical and equalizing pulses are usually not required. In most cases the combination sync-blanking pulses are generated in the camera control units, and are sent to the camera on separate lines. A composite video signal is then sent to each viewer. In some systems the pulses are generated at the camera. Instead of mixing sync and video, it is also possible to transmit them as separate signals over separate lines.

An r-f carrier method may be used. In this application a VHF oscillator, located in the camera or camera control unit is tuned to an unused commercial channel, and modulated by the composite video signal. This signal can then be fed directly to the antenna terminals of a standard TV receiver. This modulated r-f signal is usually not radiated, but is transmitted over coaxial cable to the viewers.

Not all ITV viewers and monitors require the same number of circuits. This depends upon the type of signal to be handled. For example, a monitor that must operate from a modulated r-f signal must provide suitable r-f amplification, video detection, sync separation and amplification, as well as the video circuits. As a matter of fact, this is essentially a complete receiver. If an r-f carrier is not used, and video is sent out directly, the r-f, i-f, and video detector sections can be eliminated. If sync and video are sent over separate lines, even the sync separator need not be included.

## Camera Chain

A single camera chain in its most basic form consists of a camera, camera control unit, and a monitor. The camera is pictured in Fig. 2, and its block diagram is shown in Fig. 3.

The camera contains a vidicon pickup CRT, deflection components, video preamplifier, and a blanking amplifier. Electromagnetic deflection, focus and alignment are used in much the same manner as a TV receiver. The blanking amplifier builds up a 3.5 volt peak-to-peak signal from the sweep chassis in the camera control unit, to 35 volts peak-to-peak, and feeds it to the grid of the vidicon, to block it during periods of retrace.

The camera control unit mounted under the master monitor in Fig. 4 is shown in block diagram in Fig. 5. There are actually five subassemblies in this control unit. In addition to the three shown, there is a two-chassis power supply, one holding the regulator, and the other, the rectifier sections.

Video from the camera is amplified in the video chassis from a level as low as 0.15 volts peak-to-peak to a 1-volt peak-to-peak signal. The video signal is then cor-



Fig. 4—Control unit under the master monitor contains sync, sweep and video chassis. Corrected for phase, clamped, additional blanking added, and then fed to the monitor through a level control. An

Fig. 3—Electromagnetic focus and deflection are used in this camera chain. The blanking amplifier feeds the blanking signal to the vidicon to block it during retrace periods.

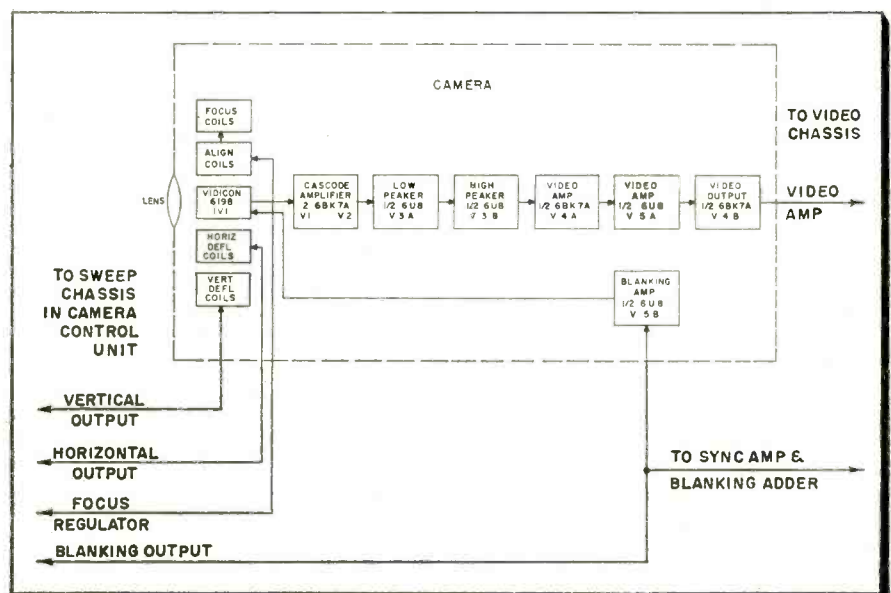

r-f oscillator is included in this chassis to provide a modulated r-f output if desired. The r-f frequency can be set for any channel from 2 to 6. Other external oscillators can extend the frequency limits to include the upper channels. The electronic aperture correction circuit can be switched in or out, or to intermediate positions to compensate for various lighting conditions.

The sync chassis provides both horizontal and vertical drive pulses. In this particular case a 31.5 kc oscillator is divided by 2 for the 15,750 cycle horizontal frequency, and by 25 and then again by 21 to obtain 60 cycles for the vertical section. In the event of trouble with the vertical frequency dividers it is possible to switch into the 60-cycle power line for line-locked scanning.

In the sweep chassis both horizontal and vertical deflection signals are generated and fed through the camera cable to the vidicon deflection yoke. The horizontal drive signal is, clipped, amplified, and mixed with vertical drive to produce blanking for the entire system. Amplified horizontal drive is also used to actuate the video clamping circuit in the video processing chassis. A single tube constant current focus regulator is included to hold vidicon focus current constant. The sweep

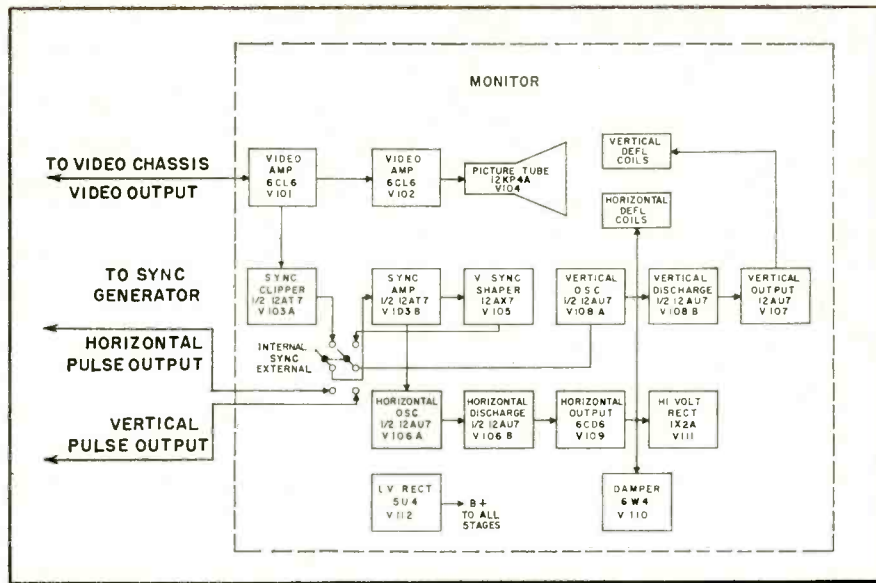

Fig. 6—Master monitor resembles conventional TV receiver, but has fewer circuits.

chassis also contains an electronic sweep failure protection circuit which extinguishes the vidicon beam in the event either horizontal or vertical sweep circuits fail, thus insuring the vidicon against damage.

The master monitor pictured in Fig. 4, and the block diagram in Fig. 6 resembles a conventional TV set in many respects. It presents no new situations to the TV technician. Up until this point, nothing has been

said of sound. The set-up for audio is the equivalent of an intercom or paging system. It may be a one way affair or provisions for talking back and forth can be arranged. It is highly desirable to centralize audio control at the master monitor, so that the same video operator can maintain complete overall control. •

Illustration Credits  
General Electric Co.

Fig. 5—In addition to the 3 chassis shown, the camera control unit contains a two-chassis power supply. An R-F oscillator is included in the video chassis for R-F carrier transmission. For vidicon protection in the event of sweep failure the beam is automatically extinguished. A single 31.5 kc oscillator in the sync chassis is divided by 2 for horizontal and by 525 for the vertical frequencies.

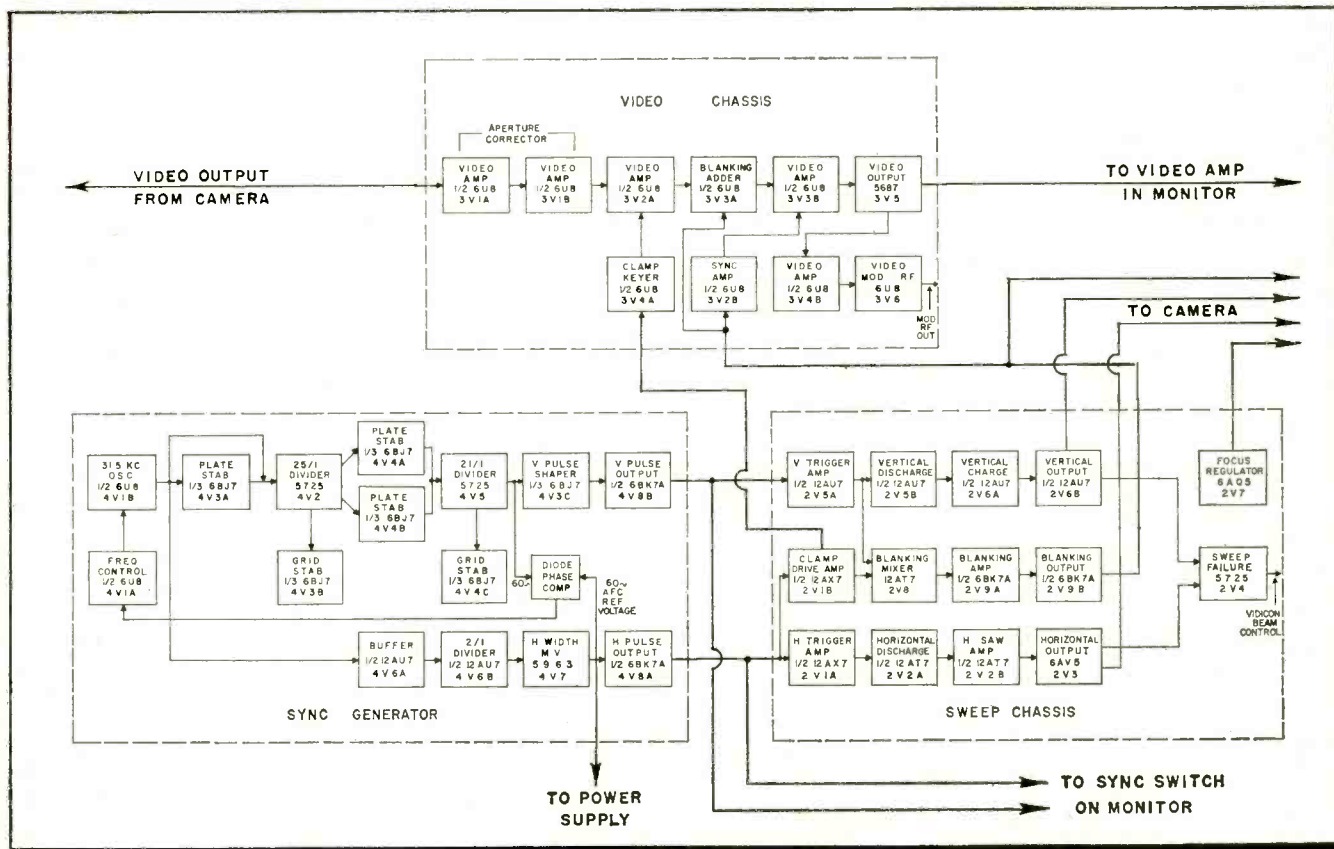

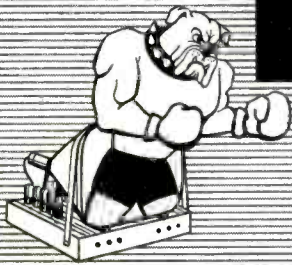

# "Tough Dog"

# Corner



## Difficult Service Jobs Described by Readers

### High Voltage Filter

This interesting case involves a 21" Zenith having a vertical chassis. Another shop had thrown in the towel. The problem was—very poor vertical-sync stability. The picture would hold if the vertical hold control was set just right, but the picture was very touchy and would pop right back out again. Also, I noticed that if the horizontal hold was mis-adjusted, the vertical hold would improve to the point where it would lock in very nicely. Tracing through the circuits with an oscilloscope revealed the presence of horizontal interference in the video and sync signals, all the way back to the video detector. That is to say, there were horizontal pulses being fed back somehow, in a manner such as to cause crosstalk with the vertical sync pulse. This would normally indicate an open filter or bypass. After bridging a capacitor across all sections of the filters, and eliminating all other means of entry through the various circuits, I decided there must be some other cause. I noticed that whenever my hand was inserted in the area between the picture tube and the vertical chassis, the interference would disappear and the vertical hold would lock in. I then looked for anything which could cause poor shielding or excessive pickup, but found nothing.

Not until much later, did I hit upon the cause of this dilemma. Someone had installed a rebuilt pic-

ture tube which had no external aquadag coating. This would have been acceptable, were it not for the fact that there was also no high voltage filter in the circuit. This meant that the pulsating 15,750 cycle voltage on the high voltage lead was completely unfiltered, and free to radiate off the picture tube's internal coating.

The obvious cure for this situation was to install a high voltage filter capacitor. This eliminated the trouble.—*Donald E. Tucker*

### Tough Cat Needed For Industrial Electronics

The most exasperating intermittent occurred in an automatic sand dispensing system. Sand from casting molds in dumped into a sand cleaning machine on the floor below. A conveyor then carries the cleaned sand up two stories into a large storage tank. When needed the sand from the storage tank is fed to the molding presses.

One cold morning, the storage tank ran dry. The photocell controlling the conveyor had failed to actuate a relay. Everything on the relay chassis seemed normal when visually inspected. A technician started up the ladder to the storage tank to inspect the light and cell, but before he reached the catwalk surrounding the tank, the conveyor tripped into operation. It ran until the tank was full, and then shut off in a normal manner. The reason for the failure could not be explained. Within a few weeks, the same malfunction re-appeared several times. The lamp and photocell were replaced, but to no avail. A new cable was installed from the photocell to the relay box. The old cable didn't look too good. Operation was still erratic. The bias on the relay tube was monitored around the clock. Sure enough, as suspected, the

photocell did not conduct when the trouble developed again. Again the climb up the ladder, and again before the catwalk was reached the conveyor started moving again.

It goes without saying, that by now, the baffled service crew were the laughing stock of the foundry, and worse, the ire of the management. Each breakdown meant a ten-minute interruption of the whole process which involved about 15 men.

The possibility of the two glass portholes in the tank either frosting or fogging up was investigated. The windows were found to be coated with soot and wiped clean, also some cobwebs were removed from their vicinity. Spring and warm weather arrived by then, and the trouble disappeared. It was impossible to tell whether or not the malfunction had been corrected. Everything worked nicely until the following winter. One cold morning, it happened! Same story.

Instead of approaching the catwalk from the bottom, the trouble-shooter went to the next higher floor, and inspected the photocell and light assembly from above. Suddenly he turned around, came down, picked a large screwdriver from his toolbox and was gone for about ten minutes. Ever since then, the machine was fully automatic, free of failure.

What had he noticed that everyone else had overlooked for so long? On the catwalk, he found shreds of newspaper, and other telltale evidence. The repair? Unscrew the light housing, move it forward about four inches, until the lens nearly touches the glass of the porthole, and fasten it in place. Now it was the rat's turn to be frustrated, since he could no longer warm himself on the beam!—*Paul Boller, Springfield, Ohio*

### TOUGH DOGS WANTED!

\$10 for acceptable items. Use drawings to illustrate whenever necessary. A rough sketch will do. Photos are desirable. Unacceptable items will be returned. Send your entries to "Tough Dogs" Editor, ELECTRONIC TECHNICIAN, 480 Lexington Ave., New York 17, N. Y.

# Troubleshooting Non-Linear

## Speed Analysis By Recognizing The Source Of Distorted Traces

### DISTORTED WAVEFORMS

- Detector Non-linearity**  
Signal Level
- Differential Overload**  
Frequency Response
- D-C Balance**
- Horizontal**  
Sawtooth Sweep  
Sinewave Sweep
- Vertical**  
Scope Sensitivity

ROBERT G. MIDDLETON

• Waveform distortion as observed on a scope tells much about circuit faults in receivers. Non-linearities can also indicate defects in the scope. Fig. 1 shows a sawtooth current wave obtained by inserting a small resistor in the return lead of the horizontal yoke winding. The scope is then connected across the resistor. The slight "wiggle" at the start of the sawtooth is an indication of ringing in a portion of the deflection current, and is a receiver fault. However, note that the consecutive sawtooth waveforms are not uniform. The first is convex,

Fig. 1—Changes in wave shape indicate a scope fault. Ringing is a receiver problem.

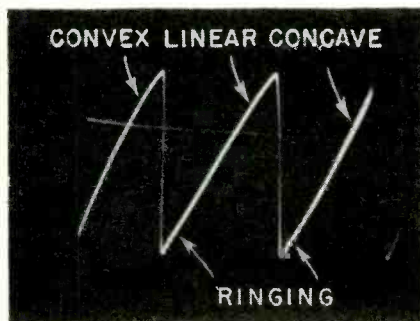

the second linear, and the third concave. This non-linearity is a scope fault, and in this particular case was due to low plate voltage on the scope's sweep multivibrator. Non-linearity in a TV receiver is readily noticeable either by the appearance of flat or pin heads, shrunken or

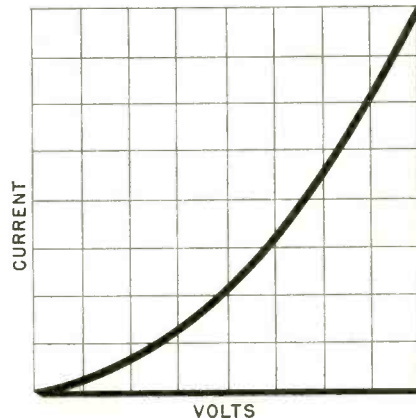
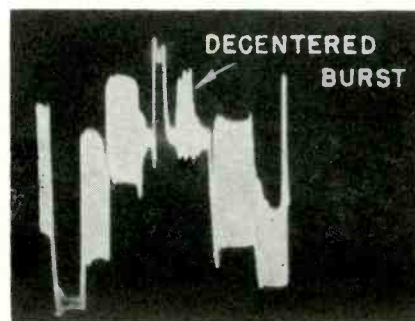

Fig. 2—Non-linear response curve of video detector requires proper signal level and loading for distortion-free output.

stretched legs, round circles appearing as ovals, objects changing in size as they move across the screen, etc. Distortion viewed on the scope whether or not it is due to the test instrument, its probe, or the circuit under test, is a bit more difficult to recognize because of the nature of the single line trace.

Here again experience is the best

Fig. 3—Too low a signal level at the detector expands top of waveform more than bottom. Note position of the burst.



teacher. Knowing what to expect, what to look for, and what to do about it comes from practice. Detectors and other inherently non-linear devices are responsible for the greatest number of distortion complaints. Many so-called linear devices are linear over a relatively small portion of its response curve, and if the operating point is shifted one way or the other, non-linear distortion is the result. A simulated response curve for a video detector is shown in Fig. 2. The amount of curvature varies from detector-to-detector and depends upon loading characteristics. The curve illustrates the cause of one type of distortion at lower signal levels. At higher signal levels, the response is more linear. As a result, at low signal level, the tendency is to expand the top of the waveform and compress the bottom.

The off-center color burst in Fig. 3 is a result of this type of non-linear distortion. The burst extends more in the upward direction from the back porch of the horizontal sync pulse. The wavy edges on the waveform may be attributed to a 920 kc beat note obtained from the 3.58 mc color subcarrier and 4.5 mc sound carrier in the receiver.

The opposite type of non-linear distortion is shown in Fig. 4. Here, the burst is also off center but this time it is farther below the back porch. This distortion is caused by

Fig. 4—Differential overload can be attributed to the scope's inability to handle all frequencies equally.

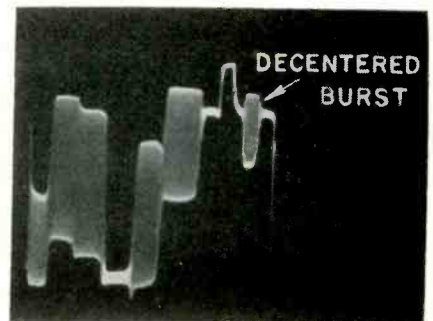

# Waveforms in Oscilloscopes

Which Can Be Caused By The Scope Or The Circuit Under Test

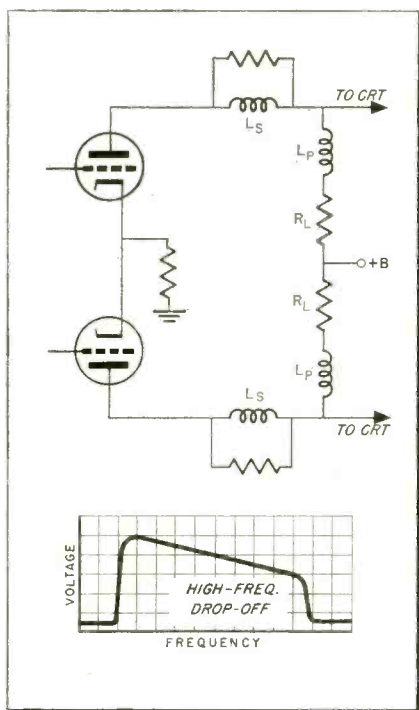
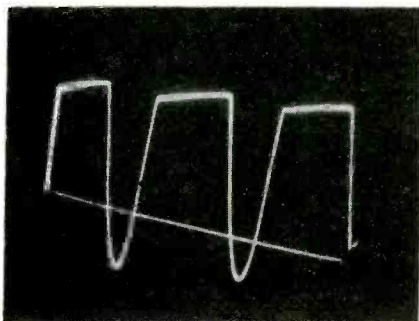

Fig. 5—Frequency response falls off as the load increases. Peaking coils, and stagger peaking flatten out the response.

differential overload in the scope. Differential overload simply means that the vertical amplifiers overload at certain frequencies before they overload at others. In the case of the 3.58 mc color burst, the response was limited. Differential overloading may be caused by a lack of flat frequency

Fig. 6—Overloaded scope shows up as clipping. Reduce sensitivity by setting vertical step attenuator to a lower position.



response in the last stage of the scope's vertical amplifier as shown in Fig. 5. The low-frequency response is determined by the values of the load-resistors, and the high-frequency response is built up by the peaking coils.

Should the load resistors have too high a value, the frequency response exhibits a high-frequency drop-off. One way to compensate for this condition is by stagger-peaking. Increased high frequency response can be built into a preceding stage. However, the scope is now susceptible to differential overload. The output stage can now be driven hard enough, by the higher frequencies to overload. Consider also that a high-frequency drop-off in the response of the output stage effectively reduces the load impedance at the higher frequencies. Accordingly, the signal-handling capability of the stage becomes still less at higher frequencies. As a result high frequency portions of the waveform are likely to go into an overload condition first. This non-linear distortion can be detected by advancing the vertical gain control, and observe the scope for any changes in the waveform. The remedy is to have each of the vertical-amplifier stages provide a flat frequency response. Incorrect vertical gain-control settings can cause severe non-linear distortion in many scopes. The input stage is generally

Fig. 7—Flattened non-linear sawtooth sweep voltage in the scope's horizontal amplifier cramped the right side of the waveform.

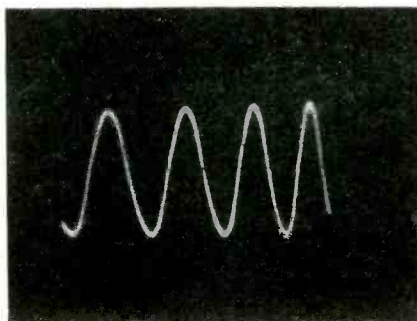

a cathode follower. When overloaded, severe clipping may occur, as shown in Fig. 6. To avoid this type of distortion set the course or step vertical-gain control as low as possible, and the vernier vertical-gain control as high as possible.

The horizontal amplifier is also a source of non-linear distortion. Fig. 7 shows a 60-cycle sine wave cramped on the right. Poor low-frequency response in the horizontal amplifier could be responsible for this condition. In this case the sawtooth deflection voltage in the scope was non-linear, and flattened towards the top. It was cured by increasing the value of the grid resistor in the horizontal amplifier. Fig. 8 is a more extreme case, and shows clipping in the horizontal amplifier. This condition can be attributed to more than just poor low-frequency response. This was the result of low plate voltage on the horizontal-amplifier output stage.

## D-C Scope

In a d-c scope, the d-c component can be determined from the relative vertical position of the trace. If a waveform has a zero d-c component, it will normally remain centered on the scope screen. However, if an a-c waveform moves up or down as the vertical-gain control is varied, a false d-c component is introduced by

(Continued on page 73)

Fig. 8—Clipped or flattened horizontal sweep voltage in the scope shows up as a more severe case of cramping.

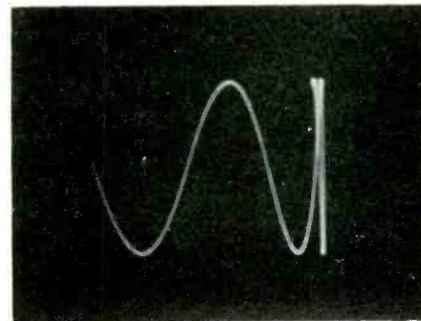

# Detecting Pulsed Damaged

## Transient Characteristics Of Pulse Signals Conceal Their

### SUMMARY

Open bypass and filter capacitors can cause resistors to burn out because of excessive peak-to-peak voltage. Resistors can also burn out even when everything else in the set is operating normally. Power dissipation ratings should be based on both ac and dc currents. When parts fail for no apparent reason, look for excessive pulse signals. The scope is an essential test instrument for troubleshooting this type of difficulty.

ALLAN KINCKINER

• When components seem to fail for no apparent reason, look for pulse signals. Unfortunately, because of the transient character and low average voltage of these signals, extremely high peak pulses can escape detection when the scope is not used. VOM's and VTVM's are average voltage indicators and while they may be calibrated for rms and peak-to-peak readings, these indications are usually for sinusoidal waveforms only. High pulsed voltages are found mostly in and around the horizontal output section, and improperly filtered B+ circuits. Some AGC and AFC circuits are purposely exposed to a sample of the flyback pulse, and

when a circuit upset causes this sample to be too small or too large, various types of difficulties present themselves. Too often these troubles are so subtle that they are difficult to define. In spite of this, just an awareness of the potential problem and an oscilloscope can make pulse hunting a routine troubleshooting procedure.

Resistors change in value or burn out when they are subjected to excessive heating conditions. The general rule of using resistors with a wattage rating of four times larger than the anticipated circuit requirements is often compromised to begin with, and too often only d-c characteristics are considered. Both B+ and signal voltages must be taken into consideration. True, many pulse signals are of short duration, and their rms values are small, but even under normal operating conditions these signal currents do contribute to the heat developed in a resistor.

Troubles can be attributed to two major conditions: Those that develop over a long period of time because of the use of resistors which are operating too close or beyond their wattage rating; usually, in this case, all voltages and other compo-

nents are normal, and there is seemingly no breakdown. The other major condition involves abnormally large pulses due to defective bypass and filtering capacitors, and other circuit faults.

Under these circumstances, trouble symptoms develop rapidly. In both cases, the scope will help to determine the extent of repairs necessary. Where normal peak-to-peak waveforms exist, the solution is to use larger wattage resistors. Where waveform amplitudes are excessive, it is necessary to find the circuit fault, as well as to replace the burned out resistor. To further emphasize and demonstrate the techniques and problems involved, some actual situations are presented.

"No raster, something burning. Check horizontal hold when repaired—hold was critical before the set went dead," were the complaints on a General Electric U chassis. A partial schematic is shown in Fig. 1. A 330-ohm, 1-watt resistor, R310, was badly charred and was easily found, just by visual inspection. An ohmmeter test confirmed the visual check; the meter indicated infinite resistance. Further tests with the ohmmeter failed to turn up any

Fig. 1—No raster, something burning—resistor R310 was damaged by pulse currents due to open filter capacitor C400B.

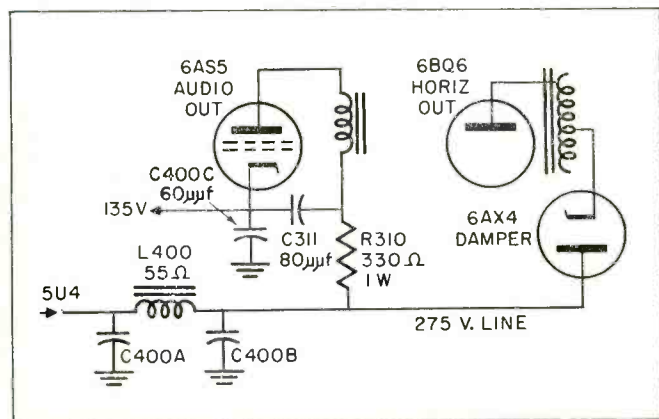
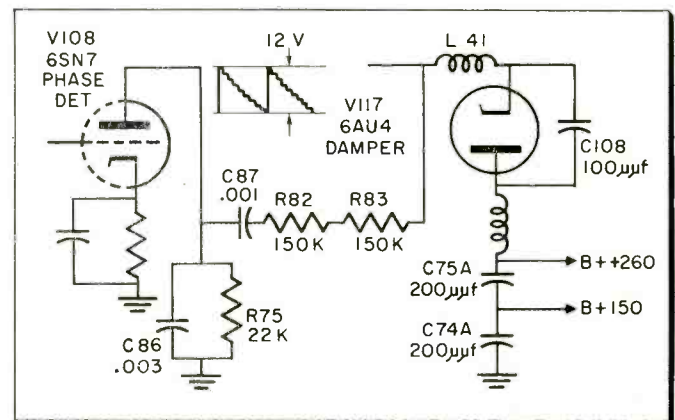

Fig. 2—When resistor R82 was damaged for no apparent reason, shock treatment exposed an intermittent capacitor C75A.





# Components In TV Receivers

## Identity And Potential Unless Viewed With An Oscilloscope

reason for the burn-out. The possibility of an intermittent short causing the trouble was considered. A new resistor was wired in and the set turned on. Sound and picture came in fine; the raster was slightly narrow, and the horizontal hold control adjustment was extra critical. In addition, the new resistor was overheating. The voltage drop across this resistor was measured and found to be 15 volts. This would normally indicate a power dissipation of only 0.68 watts. Certainly not great enough to cause so much heat to be developed in so short a time.

What then? The scope, when connected to the plate side of the resistor and ground, revealed an undulating signal having peaks in excess of a hundred volts. Further investigation led to an open filter capacitor C400B. The pulse which would normally be passed to ground through this capacitor, was now returning to ground through R310, C311 and C400C. It was now evident that this pulse was responsible for the open resistor. Replacing the filter cleared the trouble. The pulse could not return to ground through the 55 ohm choke and capacitor C400A. While the choke is only 55 ohms to dc, it is a 1-henry affair and at 15,750 cycles, it presents a reactance of about 99,225 ohms. This case history might appear as an odd situation to those not familiar with pulse problems. Usually a resistor will be damaged by a shortened capacitor, and not by one that is open. An open capacitor, or one that has lost a portion of its capacitance, loses its ability to bypass ac and results in higher-than-normal a-c voltages.

As usual, intermittent component failure is the most difficult to track down, and when it happens in circuits suffering from pulse damage, a benchman might really have something to talk about. This Motorola

chassis TS528, Fig. 2, stressed the importance of experience. The symptoms were extremely critical horizontal hold. Camera switching or channel changing would cause the picture to tear out. New sync and horizontal AFC tubes made no difference. The scope showed sync pulses present on the grid and cathode of the AFC tube, but the pulse from the flyback was absent at the plate. In order to trace the circuit, the cover over the horizontal output transformer and associated parts were removed. It was then discovered that resistor R82 was badly burned. R82 and its companion R83 were replaced with 2-watt resistors instead of the 1-watt units. AFC action and horizontal hold were thus restored to normal.

However, previous experience with similarly defective sets indicated that these resistors usually burned out only when C75A was open. The scope showed no pulse across the capacitor and therefore the capacitor seemed to be functioning properly.

Not being satisfied, C75A was shocked by momentarily shunting it with another 40  $\mu$ f unit, while the scope was still attached. Sure enough, C75A opened. Further shock treatment would alternately open or heal the filter, thus revealing an intermittent condition. Capacitor C75A was replaced. Difficulties often arise when either of these resistors change in value. Poor horizontal hold and christmas-tree effect may be encountered.

Unfortunately, resistors that have changed in value, do not always result in a significant trouble symptom. This is particularly true when the change is gradual, and another set is not available for comparison. Since many characteristics of TV are relative, and some of the shortcomings have been more or less accepted, it is quite possible for a slight departure from normal operation to be overlooked. One might ask, "If trouble isn't noticeable, why bother?" The reasoning behind a correct answer (Continued on page 88)

Fig. 3—Resistor R436 changed in value, reduced the drive, decreased the width and prematurely ruined the horizontal output tube. Since no other components were defective a higher wattage resistor was used to prevent recurrence of the trouble.

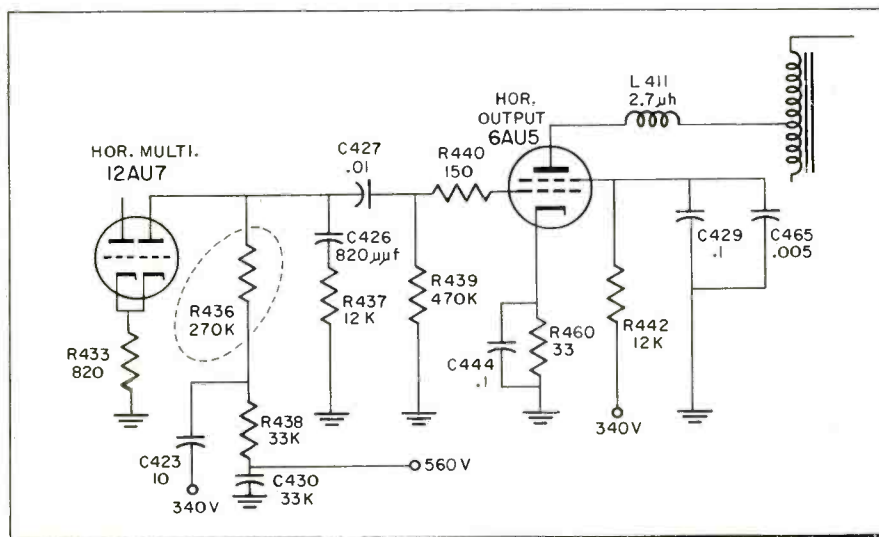

# SHOP HINTS



## Tips for Home and Bench Service

### Sliding Rack For Test Equipment

Special trucks, racks, stands and tables for test equipment have been on the market for some time now. I find they leave much to be desired. The main trouble is that the test leads are usually in the way and when trying to get around one end of the set or the other, one has to be a contortionist to avoid shorts, broken tubes and leads. I have

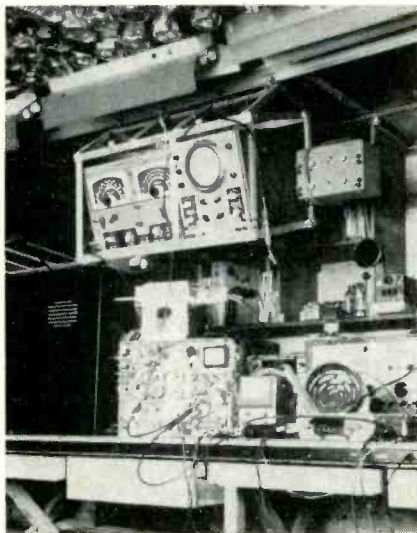

Overhead sliding equipment rack provides more room on the bench, and speeds servicing.

struggled and tried many devices and ideas in an effort to get a decent set-up, which would eliminate moving either the set to be serviced or the test equipment. I designed an equipment carrier which holds my scope, signal generator and electronic switch. The carrier is a cage-like framework made up of 1" angle iron, and some 1" flat stock. An old bedspring and parts of a large wall-mount antenna bracket set may also be used to build the carrier. After the cage is assembled, it can be mounted on a track installed over the bench. Track and roller kits designed for roll-away doors were

used. Since these kits are usually only 6 feet long, two of them were obtained and placed end-to-end. This permitted the cage to slide over a 12 foot length of the bench. The test equipment was mounted at an angle to facilitate viewing from either a standing or sitting position. When in use, the test leads drop almost straight down, thus assuring maximum freedom of motion and minimum damage. When the equipment is not in use, the leads can be conveniently hung on a couple of hooks installed at the top of the frame, as shown in the photograph. Total cost of the carrier is approximately \$27.00—C. R. Williams, Baltimore, Md.

*This seems like an ideal set-up for the integrated test equipment approach described on page 34 of the September 1958 issue of Electronic Technician. The overhead jars in the photo look like the makings of another shop hint.—Ed.*

### Color TV Focus

In some cases where the focus control has failed in the RCA 800 series color receiver, it has been found that the focus voltage black wire from the kinescope socket to R122 has been pinched under the high-voltage compartment cover. This can cause arcing at this point, and may contribute to failure of the focus control. Proper lead dress will prevent this. When re-installing the HV compartment cover, make sure that this wire is placed in the cutout in the cover, and not under the cover itself.—RCA Service Co., Camden, N.J.

### Hidden Sputter

Shop Hint or Tough Dog? Either way, it may be of value. Use it as you please.

Intermittent fuse blowing for no apparent reason and a slight sput-

tering sound would be heard at times from the interior of the receiver were the symptoms on this portable RCA chassis KCS102. This trouble could also happen on other sets. All tubes checked ok, even when the damper, horizontal oscillator, high voltage rectifier and horizontal output tubes were replaced, the fuse would still blow out. Sometimes the receiver would operate for a day or two without trouble. With the rear cover plate off and a cheater cord plugged into the receiver, I allowed the set to operate while I went on about some other repair jobs. When the sputtering next occurred, I noticed a faint glow in the vicinity of the yoke. Fortunately I happened to be looking at the set just as it started to sputter. I removed the CRT socket and ion trap, unsoldered the four yoke leads from the terminal strip on the chassis, and slid the yoke off the neck of the tube. Close examination of the yoke showed a small burned spot at the edge of the winding closest to the bell of the CRT. Matching this spot with the bell, I found the cause of the trouble. A foil-covered, thin-cardboard strip clamped around half of the yoke opening in the chassis had bent inward (possibly from electrostatic attraction) and was just touching the edge of the yoke winding. I bent and dressed the cardboard back out of the way, and cleaned the burned spot. Two coats of coil dope and two strips of high voltage tape cured the trouble.—Maurice G. Goldberg, St. Paul, Minn.

### SHOP HINTS WANTED!

\$3 to \$10 for acceptable items. Use drawings to illustrate whenever necessary. A rough sketch will do. Photos are desirable. Unacceptable items will be returned. Send your entries to "Shop Hints" Editor, ELECTRONIC TECHNICIAN, 480 Lexington Ave., New York 17, N. Y.

# Hi-Fi Rating Organizations

Special Report Examines Qualifications Of "Judging" Groups.

Proposal Outlines Self-Policing Goal For Industry.

ALBERT J. FORMAN  
Editor

• For many years the hi-fi industry has observed the judgment passed on its products by Consumers Union and similar groups. Now two new organizations have entered the field: the High Fidelity Consumer's Bureau of Standards, and the American Audio Institute. Their procedures vary, but basically all are dedicated to testing and rating equipment. It is not improbable that other similar organizations with Institute, Bureau, League or Society names may be set up.

There are several important aspects to the problems posed by rating organizations, but the two most important points—one pro and one con—are, in our judgment, as follows:

1) These organizations cannot be shrugged off as a group of self-seekers or unrealistic do-gooders. A need exists for establishing hi-fi standards, and enforcing compliance by educating the public to recognize true hi-fi. Failure of the industry to monitor itself and establish hi-fi recognition has created the void which rating organizations are attempting to fill, presumably in good faith.

2) Rating organizations, as they are presently constituted, are not geared to function with all the broad-based support, singular recognition, extensive knowledge and assured "purity" required of a group exercising such great responsibility and authority. In the words of one observer, "Who appointed them?" What is to stop a dozen others from

cropping up? Who will judge the judges?

## Evaluating The Rating Organizations

There are numerous other shortcomings in each organization's operation—shortcomings which could disqualify each from becoming the final arbiter of hi-fi rating . . . despite their good intentions. Their most constructive aspect is the attention they focus on the need for widely accepted hi-fi standardization. Consider the following drawbacks applicable to one or more of the three rating groups mentioned:

1) Two of the three require direct payment for each test from the manufacturer whose product is being tested. A manufacturer is free to take his business to the most appreciative group.

2) Two of the three do not release actual laboratory measurements.

3) One of the three does not reveal who are its officers, directors and technical staff members.

4) None have developed and released sufficiently extensive standards for making the measurements upon which their ratings will be based. (Comparison: Final draft of Measurement Standards for High Fidelity Tuners, prepared by close to 20 top industry engineers on the Institute of High Fidelity Mfrs. Committee, runs 31 pages . . . for tuners alone).

5) Two of the three have not yet made available a description of the instruments and facilities used in making the tests.

6) Two of the three are new organizations, formed around a small nucleus of individuals, rather than the official outgrowth of a proven and recognized association such as the Audio Engineering Society or the

Institute of High Fidelity Manufacturers.

7) None require testing all products in a manufacturer's line. Thus approval or disapproval of one unit reflects favorably or unfavorably on other products in the line.

8) None has established a real review procedure whereby incorrectly rated products may appeal and have "equal time" if an error is shown.

There are other possible shortcomings—both technical and political—but the important point is that there are too many loopholes or too few check-and-balance controls. Such flaws are not mere oversights caused by hasty organization. On the contrary, rating organization procedures show thoughtful consideration. The limitations are inherent in existing organization structures and basic policies. These groups would serve better to concentrate on testing and providing engineering consultation for manufacturers, instead of attempting to act as judge and jury.

The problem of developing public recognition for true hi-fi still remains . . . and we would like to propose a solution which draws upon the experience of the much older publishing industry.

But before we do, let's examine each of the three organizations individually.

**HIGH FIDELITY CONSUMER'S BUREAU OF STANDARDS**, Box 268, Madison Square Station, New York 10, N.Y. William J. Gettens, Director. Does not reveal names of officers, directors and consultants; people said not to be affiliated with any companies in hi-fi-field. Newly formed, in process of being incorporated. Attorney is Richard Rowe, of Breed, Abbott & Morgan, 15 Broad St., New York City. Test facilities

(Continued on page 46)

Improve Your Skills By

# Building a Technical Library

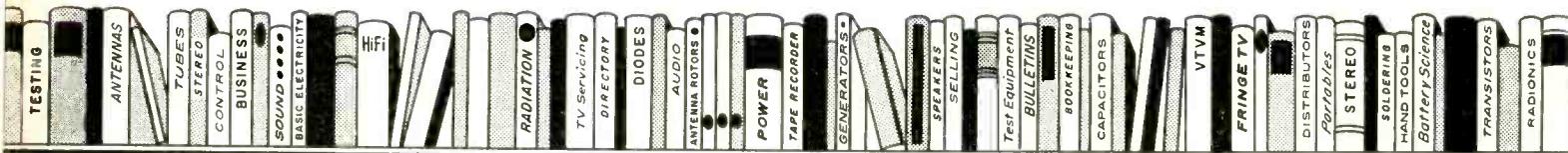

## HOME AIR CONDITIONING INSTALLATION & REPAIR

By J. Derman, F. Makstein & H. Seaman. Both theory and practical construction designs are examined, along with maintenance techniques and procedure for determining size of air conditioner required. Covers motors, compressors, condensers, evaporators, regulating valves, circuits and other system elements. Soft cover, 160 pages. Price \$3.50.

## INDUSTRIAL CONTROL CIRCUITS

By Sidney Platt. Excellent starting point for TV technician interested in learning about industrial electronics. Non-mathematical text explains circuitry and operation of power controls, relays, timers, photoelectric devices and instrumentation found in factories. Practical applications shown. Soft cover, 200 pages. Price \$3.90.

## REPAIRING HI-FI SYSTEMS

By David Fidelman. How to find and correct troubles in hi-fi equipment with either little or elaborate test equipment. Among the many subjects covered are servicing amplifiers, preamps, tuners, tape recorders, changers, pickups and speakers. Construction and custom installations are discussed. Soft cover, 212 pages. Price \$3.90.

## PORTABLE AND CLOCK RADIOS

By Ben Crisses & David Gnessin. Written from a practical viewpoint with theory kept to a minimum, this practical volume emphasizes repair, design, replacements, alignment, current drain and related circuit problems. Dial stringing, clock mechanisms and transistorized circuits are covered. Soft cover, 128 pages. Price \$2.75.

## SHOOT TV & RADIO TROUBLE FAST

By Harry G. Cisin. The first part of this book relates to symptoms, faults and remedies for ac-dc radios. The second part covers TV, with each practical test and repair explanation related to a specific problem. Printed circuits are discussed. Soft cover, 40 large pages. Price \$1.50.

## BASICS OF DIGITAL COMPUTERS (3 vols.)

By John S. Murphy. Using the easy-to-learn picture book technique, these three volumes explain the theory and functions of digital computers. Very little mathematics. Covers counting systems, computer language, programming, memories, logic diagrams, flip-flops, clamping, input-output and data processing. Soft cover, 416 pages. \$6.95/set.

## IMPEDANCE MATCHING

By Alexander Schure. Divided into five major sections, this informative book covers power transfer, impedance matching devices, matching at audio and r-f, and matching in transistor circuits. Complete with tables, schematics and computation examples. Soft cover, 128 pages. Price \$2.90.

## RADIO OPERATOR'S LICENSE Q & A MANUAL

By Milton Kaufman. This sixth edition gives you the information you need to pass FCC license examinations. In question and answer form similar to actual FCC tests, all eight elements are covered, including law, radiotelephone, radiotelegraph, aircraft and ship radar. Abbreviations, code, etc. included. Hard cover, 736 pages. Price \$6.60.

## HOW TO SERVICE TAPE RECORDERS

By C. A. Tuthill. Starting with basic magnetic principles, the text goes through the recording operation, recorder mechanisms and circuitry. In addition to an explanation of the functions of the various recorder elements, the techniques for repairing various troubles and making tests are presented. Soft cover, 160 pages. Price \$2.90.

## ELECTRONIC MUSICAL INSTRUMENT MANUAL

By Alan Douglas. This third edition guide to the theory, operation and design of electronic organs and related equipment goes into detailed description of musical waveforms, music producing circuits, sound generators, and operating controls. Complete diagrams are given for various commercial units. Hard cover, 254 pages. \$7.50.

## STEREOPHONIC SOUND

By Norman Crowhurst. This first assessment of the new stereo techniques sweeping the hi-fi field starts with the basics of binaural listening, and then concentrates on actual systems. Subjects include radio, disc, tape, recording procedure, speaker placement, system construction and theatre systems. Soft cover, 128 pages. Price \$2.25.

## REPAIRING RECORD CHANGERS

By Eugene Ecklund. This practical manual on the repair of record changers covers mechanical elements, such as drives, tripping and dropping mechanisms, change actions and spindles. It also explains pickups, needles and motors. Amplification compensation, fault location and tests are included. Hard cover, 278 pages. Price \$5.95.

## ELECTRONICS IN INDUSTRY

By George Chute. How various electronic devices operate, and how they are employed in industry is clearly explained with little use of mathematics. Subject matter includes rectifiers, time delays, gas tubes, welding controls, ignitrons, heat and light relays, thyatrons, motors, servos and others. Hard cover, 431 pages. Price \$8.00.

## OBTAINING & INTERPRETING TEST SCOPE TRACES

By John F. Rider. This handbook shows how to get the most out of your oscilloscope. Over 800 traces are shown, including sine, square, rectangular, trapezoid, sawtooth differentiated and integrated types. Explains scope connections, manipulating controls and test setups. Soft cover, 190 pages. Price \$2.40.

## SMALL APPLIANCE SERVICING

By P. T. Brockwell, Jr. This volume gives you professional small appliance servicing techniques and business procedures. Illustrated instructions tell how to test units. Covers irons, toasters, mixers, roasters, coffee makers, waffle irons, rotisseries and others. A profitable sideline for TV technicians. Hard cover, 180 pages. Price \$4.50.

ELECTRONIC TECHNICIAN editors have carefully selected these books by the world's leading technical publishers. Order direct from our Book Department. Fill in coupon or separate sheet. Money-back guarantee.

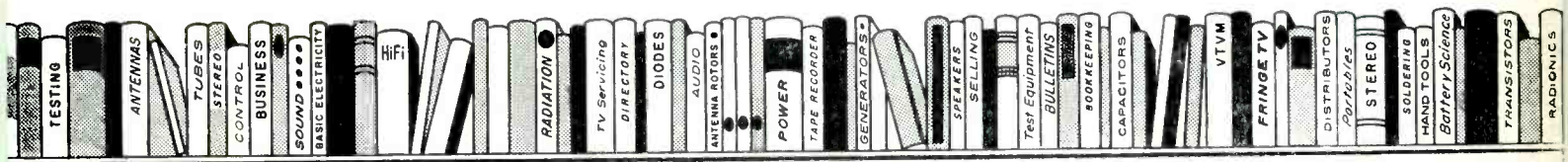

### TRANSISTORS IN RADIO AND TELEVISION

By Milton Kiver. With transistorized receivers becoming increasingly important, technicians should find interest in this descriptive treatment of both point contact and junction types. Circuits described include both amplifiers and oscillators. Servicing, experiments and characteristics are discussed. Hard cover, 340 pages. Price \$7.00.

### HOW TO RUN A SMALL BUSINESS

By J. K. Lasser. Here is a basic business guidebook for service dealers and other operators of retail and small manufacturing firms. Covers record keeping, avoiding frauds, tax management, credit sales, insurance programs, how to buy an established business, financing and other important topics. Hard cover, 400 pages. Price \$4.95.

### HANDBOOK OF BASIC CIRCUITS, TV, FM, AM

By Matthew Mandl. The schematics and functions of 136 carefully selected circuits found in home and industrial electronic products are analyzed. AVC bridges, AGC, dampers, sawtooth, discriminators, limiters, splitter, sync stretchers, multi-vibrators and doublers are among the many important ones presented. Hard cover, 365 pages. Price \$7.50.

### Books Described in Previous Issues

BASIC TELEVISION (5 vols.)	\$10.00
INTRODUCTION TO PRINTED CIRCUITS	\$ 2.70
BASIC ELECTRONICS (5 vols.)	\$10.00
INTRODUCTION TO COLOR TV	\$ 2.70
INTRODUCTION TO UHF CIRCUITS & COMPONENTS	\$ 7.50
PROFITABLE RADIO TROUBLE-SHOOTING	\$ 5.95
ELEMENTS OF MAGNETIC TAPE RECORDING	\$ 7.95
MANDL'S TELEVISION SERVICING	\$ 6.50
CLOSED CIRCUIT & INDUSTRIAL TV	\$ 4.95

### PINPOINT COLOR TV TROUBLES IN 15 MINUTES

By Harold P. Manly. This practical troubleshooting book covers 150 types of faulty pictures with over 1000 troubles. The "check-chart" system points up possible troubles. Circuits explained include i-f, agc, detector, luminance, chrominance, subcarrier, sync and others. Plastic spiral bound. Soft cover, 548 pages. Price \$5.95.

### TV DOCTOR

By Harry G. Cisin. This compact text presents the basic practical knowledge required to recognize and remedy TV receiver troubles. Chapters are also devoted to color TV, easy checks, antenna techniques, UHF and circuit symbols. A helpful servicing starter. Soft cover, 37 large pages. Price \$1.

Also See New Books On Page 72

# FREE!!

### STATION LISTINGS BOOK

With every book order for \$7.50 or more, you will be sent—without charge—a copy of the 64-page reference book, "Jones North American AM-FM-Radio-TV Station Listings." It lists over 5000 stations from official FCC information. Covers the United States and possessions, Canada, Cuba, Mexico and West Indies. Stations are cross-referenced by geographic location, by frequency, and by call letters. Lists AM and TV network affiliations and AM operating power. A wealth of broadcasting information!

CUT HERE

11-58

ELECTRONIC TECHNICIAN Book Dept.  
480 Lexington Avenue  
New York 17, N.Y.

*I plan to build my technical library. Please send me the books I have indicated below. You will pay postage. I understand that if I am not satisfied with any book for any reason, I may return it to you prepaid in good, clean condition within 7 days of receipt and receive a complete refund. If my order is for \$7.50 or more, I will receive a free copy of the Station Listings Book.*

*Enclosed is my check or money order, in full payment, made out to ELECTRONIC TECHNICIAN.*

___ Home Air Conditioning Installation & Repair	@ \$3.50	___ Repairing Record Changers	@ \$5.95
___ Industrial Control Circuits	@ \$3.90	___ Electronics in Industry	@ \$8.00
___ Repairing Hi-Fi Systems	@ \$3.90	___ Obtaining and Interpreting Test Scope Traces	@ \$2.40
___ Portable and Clock Radios	@ \$2.75	___ Small Appliance Servicing	@ \$4.50
___ Shoot TV & Radio Trouble Fast	@ \$1.50	___ Transistors in Radio and Television	@ \$7.00
___ Basics of Digital Computers	@ \$6.95	___ How to Run a Small Business	@ \$4.95
___ Impedance Matching	@ \$2.90	___ Handbook of Basic Circuits, TV, FM, AM	@ \$7.50
___ Radio Operator's License Q & A Manual	@ \$6.60	___ Pinpoint Color TV Troubles in 15 Minutes	@ \$5.95
___ How to Service Tape Recorders	@ \$2.90	___ TV Doctor	@ \$1.00
___ Electronic Musical Instrument Manual	@ \$7.50		
___ Stereophonic Sound	@ \$2.25		

BOOKS IN PREVIOUS ISSUES:

Enclosed is total payment of \$ \_\_\_\_\_ @ \$ ...  
(New York City address, add 3% sales tax)

Name \_\_\_\_\_  
Address \_\_\_\_\_  
City \_\_\_\_\_ Zone \_\_\_\_\_ State \_\_\_\_\_

# QUALITY ISN'T SOMETHING YOU SWITCH ON AND OFF!

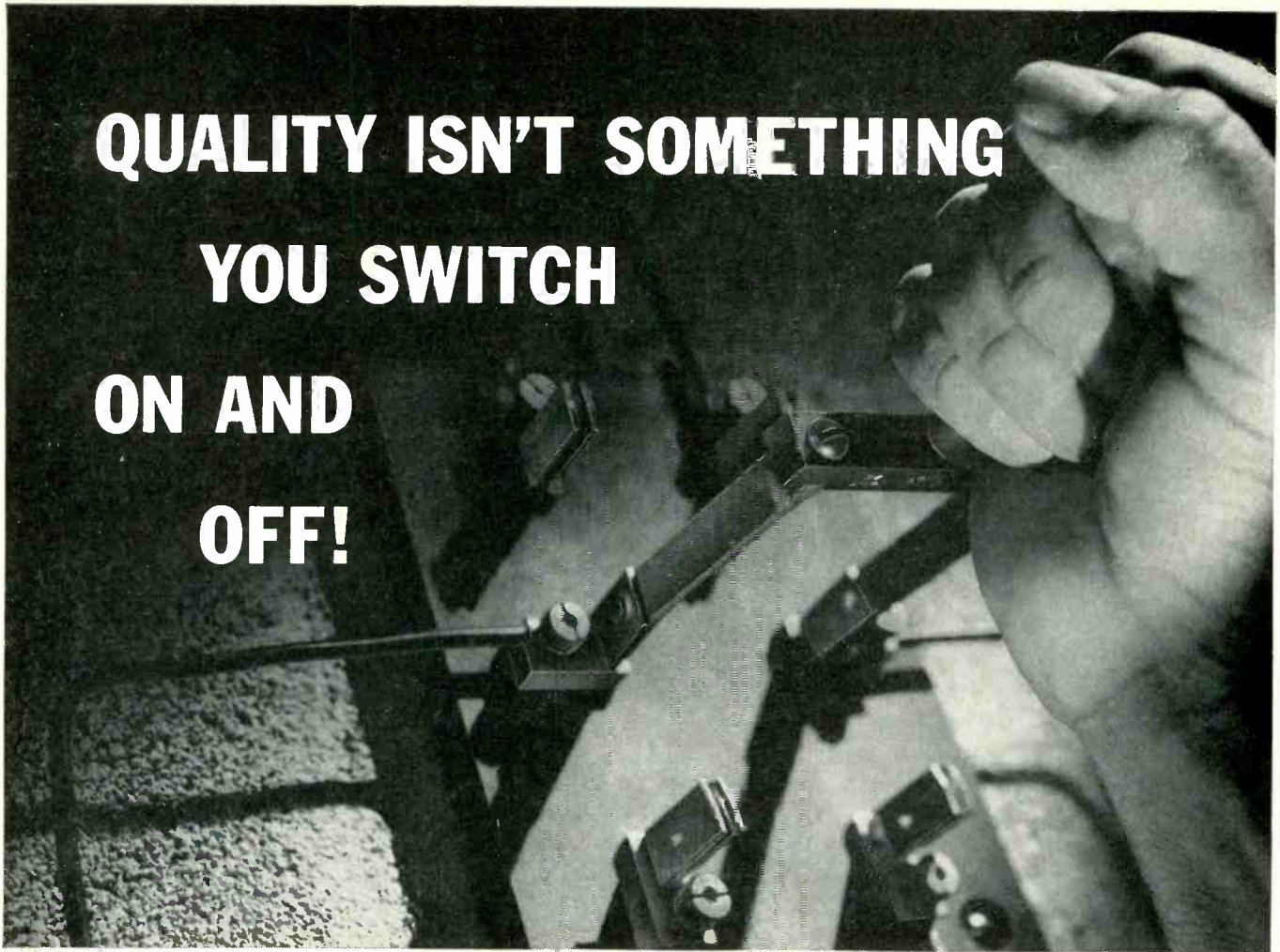

**You can't pull a switch and suddenly start claiming quality. Quality is more than a claim. At Zenith, quality has been the policy for forty years with no switching on and off. And this policy has insured continuous quality in Zenith products.**

There are some who believe that a quality reputation can be created as simply as pulling a switch. Actually, quality can't be "switched on and off" depending on the needs of a marketing situation.

You can't slight quality over a period of time and then start building quality overnight. Quality is more than a claim—it is more than a desire. Quality requires long range planning, thinking and training.

At Zenith we believe in quality. It began at Zenith 40 years ago. We know that quality is not merely a combination of quality parts and components built to the highest standards. It is not only skilled engineering and craftsmanship. At Zenith every employee must be trained in quality over a long period of time and must dedicate

himself to thinking constantly in terms of quality.

You get quality by working at it—constantly, continuously over the years. Quality is an attitude—a state of mind—a policy that every individual of the Zenith family practices and believes in.

We are grateful for the dealer acceptance and customer satisfaction that Zenith quality products have earned. It is the result of this constant and continuous determination by the entire Zenith family to produce only the finest.

Zenith's success is the result of *quality* and a 40 year determination not to switch it on and off. We don't believe that others can suddenly decide overnight to start making quality. It's a way of life that is built over the years and that's why at Zenith *the quality goes in before the name goes on.*

# ZENITH

Zenith Radio Corporation, Chicago 39, Illinois



THE QUALITY GOES IN  
BEFORE THE NAME GOES ON

40 years of leadership in radionics exclusively. The Royalty of television, stereophonic high fidelity instruments, phonographs, radios and hearing aids.

# FREE LITERATURE

To receive the literature below without charge, simply circle the numbers on the coupon corresponding to the items of interest. Cut out and mail to **ELECTRONIC TECHNICIAN**

**1 Capacitors:** Colorful descriptive literature covers the new ARCOlytic type CE series capacitors. Part numbers, specifications and prices are included. Fabricated from high purity etched aluminum foil. Available in single, dual, and triple sections. Packed 5 in a box. (1B11: Arco Electronics Inc.)

**2 Cords & Cord Sets:** Catalog 1758 shows a new, expanded, line of stock power supply cords and cord sets for all types of appliances, tools, machines and all other electrical equipment. Featured are the unbreakable plugs with grip prongs. (2B11: Belden Mfg. Co.)

**3 PEC Guide:** The 5th edition of this packaged circuit guide is one-third larger than the previous edition. 16 pages of technical data on selecting, testing, and replacing PEC circuits, plus description of 9 new circuits and 97 others. Includes test information; circuit diagrams component values; and a cross-reference chart of replacements for units of other manufacturers. (3B11: Centralab Div., Globe Union, Inc.)

**4 Tube Testers:** A new and revised edition of "Operating A Successful Tube Tester Route" is available. In its 12 pages, the story is told of how this business has grown. Necessary operating procedures are given. Points covered, among others are: basis of the self-service tube testing business; how it operates; advantages; financing; buying tubes; how to sign up locations; and how to service locations. (4B11: Century Electronics Co.)

**5 Capacitors:** 3,525 listings of "prepared" twist prongs and tubular electrolytics are provided in a new 24-page substitution cross index. (5B11: Cornell-Dubilier Electric Corp.)

**6 Rectifiers:** A new 17-page booklet, EGC-327, covers circuit fundamentals for use of the newly developed ZJ-39A silicon controlled rectifier. The rectifier will be in mass production in December. Pre-production samples, now generally available, are capable of handling 16-amps at peak inverse voltage ratings ranging from 40 to 300v. (6B11: General Electric Semiconductor Products)

**7 Hi-Fi Units:** Brochures C-959 and P-958 respectively cover the Custom and Premier series of stereo and monophonic units. Both new series have distinctive styling, performance improvements and control flexibility. (7B11: Grommes Div. Precision Electronics, Inc.)

**8 Antennas:** The new 1959 catalog of portable TV antennas is available. It lists all portable TV sets, past and present, by model, year manufactured, screen size, and exact duplicate antenna catalog number. Also illustrates and describes the firm's portable TV antenna line. (8B11: JFD Electronics Corp.)

**9 Solar Cells:** Technical Information Bulletin 32-58 is a new 4-page brochure on the electrical and physical characteristics of silicon solar cells. Data includes: complete design parameters; application notes on 9 types of cells; spectral response curves; current voltage characteristics at various light levels; variations of available power according to temperature; and a magnified view of

construction details of a typical solar cell. (9B11: Hoffman Electronics Semiconductor Div.)

**10 Resistors:** The new, wire-wound power resistors, described in Bulletin 153, feature a jacket of silicone-ceramic material which, in addition to other advantages, provides a uniform, moisture-proof, high insulation resistance covering. Resistance tolerances, in which the units are furnished, and maximum resistance values for each of the 3, 5, and 10-watt size are included. (10B11: Ohmite Mfg. Co.)

**11 Capacitors:** Bulletin M-755 describes a new film dielectric paper tubular. The Isofarad displays capacitance stability of  $\pm 0.5\%$  over an operating temperature range of 25° to 80°C. The negligible temperature coefficient is linear. Phenolic housing protects the capacitor against moisture and mechanical damage. It is particularly suited for TV, radio, precision amplifiers, lab instruments, and design circuits. (11B11: Sprague Products Co.)

**12 Generators:** Model SSX-2, a new sweep and signal generator is described in Technical Bulletin T-206. The unit covers the entire low RF and common IF frequencies and simplifies testing of amplifiers and other low frequency devices by combining functions of sweep generator, signal generator, pulsed CW, and marker generator into one compact, precision instrument. (12B11: Telonic Industries Inc.)

CUT HERE

This coupon must be used before December 10, 1958

1. Circle free literature numbers. 1 2 3 4 5 6 7 8 9 10 11 12

2. For more data on new products and bulletins write in code numbers

..... 11-17

3. Fill in your name and address. Mail promptly.

Name .....

Position ..... Firm .....

Address .....

City ..... Zone ..... State .....

1. Circle numbers of free literature desired.

2. For more data on new products and bulletins described in this issue, write in ELECTRONIC TECHNICIAN code number found at end of each item.

3. Fill in name and address. Mail to ELECTRONIC TECHNICIAN, 480 Lexington Ave., New York 17, N. Y.

## Hi-Fi Ratings

(Continued from page 41)

are primarily those of Hirsch-Houck Labs., New Rochelle, N.Y. Participation fee paid by manufacturer equal to twice the retail cost of item tested.

Services: After manufacturer furnishes two samples, which are exchanged for equivalent off-the-shelf units at a retail store, products are tested to determine whether or not they comply with performance standards stated in 10-page standards specification covering most components. Measurement methods are said to be essentially those published by the Audio League some time ago. Confidential test report is sent to manufacturer, along with notification whether or not results comply with standards. Results of measurements are not released publicly. Rejection of a product is not made known publicly either. If a product does meet Bureau standards, the manufacturer may be licensed to use the Seal of Approval in ads, packaging, stickers, etc. The Gold Seal is issued for premium quality hi-fi; the Silver Seal, based on less stringent standards, represents basic but true hi-fi.

AMERICAN AUDIO INSTITUTE, 394 E. 18 St., Paterson 4, N.J. Felix R. Bremy, Executive Director; Edwin Calkin, Engineering Head; Philip Hendrick, Chief Assistant; Norman H. Crowhurst, Dr. Abraham Apter, Walter Schoeder, August A. Perticone, members of Professional Advisory Council. Newly formed. Will have own test facilities. Manufacturer pays fee for Evaluated Test Reports, amount not disclosed.

Services: This group releases test reports on a standardized form. For example, the amplifier report covers 23 items (frequency response, power output, loudness contours, etc.), 9 of them in graph form. The result of each measurement is evaluated on a 0 to 100 point scale according to the value to the consumer. To arrive at an overall performance rating, each test is weighted by an "importance factor" to arrive at a numerical evaluation. Prices and manufacturer's own specs are not considered in the rating.

CONSUMERS UNION OF U.S., 256 Washington St., Mt. Vernon, N.Y. Dexter W. Masters, Director; Colston E. Worne, President; Morris Kaplan, Technical Director; Audio Division Chief, Mitchell A. Cotter; other personnel listed in monthly

## COMMUNICATED DATA

Modern military weapons systems require instantaneous computation of data... Burroughs, consistent with its recognized leadership in equipment, skills and manpower, is providing the answers for complex military weapons systems through automatic suprahuman computation.

The qualified electronics technician who seeks in his work a sense of gratification for a challenge imaginatively met... will find that challenge and its reward in a career in digital computation with Burroughs Military Field Service Division.

### Add up these facts

1. Formal 22 week training program in Data Processing Systems, PLUS
2. Starting salaries commensurate with ability and experience, PLUS
3. Full salary during entire training program, PLUS
4. Advancement opportunities based on individual performance, AND
5. Fine fringe benefits including educational assistance (in addition to above training), PLUS
6. Nationwide field assignments after completion of training program.

If you are a graduate of an accredited Technical School and/or have military training in radar or communications equipment, plus at least 2 years' experience in electronics, you are invited to address your inquiries to Personnel Department, MILITARY FIELD SERVICE DIVISION, 511 North Broad Street, Philadelphia 23, Pa.



**Burroughs Corporation**

"NEW DIMENSIONS / in electronics and data processing systems"



Send 10c to Sprague  
for window-size blow-  
ups of this message.



## **YOUR TV TECHNICIAN GUARANTEES YOU THE BEST SEAT IN THE HOUSE!**

Did you ever stop to think how many millions of dollars in entertainment your TV set brings you? A national half-hour show once each week costs its sponsor about \$7,000,000 a year. And you can watch it all for free . . . from the best seat in the house!

When something goes wrong, you can thank your local *independent technician* that it won't stay that way for long. Before you even got your set, he spent years of study in television techniques . . . repaired hundreds of sets . . . bought all kinds of necessary expensive test equipment to do the job right. That's why, when you

call him you'll find he already knows your set and has the knowledge and equipment to fix it promptly. Call him at the first sign of trouble, and you won't have to spend a single night without TV.

As a responsible member of your community, your service technician stakes his reputation on your satisfaction. He'll charge a fair price for his work, based upon his time and the quality of replacement parts he uses. But you'll be able to go back to enjoying millions in entertainment—all for free!

**THIS MESSAGE WAS PREPARED BY SPRAGUE PRODUCTS COMPANY,  
DISTRIBUTORS' DIV. OF SPRAGUE ELECTRIC CO., NORTH ADAMS, MASS. FOR**

**YOUR INDEPENDENT TV-RADIO TECHNICIAN**

# NO OTHER TUBE TESTER MADE - AT ANY PRICE - can MATCH the VALUE of the CENTURY FAST-CHECK

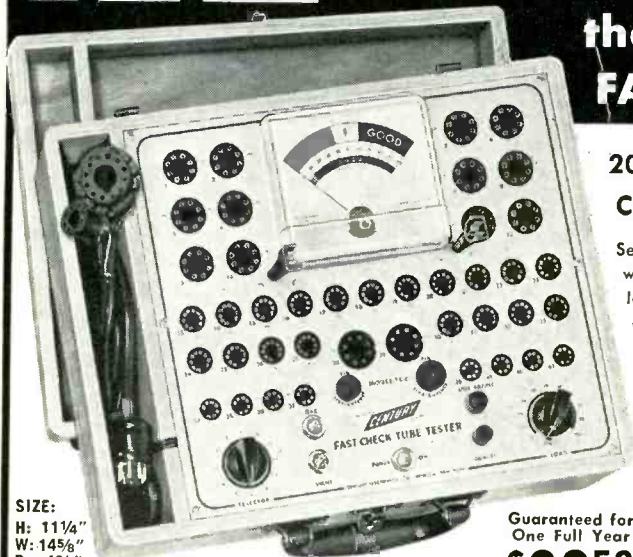

SIZE:  
H: 11 1/4"  
W: 14 5/8"  
D: 4 3/8"

Model FC-2—housed in sturdy wood carrying case complete with CRT adapter . . . only

Special compartment accommodates line cord and Picture Tube Test Adapter

## PICTURE TUBE TEST ADAPTER INCLUDED WITH FAST-CHECK

Enables you to check all picture tubes (including the new short-neck 110 degree type) for cathode emission, shorts and life expectancy . . . also to rejuvenate weak picture tubes. This feature eliminates the need of carrying extra instruments and makes the FC-2 truly an all-around tube tester.

FAST-CHECK'S low price is made possible because you are buying direct from the manufacturer.

## 20,000 SERVICEMEN CAN'T BE WRONG!

See for yourself—AT NO RISK—why over 20,000 servicemen selected the FAST-CHECK above all other tube testers—regardless of price. With the FAST-CHECK you will make every call pay extra dividends by merely showing your customer the actual condition and life expectancy of the tube. The extra tubes you will sell each day will pay for the FAST-CHECK in a very short time.

Guaranteed for One Full Year  
**\$69.50** Net

## Just 2 settings on the FAST-CHECK TUBE TESTER tests over 650 tube types completely, accurately — AND IN SECONDS!

- **POSITIVELY CANNOT BECOME OBSOLETE**  
Circuitry is engineered to accommodate all future tube types as they come out. New tube listings are furnished periodically at no cost.
- **NO TIME CONSUMING MULTIPLE SWITCHING**  
Only two settings are required instead of banks of switches on conventional testers.
- **NO ANNOYING ROLL CHART CHECKING**  
Tube chart listing over 650 tube types is conveniently located inside FAST-CHECK cover. New tube listings are easily added without costly roll chart replacement.

## COMPARE FAST-CHECK WITH OTHER TESTERS RANGING FROM \$40 TO \$200

### RANGE OF OPERATION

- ✓ Checks quality of over 650 tube types, which cover more than 99% of all tubes in use today, including the newest series-string TV tubes, auto 12 plate-volt tubes, OZ4s, magic eye tubes, gas regulators, special purpose hi-fi tubes and even foreign tubes.
- ✓ Checks for inter-element shorts and leakage.
- ✓ Checks for gas content.
- ✓ Checks for life-expectancy.

Other testers may have some of the above features . . . but only the FAST-CHECK has them all!

### IMPORTANT FEATURES

- Checks each section of multi-section tubes and if only one section is defective the tube will read "Bad" on the meter scale
- Less than 10 seconds required to test any tube
- 41 long lasting phosphor-bronze tube sockets accommodate all present and future tube types . . . cannot become obsolete
- 7-pin and 9-pin straighteners mounted on panel
- Large D'Arsonval type meter is extremely sensitive yet rugged — fully protected against accidental burn-out
- Special scale on meter for low current tubes
- New tube listings furnished periodically at no cost
- Compensation for line voltage variation.

## SHIPPED ON APPROVAL FOR 10 DAY FREE TRIAL

Try the FC-2 before you buy it! No obligation to buy.

## PAY IN SMALL MONTHLY PAYMENTS

Easy to buy if you're satisfied. Pay at net cash price . . . no financing charges.

NO MONEY REQUIRED WITH ORDER . . .

## CENTURY ELECTRONICS CO., INC.

Dept. 511, 111 Roosevelt Ave., Mineola, N. Y.

Rush the FAST-CHECK for a 10 day trial period. If not completely satisfied I will return the instrument within 10 days without further obligation. If fully satisfied I agree to pay the down payment within 10 days and the monthly installments as shown. No financing charges are to be added.

Model FC-2 . . . \$69.50 — Pay \$14.50 within 10 days. Balance \$11.00 monthly for 5 months.

Name.....

Address.....

City..... State.....

F.O.B., Mineola, N.Y.

publication, "Consumer Reports" claimed to reach 800,000 readers. Established 1936. Has adequate test facilities. Buys products to be tested from retail outlets. Accepts no payments from manufacturers. Hi-Fi is one small aspect of overall testing.

Services: This well-known group generally tests and rates a broad, but incomplete, sampling of a particular type of product. Brands are commonly listed "best buy, checked, acceptable or unacceptable." Published discussions are semi-technical. Actual test measurements upon which ratings are based are rarely revealed. CU has large national following.

Each of the above three organizations either has contributed, or is potentially capable of contributing to public recognition of true hi-fi equipment. However, there are shortcomings attached to each which would make an industry-established self-policing system more effective, reliable and knowledgeable.

## There Is A Solution!

Through the Institute of High Fidelity Manufacturers (IHFMM) Standards Committee, progress is being made . . . slowly, but with the sureness of the collective thinking of the industry's top engineers. The first step is to agree on how to make measurements upon which specs are based. This is close to accomplishment by IHFMM for tuners and amplifiers. Other products will eventually be covered.

The second—and more difficult—step is to decide how to apply the standardized measurements. One approach is to say exactly what performance constitutes "true hi-fi." That is, minimum specs would determine whether a product is or is not hi-fi. This is a fairly good approach, but it has some major drawbacks. A yes or no hi-fi rating does not greatly encourage advancement of the art. And very important, top experts do not agree on the exact criteria for defining hi-fi.

The answer may lie in the approach used in the publishing industry. Many years ago, circulation claims by publishers were often exaggerated, if not falsified outright. To establish honest and verifiable claims which advertisers could rely on, a self-policing audit system was established. Reputable magazine publishers banded together to form such impartial groups as the Audit Bureau of Circulations (ABC). Since ABC has become "bigger than any of its members," publishers must conform to its strict rules. The

# THIS SELF-SERVICE TUBE TESTER IS YOUR STEPPING-STONE TO A BRIGHT NEW PROSPEROUS FUTURE

## EARN BIG MONEY AND ACHIEVE FINANCIAL STABILITY

If you've ever longed for a business of your own... to be your own boss and to work your own hours, then here's your opportunity to get in on one of today's biggest money-making opportunities — the self-service tube testing business. It's the easiest business to get into... requires no experience, little time and small investment.

A basic principle for making money is to have something work for you, rather than you yourself doing the work. As an operator of a FAST-CHECK SELF-SERVICE TUBE TESTER ROUTE you can be the proud owner of a solid fast-growing business... earning money while you take life easy. Business can be started without giving up your present source of income and can be operated from home. All you do is make calls once a week to restock testers and collect profits.

### WHAT IS THE SELF-SERVICE TUBE TESTING BUSINESS?

The self-service tube testing business is a take-off on the highly profitable vending machine business... Drug stores, luncheonettes, supermarkets, etc. welcome having a tube tester placed in their store. You place testers and tube stock in stores on consignment — the store location contributes floor space for the self-service tube tester — store patrons are offered the use of the tube tester free — they in turn buy their replacement tubes from the tube stock in the tester. The store pays you for all the tubes sold less his commission. Each tester placed can net up to \$1000 a year for you.

### NO SELLING REQUIRED

Century's self-service tube testers check and sell TV and radio tubes automatically 12 hours a day — 7 days a week. Consumers do their own testing and defective tubes are replaced on the spot for highly profitable sales. Your testers are your high powered salesmen.

### MANUFACTURER-TO-YOU PRICES

Since we are the manufacturers and sell direct to you, we have been able to price the FAST-CHECKS so low that they represent the greatest value in testers available. Our unusually low prices enable you to place more units with less investment.

### FAST-CHECK SPECIFICATIONS

- 46 long lasting phosphor-bronze sockets accommodate all present and future tube types — cannot become obsolete.
- Attractive red and hammer-tone gray durable metal cabinet. Takes only 19" x 19" of floor space.
- Tube compartment with own lock holds 400 or more tubes.
- Removable tube storage trays with specially designed dividers separate tube cartons — make it easy to restock tubes that are sold.
- Large seven inch easy to read meter is extremely sensitive yet rugged — is fully protected against accidental burn-out.
- Completely self-service — easy to operate.
- Built-in 7-pin and 9-pin straighteners on panel for customers convenience.
- Quick reference tube chart lists over 650 tube types — conveniently mounted.
- A colorful illuminated point-of-sale display tops the cabinet — designed to attract everyone that comes into the store.
- Each unit is covered by a 3 month guarantee.

### FREE BOOK TELLS ALL ABOUT THIS BOOMING BUSINESS

If you are interested in starting a lifetime business, then ACT NOW and send for FREE book to convince yourself that this is today's greatest business opportunity.

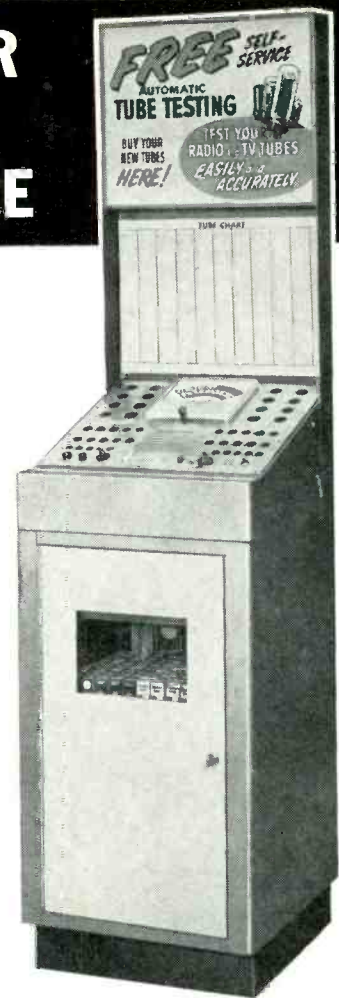

Model SS-1F (floor model) FAST-CHECK SELF-SERVICE TUBE TESTER **\$134.50** Net

Model SS-1C (counter model) An ideal unit for shops with limited floor space. **\$98.50** Net

## ATTENTION SERVICE SHOP OWNERS

Put the FAST-CHECK SELF-SERVICE TUBE TESTER in your shop with only a \$34.50 down payment. You'll gain a valuable profit producing assistant working for you every open hour.

Do-it-yourself customers will welcome the opportunity to bring their tubes to your store where they can test tubes to their heart's content. If the tubes register "Bad" or "Weak" you are assured of profitable tube sales. And best of all you don't have to stop working when a customer brings in a bag of tubes to check. The FAST-CHECK does it all for you. If on the other hand a customer's tubes register "Good" you are on the spot for consultation or a service call.

Colorful window streamers and advertising material provided FREE by us will attract many new customers to your shop. Servicemen are not only increasing tubes sales, but are actually enlarging their service business as well, with a FAST-CHECK in their shop. Act now! Place a unit in your shop and double your tubes sales... save valuable working time.

## TIME PAYMENT PLAN

Pay in small monthly payments at net cash prices.

## NO INTEREST OR FINANCING CHARGES

## CENTURY ELECTRONICS CO., Inc. 111 ROOSEVELT AVENUE Dept. B-11, Mineola, N. Y.

Please send the units I have indicated below on your TIME PAYMENT TERMS. Include a complete plan of operation — plus all advertising material needed to get started in the self-service tube testing business. I understand no interest or financing charges will be added, and they are shipped on a 10 day money-back guarantee.

Quantity	Description	Unit Price	Extend Total
	<b>Model SS-1F (floor model) FAST-CHECK TUBE TESTER</b> Enclose \$34.50 down payment with order for each tester. Balance payable in 5 monthly payments of \$20.00 for each tester starting 30 days after shipment.	<b>\$134.50</b>	
	<b>Model SS-1C (counter model) FAST-CHECK TUBE TESTER</b> Enclose \$23.50 down payment with order for each tester. Balance payable in 5 monthly payments of \$15.00 for each tester starting 30 days after shipment.	<b>\$ 98.50</b>	

All prices net F.O.B. Mineola, N. Y.

I am interested. Please send me FREE book and particulars about setting-up a tube tester route. No salesman will call.

Name..... Please Print  
Address.....  
City..... State.....

Total Amount  
Advance Payment  
Balance

### CHECK HERE TO SAVE SHIPPING CHARGES

Enclose total amount with order and Century will pay all shipping costs. 10 day money-back guarantee.

# NEW improved model Simpson 260!

TRADEMARK

**RUGGED  
PRINTED  
CIRCUIT!**

still  
only  
**\$43<sup>95</sup>**  
Complete with leads and  
Operator's Manual.  
Also available in  
Roll-Top model at  
only . . . \$49.95

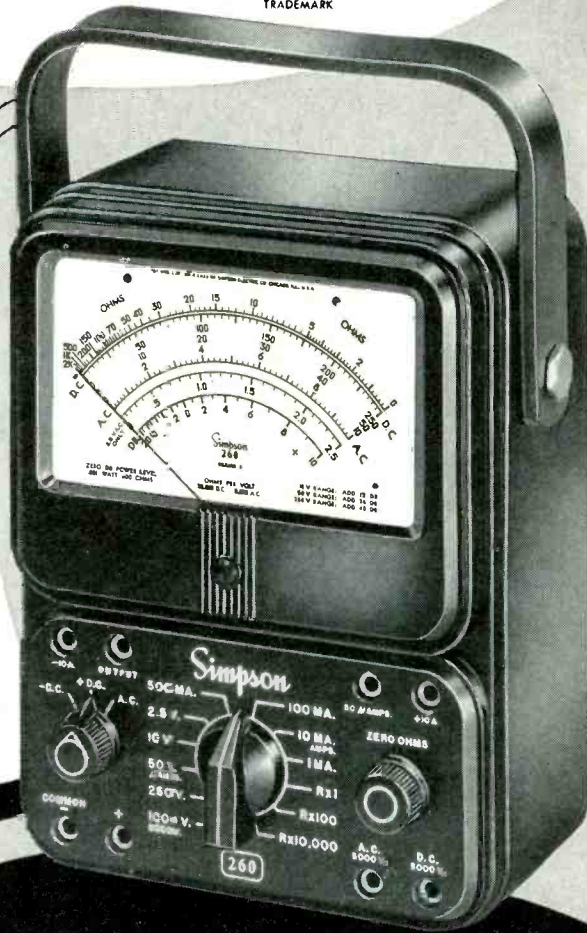

**... the VOM that outsells  
all others combined**

**MANY NEW FEATURES MAKE THE 260  
MORE VALUABLE THAN EVER!**

- POLARITY REVERSING SWITCH
- 50 MICROAMPERE—250 MILLIVOLT RANGE
- EASIER-TO-READ SCALES
- LESS CIRCUIT LOADING
- POPULAR DBM RANGES
- FULL-WAVE BRIDGE RECTIFIER SYSTEM
- RUGGED PRINTED CIRCUIT
- ALL COMPONENTS EASILY ACCESSIBLE

● IMPROVED FREQUENCY RESPONSE IN A. C. MEASUREMENTS

See it at your Distributor, or write

**SIMPSON ELECTRIC COMPANY**

5208 West Kinzie Street, Chicago 44, Illinois  
Phone: EStebrook 9-1121

In Canada: Bach-Simpson Ltd., London, Ontario

**WORLD'S LARGEST MANUFACTURER OF ELECTRONIC TEST EQUIPMENT**



ABC symbol is a mark of reliability, and advertisers can depend on the circulation claims of ABC publications.

An ABC trade publication can claim any amount of paid circulation in any occupational categories. However, when the ABC auditor comes around to check on a publisher's statement, if his claims turn out to be incorrect, the ABC *publicly* announces the error, and tells what the correct figures are. All ABC member publications in the same industry use precisely the same standard form, offering a simple comparison of each publication's circulation claims. On this basis it can be determined whether or not the extra cost of advertising in one publication is justified by the quality and quantity of the ABC circulation. The ABC and similar audits have achieved such recognition that non-member publishers are often looked upon unfavorably; their claims are frequently in question.

Why not a similar approach for hi-fi? The hi-fi producer could, like the ABC publisher, be required to reveal the most important specs about each component. Then, through the single "Hi-Fi Audit," using the facilities of approved laboratories, this component could be tested according to the standard procedure (equivalent to the ABC auditor). If the measurements verify the claim, the manufacturer may continue to make the claim, and support it with the IHFM or similar industry symbol. The IHFM could promote the veracity of claims bearing its seal. Of course, if the tests of IHFM-approved labs showed the claims were not correct, the manufacturer would have to desist immediately . . . or else be publicly discredited and expelled from membership.

An important point is that *all* product claims in the manufacturer's line would be covered, not just one or two units. This would avoid the favorable or unfavorable reflection on a company's entire line which results when present rating organizations pass judgment on just one unit in that line.

An ABC-type hi-fi industry test arrangement is an imposing undertaking. It will cost hi-fi manufacturers a considerable amount in time, money and effort.

But it is vital!

Failure to set up an industry-wide standardized audit system can have two serious and harmful effects on those manufacturers who are trying their best to sell quality and value in their products: 1) All spec claims

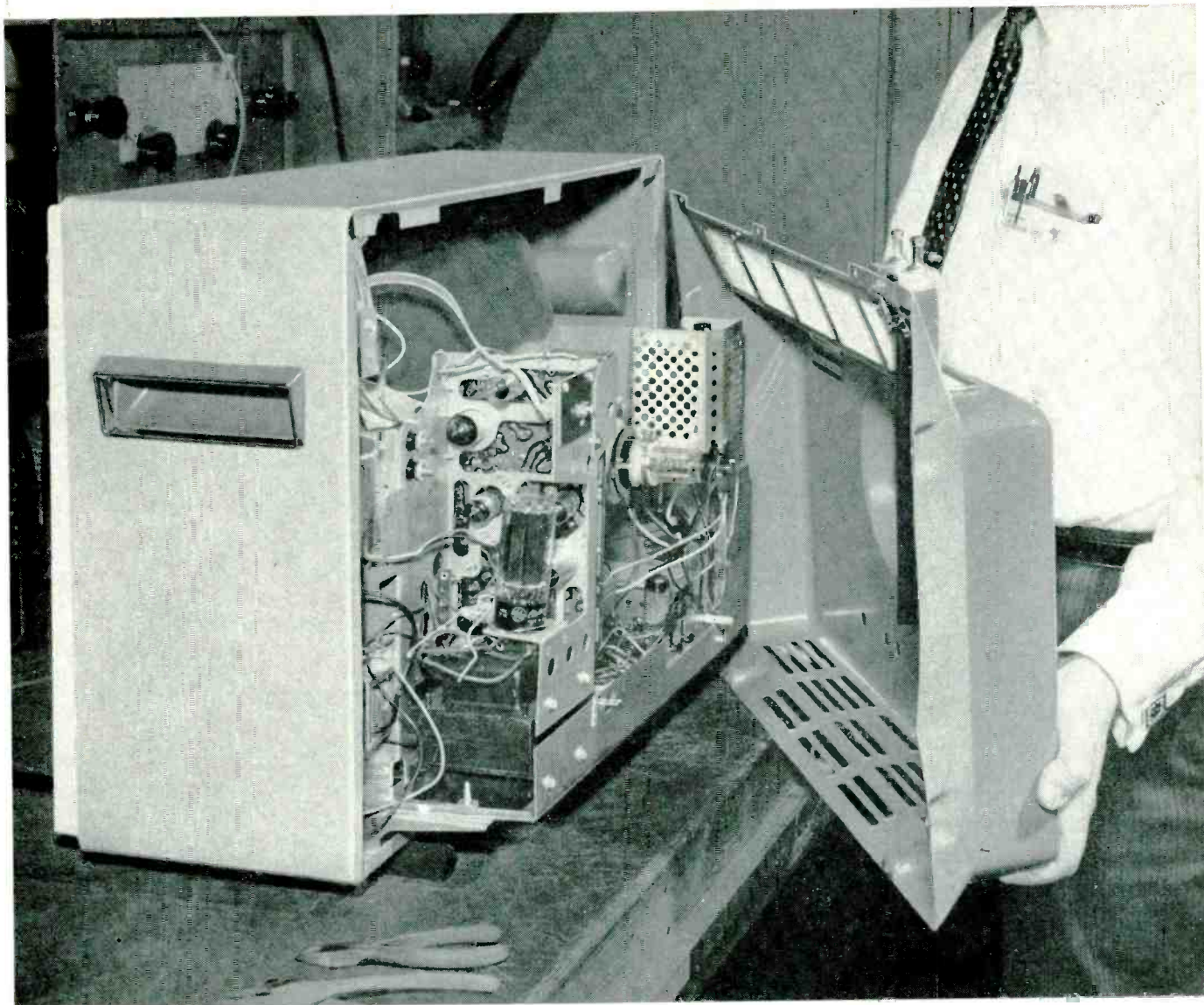

Take the back off the General Electric "Designer" TV set and you can do 85%-90% of service jobs without pulling the chassis

*You cut your time-per-repair by up to 40% . . . make more calls—and money—in the same amount of time!*

Take off the back and there you are—in easy reach of up to 90% of service jobs. Look at the chart!

**Look inside!** Both sides of the reliable printed circuit boards are easy to reach for service.

No series string filaments—no extension cables needed . . . the new "Designers" are certainly the easiest-to-service sets in all television. You'll wish every set was a General Electric "Designer."

*Progress Is Our Most Important Product*

**GENERAL  ELECTRIC**

TEN TYPICAL JOBS THAT CAN BE DONE WITHOUT REMOVING THE CHASSIS				
JOB	G-E "Designer"	Set A	Set B	Set C
Replace most resistors	yes	no	no	no
Replace most capacitors	yes	no	no	no
Replace deflection yoke	yes	no	no	no
Replace video detector	yes	yes	no	no
Replace audio detector	yes	no	no	yes
Replace horizontal phase detector	yes	no	yes	yes
Replace power rectifier	yes	no	no	yes
Adjust tuner oscillator	yes	no	yes	yes
Replace inter-stage transformers	yes	no	no	no
Replace size and linearity controls	yes	no	yes	yes

General Electric Co., Television Receiver Dept., Syracuse, N. Y.

look what  
**\$28<sup>95</sup>**  
 buys in  
 high fidelity  
 equipment!

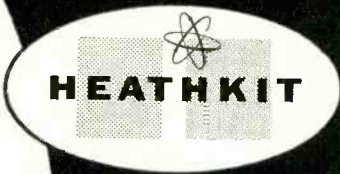

Manufacturer  
 of the finest  
 electronic equipment  
 in kit form



A complete 12-watt hi-fi amplifier-preamplifier combination in one stylish unit . . . and at less than half the price you would expect to pay!  
 Only

**\$28.95**

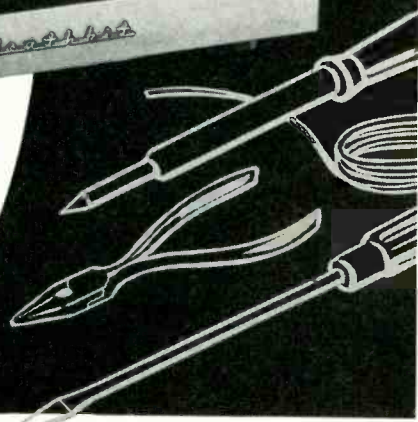

**BOOKSHELF 12-WATT AMPLIFIER KIT**

An amplifier and preamplifier in one compact unit. The EA-2 has more than enough power for the average home hi-fi system and provides full range frequency response from 20 to 20,000 CPS within  $\pm 1$  db, with less than 1% harmonic distortion at full 12 watt output over the entire audio range (20 to 20,000 CPS). IM distortion is less than 1.5% at 12 watts with low hum and noise. EL84 tubes are used in a push-pull tapped-screen output circuit. Inputs consist of crystal phono, tuner, and mag phono with RIAA equalization. Separate bass, treble and hum balance controls are featured. Taps provided for 4, 8 and 16 ohm speakers. Add this unit to your present system for simple stereo conversion. Complete instructions and pictorial diagrams show where every part goes and assures you of quick, easy assembly. Handsome vinyl clad steel cover measures 12½" W. x 8¾" D. x 4¾" H. Neon pilot light on front. Shpg. Wt. 15 lbs.

many more kits  
 to choose from!

Send for this free catalog describing over 100 easy-to-build kits in hi-fi-test-marine and amateur radio fields.

**HEATH COMPANY**

Benton Harbor 18, Mich.



a subsidiary of Daystrom, Inc.

name \_\_\_\_\_  
 address \_\_\_\_\_  
 city & state \_\_\_\_\_

could become meaningless, favoring those companies which want to market a "black box" with unknown performance characteristics; 2) A variety of independent rating organizations, all with different standards, could end up passing judgment on hi-fi equipment. This way lies confusion and disrespect for the industry.

A top industry executive should be elected to head the impartial bureau. He would have several test engineers who would perform the tests on the various pieces of equipment. These engineers would be the equivalent of the publishing industry's auditors.

There are many details to be worked out, none insurmountable. This will not be done overnight. But the best qualified people to set up the "Hi-Fi Audit" and those with the most at stake, are not the independent rating organizations, but hi-fi manufacturers themselves. Also, the Federal Trade Commission will be induced to curb misleading promotion after industry-wide standards are in effect. One "auditing" organization, with access to the most extensive technical know-how, operating under industry-wide scrutiny, possessing the extensive facilities and support of all producers . . . that is our proposal for a hi-fi industry goal. •

**Capacitor Contest Winners**



Lucky winner, Edward Denzler (1), West Babylon, New York technician, receives the keys to a Ford Station Wagon which he won for his entry in the Tobe Deutschmann Capacitor Contest. Bill Schoneberger, Tobe sales manager, made the presentation in New York City after a luncheon at the Savoy Hilton Hotel in honor of the three top winners. Harold Halvorson of Duluth, Minn. won second prize, a Mink Stole, and J. D. Beimel of Thiells, N. Y., took third prize, a room air conditioner. Forty-seven other prize winners were also notified of their good fortune. Other prizes range from complete home movie outfits to shavers.



Ralph Bellamy, starring in "Sunrise At Campobello", listens to stereo on his Collaro changer and Goodmans Triaxonal Speaker System.

## Collaro—your silent partner for Stereo

*Silence* is the requirement — and *silent* performance is what you get when you select the new Collaro stereo changer for your stereo system. Collaro engineers have designed *the* high fidelity changer precision-engineered to meet stereo's rigid quality demands. Collaro's *silent* operation assures flawless reproduction of the exciting new stereo records every time. Here is why Collaro is your best buy.

**Five-terminal plug-in head:** Exclusive with Collaro. Provides two completely independent circuits thus guaranteeing the ultimate in noise-reduction circuitry.

**Transcription-type tone arm:** Another Collaro exclusive. As records pile up on a changer, tracking pressure tends to increase. Result may be damage to records or sensitive stereo cartridge. This can't happen with Collaro's counter-balanced arm, which varies less than 1 gram in pressure between the top and bottom of a stack of records. The arm accepts any standard stereo or monaural cartridge.

**Velocity trip mechanism:** Unique design of this sensitive mechanism insures that the Collaro changer will trip at extraordinarily light tracking pressures — a requirement of many stereo cartridges.

New Collaro changers include *all* of the best features which have made Collaro the largest manufacturer of record changers in the world — as well as important new features vital for superb stereo as well as monaural performance. There are three Collaro changers priced from \$38.50 to \$49.50. The changer illustrated here is the new Continental, Model TSC-840.

For full information on the new Collaro stereo changers, write to Dept. ET-11, Rockbar Corp., Mamaroneck, N. Y.



American sales representative for Collaro Ltd. and other fine companies. RC-7

Another **FIRST** from **PRECISION**

**NEW**  
MODEL  
**10-60**

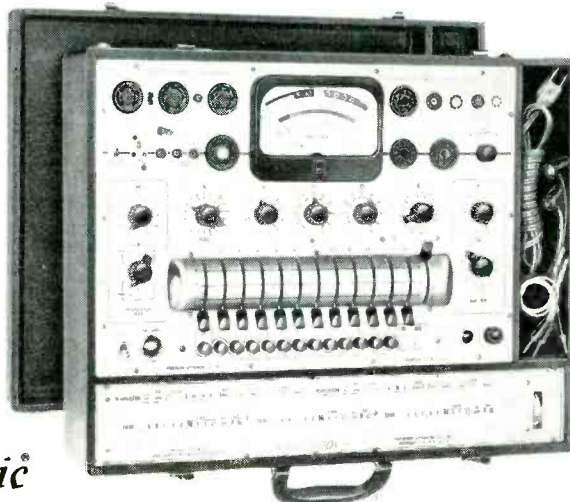

*Electronamic*

**TUBE and TRANSISTOR CHECKER**

with PICTURE-TUBE BEAM-CURRENT TEST **\$195<sup>00</sup>**

Net Price:

**LOADED  
WITH THE  
FEATURES  
YOU NEED**

- **Comprehensive Tube, Transistor, Crystal Diode, and Picture Tube Testing.**
- **Ultra-Sensitive Gas Test Read Directly on Meter.**
- **Functional Testing of Voltage Regulator Tubes.**

**TUBE TESTING FEATURES**

- Positive, all-inclusive tube performance testing ... not limited to mutual conductance alone
- Tests tubes over a complete path of operation ... not at just one arbitrary point
- Actively tests all tube elements in **PRECISION** Electronamic tube testing circuit
- Tests all modern tube types ... including sub-miniatures
- Dual short-check sensitivity. Special low voltage short-check circuit guards against damage to tubes under test
- Built-in stainless steel pin-straighteners for 7 and 9 pin tubes
- Functionally tests voltage regulator tubes for voltage regulation at manufacturer's specified current limits
- 5-window, geared roll chart provides convenient reference for all tube and transistor test settings
- Ultra-sensitive gas test circuit directly detects troublesome gas content on sensitive PACE microammeter

**TV PICTURE TUBE TESTING**

- TV picture tubes tested in specially engineered circuit—for picture producing beam current (requires optional accessory PTA picture tube cable adapter and PAA 110° socket adapter).

**TRANSISTOR AND CRYSTAL DIODE TESTING FEATURES**

- Designed in accordance with recommendations of leading semiconductor manufacturers
- $I_{cbo}$  readings directly related to true collector current
- Wide spread  $I_{cbo}$  ranges cover all types of transistors—low, medium and high power
- Wide range of collector potentials: .5 volts DC to 160 volts DC in 22 steps
- Direct-reading beta ranges: Employs separate injection currents for low and high power types
- Leakage: Reliable check of emitter to collector leakage current provides basis for accurate gain tests
- Crystal diode tests: 22 selected DC voltages for forward and reverse current tests in accordance with manufacturers' specifications
- Lever element selector system provides for accommodation of all present and future semiconductor releases

**MODEL 10-60:** Etched, satin-brushed aluminum panel. Sturdy carrying case with tool compartment and removable cover. Dimensions: 20 x 15 x 7". Code: FRIAR .....Net Price: \$195.00

**PICTURE TUBE TESTING ACCESSORIES AVAILABLE—**  
Model PTA Picture Tube Adapter.....Net Price: \$7.75  
Model PAA 110° Adapter.....Net Price: \$5.00

**ALSO  
AVAILABLE**

**MODEL 10-40**—Physically and electrically similar to Precision Model 10-60, but without transistor and crystal diode testing facilities. Code: FERRY .....Net Price: \$149.50



**PRECISION Apparatus Co., Inc.**

70-31 84th Street, Glendale 27, Long Island, New York  
Export: Morhan Exporting Corp., 458 Broadway, N. Y. 13, N. Y., U.S.A.  
Canada: Atlas Radio Corp., Ltd., 50 Wingold Ave., Toronto 19, Ontario

**NEW PRODUCTS  
FOR TECHNICIANS**

For more information, write in **ELECTRONIC TECHNICIAN's** new product code number on coupon on page 45.

**Stancor TRANSFORMERS**

Two new exact replacement flyback transformers for RCA are: No. HO-289 replaces RCA part Nos. 104236 and 972440-3 in sixty models in the KCSI113 series chassis; and No. HO-290 which replaces RCA part Nos. 104481 and 973432-1 in eighteen models of the

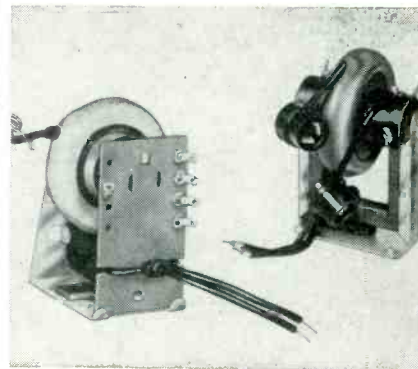

KCSI09 series chassis. As these transformers are exact duplicates both electrically and physically of the original units, no chassis or circuit alterations are required. Chicago Standard Transformer Corp., 3501 W. Addison St., Chicago, Ill. (**ELECTRONIC TECHNICIAN** 11-1)

**Wen POWER SAW**

Model 909 "All-Saw," weighing only 6½ lbs., is portable, fast-operating, and designed to cut pipe, lumber, thin gauge sheet metal, sheet steel, styrofoam, foam rubber, leather and all materials cut with a knife. Features include cutting blade in sight, finger control trigger

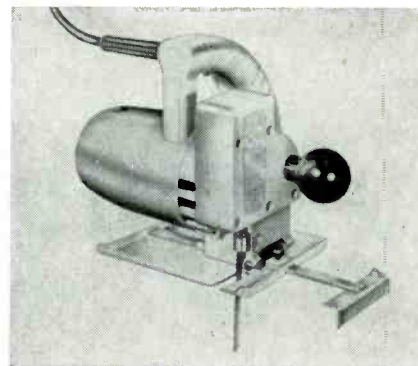

switch, and heavy duty hardened gears. Has a circle gauge to cut curves and perfect circles, and a curved foot plate which starts its own inside cut whenever desired. Wen Products, Inc., 5806 Northwest Hwy., Chicago 31, Ill. (**ELECTRONIC TECHNICIAN** 11-2)



sell the



# SATELLITE-HELIX

the TV antenna that **shrinks the miles...**  
**flattens the mountains!**

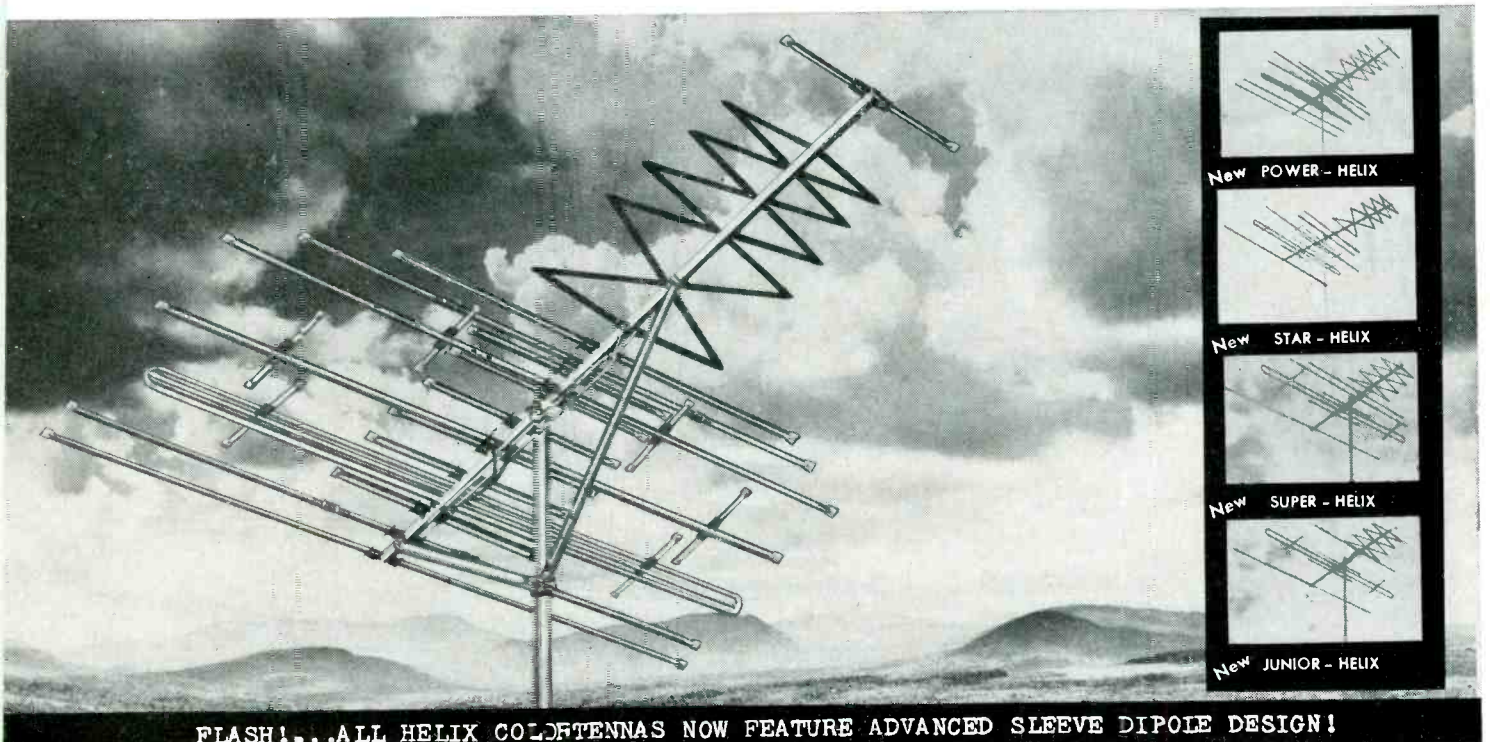

**FLASH!...ALL HELIX COLORTENNAS NOW FEATURE ADVANCED SLEEVE DIPOLE DESIGN!**

No other fringe TV antenna has ever captured the imagination of service-dealers like the exciting Satellite-Helix. *Proof is the fact that more Satellite-Helices have been sold in the last 6 months than any other deep-fringe TV antenna!*

Profit-squeezed servicemen, installers and dealers know that here at last is the antenna that gives their customers the reasons to buy *now*—performance and construction features with the dramatic *difference* they can *show* and *sell!*

- \* 28 WORKING ELEMENTS THAT CONQUER DISTANCE!
- \* ALL-NEW BALANCED SLEEVE DIPOLE DESIGN!
- \* ROCK-OF-GIBRALTAR RUGGEDNESS!
- \* HONEST ANTENNA VALUE AT A REALISTIC PRICE!
- \* A HARVEST OF PROFITS FOR YOU!
- \* A HARVEST OF TV ENJOYMENT FOR YOUR CUSTOMERS!

**Plus** OTHER POPULAR-SELLING HELIX COLORTENNAS NOW WITH NEW SATELLITE SLEEVE DIPOLE DESIGN (REGULAR OR GOLD ANODIZED) TO GUARANTEE LEADERSHIP IN EVERY MARKET! POWER-HELIX • STAR-HELIX • SUPER-HELIX • JUNIOR-HELIX

It all adds up to the most dynamic product and promotion package ever put to work in the TV antenna industry—*your* HARVEST OF PROFITS in '58 and '59.

**SEE YOUR JFD DISTRIBUTOR NOW! GET YOUR FAIR SHARE OF TODAY'S 40 MILLION DOLLAR ANTENNA REPLACEMENT MARKET!**

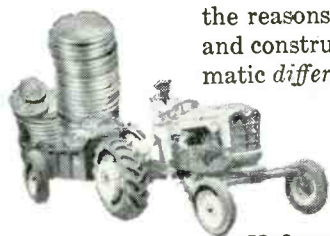

JFD Canada Ltd.  
51 McCormack Street  
Toronto, Ontario, Canada

JFD International  
15 Moore Street  
New York, New York

Pioneers in electronics since 1929  
**JFD ELECTRONICS CORPORATION**  
BROOKLYN 4, NEW YORK

a major  
breakthrough  
in  
TV-FM  
reception!



# New **JERROLD** Amplified TV-FM HOME SYSTEM

IMPROVES TV-FM RECEPTION... IN EVERY ROOM!

Permits simultaneous operation of TV and FM sets in every room... provides better reception from existing antenna than if each set has its own antenna! Any number of additional receivers can easily be plugged in!

- Increases enjoyment of all TV Channels, FM Stations!
- Improves Color TV, Stereo and AM Radio Reception!
- Quick, easy Screwdriver Installation in New or Existing Homes!
- Use With Any Antenna—Indoor or Outdoor!

As Necessary to Modern Living As Electrical Outlets!

## HOME SYSTEM KIT

Model HSK-300 \$6775 List  
Contains everything (except antenna)  
for installing 5-outlet system... including Twin-Lead.

JERROLD's wire-gripping  
plugs and outlets  
require no wire stripping...  
no soldering!

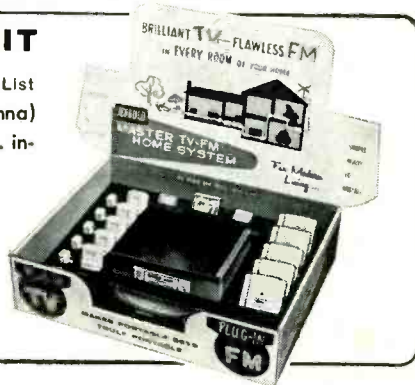

Write for Free 16-Page Booklet on  
JERROLD TV-FM Home System

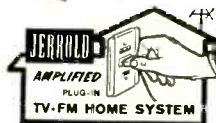

# JERROLD

## ELECTRONICS CORP.

Dept. PD 98 The Jerrold Building, Philadelphia 32, Pa.  
Jerrold Electronics (Canada) Ltd.  
Export Representatives, CBS International, New York 22, N.Y.

LOOK TO JERROLD FOR AIDS TO BETTER TELEVIEWING

## Acme STABILIZERS

A redesigned line of constant voltage stabilizers incorporates automatic overload or short circuit protection when load current is excessive. Voltage fluctuation caused by inductive surges is corrected within 1/2 cycle. Units for 190-260 volt input, as well as 95-130

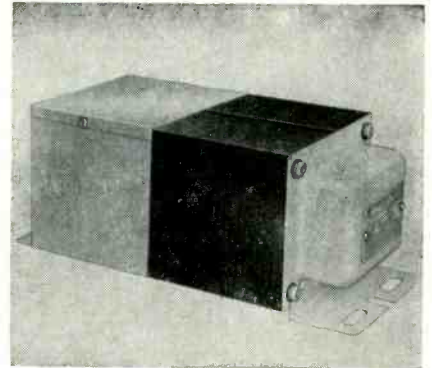

volt input circuits, are included in the expanded line. In addition to standard 120 volt and 240 volt outputs, units are available for 6.3 volt output. Capacities range from 15 to 2,000 watts. Acme Electric Corp., Cuba, N. Y. (ELECTRONIC TECHNICIAN 11-3)

## CBS CADDY

The SH-38 is a new Junior Tube-and-Tool Caddy, measuring 7 1/4 x 14 1/4 x 17 1/2 inches. It is designed to carry 64 miniatubes, 38 GT's, and 16 of the larger type tubes; has two compartments for tools and small parts; and two miniature tube pin-straighteners built into the molded plastic handle. It has scuff-proof plastic covers with metal-reinforced corners. CBS-Hytron, Danvers, Mass. (ELECTRONIC TECHNICIAN 11-6)

## Hitachi RECEIVING TUBES

A line of imported receiving tubes, that are skillfully engineered and manufactured to highest quality standards. They are designed to meet American requirements for both original equipment and replacements. Packed in attractive, colorful tube boxes for quick



easy identification. These boxes make a striking shelf, store, or window display. Popular tube types available. All carry the usual guarantee. Electronic Utilities Co., 2244 S. Western Ave., Chicago 8, Ill. (ELECTRONIC TECHNICIAN 11-4)

SUPERIOR'S NEW MODEL 83

# C.R.T. TESTER

Tests and Rejuvenates ALL

## PICTURE TUBES

### ALL BLACK AND WHITE TUBES

From 50 degree to 110 degree types—from 8" to 30" types.

### ALL COLOR TUBES

Test ALL picture tubes—  
in the carton—  
out of the carton—in the set!



**Model 83 — C.R.T. TUBE TESTER . . . Total Price \$38.50 — Terms: \$8.50 after 10 day trial, then \$6.00 monthly for 5 months.**

### *Specifications:*

- ✓ Model 83 is not simply a rehashed black and white C.R.T. Tester with a color adapter added. Model 83 employs a new improved circuit designed specifically to test the older type black and white tubes, the newer type black and white tubes and all color picture tubes.
- ✓ Model 83 provides separate filament operating voltages for the older 6.3 types and the newer 8.4 types.
- ✓ Model 83 employs a 4" air-damped meter with quality and calibrated scales.
- ✓ Model 83 properly tests the red, green and blue sections of color tubes individually—for each section of a color tube contains its own filament, plate, grid and cathode.
- ✓ Model 83 will detect tubes which are apparently good but require rejuvenation. Such tubes will provide a picture seemingly good but lacking in proper definition, contrast and focus. To test for such malfunction, you simply press the rej. switch of Model 83. If the tube is weakening, the meter reading will indicate the condition.
- ✓ Rejuvenation of picture tubes is not simply a matter of applying a high voltage to the filament. Such voltages improperly applied can strip the cathode of the oxide coating essential for proper emission. The Model 83 applies a selective low voltage uniformly to assure increased life with no danger or cathode damage.

Model 83 comes housed in handsome portable Saddle Stitched Texon case—complete with sockets for all black and white tubes and all color tubes. Only **\$38<sup>50</sup>**

### *The Problem:*

Required, a tester—housed in a single carrying case capable of testing and rejuvenating all picture tubes including black and white and color; 50 degree, 90 degree or 110 degree. A tester capable of testing these ever increasing types speedily and efficiently. A tester capable of proving to the satisfaction of the set owner that the picture tube is definitely good, bad or weak. To do so the serviceman must be able to instantly switch from the comparative simple testing of a black and white tube to the complex requirements for testing each individual section in a tri-gun color tube.

### *The Solution:*

The Model 83 more than meets the requirements specified above. It will not only test every type of picture tube ever made but will test them for leakage, emission and gas content. Furthermore even if the tube tests "good" Model 83 will help you to predict the length of time the tube will remain "good." The Model 83 will also enable you to extend the useful life of a "weak" tube by properly controlled application of rejuvenating voltage.

# SHIPPED ON APPROVAL NO MONEY WITH ORDER — NO C. O. D.

Try it for 10 days before you buy. If completely satisfied then send \$8.50 and pay balance at rate of \$6.00 per month for 5 months—No Interest or Finance Charges Added. If not completely satisfied, return to us, no explanation necessary.

MOSS ELECTRONIC, INC.  
Dept. D-547 3489 Tenth Ave., New York 34, N. Y.

Please rush one Model 83. If satisfactory I agree to pay \$8.50 within 10 days and balance at rate of \$6.00 per month. If not satisfactory, I may return for cancellation of account.

Name \_\_\_\_\_

Address \_\_\_\_\_

City \_\_\_\_\_ Zone \_\_\_\_\_ State \_\_\_\_\_

All prices net. F.O.B., N.Y.C.

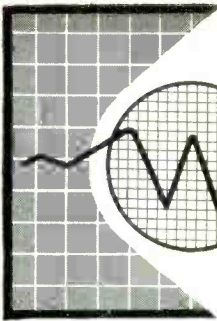

# TIME SAVING MULTIPLE USE also STICKLEBACK TOOLS

FOR HUNDREDS OF JOBS IN THE SHOP—AT HOME—IN INDUSTRY

Cut any size or shape hole in wood, plaster, plywood, plastic, masonite, etc., twice as fast as any conventional tool. Can be used for drilling, sawing or routing. Try one at your parts distributor.

## DRILL ROUTERS



DRILL  
OR  
SAW

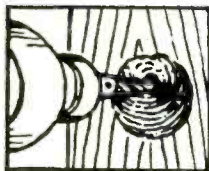
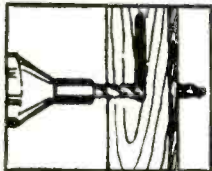

ROUT

For power tools, fit any  $\frac{1}{4}$ " chuck. Six sizes from  $2\frac{3}{4}$ " long,  $\frac{1}{4}$ " diam. (No. 588-01, \$2.35 List) to 7" long,  $\frac{1}{2}$ " diam. (No. 588-06, \$5.40 List)

## DRILL SAWS

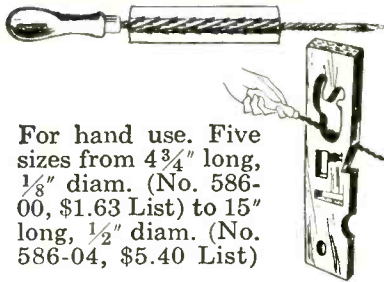

For hand use. Five sizes from  $4\frac{3}{4}$ " long,  $\frac{1}{8}$ " diam. (No. 586-00, \$1.63 List) to 15" long,  $\frac{1}{2}$ " diam. (No. 586-04, \$5.40 List)

## FILE RASP



Three times as fast as an ordinary file. Can be used as a plane. Has coarse side for rough work, fine side for finishing. Part No. 587, List Price \$3.25.



## STRIP-ER-CLIP WIRE STRIPPER

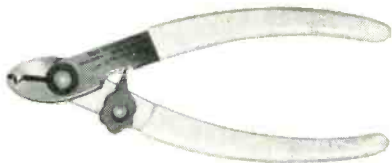

Compact, efficient unit that is perfect for your tool case. Gets into tight places and does a clean, fast job without damaging the wire strands. Special 7-stop gauge quickly adjusts to any wire size from 14 to 26 gauge. Has heavy insulated grips. Part No. 595, List Price \$2.30.

## TEKNI-LABELS



Handy decals that give your electronic equipment a professional appearance. Sets in black or white (each with hundreds of titles) for receivers, transmitters, television, dial marking, audio-hi-fi, panel markings (gold only), receiving tubes, etc. Only \$1.35 net per set.

**FREE:** Walsco's new 64 page catalog with thousands of tools, chemicals and items for hi-fi, radio and TV servicing. Ask your distributor or write Walsco for your copy.

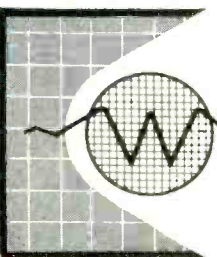

Walsco-ELECTRONICS MFG. CO.  
A Division of Textron Inc.  
West Coast Plant: Los Angeles 18, California  
MAIN PLANT: 106 W. GREEN ST., ROCKFORD, ILL., U.S.A.  
In Canada: Atlas Radio Corporation, Toronto 10, Ontario

## LATEST TEST EQUIPMENT

For more information, write in ELECTRONIC TECHNICIAN's new product code number on our coupon on page 45.

### Seco CURRENT CHECKER

Model HC-6 is a new fast current checker for on-the-spot checking of horizontal output circuits. No need to cut wires, it immediately indicates whether cathode current of the horizontal output tubes is within recommended limits. Also minimizes the

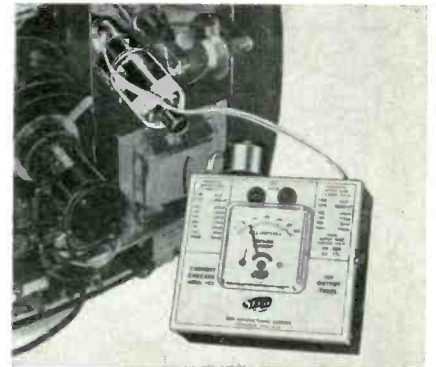

chance of premature failure of horizontal output transformer; and is an accurate indicating device for adjusting horizontal drive and linearity for minimum cathode current. Net \$12.95. Seco Mfg. Co., 5015 Penn Ave. South, Minneapolis, Minn. (ELECTRONIC TECHNICIAN 11-8)

### Precision TUBE TESTER

Model 10-40 "Electromatic" is a new tester for all modern type tubes. Some of the features are: testing amplifier tubes over a complete dynamic range of operation; dual sensitivity short-check; functional testing of voltage reg-

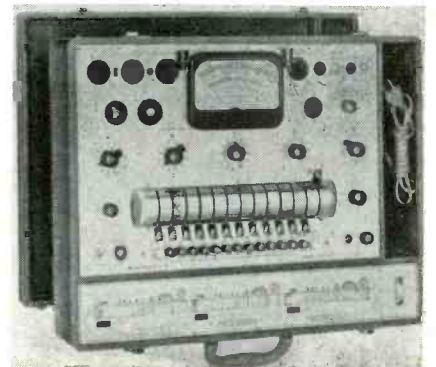

ulator tubes; ultra sensitive gas test circuit; specially engineered circuit for TV picture tubes; special beam current tests for CRT's. Requires optional accessory cable. Precision Apparatus Co. Inc., 70-31 84th St., Glendale, L.I., N.Y. (ELECTRONIC TECHNICIAN 11-9)



# INSTALL THE PICTURE TUBE MILLIONS KNOW BY NAME!



You make more money by handling products the public knows...and wants. "Black-Daylite" is a brand name familiar to TV set owners everywhere. Black-Daylite stands for quality, for real-life picture performance.

## **BLACK-DAYLITE**

**ALUMINIZED PICTURE TUBE**

These tubes are better-built and better-tested, to give your customers the finest in television reception. Because their long history of quality is tops, Black-Daylite Aluminized Picture Tubes are preferred in every home. When you install them, you supply a *pre-sold* product—with a name backed by years of G-E marketing effort and millions of dollars of consumer advertising.

Three modern, fully-equipped General Electric plants, located for fast deliveries, build Black-Daylite picture tubes to the industry's highest standards. Your nearby G-E tube distributor stocks these well-known, fast-selling tubes in an across-the-board range of types. Phone him today! *Distributor Sales, Electronic Components Division, General Electric Company, Owensboro, Kentucky.*



*Progress Is Our Most Important Product*

**GENERAL  ELECTRIC**

11-13-201

Micro-inspecting G-E picture tube guns for precision workmanship.

100% testing: one reason why G-E Black-Daylite picture tubes are superior.

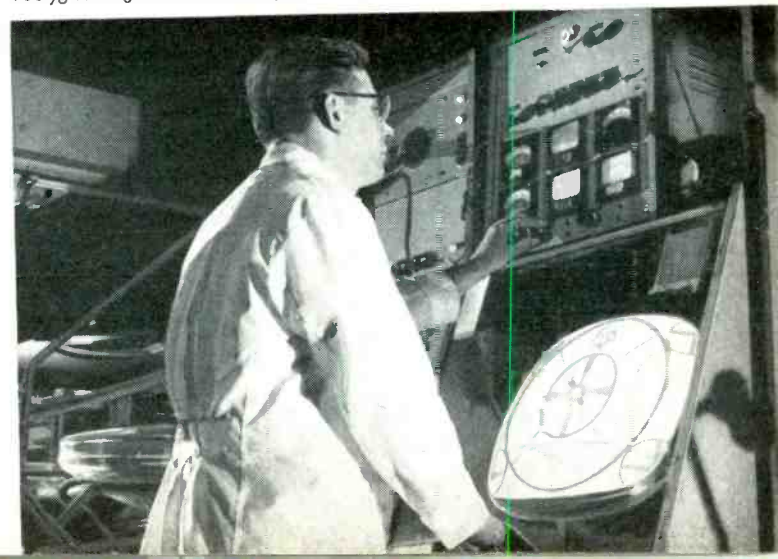
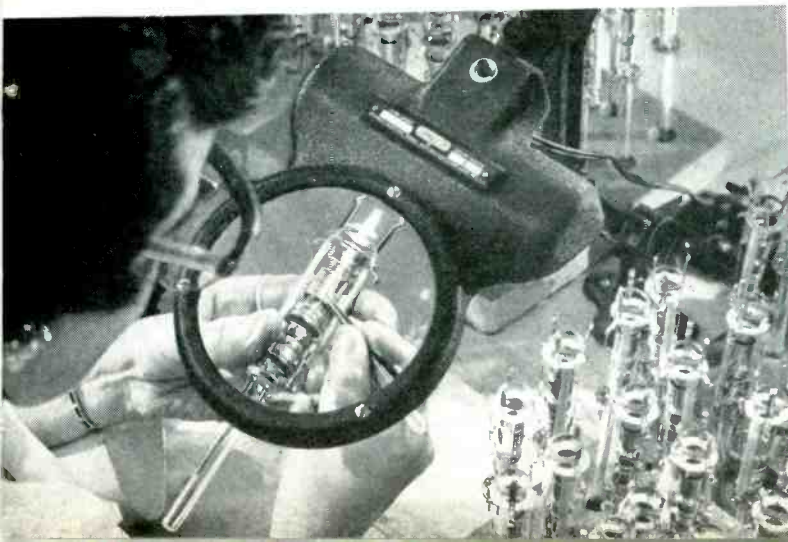

# RCA POWER TUBES

## Set High-Performance Records at Owens-Illinois Co.

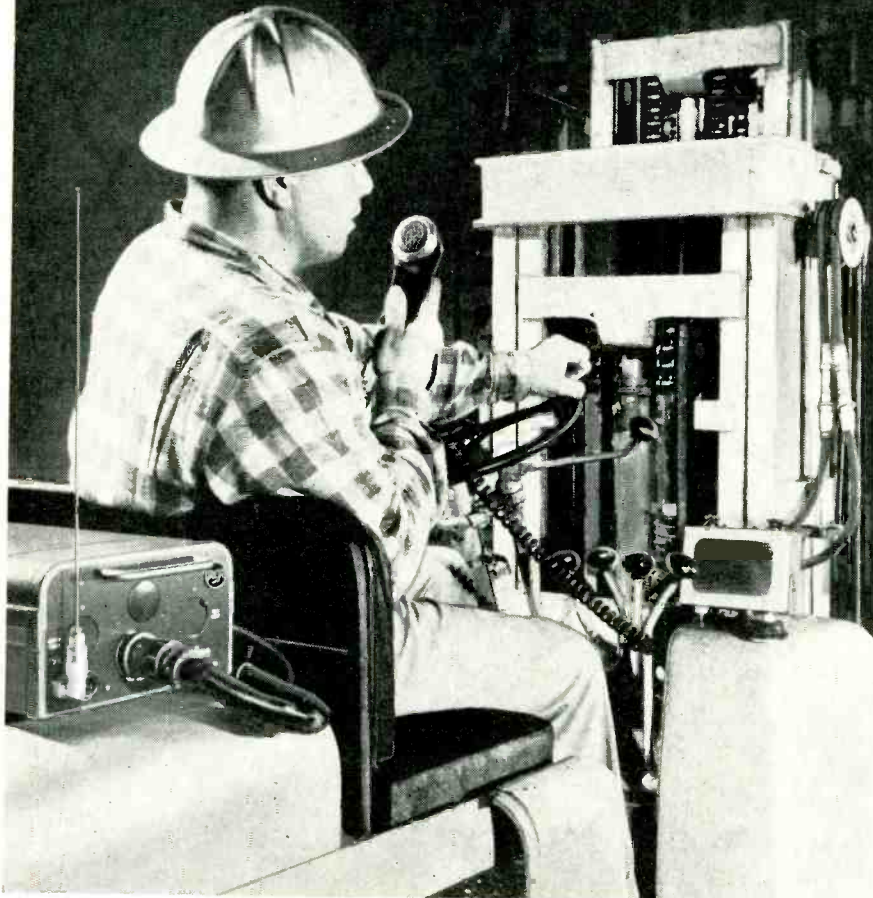

Two-way radio with RCA Power Tubes adds more "payload" mileage to fork-lift trucks

At Owens-Illinois' huge, 50-acre plant in Bridgeton, N. J., 27 fork-lift trucks—each equipped with a radio installation—cover a lot of ground. On this job RCA Power Tubes get a man-sized workout. No problem here though, because the RCA Power Tubes are rugged—designed for rough going under conditions of shock, vibration, and changing voltage. For dependability over the long haul, specify RCA Power Tubes, the choice of leading mobile-radio-equipment manufacturers.

Whenever you need an RCA tube type—fast—call your RCA Industrial Tube Distributor. You can count on him for prompt delivery.



RCA BEAM POWER TUBES—  
foremost in mobile communications

**RCA** RADIO CORPORATION OF AMERICA  
Electron Tube Division  
Harrison, N. J.

### Vis-U-All TUBE TESTER

The new model V200, featuring a "magic eye" voltage indicator, tests and reactivates all types of TV picture tubes including 110°. It also gives an immediate check on the proper functioning of the grid and cathode with respect to bias cutoff. Selector switch



facilitates bias, life and short tests. It is compact and portable. It is built into a 10 x 6 x 5 inch steel cabinet with carrying handle. Net \$59.95. Vis-U-All Products Co., 303 Fuller Ave. N. E., Grand Rapids, Mich. (ELECTRONIC TECHNICIAN 11-10)

### Kingston GENERATOR

To simplify the location of open filaments in series string receivers, the model AC-1 transistorized, battery operated, pulse generator injects a signal into the receiver under test through the line cord receptacle, and is picked up by the absorption analyzer. Net \$29.95, without battery. Battery is a standard type, and is good for 72 hours. Kingston Electronic Corp., Medfield, Mass. (ELECTRONIC TECHNICIAN 11-13)

### Heath LAB STANDARDS

Heathkit LSR-LSC laboratory standards consist of 4 separate units, 2 resistive and 2 capacitive. Each unit contains 7 precision standards and is designed for calibrating, or checking calibration of various lab instruments such as ohmmeters, capacity meter, impedance

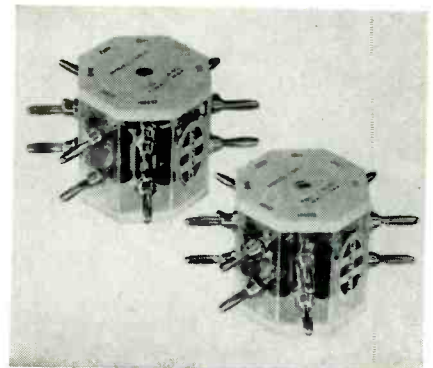

bridges, etc. Banana-pin connectors with the standard 3/4" spacing can be plugged directly into most instruments for minimum stray capacity and lead resistance. Also handy in substitution tests to determine unknowns in circuits. Heath Co., Benton Harbor, Mich. (ELECTRONIC TECHNICIAN 11-11)

### B-T TV ANTENNA COUPLERS

Two new couplers, model A-105 Hi-Lo VHF and A-107 UHF-VHF, features: new filter and non-powered circuit; weather-resistant and non-breakable plastic cases; and may be mounted outdoors with model A-100 mounting kit. The A-105 can combine 300-ohm high and low band VHF antennas or provides two separate outputs from an all-

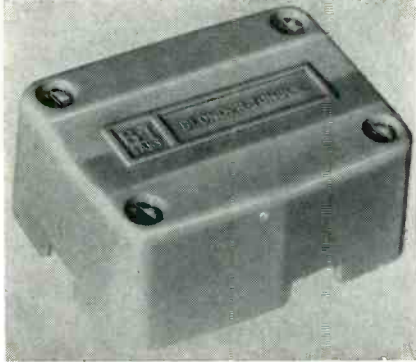

channel antenna. Isolation exceeds 21 db and insertion loss is only 1 db. The A-107 can combine 300-ohm UHF and VHF antennas or split a common line into separate isolated outputs. Loss is less than 2 db. Priced at \$3.50 each. Blonder-Tongue Labs. Inc., 9 Alling St., Newark 2, N. J. (ELECTRONIC TECHNICIAN 11-24)

### RCA TUBES

The 6EM5 and 8EM5 are high-perveance beam power tubes of the 9-pin miniature type designed primarily for use as vertical-deflection amplifier tubes in TV receivers having diagonal deflection angles of 110° and operating at ulior voltages up to 2,000 v. The 6EM5 utilizes a 6.3v 800 ma heater; the 8EM5 an 8.4v 600 ma cwu heater. Both have a maximum peak positive-pulse voltage of 2,200v (absolute) and a maximum peak cathode current of 210 ma.

12DS7, a 9-pin miniature type contains two diodes and a high perveance power tetrode in one envelop. Designed for use in hybrid auto receivers in which the tube and transistor electrode voltages are obtained directly from a 12v storage battery. Radio Corp. of America, Tube Div., Harrison, N. J. (ELECTRONIC TECHNICIAN 11-22)



"There, that's more likely to give my lazy husband the stereo effect."

## CORNELL-DUBILIER CAPACITORS



### The extra values are "on the house"

Want more capacitor for your dollar? Here's how: Cornell-Dubilier has originated a "preferred-type" program on twist-prong electrolytics. Now, a relatively few types fill over 90% of all replacement requirements. You need less - to do more. Fewer types means improved production efficiency, lowered costs - savings to you. How is it done? Instead of producing hundreds of types with odd and critical capacitance and voltage ratings, each "preferred type" carries the highest value and rating called for in each category. In most cases you get more capacitor at lower cost - plus added safety factor, improved performance and "call-back" protection. It's on the house! To get more capacitor for your dollar, ask your C-D Distributor about Preferred Type Twist-Prong Electrolytics or write Cornell-Dubilier Electric Corporation, South Plainfield, New Jersey.



## CORNELL-DUBILIER CAPACITORS

Consistently Dependable

# RADIART VIBRATORS



## Consistently dependable power

Next time an auto-radio vibrator replacement is called for, try Radiart. There's a complete line for all 6-volt and 12-volt applications. And no waiting for the type you want, because your local Radiart Distributor maintains a full stock for your convenience. Ask him for your free copy of the Radiart Vibrator Replacement Guide, or write to Dept. ET-11, The Radiart Corporation, Indianapolis 5, Indiana.



# RADIART TOBE Vibrators

Old Hands at Dependability

## NEW PRODUCTS

For more information, write in *ELECTRONIC TECHNICIAN*'s new product code number on coupon on page 45.

### Sarkes Tarzian TRANSLATOR

A new translator, model TRU 1, was announced. Channels 70 to 83 can be

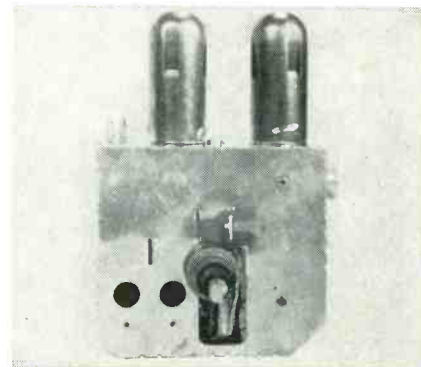

converted to channels 5 or 6. It features a gain of 10 db. Sarkes Tarzian, Inc., Bloomington, Ind. (*ELECTRONIC TECHNICIAN* 11-27)

### Centralab PACKAGED CIRCUITS

Eight new PEC packaged circuits PC336 through PC343, for replacement applications in Philco, RCA, Motorola, Packard-Bell and GE sets are available. There are almost one million of these units now in the field in original equipment, mostly in TV sets. Centralab Div., Globe-Union, Inc., 900 E. Keefe Ave., Milwaukee 1, Wisc. (*ELECTRONIC TECHNICIAN* 11-23)

### ICM TRANSCEIVER

The "Citizens' Bander" is a new 27 mc transmitter-receiver. It is crystal controlled, has a tolerance of 0.005% and a maximum input of 5 watts, as required by the FCC. It has a double conversion superhet receiver and is operable on 115v ac. Also available for 6 or 12v dc. Range is up to 10 miles. Ideal for home, office, industrial and farm use. International Crystal Mfg. Co., Oklahoma City, Okla. (*ELECTRONIC TECHNICIAN* 11-5)

### Du Mont FREQUENCY METER

Type 5890-B, a new transistorized frequency meter for use with land-mobile communications equipment, is designed to latest FCC split channel specifications as well as adjacent channel requirements. With a built-in thermometer, the crystal controlled instrument covers any r-f channel within the 25 to 470 mc range, with an accuracy to  $\pm 0.00025\%$ . It is also a precision instrument for i-f channels in the 100 kc to 100 mc range. Some of its functions are: carrier frequency error indication, relative transmitter field strength, modulation deviation measurement, receiver i-f alignment generator, etc. Allen B. Du Mont Labs. Inc., 750 Bloomfield Ave., Clifton, N. J. (*ELECTRONIC TECHNICIAN* 11-15)



## Channel Master TRANSISTOR RADIOS

A new line of transistor radios has been introduced with two 6-transistor models in the initial offering. Model 6506 including four 1½ v batteries and

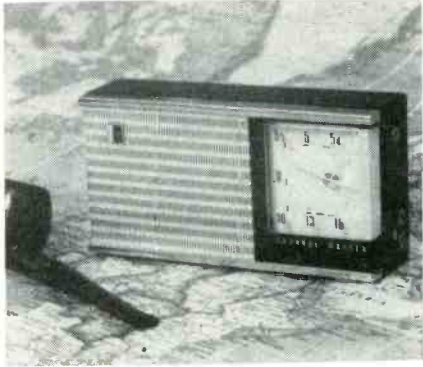

accessories is \$49.95. Model 6501 and a 9 v battery is \$34.95; accessories are \$4.95. Accessories include: carrying case, shoulder strap, and magnetic ear-phone with case. Channel Master Corp., Ellenville, N. Y. (ELECTRONIC TECHNICIAN 11-25)

## ASD TUBE TESTER

The new self-service tube tester, model A-1000F "Automatic" is designed to fully test every section of practically every receiving tube in use. Can test auto radio vibrators and OZ4's, as well as fuses and lamps. It requires no set-up, just press a test button. Service calls increase when the tester, bearing the service shop name and address, is placed in local stores. American Scientific Development Co., P. O. Box 109, Redlands, Calif. (ELECTRONIC TECHNICIAN 11-12)

## G-C SCREW DRIVER

Available in two sizes, the "Mini-Hold" is designed as an aid in stereo cartridge change-over. A special holding device in the shaft grips the tiny screw and holds it in place while the shaft turns it out. Fumbling around in

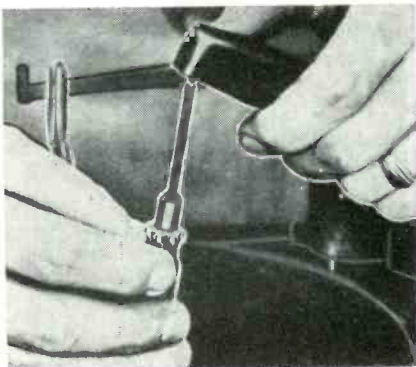

tight fitting cartridge housings is eliminated and better fastening is assured. No. 9346, 3¼" long, priced at \$3.50. No. 9347, 7" long, priced at \$3.75. General Cement Mfg. Co., 400 S. Wyman St., Rockford, Ill. (ELECTRONIC TECHNICIAN 11-26)

ELECTRONIC TECHNICIAN • November, 1958

# TOBE

## America's Fastest-Growing Service Capacitor Line...



# NEW!

## TOBE MYLAR\* MOLDED TUBULAR CAPACITORS

- *Molded of DuPont Mylar*, one of the finest insulation materials ever developed.
- *Thermoset Case Construction* secures leads and sections firmly to withstand extremes of handling, vibration, shock and soldering temperatures.
- *High Insulation Resistance*: Average megohm values per unit 10,000 at 25°C. Small capacitance variation with thermal change.
- *Temperature Operating Range*: -55° to +130°C.
- *Moisture Resistant*: Exceeds JAN-C-91 requirements.
- *Non-Inductive*: Extended foil construction insures low resistance connections and low RF impedance.

### DESIGNED FOR SERVICE DEALERS



### NEW TOBE MYLAR\* CAPACITOR KIT

FREE KIT CONTAINS  
80 CAPACITORS

ONLY

# \$15<sup>84</sup>

Compact, clear-plastic dispenser contains an assortment of 80 Tobe Mylar capacitors in the most popular sizes, ratings and quantities for quick, efficient servicing. Covers over 60 different ratings at 200, 400 and 600 working volts and from .0001 to 1.00 mfd. Dealer pays only for the Tobe Mylar capacitors, kit is free.

# TOBE RADIART CAPACITORS

\*DuPont trademark

TOBE DEUTSCHMANN CORPORATION, NORWOOD, MASSACHUSETTS

# Save tube sales for yourself!

## NEW, LOW-COST

S-18

# TEST-O-MATIC®

## ONLY \$149.95!

dealer net

NOW . . . at this amazing low cost for a quality self-service tube tester you can have that business that's been getting away from you. Over 5,000,000 tubes a year are sold thru self-service machines. Why not get your share.

An S-18 in your store allows "do-it-yourself" customers to test their own tubes. Saves bench time and effort. When you place a Test-O-Matic in the corner drug store or your friendly supermarket, more business comes your way. Now's the time to ask your jobber about the new S-18 Test-O-Matic.

18 sockets test over 800 tube types. Test each side of multi-purpose tubes. Tests 6 and 12 volt vibrators. Three controls . . . Full emission test. Colorful unit takes only 15" x 19" of floor space. 6 feet high. Holds over 400 tubes in handy sliding drawers.



**\$79.95**  
dealer net price

### NEW PORTABLE P-18 TUBE TESTER FOR SERVICE CALLS

Handsome, lightweight (12 lbs.) portable tester contains same testing panel as S-18. Available in black-grained finish attache case. Operates 110V AC.

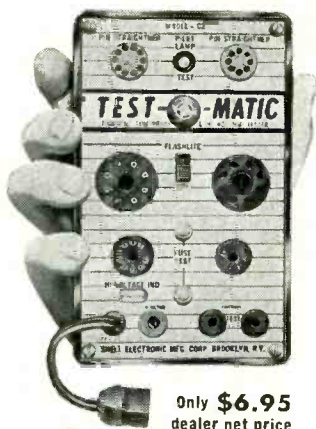

Only **\$6.95**  
dealer net price

### HANDY MODEL C-2 TEST-O-MATIC ALL PURPOSE TESTER

Only 6" x 3 3/4" and battery operated. Test all tubes for filament continuity. High Voltage tester indicator. Check picture tubes, appliances, any tube or circuit. Contains own flashlite.

### C-D CAPACITORS

New electrolytic capacitors have terminal and mounting ends designed for practically all printed circuit requirements. Insertion is fast, simple and foolproof. An offset index lug allows the unit to be inserted only in the right way. UPL long pin terminals can be

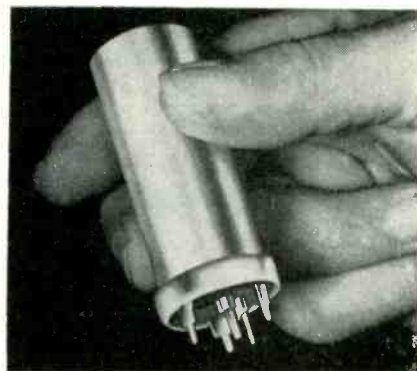

bent to hold the unit securely. Snap-in type UPSC clicks into position for firm contact permitting frequent handling of printed boards. Available in hundreds of voltage and capacitance combinations. Cornell-Dubilier Electric Corp., South Plainfield, N. J. (ELECTRONIC TECHNICIAN 11-16)

### Tobe CAPACITOR KITS

Kit of 76 fast-moving molded plastic tubular capacitors are all tested at twice their rated voltage to assure capacity stability. Applications include replacement in TV sets, auto radios and other compact electronic equipment. These capacitors are 50% smaller in size than some other units of equal ratings. Tobe Deutschmann Corp., Service Division, 2900 Columbia Ave., Indianapolis, Ind. (ELECTRONIC TECHNICIAN 11-21)

### Valor TRANSISTOR CHECKER

A new transistor checker is battery-operated, small and compact. It is designed to check for burned out and ruined transistors. It provides an instantaneous go-no-go check and may be used for measuring leakage currents and breakdown voltages, as well as identify transistor type. Valor Instruments, Inc., 13214 Crenshaw, Gardena, Calif. (ELECTRONIC TECHNICIAN 11-14)

### Pyramid MYLAR CAPACITOR

The new "Gold Standard" Mylar capacitor for the radio & TV replacement market has a capacitance tolerance factor of  $\pm 10\%$ , and a temperature range of  $-30^{\circ}\text{C}$  to  $85^{\circ}\text{C}$ . It features a non-hygroscopic dielectric which gives it high resistance to moisture and high insulation resistance. Available in standard capacity and voltage ratings at the same price as certain other capacitors. Pyramid Electric Co., North Bergen, N. J. (ELECTRONIC TECHNICIAN 11-20)



For complete information on New Shell Products,  
see your parts distributor or write to

**SHELL ELECTRONIC MANUFACTURING CORP.**

Dept. E-11 1688 Utica Avenue, Brooklyn, New York

Export: RIISE International Corp., 204 East 38th Street, New York, N. Y.

# WANTED

\$  
UP TO **20,000**  
**REWARD**



This \$20,000.00 can be yours in additional annual business through selling and/or installing an electronic unit which is about to revolutionize the industry. The Paxton GDO is specially designed for extremely easy installation. We mention this first because the Paxton is so different from all others on the market. It's easier to install than a T.V. antenna, and there's more profit in it.

The Paxton Electronic Garage Door Operator is combined with a radio receiver in one small, compact unit, no larger than a portable radio. The unit is installed on the header beam above the garage door. Only three lag screws are required; no cumbersome hardware, tracks, rods or posts. The unit is backed by a 5 year warranty, and is approved by Underwriters Laboratories.

The Paxton electronic system operates on frequencies in the F.C.C. approved 200 to 400 kilocycle band. Our engineers have designed a revolutionary triple code, which is used from the car transmitter to actuate the receiver in the garage. Two radio frequencies are transmitted in alternate bursts, and both these frequencies must be present at the receiver before it will actuate the operator to open or close the door. The Paxton highly selective, factory-tuned receiver system is insensitive to spurious transmissions, ham operators, and other transmissions on the citizens' band (27 M.C.).

The Paxton unit is the result of over three years of research, development, and field testing. We are now in full production at our ultra-modern plant. The unit is extensively covered with patents to protect you from copyists. Transistorized electronic systems are also available.

We show you how to sell, install, and service. To start as a Paxton dealer, no selling experience is required, because the Paxton practically sells itself. All your customers with garages are immediate prospects. Each installation you make immediately becomes a demonstrator, helping you to sell the customer's friends and neighbors. Result: more garage door operator business and more contacts and prospects for the other lines you carry. To get further information about this wide-open market opportunity and profit-building business, write, wire or phone today and ask for our dealership program. Statewide distributorships are also available. Contact Paxton Products, 929 Olympic Boulevard, Santa Monica, California. Telephone EXbrook 4-2751.

... another  
**MALLORY**  
 service-engineered  
 product

## Mallory "Sta-Loc" Controls Let You Replace the Line Switch by Itself

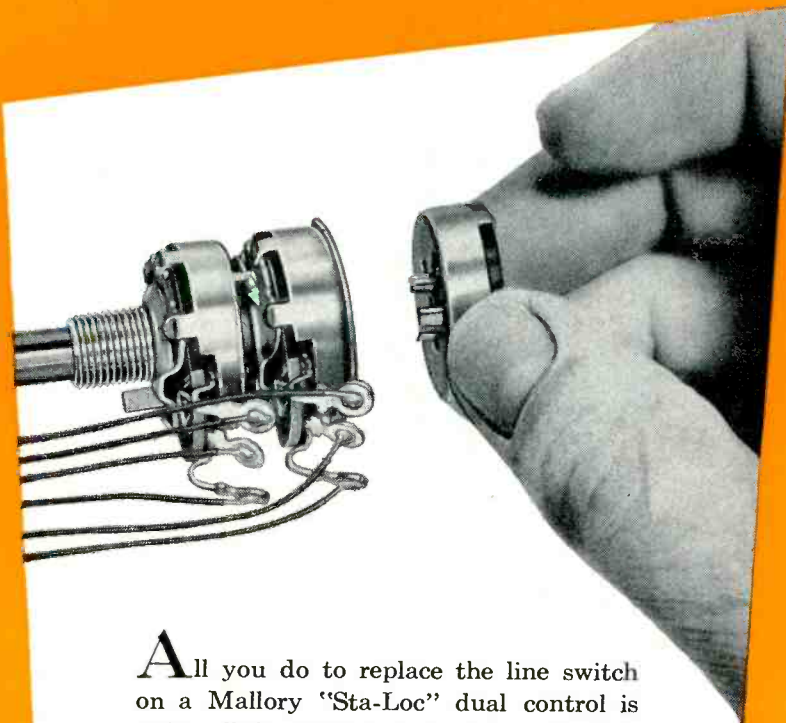

All you do to replace the line switch on a Mallory "Sta-Loc" dual control is twist off the locking ring, remove the line switch element and put on a new one. No need to replace or rewire the control sections. That's why replacing with "Sta-Loc" controls is your best insurance against lost repair time. Mallory line switches, with exclusive "floating ring" contacts, give longer life too. Your Mallory distributor can supply the exact "Sta-Loc" dual concentric control you need. See him today.

P. R. MALLORY & CO. Inc.  
**MALLORY**

P. R. MALLORY & CO. Inc., INDIANAPOLIS 6, INDIANA

- Capacitors
- Vibrators
- Resistors
- Power Supplies
- Mercury and Zinc-Carbon Batteries
- Controls
- Switches
- Filters
- Rectifiers

# AUDIO

## PROGRESS • PEOPLE

EXCISE TAX bill includes exemption of tape and wire recorders, except business machines, from 10% tax. It's classed as an infant industry. Phono tax continues.

CAUTION ON NOMENCLATURE: Tape recorders which are stereo for playback only—but monaural for record—should not be labeled stereo without distinct qualification. Worse still are those producers calling equipment stereophonic, when all they mean is that it is adaptable to stereo with an added unit at extra cost.

DEPARTMENT STORE HI-FI activity has been puzzling several Audio Newsletter readers. Does it exist in quantity? So we checked the more than 1300 pages in "Sheldon's Retail Trade," covering department and specialty stores. Not only is hi-fi not listed, but out of 2584 stores, only 852 sold radios. From personal contact we found two department stores selling hi-fi components regularly. Evidently hi-fi and department stores go their own merry ways.

AUDIO ENGINEERING SOCIETY's 1957-58 lecture series on "Principles and Practices of Tape and Disc Recordings" has been published in book form covering 15 lectures by various authorities, reports AES Pres. Sherman Fairchild. Copies are available at \$5 for members, \$7.50 for non-members, from Sumner Hall, Lecture Series Chairman, Amityville, L.I., N.Y. A second volume on the remaining lectures in the series will be published shortly. Topics to be covered in future lectures are test rec-

# NEWS

## PRODUCTS • PRICES

ords, stereo discs, tape editing, noise suppression, and others.

INTERNATIONAL ELECTRO-TECHNICAL COMMISSION Publication 94, "Recommendations for Magnetic Tape Recording and Reproducing Systems: Dimensions and Characteristics," is available for \$2.40 from American Standards Association, 70 E. 45 St., New York 17, N. Y.

**MORE FM NEWS:** An FM car radio will be introduced soon by ERIC ENGINEERING, Los Angeles. CROSBY LABS, Hicksville, N.Y., is reported to be signing FM multiplex license agreements with some hi-fi producers. Crosby developed a system several years ago.

"WHAT'S ALL THE TALK about one-step and two step?" is the rhetorical question of an influential hi-fi producer. Reflecting the attitude of several large and small companies we've spoken to, he goes on to say: "No manufacturer in his right mind is going to give up his jobbers, so one step is here to stay. At the same time, anyone who gets out in the field can quickly learn that a lot of dealers and servicemen are buying from hi-fi jobbers at 20% to 25% discounts on longer margin lines. So two-step is also here to stay. Despite preconceived notions, both one-step and two-step can—and are—working well side by side."

CENTRALAB Pres. William S. Parsons has been elected president of the Electronic Industry Show Corp. (May Parts Show in Chicago). VP

... another  
P. R. MALLORY & CO. INC.  
**MALLORY**  
service-engineered  
product



## Your Distributor Has MALLORY-RMC Discaps® "On File"

Mallory-RMC Discaps, long the standard in original equipment, are now available for service work. These high quality ceramic disc capacitors are "on file" at Mallory Distributors... especially packaged for your convenience.

Discaps are packed 5-of-a-kind on a handy 3"x5" file-card. Knockout panels on the back of the package let you remove one capacitor at a time without disturbing the others or destroying the package.

Mallory-RMC Discaps are made by the world's largest manufacturer of ceramic disc capacitors—are available in popular ratings. You can depend on Discaps for the most critical applications.

**Get these from your Mallory Distributor—today.**

P. R. MALLORY & CO. Inc.  
**MALLORY**

P. R. MALLORY & CO. Inc., INDIANAPOLIS 6, INDIANA

Capacitors • Vibrators • Resistors • Controls • Switches • Filters • Rectifiers  
• Power Supplies • Mercury and Zinc-Carbon Batteries

Mr. Dealer  
**PHILCO**

offers you a Complete and Universal line of  
**FULL FIDELITY NEEDLES**

- DIAMOND
- SAPPHIRE
- OSMIUM

Now, one complete line of precision-engineered and custom-designed needles to fit every make and model phonograph and High Fidelity receiver. Every Philco needle measures up to the highest quality and life test standards. All Philco needles are individually packaged for absolute protection.



**FREE! NEEDLE COUNTER DISPLAY!**

Ask your Philco Distributor how you can get this sparkling, jewel case needle dispenser free. It's a sales-maker for you right on your counter at the point of sale.



**COMPLETE PHILCO NEEDLE CATALOG**

The most accurate, up-to-date, easy-to-read needle catalog in the industry. Cross references are complete... Illustrations are big... Makes selling easy.

**PHILCO FIDELITAPE**

will bring new customers into your store. Unequaled in uniformity of output. Guaranteed splice free. Extra strength and extra length.

**See Your Philco Distributor Today!**



**World-Wide Distribution**

Service Parts • Power-Packed Batteries • Universal Components • Long-Life Tubes • Heavy-Duty Ectors • Star-Bright 20/20 Picture Tubes • Long-Distance Antennas • Appliance Parts • Laundry Parts • Universal Parts and Accessories

**PHILCO®**  
*Accessory Division*

is William H. Thomas, pres. of JAMES B. LANSING; Secy., Morris Green, pres. of ALMO RADIO; Treas., Karl W. Jensen, pres. of JENSEN INDUSTRIES.

FANON has appointed Hank Lieberman, Dallas, and B. Bernstein, Phoenix, as reps in the Southwest, Gary Cohen New York regional sales manager.

JENSEN MFG. appoints Frank D. Lintern asst. distributor sales manager.

MASCO announces rep appointments: E. C. Short, Vancouver, B. C.; William M. Hummel, Ontario, Canada; S. W. Simberkoff, Hoboken, N. J.; Paul Hayden, East Point, Ga.

ORRADIO names David Petrig chief engineer for manufacturing.

ROBINS INDUSTRIES names Robert Shaw Co., Mo., as rep.

ROBINS INDUSTRIES appoints Stang Sales to represent the firm's audio accessories and tape splicers in metropolitan New York.

ARGONNE ELECTRONICS announces the AR230 pistol grip power megaphone @ \$39.50. Weight is 4 1/2 lbs. Uses 4 flashlight cells.

AUDIO DEVICES is introducing the Echoraser which removes print-through from echo-ridden tape recordings. It consists of an upright chromium-plated brass bar, 1 1/2" x 3/8" x 1/4", with small energized area. Bar is mounted permanently on transport, contacting moving tape.

BARKER SALES has introduced the 10" Stentorian HF1016U Universal @ \$36.50, and the T-358 3.5" tweeter @ \$14.95.

COMPONENTS CORP., Den-ville, N.J., announces the Stereo-Vertor @ \$39.50. It will play both 45/45 and Minter's MSD stereo records, the latter by demodulating an FM multiplex sub-carrier. The firm also has a 33-1/3 stereo test record, #58-45/45 @ \$1 for checking 45/45 cartridge balance, channel separation and rumble.

FISHER has introduced the Model 30-C master audio control and preamp, which may be stacked in pairs for stereo. Price is \$59.50; cabinet \$12.95.

GROMMES div. of Precision Electronics has introduced the Model 208 stereo preamp, designed to work with two power amplifiers. It features two independent channels for each of five inputs with ganged selector, turn-over, roll-off, volume, bass and treble controls.

KARLSON has started to use the same hardwood plywood in finished and kit enclosures, increasing weight 30% in latter. Karlsonite and Luxorwood units have been discontinued. Prices remain the same.

MASCO announces the Electronic Butler door-answering 3-station intercom @ \$108.75, and the Conference Talk 6-station system @ \$56.25 each.

N. C. B. is introducing a professional quality standard alignment, equalizing and inspection tape for mono and stereo. Furnished in 15 and 7 1/2 ips speeds on 7" and 5" reels respectively, using 1-mil mylar. Prices are \$11.95 and \$9.95. 3 3/4 ips tape will also be available at \$9.95. Inquiries to N. C. B. "Signature," P.O. Box 491, Ithaca, N. Y.

UNITED AUDIO announces the Wigo StereoSet, two matched 2-way speaker systems in enclosures, priced at \$169.50.

# sales without selling

16 million worn out antennas are due for replacement. Here's how you can get this extra business on your regular service calls...

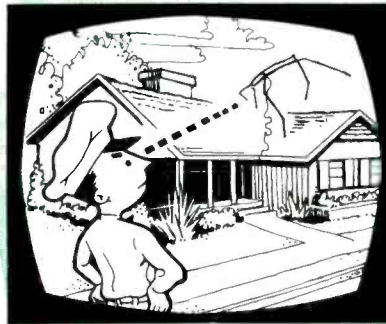

## 1 LOOK UP!

Look up at your customer's antenna before every service call. See if there are missing or sagging elements, corrosion or other signs of a worn out TV antenna.

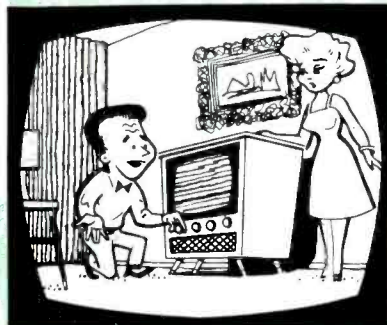

## 2 TALK UP!

Tell your customer what you've seen... also how an antenna loses up to 50% of its efficiency after three years. Explain how much clearer their TV picture will be with a new antenna.



## 3 PUT UP!

Stock CLEAR BEAM Do It Yourself Kits on your truck. Make the installation while you're there...or sell kits outright to Do It Yourselfers. Either way you'll pick up extra profits.



Complete Installation Kits for Every Popular Antenna  
Conicals — Arrows — Yagis —  
Inlines



**CLEAR ANTENNA CORP.,**  
**BEAM CANOGA PARK, CALIF.**

# Never over or underheats!

## Gives more reliable soldering!

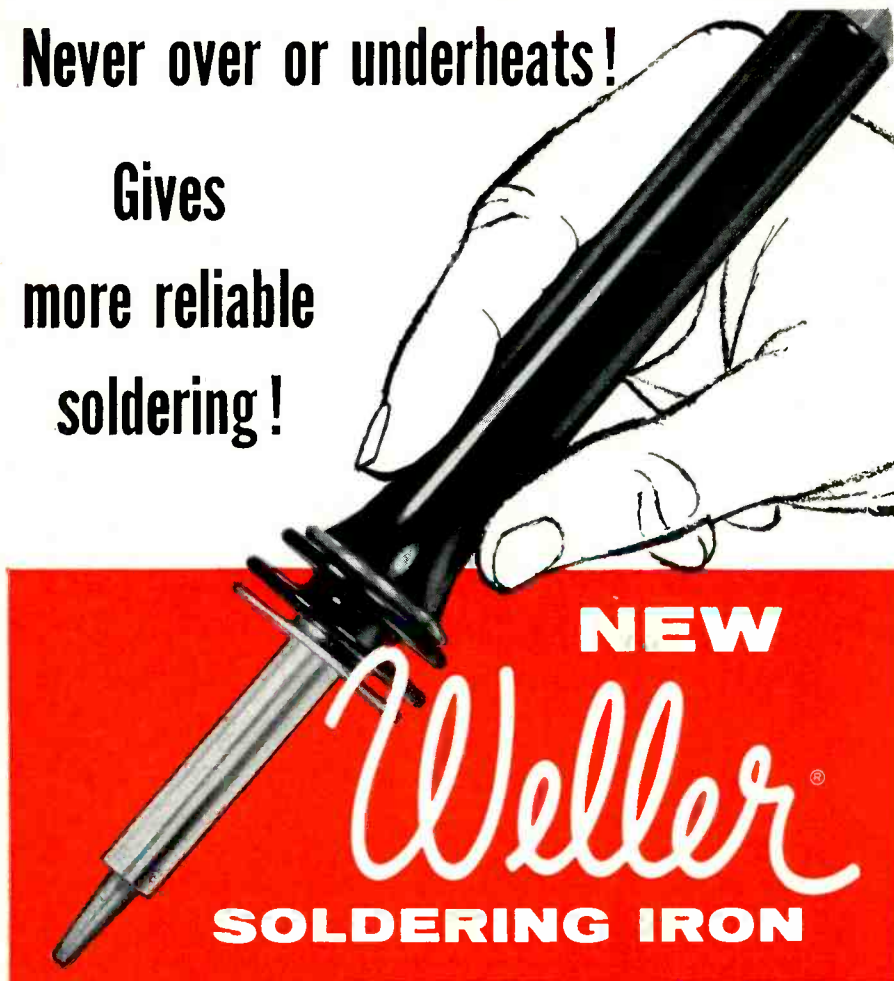

*with built-in MAGNASTAT  
Temperature Control*

A revolutionary new soldering tool from Weller—long-time leader in the soldering field. Automatically maintains correct soldering temperature—and it's all self-contained. Sensing device is in the tip. Unmatched for reliable TV, radio, printed circuit and other precision soldering. 3 models available for all your service requirements from controlled lower temperature to heavy electrical soldering. Priced from \$8.00 list, up.

SOLDERING IRON PERFORMANCE — Temperature vs Load

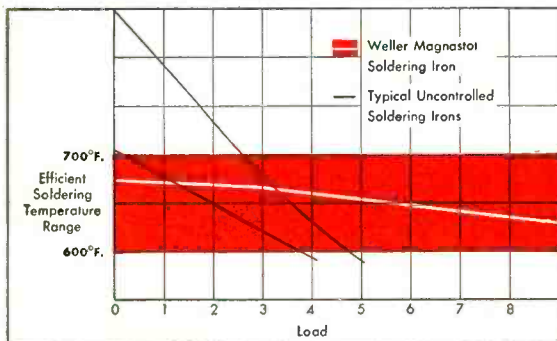

- Approximately 1/2 weight of uncontrolled iron.
- Delicate balance—cool handle.
- Cord plugs into handle.
- Saves current when idling—tips last longer.
- Reaches full heat quickly.

Order From Your Distributor or Write for Bulletin

**WELLER ELECTRIC CORP.** 601 STONE'S CROSSING ROAD  
EASTON, PA.

STEREO-ETTE, Chicago, announces the Gold Bug stereo adapter @ \$16.75.

FISHER reports price change on Model 30-C audio control to \$59.50.

H. H. SCOTT has released prices on its new components. Model 130 stereo preamp @ \$169.95; Model 299 stereo amplifier-preamp @ \$199.95; Model 209 monaural amplifier \$139.95.

PRICE TRENDS, courtesy Audio-File div., United File-O-Matic:

ASTATIC 6 PAK and 12 PAK cartridge needles decreased to \$18.75 and \$40.47.

FAIRCHILD cartridge 216-A increased to \$85; turntables 412-4 and 412-ED increased to \$246 and \$147.50, respectively.

UNIVERSITY driver unit PA-30 discontinued.

JENSEN MFG. speakers CX-120, CX-225, DX-120, G-600 and K-80 increased to \$52.50, \$61.75, \$27.50, \$134.50 and \$17.75, respectively.

SCOTT turntable 710A decreased to \$129.95.

GE A1-500 baton tone arm discontinued.

PICKERING 190D tone arm discontinued.

REVERE tape recorder T-710D discontinued.

RACON speakers MP-623, RE-50, RE-60 increased to \$30, \$33, and \$39.

STEPHENS: HF driver P-30 decreased to \$97.

OXFORD: 8 ohm extended range speaker C012JB decreased to \$19.50.

UNIVERSITY: Powrpage PP-1 & PP-2 decreased to \$57 & \$45.

BOGEN: Discontinued items: Speaker case 240; base PS-1.

JENSEN MFG: Discontinued items: Cabinet BL-80; Speaker F10-S.

DUOTONE: Transcription needles discontinued: 710B, 725B, 750B, 777.

ASTATIC: Needle D-AG-M decreased to 90¢ net.

PERMOFLUX: Speaker systems LD-1, LM-1, LM-2 and WD-1

(Continued on page 93)



## BINDERS FOR YOUR CIRCUIT DIGESTS

... to hold your schematics for  
convenient reference  
\$2.95 each—Postpaid  
Canada—please add 50¢ for ad-  
ditional mailing costs

### ELECTRONIC TECHNICIAN

480 Lexington Ave.  
New York 17, N. Y.

Please ship .... "ELECTRONIC  
TECHNICIAN Circuit Digests  
Binders." I enclose \$.....

(please print)

Name .....

Street & No. ....

City..... Zone... State....

## BINDERS FOR YOUR ELECTRONIC TECHNICIAN

... to keep your copies for  
convenient reference  
\$3.50 each—Postpaid

Canada and Foreign—please add 50¢  
for additional mailing costs

### ELECTRONIC TECHNICIAN

480 Lexington Ave.  
New York 17, N. Y.

Please ship .... "ELECTRONIC  
TECHNICIAN Magazine Bind-  
ers." I enclose \$.....

(please print)

Name .....

Street & No. ....

City..... Zone... State....



## in Astatic cartridge line

ASTATIC Takes Positive,  
Extensive Action Against  
Cheap, Imported Cartridges

SWEEPING, DRASTIC PRICE REDUCTIONS  
EFFECTIVE SEPT. 1, 1958

Astatic's answer to inferior, cheap foreign cartridges is a SENSATIONAL SLASH of prices in its famous cartridge line. The drastic reductions make the price differential of the imported cartridges either non-existent or insignificant. Of course, the design and fine performance qualities of the Astatic Cartridges remain unchanged. Cheap, foreign-made cartridges have never come close to competing on a performance basis. Thus, Astatic's action strips them of their single previous advantage—low cost.

Astatic's answer to inferior cartridges is also YOUR answer. More than ever, the Astatic Cartridge line merits your first preference.

SEE YOUR ASTATIC DISTRIBUTOR OR WRITE FOR YOUR COPIES OF ASTATIC'S NEW GENERAL CATALOG 33-3 AND NEW CARTRIDGE CROSS-REFERENCE AND REPLACEMENT CHART CRC-58.

*Leader with originals—first with replacements*

THE

**Astatic**  
CORPORATION

KNOWN THE WORLD OVER  
CORPORATION, CONNEAUT, OHIO

IN CANADA: CANADIAN ASTATIC LIMITED, TORONTO, ONTARIO

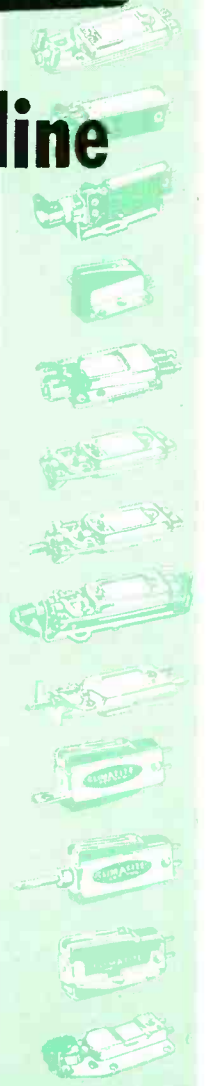

Something New Has Been  
Added to the World's Finest  
TV Service Information  
... the finest transistor  
radio service information

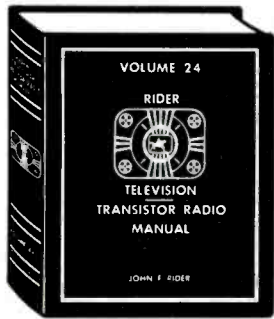

**Rider's Combination TV 24  
and Transistor Radio Manual**

With the sales boom in transistor radios comes the need for accurate, factory service information in one reliable source to save you servicing time. Now, Rider's TV 24 includes a complete compilation of service information on TRANSISTOR RADIOS (home and portable types) ... the whole story under one cover. This, of course, is in addition to the complete presentation of manufacturers' service data on television receivers.

Rider TV Manuals are the only bound source of *unabridged*, accurate TV receiver and transistor radio servicing information prepared by receiver manufacturers.

**COMPLETELY CURRENT WITH TV AND  
TRANSISTOR RADIO PRODUCTION**

TV 24 covers 20 TV receiver manufacturers and 23 transistor radio manufacturers (1956-7-8) and includes the latest color TV sets, portables and 110" slim sets. It covers the factory-approved and factory authorized data of TV and Transistor Radio manufacturers including VHF-UHF tuner data; production runs and changes; cumulative index—volumes 1 to 24; manufacturers' circuit descriptions; current information on private label brands; printed circuit layouts; installation data; signal waveforms for trouble shooting; alignment; voltage charts; test equipment setups; tube layouts; printed circuit bottom views; frequent component callouts.

**SAVES SERVICING TIME**

No more hunting down of hard-to-get schematics...no more guesswork...no more trial and error! Factory accuracy and factory coverage. With Rider's TV 24 you get the most accurate and most reliable service information on television and transistor radio receivers. All in one place—instantly available—a permanent file of dependable service information at an economical price.

Keep your Rider TV manual library up to date with TV 24. If you currently do not use Rider TV manuals, why not start your TV manual library today with TV 24 and see how you will save time and money. Place your order with your jobber today—limited printing. Only \$27.00.

**JOHN F. RIDER PUBLISHER, INC.**  
116 West 14th Street, New York 11, N. Y.

**New Books**

Books marked with an asterisk (\*) may be obtained prepaid from Electronic Technician

\***TELEVISION SERVICING, 3rd Ed.** By Walter Buchsbaum. Published by Prentice-Hall. 398 pages. Hard cover. \$6.75.

This third edition is another worthwhile addition to the list of helpful texts on TV operation and maintenance. It discusses general theory, alignment, installation and troubleshooting. Coverage of various TV topics is broad, but with some subjects, such as color TV and test equipment, there is too little practical "how to" information. It is adequately illustrated.

\***BASIC PULSES.** By Irving Gottlieb. Published by John F. Rider Publisher. 176 pages. Soft cover. \$3.50.

Practically every important electronic device relies on pulses ... TV receivers, industrial controls, computers and radar, to name a few. Yet many electronic technicians are not thoroughly familiar with the subject. Therefore, this volume with its remarkably easy-to-understand pictures is highly recommended. Without any complex mathematics, here are some of the many items explained: pulse wavetrains, Fourier analysis, RC networks, waveshaping, differentiation and integration, dc restoration, sawtooth generators, blocking oscillators and others. It's a basic and most informative book.

\***FUNDAMENTALS OF TRANSISTORS, 2nd Ed.** By Leonard Krugan. Published by John F. Rider Publisher. 176 pages. Soft cover. \$3.50.

Here is a comprehensive data-packed revision of the 1954 edition, with important new material added. This up-to-date volume covers both older information, and new presentations on surface barrier, intrinsic, drift, avalanche and spaciator types. Grounded base, emitter and collector transistors are discussed, along with amplifiers and oscillators. At the end of each chapter are questions and suggested references for further study. Another textbook asset are the substantial number of sample computations shown.

\***PINPOINT RECORD CHANGER TROUBLES IN 5 MINUTES.** By P. Sheneman. Published by Coyne Electrical School. 330 pages. Soft cover, plastic lay-flat binding. \$3.95.

This is a practical servicing book covering the changers used in phono systems made by some 95 manufacturers. There are over 400 time saving photos and illustrations, and 58 trouble check charts. Adjustments and service hints are given for each of the manufacturers, with only two important omissions. For the growing number of technicians in hi-fi work, this volume will be a most valuable maintenance aid.

(Continued on page 76)

**BETTER SERVICING...  
MORE INCOME**

**RIDER BOOKS AND MANUALS**

**HOW TO TROUBLESHOOT A TV RECEIVER** (2nd Edition) by J. Richard Johnson. The second edition of this bestselling guide to diagnosing TV receiver faults and correcting them brings the original up-to-date, and adds several valuable new categories on troubleshooting data and procedures. Latest developments such as vertical chassis, portable TV receivers, servicing of printed circuit boards, are thoroughly explained.

The subject of controlled-warmup tubes, their uses and electrical characteristics is discussed in detail. Provides guidance in checking picture tubes and correcting faults. Explains how to get the most out of TV service data; shows you how to recognize faults from raster or picture distortion; explains all TV set controls and how to adjust them. #152, soft cover, 160 pp., \$2.50.

**HOME AIR CONDITIONING—Installation and Repair** by J. Derman, F. Makstein, H. Seaman. Modern, practical text by three experts, enables you to understand the organization, operation, installation and repair of all types of home air conditioners. You will understand the function of each part; trouble-shooting and repair techniques; how to select the proper unit to meet the requirements of a specific installation. #211, \$3.50.

**REPAIRING HI-FI SYSTEMS**, by David Fidolman. Locate the troubles and repair the faults in hi-fi equipment with no test instruments—simple equipment and elaborate equipment—by reading this book. Analyzes typical troubles and their repair through a system of logical steps. #205, \$3.90.

**PORTABLE AND CLOCK RADIOS**, by Ben Crisses and David Gnessin. You can learn all about portable and clock radios—their circuitry, their repair, in this modern book. Beginning with typical portable radio circuits, emphasis is placed on filament circuitry and how major problems of current dispersion are handled. Transistor circuitry is covered. Stress is placed on portable radio power supplies for battery circuits and battery and AC-DC circuits. Numerous battery testing techniques explained. Covers repair, replacement and alignment plus a detailed discussion of probable mechanical troubles, replacement procedures and short-cuts. Tips on extending the life of the set are discussed. Clock radios, their circuitry, a wide variety of clock movements, how to adjust them and locate defects also covered. Tips on cleaning and lubricating clock mechanisms. #224, \$2.75.

**REPAIRING TELEVISION RECEIVERS**, by Cyrus Glickstein. The most modern completely practical book, written by an expert with long experience in television receiver repair. Devoted to trouble-shooting and repair techniques which are modern, yet down-to-earth. Covers the use of simple as well as elaborate test equipment of all kinds. Profusely illustrated. Soft Cover, #191, \$4.40.

**3rd SUPPLEMENT to the RECEIVING TUBE SUBSTITUTION GUIDEBOOK**, by H. A. Middleton. A must for every technician! Contains more than 830 latest receiving tube substitutions • more than 200 picture tube substitutions • more than 230 American to European tube substitutions • more than 200 European to American tube substitutions • a cumulative index listing the tube types treated in the basic book and all 3 supplements. It pays for itself almost immediately! #139-3—Soft Cover, 72 pp., 8½" x 11", illus. Only \$1.35.

**RECEIVING TUBE SUBSTITUTION GUIDEBOOK**, by H. A. Middleton. #135—Soft cover, 224 pp., 8½" x 11", illus., \$3.00. **FIRST SUPPLEMENT**, #139—Soft cover, 48 pp., 8½" x 11", illus., \$.99. **SECOND SUPPLEMENT**, #139-2—Soft cover, 48 pp., 8½" x 11", illus., \$.99.

**ADVANCED TV SERVICING TECHNIQUES**, by Zbar and Schildkraut. A complete advanced TV servicing course, developed by the Radio-Electronics-Television Manufacturers Association. Shows how to use every conceivable type of test equipment, how to service every part of a TV receiver. Explains latest techniques. Soft cover, 8½" x 11". **MAIN TEXT**, 192 pp., illus. #161, \$3.60.

**LABORATORY WORKBOOK**, 32 pp. #161-2, \$.95.

**TV PICTURE TUBE CHASSIS GUIDE**, by Rider Lab Staff. This easy-to-use TV tube type chassis guide covers all picture tube types used in TV receiver production from 1946 to February 1957—over 7,000 listings. Organized by chassis number, and in some cases, by models so that the technician can immediately locate the correct picture tube type simply by knowing the chassis number, #204, Only \$1.35.

Rider Books are sold by parts distributors and bookstores. Look for the familiar Rider Bookseller. It carries a wealth of electronic know-how in the many titles covering every phase of radio, TV, audio and electronics. There's a Rider Book that will make servicing more profitable, increase your income. If these books are not available, order direct: ET-11



**JOHN F. RIDER PUBLISHER, INC.**  
116 West 14th Street, New York 11, N. Y.

## Non-Linear Waveforms

(Continued from page 39)

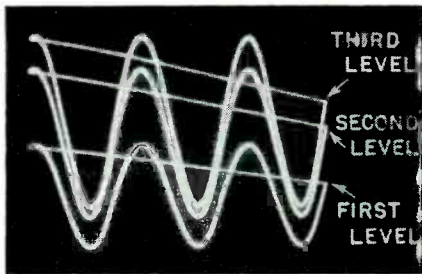
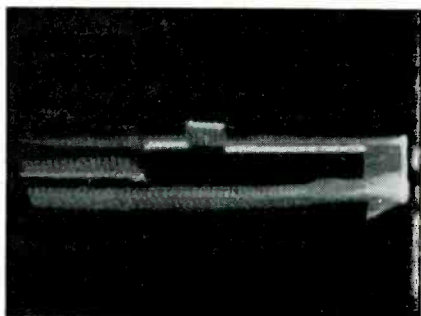

Fig. 9—DC unbalance in the scope's vertical amplifier causes the waveform to change position as the gain control is varied.

the scope amplifier. The apparent d-c component usually increases as the vertical gain is advanced as shown in Fig. 9. To correct for d-c distortion, the vertical amplifier must be balanced. Unequal values of load resistors, tube characteristics and plate resistances in push-pull stages can cause d-c unbalance. Most d-c scopes have a vertical-amplifier balance control which can compensate for small variations in load and tube resistance values.

Sinewave sweep may cause non-linear distortion on some types of tests. A frequency response curve displayed on a scope by a 60-cycle sinewave sweep is horizontally linear because the sweep generator is frequency-modulated at the same 60-cycle sinusoidal rate. If a vertical sync pulse is displayed on 60-cycle sinewave sweep, the ends of the display will usually show severe horizontal non-linearity and fold-over, as shown in Fig. 10. The composite video signal is generated for display on sawtooth sweep. This is the opposite situation found in troubleshooting vertical sweep circuits by the signal injection method. If a 60-cycle sinewave were injected into the grid of the vertical amplifier instead of a 60 cycle sawtooth, the same non-linear and foldover conditions would prevail in the TV set. •

Fig. 10—Sinewave instead of sawtooth sweep presents horizontal non-linearity and foldover while observing vertical sync pulses.



### VERSATILE . . .

Aerovox Hi-Q disk capacitors are excellent replacements for molded mica, ceramic-cased tubulars, and paper tubular capacitors in many applications, such as by-pass and filtering. These versatile disk ceramic capacitors help you to do a better service job faster. They're available in a wide variety of types and sizes from by-pass and coupling types to temperature compensating types to vibrator buffer units. Your local Aerovox Distributor stocks the complete line of Aerovox ceramic capacitors along with thousands of other top quality Aerovox capacitors.



### RUGGED DEPENDABILITY . . .

High-voltage "Cartwheel" ceramic capacitors capable of providing long and dependable service life while withstanding rugged high voltages. Available in a new universal type (UV) with interchangeable terminals in 5 styles for use in filter and by-pass applications in TV high voltage power supplies. Available from your local Aerovox Distributor in 10,000, 20,000 and 30,000 volt sizes at 500 mmf.

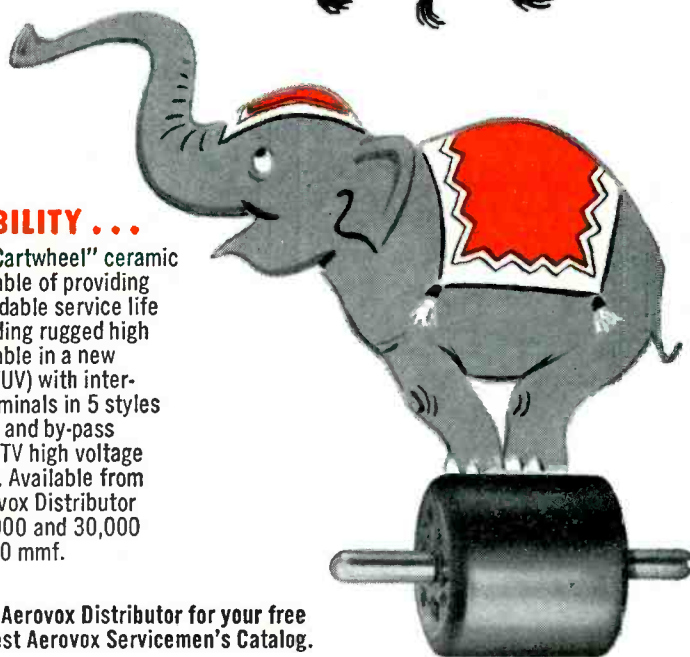

Ask your local Aerovox Distributor for your free copy of the latest Aerovox Servicemen's Catalog.

## AEROVOX CORPORATION

DISTRIBUTOR DIVISION

NEW BEDFORD, MASS.

**LEADING  
SET  
MAKERS  
SPECIFY  
TUNG-SOL**

**HIGH  
IN PERFORMANCE**

**BLUE CHIP  
QUALITY**

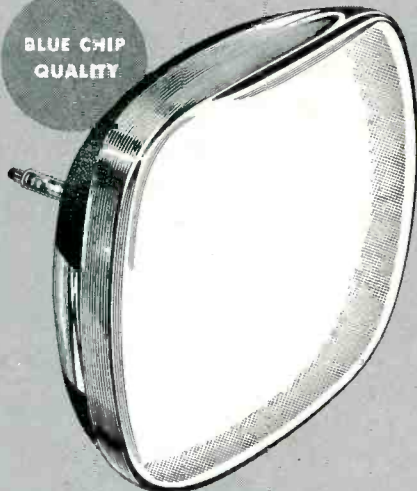

**TUNG-SOL®**  
Magic Mirror Aluminized  
**PICTURE TUBES**

ELECTRON TUBE DIVISION  **TUNG-SOL ELECTRIC INC.**  
NEWARK 4, NEW JERSEY

## *New Standards* **Capacitance**

• Because of the important role that electricity and electronics play in modern science and industry, the National Bureau of Standards must work continually to improve the accuracy of electrical measurements, measuring devices, and standards. The most recent stride forward in this area is the development of an accurate capacitance-measuring bridge and an accompanying calculable standard of capacitance. An important result of the new capacitance standard is the possibility of more accurately assigning the value of the ohm, in terms of length and time by measurements of capacitance and frequency.

Recently completed apparatus for the precise inter-comparison of small capacitors employs a special 3-winding transformer and a bank of very stable capacitors which are combined to balance an unknown capacitance. Both the sensitivity and precision of capacitance measurements were improved. An improved absolute standard of capacitance has also been constructed. Its design, based on a recently discovered theorem in electrostatics, allows its value to be calculated in terms of a single measured length. It is believed that the uncertainty in the value assigned to this standard does not greatly exceed one part in a million. Both the transformer bridge techniques used, and the calculable standard capacitor offer immediate gains in the accuracy of capacitance measurements. In addition, they provide an opportunity for an absolute ohm determination in terms of capacitance and frequency. The primary standard of resistance is presently based on a calculable inductance and frequency.

The basic principles of transformer bridges have been

Design of the improved standard of capacitance is based on a recently discovered theorem in electrostatics, which allows capacitance value to be calculated in terms of length. Removable sections of the center cylinder eliminate end effects.

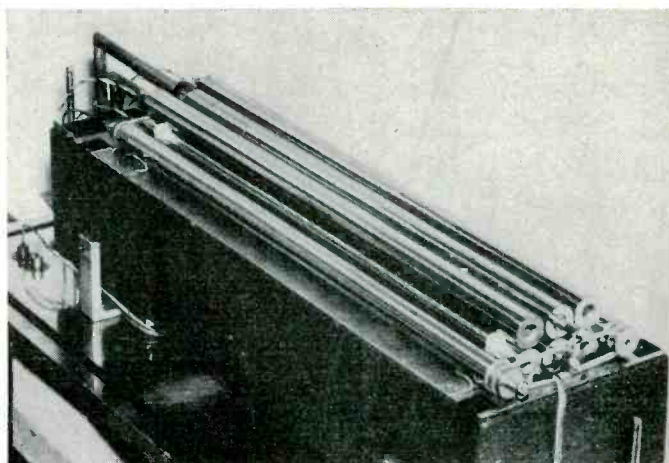

known for some time and a number of such bridges have been constructed during the past 20 years. The very great accuracy with which bridge measurements can be made is due mainly to the construction of the acting source of voltage—the transformer. Capacitance evaluation depends on knowing precisely the ratio of terminal voltages, and this, in turn, depends upon the stability and exactness of the ratio of the induced voltages in the transformer windings. Stable voltages having a known ratio to one another depend on the turns ratio of the secondary windings. Careful consideration must be given to all the elements of the transformer, its windings, and shields. The transformer primary, wound on a toroidal core of high permeability and large cross section, is designed to provide a uniform distribution of magnetomotive force. Furthermore, to insure that the core flux generated by the primary winding is the only source of voltage in the two secondary windings, copper shields are used to enclose the primary completely; secondaries are also shielded.

#### Lampard's Theorem

The new theorem in electrostatics on which the calculable capacitor design is based is known as Lampard's theorem. It states that four parallel cylindrical electrodes arranged to fulfill certain symmetry conditions have a direct capacitance of a certain number of electrostatic units for each centimeter of cylinder length.

A simple way of meeting the requirements of Lampard's theorem is to arrange four cylindrical bars so that their axes are all parallel and the centers of the circles which form their cross sections lie at the corners of a square.

Lampard's theorem specifies the capacitance per unit length exactly only if the cylinders are infinite in length. However, in the practical case, a bar with a removable section allows the difference between two measurements to be determined—this difference represents the capacitance of the removable section. The end effects are the same in the two measurements and can be eliminated when using the difference technique. By measuring the length of the removable section, the capacitance associated with this length can be computed. •

Temperature-compensated capacitors were built as secondary standards to maintain the unit of capacitance. Components left to right: Two duralumin guard electrodes, brass inner electrode, center supporting post, assembly in case ready for hermetic sealing, assembled capacitor, brass outer electrode, and partially assembled capacitor showing inner and guard electrodes in place.

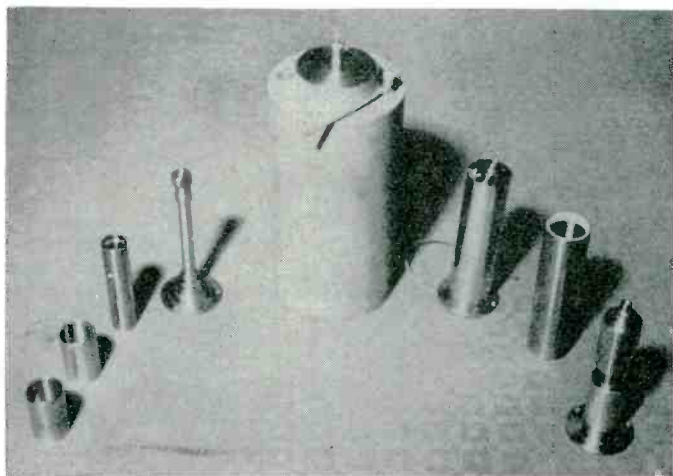

# LEADING INDEPENDENT SERVICE DEALERS CHOOSE TUNG-SOL

# LOW IN CALLBACKS



BLUE CHIP  
QUALITY

## TUNG-SOL® RECEIVING TUBES

ELECTRON TUBE DIVISION  TUNG-SOL ELECTRIC INC.  
NEWARK 4, NEW JERSEY

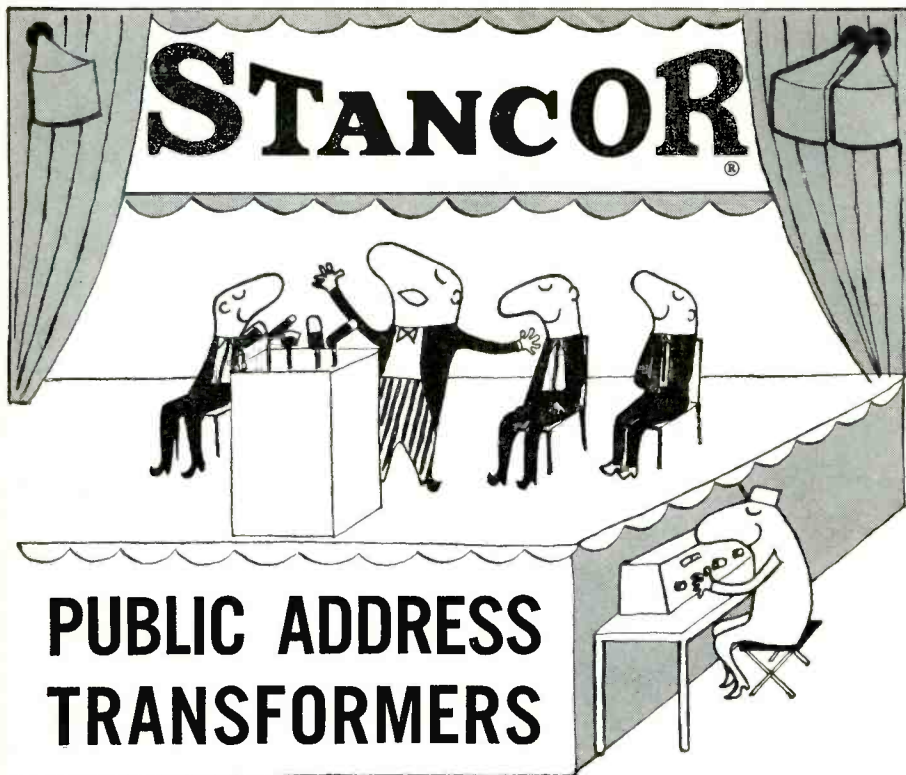

## PUBLIC ADDRESS TRANSFORMERS

*The MOST COMPLETE LINE in the industry*

For all your public address needs, STANCOR offers your widest choice of transformer types and ratings:

- \* 25 Volt Line to Voice Coil
- \* 70.7 Volt Line to Voice Coil
- \* 140 Volt Line to Voice Coil
- \* Intercom and Transceiver
- \* Microphone to Grid or Line
- \* High Fidelity Output



**FREE:** STANCOR's General transformer catalog listing 700 transformers including over 200 units for public address use. See your STANCOR distributor or write Chicago Standard for your copy.



### CHICAGO STANDARD TRANSFORMER CORPORATION

3513 ADDISON STREET • CHICAGO 18, ILLINOIS



SERVICE MEN KNOW THERE IS JUST ONE

#### HUSH

Reg. U. S. Pat. Off.

*Chemically engineered for tuners and switching mechanism*

Hush comes in a 6 oz. pressure can with sufficient pressure to reach all contacts to wash-away that dirt, leaving clean and positive contacts, protected with a lasting lubricant film.

Hush also available in 2 oz., 8 oz. and 32 oz. containers. **\$2.25 net**

#### EVER-QUIET

Reg. U. S. Pat. Off.®

*Since 1949 the Original Volume Control and Contact Restorer*

EVER-QUIET is a free-flowing liquid that leaves no powder residue. Scientifically designed to seep around the shaft and penetrate the control or potentiometer, cleaning and contacts and leaving a safe protecting film. Harmless to metals, wire or carbon. Will not affect inductance, capacitance or resistance.

2 oz. bottle with handy dispenser (32 oz. size available) **79¢ net**

See your distributor or write to



CHEMICAL ELECTRONIC ENGINEERING, INC. Matawan, New Jersey

(New Books. Continued from page 72)

\***GAS TUBES.** Edited by Alexander Schure. Published by John F. Rider Publisher. Soft cover. 80 pages. \$1.50.

Thyratrons, gaseous rectifiers and voltage regulators are among the tube types which this helpful basic text discusses. It explains in easy to understand language how gas functions give these tubes their special characteristics. The material should be of interest to electronic technicians generally, and particularly to those who are starting to get interested in industrial electronic controls.

\***MAGNETIC AMPLIFIERS: THEORY & APPLICATION.** By Sidney Platt. Published by Prentice-Hall. 248 pages. Hard cover. \$7.00.

Magamps have developed in a relatively short time as an important device for industrial control. Starting with the fundamentals of magnetism, the author takes the reader through the saturable reactor, magnetic amplifiers with and without feedback, servomechanisms and miscellaneous circuits. It's a good book for all technicians interested in the industrial end of electronics.

**FOUNDATIONS OF WIRELESS.** 7th Edition. By M. G. Scroggie. Published for Wireless World by Iliffe and Sons, Ltd., Dorset House, Stamford St., London, S. E. 1, England. 383 pages. Hard cover, Price 15s.

An enlarged, completely revised, and almost entirely re-written edition covers basic theory, starting from the most elementary principles. No previous technical knowledge on the part of the reader is assumed. Though the background of the book is still sound broadcasting, there is now more emphasis on FM, VHF, and TV, including color. Transistors are also covered.

## New Products

### Colman RESISTORS

A new and complete line of fuse resistors range from 4.7 to 150 ohms. They are packaged on display cards, in 10-pack kits, or in bench-size assortments in plastic boxes. Colman Tool & Machine Co., Electronic Distr. Div., Amarillo, Texas. (ELECTRONIC TECHNICIAN 11-30)

### Sprague CAPACITORS

Print-Lok electrolytic capacitors feature a new 3-in-1 universal base designed to fit all printed wiring boards. A pair of pliers is all that's needed to adapt these capacitors to any one of three different types of printed circuit bases. The improvement is expected to simplify radio-TV servicing and reduce replacement capacitor inventories. Sprague Products Co., North Adams, Mass. (ELECTRONIC TECHNICIAN 11-29)

# WHAT'S NEW ABOUT STEREO?

NORMAN CROWHURST

• Some of the "hard core" adherents of stereo, who have been listening to it, on and off, for years now, must have somewhat mixed feelings as each fresh manufacturer "launches" stereo, with "At last, a new miracle of sound is here!" Stereo is not new. The first experiments were demonstrated at the Paris Exposition of 1881—long before the advent of electrical recording or the extensive use of radio for broadcast entertainment. So what is new about stereo?

The introduction of a practical stereo disc seems to be the spark

that has made stereo the king of reality that will bring it into the homes of a mass market, rather than an elect few. All the while stereo remained about twice as expensive as "high fidelity" (whichever grade this term might mean for the moment!), most people reacted, "Yes I'd like it, but it isn't worth twice the price." The difference is that now stereo has become available at prices only slightly higher than an equivalent grade of high fidelity.

More than this. As other writers have observed, one advantage of stereo is that the cost of improving a monophonic system by adding a second channel is actually lower than trying to improve single channel reproduction to an equivalent degree. (If that is possible.) We all know that department store "high fidelities" give quality that will satisfy a large market, but if you really

want the best, you can pay much more than ten times the price for a system. Sure it's better, but is it more than ten times better? In stereo, comparatively inexpensive additions give a much enhanced realism.

You may have heard, at some time or other, one of the demonstration stereo-type radio transmissions—by dragging in the kitchen radio for the "other channel." The stereo illusion worked, but it wasn't spectacular—how could it be, over the kitchen radio? But now, from quite a choice of program sources, you can get good stereo at realistic prices.

Stereo discs have made it possible to supply this form of program at a cost that is only nominally higher than the monophonic LPs or EPs. As soon as more stereo discs become  
(Continued on page 81)

## STEREO PROFITS START HERE

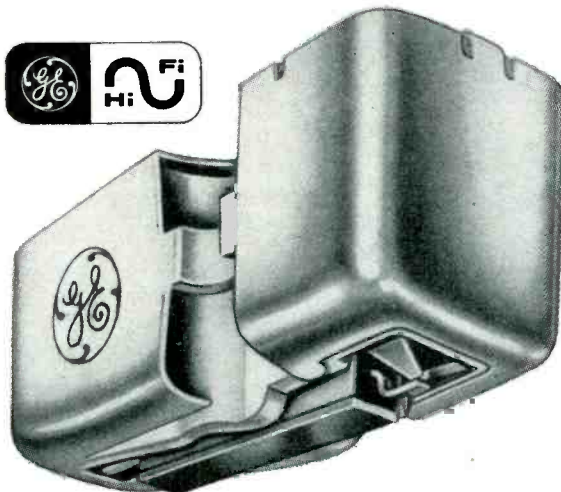

- Compatible with both stereo and monaural records
- Full frequency response, 20 through 20,000 cycles
- "Floating armature" design for increased compliance and reduced record wear. Effective mass of stylus approximately 2 milligrams
- High compliance in all directions—lateral compliance  $4 \times 10^{-6}$  cm/dyne; vertical compliance  $2.5 \times 10^{-6}$  cm/dyne
- Recommended tracking force with professional-type tone arm 2 to 4 grams
- Consistently high separation between channel signals. (Specifications for Model GC-5.)

### New G-E "Golden Classic" Stereo-Magnetic Cartridge

**Easier to sell...because it's magnetic  
...and because it's G-E!**

Stereo installations and conversions can open up a whole new field of profitable business for you. And you can start your customers converting to stereo *right now*—with G.E.'s new "Golden Classic" stereo-magnetic cartridge (fully compatible with LP monaural records). It's easy when you tell them how a magnetic cartridge can best provide the high compliance, low distortion, and channel separation required by the new stereo discs. Just as important, General Electric is the name *all* your customers know and trust.

**GENERAL  ELECTRIC**

Specialty Electronic Components Dept., W. Genesee Street, Auburn, N. Y.

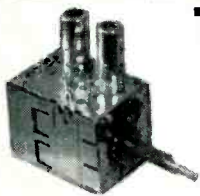

# TV TUNERS REBUILT \$9<sup>95</sup><sub>NET</sub>

ALL MAKES & MODELS

THOUSANDS OF TUNERS IN STOCK  
 ALIGNED TO ORIGINAL STANDARDS  
 ALL WORK PERFORMED BY TUNER EXPERTS  
 WITH YEARS OF EXPERIENCE IN THE TUNER FIELD

UHF/VHF UNITS

\$19.90

90 Days Warranty

EXCHANGE TUNER SHIPPED SAME DAY (OTHERWISE DEFECTIVE TUNER OVERHAULED AND RETURNED: WITHIN 48 HOURS IN MOST CASES.)  
 Price includes WORN parts only.

Replacement tubes and smashed or missing parts are charged extra.

Forward Tuner with All Smashed Parts: Quote Make and Model F.O.B. Chicago or Toronto We will ship C.O.D.

## Castle Television Tuner Service

1723 W. LUNT AVE., CHICAGO 26, ILL. U.S.A. ● 152 MAIN ST., TORONTO 13, ONT. CANADA  
 Suppliers of rebuilt TV Tuners to leading manufacturers, technicians & service dealers, coast to coast. Original and Only Complete TV Tuner Service covering the North American Continent.

No. 6 of a series of questions for progressive technicians.

### Can You Handle This Problem?

audio output stage

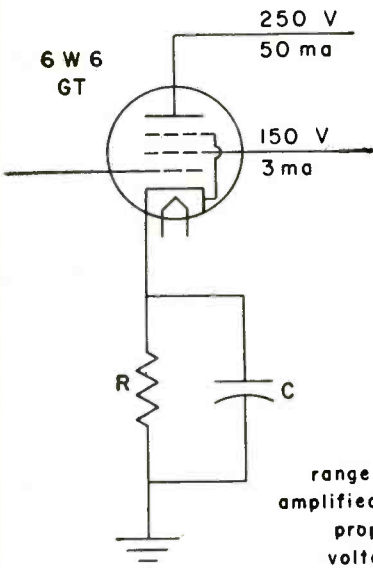

# What Value Should You Use for R And For C?

(Answer printed below)

range of frequencies amplified: 100 to 10,000 cps  
 proper grid bias voltage -9 volts

This may at first look like a difficult problem. Yet, for any technician who knows basic electronic fundamentals, it can be easily solved.

Knowing these principles and fundamentals is your key to getting ahead today in electronics. Unless you really know fundamental elec-

tronic theory, you can't take advantage of your opportunities.

It will pay you to find out how to increase your income by adding to your kit of "mental tools".

Answer to problem above:

Answer: C = 50 microfarad, R = 170 ohms

### Cleveland Institute of Radio Electronics

4900 Euclid Avenue, Desk T-15, Cleveland 3, Ohio

Please send me detailed solution to problem above and information on how I may prepare for the increasing opportunities in electronics. There is no obligation.

NAME .....  
 ADDRESS .....  
 CITY ..... ZONE ..... STATE .....

Accredited by The National Home Study Council

T-15



## NEW AUDIO PRODUCTS

For more information, write in ELECTRONIC TECHNICIAN's new product code number on coupon on page 45.

### EV MICROPHONES

Three new microphones include models 727, 718 and 649A. The 649A miniature lavalier (right) dynamic type weighs only 2 oz. It is nondirectional and has a frequency response of 60 to 12,000 cps. Model 727 slim ceramic (center) is for PA, recording and general use. Frequency response is 60 to 8,000



cps. Available with or without switch. Model 718 ceramic microphone (left) was designed as an improved replacement for inexpensive home recording microphones. Electro-Voice, Inc., Buchanan, Mich. (ELECTRONIC TECHNICIAN 11-31)

### GE STEREO PREAMP

Model MF-1 stereo preamp is designed primarily for use with magnetic stereo cartridges, for conversion of ceramic systems where necessary pre-amplification is not available. Price is \$24.95. The MF-1 is equipped for use with stereo tape heads. Specs are: Sen-

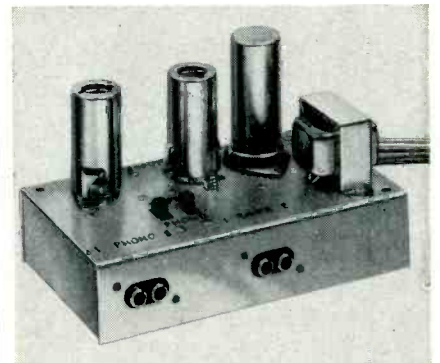

sitivity, 4 mv for 0.6 v out; Hum and noise, better than 60 db below 1 volt out; Distortion, 0.2% harmonic at 1 kc; Separation 40 db. General Electric Co., Specialty Electronic Components Dept., W. Genesee St., Auburn, N. Y. (ELECTRONIC TECHNICIAN 11-32)



### Heath CARTRIDGE

MF-1 is a low mass moving-magnet type monophonic cartridge. Impedance is 5,000 ohms. Output at 5 cm-per-second recorded velocity is 7 mv at 1 kc  $\pm 1\frac{1}{2}$  db. Vertical tracking force is between 2 and 6 grams. It will track velocities at up to 30 cm-per-second at maximum of  $4\frac{1}{2}$  grams. It is nominally

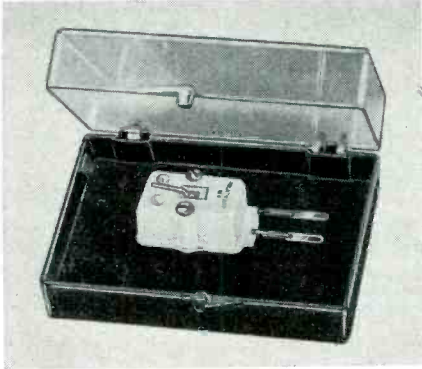

flat from 20 to 20,000 cps. Vertical compliance is  $1(\times 10^{-6})$  cm/dyne. Lateral compliance is between 2.2 and 3.1. Recommended load resistance 47 k. \$26.95 Heath Co., Benton Harbor, Mich. (ELECTRONIC TECHNICIAN 11-33)

### American STEREO CARTRIDGE

New stereo cartridge sells for \$4.50 audiophile net with sapphire needles. The cartridge is a high output turnover type, designed to play  $33\frac{1}{3}$  rpm stereo records as well as 45 and 78 rpm speeds. Americal Microphone Mfg. Co., Div. of G-C Textron Inc., 412 S. Wyman St., Rockford, Ill. (ELECTRONIC TECHNICIAN 11-35)

### Goodmans' SPEAKER

The Stereosfere, S10-30 is designed as a second speaker for stereo system. Since the ear cannot detect the accurate position of the source below 300 cps, bass sound is channeled to the existing full-range speaker through the IDM-30

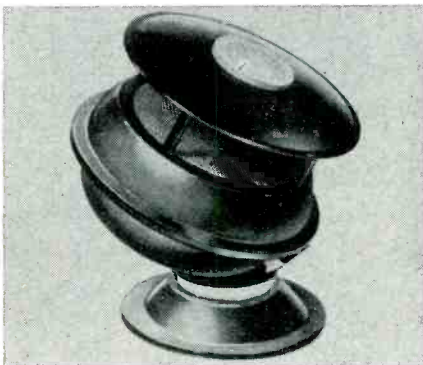

frequency dividing network. All frequencies above 300 cps are divided into the Stereosfere and full-range. Only 10" in its largest dimension, it can be tilted, swivelled, hung from the ceiling or wall, or placed at normal height. Rockbar Corp., 650 Halstead Ave., Mamaroneck, N. Y. (ELECTRONIC TECHNICIAN 11-34)

## DESIGNED FOR THE NEW BUSINESS RADIO SERVICE

# COMCO'S ALL NEW "580 FLEETCOM"

## VHF-FM MOBILE RADIO



The new "580" is compact, light weight, has high performance, and features an original concept in Mobile equipment packaging by combining the control head, speaker, and transistorized power supply in one small easily mounted case assembly.

**\$398** f.o.b. factory

### FEATURES

- ★ HIGH PERFORMANCE...meets "split channel" technical requirements, all FCC and FCDA requirements.
- ★ FULL POWER OUTPUT...35 Watts in 25-50 Mcs. 25 Watts in 144-174 Mcs.
- ★ BUILT-IN RELIABILITY...Preproduction Models field tested in 5 states and 3 foreign countries before starting production.
- ★ SMALL AND LIGHT WEIGHT...Chassis in case  $13" \times 9\frac{1}{2}" \times 5\frac{1}{2}"$ . Control-power Supply-Speaker case  $5" \times 5" \times 3\frac{3}{8}"$ . Complete Mobile installations 24 lbs.
- ★ EASY TO INSTALL... "Two-unit" package so small most installations are under dash.
- ★ EFFICIENT...Transistor power supply gives high efficiency. Total standby drain 5.25 amp.
- ★ INTERCHANGEABLE CHASSIS... Mobile transmitter-receiver chassis instantly interchangeable with base stations in simplex systems.

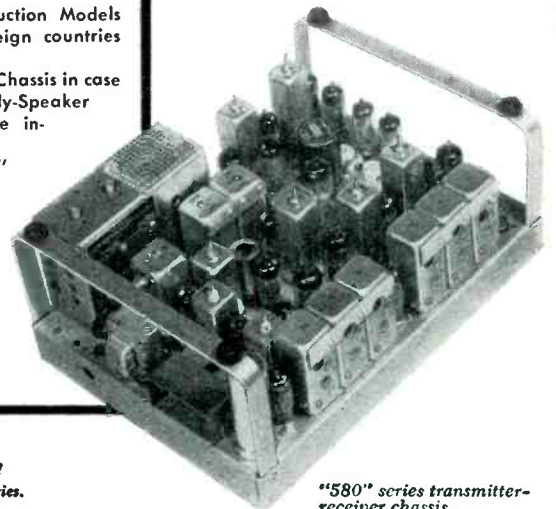

"580" series transmitter-receiver chassis.

**ATTENTION DEALERS!**  
Write for available territories.

**COMCO**

DESIGNERS AND MANUFACTURERS OF RADIO COMMUNICATIONS EQUIPMENT

## COMMUNICATIONS COMPANY, Inc.

FOUNDED 1938 CORAL GABLES, MIAMI 34, FLORIDA

## DEPENDABLE TV-RADIO TUBES

**ZALYTRON** Tubes for TV-Radio Servicemen, Dealers, Experimenters.

Nationally sold ZALYTRON Tubes are BRAND NEW Quality Tubes, priced low to help you meet competition in your area -- and guaranteed to perform as well and as long as tubes much higher priced. Why pay more? Try them once, you'll buy them always. Every tube we ship is covered by our Full Refund Guarantee... YOU be the judge! Send today for new Price List "ET"

**1-YEAR GUARANTEE**

## BE YOUR OWN BOSS

RUN A SELF-SERVICE TUBE BUSINESS

Get This Modern Sturdy Tube Tester

# FREE

with "Package Deal" order for nationally sold ZALYTRON Quality Brand Receiving Tubes. We'll show you how to start a successful Tube Tester Route, and get YOUR share of today's Big Profits in Self-Service Tube Sales! This is no "Get-Rich-Quick" scheme but a solid, proven business that will reward you well -- if you WORK at it. But, INVESTIGATE before you INVEST! Get full details on the best "Deal" now being offered, send today for our Booklet "E"

**ZALYTRON TUBE CORP.**  
220 West 42nd St.,  
New York 36, N. Y.

# GREGG

## SOLDERING GUNS

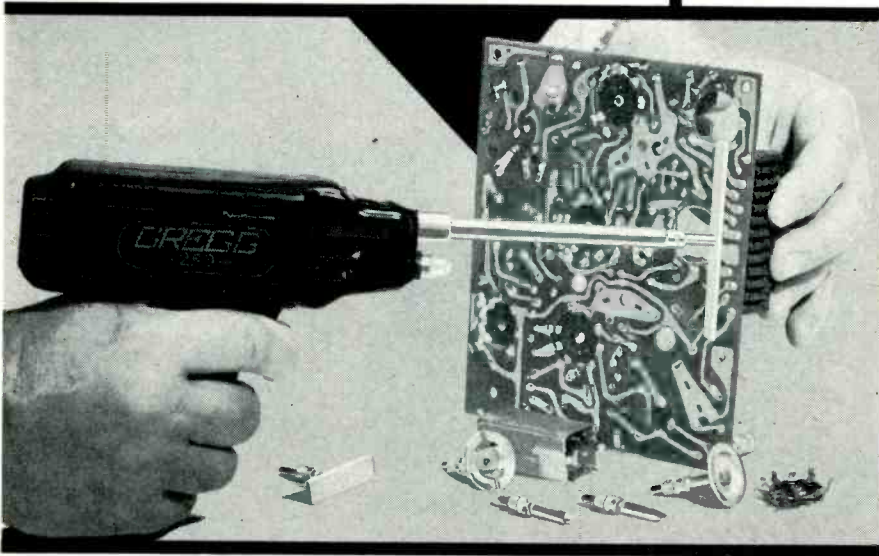

### REPLACE PRINTED CIRCUIT COMPONENTS IN A FLASH

Gregg's Solder Tip Kit\* is a must for printed circuit repairs! It is invaluable to unsolder several terminals simultaneously, removing components safely and quickly. Kit has four interchangeable tips for tube sockets, IF transformers,

electrolytic condensers and two sizes for condenser resistor boards. Each tip contains its own heating element which distributes the proper heat over its entire surface. Pays for itself on the first job!



### AMERICA'S FINEST GUN

- Two second heating — no waiting. Heat is generated right at the soldering point.
- Permanent alloy tip does away with filing and cleaning — just a wipe and it's ready. Outlasts copper tips 5 to 1.
- Single barrel construction — reaches into deep places without damage to wiring or components. Rigid tip makes it easy to remove wires and clean terminals while hot. Other barrels available in 6", 8", 10" and 12" lengths.

MODEL 250A

WRITE FOR FREE BOOKLET ON REPAIRING PRINTED CIRCUITS

**GREGG** electric sales, co.  
620 Essex St., Lawrence, Mass.

\*Pat. Appl'd for.

### YOUR BEST BUY!

*Vitreous Enameled*

# RESISTORS

*Pride of the industry!*

Your jobber has them or can get them for you.

**MILWAUKEE RESISTOR CO.**

700 W. Virginia Street

Milwaukee 4, Wis.

### Hartley ENCLOSURE

A new enclosure, the Cameo, houses the model 217 full-range speaker. It can be used for mono or stereo. It comes with 6" legs, and can be mounted vertically or horizontally. In unfinished birch, the Cameo sells for \$63., or with speaker, \$128. Finished walnut, mahogany or blond, \$80., or with speaker \$145. Hartley Products Co., 521 E. 162 St., New York 51, N. Y. (ELECTRONIC TECHNICIAN 11-38)

### Fannon STEREO SYSTEM

Retailing at \$189.90, the new stereo system consists of two units. The console cabinet contains V-M 4-speed automatic changer with stereo turnover cartridge. The dual-channel 3-tube amplifier (plus selenium rectifier) drives a co-axial 4-speaker system consisting of two 8" woofers and two tweeters in the console cabinet. The second channel speaker unit contains one 8" woofer and a co-axial tweeter. Fannon Electric Co., 98 Berriman St., Brooklyn 8, N. Y. (ELECTRONIC TECHNICIAN 11-37)

### Masco INTERCOM

A new 6-station "Mix-A-Phone" master intercom. It offers master-to-remote operation, master-to-master operation, and master-to-master-to-remote intermixed operation. Master stations can have up to 3 separate two-way conversations in privacy at the same time. Stations can be located 500 feet apart. Master is \$42.50; remotes \$12.50 to \$19.88. Mark Simpson Mfg. Co., 32-28 Forty-Ninth St., Long Island City 3, N. Y. (ELECTRONIC TECHNICIAN 11-39)

### Bogen MUSIC SYSTEM

A wall-mounting home music system of stereo components, known as the "Music Wall," consists of two units, available separately or as a matching system. They house a DB 212 stereo dual 12-watt preamp-amplifier and 4-speed phono in the basic unit, and the ST 662 AM/FM stereo tuner in the companion unit. The latter also provides record storage space. David Bogen Co., Box 500, Paramus, N. J. (ELECTRONIC TECHNICIAN 11-36)

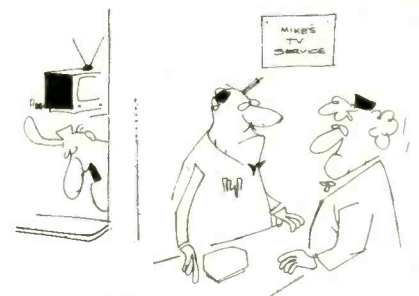

"Boss, you can call old blabbermouth and tell her to pick up her set."

## STEREO

(Continued from page 77)

available, the prices will be identical with the monophonics. Tape people did a lot of pioneering in stereo. The disc has solved one of the disadvantages of tape, its cost. As if in reply to this the tape cartridge or magazine has been developed. This keeps tape in the picture cost-wise, and makes it easier to handle. Its quality is acceptable.

Many of the earlier radio broadcast experiments were "live". Until recently, it looked as if the need for separate transmitting channels—and receivers for them—would keep radio impractical for widespread use as a stereo source. But compatible multiplex can do for radio what the stereo disc has done for the record player.

The changeover to stereo necessitates alteration in the components used, and in our orientation to them. Styli have to be smaller. Pickup designers have not only reoriented the cartridge element by 45°, they have altered their perspective. For example, the once not too respected crystal (modern version is ceramic) has produced some promising stereo pickups at really competitive prices. To carry the stereo pickup properly, changers, arms and turntables need a face-lift—although not too badly; requirements are just a little more difficult to meet.

In the real enjoyment of stereo, however, one of the important factors is the speaker question. Most living rooms were not designed for listening to stereo. Recently one enthusiast described how he had built a room—like a small acoustically designed theatre—to get almost perfect stereo. But most people will not be prepared to rebuild their house to get good stereo. Skillful use of the facilities at hand, with the right choice of speakers, must take the place of a rebuilding job—and it can.

One more thing should be discussed briefly. Stereo is here. "Is it here to stay?" people are asking. Some mention the craze for stereo pictures. One sees few "two-eyed" cameras about these days. But the comparison with stereo pictures is hardly fair. You don't have to look through a viewer or for that matter to listen to a pair of headphones to enjoy stereo. Stereo, properly used provides an illusion of realism which cannot be attained even with the use of high fidelity equipment on a

monophonic source. Two things—almost extremes—have often prevented stereo program material from being its best:

- 1 Emphasis on effects rather than on the program itself—trains through the living room, recording orchestras with two halves in separate studios, etc., and
- 2 the attempt at "academic" stereo—based on a lazy belief that, if the playback speakers are so many feet apart, the recording microphones should be identically spaced and good

stereo should automatically result.

The purveyors of program source material must do their part right. They must use that extra channel to provide programs that more closely resemble the original performance.

Stereo as we know it today, is another step forward in the high fidelity field. It is not a radically new field, nor is it an answer to the kitchen radio. It is just as important as ever to have a system include the best components one can afford to buy. Two crummy speakers will not take the place of one good one. •

### You can rely on QUAM SPEAKERS in every SOUND SYSTEM installation

You get trouble-free operation and excellent sound reproduction with Quam Adjust-a-Cone Public Address Speakers. Their wide frequency response range and heavy rugged construction assure you of complete customer satisfaction.



Quam—and only Quam

—gives you these important benefits:

Lowest possible flux loss  
Accurate magnet alignment

made possible by the patented U-Shaped Pot

Precise centering and  
voice coil alignment

because of the patented Adjust-a-Cone  
Suspension

Greater heat and humidity  
protection in outdoor  
speakers

with the new exclusive Humi-Gard Cone

Over 25 years of engineering "know-how" is built into every Quam speaker. EIA standards are rigidly adhered to, your assurance of top quality and performance.

Write for your free copy of Catalog S-757, describing the complete line of Quam Public Address, Outdoor and Intercom speakers.

*QUAM, the quality line, for all your speaker needs*

**QUAM-NICHOLS COMPANY**

226 EAST MARQUETTE AVENUE • CHICAGO 37, ILLINOIS

In Canada: A. T. R. Armstrong, Ltd., 700 Weston Road, Toronto 9, Ontario  
D. Eldon McLennan, Ltd., 1624 W. Third Avenue, Vancouver 9, B.C.

# Association News

## Arizona

Better Electronic Service Technicians of Arizona, Inc. (BEST) has done a fine job with its first publication. Its officers in Phoenix are: Pres., Philip Prentice; VP, Neil Anderson; Sect'y, Dick Ramos; Treas., Hal Horowitz; and Board Members, Ray Oxman, Carl Hendricks, Ralph

Master, Chic Myers, and David Gordon. The chapter in Tuscon is made up of: Pres., Jack Hass; VP, Marvin Reynolds; Treas., Wayne White; Sect'y, Donald Wallace; and Board Members, G. E. Kasmir, George Prince, Herbert Nickels, Louis Wolf, and Charles Lipenski. BEST is an association of independent service shops dedicated to promote the standards of the servicing industry. In addition to an apprenticeship training program, and a program to safeguard the financial

interests of its members, they are desirous of forming other chapters in their state. The training program as worked out with the advice of the U. S. Dept. of Labor consists of 4 years of training, and includes at least 144 hours a year of classroom work, either at Phoenix Technical High School, or Arizona State College and on-the-job training. A new shop every 6 months, plus an increase in pay for the apprentice who makes satisfactory progress is promised. A diploma will be issued by the Dept. of Labor.

## California

RTA Santa Clara Valley's vote of protest against lengthened service and parts guarantees by some manufacturers, was passed by a heavy majority. A letter of protest to major manufacturers stating the Association's stand was prepared. A realistic warranty structure is sought. An apprentice plan is developing in this community. It calls for 4,000 hours of on-the-job training. This amounts to 4 years of work; also required is about 6 hours a week of additional schooling.

RTA San Gabriel Chapter and Pasadena Area Chapter in a joint

# NEW from *South River*

## NOW MAKE IT EASY FOR YOURSELF



With SOUTH RIVER'S  
NEW Antenna Mountings  
designed for faster, easier  
television antenna  
installations!

THE MOST CONVENIENT ROOF TOP MOUNTING AVAILABLE.  
CHECK THESE TIME AND MONEY SAVING FEATURES.

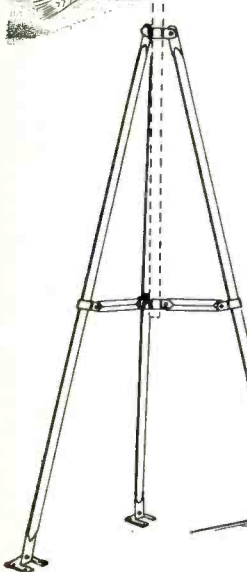

- COMPLETELY PRE-ASSEMBLED.
- SELF SUPPORTING AT ALL TIMES DURING INSTALLATION.
- SEALING COMPOUND PERMANENTLY AFFIXED TO ADJUSTABLE FEET TO PROVIDE A POSITIVE, LEAK-PROOF INSTALLATION.
- FITS ALL PEAK OR FLAT ROOFS.
- ELIMINATES GUY WIRES, TURNBUCKLES, ROOF HOOKS & GUY CLAMPS.
- SPECIAL, HARDENED, SCREW NAILS INSURES STRONG, RIGID FASTENING TO ROOF.
- FABRICATED OF HOT DIP GALVANIZED STEEL TUBING.
- FIELD TESTED BY THOUSANDS OF INSTALLATIONS THROUGHOUT THE U.S. FOR OVER FIVE YEARS.

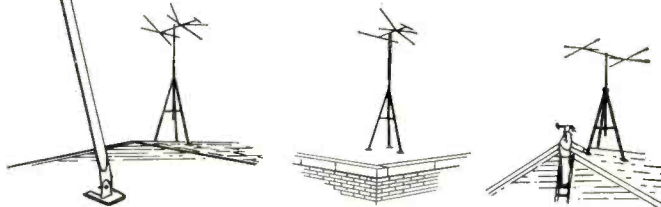

SAVE LABOR COST ON EACH ROOF INSTALLATION! NO ADDITIONAL MAN NEEDED ON ROOF!  
AVAILABLE IN TWO SIZES. MODEL BT-5 USED WITH A 1 1/4" O.D. X 5' MAST MAKES A 7 FOOT INSTALLATION.  
MODEL BT-10 WHEN USED WITH A 1 1/4" O.D. X 5' MAST MAKES A 9 FOOT INSTALLATION AND WHEN USED WITH A 10 FOOT MAST MAKES A 13 FOOT INSTALLATION.

MODEL No.	DESCRIPTION	LIST PRICE
BT-5	Bantam Tower (less mast)	\$7.25
BT-10	Bantam Tower (less mast)	\$9.95

*South River* SOUTH RIVER, NEW JERSEY  
METAL PRODUCTS CO., INC.,  
PIONEER AND OUTSTANDING PRODUCER OF THE FINEST LINE OF ANTENNA MOUNTINGS  
Write for Complete Catalog

CANADA: LEN FINKLER & CO., TORONTO

## NEW! IMPROVED!

# SENCORE TRC4 TRANSISTOR CHECKER

*Another Sencore Time-Saver*

Only tester that checks car radio power transistors

**NOW CHECKS:**

- ★ **Transistors** for opens, shorts, leakage and current gain. Includes new gain test on power transistors.
- ★ **Crystal Diodes** checks forward to reverse current ratio on all diodes.
- ★ **Selenium Rectifiers** checks forward and reverse currents.

Controls are accurately set for each transistor by referring to replaceable set-up chart on rear. Test leads or socket provides for fast hook-up. See your parts distributor.

SIMPLE TO OPERATE  
**ONLY \$17.95**  
Dealer Net  
Cannot become obsolete. Approved by leading manufacturers

Mfg by **SENCORE** SERVICE  
INSTRUMENTS CORP.  
171 OFFICIAL RD., ADDISON, ILL.

Cut out this ad now for further information

meeting met with Admiral's Service Manager Kelvin McClellan, and Field Manager George Felsch. Members participated in demonstration, door prizes, and refreshments.

### Illinois

NATESA listed number of cardinal sins and called for a meeting with EIA, NEDA, EP&EM, Reps, key manufacturers and other interested persons. Items were: Captive service schemes by set producers on highly uncompetitive basis; improper wholesale parts sales practices, and direct sales by tube factories to outsiders who are foisting upon the public tube testers which the factories repeatedly have said are highly unreliable. The feeling is that unless industry cleans its own house very soon, the government may step in.

### Kentucky

KTRTA elected the following officers: Pres., C. T. Simmons; VP, Jim Hall; Treas., Art Johnson; and Sect'y, Lou Wilkes.

### Michigan

IDEA—Independent Dealers' Electronic Activities Committee—recently organized to combat the captive service programs of some TV set manufacturers which threaten the existence of the independents, now has the pledged support of more than 20 state and local associations of independent service dealers. The objectives of IDEA are: 1. To unite all segments of the service industry in an effort to assure and maintain the future of the independent service dealer; 2. To provide interested parties an opportunity to participate collectively in establishing effective action in industry relations and merchandising services, and 3. To foster the enactment of equitable legislation. The mushrooming of set manufacturer service facilities across the country, together with parts warranties and "free service policies" are harmful to the independent service dealer. IDEA, according to Karl Heinzman, president of TSA-Michigan, is and will function as a committee and not as an association. It intends to speak for state and local independent associations and represent the independent service dealer on a national front.

RTA-Lansing elected: Pres., Dean Pope; VP, Louis Winters; Sect'y, Melvin Parks; Treas., Wm. Summers; and Directors, Michael Skory

for 1 year, and John Hawkins for 2 years.

### Missouri

TSE-SW elected: Pres., Carl Adcock; VP, Glen Davison; Sect'y, George Scott; Treas., August Buehler; NATESA Director Carrol King; Alternate, J. H. Gulliford; and Reporter Ed Muhleman. Experiments are in progress for certification procedures for its members.

### Pennsylvania

Federation of Radio-Television Service Associations of Pennsylvania unanimously voted to start a program of selling service rather than new TV sets in order to combat "captive service." Delegates from 15 chapters adopted the theme, "Let's kill the new-set sale, let's sell service." Purchase of color TV may also be discouraged because of the set maker's policies.

# NEW



Type "SA" . . . small single section electrolytics for printed circuit boards. . . hermetically sealed in aluminum tubes covered with red kraftboard insulating jackets . . . extra heavy tinned terminals anchored for proper spacing by a high melting point wax . . . for 85°C operation . . . individually packaged. Recommended for TV, radio and industrial applications .

~  
"ENGINEERED FOR QUALITY"

GUARANTEED FOR ONE YEAR

~  
See Your Parts Distributor

**PLANET SALES CORPORATION**  
225 Belleville Avenue  
Bloomfield, N. J.

**YOU CAN  
"BET  
YOUR LIFE"**



**ON  
WRIGHT  
WIRE STRAND**

Wright TV Guy Wire Strand is your guard against irritating snarls. Each concentric coil measures two feet. You save money in guying antennas. Greater flexibility, heavily galvanized continuous connected coils. Prompt delivery from stocks in Worcester, Chicago, New Orleans, Dallas, Los Angeles, San Francisco and Portland, Oregon.

Non-Snarling Pre-Measured Wire Strand  
Sold only through Wholesale Distributors

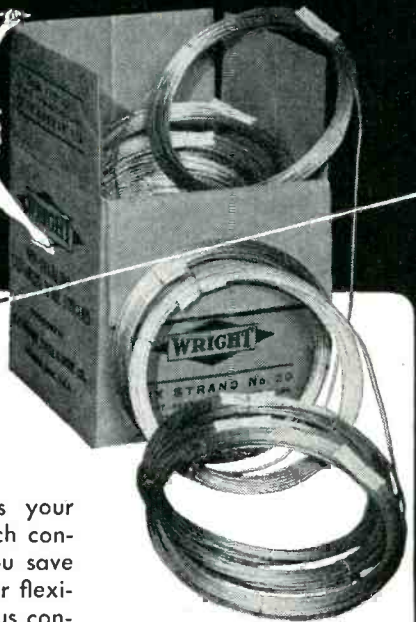

**G. F. WRIGHT STEEL & WIRE CO.**  
250 Stafford St. • Worcester, Mass.

## NEW PRODUCTS

For more information, write in **ELECTRONIC TECHNICIAN's** new product code number on coupon on page 45.

### Ohmite MINIATURE RHEOSTAT

Model "E" rheostat, smaller than many 1 or 2-watt potentiometers, is capable of 12½ watts dissipation at 40°C. Among its features are; a ceramic hub, independent contact arm pressure, and vitreous enamel coating. Operates in high ambient temperatures. It is 7/8"

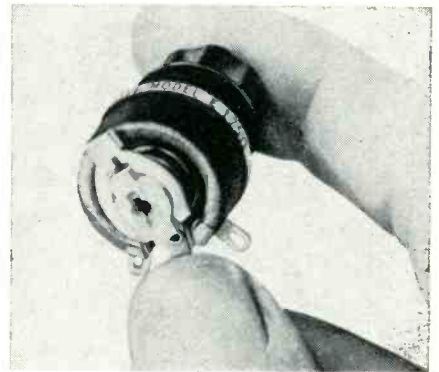

in diameter and extends 11/16" behind the mounting panel. Linear or non-linear taper, tandem mountings, and other features can be provided. Ohmite Mfg. Co., 3698 Howard St., Skokie, Ill. (ELECTRONIC TECHNICIAN 11-19)

### Int'l RECTIFIER

To cover current requirements of TV sets having higher than 500 ma rectification needs, the new 750 ma rated Unistac TV-500 is available. Eyelet construction eliminates the need for special sockets, drilling, or conversion kits. It is a silicon diode mounted on a finned

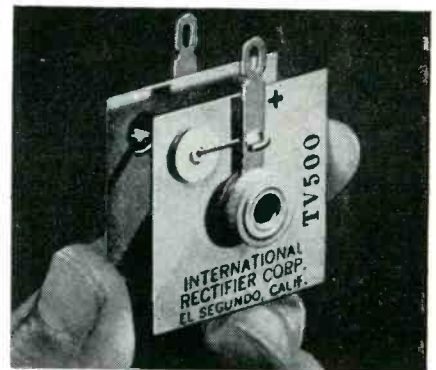

heat exchanger. One unit in a half-wave circuit delivers 750 ma and 130 v dc, with an input voltage of 117 v rms. Two units in voltage doubler circuit delivers 750 ma and 240 v dc. International Rectifier Corp., 1521 E. Grand Ave., El Segundo, Calif. (ELECTRONIC TECHNICIAN 11-18)



**MICROPHONES  
CARTRIDGES  
TONE ARMS  
EARPHONES  
HARDWARE**

**Finest Quality  
COMPONENTS  
at Economy Prices**

- ★ Hi-Fi Components in various series
- ★ Wide selection of electronic hardware
- ★ Sold nationally . . . for replacement or use in original equipment
- ★ Rystl Cartridges feature Moisture Resistant elements

**FOR BIG SAVINGS USE RYSTL . . . Send for Rystl product and price information**

Rystl Distributorships still available . . . inquiries about exclusive franchises invited

**DAVID RIEMER COMPANY, INC.**  
601 West 26th Street, New York 1, N. Y.

**ANOTHER GREAT  
TRIO®  
TV ANTENNA FEATURE**

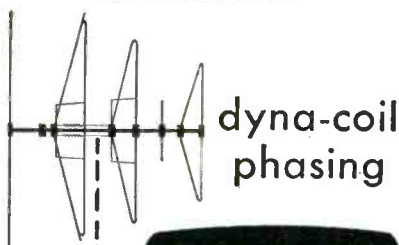

**dyna-coil  
phasing**

Increased performance from uniform transmission of signal strength of each active dipole in a multi-dipole system—AND MAKES POSSIBLE COMPLETE FACTORY ASSEMBLY.

Just one of the features that makes Trio the most advanced TV Antennas in the world. Choose from Trio's complete Zephyr and Color Series Antennas.



**Rohn HEAVY-DUTY TOWER**

Suitable for all types of communication needs, this new heavy-duty tower is constructed of 13 different tower sections of varying size, weight, structural strength and taper. It is self-supporting to a height of 130 feet. The individual sections can be used in making additional combinations to build self supporting towers of variable heights and structural capacities. Rohn Mfg. Co., 116 Limestone, Peoria, Ill. (ELECTRONIC TECHNICIAN 11-7)

**TACO ANTENNA COMPARATOR**

A new antenna comparator designed to provide a direct comparison, on the customer's TV screen, between the existing antenna and a new one. A flick of a switch and it shows, in minutes, what the new antenna will do. Unit includes: three stakes; clamping device;

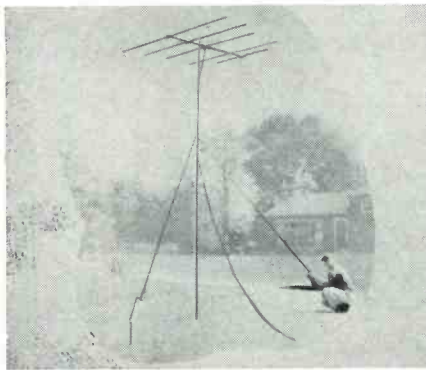

rotatable guy ring; three guy ropes, one of which has a take-up device; two-position switch; and two wing nuts. Technical Appliance Corp., Sherburne, N. Y. (ELECTRONIC TECHNICIAN 11-28)

**GE TV RECTIFIERS**

Replacing the entire line of five TV snap-in germanium rectifiers, the following two new units are available: type 1N1008, 400-milliampere halfwave; and 1N1016, 400-milliampere doubler. Prices are 5 to 10% lower. They are designed for direct replacement of all

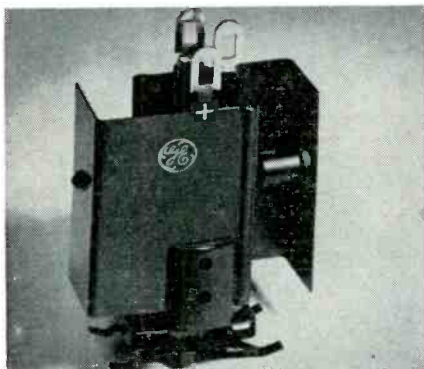

selenium rectifiers in TV sets. Both rectifiers are rated at a peak inverse voltage of 380 volts and an rms input voltage of 130 volts. General Electric Semiconductor Products, Syracuse, N. Y. (ELECTRONIC TECHNICIAN 11-17)



**AT LEAST THEY AGREE ON FIDELITONE** — Tempers can flare between Servicemen over technical disagreements. But it's mind over emotion when it comes to Fidelitone. Servicemen everywhere recognize the long standing superiority of Fidelitone Phonograph Needles. If their customers don't ask for Fidelitone — and most do thanks to Fidelitone's national advertising and promotion — the servicemen recommend Fidelitone. Stock the fastest selling, easiest selling needle line on the market. Promote Fidelitone for profitable sales. Fidelitone, Inc. — Chicago 26, Illinois, Export Dept., 13 E 40th St., New York 16, N.Y.

**Fidelitone**

*"Best buy on records"*

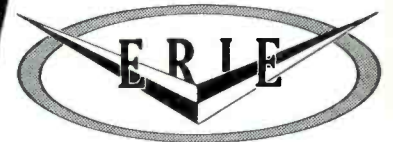
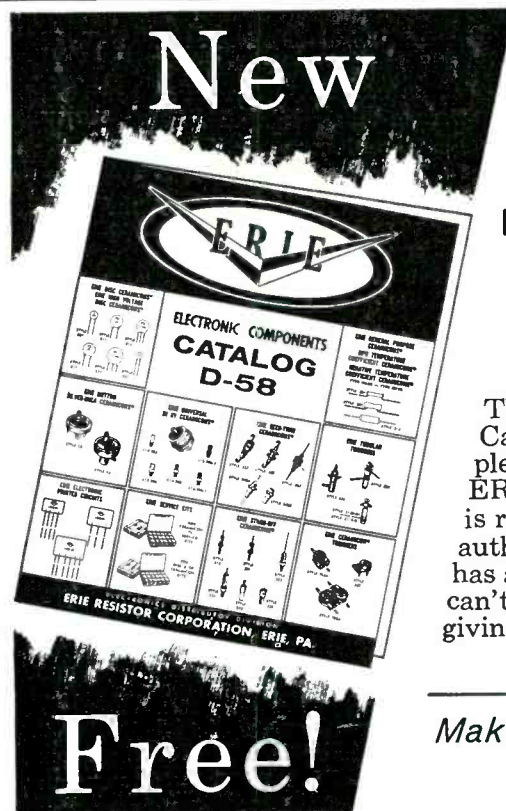

**D-58 CATALOG**

at your  
Authorized  
**ERIE DISTRIBUTOR**

The new ERIE D-58 Catalog, including the complete and enlarged line of ERIE Electronic Components is ready. Your authorized ERIE Distributor has a copy for you. If he can't supply you, write us, giving his name.

Make the *ERIE* Catalog  
Your Catalog

**ERIE** *Electronics Distributor*  
DIVISION  
**ERIE RESISTOR CORPORATION**  
ERIE, PA.

# MORE ACTIVE! EFFECTIVE!

## KESTER "RESIN-FIVE" CORE SOLDER



**THE BEST FOR TV-RADIO WORK . . .**  
**EVERYTHING ELECTRICAL**—Kester "Resin-Five" Core Solder is better and faster than any solder ever developed. It has an activated flux-core that does a perfect job on all metals including zinc and nickel-plate. The flux residue is absolutely non-corrosive and non-conductive.

Available in all practical Tin-Lead Alloys; 40/60, 50/50 and 60/40 in diameters of  $\frac{3}{32}$ ",  $\frac{1}{16}$ ",  $\frac{3}{64}$ ",  $\frac{1}{32}$ " and others.

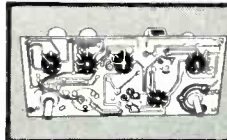

**Printed Circuit Soldering**  
 On Copper-etched boards use 60% Tin-40% Lead Alloy . . . for those that are Silver-surfaced use 3% Silver-61½% Tin-35½% Lead

## KESTER SOLDER COMPANY

4264 Wrightwood Avenue, Chicago 39, Illinois • Newark 5, New Jersey, Brantford, Canada



**MAKE SURE IT FITS!**

## OXFORD SPEAKERS

When you order a speaker (for replacement or original installation), demand units that meet your most exacting needs.

Each OXFORD SPEAKER is "tailor-designed" to actually "fit the application."

The next time you specify speakers, make certain they fit the job by selecting OXFORD . . . unsurpassed quality for over thirty years.

Write for the latest Oxford catalog



<p><b>RADIO &amp; TV SPEAKERS</b></p> <p>OXFORD Speakers are used by more original set manufacturers — find out why!</p>	<p><b>OUTDOOR SPEAKERS</b></p> <p>For rugged, steady performance under any conditions, OXFORD Weather-proof speakers will meet the need.</p>
<p><b>DUAL CONE HI-FI SPEAKERS</b></p> <p>Oxford's newest development to provide maximum performance. For Hi-Fi and rear deck applications.</p>	<p><b>PORTABLE RADIO SPEAKERS</b></p> <p>More Oxford speakers are used in portable sets than ever before . . . there must be reasons!</p>

**OXFORD Components, Inc.**  
 Subsidiary of Oxford Electric Corp.  
 556 West Monroe Chicago 6, Ill  
 Export: Roburn Agencies, New York City  
 In Canada: Atlas Radio Corp., Ltd., Toronto

## Catalogs & Bulletins

**TRANSFORMERS:** A 24-page catalog describes the firm's complete line of miniature, subminiature, transistor, and industrial transformers available from distributor stock. New transistor transformers are featured. Microtran Co., 145 E. Mineola Ave., Valley Stream, N. Y. (ELECTRONIC TECHNICIAN B11-6)

**RELAYS:** A new catalog of the latest relays lists each major manufacturer's line in alphabetical order according to code letters and numbers. To quickly locate any relay, the purchaser need know only the manufacturer's name and the relay number. Relay Sales, Box 186, West Chicago, Ill. (ELECTRONIC TECHNICIAN B11-7)

**RELAYS:** New reference sheets give specifications, typical adjustment schedule, dimensional and circuit diagrams, and other data on single and double-pole micro-miniature relays. Both current-sensitive and voltage-sensitive types are covered. Electronics Div., Iron Firearm Mfg. Co., 2838 S. E. 9th Ave., Portland 2, Ore. (ELECTRONIC TECHNICIAN B11-5)

**AMMETERS:** The complete line of Tong Test AC-DC Ammeters is described in a new 8-page illustrated bulletin. Actual size scale ranges, prices and shipping weights are included. Information is given also on the AC-1 Volt-Ammeter and the new UV-1 AC-DC Voltmeter. Columbia Electric Mfg. Co., 4519 Hamilton Ave., Cleveland 14, Ohio (ELECTRONIC TECHNICIAN B11-3)

**CONNECTORS:** XLR-3 is a new 4-page catalog describing a new connector series for microphones, tape recorders, amplifiers, etc. Illustrations are color-coded for quick identification of mating plugs and receptacles. Ordering nomenclature and dimensions are included. Cannon Electric Co., 3208 Humboldt St., Los Angeles 31, Calif. (ELECTRONIC TECHNICIAN B11-1)

**COMPONENTS:** Modern electronic components are described and illustrated in a colorful 8-page folder. Includes specifications on diodes and rectifiers, silicon and germanium transistors, tantalum capacitors, silicon resistors, and precision carbon film resistors. Also available is Volume 2, Number 3 issue of New Parameter News which announces and describes two new types of silicon diodes for 0.4 and 10 watt applications. Texas Instruments Inc., Semiconductor Components Div., 13500 N. Central Expressway, Dallas, Texas (ELECTRONIC TECHNICIAN B11-2)



# NEW HICKOK TRANSISTOR-RADIO TESTER

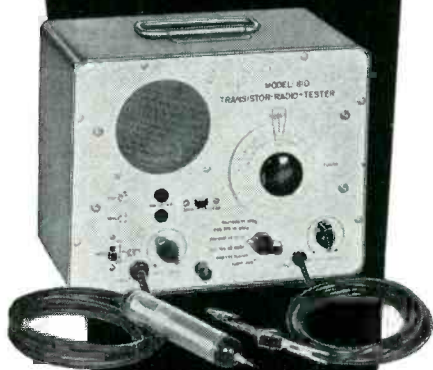

Model 810

## 3 TESTERS IN 1

- ★ Tuned Receiver
- ★ AM Generator
- ★ Transistor Tester

Specifically designed with all necessary features for complete troubleshooting of transistor radios. Almost all portables made today are transistorized. With the 810 you can profit immediately from service in this large, new field. The instruction book included contains an easy-to-learn course in transistor radio servicing. Now, any serviceman can quickly troubleshoot and profitably repair transistor radios.

**TUNED RECEIVER**—200 to 500 KC for troubleshooting IF. 550 to 1600 KC for troubleshooting RF. A cathode follower input probe minimizes loading. Loudspeaker indicator for signal tracing.  
**AM SIGNAL GENERATOR**—200 to 575 KC for IF alignment. 550 to 1600 KC for RF alignment. 400 cycle audio output for signal injection.  
**TRANSISTOR TESTER**—Test circuit for checking transistors—leakage and gain.

The 810 will pay for itself in a short time . . . and give you many years of accurate, dependable service.

**\$109<sup>90</sup>**  
**NET**

Now is the time to...  
**TRADE UP TO A HICKOK**

Ask for a demonstration of the new 810 from your Authorized Hickok Distributor.

**THE HICKOK ELECTRICAL INSTRUMENT CO.**  
10514 Dupont Ave. • Cleveland 8, Ohio

**SOLDERING TOOLS:** A new catalog covers soldering irons, soldering tool holders, solder pots, glue pots, wax pots and branding irons. Includes specifications and prices, illustrations, descriptions and technical information. Vulcan Electric Co., 88 Holton St., Danvers, Mass. (ELECTRONIC TECHNICIAN B11-9)

**PILOT LIGHTS:** Technical bulletins and brochures are available as follow: Technical bulletins 100 and 101, covering high brightness neon lamps, and heavy duty oil tight pilot lights, respectively; brochures are form L-160 and L-156-C, on Datalites, the firm's ultra miniature indicator lights, and 2-terminal sub-miniature indicator lights, respectively. Also: forms L-157-A and L-158-A covering 1-terminal sub-miniature indicator lights. Dialight Corp., 60 Stewart Ave., Brooklyn 37, N. Y. (ELECTRONIC TECHNICIAN B11-4)

**SWITCHES:** Bulletin 858A describes latest line of precision snap-action switch for use in major home appliances, automatic devices, signal and alarm systems, etc. Bulletin 958SS covers sealed sub-miniature snap-acting switches for use where very small and sealing protection against moisture and dirt are essential. Photographs, dimension drawings and electrical ratings are included. Uni-max Switch Div., W. L. Maxson Corp., Wallingford, Conn. (ELECTRONIC TECHNICIAN B11-8)

**BATTERIES:** A new 100-page Engineering Manual contains complete data on dry batteries, including chapters on basic information, explanation of various types of cells, performance standards, etc. Also includes: list of standard types arranged in order of increasing voltage and physical size; photos; curves for estimating dry battery performance; terminal illustrations; dimensions; etc. Engineers engaged in the design of battery-powered equipment may obtain a free copy. Write directly to Burgess Battery Co., Freeport, Ill. Others may purchase the manual for \$1.00.

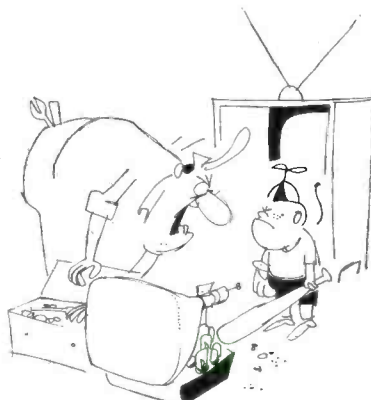

"I know it's five minutes to Captain Kangaroo."

# NEW BOOK TELLS HOW NEW TECHNIQUE Makes TV Trouble Shooting FASTER and EASIER

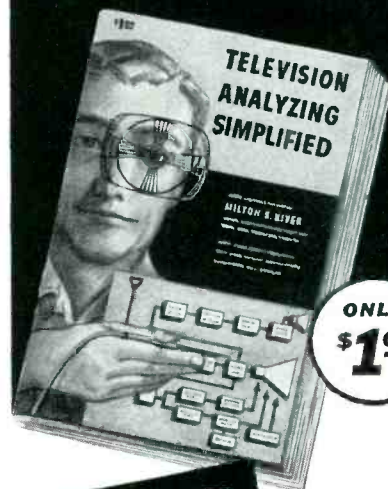

ONLY  
**\$1<sup>00</sup>**

**"TELEVISION  
ANALYZING  
SIMPLIFIED"**

By  
**MILTON S.  
KIVER**

Author of "Television Simplified"  
"Transistors in Radio and Television"  
and many other books

### Tells How to Save Time and Make Money

Compares servicing methods. Explains newest, simplest, fastest way for even the inexperienced serviceman to spot and correct the exact source of video or audio trouble, after tube changing has failed.

Tells how you can inject your own TV signals at any time. No guesswork. No waveform interpretation. No complicated diagram references. No lost hours.

Shows how amazing new technique enables you to service more sets in much less time, satisfy more customers, and make more money.

### 10-DAY MONEY-BACK GUARANTEE

Get this practical, trouble-saving new book now, for only one dollar! After reading this book, if you are not satisfied, return it and get your money back. Available at your parts distributor or send coupon today.

B & K MANUFACTURING CO. Dept. T  
3726 N. Southport Ave., Chicago 13, Illinois  
Enclosed \$1.00 for "Television Analyzing Simplified."  
Send postpaid, on 10-day money-back guarantee.

Name \_\_\_\_\_  
Address \_\_\_\_\_  
City \_\_\_\_\_ Zone \_\_\_\_\_ State \_\_\_\_\_

# A Profitable New Field!

## INDUSTRIAL ELECTRONIC SERVICING

with  
**OHMITE®**  
QUALITY  
Components

Industrial electronic servicing is profitable new business for you. Especially when you stock and replace with dependable Ohmite components . . . the line your industrial customers know and prefer. Service such industrial equipment as mobile radio, aircraft and marine radar and radio, electronic controls for factory processes and automation, industrial P.A. and intercom systems, and—medical and dental electronics.



### AXIAL-LEAD RESISTORS

Vitreous-enamelled, power-type units designed to withstand high temperatures. In 3, 5, and 10-watt sizes.

### BROWN DEVIL® RESISTORS

Vitreous-enamelled. In 5, 10, and 20-watt sizes.

### LITTLE DEVIL® COMPOSITION RESISTORS

Meet all MIL-R-11A requirements. Available in 1/2, 1, and 2-watt sizes in all standard EIA values.

### MOLDED COMPOSITION POTENTIOMETERS TYPE AB

Resistance material is solid-molded, noise-free. Rated at 2 watts.

Write for Stock Catalog 28

# OHMITE®

DEPENDABLE  
RESISTANCE  
UNITS

OHMITE MANUFACTURING COMPANY  
3687 Howard Street, Skokie, Illinois

## Pulse Damage

(Continued from page 39)

Answer to this query would have to consider the rate of further depreciation. It is more than likely that once a resistor has started to change its value, additional drift will become accelerated, and perhaps in a matter of a few days or weeks, the set will be back in the shop again. Sometimes the only noticeable deficiency is that the raster takes a little too long to come on, at other times poor linearity is the complaint. In one case snivets were present. In many instances the horizontal output tube will have a shorter than normal life span, and occasionally the horizontal output transformer may run too hot. Trouble may also be indicated if it becomes necessary to make a special selection of tubes, as in the following case.

A Westinghouse V-2207 chassis had no raster except at a low setting of the brightness control, even then only a narrow portion of the screen could just about be seen. New horizontal oscillator, output and damper tubes increased the brightness, but not up to normal, nor could sufficient width be obtained. Knowing that some 6AU5 tubes are hotter than others, several were tried and one finally managed to supply enough width and brightness. Not being satisfied with this servicing method, further checks were made with the oscilloscope. A partial schematic is shown in Fig. 3. The sawtooth waveform at the plate of the horizontal multivibrator had a peak-to-peak amplitude of 90 volts instead of 130 volts peak-to-peak. A simple resistance check revealed that R436 had changed value from 270,000 ohms to 440,000 ohms. A 1-watt unit of the correct resistance value was installed. Normal operation was restored. Now any of the 6AU5 tubes produced width and brightness, except for the old tube. It checked good on a tube checker but wouldn't function properly in the set. Insufficient drive had probably prematurely weakened the tube, since it was in use for less than a year.

Pulse damage is responsible for much undeserved criticism of components. All tubes and parts have certain design center ratings, and when operating conditions go beyond these ratings, rapid depreciation and breakdown are sure to develop. When difficulties arise for no apparent reason, its time to put the scope to work. •

## FAST! ACCURATE!

### SECO Test Equipment

Saves time . . . makes  
more money for you!

WRITE TODAY FOR COMPLETE  
SPECIFICATIONS AND FEATURES!

- Outstanding Reliability and Performance!
- Unique, Time-Saving Features!
- Low First Cost Makes You Money From the Start!

#### 107 TUBE TESTER—

Outstanding performance and accuracy—provides 3 important tests: amplifier types tested for gain by Dynamic Mutual Conductance method—power types tested for cathode current by Cathode Emission method—all types tested for shorts and grid error by Grid Circuit Test developed and patented by Seco. Dynamic Mutual Conductance Test pre-wired to eliminate elaborate set-up. Cathode Emission Test done by free point pin-selector method—will not be obsolete. Completely self-contained in portable carrying case. Furnished with handy flip chart for fast tube set-up data.



MODEL 107 . . . . . \$139.50 NET



#### GCT-8 GRID CIRCUIT TUBE TESTER

—Perfect companion to any tester—checks critical "control grid" condition of vacuum tubes fast, accurately. Electron eye tube indicates faults at a glance. As many as eleven simultaneous checks—automatically.

MODEL GCT-8—Kit . . . . . \$19.95 NET

MODEL GCT-8—Wired & tested . . . 29.95 NET



208VTVM—" fool-proof"—many new features! Easy-to-read 4 1/2" 200 microamp meter mounted on sloping panel—7 DC, 7 AC, 7 ordinary Ohm ranges, plus RETMA (EIA) Ohm scale to check standard color-coded resistance values and tolerance limits. Specially designed "shift-lever" type function switch identifies and automatically connects proper probe. With stand, 40" leads, and common lead with clip.

MODEL 208 . . . . . \$74.50 NET

Leather, felt-lined carrying case. \$9.95 NET



PS-2 BATTERY ELIMINATOR—Compact unit takes place of battery normally used to operate and service low-powered transistorized equipment. Supplies clean, filtered DC—can't be damaged by a short. Quickly spots faulty batteries by substitution. Output continuously variable from 0 to 15 V.—ideal for experimenters. Complete with jacks, leads, and clips.

MODEL PS-2 . . . . . \$13.95 NET

FB-4 FLYBACK CIRCUIT AND INDUCTANCE ANALYZER—Quick "yes" or "no" answer on condition of flyback transformer and yoke—100% accuracy!

MODEL FB-4 . . . . . \$38.95 NET

#### NEW! HC-6 CURRENT CHECKER

Provides positive, on-the-spot method of checking TV horizontal output circuits—fast, accurate way to adjust horizontal drive and linearity. Easy to use—can be placed in circuit in seconds—compact size. Complete, ready to use.

MODEL HC-6 . . . . . \$12.95 NET

Get the complete story on Seco's exciting line of test equipment. See your distributor—or write for complete information today!

SECO MANUFACTURING CO.



5015 Penn Avenue So.  
Minneapolis, Minn.

# Do You Want A Partner?

*A Good Partner Can More Than Double The Size Of An Operation,  
But A Bad One Can Destroy The Business.*

ERNEST W. FAIR

• "There are times when I really wish I had a partner. Then we could get away more often and——."

The number of shop owners who have made such a statement to their wives and friends at one time or another without a doubt runs into many thousands. This desire is also expressed many times when the shop owner looks at an overflowing list of work to be done and visualizes how much easier it would be for two instead of one to handle it.

Partnership in business has definite advantages and it also has disadvantages. While it is a local and individual affair, there are a number of general conditions which should be considered when the time arrives to decide on a partnership arrangement. Some of the more important advantages are:

**MORE LEISURE**—The shop owner whose business provides him with little, if any spare time is surely impairing his future usefulness. The human body, no matter how strong or well constituted, must have some relaxation. A partnership offers a solution to this problem and without loss of business. However, in many cases it may be far less expensive to close the shop from time-to-time than to have to split the profits.

**SICK LEAVE**—Continuation of business during periods of long illness or other emergency is usually a matter of great concern. The customers won't wait. A closed shop for any length of time may result in the virtual disappearance of the business. Such a thing is not likely to happen in a partnership.

**CAPITAL**—Funds for expansion alteration, buying additional equipment, etc., may be obtained from a new partner. Years of actual experience have shown that where two partners have contributed equal financial resources to an enterprise, the chances for success are greater. However, before getting a partner

for his money only, consider the possibility that it may cost less to borrow the needed cash than to have to split the profits.

**GREATER VOLUME**—More customers may be handled. This may be good or bad. It is well to compare present earnings against the projected figures minus the partner's take. Too often only the gross earnings are considered, and added costs of doing more business are neglected.

**ADDED SKILLS**—No one person is best at everything. Some are excellent technicians; some are very good business men, and some are top-flight salesmen. Even when an individual can boast of all these attri-



butes, he seldom has enough time to perform the different activities and achieve maximum results during the course of a regular working day.

There may be other reasons for forming a partnership; individuals may be very good life-long friends, or related to each other. One person may have a desirable location to offer; another may have a loyal clientele, and still another may offer an opportunity of expansion and diversification because of his experience in another phase of the electronics business. As a general rule, it is not good practice to allow the importance of any one major asset to blank out the need for also considering all the other angles.

More than one partnership has failed, and more than one team of friends have been separated because of the lack of consideration of some important factor. A profitable oper-

ation will often minimize an undesirable factor in a partnership; the real test occurs when the business is not holding its own. It is, therefore, advisable to establish as favorable a set of conditions as possible.

Aside from profit sharing, which is a basic concept in any partnership, a partner usually draws a higher salary than an employee doing the same work. On the other hand, there are many instances where partners in a new business will be satisfied with smaller wages, for a period of time, to help capitalize an enterprise even more. A hired hand could not be expected to contribute in this manner. Sharing profits is fine, but what happens when losses have to be shared? Is the bond strong enough to ride out a business storm?

Sharing of liabilities should never be overlooked. The other fellow's liabilities as well as his assets are important factors. This does not pertain to just money matters, it includes personality, mannerisms, skills, standing in the community. **TEMPERAMENT**—Judgment should not be based on casual observation but upon a careful private investigation. Men engaged in a partnership, of opposite temperament, can look forward to nothing but trouble and chaos and an eventual disruption of their arrangement.

**CITIZENSHIP**—The circles in which one moves should be considered. It is much better for a business to select a man who moves in entirely different social, professional, and business areas than oneself. This is true not only from the standpoint of building the business, by being able to reach more people, but from another as well—two men who see each other day-in and day-out can become quite tired of each other. Age, experience and health should be considered. When there is too much difference between two men, troubles are likely to develop. De-

*(Continued on page 92)*

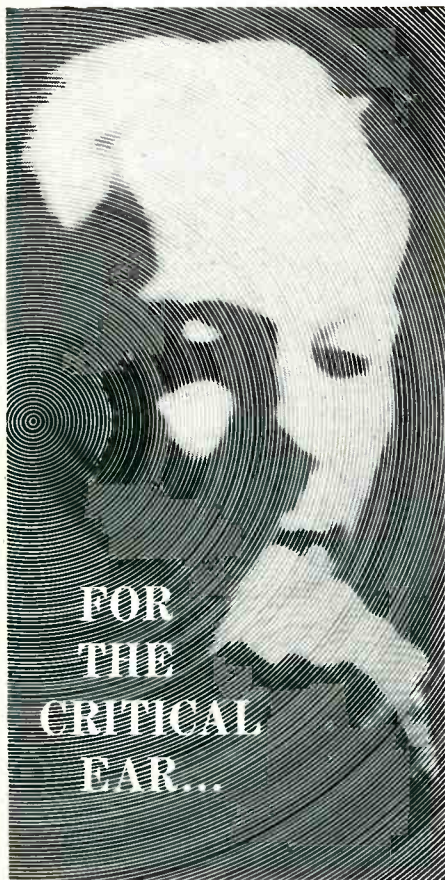

FOR  
THE  
CRITICAL  
EAR...

the incomparable

**SHURE**  
PROFESSIONAL

*Stereo Dynamic*  
CARTRIDGE

The Shure Stereo Dynamic Moving-Magnet Cartridge is designed and made specifically for the listener who appreciates accuracy and honesty of sound. It separates disc stereo sound channels with incisive clarity. It is singularly smooth throughout the normally audible spectrum...and is without equal in the re-creation of clean lows, brilliant highs, and true-to-performance mid-range.



**MODEL M3D**

Fits 3 and 4-lead transcription type and record changer stereo arms. Completely compatible, plays monaural or stereo. 10-second stylus replacement. Individually tested to meet or exceed these specifications: Frequency response, 20 to 15,000 cps. Output level, 5 mv at 1,000 cps. Compliance, 4.0 x 10<sup>-6</sup>cm per dyne. Channel separation, more than 20db throughout the critical stereo frequency range. Recommended tracking, 3 to 6 grams.

*Note to Service Technicians:* Shure Stereo-Dynamic cartridges are checked electrically, mechanically and acoustically to insure trouble-free performance that puts an end to profitless service call-backs.

Literature available: Department 14-K  
**SHURE BROTHERS, INC.**  
222 Hartrey Avenue, Evanston, Illinois

(Audio News. Cont. from page 26)

MARANTZ announces the Model 6 stereo adapter, converting two preamps into a master control system, @ \$45.

GENERAL ELECTRIC announces the LH-12 Stereo Classic speaker system in infinite baffle enclosure, with 12" woofer, 2" tweeter, @ \$129.95.

BRITISH INDUSTRIES announces the GARRARD TPA/12 stereo tone arm @ \$19.50; 4HF manual transcription player @ \$59.50; LEAK Point One stereo amplifiers, 50-watter @ \$189, 20-watter @ \$149.

CROWN tape recorders by International Radio & Electronics, Elkhart, Ind., has introduced the Stereo-Matic tape player @ \$617. This 2-speed unit will play up to 16 hours unrepeat with a 14" reel at 3 3/4 ips.

COOPERATIVE PROMOTION to clarify stereo for consumers is being launched in a joint ad campaign by ELECTRO-VOICE, HARMAN-KARDON and REK-O-KUT. "Your Guide to Stereo" will be offered by writing to Stereo Components, 444 Madison Ave., New York 22, N. Y.

IHFM STANDARDS COMMITTEE has approved the final draft on hi-fi tuner measurement standards. Copies will be circulated to all hi-fi tuner manufacturers in the country. Acceptance by a majority will constitute Institute adoption. Standard will then be presented to IRE, AES and EIA. If agreement is reached by all four organizations, the standards will be presented to ASA. The committee also recommended a standard presentation for hi-fi component ads and specs. It includes: TUNERS—useable sensitivity, distortion, hum & noise; PREAMPS—distortion, hum & noise, frequency response; AMPLIFIERS—output, distortion, frequency response.

**NEW**  
**IMPROVED**  
**SENCORE**  
**LC3**  
**Leakage Checker**

*Another Sencore Time-Saver*

Check these outstanding New Features  
Now — For the first time...

- Checks 156 different tube types — more than any other "grid circuit" type checker. Includes UHF and latest type tubes.
- Checks picture tubes without removing tube from cabinet or chassis.
- New Roll Chart prevents obsolescence — just dial the tube type and save time. Chart is easily replaced at no extra cost.
- Dynamic Filament checks including heater to cathode leakage & shorts — no need for a second filament tester.
- Two spare preheating sockets to cut down testing time.
- Capacitor checks simplified.

The LC3 provides all these new improved features in addition to those employed in earlier leakage or "grid circuit" testers. A must for any TV service technician.

**DEALER NET**  
**\$28.95**  
*Really Whips Tough Dogs*

**IN STOCK**  
at your local parts distributor

**INSTRUMENTS CORP.**  
171 Official Rd • Addison, Ill.

**Cut out this ad now for further information**

**ANOTHER GREAT**  
**TRIO**  
**TV ANTENNA FIRST**

**no-strip lead-in connector\***

Requires no stripping, no soldering, no wire holders — holds the complete insulated wire.

Just one of the features that makes Trio the most advanced TV Antennas in the world. Only the Trio Zephyr and Color Series Antennas have the no-strip Connector.

**TRIO**  
Manufacturing Company  
GRIGGSVILLE, ILLINOIS

\* Patent Pending

## "So Smooth & Clean-

is the response of the Atlas WT-6 that we demonstrate it in our high-fidelity Audio-Torium," says Anton J. Schmitt, Harvey Radic Co., Inc., New York, N. Y.

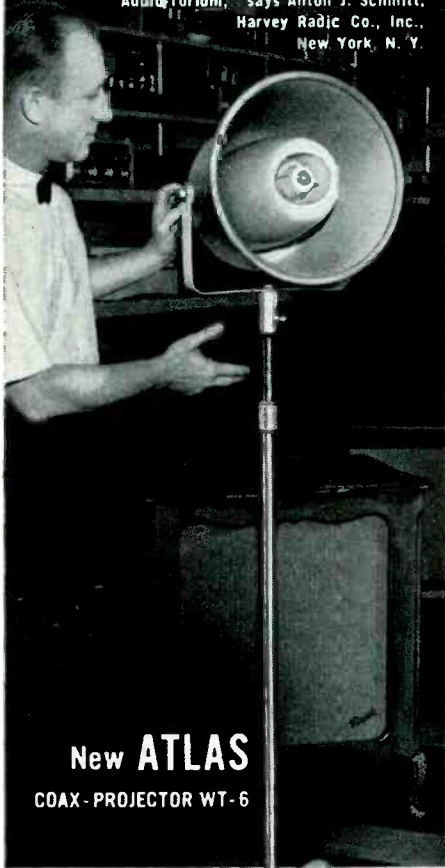

**New ATLAS**  
COAX-PROJECTOR WT-6

WT-6 NET \$34.50  
support stand only,  
SS-4 NET \$12.60

**ALL-WEATHER**— install it, forget it! —  
**HIGH-EFFICIENCY . . . COMPACT . . .**

True **HIGH FIDELITY TWO-WAY** system — not just a "compromise" of two horns coupled to a single diaphragm. The WT-6 comprises a weather-proof cone type driver (with 6-inch throat) coupled to its individual woofer horn; a separate pressure-type driver loaded to its separate tweeter horn. The built-in crossover electronic filter supplements the electro-mechanical frequency-limiting characteristics of the 2 individual reproducers — providing for smooth frequency division as each speaker functions within its engineered range of frequencies.

Universally adjustable "U"-type rugged steel mounting . . . finished in high temperature baked modern beige enamel.

**Power Rating** 15 watts continuous  
**Freq. Resp.** 140-15,000 cps  
**Impedance** 8 ohms  
**Dispersion** 120°  
**Dimensions** Bell opening 15",  
overall depth 12"

See the WT-6 at your local distributor.  
Send for complete catalog ET-11.



**ATLAS**  
**SOUND CORP.**  
1449-39 St., Brooklyn 18, N. Y.  
Atlas Radio Ltd., Toronto, Canada

BOGEN President Lester H. Bogen resigns.

SHURE appoints Charles L. McCabe as sales manager in charge of sales to original equipment manufacturers.

WALSCO introduces the WS-300 stereo/monophonic test record @ \$3.98.

BOZAK releases a 6-page condensed catalog of speakers and enclosures.

REEVES introduces a bonus stereo tape recording in a Premium Pak with another reel of blank tape. Price is \$1 more than regular 2-reel cost.

AUDIO ENGINEERING SOCIETY elects Donald J. Plunkett of Capitol Records as president for 1958-1959. Harry L. Bryant of Radio Recorders is vp.

JENSEN INDUSTRIES sales manager Mike Remund tells how he used the firm's magnified putty model of a stereo record groove to explain stereo to a hi-fi service technician. The serviceman felt the groove with his fingers. You see, he was blind.

UNIVERSITY LOUDSPEAKERS is promoting the stereo adaptability of its dual voice coil woofers, sold initially as "dual impedance" speakers. Second channel can be connected directly without the need for an adapter or control filter network.

ASTATIC announces "drastic price reductions" in its phono cartridge line, effective Sept. 1, 1958. The move is designed to curtail the influx of inexpensive foreign cartridges. Sales director Len Werner urges other U.S. manufacturers to "join forces with us in making quality cartridges available to American distributors, dealers and the public, at a price so low that it will be unnecessary as well as unwise to toy with inferior foreign copies."

Specify

# Tarzian



*Ferrule Mount*

# OR

40K

*Pigtail Lead Mount*

## SILICON RECTIFIERS

*for simplified, economical replacement of all existing radio and TV rectifiers.*

*Only two types to stock.*

WRITE FOR DATA SHEETS

**SARKES TARZIAN, INC., Rectifier Division**  
DEPT. T-4, 415 N. COLLEGE AVE., BLOOMINGTON, IND.

IN CANADA:  
700 WESTON RD., TORONTO 9, TEL. ROGERS 2-7535  
EXPORT: AD AURIEMA, INC., NEW YORK CITY

high fidelity

P.A.



*Grommes*

PREMIERE  
SOUND

P.A. sound, sparkling clear and natural . . . high fidelity which exceeds broadcast specifications. Created and engineered for the highest quality installations. This new sound amplifier series combines rugged durability, smooth versatile operation and true natural fidelity. Available in undistorted 20, 30 and 50 watt models. Ask your sound dealer for a Grommes Premiere Sound demonstration or for complete details, write . . .

**GROMMES**—Precision Electronics Inc.  
Dept. T-11

9101 King St., Franklin Park, Ill.

Send details—Premiere Sound.

Name.....

Company.....

Street.....

City.....State.....

## Do You Want A Partner?

(Continued from page 89)

sirable personality and other good traits may be compensating factors when considering the age difference.

We know our own reasons for the proposed venture, but why does the other fellow want the partnership? If his reasons are based on something which cannot materialize then trouble may develop in the future.

**STATUS**—Equal partner, senior, or junior? This can be most important. The best procedure is usually on an equal basis. If a "junior" arrangement is made, provisions for equal partnership in the future should be discussed right at the start.

Decision sharing is a must in a successful operation of any kind of partnership. It may not be easy to work with someone else especially if the business was previously established, and one of the previous owners is a partner in the new team. How readily a person is willing to give up his autonomy must be judged at the start. Who will be the boss when it comes to making basic decisions when there is a disagreement? Such procedures must be established in the beginning. It is important that each man make up his mind to adhere to the rules.

**FACILITIES**—Is the shop big enough for two or is an additional investment required? The need for more business may make it necessary to move to a busier section of town. Will the resulting benefits justify the added cost of the move, purchase of additional equipment and increased overhead?

**CONSULTATION**—Obtain expert advice from the lawyer, accountant and banker. Tax matters are rather complex, and it takes an expert to predict the advantages of one type of business organization over another in any given situation. Chances of survival are much enhanced if other responsible people in the community are called upon for help. The Chamber of Commerce, Better Business Bureau, and other local merchants associations are logical sources for information and perhaps customers.

Temporary expedients too often form the basis for partnership agreements. They almost invariably result in a loss. It's always good procedure, when considering a partnership, to stop and ask this question: "Will it be a good deal a year from now?" •

STAMP  
OF  
APPROVAL!

QUIETROLE

Only Known Merit marks a product as the "BEST"

for quieting Noisy Controls and Switches QUIETROLE produces results superior to any other product. That's why it's known as the "Best" and that's why more users prefer it to any other. It's the dependable Original product of its kind . . . a first in the Industry.

QUIETROLE  
Spray-  
Pack



In 2 oz. bottle with dropper and 6 oz. QUIETROLE SPRAY-PACK

or the QUIETROLE Bottle with the Eye Dropper Cap

QUIETROLE offers you both types of containers. Either way assures you of the same un-failing results that QUIETROLE is known for.

The Lubricant Cleaner of the Electronic World. Tailored for the industry by over 15 years of authentic research, plus 4 years of rigid and exacting tests before marketing.



Ask for QUIETROLE and be sure you get it!



manufactured by

QUIETROLE  
COMPANY

Spartanburg, South Carolina

Cut Down Call Backs...

INSTALL A *GL* WUERTH

**SURGISTOR**  
ON EVERY SERVICE CALL



G-C Wuerth No. 5301  
... For Black & White  
TV ..... List \$1.65

G-C Wuerth No. 5302  
... For Color TV Sets  
..... List \$1.95

Stops harmful voltage surges to picture and radio tubes. Sell your customers tripled tube life and you'll profit on each installation. Simply connect directly into power line. Functions like a combination resistor-relay to preserve electrolytic capacitors, dry disc rectifiers, transformers, pilot bulbs and other components as well as tubes.

Available right now from your local electronics parts distributor or write direct to:

**G-C ELECTRONICS MFG. CO.**

division of G-C TEXTRON INC.  
Western Plant: Los Angeles 18, Calif.  
Main Plant: ROCKFORD, ILLINOIS, U.S.A.

I watched  
a child die  
of cancer



SHE WAS too weak to speak . . . this child of eight. But the words were plain to see in her eyes: "Can't you make me well again, Doctor?"

It's terribly hard . . . even for a doctor who sees tragedy enough . . . to watch a child fade from the sunlight of life—a victim of cancer.

We had succeeded in prolonging her life by many months—thanks to recent advances in the treatment of leukemia.

But that's not enough! Cancer is a disease that ranks today as the Number 1 disease-killer of children. We can . . . we must . . . find ways to battle it, and win over it.

Research, supported by the American Cancer Society, is striving towards that goal.

Let's give . . . boldly, generously to the American Cancer Society Crusade . . . and help eliminate this mortal enemy which will take the lives of more than 250,000 Americans this year alone.

Send your gift to **CANCER** in care of your local post office.

**AMERICAN  
CANCER  
SOCIETY**

## Audio News

(Continued from page 70)

increased to \$49.50, \$24.95, \$34.95, and \$59.50, respectively.

**DYNAMIC:** Gold Dot replacement speaker line discontinued.

**PILOT:** Amplifier AA-902A and console PT-1040B discontinued.

**WEBSTER ELECTRIC:** Cart-ridge B-200 reduced to \$3.90.

**JENSEN INDUSTRIES:** 333 needle display card reduced to \$10.40.

**BOZAK:** E-305 provincial cabinet reduced to \$250.

**SHURE:** Increases Needle A68D to \$2.10; Cartridges W-21F, W-31AR, W-56N & WC-38 to \$5.34, \$4.50, \$6 & \$4.50, respectively.

## Combat Computer

A completely automated and highly mobile combat computer and data processor are being developed for battlefield use with the U. S. Army. This ruggedized, mobile equipment, all of it air-transportable, will be used to process data for commanders in the field. It will provide continuous information during battle on such changing conditions as intelligence, logistics support, fire-power and troop strengths. Development work on two solid-state mass information processing systems of advanced design has been started by the International Business Machines Corp. under contract to the U. S. Army Signal Corps, as part of the Army's FIELDDATA program.

The systems will be of modular construction to permit easy replacement of assemblies and sub-units. They are designed to withstand the shock of air and truck transport. Weight of a complete operational computer has been reduced to approximately 175 pounds. This computer, though light and compact, will be extremely fast. Technicians estimate that it will be capable of adding 30,000 ten-digit numbers per second. Error checking devices will be built into the equipment. Maintenance test devices will also be built-in to detect deterioration in any of its components. The systems have been designed to permit relatively inexperienced operators to substitute and replace packaged circuit and logic units with a minimum of disruption to operations.

the specs are the proof . . .  
the **BEST BUYS** are **EICO**<sup>®</sup>  
for **COLOR & Monochrome TV servicing**



**COLOR**  
and Monochrome  
dc to 5 mc lab & tv  
5" **OSCILLOSCOPE**  
#460  
Factory wired \$129.95  
Kit \$79.95

### • Features DC Amplifiers!

Flat from DC-4.5 mc, usable to 10 mc.  
**VERT. AMPL.:** sens. 25 rms mv/in; input 2.3 megs; direct-coupled & push-pull thruout; K-follower coupling bet. stages; 4-step freq-compensated attenuator up to 1000:1.  
**SWEEP:** perfectly linear 10 cps-100 kc (ext. cap. for range to 1 cps); pre-set TV V & H positions (30 & 7875 cps); auto. sync. ampl. & lim. PLUS: direct or cap. coupling; bal. or unbal. inputs; edge-lit engraved lucite graph screen; dimmer; filter; bezel fits std photo equip. High intensity trace CRT. 0.06 usec rise time. Push-pull hor. ampl., flat to 400 kc, sens. 0.6 rms mv/in. Built-in volt. calib. Z-axis mod. Sawtooth & 60 cps outputs. Astig. control. Retrace blanking. Phasing control.



**TV-FM SWEEP  
GENERATOR  
& MARKER #368**  
Factory wired \$119.95  
Kit \$69.95

Entirely electronic sweep circuit (no mechanical devices) with accurately-biased inductor for excellent linearity. Extremely flat RF output: new AGC circuit automatically adjusts osc. for max output on each band with min. ampl. variations. Exceptional tuning accuracy: edge-lit hairlines, 6:1 vernier. Sweep Osc. Range 3-216 mc in 5 fund. bands. Variable Marker Range 2-75 mc in 3 fund. bands; 60-225 mc on harmonic band. 4.5 mc Xtal Marker Osc., xtal supplied. Ext. Marker provision. Sweep Width 0-3 mc lowest max. deviation to 0-30 mc highest max. dev. 2-way blanking. Narrow range phasing. Attenuators: Marker Size, RF Fine, RF Coarse (4-step decade). Cables: output, 'scope horiz., 'scope vertical.

### DYNAMIC CONDUCTANCE



**Tube &  
Transistor  
Tester  
#666**  
Factory wired \$109.95  
Kit \$69.95

### COMPLETE with steel cover and handle.

**SPEED, ease, unexcelled accuracy & thoroughness.** Tests all receiving tubes (& Color & Monochrome pic tubes with adapter). Composite indication of Gm, Gp & peak emission. Simultaneous sel of any 1 of 4 combinations of 3 plate voltages, 3 screen voltages, 3 ranges of continuously variable grid voltage (with 5% accurate pot). New series-string voltages: for 600, 450, 300 ma types. Sensitive 200 ua meter. 5 ranges meter sensitivity (1% shunts & 5% pot). 10 5IX-position lever switches: free-point connection of each tube pin. 10 pushbuttons: rapid insert of any tube element in leakage test circuit & speedy sel. of individual sections of multi-section tubes in merit tests. Direct-reading of inter-element leakage in ohms. New gear-driven rollchart. Checks n-p-n & p-n-p transistors: separate meter readings of collector leakage current & Beta using internal dc power supply.

See the 50 EICO models  
IN STOCK at your neighborhood distributor.  
Write for  
**FREE Catalog ET-11**  
33-00 Northern Boulevard, L. I. C. 1, N. Y.

Prices 5% higher in West.

Operate your...

- tape recorder
- P. A. system
- portable TV set
- hand tools

FROM YOUR CAR, Boat or Plane!

with



## INVERTERS

FOR CHANGING YOUR STORAGE BATTERY CURRENT TO

A.C. HOUSEHOLD ELECTRICITY ANYWHERE...in your own CAR, Boat or Plane!



OPERATES PORTABLE TV SET directly from your car!

OPERATES

- TAPE RECORDERS
  - DICTATING MACHINES
  - PUBLIC ADDRESS SYSTEMS
  - ELECTRIC SHAVERS
- directly from your car!



MAKE YOUR CAR, BOAT OR PLANE "A ROLLING OFFICE!"



OPERATES

- RADIOS
  - RECORD PLAYERS
  - MIXMASTERS, ETC.
- directly from your car!

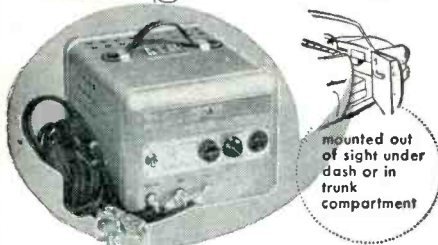

mounted out of sight under dash or in trunk compartment

## ATR UNIVERSAL INVERTERS

Especially designed to change 6 or 12 volt D.C. to 110 volt A.C. 60 cycles.

for...

- EXECUTIVES
- SALESMEN
- OUTDOOR MEN
- POLICEMEN
- REPORTERS
- FIREMEN
- PUBLIC OFFICIALS

MODELS 6U-RHG (6 volts) 125 to 150 watts. Shipping weight 27 lbs. List price.....\$89.95

DEALER NET PRICE.....\$59.97

12U-RHG (12 volts) 150 to 175 watts. Shipping weight 27 lbs. List price.....\$89.95

DEALER NET PRICE.....\$59.97

Write for literature on other Sizes and Models of ATR INVERTERS, priced as low as \$9.95 list.

### SEE YOUR JOBBER OR WRITE FACTORY

- ✓NEW MODELS ✓NEW DESIGNS ✓NEW LITERATURE
- "A" Battery Eliminators • DC-AC Inverters • Auto Radio Vibrators



AMERICAN TELEVISION & RADIO CO.

Quality Products Since 1931

SAINT PAUL 1, MINNESOTA, U. S. A.

## Self-Service TUBE MERCHANDISER

Tradition breaking plans have been initiated by Raytheon to sell tubes by way of a new self-service tube merchandiser with an easy-to-use, built-in testing device. This is the first brand-name manufacturer to sponsor "Tube Mart" a point of purchase tube dispenser. It is intended to be a step in a strengthened program to help the independent TV and radio service dealers recapture the consumer tube business

quality tubes, will be offered through Raytheon's regular marketing channels of electronics parts distributors to TV and radio dealers who in turn will place them in other retail outlets in their service areas. This plan offers a profit split, 30% discount to the service dealer, and 30% to the local merchant where Tube Mart is located. It should help keep the flow of replacement tubes in legitimate service dealer channels.

A literature rack built into the Tube Mart carries Raytheon-prepared and dealer-imprinted literature calling the user's attention to the local sponsoring service dealer for all service other than that of an emergency tube replacement nature. The folder describes the operation of The Tube Mart and encourages the set owner to call the service dealer if a simple tube substitution fails to make the set right for sound and sight.

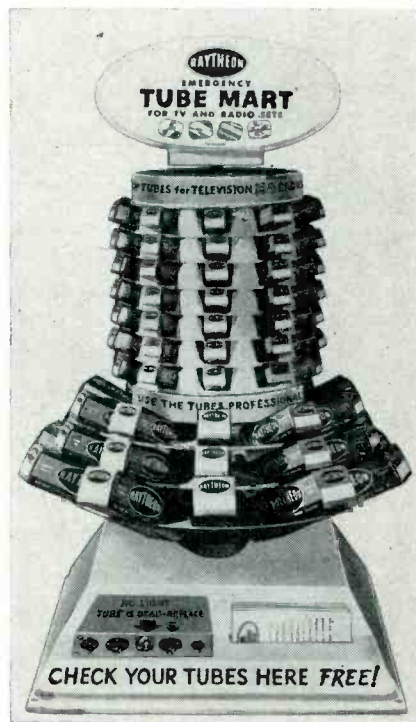

Emergency Tube Mart to be placed on consignment by authorized service dealers.

now being lost. The new emergency tube merchandiser will be placed on consignment in suitable market places by authorized TV and radio service dealers. Dealers do not pay for the display.

Tube Mart is a lazy susan type display 15" square by 30" high. A hundred of the most often required tube types for replacement service are inserted in the pockets of the stand and a simple filament continuity indicator is incorporated in the base. It cannot injure tubes by consumer failure to follow instructions, but it is not capable of making a complete series of tube tests.

The Tube Mart, filled with first

STATEMENT REQUIRED BY THE ACT OF AUGUST 24, 1912, AS AMENDED BY THE ACTS OF MARCH 3, 1933, AND JULY 2, 1946 (Title 39, United States Code, Section 233) SHOWING THE OWNERSHIP, MANAGEMENT, AND CIRCULATION OF ELECTRONIC TECHNICIAN, published monthly at Bristol, Conn., for October 1, 1958.

1. The names and addresses of the publisher, editor, managing editor, and business managers are: Publisher, Howard A. Reed, 174 Waverly Rd., Scarsdale, N. Y.; Editor, Albert J. Forman, Woodbrook Dr., Stamford, Conn. Managing Editor, none. Business Manager, none.

2. The owner is (if owned by a corporation its name and address must be stated and also immediately thereunder the names and addresses of stockholders owning or holding one per cent or more of total amount of stock. If not owned by a corporation, the names and addresses of the individual owners must be given.) Electronic Technician, Inc., 480 Lexington Ave., New York 17, N. Y.; Beatrice S. Berger, 109-01 72 Rd., Forest Hills, N. Y.; Charles F. Dreyer, 300 Hayward Ave., Mt. Vernon, N. Y.; Albert J. Forman, Woodbrook Dr., Stamford, Conn.; Nancy M. McGaughan, 83-02 Cornish Ave., Elmhurst, N. Y.; Robert E. Nickerson, 27 Meadowbank Rd., Old Greenwich, Conn.; Howard A. Reed, 174 Waverly Rd., Scarsdale, N. Y.; Morris J. Rubin, 70-33 175 St., Flushing 65, N. Y.

3. The known bondholders, mortgagees, and other security holders owning or holding 1 per cent or more of total amount of bonds, mortgages, or other securities are: (If there are none, so state.) M. Clements, 114 Ludlow Ave., Spring Lake, N. J.

4. Paragraphs 2 and 3 include, in cases where the stockholder or security holder appears upon the books of the company as trustee or in any other fiduciary relation, the name of the person or corporation for whom such trustee is acting; also the statements in the two paragraphs show the affiant's full knowledge and belief as to the circumstances and conditions under which stockholders and security holders who do not appear upon the books of the company as trustees, hold stock and securities in a capacity other than that of a bona fide owner.

(Signed) ALBERT J. FORMAN, Editor Sworn to and subscribed before me this 24th day of September, 1958.

MORRIS J. RUBIN, Notary Public State of New York, No. 41-3389950 Queens County Term expires March 30, 1959



## INDEX TO ADVERTISERS

November 1958

Aerovox Corp.	73
American Telephone & Telegraph	18
American Television & Radio Co.	94
Astatic Corp.	71
Atlas Sound Corp.	91
B & K Manufacturing Co.	26, 27, 87
Blonder-Tongue Laboratories, Inc.	21
Burroughs Corp.	46
Bussmann Manufacturing Co.	14
Castle TV Tuner Service	78
CBS-Hytron	28
Centralab Div., Globe-Union, Inc.	8
Century Electronics Co., Inc.	48, 49
Channel Master Corp.	4, 5
Chemical Electronic Engineering, Inc.	76
Chicago Standard Transformer Corp.	76
Clearbeam Antenna Corp.	69
Cleveland Institute of Radio Electronics	78
Communications Co., Inc.	79
Cornell-Dubilier Electric Corp.	61
Delco Radio Div., General Motors	13
Deutschmann Corp., Tobe	62, 63
EICO	93
Electro-Voice, Inc.	23
Erie Resistor Corp.	85
Fidelitone, Inc.	85
General Cement Manufacturing Co.	92
General Electric Co.	6, 7, 51, 59, 77
Gregg Electric Sales Co.	80
Harman-Kardon	16
Heath Co.	52
Hickok Electrical Instrument Co.	87
International Resistance Co.	Cover II
Jerrald Electronics Corp.	56
JFD Electronics Corp.	55
Kester Solder Co.	86
Mallory & Co., Inc., P. R.	66, 67
Merit Coil & Transformer Corp.	96
Milwaukee Resistor Co.	80
Moss Electronic Distributing Co., Inc.	57
Ohmite Manufacturing Co.	88
Oxford Components, Inc.	86
Paxton Products	65
Philco Corporation	19, 22, 68
Planet Sales Corp.	81
Precision Apparatus Co., Inc.	54
Precision Electronics, Inc.	92
Quam-Nichols Co.	83
Quietrol Co.	92
Radiart Corp.	62, 63
Radio Corp. of America	60, Cover IV
Raytheon Manufacturing Co.	2, 3
Recoton Corp.	95
Rider Publisher, John F.	72
Riemer Co., Inc., David	84
Rockbar Corp.	53
Rohn Manufacturing Co.	Cover III
Seco Manufacturing Co.	88
Service Instruments Corp.	82, 90, 95
Shell Electronic Manufacturing Corp.	64
Shure Brothers, Inc.	90
Simpson Electric Co.	50
Sonotone Corp.	12
South River Metal Products Co., Inc.	82
Sprague Products Co.	47
Sylvania Electric Products, Inc.	9, 20
Tarzian, Inc., Sarkes	91
Trio Manufacturing Co.	84, 90, 95
Tung-Sol Electric, Inc.	74, 75
V-M Corp.	25
Volkswagen of America, Inc.	17
Walco Electronics Manufacturing Co.	58
Weller Electric Corp.	70
Westinghouse Electric Corp.	15, 24
Winegard Co.	10, 11
Wright Steel & Wire Corp.	84
Zalytron Tube Corp.	79
Zenith Radio Corp.	44

While every precaution is taken to insure accuracy, we cannot guarantee against the possibility of an occasional change or omission in the preparation of this index.

# Recoton-Goldring

## VARIABLE RELUCTANCE TURNOVER CARTRIDGE

now in **STEREO**

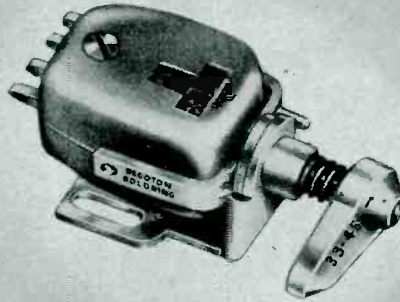

The famous Recoton-Goldring Magnetic Cartridge is now available for Stereo. One side has a diamond stylus for Stereo and is compatible for LP. The other side features a sapphire point for either LP or standard records. It can be used for all turntables or record changers with 1/2" standard mounting.

Giving faithful reproduction and full range symphonic channel separation, this new Stereo cartridge truly lives up to the high standard of quality set by Recoton-Goldring cartridges!

RG745-3SD With diamond stylus for stereo and monaural LP's and sapphire stylus for 78RPM.

RG745-1SD With diamond stylus for stereo and monaural LP's and sapphire stylus for LP's.

Audiophile Net \$29.95

At leading hi-fi distributors or write to

**RECOTON CORPORATION** 52-35 Barnett Ave., Long Island City 4, N. Y.

## SENCORE

# Handy "36"

R-C

### Substitution Unit

Another Sencore Time-Saver

"36"

Most Often Needed Components At YOUR Fingertips!

3 pole, 12 position switch individually selects one of the "36" components for direct substitution.

Contains:

- ★ 12-1 watt 10% resistor from 10 ohms to 5600 ohms
- ★ 12-1/2 watt 10% resistor from 10K ohms to 5.6 megohms
- ★ 10-600 volt capacitors from 100-mmf. to .5mf.
- ★ 1-10mf., 450V Electrolytic
- ★ 1-40mf., 450V Electrolytic

ONLY \$1275 DEALER NET

Completely isolated

POPULAR SENCORE PRODUCTS

- Transistor Tester
- Leakage Checker
- Filament Tester
- Voltage Regulator
- Bias Supply

AVAILABLE AT ALL PARTS DISTRIBUTORS!

SERVICE INSTRUMENTS CORP.

171 OFFICIAL RD., ADDISON, ILL.

## ANOTHER GREAT

# TRIO®

### TV ANTENNA FEATURE

wing dipole and wing director

Today's most powerful combination. The Wing Dipole contains 3 active elements on the high, forward Vee to the low band section, plus integrated director. The Wing Director obtains maximum results from the Wing Dipole.

Just one of the features that makes Trio the most advanced TV Antennas in the world. Choose from Trio's complete Zephyr and Color Series Antennas.

TRIO®

Manufacturing Company

GRIGGSVILLE, ILLINOIS

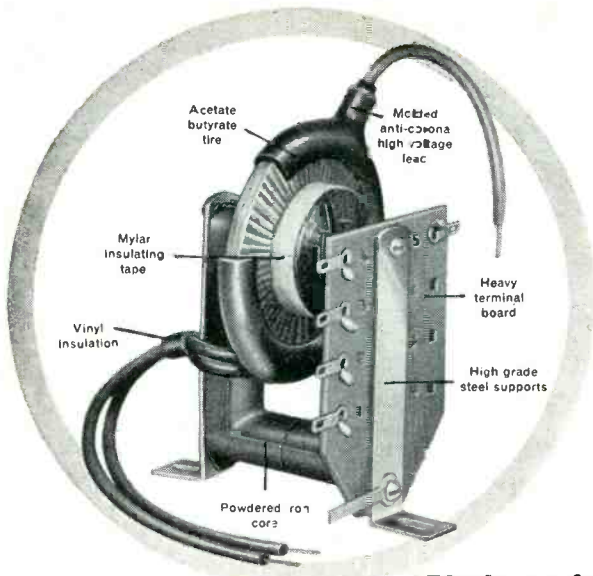

**Flybacks**

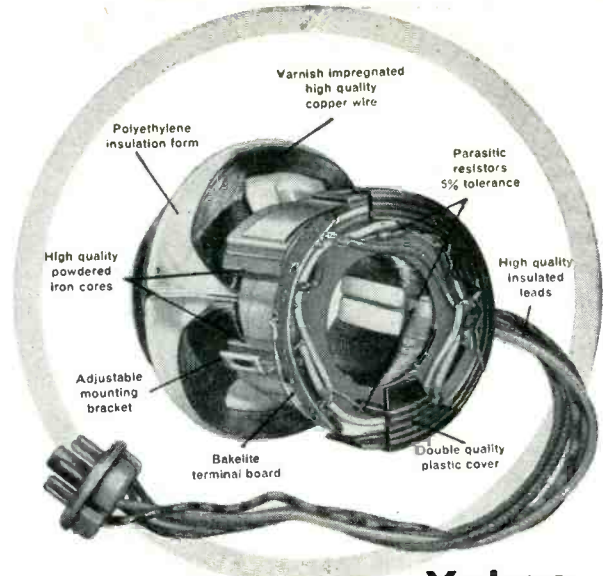

**Yokes**

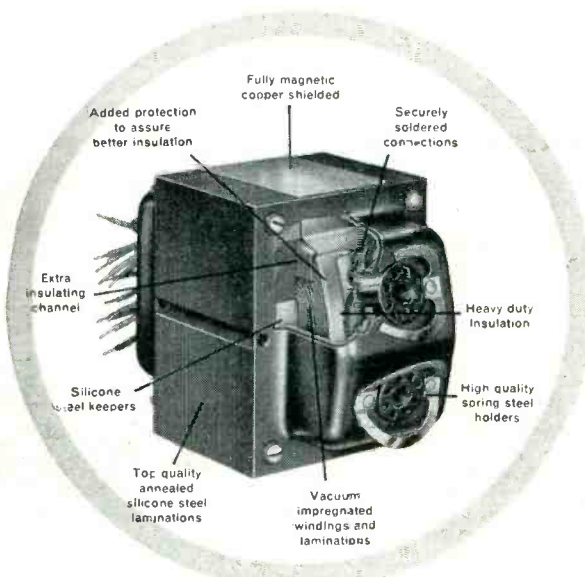

**Transformers**

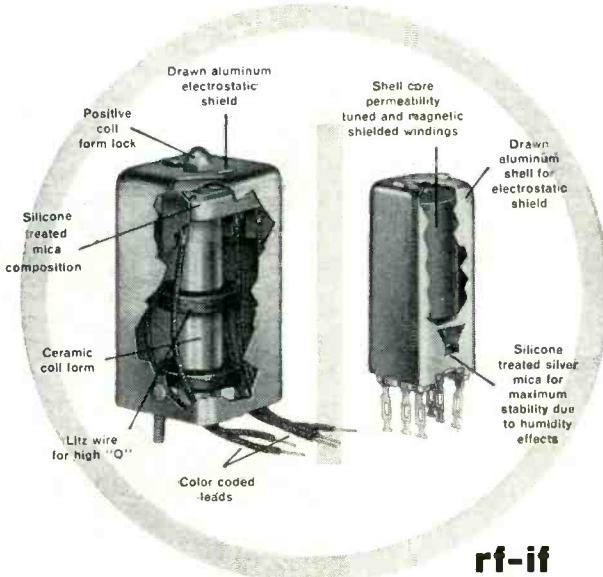

**rf-if  
Transformers  
and Coils**

# MERIT COILS and TRANSFORMERS are the first choice of Independent Service Dealers and Technicians

FIRST in Quality • FIRST in Sales Aids!



**"COMPARE IT WITH MERIT"**

MERIT COIL AND TRANSFORMER CORP.  
MERIT PLAZA • HOLLYWOOD, FLORIDA

# ROHN Designs Amazing No. 25 Tower to reach new heights in tower engineering

**NEW GENERAL-PURPOSE COMMUNICATION OR HEAVY-DUTY TV TOWER**

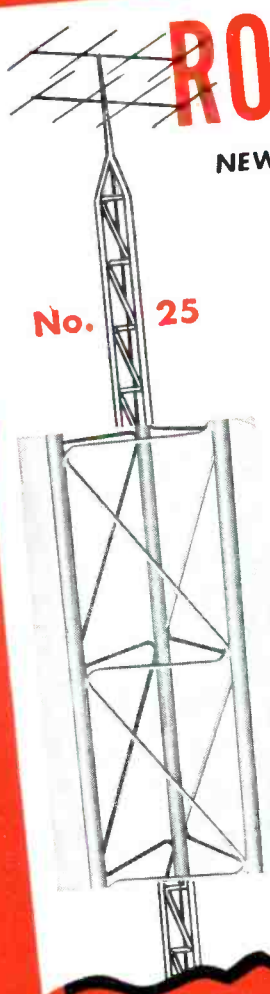

**No. 25**

ROHN now offers a tower a full 33% stronger and more durable than similar sized and similar type towers that are found on the market today!

These amazing results are achieved through using heavier-duty side rail tubing, quality steel that is of the highest grade and a new "zig-zag" cross bracing design.

The strength of this tower allows it to be self-supporting under most condi-

tions to 50' and under guyed conditions up to 150'. The tower has been built to fit a tremendously wide range of needs in communications, amateur use and as a heavy-duty TV tower.

**FLASH!** The "RohnKote" enameling plant is in operation and ROHN products are available not only in **HOT-DIPPED GALVANIZING** but also in a specially developed 6-step enameling process known as "RohnKote".

## NOW! 10 Different Lines of ROHN TOWERS, Including:

### No. 6

Widely used for home TV, this tower features "magic triangle" cross bracing construction.



Packaged Towers in which the sections nestle inside each other.

### No. 40

Heavy-duty communications tower suitable self-supporting at heights up to 60' or guyed as high as 300'. Ideal for communications uses of all types, microwave, radio telephone, etc.



### No. 20 & 30

Heavy-duty communications towers in RohnKote enamel.

### Fold-Over Towers

Ideal for amateurs and experimenters inasmuch as the tower folds over for convenient antenna changing, etc. Supplied in both medium and heavy-duty sizes to handle practically any size beam.



### Look to ROHN for these requirements, too:

A wide line of all types of accessories for towers is available but in addition, ROHN produces a complete line of:

#### MASTS

ROHN masts are outstanding in design and have special features that make them the best in the field and in addition, are as low or lower in cost than any other.

#### TUBING

Complete line of tubing, either plain or with 6" expanded end; in 10' and 5' length; 16 or 18 gauge; and in either hot-dipped galvanized or "RohnKote" enameling.

#### ROOF TOWERS

Specially designed roof towers have received tremendously wide acceptance and are available from heights of 2 1/2' to 10'.

#### BASES

A wide selection for mast and other type installations; wall mounts—for inexpensive installations; gable mounts; special mounts for antennas; drive-in ground mounts; and dozens of other specially designed items.

Make sure you have full details, catalog and prices on the entire ROHN line. Contact the ROHN representative in your area, or distributor, or contact:

# ROHN Manufacturing Company

116 LIMESTONE, BELLEVUE

PEORIA, ILLINOIS

PHONE 4-9156



There's  
no question  
about it!

**IF IT'S AN RCA TUBE...IT HAS TO BE "HEALTHY"!**

RCA specializes in the production of "healthy" tubes. Take the RCA-6AX4-GT, for example. It features important built-in safety factors that minimize internal breakdowns and "arc-over", reducing early-hour failures—while providing reliable performance in TV damper circuits. Here are some of the ways RCA builds this "good health" into the 6AX4-GT:

Heater wire has been specially developed to improve welds, thereby reducing early-hour failures due to an open circuit at the weld point. Heater-spacer assemblies are pre-fired to eliminate leakage-producing contamination during tube production. And micas are specially sprayed to control plate-to-cathode leakage.

These are some of the reasons why many designers and manufacturers of TV sets specify RCA's 6AX4-GT—the very same reasons why you should always ask your RCA Tube Distributor to "Ship RCA Only"!

**RCA Technical  
Booklet Available**

RCA Receiving Tubes and Picture Tubes for AM, FM, and Television Broadcast (1275-H) . . . includes socket information and useful data for more than 700 tube types. Ask your RCA Tube Distributor for your copy today!



**RADIO CORPORATION OF AMERICA**

Electron Tube Division

Harrison, N. J.