

June 49

RADIO & TELEVISION RETAILING



Springboard for Summer Selling of

AM, FM, TELEVISION • ELECTRICAL APPLIANCES
RECORDS & PHONOGRAPHS • SERVICING & SOUND

June • 1949
CALDWELL-CLEMENTS, INC.

SHOOTING

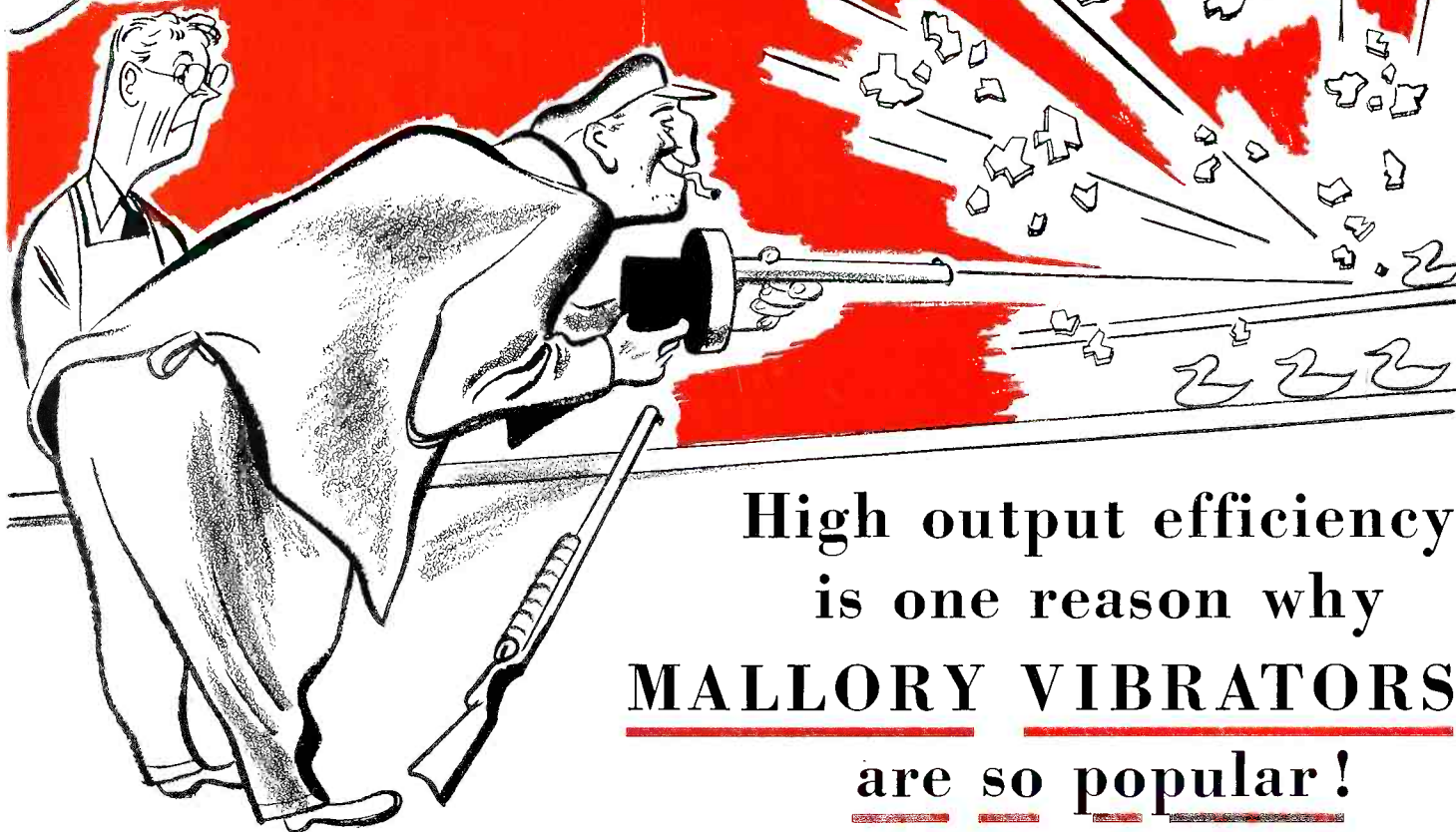

High output efficiency is one reason why **MALLORY VIBRATORS** are so popular!

High output efficiency! That's one of the vital reasons why more Mallory Vibrators are in use today than all other makes combined.

You get maximum efficiency from a Mallory Vibrator because its related parts are carefully

matched. Every part is carefully balanced with its counterpart by an exclusive Mallory method.

All working parts of Mallory Vibrators are Mallory-designed and Mallory-made. For Mallory focuses on Vibrator design an unusual combination of engineering talent and resources in electronics, electrochemistry and metallurgy.

The result is not only *high output efficiency* from Mallory Vibrators, but *long life* and *dependable starting*. No wonder more Mallory Vibrators are used in original equipment than all other makes combined. No wonder they make the best replacements. See your Mallory Distributor.

Mallory "2448" Vibrator Deal

This deal gives you a handsome storage and display cabinet for your stock of vibrators, together with a selection of vibrators and buffer capacitors that will answer 75% of your requirements.



You pay only the service man's net price for the six vibrators and twelve buffer capacitors. There is no charge for the attractive, convenient cabinet. Your Mallory distributor has them in stock for immediate delivery.

More Mallory Vibrators are used in original equipment than all other makes combined

P. R. MALLORY & CO. Inc. MALLORY

CAPACITORS • CONTROLS • VIBRATORS • SWITCHES • RESISTORS
• RECTIFIERS • VIBRAPACK* POWER SUPPLIES • FILTERS

*Reg. U. S. Pat. Off.

APPROVED PRECISION PRODUCTS

P. R. MALLORY & CO., Inc., INDIANAPOLIS 6, INDIANA

RADIO & TELEVISION RETAILING

Including "Radio & Television"
and "Radio & Television Today"

Established in 1922
as ELECTRICAL RETAILING

ORESTES H. CALDWELL
Editorial Director

M. CLEMENTS
Publisher

JOHN L. STOUTENBURGH
Executive Editor

RUTH MORRIS
Records Editor

EDWARD A. CAMPBELL
Technical Editor

CHARLES F. DREYER
Art Director

BUSINESS DEPARTMENT

M. H. NEWTON
Sales Manager

EDWIN WEISL, JR.

M. E. SCHNEIDER
Production Supervisor

BRANCH OFFICES

CHICAGO 6

S. M. GASKINS, Manager
JOHN ROMANCHAK

201 N. Wells St. Randolph 6-9225

LOS ANGELES 14

DUANE WANAMAKER
610 S. Broadway
Mutual 2161

CIRCULATION DEPARTMENT

B. V. SPINETTA
Circulation Director

W. W. SWIGERT
Credit Manager

Radio & Television Retailing*

June 1949, Vol. 49, No. 6, 35 cents a copy. Published monthly by Caldwell-Clements, Inc. Publication Office, 1309 Noble St., Philadelphia 23, Pa. Editorial, Advertising and Executive Offices, 480 Lexington Ave., New York 17, N. Y. Subscription rates United States and U. S. Possessions \$2.00 for one year, \$3.00 for two years, \$4.00 for three years. Canada \$3.00 for one year, \$4.00 for two years, \$5.00 for three years. Pan American Countries \$4.00 for one year, \$5.00 for two years, \$6.00 for three years. All other countries \$5.00 for one year, \$7.50 for two years, \$10.00 for three years. Printed in U.S.A. Entered as second class matter February 21, 1949, at the Post Office at Philadelphia Pa., under the act of March 3, 1879. Member of Audit Bureau of Circulations.

*Trade-Mark Reg. U. S. Pat. Off.
Copyright 1949 by

CALDWELL-CLEMENTS, Inc.
Publishers also of TELE-TECH

IN THIS ISSUE

JUNE, 1949

★ *AM, FM, Television*

COVER—Springboard for Summer Selling	
EDITORIAL—Today's Customer Must Be Sold	25
WHAT'S AHEAD—In Radios, Appliances, Records and Television	26
WHAT MAKES THE PRICE-CUTTER TICK?	30
DEALERS HIT PRICE-CUTTING	33
SUMMER SELLING	34
"TRY" TV SETS IN THE HOME	36
SALES-MAKING STORE	38
NEW AM, FM, TV SETS	40
NEW TELEVISION RECEIVERS	42
LETTERS FROM READERS	44
TV STATIONS ON THE AIR	48

★ *Records, Phonographs, Accessories*

COVER—Thirty Years of Record Sales	51
BEST-SELLING DISCS	54
RECORDING NEWS	56

★ *Electrical Appliances*

COVER—TV—Your Star Appliance Salesman	59
APPLIANCE PROFIT-MAKERS FOR DEALERS	60
OPERATING COST FIGURES	62

★ *Servicing and Sound*

COVER—Admiral 3-Speed Record Changer	63
TELEVISION TECHNICIAN	64
NEW PHILCO TV FRONT END	65
TV SIGNAL BOOSTERS	66
NEW SOUND EQUIPMENT	68
THREE-SPEED RECORD PLAYERS	70
NEWS OF THE INDUSTRY	Begins on page 72

Photo Credits

Philip Gendreau, N. Y.	Cover, and p. 34
Underwood & Underwood	36

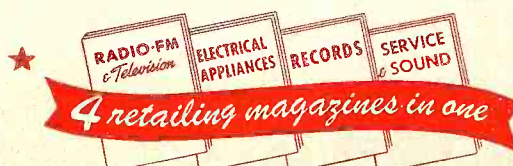

Member of
**AUDIT BUREAU
OF CIRCULATIONS**

CALDWELL-CLEMENTS, INC.
480 Lexington Ave., New York, N. Y.

Dealers— MANUFACTURER to ~~DISTRIBUTOR~~ Direct

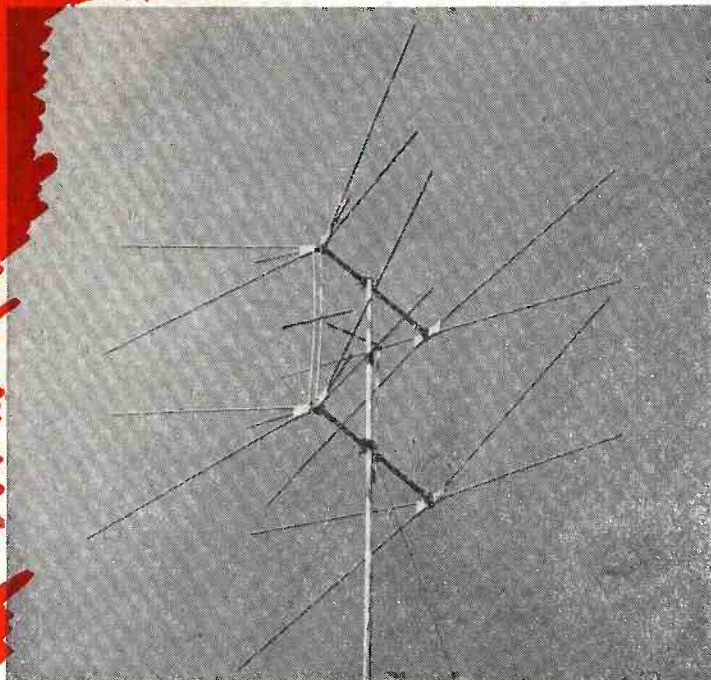

The WARREN "Coronet" Conical Antenna (above), priced **DIRECT** to Dealer:
 1 -11 \$16.00 ea. 50-99 \$14.60
 12-49 \$15.40 100 & over \$14.00

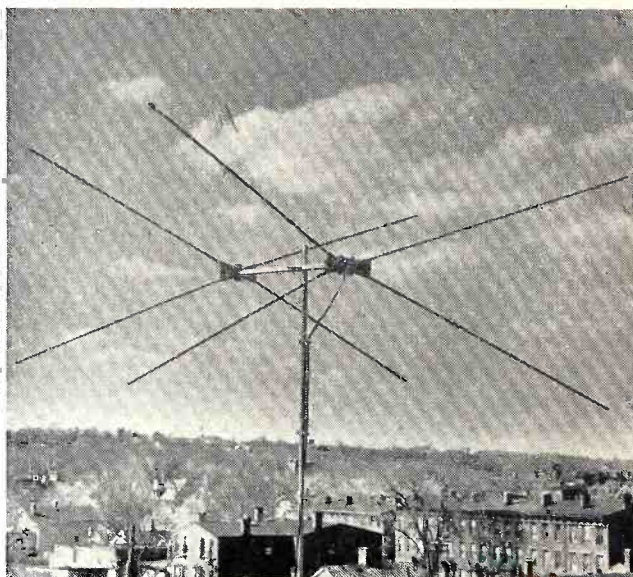

The WARREN "Broadband" Conical Antenna (right). **DIRECT** prices:
 1 -11 \$7.55 50-99 \$6.85
 12-49 7.25 100 & over 6.55

Here's How You Save . . .
 WARREN Antennas and Accessories
 are now shipped **DIRECT** from **FAC-**
TORY to **DEALER**.

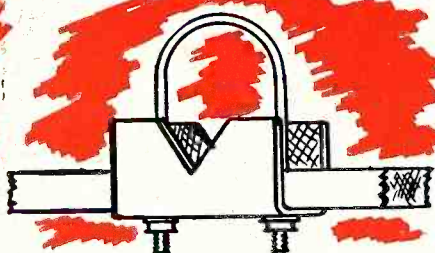

4" U-Bolt with Bracket. Priced **DIRECT** to Dealer:
 1 -23 .18 each. 49 & over .14
 24-48 .16 Standard Pkg. .24

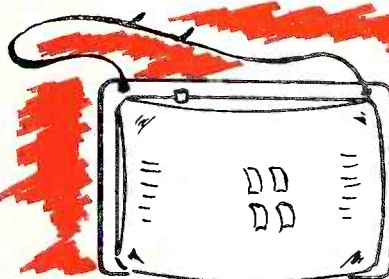

WARREN Magnifying Lens for 10" or 12" screen. **DIRECT** prices:
 1-5 \$9.95 each
 6 & over 9.30

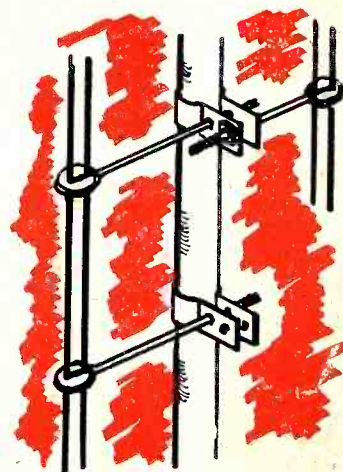

WARREN Sway-Proof Clamps, with 3" Screw Eyes.
 100 \$6.50 per C
 500 6.00 "
 1000 5.25 " Standard Pkg. 50

Start building profits today! Contact your nearest factory outlet listed below in person or by phone, or write main office.

WARREN

**Partial List
of Outlets**

Springfield, Mass.
 14 Wight Place
 L. Del Padre, Mgr.
 Phone 9-5658

New Haven, Conn.
 130 Bradley Street
 W. Schneider, Mgr.
 Phone 8-0595

Highland Falls, N. Y.
 82 Main Street
 N. Schneider, Mgr.
 Phone 2041

Save 40%!

to DEALER . .



These **BIG SAVINGS** are passed on directly to the dealer in the form of the **LOWEST PRICES** ever placed on quality TV equipment.

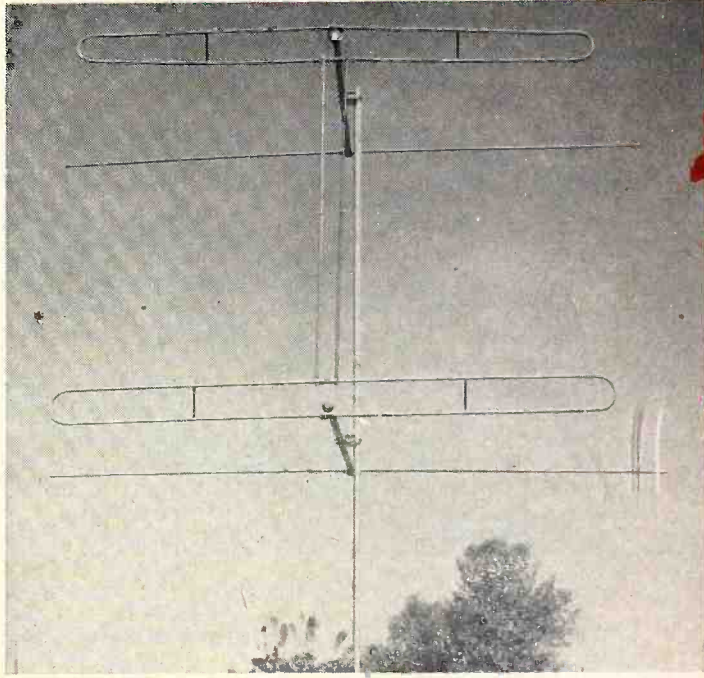

The WARREN Folded High-Low Antenna (left).
DIRECT prices:
 1 -11 \$4.95 50-99 \$4.45
 12-49 4.75 100 & over 4.10

The WARREN Stacked Folded Low Antenna (above).
DIRECT prices:
 1 -11 \$7.75 50-99 \$7.05
 12-49 7.35 100 & over 6.75

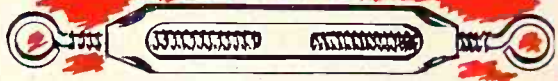
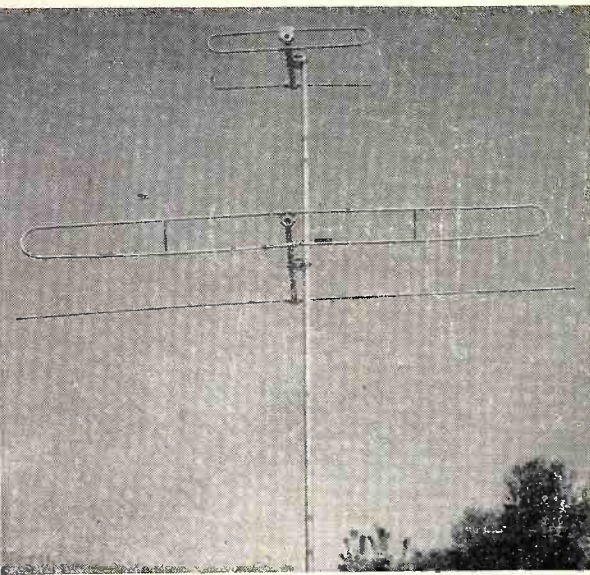

Turnbuckles. Priced **DIRECT**:
 1 -11 .10 ea. 1 -11 .12 ea.
 4 1/2" 12.72 .08 5" 12-72 .10 Standard Pkg.—12
 73 & over .07 73 & over .09



Hook-Eyes. Priced **DIRECT**:
 1 -36 .05 ea. 73 to 144 .04
 37-72 .04 1/2 Standard Pkg.—36



Screw-Eyes. Priced **DIRECT**:
 .04 each .05 each
 100 \$3.00 per C 100 \$4.50 per C
 3 1/2" 500 2.85 " 7" 500 4.20 "
 1000 2.75 " 1000 4.00 "
 5000 2.65 " 5000 3.85 "
 Standard Pkg.—100

WARREN Heavy Steel Cadmium-plated Chimney Mount (right).
DIRECT prices:
 1-11 \$1.39 each
 12-72 1.28
 73 & over 1.13

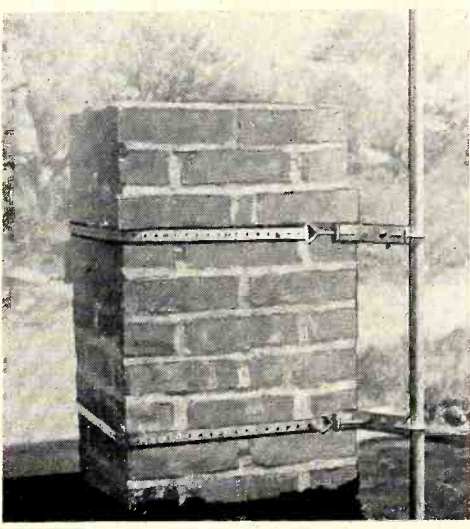

M F G. C O., Inc.

Bronx, N. Y.
 2101 Boston Road
 J. Friedman, Mgr.
 LUdlow 4-8620

Ardmore, Penna.
 42 Rittenhouse Pl.
 W. Fordyce, Mgr.
 Phone 7820

Yonkers, N. Y.
 825 Central Avenue
 R. Lowell, Mgr.
 Yonkers 5-1352

White Plains, N. Y.
 114 Main Street
 R. Lowell, Mgr.
 White Plains 6-4400

Trans-Vue

LEADING MANUFACTURERS
OF COMMERCIAL TELEVISION

NOW DOUBLES THE SCORE!

WITH NEW Ciné Television



TRANS-VUE—NATIONALLY KNOWN FOR QUALITY TELEVISION SYSTEMS AT CONSUMER ACCEPTED PRICES

Now you can satisfy your most discriminating customers . . . with Trans-Vue's Ciné home television receiver. Like the Trans-Vue multiple remote control television system, the Ciné is designed and engineered for sales appeal and customer value. This means *greater customer satisfaction . . . greater profits for you!* The enthusiasm which Trans-Vue distributors have shown for the Ciné is not unfounded. It has everything . . . newest engineering developments . . . performance beyond compare . . . and is priced to reach all income levels!

TRANS-VUE WILL PUT YOU IN THE PROFITABLE TELEVISION PICTURE!



Limited areas open for distributorships. For full details, write, wire or phone!

Trans-Vue's multiple unit remote control television . . . THE
WORLD'S FIRST AND FINEST COMMERCIAL TELEVISION SYSTEM!

Trans-Vue Ciné 145, 31 tube Consolette model, available in rich mahogany cabinet and blonde bisque finish. Washable woven plastic grille. World's largest direct view picture of 145 square inches on 15" Dumont tube. "Instantuner" dial for rapid, sensitive, accurate tuning, and positive "locked-in" picture control.

Sensational New Type Table Consolette also available, 25 tube equivalent. (not shown).

HERE'S WHAT TRANS-VUE CINÉ
MEANS TO YOUR CUSTOMERS:

- ★ 145 SQUARE INCHES OF ANIMATED ENTERTAINMENT!
- ★ WIDE ANGLE VISION FOR EYE COMFORT!
- ★ EXCLUSIVE "INSTANTUNER"...50% LESS MOVING PARTS!
- ★ FM STATIC FREE T-V SOUND!
- ★ AUTOMATIC VIDEO CONTROL FOR PICTURE BRILLIANCE!
- ★ SIMPLE, FAST OPERATION... ONLY 4 CONTROL KNOBS!
- ★ TELEVISION, AM, FM, PHONOGRAPH ADAPTOR IN 1 UNIT!
- ★ EXCLUSIVE CABINET DESIGN BY PIERRE RENAULT!



Trans-Vue

CORP.

1139-41 S. WABASH AVE.
CHICAGO 5, ILLINOIS

now Wilcox-Gay gives you

Complete Recording!

RECORDS ON TAPE



RECORDS ON DISCS



RECORDS FROM ONE TO THE OTHER



● The new Tape-Disc RECORDIO offers recording facilities never before available for educational or business uses—and for the home, too. Using either microphone or radio, this versatile instrument makes full-hour recordings on tape—and then re-records from tape to disc. And it is just as simple to record from disc to tape. Yet, with these and other exclusive features, the new Tape-Disc RECORDIO is priced surprisingly low!

note these ...

AMAZING FEATURES

- Records from microphone or radio on tape.
- Records from microphone or radio on discs.
- Records from discs to tape.
- Records from tape to discs.
- One hour recording time per reel.
- Can be used as public address system.

Portable!

WEIGHS ONLY 27 POUNDS!

The new Tape-Disc RECORDIO can be carried anywhere. Weighs only 27 pounds. Comes complete with attractive two-tone brown leatherette carrying case.

Case dimensions: 18½" x 16½" x 9¾"

KEEP YOUR EYES OPEN FOR
TV by WG

It's on the way—America's newest
television—Wilcox-Gay!

TAPE-DISC Recordio

TRADE MARK REG. U. S. PAT. OFF.

WILCOX-GAY CORPORATION, CHARLOTTE, MICHIGAN

In Canada: Canadian Morconi Company

YOU WILL

PROFIT

3 WAYS

when you sell the Square Root
all channel TV and FM antennas

YOU PROFIT from customer satisfaction
Satisfied customers are your best
new set and antenna salesman

YOU PROFIT from high volume
Low cost and high quality insure
rapid turnover

YOU PROFIT from liberal discount

Quad-Loop*

ALL CHANNEL TV FM ANTENNA

Quad-Loop, a quadrature-phasing antenna, combines all the advantages of a mechanically rotated antenna with the low cost of the fixed type. Electronically rotated at the receiver by a single control, Quad-Loop selects maximum gain for each channel, regardless of the geographic location of the transmitting station. There is no rotated antenna regardless of cost which will surpass Quad-Loop performance.

Di-Loop*

ALL CHANNEL TV FM ANTENNA

Di-Loop is a high-gain antenna. Simply constructed—a loop and a dipole element—of sturdy all metal design, Di-Loop insures speed installation and a long life of excellent performance. A leading radio manufacturer tested 30 antennas in this price range and found Di-Loop outperformed all the rest.

Wind-□-Loop*

ALL CHANNEL TV FM ANTENNA

Wind-O-Loop is a completely novel approach to the problems affecting apartment house or restricted zone installation of television receivers. Constructed of a single rectangular loop and a dipole element, Wind-O-Loop is attached to the pane of any window, indoors or out, by means of two rubber suction cups. An all channel antenna, Wind-O-Loop may be oriented through 180° and permanently clamped for maximum gain.

WRITE TODAY for complete specifications
and discounts.

* Trade Mark Registered
Patent Pending



MANUFACTURING CORPORATION

901 Nepperhan Avenue • Yonkers 3, New York

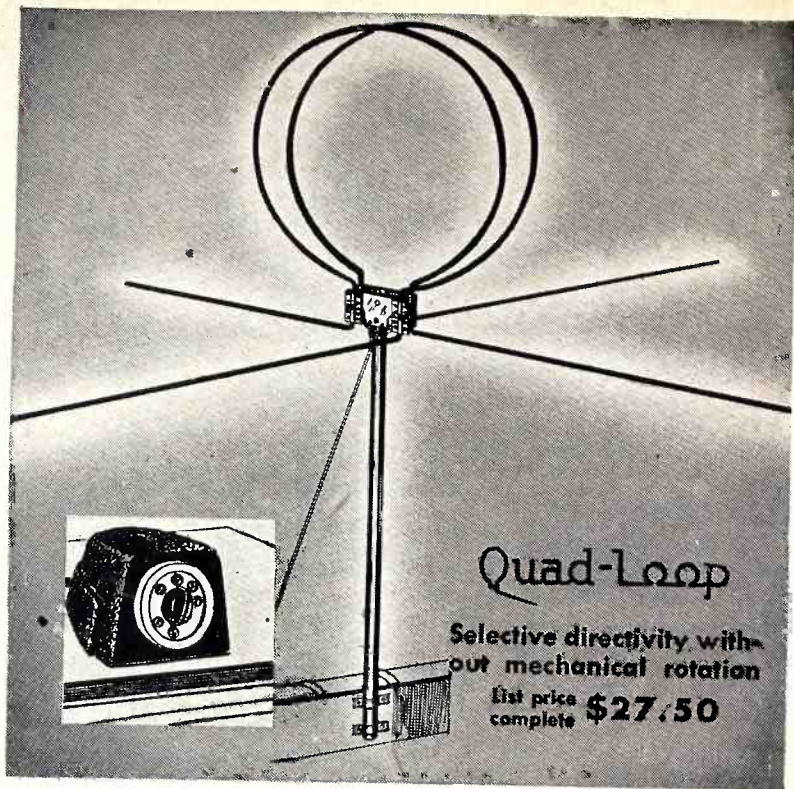

Quad-Loop

Selective directivity with-
out mechanical rotation

List price complete **\$27.50**

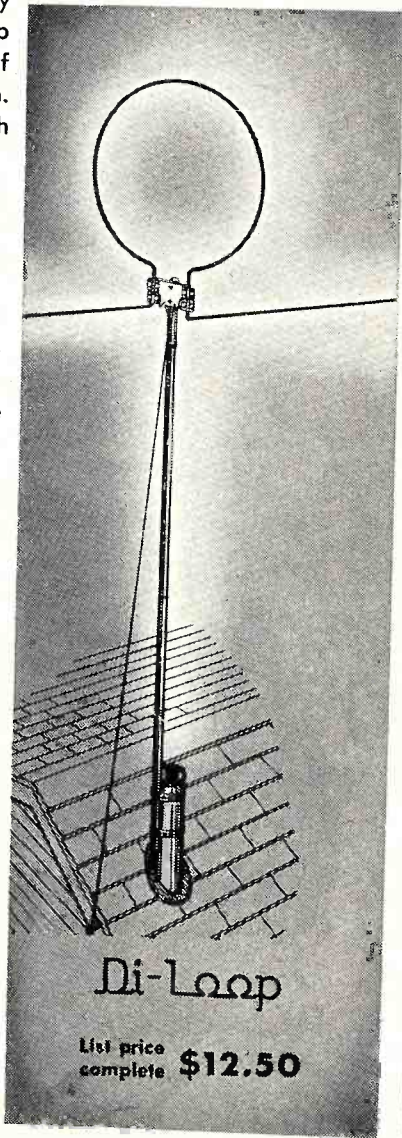

Di-Loop

List price complete **\$12.50**

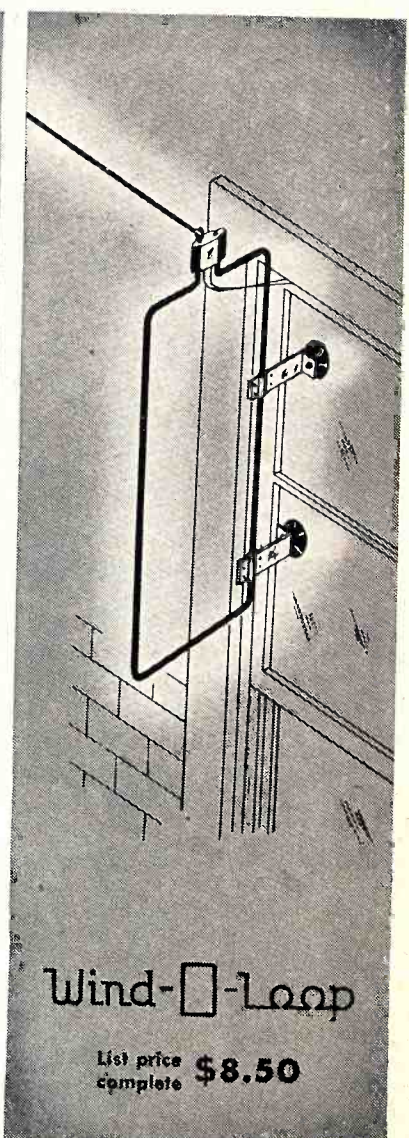

Wind-□-Loop

List price complete **\$8.50**

"KEN-RAD TUBES MEAN SATISFIED CUSTOMERS— INCREASED BUSINESS!"



H. A. GEORGE, Carr Radio & Appliance Store, 7604 South Cottage Grove, Chicago, Illinois, is another serviceman who knows by experience that Ken-Rad Tubes are fast, dependable sellers.

"We've sold a lot of Ken-Rad Tubes in our shop through the years, so I know what I'm talking about.

"Believe me, Ken-Rad Tubes have what it takes to keep customers satisfied. A satisfied customer is a steady customer—and steady customers mean faster turnover, more money in the till.

"There's no substitute for quality—that means there's no substitute for Ken-Rad Tubes!"

"KEN-RAD TUBES ARE TESTED OVER AND OVER AGAIN—TO GUARANTEE SATISFACTION!"



ROBERT W. FIELD, Circuit Engineer, is in charge of special stroboscopic vibration test (below). This helps to determine the numerous tests Ken-Rad Tubes must pass before being approved and shipped to dealers.

"From start to finish of production, Ken-Rad Tubes must pass one comprehensive test after another.

"These are based on work such as the special stroboscopic vibration check developed by General Electric engineers.

"Tubes are placed in a special spring-supported socket which is driven from a variable-frequency audio oscillator.

"A stroboscopic light then is used to illuminate the tube while it is studied for vibrating elements or loose parts under a high-power microscope.

"No wonder Ken-Rad Tubes satisfy customers!"

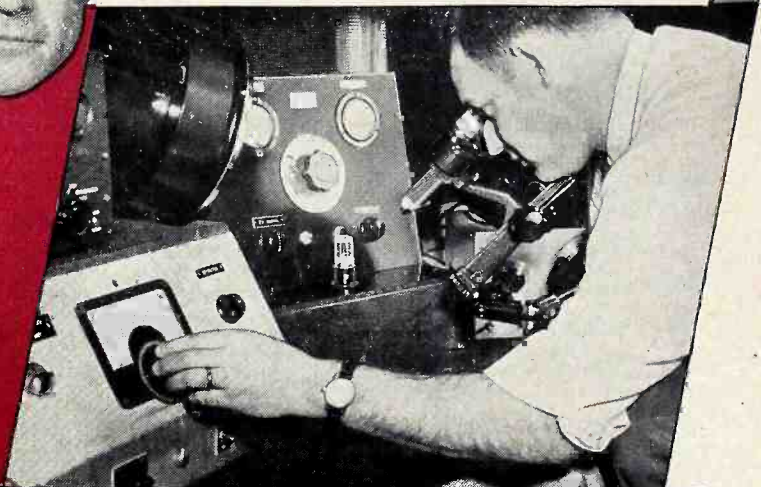

THE SERVICEMAN'S TUBE

... backed by profit-making sales aids which your Ken-Rad distributor gladly will show you. Phone or write him today!

KEN-RAD *Radio Tubes*

PRODUCT OF GENERAL ELECTRIC COMPANY

Schenectady 5, New York

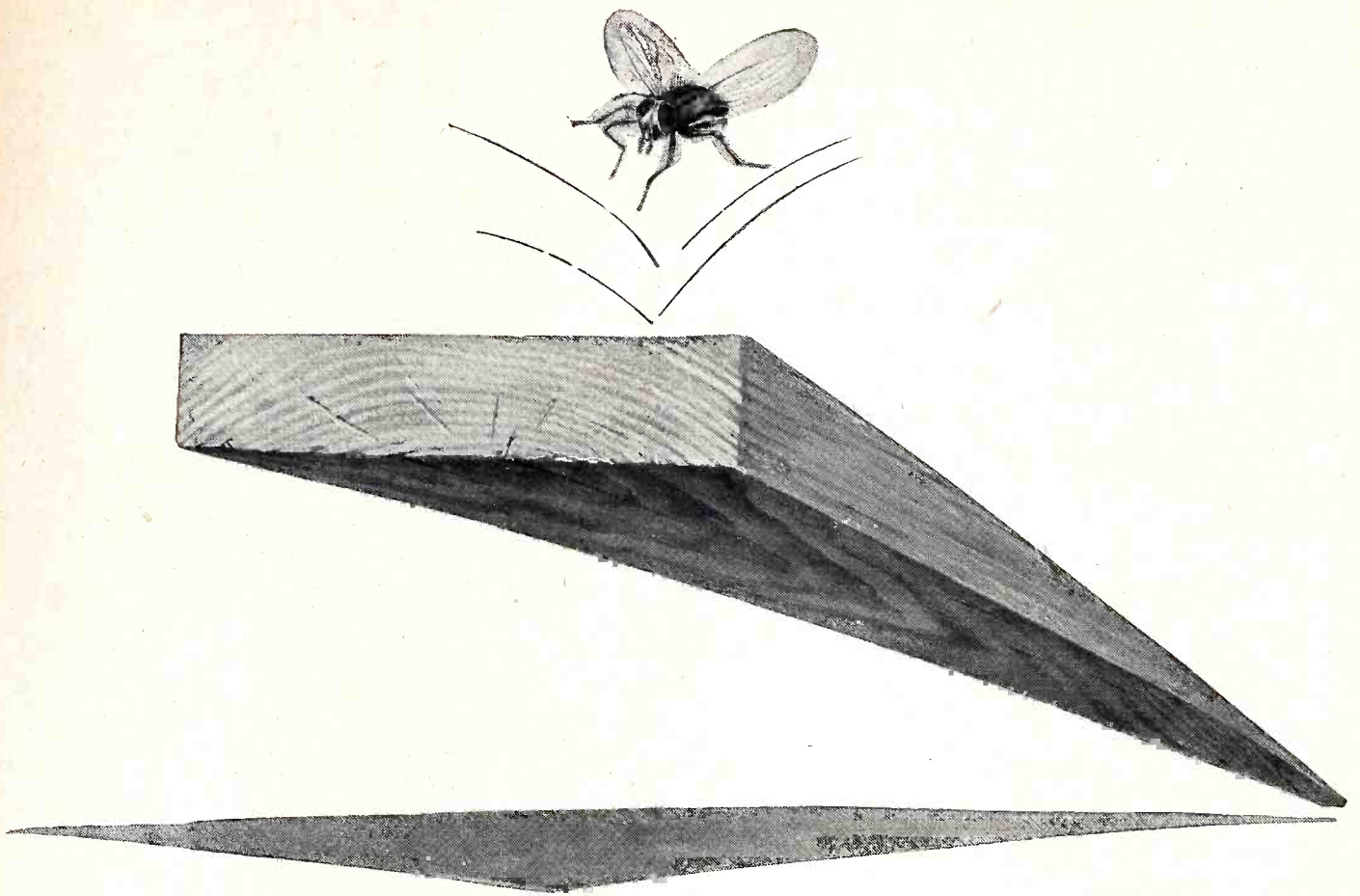

Supersensitive electron tube, developed by RCA, makes possible more accurate measurement of minute vibrations.

Can a housefly make a board bounce?

Surprising though it seems, a fly—when it lands on a board—causes distinct vibrations. They can be detected by a remarkable new RCA electron tube.

Slimmer than a cigarette, and only half as long, RCA's tube picks up vibrations with a pin-sized shaft—and these vibrations may then be converted to visible or audible signals. More important, the new tube can be used to make measurements of the degree of vibration.

Scientists predict many practical uses for this *electronic transducer*. Airplane designers can hitch it to engines or whirling propellers and locate vibrations which might lead to trouble. Oil men can use it to measure the sound waves with which they scout for oil.

And your smooth-running automobile of the future may be an even better car when the facts gathered by RCA's new tube are put to work.

Another RCA "first":

This, the first electronic transducer, is only one research achievement pioneered at RCA Laboratories. Such leadership in science and engineering adds *value beyond price* to any product or service of RCA and RCA Victor.

Examples of the newest developments in radio, television and electronics can be seen at RCA Exhibition Hall, 36 West 49th St., N. Y. Admission is free. Radio Corporation of America, Radio City, N. Y. 20.



RADIO CORPORATION of AMERICA
World Leader in Radio — First in Television

Newest LYTE Sensation... **INSTANTENNA!** ...for *speediest* antenna installation!

No more time-wasting assembly of small parts! With Lyte's larger, pre-assembled units set-up time is reduced 75% !!!

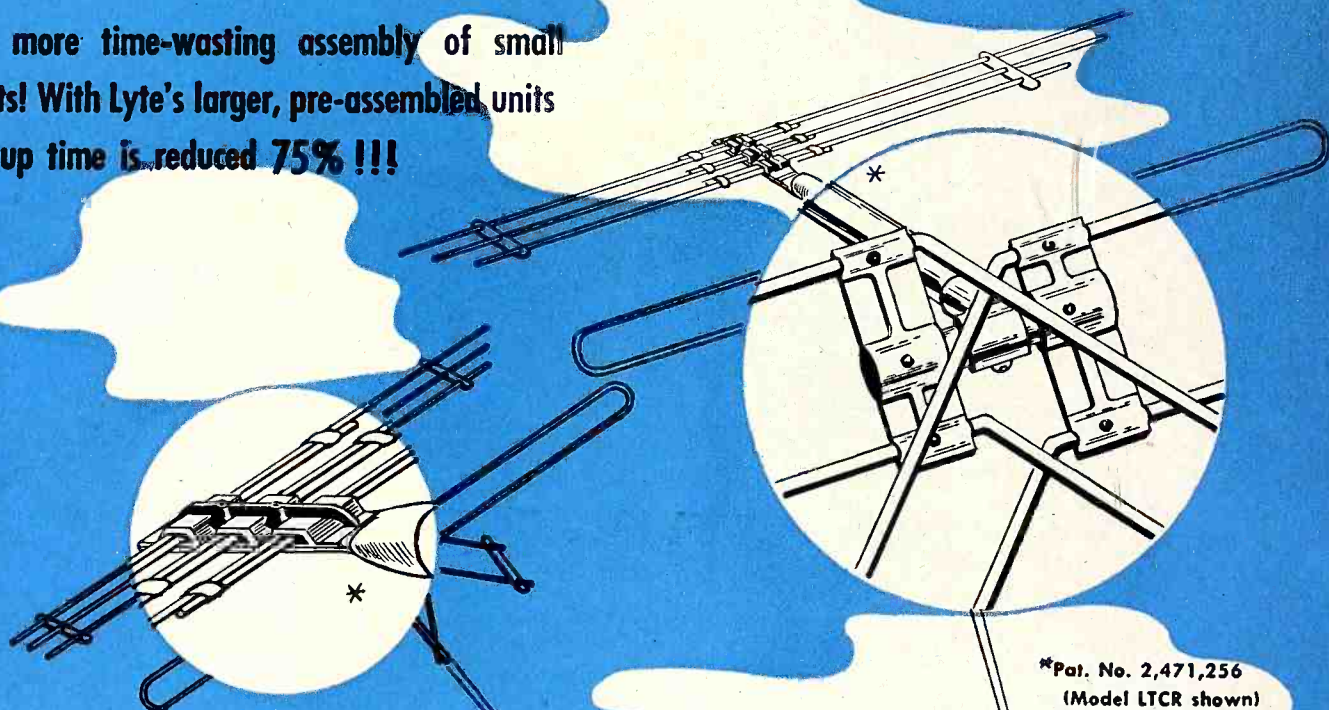

*Pat. No. 2,471,256
(Model LTCR shown)

The same Lyte dependability and performance PLUS faster, easier installation than ever before — that's INSTANTENNA!

Reflector elements (inset, left above) are installed simply by extending the poles to predetermined lengths, and tightening two bolts: Proper overlap is allowed for sufficient structural strength.

Antenna elements (inset, right above) become a part of the array ready for attaching to the unit by inserting and tightening two more bolts which also serve as lead-in terminals. Improved spacing of antenna and reflector eliminates matching stub.

Lyte INSTANTENNAS incorporate all the proved Lyte engineering features for 100% clearer, sharper, brighter pictures.

DISTRIBUTORS—DEALERS: Some protected territories are still open for Lyte INSTANTENNAS and SKY TUNER, the perfected antenna rotator. Don't miss the opportunity to profit with Lyte by merchandising the best. All Lyte products are fully guaranteed and backed by national advertising. A post card will bring full particulars without obligation.

LYTE PARTS CO.

11 Washington Ave.
Plainfield, New Jersey

195 Main Street
Dubuque, Iowa

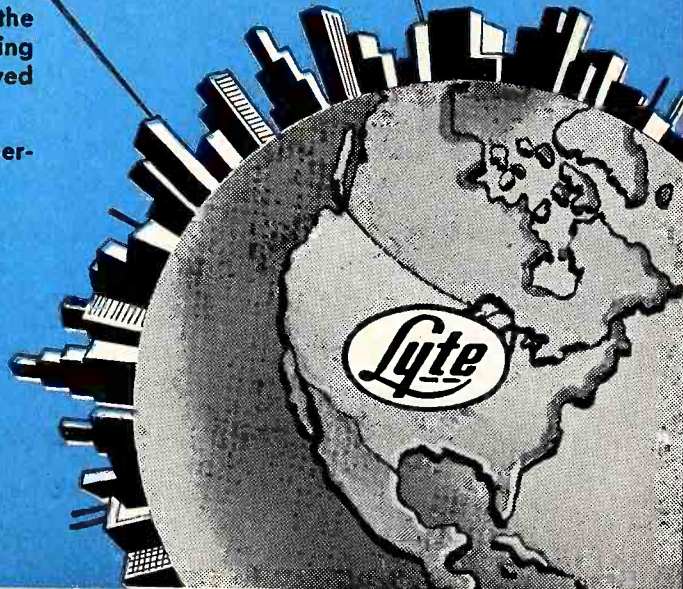

FADA TELEVISION

provides the surest, quickest way to capture your big share of this rapidly expanding market.

Why Fada?

BECAUSE:

Of superb custom quality cabinetry unsurpassed in the Television industry.

Of incomparable fringe area performance proved by test to be unequalled.

Of peerless FADA engineering "Know How" built into every Television model, experience gained through many years of producing quality electronic products.

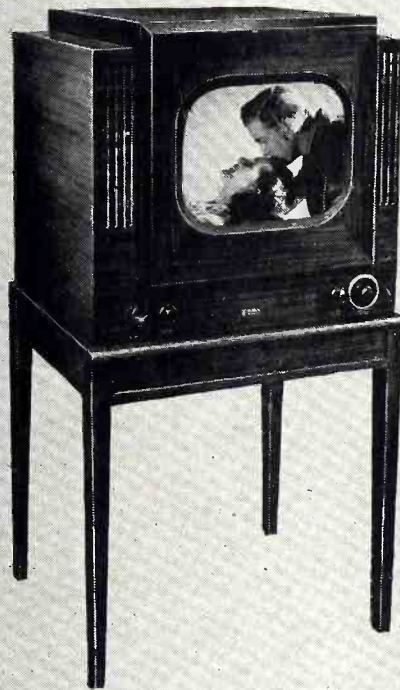

Matching Consolette tables available

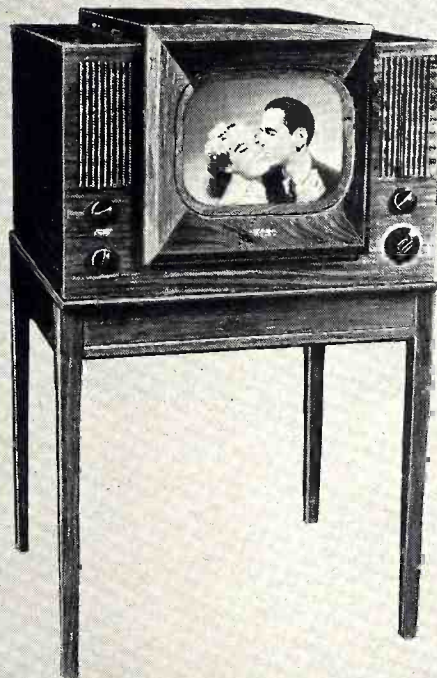

• MODEL 925 •

16 INCH

Direct View Picture

126 Sq. In. Viewing Area

Fada's own revolutionary 'Dual Sensitive-Tone' three dimensional sound system in acoustic chambers provides big concert tone quality miracle sound reproduction. Television's greatest performer in Local and Fringe areas. In genuine Mahogany, Walnut, Bleached Blonde Mahogany or Limed Oak veneer cabinets.

• MODEL 930 •

12½ INCH

Direct View Picture

72 Sq. In. Viewing Area

Proved to be the ultimate in performance in Fringe areas, it brings clear, steady, flickerless, brilliant pictures even in bright daylight. Big concert quality is provided by Fada's miracle 'Dual Sensitive-Tone' Sound system. Classic cabinets of genuine Mahogany, Walnut, Bleached Blonde Mahogany or Limed Oak veneer.

"Pioneers in Radio & Electronics Since 1920"

FADA RADIO & ELECTRIC CO., INC., BELLEVILLE, NEW JERSEY

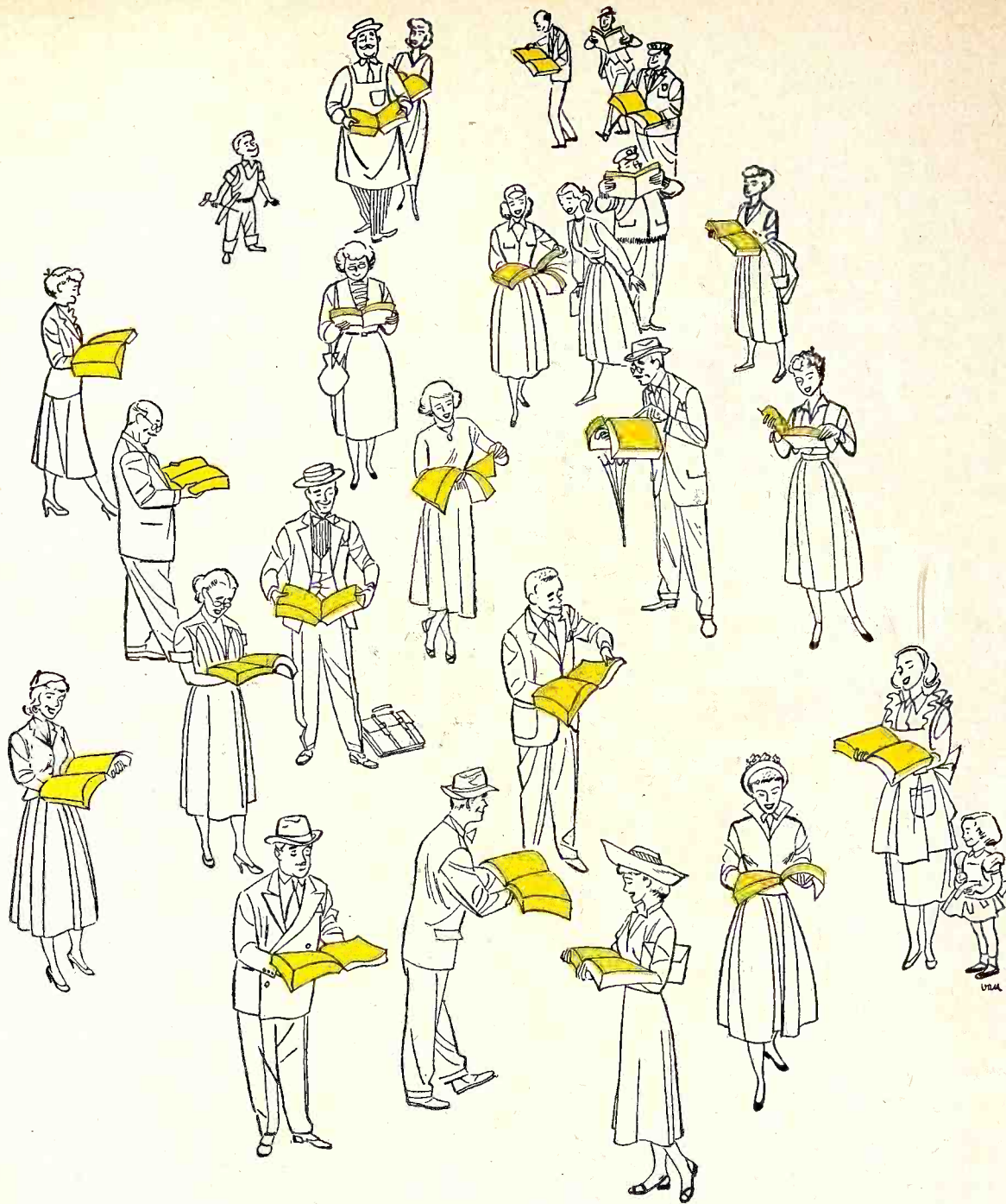

A "Best Seller"... in your town

...that leads buyers right to you

'Yellow pages' in homes... in offices... at the corner drug store. People everywhere use the 'yellow pages' of the telephone directory as a *buying guide*.

You can feature *your* name in those 'yellow pages.' You can have

it listed under every important product you sell. In that way you'll be reaching shoppers just when they're ready to buy.

Why not put this important selling tool to work for you? Call your local telephone office today.



AMERICA'S
BUYING
GUIDE FOR
60 YEARS.



f e d e r a l
TELEVISION
CORPORATION

Trade Mark

your MODERN MIRACLE TELEVISION line!

REVOLUTIONARY — 3 MAGIC DIALS TO PERFECT PERFORMANCE

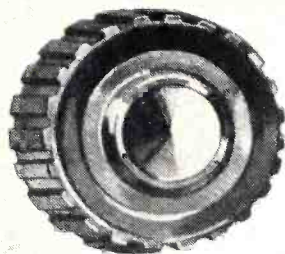

STATION SELECTOR
Just a turn for accurate tuning



VOLUME CONTROL
Unusual clarity of sound



PICTURE CONTROL
Bright, clear, sharp pictures

"THE PAGODA," in ebony with Chinese hand-decorated gold embossing. 12½" picture. FM receiver. Table included.

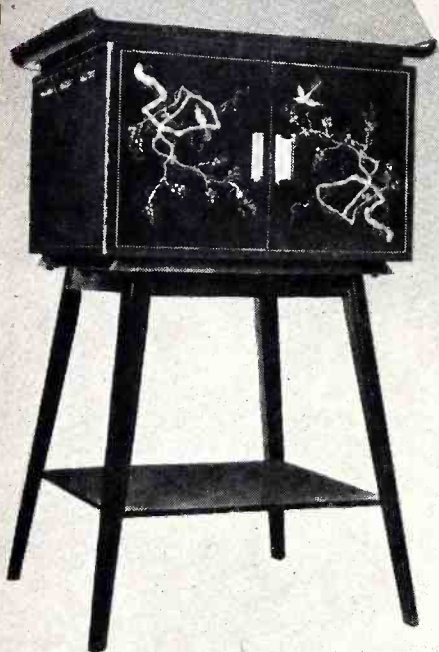

"THE MAYFAIR," in Korona woods or rich mahogany. 12½" screen... 3-speed record changer... 12" concert speaker. FM receiver. Liberal album space.

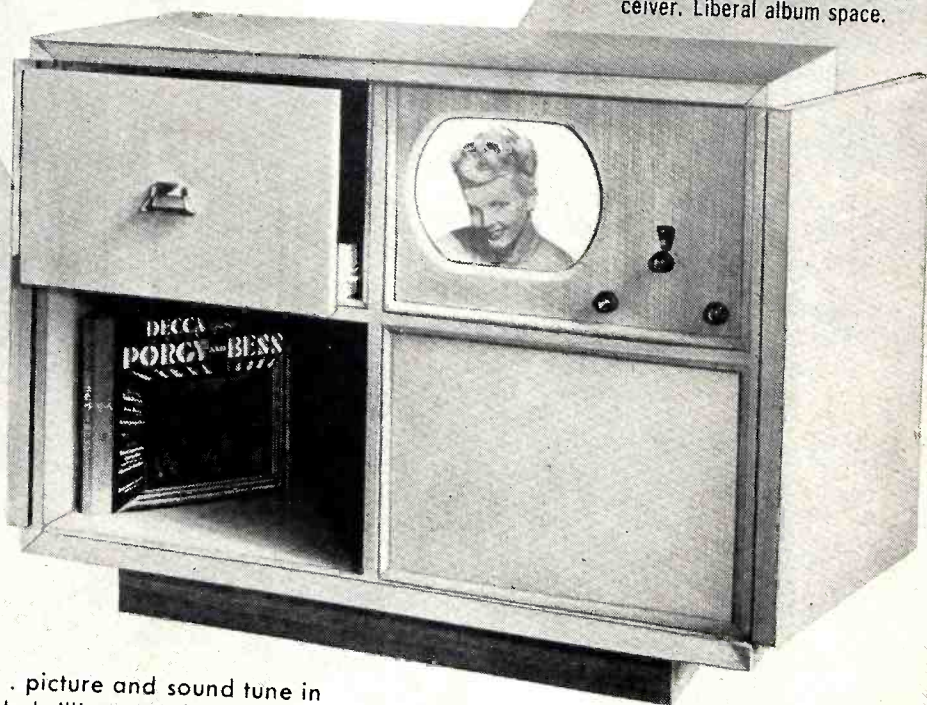

One easy turn of the dial and presto . . . picture and sound tune in simultaneously! No vertical, horizontal, brilliance or focus control! Remarkably brilliant and "flicker-free" pictures . . . amazingly sharp details . . . wonderfully clear reception. That is the miracle of Federal Television . . . so simple a child can operate it!

OTHER OUTSTANDING FEDERAL TELEVISION FEATURES

- DISTINCTIVE STYLING!
- TELEVISION SCREENS 12½ INCHES AND UP!
- POWERFUL NEW CIRCUITS!
- AUTOMATIC GAIN CONTROL!
- FULL CHANNEL COVERAGE!
- AUTOMATIC PICTURE LOCK!

All Federal Television Receivers carry a "slave" unit receptacle which enables viewing programs in more than one part of the house—or outside the house—at the same time. All table models are equipped with phonograph receptacles, too!

**HERE'S YOUR 1950 LINE NOW!
SLATED TO BE YOUR BIGGEST SELLER TODAY!**

CHOICE TERRITORIES AVAILABLE!
WRITE, WIRE OR PHONE DEPT. 6F FOR DETAILS!

f e d e r a l
TELEVISION
CORPORATION

T.M.

137-9-41 DUANE ST. • NEW YORK 13 • FACTORIES: NEW YORK • CONNECTICUT

Walco

startles the Industry
with the Greatest
Money-maker of all!

New TELE-VUE-LENS[®] Line

Patented: U.S. Pat. Off. 2449886

Decorator-Styled... with BUILT-IN

**FILTER
ADAPTER**
including
REMOVABLE
FILTER
AT NO EXTRA COST

● ADJUSTABLE
IN ALL DIRECTIONS

A bigger, brighter sales picture for you is assured, with the smartest money-maker of them all—the new Walco “Decorator Styled” enlarging lenses.

No wonder set owners prefer Walco lenses—they enhance set beauty and assure big-picture perfection. Fits all television cabinets. It's felt-lined for cabinet protection.

Tie-in now, with Walco's intensive national advertising and merchandising programs. Make your television picture even bigger, brighter and more successful from the all-important standpoint—actual sales!



NEW OVERHANG
Feature
NO SCREWS! NO BOLTS!

MODEL 512
7" TUBE
ENLARGER

MODEL 519
7-10" TUBE
ENLARGER

MODEL 529
10-12" TUBE
ENLARGER

MODEL 539
10-12" TUBE
DE LUXE ENLARGER

Walco
TELE-VUE-FILTER

easy to insert
or remove

DISTRIBUTORS!
FACTORY REPRESENTATIVES

Come along with the hottest lines in the industry. Good sales areas are open for those who can handle big volume.

Walco INC.

60 FRANKLIN STREET
EAST ORANGE, NEW JERSEY

Walco — manufacturers of standard and micro-groove phonograph needles and a complete line of enlarging lenses, television filters and other television accessories.

as selling gets tough—

QUALITY COUNTS!

sell **MAHOGANY!**



Here we are, smack in the middle of a buyers' market.

And what is a buyers' market? A time when customers get more quality for their money—or they don't buy!

In furniture, quality and Mahogany are one—and your customers know it. All their lives, they've associated Mahogany with good taste . . . gracious living . . . a mark of distinction in their homes. And now, with the buyers' market, they mean to have it!

Happily, you have the means to bring it to them—genuine Mahogany is now in good supply. And you also have the *ways*—fully explained in your free copy of "Facts to Help You Sell Mahogany" (see below).

Don't let customers go elsewhere for the quality they demand. Sell the best—*sell Mahogany!*

facts to help you

sell **MAHOGANY**

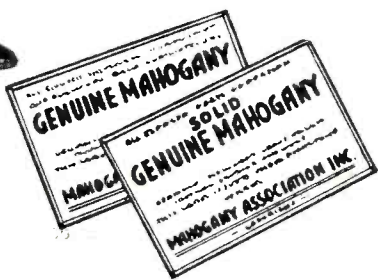

Just as genuine Mahogany is the unquestioned mark of quality, so these labels are the mark of genuine Mahogany. They are issued by The Mahogany Association to protect you and your customers from substitution . . . *to help you sell Mahogany.*



MAHOGANY

ASSOCIATION, INC.

Suite 803-C, 75 East Wacker Drive Chicago 1, Illinois

"AFTER ALL . . . THERE'S NOTHING LIKE MAHOGANY"

Just issued! This free booklet has all the answers to the questions customers ask—answers that *sell*. Helps you sell period pieces and modern . . . all-Mahogany items . . . veneers . . . plywoods. Tells you what to look for, how to promote it. And besides, this folder is a handy guide to your 7th Edition Mahogany Book. If you don't have the Mahogany Book, write for it. And write today for "Facts to Help You Sell Mahogany."

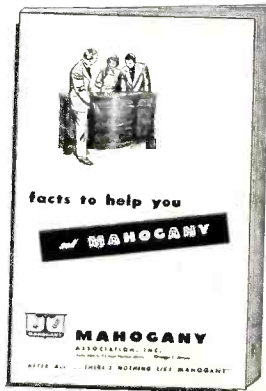

WARD SMASHES TV ANTENNA INSTALLATION COSTS!

IT COSTS ONLY 6c IN LABOR TO ASSEMBLE WARD'S SENSATIONAL MINUTE MAN ANTENNA

(WP) CLEVELAND, OHIO

The Chief Engineer of the Ward Products Corporation states that the new sensational Minute Man antennas are being made of PERMA-TUBE — a newly perfected non-corroding coated steel tubing, created especially for Ward by the Jones and Laughlin Steel Corp., Pittsburgh, Pa. Independent laboratory tests on over 30 metals commonly used for antennas have proved PERMA-TUBE the best for all weather installations. Aluminum is too weak and other types of coated steel corrodes. Ward is the only manufacturer using PERMA-TUBE in constructing antennas. See your Ward Distributor today.



Dick Moss, television engineer, flicks up dipole in assembly operation of Ward Minute Man antennas. (Model TV-46).



A few seconds later and Dick snaps the high frequency dipole into position. It costs only 6c in labor to assemble this Ward Minute Man antenna.

FLASH!

WARD USES PERMA-TUBE IN CONSTRUCTING MINUTE MAN ANTENNAS.

(WP) CLEVELAND, OHIO

The Ward Products Corporation, a Division of the Gabriel Company, disclosed today their new Minute Man line of TV antennas. These 13 antennas, ranging in list prices from \$2.45 to \$49.95 are completely pre-assembled. Where it formerly took two installation men three-quarters of an hour (or approximately \$7.50 in labor) to assemble the ordinary TV antenna, one man can assemble any Ward Minute Man antenna in a few minutes. This is the greatest technical engineering improvement in the antenna field and the Ward engineers are to be congratulated on its achievement. They have spent many months in their laboratory perfecting the many ingenious construction features. See your Ward distributor today.

GREATER INCOMES AND PROFITS REALIZED BY INSTALLING WARD ANTENNAS.

(WP) NEW YORK, N. Y.

Now you can make big money on a standard installation fee. It has been reported that servicemen and retailers are realizing greater profits by installing Ward Minute Man Antennas. The quick 3 minute installation makes the big difference. It means more installations per day and at greater returns. No consumer complaints have been registered by big labor bills. See your Ward distributor today.

**See Your
Ward Distributor
Today**

INTRODUCING WARD'S NEW "MINUTE MAN" TV ANTENNAS

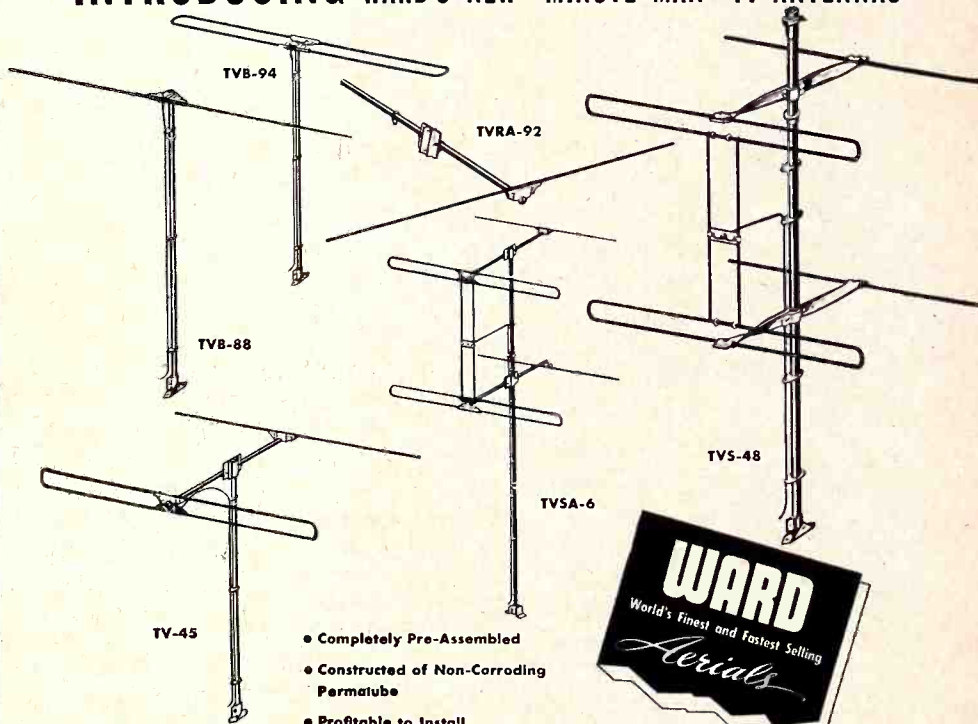

- Completely Pre-Assembled
- Constructed of Non-Corroding Permatube
- Profitable to Install



There are Ward Minute Man Antennas for every purpose and use from any distance from the transmitter. See your distributor today.

as selling gets tough—

QUALITY COUNTS!

sell **MAHOGANY!**



Here we are, smack in the middle of a buyers' market.

And what is a buyers' market? A time when customers get more quality for their money—or they don't buy!

In furniture, quality and Mahogany are one—and your customers know it. All their lives, they've associated Mahogany with good taste . . . gracious living . . . a mark of distinction in their homes. And now, with the buyers' market, they mean to have it!

Happily, you have the means to bring it to them—genuine Mahogany is now in good supply. And you also have the *ways*—fully explained in your free copy of "Facts to Help You Sell Mahogany" (see below).

Don't let customers go elsewhere for the quality they demand. Sell the best—*sell Mahogany!*

facts to help you

sell **MAHOGANY**



Just as genuine Mahogany is the unquestioned mark of quality, so these labels are the mark of genuine Mahogany. They are issued by The Mahogany Association to protect you and your customers from substitution . . . *to help you sell Mahogany.*



MAHOGANY

ASSOCIATION, INC.

Suite 803-C, 75 East Wacker Drive Chicago 1, Illinois

Just issued! This free booklet has all the answers to the questions customers ask—answers that sell. Helps you sell period pieces and modern . . . all-Mahogany items . . . veneers . . . plywoods. Tells you what to look for, how to promote it. And besides, this folder is a handy guide to your 7th Edition Mahogany Book. If you don't have the Mahogany Book, write for it. And write today for "Facts to Help You Sell Mahogany."

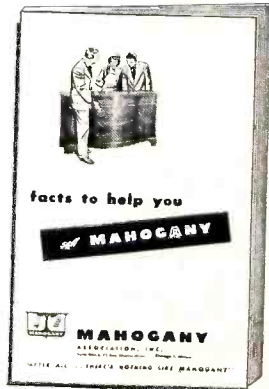

"AFTER ALL . . . THERE'S NOTHING LIKE MAHOGANY"

WARD SMASHES TV ANTENNA INSTALLATION COSTS!

IT COSTS ONLY 6c IN LABOR TO ASSEMBLE WARD'S SENSATIONAL MINUTE MAN ANTENNA

(WP) CLEVELAND, OHIO

The Chief Engineer of the Ward Products Corporation states that the new sensational Minute Man antennas are being made of PERMA-TUBE — a newly perfected non-corroding coated steel tubing, created especially for Ward by the Jones and Laughlin Steel Corp., Pittsburgh, Pa. Independent laboratory tests on over 30 metals commonly used for antennas have proved PERMA-TUBE the best for all weather installations. Aluminum is too weak and other types of coated steel corrodes. Ward is the only manufacturer using PERMA-TUBE in constructing antennas. See your Ward Distributor today.



Dick Moss, television engineer, flicks up dipole in assembly operation of Ward Minute Man antennas. (Model TV-46).



A few seconds later and Dick snaps the high frequency dipole into position. It costs only 6c in labor to assemble this Ward Minute Man antenna.

FLASH!

WARD USES PERMA-TUBE IN CONSTRUCTING MINUTE MAN ANTENNAS.

(WP) CLEVELAND, OHIO

The Ward Products Corporation, a Division of the Gabriel Company, disclosed today their new Minute Man line of TV antennas. These 13 antennas, ranging in list prices from \$2.45 to \$49.95 are completely pre-assembled. Where it formerly took two installation men three-quarters of an hour (or approximately \$7.50 in labor) to assemble the ordinary TV antenna, one man can assemble any Ward Minute Man antenna in a few minutes. This is the greatest technical engineering improvement in the antenna field and the Ward engineers are to be congratulated on its achievement. They have spent many months in their laboratory perfecting the many ingenious construction features. See your Ward distributor today.

GREATER INCOMES AND PROFITS REALIZED BY INSTALLING WARD ANTENNAS.

(WP) NEW YORK, N. Y.

Now you can make big money on a standard installation fee. It has been reported that servicemen and retailors are realizing greater profits by installing Ward Minute Man Antennas. The quick 3 minute installation makes the big difference. It means more installations per day and at greater returns. No consumer complaints have been registered by big labor bills. See your Ward distributor today.

**See Your
Ward Distributor
Today**

INTRODUCING WARD'S NEW "MINUTE MAN" TV ANTENNAS

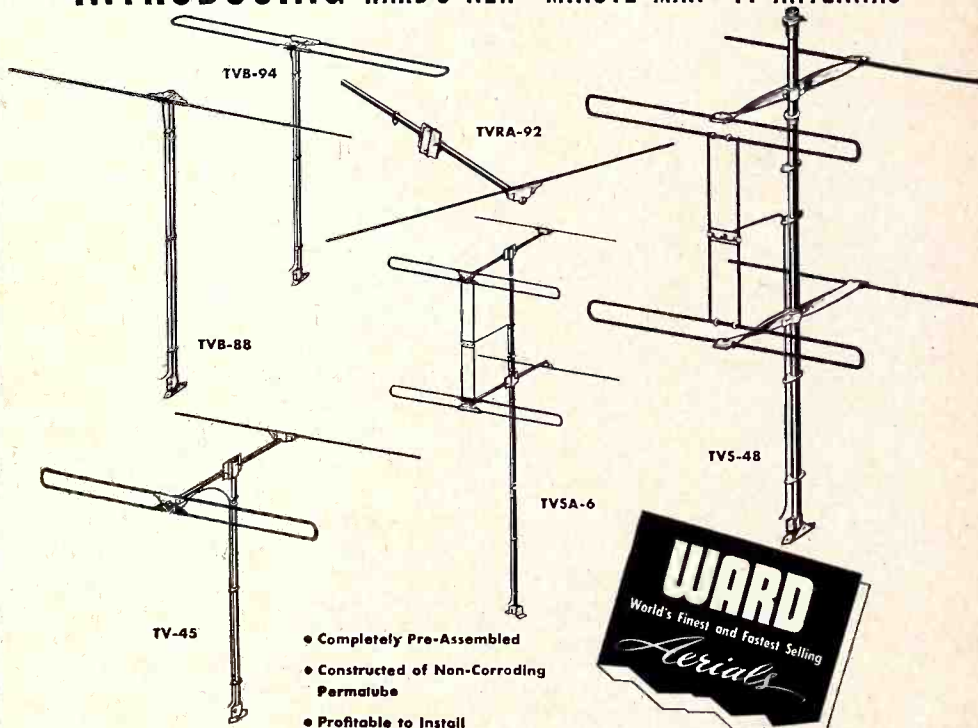

- Completely Pre-Assembled
- Constructed of Non-Corroding Permatube
- Profitable to Install



There are Ward Minute Man Antennas for every purpose and use from any distance from the transmitter. See your distributor today.

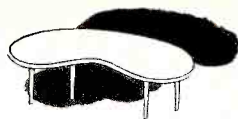
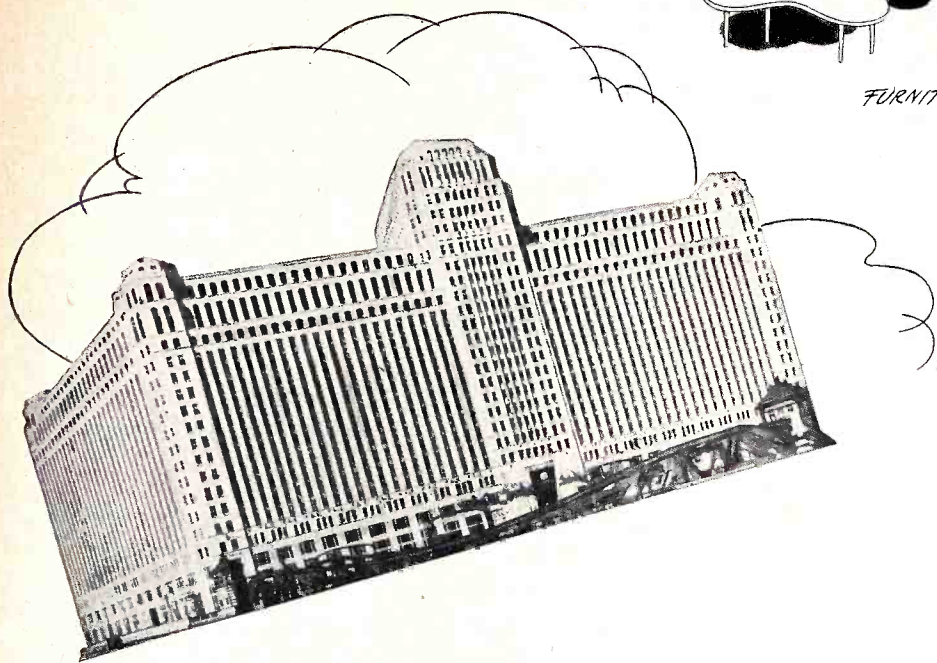

FURNITURE.

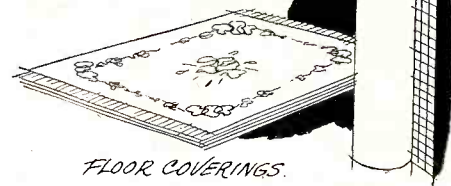
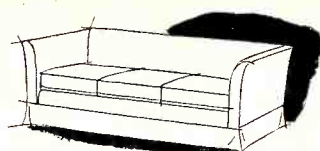

FLOOR COVERINGS.



CHINA, GLASS AND POTTERY.

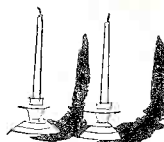

GIFTWARES.

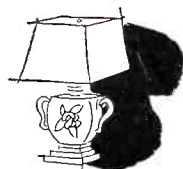

LAMPS AND SHADES.

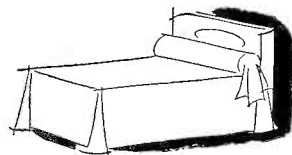

BEDS AND BEDDING.

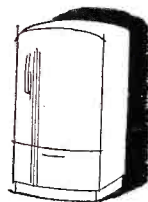

MAJOR APPLIANCES.



LINENS AND DOMESTICS.

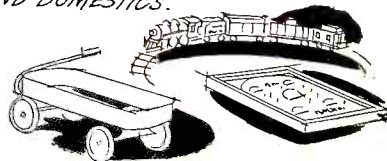

TOYS, GAMES AND WHEEL GOODS.



HOUSEWARES.

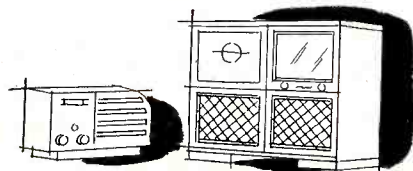

RADIOS AND TELEVISIONS.

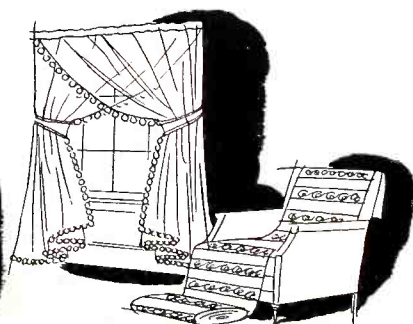

CURTAINS, DRAPERIES AND UPHOLSTERY FABRICS.

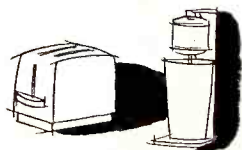

SMALL APPLIANCES.

The
World's Largest
Home Furnishings Show
July 5th to 16th, inclusive

in
**THE
MERCHANDISE
MART**

'WORLD'S GREATEST MARKET CENTER
CHICAGO

announcing...
OUR NEW LINE

Starrett

TELEVISION

Designed for the finest homes



The Cosmopolitan

Entirely new! Twelve 16 inch tube models all for immediate delivery

Breathtaking in their majestic beauty . . . engineering perfection achieved . . . these new Starrett models offer a higher standard of television performance. Decorator inspired cabinets . . . crystal clear pictures (128 square inches of it) makes Starrett the set that distinguishes a home.

NOW . . . PERFECTION IN TELEVISION

Compare! What other TV set has *all* these features?

1. Chassis with full complement of 36-46 tubes in addition to picture tube.
2. New improved super-powered circuits that produce brighter images in all areas.
3. Two speakers — Double audio system for life-like sound reproduction.
4. Craftsmanship in cabinetry that produces fine furniture cabinets of lasting beauty.
5. If you are in a "poor TV zone" or "fringe area" see how Starrett higher voltage sets bring in amazingly clear, bright, steady pictures.

Starrett . . . television's most complete line of 16 inch tube sets . . . twelve outstanding models.

Starrett

Write for the name of your representative.

601 WEST 26th STREET • NEW YORK 1, N. Y.



The Ambassador

"Protected Profits" assured with Starrett's "selected dealer plan." If you are a qualified dealer write today for details.

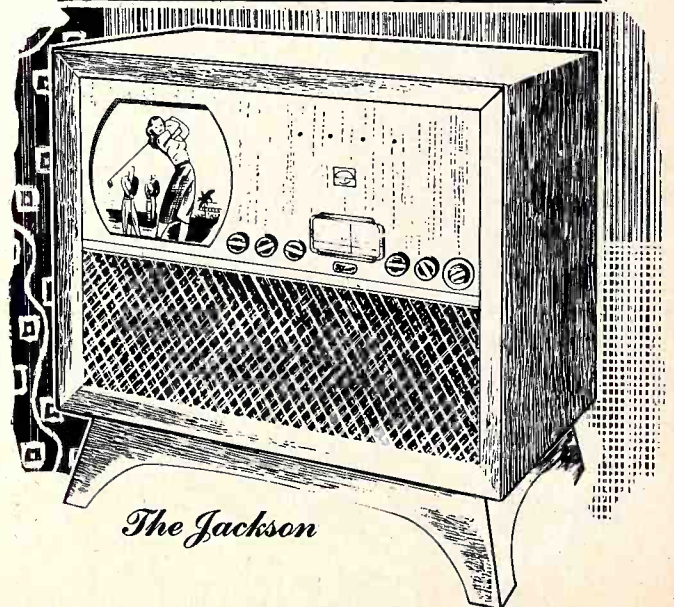

The Jackson



9-409 M
"Family Theatre"

CROSLEY PRODUCTS BUILD...



Bigger profits for you!

Your key to bigger profits lies in Crosley's outstanding new TV line. You'll find yourself selling more enthusiastically when you tell your customers about the value-packed Crosley products. With Crosley's beautiful new styling, precision engineering, and expert craftsmanship, you've got a real competitive advantage. And the sale's already started for you by Crosley's powerful new advertising campaign that hits thousands of prospects right in your own home town.

The sensational new FAMILY THEATRE (pictured above) combines all the big features that mean complete entertainment for the whole fam-

ily. That handsomely styled Carrollton cabinet houses a wealth of sure-fire sales points.

- Steady, true-picture TV on a big 12½" picture tube
- Velvet-toned record player with three different speeds — for standard... long-playing... or the new 45-rpm records.
- All-channel TV with static-free FM sound and a full-range FM radio, too.
- Powerful AM radio

The distinguished new FAMILY THEATRE is just one reason why you help yourself to *bigger profits* when you sell Crosley's full line of *better products for happier living*.



9-420 M
"Good Neighbor"

QUICK PROFIT BUILDER! You'll find that sales come faster—yes, *easier*—when you demonstrate Crosley's beautiful new 10" picture tube TV console. Have your order pad handy, ready to wrap up the sale when you tell prospects about—

- This handsome Carrollton cabinet of rich mahogany veneer
- Bright, clear image, controlled by simplified tuning
- All-channel TV with static-free FM sound and a full-range FM radio, too.

TELL YOUR CUSTOMERS about the sensationally priced new 12½" picture tube TV table model with big expanded picture screen. Here are selling points that will make your cash register ring—

- Large screen, with full 85 square inches of bright, steady image
- Automatic picture synchronizer, with simplified controls... built-in connection for record player
- All-channel TV with static-free FM sound and a full-range FM radio, too.



9-419 M
"Popularity"



9-403 MA
"Good Time"

REAL SALES APPEAL is built in the new low-priced Crosley 10" picture tube TV table model. Satisfied customers praise its many fine features—

- Big screen with unusually bright, steady pictures
- Simplified controls that even a child can operate
- All-channel TV with static-free FM sound and a full-range FM radio, too.

SALES HIT OF THE SEASON is Crosley's new giant screen 16" picture tube TV console! Look at these outstanding selling features—

- Clear, bright pictures on a big 142-square-inch screen
- Special prism tuning viewer and simple controls
- All-channel TV with static-free FM sound and a full-range FM radio, too.
- Quick connection for record player

9-422 M
"Master Showman"



REAL PROFIT OPPORTUNITIES ARE YOURS WITH CROSLLEY!

For full details about *better products for happier living*, get in touch with your nearest Crosley distributor. Or write:

Crosley Division,
Avco Manufacturing Corp.,
1329 Arlington Street,
Cincinnati 25, Ohio

CROSLLEY

Better Products for Happier Living



SHELVADOR* REFRIGERATORS . . . RANGES . . . KITCHEN FREEZERS . . . RADIO PHONOGRAPHS . . . RADIOS . . . TELEVISION

Norelco PROTELGRAM

LIFE-SIZE
MORE
LIFE-LIKE
Television!

from this 2½" tube

Chosen by these famous makers of quality projection TV receivers

**ANSLEY • EMERSON
FADA • FISHER
PILOT • SCOTT
STEWART WARNER
INTERNATIONAL
TELEVISION
BRUNSWICK**

and others soon to be announced

PROTELGRAM is the result of nearly fifteen years of research by the world's greatest electronics laboratories. This scientifically designed, optically correct projection system makes possible, *for the first time*, a *life-size* distortion-free picture of nearly 200 square inches (20" diagonal) ... a more *life-like* picture without glare or eyestrain. And from a tiny long-life, low-cost picture tube!

PROTELGRAM-equipped sets provide your finest profit opportunity for 1949 because they offer your customers what they want—a bigger, clearer picture that is easier on the eyes. Get the facts *today* from the above manufacturers on the outstanding sales and profit advantages of their PROTELGRAM-equipped receivers. Or write to Dept. PE-6, North American Philips Company, Inc., 100 East 42nd St., New York 17, N. Y.



PROTELGRAM

for
life-size,
more
life-like
television



An Exclusive Development of

NORTH AMERICAN PHILIPS

RADIO & TELEVISION RETAILING

Including "Radio & Television"
and "Radio & Television Today"

Established in 1922
as ELECTRICAL RETAILING

O. H. CALDWELL, Editorial Director



M. CLEMENTS, Publisher

Today's Customer **MUST BE SOLD**

There's no denying the fact that retail sales are tightening up. People are no longer *asking to buy*. Instead, they *are asking to be sold*. High living costs are making consumers extremely cautious. Today's customer must be convinced that the product is worth the price asked; that he needs it now, and hence is justified in purchasing it.

Because of this more or less abrupt change in buying habits, too many merchants are crying the blues. Too many are saying that business is shot to the nether regions. Instead of gearing up to meet present conditions via stepped-up sales effort, some dealers are trying to stimulate sales by cutting prices, a dangerous procedure in these days of short discounts and increased operating costs.

Those retailers who face the present situation *realistically* and *optimistically* can do a bigger volume of business in '49 than they've ever done before.

Realistically, they need to face the fact that sales transactions come harder these days. Would-be buyers need to be convinced through good salesmanship. Names of store visitors must be obtained. Interested prospective buyers need to be followed up. Evening calls will have to be made. Those who say they cannot afford to lay out cash should be offered time-payment facilities.

Optimistically, the merchant must sell himself that business can be good—very good—if he *goes after it* hammer-and-tongs. Look at it this way: In the "good old days" before the War, things were really tough! During and immediately after the War, sales were push-overs, but dealers had all sorts of headaches trying to get merchandise, and trying to keep their customers happy.

Now, however, we're settling away to an era of *enormous potential business*. We have the *products*, the *prospects* and the *buying power*. We have all of the things we've hoped for.

From here on, it's up to us to capitalize on our present opportunities through the same type of aggressive action we were once *forced* to employ, "strictly from hunger!"

What's Ahead!—in Radio,

FROM HERE ON, LOOK FOR FEWER announcements of price reductions by manufacturers on existing electrical appliance models, though there will undoubtedly be numbers of new models brought out at comparatively lower prices.

EVEN IN CUT-PRICE STORES, very few installment buyers are asking for anything "off" these days. By and large, only the cash-buyer is permitted to indulge in chiseling.

VERY DEFINITE TREND TOWARD smaller size portable radios, with manufacturers taking advantage of newly-designed, more compact radio batteries for carry-about sets.

FURTHER RELAXATION OF REGULATION *W. Federal Reserve System's new terms: Maximum maturity 24 months instead of 21 months, and reduction of down payment from 15 to 10 per cent, with articles costing less than \$100 exempted from the scope of the regulation. (Covers radio products and electrical appliances.)*

FARMERS, EYEING FALLING FOOD PRICES and unsettled agricultural legislation conditions, not buying as readily as they used to, dealers are finding out. However, merchants in farming communities don't see any serious decline in farm incomes in the immediate offing. In the meantime, the farm operator's expenses remain high; both for feed and for labor.

COLD TO NY TV SHOW—A meeting of New York representatives of leading television and appliance makers threw cold water on proposal to hold a television show for the public in Grand Central Palace during April, 1950, under auspices of local Electrical Association. Show plans have therefore been dropped for present.

PRACTICE OF SHIPPING TV SETS with picture tube installed seems to be on the increase, with very few ill effects (that is, breakage) noted due to good shock- and vibration-proof mountings. This cuts one step from the installation process, makes possible adjustment of the set at the factory with the picture tube which will be used with it.

NEW TELEVISION STATIONS

Seven new TV stations are scheduled to come on the air this month:

WGAL-TV	Lancaster, Penna.	June 1
WFBM	Indianapolis	June 1
KSL-TV	Salt Lake City	June 1
WKY-TV	Oklahoma City	June 6
WHAM-TV	Rochester, N. Y.	June 11
WCPO-TV	Cincinnati	June 14
WDEL-TV	Wilmington, Del.	June 15

Four stations (WGAL-TV, WKY-TV, WOR-TV, WJAR-TV) had been scheduled earlier but were held up for one reason or another.

HERE'S A SIGNIFICANT TREND IN THE INDUSTRY which may help in a great measure to eliminate dumping and stagnant inventories. Radio and appliance manufacturers are moving faster (even the giants) in gearing production up or down to meet market conditions. That "I'll-make-more-than-the-other-fellow-or-bust" attitude appears to be old-hat—and fortunately so.

AN IMPORTANT DATE TO KEEP IN MIND: *The big Music Show to be staged by the National Association of Music Merchants at the Hotel New Yorker, New York, July 25 to 28. Watch for RADIO & TELEVISION RETAILING'S big special show issue!*

TALKS WITH NUMBERS OF DEALERS who modernized their stores disclose the need for long and careful planning of changes and improvements before taking any actual steps. Many a dealer has found that the new lay-out has certain drawbacks which should have been foreseen in the planning stage.

AN AUTOMATIC CLOTHES DRYER, recently announced, is the first major addition to Horton Mfg. Company's home laundry equipment line in more than 25 years.

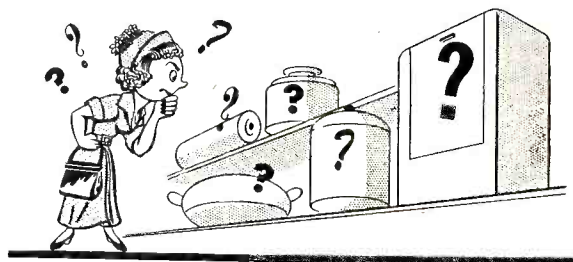

KEEP DESCRIPTIVE MATERIAL BESIDE appliances in show-windows, particularly so far as products most likely to confuse the passerby are concerned. To point out the necessity for such identification, consider the case of the normal, adult consumer who described an unlabelled broiler (with the cover on) as a "hair-dryer"; a hair-dryer as a "paint sprayer"; a midget washer as a "canning kettle", and an electric clothes dryer as a "food freezer." To this woman, a garbage-disposer looked something "like an ice-cream freezer."

TV'S RAPID SELLING PACE being stepped up even faster by baseball. The National Game will make many a public video viewer into a purchaser.

AN ACT TO LICENSE TV SERVICERS has been proposed in the state of Illinois. If passed, the act would provide that licenses be issued only to persons who have attended a school, recognized by the state, covering TV subjects itemized by the state, and lasting at least 36 weeks. The proposed act would make no provision for licensing on the basis of experience.

Appliances, Records and Television

TALKS WITH NUMBERS OF URBAN consumers reveal the need for "missionary" work in selling home freezers. Too many householders look on this appliance as a product for the storing of frozen foods exclusively. It's up to the dealer to correct this impression; to point out the desirability and economy of saving leftovers, freezing fresh products, and preparing whole meals in advance. Many manufacturers have figures available to prove that a food freezer can be made to pay for itself in a very short time.

SOME BIG-CITY DEALERS are selling numbers of refrigerators to apartment occupants who, because of the still acute housing situation are unable to get landlords to buy new equipment. Since many of the renters in multi-dwellings consider themselves to be in temporary quarters, they're willing to buy refrigerators to move to the "dream home" in their futures.

"AMONG THE SALVAGED VALUES FROM the great war effort is the higher standard of quality for radio components. In our war contracts we were obliged to meet what seemed mighty tough specifications . . . And in doing so, many component manufacturers got into the habit of turning out far better components than those of prewar standards . . . We have kept right on turning out these war-standard components which have become regular standard trade items."—Charley Golenpaul, of Aerovox.

CITIZENS RADIO NOW FULL-FLEDGED SERVICE. Rules for the licensing of Citizens Radio Service stations on a regular basis, proposed and issued by the FCC in August, 1948, were adopted as final and became effective June 1, 1949. Licenses issued heretofore were under the Commission's experimental rules. Under the new rules, licensing has been simplified, and persons desiring to operate type-approved transmitting equipment may submit application on a single card form. Citizens Radio Service is designed primarily to afford a two-way, short-range, private (that is, non-commercial) communication service in the 460-470 megacycle band.

FREE SERVICE, SANS SALES. The other day we saw a radio dealer put a new plug on the service cord of a battered table model set, returning it in a matter of minutes to the good customer, without charge. Such free service may be good business under certain circumstances, but it seemed to be a most opportune occasion for the merchant to have offered a trade-in on one of the many new table models he had in stock.



AN IMPORTANT DATE TO KEEP IN MIND: The big Music Show to be staged by the National Association of Music Merchants at the Hotel New Yorker, New York, July 25 to 28. Watch for RADIO & TELEVISION RETAILING'S big special show issue!

IN A LETTER TO ITS DEALERS, Allen B. DuMont Laboratories, Inc., comments on price-cutting and transshipment with the announcement that it has again taken on a "shopping service" and will "deal summarily with any dealer found guilty" of such practices. The letter is signed by E. A. Marx, general manager of the firm's TV receiver sales division.

"THE BUREAU OF INTERNAL REVENUE may soon issue an announcement that will mean some real folding money for many retailers. It is reported in reliable quarters that the Bureau has decided to grant LIFO retroactive back to 1940 for retailers who choose to use this method of inventory figuring for tax refunds. LIFO is too complicated to explain here, but you know it has to do with last in, first out inventory calculations and means a great deal in tax matters. Some \$500,000,000 in tax refunds may be involved. Appliance dealers have a healthy stake in this decision."—From bulletin issued by The Electric Institute of Washington (D. C.).

FUTURE EVENTS OF INTEREST TO READERS

JUNE 19-24: Store Modernization Show, Grand Central Palace, New York.

JUNE 20-22: American Society of Heating and Ventilating Engineers Semi-Annual Meeting, Hotel Nicolett, Minneapolis.

JUNE 20-24: American Institute of Electrical Engineers, Summer General Meeting, New Ocean House, Swampscott, Mass.

JULY 2-9: New York State Association of Electrical Contractors & Dealers, Inc., Golden Anniversary Convention, Saranac Inn, N. Y.

JULY 25-28: National Association of Music Merchants, Annual Show, Hotel New Yorker, New York City.

AUG. 1-6: Western Summer Market, Western Merchandise Mart, San Francisco.

AUG. 30-SEPT. 1: West Coast Electronics Manufacturers Association 1949 Electronic Exhibit, 1949 IRE Western Regional Convention Civic Center, San Francisco.

SEPT. 26-28: 1949 National Electronics Conference, Edgewater Beach Hotel, Chicago.

SEPT. 30-OCT. 9: National Television & Electrical Living Show, Chicago Coliseum, Chicago.

NOV. 13-18: National Electrical Manufacturers Association, Chalfonte-Haddon Hall, Atlantic City, N. J.

NOV. 14-18: 6th All-Industry Air Conditioning & Refrigeration Exposition, Atlantic City, N. J.

DEC. 4-7: The American Society of Refrigerating Engineers, 45th Annual Meeting, Edgewater Beach Hotel, Chicago.

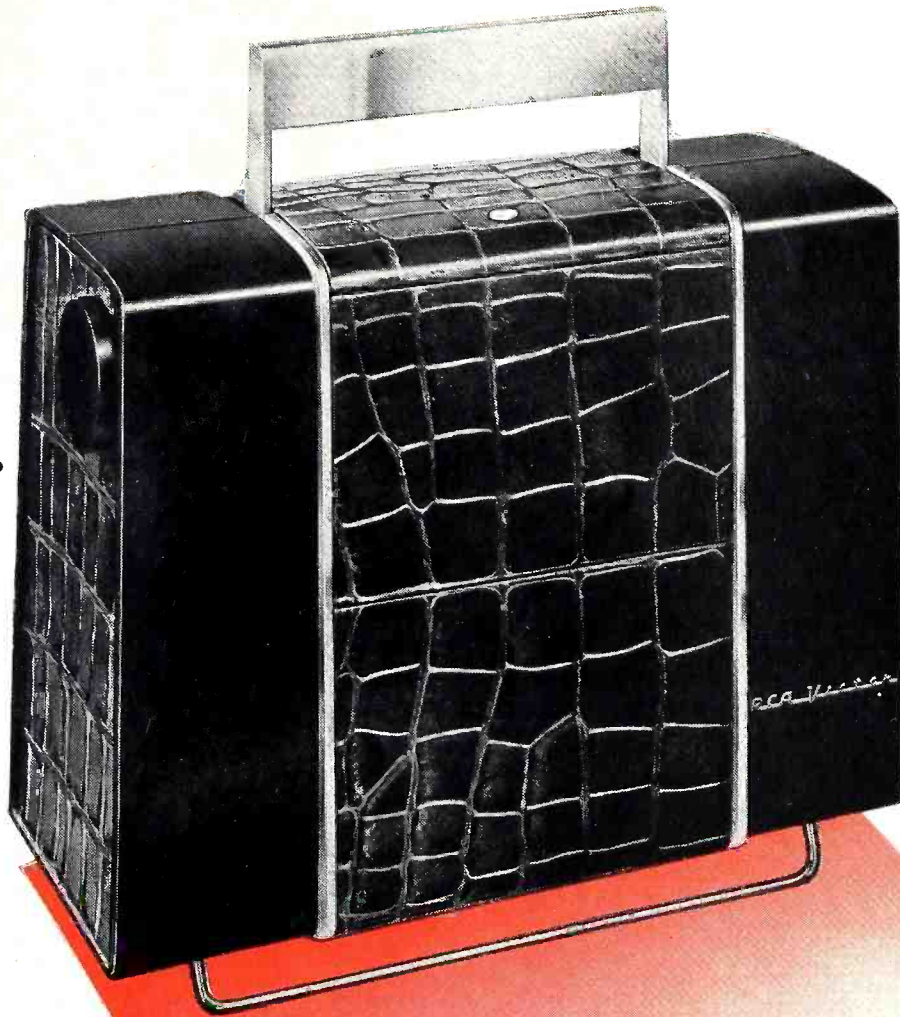

SENSATIONAL NEW INDOOR-OUTDOOR RADIO—9BX56

Your customers will enjoy the quality of tone, unusual beauty, and "different" note of RCA Victor's remarkable new radio. They'll hear their favorite standard programs through the "Golden Throat" on either AC-DC current . . . or with the self-contained battery.

The 9BX56, like all RCA Victor instruments, has faster turnover because it offers your customers highest possible quality at a fair price. Give it a good spot on *your* display floor.

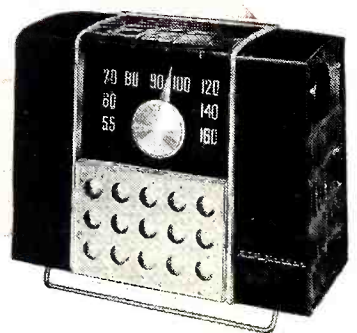

ONLY RCA VICTOR HAS THE "GOLDEN THROAT"

ONLY RCA VICTOR MAKES THE VICTROLA

"Victrola"—T. M. Reg. U. S. Pat. Off.

RCA VICTOR



DIVISION OF RADIO CORPORATION OF AMERICA

RADIO & TELEVISION RETAILING • June, 1949

Here's why your profits are greater with this RCA VICTOR

*Higher quality and outstanding selling points of
ALL RCA VICTOR instruments keep turnover high!*

Talk up these 4 big features for faster 9BX56 summer sales!

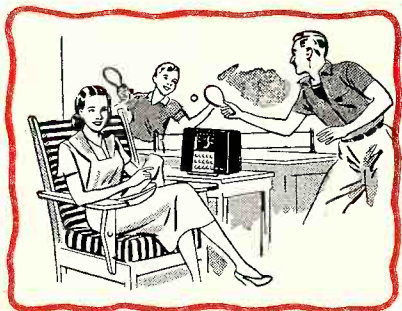

Indoors or Outdoors . . . in the den, on the porch, in the garden. Here's a remarkable table set which plugs in an AC or DC outlet . . . or plays on a self-contained battery.



Plays while it travels . . . from indoors to outdoors, from one table to another. It's a well balanced set for easy carrying—and there are no protruding parts.

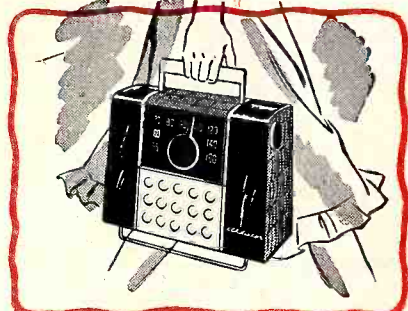

Comfortable Swinging Handle . . . that recesses in the case when the set is not being carried. It's an exceptionally sturdy handle, too—made of gold-colored forged aluminum.

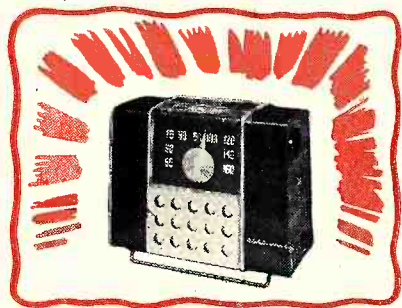

Striking Design . . . with inset case ends and wide center strip in rich simulated alligator plastic. Airplane type dial is concealed by alligator effect plastic drop door. Interior design has gold-colored background.

It's another
example of
RCA Victor
leadership

RCA Victor developed and marketed the *first portable radio*. Then they led the field in the presentation of the *first personal type radio*. Now—RCA Victor is *first again* with a sensational new *indoor-outdoor radio*. Added proof that you'll always be *first* with the RCA Victor line!

*You are cordially invited to visit us at the N. A. M. M. Show
Hotel New Yorker, July 25-28 • East Room and Booths 1, 2 and 3*

RCA VICTOR—World Leader in Radio . . . First in Recorded Music . . . First in Television

What Makes the

A Day in the Life of a High-Pressure Store Operator Furnishes Some Surprising Answers — and a Possible Remedy for Our Number One Evil

• The list-price-minded radio-appliance retailer doesn't give a hoot in the hot-place for news telling him that price-cutting is rampant. He's reminded of the fact that such practices are prevalent every time he picks up the daily newspaper to scan the ads, and every time a would-be purchaser tells him that the product being considered is being currently offered at a lower price at a competitor's.

What he does want to know, though, is the answer to this question: "How can my competitor sell *standard merchandise* at prices that are sometimes lower than my *wholesale cost*?"

And he's not speaking about *distressed* products that have been dumped on the market. He knows all about such merchandise, because he is often able to stock such products himself, but, brother, when the competitor sells, for instance, a current-model, hot-selling television set, or a famous-brand refrigerator at fantastically low prices, the list-price-minded retailer sees red. And, at the same time he cannot for the life of him understand how the competitor can keep on doing such obviously unprofitable business and still *stay in the black*.

Not Done With Mirrors

But the big-time price-cutter seldom offers a deal that's not profitable to his firm, and this in spite of indirect hints to the contrary which he sometimes uses in his ad copy. Actually, the large price-cutting outlet is often able to give "something off" to the cash customer because it has been enabled to do so by a jobber or a manufacturer who has given such outlet a *better deal* than is available to the competitor down the street.

Let's take a look at a hypothetical cut-price dealership to get a better picture of how *preferential* treatment by some suppliers in search of big volume and "prestige" business earn themselves the dubious honor of being one of the outstanding taproots of this ever-present merchandising evils—price-cutting.

The scene is laid in the office of the Big-Shot himself, who puts in long hours and hectic ones as the main wheel of the organization, serving as he does as buyer, sales manager and policy-maker of all the stores. The office is a regular mad-house be-

cause the Big-Shot, whatever else he may be, is anything but a lazy man.

Outside a number of salesmen, representing wholesale houses and manufacturers, are cooling their heels.

As the curtain goes up, we hear Mr. Big-Shot talking, not *with* but *to* a salesman:

Mr. Big-Shot: "Don't make me laugh. I haven't got time. I don't care whether your television set is a big make or not. I've got enough brands now to sink a ship. The point is, what's the best PM?"

The Salesman: "I told you, Mr. Big-Shot, it's . . ."

Mr. Big-Shot: (*interrupting*): "Are you kidding? 28 per-cent! Get out of here!" (*He begins riffling through a mass of papers on his desk.*)

The Salesman: (*Who has been told to land this prestige account or else!*): "Well, we could stretch it a . . ."

Mr. Big-Shot: "Yeah? Now you're beginning to get smart. You know what kind of customers we have. They'll chisel our eyes out and eat them as grapes. If your firm won't give me a break, I can't give the customers one."

Salesman: "But your time-buyers don't ever ask for anything off, and . . ."

Mr. Big-Shot: "Look, I'm getting tired. Sharpen up your pencil and figure forty off or it's no dice!"

Salesman: (*Gulping*): "But . . ."

Mr. Big-Shot: "Forty off or no soap."

Salesman: "Well, if I stretch it to

forty, how many units will you take, and how many models?"

Mr. Big-Shot: "Look. Let's get one thing straight. I don't even want your stuff. I can live without it. You're pressuring me. I'm not pressuring you. I know the set-up. You want your merchandise in my stores."

Salesman: "How about twenty of each model?"

Mr. Big-Shot: (*Assuming a pained, impatient look*): "Don't bother me, will you? Twenty of each model. That's a hundred units. Are you kidding?"

Salesman: "But forty off is for quantity."

Mr. Big-Shot: "One of each."

Salesman: "One of each!"

Mr. Big-Shot: "You heard me. One of each, and I'll see how they go. Just a sample deal."

Salesman: "But twenty-eight off's the deal for less than five."

Mr. Big-Shot: "Don't take up any more of my time, will you? I'm a busy man."

Salesman: "I'll tell you what I'll do. Forty off on one of each TV's and I'll ship you one of each of the radios and combos in the line at forty off, too. The portable's hot as a pistol, and that new combination console is . . ."

Mr. Big-Shot: "Look, junior, I'm not a sucker. I wasn't born yesterday. I wouldn't touch one of your straight sets with a ten-foot pole. And besides, don't you know that assortment deals are unethical? See you again some time." *He picks up phone.*

Mr. Manufacturer — Mr. Wholesaler

Here's one way you can help to do away with Merchandising's Number One Evil—Price-Cutting . . .

Give ALL dealers a fair and square DISCOUNT DEAL. Do away with "preferential" treatment and you'll stop giving the chiseler something to play with.

"Prestige accounts" who are given "breaks" only serve to injure your prestige . . . to hurt the industry as a whole. Policing list-prices is a tough job, but playing fair is a simple remedy.

Price-Cutter Tick?

When the "pet-account" operator gets a better deal, the deck is stacked against his competitor.

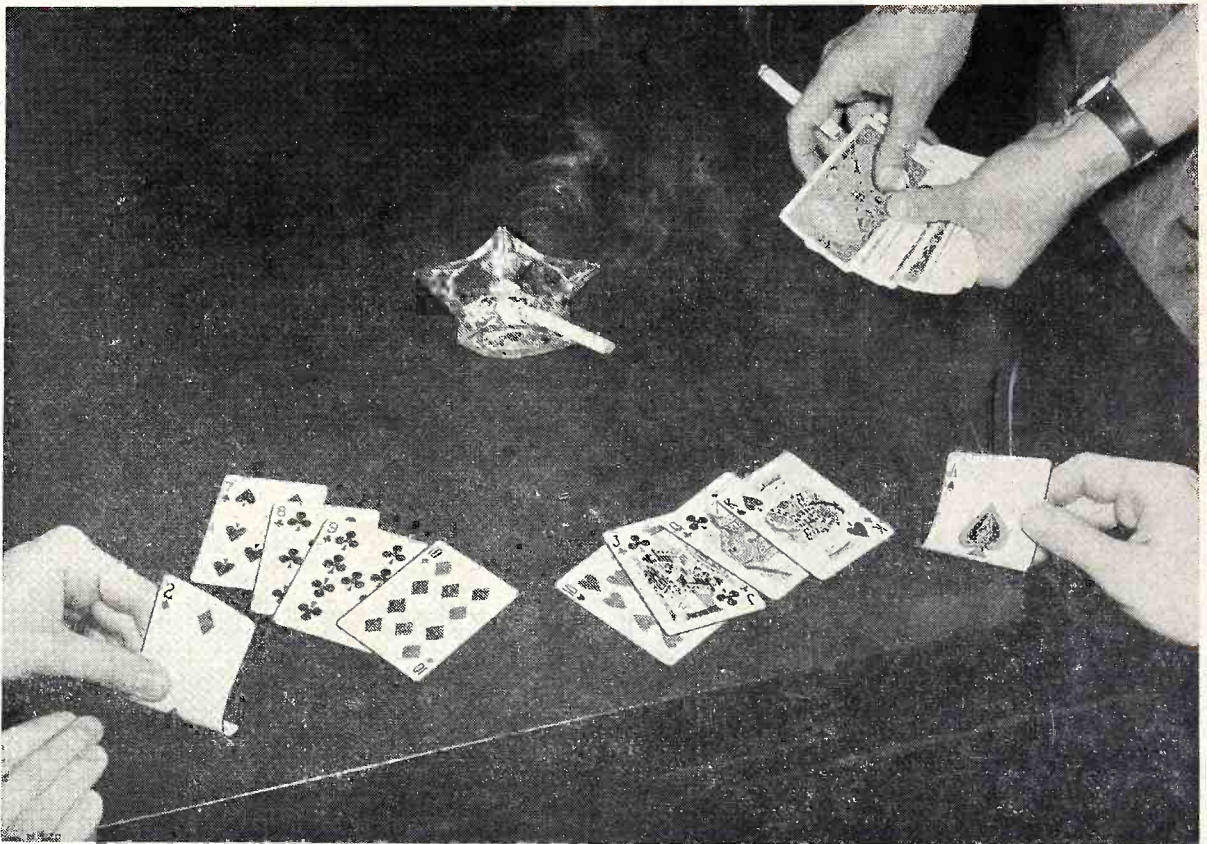

Salesman: "All right, Mr. Big-Shot, one each of the TV sets at forty off, but the JV664547 model is in short supply, and it'll be a couple of weeks before . . ."

Mr. Big-Shot: "I want it along with the other stuff in six days or I'll cancel the order. Tell Mack back at your place. He'll needle the shipment."

Salesman: "Now about the terms."

Mr. Big-Shot: "What's the matter, isn't our credit good?"

Salesman: "Yes, but . . ."

Mr. Big-Shot: "Sixty days, with 2 per cent off."

Salesman: "But, Mr. Big-Shot . . . Mr. Big-Shot . . ."

Mr. Big-Shot: "Take the deal back to your shop. They'll go for it."

Something to "Play With"

After the salesman leaves, Mr. Big-Shot makes a phone call: "Hello, George. Listen, I just took a sample of the XYZ line of TV sets. See how they go, will you. And, listen, George there's a few bucks to play around with in them."

The salesman, experiencing a mixture of emotions, goes back to his office. He feels himself a little "Big-Shot" for having started the line into the big store organization, and at the same time a chump for having given

away his commission. His immediate superior gripes a little over the deal which he describes as "unprofitable," but grudgingly admits that the transaction is an opening wedge.

In the meantime, the little dealer around the corner has a stock of the XYZ sets which he bought at twenty-eight off, plus an "assortment" of the firm's radio models, including two "dogs." Sooner or later, some customer may drop in and spill the bad news that Mr. Big-Shot's store, now well-stocked with XYZ receivers, is offering the TV sets at figures up to twenty off. Such news will surprise Mr. Little Dealer, but disagreeably, and at the same time he will ask himself, "How do they do it?"

Exaggerated? Well, perhaps our little drama concerning a hypothetical store group is a bit on the fantasy side, but there's more than a grain of truth to the picture as a whole.

Price-cutting is merchandising's Number One Evil, and it's high time that we made an honest endeavor to combat it. As will be seen, the preferential deal, motivated by the desire to sell more goods through "prestige" accounts will, if permitted to grow, force many an ethical dealer and distributor out of business, and injure the reputation of numbers of brand names.

It's one thing for the dealer to be able to sell a customer away from a typical back-door discount house where no service is available, but it's getting tougher and tougher for him to cope with the established pet account whose chief customer appeal is the reputation for "low prices," and whose service, we hate to admit, is greatly improved over pre-war days.

It is seemingly impossible for any supplier to enforce his list prices a hundred per cent, but it is within his power to administer his discount rates fairly and squarely on ethical quantity bases so that the chiseler will not have anything to "play with," and the list-priced-minded dealer will not hesitate to plug a brand, and back it with the sort of loyalty that is of inestimable value to the manufacturer and to the industry as a whole.

In survey, made by this magazine, dealers list price-cutting as trade's Number One evil. Read article on page 33.

HOLD

HERE COMES THE MOST
SENSATIONAL NEWS OF ALL
FROM THE PACESETTER
IN TELEVISION VALUE

EVERYTHING

Olympic
Star☆brite TELEVISION

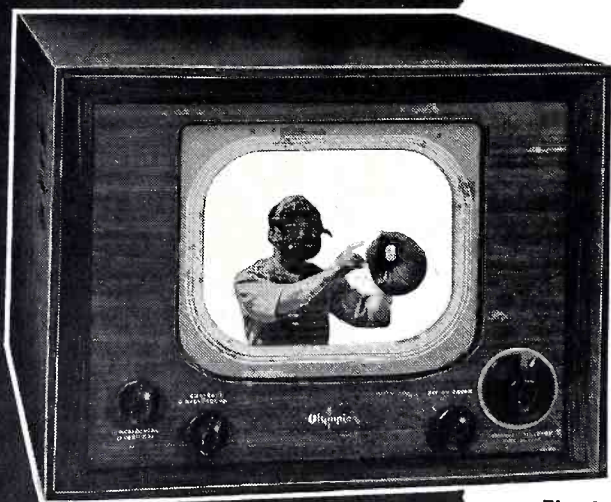

this **BIG 10 INCH PICTURE TUBE**
and this **QUALITY TELETES-
TED CHASSIS**
plus **GENUINE MAHOGANY CABINET**

\$199⁹⁵

AT THIS
RECORD RETAIL LOW

The Challenger TV 106



OLYMPIC
DOES IT AGAIN!
LOWEST PRICE . . . HIGHEST QUALITY

BIG 90 SQ. IN.
"WIDE SCREEN" PICTURE

\$299⁹⁵

AT THIS
RECORD RETAIL LOW



The Champion TV 946

ORDER NOW!

WRITE . . . WIRE . . . PHONE

OLYMPIC RADIO & TELEVISION INC.
34-01 38th Avenue
Long Island City 1, N. Y.

Dealers Hit Price-Cutting

Back-Door Selling, Too Many Dealers, Loose Franchising Policies Cited as Causes

Results of a survey just completed by RADIO & TELEVISION RETAILING on "basic trade evils" reveal that 47%, or almost half of the dealers reporting listed price-cutting as the Number One ill of the industry today.

The greatest number of the respondents cited barefaced (and often advertised) price cuts by dealers, while many listed more subtle or concealed methods—mostly by dealers, some by distributors.

Among the practices complained of are: "Discount clubs," discount cards or "courtesy cards" issued to employes of various companies, factories, GI schools, and building contractors; free installation of television; free service; large trade-ins, especially of radios for TV sets; and direct sales to consumers by distributors.

Gripes about low discounts accounted

for 22% of the replies. A great many attributed price-cutting to this situation, saying that it was not worth while for dealers to handle low-discount items, particularly TV, and therefore they cut price to move this merchandise out of the store.

Eleven per cent of those answering said there are too many dealers, and most stated that this factor (usually described as a loose franchising policy on the part of the distributor) made franchising a joke, price-cutting a necessity.

Distributors Cited

Singled out for emphasis in the "too many dealer" complaints were non-radio type outlets.

Some other "evils" which accounted for sizable responses were directed at the distributor (dumping, tie-in deals,

poor follow up on service) and at the manufacturer (change models too often, sets require too much service, prices too high for quality offered, and sudden price cuts without protection to the dealer).

Many of the dealers who cited price-cutting as the Number One evil criticized the distributors for ignoring, condoning, or even encouraging this practice, for making no effort to protect list prices.

A Few Quotes from the Survey:

San Francisco, Calif.: "Prices are not maintained by distributors' efforts. Unethical houses sell below fair trade prices and are not deprived of franchises because of their size; admitted by distributors. Ethical stores are thereby penalized."

Dubuque, Iowa: "Wholesale distributors selling direct to retail trade at dealers' costs or at lower than regular. This tends to disrupt the regular retail sales and fair trade prices."

Lewiston, Maine: "We feel that we should have the same prewar discount on radios in order to hire salesmen and give good allowance for the customer's old radio. We can make many more sales by giving the customer more money for his old radio regardless of the price of the new one."

Ithaca, N. Y.: "The distributors are giving lines to too many new outlets."

Amarillo, Texas: "Distributors selling to grocery stores, filling stations, etc. Also selling at cost to any merchant who does not have an appliance franchise, and to small builders who may build only one or two houses, at cost."

Readjustment Needed

Tonowanda, N. Y.: "Most major plants in our area have employe purchase arrangements which are ruining our business, and many retailers are suffering."

McKeesport, Penna.: "The retail markup on TV receivers makes the sale an unprofitable venture in any event, especially in a dropping market. Everyone is willing to unload quickly as they make no profit in the first instance, and are afraid of losing money. A readjustment by the leaders in the industry would tend to stabilize the market and make it possible for the retailer to take a chance."

Altoona, Pa.: "Too many dealers of one make of appliance in one location."

Baltimore, Md.: "Operating expenses show increase because most of the merchandise received from all manufacturers today has to be repaired before it is salable."

Seattle, Wash.: "Too many customers buying at wholesale."

St. Louis, Mo.: "Industrial discount cards passed out by some dealers. If these conditions prevail in TV's infancy, what will they be in a few years?"

Denver, Colo.: ". . . loose policies by factories and distributors. . . . I have in

Price-cutting — America's Number One merchandising evil.

TERRIFIC PRICE REDUCTIONS!

**IF WE TOLD YOU THE MAKE
YOU'D RUSH IN TO BUY!**

Slashed To the Bone!

Save A Hundred-Dollar Bill On This TV Set

WAS \$592.50—NOW ONLY \$325.00

Standard-Make Refrigerators at Big-Saving Prices

LESS THAN WHOLESALE COST!

BELOW MANUFACTURER'S COST

NATIONALLY-FAMOUS BRANDS Reduced for Quick Clearance

We Meet All Competition—Get Our Prices First!

(Continued on page 81)



Springboard

**Plan to Put the Heat on
to Prevent Volume DROP When the Mercury CLIMBS
—Planned Activities Will Pay**

• Sales slowed down all over the country last summer, but that isn't anything new to the retailing business. Sales are always off during hot weather, but volume is especially and unnecessarily low in the establishment where a summer-long series of siestas are permitted to exist.

Too many dealers and salesmen talk about the scorching weather, failing the while to do anything about it, when actually there's something they can do.

The dealer who takes the summer slump lying down will get just exactly what he deserves, and that's a big drop in sales, with no decrease in his overhead.

The *manana*-minded salesman who's sold himself the idea that he can't do anything about this summer slump, will see his earnings go down as the mercury goes up.

No Defeatist Attitude

Business belongs to the man who goes after it—in spite of the weather, and the summer is no exception. The merchant who puts the heat on summer selling, laying his plans now, in advance, will find himself well repaid for his effort.

While it's true that business as a whole is off during the hot weather in most parts of the country, it is also true that volume can be kept from sinking to the very lowest depths through a well-organized program of activities.

Summer sales action needs to be aimed at attracting more people to the store, the creation of desire-to-buy displays, and a realistic, energetic job of work in the field.

For the retailer who really wants to keep his sales at a healthy level there are numerous ways and means to accomplish just this. To begin with, the

members of the sales force should be urged to overcome any defeatist attitudes they may hold toward hot-weather selling. They should not permit themselves to believe that there are only a

handful of items that can be sold in the good old summertime.

Too many salespeople believe that about all there is to summer merchandising is the moving out of a bunch of

Summer—

TIME FOR SALES, NOT SIESTAS!

Plan now to put the heat on
for more hot-weather business

Use timely window displays—
provide extra in-store comfort

Canvass in business district
and among homes in your area

Don't take the traditional seasonal slump
lying down

**THERE'S NO PEAK SEASON
FOR POCKETBOOKS!**

People have just as much money to spend
in the summer as they have in the
winter—sometimes more!

To obtain results, ask them to buy;
make it easy for them to buy,
and show them why they should buy.

for Summer Sales

electric fans during a very short season; then calling it quits. Actually, there isn't a single product in a dealer's store that isn't being bought every day in the year. A little extra effort, tied in with the hot weather as a reason the customer should buy this-or-that will obtain satisfactory results.

Isn't it a fact that a woman struggling with an inefficient, out-of-date electric iron on a roasting hot day is a red-hot prospect for a new one? Isn't it true that an electric roaster is just what the doctor ordered for cooking summer meals without "cooking" the kitchen? It goes without saying that there are hundreds of other products, too, refrigerators, vacuum cleaners, food freezers, washers and ironers and table appliances, that lend themselves well to summer selling, either as first purchases or as replacements for broken-down equipment that becomes all the more annoying to the owner during the hot weather when tempers are short.

Use Show-Windows

Looking at the radio picture, the dealer who is on the ball can see many sales angles. Of course, portables can be sold in large numbers; TV is a steady, year-round seller, and FM lends itself better to summer selling than almost any product one can think of, as it can be effectively demonstrated as a static-free performer during the most severe thunderstorm. Records and record players can be made to bring in additional summer revenue when properly plugged by the merchant during warm weather. Popular discs sell especially well in the summer when so many youngsters are at home during the long vacation period.

The summer provides numerous window display themes for the alert merchandiser. "Cool" windows certainly ring a bell with the passerby at times when it's hot enough to fry an egg on the sidewalk. While the smart dealer gets his electric fans in the window early in order to make his store known as air-circulating headquarters, he never fails to tie other hot weather products in with timely displays as well.

"Cool" windows, using blue color themes, can be used most effectively to promote sales of products that suggest themselves as labor-savers or comfort-

bringers in hot weather. Electric fans of all kinds, including compressor-type room coolers, can be used to provide motion in such windows where cool-to-operate electric ranges are being featured along with refrigerators, food freezers and a variety of table and kitchen appliances. Recreation scenes, such as those simulating summer resorts, can be used to plug records, portable radios and TV sets, and small appliances such as hair dryers, drink and food mixers, vibrators, etc.

Inside the store an all-out effort should be made to provide for the prospective customer's comfort. In cases where air-conditioning is not installed, sufficient electric fans should be set up in order to maintain a desirable temperature. It is important that such fans should operate quietly so as not to annoy the customers. Many dealers make cold beverages available to store visitors and find that such gesture is a most welcome one.

Planned outside activities can be profitably undertaken during the summer. The dealer can often obtain extra revenue through exhibits at bazaars and cooking schools, and through canvassing, he can sell products such as air-circulators, water coolers, refrigerators, PA systems, TV sets, record players, recorders, etc., to his non-competitive fellow merchants, as well as to professional, commercial and manufacturing accounts.

Profitable Field Work

The longer summer days are ideal for outside canvassing of homes in the territory, when the salesman is more than likely to encounter numbers of homeowners at work on the grounds. It frequently happens that the man of the house welcomes a visit by the salesman under such conditions, particularly when it gives the resident the excuse to take a little breather from his task of mowing the lawn or weeding the flower bed.

Canvassers will find people more than willing to talk television these days. They want to know about prices, and about reception problems. TV is a magic door-opener for the sales of receivers and other products, and the man of the house is usually in his most receptive buying mood when on his own premises.

All in all, the summer season can be made profitable for the dealer who digs faithfully for sales, refusing to let that traditional sales valley dip down to abysmal depths. The thing to remember is that people have just as much money to spend in the summer as they do in the winter—many of them have more.

June is the springboard for summer selling. The merchant who plans this month to get more business during the hot weather period ahead, and who carries out such plans to the best of his ability, will find that his sales volume has been definitely upped as a result.

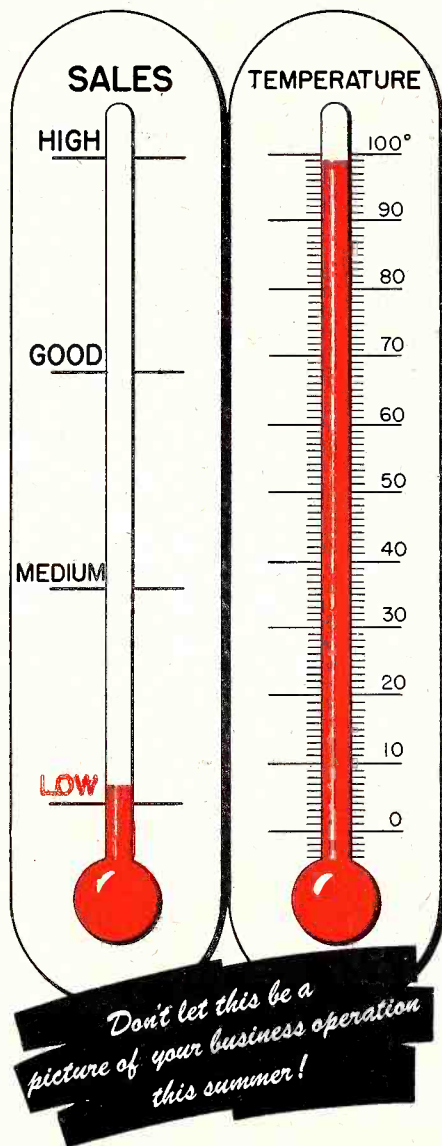

Is It Good Business to Let Them

"Try" TV Sets in the Home

Dealers Eye New Plan to Speed Sales — Profitable Methods Outlined

• One aspect of competitive selling which is already on the march in TV, and which is likely to increase from here on, is the "free home trial plan." The opinion of certain merchandisers is that this technique has many good features, since it is usually the case that once the customer has the set in his home and has seen a couple of programs, he won't give it up for anything. The exception, of course, is in instances where good reception is impossible, and under such conditions, the merchant is actually much better off than if he had sold the set from the salesfloor without a trial.

Plans Need Weighing

Those who favor the home trial offer point out that it should be a good way to cut down the high walk-out rate, feeling that this method should enable them to close a very high percentage of sales.

In viewing the free trial situation as a method for closing more sales, and increasing TV sales volume, the dealer must take into consideration his own local conditions.

If, for instance, his competition is presently offering to send out TV receivers on "free trial," he may find it wise to follow suit, particularly if he is losing numbers of sales to those employing such method. Before launching any such plan, the merchant must figure out whether he can operate an all-out home trial program profitably. This angle is particularly important to

investigate because of the present low discount rate.

Every well established dealer has numbers of good customers who can arrange, even through a telephone call, to have any merchandise sent to them for trial, with no questions asked. It goes without saying that dealings of this nature with such customers are nearly always satisfactory and profitable.

If, for instance, a merchant sends a "trial" TV set to a patron with whom he's had satisfactory relations for some time, he is reasonably certain that the customer will not send the receiver back and buy elsewhere. He knows that if the particular set is not exactly what the customer wants, that the latter will be satisfied with an exchange.

The merchant hasn't anything to worry about so far as his established customers go in instances where home trials are involved, but he needs to proceed with the utmost caution with plans for inviting new accounts to accept free trials of TV receivers, in cases where the set is to be left any length of time.

Safe Procedure

Since television sets are fairly heavy, their delivery usually involves the time of a couple of men, the use of a truck, and installation service in order to obtain even "trial" reception. Such services cost the dealer money, and he needs to do all in his power to protect himself in such transactions.

Following are some suggestions for operating safely and profitably on a

widescale free home trial basis plan:

1. Scan every request carefully. Try to determine whether the prospective customer is sincere and financially responsible.

2. Don't send trial sets into territories where it is impossible to get satisfactory reception.

3. Have customer sign all "trial" transactions as either cash or time sales orders, with the proviso that the set may be returned for any reason within a certain length of time, and that any money paid will be refunded. (Most persons signing such agreements actually intend to buy if they can be satisfied with the receiver.) Include in such agreement the stipulation that the user be responsible for any damage to the receiver during the trial period, and that permission is granted for the dealer to enter the premises and remove the receiver in case it isn't purchased.

4. Be sure that customer understands all terms of the "free trial offer." Exercise great care in making all sales presentations of the plan understandable—orally, and in advertising copy.

Numbers of dealers prefer home demonstrations to "trial" offers. The in-home demonstration technique involves taking the set to the customer's home, and operating it with portable antenna equipment. If the sale cannot be closed, the receiver is taken back to the store the same day. In areas where nothing but test patterns can be shown on in-store demonstrator sets during the day, and where customers are unwilling to visit the store at night, the in-home demonstration is certainly made to order.

While the dealer can certainly justify the request that any would-be buyer sign a purchase order for any TV set left at the home for trial, he cannot expect to obtain such agreement in cases where the set is demonstrated by a salesman in the home on a buy-or-take-back-basis.

High Walk-Out Rate

Television merchandising is too new a thing to provide accurate data on the efficacy of the various methods being used in selling the receivers in the home. Conditions vary in many parts of the country, and competitive activities are usually geared to meet specific situations.

While TV is selling at a phenomenal pace in most areas, it is certainly true that the walk-out rate, as previously pointed out, is unduly high, and that salesmanship is, for the most part, still operating on the old take-it-or-leave-it

(Continued on page 82)

If the "trial" set performs well, members of the household will "sell" themselves.

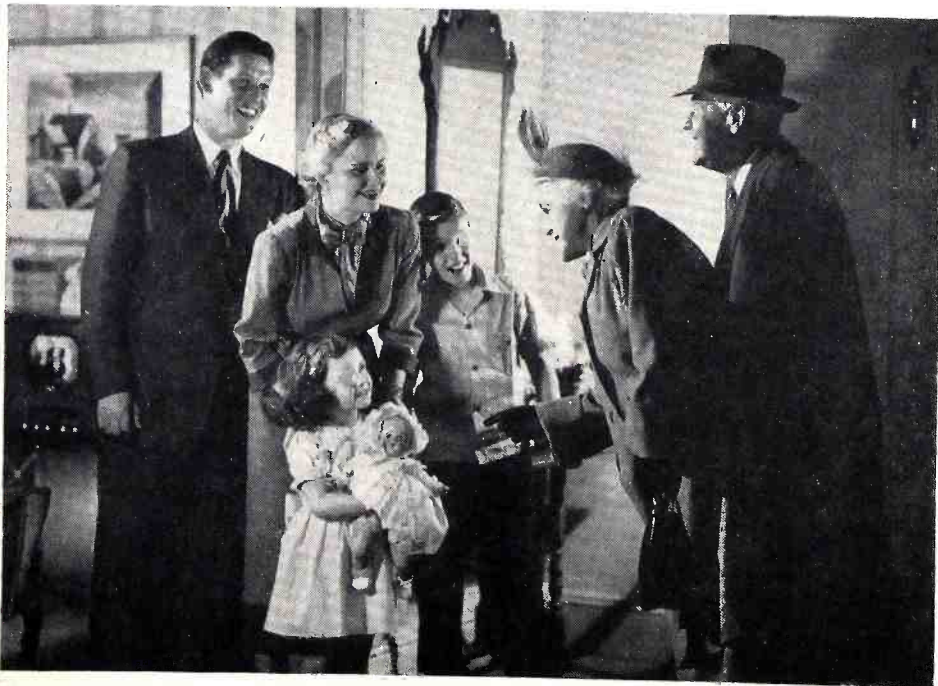

YOU
are the leading dealer in
your community when you
feature the leading line . . .

DuMont

the acknowledged leader in television

DuMont's outstanding position in television is the natural result of having developed the cathode ray picture tube—the heart of every television receiver. Through continuous improvement, DuMont has succeeded in producing a bigger, clearer, brighter, more detailed picture—free from flicker and distortion. **compare**, and be sure your television receiver has the size and quality of picture that only a DuMont cathode ray tube can give. **compare** tuning. Will it receive all 12 television channels and FM, too? **compare** cabinet design and craftsmanship. **compare** the maker's reputation in television. **compare**, and see if DuMont doesn't give you the most for your money.



The DuMont Colony—116 square-inch direct-view television screen. AM and FM radio, and dual-speed automatic record player. One of a complete line of television receivers.

DUMONT *first with the finest in television*

Cabinets designed by Herbert Rosengren

Allen B. DuMont Laboratories, Inc. • Gen. Television Sales Offices and Station WABD, 515 Madison Ave., N.Y. 22, N.Y. • Home Offices and Plants, Passaic, N.J.

A Sales-Making Store



Famous Brands, Big Selection, Efficient Service and Eye-Catching Displays Factors in Melgreen's Successful Operation

No need to dress windows here; the whole store's a show-window. Situated on a main thoroughfare in Yonkers, the fifth largest city in New York (population 160,000), Melgreen's bought and remodeled this building in 1945. At right, is the structure before it got a face-lifting. Fluorescent lamps, behind letters, create attractive lighting effect.

• Melgreen Electrical Company, 405 So. Broadway, Yonkers, N. Y., enjoys a steady volume of sales among a large group of long-time customers, and continues to attract new ones through a policy designed along sound, effective business lines.

To begin with, this firm, established about fifteen years ago, considers service to be the backbone of its operation, and because of its facilities and know-how, obtains much factory-referred

business from a number of the country's largest manufacturers. This set-up not only provides considerable revenue but brings much local prestige to the organization.

Stocking a large selection of famous brands of radios, TV and electrical appliances, Melgreen displays these products in its modern store with an eye toward creating desire to buy on the part of the visitor. "Live" demonstrators help make sales as do "package-priced"



kitchens laid out on the show-room floor.

The founder, and present owner, Aaron L. Greenberg, is a veteran merchandiser, who prior to establishing this business was in wholesaling activities. He takes part in many civic movements, and is, at this time, president of the South Yonkers Merchants Association.

Owner Greenberg explains the features of a product to customers. Sincere selling methods built fine reputation of this dealership. In foreground, note novel utilization of pillar as a comfortable seat.

As sales manager, S. Siciliano, right, looks on, Mr. Greenberg shows small "packaged-kitchen" (enclosed within dotted lines), selling at less than \$300. Buyer gets refrigerator, cabinets, mixer and portable table-top electric range.



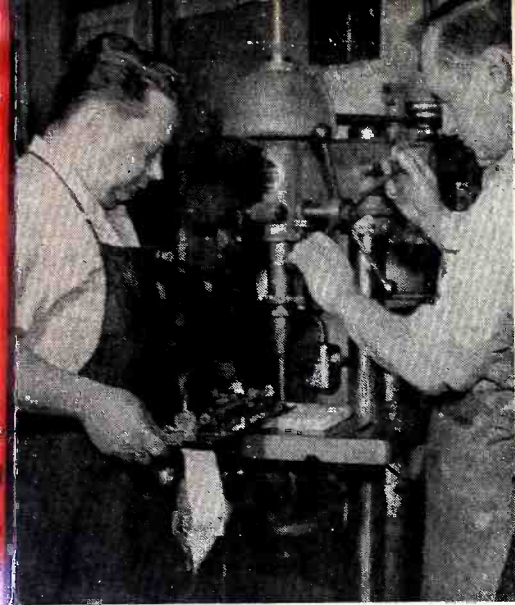

In Melgreen's second-story shop appliances are serviced by experts. Shown at left is P. Karroll, holding sewing machine, while Joe Gleason operates drill press. Below, one of the modern equipment in use here. Bread on shelf is used to test toasters.

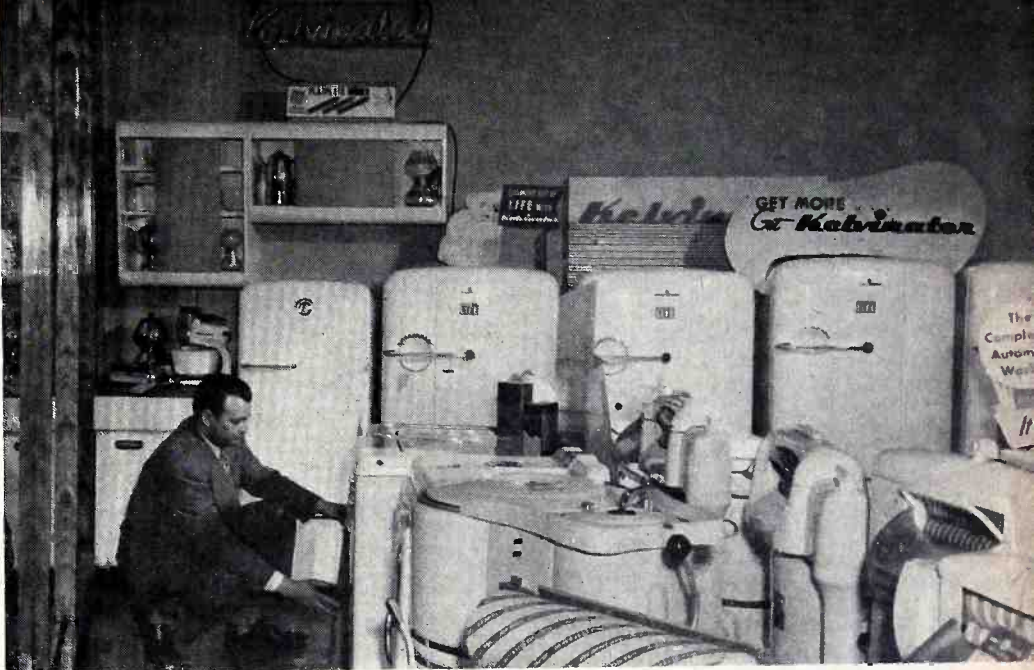

Above, considerable planning is necessary to provide aiseways in this store where a great many products are featured in open displays. Here, sales manager Siciliano does some measuring for a new layout idea.



Comfortable facilities for signing orders and time contracts are provided in locations outside heavy traffic areas.



TV sets are shown in front of glassed-in office. At right is counter for receiving and delivering repairs. Products are sent to shop via dumbwaiter.



Refrigerators, home laundry appliances and other products are grouped for ease of selection by customers.



NEWEST AM-FM-TV SETS

Emerson PORTABLE

The new Model 613, for AC, DC or battery operation, lists at \$29.95 less batteries. The outstanding feature of this model is retractable built-in loop antenna which elevates to a position above the cabinet, and folds back into the set when not in



operation. Raising the antenna away from the chassis is said to give increased sensitivity. The Model 613 is housed in a compact maroon plastic case, 8" high, 6½" wide, 3¾" deep. Emerson Radio and Phonograph Corp., 111 Eighth Ave., New York 11, N. Y.—RADIO & TELEVISION RETAILING.

Zenith FM SET

A new FM-only table set, "The Major," listing at \$39.95, has a sensitivity of about 10 microvolts, which makes it much more sensitive than any home FM radio receiver heretofore manufactured, the maker states. The set has seven tubes plus a selenium rectifier. An FM light-line antenna is built in and provides reception in primary service areas without the need for an outside antenna or dipole. Zenith Radio Corp., 6001 W. Dickens Ave., Chicago 39, Ill.—RADIO & TELEVISION RETAILING.

Garod PORTABLE RADIO

Model 5K1 "Starlet" is a 3-way personal portable with metal case and plastic cover, featuring loop antenna built-in to the lid. Set will retail for \$34.95 including batteries.



Two other personal models, for battery operation only (4A1 and 4B1) will retail for \$24.95 and \$22.95. All models weigh 4½ pounds or less. Garod Electronics Corp., 70 Washington St., Brooklyn 1, N. Y.—RADIO & TELEVISION RETAILING.

Arvin PORTABLE RADIOS

Two new 3-way portables, models 350P and 351P will retail for \$34.95 plus batteries. The model 241P, 3-way portable at \$29.95 and 240P, battery only at \$19.95 are

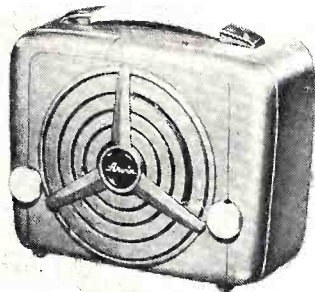

also being continued. 350P and 351P carry 5 tubes plus rectifier. Noblitt-Sparks Industries, Inc., 1531 13th St., Columbus, Indiana.—RADIO & TELEVISION RETAILING.

RCA CARRYING CASE

RCA Victor carrying case (PCC-93) is designed for this company's portable 45 RPM phonograph (Model 9EY3). Case is made of genuine pigskin with a suedine lining. Records can be carried in the cover of the case, and a zipper closing is provided. Suggested Eastern retail price is \$9.95. RCA Victor Division, Camden, N. J.—RADIO & TELEVISION RETAILING.

Industrial TV RECEIVER

Model IT-40R "Essex 20" television set features 20-inch direct view TV set with remote control unit. Cabinet styling and remote operation facilities make the unit suitable for taverns, clubs and institutions. Industrial Television, Inc., 359 Lexington Ave., Clifton, N. J.—RADIO & TELEVISION RETAILING.

Motorola PORTABLE RADIO

Model 49L11 battery operated portable radio features light weight (4 lbs.) and low cost. Retail price is \$19.95. Also announced in the portable line is model 5A9, 3-way

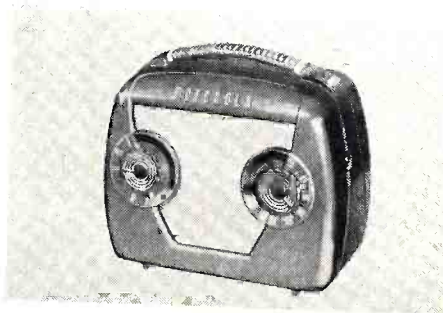

personal radio selling for \$39.95 and a de luxe model with plastic covering resembling woven fibre, listing at \$49.95. Motorola, Inc., 4545 Augusta Blvd., Chicago 51, Ill.—RADIO & TELEVISION RETAILING.

Symphonette RECORD PLAYER

Model #90 is a single record player in a rounded corner carrying case, covered in Buffalo Grain simulated leather, incorporating a 2-Tube amplifier and 5" speaker with



volume and tone control, operating on 78 RPM. A complete line of all-speed players is also available. Symphonette Corp., 112 E. Walton Place, Chicago 11, Ill.—RADIO & TELEVISION RETAILING.

Stewart-Warner RADIO CONSOLES

"Contemporary" is an AM radio-phonograph with facilities to intermix 10 and 12 inch 78 RPM records. The radio has five tubes plus one rectifier and lists for \$109.95. The "Boulevard" is similar in features and in appearance except that there is no phonograph. Instead a built-in connection and two-position switch is provided. List price is \$79.95. Stewart-Warner Corp., 1826 Diversey Pkwy., Chicago 14, Ill.—RADIO & TELEVISION RETAILING.

Stromberg-Carlson TV CONSOLETTA

The "Weymouth," model TS-125-IM combines TV, FM-AM with phonograph jack included. Picture tube is 12½ inch, with 92 square inch screen. Set lists for \$565 in Eastern zone. A 12-inch loudspeaker is a feature of the set. Stromberg-Carlson Company, Rochester 3, New York.—RADIO & TELEVISION RETAILING.

Mars 15" TV SET

"Princeton" is a 15-inch table TV receiver with 31 tube chassis. Knobs are concealed by a panel in the front of the cabinet. Cabinet measures 23½ inches wide by 23½ deep by 23 high, and list price is \$549. Mars Television Inc., 29-05 40th Road, Long Island City, N. Y.—RADIO & TELEVISION RETAILING.

Rembrandt TV SETS

The 1949 line includes three 12-inch sets and three 15-inch sets, all with FM radio included. Table model #1950 with 12-inch picture tube has 72-square inch screen and lists for \$425, in mahogany or walnut. Blonde mahogany, maple, knotty pine or oak list at \$30 extra. Remington Radio Corp., 80 Main St., White Plains, N. Y.—RADIO & TELEVISION RETAILING.

PERFORMANCE!
POWER!
STYLE!
TONE!
PRICE!



ARVIN
Performance
Tested
RADIOS

Never Before HAS SO MUCH
BEEN OFFERED FOR SO LITTLE!

Strikingly beautiful! Real heavy-duty, long-range performance! Weighs only six pounds, with batteries! Portables of such amazing sales appeal have always been priced beyond the reach of your average customers—but Arvin brings the price down to earth. Only when you see it, hear it, operate it yourself can you fully appreciate the Arvin Model 350P! Then you'll marvel at the price..... ONLY

\$34.95

(less batteries)
Kingfisher Blue
or Stunning Jade
Green

240P
Battery-only portable in popular compact size, ruby-red plastic, excellent range and tone **\$19.95**

241P
Three-way portable in same styling, red, brown, or ivory, **\$29.95**
Underwriters' listed.....
less batteries

242T
Kid-proof, shatterproof AC/DC superhet in six smart colors—red, yellow, green, ivory, sand-bronze or gunmetal. Over a million sets sold. Under **\$14.95***
writers' listed.....

NOBLITT-SPARKS INDUSTRIES, INC.
Columbus, Indiana

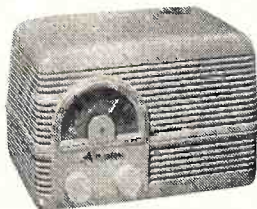

359T
Absolute peak in 5-tube range, tone, and value! Performs rings around any other set in this popular price class. New cabinet styling in brand new willow green color. Slide-rule dial. Under **\$19.95***
derwriters' listed.....
*Slightly higher in Zone 2

New Television Receivers

RCA TV TABLE SET

The new model 9T240 is a 10-inch direct-view set with 61-square inch picture listed to retail for \$269.50, the lowest priced RCA 10-inch set so far produced. Receiver has 21 tubes plus two rectifiers and picture tube, with 5 by 7 inch speaker located in



the top of the cabinet. The set is available in limed oak finish at \$284.50. Special matching table for dark wood models is \$15.50. RCA Victor Division, Camden, New Jersey.—RADIO & TELEVISION RETAILING.

Federal TV RECEIVERS

New Federal line offers sets with 12½ and 15½ inch picture tubes, all with FM radio included. Sets range in price from \$425 for the "New Yorker" table model to \$1795 for the "Scarsdale" Breakfront. All sets are equipped with "slave unit" re-

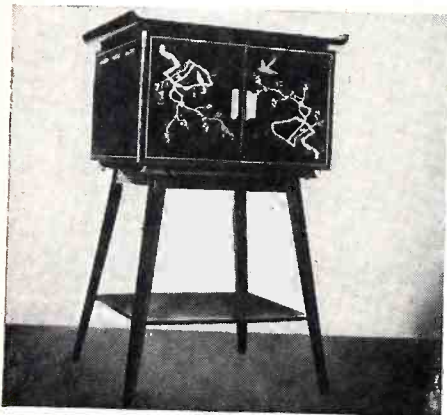

ceptacles which permit the addition of additional viewing units, as well as phono receptacles. A feature of the sets is the simplified "three dial" tuning system, which eliminates horizontal and vertical, brightness, focus and fine tuning controls. Federal Television Corp., 137 Duane St., New York 13, N. Y.—RADIO & TELEVISION RETAILING.

Air-King TV LINE

The line consists of 10 and 12½ table models and consoles, highlighted by the model A-2000, 10-inch table set listing at \$239.95. Set has 20-tube chassis, automatic gain control, 5-inch loudspeaker and 61 square inch screen. Model A2001 12-inch table set lists at \$299.95. Air King Products, 170 53rd St., Brooklyn 32, N. Y.—RADIO & TELEVISION RETAILING.

Westinghouse TV CONSOLE

Model H-216 is the first Westinghouse receiver to incorporate a 16-inch picture tube. To conserve space, tube is mounted vertically in cabinet, rotated manually into viewing position. Set has 27 tubes plus 5 rectifiers and picture tube, and 10-inch PM

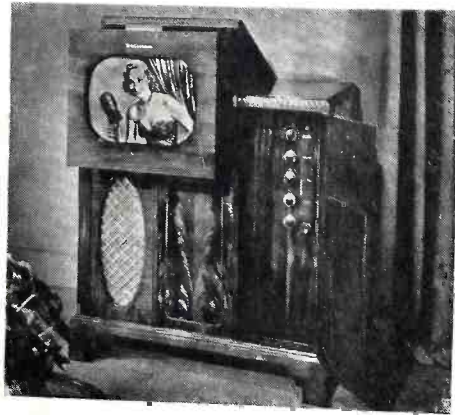

speaker. Suggested retail price is \$599. Westinghouse Electric Corp., 306 Fourth Ave., Pittsburgh 30, Penna.—RADIO & TELEVISION RETAILING.

Ansley TELE-MOVIE

Featured in the new Ansley line of TV receivers is a chairside unit which projects a 3 by 4 foot picture on a movie screen. Called "Tele-Movie," the unit measures 23 inches high by 21 wide and 26 long, and will retail for \$795, including screen. Also

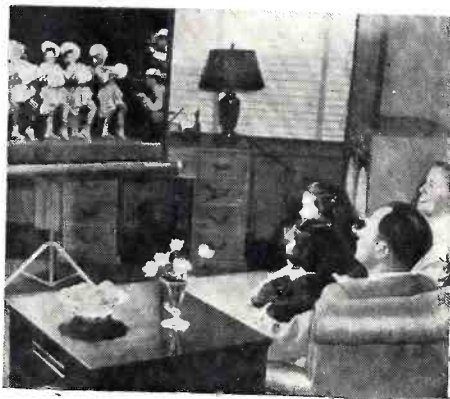

in the line is a 12 x 16 inch projection console listing for \$695, two 16-inch consoles with AM-FM radio and 3-speed phono, at \$895 and \$995, a 16-inch TV-only console at \$495, in addition to four 12-inch and one 10-inch model. Ansley Radio & Television, Inc., Trenton, New Jersey.—RADIO & TELEVISION RETAILING.

Aero TV LENS

AeroLens, a liquid-filled magnifying lens is available in two sizes, #2300 for 7" screens to retail at \$19.95 each and #4800 for 10" and 12" screens to retail at \$36.95. Aero Needle Co., 619 N. Michigan Ave., Chicago 11, Ill.—RADIO & TELEVISION RETAILING.

Tele-King TV SETS

Four new models have been announced, two 10-inch and two 12-inch sets. Model T-410 is a 10-inch table set listing at \$229.95, C-710 10-inch console is priced



at \$289.95, T-512 12½-inch table set is \$329.95 and C-612 12½-inch console will retail for \$389.95. Tele-King Corp., 601 W. 26th St., New York, N. Y.—RADIO & TELEVISION RETAILING.

Crosley TV CONSOLES

Two new 10-inch consoles have been announced, both with FM radio included. Model 9-420M in mahogany veneers carries a Zone 1 list price of \$329.95, and model 9-424B in modern blond oak retails for \$339.95. In addition, two new 12½-



inch sets and a 16-inch model are included in the new line. The latter, model 9-422M, is a console with 142 square inch screen and FM radio listing at \$569.95. Crosley Division, Avco Mfg. Corp., Cincinnati, Ohio.—RADIO & TELEVISION RETAILING.

More New Sets
Elsewhere in
This Issue



Stock these fast-moving types and watch your business grow! VS002; VS013; VS016; VS019; VS036; VS047; VS050.

Battery Headliners... These 7 RCA Batteries cover more than 80% of your portable type requirements!

NOW... you need handle only these seven RCA battery types to meet most of your customers' requirements! Here are seven types that simplify your stocking problems... give you quick turnovers... and a tremendous repeat business.

And... for your special needs... RCA also has the slower-moving and "hard-to-get" types... locally warehoused for quick delivery through your RCA Battery Distributors.

Remember, too... RCA's *selective distribution* primarily to the RADIO TRADE steers customers back to *you* for repeat sales.

Build *your* business with the battery that's *radio-*

engineered for *extra* listening hours! The RCA Trade Mark and attractive packaging guarantee immediate customer acceptance!

Put those Profitable "Portables" right on the Selling Line!

Another RCA First—this compact counter merchandiser sells RCA Batteries on sight. Ask your RCA Battery Distributor about the greatest array of selling aids in battery history... *all geared to the Radio Trade.*



ALWAYS KEEP IN TOUCH WITH YOUR RCA BATTERY DISTRIBUTOR



RADIO CORPORATION of AMERICA

HARRISON, N. J.

Letters From Readers

How Do They Do It?

Editor,
RADIO & TELEVISION RETAILING:

I read with interest your current articles on "How to Charge for Profitable Servicing." What I want to know is how any radio service business can be conducted profitably when charges for service are \$1.00, regardless of the time required to repair the set. The two ads enclosed appear regularly in *The Denver Post*.

Naturally, we can't dictate to any business on its schedule of charges, but I have had several people inquire as to why my charges average more than the above ads would . . . I don't know how they do it and stay in business.

Roy M. Sadler,
Sadler Radio Service,
Clayton, New Mexico.

Editor's note: Ads mentioned by Mr. Sadler offer to service any radio for \$1.00, plus parts.

Praises "How to Charge for Profitable Servicing"

Editor,
RADIO & TELEVISION RETAILING:

Congratulations for your very fine article, "How to Charge for Profitable Servicing" appearing in your recent issue. This certainly supplies information sorely needed by the service trade at a time when all of us are concerned about the welfare of the industry.

I am so interested in your subject I would like to be sure every service account that we serve has a copy of these articles. Can you supply 150 reprints of the entire series of articles to us?

Grattan Hammond, Jr.
Hammond-Morgan, Inc.
Orlando, Florida
(Distributors)

"Platter-Puss" Made a Hit Says This Reader

Editor,
RADIO & TELEVISION RETAILING:

Boy, you fellows coined a phrase when you urged the record dealer, in your magazine, not to go about wearing a "platter-puss"! Incidentally, your publication was quick to view the "record war" optimistically, and to give the merchant all the low-down on the situation, plus down-to-earth advice. I'm what you term a "Four-Way" dealer, but am signing my name.

3-Speed Retailer,
New York, N. Y.

On Back-Door Selling

Editor,
RADIO & TELEVISION RETAILING:

I live in an area greatly affected by the gripes. I list herewith some that you are doubtless familiar with, hoping that somehow an answer will be found to the \$64.00????

It is surprising how many people are in a "position" to purchase appliances and radios, especially the latter, at wholesale and even factory prices. Included are employes of oil companies, hardware jobbers, school teachers, and farm organization employes, to mention a few. There are more. Many of the products supplied at cut prices are off-brands, but some name brands are included. Add to the above the chain store and mail-order purchases and you see much of the business of the local independent dealer, who is the forgotten man, disappears. We, the local dealers, get the crumbs when customers want their *bargains* serviced for two-bits. The above conditions, if continued, will eventually eliminate many appliance merchants from the retail field.

A. W. Mitchell,
Mitchell Radio Service,
Waldron, Indiana.

Distant TV Reception

Editor,
RADIO & TELEVISION RETAILING:

Regarding the TV-DX reception given on page 68 of the January issue, I believe I can go that one better, maybe.

While trying out a GE 810 set using a simple folded dipole and reflector in Huntingdon, Pa., we received the following: Baltimore, 110 miles; Washington, D. C., 140 miles; Pittsburgh, 100 miles, and Philadelphia, 190 miles. The elevation was approximately 800 feet and set among hills.

Incidentally, while the antenna was about a foot off the ground, that is, the folded dipole was facing the ground and the reflector above it, we could get the test pattern from Washington.

CHAS. A. WEAVER, W3VK
689 Wangler Ave.
Sharon, Pa.

P. S. Above results obtained with antenna only 21 feet high!

Cites Problems of TV Sales and Servicing

Editor,
RADIO & TELEVISION RETAILING:

We certainly wish to congratulate your magazine, also Mr. Warren H. Lightfoot for his fine article, "High Hopes and Hard Facts of Television Selling" in the March issue of RADIO & TELEVISION RETAILING. Certainly we need more of this to wake up the manufacturers, or distributors which-

ever is responsible for the small margin of discount on television.

We have handled television since KSD of St. Louis first went on the air and pioneered it in the fringed area. When we first started to handle same one could offset the short discount by getting a good installation fee. However, as the result of our pioneering the distributors turn each of their radio outlets loose with television with no facilities for service. Consequently poor installations, a reduced installation charge, and now these same dealers crying on the serviceman's shoulder to help them out to keep their customers. Why? Simply because the majority of the distributors do not have competent service men themselves and so they are again digging the retailer for excessive service charges for any repairs in their shop. In fact all of the distributors for this area (no exceptions) just merely ship out the sets without uncrating and should they be defective have the nerve to charge one for anything they might do to the sets. We certainly need more articles like Mr. Lightfoot's to wake someone up. We are the ones that the customer looks to, not the distributor nor the manufacturer. It does seem that competent service shops should at least be entitled to a better discount to take care of the service they have to offer.

We are, we know, very small and have sold and installed approximately 250 sets. However, we have invested about \$1,700 in test equipment alone, not considering the two trucks, tubes and various component parts necessary to insure service to our customers, and again that sum does not include paying men for installing and servicing.

Heretofore, when such facts are brought up to the manufacturer and distributor they always have the excuse that they are working on a very short margin. However, we will cite one instance where this in our opinion is a very poor excuse. We were handling one particular set recently on a 27 percent discount from distributor, yet over night they cut this set from \$339.95 to \$299.95. Now if the manufacturer can sell this set for the last named price at a profit, and evidently he is as he certainly has not discontinued it from his lines, then why could he not have given the distributor and the retailer a fair margin of profit?—especially the retailer, so that he could be in a position to handle and push his merchandise more successfully. Therefore, we who have efficient service have but one answer and that is to pass up sales or not make a sale unless we can get sufficient charges for installations to make up the loss for the short discount.

May we again congratulate you and may we have more articles like these in the future. Maybe such articles will eventually wake up the manufacturers and distributors.

H. C. Scheppel, partner,
Carlyle Electric Store,
Carlyle, Illinois.

Snyder

PHILADELPHIA

means BUSINESS

Radio-Television Aerials & Accessories

TELE-PORT Portable TV Aerial

3 section telescopic dipoles. All channels. All-way orientation. Admiralty brass xxx chrome plated staffs. Brown bakelite and chrome appointments. Complete with cable.

\$5⁹⁵

List



MODEL P-TV

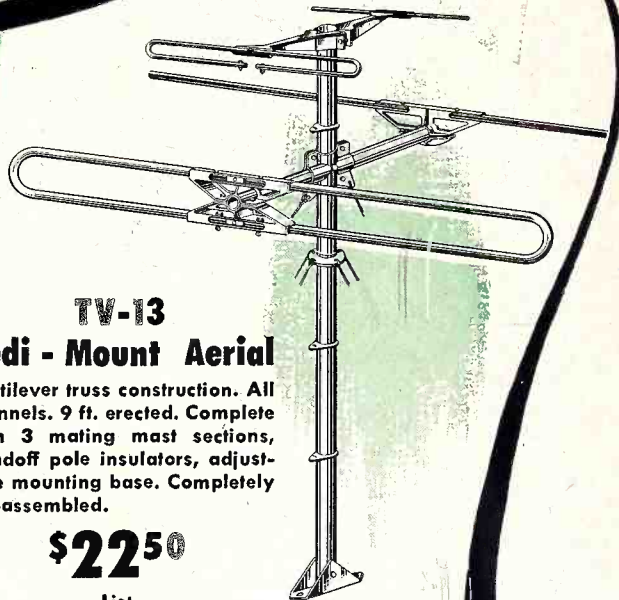

TV-13 Redi - Mount Aerial

Cantilever truss construction. All channels. 9 ft. erected. Complete with 3 mating mast sections, standoff pole insulators, adjustable mounting base. Completely pre-assembled.

\$22⁵⁰

List

C-3W Auto Aerial

3 section 66" extended. Complete with tenite insulators, static ball, shielded low-loss lead.

\$2⁹⁵

List



FC-3 Auto Aerial

3 sections. 52" extended. Concealed fender or top cowl installation. Waterproof. Self-aligning adjustment fits all contours.

\$4⁹⁵

List

WB-2 Wall Bracket

Heavy duty rustproof steel. Adjustable to desired angle. Adjustable span.

\$6²⁵

List

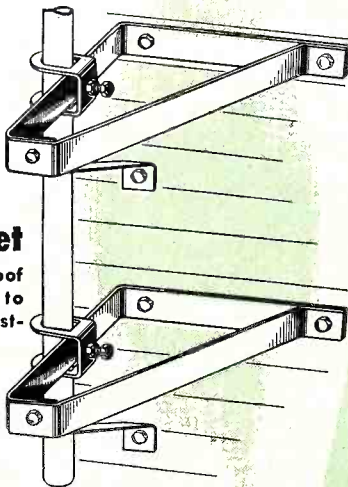

WRITE FOR OUR COMPLETE CATALOGS

SNYDER MFG. CO.

ANTENN-GINEERS*

22nd & ONTARIO STS., PHILADELPHIA 40, PA., U.S.A.

EXPORT DIVISION: ROBURN AGENCIES, INC., NEW YORK 7, N. Y.

*U. S. PAT. OFF.

Eleven

NEW MODELS



FIVE-NEW 7" MODELS

P7-T	ST-804	P7-T	ST-807
P7-U	ST-806	F7-T	ST-809
	F7-U	ST-808	

FIVE NEW 6"x9" OVAL MODELS

P69-S	ST-812	P69-T	ST-811
P69-V	ST-810	F69-T	ST-814
	F69-U	ST-813	

ONE NEW 5 1/4" MODEL

P525-V	ST-803
--------	--------

The addition of these new models brings the number of speakers in the Jensen Standard Series to fifty-three — the most complete array in speaker history. In addition are the Jensen Concert Series, Special Series, Coaxial, and Professional Series. There is a genuine Jensen available for every purpose.

Write for Catalog 1010-F

Jensen

MANUFACTURING COMPANY

Division of the Muter Company

6625 SOUTH LARAMIE AVENUE
CHICAGO 38, ILLINOIS

In Canada: Copper Wire Products, Ltd., 351 Carlaw Ave., Toronto

Better! Stronger! Last Longer!

Because  Flat Cell "B" Batteries Are

INTERLOCKED

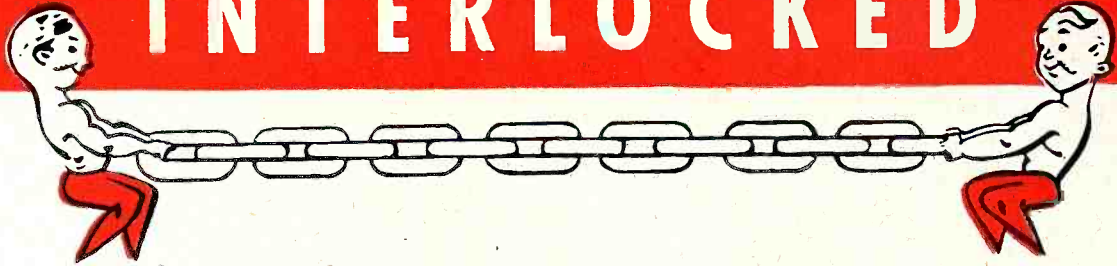

The principle of *interlocking* is simple—and complete assurance of maximum strength. For example, you'd naturally prefer a tire chain which is *interlocked* with equally strong links to one with its links taped or tied together. For the same reason

both you . . . and your customers . . . will prefer OLIN flat cell "B" batteries since they have triple-sealed, equally-strong, *interlocked* flat cells . . . instead of ordinary cells bound together with paper tapes or other types of wrapping.

They Are The ONLY Flat Cell Radio "B" Batteries in Which Each Cell Is

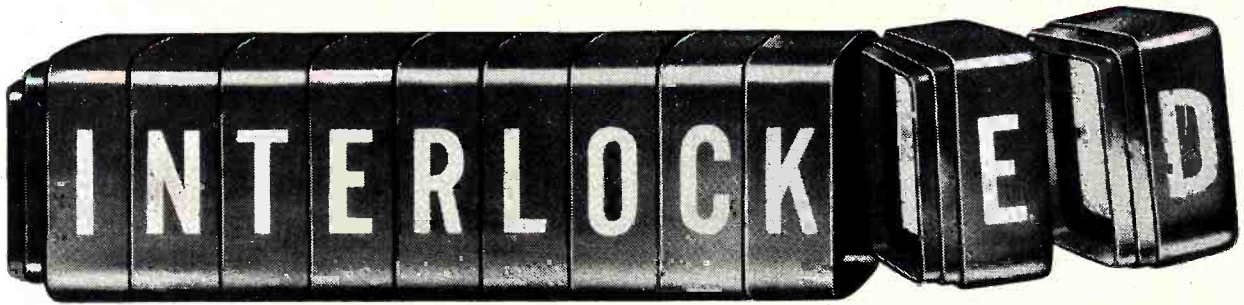

"Greatest development in 20 years for battery radios" say radio manufacturers. And backing up their judgment OLIN

interlocked flat cell "B" batteries are recommended as standard or replacement equipment by leading radio manufacturers.



Look What It Means

Each cell holds only power-producing chemicals with no waste space.

Triple sealing, under fixed pressure, insures against power leakage.

Up to 91% fewer soldered connections greatly reduce battery "hum" or failure—give longer life.

We guarantee these . . . the ONLY radio batteries with *interlocked* flat cells . . . to give more listening hours, and clearer reception under normal conditions.

See How It's Done

Note in the magnified view showing the enlarged cut-away section how each cell is *interlocked* . . . Patented U. S. Pat. No. 2416576.

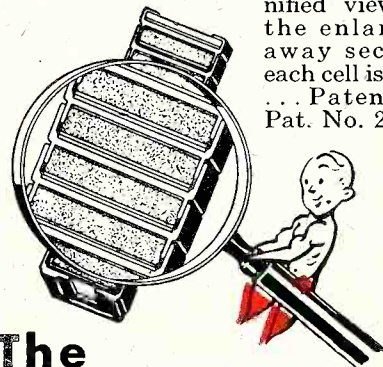

IT'S EXCLUSIVE WITH OLIN!



Available Only In The

WINCHESTER and **BOND** Lines

of OLIN INDUSTRIES, INC., Electrical Division, New Haven 4, Connecticut.

Mr. RETAILER: Order From Your Wholesaler's Salesman Today To Be Ready For The Vacation Selling Season!

Status of TV Stations in the U. S.

• The present situation is based on the re-allocation of channels by the FCC in 1945. At that time about 400 channels or stations were allotted.

The status of channels are one of four: (1) station operating, (2) construction permit (CP) granted and station presumably under construction, (3) application for construction permit pending approval by FCC, or (4) no

application made.

Last fall the FCC "froze" applications pending settlement of the problem of how to provide more channels.

The status of TV under these conditions is listed below. It should be understood that "application pending" has no particular significance until the lifting of the freeze, and that "channels allocated" may be changed after the

thaw. It should also be noted that although 13 channel frequencies were provided under the original allocation, channel 1 was subsequently deleted.

The total number of stations possible until the freeze is lifted is 121. As of June 1 there were 66 stations on the air, 55 CP's. By January 1, 1950 expect 99 stations, with 22 CP's left to come on during 1950.

Location State and City	Number of Channels Allocated	Number of Stations Operating	CP's Granted	Applications Pending	Location State and City	Number of Channels Allocated	Number of Stations Operating	CP's Granted	Applications Pending
ALABAMA					NEBRASKA				
Birmingham	3	0	2	1	Lincoln	2	0	0	0
Mobile	4	0	0	0	Omaha-Council Bluffs	3	0	2	2
Montgomery	2	0	0	0	NEW JERSEY				
ARIZONA					Atlantic City	1	0	0	1
Phoenix	4	0	1	3	Newark	1	1	0	0
ARKANSAS					NEW MEXICO				
Little Rock	4	0	0	2	Albuquerque	1	1	0	2
CALIFORNIA					NEW YORK				
Fresno	4	0	0	6	Albany-Schenectady-Troy	5	1	0	5
Los Angeles	7	6	1	0	Binghamton	1	0	1	0
Sacramento	3	0	0	3	Buffalo-Niagara Falls	4	1	0	5
San Diego	4	1	0	4	New York	6	5	1	0
San Francisco-Oakland	6	2	1	6	Rochester	3	0	1	3
San Jose	1	0	0	2	Syracuse	3	1	2	0
Stockton	1	0	1	0	Utica-Rome	2	0	1	0
COLORADO					NORTH CAROLINA				
Denver	5	0	0	8	Asheville	3	0	0	0
Pueblo	4	0	0	0	Charlotte	3	0	1	3
CONNECTICUT					Durham	2	0	0	0
Hartford-New Britain	2	0	0	3	Greensboro	2	0	1	1
New Haven	1	1	0	0	Winston-Salem	2	0	0	0
Waterbury	1	0	0	2	OHIO				
DELAWARE					Akron	1	0	0	2
Wilmington	1	0	1	0	Cincinnati	4	2	1	1
FLORIDA					Cleveland	5	2	1	5
Jacksonville	4	0	4	0	Columbus	4	1	2	0
Miami-Ft. Lauderdale	4	1	0	5	Dayton	2	2	0	0
Tampa-St. Petersburg	4	0	1	4	Hamilton-Middletown	1	0	1	0
GEORGIA					Toledo	1	1	0	2
Atlanta	4	2	1	3	Youngstown	1	0	0	3
Augusta	2	0	0	0	OKLAHOMA				
Columbus	2	0	0	0	Oklahoma City	4	0	1	4
Macon	3	0	0	1	Tulsa	4	0	1	5
Savannah	4	0	0	0	OREGON				
ILLINOIS					Portland	5	0	1	5
Chicago	7	4	0	5	PENNSYLVANIA				
Decatur	1	0	0	0	Altoona	1	0	0	2
Peoria	3	0	2	0	Easton-Allentown-Bethlehem	1	0	0	2
Rockford	1	0	0	1	Erie	1	1	0	1
Rock Island—See Iowa					Harrisburg	1	0	0	2
Springfield	2	0	0	1	Johnstown	1	0	1	0
INDIANA					Lancaster	1	0	0	0
Bloomington	1	0	1	0	Philadelphia	4	3	0	2
Evansville	2	0	0	1	Pittsburgh	4	1	0	7
Ft. Wayne	4	0	0	2	Reading	1	0	0	2
Indianapolis	5	1	0	4	Scranton-Wilkes Barre	1	0	0	3
Terre Haute	1	0	0	0	RHODE ISLAND				
IOWA					Providence	1	0	1	1
Ames	1	0	1	0	SOUTH CAROLINA				
Cedar Rapids	2	0	0	1	Charleston	3	0	0	0
Davenport-Moline-Rock Island	4	0	1	1	Columbia	3	0	0	0
Des Moines	4	0	0	5	TENNESSEE				
Sioux City	4	0	0	0	Chattanooga	4	0	0	0
Waterloo	3	0	0	0	Knoxville	4	0	0	0
KANSAS					Memphis	5	1	0	5
K. C.—See Missouri					Nashville	4	0	1	3
Topeka	2	0	0	2	TEXAS				
Wichita	4	0	0	1	Amarillo	4	0	0	1
KENTUCKY					Austin	3	0	0	2
Louisville	2	1	1	1	Beaumont-Port Arthur	4	0	0	1
LOUISIANA					Corpus Christi	4	0	0	1
New Orleans	5	1	2	2	Dallas	3	0	0	1
Shreveport	4	0	0	5	El Paso	3	0	2	4
MAINE					Ft. Worth	4	0	0	2
Portland	2	0	0	2	Galveston	3	1	0	2
MARYLAND					Houston	3	0	0	0
Baltimore	3	3	0	0	San Antonio	4	1	0	4
MASSACHUSETTS					Waco	5	0	2	5
Waltham	1	0	1	0	UTAH				
Boston	5	2	0	6	Salt Lake City	4	0	0	1
Lowell-Lawrence-Haverhill	1	0	0	2	VIRGINIA				
Springfield-Holyoke	1	0	0	3	Norfolk-Portsmouth-Newport News	5	2	0	4
Worcester	1	0	0	2	Richmond	4	0	1	4
MICHIGAN					Roanoke	4	1	0	4
Detroit	4	3	0	2	WASHINGTON				
Flint	1	0	0	2	Seattle	3	0	0	0
Grand Rapids	2	0	1	1	Spokane	4	1	0	6
Kalamazoo	1	0	1	0	Tacoma	5	0	0	1
Lansing	1	0	1	0	WEST VIRGINIA				
Saginaw-Bay City	3	0	0	1	Charleston	3	0	0	2
MINNESOTA					Huntington	1	0	0	2
Duluth-Superior	4	0	0	0	Wheeling	1	0	1	0
Minneapolis-St. Paul	5	1	2	3	WISCONSIN				
MISSISSIPPI					Madison	1	0	0	1
Jackson	4	0	0	1	Milwaukee	1	0	0	3
MISSOURI					Superior—See Minnesota	4	1	0	3
K. C.	4	0	1	6	DISTRICT OF COLUMBIA				
St. Joseph	1	0	0	6	Washington	4	4	0	0
St. Louis	5	1	0	6	TOTALS	399	66	55	256
Springfield	4	0	0	0					

NOW — A COMPLETE LINE! ZENITH TELEVISION

WITH
GIANT CIRCLE SCREEN *and* BULLS EYE AUTOMATIC TUNING

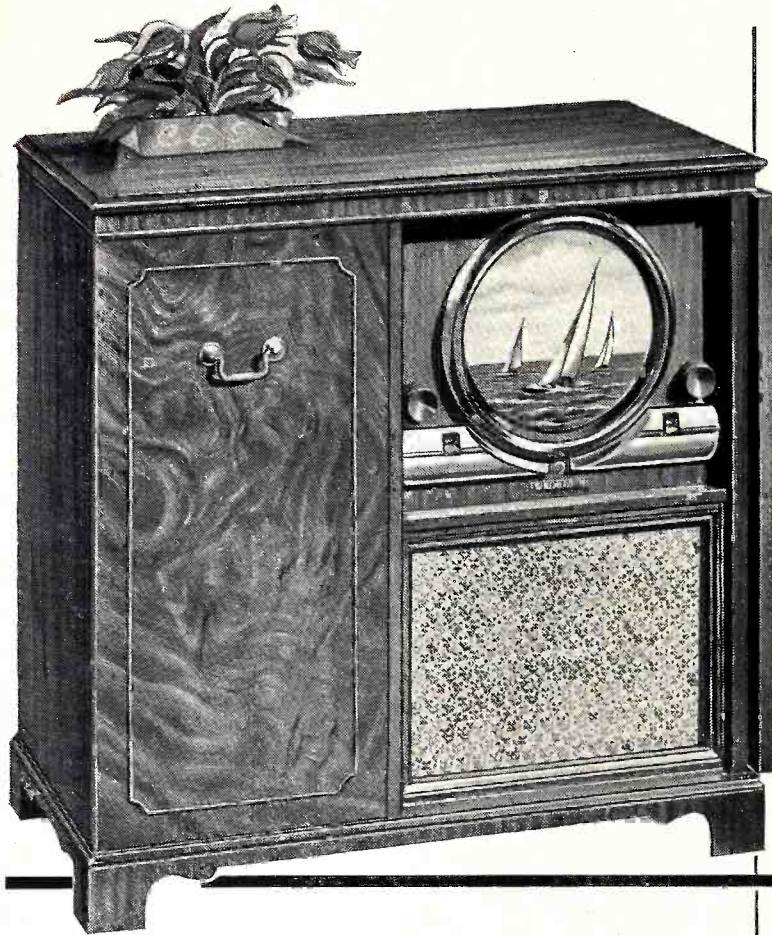

THE ZENITH GOTHAM. Zenith Television with "Big B" Giant Circle Screen; "Twin Cobra"† Tone Arms; Genuine Zenith-Armstrong FM and Zenith long distance AM radio; all superbly combined in a console of breathtaking beauty in imported mahogany veneers. **\$695***
(plus Federal excise tax.)

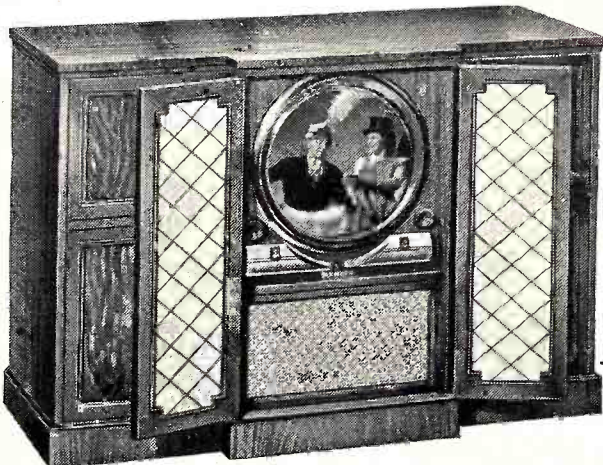

THE ZENITH MARLBOROUGH. Super deluxe! Zenith Television with "Giant C" Giant Circle Screen. Plus "Twin Cobra" Record Player; FM-AM and Short Wave Radio. In an authentic Regency console of hand glazed Honduras mahogany veneers, a masterpiece of the furniture craftsman's art. **\$1150***
(plus Federal excise tax.)

From the ultra-magnificent combinations to the beautifully streamlined table models, every Zenith† Television set hits the "bulls eye" for sales appeal. Every one has the sensational Zenith advancements found in *no* other television set... the Giant Circle Screen for a bigger, brighter, clearer picture... and Bulls Eye Automatic Tuning—one knob, one twist, there's your station, your giant picture, your sound... automatically pre-tuned to perfection!

Yes, Zenith has what it takes to assure the ultimate in customer satisfaction and bring you the most beautiful profit picture in television.

SEE YOUR ZENITH DISTRIBUTOR

ZENITH RADIO CORPORATION

6001 Dickens Ave., Chicago 39, Ill.



THE ZENITH WALDORF. Modern television console of imported Afara veneers in blonde finish. With "Big B" screen. **\$489⁹⁵***

WILSHIRE model with "Super A" screen, \$449.95. * Both models also available in mahogany finish.

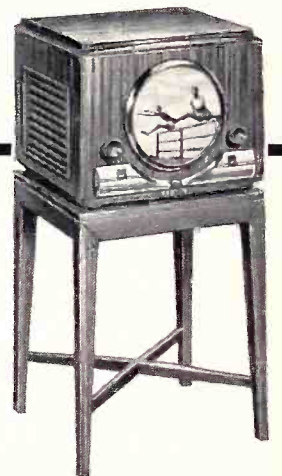

THE ZENITH MAYFLOWER. Period table set in mahogany-finished veneers of imported Afara. Has "Super A" television screen. **\$389⁹⁵***

Matching table, 26 inches high, available at \$29.95. * Receiver and table also in blonde finish.

ZENITH HAS THE GREAT VALUES
TELEVISION
and long distance **RADIO**

*Suggested retail price.
West Coast prices slightly higher.
Prices subject to change
without notice.

NOT ONE...NOT TWO...*But*

3 SPEEDS

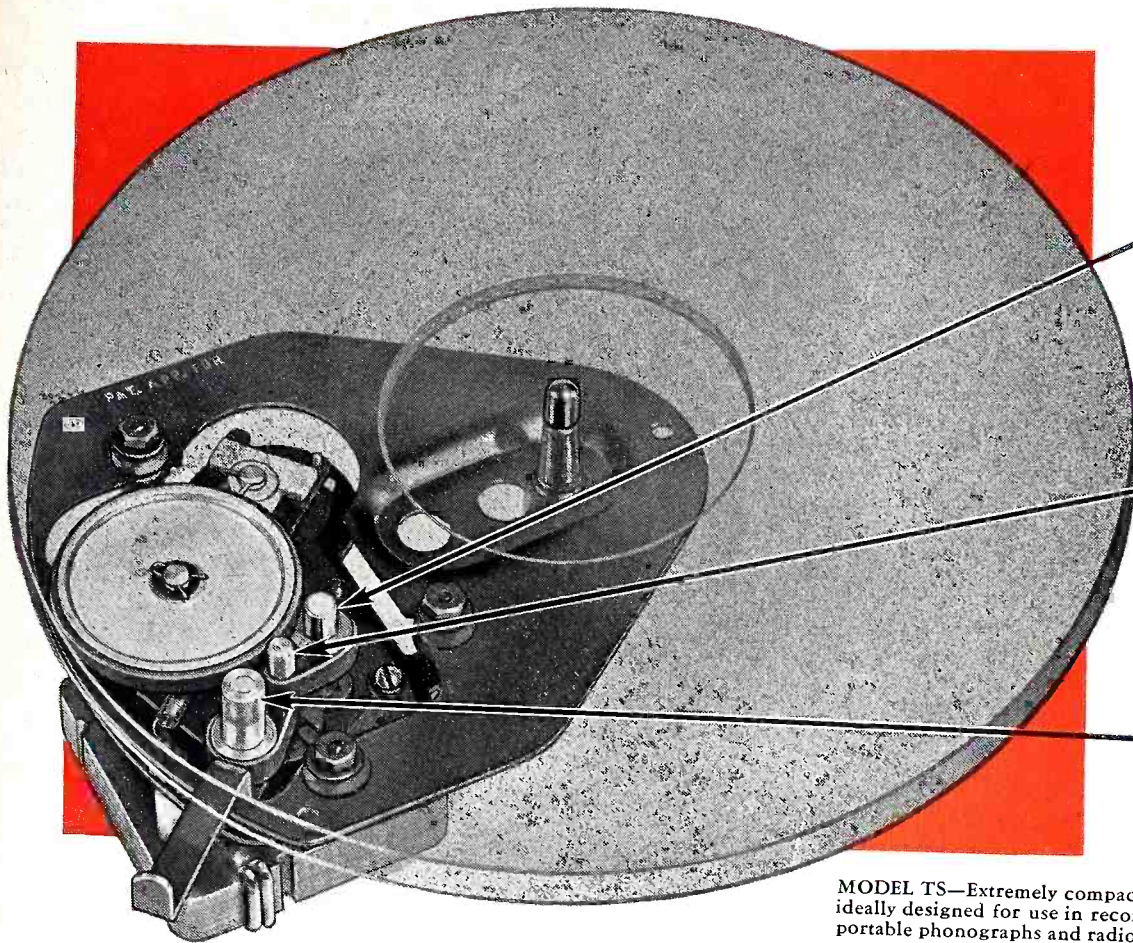

33 1/2
RPM

78
RPM

45
RPM

MODEL TS—Extremely compact 2 pole, shaded pole motor ideally designed for use in record changers and all types of portable phonographs and radio-phonograph combinations.

with this revolutionary New **GI** PHONOMOTOR!

Here it is . . . General Industries' newest development in phonomotors . . . a dependable, single-powered unit for *all three* types of records—78 RPM, 33 1/2 RPM and 45 RPM.

Speed shifting is accomplished by means of an external shift lever which ingeniously positions various spindles in contact with the idler wheel. At 78 RPM, the rotor shaft is in direct contact with the idler wheel. For the slower speeds, the

rotor shaft is automatically disengaged and one of two secondary spindles is moved into contact with the idler wheel to produce the desired speed. Both secondary spindles are driven from the rotor shaft by specially compounded oil-resistant Neoprene belts.

For additional information—specifications, blueprints and quotations—write, wire or phone *today*.



The GENERAL INDUSTRIES Co.

DEPARTMENT I • ELYRIA, OHIO

RADIO & TELEVISION RETAILING • June, 1949

RECORDS

Section of **RADIO & TELEVISION RETAILING**

Thirty Years of Record Sales

A New Level for "Normal" Disc Sales Is Indicated

● So many reasons have been brought forth to explain what is wrong with the record business that we shall not bother at this time to add any more. Instead we will counter by saying that there is nothing radically wrong with it.

By now almost every business has gone through a readjustment period since the gay days just after the war when sales surpassed all previous marks.

Most industries (except relatively new ones, like television and home freezers) have a set of pre-war figures to fall back on, and are beginning to content themselves if they can maintain those levels. (slightly adjusted to take into account the increase in population and the decrease in the value of the dollar.)

The record business is not so constituted, however. Most record dealers who were in business before the war would shudder to go back to those days, as a glance at the graph on this page will explain.

No Pre-War Bonanza

There are many reasons for this, which can be summed up by saying that the record business never really got going until the war. The mechanically recorded and reproduced disc enjoyed sizeable sales from the time of its inception at around the turn of the century up until 1929 because it was the sole form of home entertainment. Radio, starting at scratch around 1920, had reached considerable stature (9½ million homes) by 1929. This, combined with the depression, spelled the end of the old form of records.

Electrical recording started in 1925, and electrical phonographs appeared during 1927, but the high cost of the

latter prevented them from keeping platters in the public eye. It was not until around 1934-35 that the combination of low-priced record players, "le jazz hot" and juke boxes started records on the uphill climb. Disc jockeys also began to appear at about that time, eventually gaining an important position in influencing record sales.

With this background in mind, we can now consider the postwar situation. Record-players in homes have more than doubled in number since the war. Consequently there are many more potential record buyers today than there were in 1941, and certainly many times the number there were in

(Continued on page 85)

MILLIONS OF RECORDS

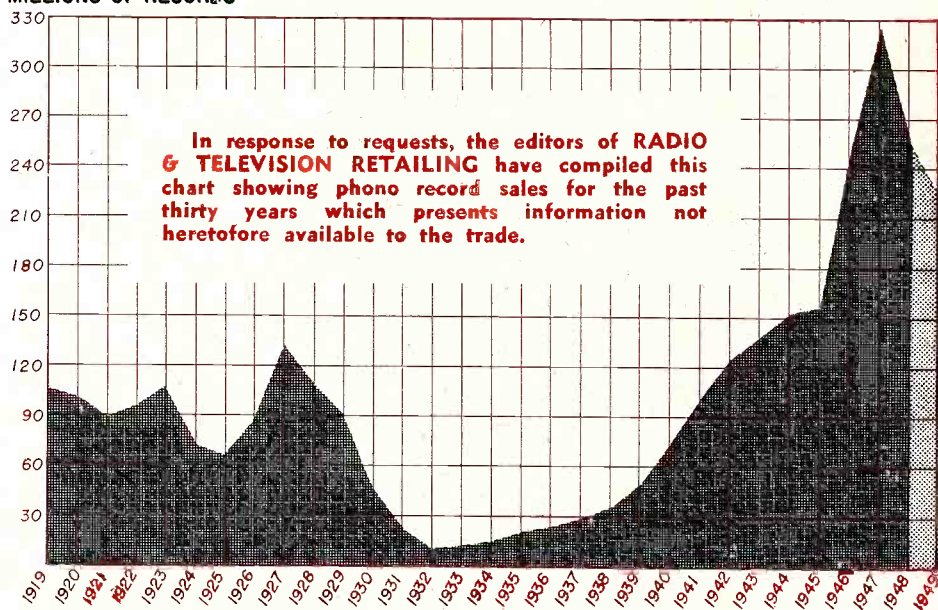

Year	Millions	Year	Millions	Year	Millions	Year	Millions
1919	110	1927	130	1935	20	1943	130
1920	100	1928	110	1936	25	1944	138
1921	90	1929	90	1937	30	1945	148
1922	95	1930	45	1938	36	1946	250
1923	110	1931	20	1939	50	1947	325
1924	70	1932	10	1940	75	1948	250
1925	65	1933	12	1941	100	1949	225
1926	90	1934	16	1942	125		(estimated)



COLUMBIA RECORDS PRESENTS:

America's largest of high fidelity

Since 1939, Columbia has recorded great music on original masters of full range and undistorted quality. Today, the LP Catalog—fastest growing in the business—means a growing market for you—a broader opportunity to win new customers, to keep present customers coming back for more! Work this angle for extra sales and profits—*now!*

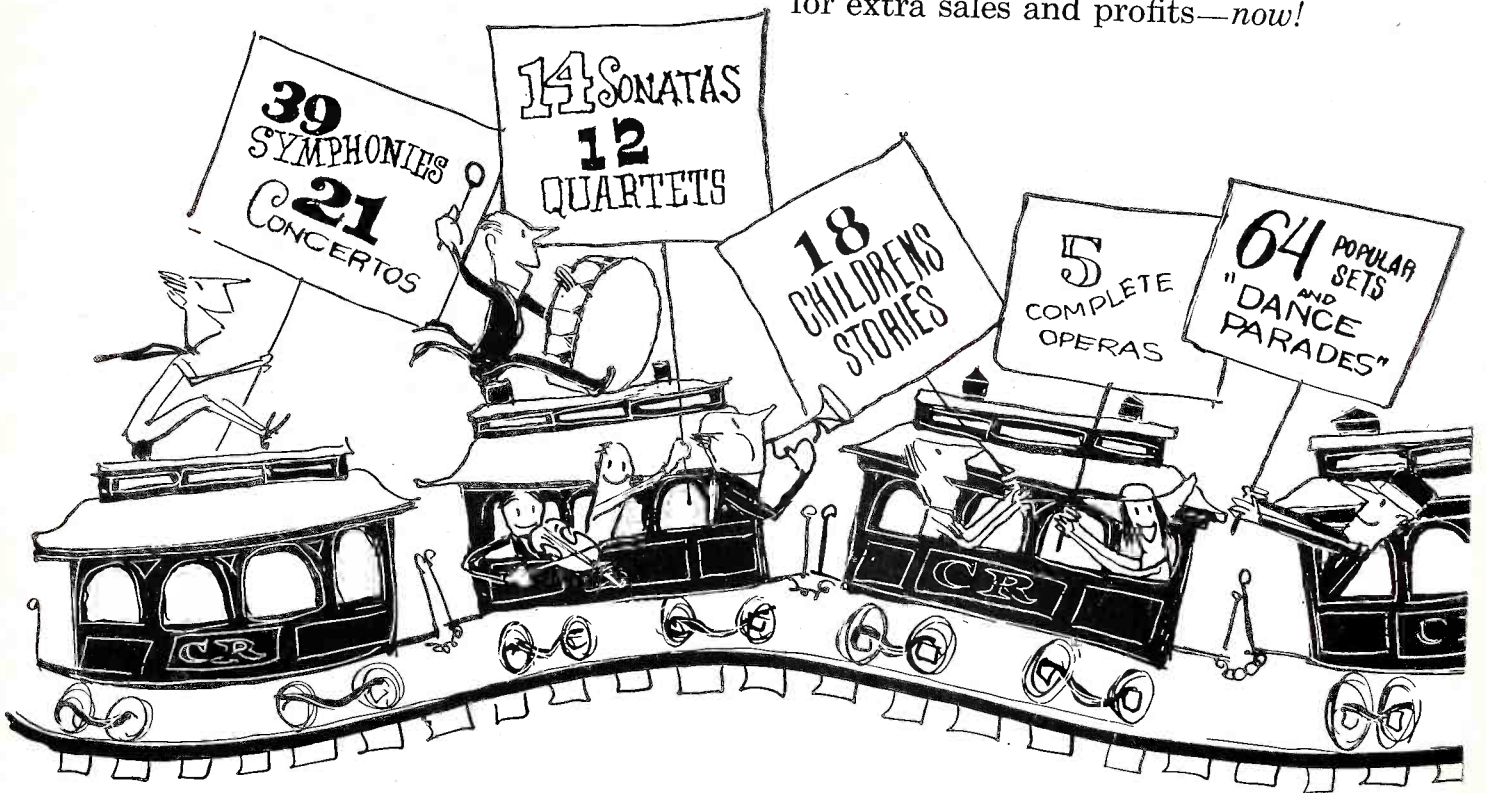

*They all add up to more
than 300 LP Records—
more than 1000 selections!*

Here they come! MORE AND MORE LP selections to meet the mounting demand . . . More music of every type—from Bach to Boogie-Woogie—including outstanding triumphs in complete LP recordings, such as Puccini's *La Boheme*, Handel's *Messiah*, Beethoven's 9th Symphony, the Broadway hit, "Kiss Me, Kate," and the latest smash success, "South Pacific"—both with original casts! AND MORE TO COME!

catalog recordings

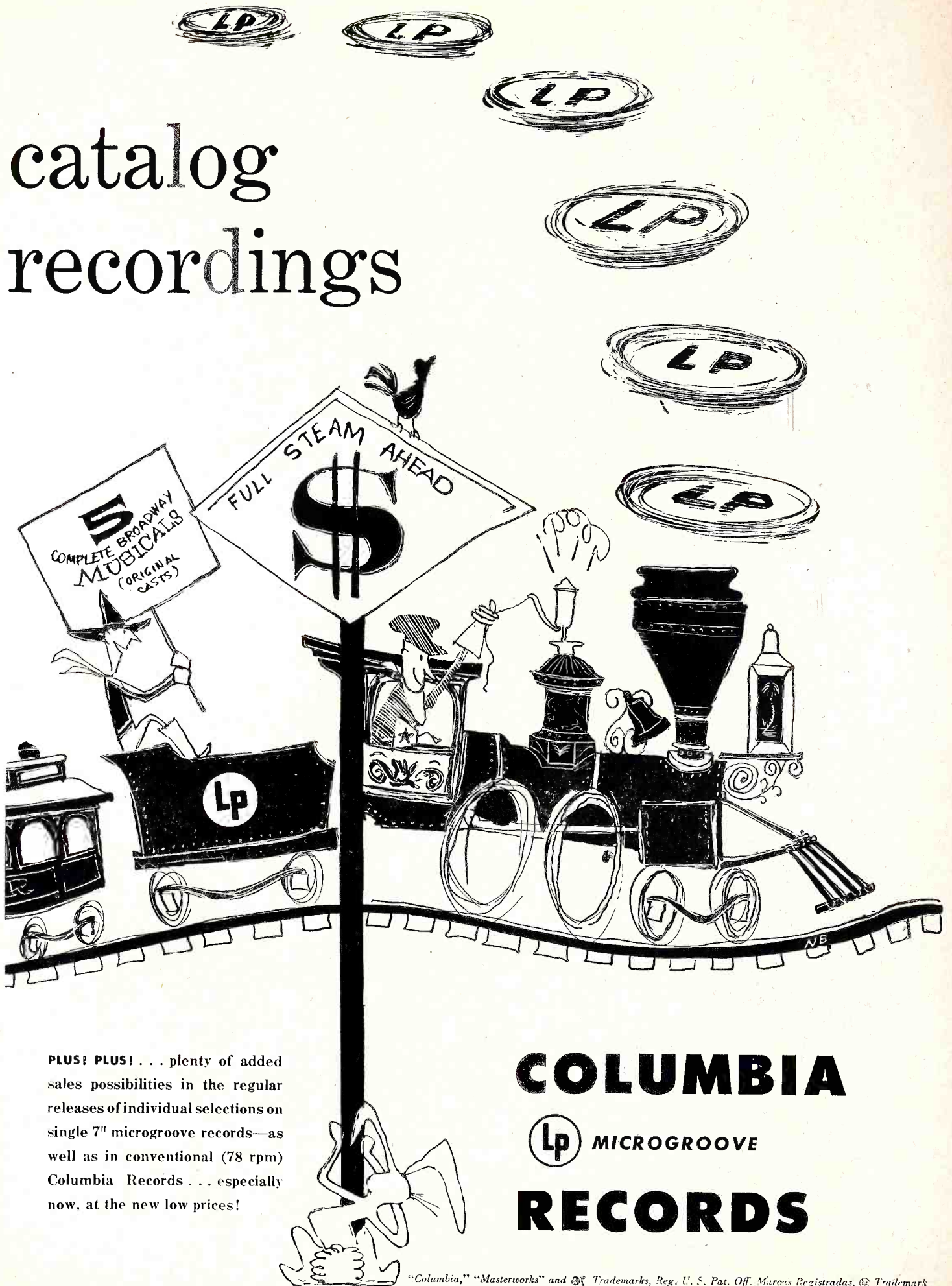

PLUS! PLUS! . . . plenty of added sales possibilities in the regular releases of individual selections on single 7" microgroove records—as well as in conventional (78 rpm) Columbia Records . . . especially now, at the new low prices!

COLUMBIA

LP MICROGROOVE

RECORDS

"Columbia," "Masterworks" and  Trademarks, Reg. U. S. Pat. Off. Marcus Registradas, © Trademark



Columbia Records window display piece features its Dance Parade series and four additional popular albums which are being plugged in the campaign.

Best-Selling

FAVORITE SONG STYLISTS

Top popular vocals include tunes from score of "South Pacific," with almost all the labels issuing several or more selections. **Dinah Shore** does "I'm Gonna Wash That Man Right Outa My Hair," from the musical in a tuneful fashion. "Kiss Me, Sweet" is paired with it. (Columbia 10" 38487, 7" 1-223.)

Frank Sinatra's "The Huckle Buck," with the Ken Lane Quintet (Columbia 10" 38486, 7" 1-222), also looks good from here. "It Happens Every Spring," from film of same name, backs up-and-coming "Huckle Buck."

Columbia has also introduced a new

10-inch disc series titled "Popular Favorites," as its latest innovation in special LP Microgroove releases. The current platter (CL-6057) provides 24 minutes of words and music by vocalists **Frank Sinatra**, **Dinah Shore**, **Arthur Godfrey**, **Doris Day** and **Dorothy Shay**, and by the bands of **Frankie Carle**, **Les Brown** and **Frankie Yankovic**.

The one and only **Billy Eckstine** does "Night After Night," a dreamy ballad, and "New Shade of Blue," a mood indigo release. (MGM 10422)

Vic Damone follows up his "Again" hit with "You're Breaking My Heart" and "Four Winds and Seven Seas." (Mercury 5271) "Heart" is the side to watch.

The Coral label has had its share of successful discs in its brief history, and the **Connie Haines** follow-up to her "It's a Lie" success should be pleasantly received. "Maybe It's Because" is backed with "Hang on the Bell, Nellie." (Coral 60070)

The current trend toward duets on pop discs gets another pleasant rendition from **Jo Stafford** and **Gordon Macrae**. (Capitol 57-566) The pair does "My One and Only Highland Fling," from the "Barkleys of Broadway," in a pleasant and humorous fashion, plus "Thank You," a rhythm ballad.

The **Andrews Sisters** do their first recording without another top artist, in a long time. "Hohokus, N. J." and "Malaguena" (Decca 24648) are welcome additions. The **Ravens**, National Records' outstanding vocal group, are back again with an unusual coupling. (9073) "The House I Live In" (That's America to Me) and the reverse, "Ricky's Blues," an original tune in a rockin' blues tempo.

FOR DANCING & LISTENING

Despite what appears to be a slump in the band business, the top orchestra leaders in the country have been doing quite well with current recordings. "Trumpet Time," a new 4-record **Harry James** album (Columbia C-82), includes seven reissues of Harry James disc hits. **Sammy Kaye** does "Room Full of Roses" (RCA Victor 47-2908; 20-3441),

which, incidentally, was also recorded for the label by Sons of the Pioneers. The coupling, "It's Summertime Again," features vocal by **Tony Alamo**.

Rousing style of **Ray McKinley** featured on "I'm Not Too Sure of My L'Amour," and "I Wanna Be Loved." (RCA Victor 47-2904; 20-3436)

More orchestral music for dancing feet contributed to the current wax scene by: **Xavier Cugat** in two bright rumba numbers, "Los Timbales" and "Muchachita" (Columbia 10" 38477; 7" 1-214); **Frankie Carle's** orchestra with **Marjorie Hughes** and **Bob Lochen** do "Tulsa" and "Save a Piece of Wedding Cake for Me," respectively (Columbia 10" 38457; 7" 1-192); a tuneful production number by **Art Mooney** and orchestra, "There's Something About Patee" (MGM 10418) paired with "Barroom Polka"; **Benny Goodman's** musical contribution is from the film, "Sorrowful Jones," and is a rhythm ballad, "Having a Wonderful Wish" backed by "Shishkabop," an instrumental. (Capitol 57-568)

In the blues field, the inimitable **Ella Fitzgerald** has waxed what promises to be another classic of its kind, "Lover's Gold," backed by "Black Coffee" (Decca 24646). **Gordon Jenkins** gives Ella a really unusual musical backing, lush with strings. The Fitzgerald gal teams up with **Louis Jordan** for their first waxing together in a long time for another Decca hit. "Baby, It's Cold Outside" and "Don't Cry, Cry Baby" (24644).

Charlie Ventura's sax sparks the bop, "Deed I Do," and the flip, "Pennies From Heaven" (National 9077). **Frankie Laine** takes a crack at "bebop" in "Be Bop Spoken Here" (Mercury 5301). The reverse is "Nevertheless," a smooth ballad. **Duke Ellington** and company revive an old favorite, "Singin' in the Rain," with a nice instrumental arrangement; backing is "Don't Get Around Much Anymore" (Columbia 10" 38464; 7" 1-203). **Maurice Rocco**, a night club favorite, debuts on RCA Victor with "Close Your Eyes," a rumba-flavored release; "Why Does It Have to Be Me" is the coupling (22-0019).

FOR FOLK MUSIC FOLLOWERS

Hillbilly music is a steady favorite,

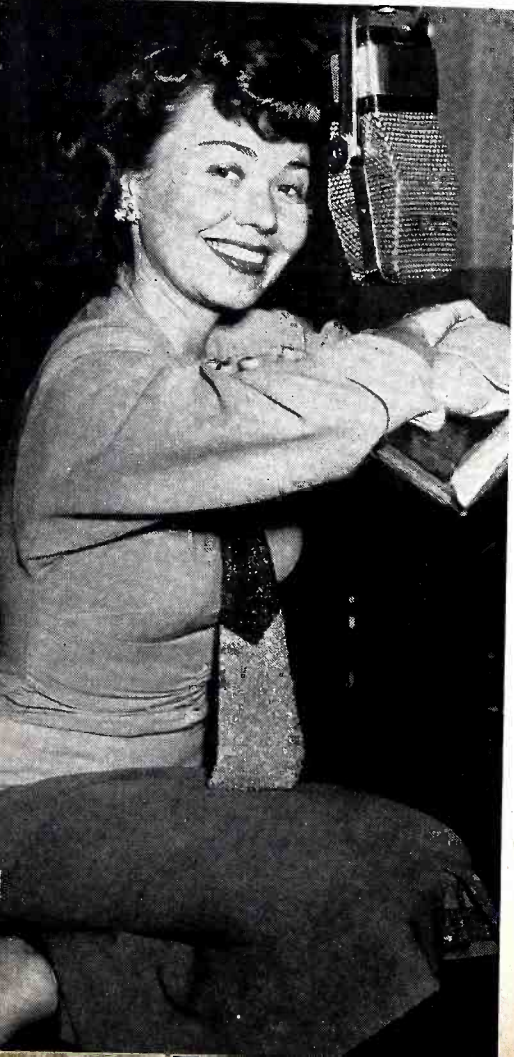

Watch songstress **Connie Haines'** current Coral discings . . . they're hot!

Popular Movie and Show Tunes

in the Limelight; Selling Well—

More Releases Available in the

New Speeds than Ever Before

Discs

Another in the series of ballet music releases issued by RCA Victor that is bound to be a profit-maker.



th dealers finding audiences who like the folk flavor extending from cow country to sophisticated big cities. "Old Time Square Dances" (Square Dances Without Walls) has been issued by Columbia Records (H-8) and features Roy Acuff and Smoky Mountain Boys in a collection of eight sides. Columbia is also issuing a new Long Playing Microgroove record series titled, "Current Country Hits," which will contain eight current best-selling single records in the hillbilly and Western catalogs. The first of these (HL 9008) features artists Gene Autry, Johnny Bond, and Floyd Tillman, as well as George Morgan, Jimmie Dickson, and Leon McAuliffe, three newcomers to the label. "Gene Autry's Western Classics, Vol. II" (Columbia H-7; HL-9002), is another album by the cowboy singing star of perennial favorites that will please young and old.

RCA Victor's Eddy Arnold, "The Tennessee Plowboy and His Guitar," features "The Echo of Your Footsteps" (21-0051) on his latest release. "One Kiss Too Many" is the other side. Spade Cooley and fiddle do some hoedown serenades in "I Had My Heart Set on You" and "Don't Take My Word, Take My Heart" (RCA Victor 47-2905; 20-3437). Elton Britt demonstrates once again his winning ways in "Lorelie," his newest RCA Victor platter (48-0049; 21-0056), with unique echo chamber effect.

(Continued on page 56)

Right: Margaret Whiting, Capitol songstress, hits the jackpot again with her latest releases. Lower left: Judy Garland, star of the new MGM album, "In the Good Old Summertime." Below: Decca's entry into the "South Pacific" sweepstakes features this all-star cast of favorites.



BING CROSBY
DANNY KAYE
EVELYN KNIGHT
ELLA FITZGERALD

SING THE SONG HITS FROM
"SOUTH PACIFIC"

Music — RICHARD RODGERS Lyrics — OSCAR HAMMERSTEIN II

WILL YOU? SOME ENCHANTED EVENING } <i>Bing Crosby</i>	THERE'S NOthin' LIKE A DAME HONEY BUN } <i>Danny Kaye</i>
A WONDERFUL GUY A COCK-EYED OPTIMIST } <i>Evelyn Knight</i>	I'M GONNA WASH THAT MAN RIGHT OUTA MY HAIR HAPPY TALK } <i>Ella Fitzgerald</i>

TITONE

**Now! A
\$10 SALE**
for every
record-player
in your area!

LIST PRICE \$7.50

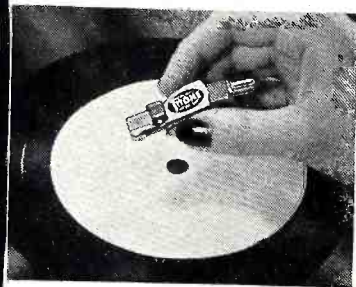

**SELL NEW
TITONE
PICKUP**
to every customer!

Here's a way to quick profit from every player owner who visits your shop! Have your salesmen "plug" it on every service call! First basic pickup advance in over 10 years—the original piezoelectric ceramic pickup, made by SONOTONE, famous makers of hearing aids and miniature tubes!

- SELLS ITSELF IN A 2-TO-5-MINUTE CALL! Fits all tone arms. Let all your customers hear TITONE. They'll say "SOLD!" because—
- TRANSCRIPTION TONE QUALITY! Full frequency to 10,000 cycles! Real high fidelity! Bell-like supertone makes even old players thrilling!
- SURE-FIRE IN HUMID CLIMATES! Utterly unaffected by climate, moisture, fungus! Booms sales, wins back customers.
- DOUBLES RECORD LIFE AND PLEASURE! Gives "ordinary" records sparkling quality—revives worn favorites. Will play down to 1/2 normal pressure. NO "needle talk"!
- RUGGED! PERMANENT! No crystals, magnets, filaments to fail! No pre-amplifiers. Ceramic TITONE performs perfectly for years!

**NO TONE LIKE
TITONE**

CALL YOUR JOBBER—
or write now to
SONOTONE, Box T-1, Elmsford, N. Y.

(Continued from p. 55)

VOCAL ARTISTS

Metropolitan Opera Baritone Robert Merrill offers listeners an album of "Folk Songs of the British Isles" (RCA Victor WMO-1306; MO-1306), for an off-the-beaten track addition to the collector's shelves. Some first-rate singles are included in this month's vocal releases. Christopher Lynch, tenor, does "Sing a Song of Six-pence" and "Little Boy Blue" (RCA Victor 4552-M; 2-159) for an unusual recording suited for children and delightful adult listening. Ezio Pinza, the popular basso, demonstrates his talents with this aria from Verdi's "Don Carlos" (Columbia 72802-D; 3-148). Tenor Jan Peerce sings the timely wedding theme, "Oh, Promise Me" (RCA Victor 12-0795) and the lovely "Serenade" from Romberg's operetta, "The Student Prince," for a definitely appealing single. Soprano Licia Albanese sings two lovely arias, one from the little-known opera, "Adriana Lecoucreur," and one from Mozart's "Don Giovanni" (RCA Victor 12-0658), for another ample demonstration of her wide ability and talent. Marilyn Cotlow, Metropolitan soprano, makes her RCA Victor record debut with two ballads, "Sleep, Now," by Samuel Barber, and "At the Well," by Hageman.

Rise Stevens sings melodies derived from works of five of the great composers in Columbia's "Symphonic Songs" (MM-826; ML 2039). Selections such as "Tonight We Love," from Tchaikovsky's First Piano Concerto; "Full Moon and Empty Arms," from Rachmaninoff's Second Piano Concerto, are included. In the RCA Victor "Spot-Light Series" Alfred Drake sings "Malaguena" in an exciting new manner, and couples it with the waltz, "In the Spring of the Year." Altogether a completely captivating disc.

FOR SERIOUS MUSIC ENTHUSIASTS

RCA Victor's June Red Seal list marks the first month that a complete set of new releases is being made available simultaneously on 45 RPM discs as well as conventional type records. Serge Koussevitzky conducts members of the Boston Symphony Orchestra in Mozart's "Serenade No. 10, in B-Flat" (WDM-1303; DM-1303). It has been suggested that dealers plan displays stressing Dr. Koussevitzky's 25th anniversary with the Boston Symphony. Another Mozart work, the "Concerto No. 1, in B-Flat" (RCA Victor WMD-1304; DM-1304), has been released with Arturo Toscanini directing the NBC Symphony.

Columbia Masterworks releases offer dealers a chance to stock some newly recorded material that range from Bach to Prokofiev. "Scythian Suite, Op. 20" will appeal to Prokofiev collectors. Eugene Ormandy conducts the Philadelphia Orchestra in this musical masterpiece of pagan legends and rites (Columbia MM-827; ML-4142).

Virtuosi releases spotlight Jascha Heifetz' addition to his recorded repertoire of Mozart sonatas for violin and piano, an RCA Victor album of "Sonata No. 8 in C" (DM-1290); Emanuel Bay is at the piano. The well-known Sonata combined with the deft Heifetz touch will definitely be a seller. More evidence of Yehudi Menuhin's technique is found in his recording of Sarasate's "Habanera" and Wieniawski's "Scherzo Tarantelle" (RCA Victor 49-0404; 12-0922). Both works are concert favorites of the artist.

tri-o-matic

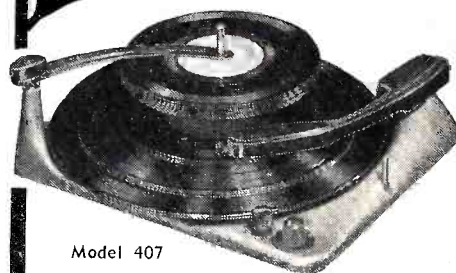

Model 407

**PLAYS AUTOMATICALLY
ALL RECORDS—ALL SPEEDS
ALL SIZES**

The new V-M Tri-O-Matic Record Changers are original equipment on most "Name Brand" Radio-TV-Phono's. Records are LOWERED—NOT DROPPED—on spindle shelf, affording positive record protection. V-M Models 406 and 407 Trio-O-Matic are available as replacement units and on plug-in bases. Get full details from your local distributor.

Immediate Delivery!



BENTON HARBOR, MICHIGAN

**And Now . . . Introducing
Movement with LIGHTS!**

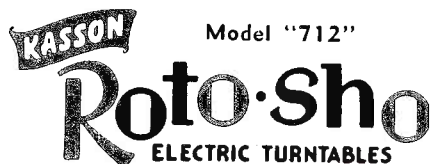

Model "712"

**The ACTION Display-Way
To Boost Your Sales!**

MODEL "712" ROTO-SHO's two-way built-in electric outlet permits novel, self-contained lighting effects as well as operation of electrical devices while the turntable revolves three times a minute! (Lights turn with table.)

There's nothing like "712" to revolutionize your window trim, because motion plus correct lighting is the key to successful displays. Sturdy construction, guaranteed, carries up to 200 lbs. Table 18" in diameter. A.C. only.

Write for our complete ROTO-PRODUCTS catalog!

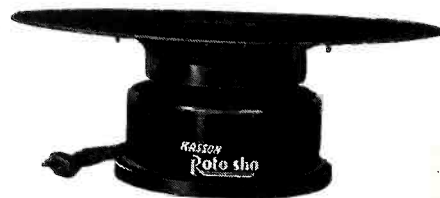

GENERAL DIE AND STAMPING CO.
Dept. TV, 262 Mott St., New York 12, N. Y.

America has seen it... America has heard it...

America says it's
WONDERFUL!



... The **ECONOMY** of the new RCA Victor 45 rpm system is making player-owners of *more people!*

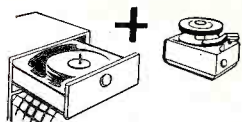

... Many owners of 78 rpm players are *adding* the finer, more economical 45 rpm changer to their equipment!



... Lower cost-per-record is getting all 45 rpm owners to buy *more records!*

All across the country, people have read about, seen, and heard RCA Victor's amazing new 45 rpm system...

Thousands have said immediately, "That's for me!" And no wonder! Look at some of the attractions of the 45 rpm system that make people eager to own it:

- Astonishing "live talent" **TONE**... distortion-free...with virtually *no* surface noise!
- World's fastest record changer... a marvel of trouble-free, trigger-action simplicity!
- Record-saving "Silent Sapphire" permanent pick-up! Only 1/8 oz. pressure. Records sound "new" *far longer!*
- Vinylite records are non-breakable! Surface-saving shoulders prevent damage to music grooves!
- All records the same size. One foot of bookshelf holds 150 singles, or 18 average albums!
- 7 eye-catching colors make it easy to select the 7 types of music!

● **Economy!** Every day there are more **NEW** record-player homes! And many 78 rpm homes are *adding* the finer 45 rpm system to their equipment! So your record market has now grown to include:

- 78 rpm owners
- Owners of *both* 78 rpm and 45 rpm
- New owners of 45 rpm players only

What's more, the lower cost and finer tone of Victrola 45 rpm records is leading to *more frequent record buying!*

Take full advantage of this new buying habit—it's your sure way to bigger turnover and profits! RCA Victor's "new standard in the field of recorded music" will pay off for you, more and more!

There are still 16 million 78 rpm players! That's why RCA Victor will go on matching every 45 rpm release with 78 rpm records! None of your customers will be cut off from "the music they want when they want it."

RCA VICTOR



"Victrola" T.M. Reg. U. S. Pat. Off.

DIVISION OF RADIO CORPORATION OF AMERICA

PIONEER AND WORLD LEADER IN RECORDED MUSIC



She'll say **YES, YES**
to your **gift suggestion**

YES! ... if you feature traffic appliances that make *attractive* gifts — nationally advertised items — **THE LINES DISTRIBUTED BY GraybaR**
YES! ... if you use good selling methods — modern merchandising and promotion tools — **THE SALES HELPS AVAILABLE FROM YOUR LOCAL GraybaR APPLIANCE SPECIALIST.**

Yes, and you'll get prompt deliveries from a Graybar warehouse near you.

These are a few reasons why thousands of dealers throughout the nation make Graybar their No. 1 source of electrical appliances.

4960

Appliance Department
GRAYBAR ELECTRIC COMPANY, Inc.
 Executive Offices:
 Graybar Building, New York 17

THEY SAY YES WHEN YOU FEATURE APPLIANCES ... recommended by **GraybaR**

IN OVER 100 PRINCIPAL CITIES

ELECTRICAL APPLIANCES

Section of **RADIO & TELEVISION RETAILING**

TV—Your Star Appliance Salesman— Not Your Competitor!

• From all viewpoints, Television is stealing the retail merchandising show.

This video infant is successfully challenging gigantic, long-established industries in bids for the consumer's dollar.

And that's not the most amazing part of the story, either. Not by a long-shot!

The most astounding "competitor" this limelight-hogger, Television, is providing at the moment is being felt by the television dealer himself who finds his salesmen "neglecting" electrical appliances, phonograph records and other products. They can't be made to dig iron out of the mine when there's gold in the same pit.

Following the lines of least resistance, salesmen are automatically "specializing" in obtaining those easy big-ticket TV orders. As a result other products are gathering dust in the stores.

Grab the Easy Sales

Dealers are worried. So are those manufacturers of electrical appliances who have no radio products. And equally concerned are the makers of phono records and playing equipment who have no irons in the TV-radio picture.

So real and virile is this television "competition" that at least one large

manufacturer, making appliances exclusively, has been urging dealers, at its sales meetings, to soft-pedal TV selling, and to get more action into merchandising its products because of the larger profit-rate.

Many retail merchants have revamped sales operations because of this "competition." While they are duly enthusiastic about the rapid-fire selling action of TV, and the profit such action brings, they want to keep the volume up on other merchandise too. In meeting the situation, most retailers are offering a lower rate of commission on TV sales. Many merchants have set up separate television departments, manned by salespeople who sell nothing but TV receivers. Several others have opened exclusive television stores at other locations in order to get a better play for non-TV products.

So far as salesmen go, the dealer knows that they will grab the easy pickings first. Therefore, the retailer is wise to set up facilities designed to move other products he has his money tied up in, and, at the same time try to keep TV sales at peak levels, by doing nothing to discourage salesmen in their enthusiasm for TV selling.

Potent Sales Weapon

Thus far we have viewed Television as a kind of competitor of ours . . . a sort of glorified star boarder.

We've looked at Television as a seller obtaining its results by rolling over the bodies of other products it has killed . . . as a sort of merchandising Frankenstein's Monster.

A most unfair, unkind and unnecessary viewpoint because Television can be made to be the most potent sales weapon we know of to sell other products.

Think of it this way: Television is the
(Continued on page 83)



New Profit-Making

Universal REFRIGERATOR

Deluxe 8.5 cu. ft. model refrigerator, shown, features a freezer locker giving ample frozen food space in its 1.5 cu. ft. capacity; locker is horizontal in design, holds 50 lbs. of frozen meats, fruits and vegetables as well as four aluminum "quickout" ice cube trays. Adjustable sliding shelves, twin service crispers, which

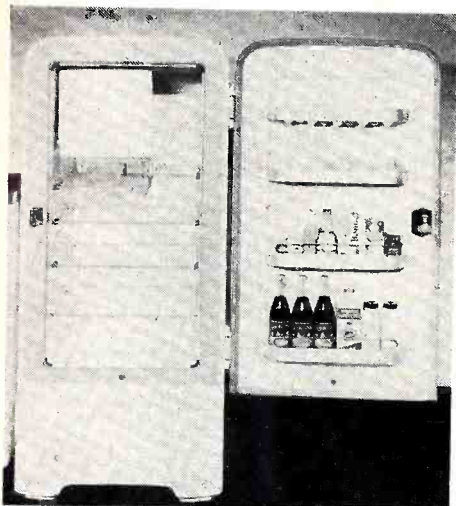

can be converted to auxiliary meat drawers, large storage cellar. The standard 9 cu. ft. refrigerator features a large .7 cu. ft. capacity large speed freezer equipped with two "easyout" ice cube trays and one desert tray; holds up to 30 lbs. frozen foods. Other features found in both the deluxe and standard model refrigerators include: eye-level temperature control adjustable to 10 positions; aluminum ice cube trays; automatic interior recessed light; hermetically sealed economy freezing unit; seal-tight automatic door latch. Landers, Fray & Clark, New Britain, Conn.—RADIO & TELEVISION RETAILING.

Westinghouse MILK CAN HOIST

The hoist comes as an attachment to the milk cooler and has a suggested retail price of \$32.95. It uses a standard steel cable. The new hoist reduces the lifting operation to fastening a clamp onto the milk can and turning a self-locking crank; eases dairy farmers' work of lifting heavy milk cans in and out of electric milk coolers. Westinghouse Electric Corp., E. Springfield, O.—RADIO & TELEVISION RETAILING.

All American DISHWASHER

Dishwasher features easy installation by simply snapping one hose onto hot water faucet and loop drain hose into sink; no plumbing necessary. Dishwasher rolls on over-size fibre casters. Compact size 22 x 16 x 36 inches. Features: 5 motor-powered hydrojets; uses 3½ gallons of hot water; white laminated-fiberglass cover and tub; rust-resistant racks; heavy-duty double-acting marine pump. American Dishwasher Co., 299 Madison Ave., New York 17, N. Y.—RADIO & TELEVISION RETAILING.

Hotpoint RANGES

Full size standard model range to retail at \$179.95 featured in new range program. Program also places new use-value features, including oven timers and a combination raisable unit, on other models, with some prices as much as \$15 less than on previous corresponding models. Hotpoint, Inc., 5600 W. Taylor St., Chicago 44, Ill.—RADIO & TELEVISION RETAILING.

L & H ELECTRIC RANGE

Two-oven automatic electric range features: two 7-heat monotube surface units; two 5000 super ovens with automatic pre-heat oven temperature control for each

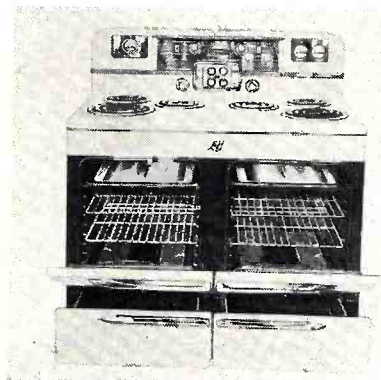

oven; automatic time control and electric clock; selector switch for automatic timing of right oven, appliance receptacle, two left surface units, interval timer; fluorescent range lamp. Has two roomy service drawers below. Lindemann & Hoverson Co., Milwaukee.—RADIO & TELEVISION RETAILING.

Everhot PRODUCTS

Model 858 Roasterette, replaces No. 851; electric casserole unit combines deep well cooker, roaster, casserole, bean cooker and food warmer. Has two-heat control; white heat-resistant exterior. List price is \$9.95. Deluxe Rangette, model 828 shown, is

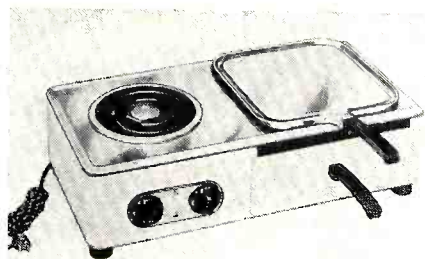

equipped with Tuttle & Kift tubular heating element, is priced to sell for \$41.95. Features: stainless steel top deck; cast aluminum frying griddle; broiler drawer fitted with aluminum pan and two-position broiling rack. All electric timer-clock, model 927, makes appliance operation automatic. Plug into appliance and set with one knob, hour at which cooking or heating is to stop, length of time current is required. The Swartzbaugh Mfg. Co., Toledo 6, O.—RADIO & TELEVISION RETAILING.

Crosley SHELVDOR REFRIGERATOR

AA-7 refrigerator priced to retail at \$199.95. Model has full 7 cu. ft. capacity;

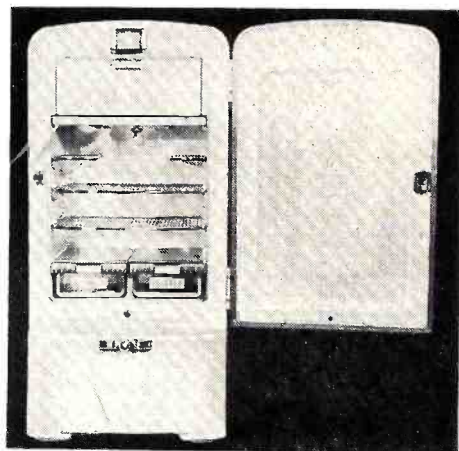

exterior cabinet requires no more floor space than standard four foot model. Crosley Division, Avco Mfg. Corp., Cincinnati, O.—RADIO & TELEVISION RETAILING.

Telechron CLOCK

Kitchen clock to sell for \$3.98, model 2 H 19. It has a plastic case of red or white

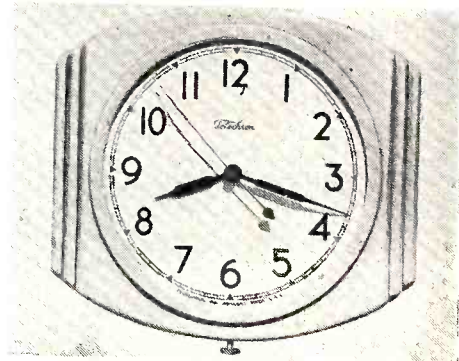

with a four-and-a-half-inch dial. Clock runs on silent synchronous motor. Telechron Corp., Ashland, Mass.—RADIO & TELEVISION RETAILING.

Markel WALL HEATER

250 series of intermediate-duty Heetaires includes wall-attachable and wall-insert models. Feature: optional thermostatic control, increased heating efficiency, automatic re-set, safety switches, scientifically designed air intake, and other improvements. Built-in thermostats control the operation of both the heating element and an 8-inch four-bladed fan on models 250 KT and 250 KTW. The wall-insert models attach to a Heetaire box which is recessed in the wall, forward edges flush with the wall surface. Markel Electric Products, Inc., and La Salle Lighting Products, Inc., Buffalo.—RADIO & TELEVISION RETAILING.

Appliances for Dealers

Horton CLOTHES DRYER

Electric model E49; gas G49, automatic clothes dryer. Dial can be set for damp dry or fluffy dry and the dryer stops auto-

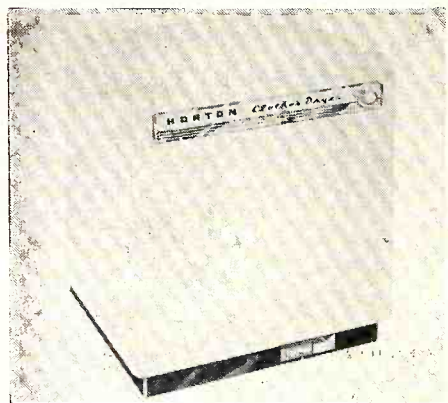

matically: automatic cooling period. Capacity 9 lbs. dry clothes; 20 lbs. wet clothes. Dimensions: 30 inches wide, 24 $\frac{3}{4}$ inches deep, 36 inches high. Horton Mfg. Co., Ft. Wayne 1, Ind.—RADIO & TELEVISION RETAILING.

Cordomatic RETRACTABLE REEL

Reel hooks on to blower end of any make tank cleaner; is permanently secured at the turn of a thumbscrew. Does not affect cleaner suction. Any desired cord length up to 20 feet rolls out as required and rewinds automatically. Reel provides a pedestal base upon which to store tank cleaner in closet. The Vacuum Cleaner Corporation of America, Philadelphia, Pa.—RADIO & TELEVISION RETAILING.

Guth AIR CIRCULATOR

"Guthfan" air circulator features modern styling and design. Types include both close ceiling and suspended models, and in combination with luminous bowl lighting fixtures. Offer "complete cycle" circulation. Pulls up cooler lower air and circulates it in all directions. Edwin F. Guth Co., St. Louis 3, Mo.—RADIO & TELEVISION RETAILING.

Hopax CIRCUIT BREAKER PLUG

A new attachment plug that doubles as a circuit breaker is designed to guard against dangerous overloading, stalling or rotor locking on any machine employing a fractional horsepower motor. According to the manufacturer, to reset the plug it is only necessary to remove it from the receptacle, then raise and lower the lever between the prongs. The Hopax Circuit Breaker Plug is available in a range of ratings up to 10 amperes and should be used at equal to the rated capacity of equipment it protects. Hopax Electric, Inc., 547 Greenwich St., New York 13, N. Y.—RADIO & TELEVISION RETAILING.

Maytag WASHER

Automatic washer available in model AM (gravity drain) and model AMB power driven water discharge pump. Dimensions: 36 inches high, 25 $\frac{1}{2}$ inches wide; 27 $\frac{1}{4}$ inches deep. Cabinet is finished in white,



high-baked enamel; water capacity of 13.4 gallons. Features: top loading; gyrofoam washing action; and spin dry process; safety lid; sealed in oil power unit. Provision for simple attachment to hot and cold water, and convenient access to a drain, makes for easy installation. The Maytag Co., Newton, Iowa.—RADIO & TELEVISION RETAILING.

Paragon TIMER

"Time Aid" 3-purpose precision timer shuts off any electrical appliance automatically after pre-set time; buzzer signals time



accurately in minutes to one hour; shuts off any electrical appliance and signals completion of time elapsed. All electric; non-breakable case. Retail for \$9.95. Paragon Electric Co., Two Rivers, Wis.—RADIO & TELEVISION RETAILING.

Sno-Breze AIR COOLER

Model 15 F 49PS "self-contained" evaporative air cooler, for use particularly in rooms where a water connection or drainage is impractical. Unit weighs 29 lbs., is 24 inches wide, 23 $\frac{1}{2}$ inches high. Easily installed. To operate, fill with water and "plug in." During winter months unit can be used inside the house as an indoor humidifier and heat circulator. Palmer Mfg. Corp., Phoenix, Ariz.—RADIO & TELEVISION RETAILING.

Ultra-Chef REFRIGERATOR-RANGE

Model 500-G combination refrigerator, gas range, extra large oven, and adjustable roll-



out broiler. Range top has two regular size burners, two giant burners. Included in the refrigerator are 2-tray ice makers, drip pan, vegetable storage bin. Overall dimensions: 46 inches long, 26 inches high, 25 inches deep. Ultra-Cold, Inc., 2615 Exposition Place, Los Angeles 16, Calif.—RADIO & TELEVISION RETAILING.

Chelsea WINDOW FAN

Outside window fan type AP; belt driven for convenient mounting. Available with either hood or automatic shutter. Equipped with cord and plug and pull-chain switch. Available in 24 inch and 30-inch sizes. Chelsea Fan & Blower Co., Inc., 1206 Grove St., Irvington, N. J.—RADIO & TELEVISION RETAILING.

Safe-stor IRON HOLDER

Iron holder made of 8 gauge zinc coated steel; 8 x 5 $\frac{1}{2}$ x 5 $\frac{1}{2}$ inches. Fits any iron.

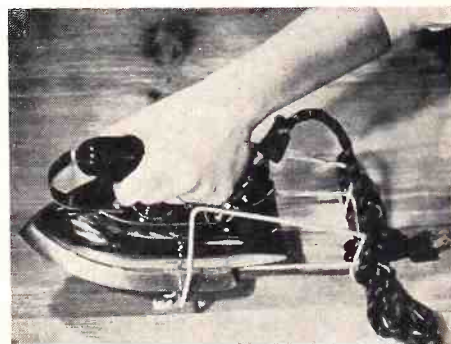

electric or steam; easily attached to closet door or wall, out of child's reach. Sells for 39c. Cornel-Morgan Corp., 17 E. 42nd St., New York, N. Y. RADIO & TELEVISION RETAILING.

Floralite LIGHTING UNIT

Electric garden lighting unit available in an assortment of models; seven existing types consist of the 15, 30 and 60 foot cord sets; the add-a-floralite with receptacle in base for connecting a number of units together. Ideal for garden lighting needs. Steber Mfg. Co., Broadview, Ill.—RADIO & TELEVISION RETAILING.

Operating Cost Figures Help You Sell More

• When your customer wants to know the approximate cost of operating a radio or appliance, be certain that you have an answer ready—an answer the customer may readily understand.

A great many home-owners hesitate buying additional appliances because they fear such devices will increase their electricity bills.

Most of the buyers have exaggerated ideas about costs of operating radios and appliances, and dealers know customers who hesitate buying an electric clock because "it runs all the time, and costs a lot to operate." While such "notions" may seem ridiculous to the re-

tailer, it is a fact that they exist in the minds of many, and it is up to the dealer to set the buyer right in these matters.

In most communities the utility offers "sliding" rate scales, and where this practice prevails, the dealer should point out to the customer that the more current he uses, the lower the rate.

The salesman who has appliance operating costs on the tip of his tongue helps break down still another sales barrier, and, importantly enough, also becomes an "expert" in the eyes of the customer.

More and more there is less and less sales resistance to new electrical "servants" for the home, but the purchase of *additional* equipment by some people is still held in abeyance because of preconceived ideas that electric consumption bills will increase materially as a result.

The accompanying tables have been prepared by the editors for the convenience of dealers. Items marked * cost even less than the figure shown because they are intermittent in operation, cutting in and out or automatically dropping to lower wattages:

APPLIANCE	Average wattage	Cost per hr at 4¢ kw-hr rate	AVERAGE ANNUAL COST (DOMESTIC USE)	
Blanket, electric.....	215*	½ of 1¢	Water Heater.....	\$75.00
Bottle Warmer.....	400	2¢	Cooking Range.....	50.00
Broiler.....	1000	4¢	Food Freezer.....	21.00
Clocks, electric.....	2	8/1000 of 1¢	Clothes Dryer.....	14.00
Clothes Dryer.....	4000	16¢	Refrigerator.....	13.00
Coffee Maker, glass.....	450	2¢	Oil Burner.....	12.00
Cooker (egg).....	600	2¢	Television Set.....	12.00
Corn Popper.....	550	2¢	Roaster.....	8.00
Curling Iron.....	20	8/100 of 1¢	Fan, attic, 48".....	7.00
Dishwasher.....	350	1¢	Blanket, electric.....	6.00
Disposal Unit.....	310	1¢	Ironer.....	5.00
Food Freezers, domestic.....	200	8/10 of 1¢	Space Heater (1250 watt).....	4.00
Fan, 8" desk.....	25	1/10 of 1¢	Hand-iron (1000 watt).....	4.00
Fan, 10" desk.....	45	2/10 of 1¢	Console Radio.....	4.00
Fan, 12" desk.....	50	2/10 of 1¢	Room Cooler.....	3.00
Fan, attic ventilator, 24".....	200	8/10 of 1¢	Broiler.....	3.00
Fan, attic ventilator, 48".....	320	1¢	Automatic Toaster.....	3.00
Grill, sandwich.....	800	3¢	Washing Machine.....	2.50
Hair Dryer.....	100*	4/10 of 1¢	Hot Plate (1000 watt).....	2.00
Heat Lamp (infrared).....	250	1¢	Small Radio.....	2.00
Heaters, space.....	660-1250	3 to 5¢	Percolator.....	2.00
Irons, hand, automatic.....	800-1000*	3 to 4¢	Dishwasher.....	2.00
Ironers.....	1400*	6¢	Disposal Unit.....	2.00
Juice Extractor.....	50	2/10 of 1¢	Sandwich Grill.....	1.00
Mixers, food.....	75	3/10 of 1¢	Vacuum Cleaner.....	1.00
Oil Burner.....	250	1¢	Fan, desk, 12".....	.85
Pads, heating.....	75*	3/10 of 1¢	Heat Lamp (infra-red).....	.80
Percolator.....	450	2¢	Sun Lamp.....	.80
Range, cooking.....	7500	special rate	Sewing Machine.....	.75
Radio, small.....	30	1/10 of 1¢	Cooker (egg).....	.67
Radio, large.....	100	4/10 of 1¢	Clock, electric.....	.60
Television Set.....	300	1¢	Waxer, floor.....	.56
Razor, electric.....	10	4/100 of 1¢	Hair Dryer.....	.40
Refrigerator.....	200	8/10 of 1¢	Waffle Iron.....	.38
Room Coolers.....	600	2¢	Bottle Warmer.....	.38
Roaster.....	1320*	5¢	Electric Razor.....	.35
Sewing Machine.....	80	3/10 of 1¢	Food Mixer.....	.27
Stove, table, 3-heat.....	350-550-1000	1-2-4¢	Heating Pad.....	.20
Sun Lamp (SI bulb).....	400	2¢	Corn Popper.....	.18
Sun Lamp—RS type.....	275	1¢	Curling Iron.....	.16
Toaster, automatic.....	800*	3¢	Vibrator.....	.08
Vacuum Cleaner.....	250	1¢		
Vibrator.....	45	1/6 of 1¢		
Waffle Iron, automatic.....	800*	3¢		
Washing Machine.....	200	8/10 of 1¢		
Water Heater.....	2660*	10½¢		
Waxer, floor.....	200	8/10 of 1¢		

SERVICE & SOUND

Section of RADIO & TELEVISION RETAILING

Admiral 3-Speed Record Changer

● The new Admiral RC221 and RC222 record changer is one of the first units to appear in sets which is capable of automatically changing all of the current sizes and speeds of records. The ingenuity of such a device will be apparent when it is considered that it is necessary to accommodate: 3 speeds, 3 record diameters (7, 10 and 12 inch), 2 spindle sizes ($\frac{1}{4}$ inch and $1\frac{1}{2}$ inch), and 2 different stylus tips (3 mil and 1 mil). In addition, the Admiral changer provides for two different types of tripping (oscillating trip for 78 and $33\frac{1}{3}$ RPM, position trip for 45's), since the 45 RPM records do not have an eccentric groove. Changing needle pressures for the two different needles has, however, been obviated

and for convenience in identification, the "LP" needle is painted red, and the needle guard on the LP side of the cartridge is also painted red.

Records are supported by one post and the spindle. For 10 and 12 inch records, a conventional spindle with offset shelf is used to hold the records. For 7-inch records, a spindle with a decided slant near the top is used so that the offset shelf is closer to the post. The post (called head assembly) has two positions, one for 7 and 10 inch records, and one for 12 inch records.

A "record size selector" on the tone arm adjusts the set-down point for the different sizes of records (extreme left for 7-inch, extreme right for 10 and 12-inch records).

The needle cartridge rotates. When "78" faces up, the proper needle (3 mil) for 78 RPM records is in position. When "LP" is up, the proper needle for either $33\frac{1}{3}$ or 45 RPM records is in position. Both needles are replaceable,

and for convenience in identification, the "LP" needle is painted red, and the needle guard on the LP side of the cartridge is also painted red.

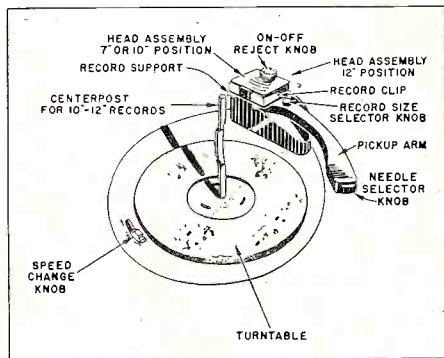

with a light-weight cartridge which can track both types (standard records and microgrooves).

The turntable speed is determined by the diameter of the drive shaft that drives the idler wheel (see fig. 1). The 78 RPM drive shaft is a part of the motor armature. The $33\frac{1}{3}$ RPM and 45 RPM drive shafts are driven by the 78 RPM drive shaft by two rubber belts, and are moved in and out of position mechanically when the speed change knob is moved. When the speed change knob is moved to the "45" position, the change to position trip is ef-

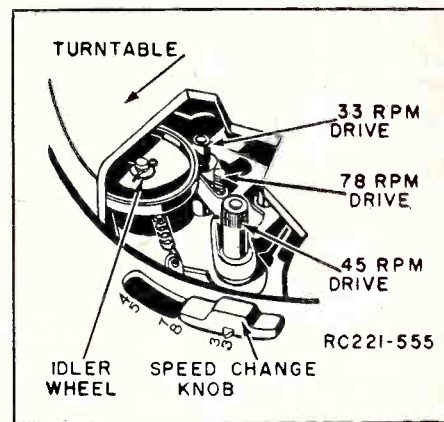
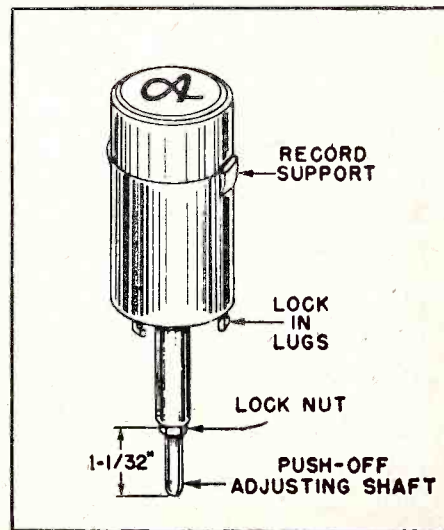
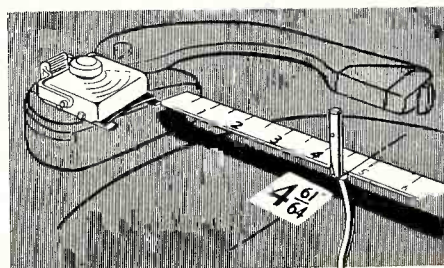
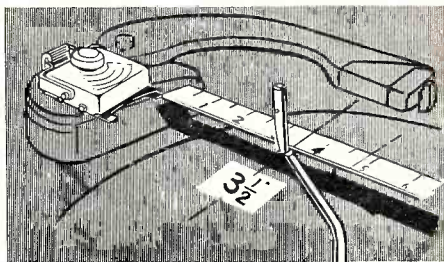

Figure 1

A special spindle for 45 RPM records is provided (this makes 3: one for 10 and 12 inch records; one for 7 inch, (Continued on page 80)

Figure 2: The three spindles—to the right, the 45 RPM spindle; top left, the bent spindle for 7-inch $33\frac{1}{3}$ RPM records; bottom left, the conventional spindle for 10 and 12 inch 78 and $33\frac{1}{3}$ RPM records



TELEVISION TECHNICIAN

Section of RADIO & TELEVISION RETAILING

Lyte SKY TUNER

Sky Tuner is an antenna rotator controlled by a remote control unit at the receiver, connected to the motor unit by a 3-conductor cable. The antenna, after being rotated, is gear-locked into position.

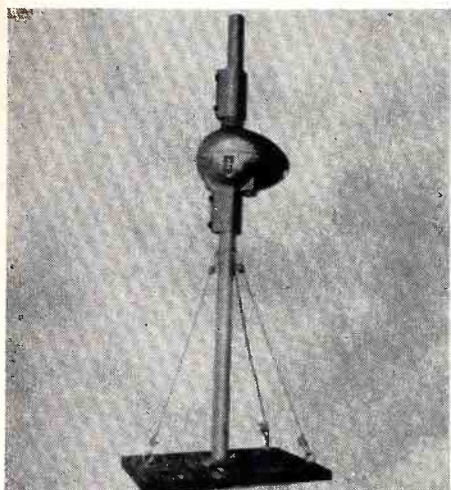

The Sky Tuner is said to support antenna weight up to 150 lbs. Interference and ghosts can be eliminated, the maker states, by pin-point orientation. Lyte Parts Co., 312 Park Ave., Plainsfield, N. J.—RADIO & TELEVISION RETAILING.

Quad-Loop TV ANTENNA

The Quad-Loop, a quadrature phasing antenna, consists of two loops and two dipole sections, 90 degrees out of phase. Quad-Loop is a stationary antenna which achieves the effect of a mechanically rotated antenna through the use of a patented phasing device located at the receiver. The Quad-Loop need not be oriented when installed and thus requires but one man for the installation. Quad-Loop uses the loops for high frequency reception and the dipoles for low. When used on lower frequencies the loops act as resonated sections for the dipoles. Square Root Mfg. Corp., 901 Nepperhan Ave., Yonkers 3, N. Y.—RADIO & TELEVISION RETAILING.

Vidi-Master TV ANTENNAS

The new broad band antenna principle employed in Vidi-Master antennas is the use of two folded dipoles of unequal length driven by a phasing section in a close spaced array. Double resonance response characteristic is said to provide higher gain over wider frequency range. Bi-directional or uni-directional low band patterns are obtained by connecting phasing section in or out of phase. Higher front to back ratio than any other two element broad band antenna is claimed by the maker. Vidi-Masters are pre-assembled to match either 72 ohm or 300 ohm transmission lines. Communication Measurements Laboratory, Inc., 120 Greenwich St., New York 6, N. Y.—RADIO & TELEVISION RETAILING.

Grayhill TWIN-LINE CONNECTOR

By means of this new connector, it is suggested, different combinations required for varying conditions of operation may be easily hooked into the TV circuit. Such accessories as inside and outside antennas, boosters, matching stubs and matching devices, etc., are quickly connected. Added lengths of line can be easily inserted for

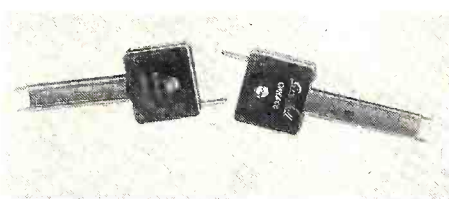

standing wave correction. Smaller sets are made portable, since the connector makes it possible to move them around the house. To attach the wire, the screw holding together the two sections of the molded phenolic housing is removed and the wires are inserted into the pin connectors. Grayhill, 1 North Pulaski Road, Chicago 24, Ill.—RADIO & TELEVISION RETAILING.

Philco TV ANTENNA

An indoor television aerial which can be placed anywhere in the room and is completely adjustable as to channel and direction is now available. The V-shaped aerial has two dipoles, each of which can be extended to a length of 44 inches. It is priced at \$6.95. Philco Corp., Tioga and "C" Sts., Phila., Pa.—RADIO & TELEVISION RETAILING.

Eico OSCILLOSCOPE KIT

A new 5" Oscilloscope, model 400, is available both as a kit and a fully wired and tested oscilloscope. The scope has a horizontal sweep circuit of 15 to 30,000 c.p.s. Frequency response of horizontal and vertical amplifiers is 50 c.p.s. to 50,000 cycles.

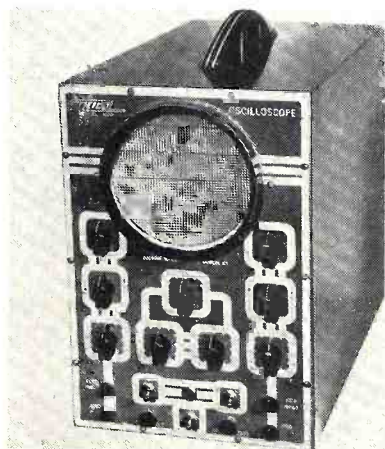

Deflection sensitivity: .30 volts per inch. The scope in kit form comes complete with all necessary components, tubes, and full schematic and pictorial diagrams and instructions. Electronic Instrument Co., Inc., 276 Newport St., Brooklyn 12, N. Y.—RADIO & TELEVISION RETAILING.

RCP TEST EQUIPMENT

Two important price reductions have been announced on RCP test equipment. Model 805B Combination Tube and Set Tester, which has sold for \$89.50, has been reduced \$12.00 to sell now for \$77.50. Model 316 Combination portable-counter tube tester, which sold for \$63.50, has been reduced \$10.00 to sell now for \$53.50. Radio City Products Co., Inc., 152 West 25th Street, New York 1, N. Y.—RADIO & TELEVISION RETAILING.

Transvision SIGNAL GENERATOR

The new Transvision sweep signal generator, model No. SG, for television and FM offers the following advantages: Complete frequency coverage from 0-227 MC with no band switching; sweep width from



0-12 MC completely variable; accurately calibrated built-in marker generator. Directly calibrated markers, 20-30 MC for trap, sound and video IF alignment. Transvision, Inc., New Rochelle, N. Y.—RADIO & TELEVISION RETAILING.

Markwell TV TACKER

Markwell is now marketing the new L4 "TV"-Tacker designed and constructed for tacking round coaxial cable securely to any wood or plaster using Markwell "L4D" (1/2" leg) staples. The L4-"TV"-Tacker is also used for tacking 300 ohm Twin-Lead using the Markwell "L4C" (3/8" leg) staple which is driven parallel and between the two outside wires. Markwell Mfg. Co., Inc., 200 Hudson St., New York 13, N. Y.—RADIO & TELEVISION RETAILING.

Wincharger TV TOWERS

The self-supporting feature of these towers eliminates unsightly guy wire "wind bracing" and troublesome attachments. The towers are built in two heights—designed to accommodate a pipe extension which can be raised and lowered for ease of installation and service. Design of the tower makes possible easy installation on either sloping or flat roofs. Wincharger Corp., Sioux City, Iowa.—RADIO & TELEVISION RETAILING.

New Philco TV Front End

2-Tube Rotary Switch Tuner First Appears In Model 49-702

• This is a twelve channel tuner of the wafer-switch type (rotary tap), with a manual tuning shaft concentric with the wafer switch. The tuner includes an RF amplifier stage utilizing a 6AG5, and a 7F8 dual triode is used for an oscillator and mixer.

The signal to noise ratio is said to be improved by the use of a triode for the converter tube.

There are two broad band input transformers, one for the high band (channels 7-13), the other for channels 2-6 in the low band. These transformers are designed to provide a good antenna match and to reduce unbalanced noise.

Pre-Tuned Coils

The coils of this tuner are built in and are factory adjusted, with individual oscillator and RF coils for each channel. One each RF and oscillator coil (T2 and L2) are used for channel 2, and two each for the other channels (T2 and one other in parallel, and L2 and one other in parallel to it). Temperature compensated capacitors are used to minimize drift.

The switch consists of four double-sided wafers, as shown in figure 1. Provision is made in this tuner for the use of separate high and low band antennas although it is generally used with a single antenna. Switch selection of the proper input transformer for high or low bands is ganged in with the band-switch so that the low band position is held through channels 2-6 and the high band position is held for 7-13. The tuner is designed for a 300-ohm balanced input, but the maker states that 70 ohm coaxial lead-in may also

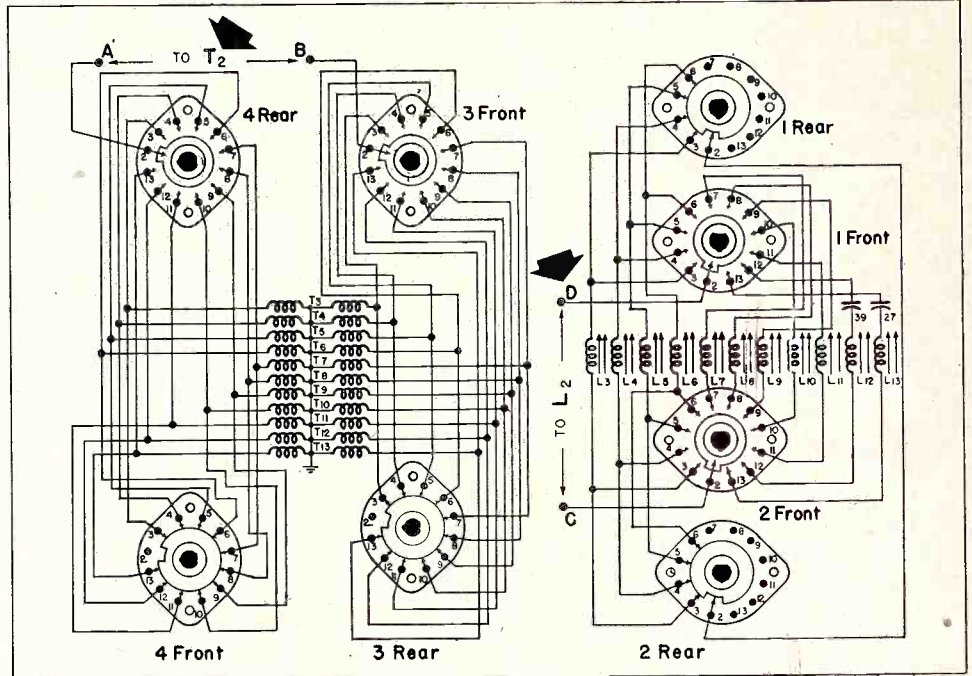

be used satisfactorily for this purpose.

The coupling circuit between the RF amplifier and the first detector and oscillator is an overcoupled bandpass circuit about 6 mc wide. The first IF transformer is also incorporated in the tuner. Range of manual tuning is plus and minus 1 mc on the low band and plus and minus 2 mc on the high band.

Although the grid of the RF tube is shown going to the contrast control, the bias is controlled by AGC. The contrast control varies the video amplification.

The performance of this tuner has been thoroughly tested in the Philco life test laboratories as shown in the

accompanying photo. Also in rigorous field tests of performance, this tuner is said to have given definitely superior results on the high band as compared to previous tuner designs.

Life test rack below on which tuners are operated thousands of time mechanically.

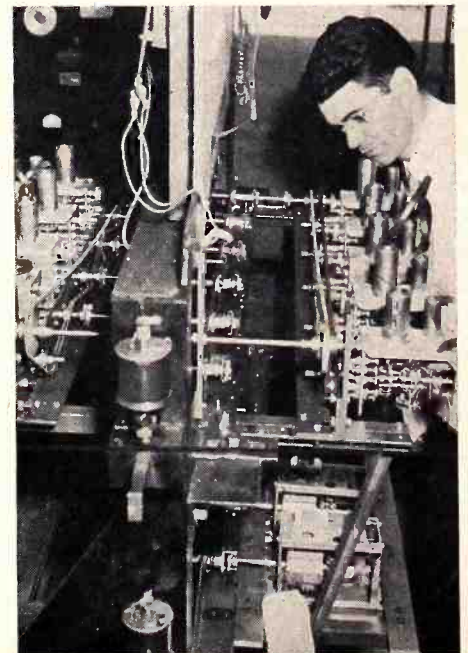

In this diagram of the new tuner, arrows indicate switching points. Fine tuning control is the 4-7 mmfd. trimmer on the extreme right. Note that input can be tuned via 5-50 mmfd. trimmers.

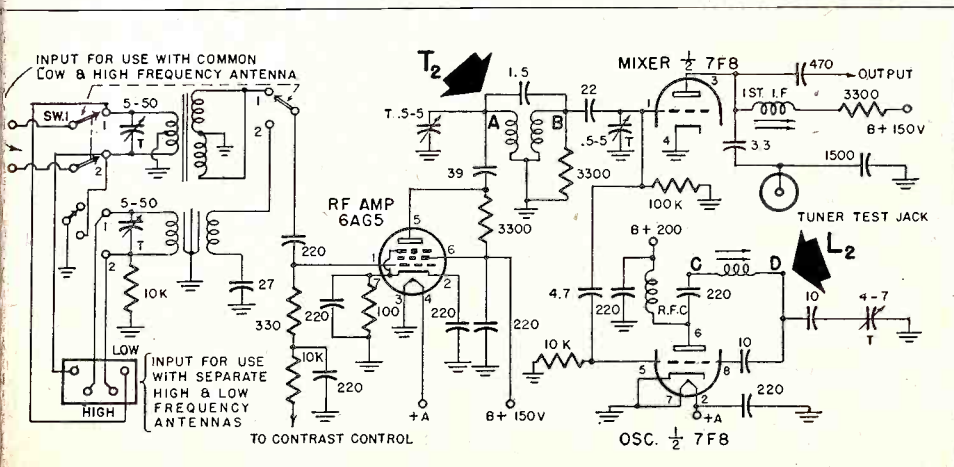

TV Signal Boosters

Preamps Can Solve Many Problems for Salesman and Servicer

Improved TV pictures may often be obtained by the use of boosters, or pre-amplifying units. The word "booster" is perhaps ill-chosen because it implies that signal amplification is the only function of the unit. Actually the booster may improve the picture without amplification (indicated by the necessity for turning the receiver contrast control down after inserting the booster), or it may improve the picture in other ways besides amplification.

Signal amplification is to a great extent limited by external noise and tube noise. However, we find pictures improved, not only by some boost but by increased selectivity, rejection of interference and unwanted signals, better match to the antenna (resulting in a better transfer of power, and also reduction of standing waves which may cause apparent ghosts), and decreased bandwidth.

Other Uses Besides Preamp

Since many TV sets have an untuned input, the addition of a tuned stage in front of it will give better selectivity, while at the same time improving the impedance match to the antenna. The impedance match is important because 1) actual input impedance of receiver is often not exactly the stated 300 ohms, 2) antenna impedance varies widely between 54 and 216 mc, and 3) no antenna except a single folded dipole has an output impedance of 300 ohms at the frequency for which it is cut unless special matching sections are added. Selectivity is important not only be-

cause of the increase in gain realized, but also because many sets have been observed not to have sufficient selectivity to reject unwanted RF signals, and interference can render unusable an otherwise adequate picture.

Bandwidth enters in because it is axiomatic in radio that as the bandwidth of a stage is decreased, the gain increases. While this may mean a reduction in the video bandwidth of the channel from 4.5 mc to 3 or even 2.5 mc with resultant loss of definition, the gain realized may produce an acceptable picture which was not possible before.

At least 15 manufacturers are now making TV boosters of a great variety of types and price ranges. Essentially the booster is a one, two or three stage wideband RF amplifier tunable to some one or several of the TV channels, with input and output impedances matched to a 72 or 300 ohm line or both, and a self-contained power supply. Models are available with either fixed tuned, continuous tuning, or selector switch tuning. Some have separate input and output channels for low (2-6) and high (7-13) bands, and most have a switch position which enables the transmission line to feed straight through without amplification if so desired on some channel. Many have bezel lights, illuminated dials, and other refinements. Selection of a particular model will depend somewhat on the gain necessary in that area, the channel or channels assigned to that area, and whether amplification is necessary on more than one channel.

Booster Circuits

Booster circuits are similar to the RF stages in the sets themselves, except for the tuned input feature, and the more or less general use of capacity-tuning. Due to similarity of switching arrangements, and power supplies (with selenium rectifiers and filament transformers), these features are not illustrated. In the amplifier circuits proper, we usually find one stage for each band, although sometimes there are two or more as in Figure 1. In the latter (Transvision) we also find the input loaded down to broaden the bandpass, whereas in some other models only the output circuit is so loaded.

While triodes are shown, it is worthy of mention that the choice of tubes follows two schools of thought, one of which feels that triodes are superior because of lower tube noise, while another favors pentodes because of higher gain. Neutralization to avoid feedback is shown in the Transvision model, whereas in the Anchor Booster (not shown) tendency toward oscillation is claimed to be overcome by the use of an impedance matching transformer (constructed of transmission line).

Value to Dealer

From the foregoing discussion, it can be seen that boosters may have other values to the installer or servicer than just boosting in fringe areas. They may be used to provide sufficient signal for several sets from one antenna, to prevent oscillator radiation onto the antenna, to eliminate interference by increased selectivity, and to improve antenna match by tuning the input to the receiver. In many cases, the booster may provide a quicker, easier solution of interference troubles than the methods of traps and stubs outlined in the December, 1948, issue of RADIO & TELEVISION RETAILING, or it may indicate what is needed. For instance, if ghosts disappear when a booster is tuned, antenna mismatch is indicated, and may be corrected.

Servicing the booster will be relatively infrequent due to its simplicity. One flaw which may crop up is poor regulation in the filament transformer resulting in 8 volts or more output. This voltage should be checked with the tubes in operation, and a limiting resistor added if necessary. Tubes can best be checked by substitution. Bandswitches may sometimes need a treatment with carbon tetrachloride or lubriplate if intermittent conditions arise.

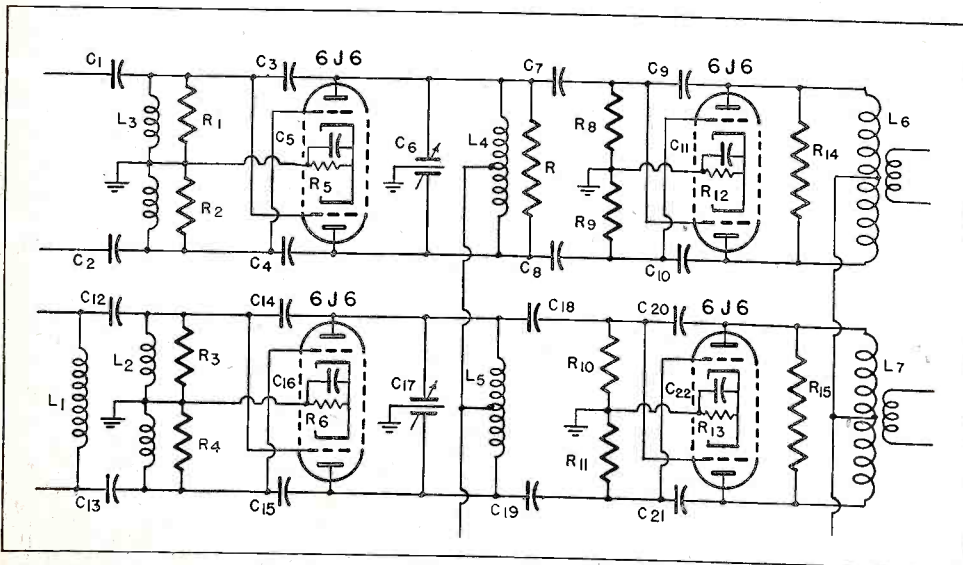
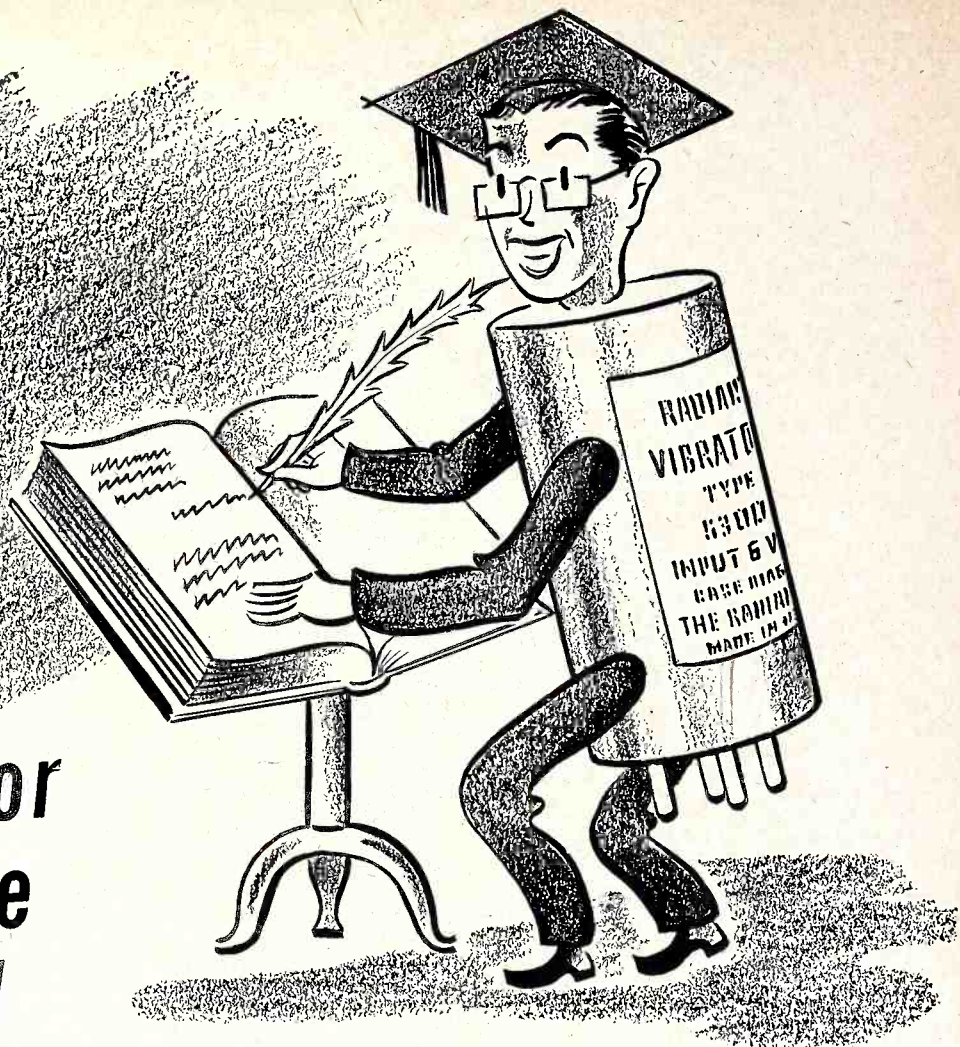

Fig. 1: Transvision booster, with two triode stages in each section (high and low band), loading in input as well as output. Power supply and switching not shown.



The Vibrator that Wrote the Book!

When books are written on vibrator performance . . . and dependability — RADIART RED SEAL VIBRATORS are the ones that do the writing!

Radiart has established and maintained leadership because of its many points of superiority! QUIET . . . QUICK STARTING . . . DEPENDABLE . . . UNIFORM . . . precision manufacture plus the famous RED SEAL . . . these are a few of the factors that make Radiart Vibrators the preferred vibrator with servicemen and jobbers everywhere! And the "best seller" book in the vibrator field is the Radiart Replacement Guide — the catalog and manual that has become the "bible" of the industry!

For the best deal you can give your customers . . . and for trouble-free service always . . . the best buy always . . . RADIART!

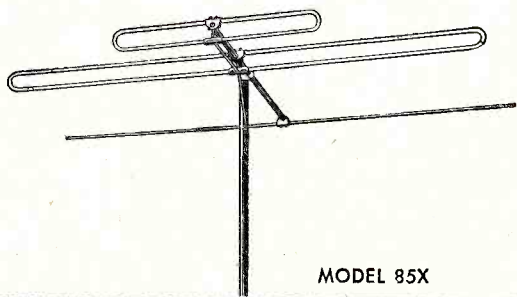

MODEL 85X

**RADIART TV AND FM ANTENNAS ARE THE FASTEST GROWING LINE IN THE COUNTRY...
.... MAKING GOOD TELEVISION... BETTER**

IT'S RIGHT WHEN IT'S RADIART!



THE RADIART CORPORATION
CLEVELAND 2, OHIO

MANUFACTURERS OF THE RADIART TV-FM ANTENNAS AND AUTO AERIALS

New Sound Equipment

Perfect FM TUNER

The FM Perfectuner uses 5 tubes plus a selenium rectifier and a heavy duty power transformer. The unit is said to be extremely sensitive and has a temperature compensated oscillator to minimize drift. It incorporates a built-in antenna for local reception. Tuner retails for \$29.95 plus Fed. Ex. Tax. Perfect Products Co., 82-27—217th St., Queens Village, N. Y.—RADIO & TELEVISION RETAILING.

Signet LOUDSPEAKERS

The Signet Development Co.'s fire and explosion-proof loudspeaker is so constructed that it completely eliminates the danger of fire or explosion from inhibited combustible gases. Immediate applications for the fire and explosion-proof loudspeaker include mines, gasoline cracking plants, refineries, chemical plants and areas, munition mills and elevators, and military uses. The units are available in both permanent magnet and electro-dynamic models in sizes from 3 through 12-inch diameter, round, and also 4 by 6 inches and 6 by 9 inches oval shapes. Signet Development Co., 188 West Randolph St., Chicago 1, Ill.—RADIO & TELEVISION RETAILING.

Instant SOLDERING IRON

The new Super-Instant soldering iron is said to offer a new design in quick heating irons, by employing a quick-heating element, to bring the tip to soldering temperature, and a "bucking coil" to maintain this temperature and prevent overheating and scaling. The Super-Instant is designed for intermittent use by servicemen. Instant Tool Corp., 231 West 29th Street, New York City 1, N. Y.—RADIO & TELEVISION RETAILING.

Newcomb PORTABLE RECORD PLAYER

The Newcomb Model TR16B combines the ability to play the new 45 RPM and 33 $\frac{1}{3}$ LP microgroove records as well as 33 $\frac{1}{3}$ broadcast type transcription up to 17 $\frac{1}{4}$ inches in diameter plus regular 78 RPM standard recordings. Input for mike



with separate mike and phono volume controls permit mixing of speech with records or use of each independently. 10 watts power output from push-pull 6V6, inverse feedback, low distortion amplifier response within 2 db from 50 to 10,000 cycles. Newcomb Audio Products Co., 6823 Lexington Ave., Hollywood 38, Calif.—RADIO & TELEVISION RETAILING.

Markel 3-SPEED CHANGER

This new record changer which plays all three record sizes in all three speeds automatically and has the additional characteristic of automatically playing one or both sides of all 10" and 12" records. The new Duo Playmaster model numbers 74 and 75 of Markel's two sided record changer line permit the playing of both

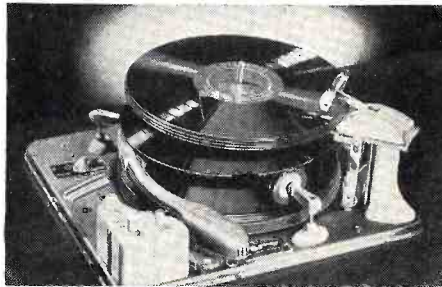

sides of one record before the next record is played. The Model 74 will fit most radio-phonograph and television combinations, and the Model 75—with a wood finish cabinet base—will attach to any radio or television receiver. The new model also incorporates automatic stop and the standard rejection feature. Markel Electric Products, Inc., Buffalo 3, N. Y.—RADIO & TELEVISION RETAILING.

Jensen SPEAKERS

Eleven new loudspeaker models, additions to the Jensen Standard Series line, bring to 53 the total number of models offered in the Standard series and provides a speaker size for 99% of the television and auto receiver replacement needs. These eleven new models include five ovals in the popular 6 x 9" size, five 7" speakers, and one 5 $\frac{1}{4}$ " model. Jensen Manufacturing Co., 6601 S. Laramie Ave., Chicago 38, Ill.—RADIO & TELEVISION RETAILING.

Milwaukee 3-SPEED CHANGER

Model #11600 all purpose record changer will play automatically all types of records, including the conventional 78 RPM, Columbia 33 $\frac{1}{3}$ LP, and Victor 45 RPM without the use of adapters to reduce the hole size. One pickup cartridge and one needle pressure plays all types of records. Milwaukee Stamping Co., Milwaukee, 14, Wisconsin.—RADIO & TELEVISION RETAILING.

Turner CARDIOID MIKE

The Model 77 is engineered with a wide range pickup at the front and a sharply attenuated output at the rear with approximately 15 db discrimination between front and rear at all frequencies. The "Tru-Cardioid" pickup pattern reduces feedback to a minimum and practically eliminates interference from extraneous sound arriving from the rear of the microphone. Response is substantially flat from 60 to 10,000 c.p.s. Built-in switch gives choice of 50, 200, 500 ohms or high impedance. The Turner Co., Cedar Rapids, Ia.—RADIO & TELEVISION RETAILING.

Shure TURNOVER PICKUP

This new pickup, Model 901D, features the all-purpose "vertical-drive" lightweight cartridge, which has two individually replaceable needles for use in playing both standard and fine-groove recordings with the same pickup head. The pickup has a small turnover knob to change the cartridge from one playback position to the other. The pickup comes with either Osmium or Sapphire long life "Muted Stylus", one mil and three mil needles. Shure Brothers, Inc., 225 W. Huron St., Chicago 10, Ill.—RADIO & TELEVISION RETAILING.

Electro-Voice TWIN-TILT PHONO CARTRIDGE

The "Twilt" — a new torque drive Twin-Tilt phono pickup cartridge for all three speeds features a single Twin-Tip replaceable needle which plays 78, 45 and 33 $\frac{1}{3}$ rpm records without weight change and with a tracking pressure of only 6 grams on either needle-tip. You merely tilt the "Twilt" to select the one mil (.001) or the three mil (.003) needle-tip, as you wish. Frequency response closely follows NAB standard curve, the maker states. Output voltage is 1 volt on RD90 test record at 1000 cps. The "Twilt" (Twin-Tilt) cartridge mounts in most any standard pickup arm. Model 16-TT crystal Twilt and Model 26-TT magnetic Twilt, complete with needle, list at \$12.00 each. Electro-Voice, Inc., Buchanan, Mich. — RADIO & TELEVISION RETAILING.

Rauland PHONOGRAPH AMPLIFIER

The new Rauland 1825 high-fidelity phonograph amplifier is designed expressly for custom installations. An exclusive feature of the new amplifier is a detachable remote control preamplifier designed to mount in any position to meet the mechanical requirements of any custom installation. A feature of the model 1825 is five-position

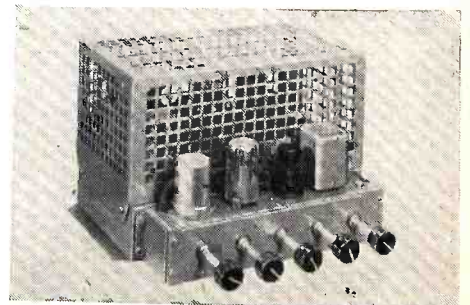

frequency cut-off for elimination of needle scratch and noise. Two separate controls provide bass and treble boost. Plug-in equalizer is included to compensate for variations in response of phono pickups. Power output is 25 watts, frequency response 40 to 20,000 CPS. Rauland-Borg Corp., 3523 Addison St., Chicago, Ill.—RADIO & TELEVISION RETAILING.

FOR EVERY RADIO SERVICEMAN!

The new Sylvania FM-AM Signal Generator Type 216

Supplies all signals necessary for complete stage-by-stage alignment of AM and FM receivers.

Frequency Coverage:

80 kc to 60 mc AM and 80 kc to 120 mc FM, continuously variable in seven bands on fundamental frequencies. Useful AM and FM harmonics to 240 mc.

For FM service:

±350 kc Sweep: up to 120 mc with 60 cps modulation.

±75 kc Sweep: up to 120 mc with 400 cps modulation.

In addition, sawtooth external modulation may be used.

For AM service:

±15 kc Sweep up to 61 mc with 60 cps modulation.

0 to 100% Modulated AM with 400 cps modulation.

In addition, external modulation may be used.

Check these Sylvania features! They're "musts" for complete FM and AM servicing:

AM modulation: 0 to 100%, continuously variable.

Accurate calibration: 1/2 of 1%.

High rf output: 1 volt on all ranges.

True rf meter for constant reference level.

Both step-by-step and smooth attenuator output controls.

Regulated power supply.

Oscilloscope synchronizing voltage output.

Crystal check point circuit.

Multiple shielding and filtered for minimum leakage.

Heterodyne detector for frequency comparison.

Mar-resistant, pearl-gray crackle finish baked on a treated steel case.

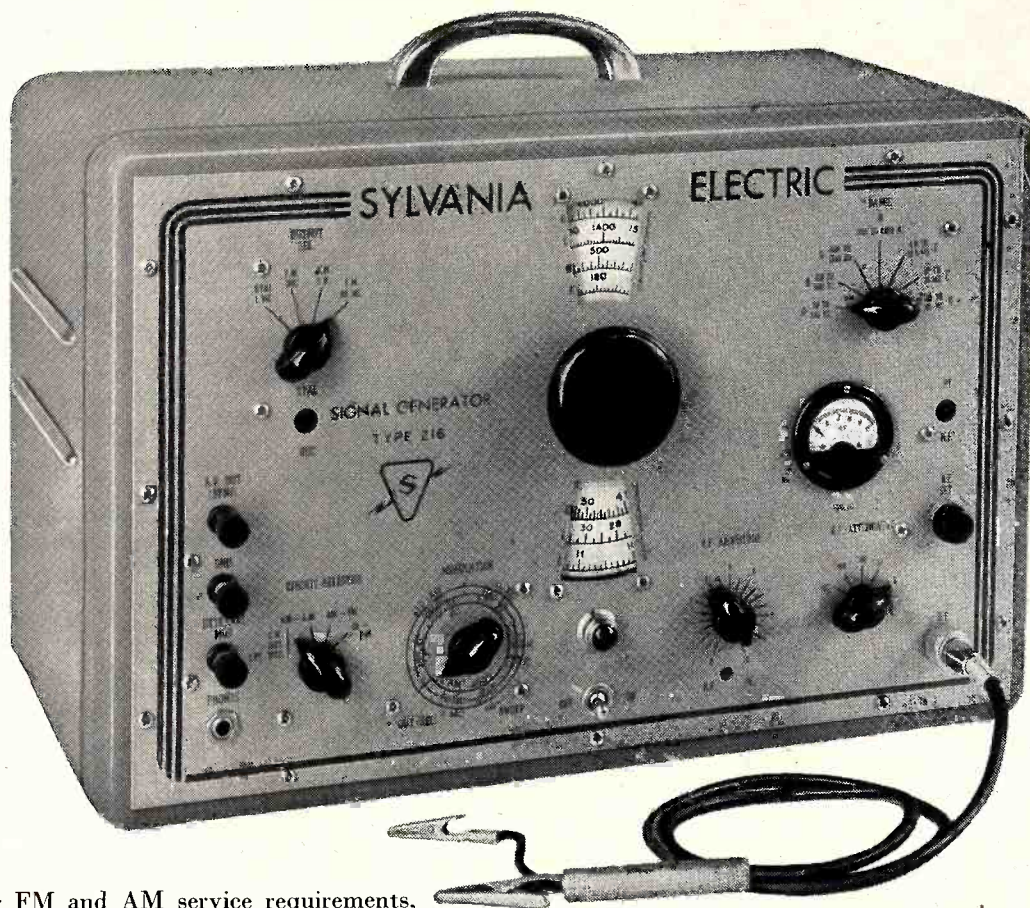

To meet your FM and AM service requirements, you'll want Sylvania's new Signal Generator Type 216! With it you can align the rf and if sections of all FM and AM receivers, adjust all types of FM detectors, and make overall receiver checks. Its high level output and accurate calibration make it also a valuable instrument for other service and laboratory uses requiring a high quality rf signal source. Beautiful styling in keeping with modern service shop environment. Dimensions: 11-3/8" x 17-1/16" x 10-5/8". Weight: 24 1/2 lbs. Priced at \$189.50. Mail coupon for complete details!

SYLVANIA ELECTRIC

ELECTRONIC DEVICES; RADIO TUBES; CATHODE RAY TUBES; FLUORESCENT LAMPS, FIXTURES, WIRING DEVICES, SIGN TUBING; LIGHT BULBS; PHOTOLAMPS

Sylvania Electric Products Inc.
Advertising Dept. R-2106
500 Fifth Ave., New York 18, N. Y.

Gentlemen: Kindly forward full details on your new Sylvania FM-AM Signal Generator Type 216.

Name.....

Address.....

City..... State.....

Record Playing Equipment

Dynavox 45 RPM CHANGER

Model AP-459 consists of RCA 45 RPM changer, 3-tube amplifier and 5-inch speaker in portable leatherette case measuring

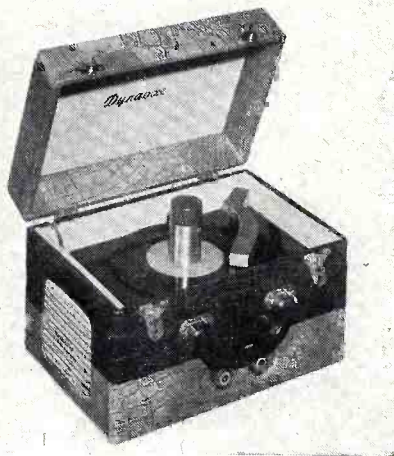

12½ by 8½ by 8¼ inches. Tone and volume can be controlled with the lid closed. Dynavox Corp., 40-05 21st Street, Long Island City, N. Y.—RADIO & TELEVISION RETAILING.

Carbonneau 3-WAY RECORD PLAYER

"Plays-All" converts any phonograph into a 3-speed phono by means of a carriage which fits over the spindle of the existing player and rests on the turntable. The speed can then be changed to either 33½ or 45 RPM. A light-weight tone arm with cartridge and needle designed to play



the fine-groove records is mounted on the carriage. Retailing for \$12.50, the device is said to be simple enough for a child to install. Manufactured by Carbonneau Industries of Grand Rapids, the device will be merchandised by National Merchandise and Sales Co., 1383 Bedford Road, Grosse Pointe 30, Michigan.—RADIO & TELEVISION RETAILING.

Symphonic 45 RPM PLAYER

The "Collegiate" model 69 features an RCA 45 RPM changer with amplifier and speaker in simulated leather carrying case measuring 12½ by 8 by 9¼ inches, and

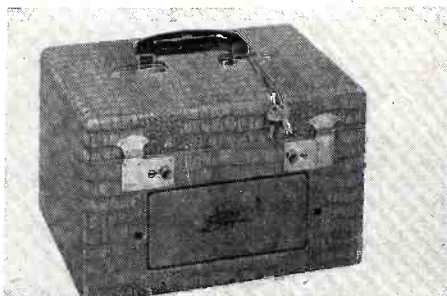

weighs 12 lbs. Unit includes space to carry records, and will retail for \$49.95. Symphonic Radio and Electric Corp., Cambridge, Mass.—RADIO & TELEVISION RETAILING.

Trylon TRIO SPEED PORTABLE CHANGER

Model DA-215 is a record changer, with 3-tube amplifier and loudspeaker, which will play all speeds and sizes of records automatically. Luggage-type carrying case

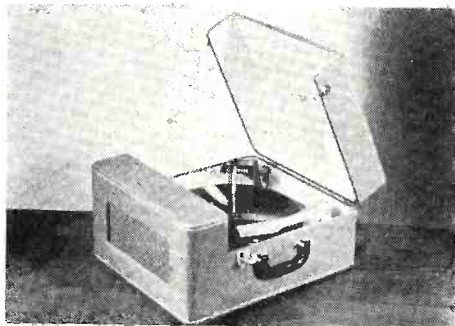

measures 16¼ by 14½ by 8½ inches. Model DA-210 is similar except that only 78 and 33½ RPM are accommodated. Trylon Radio Laboratories, Philadelphia 23, Penna.—RADIO & TELEVISION RETAILING.

Webster RECORD CHANGERS

Several new models have been announced to accommodate the new types of records. The "Duo-Seven" models will play both 33½ and 45 RPM 7-inch records, and is said to be equivalent in size and price to 45 RPM changers. Model 755 is an attachment type; model 745 is complete with amplifier and speaker. In addition, model 356 will play all three speeds and sizes of records, utilizing a tandem-tip needle, and a collar on the spindle to accommodate the RCA center hole. Webster-Chicago Corp., 5610 W. Bloomingdale, Chicago 39, Ill.—RADIO & TELEVISION RETAILING.

Beam 45 RPM PLAYERS

Four new single-record players for 45 RPM records range from \$16.95 to \$29.95 list. Models are: TD8 attachment for radio TD9 wireless player, TD6 with amplifier



and speaker, and YD6, same as TD6 but in closed wood cabinet. Beam Radionics Corp., 3700 W. Roosevelt Road, Chicago 24, Illinois.—RADIO & TELEVISION RETAILING.

Meck 3-SPEED RECORD PLAYER

The "Saratoga" is a single-record player for all three speeds, offered in three versions: attachment for radios, wireless player for use with radios, and self-contained unit with built-in amplifier and speaker. Prices start at \$19.95. John Meck Industries, Inc., Plymouth, Indiana.—RADIO & TELEVISION RETAILING.

Knight 45 RPM PORTABLE PHONO

RCA type 45 RPM record changer with built-in amplifier and 5¼-inch speaker is housed in portable case of brown rawhide

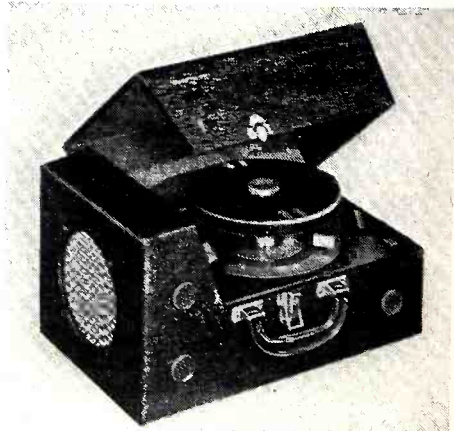

fabric, measuring 15 by 8½ by 9¼ inches. Unit weighs 12½ lbs., and contains space for carrying records. Allied Radio Corp., 833 W. Jackson Blvd., Chicago, Ill.—RADIO & TELEVISION RETAILING.

More Items of Interest to
Dealers Elsewhere in
This Issue

SRO

**has a
new meaning
now!**

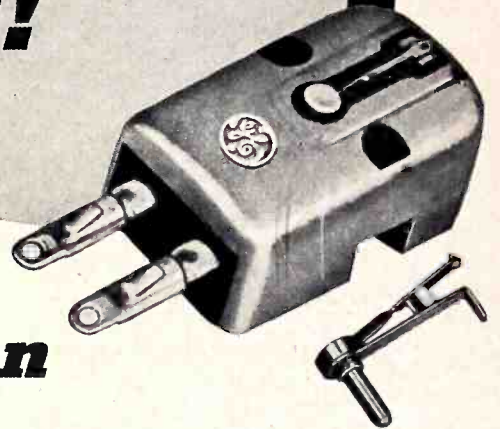

Stylus Replacement Often

WHEN the big attraction hit town they hung the "Standing Room Only" sign—it meant overflow business.

It still means that, but the big attraction now drawing overflow business for distributors and dealers is the G-E Variable Reluctance Cartridge with the Replaceable Stylus.

Why? Because record fans who know their records best wanted the finest reproduction possible. The G-E Variable Reluctance Cartridge gave them just that. To secure peak performance they often replaced the cartridge when the stylus was only slightly worn.

Now, with the Replaceable Stylus, cartridge replacement is no longer necessary. In four easy steps the cartridge can be removed from the tone arm, the stylus changed and listening pleasure increased.

Economy is the big feature but this redesigned cartridge has many other advantages. Smaller in size, it can be adapted to many

more tone arms. Higher lateral compliance provides more faithful tracking, hence better fidelity. Frequent stylus replacement reduces record wear and adds hours of top listening pleasure. Needle talk and needle scratch are negligible, giving cleaner, finer reproduction.

Best of all, the cartridge is available for either the new LP records with 1 mil stylus or for conventional records with the 3 mil stylus.

Now for the *Big Extra* to step up sales! A neat dispensing unit for the counter with two cartridges and six stylii recessed in a gold-flocked panel to catch the eye. The entire unit is finished in an attractive blue and has a compartment in the rear for additional stock. It is a silent salesman that keeps selling. See your distributor right away for details.

For complete information on Variable Reluctance Cartridges and Replaceable Stylii write to: *General Electric Company, Electronics Park, Syracuse, New York.*



The counter sized dispensing unit for greater sales—7¼" long, 5½" wide, 4¾" high at the back.

You can put your confidence in—

GENERAL  ELECTRIC

What's Doing in Jobber and Rep Circles

A. J. Lindemann & Hoverson Co., Milwaukee, announces the appointment of the following distributors for L&H electric ranges and water heaters in their respective trading areas: **Air Engineers, Inc.**, Birmingham; **Williams & Martin Corp.**, Cincinnati; **Lack's Wholesale Distributor, Inc.**, Houston.

The D. J. Roesch Co., of 2200 South Figueroa St., Los Angeles, has been appointed southern California distributor for Industrial Television, Inc., of Clifton, N. J., it is announced by Horace Atwood, Jr., president.

Radio Electronic Supply Co., 443 South Division St., Grand Rapids, Mich., has been appointed distributors for Tele-

tone Corp.'s entire line of radios, television sets and record players, announces Morton M. Schwartz, general sales manager of Tele-tone.

Tom McDowell, who has been in the radio and electrical appliance business for many years, has joined the **John P. Ludgate Associates**, of Pittsburgh, Air King radio and television representatives for Ohio, Kentucky, West Virginia and western Pennsylvania.

Motorola-New York, distributors of radio and television receivers manufactured by Motorola, Inc., of Chicago, has announced the addition of three new men to its sales force. Jack Steinman comes to Motorola from Admiral Radio & Tele-

vision Corp. He has also worked as a salesman for Sonora Radio & Television in California, and before his war service was with Pilot Radio Corp. Gabe Ashley was formerly a salesman for Philco. The third appointee, Fred Satloff, has had experience with Philco and Admiral.

Transmirra Products Corp., manufacturers of the Transmirra image definer television filter, has appointed the **Fort Orange Distributing Co.**, in Albany as distributor for its product in the following outlined area: Westchester County—north to Canadian border, Herkimer County, Berkshire County, Mass., and the State of Vermont.

The Crosley Division of Avco Manufacturing Corp., has appointed its wholly-owned subsidiary, **The Crosley Distributing Corporation** as its distributor in Portland, Oregon, J. W. Craig, vice-president of Avco and general manager of its Crosley Division, has announced.

International Harvester Company has announced the appointment of **Remco, Inc.**, 545 North LaSalle St., as wholesale distributor in the Chicago area for the complete line of International Harvester refrigerators and home freezers.

Michael Scott, former sales manager of Hallicrafters has established the **Michael Scott Co.**, manufacturers' representatives for electronic and television equipment, 8 Todd Road, Cohasset, Mass.

Smitty's Electronics, 126 West Broadway, Butte, Montana, has been appointed distributor for the Radio Division of Sylvania Electric Products, Inc., according to an announcement by H. H. Rainier, manager of distributor sales. He said that they would distribute Sylvania radio and television tubes, cathode ray tubes and electronic devices.

H. H. Rainier, manager of distributor sales for the Radio Division of Sylvania Electric Products, Inc., has announced the appointment of the **Radio Supply Co.**, 6335 Hudson Blvd., No. Bergen, N. J., as distributor for Sylvania Radio Products.

Admiral TV Executive



Appointment of Edwin J. Sherwood, shown, as television promotional manager of Admiral Corp., Chicago, has been announced by Seymour Mintz, director of advertising.

This is it!
**A TELEVISION
 BOOSTER THAT
 REALLY DOES THE JOB**

THE ANCHOR TV-PRE-AMPLIFIER

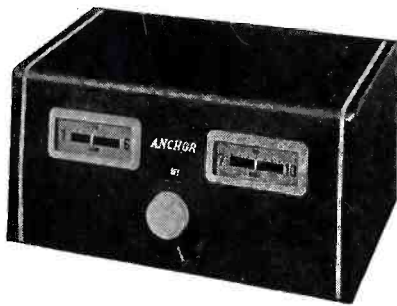

*Here's What Others Say!**

"IT DOES HAVE MORE USEABLE GAIN THAN ANY OTHER 'BOOSTER' I HAVE SEEN, YIELDING SNOW-FREE PICTURES UNDER THE MOST DIFFICULT CONDITIONS."

JOHNSON & ELLIOTT
 MONTICELLO, N. Y.

**An unsolicited statement from an independent service engineer.*

**NOT MERELY ANOTHER BOOSTER — ANCHOR
 WILL POSITIVELY DO EVERYTHING AS
 CLAIMED OR YOUR MONEY BACK**

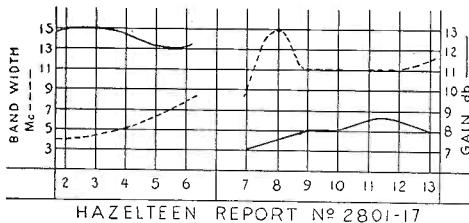

**IT'S NEW — DIFFERENT
 HAS AMAZING PERFORMANCE**

An ANCHOR TV-PRE-AMPLIFIER will out-perform any similar equipment in its class. Don't take anything less than the best—don't take anything less than ANCHOR.

Check These Features

- * 4 mc minimum Bandwidth on all channels
- * Impedance matching to receiver
- * Simultaneous iron core tuning of grid and plate
- * 2½ times average gain (Voltage Ratio)
- * Guaranteed coverage of low and high TV-Band

Carefully, thoroughly engineered, ANCHOR TV-PRE-AMPLIFIER is a product of long research—it is compact, beautifully styled and precision built to give outstanding, trouble-free performance. When you install an ANCHOR TV-PRE-AMPLIFIER you give your customers the best. Don't wait—don't miss this—see your jobber today. **LIST PRICE \$37.50**

Dealer aids available — Write for Further Information

2215 SO. ST. LOUIS AVE. CHICAGO 23 ILLINOIS

ANCHOR

RADIO CORP.

2215 S. St. Louis Ave.
 Chicago 23, Ill.

Verne Roberts



W. L. Hasemeier, vice-president in charge of sales of the Wilcox-Gay Corp., Charlotte, Mich., announced that V. L. Roberts, above, has been appointed sales manager of the company.

Jobber News Notes

Garod Electronics Corp., Brooklyn, N. Y., announces the appointment of **Milton Benjamin** and **Henry Goldsmith** as factory sales representatives for the firm's line of "Tele-Zoom" television receivers and allied radio products, according to Louis Silver, executive vice-president and general manager. Mr. Benjamin will be responsible for sales activities among distributors in the New England area. His headquarters will be in New York. Mr. Goldsmith will travel the Midwest area, maintaining his headquarters in Chicago.

Electric Sales & Service Co., 209 Walton St., Atlanta, Ga., has been appointed distributor for the Tele-tone radio and television line, it is announced by Morton M. Schwartz, general sales manager of Tele-tone Radio Corp.

Appointment of **Olson & Company, Inc.**, as distributors in the Philadelphia area is announced by Ernest A. Marx, general manager of the television receiver sales division, Allen B. DuMont Laboratories, Inc. Victor E. Olson, who will head the new distribution organization is presently sales manager of DuMont's receiver sales division. He will continue to perform duties in that position until a successor is named.

Appointment of **Callander-Lane Co.**, Columbus, Ohio, as Norge distributor for central Ohio has been announced by H. L. Clary, director of sales, Norge division, Borg-Warner Corp. Callander-Lane Co., is headed by D. G. (Gale) Callander, president, and R. H. (Dick) Lane, vice-president and treasurer, both of whom began their business experience in 1930 with the Columbus Philco distributor. During the war Callander became sales manager for this concern, later served as district manager for Kelvinator. Lane spent the war years with the Columbus division of Curtiss Wright Corp.

The **L. S. Taufenbach** organization has been appointed sales representative for the Pacific coast by Radion Manufacturing Corp. of Chicago, to place and to direct distribution of Radion portable antennas, according to announcement by D. T. O'Connell, sales manager.

Century TABLE TOPPER

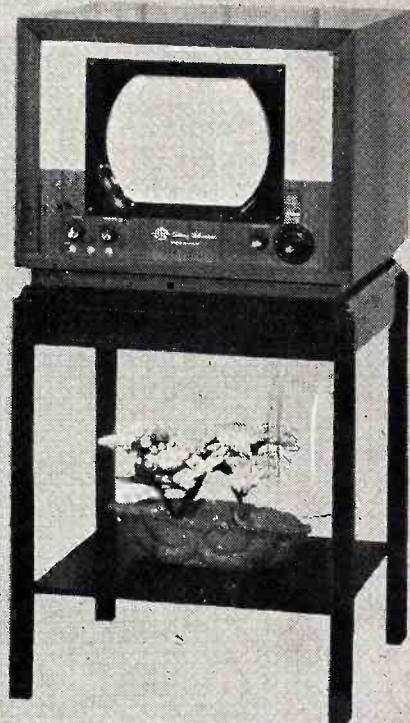

with VISUAL TUNING

Century's Table Topper—with 12½" picture tube—has the same simplified circuits and rugged unit construction that have helped to make our commercial receivers famous. That means clear, steady pictures. It means trouble-free performance—fewer service calls!

And all Century sets have Visual Tuning—the natural way to tune. You tune by eye instead of ear. You tune the picture, not the sound. Your prospects will be thrilled by this new ease of tuning and superb picture quality.

The complete Century line brings you 16" remote control units for the class market, 12½" receivers for the mass market. Semi-automatic tuning with just two picture controls. Magnificent, hand-finished Swedish Modern cabinets. Lower power consumption—about 33% less.

Now you can make larger profits and avoid tie-in buying. Stay ahead of competition with ITI—the vision in television. Write today for a set of catalogue sheets on the Century line. They give all the exciting facts.



INDUSTRIAL TELEVISION INC.

359 Lexington Avenue
Clifton New Jersey

Magnetic Recorder Market Tops
\$50 Million Mark Annually

Chicago Dealer Sells 66 Units
From One 4 Column Ad

Get Your Share With This
**PROFIT-PROVEN
PENTRON LINE**



All recorders
play or record con-
tinuously for 1 full hour.

List
\$199.50*
Complete
No. W 748
*Slightly higher
west of Rockies

4-IN-1 COMBINATION WIRE RECORDER • RADIO • PHONO

Fastest seller on the market . . . proof of profit definitely assured!
4 prospects instead of one. Precision-built for high-fidelity response,
dependable wide-range performance. Simple operation.

- Wire Recorder records, plays back own radio, phono, mike
- Superbet. Radio, highly selective, built-in antenna
- Record Player has tru-tracking arm and Astatic Cartridge
- P. A. System, medium gain
- Synchronized Timing Meter indexes all recordings
- 2-Way Automatic Shut-Off stops wire tangle, breakage



List
\$149.50*
Complete
No. W 449

WIRE RECORDER

Only recorder at this price with high-fidelity, dynamic range. Engineered for trouble-free operation.

- Wire Recorder records from mike or radio
- P. A. System, medium gain
- Synchronized Timing Meter
- 2-Way Automatic Shut-Off



List
\$179.50*
Complete
No. T 549

2-Channel TAPE RECORDER

Unmatched full-range tonal fidelity. Exclusive features unobtainable in other recorders at this low price.

- Tape Recorder, high gain P. A. system
- Fast Speed, forward and reverse. No rethreading
- Synchronized Timing Meter

See Us at the MUSIC MERCHANTS SHOW, Hotel New Yorker, Room 704
All Fully Covered by Product Liability Insurance

FREE! TESTED SALES AIDS BUILD MORE LOCAL TRAFFIC

See Your Distributor or Write to

THE PENTRON CORP., 611 W. Division St., CHICAGO 10, ILL.

PREMAX

**Why the Adjustable "V" Antenna
Is Best for Television**

Premax Adjustable "V" Dipole Antennas permit the proper vertical or horizontal adjustment of the elements to correct the combining of a "direct" and a "reflected" signal, making the two signals combine in phase, thereby increasing rather than reducing the received signal.

Premax dipole elements permit any desired adjustment of the angle for strongest reception (usually 35° to 45° above the horizontal plane).

Another Premax feature is that, properly mounted, it permits a sufficient signal energy at the antenna terminals to minimize the importance of the otherwise difficult task of perfect impedance matching.

Many leading radio engineers find the Premax Adjustable "V" Dipole Antenna, mounted reasonably high and in the clear, insures optimum reception of signals from ALL of the TV stations within line of sight.

SEND FOR SPECIAL BULLETIN

PREMAX PRODUCTS

DIVISION CHISHOLM-RYDER CO., INC.

4906 HIGHLAND AVENUE, NIAGARA FALLS, N. Y.



Announcing

**A New Line of PROFIT MAKERS
Television Tables
For Table Model Sets**

Ideal For Tie-In SALES!

You cash in on those profitable tie-in sales with one of these 5 styles of tables especially designed for table model television sets. Your customers will like the modern design, top quality construction, versatile uses. You will like the mark-up and sales making features. Model shown, #202, of solid and plywood mahogany, top 28 x 21", 32" high. Ideal for television, radio, record changer, albums. For sample order Table #202, send \$17.95. F.O.B. Chicago.

Write for Literature, Price List.

OMARA FURNITURE MFG. CO.
2141 W. Hubbard St., Chicago 12, Ill.

Named Emerson Jobber



Emerson Radio & Phonograph Corp., signed Interstate Electric Co., New Orleans, as distributor for Louisiana and Mississippi. L. to r. are: Roger Brown, Dallas, southwestern district manager for Emerson, Don Smith, sales manager of the major appliance division of Interstate, Stanley M. Abrams, Emerson general sales manager, and Leon Mattes, seated, vice-president in charge of sales for Interstate.

Chicago Town Meeting

At the Town Meeting of Radio Technicians in Chicago, April 11-13, a number of technicians in the audience turned in their lapel tags to indicate they had earned Certificates of Leadership in Television. Unfortunately, some of the registrations were mislaid so that Certificates could not be written up for the persons involved. If technicians who turned in tags but have not received Certificates will send their full names and addresses to Room 805, 21 East Van Buren St., Chicago 5, Illinois, they will receive their Certificates properly inscribed in short order.

Lohman Joins Du Mont

George P. Lohman has been appointed sales representative for the receiver sales division, Allen B. Du Mont Laboratories, Inc., Victor E. Olson, sales manager, announced.

Bace 16-Inch TV Set

Charles N. Bace, president, Bace Television Corp., South Hackensack, N. J., says that production has begun on a new line of direct view large 16-inch screen home television sets in table and console cabinet models. The Bace set features a 16-inch glass cathode ray picture tube for wide angle viewing and has 31 tubes including the picture tube.

Nationwide TV Clinics

Radio-television dealers, repairmen and engineers in 21 metropolitan areas from coast to coast are attending the series of clinical meetings conducted by the Coastwise Electronics Co. of Los Angeles. All phases of alignment, repair, and servicing are discussed, with schematic drawings and blackboard sketches illustrating the talks.

New Acme Refrigerator

Supplementing its space-saving refrigeration line, Acme-National Refrigeration Co., Inc., 634 Dean St., Brooklyn 17, N. Y., has introduced a new full 5.6 cu. ft. lowboy with 10 sq. feet of shelf space at a price of \$199.50.

Philco Refrigerator Week

A Philco "Conservador" window display contest, open to all Philco franchised refrigerator dealers, was one of the merchandising features of National Philco Refrigerator Week which started May 16 throughout the country. Raymond B. George, sales promotion manager, announced that fifty cash prizes are to be awarded. First grand prize, \$1,000; second grand prize, \$500; next three prizes, \$250; next five prizes, \$100; next ten prizes, \$50; next 30 prizes, \$25; all cash. Mr. George also stated that Philco distributors will participate in the contest by awarding local prizes for the best windows in every distributor territory.

Judges for the national grand prizes include Walter Eichelberger, sales man-

ager, Philco Refrigerator Division; John F. Gilligan, Philco advertising manager; R. B. George, Philco sales promotion manager, and a number of trade paper editors.

Pay-As-You-Go TV Service

A new guarantee policy has been put into effect by Harry Alter, Chicago Crosley distributor. Under the new arrangement, the customer will pay in advance only the installation and parts warranty: \$40. for outside installation and \$15. for indoor. If there were no service calls, there would be no additional charges. Service calls would be made at a \$4.00 flat charge, up to 8 calls (\$32.) and any number over 8 calls would be made free of charge.

IT'S HERE High-Fidelity Rauland 1825 Phonograph Amplifier

TOPS FOR CUSTOM INSTALLATION

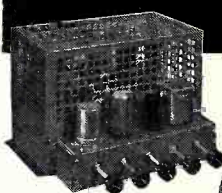

1825 Amplifier with cover

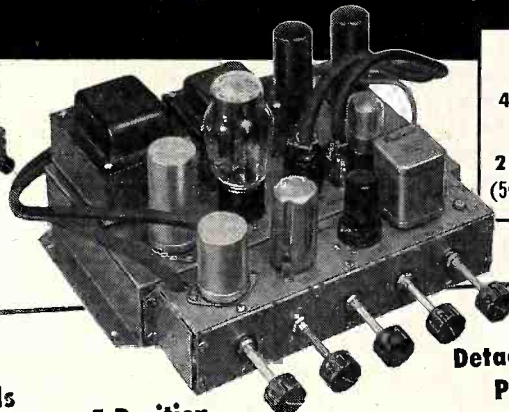

± 1 DB
40 TO 20,000 CPS
25 WATTS OUTPUT
(5% harmonic distortion)

Underwriters Listed

Boost Type Tone Controls

Two separate controls provide plenty of Bass and Treble boost; permit adjustment for correct tonal response to suit individual listening taste.

Plug-in Equalizer

Designed to compensate for variations in response of phono pickups. Proper equalizer is available for every type of pickup.

5-Position Frequency Cut Off

Eliminates needle scratch and noise—in five steps of frequency cut off. Restores original clarity to favorite recordings.

Dual Volume Controls

Auxiliary volume control on power amplifier prevents "cramping" of main volume control, and improves signal-to-noise ratio.

EXCLUSIVE! Detachable Remote Preamplifier

Preamplifier is detachable; mounts in any position to meet mechanical requirements of any custom installation. Compact; only 2 3/8 x 2 3/8 x 1 1/4". Unlimited flexibility for custom-builders.

Dual Input Selector

Two-position switch selects permanently connected phonograph and auxiliary inputs to Preamplifier.

You'll dominate the custom-installation market with the new RAULAND 1825 High-Fidelity Phono Amplifier. It's out in front with unprecedented mechanical installation features. Amazing in performance—it brings real tonal magic out of any recording, regardless of condition. There's nothing comparable on the market for features and value. Available for immediate delivery from stock. Get the full-details today!

See your RAULAND-BORG Distributor for full information on the RAULAND 1825 High-Fidelity Phono Amplifier. Get your profitable share of the big market for quality custom installations with this fast-selling unit. It's unbeatable for advanced features and value custom-builders appreciate and want.

Electroneering is our business

SOUND
EQUIPMENT

Rauland

INTER-
COMMUNICATION

RAULAND-BORG CORPORATION • 3523-L Addison St., Chicago 18, Ill.

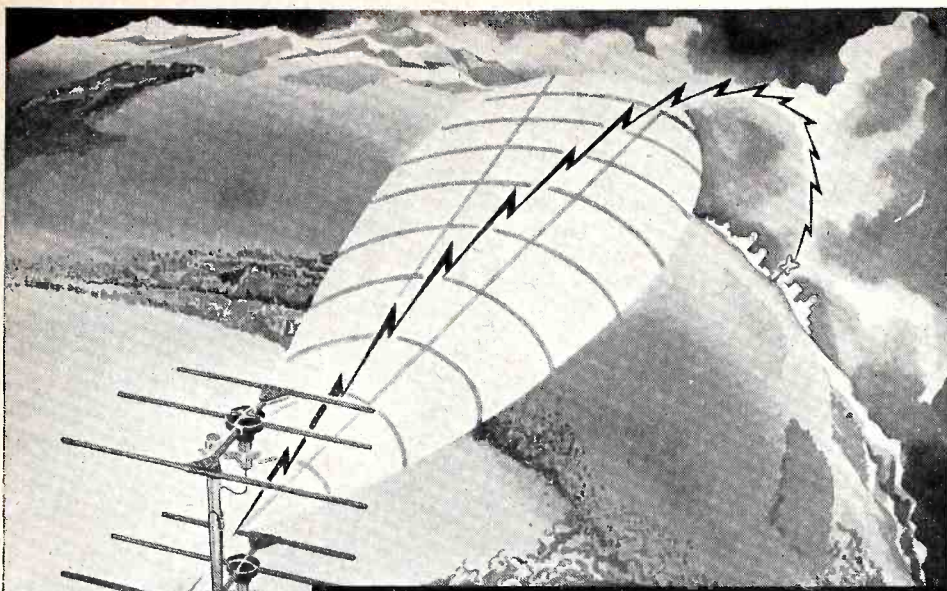

TELEVISION RECEPTION PROBLEM — No. 2 of a series.

WORKSHOP TV ANTENNAS REDUCE CO-CHANNEL INTERFERENCE AND NOISE TO A MINIMUM

The very sharp directional pattern of Workshop's Super High Gain 6-Element Array combined with its high "front-to-back ratio" cut interference so that fringe areas enjoy sharp, brilliant reception.

INTERFERING CO-CHANNEL SIGNAL

Send for the new Workshop TV Catalog (No. 49)

THE WORKSHOP ASSOCIATES, Inc.

Specialists in High-Frequency Antennas

57 NEEDHAM STREET, NEWTON HIGHLANDS 61, MASSACHUSETTS



Two Way Antenna Alignment Communicator

NO EXTRA WIRES TO ROOF

USES TV TRANSMISSION LINE FOR SIGNAL

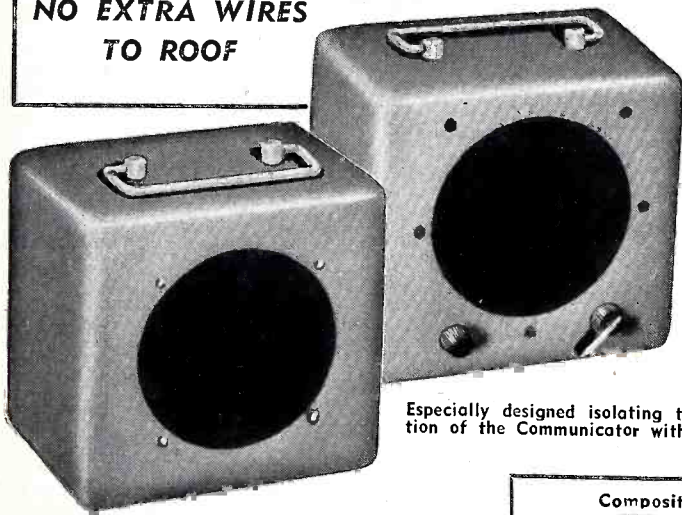

Better TV Antenna Installations in Half the Time!

The Model 3AW8 Communicator uses the 300-ohm lead-in as an interconnector between the roof and the television receiver. Two men in constant voice contact can quickly determine the proper location and orientation for best possible reception.

Especially designed isolating transformers permit the operation of the Communicator without disturbing the picture.

Specifications

Size (Each unit): 6½" x 6½" x 4¾"
 Weights: (Master unit) 4 lbs. 10 oz. (Remote Unit) 2 lbs. 12 oz.
 Speakers: 5 inch P. M. in both units
 Operates on 115 V. A. C. or D. C.
 Price (1 Master and 1 Remote Unit) Only \$39.95
 F. O. B. Factory—Fully Guaranteed

Composite Video Generator



Write for Bulletin 30G1

Important for service department use in aligning television receivers particularly when no station signal is available. Laboratory quality yet priced at a fraction of cost of comparable equipment. Only \$300.00 F.O.B. Factory. ...

J. & A. TELEVISION & MFG. CO.

5066 BROADWAY

CHICAGO 40, ILLINOIS

Metalace EAVE MOUNT

A simple adjustment of the vise-type clamps on the new adjustable eave mount (model EMX) permits variance of a stand-off from 8" to 10" or 12". Accommodating

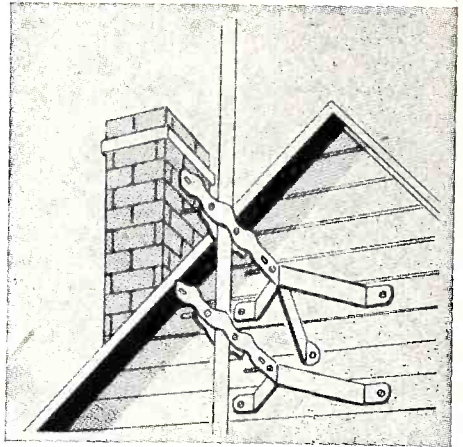

masts of ¾" to 2½" this tripod support is designed for use under eaves. List price is \$5.00 per set. Metalace Corp., 2101 Grand Concourse, New York 53, N. Y.—RADIO & TELEVISION RETAILING.

Ward TV ANTENNAS

The new "Minute Man" series consists of 13 pre-assembled TV antennas ranging in list prices from \$2.45 to \$49.50. According to the maker, even the most complicated array can be installed by one man in a few minutes. Also being featured is

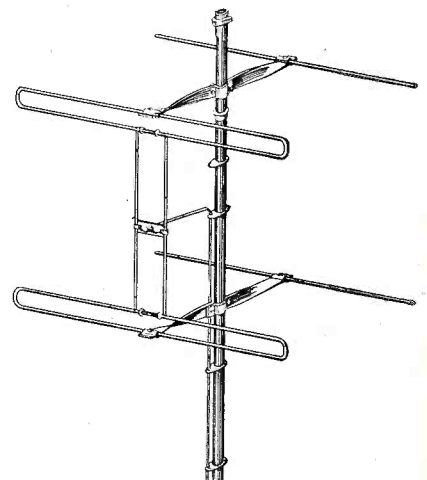

Stacked folded dipole.

a new indoor antenna TVI-49 a tip-proof antenna with polished aluminum telescopic dipoles listing at \$6.95. Ward Products Corp., 1523 E. 45th St., Cleveland, Ohio.—RADIO & TELEVISION RETAILING.

Garod Ad Program

An intensive drive to secure increased cooperative dealer newspaper advertising of "Tele-Zoom" television receivers has been instituted by Garod Electronics Corp., Brooklyn, N. Y. Dealers are being furnished two series of ad mats graphically describing the operation of "Tele-Zoom" as well as featuring individual Garod TV models. The education series explaining "Tele-Zoom" includes a 450 line and 1000 line ad illustrating the two sizes of pictures possible with "Tele-Zoom." The popular "Howdy Doody" of NBC Television is shown in a regular rectangular picture, and in an enlarged circular close-up.

Speakers Talk on State of Market at NEWA Annual Convention

• Timely subjects at manufacturing, wholesaling and retailing levels were discussed by prominent executives at the 41st annual convention of the National Electrical Wholesalers Association, at the Netherland Plaza Hotel, Cincinnati.

Ross D. Siragusa, president of Admiral Corporation, characterized today's market as "nothing either novel or frightening" in contrast to the war-born interlude of scarcity and inflation.

Siragusa Looks Ahead

He stressed the fact that, although competition was back in full force, the consuming public is in a strong position relative to employment, incomes, savings and installment credit. To support this view he noted that there are 57 million people at work with some three to four million unemployed, counting normal seasonal unemployment. Personal income last year reached a new all-time high of \$214 billion and for the first three months of this year income was at an annual rate approximating \$220 billion. Similarly, savings in 1948 totaled \$15 billion, a sharp increase over the first two or three post war years. This figure compares with \$10 billion in 1941 and \$3.7 billion in 1940.

"The big question of 1949," Mr. Sira-

gusa added, "is not whether business generally is going to be good by any reasonable standard, but rather what industries and what companies are going to make the most of the favorable situation." He predicted that more people and better trained people are going to be engaged in distribution than ever before. Older industries, he said, are going to be extremely hard pressed.

Television may take the place of the automobile in the No. One preference of what consumers plan to buy next, and Mr. Siragusa also predicted a great future for the new and improved electrical appliances, such as the new refrigerators, dish washers, etc., that are designed to make the homemaker's job much easier.

Blees Addresses Group

William A. Blees, vice-president of Avco Mfg. Corp., and general sales manager of the Crosley Division, delivered an important address dealing with such subjects as overproduction, price situations and dealer discount structures. He summed up his speech by saying "that to help dealers make money we need to stop overselling them and help them keep control of inventories. See to it that they carry adequate but not excessive stocks. We

must help dealers get good accounting and management into their operations. We must immediately study our discounts and review them in line with the present day cost of doing business. We must get our wholesale men to become more retail minded. We must not pack territory with dealers. If we do these things, we will build confidence in the minds of our dealers and have a prosperous organization."

Message to Jobbers

M. F. Coates, executive vice-president, Motor Wheel Corporation and general manager of the Duo-Therm Division, spoke on appliance merchandising in 1949. He closed his talk with the following message to distributors: "I think it is vitally important that you streamline your sales organizations, and educate them to do a hard-hitting, intelligent selling job. It is also important that you make a complete analysis of your present operations; from a standpoint of profits and expenses, to insure your continued healthy financial condition and successful operation in the future."

Among others who spoke was NEWA managing director Charles G. Pyle, who presented the organization's annual report.

(More about the NEWA Convention, election of officers, on page 79)

Leaders in the Specialty Radio Field!

JEWEL *Wakemaster*

with TELECHRON ALARM MOVEMENT

America's newest mode for waking! TELECHRON Alarm Movement automatically turns on the superheterodyne radio. 10 minutes later, alarm sounds to make doubly sure. Clock has sweep second hand. Radio or clock can be used independently. Decorator-styled walnut or ivory plastic cabinet.



MODEL 920-A

PERSONAL PORTABLE

Tiny Battery Radio in all-
plastic cabinet in choice of
ivory and assorted colors.
Plastic shoulder strap. 4 tube
superheterodyne circuit;
built-in loop antenna. It's the
size of your hand. Has exclu-
sive Jewel "Sound-Focus"
feature which means speaker
is aimed at ear of listener.

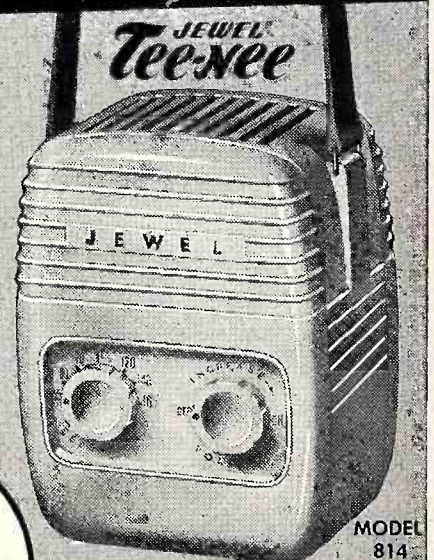

MODEL 814

*Built to Sell!
Styled to Sell!
Priced for fast Selling
and Worthwhile
Profits!*

DISTRIBUTORS!
Factory Representatives
Some good territories are
open. Write for details.

JEWEL RADIO CORP.
10-40 45th AVE., LONG ISLAND CITY 1, N. Y.

it's new!

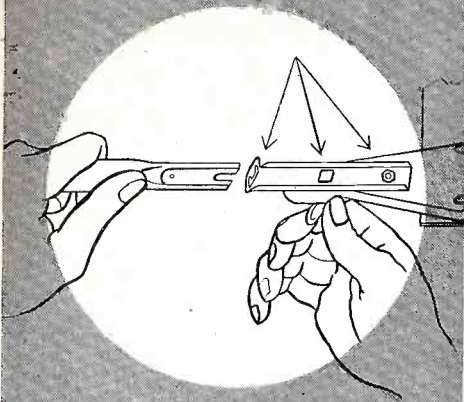

The **RMS** TV
ANTENNA LINE with the
New, Exclusive feature

SPEE-D-LOK*

assembly

Dealers and service men across the country recognize these facts about the RMS Antenna Line:

1. GREATER EFFICIENCY — BETTER RESULTS
2. SPEEDIER INSTALLATION IN MATTER OF SECONDS
3. MODERATELY PRICED



THANKS, JOBBERS! for your tremendous interest in our Spee-D-Lok line, displayed at the Chicago Trade Show in May.

Send for the NEW Spring 1949 Catalog # 215.

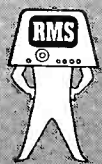

RADIO MERCHANDISE SALES, INC.
550 Westchester Avenue, New York 55

New Radio, TV Items on the Market

Meck PORTABLE TV SET

7-inch TV set with 18 tubes plus 4 rectifiers and picture tube is covered in luggage tan and can be completely enclosed

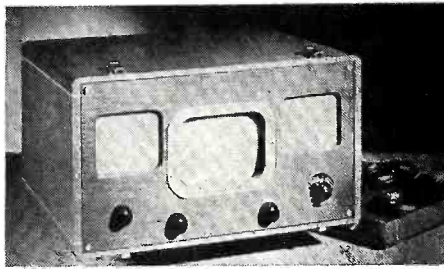

for carrying. Set is furnished with 5-inch speaker, portable antenna, and retails at \$169.00. John Meck Industries, Inc., Plymouth, Indiana.—RADIO & TELEVISION RETAILING.

Philco TV TABLE SET

New Philco model 702 is a 7-inch table model TV set with "wide angle" viewing screen with automatic channel selector for 12 channels, and separate background and contrast controls. The modern cabinet is of mahogany veneer. Field tests of this receiver are said to have shown exceptional performance in areas of weak, noisy signals. Philco Corp., Tioga and "C" Sts., Philadelphia, Penna.—RADIO & TELEVISION RETAILING.

Zenith PORTABLE RADIO

"Holiday" is a 3-way portable in a plastic cabinet with 4-inch loudspeaker, featuring "flipup" panel revealing dial and Wavemagnet antenna. Measuring 8½ by 5½ by 11½ inches, the set retails for \$39.95 less batteries. Zenith Radio Corp., 6001 W. Dickens Ave., Chicago 39, Ill.—RADIO & TELEVISION RETAILING.

U.S. TV RECEIVERS

Two new models have been announced: a 16-inch consolette with FM radio, 26 tubes plus 3 rectifiers and picture tube, to list at \$625, and a 12-inch table model with 85-square inch "wide screen" at \$369.50. In addition, the 15-inch consolette has been reduced from \$625 to \$569.50. U. S. Television Mfg. Corp., 3 West 61st St., New York 23, N. Y.—RADIO & TELEVISION RETAILING.

Durable TV LENS

A new magnifying lens that filters and enlarges at the same time has recently been developed which is made of a special DuPont perfected material which enables the lens to enlarge and clarify with magnificent intensity, the maker claims. A feature of Durable's filter-magnifying lens is its brackets, which enables the lens to fit any shape set and also permits the doors to be open and closed. Durable Formed Products, Inc., 6 Greene St., New York 13, N. Y.—RADIO & TELEVISION RETAILING.

Trav-Ler TV CONSOLES

Models 10TM and 10TB are similar except that 10TM is in mahogany finish and 10TB Blond finish. Sets feature 10-inch tubes with approximately 60 square inch



screen, push-button tuning over 12 channels, automatic gain control, intercarrier sound system, all service controls located in front behind removable panel. Trav-Ler Radio Corp., 571 W. Jackson Blvd., Chicago 6, Ill.—RADIO & TELEVISION RETAILING.

Polaroid TV FILTERS

Polaroid filters are now available for round screen TV sets. Special models are available for Zenith sets (10-inch model 1025, 12 inch model 1225) and for all other round screens (10 inch model 1050 and 12 inch model 1250). 10 inch models are \$12.50, 12 inch models are \$16. Pioneer Scientific Corp., 295 Lafayette St., New York 12, N. Y.—RADIO & TELEVISION RETAILING.

Sparton TV CONSOLETTA

Model 4944TV has 16-inch direct-view screen, 28 tubes, and automatic brightness control. Set features hand-rubbed mahog-

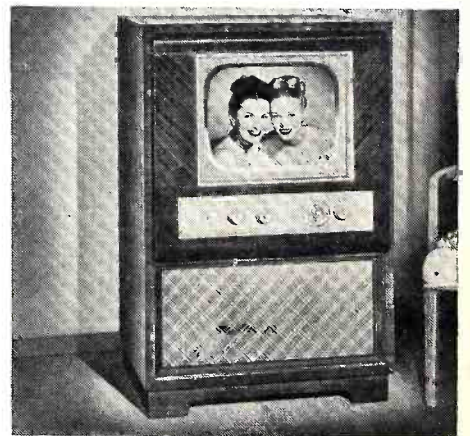

any veneer cabinet, and is nationally priced at \$495. Sparks-Withington Co., Jackson, Mich.—RADIO & TELEVISION RETAILING.

See Additional Items Elsewhere
in This Issue

NEWA Elects Officers

D. M. Salsbury, president, Westinghouse Electric Supply Co., New York, was elected president of the National Electrical Wholesalers Association following the general session of the Association's forty-first Anniversary Convention held in Cincinnati.

Also announced at the close of the luncheon and organization meeting of

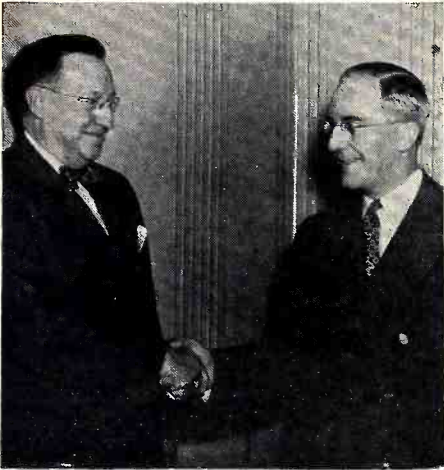

D. M. Salsbury, right, newly elected president, is shown being congratulated by his predecessor, E. B. Ingraham.

the Board of Governors was the election of R. M. Johannesen, Johannesen Electric Co., Greensboro, N. C., as vice-president and chairman of the Apparatus and Supply Division. W. G. Peirce, Jr., Peirce-Phelps, Inc., Philadelphia, was re-elected as vice-president and chairman of the Appliance Division.

George F. Hessler, Graybar Electric Co., Inc., New York, and C. E. Mason, Novelty Electric Co., Inc., Philadelphia, were elected to the Executive Committee.

The following members were newly elected to the Board of Governors: R. A. Stott, Tristate Electric Supply Co., Hagerstown, Md.; W. H. Butts, Butts Electric Supply Co., Charleston, S. C.; E. J. Rueth, Frankelite Co., Cleveland; C. M. Mackey, Westinghouse Electric Supply Co., Dallas; Frank Argast, Farrell-Argast Electric Co., Indianapolis; W. E. Guy, Graybar Electric Co., Inc., Chicago, and Titus B. Schmid, Crescent Electric Supply Co., Dubuque, Iowa.

RCA Tube Carton

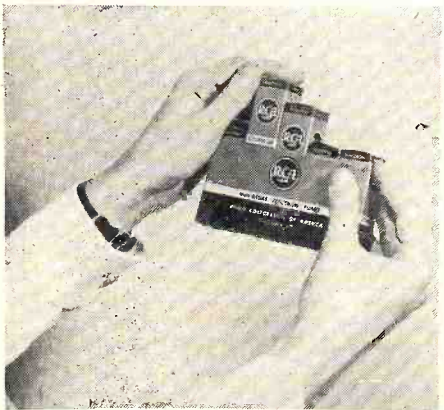

A new miniature-tube carton designed to eliminate the problems of handling and stocking miniature types has been introduced by the RCA Tube Department. The carton contains five individually packaged tubes.

SPEED TELEVISION SALES and SERVICE!



TV—FM ANTENNA ROTATOR

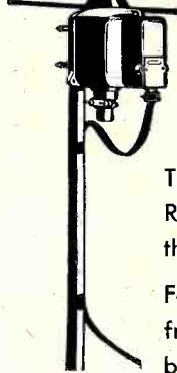

**Faster Installations! Fewer Call-Backs!
Bigger Profits! Happier Customers!**

Television dealers and service stores find Tenna-Rotor speeds installations—saves manhours on the job—brings an end to costly service call-backs.

Foolproof, weatherproof, instantly controlled from the set—this antenna beaming device brings up pictures sharp and clear, tunes out "ghosts" and reflections—in fringe or multi-station areas it **gets that station you couldn't get before!**

Join the trend to Tenna-Rotor! It pays off with more sales, faster service and happier customers!



List price—\$39.95.
(slightly higher west of Rockies)

Be sure to ask for ALLIANCE Tenna-Rotor 4-conductor cable

ALLIANCE MANUFACTURING COMPANY • ALLIANCE, OHIO

Export Department; 401 Broadway, New York, N. Y., U. S. A.



Model CT-104
12½" TUBE

DEWALD
HIGH DEFINITION
TELEVISION
10" - 12½" - 16" MODELS

Quality—Performance—Value
. . . you'll find all the things that make satisfied customers, increase sales and profits, in the new DeWALD Line of Television and Radio.

Quality Proven for More Than a Quarter-Century

JOBBERS — REPRESENTATIVES

Some choice territories now available.
Write for full information.

in
RADIO
and
TELEVISION

for
SOMETHING
BETTER,
it's

DEWALD

DEWALD RADIO MFG. Corp. 35-15 37th Ave., Long Island City 1, N. Y.

TACO

LAZY X

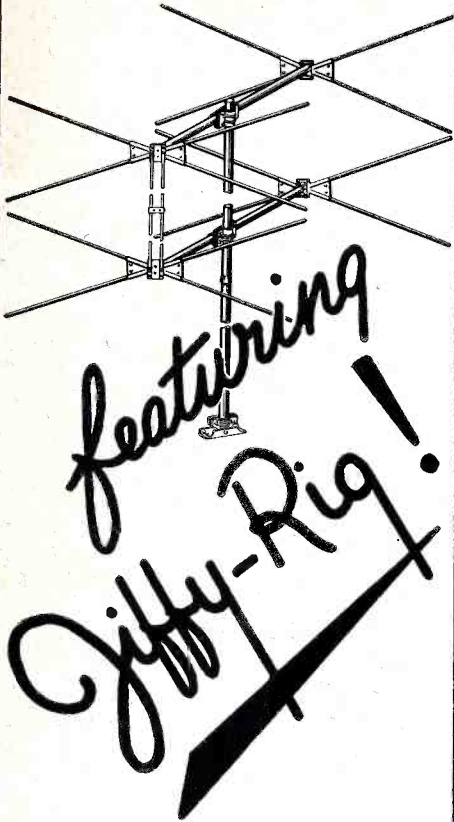

•First introduced by TACO in 1940 as the Double Vee, the new TACO Lazy X incorporates all the outstanding features that have made TACO antennas the leaders in the field.

An all-band antenna, available in single or stacked arrays, the TACO Lazy X gives very flat response over the entire TV band. All-aluminum construction assures long service life. A twist of the wrist, a few nuts to tighten, and the antenna is ready for use without sacrificing any mechanical or electrical characteristics due to the TACO JIFFY-RIG construction.

TACO INDOOR ANTENNA

•An indoor antenna that works! Engineered as only TACO engineers. Beautiful appearance. Mounting feet for attic installations. Low cost.

AT ALL LIVE-WIRE JOBBERS... SEE YOUR JOBBER TODAY!

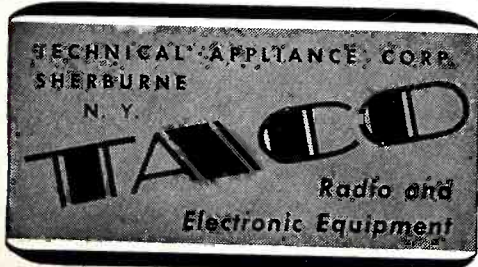
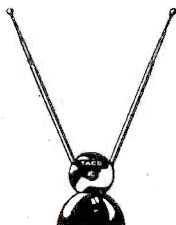

In Canada: Stromberg-Carlson Co., Ltd., Toronto 4, Ont.

Admiral Changer

(Continued from page 63)

and one for 45 RPM). This spindle, shown in fig 2, is to all intents a duplicate of the spindle on the RCA changer shown in the May issue of RADIO & TELEVISION RETAILING. The push-off adjusting shaft fits into the spindle hole in the turntable, and the spindle is turned so that the lock-in lugs fall into slots in the turntable. When playing this type record, the speed change lever will be set at 45 (and consequently the tripping mechanism will automatically be set for position trip), the needle will be set for "LP," the head assembly will be in the 7-10 inch position, and the record size selector will be set at the 7-10 inch position. 45 RPM records are supported solely by the spindle, and change mechanism is housed in the spindle as explained in a previous article on the RCA changer, mentioned above. During the change, the push-off adjusting shaft is pushed up into the spindle, operating the slicer blades.

The only thing this changer will not do is to mix records of different sizes and types. As mentioned in an earlier issue, the "Triple Play" changer is now incorporated in all Admiral TV sets, and all radio-phonographs priced from \$69.95 and up.

Mueller TENNA-CLAMP

COMPLETELY NEW and DIFFERENT!

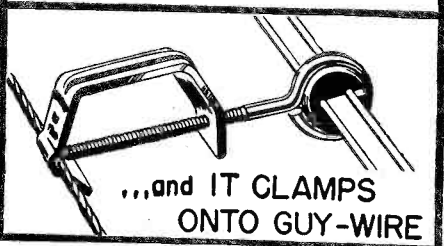
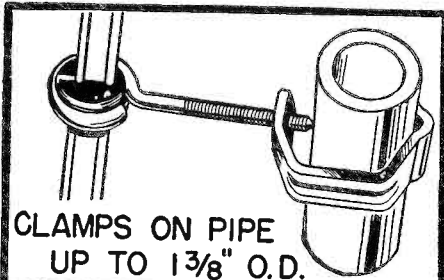

SUPPORTS TV LEAD-INS ON MASTS, PIPES, CROSS-ARMS, GUTTERS AND GUY-WIRES

- ONE STANDARD SIZE solves all sorts of lead-in problems.
- BRINGS LEAD-IN TO EDGE OF ROOF—right where you want it—holds lead-in away from gutters.
- DULL POINTED SCREW—solid grip on mast.
- ON MASTS TOO BIG for clamp—use the guy-wire.
- AVAILABLE FOR COAX and double lead-ins.

LOW PRICES!

9¢ net—only \$7.80 per 100

SEND FOR FREE SAMPLE & CATALOG 1902

Mueller Electric Co.
1601 E. 31st St., Cleveland 14, Ohio

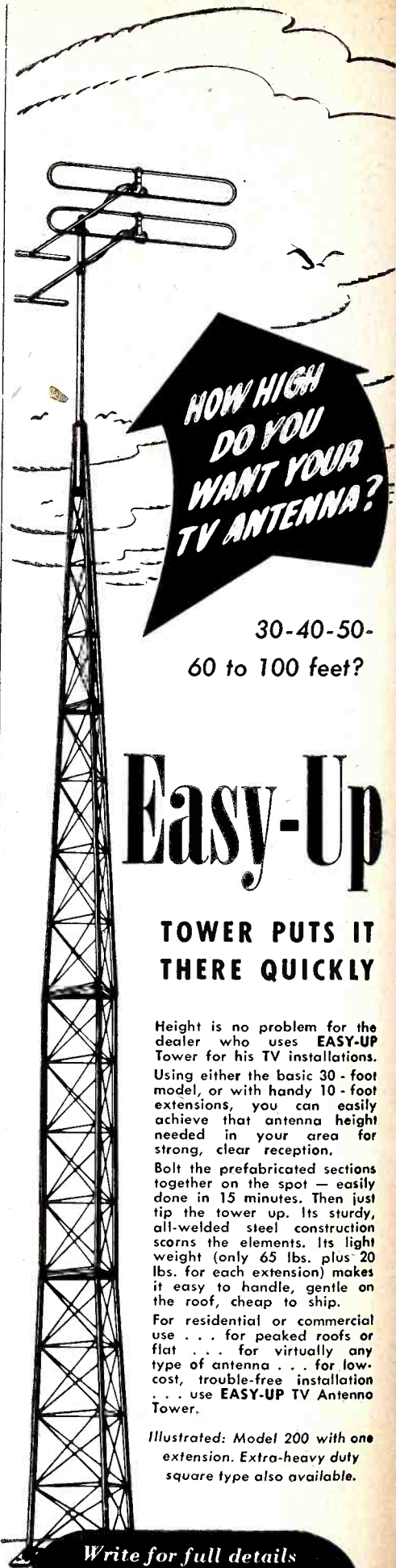

30-40-50-60 to 100 feet?

Easy-Up

TOWER PUTS IT THERE QUICKLY

Height is no problem for the dealer who uses **EASY-UP** Tower for his TV installations.

Using either the basic 30-foot model, or with handy 10-foot extensions, you can easily achieve that antenna height needed in your area for strong, clear reception.

Bolt the prefabricated sections together on the spot—easily done in 15 minutes. Then just tip the tower up. Its sturdy, all-welded steel construction scorns the elements. Its light weight (only 65 lbs. plus 20 lbs. for each extension) makes it easy to handle, gentle on the roof, cheap to ship.

For residential or commercial use . . . for peaked roofs or flat . . . for virtually any type of antenna . . . for low-cost, trouble-free installation . . . use **EASY-UP** TV Antenna Tower.

Illustrated: Model 200 with one extension. Extra-heavy duty square type also available.

Write for full details

Easy-Up Tower Co.

3800 Kinzie Ave.
Racine, Wis.

GE Appoints Fassler



S. M. Fassler, above, has been named manager of advertising and sales promotion for the Receiver Division of the General Electric Company's Electronics Department, Syracuse, N. Y., announced W. M. Skillman, manager of sales for the division.

Tele-tone Price Policy

S. W. Gross, president of Tele-tone Radio Corp., New York City, declared at a meeting of the company's sales force, that moderate and low income families are buying television receivers on a markedly increasing scale. Mr. Gross based his statement on reports from the firm's dealers as well as on survey figures. "The video sales increase among lower-salaried groups," Mr. Gross stressed, "underlines the established policy of Tele-tone Corp., which has consistently tailored its products and prices to the mass pocketbook."

Dealer Reaction

(Continued from page 53)

mind unloading of certain models, no servicing set-up, uncontrolled trade-in advertising, overfranchising, etc."

Chattanooga, Tenn.: "Dealer discounts should be not less than 40% on small sets and 50% on sets retailing for over \$50.00."

Long Beach, Calif.: "Price-cutting and complete lack of price protection on radio and television."

Minneapolis, Minn.: "Too many dealers on each line."

Some Price-Cutting Causes

- Over-production
- Longer discount rates to "pet accounts"
- Assortment Deals—Dumping
- Back-door selling by distributors
- Products too high-priced or not in demand
- Stagnant inventories — need for ready cash
- Stores always featuring price-cut merchandise
- Disregard of need for policing prices by certain manufacturers and wholesalers
- Surprise launching of new models
- Too many retail outlets
- Loose Franchising Policies

BIGGER

DEALER DISCOUNTS

and **TERRIFIC**

PERFORMANCE with

Videola TELEVISION



Videola A Symphony of Sight and Sound!

COMPLETE LINE OF 91 AND 135 SQ. INCH TV RECEIVERS

From any angle you're on top with Videola. Bigger dealer discounts — no tie-in deals — exclusive advanced R.C.A. electronic features . . . all helping you sell more and more Videola sets!

Write to Dept. E for new brochure of our complete line.
Distributors: Some territories still open. Wire—Write today.

Video Corporation of America
229 WEST 28th STREET • NEW YORK 1, NEW YORK

**FOR EVERY TYPE OF
ANTENNA INSTALLATION**

SpeedMounts

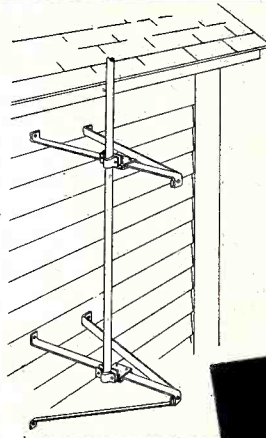

WALL MOUNT PAM-6

Adjustable from 1" to 19" from wall. Mounts on uneven surfaces—clears eaves, power wires, and other obstructions. Clamp holds masts 3/4" to 1 1/2". Strong and rigid —made of cadmium plated, heavy gauge steel. **\$7.00** LIST PRICE

CHIMNEY MOUNT PAM-5

Fast, one-man installation. Fits any type chimney. Adjustable clamp holds masts 3/4" to 1 1/2". Heavy gauge steel construction, cadmium plated. New low price! **\$3.95** LIST PER PAIR

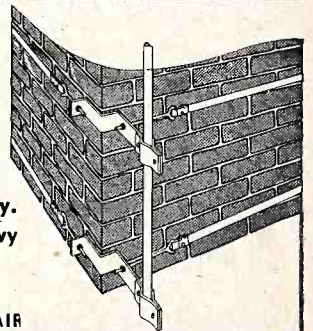

PHOENIX ELECTRONICS INC.,
Lawrence, Massachusetts

WRITE FOR CATALOG R
At Leading Jobbers

and Dealers Everywhere

FOUND!

the "MISSING LINK" to
GOOD TV ANTENNA
INSTALLATIONS

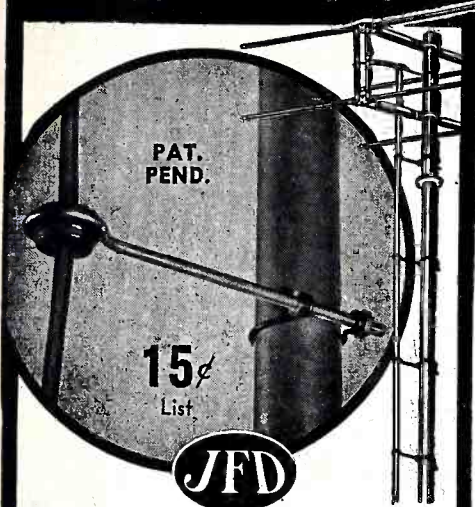

MAST CLAMP LEAD-IN SUPPORTS

Made with POLYETHYLENE
(the ultra-low loss insulation material)

Now you can make any old or new TV installation last longer, look neater, perform better with the unique JFD Mast-Clamp Lead-In Supports. These new Screw Eye Insulators are JFD-engineered to anchor lead-ins firmly in place and assure better TV/FM reception.



TL100-350
1" Clamp with 3/2" Screw
Eye for Twin Leads. **15¢**
List



RG100-350
1" Clamp with 3/2" Screw
Eye for Coaxial
Cable. **15¢**
List



DTL100-350
1" Clamp with 3/2" Screw
Eye for two Twin
Leads. **35¢** List

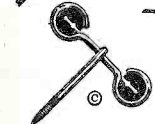

DBR18TL3
3/2" Screw Eye with wood-
screw thread, for two Twin
Leads. **28¢** List

Mast Clamps are made in all sizes for all applications, individually designed to fit masts from 1/2" to 2" O.D. Screw Eyes range from 3/2" to 12" in length.

JFD MANUFACTURING CO. Inc.

6115 16th Avenue
Brooklyn 4, New York

WRITE TODAY

for Valuable 4-page Bulletin #DBR

© Copyright 1949 by JFD Mfg. Co. Inc.

FIRST In Television Antennas and Accessories

10" Tube Price Reduction

RCA has reduced the price of the 10BP4 television picture tube approximately 10%. The tube now carries a suggested list price of \$41.50 as compared to the former price of \$44.50. The move is said to be made possible by improved production facilities and increased volume.

Bendix Price Reductions

Price reductions on five models in the 1948 Bendix Radio line were announced. The plastic 3-way portable, model 55X4, was reduced from \$39.95 to \$29.95; the 6-tube console 75M8 was reduced from \$189.95 to \$129.95, and the three consoles 75B5, 75M5 and 75W5 were reduced from \$149.95 to \$99.95.

"Try" TV Sets in Home

(Continued from page 36)

basis. Also, it is definitely true that sales resistance is stiffening. For all of these reasons, the dealer must view the market with a promotional eye. Even in cases where he can sell all the sets he can get hold of right now in his store, he needs to consider a tomorrow when he may have to fight for every sale.

In light of the obvious necessity for employing aggressive merchandising methods, even in cases where sales are still "making themselves," dealers are looking out of their stores and into the homes in their territories. Numbers are canvassing business today, while still others work for home demonstrations, and a growing number are offering the "free trial" program to customers.

In looking at such outside activities, the merchant sees that carefully administered in-home selling can be profitable. Certainly, if he can secure a signed order, as previously outlined, a home "trial" deal doesn't seem particularly risky from any angle. Too, every retailer knows that home demonstrations have always been effective, and that the salesman employing such technique can bat a very high sales average.

All dealers today have numbers of good, regular customers who've been in several times to "look" at television receivers, becoming more bewildered with each visit—unable to make up their minds. In such cases, the solution seems to lie in an offer to send out a set for trial in the home without obligation of any kind, other than the signing of a delivery receipt. With such people, the dealer has something very worthwhile to go by—the patron's past performance as a customer.

Whatever sales promotion plan the dealer uses to get more TV volume via activities in the field, he should by no means neglect his store. A sale made at headquarters is nearly always more profitable than a sale made on the outside. But because competition is increasing, and sales are becoming harder and harder to close, the smart retailer is also interested in the possibilities for more business through canvassing, home-trial plans and in-home demonstrations.

new **Bogen H 623**

**23 WATT UNIVERSAL
MOBILE AMPLIFIER**



- FOR 6 VOLT DC and 110 VOLT AC
- SIX POSITION MULTI-RANGE TONE CORRECTOR
- "CRISP" POSITION FOR IMPROVED OUTDOOR PERFORMANCE
- SPECIAL MOBILE PHONOGRAPH PICKUP
- REMOTE CONTROL OF PLATE SUPPLY
- CONSTANT VOLTAGE OUTPUT
- UNDERWRITERS' LABORATORIES APPROVED

LIST PRICE: \$177.50
(ZONE 2: \$182.00)

David Bogen



CO., INC.

663 BROADWAY, NEW YORK 12, N. Y.

Write for literature

Portable **TRI-TUBE**



Antenna
MASTS

**TELEVISION
FM • AMATEUR
COMMERCIAL**

LOW
COST
•
LIGHT
•
QUICK
•
EASY

Mast section is triangular in construction using 1" ID steel tubing with proper bracing, all electric welding. Lower unit is 20 ft. long hinged on frame with locking device. Levelling device compensates for position of vehicle on any test location. Upper unit is a smaller triangle and telescopes into lower unit on rollers, which allow smoother operation. Cable and drum provided with pin assembly for safety and locking into any height. Antenna mast can be set up by two men in a few moments... NO GUYS - NO WRENCHES - NO BOLTS All bolts have 'T' handles. Demountable by removing two bolts in four minutes. Aluminum painted ready to mount.

- 250 BASIC UNIT COMPLETE 50 ft., 10 ft. pole
- 251 SAME AS 250-ORIENTATION AT ANY HEIGHT
- 252 SAME AS 251, WITH ANTENNA HEIGHT 70 FEET

A. A. PETERS

TRI-TUBE MASTS

231 N. 7th Allentown Pa.

SHIPPED F. O. B.
ALLENTOWN, PA.

\$295

and up



Manufacturer Sales Aids for Dealers

Emerson Radio & Phonograph Corporation announces that its new "Window Merchandiser," No. SS-3 Display, is finding a good reception with Emerson dealers throughout the country. This little "silent salesman" is designed with illumination and platform for holding one or more radios. The feature of the design provides for an interchange of display cards. It is furnished to dealers with an assortment of double-face cards, each side of the cards carrying a compelling consumer selling message.

A counter identification card for its new two tone plastic circulators has been produced by the Fresh'nd-Aire Co., of Chicago, division of Cory Corporation and manufacturers of Fresh'nd-Aire electric fans, air circulators and humidifiers. The card attaches to the back of either of the company's new models 90 or 120—says "Here it is! The new FRESH'ND-AIRE Circulator! Copy explains the 90 degree finger tip directional airflow control of the new models . . . the versatility of use (use them as floor, window or table models), the new furniture styling and the safety features of the plastic free-flow guard design. The display card is attractively printed in two colors.

"Even Strong Flavors Stay Put in the New 1949 Admiral Dual Temp" is the dominant theme of Admiral's refrigerator advertising and sales campaign for this year, along with a consistent plugging of the "no defrosting" feature that has for years focused consumer attention on Admiral's Dual-Temps.

Arvin dealers have received shipments of a portable promotion display stand to aid them in merchandising and sales of the new Arvin Portables recently announced. Known as Portable Radio Sales-maker No. 101, the new display piece is printed in red and chrome yellow and is accompanied by streamers and ad mats.

Universal Display



Landers, Frary & Clark, New Britain, Conn., has available for dealer use an attractive three-color window and counter card with recessed red foil background, highlighting the new Universal Coffeematic.

Oak Ridge VIDEO TURN TABLE

This turntable can be placed under most standard table model sets and will allow complete orientation of the set so that it will face any position in the room. It is constructed of heavy duty tempered masonite with 12 special rollers to allow free turning of the television set. Bottom of turntable complete with insulated pads to prevent marring of table tops. List price \$5.00. Oak Ridge Antenna Co., 239 E. 127th St., New York 35, N. Y.—RADIO & TELEVISION RETAILING.

Deitz TV LENS

By attaching the lens to the tube and sealing it with oil, the lens becomes a part of the tube. Maker states that a ten inch tube will become equivalent to a 16" tube, and a 7" will become equivalent to a 12" tube. Now in kit form for assembly at installation or at the service man's shop. Deitz Miracle Lens, 141 President St., Passaic, N. J.—RADIO & TELEVISION RETAILING.

TV Sells Appliances

(Continued from page 59)

best salesman any dealer can employ to sell electrical appliances, phonographs, records and other merchandise.

Look at it like this: Today's Number One "commercial" visitor of importance to the home is Mr. Television Man. He has the run of the house. He's welcomed at the front door.

If he's the technician, the members of the family look upon him as a sort of Superman and Thomas A. Edison rolled into one. His services in making the television set perk again rank second only in importance to those of the family physician who calls in the interest of health. His expert advice is sought on household electrical problems, on prospective purchases of all kinds of new electrical equipment.

Or maybe the Television Man visiting the home is the salesman, come to check up, as he should, the operation of the set, or to get some user-recommended leads. The reception he gets is in keeping with that accorded any person who could bring an equal amount of superb entertainment into the home. Brother, the TV man is really in the front ranks on the sales firing-line. He's in the home where all sales originate!

With a set-up like that we've just seen where the television man is the fair-haired boy in the American home, Television can be used to increase sales of various other products better than any single method one can possibly think of. Servicers and salesmen need to be firmly briefed on the necessity for using TV to push sales of all merchandise the store carries.

Let's capitalize on our reputations as TV experts, on our all-out welcome into the home, and upon this whole, tremendous television interest in order to keep sales of electrical appliances, large and small, records and other equipment at satisfactory levels.

It can be done if we'll use Television as a "salesman," and quit looking upon it as a "competitor"!

Sensational New universal clamp

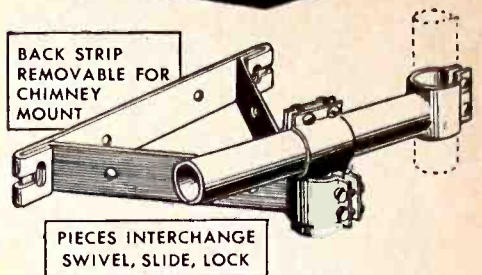

Licks EVERY antenna mounting problem! \$8.25

LIST LESS REGULAR DEALER DISCOUNTS

UNIMAC is an installer's dream come true! This one unit completes your kit. UNIMAC mounts anywhere, in any position, handles all 1 to 1 1/4" masts, and swings them free and clear to perfect, upright position. NO GUY WIRES REQUIRED.

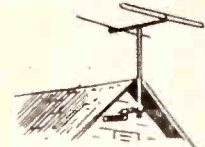

Clears overhanging eaves on gables . . . masts need not be bent . . . mount fastens directly to house without extension blocks. NO GUY WIRES.

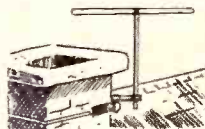

Clears lips on chimneys . . . choice of lag screw or strap mounting provided on part . . . NO GUY WIRES.



Base mounts easily on pitched surfaces . . . full adjustment for erecting mast and orienting antenna. NO GUY WIRES.



Mounts on horizontal or vertical window sash . . . swings antenna clear of obstructions. NO GUY WIRES.

UNIMAC is constructed of heavy steel throughout, with all joints welded, eliminating part failures. Sturdy, clean-cut appearance pleases customers, increases business. ONE-MAN CREWS NOW PRACTICAL.

There's no call back when you use Unimac



MARVIN RADIO-TELEVISION
Buckeye at East 89th St., Cleveland 4, Ohio

- Enclosed find \$5.10 (\$4.95 plus postage) for one sample.
- Enclosed \$..... for..... boxes of UNIMACS at \$29.70 per box of 6.

Name.....

Address.....



Jack D. Mendelson, above, has been appointed New York sales manager for Tele-tone Corp., New York City, it was announced by Morton M. Schwartz, general sales manager of the company.

Herschel L. Johnson has been appointed Coolerator district manager for the Southeast, it was announced by William C. Conley, Jr., Coolerator sales manager. In his new position, Johnson will supervise the sale of Coolerator refrigerators, electric ranges, and family-size home freezers in Georgia, Florida, North Carolina, and South Carolina.

Bob Siegel, formerly program director of WGYM-FM in New York City, has transferred his activities to the United States Television Mfg. Corp., where he is currently engaged in advertising and sales promotion.

Monte M. Wheeler has been appointed assistant manager of General Electric appliance sales in the company's north central district, it has been announced by J. S. Strecker, district manager. His headquarters are in Chicago.

John P. Vail has been appointed distributor sales representative for the Radio Division of Sylvania Electric Products, Inc., in Pennsylvania, Ohio, Michigan, West Virginia and Maryland, according to H. H. Rainier, manager of distributor sales.

The R. W. Fordyce Company, of Ardmore, Pa., district merchandiser of Bendix Radio and Television for eastern Pennsylvania recently announced the appointment of John E. Kane, of Easton, Pa., as district salesman for the eastern portion of their territory. Mr. Kane has had many years' experience in both retail and wholesale distribution of radios and appliances.

Alex Kuehlthau has been appointed Coolerator district manager for the Pacific Northwest territory.

Two new Maytag regional managers have been assigned to sales territories in Wisconsin and Michigan. Arthur A. Schlack, formerly of Lansing, Michigan, will take over fourteen counties in Wisconsin. Harvey A. Gridley, of Hartford, Michigan, has been assigned to nine counties in east central Michigan.

Sales-Stimulator

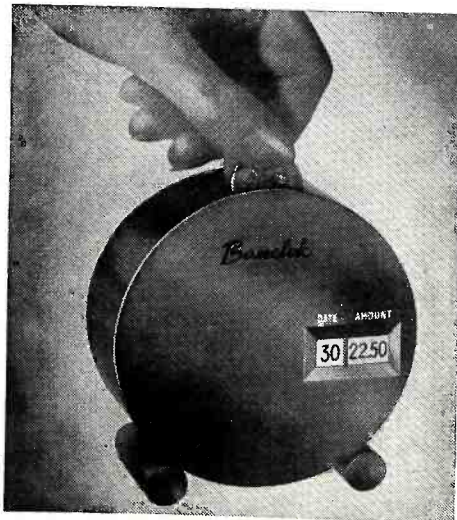

Banlok registers to \$22.50 in quarters. Date changes with each insertion. Manufacturer suggests use as sales stimulator by dealers who lend or sell banks to customers to use as down payments, monthly payments, etc. Retail at \$3.50. Dealers may obtain banks imprinted. Made by Leecraft, 405 Lexington Ave., New York 17, N. Y.

John E. Fox, manager of industrial relations for the Westinghouse Lamp Division, Bloomfield, N. J., the past three years, has been appointed staff assistant to Ralph C. Stuart, vice-president in charge of the division.

Irving B. Shurack has been appointed special factory sales representative for the New York Metropolitan area by Emerson Radio and Phonograph Corporation, it is announced by Charles Robbins, vice-president in charge of sales.

Harry Estersohn has been appointed sales manager of the Jerrold Electronics Corporation. The Jerrold firm is a manufacturer of television accessories. Principal products of the company are the Jerrold TV-FM preamplifier, and the Jerrold In-Tenna, indoor television antenna. Executive and sales offices are located at 121 N. Broad St., Philadelphia.

George C. Foerstner, manager of the Refrigeration Division, Amana Society, has announced the appointment of Peter B. Gerdes as regional sales manager for Amana home freezers.

A. J. Lindemann & Hoverson Company, Milwaukee, announces the appointment of Don H. MacQuarrie, of Springfield, Mass., as district manager in New England and New York State for L&H electric ranges and water heaters, as well as the Kerogas line of oil ranges.

Almo Radio Company, of Philadelphia, has opened a new branch store at 6205 Market St., Philadelphia. This is the second new branch to be opened in line with Almo's expansion policy. The first branch was opened in December.

A new dealer display, highlighting the "go-to-sleep" and "wake-up-to-music" features of GE clock radio models 64 and 65, has been announced by the Receiver Division of the General Electric Company at Electronics Park, Syracuse, N. Y. Multi-colored, the display is 29 inches wide, 26 inches high, and 8 inches deep. A sturdy platform to hold two clock-radios is also included.

Everybody agrees
ATR VIBRATORS
are **TOPS!**



AUTO RADIO VIBRATORS
have Ceramic Stack Spacers



A COMPLETE LINE OF VIBRATORS...

Designed for Use in Standard Vibrator-Operated Auto Radio Receivers. Built with Precision Construction, featuring Ceramic Stack Spacers for Longer Lasting Life.

Backed by more than 17 years of experience in Vibrator Design, Development, and Manufacturing.

ATR PIONEERED IN THE VIBRATOR FIELD.

NEW VIBRATOR GUIDE FREE



"A" BATTERY ELIMINATORS

for DEMONSTRATING AND TESTING AUTO RADIOS

New Models . . . Designed for testing D. C. Electrical Apparatus on Regular A. C. Lines. Equipped with Full-Wave Dry Disc Type Rectifier, Assuring Noiseless, Interference-Free Operation and Extreme Long Life and Reliability.

NEW MODELS ✓ NEW DESIGNS
NEW LITERATURE ✓
ATR "A" Battery Eliminator, DC-AC Inverters, Auto Radio Vibrators
See your jobber or write factory

AMERICAN TELEVISION & RADIO Co.
Quality Products Since 1931
SAINT PAUL 1, MINNESOTA-U. S. A.



One Charge
**for this
 COMPLETE
 dependable
 shipping service!**

RAILWAY EXPRESS charges cover everything . . . pick-up and delivery in all principal cities and towns, receipt protection, automatic valuation allowance. You know where you stand when you use this dependable service. You deal with one responsible carrier, geared to meet your exact industrial and personal shipping needs with fast, economical rail-air service.

Whether you're the sender or the receiver, it's sound business judgment to say, "Ship it RAILWAY EXPRESS!"



The Railway Express vehicleman who calls for and delivers your shipments is a member of a typical American way business providing an essential service to your community. His efficient, courteous help is always available when needed.



NATION-WIDE RAIL-AIR SERVICE

Snyder Antenna

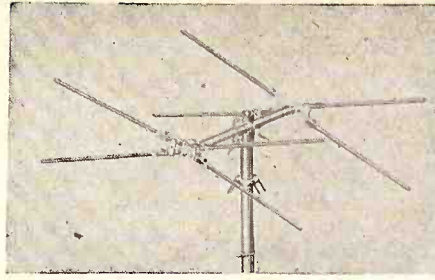

Snyder "Lazy X" conical TV antenna manufactured by the Snyder Mfg. Co., 22nd and Ontario Sts., Philadelphia 40, Pa.

Years of Record Sales

(Continued from page 51)

1927, when we sold 130 million records. And there are important influences at work to get even more record players in homes: first the necessity for buying a player which will play the new types, and second the sale of TV consoles with phono included.

It is a well known fact that new buyers of record-players are the best buyers of discs, and therefore it is reasonable to assume that, properly exploited, this trend will buoy up record sales.

Second, we must consider the tremendous program of advertising and point-of-sale aids that is being undertaken by the leading record companies to foster the growth of their new type records. This can be a decided stimulus to record sales if the dealer takes full advantage of it.

Third, the record ban is over, and there is nothing to impede the timely exploitation of new tunes, such as movie and show scores, etc.

Fourth, record (list) prices are coming down in the competition between the new types of records, bringing those prices closer to the consumer's tightened pocketbook.

Fifth, added selling qualities of the new records give the dealer more hooks to actually sell (instead of dispense) records: such qualities as better tone, longer wear, smaller size, and non-breakable construction. In addition, the customer now has three separate and distinct types of records to choose from, and he may still buy the "standard" type if he so prefers (or if he doesn't wish to buy a new player). Demonstration of the three types, however, is a "must" in dealer's operation.

Summing up, we see that it was inevitable that the record business should "readjust" from its 1947 peak, but that many factors equally inevitable point to a new "norm" considerably above pre-war highs, probably in the neighborhood of 225 million records annually (with the inevitable seasons, peaking around Christmas). This new level will support many more disc dealers than pre-war, but not as many as 1946, and those who do business successfully will have to pursue an aggressive and alert sales plan in order to get it.



The Sensational NEW
YAGI Array

HIGH GAIN AT LOW COST

Here is an antenna which is the most sensational single channel performer yet to be manufactured. VEE-D-X engineers have attained astonishing results in producing an array combining every desirable characteristic necessary for optimum performance.

- Four element beam cut especially for each particular channel.
- High forward gain and sharply directional.
- Stepped-up driven element affords an excellent match to 300 ohm transmission line.

NEW Versatile
All Angle Mount

Here is a rugged, low cost antenna mount which keeps installation costs to a minimum and yet affords you all the advantages of a high cost installation.

- Particularly suited for mounting on side of house near a window for manual rotation of antenna.
- Swivel joint facilitates raising and lowering of antenna.
- Accommodates all popular size masts up to 1-3/8" O.D.

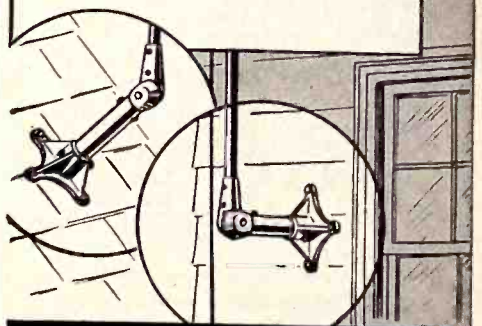

VEE-D-X means video distance

LaPOINTE-PLASCOMOLD CORP., Unionville, Conn., 4
 Gentlemen: Send me new literature and prices on the complete line of VEE-D-X television accessories.

Name _____
 Company _____
 Street _____
 City _____ Zone _____ State _____

Names in the News

Ben Singer has been named head of the newly-established TV specialties engineering department of Tele-tone Radio Corp.

C. R. Courtleigh, vice-president and general manager of **Associated Stores, Inc.**, has announced the promotion of W. R. Brouhard to manager of the Sarasota store. The firm has outlets in a number of Florida cities.

The appointment of Paul P. Smith as renewal sales representative for the radio tube division of **Sylvania Electric Products, Inc.**, has been made known by C. W. Shaw, general sales manager.

Gordon T. Ritter, director of sales for **Arvin division of Noblitt-Sparks Industries, Inc.**, announces that Craig Britton has been appointed as field representative to cover the Minnesota, North and South Dakota territory.

Gene Miller has been appointed to a position in the sales promotion department of the **Gibson Refrigerator Co.**, according to Gregory V. Drumm, manager advertising and sales promotion.

Ab Waxman has become sales manager of the magnetic recorder division of **Air King Products Co., Inc.**, Brooklyn, N. Y. Mr. Waxman is well known in the industry having been advertising and sales promotion director for Wire Recording Corp. of America. He also developed Duplicording, a process which permits the economical multiple reproduction of recordings on wire.

J. J. Anderson has become merchandising manager of household refrigeration for the **Westinghouse Electric Appliance Division, Mansfield, Ohio**. The appointment was announced by T. J. Newcomb, sales manager.

Robert Walcutt, vice-president of **Walco, Inc.**, East Orange, N. J., makers of Walco standard and micro-groove long-playing phonograph needles, Walco

Admiral Plastic TV Set



The Siragusa brothers, left, Dom, president of Molded Products Corp., and Ross, right, president of Admiral Corp., discuss Admiral's new 24 tube TV plastic console. The set has a 10-inch picture screen, and list price is \$249.95. The cabinet is Bakelite phenolic and weighs 35 lbs.

Tele-Vue lens, and Walco television filters, announces the appointment of Eugene B. Lucas as its sales manager.

Coinciding with a program of over-all sales expansion, the appointment of Johnny Parsons to the position of sales promotion manager of the **Hoffman Radio Corporation, Los Angeles**, has been announced by R. J. McNeely, general sales manager of the company.

Rex D'Agostino, formerly of the **Lafayette Radio** store in Newark, New Jersey, has been appointed national merchandise manager for the company. In his new post he will serve all seven stores—at 100 Sixth Avenue, New York City, Bronx, Newark, Boston, Chicago, and Atlanta.

Frank A. D. Andrea, president of the **Andrea Radio Corp.**, manufacturers of Andrea "Sharp-Focus" television sets, announces the appointment of Harry Shooer to the sales staff of the Andrea Sales Corp. Shooer will be in charge of the Nassau and Queens County sales area for Andrea.

The appointment of Hugh Wainwright as sales engineer for the Electronics Division of **Sylvania Electric Products, Inc.**, has been announced by George C. Connor, general sales manager.

Gordon T. Ritter, director of sales for the **Arvin division, Noblitt-Sparks Industries, Inc.**, announces that Allen D. McGehee has been named as district manager to handle the western areas of New York and Pennsylvania, and that Walden Johansen has been made assistant field sales manager for the division.

VUE-SCOPE

TELEVISION MAGNIFYING LENS

MAGIC MOUNT

Write Today For

VUE-SCOPE'S

1949 MERCHANDISING PROGRAM

See Vue-Scope Before You Buy
CELOMAT CORP., 521 West 23rd St.,
New York 11, N. Y.

At Last! A New Practical INDOOR TV ANTENNA

No pushing or pulling of rods to adjust

- Low-priced
- Simply move knob to channel desired and you are "on the beam" — automatically electrically adjusted
- Under 2:1 standing wave ratio in all bands
- Small and compact — attractive appearance
- For portable units can be placed inside cover of set
- Individually boxed — packed 24 to a shipping carton — wt. 31 1/2 lbs. per carton

The "vidiette" Tricraft Model "700"



Small Compact

Introducing The Tricraft "Minuteman" Model 950

Can be completely set-up in one minute

- Factory assembled • High and low band sections orient individually
- Sturdy and completely weatherproof • Height 8 ft.



WRITE FOR YOUR COPY OF OUR NEW CATALOG!

Tricraft Products Co.
1533 North Ashland Ave., Chicago 22, Ill.

Manufacturers of complete line of Television, FM and AM antennas and accessories

NOW!

only

**JERROLD
TV-FM BOOSTER**

**Comes Equipped With
AMAZING, NEW**

MATCH-A-TRAN

**INCLUDED AT NO
INCREASE IN PRICE**

The Jerrold TV-FM Booster, and only the Jerrold Booster—is now equipped with the amazing, new built-in Match-A-Tran. . . . A new, variable step-impedance transformer that helps provide a perfect match between Booster output and any television receiver for all channels. It is especially efficient on the high channels.



**IMPROVES DISTANCE
RECEPTION**

Here, at last, is the secret of good television reception and more TV sales over a wider fringe area. The Jerrold TV-FM Booster with Match-A-Tran puts more gain into the receiver than any other booster. This means better definition, greater stability and a much longer distance reception for any television receiver. It means clearer, brighter, sharper pictures for distant areas.

You can see the Jerrold Booster with Match-A-Tran at your radio wholesaler or parts-jobber. Or write us for information.

\$37⁵⁰
List

JERROLD ELECTRONICS CORP.
121 N. BROAD ST. PHILA. 7, PA.

Advertisers' Index—June 1949

Admiral Corp.	14, 15
Alliance Mfg. Co.	79
American Telephone & Telegraph Co.	13
American Television & Radio Co.	84
Anchor Radio Corp.	72
Bogen Co., Inc., David	82
Celomat Corp.	86
Columbia Records, Inc.	52, 53
Commercial Credit Corp.	10
Crosley div. AVCO Mfg. Corp.	22, 23
DeWald Radio Mfg. Corp.	79
DuMont Laboratories, Inc., Allen B.	37
Easy-Up Tower Co.	80
Fada Radio & Electric Co., Inc.	12
Federal Television Corp.	16
General Die & Stamping Co.	56
General Electric Co.	7, 11, 71
General Industries Co.	50
Graybar Electric Co., Inc.	58
Industrial Television, Inc.	73
Jensen Mfg. Co.	46
Jerrold Electronics Corp.	87
Jewel Radio Corp.	77
J.F.D. Mfg. Co., Inc.	82
J. & A. Television Mfg. Co.	76
LaPointe Plascomold Corp.	85
Lyte Parts Co.	9
Mahogany Association, Inc.	18
Mallory & Co., Inc., P. R.	Cover 2
Marvin Radio-Television	83
Merchandise Mart	20
Motorola, Inc.	Cover 3
Mueller Electric Co.	80
Noblitt-Sparks Industries, Inc.	41
North American Philips Co., Inc.	24
Olin Industries, Inc.	47
Olympic Radio & Television, Inc.	32
Omara Furniture Mfg. Co.	74
Pentron Corp.	74
Peters, A. A.	82
Phoenix Electronics, Inc.	81
Premax Products div., Chisholm-Ryder Co., Inc.	74
Radiart Corp.	67
Radio Corp. of America:— Institutional	8
RCA Victor Division	28, 29, 57
Tube Department	43, Cover 4
Radio Merchandise Sales, Inc.	78
Railway Express Agency	85
Rauland-Borg Corp.	75
Rider Publisher, Inc., John F.	88
Snyder Mfg. Co.	45
Sonotone Corp.	56
Square Root Mfg. Corp.	6
Starrett Television Mfg. Corp.	21
Sylvania Electric Products, Inc.	69
Technical Appliance Corp.	80
Telrex, Inc.	87
Trans-Vue Corp.	4
Tricraft Products Co.	86
Video Corp. of America	81
V-M Corp.	56
Walco Sales Corp.	17
Ward Products Corp.	19
Warren Mfg. Co., Inc.	2, 3
Wilcox-Gay Corp.	5
Workshop Associates, Inc.	76
Zenith Radio Corp.	49



- ★ The ONE antenna for ALL channels (no high frequency head needed)
- ★ Maximum efficiency on ALL channels
- ★ Better than 12 DB front to back ratio on all frequencies

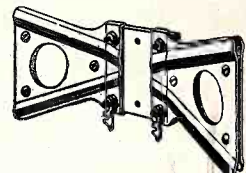

TELREX Conical Antennas provide the highest possible gain to the receiver — since the full strength of the signal (as received at the antenna) is carried to the set with negligible loss—and with a definite reduction in the strength of ghosts or reflections. TELREX Conical Antennas are built better. Note this center clamp which provides such a strong grip over better than 3" of each rod surface. It is both a mechanical support and electrical contact second to none. And is only one of the features which result in improved and steadier pictures — from a better antenna—a TELREX antenna.

**The 4X-TV
CONICAL "V" BEAM**

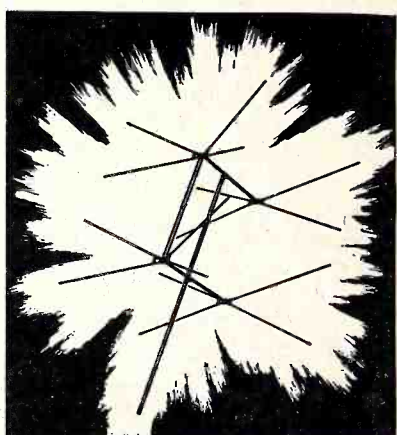

- Hi-Gain Stacked Conical "V" Beam—Channels 2 to 13
- Broad Band—Full Audio and Video Band Pass
- Low Inception Angle, Minimum Reflections
- Maximum Signal to Noise
- Better than 12 DB Front to Back Ratio All Frequencies
- 150 Ohm Non-Varying Center Impedance
- Use 72, 150 or 300 Ohm Transmission Lines
- Universal Mounting Clamp

Telrex Conical Antennas are available in a variety of models to meet any need.

© 1949 Telrex, Inc.

At your distributor or write

TELREX, INC.
ASBURY PARK 2, NEW JERSEY

the only "Radio Circuit
Library" of its kind!



**20 YEARS OF
RIDER MANUALS**

*Comprise a Complete,
Chronological History
of FACTORY-AUTHORIZED
American Circuits and
Data on Radio Receiver
Design and Operation*

RIDER AM-FM RADIO MANUALS

18 Volumes to date
25,836 Pages
13,665 Chassis
26,309 Models

RIDER TELEVISION MANUALS

2 Volumes to date
Equivalent of 4,300 Pages
227 Chassis
300 Models

RIDER PUBLIC ADDRESS MANUALS

1 Complete Volume
2024 Pages
1106 Chassis
1285 Models

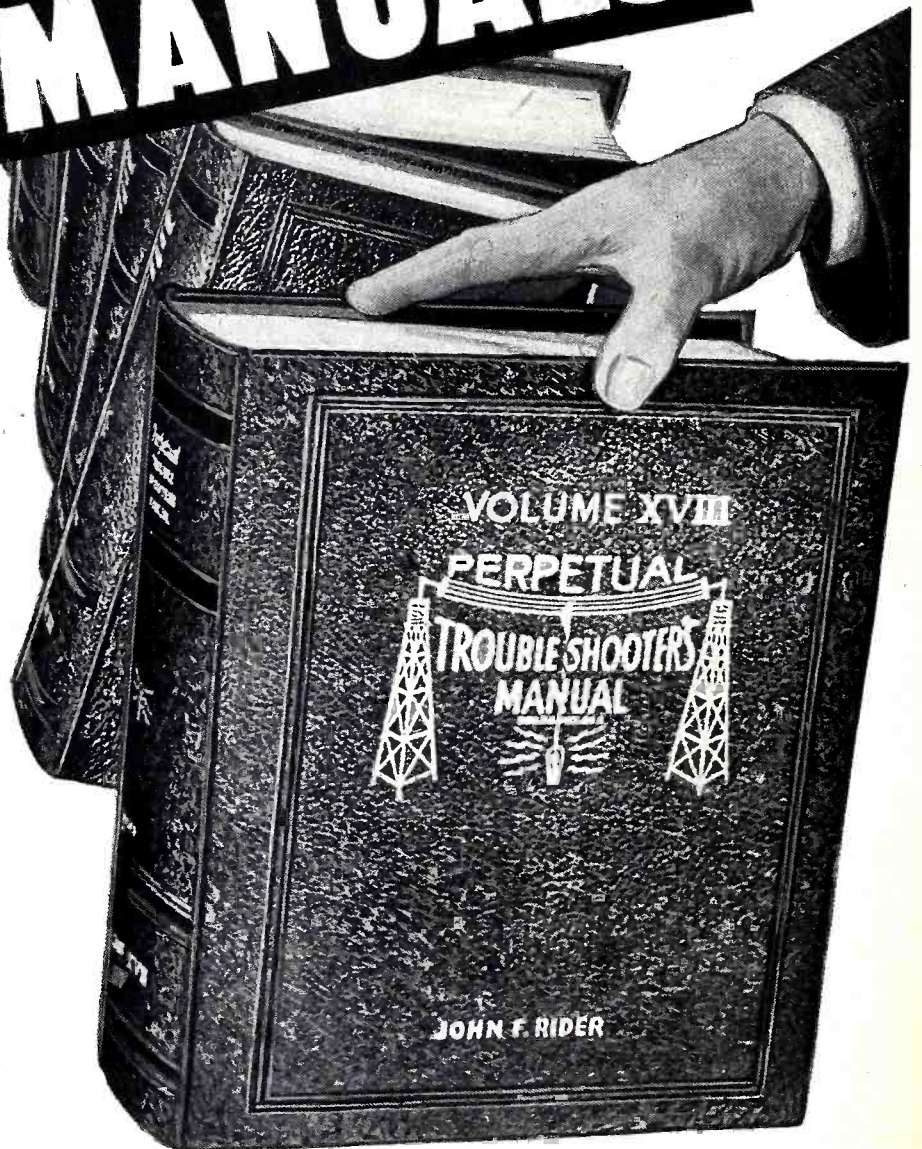

Every Set Manufacturer, Design and Research Laboratory (whether government or commercial), Component Parts Manufacturer, Public Library, Vocational School Library, High School and College Library — SHOULD OWN a Complete Set of RIDER MANUALS.

No other source offers such a wealth of authentic, reliable, FACTORY-AUTHORIZED information, direct from the manufacturers themselves. Compiled in compact, handy, easy-to-follow form. Here are data on practically all Broadcast Receivers, AM and FM; Television Receivers; Record Changers and Recorders; and Public Address Systems. WRITE TODAY FOR FREE CATALOGUE.

JOHN F. RIDER PUBLISHER, Inc., 480 Canal St., New York 13, N.Y.

Export Agent: Rocke International Corp., 13 East 40th Street, N. Y. C., Cables, ARLAB

vacation time.... is portable selling time...

cash in now—during the out-of-doors

months... good ol' summertime adds up to beach parties, hikes, barbecues, picnics and vacations in the great outdoors! All this, in turn, adds up to whopping big portable radio sales. Keep your register singing all summer with Motorola—the portable line that's consistently first for performance—first for beauty—and first for value!

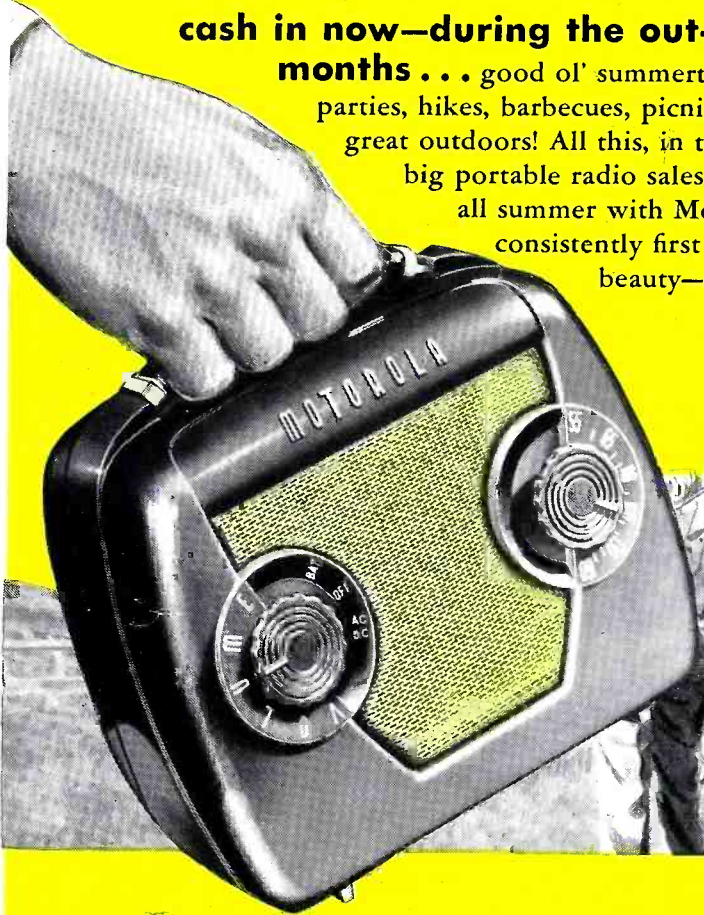

the GIGANTIC
Motorola
PORTABLE PROMOTION—
at its peak during
JUNE and JULY!

Motorola
PORTABLES

The '49 Motorola Portables Are Better Than Ever!

Model 59L12. 3-way operation—AC/DC or battery. Packs big power for full volume and rich tone. Stunning maroon or black plastic with bronze-gold metal grille and trim.

Model 49L11. Compact battery operated set. Color choice: mottled tan or green plastic with bronze-gold metal grille and trim. Low priced!

Model 5A9... Playmate Jr. Glamour baby of personal portables! "Big-set" power and tone. Gets distant or local stations with equal ease. Maroon or black leather effect metal case with bronze-gold trim. AC/DC and battery operated.

Model 69L11... None Finer! A "luxury" radio in every sense but price! Walloping power, marvelous tone. 6 tube fully tuned R.F. stage. Exclusive "dial-in-handle." Beautiful basket-weave, plastic-coated fabric case with aluminum trim. AC/DC and battery.

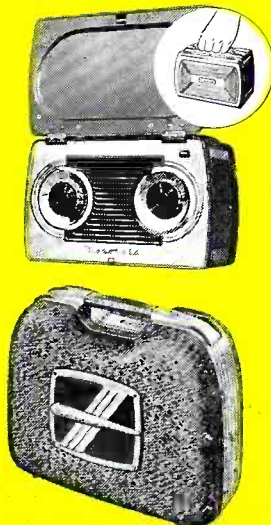

Phone, write or wire your nearest Motorola Distributor for details.

MOTOROLA INC. • 4545 AUGUSTA BLVD. • CHICAGO 51

Names in the News

Ben Singer has been named head of the newly-established TV specialties engineering department of Tele-tone Radio Corp.

C. R. Courtleigh, vice-president and general manager of Associated Stores, Inc., has announced the promotion of W. R. Brouhard to manager of the Sarasota store. The firm has outlets in a number of Florida cities.

The appointment of Paul P. Smith as renewal sales representative for the radio tube division of Sylvania Electric Products, Inc., has been made known by C. W. Shaw, general sales manager.

Gordon T. Ritter, director of sales for Arvin division of Noblitt-Sparks Industries, Inc., announces that Craig Britton has been appointed as field representative to cover the Minnesota, North and South Dakota territory.

Gene Miller has been appointed to a position in the sales promotion department of the Gibson Refrigerator Co., according to Gregory V. Drumm, manager advertising and sales promotion.

Ab Waxman has become sales manager of the magnetic recorder division of Air King Products Co., Inc., Brooklyn, N. Y. Mr. Waxman is well known in the industry having been advertising and sales promotion director for Wire Recording Corp. of America. He also developed Duplicording, a process which permits the economical multiple reproduction of recordings on wire.

J. J. Anderson has become merchandising manager of household refrigeration for the Westinghouse Electric Appliance Division, Mansfield, Ohio. The appointment was announced by T. J. Newcomb, sales manager.

Robert Walcutt, vice-president of Walco, Inc., East Orange, N. J., makers of Walco standard and micro-groove long-playing phonograph needles, Walco

Admiral Plastic TV Set



The Siragusa brothers, left, Dom, president of Molded Products Corp., and Ross, right, president of Admiral Corp., discuss Admiral's new 24 tube TV plastic console. The set has a 10-inch picture screen, and list price is \$249.95. The cabinet is Bakelite phenolic and weighs 35 lbs.

Tele-Vue lens, and Walco television filters, announces the appointment of Eugene B. Lucas as its sales manager.

Coinciding with a program of over-all sales expansion, the appointment of Johnny Parsons to the position of sales promotion manager of the Hoffman Radio Corporation, Los Angeles, has been announced by R. J. McNeely, general sales manager of the company.

Rex D'Agostino, formerly of the Lafayette Radio store in Newark, New Jersey, has been appointed national merchandise manager for the company. In his new post he will serve all seven stores—at 100 Sixth Avenue, New York City, Bronx, Newark, Boston, Chicago, and Atlanta.

Frank A. D. Andrea, president of the Andrea Radio Corp., manufacturers of Andrea "Sharp-Focus" television sets, announces the appointment of Harry Shooer to the sales staff of the Andrea Sales Corp. Shooer will be in charge of the Nassau and Queens County sales area for Andrea.

The appointment of Hugh Wainwright as sales engineer for the Electronics Division of Sylvania Electric Products, Inc., has been announced by George C. Connor, general sales manager.

Gordon T. Ritter, director of sales for the Arvin division, Noblitt-Sparks Industries, Inc., announces that Allen D. McGehee has been named as district manager to handle the western areas of New York and Pennsylvania, and that Walden Johansen has been made assistant field sales manager for the division.

VUE-SCOPE

TELEVISION MAGNIFYING LENS

MAGIC MOUNT

Write Today For
VUE-SCOPE'S
1949 MERCHANDISING PROGRAM

See Vue-Scope Before You Buy
CELOMAT CORP., 521 West 23rd St.,
New York 11, N. Y.

At Last! A New Practical INDOOR TV ANTENNA

No pushing or pulling of rods to adjust

- Low-priced
- Simply move knob to channel desired and you are "on the beam" — automatically electrically adjusted
- Under 2:1 standing wave ratio in all bands
- Small and compact — attractive appearance
- For portable units can be placed inside cover of set
- Individually boxed — packed 24 to a shipping carton — wt. 31½ lbs. per carton

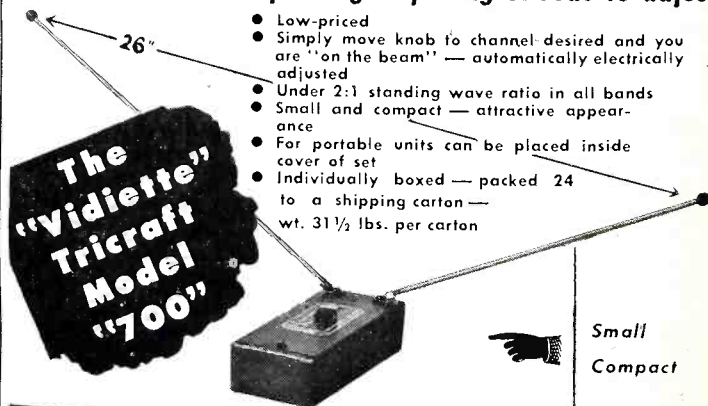

Introducing The Tricraft "Minuteman" Model 950
Can be completely set-up in one minute

- Factory assembled • High and low band sections orient individually
- Sturdy and completely weatherproof • Height 8 ft.

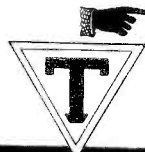

WRITE FOR YOUR COPY OF OUR NEW CATALOG!

Tricraft Products Co.
1533 North Ashland Ave., Chicago 22, Ill.

Manufacturers of complete line of Television, FM and AM antennas and accessories

NOW!

only

JERROLD TV-FM BOOSTER

Comes Equipped With
AMAZING, NEW

MATCH-A-TRAN

INCLUDED AT NO INCREASE IN PRICE

The Jerrold TV-FM Booster, and only the Jerrold Booster—is now equipped with the amazing, new built-in Match-A-Tran. . . . A new, variable step-impedance transformer that helps provide a perfect match between Booster output and any television receiver for all channels. It is especially efficient on the high channels.

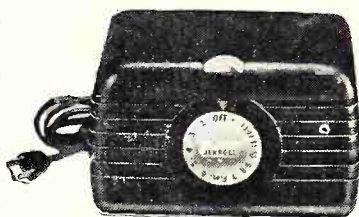

IMPROVES DISTANCE RECEPTION

Here, at last, is the secret of good television reception and more TV sales over a wider fringe area. The Jerrold TV-FM Booster with Match-A-Tran puts more gain into the receiver than any other booster. This means better definition, greater stability and a much longer distance reception for any television receiver. It means clearer, brighter, sharper pictures for distant areas.

You can see the Jerrold Booster with Match-A-Tran at your radio wholesaler or parts-jobber. Or write us for information.

\$37⁵⁰
List

JERROLD ELECTRONICS CORP.
121 N. BROAD ST. PHILA. 7, PA.

Advertisers' Index—June 1949

Admiral Corp.	14, 15
Alliance Mfg. Co.	79
American Telephone & Telegraph Co.	13
American Television & Radio Co.	84
Anchor Radio Corp.	72
Bogen Co., Inc., David	82
Celomat Corp.	86
Columbia Records, Inc.	52, 53
Commercial Credit Corp.	10
Crosley div. AVCO Mfg. Corp.	22, 23
DeWald Radio Mfg. Corp.	79
DuMont Laboratories, Inc., Allen B.	37
Easy-Up Tower Co.	80
Fada Radio & Electric Co., Inc.	12
Federal Television Corp.	16
General Die & Stamping Co.	56
General Electric Co.	7, 11, 71
General Industries Co.	50
Graybar Electric Co., Inc.	58
Industrial Television, Inc.	73
Jensen Mfg. Co.	46
Jerrold Electronics Corp.	87
Jewel Radio Corp.	77
J.F.D. Mfg. Co., Inc.	82
J. & A. Television Mfg. Co.	76
LaPointe Plascomold Corp.	85
Lyte Parts Co.	9
Mahogany Association, Inc.	18
Mallory & Co., Inc., P. R.	Cover 2
Marvin Radio-Television	83
Merchandise Mart	20
Motorola, Inc.	Cover 3
Mueller Electric Co.	80
Noblitt-Sparks Industries, Inc.	41
North American Philips Co., Inc.	24
Olin Industries, Inc.	47
Olympic Radio & Television, Inc.	32
Omara Furniture Mfg. Co.	74
Pentron Corp.	74
Peters, A. A.	82
Phoenix Electronics, Inc.	81
Premax Products div., Chisholm-Ryder Co., Inc.	74
Radiart Corp.	67
Radio Corp. of America—	
Institutional	8
RCA Victor Division	28, 29, 57
Tube Department	43, Cover 4
Radio Merchandise Sales, Inc.	78
Railway Express Agency	85
Rauland-Borg Corp.	75
Rider Publisher, Inc., John F.	88
Snyder Mfg. Co.	45
Sonotone Corp.	56
Square Root Mfg. Corp.	6
Starrett Television Mfg. Corp.	21
Sylvania Electric Products, Inc.	69
Technical Appliance Corp.	80
Telrex, Inc.	87
Trans-Vue Corp.	4
Tricraft Products Co.	86
Video Corp. of America	81
V-M Corp.	56
Walco Sales Corp.	17
Ward Products Corp.	19
Warren Mfg. Co., Inc.	2, 3
Wilcox-Gay Corp.	5
Workshop Associates, Inc.	76
Zenith Radio Corp.	49

Telrex INC.
CONICAL ANTENNAS
America's Outstanding Television Beam

- ★ The ONE antenna for ALL channels (no high frequency head needed)
- ★ Maximum efficiency on ALL channels
- ★ Better than 12 DB front to back ratio on all frequencies

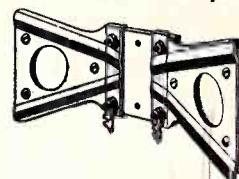

TELREX Conical Antennas provide the highest possible gain to the receiver — since the full strength of the signal (as received at

the antenna) is carried to the set with negligible loss—and with a definite reduction in the strength of ghosts or reflections.

TELREX Conical Antennas are built better. Note this center clamp which provides such a strong grip over better than 3" of each rod surface. It is both a mechanical support and electrical contact second to none. And is only one of the features which result in improved and steadier pictures — from a better antenna—a TELREX antenna.

The 4X-TV
CONICAL "V" BEAM

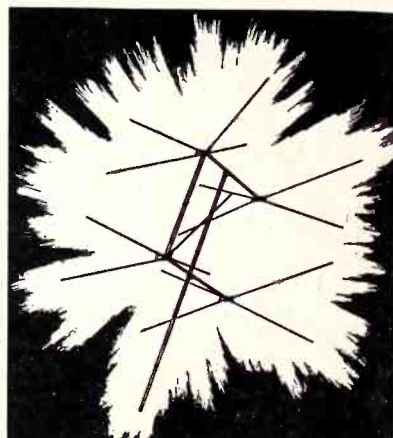

- Hi-Gain Stacked Conical "V" Beam—Channels 2 to 13
- Broad Band—Full Audio and Video Band Pass
- Low Inception Angle, Minimum Reflections
- Maximum Signal to Noise
- Better than 12 DB Front to Back Ratio All Frequencies
- 150 Ohm Non-Varying Center Impedance
- Use 72, 150 or 300 Ohm Transmission Lines
- Universal Mounting Clamp

Telrex Conical Antennas are available in a variety of models to meet any need.

© 1949 Telrex, Inc.

At your distributor or write

TELREX, INC.
ASBURY PARK 2, NEW JERSEY

the only "Radio Circuit Library" of its kind!



**20 YEARS OF
RIDER MANUALS**

Comprise a Complete, Chronological History of **FACTORY-AUTHORIZED American Circuits and Data on Radio Receiver Design and Operation**

RIDER AM-FM RADIO MANUALS

18 Volumes to date
25,836 Pages
13,665 Chassis
26,309 Models

RIDER TELEVISION MANUALS

2 Volumes to date
Equivalent of 4,300 Pages
227 Chassis
300 Models

RIDER PUBLIC ADDRESS MANUALS

1 Complete Volume
2024 Pages
1106 Chassis
1285 Models

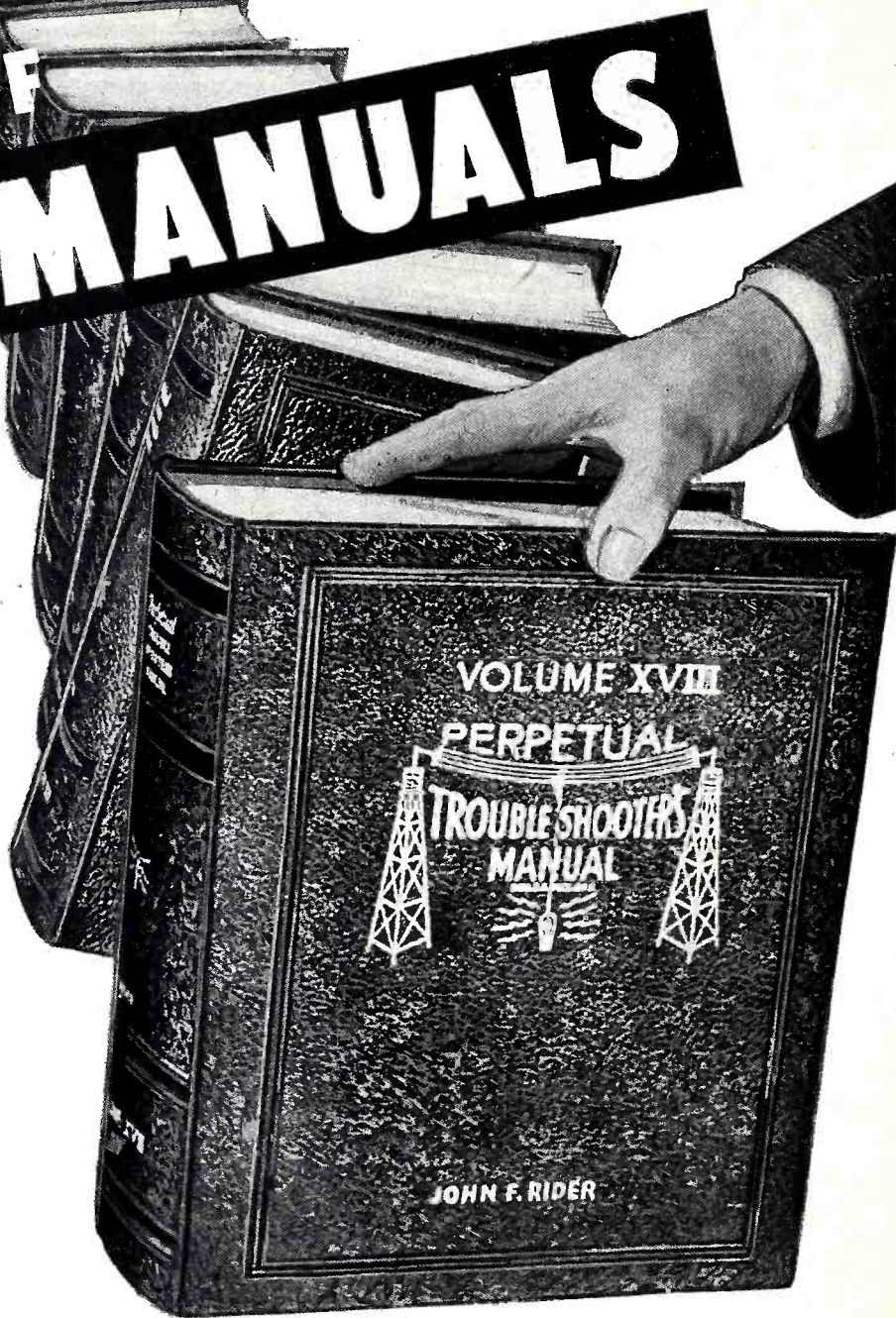

Every Set Manufacturer, Design and Research Laboratory (whether government or commercial), Component Parts Manufacturer, Public Library, Vocational School Library, High School and College Library — SHOULD OWN a Complete Set of RIDER MANUALS.

No other source offers such a wealth of authentic, reliable, FACTORY-AUTHORIZED information, direct from the manufacturers themselves. Compiled in compact, handy, easy-to-follow form. Here are data on practically all Broadcast Receivers, AM and FM; Television Receivers; Record Changers and Recorders; and Public Address Systems. WRITE TODAY FOR FREE CATALOGUE.

JOHN F. RIDER PUBLISHER, Inc., 480 Canal St., New York 13, N.Y.

Export Agent: **Rocke International Corp., 13 East 40th Street, N. Y. C., Cables, ARLAB**

vacation time.... is portable selling time...

cash in now—during the out-of-doors

months... good ol' summertime adds up to beach parties, hikes, barbecues, picnics and vacations in the great outdoors! All this, in turn, adds up to whopping big portable radio sales. Keep your register singing all summer with Motorola—the portable line that's consistently first for performance—first for beauty—and first for value!

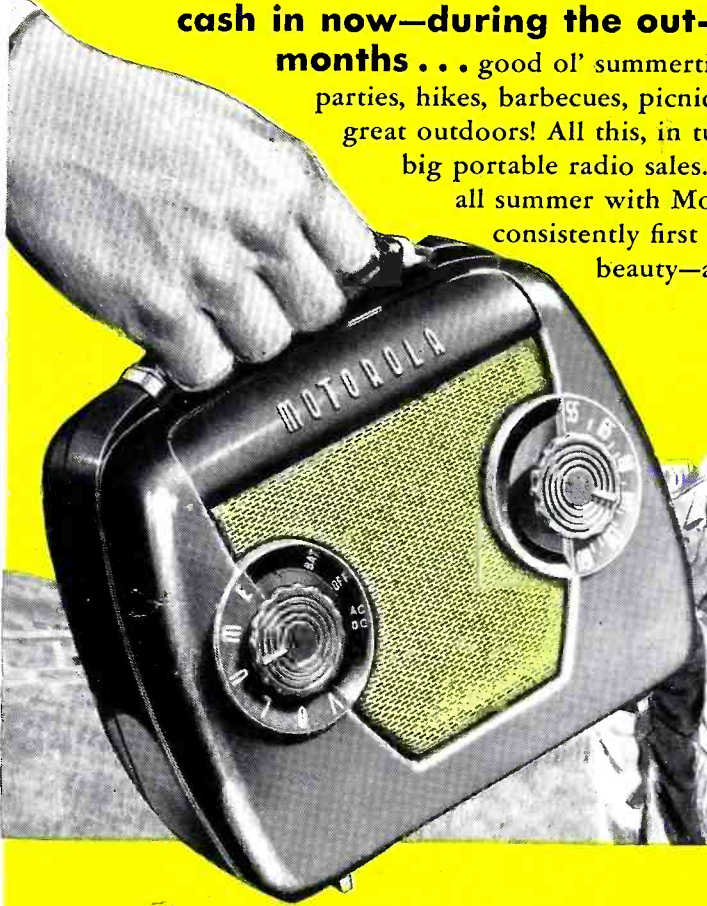

the **GIGANTIC**
Motorola
PORTABLE PROMOTION—
at its peak during
JUNE and JULY!

The '49 Motorola Portables Are Better Than Ever!

Model 59L12. 3-way operation—AC/DC or battery. Packs big power for full volume and rich tone. Stunning maroon or black plastic with bronze-gold metal grille and trim.

Model 49L11. Compact battery operated set. Color choice: mottled tan or green plastic with bronze-gold metal grille and trim. Low priced!

Model 5A9... Playmate Jr. Glamour baby of personal portables! "Big-set" power and tone. Gets distant or local stations with equal ease. Maroon or black leather effect metal case with bronze-gold trim. AC/DC and battery operated.

Model 69L11... None Finer! A "luxury" radio in every sense but price! Walloping power, marvelous tone. 6 tube fully tuned R.F. stage. Exclusive "dial-in-handle." Beautiful basket-weave, plastic-coated fabric case with aluminum trim. AC/DC and battery.

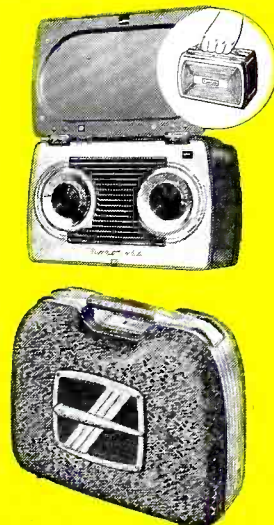

Motorola
PORTABLES

Phone, write or wire your nearest
Motorola Distributor for details.

MOTOROLA INC. • 4545 AUGUSTA BLVD. • CHICAGO 51



RCA has pioneered the development of miniature tubes

One high quality—for TV-FM-AM —at no extra cost

● In TV and FM—where tube quality counts—RCA tubes more than meet the critical requirements. That's because the quality level of RCA tubes has been continually advanced in step with circuit progress. Improved design... more rigid control over manufacture and inspection... and more exacting tests, account for these higher quality standards. They apply to *all tubes* of a type... at no extra cost.

This single standard quality benefits all users. This extra quality cuts down costly service call-backs... builds customer confidence... brings you *more business*.

When you push RCA tubes you're selling the brand that holds top customer acceptance. So—*push RCA tubes and watch your business grow!*

ALWAYS KEEP IN TOUCH WITH YOUR RCA TUBE DISTRIBUTOR



NEW...

handy miniature package

Now RCA miniatures come neatly packaged, five of a type, in attractive, expendable cartons. They're easier to handle, easier to stock, and a great aid in keeping track of your inventory. No extra cost... but plenty of extra convenience!



RADIO CORPORATION of AMERICA
ELECTRON TUBES
HARRISON, N. J.