

OCTOBER, 1935

INCLUDING
SERVICE
AND
INSTALLATION
SECTION

RADIO RETAILING

THE BUSINESS MAGAZINE OF THE RADIO INDUSTRY

Sales power of RCA Metal Tubes proved at New York Radio Show

IN RADIO, as in automobiles, the annual New York Show sets the pace for the industry, indicates where it is going during the following year. So, let's take a look at what happened at the recent New York Radio Show.

RCA Metal Tubes were the big drawing card! Radios without metal tubes just didn't register with the public.

"Has it got metal tubes?"

"Where are the metal tubes?"

Such were some of the questions asked by the public, which had its first glimpse of these tubes, the greatest tube advance in 28 years, designed in the famed Research Laboratories of the General Electric Company and made and guaranteed by RCA. Here is conclusive proof that for best sales results, you should feature radio sets equipped with RCA Metal Tubes.

*Only radio tubes bearing the RCA Monogram
are made and guaranteed by RCA*



RCA RADIO TUBES

RCA RADIOTRON DIVISION • RCA MFG. CO., INC., CAMDEN, N. J. • A SUBSIDIARY OF THE
RADIO CORPORATION OF AMERICA

THE KIND OF

Trade Talk

GOING AROUND ABOUT

ARVIN

RADIO

"They have a good name, and policies keyed to the trade point of view."

"They back you up with merchandising on a profitable basis."

"Their line includes 11 models, metal and glass tubes, 3 battery sets."

"They build fine quality sets and price them right for volume sales."

"Their custom-built car radios with overhead speakers are the sales hit."

"Their new home radios are the best sets for the money I've ever heard."

"Their Band-Beam Station Finder is a real contribution to all-wave tuning."

"They're good folks to do business with because their trade policies are sound."

FOR THE HOME
FOR THE CAR



● Regardless of the radio line you may be handling now, you'll want Arvins, too. You'll understand why when you see . . . hear . . . and compare them. Model 81, shown at left, is an 8-tube all-wave walnut console with 12-inch speaker, band-beam station finder, that simplifies all-wave tuning, and numerous other Arvin innovations. List price only \$89.50—with 9 metal tubes, \$99.50. An exceptional value. And that is only one of eleven beautiful models—metal as well as glass tubes—battery sets—\$19.95 to \$99.50 list.

In radio for the car, Arvin is making the sales hit of the year with the beautiful custom-built models that have overhead speakers and matching panel controls—\$11.95 and \$15.95 list. Every profit-minded dealer needs the Arvin Radio line to boost his sales volume. See your jobber.

NOBLITT-SPARKS INDUSTRIES, Inc., Columbus, Indiana
Also Makers of Arvin Hot Water and Steam Car Heaters

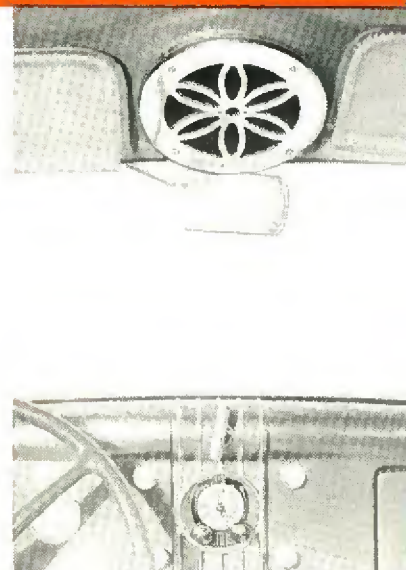

ZENITH SALES ARE WAY UP!

THE MOST SENSATIONAL RADIO LINE IN HISTORY!

**ZENITH IS SELLING LIKE HOTCAKES!
—FOR INSTANCE LOOK WHAT YOU GIVE
YOUR CUSTOMERS FOR ONLY \$69.95!**

A line that's full of winners . . . that's sweeping the country! Thousands have already bought the new 1936 Zenith. Thousands more will buy them in the next few months. It's easy to see why with values like this. Imagine—you sell this model for only \$69.95! You know what competitive values cost the public. Is it any wonder then that Zenith dealers are cashing in big! That Zenith sales *everywhere* are way up! Find out all about this profit line *today!*

Specifications for Model 6-S-52—6 tubes. Tunes American and Foreign Stations; police, amateur, aviation, ships at sea. Tuning range of 5 wave bands on 3 simplified dial ranges. 10-inch dynamic speaker. Black Magnavision Dial, bands individually illuminated in colors; Split-Second Tuning, Overtone Amplifier. 39 inches high.

**The Big Black
Dial Identifies
The 1936 Zenith**



**Eye Value
Plus
Performance**

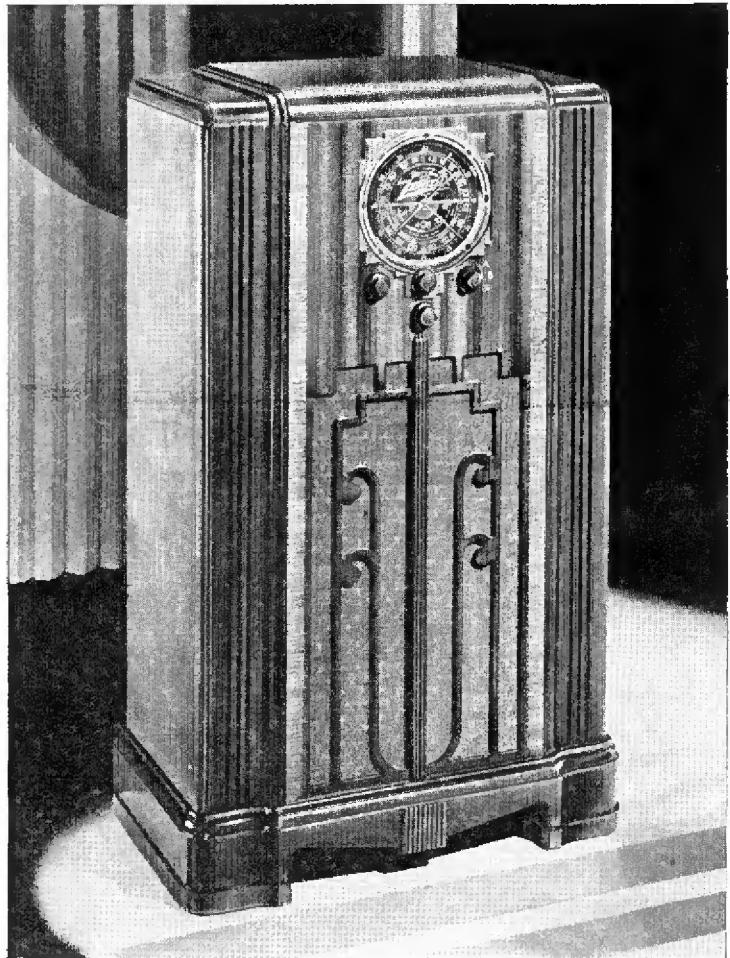

INVESTIGATE



ZENITH RADIO CORPORATION, 3620 Iron Street, Chicago, Illinois

YOU HAVE SEVEN HIGH FIDELITY
Stromberg-Carlsons
 TO CHOOSE FROM



NO. 63
 HIGH FIDELITY

There is no danger of losing those profitable High Fidelity sales if you are a Stromberg-Carlson dealer. For this great line includes SEVEN High Fidelity models,—one of which is sure to suit your most particular prospect.

Look them over—they have everything. Real High Fidelity reproduction, eye appeal, the famous Stromberg-Carlson name and prices that ever-increasing-sales prove right.

This large group of High Fidelity instruments, together with the other models that make up the line with the longest price range in the industry, gives Stromberg-Carlson dealers unusual advantages in competition this season.

*Stromberg-Carlsons are priced from \$59.50 to \$985.
 All prices slightly higher Texas, Rockies and West.*

STROMBERG-CARLSON TELEPHONE MFG. COMPANY, ROCHESTER, N. Y.

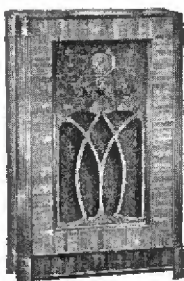

NO. 62 HIGH FIDELITY

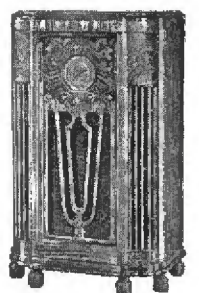

NO. 84 HIGH FIDELITY *

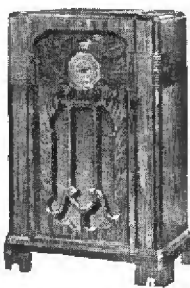

NO. 83 HIGH FIDELITY

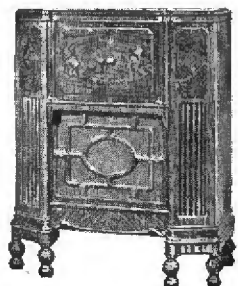

NO. 70 HIGH FIDELITY *

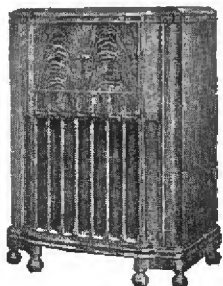

NO. 72 HIGH FIDELITY *

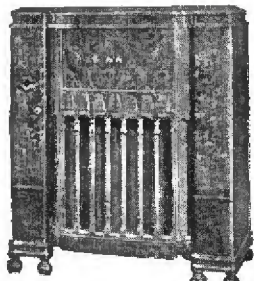

NO. 74 HIGH FIDELITY *

Stromberg-Carlson

* With the
 exclusive
 ACOUSTICAL
 LABYRINTH

Emerson Radio

"RE-CREATES THE ARTIST

IN YOUR HOME"

19 Models—\$17.95 to \$129.95



With METAL TUBES

Every model is a "4-Star" hit—every model is a DEMAND item—every one is a crowd-stopping feature in windows and in stores—and every Emerson has the merchandising qualities which favor volume and substantial profits. These facts, plus Emerson co-operative promotion, explain why Emerson distributors and dealers are enjoying unprecedented prosperity.

NOTE: Arrangements have been made between Emerson Radio and the C.I.T. whereby dealers may now discount their paper with that finance corporation — branches in all principal cities.

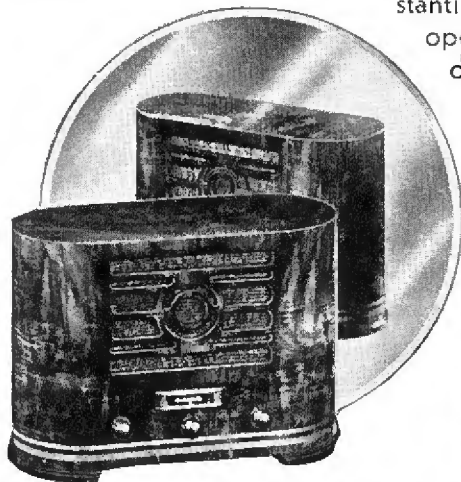

"Duo-Tone" Model 106... **\$39.95**
2-Band, 6-Tube AC-DC with Metal Tubes
Identical Grille Front and Back

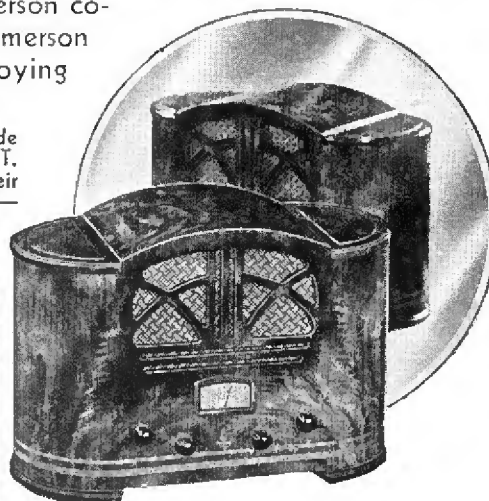

"Duo-Tone" Model 107... **\$49.95**
3-Band, 6-Tube AC-DC with Metal Tubes
Identical Grille Front and Back

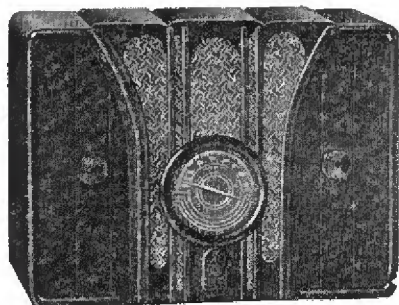

Emerson Compact Model 109. **\$17.95**
AC-DC Superheterodyne. Illuminated
Aeroplane Dial. Bakelite cabinet

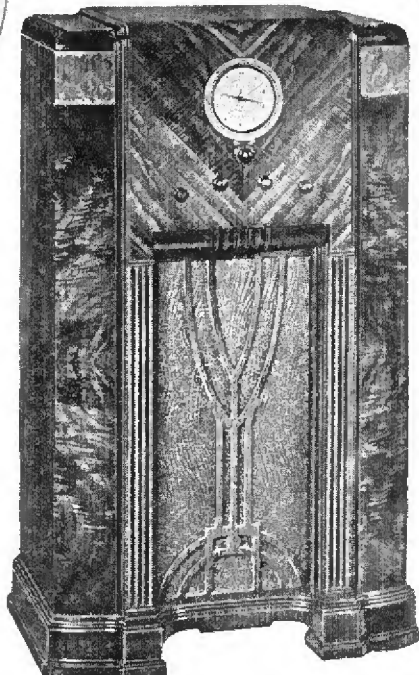

High Fidelity Model 105... **\$129.95**
11-Tube Superheterodyne—16 to 555 Meters.
12-inch, Auditorium Dynamic Speaker

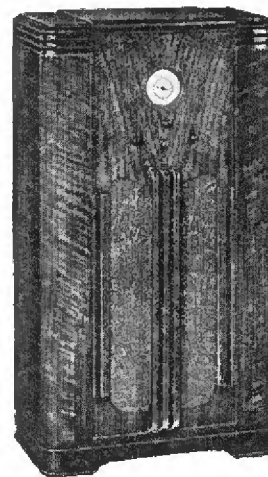

Emerson Model 101... **\$59.95**
3-Band 6-Tube AC Superheterodyne
Incorporating Metal Tubes



Emerson Model 108... **\$24.95**
2-Band, 5-Tube AC-DC Superheterodyne. Aeroplane Dial. Bakelite Cabinet

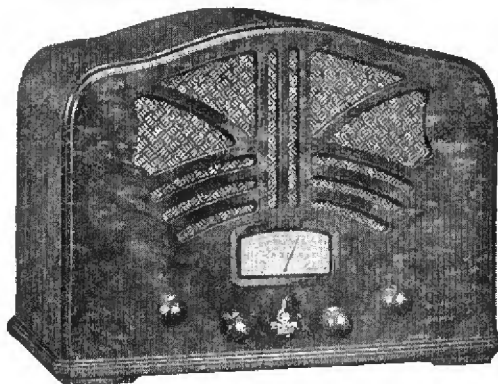

Emerson Compact Model 111... **\$44.95**
3-Band, 6-Tube AC-DC with Metal Tubes

Send for
Distributor
and Dealer
Proposition



Prices Slightly
Higher in South and West Coast

EMERSON RADIO & PHONOGRAPH CORPORATION, 111 Eighth Avenue, New York, N. Y.
The EMERSON Line Also Comprises Models for Every Foreign Market Cable Address: EMPHONOCO, N. Y.

HERE'S HOW "BILL" FORGES AHEAD

with **FADA**



William ("Bill") Muttitt

crack service man—ten years' radio selling on all leading lines, makes good as Westport's most popular local dealer from scratch.



FADA offers a radio for every purse. . . . from compact to HI-FIDELITY console . . . straight AC and AC-DC WORLD-WIDE receivers . . . from \$19.99 to \$144.50. Wire for Distributor or Dealer proposition.

His own words . . .

"I have listened—demonstrated—tested—sold radios for ten years. Two weeks ago I attended a demonstration of Fada Radios at the Algonquin Club, Bridgeport. In all my experience I have never heard a complete demonstration without going to regular broadcast stations. Generally we 'get' the big New York and our local stations. To my amazement the entire demonstration was picking up London and European stations—which came in just as clear and distinct as our regular broadcast test stations. That's some Radio, the 1935 Fada line and I am going to tell 'em so in my town.

"I am sold on your all metal tube chassis, your good looking cabinets and, of course, (as you call it) Fada superb tone."

W. A. Muttitt

WESTPORT, CONN.

YOU can forge ahead
with



FADA RADIO & ELECTRIC COMPANY
LONG ISLAND CITY, N. Y.

RADIO RETAILING

RAY V. SUTLIFFE
Editor

W. W. MacDONALD
Managing Editor

T. H. PURINTON
Assistant Editor

HARRY PHILLIPS
Art Director

•
HOWARD EHRLICH
Vice-President

H. W. MATEER
Manager

•
Tom Blackburn
Chicago

George Tenney
San Francisco

Leonard Church
Cleveland

H. S. Knowlton
Boston

Vol. 20

No. 10

CONTENTS, OCTOBER, 1935

Copyright, 1935, by McGraw-Hill Publishing Company, Inc.

<i>News and Views</i>By Ray V. Suttiffe	9
<i>Sales Figures for the Third Quarter</i>	10
<i>How Small Dealer Combats Gyps</i>	12
<i>The Tube Controversy</i>	16
<i>How Metal Tubes Are Made</i>A Pictorial	19
<i>Finance Companies Take Radio Paper</i>	20
<i>Notables at the New York Show</i>A Pictorial	22
<i>Wired Radio in Cleveland</i> ... By Leonard Church	24
<i>A Carload of Refrigerators</i> ... By Tom Blackburn	26
<i>Cash Discount Evil</i>By Milton Samuels	28
<i>News of the Month</i>	30
<i>FHA Will Finance P.A. Sales</i>	32
<i>New Records You Can Sell</i> ... By Richard Gilbert	42
<i>Selling Words</i>By George Solomon	43
<i>Programs, Profits and Politics</i>	44
<i>New Metal Tube Testers, Other New Products</i> ...	46
<i>New Electrical Appliances</i>	50
<i>Letters from Readers</i>	52
<i>Electrical Appliance News</i>	54
SERVICE SECTION	57

GOING PLACES

The Grand Central Palace show closed with an attendance of 173,000, topping last year's figure by 37 per cent. The Philadelphia exposition, in size and interest value, bids fair, at this writing, to run its New York brother a close second. Minneapolis reports record breaking crowds—and business—at its affair. And, from the West Coast, come many similar indications of an unusual public interest in the new sets.

Radio manufacturers' billings are up 30 per cent over last year's third quarter. Every set and tube maker in the industry reports production-taxing orders.

The metal tube situation, on the lap of the Gods a month ago, has improved immeasurably. Ample delivery and performance now seems assured.

Last month's Louis-Baer fight, radio sponsored by Buick, squelched for all time that boggy man, "they won't buy tickets if they can hear the fight at home." And now Mr. Ford has looked after our friends who wanted to hear the World Series.

Two other hot spot radio performances—the European-African situation (with short wave on the job for direct listening) and the coming election squabbles—will keep the kettle boiling all next year.

WE'RE GOING PLACES!

ATWATER KENT



IF THIS WERE YOU here in the control-room you'd hear radio at its best — the way it can sound in your home when you listen to an Atwater Kent.

Behind the Scenes

in the broadcasting studio, Jessica Dragonette sings her lovely songs as guest star on one of the Thursday night Atwater Kent Radio Hours.

In the Control-Room

over sensitive radio speakers, every note of music, every whisper of sound is heard perfectly by the engineer, just as you should hear it in your home.

In Your Own Home

what you hear depends on your radio. With an Atwater Kent each tone is captured, just as if you were listening in the control-room at your favorite station.



HEAR THE ATWATER KENT RADIO HOUR THURSDAYS AT

The Metal-Tube Radio

with

CONTROL-ROOM RECEPTION

THERE'S no need of high pressure selling when you show your customers the new 1936 Atwater Kent. Demonstrate any model—let them listen to the clear, smooth flow of voices and music that makes Atwater Kent the best "buy" for 1936!

Show them the chassis, with the new metal tubes, around which entirely new circuits have been designed to get the most in tone and performance out of these new tubes. Every polished part

you see is a tribute to the accurate craftsmanship that makes Atwater Kent the set customers come back to buy a second time.

Your ears—and your eyes—will tell you there isn't any better set, dollar for dollar, in 1936 than the Atwater Kent—the radio with the tone realism of Control-Room reception.

ATWATER KENT MANUFACTURING CO.
A. Atwater Kent, Pres. Philadelphia, Pa.

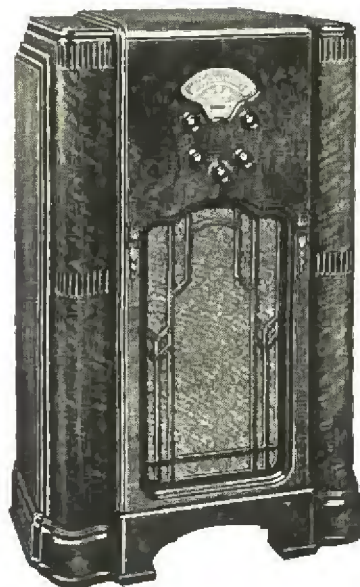

MODEL 810 (at left) This beautiful console model is one of the finest radio receivers ever built by Atwater Kent. 10 metal tubes. Rich full tone quality, fine selectivity with new Selectivity-Fidelity switch. Superior sensitivity. Full vision dial and shadow tuning. Foreign and domestic reception, police, amateur and airplane broadcasts.

MODEL 976 (at right) A 6-metal-tube console for standard and short-wave broadcasts. 3 tuning ranges with airplane type dial and automatic light illuminating only the band in use. Built for precision and beauty with greatly improved selectivity and uniform full tone quality.

**ATWATER KENT
1936 RADIO
PRICES RANGE FROM
\$27.50 TO \$150.00
f. o. b. factory**

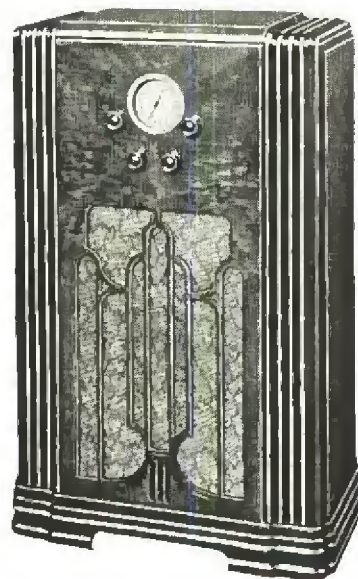

MODEL 856 A 6-metal-tube convenient compact receiver. Improved selectivity. Full rich tone quality. Foreign and domestic reception.

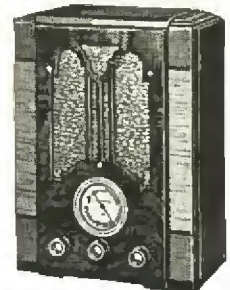

MODEL 225 A 5-tube A.C. compact with new metal tubes for foreign and domestic programs.



MODEL 337 For standard and short wave reception it would be difficult to find a better receiver than this 7-metal-tube compact.

8:30 P.M., E.S.T., COLUMBIA COAST-TO-COAST NETWORK

Which Would YOU Rather Sell as more **DEPENDABLE?**

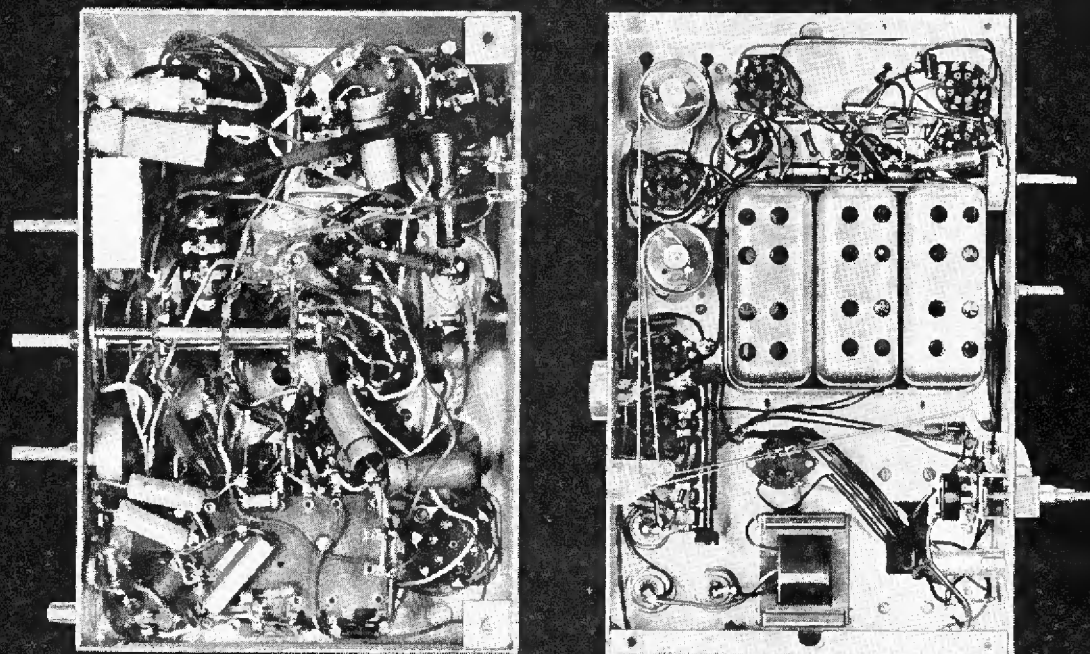

What the Radio Buyer seldom sees — the underside of his radio. Left, under-view of ordinary radio practice. Right, similar view of new American-Bosch CentrOmatic Radio. Which would you prefer to sell for greater dependability?

AMERICAN-BOSCH . . . combining Metal Tubes with the new CentrOmatic Unit . . . sets the pace for provable sales features!

AS A RADIO EXPERT or as a novice, you can instantly see the difference CentrOmatic engineering makes by comparing the chassis of American-Bosch with ordinary radio practice!

Notice how the CentrOmatic Unit centralizes all the sensitive radio elements—separates and anchors them from "feed-back" noises in the radio. Now turn the chassis upside down. You'll notice a wholesale elimination of wiring—90% less wiring! 104 fewer soldered connections. Coils, condensers and switches in an entirely new rigid, anchored mounting that insures factory precision standards throughout the life of the set.

Impressive to you as an expert? Even more impressive to your customers! You can assure them

that the CentrOmatic Unit guarantees: 1. More long and short wave stations. 2. Higher tone fidelity on all wave bands. 3. Greater freedom from noise both on station and between stations. 4. Easier tuning even on short wave. 5. Surpassing dependability and durability.

Here is the big radio news of 1936—the new CentrOmatic Unit and the new metal tubes—combined in one radio—American-Bosch. The combination is proving a truly dynamic force in creating and clinching sales for go-getting dealers everywhere.

UNITED AMERICAN BOSCH CORPORATION
SPRINGFIELD, MASS. NEW YORK CHICAGO DETROIT

American-Bosch Radio is licensed under patents and applications of R. C. A. and Hazeltine Corp.

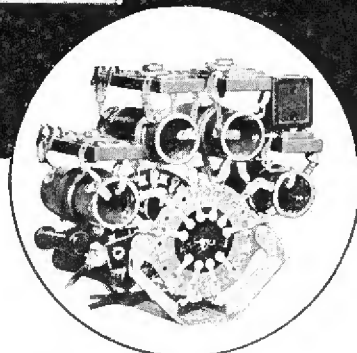

For the first time in radio, switches, coils and condensers are rigidly anchored to a steel frame in groups, separated and armored to eliminate interference and electrical losses.

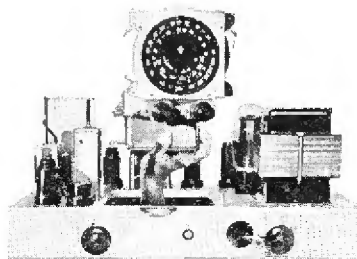

Behold the CentrOmatic Unit, which centralizes all sensitive radio elements.

AMERICAN-BOSCH *CentrOmatic* RADIO

Its style leadership sells the woman . . . its engineering leadership sells the man

OCTOBER
1935

News and Views

FOUR-HUNDRED readers of the Oakland, Calif., *Tribune* report that the average age of their sets is 4½ years . . . The dealer's best bet is the replacement market.

Of 61 makes mentioned, 33 were orphans . . . Here's a good reason for holding down trade-in allowances.

47 per cent of those interviewed had no special brand preference, favored no particular dealer . . . Evidence that the retailer generally can sell any set he pushes.

* * *

WHEN a radio jobbers allows his own men to sell sets to friends at a discount, thus taking business from his own dealers, he commits, in the words of Mark Anthony, "the most unkindest cut of all." Yet this practice prevails to an alarming extent, according to many complaints which have recently been called to our attention.

Manufacturers, dealers and jobbers should issue a "cease and desist" order, at once, against this shortsighted practice.

* * *

ANOTHER COMPLAINT, from a well known western retailer, calls our attention to the promiscuous granting of liberal credits to financially weak sisters—thereby sustaining a type of outlet which specializes in cut prices and whose lack of stability and business knowledge is a constant menace to the deserving dealer.

Just another case of "Penny wise and pound foolish" philosophy.

* * *

MANY INQUIRIES have reached our desk concerning the latest trends in circuits. Which leads us to observe that no matter how important a circuit

design improvement may be the public is more easily impressed by the simple, mechanical things readily recognized as "different." Every prospect knows that the tube is the heart of the set. So, to the question "What feature will exert the greatest sales pull this year?" the answer would appear to be: "The new type tubes."

* * *

EN ROUTE to a large service convention last month a transformer magnate stated to the writer that the parts manufacturers and jobbers can afford to support just so many shows—and no more. No longer can they stand the strain of being coerced into taking space and giving away prizes promiscuously.

So here's a tip for service associations: When planning conventions, cooperate with nearby groups and run one bang up affair. If you don't do this boiling down then the manufacturers must—and may slight deserving organizations in the process.

* * *

"WANAMAKER'S On the Air Again!" And how! "Over the latest development in radio . . . The True Fidelity Station W2XR—1550 Kilocycles," quoting from an ad in the Sept. 16 *New York Sun*.

Thanks, Mr. Wanamaker. Here's an interesting new trend, a boost for the newer sets (old receivers can't make this grade). We tuned in the other night and the tone performance was truly remarkable.

This is John Hogan's station under the company name: Scientific Broadcasting Service. Located on Long Island—1000 watts, 20 kc. channel—eastern dealers should get it, on this new broad channel, high fidelity side of their modern sets, over a 400 mile radius, night-time reception. Tune it in on your next demo. Monday to Friday, from seven to eight p.m. eastern time.

THIRD QUARTER UP 25%

NUMBER OF SETS SHIPPED (including exports)

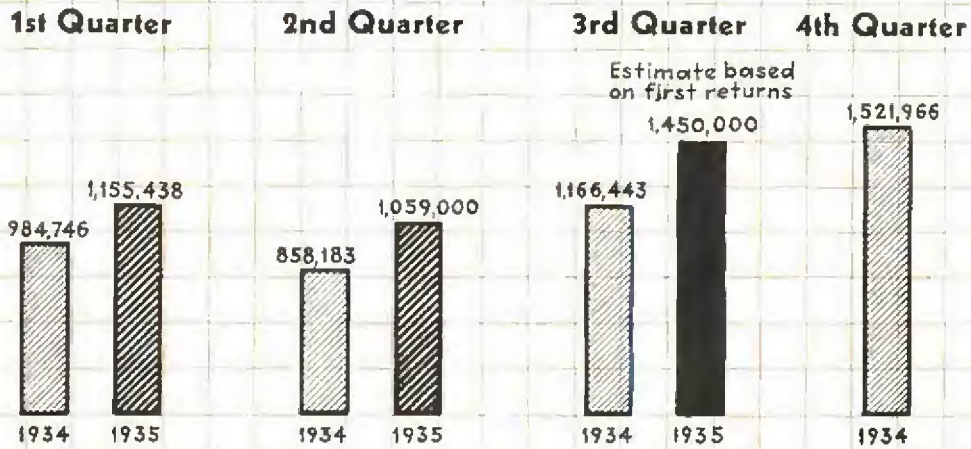

MANUFACTURERS' BILLINGS

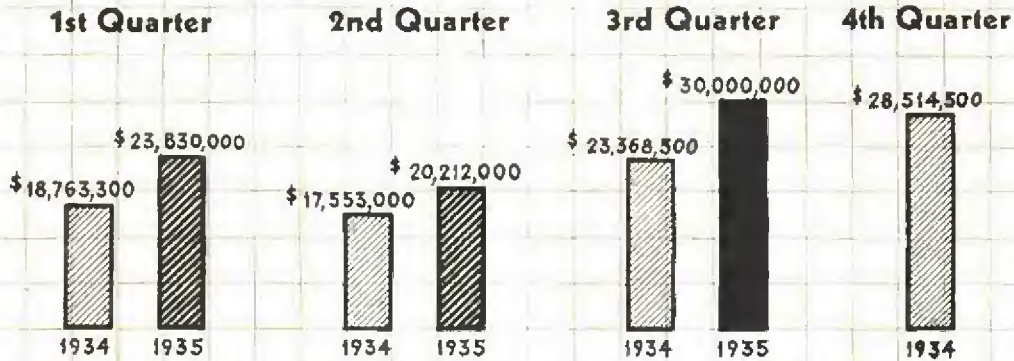

We Interviewed 1183 Dealer-Readers of "Radio Retailing"

- 870 sell one or more electrical appliances
- 677 handle refrigerators
- 507 " washing machines
- 401 " vacuum cleaners
- 294 " heating appliances
- 101 " oil burners
- 28 " coal stokers

How the 870 Split Gross Sales

Category	%
Radio Equipment	59.7
Electrical Items	25.2
Other Lines	15.1

UNEMPLOYMENT

Sept., 1934	10,223,000
Sept., 1935	9,901,000

FARM INCOME

(First 8 months)

1934	\$3,754,000,000
1935	\$4,020,000,000

PERCENTAGE, CONSOLE SALES

(20 jobbers were interviewed)

1934	35%
1935	54%

News and Views

LAST WEEK'S personal survey of field conditions found the smaller dealers enthusiastic over the business outlook; with a strong demand for the better models—and the customer willing to pay the full price.

—And the large outlets dumbly offering fine values at give-away prices.

Price cutting is bad enough even when necessary. But when large outlets and department stores who ought to know better voluntarily—without even a hint from the prospect—offer 20, 25, yes, 30 per cent off the list on genuine 1936 models, this practice becomes as reprehensible as the scuttling of a passenger ship on the high seas.

* * *

"YES" was the reply of 248 newspapers when, after a try-out, they were asked if they desired the foreign shortwave program and news service of the Radio Manufacturers Association continued.

Hiding its light under a bushel, the RMA, these many months, has been collecting and sending out s.w. programs to over 600 daily papers. The exigencies of the situation have prevented this magazine from telling its readers about this promotional service heretofore.

Now it can be said! Congratulations, RMA Service Bureau, for your splendid job in giving the public its only source of up-to-the-minute foreign program dialings.

* * *

AMERICAN radio research is still well in advance of Europe's, despite recent progress there, David Sarnoff, president of the Radio Corporation of America, stated upon his arrival in New York City after two months abroad.

* * *

WE WONDER just how much consumer interest was lost due to the almost complete exclusion of *technical* displays from this year's radio shows? Inside the portals were found plenty of ready-made receivers all dolled up and ready for sale but few sets were displayed so that the radio fan could determine what made them "tick."

In the old days the displays of parts, kits, testing instruments and amateur equipment attracted many who liked to "roll their own." The home builder is, of course, no longer a major factor in the business—but "hams," servicemen and

the still important number of tinkers who might be attracted by such displays almost invariably bring prospects for package merchandise with them.

In our estimation it would be good business, if necessary, to *give* parts, testing equipment and amateur equipment makers space and charge it to show publicity.

* * *

ROY DAVEY of American Bosch, when asked at the New York Show why his company, among others, includes a long-wave band in several models when only weather reports of interest to a few listeners are to be found there replied: "The big sales advantage is that we can tell prospects that no matter on what frequency new broadcasting services may be assigned our sets will receive them, remaining modern for years to come. Ability to receive weather broadcasts is merely the immediate justification."

This is good sales psychology, useful to many dealers, as 18 per cent of the new, 1936 models tune in longwave channels.

* * *

ADVERTISE the metal tube, by all means, states Samuel Elovitz, shrewd New England retail operator, but be conservative in your claims. Use it as a demonstration getter.

"We believe that this new tube is far superior to last year's model—but we want you to be the judge. Try it in your own home."

This type of copy has been found highly successful by this Hartford, Conn., dealer.

* * *

IN THIS CONNECTION we note the, to be expected, advent of misleading advertisements ballyhooing "metal" (?) tube receivers. Honestly handled, this new feature can be made a real business producer.

Public confidence is a precious thing. Wise dealers will not abuse it.

* * *

FULL OF ENTHUSIASM for the 1936 models, with all their new gadgets, many dealers may overlook the fact that, after all, the set in itself is merely a means toward an end; that what the

prospect really wants is program entertainment or program enlightenment.

In many cases, as *Radio Retailing* so frequently has stressed, the selling job should start by creating a lively desire to hear the new and tremendously interesting broadcasts.

What factor sold sets in 1928 and 1932? The Presidential Election!

This year, and next, a citizen without a modern radio will be a citizen unequipped to properly weigh, from first hand information, the vital political issues which will be fought out on the air. This news feature alone—to say nothing of an international war situation now developing—will create rich opportunities for double barrel selling.

* * *

DAVEGA-CITY RADIO, New York's largest chain, is flooding Metropolitan homes with postcards (return postage prepaid) offering to tune up sets for \$1 (\$1.50 outside 20 mile radius). For the buck it will inspect antenna, remove ground corrosion, tighten connections, test and label tubes, tighten shields, inspect speaker, check volume control, tighten knobs and clean chassis. Object: To pick up loose service business, sell replacement parts, tubes and locate prospects for replacement sets.

* * *

A GOOD IDEA at this season and particularly interesting in view of a rumor that one of the largest set makers in the business will shortly break a fall campaign along the same lines, using lavish newspaper and consumer magazine space.

* * *

WENT to a New York night club the other night with some friends. Just after our arrival the floor show started and the master of ceremonies dragged a mike out on the floor to do his stuff. Was that amplifier rotten! Honestly, any self-respecting radioman had to blush with shame. It was impossible to understand more than three words out of a dozen despite high volume level.

Here's one of the real reasons for the sluggish progress of public address. Too many men in the business, avid to make a sale, will sell anything in order to meet the purchaser's idea of what the job should cost. As a result, a large number of the smaller installations actually scare business away, instead of selling others.

The industry is going to learn fast, through loss of business, that a *bum amplifier*, at any price, is still a *bum amplifier*.

Ray V. Sutcliffe

EDITOR

Big City Dealer Shows Up Cut-Price Competition

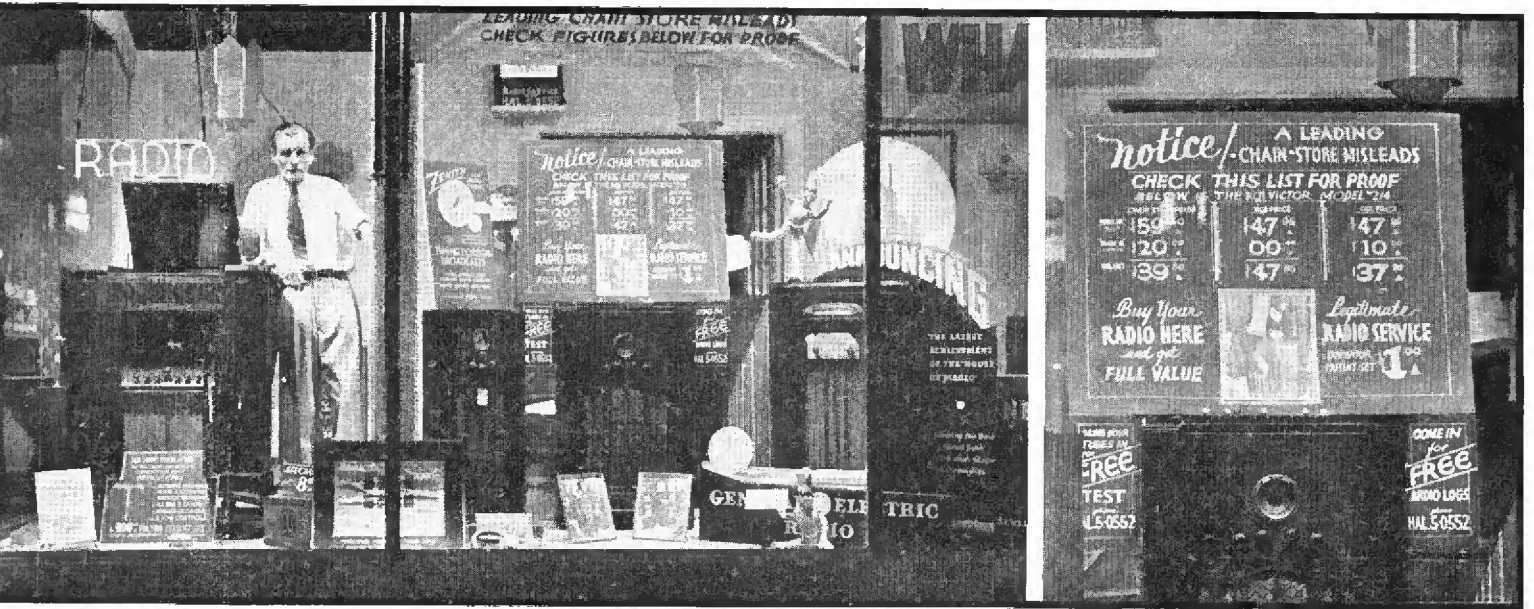

"Leading Chain Store Misleads," Says John F. Wilhelm, Who Uses His Window To Combat "Come-On" Advertising

NEW YORK—Unable to obtain standard brand leader merchandise in today's relatively clean market certain chain stores in the Metropolitan area are upping lists to fictitious highs in order to cut them down again in window advertising and so snare bargain-hunters. Typical example of this latest form of gyp promotion is a large operator's recent display of a popular console actually listing at \$47.95 together with a sign reading; "Slashed to \$39.50 from \$59.50."

Dealer John F. Wilhelm of up-town's Radio Specialist Company is endeavoring to combat this competition by showing up the fraud in his own window. He tucks a candid camera under his arm, locates a set advertised at a fictitiously high list in a competitor's window and shoots a photo of it. The shot is then enlarged and placed in his own window over a

set of identically the same model with a large sign proving that he sells it as cheaply and sometimes more cheaply than the chain.

A crusader for honest advertising, Wilhelm contends that the best way to combat misleading advertising is to fight it with facts and figures on its own ground, in the window, or in the local newspaper.

Windmill Chargers Re-Open Rural Market to Dealers

Schmutzler Uses New Devices To Sell 40 Battery Radios To Every 100 Farmers Called On



WATERTOWN, WIS.—L. E. Schmutzler & Son, one of the first retailers to fully grasp the possibilities of the new windmill-type battery chargers, is hanging up a sales record in farm radios by backtracking over his calls in rural areas, selling the farmers added radio convenience.

Out of every 100 calls on homes removed from electric light lines this dealer reports the sale of 40 sets, largely attributed to the pulling power of the new battery keeper-uppers. "Now that it is so easy and inexpensive to keep batteries charged," he



Novel Store Fronts

LEFT

The Radio Den's layout, Compton, does not seem novel . . . until you realize that it is located in one end of a huge, sprawled-out market. The shop occupies 10 feet of frontage in a 100 foot wide building.

LOWER LEFT

California's much-touted climate permits this company to maintain an open-air display all year round. The store itself, in Los Angeles, is long and shallow so that this arrangement uses display space to the full.

BELOW

Washer Wilson, past master of sales showmanship, attracts the passerby with this two-story replica of a set. The dial is a clock. City: Los Angeles

BELOW

A tower, visible for blocks, literally straddles the shop of A. C. Dove, South Gate, California, is at once a striking advertisement and a support for an excellent antenna.

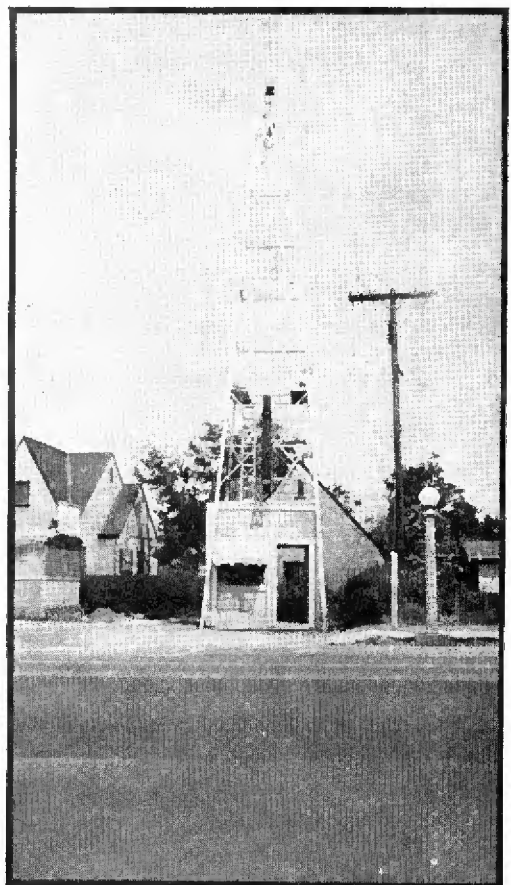

states, "farmers can buy sets as large and good as a.c. jobs without worrying about the cost of keeping batteries

charged every three or four weeks." A mounted floor display, shown in the photograph, aids store sales.

Oscillograph Makes Swell Action Window, Says Hodge

New Hampshire Repairman Uses New Test Device First As Display

CLAREMONT, N. H.—Following purchase of a new oscillograph V. W. Hodge of Radio Repair Service ran a newspaper ad here reading: "See your

voice. Talk into the microphone and watch the light wave vibrations in the oscillograph. In the V. W. Hodge window. Today and tomorrow."

The instrument was set up in the center of his window, raised to eye-level and about one foot back from the glass. A hand microphone was fastened to the frame above the window, outside the store, permitted to hang down in front of the oscillograph to a point about a foot above the average window-shopper's head. "Scotch tape" was used to fasten it securely to the window, avoiding a tendency to swing.

Asked for an explanation of how the device was hooked up Hodge explained: "The mike was connected to a small p.a. amplifier, the output of the amplifier connected to the vertical plates of the oscillograph. The controls were set so that anything said in a normal, natural tone of voice while

looking at the screen produced an envelope nearly filling the entire screen.

"A small sign telling people to talk and see their voice reproduced should, of course, be fastened to the mike. Incidentally, I leave the amplifier's speaker connected and have had many a laugh listening to what people say. Several of the 'Casper Milquetoast' variety were heard to cough discreetly several times and then look around to see if anyone was watching them!"



Car-Top Sign Boosts Service Volume

P. F. Alexander Says Display Outpulls Other Forms Of Advertising

LOS ANGELES—P. F. Alexander, this city, has just installed a sign advertising service atop his Auburn sedan, says it pulls better than ordinary forms of repair service advertising because it is so unusual. The sign appears in immediate danger of toppling off the roof, yet it is held firmly in place and stays "put" even in high winds.

The sign stands three feet high and

is constructed on a one-inch frame braced crosswise by two 2 x 4 supports used at the bottom. These are bolted to the top of the car, holes having been bored through two cross-braces for this purpose. It can be dismantled in two minutes and removed from the car.

The front and back overhang, rather than the height is, Alexander thinks, the striking feature.

weekly sales meetings has forced men to improve their approach when actually in the field, increasing radio sales.

Sales meetings are held each morning. Once a week a meeting is devoted to demonstration, each man on the force attempting to sell another, acting as a customer, a set by putting it through its paces. A \$5 prize is offered to the winner each week, work being judged on a point basis by Hannah and the remainder of the sales force.

The sales manager has 50 per cent of the vote in judging contestants while the sales staff itself holds the remaining award power. This avoids any feeling that the manager may be prejudiced in favor of certain contestants, gives the men added interest in the contest. If any salesman exhibits dissatisfaction with verdicts he has the opportunity of protesting, repeating his demonstration. He may change his approach or appeal in the second "act" if he so desires. If the second decision is counter to the first and anyone else is dissatisfied they have the right to challenge the second winner. And so the competition continues to hoist itself by its own bootstraps until demonstrations achieve near perfection.

"We're banking on convincing demonstrations to sell sets this season, believing that the replacement market is the big thing," says Hannah.

Grabe Starts Demonstration Contest Among Own Salesmen

Radio Sales Rise As Competing Employees Employ Rehearsed Demos In Field

TUCSON—B. F. Hannah, sales manager for Grabe Electric, this city, reports inauguration of a "demonstration

contest" among his own salesmen, advises that polishing up of stories for use during the contest conducted at

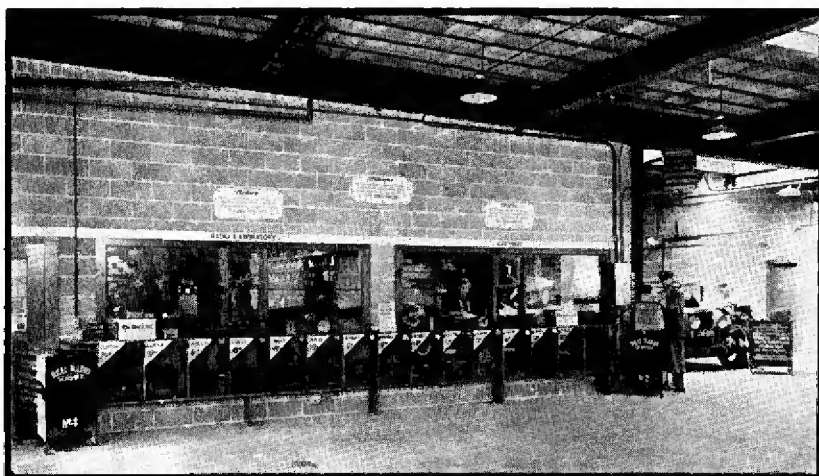

(Left) Doing business in a "drive-in" roadway between two buildings, roofed over to form a car radio installation room, Real Radio Service repairs home sets, does its book-keeping within the building proper, behind glass. Note the efficient installation wagons, effective panel-board display of new sets.

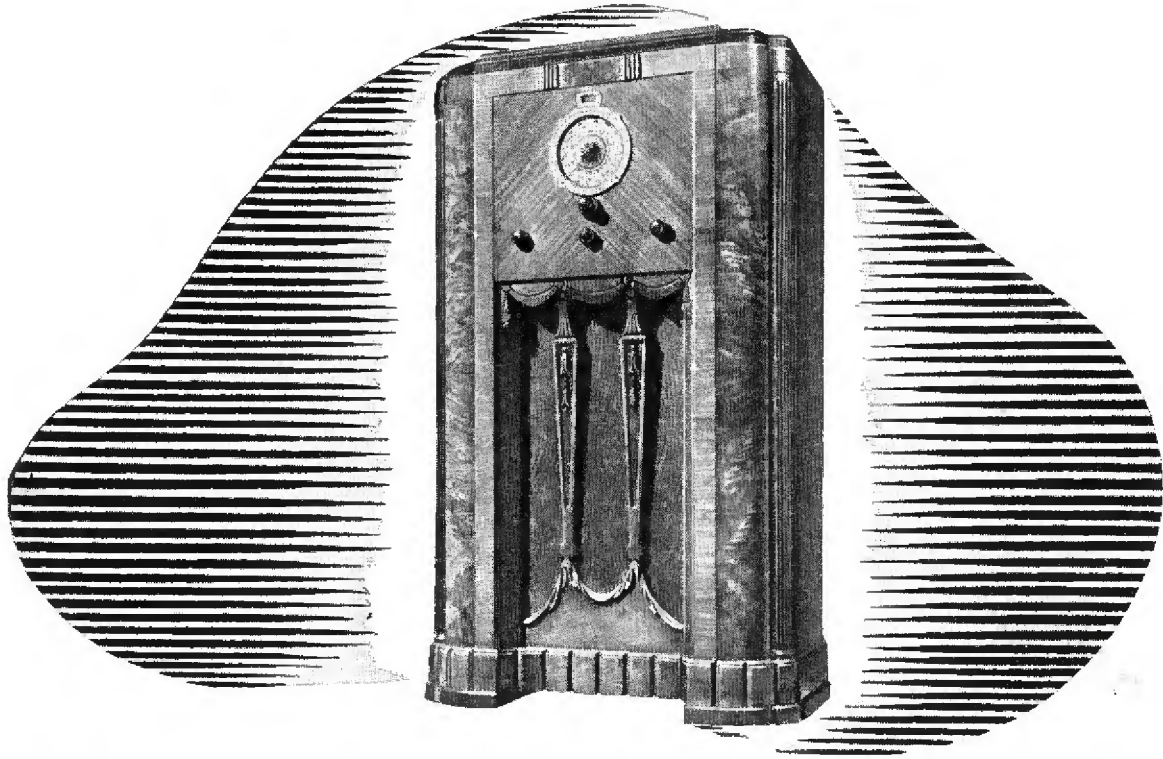

FERRODYNE . . . A NEW NAME . . . A NEW ACHIEVEMENT . . . IN RADIO!

● You know it as well as we do—surprises are few in the radio trade.

But the new Stewart-Warner Ferrodyne came as a surprise even to those who thought themselves immune to surprises! The skeptics . . . the men who “wanted to be shown”—all found something in the new Ferrodyne to rave about.

Why? Perhaps they remember that Stewart-Warner were pioneers with simplified round-the-world reception, that started a new demand for radio sets. Perhaps they realized that with Ferrodyne—an *exclusive* Stewart-Warner development—they’ll have a feature that puts them way out in front of competition.

Or, perhaps it is because they know the Stewart-Warner Ferrodyne has *all* the new features. All-metal tubes—plus a circuit especially designed for them. Automatic station register. Striking Craft-Built cabinets. New Diffusalite Magic Dial. Something new and different in *every* set, from the smallest, low-priced table model to the big de luxe console.

When the trade takes so enthusiastically to a new set, the public will welcome it in the only way that’s important . . . sales! Why not learn about the Stewart-Warner plans that make it easy for you to earn profits on Ferrodyne? Write, wire or phone today.

STEWART-WARNER CORPORATION
CHICAGO, ILLINOIS

The New **STEWART-WARNER**
Ferrodyne **RADIO**

Why we use METAL tubes

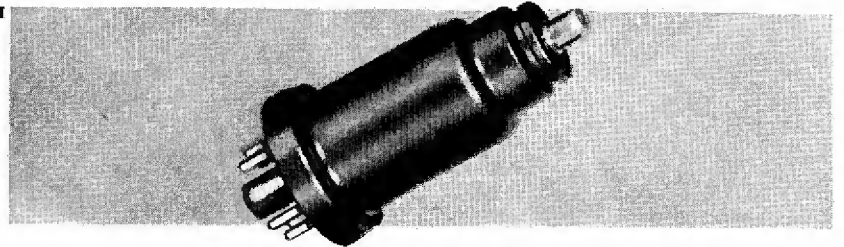

R. J. Cordiner

Asst. Mgr., Appliance Sales
General Electric Co.

When the General Electric Company decided, more than two years ago, to engage in the design and manufacture of its own radio receivers it was agreed that since the radio-minded public had become shortwave

conscious, the new GE receivers should be designed to provide the maximum efficiency and enjoyment of this type of reception. It was recognized that in a new receiver built to the exacting requirement of shortwave reception, its efficiency on broadcast reception would be automatically improved—and a great instrument would be the result.

Every phase of radio design was studied with a view toward possible improvement. The tube was first and, despite its advanced design, it was found wanting for the new General Electric radio. And so the GE Research Laboratory undertook to develop a radio tube that *would* meet the exacting requirement of stabilized, dependable

shortwave reception. The result is the new metal radio tube, first introduced for General Electric radio, and with which all GE radio models are completely equipped. Its use has made possible receivers which provide efficiency and enjoyability hitherto thought impossible to attain.

In the metal tube General Electric offers a radio vacuum tube of sturdy construction both internally and externally. The elements themselves are full size—as large as has been found practical in former types of tubes. However, since metal working technique can be held to extremely close tolerances, the shell, which is the tube's own shielding, may be placed very close to the elements, thus insuring greater shielding effect. Also, since the overall dimensions of the tube are so much smaller, the tubes may be located in the chassis much closer to the ideal position, with respect to affiliated circuits, thus eliminating further the variables caused by long wire leads between the associated parts of the circuit.

Metal tubes have proved so thoroughly satisfactory in exhaustive tests over a period of more than two years, that the General Electric Company has adopted the policy of using nothing but metal tubes in any of its receivers.

Furthermore, the advantages of using metal tubes have been substantiated by practically every worthwhile radio set manufacturer, each of whom has incorporated metal tubes in the design of its product.

+ + +



William Grunow

President
General Household Utilities Co.

Metal tubes eliminate breakage difficulties and the almost impossible problems connected with making uniform, balanced tubes with glass. For the first time, it is feasible to make perfectly matched tubes, an

essential factor in securing proper reception.

Metal tubes give greater sensitivity. You can get distant American and foreign stations louder, clearer and with less distortion and better tone.

Because of their perfect self-shielding they can be worked to higher capacities in the radio circuit without oscillation—thus getting the most from every tube.

These are the chief reasons why General Household is featuring the new metal tubes in its 1936 line.



John F. Ditzell

Sales Manager
Stewart Warner Corp.

Metal tubes are no mere novelty, "gadget" or talking points. They are the result of four long years of patient research in order to overcome the natural inaccuracies of the glass tubes. As is generally known,

metal can be machined to limits of extreme precision. Glass, on the other hand, is subject to wide variation. Tubes made of glass differ in size as much as three-sixteenths of an inch. Metal tubes of the same type do not vary more than 3/10,000 of an inch. As a result it is now possible to build multiple-tube circuits which develop a quality of reception never before achieved.

My company is using metal tubes because they possess
(Please turn to page 55)

Why we use GLASS tubes

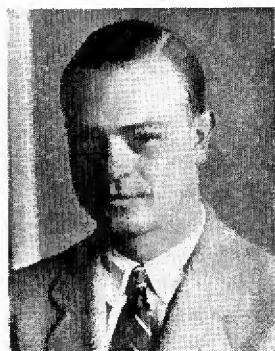
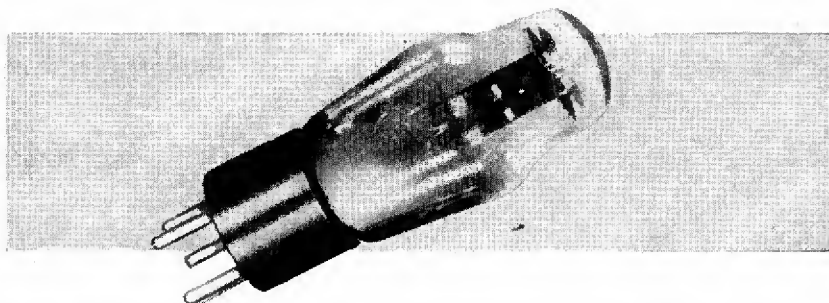

Sayre Ramsdell

Vice President
The Philco Radio & Tel. Corp.

Our 1935-36 line of radios is equipped entirely with glass tubes for the very simple reason that metal tubes are still in an experimental stage, and glass radio tubes are of the highest radio performance value today. We use glass tubes because perfected high efficiency tubes are available in every conceivable single and multiple function type; they make possible a greater output of pure tone; the ruggedness of glass tubes has been proved through widespread use in radio sets and in automobile radios. Also, loss of vacuum is practically unknown in glass tubes and glass tubes give better short-wave, foreign reception.

Philco does not use metal tubes because these smaller tubes, with the same amount of heat to dissipate, operate at a higher temperature which tends to shorten tube life. It also tends to change the characteristics of nearby coils, resistors, etc., which impairs the delicate balance of all the various parts of the radio set.

Many highly desirable multiple-function tubes now in

general use are not available in metal. Metal tube sets cost more money and deliver less performance and the replacement cost of a set of metal tubes is approximately double that of glass. The inability to see inside a metal tube is a real disadvantage; the transparency of glass often allows the user, the service man and the factory inspector to determine when a tube is not functioning. Loss of vacuum is a serious hazard in metal tubes.

Philco has experimented with, tested and retested metal tubes. They have been "weighed in the balance and found wanting." Their performance is inferior to glass, their cost is higher, their reliability in service is less. So Philco uses glass.

Performance is what counts. It is of no importance to Philco—nor to the public—whether tubes are made of glass, metal, wood or porcelain, so long as they do their full share to enable the radio as a whole to give maximum performance.

Today there is no excuse for the radio industry to experiment at the public's expense. In the early days of radio, there may have been some excuse for the radio industry to conduct experiments outside the laboratory; for asking the public to assume the expense of testing new radios, new tubes, new circuits. Our policy, however, is to confine experimentation to our own research laboratories.



Why We Provide Interchangeability



W. Keene Jackson

Sales Manager
International Radio Corp.

Great claims are being made for the new metal tubes. So widespread is the publicity on this innovation that the metal tube is sure to be an important selling factor this year which cannot safely be overlooked.

My company has met this condition by designing a chassis that permits the interchangeable use of either the metal tubes or their glass counterparts. The dealer can offer whichever the customer desires. Tube interchangeability gives the dealer a price advantage where glass is acceptable to his prospect. Also permits the purchaser to switch from glass to metal, or vice versa, later on.

This also provides "Kadette" dealers with a sales argument towards the immediate purchase, where a customer wants to wait for greater perfection in metal tubes. The dealer also can assure him that he will avoid any delay in replacements which might be caused by a present shortage of the new tubes.

Why We Use "Metaglas" Tubes



E. F. McDonald, Jr.

President
Zenith Radio Corp.

All 1936 Zenith chassis are designed to use the new Metaglas tubes, as new as the metal tube itself, with all of the characteristics of the metal tube.

Zenith's policy as regards tubes was arrived at through
(Please turn to page 55)

Consumer Intrigued by METAL TUBE

Trade, On the Fence, Inclined to Avoid Over-Selling Until Advantages Become More Obvious

CONCEDED to be one of the best potential talking points since sets were changed from battery to line power, the dealer is still "from Missouri" as far as the exact status of the new metal tube is concerned—and the public has yet to hear a facts-plus, reason-why story which is entirely convincing.

This is the picture as of October first. It comes to *Radio Retailing* from its reporters in the field. Many dealers already have found, in this development, decidedly helpful sales ammunition. But the big offensive is yet to be launched. The character of the job which must be performed by manufacturer and retailer, is indicated by the following comments from dealers and our field editors:

CHICAGO—Metal tube sets are being well advertised and trade pleased with their promotional possibilities. Deliveries rapidly catching up with stock commitments. No new merchandising methods yet worked out but many plans being laid to cash in on this latest gadget at proper time.

CLEVELAND—Metal tube sets are being well displayed, bringing many additional prospects into the stores. Deliveries much improved and public interest lively—but actual closings can be swung either way depending on sales presentation used. Dealer attitude, so far, one of "straddling" but open minded and want to be shown.

HARTFORD—This town is putting on a brand of real initiative in using the metal tube to swing sales. One dealer attributes a 30 per cent increase in sales to this one cause. "But you've got to be there with real reasons why and use a little showmanship."

CINCINNATI—The situation here is neutral. The trade is advertising the new tubes but doesn't know how to sell them. Inclined to favor the glass or optional types for the present pending demand and performance developments. Allowance should be made for the fact that advertising of the new tube has not yet had time to take hold—and that metal tubed sets have been hard to get. Retailers say they will know more in October. They need to be educated. Someone could make a name for himself by jumping into this arena and showing the dealers how to go about selling this interesting 1935 feature.

MILWAUKEE—Small dealer attitude reflected by following statement from live independent: "We're backing metal tubes. They represent progress and we think will go places. We invite the public in to see them and this has increased store traffic." On the other hand, the larger outlets, while advertising the new tubes, are pro-

ceeding with caution; do not wish to take chances with customer good-will until in a position to make deliveries, guarantee performance and effect quick replacements from store stocks. "The metal tube is a good thing, will attract traffic and make two-year-old sets seem obsolete. But you must wait a few months for our final answer."

BOSTON and PROVIDENCE—Calls on 12 dealers in these towns indicate rising popular interest in metal tube sets. Dealers generally are optimistic and anticipate that the talking points of the new tubes will stimulate sales this fall; also that the holiday trade will require an increasing output of such sets. At the moment, advertising and publicity have little more than begun to work but as more space and good displays are multiplied the present mild awareness of the public regarding metal tubes is expected to develop into a vigorous demand.

Few of these dealers were skeptical although one or two complained that deliveries are too slow. The test of field experience is still very limited but many dealers bank on the exhaustive research and laboratory work of the tube makers as a virtual guarantee of results. One dealer claims demonstrations are revealing superior reception from overseas stations compared with glass tubes.

Thus far, too little originality and energy have been displayed by New England dealers in pushing the metal tube idea. Newspaper advertising has been lacking in focus. Most dealers showing metal tube sets placard them nicely as such, but the advantages of such tubes are largely left to the prospective customer's imagination until the salesman gets the conversation well under way.

However, Clark & Mills Electric Company, Boston, attracted an amazing amount of attention at their Back Bay store by the simple scheme of showing a metal tube GE set in the window with the rear of the box turned toward the front.

At the World Radio Corporation store, Boston, a fine window display featured the new line of Atwater Kent metal tube sets and new tubes were displayed at the front of the window to give the visitor an idea of their compactness and lack of fragility. The Outlet Company, Providence, had another fine showing of RCA metal tube sets, well placarded. Is about to start comprehensive newspaper advertising. The Berman Company, Boston, put a metal tube set in the store doorway, and such a crowd collected that it had to be pulled inside.

WEST COAST—Already a great deal of interest in the new "supers" with metal tubes. Most dealers ready to give the metals a big play next month. There is more radio activity out here than most Easterners realize. Trade expects this season to be biggest since the boom days of '29.

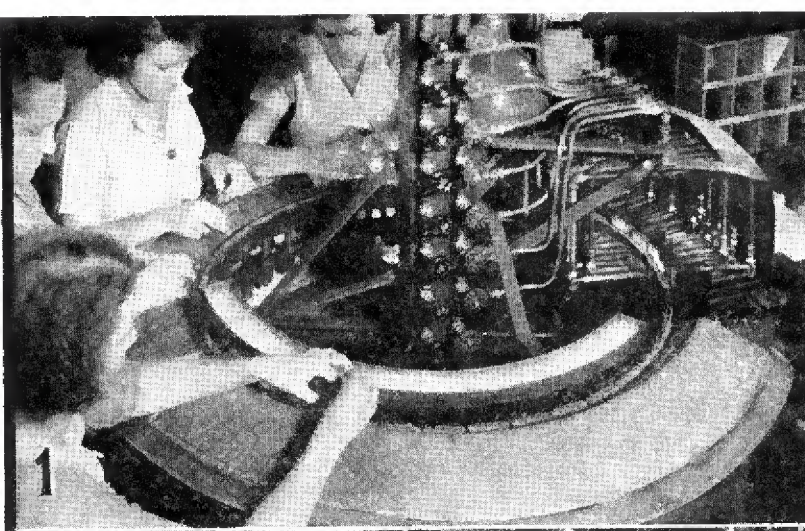

1

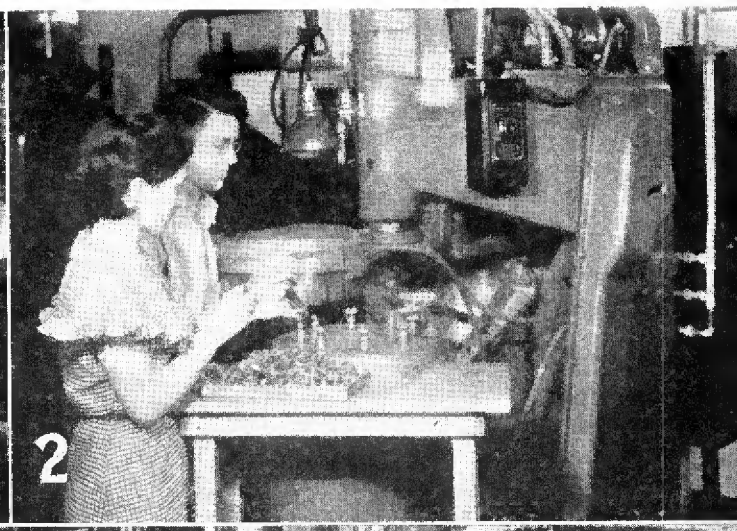

2

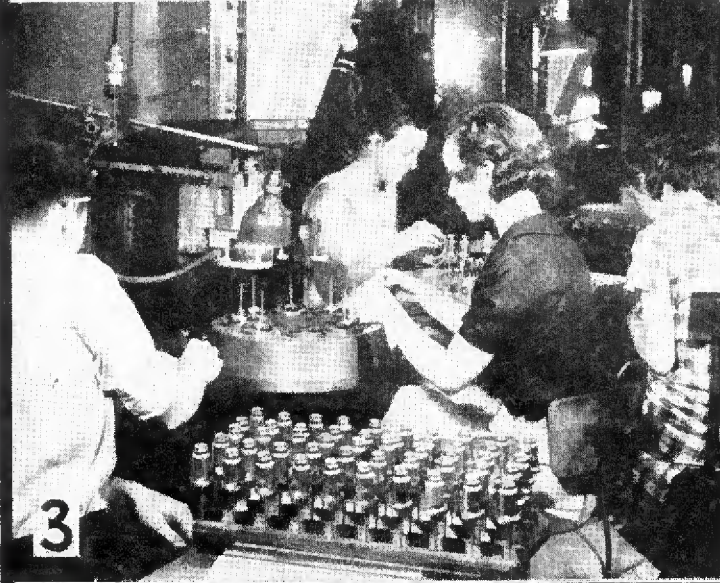

3

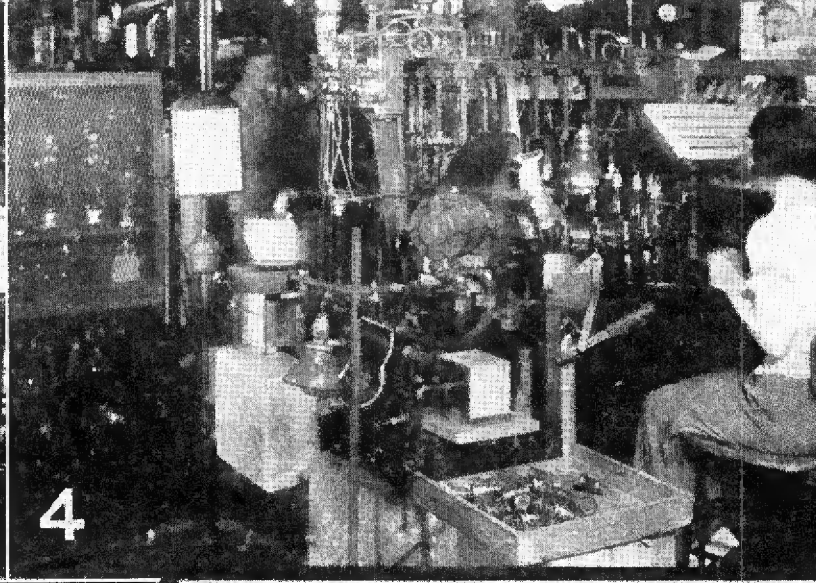

4

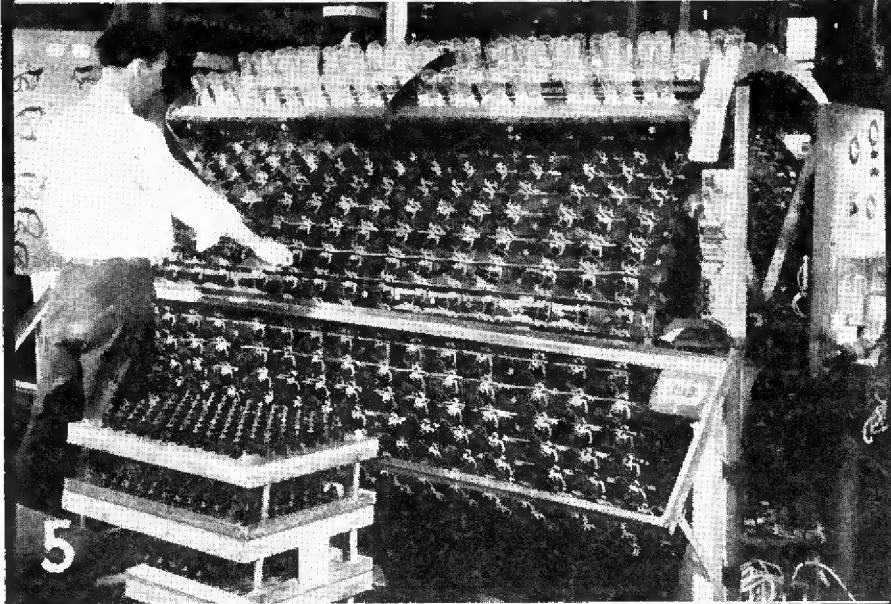

5

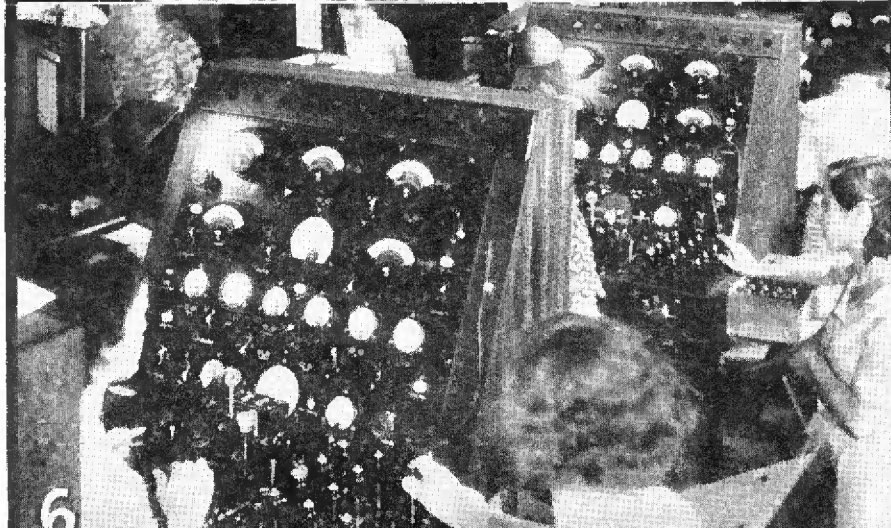

6

HOW METAL TUBES ARE MADE

Photographs courtesy
RAYTHEON PRODUCTION CORP.

- 1 Fusing seal glass to metal lead wires
- 2 Welding exhaust tube to header plate
- 3 Welding metal shell to header plate
- 4 Exhausting tube, product near completion
- 5 Bulk "Seasoning" of the finished product
- 6 Running complete characteristic test

Finance Companies Re-Enter Field

Renewed Interest in Radio Attributed to Stabilization of Industry and Higher Unit Sales

NEW YORK—A major factor in the financing of retail radio sales prior to 1929, commercial handlers of time-payment paper tapered off in this field following the market crash until, in 1932, such financing was practically non-existent. Dealers found it necessary at a time when money was tight to revert to their own local credit facilities, which resulted in material retardation of sales for those outlets which were not particularly well "heeled."

Now leading finance companies have once again become interested in radio. Why? The new attitude toward radio time-payment financing, as explained by executives of C.I.T. and other leaders in the finance field may be taken as typical.

See Stability Improved

A quick glance into the past is necessary in order to understand the changed attitude toward radio deferred payment sales paper. Prior to 1932 finance companies were active in buying such paper. Then dark days befell the radio industry, with rapidly changing models, falling prices, the introduction of "package goods" receivers leading to serious distress merchandising problems. Under the circumstances it was necessary for sales finance companies to curtail their investments in radio paper. It would have been necessary to raise rates so high as a means of self-protection that finance company services would no longer have been attractive to the radio dealer even if they were available.

Like a mountain lake, however, the industry, coming to the time when purging was necessary, developed its own method of working free of impurities. Many of the small, speculative manufacturers were eliminated, the law of survival of the fittest coming into play. Mechanical improvement in receivers necessitated the development of better and, consequently, higher-priced receiving sets, a

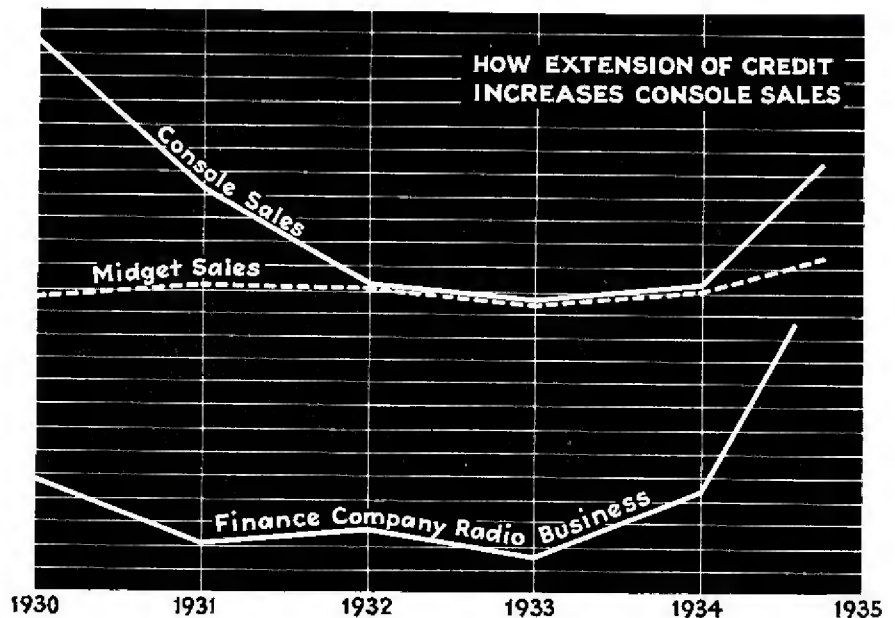

trend particularly noticeable this year.

The Radio Retail Code corrected many abuses and inaugurated improvements which have persisted even though the Code later became inoperative. Price-cutting and dumping have been largely eliminated and while the industry is not yet completely "clean" by any means all of the factors which were so troublesome in 1929 have been whittled down to a point where it is again possible for the finance companies to do business with reasonable safety and on a basis attractive to the dealer.

Healthier conditions within the industry, then, is the reason for the re-entry of finance companies. C.I.T., among others, conducted a survey of the business and determined on a program of experiment and experience before expansion, has since extended its services to several industry leaders. (RCA, Stromberg, Atwater Kent, Stewart-Warner, Crosley, Sparks-Withington, Graybar, Grunow and, as we go to press, Emerson, the household sets of Noblitt-Sparks.)

Collection Method Changed

In 1929 the majority of time-payment sales were financed on the indirect, or dealer collection, plan. Because finance companies waived full control of the credit investigation of the purchaser as well as the collection of installments requirements were necessarily high so that only the most strongly financed dealers could qualify. Today C.I.T. offers a direct collection plan under which it con-

trols the credit investigation and handles collections, a procedure resulting in substantially lower dealer credit requirements. The increased safety factor resulting from the use of such plans, coupled with the greater stability of the radio industry, enables the majority of radio dealers to obtain finance accommodation and the dealer, freed of the responsibilities of financing, credit investigation and collection, can concentrate on the business of selling and servicing.

The indirect collection plan is still used by many well-financed dealers, as in the past, but emphasis, both by the dealers and the finance companies in the field, seems to be on direct collection.

Acknowledge Industry Improvement

Remembering how long finance companies have remained aloof from the radio industry renewed interest in this field is significant to the dealer, distributor and manufacturer. So marked a change in attitude toward the radio business seems to justify prediction of better and brighter days. This, not only because a dealer can sell his time-payment market with all the safeguards that large financing institutions throw around their operations but because conservative and justifiably cautious finance companies, by their attitude today, acknowledge that the industry is definitely on a firmer, stronger basis.

It is estimated that fully 70 per cent of all consoles are now sold on time. Thus the big retail bottleneck is financing.

2,401,126 Farmers

ARE BEING SOLD Sentinel FARM RADIO THROUGH NATIONAL ADVERTISING!



Modern FARM RADIO without BATTERY TROUBLES!

\$29.95 to \$79.95

For eight years SENTINEL has been the leading manufacturer of Farm Radios. As a result, our name is well known throughout the country. We have pioneered a unique program, popular every where, for the purpose of advertising our products through the use of the national advertising plan. We have a complete line of booklets, battery chargers, and other accessories. Write for a copy of our new book, "The Modern Farm Radio," which tells you all about the many advantages of a battery charged radio and complete information on how to get the best results from your radio.

FREE!

RADIO NEWS SPECIAL EDITION

Sentinel News

SENSATIONAL INVENTION!

A FARM RADIO PAYS FOR ITSELF. THOSE DAYS ARE GONE FOREVER! PUTTING THE WIND TO WORK!

HEAR THEM PLAY BEFORE YOU BUY YOU WANT TO HEAR THE NEW SENTINEL FARM RADIO

Progressive Farmer

1935 OCTOBER 10¢ IN THE CANADA

COUNTRY GENTLEMAN

Sentinel — The leading manufacturer of Farm Radios for years, backs up their outstanding sets with a national advertising campaign. Get your share of the profits Sentinel is piling up for live dealers. **MAIL THE COUPON** for full details on the entire line and Sentinel's sensational national advertising campaign and dealer cooperation plan.

MAIL THIS COUPON!

Sentinel Radio Corporation
 9222 Diversey Parkway
 Chicago, Illinois

Please RUSH me full details on the proven Sentinel line of Farm Radio.

Store: _____
 Address: _____
 By: _____

Sentinel MAIL THIS COUPON!

9222 DIVERSEY PKY., CHICAGO

SENTINEL, CHICAGO
 RADIO CORP.
 9222 DIVERSEY PARKWAY, CHICAGO
 Please mail me full details on your line of Farm Radios. I will also enclose my order for \$12.50.

Name: _____
 Address: _____
 City: _____

SENTINEL RADIO CORPORATION
 Export Dept.: 330 W. 42nd St., New York, N. Y.

RESTING TIRED DOGS . . .
John Ditzell of Stewart-Warner



WRAY



HIGH TENSION . . . R. H. McMann
of New York (right)

OLDTIMERS . . . Milt
Sleeper of Pilot (right)
and Editor Ray Sutcliffe



PIPE OF PEACE . . . Roy Davey
of American Bosch

S

hots from the Show

Candid Camera Photos Snapped at Grand Central Palace

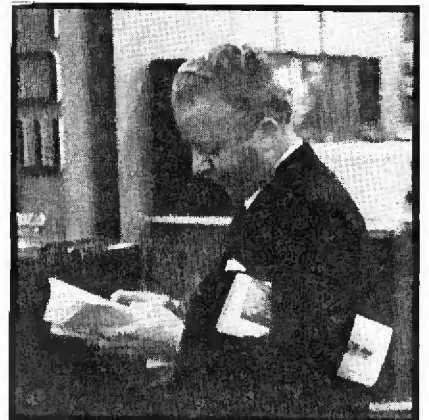

DOTTED LINE . . . The Colen
of Colen-Gruhn



BOTTOMS UP . . . John Krause
of Radiobar



FACE WITH SMILE . . . Dave
Wald of Pierce-Airo



MAN AT WORK . . . Lou Chatten
of Fada (right)

Metal-Tube Merits

PLUS

Glass-Tube Efficiency...

ARCTURUS "G" TUBES

(GLASS COUNTERPART
OF ALL-METAL TUBES)

SELDOM has any development so quickly been accepted by critical engineers, dealers and servicemen who must be sure, in advance, of their every move.

Tested and efficient performance is assured in Arcturus "G" Tubes, built along experience-proved methods.

Arcturus "G" Tubes, identical in characteristics and pin connections to all-metal tubes, are interchangeable, and will do all that the metal tube does—and do it better!

No wonder, then, that several leading manufacturers use "G" Tubes in their sets and are able to ship in quantities...that the trade is using and preferring "G" Tubes where efficiency must be a certainty.

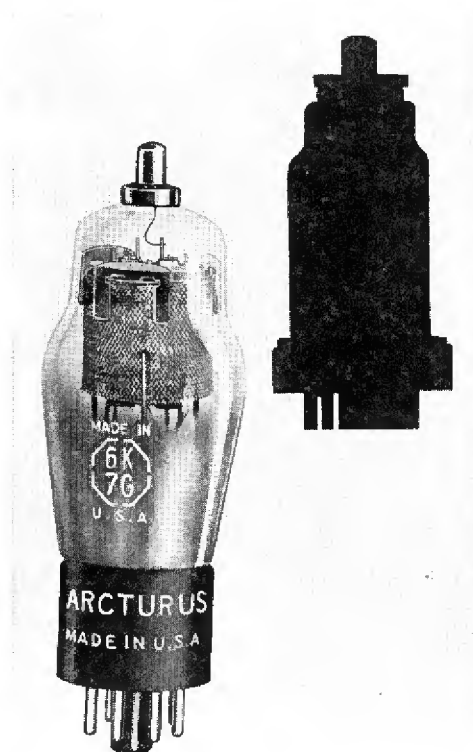

Showing general appearance of the "G" Line Tubes with all-metal tube base connections and guide pin.

Some of their salient features are:

1. Characteristics identical to all-metal tubes.
2. Pin connections and base same as all-metal tubes.
3. Type numbers correspond to all-metal tubes (except that our 5Y3 is a counterpart of the 5Z4).
4. Positively interchangeable with all-metal tubes.
5. Proved efficiency; built along conventional manufacturing practices; not an experiment.
6. Available now in quantities.
7. Currently used as initial equipment by several leading set manufacturers.

Characteristic Chart on "G" Tubes available on request. Arcturus Radio Tube Co., Newark, N. J.

ARCTURUS

RADIO TUBES

Pioneer of 6 out of the 7 Fundamental Developments in a. c. Tubes.

WIRED RADIO

Goes Commercial On Small Scale

By Leonard Church

CLEVELAND—In July the Muzak Corporation of Ohio, subsidiary of Wired Radio, Inc., in turn a subsidiary of The North American Company, holding company controlling The Cleveland Electric Illuminating Company, placed 662 instruments capable of receiving programs transmitted over light lines in Lakewood (suburb of Cleveland) homes on three weeks free, experimental trial.

Checkup and interview now discloses that the experiment was sufficiently encouraging to induce Waddill Catchings, chairman of the board, C. W. Hough, president, and H. D. H. Connick, vice president, to extend the service on a commercial basis and while information concerning the number of paid subscribers is not disclosed it is known that 5,000 people are daily receiving recorded and studio-originated programs over the light lines, 2,000 more via the wires of the Ohio Bell Telephone Company in an area known to possess radio in 91 per cent of its homes.

No attempt is being made to supplant radio in any of the concern's several elaborate sales booklets. Competition it is, of course, but I am told that the company would positively welcome production by some set manufacturer of an instrument capable of receiving both types of programs. Just how many people will maintain radios and wired radio both, how many will drop one in favor of the other, is an



A studio-originated play

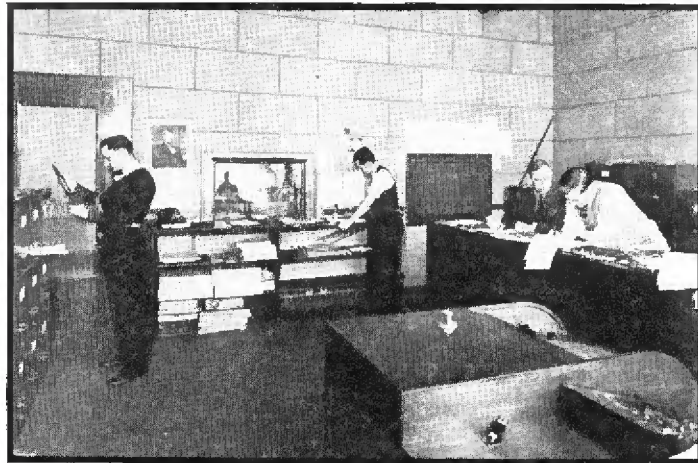

Muzak's library of recordings, reputed to be one of the most complete in the country

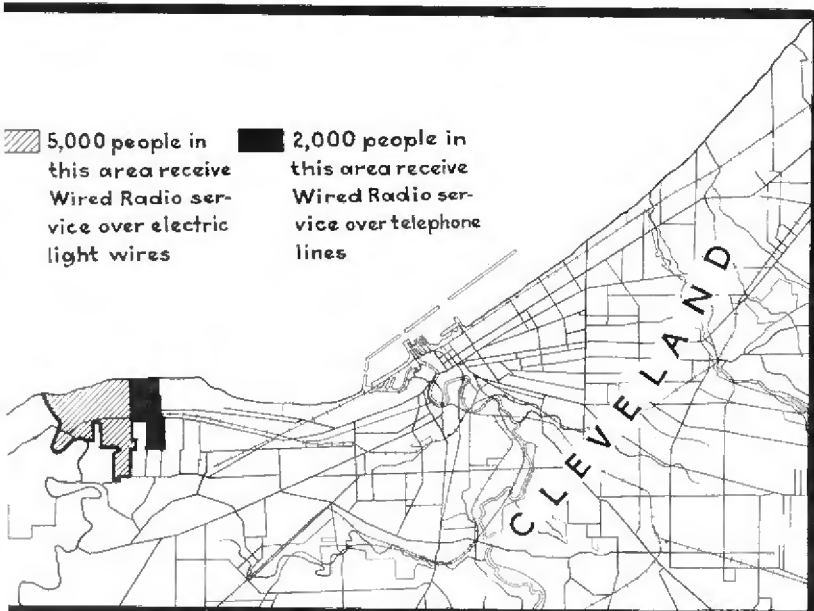

Map showing Lakewood section of Cleveland in which wired radio is in use. The large area (5,000 installations) is served over light wires, the small (2,000 sets) over 'phone lines

unanswerable question, hinging almost entirely upon the character of programs made available by these two services over an extended period.

Transmission, Programs

Transmission is by the "wire carrier" method, signals generated at 26, 39 and 52 kc. being super-imposed on and confined to light and phone lines. Originated in the Muzak studios, programs are passed for distribution to the Lakewood exchange of the telephone company and to the Lauderdale substation of the light company.

Control equipment now used (General Radio, Western Electric) is not the latest available but I am told that new,

Trial Period Over, Cleveland Suburb 91 Per Cent Radio-Saturated Gets 7,000 Receivers—Sponsor, Backed by Well-Financed Utility Holding Company, Avoids Direct Competition With Broadcasting

fully modern equipment will shortly be placed in operation. Provision for putting out programs over 5, in place of the 3 channels now used, is being made and the fourth is already being piped around the experimental laboratory, presaging early release to subscribers. Channels 4 and 5, or just 5, may serve restaurants, hotels and similar institutions exclusively.

James Church, with upward of nine years of experience in commercial broadcast fields, formerly with WGAR, is program director, the first man to my knowledge whose job is simultaneous direction of three concurrent, yet completely different programs. He is, at present, providing 292 hours of programs per week, a large proportion of them being recordings made by Muzak. These are said to be truly high-fidelity in character, transmission being relatively flat from 50 to 9,000 cycles, a range which gets right to the consumer's ears in essentially its original form because of the channel widths available over the private carrier system and the relative absence of transmission noise.

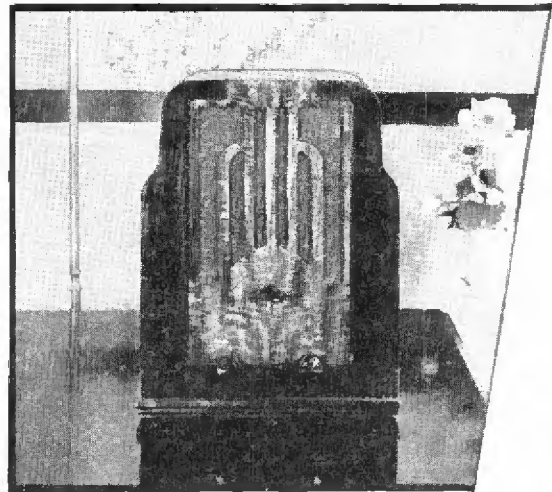

(Center) Typical day's program, indicating diversity of topics. Musical items are largely recordings

MONDAY, September 2	
6:00 to 6:30	CRANNY 1 Ray Noble
6:30 to 7:00	CRANNY 2 Fanny Brice
7:00 to 7:30	CRANNY 3 Program of the Week
7:30 to 8:00	CRANNY 4 Early Bird Muzak
8:00 to 8:30	CRANNY 5 Star of Morning Muzak
8:30 to 9:00	CRANNY 6 Early Bird Muzak
9:00 to 9:30	CRANNY 7 Muzak Muzak
9:30 to 10:00	CRANNY 8 Muzak Muzak
10:00 to 10:30	CRANNY 9 New Morning Muzak
10:30 to 11:00	CRANNY 10 New Morning Muzak
11:00 to 11:30	CRANNY 11 New Morning Muzak
11:30 to 12:00	CRANNY 12 New Morning Muzak
12:00 to 12:30	CRANNY 13 New Morning Muzak
12:30 to 1:00	CRANNY 14 New Morning Muzak
1:00 to 1:30	CRANNY 15 New Morning Muzak
1:30 to 2:00	CRANNY 16 New Morning Muzak
2:00 to 2:30	CRANNY 17 New Morning Muzak
2:30 to 3:00	CRANNY 18 New Morning Muzak
3:00 to 3:30	CRANNY 19 New Morning Muzak
3:30 to 4:00	CRANNY 20 New Morning Muzak
4:00 to 4:30	CRANNY 21 New Morning Muzak
4:30 to 5:00	CRANNY 22 New Morning Muzak
5:00 to 5:30	CRANNY 23 New Morning Muzak
5:30 to 6:00	CRANNY 24 New Morning Muzak
6:00 to 6:30	CRANNY 25 New Morning Muzak
6:30 to 7:00	CRANNY 26 New Morning Muzak
7:00 to 7:30	CRANNY 27 New Morning Muzak
7:30 to 8:00	CRANNY 28 New Morning Muzak
8:00 to 8:30	CRANNY 29 New Morning Muzak
8:30 to 9:00	CRANNY 30 New Morning Muzak
9:00 to 9:30	CRANNY 31 New Morning Muzak
9:30 to 10:00	CRANNY 32 New Morning Muzak
10:00 to 10:30	CRANNY 33 New Morning Muzak
10:30 to 11:00	CRANNY 34 New Morning Muzak
11:00 to 11:30	CRANNY 35 New Morning Muzak
11:30 to 12:00	CRANNY 36 New Morning Muzak

under the direction of a former Scripps-Howard managing editor assisted by a staff of five, presents five-minute programs of news and comment at 8 a.m., 10, 12, 3 p.m., 5 and 11, with baseball scores and other sport reports at 7. Classical records available include recordings of 20 of the world's outstanding Philharmonic and Symphony orchestras. Among the scheduled recordings are such names as Ray Noble, Ben Bernie, Cab Calloway.

What investment Muzak has in transmission, studio equipment; what it costs to produce transcriptions, put on studio features, is not known.

Reception, Cost

Programs are received in subscribing homes on Muzak receiving units incorporating detectors, wide-range audio amplifiers. A flat installation charge of \$5 is made, the subscriber paying from \$2 to \$5 per month thereafter

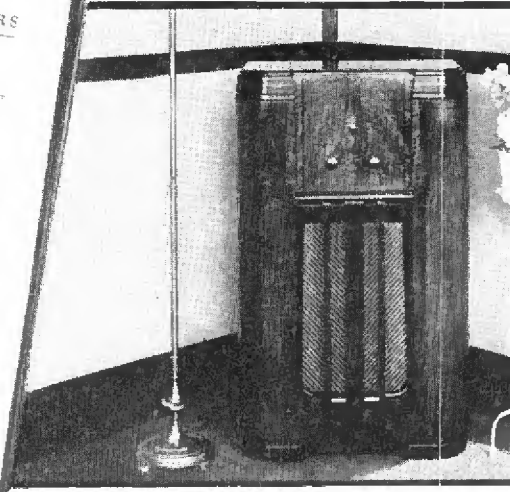

Receivers: The small rents for \$2 monthly; the large for \$4. Only 3 of the five channels provided are at present in use

The three channels available to the subscriber are diversified so the patrons may choose programs to their liking at almost any instant. Channel A, for example, is used to carry variety, news, reviews, specialties, weekdays from 6 a.m. to midnight, Sunday from 8 a.m. to midnight. Channel B supplies classical music, drama, literature, weekdays from noon until 11 p.m., Sundays from 10 a.m. to 9 p.m. And Channel C transmits dance music and popular melody from noon to 1 a.m. weekdays, Saturdays from noon to 2 a.m. and Sundays from noon to midnight.

Examination of a 14-page booklet, describing a week's programs (similar booklets are distributed to subscribers each Saturday) indicates a well-balanced fare. News of the hour is broadcast on the hour. The "Reading Room,"

for rental, the actual cost per 30-days depending upon the equipment chosen.

Available is a midget type receiver renting for \$2 per month, consoles and de luxe floor instruments renting for \$4 and \$5. Adapters permitting use of existing radios for reproduction were seen some months ago but are no longer in general use. Combination radio-wired radio instruments are apparently contemplated but no definite news on this subject is forthcoming at this time.

The cost of electricity required to operate the receivers (over and above the rental charge) is given as one cent per 2 hours for the largest console.

On-off switch, volume control and five-channel switch (Please turn to page 53)

Radio Dealer Sells Carload of

By
Tom F. Blackburn

Refrigerators

Bill Saichek, Star Salesman for Sam Shapiro of Atlas Stores, Tells How Sales Approach Differs

MILWAUKEE—Sam Shapiro, of the Atlas Stores, operating two retail outlets in this city, one in Madison and a sister chain known as Paramount Stores in Racine, Kenosha and Madison, reports the sale of a carload of refrigerators (Stewart-Warner), informs this reporter that his 1935 volume to date is running 70 per cent radio, 20 per cent refrigeration, 10 per cent washers, smaller electrical items and sporting goods. Total sales are expected to reach \$400,000 for the year.

Shapiro uses no outside salesmen, relying solely upon floor leads produced by heavy newspaper advertising and a good location, advises that his most difficult problem has been training salesmen, chiefly experienced on radio, to sell refrigeration intelligently. "With a radio playing away and good to look at, the



"You've got to talk for a refrigerator"

set talks for itself. A refrigerator is dumb and the salesman must talk for it." This is his chief theme, continually drummed home to men on the floor. How well it works is indicated by the refrigeration sales record of Bill Saichek, one of his men formerly concerned solely with radio, who is building up an enviable record on boxes.

Says Saichek: "You see a lot of salesmen wave their arms at radios and say . . . 'That's a mighty fine buy for \$99.' With the radio playing it does a lot of talking for itself and permits the salesman to get by with some sloppy work that would not sell other merchandise. That

kind of selling is 'out' when moving refrigerators. People who come in to buy are economy-minded and not in an expansive mood. There is no music to make them feel better.

"Here's my story on our refrigerators. The boxes can't talk so I do:

1. 'Just feel the thickness of that door. You can see there is a lot more insulation here than in cheap refrigerators. And insulation saves you money on electricity.

2. 'Notice this cold chamber. It is all of porcelain enamel and clean as a dish. Put your hand in there and see how

(Please turn to page 53)



Born in Kiev, Russia, Sam Shapiro emigrated to Milwaukee in 1911. Unable to understand English, he began with the A. O. Smith Auto Frame Company, started a bicycle store of his own in 1917 and caught radio on the fly in 1925

Says salesman Saichek: "A radio talks for itself"



A COMPLETE FINANCE SERVICE



**within
phone's
reach**

EVERY form of cooperation included in C. I. T.'s Radio Financing Service is extended by our Local Office in your territory.

There is none of the delay which often occurs when business has to be transacted by mail with a distant finance company. You have the advantage of frequent personal contact with the finance men who are directly responsible for checking your credits, purchasing contracts, and making your collections.

This close-range service prevents mistakes and misunderstandings. It does away with "red tape." It gets results . . . the supreme test by which any financing arrangement should be judged.

C. I. T. Plans cover all models of approved types of radios; also mechanical refrigerators and water coolers, electric ranges and electric water heaters. A large percentage of the country's most successful dealers use C. I. T. Service. A phone call to our nearest office will bring a C. I. T. field-man, glad to talk over with you how C. I. T. Service might aid you.



CALL TODAY OUR NEAREST LOCAL OFFICE

Abilene ◊ Akron ◊ Albany ◊ Altoona ◊ Amarillo ◊ Asheville ◊ Atlanta
 Augusta ◊ Bakersfield ◊ Baltimore ◊ Bangor ◊ Bay Shore ◊ Beaumont
 Beckley ◊ Binghamton ◊ Birmingham ◊ Boise ◊ Boston ◊ Bridgeport
 Bronx ◊ Brooklyn ◊ Buffalo ◊ Butte ◊ Camden ◊ Cape Girardeau
 Cedar Rapids ◊ Charleston ◊ Charlotte ◊ Chattanooga ◊ Chicago
 Cincinnati ◊ Clarksburg ◊ Cleveland ◊ Columbia ◊ Columbus
 Cumberland ◊ Dallas ◊ Dayton ◊ Denver ◊ Des Moines ◊ Detroit ◊ El Paso
 Erie ◊ Florence ◊ Fort Wayne ◊ Fort Worth ◊ Fresno ◊ Glens Falls
 Greensboro ◊ Greenville ◊ Hagerstown ◊ Harrisburg ◊ Hartford
 Hempstead ◊ Hickory ◊ Houston ◊ Huntington, W. Va. ◊ Indianapolis
 Jacksonville ◊ Jamaica ◊ Jamestown ◊ Jersey City ◊ Johnson City
 Kansas City ◊ Knoxville ◊ Lexington ◊ Lincoln ◊ Little Rock ◊ Los Angeles
 Louisville ◊ Manchester ◊ Memphis ◊ Miami ◊ Milwaukee ◊ Minneapolis
 Mobile ◊ Montgomery ◊ Montpelier ◊ Mt. Vernon ◊ Nashville ◊ Newark
 Newburgh ◊ New Haven ◊ New Orleans ◊ New York ◊ Norfolk
 Oklahoma City ◊ Omaha ◊ Orlando ◊ Paducah ◊ Paterson
 Peoria ◊ Perth Amboy ◊ Philadelphia ◊ Pittsburgh ◊ Portland, Me.
 Portland, Ore. ◊ Portsmouth ◊ Poughkeepsie ◊ Providence ◊ Raleigh
 Reading ◊ Reno ◊ Richmond ◊ Roanoke ◊ Rochester ◊ Rome, Ga.
 Sacramento ◊ St. Louis ◊ Salt Lake City ◊ San Antonio ◊ San Diego
 San Francisco ◊ San Jose ◊ Scranton ◊ Seattle ◊ Shreveport
 Spartanburg ◊ Spokane ◊ Springfield, Mass. ◊ Springfield, Ohio
 Stockton ◊ Syracuse ◊ Tampa ◊ Toledo ◊ Tucson ◊ Tulsa ◊ Utica
 Washington ◊ Watertown ◊ Wheeling ◊ White Plains ◊ Wichita
 Wilkes-Barre ◊ Wilson ◊ Yakima ◊ Youngstown

C. I. T. CORPORATION

NEW YORK — CHICAGO — SAN FRANCISCO

Completely Functioning Local Finance Offices in the Principal Cities

A Unit of

COMMERCIAL INVESTMENT TRUST CORPORATION
 CAPITAL AND SURPLUS OVER \$100,000,000

Problem:

Find the SUCKER



By
Milton Samuels

"After ten years in the business I have come to the conclusion that the ruinous practice of offering large cash discounts is due almost entirely to the salesman's deathly fear of losing a sale and not to sharp-shooting practice on the part of the prospect"

"BOY, did we have a sucker on the floor today. Sold him a set for cash at full list! If he'd held out for it I would have cut 30 per cent to make a quick turnover."

This statement was made to me by the manager of a well-known big-city radio store. Multiply his sentiment by 75 per cent of the salesmen working for large, urban dealers and one reason for current cut-price competition becomes crystal clear.

After ten years in the business I have come to the conclusion that the ruinous practice of offering large cash discounts is due almost entirely to the salesman's deathly fear of losing a sale and not to sharp-shooting practice on the part of the prospect. Another reason is the average big-shot dealer's peculiar belief that there is glory in killing off a competitor's sale at any price.

Get behind the scenes at most city sales meetings and you will hear the disciples of cash discount combat every constructive argument against its continuance with the alibi of competition. It is strange that salesmen of organizations spending millions annually in advertising to build consumer acceptance on the basis of greater dependability blurt out that they are forced to meet the competition of some obscure dealer in a remote section of town . . . and then, later, to hear that same obscure competitor rave about the other fellow's cut-price tactics.

The whole thing is a vicious circle. First one offers cash discounts. And the other follows suit. Nobody wins but the consumer, who would have given somebody a decent profit in the first place if he had not been handed a cut on a silver platter.

IN MY estimation the cash discount abuse cannot be laid at the doorstep of the modern crop of salesmen. It is a legacy passed down from the early days of radio by oldtimers. These men, who started the practice back in the days when sets were sold "less everything," making up the discount by slapping it heavily on accessories, still adhere to the policy, despite a radical change in merchandise. They don't seem to realize that today when one takes a deep cut on a set there is no possible way to make it back.

Another funny angle of the 30 per cent off racket is the attitude of some big-store executives when a set manufacturer attempts to maintain some form of price control or regulation. They resent this sort of treatment, labeling it "High-Hat" tactics. But if the manufacturer fails to make any effort at price control he is plagued with the statement that his line is being used as a football.

In the days of the Blue Eagle, when every industry attempted to set up some sort of resale value on its merchandise, I helped build a dealer organization put together for the express purpose of establishing a code of fair-selling practice. Dealers, whom the proposed code was designed to protect, killed every constructive attempt to adopt it. The moment price regulation was mentioned dealer after dealer hopped to his feet and protested that he knew competitors would not abide by the rules; that price control would prevent him from meeting competition.

It was always the other fellow who was responsible for price-cutting. Their own price-cutting was simply "protective."

Who is the sucker, the cash customer who pays full list or the dealer who voluntarily slashes? The answer seems painfully obvious.

HOWARD

Can Deliver!

METAL TUBE SETS

HOWARD foresaw the present shortage of materials and bought for the future with the largest commitments in HOWARD's long history.

As a result HOWARD *can deliver* the complete line including *metal tube sets!*

Nine receivers. 4- 5- 6- 7- and 9-tube models from \$17.95 to \$124.50. *Plus* the world's finest radio receiver—the 19-tube grand at \$295.00.

DISTRIBUTORS AND DEALERS WRITE OR WIRE FOR DETAILS! YOUR TERRITORY MAY STILL BE OPEN

HOWARD

HOWARD RADIO COMPANY

1737 BELMONT AVENUE, CHICAGO
AMERICA'S OLDEST RADIO MANUFACTURER

SHOW EXHIBITORS DECLARE BUYER'S MARKET HERE AGAIN

Crowds Take Acquisitive Interest in High Priced Consoles—173,000 View Displays and Scientific Marvels

NEW YORK—Per usual, the radio industry dominated in square footage and in attention value the National Electrical and Radio Exposition, Sept. 18-28. It was a business show marked by the absence of ballyhoo and characterized by the number of persons who came with the serious intention of comparing values and then buying a new set.

Naturally the new metal tube was the focal point of most discussions although it was apparent that the public as a whole is not as yet over-excited about this development, viewing it as another invention whose justification remains to be proven. Exhibitors reported, however, that this device, properly presented, was the deciding factor in the closing of many sales, especially with the men folks.

There never has been a radio show more colorful or beautiful in its general appearance or one at which were presented so many striking and well designed radio receivers. Every radio booth—twenty in all—displayed at least one "attention getter"—one innovational model for the Fifth Avenue trade.

To cite a few examples: Emerson with its \$150 table model with speaker grilles fore and aft, tuning knobs on one side and an electric clock on the other, the whole a finished symphony in wood.

Sparton with its blue-black mirror model and another set with gold plated trimmings.

Zenith with its display of "ebony" radios. Looked swell and caught the eye.

Stromberg-Carlson with its automatic record changer unmasked for the gaping crowds. People still like to see "what makes 'em go."

RCA-Victor had a Robot who challenged anyone to a game of checkers and guaranteed to beat his opponent—or give him a \$118 radio. No cheating allowed—if you failed to make a lawful move, Mr. Robot shook his head and refused to continue until the error had been rectified.

Then there was the popular Hall of Science where the radio knife cut into a nice piece of steak, where you could hear your own voice on a telephone arrangement, where Lew White demonstrated his pipeless "Electrovox" organ and where broadcasts were staged in the Crystal Rooms.

The trend is strong to higher priced consoles. As one manufacturer told the writer, "Last year 60 per cent of our demand was for table models, 40 per cent for consoles. This year the demand is exactly the reverse with our \$90 console the best seller.

Three Electric Kitchens

To dramatize the appealing idea of making a complete balanced workshop of the kitchen—this long neglected service

center of the home, three appliance manufacturers (General Electric, Westinghouse and Landers, Frary and Clark) installed electric kitchens. There were also many new improvements in the diverse line of electric domestic equipment, much of it a matter of design and color.

Side Lights

Practically every "Who's Who" in the industry put in an appearance at the Grand Central Palace "to check up on how things were going." The fact that the Baer-Louis bout was pulled off the same week had nothing to do with this great interest in the show, of course. All the "bigwigs" were at the fight, however, Tuesday night.

Philco pulled a clever stunt in displaying a genuine \$25,000 Stradivarius flanked by a couple of policemen with their gats prominently displayed.



George Conover

*Managing Director
Phila. Electrical Show*

Phila. Show Packs Them in at Convention Hall

PHILADELPHIA — With more than 100 exhibitors displaying over 300 electrical products, the eighth annual Electric and Radio Show of the Electrical Association of Philadelphia far surpassed those of other years.

The show, held Oct. 7-12 in the giant Municipal Convention Hall, is rated as the oldest institution of its kind in these United States, according to George R. Conover, managing director. Due largely to Mr. Conover's barrage of publicity and his initiative in securing sterling attractions attendance exceeded that of '34 (115,372) by 30 per cent. Dealers and jobbers were well pleased, reporting sales closed and good prospects secured as twice that of last year.

Crosley D. M. Campaign

CINCINNATI—The Crosley Radio Corp. has developed an

Rosen Opens New RCA/Kelvinator Headquarters

PHILADELPHIA — At 10 o'clock, Sept. 23, the Mayor of this city received a golden key from Raymond Rosen & Co. and with it opened the door to this firm's magnificent new building at 32 and Walnut Streets. This gesture, witnessed by executives of the RCA-Victor Co. and the Kelvinator Corporation, was followed by an inspection of what is probably the most modern—in appointments and service facilities—jobbing establishment in the country. All the offices and the large showroom are air-conditioned and modernistic in design.

Open house for Raymond's many dealer friends was held throughout the week.

The highlight of "Dedication Week" was the banquet held Thursday evening at the Bellevue-Stratford. There were over 1,400 guests. Speakers included E. T. Cunningham, president of RCA-Victor, and George W. Mason, president of the Kelvinator Corporation of America. The toastmaster was John B. Kennedy, widely known announcer of the National Broadcasting Company.

A special eight-page supplement to the *Philadelphia Record* was issued with its Sunday, Sept. 22, edition in recognition of the significance of this business expansion to the commercial life of Philadelphia.

outstanding direct mail campaign for its dealers. Full details have just been released through its distributing channels.



Corner of the New York Exposition showing elaborate decorations and attractive character of exhibits. Note "world's largest

chassis and metal tube," (behind radio-phonograph console in left foreground). Other booths equally imposing.

GE RINGS BELL WITH NEW IDEA IN CRUISE CONTESTS

150 Dealers—and Their Wives—Explore Scenic Beauties of St. Lawrence and Saguenay Rivers—Tour Quebec

A cruise in which pleasure was unalloyed with business, and glorified by the enthusiastic participation of the dealers' wives—and sweethearts—was tried out last month through the cooperation of General Electric distributors in Hartford, Conn., New York City and Newark, N. J. It "clicked" beautifully.

Each "package" purchase of GE auto sets entitled the dealer to a ticket for a "Normandy of the New World" cruise. Dealers were encouraged to earn two tickets. Most of them did. Those who missed this mark regretted it—when they saw what a good time the husband-and-wife teams were having.

Under the experienced management of maestro "Winnie" May, the "Canadian Special" pulled out of the Pennsylvania depot, New York, bright and early Friday morning, Sept. 6. Full facilities for whiling away the daylight hours en route to Montreal were provided. Arriving at Montreal, transfer of over 300 guests was quickly effected by busses to the palatial river steamer "Tadousac."

Then followed two days of sightseeing including the quaint city of Quebec and the awe-inspiring grandeurs of the North Capes. The party arrived home the following Monday night.

Of interest to the trade in general is the fact that no business was discussed, no quota blanks waved, or waived, and not even one set displayed. The only selling job the writer noted was the subtle enlistment of the other half of the firm as boosters for GE. And how those wives did cheer, so much so that a demand repeat performance next year is practically assured.

D. W. May Marries

NEW YORK—The marriage of Margaret LeMaire, of California, and D. Winthrop May, radio sales manager of the GE Supply Corp., New York, took place at Harrison, N. Y., on Sept. 5. What the announcement didn't state is the fact that Mr. and Mrs. May honeymooned accompanied by some 300 GE dealers and salesmen and their wives on the four day St. Lawrence River cruise. A good time was had by all.

C.I.T. to Finance Arvin and Emerson Radio Sales

NEW YORK—Commercial Investment Trust Incorporated has completed exclusive agreements with the Emerson Radio and Phonograph Corporation and Noblitt-Sparks Industries, Inc., whereby C.I.T. will act as official financing organization for Emerson and Arvin radio dealers and distributors.

Under this plan a complete retail finance service will be offered through C.I.T.'s coast-to-coast hook-up of more than 140 branch offices, and is expected to bring about a substantial increase in Emerson and Arvin radio sales. This arrangement applies only to household radio receiving set and not to automobile radio installations.

C.I.T. is also acting as time payment financing organization for eight other leaders in the radio industry, under contracts recently signed with the RCA Victor Division of the Radio Corporation of America, Atwater Kent Manufacturing Company, Stromberg Carlson Telephone Manufacturing Company,

Stewart-Warner Corporation, General Household Utilities Corporation for financing time payment sales of Grunow radios, Crosley Radio Corporation, Sparks-Withington Company and the Graybar Electric Company, Inc.

Spartonites Visit Old Point Comfort, Va.

NEW YORK—Chaperoned by Vic Meyers, of Bushwick-McPhillen, New York, a party of 30 Sparton sales ambassadors—and their wives—took a boat for Old Point Comfort, Va., Sept. the eighth. The group returned the following Friday, the sales executives then attending a conference of eastern Sparton dealers.

At the banquet held on the last day of this unique outing at the New Chamberlin Hotel, the new Sparton models were unveiled. During the three days' stay at Old Point Comfort visits were made to Jamestown and other historic spots.

Troy in New Quarters

LOS ANGELES—A new central location with greater facilities for manufacturing and distributing its line of radios is now being occupied by the Troy Radio Mfg. Co., Los Angeles. The address is now 1142 So. Olive Street. Troy will also carry a complete stock of radio supplies and parts, radio testing equipment, power amplifiers and p.a. systems at this point.

A unique window display has been issued by the Arcturus Radio Tube Company, Newark, N. J., for the use of its dealers and servicemen. Lithographed in 7 attractive colors, the display is a two-plane effect and carries three dynamic illustrations drawn by the country's leading artists.

Ploughs to Music

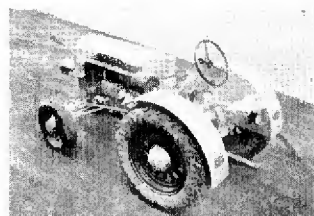

Pity the poor farmer. Silver King tractors can now be obtained complete with American Bosch radios. And a mighty good idea it is too. Anything that makes the ploughing of a field or the hauling of farm products less monotonous is a genuine boon. Probably increases efficiency, too.

RR NOMINATES for membership in its PRIME MOVERS CLUB



H. G. Erstrom

To qualify for membership in our "Prime Movers Club" one must have contributed, in an altruistic sense, to the advancement of the industry he represents.

The appointment of Harold G. Erstrom as sales promotion manager for the Leo J. Meyberg Company, San Francisco, provides a long awaited opportunity to give credit where credit is due:

Erstrom's wide acquaintance in the radio industry started when he became the executive secretary of the old Federated Radio Trade Association when it was organized in 1927. "Federated" became the National Federation of Radio Associations in 1928, at which time the independent national organization of radio distributors, the Radio Wholesalers Association, was started. Mr. Erstrom continued as executive vice president of both organizations until his resignation last August.

During the past eight years he has organized over 55 local and territorial associations of radio retailers and directed all of the national activities for the distributors on legislative matters, contact with manufacturers through the RMA, joint sales promotion campaigns, tube policies, surveys on trade conditions, etc.

When the Radio Wholesaling Code went into effect, Mr. Erstrom became manager of the National Code Authority and through this activity became further acquainted with distributors and their problems.

The Leo J. Meyberg Company is distributor for RCA Victor radios, Norge appliances and Westinghouse lamps.

Salesman-Genius

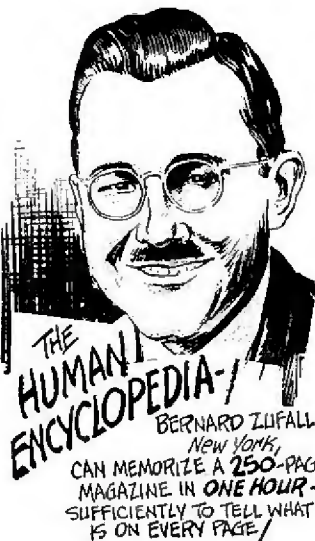

By vocation a sales representative for the General Electric Co., New York Division, Mr. Zufall's avocation is that of memory wizard.

Successful candidate for prominent mention in Ripley's "Believe It Or Not" column, also given nation-wide publicity in "Strange As It Seems," another newspaper syndicate feature, Bernard was an outstanding entertainer on a recent G.E. Canadian cruise.

FHA AUTHORIZES LOANS ON P. A. INSTALLATIONS

Broadens Market for Radio Dealers on Amplifying Equipment—How Loans May Be Obtained

WASHINGTON—The Federal Housing Administration has legalized long term loans through banks for business expansion purposes. Under a recent ruling this Act will apply to the purchase of public address equipment if it is to be permanently installed. The loan is made by the bank or other financial house—not by the Government. The Government, however, insures the loaner up to 20 per cent of his total gross amount advanced over a specific period.

This action creates a broad opportunity for radio dealers to enter the field of P. A. equipment. The chief obstacle to greater activity in this direction heretofore has been lack of money on the part of the buyer.

How Money May Be Obtained

Under the terms of this Act any manufacturer, commercial house or institution may apply for a loan from his local bank for the purchase and installation of a public address system. There are two requirements: First, the bank must be approved by FHA and, second, the borrower must be a reasonable credit risk.

These loans extend up to five years with the assurance that the bank cannot call the loan prior to its expiration. The maximum interest rate is 9.7 per cent. However, most FHA loans are being placed at much lower rates.

Loans may sometimes be obtained through the supplier (manufacturer) if he has a subsidiary financing company.

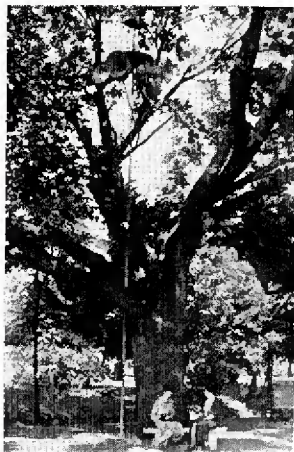

The keen observer will note tucked away in the foliage of this noble tree a four-speaker assembly. It provides suitable music in the Locustwood Memorial Park, Haddonfield, N. J. Another example of the type of P. A. equipment available under the FHA Act.

How Dealers Can Promote This

In Newark, N. J., the street front windows of the building which houses the local offices of FHA are decorated with an assembly of electric washing machines and refrigerators. A large sign tells the public that these appliances may now be purchased on the Government loan plan. While radio receivers, unfortunately, have been ruled out by Washington authorities as household "necessities," a window trim on P. A. apparatus should be installed at once and a sign with a message similar to that which appeared in the Newark window prominently displayed.

Because these P. A. transactions always run into three figures, the dealer can afford to tell this new feature in his local newspaper and make a systematic personal canvass of each prospect in his territory.

For Detailed Information

You may apply to any local FHA agency. They are now listed in your local telephone directory under Federal Housing Administration.

For further, detailed data on this plan, write to B. J. Flynn, Industries Division, Federal Housing Administration, Washington, D. C. A pamphlet is available as well as a list of approved banks and finance houses.

Government Will Not Finance Loans on Sets

WASHINGTON, D. C.—The National Housing Act does not authorize financing of radio sets, except built-in radio, according to a ruling received by RMA. Loans on receiving sets, classed as "movables" by the Federal Housing Administration, would be in jeopardy and their payment by the Treasury uncertain, according to the information to RMA. The FHA, therefore, adheres to its previous ruling that receiving sets, except built-



P. A. "Permanents" Like This are Eligible for FHA Loans

This bath house tower at famous eastern beach contains bank of powerful speakers behind grille. Carries announcements and music entire length of boardwalk.

Corner of control room for public address system at Playland, Rye, N. Y., Western Electric equipment used.

in radio, are ineligible for FHA financing privileges.

The adverse decision of FHA on financing of receiving sets was made in response to a request by RMA for extension of FHA financing privileges to receiving sets of the more expensive type, costing \$75 or up.

IRE Meets Nov. 18-20

ROCHESTER, N. Y.—The Rochester Fall Meeting of the Institute of Radio Engineers is to be held Nov. 18, 19 and 20 at the Sagamore Hotel.

On the first day there will be a discussion of new problems in metal tubes lead by Roger M. Wise of Hygrade-Sylvania. Another interesting session will be on the design of doublet antenna systems with H. A. Wheeler, Hazeltine Service Corp. in charge. The RMA Committees on broadcast receivers and vacuum tubes will also meet on the last day.

Ivan Picard with Quam

CHICAGO — Quam-Nichols Company has obtained the services of Ivan Picard as its Chicago representative. Mr. Picard was formerly sales manager for the Hudson-Ross Company.

Two Ways to Get PA Loans

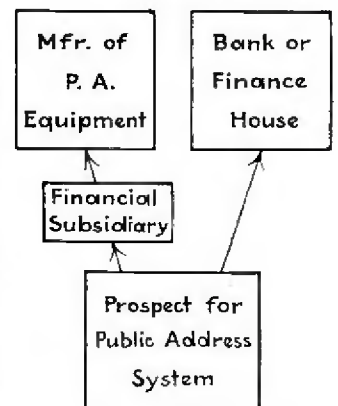

LINE UP *with* Westinghouse

... and you'll never have a customer turn away

One customer wants a set with the new Precision Tuner. *You've got it in a Westinghouse.* Another wants All-Metal Tubes. *You've got them in a Westinghouse.* Another insists on beauty of cabinet design. *You've got it in a Westinghouse.* Another is shopping for big value at a low price. **AND YOU'VE GOT THAT IN A WESTINGHOUSE.**

Smart radio merchandisers are saying: "Stock fewer lines. Carry lower inventories. Stick to quality sets." Now, you can follow that sound advice, yet never have a customer turn away from your store. You have the right answer for every buyer, in the Westinghouse Precision Radio.

FEATURING

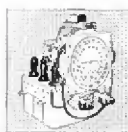

The PRECISION TUNER

An amazing control unit that automatically rules out the variables that distort tone, introduce noise and affect exact dial settings. Makes possible reception with true precision on every broadcast band

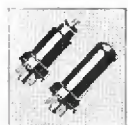

... with the new ALL-METAL TUBES

Westinghouse has the new metal tubes... just as it has every worth-while improvement in radio design and construction.

For complete descriptions and information see your nearest jobber or write Westinghouse Radio, Merchandising Headquarters, 150 Varick Street, N.Y.C.

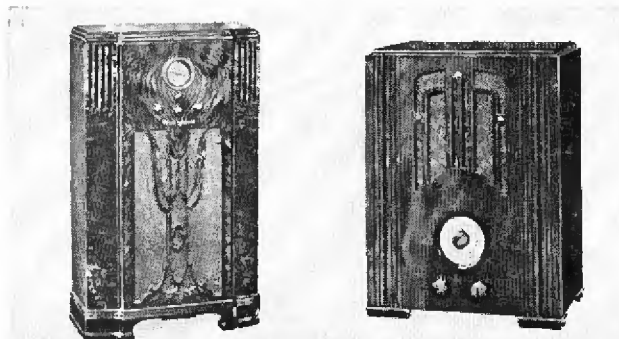

Console WR-303. Standard, Police and European Short Wave Bands

Table Model, WR-201. "The Mighty Midget"—Standard and Police Bands

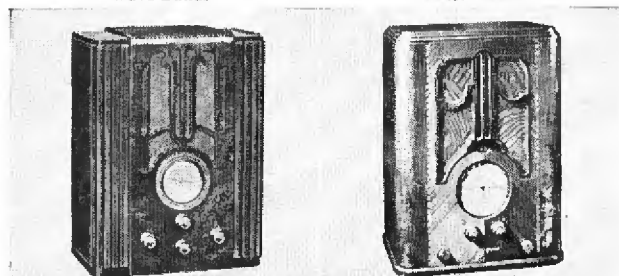
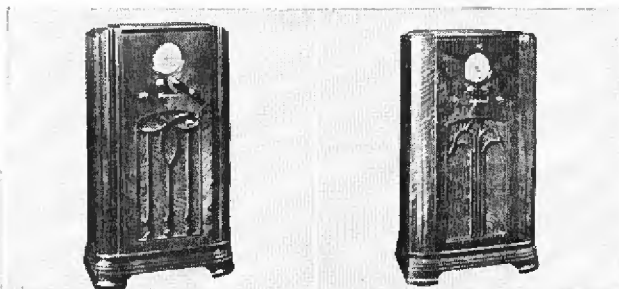

Table Model, WR-203. Standard, Police and European Short Wave Bands

Table Model, WR-205. Weather, Standard, Police, European Short Wave Bands, Precision Tuner and Metal Tubes



Console WR-301. Standard, Foreign and Police Bands, With Precision Tuner and Metal Tubes

Console, WR-305. Weather Standard, Police, European Short Wave Bands, Precision Tuner and Metal Tubes

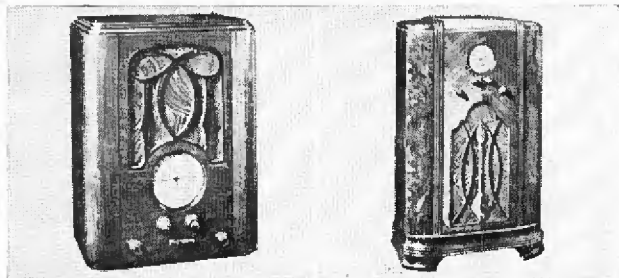

Midget, WR-101. Six tubes, Standard, Police and European Short Wave Bands

Table Model, WR-201. Standard, Foreign and Police Bands, With Precision Tuner and Metal Tubes

Console, WR-306. Four Bands, Weather, Standard, Police and European Short Wave, With Precision Tuner and Metal Tubes

Prices Start with Mighty Midget at \$19.95 up to Super Deluxe at \$139.50
(Slightly higher west of the Rockies)

Westinghouse Precision Radio

SERVICEMEN'S THIRD ANNUAL CONVENTION OCTOBER 25-27

NEW YORK—The Third Annual Convention and Parts Show of the Institute of Radio Servicemen will open at the Hotel Pennsylvania, New York City, Friday, Oct. 25. The committees of the Second Region are working diligently, promoting the event and arranging for prominent speakers. Practically all of the available space has been taken.

Maurice Despres, tube distributor, will act as chairman of all wholesaling affairs. The factory service managers will hold a regular meeting the second day. The chairman of the Service Section is F. B. Ostman, service manager for RCA Manufacturing Company.

Altogether the forthcoming Convention promises to be the most auspicious affair of the kind ever held. The interest in these events has been growing and with each successive meeting in the country's largest centers—to say nothing of similar meetings in Cleveland—the attendance of all elements of the industry has made marked advances. Last fall the attendance figures showed considerable increases over the Chicago show held in the spring of 1934. Similarly, the Chicago Convention of last spring surpassed the previous New York affair.

Crosley Wind Power Charger Available

CINCINNATI—The Crosley Radio Corporation, Cincinnati, is one of the more recent set makers to join the ranks of those offering a special low price net cash proposition on a wind power generator to all ultimate purchasers of a storage battery set. Crosley has contracted with the Ace Products Corporation, also of Cincinnati, whereby its recently perfected "Governmatic" wind charger will be available to farm set buyers at a net of \$10.

Fogelson Joins Pacific

CHICAGO — Bob Fogelson, formerly connected with the Allied Radio Corporation, large mail order distributor, is now with the Pacific Radio Corporation, licensed manufacturer of radio sets, in the capacity of sales manager.

FTC Clears Cisin

NEW YORK — A hearing held August 23, before the Federal Trade Commission has resulted in the vindication of Harry G. Cisin, trading as Allied Engineering Institute, of charges brought

against him with regard to his advertised claims for the "Air Scout" receiver. The commission admitted inability and lack of evidence to prove that the Cisin product was not all that was claimed for it.

Attorneys for the defendant conceded, on the other hand, that as confusion now exists as to the meaning of the phrase "all wave" that this claim would be discontinued until such time as its exact meaning be agreed upon.

Thompson with Radiobar

NEW YORK — The appointment of Roger Thompson as division manager of the Radiobar Company of America has been announced. Mr. Thompson occupied an important position with Philco during the past six years. The New York office of Radiobar is 60 Warren Street.

Ohmite Moves

CHICAGO—The Ohmite Mfg. Company has moved to a larger plant at 4835 Flournoy Street, Chicago. Has twice the floor space—and a fireproof vault.



Silent Salesman

If "hot shot" Willie is out in the warehouse the prospect sells herself—in 12 easy lessons. This sales educator and display piece must be seen to be appreciated

Altschul Sales Manager for Automatic, Boston

BOSTON—Frederick B. Altschul has been appointed sales manager for the Automatic Radio Manufacturing Company, of Boston, Mass. For many years Mr. Altschul operated a chain of retail stores in New York City and more recently was connected with Sears, Roebuck & Company.

In conjunction with David Housman, president of Automatic, Mr. Altschul is hard at work laying plans to promote national publicity for this concern's new line of sets which feature "Vision Ray."

New Kadette Window Display

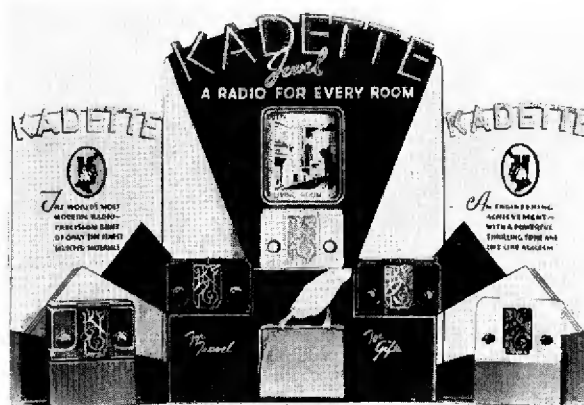

The International Radio Corporation, Ann Arbor, Mich., is supplying an ingeniously animated electrical window display that's different. Brilliantly lighted from within, a moving picture-like effect is obtained, and a succession of eye-compelling pictures appear on the central panel that has the appearance of a movie screen. Continuous movement produces a "travel-read" sales message in gleaming electrically lighted letters. The display is furnished with a second auxiliary reel which shows electric lighted photographic reproductions of the various models of the Kadette line.

Distributors will furnish these free to dealers upon the purchase of the Kadette sets it is designed to support.

Virgil Graham Joins the Hygrade Sylvania Corp.

ROCHESTER — Virgil M. Graham, engineer in charge of radio development work for the Stromberg-Carlson Telephone Mfg. Co. of this city, has resigned to become engineer in charge of the tube application laboratory of the Hygrade Sylvania Corp., Emporium, Pa.

Graham joined the laboratory staff of Stromberg-Carlson in 1923. He has always been active in national engineering circles. He edited the three editions of the NEMA Handbook of Radio Standards and also edited the present Handbook of RMA Standards and Engineering Information in 1929 and 1930. He has served as Chairman of the Standards Section of the RMA Engineering Division since 1931.

Since 1933 Mr. Graham has acted as RMA Chairman of the Joint Coordination Committee of EEI, NEMA and RMA on Radio Reception.

He is prominent in the affairs of the Institute of Radio Engineers, being at present a National Director of the Institute. At a farewell dinner given by friends and business associates at the Rochester Club, he was presented with a motion picture camera and projector as a token of esteem. Dr. R. H. Manson, vice president in charge of engineering of the Stromberg-Carlson Company, in behalf of the company, expressed their regret in his departure.

Emerson Denver Distributor

DENVER — The newly organized jobbing firm, O-K Appliance Corp., 1951 Lawrence Street, Denver, Col., will center its efforts behind the Emerson line for the Rocky Mountain district. Steven Kugler, 12 years with the May department stores, is president of this outfit. Will also handle electrical and air conditioning appliances.

Fred Stevens Promoted

CHICAGO—The Muter Company, makers of "Candolims" and other radio parts, announces the appointment of Fred Stevens as midwestern sales manager. Mr. Stevens has been in radio since 1924. Formerly with Magnavox, Rola and, recently, with Quam-Nichols.

"Radio Week" in Denver

DENVER — "Radio Week," which ended Oct. 5, went over in a big way, here and in adjacent trading territories. Sponsored by the Electrical League of Colorado and backed by every jobber in town.

Look into this



Let a Tung-Sol salesman show you how other dealers are successfully • Avoiding cut-price competition. • Furthering their reputations as dependable merchants. • Making full profit on every tube sale. • He will also give you important facts about the only consistent, successful radio tube consignment plan in operation nationally.

Locations are available for independent radio dealers and service organizations, who can qualify, and still have "elbow room".

Write to our nearest office for details relative to your appointment as our authorized agent.

TUNG-SOL Flow radio Tubes.

TUNG-SOL LAMP WORKS, INC.

Radio Tube Division

SALES OFFICES:

Atlanta, Boston, Charlotte, Cleveland, Chicago,
Dallas, Detroit, Kansas City, Los Angeles, New York
General Office: Newark, N. J.

own Sales Records!



RISING FAST!

See the figures that show what RCA Victor is doing for its dealers:

Average RCA Victor console sale this season to date

\$148⁵⁰

Average RCA Victor console sale last year

\$102

Average console sale for industry last year

\$67
(McGraw-Hill figures)



ALREADY the signs are pointing the way ahead, up to still greater heights for all those who do business with RCA Victor! Already shipments of consoles to the trade show that last year's average console sale of \$102 is being far outstripped. That means a still larger unit sale for the RCA Victor dealer, and much more money for him.

Here again you see convincing proof of the commanding position that RCA Victor occupies in the fine set field.

It won and is keeping that position by sheer merit of the product and of the sales, advertising, and promotional plans put behind this supremely superior merchandise.

Nowhere else in the world can you get a line that to the tremendous prestige of the great pioneer in radio, RCA, adds such colossal features as the "Magic Brain", the "Magic Eye", and RCA Metal Tubes. To make your sales efforts most quickly effective, to make the most money from radio, feature RCA Victor merchandise!

RCA MFG. CO., INC., CAMDEN, N. J. . . . A SUBSIDIARY OF THE
RADIO CORPORATION OF AMERICA



RCA Victor

RCA Victor beating

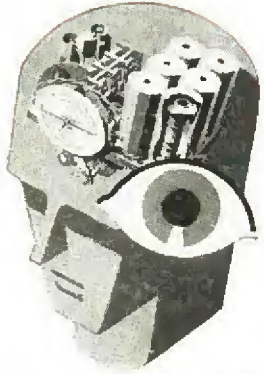

PIONEERING PAYS EVERYBODY!

Don't let anyone tell you that pioneering isn't rewarded! Look at the great industries of today, and you will find in each one of them just a few names of men and companies who had the vision and strength to pioneer and to win tremendous rewards for doing so. In radio, the great pioneer is RCA, which more than any other has been the creator of the radio of yesterday and of today, and is now developing in its laboratories the radio of tomorrow. This pioneering genius not only has made the Radio Corporation of America great, but it has made it possible for many other men and firms to make vast sums, and has brought new delight in radio to all the public.



This is a **HOT NUMBER!** It is Model C-13-2. Featured in 4-color spread in Saturday Evening Post, Oct. 12. A tremendous value at \$189.50! Has 13 tubes, 5 bands, 540 to 60,000 kilocycles, 15 watts output, 12-inch super-fidelity speaker. With a graceful, handsome cabinet. With the C.I.T. Corp. partial payment plan, no wonder it's going to market in a big way. Price F.O.B., Camden, subject to change without notice.

IT'S HOT!

"Worth a Thousand Words"



Fada Trim Merits Emulation

Illustrating an attractive assembly of table models and record playing instruments. Note how the combination instrument is featured with its accessories.

Another Trailer—with Variations



Mobile radio displays have proven out—and are blossoming forth in all sizes and designs this fall. This creation, Harry Alter's brain child, now is being used to sign up dealers. "Will then be loaned for consumer selling," states Mr. Alter.

Braun "Sales Tests" A Speaker



No transaction is too small for W. C. Braun to overlook.

To maintain an up-to-the-minute picture of trade preference, the president of the Radolek Co., Chicago, maintains a parts store where personal selling to service men, of the merchandise listed in this firm's large catalog, is conducted.

Here also Mr. Braun determines the acceptability of new items.

Sears' Radioman

If you buy from or sell to Sears, Roebuck, of Chicago, Hollis Harper of the radio department comes into the picture somewhere. Charged with the welfare of this relatively new division, he circulates something under 100,000 mail order catalogs to dealers, servicemen and licensed amateurs, listing 2,100 items



What a Modern Jobber's Office Looks Like



Here it is! A sample of the perfect appointments to be found in every department of Raymond Rosen & Company's brand new headquarters in Philly.

Left to right: Raymond Rosen, president, and Albert J. Slap, secretary.

Street Scene in Tangier, Morocco



A. M. Pinto, the RCA Victor distributor in Tangier, Morocco, believes in American methods of advertising. Here is his display on one of the main thoroughfares.

Ken-Rad Radio Tubes

MAKE THE CUSTOMER SAY

“I can depend on my tube dealer”



*Glass and Metal
Radio Tubes*

Customers won't darken your door unless they have confidence in you. Dependable, long-lived Ken-Rad Radio Tubes designed by expert engineers, built according to the most modern manufacturing methods, establish you in the hearts and minds of your trade.

Ken-Rad Radio Tubes are a profitable line. Build prestige. Attract customers. Open the way for greater sales. Our complete dealer plan gives you details. Write for it today.

Ken-Rad Radio Tubes

DEPENDABLE LONG LIFE

THE KEN-RAD CORPORATION, Inc., Owensboro, Ky.
Division of The Ken-Rad Tube and Lamp Corporation. Also Mfrs. of Ken-Rad Incandescent Electric Lamps.

Mallory Wins Patent Suit

The Ruben dry electrolytic condenser patents Nos. 1,710,073 and 1,714,191 have been upheld by the United States District Court for the Eastern District of New York. In an opinion by Judge Marcus B. Campbell in the case of Ruben Condenser Company and P. R. Mallory & Co., Inc. against Copeland Refrigeration Corporation, the Court declared both patents valid, and also held them infringed by dry electrolytic condensers made by Delco Products Corporation and supplied to Copeland in conjunction with electric motors. The decision directs the entry of a decree for injunction against future infringement.

Dry electrolytic condensers, extensively used in radio sets and as starting condensers for small a.c. motors, particularly in electric refrigerators, were originated and perfected by Samuel Ruben and the patents involved in the suit are the fundamental patents under which the licensed dry electrolytic condenser industry operates.

P. R. Mallory & Co. Inc. of Indianapolis, is the exclusive licensee under patents 1,710,073 and 1,714,191 as well as other Ruben patents relating to dry electrolytic condensers. Sub-licenses are held by The Magnavox Company, Sprague Specialties Company, Cornell-Dubilier Corporation, Condenser Corporation of America and the Aerovox Corporation.

Three New Books

Rider Publications are out with a comprehensive book titled "Cathode Ray Tube at Work." Gives full detailed information on the many uses and applications of the cathode tube. Contains 320 pages, replete with illustrations. Parts dealers and jobbers will find this a good book for resale. It is priced at \$2.50.

RCA Victor has just issued two interesting little booklets—yours for the asking. The first is titled "First-Class World Tours." As the name implies, it gives full information on tours through the ether via short-wave, tells all about the technique of dialing distant stations and concludes with two very complete logs of foreign and domestic short-wave stations.

The second booklet is an almanac and log book for farmers. Should be of great help in contacting the rural trade and as an aid to selling battery receivers.

Philco's new "Atlas of the World" is off the press. Free to adults who ask for it.

RCA Presents Leading Artists in New Sunday Series on Coast-to-Coast Chain



Kirsten Flagstad



Leopold Stokowski



Paul Whiteman



Helen Jepson



Sergei Koussevitzky



Conrad Thibault



Giovanni Martinelli



Rudy Vallee

Stellar personalities, long favorites with the stage, radio and concert public, will be featured in the new broadcasts of the Radio Corporation of America, which began, over the WJZ network, Sunday Afternoon, Sept. 29 at 2:00 EST. This series will be known as "The Magic Key of RCA." The artists will be "co-featured" with popular talks on radio technical developments.

En Route

with RVS

Radio Retailing wrote last month about the growing interest of American firms in foreign shortwave sending programs in this direction. We now hear that "Oxydol" is shooting westward a 13-week series of 15-minute recordings from a station at Luxembourg. Keen merchandisers realize that new sets are rapidly building up a honey of a shortwave audience, so they send their stuff abroad for home consumption.

From an animal that frequents the dense jungles of the Amazon river comes Carpinchoe leather—used as the cone support in the new Stromberg-Carlson high fidelity speakers. It smooths out the hills and dales.

"The parts business is getting bigger and better in a hurry." We quote a large accessory jobber well known to every service man in Connecticut and western Massachusetts. "My customers like standard parts, can stock them as they are usable on many makes of sets." Selah!

"Those who asked for mid-gets or table models (there's a difference) last year are now buying the lower priced consoles," states the radio buyer for Paterson's (N. J.) largest department store.

Time payment sales, in many instances, are reported as running up to 70 per cent of all transactions. Reasons: (1) public wants the higher priced models; (2) dealers again have financing facilities for handling time accounts.

Otsuka Sales & Service, Hawaii, celebrated its "grand opening," Sept. 21, by giving away a Grunow receiver and free balloons. No, that was one shindig we didn't attend.

The news reached this desk from the George H. Eberhard Co., General Household distributors, San Francisco. It was relayed by grandpappy Davin. Yes, Jimmie's the father, once removed, of a new baby—Mercedes Davin Franz—born Sept. 26 to his daughter Gloria Franz.

Air - conditioned, metal - trimmed, bedecked with flowers, Ramond Rosen's new wholesaling headquarters is—bar none—the most sumptuous and efficient business bourse your reporter yet has visited. A personally conducted tour revealed bar, bed and bath facilities right off the big chief's office.

My all too generous host that evening—Rosen's big banquet at the Bellevue Stratford—was

managing director George Conover, of The Electrical Association of Philadelphia. George showed me the "sold out" floor plan for his coming Radio and Electrical Exposition, stoutly claiming this affair "national" in scope and significance. With which sentiment, after viewing the Show, I agree.

British demand for radios built by American production methods has accelerated the production of radios in England, according to word received from the British plant making Philcos at Perivale, Middlesex.

No revolutionary technical changes were in evidence at the recent British National Radio Exhibition held at Olympia with manufacturers apparently giving more thought to appearance than to technical performance, according to a report to the U. S. Department of Commerce.

Every once in a while some bright chap in the radio industry rolls a "natural." Two innovations, at the New York Radio Show, are hitting the jackpots. Ernest J. Krause, president of the Radiobar Company of America, Los Angeles, is so flooded with orders for his combination instruments which provide drinks with your music (or music with your drinks) that he is seriously contemplating the purchase of a furniture factory in Kentucky, thereby insuring economic manufacture and delivery of "Radiobars" to Midwest clients.

Likewise C. L. Parris, who heads the Wincharger Corporation, Sioux City, Iowa, finds it necessary to more than double his present manufacturing facilities to take care of the demand for these little air propelled dynamos which continuously replenish the storage battery supply on 6-volt farm radio sets. Parris has signed contracts with more than a dozen prominent radio set makers within the past month.

J. Poll, Hillside Avenue, Jamaica, N. Y., has been notably successful in meeting chain store competition. Attributes this record to neighborhood location, personal service and to a floor stock of sets which includes four well known lines. When queried about inventory and cash tie-up problems, seemed surprised. Replied that his cash investment, per line, averaged \$250. That this sum makes possible a well assorted showing and that any dealer worthy of the name should expect to invest \$1,000 in his stock in trade. Also carries three lines of electric refrigerators.

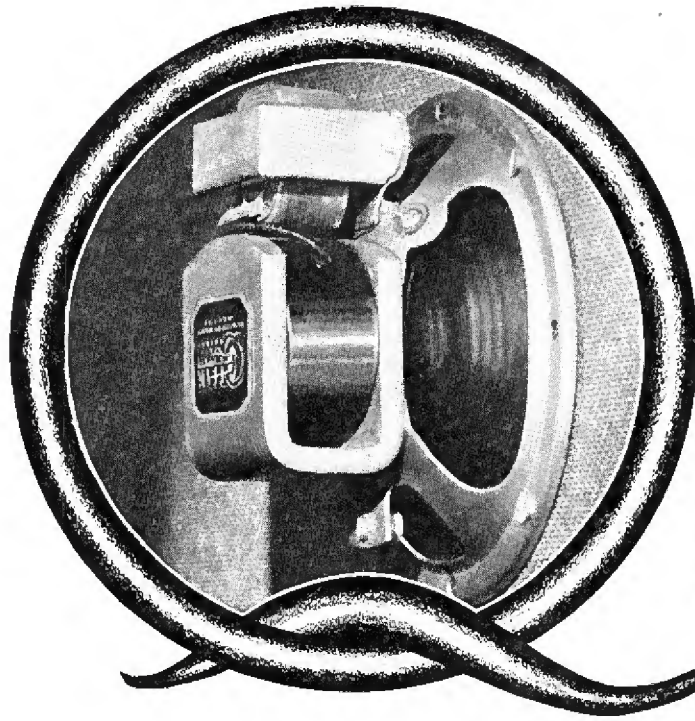

QUAM
S P E A K E R S

USED EXCLUSIVELY IN
TRAV-LER
THE WORLD'S SMALLEST
RADIO RECEIVER!

There's real engineering and real quality in that exquisite little gem box known as the Trav-ler Radio. Small enough to hold in the palm of your hand, it combines the beauty of the finest cabinet work with the perfection of performance found only in the finest of the larger receivers.

Naturally, Trav-ler was most critical in its selection of a speaker that would maintain in tone the quality of its engineering and cabinet work. The *super sensitive* Quam Dynamic with its permanently armored field coil proved to be an ideal choice, producing the mellow clear tone that permits the Trav-ler to compare favorably with much larger receivers.

Listen to the Quam Armored Dynamic! Its glorious tone enhances the fine performance of your receiver.

QUAM-NICHOLS CO.
1674 BROADWAY, NEW YORK CITY
1623 WEST 74th STREET, CHICAGO

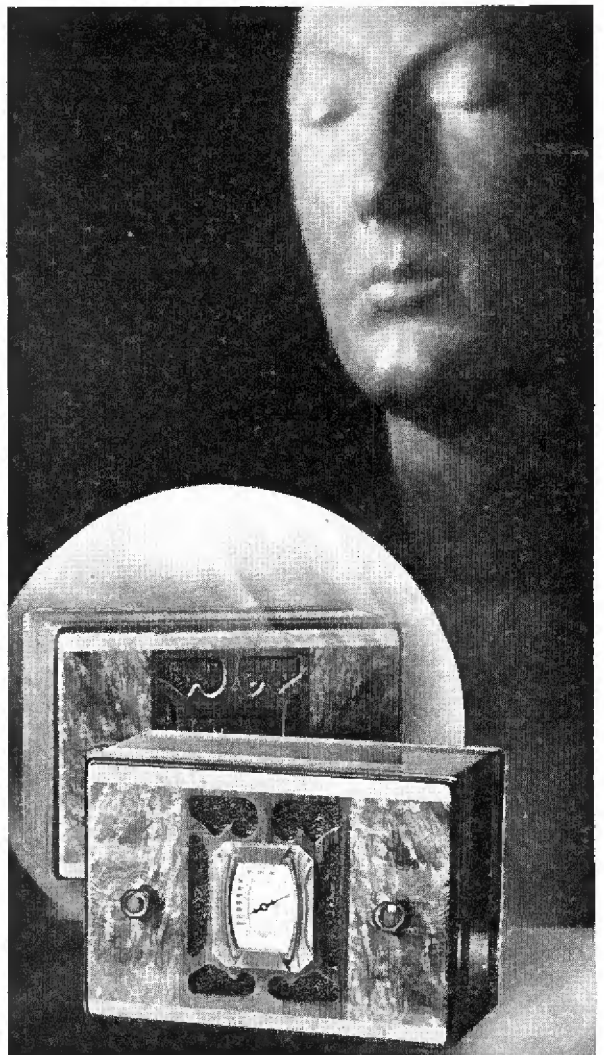

"AMERICA'S LARGEST SPEAKER MANUFACTURERS"

World's Best Music

By
Richard Gilbert

REMEMBER the old days when the back pages of all the family magazines were dignified by that famous aggregation known as the Victor galaxy of stars—when 100 musicians were grouped about the old hand-wound console phonograph, in front of which Nipper listened attentively to His Master's Voice? Those were the days of sumptuous record advertising. And the public was interested. Will this interest in phonograph records return? Listen to an idea Victor will soon launch in a nation-wide campaign.

Library of Recorded Music

Victor takes more than a page from "Dr. Eliot's Five-Foot Shelf" in assembling a compact "Library of Recorded Music," in which are included 461 records comprising representations of all types, schools and forms of musical art. This library is contained in 94 albums held in a cabinet of tasteful design, the unit calculated to merchandise at \$950. An advertising campaign (*Fortune, Town and Country, Time, Scribner's*, etc.) will bring this library to the attention of music lovers everywhere, and will feature the committee chosen to make the selections from thousands of eligible compositions ranging from the works of Bach to modern jazz. The committee, around which publicity is to be built, included Walter Damrosch, Eugene Ormandy, Jascha



in One Record Library

Heifetz, Sergei Rachmaninoff, Fritz Kreisler, Deems Taylor, John F. Royal, of the National Broadcasting Co., Warren Storey Smith, music critic, and Richard Gilbert, contributing editor for *Radio Retailing* and Phonograph Record Critic of *Scribner's Magazine*.

We've known about this set for some time and have recommended it heartily to all dealers in the record business. The advertising accompanying its release will stimulate curiosity in the better types of recorded music, and whether or not you stock the unit you may be assured that people will ask about it.

This library offers the music lover a handy, comprehensive and authoritative reference shelf of 47 symphonies, 7 complete operas, 8 albums of songs, 2 albums of religious music, 8 albums of piano music, 1 album of compositions for 'cello and string bass, 4 albums of light operas, 1 album of ancient compositions, 4 albums of jazz, 5 albums of chamber music, 1 album of organ music, 4 albums of violin music, and 1 of band music. It takes a lot of broadcast programs to compete with this array.

All dealers in combination instruments should feature this library. It solves the problem of a comprehensive selection to accompany the combination in the wealthy home.

Humorous records seemed to be a thing of the past until Columbia came along with *Old Sam*, a treat by the English comedian Stanley Holloway.

It's been a long time since the *Two Black Crows* and *Amos 'n Andy* records sold. The success of Holloway's cockney accent in the record shops of New York augur well its being liked throughout the country (No. 9004V).

The *Parlez-moi d'amour* girl, Lucienne Boyer, adds to her long list of Columbia discs with two French songs, *D'Amour en amour* and *La Voyageuse*. Most of the people who buy La Boyer's discs don't know what she's talking about, but—if sales figures mean anything—a large number like her voice (No. 241M).

The New Show Hits

Cole Porter is back again (incidentally the "Anything Goes" discs are still selling) with new hits from "Jubilee," the best recordings of which are by Paul Whiteman's Orchestra: *A Picture of You Without Me* (another *You're the Top*) and *Me and Marie*; *When Love Comes Your Way* and *Why Shouldn't I*; and *Begin the Beguine* and *Waltz Down the Aisle*, these last two by Xavier Cugat's Waldorf-Astoria Orchestra. Brunswick's "Top Hat" records are breaking all figures. We hope you tied in with the picture's appearance in your vicinity.

Columbia Masterworks offer a set which dealers in the Middle West will do well to feature: Haydn's *Symphony in E-flat*, played by the St. Louis Symphony Orchestra.

BEST SELLERS

Cotton (from "The Cotton Club Parade") Duke Ellington Orchestra. Brunswick 7525.

The Girl I Left Behind Me.
Moon With a Hangover.

Hal Kemp Orch. Brunswick 7517.

Blue Skies.

Dear Old Southland.

Benny Goodman Orch. Victor 25136.

Camembert.

St. Louis Blues.

Reginald Foresythe and A. Young.
Piano. Columbia 3088D.

Congo Caravan.

Ride, Red, Ride.

Mills Blue Rhythm Band. Columbia 3087D.

I'm On a See-Saw.

You're So Darn Charming.

Fats Waller. Victor 25120.

Selling Words

How to Use Them For Effective Closing

By
George M. Solomon

General Manager
George's Radio Co., Washington, D. C.

A CHAMPION boxer is one who has proven that he can "dish it out" as well as "take it." There is a strong resemblance in a champion salesman.

A boxer must have a good, healthy constitution. This is comparable to a salesman's background and education. A fighter must have the proper training. This is equivalent to effective sales management. And a ringman must have experience. So must a salesman.

But the final element that distinguishes a real champion from the "also rans" is a knockout punch. And this may be compared with "words that sell." When a salesman is on the floor with a prospect he is in the position of a fighter who has trained for months, studied and prepared himself and is finally on his own to defend and to win. If the other fellow has similar physical and mental qualifications it is a final something . . . termed "closing" . . . that turns the trick.

WHEN approaching a prospect do not greet him with an inane: "Yes, sir?" Or, "Yes, ma'am?" Learn to use a phrase such as: "How can I serve you?" Give the customer the impression that you are *anxious* to serve.

When a prospect expresses a desire to *see* a certain article don't offer to *show* it to him, but say: "Which would you like to *buy*, this model or that model?" Give the prospect the impression that you *expect* him to buy. If he is at all human he will not like to disappoint you.

State the features of your product clearly and forcefully and do not hesitate to repeat. Repetition very often drives a point home and makes it stick. Then be prepared to answer any questions. This means that you must "know your stuff." Complete familiarity with the merchandise, ability to answer questions readily and without beating around the bush makes a very favorable impression and is of the utmost importance.

Now you are in the position of a fighter who has his opponent groggy, ready to administer the knockout

punch, *i.e.*, ready for the closing. You have shown your article, explained its features and answered questions. The secret of success at this point is to *ask them to buy* and, if necessary, practically *insist* that they buy. Don't be afraid to try your punch after you have them on the ropes. For, should it fail you still have one ace in the whole if you work for a well-managed store.

The ace in the hole, with us, is known as the "T.O." In selling you should have the opportunity of bringing into the fight on your side another man, either the manager or another salesman, while your opponent is still gasping for air. This is where a salesman has an advantage over a fighter.

A new man comes into the fight fresh, prepared to throw knockout punches right from the tap of the gong. Should they fail he can start out from scratch again with his own sales story, working up to the crucial point once again.

ALARGE company with 100 stores found that its soda clerks were selling too many five-cent drinks instead of ten-cent ones. They discovered that the clerks were asking customers: "A large one or a small one, sir?" The clerks were told to say, instead: "A large one, sir?"

Invariably the power of suggestion won and a survey later proved that the large 10-cent drinks subsequently outsold the fives.

A good gas station attendant, when greeting the prospective gas buyer will say: "Fill 'er up?" Not: "How many?" This has definitely been found to increase the sale of fuel. Barbers are famous, or infamous, for suggesting dandruff cures . . . and getting away with it.

The power of suggestion in selling, with the proper choice of words that sell, amply repays any salesman for the time spent in training with sparring partners.

When you have 'em groggy, remember, *don't be afraid to swing that knockout punch!*

Programs, Profits and Politics

Highlighting News Salespeople Should Know About Broadcasting

PROGRAMS

Topnotch Fall programs certain to help set-peddling, stimulate radio repairs, courtesy NBC, are:

Helen Hayes in a continuous dramatic program. Tuesdays at 9:30 over the WJZ network. Movie fans cry for her.

Gabriel Heatter, popular news commentator to the tired business man. Saturdays and Sundays. WJZ group.

Jack Benny, comedian extraordinary, WJZ network, Sundays at 7.

Eddy Duchin, piano player surrounded by swell orchestra, at 9:30 over WEAJ.

Fred Allen over WEAJ at 9, Wednesdays.

Mills Brothers. Trick harmony that still glues 'em to the speaker. WEAJ group, Fridays at 10:30.

Easy Aces. One of the continuously popular continuities of home life. WJZ network, Tuesdays, Wednesdays and Thursdays at 7.

Bob Ripley, the "believe-it-or-not" man with a following, plus Ozzie Nelson and Harriet Hilliard tunes. WJZ chain, Sundays at 7:30.

Lum & Abner. Small-town stuff for city slickers. WJZ group, Mondays through Fridays at 7:30.

* * *

CBS counters with the following:

Lawrence Tibbett over the Columbia system, Tuesdays at 8:30. Popular with intelligentsia and bourgeois alike.

Kate Smith, Tuesdays, Wednesdays, Thursdays at 7:30. Sure-fire stuff for the family man.

Burns & Allen. Comedy for the nut... and who isn't. Wednesdays, 8:30.

Frank Parker, tenor with a growing rep. Saturdays at 7.

Deems Taylor in a "World Peaceways" program. If it's anything like the ads we see it will be effective. Thursdays at 9:30.

Crumit and Sanderson. How they hold their popularity. Sundays at 5:30.

Roy Perkin's National Amateur Night. Everybody listens on Sunday at 6.

Cantor. 'Nough said. Sundays at 8.

Myrt and Marge. Mondays at 7.

Guy Lombardo. Popular with dance-fans. Mondays at 8.

March of Time. News, dramatized in the perfect style. Mondays, 10:30.

Lily Pons. Wednesdays at 9.

Time given in all cases above, Eastern Standard.

PROFITS

When money rolls into the laps of the broadcasters much of it rolls right out again into the jeans of the radio dealer in the form of bigger, better programs. And the National Association of Broadcasters predicts the best second-half year's business in the industry's history.

Estimate has it that the current year's time sales will exceed 1934 by 25 per cent. Total purchases of time are expected to reach \$85,000,000, with 40,000,000 simoleons coming in during the last six months. Sales were \$6,000,000 under this figure during the corresponding period last year.

NBC comes through with further figures. For the first seven months of 1935 the aver-

age dollar expenditure per advertiser was \$147,982 as compared with \$104,502 for the same period in 1934. The average station hours used per advertiser likewise showed a healthy increase, 578 against 437.

POLITICS

Significant is the formation of The Continental Radio Company, a subsidiary of The Scripps-Howard Newspapers. Application has been filed for acquisition of the first station, understood to be WFBE of Cincinnati. Permission has been asked to change these call-letters to WCPO, identifying it with the Cincinnati "Post." It is understood that Scripps contemplates acquiring other stations.



Queen Jessica

Jessica Dragonette, elected 1935 Queen of Radio in nation-wide listener poll. Born in India and still in her twenties Jessica has made more than 700 appearances since her network debut with NBC in 1926

Via Shortwave

CANADA — Tell your short-wave fans about the nightly Canadian press bulletins heard at 10 p.m. E.S.T. over CJRO and CJRX, 6,150 and 11,720 kc. They're hot on the Ethiopian situation.

FRANCE—The Director of the French Broadcasting Service has announced that no change will be effected in wavelengths in France during 1935-36, according to present plans.

The French, incidentally, are erecting a new shortwaver (somewhere above 30 meters) at Pontoise, power 100,000 watts.

SOUTH AMERICAN reception has been fine this Fall. LS2, Buenos Aires, and YVIRC, Caracas, being received almost nightly for half-hour or so. Buenos Aires stations are loud about 9 p.m. LR6 drowned out WENR, Chicago, LR4 was as loud as WBZ, Boston, and LS8 had a clear channel.

ITALY—The new Italian station that is testing with JZII, of Japan, is IQA, according to H. S. Bradley, of Hamilton, N. Y. The operating frequency is 14.7 megacycles and the Tokyo station is on 14.6. IQA is heard also at 3:30 p.m. sending music for observation at Buenos Aires.

ETHIOPIA—Station ETA has been re-equipped with 3,000 watts power. Its frequency is 11.955 megacycles.

600 Newspapers Now Get RMA Short Wave Programs

WASHINGTON, D. C.—Over 600 daily newspapers, including most leading metropolitan journals, are now taking the RMA service of foreign shortwave broadcast programs and news. Weekly bulletins are sent from the RMA offices containing advance foreign programs, together with short-wave news, secured in cooperation between RMA and the Washington embassies of many foreign governments.

The RMA foreign program service was instituted about nine months ago by the Association's board of directors and a special promotion committee of which Powel Crosley of Cincinnati is chairman. The RMA service is furnished to newspapers without charge as a new, attractive news feature for its readers since the widespread use of shortwave sets developed. The foreign programs and news also promote interest in shortwave broadcasting and incidentally but materially develop sales, including the business of every radio interest.

New Studio for Heidt's Brigadiers

CHICAGO — The Thursday night broadcasts of Horace Heidt and his Alemite Brigadiers (Stewart-Warner sponsor) have been so stamped by fans eager to see the performance in real life, that new studio facilities have had to be arranged by the Columbia Broadcasting Co.

This air feature is now broadcast at 9:00 p.m., Central time from Columbia's studios in the Medinah Club, Chicago. Here are facilities for seating 600 spectators. Tickets for admission will be available through Stewart-Warner dealers.

Mutual

NEWARK — The Mutual Broadcasting System, composed of the four basic stations WOR, Newark; WGN, Chicago; WLW, Cincinnati, and CKLW, Detroit-Windsor, became one year old on October 1. During that time this network has developed into a strong working unit with a record of one million dollars in sponsored business for the first year and promise that that total will be doubled in the year 1935-36.

WITH the radio industry in a healthier position right now than it has been for the past five years, and the consuming public definitely in the market for better sets, alert distributors and dealers are actively watching the industry's trends, as reported and interpreted in the editorial and advertising pages of *Radio Retailing*.

You can keep these worthwhile distributors and dealers—those who do the bulk of the profitable business—informed of what you have and how it will profit them, by placing *your* selling message in the advertising pages of *Radio Retailing*.



Many manufacturers—rather than scattering their shots—find it economical and profitable to **CONCENTRATE** their trade paper advertising in *Radio Retailing*.

RADIO RETAILING

A McGraw-Hill Publication

330 West 42nd Street, New York, N. Y.



Five points that prove why Radio Retailing is your soundest advertising buy:

1. Renewal percentage of 60% is proof of reader interest.
2. Membership in ABC (Audit Bureau of Circulations) and ABP (Associated Business Papers) is proof of highest standards of circulation and editorial leadership.
3. Coverage of small town, as well as large city, dealers—60% of *Radio Retailing's* circulation being in towns of 25,000 or less.
4. Coverage of international markets as evidenced by over 1000 paid foreign subscribers—a plus advertising value.
5. Results obtained by leading manufacturers in the radio industry, who have used the advertising pages of *Radio Retailing* to secure increased sales during the past eleven years.



NEW MERCHANDISE

NEW TESTERS FOR METAL TUBES

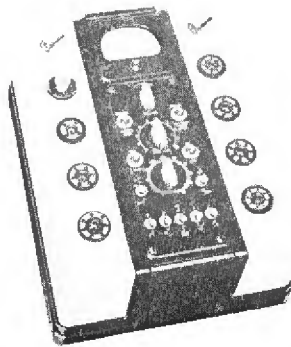

Weston M 770 Checker

This tester has socket mountings covering all pin combinations for glass and metal tubes now commercially available, with provision for combinations which may be introduced.

The circuit assembly of the new unit incorporates a fundamental advance in testing tubes on the basis of total emission, in that three separate loads, one for general purpose tubes, one for battery types and one for diodes, are available as required at the throw of a switch. Thus, total emission tests for each type of tube may be obtained on a specific load basis, and without possibility of damage to the tube structure itself.

A group of seven individual electrode switches, grouped on the center operating panel, provides a highly flexible means of setting up the various electrode combinations for any type of tube. Weston Electrical Instrument Corp., Newark, N. J.—*Radio Retailing*, October, 1935.

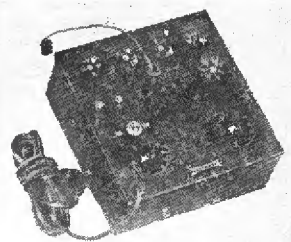

Wilco "Million" Tester

A multi-purpose instrument for the servicemen which gives visual indication on all tests as a result of a neon tube being employed in place of meters has been designed by John W. Million and is available from the Wilco Radio Co., 27-26 Northern Blvd., Long Island City, N. Y.

Will test for emission of all types of tubes—including metal. Tests for all inter-element shorts in tubes. Checks electrolytics for shorts and leakages. Measures resistance up to 10,000 ohms and up to 6 megohms, by comparison with standard. \$8.45.—*Radio Retailing*, October, 1935.

"Confidence" 3-in-1 Tester

The "Confidence" tube tester which had the complete inter-element test of all glass tubes is now combined with a non-false flash hot neon leakage test, full inter-element tests of all metal tubes, condenser testing and auto vibrator testing. The direct English reading meter scale is used for all tube testing, vibrator testing and 25-50 v. electrolytic condensers.

This instrument is known as the 3-in-1 Model 36 and is housed in a large, portable oak case. \$39.50. Obtainable from Apparatus Design Co., Little Rock, Ark.—*Radio Retailing*, October, 1935.

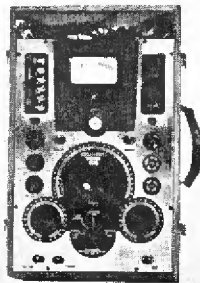

Triumph Metal Tube Testers

Model 400 of the Triumph Mfg. Co., 4017 W. Lake St., Chicago, tests emission, mutual dynamic conductance, leakage and instantly detects noisy, worn out and low grade tubes—including the metals. Separately tests diode and triode sections of multi-purpose tubes. The neonized test is clearly marked for English reading.

The striking two color effect of canary yellow against a dull ebony background makes it a particularly striking counter tester. \$34.95—counter or portable.

Model 420 RMA standardized tube tester tests all tubes thoroughly—glass, metal or glass tubes with metal bases. Employing a circuit proposed by the Tube Standards Committee, this instrument offers assurance against obsolescence even if new tubes are introduced beyond the octal types now on the market. The keynote in the design is simplicity of operation. \$29.94, net.—*Radio Retailing*, October, 1935.

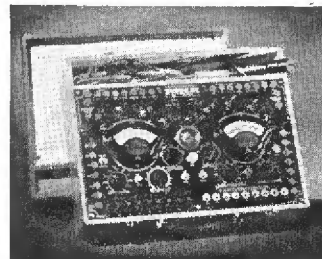
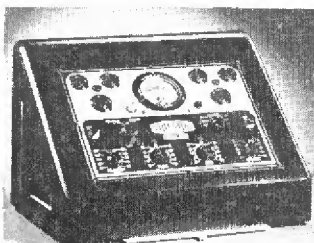

Supreme Metal Tube Testers

Included in the line of testers and analyzers made by the Supreme Instruments Corp., Greenwood, Miss., are six to accommodate the metal tubes.

Model 335 Automatic features Supreme's "uni-construction"—the engineering of a multiplicity of instruments in one compact unit, resulting in economies in production and a lower list. The 335 is a combination of the many popular features of the well known 339 de luxe analyzer and the 89 de luxe tube tester including the "free reference point system of analysis. \$77.95, net to dealer.

Model 89 de luxe tube tester is Supreme's new 7-in-1 instrument. Will accommodate all 8-pin tubes with a single 8-hole socket without use of adapters. \$45.95, net.

Model 339 de luxe analyzer virtually spreads the entire circuit of the set out on the analyzer panel like a diagram. \$39.95.

Model 89 counter display tube tester has large fan-shaped English reading meter. Comes in a two tone walnut cabinet and is extremely simple to operate. \$45.95.

Model 89 standard tube tester features Supreme's neonized leakage test. Made especially for the dealer who wants one tester for both counter and service calls but who does not care for the additional multi-purpose features of the 89, de luxe. \$49.95.

Model 391 P.A. analyzer is designed to equip the radio man to cash in on the growing opportunities for service in sound equipment of every character.—\$69.95.—*Radio Retailing*, October, 1935.

Burton Metal Tube Testers

Model 30 Burton radio set tester handles all octal base tubes and sockets. Makes point-to-point or free-point circuit analysis. Plugs and jacks are eliminated—all analysis selection being made with two simple circuit switches. Automatic "cut in" system for reading milliamperes in any circuit. This feature is completely self-contained. \$34.75.

Model 20 tube tester makes an accurate test on tubes. Each tube element is properly connected to a separate circuit and they are not connected together as in an emission tester. This testing method gives precision which relates closely to laboratory test methods and rejects

bad tubes on the basis of mutual conductance, emission, plate current, and excessive gas—all in one reading.

Provision is made for testing all standard tubes including metal tubes with an additional socket for any future tubes. For 60 cycle current, 110v. \$31.50; 25 cycle, \$34. C. W. Burton Co., 755 Boylston St., Boston, Mass.—*Radio Retailing*, October, 1935.

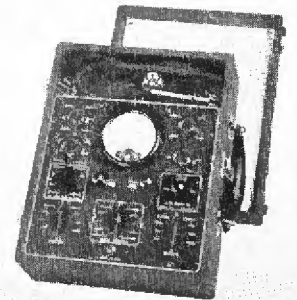

"Precision" 829 Analyzer

All tube circuits, including metal tube circuits, may be analyzed with the Series 829 Master Selective set analyzer of the Precision Apparatus Corp., 321 E. New York Ave., Brooklyn, N. Y. It gives complete free point analysis, selector controlled throughout and allows d.c. current readings to be taken at any position. Available in a panel mount for the service bench as shown. Size 22½x12x5 in. Completely steel incased. Also available in standard portable case.—*Radio Retailing*, October, 1935.

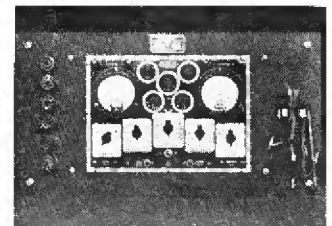

Triplett Metal Tube Testers

Ten testers, all of which take care of the new metal tubes, are available from the Triplett Electrical Instrument Co., Bluffton, Ohio.

They are: Model 1,500 power output tube tester with neon short test, \$55; Model 1310 emission type tube tester, \$15; Model 1501 multi-purpose tube tester (power output type), \$70; Model 1210-A tube tester, direct reading, \$30; Model 1230-A free-point tester for servicing all sets using metal or glass tubes, \$12.50.

Also, Model 1181-A which combines the 1125 volt-ohm-milliammeter, 1151 all-wave oscillator, 1166 free-point auxiliary set tester, and lists at \$57; Model 1206 in 1204 case, master

unit test set, a complete portable laboratory, \$107 and \$124; and, Model 1166-A free-point auxiliary set tester, \$16 in case and \$13, less case.—*Radio Retailing*, October, 1935.

Radio City Metal Tube Testers

Several new tube testers and analyzers for the new metal tubes, as well as all the glass tubes, are now being made by Radio City Products Co., Inc., 88 Park Place, New York City. The tube tester is not only a complete tube checker but also includes a capacity tester and ohmmeter as well and consequently serves as a test instrument for checking the entire

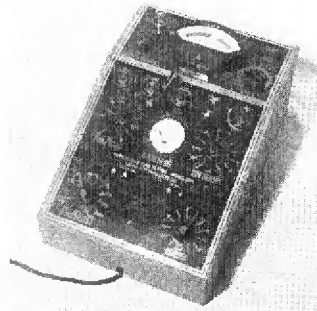

radio receiver. Provides an accurate test for the 6P7 tube. Consists of a large 5 in. fan type meter with colored English reading scale. Available in counter or portable model, in a large attractive deluxe counter display case or in kit form.

The analyzers are made in three different models to fit the

requirements and purses of the wide range of servicemen. They are extremely flexible units and the metering system will never be obsolete as it is entirely independent from the circuit switching system. All circuit switching is done by means of selector switches.—*Radio Retailing*, October, 1935.

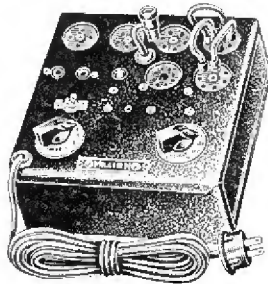

Combination Metal Tube Tester

All types of tubes—metal included—can be tested for emission using a calibrated sensitive neon lamp as a meter with the combination metal tube tester of the Million Radio & Television Labs., 361 W. Superior St., Chicago. Arrangement of sockets and connections prevents obsolescence. Tests by-pass condensers, electrolytic condensers and resistances. Reads resistance directly up to 10,000 ohms and up to 6 megs. by comparative readings.

A.c. operated, it is supplied in a rugged metal case, 7x7x3 in. Can be used as a neon resonance indicator for alignment in the field. \$8.45 net.—*Radio Retailing*, October, 1935.

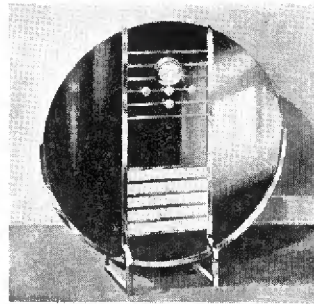

Sparton 1936 Line

The outstanding set in the new line of the Sparks-Withington Co., Jackson, Mich., is, of course, its circular, glass radio. This is an 11-tube set using metal tubes, and covering from 15 to 550 meters and 1,000 to 2,000 meters. It may be had in blue or old rose glass and lists at \$350. As can be seen from the illustration, this set is ultra-modern in conception, the creation of Walter Dorwin Teague,

one of America's foremost industrial designers.

Another of Mr. Teague's sets is a console with gold-plated trimming. This is also a 14-tube high fidelity model covering the same wave-band and having the same list price.

Sparton really has two lines, the regular line of standard consoles and midgets and the Teague line of unusual design sets.

Both are engineered with Sparton's "Presence" reproduction and include such features as super high fidelity, tone exacter, Triolian third dimension principle, "Viso-Glo" tuning and special superheterodyne circuits.

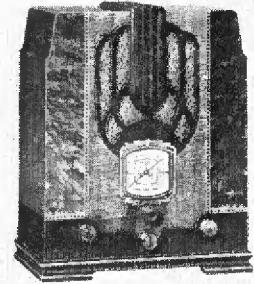

There are four table models in the regular line, one compact and three uprights. They are priced at \$29.95, \$39.95, \$49.95 and \$79.50.

The six consoles, five of which are of the down-to-the-floor cabinet style, range in size from a 6-tube set to a 14-tube super-powered Triolian. They are priced at \$69.95, \$89.50, \$110, \$170, \$200 and \$240. The latter is the 10-tube Sparton Embassy model.—*Radio Retailing*, October, 1935.

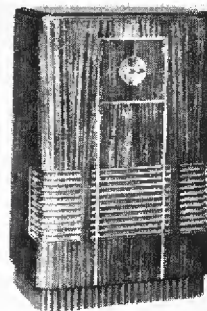

PUBLIC ADDRESS EQUIPMENT

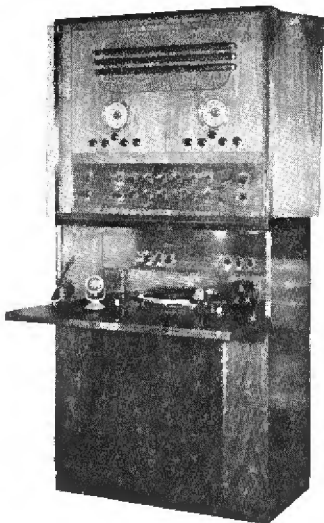

RCA Victor School Sound System

A timely new product by RCA Mfg. Co. Inc., Camden, N. J., is its assembly of a school sound system with a maximum capacity of 80 outlets. Contrary to accepted practice, this amplifier is assembled in a compact walnut cabinet and its operating controls have been greatly simplified.

By means of this electrical system, the principal can convey radio programs, recorded speech and music, and direct announcements from his office to any or all rooms in the school. Two all-wave receiving units are provided so that music may be transmitted to the music class and another program to other rooms.

Another feature is the two way "talk back" system. The party at the control board, by throwing the control switch, can hear the teachers reply or cut in on school room activities. The new type speaker, Model M16281, may be placed on a floor stand or desk or, in reverse position, hung on the wall.

This apparatus qualifies under the provisions of the FHA and may be purchased and installed on a Government guaranteed loan (see explanatory article elsewhere in this issue).

Net prices to the trade quoted on application.—*Radio Retailing*, October, 1935.

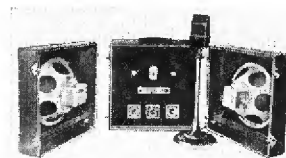
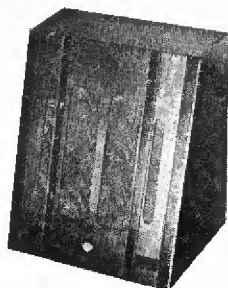

Columbia Portable P.A.

The new P. A. system of the Columbia Sound Co., Inc., 135 Liberty St., New York City, with its universal operating feature, self-contained pre-amplifier, wide range output, high-fidelity reproduction, operating economy, ease of control and finished professional appearance will interest dealers going after this type of business.

For 110-volt a.c. operation, complete with speaker and microphone, less tubes, the price is \$123; 6 volt d.c., \$150; universal operation from 110 volts a.c. and 6 volts d.c., \$170.

Columbia also makes an all-purpose recorder and P.A. amplifier and a high fidelity program recorder.—*Radio Retailing*, October, 1935.

Radolek P.A. Amplifier

Most popular among the features of the new 15-watt hi-gain dual microphone public address amplifier of the Radolek Co., 601 W. Randolph St., Chicago, are its two flat response crystal microphones which give equally good results in rendition of voice or music and a 15-watt 4-stage high gain crystal microphone amplifier which provides straight line amplification for microphones. A set of 9 matched tubes, 2 Rola auditorium type

dynamic speakers and other necessary equipment are included.—*Radio Retailing*, October, 1935.

Ansley Portable Electric Phono and P. A. System

Operating on a.c. or d.c. and weighing but 35 lb., including speaker, the entire portable combination electric phonograph and p.a. system of the Ansley Radio Laboratory, 230 W. 23rd St., New York City, folds into a compact unit. Designed for 16-in. records and with a patented crystal type pick-up, this outfit is capable of giving great volume.

To make practical the use of the new high output type 48 tubes in a universal amplifier, a new patented balancing circuit has been devised to eliminate a.c. hum.

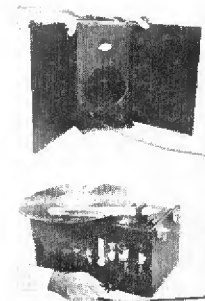

Using an 8-in. moving coil speaker in compact narrow area, the baffle is increased by the addition of two swinging sides which can be swung into any desired position.—*Radio Retailing*, October, 1935.



SELL MORE SETS

with **BROWNIE** ALL-WAVE ANTENNAE

● THE NEW BROWNIE All-Wave Antenna sells easily with every set — and keeps the set sold. For fine short wave reception is impossible without an all-wave antenna. The Brownie is one of the finest antennae on the market today. We challenge a comparison for distance, volume, clarity and freedom from interference.

The ANTENNA that Carries a Profit for the Dealer

Hook up a Brownie on a set in your showroom. Demonstrate its many superiorities. You will find it a quick money maker for there's a real profit on every Brownie you sell.

The Brownie is manufactured by a famous old line maker in the electrical field. It is constructed on the Balanced Doublet System with a new, super-efficient, matching transformer. Comes complete with necessary accessories for quick installation. Cash in on the national advertising campaign, starting soon in *Colliers* and the *Saturday Evening Post*. Write today for our quick — profit making deal.

PORCELAIN PRODUCTS, INC. Dept. A FINDLAY, OHIO

HERE'S AN ALLIGATOR



You Can Keep for a Pet Around Your Own Shop

Dress him in a red or black rubber insulator and he's absolutely harmless! He's trained to crawl into any kind of a hole and bite hard — but only where you want him to bite.

THE MUELLER ALLIGATOR CLIP

Has long, slender jaws with teeth that really mesh all along the sides and on the front end. Has both screw and barrel connection.

Is very small and handy to use.

AND—It can be had with red and black rubber insulators which cover everything but the nose.

STOCKED BY JOBBERS EVERYWHERE

Write Factory for Free Samples

No. 85 Clip only—List 6c—10 lots 4c each.
No. 87 Insulator only—List 5c—10 lots 3c each.

(Packed in boxes of 10—1/2 red—1/2 black)

MUELLER ELECTRIC CO.

1581 East 31st Street, Cleveland, Ohio



Stromberg-Carlson Model 84

A high fidelity radio covering all wave lengths from 520 to 23,000 kc., and incorporating the "acoustical labyrinth" has just been announced by the Stromberg-Carlson Tel. Mfg. Co., Rochester, N. Y. Known as No. 84, and utilizes metal tubes. This set has a full vision, four-section Selectorlite dial. The range switch not only selects and illuminates the desired range but also selects the proper antenna and automatically grounds the idle coils. The twelve tubes used are: 3-6K7, 6A8, 6C5, 6H6, 4-6F6, 6J7, and a 5Z3 rectifier.—*Radio Retailing*, October, 1935.

Patterson Model PR-16 Communication Receiver

Superseding the well-known PR-10 is the new PR-16 communication receiver of the Patterson Radio Co., 1320 So. Los Angeles St., Los Angeles, Calif. This set employs 16 tubes and the range is from 8 to 550 meters on five bands.

Some of the features are: Illuminated 360° band spread and meter on panel, phone jack on front panel, phonograph connection, camera shutter band indicator and wave change switch. All chassis in the Patterson line are completely wired for crystal filter which is optional.

The set may be had in a table model, all-metal cabinet or in a console. The latter will accommodate phonograph equipment, if a combination is desired.

Patterson has also announced the 1936 line of general 8-10-12 tube models. Circuit is super-heterodyne with a range of 15 to 550 meters on four bands. Three cabinets will comprise the series. A table set, small console and large console. The chassis is interchangeable in any of the three cabinets.—*Radio Retailing*, October, 1935.

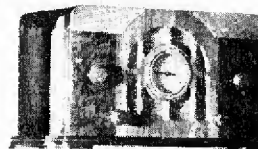

Mission Bell Radios

Two auto radios listing at \$29.95 and \$49.50 and four table sets (including an all-wave and a skip band model) priced at \$17.50, \$21.50, \$24.95 and \$32.50 make up the new line of Mission Bell Radio Mfg. Co., Inc., 823 Venice Blvd., Los Angeles, Calif.—*Radio Retailing*, October, 1935.

Belmont Model 777

Three positions on the wave band selector switch cover the entire range from 535 kc. to 18 mc. in the new Model 777, manufactured by the Belmont Radio Corp., 1257 Fullerton Ave., Chicago. Band spreading by mechanical means, permits accurate tuning despite the concentration of the entire wave band in three ranges. Metal tubes are used in the r.f., mixer and i.f. stages, with conventional glass tubes in the less critical positions.

An electro-dynamic speaker of wide frequency response and resistance coupled audio frequency power stage assure good tone. The stock design is for 50-60 cycles, 110-120 volts a.c. Other voltages and frequencies may be had upon special order.—*Radio Retailing*, October, 1935.

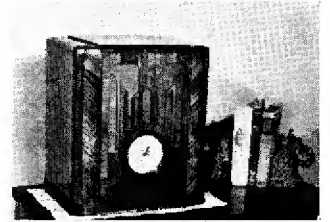

Garod Portable Radiogram

A small, light portable radiophonograph combination is offered by the Garod Radio Corp., 34 E. 12th St., New York City. The radio is a 7 tube, a.c.-d.c. receiver covering 3 bands—16 to 555 meters. The a.c.-d.c. motor on the phonograph permits using both on either current.

Available in 110, 150, 220 and 250 volts, 25 to 60 cycles. Can also be supplied with the long-wave band of 750 to 2,000 meters for the export trade.—*Radio Retailing*, October, 1935.

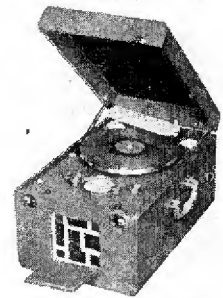

Rola Speaker

The Rola Co., 2530 Superior Ave., Cleveland, Ohio, announces two new speakers, an 8 and a 10-in. unit.

They are available in dust-proof or non-dustproof models. Curved or straight design cones optional, as are field coil and transformer specifications.—*Radio Retailing*, October, 1935.

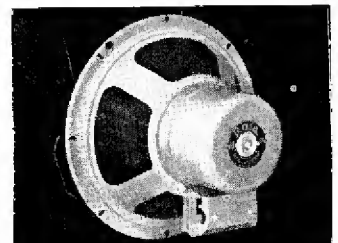

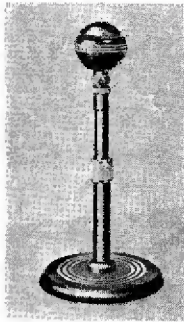

Shure "Spheroid" Non-Directional Crystal Mike

As may be inferred from the name, the new microphone of the Shure Bros. Co., 215 W. Harrison St., Chicago, has the form of a sphere. It is only 2 1/2 in. in diameter. Sound enters the unit through a horizontal annular slot and because of this symmetry of construction, pick-up is perfectly non-directional throughout a complete angle of 360°.

The "Spheroid" is the first crystal microphone which combines high output level with non-directional high-fidelity wave response, Shure Brothers claim. The list price is \$37.50 complete with plug and receptacle.—*Radio Retailing*, October 1935.

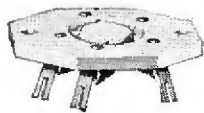

Hammarlund Guide Groove Isolantite Socket

Another interesting development—a high frequency socket with a circular "Guide-Groove"—has just been completed in the laboratories of the Hammarlund Mfg. Co. Inc., 424 W. 33rd St., New York, N. Y.

The lowest loss, strongest Isolantite made—grade "B-100" substance—is used exclusively. The new circular "Guide-Groove" feature not only makes insertion easier but prevents any errors in tube installation.

These new sockets are made in 4, 5, 6 and 7 prong style, with a large and small 7 prong type available, too.—*Radio Retailing*, October, 1935.

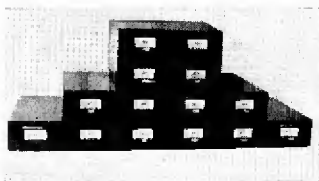

Tobe Condenser Kits

Two condenser kits have just been released by the Tobe Deutschmann Corp., Canton, Mass. Each contains the fastest moving condenser items in accordance with the company's stock movement records.

Each comes in a heavy steel cabinet called an "add-a-unit" cabinet. These sections may be clamped together so that eventually the service man has enough individual sections to make up a large useful cabinet as illustrated.

Each individual kit, including cabinet, sells to servicemen at a net price of about \$5.—*Radio Retailing*, October, 1935.

Alden Metal Tube Parts and Accessories

Over twenty-five new items pertaining to the metal and octal-based tubes have been brought out by the Alden Products Co., 715 Center St., Brockton, Mass. Among these are 9-wire octal locking analyzer plug and associate adapters; silver-plated floating "tuning fork" contact instrument sockets; miniature cap contacts for metal tubes; adapters for checking the complete series of metal tubes; universal metal tube checking adapter to check all metal tubes in any tube checker; adapters for modernizing set analyzers and testers for the new metal and glass octal-based tubes, etc.—*Radio Retailing*, October, 1935.



Automatic "Noise-Master" Antenna

The "Noise-Master" antenna, which was introduced by Cornish Wire Co., 30 Church St., New York City, several months ago, is now automatic in operation. Quoting from the literature of this manufacturer, "After the 'Noisemaster' is properly installed no adjustment is necessary and no manual operation is required, because this antenna is fully automatic electrically."—*Radio Retailing*, October, 1935.



Littelfuse Metal Shielded Fuse Mounting

The No. 1126 metal shielded fuse mounting designed for use on the new metal tube radio sets takes standard 3 AG radio fuses, has cadmium plated metal parts, measures only 2 3/8 in. overall, and meets Underwriters' Laboratories requirements in that a tool is required to remove the cover. Littelfuse Labs., 4507 Ravenswood Ave., Chicago.—*Radio Retailing*, October, 1935.

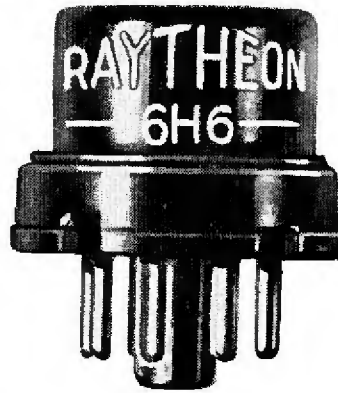
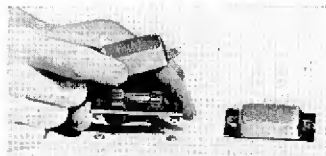

Actions Speak Louder Than Words!

The manufacturer of the famous 4-Pillar Radio Tubes is making and delivering *all* types of the new Metal Tubes as initial equipment for 1936 receivers and for jobber and dealer replacement stock.

Raytheon's 34 new service deals are now ready. Ask for complete details.

RAYTHEON

TRADE-MARK
4-PILLAR RADIO TUBES

RAYTHEON PRODUCTION CORPORATION

30 East 42nd Street, New York, N. Y.
445 Lake Shore Drive, Chicago, Illinois
55 Chapel St., Newton, Massachusetts
555 Howard Street, San Francisco, Cal.

The SHURE

"Spheroid"

1. High-Output
2. Non-Directional
3. High-Fidelity

CRYSTAL MICROPHONE

—for the first time in the history of sound reproduction, a crystal microphone with ALL these features!

Through radically new acoustic engineering principles, the "SPHEROID" provides the highest Output Level (minus 55 db) ever attained in combination with true High-Fidelity response (within 5 db from 40 to 10,000 cycles) and Non-Directional (360°) pickup! New "Grafoil" Bimorph Crystal element lowers cable loss.

These superlative performance features, together with beautiful, distinctive, modern appearance and low cost, make the "SPHEROID" the ultimate crystal microphone for high-quality sound reproduction. List price, Model 74A, complete with improved connector as illustrated, only \$37.50.

For complete technical data, write for Bulletin 131R. Licensed under patents of the Brush Development Company. Shure patents pending.

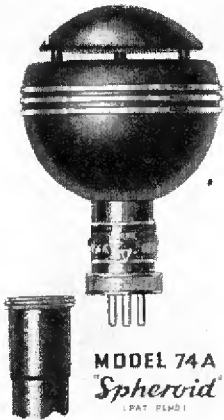

MODEL 74A
Spheroid
PAT. PEND.

SHURE BROTHERS COMPANY

Manufacturers of Microphone Headquarters Cable Address SHUREMICRO
215 WEST HURON ST. CHICAGO, U.S.A.

ELECTRICAL APPLIANCES of interest to radio dealers

A.B.C. Farm Washers

The models 44G and 18G washers for rural homes made by Altorfer Bros. Co., Peoria, Ill., are equipped with Johnson Iron Horse 4 cycle gasoline engine 1/2 h.p. motor and operate from 3 1/2 to 4 1/2 hr. on 1 qt. of gasoline. All exclusive ABC features are included in these models such as corrugated porcelain tub, French type agitator which washes clothes at the top and bottom of tub, etc. Model 44G is equipped with an extra large capacity tub and Model 18G with standard tub.—Radio Retailing, October 1935.

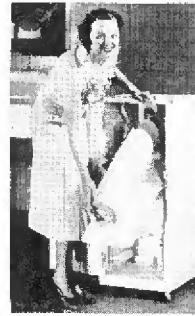

Thor "Fold-A-Way" Ironer

The "Fold-a-way" ironer of the Hurlley Machine Co., Cermak Rd. & 54th Ave., Chicago, folds into a cabinet 16x16 1/2 in. taking up less floor space than the average kitchen chair. It has 1200-watt long life element, self-aligning chrome plated shoe, full open-end roll 6 in. in diameter by 2 1/2 in. long and 1/20 hp. brushless induction motor, direct drive. \$59.50.—Radio Retailing, October, 1935.

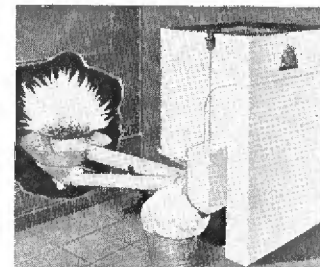

Combustioneer Stoker

A new automatic coal burner designed especially for homes of less than 8 rooms has just been placed on the market by Combustioneer, Inc., Springfield, Ohio.

It is equipped with a 400 lb. coal hopper with duct type cover. Maximum coal feed is 25 lb. per hr. regulated by temperature controls. The complete installation including controls can be made for less than \$250.

The entire Combustioneer line now comprises 11 models or sizes ranging in coal feed from 17 to 1200 lb. per hr.—Radio Retailing, October, 1935.

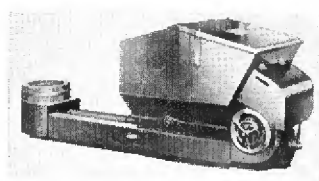

Noyes "Junior" Automatic Coal Burner

The "Junior" automatic anthracite coal burner of B. E. Noyes Co., 106 Hope St., Greenfield, Mass., has been designed primarily for the small home. The automatic feeding of the proper amount of coal depends on the outside temperature, and no shaking of the furnace is necessary. The ashes are removed from the pit automatically. The hopper has a capacity of 250 lb. which will run the burner for 48 hrs. in severe weather or 96 hrs. in mild weather.

It is furnished with a hand set control and may be equipped with thermostatic control at a small additional cost. No changes in the present furnace are necessary.—Radio Retailing, October, 1935.

Arco Air Conditioner

An air treatment machine that can be hooked in at any point on the supply line of a radiator heating system, and will condition a six-room house from that point, may be obtained from the American Radiator Co., 40 West 40th St., New York City. Only a steam or hot water connection together with water supply and drain connection are required. A Sirocco blower, of the same construction as those used in the largest air-conditioning installations, is provided to induce air circula-

Westinghouse Range

Four Westinghouse Quick-Cook open units (1-1500, 1-2000, 2-1200 watts) and two oven units, (1500 each) are available in the new Model A-64 electric range of the Westinghouse Elec. & Mfg. Co., Mansfield, Ohio. This is a white porcelain enamel model with black trim.—Radio Retailing, October, 1935.

No. MK-7 Complete Premax Mast Kit, 7-ft., listing at \$4.95



No. MK-10 Complete Premax Mast Kit 10-ft., listing at \$6.95

Telescoping Mast Kit for Every Antenna

Complete Kit, consisting of two telescoping steel masts, guys and adjustable anchors in display carton. Will be a big seller on the new unit stock plan. Get Bulletin RMX.

PREMAX SALES DIVISION
Chisholm-Ryder Co., Inc.
Niagara Falls, N. Y.

CAPITOL RADIO ENGINEERING INSTITUTE

America's Original Radio Engineering School

★ **Announces...**
A Newly Developed Home Study Course in
SERVICE
and Public Address **ENGINEERING**

Not for beginners—but for high-grade Service men who see the need for Technical Training. It is practical right from the first lesson and covers every Service angle including Acoustics. Write today for complete details.

CAPITOL RADIO ENGINEERING INST.
14th and Park Rd., Dept. RR-10, WASHINGTON, D. C.

★ FREE!

New Catalog just off the press. Many photos and complete details of all CREI courses. FREE for the asking!

tion. Powered by a 1/20-hp. motor that uses no more electricity than a 60-watt lamp.

Designed for the \$3,000 to \$8,000 home, it is priced so that it can be installed by a heating contractor for a little more than half the price of the average electric refrigerator.—*Radio Retailing*, October, 1935.

attached to an adjustable base for the purpose of regulating tension of driving belts. An automatic control panel is mounted in an inclosed steel case, operation being controlled by either room thermostat, pressure governor or temperature gauge. Steel hopper has capacity of 300 lb.—*Radio Retailing*, October, 1935.

Plymouth Stokers

The specifications on the Model 60, automatic bituminous coal stoker of the Plymouth Industries, Inc., Plymouth, Ind., are: capacity 10 to 60 lb. coal per hr.; suitable for 1200 sq.ft. steam radiation or 1600 sq.ft. hot water; low hopper holds 300 lb. fuel.

Model 120, capacity from 20 to 120 lb. per hr.; handles up to 2400 sq.ft. steam radiation or 3200 sq.ft. hot water; hopper holds 550 lb. fuel.

Former lists for \$200 and the latter for \$325, complete with all controls.—*Radio Retailing*, October, 1935.

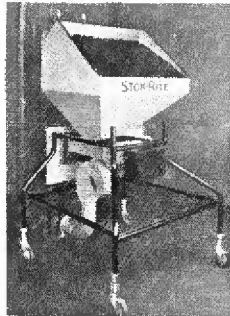

Simplex Ironer

A full size household ironer with standard 26-in. roll may be obtained from Barlow & Seelig Mfg. Co., Ripon, Wis. It is known as the Simplex Model EX ironer, and has instantaneous control. Both ends of the roll open. \$39.50.—*Radio Retailing*, October, 1935.

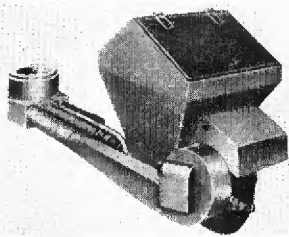

G.E. Air Conditioner

A self-contained room cooling unit which cools and humidifies may be obtained from the General Electric Air Conditioning Institute, Bloomfield, N. J.

It operates without using special power lines or water supply and drain piping. May be installed by adjusting duct connections to nearest outlet. The compressor unit consists of a hermetically sealed, trouble-proof compressor, similar to G.E. Monitor Top refrigerator compressor. Housed in an attractive cabinet.—*Radio Retailing*, October, 1935.

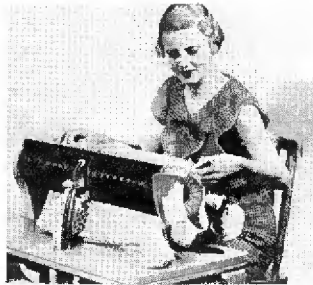

Frigidaire Air Conditioners

Four new low side units for installation in hotels, clubs, etc., may be obtained from the Frigidaire Corp., Dayton, Ohio.

These are intended for installation inside closets, in bathrooms or other small spaces adjoining sleeping or living rooms. The grill opening into the room admits conditioned air and return air is taken to other grilles or louvers in walls or closet doors. May also be used in connection with short localized duct systems. Compressors required to operate these units may be located at any convenient point.—*Radio Retailing*, October, 1935.

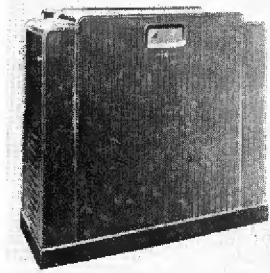

"Stok-Rite" Automatic Coal Stoker

The Stok-Rite automatic coal stoker made by the Chicago Automatic Stoker Co., 14 N. Clinton St., Chicago, Ill., is easily and quickly adaptable to any type of heating plant—steam, hot water, vapor heat, and hot air in either buildings or homes. A 1/10 hp. motor operates both fan and fuel feed

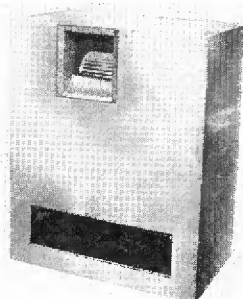

Radio Retailing, October, 1935

"I'M LOOKING OUT FOR #1"

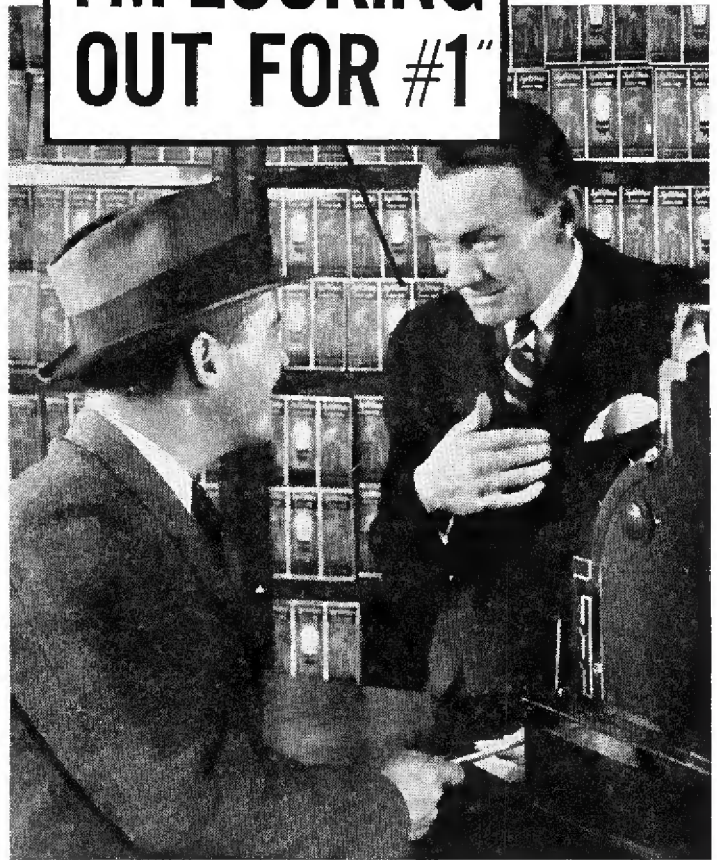

This man spoke out frankly . . . read how he built up a more profitable business on tubes!

► "You're asking me why I sell Sylvania tubes? Well, I'll tell you . . . I'm looking out for Number 1 . . . I'm selling the tube that I can make the most profit from handling.

"I could push just about any radio tube . . . There are several good ones on the market. But Sylvania is as good a tube as any made, and I get a *better* profit when I sell them.

"Radio dealers and distributors like to sell a tube they can recommend . . . and at the same time, they like to do business with a company that talks their language. Sylvania's business policies make sense to me, and that's why, as far as I'm concerned . . . I sell Sylvania's."

There's not much we can add to this. If you'd like to know more about Sylvania's Profit Policy Plan, and the better profit that goes to Sylvania dealers and distributors, write today to the Hygrade Sylvania Corporation, Emporium, Pa.

SYLVANIA

THE SET-TESTED RADIO TUBE

© 1935, Hygrade Sylvania Corp.

Our Readers Write

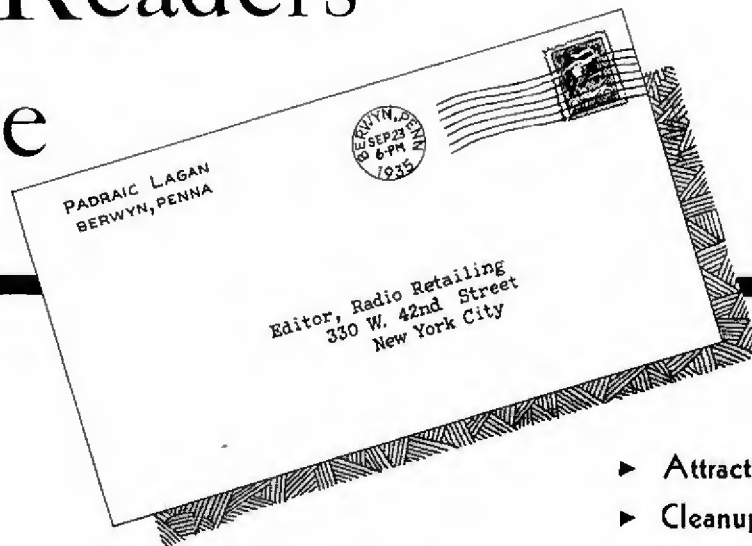

ABOUT

- ▶ Attractiveness of mail-order set prices
- ▶ Cleanup by service sales promoters
- ▶ Consumer auto radio preferences
- ▶ Model changes and the accounts receivable problem

We Favor an Ax

Editor, Radio Retailing:

In my opinion there is too much hocus-focus in modern business. Radio has two outstanding examples of it.

Mail-order houses buy sets, affix their own private brand and sell the public, on credit, cheaper than the average dealer can buy similar merchandise for from jobbers. In my estimation much mail-order merchandise is definitely a better buy for the consumer than the stuff I sell because the big fellow's buying power tempts manufacturers.

Then there is the outfit that advertises "no money down" and three years to pay. If this is to be the logical end of efficiency and economy then give me the wheelbarrow and rake.

PADRAIC LAGAN
Berwyn, Penna.

Parts Charges Will Resemble French War-Debt

McGraw-Hill Publishing Co.:

One month ago a local dealer was approached by some out-of-town gentlemen with a scheme to increase his service business by establishing a club in which the public was to participate for the membership fee of \$1.50 per year. For this fee all service required for one year was guaranteed, the only additional cost being the list price for parts or tubes required for the job.

On each customer signed up the promoters received 50 cents, the salesman 50 cents and the dealer 50 cents. A large crew was put out and the idea was apparently well received by the public, always eager to get something for nothing.

After operating for a short time the dealer discovered that his "partners" made too much and he made too little so they parted company. Immediately the pro-

motors rented a store a few doors away and continued the thing themselves. They have engaged a local attorney, taken out a state license, applied for incorporation and are evidently well within the law. However, this association holds the opinion that it is impossible for any organization to make a profit along the lines outlined above.

What is your opinion?

H. B. DUNCAN
Wilmington (Del.) Service Men's Ass'n.

Model Changes Are Both Weakness and Strength

Ray V. Sulliffe, Editor:

The writer desires to call to your attention what, in his opinion, is the "Holy of Holies" of the radio business today—*Accounts Receivable*.

Now that radio has outgrown its rompers and is about to don its first pair of long trousers some method of stabilization should be adopted governing merchandise after it has reached the consumer so that the merchant can at least hope to receive a major portion of the outstanding account before a new model is brought out and the dealer left holding the bag with another radio to sell at a loss.

I, for one, do not think it is necessary for radios to differ drastically with each series. We might tear a page out of the automobile manufacturers' book and profit thereby. There isn't so much difference between a 1934 and a 1935 car and the seller of a 1934 product can recover his outstanding balance without resorting to law.

Why isn't it possible for radio manufacturers to look a year ahead, planning cabinets so that if a repossession occurs a new chassis can be placed in an older cabinet, thereby leaving two current models on the merchant's floor instead of one?

"CONNECTICUT YANKEE"
Hartford, Conn.

More's the Pity

Radio Retailing:

The purpose of this letter is to correct an erroneous impression you seem to have received from reading a letter I wrote some weeks ago regarding your editorial in the June issue ("He Came to Service—Stayed to Sell") and to correct the erroneous impression readers of the two paragraph excerpt (Page 39, August) are quite sure to get regarding my opinion of your publication.

I am not dissatisfied with *Radio Retailing*. My former letter was not so much a "brickbat" for you as it was a protest against the efforts of store owners and those in charge of the selling part of the business to reduce the radio serviceman to a state of subservience.

One thing is quite plain to me. There must be someone to sell sets, otherwise I'll have none to service. What the sales force must be made to realize is that without someone to service sets they will not be able to sell any. I have yet to see the expert salesman who can also repair. Or an expert repairman who can also sell.

L. THORNTON
East Smethport, Penna.

Auto Radio Manufacturers Please Copy

Editor, Radio Retailing:

No one connected with the sale of automobile radio is more familiar with the likes and preferences of the auto radio buyer than the auto radio service station, such as our own. And here are my ideas for a composite receiver which answers all the demands of John Motorist, who is, in the final analysis, chief designer for all radio manufacturers:

The 1936 auto radio should install over the steering column on the left hand side of the car. This will make it unnecessary to choose between a radio and a heater.

Chassis should be as thin as 5 inches and not over 8 inches square.

Facilities for mounting flat or edgewise should be provided. This is facilitated if the overhead, or "header," type of speaker is used. Sets without header type speakers invite sales resistance. Low priced models will not be expected to have this feature but sets retailing above \$40 will.

Steering column mountings are passé but there will remain a necessity for controls adaptable to steering column use to take care of older cars. The great majority of installations will be in cars with a space provided for dash mounting control and that control will have to look right and not be an obvious compromise of steering column dial and plate adapter.

Other desirable features will be high gain antenna coils for under car antennas, no suppressors, easy accessibility for tube changing, vibrator adjustments and balancing adjustments. It seems to me that there is some possibility of making the high gain antenna coil a plug-in device, perhaps with a poly-iron core. A dealer could plug in the proper coil for use with under car or top antenna.

C. S. GOOCH
Amarillo, Texas

What Do YOU Think?

Ray Sutcliffe, *Radio Retailing*:

Do you feel with us that smart dealers can increase profits by selecting fewer lines and promoting them aggressively?

It seems to us that the time has arrived in the radio industry for the dealer to quit running a service station.

THOMAS R. STERCK
Westinghouse Electric Supply Co., New York

Nebraska Solution

Editor, *Radio Retailing*:

Monkey-Ward and Sears-Sawbuck are

legitimate competition, as I see it. If we dealers want to, we can get merchandise as good as theirs that can be sold as cheaply.

But we want to sell better stuff. So the best thing to do is for us to tell makers of legitimate merchandise that they cannot sell the catalog houses and sell us too.

BUD CRAWFORD
Seneca, Neb.

Should Servicemen Be Licensed?

Editor, *Radio Retailing*:

With the advent of the new "Iron" tubes (and television?) servicing will become more technical than ever. I believe, therefore, that the service man should be licensed by the state.

The chain stores and mail order houses would lose a great deal of cut price appeal if John Public were convinced that he would be violating the law by installing the set himself. Fire risk would be reduced and poor aerial installations removed forever from roofs.

Let us look at the following with an eye to improving the future of the business:

1. Tube prices must be kept up. Even spark plugs of the better grade list and sell at higher prices and have the same average of replacement. Our tube test equipment becomes obsolete in about a year.

2. Set sales should be made with a definite understanding that the landlord of the house where it is to be installed equally violate the law with tenant when an unlicensed installation was made.

3. Licensing will mean a considerable and new revenue to the city as well as the elimination of gyp mechanics.

4. Chain stores will be able to sell the radio but should inform the buyer that the law requires proper installation by a licensed man.

THOMAS A. PILLING
Bronx Radio & Television Co., New York

Wired Radio

(Continued from page 25)

selector (only 3 channels working at this time) are the only visible controls. Power is, of course, obtained from the light lines. Receivers (shown in photos) are strikingly similar in appearance to current radio offerings. And there is good reason. Philco of Philadelphia makes them.

From general manager Tom J. Smith, Jr.: "In discussing our service subscribers tell us that they appreciate the opportunity provided by Muzak to receive our musical and other programs without interruption or interference. In building our programs we have but one consideration, and that is to provide our subscribers with programs such as they desire."

Whether or not extension of wired radio service to other cities is contemplated, and when this is likely to occur, if at all, is apparently unknown even to Muzak's officials. Much obviously, depends upon success of the Lakewood operation from the standpoint of commercial profit.

★ ★ ★

Refrigerators

(Continued from page 26)

smooth it is. You can put a chicken, meat or anything you want to in it and it will remain perfectly clean.

3. 'Now look at the motor. You know the motor is the heart of the machine. Here it is, right up front and I want you to see that it is one of the best made. (GE)

4. 'Something else I want to tip you off about. Mr. Shapiro just sold one of these refrigerators to a personal friend of his and I am sure he wouldn't have done it if he didn't think this is the best bet on the market.

5. 'How about service? Well, we have sold these refrigerators for three years and have had practically no service calls. The box is guaranteed. There is nothing to worry about. In fact, it is so standard that we don't even have one running in the store."

Learns When to Close

Saichek is particularly adept at closing, according to his boss. His cue, we find, is based upon the following situations:

- (a) Customer stops asking questions.
- (b) Husband and wife look silently at each other.

When either of these two conditions arise Bill immediately points to the refrigerator and says: "This is the refrigerator for you." Taking out his sales book for the first time he produces a pencil and asks . . . "What is your name?" If the answer is forthcoming he next states, matter-of-fact, "This will be \$15 down and so much per month." Following this statement the customer is requested to see the credit man.

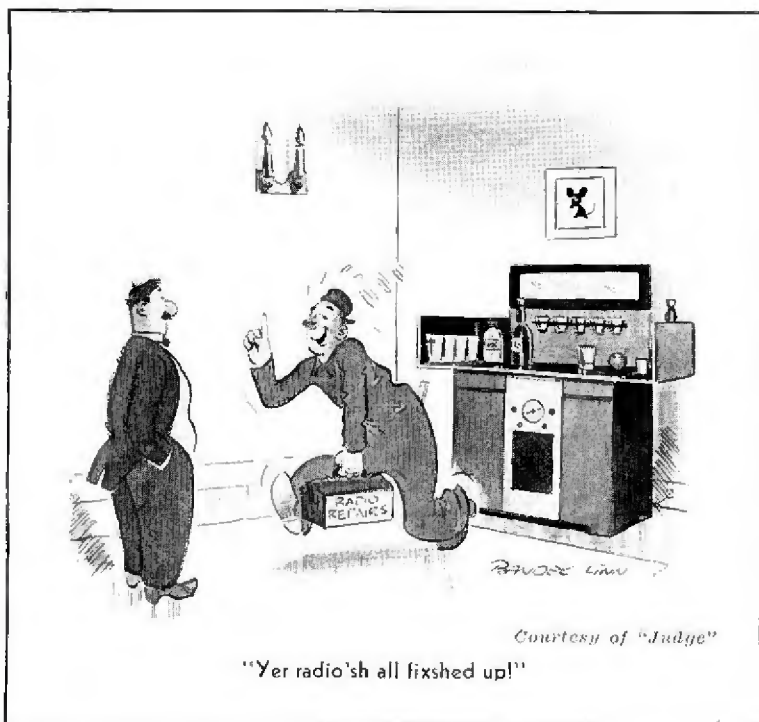

"Yer radio'sh all fixshed up!"

In the Appliance Field

Cooperative Campaign Wins Out in Wisconsin

SHEBOYGAN — Successfully combating a lethargic sales resistance through a cooperative campaign, manufacturers, dealers, distributors and the utility company succeeded in selling 251 refrigerators in Sheboygan in an intensive five weeks' campaign. The drive was conducted when the refrigeration season was practically over in northern Wisconsin.

Total sales from Jan. 1 to July 1 had been only 216 boxes. In the five weeks' effort, July 25 to Aug. 31, more boxes were sold than in all the rest of the year.

Manufacturers and distributors wanted to find out what was the matter with the Sheboygan market and how to combat sales resistance. As a test campaign nine major manufacturers and the Wisconsin Power & Light Company united with local dealers to organize the Sheboygan Electrical Refrigeration Bureau. A fund of \$2,000 was subscribed for a cooperative newspaper advertising campaign. Manufacturers participating were Kelvinator, Westinghouse, General Electric, Grunow, Crosley, Hotpoint, Fairbanks-Morse, Frigidaire, and Norge.

"Train Manpower" Greusel

Results of the campaign proved that success of any refrigeration campaign depends on good man-power, well-trained and drilled. To be successful, dealers must send their men into the field adequately trained, Frank W. Greusel of Maurer-Greusel Co., Milwaukee, general chairman of the campaign, declared.

Whereas most cooperative sales efforts start slowly and build to a peak, the Sheboygan campaign acted in reverse, 100 boxes being sold the first week. This was due to seasonal activity, Mr. Greusel said.

The campaign was built around the story of health and savings through electrical refrigeration. It included a distribution of merchandising credit certificates to 3,000 selected homes by Western Union messengers, a "cold cookery" school sponsored by the Sheboygan Press, the offer of bargain electric rates



"The Cupboard Was Bare"

E. H. Schaefer of the E. H. Schaefer Co., Milwaukee, Wis., G. E. distributor, talks things over with Miss Clara Dean, home economist from the House of Magic, Cleveland. Miss Dean conducted the Cold Cookery school in Sheboygan

by the power company, and a detailed home demonstration plan. Concerted effort was directed toward lift-box chests, selling at low prices over a 36 month period, in order to reach the pocketbook of the low income citizen.

Westinghouse Contest

With a national average of 137 per cent of quota, including 67 distributors topping 100 per cent and 11 distributors reporting 200 or more per cent of quota, the Refrigeration Department of the Westinghouse Electric & Manufacturing Company consider its recently closed national refrigeration sales contest an unqualified success. This "Call to Colors" contest, enlisting the organizations of approximately 100 distributors all over the country closed August 10.

New Horton Jobbers

FT. WAYNE—The Horton Manufacturing Co., Ft. Wayne, Ind., announces the appointment of a round dozen of new wholesalers who will distribute Horton washing machines and ironers in their respective territories. Among these we note at least five jobbers who are well known in the radio industry. These include the Aitken Radio Corp., Detroit, and the Excelsior Radio Co., Harrisburg.

Washing Machine Shipments Seven per cent Ahead

CHICAGO—Household washing machine shipments for the first eight months of this year totalled 950,070, or 7 per cent ahead of the same period in 1934 and the August total, 144,283, was the greatest month in the industry's history, J. R. Bohnen, secretary of the American Washing Machine Manufacturers' Association, announces.

Electric ironer shipments in the first eight months of 1935 were 93,535, advance of 13 per cent over the same period in 1934.

Leonard Advances Sowell

DETROIT—Appointment of Paul D. Sowell as advertising and sales promotion manager of the Leonard Refrigerator Company has been announced.

Mr. Sowell entered the electric refrigeration industry in 1928 as a retail salesman for the company's distributor at Little Rock, Ark. In 1934, he joined Leonard in the sales promotion department.

Refrigerator as Prize

GAIANNA, OHIO — Something new in the way of newspaper subscription contests was staged here recently by the *Tri-Community News*, when it offered a Model FA-50, Crosley Shelvador as grand prize for paid up subs to the paper.

At the editor's request, Powell

Crosley, Jr., selected the lucky number, and the prize went to P. W. Doran, New Albany, one of the old subscribers of the *Tri-Community News*.

B. A. Proctor New Address

NEW YORK—The new address of the B. A. Proctor Co. Inc., is 17 W. 60th St., New York City. They were formerly located at 315 W. 68th St.

Connelly Plays Host

SEATTLE — F. B. Connelly Company, northwest distributors of Grunow radios and refrigerators, conducted three meetings, attended by over 600 dealers and salesmen, at Seattle, Portland and Spokane, Sept. 13, 14 and 16 respectively. Combined dealer orders, mostly consoles, will fill three freight cars.

"Eight Ball" Mike

NEWARK—WOR takes the lead in the radio engineering field with the introduction to its studio equipment of a new type microphone — the non-directional streamline microphone.

This mike is so designed that it can pick up sound from any direction in the studio, horizontally or vertically. Bell Telephone Laboratory - Western Electric engineers, designers and builders of the microphone, assert that it covers a 360° circumference.

The microphone resembles a billiard ball in size and shape with the head of the ball "shaved." It is mounted on a long, slender stand that has a billiard cue appearance, and because of these resemblances has become known to radio technicians as the "Eight Ball" mike.

How Radio Time is Divided

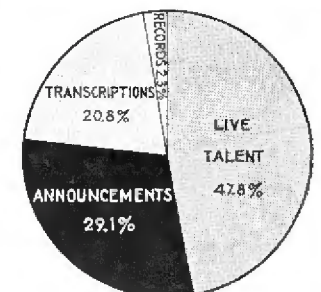

Here, according to the N.A.B., is how radio time is divided at this writing. In July (last figures available) volume of advertising by companies using live talent increased 60.5 per cent over the previous year. Transcription sales zoomed 87.6 per cent in the same period

Why We Use METAL Tubes

(Continued from page 16)

the following distinct advantages; improved short wave performance, extreme quietness, uniform, perfect self-shielding, more power, quicker heat dissipation, more sensitivity, maximum capacity without blasting, longer life, compactness, resulting in improved engineering design, nonmicrophonic, vibrationless, greater selectivity, output and finer tone quality and, in addition, they are built to closer limits of accuracy and are self-aligning and unbreakable.

* * *



F. E. Basler

Sales Manager,
Atwater Kent Manufacturing
Co.

Our company, in its early tests of metal tubes, found them so highly efficient and so satisfactory that we decided to employ them in our current 1936 line.

We believe that with the Atwater Kent circuits designed to get the utmost from these tubes we have the finest radio sets available.

The metal tube needs no defense.

Why We Use "Metaglas"

(Continued from page 17)

a desire not to use the dealer's store or the customer's home as a testing laboratory. Zenith's Metaglas tubes are encased in glass; therefore are not an experiment but they do have the tremendous advantage of being interchangeable with metal tubes, if desired.

Obviously the advantages of Metaglas tubes are tremendous—the customer is not asked to purchase an old style receiver using the old style glass tube—nor does Zenith choose to market a receiver incorporating the new metal tube that is as yet, in the opinion of Zenith engineers, in a somewhat experimental stage. The result of this thinking is an engineering strategy that provides a chassis in every respect designed and engineered for use with either metal tubes or the new Metaglas tube. Until such time as thorough tests in the Zenith laboratory prove conclusively that the new metal tube is "right," we are equipping 1936 Zenith radios with Metaglas tubes.

Owners of 1936 Zeniths can, at any time, use the new metal tubes if they so desire. Likewise, owners of new receivers equipped with metal tubes may, if they are not satisfied with their performance, use the Metaglas tubes instead.

How the Tube Situation Shapes Up

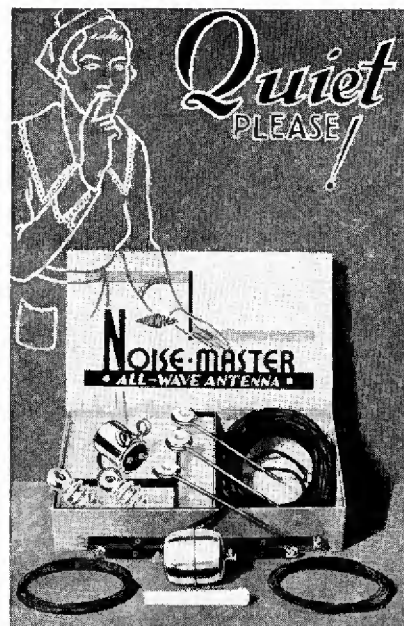
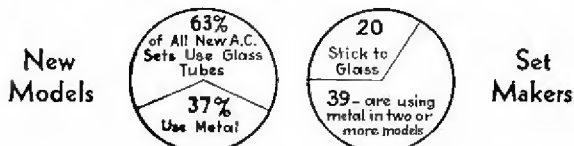

"NOISE-MASTER"

Cat. No. 14—list
price \$6.75

Electrically
AUTOMATIC
in operation

Eliminates static
on both broadcast
and shortwave
bands

Makes every
receiving set
a **BETTER** set



QUIET is what the set-owner craves, and here's the way to give 'em what they want. This A.A.K. licensed product, designed and engineered with typical CORWICO thoroughness, needs no manual operation after a qualified service-man has adjusted it. It eliminates noise and improves reception EVERYWHERE. Use it on your next installation!

Write for descriptive literature on this and other CORWICO units.

Cornish Wire Co., Inc.
30 Church Street New York City



Service men know how foolish it is to risk losing a satisfied customer by installing inferior replacement parts. They know the dependability and profit of Ward Leonard resistors, relays and rheostats. This new bulletin 507A, just off the press, lists the Ward Leonard line and gives prices. Send today . . . it helps to keep old customers happy.

WARD LEONARD PROTECTIVE MAGNETIC RELAYS

WARD LEONARD ELECTRIC CO.

South Street, Mount Vernon, N. Y.

Please send Bulletin 507A.

Name
Street
City State
Jobber RR



Model 430

18⁰⁰

DEALER NET

A new emission type Tube Tester that tests all metal and glass-metal tubes. Features:

Double Grid Cap for Metal and glass-metal tubes. Shadow-type A.C. meter for adjusting line voltage. Leakage and short test. Tubes tested under load. But four simple operations required. Handsome portable quartered oak case with all-metal panel having silvered letters on black background. Especially constructed against obsolescence.

Model 430 complete with Triplett instrument having direct reading GOOD-BAD scale, protected against damage. **Net Dealer Price \$18.00.**

Model 431—same as Model 430, except has Readrite direct reading GOOD-BAD meter. **Dealer's Net Price \$14.40.**

Readrite also manufacture all types of testers used for servicing radio sets, including: Set Testers, Tube Testers, Resistance, Continuity and Capacity Testers, Point-to-Point Testers and inexpensive Indicating Meters.

READRITE METER WORKS
DEPT. RR, BLUFFTON, OHIO, U. S. A.

NEW

Readrite

TUBE TESTER

TESTS ALL TYPES METAL AND GLASS-METAL

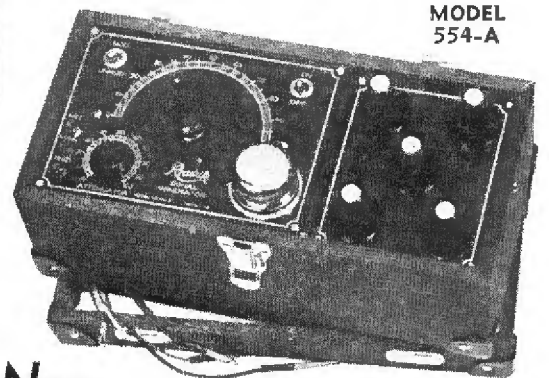

MODEL 554-A

New

ALL-WAVE Signal GENERATOR

With all improvements of present day engineering. All frequencies are fundamentals and stabilized, completely shielded and tube modulated. Plug-in coils for present 5 frequency bands, 100-21,000 kc. (Any new frequency range can be added by new coil.) Extra large scale permits accurate frequency settings. Large, accurate calibration curves supplied. In leatherette portable case complete with batteries and two No. 30 tubes. Dealer Net Price — **\$14⁴⁰**

See your Jobber

MAIL COUPON NOW

TESTERS AND METERS
RELIABILITY AT LOW COST

Readrite Meter Works
Dept. RR, Bluffton, Ohio
Please send me more information—

.....Model 430Model 431
.....Model 554-A..... Catalogue
.....
Name.....
Address.....
City.....State.....

SERVICE SECTION

CIRCUITS of the MONTH

32 Highest Voltage in New Farm Set

Because we suspect that other manufacturers will shortly follow suit and produce sets like it, we diverge from our usual policy and reproduce the complete circuit of the new Delco (United Motors Service) Model 3205 receiver designed for use on 32 volts d.c. and having no chassis voltage higher than this value.

Satisfactory sensitivity, selectivity and volume is, we understand, made possible by the use of pentodes in the r.f. and i.f. sockets, efficient application of a pentagrid converter and, more particularly, by the use of two push-pull 48's, well driven by the triode section of an 85 second detector, in the final stage. 48's are particularly efficient at low operating voltages and deliver fair power output even when operated much below normal rating, as in this case.

The filament and heater wiring is quite tricky. The 32 volt supply is first dropped to 25 by a series-parallel combination of relatively low resistances and pilot lights. This dropped voltage is applied to the string of four 6.3 volt tubes connected in series and to the two power pentodes hooked up in parallel. The speaker field is directly across the entire 32 volt supply.

The series-parallel resistor and pilot light network comes into play again when checking the bias arrangement. The 48's get 5.7 volts negative by tapping in on this system between a 7.3 ohm and a 1.8 ohm resistor. This bias is not

subtracted from the plate voltage as the drop utilized is already in the filament circuit to cut the supply down to 25 volts. A very small amount of fixed bias taken from another junction point of the divider system is applied to the 6D6, 6A7 and 6D6. Not much bias is needed in these circuits due to the low plate voltage applied.

The 85 diode develops a.v.c. voltage for application to all three preceding tubes. And a 4,800 ohm volume control serves the double purpose of providing a certain amount of cathode bias control for the r.f. and mixer tubes, simultaneously short-circuiting more or less of the antenna voltage to ground.

Metal Tube Tester Has "Roaming" Filament Switch

In all of the new metal and metal-glass 8-pin, or octal, tubes, the filament enters the No. 2 pin, adjacent to the No. 1 or "shell" pin. Although the No. 7 pin constituted the other filament of heater pin in the first series, it was expected that pins other than the No. 7 pin might be used in octal tubes to be announced later and, in order to preclude the possible early obsolescence of their testers, Supreme engineers designed a non-shorting circuit-breaking "Filament Return Selector" switch to effect the proper connections for the "roaming filaments" of such new tubes.

The switch connections are illustrated

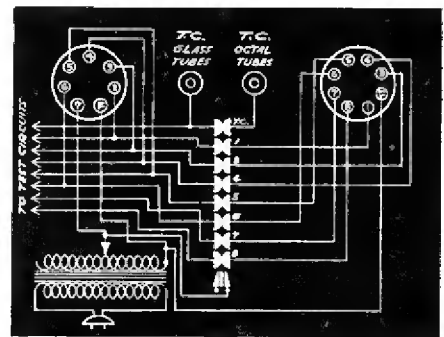

in the accompanying drawing, from which it will be observed that the original series of octal tubes require a switch setting at position No. 7 in order to connect the filament transformer winding to contacts No. 2 and No. 7 of the 8-hole socket.

The value of the switch for preventing obsolescence is now demonstrable in view of the new octal tube types 5Z4 and 6P7. The type 5Z4 uses pins numbered 2 and 8 as filament pins, so that this type is accommodated by setting the switch at position No. 8. The type 6P7 uses pins numbered 2 and 3 as filament pins, so that this type is accommodated by setting the switch at position No. 3. If future octal tube types use the "top cap" or any one of the other tube pins for filament or heater "return" terminals, they can be accommodated by setting the switch at the numbered positions which correspond to the numbers of the pins used.

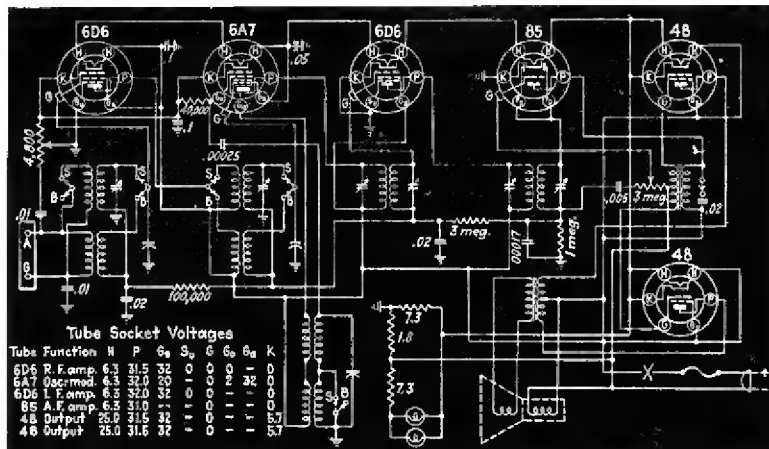

New, Smaller 5Z4

Hygrade-Sylvania tells us that a new, metal 5Z4 is in the immediate offing. It will be built in the same size shell as the 6F6 power tube instead of the considerably larger covering which has come to be known among servicemen as a "bird-cage."

The internal elements of the new baby resemble the structure of the familiar 83V. Filament drain has been reduced to 1.5 amperes and, we are told, characteristics are otherwise similar to that of the original 5Z4. Maximum d.c. output current rating has been maintained at 125 mfs for operation at 400 volts a.c. per plate (RMS).

"Roaming Filaments"

The first all-metal tubes announced had the filament or heater circuits terminate at pins numbered 2 and 7. Subsequently, the metal tube 5Z4 was announced with a filament circuit terminated by pins number 2 and 8, so that two 8-prong sockets or an extra switch had to be incorporated in tube tester designs, unless socket contacts No. 7 and No. 8 were connected together within the tester, thereby providing incomplete test of ALL octal tubes.

Supreme engineers, however, foresaw at the time that other tubes would be announced in which a filament circuit would not necessarily terminate at pins No. 2 and No. 7 or No. 2 and No. 8, but that the filament COULD terminate at any one of eight possible positions. Supreme anticipated "Roaming Filaments" and incorporated in 1936 Models an exclusive feature "Filament Return Selection" whereby the filament current,

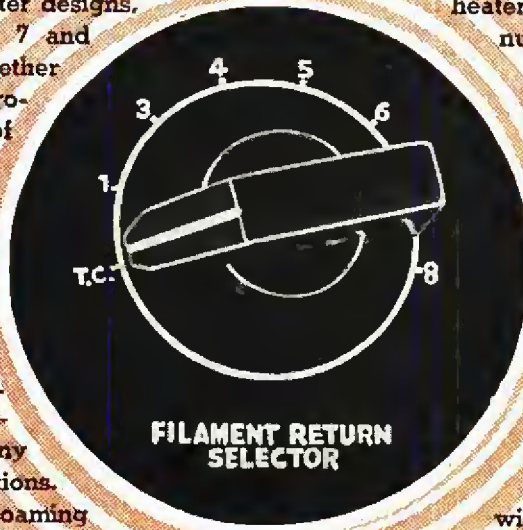

which may be considered as entering the No. 2 pin of octal tubes, could return through the "top cap" or through ANY of the tube base prongs.

This development enables Supreme owners to immediately take care of such new tubes as the type 6P7, just announced, in which the heater circuit is terminated by pins numbered 2 and 3 or any other new tube which may be announced in the future in which the filament (or heater) current returns through any pins other than those specified in the original series of octal tubes.

Remember, "Filament Return Selection" is found only in 1936 Supreme Instruments. An exclusive development of Supreme engineers, it is just one more reason most wide-awake servicemen are choosing new Supreme models in preference to any other make.

● **NEW SUPREME CATALOG NOW READY—FREE** ●
Practically all good jobbers now have these instruments in stock for demonstration and for your inspection—Supreme's new complete catalog, just off the press and sent to you without obligation, tells you more about "Roaming Filaments."

SUPREME INSTRUMENTS CORPORATION

536 Supreme Bldg.

Export Dept., Associated Exporters Co., 1457 Broadway, New York City.

Greenwood, Mississippi
Cable Address, LOPREH, New York

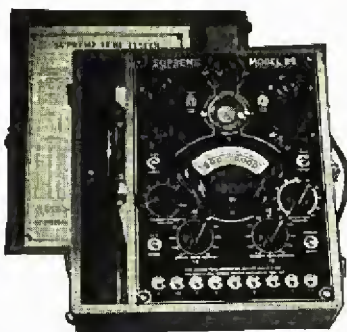

**SUPREME 89—STANDARD
TUBE TESTER**

A new low priced Tube Tester, featuring Supreme's famous Neonized leakage test. \$34.95

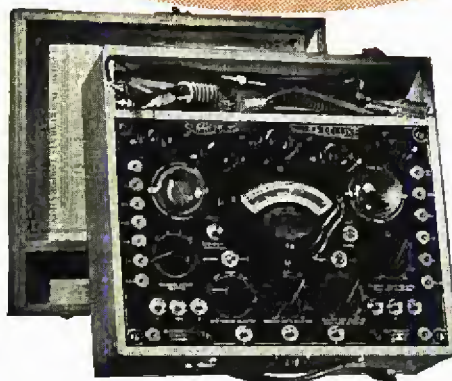

SUPREME 89 DELUXE TUBE TESTER
The 7-in-1 instrument. Resistance ranges to 20 megohms are with self-contained power supply \$45.95. Available also in beautiful Tri-Toned Walnut counter display model.

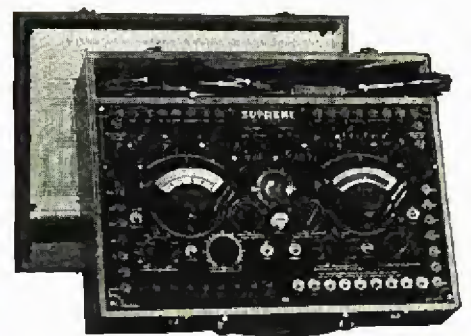

SUPREME 385—AUTOMATIC
A multi-unit instrument, combining features of 339—DeLuxe Analyzer and 89—DeLuxe Tube Tester, plus other flexibility features possible only through Supreme's exclusive uni-construction \$77.95

SERVICE SECTION

Diode Provides Residual Bias

Don't look for the customary cathode bias resistors in the r.f., first-detector and i.f. stages of RCA's Models T8-16 and C8-17. There aren't any. One diode section of a 6H6 is used as a half-wave second-detector, develops a.v.c. across the 220,000 ohm resis-

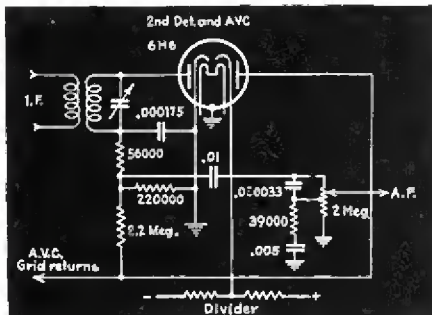

tor for application to the circuits mentioned. But the other section of the diode supplies residual bias to these tubes under conditions of little or no signal.

As it is explained to us, this second diode, under no signal conditions, draws current, which flows through the 220,000 ohm resistor and also through the 2.2 meg-ohm resistor, the drop being used as residual bias. On application of signal energy above a certain level, however, the auxiliary bias diode ceases to draw current and the a.v.c. diode takes over the biasing function.

Leather Speakers

Last month we heard a rumor that Stromberg-Carlson had a new high-fidelity speaker with a special leather suspension, checked into it. Hence the following letter from Ray H. Manson, chief engineer:

"As you probably know, all dynamic speakers capable of reproducing a range up to at least 5,000 cycles have pronounced peaks in the region between 1,000 and 2,000 cycles due to resonances in the material of the cone itself. This is more pronounced in speakers with a stiff edge suspension than the types we have been making with organ bellows leather.

"When we designed a single speaker unit to include frequencies up to 7,500 cycles it was very necessary that we eliminate these resonance peaks in order to provide smooth reproduction. One of our engineers discovered that a special leather resembling chamois in appearance provided the necessary correction factor to suppress these resonance peaks without loss of frequencies higher up in the range. This leather comes from an animal known as a "Carpinchoe," which is a native of South America and, I understand, found along the Amazon river. Obviously, there are many other factors in the successful design of single unit high fidelity speakers, such as the selection of the material for the

cone, the ribbing of the cone to provide stiffness and the use of aluminum wire in the moving coil, etc.

"We are using these single unit high-fidelity speakers in four of our new models which are provided with fidelity-selectivity controls in the chassis. We are continuing our two speaker jobs which are capable of reproducing with a flat response up to 10,000 cycles. The chassis, however, in the receivers using the two-speaker systems have fidelity controls which limit the radio reproduction to 7,500 cycles. The main advantage of the two-speaker system is the increased high-frequency response at the upper cut-off limit of the chassis and this is quite noticeable when making comparisons between the single speaker and the two-speaker system."

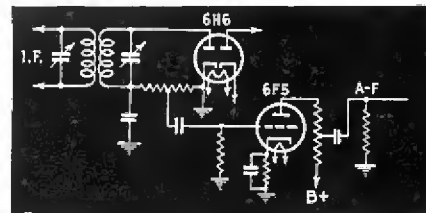

6F5 As High-Gain First Audio

The new type 6F5, because of its high gain characteristic, is particularly suitable for use in the first stage of amplifiers which must deliver plenty of "sock" with a minimum number of tubes. Hence it will probably be seen more and more frequently in new receivers.

Should you note, as in the circuit diagrammed, that the tube's input is tapped across only part of the detector's load resistor and that more audio is apparently thrown away by a similar tap in the 6F5's plate circuit you may be puzzled. The answer, according to Radiotron, is that gain is so high when the 6F5 is used that this means of avoiding distortion is permissible. How is distortion avoided?

The input circuit tap permits handling of highly modulated signals with little distortion. Where the full detector output is used heavily modulated signals may produce an appreciable amount of it. Utilization of only a part of the 6F5's output minimizes another type of distortion, due to plate current cutoff during the negative voltage excursions of the signal.

Suppressor Grid Mixing

Belmont's Model 777 receiver uses a separate oscillator, the signal generated being introduced into the mixer tube

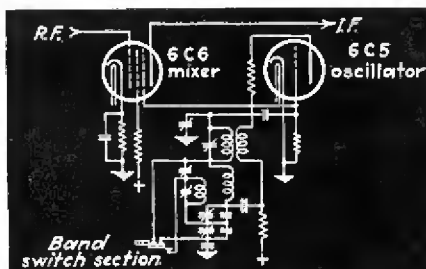

through its suppressor grid. Resembling suppressor grid modulation methods now coming into use in certain amateur phone transmitters, this system is said to reduce hiss, commonly heard in receivers having high sensitivity in the short wave channels.

Signal Generator Includes Beat-Note Frequency Modulator

Clough-Brengle's model OM signal generator, diagrammed, includes a built-in beat-note frequency modulator designed

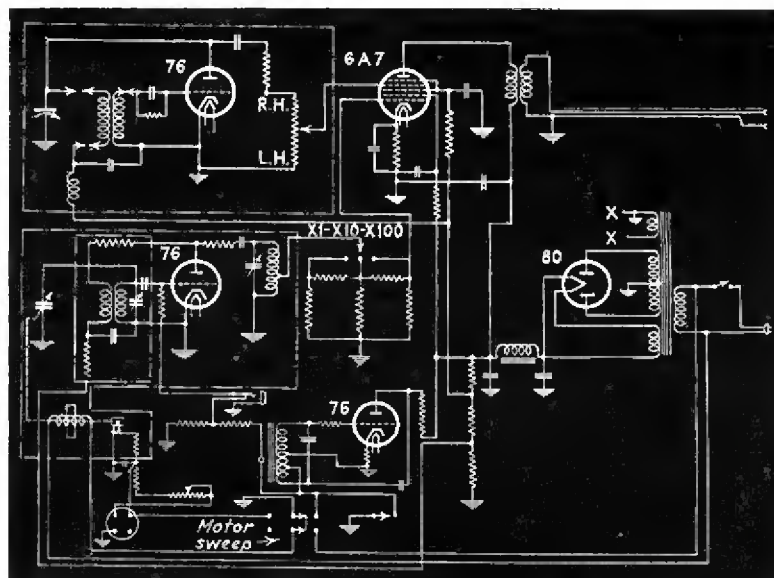

A
Great
tube salesman

THE NEW
WESTON
MODEL 770
TUBE SELLER

FOR
COUNTER AND
PORTABLE USE



AND *Real*
PROFIT - PRODUCERS
FOR SERVICING —

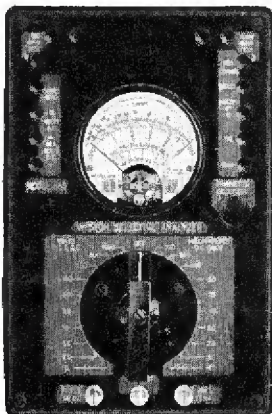

THE WESTON
SELECTIVE
ANALYZER

A life-time instrument—banishes analyzer obsolescence. Ready for the metal tubes. Measures all fundamental values including output.

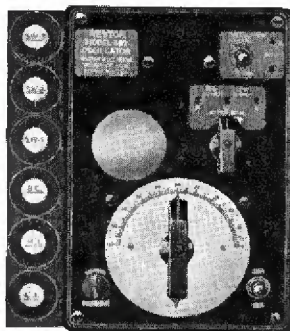

THE WESTON
ALL-WAVE
OSCILLATOR

A real all-wave oscillator—triple shielded—and with every feature you need to do an accurate servicing job on all modern receivers.

Here's the *one* choice in tube sellers today! It's Weston built. It combines *real* merchandising appeal with the ability to thoroughly and quickly check any and all tubes. Here are some of its features:

1. Neon short check while tubes are hot.
2. Condenser leakage test available.
3. A perfected total emission tester—actually tests tubes under load.
4. Individual tests on single electrodes—thus covering combination and double tubes.
5. Designed for both counter and portable use.
6. Tests all tubes, including metal—has spare sockets.
7. Finished in three colors—designed to attract and impress customers.
8. Priced low for a quality instrument.

You need this new Model 770 Tube Seller . . . just as you need these other Weston instruments for profitable servicing. They afford a profitable and *permanent* investment for those building a *permanent* business in radio. Get the facts on Weston instruments. Send the coupon today . . . Weston Electrical Instrument Corporation, 581 Frelinghuysen Avenue, Newark, New Jersey.

WESTON ELECTRICAL INSTRUMENT CORPORATION
581 Frelinghuysen Avenue, Newark, N. J.
Send bulletin on Weston Radio Instruments.

Name.....

Address.....

City and State.....

Mail this coupon

WESTON *Radio Instruments*

NEW Power Output TUBE TESTER

OTHER NEW MODELS

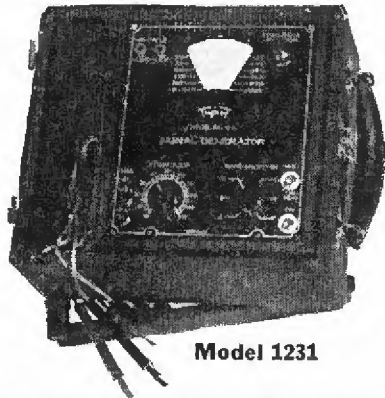

Model 1231

ALL WAVE DIRECT READING SIGNAL GENERATOR. All frequencies fundamentals, stabilized 100-30,000 KC. Jacks for 400 cycle audio note. Very accurate yet easy to operate. Model 1231 complete with batteries and two No. 3D tubes. Dealer net. Model 1232 same except uses 110-60 cycle A.C. Dealer Net\$26.67
Carrying Case Shown—Dealer Net..... 4.00

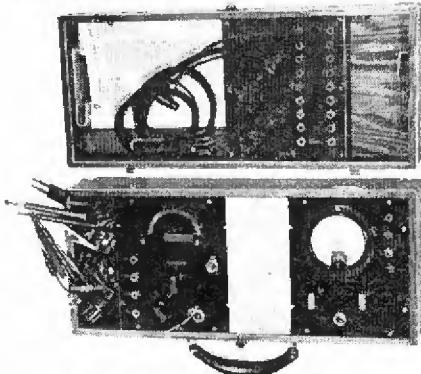

FREE POINT TEST SET Model 1181-A combines three essential units: No. 1125 Volt-Ohm-Milliammeter, 1151 All Wave Oscillator, 1166-A Free Point Auxiliary Set. Tester units can be purchased separately if desired. Dealer net price\$38.00

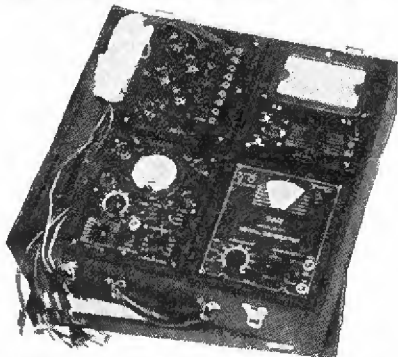

MASTER UNIT COMPLETE Model 1206—A complete, up-to-date laboratory contains Nos. 1200 Volt-Ohm-Milliammeter, 1210-A Tube Tester, 1230-A Free Point Tester, 1231 or 1232 All-Wave Signal Generator and No. 1204 Case. All items can also be purchased separately and complete unit built up over period of time. Dealer net price.....\$82.67

TRIPLETT MANUFACTURES

a complete line of electrical instruments for radio, electrical and general industrial purposes — both standard and custom built. Write for Catalogue. See them at your jobbers.



10 INSTRUMENTS IN ONE

PRECISION WITHOUT EXTRAVAGANCE

Model 1501 \$46.67
Dealers Net

THE NEW MULTI PURPOSE TUBE TESTER MODEL 1501—Radio service dealers have always wanted a tube tester that would test tubes under conditions approximating their use in a radio set. Here it is! Model 1501 combines in one unit ten instruments that are needed by radio servicemen in their daily work. Here are the ten instruments:

1. Test all type tubes (New Power Output Test).
2. Neon short test.
3. Separate Diode Tests.
4. Neon Paper Condenser Tests.
5. Electrolytic Condenser Leakage.
6. D. C. Voltmeter and Milliammeter.
7. Ohmmeter.
8. A. C. Voltmeter.
9. Decibel Meter.
10. Impedance Meter.

TESTS ALL TYPES—old style, new style, both metal and glass-metal—specially constructed against obsolescence.

Bring on your trick tubes that get by other testers—try them in TRIPLETT'S new Power Output Tester—see for yourself how this instrument can save you time in hunting for troubles and help you to sell more tubes. Each tube is measured by output test, that is, the tube is fully loaded and does not have an opportunity to reheat for an instantaneous test. It will definitely help you sell more tubes by finding more bad and weak ones.

MODEL 1500 is a power output tube tester with neon short test and shadow-graph line voltage indicator. Same case as Model 1501. Dealer net price \$36.67

THE TRIPLETT ELECTRICAL INSTRUMENT CO.
BLUFFTON, OHIO



SHOP SHORTCUTS

How to Build a Potentiometer Setup For Measuring High Resistance

By Jack Avins

Many d.c. measurements in radio require the use of a very high resistance voltmeter.

Figure 1 illustrates a practical potentiometer setup with which such measurements may be accurately made. This instrument has a range of from 0-100 volts in two steps of 0-10 and 0-100. The balancing voltage is obtained from a power supply capable of delivering 100 volts at about 10 mils. A double-pole-double-throw switch is used to simultaneously change the sensitivity of the voltmeter V and the voltage range. While a one mil meter will serve to indicate the balanced condition a 200-0-200 microammeter is to be preferred. If one is used a protective resistance of 100,000 ohms should be inserted in series when making the preliminary balance. This resistor is shorted out when making the final balance by switch S₂.

It is desirable not to obtain the 100 volt supply directly from the line by using a halfwave rectifier since this will ground the potentiometer to the a.c. line. The remedy is to use a transformer to isolate the potentiometer. Since one to one power transformers are not generally available it will probably be most convenient to use a power supply delivering about 300 volts and a voltage divider. Of course the range of the potentiometer can be extended to 300 volts if desired but this is seldom required, since the ordinary voltmeter is of sufficiently high resistance for practically all measurements involving more than 100 volts.

A double-pole double-throw switch is used to reverse the polarity of the input voltage whenever this happens to be different from that of the potentiometer. If the balance becomes progressively worse as the potentiometer voltage is increased from zero then it is an indication that the polarity is wrong.

Applications

Consider the skeleton avc circuit outlined in Figure 2. The cathode of the i.f. tube and the coil are both approximately 100 volts above ground. With no signal the plate of the avc tube is also 100 volts above ground. Now suppose, as often happens, that a leaky condition develops between coil and ground. This leak may be due to bypass condenser C being defective or to excessive moisture in the coil. It is apparent that the effect of the leak would be to increase the bias on the tube. Furthermore, the leak could not be measured with an ohmmeter since the normal resistance between coil and ground through the avc circuit is less than the leak.

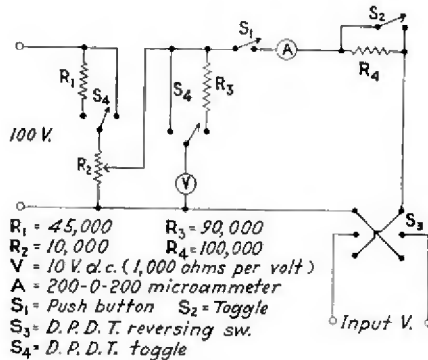

Fig. 1—Practical potentiometer setup

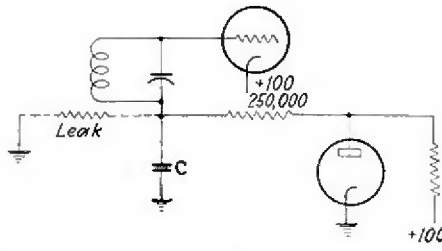

Fig. 2—Diagnosing a leaky condenser at "C"

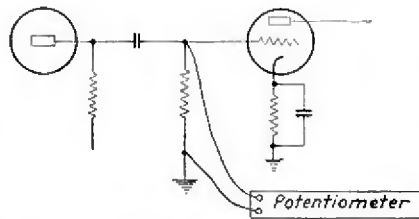

Fig. 3—Measuring grid voltage in typical A.F. circuit

With the potentiometer the actual voltage between grid and ground is at once measured and the source of trouble located.

Another example of the potentiometer's usefulness:

Consider the resistance coupled audio circuit of Figure 3. Suppose the coupling condenser develops a leak. This will place a positive voltage on the grid of the final tube. Using the potentiometer it is merely necessary to measure the voltage on the grid under actual operating conditions. A leaky condenser will then be indicated by a positive voltage between grid and ground.

1935 Car Hints

By C. S. Gooch

When radios are installed in 1935 Ford DeLuxe models interference is carried to the antenna by the dome light lead. In Standard models this form of noise pickup is not troublesome. This difference is caused by the electric oil gauge on the DeLuxe cars. A condenser on the terminal near the flywheel housing will eliminate it, although in some cases it is necessary to cut the dome lead at the dash and install a switch.

A condenser on the generator is seldom necessary in 1935 Fords if a dome-light filter, or ignition filter is used. In cars of this same year and make dress the antenna lead away from the loom containing ignition and lighting wires, inside the body under the cowl. Interference will otherwise be picked up despite apparently complete shielding. Occasionally it is necessary to wrap screen wire strip spirally around this loom where it passes through the motor compartment, spotting with solder to make the shield continuous and then grounding it.

Running-board antennas on turret-top cars must have a shielded lead in all the way down to the antenna itself for best results. The shield must be grounded to frame or running board at a point immediately above the antenna. It is necessary to bond the running-board to the front fender where these units are separate, as in the 1935 Oldsmobile.

On Chevrolet, Oldsmobile, Pontiac and Buick, all 1935 models, time will be saved by removing the kick-pad nearest the radio, running the leadin down through the joint in the body. This can be seen when the pad is removed. Slight enlargement of this opening will be necessary and this is readily done with a punch, leaving the edges of the hole smooth.

Wanted: Appliance Data

Our "sister" paper, "Electrical Merchandising," now publishes an appliance service section.

Have you any data on the adjustment or repair of household refrigerators, washers, cleaners, oil-burners or minor appliances?

Send them in to the Service Editor, "Electrical Merchandising," 330 West 42nd Street, New York City. "Merch" will pay for all accepted items, just as we do, of course.

Emergency Heat

By Marion L. Rhodes

When it is necessary to heat small parts for soldering and no iron is on hand light a "Vritropin" tablet (kidney remedy), available in any drug-store, with a match. It will burn for about



CLOUGH-BRENGLE ANNOUNCES —

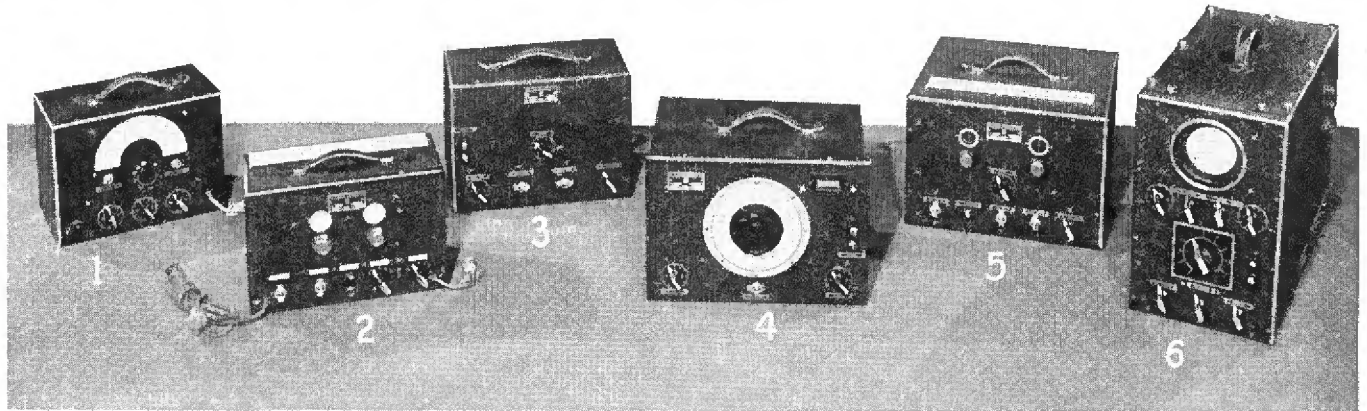

"The Most Complete Line of Radio Instruments"

MODEL 82 Direct Reading Oscillator (No. 1)—A new low price addition to the C-B line. Continuously variable from 85 k.c. to 21 m.c. on six tuning bands (all fundamentals). Ladder attenuator, 8½" scale, full vision dial, separate audio and radio frequency outputs. Precision and dependability at low price. Complete with tubes, net..... \$19.90

MODEL OC R. F. Oscillator (No. 2)—New series with direct reading frequency chart and carrying handle. The most accurate, most stable, and most rugged signal generator offered—and rightfully the most popular. A.C.-D.C. line operation with guaranteed frequency accuracy of ½ of 1%. Each instrument hand calibrated and supplied with individual frequency chart. Complete with tubes, net..... \$32.90

MODEL 81 Heterodyne Frequency Modulator (No. 3)—Provides all the advantages of calibrated selectivity curve analysis when using the Cathode-ray oscilloscope, as first introduced in the C-B MODEL OM, without the necessity of replacing your present oscillator. Operates with any oscillator and does not require any alterations or recalibration of the oscillator. Simply connect the oscillator output cord to the MODEL 81, which in turn connects to the set. Complete with built-in heterodyne oscillator, sweep motor, and tubes, net..... \$34.25

MODEL 79 Beat-Note Audio Oscillator (No. 4)—A precision instrument for audio laboratory and service work, especially adapted for use with the oscillograph. Calibrated from 50 to 10,000 cycles. Built-in vacuum-tube voltmeter to indicate zero beat and output level. Self-powered from 110-volt 60-cycle line. High voltage output to 5000-ohm line. Complete with seven tubes, net..... \$51.90

MODEL OM Frequency Modulated R. F. Oscillator (No. 5)—The only instrument specially designed for use with the Cathode-ray oscilloscope. Provides an accurately calibrated sweep of plus and minus 15 k.c. or at a switch throw becomes a standard audio modulated or unmodulated oscillator for output meter adjustments. May be externally modulated through panel jack. Guaranteed ½ of 1% accurate frequency calibration. Stabilized against line voltage and temperature variations. Used by over 50% of all American set manufacturers for laboratory and production tests. Complete with hand-drawn calibration curve, sweep motor, and laboratory tested tubes, net..... \$57.85

MODEL CRA Cathode-Ray Oscilloscope (No. 6)—Complete with linear sweep circuit, grid control synchronizing circuit, vertical input amplifier of twice the

usual sensitivity, and horizontal amplifier of special remote cut-off design for sweep compensation—plus countless other exclusive C-B features. Chart holder allows quick interchange of calibrated screens. Complete with 3-inch Cathode-ray tube and all other tubes, net..... \$84.50

MODEL CRB Cathode-Ray Oscilloscope—Identical to above, less linear sweep circuit which is not needed for receiver alignment when the MODELS OM or 81 are used. Complete with 3-inch Cathode-ray tube and all other tubes, net..... \$69.50

MODEL UC Vacuum-Tube Voltmeter—With direct reading scales calibrated 0-3, 0-30, and 0-70 volts. Measures voltage at infinite resistance, thus drawing no current from the circuit under test. Unequaled for measurement of bias voltages, stage gain, R. F. impedance, etc. Self-contained power supply for 110-volt 60-cycle line operation. Complete with all tubes, individually calibrated, net..... \$34.85

For complete description of these and the many other new CLOUGH-BRENGLE Professional Service Instruments just released from the laboratory of Kendall Clough, see your local C-B jobber or use the coupon below.

"Package-Unit" Amplifiers

The new CLOUGH-BRENGLE Series AX High Fidelity "Package-Unit" Amplifiers and Sound Systems are winning the approval of experienced sound men the world over. Designed for direct operation from crystal microphones. Write for new descriptive bulletin today.

The CLOUGH-BRENGLE Co.

1130-C W. Austin Ave., Chicago, Ill.

Get the Full C-B Announcement TODAY!

The CLOUGH-BRENGLE Co.
1130-C W. Austin Ave., Chicago, Ill.

Send your new catalog listing the complete CLOUGH-BRENGLE line of instruments.

Name.....

Address.....

SERVICE SECTION

two minutes with an intense blue flame. I carry a supply of them in my kit for country repair work.

Interpreting Oscillograph Curves

By V. W. Hodge

I have been using an oscillograph for several months and find that the big job is to know what curves mean. For example: It is possible to isolate noisy

with pigtail types use the old lugs for mounting. To prevent closing of the old resistor cut wire on the old strip with a knife inserted between edges of fish paper.

To find the resistance of open Candohms insert test prod in center of the resistor, between edges of fish paper, and measure to lug which still has continuity. Multiply the reading by two.

Tube "Stilts" Aid Balancing

By E. A. Wight, Jr.

Instead of "darkening" the filament of tubes used in neutrodyne with paper I raise three of the prongs on home-made "stilts," leaving the fourth prong open.

Break up the base of a defunct 25Z5 and obtain its prongs. Hammer the flange of the prongs (ordinarily embedded in the insulation) down flush, being careful not to damage the prong itself.

Now solder a piece of brass tubing with an inside diameter large enough to permit the entry of tube prongs to the hammered-down flange. To balance, put these "stilts" on three tube prongs and insert them in the socket.

The "stilts" make good test connectors for point-to-point readings, too.

"Listener Inner"

By Otto Buder

The device diagrammed, made in a shield can which may be seen on the bench in the photo, is invaluable when checking r.f. stages. It is a radio frequency amplifier and diode detector combination taking its supply voltages from an auxiliary shop pack. The output of the device is fed into the shop test amplifier.

By starting at the antenna with the prod one can check the performance of each individual r.f. stage, quickly discovering lack of amplification or distortion. We find it particularly useful for rapid isolation of trouble preceding the a.f. amplifier.

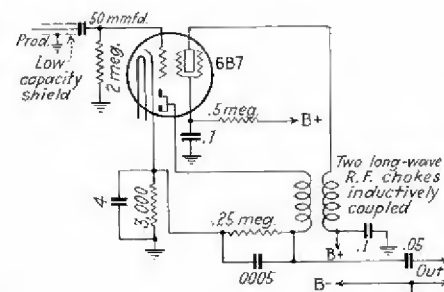

transformers, not shown by ohmmeter test, by putting 60 cycle a.c. on one winding, hooking one set of oscillograph plates to the other. Set the controls so that you get a regular 60 cycle wave on the screen. If one winding is noisy you will see small ripples on the waveform, as shown in the drawing in the upper right, whereas a good transformer will produce the curve at the upper left.

My oscillograph has been particularly useful in adjusting auto-radio vibrator points. Care in reading is especially needed here as the satisfactory waveform varies from one make to another. Hook vertical plates of oscillograph to primary of power transformer, one (grounded side) lead to set chassis, other lead to one side of primary. Use the internal 60 cycle timing wave.

Good and bad waveforms are shown on two typical packs tested here.

Candohm Resistor Repair

By George S. Carson

When replacing Candohm resistors

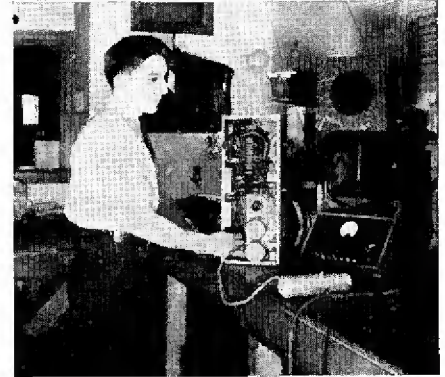

Service Chair Saves Time

By Paul G. Freed

This rough sketch shows the appearance of a chair used in my shop while doing bench work. It was purchased in a second-hand store for \$1.50, the brackets for shelves cost 30 cents and the roller casters cost 35 cents a set.

On the right hand shelf I have ar-



ranged those tools which are constantly in use while working on a repair job. They are always at my finger tips, instead of scattered out on the bench or up in front in a rack too far away to reach conveniently. I have enamelled the handles of all tools different colors so that they may be identified quickly.

On the left hand shelf I keep my circuit manual. I can check wiring without leaving the chair. The repair chair makes it unnecessary for me to use my lap as a shelf for the manual, reduces "neck strain," makes bench work much more convenient and rapid.

Battery Post Cleaning

If the posts of a storage battery are daubed with ordinary ammonia every ten days or so corrosion and attendant auto radio noise will be avoided.

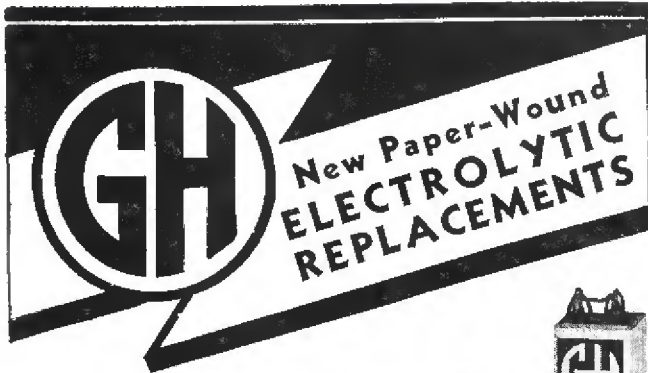

ABSOLUTE SAFETY—TESTED AT 1500 Volts • 100% Moisture Proof

Used by radio set manufacturers . . . liberal safety margin enables representatives and wholesalers to guarantee satisfaction. 100% moisture-proofed by special G-H process . . . no current leakage . . . complete standardized line . . . all shapes and capacities.



Electrolytics • Resistors

Space-saving electrolytic condensers for every make of radio . . . can, cardboard and multiple section types. Tubular, uncased and cased paper wound condensers for every purpose . . . complete line Carbon Resistors.

TERRITORIES AVAILABLE

Write for samples and catalogue sheet.

GIRARD-HOPKINS

1437 23rd Ave., Oakland, Calif.

JOBBER: SEND FOR FREE SAMPLES

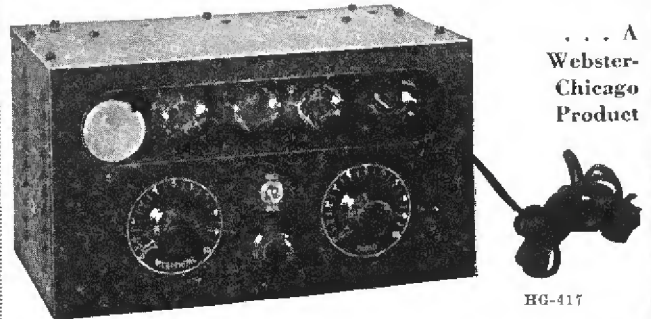

... A Webster-Chicago Product

HG-417

NEW! 4-Stage Amplifier
for Crystal Microphone or Phonograph

FOR general public address work and party call systems—schools, churches, theatres, factories—this NEW 4-Stage Amplifier for crystal microphone or phonograph is ideal.

Many Desirable Features

Self contained. Completely enclosed. Field excitation for two dynamic speakers. Output 17 watts. Tapped output transformer. Fader control system. Speaker and microphone connections terminate in polarized plugs. Tubes, 1 6C6, 1 53, 3 2A5's, 1 5Z3.

Sound Men! Dealers!

HERE'S YOUR CHANCE. Earn More!

with this new Webster-Chicago unit. Get complete details—NOW! And remember—there's only ONE Webster-Chicago. It's IN! Chicago.

Write for Bulletin—NOW!

THE WEBSTER CO., 3829 W. Lake Street, CHICAGO, ILL.

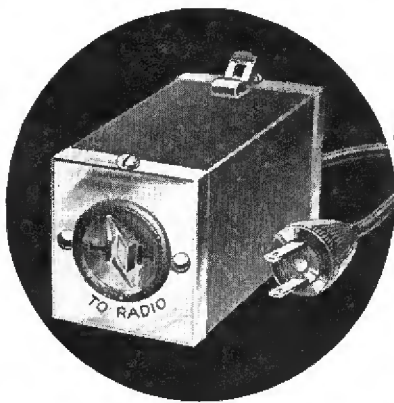

Every set needs one ...badly

LINE FILTER

No 7818

Improve the reception and selectivity of every set you install and service with this important unit. More efficient than any filter on the market and sensationally priced, it offers you a positive solution to the crackling, sizzling noise problem caused by household appliances and power line disturbances which "noiseless" antennae cannot eliminate.

Just plug it in—no adjustment or attention, and it lasts a lifetime. Handsome chromium and black Kem-Art metal case, rubber cord and unbreakable plug. Shipping weight 16 oz.

Try this extra profit-builder today. Order from your distributor, or write



J. W. MILLER COMPANY
5917 So. Main St., Los Angeles Cal.

\$4.00



Tear out this ad and pin to your letter-head for FREE copy of the NEW UTAH General Catalog of vitalized radio parts

UTAH RADIO PRODUCTS CO., Orleans St., Chicago

STEP AHEAD

IN THE SERVICE PROFESSION WITH CASE RECORDS OF BROADCAST RECEIVER REPAIRS



- Add 10,000 hours to your service experience!
- ELIMINATE GUESS-WORK IN YOUR SERVICING!
- DON'T PUZZLE YOUR PROFITS AWAY!

Your work is already done and recorded for you in "CASE RECORDS". This 8x12" leatherette binder CONTAINS 1,700 alphabetically and numerically arranged case records of SUCCESSFULLY COMPLETED SERVICE JOBS. Each Record tells—symptom—parts responsible—electrical values—location—and best replacement or repair. Fastest Servicing technique known. 114 Receiver Makes—\$500 Models. SUPPLEMENTED QUARTERLY FREE for 1 year.

CAPITOL RADIO RESEARCH LABORATORIES, Inc.
993 National Press Bldg., Washington, D. C.

\$4.75 Postpaid.

Kindly forward full details on "CASE RECORDS", with your DISTRIBUTORS PLAN, and your Data Sheet on BUILDING AN ANALYZER ADAPTER.

NAME _____
ADDRESS _____

FREE

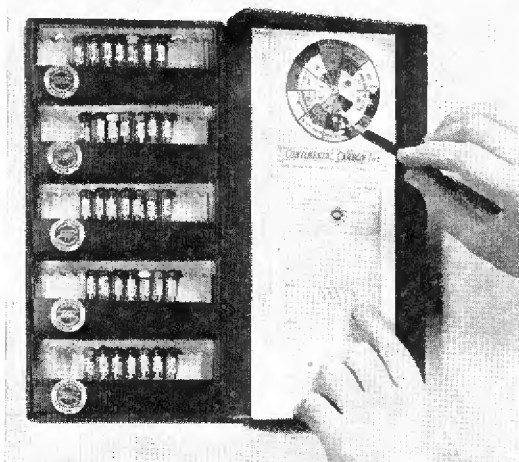

RESISTOR CABINET

—with purchase of 35 CONTINENTAL insulated 1/2 or 1-watt resistors at your regular net price of \$4.20. Cabinet for resistor stock hangs on the wall; dial the rotary color code like an automatic telephone. A watt-ohm-volt chart appears below the colored dial.

• Condenser Engineering Bulletin 103 Free •
Ask your Jobber for your copy



13902 Lorain Ave., Cleveland, Ohio
Canadian Factory: Toronto, Ontario

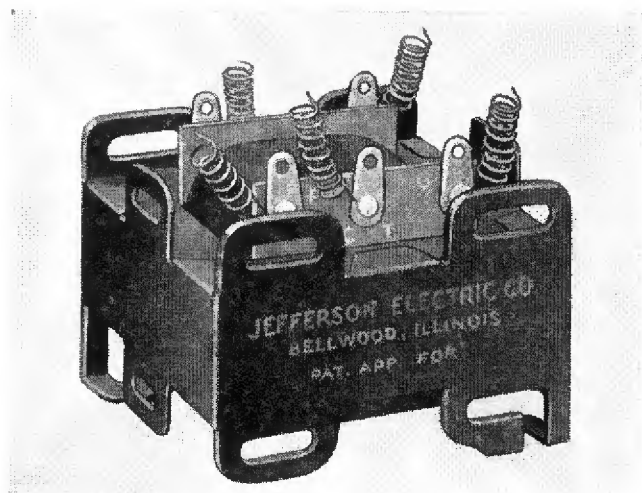

Universal Input Transformer No. 467-168. Has silvered lugs and leads, vacuum-treated windings, and is adaptable to all types of receivers. Compact—low cost. Also can be used as audio by omitting center tap.

**For True
PROFIT
Replace with Jefferson**

TRUE profits on replacement parts and repair work are not what you take in, but what you keep. In other words, every part must satisfy—there must be no return service calls, without charge, to eat up your profit.

The safe way to make profits you can keep is to sell only parts as good or better than were used originally in the set. Ever since the birth of radio, leading manufacturers have used Jefferson Transformers year after year.

Protect yourself by selling replacement parts of recognized quality. Established wholesalers can supply you from stock. Be sure to ask your wholesaler for the latest Jefferson Catalog and Amplifier Circuits. You can build commercial type amplifiers profitably with Jefferson Foundation Kits. If your wholesaler is not yet able to supply you with Jefferson products and literature write us mentioning his name.

JEFFERSON ELECTRIC COMPANY
Bellwood (Suburb of Chicago) Illinois
Canadian Factory: 535 College Street, Toronto

**NATHANIEL
BALDWIN
CONTROLLED RESONANCE
SPEAKERS**

This ad pinned to your letter-head will bring complete data on the great BALDWIN line of Replacement Speakers.

CONSOLIDATED RADIO PRODUCTS CO., 361 W. SUPERIOR ST., CHICAGO
280 BROADWAY, NEW YORK, N. Y.

**DON'T LET
RADIO
NOISE GET YOU DOWN**

TOBE FILTERETTES

Will stop all radio interference. It's the accepted remedy for radio noise, made by the recognized authority on radio interference and endorsed by all leading radio and electrical manufacturers.

Write today for free bulletin F-635 or send 50 cents for big 8 1/2"x11", 76-page Noise Manual.

TOBE DEUTSCHMANN CORPORATION
CANTON Filterette Division MASSACHUSETTS

JEFFERSON Radio Transformers

Sell the

**Pioneer Air-Flo
at the
Lowest Jobber Dealer Price
of all!**

THIS wind driven charger, is manufactured by the largest exclusive dynamotor laboratory in the country, of entirely new parts, every one of which is designed solely for its purpose in the Air-Flo. There is not a single re-manufactured or rebuilt part in the entire assembly. It's designed, tested, built and proved under the supervision of the same engineers who designed the airplane dynamotors used by the leading air lines. It's a quality product throughout, and yet is offered at the lowest wholesale price of all.

Why waste good sales and service effort on a profitless article? Make money by selling the Air-Flo—it's lowest in price.

Send for circular on Pioneer's complete line of high voltage dynamotors and Gas Engine driven Dynamotors.

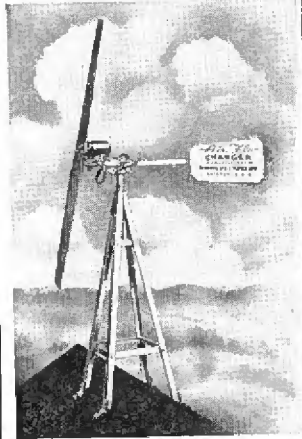

Write for complete details today!

PIONEER GEN-E-MOTOR CORP.

458-J West Superior St.

Chicago, Illinois

Check up on your knowledge

of present-day
radio operating
equipment, methods,
etc.

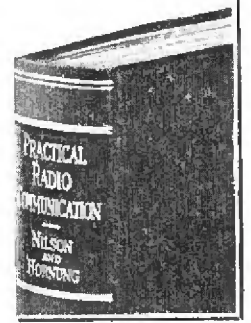

**Just
Published**

This new book provides a complete text in practical radio communication based on theoretical introduction, suitable for use by radio operators, technicians and engineers.

See this book for a balanced treatment of radio operating principles and practice that includes the latest in equipment, operation, etc., in broadcasting, marine, police, aeronautical, and amateur radio transmitting and receiving.

Practical Radio Communication

*Principles—Systems—Equipment—Operation
Including Short-wave and Ultra-short-wave Radio*

By Arthur R. Nilson, Lieutenant (Technician) (Communications) U. S. N. R. (Retired), and J. L. Hornung, Formerly Radio Instructor, Guggenheim School of Aeronautics, New York University. 754 pages, 6x9, 435 illustrations, flexible. . . . \$5.00

THIS book covers the requirements for all classes of radio operator's license examinations; treats long, medium, short, and ultra-short-wave radio; includes all classes of radio stations—is in general a complete text on practical radio communications.

Use this book to prepare to pass government radio operator license examinations, ground yourself in essentials of technical and operating positions in police radio, broadcasting, aeronautical and marine radio, check up on your knowledge of developments and advances in equipment, methods, etc.

This book gives you

- full treatment of radio and electrical principles; delves deeply into radio application of alternating currents
- particular attention to broadcasting; practical description of Western Electric broadcast transmitter; information on studio acoustics and apparatus, control-room equipment and operation, etc.
- sections on ultra-short-wave radio equipments, of special interest to police operators
- radio-telegraphic and radio-telephonic treatment of aviation radio; aircraft transmitters, receivers; testing and maintenance
- marine medium-frequency equipment, high-frequency transmitters and receivers; Coast Guard low-power transmitters; direction finders; etc.
- power-supply apparatus; rectifiers; generators, etc.

Examine this new book for 10 days

**McGraw-Hill
ON-APPROVAL COUPON**

McGraw-Hill Book Co., 330 W. 42nd St., N. Y. C.

Send me for 10 days' examination, on approval Nilson and Hornung—Practical Radio Communication. In 10 days I will send \$5.00 plus a few cents for postage and delivery, or return book postpaid. (We pay postage on orders accompanied by remittance.)

Name

Address

City and State

Position

Company F-RR-10-35
(Books sent on approval in U. S. and Canada only.)

Worth Climbing For!

• The New Radolek 1935 Fall Edition of the Profit Guide is the most complete Radio Parts Catalog ever published—new, bigger and better. Everything in radio—at the right prices. Over 160 pages of valuable, money-saving "radio-buying" information. Over 10,000 separate Repair Parts—hundreds of new items—a complete, new selection of Radio Receivers and Amplifiers. Contains the most complete, exact duplicate, replacement parts listings, of volume controls, condensers, transformers, vibrators ever compiled. Nowhere, ever, has there been a Radio Parts Catalog comparable to this superb book. Every page brings you extra profits. This is your book—it's FREE. Send For It!

RADOLEK restricts distribution of the PROFIT GUIDE to those actively and commercially engaged in the Radio Business. Please enclose your Business Card or Letter Head.

THE RADOLEK CO.
639 West Randolph Street, Chicago, Ill.
Send me FREE the Big New RADOLEK PROFIT GUIDE

Name

Address

Are you a Serviceman? Dealer? Expm?

SERVICE SECTION

TRICKS of the TRADE

AIRLINE 77-95. Poor tone quality noted after replacing defective 19 tube . . . Change bias from 6 to 4½. If in cable disconnect from 6 volt pin and connect to 4½ volt pin. Static-like noise . . . Replace push-pull input transformer. IF: 175.

AK 55 (Early). Intermittent operation after a few minutes of use, reception gradually fading out completely with a buzz . . . Open secondary in second r.f. transformer. Plate lead of 24 comes through this coil and as fault is intermittent it is usually difficult to hit the open period when checking socket voltages. Application of heat from a 60 watt lamp will hasten the opening if this condition exists.

AK 40. Fading and low volume, especially where 26's are old . . . Put on additional filament leads from power pack through a hole drilled in side of pack case to filament lugs of first r.f. socket. This will lower drop in leads, raise voltage on 26's and improve performance.

COURIER 65. Oscillation, all usual remedies fail . . . Connect .1 condenser from contact of volume control (opposite the grounded contact) to ground on chassis.

CROSLEY 8H1. Common trouble . . . Balancing condensers located on top of i.f. coil cans short out to mounting screws, due to plates of condensers being out of line. Thus, when moved out of their original position they touch the grounded mounting pillars.

CROSLEY 130. Dial off frequency, or frequency settings "drift" . . . Do not adjust oscillator trimmer until you are sure the dual filter and screen grid 8 and 4 mfd. condenser is not leaky or open. Original unit breakdown voltage is 300 for the filter section, 150 for the screen. Replace with 450 volt and 200 volt sections. (IF 181.5 kc.)

GRUNOW 7-A. Volume drops intermittently but set does not go completely dead . . . Check two .1 mike condensers connected between lower end of r.f. coils and ground. Located in small can fastened to bottom of coil shields. Lugs on the can are blanks. Connections made by wire leads inside shield.

GULBRANSEN 92, 93. Tubes burned out for no apparent reason . . . Note position of B-limiting resistor connected from socket of 33 to filament prong of second detector. Arcs occur between this resistor and a nearby filament wire. IF: 175.

MAJESTIC 66. Fuse blows regularly, voltages test ok . . . Look for bad 6Y5. Sometimes test ok in checker but change it anyway. (IF 175 kc.)

MAJESTIC 66. Intermittent operation when car is operated over rough roads . . . Look for broken shielded ground wire leading inside of plug at rear of set. Take off plug and unscrew, soldering wire.

MAJESTIC 90B. Fading . . . Replace detector cathode bypass condenser. Check 27's.

MOTOROLA TWIN 8. Excess vibrator hash . . . Screw in bottom of set holding pack in place should first be tightened well. If this fails to remedy noise put a .5 mfd. automotive type condenser on the hot A lead where it fastens on terminal lug and ground to case of set.

PHILCO TRANSITONE 5. Oscillation "birdies" in older models . . . Generally curable by pulling 15,000 ohm resistor in 2A7 circuit up toward front of set. Tendency to "swish" . . . Change 78.

PHILCO 18. Cuts out for short interval and then resumes playing . . . Examine a.v.c. coupling condenser for leaks or broken wire connection in bakelite case, causing it to make or break contact. Tape wooden or rubber handle of screwdriver and tap all bakelite cased condensers while set is in operation, note if volume changes. Where condensers are faulty the pitch is usually melted through the connection hole.

PHILCO 60. Intermittent loud buzzing similar to outside motor interference but originating in set . . . Replace 6A7 oscillator-first detector even though it tests ok.

PHILCO 806. Rattles . . . Bond all ground terminals riveted to sockets to chassis.

RCA R12. Motorboating . . . Replace type 47 tubes and connect a 5,000 ohm resistor in series with the screens to prevent recurrence of the trouble.

RCA R50, GE H32, R55, RAE59. Sets play only when 27 a.v.c. tube is removed . . . Look for open resistor in a.v.c. return, also for high negative bias on r.f. and i.f. control grids. Oscillation . . . Usually caused by open circuit in .1 mike screen by-pass condenser. Fading . . . Look for open or leaky .1 by-pass across resistor in a.v.c. circuit, usually found in the power pack connected to the blue lead from the condenser block.

RCA 321. Phonograph plays but not the radio . . . Check for short in condenser having blue lead to terminal near oscillator padding condenser. When replacing be sure to include 30,000 ohm resistor in original position. Use 4 mike unit with 500 volt rating.

SILVERTONE 172, 36, 41, 37. To increase pep in these sets, volume controlled by primary coil movement into secondaries . . . Loosen setscrew on volume control shaft on rear of condenser gang and move primaries ¼ to ½ in. farther into secondaries. Tighten screw, align trimmers on gang to cut out oscillation and insert 35 type tubes in r.f. sockets instead of 24's.

SILVERTONE 1640. Blurring at high volume levels . . . Reverse transformer secondary leads to grids of 46's.

SILVERTONE 1711. When changing to standard tube types . . . Replace 951's with 32's. Replace 950's with 49's, not with 33's as the latter draw excessive filament current and will blow ballast tube.

SPARTON 410. Set breaks into oscillation after warming up although all voltages, bypasses and ground connections are ok . . . Try two new 183 type tubes.

STEWART-WARNER 1181, 1182, 1183. Won't play unless local switch is clicked on and off . . . Change 50,000 ohm resistor on 6A7 socket to 60,000 ohms. If set goes into oscillation put a .25 mike condenser from cathode to ground on the 6A7.

STEWART-WARNER 1181, 1182. Bell-like rattle . . . Traceable to tubular condensers inside power transformer cover. These units break off and strike against cover. Remove four screws, pry off cover, resolder and tape condensers to transformer and replace cover. Set inoperative except for faint response on powerful locals . . . Look for broken lead on coupling condenser connected to movable arm of volume control. Mounting hint . . . Sets are equipped so that speaker may be pointed outward but trouble will be experienced in this position due to the horizontal position of the vibrator and tubes. Use side or end mounting with speaker downward.

U. S. RADIO AND TELEVISION 10. Hum, volume control will not reduce volume to zero . . . Replace the 8 mike condenser under the resistance strip in the center of the chassis. It frequently opens, causing this trouble.

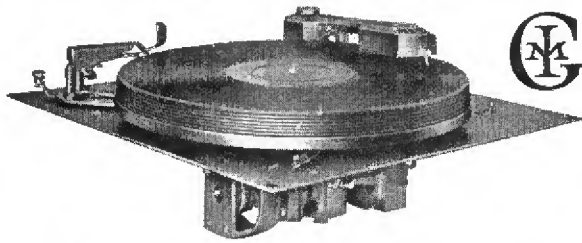

A SURPRISE COMING To Radio-Phonograph Manufacturers

UNTIL you actually see the new General Industries Automatic Record Changing Units *work*—test them out yourself in your own radio-phonograph combinations—and find out their **LOW COST**—you cannot realize what *highly important* sales opportunities they open up for you. You'll be surprised, yes—and glad you ordered samples to test.

Complete—motor, turntable, pickup and changer mechanism all assembled in one compact, self-contained unit, ready to place in cabinet. Installation labor cost is *nil*. Motor—latest type two-speed General Industries FLYER, instantly adjustable for 33 1/3 or 78 r.p.m. records. Pick-up—flat-type. Changing mechanism—a modernized, simplified, fool-proof General Industries development. Small space required for installation.

Two types. Model "L," shown above, plays and automatically changes **EIGHT** 10-inch or **SEVEN** 12-inch records, repeating last record. Model "K," especially for 10-inch records, plays and changes eight records. Will play 12-inch records changed by hand.

Order test samples NOW, specifying exact voltage and frequency of current you use.

The GENERAL INDUSTRIES CO.
3537 Taylor St., Elyria, Ohio

"I'll Pay a Few Cents More For a SPRAGUE Any Day!"

"Remember," writes a successful serviceman, "if filter condensers fail to supply the proper voltage (as many 'bargain' condensers do) nothing about a radio can be wholly right. Other essential parts will work far below their standard of efficiency. The set might play, but never with its greatest volume or best tonal quality.

"I was surprised to find what a whale of a difference Sprague Condensers actually made in pepping up 'sick' sets. That's why I use 'em on every job. They're cheaper in the long run—and they've helped me build a real reputation for getting *better than average results* from the average radio set."

Made in a complete line for every radio need. Sold by leading jobbers. Write for catalog.

SPRAGUE PRODUCTS CO.
North Adams, Mass.

SPRAGUE CONDENSERS

MADE
RIGHT



PRICED
RIGHT



YOUR OBSOLETE ANALYZER "PRECISION" MODERNIZED

INTO A TWO METER MASTER
ROTARY SELECTIVE SYSTEM

Write for our Plan

Mention Model Number of
Your Old Analyzer

PRECISION APPARATUS CORP.

Modernization Division—Dept. R
821 E. New York Ave. Brooklyn, N. Y.

**RELIABLE
AS THE NORTH STAR**

**NEW
INSULATED
IRC
RESISTORS** Metallized

The first fully sealed and INSULATED Resistors—ideal and modern for every purpose. Use them anywhere without fear of shorts or opens. Quiet—vibration-proof—moisture-proof. The outstanding resistance development in years!
INTERNATIONAL RESISTANCE CO.,
Toronto, Canada Philadelphia, Pa.

IT'S COMING • THE BIGGEST

MANUAL WE'VE EVER PUT OUT • IT'S
A MANUAL YOU NEED • A MANUAL
YOU'VE HELPED CREATE WITH YOUR SUG-
GESTIONS • NOW IT'S COMING OUT
• WATCH FOR IT!



RIDER JOHN F. RIDER
PUBLISHER
Publications
1440 BROADWAY • NEW YORK

Flash!! Did you get your copy of Rider's "The Cathode Ray Tube At Work"? 336 pages \$2.50 Postpaid.

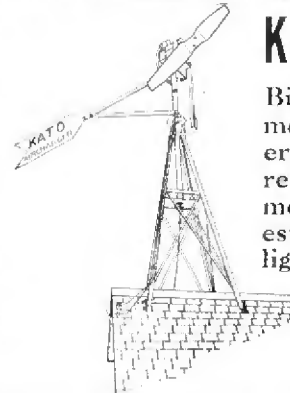

KATO AIRCHARGER

Big generator—15 amps. in moderate winds, self governing. Collector ring current take off, roof or post mounting. Write for interesting literature. Also A.C. lighting plants, converters D.C. to A.C., 3 and 6 kw. Diesel plants, generates current at about 1¢ per k.w.h.

KATO ENGINEERING CO., Mankato, Minn., U. S. A.

★ CLAROSTAT ★ PRODUCTS

... old sets need them
... new sets have them

The Clarostat line has been developed over a period of fifteen years to include a wide range of quality components. Insure against "come backs" by using CLAROSTAT parts for replacements.

- | | |
|------------------------------------|------------------------------------|
| Wire Wound Potentiometers | Ballast Resistors |
| Wire Wound Rheostats | Line Reducing Resistors |
| Composition Element Potentiometers | Compression Rheostats |
| Constant Impedance Controls | Fixed Resistors |
| Mixer Controls | Fixed Center Tapped Resistors |
| Faders | Flexible Resistors |
| Tone Controls | Metal Covered Heavy Duty Resistors |
| Volume Controls | Metal Covered Voltage Dividers |
| Automatic Voltage Regulators | Variable Center Tapped Resistors |
| | L Pads and T Pads |

CLAROSTAT MANUFACTURING CO.

285 N. 6th St.
BROOKLYN NEW YORK



SEND FOR LATEST CATALOG

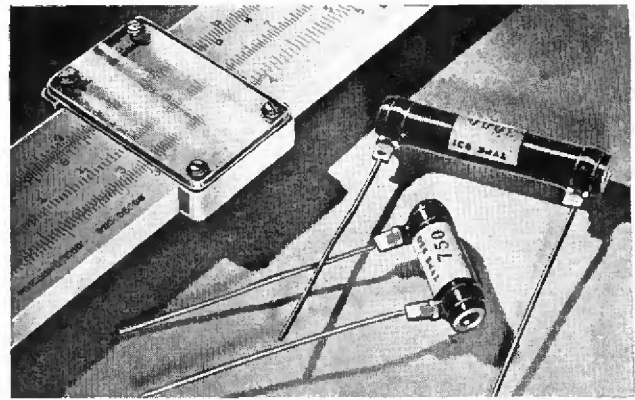

PYROHM Jr. RESISTORS

Crack-proof tubing . . . ample heat dissipation.

Quality resistance wire . . . space wound under tension.

Wire ends brazed to lugs. Pigtails soldered to terminal bands. Enamel coated.

Genuine wire-wound vitreous-enamel resistors. Nothing sacrificed except troublesome bulk. Available in 5, 10, 15 and 20 watt ratings. And all standard resistance values. For compact assemblies. And stay-put servicing.

DATA Send for latest catalog covering complete condenser and resistor line. Also sample copy of Research Worker . . . the cream of the crop of practical radio information.



AEROVOX

CORPORATION
74 Washington St. :: :: Brooklyn, N. Y.

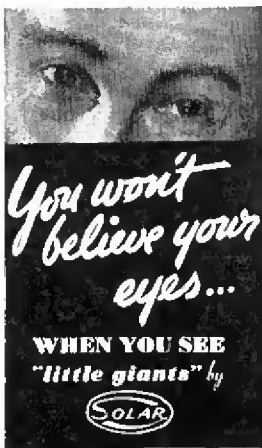

You won't believe your eyes...

WHEN YOU SEE "little giants" by SOLAR



Ultra-Compact ELECTROLYTIC CAPACITORS

A genuine engineering triumph! "LITTLE GIANTS" are half the former size—yet you get full capacity and full voltage protection. Minimum thickness enables them to fit anywhere. Little giants that do a BIG job!

IN TWO RATINGS
450 v.w. and 200 v.w.

Send for Complete Literature Also ask for "ELIM-O-STATS" Catalogue No. EL-1

SOLAR MFG. CORP.
599-601 Broadway N. Y. City
Manufacturing Affiliates in London, Paris, Berlin, Milan

WIRE WOUND TUBULAR RESISTORS

of nationally recognized high quality and precision



The most complete line of Replacement Voltage Dividers in fixed and adjustable types.
5 and 10 Watt Pigtails up to 50,000 Ohms. Accuracy 2%. Resistances to your specifications—3 to 300 Watts.
FREE—Write for NEW 1936 Catalog.
Manufacturers' Representatives wanted for territories available.

ATLAS RESISTOR CO.
423 Broome St.
New York, N. Y.

Atlas Carries the Load



New! MUTER Interference Filters



Man Made Interference!

This "Traffic Cop" of Radio absolutely eliminates the man-made interference that comes in over the power line by merely attaching the Filter directly to the set itself.

Sell these filters with confidence and **GUARANTEE** their operation, because *they will do the job*. There's a real need for them.

Ask your jobber or take advantage of our trial offer. Write Dept. A-10.

MAIL THE COUPON

THE MUTER COMPANY,
1255 South Michigan Avenue
Chicago, Illinois



Please ship me one Muter Interference Filter at your trial offer of \$1.80 (\$3.00 list, less 40%.)
 I am enclosing \$1.80. Ship it C.O.D. for \$1.80.

Name
Address
City State

Calling All Service Men!

Radio Retailing considers the service men—both those in business for themselves and those affiliated with distributors or dealers—an important group of our readers.

We invite you to stop at our booth at the Fall Show of the Institute of Radio Service Men, October 25-27, at the Pennsylvania Hotel, New York, and—

Meet an old friend—

RADIO RETAILING

INDEX TO ADVERTISERS

	Page		Page
Aerovox Corp.	71	Precision Apparatus Corp.	70
Arcturus Radio Tube Co.	23	Premax Sales Div. (Chisholm-Ryder Co., Inc.)	50
Atlas Resistor Co.	71	Quam-Nichols Co.	41
Atwater-Kent Mfg. Co.	6-7	Radotek Co., The	68
Capitol Radio Eng. Inst.	50	Raytheon Production Corp.	49
Capitol Radio Research Labs.	66	RCA Mfg. Co. (Tubes)	Front Cover
Clarostat Mfg. Co.	71	(Sets)	36-37
Clough-Brengle Co., The	64	Readrite Meter Works	56
Commercial Investment Trust Corp.	27	Rider, John F.	70
Consolidated Radio Products Co.	67	Sentinel Radio Corp.	21
Continental Carbon, Inc.	67	Shure Bros. Co.	50
Cornish Wire Co.	55	Solar Mfg. Corp.	71
Crosley Radio Corp.	Inside Back Cover	Sprague Prod. Corp.	70
Deutschmann Corp., Tobe	67	Stewart-Warner Corp.	15
Emerson Radio & Phono. Corp.	3	Stromberg Carlson Tele. Mfg. Co.	2
Fada Radio Electric Co.	4	Supreme Instruments Corp.	58
General Electric Co. (Radio)	Back Cover	Triplet Elec'l Instr. Co.	62
General Industries Co., The	70	Tungsol Radio Tubes, Inc.	35
Girard-Hopkins	66	United American Bosch Corp.	8
Howard Radio Co.	29	Utah Radio Products Co.	66
Hygrade Sylvania Corp.	51	Ward Leonard Electric Co.	55
International Resistance Co.	70	Webster Co., The	66
Jefferson Electric Co.	67	Westinghouse Elec. Supply Co. (Radio)	33
Kato Engineering Co.	70	Weston Elec'l Instr. Corp.	60
Ken-Rad Corp., The	39	Zenith Radio Corp.	1
McGraw-Hill Book Co.	68		
Miller Co., J. W.	66		
Mueller Electric Co.	48		
Muter Co., The	71		
Noblitt-Sparks Industries	Inside Front Cover		
Pioneer Gen-E Motor Corp.	68		
Porcelain Products, Inc.	48		

SEARCHLIGHT SECTION

Classified Advertising

Classification	Page
CATALOGS	72
REPRESENTATIVE AVAILABLE	72
RADIO STOCKS	
Allied Radio Corp.	72

McGraw-Hill Publishing Company, Inc., 330 West 42d Street, New York, N. Y. Branch offices: 520 North Michigan Ave., Chicago; 533 Mission St., San Francisco; Aldwych House, Aldwych, London, W. C. 2; Washington; Philadelphia; Cleveland; Detroit; St. Louis; Boston; Atlanta, Ga. James H. McGraw, Chairman of the Board; Malcolm Muir, President; James H. McGraw, Jr., Executive Vice-President; Howard Ehrlich, Vice-President; B. R. Potnam, Treasurer; D. C. McGraw, Secretary. Member A.B.P. Printed in U. S. A. Printed by The Schweitler Press, N. Y.

SEARCHLIGHT SECTION

EMPLOYMENT and BUSINESS OPPORTUNITIES—SURPLUS STOCKS—DISCONTINUED MODELS

UNDISPLAYED—RATE PER WORD:

Positions Wanted (full or part-time salaried employment only), 10 cents a word, minimum \$2.00 an insertion, payable in advance. (See ¶ on Box Numbers.)

Positions Vacant and all other classifications, 15 cents a word, minimum charge \$3.00.

Proposals, 40 cents a line an insertion.

INFORMATION:

Box numbers in care of our New York, Chicago and San Francisco offices count 10 words additional in undisplayed ads. Replies forwarded without extra charge.

Discount of 10% if one payment is made in advance for four consecutive insertions of undisplayed ads (not including proposals).

DISPLAYED—RATE PER INCH:

1 inch \$8.00
2 to 3 inches 7.80 per inch
4 to 7 inches 7.60 per inch

Rates for larger spaces, or yearly rates, on request.
An advertising inch is measured vertically on one column, 3 columns—30 inches—to a page. Radio Retailing

RADIO SERVICE MEN 1936 RADIO CATALOG FREE!

The new 1936 ALLIED Catalog is ready! Packed with complete listings of all new metal tubes and test equipment for servicing metal tube circuits. Also latest model metal tube receivers, new Public Address equipment; set-building kits; thousands of replacement parts, tools, etc.—at lowest wholesale prices. Send for this new Catalog—yours for the asking.

ALLIED RADIO

ALLIED RADIO CORPORATION
833 W. Jackson Blvd., Chicago, Dept. S.E.
 Send me your FREE 1936 Catalog.
Name _____
Address _____

MANUFACTURERS ATTENTION!

American factory representative heading for Europe. Has offices in London with own agency connections all over the world. Desires to represent manufacturers of radio, washing machines, refrigerators, novelties, and electrical appliances. Communicate immediately.

DAVID L. MARKS

356 Broadway, Albany, New York

Original List of 25,000 Radio Dealers on Cards including foreign at only \$3.00 per M for the lot. Less quantity \$4.00 per M. Wonderful Opportunity.
S. S. JOBBING HOUSE
139-149 W. 19th St., New York, N. Y.

New "SEARCHLIGHT" Advertisements

must be received by the 30th of the month to appear in the issue out the following month.

Address copy to the
Departmental Advertising Staff
Radio Retailing
330 West 42d St., New York City

"SEARCHLIGHT"

IS

Opportunity Advertising

—to help you get what you want.

—to help you sell what you no longer need.

Take Advantage Of It

For Every Business Want

"Think SEARCHLIGHT First"

THE **NEW** in RADIO • AND **ALL** THAT IS **NEW!**

The New 1936 **CROSLLEY** Line



\$19.99

THE CROSLLEY FIVER
Table and Console



\$37.50

CHASSIS—Five-tube super-heterodyne. Two bands—Standard and police, amateur, aviation broadcasts. Illuminated full-vision airplane type dial—5 to 1 ratio drive. Tone control. New 6B5 Triple-Twin output tube. Full floating moving coil electro-dynamic speaker.

CABINETS—Half an eye can see their beauty and charm—equal in every way to their superb tone. Between these and the Constitution models are a full range of receivers for every purse and type of use.

From the Fiver, giving standard, police, aviation, amateur reception for \$19.99 to the **CONSTITUTION** five-band metal tube all-wave that gets virtually all that's on the air . . . the new Crosley 1936 Line leads the field. In every price range the Crosley gives more for the money in beauty, performance, selectivity . . . in everything that makes for radio satisfaction.

FEATURES! Innovations! Master-strokes of engineering. In this new 1936 radio line Crosley has tapped all the resources of experience dating back to the pioneering stage; all the creativeness and inventiveness of today. Never has a line so stepped out to capture the imagination of a country. Never a line with so many "want-able" features. Never a line with equal value for the radio dollar.

The beauty of the line is alone an eye-stopper anywhere. But the more you explain the in-built quality, the new features, the reason for the extraordinary tone, selectivity, truthfulness of reproduction . . . the more your customers will select—from this line—the set that best fits their means and their wants.

Everywhere the groundwork of **SALES** is being laid with this line. Get in on this from the start by getting in touch with your Crosley distributor.

THE CROSLLEY RADIO CORPORATION
CINCINNATI POWELL CROSLLEY, Jr., President
Home of "the Nation's Station"—WLW—500,000 watts
—most powerful in the world—70 on your dial.

Prices in Florida, Rocky Mountain States and West slightly higher.



\$49.95

THE CROSLLEY CONSTITUTION
Table and Console

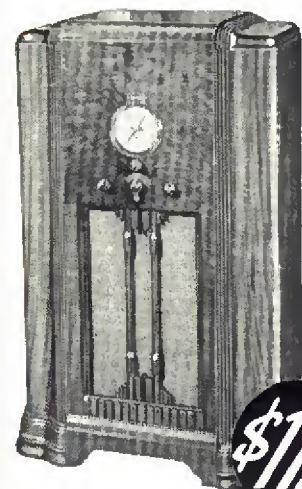

\$715.

CHASSIS

This all-wave 10-tube superheterodyne using all-metal tubes, commands the air. Five bands, receiving American, foreign, weather, amateur, police, aviation broadcasts. Shadow tuning. Automatic volume control. Full-vision airplane type dial. Tone control. Dual ratio tuning control. Full floating moving coil electro-dynamic speaker.

AMONG THE FEATURES...

- Three-gang tuning condenser with many notable improvements.
- New velvet action two-speed dial—planetary ball-bearing drive.
- New high-wattage, metal-to-metal tone control—far superior to conventional tone control.
- New triple-tuned I. F. transformer—far better selectivity, higher fidelity.
- New H-Q-t-layer bank wound Litzendraht broadcast coils—providing better signal-to-noise ratio.
- All-metal tube and all-glass tube models—a set for every need.
- NEW SHADOW TUNING, NEW 5-COLOR AIRPLANE DIAL
- NEW COLOR-BAND DESIGNATION.

You're there WITH **CROSLLEY**

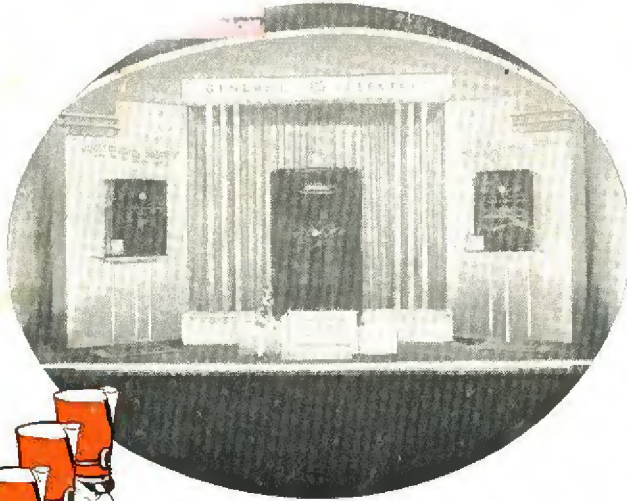

Catching

**THE EYES OF THE
PASSING PARADE**



Merchandise adequately displayed is already half sold. Every aggressive merchant knows that his displays—window and interior—are his most important asset.

Months before the new General Electric Radio — with the tube that's "sealed in steel" — was announced, our merchandising experts began developing and pre-testing display material that would drive home the G-E Radio message. No expense or effort was spared to originate display items that would lead the parade in making dealers' windows and interiors bright, attractive, inviting and sales producing. As a result eye-catching displays were designed for (1) department stores and large merchandisers (2) the average-size retailers and (3) small dealers.

Here you will find the DELUXE FLOOR SETTING and WINDOW DISPLAY . . . a beautiful white and

orange display, 6½ feet high, 12 feet wide. Picture the SPOT DISPLAY opposite elevators and entrances. Then, there's the LIGHTED DISPLAY STAND — a complete radio department in a few square feet of floor space. A series of LITHOGRAPHED WINDOW DISPLAYS will enable you to tie-in with General Electric's huge national advertising campaign. There's a BANDMASTER DOLL for use in your window, on your counter, in floor displays. Let the CELLOPHANE SPOTLIGHT STRIP show you the way to better sales. But this is only the beginning. Many of these eye-catching displays have been combined with a full range of other sales promotion aids in *three* Promotion Services offered to General Electric Radio dealers.

All we ask is that you learn how G-E Radio sales promotion aids turn passing prospects into buyers and merchandise into profits. Your General Electric Radio Distributor will gladly give you complete details.

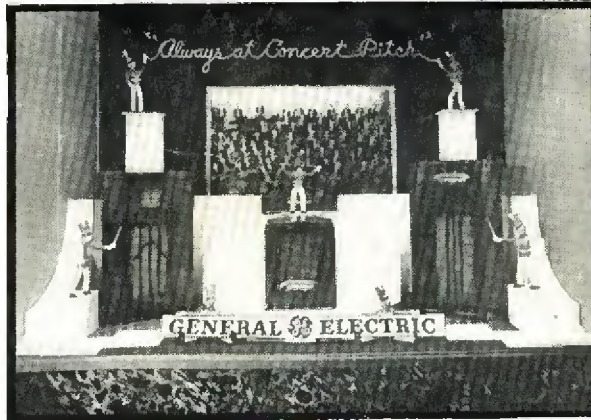

GENERAL  ELECTRIC
RADIO

MERCHANDISE DEPARTMENT, GENERAL ELECTRIC COMPANY, BRIDGEPORT, CONNECTICUT