

# RADIO RETAILING

HOME ENTERTAINMENT MERCHANDISING

**NOW** . . . *make automobile radio  
ALL-ELECTRIC through the*

# MALLORY *ELKON*

## "B" ELIMINATOR

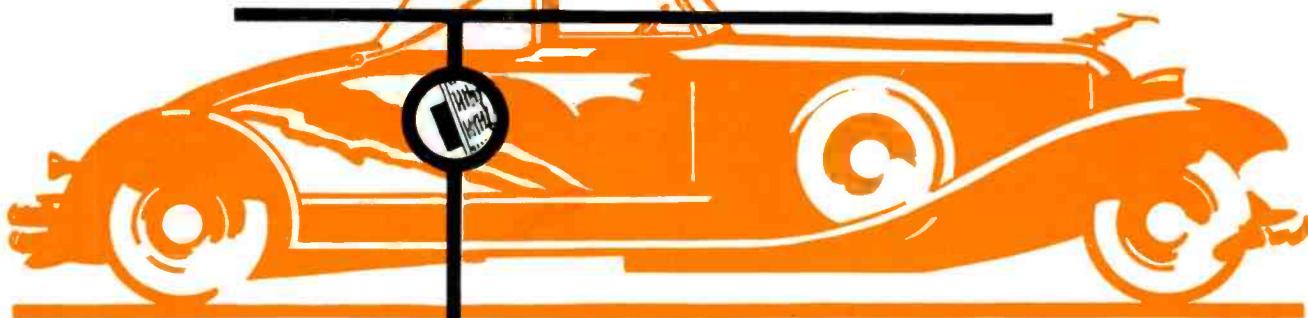

LIST PRICE

**\$24.50**

Nothing else to buy  
SIZE: 10" x 7" x 3 1/4"

• The MALLORY-ELKON "B" Eliminator—small, compact—fits any one of a half dozen places on the car. No rotary parts to set up interference. No water to add. Nothing to get out of order. Tested, proven and guaranteed.

*Send for full information now.*

P. R. MALLORY & CO., Inc., Indianapolis, Ind.

*Used by Police Departments of leading cities  
day in and day out on 24-hour duty.*

GIVE YOUR CUSTOMERS A REASON FOR BUYING . . .

AND YOU CAN  
SELL TUBES!

PEOPLE with technical experience, like radio engineers, dealers and service-men, can understand at a glance why Eveready Raytheon 4-pillar Tubes give better reception. They know the importance of *accuracy* in a radio tube, and they see how Eveready Raytheon's 4-pillar construction assures a far greater degree of accuracy than was ever possible before.

It's as simple as two times two. *Four* pillars anchor the elements in an Eveready Raytheon Tube, giving many times more strength and rigidity than the usual tube construction. This protects the accurate spacing of the elements against the knocks and jolts all tubes receive in handling, and against the dangerous vibration from powerful dynamic speakers. The result, naturally, is far better reception.

This is a story which any customer can understand. His ears will verify it, too, when

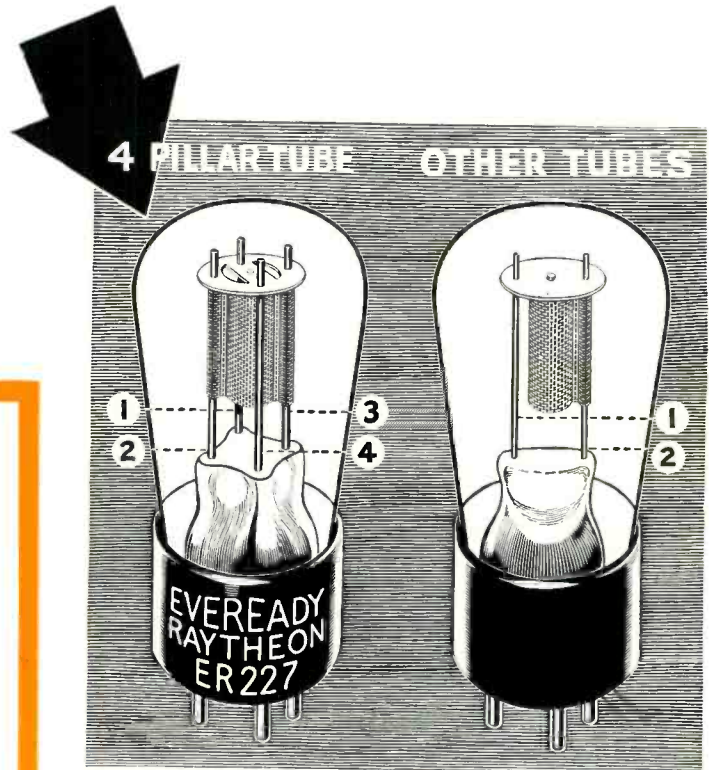
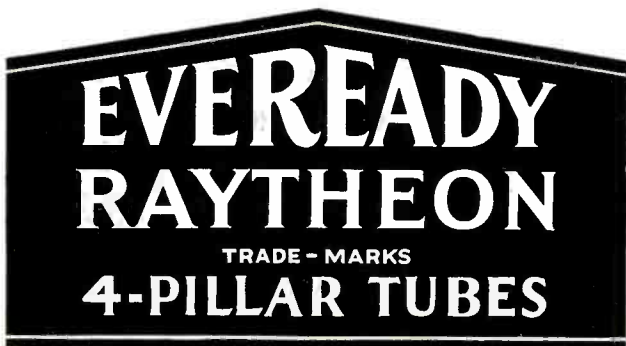

*Notice the four strong pillars. With this solid foundation the fragile parts cannot move a hair's breadth from their fixed position. Other tubes have only a two-pillar foundation. Two supports instead of four! Jolts, bumps and vibration often impair their vital accuracy.*

he once tries 4-pillar tubes in his own radio. Show him a 4-pillar tube . . . explain these simple facts . . . let him hear the difference that *accurate* tubes will make. He'll buy that tube . . . often a complete set . . . for he will never be satisfied until he has Eveready Raytheons throughout.

★ ★ ★

*SERVICE-MEN! Information and sales-helps, designed for service-men's use, will gladly be sent to you free. Among them is a blue-print, giving complete engineering data on 4-pillar tubes. Thousands of service-men are using this material to advantage. MAIL THE COUPON BELOW.*

NATIONAL CARBON COMPANY, Inc.  
30 East 42nd Street, New York, N. Y.

Please send me, *FREE*, your sales-helps for service-men.

Name \_\_\_\_\_

Address \_\_\_\_\_

RR-3

# RADIO RETAILING

HOME ENTERTAINMENT MERCHANDISING

O. H. CALDWELL, *Editor*

RAY V. SUTLIFFE, *Managing Editor* . . . W. W. MACDONALD, *Technical Editor* . . . T. H. PURINTON, *Assistant Editor* . . . HARRY PHILLIPS, *Art Director* . . . M. E. HERRING, *Publishing Director* . . . P. WOOTON, *Washington*

## CONTENTS

Copyright, 1932, by McGraw-Hill Publishing Company, Inc.

*The Challenge of the Figures* . . . . . AN EDITORIAL 17  
This Year We Must Meet This Challenge

*Annual Statistics of the Industry* . . . . . 18  
Reviewing a Decade of Radio Development

*If You Manufacturers Will BUILD UP, We Dealers Will SELL UP* . . . . . 22  
Dealer Duncan talks out in meetin' and gives sales manager Lucas food for thought

*Refrigeration Saved My Shirt* . . . . . 26  
Making the one sales crew do double duty.

*For President* . . . . . 29  
Prepare now to merchandise broadcasting's best bet in 4 years

*Seven Sales—\$7,267* . . . . . by RAY V. SUTLIFFE 30  
The story of one of the most remarkable achievements in the history of selling radio

*Uncle Radio* . . . . . 32  
How to reach the parent through the child

*On Their Toes* . . . . . 34  
Two pages of live selling ideas

*Getting the Most From Your Radio Set* . . . . . 36  
Radio Retailing starts a nationwide campaign

*Help! Police!* . . . . . 37  
Listing of all American police transmitters, together with their frequencies

*Editorials* . . . . . 38  
If the Government owned radio broadcasting.

*Auto-Radio B-Eliminators* . . . . . by W. W. MACDONALD 40  
A complete description of storage battery driven types

*Service Shortcuts* . . . . . 42  
Practical repair suggestions by and for service men

*News of the Month* . . . . . 44  
Progress of the Trade Show plans

*New Merchandise* . . . . . 47

McGRAW-HILL PUBLISHING COMPANY, INC., 330 WEST 42d STREET, NEW YORK, N. Y.

CHICAGO . . . 520 North Michigan Avenue . . . SAN FRANCISCO . . . 883 Mission Street . . . LONDON, W. C. 2 - Aldwych House, Aldwych  
Cable Address: "MCGRAWHILL, N. Y."

JAMES H. MCGRAW, Chairman of the Board . . . EDGAR KOPEK, Vice-President . . . WASHINGTON, National Press Building . . . ST. LOUIS, 1550 Bell Telephone Building  
MALCOLM MUIR, President . . . H. C. FARMELBE, Vice-Pres. and Editorial Director . . . DETROIT, 2-257 General Motors Building . . . BOSTON, 1427 Stutler Building  
JAMES H. MCGRAW, JR., Vice-Pres. and Treas. . . HAROLD W. MCGRAW, Vice-President . . . CLEVELAND, 501 Guardian Building . . . GREENVILLE, S. C., 1301 Woodside Building  
MASON BRITTON, Vice-President . . . C. H. THOMPSON, Secretary . . . PHILADELPHIA, 1600 Arch Street . . . LOS ANGELES, 339 Chamber of Commerce Building

Member A.B.P., Member A.B.C. Printed U. S. A.



## A MESSAGE FOR MARCH TO RADIO DEALERS

It is not alone the discount you get from the manufacturer or jobber that counts. It is also the retail price you receive from the customer.

What good does it do you to get a big discount, if the same radios are being sold at reduced prices by other dealers in your locality, and if, in order to meet such reduced prices, you must pass on to the customer a substantial portion of your discount?

Our discounts are liberal. They are big enough to assure you a good profit on every Stromberg-Carlson sale. And we expect to keep our discounts genuine by selecting the best type of dealers and only enough dealers in every locality.

• • •



1894

# Stromberg-Carlson

MAKERS OF VOICE TRANSMISSION AND VOICE RECEPTION APPARATUS FOR MORE THAN THIRTY-FIVE YEARS



1932

# Why THE DIFFERENT DESIGNATIONS?



**Arcturus 124 Other Manufacturers—'24A**

**Arcturus 551 Other Manufacturers—'35**

**Arcturus PZ Other Manufacturers—'47**

**124 ('24A)** When Arcturus introduced the first Type 124 Screen Grid Tube to the industry, it was a quick-heater. The advantages of the quick-heater created an acceptance and demand so pronounced that other tube manufacturers eventually changed to the quick-heater type of screen grid tube. To distinguish their quick-heater type from their old slow-heating tubes, they added an "A" to the designation.

Arcturus did not want to confuse its many users by changing type numbers when no change had been made in the tube.

**551 ('35)** The Types 551 Variable-Mu and **PZ ('47)** PZ output Pentode were pioneered by Arcturus. Many contracts were closed and great numbers of these tubes were made and sold before other tube manufacturers announced their types. Although adopting Arcturus standards, they introduced other symbols.

Arcturus, not to confuse the multitude of users who had been using these tubes from the time they were developed, did not change the designations.

Today—

*the Type 124 is interchangeable with '24A*

*the Type PZ is interchangeable with '47*

*the Type 551 is interchangeable with '35*

In choosing these types of Arcturus Blue Tubes you get a product with a year more experience behind it than any other make of tube. These are the tubes that critical engineers, set manufacturers and users approve as the *quality* tubes of the industry.

ARCTURUS RADIO TUBE COMPANY, Newark, N. J.



# ARCTURUS

*The BLUE TUBE with the LIFE-LIKE TONE*

# STRADIVARIUS WAS RIGHT



IF STRADIVARIUS were alive today, the chances are he'd be getting the merry razzberry from some of the high-powered boys of '32.

"That old codger hasn't got any merchandising ideas", they'd say. "Now if *I* were in his shoes, I'd be putting out a combination fiddle and cocktail shaker. Man, wouldn't *that* sell!"

But Stradi was right. He stuck to functions and achieved the outstanding instrument of all time.

And just between friends, we wonder if that isn't one of the things the radio industry should battle out with itself? Assuming that

a radio is essentially an instrument of sound, is it wise to sponsor models that *can't* do a satisfactory job of reproduction? Sets, for instance, which for want of balanced engineering, are not provided with adequate baffles or cabinets acoustically correct?

Ever since the beginning of the radio industry, Adler has devoted itself to the manufacture of *good* cabinets, properly designed for both salable appearance and tone. This invaluable experience is now being utilized by an increasing number of prominent manufacturers. ★ It is available to you—and at no premium in cost. *Address:* Adler Manufacturing Co., *Incorporated*, Louisville, Ky.

## ADLER-ROYAL *Cabinets*

★ *Some of the manufacturers with whom we have collaborated:* Atwater Kent, Colonial Radio, De Forest, Edison-General Electric, Jewell Electrical Instrument, Magnavox, Moosehead-Whitely Exercisers, National Carbon, J. C. Penney, Samson Electric, Sears-Roebuck, Sylvania, Transformer Corp'n of America, Webster Products, Westinghouse Distributors.



# What Powered for the **TROPICS**

*means to the dealer  
and the user*



● THE ROLLATOR—A roller rolls and there's ice... the action of the Norge Rollator is just as smooth and simple as that. It's extra powered... simple... service free... almost everlasting.

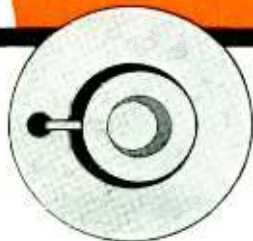

You've seen Norge advertised as "Powered for the Tropics"... the phrase is full of meaning for the Norge Rollator Refrigeration Dealer and for the user.

In the Norge factory, Hot Room Tests are made in a room heated to 120° Fahrenheit. Every Norge must be able to refrigerate and make ice in this torrid zone temperature.

The extra cooling power of Norge results from the use of the Rollator... the original and exclusive Norge Mechanism which is big enough to do the job.

Norge makes more cold than will ever be needed from day to day in the kitchen... but that extra power comes to the user in terms of unwavering refrigeration... power to meet all emergencies and a surplus for long life... more years of Norge usefulness.

Actual user satisfaction has brought about the enormous popularity of Norge. It brings additional sales to the Norge dealer from friends of Norge users... it simplifies selling and cuts selling costs.

The direct benefit of Norge power to the dealer is the service free feature of the mechanism. The Rollator has only three moving parts revolving in a permanent bath of protective oil, under pressure. There are few requests for service from Norge users... the service that is required is simple and represents a minimum of cost.

With Norge the dealer keeps what he makes... his profit does not dissolve in excessive service calls.

With the Norge Merchandising Plan, the Norge Advertising Program and the Extra Cooling Power of Norge the Rollator Refrigeration dealer is sitting pretty!

# NORGE

*Rollator refrigeration*

NORGE CORPORATION, 654 EAST WOODBRIDGE STREET, DETROIT, MICHIGAN  
NORGE CORPORATION IS A DIVISION OF BORG-WARNER CORPORATION, ONE OF THE  
WORLD'S LARGEST MAKERS OF PRECISION PARTS, INCLUDING AUTOMOTIVE FREE WHEELING

# they Pass your most exacting inspection

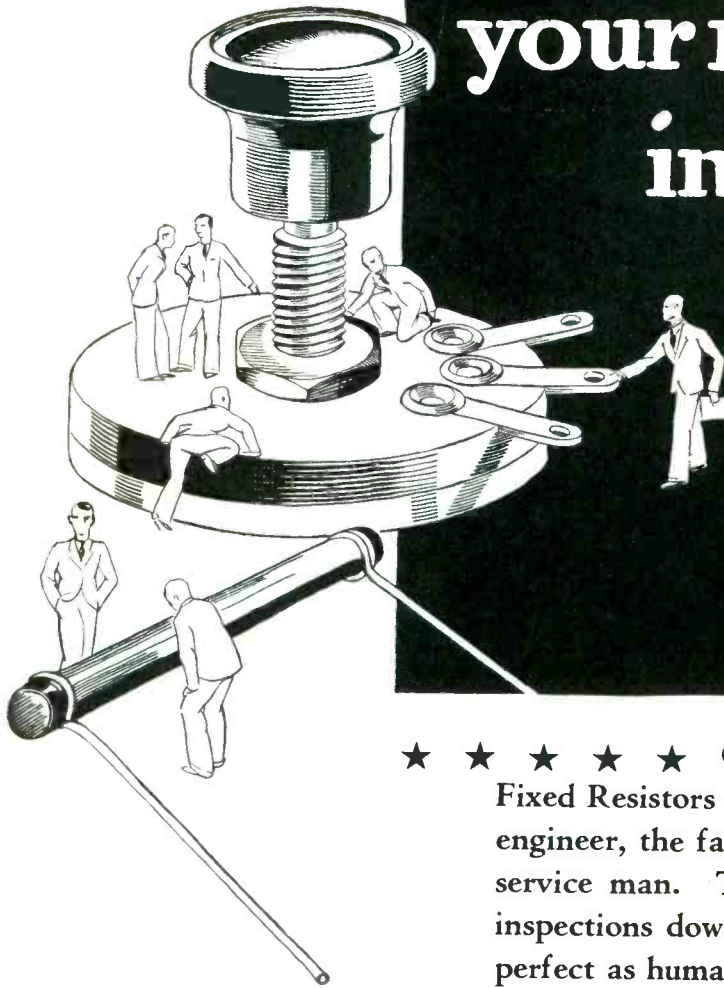

These  
books will  
interest you

**CENTRALAB VOLUME CONTROL GUIDE** at a quarter in coin or stamps . . . tells just what volume control to use on all replacement work. The "Baptism of Fire" explains how **CENTRALAB** Fixed Resistors are made. It is free for the asking. Send for one or both.

★ ★ ★ ★ ★ Centralab Volume Controls and Centralab Fixed Resistors easily meet the exacting requirements of the engineer, the factory and the sales personnel as well as the service man. These controls and resistors pass countless inspections down the production line and emerge as nearly perfect as human and mechanical skill can make them.

Whether in the original receiver or as a **REPLACEMENT UNIT** Centralab products offer the most satisfactory kind of service. Insist that your service man use **CENTRALAB** Volume Controls and Fixed Resistors for all **REPLACEMENT** jobs. They're cheapest and best in the long run.

**THE CENTRAL RADIO LABORATORIES**  
MILWAUKEE, WIS.

# Centralab

CENTRAL RADIO  LABORATORIES



# Leading

# THE FIELD BY A YEAR

. . . Sweep toward Dual Wave Sets Puts Stewart-Warner Dealers Far Ahead with the **PROVEN**

## STEWART-WARNER ROUND THE WORLD RADIO

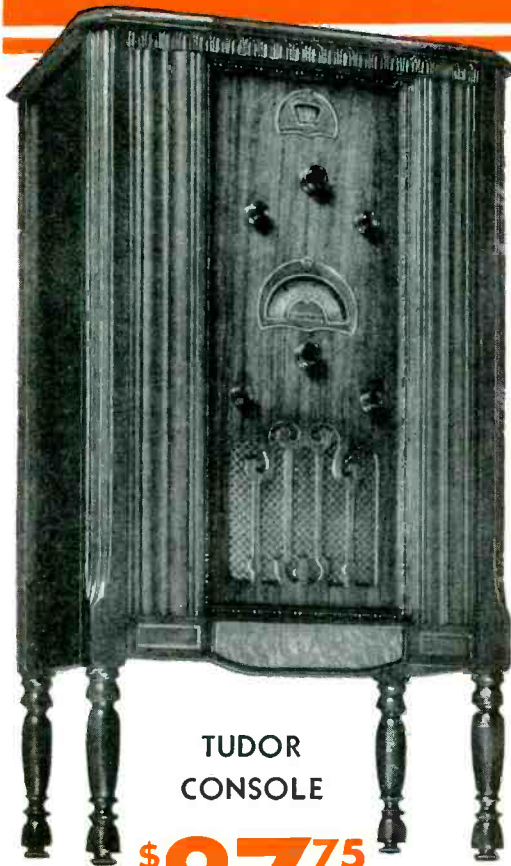

TUDOR CONSOLE

**\$87<sup>75</sup>** with tubes

equipped for both standard and short-wave receptions

Same model equipped for standard-wave reception only, complete with tubes . . . . . **\$65<sup>75</sup>**

Stewart-Warner was first with a simplified Round-the-World Radio. It was the sensation of last year—gave the public the first new thrill radio had offered in years.

The present trend of the industry conclusively proves combination short-and-standard-wave radio is here to stay. As the first manufacturer to perfect such radios, Stewart-Warner enjoys the full advantages of unchallenged leadership with the radio that is leading the field by a year—tried, proven and recognized.

Stewart-Warner dealers share these tremendous advantages. Their position is fortified, now and in the future, by the same courage, foresight and produc-

tive facilities that lead to the creation of the new Short-Wave equipped Stewart-Warner Radio—and that assures them of always profiting from being *First* with the latest.

Investigate the opportunity offered by this line, which includes console models with and without built-in Short-Wave Converter, retailing from \$34.95 to \$104.75. You can also profit by selling the separate Short-Wave Converter which can be used with virtually any A. C. set of adequate sensitivity.

Get in touch with your Distributors, or write Stewart-Warner Corporation, 1826 Diversey Parkway, Chicago, Illinois.

### New Stewart-Warner SHORT-WAVE CONVERTER

Improved new superheterodyne principle. Can be used with virtually any make A. C. set of adequate sensitivity. Complete with tubes . . . only **\$23<sup>95</sup>**





**\$59.50**

**Not a Converter nor  
a Makeshift Design**

Not a 1931 set with a short-wave converter added -- not last year's set remodelled. The DRAGON is entirely new in principle, in design, in operation.



### NO PLUG-IN COILS

The DRAGON is the only all-wave set that can be tuned with ONE hand. It has only ONE tuning knob, ONE dial, and ONE pointer. There is no other control, such as a trimmer or balancing condenser.

★ ★

The DRAGON covers all waves from 18 to 555 meters. For this purpose, four independent sets of coils are used, controlled by a 46-contact band-selector switch which completely disconnects all coils not in use, and eliminates all dead-end losses.

★ ★

By eliminating the need for a converter, this new PILOT super-heterodyne circuit reduces back-ground noise, increases efficiency, and improves reception amazingly. You will have an entirely new idea of short-wave reception when you hear the DRAGON.

# PILOT

ANNOUNCES  
A Totally NEW  
Kind of Radio Set

**ALL-WAVE-DRAGON**

## One Hand Control

18 to 555 Meters with One-Dial  
Short-Wave PLUS Broadcast Reception  
at the Price of an Ordinary Broadcast Set

## PILOT DRAGON

Setting New Sales Records for PILOT Dealers

Here is the answer to your need for new merchandise to stimulate radio sales!

"YOUR announcement of the DRAGON in the New York Times evoked more interest and comment than any radio advertisement in years," said an official in the advertising department of this newspaper.

Why? Because the PILOT DRAGON is a totally NEW kind of radio set.

In these times, when radio tastes are jaded, when price-cutting is useless, when the market is soft and the buyer hard-boiled -- the DRAGON is showing the radio trade that there is a market for something radically new, something distinctively different, something decidedly superior.

Put your sales efforts behind the DRAGON, and discover the volume waiting for a set worth buying! Write at once for complete information.



DISTRIBUTORSHIPS ARE OPEN IN  
SOME TERRITORIES TO AGGRESSIVE JOBBERS



## PILOT RADIO & TUBE CORP.

(Short Wave Headquarters - Established 1908)

FACTORIES - LAWRENCE, MASSACHUSETTS



# A DUAL OPPORTUNITY FOR PROFIT IN Westinghouse *Dual-automatic Refrigeration*

## 1 THE REFRIGERATOR LINE THAT HAS CAPTURED AMERICA

Sell the ONLY refrigerator in America that is *completely automatic* under *all* conditions . . . the ONLY one that affords *all* the features demanded by modern buyers PLUS the *extra value* of *dual-automatic* operation. Here's a complete line of thirteen handsome models that has already won public preference. It's backed by a concern whose name is a guarantee to millions . . . and supported by a smashing national advertising campaign reaching 20,000,000 homes every month PLUS generous local advertising and sales co-operation.

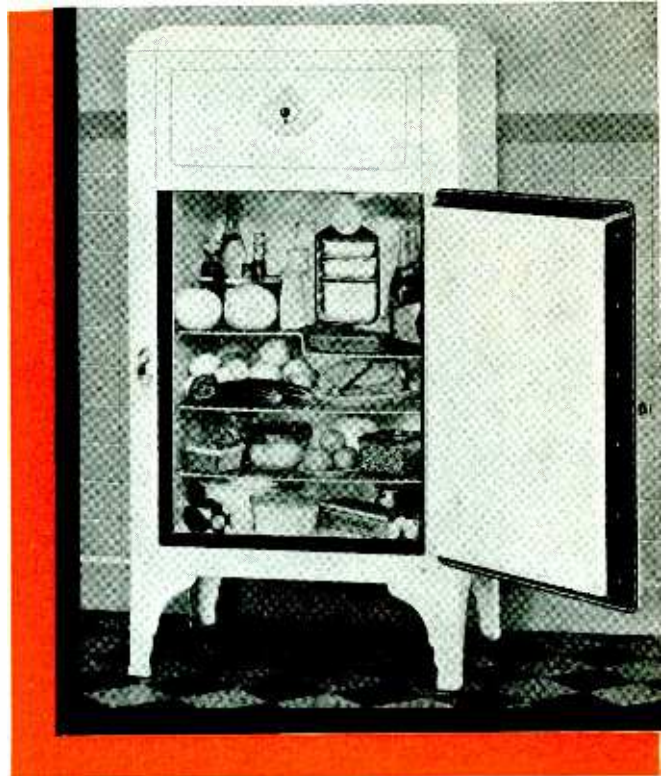
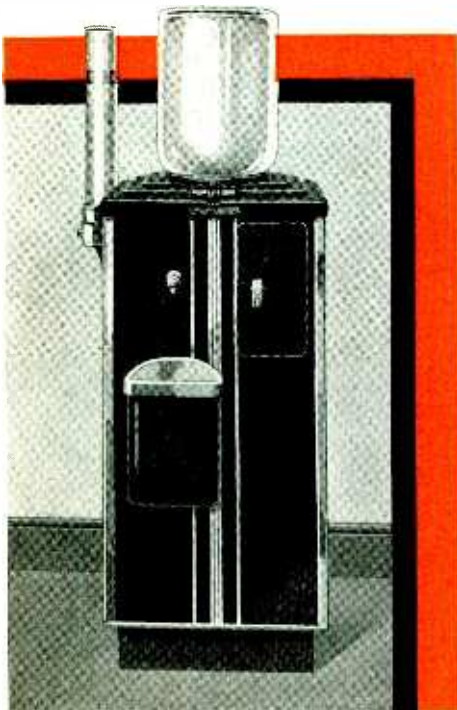

## 2 THE MOST BEAUTIFUL LINE OF WATER COOLERS IN THE WORLD

Westinghouse Dual-automatic Water Coolers now *double* sales opportunities for Westinghouse dealers. There are four strikingly - designed models with black Micarta cabinets and Chromium - trim . . .

bottle and pressure types . . . two with lock-compartments for bottled beverages. There is also an industrial model of attractive design. Write, wire or telephone for full details about our powerful sales promotion plan.



WESTINGHOUSE ELECTRIC & MANUFACTURING COMPANY  
Refrigeration Department · Desk 1303 · Mansfield, Ohio



*“Are your plans  
Complete  
for 1932?”*



● No kitchen repairs, intricate adjustments, or replacement of parts . . . fewer moving parts with none exposed . . . clean, quiet and economical . . . compact cabinets with maximum food storage capacity . . . no installation problem in any building.

**SERVEL**  
**HERMETIC**  
*Simplified Refrigeration*

**S**ERVEL is ready—thoroughly organized and ready, for the busiest selling season in the history of electric refrigeration.

The successful operation of retail sales work has been worked out to the smallest detail—a simple and highly efficient program that any dealer can put into effect tomorrow.

Servel Dealers have the most advanced electric refrigerator on the market today—the Servel Hermetic—with many refinements and improvements introduced after the most successful year in the company’s history.

This highly simplified refrigerator is a “package job”—complete in one crate—simple to sell—simple to deliver—simple to install. It has a big, active market in your territory.

We not only give you sound plans to get a big share of the business—but we work with you constantly to make these plans produce.

Write—NOW—for full details of our attractive Dealer Plan for 1932.

**SERVEL SALES, Inc.**

Evansville, Indiana

*Makers of a complete line  
of household and commercial refrigeration*

# Now Sparton OFFERS YOU THE MOST POWERFUL SALES HELP IN RADIO HISTORY

*Announcing the Most Practical Selling and Merchandising Plan Ever Devised for the Benefit of Radio Retailers*



How can I sell quality, maintain my prices and make money . . . in the face of price competition?

How can I handle demands for unreasonable trade-in allowances . . . and get the business at a profit?

How can I sell the people who come to my store "just looking around"?

Questions like these confront every radio dealer today.

And the Sparton Sales Plan answers them!



## Equip Yourself With Radio's Most Practical Sales Tool

*The Sparton Sales Plan* tells you—  
How to conduct a successful demonstration in your store or in the prospect's home.

How to explain value.

How to overcome the actual objections raised by prospects.

How to close sales.

How to develop new prospects.

How to make sales outside of the store.

*The Sparton Sales Plan* includes a brand new type of Sales Portfolio which shows you—

How to hold the interest and attention of your prospect.

How to back up your sales statements by printed proof.

*The Sparton Sales Plan* includes a series of six well-organized programs for live, resultful sales meetings, and—

A complete handbook on retail sales management—a concise, clean-cut sure-fire guide to the successful sales-managing of the radio store.

And remember this—only Sparton enables you to equip yourself with this complete and priceless set of sales-building tools.

Your Sparton distributor will gladly give you the facts about the newest and most remarkable development in radio selling. Or, if you prefer, communicate direct with us. Write or telegraph your inquiry today.

THE SPARKS-WITHINGTON COMPANY (Established 1900)  
JACKSON, MICHIGAN, U. S. A.

# SPARTON RADIO "Radio's Richest Voice"

*Only Sparton has the Musical Beauty of Sparton*



Radio



Refrigerator



Home Movie-Talkies



Automobile Radio



Tubes



Automobile Warning Signals

(771)

What  
Captain Sparks Says  
About the Sparton  
Radio Sales Plan



Here is a set of keen-edged sales tools the like of which this business has never known before.

These tools have been forged and fashioned to fit your hands.

They are ready for you to use.

And it is my sincere conviction that any dealer or salesman who schools himself to work with them—and does work with them with determination and diligence—will hew himself out a solid structure of increased earnings surpassing even his highest expectations.

*President-General Manager,  
The Sparks-Withington Co.*

### C O U P O N

The Sparks-Withington Co.,  
Jackson, Michigan

I am interested in the new Sparton Radio Sales Plan. Please send full particulars

Firm Name \_\_\_\_\_

Address \_\_\_\_\_

City \_\_\_\_\_ State \_\_\_\_\_

RR 3-32





# SELL *the* SPARTON *Lifetime Refrigerator*

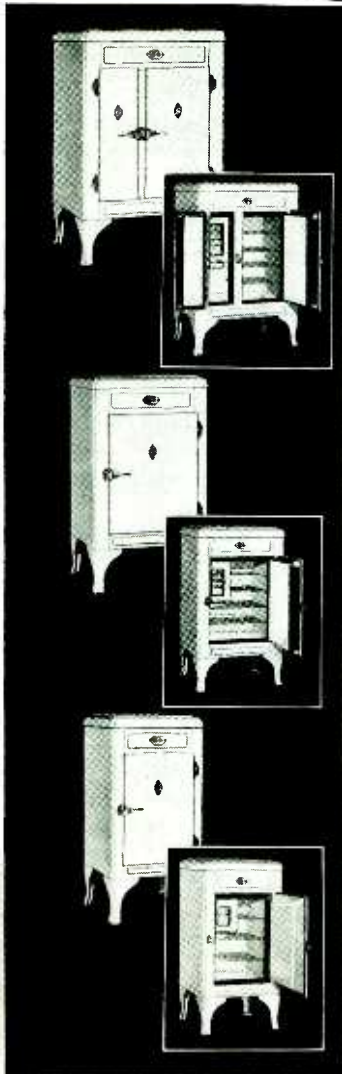

## *There's a big field of PROFIT waiting for you!*

• 1931 was a good year for electric refrigerator dealers. 1932 should be better. There is a *big* market almost untouched. Only 17% of this market has been sold.

To cash in on 1932 refrigerator sales and profits, you must start now. Every family wants an electrical refrigerator. Statistics show that families with incomes of \$3,000 to \$5,000 are good prospects. Yet this field is practically untouched. Efforts heretofore have been focused on families of \$5,000 or over.

The Sparton LIFETIME refrigerator makes it easy for you to cash in on refrigerator profits. Here is a refrigerator that combines ALL the most desirable features in the field of engineering with ADDED features that make selling easy. Sparton is the refrigerator of EXTRA-CONVENIENCE.

Sparton high quality has made the name of Sparton most favorably known to hundreds of thousands of enthusiastic owners of Sparton radios.

In Sparton you can sell *beauty* worthy of the most delightful kitchen — *dependability* and *mechanical precision* long associated with the name Sparton — and greater *economy*. All these reach new high standards.

Sparton dealers are backed by a sales plan that assures prospects, sales, volume-business and extra profits. Investigate the Sparton proposition immediately. Write or wire for details. No dealer can afford to miss this unusual opportunity . . . The Sparks-Withington Company, Jackson, Michigan. Sparton of Canada, Limited, London, Ontario.

## SELL THE SPARTON *Lifetime Refrigerator*





{Above}  
**SYLVANIA COMBINATION DISPLAY ANALYZER**  
 Showcase dimensions: width 34"—depth 20"—height 40". Clip the coupon. Learn how to get this combination unit AT NO ACTUAL COST TO YOU.



{Left}  
**THE SYLVANIA COUNTER ANALYZER**

for use in stores where floor space is too limited to permit the use of the Combination Display Analyzer. Overall dimensions: width 25"—depth 14 7/8"—height 16 1/2".

**"I SOLD 153 tubes and got 7 radio prospects in one day thru the use of the Sylvania Analyzer"**

**J. T. SURINA, Elkland, Pa.**

# A modern Circuit-Rider

J. T. Surina, of Elkland, Pa., had such splendid results with his Sylvania Tube Analyzer in his home town that he goes into surrounding towns on appointed days—announcing his coming with local newspaper advertising, rents space in the best window he can find, sets up his Analyzer and starts selling tubes.

But let Mr. Surina tell it—"People bring in tubes in their pockets, bags, market baskets and every way conceivable. In one town we sold 153 tubes in one day and got 7 radio prospects thru the use of the Sylvania Analyzer."

The Sylvania Combination Display Analyzer represents the most forward selling step ever taken in the tube industry.

In one self contained unit you have:

- (A) The finest Analyzer to be had—gives simple visual readings that the customer will quickly understand and believe.
- (B) A handsome showcase (exclusive with Sylvania) with illuminating unit, mirror doors, glass shelves and three-sided glass front.
- (C) Metal storage racks in rear protected by sliding door and tamper proof lock, providing sufficient space for a good sized live stock of Sylvania Tubes.

If you already own a testing meter get a Sylvania Display Case. Take your meter off the counter where it can never do more than a half-way job and put it on a Sylvania Display Case where it can really go to work for you.

Sylvania also has a complete selling plan—window streamers, mailing pieces, counter pieces and newspaper mats.

Best of all, you can get a Sylvania Combination Display Analyzer at no actual cost—this also applies to the Sylvania Show Case alone. Send in the coupon below and we'll tell you how.

**TUNE IN** The Sylvanians! 40 flying fingers on the piano at one time! Sunday 7:45 E. S. T., Columbia Network.

**STOP AT** The Sylvania Booth, R. M. A. Show, Chicago, May 23, 24, 25, 26.

HYGRADE SYLVANIA CORPORATION  
 Sylvania Division, Dept. R-3-2, Emporium, Penna.

Please send me full details of the Free Sylvania Analyzer Plan.

My principal Jobber is..... City.....

My Firm Name .....

Address.....

City..... State.....

**Sylvania**  
REGISTERED U.S. PAT. OFF.  
**THE SET-TESTED TUBE**

# JUDGE *for* YOURSELF



## DALLAS

DALLAS TEXAS  
 ..... COMPLETE TOTAL OF ORDER BOOKED YESTERDAY DALLAS MEETING  
 ..... MORE IF POSSIBLE TO INSURE SUCCESSFUL INTRODUCTION STOP DEALERS  
 UNANIMOUSLY AGREE NEW MAJESTIC LINE FAR SUPERIOR TO ANYTHING ON  
 CROWD ON DELIVERIES.....  
 W L COHN RADIO EQUIPMENT COMPANY OF TEXAS

## NEW YORK

NEW YORK N Y  
 ..... IMPERATIVE WE HAVE MINIMUM TWO THOUSAND SETS THIS WEEK  
 MORE IF POSSIBLE TO INSURE SUCCESSFUL INTRODUCTION STOP DEALERS  
 UNANIMOUSLY AGREE NEW MAJESTIC LINE FAR SUPERIOR TO ANYTHING ON  
 CROWD ON DELIVERIES.....  
 BILL COLEN MUSICAL PRODUCTS

## HARTFORD

HARTFORD CONN  
 ..... ENTHUSIASTIC RECEPTION OF NEW LINE AT HARTFORD LAST NIGHT  
 WITH SUBSTANTIAL ORDERS ACCOUNTS THAT HAD GONE DEAD RETURNING  
 TO MAJESTIC FOLD SHOWING NEWHAVEN TONIGHT.....  
 JACK MURPHY STERN AND CO

## NORFOLK

NORFOLK VIR  
 ..... HAVE NOT RECEIVED CAR NUMBER AND CONTENTS OF CAR WHICH  
 YOU PROMISED TO SHIP TODAY STOP OUR DEALERS CLAMORING FOR  
 DELIVERIES.....  
 WOODHOUSE ELECTRIC CO INC

## BOSTON

BOSTON MASS  
 ..... DEALERS ACCLAIM NEW LINE AS BEST EVER AND SAY NO QUESTION  
 WE ARE FAR AHEAD OF ALL COMPETITION STOP HAPPY DAYS ARE HERE AGAIN.....  
 GALT AT F D PITTS CO

## SEATTLE

SEATTLE WASH  
 ..... HAVE HAD MOST OF DEALER MEETINGS OUR TERRITORY WITH GREAT  
 SUCCESS AND SOLD FIRST CAR ALREADY.....  
 WILLSON MAJESTIC DIST COMPANY

## SAN ANTONIO

SAN ANTONIO TEXAS  
 ..... NEW SET ENTHUSIASTICALLY RECEIVED BY SAN ANTONIO DEALERS  
 PLEASE WIRE ME SAN ANTONIO IF SETS SHIPPED YESTERDAY IN  
 ACCORDANCE WITH PHONE CONVERSATION.....  
 W L COHN RADIO EQUIPMENT CO

## PITTSBURGH

PITTSBURGH PENN  
 ..... OUR ATTENDANCE NUMBERING TWELVE HUNDRED SEVENTY IN OUR  
 FOUR SECTIONAL MEETINGS WHICH PROVES MAJESTIC WAS GREAT DRAWING  
 POWER STOP DEALERS HAVE ACCLAIMED ANOTHER MAJESTIC YEAR FOR IS  
 NINETEEN THIRTY TWO STOP ORDERS FLOWING IN ALL WE NEED NOW IS  
 MERCHANDISE STOP ENTHUSIASM IN DEALERS AND IN OUR ORGANIZATION  
 UNHEARD OF BEFORE STOP BEST WISHES AND SUCCESS.....  
 HAROLD RAY HAMBURG BROTHERS

## MEMPHIS

MEMPHIS TENN  
 ..... THE NEW LINE IS THE MOST GORGEOUS THAT MAJESTIC HAS EVER  
 OFFERED AS ONE DEALER EXPLAINED TODAY IF ALL RADIOS WERE GIRLS  
 AND PLACED ON THE STAGE MAJESTIC WOULD BE ZIGFELDS FOLLIES STOP  
 ALL THE SAME THEY ARE INDIVIDUAL IN APPEARANCE AND EACH STANDS  
 OUT IN ITS OWN CLASS.....  
 Z A ZANONE RADIO SALES CO

## LOS ANGELES

LOS ANGELES CALIF  
 ..... DEALERS RECEPTION NEW MODELS EXCELLENT STOP SO FAR WE HAVE  
 FRANCHISED EIGHTY DEALERS IN TWO DAYS STOP NOTHING BUT WORDS OF  
 PRAISE FROM THESE DEALERS FOR NEW LINE STOP FEEL THAT FACTORY IS  
 TO BE CONGRATULATED ON MAKING SUCH OUTSTANDING MERCHANDISE  
 FIND IT NECESSARY TO INCREASE ORDER STOP NOT A SINGLE DEALER HAS  
 HAD ONE OBJECTION OR HAS REFUSED TO ORDER MERCHANDISE OR SIGN  
 FRANCHISE STOP WE FEEL THAT THIS LINE WILL COMMAND MORE THAN ITS  
 SHARE RADIO BUSINESS.....  
 UNGAR AND WATSON INC

## BALTIMORE

BALTIMORE MD  
 ..... FIRST SHOWING AT HAGERSTOWN TREMENDOUS SUCCESS STOP  
 SALISBURY SHOWING THURSDAY AND FRIDAY STOP PLEASE COOPERATE  
 WITH US REGARDING SHIPMENTS 8 AND 10 TUBE SETS IN ORDER TO  
 KEEP PRESENT ADVANTAGES OBTAINED REGARDS.....  
 RUDY DEUBELL EISENBRANDT CO INC

## PHILADELPHIA

PHILADELPHIA PENN  
 ..... TOO BUSY TAKING ORDERS TO SAY MUCH EXCEPT THAT EVERYBODY  
 AGREES NEW LINE A REAL SENSATION STOP DEALERS STORMING US FOR  
 MERCHANDISE.....  
 TREV -- PEIRCE PHELPS INC

## BROOKLYN

BROOKLYN N Y  
 ..... THE ONLY THING MAJESTIC HASNT GOT IS FREE WHEELING IS THE  
 WAY ONE OF OUR DEALERS EXPRESSED THE CONSENSUS OF OPINION ON NEW  
 SETS STOP IN ANNOUNCING NEW SETS I AM HAPPY TO SAY SETS AND ORDERS  
 DOING FINE REGARDS.....  
 JULIEN LOEB

## CHARLOTTE

CHARLOTTE N CAR  
 ..... TREMENDOUSLY SUCCESSFUL MEETING AT SHAW'S STOP VERY NECESSARY  
 YOU RUSH MERCHANDISE.....  
 RAY ERLANDSON AT SHAW'S INC

## KANSAS CITY

KANSAS CITY MO  
 ..... ALL NEW MODELS AND PRICES APPROVED WITH GREAT ENTHUSIASM  
 OVER ONE HUNDRED FIFTY DEALERS SHOWED NEW LIFE AND CLAIM MAJESTIC  
 HAS COME BACK.....  
 STERLING RADIO

## BUFFALO

BUFFALO N Y  
 ..... OPENING DAY OF SHOW A SUCCESS STOP SIGNED UP 26 NEW  
 DEALERS NEVER SOLD BEFORE SOLD 205 SETS MAILING IN ADDITIONAL  
 ORDERS.....  
 E RUTLEDGE SPECIALTY WHOLESALERS

All brand new models . . . ELEVEN superheterodynes and a Short Wave Converter . . . 6, 8, 10 and 12 tubes . . . new Duo-Diode detection . . . Twin Speaker models . . . new advertising plan. See the Majestic Distributor immediately.

GRIGSBY-GRUNOW COMPANY, CHICAGO, ILL.

# Majestic

## SUPERHETERODYNE

# RADIO



# G-E BRINGS OUT TWO NEW CLOCKS

**LOWEST PRICES EVER  
PLACED ON ANY GENERAL  
ELECTRIC CLOCKS!**

Bridgeport, March 1.—Announcement was made today of an important new price range for General Electric Clocks. Recent economies in manufacturing have made it possible to place on the market two new models at the lowest list prices ever set on any clocks bearing the famous G-E Monogram. This major step is taken while still maintaining the same high standard of quality.

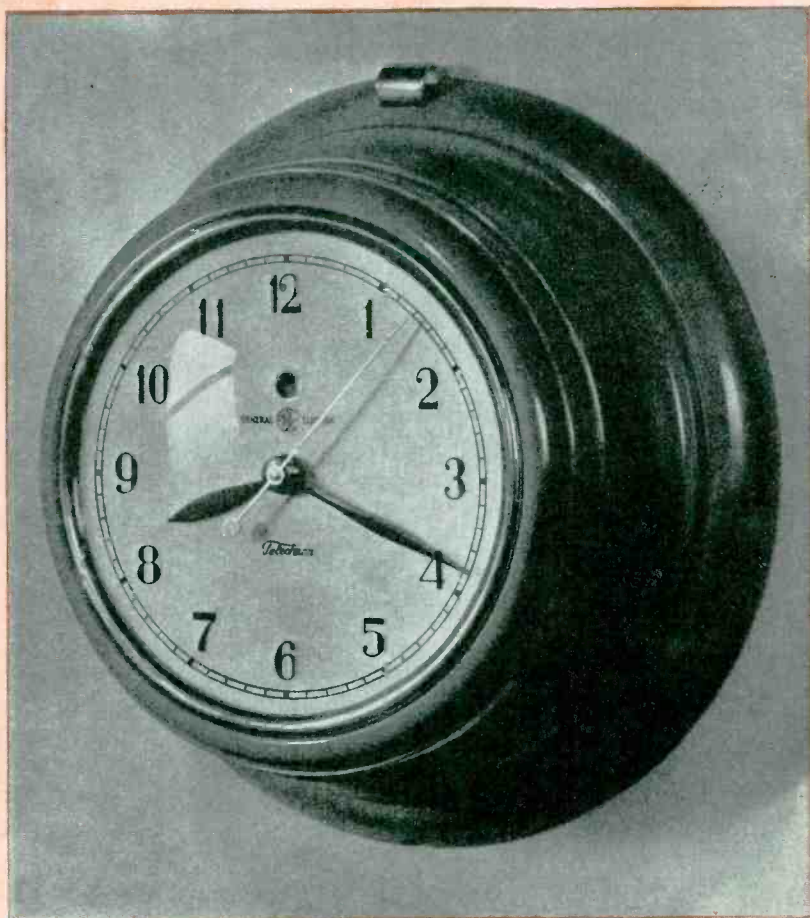

Model AB 458—Brand new, full sized Kitchen Clock in choice of green, ivory, white and blue enamel finish. List \$5.50.



Model AB 330—Beautiful, new mahogany Desk Clock of true Colonial design, ideally suited for almost any type of room. Polished lacquer finish. List \$5.95.

### Bigger Volume For Dealers

The tremendous value represented in the new Desk Clock and the Kitchen Clock open up an entire new market for dealers. The styling, beauty and popular prices are ideal for special campaigning. Dealers who are quick to take advantage of these new offerings have every opportunity to experience a most gratifying increase in sales volume.

### New Illustrated Broadside—Free

In addition to these remarkable new numbers . . . General Electric is now showing an advanced line of Alarm Clocks in delicate pastel shades. All of these 1932 models are beautifully illustrated in a broadside just off the press. See your nearest G-E Distributor for full details of these amazing new clock values.

**GENERAL  ELECTRIC CLOCKS**

SECTION T-683, MERCHANDISE DEPARTMENT, GENERAL ELECTRIC CO., BRIDGEPORT, CONN.



# 9:20

## The first real job in M.C.R. YOUR FIRST REAL CHANCE FOR PROFITS

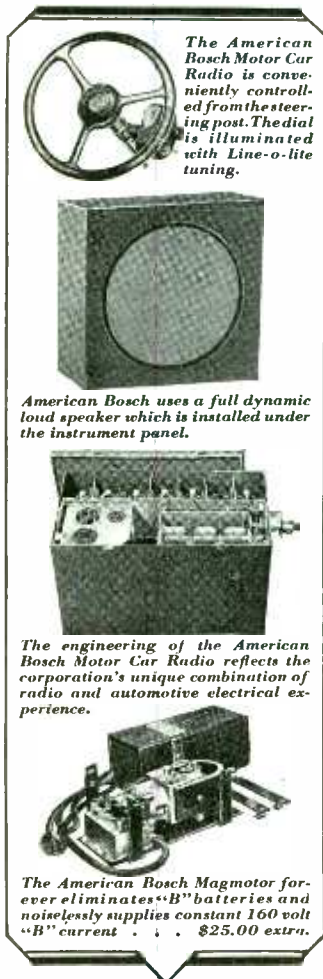

The American Bosch Motor Car Radio is conveniently controlled from the steering post. The dial is illuminated with Line-o-lite tuning.

American Bosch uses a full dynamic loud speaker which is installed under the instrument panel.

The engineering of the American Bosch Motor Car Radio reflects the corporation's unique combination of radio and automotive electrical experience.

The American Bosch Magmotor forever eliminates "B" batteries and noiselessly supplies constant 160 volt "B" current . . . \$25.00 extra.

EVER since the thrill of radio was added to the joy of motoring, the trade has been hungering for a real manufacturing job to be done.

Everybody knew that some day some organization that knew a great deal about motor cars and about radio, too, was going to come along and do a real job. Not merely adapt a household radio to automobiles. But start from scratch and design a radio especially for motor car use.

At last it has been done. And American Bosch has done it. The result is the American Bosch 9:20 Motor Car Radio—a finer set than most people have in their homes. It is actually 500% more sensitive than the average home set. It delights the novice and the fan with the way it pulls in station after station. It has such sensitivity that the faintest signal is caught and automatically built up into the kind of clarity and volume hitherto obtainable only in the better home sets.

But no matter how much we praise the American Bosch 9:20, still its performance will surprise and amaze you. Its performance—more than anything we can say—will show you what we mean by the first real job in motor car radio.

Here at last is a motor car radio worth your time and effort. Here is a motor car radio that will make money for you. See your jobber at once about the American Bosch 9:20, or write us direct for full information, prices and discounts.

**UNITED AMERICAN BOSCH CORP.**  
Springfield Massachusetts

Branches: New York Chicago Detroit San Francisco

### 20

#### MAJOR DEVELOPMENTS

\*9 of them combined for the first time in any motor car radio set.

- \*1. Over 500% greater sensitivity
- \*2. Full automatic elimination of fading and overloading
- \*3. Magmotor which forever eliminates "B" batteries
- \*4. Double-detection superheterodyne
- \*5. Knife edge selectivity
- \*6. Power-saving tubes save 16% battery drain
- \*7. Home-like reception
- \*8. Improved dynamic speaker
- \*9. Diode-Triode tube
- \*10. 3 Pentode Power tubes
- \*11. Completely armored against ignition interference
- \*12. Internal filtering of extraneous noises
- \*13. Under-car plate antenna with matching coil
- \*14. Double-quick-heating tubes
- \*15. Removable or replaceable in 30 seconds
- \*16. Plug-type connections
- \*17. Rugged construction
- \*18. Illuminated dial
- \*19. Steering post station selector
- \*20. Low cost

## \$88<sup>50</sup>

Complete with tubes and all accessories (except "B" batteries and antenna); ready to install.

# AMERICAN BOSCH 9:20 Motor Car RADIO

American Bosch Radio is licensed under patents and applications of R. C. A.

# RADIO RETAILING

HOME ENTERTAINMENT MERCHANDISING  
Established 1925

O. H. CALDWELL,  
Editor

McGraw-Hill Publishing Company, Inc.

## The CHALLENGE!

**I**N 1929 we sold the American public \$842,000,000 worth of radio products. Everyone was happy. Incidentally, the quality of the average broadcast program, and of the equipment through which it was received, rated high. Sales for 1930 dropped to \$501,000,000—"mainly due to the depression," we said.

But our dollar total retail business for 1931 shows altogether too great a shrinkage; sixty-three per cent from the 1929 peak and thirty-eight per cent less than for 1930.

To what extent is this trend due to the general slowing up of purchasing power and to what extent are we ourselves to blame?

The decline in general business activity, according to the index kept by the *Business Week*, reveals 1929 as averaging 7 per cent above normal, 1930 as 10 per cent under, and '31 as having an average activity of 75 (100 being normal), with December closing at 65.3.

**N**O, RADIO'S showing has been due mainly to causes within the industry. In our mad race for quantity, prices have been unduly lowered and quality, in many instances, has been sacrificed. Thus the public has not profited as it should have from these price reductions. The showing for 1931, reflects the grey "morning after" effects of trusting to unstable retailers and to the appeal of price to move merchandise.

When an industry contracts as ours has done—nationwide depression notwithstanding—the duty of the trade paper serving that industry becomes one of ascertaining causes and discussing remedies. These functions *Radio Retailing* consistently has performed—and is performing elsewhere in this issue.

**R**ATHER than be discouraged by the sales figures of '31, however, we see in this situation the necessary challenge needed to arouse the fighting spirit of the industry. Again we start from scratch—but with the tremendous advantage of hard-earned experience to help us. Consider also this bright side of the picture: Almost a million new homes a year are established in America—prime new business potentialities for radio sets. Then there is the promise of television. Who knows how great will be the ultimate development of this new science—its possibilities awes the imagination. Of immediate help is the rapidly growing popularity of short wave receivers and automobile sets.

Business off thirty-eight per cent—what of it! We've not been afraid to look the facts in the face . . . and that's half the battle. And, sighting from these facts, wise radio manufacturers will refine their product, so that the public will not unconsciously tire of radio; and they will pay more attention to developing their retailers into aggressive specialty salesmen.

Our real future is yet to arrive. With an art as wonderful as radio, who shall attempt to measure or to limit the heights which we ultimately may attain?



# 3,420,000 SETS

Retail Value — *All Radio Products* . . . . \$309,270,000

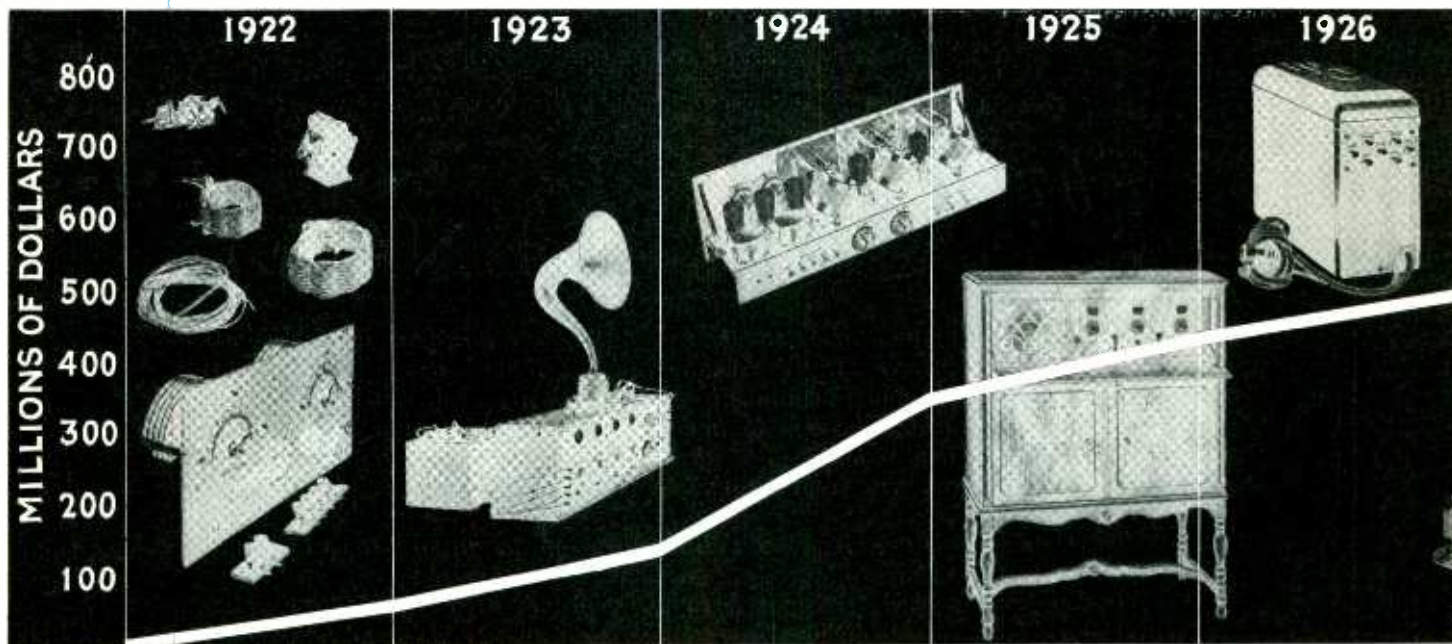

*Total Sales of Radio*

PRODUCT	1922	1923	1924	1925	1926
RADIO SETS, ALL TYPES AND COMBINATIONS	<b>100,000</b> \$5,000,000	<b>250,000</b> \$15,000,000	<b>1,500,000</b> \$100,000,000	<b>2,000,000</b> \$165,000,000	<b>1,750,000</b> \$200,000,000
TUBES	<b>1,000,000</b> \$6,000,000	<b>4,500,000</b> \$17,000,000	<b>12,000,000</b> \$36,000,000	<b>20,000,000</b> \$48,000,000	<b>30,000,000</b> \$58,000,000
SPEAKERS ONLY	<b>25,000</b> \$750,000	<b>500,000</b> \$12,000,000	<b>1,500,000</b> \$30,000,000	<b>2,000,000</b> \$32,000,000	<b>2,000,000</b> \$30,000,000
A-B-C (DRY) BATTERIES	\$4,500,000	\$6,000,000	\$55,000,000	\$66,000,000	\$80,000,000
A-B POWER UNITS, STORAGE BATTERIES AND CHARGERS	.....	\$7,000,000	\$25,400,000	\$30,000,000	\$55,000,000
OTHER ACCESSORIES*	\$3,750,000	\$4,000,000	\$11,600,000	\$24,000,000	\$33,000,000
PARTS SOLD TO CONSUMER	\$40,000,000	\$75,000,000	\$100,000,000	\$65,000,000	\$50,000,000
<b>TOTALS</b>					
SETS AND COMBINATIONS	\$5,000,000	\$15,000,000	\$100,000,000	\$165,000,000	\$200,000,000
PARTS	\$40,000,000	\$75,000,000	\$100,000,000	\$65,000,000	\$50,000,000
ACCESSORIES	\$15,000,000	\$46,000,000	\$158,000,000	\$200,000,000	\$256,000,000
<b>GRAND TOTALS FOR YEAR</b>	<b>\$60,000,000</b>	<b>\$136,000,000</b>	<b>\$358,000,000</b>	<b>\$430,000,000</b>	<b>\$506,000,000</b>

\* Includes aerial equipment, meters, pick-ups, turntables, headsets, furniture, etc.

471,000 SETS EXPORTED DURING 1931  
The 1931 total set sales figure (3,420,000) does not include 471,000 American sets which were exported last year. Neither does it include receiver equipment used in

public address or centralized radio installations nor in police or other commercial jobs. Thus it is apparent that the total number of receivers, for all purposes, manufactured in the United States during 1931 was ap-

proximately 4,000,000—a very satisfactory showing in unit sales. Unfortunately the lower average unit sales price (\$62 as against \$87 for 1930) brings dollar volume to too low a level.



# Sold in 1931

Retail Value — *Radio Receivers* . . . . \$212,040,000

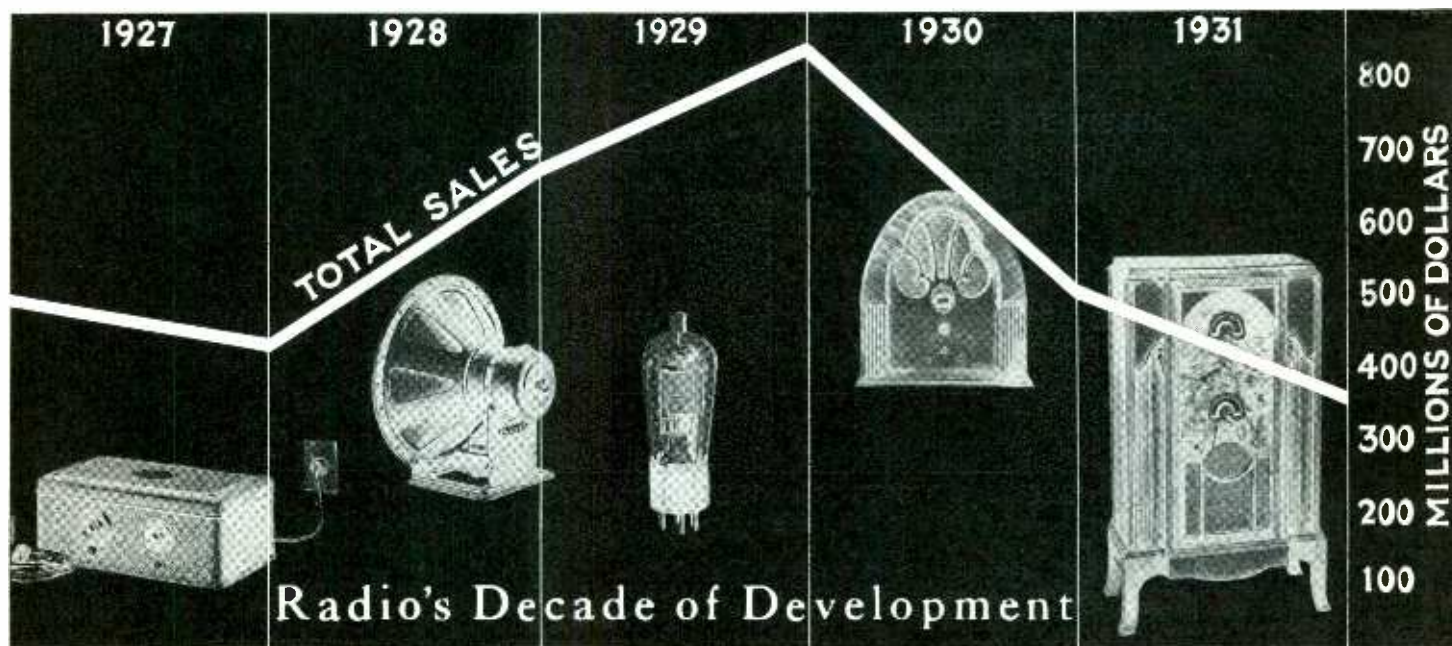

## Products at Retail (1922-1931)

Copyrighted. All rights reserved.

1927	1928	1929	1930	1931	PRODUCT
<b>1,350,000</b> \$168,750,000	<b>3,281,000</b> \$388,000,000	<b>4,438,000</b> \$592,068,000	<b>3,827,800</b> \$332,198,000	<b>3,420,000</b> <b>\$212,040,000</b>	RADIO SETS, ALL TYPES AND COMBINATIONS
<b>41,200,000</b> \$67,300,000	<b>50,200,000</b> \$110,250,000	<b>69,000,000</b> \$172,500,000	<b>52,000,000</b> \$119,600,000	<b>53,500,000</b> <b>\$69,550,000</b>	TUBES
<b>1,400,000</b> \$28,000,000	<b>2,460,000</b> \$66,400,000	<b>800,000</b> \$16,000,000	\$3,500,000	<b>\$375,000</b>	SPEAKERS ONLY
\$68,000,000	\$50,400,000	\$30,530,000	\$21,514,000	<b>\$13,100,000</b>	A-B-C (DRY) BATTERIES
\$34,000,000	\$17,500,000	\$14,350,000	\$6,920,000	<b>\$4,000,000</b>	A-B POWER UNITS, STORAGE BATTERIES AND CHARGERS
\$38,550,000	\$46,000,000	\$9,600,000	\$6,700,000	<b>\$4,205,000</b>	OTHER ACCESSORIES
\$21,000,000	\$12,000,000	\$7,500,000	\$6,000,000 (estimated)	<b>\$6,000,000</b> <i>(estimated)</i>	PARTS SOLD TO CONSUMER
\$168,750,000	\$388,000,000	\$592,068,000	\$336,717,500	<b>\$212,040,000</b>	<b>TOTALS</b>
\$21,000,000	\$12,000,000	\$7,500,000	\$6,000,000	<b>\$6,000,000</b>	SETS AND COMBINATIONS
\$235,850,000	\$290,550,000	\$242,980,000	\$158,234,000	<b>\$91,230,000</b>	PARTS
					ACCESSORIES
<b>\$425,600,000</b>	<b>\$690,550,000</b>	<b>\$842,548,000</b>	<b>\$500,951,500</b>	<b>\$309,270,000</b>	<b>GRAND TOTALS FOR YEAR</b>

Permission to quote statistics in this issue is granted if credit is given "Radio Retailing"

**108,000 AUTOMOBILE RADIO SETS**  
Included in the 1931 unit set sales figure are 108,000 automobile radio sets. At an average price of \$55 (less tubes and installation) this new field yielded a gross

of \$5,940,000 last year. During 1930 34,000 auto-radio sets were sold.

**SETS ARE PRICED LESS TUBES**  
Because of the advisability of separately

listing all tube sales, it should be remembered that *Radio Retailing's* statistics of the retail value of sets sold do NOT include tubes. Note that more tubes were sold in 1931 than in '30, but dollar volume was less.

# A Decade of RADIO

Radio Retailing's tenth annual presentation of the factual status of the industry—Obtained from key sources and accepted as official and authentic

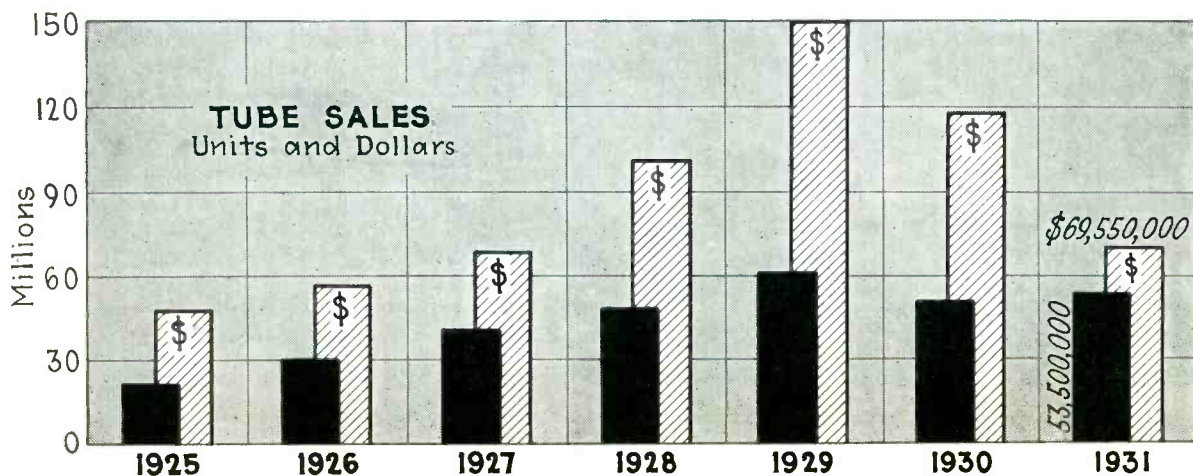
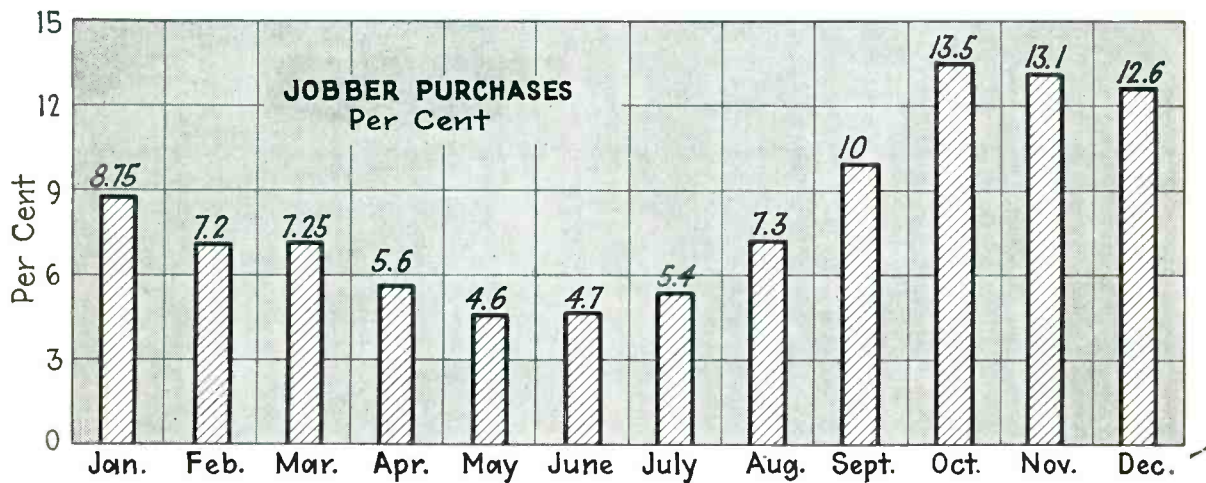
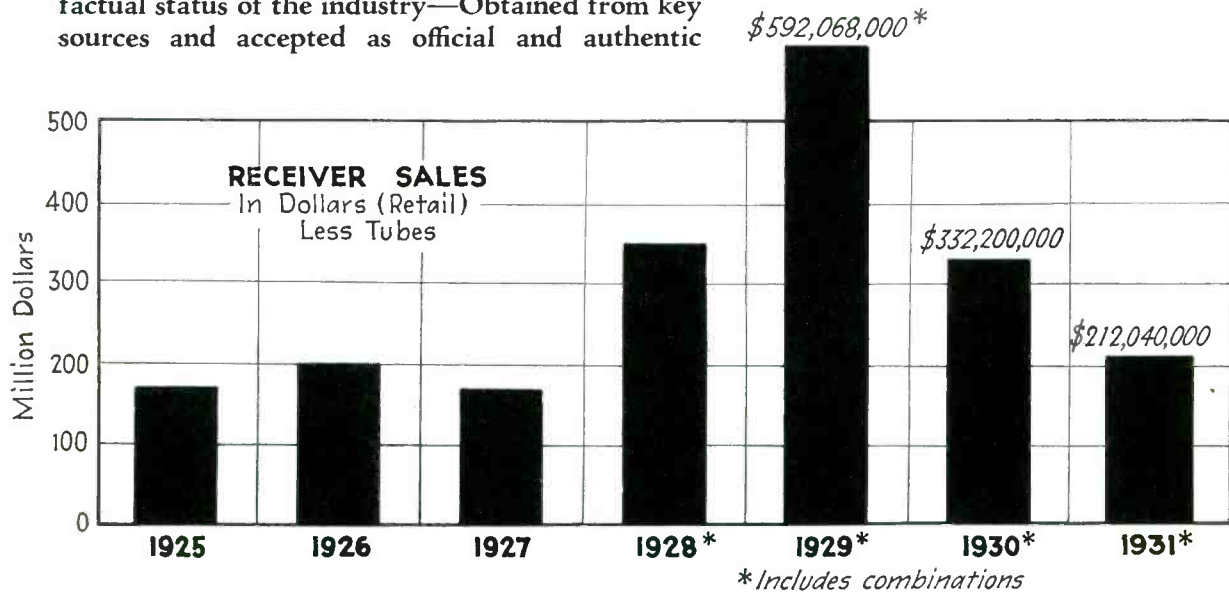



# DEVELOPMENT 1922-1931

Copyrighted. All rights reserved.

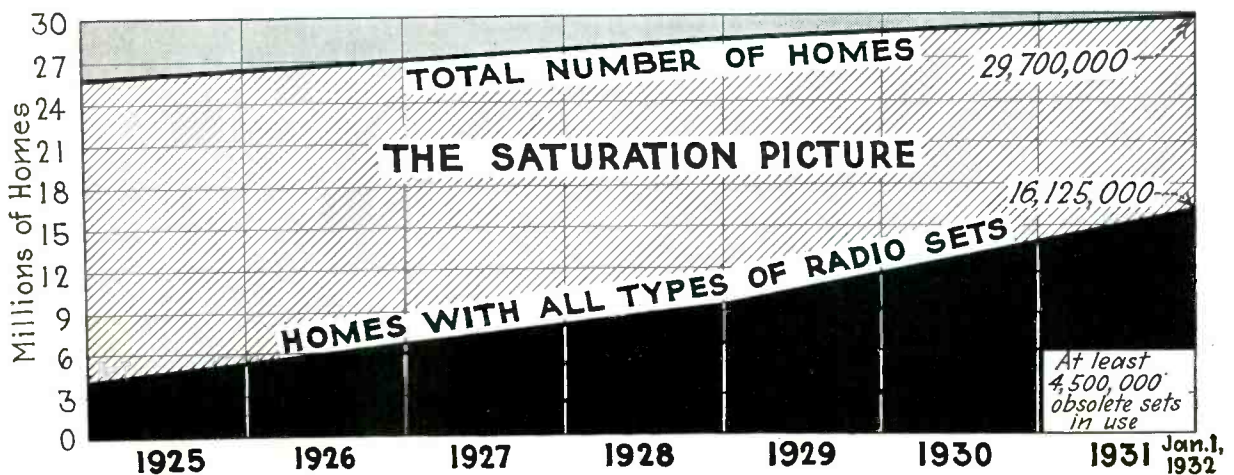
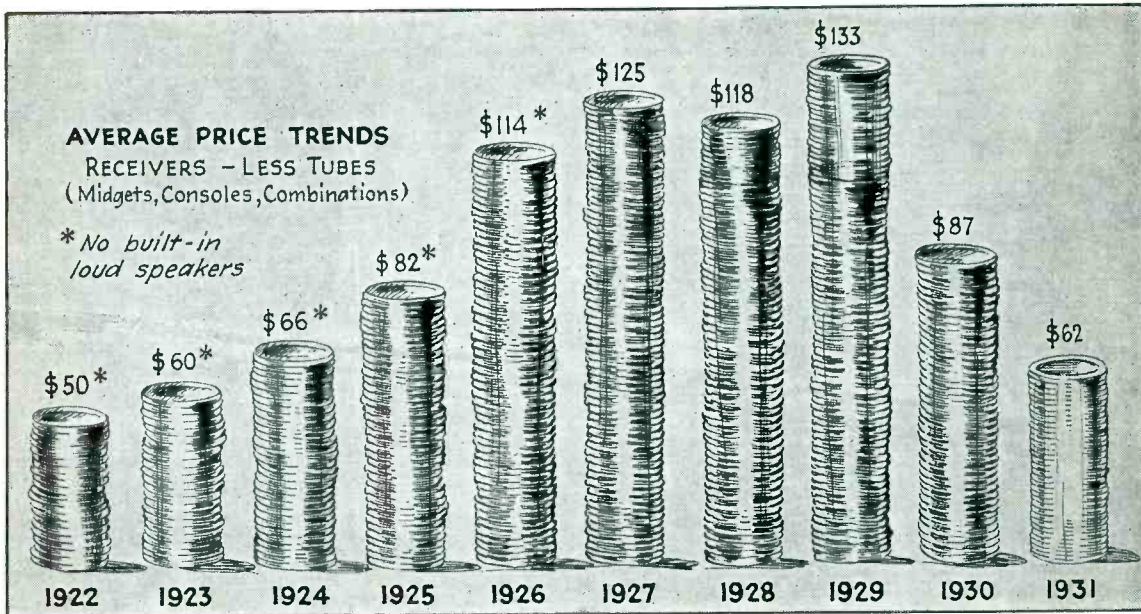
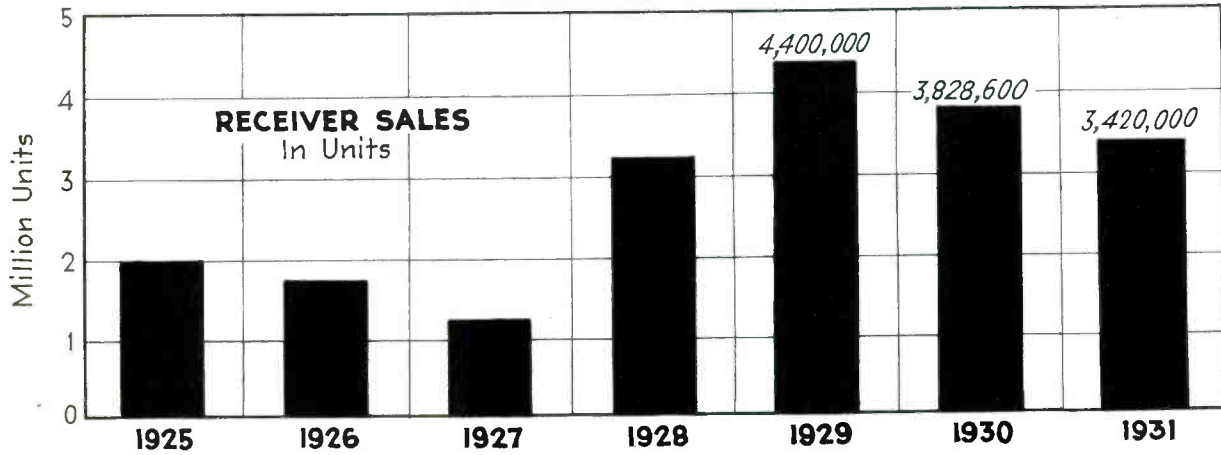

*If you Manufacturers will*

# BUILD UP.....

**M**erchandising practices tending to destroy our industry are increasing rather than diminishing.

**M**ust we wait until public confidence in radio values and in the stability of our selling policies has been annihilated?

**M**ust we wait until we are "out" as well as "down" before we put our house in order?

**"L**et George do it," has been a favorite sidestep in the past. But today, if the job of reconstruction is to be done, each and every member of the industry must lend a hand.

*In the following conversation, between a successful radio dealer, his jobber and the sales manager of a set manufacturer, "Radio Retailing" focuses attention on certain practices which have been retarding the orderly progress of selling sets. It does this in the hope that a greater appreciation of sound merchandising policies may be created, which, in turn, will lead to definite action.*

*Jobber Jones:* Bill, meet Mr. Lucas, sales manager for XYZ.

*Dealer Duncan:* Glad to know you, Mr. Lucas.

*Jobber:* How's business?

*Dealer:* Could be better.

*Jobber:* What's the trouble, depression?

*Dealer:* If it was just that I'd have no kick coming. In fact, I probably would be a little better off than most of the other dealers in town. What boils me up is the hectic state of our industry due to its own damn foolishness.

*Sales Manager Lucas:* You're just the man we're looking for. Frankly, Jones and I are out after ideas. My concern believes in getting down to brass tacks. Let's talk it over.

*Dealer:* There are a lot of things that we dealers are to blame for; and some things that the manufacturer could do to help us, and incidentally himself.

*Lucas:* Shoot!

## *When You Build Down*

*Dealer:* Well, let me give you an actual illustration of what I'm thinking about: Last month Jones called us all in for a "pep" meeting, and to introduce the new lines. Made a darn good speech, too, about selling up, getting full list,





# .. *we Dealers will* SELL UP

relation of fixed overhead to net profit, and a lot of other things. Then they "unveiled" the new models. And what did we see? *Seven* new items—in *January*—and all but two priced under \$90, and prices lower than on last year's models of almost identical appearance and performance.

How can I "sell up" I thought, when my manufacturer is *building down*?

How can I raise my average unit sale figure when practically every big set maker in the country is, in effect, cutting prices by bringing out new models at lower lists?

And that wasn't all. I knew that almost before I could get home there would be plenty of the old (?) models—introduced only last June—available for anyone who wanted them at special discounts.

If you fellows—say just four of the leading manufacturers—would raise your price levels and devote your consumer copy to telling the story of why a good set cannot be made and sold for less than \$100, we would get somewhere. Give us retailers that kind of support—stop fighting among yourselves—and we'll do our bit, don't worry. We could lick dumping of orphans, chain store prices and even competition from cheaper, less known lines, if the national manufacturers would play ball with us. Even today, the majority of prospects favor the set with a national reputation, they want quality, and they would pay the right price for these things if they had to.

## *What Can I Tell Mrs. Smith?*

*Sales Manager Lucas:* But competition has forced us to . . .

*Dealer:* Now just let me finish. What happens to the franchised dealer? Before long other dealers are advertising XYZ's "1932 models" at "40 per cent reductions." What am I going to tell Mrs. Smith who absolutely refuses to make any more payments on her model 28 because she's seen your new "improved" model just announced at a lower price—and her



own set for sale at less than the balance she owes me?

*Lucas:* But, we think that . . .

*Dealer:* One more minute! Next in importance to building better sets at higher prices is the matter of too many models and too many new model announcements. I'll bet you a new hat that 49 out of every 50 dealers you interview will tell you that once a year is often enough for a new line to be brought out. And it should be when business is slowest, in May or June. Certainly not at the peak of sales, when we are loaded up with last year's stuff. They don't do that in the automobile business, or any other business I know of.

I wonder if you manufacturers realize how comparatively unimportant, from a consumer standpoint, new models are? Mrs. Brown can't tell the difference. The cabinets look almost alike. And she's not very much interested in certain minor, and highly technical, tube and circuit improvements.

## *You've Been Kidding Yourself*

Frankly, you've been kidding yourselves. Do you realize that the little artificial spurt in manufacturers' shipments in January is more than offset by "dealer fear" and let-down in selling

for the two months which precede these anticipated "announcements"?

Get this: the average dealer isn't such a damn fool after all—although I understand it is a great indoor pastime to so label him. We're the fellows that have to sell your stuff. We *know* what will sell and who will buy. I wish more manufacturers would send their top men out into the sticks occasionally. It certainly would help matters.

*Lucas:* You're right! This visit has been mighty interesting so far.

*Dealer:* Just one more thing: Why so many models? I have to stock 10 sets just for floor samples. And that reminds me: Why did you let Don's Radio Shop in on your line?

*Jobber Jones:* I'll answer that one. Frankly, Bill, we needed that extra outlet to give us the necessary volume in this territory to meet our quota.

*Dealer:* Are you getting it?

*Jobber:* Well, it's a little early yet to say.

*Dealer:* Did you happen to notice his ad this morning, or see the price cards on your sets in his window?

*Jobber:* Can't say that we did.

*Dealer:* Well, Don is cutting already, and I was just about ready to quit you fellows when you came in here this morning. Any "long-time prosperity" in that situation?

### *What's the Answer?*

*Lucas:* What's the answer, Mr. Duncan? We're willing to listen.

*Dealer:* Protection! That's the answer. Just plain, common sense shoulder-to-shoulder working together. Mutual confidence and exchange of ideas . . . That's all.

Stop looking upon the dealer as just a warehouse. Consult him before you make policy and set changes—not afterwards. Give him territorial protection, stay with him, *after* he builds up your line locally, as well as before. Concentrate on helping him sell, not on hounding him with price and model changes. And, of course, keep your sets out of the hands of the price cutters just as much as possible.

We're willing to be reasonable. We dealers know that the manufacturer has his troubles, and just about what they are. And, as I said before, it's up to us to meet the competition of the dodo makes. And we can do it, if you big fellows keep your own line clean and stabilize your models.

*Lucas:* It's been a pleasure to meet you, Mr. Duncan. Just as soon as I get back to the factory these matters will be reviewed by our board. And I will write you a personal letter to let you know what my concern's attitude is going to be.

*Dealer:* Fair enough! Come around again. And remember! Build up and we'll sell up!

## . . . . . *and from other* JOBBERS *and* DEALERS

*The following statements, from actual dealers and jobbers, substantiate the arguments presented in last month's article, "Solve Claremont," and also in the preceding conversation between Messrs. Duncan, Jones and Lucas.*

### FOR PERMANENCE, FAVOR THE INDEPENDENT

*Gentlemen:*

The radio manufacturer can help the price situation by cutting out quantity discounts, advertising allowances and special "key" or "chain store" concessions. When we all pay the same price we all have the same opportunity. The money the set maker saves on these special allowances could well be used in advertising the wisdom of buying a quality set.

And remember, the permanent future of radio lies with the success of the independent radio retailer, not in the hands of chains, furniture stores and opportunists

in stencil brands, job lots and distress merchandise.

The radio specialist concentrates largely on driving home the idea of "radio as a family necessity," and features nationally advertised lines. This type of dealer must stick to radio. Therefore he is not prone to engage in fly-by-night schemes—he must build for the long pull. Other outlets will drop radio like a hot potato the minute it ceases to return a profit.

The manufacturer who figures on remaining in business *must* encourage and play with the permanent retailer of radio.

PAUL HELFER, INC.

*New York City.*



This article appeared in last month's issue. It received wide and favorable comment.

NEXT MONTH  
Radio Retailing  
will continue its  
campaign, for  
rebuilding our  
industry on a  
firmer basis,  
from yet another  
angle... Watch  
for it.



## SOLVE Clarendon!

**EDITORIAL FOREWORD**

Let me first state that the editorial staff of Radio Retailing was not primarily in quest of Clarendon, Va. The Clarendon area was chosen for the help received from an old established radio dealer in that area. The editor leaves it to you to decide whether or not Clarendon was chosen for this purpose. The main purpose of this article is to show the radio dealer who has a serious case of trouble all over the country.

Radio retailing is a business that has been suffering in a serious way since the beginning of the year. The dealer's position of selling radio sets is becoming more and more difficult. The radio set is no longer the big item, but the small radio sets are becoming more and more important. The dealer's position is becoming more and more difficult. The radio set is no longer the big item, but the small radio sets are becoming more and more important. The dealer's position is becoming more and more difficult.

Read the many reasons for the serious condition of the radio business in our area. It is falling in our area. We have never seen a radio set before. Read the many reasons for the serious condition of the radio business in our area. It is falling in our area. We have never seen a radio set before.

Read the many reasons for the serious condition of the radio business in our area. It is falling in our area. We have never seen a radio set before.

Read the many reasons for the serious condition of the radio business in our area. It is falling in our area. We have never seen a radio set before.

**Small Town Policies Must Be Revamped Or 60% Of Our National Market Will Stagnate**

DEALER	TYPE	1931 Retail Sales
1	Radio Store	\$12,000
2	Radio Store	12,000
3	Radio Store	11,700
4	Radio Store	11,300
5	Radio Store	7,000
6	Radio Store	6,000
7	Radio Store	5,000
8	Radio Store	4,000
9	Radio Store	3,000
10	Radio Store	2,000
11	Radio Store	1,000
12	Radio Store	1,000
Total Sales by Clarendon Dealers		\$100,000

Clarendon, Va. is a typical example of the radio business in our area. It is falling in our area. We have never seen a radio set before.

### CLAREMONT, A TYPICAL EXAMPLE

Dear Mr. Sutcliffe:

I was much interested in reading your article on Clarendon. It depicts accurately a condition which exists generally in our industry. Many dealers are now forced to consider discontinuing the sale of radio because it no longer is possible to make a profit out of it.

I doubt that any specific recommendations can be made to correct the existing troubles. The major factor in this respect would be, of course, the elimination of a majority of the irresponsible concerns now making sets. This would reduce destructive competition.

Just how this can be accomplished, I am at a loss to understand, but certainly this vital condition must be cleaned up.

So long as surplus radio merchandise is manufactured, outlets will be found, whether good, bad or indifferent, and the brand of competition that now exists will be continued. Possibly we will have to leave it to the laws of economics to work out this problem.

LOUIS BUEHN

Formerly president, The National Federation  
of Radio Associations and president of  
Philadelphia, Pa. the Louis Buehn Co.

### "CONGRATULATIONS"

Editor, Radio Retailing:

Congratulations on your article, "Solve Clarendon." It applies to us and to thousands of other dealers. In our case we are only 30 miles from Louisville. The inclosed ad from the Louisville Herald is a sample of what we are up against.

We have pioneered the radio business in our little city for eleven years. At the beginning of each season we start out with a lot of vim and vigor. But as each holiday season approaches, and with it the cut price competition, we feel that we want to quit the game.

More power to you and to your great magazine.

Radio Retailing, March, 1932

Radio Retailing. You are doing more to clarify the situation than any other source. **JESSE C. OWEN**  
Shelbyville, Ky. Owen Bros. Hardware Co.

### START WITH THE MANUFACTURERS

Dear Mr. Sutcliffe:

Am in full accord with all the sentiments you express in your letter of February 10 and with your efforts to prevent the radio industry from destroying itself.

The correction of present day conditions ought to start with the radio manufacturers but the time is not yet opportune. Too many are still too selfishly intent on complete domination of the radio industry. Smaller, weaker manufacturers are too frantically grasping at straws to prevent their going under.

We feel awfully lonesome in our efforts to maintain the kind of constructive merchandising policies which the industry must get back to if it is to get out of its present slough of despond.

We are with you, heart and soul, in what you are trying to do and we are gaining, from your attitude, encouragement to "carry on" ourselves.

W. ROY MCCANNE, President  
Rochester, N. Y. Stromberg-Carlson Tel. Mfg. Co.

### AN ACCURATE PICTURE

Gentlemen:

We wish to congratulate you for your article on "Solve Clarendon" in the February *Radio Retailing*. We believe that this gives a very accurate picture of the industry as a whole. It seems to us that the only practical way to arrive at a cure is through the manufacturers. If they cannot remedy the situation with their more concentrated interests, there isn't much hope that the retailer can do anything effective.

Trusting this article will at least arouse some interest among the powers that be. **C. F. COWAN**  
Fresno, Calif. Hockett-Cowan Music Co.



CHARLES L. REYNOLDS  
and his organization

RIGHT

*The two lines are freely intermingled in the main showroom and all the men are qualified to demonstrate either. The glassware on the table was offered to old customers in a "turn in a prospect" contest with highly successful results*

# "Refrigeration

"TWO oars are better than one," says Charles L. Reynolds. "I proved that to my own satisfaction in the fall of 1931 by taking on refrigeration. From August, 1930 to April of last year, Radio Testing Station salesmen sold 534 receivers in Binghamton (N. Y.), earning an average of \$39 weekly, but in May radio slumped and I know now that we would have been hard-pressed if it had not been for the fact that these same salesmen were able to sell 141 electric refrigerators (Norge) between then and November. As it was, average weekly earnings dropped to \$31."

Reynolds, who has heretofore specialized—graduating successively from amateur operator in the early "coherer" days to small-scale manufacturer, to jobber and finally to retailer—operates the oldest radio store in the city and despite the fact that it is on a sidestreet and over a mile from the shopping district has placed 2,700 sets and has more than 1,000 active accounts on his books. Fifty-three per cent of the concern's 1931 customers bought in the store, again proving that shoppers continue to beat paths to distant doors to find better "mousetraps." The remaining equipment (Zenith, Philco, RCA-Victor and Crosley) was peddled by 10 outside salesmen working on salary and commission, the boss taking all floor time.

*Binghamton, N. Y., set sales slump by moving salesmen's weekly earn*

This salesforce, composed of 5 experienced radio men plus 5 recruited from other fields and hand-trained, was moulded several years ago and proved especially versatile when domestic boxes were added, enabling the organization to take hold of the new complementary line with scarcely any preliminary waste motion.

## GETTING STARTED

"WHEN I decided to tackle refrigeration the fact that my outside sales crew was already organized and functioning smoothly was a distinct advantage," says Reynolds, "for outside effort is even more essential in this field than radio. Where store-selling organizations would have found it necessary to hire and break-in men untried by the management in order to obtain volume I had merely to equip a proven force for a new



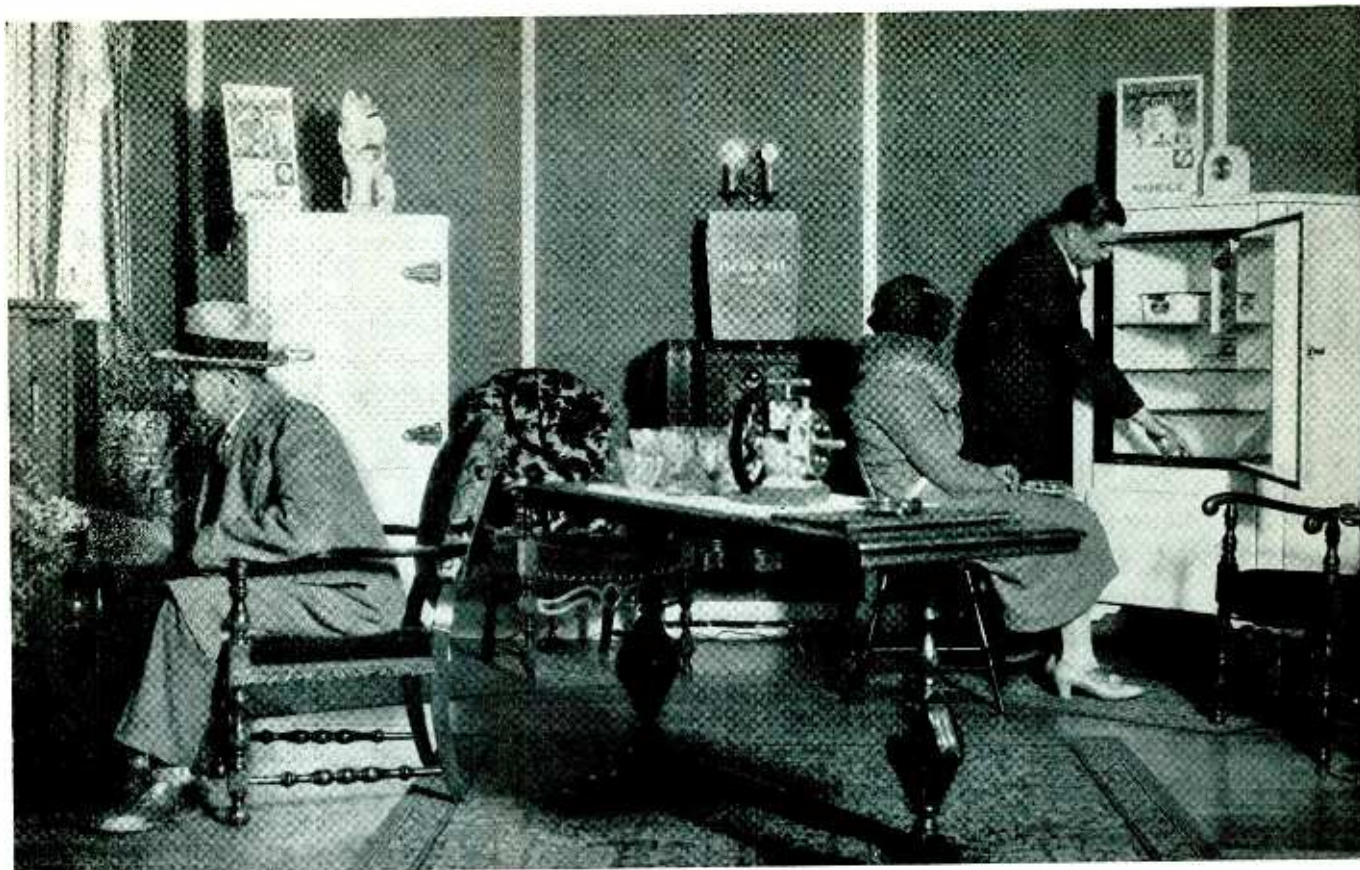

# *Saved My SHIRT!*”

*dealer weathered 1931  
141 domestic boxes. Kept  
ings up to \$30 average*

job. This was accomplished simply by packing the entire crew off to Syracuse where, in the office of my jobber, they received a two-day course in refrigeration, absorbing not only technical fundamentals but also all the practical selling suggestions experienced men could supply.

“I had three servicemen at the time and the oldest was introduced into the repair department maintained by the jobber long enough to acquire a working knowledge of the box. Upon returning home I hired an additional man and at present have three working exclusively on radio repairs and installation while the fourth splits time between the two lines. My experience with service has so far been most favorable and, incidentally, the department is now self-supporting.

“Thus when the first shipment of refrigerators came in the men were fully familiar with them and knuckled

2 OARS  
Better than One

*“When my first shipment of refrigerators arrived in May, I temporarily relaxed pressure on radio, concentrating on the new line*

*“This was a mistake. I should have pushed both. This year they will receive equal effort”*

Charles L. Reynolds

down to work without delay. Fortified by heavy initial newspaper advertising they first approached customers to whom they had already sold radio and the fact that 61 per cent of sales to date have been made to these people is ample proof that it was a wise opening move. Just one error of judgment occurred. We were all so eager to put the new line across that we unconsciously relaxed pressure on radio and I see now that our total sales record could have been improved if we had continued to push both with equal enthusiasm.

"Throughout 1932 my salesmen will approach prospects with open minds, ready to sell either product, depending upon resistance encountered in each individual case. I am firmly convinced that it is unwise to push refrigeration at the expense of radio in the summertime or to push radio at the expense of refrigeration in winter. If there is a natural seasonal preference this is beyond our control. But we certainly do not intend to accentuate it."

#### CREW DIRECTION

"**T**RAINING of the salesmen was not dropped with the initial course of sprouts. Every few months the trip to Syracuse is repeated for further expert instruction and in addition regular sales meetings are held weekly in my office where the men discuss current problems to their mutual advantage. Although there were some faint misgivings about ability to move such totally foreign equipment the crew now talks boxes and sets with equal facility. I have no man who might be said to specialize; believe in a complete wedding of the two lines insofar as the sales force is concerned and am convinced that the men can obtain not only refrigerator business from radio customers but also radio business from refrigeration customers, the latter type sale increasing as we get more boxes out.

"The men work from 9 a.m. until late in the evening and while I suggest that they spend mornings cold-canvassing this is not insisted upon as the force appears to work best when left to its own initiative. Radio logs carried by the entire crew constitute excellent approach material. Where cold-canvass prospects accept them the men put out a feeler first on refrigeration and where the logs are rejected it is logical to assume either that the family has no radio or that it is not working. Leads

sufficient to keep the force busy are usually obtained as a result of prize campaigns in which old customers participate. I recently offered a set of glassware (see store photo) for the name of a prospect interested in radio or refrigeration on the condition that the sale involve \$100 or more. The prize proved much more effective than cash, probably because my discount made it possible to offer merchandise worth considerably more at retail.

"We have also used the time-payment 'clock' idea with some success. Quarter-bank clocks were furnished with several machines as an experiment last summer and worked out well enough to permit us to advertise the idea. About 18 such installations are now in force but in each case we have found it advisable to depart from suggested practice and obtain signed contracts just as if the box had been sold without the quarter-clock. Thus we can replevin in the event that there are not enough coins in the bank at the end of each specified period to meet contract obligations. We furnish the clock-bank as a convenience for customers, in other words, but avoid writing it into the contract."

#### FUTURE PLANS

"**W**HICH line will bring you the most revenue in 1932?", we asked this dealer. "Refrigeration, undoubtedly," was the reply. "This will be a difficult year for all selling due to the general low-ebb of business but radio will be the harder-hit of the two because of its greater saturation, stiffer competition.

"What will happen in the more distant future is more difficult to predict. Many new manufacturers are entering refrigeration, hence cheaper boxes will be offered, with consequent rapid increases in both saturation and competition. And when replacement becomes a factor, refrigeration will be no more attractive than radio. So while I may round out my line from time to time with other items, these even temporarily eclipsing set volume, radio will probably remain the mainstay for I feel that it has greater potentialities than any other specialty for the home.

"Refrigeration saved my shirt last season and it would be difficult to over-estimate its importance to me this year. Our quota for 1932 is 350 refrigerators. We'll top it. But meanwhile radio will not be neglected."

*One of the company's four servicemen at work in a corner of the well equipped shop. This department is now operating at a distinct profit*

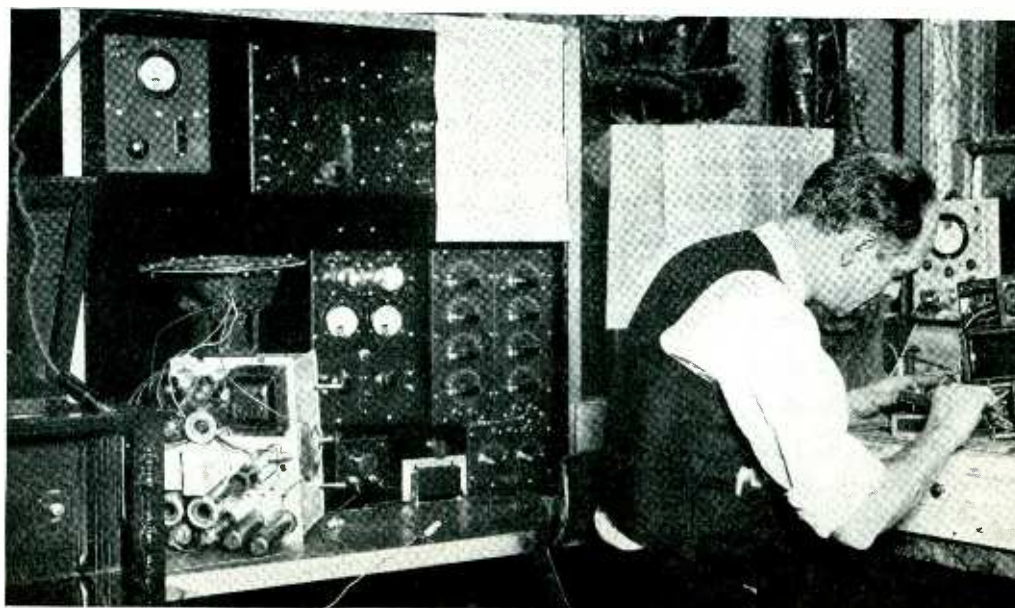



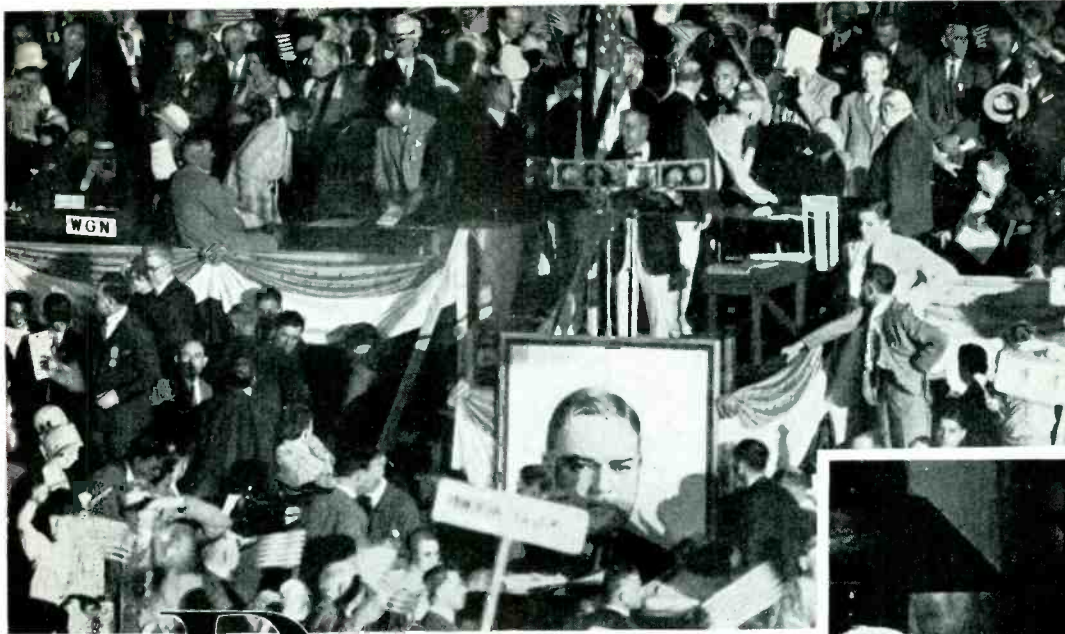

*Politics will pre-empt the spotlight in early spring, interest reaching fever-pitch at Chicago, with an exciting November culmination*

# for President



ALFRED E. SMITH



HERBERT C. HOOVER



FRANKLIN D. ROOSEVELT



ALBERT C. RITCHIE



*Prepare NOW To  
MERCHANTISE  
BROADCASTING'S  
Best Bet in 4 Years*

Republican National Convention  
June 12  
Democratic National Convention  
June 27

*The public will want to hear  
their planks and politics  
over national networks*



# SEVEN *Sales* . . .

**This amazing selling job, probably never exceeded in the history of merchandising radio products for the home, may sound "too good to be true." The writer, however, personally checked the authenticity of the figures quoted and, further, will furnish additional confirmation of the facts in this article upon request**

**S**EVEN consecutive sales of a certain radio product: each averaging \$1,038, and each a cash transaction. It sounds unbelievable. We report this merchandising achievement, not because of its spectacular nature, but more in the hope that it will inspire and guide our readers. If the well-to-do music lovers of New Haven, Conn., respond to the merit of a thousand dollar radio-phonograph instrument, certainly there should be prospects in other cities who will do likewise. And these sales were closed, not in boom times, but less than four months ago.

We grant that certain conditions must prevail if one would hope to duplicate the record of the Loomis Temple of Music. This concern, for example, has been an intimate part of the pattern of the musical history of the state of Connecticut for 66 years—it was founded in 1865. Its clientele is composed largely of prosperous people of discriminating musical tastes. Rosa Ponselle, in her early days, was a frequent and appreciative patroness of this house. And of course the ability of the sales persons, and their musical education, is of the

highest order. Florence Leichter, the woman largely responsible for selling these instruments, is, herself, a musician. She knows the libraries of recorded music, the musical classics, and the personal musical tastes of her customers thoroughly.

"But will anybody, in these days, pay \$995 for a combination set—and if so, why?" I asked this efficient young lady.

Miss Leichter smiled. "Yes, they will," she replied, "Provided it will perform like this instrument of ours does, play both sizes of records, both sides, shift them automatically, and is, mechanically, electrically, acoustically and in external appearance practically perfect. But, of course, the big selling point is tone," she added. "Just listen to this record—and you should hear how it brings in radio programs."

In my humble opinion the beauty of sound which issued from this instrument was enchanting. In personally stressing the tonal feature I am taking editorial liberties. But certainly tone must be perfect when the unit sales price is almost \$1,000. And the selling strength of such an argument always will be a paramount factor.

**N**ATURALLY, the conversation then shifted to selling methods. So far no special "drive" has been conducted. Whenever the right type of customer comes in the store he is "exposed" to the tonal beauties of this device. This is sometimes done quite frankly and directly and sometimes by simply starting the machine. It is located midway down the center isle, the most prominent position on the floor, and about 15 feet from the record counter. While Mr. or Mrs. Prime Prospect is looking over the latest classical recordings Miss Leichter places a record, which she knows will appeal to the particular musical taste of the "victim," on the turntable and turns on the switch. In nine cases out of ten the customer is



# The Story of a Remarkable Achievement

## Merchandising a De Luxe Musical Instrument

By  
Ray V. Sutcliffe

**\$7,267**

attracted by the realistic tonal values and strolls over to investigate. Incidentally the magazine of this instrument is loaded with carefully selected records which will bring out the high and low registers and otherwise are unusual and recent recordings.

People who buy the best in musical instruments seldom require high pressure sales attention, expert advice is much more effective. And with the automatic record changer type of combination the prospect should be left alone just as long as he or she desires. Ample opportunity for "self-selling" should be provided and will be found most productive when dealing in the high price brackets, according to Miss Leichter.

Another interesting angle to this type of selling is the amount of the record business which always is a part of each instrument sale. Glance at the accompanying table of case histories. Note that people who pay \$995 for their radio-phonograph musical pleasures seldom buy less than \$40 worth of records at the time of the original transaction. Actually, the ultimate unit sale totals much higher. Within 30 days from the time the instrument itself was delivered to the home—all of Loomis' sales were to domestic users—an average total of \$118 worth of records, *per customer*, had been purchased. One lady bought records to the tune of \$272 within a six weeks' period. Another ordered an assortment totaling \$50 "as a Christmas present for my husband." All of these statements are facts, not editorial fancy. They are vouched for by one of the oldest, most conservative and reliable musical houses in America.

Quite a number of other interesting things may be learned by studying this table. Note that one man drove

### WITHIN 90 DAYS

#### The Case Histories of THESE SEVEN — \$995 TRANSACTIONS

Type of Customer	Terms	Amount	Records Pur. at Time of Original Sale	Additional Records Pur. within 30 Days
Business executive who twice drove in from a town 80 miles away for demonstrations.	Cash (gave old set away)	\$995	\$65	\$70
A railroad locomotive engineer.	Cash	995	25	20
Retired officer of large corporation.	Cash (the only trade-in)	995	60	90
A lawyer and patron of the fine arts.	Cash (gave old set away)	995	50	50
Wealthy widow who never before could be induced to buy a radio set.	Cash	995	112	160
Well known playwright.	Cash	995	40	35
Merchant.	Cash	995	20	28
		<b>\$6,895</b>	<b>\$372</b>	<b>\$453</b>

down from Winchester, Mass., for a second, and final, demonstration; that a railroad engineer bought; that one wealthy woman, who never before had owned a radio set or a phonograph, capitulated; that but one trade-in was involved; that three customers gave their old sets away and that not one time-payment contract was written.

"Interest in good music and in the better recordings most certainly is on the increase," declares Miss Leichter. "Our clients want to hear the great symphonies and operas in their entirety. The instrument we sell makes possible the fulfillment of this desire. In other words conditions, psychologically are favorable. I know of five real 'hot' prospects for his proposition right now."

A \$995 automatic combination is obviously a luxury, but times are apparently never so blue but what someone, somewhere, still has money to buy luxuries. Prospects are fewer, farther between, but when found make the search ever so much more worth the dealer's while. As much gross profit is involved in the sale of a single device such as Miss Leichter's as in 15 ordinary set sales. She extracted as much profit from seven customers as the ordinary radio dealer would from 100 or more. And with infinitely less labor and expense.

# “Uncle”

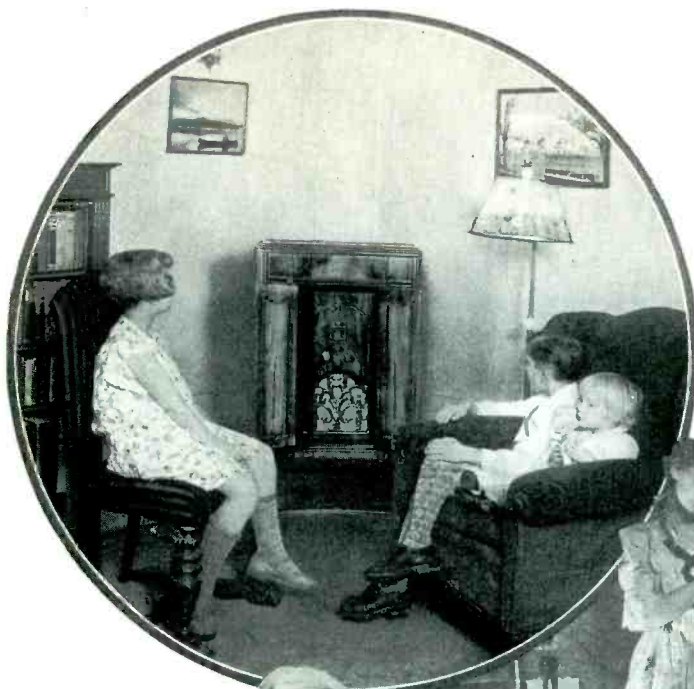

Uncle Olie and His Gang (right). Below, Jolly Bill and Jane.

These programs are unusually popular with children.



**K**NOW your broadcasting onions! Appreciating the fact that a working knowledge of what's on the air should be a part of the mental equipment of every radio salesman, this magazine repeatedly has published informative material about programs and broadcasting artists.

In this article we concentrate on two unusually popular, national chain programs for children. The one in the morning, "Jolly Bill and Jane," goes out over an extensive NBC network; the other, "Uncle Olie," an evening affair, over Columbia's wires.

Many times, when all other appeals fail, parents can be swung to radio if the worth and pleasure of these "kid" features can be driven home. Invariably such programs stress proper eating and good habits for children. We know of one radio merchant whose strongest trump card, which has captured dozens of sales, is this plea to parent love—the strongest of all human emotions.

**P**ERHAPS we are a little biased when it comes to writing about William Steinke, because "Jolly Bill," before achieving his present fame as one of America's foremost child entertainers, was a member of the art staff of *Radio Retailing*. Old subscribers will remember his



*Reach the Parent Through the Child By Specific*



# RADIO



## *The Family's MOST POPULAR Guest*

clever cartoons, depicting the "evils" of the radio industry along about 1927-28. Today this man's mail is well above 500 letters a day, from children all over the country, who listen every morning to his stories of childhood adventure.

Jolly Bill and Jane will have been on the air 737 consecutive days by February first. Early in January Jolly Bill offered a copy of one of his cartoons to each child writing for it. The week of January 11-16 he received 35,000 letters, making 275,000 in two years.

A large number of Mr. Steinke's letters come from parents and school teachers who praise the program as a helpful and wholesome influence in developing regular habits with children, and inducing them to get dressed in time to hear Jolly Bill and Jane while breakfasting and then be ready to start for school. As a result of this program children are persuaded to eat cooked cereals. After the program had been on the air six months the "Cream of Wheat" people informed Jolly Bill that sales in the New York area had increased 15 per cent.

Jolly Bill is a great big, fat, laughing man who knows more stories to tell to children than anyone else in the world. In fact, "Jolly Bill and Jane" is a program that is just one grand romp for everybody. And everybody, so far as the studio is concerned, means "Fritzie the Fiddler," the "Three-legged Piano-Man," the "Bugle-Man" and just everybody else that Bill and Jane know.

ANOTHER highly entertaining program for children is the series featuring "Uncle Olie and His Kre-Mel Gang," heard over WABC and a coast-to-coast network of more than 40 stations of the Columbia System. It has been on the air three times weekly since November 9,

1931, being heard from 5:30 to 5:45 P.M., EST., on Mondays and Fridays and from 5:15 to 5:30 P.M. on Wednesdays.

The program features Uncle Olie, hearty and genial Swede; the Blue Ridge Boys, a real hill-billy vocal and instrumental quartet brought to New York from Smithville in the Blue Ridge Mountains of Virginia; a variety of diversely talented child performers ranging in age from five to fourteen; and a 12-year-old announcer.

The broadcasts are presented as children's parties. Uncle Olie acts as host. Although he occasionally tells an amusing story with an underlying moral, he is primarily a master of ceremonies. He is ably assisted by Peter Donald, who does all but the commercial announcing. Peter, who has had considerable stage experience, attested to by a good sized book of clippings containing more praise than the critics usually lavish on child actors, is a competent announcer, and he is believed to be the youngest to announce on a nationwide network.

The members of the gang are recruited from the ranks of stage, screen and vaudeville children. Several regular members are on hand at every program, and their number is augmented from time to time by guest stars.

A hilarious spontaneity pervades all these broadcasts, the child performers deriving as much fun from them as do the child listeners.

That the Kre-Mel program appeals strongly to children is evidenced by the steady growing heaps of letters, written in the large and rambling characters of childhood, which daily flood in upon "Uncle Olie."

Radio dealers may safely play up these two outstanding features, "which will mean so much to your daughter, Joan, Mrs. Brown"—with all difficult-to-close prospects.

## *Knowledge About Popular Juvenile Programs*

# On Their TOES



BOXES, BUT NOT DEALER "OUT IN COLD"

*Radio Electric won first prize in the manufacturer's recent national sales contest and no wonder—with ideas like this. The store secured increased "floor-space", and outside at that, merely by asking the police for it*

## "Be Your Own Coach"

PACIFIC Coast dealers who have adopted home movies as a sideline are finding a ready market for cameras and projectors among golfing enthusiasts, many of whom are having pictures taken of themselves in action in order that they may study their stance and use of clubs. Interest created by the Bobby Jones lesson series shown in local theatres is said to be responsible for this latest dealer opportunity.

"Be Your Own Coach." Here is an ad line that will appeal to most all sportsmen. The golfer is not the only man interested in perfection of form.

## Music Hath Charms

IN a special two-day drive for business, Harry Sommers, Atlanta, Ga., used-car dealer, offered auto-radio, less batteries and tubes, with each purchase running over \$295. Harry cleaned up, selling more cars in two days than he had in weeks prior to the sale, and a cooperating radio dealer did a profitable week's work installing the sets and selling the batteries and tubes.

## Crate 'Em!

WHEN new models were announced in February, W. A. Forbes of Cheyenne, Wyo., found himself with a small stock of 1931 models and decided to move these at once by dropping the lists. He proceeded to fill the store window with these sets, marked down, and

When Dealers Simply Must Have More Business Sales Ideas Like These Evolve

awaited results. Nothing happened. Window-shoppers evidently assumed that the sets were used, or demonstrators.

So Forbes replaced them in their original packing cases, omitting just enough boards to permit each set to be seen, and replaced them, cases and all, in the window. Five sets sold the first day and the remainder of the stock was liquidated before the new models arrived.

## Knots

DEALERS in a certain Southern city are effectively combating the "joyride" evil through universal use of simple little knots. One is tied in the customer's lead-in when a free home demonstration is made to telegraph its message to the next salesman who comes along with a set under his arm.

Now if we could tie a "granny" in the prospect's necktie to indicate "poor credit" everything would be jake.



"TRICK" SHELF + SMALL APPLIANCES = MORE BUSINESS

*In this shop small household appliances are lined up against the wall between radios on a shelf formed of cheaply assembled pipe-stands resembling music racks used by orchestras with plate-glass shelving*





"SOLD 500 EXTRA TUBES  
IN TWO WEEKS"

Hickson's normally sells about 200 tubes per week. This window attracted so much attention in Rochester, N. Y., that sales skyrocketed to 900 during the 16-day period in which it was used

### *They Earn Their Salt*

THE renting of trade-ins is a profitable source of extra business for Ted Kobbervig, manager of the Broadway Radio & Music Co., Tacoma, Wash. He advertises in the classified phone book and gets most of his calls from hotels and apartment houses.

The Hotel Winthrop permits him to have cards, advertising the service, in each room for a small commission per rental. Fees are \$1 for the first day and \$.50 per night thereafter, with a special \$7 monthly rate. Kobbervig has a steady turnover of about 50 second-hand machines which he estimates bring in between \$5 and \$15 in rentals, and then may be sold just as easily as if they were placed on sale immediately upon being taken in trade.

### *Un Stock de Disques Francais*

THE White House, San Francisco department store, had a stock of foreign phonograph records to dispose of and adopted a novel means of advertising them. A sales letter describing the records available was prepared in French and mailed to a selected list of customers.

"Most of the people who will be interested in the records will be able to read the language," the sales manager reasoned. "And in addition, many who are good prospects for the classics, even though the language is not understandable, will take the letters to a friend for translation." This reasoning proved sound for the letters materially increased record sales.

### *A Good Guy to Know*

WHEN E. A. Portal of San Francisco sells a set to an apartment dweller, or when he sends a serviceman to an apartment, the apartment house manager is always called upon. He is a good guy to know.

These men are more or less familiar with their tenants and can often pass along a good tip for radio sales or service.

MAKES READING ADS A PLEASURE

To what feature do most newspaper readers turn first? "The 'funnies'—that's why my ad service picturing embarrassing moments pulls," says Mayfield. "People like to look at comic cartoons"

### *Re-Tune for Tone*

BALDWIN Piano Company of Cincinnati, Ohio, has hit on an advertising theme that produces profitable service work. "Let Us Re-tune Your Set," the concern writes, much as it would about pianos. Quality of reception is referred to as "Tone Pitch."

Curiously enough, many old sets are really in need of "re-tuning"—or "aligning" to be more exact. Selectivity, sensitivity and tone is ruined when condensers no longer track. And tuning-up naturally includes new tubes where the old ones have lost emission.

This idea is one which stops newspaper readers, injects a new thought into direct mail and is aiding sales.

# Radio Retailing Starts a Nation Wide Campaign for "Getting the Most from Your Radio Set"

*Secures Cooperation of the Big Chain  
Broadcasters—Set Owners Will Be Told  
to "See Your Nearest Radio Dealer"*

**D**URING March, under the leadership of *Radio Retailing*, there will get underway a nationwide campaign to bring better radio reception conditions to millions of radio listeners,—a campaign which will prove of tremendous benefit to the listening public, dealers, jobbers, manufacturers, and broadcasters.

With the help of the broadcasting stations, newspapers, magazine articles, etc., the listening public will be reminded and informed of the standards of good reception which it should be enjoying, viz.:

1. Freedom from noises, clicks, and buzzes.
2. Fidelity of tone,—“reality.”
3. Ability to hear clearly all nearby stations.

*Radio Retailing* believes that reception conditions in millions of homes and for millions of listeners can be greatly improved,

through service calls and set overhauls by local radio dealers or service men.

*Radio Retailing* urges radio dealers to begin at once making canvasses of their neighborhoods to improve listeners' reception. Such canvasses and calls will open large opportunities for tube replacements, antenna reconstruction, parts sales, etc., besides leading to many sales of new sets.

In this work of bringing “Satisfactory Radio” to customers in his vicinity the dealer will have his way paved by informative broadcasts over the great broadcasting chains telling the listener about the standards of good reception he should be getting, and by frequent 20-word reminder announcements, morning, noon and night, urging the listener to “See Your Nearest Radio Dealer.”

Thus up and down the industry all forces are thus being marshaled to help you bring to every home “Satisfactory Radio.”





# Why Customers Complain

---

---

## Other Comment

### *Where the Fault Lies*

FROM all parts of the country, complaints continue to be received from both the public and the radio trade, concerning the peculiar "mushing" and distortion that momentarily comes over radio programs from stations 30 to 80 miles distant.

The voice of a speaker will be coming in clear and distinct, and then suddenly it will become nasal and almost unintelligible. After ten to thirty seconds of this distortion the voice becomes as distinct as before. Music is affected in much the same way.

In communities which depend for broadcasting service chiefly on some favorite station 30 to 80 miles away, this "mushing" phenomenon of the past season or two has been the despair of radio dealers and service men. Complaints are made by customers, service men go out next day and find reception excellent (as this trouble occurs only after nightfall). Then ensues a fruitless argument between set owner and dealer. Instances have occurred where this nightly "mushing" spoiled the sale of sets on time payments.

Radio dealers and service men should realize that for this curious "mushing" which has been with us all of the present winter, and part of last, neither broadcasters, radio sets, nor installations are to blame. The condition is due to the present state of the Heaviside-Kennelly reflecting layer, which acts like a great mirror in the sky, paralleling the earth's surface 100 miles above it. This reflecting layer has been an almost perfect radio mirror during the past year. From its smooth surface come down to us in great volume, the sky waves from distant stations. Stations are now heard with ease clear across the continent. And stations a thousand miles away often "come in like locals."

But the same smoothness of reflecting surface which brings in distant signals also pours back upon the ground the sky waves of nearby stations, causing interference between the ground wave and sky-wave, and producing fading and mushing.

During the day time only the ground-wave comes from the nearby station, and reception is clear and undisturbed. A 50-kw. station, for ex-

ample, will give good daytime service even 80 miles away, because in daylight only the ground wave gets out. But after nightfall the sky-wave of the same station comes reflected back in such volume as to chop up the ground wave. And distortion and mushing result. At points beyond 80 to 100 miles, where the ground wave is weak and the reflected sky-wave is much stronger, only the sky-wave is heard, and reception is also clear. This explains why mushing is not heard on greatly distant stations.

The change in the reflecting layer seems to be cyclic, coming every eleven years as a result of the sunspot cycle. Radio pioneers will recall that back in the early days of radio, in 1922 and 1923, little 50-watt stations could be heard clear across the continent. Apparently we are back to those days once more.

Unfortunately this phenomenon has been confused in some instances with the work that has been going on in station synchronization, and in the region of synchronized stations, synchronizing has been blamed for this distortion. Of course the two have no relation whatever. It is unfortunate that the general mushing trouble should give point to complaints against synchronizing. For the experiments now going on in the synchronizing of broadcast stations and the eventual operation of a number of large stations on the same channel, offer the greatest possibilities for the future in bringing additional programs and a wider range of choice to every radio listener.

In the interest of the future of better, richer radio, every listener and every radio man should be patient with the experiments now going on in synchronizing, and keep it free of the blame for the cosmic mushing which we shall have to endure for another year or more.

### *March—The Ten Million Month*

MARCH will usher in the first of two intensive drives scheduled by the Electric Refrigeration Bureau to help dealers sell refrigerators. It has been designated as, "The Million Call Month," in the expectation that 10,000,000 calls will be made, throughout the country, on prospects for electric refrigerators this month.



# about "MUSHING" Sound

by the Editors

Quoting from the plan book of the Bureau:

"For any community the quota of refrigeration calls for March is one half the number of domestic customers on the lines of the central station. The quota for March calls for any individual sales outlet is found by multiplying by ten the estimated total number of domestic refrigerators expected to be sold locally in 1932.

"Towards the end of February local Bureaus and individual dealers should advertise extensively in the local papers, also send to every prospect direct mail materials which may be obtained from the manufacturer and from Bureau headquarters."

Further working details for making March the biggest month in the history of the refrigeration industry, and about many other promotional ideas for the balance of the season, will be found in this plan book. Its title is, "Another Million in 1932." It may be obtained by writing to the Electric Refrigeration Bureau, 420 Lexington Ave., New York City. "Every radio-refrigeration retailer should obtain a copy of this booklet.

## Old, and They Look It

"IF PEOPLE were forced to display their radios on a front-yard pedestal there would be such a flood of replacement business that set manufacturers couldn't keep up with the demand." This interesting statement comes from a Rochester, N. Y., dealer who contends that many set owners would be ashamed to park a car as old as their radio before their door.

Certainly the fact that car owners feel that they must keep up with the Joneses is largely responsible for the rapid obsolescence of this merchandise. Pride of ownership plays an important part in most transactions.

"Would you be ashamed to park your present radio in front of your home?" Here is an advertising theme that the radio industry could adopt.

## Like Begets Like

THE leading editorial in the September issue of *Radio Retailing* stated that a growing and worthwhile replacement market lies just ahead. This statement was based on the observations of field investigators and on a special questionnaire mailed to 1,000 dealers.

Real radio merchandisers will take steps to stimulate this demand. To this end, it will be necessary to sell new prospects radio equipment of outstanding merit and performance. The reason for this is that only through hearing modern quality reception in the home of a friend does the average owner of an old type model realize that "the world has revolved a few times" and that his own set is out of date.

## When the Government Owns Radio

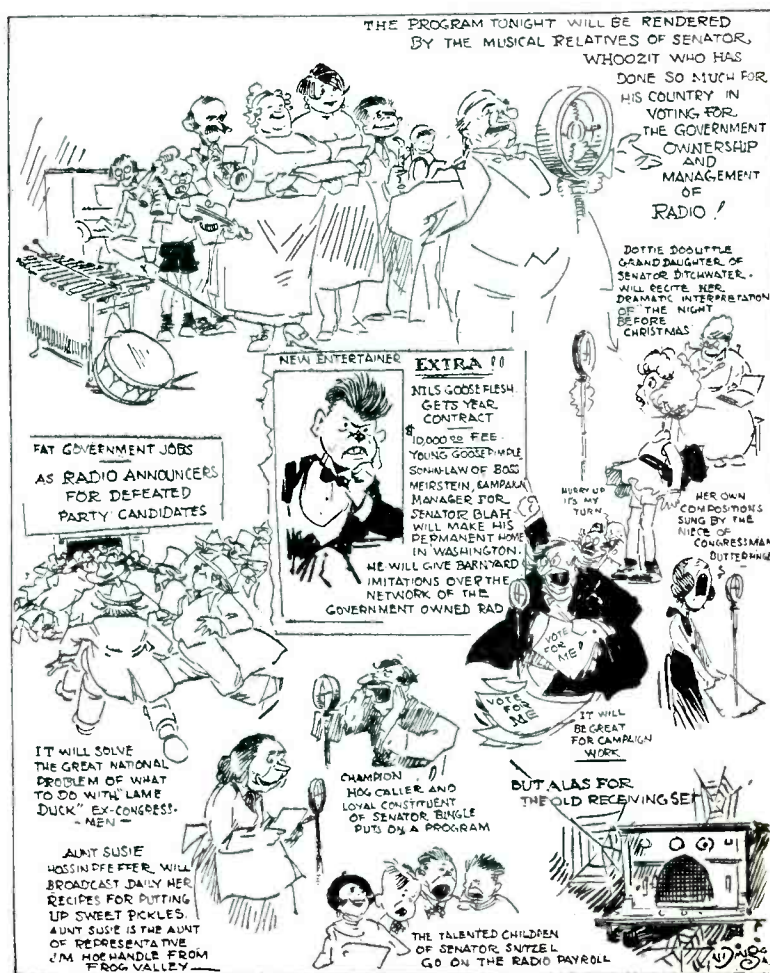

Courtesy of N. Y. Tribune, Inc.

# Auto-Radio

## “B” Eliminators

*New devices supply from 20 to 50 milliamperes of plate current, obtaining power from car storage batteries*

By W. W. MacDonald



Dynamotor. (Emerson) Filter designed to eliminate commutation ripple is in the square "can"

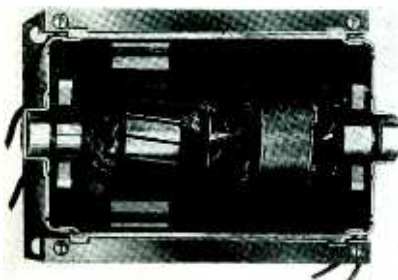

Rotary transformer. (Pines) An "exploded" view of the unit shown schematically on these pages

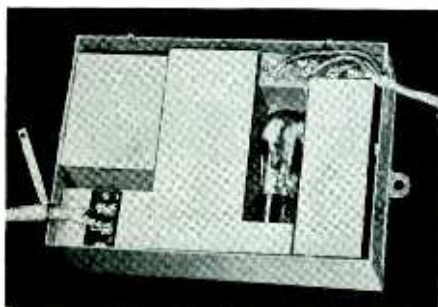

Interrupter type. (Mallory) Has a plug-in vibrator unit and a gaseous, half-wave, rectifying tube

IN THE January issue of *Radio Retailing* (page 21) the early introduction of "B" eliminators for automobile radio was predicted. Nine manufacturers have since announced such devices, these being actuated by car storage batteries. Three more are in process of design and others will no doubt follow. These eliminators are offered for use in unwired homes, as well as for automobiles, airplanes and boats, and it is pointed out that in addition to their convenience, the new accessories usually improve reception by providing higher plate voltages than would ordinarily be deemed economical with dry cell supply.

Two general types—"dynamotors" and "interrupters"—have been introduced. An auto-radio dynamotor may be briefly described as a simplified form of motor-generator in which a d.c. motor, driven by a low-voltage battery, revolves a high-voltage d.c. generator. Motor and generator windings are combined on one armature, a single field winding being common to both units. Two "commutators" are employed, as in the true m.g. set, one comprising part of the motor and the other part of the generator. (All good electrical textbooks describe dynamotors in detail.)

The interrupter type takes many forms but the basic principle of operation is readily grasped. D.C. current taken from the supply battery is interrupted in some manner. This may be accomplished by means of a vibrator (an old Ford spark-coil steps-up voltage in this way) or by "chopping" the battery current on and off with a rapidly rotating switch. The pulsating current so produced is essentially a.c. in character and may be raised in voltage by a transformer. In the eliminators under discussion it is stepped up (or down) to the required voltage and then rectified by either mechanical or electrical means.

Both types of equipment are provided with filters, the dynamotors to suppress commutator ripple and the interrupters to iron out pulsations present after rectification and also to eliminate any high frequency disturbance generated by the interrupter mechanism. Filters ordinarily consist of iron-core chokes and high capacity condensers in simple brute-force systems. (See circuit diagrams.) One

eliminator uses a two-section filter, the first being tuned to resonate at the interrupter frequency.

Several devices are provided with voltage dividing resistors fitted with sliders or taps by means of which servicemen may obtain intermediate voltages for detector, r.f. stage, screen-grid or control grid bias. Many thus eliminate "C" as well as "B" batteries. Dividers also serve as "bleeders" in many cases, improving regulation. Where not included by the manufacturer it is not difficult to design external units.

The two basic types outlined will be readily recognized in the following detailed descriptions:

**ELECTRIC SPECIALTY "Dyna-B":** Typical dynamotor with inbuilt filter and voltage divider. Wool-packed bearings, or ball-bearings slightly higher. Equipped with switch. Available on metal base plate for mounting in existing battery boxes or complete in protective box. Made for 12 and 32 volt primary supply as well as for 6 volt batteries.

**EMERSON ELECTRIC:** Dynamotor with usual single field and double armature winding. 18 lb. Filter includes single section choke (between 15 and 30 henries) and two condensers. (1 to 2 mfd.) The two capacitances are in series across final output of choke, midpoint being grounded to frame. An additional condenser is used across the storage battery input leads. ( $\frac{1}{3}$  to 1 mfd.) Strap mounting permits dynamotor itself to be mounted

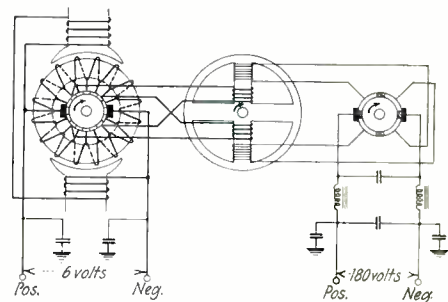

This device (Pines) has an actuating motor, novel rotating transformer and synchronous rectifier all on the one shaft



Manufacturer	Type	Output Characteristics	Battery Drain	List Price	Dimensions
Electric Specialty Co., Stamford, Conn.	Dynamotor	135 v., 25 ma.	2.2 amp.	\$40.00	Smaller than batteries
	Dynamotor	180 v., 30 ma.	2.8 amp.	\$40.00	
Emerson Elec. Mfg. Co., St. Louis, Mo.	Dynamotor	180 v., 40 ma.	2.0 amp.	\$29.75	7½x7½x6 in.
Howard Radio Co., South Haven, Mich.	Commutator	180 v., 46 ma.	6.5 amp.	.....	Smaller than batteries 4¼x6x12½ in.
	Commutator	(or 210 v., 30 ma.) 175 v., 35 ma.	4.2 amp.		
Hutch-Gard Corp., Ltd.,* San Francisco, Calif.					
Janette Mfg. Co., Chicago, Ill.	Dynamotor	135 v., 50 ma.	3.0 amp.	\$34.50	12x5½x6 in.
	Dynamotor	180 v., 40 ma.	3.0 amp.		12x5½x6 in.
Mallory, P. R. & Co., Indianapolis, Ind.	Vibrator	180 v., 35 ma.	2.4 amp.	\$24.50	7x10x3 in.
	Vibrator	135 v., 26 ma.	1.5 amp.		7x10x3 in.
Motor Car Devices Co., Los Angeles, Calif.	Vibrator		1.0 amp.	\$18.50	4½x4½x3¼ in.
Pines Winterfront Co., Chicago, Ill.	{ Rotary Transformer }	135 v., 30 ma.	2.5 amp.	\$30.00	5½x8x6¼ in.
		180 v., 30 ma.		\$30.00	5½x8x6¼ in.
United Amer. Bosch Corp. Springfield, Mass.	Perm. Magnet Field Dynamotor	160 v., 40 ma.	2.6 amp.	\$25.00	10x4x5½ in.
Universal Auto Radio Corp., Chicago, Ill.	*Vibrator	135-180 v.	1.8 amp.	\$20.00	2½x8x5 in.
U. S. Electric Works., Chicago, Ill.	Dynamotor	180 v., 35 ma.	2.0 amp.	\$29.50	5x5½x9½ in.
Utah Radio Products Co.,* Chicago, Ill.					

\*Device in process of design

vertically or horizontally for proper bearing lubrication. Manufacturer says: "Don't mount under hood." (Because of excessive heat?) Bleeder not included but may be used.

HOWARD "AC-verter": 6 volts d.c. is taken from the battery and changed over into 4.3 volts a.c., 60 cycle, then stepped up to a higher value by means of a transformer. Then, by synchronous commutation, this higher voltage is changed back to pulsating d.c. and fed through a two-stage filter to a standard B stick. Type A is for older sets having high plate drain requirements and may be mounted in existing battery boxes. Type B is for attachment to fire wall or behind rear seats.

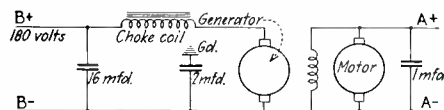

Conventional dynamotor. (U. S. Electric) One field winding, two windings on a single armature, two commutators

HUTCH-GARD: Planning to announce eliminators for both 6 and 32 volt d.c. supply early in April.

JANETTE "Auto-B-Power": Another dynamotor. Equipped with filter and voltage-dividing potentiometer. Two commutators, one at each end of shaft. Ball-bearings, balanced armature, steel frame with laminated pole-pieces. 20 lb. Black-enameled steel box.

MALLORY "Elkon": Interrupter converts battery current into pulsating d.c. which is transformed and then passed to half-wave, gaseous tube rectifier. Inter-

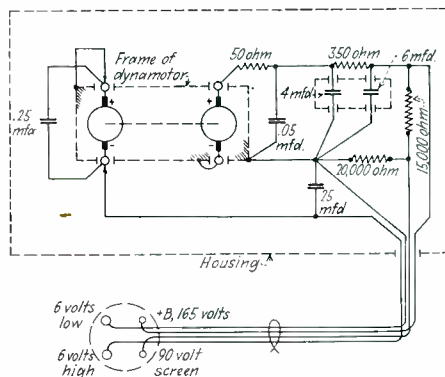

Modified dynamotor. (Bosch) Uses a permanent-magnet in place of the more usual field-coil to reduce battery drain

rupter points of "Elkon-H" metal, unit completely shielded. Two-stage filter with tuned primary section, three dry electrolytic condensers totaling 24 mfd. Small r.f. choke and voltage divider included. Neither primary or secondary is grounded to eliminator chassis, a small condenser serving as a.f. by-pass between -B and ground. Transformer shield minimizes interference generated by vibrator. Relay, automatically connecting and disconnecting unit, included.

MOTOMASTER: All available data included in chart on this page.

MOTOR CAR "Aut-O-Bee": Not a rotating device. 5 lb.

PINES: A 6 volt (or 12 volt if specified) d.c. motor in combination with a rotary transformer steps supply current up to high-voltage a.c. and then synchronously rectifies it. Two commutators, one part

of the motor and the other part of the rectifying mechanism. Filter included.

BOSCH "Magmotor": Strictly speaking, a dynamotor, but with a permanent magnet instead of an electro-magnetic field. No field current required. Two armature windings and two sets of brushes. Ball-bearings. Divider and filter.

UNIVERSAL: Vibrator type. 6 lb.

U. S. ELECTRIC "Genemotor": Dynamotor. 10½ lb. Impedance coil and condenser filter. Voltage divider. Otherwise standard.

UTAH: Not yet ready for distribution.

Careful shielding of supply and output leads is recommended by most eliminator manufacturers and several supply the proper type of cable with their equipment. Set and eliminator may usually be controlled by inserting a common switch in one leg of the supply cable from the storage battery but in some cases it will be found necessary to break the leads to the supply device and those to filament circuits separately. Relays may be employed.

It will of course be necessary to advance the charging rate of the car generator when an eliminator is used. The extent of the advance will depend upon the current demands of the particular unit selected and the frequency and duration of its use. Some idea of the efficiency and regulation of a typical dynamotor (U. S. Electric) may be gained from the accompanying performance table:

Volts	Input Amps	Volts	Output Amps	EFF%	Regulation
6	1.5	200	0.020	44.4	0.93
6	1.7	195	0.025	47.79	0.91
6	1.83	190	0.030	51.35	0.89
6	2.03	185	0.035	52.64	0.86
6	2.2	178	0.040	53.86	0.83



# SERVICE SHORTCUTS

## A.C. Tube Checker Used As Oscillator

By W. T. Golson

A.C. tube checkers such as the Jewell model 210 may be used as modulated oscillators without altering connections. Insert a type '24 or '35 screen-grid tube in the proper socket, turning the filament control rheostat to 2.5 volts. Plug the screen-grid lead into the panel jack in the usual manner but do not connect the clip to the cap of the tube—let it hang over the side of the tester instead.

Make sure that the zero re-set knob on the checker panel is in the zero position and wait for the tube to heat up. It should oscillate due to the omission of screen voltage, the large meter on the panel reading between 16 and 20 milliamperes plate current. The signal generated will be modulated by the 60 cycle line which will also provide the necessary coupling between oscillator and receiver under test.

With a '24 tube in place my Jewell generates a signal having a 650 kc. fundamental with harmonics at 880, 1080 and 1280. With a '35 tube the fundamental is at 645 kc. with harmonics at 1450, 1250, 1050 and 850. Different filament voltages vary these operating frequencies.

## Simple Tube Short Tester

By Paul G. Freed

Because of a shorted tube an expensive repair was necessary on our store tester. In order to prevent repetition we con-



Two 1 in. by 2 in. wooden uprights with "T" cross-arms form a convenient rack for chassis in the Beaucaire & Mitchell (Rochester) shop, taking up little floor space

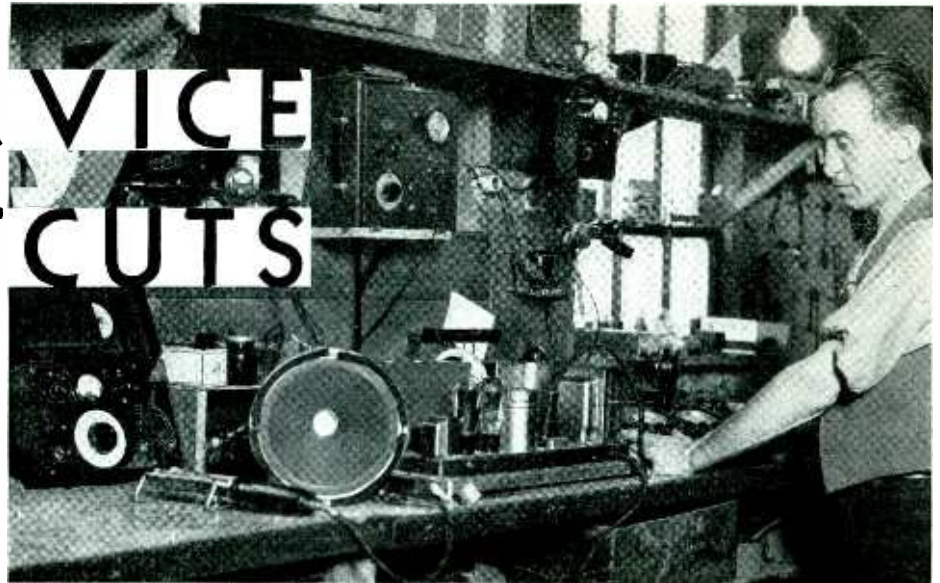

## Turntable Shaft Repair

By W. T. Malcomb

Trouble often develops in the main, or top, bearing of phonograph turntables. Wear, or improper lubrication, either locks the motor or results in noisy operation. Upon receiving a service call of this type, remove the motor to the shop and loosen the set-screws in the fibre gear and disc. Next, take the bottom bearing out (being careful not to lose the bearing ball) and drive out the shaft. Wash all parts except the coils with cleaning gasoline.

If the shaft appears to be worn rough at the top bearing, sand it with 00 gauge paper, very lightly. Replace the shaft, disc and fibre gear and set the lower bearing until the disc runs freely between the eddy-current coils. Apply while vaseline, slightly heated, to the gears, governor and shaft bearings. Pack it around the shaft at the top bearing and heating the end of a screw-driver apply this instrument to the packed vaseline with the motor running. This will cause it to flow into the bearing.

Apply the hot screw-driver also to the lower bearing. The more the motor runs when the job is completed the warmer the shaft will become and the better the bearings will be lubricated. The "body" of the vaseline will remove noise caused by all ordinary bearing wear.

## Oil Burner Filter

By James R. Dunphy

A filter which will stop most oil burners from radiating interference into the lines may be constructed of two old "A" chokes and four 2 mfd. condensers designed to

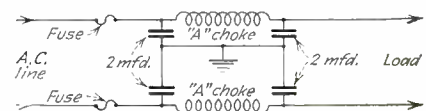

safely stand 110 volts a.c. Remove the iron cores from the chokes and connect them as shown, using heavy, well insulated wire,

structed the short checker schematically described herewith.

B is a pilot light bulb, A—flashlight cells, V1—four prong sockets, V2 and V3—five prong sockets and C—external grid connec-

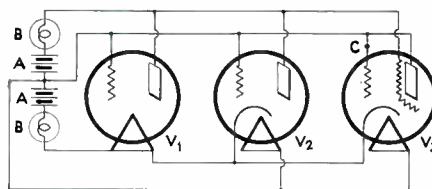

tion. Cathode-filament shorts, which are so troublesome, show up readily when the tube under test is struck sharply.

## Curing Hum in 106's

By M. G. Goldberg

When type 106 Radiola speakers using dry-disc rectifier stacks develop serious hum after long use, or when the discs no longer rectify properly, drawing excess current from the a.c. line, the speaker may usually be reconnected so that it takes its field current directly from the power-pack of the receiver, eliminating the rectifier discs entirely.

The usual receiver power pack has two chokes of approximately 25 hrs. each, with from four to eight mfd. of condenser in the filter circuit. Cut out the choke closest to the receiver chassis, electrically, and connect the field of the speaker pot magnet in its place. Remove the rectifier stacks. If the set has no bleeder resistor across the high-voltage supply leads put one in, lowering the value until the tone is good at a little more than normal volume, maintaining close to the original voltages at the tubes.

If the pack uses a single section choke cut the speaker field into the circuit in its place and connect an eight mfd. filter condenser across the rectifier output in place of the one or two mfd. unit usually included. Insert a bleeder across the power pack output. From 10,000 to 25,000 ohms is usually best.



including fuses to safeguard the line should the condensers blow.

Connect the filter in the a.c. line supplying the oil burner motor. I have made several devices of this kind, building them into old Philco trickle charger cases and they have always worked satisfactory.

## Adapting Pentodes to Push-Pull

By Frank L. Bowers

Pentodes may be adapted to push-pull audio circuits designed for '45's without breaking any leads. The material necessary is:

- 2 UX tube bases
- 2 UY sockets
- 1—5 watt, 1,000 ohm resistance
- 1—5 watt biasing resistor

From the K terminal of each UY socket run a well insulated lead to center tap of output transformer or high side of speaker field. This lead is broken by a 1,000 ohm,

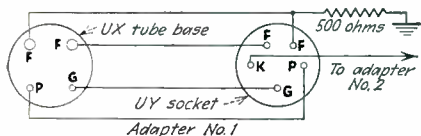

5 watt resistor to prevent the screen from being at higher than average plate potential. No bi-passing required. The average '45 bias resistor value when two tubes are in push-pull runs around 850 ohms. Now we desire to apply 16.5 volts to the control grids of the '47's. Complete the necessary resistance as follows:

$$R = \frac{R1 \times R2}{R1 + R2} \quad \text{or} \quad R = \frac{850 \times R2}{850 + R2}$$

The proper resistance for biasing can also be determined by trial. For a lower value than  $R1$  use lower trial value  $R2$  so we pick 500 ohms, which gives us approximately 315 ohms. Therefore 1—500 ohm, 5 watt resistor from one of the filament contacts to ground. This has been found to give good results.

## Installation Time Saver

By S. J. Lyon

To install an auto-radio designed to bolt up under the chassis place the set in the center of a board long enough to reach from one side of the car to the other with a foot or two to spare. Slide the board under the car and have one man at each end raise it slowly while a third, under the car, jockeys the set in place and guides the bolts home.

## Swinging Service Bench

By Charles H. Willey

At the radio workbench where the serviceman has much tinkering to do, it will be

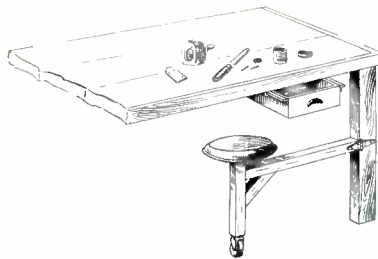

found convenient to have a swinging stool attached to the bench post with a common hinge. When not in use the stool rolls under the bench on its castor.

A large sliding tray is convenient as a "napkin" to catch dropped parts.

## Stickers on Chassis

By Murl Ed de Beauchamp

When pasting gummed stickers on metal chassis, paint the metal with  $T_R$  Benzoin first. This is obtainable at any drug store, dries quickly and prevents the gummed sticker from curling up and dropping off when the gum dries.

## Three New Books

**PRACTICAL RADIO**—Moyer & Westrel (McGraw-Hill Book Co., Inc., New York. \$2.50). Third edition of a not-too-technical work explaining the principles of radio and particularly equipment used in its reception, with new chapters on photoelectric cells, neon-glow tubes, television and other recent developments. Not a "method" treatise for the workbench but useful nevertheless, as it supplies much necessary groundwork.

**RESISTOR REPLACEMENT HANDBOOK** (Electrad, Inc., New York. \$1). A 5 in. by 8 in. Fabrikoid covered, loose-leaf offering which contains helpful data on volume controls, voltage dividers, grid-bias and suppressor resistors as used in standard receivers. Values given, and book kept up to date at no extra charge for one year. Sold, according to manufacturer, at estimated cost.

**RADIO AND ELECTRONIC DICTIONARY**—Manly (Frederick J. Drake & Co., Chicago. \$2.50). Just what the title indicates—a good dictionary of radio and electronic terms. Illustrated and a handy thing to have 'round if one peruses knotty technical literature and is often stumped by terms.



J. A. Bellemare, one of our subscribers up in Shawinigan Falls, Quebec, turns out repair work in this well equipped shop

## Pilot Lights

**PHILCO SPEAKERS.** When a field coil goes haywire it is necessary to remove the core, which is riveted to the speaker frame, in order to replace it. Remove the cone from the cabinet and unsolder the field leads. Hold the unit in the lap with the cone frame down and, using a 1 ft. length of  $\frac{3}{4}$  in. pipe as a punch, carefully drive out the core. Replace the field coil and reverse the process outlined to put back the core. Tap the outer edges of the core with a flat-edged punch to hold it securely.

**G. E. REMOTE CONTROL.** If the receiver turns itself on and off when room temperatures vary widely, especially in the Grandfather clock model, replace the retaining spring which normally holds the armature in the "on" and "off" positions.

**MAJESTIC 20 AND 60.** When the plate by-pass condenser of an i.f. stage shorts it is not necessary to replace the transformer just because the condenser is mounted within the case. The condenser is mounted at the bottom of the case in the right-front corner (looking at the trimmer condenser adjustments). Open the case as you would a can of sardines in the lower right corner (on the side at right angles to that having trimmer condenser adjustments) by cutting two slots  $\frac{1}{2}$  in. long at right angles to each other following the angle formed by the bottom and vertical front edge of the can. Bend back the triangular aluminum flap so formed and in this opening find a red wire. Pull this wire right out of the compound, which disconnects the shorted condenser. Mount a new by-pass unit on the chassis using the shortest leads possible.

**MERSON ELECTROLYTICS.** Defective type 52 and 60 condensers taken from Zenith models make dandy repair sections for Majestic 70 and 90 power-pack condenser blocks. Ground the can either by soldering or clamping and run leads to anode studs formerly on the blown-out section of the block.

**PHILCO 111 AND 112.** Sometimes, after carefully compensating both r.f. and i.f. stages stations on the lower end of the dial do not come in with the usual pep. This may be remedied as follows: Re-set the shop oscillator to 600 kc. and adjust the output meter to  $\frac{1}{2}$  scale deflection. Then, looking at the chassis from the front you have the four-gang tuning condensers with a set screw on the top front of each to allow the spacing of the stator and rotor plates. Starting at the left loosen the set screw and adjust the spacing between the rotor and stator plates (at 600 kc. the plates are almost entirely meshed) on the first condenser for maximum reading on the output meter. Then tighten set screw when at maximum and follow this procedure on the other three condensers.

# What's Happening

March, 1932

Condensed for

## TELEVISION AND TRADE SHOW DISCUSSED BY RMA DIRECTORS

### *Defeat of Special Radio Tax Proposal Appears Likely*

A statement on the progress of television laboratory and broadcasting experiments will be issued soon by the Radio Manufacturers Association. This report, describing the actual present engineering status and future prospects of television was approved and ordered published by the Board of Directors of RMA, meeting at the Statler Hotel, Buffalo, N. Y., February 19. It will be presented by Dr. C. E. Brigham, of Newark, N. J., chief of the RMA Engineering Division, and Dr. E. Replogle, of Passaic, N. J., chairman of the association's special television committee.

Television progress promises to be a feature of the eighth annual convention and trade show of the RMA at Chicago next May, for which plans were developed at this same meeting. President J. Clarke Coit of the RMA presided and upon receipt of detailed trade show plans from B. G. Erskine of Emporium, Pa., trade show committee chairman, it was stated that success of the May 23-26 radio and electrical exhibit was assured.

"I feel the utmost confidence," said President Coit, "that next May we will have one of the biggest shows ever. I am very much encouraged over the outlook for radio business."

Mr. Leslie F. Muter of Chicago, RMA treasurer, was appointed by President Coit as chairman of a special committee on convention arrangements and reception of the thousands of radio trade visitors expected. Special events for interesting meetings and entertainment of the trade are being planned by Chairman Muter.

### *Electrical Appliances Included*

The board of directors approved enlargement of the trade show to permit exhibition by members of their refrigeration and other electrical products. Extension of the trade show and association privileges to manufacturers of refrigeration and other electrical products who are not radio makers was discussed but the directors decided unanimously to confine such privileges strictly to makers of radio.

Prospects of successful opposition by the RMA to the proposal in Congress for a special five per cent tax on radio were reported by H. B. Richmond, of Cambridge, Mass., chairman of the association's legislative committee, and Frank D. Scott, its legislative counsel. At the recent hearing accorded the RMA by the House Ways and Means Committee in Washington, in opposing the special discriminatory tax on radio, it was stated that the radio industry would prefer a small general sales tax on manufactures. This now appears probable. Problems affecting radio manufacturers in broadcasting, copyright and resale price

fixing and anti-trust law revision legislation pending in Washington also were discussed.

An invitation from the U. S. State Department to have RMA representation at the International Radio and Communications Conference next September in Madrid, Spain, was discussed by the association's directorate and it is planned to send a prominent radio technician to the conference.

Progress on patent problems was reported by President Coit to the board. The negotiations looking to possible establishment of a radio patent pool, considered by the U. S. Department of Justice, are continuing.

### *Merle Eagle Wins Sparton Service Contest*

Winners in the nation-wide Service Questionnaire Contest for Sparton service men have just been announced by the Sparks-Withington Company.

The first prize, a Model 26 Sparton set, was awarded to Merle H. Eagle, of the Young, Lorish and Richardson Company, Chicago. The second prize, a Model 15 Sparton set, went to C. L. Larson, of the Motor Power Equipment Company, St. Paul, Minn.

Each contestant was required to answer a comprehensive list of questions dealing with every-day service problems. As a result of this contest, Sparton feels that all the men who participated are prepared to do more intelligent and thorough work in the maintenance and repair of Sparton sets.

### *Tito Schipa Looks 'Em Over*



Tito Schipa, premier tenor of the Chicago Civic Opera Company (left), accompanies Don Compton, G M of G-G, on an inspection tour of the Majestic plant.

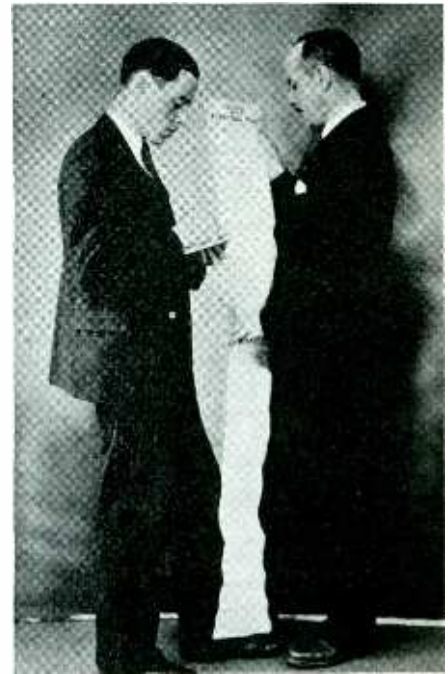

### *521—Count 'Em*

After George Lewis, Arcturus Radio Tube's vice-president (right), had compiled a list of 521 industrial uses for electronic tubes, he called on Jack Gaertner, his associate, to do the double checking

### *AK Tuning Contest*

A unique mid-season sales promotion activity that is attracting widespread public attention in the Atwater Kent Neon tuning name contest.

Prizes, including \$1,000 for the best name for Atwater Kent's newest feature, will be awarded on March 31. AK dealers will be the only source by which entries can be made.

Those competing must obtain a blank from an Atwater Kent dealer and file a duplicate with their name and address and other information as to whether or not they own a set, its make, etc. Dealers are furnished with striking window streamers, advertising mats and other helps.

### *Bosch Personnel Changes*

Sales administration of both the radio and automotive products of the United American Bosch Corp. will be under Hermann Waker, vice-president. Morris Metcalf will continue to maintain his close touch with the radio industry as formerly.

Roy Davey will head the newly organized Sales Planning division, while George Stackman, who comes to Springfield, Mass., from the San Francisco branch, will be in charge of the Sales Operating division. George Shortmeier is in charge of field sales.



# in the Industry

the Busy Reader

New York, N. Y.

## Wisconsin Association Broadens Its Activities

The Wisconsin Radio Trade Association, realizing the need for embracing the allied lines to which radio dealers and distributors have turned, is first to follow the lead of the national radio associations by changing its name and scope of activities to include refrigeration and other electrical household appliances. Hereafter it will be known as the Wisconsin Radio, Refrigeration and Appliance Association.

For the past nine years WRTA, now WRR and AA, has been one of the most successful radio trade groups in the country. The Milwaukee and adjacent markets have been considered outstanding examples of clean merchandising practices, even in times of distress. This experience in cooperative action will be extended to refrigeration and other electrical appliances.

## Radio Jobber to Handle Ranges

One of Philadelphia's best known specialty distributors enters the electric range field. Electromaster, Inc., announces the appointment of Trilling and Montague as Electrochef distributors for eastern Pennsylvania, Delaware and southern New Jersey. Trilling and Montague have been outstandingly successful in the refrigeration and radio fields.

## "Hello Mars!"

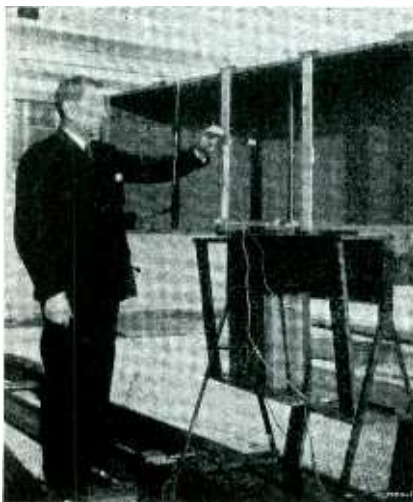

Today Westinghouse engineers are talking on a 42 centimeter beam from station W8XI to their engineering laboratory, a mile away. There a parabolic metal mirror gathers the waves, and passes them through a special detector tube to an ordinary receiving set.

"It is conceivable that the power we have succeeded in getting into our 42-centimeter beam will pierce the Heavens layer and travel the 35,000,000 miles to Mars," states engineer Mourntseff, who here is shown examining the detector detail.



## Florida, "Hot" Refrigeration Market

The two sales districts making the best sales showing for Frigidaire during '31 are both in Florida. Here we have Sales Manager H. W. Newell congratulating Cecil Kirby (left) of Miami, and Claude Wolf, Tampa (right). They were made president and vice-president respectively of Frigidaire's honor organization.

## Spartan Has Film Library

A film library is a recent innovation by The Sparks-Withington Co. in connection with the sale of its home-talkie instrument, the Visionola. This library provides for the rental of movie reels and synchronized recordings of talking and sound effects at a very nominal rate. Spartan distributors and dealers report that the plan is proving extremely helpful in opening up new fields for this product.

When the customer purchases a Visionola, he receives from the dealer a coupon book entitling him to three films and records each week for the first sixteen weeks of ownership. When the dealer delivers the instrument, he leaves the first week's allotment of films and records and tears the first coupon from the book. At the end of the week the customer is expected to return the borrowed equipment to the dealer. If the dealer has several owners in his territory, he keeps these films and records in circulation by exchanging them among the various owners.

## Wilson, RMA Director

Charles Wilson, vice-president of General Electric at Bridgeport, is a new director of the Radio Manufacturers Association. He was elected to fill a vacancy caused by the resignation of Roger J. Emmert of the General Motors Radio Corp.

## Radio Specialty Gets Philco

Dealers in Wisconsin and northern Michigan will purchase Philco radio henceforward from the Radio Specialty Co., Milwaukee. This outfit will be remembered as former Atwater-Kent distributor. ABC washers, Universal electric ranges, Servel refrigerators and a vacuum cleaner obtainable here also.

## RCA CLAMPS LID ON TUBE ABUSES

### Return Privilege Cancelled On 8 Types Out 6 Months Or More, To Curb Abuses

Abuse of its tube replacement policy by the consumer and the trade is cited by the RCA Radiotron Company as the reason for cancellation of the return privilege on certain models of 8 tube types, effective February 6. This policy, adopted by the Harrison, N. J., manufacturer, affects "obsolete" models of types '24, '27, '45, '80, '26, '01A, '71A and '12A, shipped 6 months and more ago. These are identified by variations in their markings. Obsolete model guides have already been mailed to the trade. Consumers have used these tubes, the manufacturer points out, not less than three months and in many cases fully a year. 95 per cent of all tube claims are made within 30 days of purchase, it is further stated.

Commenting on the new company policy, E. T. Cunningham, president, says: "The industry must recognize that the abuse of proper tube guaranties is a general industry problem. If the abuses and wrong features of the present practices are to be cured it must be done by broadminded co-operation on the part of the entire industry and not by the unsupported action of an individual company.

"I estimate that at today's prices the annual gross profit loss to distributors and dealers on tubes improperly replaced amounts to between one and one and a half million dollars at 1931 sales rates, not to mention extra handling expense. Fully 40 per cent of the tubes returned to us in recent months had seen from 90-days to a year's service and thus were not fairly entitled to credit.

"In instituting the present system of coding and dating we are commencing on an unusually liberal basis. As we progress and policies improve the return time will be shortened."

## "Dick" Smiley Leaves Ken-Rad

R. E. Smiley has resigned as sales manager of Ken-Rad to accept a lucrative position with Erwin, Wasey & Co., Chicago. Dick leaves with the best wishes of the entire Ken-Rad organization where he has served honorably and effectively.

## Mallory Licenses Magnavox

P. R. Mallory & Co., Inc., who pioneered and developed the field of dry electrolytic condensers under the Mallory-Elkon Brand, has granted a license to Magnavox Co., Ltd., through their subsidiary, Electro-Formation, Inc.

## Five New Executives Strengthen Majestic Organization

The following executive appointments recently have been announced by the Grigsby-Grunow Company, Chicago:

JOHN DITZELL joined the Majestic family last September. He now has been given the responsibilities and title of General Sales Manager of Refrigeration. Ditzell was a distributor for Electrolux and a vice-president of the Harry Alter Company. He rates 12 years merchandising experience with Victor Talking Machine Company and Brunswick.

LARRY COEN, formerly with the Cincinnati Electric Club and the Union Light, Heat and Power Company, has joined Grigsby-Grunow in the capacity of Director of Public Utility Relations. He brings a wide knowledge of central station problems. He will assist utilities interested in the sale of Majestic refrigerators.

"SAM" VINING, formerly with Servel, comes to Majestic as refrigeration sales counsellor and sales promoter. Vining has a background of refrigeration lore dating from his early days with Copeland.

And "DEB" GAINES is another refrigeration veteran recently annexed by G-G. He formerly was sales manager of Absopure and Universal Cooler Corporation. Gaines is functioning as general service manager of the refrigeration department.

W. L. GALT, better known as "Poke", who for the last several months has served as district manager in New England, has been called to headquarters to assume new duties as radio sales promotion manager for the entire company. Mr. Galt has had a long experience in radio merchandising and brings to his new position, in addition to a skill for conceiving, planning and promoting successful advertising and selling campaigns, a thorough knowledge of merchandising problems.

## Kolster Sets to be Distributed by Westinghouse Electric Supply Company

As we go to press, word is received that arrangements have just been consummated whereby 1932 Kolster International radio receiving sets will be distributed in the United States by the Westinghouse Electric Supply Company and a supplementary group of electrical wholesalers doing business with that company and located in approximately one hundred strategic centers. This announcement is released by Ralph Austrian, sales manager for Kolster.

### Adds Norge to Zenith

Ray P. Harten, president of the Harten-Knodel Distributing Co. of Cincinnati, has been awarded the Norge refrigerator distributorship and will sell this line in southern Ohio, southeastern Indiana and northern Kentucky along with Zenith radio. Mark Lintner, experienced refrigerator hand, will be "key man" in the new activity. Alvin G. Arens will travel both lines.

# DETECTOR LISTENS IN and hears that . . . .



Bosch sales in Colorado, Wyoming, New Mexico and western Nebraska will henceforth be under the wing of Midwestern Distributors, Inc., operating out of Denver. A subsidiary of Knight-Campbell Music, this concern, which runs 15 retail stores of its own, also distributes electric refrigerators, washers and sweepers.

From Denver: Colorado Radio Trades Ass'n. re-elects C. B. Biedler of Knight-Campbell Music president, George A. Flannigan, secretary. New officers are Robert Jacobus, v.p.; I. H. Parks, treas. Daniel C. Dodge, I. H. Parks, Robert Jacobus, LeMoine Bechtold, C. B. Biedler, W. D. Pyle, J. H. Blinn and Fred Haberl, Jr., are directors.



R. G. Nelson—his business is trouble. Just appointed national service manager for Norge, stationed at Muskegon plant. I. H. Reindel steps up to president's assistant.

Transitone has a new vice-president in the person of Russell L. Heberling, successively Chicago and New York district manager. 22 years with Philco.

This is news. Ernest Ingold, Inc., and Coast Radio Supply have consolidated under the name of the latter with headquarters at 123 Tenth St., San Francisco. H. E. Lapkin runs the ranch, distributing Sparton, A-K, Black & Decker and Cinderella lines. Ingold now deals in first trust deeds at 1182 Market.

The untimely death in an airplane accident of Francis R. Ehle brought about several organization changes at International Resistance. President Ernest Searing advises that activities are now headed by W. G. Porter, v.p., and Harry Kalcker, sales manager.

Crosley is to be distributed in the Philadelphia territory by the Lewis Radio Co., Inc. with exclusive rights. Radio and refrigeration.

PAUL S. ELLISON goes with the Sylvania division of Hygrade Sylvania Corp. in the capacity of advertising manager. Mr. Ellison recently resigned a position of similar responsibility with the Brunswick Radio Corp.

EDWARD G. HEFTER has been advanced to the post of regional sales director, eastern division, for Zenith. Ed will be at home to his many friends at 1225 Broadway, New York City.

A. B. Ayers, formerly of Sprague Specialties, has gone over to M. H. Rhodes, Inc., maker of the tricky little "Mark-Time" switch. Offices in Hartford, Conn. Same capacity—sales promotion manager.

Dave Trilling is bragging (with good reason) about the attendance at Trilling & Montague's recent Norge salesmeeting. 600 dealers attended in Philadelphia to hear Howard E. Blood and John E. Knapp of the factory and Dr. C. W. Allison.

Twenty-two more radio salesmen in the New England territory are now hopped up about refrigeration. The H. M. Tower Corporation, with offices in Boston, New Haven and Springfield, has just taken on the Gibson line for distribution.

Fada has appointed the F. C. Henderson Company of Boston wholesale distributor for the local territory and counties in Massachusetts and New Hampshire.

J. P. Miller has joined Fada, representing the Long Island concern in western Pennsylvania, Ohio, West Virginia and Kentucky.

This familiar face is C. W. Geiser's. "Bill" left A-K, you will remember, to horn into the oil-burner game but evidently couldn't stay away from radio. He is now batting for Sparton in the southern territory.



While we are on refrigeration, Leonard has added to its list of distributors the Aeolian Co. of St. Louis, Interstate Electric of Shreveport, How & Co. of Boston, Columbus Ignition of Columbus, B. W. Smith, Inc., Cleveland, E. S. & E., Albany and A. A. Schneiderhahn, Des Moines. All are radio jobbers.

RALPH HILL joins the Ohmite Mfg. Co., Chicago, as sales manager of its resistor department. Hill was formerly with the Yaxley Mfg. Co.

Leigh Borden is now president and g.m. of Pacific Wholesale, Ltd.

S. H. KEHOE has been appointed to represent Fada on the Pacific Coast. The southern territory of this concern will be covered by W. R. McAllister. These appointments follow hard on the heels of Fada's entry into the electrical refrigeration and appliance fields.



# NEW MERCHANTISE



## Trav-Ler Television and Broadcast Set

A SHORT-WAVE chassis to receive television signals, and a superheterodyne chassis to receive programs on the broadcast bands, are included in the modernistic cabinet which houses the combination television and broadcasting receiver of the Trav-Ler Radio & Television Corp., 1818 Washington Ave., St. Louis, Mo.

The picture is projected on a screen approximately 7 in. x 8 in., that can be viewed from a side angle by those in the room. A Taylor Neon Arc lamp is used to project the picture in conjunction with a lens scanning disc driven by a synchronous motor. The instrument will list for approximately \$350.—*Radio Retailing*, March, 1932.

## Fada "Round-the-World" Receiver

FROM the Long Island City, N. Y., headquarters of F.A.D. Andrea, Inc., comes the announcement of a 10-tube superheterodyne all-wave set to sell for \$99.50, complete.

It will be known as the Model 66 "Round-The-World" receiver, and comes in a console set in which the two receivers and large dynamic speaker are housed.

This set has automatic control on both the short and normal waves, and the range covers from 15 to 550 meters, with a switch-over from the low to the normal band, without any plug-in coils.

On the shortwave set, slow motion shaft rotation is obtained by a reduction ratio gear of 36 to 1, which facilitates the tuning of shortwave stations. A tone filter and noise suppressor are incorporated in both receivers. The intermediate frequency on shortwave tuning is 1525 kilocycles, instead of the customary 1,000. At the 1525 kc. intermediate frequency the tuning is beyond the normal wave band which prevents interference from local stations, Fada claims.—*Radio Retailing*, March, 1932.



## GE Model J-80

IN ITS new model J-80 table radio, the General Electric Co., Bridgeport, Conn., has incorporated an 8-tube superheterodyne chassis with automatic volume control and tone control. It will sell for \$59.95.

The attractive columns at either side of the set, and the long panels over the grill cloth give the effect of a cathedral window, which is particularly well suited to its Gothic design.—*Radio Retailing*, March, 1932.

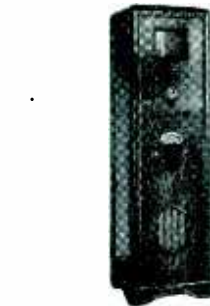

## International Sets

IN addition to the 8-tube duo-set brought out last August, the International All-Wave Corp., Ann Arbor, Mich., has added several new numbers.

Model T-61 is a regular broadcast set with 4 tubes in a t.r.f. circuit, 6½ in. dynamic speaker, built-in antenna. No list price given.

Model TS-61 is the same as the above model, but has short and longwave coils, with a range of from 75 to 200 meters, and 200 to 550 meters. The switch is located on the front panel. Price, with tubes, \$24.50.

Model C-62 is a 5-tube superheterodyne compact set with 6½ in. speaker, \$32, complete. As long and shortwave set, with the same range as the TS-61, the price is \$34.

Model J-63, a regular 5-tube broadcast superhet in a Gothic type cabinet, has 8 in. dynamic speaker and lists at \$34 complete. This set has full range tone control.

Model JS-63, the same, with shortwave accommodations, is \$36.

The chassis may be purchased separately, with speaker, knobs and escutcheon plates.—*Radio Retailing*, March, 1932.

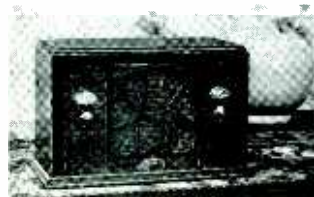

## Erla Shortwave Converter

A THREE-TUBE, self-powered shortwave converter has been placed on the market by the Electrical Research Laboratories, Inc., 1731 W. 22nd St., Chicago, Ill. It tunes from 20 to 200 meters with a switch for changeover from regular to short waves. This converter can be easily installed by the consumer, Erla says. \$12.50 complete with tubes to dealers.—*Radio Retailing*, March, 1932.

## RCA Shortwave Converter

RCA-VICTOR CO., INC., Camden, N. J., presents a new shortwave converter encased in a table type cabinet resembling that of a midget. Plug-in coils are eliminated in the new device, a range changing switch being incorporated instead. The unit tunes from 1,500 to 21,700 kc. (200 to 13.8 meters). The converter has its own filament transformer, operating from any 110 volt, 60 cycle line, but plate current must be obtained from the receiver to which it is attached, a wafer adapter being provided for this purpose. A source of power furnishing from 200 to 260 volts, d.c., at 4.5 to 6.5 milliamperes, is required.—*Radio Retailing*, March, 1932.



## Microphone for Home Broadcasting

IF YOU like to broadcast your own music or talk from any part of the house through the radio loudspeaker, the home broadcasting microphone being made by the World Microphone Mfg. Co., Chronicle Bldg., San Francisco, Calif., will interest you. It is easily attached to any receiver, cutting out all local stations and permitting you to take part in any regular program. \$2.50.—*Radio Retailing*, March, 1932.

## Auto-Radio Set

NORTHWEST Specialty Service of Waukegan, Ill., is now making a six tube t.r.f. auto-radio receiver with push-pull amplification in the final stage. Requires no C-battery and can be operated by either B-batteries or B-eliminator. The chassis is mounted in a practically water tight case and can be taken out for servicing by the removal of three screws as connections are made by a system of plugs and jacks. Retail price, \$19.50, less tubes and batteries.—*Radio Retailing*, March, 1932.



## Filmo Projector Model JL

USE of the new 400-watt biplane filament lamp just perfected by lamp engineers, is possible with the Model JL Filmo projector brought out by Bell & Howell Co., 1301 Larchmont Ave., Chicago. This projector, a slight modification of the recently developed Model J, brings increased brilliance, plus uniform direct illumination on every fraction of the screen area to 16 mm. projection, it is said. Especially in Kodacolor projection, the superiority is marked, for the new lamp eliminates color wedging, lost color values and color distortion, the release states.

The use of the biplane filament lamp is made practical by the combination of the fan and aero-type cooling used in Model J, and the new lamp will hereafter be supplied as regular equipment in the slightly modified Model J known as Model JL.—*Radio Retailing*, March, 1932.

## Electric Clocks for Radio Panels

DEALERS can now install a Telechron electric clock right on the panel of the radio set, either before it is sold or at the request of the customer. This midget model is being made by the Warren Telechron Co., Ashland, Mass.

The diameter of the clock, including the outside of the bezel around the dial, is 3¼ in.



while the overall dimension from the panel face to the back of the movement is 2¼ in. A re-setting knob is provided on the lower part of the bezel.

If there is a current interrup-



tion this clock will start after the current has been resumed, a red signal appearing in the opening beneath the figure 12 to notify that the clock is wrong and should be reset.

This model may also be installed on electric ranges and other places where an electric time piece is required.

The panel on which the clock is mounted in the photograph is not supplied as standard equipment. — *Radio Retailing*, March, 1932.



### Pilot "Dragon" All Wave Set

COVERING 18 to 550 meters, and employing a nine-coil superheterodyne circuit which is tuned by a single knob, the "Dragon" all wave set has been announced by the Pilot Radio & Tube Corp., Lawrence, Mass. It is priced at \$59.50.

It uses a new kind of audio amplifier. The tuning circuits track over the entire wave length without the need of any trimmer adjustment by the listener. To bring out the full quality of the audio amplifier system, a special acoustic cabinet has been designed. — *Radio Retailing*, March, 1932.



### Arlington Electric Alarm Clock

AN electric alarm clock which rings instead of buzzing, has made its debut as a part of the line of the Arlington Time Laboratories, Inc., 8440 S. Chicago Ave., Chicago, Ill.

While primarily intended for the bedroom, it is appropriate for almost any room in the house. The price is \$3.95. — *Radio Retailing*, March, 1932.

### Resistor Kit

IN RESPONSE to the demand service men for a compact resistor kit, the International Resistance Co., Philadelphia, Pa., has brought out a metalized resistor replacement kit. The handy box with sliding cover contains twenty 1-watt resistors of the most used resistance values from 500 ohms to 3 megohms. By following the instructions, thousands of resistance values may be obtained to meet precise requirements. — *Radio Retailing*, March, 1932.



### Stromberg-Carlson Police Radio

AFTER two or three years' experience with police radio systems, Stromberg-Carlson has found that compactness is a prime essential. For this reason, they have designed a heavy sheet steel box, in which the receiver, together with the B and C-batteries, filters, terminals, etc., are mounted. This box is 20 in. long by 15½ in. high, by 9½ in. deep, and may be installed between the front and rear seats of a sedan, or in a corner of the rear deck of a coupe or roadster. One side of the box may be removed, so that all parts are accessible.

In order to simplify the system further, the speaker and potentiometer control and switch are mounted directly on top of the box, to eliminate wiring when the speaker is placed in the roof and the potentiometer control and switch is placed on the steering post, as in the average installation.

Two sturdy handles make it possible to move the receiver from one car to another. The only connections necessary are to the antenna and ground. The chicken screen wire or copper mesh screen antenna is installed in the roof. Stromberg-Carlson Telephone Mfg. Co., Rochester, N. Y. — *Radio Retailing*, March, 1932.

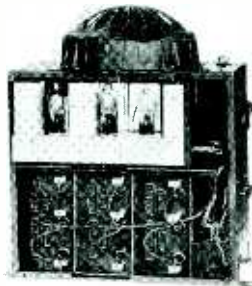

### White Mountain Refrigerators

SEVERAL new household electrical refrigerators have been placed on the market by the Maine Mfg. Co., Nashua, N. H., under the "White Mountain" trademark.

Sliding shelves, broom high legs, vegetable crisper, rounded corners, and chromium hardware are features of the five models ranging from 4½ cu.ft. to 11 cu.ft.

Colored refrigerators to harmonize with the kitchen are available, also.

The unit is vibrationless, the result of five years' experience by the engineers who cooled the Holland Tunnel, R.K.O. Theatres and the Chrysler Building. — *Radio Retailing*, March, 1932.

### Victor Model 7 Ciné Projector

COMPLETE information on the new Model 7 series of Ciné projectors made by the Victor Animatograph Corp. of Davenport, Iowa, has just been released.

Model 7 Regular is equipped with 300 watt "no resistance" lamps (100 to 120 volt).

Model 7-G, has 50-60 cycle a.c. transformer built into base to permit use of high intensity 250 watt, 20 v. lamp. Current may be diverted from transformer to permit use of 200 and 300 watt lamps of 100-120 v. on either direct or alternating current.

Model 7-R has No. 11 Victor variable resistance lamp rheostat, mounted with swivel post on projector base. This model accommodates (on either a.c. or d.c.) the 250 w.-50 v.; 375 w.-75 v. and 165 w.-30 v. high intensity lamps, as well as regular 100-120 volt-200 and 300 watt lamps.

Among the improvements in this series are an improved optical system for better illumination; wider speed range and more quiet operation.

The prices run from \$175 to \$205, with carrying case, accessories, etc. — *Radio Retailing*, March, 1932.

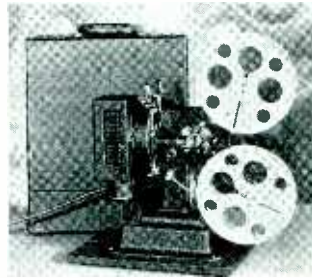

### Mayflower Refrigerators

THE "speed-freeze" cooling unit in the Mayflower refrigerators made by the Trupar Mfg. Co., Dayton, Ohio, provides ice cubes in 90 minutes. Removable shelves permit storage for a great number of tall bottles and built-in shelf ledges replace shelf hooks. The interior, including the cooling unit, is porcelain and the exterior may be had in white porcelain, or processed lacquer. Mayflower units come equipped with flexible rubber tray, vegetable freshener and water bottle. — *Radio Retailing*, March, 1932.

### Ward Products

HARRY Ward Co., 10609 Superior Ave., Cleveland, Ohio, makes a police reporter—a combination unit for either 27 or 24 type tubes. This company also makes an oscillation control, automobile radio antennas, suppressor kits, grounds, clamps, pinjacks, screen grid clips, test prods, neutralizing tools, and antenna kits. — *Radio Retailing*, March, 1932.

### Miles Microphones

SEVERAL new items have been added to the line of microphones made by the Miles Reproducer Co., Inc., 26 E. 22nd St., New York City. They are:

Type 501, a midjet microphone of extreme compactness, \$10; Type 306-M also a midjet model, supplied with hook to fit hand or lapel, \$5; Types 507 and 508, two-button heavy-duty type microphones, \$35 each; Type 502, claimed to be the smallest commercial microphone produced, \$20; Type 503, midjet two-button microphone, same size as the M-501, \$15.

Miles also makes a home desk



### Electric Broom

THE new electric broom of the Electric Broom Corp., 113 W. 42nd St., New York City, has a three-way function in the home—as an electric broom, as an electric dust mop and as a light-weight, high-speed vacuum cleaner.

The sweeper nozzle is spring mounted and entirely flexible. It is of motor car tire variety and is capable of the roughest use around obstructions and in recesses without injury to broom or furniture.

Through the top of a simple filter, the fine dirt is discharged into a bakelite receptacle which arrangement, it is explained, insures perfect operation and 100 per cent efficiency throughout the life of the broom.

By means of an automatic cord release, this new "Electric broom" can be put into use in a fraction of a second. Another outstanding feature is the automatic handle which, when grasped, starts the motor. When the handle is released, the motor stops. The intended retail price is \$14.95. — *Radio Retailing*, March, 1932.



telephone for private intercommunication purposes, \$12.50; a combination mike and earphone, \$7.50; a combination enclosed mike and earphone, \$10; and a portable microphone outfit, consisting of microphone, input transformer, potentiometer, battery pocket for one dry, 4½ volt C-battery, toggle switch for on-and-off, and 25 ft. of cord, all self-enclosed in a wooden cabinet, \$20. — *Radio Retailing*, March, 1932.



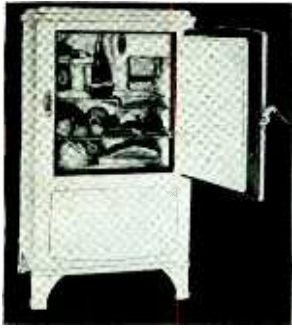

## Apex Rotarex Products

**A**PEX ROTAREX CORP., Cleveland, Ohio, has brought out three new electric refrigerators, Models 600, 800 and 500, the latter being slightly smaller than the first two. The cabinets are attractive in design and sturdy in construction.

A wringer-type washer with motor driven pump, Model 35, is also ready. This washer replaces Model 30. It is equipped with new type Mullins wringer and has double tube heat retaining construction.—*Radio Retailing*, March, 1932.

## Electrochef

**A** COMPLETE line of 1932 models of the "Electrochef" is announced by the Electrochef, Inc., Detroit, Mich. There are no material changes in the design and mechanics, but several refinements of equipment have been added. Every model includes as standard equipment four condiment shakers, porcelain enamel back-plate shelf and smokeless broiler. All are equipped with a 3-way receptacle for plugging in either a hand wound or synchronous electric clock for controlling the oven. The 1932 Electrochefs are finished in green or white porcelain enamel. For the family whose cooking requirements exceed the capacity of one oven model BM-24 Electrochef is an ideal model. There are four surface cooking elements.—*Radio Retailing*, March, 1932.



## Portable Amplifier

**P**OWERTONE Radio Laboratories, Inc., 56 Vesey St., New York, have developed a new type light-weight, portable amplifier for use in conjunction with home talkies, small halls, auditoriums and public address systems.

The amplifier, which weighs but 20 lb., is made in a small carrying case and includes input transformer, a.c. amplifier, dynamic speaker, and microphone, with connection for phonograph pick-up.

The approximate dimensions are 15x15x12 ft.

It sells in the popular price range.—*Radio Retailing*, March, 1932.

## Stromberg-Carlson Model 29

**T**WENTY-NINE advance - tments, many of them never offered before, are embodied in the new Model 29 superheterodyne made by the Stromberg-Carlson Telephone Mfg. Co., Rochester, N. Y. Among these are level-action automatic volume control; visual tuning with sensitive meter; adjustable automatic clarifier; "detectomatic" duo-diode detector, and image suppressor. Priced at \$197.

The rest of the 1932 line consists of the Model No. 14-AX multi-record "Telektor" radio; Models 22 and 27 Telektor type (remote control) sets; the Model 25 standard radio and the Model 26 convertible console.

Model 14-AX is equipped with a new phonograph unit which plays and shifts automatically 12 of the new 10-in. 33½ r.p.m. program transcription records, or 12 of mixed sizes of the standard 10 and 12 in. 78 r.p.m. records. The new 12-in. long playing records may be played singly.—*Radio Retailing*, March, 1932.



## Copeland Refrigerators

**S**LIDING baskets, telescopic shelves, bottle opener on door catch, electric light in cabinet, greater ice and storage capacity, these are some of the high lights of the new Copelands, made by Copeland Products, Inc., Mt. Clemens, Mich.

Thirteen new models have just been introduced, bringing the total to over one hundred. Large commercial models are now available, the Dreadnought producing refrigeration equivalent to the melting of 2,375 lb. of ice in 24 hours.

Copeland can now supply not only home and commercial electric refrigerators but a room cooling device and gasoline-engine-driven refrigeration equipment for use on farms and places not reached by electric power.—*Radio Retailing*, March, 1932.

## Onan Electric Light Plants

**T**WO small models of Onan electric lighting plants have been placed on the market by D. W. Onan & Sons, 51 Royalston Ave., Minneapolis, Minn.

They are small plants of 300 watt capacity, sufficient to handle light and appliances for a 4 to 6-room house. These plants will run approximately 10 hours on a gallon of gas.

Light in weight and portable they are of the same general design as those offered by this company for a number of years.

The 110 or 32 volt d.c. plant sells at \$99, and the a.c. model is \$148. The latter is well adapted for radio and sound car operation.—*Radio Retailing*, March, 1932.



## Telechron Clocks

**I**VORY, green, blue and orchid non-fading, enamel finishes may be obtained for the "Tel-alarm" electric alarm clock being produced by the Warren Telechron Co., Ashland, Mass. Available only with illuminated dial. \$8.95.

As special campaign numbers, Telechron offers a kitchen model at \$5.50 and an upright desk model at \$5.95, special low prices.

The kitchen clock is 7½x7½ in. and has a case of dura alloy, finished in sprayed enamel lacquer. It comes in light green, light blue, ivory and white.

The mahogany desk model has a polished lacquer finish and 3 in. ivory enamel finish dial.—*Radio Retailing*, March, 1932.

## Operadio Record-Playing Attachment

**A** PORTABLE and completely self-contained unit for reproducing records through radio sets and power amplifiers has been announced by the Operadio Manufacturing Co., St. Charles, Ill. Housed in the leatherette carrying case are an electric phonograph motor and turntable, and a sensitive electromagnetic pick-up. Space is provided in the cover for several records.

This unit is adapted for use with all radio sets and amplifiers having provision for connection to either high or low impedance pick-ups. Adapters are available for connections to most other radio sets.

It is available with either high or low impedance pick-up, and with 78 or 33½ r.p.m. motors, for 25 or 60 cycle, 110 volt power supplies.—*Radio Retailing*, March, 1932.



## Shortwave Superhet Coil Assembly

**A**N ASSEMBLY of short-wave coils and a low capacity switch eliminating the inconvenience of plug-in coils, is being made by the Best Mfg. Co., 1200 Grove St., Irvington, N. J.

The coils may be readily

wired into a shortwave converter circuit for use with t.r.f. or superheterodyne broadcast receiver. The circuit is so arranged that all power for the converter is furnished by the broadcast set. Complete wiring diagram and instructions for building short-wave converter is furnished with each assembly, which is equipped with knob and escutcheon plate marked with wave length. The overall dimensions of entire coil and switch assembly are 4½ wide by 4½ high, by 6½ long.

Model S.W.C.-1 for 10-200 meters is \$12. Model S.W.C.-2 for amateur bands only, \$12. Shortwave low capacity three pole, four point switch as used in coil assembly, with knob and escutcheon plate marked with wave length, is \$4.—*Radio Retailing*, March, 1932.

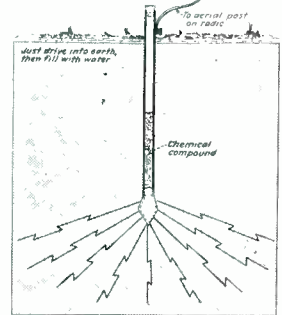

## Brass Ground-Antenna

**T**HE brass ground-antenna made by Harry Kessler & Co., 3752 Lemon Ave., Long Beach, Calif., is set up by driving it into the earth and filling it with water. The lower part of the rod is filled with a chemical compound said to increase radio energy. The list price is \$1.50.—*Radio Retailing*, March, 1932.

## ABC Ironer

**T**HE lowest priced ironer ever built by Altorfer Bros. Co., Peoria, Ill., is now ready. It is mounted on a steel table which may easily be moved, and it is equipped with two extra leaves for extra table surface. This ironer is fully automatic and carries the ABC trade mark.—*Radio Retailing*, March, 1932.

## New Tubes

**R**CA RADIOTRON COMPANY, Inc., Harrison, N. J., and E. T. Cunningham, Inc., New York City, have just made available a detector-amplifier tube designated respectively as the RCA-864 and CX-864. It is a high vacuum, three electrode tube of the general purpose type, constructed for use under conditions where freedom from microphonic disturbance is required. It is applicable as detector, amplifier, or oscillator to battery-operated equipment which may be subject to either impact or continuous vibration.

These two companies have also brought out the RCA-234 and the CX-234, a super-control r.f. amplifier pentode, designed primarily for service in receivers operating from dry cells, or from a storage battery where economy of filament-current drain is important.

The 234 is recommended for use as an i.f. or r.f. amplifier, and first detector in battery-operated receivers. Its design makes it especially useful in portable receivers.—*Radio Retailing*, March, 1932.

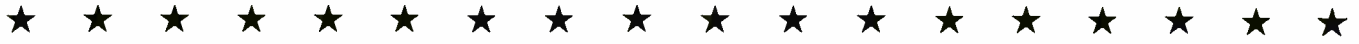

THE **T**ime has come  
 when radio dealers  
 must be from MISSOURI

Any man who has been in the radio business more than six months knows it is a fast-changing field. New conditions demand new courses of action. The time has come to stop, look and take stock. The time has come to say "Show me!"

So ask yourself a few plain questions. Take nothing for granted. Question the one factor which can most influence your success or failure—the line of radios you are handling.

*Is the line of radios you sell on the way up?* A line which was "hot" last year can be this year's dud. But one radio which definitely *is* on the way up is General Electric—a radio that has convinced people of its superiority by urging them to "Believe Your Own Ears"—a radio that more and more people are coming to think of as the finest made!

*Does the radio you handle offer a complete line at favorable competitive prices?* General Electric offers you a complete line below \$100, a complete line above \$100. A 7-tube superheterodyne table model selling for \$46.75; a superb 7-tube superheterodyne console for \$66.50. Grandfather clocks of authentic design. Consoles to satisfy the most discriminating

buyer. A magnificent radio-phonograph.

*Is your line backed by continuous advertising?* G-E Radio's famous "Believe Your Own Ears" national advertising tells over 8,000,000 readers about G-E's tone superiority—and does it month after month *right through the year* in the country's largest weekly publications. In 1932 there will be 61% more national magazine advertisements on G-E Radio than in 1931!

*Does the manufacturer of the line have prestige with the public?* General Electric, the largest electrical organization in the world, is known and respected everywhere. More of its electrical products are in every-day use in homes than those of any other electrical manufacturer. Its prestige is promoted by two billion General Electric advertisements every year.

To alert dealers who are thinking ahead—who are planning their future as well as their present—General Electric extends an invitation to investigate its radio franchise. Get in touch with your own distributor, or with General Electric Company, Merchandise Dept., Bridgeport, Conn.

GENERAL  ELECTRIC RADIO



# "When customers come in to buy tubes they also buy other merchandise"

— say Noble and Peterson. Thousands of other dealers, too, have been successful in increasing their profits by this proven merchandising method.

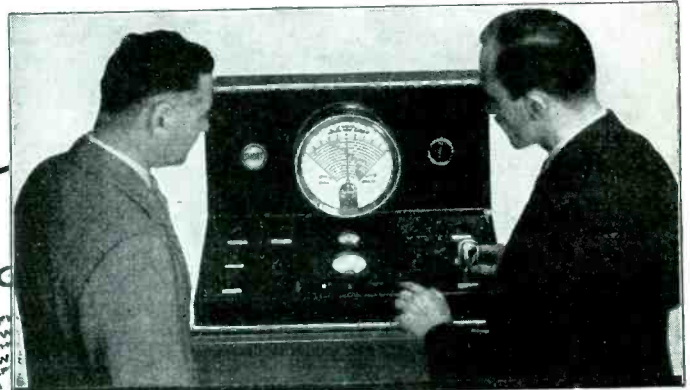

The Pattern 538 Tube-Seller embodies the maximum in impressive appearance. A 9-inch test meter with direct reading dial makes tube selling easy.



**NOBLE & PETERSON**  
ELECTRICAL, RADIO, SPORTING  
Chicago, Illinois

MAIN OFFICE  
303 W. W  
TELEPHONE  
4712  
TELEPHONE  
2821  
TELEPHONE

December 3,

Jewell Electrical Instrument Company,  
1650 Walnut Street,  
Chicago, Illinois.

Gentlemen:

I am sure you will be interested to know that your big Pattern 538 Tube-Seller has revolutionized our conception of tube selling. This big instrument has dramatized tube testing so effectively that the attention of our sales people has been focused on tube replacement with amazing results.

People watch the big meter and follow closely the readings. They are satisfied that their tubes are actually tested when we use this big Pattern 538. Hundreds of customers bring in their tubes for testing, regardless of whether or not their sets are working satisfactorily.

We have learned another thing—that is, when customers come in to buy tubes, they also buy other equipment. So we are featuring free tube testing harder than ever.

Since the first Jewell Tube-Seller was bought, we have purchased three more. We now have four in operation.

We feel that Jewell has done so much for radio dealers in the development of this big instrument that we are glad to do anything we can in return.

Yours very truly,  
NOBLE & PETERSON, INC.

*W. A. Noble*

By



The Pattern 533 Tube-Seller brings the famous Jewell 3-color test meter to even the smallest store.

Western Gray

**LEARN** How Jewell Tube-Sellers are increasing tube and set profits, as well as increasing store traffic and merchandise sales for thousands of radio dealers. Mail the coupon.

**Jewell Electrical Instrument Company**  
4 Haynes Ave., Newark, N. J.

Certainly we want to know all about new merchandising methods. Send the complete story at once.

Name.....  
Address.....  
City.....State.....

32 YEARS MAKING INSTRUMENTS

# JEWELL

# ATWATER KENT RADIO

*Will one of your customers win*



**\$1,000**

FOR NAMING THIS



**NEW  
ATWATER  
KENT  
FEATURE?**

**A**TWATER KENT offers dealers, in addition to the great new Atwater Kent line, a sure-fire trade-builder and profit-accelerator in the

**\$1,500 PRIZE CONTEST**

now open to the public

Coming at a time when the public eats up cash competition as never before, this Atwater

Kent Contest is your opportunity for personal profit. Only through entry blanks obtained from Atwater Kent dealers themselves can the public submit their choice of names to win one of the 55 cash prizes, the first of which is \$1,000.

If you do not already know all the details of this Prize Contest, ask the Atwater Kent distributor in your territory or write to us direct.

**And the public will find every other great feature in  
the new ATWATER KENT Models**

**F**OUR-GANG CONDENSERS even in the lowest-priced Compact... 7, 8, or 10 tubes, and every tube doing its full job... every model a powerful super-heterodyne... automatic volume control on most models... tone control and static reducer... sensitivity switch, a great new feature assuring maximum reception on nearby or distant stations... Quick-Vision Dial... velvet-action station selector... improved Golden

Voice electro-dynamic speaker... genuine American walnut cabinets—nothing cheap or “faddy,” but all designed for a long-time home satisfaction... new low prices... famous Atwater Kent watchmaker precision workmanship.

One touch of the dial—one glance at the exquisite chassis inside the cabinet—tells you: “Here’s the radio that works right because it’s built right.”

*An Interested Caller at Your Store is Three-Quarters Sold*

ATWATER KENT MANUFACTURING COMPANY • 4700 Wissahickon Ave. A. Atwater Kent, Pres. Philadelphia, Pa.



---

Here's how to increase  
volume and speed turnover—

1—Look at **THE AMERICAN WEEKLY**  
every Sunday

2—Note the products advertised on  
its pages

3—Display those products in your  
windows and on your counters

—because this mighty magazine,  
with its 5,500,000 circulation, influences  
the buying habits of nearly twice as  
many families as any other magazine  
in the world.

---

**THE AMERICAN**  
*Greatest  
Circulation  
in the World* **WEEKLY**

*Main Office: 959 Eighth Avenue, New York City*

*Branch Offices: PALMOLIVE BLDG., CHICAGO . . . 5 WINTHROP SQUARE, BOSTON . . . 753 BONNIE BRAE, LOS ANGELES . . . 222 MONADNOCK BLDG., SAN FRANCISCO  
11-250 GENERAL MOTORS BLDG., DETROIT . . . 1138 HANNA BLDG., CLEVELAND . . . 101 MARIETTA ST., ATLANTA . . . INTERNATIONAL BLDG., ST. LOUIS*

---



*Read*

**Y**OU may already be in the electric refrigeration business. Or, you may be looking around for the *right* Franchise. Regardless, read this announcement to your wife. Women know values. They are smart buyers. And, they know *salable merchandise*.

In 18 years, Kelvinator has never built a finer electric refrigerator *at the price* than the new, *low-priced* "K" Model. It represents all Kelvinator has learned in engineering, in designing and in manufacturing during 18 long, successful years devoted entirely to electric refrigeration. And experience *does count*—as many electric refrigeration dealers are *finding out*.

Look again at the illustration of the four foot job. It *is* beautiful. And beauty *is important* because women have a natural eye for and an appreciation of beauty. So have the men, for that matter, but in an electric refrigerator they place economy and performance ahead of beautiful lines.

Study it carefully. Notice the flat top—the thickness of the door—the scientific arrangement of the shelves—the chrome tray fronts—the all-porcelain cooling unit—the Temperature Control, with 8 different freezing speeds—the rounded corners of the porcelain interior and, the harmonious lines of the cabinet as a whole.

There are 4 different sizes—4, 5, 6 and 7 cubic feet food storage capacity and two different finishes—porcelain inside and out or porcelain interior and snow-white lacquer exterior. This makes 8 Models—a Model for 85% of the people who will buy electric refrigerators in 1932.

There are many other points of interest to prospective dealers—points about the "K" Line—about the new medium-priced Standard Line—about the new DeLuxe Line, the finest money can buy—about the complete Kelvinator Commercial Line—and about the big Kelvinator Program for 1932, that we shall be glad to discuss with responsible merchants.

Write, wire or phone to-day

KELVINATOR CORPORATION, 14263 Plymouth Road, Detroit, Michigan  
Kelvinator of Canada, Ltd., London, Ont. • Kelvinator Ltd., London, England

(495)

*this* **ANNOUNCEMENT**

*to your*  
**WIFE**



**Kelvinator**



# NOW ... A MODEL FOR EVERY PROSPECT



THE DELCO HAND-Y VACUMATIC offers a new field of profit-making possibilities.

**THE DELCO VACUMATIC, WITH FINGER-TIP CONTROL, OFFERS A COMPLETE LINE—NEW STANDARDS OF PERFORMANCE, NEW LIGHT WEIGHT, NEW FEATURES THAT WILL BRING NEW PROFITS TO YOU**

Delco engineers "started something" with the Finger-Tip Control Delco Vacuumatic. Set a new pace in standards of efficiency. Produced a new kind of vacuum cleaner, as nearly automatic in action as humanly possible to make. A cleaner that all but runs itself. The kind modern homemakers have always wanted and never had before.

Here is a cleaner you can demonstrate with pride. For it has more distinctive features—more revolutionary improvements—than any cleaner you've ever shown before.

Finger-Tip Control and the exclusive Three-Position Lock eliminate stooping, lifting, foot manipulation. Aluminum construction combines extremely light weight with amazing strength. The extra long and specially designed nozzle makes it easy to reach under chairs and out-of-the-way places; adjusts itself *automatically* to different heights of rugs without any hand manipulation. The famous Delco motor insures dependable operation and maximum suction. The extra large wheels make operation virtually effortless. The floating brush of the one model—the rotary brush of the other—gives every woman the type of cleaner she prefers. And the Delco Hand-y Vacuumatic completes the line.

The Delco Vacuumatic marks a new era in house cleaning methods for women; a new era in profit-making possibilities for you. Mail the coupon for detailed information on the Delco Selling Plan today.

DELCO APPLIANCE CORPORATION, Rochester, N. Y.



DELCO FANS made new sales records for distributors and dealers last summer. The coming season should be even better. These fans offer new beauty, new quietness, new economy—new profit-making possibilities. Get ready now for a big summer season. Write today for sales plan.

● *The Delco Vacuumatic with Rotary Brush*—for many users who prefer the rotary brush type of cleaner. The sweeping action, combined with powerful suction, makes this model an extremely thorough cleaner. Patented, self-cleaning brush is an exclusive feature with Delco.

● *The Delco Vacuumatic with Floating Brush*—In this model the brush does not rotate, but is automatically adjusted to the height of pile, so that it cleans any type of rug or carpet with equal efficiency. Extra strong suction, because of smaller nozzle opening. This model also has self-cleaning brush.

FINGER • TIP CONTROL  
**DELCO VACUMATIC**  
*... all but runs itself*

A G E N E R A L M O T O R S V A L U E

DELCO APPLIANCE CORPORATION,  
 Dept. O-21, Rochester, N. Y.

Please send me your Delco Sales Plan and complete information about the Delco line of Vacuumatics and Fans.

Name.....

Address.....



# *The proven*

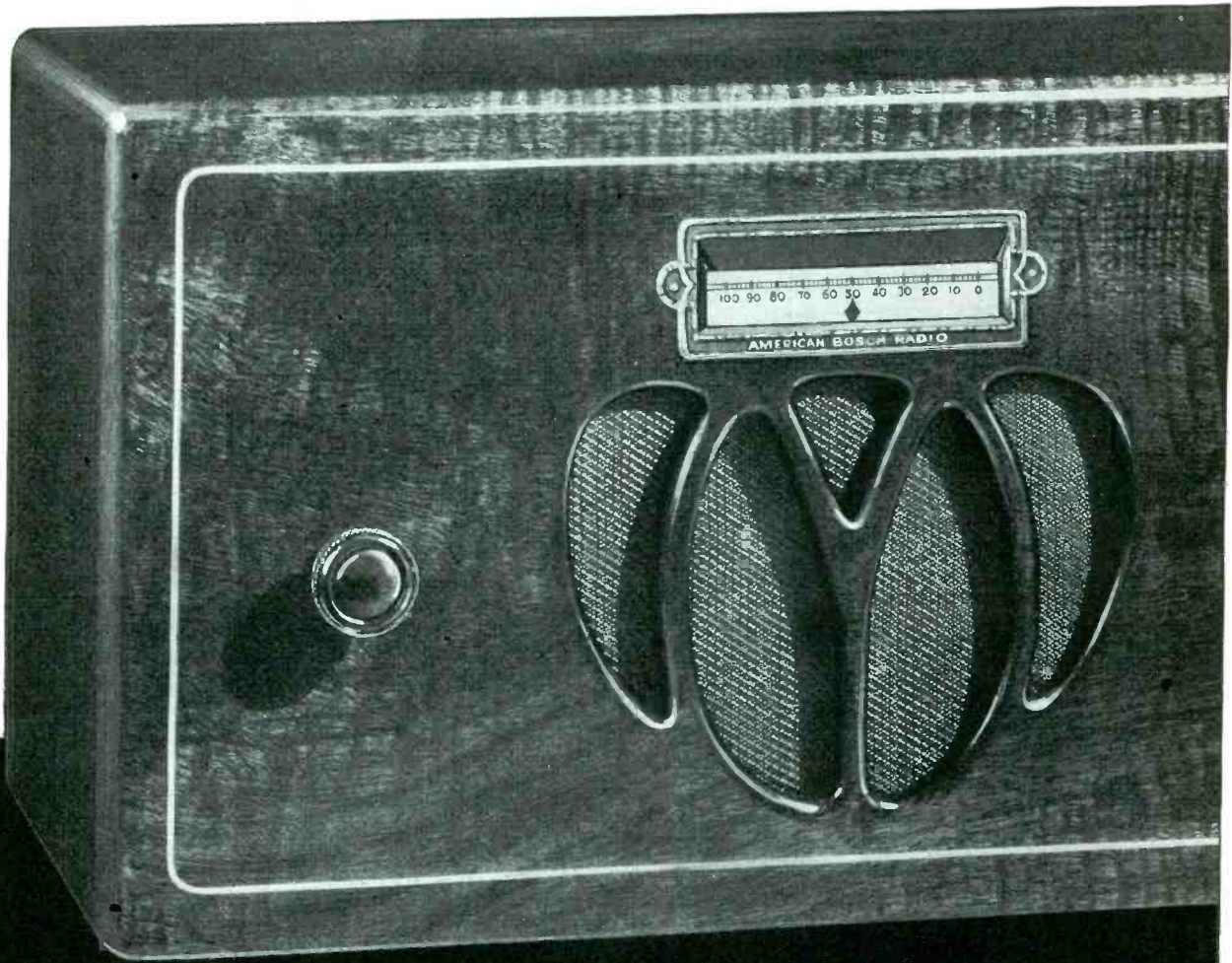

**\$45**  
COMPLETE  
WITH TUBES

*the new* —  
**AMERICAN**



# BEST SELLER

*improved into a*  
**SUPER-HETERODYNE**  
*for this year*



Dealers tell us that no radio set—big or little—has ever been received so enthusiastically as the American Bosch Personal Radio.

If ever any one radio has proven to be a best seller, it is this Personal Radio. It has actually enlarged the radio market. As an extra set for the home, it has created new radio sales. Upstairs or down, it is as portable as an electric fan. It weighs but 21 lbs. It is ideal for office use.

And now for 1932 we have made it better than ever. Refined and beautified the solid mahogany cabinet. The improved chassis is a 6 tube superheterodyne, with sensitivity and selectivity unusual even in sets three times its cost. New features of ruggedness are added to the set. Bass note reproduction in the full toned dynamic speaker provides really exceptional tone quality. Price, \$45.00 complete with tubes.

The new Personal Radio is only one of many developments in the comprehensive American Bosch line for 1932 which offers the *newest* line in radio. New cabinets—three new chassis—all superheterodynes—Duo-Diode system—full automatic volume control and other newest principles. Radio jobbers and dealers interested in bigger 1932 profits are invited to write for the new American Bosch sales plan.

**UNITED AMERICAN BOSCH CORP.**  
**SPRINGFIELD MASS.**

Branches: NEW YORK CHICAGO DETROIT SAN FRANCISCO

*American Bosch Radio is licensed under patents and applications of R. C. A.  
 Western Prices Slightly Higher.*

# BOSCH

*personal radio*

# A "NATURAL" FOR RADIO DEALERS

## • THE NEW LEONARD ELECTRIC •

LEONARD offers you the kind of electric refrigerator franchise you would write yourself. Five simple facts explain its unusual popularity with the radio dealers:

Many *extra* selling features, including the exclusive LEN-A-DOR—which women are calling the greatest convenience feature in electric refrigeration, and which by itself is selling many Leonards;

A complete, compact line of "package merchandise"—8 models, 2 all-porcelain, requiring no installation except plugging in at an electrical outlet;

The beauty and evident quality of this new line—backed by Leonard's 51 years of refrigeration experience;

Low price and favorable discounts;

The backing of a liberal advertising plan, and a complete program of selling and merchandising helps.

In the past few weeks, 23 important distributors, with large, strong dealer organizations, have taken on the Leonard franchise. If *you* are interested in this unusual profit opportunity, write or wire promptly, as desirable territories are being rapidly closed.

LEONARD REFRIGERATOR COMPANY  
14259 Plymouth Road, Detroit

**WITH THE LEN-A-DOR**

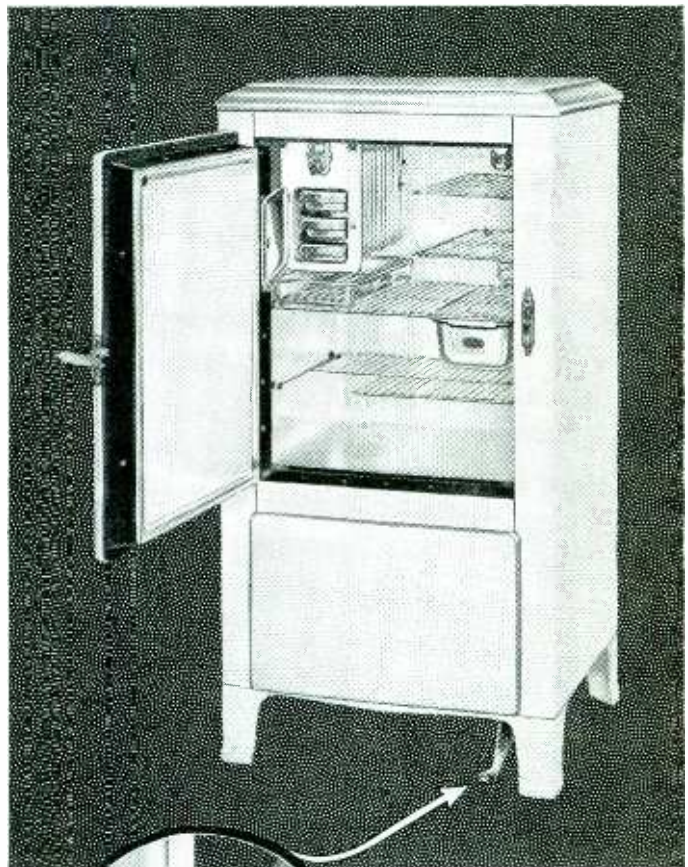

A TOUCH OF THE TOE AND  
THE DOOR SWINGS OPEN

# LEONARD

ELECTRIC

REFRIGERATOR



(451)



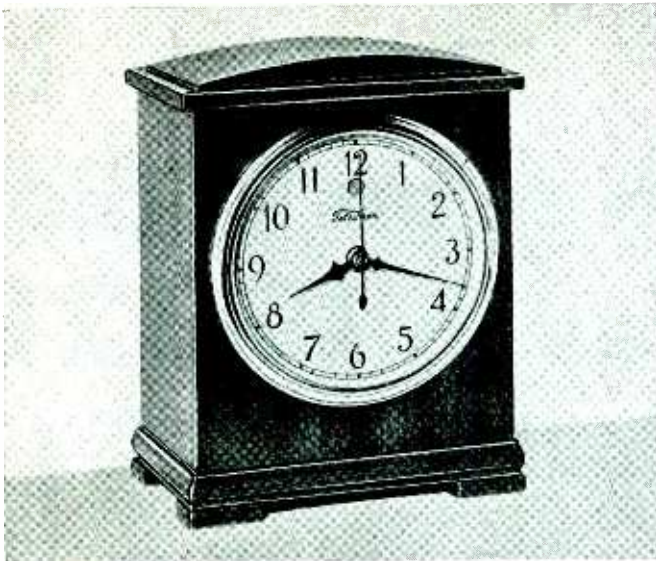

329 — Polished mahogany case, 5¼" high, with solid wooden back finished same as front. A clever desk clock to retail at **\$5.95**

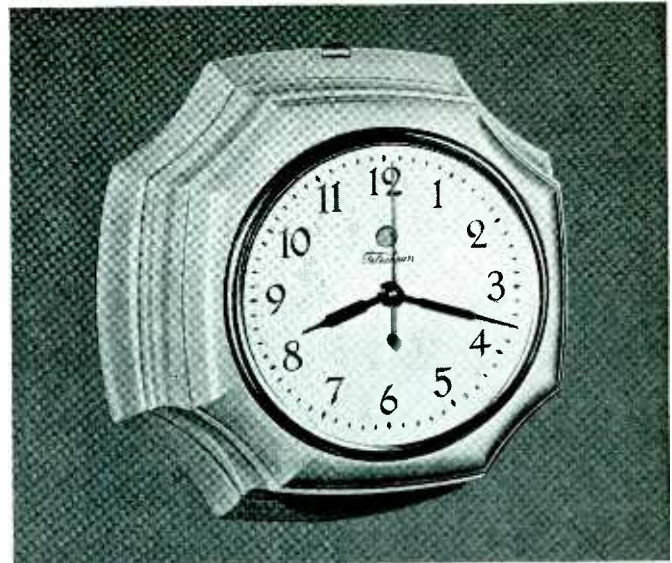

457 — Metal case in choice of white, ivory, green or blue. Diameter 1½". Special hanger for wall mounting. Retail **\$5.50**

# LOWEST PRICES EVER OFFERED!

## TWO NEW TELECHRON CLOCKS

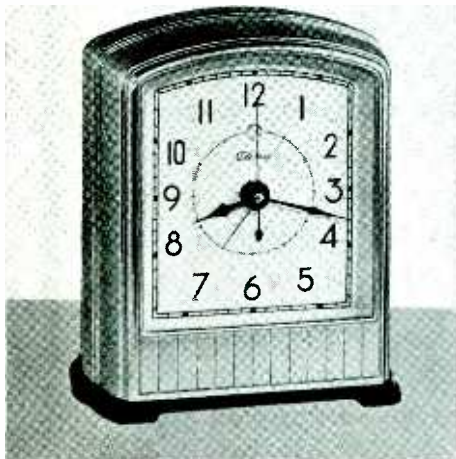

715 — Telalarm, "Dura-silver-alloy" case, with alarm. Retail, \$8.50.

711 — Same model with illuminated dial. Retail, \$9.95. In ivory, green, blue or orchid, \$8.95.

TELECHRON dealers have led the parade, since electric time began. And the two new models pictured at the top of this page, will put them even farther out in front!

They're genuine self-starting Telechrons, these two, of the same high quality as all Telechron clocks. One for the desk and one for the kitchen wall—both popular locations. *Made right—priced right—to sell in big volume right now!*

Telechron dealers benefit by big-space national advertising all year round—by the wide range of prices and rich variety of models only Telechron offers. Why not join the Telechron parade? The coupon below will show you how easy it is.

The Revere Clock Company, of Cincinnati, Ohio, manufactures strike and chime clocks with Telechron motors, priced up to \$650. WARREN TELECHRON COMPANY, ASHLAND, MASS. THE REVERE CLOCK COMPANY, CINCINNATI, OHIO



R-818 — Mahogany case with decorated glass door. Early-American design, 15" high. Westminster chimes. Retail, \$48.

# Telechron

(Reg. U. S. Pat. Off. by Warren Telechron Co.)

WARREN TELECHRON COMPANY, 33 Main Street, Ashland, Massachusetts  
Please tell me all about your Authorized Dealer Franchise.

Name \_\_\_\_\_

Address \_\_\_\_\_

# Make Money on Radio Tubes in 1932!

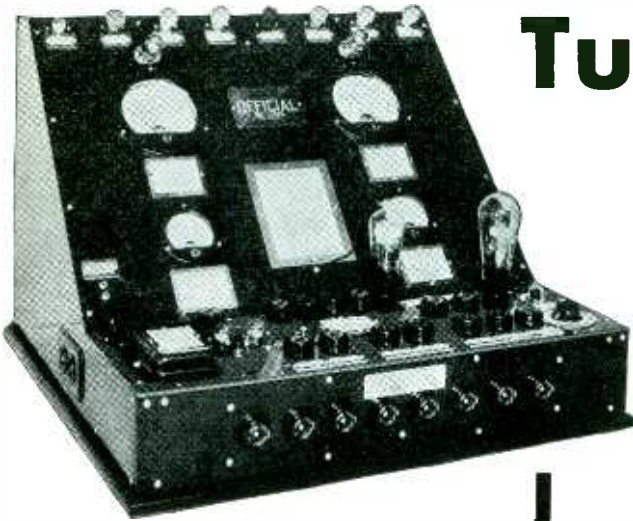

Tung-Sol sales have shown a steady and substantial increase right through these last two years, in spite of the fact that decreased demand has forced many manufacturers to reduce production.

Not a dollar's worth of this business was gotten on a price basis. Every dealer who participated in it had an opportunity to receive full profit on every tube he sold.

The signs point to a trading up season throughout the radio business. Get your tube business in line with that trend. There is no better way to do it than to tie up with Tung-Sol—the tube that the price cutters have not been able to touch.

Tung-Sol has a *sound* merchandising plan and an effective scheme of dealer helps ready for you. You ought to know about them, and if you'll write us, a Tung-Sol salesman will gladly give you the whole story.

**Draws 'Em into the Shop!**  
**—this \$750 Tube Tester**

## FREE!

- Reads dynamic mutual conductance directly on meter.
- Reads plate current directly on meter.
- Reads grid current or gas directly on meter.
- Checks for cathode-filament leakage.
- Indicates shorts between all elements of tubes on series of colored lamps.
- Supplies up to 250 volts DC for plate circuit, thus making possible a dependable and accurate test.
- Checks all type tubes.
- Operates from 60 cycle 110 volt AC line—requires no batteries of any kind.
- Compensates for all line fluctuations.

## TUNG-SOL

RADIO TUBES



**Made by TUNG-SOL RADIO TUBES Inc.**  
**NEWARK, NEW JERSEY**

*(Licensed under patents of Radio Corporation of America)*

Sales Divisions:

Atlanta, Baltimore, Boston,  
Charlotte, Chicago, Cleveland,  
Detroit, Kansas City, Los  
Angeles, New York, St. Paul.



# For Auto Radios

## EMERSON "B" POWER UNIT

Provides Constant "B" Power... Improves tone quality and volume

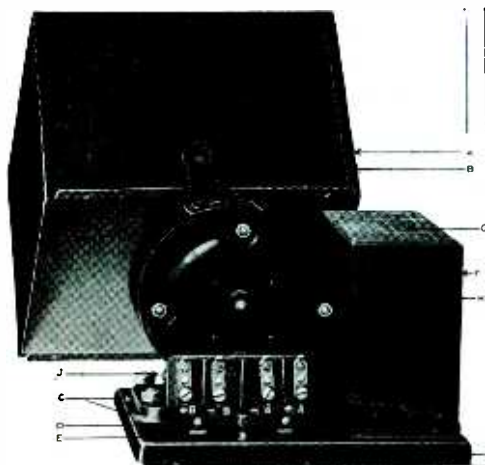

### Mechanical Features

- A. Metal cover excludes dust, dirt, moisture.
- B. Slotted cover, removable without disturbing wiring.
- C. Rubber mountings prevent vibration and noise.
- D. Handy terminal plate for "A", "B" and ground connections.
- E. Ground connection post.
- F. Filter pack prevents commutator interference.
- G. Convenient wiring diagram.
- H. Oil holes. Lubricate once a year.
- I. Steel base plate.
- J. Adjustment screws permit various mounting positions.
- K. Bolt holes for mounting.

Operates from auto battery. Delivers 180 volts D. C. Consumes approximately 2 amperes current.

Tests indicate that the life of the brushes (the only real wearing part) is not less than 3,000 hours, probably much longer.

YOUR customers want peak performance from their sets at all times. Now they can have it, day in, day out — *always uniform reception* comparable with the reception of a home radio set. This better reception is the result of constant "B" power which the Emerson "B" Power Unit (motor generator) delivers at all times, eliminating the "B" battery whose power diminishes daily with use. Its first cost is its last cost. No replacements are needed. No attention is required except oiling once a year.

Here's a real money-maker for you. It improves set performance thereby reducing complaints and building up satisfied customers. It pays for itself eliminating battery replacements. Liberal discounts and a fast-growing demand mean big new profits for you. Ask your radio distributor or write for full information today. Stock up. Get ready for the auto radio season. It's just around the corner.

Other markets include radio-equipped police cars, motor boats, farms, camps and other places where electric current is not available.

Compact. Fits in regular "B" Battery compartment. Size  $8\frac{7}{8} \times 7\frac{3}{4} \times 6$  inches.

Made and fully guaranteed by the makers of Emerson Motors and Fans.

\$ **29**<sup>75</sup>  
LIST

Advertised in the Saturday Evening Post starting April 23rd.

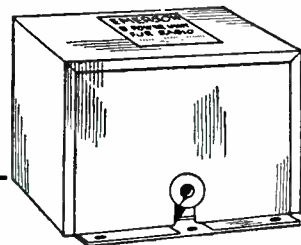

The Emerson Electric Mfg. Co.,  
2018 Washington Avenue, Saint Louis.

Send me full information and discounts on the Emerson "B" Power Unit.

My principal jobber is \_\_\_\_\_

\_\_\_\_\_ City, \_\_\_\_\_ State

My Name \_\_\_\_\_

Address \_\_\_\_\_

# Motorola sets the pace in Auto • Radio

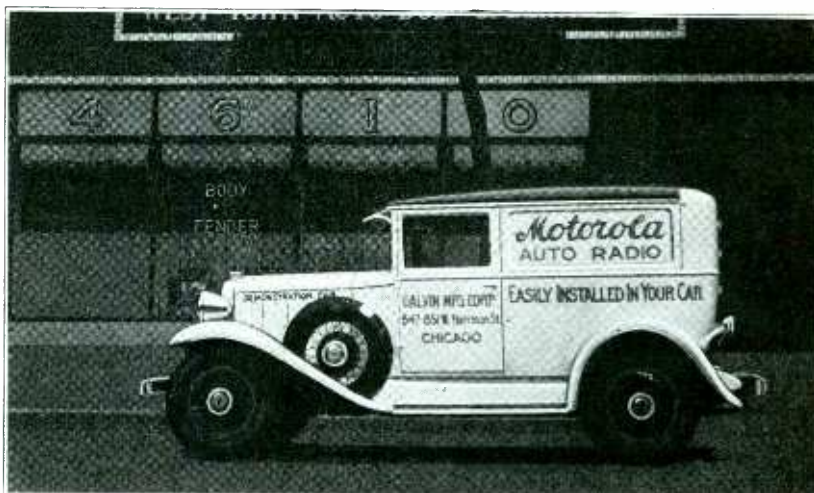

**Now • a sales and service fleet is out to help build your business**



Watch and listen for one of the *MOTOROLA* Sales and Service Cars—they're out demonstrating and advertising *MOTOROLA All-Electric Superheterodyne* Auto-Radio. They're helping dealers sell and showing them how easy it is to make quick, profitable installations, the simplified *MOTOROLA* way.

Yes, *MOTOROLA* sets the pace in Auto-Radio—in performance, in "home-radio" features, in easy installation, and in profits for *YOU*.

The big season's starting—send for the profitable facts about *MOTOROLA* today.

### Compact—Easiest to Install

*MOTOROLA* is the most compact Auto-Radio built—a hand covers it—it *FITS* any car. Only 2 hours or less to install. Only 4 tiny holes in the bulk-head. Sell and install *MOTOROLA*—it pays!

<p><b>MOTOROLA Super-Deluxe</b></p> <p>All-Electric heterodyne Super- sells for \$94</p> <p>Installation Extra</p>	<p><b>MOTOROLA Super-Deluxe</b></p> <p>Battery - Operated Superheterodyne. sells for \$69.50</p> <p>Less "B" Batteries Installation Extra</p>	<p><b>MOTOROLA Standard</b></p> <p>5 Tubes — Battery-Operated. sells for \$49.50</p> <p>Less "B" Batteries Installation Extra</p>
--	---	---

**GALVIN MFG. CORPORATION**  
*PIONEERS IN AUTO RADIO*  
**847-851 West Harrison St., Chicago**



# The new 1932 line of *the famous* **ICE-O-MATIC** *is ready!*

**H**ERE is the finest line of precision-built electrical refrigerators the entire market affords. Built—not just assembled—by the makers of the world-famous Williams Oil-O-Matic oil burners, these new 1932 Ice-O-Matic models offer an array of 15 quality features which give you a definite “edge” in any sales situation.

Ice-O-Matic is the most

flexible line of electric refrigerators in America. There is a size and a type of Ice-O-Matic for every refrigeration need, commercial as well as domestic.

Ice-O-Matic precision manufacture and rigid requirements as to materials are jointly responsible for a record of phenomenally low service costs, over the years.

There is good Ice-O-Matic territory available—perhaps yours. The coupon will bring you full information on the money-making opportunity with Ice-O-Matic. Send today.

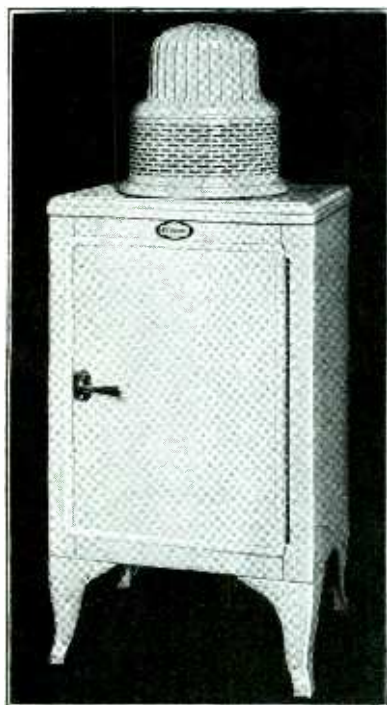

- 1** Greater cooling capacity—using less electric current.
- 2** Quiet operation—and no radio interference.
- 3** Large food space, conveniently arranged.
- 4** Eye level temperature control for faster freezing.
- 5** Sealed unit on top or below.
- 6** Furniture designed cabinets of finer quality.
- 7** Plugs into light socket simply as a lamp.
- 8** Extra heavy insulation.
- 9** “Acid proof” porcelain, easily cleaned.
- 10** Concealed automatic door latch.
- 11** Easily sliding shelf bars.
- 12** Chromium finished hardware—full length piano hinge.
- 13** Forced air circulation.
- 14** Generous ice cube capacity.
- 15** Built the Williams way—materials of quality, superiority of workmanship.

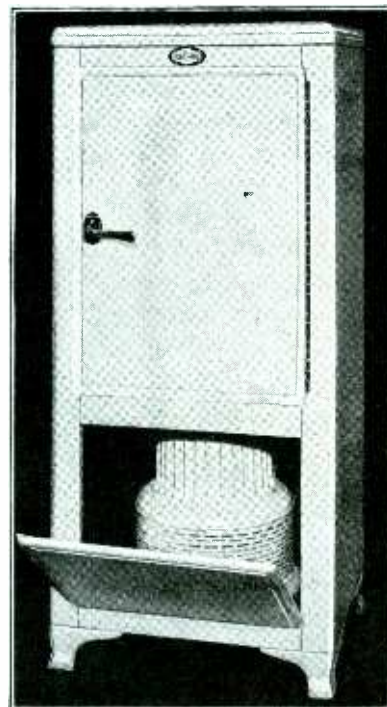

**WILLIAMS**  
**ICE-O-MATIC**  
REFRIGERATION

**WRITE—TODAY!**

RR-3  
Williams Oil-O-Matic Heating Corp., Bloomington, Ill.  
Send me complete information on your exclusive, full-profit Ice-O-Matic dealer franchise for my territory—right now!

Name.....  
Address.....  
City..... State.....

**T**HE time has come, Mr. Dealer, to realize that the size of the discount plays a *minor* role in making profit for you. Profit no longer can be measured in terms of percentage...figured at the time you *buy*; it must be based on the number of *dollars* you can make...at the time you *sell*. ¶ After all, what does any discount amount to...whether 40%, or 50%, or even 60%...if the price at which you are *compelled* to sell makes a

virtual joke of the list price from which the discount had been figured? We repeat, what does any discount amount to if the radio itself does not command its full, or nearly full, list price when it is sold to the consumer? ¶ Fictitious or elastic discounts...so prevalent, and so disastrous to the radio dealer...have no place in the Zenith picture. Not only because Zenith radios command full price from the public, but also because Zenith dealers have been influenced by this consumer acceptance to *demand* a full price for Zenith radios. In short, the Zenith discount is not only a liberal discount, but a *definite* discount on which you *know* you will enjoy a *maximum* profit. ¶ Remember, Mr. Dealer, your profit today depends not on how much you get in *buying*, but on how much you make in *selling*!

# PERCENTAGE *or* PER DOLLARAGE ?

Proving that figures often lie, Mr. Radio Dealer . . . when it comes to Profit or Loss!



ZENITH RADIO CORPORATION, CHICAGO, ILL.



# for 1932 sell PERFORMANCE

Mr. and Mrs. Consumer are educated! Today's public demands performance — a demonstrable tangible promise of performance.

Beautiful boxes — inconsequential gadgets — are not enough. With boxes as handsome, and as modernly equipped, as any in the industry, ZEROZONE still insists that the UNIT is the thing: *the refrigerator with demonstrable unit-superiority is the best—the most profitable refrigerator to sell.*

The ZEROZONE Unit is undoubtedly the finest unit it is possible to make!

Made completely (all but the motor) under one roof in the famous ZEROZONE precision factory with a fine tradition of glowing performance since pioneering days, every ZEROZONE Unit is oversize — actually larger — than standard for each size of box! You can *show* this to your customer, *sell* on the strength of it.

Extra freezing speed, extra economy, extra life, extra dependability, all come from the EXTRA capacity of the ZEROZONE Oversize Unit. This wins business — **KEEPS BUSINESS** — makes ZEROZONE franchises increasingly valuable.

The ZEROZONE Distributor-to-Dealer-to-Consumer RESELLING Plan creates profitable selling. A few distributorships still open. Write or wire.

**ZEROZONE, 40 East 49th Street, New York City**  
Factory: Chicago, Ill.

## Zerozone *The Refrigerator with the* OVERSIZE UNIT

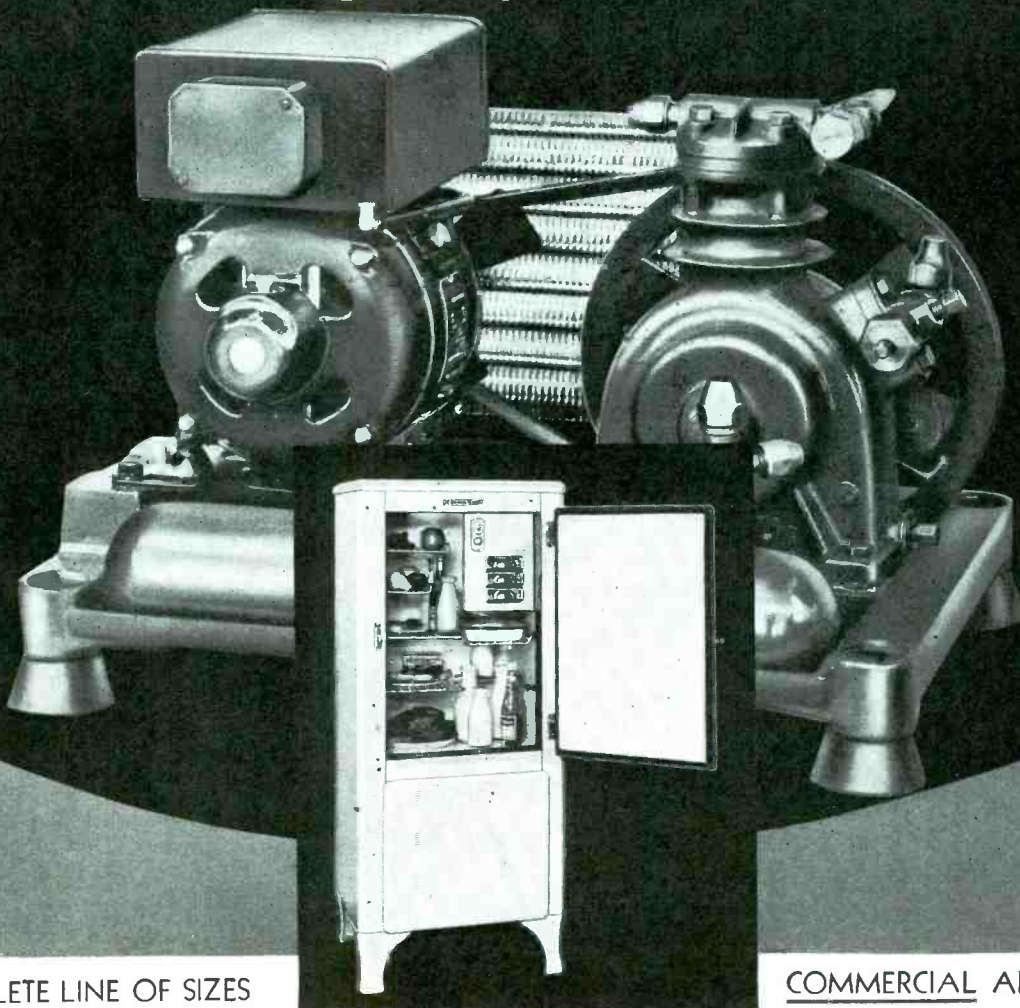

A COMPLETE LINE OF SIZES

COMMERCIAL AND DOMESTIC

# When you sell a MAYFLOWER

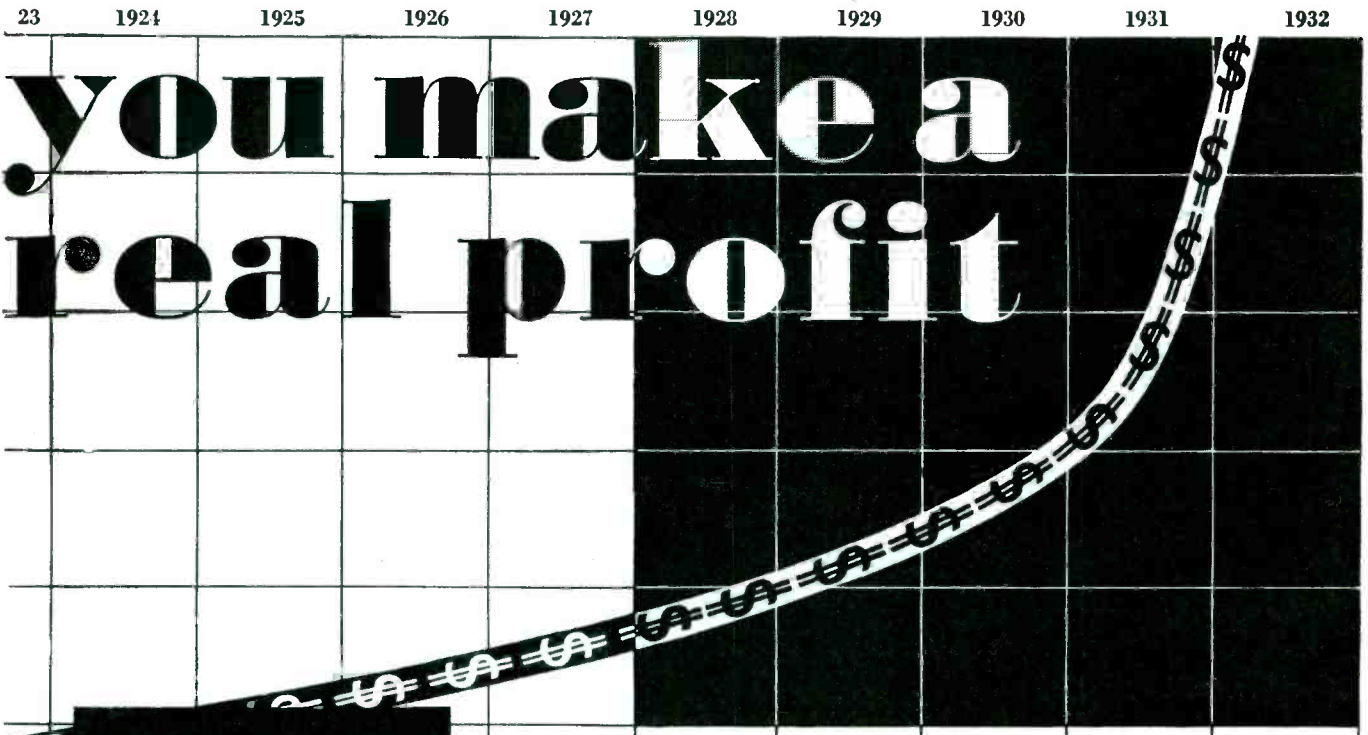

Sold thru retail outlets only

Period-styled cabinets

Pre-sold by national advertising

A complete refrigeration line

Refrigeration since 1920

The Mayflower sales curve shows a sound and steady progress. But sales alone are not enough. There must be a parallel profit curve. And that is where Mayflower offers you a definite advantage over electric refrigerators that sell on price alone.

In the electric refrigeration industry today there is one strategic point where price and sales combine to produce the greatest profit for the dealer. Below that point, low price allows too small a profit. Above it, sales decrease as prices rise.

Mayflower—backed by more than eleven record-breaking years and by a strong national advertising campaign—offers the retail merchant a product and a selling plan built around that profit-paying point. Get the facts and figures now. Trupar Manufacturing Company, Dayton, Ohio. Canadian factory: Mayflower Corporation of Canada, Ltd., Hamilton, Ontario.

**MAYFLOWER**  
ELECTRIC REFRIGERATION



Send us your name and address and we will mail you our booklet outlining the complete Mayflower retail merchandising plan.



# INTRODUCING

# COMMANDER OF THE AIR

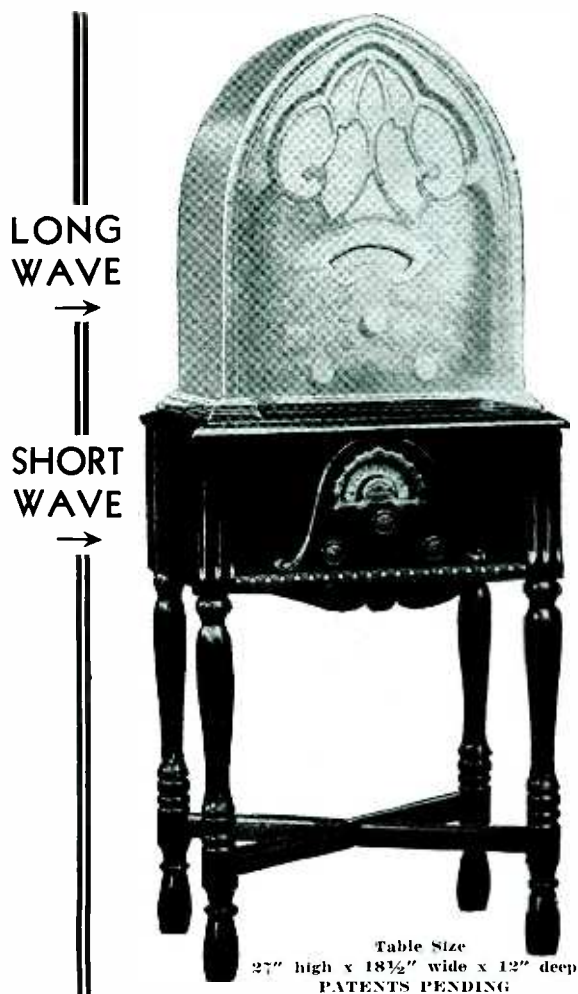

Table Size  
27" high x 18½" wide x 12" deep  
PATENTS PENDING

COMMANDER OF THE AIR is a direct factory-to-dealer proposition.

COMMANDER OF THE AIR receivers have been featured by dominant radio merchandisers in every large center in the United States.

COMMANDER OF THE AIR is now available to every *live* radio dealer in the country.

## SHORT WAVE TABLE

Be the first in your community to offer the Commander Short Wave Table with midget sets you now handle!

The Commander Short Wave Table is a short wave converter of the very latest design. It tunes down to 20 meters and is installed in a very beautiful table. The Commander Short Wave Table can be used with midgets you *now handle* or with modern midgets you have *previously sold*.

Thrill after thrill is in store for your customers if they combine a Commander Short Wave Table with the midget they now have or may purchase.

By featuring the Commander Short Wave Table with *any* nationally advertised midget you will be featuring in your community the *lowest priced nationally advertised all wave receiver*.

## HERE IS SOMETHING YOU SHOULD KNOW

*HUNDREDS of Thousands of Dollars* have been spent in newspapers advertising **COMMANDER OF THE AIR** during the last few years.

*Wire or write* for our complete proposition at once.

LICENSED UNDER PATENTS OF RADIO CORPORATION OF AMERICA  
MANUFACTURED BY

## AUDIOLA RADIO Co.

430 South Green Street, Chicago, Illinois

HIGH GRADE SET MANUFACTURERS *CONTINUOUSLY* SINCE 1921

**New!** for Jobbers—Dealers—Servicemen

**LYNCH Resistor Replacement Manual**

FREE with purchase of 10 LYNCH Metallized Resistors at regular trade discount, or Manual may be bought for \$1.00.

All the RESISTOR INFORMATION you will ever need! Saves TIME and experimenting. Useful, authoritative, invaluable. More than 200 circuits—nearly every popular make of radio receiver. Gives value, R.M.A. Color Code schedule and table of Resistance Values, together with data on Multipliers.



**FREE**

**New Low List Prices**

1 Watt 30c.; 2 Watt 40c.; 3 Watt 50c.

**FREE**  
Steel 50-Drawer Resistor Cabinet

Useful, Durable

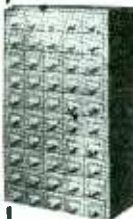

Drawers 8x3 x2 1/2 inches inside Case 18 3/8 x 18 1/2 x 8 1/2 inches

Write TODAY for details



Metallized 1, 2, 3 Watts

**LYNCH RESISTORS**



Precision Wire Wound Pigtail and Cartridge Types.

Send order today for Manual, new reduced price catalog and RMA Color Code Card.

LYNCH MFG. CO., Inc., 1775R Broadway, New York City

**MAKING A BIG HIT! with Dealers and Service Men everywhere » »**

because they insure customer satisfaction and mean a real profit to you.



**MORRILL CONDENSERS**

eliminate comebacks, stand up under extreme voltage shocks—exceptionally compact—convenient for stacking.

**MORRILL CARBON RESISTORS**

Accurate and maintain their accuracy under severest conditions—Stay noiseless—moisture proof—generously rated.

**JOBBERS WANTED!**

**MORRILL and MORRILL** Dept. H-2  
30 Church Street  
New York, N. Y.

Sole U. S. A. Distributors of the Siemens & Halske Condensers and Resistors.

**FULCO RADIO COVERS**



"FULCO" Radio Covers insure deliveries in perfect condition—without scratches or broken parts. Well padded, strongly sewed, and made to give maximum service at minimum cost. Also Dust Covers. Write for prices.



**Fulton Bag & Cotton Mills**

Manufacturers Since 1870

Atlanta St. Louis Dallas  
Minneapolis Brooklyn New Orleans, Kansas City, Ken.

**NOW Auto-Radio without DRY BATTERIES**

**JANETTE**

"Auto-B-Power"



Completely does away with dry batteries. Transforms the 6 (or 12) volt current from automobile or airplane storage batteries into 135 or 180 "B" current. Also available with voltage-divider for tapping off "C" current as well. Low battery current consumption.

**Clear Reception**

The "Auto-B-Power" is equipped with a Filter of Janette design which practically eliminates ripple or hum.

**Delivers Pure D. C.**

The "Auto-B-Power" embodies a JANETTE dynamotor which generates a pure continuous D.C. similar to battery current, rather than the pulsating type of D.C. delivered by the vibrator or interruptor types of current transformers.

**Low Price**

Considering the high quality of this unit which is in every way comparable to the world-famous JANETTE Rotary Converter, the "Auto-B-Power" is priced remarkably low. Built to outlast the radio set.

**MAIL COUPON TODAY**

JANETTE MFG. CO., 555 West Monroe St., Chicago, Ill.

Please send complete information on your "Auto-B-Power."

Name .....  
Address .....  
City ..... State .....



**RADIO WIRE PRODUCTS**

- ANTENNA WIRE
- ANTENNA KITS
- ANTENNA ACCESSORIES
- LIGHTNING ARRESTERS
- LEAD-IN WIRES
- HOO-K-UP WIRES
- ANNUNCIATOR WIRES
- CABLES

WRITE FOR CATALOG AND PRICES

If Your Jobber Cannot Supply You—Order Direct  
**CORNISH WIRE CO.** 30 CHURCH ST., NEW YORK, N. Y.

Makers of the Famous

**BRAIDITE HOOK-UP WIRE**

**A.C. Electric Plants**

ALTERNATING CURRENT ELECTRIC PLANTS now available in sizes from 500 to 10,000 watts. Ten models of modern generating units furnishing the SAME CURRENT as SUPPLIED BY POWER COMPANIES—A.C. 110/220 volt, 60 cycle, single or three phase. Ideal standby units.

**OPERATES A.C. RADIO, PUBLIC ADDRESS AND SOUND CAR EQUIPMENT**

Runs Washing Machines, Water Pumps, Refrigerators, A.C. motors. For all Household and Commercial Requirements. All models complete and ready to run. Cost of operation and upkeep very low.

**D.C. MODELS AS LOW AS \$99**

Direct Current models in 110 or 32 volt, sizes 300 to 1500 watts, ranging in price \$99 and up.

ONAN High-grade, less expensive ELECTRIC PLANTS offer opportunity for many sales of plants, wiring and appliances. Write for details.



**D. W. ONAN & SONS**  
269 Royalston Ave., Minneapolis, Minn.



# 3 Profits instead of 1

with these  
business building  
combinations from  
"RADIO HEADQUARTERS"

"Sensational"  
is the word!

RCA Victor  
Model RE-18—  
9 tubes in the  
radio — two-  
speed turntable  
for the phono-  
graph. New  
"whisper" vol-  
ume control for  
records.

Complete  
\$147<sup>50</sup>

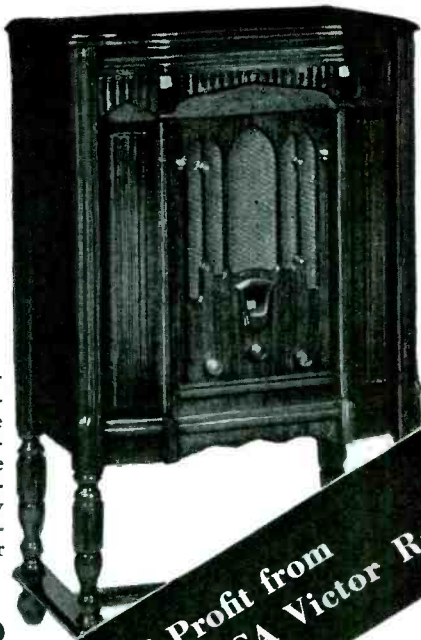

**1st profit** Normal Profit from RCA Victor Radio

**2nd profit** Extra Profit from Phonograph Combination

**3rd profit** Profit from Victor Records and Program Transcriptions



Tie this—if you can!

RCA Victor Model RE-19—8-  
tube radio combined with two  
speed phonograph. Complete  
with tubes, believe it or not, at

\$129<sup>50</sup>

TRY *this* little stunt, you wide-awake deal-  
ers, and see what a pretty tune it plays on  
your cash-register keyboard!

Get behind RCA Victor's sensational new line  
of radio-phonographs at their "step ahead" low  
prices. Push the 3-in-1 idea, the complete home  
entertainment idea, as hard as you have pushed  
table models and \$50 radios. Tie in with Victor's  
new long-playing record—really go after the rec-  
ord business as revitalized by Victor's new releases.

In short—dig for business worth digging for.  
Sell the numbers that mean repeat sales. The  
prices alone—undreamed of before RCA Victor's  
"Step Ahead" program—will sell these instru-  
ments. See your RCA Victor distributor—and  
let him show you!



Generous margin  
here, all right!

RCA Victor Model RE-20—10  
tubes. Complete Synchronized  
Tone System. Two-speed phono-  
graph turn-table.  
Home Record- ing. Complete, \$199<sup>50</sup>

## RCA Victor Company

### "RADIO HEADQUARTERS"

CAMDEN, N. J.

A Radio Corporation of America Subsidiary



# POPULAR, YES!

*Brings New "Long-Playing" Trade*

## The **NEW** **TWO-SPEED** **GREEN FLYER** Model D Motor, at \$15

ONE demonstration and they want it. Put on a new Long Playing Phonograph Record. Explain its merits. Show the slow 33 1/3 r.p.m. turntable speed. Then change to a Regular Phonograph Record, with turntable speed shifted easily to 78 r.p.m. by pushing the speed-change lever.

They want the Two-Speed Green Flyer Motor. They want new Long Playing Records. You're making a \$15 to \$20 or \$25 sale, that will bring the same customer back for more records. That will bring you other customers for motors and records.

Each motor furnished with 10 in. turntable (slight extra charge for 12 in.), speed regulator dial and speed-change escutcheon. Automatic stop is optional. Retail list price \$15.

Backed by over 15 years of Flyer Phonograph Motor and electrical manufacturing success. Responsibly guaranteed. Order a sample TODAY, from your jobber or direct.

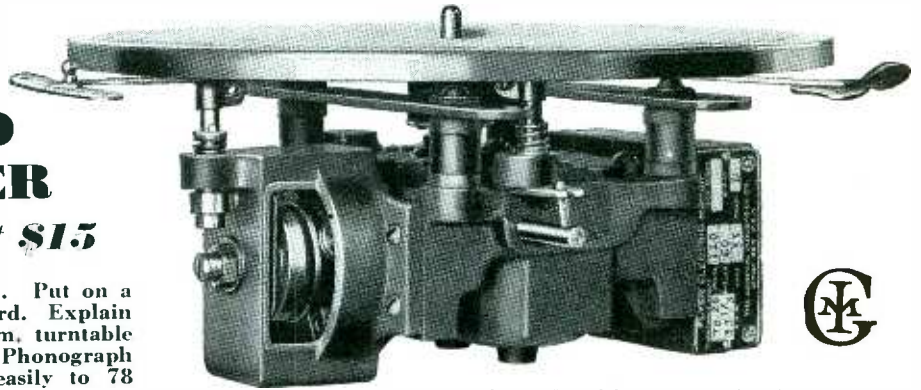

Two-Speed—33 1/3 and 78 r.p.m.

MODEL D Green Flyer Radio-Phonograph Motor. For all voltages and frequencies; also supplied for direct current, either 110 or 220 volts. Self-starting induction type, with ample power. Governor control with 10% range of speed adjustment. Pulls all new Long Playing 33 1/3 r.p.m. and Regular 78 r.p.m. records with equal perfection.

*In ordering, please specify voltage and frequency needed.*

**The GENERAL INDUSTRIES CO.**  
3214 Taylor Street, Elyria, Ohio

# ERLA

## SHORT WAVE CONVERTER



Self Powered

**\$12.50**

With RCA Tubes

**NET TO DEALERS**

Discounts to Distributors

Capitalize on the demand of 12 million set owners for something new in radio. Sell them the new Erla S-W Converter. Three Tubes—Easily attached—Performance normally found in higher priced models. Write at once for full details on this profit building item.

*Dealer orders must be accompanied by certified check or money order, balance COD.*

**Electrical Research Laboratories Inc.**  
1731 West 22nd St. Chicago, Ill.

# DE WALD RADIOS

LICENSED BY R.C.A.

MAKERS OF FINE RADIO SETS  
FOR TEN YEARS

*A Radio Chassis for Every Purpose  
Tell us your needs*

**PIERCE-AIRO, INC.**  
510-518 6TH AVE., NEW YORK

**\$19.50**  
Complete  
*less tubes and batteries*

The new WALTON motor radio using six tubes of the latest automobile type, Utah dynamic speaker and illuminated remote control drive. Easily installed all connections made by special plugs and jacks.

Act quickly: territories now being assigned; order your sample and decide immediately if you wish to handle this profit making line or have it for competition. We also present the new Walton Auto-B for use on any type auto radio, 180 volts at 30 mils. Your net price, \$9.95. Terms cash with order or 25% deposit, balance C.O.D.

**NORTHWEST SPECIALTY SERVICE, LTD.**  
Manufacturers Terminal, Waukegan, Ill.



**NATIONAL UNION**  
**OFFERS AN AMAZING**  
**New**  
**Tube Tester**

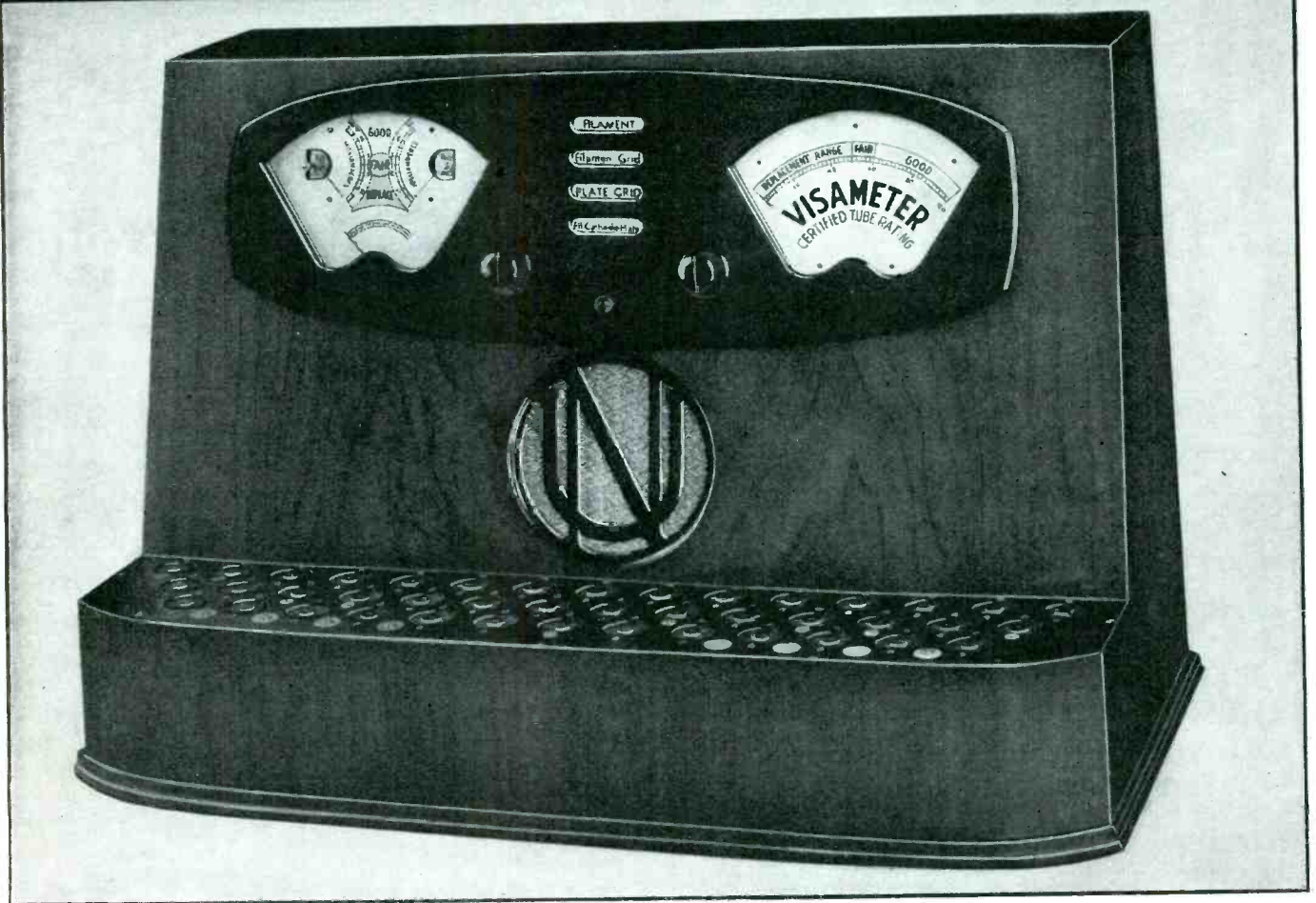

.. An utterly new kind of tester, easy to operate, far simpler than any tube tester you've ever seen before. Now offered exclusively by National Union. Coupon below brings full information on how to get it.

reputation of being "the standard tube for standard sets." We can offer you the Visameter at the very low price of \$149.50 . . . but you do not have to buy one to enjoy the profits it will bring to you. The National Union plan makes it possible for every dealer to own this equipment without cost. Mail coupon today!



Aggressive radio merchants cannot afford to ignore the profit possibilities which tube testing offers. Here is the new Visameter offered to you by National Union . . . a tester so simple that your customers can test tubes for themselves. It has numerous remarkable, new features . . . a "noise test" for microphonic tubes . . . a special double dial, which gives a reading on both sides of the Type 280 or 81 at the same time . . . a device which shows exactly in what part of a tube a "short" may be. The Visameter is of the same high quality as National Union tubes—the quality which has won for them the

**NATIONAL UNION RADIO CORPORATION**  
**400 MADISON AVENUE · NEW YORK CITY**

Dear Sirs: Please tell me how I can have the VISAMETER now offered by National Union installed in my store.

NAME \_\_\_\_\_

ADDRESS \_\_\_\_\_

CITY \_\_\_\_\_ STATE \_\_\_\_\_ R. R. \_\_\_\_\_

# COUNTER TUBE TESTER

No. 406



**\$15.00** DEALER'S PRICE  
(60 Cycle)

## SOMETHING NEW

*A Simple A.C. Tester  
with only one button to press*

# Readrite

**ILLUMINATED DIAL**—easy to read.  
**REMOVABLE METER** in tip jacks.  
**RENEWABLE FUSE** attached to bottom of meter.

Tests all tubes, including rectifier (both plates) pentode, power and screen grid. Handy card—lacquer covered—shows reading of all tubes, no adapters, with removable cover, in a strong leatherette covered case. Rubber feet and leather corners.

A tester for new and old tubes you can always rely upon. Fully guaranteed. Get yours today at your jobbers. If not available remittance must accompany order for direct shipment.

## Readrite Meter Works

Established 1904

16 College Ave.

Bluffton, Ohio

# Do You WANT TO KNOW...

- the secrets of the chains and department stores?
- what the six selling seasons are and how to utilize them?
- how to determine quickly the salability of items as they are offered to you?
- what makes the best stores friendly, pleasant and interesting?
- how to price-line merchandise?
- the steps necessary to getting rid of all overstocks?

They are only a few of the important factors of retail profits that are laid before you in this important new book. Here is a book—with recommendations right in its pages from eleven nationally prominent men who *know retailing*—that takes the high-powered chain and department store methods apart, scales them down to *your* size, then shows you step-by-step how you can use these methods that have built the biggest retail successes of the country.



Just Published

## The 7 Keys to Retail Profits

by CLYDE BEDELL

Sales and Advertising Director, Butler Brothers, Chicago

450 pages, 6 x 9, illustrated, \$3.50

[Already in its third printing.]

**H**OW to avoid mistakes in buying—what to do with merchandise for your best advantage when it arrives in your store—advertising with bargains—keeping simplest possible track of transactions in order to force a profit and keep it coming—modern inventory as a source of money making—watching mark-downs as a source of profit—these are some of the things Bedell describes and shows you how to use in the Seven Keys to Retail Profits. There is not a page of theoretical suggestion in the entire book. It is the meat—the distilled step-by-step activity which is *producing profits today*—scaled down to fit the average store—dry goods, variety, drug, or specialty—*your* store.

*Each one of these men recommends this book in a signed foreword printed right in the book*

- Dr. Julius Klein
- Flint Garrison
- D. F. Kelly
- Amos Parrish
- Fred W. Shibley
- James L. Fri
- William Nelson Taft
- A. I. Boreman
- Emmet D. Borden
- Louis Wiley
- Kenneth Collins

"I believe that *The Seven Keys to Retail Profits* comprehensively explains the fundamentals of good business. It should be of considerable value to any retailer."

KENNETH COLLINS  
Vice-President, R. H. Macy & Co.

At least see this helpful, easy-to-understand book. Sent for free examination for ten days. Use the coupon below, pay for the book after you see how it can help you.

## McGraw-Hill FREE EXAMINATION COUPON

McGraw-Hill Book Company, Inc., 330 W. 42d St., New York City  
Send me a copy of Bedell's *The Seven Keys to Retail Profits*, \$3.50, postpaid, for 10 days' free examination. I agree to remit for the book or return it postpaid within 10 days of receipt.

Signed .....

Address .....

City and State .....

Official Position .....

Name of Company .....

(Books sent on approval to retail purchasers in the U. S. and Canada only.) R.R. 3-32



**POSITION WANTED**

WANTED: Position by experienced Radio-Frigidaire service man. Can assist with sales. References furnished. Salary very reasonable. G. A. Oyster, Sebring, Ohio.

**SALESMEN WANTED**

Brand New Opportunity For Salesmen With Cars Call on radio dealers, service men and jobbers. Popular low-priced specialty every service man needs and wants. Men now making \$25 to \$40 weekly as sideline. Write today. Give details and territory you can cover. SW-164, Radio Retailing, 330 West 42d St., New York.

**SALESMEN AVAILABLE**

SALESMAN, eight years' experience managing radio department, would like position with manufacturer on the road. SA-163, Radio Retailing, 520 No. Michigan Ave., Chicago, Ill.

**BUSINESS OPPORTUNITIES**

**Incorporate Liberal Delaware Laws**

Preparatory financing inventions, business. Secure organizers perpetual control. Reasonable. Booklet, forms free. Universal Charters Syndicate, Dover, Del.

**A Belgian Importer**

Who has 600 retailers wants to get in touch with manufacturers of chassis and radio sets of high grade. Preferably sets for short and long wave, for A.C. and for D.C. Highest references. Arnold Stern, 64 Rue De Locht (Place Liedts), Brussels, Belgium.

**FREE BULLETIN**

FEDERATED Purchaser, Inc., 25 Park Place, New York City. 68 page, 10" x 14" Radio Bargain News No. 11, illustrated and classified, containing complete sets, replacement parts, shop equipment, etc., etc.

**FOR RENT**

**STORE BASE & SUB-BASEMENT**

25x150. 81 Chamber St., N. Y. C. Formerly occupied by Victor Phonograph & Radio Store for about 29 years. Inquire.

**FRUCHT & SON**  
59 Reade St., N. Y. C.

**SPECIAL NOTICE:**

**To the Radio Industry**

Advertising in connection with legitimate offers of surplus stocks and discontinued models of radio merchandise is acceptable in this section of "Radio Retailing."

Extreme care will be exercised by the publishers to prevent the use of advertising in the Searchlight Section to encourage price cutting on current models of merchandise or equipment. Nor will advertising which invites violation of the dealer's contract with the manufacturer be acceptable.

All merchandise offered in the Searchlight Section must be accurately and fully described and must be available on order.

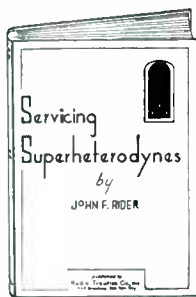

The Best Seller  
in Radio Books

**Servicing Superheterodynes**

By John F. Rider

Have you got your copy? The majority of modern receivers are superhets. These receivers require service. . . . Are you prepared to tackle superhet service problems? . . . 5000 of these books were sold in the first 40 days after the announcements. No service department or organization is complete without one of these books. . . . Get your copy today. . . . Price \$1.00 postpaid.

161 pages . . . type set . . . bound in canvas cover . . . size 7 3/8 x 5 1/4. Sold with a Money Back Guarantee.

**RADIO TREATISE CO., Inc.**  
1440 Broadway, New York City

**Electrical RECORDINGS**  
MADE TO ORDER

24 Hour Service, Finest Quality new metal alloy recordings; For Announcements; Public Address Sound Truck Advertising, Etc. Low cost, long life, light weight, unbreakable records; all sizes. Write for details. ROYAL RECORDING & FILM STUDIOS, Dep't R. 661 N. Michigan Ave., CHICAGO.

**BUYERS of SURPLUS MERCHANDISE**

Cash is always available for any desirable lot of surplus parts. Send sample quoting quantities.

We have immediate outlets for the merchandise and can therefore pay highest prices.

Clean out your stocks for the coming season without disturbing your present marketing plans.

Write, submitting samples, and we will show you how you can realize more.

"The Industry's Leading Surplus Specialists."

**Fulton Radio Corporation**

16 Hudson St.



New York, N. Y.

**RADIO DEALERS**

Bolster up your business with the sale of RE-NEWED vacuum cleaners and replacement parts. Free illustrated folder on request. Standard makes —\$5.00 and up. Armature rewinding, replacement parts, attachments. 24-hour service.

**RE-NEW SWEEPER COMPANY**  
2262 Gratiot Avenue, Detroit, Mich.

**NEW LOW PRICES**

**Rebuilt Vacuum Cleaners 1-Year Guarantee**

Premier . . . . .	\$6.00	Hamilton Beach	\$7.85
Bee-Vac . . . . .	6.00	Eureka . . . . .	9.25
Royal . . . . .	7.75	Airway . . . . .	11.00
Western Elec.	7.75	Premier Duplex	11.00
Universal . . . . .	7.75	Hoover . . . . .	11.50

Attachments—\$3.25, Hoover \$4.25 (Complete Set)

20% with order, balance C.O.D.

**Empire State Tube & Electric Co.**  
303 4th Ave., New York City

**For Sure, Quick Money, Sell Portable Sound-on-Film**



to Theatres, Schools, Churches, Clubs.

Write for manufacturers' prices on Soundheads, Photocells, Optical Systems, Rectifiers, Amplifiers, Horns, Faders, Synchronous Motors, Projectors, Lamphouses, Screens, Microphones, etc.

**S.O.S. CORP.**  
(Dept. R. R.)

1600 B'way, N.Y.C. Cable "Sosound"

**Leading German Manufacturer of Electric Fixed Condensers**

of outstanding quality, available for all voltages and for all purposes, wants suitable

**Agent**

who would operate on commission basis or for own account. Best connections with industrial and commercial circles in all trading centers required. Write in detail to

**LUDWIG BAUGATZ & CO., G.m.b.H.,**  
Kondensatorenfabrik,

Knesebeckstrasse 136/138, Berlin-Neukoelln  
(Germany)

**RADIO DEALERS RADIO SERVICEMEN**

**NEW Radio Handbook**

CONTAINING:

Technical Information.  
Volume Control Guide.  
Transformer and Condenser Guide.  
Radio Replacement Parts Catalog.

Sent postpaid anywhere for only  
**25 Cents**

Hard To Get Parts—We have them. Send us your repair work for estimate.

**Grant Radio Laboratories**  
6521-R South Halsted Street, Chicago, Ill.



**THIS IS A**  
*Profitable* **TUBE**  
 for **DEALERS and JOBBERS**

Every customer of yours who owns or operates any of the following sets, must use Kellogg 401 A.C. tubes for replacements:

KELLOGG Sets—510, 511, 512, 514, 515, 516, 517, 518, 519, 520, 521. McMILLAN Sets—26, 26PT. MOHAWK Sets, Sparton Sets—62, 63, A-C 7. DAY FAN Sets—5143, 5144, 5145, 5148, 5158. MARTI Sets—TA2, TA10, DC2, DC10, CS2, CS10, 1928 Table, 1928 Console. CLEARTONE Sets—110. And the first A.C. models of the following: Bell, Walbert, Wurlitzer, Pathe, Shamrock, Bush & Lane, Minerva, Crusader, Liberty, Metro, Supervoix and Case.

Get your share of business from this profitable market by stocking and displaying Kellogg tubes now. Write Dept. 59 for name and address of your nearest jobber.

**KELLOGG**  
 SWITCHBOARD AND SUPPLY COMPANY  
 1066 West Adams Street - - CHICAGO

**ALPHABETICAL INDEX TO ADVERTISEMENTS**

	Page
Mallory Co., P. R. ....	Front Cover
McGraw-Hill Book Co. ....	74
Morrill & Morill ....	70
▼ ▼ ▼	
National Carbon Co., Inc. Inside Front Cover	
National Union Radio Co. ....	73
Norge Corporation ....	5
Northwest Specialty Service Co. ....	72
Onan & Sons, D. W. ....	70
Pierce-Airo, Inc. ....	72
Pilot Radio & Tube Corp. ....	8
RCA Radiotron Co., Inc. Back Cover	
RCA Victor Co., Inc. ....	71
Readrite Meter Works ....	74
Revere Clock Co. ....	59
Servel Sales, Inc. ....	10
Sparks-Withington Co. ....	11, 12
Stewart-Warner Corp. ....	7
Stromberg-Carlson Tel. Mfg. Co. ....	2
Trupar Mfg. Co. ....	68
Tung-Sol Radio Tubes, Inc. ....	60
United American Boshel Corp. 16, 56-57	
Warren Telechron Co. ....	59
Westinghouse Elec. & Mfg. Co. ....	9
Weston Elec. Instr. Co. ....	64
Williams Oil-o-matic Htg. Corp. ....	63
Zenith Radio Corp. ....	66
Zerozone ....	67
Adler Mfg. Co. ....	4
American Weekly ....	53
Areturus Radio Tube Co. ....	3
Atwater Kent Mfg. Co. ....	52
Audiola Radio Co. ....	69
Barr-Thorp Elec. Co. ....	76
Central Radio Lab. ....	6
Cornish Wire Co. ....	70
Crosley Radio Corp. Inside Back Cover	
Deleo Appliance Corp. ....	55
Electrical Research Lab. ....	72
Emerson Elec. Mfg. Co. ....	61
Fulton Bag & Cotton Mills ....	70
Galvin Mfg. Corp. ....	62
General Elec. Co. ....	15, 50
General Industries Co. ....	72
Graybar Elec. Co. ....	65
Grigsby-Grunow Co. ....	14

**SEARCHLIGHT SECTION**

*Classified Advertising*

Hygrade-Sylvania Corp. ....	13	AGENTS WANTED ....	75
Janette Mfg. Co. ....	70	BOOKS ....	75
Jewell Elec. Instr. Co. ....	51	BUSINESS OPPORTUNITIES ..	75
Kellogg Switchboard & Supply Co. ....	76	ELECTRICAL RECORDINGS ..	75
Kelvinator Corporation ....	54	EMPLOYMENT ....	75
Leonard Refrigerator Co. ....	58	RADIO STOCKS	
Lynch Mfg. Co. ....	70	Empire State Tube & Electric Co. ....	75
		Fulton Radio Corp. ....	75
		Grant Radio Laboratories ..	75
		Re-New Sweeper Co. ....	75
		Royal Recording Film Studios	75
		S.O.S. Corp. ....	75

This index is published as a convenience to the reader. Every care is taken to make it accurate, but *Radio Retailing* assumes no responsibility for errors or omissions.

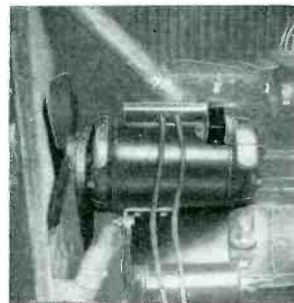

**ALTERNATING  
 CURRENT CAR  
 GENERATOR**  
 FOR SOUND  
 EQUIPPED CARS  
 OR TRUCKS

PATENTS PENDING  
 put 3 amps. at 115 volts—Lowest operating cost—Continuous power available—Dependable—Built for years of service.  
 A-C Cargen Generator Model S.E. 1A. List \$195.00.  
 Mfgd. by BARR-THORP ELEC. CO., 509 E. 16th St., Kansas City, Mo.



# The Public Approves These Sensational Low-Priced **CROSLEY** **SUPERHETERODYNES**

## The Crosley **LITFELLA**



**\$ 36<sup>36</sup><sub>-</sub>**  
COMPLETE WITH 5 TUBES  
AND TENNABOARD

The tremendous success and extreme popularity of this sensational table model radio receiver is proof of its unusual value. The front panel is of beautiful figured walnut veneer. The arch of Oriental veneer is supported at the sides with delicately fluted pilasters. The five tube superheterodyne chassis incorporates pentode output, variable mu, continuous (stepless) tone and static control and on-off switch, volume control, illuminated hairline shadow dial with vernier drive. The speaker is the full floating moving coil dynamic type. The price of this radio marvel is extraordinarily low. Dimensions: 17" high, 13" wide, 8 1/2" deep. The same chassis is contained in The **BIGFELLA**, a console, for \$18.48, and The **PLAY-TIME, Jr.**, grandfather clock model, for \$79.75.

## The Crosley **PLAYBOY**

The recessed front panel of this unusual radio receiver is of figured walnut veneer finished in two-tone effect and high-lighted. A pierced overlay extends from the base of each pilaster; above the overlay the pilasters are coved and finished in black. The front panel arch is of burl maple overlay. The 8-tube superheterodyne chassis incorporates push-pull pentode output, variable mu, continuous (stepless) tone and static control, illuminated hairline shadow dial with vernier drive. Full floating moving coil dynamic speaker is used. Dimensions: 17 1/2" high, 16" wide, 9 7/8" deep. The same chassis is contained in console models and a grandfather clock model with dual speakers, at sensationally low prices—all under \$100. See your Crosley Distributor for details.

**\$ 49<sup>75</sup><sub>-</sub>**  
COMPLETE WITH 8 TUBES  
AND TENNABOARD



## The Crosley **TYNAMITE**

The gem of all radio receivers! The attractive cabinet is of fine selected woods carefully finished and high-lighted. The 4-tube superheterodyne chassis incorporates pentode output, variable mu, image suppression pre-selector, combined volume control and on-off switch, illuminated station selector. Full floating moving coil dynamic speaker is used. Here are big set features at a remarkably low price. Dimensions: 13 1/2" high, 9 3/4" wide, 7 1/2" deep. The same chassis is housed in a lowboy console model, The **BONNIBOY**, selling for \$39.75.

**\$ 29<sup>75</sup><sub>-</sub>**  
COMPLETE WITH 4 TUBES

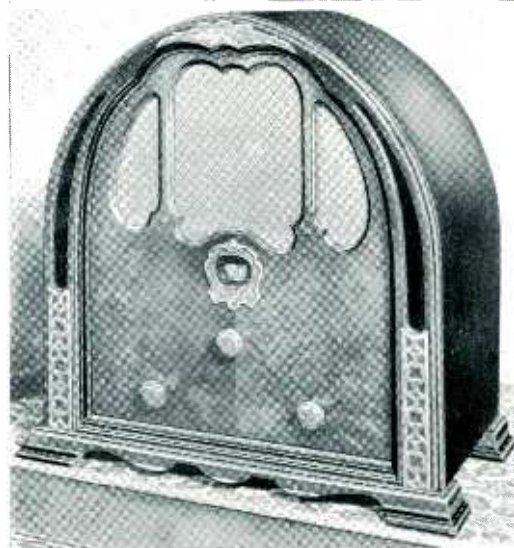

### Crosley 10-tube Superheterodyne with Automatic Volume Control and Meter Tuning

The Crosley **TENSTRIKE**, a table model at \$69.50 and The Crosley **HAPPY HOUR**, a console at \$99.50 (with dual speakers \$109.50) incorporate a 10-tube superheterodyne chassis, Automatic Volume Control, Meter Tuning and other recent radio refinements.

Montana, Wyoming, Colorado, New Mexico and west, prices slightly higher.

### Combined **SHORT** and **LONG** Wave Receivers

The 7-tube Crosley **DISCOVERER** at \$77.50 and the 12-tube Crosley **ADVENTURER** at \$119.50 are the most up-to-date radio receivers. Every channel from 14 to 550 meters is covered. These Superheterodynes are housed in beautiful cabinets, and are priced amazingly low.

## THE CROSLEY RADIO CORPORATION

Powel Crosley, Jr., President

CINCINNATI

Home of "the Nation's Station"—WLW

Also manufacturers of the Crosley **ROAMIO** Automobile and Motor Boat Radio Receiving Set and Crosley Battery Radio Receivers

YOU'RE THERE WITH A CROSLEY  
**CROSLEY RADIO**

X



**"In Two Months  
My Monthly Tube  
Sales Jumped from  
\$188.45 to \$400.00**

*— the Radiotron  
Star Merchandiser and  
tube testing did it! "*

says

*Benjamin Kemper  
Apex Radio  
Brooklyn, New York*

Mr. Kemper is a progressive dealer who is always on the lookout for new ways to increase his tube business. He is a confirmed user of Radiotron sales aids. The Star Merchandiser struck him just right.

In August, his tube sales were \$160.15; in September, \$188.45. He installed the Merchandiser on October 1, and in that month raised the figure to \$210.00. Then, in November, his sales jumped to \$400.00!



At this writing, Mr. Kemper is concentrating on the sale of complete renewals and is finding the Merchandiser of immeasurable assistance. Never content to stand still, this dealer is confident of increasing his sales by an even greater margin in the months to come.

Any capable merchant can bring about a similar development in his Radiotron business by using the sales-building plans and material that we make available.

RCA RADIOTRON COMPANY, INC., HARRISON, NEW JERSEY

*A Radio Corporation of America Subsidiary*

# RCA Radiotrons

THE HEART OF YOUR RADIO