

RADIO RETAILING

HOME ENTERTAINMENT MERCHANDISING

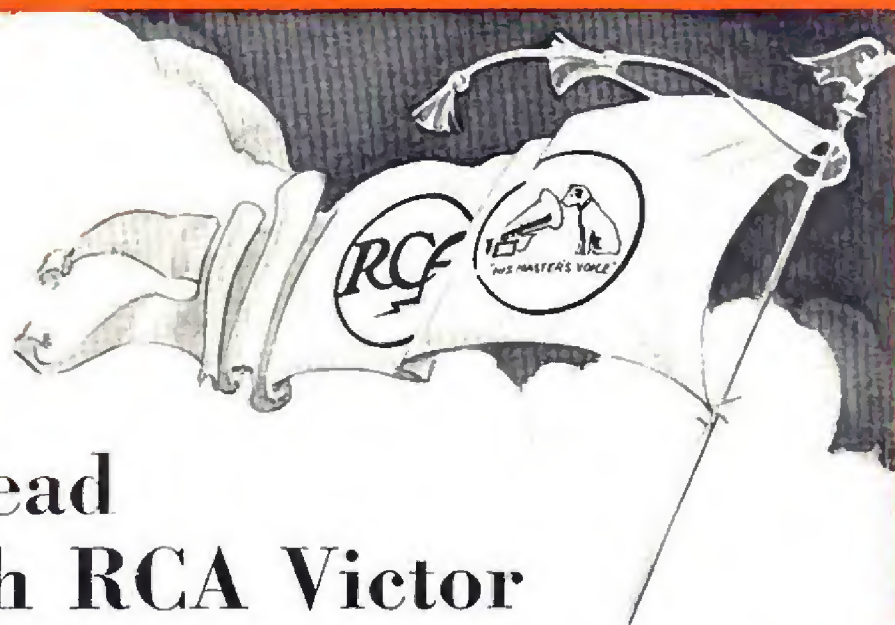

Look ahead with RCA Victor

A leader in 1922 . . .
"RADIO HEADQUARTERS"
 Leads again in 1932 . . . toward
 better business . . . a sounder founda-
 tion for retailers . . . profits
 worth working for!

1931 IS PAST. What of 1932? RCA Victor stands on the solid foundation of Victor's 30 years and RCA's 12 years in the business of providing entertainment in the home.

With a line crystallized and established—a line built on quality with price . . . With two great names, two great records, linked in one

common bond of leadership through the years.

And with new things—great things—daring things in store for the coming 12 months!

Dealers who realize that the present situation is a passing phase—dealers who are building a business, not operating a one-night stand—will march with RCA Victor in 1932.

If you want a soundly founded business—if you want an established place as a merchant—if you want steadier income for a more solid business—keep in touch with your RCA Victor distributor. Watch RCA Victor in 1932.

RCA Victor Company, Inc., "RADIO HEADQUARTERS," Camden, N. J. *A Radio Corporation of America subsidiary.*

"BUILD FOR THE FUTURE WITH RCA VICTOR"



RCA Victor

"RADIO HEADQUARTERS"

Radios . . . Phonograph Combinations . . . Victor Records

An announcement of tremendous importance to the radio music industry

● **BRUNSWICK** *announces*

that its laboratories have been concentrating for a long time on the development of new instrumentalities—instrumentalities that will be unique—that will interest the buying public—that will command and justify higher unit prices to the consumer—that will permit the dealer to sell “up” not “down”.

● **BRUNSWICK** *anticipates*

the opportunity to publicly announce, within three or four months, the final perfection of these new instrumentalities, whose introduction will have far-reaching consequences in the trade.

● **BRUNSWICK** *is confident*

that these new instrumentalities will materially broaden profit opportunities and promote higher standards of merchandising in the Radio Music Industry—and that their sale can be profitably harmonized with currently-known radio products.

● **BRUNSWICK** *thanks*

its dealers for service and loyalty that transcends ordinary business ethics—and assures them that they will have the first opportunity to profit by the new instrumentalities developed in our laboratories.

BRUNSWICK RADIO CORPORATION

DIVISION OF WARNER BROTHERS PICTURES, INC.

120 WEST 42nd STREET, NEW YORK, N. Y.

RADIO RETAILING

HOME ENTERTAINMENT MERCHANDISING

Vol. 14

No. 6

Contents for December, 1931

Copyright, 1931, by McGraw-Hill Publishing Company, Inc.

| | |
|---|----|
| <i>The Dealer Carries On</i> An editorial by Ray V. Sutcliffe | 17 |
| <i>Radio Is Cheaper</i> by W. W. MacDonald | 18 |
| <i>Concealed Radio</i> A Pictorial | 21 |
| <i>Crutches No Handicap</i> by Fred Even | 22 |
| <i>Detroit Sells Radio—Not Price</i> | 24 |
| <i>Census Shows 15,800,000 Sets in Use</i> | 26 |
| <i>He Knows the Combination</i> | 27 |
| <i>A Day with a Refrigerator Salesman</i> A Pictorial | 28 |
| <i>Wise Spenders</i> | 30 |
| <i>You Can Sell "Electric Eyes"</i> by O. H. Caldwell | 32 |
| <i>Editorials</i> | 34 |
| <i>Dealer Fights Back</i> | |
| <i>Tube Replacement Policy</i> | |
| <i>Long Playing Record</i> | |
| <i>They Buy the Best in Alaska</i> | |
| by Howard C. Pyle | 36 |
| <i>Louder and Funnier</i> by J. M. Kuhlík | 38 |
| <i>Metered Refrigeration</i> | 39 |
| <i>Shortwave Converters</i> by Lewis Winner | 40 |
| <i>Service Shortcuts</i> | 43 |
| <i>News of the Month</i> | 44 |
| <i>New Merchandise</i> | 48 |

O. H. CALDWELL,
Editor

RAY V. SUTLIFFE
Managing Editor

W. W. MACDONALD
Technical Editor

T. H. PURINTON
Assistant Editor

HARRY PHILLIPS
Art Director

P. WOOTON
Washington

M. E. HERRING
Publishing Director

The Theatre of the Home

BECAUSE *Radio Retailing* believes that the day is not far distant when many varied forms of entertainment will find expression in the home, through further developments of the electronic arts, it carries on its front cover these words: "Home Entertainment Merchandising."

This publication does not stand alone in this broad viewpoint. A majority of the leading radio technicians of the country agree with us. The latest of these to express this opinion, which is full of promise for the radio dealer, is W. R. G. Baker, vice-president of the RCA-Victor Company. Mr. Baker visions the outlook as follows:

"The day is in sight, when every new home costing \$10,000 or more will have a room fitted up exclusively for radio-electrical entertainment. The "Home Theatre" will become another American institution. Television and home talkies will share with a radio news bulletin and talking books, that read themselves aloud.

"Just as the 'Home Theatre' will not interfere with the public theatre, the radio bulletin will merely supplement the newspaper, by flashing spot news dispatches and photographs to the home. The vast engineering and manufacturing facilities that have made possible the present-day radio sets and phonographs, will bring forth new marvels that may change the whole trend of future life."

Dr. Parmelee Advanced

DR. H. C. PARMELEE, editorial director of the McGraw-Hill Publishing Co., Inc., has been made a vice-president of the company.

Dr. Parmelee brings to his new executive position a background that covers the presidency of the Colorado School of Mines and some twenty years' experience in important editorial capacities in the McGraw-Hill organization, including the editorship of *Chemical and Metallurgical Engineering*

McGraw-Hill Publishing Company, Inc.

330 West 42d STREET, NEW YORK, N. Y.

CABLE ADDRESS:
"MAGNIBIST, N. Y."

CHICAGO - - 520 North Michigan Avenue
SAN FRANCISCO - - 883 Mission Street
LONDON, W. C. 2 - Aldwych House, Aldwych

WASHINGTON - - - - National Press Building
PHILADELPHIA - - - - - 1600 Arch Street
CLEVELAND - - - - - 501 Guardian Building
DETROIT - - - - - 2-257 General Motors Building
ST. LOUIS - - - - - 1558 Bell Telephone Building
BOSTON - - - - - 1427 Statler Building
GREENVILLE, S. C. - - - 1301 Woodside Building
LOS ANGELES - 330 Chamber of Commerce Building

JAMES H. MCGRAW - - - - Chairman of the Board
MALCOLM MUIR - - - - - President
JAMES H. MCGRAW, JR. - - - Vice-Pres. and Treas.
MARION BRITTON - - - - - Vice-President
EDGAR KOBAK - - - - - Vice-President
H. C. PARMELEE - Vice-Pres. and Editorial Director
HAROLD W. MCGRAW - - - - Vice-President
C. H. THOMPSON - - - - - Secretary



IS YOUR Sales Cost HIGHER THAN YOUR "Mark-up"?

THE average cost of selling a radio set has stayed way up compared with the "mark-up" on an average priced radio set. If you doubt that statement just divide your cost of doing business last year by the number of sets you sold and get a surprise.

Suppose the average cost of making a sale and delivery is \$35 per set (in addition you have the trade-in problem). Assume you average 40% gross profit on the sale—what does that leave you when your average sale drops even to \$125?

You are sure of a profit on Stromberg-Carlson sales, because the lowest priced Stromberg-Carlson radio is \$175.

Dealers have discovered, too, that practically every radio prospect believes: "There Is Nothing Finer Than a Stromberg-Carlson."

Distinctive Stromberg-Carlson Consoles from \$175 to \$375. The Multi-Record Radio, (automatic radio-phonograph combination, electrical), \$660. (Time prices, complete with tubes, East of Rockies.)

STROMBERG-CARLSON TELEPHONE
MANUFACTURING CO.,
ROCHESTER, N. Y.

No. 19 Superheterodyne
(illustrated). Mahogany
finish.

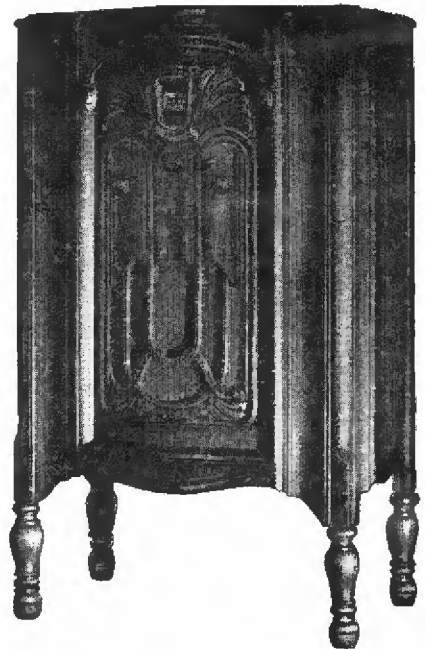

1894

Stromberg-Carlson

MAKERS OF VOICE TRANSMISSION AND VOICE RECEPTION APPARATUS FOR MORE THAN THIRTY-FIVE YEARS



1931

THE HAWLEY HALL OF FAME

These famous radio set and speaker manufacturers equip their speakers with Hawley Moulded Diaphragms

- | | | |
|------------------------------------|-----------------------|--------------------------------|
| Magnavox | Jensen | Majestic |
| Utah | Rola | Stromberg-Carlson |
| Stewart-Warner | American Bosch | Crosley |
| Operadio | Trans. Corp. of Am. | Melber (Germany) |
| De Forest Radio Corp. of Canada | P. Smith Stamping | Sachenwerk (Germany) |
| Lansing | Oxford Radio Products | Feldman (Germany) |
| Colonial | Best | Neufeldt & Kuhnke (Germany) |
| Northern Engraving | Angsten | Platon Texido (Spain) |
| | Quam-Nichols Co. | |

Such Overwhelming Preference *must be deserved!*



Accurate determination of magnetic and voice coil constants is a preliminary step toward improving speaker design.

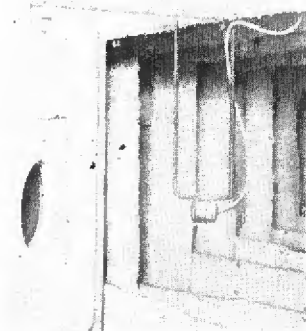

Elaborate sound chambers are part of the Hawley laboratory equipment for obtaining accurate response curves on all types of diaphragms.

Is there a more convincing testimonial of manufacturing success in the radio and sound equipment industry than the Hawley "Hall of Fame"?

Such overwhelming preference for the Hawley Moulded Diaphragm must be deserved. The reason is found in the unparalleled perfection of the Hawley Diaphragm. Being moulded in one piece from mounting flange to apex, it achieves a new standard of performance which can never be equalled by the ordinary "pasted-up" diaphragm. The Hawley Process, plus Hawley Acoustical Engineering, is making an outstanding contribution to the production of better sound equipment.

Radio sets and speakers are easier to sell when equipped with Hawley Moulded Diaphragms because these diaphragms are engineered to fit the individual needs of each type of speaker unit. The famous radio set and speaker manufacturers, listed above, have standardized on Hawley Diaphragms to make sales easier and quicker for you. Capitalize the advantages of Hawley Moulded Diaphragms when you make your next demonstration.

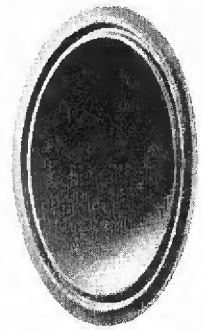

Hawley diaphragms are moulded in one piece from mounting ring to voice coil support. There are no strains in the diaphragm to cause distortion.



Hawley Diaphragms are made to any size or specification. Careful production tests assure perfect tone quality.

HAWLEY

MOULDED  DIAPHRAGMS

PRODUCTS AND PROCESSES FULLY COVERED BY PATENTS AND APPLICATIONS

HAWLEY PRODUCTS COMPANY, 205 N. FIRST AVENUE, ST. CHARLES, ILLINOIS

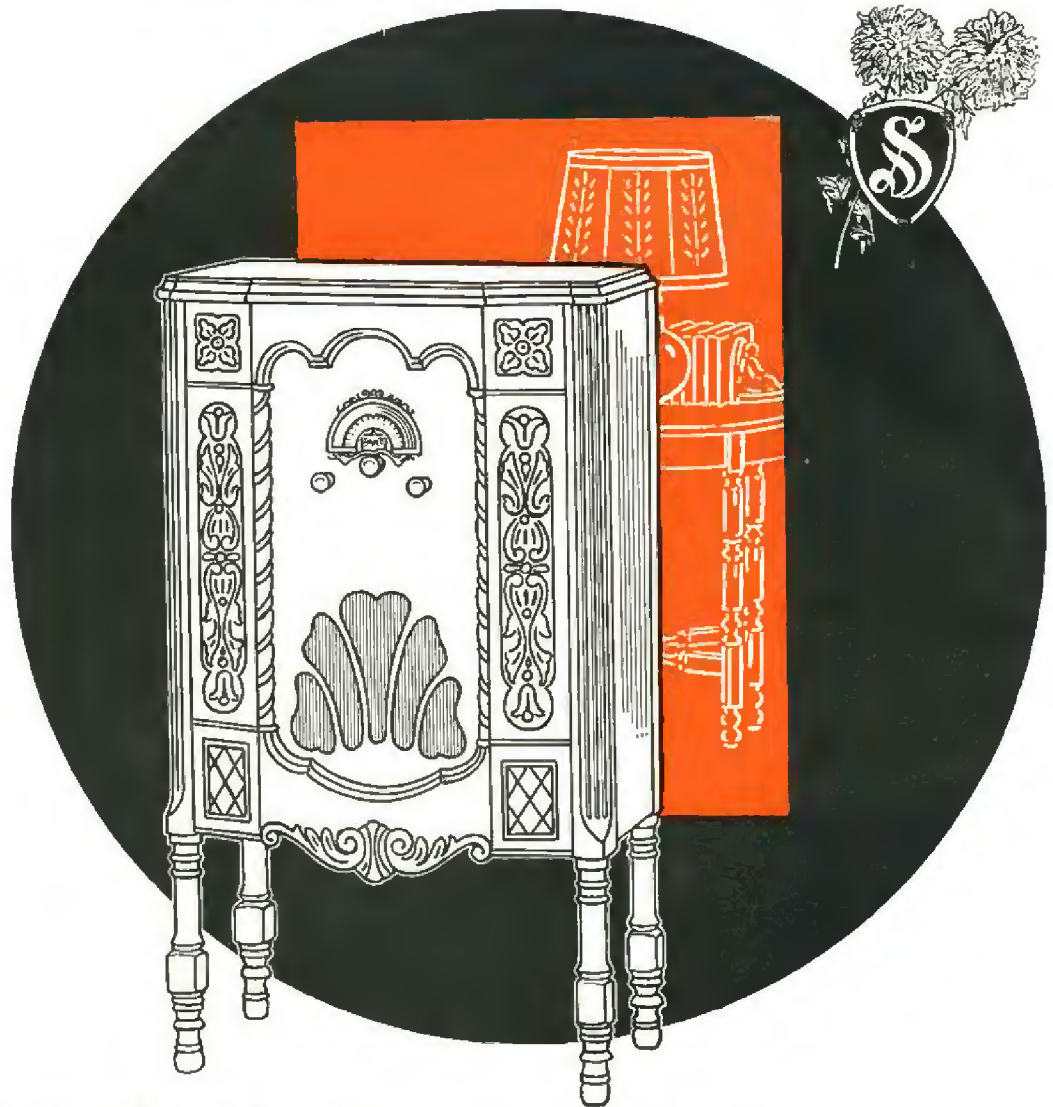

Sparton dealers

WELCOME the value-seeker

The type of purchaser who demands *value* is invariably impressed with Sparton.

Sparton believes that the biggest help we can give Sparton dealers—at this or any other time—is to build the kind of product that attracts precisely this type of buyer.

To satisfy yourself as to what has been accomplished, communicate with the Sparton distributor in your district.

On the score of value—no less than on the score of tone, performance and outward charm—the new Spartons deserve your attention.

THE SPARKS-WITHINGTON COMPANY, JACKSON, MICHIGAN, U. S. A.
{Established 1900} (748)

Only Sparton has the Musical Beauty of Sparton

SPARTON RADIO

"Radio's Richest Voice"

Would you like to receive a copy? Write to The American Weekly, 959 Eighth Ave., at 57th Street, New York City.



When a retailer features merchandise advertised in THE AMERICAN WEEKLY it is a tie-up bound to increase sales, for THE AMERICAN WEEKLY reaches 5,500,000 families — nearly twice as many as reached by any other magazine

... (text partially obscured)

... (text partially obscured)

Continued on Page 18

CHARLES DERRINGER

Men, give yourselves real profits for CHRISTMAS!

If you want to make a sweet Christmas profit, start a drive on G-E Radio right now. It's the one radio that's gone out and *proved* its better tone—proved it by overwhelming other sets in conclusive

tone-tests! A complete, beautiful line, with a man-sized profit from every model. Get your window displays up now. Push G-E Radio for the fattest holiday profits!

A supremely beautiful, unusual gift!

LONGFELLOW GRANDFATHER CLOCK-RADIO

\$285
WITH
TUBES

An authentic colonial grandfather clock, with solid mahogany case and G-E electric clock. Concealed radio is a 10-tube, screen grid superheterodyne, using 2 Pentode output tubes. Automatic volume control. Tone control. G-E also makes a slightly smaller Grandfather Clock-Radio, the Georgian, which sells for \$179, with tubes.

The ideal gift for the
girl or boy away at college!

G-E JUNIOR

\$72⁵⁰ WITH
TUBES

Great value! 8-tube, screen grid superheterodyne. 2 Pentode tubes. 8" dynamic speaker. New tone control. Compact. *Portable!* Eighteenth Century brown walnut cabinet, of mantel clock design.



PUSH also the brilliant, new General Electric Junior Lowboy at \$89.95, the fast-selling Popular Console at \$124.75 and the superb DeLuxe

Lowboy at \$164.50—gifts for the whole family; and the Radio-Phonograph Combination, at \$345, the supreme gift for music-lovers.

GENERAL ELECTRIC RADIO

FULL RANGE PERFORMANCE

**ESCAPE
THIS ?
*never!***



EVERY ARCTURUS TUBE
must pass 137 TESTS and CHECKS

Reductions in prices or revisions in methods cannot . . . will not . . . interfere with Arcturus' rigid standards of giving each blue tube 137 tests and checks before it leaves the factory. The quality of Arcturus Blue tubes, recognized by critical engineers of leading set manufacturers, jobbers, dealers, consumers . . . and even conceded by other tube manufacturers . . . will not be sacrificed for any reason!

Not an Arcturus Tube escapes these 137 tests and checks. All raw materials, each operation, every part . . . each tube is in-terminably "third-degreed."

Each Arcturus Tube must meet the rigid Arcturus limits, closer than those of any

other manufacturer; it must check for the highest degree of vacuum practically obtainable, precise characteristics, humless and undistorted reproduction in actual receivers, gruelling life tests, continuously checked and re-checked. Then, and only then, is the tube ready.

Arcturus Blue Tubes, jealously guarding an established reputation for quality, reliably back-up the reputation of your store. You can depend on them to satisfy your customers, to make the sets you sell stay sold and to create a "blue" tube repeat business for your store. Get the details of these most profitable, fastest selling blue tubes from your jobber, or write us.



ARCTURUS RADIO TUBE CO., Newark, N. J.

ARCTURUS

The BLUE TUBE with the LIFE-LIKE TONE

For
Christmas

**A LOW-PRICED GIFT
 PACKAGE THAT EVERY
 RADIO DEALER CAN SELL...**

A TESTED product, a novel gift, an arresting display . . . that's the Sylvania Christmas Emurgency Kit. No dealer can afford to neglect it and no customer will be able to pass it by.

WHAT IT IS

The Sylvania Emurgency Kit contains tubes to fit each socket in more than 300 different radio sets. Through the medium of Saturday Evening Post and newspaper advertising, and through radio broadcasting, these Kits are being sold to millions of consumers. Christmas gives them a new value. People are grateful to receive them, doubly grateful when the time comes to replace a worn-out tube and save an evening's entertain-

ment. This Christmas Kit is one of the few radio gifts within the reach of every pocketbook—and every set-owner is a good prospect, too.

WHAT THE DEALER GETS

The Christmas Emurgency Kit—four tested tubes in a sturdy box, with Christmas wrapping in color—costs no more than the tubes alone. Handsome Christmas window streamers attract the eye and sell the product. Special counter circulars, newspaper mats, and window display ideas are also at every dealer's disposal.

HOW TO ORDER

Order NOW through your Sylvania Jobber . . . or send order blank direct.



**CUSTOMERS BUY WHERE
 THEY SEE THIS SIGN**

Sylvania
REGISTERED U.S. PAT. OFF.
THE SET-TESTED TUBE



Handsome Christmas wrapping can be slipped off and discarded at end of season.

Put this Sylvania Christmas Streamer in your store window. It stops people and makes them buy. Full color, 36 inches long. Free.

A CHRISTMAS GIFT

DIFFERENT · SENSIBLE · INEXPENSIVE

Recalling the thoughtfulness of the giver four times during the year

Sylvania

EMURGENCY KIT

The Universal Gift Package for Family and Friends

In a Christmas Package

containing one each of the 4 types of tubes in your set for an Emergency Replacement



HYGRADE SYLVANIA CORPORATION, INC., Dept. R-12-1
Sylvania Division, Emporium, Penna.

Please have the following Sylvania Emurgency Kits supplied to me through your local jobber.

- No. 1 Kits at \$4.70 each
(Contains 1-SY 224; 1-SY 227; 1-SX 245; 1-SX 280)
- No. 2 Kits at \$3.70 each
(Contains 1-SY 227; 1-SX 280; 1-SX 226; 1-SX 171A)
- No. 3 Kits at \$4.10 each
(Contains 1-SY 227; 1-SY 227; 1-SX 245; 1-SX 280)
- No. 4 Kits at \$5.30 each
(Contains 1-SY 224; 1-SY 224; 1-SX 245; 1-SX 280)
- No. 5 Kits at \$3.90 each
(Contains 1-SY 227; 1-SY 227; 1-SX 280; 1-SX 171A)
- No. 6 Kits at \$4.50 each
(Contains 1-SY 224; 1-SY 227; 1-SX 280; 1-SX 171A)
- No. 7 Kits at \$5.75 each
(Contains 1-SY 224; 1-SY 224; 1-SY 247; 1-SX 280)
- No. 8 Kits at \$7.80 each
(Contains 1-SX 232; 1-SX 232; 1-SX 231; 1-SX 230)

SYLVANIA EMURGENCY KITS fit all makes and models of radio sets including Atwater Kent, Audiola, Bosch, Brunswick, Clarion, Colonial, Columbia, Crosley, Edison, Eral, Fada, General Electric, General Motors, Gloritone, Graybar, Grebe, Gulbrandsen, Howard, Kennedy, Lyric, Majestic, Philco, Radiola, Radiotone, RCA Victor, Silver Marshall, Simplex, Steinite, Sterling, Stewart Warner, Story & Clark, Stromberg Carlson, U. S. Apex, Victor, Westinghouse, Zaney Gill, Zenith.

Jobber's Name _____

Your Name _____

Address _____

City _____ State _____

USE THIS ORDER BLANK NOW

Champion Grouping

VERSUS

“bunking”

Results coming fast to those who have joined the *debunking* parade.



Champion
Group Prices
RADIO TUBES

YOUR
KEY TO
PROFITS

OCTOBER 24, 1931 SCHEDULE

| | | | | | |
|------------------|--------|------------------|--------|------------------|--------|
| 50c | | \$1.00 | | 75c | |
| GROUP LIST PRICE | | GROUP LIST PRICE | | GROUP LIST PRICE | |
| 171A | \$.50 | 224A | \$1.00 | 112A | \$.75 |
| 201A | .50 | 235 | 1.00 | 227 | .75 |
| 226 | .50 | 247 | 1.00 | 245 | .75 |
| | | V199 | 1.00 | 280 | .75 |
| | | X199 | 1.00 | | |
| \$1.50 | | | | \$3.00 | |
| GROUP LIST PRICE | | | | GROUP LIST PRICE | |
| 233 | \$1.50 | 230 | 1.00 | 210 | \$3.00 |
| 236 | 1.50 | 231 | 1.00 | 250 | 3.00 |
| 238 | 1.50 | 232 | 1.00 | 281 | 3.00 |
| | | 237 | 1.00 | | |

Champion
Group
List-price
Chart.
Oct. 24, 1931
Schedule.

CHAMPION NEVER CONCEALS THE TUBE IN THE BOX
CHAMPION WILL NEVER CONFUSE THE PRICE
CHAMPION RADIO WORKS, DANVERS, MASSACHUSETTS

CHAMPION RADIO WORKS

DanVers, Mass.

Licensed under patents and applications of R. C. A., Hazeltine, La Tour, Lowell & Dunmore, and Buonton Research Corporation.

Majestic

Superheterodyne RADIO

offers you TEN great models from which to choose



CHELTENWOOD

Majestic dealers can carry the entire line to satisfy every possible whim and budget of their prospects or can put on their floors an assortment of cabinets which, from experience, they know will "go" well in their neighborhoods.

Every Majestic is a superheterodyne . . . every model incorporates Multi-Mu and Pentode tubes. The Majestic dealer, however, has the additional exclusive advantage of Spray-Shield tubes, Twin Power Detection and the "Modulated" superheterodyne circuit. These are features which Majestic gathered and perfected from all over the world.

You do not have to explain who the manufacturer is . . . you do not have to "talk up" the quality. Over 3,000,000 Majestic sets have made the name and performance known the world over. It will pay to have a talk with the Majestic distributor.



HAVENWOOD



SHERWOOD

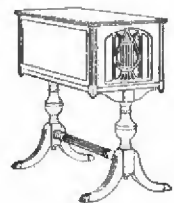

FYFEWOOD

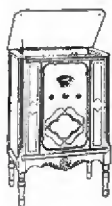

CASTLEWOOD

GRIGSBY-GRUNOW COMPANY, CHICAGO, ILL.
World's Largest Manufacturers of **COMPLETE** Radio Receivers



BRUCEWOOD

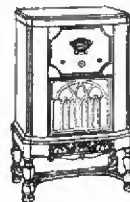

BRENTWOOD

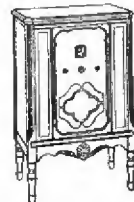

ELLSWOOD



COLLINGWOOD

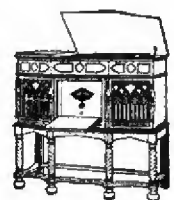

ABBEYWOOD

Majestic Electric Refrigerator

Perfectly balancing the seasonal sales of radio is the now famous Majestic Refrigerator . . . Mighty Monarch of the Arctic. A quality product . . . priced right . . . it took

hold with the public as have few products in recent years. It is made in the three most popular sizes . . . is exceptionally attractive in appearance . . . and carries a 3-year guarantee.

Echophone produces a new sales **WINNER**



Above is our new model Low Boy Console No. 65, Superheterodyne, seven tubes including Pentode and three Variable-Mu, Jensen Dynamic Speaker, Full Vision Dial, Tone Control, Phonograph Jacks, Full Walnut Veneer Cabinet, 36½ in. high, 19½ in. wide, 12½ in. deep.

\$63.75 complete

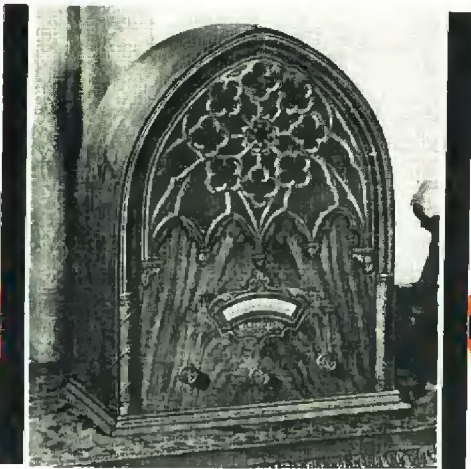

Model "60" Superheterodyne, Seven tubes including Pentode and three Variable-Mu, Jensen Dynamic Speaker, Full Vision Dial, Tone Control, Phonograph Jacks, Walnut Cabinet—6 inches deep. **\$53.75** complete

MODEL 65

Now successfully meeting the increasing demand for a popular priced

LOW BOY CONSOLE

■ Echophone is primarily interested in seeing that its distributors and dealers make money and that Echophone too realizes a fair profit on its high quality and sound merchandising. Excessive production that demands "high-pressure" factory selling and consequently over-stocked dealers is not a part of the Echophone policy.

In Model 65 we strengthen your position and give you a sure opportunity to profit through a real market for a Low Boy Console. Here again it's the famous Echophone quality translated into today's big merchandising need. The complete Echophone line is well balanced, highly attractive, reasonably priced, and represents the finest we have yet produced.

■ Other Echophone models are:

Echoette Model "40" four tubes including Pentode and Variable-Mu.

\$32.75 complete

Model "70" direct current Superheterodyne 7 tubes.

\$59.50 complete

Model "80" Superheterodyne, eight tubes including 2 Pentodes Push Pull and 3 Variable-Mu.

\$69.50 complete

Model "90" Superheterodyne, eight tubes including 2 Pentodes Push-Pull and 4 Variable-Mu.

\$89.50 complete

Investigate NOW! Action on your part will result in some profitable business for you. Get in touch with our nearest distributor or write us direct.

ECHOPHONE RADIO MFG. CO., LTD.

Executive Offices and Factory
WAUKEGAN, ILLINOIS

Export Division—Echophone Company Export
44 Whitehall St. New York, N. Y.



This
EXACT
MARKET
Buys Only
KELLOGG
TUBES



EVERY customer of yours who owns and operates any of the following sets, must buy Kellogg 401 A. C. Tubes for replacements.

KELLOGG Sets—510, 511, 512, 514, 515, 516, 517, 518, 519, 520, 521. McMILLAN Sets—26, 26PT. MOHAWK Sets, SPARTON Sets—62, 63, A-C7. DAY FAN sets—5143, 5144, 5145, 5148, 5158. MARTI Sets—TA2, TA10, DC2, DC10, CS2, CS10, 1928 Table, 1928 Console. CLEARSTONE Sets—110. And the first A.C. models of the following: Bell, Walbert, Wurlitzer, Pathe, Shamrock, Bush & Lane, Minerva, Crusader, Liberty, Metro, Supervox, and Case.

The manufacturers specifically designed these sets to use, and originally equipped them with Kellogg 401 A.C. Tubes. In your own locality there are many prospects for 401 tube business — set owners who can use no other tubes.

The market is already established for you, — profits per sale are large. Price levels are maintained — always. Here is an opportunity that you cannot afford to miss. Get your share of this business by supplying the demand in your locality. Stock and display Kellogg tubes now. Write department 58 for the name and address of your nearest Kellogg jobber.



KELLOGG

SWITCHBOARD AND SUPPLY COMPANY
 1066 W. ADAMS ST. CHICAGO, ILL.

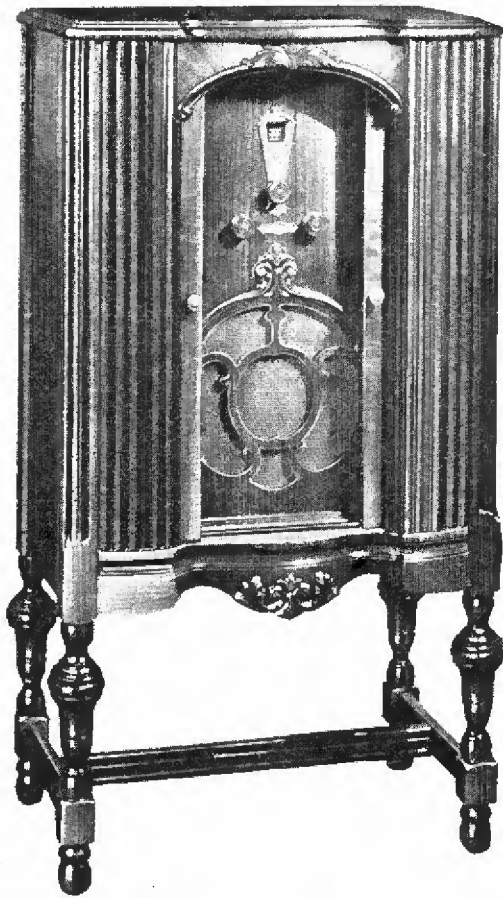

A
NEW
 OPPORTUNITY
to DOMINATE
the field

MODEL 31-G SUPERHETERODYNE WITH SLIDING DOORS \$87.50 COMPLETE WITH TUBES

AMERICAN BOSCH RADIO

● **The New American Bosch Superheterodyne in the Most Beautiful of Sliding Door Cabinets for \$87.50 complete with Tubes**

One of the finest examples of the cabinet maker's art—a real furniture piece with sliding doors that will attract buyers to your store and put profits in your bank balance. This fine Superheterodyne is American Bosch precision-built, which means everything that is modern in design and superior quality in manufacture. Tone, selectivity, sensitivity—all the features of performance which keep radio merchandise sold are built into this new model as only American Bosch knows how to build. This is new and timely merchandise which carries a full profit so write or wire at once.

UNITED AMERICAN BOSCH CORPORATION
 SPRINGFIELD, MASS. • Branches: NEW YORK • CHICAGO • DETROIT • SAN FRANCISCO

American Bosch Radio is licensed under patents and applications of R. C. A. Western prices slightly higher.

**8 NEW MODELS
2 ALL-PORCELAIN**

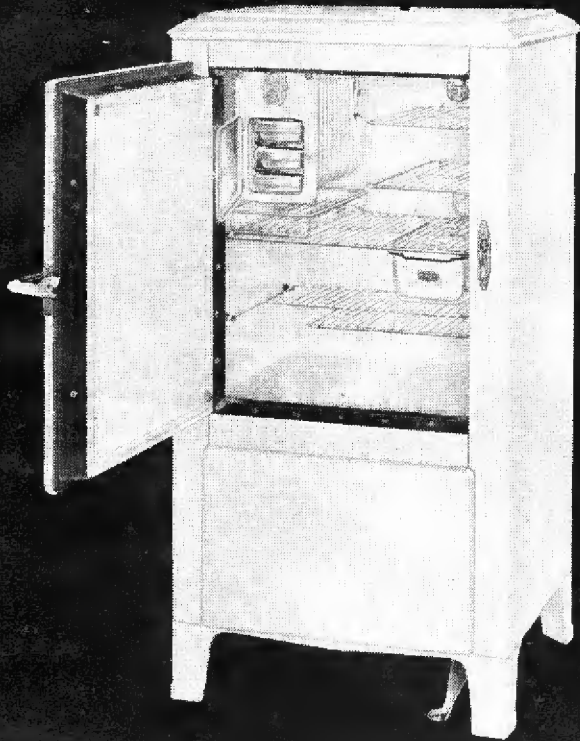

**A touch of the toe
and the
door
swings
open**

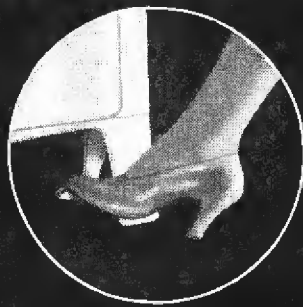

ANOTHER SOURCE OF PROFIT
FROM THE SAME OVERHEAD

THE NEW
LEONARD
E L E C T R I C

with the "LEN-A-DOR"
and many other

EXTRA FEATURES!

Everyone who has seen the new Leonard—distributors, salesmen, competitors, newspaper men and engineers—is agreed that it is a beauty—and that it **WILL SELL**.

It has many features—some of which are exclusive—others that can be had only on the larger, more expensive electric refrigerators.

The "LEN-A-DOR"—a touch of the toe and the door swings open—is unmistakably the greatest sales feature in electric refrigeration to-day. And *only Leonard has it*. But you must see this remarkable Leonard achievement before you can appreciate how *outstanding* it really is. It is the result of more than half a century of experience in household refrigeration.

The Leonard franchise offers an unusual opportunity for radio dealers to level the peaks and valleys of seasonable business, and insure steady, profitable volume. Wire or write for details without delay, as territory is being rapidly closed.

LEONARD REFRIGERATOR COMPANY
DETROIT, MICHIGAN

(420)

LEONARD

E L E C T R I C



R E F R I G E R A T O R

ZENITH
 LONG DISTANCE AUTOMATIC RADIO

**8-TUBE
 SUPER-HETERODYNE**
 Highboy (Model 90)
\$135
 COMPLETE

**10-TUBE
 SUPER-HETERODYNE**
 Semi-Highboy (Model 91)
\$155
 COMPLETE

**10-TUBE
 SUPER-HETERODYNE**
 Highboy (Model 92)
\$195
 COMPLETE

**14-TUBE
 HYPER-HETERODYNE**
 Highboy (Model 103)
\$290
 COMPLETE

**COMPLETENESS
 OF LINE . . . OF PRICE RANGE**

The Zenith franchise is a money maker! In every price range, outstanding Zenith and Zenette values are priced to give you outstanding profits. No matter what your customer's want . . . Zenith or Zenette gives them more for their money. Cash in on these quicker-selling, quality lines!

For Western prices slightly higher
 ZENITH RADIO CORPORATION, 3620 Iron Street, Chicago

**7-TUBE
 SUPER-HETERODYNE**
 Table Model (Model LH)
\$49.95
 COMPLETE

**7-TUBE
 SUPER-HETERODYNE**
 Lowboy (Model WH)
\$69.95
 COMPLETE

**7-TUBE
 SUPER-HETERODYNE**
 Highboy (Model MH)
\$79.95
 COMPLETE

Zenette

MCGRAW-HILL PUBLISHING COMPANY, INC.

The Dealer

"CARRIES ON"

*Back From a Swing Around the Country Interviewing
Dealers and Jobbers What I Found Out*

I HAVE just returned from a month's trip contacting dealers and distributors in eight different states—North, East, South and West. The one outstanding viewpoint obtained from this personal observation of the activities of almost 200 representative radio outlets in this wide spread area is that the dealer is keeping his head and carrying on.

True, the "marginal" and the "weak sister" opportunist has, in many instances, passed out of the picture, but the merchant whose main interest was, and is, radio is displaying a brand of courage which constitutes a challenge to every set maker. This, in the face of vacillating policies and "dumping" tactics in which the latter has been indulging. If manufacturers and distributors will show the same brand of resourcefulness in extending help to the dealer that many dealers have shown in maintaining their own business on at least a "living wage" basis, the industry will soon be in much better condition. That marginal dealers are dropping out is a healthful trend. Fewer dealers, more fitted to the sale of radio and home entertainment devices, and a higher degree of cooperation with them on the part of distributor and manufacturer, is the solid foundation upon which a healthy radio industry must be built.

A SECOND factor of importance was seen in the careful study which every worthwhile radio dealer is giving to supplemental lines. The one product which seems to have received

universal recognition on the part of the radio trade is electric refrigeration. Radio dealers everywhere have contributed largely to the sales gain of this industry during 1931.

While radio specialty stores, music houses, the radio section of department stores and electrical dealers—the backbone group of radio's retail structure—were intensely interested in selling electric refrigerators, it was noteworthy that the above "big four" group is not losing its original identity. Fundamentally they still are dealers in radio and other home entertainment products. These retailers simply are broadening their vision and grasping a new concept of the full scope of their future markets.

IF, UNDER present conditions, live dealers are "getting by" it follows that, with the return of normal conditions, the permanent success of the retailer of radio will be assured. And let us not forget the promise of practical television and of "sound-on-film" home talkies. While they may not be just around the next corner, certainly they are right down the street on which we live.

No, the dealer most decidedly has not lost heart. Given active, constructive cooperation and the honest support of the manufacturer, he will pull through the present depression with flying colors.

Ray V. Sutcliffe

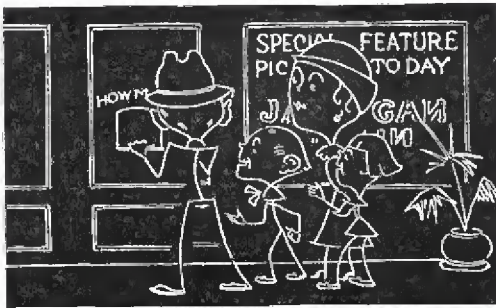

ONE HOUR AT THE MOVIES COSTS 60c.*

In 1930 the country's 22,600 picture palaces sold \$1,500,000,000 worth of tickets to movie fans. Admissions averaged 30 cents, the average family of four spending \$28 during the year for this form of entertainment.

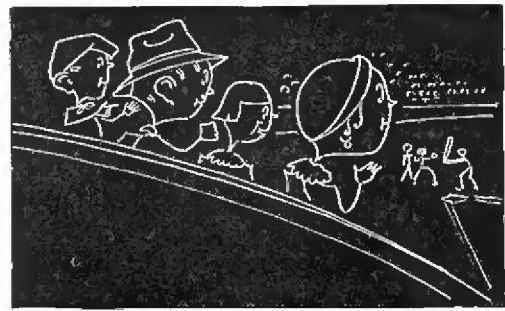

ONE HOUR AT A BASEBALL GAME COSTS 45c.

Games provide entertainment for entire families. More than 10,000,000 people alone attended Big League baseball contests during the past season, admissions averaging 95c. Untold millions spent part of their entertainment dollar to witness minor league and "back-lot" games.

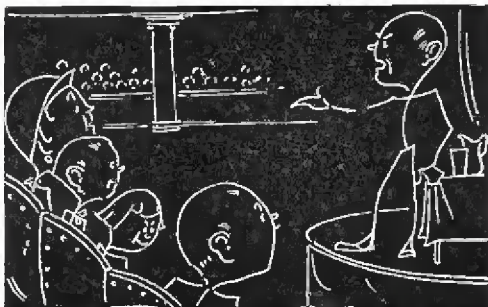

ONE HOUR AT A LECTURE COSTS 60c.

Lectures, attended by vast armies of people annually, are more nearly duplicated by radio than other forms of entertainment. Little is lost through inability to see the speakers.

With earnings down, families are turning to more economical forms of entertainment

Radio is CHEAPER

WITH earnings generally lower and the prospect of a rather chilly winter ahead, the Great American Public is faced with the necessity of reducing expenses whether it relishes the idea or not. And, if we know our neighbors, the average family will be reluctant to lower its standard of living by moving to a cheaper apartment, by wearing last year's clothing or by economizing on its stomach.

Savings, where these prove necessary to keep the wolf in the woods, will probably be effected chiefly in entertainment expenditures. People will continue to go to the movies, to Sunday-drive all over the landscape and to spend money on the hundred-and-one other things which compete for their entertainment dollar. But in our estimation they will do these things less often. Many will be forced to cultivate a taste for less expensive forms of amusement.

Only 2.5 Cents an Hour

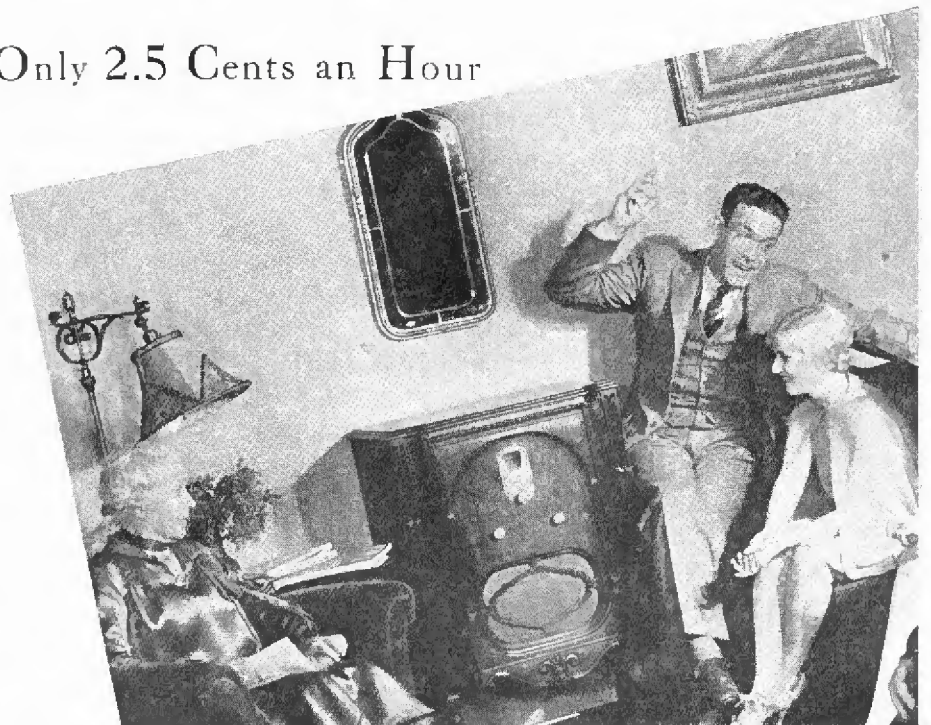

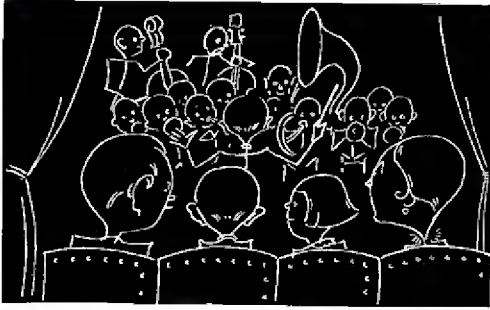

ONE HOUR AT A CONCERT COSTS \$1
 No figures are available on the total revenue from concerts alone but approximately \$500,000,000 is spent each year by American families on concerts, lectures and theatres other than movies.

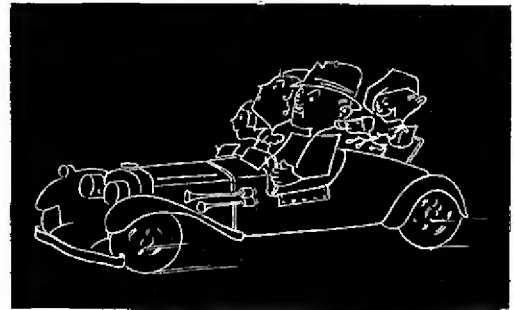

ONE HOUR OF MOTORING, \$2.40
 The public paid \$2,067,000,000 for 2,910,187 passenger cars last year, footing the bill for millions of dollars worth of gasoline, oil and accessories as well. Autos now exceed telephones, 23,042,840 against 20,098,059.

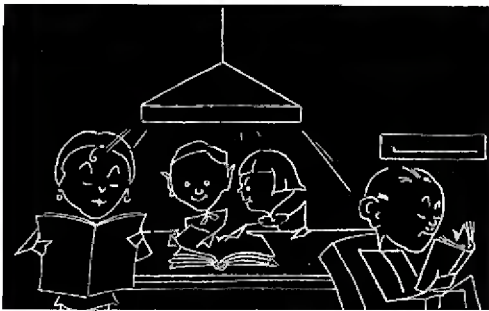

ONE HOUR WITH BOOKS OR MAGAZINES COSTS 15c.
 155,170,097 books (exclusive of those printed for school use) were sold in the United States in 1929. Fiction had the largest billings with 45,880,162 copies while juvenile books ran a close second with 36,885,167. Magazine publishers did a \$500,000,000 business, the public paying this sum plus wholesale and retail profits.

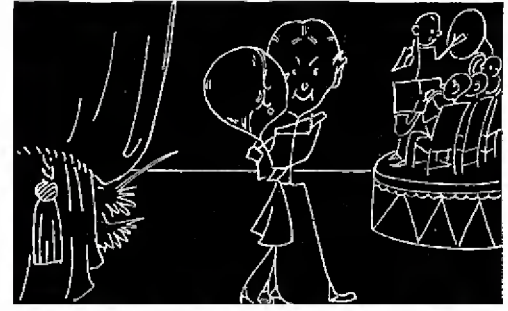

ONE HOUR OF DANCING COSTS 30c.
 Dance halls, to which many couples look for their entertainment, take in more than \$100,000,000 annually.

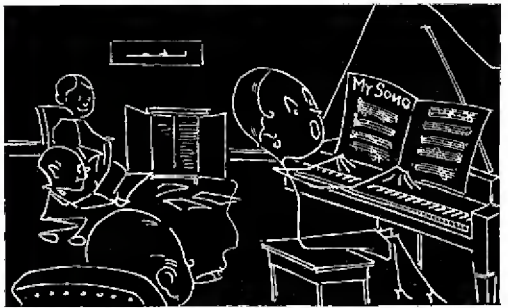

ONE HOUR'S USE OF SHEET MUSIC COSTS 4c.
 "Canned music" in the form of piano rolls or phonograph records entertains at about the same hourly figure. Factories sold \$16,354,981 worth of sheet music, \$2,576,511 worth of piano rolls, \$34,128,735 worth of records and \$1,971,774 worth of phonograph needles in 1929. Values are at wholesale.

**There are 4.1 persons in the average family*



The times are most propitious for radio sales. For when wage earners seek more for their pleasure - dollar radio steps right to the head of the class. While it is not a wholly satisfying substitute for Greta Garbo, radio offers more entertainment for less money than any other service available to the public today. Broadcasting may not constitute a carbon-copy substitute for the things upon which much money has been spent in the past but it does offer a mighty fine brand of entertainment which can do much toward taking the sting out of economy.

Broadcasters are ready, and willing, to take up the national entertainment burden. The world's best talent, \$35,000,000 of it, is sched-

uled for transmission during the present season. Approximately \$20,000,000 of this tremendous bill for entertainers will be footed by 10,000 advertisers, the stations themselves spending \$15,000,000 on their own studio and news features. Less than 3 per cent of the total time contracted for by national advertisers will be taken up by advertising messages.

Over 10,000 people, employed by 615 stations operating 50 hours a week, will make it their business to

A Chain's Average Week*

| PROGRAMS | TOTAL TIME |
|----------------|------------|
| <i>Music</i> | |
| Popular | 31.5% |
| Novelty | 4. % |
| Semi-Classical | 6.6% |
| Classical | 16.5% |
| Light Music | 8.2% |
| Religious | 4.2% |
| Foreign | 1.6% |
| <i>Talk</i> | |
| Educational | 2. % |
| Events | 5. % |
| Script | 12. % |
| Humor | 2. % |
| Religious | 2. % |
| Economics | 4.4% |

*Columbia System, based on a 10-week survey. Other chains and local broadcasters further amplify service.

see that the public gets its radio features on schedule. Some idea of the wealth of material transmitted may be gained from the knowledge that 20 leading 5,000 watt stations spent an average of \$12,500 monthly during 1930 for talent alone.

The problem of arranging programs for just one major chain is more difficult than that of all Broadway's theatres combined. The National Broadcasting Company, for example, schedules 2,500 programs a month, presenting greater variety in two weeks than the Great White Way provides in an entire season. Other chains and local broadcasters further diversify service so that the choice of good features on the radio dial at almost

any hour of the day or night runs up into telephone numbers.

There is no rest for weary program directors in the broadcast business. Even the best features are only "one night stands."

Fully \$25,000,000 worth of broadcast equipment is engaged nightly in passing the best entertainment available over the radio channels to people with sets. And the cost of extracting this entertainment from the air is exceedingly low.

THE man who wishes to compare entertainment values need not be a statistician to prove to himself that radio is the depression's best bet. Here are facts and figures:

The average 1931 receiver sells for \$63 and on the basis of past replacement experience it can be expected to last 3 years. Users play their sets 4.04 hours daily, according to a national survey made by the Massachusetts Institute of Technology in September of this year. Replacement tube sales indicate that the average user buys 3 new tubes annually and \$2 easily covers a year's service. Power cost per set, using the average lighting rate and consumption figure, is \$6.28 per year. Boiling all this information down to one hour of use this is what we get:

Radio's Cost Per Hour

| | |
|-------------------|-------------|
| Depreciation | 1.6c |
| Power | .4c |
| Replacement tubes | .3c |
| Service | .2c |
| TOTAL | 2.5c |

By extracting their entertainment from the air, people who insist upon being entertained despite business condition can come pretty near having their pie and eating it too. For radio, under whose banner the greatest galaxy of stars ever known have gathered, can be used for the small sum of 2½ cents an hour!

They FORGOT to REMEMBER Until—

WHEN Paul G. Freed of Freed's Radio, Philadelphia, found that his offer of \$5 to every customer reporting the name of a friend who bought a radio, was going begging, he decided to do a Sherlock Holmes and find out why. And the answer was so simple it probably has not occurred to many other radio dealers. It was just this—they forgot to remember.

This being the case, Mr. Freed decided to see they remembered to remember and started a little campaign of clever, snappy mimeographed notes, one a week for eight or nine weeks. Some were in long hand, some were typewritten, but each was written in a light, easy manner calling attention to his "You Tell Them, We'll Sell Them" idea.

These letters started with a bright saying, the rest of the text following up the thought. They were humorous enough to hold the attention, yet sufficiently forceful to get the point over.

Mr. Freed was so satisfied with the results he intends to repeat the idea again. More than one-half of the sets sold during the season following the last campaign were directly traceable to old customers.



5051 BALTIMORE AVENUE
PHILADELPHIA, PA.

September 30, 1931

Dear Customer:

"Still Waters Run Deep."—But you never heard of
them saking money.

At that bridge party this week, tell your friends how little (if any) trouble you have had with your radio, and how prompt and courteous Freed's service is. Have them request a demonstration. Please report your prospects promptly to insure credit to your account.

"You tell them; we'll sell them," and \$5 goes to
you for each sale you recommend.

Cordially yours,
Paul G. Freed

Concealed

Radios With "Hidden Charm" For Both Home and Office

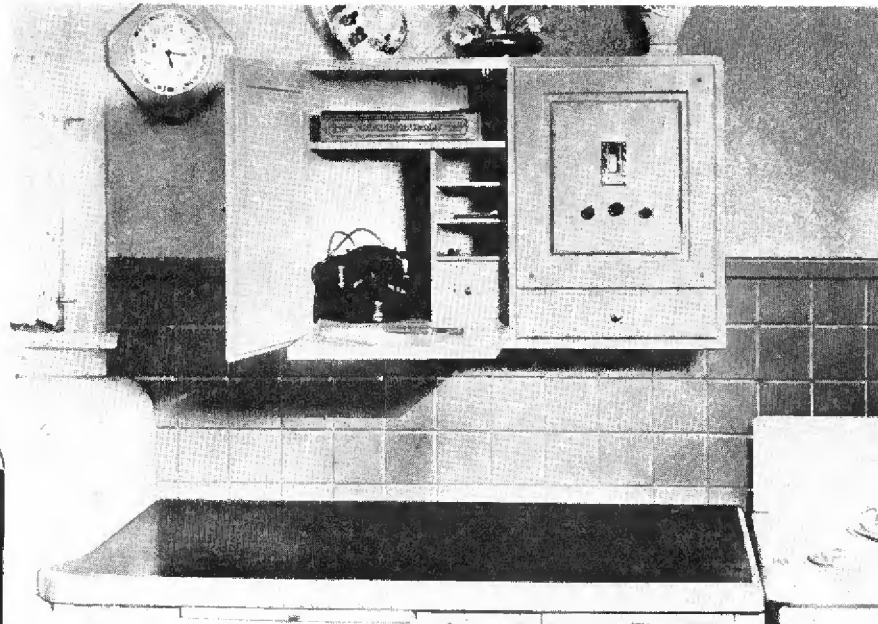

To lighten the "home manager's" work and make the kitchen one of the pleasantest rooms in the house, the "Cabidesk" has made its debut under the joint sponsorship of Mutschler Bros. Co., Nappanee, Ind., and the Zenith Radio Corp., Chicago. This kitchen secretary incorporates a Zenette radio, telephone section, business desk, file and shelf space. It comes in two types, wall and floor, retailing at \$62.50 and \$74.50 complete

No longer need the business man leave his desk to get stock quotations, news flashes or even to "sit on the 50-yard line" at the big game. There is now the radio desk introduced by the Shaw-Walker Co., Muskegon, Mich. The set is housed in the lower right-hand drawer. The current is automatically turned on when the drawer is opened and shut off when closed. All wiring is concealed

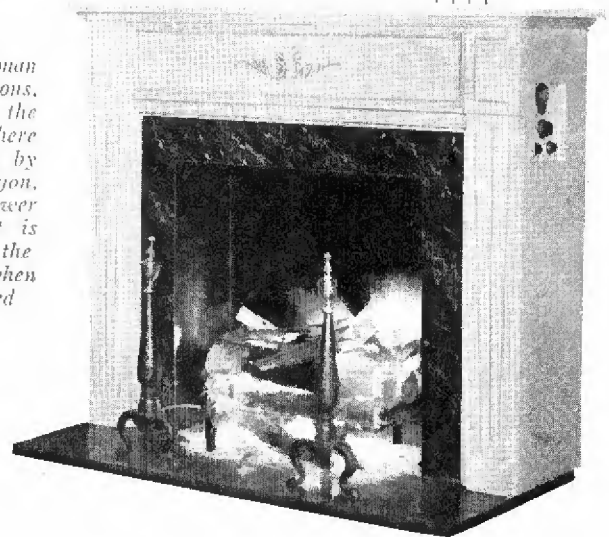

A radio in a portable fireplace! The effect of the flickering logs, with the music seemingly coming from the very flames, is astonishing.

The hearth and mantel are built as one unit. The complete unit as shown, including tubes, andirons and logs, is designed to retail at \$147.50 in New York City; \$157.50, outside, for either a.c. or d.c. operation. Manufactured by J. Kraft, 225 Fifth Avenue, New York

Fred Even does the phone-work while two salesmen do the foot-work



By
Fred Even

Crutches *No Handicap*

WHEN I became bedfast after many years as an automobile salesman I knew I'd have to turn to something else for a livelihood, especially when I learned that I'd never be able to drive a car again. I was determined to carry on in spite of my handicap and radio seemed to offer a means of doing it.

Here was a luxury now a *necessity* in most homes. I could not take my prospects for a ride in a brand new "6" or "Straight 8" but I *could* take them for a trip through the ether, bringing grand opera, vocal and instrumental music and the world of sport and politics to their very doors.

I got a franchise for a popular radio and started my venture. With lots of low-priced sets on the market I turned to a moderately-priced quality line featuring good tone as I have always felt that true merit must be recognized—and there is greater profit in the sale of such merchandise. My experience as an automobile salesman taught me that continuous plugging, plus quality goods, attracted business even in slack times.

Not being able to do the outside saleswork myself, I started with one hired salesman to follow up leads furnished by friends and acquaintances. Sales made to these people formed the nucleus of my business. I secured more leads by telephoning to these satisfied users.

Confined to His Home, This Dealer Had to Make Himself Proficient in:

- 1 The Direction of Outside Salesmen*
- 2 Solicitation of Leads by Telephone*
- 3 The "Sale" of Broadcast Programs*

Every day I made it part of my routine to hobble to the phone to call up several of the people with my radios, asking them how the sets were performing. Very often they would voluntarily tell me about neighbors and friends who had heard their set and were in the market for one like it. If these tips did not automatically come through in the course of conversation I would ask for them directly. The bulk of my business is still obtained in this manner. Advertising, though it produces some business, is more expensive and less effective.

My enforced hours of listening, have made me familiar with broadcast programs and I merchandise this knowl-

edge. My familiarity with popular features has been particularly valuable when soliciting business over the telephone as it gives me something to talk about which really interests the person who has no radio. I know what they are missing and can really talk about it convincingly.

Naturally, when a business is built around customer satisfaction the customers must be *satisfied*. For this reason I have been particularly fussy about my service. We sell good sets and then see to it that they keep running in apple-pie order. It costs money to give good service but fortunately we have it to spend. There is ample margin for service in quality merchandise. This, perhaps more than any other single factor, has enabled me to carry on.

MY SALESMEN are good men, accustomed to doing their own closing, but I have found that my detached thinking often helps them in a pinch. When I give them a lead my analysis of the prospect's needs and ability to pay usually goes along with it. Later, when they strike snags, I can often suggest a method of closing because of what I have learned about the family in the initial telephone work.

Sometimes a salesman will come in and tell me: "They like the set I took out with me but don't want to pay so much money for one. They claim that they can buy a good radio cheaper." My answer would be: "Let them order a cheaper set, either from us or from a competitor, but leave the good set there too. Go back to see these people after the cheap set has been installed and prove to them by actual comparison that the better set is really worth the money from the standpoint of tone quality alone. Some people are satisfied with cheap radio if they do not have the opportunity to compare it with quality reception but a little salesmanship will usually convince them that they really get value when they pay more."

Now, my men almost invariably come back from such comparative demonstrations successful. While in some cases it is necessary to sell a cheap set in order to retain the sale these are few and far between. Usually, we let our competitors take the cheap business, and welcome to it. We never start with a low-priced set if we know the people can afford better. It requires a little harder work to sell under such conditions but in the end the customer is better satisfied and, as I tell the boys, we work harder but get better pay for it if we win.

The sales I have lost were rarely where my men had installed a quality set on trial.

Recently I have started to solicit business from farmers with their own 32-volt electric light plants. I sell them a converter in which there is a nice profit. There are plenty of good prospects for such equipment in my section. We also plan to sell automobile-radio next spring. And next may come Television, who knows?

I keep my overhead down and pay my salesmen a good commission. This, I think, is a step in the right direction for they really do most of the work. We all look for a good winter business and hope to branch out next year with additional quality lines and *super*-service.

Now, I do not want to give the impression that I claim to be a "super-man"—that would be misleading. Or that I do an enormous volume of business. I can and do say, however, that I think I have done pretty well—considering my handicap—building my business economically on a foundation of satisfied customers principally through telephone solicitation and the "sale" of programs.

TWO years ago Fred Even was a vigorous, table-bodied automobile salesman. Then came a serious motor car accident—crippling him, it is feared, for life. Was Even down-hearted? No! For he had been a radio fan and already had sensed the worth of this boon from a business standpoint.

"When I became bedfast," he writes, "I knew I would have to turn to something else for a livelihood. Radio seemed the answer. From my many enforced hours at the dials I began to appreciate what a wonderful thing this invention really was . . . I learned how to pick programs intelligently—and lots of other things about the art and pleasure of having the world at one's finger tips. Mainly to this foundation knowledge of radio as a vital, living part of one's life I attribute whatever success I may have achieved as a radio merchant."

Here, then, is a courageous soul who, though confined to bed and crutches, not only has made money in radio, featuring merit rather than price, but provides work for two salesmen and a technician. If Fred Even can do this, should healthy dealers complain? Read this story, in Fred's own straightforward language, and draw inspiration therefrom



Before
His
Accident
Fred Even
was a
hustling
auto-salesman

Detroit Sells RADIO

Trade, Cooperating with Newspapers, Stages Tremendous Free Publicity Campaign Boosting "Radio Season"

"SELL the wonders of radio—Not the cheapness of sets!" For three years this cry has been echoing in the market places—generally producing no more tangible results than an empty echo. Now, however, comes Detroit, pointing the way to actual accomplishment with its "Radio Season" newspaper publicity campaign done in a great big way.

Granted that the theme of this particular publicity punch centered about the opening of the fall season, and is suited, only to the months of September and October, its principles can be applied in other towns, and at other times of the year, with slight variations in the handling. Further, as live merchandising news, we report it in this issue in the hope that many readers will hold the article and apply its suggestions just prior to radio's next buying peak.

How, then, did the radio trade of Detroit secure, without cost, a total of 4,500 inches of precious editorial radio publicity, in the three leading local newspapers, valued at not less than \$50,000, as well as the help of theatres and broadcasters?

THE decision of the newspapers of Detroit to give radio a publicity play came about as the offspring of another plan for paid publicity, evolved previously by C. R. Moores, president of State Distributors, Inc. This first plan called for a total cash contribution of \$1,200 from ten leading local distributors. As conceived by Mr. Moores, this nest egg was to be spent for twelve full-page advertisements, over the signatures of these firms, playing up radio and radio programs—

A GOOD PROGRAM DES

educating the public in the merits of radio, instead of its cheapness.

It was an admirable plan but it couldn't be made to jell. Why? One guess! You're right; the jobbers didn't come through with the cash.

But by this time the business managers of the papers were aroused to the possibilities of increasing the expenditures of the radio trade in newspaper copy. "Let's give this industry a big boost anyway. We'll do it editorially," they said, "and trust to this gesture to get that extra, tie-in paid-for space."

Many meetings were held. Moores, chairman of the "Better Radio Season" general committee, got the *Times*, *Free Press*, *News*, the broadcasters, even certain prominent theatres, to feature "Radio Season" and the slogan: "In a Radio You Get Only What You Pay For."

Sam Lind, chairman of the dealers' committee, arranged for window cards—paid for by the distributors

Not PRICE

Glorifying all that's new in the world of radio

Better Radio Season is here... here with all the new delights that a thousand to you over the air waves. Voices span oceans and girdle the world... battles of arena and stadium and the ballroom... the thoughtful addresses of statesmen and men of affairs are all yours in the privacy of your home via the radio.

Perhaps you feel that the set you own is all-sufficient... that there can be no better radio. If that be true, may we suggest that you hear the newer radio receivers. You will be astonished at the difference between what you believe is a good radio and the radio of today.

Better Radio Season now being celebrated in Detroit glorifies all that's new in radio and demonstrates the progress of a great industry, whose service has become of such truly tremendous value to mankind.

Go today to your radio dealer and ask him to demonstrate the receiver of 1931 and '32.



The Detroit Free Press



ies of THE DETROIT TIMES

—and for screen “trailers” to be run four times a day by the ten picture houses participating in the event.

THE campaign started September 27. News items (see illustration) appeared every day for three weeks. Display, promotional, and institutional advertisements of assorted sizes—prepared by the jobbers and run free—appeared at frequent intervals. The *News* featured also a \$700 slogan contest for the best reason for buying a *modern, high quality* radio set.

During the first three weeks of this drive the papers ran no commercial radio advertisements, the entire effort being concentrated of this high type of “inspirational” copy.

As a financial reward for this splendid and most unusual publicity it was agreed that this effort should be climaxed by the issuance of a special radio section, by each of the three contributing newspapers, Sunday.

October 18. These supplements were generously supported by large paid ads from most of the radio firms in the Detroit area.

An extraordinary instance of theatre cooperation was contributed by The Michigan, one of the Publix chain. Twelve nationally known sets were displayed in its lobby during the week of October 3-10. The stage presentation that week was built around the theme, “Radio.” A cut-out of a huge chassis, with mammoth tubes, occupied the entire width of the stage. An orchestra was seated in the midst of the power pack and 16 girls danced within the lighted tubes.

WITH respect to results: “Practically every dealer and jobber in Detroit noticed a marked increase in the demand for good sets, not only while the campaign was at its height but for several weeks after,” states

(Please turn to page 52)

15,800,000 Homes with Sets

BASED on the Government's final tabulations by states of its radio census, as of April 1, 1930, *Radio Retailing* presents to the industry the final set saturation picture—as of December 1, 1931. The second and third columns of the accompanying table—sets installed since the census in homes formerly without radio, and total number of families now owning radio receivers—were obtained from the records of the set makers; proper allowance being made for duplication due to replacement sales.

This information is an exclusive and copyrighted RADIO RETAILING service, published for the first time.

THERE are approximately 30,000,000 families in the United States. While a national saturation of 52.7 per cent—15,801,620 homes with sets may appear high from a future business opportunity viewpoint, it should be remembered that at least 8,000,000 of these families are prime prospects for a modern receiver. From now on the replacement market will become more and more of a worthwhile factor. It should account for a minimum of 50 per cent of all future sales. There is no reason why this industry should not enjoy a year in and year out demand for at least 3,400,000 sets—grossing approximately \$275,000,000.

| State | U. S. Census Homes With Radio as of April, 1930 | Since Census Sales to Homes With- out Radio | Total Homes With Radio as of Dec. 1, 1931 | State | U. S. Census Homes With Radio as of April 1, 1930 | Since Census Sales to Homes With- out Radio | Total Homes With Radio as of Dec. 1, 1931 |
|----------------------|--|---|---|--------------------|--|---|---|
| NEW ENGLAND | | | | | | | |
| Maine..... | 77,803 | 24,000 | 101,803 | West Virginia.. | 87,469 | 27,000 | 114,469 |
| New Hampshire | 53,111 | 16,400 | 69,511 | North Carolina | 72,329 | 22,300 | 94,629 |
| Vermont..... | 39,913 | 12,300 | 52,213 | South Carolina | 28,007 | 8,650 | 36,657 |
| Massachusetts.. | 590,105 | 182,000 | 772,105 | Georgia..... | 64,908 | 20,000 | 84,908 |
| Rhode Island... | 94,594 | 29,200 | 123,794 | Florida..... | 58,446 | 18,000 | 76,446 |
| Connecticut.... | 213,821 | 65,700 | 279,521 | | | | |
| MIDDLE ATLANTIC | | | | EAST SOUTH CENTRAL | | | |
| New York..... | 1,829,123 | 564,000 | 2,393,123 | Kentucky..... | 111,452 | 34,400 | 145,852 |
| New Jersey.... | 625,639 | 192,500 | 818,139 | Tennessee..... | 86,229 | 26,600 | 112,829 |
| Pennsylvania... | 1,076,770 | 332,000 | 1,408,770 | Alabama..... | 56,491 | 17,410 | 73,901 |
| | | | | Mississippi.... | 25,475 | 7,860 | 33,335 |
| EAST NORTH CENTRAL | | | | WEST SOUTH CENTRAL | | | |
| Ohio..... | 810,767 | 250,000 | 1,060,767 | Arkansas..... | 40,248 | 12,400 | 52,648 |
| Indiana..... | 351,540 | 108,300 | 459,840 | Louisiana..... | 54,364 | 16,550 | 70,914 |
| Illinois..... | 1,075,134 | 332,000 | 1,407,134 | Oklahoma..... | 121,973 | 37,550 | 159,523 |
| Michigan..... | 599,196 | 184,700 | 783,896 | Texas..... | 257,686 | 79,400 | 337,086 |
| Wisconsin..... | 364,425 | 112,200 | 476,625 | | | | |
| WEST NORTH CENTRAL | | | | MOUNTAIN | | | |
| Minnesota..... | 287,880 | 88,600 | 376,480 | Montana..... | 43,809 | 13,540 | 57,349 |
| Iowa..... | 309,327 | 95,500 | 404,827 | Idaho..... | 32,869 | 10,150 | 43,019 |
| Missouri..... | 352,252 | 108,600 | 460,852 | Wyoming..... | 19,482 | 6,020 | 25,502 |
| North Dakota.. | 59,352 | 18,300 | 77,652 | Colorado..... | 101,376 | 31,300 | 132,676 |
| South Dakota.. | 71,361 | 22,000 | 93,361 | New Mexico... | 11,404 | 3,525 | 14,929 |
| Nebraska..... | 164,324 | 50,600 | 214,924 | Arizona..... | 19,295 | 5,950 | 25,245 |
| Kansas..... | 189,527 | 58,500 | 248,027 | Utah..... | 47,729 | 14,720 | 62,449 |
| | | | | Nevada..... | 7,869 | 2,440 | 10,309 |
| SOUTH ATLANTIC | | | | PACIFIC | | | |
| Delaware..... | 27,183 | 8,390 | 35,573 | Washington.... | 180,229 | 55,500 | 235,729 |
| Maryland..... | 165,465 | 51,100 | 216,565 | Oregon..... | 116,299 | 35,900 | 152,199 |
| Dist. of Col.... | 67,880 | 20,920 | 88,800 | California..... | 839,846 | 258,500 | 1,098,346 |
| Virginia..... | 96,569 | 29,800 | 126,369 | | | | |
| NATIONAL TOTALS..... | | | | | 12,078,345 | 3,723,275 | 15,801,620 |



HE knows the Combination

*Tune In On My
Record Program Tonight*

CLINTON ISAACS

of Medford, Ore.

*Phones Combination Owners.
After the Broadcast, Many
Ring Back and Order Discs*



THE score at the end of the sixth (month) in the "contest" between Radio-Phonographs and Straight Radios is 4 to 4½. With the introduction of the long-playing records, the

importance of this, he even contacts other radio dealers who do not have a general music business on the side. He follows up their combination purchasers just as he follows up his own. Mr. Isaacs overlooks no avenue to more sales.

Palmer Music House, Medford, Oregon, where the "game" is being held, hopes to make the score tie.

Clinton H. Isaacs, being an old music man, appreciates the advances made in the phonograph. Fully believing in the outstanding value of the duo-purpose instrument he has little difficulty in convincing his customers of it, too. A record of 180 sales in a city of 11,000 in a 12-month period proves that and he hopes to keep the average up.

His emphasis in selling is on the phonograph rather than the radio. The usual method is to tune in the radio, then without saying anything, switch on a record. "Ah, that is something like it," says the customer. "What station is that?" When it is explained it is a record and that he is assured of just the programs he wants when he wants them, the machine is usually sold. Frequently a prospect expresses a wish that there was some station that never put on jazz, or, on the contrary, he longs for continuous programs of dance music. That is the time to sell him a combination.

Selling records in Mr. Isaacs' opinion is quite as important as the original sale of the set. A combination with the phonograph portion idle is a positive menace to other sales. How many times have you heard some one say, "Why buy a combination? It costs more and I never get any use out of it." Because he firmly believes

An exceptionally clever and profitable tie up between his weekly half-hour broadcast and his customers has been worked out. At the beginning of each program, he calls up a number of owners of radio-phonographs telling them that some interesting new records are now on the air and suggesting they listen in for the next half hour. This means a private demonstration for each set owner and brings phone orders after the program.

One of the advantages of these machines is that they are readily sold as store merchandise. Of the 180 sold last year, 103 were from the floor. Selling is not confined to the shop by any means, however. Seventy-three were sold throughout the countryside from Mr. Isaacs' car. The fact that this merchandise is not seasonal is another of its advantages. The Palmer Music Shop demonstrated the truth of this fact by selling 62 combination sets in the month of August.

It is by no means necessary to confine your selling to well-to-do portions of the community. Mr. Isaacs' best customers are the farmers.

Of course, much of the business is on time-payment basis, but radio-phonographs are less apt to give trouble in collections as the customer has a larger initial investment at stake. In addition, he has a stock of records which are not returnable.

9:15—12:30

Follows up leads. Cold-calls, using recipe book to break the ice



HE STARTS HIS DAY
8:30—9:00 A.M.

Reports at store for morning sales meeting, receiving leads accumulated by office, then leaves for his territory

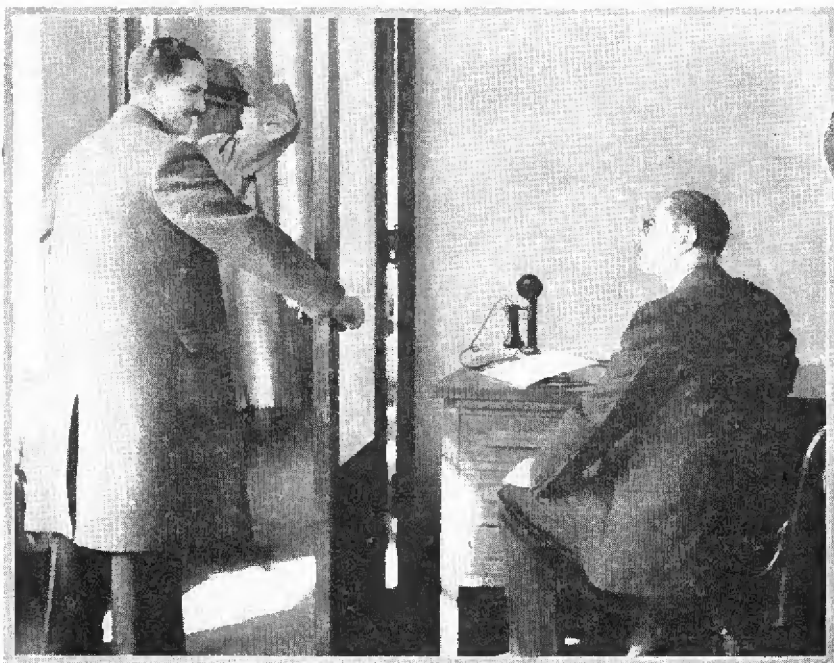

Each hour in the working day of the specialty man should be scheduled ahead

A DAY WITH A

7:00—9:30 P.M.

Keeps appointments made by 'phone, canvassing if these "peter out" too early



12:30—1:30

Lunches, in his territory



1:30—4:45

Calls back on users, presenting water bottle and soliciting leads. Follows up some of these leads

REFRIGERATION SALESMAN



*This effective routing
is as applicable to
RADIO as to REFRIGERATION*

5:00—5:15

*Returns to store, arranges
night appointments by tele-
phone, turns in reports*



5:30—6:45

Dinner and relaxation

Radio Retailing, December, 1931

W i s e

*These dealers
have learned
how to get
more for
their
advertising
dollar*

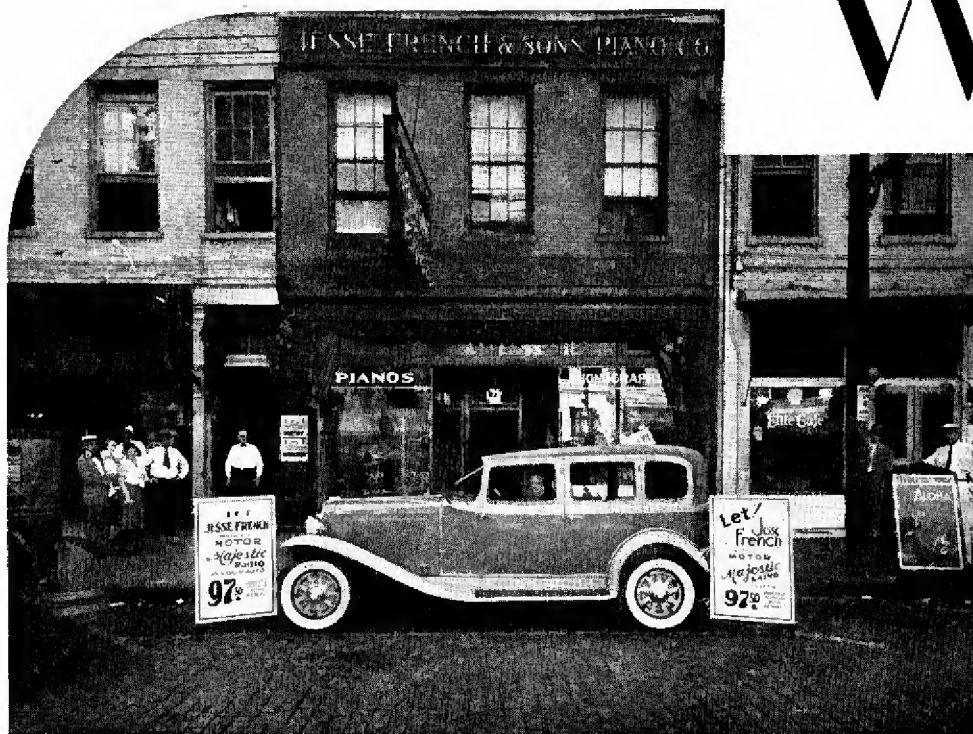

This "curbside" demonstration cost little but pulled big

“WISE SPENDERS.” These are the dealers who have continued to advertise, cutting costs by making each advertising dollar produce more business rather than by spending fewer dollars. Such a concern is Jesse French & Sons Piano Co., Montgomery, Ala. W. S. Yougene, Jr., sales manager, has found it particularly easy to promote the sale of auto-radios at low cost.

When Yougene received his first shipment of sets (Motor-Majestic) he went to his precinct police captain and secured permission to park a car all day parallel to the curb in front of the store. Then he enlisted the cooperation of a neighborhood automobile agency, securing a new Auburn in which to install and demonstrate the first set. The local distributor was induced to share the cost of a newspaper ad announcing a “curbside demonstration.”

On the following day a pretty girl kept the set in operation all day, attracting a considerable crowd. In the week that followed this stunt not only sold more than enough sets to cover its expense but was also directly responsible for two car sales. Now it is repeated every second week, a car of a different make being used each time to keep up the double interest. And it has proven so fruitful as a source of leads for car salesmen as well as for radio salesmen that car agencies now pay the entire cost of the preliminary newspaper announcement!

Yougene wanted to introduce another new line of sets some time ago. What did he do—sink a lot of money in newspaper ads? No. He had his service department fit up a broadcast oscillator with a microphone and a simple modulation circuit so that the device was in reality a miniature broadcast transmitter, incapable of radiating more than a few feet without an antenna but putting out a sufficiently strong signal to operate a receiver placed only a few feet away. The rig, with its microphone,

was placed in the window and one of the new sets to be introduced stood about 3 feet away in front of the store, on the sidewalk. Then a kid about 13 years old, who has quite a voice for his age, performed, his singing being picked up in the sidewalk set and literally jamming the street.

Still a third method of making each advertising dollar produce is employed by this Alabama dealer. The concern owns an Austin, which is repainted a new, brilliant color each month. Every day a list of people who have just moved to town is received from the Chamber of Commerce. A contact man calls on each and every one of these people in the “easter egg,” making no immediate attempt to sell but merely welcoming them to town and asking them to consider Jesse French when in the market for musical instruments.

The contact man has consistently brought in enough business to support his activity.

Direct Mail, When?

A CHICAGO dealer has this to say about direct mail effectiveness: “If merchants do not get good results from their direct mail advertising it may be because they do not mail it at the right time.

“Seemingly any one time of the month is as good as any other. Yet, in many instances such is not the case. The first of the month is usually poor as the mails are flooded with bills and customers are thinking of ways to meet old obligations rather than assuming new debts. The only exception is where the town is a large industrial center in which many pay-rolls are met on about the first of the month. The mailing problem is simplified here as

Spenders

in the small towns having few industries it would be desirable to make up several mailing lists corresponding to the various pay-roll dates of leading industrial plants."

Farm Finance

R. H. SHINN of Dunham, Ohio, reports that he is selling more radios to farmers by helping them budget their business. Direct-mail cards carrying the following message are the backbone of his plan:

"When you sell a case of eggs or a can of cream put aside one-tenth of the proceeds for that new radio you need. The amount may seem trivial but it will prove sufficient to provide modern radio service in your home with a surplus for upkeep and repairs."

He says the ten per cent works out about right and that many farmers in his territory now use this plan to pay for their sets on time and still others to save money with which to pay cash. The plan seems essential inasmuch as farmers have no regular "pay-day" and hence find it difficult to budget for weekly or monthly payments.

Dial R-A-D-I-O

WHEN the new dial telephones went into effect in San Diego, California, Dutton's Radio Store was foresighted enough to secure R-2346 for its telephone number. Translated into letters, this reads R-A-D-I-O and the Dutton advertising features this happy coincidence. "Dial R-A-D-I-O" is the slogan carried in each

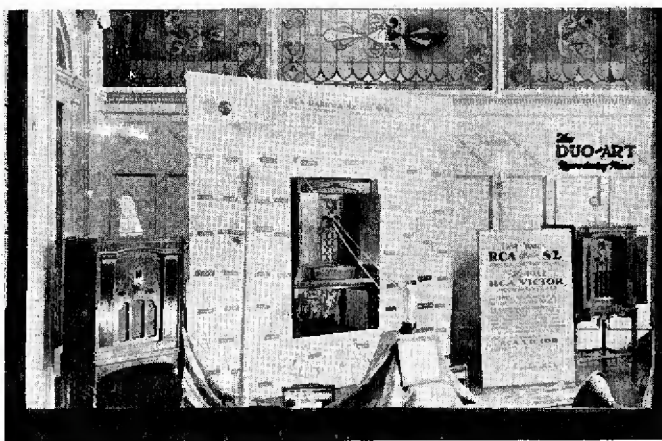

Denton, Cottier & Daniels, Inc., of Buffalo, N. Y., found this DX window to be particularly effective advertising, bringing in many more window shoppers than its low cost would seem to justify. The window card told how J. W. H. Johnston had won the Buffalo Evening News DX prize by pulling in 411 stations on a receiver sold by the store.



In the summer time the Peoples Electric Company of Medford, Ore., puts its display radios up on the balcony, installing refrigerators on the main sales floor in place of the sets. When winter comes the process is reversed—a cheap but effective form of advertising

newspaper ad and on the sides of company trucks, together with a reproduction of the telephone dial.

Here is one telephone number that the customer never forgets.

"Tube-Conscious"

LAZAR AND BRASCH, Chicago dealer, made its neighborhood "tube-conscious" recently by filling half a show-window with old tubes. An eye-catching sign read: "10,000 TUBES WANTED FOR THIS DISPLAY. 10c. in trade on a new tube is the offer made for each old bulb."

"The idea back of this trade-in offer," commented Mr. Brasch, "was, primarily, to get new customers into our store. The offer is only a week old but it has already brought new faces to our sales counter and has resulted in a number of service jobs where customers decided, on our suggestion, to have their sets checked over simultaneously with the purchase of new tubes."

A Good Guy to Know

WHEN E. A. Portal of San Francisco sells a set to an apartment dweller, or when he sends a serviceman to an apartment, the apartment house manager is always called upon. He is a good guy to know.

These men are more or less familiar with their tenants and can often pass along a good tip for radio sales or service. Often he permits circulars to be distributed to the various tenants, something which may not be easily accomplished in any other way.

You
Can
Sell

“Electric

A typical “electric eye.” The case is removed, revealing the light-sensitive cell, with auxiliary amplifier and circuit controlling relays

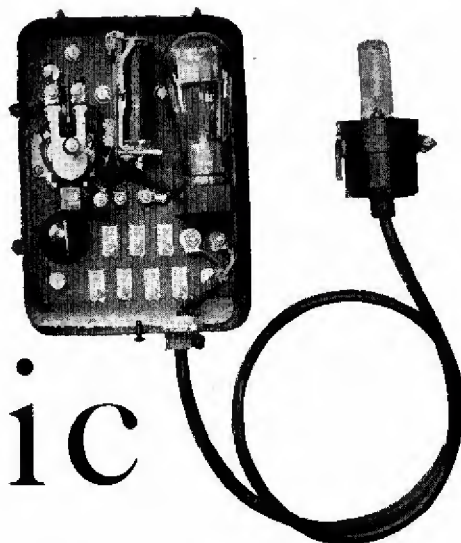

SCHOOL ROOMS

Little eyes must be carefully guarded. The photoelectric cell, in the window, does this automatically

IN the public's attention, in newspaper headlines, in manufacturers' advertisements and in jobbers' catalogs a new electrical device has made its appearance during the last twelve months.

Next to the miraculousness of radio itself, this new appliance is the wonder-worker of the present age, the magic “electric eye” which is finding such remarkable and varied applications in everyday life, in factories and in scientific laboratories.

While the idea of a light-sensitive electrical unit—which can control electrical circuits by merely throwing a beam of light on its surface—is not new, yet it has been only within a short time that such photo-electric cells have been manufactured complete with amplifiers and relay switches, ready for installation by any electrical or radio man.

Thus to-day there are on the market half a dozen or more different “electric eye” units which are as simple to apply or install as any push-button switch. It is merely

necessary to mount the “electric eye” in a position where the light beam falls upon it, and to connect up the binding posts leading to the load to be controlled. These new units are made in a variety of types for controlling directly currents from 2 amp. to 10 amp. at 110 or 220 volts. Prices range from \$33 to \$100 for the complete units, ready to operate.

NOW LISTED IN CATALOGS

ALREADY these commercial electric eyes have become regular articles of merchandise. Radio and electrical jobbers are stocking them, and listing them in their regular catalogs, and many dealers and radio and electrical installers are exhibiting them in their show-windows and stores, and offering to make installations.

The public interest and public demand for such electric eye installations is just beginning. Every community has uses for these remarkable labor-saving control devices, depending on the ingenuity of the man who sells them, and the needs of industries, businesses and homes.

For counting objects large or small, for opening doors automatically, for safety-first protection around dangerous machines in manufacturing plants, and for turning on signs and lighting circuits at a pre-arranged degree of darkness, the electric-eye unit has prospects in every town and neighborhood. Being an electrical and vacuum-tube device, its installation and adjustment can easily be handled by any radio serviceman, so that the application of these electric eye units in a community becomes a logical opportunity for the radio dealer and his service crew. It also has the advantage of broadening his market into industrial and commercial fields, removing the seasonal limitation formerly placed on his radio business.

Wherever a light beam can be interrupted, modulated or deflected, and thus used to control electrical apparatus, electric-eye units can be utilized.

CONTROLLING LIGHTING AND SIGNS

ONE of the most important future uses of the “electric eye” in point of numbers, will be that of controlling interior illumination. For years we have automatically adjusted the temperature of our rooms by means of thermostats. Is it any less logical or less important to control the intensity of the lighting in workrooms, schoolrooms, etc., by means of a “light-o-stat” or light-sensitive cell?

In the average schoolroom, during the winter months, the natural illumination goes through wide changes, imposing extra burdens on little eyes. But with a photo-

Modern, Light Controlled Switches Have Many Practical Uses in FACTORIES STORES AND HOMES

EYES

SIGNS

An immediate use for light cell switches is to turn off and on electric signs (top)

YARD ILLUMINATION

When the automobile headlights strike a concealed photoelectric cell, in the garden wall, a switch relay turns on the yard floodlights and opens the garage door

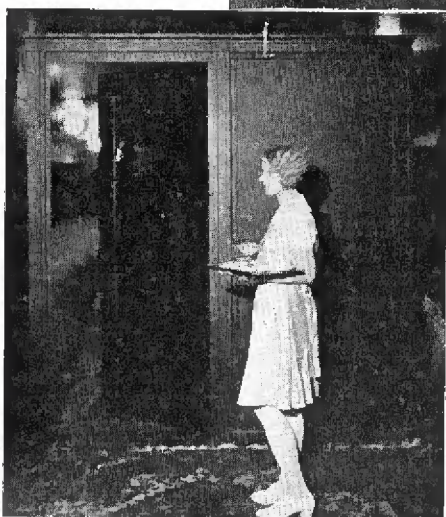
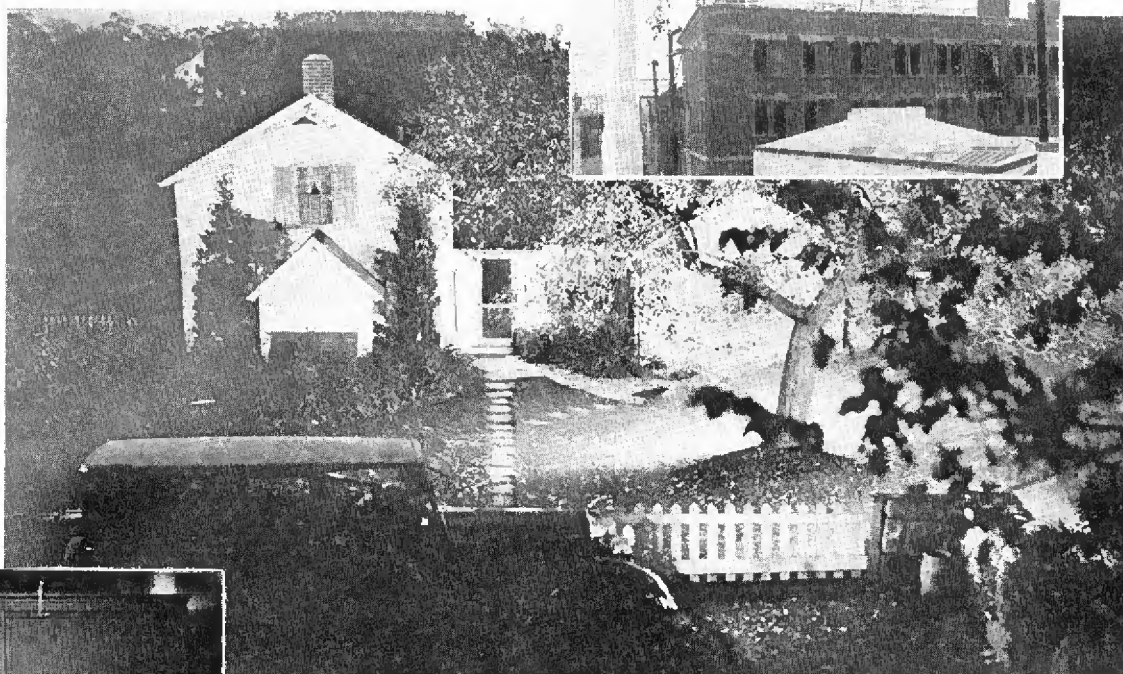

DOOR OPENER

The waitress intercepts the light ray, and the door to the kitchen swings open

cell on guard, electric lights will be automatically switched on, each time the natural light falls below a predetermined value. Since there are 400,000 school-rooms in schools having electric lights, the commercial opportunity for photocell control here is apparent.

Factories and machine shops offer another large field for automatic light control. Tests recently conducted by a large industrial company, show a saving, by photocells, of at least 50 per cent of the electricity required in the ordinary hand-controlled shop lighting system.

While the home has been recognized as a vast field for the installation of photoelectric devices, as yet few practical uses have been found.

Photoelectric garage door openers are handy things, especially for use in wet or cold weather. The driver merely turns his headlights on the secreted electric eye and the door rolls open.

Undoubtedly the day will come when the intensity of illumination will be controlled in certain rooms of the average home, just as the temperature is automatically controlled today. Meanwhile the inventor and manufacturer who can find a photocell application needed in every household, will have a ready-made market of 19,000,000 homes awaiting him.

Possible uses of the "electric eye" or photocell in industry, in commerce and everyday life are already legion. The further spread of these devices into all manner of applications will depend only upon the recognition of needs and uses for them, and on the ingenuity of engineers, and dealers fitting these ubiquitous and all-useful electric eyes into the workaday world.

The following concerns have on the market "electric eye" controlled switches, ready to operate:

- Allen-Bradley Co., Milwaukee, Wis.
- Burgess Battery Co., 202 East 44th Street, New York.
- General Electric Co., Schenectady, N. Y.
- G-M Laboratories, 1735 Belmont Ave., Chicago.
- Struthers Dunn, Inc., 148 N. Juniper St., Philadelphia.
- Westinghouse Elect. and Mfg. Co., Pittsburgh
- Weston Electrical Instrument Corp., Newark, N. J.

Concerning Self Defence...

The Dealer Fights Back

WHAT recourse has the franchised dealer when his manufacturer "dumps" locally and through an unauthorized channel? Should he take it lying down or fight back? If the latter, how can he discipline the set maker?

One of the leading radio centers of the country, containing a group of radio merchants whose ethics are of the highest, has supplied the answer. Here is the case history:

Nine substantial radio dealers in this mid-western city received and signed, within the past six months, authorized sales agency franchises from a well known set manufacturer. This franchise contained the customary dealer protection clauses.

About one month ago a sizeable quantity of old model sets came into the possession of the jobber covering this territory for this manufacturer. Eventually, despite agreement to the contrary between this local jobber and his dealers, these sets were offered to the public through the public press, by a heretofore unfranchised dealer (a department store) at "less than half price." The advertisements of this sale contained statements which were considered by this dealer group as misleading, confidence destroying and otherwise derogatory to the best interests of fair play and fair trade.

These nine dealers, as one body, fought for their rights by: (a) Notifying both manufacturer and distributor of their objections to this proposed dumping; urging that it not be undertaken and threatening the cancellation of each and every franchise if dumping actually occurred. (b) Failing in this preliminary move *these dealers resigned, collectively and individually*, as local representatives of said manufacturer. (c) They prepared a complete history of the case, in the form of written resolutions, served it on the president and on each member of the local radio trade association and on the manufacturer and distributor involved. And (d) they notified the Better Business Bureau of the untruthful statements contained in the publicity of the department store.

If radio set makers cannot budget output to demand, and if they continue to plunge blindly or

obstinately into dumping practices—over the heads of their own dealers—who shall say that dealers are at fault if they fight back?

Dealers *can* defend their rights! The preceding instance suggests the weapons to use. A few more cases of this kind of courage, and one of the worst evils of our industry would pretty well be corrected.

For a Stricter Tube Replacement Policy

THE recent reductions in tube prices again focus attention on the need for formulating a new and more equitable tube replacement policy. This need springs primarily from the present predicament of the jobber. Dollar margins are now so constricted that many wholesalers have lost all interest in pushing this important radio commodity.

The practical angles of this situation have been voiced, in an open letter to a well known tube manufacturer, and to the industry at large, originating from the pen of one of the largest distributors in the industry.

We quote in part from this letter:

"IN MY estimation the sale of radio tubes by the dealer and distributor at present new low prices can be profitable only if each sale is made on a basis of *finality*. By this I mean that to continue to handle tubes on the existing replacement guarantee basis will not only absorb what profit there may be in this business for the distributor but will occasion an actual cash loss. As a matter of fact the existing abuse of the replacement privilege already is divorcing we distributors from pushing tubes.

"Further, I do not believe that the manufacturer can make a profit on tubes any longer if he continues to grant the same liberal replacement terms which have been in force for so many years. When tubes sold for \$5 each, with questionable life, it properly became the manufacturer's obligation to guarantee them for a reasonable period. That time has passed, and the existing perpetual replacement policy now should be changed.

"May I suggest, therefore, as a logical means of checking the present vicious cycle, the following *new* replacement plan: First, the definite testing of each tube by the dealer, to the consumer, at time of sale. If the tube is found to be in first class condition at that time, it becomes a final sale—*without recourse*. Similarly, the jobber should test his tubes before shipment to the dealer. All claims on said jobber by the dealer must be made within five days—tubes to be specially identified by the jobber, before shipment to dealer, to eliminate present abuses which the dealer is making of the privilege of returning tubes.

Tube Policies . . . Records

"Analysis shows that in our business we handle a tube on an average of *seven* times for each sale: once upon its initial receipt, again when shipping to dealer. For each tube sold we get one back from the dealer for inspection—a third handling. Our bench tests makes a fourth, the shipping department's replacement to the dealer a fifth, that same department sending the old tube to the manufacturer, the sixth—and, finally, a *seventh time* upon receipt of our replacement tube from the tube concern. Furthermore, the jobber must bear the burden of most of the many transportation costs arising from the present wasteful "guarantee" practices.

"Our experience shows that of 100 tubes taken from our stock and tested the minimum life is three months and less than five per cent actually are defective. The difference between this five per cent and the vast number of tubes we must rehandle for our dealers, from 20 to 50 per cent, is too great. These additional claimed defects should be branded for what they are—polite racketeering.

"No individual distributor can stop this abuse. But the tube makers, working together, can. They should accept their moral responsibility for the correction of this evil.

"I realize that this matter involves the education of dealer end of the public. In taking such a drastic step the tube manufacturers would receive the wholehearted support of the entire industry."

F. E. STERN, *president*
Stern and Company, Inc.
Hartford, Conn.

CERTAINLY there is a wealth of truth in the preceding statements. Granted that it may yet be too soon to successfully put into effect such radical rulings, and that every tube concern in the country would have to get behind such a plan, *Radio Retailing* presents it as worthy of individual consideration and mutual discussion.

If, by May Trade Show time, the present "saber toothed" traits of the replacement tiger are not accomplishing its own destruction, then, starting from certain of the fundamentals outlined by Mr. Stern, the tube manufacturers should formulate a new, a better, and a more mutually profitable tube replacement or guarantee formula than now exists.

The Status of the Long-Playing Record

THE advent of the long-playing (15-minute) record opens up great possibilities for the radio trade in a rejuvenated phonograph business of a new kind. In the face of spectacular advertising, failure to have ready a suitable speed-conversion mechanism which would enable these

33- $\frac{1}{3}$ r.p.m. records to be played on existing 78 r.p.m. turntables, has caused considerable disappointment.

At the last moment it was found that the old turntables did not afford sufficient constancy of speed, and the plan for geared converters had to be abandoned in favor of new motor-boards, with switch control affording the two speeds. These motor boards can be dropped in place in any existing machine, and so comprise a profitable job for the radio dealer's service man. It is predicted that the retail price of the new motor-board will be between \$20 and \$25.

Immediately a first-rank market of at least a million recent combination and phonograph units is opened up for conversion, in order to play the new long-time records, with 15 minutes of music on each side. In addition there are about 15,000,000 radio sets, which can be converted into electric phonographs by means of **plug-in** turntable kits, with electric pick-ups. Conversion and equipment of all this tremendous market rests in the hands of the radio service man, for the new apparatus, being electric amplifying equipment, will require a technician to make the cut-over.

Reports from the laboratories indicate the constantly improving tone quality of the latest records of the long-playing type. The records now coming off the presses are declared to be far ahead of those offered at the beginning. And some recent further improvements which have already been demonstrated in the laboratory, will be available commercially in a few months. These supply a tone richness, a wide range of volume, from delicate passages without ground-noise or needle scratch up to the full crash of a great orchestra, that have never been approached before in home musical instruments.

Already it is clear that the new long-playing record is going to restore the home reproduction of music, independent of broadcasting, on a new scale of excellence, fidelity and interest. The long-playing record seems to supply the means of filling in the valley of radio sales, and radio and music dealers will watch closely this new item which should bring a marked Indian Summer into "the winter of our radio discontent!"

They BUY *the Best*

By
Howard S.
Pyle

*Why
Standard Makes
are Demanded*

▼
*A Market Waiting
for a
Good Battery Set*



SIX hundred miles north of our own West Coast lies Alaska—"Uncle Sam's Attic." Each of the towns in the southeastern division of this great frontier boasts at least one radio dealer. Ketchikan has eight, Juneau fourteen, Wrangell, Petersburg, Sitka and Skagway all have one legitimate dealer and two or three "curbstoners."

The majority of dealers combine radio with other lines, although a few exclusive dealers are managing to show a profit. Smith Electric in Ketchikan, does a good radio business along with electrical contracting and fixtures. Mayor Walker of Ketchikan, proprietor of Walker Drug Company, has a separate and attractive establishment in which he handles phonographs, records, radio and refrigerators. In Juneau, the Alaska Light & Power Co., owner and operator of KFIU, has a complete radio sales department. Cash Cole combines radio with his electrical business.

Practically all merchandise handled is of standard, recognized manufacture. Most of the Alaskan radio dealers are on the mailing list of the so-called "salvage

houses" of the U. S., but very little of this merchandise finds its way into the territory. A radio set *must be good* to sell there as the nearest "States" broadcast that can be tuned in is more than five hundred miles to the south and over mountainous country notorious for its dead spots. There is no place here for sets of questionable manufacture or unreliable performance. Alaska has good radio service men but the delay in obtaining parts from United States factories, discourages the handling of anything but merchandise of reputable manufacture.

THERE is a wide field here for battery sets. While the main centers are equipped with modern light plants, most of the smaller settlements have limited electric service or none at all. Thousands of fishing boats operate from southeastern Alaskan ports during the summer season, and practically all of them must have some sort of battery receiver with which to brighten up the long, lonely hours at the fishing grounds. Many obsolete battery sets have found a ready sale here at fair prices but *a manufacturer with a modern, compact battery set,*

in ALASKA



JUNEAU

reasonably priced, would find an excellent market for his wares.

Considerable interest has been evidenced in short wave equipment and a number of such receivers have been sold, the purchaser hoping to get distant daylight reception. Results so far have been more or less discouraging and it is felt that more scientific progress must be made in high frequency transmission and reception of voice before reasonable success will be attained.

IN THE populous southeastern strip there are two, low power stations: KGBU, at Ketchikan, 900 kilocycles; and KFIU, at Juneau.

Radio occupies a big place in the lives of the people of the North. Often it is their only contact with the outside world for several months. Reception, generally, is good.

The local stations serve a useful purpose in that they represent the only source of daylight reception in their respective areas during the summer months, when, due to the long hours of daylight, it is impossible to hear the United States Pacific Coast stations until about nine o'clock in the evening.

During the winter, when darkness falls at about four in the afternoon, stations in the States come through in good shape from that time on, and many logs have been shown me that would be the envy of some of our DX hounds in the States.

Alaska is a great country, with a keen, intelligent people. They are determined to have the best and willingly pay fair prices for such. It is a most excellent potential market for good, reliable merchandise, sold at a fair figure, but woe betide the "fly-by-night" maker of questionable goods who attempts to "gyp" these people of the North.



SITKA



KETCHIKAN

Louder and Funnier

Some Unusual But Practical Uses For Public Address Systems

By J. M. Kuhlik

THE variety of new uses for public address equipment developed by dealers is a tribute to their ingenuity and imagination. Some of these new uses are amusing, though practical, and it is with the hope that they may suggest others that the following experiences of customers of the Miles Reproducer Company, New York, are described:

WALLS, WITH EARS

Several weeks ago, a prominent department store decided to have the manager of its jewelry department eavesdrop on conversations between customers and clerks. So the store concealed microphones beneath the counters. Now, this is what happens when "big game" approaches:

Customer: "How much is this diamond ring?" *Clerk:* "\$1500." *Customer:* "Have you any at about \$800?" *Clerk:* Certainly, we have lots of good buys at that figure. (switches in microphone).

The manager, who has overhead and decides that an \$800 prospect is worthy of his personal attention, arrives on the scene and both boss and clerk, bring all guns to bear on the sale.

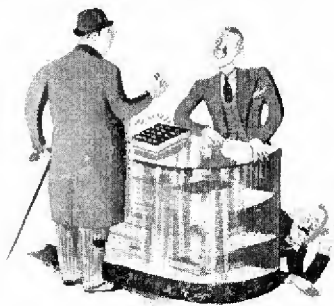

SCAT! 1931 VERSION

A dog breeder up in Westchester County had a lot of trouble with his dogs at night. They set up an ungodly howling at 2 a.m. each morning, causing no end of embarrassing complications with the neighbors.

The only way to quiet the brutes was to get dressed and go down to them—not a pleasant duty even in the summer and unadulterated misery with snow on the ground. The man-who-had-done-without-sleep licked his problem by installing a speaker and an amplifier at the kennels and giving the dogs a piece of his mind via microphone from the bedroom.

Not a bad idea, incidentally, for shooing operatically inclined cats off the back fence!



LITTLE MAN, BIG VOICE

A fruit peddler in a western metropolis found himself running a very bad second to a competitor. Trouble: Said competitor had a voice like a metropolitan opera star (in volume, if not in musical quality) and scooped the business by the simple process of shouting.

The little fellow put in an amplifier and speaker and now outshouts his competition.

WOLF TROUBLE

In certain parts of Russia (U.S.S.R. to you) small villages located in the heart of the wilderness guard themselves against the attacks of hungry wolves by frightening the animals away with powerfully amplified shouts issuing from loud speakers surrounding the town.

Now here is something that can be sold to the unemployed!

HASH BY WIRE

One of the "Childs" restaurants in New York has installed a system which greatly improves service. Instead of a waitress running back and forth between tables and kitchen she plugs a microphone into a wall jack and places her orders by wire.

Out in the kitchen, amid the pots, pans and parsley, an amplifier and speaker spout orders to the chef.



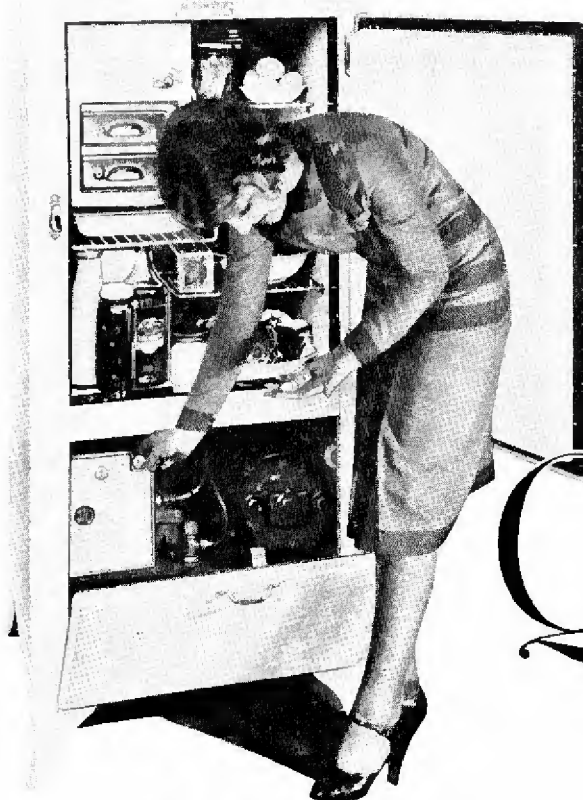

Will a quarter a day keep the ice man away?

The Development of "METERED" Refrigeration Payments.

Danger Points and Advantages

A Quarter a Day

SUFFICIENT time has now elapsed, since the application of the "metered" payment plan to the purchase of an electric refrigerator, to make possible a partial analysis of the value of this stimulant. Stories of the phenomenal success of the 25-cents-a-day idea have been given wide publicity. On the other hand many merchandisers claim that, for the smaller dealer at least, the plan is unsound because of the undue credit risks involved, the tendency to feature terms and the extra capital required by the dealer to purchase the metering device.

The "metered" payment plan provides for the attachment, during the life of the contract, of a small bank and time regulated current-cutoff to the electric refrigerator—or certain other electrically operated major appliances. Once a day a quarter must be inserted in the bank or the current automatically will be shut off. Another, simpler, method involves only the conveniently placed bank on top of the box, sometimes with an electric clock, thrown in for good measure, or perhaps for its psychological effect.

Devices of the first, or positive, class are now on the market under these trade names: "Meterice," "Metermatic," "Pay-a-Day," and "Mills." They cost the dealer about \$25 apiece. Obviously 50 meters (investment approximately \$1,200) will keep 50 refrigerators, at \$7.50 a month, in the payment process at a time.

So far, only the larger and more aggressive outlets, particularly the department stores, have worked this stunt. Hartman's, a large furniture concern in Chicago, offered its refrigerators under this plan without down payment or installation charge on contracts under \$225. The buyer agrees simply to deposit 25 cents a day in the meter box. Once a month a collector empties the box. Bloomingdale's, New York, requires a \$10 deposit and provides a bank and electric clock, the customer

being morally obligated to drop in his quarter a day. If the collections are not sufficiently substantial at the end of the month the refrigerator is removed. Put into operation October 5, following a half page in the *New York Times*, this "come on" sold 300 boxes within the next 30 days; quadrupling October sales for the year previous. This department store also has applied the "bank" idea to slow-moving radio sets with considerable success. Another case: May's, Los Angeles, using a meter cut-off device, claims to have written \$102,000 worth of refrigeration business in less than ten days.

IN THE first instance (Hartman's), it will be observed that an electric refrigerator now may be obtained on a first payment of but the quarter part of a dollar. This practice would seem to be unsound and may quickly lead to disastrous price cutting, the more conservative contend. Furthermore, the dealer must tie up an average of \$25 more per machine—the cost of the coin-operated mechanism. Discounting this type of a "bill of sale" is another hurdle which the ordinary dealer may find insurmountable. In other words, the risk and burden imposed on the vendor is too great it is claimed.

To summarize: coin meters, or conveniently placed banks, are used to "dramatize" the daily payment plan. To date, the records of concerns featuring this plan show a marked increase in refrigeration sales over normal. New factors have been introduced which will require careful weighing, and may need to be adjusted, before the meter-box payment plan can be said to have arrived as a permanent, constructive and profitable merchandising process. These factors are: The stressing of terms—attracting the questionable credit-risk type of prospect; the added first cost of this accessory device; long terms—from two to three years; added difficulties

(Please turn to page 52)

Shortwave Converters

THERE are three types of apparatus in general use for the reception of shortwave, or high-frequency, signals. In the first class we have the "tuners" designed expressly for this purpose and also sets of the "all-wave" variety. Then there are the "adapters," tuning units that utilize only the audio amplifier of the broadcast receiver with which they are used. "Converters" form the third group.

The first two systems mentioned are understood by most servicemen and so we confine ourselves in this article to the third, which is less familiar.

The converter is really a frequency changer, operating on the superheterodyne tuning principle. It consists, essentially, of a tuned, local oscillator and a modulator, or first detector. The oscillator may be made to heterodyne with different incoming shortwave signals, resulting in a constant beat-note or "difference frequency" for any setting of either the oscillator control alone, or both oscillator and tuning controls. To explain further, by blending two frequencies, that of the signal and that of the oscillator in a modulator, an intermediate frequency is produced. The output of the converter is carried to the antenna post of a broadcast receiver, which is tuned to this new frequency (which may lie anywhere between 200 and 600 meters, depending upon converter design.)

A number of manufactured converters have come into use. Representative types are described below:

BRUNSWICK Model 100, is a two



By Lewis Winner
Hammarlund Mfg. Co., Inc.

tube converter, using a type '24 tube as a detector and a '24 as an oscillator. A special plug-in switch arrangement, permits tuning from 20 to 36 (black coil), and 37 to 60 meters (red coil). Changeover is accomplished simply by flipping the switch. For the 120 to 200 meter band an additional coil (green), which must be plugged in, is provided. Each coil has four windings. A 70 mmf. double midline condenser is incorporated for tun-

ing. Plate and heater voltages are secured from the broadcast set.

PHILCO Model 4, is a 3 tube unit using a '27 oscillator, '24 detector and an '80 rectifier. Switch arrangement is used, affording rapid tuning from 15 to 200 meters. One major tuning control.

SILVER-MARSHALL Model 739, is a three tube converter using a '24 detector, '27 oscillator and '80 rectifier. Has a novel a.c. power arrangement in that provision is made for operation off either the 110-120 volt, 25-60 cycle line or off a 200-240 volt, 25-60 cycle line, simply by changing the position of primary leads to the transformer. A wave changing switch is used providing tuning in four settings from 10 to 20; 20 to 40; 40 to 80, and 80 to 200 meters, with a double 140 mmf. midline midget tuning condenser.

COLIN B. KENNEDY Globe Trotter, Model 54 uses two tubes, a '24 detector and '27 oscillator, having its own heater transformer but receiving plate supply from the broadcast set. Detector tube feeds into a tuned 1525 k.c. transformer, in which neighborhood the broadcast set must be also adjusted. Switch arrangement used permits tuning from 15 to 25; 25 to 47; 47 to 85; and 85 to 200 meters, with a 150 mmf. midline condenser for tuning each circuit.

WORKRITE Model 4X, is a four tube device using a stage of untuned r.f. with a '24 tube, a '24 as detector, a '27 oscillator and an '80 as a rectifier. Uses plug-in coils, covering from 14 to 200 meters.

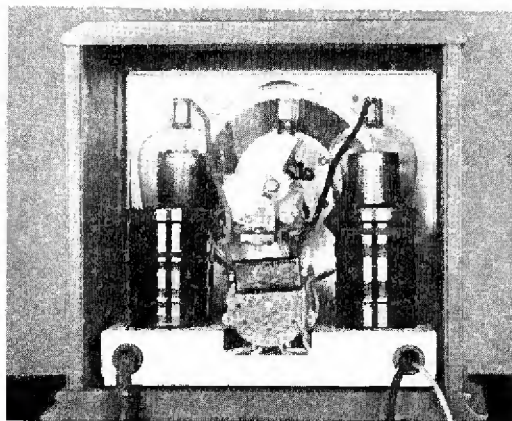

TYPICAL CHASSIS

The Brunswick device obtains both plate and heater voltages from the broadcast chassis to which it is attached (Left)

Pilot's unit has its own "A and B" power-pack using a type '80 rectifier (Right)

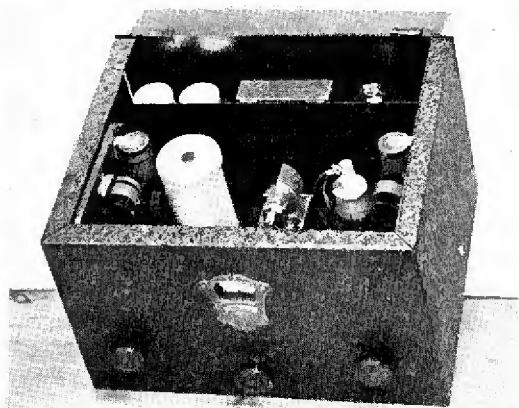
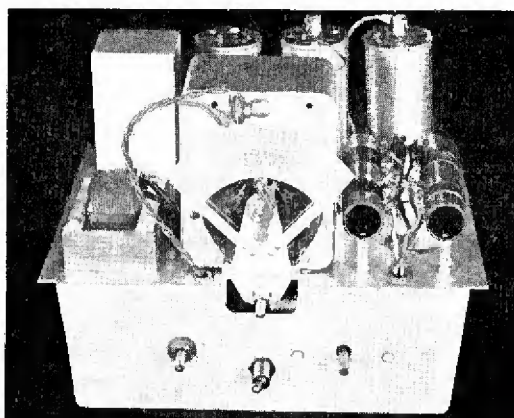

The Jackson Job includes a pack utilizing a type '26 tube as a half-wave rectifier (Left)

Kennedy's converter has its own heater supply transformer but takes plate current from the long-wave set with which it is used (Right)

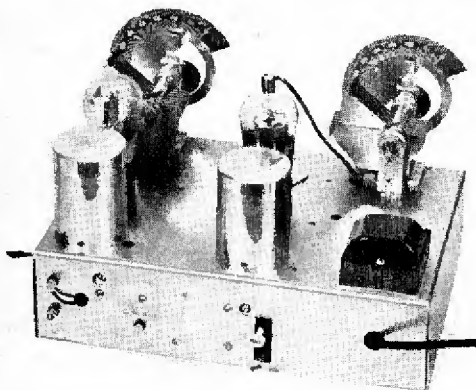

SUPERTONE Model 200-M, is a three-tube converter using a '24 detector; '24 oscillator, and a '27 as a rectifier. Novel switch arrangement with single coil permits tuning from 20 to 125 meters, using a 200 mmf. midget midline condenser.

STEWART-WARNER produces a converter alone, as well as a combination broadcast receiver and converter. The design in both cases is the same, a '24 tube being used as a detector and a '27 as an oscillator, plate supply being secured from broadcast set. A heater transformer is built-in. Uses switch arrangement covering from 20 to 200 meters.

CROSLLEY Model 7-1 is a three tube device using '24 detector; '27 oscillator and '80 rectifier. Employs five sets of plug-in coils, two to a set, having the following approximate ranges: 10 to 18 (red coil); 17 to 31, (blue coil; 30 to 56 (yellow coil); 54 to 95 (black coil) and 81 to 201 (green coil) meters. A two control job with power supply included.

RCA-VICTOR produces a three tube unit, using an untuned R.F. stage with a '24, a '27 as detector, and a '27 oscillator, with plate supply being secured from set. Heater transformer is provided. Four sets of plug-in coils, two to a set, are used, with following ranges: 16 to 25; 23 to 45; 36 to 60, and 55 to 110 meters. All coils are marked. Two controls are used. An additional model may be expected after the first of the year.

JACKSON LC-3 converter uses three tubes, a '24 detector, a '35 as oscillator and a '26 as a half-wave rectifier. Four sets of coils operative by four switches are used, the knob having color indications as to meter ranges. That is, when knob is turned to green spot, the 16 to 35 meter band is in play. The 31 to 68 band is the red indication, 64 to 128 meters is the blue and 111 to 184 is the orange. Has one major tuning control.

NATIONAL NC-5 converter uses five tubes, a '35 first R.F. (semi-tuned); '24 detector coupled to a '27 output coupling tube by a 575 k.c. tuned transformer; a '35 oscillator and an '80 rectifier. Has same coil arrangements as Jackson LC-3, except that yellow is substituted for orange in color arrangement.

PILOT Super-Wasp converter comes as a separate unit and also as part of the "all-wave" set, consisting of a '24 detector; '27 oscillator; '27 coupling tube and '80 rectifier. Tuned 550 k.c. coupling method, linking output of mixing system to coupling tube, used. Switching system covers 10 to 200 meters with five knob positions, i.e., 10 to 19; 19 to 35; 35 to 65; 65 to 110, and 110 to 200 meters.

FRANKLIN'S "Rembert" model, having its own power supply system and three tubes, '24, '27 and '80, uses a switch for band changing and one tuning control. Range, 14 to 200 meters.

SHORTWAVE & TELEVISION builds a three tube converter into a console cabinet along with a broadcast chassis as well as separately. The device, which tunes down to 19 meters, uses three tubes and a band changing switch, taking its plate power from the broadcast power-pack. A transformer supplies heater voltages.

KOLSTER is planning to announce a converter soon.

As will be noted, several manufacturers use coupling transformers tuned to a specific frequency. This means, of course, that the broadcast receiver must be tuned

PHILCO

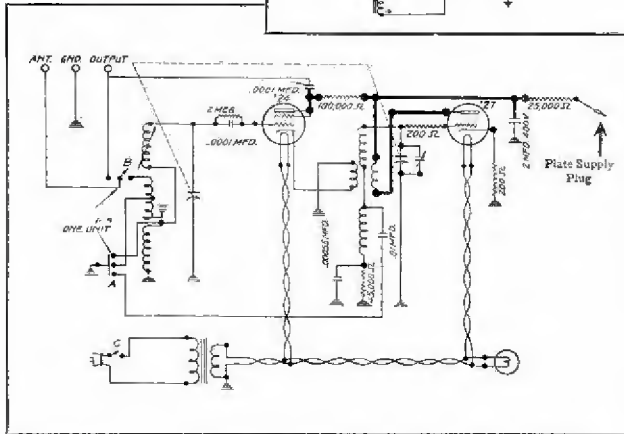
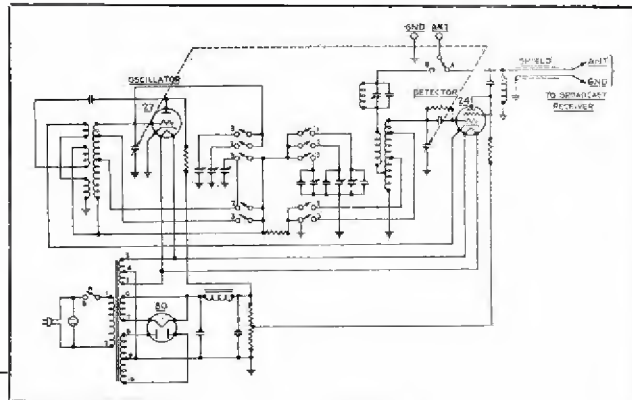

STEWART-WARNER

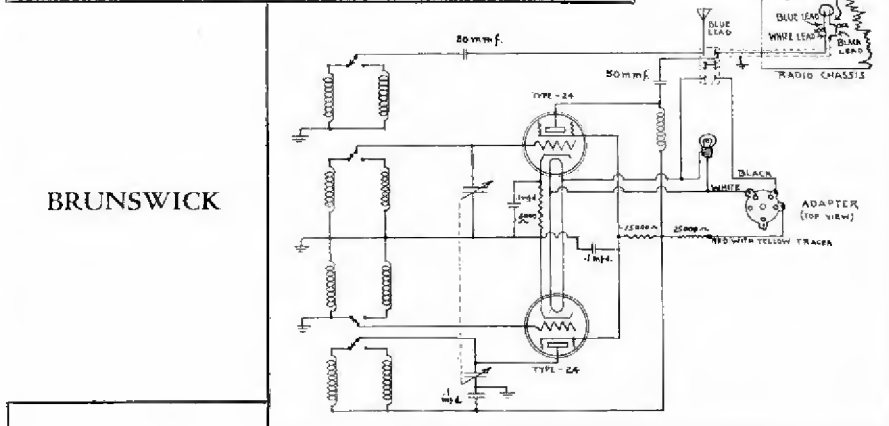

BRUNSWICK

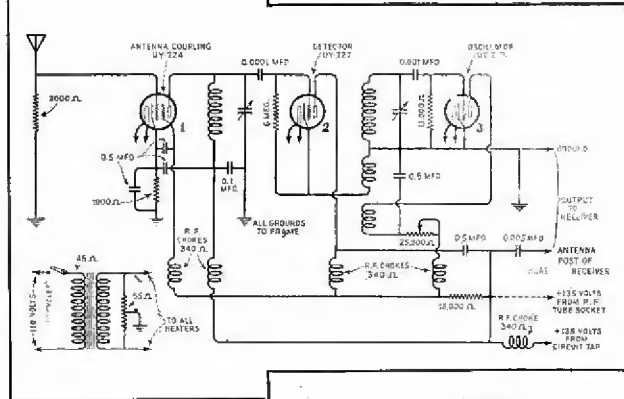

RCA VICTOR

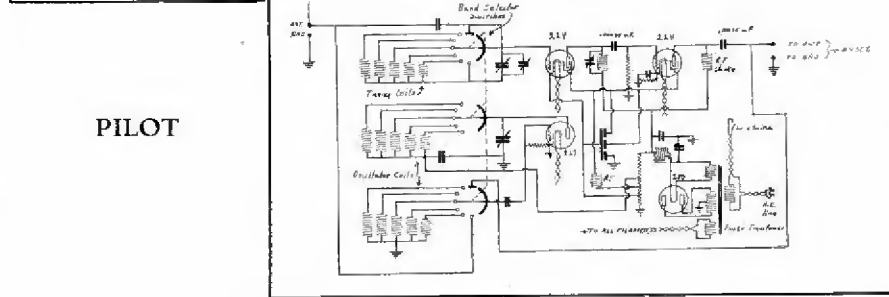

PILOT

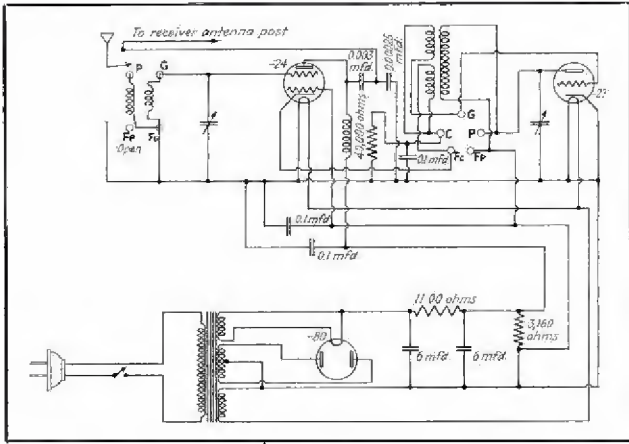

CROSLY

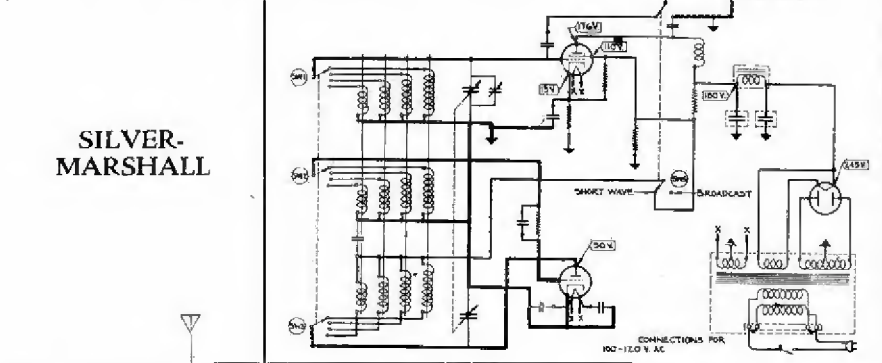

SILVER-MARSHALL

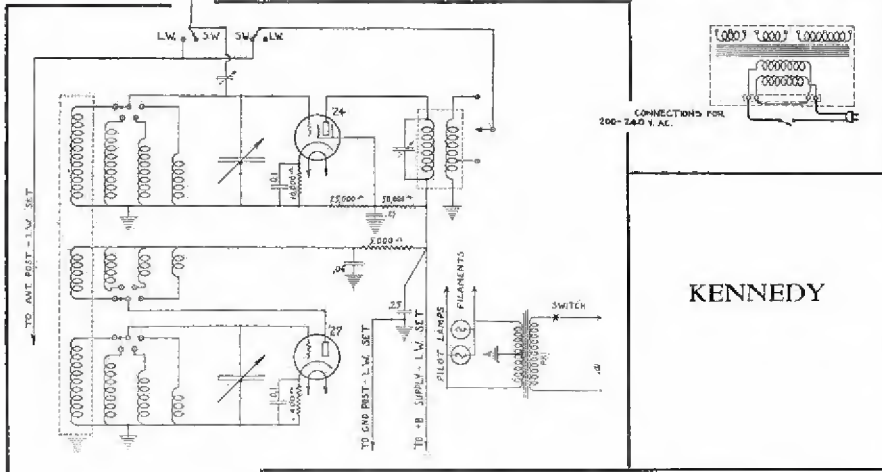

KENNEDY

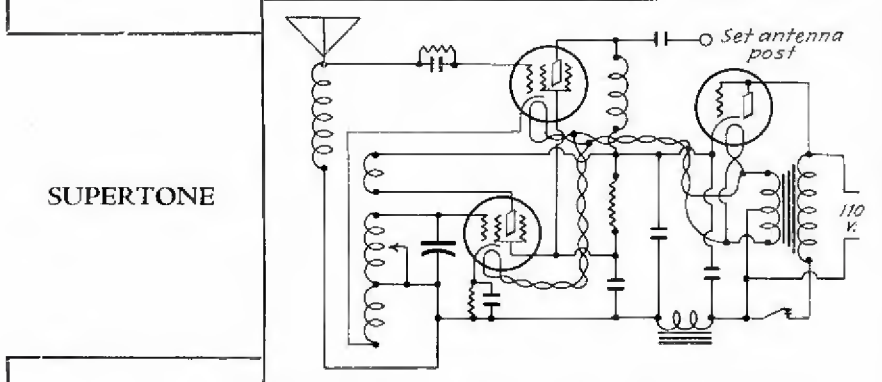

SUPERTONE

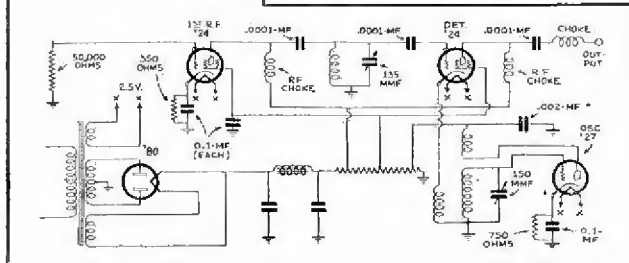

WORKRITE

to about the same point if the signal is to be properly amplified. At this point no broadcast signal should exist, since such a signal would interfere with the incoming shortwave signal.

The success of any converter is really largely dependent upon the broadcast set with which it is used.

Most converters can be used with modern t.r.f. sets, having a sensitivity of 100 microvolts or better at about 525 meters. Some receivers use band-filter pre-selector or similar "blocking input" systems having considerable attenuation. In such cases the converter output must usually be connected directly to the first tube circuit. Converters designed for use with superheterodynes sometimes have a stage of amplification after their oscillator to afford increased amplification. This is sometimes carried out in the receiver itself, and consists essentially of a single tuned r.f. circuit.

A very important point in successful converter operation is the application of proper plate voltage. When it is necessary to secure "B" voltage from the broadcast receiver, in most cases this voltage is securable from the screen-grid cap of a tube in the broadcast set. In such cases contact should be very secure and may be in the form of a lug or looped wire which will fit over the prong. Usually the last r.f. screen-grid tube will provide a constant "B" voltage from the screen. Since the average converter draws about 12 mills of plate current in a receiver which provides screen-voltage dropped through a series resistor, excess current flowing through the resistor may lower the voltage to a point where oscillation is prevented. An extra 1 mfd. condenser connected between the "B" plus lead of the converter and the ground usually adjusts this problem.

Some manufacturers recommend that plate voltage for the converter be obtained from a point in the broadcast receiver power supply system rather than at a tube, where additional current drain through common resistors may affect voltage supplied to other tubes.

Tuning of converters is a salient topic. After the switch of the receiver is turned on and the tubes and converter are lighted, the proper coil adjustments made, the broadcast receiver should be tuned to the frequency recommended by the maker of the converter. Listen for the familiar rushing sound in the speaker. If this sound is not present, turn up the volume control until it appears.

If the broadcast receiver oscillates at the high frequency to which it is tuned, you may not be able to tune in short waves. Be sure that the receiver is not oscillating, but if possible operate it just under the point of oscillation. If it is a stabilized receiver operate it near the maximum volume control position. Now, very slowly, the tuning dial of the converter should be rotated, remembering that it is very easy to pass over a shortwave signal.

A tube which is a good oscillator must be used. This is the first thing to check up if the converter does not operate properly. The detector tube should also have maximum sensitivity. A trouble commonly found in converters is that of poor contact between switch points or between coil prongs and the socket connections. Resistance caused by this difficulty will impair sensitivity and sometimes prevent oscillation.

SERVICE SHORTCUTS



R. F. Pentode Announced

RADIO frequency pentodes, about which there was considerable hullabaloo two years ago, have finally made the "big time," entering the picture by way of the auto-radio route—as so many new tubes do. RCA Radiotron and Cunningham both have announced a tube to be known henceforth as type '39, bearing the impressive designation "Super-Control Radio Frequency Amplifier Pentode."

The tube has been designed for use in auto-radios and 110 volt d.c. sets, being particularly efficient, so they tell us, as an r.f. amplifier in circuits where only comparatively low plate voltages are obtainable. The "super-control" feature is borrowed from the popular variable-mu tetrode, being a split-grid construction

current is supplied by a 6 volt storage battery while series operation is recommended when the tubes are used in sets operating from the 110 volt d.c. line.

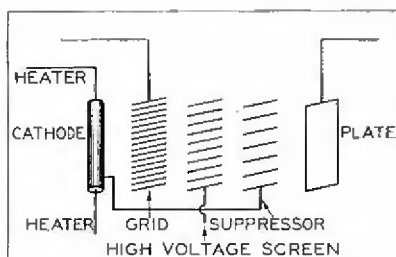

The preliminary rating and characteristics are as follows:

| | |
|------------------------------|------------------------------|
| Heat volt. | 6.3 Volts D.C. |
| Heat cur. | 0.3 Amp. |
| Plate volt. | 180 Volts, max |
| Screen volt., max. | 90 Volts |
| Grid volt., var. | -3 Volts, min. |
| Plate cur. | 4.4, 4.4, 4.5 Ma. |
| Screen cur. | 1.3, 1.2, 1.2 Ma. |
| Plate res. | 375,000 540,000 750,000 Ohms |
| Amp. factor | 360 530 750 |
| Mut. cond. | 960 980 1000 Mhos. |
| Mut. cond. at -30 volts bias | 10 10 10 Mhos. |
| Base | Small 5 prong |

*Recommended values for use in receivers designed for 110 volt d-c operation.

Auto-Radio Kink

By M. G. Goldberg

In installing auto-radio in some of the better makes of cars I have noticed that while the ignition is not annoying when the driver is out of the car it immediately becomes objectionable when he sits behind the wheel and places his feet on the clutch and brake pedals. This is particularly noticeable when the distributor is just on the other side of the kick-board from the accelerator pedal and is due to conductivity through the driver's body to the aerial above him.

This trouble may be cured by placing a thick sheet of galvanized iron under the floor boards below the accelerator, clutch and brake pedals and grounding this plate at each end to the frame with a piece of braided wire.

Holding Analyzer Plugs

By A. C. Schmitt

Most service test set adapters are fastened together by means of a hollow shaft, then crimped over. These adapters, when placed on a plug and inserted in a tube socket often pull loose and stay in the set. When this happens considerable trouble is experienced in removing them. Most servicemen do it by driving a long thin screw into the shaft and then hauling on it with a pair of pliers.

Trouble with adapters may be permanently eliminated by tapping the hollow shaft and then tightening a long round headed screw in place, holding it firmly to the plug. If the screw head is not large enough to prevent its pulling through the hole in the plug a washer may be soldered to it.

One Cause of Hum

By A. W. Lengarn

If a set develops excessive hum, tighten all the bolts that hold the laminations in the power transformer and filter chokes. If this fails to stop the hum, drive a small wooden wedge in between the windings and laminations.

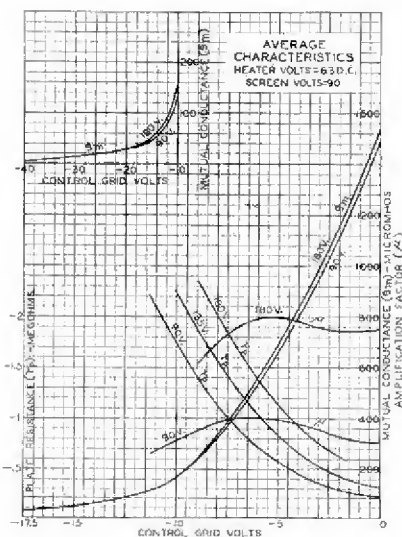

which eliminates the necessity for local-distance switches, helps tone quality considerably at low input levels and lends itself to automatic volume control circuits.

The tube has a coated d.c. heater, electrically isolated cathode, control-grid, screen-grid, suppressor-grid and a plate, the suppressor being connected to the cathode within the tube as in the case of the more familiar power pentode. No heater circuit resistor is required when

Emergency Resistors

By J. Howard Parry

Often on a job, a small resistor is immediately suspected of being defective. When this is the case much time is saved by substituting another resistor, even one of slightly different value and noting the effect, instead of going through all the routine analyzer tests.

Since a serviceman can scarcely carry a wide assortment of replacement resistors, a method of substituting for the purpose of testing must be found. I use the internal resistance of my analyzer voltmeter for this purpose, starting with the instrument set at its highest voltage range to avoid wrapping the pointer around the peg. A.c. instruments serve as comparatively low resistances with somewhat higher current carrying possibilities than d.c. types.

MORE PUBLICITY FOR RADIO

RWA Promoting "Radio Week" in Many Cities

A newspaper publicity campaign, similar in principle to the one run in Detroit, and covered in a feature article elsewhere in this issue, is, as we go to press, being promoted in Chicago. Full details of this plan have been sent to all local associations of Federated by the Radio Wholesalers Association. Radio Publicity weeks, therefore, will soon be observed, or already have been consummated, in a dozen key cities throughout the country.

The Chicago group has enlisted the cooperation of all the leading local papers with the result that there now is appearing in that city promotional advertising copy, box editorials, news releases, feature items and cartoons urging the public to buy a quality modern receiver. This idea is being backed by the Major Market Newspaper organization and by the Hearst syndicate. Through the latter, Radio Week has been scheduled for other places as follows: Atlanta, Nov. 25; Omaha, Nov. 16; Albany, Nov. 30; Baltimore, Nov. 29; Rochester, Dec. 6, and Washington, Nov. 30. Boston, Syracuse and New York are expected to get aboard this band wagon in the near future.

Briefly, the newspapers will prepare and print promotional copy during the first week of these campaigns. The following week the radio trade, cooperatively and individually, will run extra space feature advertisements tying in with the main theme, already registered editorially by the papers, "Buy a Better Set."

In Chicago the broadcast stations are running special programs and at least three theaters will present special stage performances. Through the cooperation of the Music Corporation of America, posters have been placed in all the leading cafes to the effect that their artists are also sponsoring this event.

Nick Carter Forms Television Co.

Nick Carter has resigned as president of the Carter Radio Company, and withdrawn from active management of that company, although he remains a stockholder and director of the Utah Radio Products Co., of which Carter is a subsidiary, and has announced the formation of the Carter Television Company at 2657 Farwell Ave., Chicago.

He will shortly announce the production of a new type television instrument, improved automobile remote control and B eliminator for automobile-radio, as well as a complete line of dynamic speakers.



Strictly Radio

Van-Ashe Radio Company claims to be the only wholesale firm in St. Louis that tenaciously stuck to radio since its inception a decade ago. However, they have now added refrigeration, having just been appointed Lyric Radio and Mohawk refrigerator representatives. Left to right are Geo. W. Van Sickle, Gen. Mgr., Tom H. Phillips, Lyric district mgr., and W. W. Van Sickle, president.

MICRO-SCOOPS

Studio Gossip for Dealer Ears

By JAMES CAULFIELD

THE METROPOLITAN OPERA will be on the air Saturday afternoons starting after New Year's day, over the NBC system. This short announcement should mean a lot to the radio dealer in stimulating new set sales to new prospects. Thousands of homes in this country are lacking receivers because of the over-emphasis of jazz. Canvass and follow up every music teacher, music pupil and music lover. Get a list of music minded people from the music schools in your vicinity. Use this announcement to swing your prospect away from the cheap set. Lay stress on the higher priced models that are necessary in order that these colossal productions may be reproduced with fidelity.

THE VERY LATEST sensation is the four Mills brothers, the new colored quartet over the Columbia system. These four boys imitate an orchestra and yet they only employ a guitar. Their effects are so perfect that it is said they sound "more like an orchestra than an orchestra itself."

JIMMY WALLINGTON, who supports Eddie Cantor on the latter's Sunday night broadcast for President, suggests that they adopt a plank to help the farmer by making the million students in college each bring the

teacher an apple in order to give the farmer a break. Eddie suggested they give them all a break by bringing the teachers apple-jack.

THE BROADCASTERS are working hard on their Yuletide programs and as we go to press we have learned that the first star to be signed up is Madame Schumann-Heink. She will sing "Silent Night, Holy Night" on Christmas eve.

HAVE YOU TUNED in on three of the better known aerial boys lately. Morton Downey has injected a more serious note to his quarter hour. Bing Crosby is now singing more nearly the way he did on his earlier records that you are familiar with. And Guy Lombardo has polished up his program and eliminated some of his vocal choruses.

RAY PERKINS, NBC's jester, master of ceremonies and philosopher, christened his airplane, "Peacock," because it has wings and struts.

BILL MUNDY, the Georgia drawl and football commentator, enroute to a recent football game picked fourteen winners out of a possible fifteen. The only game he failed to predict correctly was the contest he later announced.

ONE OF THE LEADING exponents of "blues" and southern mammy songs is Lee Morse, appearing on several network programs through NBC. She is a southern girl and once was a choir singer in Kooski, Idaho, where her father served as a minister.

RALPH AUSTRIAN

In charge of all divisions of domestic sales of Kolster Radio. Formerly identified with Gimbel Bros., New York, and vice-president of R. B. Rose Co., Inc. He comes to Kolster from Westinghouse.



Utah Goes In New Home

Increased production and the addition of new lines of products is announced by the Utah Radio Products Co., following its move to larger quarters at Orleans & Institute Place, Chicago. The main manufacturing plant, now in Salt Lake City, Utah, will be moved here and combined with the Chicago unit.

Firing Line

the News Bombardments

New York, N. Y.

Radiotron and Cunningham to Have Unified Management

E. T. Cunningham, president of the RCA Radiotron Company, and G. K. Throckmorton, president of E. T. Cunningham, Inc., have announced the unified direction of the sales activities of these two tube concerns. At the same time Mr. Cunningham made known the following appointments: vice-president in charge of sales, G. C. Osborn; eastern sales manager, Meade Brunet; central sales manager, M. F. Burns, and western sales manager, F. H. Larrabee.

In announcing these changes Mr. Cunningham said: "During the past two years the sales divisions of E. T. Cunningham, Inc., and the RCA Radiotron Company, Inc., have been concentrating their efforts on the development of the radio tube renewal market.

"Our experiences with test sales activities have indicated that the radio tube business of the country could be doubled by the proper application of proven sales methods. The result was the recommendation, by the sales executives of RCA Radiotron Company, Inc., and E. T. Cunningham, Inc., that certain sales activity should be unified so that our combined forces would be working for the accomplishment of a common objective.

"The individuality of both the Radiotron and Cunningham brands will be maintained by two distinctive sales promotion programs."

L. S. Gordon New DeForest-Jenkins Head

Announcement has been received of the resignation of Charles G. Munn as president of the DeForest Radio Company and the Jenkins Television Corporation, and his election as chairman of the executive committee of both companies.

Leslie S. Gordon, who has been identified with banking and manufacturing activities in Chicago, succeeds Mr. Munn as president of both firms.

Rogers President Strevell-Paterson

G. A. Rogers has been elected president and general manager of the intermountain firm of Strevell-Paterson Hardware Company, Salt Lake City. He succeeds F. W. Hornung, who has retired after 30 years with this concern.

Strevell-Paterson have been wholesalers of radio since 1924. This concern also is the exclusive distributor of Norge refrigerators. It is said that this house has the exclusive distribution of more special lines than any other jobber between Chicago and the Pacific Coast. It employs 25 regular salesmen and many special representatives.



On the Side

Gene Redewill of Phoenix, Ariz., one-time pioneer in the radio field, is now carrying airplanes as a side line. Both Mr. Redewill, (left), and his partner, Ted Kress, (center), have learned to fly. Mrs. Redewill is shown at the right

International Resistance Elects New Officers

Following the untimely death of its president, Francis R. Ehle, who was instantly killed in an airplane crash, the International Resistance Co., Philadelphia, has appointed Ernest Scaring, former vice-president and director, to succeed to the presidency.

Wm. G. Porter has been elected vice-president and a director, and Ruth N. Shires, formerly secretary, has been made secretary and treasurer.

Pioneer Opens Branch Factory

A branch factory and office at 2500 Market St., San Francisco, Calif., has been opened by the Pioneer Radio Mfg. Co. N. Feldstern is manager.

The home office and factory are in New York.

A DATE FOR YOUR CALENDAR

SIXTH ANNUAL CONVENTION
NATIONAL FEDERATION OF RADIO
ASSOCIATIONS, INC.

AND
RADIO WHOLESALERS ASSOCIATION,
INC.

FEBRUARY 16-17, 1932

PHILADELPHIA, PENNSYLVANIA

RMA DIRECTORS MEET JOBBERS

Joint Luncheon at Cleveland—Manufacturers Discuss Proposed Sales Tax

Sales promotion plans, television, the patent problem, the proposed sales tax on radio and many other important industry problems were considered by the RMA board of directors at its meeting November 19, at the Hotel Cleveland, Cleveland, Ohio. Preliminary plans for the 8th annual RMA convention and trade show at Chicago, beginning May 23, the only official industry show, also were approved. J. Clarke Coit of Chicago, president, presided.

Officers and directors of the National Federation of Radio Associations and the Radio Wholesalers Association also met at luncheon with the managing committee of the RMA for a conference on sales promotion projects and improved radio merchandising practices. Development of cooperation on mutual industry problems was effected, especially toward improved merchandising practices. Special consideration was given to the sales promotion campaign of "Radio Week" in Chicago, November 30-December 5, following the Thanksgiving holiday.

The RWA group was headed by Louis Buehn of Philadelphia, president. Others attending the conference were James Aitken of Toledo, president of the NFRA; Ray Bechtol and Howard Shartle of Cleveland.

The probability of Treasury recommendations to Congress of a manufacturers sales tax on radio products was presented to the RMA board by Frank D. Scott, the Association's Washington legislative counsel. Action in the sales tax matter was deferred to await developments in Washington.

President Coit reported progress on the patent problem, in which negotiations and conferences have not been completed.

Deploring many false reports regarding television and "blue sky" television stock promotions, the RMA Board will take steps to advise the industry and the public regarding the true progress at present of television. A special statement on the actual status of television will be prepared and issued.

Free Film Directory

The 4th Revised Edition of the Victor Directory of Film Sources is now ready, according to an announcement by the Victor Animatograph Corp., Davenport, Iowa. It lists over 250 sources of free loan subjects, and virtually all known productions, sales and rental sources.

Tube Replacement Kit Stimulates Business

A tube merchandising idea that should cause people to think of stocking spare tubes in the same way they now consider spare tires for automobiles, seems slated for special popularity during the Christmas season. Both present set owners and new buyers are being convinced, through the use of an emergency tube kit, such as that put out by Hygrade Sylvania Corporation, that uninterrupted radio entertainment may now be obtained.

Accessories, home service, and similar means of keeping contacts and promoting good will, have long been recognized as valuable leads to the sales of



Special kit boxes, similar to this one, are available for more than 300 models of sets

new radio sets. This tube merchandising idea is an advance along these lines in addition to being profitable in itself. Each kit contains four tubes. Selling emergency kits, however, means something more than just selling spare tubes. It means convincing radio owners to keep radio reception at its best by changing tubes before they burn out, by changing tubes more frequently, by keeping the real life of the set up to scratch.

As a seasonal merchandising idea, these kits are packed in Christmas cartons in color, and advertised as unusual and useful gifts for every radio owner. The decorative cover can be discarded at the end of the season.

The Merit of the Horn Speaker A Correction

On page 35 of our November issue George J. Saliba stressed the dynamic speaker for quality work and "horns" where quality was "not so important." The word *magnetic* should have preceded the word "horn" as our contributor meant to distinguish between dynamic and magnetic type speakers rather than between cones and horns. Naturally, the dynamic types recommended might be either cones or horns and no implication that cones were superior to horns was intended.

NEW JOBS . . . NEW JOBBERS

JAMES J. DAVIN, formerly sales promotion manager of Majestic, and more recently associated with the Grunow group activities, has joined Norge as sales manager. He will act in the capacity of divisional manager for New England and New York.

CARL GROSSWENDT is now with Pacent as production manager.

JAMES D. GIBSON has been made representative for Pilot, in and around Chicago. He is the same "Jimmy" Gibson who carried the Freed-Eisemann, Grebe and Fada messages to the trade in earlier days.

JAY KENNEDY will act as Pacific Coast regional manager for Copeland Refrigerator in the territory lying between the Rocky Mountains and the Pacific Coast. Mr. Kennedy was formerly with the Frigidaire.

I. KAUFMAN has joined the sales ranks of Ollendorf & Hirsch, Inc., RCA-Victor distributors in Baltimore, Washington and Richmond.

JAMES MCKEE has joined the sales staff of Kolster Radio to assist sales manager Ralph Austrian. Jim is well known in radio circles, due to his delightful personality and his seven years' experience with Atwater Kent and Westinghouse.

MORTON D. JOYCE has been elected to the offices of secretary and treasurer of the Dubilier Condenser Corp. Mr. Joyce has been a director for several years.

CHARLES GILBERT, formerly with DeForest, Brandes-Kolster, and more recently executive vice-president of Pilot, is now assistant to the president, William Dubilier.

WILLIAM M. BAILEY, C. D. FLETCHER and F. A. SHAILER, formerly department heads of the Wireless Specialty Apparatus Company, in charge of design, manufacture and sale of Faradon Mica Condensers, have joined Dubilier.

Norge Corp., Detroit, manufacturers of Rollator refrigeration, announces the addition of the following men to direct its field selling operations: E. S. Ridgway, F. O. Fleischer, J. J. Davin and J. R. Blotcher.

This group of divisional managers is to supplement the already established field representation which Norge offers to their distributors.

Kolster International Radio is now being distributed in the metropolitan territory from Kolster's own New York office at 67 Broad St. W. E. and W. H. Jackson, Inc., San Francisco, is handling the set in northern California.

Gilham Electric Co., Atlanta, Ga., has been appointed distributor for Clarion radio. City Electric Co., Syracuse, N. Y., Rodefeld Company, Richmond, Ind., and Electrical Warehouse, Inc., Detroit, Mich., are also handling the Clarion line now.

The western half of the State of Maine is being covered for Zenith by the King & Dexter Co., Portland.

The following additions have been made to the distributing organization of Pilot: Farrar-Brown, Portland, Me., Splitdorf, Boston, Varrick Co., Manchester, N. H., Whittemore Bros., Worcester, Mass., Lyons Battery & Electric Co., Altoona, Pa., and R. J. Loocke, Baltimore, Md.

The Ken-Rad representative in the South is now Moeser & Jordan, Inc.

Motor Hardware & Equipment Company, with headquarters at San Diego, Calif., and a branch at El Centro, is the latest addition to the list of American Bosch distributors.

Royal Eastern Electrical Supply Company, New York City, will now distribute DeForest tubes in the metropolitan New York area.

Ray Thomas, Inc., distributor of Atwater Kent radios in southern California, has been appointed distributor of the Westinghouse refrigerator. Display rooms are being fitted up in Los Angeles, Pasadena, Hollywood, Long Beach and Santa Monica.

Williams Philco, Inc., Aurora, Ill., handle 33 counties in the northern half of Illinois, and not 8, as stated in the November issue. We apologize, Mr. Williams.

Sterling Pushes Appliances

The well-known Sterling Radio Co., Kansas City, H. C. Bonfig, general manager, not only is pushing electric refrigerators, but recently opened a new department, in the charge of L. N. Brown, to develop retail sales for washing machines. Sterling's plan of departmentalization according to product is meeting with marked success.

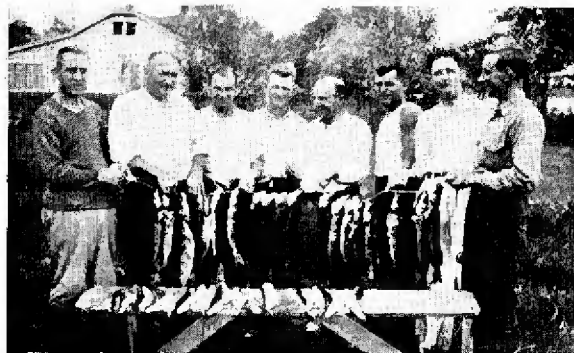

Fresh Fish for Sale

To disprove certain aspersions cast upon the ability of Erla executives as fishermen, the accompanying photograph was taken—the result of a catch at Shawano Lake in northern Wisconsin.

Vice-president Alschuler and sales manager G. W. Russell chaperoned the party.

Detroit Sells Radio—Not Price

(Continued from page 25)

Mr. Moores. "It is no cure-all for such a general business depression as we are experiencing but we do know that the public got the message of quality and that it responded to it. Further, the lasting effects of an educational effort such as we put on is a prolonged one."

Another reaction to this idea, indicative of its scope and merit, is seen in the numerous requests from other cities and from radio trade associations for full details so that they, too, might duplicate the plan. The fact that the *Detroit News*, one of the leading newspapers of the country, gave more free space to promoting listener interest in radio programs and the advantages of a good receiver than to any other subject it ever got behind, created interest among papers all over the country.

Grand Rapids started its publicity campaign October 22—with the slogan: "A Better Reception with a Better Radio." Chicago (Mid-West Trade Association) has held its preliminary meetings and plans are well under way for the same kind of a stunt. The 100,000 Club, a national newspaper organization, has requested complete details and copies of all publicity material for dissemination to its members. Lastly, Mr. Moores tells us that he has personally presented the plan to a dozen Michigan cities and that many of these will put it into effect.

The accompanying illustrations tell the rest of the story better than words. Dealers who are seriously interested may communicate with C. R. Moores, State Distributors, Inc., Tenth and Fort Streets, Detroit, Michigan, or with H. G. Erstrom, National Federation of Radio Associations, 32 West Randolph Street, Chicago.

A Quarter a Day

(Continued from page 39)

of discounting this long-term paper and, where a substantial down payment is not required, the delivery, installation and replevin costs in case the customer runs out of quarters. It costs the dealer about \$10 to perform these last three functions. The devastating effect on profits of frequent replevin operation is obvious.

Before radio dealers, who also handle refrigerators, make their final decision as to whether or not they will look further into this matter they should consider these arguments favoring the daily payment plan:

Competition in appearance, performance and price of many makes of electric refrigerators now on the market has created a striving for some unusual talking point. The "metered payment" idea has proven a remarkable, though perhaps temporary, business getter. If the plan can be applied on a constructive basis, and its danger points eliminated, it should be adopted.

With respect to discounting this type of time-payment contract, this is being done by certain finance houses where the endorsement of the dealer is backed by an unquestioned financial standing.

The experience of many stores—May's, Baltimore, for example—is that a substantial percentage of those who are induced to buy because of the apparent ease of paying (many sell themselves, the plan sounds so attractive) switch to larger monthly payments, on the old-time basis, within two months. "We can't get along without the refrigerator but the bank plan is a nuisance," these people declare.

Whether, in the long run, "25 cents a day" will benefit the refrigeration industry or whether this idea is but transitory, will depend largely upon the judgment used in the extension of this plan. Certainly the average dealer must continue to get a substantial down payment and to watch his credit risks just as carefully under this new dispensation as formerly.

Whether this plan will tend to direct prospects already interested, through the house-to-house sales methods of specialty dealers, to department stores and other large outlets who do not maintain outside sales crews, is another problem for the electrical refrigeration manufacturer and distributor to seriously consider.

What's What in Radio Furniture

THE folly of buying a radio housed in a cabinet that will not stand the destructive effects of climate, changes of household temperature, and the wear and tear of time is becoming plain to millions of radio owners as their instruments get older. People who would be horrified at the idea of buying a cheaply veneered dining room suite, purchase a radio cabinet without a thought as to its lasting qualities." A cabinet designer for Sparton made this statement recently in an address to 2,000 dealers and followed it with a demonstration of what good craftsmanship really is.

"Beginning with what is most obvious," he continued, "look first at the ornamentation. It is not hard to distinguish genuine wood carving from the cheap wood-putty imitation that is simply glued on. Naturally the latter, in time, will crack and become detached.

"Another thing to examine carefully is the paneling. Millions of sets have been sold on which the most beautiful effects have been obtained with a 'grain' that is simply paper, printed in imitation of wood, and carefully glued on like veneer. Amazing and unusual 'wood' effects are obtained, but under the influence of summer heat and dry winter heating they are quickly ruined. Make sure that the 'wood' really is wood.

"Another point in the paneling is its weight or thickness. Good furniture construction calls for 5-ply panels, that will not warp, crack or be easily injured. This five-ply paneling costs money. It is necessary for a good cabinet, but three-ply paneling is much cheaper. It is often used to the sorrow of the buyer.

"The way a cabinet is put together is a vital factor in its permanence but hard for the amateur to determine. A properly built piece of furniture is so designed that every element is locked into place. It can be assembled without nails, glue or screws, and it will stand rigid and firm, even before finally fastened.

"Standard construction demands that corner posts be morticed to receive the panels, but too often the panels are simply held in place with corner blocks. Interlocking should be accomplished wherever two pieces of wood came together, but there are cabinets on the market today where hardly two parts are interlocked together. Glue, nails and screws are not sufficient. Every part must fit into another.

"After all, the difference between good furniture and bad is simply permanence. Good furniture lasts indefinitely. The world is full of chairs that creak, tables that shudder at a touch, and all kinds of woodwork that warp and split. The only way to avoid such deterioration is to buy the right kind in the first place, and this applies to radio cabinets, too."

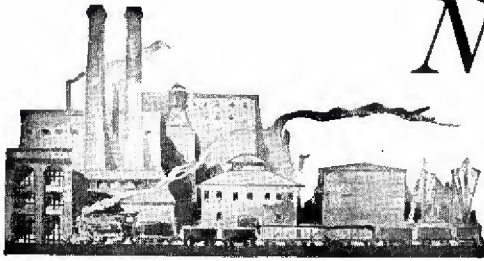

New Products for

All announcements appearing on these pages are published without advertising considerations of any kind whatsoever.

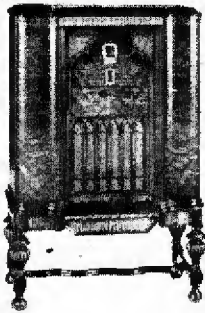

Gulbransen "Twin Voice" Superhets

"TWIN-VOICE" radio tone, involving the use of two dynamic speakers, blended and balanced to cover and reproduce the entire range of the human voice, as well as orchestral instruments, is one of the advancements of the new 10-tube superheterodynes brought out by the Gulbransen Co., 3232 W. Chicago Ave., Chicago. The tubes used in these new models include four 35's and two pentodes in push-pull. These sets are equipped with automatic and manual volume control, tuning meter and power-quiet switch.

Model 236 is of the six-legged, French door, highboy type. \$148.50.

Model 237 is a semi-highboy. \$118.50.—*Radio Retailing*, December, 1931.



New Majestics

SHERWOOD, a grandfather clock model in the Sheraton style, and Brucewood, a highboy, have been released by the Grigsby-Grunow Co., 5301 Dickens Avenue, Chicago, Ill. Sherwood utilizes the model 15 superheterodyne chassis, with the new spray-shield tubes. \$84.50 complete.

Brucewood is a 5-tube superheterodyne with twin power detection. The cabinet is a modernization of Early English, and the list price is \$129.50.—*Radio Retailing*, December, 1931.

Delco 32-Volt Set

A 32-VOLT, direct current radio designed for operation with individual farm electric plants is being offered by the Delco Appliance Corp., Rochester, N. Y.

It is a six-tube model using four screen grids and two pentodes, and comes complete with speaker, speaker power unit and tubes.

This set comes in three lowboy consoles and in a midget cabinet.

Delco also makes a line of 110-volt a.c. sets (7-tube superheterodyne) and three battery radios, using the 2-volt tubes and air-cell batteries.—*Radio Retailing*, December, 1931.

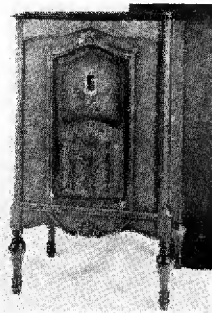

Telechron Clock

WARREN TELECHRON CO., Ashland, Mass., announces a new tambour model, the Huntington, to retail at \$9.95. It has a 4½ in. dial, and comes in a mahogany case.—*Radio Retailing*, December, 1931.

"Super-Thru" Radio-Lead

A COMBINATION lightning arrester, lead-in, inside plate and plug has been placed on the market by Woodruff & Co., Meridian, Miss. This device has the trade name of "Super-Thru" and lists at \$1.85.

It is used to bring the lead through the wall instead of by the old wires-under-the-window-screen method, eliminating the need for window wires. The entire installation is made through a 1½ in. opening, and the Super-Thru is adaptable to any thickness of wall.—*Radio Retailing*, December, 1931.

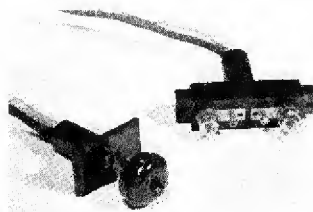

Sentinel Superhets

FOLLOWING announcement of Model 116, the United Air Cleaner Corp., 9705 Cottage Grove Ave., Chicago, has placed on the market Models 114, a 9-tube superhet, and 118, a 10-tube.

Model 118 features full wave second detection which involves the use of two 227 tubes, a 224 screen grid for the first-stage audio amplification, and two pentodes in push-pull for the power output stage. It is on a lowboy console, 44½ in. high.

Model 114, the 9-tube set, has automatic volume control, and has all the features of the Model 118 except that it is designed for half-wave second detection. The cabinet also is very much like the above model.—*Radio Retailing*, December, 1931.

Trav-Ler Television Kit and Receiver

ENTHUSIASTS who like to build their own television receiver can buy a knocked-down kit for \$95.50 complete with tubes and cabinet from the Trav-Ler Radio & Television Corp., St. Louis, Mo. For those who wish the completed job in cabinet, it may be purchased for \$124.50.

The kit includes the scanner unit and the short-wave unit. The receiver uses six tubes. The cabinet is of the compactable type.

Each unit may also be purchased separately, if desired.—*Radio Retailing*, December, 1931.

Leonard Electric Refrigerators

A FEATURE of the new models of the Leonard Refrigerator Co., Detroit, Mich., is the "Len-A-Door" by which the refrigerator door can be opened with a touch of the toe if both hands are full.

This is included in each of the seven new styles with the exception of the apartment house model.

Seven freezing speeds, egg basket, automatic light and table top are a few of the advantages of Leonard refrigerators.—*Radio Retailing*, December, 1931.

"Dynatropé" Converter

NOW you can use a midget N.a.c. set in your car with the new "Dynatropé" converter which furnishes 110 volt, 60 cycle a.c. from the 6 volt automobile battery. Ignition system suppressors or filters are unnecessary, it is said. This converter also permits the use of such household conveniences as curling irons, hot plates, electric fans, etc., on a camping trip. It is also useful on a boat as it not only supplies power for an a.c. radio but for other electrical devices as well.

Dynatropé measures 4x4x10 in. and can easily be transferred from auto to boat.

The current is taken from the battery intermittently and the added drain is compensated for by stepping up the generator approximately 15 amp. A safety fuse prevents battery drain to a danger point.

It is made by the Hutch Gard Corp. Ltd., 1043 Monadnock Bldg., San Francisco, Cal., and lists at \$39.50.—*Radio Retailing*, December, 1931.

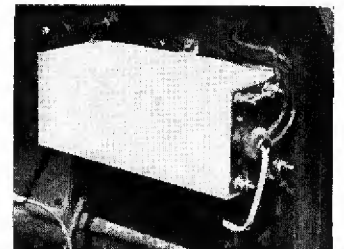

Revere Radio

REVERE "Patrician" midget, made by the Revere Radio rather unusually designed cabinet, with the speaker tower "set-back" from the front panel and ends of the cabinet body. It lists at \$47.50 complete. With electric clock, \$2.45 extra.

Model 39, also a compact set, with 5-tube chassis, is 17½ in. high by 13 in. wide, and lists at \$39.95 complete.

Console Model 59, with 5-tube chassis, is \$59.50 complete.—*Radio Retailing*, December, 1931.



Dealers to SELL

This editorial section is prepared purely as a news service, to keep readers of "Radio Retailing" informed of new products.

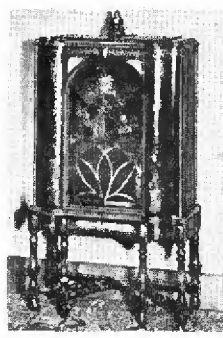

HFL "Mastertone" Sets

A COMPLETE new line of "Mastertone" receivers made by the High Frequency Laboratories, 3900 N. Claremont Ave., Chicago, and sold by the Radio Manufacturers Corporation of the same address, has been announced.

Model 5-269, a 5-tube t.r.f. set, console type, is \$49.95; 7-tube superhet chassis, \$62.50.

Model 7-292, 7-tube superhet, \$69.50; with 9-tube chassis, \$86.50.

In the midget line, there is a 5-tube t.r.f. set at \$38.50; a 7-tube superhet at \$49.50, and a 4-tube pentode model at \$29.50.—*Radio Retailing*, December, 1931.

New Crosley Sets

AUGMENTING its present line with two 10-tube superheterodynes, the Crosley Radio Corporation, Cincinnati, Ohio, has announced the "Tenstrike" and the "Happy Hour."

Tenstrike is a compact table model, listing at \$69.50 complete, and Happy Hour is a six-legged console priced at \$99.50.

The chassis used is a 10-tube with push-pull pentodes, meter tuning and automatic volume control.—*Radio Retailing*, December, 1931.

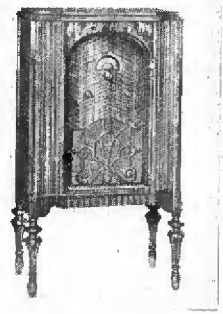

Freed 5-Tube Midget

A SECOND edition of its "mighty miniature" featuring five tubes in place of four and spotlight tuning in place of a full vision dial, has been released by the Freed Television & Radio Corp., 2219 Wilbur Avenue, Long Island City, N. Y.

This set employs a full size electro-dynamic speaker and pentode and variable-mu tubes. It is offered in both a.c. and d.c. models, the latter using the new d.c. tubes.—*Radio Retailing*, December, 1931.

Victor "Blimp" Animataphone

THE Animataphone 16 mm. talking movie projector with vertical turntable, which made its appearance several months ago, is now available in a compact "blimp" type case. The turntable is attached from the outside to a shaft, which protrudes through an opening in the side. During operation, the case is closed rendering the sound of the projector motor and film movement practically inaudible.

The vertical tone arm, which operates on the pendulum principle, is a new idea. The needle retains relatively the same position in the groove, laterally and vertically, from the beginning to the end of the record, eliminating distortion.

A push-pull pilot light to aid in properly setting the needle on the record is another feature.

The Animataphone is a product of the Victor Animatograph Corp., Davenport, Iowa.—*Radio Retailing*, December, 1931.

"Movie Maker" Camera and Projector

VITASCOPE CORP., 200 Fifth Ave., New York, has placed on the market a Movie-Maker camera and projector, retailing at \$10 and \$12.75 respectively.

The camera is of the hand crank type, using standard 16mm film, and weighs but 2½ lb. The lens are Achromatic F's, universal focus.

The projector operates by a hand-crank at any speed desired and is equipped with 100-watt standard projection lamp, pre-focus type, and two 400 ft. reels. It operates on a.c. or d.c.—*Radio Retailing*, December, 1931.

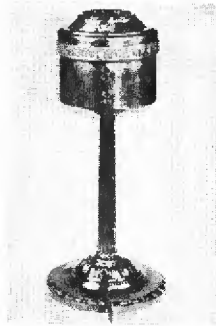

G-M Superheterodyne Converter

SOMETHING new in radio, a converter which transforms a t.r.f. type of set into a superheterodyne and at the same time functions as a remote control unit, is being marketed by the General Motors Radio Corp., Dayton, Ohio.

It is built to resemble a portable smoking stand with an illuminated dial set into its beveled edge, and operated by a small knob just beneath it. Volume also is controllable.

Remote control is accomplished entirely by electrical means, tuning being accomplished exactly as if operating the dials on the receiver. Only a few minutes are required to connect the converter. It is an attractive piece of furniture, with antique brass finish.—*Radio Retailing*, December, 1931.

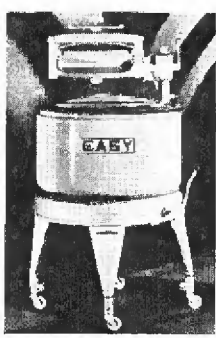

"Easy" Washers

MODEL 3F washer now in dealers' hands, is offered at the lowest price ever placed on an "Easy" washer, the product of the Syracuse Washing Machine Corp., Syracuse, N. Y. It is of the wringer-agitator type, and the mottled gray porcelain enameled tub has satin silver base, legs and wringer.

Model 4F is designed to sell in the intermediate price field, and has a greater capacity and a bigger agitator.—*Radio Retailing*, December, 1931.

Filmo Projector

PICTURE brilliance said to be practically 30 per cent greater than that afforded by previous models, is attained with the new Model J projector of the Bell & Howell Co., 1801 Larchmont St., Chicago, Ill.

It is entirely gear-driven, hence dispensing with all belts and chains. The increase in picture brilliance has been procured by an improved 375-watt lamp, a new Cooke 2-in. F 1.5 projection lens, improved condenser, large reflector and refined reflector adjustment. Many other important innovations have been included in this new projector.—*Radio Retailing*, December, 1931.

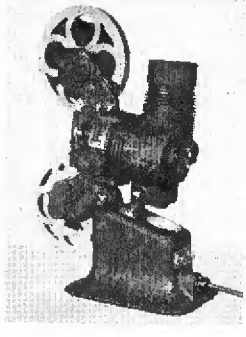

Blazer Radio

A 4-TUBE midget using the multi-mu, pentode and screen grid tubes, with a dynamic speaker, is offered by the Blazer Organization, 165 E. Ontario St., Chicago, Ill.

The cabinet is of a special material, neither wood nor metal, and comes in studio bronze or antique platinum. The sets are encased in gift boxes, which, when unpacked, may be used for waste baskets.—*Radio Retailing*, December, 1931.

Jenkins Television Set in Console Cabinet

COMPLETE and self-contained, the Model A Jenkins Radio-Television Console offers a choice of either broadcast reception or short-wave reception, in addition to the television function.

The console contains an all-purpose receiver and a projector-radiovisor. The receiver is designed for operation in the television, short-wave or broadcast band by an interchangeable tuning system.

The pictures are projected on a ground glass screen in the front of the console, and may be viewed by a group arranged in a quarter-circle, it is said. Jenkins Television Corp., Passaic, N. J.—*Radio Retailing*, December, 1931.

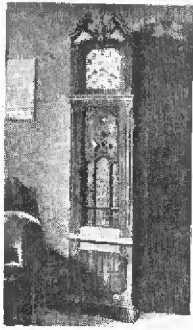

Philco Clock Set

THE latest addition to the line of the Philadelphia Storage Battery Co., Philadelphia, Pa., is a 7-tube superheterodyne in a mahogany grandfather clock cabinet about 6 ft. high. It is priced at \$89.50 complete. The set is installed in a normal position rather than being set on its side.—*Radio Retailing*, December, 1931.

Jewell Tube Sellers

JEWELL Electrical Instrument Co., 1850 Walnut St., Chicago, has developed a portable tube seller for house-to-house selling, where the tube value is indicated directly on an attractive three-color instrument dial in terms the customer can understand—Satisfactory, Doubtful and Unsatisfactory. It is called Pattern 540 and housed in a leatherette carrying case with heavy strap handle. It can be converted into a counter testing device, if desired. For small stores, a lower-priced tube-seller is announced, Pattern 533. Provision is made for testing, without adapters, all standard tubes.—*Radio Retailing*, December, 1931.



Rembert Short Wave Converter

FOLLOWING the reorganization of the former Van Horne Tube Co., under the name of Franklin Radio Corp., Franklin, Ohio, the new organization has produced a short wave converter. It is known as the "Rembert," and is housed in a walnut cabinet, controlled by a single dial for tuning. The change in meter wave bands is accomplished by a switch. This converter works well in connection with a superheterodyne and at the same time will convert a t.r.f. set to a superheterodyne short wave receiver. It contains its own power supply, using a 224, a 227 and a 230. The price is \$29.75. Franklin is also making a D-32 tube checker, incorporating quick and accurate facilities for reading all types of tubes. The tube checker line will be augmented by more elaborate models and a combination tube checker and set analyzer, all with the trade name "Rembert."—*Radio Retailing*, December, 1931.

"Gypsy" Auto-Radio

AN ingenious clamp permits the installation of the "gypsy" auto-radio in four positions on the steering column or direct to fire wall to the right of driver. Made by the Grand Rapids Radio Mfg. Co., Grand Rapids, Mich. It measures 4½ in. wide by 6½ in. high by 9 in. deep, and has illuminated dial. The price is \$69.50 complete.—*Radio Retailing*, December, 1931.



Onan A.C. Electric Plants

A LINE of a.c. electric light plants in sizes 2, 3½, 5 and 10 kilowatts has been announced by D. W. Onan & Sons, 308 Royalston Ave., Minneapolis, Minn. These plants furnish a.c. 110 or 220 volt, 60-cycle. They consist of a 4-cylinder gasoline engine and a.c. generator mounted on a steel base and assembled in unit construction. The engine is 4-cyl., 2½ in. bore, 3½ in. stroke, water-cooled, with radiator and thermal circulation. The generator is revolving field type. Voltage is regulated electrically at the carburetor and constant voltage is maintained regardless of load to be handled. The starting system is 6-volt using 6-volt battery and motor with conventional bendix drive.—*Radio Retailing*, December, 1931.

Standard Electric Stoves

THERE are two surface burners in the 6 in. size and one 8 in. burner, which may be had either in open or enclosed type, or any combination of the open and enclosed types, on the new model 360BU electric stove made by the Standard Electric Stove Co., 1718 N. 12th St., Toledo, Ohio. The oven is aluminum lined with recessed burners and with temperature control and timer on order. The stove is furnished with either right or left-hand ovens, and the finish is all-white with chromium trim.—*Radio Retailing*, December, 1931.

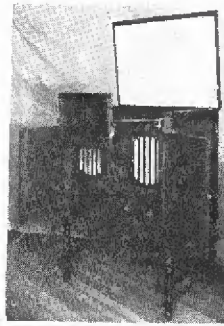
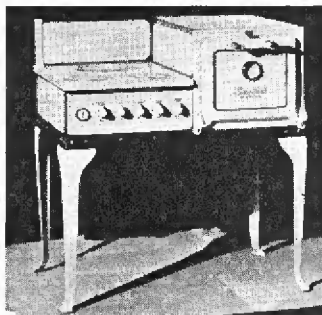

Sound-on-Film "Talkie" Unit

A COMPLETE projection unit using sound on 16 mm. film has been announced by C. Francis Jenkins, Inc., 1515 Connecticut Ave., Washington, D. C. Perforations are left out on one side of the film which permits a 150-mil width of sound-track. The screen for the picture is provided in the top of the cabinet though other screens may be used. Optical reduction is used in making the 16 mm. sound films.—*Radio Retailing*, December, 1931.

"Metro-Meter" Coin Collector

A SELF-STARTING motor is used in the "Metro-Meter" daily coin collector for refrigerators, so that if there is a current failure, the motor starts as soon as the current is resumed eliminating food spoilage. This device is made by J. P. Seelburg Corp., 1510 Dayton Street, Chicago, makers of automatic phonograph and coin devices for a number of years.

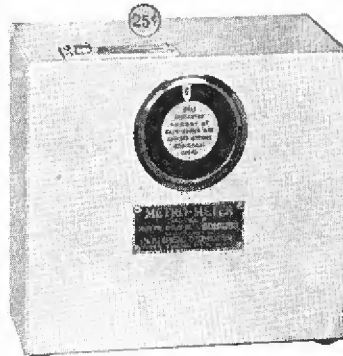

and is sold through the General Refrigerator Products, 230 N. Michigan Ave., Chicago. This is the type of meter which cuts the power off when another 25c. is due. Twenty coins may be inserted at one time for continuous service. All coins are registered, and the meter shows only the unused coins.—*Radio Retailing*, December, 1931.

Adda-Outlet System

A NEW method for adding wall outlets around the room is offered in the "Adda-Outlet" system of the Belden Mfg. Co., 4689 W. Van Buren St., Chicago, Ill. The outfit consists of a 5-ft. master unit which plugs into the original wall outlet. One or more extension units may be added to the master unit and to each other, as needed.—*Radio Retailing*, December, 1931.

Arlington Electric Clocks

EACH electric clock made by the Arlington Time Labs., Inc., 8440 S. Chicago Avenue, Chicago, is encased in an artistic carton carrying out the motif of the model it holds. The eye-value of the line indicates that its sponsors have aimed at the great woman market. "Old English" carries the traditions of the Sheraton period, and is made of walnut with light overlay. \$12.50. "Miss America" is designed for the modern kitchen. It is made of wood, and can be placed on a shelf as well as on the wall. Blue, ivory, green and white. \$6.75. "Heirloom" in the tambour style is made for the mantel or radio cabinet. \$10.50. Illustrated "Milady" model is for the boudoir and comes in green and rosewood. The price is \$7.50; with alarm \$8.75.—*Radio Retailing*, December, 1931.

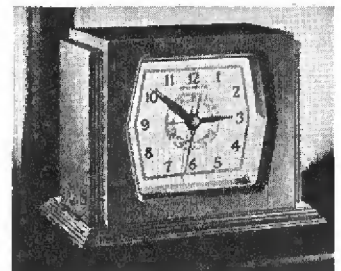

Buss Radio Fuse Assortment

A NEW radio fuse assortment is now on the market, the product of the Bussmann Mfg. Co., St. Louis, Mo. Copying a similar step taken by this company in the automobile fuse field in 1926, a radio fuse assortment to supply the radio dealer and service man with an assortment of fuses which will service various makes of radio, is now offered.—*Radio Retailing*, December, 1931.

Magnavox 150 Speaker

THE latest addition to the Magnavox family of speakers is Model 150. It has a cone diameter of 5½ in. The outside diameter of the cone housing is 6½ in., and the transformer mounted on the rear of the housing, does not protrude beyond this diameter. The magnetic structure is of the U-type Magnavox Co., Chicago.—*Radio Retailing*, December, 1931.

ABC "Liberty" Washer

RECENTLY added to the ABC line of porcelain washers (centrifugal and wringer types) is the new "Liberty" model, offered at the lowest price an ABC washer has ever been available. It has over-sized balloon rolls, three-wing floating agitator which controls cushioned washing action, Westinghouse standard motor, 55-lb. capacity, and is made by Alter Bros. Company, Peoria, Ill.—*Radio Retailing*, December, 1931.

Another dealer says "GIVE ME NATIONAL UNION TUBES"

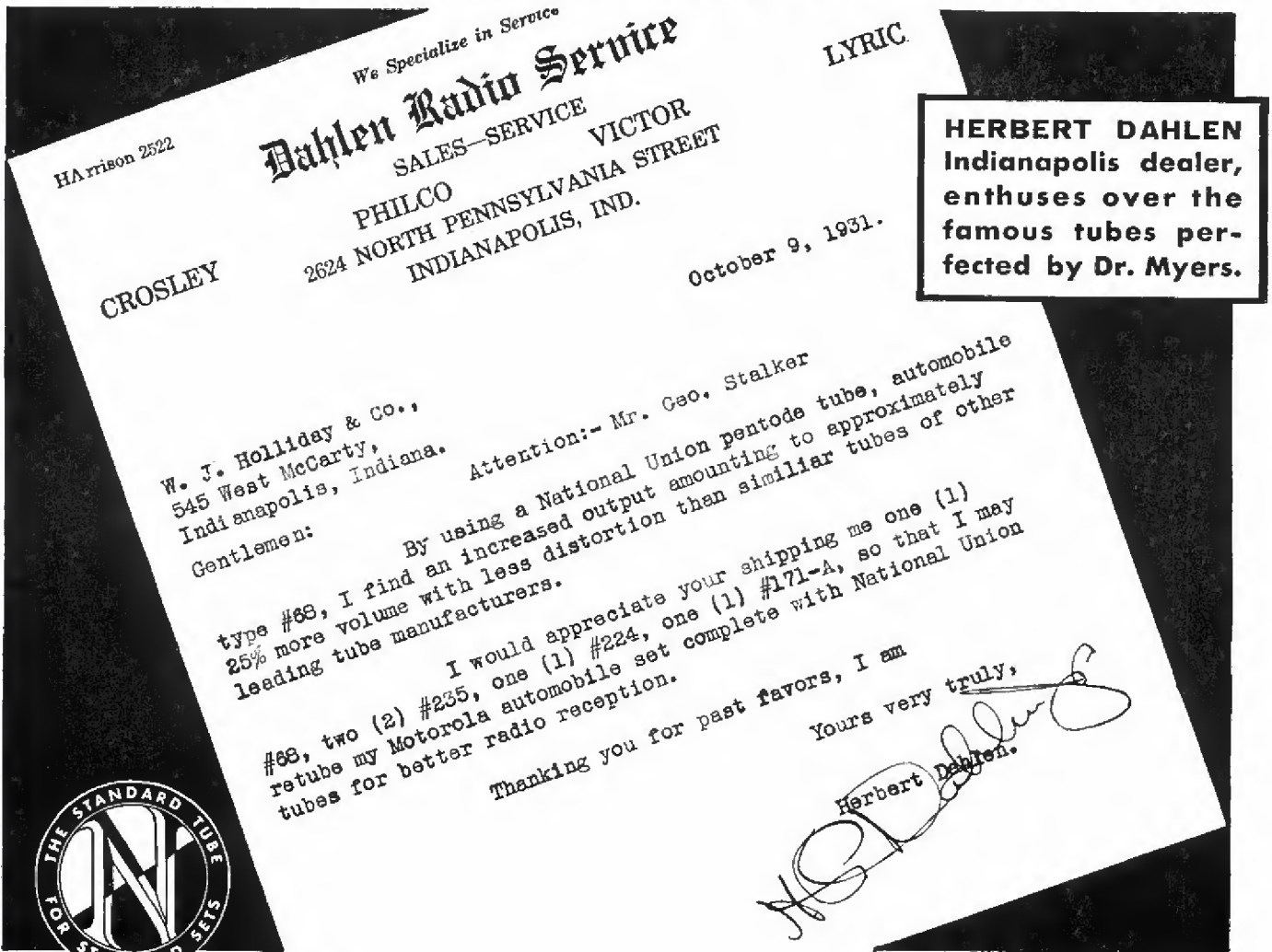

Dr. R. E. Myers, recognized authority on vacuum tubes, scientist, and pioneer in radio tube production, now vice-president in charge of engineering and production of National Union Radio Tubes.

WHY do National Union tubes give such extraordinary service? Why are dealers everywhere pushing them, endorsing them, choosing them for use in their own homes? Simply because National Union tubes give fully 25% better reception—longer life, greater power. Based on sound scientific principles, they have proved their superiority. Proved it and reproved it, in laboratory tests, and in actual use. They were perfected, you will re-

member, by Dr. Ralph E. Myers and his staff of 15 Scientists. Their ready acceptance by set manufacturers has made them known as the "standard tube for standard sets." So order a complete assortment of National Union Tubes. And then go out and sell them!—with utter confidence. If you have no stock of National Union Tubes on hand at present, call your jobber. He can supply you. Or write to the National Union Company. Address below.

**NATIONAL UNION RADIO CORPORATION
400 MADISON AVENUE • NEW YORK CITY**

Would you sell a set without a name

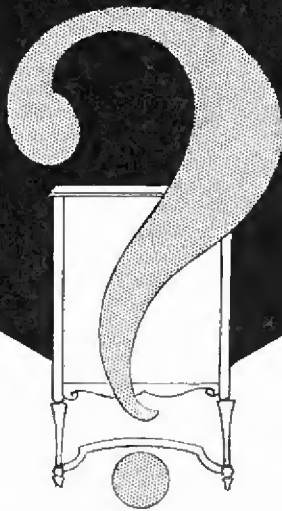

Under existing conditions many radio set prospects are using their old sets for another year. Build for Future sales by specializing in competent service.

Centralab Replacement Volume Controls and Fixed Resistors are available in a type for every set requirement. Adequate stocks maintained for quick delivery by distributors everywhere. Be sure to consult the new 3rd edition of the CENTRALAB VOLUME CONTROL GUIDE. Order your copy now.

Centralab
CENTRAL RADIO  LABORATORIES

MAIL COUPON NOW

CENTRAL RADIO LABORATORIES
920 Keefe Ave., Milwaukee, Wis.

Enclosed find 25c. for which send me your new VOLUME CONTROL GUIDE.

Name

Address

City State

Rad. Ret.

Q We have just published a booklet entitled, "A BAPTISM OF FIRE" describing how Centralab Fixed Resistors are made. It is FREE for the asking. Write for it, mentioning Radio Retailing.

if you do occasionally it is with a direct or implied apology. Your prospect judges performance by the name . . . he has learnt to expect certain things from well known, well-advertised sets.

Manufacturers too, have learnt to expect big things from all CENTRALAB Volume Controls . . . for here is a name that stands for smooth, quiet, velvet-like performance.

You'll find it helps to sell a radio if you mention that it is CENTRALAB equipped

Announcing SPARTON

REFRIGERATION

This will serve to formally announce Sparton's entrance into the Refrigerator Field on January 1, 1932.

This is only a logical step, following thirty years of manufacturing precision products.

We are pleased to accept dealer and distributor applications for open territories.

The Sparks-Withington Company

Jackson, Michigan, U. S. A.

and

SPARTON OF CANADA, LIMITED

London, Ontario



Increase Your PROFITS by Eliminating Radio Interference!

Lost sales and unnecessary service calls are expensive. All interference except natural static can be eliminated. Where to look for the causes—How to correct them—Practical solutions based on six years' experience and 15,000 cleared cases form the background for the booklet.

RADIO INTERFERENCE—Its Causes, Effects and Cures.

By **George R. Walters**, Radio Engineer, Radio Interference Department, Radio Trades Association of Southern California; Chairman, California Radio Interference Association.

Every Radio Dealer and Service Man should have a copy. *Write for yours today.*
Price 50 cents.

GEORGE R. WALTERS, 234 Chamber of Commerce Bldg., Los Angeles, Calif.

Major Subjects

- Power Lines
- Street Railway Systems
- Medical High-Frequency
- Household Appliances
- Special Antennas
- Ordinances
- Test Equipment
- and
- Methods of Tracing Interference



Universal Microphones
Proved Value—Superior Performance

Unparalleled values at rock-bottom prices. Enthusiastically endorsed for every sound use. Exclusive design features. Super-careful workmanship. Tested performance. Complete line of microphones, stands, cables, etc., at challenging prices. Unconditionally guaranteed. Consider carefully the UNIVERSAL line before you buy. For sale by dealers everywhere.

2-Button Hand-Mike
List Price \$15

UNIVERSAL MICROPHONE CO., LTD.
1163 Hyde Park Blvd. Inglewood, Calif., U.S.A.

The New MODEL "BB"
List Price \$25.00

Jobbers — Dealers — Servicemen!

LYNCH RESISTOR Replacement Manual **FREE**

with purchase of 10 Lynch Metallized Resistors, or it may be bought for \$1.00

All the RESISTOR INFORMATION you will ever need. Saves TIME and experimenting. Useful, authoritative. Invaluable. More than 200 circuits—nearly every popular make of radio receiver. Gives value, code and position of each resistor in the circuit.



LYNCH METALLIZED RESISTORS

Write today for new reduced prices, or enclose \$1 for Manual.

LYNCH MFG. CO., Inc.
Dept. R, 1775 Broadway, N. Y.

Metallized 1, 2 and 3 Watts

Precision Wire Wound Pigtail and Cartridge Types

THE POLICER

Short-Wave Adapter for police calls and short-wave reception. An excellent accessory item for dealers and service men to sell.

Installation simple — adapter plugs into tube socket in the receiver — then the tube is plugged into the adapter.

These adapters will work on approximately 90% of the T.R.F. receivers and 50% of the superheterodyne receivers now in use. They will not operate with all receivers because of the many different circuit hook-ups.

Deluxe model 224 and deluxe model 227 each list at \$3.50. Both deluxe models have switch permitting permanent installation of the adapter. Receiver may be switched from long to short waves without removing adapter. Extension cord and socket on deluxe models permits ease of installation and allows plenty of room.

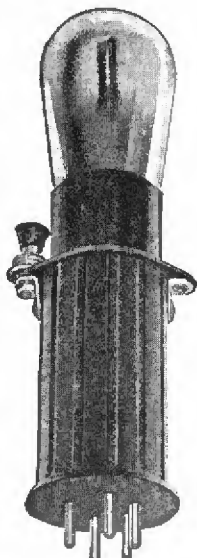

Standard Model 227, list price \$2.50

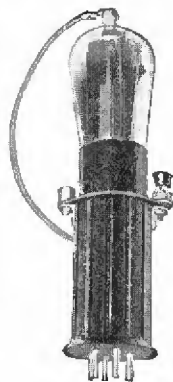

Standard Model 224, list price \$2.50

Order a supply at once —write for literature, prices and discounts.

THE RAHM CORPORATION
1481-A Merchandise Mart, Chicago, Illinois

New Sales Ideas For Sale At 8 Cents a Month!

Yes, *Radio Retailing*, published monthly, serves its many readers with dozens of practical sales plans, service kinks, window displays, collection and accounting plans and many other workable ideas at a cost of only 8 cents a month. One dollar a year.

This introductory offer is for cash with your order only. The regular price of *Radio Retailing* is \$2 a year. If you already subscribe to *Radio Retailing* send in your \$1 and have your present subscription extended at the reduced price.

FILL IN THE ORDER BLANK AND MAIL IT TODAY
Cash must accompany order for half price rate.

RADIO RETAILING R. R. 12
330 W. 42nd St., New York, N. Y.

Attached is \$1. Enter my order for *Radio Retailing* for one year .
Extend my present subscription for one year .

Name

Street

City.....State

Company.....Position

Canadian Subscription Price \$2 per. Cash with order only.

AMERTRAN DYNAMIC FIELD SUPPLY (TYPE P-108)



AmerTran offers a new addition to their line of power supply units—the Dynamic Field Supply. This rectifier unit is designed to supply filtered d c of the proper value to energize the field windings of dynamic type loud speakers used in large installations. It is unusually flexible supplying as many as nine dynamic fields or may be quickly and accurately adjusted to the number of speakers actually in use.

Write for complete descriptive list of power supply units with technical data.

American Transformer Company

Factory and Main Office—
178 EMMET STREET
Newark, N. J.



New York Office
Room 1963
HUDSON TERMINAL
50 Church Street

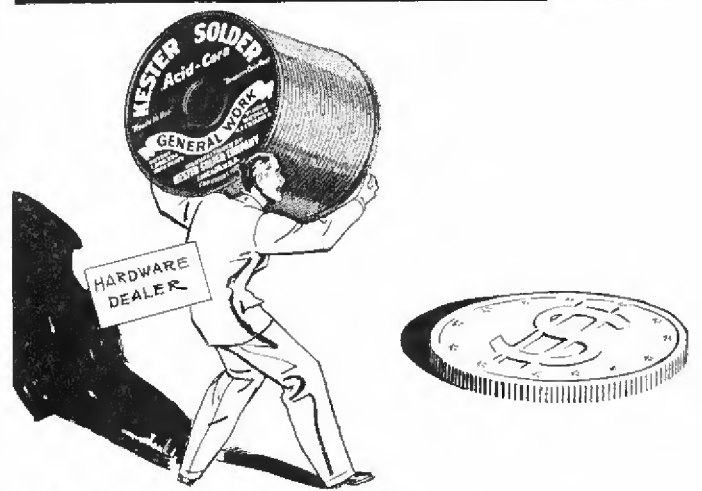

Found! Big and Steady New Profits!

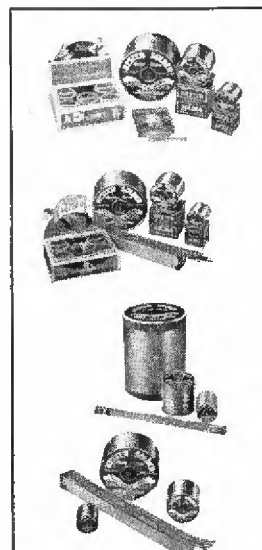

Here's the Complete Kester Line

Kester Acid-Core Solder—for general home repair use. 1, 5 or 20 lb. spools and Metal Mender Package. *Kester Rosin-Core Solder*—used principally for electrical and radio work. 1, 5 or 20 lb. spools Radio Solder Package, and 5 lb. boxes of 18 inch sticks. Also *Kester Paste-Core Solder*, *Body Solder*, *Bar Solder* and *Solid-Wire Solder* for home and industrial uses.

KESTER is one of the neatest profit-building items you can possibly have in your store!

Everybody wants Kester these days. Housewives and handy men around the house who never used to touch a soldering iron are doing their own soldering regularly now. Kester is responsible. Kester originated the solder with a self-contained flux . . . so simple to use that even a first-timer gets perfect results. And for years, as well as this year, generous space in national magazines to tell the Kester story! Now the demand for Kester is big . . . and steadily growing. Make it known that you sell Kester. That will bring customers into your store who have never been there before. Stock Metal Mender, and Radio Solder both . . . the larger Kester spools for steady users, too. See your jobber about this right away. There's money just waiting to be picked up from under every Kester can and spool!

Kester Solder Co., Inc. 1899

Main Office & Plant,
4262 Wrightwood Ave., Chicago
Eastern Plant, Newark, N. J.

Canada

Kester Solder Co. of Canada, Ltd.,
Brantford, Ont.

KESTER
FLUX-CORE
SOLDER
Acid-Core • Paste-Core • Rosin-Core

Now!

Proven Television SEE-ALL
Television Kit

Television is here to stay. Over 30 powerful stations now telecasting daily. Be the first in your locality to enjoy its features. SEE-ALL proven equipment makes it easy and the cost is so little.

Anyone can assemble SEE-ALL in less than 20 minutes

All essential parts and simple instructions to assemble a foolproof television included. Contains self-synchronizing motor.

SEE-ALL Short-wave Receiver lists for \$39.50 less tubes.

Distributors: Sell some good territory open. Wire or write for proposition.

List **\$1975**

Individual parts sold separately



TELEVISION MFG. COMPANY
OF AMERICA, INC.
5 UNION SQUARE NEW YORK CITY

Useful, Durable Steel 50-Drawer Resistor Cabinet **FREE**

(Drawers 8x3x2 1/4-in. Inside. Case is 33x18 1/2x8 1/4-in.)

with Special Introductory Deal

This Unusual LIMITED offer has proved so popular we are repeating it. Write today for details.

LYNCH
 METALLIZED—PRECISION WIRE WOUND
RESISTORS

JOBBERS—It will pay you to write today for our new reduced prices and plan of sales-co-operation.

LYNCH MFG. CO., Inc.
 Dept. R, 1775 Broadway, N. Y.



1, 2 and 3 Watts

Precision Wire Wound Pigtails and Cartridge Types

Now Ready

New 1932 Catalog
ICA Products

RADIO-TELEVISION- SHORT WAVE
 Receivers, Parts and Accessories

FREE—Write for your copy now. Quantity limited

Insuline Corp. of America
 25 Park Place New York

Subsidiary of
 Standard Television & Electric Corp.

SPEED

RCA Licensed

RADIO TUBES

- no **FREE** merchandise
- no **TRICK** bonuses

— just a business-like quotation which assures a clean profit in resale

CABLE RADIO TUBE CORP.
Executive Offices
230-240 N. 9th St. Brooklyn, N. Y.

CORWICO

RADIO WIRE PRODUCTS

ANTENNA WIRE LEAD-IN WIRES
 ANTENNA KITS HOOK-UP WIRES
 ANTENNA ACCESSORIES ANNUNCIATOR WIRES
 LIGHTNING ARRESTERS CABLES

WRITE FOR CATALOG AND PRICES

If Your Jobber Cannot Supply You—Order Direct

CORNISH WIRE CO. 30 CHURCH ST., NEW YORK, N. Y.
Makers of the Famous

BRAIDITE HOOK-UP WIRE

Only Reliable Products
 can be continuously
 advertised



THE SIXTH ANNUAL
RMA TRADE SHOW
AND 8TH ANNUAL CONVENTION
MAY 23-26, 1932
CHICAGO



THE ONLY OFFICIAL R M A TRADE SHOW—
RADIO'S BIG ANNUAL CONCLAVE

Held by and for the Industry—Advanced to May, for Early Trade

NOTE—The May, 1932, Trade Show is the only Radio Show sponsored by the RMA and under its management, for RMA members, Jobbers and Dealers.

IMPORTANT

Radio sales will be helped greatly by the 1932 Presidential Election Campaign!

The Republican and National Conventions are planned next June. Therefore, the annual "JUNE" trade show and Convention of the R. M. A. is being advanced to the week of *May 23rd, 1932*—for the Radio Industry to start early, before the Presidential nominating Conventions and Campaign.

Everybody in Radio will be at Chicago during the week of May 23rd.

This is the Radio Industry's own and largest annual meeting! Thirty thousand (30,000) square feet of Radio Exhibits in the Stevens Hotel. Public not admitted. For the trade only.

All Exhibitors *required* to show current merchandise—no vacant booths.

Twenty thousand (20,000) radio manufacturers, jobbers and dealers to attend.

Reduced railroad rates—Special trains.

Official Hotels—Stevens Hotels and The Blackstone—
together on Michigan Avenue.

Joint meetings—Radio Wholesalers Association, National Federation of Radio Associations and other industrial organizations.

Invitation credentials for the Trade Show will be mailed about April 15th, 1932. **REMEMBER THE DATE—MAY 23rd—AT CHICAGO!**



STEVENS HOTEL

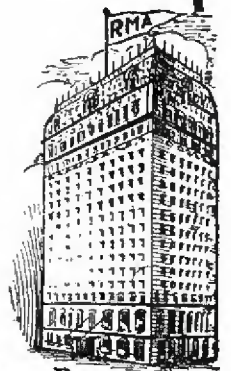

BLACKSTONE HOTEL

RADIO MANUFACTURERS ASSOCIATION
11-W. 42ND ST. N.Y. CITY 32 W. RANDOLPH ST. CHICAGO



**UNIVERSAL
AUTO RADIO**
Quality Sets
Priced Low
BACKED BY A
STRONG COMPANY

LOOK! Dealers! Distributors! Here are New Profits for You!

Get your share of the liberal profits already being made on Universal Auto Radio! Here are two compact, powerful sets giving wonderful, dependable performance. The \$69.50 set includes 6 tubes and ALL accessories, including Remote Control. New Pentode feature, Super Dynamic Speaker and Automatic Volume Control! The Standard model has same features except 5 tubes and sells for only \$59.50 complete. Standard installation charge at authorized dealers.

Your customers will like the marvelously simple, conveniently-placed Remote Control. Right at fingertips under steering wheel. No backlash — no detuning! Only one of many outstanding features which makes Universal Auto Radio your logical choice.

Territories Going Fast! Write Today!

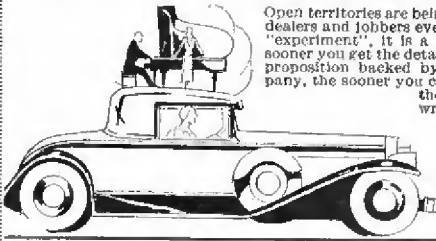

Open territories are being snapped up by wideawake dealers and jobbers everywhere. Universal isn't an "experiment", it is a time-tested success and the sooner you get the details of our attractive franchise proposition backed by a firmly established company, the sooner you can decide whether you want these new, extra profits. Wire, write or phone today!

UNIVERSAL AUTO
RADIO CORP.
1221 S. MICHIGAN AVE.,
CHICAGO

Your name stamped on this book FREE

At no additional cost to you, we will stamp your name, or a friend's name, in gold on the front cover of any copy of Moyer and Wostrel's Radio Handbook ordered from this advertisement. This is a special Christmas offer, limited to acceptance before January 1, 1932.

a complete, modern manual of practical and technical radio information

THE RADIO HANDBOOK

Including Television and Sound Motion Pictures

by JAMES A. MOYER and JOHN F. WOSTREL

Both of the Massachusetts Department of Education: Authors of Radio Receiving Tubes, Practical Radio Construction and Repairing, etc.

886 pages, 5 1/2 x 8, 650 illustrations, flexible, \$5.00

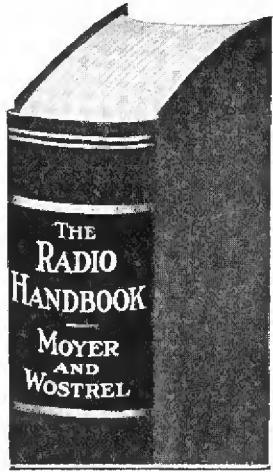

HERE at last is a handbook that meets the need for a complete digest of authoritative radio data, both theoretical and practical, in one logically arranged and thoroughly indexed volume. From the fundamentals of electricity, magnetism and electron theory right down to full details on latest commercial and industrial applications, this book covers the whole field of radio, with descriptions, definitions, design data, practical methods, tables and illustrations in profusion.

Over 850 pages of latest data on such topics as:

- modern transmitters, Piezo crystal, 100% modulation, etc.
- commercial and amateur short-wave receivers and transmitters, Kennelly-Heaviside layer, etc.
- marine radio equipment, auto alarm, etc.
- automobile radio sets.
- all latest tubes, photo-electric cells.
- television and sound motion pictures, etc.

Send your free stamping order today

Do you want to make a friend a gift combining personal thoughtfulness with real utility? Do you want a copy of Moyer and Wostrel's Radio Handbook that you will doubly prize? Then take advantage of this free stamping offer. Send the coupon today. (Proper remittance should be enclosed with orders and, of course, stamped copies are not returnable.)

SPECIAL HOLIDAY OFFER COUPON

McGraw-Hill Book Company, Inc., 330 West 42d Street, New York. Send me Moyer and Wostrel's Radio Handbook, with name stamped in gold on the front cover. I enclose \$5.00 and understand that stamped books are not returnable. (This offer expires Jan. 1, 1932.)

(Name to be stamped. Please print.)

Name

Address

City and State

R.R. 12-31

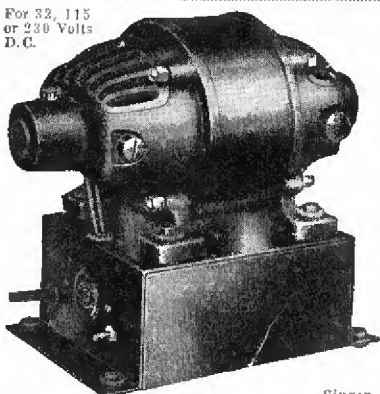

THE ANSWER to your D.C. PROBLEM!

The sensationally low price of the JANETTE Rotary Converter

makes it easy to sell A.C. sets to the thousands of D.C. users on farms and in cities. You profit on both receivers and converters.

Write for dealer discounts and bulletins.

JANETTE MFG. CO.
555 West Monroe St., Chicago, Ill.

Singer Bldg., 149 Broadway, New York, N. Y.; Real Estate Trust Bldg., Philadelphia, Pa.; Harrison Sales Co., 314 Ninth Ave., N., Seattle, Wash.; Lombard Smith Co., 324 N. San Pedro Ave., Los Angeles, Calif.

AUDIOLA

"Known for Its Tone"

SUPERHETERODYNES AND MIDGETS

High Grade Set Builders Since 1921

AUDIOLA RADIO CO.
430 So. Green St. CHICAGO

SEARCHLIGHT SECTION

EMPLOYMENT and BUSINESS OPPORTUNITIES—SURPLUS STOCKS—DISCONTINUED MODELS

UNDISPLAYED—RATE PER WORD:

Positions Wanted, 5 cents a word, minimum \$1.00 an insertion, payable in advance.

Positions Vacant and all other classifications, 10 cents a word, minimum charge \$2.00.

Proposals, 40 cents a line an insertion.

INFORMATION:

Box Numbers in care of any of our offices count 10 words additional in undisplayed ads.

Discount of 10% if one payment is made in advance for four consecutive insertions of undisplayed ads (not including proposals).

DISPLAYED—RATE PER INCH

| | |
|--------------------|--------------|
| 1 inch..... | \$7.50 |
| 2 to 3 inches..... | 7.25 an inch |
| 4 to 7 inches..... | 7.00 an inch |

Rates for larger spaces, or yearly rates, on request.
An advertising inch is measured vertically on one column, 3 columns—30 inches—to a page. Radio Retailing

POSITION WANTED

COSTS TOO HIGH? Practical engineer and executive, with diversified production experience in mechanical and electrical fields, is interested in opportunity to cut costs for reliable manufacturer. Specialized in the development of production equipment. Interview welcomed. PW-156, Radio Retailing, 330 West 42d St., New York.

REPRESENTATIVES AVAILABLE

Electric Refrigerator Line

Wanted by well established factory representative traveling several men in Southeastern states from Atlanta. RA-155, Radio Retailing, 330 West 42d St., New York.

WANTED

Want To Buy

Several Model 26 Radiola portable receivers, either new or used. Must be in first-class condition. State quantity and lowest price. Write Purchasing Department, Wisconsin Power and Light Company, Madison, Wisconsin.

Here Is a California Investment Opportunity

You may remember me. I have owned and operated a radio business with a volume exceeding a million dollars annually. In my own field—Radio—I have never lost a cent. Outside investments lost me a fortune. In the radio merchandising field, with headquarters in the East, I have been successful and respected.

Six months ago with \$20,000.00, I started in the radio manufacturing business, establishing a modern plant in San Francisco. Since then this business has developed very satisfactorily. An R.C.A. license has been secured. Local sales in California have been more than good.

Lack of capital prohibits volume manufacturing. With capital I can fill orders at real profit. The sets—auto, console, midget and a real D. C. unit have ready sale.

If you have \$20,000.00 to match the same investment I have, we can both make money. This is not a "get rich quick" deal. Investigation by you will prove it. If you want facts, write me in care of BO-154, Radio Retailing, 333 Mission St., San Francisco, Calif.

SPECIAL NOTICE :

To the Radio Industry

Advertising in connection with legitimate offers of surplus stocks and discontinued models of radio merchandise is acceptable in this section of "Radio Retailing."

Extreme care will be exercised by the publishers to prevent the use of advertising in the Searchlight Section to encourage price cutting on current models of merchandise or equipment. Nor will advertising which invites violation of the dealer's contract with the manufacturer be acceptable.

All merchandise offered in the Searchlight Section must be accurately and fully described and must be available on order.

SELL PORTABLE

Talkie Sound-on-Film

To Theatres, Schools, Churches, Clubs

Write for manufacturers' prices on Soundheads, Photocells, Optical Systems, Rectifiers, Amplifiers, Horns, Faders, Synchronous Motors, Projectors, Lamp-houses, Screens, Microphones, etc.

Dept. RR—S.O.S. CORP.
1600 Broadway, New York City
Cable Address "808OUND"

Surplus Stocks

When you have surplus stocks of radio equipment to sell—coils, tubes, sets, speakers, cabinets, insulators, etc., or when you are in the market to purchase such surplus stocks of other dealers—

Use a "Searchlight" Ad.

RR-5

RADIO DEALERS RADIO SERVICEMEN NEW

Radio Handbook CONTAINING:

Technical Information.
Volume Control Guide.
Transformer and Condenser Guide.
Radio Replacement Parts Catalog.

Sent *postpaid* anywhere for only

25 Cents

Specials from our Catalog

| | |
|-------------------------------------|----------|
| Atwater Kent 37 Block with chokes | } \$2.95 |
| Atwater Kent 37 Transformer, ea. | |
| Majestic Super "B" Eliminator Block | } \$2.25 |
| Electrolytic 2 anode Condenser, ea. | |

Hard To Get Parts—We have them.
Send us your repair work for estimate.

Grant Radio Laboratories

8521-R South Halsted Street, Chicago, Ill.

Electrical RECORDINGS MADE TO ORDER

24 Hour Service, Finest Quality new metal alloy recordings; For Announcements; Public Address Sound Truck Advertising, Etc. Low cost, long life, light weight, unbreakable records; all sizes. Write for details. ROYAL RECORDING & FILM STUDIOS, Dept R. 661 N. Michigan Ave., CHICAGO.

A NEW BOOK!

which cuts superheterodyne servicing time in half and means more profitable operation.

Sold with a Money Back Guarantee



Servicing Superheterodynes

by

JOHN F. RIDER

PRICE \$1.00

published by
Radio Treatise Co., Inc.
1440 Broadway New York City

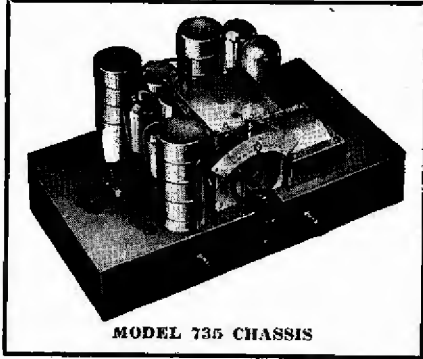

MODEL 735 CHASSIS

DEWALD

PENTODE SUPER SERIES 1932
 LICENSED UNDER R. C. A. PATENTS

A Complete Line of Super Quality Radios at New Lower Prices On Which You Can Make Bigger Profits

Why handle non-descript merchandise on which you sacrifice profits as well as your reputation, when you can buy the nationally known line of Pierce-Airo Receivers at new low prices, maintain your reputation for quality and service, make a better profit and offer

A RADIO CHASSIS FOR EVERY PURPOSE

| | | | |
|---|--|---|---|
| MODEL 735 Pentode Variable-Mu Super Het chassis. Same chassis with 8 tubes—Model 746 M. For A.C. current. | MODEL 535 Pentode 5-tube Super-Tuned radio frequency, Variable-Mu chassis of tremendous power. For A.C. current. | MODEL 637 Pentode 5-tube direct current chassis; employs all heater type tubes and provides for wide variation of line circuit. | MODEL 547 A Pentode 5-tube Super-Tuned radio frequency, Variable-Mu. The mighty "Cub" of the Air. For A.C. current. |
|---|--|---|---|

Write today for circular illustrating and describing the entire line of new 1932 DeWald—R.C.A. Licensed Receivers.

PIERCE-AIRO, Inc. 510 Sixth Ave. New York City
 MANUFACTURERS OF FINE RADIO SETS FOR TEN YEARS

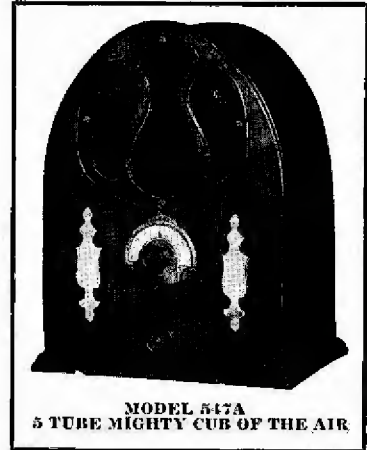

MODEL 547A
 5 TUBE MIGHTY CUB OF THE AIR



| | |
|------------------------|------|
| | Page |
| General Elec. Co..... | 6 |
| Grigsby-Grunow Co..... | 11 |

| | |
|--------------------------|------|
| | Page |
| McGraw-Hill Book Co..... | 58 |

| | |
|--------------------------------|------|
| | Page |
| United American Bosch Corp... | 14 |
| Universal Auto Radio Corp..... | 58 |
| Universal Microphone Co..... | 54 |

ALPHABETICAL INDEX TO ADVERTISEMENTS

| | |
|------------------------------|------|
| | Page |
| American Transformer Co..... | 55 |
| American Weekly..... | 5 |
| Arcturus Radio Tube Co..... | 7 |
| Auriola Radio Co..... | 58 |

| | |
|----------------------------|-----|
| Hawley Products Co..... | 8 |
| Hygrade-Sylvania Corp..... | 8-9 |

| | |
|--------------------------------|----|
| National Union Radio Corp..... | 51 |
|--------------------------------|----|

| | |
|----------------------|----|
| Walters, Geo. R..... | 54 |
|----------------------|----|

| | |
|-----------------------|----|
| Pierce-Airo, Inc..... | 60 |
|-----------------------|----|

| | |
|------------------------|----|
| Zenith Radio Corp..... | 16 |
|------------------------|----|

| | |
|--------------------------------|----|
| Insuline Corp. of America..... | 56 |
|--------------------------------|----|

| | |
|--|-------------|
| RCA Radiotron Co., Inc. | Back Cover |
| RCA Victor Co., Inc. (Radiola Div.)..... | Front Cover |
| Radio Manufacturers Association | 57 |
| Rahm Corporation..... | 54 |

| | |
|-----------------------|--------------------|
| Brunswick Radio Corp. | Inside Front Cover |
|-----------------------|--------------------|

| | |
|--------------------------------------|----|
| Kellogg Switchboard & Supply Co..... | 13 |
| Kester Solder Co..... | 55 |

| | |
|---------------------------------|-------|
| Sparks-Withington Co..... | 4, 53 |
| Stromberg-Carlson Tel. Mfg. Co. | 2 |

| | |
|---------------------------|-------------------|
| Cable Radio Tube Co..... | 56 |
| Central Radio Lab..... | 52 |
| Champion Radio Works..... | 10 |
| Cornish Wire Co..... | 56 |
| Crosley Radio Corp. | Inside Back Cover |

| | |
|------------------------------|--------|
| Leonard Refrigerator Co..... | 15 |
| Lynch Mfg. Co..... | 54, 58 |

| | |
|---------------------|----|
| Television Mfg. Co. | 56 |
|---------------------|----|

| | |
|------------------------------|----|
| Echophone Radio Mfg. Co..... | 12 |
|------------------------------|----|

This index is published as a convenience to the reader. Every care is taken to make it accurate, but *Radio Retailing* assumes no responsibility for errors or omissions.

SEARCHLIGHT SECTION

Classified Advertising

| | |
|--------------------------------|----|
| BOOKS | 59 |
| BUSINESS OPPORTUNITY | 59 |
| ELECTRICAL RECORDINGS | 59 |
| EMPLOYMENT | 59 |
| RADIO SERVICE | 59 |
| RADIO STOCKS | |
| Royal Recording Film Studios | 59 |
| Grant Radio Laboratories | 59 |
| S.O.S. Corp. | 59 |

CROSLEY SUPERHETERODYNE RADIO RECEIVERS

are the Greatest of ALL Radio Values

**Pentode Output..Variable Mu
Full Size Dynamic Speaker
SUPERHETERODYNE**

The Crosley LITFELLA \$36³⁶
Complete with Tubes

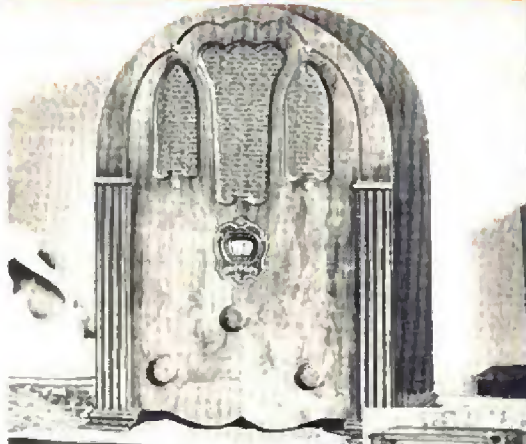

The Crosley LITFELLA (above) is an entirely new and utterly different 5-tube Pentode output, variable Mu Superheterodyne using a full size Crosley full floating moving coil dynamic speaker. Sensationally low priced for such super performance. The attractive cabinet of beautiful veneers is only 17 inches high.

The Crosley LITBOY

An exquisite looking console (right) housing the same chassis and dynamic speaker as The LITFELLA. Front panel is of American black walnut. Posts and stretchers are walnut veneer. \$48⁵⁰

Complete with Tubes

**New 10 Tube Push Pull Pentode Output
Variable Mu. Dynamic Speaker
Automatic Volume Control
SUPERHETERODYNE**

The Crosley TENSTRIKE \$69⁵⁰
Complete with 10 Tubes

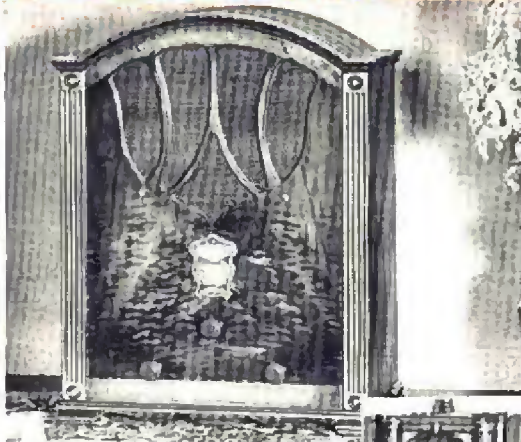

A compact table model receiver (above) incorporating the new Crosley 10-tube push-pull Pentode output, variable Mu Superheterodyne chassis with meter tuning, automatic volume control and *audiotron* size Crosley full floating moving coil dynamic speaker. The magnificent all wood cabinet is 20 1/2 inches high.

The Crosley Happy Hour

A magnificent 44-inch six-legged console (right) incorporating the same chassis and features as The TENSTRIKE and an *audiotron* size full dynamic speaker. \$99⁵⁰

Complete With 10 Tubes

No matter what comparisons you may make, you'll not find as great a value for the dollar in a radio receiver as you'll find in these new Crosley models. From the Crosley LITFELLA, a SUPERHETERODYNE using Pentode and variable Mu tubes and incorporating a full size full floating moving coil dynamic speaker, to the Crosley HAPPY HOUR, a 10-tube push-pull Pentode output, variable Mu SUPERHETERODYNE enclosing meter tuning, automatic volume control, and using an *audiotron* type full floating moving coil dynamic speaker, there is a CROSLEY to meet every demand for radio reception and to satisfy every purse. Every Crosley receiver shown is a SUPERHETERODYNE—every one under \$100!

**8 Tube Push-Pull Pentode Output
Variable Mu.. Dynamic Speaker
SUPERHETERODYNE**

The Crosley PLAYBOY \$49⁷⁵
Complete with 8 Tubes

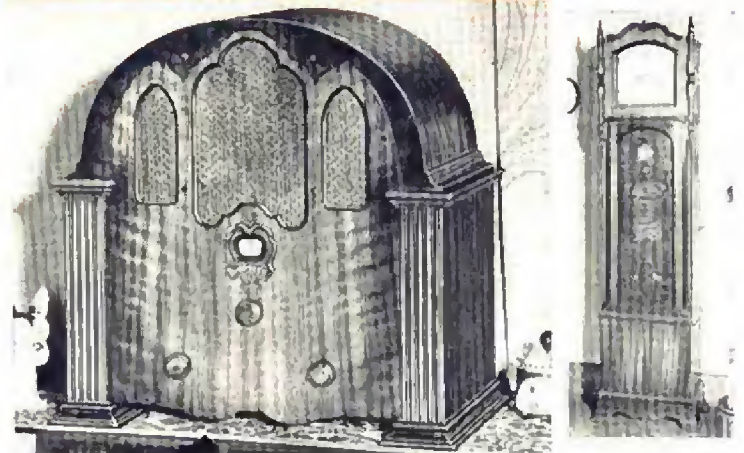

An exquisitely designed wood table or mantel model (above) 47 inches high, 17 1/2 inches wide, 10 1/2 inches deep. Front panel is of imported Oriental wood finished in two-tone effect. The solid side panels and arch top are of high-lighted walnut finish. Incorporates the new Crosley 8-tube push-pull Pentode output, variable Mu Superheterodyne chassis and latest Crosley full floating moving coil dynamic speaker. Embodies all the new Crosley features. Never before such superlative radio performance at so low a price.

The Crosley ANNOUNCER

One of the most beautiful door console models (right). Stands 42 inches high. Incorporates the new Crosley 8-tube push-pull Pentode, variable Mu Superheterodyne chassis plus the new type Crosley *audiotron* size full floating moving coil dynamic speaker. \$85⁰⁰

Complete With 8 Tubes

The Crosley CHEERIO

A magnificent cabinet of rare beauty, full 40 inches high, housing the new Crosley 8-tube push-pull Pentode, variable Mu Superheterodyne chassis and newest Crosley full floating moving coil dynamic speaker. All new Crosley features are included. \$65⁰⁰ rated. Complete With 8 Tubes



The Crosley MERRY MAKER

Another 40-inch console of unusually attractive design and sound construction. Housing the new Crosley 8-tube push-pull Pentode, variable Mu Superheterodyne chassis plus the new type Crosley *audiotron* size full floating moving coil dynamic speaker. \$75⁰⁰ rated. Complete With 8 Tubes



The Crosley PLAYTIME

Here it is! A dream come true! A granddaddy type A. C. electric ball clock incorporating the new Crosley 8-tube push-pull Pentode, variable Mu Superheterodyne radio receiver and Crosley *audiotron* size, full floating moving coil dynamic speaker. The same A. C. battery current conversion operating ball clock and \$95⁰⁰ radio.

Complete With 8 Tubes

THE CROSLEY RADIO CORPORATION
POWEL CROSLEY, Jr., President Home of "The Nation's Station"—WLW
CINCINNATI

(Montana, Wyoming, Colorado, New Mexico and west, prices slightly higher.)

YOU'RE THERE WITH A CROSLEY
CROSLEY RADIO

It Pays for Itself

and then some!

One of the most remarkable facts about the Radiotron Merchandiser is that it pays for itself so quickly. Sell one extra Radiotron—just one—every day, and the Merchandiser will be paid for in less than six weeks. Before you know it this small initial item will be wiped out and you will be on your way to bigger profits.

The Merchandiser is a selling sensation. Placed in a prominent position in the store, it will increase any dealer's business with little more effort than is needed to wrap up the merchandise.

■ ■ ■

Many of the hundreds of merchants who have obtained Radiotron Merchandisers immediately increased their daily sales by many more than one—and we have testimonials to prove it.

The opportunity for profit is one no live dealer can afford to overlook. Order your Radiotron Merchandiser today and experience the surprisingly pleasant sensation of having your Radiotron business boosted for you!

RCA RADIOTRON CO., INC.
HARRISON, NEW JERSEY
A Radio Corporation of America Subsidiary

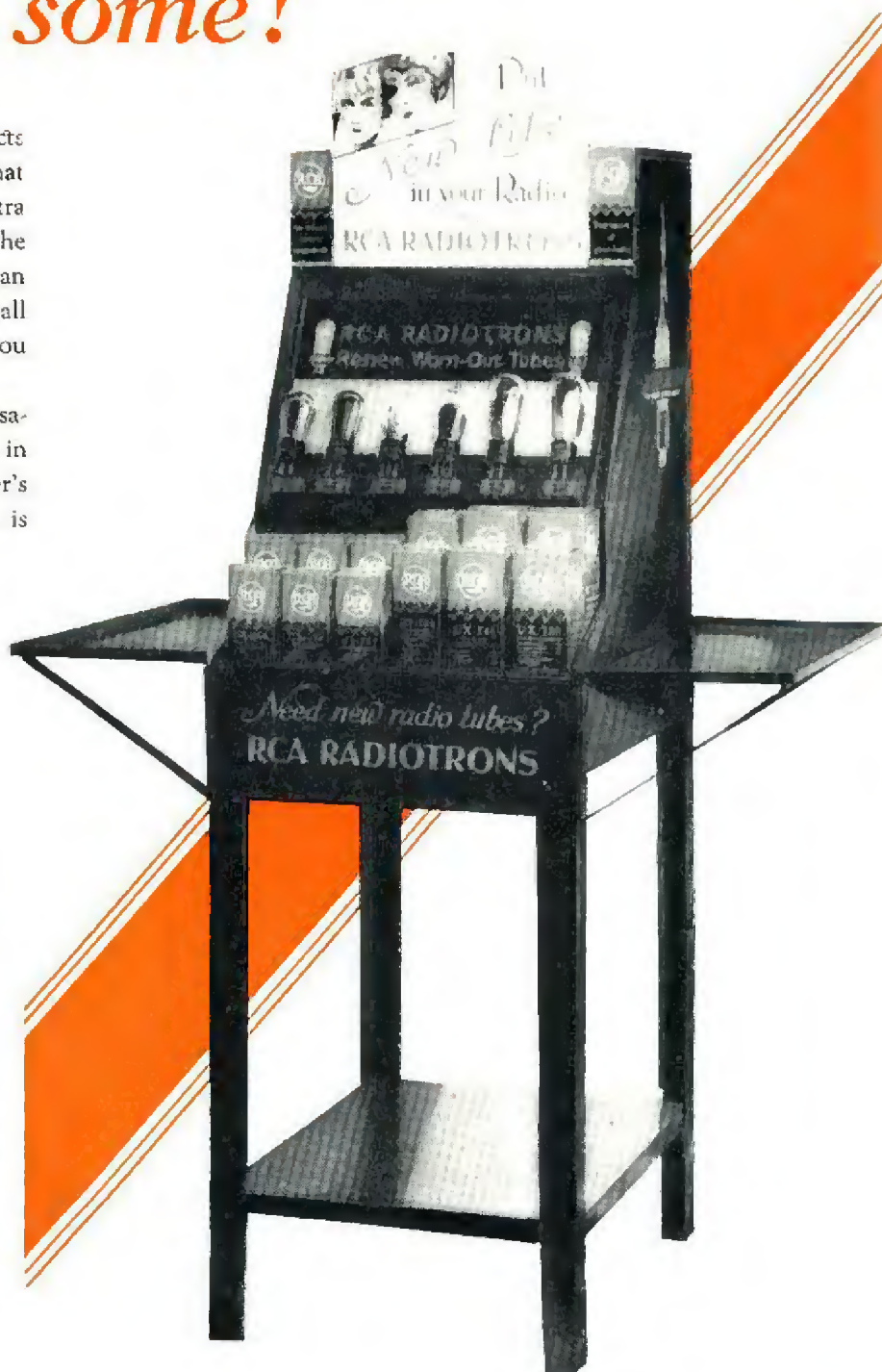

RCA Radiotrons

THE HEART OF YOUR RADIO