

# Radio Retailing

The Business Magazine of the Radio Industry

## Trustworthy!

Type B-2 5 tubes, 2 Control,  
two stages tuned r-f, detec-  
tor, two a-f. Price \$115.00



Type B-3 6 tubes, single  
Control, three stages tuned  
r-f, detector, two a-f. Price  
\$155.00

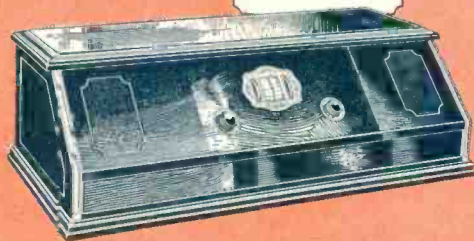

On Both Models.. Add \$10 West of Rockies

### BOSWORTH GUARANTEE

We guarantee this set to be in perfect condition. We will repair it free of charge, or, at our option, replace it with a new set, if found to be defective --- within one year from date of purchase

THE BOSWORTH ELECTRIC MFG. COMPANY

#### Picture what this means

This guarantee is our pledge that every Bosworth Set is dependable and free from service.

This freedom from service and uniformity of performance of Bosworth Receivers should be seriously considered by jobbers and dealers who are carefully planning for the future.

Write for our new portfolio, "Product and Policy."

The Bosworth Electric Mfg. Co.  
Norwood, Cincinnati, Ohio

# BOSWORTH RADIO

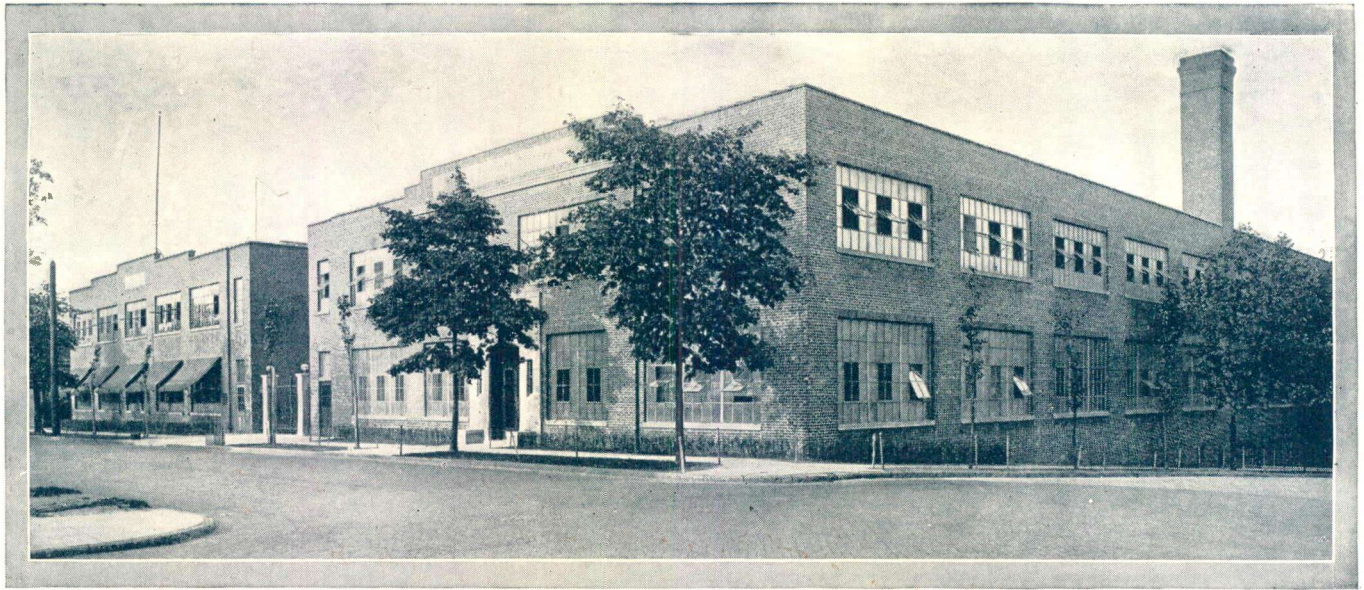

*Brandes Factory at Newark, N. J.*

**I**N any young industry—and referring to radio in this case—it is always a significant sign of stability when a concern and its distributors who start together in the early days continue their relations year after year.

It also demonstrates that the manufacturer's policy is sound, his operations substantial and his position in the industry permanent.

In these formative days of radio, Brandes considers itself fortunate to have such desirable representation in the trade, and the Company will continue to court their favor by maintaining Brandes leadership in acoustical development.

Acoustics by  
**Brandes**  
means the ultimate in reproduction

BRANDES PRODUCTS CORPORATION  
200 Mt. Pleasant Avenue, Newark, N. J.

**ALL EYES ON UTAH**

Next Month Watch  
For Double Page

**Announcement Extraordinary**



**THE UTAH LINE OF 1926**

*Coming*—A New Utah Speaker  
which will

**REVOLUTIONIZE**  
the Radio World

**DEALERS DON'T MISS THIS!**

UTAH RADIO PRODUCTS CO.  
1421 So. Michigan Ave., Chicago

**WE ARE MANUFACTURERS—NOT ASSEMBLERS**

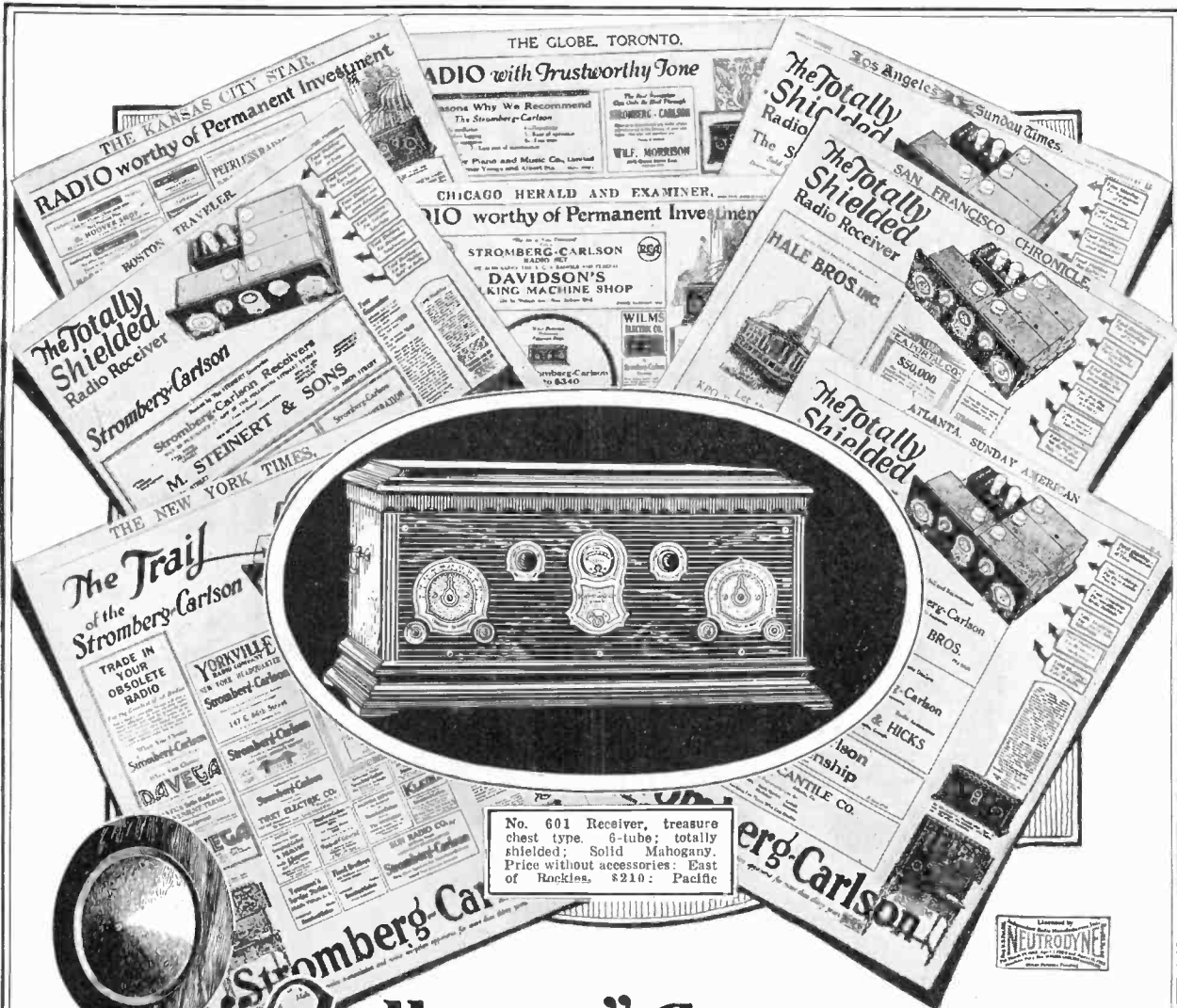

No. 601 Receiver, treasure chest type. 6-tube; totally shielded; Solid Mahogany. Price without accessories: East of Rockies, \$210; Pacific

# "Full page" Co-operation

QUALITY of performance in Stromberg-Carlson products—persistence of advertising—integrity of direct-to-dealer merchandising—prestige of association with the industry's proudest group of merchants—these are the elements that make a Stromberg-Carlson franchise desirable.

That dealers who hold the Stromberg-Carlson franchise value it highly is evidenced throughout the country by their enthusiastic full page newspaper advertising co-operation.

**Stromberg-Carlson Telephone Manufacturing Co.**  
Rochester, N. Y.

*Makers of voice transmission and voice reception apparatus for more than thirty years*

5-A Cone Speaker. Prices: East of Rockies, \$35; Pacific Coast, \$40; Canada, \$45. Licensed under Lektrophone patents 1271527 and 1271529. Others pending.



602 Art Console Type. American Walnut. Price without accessories: East of Rockies, \$340; Pacific Coast, \$360; Canada, \$470.

# Stromberg-Carlson

# Sell the Synchronphase Now!

**S**UMMER weather has little effect on Grebe reception, so why not keep business active?

You can sell this set now with every assurance that your customer will have real radio enjoyment this summer. And this satisfaction will continue to your benefit, for every Grebe owner is a booster. Prove it—ask some of them.

Of course, there are a number of sound reasons why this year less than two-tenths of one percent of Grebe Synchronphase sets were returned to the factory for adjustment.

*Learn why Grebe sets stay sold and about our money-making proposition to dealers.*

A. H. Grebe & Co., Inc., 109 West 57th Street, New York

Factory: Richmond Hill, N. Y.

Western Branch: 443 So. San Pedro Street, Los Angeles, Cal.

## The GREBE SYNCHROPHASE

TRADE MARK REG. U.S. PAT. OFF.



This Company owns and operates stations WAHG and WBOQ; also low-wave rebroadcasting stations, Mobile WGMU and Marine WRMU.



"Good and evil are rewarded at last."

—Confucius

The reward for the sound design and construction of the Synchronphase lies in the increasing business that consumer satisfaction brings.

*Doctor W. H. A.*

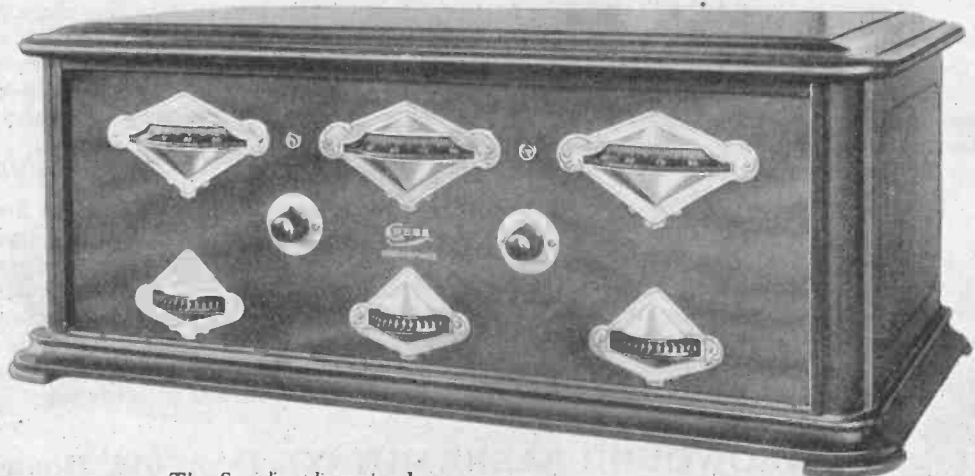

The Synchronphase is also supplied with battery base

All Grebe apparatus is covered by patents granted and pending.



### *Unequaled for Range and Power*

Here is Power to bring in the distant stations—power to build up the weak signals from smaller stations and make them into “radio”—super-power perfectly controlled, from a whisper to a roar.

### *It Tunes all Stations*

Here's radio at its best—a Super-Power Radio Set that tunes the entire wave band—from the lowest to the highest—from 200 meters to 550 meters [the official wave band]. The stations are accurately separated on the dials—there is no crowding of stations on one dial setting—you get them all—but just one at a time.

### *A Big Powerful 6-Tube Set*

The 1927 Model NEUTROWOUND is a real six-tube super-power set. Six powerful tubes—every one effective, produce wonderful volume, pure and clear. All six tubes are used to produce radio, and not a one is put there for effect, or to neutralize a shortcoming elsewhere. When you buy a NEUTROWOUND you are not paying for six tubes

and getting five tube results—you get six tube performance—distance, volume, tone quality and selectivity. You get the entire range of the wave band—all the radio there is—noiselessly, and free from howls, distortion and interference.

### *3 Stages of Audio-Amplification*

NEUTROWOUND has three tubes [three stages] of audio-frequency amplification. That tells the story—radio without a compromise—power with pure tone quality. You get that perfect balance between selectivity and volume which is necessary to meet the varying radio conditions.

### *All Metal “Shielding” Case*

The Neutrowound is the first radio set ever made with an all-metal case. Radio engineers have endeavored to apply the shielding principle—without obtaining successful results. Our engineers have developed and perfected this principle, and have designed an all-metal case that not only serves as a sturdy protection for the vital parts of the receiving set—but also acts as an electro-magnetic shielding against outside interference.

NEUTROWOUND RADIO MFG CO., Dept. 612, Homewood, Ill.  
Radio Division, ADVANCE AUTOMOBILE ACCESSORIES CORP'N

# The 1927 Model SUPER-POWER Neutrowound

REG. U.S. PAT. OFF.

Neutrowound Radio Receiving Sets are manufactured under our own patents and under a Reciprocal License from the Navy Department of the United States Government

### Super-Power Under Positive Control

The Neutrostat is a specially designed unit—used exclusively on the Neutrowound—that controls the oscillation of the set on all wave lengths, reduces "B" battery consumption, and enables distant stations to be tuned in with the volume and clarity of local stations.

The Neutrostat actually makes it possible to "build up" the strength of any signal, that has sufficient intensity to be detected, to the power and volume of local reception.

It varies the effective plate potential, which governs the output energy, and makes it possible to obtain the ultimate radio amplification—consistent distant reception—unusual selectivity—clarity and volume—all far beyond anything that has been obtained heretofore, by any receiving instrument.

### Why It Has 3 Dial Control

A radio set has three distinct circuits, each tuned by a variable condenser. Efficient tuning of distant stations depends upon putting these three circuits into resonance with each other and with the broadcasting station. This can be done only by individual control of each condenser.

NEUTROWOUND'S outstanding station getting ability is recognized wherever good radio is known. We are unwilling to sacrifice in the least this first essential of a radio set in a futile attempt to do something which, in itself, is electrically and mechanically impossible. Neutrowound retains individual control of variable condensers as indispensable to good radio.

### How the Stations are Separated

The specially designed Straight Line Frequency, variable Condensers, used exclusively in the Neutrowound, space out the stations evenly on the dials. They are designed and manufactured to close precision limits, to give absolute straight line frequency dial calibration, and prevent the *piling up or crowding of stations on one dial setting.*

These condensers are of the low-loss type, which insures sharper tuning and greater receiving efficiency. They are designed especially for the purpose of tuning the receiving circuit to any desired wave length, or station. The intervals between the stations are all equal—the separation is the same throughout the entire wave band—therefore all stations come in with positive regularity at exactly their allotted space on the dials.

### Only One Model—Easy to Sell

Neutrowound is made in but one model—a precision instrument of the finest quality—handsomely finished. In this one model is contained all the Radio that it is possible to buy at any price.

### No Cut Prices—No Bargain Sales

Neutrowound is sold exclusively through Authorized Distributors and Sub-Distributors—who are fully protected. It is not sold by "Gyps," Department Stores or Cut Price Stores, yet during the past season we were absolutely unable to build enough sets to fill the flood of orders that we received. It was the outstanding success of the year—yet there was not a single Neutrowound Set advertised at "Bargain Prices" throughout the entire United States.

**\$85** Buys a NEUTROWOUND Six-Tube, Super-power set, and you couldn't buy more radio if you spent a thousand dollars.  
West of Rockies, \$90 In Canada, \$115

Station WOK—operating on 5000 Watts—wave length 217.3 meters—owned and operated by NEUTROWOUND RADIO MFG. COMPANY, HOMEWOOD, ILL.

**DEALERS:** Fill out and mail coupon for full information about the 1927 Super-power NEUTROWOUND and our exclusive territory proposition to sub-distributors.

**NEUTROWOUND RADIO MFG. CO.**  
Dept. 612, HOMEWOOD, ILL.  
Radio Division Advance Automobile Accessories Corporation

### Dealers Coupon

NEUTROWOUND RADIO MFG. CO.  
Dept. 612, Homewood, Ill.

Send complete information Dealers' Discounts and Neutrowound Sales Plan.

Name.....

Street.....

City.....

State.....

# SPARTON



Sparton Radio is built by the manufacturers of the world-famous Sparton horns for motor cars. Its production is a logical development of the Company's quarter-century of precision manufacture of electrical equipment.



The remarkable success of Sparton Radio is the natural reward of skill and expertness acquired after years of concentration upon precision electrical equipment.

The Sparton is a perfectly balanced five-tube tuned Radio Frequency circuit, producing clear, powerful volume with a positive realization of that rare and much sought combination—Selectivity with long range. Cabinets are in rich two-toned walnut, at prices of \$63.00 and upward.

*Western and Canadian prices slightly more.*

THE SPARKS-WITHINGTON COMPANY (Established 1900) JACKSON, MICHIGAN



# RADIO

*"The pathfinder,  
of the air"*

## Model 5-26

Roomy cabinet with space for B batteries—Drop front provides a substantial arm rest for tuning, and closes to protect panel when not in use—Inside-illuminated dials—Micrometer tuning.

Price \$83



## Model 5-15

Compact type cabinet, open front—Inside dials—Materials, finish and performance ability identical with Model 5-26.

Price \$63.00

Sparton-built from coils to cabinet, with a background of two years of intensive research work, by the best radio experts—Twin-cylinder coils, providing the finest selectivity with unmatched quality and volume—Highly efficient shielding against outside interference—Positive neutralization by a patented method—Inside dials—Sparton-built straight-line frequency condensers, greatly simplifying tuning on short wave stations—Operation by indoor or outdoor antenna—Every receiver carefully tested by Sparton inspectors to actual broadcast reception.

Sparton radio has been sold throughout the country this past season by a restricted list of connections, and has proved itself beyond question. Sparton franchises in limited number will now be granted in your territory.



THE SPARKS-WITHINGTON COMPANY (Established 1900) JACKSON, MICHIGAN

# The First News of a Tremendous Radio Story



Broad and easy or fine and selective—virtually two sets in one cabinet.



A type of set for every type of buyer.



A national advertising campaign in leading periodicals and farm papers.



Exclusive sales territory for every A-C DAYTON dealer.



1930 THE A-C ELECT. MFG. CO.

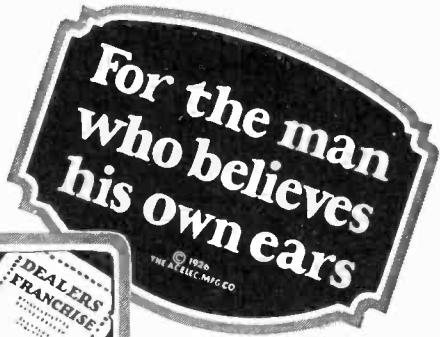

Our strength protects your business. Our policy protects your price.

**A** CCEPT these facts from a company of more than 20 years standing—which has been prominently identified with radio for six years and is noted for square dealing and sound management.

The A-C Dayton story concerns an original development in radio tuning, which not only establishes new standards of set performance but which supplies the direct answer to your biggest problem in selling radio receivers.

It concerns a balanced line of six models, incomparable in design,

from \$56 to \$255 in price—and strong national advertising in leading periodicals and farm papers of more than 7,000,000 circulation.

Lastly, it concerns the building of an exclusive and permanent organization of dealers, each with his own protected territory—protected as to sales—protected as to price.

This last is tremendously important today. Time will not wait. Territories are being allotted. Regardless of your present plans or connections we urge you—get the facts in your hands immediately.

THE A-C ELECTRICAL MANUFACTURING CO.  
DAYTON, OHIO

Makers of Electrical Devices for More Than Twenty Years

## A-C DAYTON RADIO

### Use the Coupon

To aggressive dealers of proven ability we say: Don't write us next week. Write us now—today

The A-C Electrical Mfg. Co., R-R-6 Dayton, Ohio.

Gentlemen: Send me full information about the A-C DAYTON exclusive dealer franchise, prices, advertising, etc.

Name \_\_\_\_\_

Address \_\_\_\_\_

City and State \_\_\_\_\_



The A-C DAYTON line of six handsome models. Priced from \$56 to \$255—prices slightly higher Denver and west.

# The Last Word In Resistance Coupled— The Allen "5" Rectaflex

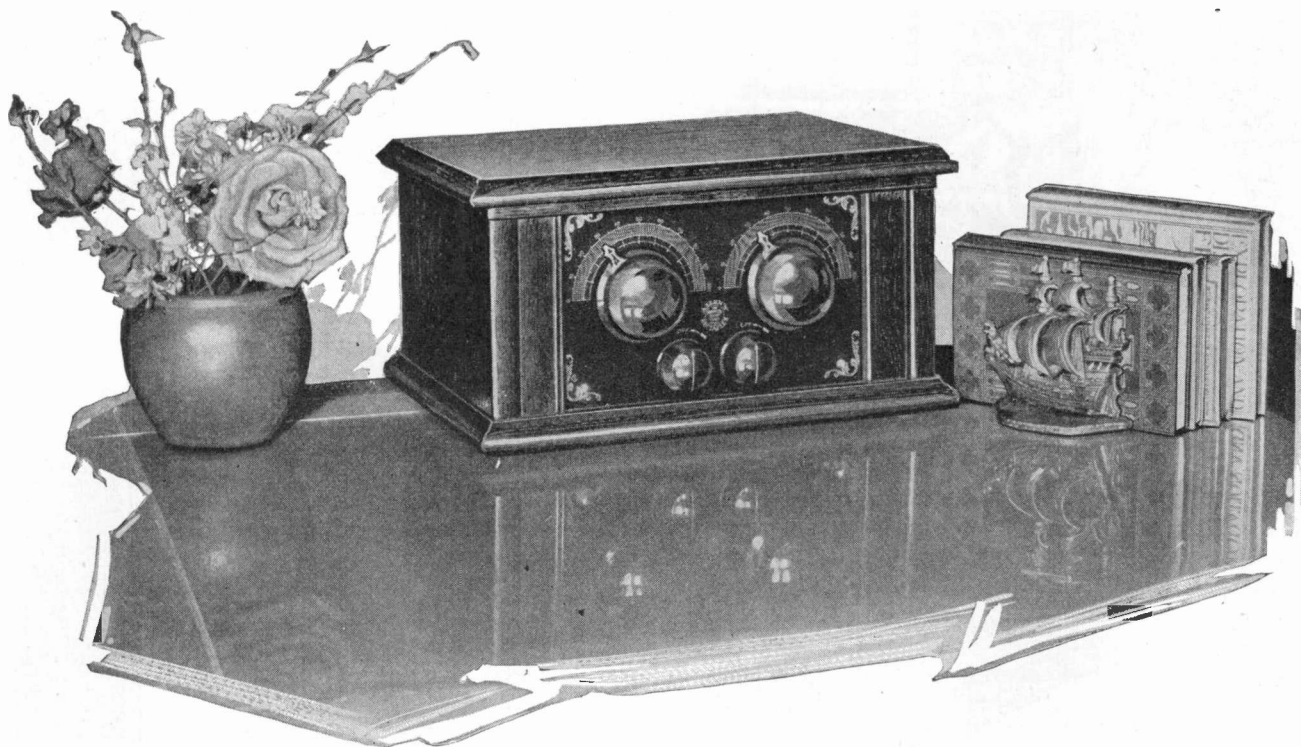

Marvelous clarity of tone—splendid range—compact as a lady's watch—attractive cabinet—mahogany finish metal panel beautifully engraved in gold—ease and convenience in tuning and volume control—all these are intrinsic qualities of the Allen "5" Rectaflex.

**\$37.50**

Five tubes—one tube reflexed, giving the equivalent of a six tube set, resistance coupled, non-howling, non-radiating.

List price \$37.50—liberal discounts.

Get acquainted with the Allen "5" Rectaflex. The coupon is for your convenience.

**The Premier Radio Corporation**  
Defiance, Ohio, U. S. A.

.....  
**The Premier Radio Corporation**  
 Defiance, Ohio  
 Please tell me more about the Allen "5" Rectaflex.  
 Name .....  
 Address .....

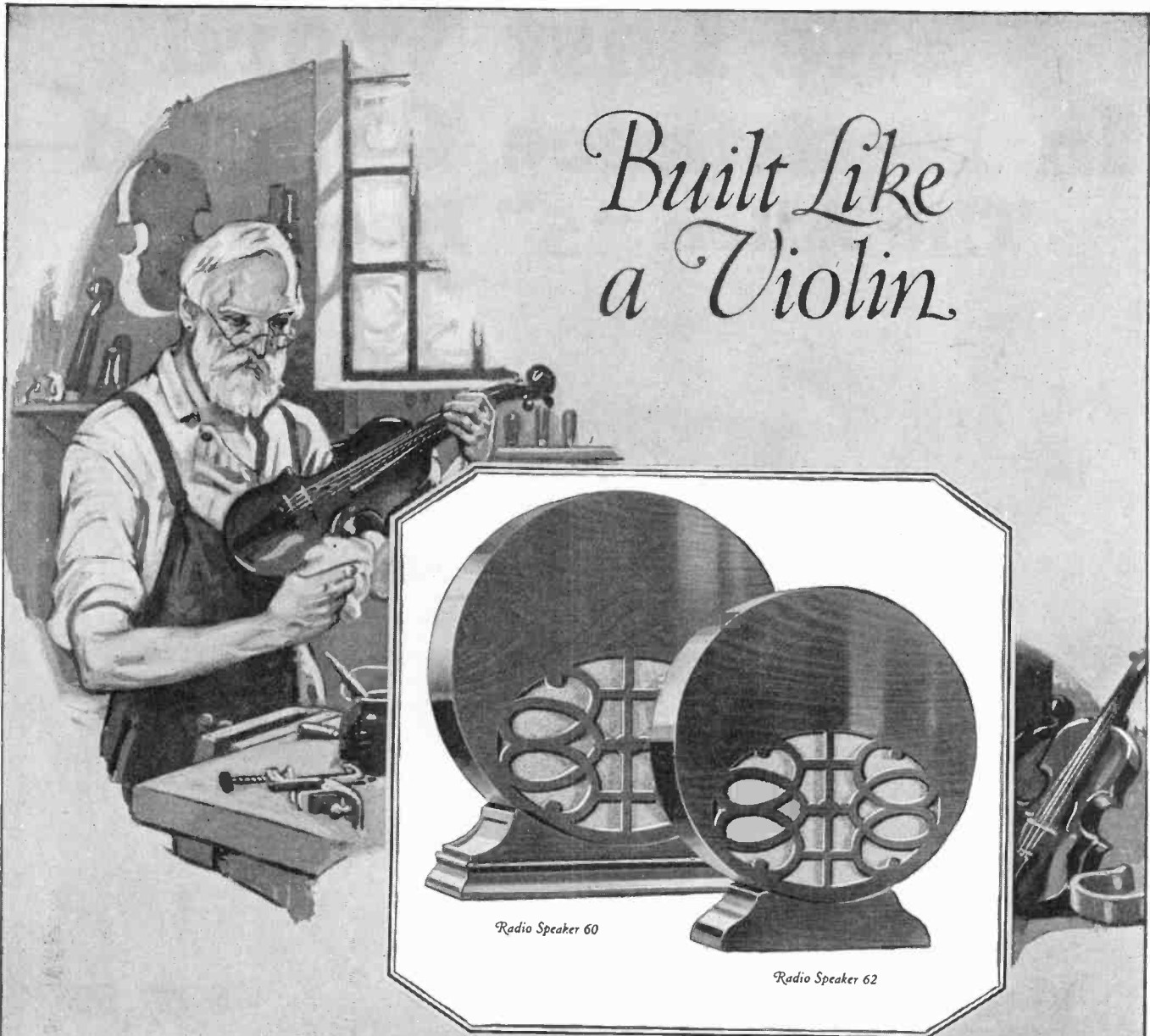

*Announcing the exquisite . . .*  
*Radio Speaker 60 . . . \$32.50*

A new Teletone, embodying the principles which have made Teletone synonymous with tonal fidelity; and far finer, with an exterior in either American Black Walnut or African Mahogany, beautiful in the restraint of its design.

*and the charming Radio Speaker 62 ..*

Precisely the same in mechanical construction, finished with equal nicety, but slightly smaller. *\$22.50*  
 Mahogany only

**TELETONE CORPORATION**

# TELEPHONE

## Radio Speaker

Your introduction . . .  
to a new character . . .

☞ In the incessant quest for profit, real profit opportunities are often overlooked. All we people in business are so close to it that the *human side*—which is the *real profit side*—passes us by in the wild scramble.

☞ The old violin maker has lived his art. He fashions his spruce with infinite nicety into tonal instruments of such rare beauty that nothing remains but music alone.

☞ He is the symbol of Teletone. All his training, his mind, his deft hands, his art, *are* Teletone. His picture and his spirit will visualize to broadcast listeners, that all for which the violin is regarded, is reborn in Teletone.

☞ For here we offer you the violin of radio. The time-tried tone amplifying principles of Teletone remain—beyond improvement.

☞ And added to this an exterior—beyond words.

☞ There is large profit in Teletone. The Teletone franchise is more sought than seeking. The presence of Teletone in radio stores begets confidence in the store and the man who runs it.

☞ Advertising, planned with a full knowledge of markets, of your difficulties and ours; advertising toned to the high estate of Teletone itself, is offered you liberally to bring rapid turnover and profits which you will call generous. Get in touch with us, that we may open for you a new opportunity.

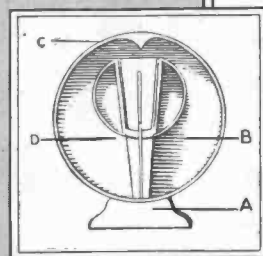
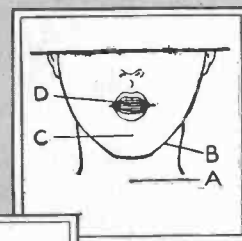

Note that a sound-wave coming from the sound-producing unit "A" (the human vocal cords) is amplified through the orifice "B" (the human larynx) until it reaches the conducting area "C" (the back of the throat), whence it is again conducted to the point of greatest amplification "D" (the correctly formed and opened mouth of the singer.)

of **AMERICA**

449-453 West 42nd Street, New York City.



# Steady Unfailing POWER in the MODERN "B" Power Unit

"The 'Modern' B Power Unit," in the words of one of our Kansas City jobbers, "is the one satisfactory unit among seventeen tested."

Its ample capacity guarantees 60 milliamperes and a steady unfailing current. It has the RAYTHEON Tube.

The "Modern" B Power Unit is not sold on price, quality being our first consideration.

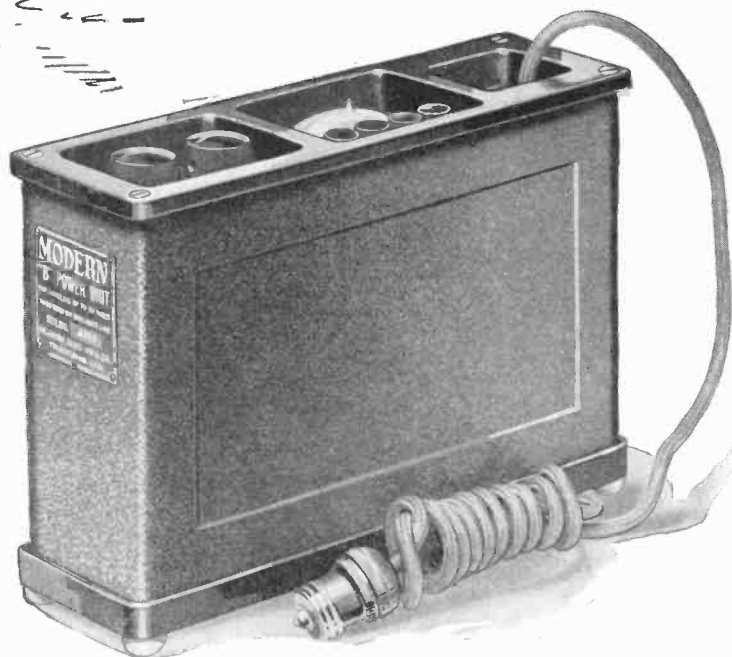

List Price, \$50.00

Slightly Higher West of the Rockies

The Modern Electric Manufacturing Co.  
Toledo, Ohio

The new Freed-Eisemann factory—made possible by 6,500 satisfied dealers.

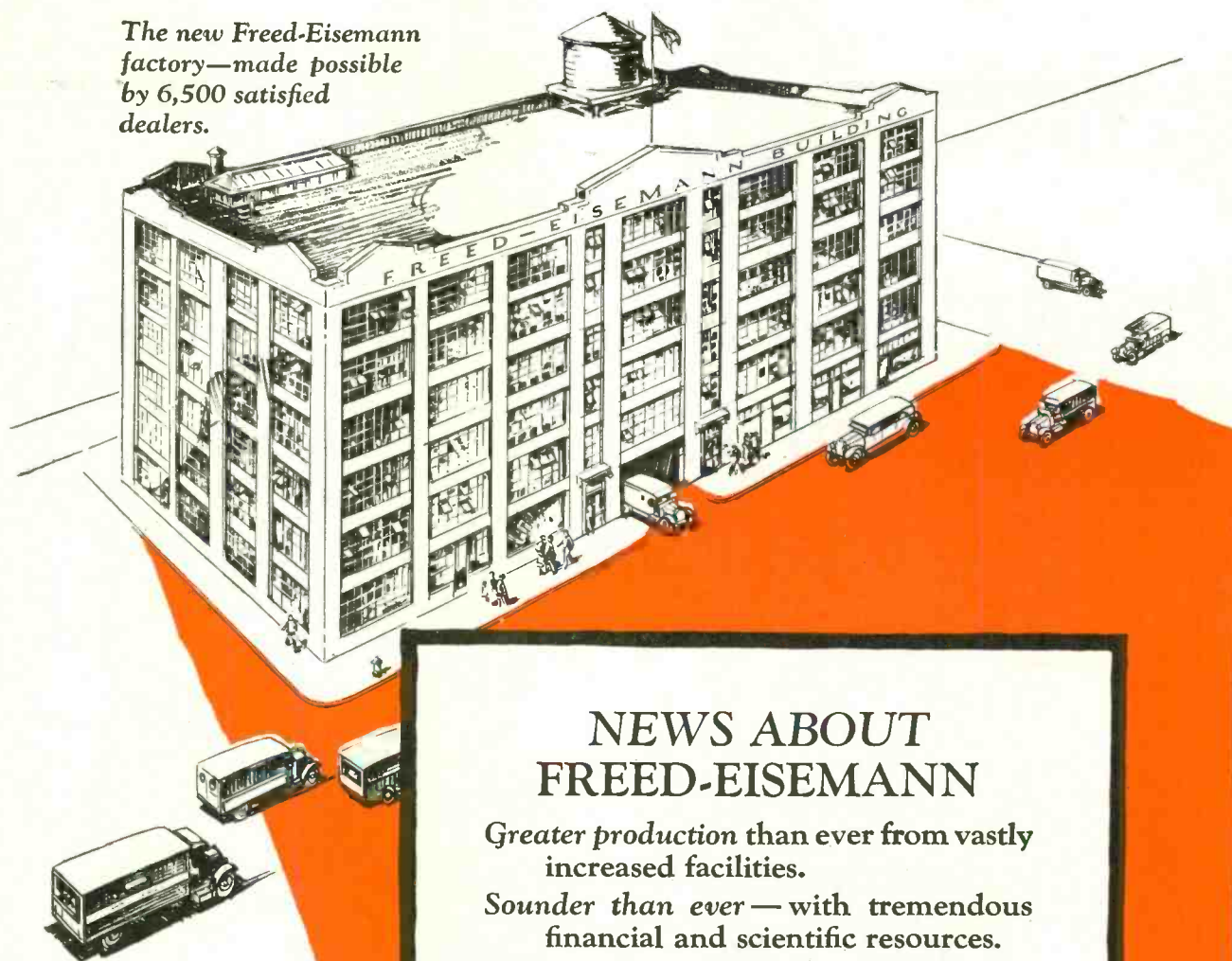

## NEWS ABOUT FREED-EISEMANN

*Greater production than ever* from vastly increased facilities.

*Sounder than ever*—with tremendous financial and scientific resources.

*An even better line*—shortly to be announced—incorporating striking new features.

*A strong policy of dealer protection*—limiting the line to authorized dealers only.

*Greater profits than ever*—The Freed-Eisemann franchise was valuable last year. This year it will be even more valuable.

Be sure to look into the details of the Freed-Eisemann proposition. It's important to you.

Freed-Eisemann Radio Corporation  
Junius St. & Liberty Ave., Brooklyn, N.Y.

# FREED-EISEMANN



The United States Patent Office  
on April 27, 1926, granted  
United States Letters Patent

No. 1,582,470

*Covering the fundamental  
exclusive circuit system that  
makes possible the famous  
Ortho-sonic\* reproduction*

ORTHO-SONIC

REG. U. S. PAT. OFF.

*In the field of Radio, only Fed-  
eral Receivers produce the Ortho-  
sonic tones — rived only by reality.*

FEDERAL RADIO CORPORATION, Buffalo, N. Y.  
(Division of Federal Telephone and Telegraph Company)  
Operating Broadcast Station WGR at Buffalo



\*MEANING—Of, pertaining to or producing tone values in  
sound reproduction corresponding exactly to the natural tones



# DUDLO

MAGNET WIRE AND WINDINGS



## Volume

Makes it possible for this plant to supply manufacturers of electrical apparatus unequalled products and service in

### Fine Magnet Wire and Coils For Every Purpose

This has become such a *highly specialized* field that even the largest electrical manufacturers in the country are now using DUDLO Wire and Coils instead of attempting to make their own. They find it *pays from every standpoint*.

Automobile manufacturers, whether large or small, have found that it does not pay them to try to make such parts as spark plugs or tires. These are special lines of manufacture. For the same reason, manufacturers of electrical apparatus do not attempt to produce their own coils or windings, but find their greatest success results from concentration on their own products.

Manufacturers are invited to make our experimental laboratories a department of their own business. We suggest you allow our engineers to develop coils for your products. No obligation. Estimates will be gladly furnished on coils built to your specifications.

This illustration pictures a small section of the great DUDLO plants at Fort Wayne, Indiana, the world's largest factories devoted exclusively to quality Coils and Magnet Wire

Eastern Office and Warehouse  
412 Chamber of Commerce Bldg.  
NEWARK, N. J.

Chicago Office  
160 N. La Salle St.  
CHICAGO, ILL.

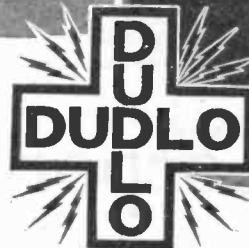

**DUDLO MANUFACTURING CORPORATION FT. WAYNE, IND.**

# Patent Information

*furnished by* Radio Corporation of America

Many inquiries are made in respect to the patent situation on vacuum tubes, such as are used for radio purposes. The Radio Corporation of America takes this method of answering these inquiries and states that there are numerous patents under which its tubes are manufactured and sold. Among these patents, not excluding others, are the following:

921,526, May 11, 1909, Eisenstein	1,316,967, Sept. 23, 1919, Moore
954,619, Apr. 12, 1910, Fleming	1,329,283, Jan. 27, 1920, Arnold
982,873, Jan. 31, 1911, Regenstreif	1,341,006, May 25, 1920, Babcock
1,022,182, Apr. 2, 1912, Dempster	1,353,976, Sept. 28, 1920, Stoekle
1,032,476, July 16, 1912, Fagan	1,354,939, Oct. 5, 1920, Arnold
1,066,468, July 8, 1913, Chubb	1,374,679, Apr. 12, 1921, Pratt
1,082,933, Dec. 30, 1913, Coolidge	1,398,665, Nov. 29, 1921, Arnold
1,105,050, July 28, 1914, Whitney	Re-15,278, Jan. 31, 1922, Langmuir
1,113,745, Oct. 13, 1914, Blow	1,409,658, Mar. 14, 1922, Brann
1,116,595, Nov. 10, 1914, Knight	1,423,956, July 25, 1922, Mitchell & White
1,124,555, Jan. 12, 1915, Thatcher	1,423,957, July 25, 1922, Mitchell & White
1,140,134, May 18, 1915, Eldred	1,444,438, Feb. 6, 1923, White
1,140,136, May 18, 1915, Eldred	1,456,505, May 29, 1923, Knoop
1,154,081, Sept. 21, 1915, Weintraub	1,456,528, May 29, 1923, Arnold
1,180,264, Apr. 18, 1916, Lederer	1,461,360, July 10, 1923, Lederer
1,191,630, July 18, 1916, Weintraub	1,464,104, Aug. 7, 1923, Nicolson
1,196,744, Aug. 29, 1916, Chubb	1,472,477, Oct. 30, 1923, King
1,203,495, Oct. 31, 1916, Coolidge	1,477,868, Dec. 18, 1923, Donle
1,204,456, Nov. 14, 1916, Knight	1,477,869, Dec. 18, 1923, Donle
1,209,324, Dec. 19, 1916, Nicolson	1,478,072, Dec. 18, 1923, Van der Bijl
1,231,764, July 3, 1917, Lowenstein	1,479,778, Jan. 1, 1924, Van der Bijl
1,244,216, Oct. 23, 1917, Langmuir	1,480,219, Jan. 8, 1924, Nicolson
1,244,217, Oct. 23, 1917, Langmuir	1,498,908, June 24, 1924, Fink
1,268,647, June 4, 1918, Van Keuren	1,506,468, Aug. 26, 1924, White
1,266,394, Dec. 3, 1918, Northrup	1,529,597, Mar. 10, 1925, Langmuir
1,287,265, Dec. 10, 1918, Dushman	1,531,966, Mar. 31, 1925, Mackay
Re-14,572, Dec. 17, 1918, Nicolson	1,536,855, May 5, 1925, Houskeeper
1,293,781, Feb. 11, 1919, Hoyt	1,558,436, Oct. 20, 1925, Langmuir
1,294,694, Feb. 18, 1919, Nolte	1,558,437, Oct. 20, 1925, Langmuir
1,303,579, May 13, 1919, Nicolson	1,565,857, Dec. 15, 1925, Kelly
1,307,510, June 24, 1919, Nicolson	

To enforce the rights secured by these patents, suits have been brought and are now pending on the following patents included in the above list:

1,558,436, Langmuir	1,529,597, Langmuir
1,082,933, Coolidge	1,341,006, Babcock
1,231,764, Lowenstein	1,423,956, Mitchell & White
1,244,216, Langmuir	1,423,957, Mitchell & White
1,244,217, Langmuir	Re-15,278, Langmuir

*Suits on other patents in the above list are in preparation and such further steps as may in the future be deemed necessary will be taken to fully enforce the rights which these patents grant.*

# Radio Corporation of America

# SPLITDORF

1926 Radio line

ready NOW

OUR company already has started production on its leading model for the coming season. This will enable every Splitdorf dealer to get his sample line immediately he signs up for his franchise.

The Splitdorf 5-tube receiver, which will be the leader for volume sales, represents many outstanding refinements in construction and operation. Better tone quality, greater volume and easier tuning are assured.

— M. W. BARTLETT, *President*  
 Splitdorf Electrical Company  
 392 High Street Newark, N. J.  
*Subsidiary of*  
 Splitdorf-Bethlehem Electrical Company



*Succeed with Splitdorf*

Get in touch with us  
 at once

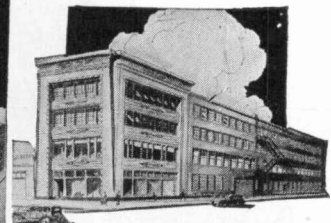
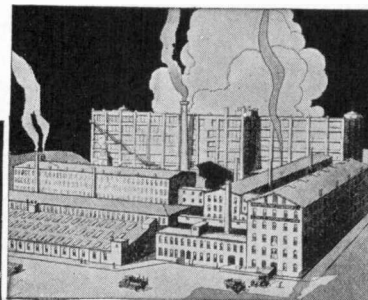
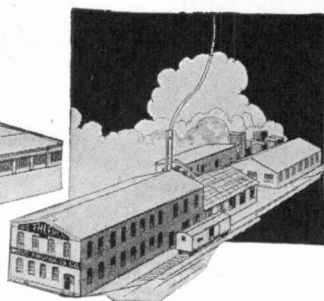
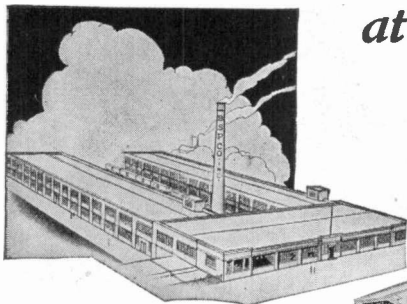

PLANTS IN BETHLEHEM . . . NEWARK . . . CHICAGO

# MAGNAVOX

Trade Mark Reg. U. S. Pat. Off.

## The most worthy successor to the *original* radio loud speaker

The earliest and most popular loud speaker was a Magnavox—a wonder. The latest and finest is a Magnavox, too—a sensation. Fifteen years sound amplifying experience evolved and perfected in turn the Magnavox horn, cabinet and now the *CONE*, each the most advanced for its day. To hear the Magnavox Cone is a revelation in clear, rich, life-like reproduction. Wait for it.

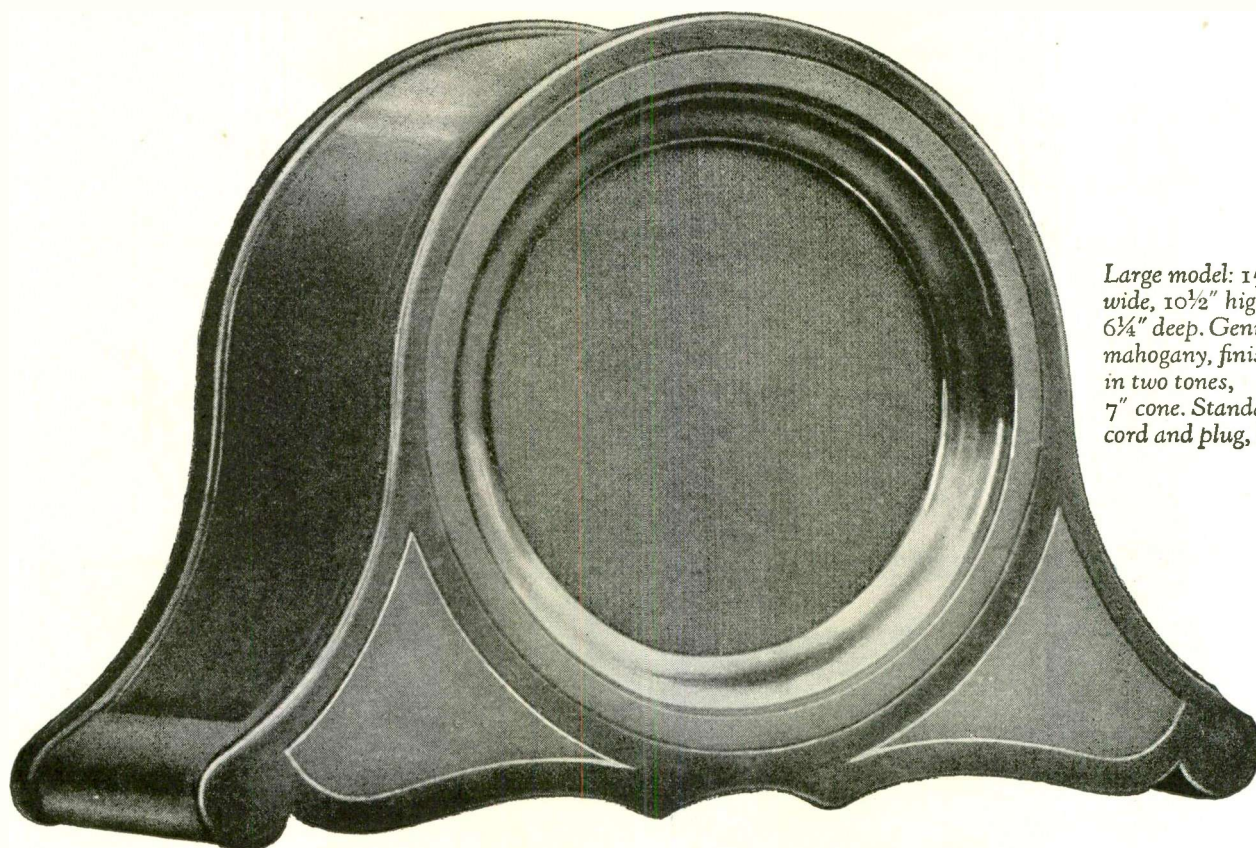

Large model: 15¼" wide, 10½" high, 6¼" deep. Genuine mahogany, finished in two tones, 7" cone. Standard cord and plug, \$35.

SOME OPEN TERRITORY LEFT—WRITE US

# CONE SPEAKER

Patented

Small model:  $9\frac{1}{4}$ " wide, 11" high, 5" deep. Artistic, non-resonant, metal finish, genuine mahogany base, finished in two tones, 7" cone. Standard cord and plug, \$22.50.

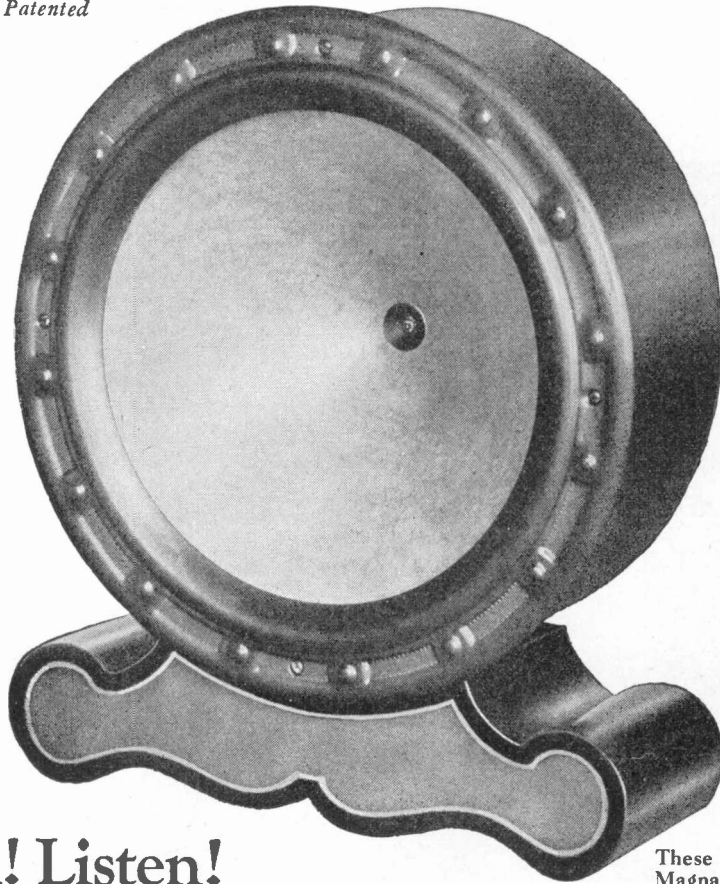

## NOTICE

All present models of Magnavox Radio Sets and Cabinet Speakers are continued indefinitely and prices guaranteed till January 1, 1927.

**Stop! Look! Listen!**  
—and another sale made

Magnavox Cone Speaker, as you would expect, goes far beyond any on the market in sales-making features. It covers the complete tonal scale—from below 50 to about 10,000 cycles.

It has a full floating cone—resiliently mounted to give greatest free movement to the entire cone. No side vibrations to neutralize low tones and give a “snary” effect. Two models—with identical mechanism, varying only in size, shape and finish. Artistic mountings complete the sales appeal. Vigorous advertising to make sales easy.

These speakers are made under Magnavox patents. Distributors and dealers are fully protected against infringement liability.

**All dealers are urged to write nearest distributor named below or to our nearest office**

F. D. Pitts Co., Boston  
Wholesale Radio Equipment Co.,  
New York City, Newark, Buffalo  
Girard Phonograph Co., Philadelphia  
Doubleday-Hill Electric Co., Pittsburgh  
Lee-Kountze Hardware Co., Omaha  
Commercial Electric Supply Co., Detroit  
The M. D. Larkin Co., Dayton  
American Radio & Equipment Co.,  
Milwaukee  
Terry-Durin Co., Cedar Rapids  
Shawnee Radio Co., Kansas City  
Listenwalter & Gough,  
Los Angeles, San Francisco  
The Harco Co., Chicago  
Doerr-Andrews & Doerr, Minneapolis  
Spurlock Neal Co., Nashville

## THE MAGNAVOX COMPANY

General Offices and Factory: Oakland, Calif.

Chicago Sales Office: 1315 South Michigan Avenue, Chicago

# Cabinet Business Sell Radio



# Without "Trade-ins"

## Master Cabinets

### Fit Any Table

Sale of cabinet style radios is bound to bring from the public a demand for trade-in allowances on old sets.

By selling Radio Master Cabinets you entirely avoid the need for trading in old sets—you have all the profit of cabinet business without any of the trouble or expense.

Any table set fits into a Radio Master Cabinet. Installation requires only a very few minutes, and the result is a beautiful, convenient cabinet radio of enduring value.

Pull out radio frame makes tubes accessible from front. Plenty of space for batteries, charger, etc. below the panel. A built-in wood horn above is arranged to receive your favorite speaker unit. All wiring is concealed.

Eight splendid models in walnut and mahogany. Some have striped walnut and burl overlays. Cabinet work and finish is by master of their craft.

Low list price makes wide market available. Fixed jobber and dealer policy and liberal discounts guarantee continued good profits.

If you are not selling Radio Masters, you are missing a most profitable development—fill in the coupon now—get full information.



# Radio Master

## Corporation of America

*One of the Ward Industries*

Bay City, Mich.

# RED SEAL DRY CELLS

## Now a National Carbon Product

ON MAY first the Red Seal Dry Battery business of the Manhattan Electric Supply Company was purchased by the National Carbon Company, Inc., and Red Seal Dry Batteries are now being manufactured and sold by the National Carbon Company organization.

The Red Seal brand of dry batteries will be continued on the market and will have the same high quality as heretofore. This change in brand ownership will, we believe, bring advantages that the trade will be quick to realize. Adequate stocks will be regularly carried at National Carbon Company factory and warehouse points, which will insure prompt

and efficient service to the trade.

Present stocks of Red Seal cartons, display material and literature will be used until exhausted, after which the only change will be the appearance of the name of the National Carbon Co., Inc., as the manufacturer. Abundant window display material of the most effective kind will be supplied Red Seal dealers.

The manufacture of Red Seal Dry Cells, therefore, not only is being continued as heretofore, but preparations are being made to expand the production of Red Seal Cells to whatever extent may be necessary to meet your demands. Order Red Seal Dry Cells from your jobber.

*Manufactured and guaranteed by*

**NATIONAL CARBON COMPANY, INC.**

Atlanta

Chicago

Dallas

Kansas City

Pittsburgh

Canadian National Carbon Co., Limited, Toronto, Ontario



# Play Safe, Mr. Dealer!

*You may bank on it that quality, value and service are going to run the radio business from this day hence. If this last year didn't entirely satisfy you, the message below is of importance*

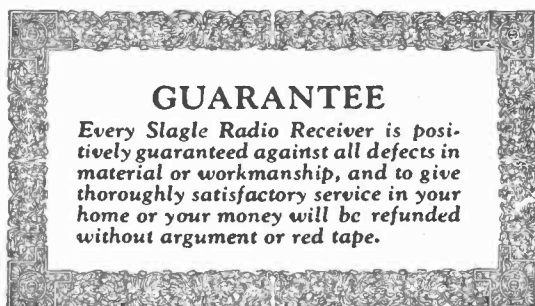

**T**HIS plain spoken promise and the keeping of it have given this company a steady growth through 14 years of the radio business.

Good years and bad have run about the same. We build just as many sets as we can build right and not a single one besides.

We use the finest parts that money can buy. They are put together in "hook-ups" designed by radio engineers of many years experience. Assembly is closely checked by experts at every stage of the game. Every set is thoroughly tested "on the air." We know it will give satisfactory service when properly installed. We have never built sets any other way.

Dealers who have handled our line now enjoy a steady, safely-growing business. They make money. Customers feel that they get their money's worth, in reception, in appearance and in service. They are thoroughly satisfied, and that's what builds profit in the radio business or any other.

We have a full line of sets ranging from \$70 to \$250 that you can sell, knowing that you're giving true value. We furnish strong selling helps and direct work on your prospects. We support you with strong, selling advertising in the leading publications that cover your territory. The time is ripe now to line up for good business next fall. We shall be glad to give full details of our proposition to you. Let us hear from you.

## SLAGLE RADIO COMPANY

Fort Wayne, Indiana



# Slagle Radio



# THE EAR SAYS BUY!

"Hearing is believing," says the radio buyer of today. Faith in the maker's name may shape his preference, but no longer does he decide beforehand. Hearsay has given way to *earsay*. Prestige follows performance. The printed claim may draw him storeward, but the claim upon the Ear decides his purchase.

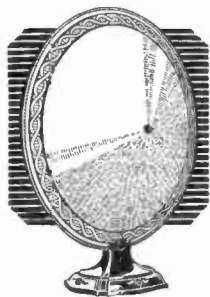

From the first day it voiced its peerless quality, the Farrand Speaker has caught and held the listening Ear—setting a standard in all-around performance unapproached by other speakers. Today, with similar-shaped speakers following in the wake of its leadership, its supremacy is more manifest than ever. ~ ~ ~

FARRAND MANUFACTURING CO., Inc. • Long Island City, N. Y.

*Farrand  
Speaker*

## First in the Field

We feel proud and boastful in announcing that after many severe tests and continuous running of over 1000 hours our Joyce Bros. A Filter Circuit still functioned in perfect condition.

*No hum No battery  
No bother*

Thousands can be sold at once to those radio fans who now have old wet batteries. If they have the charger, a simple replacement for the old battery. If they haven't there is a chance for a double sale, because by demonstration on your own set you can easily prove better reception, and when once installed this A Power Plant needs no further attention.

Sell your customers one of your chargers now in stock and one of our filters or stock our complete A Power Unit which lists at \$40.00.

Forget summer sales resistance. Here's an item that will help kill the seasonable idea of radio.

JOYCE BROS.  
FILTER CIRCUIT

\$19 LIST

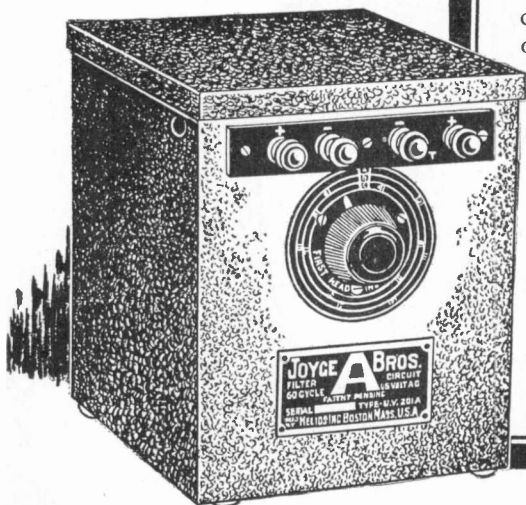

THE JOYCE BROS.  
"A" ELIMINATOR

LIST \$40

# It makes every <sup>Balkite</sup> <sup>Rectigon</sup> <sup>Tungar</sup> charger an "A" unit

IF YOU USE THE FILTER—YOU GAIN. A neat looking box which you connect up and forget. When you want power,

turn on the switch and when you are finished, turn it off. Will consume as much electricity on a five-tube set as a 40-watt lamp.

## JOYCE BROS. FILTER CIRCUIT

HELIOS CO., Inc., Boston, Mass.

BRANCH OFFICES

CHICAGO, ILL.  
Park & Company  
128 No. Wells

CINCINNATI, OHIO  
William Kroeb  
1228 Vine Street

MINNEAPOLIS, MINN.  
L. C. Kohn Noah Co.  
917 Phoenix Building

SEATTLE, WASH.  
Strimple & Gillette  
169 Jackson Street

NEW YORK CITY, N. Y.  
Ellis Cohen  
17 Waverly Place

TENNESSEE ENGINEERING AND SALES  
Knoxville, Tenn.

KANSAS CITY, MO.  
Reid Sales Co.  
317 E. 17th Street

OMAHA, NEB.  
Lenord C. Kohn  
625 Securities Building

ARKANSAS  
Stephen Brown  
Fort Smith

PORTLAND, ORE.  
Strimple & Gillette  
Corbett Building

DENVER, COLORADO  
Moore-Speaker Co.  
Sugar Bldg.

PHILADELPHIA, PA.  
Gray Sales Co.  
Widener Bldg.

SAN FRANCISCO, CALIF.  
Baldwin Pacific Co.  
Pacific Bldg.

SPOKANE, WASH.  
Stumph & Gillette  
Rookery Bldg.

# STEWART- Matched ~



Model 300  
\$65.00



Model 400  
Reproducer  
\$25.00



Radio Tube  
Model S-W  
501-A  
\$2.00



Model 310  
\$175.00

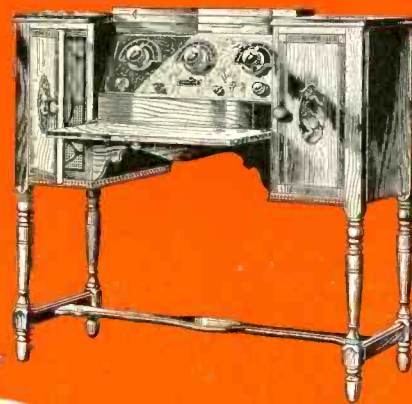

Model 315  
\$250.00



### Tune in STATION WBBM, 226 METERS The Stewart-Warner Air Theatre

Sunday—12:30 to 2:00 P.M., 4:00 to 6:00 P.M., 8:00 to 10:00 P.M.  
 Monday—12:01 to 3:00 A.M., 4:00 to 7:00 P.M.  
 Tuesday—4:00 to 6:00 P.M., 8:00 to 12:00 P.M.  
 Wednesday—4:00 to 6:00 P.M., 8:00 to 10:00 P.M.  
 Thursday—12:01 to 2:00 A.M., 4:00 to 6:00 P.M., 8:00 to 12:00 P.M.  
 Friday—4:00 to 6:00 P.M., 8:00 to 10:00 P.M.  
 Saturday—4:00 to 6:00 P.M., 8:00 P.M. to 2:00 A.M.  
 CHICAGO TIME

T W E L V E M I L L I O N P E O P L E A R E T O D A Y

# WARNER Unit Radio

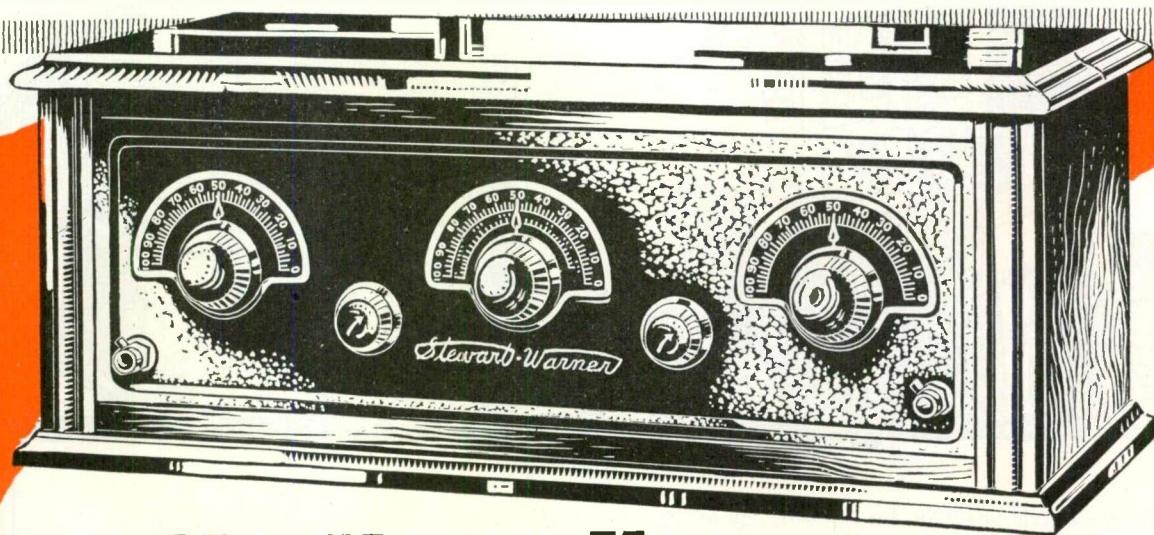

Model  
325  
\$75.00

## Are You Keyed Up *for* Bigger Profits This Summer?

**R**IGHT in your own locality are many people who are ready to buy Radios now. And many others will buy during the summer months.

This summer, as never before, the public is realizing that radio enjoyment is not confined to any single season—that *every* day is Entertainment Day on the air. Never have broadcasting stations been more active than now. And they'll keep up the quantity and quality of entertainment all summer.

Are you prepared to reap your full share of the profits from summer sales?

Dealers who sell Stewart-Warner Matched-Unit Radio can look with full confidence to a successful and profitable summer selling season.

They know that the product is ideal for summer selling—all the units, Instrument, Reproducer, Tubes and Accessories, are made by Stewart-Warner and *matched* to give maximum performance in Summer and Winter alike.

They also know that there will be no bargain or summer clearance sales on Stewart-Warner Radio products. The policy of "no yearly models" protects the dealer against unloading and other injurious trade practices.

They know, too, that the big advertising campaign which is creating real acceptance of Stewart-Warner Radio among millions, will continue undiminished all through the summer months. And that will *make selling easier* this summer.

Don't let your summer profits go to the other fellow down the street. Sell Stewart-Warner Matched-Unit Radio and clinch your profits for yourself.

\* \* \* \* \*

The exclusive Stewart-Warner Radio Franchise means Profit, Prestige, Protection and Permanence to every dealer who can qualify.

If you are in the Radio business to *stay* and *succeed*, and if you possess qualifications that entitle you to the highest type of Radio Franchise, write or wire us at once.

STEWART-WARNER SPEEDOMETER CORPORATION  
1820 DIVERSEY PARKWAY CHICAGO, U. S. A.

*Stewart-Warner*

U S I N G   S T E W A R T - W A R N E R   P R O D U C T S

# Popular Preference

*established through years of*

# Unfailing Service

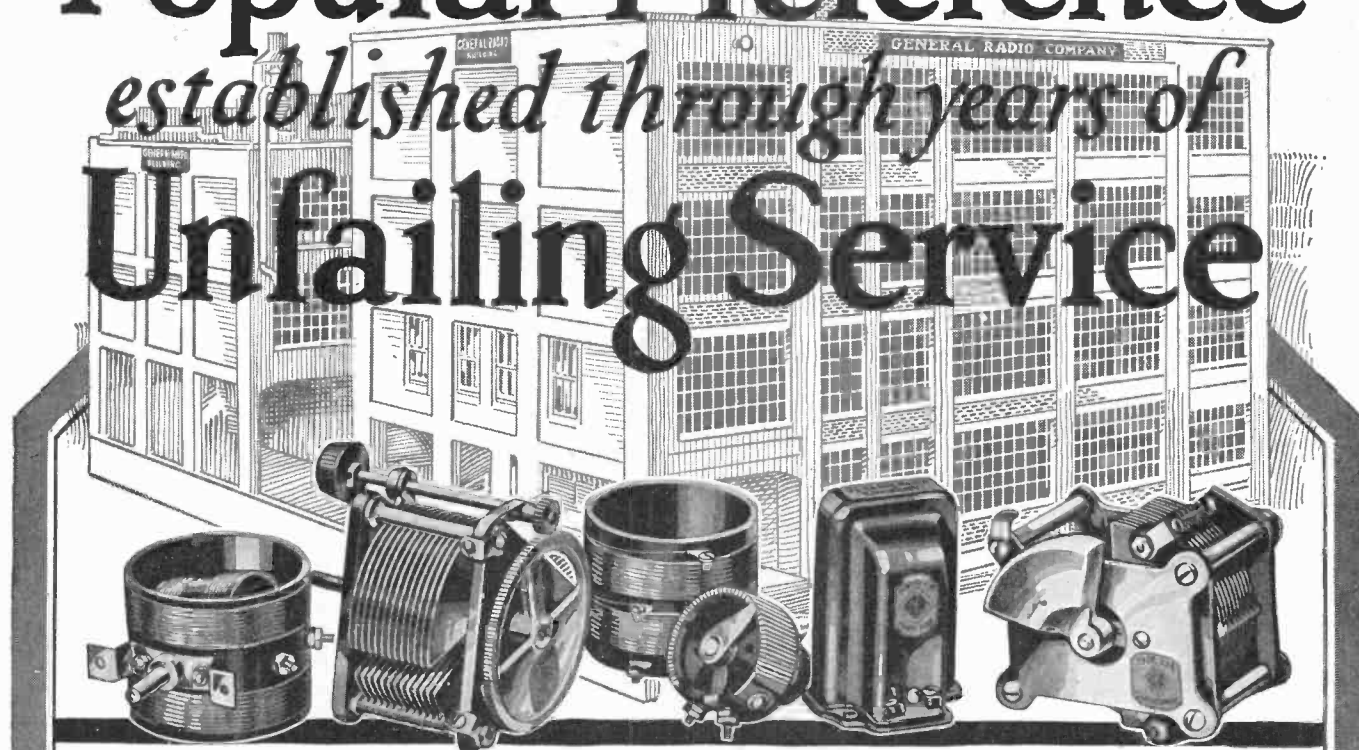

"By ye deeds shall ye be known," is an old yet significant proverb that applies to industry as well as to the individual. It is but natural that a pioneer organization which has pursued a steadfast policy of integrity should be the present day leader in its particular field of endeavor.

The General Radio Company has attained its position as the outstanding manufacturer of radio parts and laboratory instruments through the recognized merits of its products.

Since the early days of radio, amateur operators and set-builders have looked upon the General Radio Company as a time-tried producer of dependable apparatus.

The careful and conservative buyer of radio parts looks first to the reputation of the manufacturer. He knows from his own experiences and those of others whether this

reputation warrants his confidence. It is this self-same confidence upon which the popular preference for General Radio parts is based.

All products of the General Radio Company whether for the scientist or set-builder embody the same outstanding craftsmanship and materials in their construction.

As a consequence the General Radio Company has gained the esteem and confidence of amateur operators and experimenters—an enthusiastic group who are thoroughly familiar with the technique of radio design and to whom the science of radio owes much of its rapid advancement.

You will invariably find General Radio parts "behind the panels of better built sets."

Today General Radio precision instruments are standard equipment in nearly all the commercial and technical school laboratories throughout this and many foreign countries.

Every instrument made by the General Radio Company is thoroughly guaranteed.

Write for Parts Catalog 924-P.

GENERAL RADIO Co. CAMBRIDGE 39, MASS.

# GENERAL RADIO

*Behind the Panels of Better Built Sets*

# PARTS

# BOSCH RADIO Plans are GREAT!

*The Radio Policy Bosch Announced  
at the start of its Radio Program  
is the Policy in effect today. . . . .*

## BOSCH RADIO POLICY

1. BOSCH PROTECTION FRANCHISE  
NO DISCOUNTS TO OTHER THAN  
AUTHORIZED DEALERS HOLDING  
THE BOSCH FRANCHISE.
2. BOSCH TERRITORIAL PROTECTION  
TERRITORIAL FRANCHISE DEFINED  
AND ALL RIGHTS PROTECTED
3. BOSCH PRICE GUARANTEE  
THE DEALERS PROFITS ARE PROTECT-  
ED BY GUARANTEE AGAINST PRICE RE-  
DUCTIONS UNLESS DEALER IS REBATED
4. BOSCH RATIFIES DEALER CONTRACTS  
ALL CONTRACTS MUST BE RAT-  
IFIED BY THE MANUFACTURER
5. BOSCH CO-OPERATION  
EXTENSIVE CONSUMER AND TRADE  
ADVERTISING IN NATIONAL PUB-  
LICATIONS. CLOSE LOCAL NEWS-  
PAPER CO-OPERATION
6. BOSCH STABILITY  
THE BOSCH RADIO POLICY MAIN-  
TAINS THE SAME ETHICAL STAND-  
ARDS WHICH HAS BEEN THE BOSCH  
PRACTICE FOR 15 SUCCESSFUL YEARS
7. THE BOSCH DEALER  
THE BOSCH FRANCHISE IS A MAIN-  
SIZED, TWO FISTED OPPORTUNITY  
FOR ONE RECOGNIZED BUSINESS  
MAN IN A LOCALITY—WHO IS  
ABLE TO CONDUCT AN INTELLI-  
GENT SUCCESSFUL BUSINESS  
OVER A COURSE OF YEARS.  
ARE YOU THE MAN?



ARE YOU THE MAN TO SELL BOSCH RADIO?

AMERICAN BOSCH MAGNETO CORPORATION

MAIN OFFICE AND WORKS: SPRINGFIELD, MASSACHUSETTS  
Branches: New York :: Chicago :: Detroit :: San Francisco

Bosch very shortly will announce its plans for 1926-1927. Obviously, they include expansion in certain territories. They should appeal to every successful radio merchant regardless of the lines he now carries. There are many other merchants who have delayed taking on radio who will now recognize in the Bosch Plans an opportunity to add to their profits through a substantial new business.

Are you ready to advance your business along the lines of a sane, sensible and constructive radio merchandising program? If so, tell us who you are, what your business is, the territory you can cover profitably, your financial position and your merchandising background. This will be held in extreme confidence. We will tell you then, through a visit or by letter, how Bosch has provided for the all-year-round success of Bosch merchants and the benefits to be had through many years of active association.

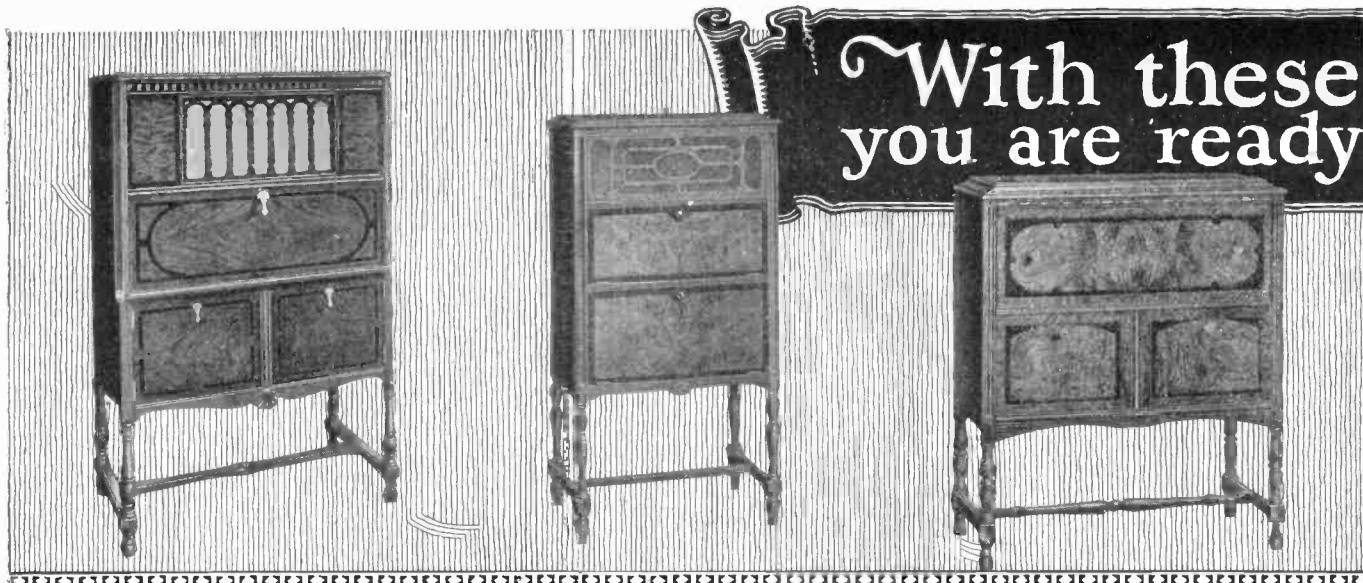

With these you are ready

**Model 1100-R-2**  
Mahogany or walnut, with built-in Pooley (patented) floating horn, Atwater Kent reproducing unit, and Atwater Kent receiving set. Height 52½", Width 33", Depth 15½"

**Model 1900-R-2**  
Walnut, with built-in Pooley (patented) floating horn, Atwater Kent reproducing unit, Atwater Kent receiving set. Height 45½", Width 24¼", Depth 15"

**Model 1600-R-2**  
Mahogany or walnut, with built-in, Pooley (patented) floating horn, Atwater Kent reproducing unit, and Atwater Kent receiving set. Height 41½", Width 35½", Depth 16¼"

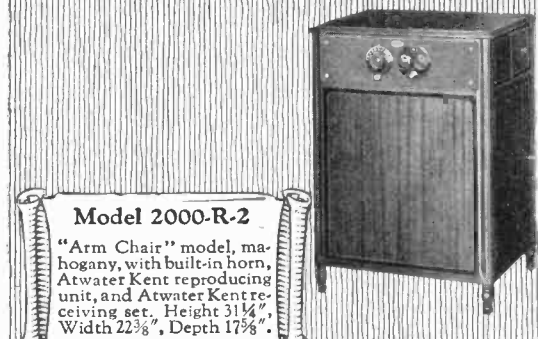

**Model 2000-R-2**  
"Arm Chair" model, mahogany, with built-in horn, Atwater Kent reproducing unit, and Atwater Kent receiving set. Height 31¼", Width 22¾", Depth 17¾"

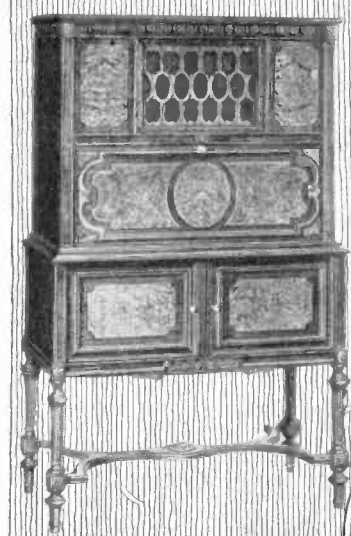

**Model 1200-R-2**  
Walnut only, with built-in Pooley (patented) floating horn, Atwater Kent reproducing unit, and Atwater Kent receiving set. Height 56½", Width 36", Depth 18"

WHAT a range of purse and purpose these ten Pooley models cover! Study them, for you will see what great possibilities they offer you.

Here are two facts worth noting. (1) Half the radio public wants cabinet radio. (2) Pooley leads the radio cabinet field, in cabinet design, in tone—and in people's minds.

Cabinet radio is in demand. Pooley Radio Cabinets, equipped with the latest types of Atwater Kent Receivers, are in particular demand. On top of that, Pooley advertising is sure to reach all your possible Pooley customers, to tell them of the complete variety of Pooley Models to choose from. The new cabinets widen your market; the variety makes selling easier.

Your market is ripe; your Pooley merchandise is right. Who is better armed than a Pooley dealer to meet competition?

Urge prospects to hear and compare the Pooley tone—to examine Pooley cabinetry. You can have no stronger talking points.

**POOLEY**  
RADIO CABINETS  
*with*  
**ATWATER KENT**  
RADIO

**THE POOLEY COMPANY**  
1600 Indiana Avenue Philadelphia, U. S. A.

Beware of imitations—Look for the name "Pooley" on the arm rest.



# Pooley models for everybody



**Model 1400-R-1**  
Console (without set), mahogany only, with built-in Pooley (patented) floating horn, Atwater Kent reproducing unit and battery compartment. Height 31½", Width 34", Depth 15¾".

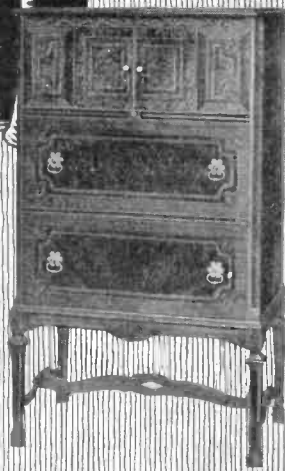

**Model 1700-R-2**  
Mahogany or walnut, with built-in Pooley (patented) floating horn, Atwater Kent reproducing unit, and Atwater Kent receiving set. Height 50", Width 30", Depth 18".

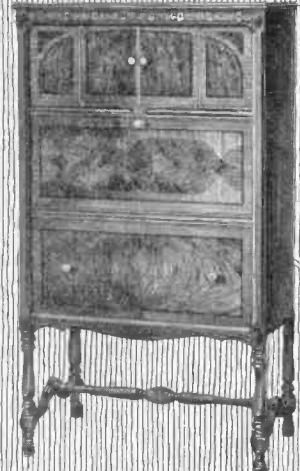

**Model 1300-R-2D**  
Mahogany or walnut, with built-in Pooley (patented) floating horn, Atwater Kent reproducing unit, and Atwater Kent receiving set. Height 50¾", Width 29¼", Depth 15½".

## The Built-In Pooley Floating Horn (Patented)

Every Pooley Cabinet, Console and Speaker contains the built-in Pooley horn. It is lastingly constructed of choice spruce—the wood of violins; the reason for its rich and mellow tone. It is exceptionally large, for full tone volume. It floats on cubes of sponge rubber—and the tone is clear and smooth. There is nothing about it to wear out or give trouble. This patented horn with the celebrated Atwater Kent reproducing unit, *produces a volume, clarity and truth of tone surpassing anything radio science has yet developed.*

### Pooley Radio Cabinets—a complete line

Thousands who have determined to have cabinet radios, will be attracted irresistibly by the new Model 1900-R-2; and those who want their radio at their finger tips will appreciate Model 2000-R-2—the "arm chair model". They have the golden voiced Pooley horn, the excellent Pooley craftsmanship, just like the higher priced models. Wonderful offerings, truly, made possible only by deep knowledge of furniture making and large scale production.

The other models you know. They have already proved their appeal. Their varied styles, sizes and prices afford your customers ample opportunity to select something that suits them. With the new Atwater Kent Receivers, Pooley means more than ever this season.

Get in touch with your Pooley distributor to see and hear the Pooley Speakers and the Pooley Radio Cabinets.

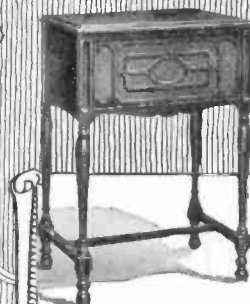

**Model 2100**  
Pooley Speaker, mahogany, with built-in Pooley (patented) floating horn and Atwater Kent reproducing unit (without battery compartment). Height 30½", Width 21¾", Depth 14½".

## Pooley Speakers —new sales for you

Here is Pooley's answer to the demand for a truly good speaker at a reasonable price. A momentous addition to the Pooley line, promising to you and to us a decidedly interesting growth in sales. Designed and constructed with the same care that is given to all Pooley products. Each one contains the Patented Pooley built-in floating horn equipped with the celebrated Atwater Kent reproducing unit.

### Model 2200

Pooley Speaker, with battery compartment, mahogany, with built-in Pooley (patented) floating horn and Atwater Kent reproducing unit. Height 33¾", Width 21¾", Depth 14½".

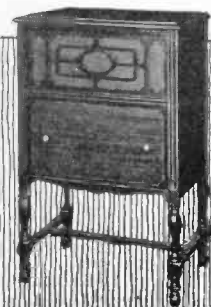

**POOLEY**  
RADIO CABINETS  
*with*  
**ATWATER KENT**  
RADIO

# ATWATER KENT RADIO

It's easier to sell a man something he asks for than to talk him into buying something he never heard of

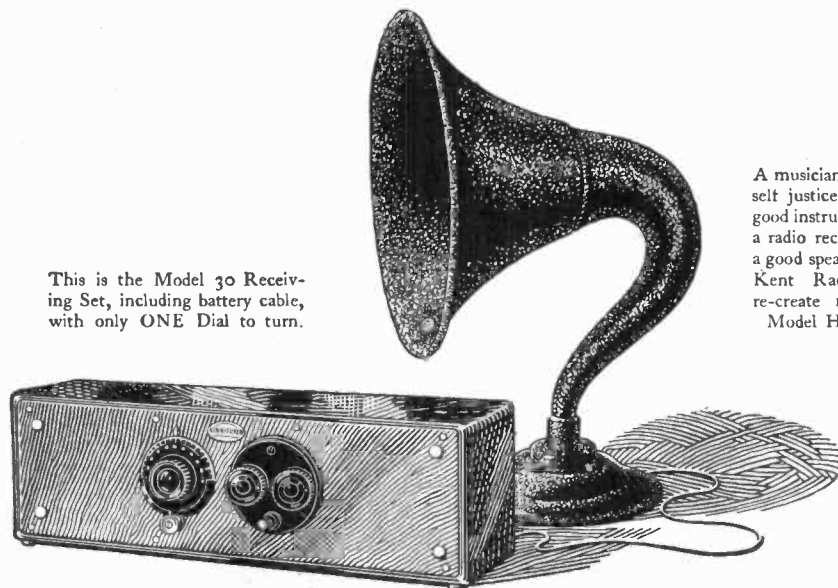

This is the Model 30 Receiving Set, including battery cable, with only ONE Dial to turn.

A musician can do himself justice only with a good instrument. Just so a radio receiver requires a good speaker. Atwater Kent Radio Speakers re-create natural tone. Model H illustrated.

ATWATER KENT MFG. CO. · A. Atwater Kent, President · 4733 WISSAHICKON AVE., PHILADELPHIA, PA.

E. E. WHITEHORNE,  
Contributing Editor  
S. J. RYAN,  
Merchandising Counsellor  
J. ANDREW WHITE,  
Contributing Editor  
L. E. MOFFATT,  
Associate Editor  
PAUL WOOTON, Washington

# Radio Retailing

The Business Magazine of the Radio Industry

O. H. CALDWELL, Editor

WILLIAM C. ALLEY,  
Associate Editor  
H. W. BAUKAT,  
Assistant Editor  
OVID RISO,  
Assistant Editor  
RAY SUTLIFFE, Chicago  
H. S. KNOWLTON, Boston  
C. GRUNSKY, San Francisco

## Table of Contents June, 1926

Radio's Place in the Sun <i>Important points about radio's future brought out at the RMA convention.</i>	553
Profit—and Loss <i>An expert merchandising analysis of why one dealer showed a loss on his year's business.</i>	554
Selling Radio Outlets for Every Room <i>Every owner needs a radio outlet and speaker in each room of his home.</i>	558
Proving Radio Can Be Sold in the Summer <i>Sales plans and methods successful dealers have used to combat the hot weather depression.</i>	560
"Know What the Public Wants" <i>"Never let a customer leave the store dissatisfied," is the advice of S. J. Ryan.</i>	563
The Danger Line in Retail Selling Costs <i>"If your selling costs average more than these figures—find out why!"</i>	564
Our Readers Are Optimistic <i>Expressions from the trade itself show many dealers are not "laying down" this summer.</i>	568
"There Is No Slump!" <i>How one New Jersey dealer manages to keep radio sales going all summer long.</i>	570
Tone Quality Depends on the Audio Transformer <i>Dealers should sell a new transformer as well as a speaker, to get better tonal depths.</i>	572
"Our Infant Industry" <i>H. I. Phillips, in "Collier's Weekly," obtains a few laughs from "this radio business."</i>	577
"Keep Your Store in the Spotlight" <i>Aldrich of South Carolina keeps his store before the public by a variety of publicity stunts.</i>	578
What This Industry Needs <i>"Give us fewer 'new models'" is still the plea from dealer, jobber and manufacturer.</i>	582
<b>Departments</b>	
Radio Window Displays	567
Specifications of Audio Transformers	574
Radio in the Month's News	585
"Your Editors Have This to Say—"	586
For the Service Man	588
New Merchandise for the Dealer to Sell	592
What the Trade Is Talking About	597
New "Dealer Help" Material	601

## "Reader Acceptance"

READER acceptance is the goal toward which every publication strives. If the readers of *Radio Retailing* admire and respect it, the editors and publishers will feel amply repaid for their efforts, for it is upon that one thing that any publication stands or falls.

In its comparatively short existence, the editors believe *Radio Retailing* has won a very gratifying degree of reader acceptance, and the following incident offers definite evidence to bear out their belief.

The Garod Corporation desired to ascertain just what their radio dealers think of *Radio Retailing*, so a questionnaire was sent out to the manufacturer's own list of dealers, on the manufacturer's own letterheads, asking them, among other things, if they receive and read *Radio Retailing*? 77 per cent said they do.

Some of the dealers' comments, wholly voluntary, picked at random from the answers, follow:

"I read every word contained therein."

ROSEN AUTO SUPPLY COMPANY, Covington, Ky.

"I read this magazine thoroughly."

P. L. O'BRIEN, Vincennes, Ind.

"I read this magazine from beginning to end."

CLINTON SHAIN, Hartford, Conn.

"Read carefully—a real help."

THE LION STORE, Toledo, Ohio

"Every word."

SISSON BROS. & WELDON CO., Binghamton, N. Y.

"From cover to cover."

H. H. HARTGEN, Brooklyn, N. Y.

"Read everything in it."

NEVILLE RADIO SHOP, Inglewood, Calif.

"Very interesting. We pass it along to all members of our staff."

F. H. BUNNELL, New York, N. Y.

"We believe it the best of its kind."

KANSAS RADIO CO., Kansas City

And—out of the 700-odd replies—one staggering blow—

"Yes, but don't think much of it."

Ouch! We'll never quite recover from that one.

McGRAW-HILL PUBLISHING COMPANY, INC., Tenth Ave. at 36th St., New York, N. Y.

JAMES H. MCGRAW, President  
JAMES H. MCGRAW, JR., Vice-Pres. and Treas.  
MALCOLM MUIR, Vice-President  
EDWARD J. MEBHREN, Vice-President  
MASON BRITTON, Vice-President  
EDGAR KOBAK, Vice-President  
C. H. THOMPSON, Secretary

Electrical World Journal of Electricity Ingeniería Internacional  
Industrial Engineer Engineering and Mining Journal-Press  
Chemical & Metallurgical Engineering American Machinist  
Electrical Merchandising Power Electric Railway Journal  
Bus Transportation Engineering News-Record  
Coal Age Successful Methods  
Copyright, 1926, by McGraw-Hill Publishing Company, Inc.  
Cable Address: "Machinist, N. Y."  
Annual subscription rate is \$2 in United States and Canada.

WASHINGTON, D. C., Colorado Bldg.  
CHICAGO, 7 South Dearborn St.  
PHILADELPHIA, 16th and Parkway  
CLEVELAND, Guardian Bldg.  
ST. LOUIS, 713 Star Bldg.  
SAN FRANCISCO, 883 Mission Street  
LONDON, E. C., 8 Boulevard St.

# How About it This Summer— Are You Going to Lose Money or Make Money???

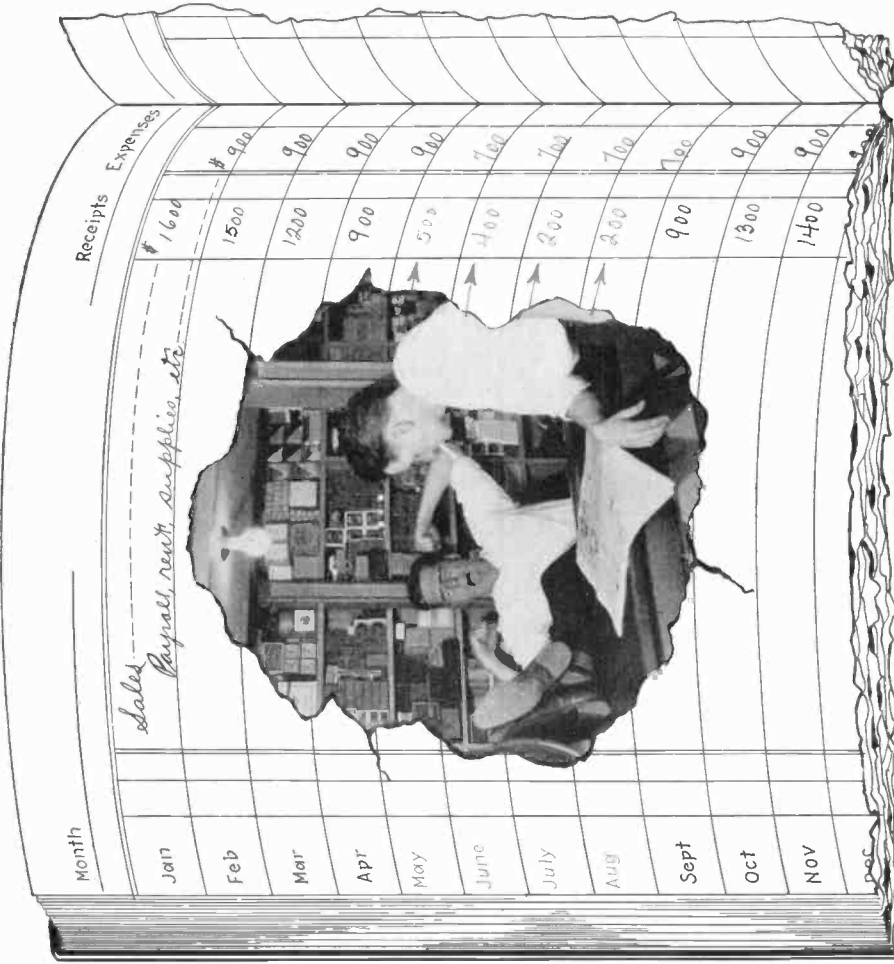

**T**HE picture at the left illustrates a scene any hot summer day in the average, or slightly worse than average, radio store. The little red figures in the columns at the right also illustrate the losses this particular dealer is suffering by sitting back in his deserted store and shooting the flies away from the electric fan. He hopes someone will come in and buy something, and there his activities, mental and physical, cease. He is the dealer who complains loudly about the summer slump.

**Are you Mr. O. Lookatim Yawn over here at the left—**

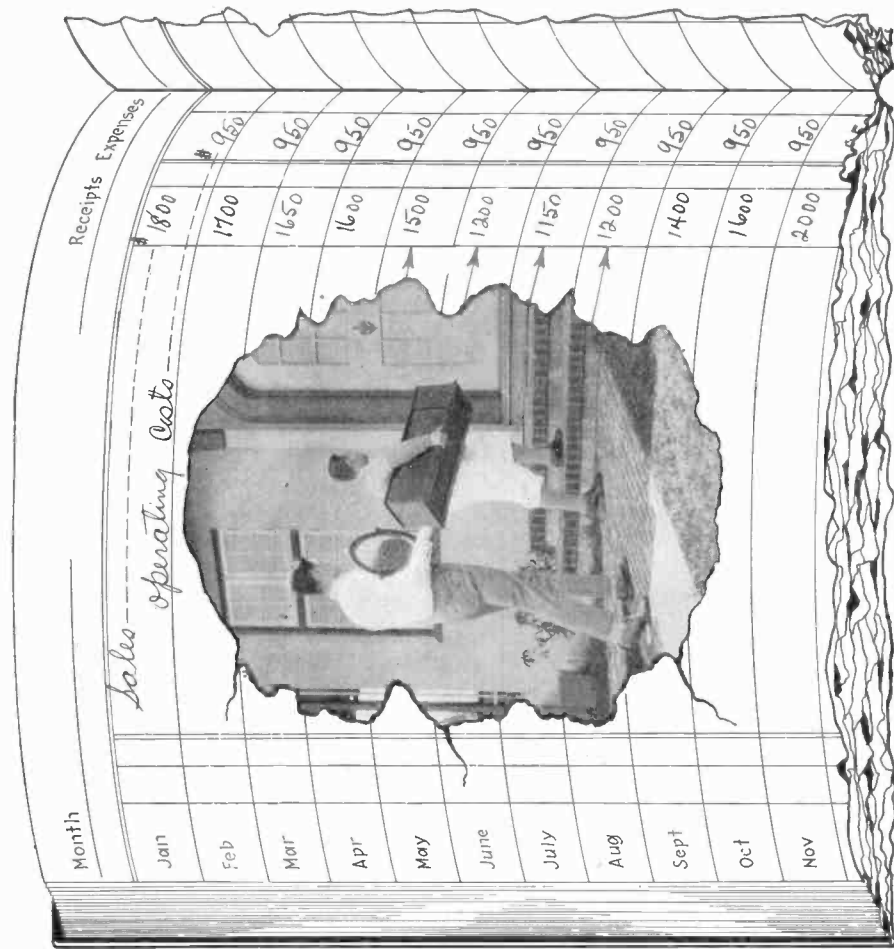

**T**HE picture above, some will think, is purely allegorical. Some may wonder whether or not it is an actual occurrence, for it portrays the unheard-of feat of a dealer and a salesman taking a set up to the front door of somebody's home and attempting to sell it! But there are successful dealers who are doing exactly this. And such a dealer's summer profits are shown in the two columns at the right. You may compare them, if you care to, with the corresponding figures of our lazy friend across the way.

**Or are you Mr. Go-Outan Gettem over here at the right?**

# Radio Retailing

With Which Is Incorporated *Electrical Retailing*

VOLUME 3

JUNE, 1926

NUMBER 6

## *Radio's Place in the Sun*



**R**ADIO'S position as a primary industry daily becomes stronger and more clear-cut. Radio in 1926 has taken its place alongside electrical devices and other specialties as a major line of production and distribution. The demand for radio is becoming stabilized. And, measured from year to year, that demand is growing soundly.

No observer could come away from the excellent convention of radio trade interests held at Atlantic City in May, under the auspices of the Radio Manufacturers' Association, without some such gratifying conclusion as the above, based upon all that was said and reported at the sessions by manufacturers, distributors and dealers.

True it is that radio is still seasonal. There are months in the year when the radio retailer will want to divide his time and store investment with other lines that have a distinct summer appeal. Such side-lines will increase both his business volume and his list of regular radio customers.

But radio must be the primary business of the merchant who would retail radio successfully and give full service to the public. For, as it now appears, you can easily teach a radio man to sell side lines in summer-time. But to make a real merchant of radio out of some other kind of dealer is in practice pretty generally proving to be the wrong way 'round. This is the practical testimony of experience, as reported to the councils of the industry, in convention assembled.

A census of the trade, now being conducted by this publication, shows that, from every standpoint, the dealer who sells radio as a primary product is going to be the most successful radio merchant, generally, in the days to come. Not only do the primary radio stores outnumber every other class of radio retail outlet, but, excluding the electrical trade, outvalue in radio investment all other classes put together.

Also, the total investment of the primary radio stores as a whole is greater than any other class of outlet, and—what is most important—their average individual investment in radio is by far the greatest. In other words, the majority of radio products will be distributed through radio stores, which will sell radio twelve months a year, and which may or may not handle a sideline during the summer.

In any event, the dealer who handles radio as a sideline, closing it out in the summer and devoting himself to another line, is not going to be the logical outlet for radio in the future, exclusive, perhaps, of a few individual successes.

### *Sales Curve Slowly Creeping Upward*

**A**LSO, brought out at the convention, was the fact that manufacturers, who, after all, are the guardians of the industry, will work out some plan of co-operative propaganda to keep the public's interest in radio "full speed ahead" throughout the summer, not only by advertising and publicity, but by providing broadcast programs of outstanding merit during the hot months.

This summer let-up, by the way, is becoming less and less significant each season. Manufacturers report that high-power broadcasting, better receivers and programs of intense interest, are helping the trade carry through. Manufacturers' sales are slowly but surely creeping upward from May to September, they report, a little at a time, to be sure, but nevertheless creeping upward, and this healthy trend toward a straightening out of the sales curve cannot help but be reflected in the retail trade as well. The spirit shown at the Atlantic City convention makes the outlook today brighter than it has been for many months.

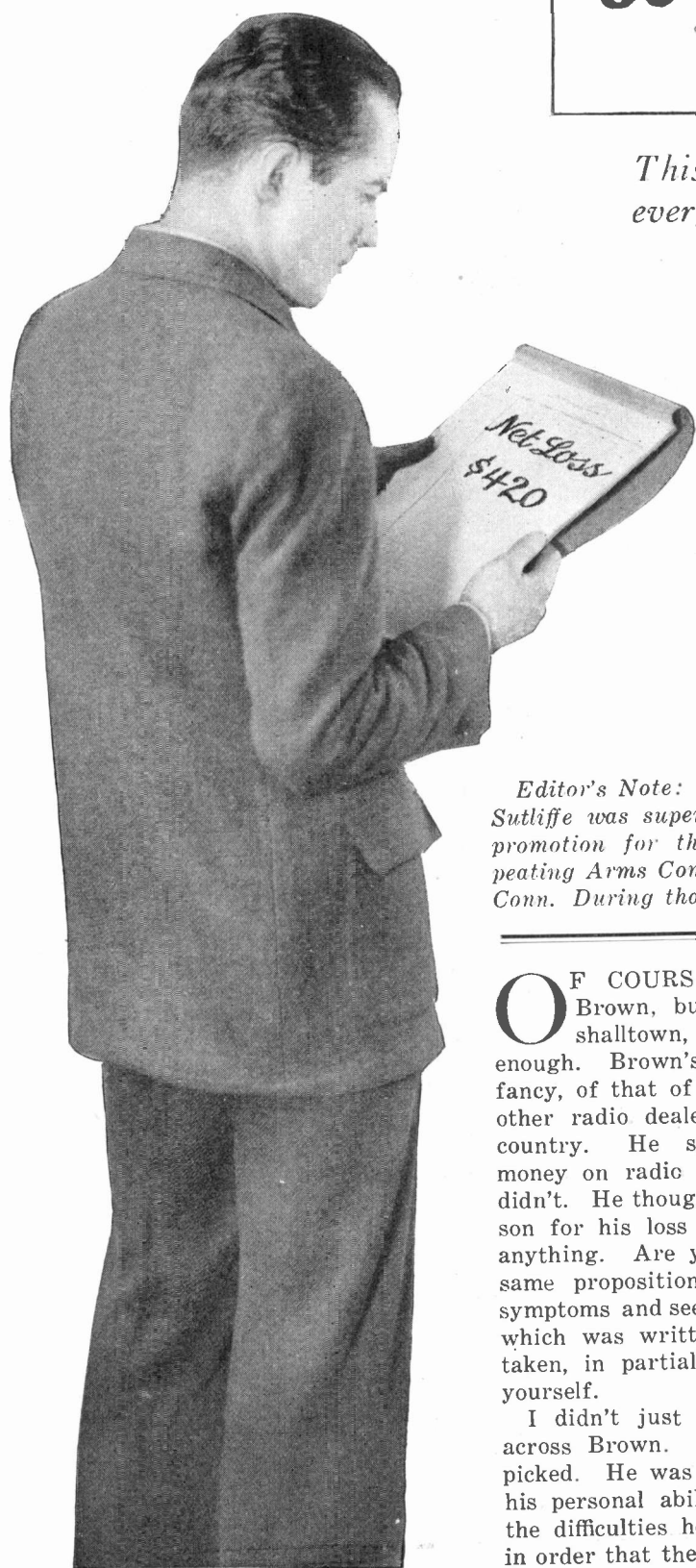

S	M	T	W	T	F	S
16	17	18	19	20	21	22
23	24	25	26	27	28	29
30						

 Three vintage radio sets are arranged in the center of the calendar grid. One is positioned over the dates 19, 20, and 21. Two others are positioned below it, one over 26 and 27, and another over 27 and 28.

*This dealer sold 76 sets last year—three sets every two weeks—and lost \$420. IF he had sold*

*That Sale You Missed the Other*

# LOSS— and

By RAY V. SUTLIFFE  
Western Editor, "Radio Retailing"

*Editor's Note: For five years Mr. Sutcliffe was superintendent of sales promotion for the Winchester Repeating Arms Company, New Haven, Conn. During that time he analyzed the business problems of many retailers. The wide merchandising experience thus gained stands him in good stead in pointing out the flaws in this dealer's sales policies.*

**O**F COURSE his name isn't Brown, but the town—Marshalltown, Iowa—is authentic enough. Brown's case is typical, I fancy, of that of many hundreds of other radio dealers throughout the country. He should have made money on radio this season but he didn't. He thought he knew the reason for his loss but couldn't prove anything. Are you up against the same proposition? Check Brown's symptoms and see if the prescription which was written for him can be taken, in partial doses at least, by yourself.

I didn't just happen to stumble across Brown. His case was hand picked. He was selected because of his personal ability and because of the difficulties he was up against—in order that the suggested remedies

would have the widest application to the greatest number of readers of *Radio Retailing*.

Marshalltown has a population of 18,000. It is a combined manufacturing and farming center. It has a sixteen-mile radius of farmers reached over dirt roads. In all, about 6,000 real homes come within the range of Brown's automobile.

Brown is a college graduate. He is intelligent. He is a good radio technician and knows how to service. He has a store with reasonable rent and of ample size to carry his necessary stock. A clerk keeps the books and helps out in the store. During the rush season, he hired an extra salesman. Looks as though, with this layout, he should have made money, doesn't it?

Now for the weeping and gnash-

*Radio Retailing, A McGraw-Hill Publication*

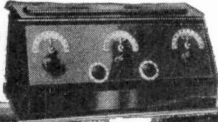
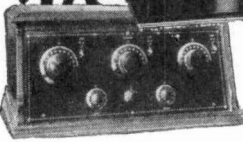
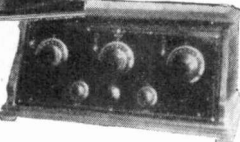
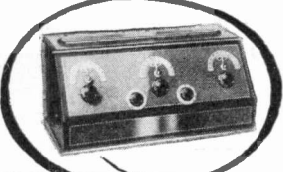
S	M	T	W	T	F	S
16	17	18	19	20	21	22
23		26	27	28	29	
						

FOUR sets in the same length of time, he would have shown a profit of \$505.

Day May Be the Difference Between

# Profit

ing of teeth. Brown did a radio business from May, 1925, to May, 1926, of \$17,300. Yet, after deducting his own modest salary of \$2,300—surely not a princely sum—he showed a net loss of \$420.

Why? It was to answer this question, if possible, that I made a pilgrimage to Iowa “where the tall corn grows.” *Radio Retailing* felt that it owed it to the thousands of “Browns” in this great land of ours to throw the searchlight of modern business analysis on this vital subject—this question so close to the heart of every dealer.

“What’s wrong?” asked Brown.

I found Brown willing to talk—he had nothing to lose and everything to gain by so doing. He poured his story into my receptive ears and opened his books to my sympathetic eyes.

“What’s wrong?” said Brown.

“Let’s get the figures in proper shape before I attempt an answer to that poser,” I replied.

Brown kept a simple set of books and had certain foundation figures which we were able to rearrange so that they could be analyzed. After the new columns were added up we

devised two basic business tables. These forms are drawn up in the manner recommended by many of the country’s foremost business experts and are reproduced on the following pages. Why not adapt them to *your* business?

“Here’s What’s Wrong, Mr. Brown!”

The head of the merchants’ service bureau of the world’s largest manufacturer of mechanical devices for keeping business records made this statement to me not two months ago:

“Mr. Sutcliffe,” he said, “I have about made up my mind, after analyzing the business troubles of over ten thousand retail merchants, that a dealer must do a business of at least \$25,000 a year to carry his necessary fixed and movable expenses. In other words, if he can’t make that grade he had better quit and get a job working for someone.”

Now most of Brown’s operating expenses are well within reason. His gross margin is too narrow—that’s trouble number one. Brown could handle more business than he did last year with practically no increase in his operating expenses. Re-

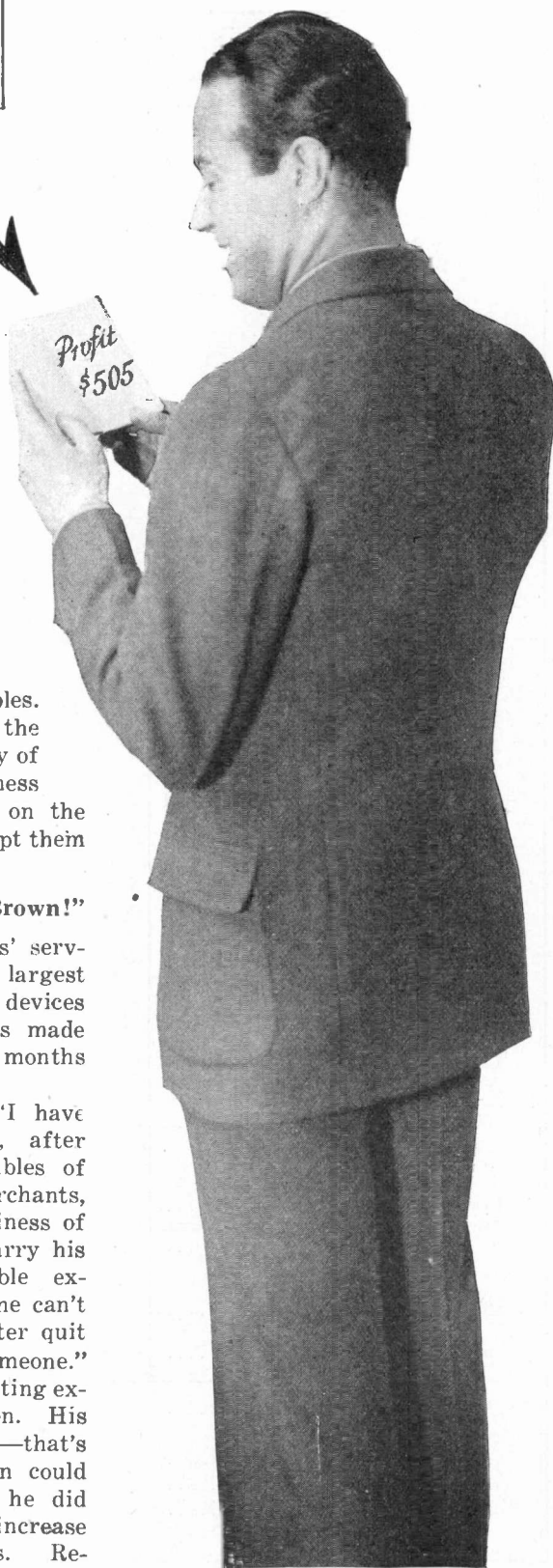

## Statement of Operating Expenses

A	B	C	D	E
Expense Items of Brown's \$17,300 Business	Amount	Danger Column	Comment	Suggested Amount Commen- surate with a \$20,000 Business
1. Publicity.....	\$415	.....	Good. Approximately 2½ per cent of gross sales. A dealer should spend about this sum. With low newspaper rates and by using the mail Brown secured adequate publicity.....	\$500
2. Pay Roll				
Store Clerk.....	1,150	← Danger	\$3,900 is too much with but \$5,860 total gross margin to play with. Too many demonstrations in proportion to sales and a two months peak ran up this item. (See also comment in body of article).....	1,200
Salesman..... (for 3 months).....	450	← Danger		2,500
Owner's salary.....	2,300			
3. Interest on loans (\$800).....	48	.....	Entirely satisfactory.....	50
4. Interest on capital (\$2,500).....	150	.....	Entirely satisfactory. Capital involved in respect to sales lower than the average ratio.....	150
5. Discounts (on auto payments)...	48	.....	Buying auto on time. Cost of auto goes on statement of assets but this item of interest charges on payments is an operating expense	48
6. Rent, heat, light.....	360	.....	But \$30 a month. Most reasonable. No cause for worry here.....	360
7. Losses on debts and collections	140	← Danger	A trifle high.....	140
8. Insurance, taxes.....	40	.....	In line.....	40
9. Depreciation (on auto and equipment).....	130	.....	As it should be.....	130
10. Depreciation on stock.....	120	.....	O. K. Dealers——don't overlook these four items just given. It is necessary to include them in any study of true operating expenses..	130
11. Freight and express.....	180	.....	Can't save much here.....	220
12. Postage.....	74	.....	No loss on this item.....	90
13. Special allowances on sets (allowed because of trade-ins, condition of new set, competitors' offers, etc.).....	280	← Danger	This is less than \$4 per set yet the total might mean the difference between profit and loss.....	200
14. Office-printing and supplies.....	65	.....	Very reasonable.....	75
15. Auto operation (oil, gas, tires, repairs).....	280	← Danger	High for volume of business which must support this expense.....	280
16. Miscellaneous.....	50	.....		50
a Total expense.....	\$6,280	.....		\$6,163
b Cost of goods.....	\$11,440			\$13,332
c Total cost (a and b).....	17,720			19,495
d Sales.....	17,300			20,000
e Net loss (c-d).....	\$420			
f Net profit.....	.....			\$505



ferring to the large table in column E, I have attempted to point out how—by increasing his yearly gross sales but \$2,700 (selling only 19 more sets during the year—or one more every 19 days) and correcting the danger spots—he could turn a loss of \$420 into a profit of \$505.

In order to bring this condition about, his advertising allowance has been raised to \$500. This is but a preliminary step, however. Radio can be profitably sold in Marshall-town just as it is in almost every other American city and town—by giving a satisfactory demonstration followed up by a persuasive and forcible salesman who can close the deal then and there.

Brown told me that, because of competitive conditions in his territory, he was obliged to make over 200 demonstrations to sell the 76 sets he did, much less the 19 extra ones. He further stated that he understood that the competitor who caused him to lose so many sales—you know the tactics—hadn't made any money either. These demonstration difficulties show up in items Nos. 2, 10, 13 and 15. Remedy—when the demonstration has been given, bear down hard on the closing arguments. Brown will simply have to increase his percentage of sales to demonstrations. Why not have a heart-to-heart talk with the other radio dealers in town, Mr. Brown? Point out to them these simple fundamentals of good business practice and try again to agree on a code of mutually profitable demonstration ethics. It's being done with marked success in many other places.

This brings us to item 2—the payroll.

"We had a rush season of about two months, when it was necessary for me to hire extra help," Brown informed me. Regardless of the reason, Brown's gross margin of \$5,860 will not carry a \$3,900 payroll, including commissions. I suggest that he dispense with his \$1,150 store clerk and bookkeeper and that he run the store and keep the books himself. During the radio buying months, he should hire a real good salesman—a man who can get that old signature on the line, be it

<b>Brown's Profit and Loss Statement</b>	
<i>May, 1925, to May, 1926</i>	
<b>Sales</b>	
76 sets, at an average price (equipped) of \$143 .....	\$10,875
Parts, accessories, battery charging, aerals and service.....	6,425
	\$17,300
<b>Costs</b>	
76 sets less 35 per cent (average).....	\$7,070
Parts and accessories less 32 per cent (average).....	4,370
	\$11,440
Total cost of goods.....	\$11,440
Operating expenses.....	6,280
	\$17,720
<b>Recapitulation</b>	
Sales.....	\$17,300
Costs.....	\$17,720
	\$420

dotted, ruled or imaginary. In other words, instead of spreading his money over the lean months, let him save as much of it as possible in order that he may hire a real "go-getter" during

**K**NOWLEDGE of costs and the relation of sales to expenses is good business practice. This analysis of "Brown's" business emphasizes the need for itemizing costs and indicates the manner in which a merchant may study his own business ills and prescribe his own cure.

the peak, to put over those necessary nineteen extra sales. Brown cannot afford any help except that of a part-time, commission salesman. It's a case of concentrating on volume sales when the "goins good" and of paring to the bone during the other months of the year.

While a discussion of sidelines for summer fill-in business is beside the point in this particular analysis it seems to me that in Brown's case—because he has space in an attractive store, well located and with a store traffic already established—there is no question but that he should add some article or articles of appeal to housewives this summer.

A study of columns B and E reveals the fact that friend Brown was almost over the top. I doubt, however, that he realized it at the time. A little more publicity, a little more outside sales effort and less inside clerical expense, a firmer stand on demonstration policies, fewer calls per sale in the rural districts—and the deed is done.

Brown's temporary setback was not due to neglect or excessive expenditures—if this were the case this article would not have been written—it was simply a lack of appreciation of the relation of margin to profit in a small business and of the law of increasing sales after the

selling expense limit has been reached. If Brown had estimated in advance his necessary expenses and the volume of business required to cover them, he could have changed his selling tactics, or, failing to attain the volume required by his expenses, added other lines or made a strictly one-man business of it.

**This Summer—"Go Where the Crowd Goes"**



Take advantage of the Sunday and holiday crowds this summer by giving "outdoor demonstrations"

# Showing How Dealers May Sell a Radio



With the phonograph one could have music in only one place in the house. But with radio it is possible to multiply the sources of sound so as to have music in every room if desired.

These pages illustrate some of the satisfactions of having the house so wired that loud speakers can be "plugged-in" in any room. The circuit diagram at right shows the wiring to the wall-jacks. The two-way control wiring enables the set to be switched on or off from either the first or second floors.

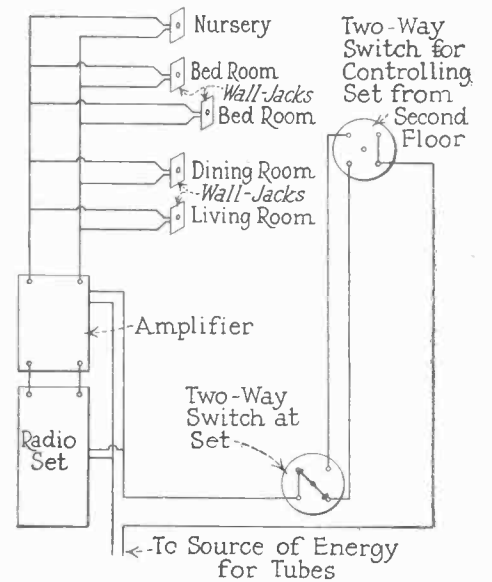

# Outlet and Loud Speaker for Every Room

As shown in the circuit diagram, two-way switches can be so wired that the radio set can be turned on or off from two or more positions: One at the set itself; the other at some upstairs position, perhaps alongside the owner's bed.

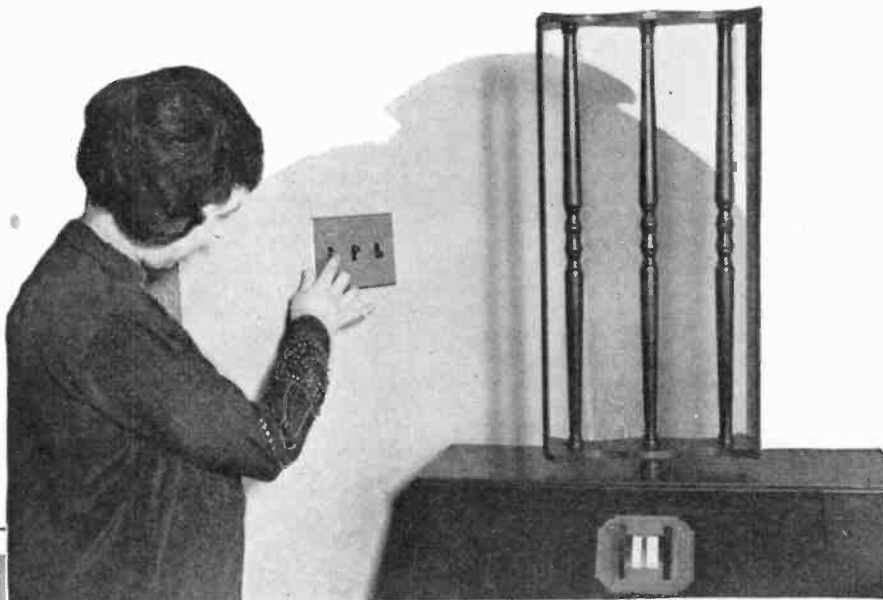

"Take the loud speaker into the kitchen" and listen to concerts and lectures while doing the chores, peeling potatoes, shelling beans or washing dishes—here's a message for your women customers. A kitchen radio outlet makes kitchen drudgery pass quickly.

"Radio outlets in every room" present another installation service for the radio dealer and service man. To operate the loud speakers, circuits of bell wire ending in wall jacks can be run at \$3 to \$5 each, with a good margin of profit for the installer. Here's a lead for valuable summer business.



# These Actual Dealer Experiences Prove

Facts and ideas gathered by the editors from a wealth that radio sets CAN be sold twelve months a year by

## Takes Set on Auto Trips

Curiosity may kill cats but according to Francis J. McCaffrey, Atlantic City, N. J., dealer, it is the finest thing in the world for summer radio business. Each week-end during the summer months McCaffrey packs the wife, lunch and a radio set into the family car and heads for the country. When lunch time arrives the car is parked by the roadside and the receiver started, utilizing a tree for an antenna. "You'd be surprised how many autoists stop in the



This dealer takes a set with him on his auto trips every Sunday

course of the lunch hour," says McCaffrey, "and inquire about the set and admire its tone qualities. The picnic grounds in the smaller towns are particularly good for parking, as the majority of Sunday tourists pick out such a spot to camp for lunch. Of course I do not use high-powered sales methods when people ask about the set, but I find they are interested enough when I tell them that a portable set can be bought at a very reasonable cost and may be carried from place to place without damage."

## Demonstrates in Store Window

A radio receiver has been installed in the main show window of the Electric Service Shop, Floral Park, N. Y., by the proprietor, W. B. Simpson. This window is large and arranged to represent a home living room. A chair placed in front of the set, supplemented by a small row of steps from the floor of the store to the window platform makes it possible for a complete demonstration to be given in the window itself.

## Piano Salesmen for Outside Selling

Instead of employing a number of outside salesmen, to sell radio sets exclusively, the Model Radio Company, Paterson, N. J., utilizes for this purpose ten men already engaged in selling pianos on a commission basis. This method is particularly advantageous to the dealer as these men work on a straight 10 per cent commission basis

and already have an established clientele easily sold the higher grade radio sets. The piano salesmen find this plan very attractive, as leads may be used either for the sale of a piano or a radio. Both are musical instruments, yet neither line conflicts with the other. These men are invariably of the type so necessary for successful home selling of radio.

The shop proprietor has linked up with several organizations in this way and also has a few men who sell electrical appliances handling radio for him on a similar basis. Salesmen do not

of interested people were secured. Out of these 5,000 notices mailed, approximately 500 attended the concert."

## "Move the Shop to the Customer"

"If the customer doesn't come to the shop, move the shop to the customer." This is the motto of the Maine Electric Light & Power Company, Bangor, Me. Bangor has a population of only about 26,000 but it is surrounded by innumerable small towns, so the company has equipped an auto truck with the necessary signs and demonstrating equipment, running this "portable shop" around the surrounding country. Radio demonstrations and sales may be made in the car just as if the customer and salesman were back in town in the store itself.

## Intentionally Rings Wrong Doorbell

While delivering a storage battery to a customer in an apartment house, F. L. Wickham, manager of Norman Johnson Radio Company, Port Richmond, N. Y., accidentally knocked at the door of the wrong apartment. A woman opened the door and he asked if Mrs. Smith lived there, as he wished to deliver a radio battery she ordered. Mrs. Smith did not live there but the result of the mistake was that he discovered Mrs. Jones had no radio and was interested in securing one. Result—sale of a \$250 console receiver. Wickham now rings the wrong doorbells purposely, and has succeeded in selling several receivers in this way.

## Free Calls Sell Accessories

The most difficult phase of selling radio accessories outside the store is undoubtedly making the initial opening, or getting into the home. The radio store of M. B. Ross, East Orange, N. J., has solved this difficulty and makes accessory sales by phoning customers already on the firm's books advising them that a free inspection call will be made and a man sent up to examine

## Gives Concert in Hotel

The Mort-Smith Radio Service Company, Paterson, N. J., relies on an outside sales campaign to put over its receiver quota during the summer. "House-to-house canvassing seems to be a wasteful and inefficient method of getting prospects, as many 'duds' are encountered," says Mr. Smith. "In getting leads for our campaign, we have used a 'weeding out' process and have managed to obtain a higher percentage of live prospects. This was done by announcing that a radio concert would be given during a popular broadcast program, in the ballroom of the town's largest hotel. Some 5,000 notices of this event were mailed, a month in advance, to country clubs, musical associations, bank directors, city officials, etc. In order to obtain tickets, it was necessary to write us and ask for them. In this way the names and addresses



One dealer ties up with a local theater and displays a set in the lobby

# That Radio Can Be Sold in the Summer

of material which show beyond the shadow of a doubt keeping sales efforts ALWAYS at mid-winter speed

the installation without charge. The following day a man essentially a salesman but familiar with technical radio, calls and examines the set, suggesting improvements which may be made or selling necessary replacement batteries or tubes. Accessories ranging all the way from batteries to loud speakers are sold on these calls.

According to R. Haig, of the company, this man makes fifteen calls per day and has not only paid his expenses but has added quite a considerable sum to the store total. This free inspection has the additional effect of establishing the feeling with the customer that the dealer is taking genuine personal interest in him.

## Installment Collectors Sell Radio

Getting the entry into the prospect's home is no doubt the most difficult part of outside selling. A Brooklyn, N. Y., dealer, has a unique method of getting leads. He interviewed the sales managers of several furniture houses in his neighborhood which made a specialty of time-payment sales, but which did not sell radio. Each of the concerns employed a number of men who collected time payments directly from the customers and were therefore familiar with many of them and had entry to the homes. The dealer pays the furniture houses 10 per cent commission on every set sold from a lead obtained by their collection men, leaving the furniture store to make its own payment arrangement with its men.

## The Seagoing Salesman

Here's an account of a dealer who combines business and pleasure to the advantage of both. Each summer, the proprietor of a Providence, R. I., radio store, William S. Hull, installs a radio receiver aboard his boat and whiles away the summer evenings out in the bay, away from business but not from customers. Reception is well nigh perfect due to the absence of obstructions and the perfect ground afforded by a copper plate in contact with the water and many boat owners draw up to Mr. Hull's boat to listen. Prospective customers are invited aboard, cigars are passed out, and within the course

of the next few days these casual acquaintances drift into the Providence shop and Hull makes another sale.

## Collects His Own Accounts

S. C. Nelson, 6 Graham Street, Jersey City, N. J., likes to collect his monthly time payment accounts himself. "I have about forty customers who are buying their sets on time," he says. "I call on these people once a month to collect what they owe me. It

trade-ins as an inducement to prospects to buy up-to-date models, and he figures that he may safely allow five per cent of his new margin in order to secure a sale. Last summer he made all obsolete traded-in sets which had not been sold secure a good amount of publicity. Twenty-two of them were donated to a seaside home, maintained by a local church and each set was equipped with a small plate bearing the name of the donor. Three local newspapers commended him in their news columns for his generosity and Herzog says that



Give "neighborhood demonstrations" on the sidewalk with a set in an auto

takes me three or four evenings but it is time well spent because I usually end up with the names of twenty-five or more new prospects which my set owners have given me." Mr. Nelson further states that he takes this opportunity to check up on how the sets are working and to adjust any minor difficulties then and there.

## Give Outside Salesmen Something to Work On

"Give your outside men something to work on," says L. Pike, manager of the Holland Battery Service Company, Holland, N. Y. "I have had three men on my sales force for over a year and pay each one only a five per cent commission. Each man has averaged over \$40 per week during this period, because I give them vacuum cleaners and electric refrigerators to sell as well as radio."

## Uses Obsolete Trade-ins to Get Publicity

Frank Herzog, proprietor of the Park Radio Shop, Rockaway Beach, N. Y., has long made a practice of accepting

these small "honorable mentions" have been worth more to him than many pages of paid advertising.

## Demonstrates Receiver From Automobile

Theft of household appliances by men posing as salesmen has given a black eye to outside selling in many localities. Such being the case, why enter the homes at all? Last summer a New York City dealer installed a receiver, ready for operation, on a car and sent this car in charge of a driver and several salesmen to the suburbs. The car was driven to a promising section and the salesman made a house-to-house canvass while it followed them from block to block with the receiver in operation. When a prospect was located, the car was signalled and the demonstration was made at the car in front of the prospect's home. This method proved of threefold value. The demonstration was made in little time, the home was not necessarily entered and neighbors who saw the demonstration came out to investigate. The car carried several receivers for cash sales and it rarely returned to the shop with this stock.

## Mails "Check" to Customers

A Washington dealer mails a signed check, an exact duplicate of a bank check, made out for \$2, to prospects on his mailing list. Printed on this form is a statement that it is good for \$2 on the purchase of apparatus amounting to \$25 or more. This inducement is just enough to steer customers who are

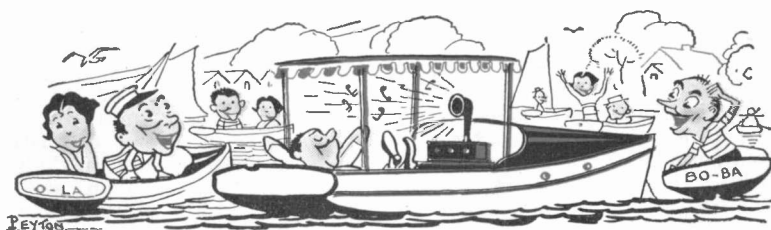

Another dealer owns a boat and makes it sell sets to other boat owners

in the market for a receiver, into his shop rather than to one of numerous other stores.

### **Reaches Summer Residents Through Gas Company List**

"In the summer resort section, the sale of radio receivers is not so rosy as it at first appears," says R. Jacobs, proprietor of the Manning-Hall Radio Company, Far Rockaway, N. Y. "The prospects are there—true, the difficulty is to find them."

The Manning-Hall Company has found a way to do just that. An arrangement has been made with the local gas and electric company whereby, for the sum of \$25 for an original list and 1½c. for each new name, the company gives the dealer, in the form of periodic bulletins, the names and addresses of those who have just secured gas and electric service.

Jacobs says that this a customary central station service which other retailers in town have used for some time. Why not "try it out" with your local utility company?

### **Movie Star Contest Keeps Them Interested**

A contest of skill in which prizes are offered is used by the Radio Products Company, Greenville, S. C., with the help of a local movie theatre, to stimulate interest in summer radio and attract people to the store. Once persuaded to look in the store window, or to enter for information relative to the contest, salesmen and attractive displays do the rest. W. B. Coxe, the manager, secures a number of photos of screen celebrities from the local theatre, preferably those who are to appear in a coming attraction, and numbers these photos. He then places them in his window, changing them daily, together with the prizes offered to contestants who most correctly guess the stars' identities. Several comparatively unknown players are used as well as the stars, in order to make the contest more difficult than it at first appears. The local newspaper is notified of the contest and is usually glad to run a full account of the progress of contestants each evening as well as printing the contest photos. Blanks are provided for entrants, and are numbered according to the numbers on the photos. The contest brings customers to the store, as they must come there to examine the photos, which are indistinct in the newspaper, it advertises the theatre's stars and attractions and it increases the sale of the local paper, thus being of value to all three co-operating parties.

### **High School Students Sell Speakers**

House-to-house canvassing of radio equipment should not be confined to complete receivers. In fact, with the advent of the cone type speaker, such a vast improvement in tone quality is noticeable when comparing the old and

the new that this opens up an entirely new sales field. One Missouri dealer obtains the services of high school students who are given the opportunity to make a little "pin money." Each "salesman" is equipped with a new speaker and is told to go out and make a canvass of his immediate neighborhood. The most successful salesmen seem to follow one course, which is to note the houses on which antennas are installed and wait until they hear the set in operation. Then they call and ask to be allowed to demonstrate the new speaker.

### **Co-operation Keeps Business Going**

One of the most profitable things in a retail business, whether it be radio, electrical contracting or automotive lines is co-operation between local merchants. Opportunities often come the way of a retailer to sidetrack business to his neighbor. A Lynbrook, N. Y., dealer tells us that a large percentage of his business during the summer months comes from the recommendation of some other merchant in town. He is in the radio and storage battery business and another retailer down the street handles automobile ignition and lighting supplies. Both stores send customers for their respective lines to each other.

This local co-operation may be carried still farther. Material for window displays may be borrowed from other local stores and credit given by means of a card in the display and the radio dealer may, in turn, loan radio equipment to other storekeepers, receiving credit in the same way.

### **Radio Set "Subs" for Orchestra**

By no means a new idea, but worthy of repetition is the latest sales stunt of R. Brody of the Brody Music Shop, Far Rockaway, N. Y. A new restaurant was to be opened in town and Brody no sooner heard of it than he looked up the proprietor and induced him to install a radio receiver in place of an orchestra. Through the week, the radio set will be used to supply dance music and on the "rush" nights a regular orchestra will be engaged. Brody's argument struck the restaurant proprietor as being a way to save money on the orchestra during the week.

### **Photo Developing Is Radio Sales Magnet**

The Terminal Radio and Phonograph Shop, New York City, displays a large sign, "Photos Developed and Printed." According to J. Polen, the proprietor, the business in accessories has nearly doubled since this has been done, as many Kodak customers, are also set owners. The beauty of this service is that the store does nothing but collect the films as a local photographer does the work, calling for and delivering the films. This service produces a 25 per cent clear profit for the shop, aside from stimulating accessory sales.

### **Radio Logs as "Ice-breakers"**

When a house to house canvasser knocks at the door of a prospect his greatest difficulty is undoubtedly to determine whether the prospect has a receiver, is dissatisfied with one or is contemplating the purchase of such an instrument. It is also difficult to get a conversation under way before the door is gently but firmly closed. According to a Morristown, N. J., dealer an outside salesman may determine whether the prospect has a set or is interested in one by offering a complimentary radio log sheet when the front door opens. The usual comment a woman makes is, "Oh, we haven't a radio," or "We have a receiver but it isn't working very well." In either case the salesman has the required information and the conversational "ice" is broken.

### **Sells Radio on Wiring Jobs**

"The electrical contractor who overlooks the fact that radio receivers may be sold while he is out on wiring jobs is missing one of his best bets," says the manager of the Electrical Shop, Tompkinsville, N. Y. "More than fifty per cent of my radio sales are made while I am out on electrical wiring jobs, by talking to the customer and getting his permission for a demonstration. When you have already done business with a man he naturally has more confidence in you than if you are entirely unknown. Many good prospects for radio sets are obtained in this way."

### **Pays Customers to Sell Sets**

While the best business is undoubtedly that which the dealer obtains through the recommendation of satisfied customers the difficulty often is that these customers do not bother to mention their sets to friends. The Smith & Ayers Electric Shop, Morristown, N. J., offers each customer \$10 or its equivalent in merchandise for each name supplied which leads to a \$150 sale. In this way live prospects are obtained. Customers often know of some friend who is on the verge of buying a set and have just enough influence to swing him to the interested dealer. Last season the service man obtained a number of leads from a customer in a nearby Polish settlement and as a result sold several receivers in this one community.

### **Service Man Replaces Tubes**

Tubes and accessories at the end of the winter period often require replacing. An Iowa dealer has equipped his service man, who would ordinarily spend most of his time in the shop during the summer, with a portable tube tester. The service man makes the rounds of a number of old customers each day, testing tubes, and in many instances sells several of these accessories by merely tuning in the set to its maximum volume, then replacing a weak tube with a new one and demonstrating to the owner the greatly improved volume and tone quality.

# Light Displays Give That "Cool Effect"

The generous use of white draperies adds a cool summer touch to this window of Nichols and Gates, Waterloo, Ia.

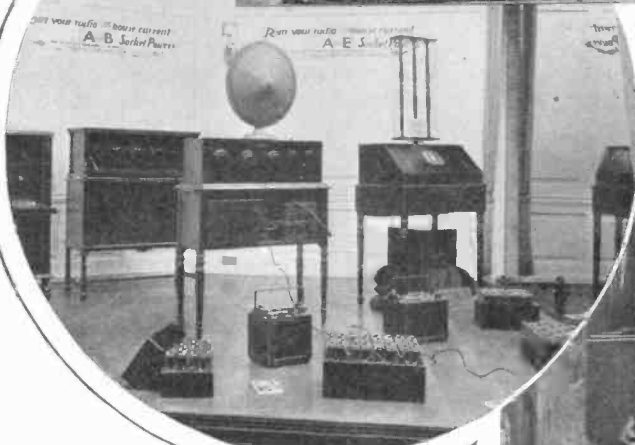
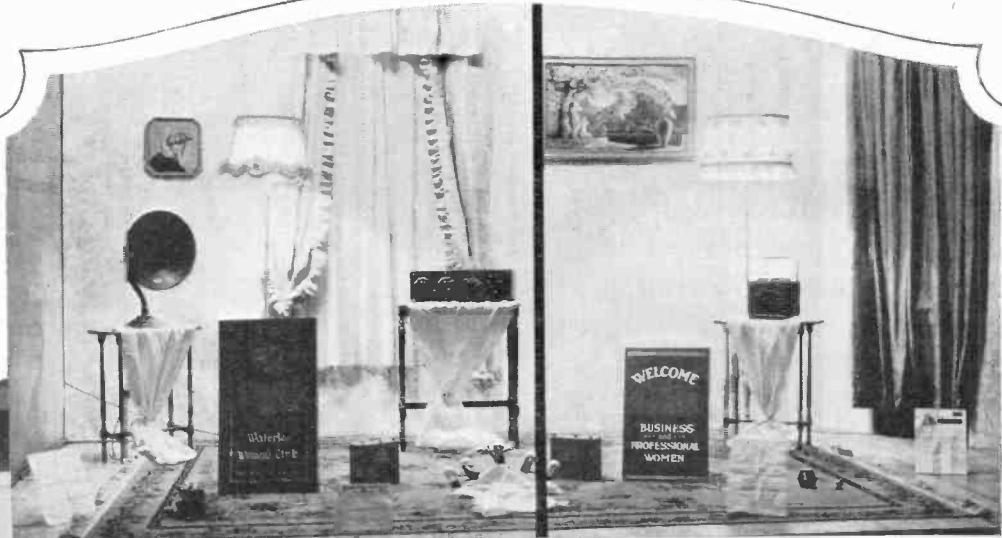

Above—Exhibit of the Hartford Electric Light Company, Hartford, Conn. This modern window is loaned to local merchants for the display of their wares under modern lighting conditions.



Above—The window of the E. A. Portal Company, San Francisco, Cal., brings out the summer atmosphere through the use of artificial foliage.



The Commonwealth Edison Co., Chicago, (left) drapes a large Spanish shawl as a background to give a light, feminine effect. A basket of flowers completes the picture.

# Where Is

# The Danger Line

## In Retail Costs?

There is a maximum figure for each division of sales expenses—The dealer who doesn't know exactly what percentage of his gross margin each selling expense eats up is courting disaster.

By J. ANDREW WHITE

Vice-president, Haynes-Griffin Radio Stores, Inc.

WE WERE in the Pullman smoker, speeding back from the radio convention at Atlantic City, when the conversation which had been rather general about the trends of trade centered upon the question of retail profits. For several hours it was concentrated on this subject, and of all that discussion one remark stands out clearest: "Now, I know you'd hardly believe it,"—the distributor in the party was talking—"but this particular dealer still believes that he can conduct a retail radio business profitably on a fifteen per cent margin!"

Well, we believed it. It so happened that all of us in the little group were veterans, and we had met many such dealers—fellows who are kidding themselves into thinking that they are running radio stores at a profit when they mark up stuff fifteen per cent above cost, or even a lesser percentage.

I like to play hunches, and since it seems increasingly clear to me

that the most useful purpose I can put these few pages to, in this issue, is a discussion of the essentials of the budget, I'm going to take a shot at it.

It will be necessary to use a few figures. Statistics are tricky things, so by way of preamble let me say about these figures that they didn't originate with any bureau of research nor did they come out of any school of administration. This is School of Experience dope.

I am going to confine myself to successful operation only and try to show on what cost basis a healthy, growing and permanently planned radio store should function.

THE whole discussion will be based upon the table of percentages which follows. Merchandise sharks may be able to pick plenty of flaws in it, and here is an open invitation for them to do so; but for the fellow who is just one jump ahead of the sheriff, or for the dealer who has run his store as an

unprofitable pastime, these percentages may be accepted as guideposts to straighten out the course of their business.

	Per Cent
Sales .....	100.
Cost of merchandise.....	66.
Gross profit .....	34.
<b>Operating Expenses</b>	
Rent .....	4.
Salaries .....	13.6
Advertising .....	6.
Deliveries .....	1.25
Commissions .....	.75
Insurance .....	.2
Depreciation .....	.5
Interest on loans.....	.2
General expenses .....	2.
Total expense .....	28.5
Net profit .....	5.5
Gross margin .....	34.

It isn't everybody who can interpret figures like these in percentages, at a glance; so—

Note that the gross margin of profit is given as 34 per cent; that's a good working average based upon the experience of dealers who get maximum prices, so I've used it as applicable to any well-run radio store. Next, the figures under the heading, Operating Expenses, are based upon percentages of sales; the

Advertising

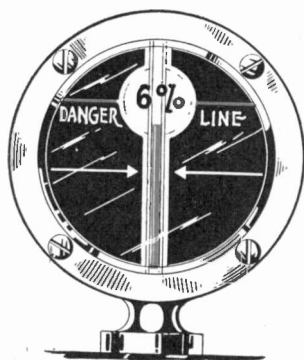

Rent

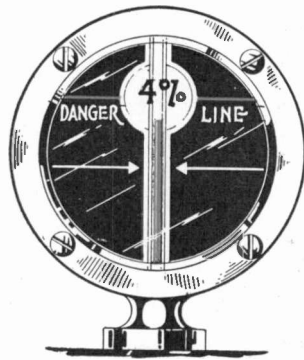

Salaries

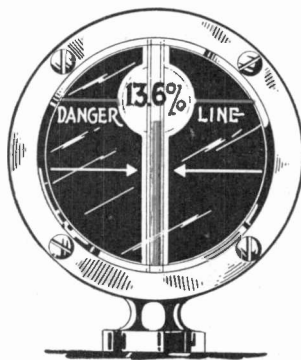

Deliveries

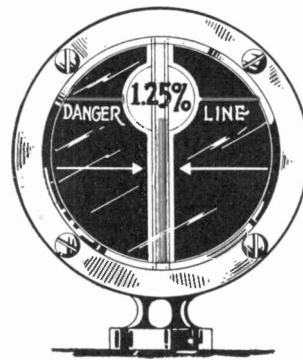

*If the Radio Selling Expenses of Your Store Are Averaging*



first item, for instance, Rent, 4 per cent, may be used as a guide in this way—if the rent of a store is \$325 per month, including light and power, or \$4,000 a year—that store must do \$100,000 a year business, or the boss had better find a cheaper store. Rent of \$100 a month, say, calls for net sales of \$30,000 a year; or the other way around, if a store's net sales run \$60,000 a year, double the rent, or \$200 per month is the maximum rent that could be paid.

And so on. The item of salaries is a heavy one, but it includes non-productive labor such as the book-keeper or the cashier and allows for the owner or owners to draw weekly, as they should if devoting their time to the business. Commissions, shown as a separate item in the table, is the net of the customary 1 per cent paid to salesmen in addition to their regular salaries, less the sales made by the boss or bosses, who naturally take no commission for themselves as their interest lies in the net profit of the business.

**T**HE various items, as they stand, need very little interpretation, as I see it; their principal value is that they are strictly radio figures, and actual percentages upon which success rests. As such, they stand an eloquent testimonial to the foolhardiness of the fellow who says he can make money on a fifteen per cent margin. He simply doesn't know what he is talking about.

That type of dealer—I mean the fellow who doesn't keep proper books and has not even a nodding acquaintance with budgets—is always looking for a long discount, 40 per cent, or better, off the list, and then says: "If my price is lowest, I'll get the business, and it's the volume that counts. Fifteen per cent is plenty for me; I'll tack that on to the

cost of the goods and let 'er ride!"

And, thinking that way, he fools himself twice; or rather, in two ways. First, if you study the percentage table I have given, it is immediately obvious that the fixed expenses cannot be cut in half. It simply cannot be done. Furthermore, note that operating expenses and the net profit total the gross margin, or gross profit, and that the gross margin, 34 per cent, is the average discount and as such is figured on the *selling price*. The gross profit or margin cannot be figured on the cost of the goods to the dealer, but *must* be figured on the price the dealer receives from the customer.

That this is the way goods are to be priced is one of the first things a retail merchant learns. But the error of taking the cost of goods as

List and sale price.....\$100  
Cost at 40 per cent discount. 60

Gross profit, 40 per cent, or \$ 40

Now, if figured on the *cost* of the goods, marking the ticket to show the same 40 per cent margin, here is what happens:

Cost .....\$60  
Add 40 per cent..... 24

Sale price .....\$84

The profit is \$24 gross, or less than 30 per cent of the actual \$84 that went into the cash register, and only 24 per cent, instead of 40 per cent of the proper selling price.

This is one form of leaking away of profits through incorrect method of calculation, and if the example serves no other purpose it clearly indicates how a business which otherwise sticks firmly to the percentages of proper operating expense in the budget I have given, may come to the end of the year with its comfortable 5.5 per cent net profit wiped out, and face a loss of 3.5 per cent.

For it is plainly obvious that with the percentages of expense fixed by the sales, and since they total 28.5 per cent of the sales income, a cut of the gross margin, when it is based on 34 per cent average discount, will show a loss if that margin is applied to the cost of goods. Figure it out and see for yourself.

**DO YOU know what percentage of your gross margin should be apportioned to each sales expense? A knowledge of selling costs, and budgeting all expenditures, is necessary before a dealer can profitably sell radio.**

100 per cent instead of the retail selling price as 100 per cent is such a common one that it may be useful to show here what happens when a dealer figures the wrong way around and prices his stock of sets, parts and accessories to make a stated profit on the figure at which they have been billed to him. For convenience, take an article which has a list price of an even hundred dollars.

**A**NOTHER common practice for which danger signals should be set is the almost universal custom of "shading" the list price. Rare indeed are the stores that sell at list, and fewer still are those which do cut, fully wide-awake to what is happening to the profits in consequence. Assuming that the dealer knows that the margin of profit should be figured on the selling price and not the cost,

General Expenses

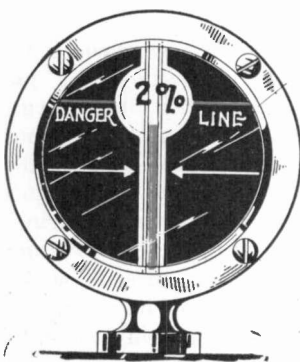

Depreciation



Insurance

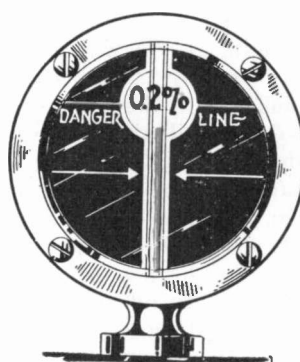

Interest



**Higher Than The Figures Presented Above—Find Out Why**

and he is the type who would greatly resent being classified among the cutthroats, how often is he unaware that this is what happens when pricing his stuff below list:

	Selling Price	Cost	Profit
At List Price	\$100	\$66	\$34 or 34%
A Cut of 5%	95	66	\$29 or 30%
A Cut of 10%	90	66	\$24 or 27%

Small cuts these, as retail radio knows them, but see what they mean in trying to get a net profit against that fixed operating expense of 28.5 per cent!

To show how far removed is this practice from the habitual price-slasher, here is what is faced by the type of so-called dealer who says, "Fifteen per cent margin is plenty for me"—

The Goods Cost..	\$66.
Margin—15% ..	11.65
Selling Price ....	77.65
A Cut of .....	22.35 per cent!!

If the fifteen per center combines both errors, and figures his supposed profit on the cost of the goods, then his cut below list is about 25 per cent, and his gross margin has shrunk to 13 per cent!

Perfectly obvious—isn't it?—on the face of it, that no man who conducts his business with honesty and fairness can show a net profit with any such ridiculous margin to work on. I am hopeful that this article will make a few dealers sit up and take notice, and do a little thinking.

Selling stuff strictly at list prices, and doing \$100,000 a year business will net a store a profit of \$5,500.

Habitual shading of 5 per cent will cut that profit down to \$1,500.

Cutting below that is courting disaster.

**A**ND to all the wise ones who answer that volume of business will obviously offset the dangers I have pointed out, the answer is—try and do it. Take a pencil and paper and figure it out. The store doing \$100,000 and maintaining list prices has the same gross margin in dollars as the 15 per cent-price-slasher doing \$183,000. And if the slasher doesn't know how to figure the percentage of gross profit correctly, then he has to do \$260,700 a year—and merely entertain the hope of possible profits for as long as he can last, whereas the reputable radio retailer is sure of a fair margin if he knows his business and budgets his operations in the manner I have outlined here.

## Why I

# Refuse to Fall for Gyp Methods

By a successful radio dealer who formerly worked for a price cutter

**B**EFORE I started in business for myself I held the positions, respectively, of clerk, outside salesman and service man for another radio dealer in this town. I worked for him for two years and would, no doubt, be there yet but I didn't like the business habits he was getting into. Not that they were the least bit shady—not at all. That wasn't it, but he was falling for all these cut-price artists and their tactics. Listening to the voice of the price tempter until it got so that, just before I left, he was selling discounts—not merchandise.

no really prominent sets and those that we did sell were giving all kinds of trouble.

Well, about this time the boss got the habit of locking up every night at 5:30 and anyone wanting service after that hour, and there were plenty of them, was simply out of luck.

At just about this juncture yours truly quit the scene of inaction and opened up a little store of his own. I have the agency for two of the best brand of sets in these United States and I'm here to say that it helps.

When these fellows come around to me with their trick merchandise I simply smile and tell them about the piece of toast under the poached egg—very little use and all wet.

### About Parts

How about parts? My attitude in this respect is the same as toward sets. One of these "distress merchandise" salesmen said to me only the other day, pointing to my upper shelves, "Lot of unsellable stock there, brother—better get rid of it at a price."

"I have \$160 tied up in those shelves," I replied, "and that costs me 80 cents a month interest, so I think I'll hold and sell my parts at my price and not upset any further the public's sense of values in radio merchandise."

It is to laugh the way some dealers buy obsolete, unknown or questionable merchandise at bargain prices and then turn right around and sell on the same basis, killing their own market for good goods and shaving their own margin to less than it costs them to do business.

Yes—my former boss is still in business. I hope he's making money, but I have reason to doubt it. I did a \$45,000 volume last year, thank you, at a net profit of 7 per cent.

---

**A CLERK in a leading radio store in a Western city of 50,000 population quit his job and started in business "on his own" because he could not reconcile his ideas and ideals with certain practices into which his boss was drifting.**

**This is the story, as told to a representative of Radio Retailing by that former clerk, of what those practices were, and why the narrator refuses to follow them in his own store.**

---

He was losing money right along by these methods and I knew it. Got in the habit of holding sales too, until they didn't mean anything except that every day was bargain day. The boss never could get a clean 30 per cent gross margin on anything, and he was then buying unknown brands of sets and parts at 50 and 10 off the so-called "list." Then he lost his good lines—couldn't stand up and fight for them and sell them for what they were worth. The result of all this was that we carried

# Know *what the public* Wants

“Sorry, we’re all out of that,”  
is a phrase that should never  
be heard in a radio store

By S. J. RYAN\*

**I**F you’ve nearly always “got what they want when they want it” you’re one of the town’s leading citizens—a real merchant prince. And what a headache when you *haven’t!*

Naturally you are trying to figure out now what they’re going to want in radio the coming fall. So am I.

My guess is quality—and phono-radio combinations. What’s yours? Of course there will be plenty of “sale” merchandise on the market—and plenty of it sold too. But the public are rapidly becoming “radio wise” and, barring the unforeseen, fall, 1926, should prove a gladsome harvest for standard radio merchandise.

Now do not misunderstand me. I most emphatically do not believe business is going to be “easy” the coming season. I mean to imply a higher percentage of the total business will be in standard merchandise of proven merit.

But aside from “how much business will I do?” the big question in my mind—and in the mind of every radio merchant I imagine—is: “Of every dollar spent by the public for radio this fall, how much of it will be for

Accessories?  
Straight radio sets?  
Combinations?

Or, in other words, how am I to lay out my buying appropriation? Very shortly the salesmen will be after me. What shall I base my decision on?

\*Merchandising counsellor, *Radio Retailing*, and merchandise manager, B. Nugent & Sons, St. Louis, Mo. Former general merchandise manager Kresge Department Store Corporation, and merchandise manager, J. L. Hudson Company, Detroit, and J. & N. Adam, Buffalo.



Of course you know just how much you sold each month last year in each division of merchandise? If you don’t, you should. Use that as a basis, making your *selling* calculations before you *buy*.

Don’t overlook the combination set for this fall, whether you carry it or not. In order to get the proper perspective on this whole subject, try to divide the public’s radio dollar into the above three parts—and then calculate your share.

For example, I believe our own customers will spend their radio dollar about as follows: 15 per cent for accessories; 60 per cent for straight radio sets and 25 per cent for combinations.

If I’m correct the dealer who does not carry combinations only has a chance at 75c of the radio dollar—and the dealer who does not carry straight radio only has a chance at 40c of it.

# Our Readers Say, "The Best Way to Sell

## Sell the Public Good Summer Reception

SUMMER is the time to buy the real radio. Why? It's merely a matter of logic that a radio which performs in summer is bound to give splendid performance in winter. Most any radio receiver will operate efficiently in the winter months but the real test is to demonstrate your best lines of receivers in the summer months to the customer's satisfaction. He then has the assurance that he's getting the best that radio has to offer.

Start a summer campaign for better radios and show the public that radio is not just a winter pastime but a real live interest throughout the whole year. Just think of the possibilities of radio in summer entertainment. Radio receivers would prove a wonderful addi-

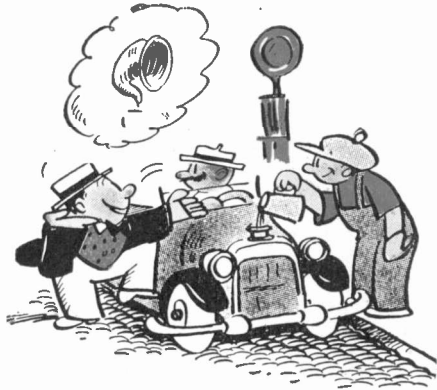

tion to camping trips, picnics and all sorts of pleasure trips.

Call on every house in the community—make friends with the people and then talk—tell them why they should have a radio this summer if they haven't one. If they already have a radio receiver in their home, endeavor to get their good-will and co-operation in boosting summer sales.

Radio has passed from a luxury to a comfort and then to a necessity, as it is now. Neither the dealer or customer can afford to let a false conception of summer radio interfere with sales and such marvelous entertainment. Let's boost summer sales, and remember a radio sold in summer more than insures reception for the whole year.

HATTIE O. HACKETT,  
Hood River, Oregon

## Don't Lose Enthusiasm During the Summer

THE radio dealer, first of all, has one thing to learn and that is to continue his own efforts toward sales throughout the entire year instead of six months.

The auto not so many years ago was stored away in the winter. Who overcame this habit? The auto dealer, not the owner. Radio is the same. The owner has got the habit of putting his

set away or forgetting it when warm weather sets in because he thinks as long as DX reception is gone, it is time to quit.

Mr. Dealer, stop this by every act and word on your part. You are selling a musical instrument, one of the finest, most fascinating and entertaining ever made; sell it for the music it will produce regardless of where it comes from. A phonograph or piano is purchased for the music it will produce—sell radio the same.

Keep up your advertising—tie your ads to all local events being broadcast. Continue in the summer to put your enthusiasm into it. Show people how pleasant it is to sit on their front porch and hear the band concerts from the park or the many sporting events.

Don't say, as many of we dealers are apt to, "Oh, this fellow's territory is different from ours." It may be different in many ways, but not for the better. At one mile above sea level, the static in summer here in Denver will raise the ear phones off your head. We have only three local broadcasting stations and practically none within 500 miles. Those three stations produce enough music for any fan to enjoy his radio for several hours out of twenty-four. Yet, would you believe it, I heard of a Denver radio dealer the other day advising his customer not to buy a set now—wait until the fall. That's ridiculous.

A department store obtains its business from newspaper advertising. I am going to consistently run radio ads all summer and with the number of people we can bring in, I know we can show a satisfactory volume in sales. Besides, it will make our fall sales several times greater.

DENVER DRY GOODS COMPANY,  
J. H. Blinn  
Denver, Colo.

## Summertime and Radio in the Small Town

HERE is how we will sell radios in the summertime—I believe that a small town or city is the place to work the hardest for the radio business, for this reason: In the small places they have less chance for entertainment. About all they have is a small picture show and maybe if they are lucky they have a band concert once a week. Outside of that, nothing to do but take a car ride, and even that gets old after a time.

So we try to impress upon the folks that nothing could be more enjoyable than to sit out on their nice cool front porch and listen-in to the big things in the far-away places, good music for young folks to dance by, for old folks to enjoy, etc.

We tell them: "Here, you go out this evening for an auto ride and when you come back we will be up to your house with a radio and demonstrate how you can sit out in the cool air and enjoy yourself with good music."

*The summer slump is these readers declare. Depression of poor warm the slump will become*

It will also keep the young folks at home which is a wonderful thing now in these days of "auto rides."

We put in a special window featuring radios and talking machines, listening-in on all the great singers and musicians.

There is no reason why dealers cannot sell radios in the summertime.

PHELPS-DODGE MUSIC COMPANY,  
Lloyd R. Cady  
Dawson, New Mex.

## Good Salesmanship Will Sell Summertime Radio

THERE is just one way to boost the sale of radio receiving sets in summertime, and that is to take them out and sell them. Each individual of your sales force can sell just as many sets during the coming summer as he has sold during the past winter if he is a real salesman and has a real set.

This is not a pet theory of the writer's, but is an accomplishment of the summer of 1925 and will be repeated during the summer of 1926.

How much business did we do and how did we do it? We concentrated on the set that gave the *very best reception*. Each sale amounted to \$300 to \$450. We sold enough so that the agency for this particular set was taken from three other dealers in our territory and given to us exclusively.

Our method is to get the sets into the homes. Don't misrepresent; don't promise the impossible; but promise good, worthwhile radio reception all summer, with better results assured for the coming winter. But—"you can't afford to miss all the wonderful programs that will be on the air all summer."

We assure our prospects that there is not the slightest obligation incurred by a home demonstration. "It's the only way that radio can be selected or sold." "If you don't buy, you will surely have



# Radio in the Summer Is to SELL Radio!"

*purely psychological, Overcome the public in-weather reception and a thing of the past.*

a good word for our set, and others will hear it while it's in your home." "It's pretty sure to mean a sale, directly or indirectly, eventually." "It's the best advertising that we can do."

We do not claim that an order-taker can take as many orders for radio in summer as in winter, but we do claim that the salesman who has the backbone to go out and work; who can inspire the confidence of others in himself; who can arouse interest in his merchandise; who can create a desire for ownership by a

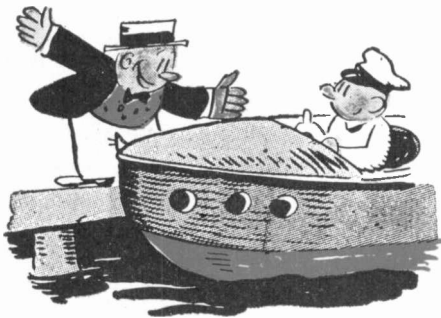

proper presentation of advantages to be derived thereby; and who has the nerve to get right down to "brass tacks" and close the sale before the prospect cools, can sell radio all summer.

THE WHITE MUSIC SHOPS, INC.,  
B. S. Fry

Danbury, Conn.

## Bring Out New Products at Start of Summer

WE HAVE felt that radio sales lag during the summer months, not because there was anything lacking in radio during that time, but because of the heavy competition incidental to summer amusements for the prospect's time. All merchandisers agree that the first and most important step in making a sale is to secure attention. Radio has made such tremendous strides during the past few years simply because it has secured this attention easily. Its novelty focused public conversation and the public press, and radio fiends and sales naturally resulted.

When combating summer sales slumps, therefore, it is only logical to be guided by past experience, and assume that if we get attention in competition with the many other summer amusements, we can make sales. The road is particularly easy for the manufacturer of radio accessories, because people owning a radio set have already made the major investment, and the problem is simply to induce them to

spend a few dollars for equipment necessary to realize the maximum amount of pleasure from their investment.

Why cannot the entire industry stimulate interest by announcing their new ideas and new products at this season of the year? I am sure many of them would do so if assured of the co-operation of radio jobbers and dealers.

CENTRAL RADIO LABORATORIES,  
H. E. Osmun

Milwaukee, Wis.

## Manufacturers Must Help to Overcome "Slump"

WE FIRMLY believe in the soundness of the proposition to extend the active radio selling period far into the summer and are prepared to "carry on" with greater zeal than ever before. It is a recognized fact, however, that the efforts of the dealer and jobber depend largely upon the co-operation received from the manufacturer. In the past the manufacturer, generally speaking, has been held chiefly to blame for permitting the fallacy of a radioless summer to exist, through his lack of advertising and selling effort following the cold season.

We pride ourselves upon representing the most progressive manufacturers in the radio industry. Let our manufacturers set the pace in promoting the present trend toward year-round radio activity.

TRILLING & MONTAGUE,  
J. Lobel

Philadelphia, Pa.

## Disregard Seasonal Lines

IN OUR opinion, one of the most joy-killing features about the whole radio business is the way that most people have resigned themselves to the so-called "radio season." It is our opinion that by getting away from yearly models which are brought out in the fall, and by utterly disregarding seasonal lines, that the great fluctuation in radio sales can eventually be brought to a more uniform state. We are greatly interested in your investigation along this line.

ALL-AMERICAN RADIO CORPORATION,  
Earl Freese

Chicago, Ill.

## Eliminating the Seasonal Fluctuation in Radio

HERE are a few suggestions of means by which the Summer radio demand might be increased:

1. Bring out a cheap and good portable receiving set. It should be dry cell and loop operated, with self-contained batteries, loud speaker, loop, etc.
2. Provide more good daytime broad-

3. Make the Summer programs lighter. Provide dance music, jazz and light opera, together with a smaller amount of classical music.

4. Eliminate seasonal models of radio sets as much as possible.

5. Bring out new sets, if any, in the Spring or early Summer. This stimulates interest and promotes buying at a time when business now falls quite flat.

6. Avoid liquidation sales. As the industry is becoming more stabilized, there will be fewer manufacturers, and these will be able to gauge more accurately the probable demand for their products.

7. The dealers should arrange for servicing the sets they sell and other sets, preferably by contracting for service calls at regular periods.

8. Concentrate on battery eliminators during the Spring and Summer.

9. Make more time payment sales of radio sets. This, of course, applies both to Summer and Winter sales.

### Dealer Should Handle Few Lines

10. The dealer should handle very few lines, possibly only one. Those dealers who have their money tied up in "Cats and Dogs" suffer most from the Summer slump.

11. Advertise the Summer use of radio in every possible way. The manufacturers should nationally advertise. The dealers should post the radio broadcasting programs in their show windows.

12. Discourage the talk about "static" in the Summer. This is very much of a bugaboo and very greatly exaggerated. Radio reception during last Summer was excellent most of the time.

13. Keep talking and selling radio. A goodly portion of the Summer slump is due to the dealer's frame of mind. He thinks he cannot sell radio and, therefore, does not try.

14. Give this subject some real thought—follow the suggestions offered. I feel certain if those vitally interested in the radio industry will give this subject serious consideration and exchange their ideas, a satisfactory solution to the problem will be worked out.

LUDWIG HOMMEL & COMPANY,  
L. Hommel.

Pittsburgh, Pa.



"Nize dealers, sell opp all de radios!"

Cartoons on this page reprinted from an earlier issue and drawn exclusively for this publication by—

MILT GROSS

# "There Is No Slump!"

*Here's a dealer who denies the existence of a hot weather let-down, increases his sales efforts and sells radio in spite of the weather man.*



*To sell radio in the summer, Wilkinson uses—  
1. Direct-by-mail campaigns*

**G**O out and get the business!" That's the summer sales policy of T. J. Wilkinson, proprietor of the Keystone Radio Service Company, East Orange, N. J. "The logical solution, when the customer does not come to the shop to buy, is to go out with your merchandise and bring it to his door," he states.

"Summer jinx? No! Although it may be necessary to make greater sales effort, to put on steam and open the throttle wide, business can be kept rolling. There's no particular secret to successful summer selling. When the slack season sets in there is only one possible and logical solution, and that is redoubled effort of all employees to close sales *now*. The prospects are still there, perhaps they have temporarily lost interest in radio and will not come to the store, but they are nevertheless there and it is up to the radio dealer to go out after them and create interest; to make inspection of new merchandise easy for the prospect.

## **Rural Districts are Retailer's Best Bet**

"Last year, when business began to fall off, I decided to start a house-to-house canvassing campaign here in East Orange, so I started out to call on residents in my immediate neighborhood. Well, this plan did not pan out so well. East Orange is quite a large town and most of its residents commute to the city each

day and are naturally familiar with all the cut-price sales. Next, there are many apartments in town and an outside salesman has a rather difficult time getting to prospects. I finally decided that there was better business to be had in the rural districts as most small town residents work right in town and go to the

---

*Wilkinson's formula for selling radio in the summertime is—*

- 1. Pave the way by direct-mail circularization.**
  - 2. Go out and make personal calls on prospects on your mailing list.**
  - 3. Clinch the sale by demonstrating in the home.**
  - 4. Make a special appeal to the farmer at this time of the year.**
- 

city perhaps 'once in a dog's age.' This is especially true in the summer months.

"After looking over the road map of the section I decided to concentrate on a small town back in the 'sticks,' Livingston, and in order to make my shop fairly well known before starting to canvass, I decided to conduct a direct-mail advertising campaign. The names of residents were secured by means of a suburban telephone book and each one was mailed an attractive form letter offering free home demonstrations of

receivers for their convenience, and also a few printed circulars bearing photographs of sets, which were obtained from manufacturers.

"About a week later, after the circulars have had time to 'sink in,' I equipped a touring car with a number of receivers and a miscellaneous assortment of parts and accessories and sent this car, in charge of one of my store salesmen, back into this town on a canvassing expedition. Well, there are about 150 homes in Livingston and in the next few days eight receivers were sold to residents, and quite a few accessories sold to those who already had sets.

## **Demonstrations Make the Sales**

"Demonstration in the home is the backbone of the entire outside sales plan. Most of the rural residents haven't time to shop in the city and hesitate to get a radio from a mail order house for fear of its failure to operate when it arrives. A demonstration right in their own home, without obligation, induces customers to buy.

"Another advantage of outside selling and home demonstrations is the fact that the prospect's entire family is present to pass the verdict when the set is tuned in. Every dealer has had more than one experience with the prospect who comes into the store, listens to a receiver and then when practically sold, springs the 'joker'—'Well, I'll have to see my wife about it first.' In

such cases the enthusiasm which the dealer has worked up on his demonstration is entirely lost, for the prospect's wife is not present and has not been 'sold.'

"Once a prospect who is interested in radio reception is convinced that a set will operate satisfactorily in his own home, he may be easily induced by a good salesman to buy one of the more expensive console type sets in place of the table type ordinarily used for the demonstration."

**Truck Farmers are Excellent Summer Prospects**

According to a recent estimate, 89 per cent of the New Jersey farmers have no radio set but can afford to

*2. Personal calls*



buy one. Keep in mind that it is in summer that the truck farmer, who is marketing his products as early as June, has money. In the fall and winter he is "holed up," saving his money, and for this reason it is more difficult to sell him.

Many farmers in the vacation belt take in boarders during the summer and a radio set is an absolute necessity. In the summer, the farmer is hard at work, he is interested for the sake of this business, if for nothing else, in the broadcast weather reports, produce market returns and methods in cultivation. Approximately 48 per cent of the Jersey truck farms employ men who are specialists in certain services. Usually there is a man who specializes in poultry, one in agriculture and another in raising stock. Each of these men is interested in news of

an entirely different nature and it is quite possible to sell several sets to each farm.

The Keystone shop takes advantage of every public gathering to get prospects for future sales, and a meeting of a local social club or a public concert will always find Wilkinson on deck with a set and a speaker. In the town high school last season, one of President Coolidge's speeches was reproduced with the aid of several speakers and a power amplifier. The direct result of this demonstration in the school auditorium was the sale of two \$250 receivers. The advertising value, aside from this is hard to estimate, and prospects are still coming into the shop to inquire about the receiver which was so good up at Willie's school."

Last June the car was parked on the main street opposite the railroad station at about the time hundreds of commuters were returning from business. A portable receiver was tuned in on the back seat, and a crowd soon collected to listen to the receiver which operated on a loop

and could be carried from place to place in operation.

As a result, several sets were sold and a number of good prospects were listed. This season Wilkinson intends to stage demonstration concerts from the bandstand of a local park, between selections by the regular town bandstand of a local park, between selections by the regular town orchestra. One of the new power speakers will be used for this purpose and he expects to attract a number of prospects. The band concerts broadcast regularly from Washington, D. C., are ideal for this purpose.

**Employs Combination Salesman and Collection Man**

A great deal of the shop's business is done on the time-payment plan and it is of the utmost importance during the summer months that all delinquent accounts be paid. For the purpose of collecting those which are far overdue and which may not be collected in the customary way, Wilkinson employs a collection man who is paid 10 per cent on such collections. In addition to this work the man follows up store leads on a 5 per cent commission basis, receiving more than this when he makes a sale from his own leads. Such a collection system should, of course, not be employed unless other means fail as bad feeling is often created by this method, regardless of the man's natural tact or ability.

*3. Home demonstrations*



# Tone Quality

## depends on the Audio Transformer

By H. W. BAUKAT

Assistant Editor, "Radio Retailing"

"YES, sir," you will hear many a radio salesman say, "just buy one of these new type loud speakers, connect it up to your set and then you'll find out what radio reproduction really is."

A comparative demonstration will then be made by the salesman, using several types of loud speakers. The results of the demonstration will bear out his statement as there will be, of course, a marked difference between a cone-type loud speaker and a speaker of the older type of several years ago. Just why this is so was all explained in the March issue of *Radio Retailing*, page 258.

But why is it that when the customer takes home his prized new speaker, bought on the strength of the demonstration in the store, he does not get the results expected? True the new speaker sounds much better, and has a more pleasing tone than the old unit, but still there seems to be something lacking.

After having been told at the store that this particular loud speaker

Full tonal depths from old apparatus cannot be expected by the mere addition of a new loud speaker

would cover the entire range of audible frequencies, to find out that all the notes were not coming through as they should is apt to be puzzling. Let's see just what is the cause.

When you stop to think the answer is very simple. Although the modern loud speaker will and does cover the entire audibility range, it cannot be expected to reproduce these frequencies with fidelity if they are not available from the receiving set.

Frequencies below 10,000 cycles per second down to about 32 cycles per second are audible to the human ear, and are therefore known as audio frequencies. Some individuals can hear sounds at frequencies above 10,000 cycles per second but this value is generally considered as the limit of the average ear.

The frequencies commonly used in radio communication lie above 15,000 cycles per second and are called radio frequencies. Frequencies be-

low 15,000 cycles per second are seldom used in radio as they give poor results.

In order for the loud speaker to reproduce properly the audio frequencies, the transformers in the receiving set must give nearly uniform amplification over the entire musical range. And what is even more important, they must cover this entire range.

In the old style audio frequency transformers, amplification fell off very abruptly on the lower frequencies and to such an extent that the majority of the bass notes were lost entirely. Then at the middle or slightly upper frequencies the resonant peak was reached. This resulted in high amplification of notes at this point which made itself known to the listener as "blasting."

Transformers for audio frequency amplification were originally intended and designed to amplify code

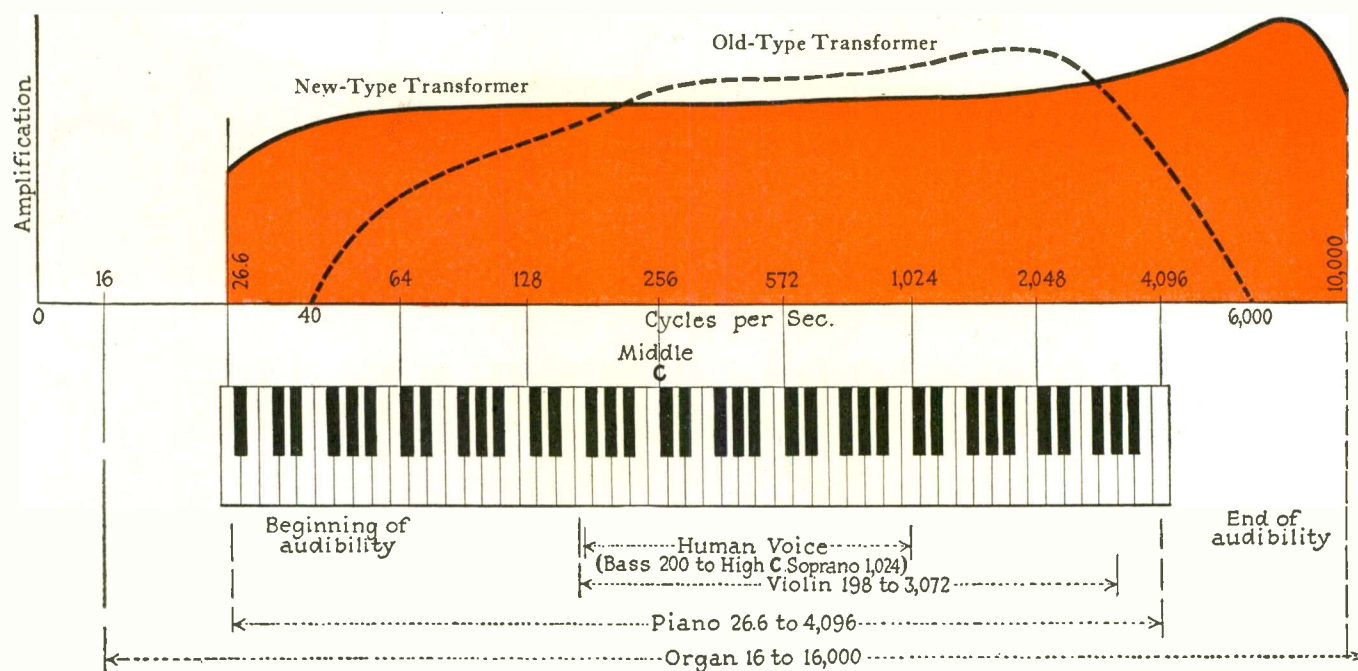

The practically flat "curve" of the new transformers means uniform amplification over practically the entire musical scale. The old transformers (dotted

line) had a limited range and amplification was not uniform which resulted in distortion. Also, the majority of the lower notes were lost altogether.



signals. These could be heterodyned and the tone changed to suit the will of the receiving operator. The main thing was to get high amplification with a minimum amount of apparatus. In such code work the word distortion was unknown. Here transformers with a resonant peak were, and still are, most desirable.

Not using a great deal of primary in connection with a large secondary, so as to get high amplification such as 9:1 ratio, results in a very sharp peak. Amplification drops except where this resonant peak occurs and here the amplification is very high.

In the newer style of transformers, the ratio has been lowered materially, which results in more uniform amplification over the entire range. The windings have also been made much larger in order to stand the increased current which is necessary with the multi-tube sets. With the older transformers, the windings are always blowing out because they were not constructed to stand the load which later development in sets placed upon them.

The iron core is another point which is overlooked by manufacturers of cheaper grade transformers. This should be made of the best grade of iron used for this purpose. The laminations should be not too thick and sufficient in number to give efficient operation. When broadcasting first was developed this cheaper transformer was among the few available and quite naturally

was extensively used. Not much thought was given to its design as long as it amplified.

In order that the reproduced vibrations from the loud speaker shall sound natural, the transformer must give uniform or even amplification over the entire audible range of frequencies. The output from most of the large broadcasting stations covers this range, so it is left up to the receiving set to reproduce them as they are sent.

As the quality of tone depends entirely on the proportion in which the natural harmonics of that tone are present, one can see how important it is that the transformers amplify evenly. If one or more harmonics are stressed more than the others the music or whatever is being reproduced is at once distorted. In the hollow tone of the flute they are almost entirely absent, in the clanging tone of the trumpet many of the higher ones are present, and if we take an instrument like the cymbals, we get the whole of the upper lot altogether. No matter how good the loud speaker is it can only reproduce the energy that is given to it by the transformers. Full fidelity of reproduction can therefore only be accomplished on transformers showing a flat curve throughout the audio frequency range.

There is a deficiency in the average loud speaker which occurs in the higher frequencies, but the added amplification of the trans-

**Fidelity of reproduction depends upon three factors:**

- (1) The audio frequency transformers,
- (2) The last tube, and
- (3) The loud speaker.

By a little study of the first-named device the dealer will find a profitable source of income.

formers which are approaching resonance at this point, compensates for this and the result is a very even and mellow tone over the entire musical range. These high tones appear as overtones in instrumental and vocal music. The distribution of energy on the harmonics is what enables us to distinguish one instrument from another. Therefore for faithful reproduction it is highly important that they are not lost or clouded.

**Lower Tones Have More Energy**

Every bass instrument requires more energy to operate it than do instruments operating above middle C. This applies to the bass drum, the bass viol, the bass tuba, and the long pipes of an organ. Human ears cannot hear sounds from an organ pipe 64 ft. long. The ear refuses to recognize a tone lower than 32-ft. but these great pipes on

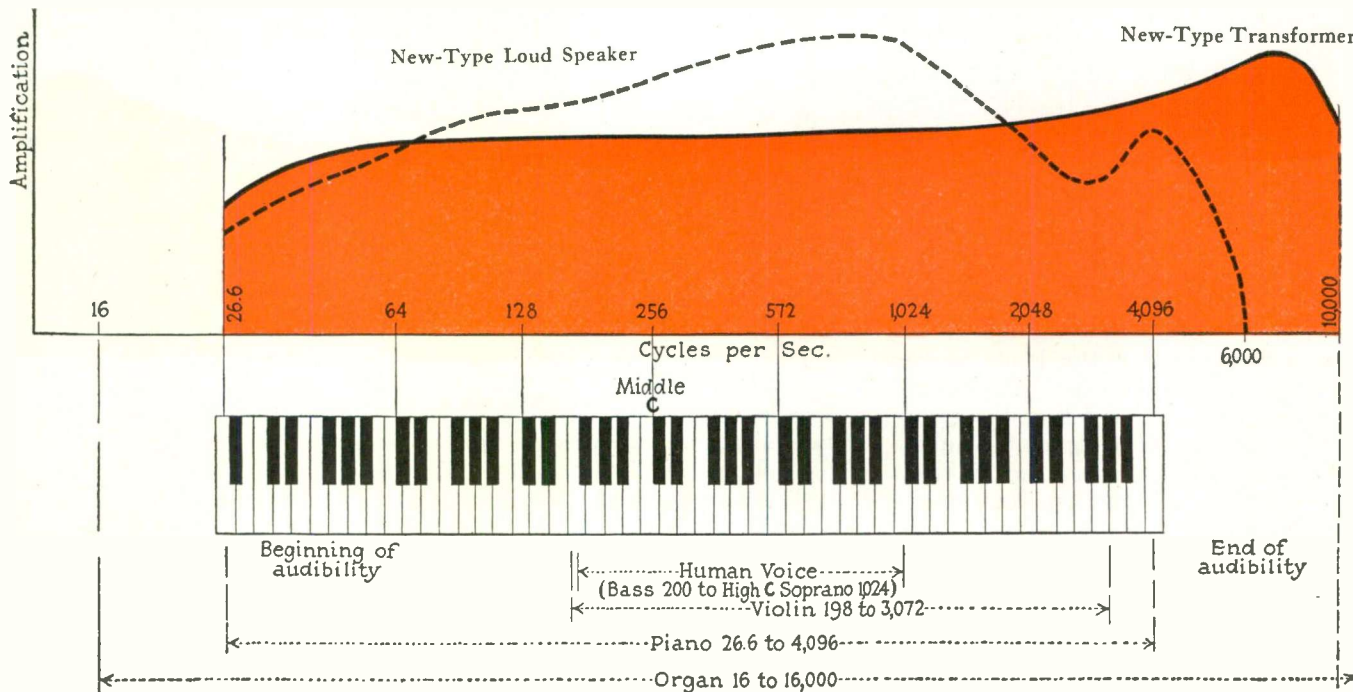

Both the new loud speakers (dotted line) and the new transformers amplify consistently throughout the range of audible frequencies. The old transformers did not supply all audio frequencies to the loud speakers, therefore they could not be reproduced.

# Specifications of Audio Frequency Transformers

**I**NFORMATION concerning radio products, with the name and address of the manufacturer, is a feature of *Radio Retailing's* editorial service published from time to time as market conditions warrant. This service is wholly for the benefit of readers and is without charge of any kind whatsoever to the manufacturers listed. It is *Radio Retailing's* desire to make these

pages a representative directory of radio products, so that, by following them as they are published, the dealer will always have at hand the information he wants to know about any radio set, reproducer or accessory. Manufacturers are invited to send specifications of their products for representation in the tables which are frequently revised and brought up-to-date. For

battery chargers, eliminators and power units see the January issue, pages 70-72. For portable receiving sets see the May issue, page 447. Complete listings of all radio manufacturers and their products appear in the *McGraw-Hill Radio Trade Catalog* which is published three times a year, in February, August and November, by the McGraw-Hill Publishing Company, Incorporated.

Name and Address of Manufacturer	Trade Name and Model Number	List Price	Turn Ratio	Plate Current Limit in Milliamps.	Dimensions in Inches		Weight in Lb. Oz.	Terminals Located at Top or Bottom	Incased in Shield?
					H.	W. L.			
Acme Apparatus Co. 37 Osborn St., Cambridge, Mass.	MA-2	\$5.00	5.00 to 1	25	2 $\frac{1}{2}$ x2 $\frac{1}{2}$ x3 $\frac{1}{8}$		2-2	Bottom	Yes
	A-2	3.00	4.25 to 1	25	2 $\frac{1}{2}$ x2x2 $\frac{1}{2}$		1-0	Top	No
All-American Radio Corporation 4201 Belmont Ave., Chicago, Ill.	R-12	4.50	3.00 to 1	12	2 $\frac{1}{2}$ x2 $\frac{1}{2}$ x2 $\frac{1}{2}$		0-12	Top	Yes
	R-21	4.75	5.00 to 1	12	2 $\frac{1}{2}$ x2 $\frac{1}{2}$ x2 $\frac{1}{2}$		0-12	Top	Yes
	R-13	4.75	10.00 to 1	12	2 $\frac{1}{2}$ x2 $\frac{1}{2}$ x2 $\frac{1}{2}$		0-12	Top	Yes
	*R-30	6.00	Input	12	2 $\frac{1}{2}$ x2 $\frac{1}{2}$ x2 $\frac{1}{2}$		0-14	Top	Yes
	*R-31	6.00	Output	12	2 $\frac{1}{2}$ x2 $\frac{1}{2}$ x2 $\frac{1}{2}$		0-12	Top	Yes
	Lyric—R-500	9.00	2.80 to 1	15	3 $\frac{1}{2}$ x2 $\frac{1}{2}$ x2 $\frac{1}{2}$		2-8	Bottom	Yes, sealed and sections insulated
American Apparatus Co. Richmond, Ind.	Amaco D-14	4.75	3.25 to 1	15	2 $\frac{1}{2}$ x2x2 $\frac{1}{2}$		1-1	1-in. from bottom	Yes, boxtype case $\frac{1}{4}$ -in. thick die cast
	High and low frequency		5.00 to 1	15	2 $\frac{1}{2}$ x2x2 $\frac{1}{2}$		1-1		
American Transformer Co. 178 Emmet Street, Newark, N. J.	AmerTran Type AF-6	5.00	5.00 to 1	12	3x2x2 $\frac{1}{2}$		0-13	Terminals on sides near top Reversible terminals considered to be at bottom	No
	AmerTran Type AF-7	5.00	3.50 to 1	10	3x2x2 $\frac{1}{2}$		0-13		No
	AmerTran de Luxe 1st Stage	10.00	3.00 to 1	3	2 $\frac{1}{2}$ x2 $\frac{1}{2}$ x2 $\frac{1}{2}$		1-6		Yes
	AmerTran de Luxe 2nd Stage	10.00	4.00 to 1	7	2 $\frac{1}{2}$ x2 $\frac{1}{2}$ x2 $\frac{1}{2}$		1-6		Yes
Branston, Chas. A. 813 Main St., Buffalo, N. Y.	Branston Twin Audio No. 204	7.00	1st 4.00 to 1 2nd 3.00 to 1		2 $\frac{1}{2}$ x4 $\frac{1}{2}$ x5 $\frac{1}{2}$		1-8	Sides	Yes
Bremer-Tully Mfg. Co. Chicago, Ill.	B-T Euphonic	5.00	2.20 to 1		2x2x3		1-5	Universal mounting brings terminals where required	Yes
	" "	5.75	4.70 to 1		2x2x3		1-5		
Conn. Tel. & Elec. Co. Meriden, Conn.	Connecticut J-121	4.00	4.25 to 1	7	2 $\frac{1}{2}$ x2x2 $\frac{1}{2}$		1-2	Side	Yes
	Connecticut J-121—No. 3	4.00	3.00 to 1	7	2 $\frac{1}{2}$ x2x2 $\frac{1}{2}$		1-2	Side	Yes
Crescent Mfg. Co. Toledo, O.	Crescent No. 210	2.50	3.50 to 1	10	2 $\frac{1}{2}$ x2 $\frac{1}{2}$ x3		0-15	Side	Yes
	Crescent No. 260	2.50	6.00 to 1	10	2 $\frac{1}{2}$ x2 $\frac{1}{2}$ x3		0-15	Side	Yes
	{ Crescent No. 250 }	6.50		15	2 $\frac{1}{2}$ x2 $\frac{1}{2}$ x3		0-15	Side	Yes
	* { Crescent No. 251 }	per pair					0-15	Side	Yes

the organ produce harmonics which wonderfully reinforce the tone of an organ. If we expect the sounds of these instruments to come forth naturally from our loud speaker, we must realize that the amount of energy applied to the loud speaker in the bass range must be sufficient. It can be easily seen that the transformers must be designed to amplify this energy in order to make it available to the loud speaker for reproduction.

Hence the dealer should realize how useless it will be to sell one of the newer type of loud speakers to be connected up to a receiving set bought several years ago and to expect perfect reproduction, when the transformers in the set are not capable of supplying the energy necessary. Obviously the remedy is

to replace the inefficient transformers in the set by a pair of transformers of more modern type. This, although involving a slight expense, will prove worth while in the end.

### Power Tube in Last Audio Stage

Now as the energy amplification increases approximately as the square of the voltage amplification, it might be well to say a word here about the last audio frequency tube. It is quite evident that if it is desired to reproduce the low-frequency notes naturally, the last audio frequency tube should be a power tube, operating at its maximum plate voltage and with the proper amount of negative grid bias so that there will be no tendency to overload.

This tube being the connecting

link between the output of the transformer and the input of the loud speaker, we must eliminate any possibility of its not being capable to handle the energy. If there is any uncertainty as to whether an overload condition exists in this last tube, obtain a milliammeter and place it in the plus B lead of the set's output. The needle will at once register the current being drawn. If the tube is overloaded the needle will not remain stationary but will beat time with the notes causing the overloading.

The dealer will do well to check up on the prospective loud speaker buyer's set to ascertain what transformers are being used. In the majority of cases it should result in the sale and installation of transformers of the newer type.

**Audio Frequency Transformers (continued)**

Name and Address of Manufacturer	Trade Name and Model Number	List Price	Turn Ratio	Plate Current Limit in Milliamps.	Dimensions in Inches	Weight in Lb. Oz.	Terminals Located at Top or Bottom	Incased in Shield?	
					H. W. L.				
Dongan Electric Manufacturing Co. 2987 Franklin Street, Detroit, Mich.	Type T		3.50 to 1	20	3 1/2 x 2 1/2 x 2 1/2		Sides	Steel Shield	
	Type 102		2.00 to 1	10	2 1/2 x 2 1/2 x 2 1/2		Bottom	Steel Shield	
	Type 101		3.50 to 1	10	2 1/2 x 2 1/2 x 2 1/2		Bottom	Steel Shield	
	Type 129		5.00 to 1	10	2 1/2 x 2 1/2 x 2 1/2		Bottom	Steel Shield	
	Type 146		3.50 to 1	10	1 1/2 x 2 1/2 x 2 1/2		Bottom	Half Shield	
	Type 42		3.50 to 1	10	2 1/2 x 2 1/2 x 2 1/2		Top	Open	
	Type 43		5.00 to 1	10	2 1/2 x 2 1/2 x 2 1/2		Top	Open	
Electrical Products Mfg. Co. 69 Sprague St., Providence, R. I.	Dymac Type H	4.00	3.00 to 1		3 1/2 x 3 x 1 1/2	0-14	Top	Yes, and sealed in wax	
	Dymac Type H	4.00	4.00 to 1		3 1/2 x 3 x 1 1/2	0-14	Top		
	Dymac Type H	4.00	6.00 to 1		3 1/2 x 3 x 1 1/2	0-14	Top		
Ford Radio I & Mica Corp. 111 Bleecker St., N. Y. C.	Supertran F. M. C.	6.00	5.00 and		2 1/2 x 2 x 2	1-4	Top	Yes	
		5.00	3.00 to 1		3 1/2 x 2 x 1 1/2	1-0	Top	No	
General Instrument Corp. 477 Broadway, N. Y. C.	G. I. Variable Audio Type 101	10.50	3.00 to 1	30	4 x 2 1/2 x 3 1/2	2-0	Bottom	Yes	
		10.50	2.00 to 1	50	4 x 2 1/2 x 3 1/2	2-0	Bottom	Yes	
General Radio Co. Cambridge 39, Mass.	Type 285 Type 285-L	6.00	5.9 to 1	10	3 1/2 x 2 1/2 x 3	1-8	Bottom	Yes	
		6.00	2.10 to 1	10	3 1/2 x 2 1/2 x 3	1-8	Bottom	Yes	
Jefferson Electric Mfg. Co. 501 S. Green St., Chicago, Ill.	Concertone Star Star Star C. S. C. S. C. S.	6.00	2.00 to 1	10	2 1/2 x 3 1/2 x 3 1/2	2-12	Bottom of each side Sides Sides Sides Bottom of each side Bottom of each side Bottom of each side	No—but sealed in the case	
		2.75	1.50 to 1	7	2 1/2 x 2 1/2 x 2 1/2	0-14			
		2.75	3.00 to 1	10	2 1/2 x 2 1/2 x 2 1/2	0-14			
		3.00	5.00 to 1	10	2 1/2 x 2 1/2 x 2 1/2	0-14			
		4.00	2.50 to 1	10	2 1/2 x 2 1/2 x 2 1/2	0-12			
		4.00	3.50 to 1	10	2 1/2 x 2 1/2 x 2 1/2	0-12			
Karas Electric Co. Chicago, Ill.	Karas Harmonik All-Stage	7.00	4.00 to 1	25	2 1/2 x 3 1/2 x 2 1/2	1-4	Bottom	Yes	
Kenyon Mfg. Co. 2344 Amsterdam Ave., New York City	Made for manufacturers 21A	2.75	2.00 to 1	15-20	2 x 1 1/2 x 2 1/2	0-14	Either	Yes	
	Made for manufacturers 31A	3.00	3.50 to 1	15-20	2 x 1 1/2 x 2 1/2	0-14	Bottom	Yes	
	Made for manufacturers 31	3.00	3.50 to 1	15-20	2 x 1 1/2 x 2 1/2	0-14	Either	No	
	Made for manufacturers 40A	5.00	3.00 to 1	15-20	2 1/2 x 2 1/2 x 2 1/2	1-8	Either	No	
Keystone Radio Laboratories, Inc. 154 Whiting St., Chicago, Ill.	Keystone Type K-4	3.00	3.50 to 1	15	2 1/2 x 2 1/2 x 2 1/2	1-4	Either	Yes	
	Keystone Type M	3.00	3.50 to 1	15	1 1/2 x 2 1/2 x 2 1/2	1-6	Bottom	Semi-shielded	
	National Type S	3.00	3.50 to 1	15	2 1/2 x 2 1/2 x 1 1/2	1-2	Top	Yes	
	Keystone Type M	3.50	3.50 to 1	20	1 1/2 x 2 1/2 x 1 1/2	1-6	Bottom	Semi-shielded	
	Keystone Type K-3	3.75	3.50 to 1	15	2 1/2 x 2 1/2 x 1 1/2	1-4	Either	Yes	
	Keystone Type K-2	4.00	3.50 to 1	15	2 1/2 x 2 1/2 x 2 1/2	1-4	Either	Yes	
	National Type S	4.00	3.50 to 1	15	2 1/2 x 2 1/2 x 1 1/2	1-2	Top	Yes	
	Keystone Type K-1	5.00	2.00 to 1	15	2 1/2 x 2 1/2 x 2 1/2	1-4	Either	Yes	
Liberty Transformer Co. 123 North Sangamon St., Chicago, Illinois	Liberty L-30	3.50	2.00 to 1		1 1/2 x 2 x 2	0-10	Either	No	
	Liberty L-32	3.50	3.00 to 1		1 1/2 x 2 x 2	0-10	Either	No	
	Liberty L-31	3.75	2.00 to 1		1 1/2 x 2 x 2	0-13	Either	No	
	Liberty L-32A	3.75	3.00 to 1		1 1/2 x 2 x 2	0-13	Either	No	
	Liberty L-33	3.75	5.00 to 1		1 1/2 x 2 x 2	0-10	Either	No	
	Liberty L-1	4.50	2.00 to 1		2 1/2 x 1 1/2 x 2 1/2	0-13	Top	Yes	
	Liberty L-5	4.50	3.00 to 1		2 1/2 x 1 1/2 x 2 1/2	0-13	Top	Yes	
	Liberty L-19	4.50	2.00 to 1		2 1/2 x 1 1/2 x 2 1/2	0-13	Bottom	Yes	
	Liberty L-20	4.50	3.00 to 1		2 1/2 x 1 1/2 x 2 1/2	0-13	Bottom	Yes	
	Liberty L-6	4.75	5.00 to 1		2 1/2 x 1 1/2 x 2 1/2	0-13	Top	Yes	
	Liberty L-21	4.75	5.00 to 1		2 1/2 x 1 1/2 x 2 1/2	0-13	Bottom	Yes	
	Types L-30, L-31, L-32, L-32A and L-33 can be furnished with 4 stud mountings 3/8" high, or with right-angle brackets 1/2"								
	Mazda Radio Mfg. Co. 3405 Perkins Ave., Cleveland, Ohio	Consomello No. 5494	5.00	2.00 to 1		2 1/2 x 2 x 2 1/2	0-9	Top	Yes
Consomello No. 5495		5.00	3.00 to 1		2 1/2 x 2 x 2 1/2	0-10	Top	Yes	
Consomello No. 5496		5.00	5.00 to 1		2 1/2 x 2 x 2 1/2	0-11	Top	Yes	
Modern Electric Mfg. Co. Toledo, Ohio	Modern No. 110	3.00	4.00 to 1	10	2 1/2 x 2 1/2 x 3	1-0	Side	Yes	
	Modern No. 111	3.15	10.00 to 1	10	2 1/2 x 2 1/2 x 3 1/2	1-3	Side	Yes	
	*Modern No. 112	7.50 per pair		10	2 1/2 x 2 1/2 x 3	1-0	Side	Yes	
	*Modern No. 113		10	2 1/2 x 2 1/2 x 3	1-0	Side	Yes		
	Modern No. 118		10	2 1/2 x 2 1/2 x 3	1-0	Side	Yes		
	Intermediate push-pull								
	Modern Symphony No. 740	6.00	4.00 to 1	10	2 1/2 x 2 1/2 x 3 1/2	1-4	Top	Yes	
Modern Symphony No. 741	5.00	2.00 to 1	10	2 1/2 x 2 1/2 x 3 1/2	1-3	Top	Yes		

Compare the two old style transformers below, in size and appearance, to the three new type transformers at the right

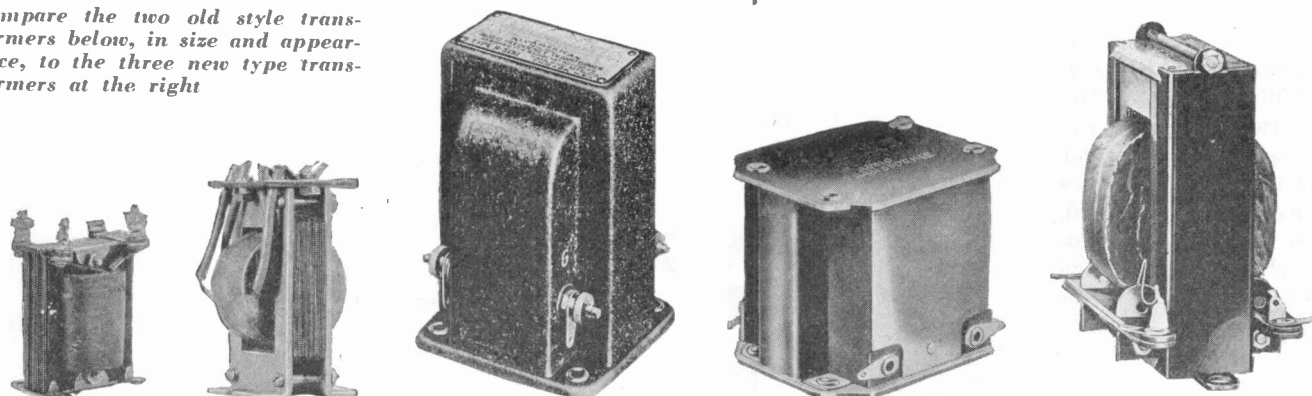

The old style audio transformers had high turn ratios and few primary turns. This combined with insufficient iron in the core gave rise to very uneven amplification. They were not shielded or sealed in any way, and the

magnetic circuit of the transformer was detrimental to the efficiency of the set; also moisture had a great effect on the winding. The new style audio transformers have a lower turn ratio with more turns on the primary, ma-

terially larger cores and are both sealed and shielded. This protects them from the atmosphere and also protects the circuit from stray magnetic field. These improvements result in uniform amplification.

Audio Frequency Transformers (concluded)

Name and Address of Manufacturer	Trade Name and Model Number	List Price	Turn Ratio	Plate Current Limit in Milliamps.	Dimensions in Inches	Weight in	Terminals Located at Top or Bottom	Incased in Shield
					H. W. L.	Lb. Oz.		
Morton Radio Co. R. I. Box 48, Stockton, Cal.		5.00	4.00 to 1	20	2x2½x2½	0-14	Side	Coil shielded in Al. case
Muter Co., Leslie 76th and Greenwood Ave., Chicago, Ill.	Muter No. 1500	2.25	3.00 to 1	10	2½x2½x2½	0-12	Side for connection from top or bottom Side	Yes
	Muter No. 1550	2.50	5.00 to 1	10	2½x2½x2½	0-14		Yes
Pacent Electric Co. 91 7th Ave., New York	26-A (mounted)	3.50	3.5 to 1	10	2½x1½x2½	0-12	Side	No
	26 (mounted)	5.00	3.5 to 1	10	2½x1½x2½	0-12	Bottom	Yes
	27-B (unmounted)	6.00	3.00 to 1	35	4x2½x3½	2-5	Bottom	No
	27-A (unmounted)	6.00	3.00 to 1	5	4x2½x3½	2-5	Bottom	No
	27-A (mounted)	7.50	3.00 to 1	5	4x2½x3½	2-5	Bottom	Yes
	27-B (mounted)	7.50	3.00 to 1	35	4x2½x3½	2-5	Bottom	Yes
Peerless Radio Corp. Newton Lower Falls, Mass.	Peerless F	1.00	3.5 to 1	20	3½x1½x2½	0-10	Top	Yes
	Peerless E	1.00	5.00 to 1	20	3½x1½x2½	0-10	Top	Yes
	Peerless D	2.00	4.25 to 1	20	3½x1½x2½	0-11	Top	Yes
	Twin-Aud	3.75	4.5 to 1	20	3½x2½x6½	2-4	Top	Yes
Premier Electric Co. Grace & Ravenswood Ave., Chicago, Ill.	Hegehog No. 103	3.50	3.00 to 1	80	1½x1½x2½	0-5½	Side	Completely shielded with its own core
	Hegehog No. 104	3.50	4.00 to 1	80	1½x1½x2½	0-5½	Side	
	Hegehog No. 105	3.50	5.00 to 1	80	1½x1½x2½	0-5½	Side	
Robertson-Davis Co., Inc. 412-420 Orleans St., Chicago, Ill.	Meloformer (Multistage*)	4.00	4.00 to 1	100	2½x2x1½	0-10	Top	Yes ½ in. iron
	Meloformer (Factory type)	4.00	4.00 to 1	100	1½x1½	0-8	Either	Yes, ½ in. iron
Sampter Radio Corp. Brooklyn, N. Y.	Selectran Model 501	5.00	5.00 to 1	93	3x2x2½	1-0	Top	Yes
	Selectran Model 301	5.00	3.5 to 1	57	3x2x2½	1-0	Top	Yes
Samson Electric Co. Canton, Mass.	Samson (6-1)	5.00	6.00 to 1	25	3½x2½x2½	2-0	Bottom	Yes
	Samson (3-1)	5.00	3.00 to 1	25	3½x2½x2½	2-0	Bottom	Yes
	Samson (2-1)	5.00	2.00 to 1	25	3½x2½x2½	2-0	Bottom	Yes and hermetically sealed
	Samson Symphonic	9.00		25	3½x2½x2½	2-0	Bottom	Yes
Splitdorf Electrical Co. Newark, N. J.	Splitdorf R-15	5.00	3.5 to 1	50	2½x1½x3 ⅞	0-12	Top	Semi-shielded
	Splitdorf R-30	5.00	5.00 to 1	50	2½x1½x3 ⅞	0-12	Top	
Sterling Mfg., Co. 2831-53 Prospect Ave., Cleveland, O.	R-356	6.00	4.00 to 1	10	2½x1½x2½	0-12	Bottom	Yes
Thordarson Elec. Mfg., Co. 500 W. Huron St., Chicago, Ill.	Thordarson R-150	4.00	3.5 to 1	10	2x1½x2½	1-0	Top	Yes
	Thordarson R-180	4.00	3.5 to 1	10	2x1½x2½	1-0	Bottom	Yes
	Thordarson R-151	4.50	6.00 to 1	10	2x1½x2½	1-0	Top	Yes
	Thordarson R-181	4.50	6.00 to 1	10	2x1½x2½	1-0	Bottom	Yes
	Thordarson R-152	5.00	2.00 to 1	10	2x1½x2½	1-0	Top	Yes
	Thordarson R-182	5.00	2.00 to 1	10	2x1½x2½	1-0	Bottom	Yes
	Autoformer R-190	5.00		10	3x2½x2½	2-4	Sides	Yes
	Thordarson R-200	8.00	2.00 to 1	10	3x2½x2½	2-4	Sides	Yes

\* Push-Pull type.

Here Is a Radio Dealer Who Knows His Costs

Hats off to Gordon L. Hayes, Troy, N. Y. Mr. Hayes keeps an accurate record of his sales and service costs.

For the year 1925 his advertising expenses and sales commissions cost him 9 per cent of his total gross sales. He spent one per cent for delivery and 4½ per cent for servicing. What are your servicing costs? Is Hayes servicing costing him too much or is he well within the limit of the average servicing expense? Radio is yet young. No precedents have been established, no standards of proportionate expenses set up to guide this newest retail trade.

You can help Radio Retailing in its efforts to determine the true yardsticks of value, and this will benefit the entire industry, if you will mail the edi-

tors your figures on what it cost you to do business in 1925 or during any fixed period.

\$25 Down and No Trial Demonstrations

There is a music house in Lincoln, Neb., that has set up a very rigid code of sales conditions and is successfully enforcing it.

"Early last season," declares G. A. Crancer, head of the G. A. Crancer

company, "I decided that if I couldn't sell radio on my terms I wouldn't sell it at all. Those terms were, and still are, as follows: Twenty-five dollars down and no free demonstrations. The last clause in my sales contract reads, however, like this—'Purchaser's money will be refunded, less installation cost, within 48 hours if set does not meet with the full approval of the customer.' Now the theory back of this," continued Mr. Crancer, "is that anyone who really

wants to buy a set will consider my terms more than reasonable. My house stands back of every set sold and my salesmen are intelligent enough to sell radio on these terms.

"Yes, no doubt I have missed a few sales—not more than five per cent—but I have more than made up this apparent loss by the clean profit I receive."

Tying Up With the Nation's Birthday

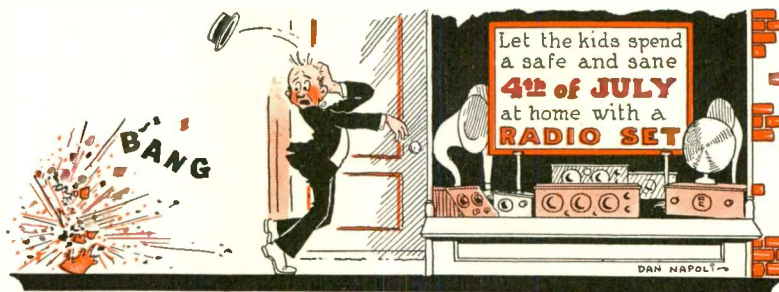

A window display along these lines will remind the public about the fine patriotic programs that are always broadcast on Independence Day

**SELECTING THE RADIO**—Selecting a radio set has become a difficult art. One no longer walks into a radio store and says, "One radio set, please. Something weighing about twenty-four pounds will do." There are more types of radio today than there are automobiles, and great caution is essential.

The first thing to do is to go to a radio salesroom. This can be done by walking about eighteen feet in any direction and turning into the nearest doorway. A few years ago a customer would be met by a mechanic welding a wicked pair of pliers and talking in kilocycles. The radio store then had the general atmosphere of a combination five-and-ten-cent store, opera house and plumbing shop.

Today these radio stores have been very largely replaced by showrooms and studios. They have Chinese rugs on the floors and tapestries on the walls. But do not become confused. Remember that the radio is now passing through the furniture period.

You say softly, "I wish to see something in a radio set."

"Period?" the salesman will ask.

"Period," you reply. "New paragraph."

"How about something in a Napoleonic sideboard?" the salesman inquires.

"Is the radio set itself any better in a Napoleonic sideboard?" you ask.

"True, you can get the same set in a cheaper case, but think what a cabinet like this means in your home!"

Custom requires that you listen attentively to this gentleman and sign on the dotted line, \$50 down and \$2 a week for six years. The next thing to do is to phone the wife that you are sending up a huge piece of furniture and that she'd better throw out the piano, bookcase and three chairs to make room for it.

**Setting Up the Set**—The wife will wish to try the ark in various parts of the room. At each exclamation of "No, not there!" the service man should rise and begin pushing it

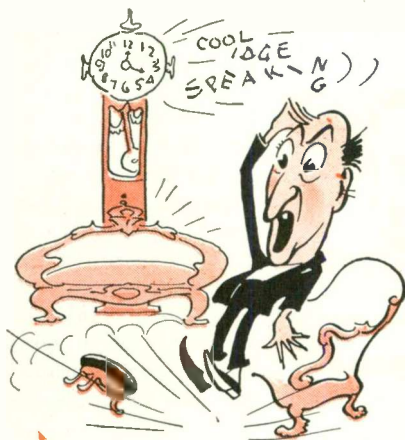

"When the President talks, stand up!"

H. I. Phillips in "Collier's Weekly,"  
Pokes Fun at

## Our Infant Industry

"The Book of Radio Etiquette" tells how to act at a radio party and how a good demonstration ought to be made. Like to laugh? Read this—

around some more, keeping to the lady's left. This sort of thing is very apt to go on for many hours and, to relieve the monotony, the well-bred service man will occasionally suggest an interval of charades, parlor games or amusing anecdotes.

After it has been placed to the lady's satisfaction the service man should bow and offer to get her WEAFF. He will then make the horrifying discovery that it is not a radio set at all, but

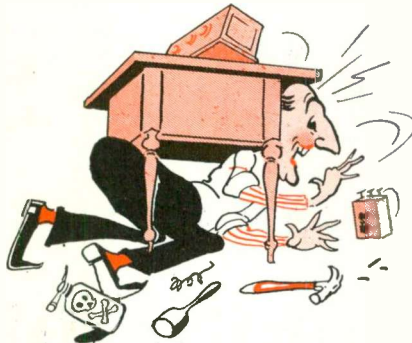

Looking for the poles—negative and positive.

an imported ice-box intended for the Smiths who live next door.

**Making the Demonstrations**—When the prospect and his family are assembling and before the dial twisting begins, the salesman should promote light conversation by darting in and out of the room, dropping loose threads of radio thought here and there, and letting the guests do what they will with them. A radio audience is very susceptible to any opinions expressed on the mechanical side of radio problems.

Talk of ohms is always appropriate—in fact, it is a good idea to ask the guests to sing that old favorite "Ohm, Sweet Ohm" occasionally if the party drags.

**Applause**—Radio applause is accomplished by means of "applause cards," something on the order of the following:

"Your radio programs have made a new man of me. Life at last is sweet. And so is your old man.

Very sincerely,

**Salutes Due Noted Radio Speakers**—When the President of the United States, the Vice-President of the United States, a Member of the United States Senate, (Representatives excepted) or a King or Queen of a Foreign Country enters a room via the loud-speaker the audience should stand, unless already standing, in which case it should sit down.

**Interpreting Returns from a Boxing Bout**—Only people who have been raised on radio know how to tell how a fight is going by what comes out of the set. It is the orthodox custom for the announcer to give a summary of each round as it concludes, telling the radio fans who won it. For example, he will say: "Well, folks, Delaney

had that round hands down. . . . Delaney is putting up a wonderful fight. . . . Berlenbach doesn't seem to be able to lay a finger on him. . . . there's nothing to it but Delaney, folks." If he says something like this after every one of the fifteen rounds, adding just before the decision, "It's been Delaney all the way. . . . I guess he's the new champion, folks," all radio fans should take it for granted that the decision will go to the other fellow.

Radio returns from baseball games are difficult to follow, and the announcer should not be taken literally. If, for instance, he says, "Meusel, I mean Ward, or rather Babe Ruth, just slashed out a two-bagger. . . . no, it was a three-base hit. . . . wait a minute. . . . he got a base hit on that," the best thing to do is to assume that none of the three players mentioned participated in the play and that somebody got a home run.

**Charging the Battery**—In every radio home much embarrassment is caused by failure to charge the storage battery. This failure is often due to a failure to pass the responsibility for the charging upon some one member of the household. Good form requires that the male head of the family assume this duty of crawling under the table on his hands and knees and feeling around in the dark for the positive and negative poles. This job should not be left to the wife, the baby, the son who is away at college or the ice-man.

Then comes the problem of remembering when the battery should be charged. The practical thing to do is to set, say every Tuesday evening at bedtime for connecting the charger with the battery, and give some neighborhood youth a quarter to throw a rock through the living-room window every Tuesday evening to remind you that it is Tuesday evening.

Reprinted through the courtesy of Collier's Weekly.

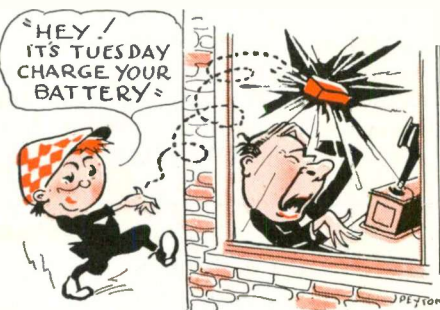

A gentle reminder that it's time to charge the battery



## Keep Your Store in the

# Spotlight

**T**HIS is the age of advertising. Not necessarily paid advertising, or newspaper advertising, or billboard advertising, but advertising that keeps men and affairs—and their products and personalities—constantly before the public eye. It's the era of publicity. The more publicity the better and the more you get the more prominent you become. The man or company that pulls the greatest number of attention-getting publicity stunts is the one that wins out in the long run.

The South Carolina Radio Shop, Charleston, S. C., is one of the best known radio stores in the Carolinas and probably in the whole of Dixie. It is, at least, one of the oldest, having been established when radio first got started back in 1920. In fact, the South Carolina Radio Shop's first publicity stunt, according to R. B. Aldrich, manager and one of the owners since its inception—his partner is J. B. Day—took place on the occasion of the first official program from KDKA, Pittsburgh, on

Election Night in November, 1920.

This stunt consisted of broadcasting the program on the sidewalk in front of the store by means of a homemade receiver. And this, crude as it was, constituted the most novel and thrilling experience that many in the audience had ever had!

Newspapers next day heralded the "voices from nowhere" as the greatest feat of the age and the South Carolina Radio Shop was put on Charleston's map firmly and decisively. Aldrich has considered it more or less of a personal duty, therefore, to see that the shop has been kept on the map ever since.

The latest stunt that brought the store sharply to the attention of the public was an essay contest for which the prize was a complete radio receiving set. Large newspaper ads

were taken in the daily papers and their editorial support was easy to secure. One of the first ads making the announcement of the contest is reproduced with this article and the rules were very simple:

First, a picture of a radio set was cut up and published in the newspaper ads in the form of a puzzle. The contestants' first duty was to cut out the individual pieces of the set puzzle and paste them together in the proper form.

Second, the contestants were required to write an essay not exceeding 150 words on the subject, "What Service After Sale Means to the Purchaser of a Radio Set."

Third, points were awarded on the following basis: Artistic value, 1; Accuracy, 1; Neatness, 1; General merit, 1. The artistic value lay in the arrangement of the finished set puzzle with the written essay.

Fourth, entries were to be addressed to the "Radio Contest Editor," of the Charleston *Evening Post*, rather than to the store itself, to give it less of a commercial aspect.

Fifth, the winner was to be announced at the store on the occasion of its formal opening in a new location a few weeks later.

That is the sort of newspaper advertising and publicity that means

---

Publicity stunts have made the South Carolina Radio Shop one of the best-known stores in the Carolinas—How it was done is worthy of attention

something. Its results were three-fold. It advertised the particular set, a picture of which was used as the puzzle; it advertised the change in address and the formal opening of a new store, and it concentrated the interest of a great many people on the South Carolina Radio Shop.

The winning essay is really a very clever grouping of the various elements and shows not only that a good deal of interest must have been aroused in the contest, but that a good deal of time and thought were devoted to their answers by the contestants. The winner was a housewife living in the suburbs of Charleston, who had never owned a radio set, yet her article on "What Service After the Sale Means" covered practically every point the average prospect wants to know about radio sales and service.

The winner prepared her answer in the form of a booklet, with a paper cover and containing six or eight pages. It was spotlessly neat and she was evidently somewhat of an artist as well, as the pages were appropriately decorated and bordered with pen and ink sketches. Also, what was considered an excellent idea, was the fact that the winner had correctly pasted the set together, pasted it down on a page of the booklet and drawn around it a pen and ink picture of her living room as it would look with the set in it.

Another publicity stunt, in which a smaller set was given away as prize was a recent search for a suitable slogan. The store's original slogan, "We Know We Know Radio," was considered a trifle threadbare after several years' usage and the store put it up to the people of Charleston to supply them with a new one. A high school youth won the set with the slogan, "To Serve and Satisfy—That's Us," which the store now uses.

The company's history seems to be replete with stunts to keep it continually in the limelight. After it was proven that radio had come to stay, public demonstrations were made at every opportunity, in schools, at club meetings, on the street and wherever and whenever possible, which probably accounts

### Some of Aldrich's Attention-Getters

1. Essay contests in co-operation with local newspapers.
2. Tie-ups with local theaters on feature motion pictures.
3. A contest for a good slogan.
4. Public demonstrations in schools, at clubs and similar places.
5. Folders distributed in autos parked on the main thoroughfares.
6. Booth and drawing for a set at the annual County Fair.
7. Pastors on every set, giving name and address of shop.
8. Direct-mail circulars to a list gleaned from the telephone book.

for the fact that Charleston seems to be far ahead of other Southern cities in radio interest and selling activities.

The South Carolina Radio Shop also operated the first broadcasting station in that section, now inoperative because of better and more powerful stations supplying the need for broadcasting. This station admirably served its purpose for two years—to get Charleston started on radio—and was known as WFAZ, 360 meters and 20 watts. "Rest in Peace," as Mr. Aldrich sadly narrates.

Another recent publicity stunt—and Aldrich could probably go on

telling about his publicity stunts for hours at a time—was a tie-up with a local theater during the presentation of the motion picture, "The Royle Girl."

The idea was that "The Royle Girl" was to arrive in Charleston on the first day of the showing of the picture and be greeted at the station by a committee of local business men. She would arrive in rags and proceed from shop to shop purchasing a complete outfit. By subscribing to a share of the advertising, Aldrich made it possible for "The Royle Girl" to "buy" her radio receiver at the South Carolina Radio Shop. Of course, due to the publicity

the stunt received, a large crowd was on hand at the railroad station to greet the girl and it grew by leaps and bounds as she went from shop to shop. By the time she arrived at the radio shop, the crowd had filled up the entire street and stopped traffic for a block. Does Charleston know there is such a place as the South Carolina Radio Shop? Aldrich don't mean maybe!

All these publicity-getting ideas are ones that any radio dealer can put across with as much success as Aldrich does, but there is one that only Aldrich and Fate could combine to accomplish. To prove that Destiny herself can be educated to lend a hand at the proper moment, let's proceed to the opening night of Aldrich's new store—last January 30th. By plugging constantly for six

Continued on Page 591

**WIN A \$115.00  
RADIO SET**

By Correctly Assembling These Pieces and Arranging Them in an Artistic Manner, and Writing an Essay of Not Over 150 Words, You Have an Opportunity to Win a 3-tube Crosley Super-Trirdyn Special Reflex to 5 Tubes Radio Set, complete and installed. This is a coast to coast \$115.00 set.

These Pieces When Properly Arranged Form a Picture of the 3-Tube Crosley Super-Trirdyn Special Radio Set.



**RULES OF THE CONTEST**

Submit your solution along with an essay of not more than 150 words on the subject "What Service After Sale Means to Purchaser of Radio" to "Radio Contest Editor," care Evening Post. The judges, in determining the winner, will consider artistic work, accuracy and neatness and general merit of essay. See that solution to puzzle is attached to essay and that your name and address is clearly written on both. Solutions must be in the office of The Evening Post not later than 12 o'clock, Saturday morning, January 30th. Winner will be announced Saturday at 8 p. m. at our store 379 King St.

<p style="text-align: center;"><b>THE WINNER</b></p> <p style="text-align: center;"><small>Will Be Announced Saturday, Jan. 30th, 8 P. M. at the</small></p> <p style="text-align: center;"><b>Formal Opening</b></p> <p style="text-align: center;"><small>of Our New Store, 379 KING STREET Between Banow &amp; Volney and Ball Street</small></p>	<p style="text-align: center;"><b>A Radio Set You'll Be Proud to Own!</b></p> <p style="text-align: center;"><small>This 3-tube Crosley Super-Trirdyn Special Radio Set includes antenna, tubes, batteries, storage battery and loud speaker. Performance of this set has been proven by the piece</small></p> <p style="text-align: center;"><small>Warner Stewart-Warner Speedometers, Bumpers and Other Automobile Accessories</small></p>
--	---

**SOUTH CAROLINA RADIO SHOP**

379 KING ST. "To Serve and Satisfy—That's Us" R. B. ALDRICH, Mgr. PHONE 4953

*The opening gun in an essay contest conducted by the South Carolina Radio Shop was this newspaper advertisement*

# START YOUR FALL

## Hints for summer selling



Sell **RADIOLA 26**—portable super-heterodyne, for indoors and outdoors.



**RADIOLA 20**—particularly suited for out-of-town homes. A distance getter.



Sell **RADIOLA III** to every boy who hikes or camps. Sell the balanced amplifier to those who previously bought Radiola III's.

SEE that all your customers have spare Radiotrons—that all the tubes in their sets are genuine RCA Radiotrons. This, too, will improve summer reception . . . and give you some extra Radiotron sales.

**LOUDSPEAKERS** offer an interesting summer selling idea. Follow up purchasers of speakers now obsolete, and sell them better reception with the new RCA Cone Loudspeakers.

**THE Duo-Rectron** can be sold any season of the year. Right now it sells well because it insures a peppy set always ready to be tuned in.

**AND** don't forget the portables. Radiola 26. And the little Radiola III that belongs in every scout camp. Big business possibilities there, that you can't equal at any other season.



**RCA LOUDSPEAKER MODEL 104**—its power performance and its elimination of batteries give a new impetus to ready sales.



**RADIOLA 28**—an eight-tube super-heterodyne for fine city and country homes.

# RCA Radiola

MADE BY THE MAKERS OF RADIOTRONS



# SELLING NOW!

EVERY RCA dealer knows today that he will have the same models to sell in the fall. Pass on this information to your customers, and you can sell *now* the sets that prospects might wait to buy in the fall. Sell *now* with the added argument of a whole summer's pleasure.

RCA can promise good programs all summer, from coast to coast. And with the new RCA line, reception as well as broadcasting is far ahead of any previous summer.

Good reception. Good broadcasting. And the assurance that the present models will not be superseded in the fall. These will help the RCA Authorized Dealer to big sales now! And RCA advertising will carry on, straight through the summer.

RADIO CORPORATION OF AMERICA  
 New York Chicago San Francisco



RADIOLA 25—a six-tube super-heterodyne for all year selling.



RADIOLA 30—no antenna, no batteries. Power for volume. And clarity. And a quality of reproduction that means sales in all seasons.

# RCA Radiola

MADE BY THE MAKERS OF RADIOTRONS

# What This Industry Needs

## Believes May is Best Time for New Models

BY HAROLD J. WRAPE  
Benwood-Linze Company,  
St. Louis, Mo.

**I**N YOUR April issue you ask for opinions of the dealers, jobbers, and manufacturers of radio apparatus and supplies as to what time they think is best to bring out new models and new apparatus.

While five or six years ago the greatest volume of our business was conducted in April and May, for the last few years the season has been shortening and for the last two years we find that our greatest volume of business now conducted on a wholesale basis is in November. Last year our volume of sales in August was quite satisfactory.

The manufacturers that we represent in this territory have told us that they will announce their models and sales plans in June which is about a month earlier than they did last year. We think this is a mighty good plan and are suggesting for next year that they announce their new models even a month earlier. We believe operating under their plan of this year that our July business will be much better than last season and if their announcement is advanced to May next year it will represent about the ideal conditions.

We have enjoyed and profited by the articles you are publishing in *Radio Retailing* and want to commend you on your good work which we hope will continue, and are sure will do much good to the industry.

## Voicing a Few "Dealer Complaints"

BY PAUL STANTON  
Vermillion, Kansas

I am taking a little time to air to you a few of my opinions on radio and radio dealers and manufacturers.

I am strong for making May or June the month to announce new models and new prices as this would let us dealers have something new to push during the slow months and I also think the manufacturers should notify all their jobbers and dealers at least a month in advance of any change in price or model so we would have a chance to clean up any of the old models or reduce stock if we wished to do so before the new models came out.

I am very strong for truth in advertisements and all literature. It's mostly the fault of the manufacturers that people look for something radical in improvement "this next fall" for some of these manufacturers will come out with the statement that "their engi-

*Dealers and manufacturers alike state that less frequent new models will solve many of the industry's ills.*

neers" have discovered some entirely new principle in a radio circuit when anyone who will use common sense knows that there are only certain ways a radio circuit can work just as there are only certain ways for a gasoline engine to work. Before there can be the "radical changes" some manufacturers claim they have in their sets, there will have to be a complete change in radio transmission and reception.

I don't know just what could be done to cure this evil but some manufacturers' association might try to enlighten the public by the way of ads and literature and tell them that there isn't any possible chance for radical changes. Show them that there isn't any more chance for changes than in automobiles. This would help to make year-round sales and would not lessen the winter sales either.

Something of this kind should be done, I think. The association could charge every dealer, jobber and manufacturer a small sum to be used for this publicity.

Another thing I don't like is for wholesale prices to be sent to every Tom, Dick and Harry. I can't buy dry goods and hardware just because I sell radio, so why should these other stores be allowed to buy their radio sets and supplies for private use or for friends? Discounts are even sent to private parties who have no more right to them than I have a right to buy a car at the factory.

I think a person should place an initial order for at least \$1,000 before he is entitled to the discount and to be called a radio dealer. There's no use trying to fool ourselves for the radio business in general has got a cleaning coming, and the sooner the better for all from manufacturer to consumer.

I want to thank you for the good you are doing with your magazine.

## Should Announce New Models in Spring

BY POWEL CROSLY, JR.  
Crosley Radio Corporation,  
Cincinnati, O.

I thoroughly agree with you that the announcement of new models should be made in May or June in order to give as good a selling season as possible, and enable the dealers to get their samples earlier so that the selling efforts can accumulate through the entire period.

There is nothing I believe, however, which will prevent manufacturers from

announcing new things as they are discovered and developed, regardless of season, although I hope to see the day come when it will be unnecessary to announce new models—when the design of radio becomes so stable that improvements can be made from time to time without complete model changes.

## Is "Splendid Idea"

BY C. D. BOYD  
Reichmann Company  
Chicago, Ill.

With reference to having representative set makers announce all new models at one time during the year, this is indeed a splendid idea, if you are able to put it over, and we think that either the month of May or June is the time to make the announcement, and we for one manufacturer will be ready with our line for announcement at that time. This enables both jobber and dealer to make their plans with reference to catalogs which are edited usually at this time of the year, and to have their merchandising plans well organized for the early fall.

## "Heartily Endorses" Less Frequent New Models

BY HUBERT MOHR  
Glenn L. Martin Company,  
Cleveland, O.

We heartily endorse the plan of new models in radio being announced at one particular time in the year. The ideal condition would perhaps be no yearly models, but at the present rate of rapid development of the art, this one, of course, out of the question. Therefore, as long as it is essential to change designs and models, it should be done at a time when the least confusion results. This would seem to indicate May or June, preferably the latter month. Jobbers and distributors would be able to incorporate all the new products in their catalogs. Salesmen could become familiar with the new items, while manufacturers would have sufficient time to complete their production, sales, and distribution plans before the heavy fall buying season.

There is no question that such a plan if put into general effect would very materially tend to stabilize the industry. Everybody would benefit. The manufacturer could plan his production schedule with more confidence; the job-

ber and dealer would be in a position to get behind his lines with an assurance otherwise lacking; and the consumer will be insured against early obsolescence of his purchase.

## "Is Only Basis for Success in Radio"

BY A. L. NORRIS  
Charlotte Furniture Co.,  
Charlotte, Mich.

New models once a year we believe is the only basis on which the radio business can be made a success, for if the radio manufacturers get into the habit of having four new models of consoles a year, the way the furniture manufacturers are doing with their furniture, it will seriously hamper production and increase the cost to the ultimate consumer.

We urge that it is quite important that the radio manufacturers get together with the cabinet manufacturers as early as February or March to develop their new cabinets for the next season, as it takes some time to get out samples and more time to make large cuttings and get stock on hand to take care of the fall rush.

It is our experience so far that most of the radio manufacturers are not acquainted with designs that mean sales to the better type of customers and think only of price in connection with their purchasing of radio cabinets. We believe that the time is coming when designs and sales appeal of the cabinet itself will be a controlling factor in the success of radio manufacturers who expect to make money.

## Stop New Models in Height of Season

BY A. B. IDESON  
Cleartone Radio Co.,  
Cincinnati, O.

Announcing new models at one time during the year, say in May or June, would be an excellent idea but some manufacturers are making a practice of announcing new models right in the height of the season and we do not see how it is going to be possible for anyone to keep manufacturers from doing just what they like in the matter. We ourselves always make our announcements of our new models in the late spring. If manufacturers would follow this practice of announcing sets at approximately the same time of the year just as the automobile manufacturers do it would be an excellent thing as the poorer months would permit the dealers to buy their samples and establish their connections for the coming season and it would give the manufacturers some idea as to what to expect from their dealer and distributor following.

As it is now, the manufacturers announce their sets before they are actually in production. This is very harm-



*Let's get this industry stabilized—Don't break up the dealer's sales campaigns by giving him new models every month from one manufacturer or another*

ful to the radio industry as people are continually waiting to see what "such and such" a new set is and when it comes out it usually is nothing extraordinary but simply some mechanical improvements on an old style or an ordinary type of set such as can be found on the market in quantities.

## Make More Thorough Market Surveys

BY M. F. BACON  
Anylite Electric Co.,  
Fort Wayne, Ind.

Manufacturers must make more scientific market surveys. Until they do so there will be overproduction, bombastic advertising and dumping.

Wholesale and retail channels must be cleared. Just as there are too many manufacturers, so there are too many self-styled jobbers and dealers of little or no business or financial responsibility. These undesirables must be eliminated, and the best way to do it is for the sales department and credit department of every responsible manufacturer and jobber to get together and do some creditably scientific pruning.

This will, in my humble opinion, clear up more evils than bringing out models at a set time. Coupled with the elimination of announcing new models long before they are ready for the market, it should go a long way toward clearing up the radio situation.

## "Would Be a Great Step Forward"

BY GEO. L. RISHELL  
Sylvania Products Company,  
Emporium, Pa.

We believe that the bringing out of new models of radio sets once a year only during the months of May or June, as proposed by you would be a very important and definite step forward in the stabilization of the radio industry.

This, of course, should also be expected to stimulate business during the summer months, when such stimulation is very much needed, particularly from the standpoint of the manufacturer, who, under present conditions, is forced to slow down his production during the corresponding period or to build larger stock than he is warranted in carrying.

## What Industry Needs Is Better Sets

BY J. C. TULLY  
Bremer-Tully Co.,  
Chicago, Ill.

I do not believe that new models once a year will solve the situation for the reason that what the industry needs is not so much periodic new models as it is radio sets of sufficient merit to continue in use for a reasonable length of time.

When a manufacturer is able to produce and offer such a model he should

be entitled to place it on the market, and his jobbers and dealers should have the assurance that it will stand up and produce for a long time to come.

The manufacturer's business will not be stabilized regardless of the time the model is offered for sale, unless it possesses merit. The dealer and jobber may compare the lines offered as you say, but on the average I question whether they can be right in their judgment that the line they have chosen will be one which will hold up through the continuing twelve months.

It would appear to me that most manufacturers having a successful model would continue with it to their advantage, but if their product was not successful and did not sell or stay sold, neither the jobber or the dealer would profit by its continuance.

There is no question about the desirability of bringing out new models less frequently, and at a stated time of the year, but my point is that this is only a minor factor and will not have any bearing on the improvement of the situation unless the real faults are corrected.

## The Parts Jobber Should Not Be Eliminated

BY H. B. RICHMOND  
General Radio Co.,  
Cambridge, Mass.

**I**N all lines of merchandise there are just two fundamental figures which represent supply and demand—the producer and the consumer. Where the consumer can watch the producer at his work and when he has a need for the product there is no need of intermediary service. Starting with this economic truth let us see when additional service is required.

The manufacture of radio parts is a production proposition. The worker and the consumer are unknown to each other. Before a sale can be made, contact from worker to consumer must be established. It is in the making of this contact that a distribution organization is required.

If a manufacturing plant is large enough and makes a great enough variety of products it can establish its own stores in every community. No radio manufacturer as yet even approximated this condition. The dealer then becomes an added necessity, he assembles the products of several manufacturers in his store and thereby cuts down the individual manufacturer's selling cost and also gives the consumer better service.

Thus we have the manufacturer, the dealer, and the consumer. But how are they to get acquainted? Remember that the producer and consumer are the only really economically interested persons. The manufacturer must then acquaint the consumer with the fact that he has a product available. He must further acquaint the consumer with the details of his product so that the latter may know that the article is just the one he desires. He can even go farther and excite in the consumer a desire for the product. It is squarely up to the manufacturer to do his own advertising.

Should the dealer advertise? Of course! His advertising, like that of the manufacturer, is directed to the consumer. It is his mission to tell the consumer that he carries the product being advertised by the manufacturer. This advertising is, of course, of a local nature.

Where does the dealer get his merchandise? He may buy it direct from the manufacturer, but unless he has more time and capital than the average dealer has available this method falls down hopelessly. In radio parts this is particularly true! There are in the order of two hundred items to be carried. The turnover is rapid but variable. It is hazardous for the dealer to carry large stocks of all items, while on the other hand when he is out of an item he loses not only a sale but good will. He needs some place close at hand to which he can turn and obtain additional stock at an hour's notice. He also usually needs the helpful reminder of a salesman, in whom he has confidence, coming around once a week to check up his stock. A credit man to watch his progress is just as helpful to the dealer as to the organization employing him.

Here again the manufacturer can have his own warehouse organization and local salesmen, but it does not take long to show that in radio parts this would be too expensive to even consider. Several manufacturers must unite in some co-operative proposition, the practical solution of which is the *jobber*.

It is the function of the jobber to carry sufficient merchandise to enable him to supply the dealer requirements in his territory, to assist the dealer by means of frequent calls in keeping his stock in balance, and to supervise the dealer's financial progress through the proper assistance in credit matters.

### Why the Jobber Advertises

The jobber directs his advertising to the dealer to tell him that he has a conveniently located warehouse containing the manufacturer's product. He may also create additional confidence in a particular article by featuring it in his advertising. But it is *not* the jobber's function to *sell* merchandise.

The highest type of jobber's salesman is the one who secures his orders on a service rendered basis rather than on sporadic high-pressure sales methods. It is this service type of salesman that the jobber requires.

Let us now look back and see just what each group between worker and consumer must do.

The *manufacturer* must produce, warehouse, service and advertise. He must have field men to watch selling conditions and to step behind a dealer's counter to tell him the sales points of the product so that the customer may be sold intelligently.

The *jobber* must carry such local stocks as are required to care for the dealer requirements of his community. He does not warehouse reserve stocks; that is the manufacturer's duty. The jobber's stocks should turn over rapidly, slow moving items going back promptly to the manufacturer. He must call on the dealer frequently,

checking his stock and replenishing it as required. He must keep the dealer acquainted with additions to the line, and price or important specification changes. The jobber must watch the dealer's financial position, taking care not to overload him with merchandise or by doing him the harmful favor of extending credit beyond the dealer's ability to utilize it at a profit.

The *dealer* must carry a stock sufficient to give his customers immediate service. He must know his merchandise sufficiently to give intelligent service, but if he sets himself up as an oracle he is headed for trouble. He must tell his community that he has the manufacturer's product on his shelves.

How is all this working out in practice? Just as any sound economic problem must work out. The jobber at first did not know enough about radio parts to be interested in them. When he found their possibilities he loaded up recklessly, forgetting, in many cases, his previous experience in kindred lines. Only too soon he found his shelves loaded with orphans whose manufacturers thought that by giving the jobber a longer discount it would enable him to sell his products.

### Jobber Now Stocks Quality Parts

In many cases the jobber, with an impetuosity equal only to the speed with which he took on lines, cleared his shelves of all parts. Today he is experiencing a change of heart and is again stocking radio parts. But this time discount is not his only objective. To be sure his discount must be such as to enable him to make a real profit, but he is picking the products of manufacturers who realize the economic function of a jobber, who themselves do the selling, and in whose product the consumer has shown confidence.

Manufacturers too are watching their jobbers. They expect their jobbers to be on the *job* and to those that are, restricted territories are being given. A new confidence from manufacturer to consumer is being shown, and it is confidence, and not distrust, that brings satisfaction with all it implies to *manufacturer, jobber dealer, and consumer*.

## "A Word or Two of Praise"

BY J. L. DONIGAN  
Radio Service League,  
Binghamton, N. Y.

It is surprising to note the number of high type dealers here who are totally closing out on radio. They give "too much service" as their explanation and further that the manufacturer is not of a protective nature toward dealers with good business intentions. I feel confident that manufacturers will realize this overmuch during the year 1926.

All power to you on your efforts toward extermination of the season idea in radio. Your word pictures are as clear and stirring as a bugle call and it is too bad they cannot be shown on twenty-four sheet posters for the effect they might have on many dealers without vision.

# Picturing Radio's Universal Usages



## Celebrating May Day

Radio played no small part in this May Day celebration in a park out in Omaha, Neb. The McGraw Company, radio distributors, provided the music via several sets.

## Radio Dispatches Trains

Right: Radio does the work of 261 men on the Illinois Central Railroad. Recently installed microphones and speakers in train dispatchers' offices facilitate switching operations in yards.



## Replacing the Band in a Parade

Here's a master stroke of publicity put over by the Findley Electric Company, Minneapolis, Minn. The company loaned a receiver to a local Boy Scout troop for a street parade, using the apparatus to supply the music for marching. (Below.)

## Providing News During the British Strike

During the recent labor tie-up in Great Britain which prevented the publication of newspapers, an enterprising radio dealer mounted a speaker and set on his car and relayed the news broadcast from London. (Above.)

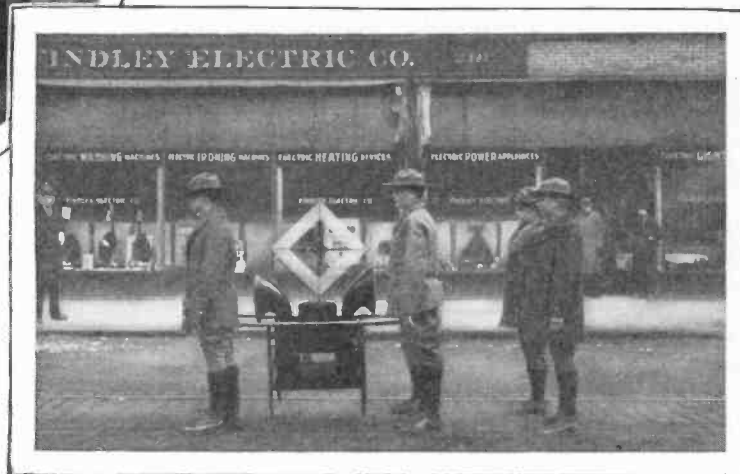

## *How Radio Legislation Stands Today*

**N**O place on the Washington legislative program has been assigned to radio as *Radio Retailing* goes to press. Senator Dill, who is in charge of the radio bill, is prepared to fight for an opportunity to consider the legislation if the leaders will not accede to his request for time.

Even if the bill is brought before the Senate it is very doubtful if it can be brought to a vote. The White bill has many friends in the Senate, although some of them believe it is better to get the Dill bill on the statute books than to have no legislation at all. They point out that the law can be amended at any time that the votes can be secured. In fact, some think it will be easier to amend the law than to amend the bill, as the weak spots in the Dill measure soon will become more glaring when an attempt is made to put those provisions into effect.

## *President May Not Veto Dill Bill*

**A**T the White House it was stated that there is no justification for the publication of the statement that the President will veto the Dill bill if it should pass. It is certain that many of the features of the White bill would have to be embodied in the Dill bill before the White House will accept the conference report. For that reason the President apparently will await the final form of the legislation before making up his mind as to the action he will take.

Before the bill can pass it will be necessary for the Senate to vote down a series of amendments which have been prepared by the so-called radical group of Senators. They want all stations put on a public utility basis and would take away from the management various rights in connection with the control of who may speak and what may be said.

## *"The Public Be Damned!"*

**T**HIS well-known expression seems to reflect the attitude of the Senate in considering radio legislation. The issue is out of the hands of those who have the best interests of radio at heart. It is now a question of politics—a question as to which of the rival factions within the Senate—the progressives or the reactionaries in both parties—will eventually get control of broadcasting licenses.

The Senate Committee, to take advantage of public sentiment in favor of the White Bill, has taken the main provisions of the Dill Bill, creating a wholly independent commission, and called it the White Bill, H. R. 9971, changing completely the main provisions of the White Bill, as passed by the House of Representatives.

This publication has always believed and still believes the radio trade and public will derive the most benefit from continued control of wavelengths by a commission under the supervision of the Department of Commerce, as provided in the original White Bill.

## *Why Dealers Lose Money*

**I**N AN article appearing in this issue *Radio Retailing* analyzes the sales and expenses of a radio dealer located in a town of 18,000 population in Iowa.

This dealer's difficulties were due, not to poor servicing, defective products or excessive expenditures but rather to his inability to attain a sufficient volume of sales to carry his necessary expenses. He gives as his reason the too liberal sales and service policies of one or more competitor dealers who, in his opinion, have also failed to show a net profit at the season's end.

This case illustrates the necessity for radio retailers to analyze their costs—item by item—and to know what percentage of the total cost of doing business each department is responsible for. Compare them with the percentages given in the two business analysis articles in this issue—one the figures of an actual dealer who showed a loss on the year, and the other a composite picture of the average successful radio retailer compiled from many states—and if your figures are higher in any department—*watch your step.*



## *"Guardians of the Industry"*

**T**HE manufacturer is the guardian of the industry. From the manufacturer must come such progressive steps as stabilization of new models and new model announcements. For several months *Radio Retailing* has been waging a campaign to have new models brought out, if they actually can be classed as new models, at one definite time of the year.

Strange as it may seem, one or two individuals have construed this plan to mean that we want every manufacturer to bring out new models every Spring, whether or not such new models are needed. Such an opinion, is, of course, uncalled-for, but shows how widely divergent are the viewpoints of the men in the radio trade. Before stabilization and standardization can be reached, radio men must start thinking along much the same lines.

## *The Millenium of "No New Models"*

**T**HE ideal merchandising system would be to have no "new models" but constant improvements. But that day, generally, is yet a long way off, despite the commendable efforts of several manufacturers to bring about that condition in their own lines. Meanwhile, the suggestion this publication advances is for those manufacturers who find it necessary to bring out new models, to do so in the Spring of the year, perhaps at a trade show, and so stop the continual breaking up of the dealer's selling plan by new model announcements throughout the entire twelve months.

# This to Say—

**Radio  
Retailing**  
Vol. 3, No. 6

## **Stock Shrinkage— a Drain on Net Profits**

FOR every \$10 lost through stock shrinkage, an added \$200 worth of merchandise must be sold in order to make good the loss, assuming a net profit of five per cent on gross sales volume. Why? Because losing that amount of stock, bought and paid for, is just like losing a ten-dollar bill out of the cash drawer. Ten dollars of your hard-earned money was exchanged for that lost stock—and yet the material dribbled away so painlessly and so unnoticeably that you hardly missed it at all.

Nothing can be done about water that has flowed over the dam but something *can* be done about *next year's* stock check.

Modern business experts are telling merchants to keep their stock and their stock records *by departments* and to take an inventory—at list-price values—*quarterly* if possible. This method permits the dealer to keep a profit-and-loss record by lines or by business activities, and it gives sufficiently accurate information about the ebb and flow of stock in time to catch a leak before it has grown to serious proportions. Furthermore, because the dealers will know exactly *where* that leak is occurring it is possible to locate the *source* of trouble as well.



## **Galloping Horses—Whoa!**

**W**HE-e-e-ss-s-S ZZee!! R-R-R-Rip! Crash -bong! Whence come these terrible noises that rush out of our loud speakers like a veritable herd of wild beasts? "Galloping Horses"—these despoilers of radio reception are sometimes called. "Local interference" starts these high strung animals on their way to disturb the peace and sanctity of countless homes.

How to tame the mad meanderings of these restless forces is the question.

There are at least five places for the radio dealer to turn for assistance. Five responsible organizations which are in a position to "shoot trouble" and which have a more or less direct interest in doing it. *Radio Retailing* points out the following sources in order that dealers who are experiencing difficulty selling sets, or keeping them sold, because of troublesome inductances, will know where to turn for help.

## **Five Sources of Interference Relief**

1. The power companies' responsible for these "electrical leakages" will undoubtedly be glad to correct the trouble and will frequently hire radio experts to locate and remedy it. Pittsfield, Mass., and Louisville, Ky., are instances.

2. The local radio dealers themselves can get together and run down the difficulties. This is frequently one of the most constructive features in a radio trade association. Rochester, N. Y. Milwaukee, Wis., and others do this.

3. The listeners can form an association and "shoot" their own trouble. This has the advantage of permitting them to "read the riot act" to one of their own members if his set is offending. Indianapolis, Ind., offers such an example.

4. The radio department of the local newspaper, as is the case in Toledo, Ohio, will equip itself to locate trouble and to report it. The "power of the press" is not to be scorned where disciplinary measures are necessary.

5. The local United States radio inspector. This man has a large territory to cover. He is apt to be quite busy. Therefore do not lean on him too heavily.



## **Sales Volume—an Essential of Store Success**

**R**EDUCE the secret of any business success to a single word, and that secret undoubtedly lies in *Sales*.

There is no getting around it; you have never heard of signal success in business that did not rest on a sound foundation of a sales income either large or steady, or both.

Skill in buying, wisdom in administration, and the correlative things that go to make up a profitable operation, all have their places and in many instances represent the difference between net profits or red figures on the balance sheet. But the fact remains that the whole store structure stands steady or sways in accord with the *totals* of the cash register.



## **It is Up to the Individual**

**O**NE of the editors of *Radio Retailing* recently had occasion to call upon two retail radio dealers in a small town not far from the cut-price district of New York City. Discussion centered about one subject—"Can a dealer located in a small town, close to big city "gyp" competition, successfully sell sets and make money?"

In the first shop the editor was promptly made the recipient of a long hard luck story, while on the second call he listened to an extremely optimistic opinion. Strangely enough the negative answer came from a dealer with a perfect location in the main business district—with a continuous stream of potential prospects passing his door—while the optimistic affirmative came from a man on a small, out-of-the-way side street who had to *get out and get his business in order to make ends meet*. One dealer had every advantage and answered in the negative—the other labored under the disadvantage of a poor location yet answered in the affirmative. The answer is—individual effort is what sells radio.

# For the Service Man

*A monthly department for the dealer, service man, and salesman. For practical ideas in 200 words—if acceptable for publication—two dollars will be paid*

## Motor Generator Interference Absorbed by Condenser

One dealer in radio supplies and accessories located in the Bronx, N. Y., has a motor generator to charge his radio and other batteries. At first he was troubled a great deal in demonstrating his sets by the fact that there was always a roar whenever the receivers on demonstration were tuned to resonance.

Various experiments were made in the conventional way to eliminate this type of "static." Condensers and chokes were tried at the motor generator, but without materially decreasing the unwelcome noise.

Finally a condenser was tried across the service line where it entered the store. A decrease in the interference was at once apparent, and by the building up of the capacity of the condenser to eight microfarads the noise was entirely eliminated.

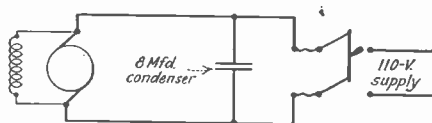

*Disturbances from a motor generator were effectively eliminated in the manner illustrated*

## Antenna Loses Effectiveness When Run Through Basement

A customer was complaining that he did not get enough volume. The set had been installed by the dealer, but the old antenna had been used which the owner had formerly used on a homemade receiver. The factory service man was sent for and this is what he found.

The antenna had been stretched from the clothes pole to the house. From there it ran down to the basement window through the full length of the cellar up to the receiver located at the front of the house. The set was tested out and found all right so naturally the service man picked on the antenna. The antenna was changed so that it ran across the roof of the house and then down to the receiver as a normal antenna should.

The receiver then gave the volume and later the distance that it was supposed to be capable of.

It must always be remembered that the height of the antenna is the average height for the full length and in this case instead of having an antenna about twenty feet above ground it was in reality less than six feet from the ground for a good part of its length. Running the antenna through the basement is very bad practice and in almost every case poor results will be obtained.

## Battery Instruction Card Saves Service Calls

One week after a radio receiver is installed by a dealer in the home of a comparatively new enthusiast, the dealer's phone invariably rings and pours forth the information that the set has suddenly developed unpleasant symptoms, or has refused to bring in more stations. This is usually due to the fact that the customer has allowed his A battery to become entirely discharged. No amount of coaching or verbal instruction at the time of the sale or installation will make it plain that batteries *must* be charged.

A Chicago dealer overcomes this difficulty by tying a card to each receiver sold, reading—"Storage batteries when received from the factory are not fully charged. Your battery will need charging on . . . . . Radio batteries do not reach maximum efficiency until they have been charged several times and may require these charges oftener for the first month." A date one week following the date of sale is inserted in the space provided which allows for partial charge and the excessive use to which the new set is subjected when still a novelty.

## Grid Leak Stops Sparking

In order to minimize sparking at the surface of a mercury thermostat, used in an electrical kitchen refrigerator at the medical school of Columbia University, New York, a

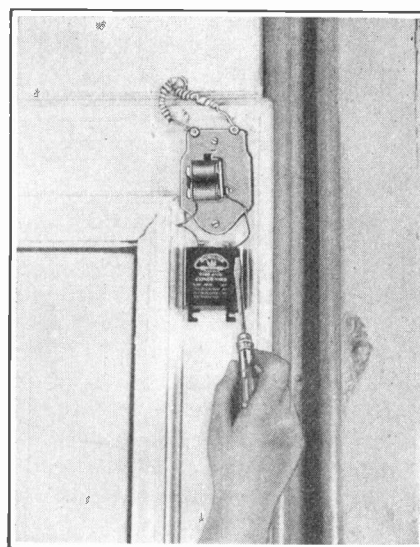

*The spark caused by the contacts of a buzzer or door-bell is sometimes very annoying. A 1 mfd. condenser shunted across the contacts will minimize, if not eliminate, the radio interference thus caused*

high resistance is shunted across the gap. A variable grid leak, 0 to 50,000-ohm, as used in radio receiving apparatus, serves admirably for this purpose.

## How to Increase Your Battery Charging Clientele

The charging of radio storage batteries is a recognized method of tiding the dealer over the slack summer season. Battery charging is profitable in itself, in many instances paying the store rent each month. In addition it affords the radio salesman an opportunity to keep in touch with customers and in the course of a season indirectly sells many sets and accessories.

The one fly in the ointment is that charging stations are numerous and it is perhaps difficult to get a clientele large enough to make such a service pay. The services at these stations are necessarily more or less uniform, prices are standard and delivery is practically the same.

## Cleans and Paints Battery

One Boston dealer tells us that he has increased his battery customer list twofold by spending a few moments on each battery and perhaps a cent or two for material. The battery, before being returned to the customer is quickly scrubbed with a wire brush, a light coat of quick-drying black paint is applied, the positive terminal is given a dab of



red enamel and vaseline is rubbed on the terminals to prevent corrosion. It is then carefully washed with a weak solution of ammonia, which neutralizes any acid which may have been spilled on the case. The entire operation takes only two or three minutes and a can of paint costing twenty or thirty cents lasts a few months.

According to this dealer, "A dissatisfied customer, or one with a complaint in a small town, means ruination for the radio dealer. If one customer is mistreated the whole town knows about it on the '5:15' next evening and by the same token a battery service or something extra gets a lot of valuable publicity."

### Unique Set Tester Speeds Service

To be able to test a radio receiving set for all sorts of conditions without actually connecting the receiving set and regardless of whether a broadcasting station is on the air or not, is a decided advantage. George Blaisdell, owner of the Radio Service Company, Pittsfield, Mass., realized this and constructed the device described in the following paragraphs.

According to Blaisdell, "The tester is really composed of two separate devices, namely, a buzzer and wavemeter and a tube tester. Then by having the various instruments connected to jacks it is possible by a system of plugs and cords to arrange the different circuits for various other tests.

"The buzzer circuit is used to produce a signal when no station is broadcasting. As the strength of the buzzer signal is comparatively constant this makes a more reliable test than checking a set on broadcast. Of course this serves as a volume test only. The wavemeter used in conjunction with the buzzer is a Gen-

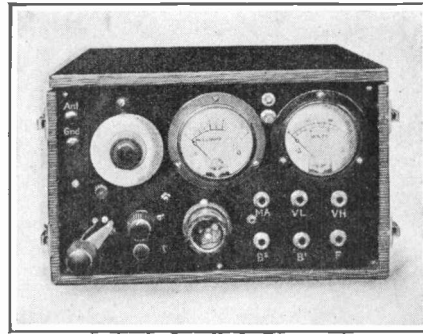

Showing the testing device used by the Radio Service Company, Pittsfield, Mass., described on this page

eral Radio type 247-W and with it it is possible to predetermine the dial settings for a station or to check the wavelength range of a receiving set.

"To use the tube testing section, two double cords are used. One is a two-wire phone cord with plugs at each end—this we will call cord A—the other is a longer double cord with a plug at one end and stiff wire prongs about 6 in. long at the other. These prongs are insulated except at the tips and are used for reaching down inside a set where it would be impossible to make a testing connection otherwise. This is called cord B.

"To test a tube, use cord A to make a connection from jack F to VL. Adjust the rheostat to proper filament voltage and take MA reading. By throwing the switch a positive or negative grid can be obtained. By testing several tubes which are known to be good an accurate chart can be made which should be followed in determining the condition of other tubes tested.

"By plugging cord B in jack VL voltages from 0-12 can be read. This can be used to determine voltage across filament terminals of sockets. Also a battery voltages.

"By plugging in VH with the same cord, voltages up to 120 can be tested. This is used for testing B batteries.

"Plugging in MA with cord B the milliammeter is brought in use. This can be used for determining the current consumption of the set or any individual tube in the set.

"By connecting B2 and VH with cord A and plugging cord B into B1, short and open circuits may be found by placing the stiff prongs of cord B across the object or circuit under test. If the circuit tested is closed the voltmeter will register and if open will not read. By noting the reading of the voltmeter a short in a transformer winding can be noted.

### Tests Parts in Set

"By using the tester a doubtful piece of apparatus can be tested without removing it from the set. Then it can be replaced with a new piece to determine whether it is causing the trouble. For instance a customer brought in a set a short time ago which he said was dead. Formerly we would have had to connect up the set and by a long process of elimination locate the source of trouble. As it was, however, by using the tester we were able in five minutes to tell the customer the cause of the trouble and the probable cost of repair.

"In testing this set we first checked the tubes, then the condensers for shorts and the coils for opens. As all these checked OK we started on the amplifier. Immediately the trouble was located in the first audio transformer. The primary winding was open.

"Since using the tester we find that we are able on an average to do triple the service work that was possible before. This of course means an extensive saving in the cost of servicing our own sets and appreciably increases the income of our general service department."

### Service Man's Trip to Factory Advertised

Radio dealers should make the most of every opportunity for building prestige and creating confidence. McMahon and Sons of State Center, Iowa, recently sent their service man to the factory of the manufacturer whose set they handle. This man spent five days taking a course of intensive training in the technical points of this particular set. Before he left his home town, and again upon his return, the local newspaper carried a news item mentioning his trip. This "reader" was supplied the

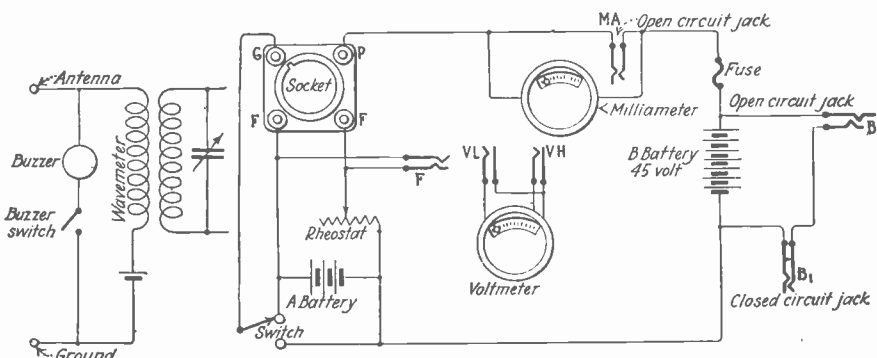

Here is the circuit used in the set tester of the Radio Service Company, Pittsfield, Mass., the panel assembly of which is shown above

paper by the dealer. McMahon and Sons also ran two, three in. single column, advertisements announcing that their service man had recently taking a special course in set servicing at the manufacturer's plant and was now fully as capable of inspecting and repairing sets as the factory expert.

### Correcting Broad Tuning Caused by Long Antenna

To install a radio receiver on the ground floor of an apartment house, and, in order that the antenna proper be above the roof, it is necessary to make the antenna system longer than is advised for best results with the receiver. The usual result of this is loss of selectivity. By placing a .00025 mfd. fixed condenser such as is used in the grid circuit, in series with the antenna at the set, tuning will be sharpened without an appreciable decrease in volume.

### Inside Antenna Construction

Many people object to an outside antenna because they think it detracts from the appearance of the landscape. The E. B. Cones Radio Laboratory, Oklahoma City, meets this objection constantly. Mr. Cones has had an opportunity to compare results in his location between an outside wire and one installed in the attic and has found no noticeable difference between the two.

Accordingly, he offers the following solution in the construction of an inside antenna:

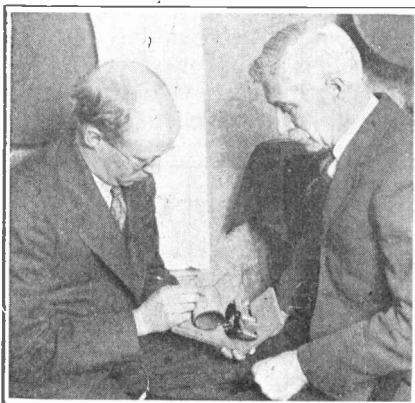

Dealers in the vicinity of super-power stations can perform a service for their customers who find the station comes in "over the whole dial" by installing wavetraps which enable the super-power signals to be tuned out. WJZ, at Bound Brook, N. J., sends investigators to the homes of nearby complainants who have difficulty in tuning out the station.



*The Radio Electric Company, South Pasadena, Cal., has found it a profitable habit to take cards, one side of which is illustrated, and tie them to the steering wheels of automobiles parked along the streets.*

"The attic wire should be supported with ordinary porcelain knobs and run on the rafters in a zig-zag manner so that the required amount of wire may be put in the limited space available. The wire is brought down through the partition of the house to an outlet receptacle, such as is used in house lighting. By drilling through the lower plate of the partition from under the house a wire may be grounded and run to the receptacle. This is a very neat arrangement and allows the set to be plugged into the wall the same way as an ordinary household appliance. Poles and insulators are also saved by this type of aerial and it is very easy to install."

### Poor Insulation in Receivers

Nothing gives such real trouble to the radio repair man as faulty insulation in a receiving set. It is very difficult to locate as the result of poor insulation may vary all the way from a slight loss of volume to burned out apparatus and tubes. If a direct short is caused it can be found readily enough, but in the case of a high resistance leakage it is not so easy.

In one case which comes to mind a poor grade of insulating tubing had been used, and the set, while it worked, did not give satisfactory results in comparison with others using the same type of circuit. The receiver was taken apart and five different places were found in the wiring where there was leakage of electricity. The places where leak-

age took place could be observed because the insulation was discolored slightly. All the points where the high potential, or B battery leads came in contact with or crossed another wire, there had been a leakage. The whole receiver was rewired and in this way the trouble cured.

### Stopping Microphonic Noises

Since the 201-A, or hard-type vacuum tube has come into general use as a detector, dealers have been having more or less trouble with microphonic noises and howls. When one of the modern multi-tube receivers is installed it is not uncommon to hear, when the tubes are turned on, a low moaning sound that gradually increases to a roar. This is very annoying as it cannot be stopped by detuning. The next time this happens try—Placing another tube in the detector socket of the set—Moving the loudspeaker to the other side of the set, or farther away—Reducing the detector B battery voltage slightly.

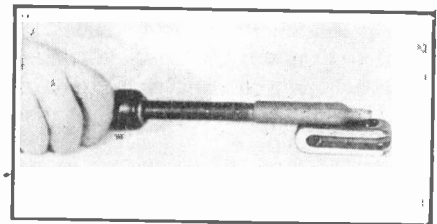

*An antenna insulator, of the type shown in the illustration, when nailed or screwed to the workbench makes a good rest for a hot soldering iron.*

### Oscillation Corrected

According to P. L. Kaiser, Williamsport, Pa., many sets such as the second harmonic super-heterodyne, have a tendency to oscillate on the lower wavelengths. "This condition," he says, "may be overcome by using a tube which tests low filament emission, in the first radio frequency socket."

A tube tester is also used by Kaiser and he tells us that "after having used one for a year and always finding it necessary to disconnect the batteries in the receiver, and attach them to the tube checker for testing, I conceived the idea of taping the batteries through the bottom of the tester. Two regular size C batteries and one very small 45-volt B battery are used. By this arrangement all that is necessary is to take the tubes out of the receiver and insert them in the socket on the tester."

## "Keeping the Store In the Spotlight"

Concluded from page 579

years on publicity stunts, Aldrich evidently has Destiny eating out of his hand. She gives him publicity on a silver platter.

Imagine—easy enough when you get used to it—Aldrich's opening night, a Saturday, too. The store has been crowded with people passing in and out and looking it over, and listening to the free radio concert going on all the time. Just get the scene clearly in your mind. Up to this moment everything has been peaches and cream, the opening has been a gratifying success and everyone is crowding around Aldrich offering congratulations on his new shop. Things are beginning to quiet down a bit after a more or less hectic evening.

Now imagine a whale of a WHAM out of the back room, followed by a few flames and some nice black smoke—just the oil stove blowing up, that's all. Followed in turn by clanging fire engines, great commotion in the street and milling crowds headed straight for the South Carolina Radio Shop to find out what all the excitement was about. Followed in turn by front page stories in all the newspapers next day at the cost of \$43 for a new stove.

Are the people of Charleston acquainted with the South Carolina Radio Shop? And how!

More publicity stunts used by Aldrich are folders distributed in parked autos along the business streets, a yearly calendar to his mailing list, the calendar including a map of the United States with the broadcasting stations indicated by city and call letters, and mailing of manufacturers' direct-mail circulars to a list gleaned from the telephone directory. This keeps the cost of getting prospects and the cost of direct-mail campaigns to a minimum, as he always uses the direct-mail stuff supplied to dealers by manufacturers without charge.

### Takes Booth at County Fair

Also, some more ideas—a booth is always taken at the county fair and a drawing for a set held, resulting in more publicity, more names and addresses for the mailing list and more ultimate prospects. Also, no set is allowed to go out of the store without a paster on the inside of the lid, reminding the customer about where

## Radio Shows and Conventions

**June 7:** Radio Section, Associated Manufacturers of Electrical Supplies. Hot Springs, Virginia.

**June 7-11:** Music Industries Chamber of Commerce Convention. Hotel Commodore, New York City.

**August 21-28:** Third Annual Pacific Radio Exposition. Exposition Auditorium, San Francisco, Cal.

**September 10-17:** The Radio Show, Grand Central Palace, New York City.

**September 13-18:** Radio World's Fair, New Madison Square Garden, New York City.

**September 13-18:** Winnipeg Radio Show. Alexander Hotel, Winnipeg, Manitoba, Can.

**September 20-26:** Cleveland Radio Exposition, Cleveland, Ohio.

**September 20-25:** Second Annual Pacific Northwest Radio Exposition, Public Auditorium, Portland, Ore.

**September 25-30:** Fourth Wisconsin Radio Exposition, Milwaukee, Wis.

**September 26-October 2:** Pittsburgh Radio Show, Motor Square Garden, Pittsburgh, Pa.

**September 27-October 2:** Sixth Annual Boston Radio Exposition, Mechanics' Building, Boston, Mass.

**September 27-October 2:** Fifth Annual Northwest Radio Show and Northwest Radio Trade Association Convention, Kenwood Armory, Minneapolis, Minn.

**September 27-October 2:** National Radio Exposition. Chicago, Ill.

**October 4-9:** Montreal Radio Show. Windsor Hotel, Montreal, Quebec, Can.

**October 11-17:** Fifth Annual Chicago Radio Show, Coliseum, Chicago, Ill.

**October 18-25:** Buffalo Radio Show, Broadway Auditorium, Buffalo, N. Y.

**October 25-31:** Fifth Annual Detroit Radio Show, Convention Hall, Detroit, Mich.

**October 25-30:** Second Annual Indianapolis Radio Exposition. State Fair Grounds, Indianapolis, Ind.

**October 25-30:** Toronto Radio Show, Coliseum, Toronto, Ontario, Can.

he bought the set and where to go when he wants new accessories.

Also, before we bid Aldrich goodbye, he is putting in a line of musical instruments—pianos, talking machines, sheet music, records and music rolls, to tide radio over the summer. Dealers should not neglect, he thinks, the opportunity to sell another line that the summer let-down in radio offers.

The Wholesale Electric Company, 817 Mission Street, San Francisco, and the Universal Electric Company, 137 Fifth Street, together with the Electric & Machine Equipment Company of Stockton, Calif., have been consolidated into one concern under the name of the Wholesale Electric Company. Their head offices are located at 1175 Howard Street, San Francisco. The Stockton, Cal., branch will be located at 130-32 N. El Dorado Street. The officers of the new organization are A. R. Fierce, president; Geo. H. Curtiss, vice-president; C. E. Condit, treasurer.

The Eldredge Electric Manufacturing Company, manufacturer of precision electrical measuring instruments, located at 3 Post Office Square, Springfield, Mass., has been reorganized under the name of the Eldredge Electrical Corporation. A. Linton Bausman is president; Guy Boynton vice-president, and H. C. Hyde treasurer and general manager.

The American Consul at Constantza, Rumania, is desirous of obtaining catalogs, descriptive matter, and prices of American made radio receiving sets and parts, which information may be shown to interested local firms who may be desirous of importing such material, according to the Department of Commerce.

Francis B. Farley, formerly connected with the Charles Freshman Company and Stromberg-Carlson Telephone Manufacturing Company has been appointed advertising manager of F. A. D. Andrea, Inc., with offices in New York City. Mr. Farley replaces K. H. Stark, who has resigned.

R. Robert Smith has been appointed advertising manager of the Freed-Eisemann Radio Corporation, Brooklyn, N. Y., to succeed Philip V. D. Stern, who resigned because of ill health. Before his promotion, Mr. Smith had been assistant advertising manager.

Leon L. Adelman, formerly associate editor of *Radio News* is now connected with the advertising and publicity department of the Charles Freshman Company.

Grier-Sutherland Company, 433 East Larned Street, Detroit, Mich., manufacturer and wholesaler of battery supplies, has increased its capitalization from \$50,000 to \$200,000. The company has also to announce the promotion, to the sales managership, of Graydon Booth, secretary and former manager of the Cleveland branch.



# What's New in Radio and

*This editorial section is prepared purely as a news service, to keep readers of "Radio Retailing" informed of new products.*

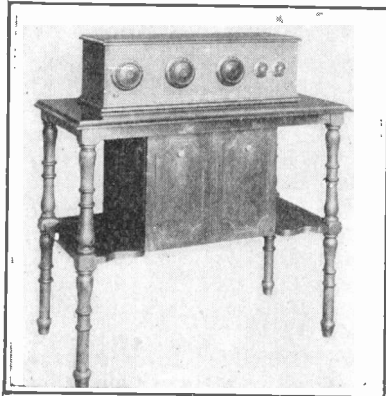

## Receiver Table with Battery Compartment

*Radio Retailing, June, 1926*

The illustrated set table is made in gum and finished in two-tone walnut by the Bethlehem Wood Products Company, Bethlehem, Pa. A separate compartment is provided for batteries with small panels hinged in front for replacements. Intended retail price, type No. 211, \$10.75.

## Five-Tube Receiver With Built-in Reproducer

*Radio Retailing, June, 1926*

The Arborphone-Duo receiver, manufactured by the Machine Specialty Company, Ann Arbor, Mich., employs a self-contained reproducer which is mounted above the receiver itself. The loudspeaker, designed with a double path for reproduced sound is hinged at the rear so that access may be had to the set interior. The set is a five-tube tuned radio frequency receiver designed for use with outside antenna and storage battery tubes. Dry cells may be used if desired. Panel size, 7 in. x 24 in., Overall size of the cabinet 27 in. long, 14 in. high and 10 in. deep. Front and sub-panels made of hard rubber. The set is equipped with two stages of transformer coupled audio and jacks are provided in each stage for phones. Intended retail price, without accessories, \$88.

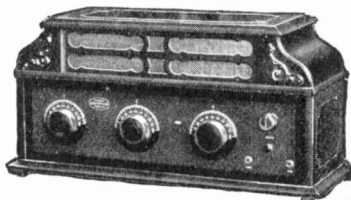

## Varnished Cambric

*Radio Retailing, June, 1926*

The Mica Insulator Company, whose offices are at 68 Church Street, New York, makes varnished cambric for purposes where high insulation is desired. This cloth is manufactured in such a manner that it is soft, pliable, and does not harden with age or use.

## Six-Tube Receivers with Parallel Audio Tubes

*Radio Retailing, June, 1926*

The new line of Trinity receivers, manufactured by the Beacon Radio Manufacturing Company, Brooklyn, N. Y., consists of one five-tube and two six-tube receivers. The six-tube table model employs two stages of radio frequency amplification, non-regenerative detector and two stages of audio amplification, two tubes being placed in parallel in the last audio stage for increased undistorted output. The console-six model is identical with the table model with the exception of the cabinet in which it is mounted. The console is equipped with a cabinet providing space in a lower compartment for batteries and a duplex loudspeaker system in which two-units are employed, diffusing the sound and improving reproduction. Both sets are equipped with five-ply mahogany cabinets and may be easily removed for inspection. Front and sub-panels are of bakelite. The Trinity five, is a cabinet model receiver, overall dimensions of which are 7 x 6 1/2 x 21 inches. Tuned radio frequency is employed in all three receivers. Intended retail price without accessories, table-model six, \$65, console-six, \$135, Trinity-five, \$40.

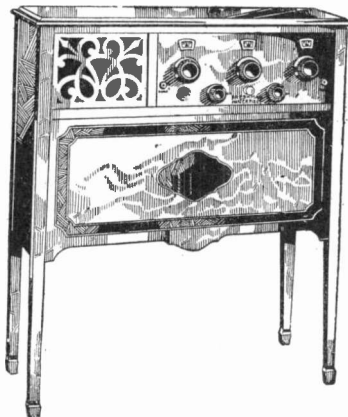
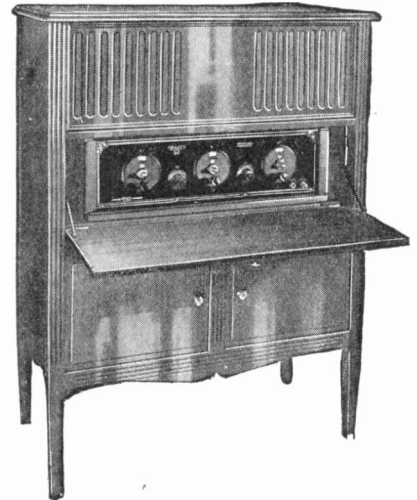

## Five-Tube Console with Built-in Speaker

*Radio Retailing, June, 1926*

The Chas. Freshman Company, Incorporated, New York, has announced a console model with built-in loud speaker and space for all batteries, eliminators, etc. This model, known as 6F3 is furnished in either of two woods, five-ply mahogany or burlied American walnut. The panel of bakelite, is grained like mahogany and the knobs are furnished to match the wood used. The circuit used is one employing five tubes incorporating two stages of tuned radio frequency, detector and two stages of audio. Vernier dials are provided on all three condensers. The dials are seen through small gold plated windows in the panels. Intended retail price \$69.50 in mahogany and \$71.50 in walnut.

## Five-Tube Receiver Operating from Slot Machine

*Radio Retailing, June, 1926*

A radio slot-machine designed for use in hotels, stores, ferries etc., is manufactured by Joseph Pinto, 1624 South Eighth Street, Philadelphia, Pa. This machine, which is designed to operate in conjunction with a standard 5-tube radio receiver operates an automatic switch which permits patrons to listen to broadcast programs for five minutes when a five-cent piece is deposited. A small light flashes one minute before the disconnecting switch operates so that the customer may deposit further coins without the interruption of programs. The attachment is manufactured in a cabinet 63 in. high, 25 in. wide and 21 in. deep and is available in two models, one for the insertion of five-cent piece fees and another for twenty-five cent insertions. Finished in walnut, mahogany and silver gray. Intended retail price \$600.

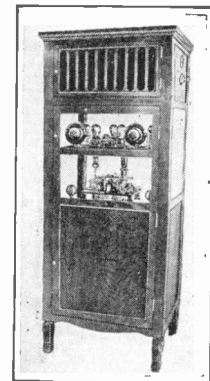

# Where to Buy It

News of Latest Products  
Gathered by the Editors



All announcements appearing on these pages are published without advertising considerations of any kind whatsoever.



## Five-Tube Receiver Operating on House Current

*Radio Retailing, June, 1926*

The illustrated model EA radio receiver made by the Garod Corporation, Belleville, N. J., operates on 110-125-volts a.c., 60-cycle current. It is 41½ in. high, 36½ in. wide, and 15½ in. deep. The rich mahogany finish harmonizes with home furnishings. Intended retail price \$275. This receiver requires no batteries whatsoever, and a small knob on the panel of the receiver controls the tone and clearness of the reception. Once it is adjusted for the tube employed, it requires no further regulation. The power conversion equipment is housed in a metal box in a compartment of the supporting table. The interior of the table cabinet is shielded. A red pilot light on the panel indicates whether power is on or off. Other models that operate without batteries are model M, model V, and the Georgian model which have intended retail prices respectively of \$115, \$195 and \$400.

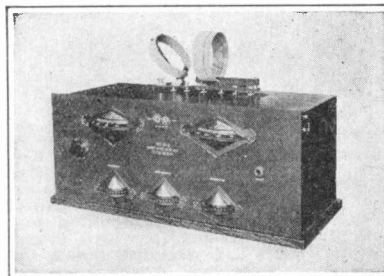

## Short Wave Receiver with Plug-in Coils

*Radio Retailing, June, 1926*

In the CR-18 short wave receiver, A. H. Grebe & Company, Incorporated, 109 West Fifty-seventh Street, New York City, has an instrument which should appeal to the short wave enthusiast, particularly the amateur. The receiver utilizes a capacity coupled regenerative circuit and is equipped with plug-in coils which cover wavelengths from 10-200 meters. One stage of transformer coupled audio frequency amplification is used. S-L-F tuning condensers, adjustable inductive primary or antenna coupling, vernier tuning condenser and cushioned sockets completes the specifications. Each receiver comes equipped with a set of regeneration and wavelength calibration curves which simplify operation. Intended retail price with antenna and 40 meter coil, \$90. With full set of inductances, \$100.

## Five Tube Receiver—Two Dial Control

*Radio Retailing, June, 1926*

The Bosworth Electric Manufacturing Company, Cincinnati, O. is making type B-2 receiver shown in the illustration. This is a five-tube receiver incorporating two stages of tuned radio frequency, detector, and two stages of audio frequency amplification. It utilizes two dials for control. The front panel is etched bronze. The cabinet is of mahogany. Both General Radio condensers and audio frequency transformers are used. This set also uses twin solenoid radio frequency coils, and except for a few of the radio frequency leads, which are bussed, the set is completely wired by the cable method.



## Pilot Lamp Bulb

*Radio Retailing, June, 1926*

The Edison Lamp Works, Harrison, N. J., is making a light which may be used to illuminate dials and panels or as a signal. Type T-3 is made in 3 sizes, for 6, 4 and ½ volts. In May *Radio Retailing* it was incorrectly stated that this lamp used 1 amp. whereas it uses .1 amp. Intended retail price 20c.

## Complete Crystal Receiver Contained in Book

*Radio Retailing, June, 1926*

A novel and complete radio outfit consisting of a 200 foot coil with sliding tuner, fixed crystal rectifier, antenna and phones all assembled in an attractive book size 6 in x 8½ in. is being made by The Listen-in Company, 115 Federal Street, Boston, Mass. All connections are well soldered and the ground and aerial leads are made of flexible rubber covered wire with clips on ends. This set is complete in every detail. Intended retail price complete \$5.

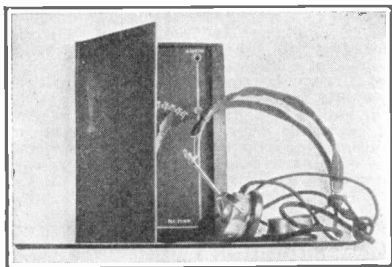

## Automatic Filament Control Unit

*Radio Retailing, June, 1926*

The "Elkay Equalizer" is the name of the automatic filament control unit manufactured by the Langbein-Kaufman Radio Company, 511 Chapel Street, New Haven, Conn. Equalizers are made in sizes which permit the use of various types of tubes with different filament voltage characteristics from the standard 6-volt battery. Thus dry-cell and power tubes may be used at will in the receiver which is wired for 6-volt fila-

ment supply without alteration in the wiring, by inserting the proper resistance unit in a filament lead. Intended retail price, 50c. with mounting 75c.



## Six-Tube Receiver Having Three Stages Tuned R. F.

*Radio Retailing, June, 1926*

Illustrated is type B-3 radio receiver being made by The Bosworth Electric Manufacturing Company, Cincinnati, Ohio. This set is a two-dial, single control outfit, having three stages of tuned radio frequency, detector, and two audio frequency. Each knob may be turned separately, but when the left hand one is turned the right hand one also turns, effecting single-knob control. The left-hand scale reads direct in wave lengths, the right hand one in frequencies. The cabinet is mahogany, including a mahogany front panel.

## What's New in Radio and Where to Buy It

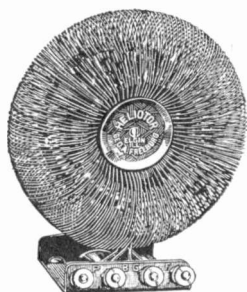

### Self Balancing Toroid Coil

*Radio Retailing, June, 1926*

The "Heliotor" toroid radio frequency coil, manufactured by the Geo. A. Freeburg Company, 169 Lovell Street, Elgin, Ill., measures 3½ in. in diameter by 1½ in. thick. Windings of No. 22 D. S. covered wire are mounted on a rigid dielectric frame to which lettered terminal posts are attached, and a light fibre strip threaded in the secondary coil itself insures solidity. The primary is mounted inside and concentric to the secondary. Manufactured in sizes which cover the broadcast band of wavelengths in conjunction with the various capacities of standard condensers. Intended retail price \$4.

### Indoor Antenna in Window Shade Form

*Radio Retailing, June, 1926*

A convenient and indoor antenna known as "Effarsee" is manufactured by the Fishwick Radio Company, Cincinnati, Ohio. It is made in the form of a mat or paper shade and consists of two sheets of waterproofed parchment paper between which numerous strands of flexible wire are embedded. The ends of these wires are clinched between metal strips to which binding posts are attached. These come in 3 ft. x 10 ft. and 3 ft. x 6 ft. sizes, may be used either as antenna or counterpoise by suspending from a wall hook, placing under rugs, etc. Intended retail price, large type, \$4, small type, \$2.50.

### Straightline Frequency Condensers

*Radio Retailing, June, 1926*

Condensers of the illustrated Straightline Frequency type are being made by the U. S. Tool Company, Incorporated, Amper, N. J. These are designed to give uniform dial readings over the entire broadcasting range and in this manner greatly facilitate tuning. Single units of .0005 and .00035 Mfd. may be had with intended retail prices of \$4.45 and \$3.95 respectively. These condensers are also made in multiple types.

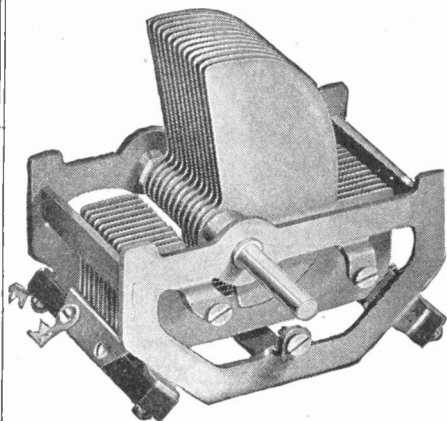

### Resistance-Coupled Amplifier

*Radio Retailing, June, 1926*

The three stage resistance amplifier manufactured by the De Jur Products Company, 199 Lafayette Street, New York City may be substituted for transformer amplification units. Standard UX sockets and resistances are mounted above a bakelite panel and all wiring which is of the metal-strip type is encased in a mahogany cover. The unit is furnished with an adapter which al-

lows the use of a power tube in the last stage. Intended retail price, \$10.

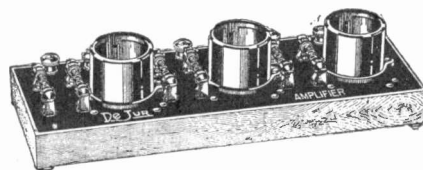

### Trickle Charger

*Radio Retailing, June, 1926*

A full wave trickle charger, for charging low capacity storage batteries is being made by Joyce Brothers, 71 Chestnut Street, Boston, Mass. This may be connected to the house lighting circuit and used while the set is in operation. Intended retail price \$10.

### Circular Loop of Small Diameter

*Radio Retailing, June, 1926*

The "Imp" loop, manufactured by the Carter Radio Company, 300 South Racine Avenue, Chicago, Ill., is wound in rigid basket-weave fashion and is but 16 in. in diameter, weighing 1 lb. Owing to the elimination of dielectric material in the field of this instrument it is said that losses are reduced to a minimum. The pure inductance of the loop is .155 microhenries, and it tunes from 180-560 meters in conjunction with a .0005 variable condenser. Taps are provided and brought out to conveniently mounted terminals every quarter turn. Intended retail price, \$7.50.

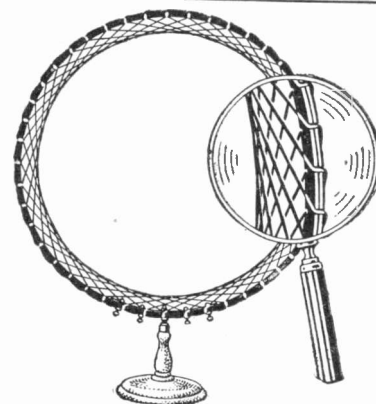

### Antenna Coupler for Radiola 28

*Radio Retailing, June, 1926*

The Radio Corporation of America, 233 Broadway, New York, is now making type AL-593 antenna coupler for use with the Radiola 28. This was designed so that the set could be used with an outdoor aerial. The coupler consists of an aircore transformer, the primary of which is fitted with terminals for antenna and ground connections, and the secondary is connected through short flexible leads to an adapter which plugs into the loop socket. A small metal cap is provided to fit into the hole left in the lid of the set, when the loop aerial is removed, so that when the set is being operated with the antenna coupler, the top of the cabinet presents a clear and unobstructed appearance. Intended retail price \$4.25.

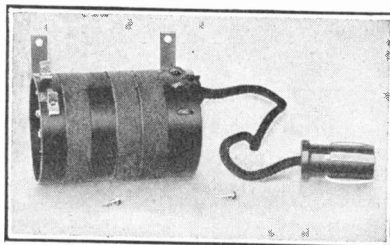

### Foundation Unit Kits

*Radio Retailing, June, 1926*

The Insulating Company of America, 59 Warren Street, New York, is making foundation unit kits, consisting of a front panel drilled and decorated, a sub-panel mounted with sockets, knobs and pointers, and a pair of bakelite brackets. All sub-panels are drilled and mounted with metal shells and phosphor bronze contacts, and will take either UV or UX type tubes. The brackets are tested to withstand 8,000-lb. pressure, and are drilled and tapped for screw mounting to the front and sub-panel.

According to the manufacturer, these kits are furnished for 30 different popular circuits. Use of these gives the novice a chance to assemble his own set and at the same time having, when finished, a set of factory-made appearance.

### Moulding Compound

*Radio Retailing, June, 1926*

The General Insulate Company, 1024 Atlantic Avenue Brooklyn, N. Y., molders of "Insulate" and "Hi-Heat" (Bakelite) has developed a moulding compound which has a property—flexibility—that has never existed heretofore in any other moulding compound; furthermore it is resilient. Practically unbreakable even in the thinnest piece; has excellent dielectric strength; mechanical strength; takes and retains a mirror-like polish, according to the maker. This material termed "Star Insulate," can be molded with the finest of threads or metal inserts; and into almost any shape, thick or thin. It can be tapped, drilled, or sawed almost as readily as hard wood. Furthermore, two pieces can be cemented together and the chemical action taking place thereby is such that they cannot then be broken apart.

## News of Latest Products Gathered by the Editors

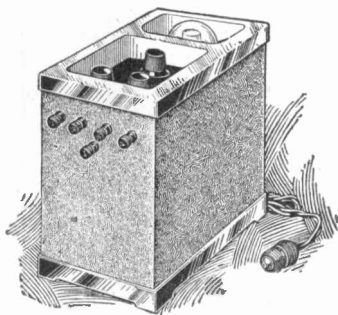

### B Battery Eliminator

*Radio Retailing, June, 1926*

The Mayolian Radio Manufacturing Company, 1991 Broadway, New York, is making the illustrated battery eliminator using a Raytheon tube. It is equipped with three separate and variable voltage taps, one for detector tube, ranging from 0 to 60 volts, one for radio frequency tubes ranging from 40-110 volts and one for audio frequency tubes ranging up to 180-volts. The total output is controlled by a panel switch which has three positions and can be set to supply the current voltage necessary to obtain best results. Overall dimensions are 5 in. x 10 in. x 9 3/4 in. The unit is encased in a mottled blue-gray metal cabinet with satin finish aluminum base and top, and engraved Bakelite panels. Type 609 for 110 volts, 60 cycle current complete with tubes, has an intended retail price of \$55. Type 607 for 110 volts, d.c. has an intended retail price of \$25.

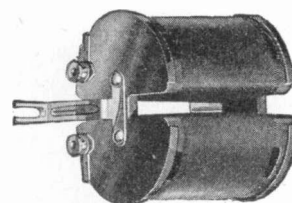

### Space Wound Radio Frequency Transformer

*Radio Retailing, June, 1926*

The illustrated radio-frequency coil, manufactured by the A. F. Henninger Corporation, 4509 Ravenswood Avenue, Chicago, Ill., stands three in. high including the mounting bracket. The coil is space wound on a ribbed, hard rubber frame in the familiar localized field manner and is furnished with convenient binding posts. The manufacturer claims low radio-frequency resistance, low distributed capacity, no interstage coupling and high amplification for the device. Designed to cover the broadcast wave band in conjunction with a .00035 variable tuning condenser. Intended retail price, per set of three, \$9.75.

### Waterproof Lightning Arrester

*Radio Retailing, June, 1926*

Illustrated lightning arrester is being manufactured by M. M. Fleron & Son, Incorporated, Trenton, N. J. This is said to be completely waterproof and built entirely in accordance with the Underwriters' specifications. Three separate arcing areas are provided so as to insure operation under all conditions. The brass parts are extra heavy and the body of the arrester is made of black porcelain with a lustrous black glaze. Two screws and

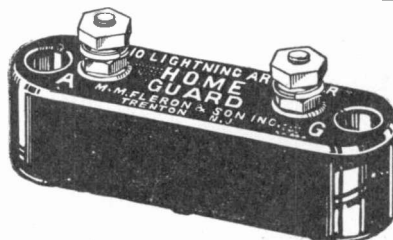

printed directions for installing are provided with each arrester. The retail price is 50c.

### Device for Ground Connection

*Radio Retailing, June, 1926*

The "Ant-Terra" being made by Bernard Kruger, 500 North Huntley Drive, West Hollywood, Calif., is a device in a metal container which is to be buried in the ground to a depth of two or more feet and used for a ground connection. It is filled with mineral and chemical elements which produce certain reactions when in contact with the damp earth. The intended retail price is \$6.50.

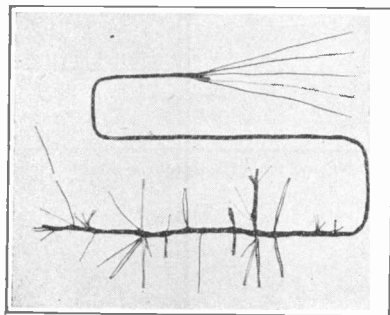

### Wiring Connection Cable

*Radio Retailing, June, 1926*

Harnesses of the type illustrated are made by the Belden Manufacturing Company, 2300 South Western Avenue, Chicago, Ill. This is one of the recent developments in the merchandising of radio kits and consists of a special cable or harness which provides connections for the various transformers, A and B battery circuits, eliminating soldering, binding posts, etc. A color code furnished with the kit enables the set builder to wire his set without danger of error. The five outgoing conductors connected to the proper batteries and the set is ready to run. Further details of all types of cables may be had from the above company.

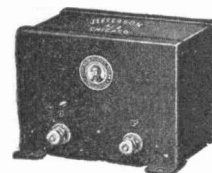

### Improved Audio Frequency Transformer

*Radio Retailing, June, 1926*

An audio frequency transformer is being made by the Jefferson Electric Manufacturing Company, 501 South Green Street, Chicago, Ill., which is said to cover the entire range of audible frequencies with a minimum of distortion. It is heavily insulated throughout and the entire transformer is sealed into a metal case making it moisture proof. By use of a large core and sufficient windings, the manufacturer states that the capacitance of the secondary has been kept low enough to prevent marked resonant peaks at the higher frequencies. The ratio is two to one. The intended retail price is \$6.

### Metallic Grid Leak

*Radio Retailing, June, 1926*

The illustrated grid-leak is manufactured by Electrad, Incorporated, 428 Broadway, New York, and embodies principles which are said to assure noiseless operation and non-inductive characteristics. The metallic resistance



is fused to the inside of the glass container which is in turn equipped with brass end caps.

### B-Power Supply Unit

*Radio Retailing, June, 1926*

"B" batteries are permanently replaced with the "Constant-B" power supply unit of the All-American Radio Corporation, 4201 Belmont Avenue, Chicago. It may be used with any radio set and is compactly designed so that it can be installed in the space occupied by one heavy duty 45-volt dry cell "B" battery or in less space than is required by two standard sized "B" batteries. The shut-off switch is conveniently located several inches away from the "Constant-B" so that it can be controlled from the outside of the cabinet. It operates from the ordinary lighting circuit. Intended retail price, complete with "Raytheon" tube, \$45.

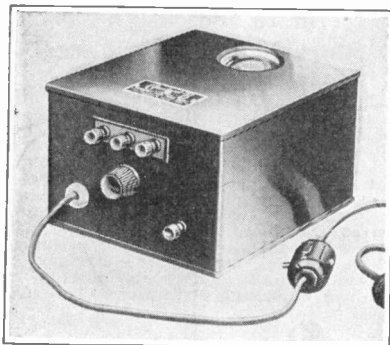

### Five-Tube Receiver, Straight Line Tuning

*Radio Retailing, June, 1926*

The Gormac five-tube, tuned radio frequency receiver, manufactured by the Gormac Electric Company, 311 West Fifty-ninth Street, New York City, measures 9 in. x 13 in., is equipped with a sloping, gold etched panel and mahogany finished cabinet. Standard tube sockets, battery cable connection and sub-panel wiring complete the specifications. Straight line frequency tuning condensers are employed. Intended retail price, \$40.

## What's New in Radio and Where to Buy It

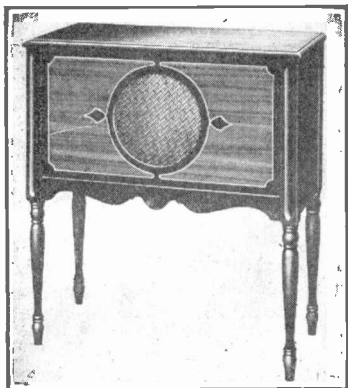

### Console Table with Built-in Reproducer

*Radio Retailing, June, 1926*

The Musiconsole, a console table having a built-in musicone and compartment for either wet or dry type batteries, has just been placed on the market by the Crosley Radio Corporation, Cincinnati, O. The reproducer is suspended behind a silk screen in the front of the two-tone solid mahogany console. An added feature of this combination console speaker is that it will harmonize with the furniture in the home. Also, that it permits concealing of all unsightly batteries, etc. Intended retail price is \$30.

### Automatic Rheostats for Use with Power Tubes

*Radio Retailing, June, 1926*

The Radiall Company, 50-52 Franklin Street, New York City, is manufacturing an "Amperite" automatic filament resistance for use with power tubes of the UX-171 type. This unit is known as No. 112 and may also be used for UX-112 type of tube.

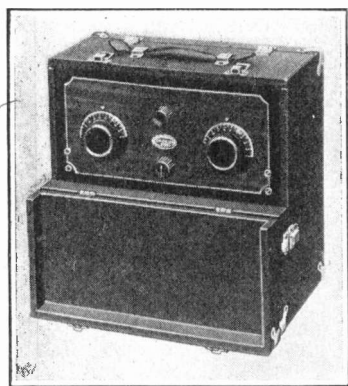

### Portable Four-Tube Receiver

*Radio Retailing, June, 1926*

A self-contained four-tube portable receiver is being made by the Crosley Radio Corporation, Cincinnati, O., known as 4-29. It has a leatherette covered case equipped with a strong strap handle. It also has a two-tone mahogany panel with black dial. The circuit has one stage of tuned radio frequency amplification, crescendo control detector and two stages of audio frequency amplification. Ample volume to operate a loud speaker is provided. Intended retail price is \$33.

### Power Tube for Use in Last Audio-Stage

*Radio Retailing, June, 1926*

Radiotron UX-171 is the latest power tube being manufactured by the Radio Corporation of America, 233 Broadway, New York. This is designed to operate loudspeakers of low impedance, at considerable volume with a minimum of distortion. It may be operated from a storage battery or by appropriate power devices from alternating current lighting mains. The general specifications are, filament volts 5; filament amp. 5; plate volts 90 to 180; negative grid volts 16.5 to 40.5; and approximate impedance 2,000-ohms. Intended retail price, \$6.

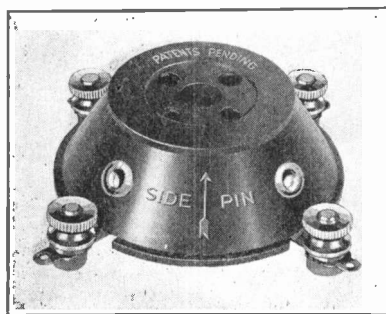

### Cone-Shaped Bakelite Socket

*Radio Retailing, June, 1926*

The illustrated socket is made by the Automatic Molded Products Company, 280 Passaic Street, Newark, N. J. It is molded in one piece of bakelite and is equipped with phosphor bronze springs. Either single hole mounting or four point suspension may be used. If the latter is used, small felt pads furnished with the sockets are put under each point of contact. Although the stock color is black, this socket can be furnished in any desired color. The U-shaped wiping contacts are easily adjustable to any desired tension. Fits all tubes and has an intended retail price of 50c.

### Small Bakelite Universal Socket

*Radio Retailing, June, 1926*

Model X socket illustrated, may be used for either UX or UV type tubes, and is made by Klosner Radio Corporation, 1022 East One Hundred and Seventy-Eighth Street, N. Y. A molded arrow on top indicates position of side pin when UV type tubes are used. Phosphor bronze spring contacts set in a bakelite casting give sturdy mechanical construction throughout. Single hole mounting is accomplished and the contact springs are bent in such a way as to give perfect contact. The holes are counterbored facilitating insertion of the prongs. Intended retail price, 60c.

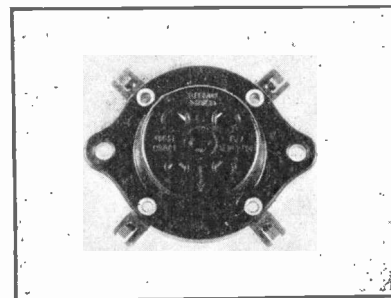

### Meter to Indicate 6-Volt Storage Battery Charge

*Radio Retailing, June, 1926*

The Sterling, No. 32, Charge Indicator is a pocket type meter designed to determine the charge of a 6-volt storage battery. It weighs 3 oz., is finished in nickel and is equipped with a black dial and red pointer. The condition of the battery on test is plainly indicated on the scale of the instrument. According to the manufacturer the specially designed resistance in the instrument shows whether or not the battery on test will actually deliver and sustain the required working voltage. Intended retail price, \$2.00.

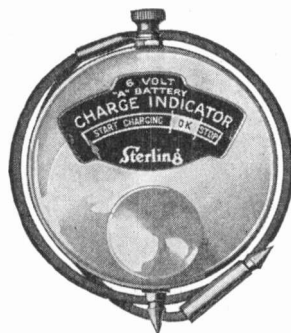



# What the Trade Is Talking About

## Radio Manufacturers' Association Holds Second Annual Convention

INTERESTING discussions on many subjects of paramount importance to radio featured the four-day convention of the Radio Manufacturers' Association held May 10, 11, 12 and 13 at Atlantic City, N. J.

At the opening session on Monday, May 10, the retiring president, Major Herbert H. Frost, gave what was probably the outstanding address of the convention when he outlined the work of the association in the one year of its existence and presented suggestions as to the vital radio matters which the association can be expected to work out in the future. Among these, Major Frost said, is the "creation of an irresistible desire on the part of the public to hear radio programs and the dissemination of propaganda designed to overcome seasonal depressions."

Other speakers at this session included Powel Crosley, Jr., Harold J. Wrape, president of the Federated Radio Trades Associations, and G. L. Noble, of the National Radio Farm Council.

Among the speakers at the various other sessions were Dr. E. A. White, director of the National Committee on the Relation of Electricity to Agriculture, who declared the best way to sell radio to the farmer is to give him programs of special agricultural interest which he can hear easily and clearly; John W. Griffin, president of the Haynes-Griffin Radio Stores, Inc., who declared the "successful radio merchants of the future are going to be culled first from the exclusive radio dealers of today who have the sense to add to their radio line, such other lines as will give them a fair volume during the summer months. It is my guess that there will be a higher percentage of present-day radio dealers who will succeed in the phonograph business than phonograph dealers who will succeed in the radio business."

Other addresses included "The Economics of Distribution," by L. H. D. Weld; "Patents Information," by Maxwell James; "Simplification in Indus-

try," by Edwin W. Ely of the Department of Commerce, and "Radio Conditions in Foreign Fields," by W. H. Lynas. Additional speakers included Jacob S. Arvey, chairman of the Mayor's Radio Commission of Chicago; Major-General C. McK. Saltzman, chief signal officer, U. S. Army; Dr. F. A. Fall, of the National Association of Credit Men; M. R. Hiler, of the Irvington Insulator Company; Dr. Vannevar Bush, of the Massachusetts Institute of Technology, and Robert Wise, of E. T. Cunningham, Inc.

Committee reports showed the organization to be growing rapidly and accomplishing much good work for its members and the industry at large. Membership now has reached 150, according to the report of Hugh Eby, chairman of the membership committee. A. J. Carter, chairman of the standardization committee, reported that definite steps have been taken to standardize a number of radio parts.

Officers elected to serve for one year were: President, Arthur T. Haugh, vice-president of the King Manufacturing Company; first vice-president, Carl D. Boyd; second vice-president, Hugh H. Eby; third vice-president, Leonard Parker; secretary, L. G. Baldwin, general manager of the Willard Storage Battery Company; executive secretary, B. W. Ruark; treasurer, Philip Lenz, Jr. Directors at large are: Carl D. Boyd, Powel Crosley, Jr., Vernon Collamore and E. F. MacDonald; Directors, Eastern Division, Hugh Eby, C. C. Colby, E. M. Squarrey, H. B. Richmond, Godfrey Gort, S. B. Trainor, D. H. Price and Herbert H. Frost; Directors, Western Division, Leonard Parker, T. K. Webster, J. A. Brennan, W. W. Dowdell, Harry Bradley, Jesse Hawley, Harry Simpson and Donald MacGregor.

The Bosworth Electric Manufacturing Company, Cincinnati, Ohio, has appointed Joseph Gerl, formerly connected with the Colonial Radio Corporation, general sales manager of the organization.

## Banquet Enjoyed by Convention Delegates

The outstanding social event of the Radio Manufacturers' Association convention at Atlantic City, was the banquet held Wednesday evening, May 12, at the Hotel Ambassador, which was attended by 600 members and guests of the association.

Major Herbert H. Frost, retiring president, and Arthur T. Haugh, newly-elected president, were prominent among the speakers. Herbert S. Houston, former president of the Associated Advertising Clubs of the World, Earl E. Whitehorne, of the McGraw-Hill Publishing Company, Inc., associate editor of *Radio Retailing*, *Electrical World* and *Electrical Merchandising*, and B. W. Ruark, executive secretary of the R.M.A., made stirring addresses and received hearty rounds of applause from the assembled guests.

The less serious side of radio was represented by Major J. Andrew White and Curtis A. Wessel, whose talks drew many laughs from the audience. Paul B. Klugh, chairman of the National Association of Broadcasters, made an acceptable toastmaster.

## Senate Recommends Independent Commission

The Interstate Commerce Commission of the United States Senate has recommended legislation establishing an independent commission to regulate broadcast licenses. On May 6th, the committee reported to the Senate and submitted a bill known as the White Bill, H. R. 9971.

Though the original White Radio Control Bill submitted to the Senate is practically completely revised the new bill retains the original name to expedite legislation. The outstanding characteristics of the bill are as follows:

1. A commission of five at \$12,000 a year salary, no person being or having been financially interested in, or an officer of a corporation financially interested in any phase of radio, being allowed to sit on the commission.



"— And a goodly crowd was there." Members of the Radio Manufacturers' Association, guests and publishers (mostly

publishers) lined up on the boardwalk at Atlantic City to have their picture taken during the RMA's second annual conven-

tion. And there wasn't a pair of ear-phones in the whole crowd. Quite a few loud speakers, though.

2. The station owner has no power of censorship or discrimination in regard to the use of stations by political candidates for public office, or for the discussion of any public question. In such cases the licensee shall be deemed a common carrier, in Interstate Commerce.

3. All government stations are allowed to accept commercial business at rates substantially the same as privately owned stations, so long as such business does not interfere with Government traffic.

4. No station can be sold for more than a reasonable value, and in no case for more than its original cost.

5. The commission is virtually the supreme authority, any aggrieved parties being allowed hearings on any questioned decision by the commission, after which the commission may affirm, modify or revoke its previous ruling.

6. Station licenses are for a period not to exceed two years.

Just what will happen to this measure is entirely a matter of speculation. On May 13th Senator Dill made an effort to gain its consideration but was unsuccessful.

### Buffalo Radio Trades Association

The Buffalo Radio Trades Association is one of the well-organized dealer associations in the east. The association has a broadcasting director, O. J. Stayley, who is the radio sales manager for Roth & Zillig, Inc., distributors of automotive equipment and radio sets. The officers of the association are as follows:

President, Thomas A. White, 108 Pearl St., Wholesale Radio Equipment Company; vice-president, Elmer Metzger, 149 Grant St., Medo Electric Company; treasurer, Mayer Goldman, 763 Main St., Haverford Cycle Company; secretary, Emil Sommer, 829 Michigan Ave., Eastern States Battery Corp.

J. B. Ferguson, Inc., announces the removal of its executive and sales offices from 3542 Forty-first Street, Long Island City, N. Y., to 225 West Fifty-Seventh Street, New York City. The factory will remain at the former

### "Radio Week" May Be Sponsored by the Industry

Next season's "Radio Week," if it is held at all, will be an industry affair, it was decided at a meeting of the International Radio Week Committee held during the RMA convention at Atlantic City. Powel Crosley, Jr., chairman of the committee, presided.

Financing of "Radio Week" will be done by radio manufacturers and a committee was appointed to interview manufacturers and secure funds for the purpose, every manufacturer contributing being entitled to a place on the committee. No definite date was decided for Radio Week and will not be decided until it is known whether the necessary funds will be forthcoming.

If held, Radio Week will take on the aspect of an industry week rather than an international broadcasting test week, it was decided, due to the failure of the 1926 international tests. The international tests will be subjugated to a "boost radio" movement, and will be held possibly on one or two nights only. More attention will be paid to the commercial value of the week and stress will be laid on the reception of distant United States stations, following out the suggestions made by the editors of *Radio Retailing* last year.

location. Demonstration and display rooms will be maintained at the new address.

The Driver-Harris Company, Harrison, N. J., announces the appointment of J. C. Bilek as Chicago district manager. Mr. Bilek has been with the Driver-Harris Company for sixteen years. H. D. Tietz, who has been with the Driver-Harris Company since his return from the World War will be associated with Mr. Bilek as assistant district manager in Chicago.

The Amplion Corporation of America, New York City manufacturer of Amplion loudspeakers, has appointed Herbert E. Mills, formerly connected with the Edison Company, Westinghouse and Brandes, Inc., production manager of its new plant. The concern is planning to produce 2,500 speaker units daily under Mr. Mills' supervision.



Here is one of the few photos of Frank A. D. Andrea that is in existence today. Mr. Andrea is reported to be extremely camera-shy, and enjoys having his picture taken as much as having a tooth pulled, which is nothing at all. However, on his return from a recent European trip, Mr. Andrea felt it necessary to doff the chapeau at Miss Liberty in New York Harbor and the cameraman sneaked up unawares.

### Andrea Resigns as Neutrodyne Head

Frank A. D. Andrea, head of F. A. D. Andrea, Inc., makers of Fada sets, has resigned as president of the Independent Radio Manufacturers, Inc., the organization composed of the licensees under the Hazeltine Neutrodyne patents. He remains on the board of directors of the corporation, after having served one full term as president and having been re-elected to serve a second term.

Mr. Andrea found it necessary to give up the presidency of the I. R. M. only because of the increasing pressure of business as president of his own company.

### Radio Jobbers Form Association

The Jobbers' Radio Association of America, Inc., an organization composed of radio wholesalers from all parts of the United States was formed at a series of meetings held at the Ambassador Hotel, Atlantic City, Tuesday and Wednesday, May 11 and 12.

The temporary personnel of the new organization is: A. J. Steelman, New York, chairman; Harry Alter, Chicago, vice-chairman; and W. C. Howe, New York, secretary and treasurer.

### Magnavox Distributors Attend Conference in Oakland

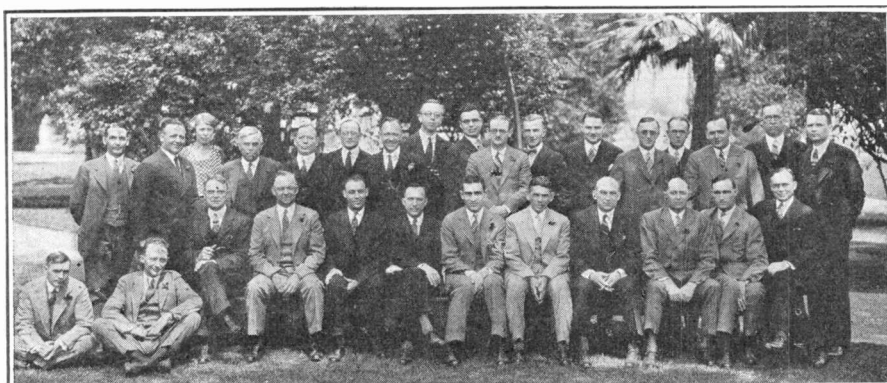

Fifteen distributors of Magnavox radio products and officials of the company were photographed on the grounds of the factory at Oakland, Cal., while at-

tending a recent conference. Distributors present were unanimous for the continuance of present set models during the ensuing season.

The Radio Manufacturers' Show Association is sponsor of the Third Annual Radio World's Fair, to be held in Madison Square Garden, New York City, September 13-18, also the Fifth Annual Chicago Radio Show in the Coliseum, Chicago, Ill., October 11-17. U. J. Herrmann is managing director and G. Clayton Irwin, Jr., general manager of the association.

## Lawyer Denies Chaotic Broadcasting Conditions

Irving Herriott, attorney for the Zenith Radio Corporation in the recent Government prosecution for alleged illegal broadcasting from Station WJAZ, denied the Wilkerson decision will cause a chaotic condition in broadcasting.

Mr. Herriott says, "The radio act of 1912, which is still in force, contains a very complete set of regulations, specifying allocations of wave lengths, means for the prevention of interference and other matters. Section 1 of the law provides that no person may operate a radio station without first obtaining a license so to do from the Secretary of Commerce and that any person who shall operate a station without a license shall be punished by a fine not exceeding \$500 and his apparatus forfeited to the United States. Section 2 provides that every such license shall be subject to the regulations contained in the law itself. Section 4 contains these regulations which are declared to be for the prevention or minimizing of interference.

Regulation 1 provides that every station shall be required to designate a certain definite wavelength as its normal sending wave, which shall not exceed six hundred meters.

Regulation 2 provides that in addition to this normal sending wavelength any such station may use other sending wavelengths, except as otherwise provided in subsequent regulations. That exception is most important.

Up to this point in the regulations you will note it is provided that each station shall designate its own normal wavelength and may use other wavelengths if it desires, except as otherwise provided. Regulation Fifteen explains that exception and creates the limitation which is our protection from the chaos which the Secretary of Commerce has predicted. Regulation Fifteen is as follows: No private or commercial station, (and that means broadcasting stations as well as code stations), not engaged in the transaction of bona fide commercial business by radio communication or in experimentation in connection with the development and manufacture of radio apparatus for commercial purposes shall use a transmitting wavelength exceeding two hundred meters, *except by special authority of the Secretary of Commerce contained in the license of the station.*

The great majority, I say at least 95 per cent of the broadcasting stations in the United States, today are not engaged in either bona fide commercial business by radio communication or in experimentation in connection with the development and manufacture of radio apparatus for commercial purposes. The Zenith Radio Corporation is engaged in experimentation in connection with the manufacture and sale of radio apparatus for commercial purposes and therefore comes within the special restricted class which has the right to use any wavelength under these regulations, provided it does not exceed six hundred meters. No other type of broadcasting station has the right to use a wavelength in excess of two

hundred meters unless the Secretary of Commerce specifically and specially authorizes such station to use a higher wavelength. It is only by reason of special authority granted by the Secretary of Commerce that the great majority of broadcasting stations are today authorized to transmit on a wavelength in excess of two hundred meters.

## New Factory for A C Electric

The A C Electrical Manufacturing Company, makers of A C Dayton radio receivers is now located in its new four-story factory in the heart of Dayton, Ohio. The new plant is ideally located and shipments to all parts of the United States and Canada may be made on short notice. Jacob W. Sands has been appointed eastern sales manager of the company and will cover the states of New York, New Jersey, Pennsylvania, Delaware, Maryland, Virginia and the Carolinas.

The Graybar Electric Company, formerly the supply department of the Western Electric Company, announces the following changes in its staff organization. W. O. Ramsburg has been appointed general service manager, G. E. Chase, broadcasting sales manager; A. J. Eaves, carrier telephone sales manager, and R. M. Hatfield, public address sales manager. C. E. Reddig has been appointed appliance engineer of the company, and W. A. Fouhy, as the new plant engineer, will supervise construction and maintenance of all company owned or leased buildings and permanent fixtures.

Resas, Inc., 556 West Fifty-second Street, New York City has announced that its sales in the metropolitan New York district will be made directly to the retailer. This wholesale distributor elimination applies only to this district and jobbers will be retained in all other territories.

The Radio Distributing Corporation, Newark, N. J., wholesale distributor of radio, has opened a branch office and warehouse at 226-228 South Warren Street, Trenton, N. J., under the management of Ogden Williams.

## Pacific Northwest Exposition

Sponsored by the Oregon Radio Trades Association, an organization which consists of 125 active trade members, the Pacific Northwest Radio Exposition will take place from September 20-25 in the Portland Civic Auditorium, Portland, Ore.

12,500 sq.ft. of floor space and 84 booths are available for this exposition and an attendance of approximately 75,000 is expected, based upon the reception given the initial exposition held last year in the largest hotel in Portland.

According to a recent estimate by the Department of Commerce only 3,251 farms out of the 55,908 in the state of Oregon have radio sets. The estimate further states that there are 6,000 tractors and approximately 75,000 automobiles in this section, which would indicate good potential market possibilities.

The Canotex Company, Auburn, N. Y., has been licensed by the Walbert Manufacturing Company of Chicago, to manufacture the Univernier Dial, Straight Line Frequency Dial, Safety Time Socket and the Isodon balancing condenser. The manufacturing change will not affect the usual marketing policy in connection with these products.

The Broadcasting Company of America, Inc., is the name of a new subsidiary company, the capital stock of which is owned by the American Telephone and Telegraph Company, which has been organized to direct the broadcasting activities of station WEAJ, New York City. According to the announcement, the formation of this separate unit was desirable in view of the growth of the activity and the special nature of the service.

The DeJur Products Company, 199 Lafayette Street, New York, has been admitted to membership in the Radio Manufacturers' Association.

The Tobe Deutschmann Company, Cornhill, Mass., has secured exclusive distribution rights in the United States for Loewe Leaks, which are sealed metallic resistors designed and developed by Siegmund Loewe of Berlin.



"Doug" Rigney, famous yachtsman and vice-president of the A. H. Grebe Company, Richmond Hill, New York, recently officiated at the launching of his new yacht, the MU-1, which is equipped with

a complete broadcasting outfit and will be used to broadcast boat races of all sorts. Its call letters are WRMU. Mr. Rigney is shown giving "mike" its first test.

## Rockford, Illinois, Dealers Organize

Twenty-two radio dealers were represented at a meeting held in Rockford, Ill., April 26 for the purpose of organizing a local radio trade association. R. A. Roberts of the Majestic Electric Company arranged the meeting and acted as temporary chairman. N. C. Beerend, vice-president of the Federated Radio Trade Association addressed those present. The constitution and by-laws of the new association are to be modeled after those governing the Wisconsin and Northwest Radio Trade Associations.

The Bruno Radio Corporation, which formerly maintained its executive offices in New York City and a factory for the manufacture of radio equipment in New Haven, Conn., has now incorporated these two divisions under one roof in a new plant at 40 Paynter Avenue, Long Island City, N. Y. The new building is of modern concrete construction and 6,500 ft. of floor space is now available for the manufacture of low-loss inductances, condensers and other radio equipment.

The Electric Service Supplies Company has moved from its former location in the Oliver Building, Pittsburgh, Pa., to new and larger quarters in the Bessemer Building, Room 1123, of that city.

L. F. Vollmer, for the past ten years manager of the Cincinnati branch of the Ohio Rubber & Textile Company, announces the severance of his connection with the company and also the retirement of the company from the Cincinnati territory.

Listenwalter & Gough, Inc., with offices in San Francisco and Los Angeles, Cal., have been appointed distributors of Magnavox radio products in California, Arizona and that portion of Nevada west of Winnemucca.

The Tafel Electric Company, Louisville, Ky., has opened a branch office and supply terminal at 616 Broad Street, Chattanooga, Tenn. Tennessee east of Nashville, Virginia, Georgia, and Alabama will be served from this branch which is in charge of Sidney Steinau.

The Bright Star Battery Company, Terminal Building, Hoboken, N. J., is expending \$100,000 in equipping an adjoining building for the production of the dry cell batteries which it manufactures. The first six floors and an additional floor and a half in the building it now occupies will be equipped with modern conveyor systems and elevators capable of transporting a fully loaded truck to all floors, with an additional floor space of approximately 165,000 square feet. The two buildings will be connected by a passageway and will be ready for occupancy early in July.

The Clapp-Eastham Company, formerly located in Cambridge, Mass., has moved its entire plant to the Chicle Building, Thompson Avenue, Long Island City, N. Y. According to Verner A. Hendrickson, president of the organization, this move was necessary in order to secure a better location for national distribution and necessity for larger quarters.

The Acme Electric and Manufacturing Company, 1444 Hamilton Avenue, Cleveland, Ohio, has received official notification from the U. S. Patent Office of the registration of its trademark, "Acme" to be used in connection with motor-generator sets, battery chargers, etc., which the company manufactures.

E. H. Wilkinson, formerly general manager of the Jewett Radio and Phonograph Company, has joined forces with Vaughn E. Morrison, manufacturer of loud speaker units, in the formation of the Pontico Corporation. The new concern will engage in the manufacture of various radio parts and

will also supply speaker units for manufacturers. The headquarters will be at Pontiac, Mich.

The Ace Radio Electric Company, radio retailer, is now located at 252 Asylum Street, Hartford, Conn. A complete line of radio apparatus and electrical fixtures and supplies will be stocked.

The Fifth Annual Detroit Radio Show and trade convention of Michigan retailers is scheduled to be held in Convention Hall, Woodward Avenue at Forest, Detroit, Mich., October 25-31. The convention will be held October 27-29. Approximately 73,000 sq.ft. is available for exhibits in this exposition, sponsored by the Radio Trade Association of Michigan.

Fred. D. Williams has resigned as general sales manager of the Music Master Corporation, Philadelphia, and is now associated with the Charles Freshman Company, manufacturer of the "Masterpiece" receivers, as Western sales manager with headquarters in the Chicago office.

Harold Herbert, Inc., is the name of a new corporation now manufacturing radio receivers of the five-tube type with factory at Long Island City, N. Y. Harold Herbert, president, is designer of several well known receivers. William Schatzkin has been appointed treasurer and vice-president, and N. H. Herbert, secretary.

R. W. Cameron & Company, 23 South William Street, New York City, exporter to Australia and New Zealand, is interested in securing information pertaining to new developments in design and manufacture of radio receivers and associated equipment and asks that its name be placed on manufacturers' mailing lists for such announcements.

E. F. Brazeau has been appointed sales representative by the Jefferson Electric Manufacturing Company, Chicago, to cover the eastern United States territory, with headquarters at 32 West 75th Street, New York City.

Ralph Bretzner, manufacturers' representative handling the products of the Van Horne Company, the Air-Way Electric Appliance Corporation, and the Selector Company of Seattle, Wash., has moved his office from 128 West Forty-second Street, New York City, to 160 West Forty-fifth Street, suite 40.

LeMor Radio, Inc., is the name of a new Asbury Park, N. J. firm which manufactures the LeMor Uni-Control Receiver. Harold M. Lewis, and M. S. Moore head the organization.

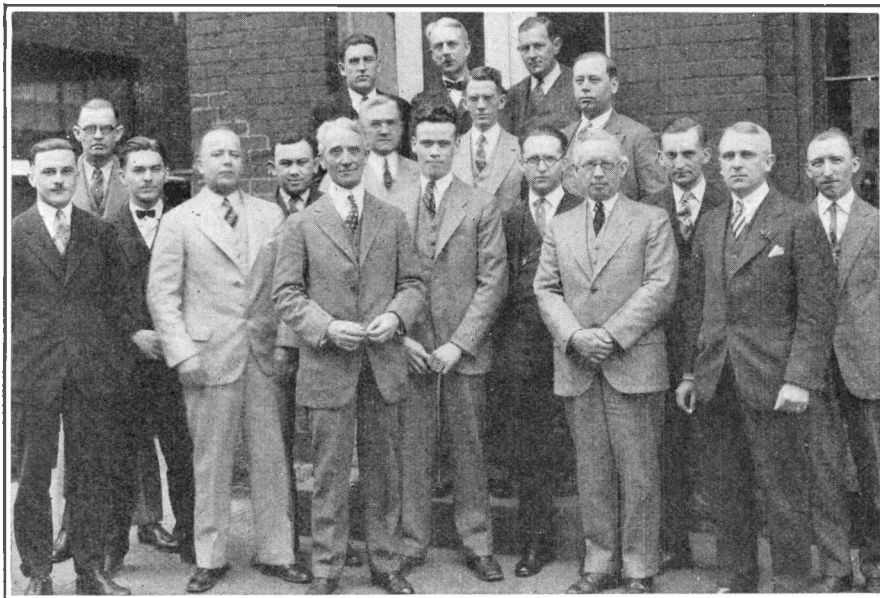

A convention of executives and district sales managers was held during the week of April 26 in the new factory of the A-C Electrical Manufacturing Com-

pany, Dayton, Ohio. O. H. Bosler, president of the organization addressed the convention relative to the merchandising policy of the company.

Roscoe Bean, manager of the Liberty Metal Products Company, Berea, Ohio, well-known manufacturer of radio loud speakers and motorcycle and auto accessories, died at his home in Berea, April 3, 1926, aged 76 years. He is survived by a wife, daughter, and son.

# New Dealer Help Material

Aids to greater profits provided by  
radio manufacturers for their dealers

## Latest Stewart-Warner Dealer Help Broadside

Authorized Stewart-Warner dealers will be interested in this reproduction (below) of the latest dealer help broadside of the company. Fig. 1 is a large replica of a 26 in. x 24 in. clock, following out the familiar "Round-the-Clock" division of broadcasting features which is used in all of the concern's advertising copy. The card is easel backed, colored in mahogany brown, red and yellow and is used as a window display centerpiece. Fig. 2 shows a 12½ in. x 18½ in. card which comes equipped with several photographic inserts similar to the one shown but depicting a radio receiver in an entirely different home scene, which may be slipped into the frame provided in order to change the display periodically without discarding the original frame. Two of these cards and photo inserts are furnished with each display kit.

In Fig. 3, the streamer caption for the window, finished in brown and yellow in conformity with the balance of the display material, is shown. The streamer is 6 in. x 37 in. and may be attached to the display window by means of small pasters provided. Two circular posters like that shown in Fig. 4 are 10 in. in diameter, printed on white stock with a narrow red border. Fig. 5 illustrates the small 18-page booklet furnished in quantity, which may be used on the store counter or for mailing purposes and contains pictures of Stewart-Warner receivers in various

home scenes as well as a complete illustrated line of the company's products with their prices.

The Glenn L. Martin Company, Cleveland, Ohio, manufacturer of the Aero B Battery Eliminator, furnishes an attractive 14½ in. x 19 in. display card, equipped with an easel back and a metal eyelet at its top, which is self supporting or may be suspended. The card shows an eliminator, a receiver and a loudspeaker in the original colors against a brilliant blue background. A few books and a vase of flowers add an artistic, homelike touch.

The Amel Radio Laboratories, Inc., 173 Greenwich Street, New York City, has issued a two-page folder, catalog 3-A, in which several of its radio products are illustrated. Details of several constants which the company manufactures are given and prices are listed.

The Birnbach Radio Company, 370 Seventh Avenue, New York City, manufacturer of the Birnbach line of battery cables, extension cords and other radio accessories, has released an illustrated price-list.

The Boudette Manufacturing Company, Revere, Mass., says "Stop-Look-Listen" on the cover of the 7 in. x 12 in. folders which it is distributing to dealers to aid in the sale of Sonochorde speakers. The folder is printed on buff stock and a space is provided for the dealer's imprint.

## An Amperite for Every Tube

Tubes with entirely different filament characteristics have appeared with such rapidity of late that the Radiall Company, New York City, manufacturer of Amperite self-adjusting rheostats supplies dealers with small wall charts which show at the glance the resistance best suited for use with the various types of vacuum tubes.

The Aluminum Company of America, Pittsburgh, Pa., has prepared for general distribution an extremely interesting and useful 47-page booklet called "Aluminum for Radio," in which the advantages of this metal in radio construction are outlined and illustrated in colors. The book contains useful general information such as tables by which inductance and capacity may be computed and the explanation of the theoretical function of vacuum tubes.

The Pressed Metal Manufacturing Company of Waukesha, Wis., manufacturer of the "Redi-mast" antenna support has devised a unique display stand by which these supports, which are too large to be shown in the store, may be shown to customers. This display is in the form of a small reproduction of the mast, approximately two feet high, mounted on two boards which are fastened together to represent the top of a peaked roof. On the top of this stand which may be placed on the store counter, is a small colored pennant bearing the trade name of the product.

The Yaxley Manufacturing Company, 217 North Desplaines Street, Chicago, Ill., has devised a 5½ in. x 8½ in. chart, which may be hung on the store wall, showing at a glance the type and resistance of the Yaxley rheostat best suited for use with a given vacuum tube. The chart is printed in orange and blue on white stock and is equipped with a mounting eyelet.

The Listen-In Company, 115 Federal Street, Boston, Mass., manufacturer of the Talking Book crystal receiver, supplies an 11 in. x 17 in. dealer help card which is printed in black and red on substantial stock and bears photographic illustrations of the receiver in various positions.

The French Battery Company, Madison, Wis., manufacturer of the Ray-O-Vac dry cell battery, supplies dealers with small booklets which may be used as throw-aways or as mailing circulars. The last three pages of this leaflet contain much useful information on "how to get longer life from your batteries" and is well illustrated. Space is provided on the cover for the dealer's imprint.



Some of the Stewart-Warner dealer helps explained above

The Pfanstiehl Radio Company, Chicago, manufacturer of the Overtone radio receiver, has a supply of attractive pennants on hand which are loaned to authorized dealers for special occasions. These banners, bearing the name, "Pfanstiehl," are made of cloth and are attractively colored in blue, white and purple enhanced by gold fringe. They are about five feet long by three feet wide, and make an outstanding centerpiece when used in the display window or in the booth at a local show.

The Bremer-Tully Manufacturing Company, Chicago, Ill., has issued the ninth edition of its small booklet entitled "Better Tuning." Its seventy-odd pages are devoted to progressive explanations of radio sets from the "crystal to radio frequency amplification," and many popular hookups and general information are given.

The Marle Engineering Company, Orange, N. J., supplies 7 in. x 3½ in. circulars which describe the new Marle type A23 impedance audio amplifier unit and the method of installing this unit in conjunction with receivers using standard transformer coupling. These circulars may be used as throwaways and are of a size conveniently placed in standard size envelopes for mailing purposes.

The C. E. Manufacturing Company, Inc., 702 Eddy Street, Providence, R. I., manufacturer of Ceco tubes, has published a pamphlet explaining in non-technical terms, the theory of the operation of the vacuum tube. Numerous processes in the manufacture of tubes are photographically illustrated in this booklet which also contains much useful general radio information.

The Brandes Products Corporation, 200 Mt. Pleasant Avenue, Newark, N. J., is distributing 19½ in. x 24 in. posters

## R. C. A. Starts "Nickel-a-Day" Poster Service

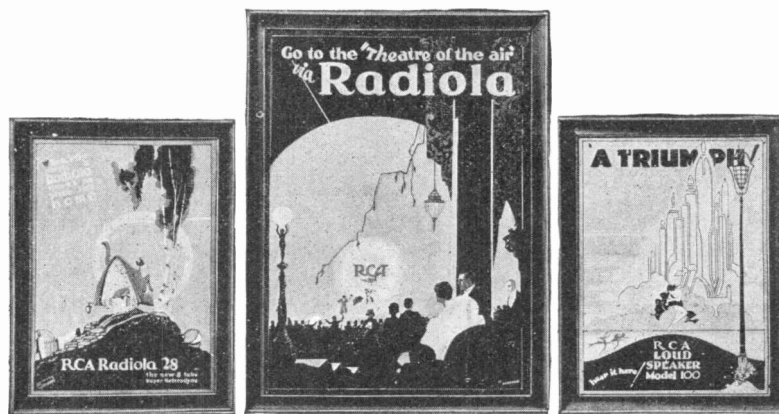

These three posters are the opening guns of the "Nickel-a-Day" art poster service which has been started by the Radio Corporation of America and have been sent to retailers free of charge as an introduction. As the name implies, this service, consisting of three attractive frames to be re-

tained permanently by the dealer and three colored oil paintings per month, is available at a cost of \$18 per year. The posters may be used indefinitely as each is executed by hand in oils, retaining its finish and color. The center frame measures 24 in. x 34 in. and those on either side 17 in. x 24 in.

printed on white stock in red and black on which the Brandes line of speakers and phones is reproduced. Each article is allotted a 5-in. square on this poster which may be displayed in the store window. Prices of the instruments are listed on the reverse side.

Consumer inquiries received at the offices of the Crosley Radio Corporation, Cincinnati, Ohio, in response to national advertising, will in the future be forwarded direct to authorized dealers instead of to wholesale distributors who were formerly given these leads to make their own local-trade distribution.

The Belden Manufacturing Company, 2300 S. Western Avenue, Chicago, Ill., aids its dealers in the sale of Belden

wire products by supplying attractive window-display equipment. The display furnished consists of a large 24 x 36-in. "centerpiece" card, four triangular window corner posters and a number of small easel-backed counter cards. When used together this material forms an attractive and inexpensive window. A small pamphlet called, "Helpful Hints for Radio Fans" is also available at a cost of fifty cents per hundred. Space is left on the cover of this fifteen-page booklet for the dealer's imprint.

The Magnavox Company, 2725 East Fourteenth Street, Oakland, Cal., has announced the periodical publication of an official organ, called, "the Magnagram." These issues will be numbered, punched for filing purposes and will serve as a "clearing house" with as many contributing members as there are Magnavox dealers, for personal sales experiences, ideas, publicity stunts, comments and criticisms. Thus the entire organization of Magnavox retailers throughout the country will aid each other.

The L. S. Brach Manufacturing Company, Newark, N. J., supplies advertising material designed to increase the sale of lightning arresters which it manufactures, in the form of small booklets called, "Why the Vacuum?" in which various types of arresters are described and the principles of operation and installation given. Easel-backed counter cards, about 12 inches high and colored in orange and blue, providing for the display of an actual arrester, are also furnished.

Harry Alter, wholesale distributor of radio sets and equipment, Chicago, Ill., has issued a 1926 summer catalog. This issue, which consists of 46 pages describing and illustrating the products of over 25 manufacturers, measures 9x12½ inches and is now available to retailers. Wholesale prices only are quoted.

The Universal Radio Company, 359 East 149th Street, New York City, distributor of standard radio equipment, has brought out a catalog listing all merchandise available to the retailer during 1926. This catalog is well illustrated and prices are listed.

## Window Display Supplied by Stromberg-Carlson

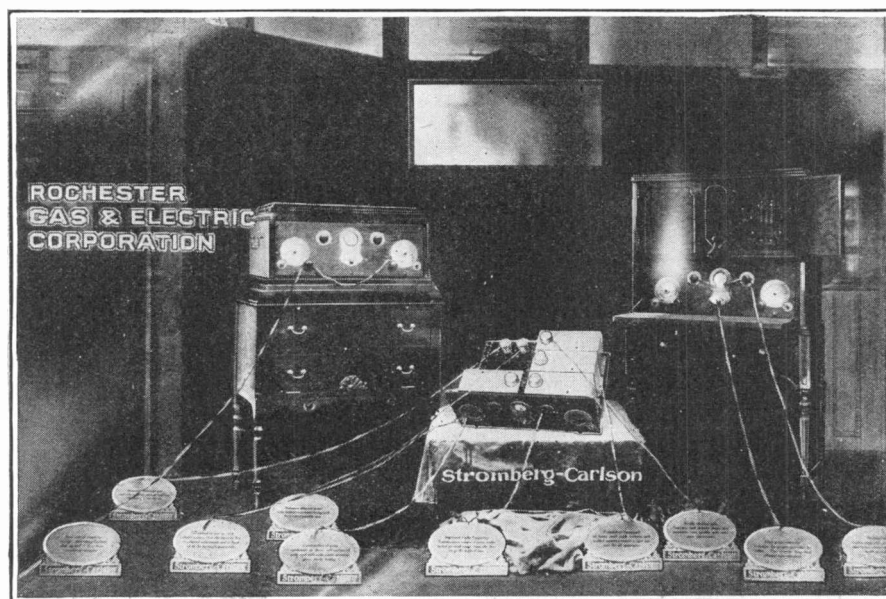

The Stromberg-Carlson Manufacturing Company, Rochester, supplies the window display cards as shown above in use in the window of the Rochester Gas and Electric Corporation. Each one of the ten cards bears a description of some feature of the receiver and is equipped with a ribbon

which may be run to the part described, forming an effective tie-up. The series, which is furnished on request to all authorized dealers, is used to best advantage in conjunction with a receiver chassis and one or two sets in cabinets as shown. Each card is equipped with a cardboard stand.



# Better now for \$9<sup>75</sup> than it was in 1920 for \$85

Recall that in 1920 a one-tube radio sold for \$85. Today Crosley makes a better one for \$9.75 (The Crosley Pup). There's the picture of Crosley manufacturing genius.

This year will see the millionth Crosley radio set produced. And somewhere, the first hundred still bring constant pleasure and satisfaction to their owners. Only this winter, one of Crosley's early one-tube radios won a nationwide radio reception contest, in which one-tube sets of all makes and dates were entered.

Powel Crosley, Jr., has so improved tuned radio-frequency circuits in the present Crosley radios that dealers the

country over have become wildly enthusiastic over their performances. "The only sets selling this Spring," writes one dealer. "The first set to beat my pet. . . .," says another. "How can Crosley do it for the money!" exclaims a third. "Doing six times the volume this Spring we did all winter," is another report.

These new Crosley sets are truly wonderful, for they not only represent a tremendous forward step in radio development, but are offered for less than even the close-out prices placed on questionable and obsolete sets.

Insure a "boom" summer with Crosley radios.

*Prices slightly higher west of the Rockies*

Write Dept. 130 for complete details of Powel Crosley, Jr.'s, latest and greatest triumph and of the Crosley dealer franchise.

**THE CROSLY RADIO CORPORATION, CINCINNATI, OHIO**

Powel Crosley, Jr., President

Owning and Operating WLW, first remote control super-power broadcasting station in America

# CROSLY RADIO

*Better - Costs Less*

Manufactured under Armstrong U. S. Patent No. 1,113,149, or under patent application of Radio Frequency Laboratories, Inc.



Mass manufacturing operations on the million scale has so saved pennies in production that the public sees them reflected in dollars saved on the retail prices of Crosley radios.

One great example of this is the Crosley Musicone.

Its success created so great a demand that a saving to the public of \$2.75 was soon effected through increased production. Today it is the fastest moving item in radio—its quality of reproduction and its low price is inducing the rapidly by which it is replacing thousands of other type speakers.

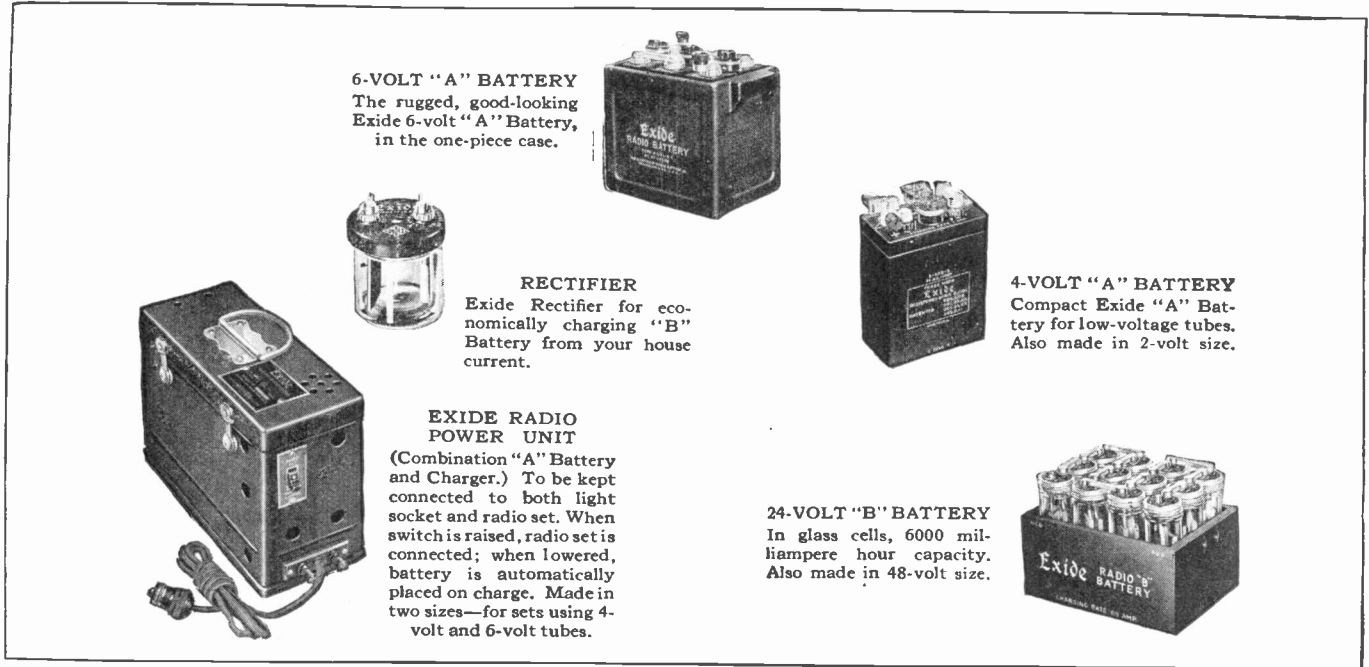

**6-VOLT "A" BATTERY**  
The rugged, good-looking Exide 6-volt "A" Battery, in the one-piece case.

**RECTIFIER**  
Exide Rectifier for economically charging "B" Battery from your house current.

**EXIDE RADIO POWER UNIT**  
(Combination "A" Battery and Charger.) To be kept connected to both light socket and radio set. When switch is raised, radio set is connected; when lowered, battery is automatically placed on charge. Made in two sizes—for sets using 4-volt and 6-volt tubes.

**4-VOLT "A" BATTERY**  
Compact Exide "A" Battery for low-voltage tubes. Also made in 2-volt size.

**24-VOLT "B" BATTERY**  
In glass cells, 6000 milliampere hour capacity. Also made in 48-volt size.

# These batteries sell themselves

*The name Exide is so well known to amateurs and experts alike that you never really have to push these batteries*

**W**HEN a customer wants a radio battery, just put an Exide on the counter — and your sale is half made.

It doesn't make any difference whether the customer is an expert on radio, or an amateur. He'll know the name Exide; he'll know that you are showing him a good battery.

Exide Batteries have gained such a reputation in other fields for steady, reliable service—they are so well known, even to people who have never actually used them—that the name Exide on a radio battery convinces the customer at once that it is a dependable product.

This is why radio dealers who want a quick turnover like to handle Exide Radio Batteries. Exides are favorably known and easy to sell. They always more than do the job expected of them.

# Exide

**RADIO  
BATTERIES**

THE ELECTRIC STORAGE BATTERY COMPANY  
PHILADELPHIA

Exide Batteries of Canada, Limited, 153 Dufferin Street, Toronto

FOR BETTER RADIO RECEPTION, USE STORAGE BATTERIES



# Your Business Protected on This New Line

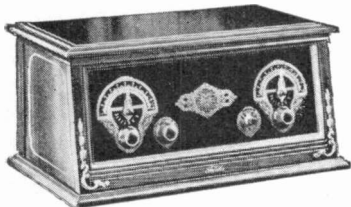

THOROLA MODEL 57

A five-tube receiver with famous doughnut coils and positive two-dial vernier control, in a beautiful genuine walnut cabinet—arranged to take power tube in last stage—distinctive in appearance—the newest thing in performance. Price \$60.

THOROLA 4 SPEAKER



The standard of loud speaker reproduction. Controlled Mica diaphragm and powerful magnet builds the faintest radio impulse into giant sound with all the true tone qualities of the broadcasting station itself. Price . . . . . \$25



THOROLA MODEL 58

It embodies the same super-excellent circuit as Model 57. With built-in Thorola Speaker and tone chamber. An exquisite compact console, beautifully finished in rich walnut following closely the Tudor design. Price . . . . . \$125

Thorola dealers will plunge into next season's business armed and protected by exclusive dealer franchises. If you have a Thorola franchise all the Thorola business in your territory is *yours*—and there will be a lot of it with the new Thorola line.

The famous Thorola Circuit is now embodied in three new beautiful models that challenge comparison with any radio made. They represent values that radio buyers cannot and will not overlook. And your profits are protected by an unflinching dealer policy.

Let us write you the full details of our new plan and of our new line of receivers and speakers. Thorola will be distributed through selected jobbers, located conveniently to give you service and immediate delivery. If your territory is still open we honestly believe that there is an opportunity to make the real money that you have always wanted to make in radio. Write or wire today. We will answer just as promptly.

REICHMANN COMPANY  
Address Dept. C, 1725-39 W. 74th Street, CHICAGO



THOROLA JUNIOR 12

It is extremely sensitive to faint signals, and the unique method of control is responsible for the Junior Model's excellent tone quality, making it ideal for smaller apartments. Price \$15.

Prices slightly higher west of the Rockies

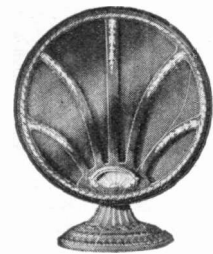

THOROLA CONE No. 9

The dual diaphragm construction exactly reproduces every note with glorious musical timbre. It has plenty of reserve volume. In artistic beauty of line the Thorola Cone stands apart. It is a beautiful work of art, harmonious with any furnishing. Price \$20.



THOROLA MODEL 59

In addition to the regular Thorola circuit this model is cunningly designed with two spacious tone chambers containing the Thorola 4 Speaker and the Thorola Cone No. 9. A beautiful compact console of Tudor design, finished in fine walnut. An ideal radio receiver for the small city apartment or the spacious country house. Price \$185.

# Thorola

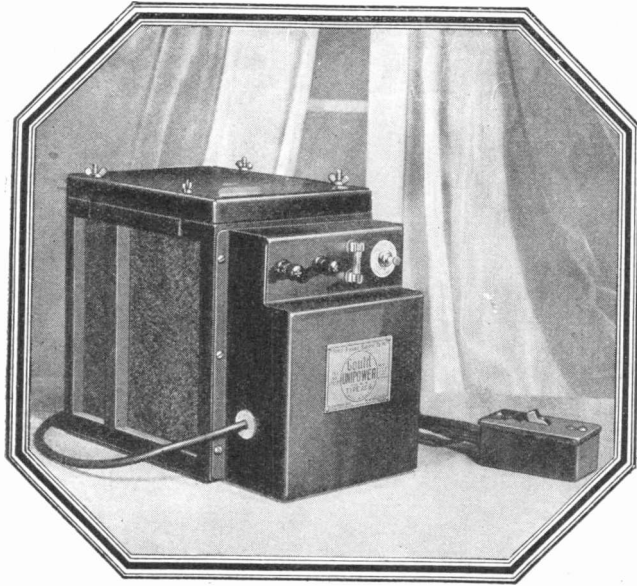

## Let Unipower speed up those slow summer sales

The winter sales peak of complete sets is past. During the summer months, radio dealers want some product that will really sell.

That's why dealers are stocking Unipower—radio's first complete "A" power unit. People are going to use their radios all summer, and there is a market for anything that will improve warm-weather reception.

One of Unipower's best selling points is the fine quality of tone, the quiet, unfailing power it gives to any radio set. The moment your customers see it in action, and hear the splendid results of its smooth, modulated current, they will be interested. And when you tell them its economies, and outline the trouble and bother it will eliminate, your sale is made!

Accurate figures prove that Unipower sales do not slow down with radio sales generally. With a little attention, Unipower will become your best selling summer line.

Unipower is supplied in two models for use with 110-125 volt A.C. Standard models are for 60 cycle. (Special models, 25-50 cycle, are available at slightly higher prices.) All are equipped with special Balkite rectifying element. The 4-volt model is for 199 tubes or equivalent and retails for \$35; the 6-volt for 201-A tubes or equivalent, retails for \$40. (West of the Rockies, prices are \$37 and \$43.)

THE GOULD STORAGE BATTERY CO., Inc.  
250 Park Avenue, New York  
Branches: Chicago, Kansas City, San Francisco

# Unipower

Off when it's on—On when it's off

## It's Good Business —Guarantee Radio Satisfaction with a WESTON

### Pin-Jack Voltmeter

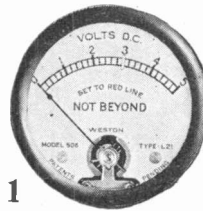

1

1. Dial of Pin-Jack Voltmeter. There's a red mark at three volts on the dial. Just turn the battery setting knob until the pointer of the voltmeter reaches the red mark. That's all!

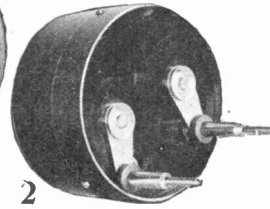

2

2. Rear of Pin-Jack Voltmeter showing adjustable Pin-Terminals for plugging into the new Radiola, Victor and Brunswick Superhets.

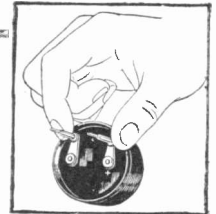

3

3. No tools, no trouble, no adjustments.

4. Three seconds to plug-in.

5. Installed: Adds beauty to any set.

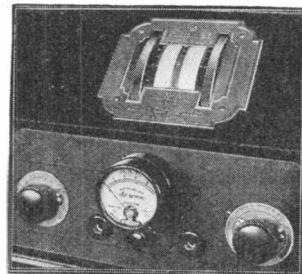

5

**POSITIVE** set control! ¶ This instrument insures the use of tubes at proper filament voltage, makes possible economical use of batteries, gives the best radio reception. ¶ It does away with 90% of radio trouble and it will cut your dealer servicing costs—just 90%!

¶ For further information address—

WESTON ELECTRICAL INSTRUMENT CORPORATION  
25 Weston Avenue, Newark, N. J.



STANDARD THE WORLD OVER  
**WESTON**  
Pioneers since 1888





## Customers specify Evereadys

MR. D. ULRICH, operating one of Brooklyn's oldest radio shops at 1235 Myrtle Avenue, Brooklyn, New York, says: "If 4 out of 5 have pyorrhea, then 99 out of 100 have Eveready Radio Batteries on their radio sets. When radio first took hold of the public, Eveready Radio Batteries were in the fore and they have remained there ever since. This is not hearsay, for the actual proof comes in wrapping them up to the music of the cash register,

"The Eveready line has been one of the most, if not the most, profitable in our store. With your continuous national advertising, I can safely say that sales resistance has taken a K. O. Nearly everyone specifies Evereadys."

Tuesday night means Eveready Hour—  
8 P. M., Eastern Standard Time, through  
the following stations:

WEAF—New York	WGR—Buffalo	WGN—Chicago
WJAR—Providence	WCAE—Pittsburgh	WOC—Davenport
WEEL—Boston	WSAI—Cincinnati	WCCO { Minneapolis
WTAG—Worcester	WTAM—Cleveland	{ St. Paul
WFI—Philadelphia	WWJ—Detroit	KSD—St. Louis

Eveready Radio Batteries are fast-turning, profitable items. Order from your jobber.

*Manufactured and guaranteed by*  
NATIONAL CARBON Co., Inc.  
New York                      San Francisco  
Atlanta                      Chicago                      Dallas  
                    Kansas City                      Pittsburgh  
Canadian National Carbon Co., Limited  
Toronto, Ontario

**EVEREADY**  
**Radio Batteries**  
*—they last longer*

# Watch For It!

The July issue of RADIO RETAILING will contain complete radio set specifications and manufacturers' announcements of new model sets, parts and accessories for the season 1926-1927. This issue will be a veritable handbook and buying guide and will aid the jobber and dealer in the selection of new lines for the coming season.

*Watch for the July Issue—*

## RADIO RETAILING

The Business Magazine of the Radio Industry

—a McGraw-Hill Publication

473 Tenth Avenue, New York City

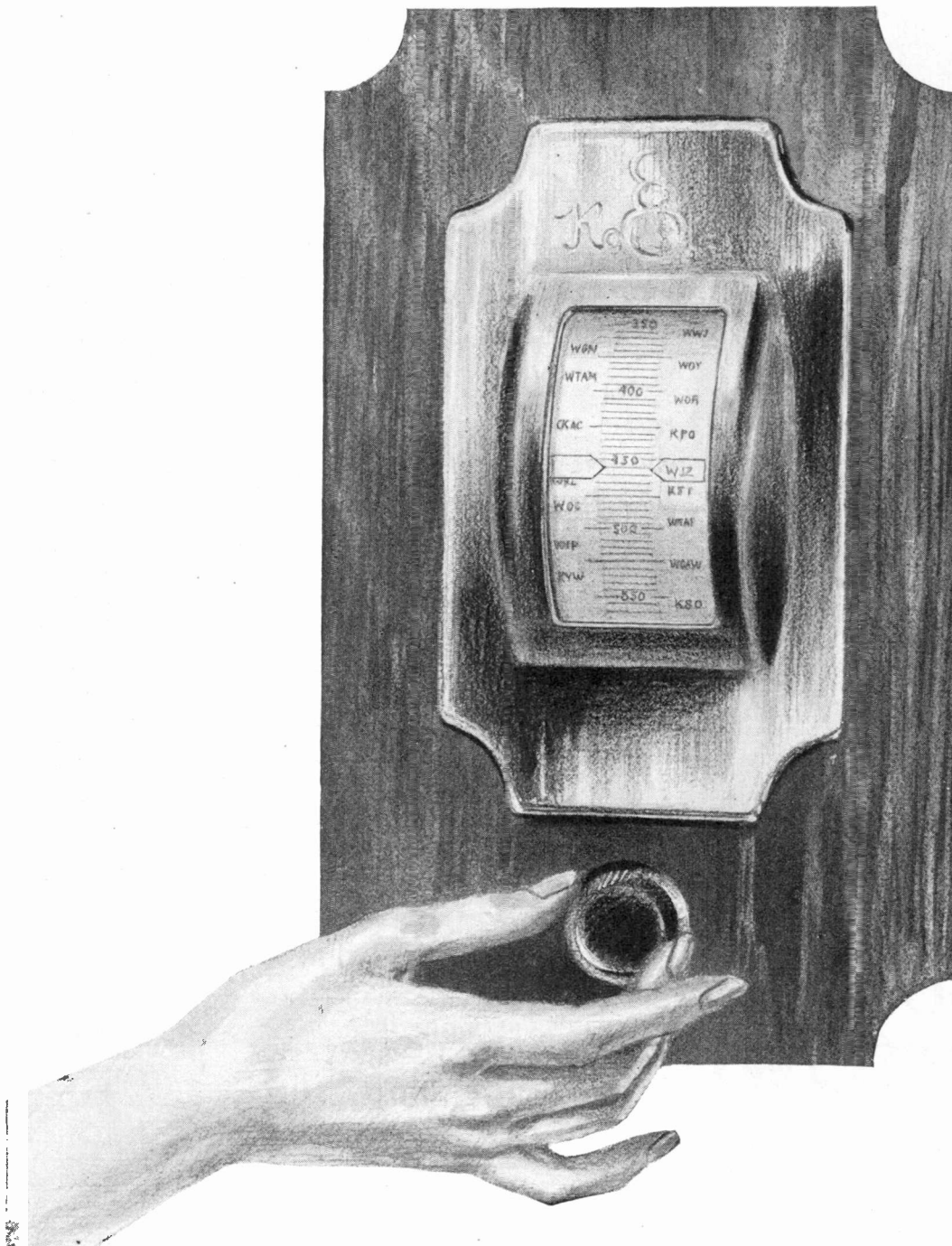

Kolster merchandising this fall will again be one of co-operation with jobbers and dealers, including always national advertising, telling the millions of Kolster simplicity and Kolster super-reproduction.

FEDERAL TELEGRAPH COMPANY  
(of California)  
Woolworth Building, New York City

# KOLSTER RADIO

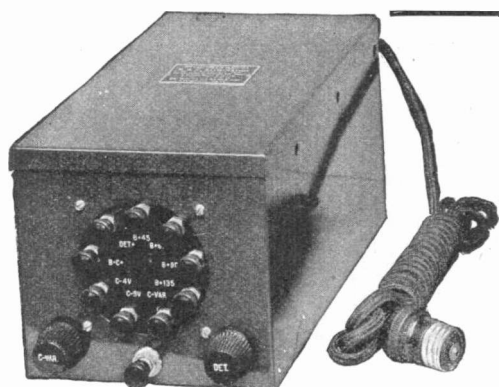

Patents Pending

## This is the New B&C Eliminator which is taking the trade by storm

Watch for the *radiola special*  
made to fit the models 25 and 28

### Note These Features

Type A Amplifier voltages in steps 45, 67½, 90 and 135 volts. This voltage and the accompanying current capacity are sufficient to operate any set on the market. Also *critical* detector voltage adjustment from 0-65 volts. Fixed "C" taps of 4½ and 9 volts and in addition a variable voltage adjustment for "C" current of from 4-40 volts. Think of the flexibility obtained! All this in a very neat, compact case at the low price of \$42.00. Type "B" is a less expensive eliminator giving variable voltage for the detector from 0 to 65 volts and 45, 67½ and 90 volts for the amplifiers. Price \$35.00. Both work on 110 volts, 60 cycles, A.C. with no hum and are guaranteed against all defects.

Let us send you literature so you can plan for boosting summer sales.



**Your customers  
appreciate this**

The fact that they can have their tubes quickly tested and matched appeals to your customers. This Dynamometer gives all important tube characteristics and perfect matching immediately *without calculation*. Send for description.

DEWITT LAFRANCE CO., North Cambridge, Mass.

CHICAGO REPRESENTATIVE: William A. Welty & Co., 36 So. State St.

# Goodrich Silvertown

*The Radio Panel Supreme!*

- 1 Easier to drill and machine.
- 2 Better color, lasting lustre.
- 3 Lower free sulphur — no discoloration.
- 4 Higher softening point—no warping.

Goodrich V.T. Sockets Spaghetti Tubing  
Radiophone Ear Cushions  
Battery Mats  
Hard Rubber Tubes for Coils

The B. F. Goodrich Rubber Company  
Established 1870 Akron, Ohio

### Get 2 Profits Instead of 1

When a  
Customer  
buys a  
WIRT  
LIGHTNING  
ARRESTER

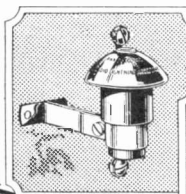

—sell him also  
a WIRT  
INSULATOR

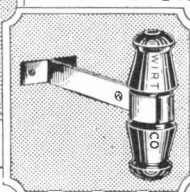

The WIRT  
Lightning Arrester

is an approved air-gap type.

Listed as Standard by

Underwriters' Laboratories

The protection is absolute. Made of bakelite, with bakelite "petticoat" which keeps out rain and dust. Brass terminals are riveted on to electrodes which are moulded in bakelite. They are far apart to avoid leakage. Lasts a lifetime. Sells easily.

WIRT INSULATOR should be installed at the same time. ANOTHER SALE—ANOTHER PROFIT. Push them both.

Wirt Lightning Arrester.....\$1.00  
Wirt Insulator..... .35

**WIRT COMPANY**  
PHILADELPHIA, PENNSYLVANIA  
MAKERS OF DIM-A-LITE

# FROST-RADIO

*Ask Your Neighbor*

**New!**

The new **FROST-RADIO** line of Bakelite and Metal Frame Rheostats and Potentiometers is amazingly better in every way than others selling for even twice our prices. Bakelite Type has ample radiating capacity for all tubes. Metal Frame Type offers a marvelous compactness and rugged construction. Both will be huge sellers the moment you show them to your trade. Order *today* from your jobber.

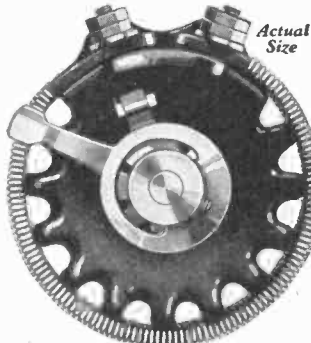

*Actual Size*

**FROST-RADIO**

The New **FROST-RADIO** Bakelite Rheostat (shown above in actual size) is a triumph of designing and quality manufacturing. It positively will not heat up even after hours of use.

*Side View Bakelite Type*

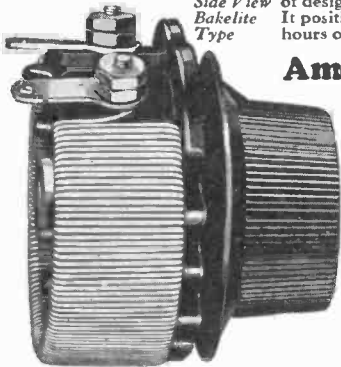

## Amazingly Better!

Supplied in 2, 4, 6, 10, 20, 25 and 30 ohm type rheostats, and 200 and 400 ohm potentiometers. List prices:

**BAKELITE**  
Rheostats 75c Potentiometers \$1.00  
**METAL FRAME**  
Rheostats 50c Potentiometers 75c

**FROST-RADIO**

This shows, also actual size, the new **FROST-RADIO** Metal Frame Rheostat, in a perspective which reveals the simplicity, sturdiness and compactness of the design. Its heavy nickel plated metal frame insures smooth working of the contact arm, perfect alignment of shaft, and absence of wear on moving parts.

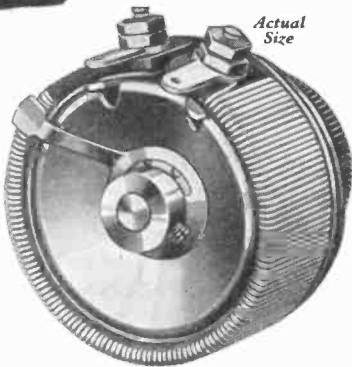

*Actual Size*

**FROST-RADIO**

**HERBERT H. FROST, Inc.**

160 North La Salle Street, Chicago  
New York Cleveland Kansas City Los Angeles



# Why Prest-O-Lite Battery dealers are enthusiastic

BECAUSE they sell more batteries; because they can do a big volume of business on a small amount of capital; because they give their customers batteries that build good-will.

Prest-O-Lite Batteries are attractively priced and provide a good margin of profit. They are nationally advertised and backed by a real merchandising plan that has proved to be a sure builder of volume sales.

The Prest-O-Lite distribution system is so wide and complete that dealers can obtain store door deliveries in a few minutes—or at most a few hours—almost anywhere in America. This enables them to do a profitable business without carrying heavy stocks on hand.

Back of all this is the built-in quality of Prest-O-Lite "A" and "B" Storage Batteries. Twenty years' experience is back of them in addition to the engineering skill of the world's largest electro-chemical research laboratories.

Write us today and we will be glad to tell you about the attractive Prest-O-Lite dealer proposition.

**THE PREST-O-LITE CO., INC.**  
INDIANAPOLIS, IND.

New York

San Francisco

In Canada: Prest-O-Lite Company of Canada, Ltd., Toronto, Ontario

# Prest-O-Lite



# HARTUNG CLIPS

*Continuous Circuit  
-Bulldog Grip*

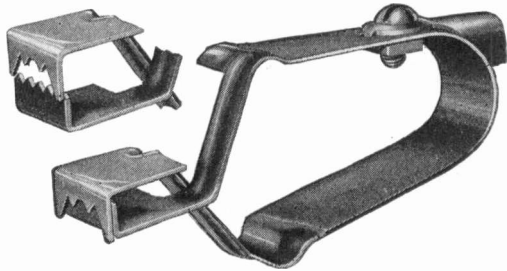

## New Distribution Policy Effective June 1st

In order to serve more effectively our many customers, both jobbers and dealers, we have revised our method of distribution, effective June 1, 1926.

The Battery & Equipment Supply Company, Chicago, Ill., which has been our exclusive distributor east of the Rocky Mountains is being replaced on the above date by a number of new distributors. The latter will carry complete stocks of Hartung Clips at centralized points for prompt shipping service.

The new plan permits a closer concentration of sales effort and better co-operation with our jobbers and dealers. We hope that it meets with the approval of all concerned.

New list of distributors is as follows:

- NEW YORK:**  
Arkay Sales Co., 5 Columbus Circle
- BOSTON:**  
G. K. Thompson, 25 Huntington Ave.
- CLEVELAND:**  
Henger-Fairfield Co., 1531 W. 25th St.
- KANSAS CITY:**  
Walter I. Ferguson Co., 14th and Walnut Sts.
- ST. PAUL:**  
Marsh-Smith, Inc., 1547 University Ave.
- CHICAGO:**  
O. J. Roskoph, 5242 Hyde Park Blvd.
- SAN FRANCISCO:**  
West American Sales Co., 516 Van Ness Ave.
- ATLANTA:**  
(To be announced later).

**C. F. Hartung Co.**  
730 East 61st St., Los Angeles, Calif.

Approved  
by Underwriters  
E-1835

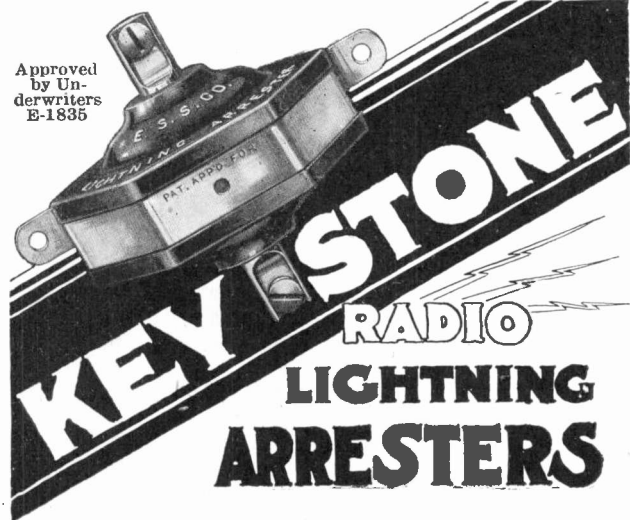

An article your customers need!

Retail price  
**\$1.50**

(In Canada \$2.00)

SUMMER brings increasing demand for lightning arresters, accelerated by pressure of insurance authorities.

Stock up with Keystone Radio Lightning Arresters to meet this demand. Backed by national advertising and widely recognized as standard equipment. A low capacity arrester which does not perceptibly diminish intensity of signals. Genuine Bakelite housing permanently protects air gap discharge electrodes from dust and moisture.



Interesting proposition for dealers—  
write today.

**ELECTRIC SERVICE SUPPLIES CO.**

50 Church St. New York, N. Y. 17th and Cambria Sts., Philadelphia, Pa. III. Merchants' Bk. Bldg. Chicago, Ill.

**SATISFIED  
DEALERS  
BECAUSE —  
WE HELP THEM**

*Catalog  
466-R  
is free  
to dealers.*

WHOLESALE

EXCLUSIVELY

**LUDWIG HOMMEL & CO.**  
929 PENN AVENUE PITTSBURGH, PA.

No trick —“no magic,” An unusually efficient  
crystal receiver in attractive book that stimulates sales

### The Talking Book

A Complete Radio Set

Pair of standard Ear Phones, Aerial and Ground Leads, Indoor Antenna. Self contained in attractive book.

Price **\$5.00** Complete

With new Celerundum Rectifying Unit—No batteries required.

We have an attractive and exclusive sales proposition for live dealers and Jobbers.

The Talking Book will  
Increase your summer sales

**THE LISTEN-IN CO.**  
115 Federal St., Boston, Mass.





# Here's an All-Aluminum Loud Speaker Ensemble with special features

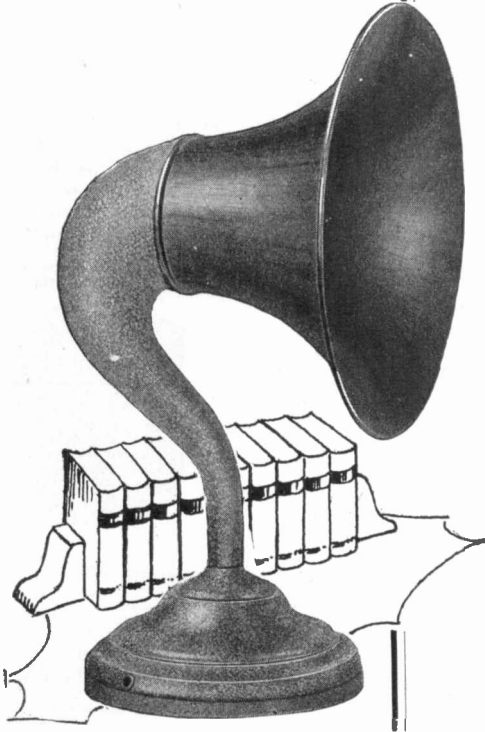

Everything complete, including Horn, Base, Protection felt, and connecting nipple.

Heavy spun aluminum bell and heavy cast aluminum goose-neck securely attached to bell with a non-vibrating joint. Base of spun or cast aluminum, fastened to horn by Threaded Brass Nipple—base can't drop off. Three styles of horns, six styles of bases, three designs of base bottoms, threaded to fit your units. Bells are finished in mahogany or walnut, while the throats and bases are furnished in twelve attractive finishes.

Rich, mellow, non-metallic tone. Price \$3.50 to \$7.00 without reproducer. Send now for dealers offer.

Union Spinning & Plating Co., Inc.  
67 Sudbury St., Boston, Mass.

## More Radio Cabinet Sales

This Standard No. 401 Radio Cabinet was designed to be highly attractive and to be most practical. Users find that it fully meets their needs.

A number of features including spruce wood horn, make this a cabinet you should consider at once.

Made in Antique Brown Mahogany or Antique Burl Walnut finish. Write for dealers' transportation allowance and discount list.

STANDARD PIANO  
BENCH MFG. CO.  
1221-1227 W. Lake St.  
Chicago, Ill.

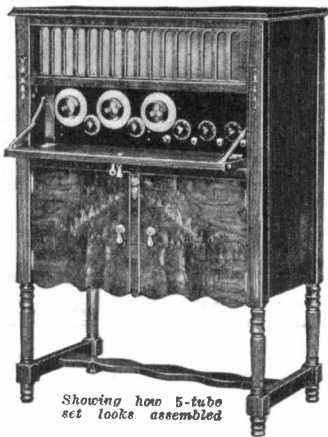

Showing how 5-tube set looks assembled



8 tubes—with 5 stages of radio frequency.

ONE tuning control graduated in wave-length meters.

## The All Year 'Round Set

A set that you can sell in *SUMMER* as well as in *WINTER*.

A Priess dealer can keep his sales going on thru June, July and August as well as in November and December.

No aerial and ground to collect static, yet its 8 tubes give maximum volume on distant stations even under summer operating conditions.

By handling the Priess you will be making sales while your competitors stand idle. Look into our attractive authorized dealer proposition.

Write or wire us to arrange for an immediate demonstration by our distributor in your territory.

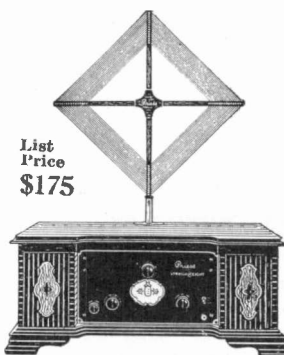

List Price \$175

*Priess*  
TRADE MARK  
STRAIGHT EIGHT  
*It's loop operated!*

PRIESS RADIO CORPORATION  
697 BROADWAY NEW YORK, N.Y.

Scranton Glass Instrument Co., Inc.  
SCRANTON, PA.

Manufacturers of

## Battery Testers

A Size and Type for Every Purpose and Every Price

Descriptive information on request

"Unless the Float Is Right  
The Reading Is Wrong"

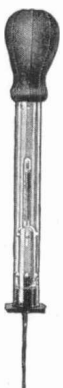

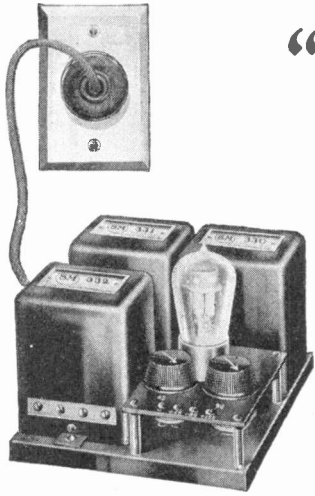

"Plug-In B" is conservatively rated at 85 milliamperes and can be operated at 100% overload. This 650-B kit has incorporated in it an absolutely new principle in filter design, developed in the Silver-Marshall laboratories and fully covered by patents. This is the greatest single advance made in "B" eliminator construction and places the assembly above all competition for power—constant power—and all around efficiency. Compact and small in size 6½ x 7½ in. Fully mounted on a metal base—all that is needed are a few wires to complete it.

## "Plug-in B"

The Silver-Marshall "Plug-In B" power supply is by far the most outstanding "B" eliminator on the market. It is as steady and constant as your electric light current. It has better voltage regulation and a higher power output than any similar product. It will not heat or distort on the heaviest continuous load. There is less of even a semblance of a hum than in any other "B" eliminator. No "static-like" distortion due to run down "B" batteries. Attach it and forget it. It is an economy and a necessity on every good receiver. \$35.00.

# SM

## The 220—

### The Audio Transformer With a Wallop

—and with as "true to color" tone reproduction as you ever heard. Guaranteed to be superior to anything on the market including impedance and resistance coupling and every transformer or practical audio amplifying device. It is a power job; designed for this fall's power tubes as well as those now available. It is husky—it's the biggest transformer built, and is *unconditionally guaranteed* to be better than anything else. The price is \$6.00.

Type 221 output transformer is designed for use between the receiver and loud speaker. It is to be used optionally with 220's and power tubes for exceptional quality.

With the advent of the 220 transformer comes a revolutionary idea in audio amplification—the falling frequency characteristic at high frequencies. This tends to compensate for actual loud speaker characteristics of a reverse nature. 220's and 221's are the only audio transformers ever really designed to operate with cone speakers—and to do it with real quality from thirty cycles up—and absolutely without hiss.

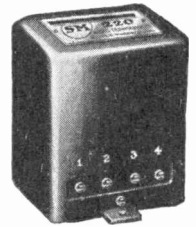

DEALERS: Get in touch with your jobber at once on these and other outstanding Silver-Marshall products—or if he is not convenient write or wire us.

Silver-Marshall, Inc. 870 West Jackson Blvd., Chicago, U. S. A.

### ART NOVELTY CABINETS



#### New advanced designs for increased Radio Cabinet Sales

Our Cabinet No. 216-R, shown here is an example of our high quality exceptionally well designed 1926 line. Art Novelty Cabinets move rapidly—Customers prefer them. Send for our latest catalog—order from it—sell more Radio cabinets.

THE ART NOVELTY COMPANY  
Goshen, Indiana

### A NEW HOYT METER for RADIO

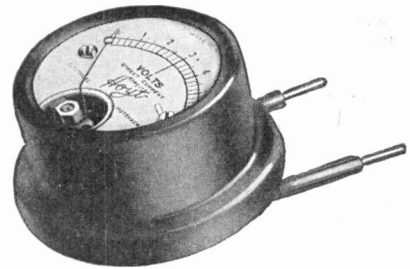

#### The HOYT "Tip-In" Voltmeter

This is one of the new HOYT Meters for Radio. A moving-coil meter in a beautiful bronze-finish case, for plugging into the jacks on the Radiola, Victor and Brunswick sets. A unique swivelling arrangement makes possible inclination of the meter at any angle, for easiest reading, and fits jacks with a wide range of spacing.

HOYT has added many new meters to the Radio line,—a pocket A. C. voltmeter, for testing line voltage, a B-Eliminator Voltmeter, the HOYT Radio CELLCHECK—a universal low-priced cell-tester replacing the Hydrometer,—the HOYT Direct Reading Static Tube Tester and Universal Test Set Model 200—which gives mutual conductance, amplification factor and plate-impedance of all kinds of vacuum tubes without calculation. HOYT has a new line of pocket meters in beautiful bronze-finish cases which should be the fastest selling pocket meter in the Radio field for 1926-27.

Dealers send for new edition of catalogue "HOYT Meters for Radio" and name of nearest jobber.

BURTON-ROGERS COMPANY  
26 Brighton Ave., Boston, Mass.

# Announcing

A new and far reaching development in Radio Speakers providing greater range. Perfect reproduction of deep toned instrumental notes--clear articulation of the higher registers. Volume is such that power amplification is unnecessary.

## VELVET RADIO SPEAKERS

The most complete line of radio speakers in America offering new satisfaction in radio reception and a model for every price level or decorative scheme.

Four models for the table, an unusual cone shape speaker without the disadvantages of the usual cone, and three cabinet models of supreme beauty and perfect acoustic engineering-- watch this page.

Sales Department  
**The ZINKE COMPANY**  
 1323 So. Michigan Ave.  
 Chicago, Illinois

Manufacturers  
**The BORKMAN RADIO CORP.**  
 Salt Lake City, Utah

### The Best Portable Buy of 1926

READY to operate under all conditions.

ABLE to perform where others fail.

MAKES your vacation a joy.

BEATS anything of its kind at any price.

LOUD SPEAKER volume on six 199 tubes.

EASY to tune, easy to carry.

REALLY a Rambler—weight only 25 lbs. with all equipment.

SELLING at half the price of inferior outfits.

INVINCIBLE for DX.

EXTRAORDINARILY selective.

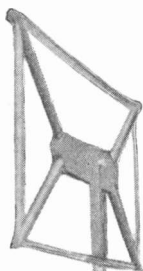

Volume, Clarity  
 Selectivity  
 Sensitivity  
 Portability

**\$90**

Without Tubes or Batteries.

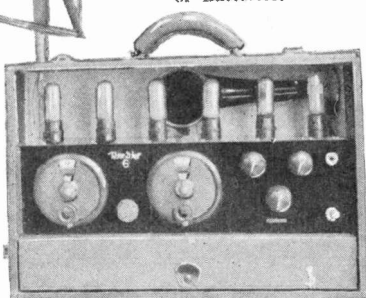

Set ready for action. Cover (not shown) makes it an easy to carry small handbag.

#### SOMETHING NEW

*A Knockdown Kit for Portable Sets*

WRITE FOR PRICES  
 MAIL ORDERS PROMPTLY FILLED

American Interstate Radio Service  
 183 Greenwich St. New York City

# TOBE

NOW—  
*A Better Resistor!*



VACUUM TIPON  
**LOEWE-LEAK**

This is the new Resistor mounted in a glass tube, which is pumped out to a high vacuum and sealed. Look for the sealing TIPON the leak—proof of the vacuum within. No moisture can possibly get into it to change its qualities. No oxidation or other chemical change can take place.

Made in all sizes from 10,000 to 10,000,000 ohms. Permanent and noiseless. Sold in individual sealed, silvered packages of exceptionally attractive design, as befits a quality product.

The growth of impedance and resistance-coupled amplifiers has brought about a great demand for a really high-grade Resistor. DEALERS, this VACUUM TIPON LOEWE-LEAK in its individual package will be a leader this coming season. Write us for name of nearest jobber.

#### LIST PRICES

10,000 ohms	.....\$1.00	1 megohm	.....\$ .50
50,000 ohms	..... .75	2 megohms	..... .50
1/10 megohm	..... .75	4 megohms	..... .50
1/4 megohm	..... .50	8 megohms	..... .75
1/2 megohm	..... .50	10 megohms	..... 1.00

*Tobe Deutschmann Co.*  
 CORNHILL, BOSTON, MASS.

How the new  
**McGRAW-HILL**  
**RADIO**  
**TRADE CATALOG**  
solves your problem of  
*permanent cataloging*

EVERY manufacturer selling to the radio industry knows the appalling waste entailed in general catalog distribution and the difficulty of *maintaining* catalog data with the thousands of dealers, jobbers or manufacturers comprising his market.

It is estimated that fully 90% of the catalogs, bulletins, etc., sent out by manufacturers are discarded, mislaid or haphazardly "filed away"—so that they cannot possibly perform the function for which they were intended.

The blame for this waste cannot be laid to the buyer. He cannot be expected to classify, file and properly index all the vast quantity of literature mailed to him—amounting possibly to thousands of pieces in the course of a year. He has neither the time, the facilities nor the inclination.

And yet he would like to be able to maintain this catalog data after it is received—to keep it in a handy place where he could quickly refer to it whenever he needed buying information.

This is the situation the McGraw-Hill Radio Trade Catalog has been designed to combat. And here is how we hope to solve the problem—for manufacturer, jobber and dealer:

1. By consolidating into one book, of convenient size and substantially bound, the condensed catalogs of representative manufacturers whose products are sold or used in the radio industry.

2. By classifying, indexing and cross-indexing all products described or illustrated in the Catalog so that the Catalog user can find what he wants without needless searching or delay.

3. By adopting a uniform typographical and copy style for the Catalog pages so that they will be easy to read and the information presented in clear, logical and concise order—devoid of generalities and exaggerated claims.

4. By distributing the Catalog among all the substantial radio jobbers, dealers and manufacturers who can use the Catalog to advantage in their buying.

*We shall be glad to have expressions of opinion from readers of RADIO RETAILING as to how the Catalog idea appeals to you personally and suggestions for making the service of greatest benefit.*

McGraw-Hill Publishing Company, Inc.

Catalog and Directory Division  
Tenth Avenue at 36th Street  
New York, N. Y.

# NO

ACID  
ALKALI  
WATER  
BULBS  
MOVING PARTS  
INTERFERENCE

2000 HOURS  
UNQUALIFIED GUARANTEE

## ELKON TRICKLE CHARGER

FOR RADIO "A" BATTERIES

SET IT—INSTALL IT—FORGET IT

**\$15<sup>00</sup>**

Complete with  
Switch

**ELKON WORKS**  
Subsidiary of P. R. Mallory & Co. Inc.

Weehawken, N. J.

Sole licensees under patents pending to Samuel Ruben

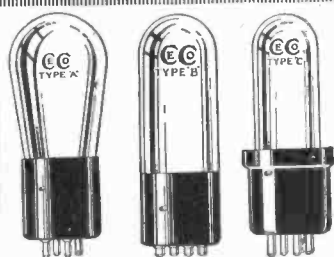
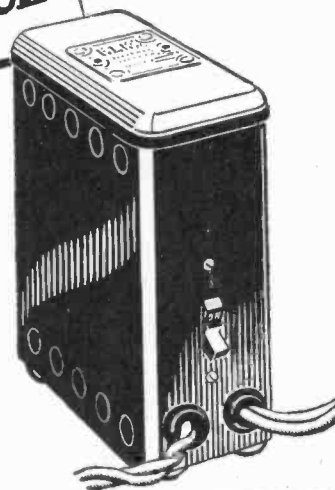

"A" "B" "C"

Filament Volts.	5.0	3.0	3.0
Filament Current	0.25	.06	.06
Plate Voltage	20 to 120	20 to 80	20 to 80

Made with Brass and Bakelite Bases  
C. E. Mfg. Co., Inc.  
702 Eddy Street,  
Providence, R. I.

YOU sell radio satisfaction when you sell CeCo Tubes.

Now ready! CeCo Tubes with new type Long PRONG BASES. Also, Power Amplifier Tubes, E (Dry Cell Type), F (Storage Battery), for last stage of Audio Frequency.

Dealers write giving jobber's name.

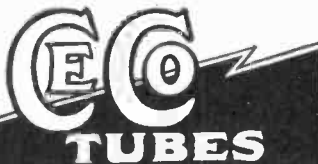

## Smash

into the Big  
Super-Ball  
Antenna Sales

A Boom to Summer  
Radio Reception

The best sales proposition in Radio History, with 100% sales help and factory co-operation with the Jobbers and Dealers.

Wherever there's a Radio, there's a prospect for a Super-Ball Antenna.

Are you ready to supply them? Write or wire for our sales proposition.

**Don't Wait!**

**Do It Now!**

National Distributors

**Yahr-Lange, Inc.**  
Milwaukee, Wis.

Mfgs. Super-Ball Antenna Co., Inc.  
Green Bay, Wis.

**SPEED UP**  
WITH  
THE 12 HOUR CHARGER



Specifications:

Charges 1 to 15 batteries at 2 to 12 ampere rate. Capacity 15 batteries every 12 hours. Made in all voltages and cycles.

"A Heyer Product"

**"TWIN SIX"**

Greater Profits—Better Service  
Batteries must be charged the year round, making a battery charger a sound investment for a Radio Store.

CONSOLIDATED  
EQUIPMENT CORPORATION  
160 Grand St., New York, N. Y.  
Write for catalog, terms and prices

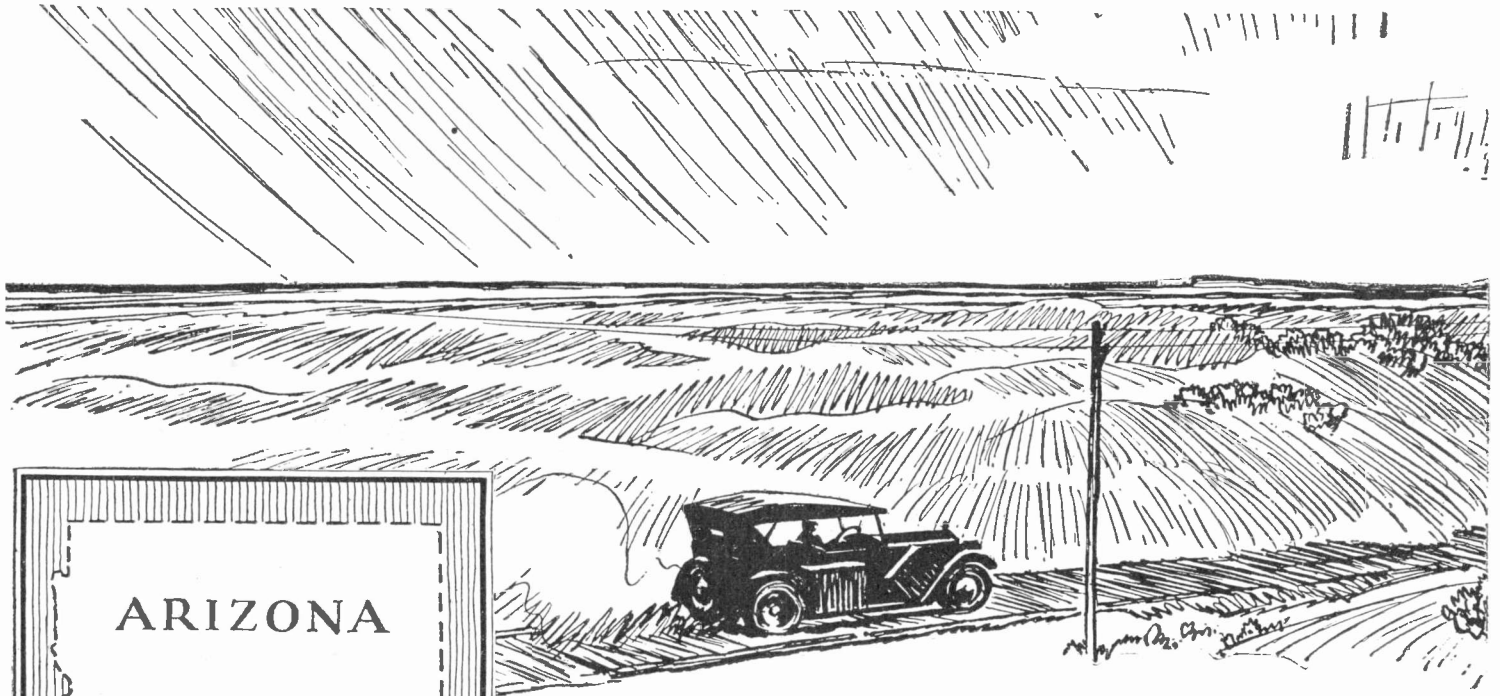

# Blazing a Trail

*Across a hundred miles of desert  
~following the winding trail along wind-swept sand dunes~over corduroy roads~  
Puffed and chugged an automobile*

## The McGraw-Hill Publications

- MINING  
ENGINEERING & MINING JOURNAL-PRESS  
COAL AGE
- ELECTRICAL  
ELECTRICAL WORLD JOURNAL OF ELECTRICITY  
ELECTRICAL MERCHANDISING
- INDUSTRIAL  
AMERICAN MACHINIST INDUSTRIAL ENGINEER  
CHEMICAL & METALLURGICAL ENGINEERING  
POWER
- CONSTRUCTION & CIVIL ENGINEERING  
ENGINEERING NEWS-RECORD  
SUCCESSFUL METHODS
- TRANSPORTATION  
ELECTRIC RAILWAY JOURNAL  
BUS TRANSPORTATION
- RADIO  
RADIO RETAILING
- OVERSEAS  
INGENIERIA INTERNACIONAL  
AMERICAN MACHINIST  
(European Edition)
- CATALOGS & DIRECTORIES  
ELECTRICAL TRADE CATALOG RADIO TRADE CATALOG  
KEYSTONE CATALOG KEYSTONE CATALOG  
(Coal Edition) (Metal-Quarry Edition)  
COAL CATALOG COAL FIELD DIRECTORY  
ELECTRIC RAILWAY DIRECTORY  
CENTRAL STATION DIRECTORY  
ANALYSIS OF METALLIC AND NON-METALLIC MINING,  
QUARRYING AND CEMENT INDUSTRIES

**I**T was taking a McGraw-Hill field man across the Yuma Desert to the only spot in Arizona at which there was a generating station, with as much as 1000 kw. capacity, where a McGraw-Hill Publication was not received and read.

He got his man and back came the laconic report, "Pull that red tack off the map!" . . . . . And out it came.

Red tacks, representing uncovered plants, are getting fewer and fewer on the big map in the McGraw-Hill Publications offices. One by one they come out as McGraw-Hill men, located in every state in the Union, visit the important industrial plants.

A recent analysis of subscriptions to McGraw-Hill Publications in Erie County, N. Y., shows that 80% of industrial buying power in that district is covered—100% in some industries. Erie County is a typical sample of McGraw-Hill circulation throughout the country.

Accepting the responsibility which goes with leadership, McGraw-Hill Publications recognize an obligation to cover their respective fields. Every worth while unit of industry, regardless of location, is a prospect and must be sought regardless of cost.

### Your Prospects as well as Ours

The manufacturer selling to industry is striving to make customers of precisely these same units.

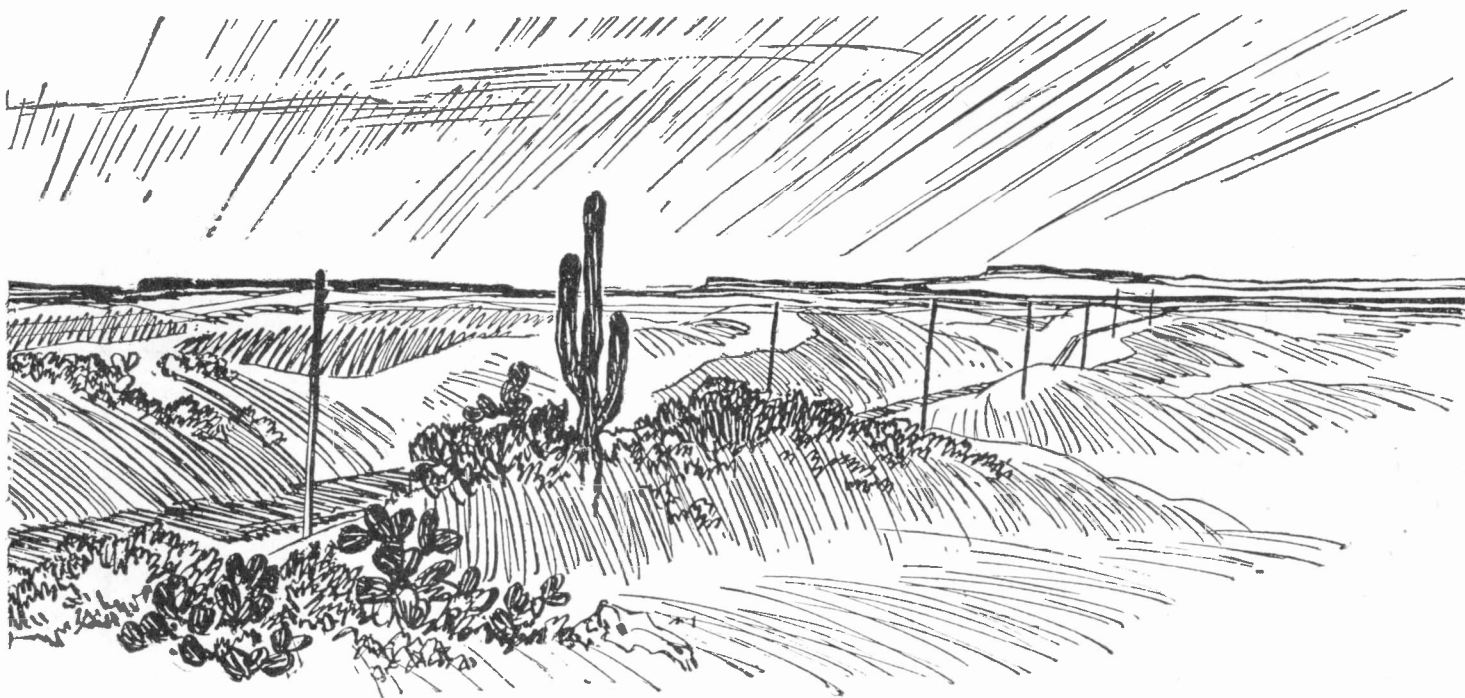

## to your Customer's Door!

We know they are the same, for they are industry's real buyers. The list of their names is an industrial directory of America. McGraw-Hill records and analyses, compiled through years of research, show the physical rating of the individual plants and their purchasing power.

Subscribers are hand picked in advance on the basis of the positions they fill, from corporation president to the key men responsible for operation and production . . . . . the men who influence or control purchases.

Is your own selling, or your client's selling to these prospects based on pre-analysis of the market . . . . . on accurate knowledge of buying power . . . . . on waste-free selling effort, which result when the *McGraw-Hill Four Principles of Industrial Marketing* are applied? These principles, upon which McGraw-Hill subscriptions are built, are:

**MARKET DETERMINATION**—An analysis of markets or related buying groups to determine the potential of each. With a dependable appraisal of each market, selling effort can be directed according to each market's importance.

**BUYING HABITS**—A study of the selected market groups to determine which men in each industry are the controlling buying factors and what policies regulate their buying. Definite knowledge eliminates costly waste in sales effort.

**CHANNELS OF APPROACH**—The authoritative publications through which industries keep in touch with developments are the logical channels through which to approach the buyer. In a balanced program of sales promotion these publications should be used effectively and their use supplemented by a manufacturer's own literature and exhibits.

**APPEALS THAT INFLUENCE**—Determining the appeals that will present the product to the prospective buyer in terms of his own self-interest or needs.

We offer to industrial manufacturers everywhere the fruits of our accumulated experience in evolving, proving and applying these Four Principles. At each of the McGraw-Hill offices are Marketing Counselors who will be glad to lay complete data before you or your advertising agent. You can communicate with our nearest office and arrange a consultation, when and where you please.

*70 salaried circulation field men cover industry in every state in the Union.  
They travel 500,000 miles a year.*

*220,000 subscribers pay for 10,000,000 copies of McGraw-Hill Publications yearly.  
50,000 McGraw-Hill subscribers change their addresses each year, and tell us so.  
Only 1 out of every 7,800 copies of McGraw-Hill Publications mailed is returned  
by P. O. Dept. for better address.*

*In a year's period 18,000 paid subscribers obtained for Radio Retailing, a record  
in business paper publishing.*

McGRAW-HILL PUBLISHING COMPANY, INC., NEW YORK, CHICAGO, PHILADELPHIA, CLEVELAND, ST. LOUIS, SAN FRANCISCO, LONDON

# McGRAW-HILL PUBLICATIONS

*45,000 Advertising Pages used Annually by 3,000 manufacturers to help Industry buy more effectively.*

# Fleron

## AERIAL EQUIPMENT





**Lightning Arresters**

Approved by Underwriters for indoor or outdoor use.  
List ..... 50c & \$1.00

**Glass Insulators**

Resist change of temperature. Strong and dependable.  
List ..... 20c & 30c

**Stand-off Insulators**

Keep Lead-in Wire away from building. 2 sizes. List 35c & \$1.25

**Complete Aerial Outfits**

Contain everything necessary for the erection of an aerial of high efficiency.  
List..... \$3.00, \$3.50 & \$5.00



**Lead-in Bushing**

Only device of its kind approved by Underwriters.  
List ..... \$1.25

The Fleron Line of Radio set accessories is sold by all leading jobbers. *Write for Folder.*

**M. M. FLERON & SON, INC.**  
Trenton, New Jersey

## The New "Windham"

A  
Low Loss  
Station  
Separating  
Condenser



Regarded as the standard of excellence and used as standard equipment by those who wish to take advantage of the result of years of high grade radio instrument service.

The Windham condenser is rugged, space saving and mechanically strong, embodying the characteristics so necessary for low radio frequency losses, easy tuning and selectivity.

*Special Offer to Set Manufacturers*

The Goyer Company offers a stock condenser for testing purposes free, to any reputable manufacturer, in order to establish proof of this low loss feature.

**THE GOYER COMPANY**  
WILLIMANTIC, CONN.

REPRESENTATIVES:

Davenport, Hickey Corp., Chicago.	Samuel Toole, Indianapolis, Ind.	J. L. Simon, Boston.
Weatherbee Bros., Dallas, Texas.	Fitzhugh Funsten, Kansas City, Mo.	
S. E. Tupper, New York City.		

### Engrave Panels for Set Builders

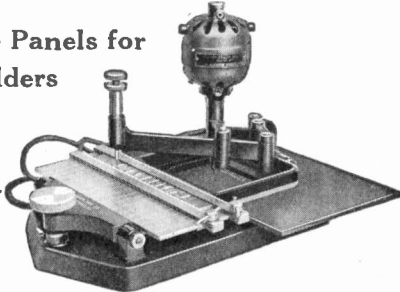

*You can earn several dollars an hour engraving panels for amateurs building their own sets.*

A low price engraving equipment for engraving the words used on radio panels, trade-marks, and border and corner designs. Will engrave on Hard Rubber, Bakelite, Aluminum and other soft metals. PRICE OF COMPLETE EQUIPMENT \$135.00.

**Branch Tool Co., Dept. P, Forestdale, R. I.**



**Don't Overlook Opportunities**

Men who regularly keep in touch with the market through other channels often overlook the many opportunities that are to be found in the

**SEARCHLIGHT SECTION**  
For Every Business Want  
*"Think SEARCHLIGHT First"*

0156



## King Cole Enamel Aerial Wire

**For Permanence And Satisfaction**

*Lasts Longer  
More Efficient  
Better Reception*

WRITE FOR OUR LATEST PRICES  
**Anylite Electric Co., Fort Wayne, Ind.**



# A Tremendous Potential Summer Market

The main point of difference between new sets to be marketed this Fall and sets in use is in greatly improved and refined audio amplifiers.

You can improve the audio systems of present sets and bring them up to date during the unprofitable summer months by canvassing your neighborhood right now.

Dealers can fit themselves for greatly increased profits from every set owner or prospective set owner as well as set builder in their neighborhood by studying the new Samson booklet on Audio Amplification. This contains information heretofore unpublished. If your distributor cannot supply you send 15 cents for a copy today.

The Samson Electric Company offers nine audio frequency units for the 1926 season. They form the most complete line of any manufacturer and are designed for use with the new tubes and tubes that may be announced at a later date.

No falling off in quality of reproduction nor burn-outs due to use with new tubes need be feared. The astonishing better tone quality from these units is permanent, unchanged by weather conditions due to hermetic sealing. Each unit is uniform in appearance, size and is interchangeable—each in its quality reflects Samson's nearly half century of experience.

Samson Symphonic Transformer, climax of several years' development, gives perfect reproduction of broadcast tones over greater range than average loud speakers can cover or is now broadcast . . . . . \$9.00

The new Samson HWA3 Transformer, 2:1, 3:1, 6:1. Standard equipment with leading set manufacturers and home constructors. Built for service as well as quality of reproduction. . . . . \$5.00

Samson Dual Impedance (Donle Design) is complete—no condensers or leaks required—being connected like a transformer, and gives far better tone quality on strong signals than resistance coupling. It keeps on giving this tone quality because hermetically sealed against moisture . . . . . \$5.00

Samson Audio Plate Impedance. A high inductance choke for use with standard or high Mu tubes . . . . . \$4.50

Samson Audio Grid Impedance, forms ideal power amplification combination with Plate Impedance . . . . . \$4.50

Samson Output Impedance, keeps direct current component out of loud speaker . . . \$5.00

No. 3 A. F. Choke. This choke helps eliminate squealing and howling due to A.F. regeneration, noises due to "B" Batteries, as well as troubles and noises due to "B" Eliminators. Due to its patented helical winding, it performs the function for which intended instead of acting as a bypass . . . . . \$3.00

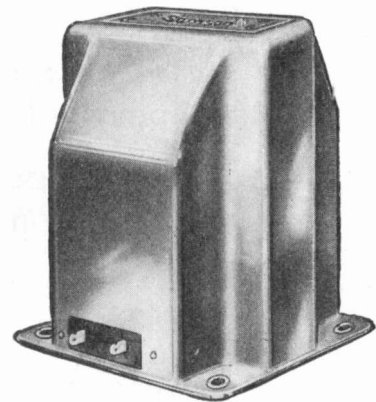

Samson Audio Frequency Unit

## SAMSON ELECTRIC COMPANY

Manufacturers since 1882

Main Offices and Factory Canton, Mass.

Sales Offices in 30 Leading Cities

Member RMA

# COILS for RADIO

Balloon Honeycombs  
Wave Wound Spirals  
Transformer Windings  
Honeycomb Inductances

*We Wind For The  
Manufacturer Only*

**COTO-COIL CO.**  
PROVIDENCE  
R. I.

## THE HOUSE of SUPER-SERVICE

*You will find more than 1000 items listed in the New Enlarged Edition of Harry Alter's RADIO CATALOG all the latest Hook-ups. Indispensable to any Radio Dealer write for a free copy*

**The Harry Alter Co.**  
ELECTRICAL and RADIO SUPPLIES  
Ogden at Carroll Ave.  
CHICAGO ILL.

# Make More Money!!



*Radio Retailing* has been a remarkable success in the development of a real service for the radio dealer.

It is used regularly by the most successful and most progressive radio concerns in every part of the country.

In a year's period, 18,000 paid subscribers obtained for *Radio Retailing* a record in business paper publishing!

Back of *Radio Retailing* stands the largest industrial publishing house in the world—

an organization of 1,200 executives, technical experts, highly trained editors in five great cities and resident associate editors in seven more, from New York to San Francisco; and an army of over 100 hustling correspondents that cover the country like a net work.

In a year's issues of *Radio Retailing* it covers all of the things you need to know to be successful in selling radio.

It is published to help you make money.

Radio Retailing, Tenth Avenue at 36th Street, New York, N. Y.

Gentlemen—

Enter my subscription to *Radio Retailing* for one year, the price to be \$2 for the year's service. Start my subscription with the next issue, please.

NAME .....

STREET .....

CITY ..... STATE .....

NAME OF COMPANY .....

BESIDES RADIO WE SELL.....

*Radio Retailing* helps its readers by showing them methods by which the most successful radio dealers are making more sales and increasing profits. The coupon at the left is convenient in subscribing to the foremost radio trade service.

# \$10 Loud Speaker

You can sell, at \$10, the most satisfactory loud speaker that money can buy—the new, improved Dulce-Tone, the per-

fectured radio-talking-machine-speaker.

Set the talking machine needle in the Dulce-Tone reed, plug in, and you have the full volume, the beautiful clear tone that only Dulce-Tone and a talking machine can give.

**THE GENERAL INDUSTRIES COMPANY**

*Dulce-Tone Division*  
Formerly named THE GENERAL PHONOGRAPH MFG. CO.  
304 Taylor St., Elyria, Ohio

Fully guaranteed to you and your customers. Nationally advertised in the Saturday Evening Post, Literary Digest and Liberty.

Write for sample and dealer's prices.



## Efficient Service on Molded Parts

**BAKELITE AND COLD MOLDED MATERIALS MADE TO YOUR SPECIFICATIONS**

**American Insulator Corp.**  
52 Vanderbilt Avenue, New York City

## Radio Retailing

Radio Retailing is a real investment for a radio business.

Through this service you are given the solutions to problems peculiar to radio retailing.

Through this service you are kept in close touch with the real radio successes in every part of the country.

*For \$2 a year Radio Retailing is a wonderful value!*



**RADIO RETAILING, Tenth Avenue at 36th Street, New York, N. Y.**

Enter my subscription to Radio Retailing for one year—\$2.

Name .....

Street .....

City ..... State .....

Name of Company .....

Besides Radio we sell.....  
5-26

Radio Retailing gives you usable facts and figures on—

- Organizing a radio store.
- Selection of stock.
- Selling methods.
- Advertising.
- Window displays.
- Time payment plan sales.
- Store layout.
- Store management.
- Demonstrations.
- Installations.
- Repairs and service.
- Battery service.
- Sales of accessories.
- Reaching the amateur
- New radio merchandise
- Stories of successful dealers.
- Selling helps manufacturers offer.
- News of the radio industry.

# SEARCHLIGHT SECTION

## SURPLUS STOCKS—BUSINESS OPPORTUNITIES

### UNDISPLAYED—RATE PER WORD:

Positions Wanted, 6 cents a word, minimum \$1.25 an insertion, payable in advance.

Positions Vacant and all other classifications, 10 cents a word, minimum charge \$2.00.

Proposals, 40 cents a line an insertion.

### INFORMATION:

Box Numbers in care of any of our offices count 10 words additional in undisplayed ads.

Discount of 10% if one payment is made in advance for four consecutive insertions of undisplayed ads (not including proposals).

### DISPLAYED—RATE PER INCH:

1 to 3 inches.....\$6.65 an inch

4 to 7 inches..... 6.40 an inch

8 to 14 inches..... 6.20 an inch

Rates for larger spaces, or yearly rates, on request.

An advertising inch is measured vertically on one column, 3 columns—30 inches—to a page.

Radio Retailing

### POSITIONS VACANT

RADIO merchandisers (three) high grade men for permanent positions in Virginia. Must have general understanding of radio trade and be capable of handling all-round work if required. Full responsibility for departments. Company co-operation. Salary and percentage basis. Give full details as to qualifications, experience, minimum compensation to start, etc. P-15, Radio Retailing, 1600 Arch St., Philadelphia, Pa.

### REPRESENTATIVES WANTED

#### Representatives Wanted

By manufacturer of line of radio tables and cabinets to call on retail radio dealers. References required. Write Watson town Table & Furniture Company, Watson town, Pa.

### BUSINESS OPPORTUNITIES

#### Manufacturers and Wholesalers

Desiring disposition of unsold radio merchandise, communicate with me. Walter M. Braun, 123 Grand Ave., Milwaukee, Wisconsin.

## Factory Representatives

A radio manufacturer with a national sales policy invites correspondence from factory representatives who carry established radio lines, and are widely acquainted with the radio jobbing trade.

AS-14, Radio Retailing, Guardian Bldg., Cleveland, Ohio

### Profitable Commission Opportunity

in side-line, securing and suggesting leads for trade-mark and copyright protection. Part or full time. A helpful service and dignified proposition. No samples, investment or legal knowledge required. Nationally known organization. Write us in confidence. Mida's Trade Mark Bureau, Terminal Bldg., Chicago.

## TO HELP YOU

LOCATE COMPETENT MEN

"Searchlight" Advertising

G-3

## ATTENTION

Manufacturers and Jobbers

## SPOT CASH

Paid for

**RADIO SETS  
AND PARTS,  
HORNS, UNITS, Etc.**

No quantity too large or too small. Submit samples or write—

### THE RADIO MARKET

76 Cortlandt St., New York

### Sell Your Surplus Stock!

We pay cash for your surplus Radio Materials and Supplies. What have you to sell? Phone: Rector 6920.

**MODELL'S RADIO CHAIN  
STORES**  
17 Cortlandt St., New York

### FOR QUICK SALE

## Copper Magnet Wire

300 lbs. net weight, Beldenamel, diameter 40, on spools net weight 2 to 8 ounces.

HARRY W. DePREZ, Shelbyville, Indiana

## How to judge your chances for prompt returns—

You generally hire a man by his record on a job similar to the one for which you need him. His past performance is your gauge as to what you may expect of him.

Likewise, when you select a medium to enable you to fill a business want; the manner in which that medium has and is, helping others is vital. It determines your chances for prompt returns.

We should like to furnish you with concrete evidence of how the

## SEARCHLIGHT SECTION

is serving others in this field. And when you have a business want of any kind that can be satisfied by others in this field you, too, will

*"Think SEARCHLIGHT First"*

0306

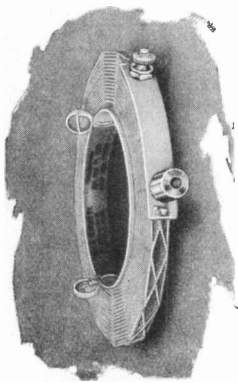

**Set Manufacturers!**

Standards of radio reception are becoming higher with each new year. 1926 models must be an improvement over those of 1925, and they will be.

Correct coils are vital to good reception. We specialize in such coils. We are producing regularly the most advanced types, built with the famous "Diamond-weave" construction.

Write us concerning your own requirements. We are prepared to furnish better coils for the new sets.

**THE F. W. SICKLES COMPANY**  
140 Union St., Springfield, Mass.

**SICKLES DIAMOND-WEAVE COILS**

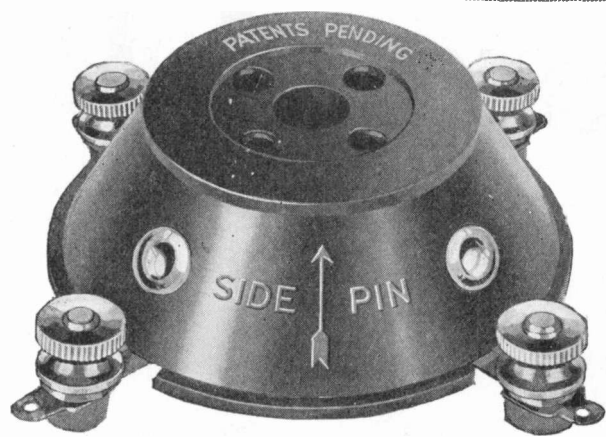

**The new RISILIO Shock Absorbing SOCKET**

The Resilio Socket provides a delicate four-point suspension so that the most minute shocks are perfectly absorbed, thus eliminating objectional horn noises and prolonging the life of the radio tube.

Absolutely perfect contact is insured. There is no possibility of loss in efficiency after continued use.

Made of Duo-Pressed Bakelite, it is sturdy, attractive.

The four connections are made with either knurled thumb nuts or by soldering.

For set makers we recommend our Special Resilio Socket for under panel wiring. Send for sample.

It fits all standard tubes.

Write for prices and literature

**Automatic Molded Products Co.**  
280 Passaic St., Newark, N. J.

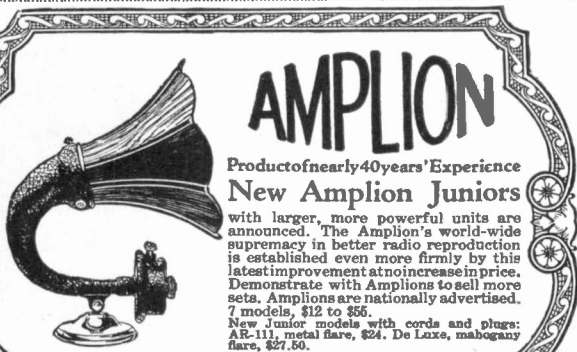

**AMPLION**

Product of nearly 40 years' Experience  
**New Amplion Juniors**

with larger, more powerful units are announced. The Amplion's world-wide supremacy in better radio reproduction is established even more firmly by this latest improvement at no increase in price. Demonstrate with Amplions to sell more sets. Amplions are nationally advertised. 7 models, \$12 to \$56.  
New Junior models with cords and plugs: AR-111, metal flare, \$24. De Luxe, mahogany flare, \$27.50.

**THE AMPLION CORPORATION OF AMERICA**  
Suite B, 280 Madison Ave., New York Chicago Branch: 27-29 N. Morgan St.  
Amplion Corporation of Canada, Ltd., Toronto

**ALPHABETICAL INDEX TO ADVERTISEMENTS**

Page	Page	Page	Page
A-C Electrical Mfg. Co. .... 526	C. E. Mfg. Co., Inc. .... 617	Goodrich Rubber Co., B. F. ... 610	Radio Trade Catalog ..... 616
Advance Automobile Accessories Corp. .... 522-523	Consolidated Equipment Corp. 617	Gould Storage Battery Co., Inc. 606	Reichmann Co. .... 605
Alter, Harry Co. .... 621	Coto Coil Co. .... 621	Goyer Co., The. .... 620	Samson Electric Co. .... 621
American Bosch Magneto Corp. 547	Crosley Radio Corp. .... 603	Grebe, A. H. & Co., Inc. .... 521	Scranton Glass Inst. Co., Inc. 613
American Insulator Corp. .... 623	De Witt La France Co. .... 610	Hartung Co., Charles F. .... 612	Searchlight Section ..... 624
American Interstate Radio Service ..... 615	Deutschmann Co., Tob. .... 615	Hommel & Co., Ludwig. .... 612	Sickles Co., F. W. .... 625
Anylite Elec. Co. .... 620	Dudlo Mfg. Corp. .... 533	Helios Battery Co. .... 543	Silver Marshall ..... 614
Amplion Corp. of America. .... 625	Electrical Products Mfg. Co., Inside Back Cover	Listen-In Co. .... 612	Slagle Radio Co. .... 541
Art Novelty Co. .... 614	Electrical Service Supplies Co. 612	Magnavox Company ..... 536-537	Sparks-Withington Co. .... 524-525
Atwater Kent Mfg. Co. .... 550	Electric Storage Battery Co. .... 604	McGraw-Hill Pub. Co., Inc. 618-619	Splitdorf Electrical Co. .... 535
Automatic Molded Products Co. 625	Elkon Works, Inc. .... 617	Modern Electric Mfg. Co. .... 530	Standard Piano Bench Co. .... 613
Benjamin Electric Mfg. Co. .... 626	Farrand Mfg. Co., Inc. .... 542	National Carbon Co., Inc. ... 540-607	Stewart-Warner Speedometer Corp. .... 544-545
Borkman Radio Co. .... 615	Federal Radio Corporation ... 532	Neutrowound Radio Mfg. Co., 522-523	Stromberg-Carlson Tel. Mfg. Co. 520
Bosworth Elec. Mfg. Co., Front Cover	Federal Telegraph Co. .... 609	Pooley Company ..... 548-549	Super-Ball Antenna Co. .... 617
Branch Tool Co. .... 620	Fleron Co., M. M. .... 620	Premier Radio Co. .... 527	Teletone Corp. of America. 528-529
Brandes Products Corp., Inside Front Cover	Freed-Eisemann Radio Corp. ... 531	Prest-O-Lite Co., Inc. .... 611	Union Spinning & Plating Co., Inc. .... 613
Burton Rogers Co. .... 614	Frost, Herbert H., Inc. .... 611	Priess Radio Corp. .... 613	Utah Radio Products Co. .... 519
	General Industries Co. .... 623	Radio Corp. of America, 534-580-581-Back Cover	Weston Electric Inst. Co. .... 606
	General Radio Co. .... 546	Radio Master Corp. .... 538-539	Wirt Company ..... 610

# Stand Pat!

*Radio Parts Selling is Now Good in All Seasons*



Radio retailing has become a steady job. Old-time retrenching by lessening inventory and expecting smaller business as warm weather approaches is a bad and unprofitable policy. Improvements in radio have made it possible for folks to enjoy its beauties every day and night of the happy summer time, when it can be used outdoors as well as indoors. Broadcast stations give us excellent programs. Benjamin Radio Parts increase sensitivity, sharpen selectivity and intensify volume to break down the summer slump in set building of the years gone by.

Now you can stand pat—your business policies of winter are just as good in summer. Benjamin merchandising is planned to increase your sales in the next few months. Summer set building is being intensified through advertising to the whole radio industry. Your winter profits are not enough. Keep them up this summer.

*Let us send you the Benjamin Better Radio Literature  
A postal card with your name will do*

## Benjamin Electric Mfg. Co.

120-128 South Sangamon Street, Chicago  
 New York San Francisco  
 247 West 17th Street 448 Bryant Street  
 Manufactured in Canada by the Benjamin Electric Mfg. Co.  
 of Canada, Ltd., Toronto, Ontario



**Cle-Ra-Tone Socket**



*Patented  
July 25, 1925  
May 2, 1911*

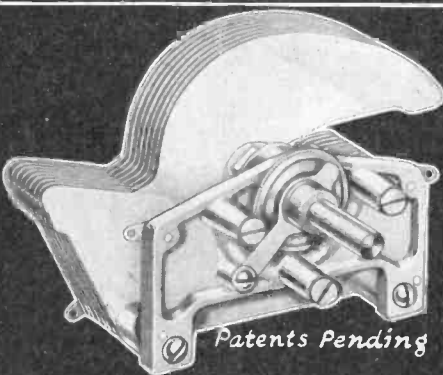

*Patents Pending*

**Straight Line Frequency Condenser**

**Tuned Radio Frequency Transformer**



*Licensed Under  
Lovejoy Patents  
Nov. 3, 1925*

# BENJAMIN

TRADE MARK

IT'S A  
**Dymac**  
PRODUCT

# Howling--Squealing--Blooping Banished By A Brand New Circuit

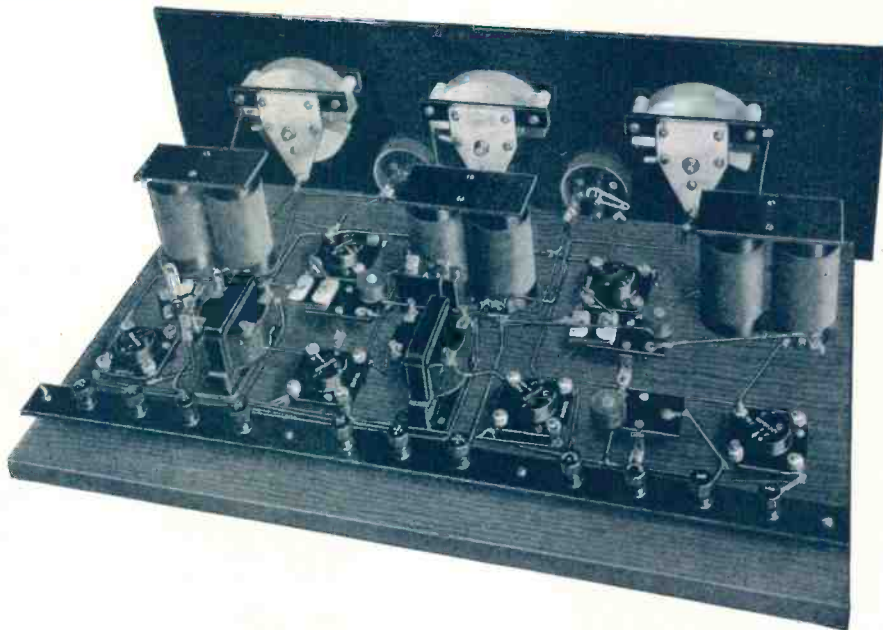

## and presented to the country in the **DYMAC Somerlog Kit**

This new Circuit, amply protected by patents, presents the only known method of permanently and completely balancing a radio receiver.

Dr. George A. Somersalo invented the DYMAC Somerlog and Charles V. Logwood, of our staff, engineered it to perfection.

The news has gone abroad that there IS a new Circuit distinctly different and better than

The DYMAC Somerlog Kit includes—

- 3 DYMAC Space Wound Twin Inductances
- 3 Somerlog Fixed Balancers
- 1 By-pass Condenser, 1 Mfd.
- 1 Complete set of working drawings

Manufactured under license of the Somersalo Corporation.

Dealers, get your jobbers on the wire immediately or write us for complete information. You can be the first in your community to show the Circuit in kit form that promises to be the sensation of the coming radio season.

anything that has before appeared. And it is safe to say that thousands of amateurs this summer will jump at the opportunity of building this new six-tube receiver, and will give dealers a splendid summer business on this item.

It now looks as though there would be a shortage of these Kits to supply the indicated demand. We will do our part by making every effort to increase production.

The Kit  
**\$19.50**

**ELECTRICAL PRODUCTS MFG. COMPANY**

69 Sprague St., Providence, R. I.

Exclusive manufacturers of DYMAC products

EVERY **Dymac** PRODUCT  
GUARANTEED FOR ONE YEAR

# Bring old sets up to date — get new business

—with the new RCA Radiotrons

**N**EW Radiotrons—new performance—better radio! By keeping up with the progress of the Radiotron laboratories, you can get greater results from old sets, and get new profits by bringing them up to date. Here is the way to equip a storage battery set today, to make it *many times better*:

1. *Distance!* Take out the detector tube and put the new RCA Radiotron UX-200-A in the socket. This new development of RCA research means greater sensitivity—longer distance reach.
2. *Quality!* Put all genuine RCA Radiotrons UX-201-A in the radio frequency sockets, and the first audio stage.
3. *Volume, the fine tone!* Use either power tube, Radiotron UX-112 or Radiotron UX-171 in the last audio stage, for volume—full, clear-toned volume.

The developments of RCA research in Radiotrons offer great profit possibilities to the wide-awake dealer. Because people demand genuine RCA Radiotrons, they are the backbone of year-round business.

Now the *new* Radiotrons—well advertised—will bring new customers to your store, and give you a chance to sell again to your old customers. Talk about the new Radiotrons to every man who comes in!

RADIO CORPORATION OF AMERICA  
NEW YORK CHICAGO SAN FRANCISCO



RADIOTRON  
UX-200-A

Special detector tube for  
storage battery sets



# RCA Radiotron

MADE BY THE MAKERS OF THE RADIOLA