

September 1, 1925  
15 Cents a Copy

# RADIO PROGRESS

Reg. U. S. Pat. Off.

*'Always Abreast  
of the Times''*

## IN THIS ISSUE

Watch Your Lightning Arrester

By HORACE V. S. TAYLOR

Shaving Static from Your Signals

Washington Likes Our Policy

More About the New Tubes

Real Super-Power Sending

Testing Tubes for Poor Performance

---

YOU WILL UNDERSTAND THIS  
MAGAZINE --- AND WILL LIKE IT

A New England Publication

# At Last! At An Unheard of Price!

A SURE FIRE

## SUPER-HETERODYNE KIT

A  
Superadio  
Product



A  
Superadio  
Product

# SUPERADIO KIT, \$17.<sup>50</sup> SUPERHETERODYNE K

MATCHED TRANSFORMERS—TUNED INPUT

EASY TO BUILD

EASY TO OPERATE

UNSURPASSED DISTANCE VOLUME AND SELECTIVITY

WONDERFUL TONE

Kit Consists of:

- |                              |                                     |
|------------------------------|-------------------------------------|
| 1 Antenna Coupler            | 1 Tuned Input Transformer           |
| 1 Oscillator Coupler         | 3 Matched Intermediate Transformers |
| 1 Special Variable Condenser | Hardware for Mounting Couplers      |

Booklet, With Diagrams and Full Layouts  
and Information

Manufactured by

## DE WITT-LAFRANCE CO., Inc.

54 Washburn Avenue

Cambridge, Mass.

Sales Representatives:

Martin, Hartley and Foss Co.

99 Bedford Street, Boston, Mass.

# NATIONAL

**VELVET CONDENSERS  
VERNIER AND DIALS**

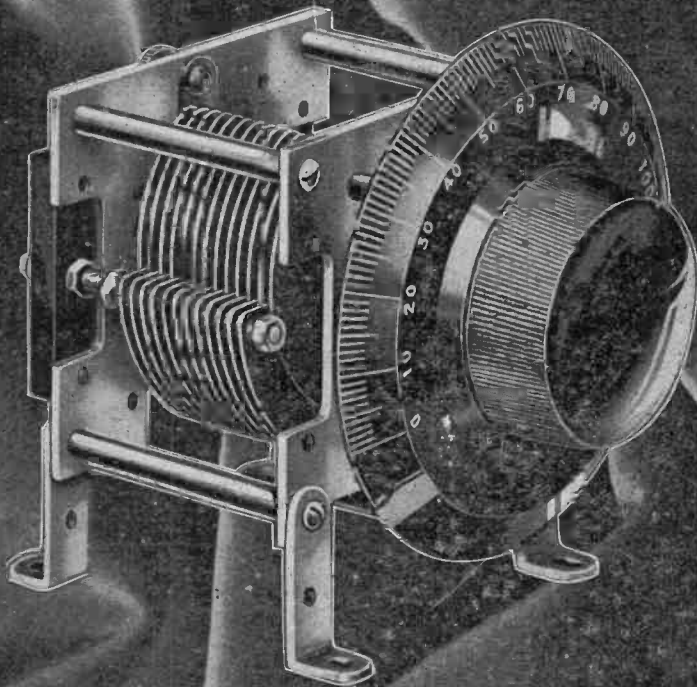

Made by the NATIONAL COMPANY, INC.

Exclusive Manufacturers of

**The NATIONAL  
Browning-Drake TRANSFORMER**

Write for Bulletin 105 R. E.

NATIONAL COMPANY, INC., 110 Brookline St., Cambridge, Mass.



# The Marvelous 5-Tube Radio Frequency Set

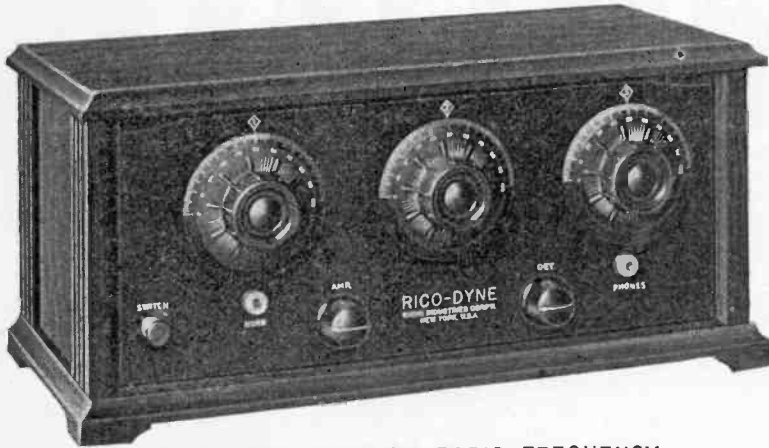

## RICO-DYNE

An assurance of perfect performance, faithful tone production and \$100 radio receiver value, all for

**\$60.**

Mahogany Cabinet  
The Set with a Punch

**AUTO BALANCED 5-TUBE RADIO FREQUENCY**  
The combination of "RICO" CELLUWELD Low Loss Coils and Variable Condensers is made mechanically perfect. The Coils are welded firmly to the support of the rotor plates, our own patented principle. Selective and non-oscillating, the "RICO" "AUTO-BALANCED" TUNED RADIO FREQUENCY SET accomplished by carefully setting the neutralizing angle of the Coils at the factory; remains permanent due to the CELLUWELD process.  
The Complete Ricodyne Kit contains everything. The set you can build in 3 hours. Price Complete.....\$38.75

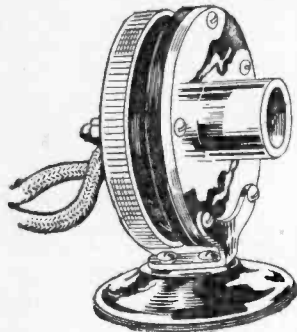

ADJUSTABLE

## MAKE FULL USE OF YOUR PHONOGRAPH

### MELOTONE — "None Better"

Adjustable phonograph unit makes your phonograph a perfect loud-speaker

**\$7.50**

The Melotone Has All the Qualities of the \$10 to \$12 Units



## THE NATION'S FAVORITE HEADSET

### RICOPHONES — The Headset of Real Value

There is more quality, real honest-to-goodness quality packed into RICOPHONES than you'll find in any headset at twice its price! Compare and see.

**\$2.95**

Manufacturers of the famous "RICO" straight line condensers, at \$1.75 each. The "Tropadyne" circuit is supplied free with every tuned "Tropaformer" that we manufacture for all long wave transmission. "Tropaformers" \$6.75 each. Dealers—write or wire for wonderful proposition.

RADIO INDUSTRIES CORPORATION,  
131 DUANE ST., NEW YORK CITY.

Gentlemen: I am enclosing \$..... for the items checked below. Kindly ship at once.

.....RICO-DYNE SET, \$60.

.....MELOTONE UNIT, \$7.50.

.....RICOPHONES, \$2.95.

My Dealer is .....

NAME .....

ADDRESS .....

CITY .....

# RICO

for all  
Long Wave  
Circuits

## RICO Products on this Page Will Improve Your Radio 100% TROPAFORMERS



The sensitivity, selectivity and volume obtained in all types of long-wave circuits depends entirely upon the intermediate frequency transformer. TROPAFORMERS have been specifically designed to meet the new scientific requirements of long-wave circuits. The TROPAFORMER combines transformer and condenser. The condenser is shunted across the secondary winding of the transformer, and by its use the transformer may be tuned to any definite wave length between 3,000 and 9,500 meters. Only in TROPAFORMERS will long-wave circuit users find these advantages, and these advantages are patented for TROPAFORMERS exclusively!

**\$6.75**

Free Hook-up of the Famous Tropadyne Circuit with Each Tropafomer Ordered.

### DID YOU EVER BUILD A SET THAT GOT "COAST TO COAST"?

You Can with the RICO-DYNE 5-Tube Auto-Balanced  
Cellu-Weld Tuned Radio Frequency Kit

**\$38.75**

Complete Knockdown Set as illustrated with full instructions how to build this marvelous set within a few hours.

#### Greatest Radio Value in History—This is What You Get:

1—Pair Ricofones. 1—Genuine Bakelite Front Panel, completely drilled and engraved. 1—Genuine laminated Bakelite Sub-Panel—with sockets already mounted. All mounting holes properly drilled. 3—Auto Balanced Tuned Radio Frequency Units—perfectly matched and balanced. 3—Beautiful 4-inch Dials. 1—Variable Grid Leak and .00025 M.F. Condenser. 1—4 to 1 Audio Transformer. 1—2 to 1 Audio Transformer. 1—.002 Fixed Mica Condenser. 1—.006 Fixed Mica Condenser. 2—Single Circuit Jacks. 1—Filament Control Switch. 1—30-ohm Rheostat. 1—10-ohm Rheostat.

### FOR THOSE WHO WANT TO BUY ONLY THE RICO-DYNE KIT

HERE IS JUST WHAT THEY WANT:

It seems unusual that with the tremendous volume, selectivity and distance-range of the Rico Auto Balanced set, it should be so simple to construct. Yet, nevertheless, this is true. We have letters from fans who tell us that they constructed their Rico set within a few hours. The plans which accompany the Rico Kit are so simple that we believe this is so. Any beginner need only to read English in order to construct the Rico set. This Kit contains 3 Auto Balanced Tuned Radio Frequency Condensers, Inductance Units, factory matched, book of instructions and drilling template. You can't go wrong!

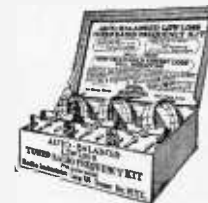

**\$16.50**

RICO-DYNE HAS SET  
NEW RECORDS IN RADIO!

for  
bliss!

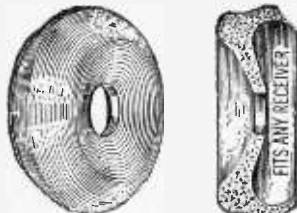

**SPONGE RUBBER**

### RICO FONEKUSHIONS

You'll know what real ear-phone comfort is when you use RICO FONEKUSHIONS. They are made of soft, pure sponge rubber, and fit any make of headphone. They are like soft, downy pillows for your distance-seeking ears..... **50c**

for  
better  
tuning

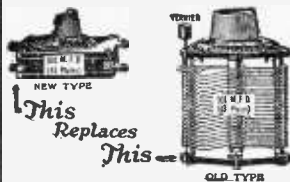

### RICO STRAIGHT LINE CONDENSERS

In the old days, folks used horses. Now they can get as much power out of one auto as from 40 horses. It was all right, too, a few years ago, for folks to use the old-time condensers, but now, since Rico brought forth the RICO STRAIGHT LINE CONDENSER, which occupies two-thirds less space than the ordinary mesh plate type, everyone modernizes his set with the RICO STRAIGHT LINE CONDENSER.

No. 411—.00025 mfd. ....\$1.75  
No. 423—.0005 mfd. .... 1.75  
No. 450—.001 mfd. .... 1.75  
Inclusive with Dials. Without Dials, \$1.50.

Each of these  
Rico products  
means added  
pleasure and  
value to your  
Radio Set.

If Your Dealer Cannot Supply You—Use This Coupon. No Money Down!

RADIO INDUSTRIES CORPORATION  
131 Duane Street, New York City

Please send me C. O. D. the following: .....Tropafomers, \$6.75 .....Straight Line  
Condensers, \$1.75 .....Ricofones, \$2.95 .....Oscillating Coil, \$3 .....Fonekushions, 50c  
.....Melotone Attachment, \$7.50.

Name ..... Address.....

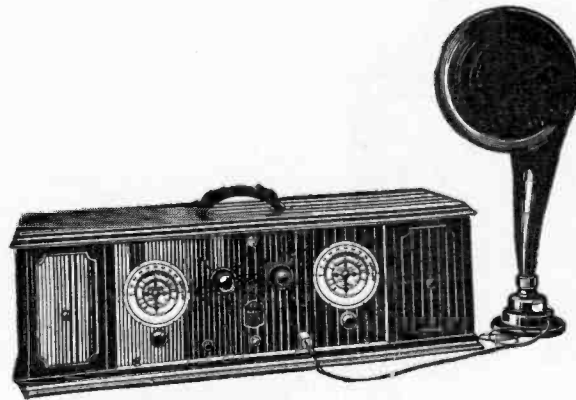

**Which is Better—**

**A Cheap Set for Cash---or  
A GOOD Set ON TERMS**



---

*The Good Set is Cheapest in the End*

---

Bay State specializes on the better grade sets, like Radiola, DeForest, Adler Royal, Magnavox, and sells on **Convenient Terms**.

Write for information. Address Dept. A,

**BAY STATE RADIO CO.**

---

**The House of Radio Service**

---

**116A Washington Street**

**Boston, Mass.**

# GRAND CENTRAL PALACE

## 4th Annual NATIONAL RADIO EXPOSITION

Grand Central Palace, New York  
September 12th - 19th incl.

- the fourth successive national exposition representing all the leading manufacturers of the radio industry;
- the only great radio exposition of 1925 to be held in the metropolitan center of New York;
- the greatest spectacle of the year in the scientific, industrial and business progress of radio!

Business Office.

AMERICAN RADIO EXPOSITION CO  
522 Fifth Avenue, New York

HAROLD BOLSTER, Director  
J. C. JOHNSON, General Manager

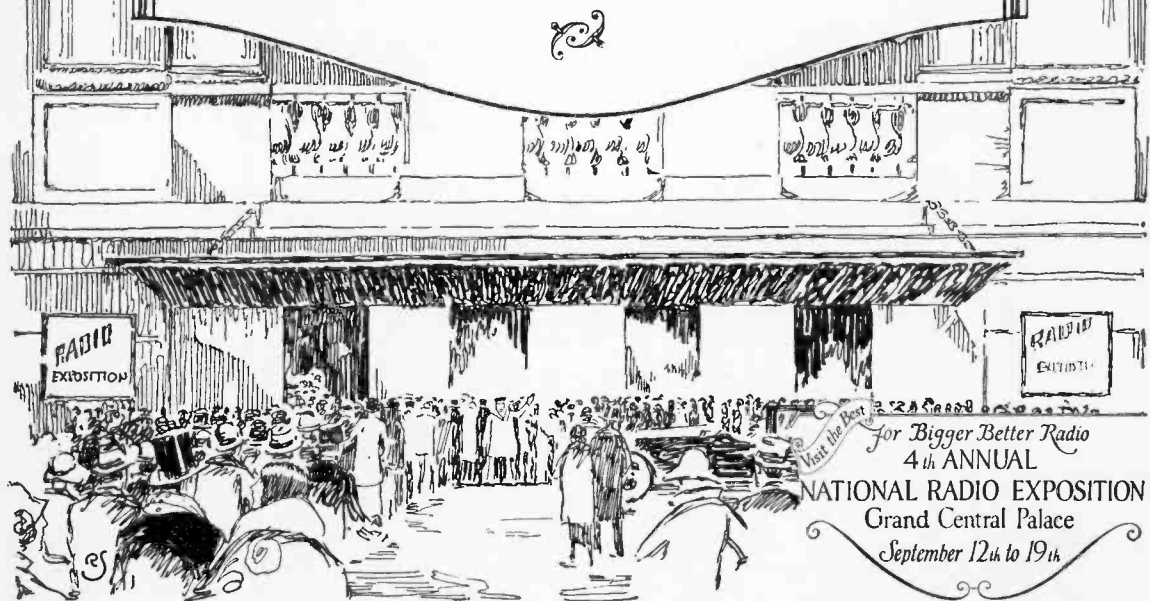

# RADIO PROGRESS

HORACE V. S. TAYLOR, EDITOR

Volume 2

Number 12

*Contents for*

**SEPTEMBER 1, 1925**

	PAGE
WATCH YOUR LIGHTNING ARRESTER. . . . .	9
AMERICAN RADIO RELAY LEAGUE. . . . .	12
SHAVING STATIC FROM YOUR SIGNALS. . . . .	13
WHAT ARE THE WILD WAVES SAYING?. . . . .	15
GERMAN BROADCASTING NOT LIKE OURS. . . . .	17
REAL SUPER-POWER SENDING. . . . .	19
WASHINGTON LIKES OUR POLICY. . . . .	24
MORE ABOUT THE NEW TUBES. . . . .	25
EDITOR'S LOUD SPEAKER:	
I'LL SEE YOU AT THE SHOW. . . . .	27
THE WANING OF THE HORN. . . . .	27
NEW LAMPS FOR OLD. . . . .	28
SOME RADIO NOVELTIES OF EUROPE. . . . .	29
TESTING TUBES FOR POOR PERFORMANCE. . . . .	31
FONE FUNS FOR FANS. . . . .	36
U. S. BROADCASTING STATIONS. . . . .	38

*New York Representative*

SHELDON C. KNIFFIN. . . . . 503 Fifth Avenue, New York—Phone Murray Hill 3149

*Western Representative*

W. T. DIEHL. . . . . 30 North Dearborn Street, Chicago—Phone Central 5410

RADIO PROGRESS is issued on the 1st and 15th of each month by the Oxford Press at 8 Temple Street, Providence, Rhode Island. John F. O'Hara, Publisher. Yearly subscription in U. S. A., \$3.00. Outside U. S. A., \$3.50. Single copies, 15 cents. Entered as second-class matter, April 4, 1924, at the Post Office at Providence, R. I., under the Act of March 3, 1879. Address all communications to RADIO PROGRESS, 8 Temple Street (P. O. Box 728), Providence, R. I. Title registered at United States Patent Office.

The publishers of this magazine disclaim all responsibility for opinions or statements of contributors which may at any time become subject of controversy.



# The Two Outstanding Parts In Radio !

**Give Low Losses and Amplification  
Without Distortion to Any Set**

**Q**UALITY and distance are what a radio set must give. To insure Quality, amplification without distortion is essential. And to insure Distance, low losses are essential. That is radio in a nutshell.

People in whose sets Acme Transformers are used, are sure of hearing concerts "loud and clear" so a whole roomful of people can enjoy them.

The Acme A-2 Audio Amplifying Transformer is the part that gives quality. It is the result of 5 years of research and experimenting. It gives amplification without distortion to any set. Whether you have a neutrodyne, super-heterodyne, regenerative or reflex, the addition of the Acme A-2 will make it better.



Acme A-2 Audio Frequency Amplifying Transformer

To get the thrill of hearing distant stations loud and clear, your set must have low losses, for it is low losses that give sharp tuning to cut through the locals, and it is low losses that allow the little energy in your antenna to come to the amplifier undiminished. That's what the Acme condenser will do for any set. And it will do it for years, because the ends can't warp, the bearings can't stick and the dust can't get in and drive up the losses several hundred per cent.

The Acme Reflex (trade mark) owes its success and its continued popularity to these two outstanding parts in the radio industry, for low losses and amplification go hand in hand.

Use these two parts in the set you build. Insist on them in the set you buy.

Send 10 cents for 40-page book, "Amplification without Distortion"

WE HAVE prepared a 40-page book called "Amplification without Distortion." It contains 19 valuable wiring diagrams. In clear non-technical language it discusses such subjects as Radio Essentials and Set-building; How to make a loop; Audio frequency amplifying apparatus and circuits; Instructions for constructing and operating Reflex amplifiers; How to operate Reflex receivers; Antenna tuning circuits for Reflex sets; "D" Coil added to Acme four tube reflex; "D" coil tuned R. F. and Reflex diagrams; and several more besides. It will help you build a set or make your present set better. Send us 10 cents with coupon below and we will mail you a copy at once.

## ACME APPARATUS COMPANY

Transformer and Radio Engineers and Manufacturers

DEPT. (AS), CAMBRIDGE, MASS.

SEND THIS COUPON



Acme Low-Loss Condenser

ACME APPARATUS COMPANY,  
Dept. (AS), Cambridge, Mass.

Gentlemen:—

I am enclosing 10 cents (U. S. stamps or coin) for a copy of your book "Amplification without Distortion."

Name .....

Street .....

City..... State.....

# ACME ~ for amplification

## September 15 is the Date for Some Very Interesting Reading

In the summertime, when the crash of static is disturbing your distant programs, do you realize that the Government has the same trouble in picking up their code messages? The Navy has been doing some experimenting along these lines and has got some good results in minimizing this bugbear. Rados explains in **"How the Navy Cut Out Static."**

When you look at a friend's radio set, what catches your eye first? Probably it is the panel, as it is in front. Not only the appearance, but also the operation of the set may depend upon this part of the equipment. It will be worth your while to read **"Give That Smart Look to Your Panel,"** by Standiford.

Most every tube set uses a grid leak. It looks very simple, and yet it is not such an easy unit to make. Different concerns favor various ways of manufacture. An intelligent choice will give you clearer music. See Taylor's article, **"How Your Grid Leak is Made."**

In order to compare different sets, it is only fair to test them under the same conditions of signal strength. But just what is meant by this term? An explanation of it and some interesting results on experiments by the Bureau of Commerce at Washington is contained in **"Some Tests on Signal Strength."**

Of course, you are following the results achieved by MacMillan near the North Pole. He has been doing some broadcasting and has found some curious results. His Eskimo artists are a funny bunch. Some of their antics appear in **"Broadcasting from the Polar Snows."**

You use various kinds of metal in a radio set. Why is this, and what is each one good for? A table of some of the ordinary properties of common metals and alloys together with notes on them by Arnold are given in **"What Metal to Use."**

The Radio Show at New York is opening the season with a bang. If you are near enough to be present of course you won't miss it. If the distance is too great, then you will want to read the article by Johnson, the manager of Fourth National Radio Exposition, **"What's New at New York Radio Show."**

The patent lawyer, Parker, has had a good deal of experience in regard to radio patents. A very entertaining article from his pen, **"Don't Try to Beat the Patent Laws,"** gives some interesting sidelights on the situation, especially as regards infringing and the penalties which are being paid.

# RADIO PROGRESS

"ALWAYS ABREAST OF THE TIMES"

Vol. 2, No. 12

SEPTEMBER 1, 1925

15c PER COPY, \$3.00 PER YEAR

## Watch Your Lightning Arrester

*It Will Not Help and It  
May Hinder Your Set*

By HORACE V. S. TAYLOR

THE firemen subdued the flames, but the man who was struck by lightning never regained consciousness." That is the report on a big fire, following a lightning stroke, where no arrester had been used.

Will that ever happen to your house? Not if you use the equipment which is required to prevent it by the Board of

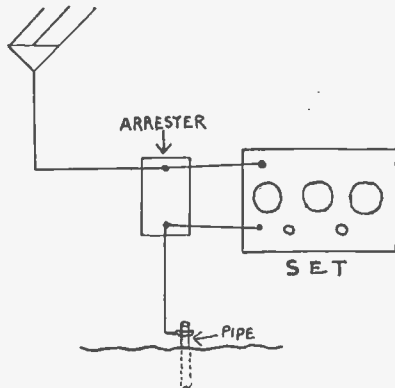

Fig. 1. This is the Method of Connecting an Arrester Recommended by the Fire Underwriters.

Fire Underwriters. Indeed that is the only thing a lightning arrester is used for, since it does not help at all in the operation of your set. As a matter of fact it may even make the music worse as we shall explain a little later on.

### Don't Need to Cut It Up

The connection for a lightning arrester is very simple. You will find only two terminals or binding posts—one marked G for ground and the other A for aerial. When hooking up the unit it is not necessary to cut your wires to the set, but instead they may be a continuous

length. In that case just insert a loop underneath the binding post as shown in Fig. 1. Of course if you prefer it does no harm to end the aerial or ground at the arrester and then run short, separate leads to the receiver. The only disadvantage is that you will have to bother with two wires under each binding post.

With this connection made how does the unit act? Nearly 100 per cent of the time it does not act at all. The radio waves come down in the aerial through the lead-in and across to the set, as shown in Fig. 2. The arrester here does not make a bit of difference and might just as well be thrown out on the dump for all the good it does your set. No current flows through it, and it is as good as an insulator holding the aerial and ground leads apart.

### When Dynamite Lets Go

Now let us suppose that a thunder storm arrives on the scene. Then we have a different story. A flash of lightning is seen. Maybe it does not strike

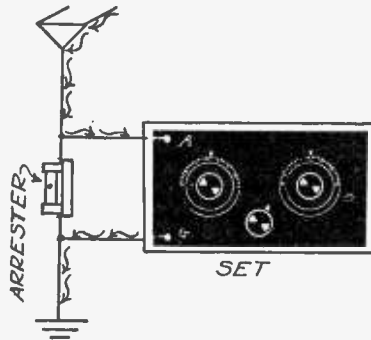

Fig. 2. The Radio Waves Completely Ignore the Arrester.

your aerial, but if it occurs within a few hundred feet then a powerful shock will be felt in your system. It is something like an explosion. You do not need to carry a stick of dynamite right in your pocket to feel the explosion when it lets go. You will know all about it, although it may be fired one or two hundred feet away.

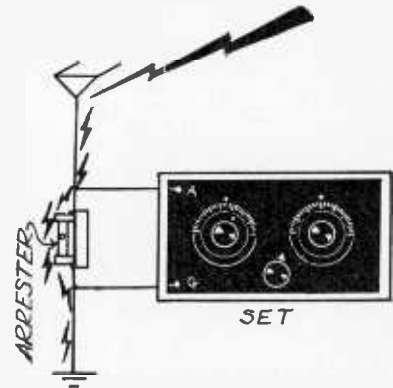

Fig. 3. When a Stroke of Lightning Rushes Down the Aerial, Set is Protected.

This shock to your aerial from the lightning stroke is manifested by a tremendous surge of current down the aerial. How will it reach the ground? We must think of it something like a body of water when a dam breaks. The little stream along the bottom of the valley, which normally carries the overflow from the dam, cannot begin to handle the vast rush of angry water. As a result houses and trees which stand in the path are overwhelmed and swept away. In the same way if you depend on the coils and connections in-

side your radio set to carry off the stream of electricity then you must expect to find melted copper and a ruined set inside the cabinet.

**Safety Valve That Doesn't Work**

If you have taken the precaution to install an arrester as Fig. 3 illustrates, then the tremendous current will pass through it direct to ground and your set and the house itself will be saved from injury. From this you can see that the arrester is intended only as a safety valve, and may never be called on to do anything as long as it is connected to your aerial. However, if you are so fortunate as never to experience such a stroke of lightning, don't blame the arrester because it never works.

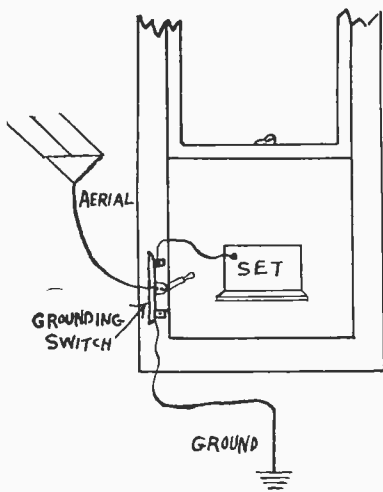

Fig. 4. Hooking Up a Ground Switch. This Disconnects the Set.

In this connection it may be well to mention that you are wasting your money foolishly if you are paying a fire insurance premium. That is, it is foolish unless you have one of these units, which the underwriters require. When you take out a policy it is in the form of a contract in which the insurance company agrees to pay you so much if your house burns down and in return for their promise you agree to pay a yearly premium and also to follow the rules of the company in regard to the electrical equipment you use.

**They Won't Pay for Fire**

If you break your contract by neglecting to install an approved arrester, then the insurance people are not bound by law to carry out their part of the contract if the building catches fire. But

suppose in the event of a conflagration you are able to prove that it caught in the daytime under a clear sky (no lightning), from a cigarette which was left smouldering? The insurance company will say "Very interesting, but what has that to do with us?" In other words, the big companies feel that you have no right to endanger the property and lives of your neighbors by using an unprotected aerial, and so they are not morally bound to pay your losses. As already explained, they are not legally bound either.

Of course, this discussion applies only to outdoor aerials. If you use an inside antenna or a loop lightning cannot reach it anyway unless it has already struck and entered the house and by that time it would be too late. The installation which has no outside wires does not need any protection at all.

**Do Not Substitute Switch**

As an added precaution, many people install a ground switch, Fig. 4. The advantage is that if anything should go wrong with the arrester or if an unusually severe direct stroke of lightning should occur on your aerial, the switch will carry off the current without endangering the apparatus. It is not a bad idea to use such a grounding switch, but it must be in addition to the arrester. The latter is connected from aerial to ground in the usual manner.

The reason that the switch is not enough to satisfy the insurance men is

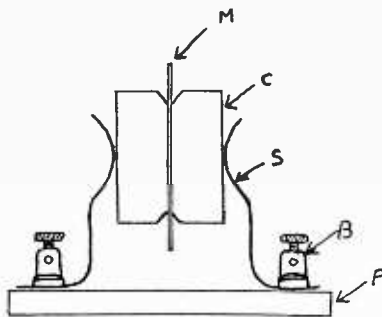

Fig. 5. Here is a Diagram of the Most Popular Type of Arrester.

this. Suppose you get accustomed to throwing the blade down each night and thus grounding the aerial. This happens night after night for months with perfect safety. But one evening you were going to a dance or had the toothache, or perhaps the baby got the colic, and as a result you forgot to throw the switch. That night there happened

to be a thunderstorm, and lightning struck the aerial. The insurance company not being a charitable institution, would naturally object to standing the loss because you had neglected to install an arrester. That is why they advise using a grounding switch in addition. But they demand that you install an arrester in any case.

**Millions of Volts Pressure**

How does this unit do its work when called on to discharge a flash of lightning? The operation is easy to follow. There are always two conducting plates which are connected to the aerial and ground respectively. Between these plates is an insulator which will break down at 500 volts or less. Since the potential of the thunderstorm is up in the millions or hundreds of millions of volts, the charge of electricity will jump across the gap and be discharged safely into the earth.

There are two general classes of arrester. The first, which is the more com-

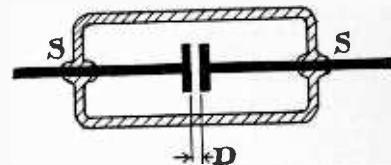

Fig. 6. This Vacuum Type is More Efficient, but Costs More, Too.

mon, is illustrated in Fig. 5. The two conducting plates, C, are made of carbon and are held in place by the springs, S. In order to separate them exactly the right distance a thin sheet of mica, M, is interposed between. This mica sheet is cut away from the center so as to allow an air gap from carbon to carbon. Of course, the length of the path between the two blocks is exactly equal to the thickness of the mica sheet. Carbon is used for electrodes since when it burns it becomes a gas (carbon dioxide) and so does not short circuit across. If metal were used here it would melt and the drop which formed would be likely to touch across and so short circuit the gap.

**Glass Tube with Nothing in It**

The other type of arrester is displayed in Fig. 6. Here the two electrodes are supported by the stems, SS, which are sealed into a glass tube. The space inside the tube is exhausted to form a moderate vacuum. Such a vacuum is quite conducting, and so the distance,

D, between the electrodes is much greater in this form of arrester than in that of Fig. 5, where air is the separator. Of course, this wide spacing makes the electrodes much easier to assemble without accidentally touching.

Both these types of arresters are quite popular. The construction of Fig. 5,

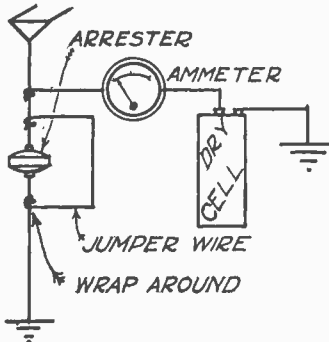

Fig. 7. If This Test Shows That the Arrester is Shorted, Scrap It.

since it does not use a glass vacuum tube, is considerably cheaper and so it has a wider appeal. Fig. 6, on the other hand, is less likely to get out of order and is probably a higher class device. The operation of both is just the same.

Nothing to Do with Radio

As already mentioned, this unit is not supposed to have anything to do with radio. If it has any effect at all on your set or its operation, it will be a disadvantage, rather than a help. It should have no conductivity at all for radio waves. If it does carry any current, you can easily see from Fig. 1 that it is robbing the set itself of whatever energy happens to pass through it. There are a good many arresters, however, which right now are stealing energy from their sets.

Maybe your own unit is weakening the signals which you are so anxious to catch. It pays to test this out every once in a while. A good method is shown in Fig. 7. Disconnect the aerial and ground leads and connect an ammeter and one or more dry cells in series as shown. The ammeter may be the style used for testing dry cells, which will cost around 75 cents or one dollar. The diagram shows one side of the battery connected to a separate ground, but it is not necessary that such an additional ground be used—the one to the arrester will do just as well.

Testing Out the Tester

It is well to put a jumper wire around the arrester as shown, in order to make sure that your meter and coils are properly connected. With the jumper in place the meter ought to show a reading. If it does not, then inspect the circuit for trouble, and adjust until a pronounced indication is seen. Then remove the jumper wire and again read the meter. It should be showing zero. If it indicates any current at all, it means that there is a leak in your aerial direct to ground.

Such a leak is most likely in the arrester, but not necessarily so. The next step is to take the leads off this unit's binding posts. If the meter continues to show current, then there is trouble somewhere in the aerial itself and not in the arrester. But if the reading is now zero, then it proves that the trouble lies in a defective arrester. In that case it is hardly worth trying to fix it, as a good approved unit can be bought for from 50 cents to \$1.50.

Testing with the Phones

Another method of testing the arrester appears in Fig. 8. This uses a pair

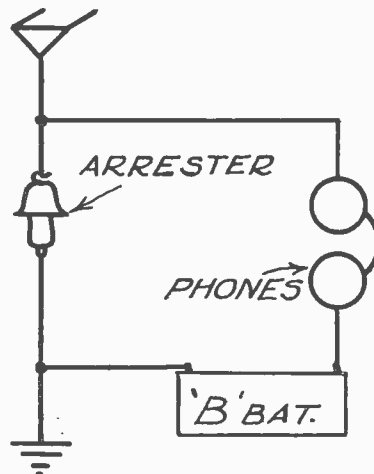

Fig. 8. This is a Simpler Test as to Condition of the Arrester.

of phones as an indicator instead of an ammeter. Your 22 or 45-volt "B" battery will serve well as a source of current. Connect your apparatus as shown and then listen with the phones while you make and break a contact on the battery. A pronounced tapping heard in your ears will show that the lightning arrester is short circuited.

This test is considerably more sensi-

tive than that shown in Fig. 7. Indeed it is almost too good in this respect as you are likely to hear a small amount of noise in the phones, owing to leakage, even when the arrester is in good shape. It requires a little practice to be able to pick out the noise from such a defective device and not be confused by the great sensitiveness of the phones. If you are in doubt you repeat the test with the arrester disconnected. If the same small click is heard as before, you will know that it does not come from a short circuited unit.

Look Out for Petticoat

In conclusion, a few words might be said as to where this device should be installed. The regulations allow this to be put either outdoors or inside the house, provided it is close to the place where the lead-in enters the building. However, an arrester intended for indoor use is not well protected from the weather and should not be used outside. Models which will stand the rain are usually shaped with a petticoat as illustrated in Fig. 8. This allows the water to drip off around the edges and keeps a large part of the surface dry. If it were to get wet all over, then the water would form a conducting layer, which would partially short circuit the device to the detriment of your radio program. Of course, such short-circuiting would not reduce the efficiency of the arrester in performing its real job—conducting a lightning flash safely to ground.

A HUSKY THREE-YEAR-OLD

WEAF, the broadcasting station of the American Telephone and Telegraph Company, which has grown from a group of five people to an organization of eighty-five, celebrated the beginning of its fourth year of operation on Saturday, August 15. The evening was of particular interest, since many of the singers and musicians who were heard on the first few weeks of the programs three years ago attended this reunion party.

**Free Mailing Lists**  
 Will help you increase sales  
 Send for FREE catalog giving complete  
 and prices on thousands of classified  
 names of your best prospective customers—  
 National, State and Local—Individuals,  
 Professionals, Business Concerns.  
 99% Guaranteed 5¢ each  
 by refund of 5¢ each  
**ROSS-GOULD CO.** 6128 10th St. St. Louis

# American Radio Relay League

## HOW THEY DO IT IN WISCONSIN

The La Crosse Radio Association, composed of radio telegraph amateurs affiliated with the American Radio Relay League, has just completed a piece of work for which it has received the heartfelt thanks of all of the broadcast listeners of that city.

In the midst of the best programs, bang, bang, BANG, BANG, noise resembling a trip hammer would cut short the enjoyment of listeners, and the problem defied every effort of power engineers for the various industries that might have been causing the noise.

The Radio Association, acting on the plan of the American Radio Relay League, organized a Vigilance Committee whose duty it is to attempt the location and removal of radio interference in the community. This committee, working with a special portable loop receiver, recently purchased by the club, set out to cover the affected area in an attempt to locate the trouble.

The committeemen covered an area of 12 city blocks with the receiver installed in an automobile. The readings were taken with care and finally the noise was located in a series of four street arc-lamps. The following night, together with a representative of the electric power company, they once more took readings, this time checking the individual lamps which were shunted in turn until the offending one was located.

A close examination made by the power company the next day showed that the insulators of this particular lamp were defective and that current was leaking to the ground. Replacement of the entire lamp and insulation equipment removed the trouble.

So great an impression has this work of the association made, that a large number of listeners-in in the community have asked to share part of the burden of maintaining the test set. Offers have been made to supply accessories to the apparatus and membership in the association shows indications of a decided jump.

## SAN JOSE WINS DISTANCE

Bruce Stone, owner and operator of radio station 6AMM in San Jose, Cal., taking part in the American Radio Relay League work of receiving and transmitting radio messages for the Navy-MacMillan expedition, succeeded in carrying out what is probably the longest distance communication which has up till now been effected with either of the stations of the expedition.

The communication came about when Mr. Stone sent out the general call of "CQ," telling his willingness to take

messages from anyone wishing to transmit. His reply came from the MacMillan expedition in the form of several messages, which due to the distance and unfavorable atmospheric conditions, were extremely difficult to take.

This fragmentary conversation marks the longest recorded distance which has thus far been reported for the stations of MacMillan expedition, and seems to promise that when certain minor difficulties are conquered, the work of these stations will come through to all points in this country with clock-like regularity.



This is What the Wisconsin Vigilance Committee Set Out to Cure

## SUPPLIES EYES FOR READERS

Radio broadcasting has been a greater delight to invalids and the blind than to any other class of individuals. The radio stations receive more mail from such afflicted persons than from any others. It requires little or no imagination to be able to understand how great a place the radio receiver has taken in their lives.

Up to recently a very important factor has been omitted from the radio broadcasts—that of reading novels, works of history and the classics to those of the

radio audience who are not able to see for themselves. To take care of this matter, Station WJZ has introduced such reading into their programs, and at 4:10 every Monday, Wednesday, and Friday afternoon, J. B. Daniel, the staff announcer of WJZ, can be heard reading short stories, novels, works of history and other good literature from its studio. Mr. Daniel has a most pleasing voice and "air personality" and in the short space of time that the service has been in use, countless messages have been received thanking him for his trouble in broadcasting this feature.

# Shaving Static from Your Signals

## What to Do When Bothered With Summer Interference

An Interview with ALFRED N. GOLDSMITH

PAT, can you play the piano?" a man was asked. "I don't know," Pat replied, "I have never tried." This old joke does not apply to radio with quite the force that it does to a piano, but at that many fans seem to think that they ought to be able to work a receiving set

quires quite a bit more care during freezing weather as compared with its care-free operation in summer, so the radio receiver requires more attention in its warm weather operation if the best results are desired.

Summer announces its presence in

off static whiskers, so that we may go on enjoying radio programs in summer as well as during the rest of the year.

Nearby programs, in which we have the advantage of a high signal level as compared with the static level, are fairly free from static whiskers.

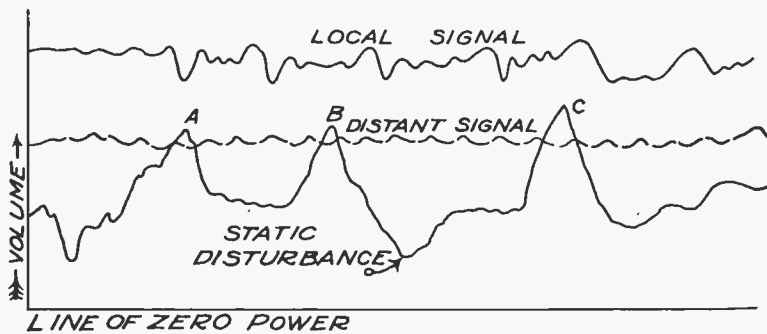

Fig. 1. Distant Signals Are Disturbed by Static While Locals Are Not Bothered

### Curve Compares Signals and Static

This is evident from Fig. 1, which shows a comparison between static and the signals of two different stations. You will see the static is very irregular in its loudness coming in with a crash and then dropping off to dull rumble in the background. This is illustrated by the height of the curve above the line of no sound.

The distant signal which is shown by a dotted line holds a pretty constant level. Of course, if it faded it would occasionally dip below this height. You see that it is not much louder than the static as a rule and at times a particular crash of noise will be quite a bit louder than it is at such points as occur at A, B, and C. The local signal on the other hand is so much louder than the static that its program can be enjoyed. Of course, the static will still be heard, but it will be an undertone which is not

without any special knowledge or experience.

The hand that twirls the receiver knob is the final link in radio. No matter how little static, no matter how good the radio programs, no matter what style the receiving set itself, the final factor—and the one that counts for perhaps as much as all the others combined—is the care exercised by the person at the receiving end.

### Learn to "Play" Radio

Not that there is anything complicated about the usual receiving set, but like a musical instrument, radio will deliver more or less in proportion to how it is played. That is why a little care in operating the radio set goes a long way in radio satisfaction.

All this becomes especially evident with the warm days of summer, when conditions are not as favorable for radio as during the cold, crisp days of fall and winter. And just as the automobile re-

radio circles by the bewhiskered make-up of signals. There are on many summer days various disturbing noises coming through head set or loud speaker, as compared with the crystal-like clarity of signals so common in cool and cold weather. Such is static. Fortunately, there are ways and means of shaving

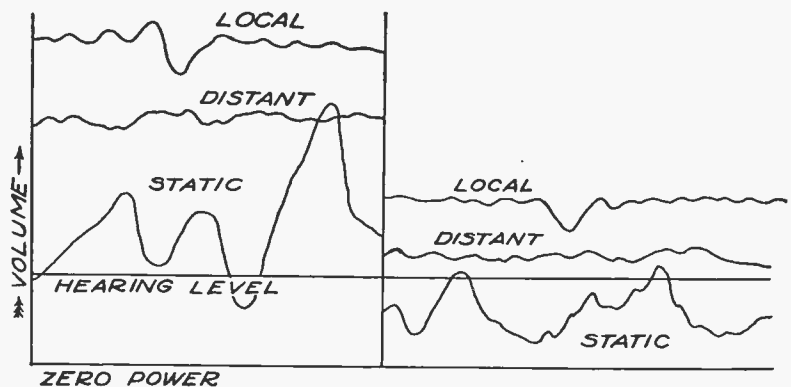

Fig. 2. Cutting the Volume to Half Drops Static So it Can Hardly be Heard, Altho Signals Still Come In.

noticed much except when the local stations have a pause between pieces.

#### Static Does Not Bother Locals

That is why good reception is always assured from nearby broadcasting stations, especially today when many of the broadcasters have gone to higher power so as to insure proper reception of their programs under any and all conditions.

When it comes to distant music from moderate-power sending stations, you must expect static. On some occasions there will be a source of disturbance, such as a thunderstorm, much nearer to your receiver than the distant broadcasting station. With the loop type of aerial the directional effect helps to increase selectivity. Often a signal may be picked up from a transmitter several hundred miles away, while a thunderstorm, less than a hundred miles off, but in a different direction, will cause comparatively slight static interference. This matter of directional reception accounts for the noticeable advantage of the loop type receiver in summer time operation.

Of course it is largely a question for the radio listener to decide: if he desires to continue his globe-trotting or radio golf in summer as well as in winter, he must expect to pick up a great deal of noise for the reasons already mentioned. If, on the other hand, he is interested primarily in good entertainment, then he should stand by local stations during warm weather. The summer time recipes for radio calls for quality not distance.

#### When Background is Scratchy

No matter what the type of receiver, the most effective way of reducing static is to select a powerful radio signal, which usually means a local station. Ordinarily, there will be little static interference with such a wave, but if the background is scratchy and blurred as the result of intense static, the output volume of the set can be cut down somewhat until the background noises are reduced to the vanishing point. Obviously, the signal volume is also decreased, but if it is sufficiently powerful to begin with, there is ample opportunity for reducing it and still have left sufficient volume at the end.

Fig. 2 makes this idea plainer. You will remember that our ears are not sen-

sitive enough to pick up all the sounds which the radio set delivers. In other words, the line of no sound lies quite a bit above the line of no output. Suppose we have static noises as shown in Fig. 2, and somewhat louder a signal as shown at the vertical line. Then we reduce the amplification so that the volume of each is halved. Remember that it is the output from the set which is cut down to half, not the music which we hear. Observe now that the irregular static line has now fallen below the sensitiveness of our ears so we hear no sound from it although it still exists. But the music, while much reduced, is now heard without the static accompaniment.

#### Time to Omit One Stage

In this connection it may be well to cut down the audio amplification. Thus the average radio listener operates his radio set at its fullest capacity, summer and winter alike, whereas, with

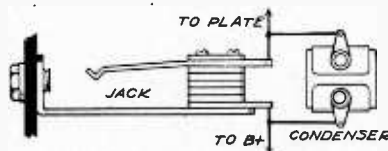

Fig. 3. This Method of Connecting a Condenser Will Often Reduce the Noise.

local stations at least, the usual receiver will provide plenty of volume for the loud speaker on only one stage of audio frequency amplification. When static interference gets to be bad, the amplification should be cut down to one stage.

In the event that static interference is terrible, such as with an approaching thunder storm, you can still listen to sufficiently powerful signals through your head set, on the detector alone without amplification of any kind. I recently listened to an important program without interruption of any kind, using a head set without any audio frequency amplification, while a nearby thunder storm was flashing and banging away. Obviously, no one is going to such lengths to listen to a radio program unless some extraordinary feature such as a thrilling sport event is in progress at the time.

#### Good Speaker for Summer

It follows that with the reduction of

the output of the receiver, in the effort to drop the static background, the loud-speaker volume will also be reduced. In this connection, it is often advisable to use one of the higher quality types of loud speakers for summer time operation.

The horn has much to do with static interference. Some loud speakers, because of the sharp "tinny" characteristics of their horns, sound much worse on static disturbances than others. However, the trend in speaker development has been more and more away from the sharp pitched metallic type of horn, and towards the soft, mellow, deep horn which does not amplify the sharp, whip-like cracks of static, but rather loses them partly by a blending of sounds. Furthermore, loud speakers are being made more and more sensitive so that they may be operated with a remarkably small output from the receiver. The high quality horn will not "ring" with a clanging noise when a burst of static is received.

#### Move Out the Horn

One phase of radio reception which is generally overlooked, and yet has a most important bearing on results, is the location of the loud speaker. It is astonishing how considerably radio music can be modified by changing the position of the loud speaker. A little experimenting along this line will generally produce worthwhile results. Especially is this true in summer time, when the static background stands out boldly unless the sound volume is reduced as already outlined. Thus the loud speaker, located indoors, will give more volume but it will also focus attention on every little detail, static background included, no matter how faint it may be.

On the other hand, if the loud speaker is brought out on the porch or on the lawn, the little details of its voice are no longer discernible and only the main theme—music or speech—remains to attract the attention of the listeners. Indeed, delightful results may be obtained with the usual horn used outdoors. The receiving set will take a brand new lease of life when heard amid new surroundings of any kind, especially in the transition from inside to out. Of course the entire receiving set need not be moved outdoors. If the receiver is of

Continued on Next Page



# What Are the Wild Waves Saying?

## *Take This Treatment to Avoid Sunstroke On a Hot Day*

By GOLDA M. GOLDMAN

NOT all the waves of Atlantic City these days are from the ocean; some of them are radio waves, emanating from Atlantic City's two active studios.

These are WPG, "World's Play Ground," the Municipal Station, located in their very beautiful new high school building, and WHAR, "Where Happiness Always Reigns," which is situated in and operated by the Sea Side Hotel. The programs from WPG are particularly attractive ones, because one of the chief purposes of the studio is to let the world know what some of the attractions are which are to be had at the famous American resort.

### Rest Your Tired Feet

For this reason a number of outside pick-up stations are operated from the large boardwalk and restaurants. One of the most attractive of these is the Ambassador Grill, where the Sea Side Serenaders entertain every Saturday evening with an eight-piece orchestra. They are under the leadership of Alec Bartha, an Atlantic City boy

Continued on Next Page



Fig. 1. E. E. Dennison Comes from Talented Family; He is Studio Manager of WHAR, While His Mother is Program Manager

### SHAVING STATIC

Continued from Previous Page

the antenna type it may be left in its accustomed place, while the two connecting wires are run outdoors to the loud speaker. The loop receiver, on the other hand, may be carried and used anywhere, so as to have the tuning controls readily available.

#### A Condenser Dislikes Static

Loud speaker reproduction often may be improved in summer time reception by bridging a small fixed condenser across the loud speaker terminals. The capacity of such a condenser obviously must vary from one type of loud speaker to another, but a little experimentation with several sizes of small fixed condensers must soon disclose the proper value for a given loud speaker. Such a

condenser arrangement tends to eliminate a part of the fuzziness of static interference and helps, particularly in listening to certain kinds of music. A value of .001 mfd. is usually about right.

With just a little care in the operation of the receiver, as already outlined, good results should be obtained with the usual outfit. It is hardly necessary to go to the trouble of installing a shorter antenna for summer-time operation, although if the radio listener is of an experimental turn of mind, he will obtain interesting results by trying out various kinds of aerial. After all, the only result of a short or indoor antenna is that the amount of energy received is noticeably less than with a full-length wire. Hence the static level falls and with it the signal level. If the static level happens to be below the signal level to begin with, this matter of drop-

ping both curves to lower values must bring the static down below the threshold of audibility, as was shown in Fig. 2. It is often an illusion, though to some a highly pleasing one. With powerful nearby signals a smaller antenna will provide ample loud-speaker volume with a clear background, but the same result can be obtained by reducing the amplification as previously mentioned.

#### How to Connect This Unit

This condenser is probably best located behind the panel of the radio set (see Fig. 3), although, of course, it might be installed on the loud speaker. As shown, it is connected with one side to the wire from the plate of the last audio amplifier, and the other side to the lead from the B +90. The probable value for the capacity lies at either .0005, .001 or .002 microfarads.

### WHAT WAVES ARE SAYING

Continued from Previous Page

who surely knows how to make the violin say what he wants it to. A Paul Whiteman orchestra may also be heard in the Hotel Traymore, through this same station. The Hotel Traymore Ensemble of five pieces also broadcasts concert music, with Ariel Rubstein as leader. Furthermore, you can dance almost every evening to a perfectly splendid dance orchestra from the Hotel Knickerbocker; and you may tune in on the classic selections from the Chalfonte's Haddon Hall Trio at 9 o'clock,

pride in the station has had much to do with the success of the civic programs which they send out. Because the taxpayers themselves like the station, they take an active part in providing features for programs, and it may be safely said that to nothing in the town do the natives look with greater pleasure than to the work which is done in making America realize that WPG actually does represent a city which is justly entitled to the claim of being the world's playground.

The other station, WHAR, has for its studio manger Eugene E. Dennison, Fig.

they also have pick-up stations on the boardwalk, notably in the Shelbourne Hotel, whence they broadcast dance music, and in the Strand Theatre, whose incidental music is very good. Dance programs are put on from the charming studio in the basement floor of the hotel, where walls draped in golden brown, a black fireplace, whose bricks are etched with gold, and a marble-square velvet carpet, form a background which is harmonious enough to serve for an inspiration.

The program manager is Mr. Dennison's very lovely mother, who is a musi-

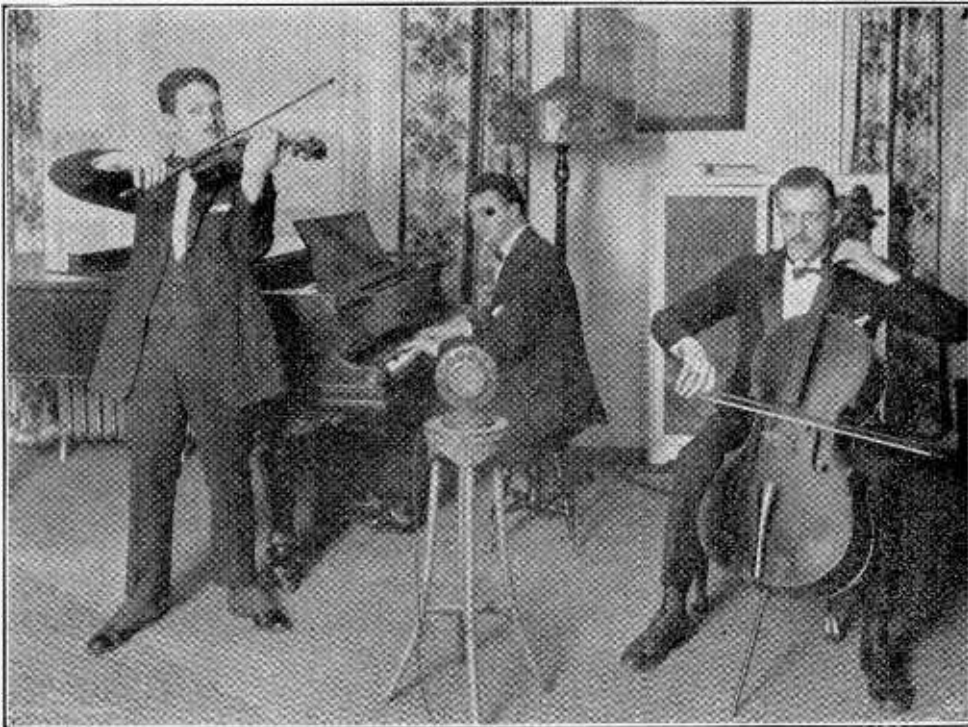

Fig. 2. You Will Now be Entertained by the Sea Side Trio; Pietro Russo, With the Violin; William Schwartz, Piano, and Martin Brook, the 'Cello

when you have tired your feet out.

The Municipal Station is at the service of any city organization which has a particularly entertaining program to present to the public. The studio itself is an attractive place with sound-proof walls, which instead of being draped, as is customary in the majority of stations, are papered with an attractive blue sanitas covering. The staff is under the direct control of the Commissioner of Public Safety, William S. Cuthbert.

#### All the Natives Help

Practically the entire force are Atlantic City born and bred, and their

1, who has for thirteen years been associated with the Sea Side Hotel. Mr. Dennison started in his musical career as a violinist, but was side-tracked by his interest in hotel work. The station was started three years ago, when Harry Cook, one of the owners of the hotel, became interested in radio. One of the most interesting features of the station is the Sea Side Trio, Fig. 2, consisting of Martin Brook, 'cellist; Pietro Rousso, violinist; and William Schwartz, pianist.

#### Eric's Etched with Gold

Since WHAR is also interested in popularizing the charms of Atlantic City

cian of note and a widely traveled person, whose knowledge of music and artists is sufficiently wide for her to gather many well-known entertainers before her microphone. Civic programs are frequently put on, just as in WPG, and city officials, school children, etc., are to be found there quite as often as in the city station.

When you are overcome by the city heat, and wish that you might be where the ocean breezes blow, just tune in and find out what the wild waves are saying, and perhaps you will feel a little cooler.

# German Broadcasting Not Like Ours

## *Most All Sets Are Crystals and Must be Licensed*

By STANLEY McCLATCHIE, Stuttgart, Germany

(Editor's Note—Mr. McClatchie is engaged in development work on electrical apparatus. He was on his way back to Stuttgart from Cleveland, and stopped over at Pittsburgh to consult officials of the Westinghouse Electric and Manufacturing Company about further relaying of KDKA programs by the German stations.)

**P**ERHAPS you think of a crystal set as just being a starter for the radio fan, who will shortly invest in a tube set. They don't in Germany, though, for most of their radios are of this style. That means that the broadcasting stations must be pretty powerful in order to reach the rural sets.

For this reason American radio listeners undoubtedly will be able to hear German radio stations as soon as cold weather arrives, with its longer hours of darkness and lessened static disturbances.

### To be Biggest in World

The first four of a dozen of the most powerful radio stations in the world being built in Germany already have been placed in operation. These will be heard in America as soon as radio reception conditions become favorable with the setting in of cold weather in the northern hemisphere

KDKA and a few other American stations were heard in Germany last winter on days when transmission conditions were especially good, while the KDKA international fast wave relay transmission was picked up on my aerial at will and relayed by the Stuttgart station, which had run a special wire to my laboratory.

The most powerful of the German stations is the one at Herzogstand, Bavaria, which has been built to deliver an energy output of 400 kilowatts. This is about eight hundred times as powerful as most

of the big American stations with their one-half kilowatt (500 watts).

### Fight Over Who Runs It

This station is completed, but due to some differences about who shall run it, it is not in operation. How much of this enormous energy can be modulated



Stanley McClatchie, the Author of This Article, is a Radio Engineer of Stuttgart, Germany.

to carry voice is problematical, as no attempt has ever been made to modulate more than an eighth of this much energy. Of course it is much easier to work such apparatus on wireless code as all that is necessary for dots and dashes is that the waves start and stop

at the right times. With broadcasting, of course, the note or tone must also be carried by the vibrations.

The station is located in the Tyrol mountains of upper Bavaria, where hydro-electric power is abundant. The sending antenna is stretched between two high peaks of the mountains, with the station in the valley hundreds of feet below.

The next most powerful broadcaster is the Trans-Atlantic station at Koenigswusterhausen, designed for power up to 50 kilowatts, where some of the existing apparatus will be adapted for voice modulation. The recent General Electric tests at Schenectady used this same amount of power and were quite successful. But there are a good many engineering problems to be worked out with such mammoth equipment.

### 500-mile Crystal Sets

The German Government, which is building all these stations, is expecting to broadcast radio telephone programs at such power that crystal set users all over Germany may hear it at any time of the day, and German people all over the world may pick it up regularly. This will mean reaching crystal sets within a radius of 500 miles.

The other sending plants will be less powerful, but will have an output of 5,000 watts (5 kilowatts). This is as big as the largest now permitted in America to do regular broadcasting. These stations will be heard in the United States next winter, as American stations of much less power were heard in Germany last winter. Three of these already are in operation, at Hanover, Dresden and Kassel, the first being especially effective for sending its signals over great distances.

### \$500,000 Received Each Month

These powerful and expensive stations are made possible by the German system

of licensing radio sets, which now is bringing in a revenue of half a million dollars every month. Broadcasting was begun in Germany only a year and a half ago, when a few low powered stations were built. The popularity of the senders grew rapidly, and the original transmitters are being replaced by the new powerful ones as fast as the money becomes available through the monthly fees on sets.

Although this fee system permits the broadcasting companies to pay all people who appear on broadcast programs, the standard of radio programs in Germany is not a bit better than in America, where practically none of the artists are paid.

There are several reasons for this. In the first place, America got a start of about two years ahead of Germany and this was a big advantage. Just think back what programs were in the United States two years ago and you will notice a tremendous improvement in what is going on the air at the present time.

#### Americans Appreciate Advertising

Another reason is the fact that American musicians see the advertising value of radio and are glad to broadcast partly for this reason and partly for the novelty. As time goes on it will probably be necessary to spend more money on talent than at present.

The German stations are built and owned by the government, but the broadcasting is done by private companies. One of these corporations leases each station, and shares in the proceeds of the fees on the receiving sets in its district.

The tax amounts to two marks per month on each crystal set. This cannot be paid in the old marks at the rate of 10 bushels to the dollar, but must be gold marks, which are worth 24 cents each. And who collects this 48 cents? The government found that the best one for this job was the postman. He is going around every day to every house, and so does not need to make any extra trips.

#### The Postman Knows It

There is another reason why he was elected. Although the tax is not large, still it is found that lots of people hate to pay it, and so try to evade this monthly fee. The postman is probably in a better position than any one else to observe whether or not a house has an aerial attached to it, or if there is

any appearance that radio apparatus is being used. The money is not payable except once in three months.

The government gets two-fifths of the money collected for building the stations and maintaining equipment. The remainder is given to the broadcasting company, and out of it the company pays its artists, maintains its offices, and pays dividends to stockholders, the dividends being limited to 10 per cent per year. There also is an arrangement that the funds of the enormously wealthy Berlin company, with its many thousands of listeners, may be used to make up deficits of other companies whose number of listeners is not so large, and whose revenue, as a consequence, is not so great.

#### Now Squeals May Enter

At present there is a restriction on the kind of radio which is used. September first will see this removed as the government feels that the people now have had enough experience so that they can be trusted to use regenerative sets without squealing in their neighbors' ears. The same license fee, however, will be continued.

The sets must be able to tune down to lower frequencies (longer waves) than 500 kc. (600 meters), since some broadcasting is done on the slower waves. For instance, the stock reports are sent out every day on these frequencies, which will not interfere with musical programs.

#### More Than Million Dodgers

A million people are paying the permit fees, while as many more may be dodging them. Practically all the million use crystal sets, as economic conditions prevent their buying the more expensive tube sets. A skilled man, who in America would be paid a dollar an hour, gets a mark (24 cents) an hour in Germany; while unskilled labor gets but one-fourth the American wages. The cost of living is almost as high in Germany as in America.

Even at that, the German workman does not receive all he earns, for 10 per cent of his wages are deducted from his regular pay envelope by his employer and handed over to the government as taxes. As a consequence, it is no wonder that most people can buy only crystal sets.



Nikolia Sokoloff, conductor of the Cleveland Symphony Orchestra, who has been leading the New York Philharmonic Society Stadium Concerts as guest-conductor. These concerts have been broadcast by WJZ, WRC and WGY during July and August.

# Real Super-Power Sending

## *What Happens When You Increase the Energy by 100 Times*

By ADAM STEIN, Jr., Managing Engineer Radio Department, General Electric

**S**TRUCK by lightning!" What a picture these words conjure up. Right away you imagine a tremendous amount of electric power let lose in a small area.

That is just what has happened recently at Station WGY, except that in this case the terrific energy is controlled and is used to *help* the progress of man rather than to hinder it. We certainly should say that the output of 50,000 watts or 50 kilowatts, if you prefer,

sending apparatus was developed to the point where it no longer bothers the broadcast listener.

Such a sending tube has an output of five watts and this is enough so that code messages from such stations have been picked up half way across the United States. However, this amount of power is small compared with the 100 watt square which comes next. The average Class A broadcasting station in the United States uses about 100 watts.

quite recently. The size of these two is shown by the middle squares of Fig. 1.

Recently a very few of the most prominent broadcasters have been given special permission by the Department of Commerce to put 5,000 watts on the air. Notice how this square towers over the ones preceding. Everyone knows such a mammoth output as "super power." Stations like WLW, Cincinnati, which was the first to increase to this figure, have found that the problem of summer



Fig. 1. The AREA of Squares Shows Power of Different Classes of Sending Stations. The LENGTH Represents Current in the Aerial. WGY is on Right.

really is tremendous compared with the product of most radio stations.

### What the Squares Mean

Fig. 1 gives a better view of this comparison. The areas of these squares represent the amount of power in the sending aerial. If the *length* of the side of the square, rather than its area, were used as measure, then the big ones would be a great deal larger still. At the left is seen a tiny dot. This represents the sending tube of the average amateur, whose dots and dashes used to cause such loud interference in your phones a couple of years ago before his

There are some more powerful than this and a great many which use less than 100 watts. Broadcasters of this size expect to be heard throughout ten or twenty states.

### Class B Are the Big Ones

The Class B broadcasting stations must have a special license from the Government, which is very hard to obtain owing to the large number of senders who want to be heard all over the country. These stations vary from 500 watts up to 2,000. Stations like WGY, Schenectady, and WEAJ, New York, have had the 2000 watt rating until

broadcasting without too much trouble from static has been solved for listeners within a circle of a good many hundreds of miles.

### Snow House to Palace

Now look at the last square, which represents 50,000 watts. It is ten times as big as the largest previous station and 100 times as great as the 500-watt Class B stations. Instead of increasing a little at a time it makes a tremendous jump in size. It is just as if a boy who had been making snow houses during the winter should decide to build a marble palace in the spring. And yet in spite of

this big jump the research engineers have designed the equipment with such skill and accuracy that the new station has been a success from the very start.

A few words as to why this big improvement was made will no doubt interest you.

The ultimate object which we hope to obtain by super-power broadcasting is, of course, an appreciable improvement in the service to broadcast listeners. To what extent super-power alone can accomplish this result has not been fully determined. While some phenomena in radio transmission vary with the *power* of the transmitter, other characteristics depend on the *frequency* and the relative location of the transmitting and receiving stations.

#### Don't Depend on Power

And recently it has been found that polarizing the waves has a very marked effect on their being picked up easily as explained by E. F. W. Alexanderson's article "Locals Which Can't Be Heard," in the August first issue of *RADIO PROGRESS*. All these last effects are entirely independent of the amount of power used.

Realizing the limitations of the present transmitting service, and appreciating the vast amount of work that remains to be accomplished, the General Electric Company has established what is undoubtedly the largest and most powerful broadcasting laboratory in the world devoted to developmental work.

#### You Can't Beat This Laboratory

This laboratory is designed to permit a thorough study of radio transmission in general, and broadcasting in particular. It provides equipment for obtaining the transmission characteristics of waves between 60,000 kilocycles (5 meters) and 100 kc. (3,000 meters), at powers up to 100,000 watts. In addition, there have been provided sufficient antenna structures so that the best type of aeri-als or radiators can be determined for the various wave speeds.

The laboratory occupies 54 acres of land, and consists of 13 buildings, with three towers 300 feet high (Fig. 2), one 150 feet in height, and a number of smaller towers ranging from 60 to 100 feet. From and between the towers is arranged a network of antennas with which we hope to secure fundamental data on the most efficient aerial for a

given wave speed and power.

#### Three Good Reasons Why

To return to the subject of what super-power can do for broadcast reception: First, it is obvious that increased power at the transmitter will provide increased energy at the receiving station, thus raising the level of the signal above that of the noise. This will tend to decrease the effect of static and other disturbances; second, it may decrease the extent to which fading interferes with reception; third, it will increase the range of the transmitter so that programs can be satisfactorily received over a greater area, and hence

Some apprehension has been felt (and quite properly) by the Department of Commerce as to the use of such tremendous power for broadcasting, believing that it might result in the program of a super-station crowding out the entertainments of the lower powered senders, particularly in the vicinity of the station itself.

For this reason, the super-power transmitter of this company is located several miles from the City of Schenectady, so that the intense field, as the electrified condition of the atmosphere is called, in its immediate vicinity will not interfere with the reception of other

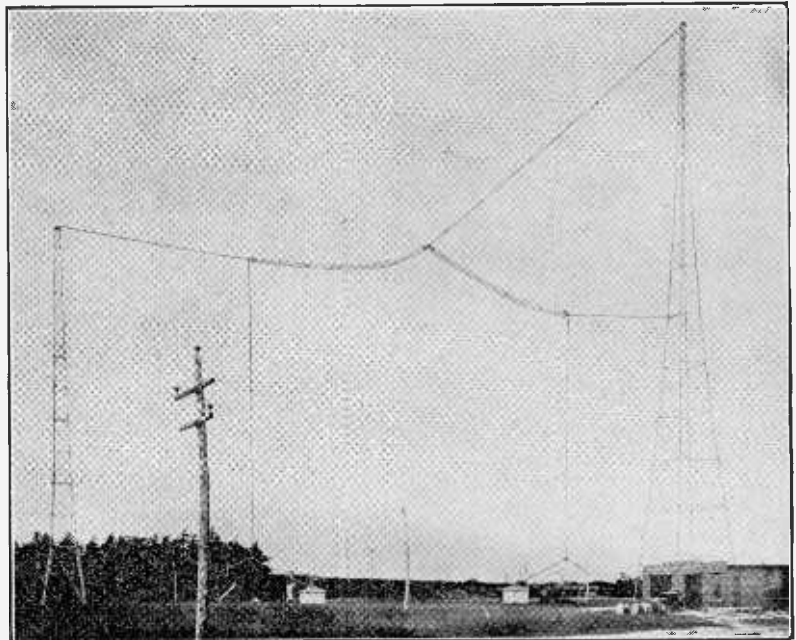

Fig. 2. This is the Aerial That Radiates 50,000 Watts. You Would Almost Expect it to be Melted. It is the Cage Type

provide better service both day and night.

At the present time, when the word "super-power" is applied to so many projects, it is perhaps difficult for the broadcast listener fully to appreciate the technical difficulties that must be overcome in building a transmitter of this size. Some idea of the problem may be gained from the fact that such a device must be capable of receiving an extremely small amount of sound energy from the voice, converting it to electrical energy, and amplifying it fifty thousand million (50,000,000,000) times without distortion.

programs by the inhabitants of Schenectady.

#### Did You Sit Up to Hear?

It is also for this reason that the first series of tests were carried on at rather unseasonable hours (after midnight), since the license for the station is an experimental one, and does not permit sending during the normal broadcasting hours. We in this way co-operated with the Department of Commerce in an effort to get exact data on super-power broadcasting before it was carried on during the earlier hours.

It should be remembered that the current in your receiving antenna and radio set is not proportional to the *power* of

the transmitter, but to the current in the sending aerial. The amperes at the sending station when doubled require four times the power, and this law is expressed by saying that the power varies as the *square* of the current. For instance, it would take nine times the power to triple the current and 16 times to get four times the number of amperes.

**100 Times Power—10 Times Current**

In this way we see that although the output of 50,000 watts is 100 times the power of the 500 watt stations, the cur-

square of the length of one side it follows that the current in the antenna is shown by the height of each separate square. If you will measure the 50,000 watt and the 500 watt squares, you will find that the former stands exactly 10 times as high as the latter, just as its aerial will have ten times the current.

**Slammed Off Their Stools**

This fact is mentioned for the benefit of those who might otherwise expect a signal strength greater than the facts called for. From many of the letters it was apparent that the observers had

There are three rectifiers each having a capacity of 150 kw. at 15,000 volts. These rectifiers convert the alternating current furnished to the station into direct current which is used for plate supply on the various transmitters.

**Grill Guards 15,000 Volts**

Fig. 3 shows this equipment quite clearly. The high voltage rectifiers take the low pressure, alternating current from the city lines and convert it into high voltage direct current ready to be used on the plates of the vacuum tubes of the sending station. Behind the pro-

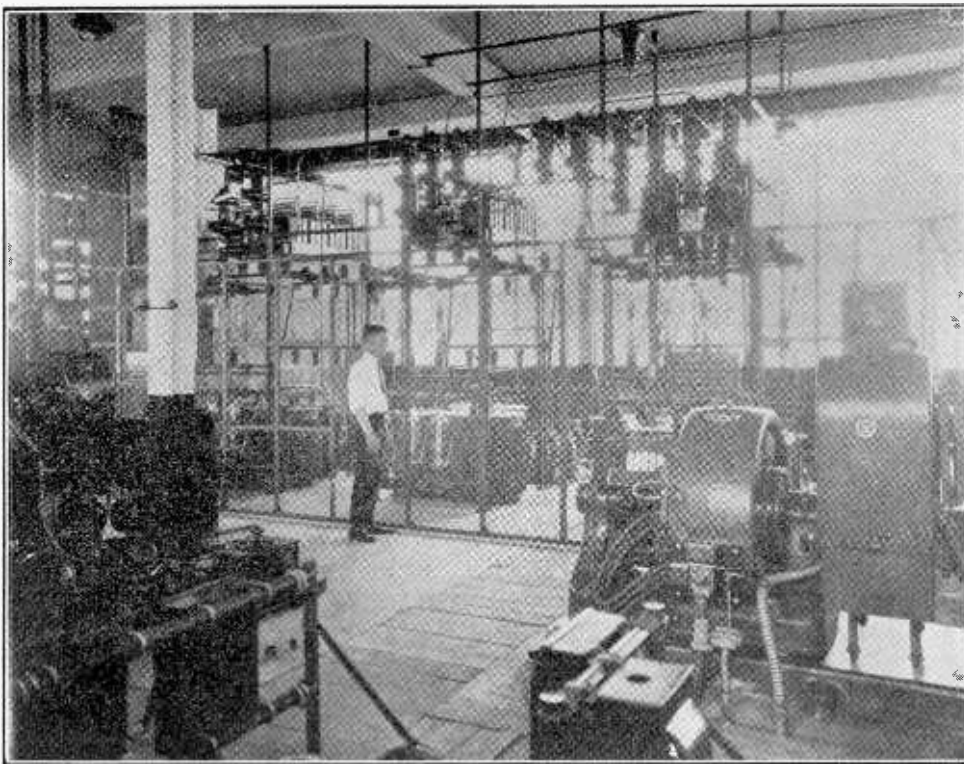

**Fig. 3. Here Are the Transformers and Rectifiers Which Give the "B" Voltage on the Plates of the Sending Tubes. The "A" Generator is in Foreground.**

rent will be only 10 times as great and so the current in your receiver will be increased only 10 times over what it would be with the smaller amount of energy. (This is because 10 squared equals 10x10, or 100.) The loudness of the signal in your phones seems to vary about as the current does and so you will expect that the signals would be about 10 times as loud.

You will now see why in our diagram, Fig. 1, the size of the squares is made so that the *area* represents the amount of power. Since the area varies as the

expected to be literally knocked from their chairs by the high power and were somewhat disappointed that something of that sort did not occur.

Perhaps you may be interested in the apparatus used to get this large output into the ether. On the 54-acre plot which has already been mentioned are one brick building, 60x100 feet, and four smaller frame buildings in which are housed transmitters. The largest building houses the power equipment, high voltage rectifiers and amplifying and modulating equipment for the station.

protective metal grill are three power "kenetron" rectifiers each with a power rating of 150 kilowatts at 15,000 volts. With each rectifier unit is a large transformer which steps up the relatively low voltage alternating current before it is passed through the rectifier tubes. The generator at the right is used for heating the filaments of the tubes and has a capacity of 1000 amperes at 33 volts direct current.

The modulating equipment may be connected with any of the smaller buildings by means of a system of overhead

transmission lines. Speech and music to be broadcast are obtained from the studio of WGY over an aerial cable circuit. It is further amplified at the station before reaching the group of metal tubes known as modulators. The transmitter to be modulated obtains its plate supply in common with the modulator tubes through a group of reactors.

#### It Would Scorch Your Hand

One of the big problems with such a large sending station is that of getting rid of the heat of the vacuum tubes. All

000 watts there will be a tremendous amount of heat to be disposed of.

What is done in an automobile engine to prevent the cylinders from getting red hot? Why, a water cooling system is used in which the water cools the engine and is then cooled itself in turn by passing through the radiator. The same idea exactly is employed with these power tubes.

#### Uses Ground for a Radiator

A circulating pump having a capacity of 150 gallons per minute supplies cool-

to use a blower for cooling, as so much heat is liberated. The water is forced through a large radiator in that case. A blower also forces a stream of air through the radiator, thus keeping the temperature of the water cool. The pressure of cooling water is approximately 55 pounds per square inch.

Since the plates of the metal tubes operate at from twelve to fifteen thousand volts above ground it is necessary to use a long column of cooling water to obtain sufficient insulation for the high direct current and radio frequency potentials existing on the plates of the metal tubes, otherwise the electricity would short circuit through the water. For this purpose a length of rubber hose is used between the plate of the tube and the pipe supplying the water. This is wound on a wooden hose reel, and is clearly seen in Fig. 4. The wood used is maple which has been given a special impregnating treatment to improve its insulating qualities.

#### Generators for 1,000 Amperes

In addition to the rectifiers, a 12,000 volt direct current generator is used for supplying plate voltage for master oscillators and other low powered equipment. Generators producing 4,000 volts and 2500 volts are used for plate supply to the smaller tubes. The filaments of all tubes are heated by direct current. There are several direct current generators of 300 ampere capacity at 33 volts and of 1000 amperes capacity at this voltage. These machines are specially constructed for a minimum commutator ripple, which would cause a hum on the air.

At present there are two transmitters located in the main building. One is operated at 50 kw. on 790 kc. (379.5 meters.) It has a master oscillator which is something like a large scale edition of a single circuit receiving set which has the tickler coil turned up too high so that it squeals. The output from this master oscillator goes through an intermediate amplifier to the modulator, where the radio waves are varied to correspond to the music which is being played. A power amplifier follows this and puts the oscillations into the aerial.

#### The Slow Speed Oscillators on 40 K. W.

The second transmitter, 2XAH, operating at 192 kc. (1560 meters) has a maximum of 40 kw. and is of the same

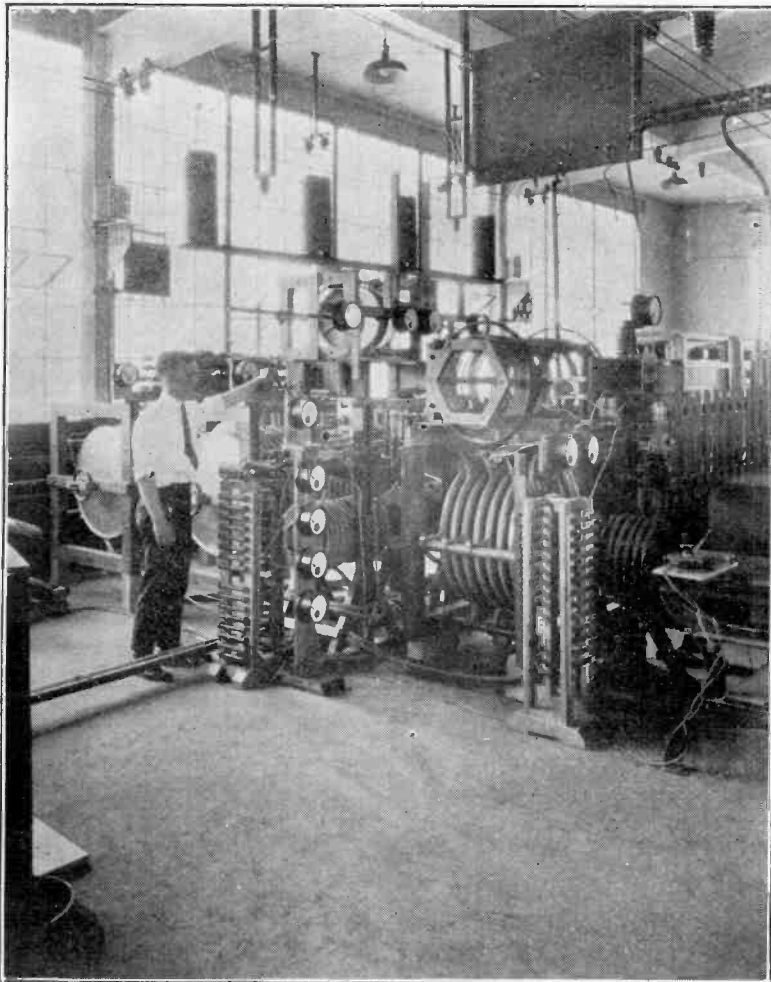

Fig. 4. This is the Sending Apparatus Itself. Don't Look for Glass Vacuum Tubes, as Glass Won't Stand the Heat—Metal is Used.

the energy supplied by the "A" battery and a part of that from the "B" is given off as heat. If you put your hand on a UV-200 tube you will find that it gets fairly warm. Such a bulb has an output of only a fraction of a watt. You can easily see that when you get up to 50,

ing water for all the tubes. The water is piped to all of the smaller buildings. The underground pipe lines provide an excellent means of cooling the water, instead of the radiator on an automobile. When tubes are being operated in the main building, however, it is necessary



general type as 2XAG except that push-pull amplifiers are used in the power stages. The 2750 kc. (109 meters) transmitter is located in one of the smaller wooden buildings. The high voltage supply is carried from the main building to this transmitter by means of overhead lines. Modulation for this equipment is provided in Building No. 1 from the main bank of modulators.

The antenna system is supported by three wooden poles each 80 feet high, arranged in the form of a triangle. This type of aerial structure has been employed in order to permit a study of the various types of antennas which may be suitable for operation at this wave-speed.

**Must Keep Machines Away**

In common with all the other fast wave transmitters, the low voltage and high current machine equipment is located in a separate building adjacent to the transmitter house proper. With fairly slow waves, the machine equipment can be placed in the transmitter house, but with high speed waves, it is necessary to not only spring-suspend the tubes, but remove the motor generator sets to a distant point in order to reduce the mechanical vibration to a minimum.

The antenna system for this apparatus is the same counterpoise which is used for high aeriels, suspended 10 feet above the ground. The 7500 kc. (40 meters) transmitter is located in a separate frame building with its power house. This equipment uses not only push-pull circuits, but also intermediate amplifiers in order to steady the frequency. The antenna system for this transmitter is designed so that many types of radiators may be used such as the vertical or horizontal doublets and reflectors. Fig. 5 shows a view of them.

**Letters from Everywhere**

In regard to the results which have already been attained, the tests on super-power up to 50 kilowatts brought thousands of letters from interested fans in every part of the country, and engineers are now engaged in a thorough analysis of these reports in the hope of arriving at some constructive conclusions.

The first series were conducted on three nights, Saturday, Tuesday and Thursday, July 25, 28 and 30. Special programs from the studio of WGY were transmitted on the experimental license

2XAG on the 50 kilowatts transmitter and listeners were asked to report on quality and volume of signal.

Letters were received from as far west as California, but the great mass came from listeners in the New England and Southern states.

Dr. S. G. Berry of Tyndall, South Dakota, reported successful reception through static, stating that WGY was the first station he had heard east of Chicago for over five weeks.

**As Loud As Local**

From Berwyn, Md., came word that

disappointment of not hearing the program quite loudly which made the listener think that the volume had fallen off. Perhaps you have sometimes seen the advertisement of a new show at the theatre which is claimed to be the best one in years. If it turns out to be only a little above the average you are apt to say it was poor merely because it fell short of your expectations. Another point is that a whole hour elapsed between the time when the ordinary power was shut off and the time when the super-power was turned on. During



Fig. 5. Wooden Pole is Used as Tower for High-Speed Aerial

the station had been received on a crystal set. J. H. Blinn of San Francisco picked up the Saturday night signals clearly. From John M. Erdis of San Anselmo, California, came word that he had received 2XAG with loud speaker volume equal to that of local reception.

These are a few of the correspondents who reported successful reception. It does not follow that all were favorable. Some, but they were in the minority, could find no improvement in signal; in fact a few thought the power seemed less.

In such cases it was undoubtedly the

this interval it is probable that this listener forgot how faint the signals were.

**No Trouble in Losing Them**

None of the letters reported that any difficulty was experienced in tuning out WGY's high-powered wave, and this, from a superficial review of the letters, is one of the most outstanding features of the reports. Even in Schenectady, within four miles of the transmitter, owners of selective sets reported WGY's wave so sharp that it could be tuned out at will in favor of middle western stations then on the air.

Continued on Next Page

# Washington Likes Our Policy

## *The Department of Commerce is Strong for the Use of Kilocycles*

WE have just received a circular from the Department of Commerce at Washington, which we quote word for word in full as follows:

In radio, "kilocycle" is gradually taking the place of "wavelength" says the Bureau of Standards, Department of Commerce. All listeners and users of sets will want to know and understand the new rating which increasingly governs their tuning in. The making or logging of dials is found to have certain advantages when in the newer terms. Already one of the oldest stations is announcing its broadcasts on the "kilocycle" or frequency rating. It is really quite simple, for frequency (waves per second) replaces wavelength (in meters.)

Just as a musician can vary the number of oscillations of his vocal chords but cannot control the length of the sound waves, which vary with the medium, so a radio station can vary the number of oscillations per second, and let the wavelengths be what they will. A high tenor "C" gives sound waves 2 feet in length, but the standard rating is frequency, or pitch, in this case 512 vibrations per second. Frequency is the number of waves produced per second, the number of waves on the air after one second of transmission. "Kilocycle" means a thousand cycles, hence a broadcast on a 500-kilocycle frequency emits 500,000 radio waves per second.

To aid radio amateurs and experts the Bureau of Standards is about to issue a table so that all can, at a glance, translate from the old rating by "wave-

length" (in meters) into the new rating by frequency (by kilocycles), and vice versa. Radio waves travel with the speed of light, about 300,000 kilometers per second. This is the sum of all the waves emitted in one second. Dividing this by the wavelength gives the frequency; dividing by the frequency gives the wavelength.

The bureau gives the simple rule to obtain the frequency when the wavelength (in meters) is known: Divide 300,000 by the wavelength in meters. The answer is in kilocycles; likewise the other way around: divide 300,000 by the number of kilocycles to get meters. It is interesting that the ratio is the same

both ways; 100 meters equals 3,000 kilocycles; 100 kilocycles is 3,000 meters.

As the new system proposed some time ago by the international and national radio conferences is taken up by the broadcasting stations and placed into effect by the Government in assigning station frequencies, it will become increasingly important to translate from wavelength to frequency in order to tune in at all.—*Government Circular.*

This is the change that RADIO PROGRESS advocated a year ago, and has been following consistently ever since. It is pleasant to have our opinion backed up by so powerful an authority as Sec'y Hoover's Department in Washington.

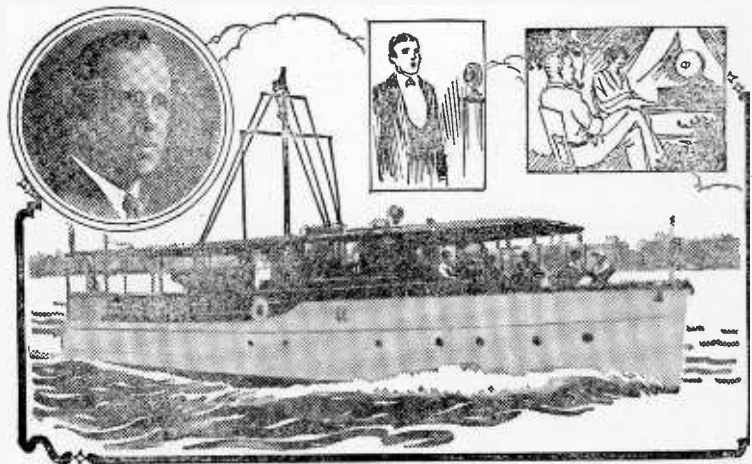

Radio fans along the Great Lakes and in Florida have been hearing from Powel Crosley, Jr.'s, motor yacht Muroma, which is equipped with a complete broadcasting station. This speed boat used to be a rum runner and was confiscated by the Government. Crosley bought it and fitted it for radio.

### REAL SUPER POWER

Continued from Previous Page

One facetious listener reported that he had connected the super-power to the family washing machine and had done the wash for the week.

#### While the Air is Crowded

The second series of tests were held early in the evening while other stations also were on the air. These occurred August 22, 23, 24, and 25. For the purpose of making a thorough in-

vestigation of super-power, that its policy with regard to it may be intelligently shaped, Secretary Hoover of the Department of Commerce requested the General Electric Company to conduct this series of tests during the hours when the maximum number of stations were on the air. The radio listener, wherever located, was asked to comment on the quality and strength of the super-power signal as compared with the signal strength and quality when normal

power was used.

As we go to press, no final statements of the benefits of super-power have as yet been made. The engineers of the General Electric Company are feeling their way in uncharted fields and they propose by tests on various wave speeds with high and low power and with a variety of antenna systems to contribute something to the radio art which will redound to the benefit of the radio public.

# More About the New Tubes

## *These Are Promised On the Market About the First of September*

By VANCE

**T**HERE is a good deal of interest displayed in the new tubes which are being put on the market by the Radio Corporation about the first of September.

In our last issue (August 15—"Announcing the New Vacuum Tubes") we had a description of them and also some photographs showing how they looked. At that time the complete data for their performance had not been released. The table, which accompanies this article gives the complete operating characteristics.

### Advantages of New Type

The new bases for the bulbs it will be recalled, used four prongs, which are fairly long, (Fig. 1) and which make contact with the springs in the socket, not on the end, but along the side. This is so that the current will not have to run through the soldered tip and also because the pressure against the side can be made much stiffer and more uniform. There is also no tendency with such construction for the tube to be pushed out of the socket by the spring pressure.

There are two sizes of base, one the large, which is used for storage battery tubes, and the other the small for dry cell operation. Of course, the dry cell tubes may be used by taking the right voltage from a storage battery and vice versa. The size and location of the four prongs is the same in both styles of base.

### What the Table Shows

The table contains in Column A the number of the tube. Notice that the letter X shows the new style of bulb. The first letter, either U or W, is used just as before. In other words, any tube starting with a W employs a filament which is coated with oxides. Those starting with a U contain only pure metals.

Column B shows what uses the units

may have. Det. stands for detector, Amp. for amplifier, and Osc. for oscillator. Almost all the tubes may be used for detector and amplifier. The exceptions are the 200, which works only as a detector; the 120, which fits only the last stage of the audio amplifier, and the 210, which makes a very efficient oscillator as well as an amplifier.

Column C shows what kind of a base is used. All the new ones fit either the large or the small UX socket. "Standard"



Fig. 1. Except for Base and Contacts, This is Like the UV-199 Tube.

refers to the standard socket, which has been used in the past for the 200 and 201A base.

### What Leak and Condenser?

Column D shows the size in megohms of the grid leak to employ when the tube is functioning as a detector. Of course, only limits can be given here, as different samples of the same tube will vary slightly in this particular. The best way to find the proper leak is to try out several which are accurately

rated or else try an adjustable leak. The grid condenser for every style is the same, .00025 mfd. The grid return when used as an amplifier should always go to the negative side of the "A" battery (or the "C" battery if used). When detector action is wanted the plus side of the filament is the proper connection in every case except with the 200. Here it is well to experiment, as it often happens that the negative side of the filament gives better results.

Column E shows the pressure of the "A" battery in volts. Where it appears as 6, a storage battery should be used. Values of 1.5 and 4.5 refer to 1 and 3 dry cells respectively. Naturally, this pressure falls off as the cells are used.

### Be Careful of Pressure

Column F indicates the pressure to be used on the filament itself in volts. Best results will be had if this figure is adhered to pretty closely. If the pressure is reduced below the amount shown the reception is apt to suffer somewhat, although the life of the tube will be extra long. On the other hand, if you turn the rheostat up so that the filament is brighter than indicated, the music will not come in any better and you will have a tube funeral so much sooner.

Column G shows the amount of current flowing through the filament when the pressure across it is adjusted to the figures of Column E. Notice that these values are just the same as for the old style tubes. The two new units, 112 and 120, take one-half ampere and one-eighth ampere respectively.

### Detector Sometimes Critical

Column H indicates what voltage to use on the tubes when operating as a detector. This may vary from 22 to 45 volts without affecting very much the operation of the 199, 112, and 201A. The 11 and 12 work best at about 22 volts, while the 200 is more critical and should be experimented on from 16 to 22 volts.

A	B	C	D	E	F	G	H	I	J	K	L	M	N
Model,	Use.	Base.	Grid Leak.	"A" Battery Volts.	Filament Volts	"A" Battery Current	"B" Battery Detector	"B" Battery Amplifier	Negative "C" Battery	Plate Current	Output Resistance	Mutual Conductance	Amplification Factor
UV-199—Det. and Amp.....	UV-199		2 to 9	4.5	3.0	.06	45	90	4.5	2.5	15,000	415	6.2
UX-199—Det. and Amp.....	Small UX		2 to 9	4.5	3.0	.06	45	90	4.5	3.5	15,000	415	6.2
UV-200—Det. only .....	Standard		1½ to 2	6	5.0	1.0	16 to 22	..	..	..	..	..	..
UX-200—Det. only .....	Large UX		1½ to 2	6	5.0	1.0	16 to 22	..	..	..	..	..	..
UV-201-A—Det. and Amp....	Standard		2 to 9	6	5.0	.25	45	90 135 90 135	4.5 9. 4.5 9.	3 4 3 4	12,000 11,000 12,000 11,000	675 725 675 725	8. 8. 8. 8.
UX-201-A—Det. and Amp....	Large UX		2 to 9	6	5.0	.25	45						
WD-11—Det. and Amp.....	WD-11		3 to 5	1.5	1.1	.25	22						
WD-12—Det. and Amp.....	Standard		3 to 5	1.5	1.1	.25	22	90	4.5	2.8	14,000	400	5.6
WX-12—Det. and Amp.....	Large UX		3 to 5	1.5	1.1	.25	22	90	4.5	2.8	14,000	400	5.6
UX-112—Det. and Amp.....	Large UX		3 to 5	6	5.0	0.5	22 to 45	135 90	9. 6.	5.8 2.4	5,500 8,800	1,435 890	7.9 7.9
UX-120—Audio Amp. ....	Small UX		.....	4.5	3.0	.125	..						
UX-210—Amp. and Osc.....	Large UX		.....	8 6	7.5 6.0	1.25 1.1	..	425 90	35 4.5	22 3.	5,000 9,700	1,550 775	7.75 7.5

Fig. 2. Here Are All the Characteristics of the Tubes, New as Well as Old. The Old Style Will Not be Made Any Longer Than Necessary

Column I shows the pressure of the "B" battery must be considerably higher when used with an amplifier than with a detector. Although the table requires from 90 to 135 volts, as a matter of fact you can use anything from 22 volts up and get fair results. Naturally the higher pressures give greater volume. The figures shown represent the upper limit to be used.

were to be used, then the "C" battery should be entirely omitted. This last fact is not shown in the table, as that is commonly understood.

Column K indicates the plate current in milliamperes or thousandths of an ampere. This current is the one which corresponds to the values of "B" and "C" battery which precede it in the table. It should be especially noted that if

**Figures for Loud Tube**

Column M reveals the mutual conductance as expressed in micro-mhos. This unit is not used except for measuring this one value. We shall not endeavor to explain it here from lack of space, but it may be said that the higher the figure of mutual conductance is, the louder will be the output as heard in a speaker or headset.

Column N gives the amplification factor for the various tubes. The higher this reading is, the greater the voltage amplification, other things being equal. However, this is not as good a way of rating the tubes as is the mutual conductance.

There are now so many different styles of tubes to select from, as well as different brands of manufacture, that it is well to preserve this table so that you will know what to ask for when you want one of the new tubes.

Fig. 3, a reprint from the last issue, shows the base of the new small tubes. The large base uses the same size and spacing of the contact prongs.

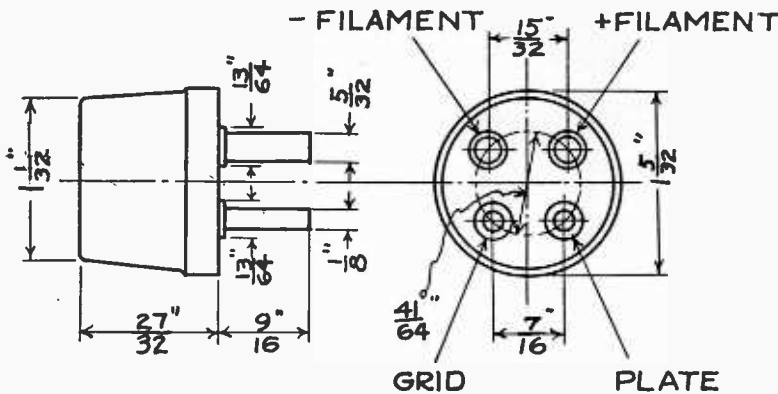

Fig. 3. Both New Bases Have the Same Contact Prongs and Spacing.

**"C" Must Correspond with "B"**

Column J displays the proper pressure of "C" battery to use as a grid bias when the "B" battery pressure in Column I is impressed on the plate. For instance, with the UV-199 tube, notice that 4½ volts of "C" correspond to 90 volts of "B." If only 45 volts of "B"

the proper "C" battery is not used as indicated, the plate current consumption will be very much greater than shown.

Column L gives the output resistance of the plate in ohms. This figure is valuable in determining what kind of loud speaker, phones, or transformer should be used.

**How to Stop Eating**

Ammonia or bicarbonate of soda will check acid that has been spilled from a battery from eating into the fibre of cloth or carpet.



## I'LL SEE YOU AT THE SHOW

Labor Day will be here in a short time, and that is usually thought of as being the end of the vacation season. What is the next happening on the program?

It looks as if the following season might be called that of the shows. The various radio associations all over the United States are announcing the dates when they will hold their mammoth expositions to display what radio has accomplished during the last year. Advance notices seem to show that these events will go over big.

### Booth Costs Real Money

The manufacturers, of course, are the first ones who must be sold on the idea of the big exposition. If they do not feel confidence enough in an event to spend anywhere from \$50.00 to \$300.00 for a booth, plus the expense of setting up an exhibit and paying the salaries of their representatives, then they will not have anything for the public to look at. If, on the other hand, they feel that such an outlay of money will be worth while for its advertising value, they will go ahead full steam to do the very best they can. If a company has grown to such a position that it can afford to exhibit at such a big show, then it naturally will be in a position to gauge how the public feels about radio.

It happens that the big manufacturers who have their ears to the ground, all say that the people of the country are even more enthusiastic about radio now than they were a year ago. Not that they are so wild about hook-ups—that craze seems to have accompanied the cross word puzzle

in and out. Just as you still see some cross word puzzle addicts with a pencil in their hand and a furrow on their brow—so you find some real radio fans who are still building them and tearing them down again.

### Sets or Parts?

The big factors in radio are quite positive that this coming year will be one for manufactured sets. Although the part makers will be strong in their exhibits, the complete sets will undoubtedly sell a great deal faster. So sure are the factory managers that there *will be* a big demand, that a large part of the space in all the prominent shows has been contracted for weeks ahead of time.

So if the present straws are any more reliable than the ground hog is in predicting weather, then you will be interested enough in the exposition to attend at least once or twice, if you can find one within a radius of fifty miles. Tell your friends, "I'll meet you at the show."

## THE WANING OF THE HORN

In the days of our ancestors it was quite the thing to have a large horn on the phonograph which stood over in the corner by the bay window. Then Victor came along and declared that it was old fashioned, so everybody swung over to the cabinet with the horn concealed inside.

It looks as if a new version of the same story was being written. There are a large number of different loud speakers on the market which are shaped more or less like the horns that used to decorate the old-style phonograph. Many of the largest and most

prosperous companies are building this type of speaker. Development has gone on so that the latest models give a surprisingly clear and life-like tone.

### Three Answers To It

But in spite of that there seems to be a sort of drift away from this shape. Many people think they are quite ugly and do not fit in the decorations of their rooms. There seems to be a swing towards three different solutions of this problem. In the first place there is the built-in speaker which is a part of the radio cabinet. The second may be called a modification of this as it resembles a separate cabinet which contains only the loud speaker mechanism. The third solution is the cone.

Comparing these three, the neatest way of handling the problem is undoubtedly the built-in mechanism. Its chief objection is that it is supplied only on the very high priced sets and must naturally be bought at the same time the set is purchased. If you decide to change your radio at a later date, you must at the same time turn in your built-in speaker, even though it may have an unusually pleasing tone. However, for those who have the price it is probably the best answer to the question of where the music comes from.

### Call Yourself in Luck

The cabinet speaker is a sort of compromise. It endeavors to look as much as possible like the preceding style. Of course it works just as well, too. The chief objection is that it usually does not match or even harmonize very well with the particular radio which you possess. If you are fortunate enough to get one which has the same shape and

finish you are in luck. The tone of these cabinet speakers is very good, being sweet and natural, although usually not so loud as the more powerful style of horn.

The third style just referred to takes the shape of a cone. The operating mechanism may be similar to that of any other type, but instead of a thin, flat circle of metal or diaphragm, as the vibrating unit, a cone of parchment shakes up the air and sets the sound waves in motion.

#### Comparing the Loudness

Such a speaker is thought by many to have a much more pleasing appearance than the horn which it replaces. It lends itself more easily to decorative schemes and does not take up much room on top of your radio set. This form is much more recent than the horn type and it is a little early to predict whether it will equal the latter in loudness and clearness on large volumes of sound. However, for an ordinary size room it gives a very pleasing effect.

If we attempted to play the role of prophet we should be inclined to predict that for filling large halls and for dances the horn type would hold its own, while for ordinary use it would give way to one of the more recent styles.

#### NEW LAMPS FOR OLD

Do you recall the story in the Arabian Nights of how the wicked magician in order to get hold of Alladin's lamp went through the streets crying, "New lamps for old?"

To read the advertisements you would think that some devices advertised for sale were able to do the same thing with vacuum tubes. They certainly do have smooth reading copy, and anyone perusing it would get the impression that all you had to do was to drop an old vacuum tube in the slot, push the button, and see a brand new one pop out.

#### Some Tubes Injured

Unfortunately, such is not the case. As has been explained before in these columns, a tube re-

juvenator is of some value in certain cases, but only a small fraction of worn out tubes can be benefited very much by this treatment. In the first place, the UV-200, WD-11 and the WD-12, and other kinds of tubes corresponding to these styles are *never* benefited by such treatment, but are always further damaged to a slight extent.



Paul Ash

Paul Ash and his merry Mad Musical Gang, Chicago's big stage success to-day, is a feature of Westinghouse station KYW. This program, which is sent direct from the McVickers Theatre each Wednesday and Friday evening, is one of the real radio treats, and is bringing forth a deluge of written applause from an appreciative audience.

The only styles which have a chance to be improved by a treatment are those which have a filament in which the metal thorium is alloyed with other metals to form the conducting wire. It is this element thorium, which for some peculiar reason has an efficiency thousands of times greater than platinum or tungsten in shooting out the electrons which

go to make up the plate current of the tube which operates your phones or loud speaker.

#### Boiling Off the Surface

If this metal is all used up in a filament then no amount of "rejuvenating" will bring back the power of the bulb. There is only one case where the treatment helps, and that is when the thorium is fairly abundant on the inside of the filament but at the surface is scarce. Such a condition occurs when a fairly new tube is burned at too high a temperature for a limited time. This causes the surface metal to be boiled away without allowing time for the interior supply to diffuse to the outside.

When this case is met with, by heating the filament up to slightly above its normal working point without any "B" battery to attract the electrons and strip off the coating as fast as it forms, then the inside thorium equalizes itself all through the mass and a share of it strikes the surface, where it remains.

#### Sweetening Your Tea

It is something like putting a lot of sugar in a cup of water. If this is left cool it will be a long time before the sugar completely dissolves and goes all through the liquid. But just put the cup down on the top of a hot stove and see how quickly the sugar distributes itself all through the mass under the influence of the high temperature.

In conclusion, if you are tempted to treat your dead and dying tubes, consider in the first place whether they have the thoriated type of filament. If not, don't do it. If so, then see whether they are likely to have plenty of this element through the body of the wire. If not, don't do it. Finally, decide whether the weakness of the tube is caused by lack of the element on the surface as a result of a short operation at too high a temperature. If the tube gets by all these three tests, then you may proceed to dip it in the fountain of youth.

# Some Radio Novelties of Europe

## *Conditions Are Not Standardized As Much As Here*

By LEE DeFOREST, Jersey City

**H**OW do they do it across the water? Almost everyone is interested to know what progress is being made abroad and with this idea in mind a group of engineers from the DeForest Radio Company have been making a close study of radio conditions in England, France, Germany and Italy. We have just returned by the steamer Mauretania and here are some of the observations which were made:

Public interest in radio throughout Europe just now is at a very high point. It is of course somewhat restricted due to the scarcity of broadcasting stations, but this is rapidly being eliminated by the constant erection of new and powerful ones.

### A Crystal to Start

Just think how it would be in the United States if there were no opportunity to use a crystal set in your neighborhood. Of course, those far away from the broadcasting centers must use tubes in order to get the programs. But in all cities of any size you will remember that in a large number of cases the first set, the one which made a fan of the listener, used the humble crystal.

There has been no chance for such development in many even of the big cities abroad, and this naturally has retarded the growth of broadcast listening.

The interest is greatest in England, probably due to the fact that there the programs are more diversified than in the rest of the European countries. France of all the nations pays the least attention to their programs and broadcasting, and with the exception of only one or two French stations, very little musical matter is put on the air. For that reason French listeners usually build receivers capable of hearing English stations, where better balanced programs are offered.

### Eighty-Seven Different Varieties

Most of the receiving apparatus is home

made, the listeners preferring to build their own, much the same as the American public did at first. The English market offers to the builder a very wide selection. I personally noted over 87 different makes of vacuum tubes or "valves," as they are termed there. They were all of very high quality, and many of them were offered at considerably lower prices than the ones sold on this side. Manufacturers vie with each other

is known here as a "well balanced" program.

### Taxes for the Talent

This is all the more surprising when you remember that in practically every country abroad the listeners must pay a tax to the government for permission to operate a receiving set. The price is usually around 50c a month for a crystal set, and the larger radios are taxed higher in proportion. At least part of

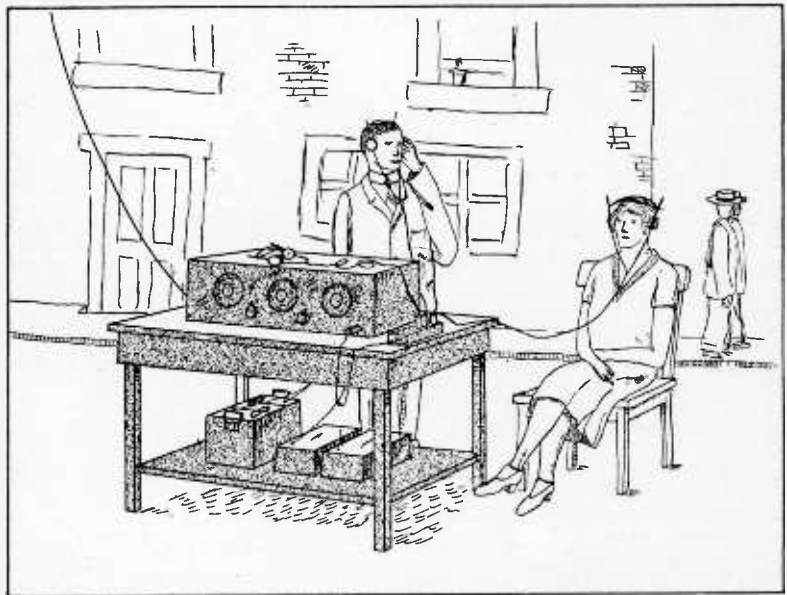

Fig. 1. This Scheme in Rome Was Making Quite a Bit of Money for the Set Owner.

in the number of types that are made, and it is not unusual for them to place from eighteen to twenty different styles on the market. Of course, every other manufacturer must follow suit and the result is one that would puzzle even the most hardened American fan. One item of considerable note, however, is that there is absolutely no cutting of prices.

In the matter of broadcasting, America is much further advanced than any of the European nations, none of which seem to have the ability to offer what

this money is used in paying for talent. But as Europe is still in its early stages in this regard, I am of the opinion that it is only a matter of time and adjustment to conditions before their programs are much improved.

The English stations which I had the opportunity of inspecting are all admirably equipped to give high class programs, especially the newly erected BBC, at Daventry, the most powerful station in the United Kingdom. It is located 50 miles from London and is

using 25 kilowatts on 187 kc. (1600 meters) to enable users of crystal sets throughout the Kingdom easily to tune it in.

Radio for 1c

Rome had quite a novelty to offer, even to a hardened and cynical radio engineer, in the form of "penny in the slot radio listening stations" run much after the manner of the penny arcades that Americans are familiar with. For the equivalent of one penny, a pair of phones are placed on the head of the listener, and he is allowed to hear one selection. There is only one master receiving set and many pairs of phones, but the listener must be content with just what the operator tunes in.

Fig. 1 shows the idea. A powerful receiving set is connected to the aerial and ground in the usual way. Instead of plugging in a loud speaker, the plug and cord is attached to a special multiple jack, which is merely a method of connecting a large number of phones into circuit together. Of course, the multiple jack may take any one of a number of forms.

They Don't Disturb Each Other

A good way is to have several phone circuits in parallel with five or six head sets in series in each line. In our drawing we have shown three rows in parallel, each with five jacks in series. That makes a total of 15 people who can listen at the same time. When a phone plug is inserted it connects its head set into the line without disturbing its

neighbors. Of course, the radio set must have at least two or even three audio frequency steps of amplification so that this large number of phones may work properly.

The owner of a powerful set can, by establishing a "listening post," make considerable money, as there are very few privately owned sets in Italy and very few evening programs. Radio interest is slightest in this country although the Italians are a music loving nation. It is probably due to the fact that information is scarce and apparatus even scarcer that this condition prevails there.

One of the most noticeable differences between European and American broadcasting is the fact that European radio fans are not forced to listen to the petty political squabbles being fought over the air. In the estimation of the European program managers, nothing is farther from the ideals around which broadcasting is built than political wrangling and mud slinging.

They Don't Do It for Love

It is too bad that the government has allowed the building and operation of sending stations by political organizations, to be used to broadcast political propaganda in its most unpleasant form—party hatred and haggling. In my mind the very application for the operation of a broadcasting station having any political connection could mean nothing less—as politicians are not moved by generosity in their willingness

to spend thousands of dollars just to keep people entertained.

The use of broadcasting stations, which are more and more being regarded as a medium for entertainment and instruction, for any other use is a prostitution of the faith of the public. It is bad enough that the advertising angle has been allowed to wedge itself into the features, without permitting it to be carried further and turned into a political weapon.

The news value of politics of course has a definite place in the broadcasting schedules. Such items as the various large conventions or meetings of the different departments of the governments are permissible, but the use of the air to enable a candidate for some office to inform the public how much good he is doing is stretching the matter several points too far. Such a squabble as recently occurred in New York over the political broadcasting coming from Station WNYC could never have occurred in Europe—such speeches are not allowed to go out on the air.

Your Friend Will Thank You

When you finish reading this magazine, don't throw it away. Just hand it to your friend. Any intelligent person can understand it, and your friend will thank you.

Izzy A. Nutt—It Happens in the Best Regulated Radios—By Harvey





# Testing Tubes for Poor Performance

## *Don't Blame Your Batteries or Set When Trouble Lies in Tubes*

By HARRY A. NICKERSON, Boston

**T**HE old story of the punctured tire which was flat in only one place applies just as much to a radio set. If you have a five-tube set and one of the bulbs is dead, it does not cut the efficiency down to four-fifths, but to nothing at all. That is why you must keep every tube working at its best if you want good performance from the set.

Probably you are familiar with the many times stated theory of the operation of the three element vacuum tube. Roughly, it is this: when the grid of the tube is made negative by connecting it, for example, to the negative terminal of a "C" battery (Fig. 1) the flow of electrons to the plate from the hot filament is retarded, so that the current, which flows from plate to filament in the plate circuit is small. This current is what operates the phones and may be measured by a low reading ammeter or milliammeter connected in the circuit as shown.

### Current Increased 2 or 3 Times

When the grid is made positive by reversing the terminals of the "C" battery, then the plate current is increased. This will be shown right away by the milliammeter in the circuit having a reading which is perhaps two or three times what it was before. The exact amount of increase depends on what value of grid voltage or bias is impressed on the circuit. When the tube is working in your set, it is not the changes in "C" battery, but the radio waves coming in through the tuning coil which causes the fluctuations in plate current through your phones.

A good milliammeter for this purpose, which will be quite useful for other tests as well costs \$6.00 or \$10.00. If you can afford such an investment it is well worthwhile, but if you do not wish to tie up so much money, then a substitute in this test may be found. This is a 1500-turn honey comb coil and a small pocket compass.

### Predicts Where You Are Going

It goes without saying that testing a bulb by merely lighting the filament is about like seeing if an automobile will run by giving it a push with your hand. If you have broken the filament by dropping it or hitting it with a slipping screw driver, then of course, it will not work and the simple lighting test will show right away that the tube is useless. Or perhaps you have mistaken the "B" for the "A" battery with the result that all your filaments have gone

efficiency is whether the grid can control a sufficient plate current.

### The Bias is What Does It

If this simple explanation is understood, it will be clear that if we can vary the charge or bias on the grid from negative to positive, then we can vary the plate current from a very small value to the limit of which the tube is capable.

The potentiometer offers a means of varying this bias in small steps and is the first essential in constructing the

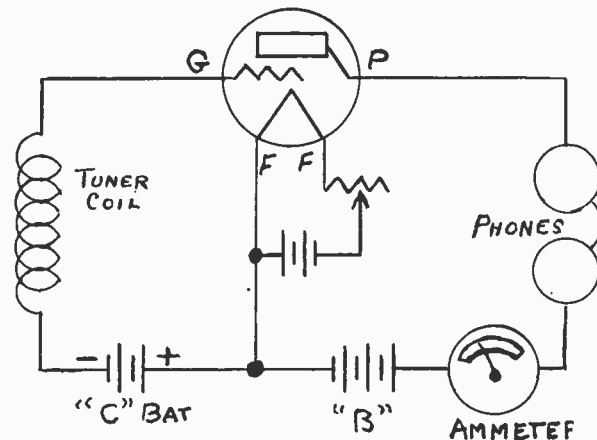

Fig. 1. This is the Simplified Hook-up for the Tube Tester. The Ammeter Must Work on 1/1000 Ampere.

up in smoke. Here again the lighting test is enough to show that you will shortly be visiting the radio store.

With the modern tubes, the high efficiency is obtained by the condition of the surface of the filament wire and if this has been injured you will not get good results from your radio set. It is like the silvering on the back of a mirror. When it is gone the glass part may be all right, but it will hardly do for reflection. The difference is that you can see the surface of the looking glass and know when it is damaged, but the filament does not tell you when it is wearing out except by reducing the loudness of the signals. The one real test of

tester. The rest of the outfit consists of the vacuum tube to be tested and its associated apparatus—socket, rheostat, "A" and "B" battery, and finally the meter that registers the plate current change.

There are of course other qualities which may be desired in a tube which is wanted for a particular use, such as small capacity between the grid and plate, absence of hiss when used as an amplifier (the hiss generally indicating a soft tube), absence of microphonic noises, ability to oscillate, high amplification, etc.

### Try Before You Buy

Tubes should be tested not only when

first purchased, but also at regular intervals during use. Dealers are sometimes willing to replace new tubes which are not up to standard. The more progressive retailers are installing apparatus for testing tubes themselves, and oftentimes they will test each unit for you as you buy it. This is a very great advantage both to dealer and purchaser, as it assures the buyer that he is getting first class stock and it also is a protection to the dealer.

It sometimes happens that in taking a tube home it gets jarred in the pocket of the radio fan and perhaps when installed in the set the grid may be touching the filament. Of course, in that case it will light, but it will not work. If the dealer has not tested such a tube in the customer's presence when the latter takes it back he will have to believe the sincere statement that the tube had not been dropped nor improperly treated in the radio set. But if the dealer can insert the same tube in his test apparatus again and show the fan that it no longer passes the plate current test, then the purchaser will be convinced, even against his will, that he must have done something to hurt the tube since it left the retailer's counter.

#### Do They Sell Sub-Standard Tubes?

If you buy your tubes from a dealer who has a test apparatus, but does not use it in your presence, then you are sure of getting a good product, provided you can trust the storekeeper. However, some dealers no doubt try to resell returned tubes which are slightly under the standard rather than go to the trouble of getting the manufacturer to replace such units which are alleged to be defective.

Placing a tube in a receiving set is a pretty fair test of its characteristics, providing one has had a good deal of radio experience, but the test is not sufficiently accurate. Thus a great difference in volume in an audio amplifier is necessary to impress itself on the human ear. More than half the life of a tube may be gone and yet the ear will not detect the difference, while a tester would tell you right away not to accept such a defective unit.

The use of such a tester involves only a small cost and a little time in making, and is well worth the trouble. Here is a list of the materials you will need:

#### Build it from These Parts

- 1 Potentiometer, 200 or 400 ohms.
  - 1 Socket.
  - 1 Rheostat.
  - 1 "A" battery.
  - 1 "B" battery.
  - 1 "C" battery, about 14 volts.
  - 7 Binding posts.
  - 1 1500-turn duolateral or honeycomb coil.
  - 1 Pocket compass.
- Busbar wire for connections.  
Panel to mount the instruments.

The socket, rheostat, "A" and "B" batteries should be of the style to fit the particular tube you are using. Thus with a UV-200, 22 volts of "B" is suf-

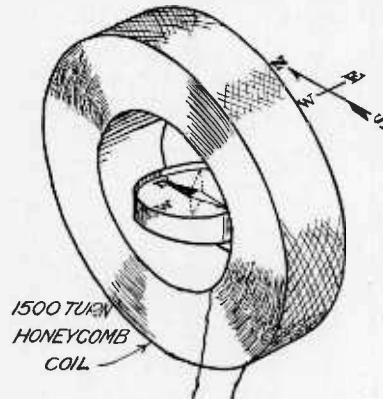

Fig. 2. This Coil and Compass May be Used in Place of Ammeter of Fig. 1.

ficient while each of the other styles will require 45 volts. No more than this is advisable, even though you may use 90 volts on your set.

The "C" battery is used to give a bias to the grid and consumes no current at all. For this reason old dry cells which have been scrapped or an old "B" battery which has dropped off to a voltage too low to give good operation on the set will serve very well. If you do not have any such discarded batteries, then put in the cheapest form of flash light cells. A tap is needed at about the center of the "C" battery. This is used so that either a plus or a minus voltage may be impressed on the grid.

#### Don't Damage the Tubes

The apparatus may be mounted on a panel and in a cabinet, or else may be hooked up flat on a board. However, as it is assembled, care should be taken that all connections are firmly made and soldered, and that wires are well insulated

or separated from each other. Slack construction may result in damaging the tube being tested.

If different types of tubes are to be tested, the simplest method is to use a standard base socket, and adapters for 199 and WD-11 styles of tubes. A dealer who would have fairly large numbers of the different sizes to try out would find an advantage in connecting three sockets in parallel so that anyone of the three bases could be accommodated immediately without the bother of hunting up an adapter to fit.

#### How to Hook Up Battery

By using a 60-ohm rheostat, all kinds of tubes may be tested on a 6-volt storage "A" battery, but it is suggested that either one or more of the three cells composing the storage battery be used or else that the right number of dry cells in series be substituted so that a 30-ohm rheostat may be sufficient. For example, with a UV-199 tube, and three dry cells for "A" battery, nearly all of the resistance would be in circuit, while with a UV-201A tube, about two-fifteenths of the total rheostat resistance would be needed to give the tube its rated current, with a 6-volt "A" battery.

We are now ready to run a test. The pocket compass is placed fairly near the center of the large honeycomb coil; the rheostat is turned on until the filament lights to normal brilliancy (or until a volt-meter placed across the socket terminals labelled F, F, registers the voltage recommended by the manufacturer.)

#### Set Up Coil and Compass

The next thing to do is to adjust the compass and coil, which should be done before the "B" battery is connected to the circuit. Fig. 2 shows a top view of this apparatus, which is used in place of a milliammeter. The compass is most sensitive when it is located at the exact center of the winding and the coil is adjusted so that it lies in the north and south line, as shown by the compass needle. In other words, the needle will point with both ends directly to the wires while no current flows through the winding. This position will give the greatest amount of deflection for a small current.

For instance, two milliamperes will make the needle swing through an angle of perhaps twenty degrees, whereas by shifting the apparatus around into other positions, the biggest change in needle

**WE SAY—**

# **The Brooklyn Radio Exposition**

**WILL BRING—**

**RECOGNITION  
STABILIZED BUYING  
NEW BUSINESS**

**WHY DID—**

Western Electric Corporation  
David Grimes, Inc.  
Marwol Radio Corporation  
Tower Mfg. Company  
Valley Electric Co.  
C. J. Boissonnault Company, Inc.  
Herzog Radio Corporation  
Powerola Radio Corporation  
Wildermuth & Co. (Atwater-Kent)  
20th Century Radio Corp. (Garod)

G. J. Seedman & Co. (Grebe)  
Victory Electric Supply Co. (Fada)  
J. W. Weber, Jr., Inc. (Eagle)  
McPhilben Radio Co. (De Forest)  
Pyramid Motor Equipment Co. (Thermiodyne)  
Marko Storage Battery  
Willard Storage Battery Co.  
and others

**ELECT TO EXHIBIT AT THE BROOKLYN SHOW?**

**ASK THEM!**

**TIME: OCTOBER 17th to 24th, 1925**

**PLACE: 23rd REGIMENT ARMORY, BEDFORD AND ATLANTIC AVES.,  
BROOKLYN, N. Y.**

**EXECUTIVE OFFICES**

**1-7 DeKalb Ave., Brooklyn, N. Y.**

**PHONE: TRIANGLE 4126**

**S. T. ROGERS, Managing Director**

position might be only fifteen degrees. The actual deflection depends on the size of the coil, the strength and length of the compass needle, and slightly on the amount of earth's magnetism in the town where you are located. Up near the North Pole the deflections are very much greater than they are near the equator.

**Really a Tangent Galvanometer**

For a small deflection, say up to fifteen or twenty degrees, the angle through which the needle turns is proportional to the amount of current flowing. That is, if one tube gives you twice the angle that another one does,

angles, then it is not giving nearly as great accuracy as if it moved about 45 degrees. In such a case it is much better to unwind enough turns from the coil so that the deflection will drop to about this value. Naturally the sensitivity of the coil for very small currents is reduced by removing the extra wire. However, you can not have one single coil which gives its best reading for a very small and also for comparatively large currents. If you should find that the compass did not move enough to get a good reading, it would mean that the compass was poor or else there were not enough turns in the coil.

at the right. The three readings of the compass needle will then be a standard which other tubes should meet.

**Plotting the Tube's Curve**

With this apparatus you can run what is called a "characteristic curve." It is only necessary to put a voltmeter across as shown dotted in Fig. 3, and then the readings of this grid voltmeter are adjusted by the potentiometer. The position of the compass is noted for each quarter of a volt. If the deflections of these two instruments are plotted on regular plotting paper, it will give a curve which shows the performance of the tube. There will be a slight inaccuracy between this curve and a standard one as drawn by the test laboratories because the compass deflections are not quite proportional to the current. However, as explained above, provided the needle does not have a reading of over 20 or 25 degrees, then the error is very small.

Of course a UV-200 or other similar soft tube must have its filament and "B" battery voltage carefully adjusted in order to determine much about it as a detector, but a very poor 200 will cause little movement in the needle with changes in "A" or "B" battery voltages with movement of the potentiometer arm toward plus, and this is a fair index of its ability as a detector.

**Getting the Highest Accuracy**

The hook-up for the above tester using a honeycomb coil and needle for the meter is shown in Fig. 3. To make the tester more accurate, the principal addition is a milliammeter. This should register from zero to about 10 milliamperes. This is substituted for the honeycomb coil and compass in the figure, being connected just as the coil is shown connected. This registers the flow of plate current in the "B" battery circuit, just as telephone receivers register changing flow of plate current for the ear to hear as sound waves. The readings now will be in fractions of an ampere instead of arbitrary degrees.

A high-grade voltmeter may be used for accurate testing of the filament pressure to insure that the tube is receiving just the voltage recommended by the manufacturer; or for less accurate results, an ordinary cheap voltmeter which reads a maximum of six or ten volts may be employed. It is to be connected

Continued on Next Page

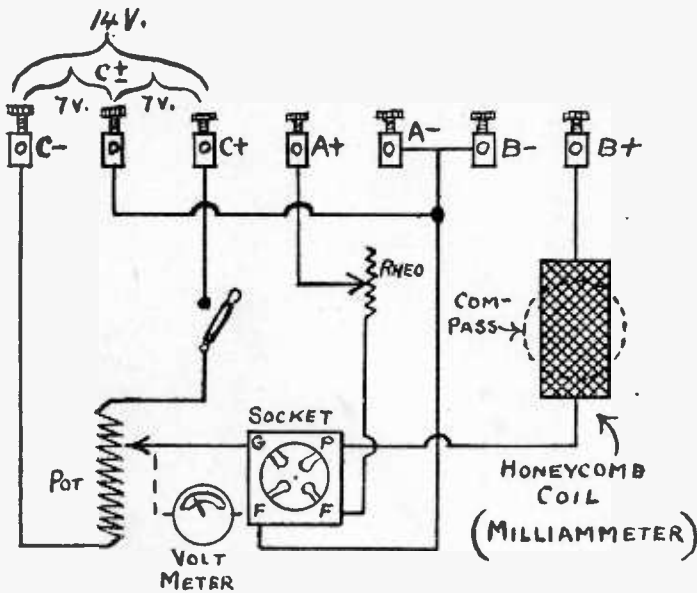

Fig. 3. Here is the Exact Wiring Diagram of All the Parts. The Switch is to Save the "C" Battery.

you will know that it is passing just twice the current. With the larger currents it is the *tangent* of the angle which is a measure of the current. The value of the tangent can be found by looking in the tables in most any handbook. The operation is just like a "tangent galvanometer" which is described in electrical handbooks.

The compass will deflect to either the right or the left, depending on which way the current flows through the coil. As we are accustomed to a meter reading to the right, it is well to reverse the leads, if you find that it originally gives a left-hand swing.

**How to Adjust Needle**

If when you are using the meter you find that the needle turns nearly to right

We are now ready to test out a tube. With the proper voltage on the filament and the "B" battery connected, turn the potentiometer so that a *positive* bias from the "C" battery is impressed on the grid. It will be the right polarity when the movable arm of the potentiometer is around at the side connected to the "C" plus terminal. For a good tube, the compass needle will fly around from 50 to 80 degrees. A tube in fair condition will give perhaps half that amount while a poor one will hardly cause any deflection. The only way you can be sure about the conditions of the tubes is to try more than one. If you have one which you know is good, then take readings with the potentiometer way round to the left, in the center, and also way

# DR RADIO PRESCRIBES.

**NOTE:** In this section the Technical Editor will answer questions of general interest on any radio matter. Any of our readers may ask not more than two questions, and if the subjects are of importance to most radio fans they will be answered free of charge in the magazine. If they are

of special interest to the questioner alone, or if a personal answer is desired, a charge of fifty cents will be made for each answer. This will entitle the questioner to a personal answer by letter. However, if the question requires considerable experimental work, higher rates will be charged.

*Question.* What is meant by a high Mu tube?

*Answer.* The letter Mu is one of the characters of the Greek alphabet and is used as the symbol for amplification factor just as the Greek letter Pi represents the value 3.14 which is the ratio of the circumference of a circle to its diameter.

The amplification factor of a tube is to some extent a measure of its usefulness as an amplifier. When the "B" battery voltage on the plate of a tube is increased it follows that more plate current will flow. When a positive voltage is impressed on the grid, this also results in more plate current. The ratio of the increase in voltage of the "B" battery compared with that of the grid necessary to give a certain additional plate current is defined as the "amplification factor."

*Question.* In a vernier condenser some

styles have an extra single plate and some use a slow speed adjustment on the entire plate assembly. Which is better?

*Answer.* Each one has its advantages. Moving only one plate gets the fine change in capacity without resorting to tremendously fine adjustment. The disadvantage of this style, however, is that the main dial cannot be logged accurately since the total capacity depends on the location of the vernier plate as well as that of the main rotor. That is why this type of control has been superseded in most sets which have accurate tuning. The other style has a disadvantage of fine movement but with this idea the dials will repeat accurately night after night for any station.

*Question.* When using a "C" battery on a neutrodyne set, what increase in the life of the "B" battery may be expected?

*Answer.* The "C" battery prolongs the activities of the "B" battery by quite a

substantial amount. Assuming that you are using 90 volts of "B," which is ordinarily recommended for a neutrodyne, you will find that a one-cell "C" battery which has a pressure of  $1\frac{1}{2}$  volts will give you about 20 per cent more life than when the set is used without it.

Two cells with a pressure of three volts, gives a 45 per cent increase, while a grid bias of  $4\frac{1}{2}$  volts from a three dry cell "C" battery will make your "B" batteries last 75 per cent longer than before this unit was added. From this it would appear that it was an advantage to keep on going up to four or perhaps five or six cells of "B", but it is inadvisable to use more than three cells with any 90 volts on the plate. The improvement in "B" battery life is not the only advantage derived from using the "C." Besides this is the increase in the clearness and naturalness of the tone from your loud speaker.

## TESTING TUBES

Continued from Previous Page across the socket terminals F and F, in the diagram.

### A Center Zero Instrument

If a high grade voltmeter is to be purchased, you might prefer to purchase one that read both ways, i. e., with the zero in the center. The ordinary voltmeter reads only one way, so that it has to be connected with its plus pole always connected to the positive terminal of the "A" battery, while the other pole has to go to minus "A."

The objection of the center zero instrument is that only half the scale is used at one time, and so the divisions are crowded together twice as much. This

cuts the accuracy of reading in two. A testing laboratory invariably prefers not to sacrifice the accuracy but instead will go to the slight trouble of making sure that the terminals are connected right. If you make a mistake here, there is no harm done—the needle merely goes to the left and strikes the stop. The remedy is to interchange the leads.

### Reverse Leads in the Middle

There is one place where a center zero voltmeter is a convenience and that is when connected to measure the grid bias, if this is to be made both positive and negative. With the ordinary meter it is necessary to reverse the leads in the middle of the test.

It is convenient to have a switch in-

serted in one of the "C" leads as shown so as to cut out the "C" battery when the tester is not in use. Without some provision of this sort, the "C" battery would be quickly discharged because the potentiometer winding is shunted across it all the time, making a slow but steady current drain. Only one single pole switch is needed.

If one can afford a good milliammeter and the additional voltmeter or voltmeters for testing grid and filament voltages, it will of course greatly improve the working of the tester to use them instead of the honeycomb coil or less elaborate arrangement shown in the figure, but the honeycomb device is not only interesting but will tell much about the worth of a tube.

# Fone Fun For Fans

### How About the "Date"?

"Dear me, how slovenly the postal authorities are! Here's a card from my husband, who's in Manchester on business, and it's got the Paris postmark."—London Mail.

### And Their Eggs from Egg Plant

"And you say you guarantee these canaries?"

"Guarantee them? why, madam, I raised them from canary seed!"—Brown Jug.

### Set Needed Operation

Friend: "What a horrible noise comes from that radio set!"

Radio Fan: "Well, I guess you would make just as bad a noise if you were coming out of ether."—*Weekly Scotsman*.

### No Pedestrian.

Said the bank teller to the new girl

who was making a deposit: "You didn't foot it up."

"No," she replied innocently, "I took a taxi."—Framingham Philomath.

### Buying on Price

"Vat meat haf you got?" the Jew asked the butcher.

"Mutton and vension," the dealer responded.

"Give me der mutton," ordered the Jew. "I prefer that vat is sheep to that vat is deer."—*The Progressive Grocer*.

### A Better Neighborhood

A woman in the suburbs was chatting over the back fence with her next-door neighbor: "We're going to be living in a better neighborhood soon," she said.

"So are we," volunteered Mrs. Next-door confidently. "What? Are you moving, too?" "No, we're staying here."—*Christian Register*.

# In 15 Minutes I Will Give You the Secret of a Perfect Memory

## I Guarantee to Increase Your Memory 100% In 10 Days

Not by any abstract, tiresome, difficult-to-master method; not by the old system of association of ideas or thoughts. Not by hard study, rotation exercises or repetition of words or sounds. It is not a book. There is nothing to study—nothing to repeat. It is by far the newest, best simplest method ever devised. I will give you a memory in one week's time that will surprise you. In one month things that occurred 30 days ago will be as fresh and clear in your mind as if they happened yesterday.



**GEO. J. SPINNER**  
Author and Educator  
professional and scientific circles; it gave me a good vocabulary, developed my powers of perception and analysis and fitted me to write on a hundred subjects.

### My Secret for 30 Years

I have given my secret to thousands. I have used it myself for more than 30 years. It enabled me

to rise to my present position as an educator in professional and scientific circles; it gave me a good vocabulary, developed my powers of perception and analysis and fitted me to write on a hundred subjects.

### Command Success

My VI-FLECT method of memory-building is for those who are ambitious to improve their business, professional, social or financial condition. VI-FLECT will develop your brain-power—your ability—lift you out of the rut; you will no longer stumble, mumble, nor grope for words with which to express yourself. You will be surprised how easily you can remember names, faces, dates, figures, appointments, duties, etc. It will enhance your importance as an employer, your value as a manager or employee, increase your worth, your ability, expertness, raise your salary, help you in business, professionally, socially, politically—in every way.

### Learn My Secret

I prefer to place my secret within the easy reach of everyone. Therefore, the price I am going to ask for VI-FLECT—my wonderful method of memory-building, which I have developed and perfected during my 30 years of constant study and application is ONLY \$5.00.

Let nothing stand between you and a successful, happy, prosperous future. If it is not convenient to enclose the money, or if you prefer, I will mail your copy of VI-FLECT and you can hand the small amount to your postman when he delivers the package. The important thing is—SEND NOW.

### COUPON

Geo. J. Spinner,  
416 S. Dearborn St., MB738  
Chicago, Ill.

Dear Sir: Please send me my copy of VI-FLECT for which I enclose \$5.00. I will try your VI-FLECT method of memory-building for 10 days, and if it does not increase my memory 100% I am to return it and you are to give me my money back without argument.

Name .....  
Address .....  
City ..... State .....

# Build Your Own A and B Battery Eliminator \$1

It is next to impossible to buy a battery eliminator that will operate rightly without alterations in your set. But for one dollar we will send you blue-print plans and instructions that will show you both how to construct a perfect eliminator and how to make the slight necessary changes in your receiver. Construction is extremely simple.

The device you will make with these plans **ELIMINATES BOTH A AND B BATTERIES**. Operates perfectly at all times from any standard house lighting current.

Send one dollar. Specify type of receiver and state whether direct or alternating current is used. Money back if not completely satisfied.

Do away with that costly, inconvenient battery nuisance!

Send for these plans to-day.

## ENGINEERS' SERVICE COMPANY

SUITE 203

15 PARK ROW, NEW YORK, N. Y.

# Biltmore Master Reflex



We wish to announce our

## Model V1 Master Reflex Receiver

which we are about to place on the market.

It has taken more than a year of constant improvement on one of the most popular reflex circuits which has ever been designed to develop this receiver.

And we have been well repaid for our efforts. We have completed this six tube machine, a set extreme in sensitiveness and excellent in selectivity.

But most important of all, the receiver is perfect in tone! We will compare it with any standard receiver, and guarantee that it wins the opinion of all who hear, that it has the finest tone of any receiver manufactured.

If your dealer is not yet supplied, we shall gladly fill your order direct, and if you are within a reasonable distance of Boston, we shall be pleased to have the receiver installed and demonstrated in your own home, and to your own satisfaction.

**MODEL V1 \$115**



**DEALERS ARE REQUESTED TO WRITE**

Please mention **RADIO PROGRESS**

**THE BILTMORE RADIO COMPANY**

**BOSTON 30**

**MASS.**

**UNITED STATES BROADCASTING STATIONS  
ARRANGED ALPHABETICALLY BY  
CALL LETTERS**

K.C. W.L. W.P.

Abbreviations: W.L., wave length in meters; K.C., frequencies in kilocycles; W.P., wattpower of station.

K.C. W.L. W.P.

KDKA—Westinghouse Elec. & Mfg. Co., E. Pittsburg, Pa.	970-309-1000
KDPM—Westinghouse Elec. & Mfg. Co., Cleveland, O.	1200-250-500
KDZB—Frank E. Siefert, Bakersfield, Cal.	1430-210-500
KFAB—Nebraska Buick Auto Co., Lincoln, Neb.	880-341-500
KFAD—McArthur Bros. Mercantile Co., Phoenix, Ariz.	1100-273-100
KFAE—State College of Washington	860-349-500
KFAF—Western Radio Corp., Denver, Colo.	1080-278-500
KFAJ—University of Colorado, Boulder, Colo.	1150-261-100
KFAU—Boise High School, Boise, Idaho	1080-278-500
KFBK—Kimball Upson Co., Sacramento, Cal.	1210-248-100
KFCF—Frank A. Moore, Walla Walla, Wash.	1170-256-100
KFDM—Magnolia Petroleum Co., Beaumont, Tex.	950-316-500
KFDX—First Baptist Church, Shreveport, La.	1200-250-100
KFDY—S. Dak. Ste. Col. Ag. & Mech. Arts, Br'kngs., S. D.	1100-273-100
KFEQ—Scroggin, & Co. Bank, Oak, Nebr.	1120-268-500
KFFV—Graceland College, Lamoni, Iowa	1200-250-100
KFGC—Louisiana State Univ., Baton Rouge, La.	1120-268-100
KFGD—Oklahoma College for Women, Chickasha, Okla.	1190-252-200
KFGH—Leland Stanford Junior Univ., Stanford Univ., Cal.	1110-270-500
KFGX—First Presbyterian Church, Orange, Texas	1200-250-500
*KFI—Earl C. Anthony, Los Angeles, Cal.	640-469-3000
KFIJ—Benson Polytechnic Institute, Portland, Ore.	1210-248-100
KFIO—North Central High School, Spokane, Wash.	1130-266-100
KFIP—First Methodist Church, Yakima, Wash.	1170-256-100
KFIZ—Daily Com'lth & Wis. R. S'les, Inc., Fondulac, Wis.	1100-273-100
KFJF—National Radio Mfg. Co., Oklahoma, Okla.	1150-261-225
KFJM—University of No. Dak., Grand Forks, No. Dak.	1080-278-100
KFKQ—Conway Radio Laboratories, Conway, Ark.	1200-250-100
KFKU—University of Kansas, Lawrence, Kas.	1090-275-100
KFKX—Westinghouse Elec. & Mfg. Co., Hastings, Neb.	1040-288-2000
KFLR—University of New Mexico, Albuquerque, N. Mex.	1180-254-200
KFLV—Swedish Evangelical Mission Church, Rockford, Ill.	1130-210-229-100
KFLZ—Atlantic Automobile Co., Atlantic, Iowa	1100-273-100
KFMQ—University of Arkansas, Fayetteville, Ark.	1000-300-500
KFMR—Morningside College, Sioux City, Iowa	1150-261-100
KFMC—Carleton College, Northfield, Minn.	890-337-750
KFNF—Henry Field Seed Co., Shenandoah, Iowa	1130-266-500
KFOA—Rhodes Dept. Store, Seattle, Wash.	660-454-500
KFON—Echophone Radio Shop, Long Beach, Cal.	1290-233-100
KFOO—Latter Day Saints Univ., Salt Lake City, Utah	1270-236-250
KFOR—David City Tire & Electric Co., David City, Neb.	1330-226-100
KFOX—Technical High School, Omaha, Nebr.	1210-248-100
KFPG—Oliver S. Garretson, Los Angeles, Cal.	1260-238-100
KFPR—Los Angeles County Forestry, Los Angeles, Cal.	1300-231-500
KFPY—Symons Investment Co., Spokane, Wash.	1130-266-100
KFOA—The Principia, St. Louis, Mo.	1150-261-100
KFQB—Searchlight Publishing Co., Fort Worth, Texas	1140-263-150
KFQC—Kidd Brothers Radio Shop, Taft, Cal.	1300-231-100
KFQU—W. E. Riker, Holy City, Calif.	1350-222-100
KFQZ—Taft Products Co., Hollywood, Calif.	1330-226-250
KFRB—Hall Bros., Beeville, Texas	1210-248-250
KFRU—Ethical Radio Co., Bristow, Okla.	760-395-500
KFSG—Echo Park Evangelical Asso., Los Angeles, Cal.	1090-275-500
KFUM—W. D. Pyle, Colorado Springs, Colo.	1240-242-100
KFUO—Concordia Seminary, St. Louis, Mo.	550-545-500
KFUT—University of Utah, Salt Lake City, Utah	1150-261-100
KFVE—Film Corporation of America, St. Louis, Mo.	1250-240-500
KFVK—Sacramento Chamber of Com., Sacramento, Cal.	1210-248-500
KFVW—Airfan Radio Corporation, San Diego, Cal.	1220-246-500
KFWA—Browning Bros. Co., Ogden, Utah	1150-261-500
KFWB—Warner Bros. Pictures, Inc., Hollywood, Cal.	1190-252-500
KFWD—Arkansas Light & Power Co., Arkadelphia, Ark.	1130-266-500
KFWH—F. Wellington Morse, Jr., Chico, Cal.	1180-254-100
KFWI—Radio Entertainments, Inc., So. San Fran., Cal.	1360-220-500
*KFWM—Oakland Educational Society, Oakland, Cal.	1430-207-500
*KFWO—Lawrence Mott, Avalon, California	1420-211-250
*KFWU—Louisiana College, Pineville, La.	1260-238-100
*KGO—General Electric Co., Oakland, Cal.	830-361-3000
KGU—Marion A. Mulrony, Honolulu, Hawaii	1110-270-500
KGW—Portland Morning Oregonian, Portland, Ore.	610-491-500
KHJ—Times-Mirror Co., Los Angeles, Cal.	740-405-500
*KHO—Louis Wasmer, Seattle, Wash.	1100-273-100
KLS—Warner Bros. Radio Supplies Co., Oakland, Cal.	1240-242-250
KLX—Tribune Publishing Co., Oakland, Cal.	590-509-500
KLZ—Reynolds Radio Co., Denver, Colo.	1130-266-250
*KMA—May Seed & Nursery Co., Shenandoah, Iowa	1190-252-500
KMO—Love Electric Co., Tacoma, Wash.	1200-250-100
KNX—Los Angeles Express, Los Angeles, Cal.	890-337-500
KOA—General Electric Co., Denver, Colo.	930-322-2000
KOB—New Mexico Col. of Agriculture, State Col., N. Mex.	860-349-750
KOIL—Morarch Manufacturing Co., Council Bluffs, Ia.	1080-278-500
KOP—Detroit Police Dept., Detroit, Mich.	1080-278-500
KPO—Hale Bros., San Francisco, Cal.	700-428-500
KPRC—Houston Printing Co., Houston, Texas	1010-297-500
*KPSN—Pasadena Star-News, Pasadena, Cal.	950-316-1000
*KQP—Apple City Radio Club, Hood River, Ore.	1110-270-100

KQV—Double-Hill Electric Co., Pittsburg, Pa.	1090-275-500
KSAC—Kansas State Agric. College	880-341-500
KSD—Post-Dispatch, St. Louis, Mo.	550-545-750
*KSL—The Radio Service Corp., Salt Lake City, Utah	1000-300-1000
*KTAB—Tenth Ave. Baptist Church, Oakland, Cal.	1390-216-500
KTCL—American Radio Tel. Co., Inc., Seattle, Wash.	980-310-1000
KTHS—New Arlington Hotel Co., Hot Springs, Ark.	800-375-500
*KIW—First Presbyterian Church, Seattle, Wash.	660-454-1000
KUO—Examiner Printing Co., San Francisco, Cal.	1220-246-150
KUOM—State Univ. of Montana, Missoula, Mont.	1230-244-250
KWKC—Wilson Duncan Studios, Kansas City, Mo.	1270-236-100
KWWG—City of Brownsville, Brownsville, Texas	1080-278-500
KWKH—W. G. Paterson, Shreveport, La.	1110-273-250
KYW—Westinghouse Elec. & Mfg. Co., Chicago, Ill.	560-535-1500
KZB—Electrical Supply Co., Manila, P. I.	1110-270-100
KZM—Preston D. Allen, Oakland, Cal.	1240-242-100
KZRO—Far Eastern Radio, Manila, P. I.	1350-222-500
WAAB—Valdemar Jensen, New Orleans, La.	1120-268-100
WAAC—Tulane University, New Orleans, La.	1090-275-100
WAAF—Chicago Daily Drovers Journal, Chicago, Ill.	1080-278-200
*WAAM—I. R. Nelson Co., Newark, N. J.	1140-263-500
WABA—Omaha Grain Exchange, Omaha, Neb.	1080-278-500
WABA—Lake Forest University, Lake Forest, Ill.	1320-227-200
WABI—Bangor Hydro-Electric Co., Bangor, Me.	1250-240-100
*WABN—Ott Radio (Inc.), La Crosse, Wis.	1230-244-500
WABO—Lake Avenue Baptist Church, Rochester, N. Y.	1080-278-100
WABX—Henry B. Joy, Mount Clemens, Mich.	1220-246-150
WADC—Allen Theatre, Akron, O.	1160-258-100
WADF—Albert B. Parfet Co., Port Huron, Mich.	1170-256-500
WAHG—A. H. Grebe Co., Richmond Hill, N. Y.	950-316-500
WAMD—Hubbard & Co., Minneapolis, Minn.	1230-244-500
WARC—Am. Rad. & Research Corp., Medf'd H'sde, Mass.	1150-261-100
WBA—Purdue University, West Lafayette, Ind.	1100-273-250
WBAK—Pennsylvania State Police, Harrisburg, Pa.	1090-275-500
WBAO—James Millikin University, Decatur, Ill.	1110-270-100
WBAP—Wortham-Carter Publishing Co., Fort Worth, Tex.	630-476-1000
WBAX—John H. Stenger, Jr., Wilkes-Barre, Pa.	1170-256-100
WBAY—Erner & Hopkins Co., Columbus, Ohio	1020-293-500
WBB—Irving Vermilya, Mattapoisett, Mass.	1210-248-100
WBBL—Grace Covenant Church, Richmond, Va.	1310-220-100
WBMB—Atlas Investment Co., Chicago, Ill.	1330-226-1500
WBMP—Petoskey High School, Petoskey, Mich.	1260-238-200
WBWR—People's Pulpit Assoc., Rossville, N. Y.	1100-273-500
WBES—Bliss Electrical School, Takoma Park, Md.	1350-222-100
WBOQ—A. H. Grebe Co., Richmond Hill, N. Y.	1270-236-100
WBT—Southern Radio Corp., Charlotte, N. C.	1090-275-250
WBZ—Westinghouse Elec. & Mfg. Co., Springfield, Mass.	900-331-2000
WCAC—Connecticut Agric. College, Mansfield, Conn.	1090-275-500
WCAD—St. Lawrence University, Canton, N. Y.	1140-263-250
WCAE—Kaufmann & Baer Co., Pittsburg, Pa.	650-461-500
WCAH—Entrekin Electric Co., Columbus, O.	1130-266-500
WCAJ—Nebraska Wesleyan University, Univ. Place, Nebr.	1180-275-100
WCAO—St. Olaf College, Northfield, Minn.	890-337-500
*WCAL—A. A. & A. S. Brager, Baltimore, Md.	1090-275-100
WCAP—Chesapeake & Potomac Tel. Co., Wash., D. C.	640-469-500
WCAR—Southern Radio Corp. of Texas, San Antonio, Tex.	1140-263-100
WCAU—Durham & Co., Philadelphia, Pa.	1080-278-500
WCAX—University of Vermont, Burlington, Vt.	1200-250-100
WCBC—University of Michigan, Ann Arbor, Mich.	1310-229-200
WCBD—Wilbur G. Voliva, Zion, Ill.	870-345-2000
WCBN—Foster & McDonnell, Chicago, Ill.	1130-266-500
WCBO—First Baptist Church, Nashville, Tenn.	1270-236-100
WCCO—Washburn Crosby Co., Minneapolis, Minn.	720-416-5000
WCEE—Charles E. Erbstein, Elgin, Ill.	1090-275-1000
*WCLS—H. M. Couch, Joliet, Ill.	1400-214-100
WCN—Texas Markets & Warehouse Dept., Austin, Tex.	1120-268-250
WCN—Foster & McDonnell, Chicago, Ill.	1130-266-500
WCSS—Congress Square Hotel Co., Portland, Me.	1170-256-500
WCST—C. T. Sherer Co., Worcester, Mass.	1120-268-500
WCUW—Clark University, Worcester, Mass.	1260-238-250
WCX—Detroit Free Press, Detroit, Mich.	580-517-500
WDAB—Tampa Daily News, Tampa, Fla.	1100-273-250
WDAG—J. Laurence Martin, Amarillo, Tex.	1140-263-100
WDBE—Gilham-Schoen Electric Co., Atlanta, Ga.	1080-278-100
WDBK—M. F. Broz Radio Store, Cleveland, O.	1320-227-100
WDBO—Rollins College, Winter Park, Fla.	1250-240-100
WDBR—Tremont Temple Baptist Church, Boston, Mass.	1150-261-100
WDBY—North Shore Congregational Church, Chicago, Ill.	1160-258-500
WDWF—Dutee W. Flint, Cranston, R. I.	680-441-500
WEAF—James L. Bush, Tuscola, Ill.	1080-278-100
*WEAL—American Tel & Tel Co., New York, N. Y.	610-492-5000
WEAH—Hottel Lassen (Rigby-Gray H. Co.), Wichita, Kas.	1120-268-100
WEAI—Cornell University, Ithaca, N. Y.	1180-254-500
WEAJ—University of So. Dakota, Vermilion, So. Dak.	1080-278-100
*WEAM—Borough of North Plainfield, No. Plainfield, N. J.	1150-261-250
*WEAN—Shepard Co., Providence, R. I.	1110-270-250
WEAO—Ohio State University, Columbus, Ohio	1020-294-500
WEAR—Goodyear Tire & Rubber Co., Cleveland, Ohio	770-389-1000
WEAU—Davidson Bros. Co., Sioux City, Iowa	1090-275-100
WEAL—Iris Theater, Houston, Tex.	1110-270-500
WEBC—Walter C. Bridges, Superior, Wis.	1240-242-100



# The Heart of Your Radio Set

A Grid Leak is essential on every set. There are few sets made which wouldn't be improved by the use of a Variable Grid Leak.

Even the set makers admit that.

But those makers say—"Show us a **good** Variable Grid Leak,"—because they know that most of the variables on the market have been a failure.

## Right now -- we're showing them

Buy It



Try It

Volt-X Ball-Bearing  
Variable Grid Leak

### If you are not satisfied, return it and get your money back

This GRID LEAK is made by an organization which has been handling delicate electrical instruments for years. We know what it means to build accurately and substantially. We KNOW that this GRID LEAK is as nearly perfect as human hands and precise machinery can make it—we're glad to have you try it with the knowledge that if it doesn't do what we claim for it, your money will be refunded.

Clip the coupon, and send it in with \$1.00—a grid leak will be mailed at once.

## BURTON & ROGERS MFG. CO.

755 Boylston St.

Boston, Mass.

Please  
send me one  
of your VOLT-X  
VARIABLE GRID  
LEAKS.

I enclose \$1.00 with  
the understanding that  
this merchandise is guar-  
anteed to give satisfaction, or  
may be returned.

NAME . . . . .

ADDRESS . . . . .

K.C. W.L. W.P.

WEBH—Edgewater Beach Hotel Co., Chicago, Ill. .... 810-370-1000  
 WEBJ—Third Avenue Railway Co., New York, N. Y. .... 1100-273- 500  
 WEBL—Radio Corp. of America, United States (portable). 1330-226- 100  
 WEBM—Radio Corp. of America, United States (portable). 1330-226- 100  
 WEBW—Beloit College, Beloit, Wis. .... 1120-268- 500  
 WEEI—Edison Electric Illuminating Co., Boston, Mass. .... 630-476- 500  
 WEMC—Emmanuel Missionary Col., Berrien Springs, Mich. 1050-286- 500  
 WENR—All-American Radio Corporation, Chicago, Ill. .... 1130-266- 100  
 WEW—St. Louis University, St. Louis, Mo. .... 1210-248- 100  
 WFAA—Dallas News & Dallas Journal, Dallas, Tex. .... 630-476- 500  
 WFAV—University of Nebraska, Lincoln, Neb. .... 1090-275- 500  
 WFBG—William F. Gable Co., Altoona, Pa. .... 1080-278- 100  
 WFBH—Concourse Radio Corp., New York, N. Y. .... 1100-273- 500  
 WFBF—Galvin Radio Supply Co., Camden, N. J. .... 1270-236- 250  
 WFBM—Onondoga Hotel, Syracuse, N. Y. .... 1190-252- 100  
 WFBM—Merchant Heat & Light Co., Indianapolis, Ind. .... 1120-268- 250  
 WFBF—Fifth Infantry, Maryland N. G., Baltimore, Md. 1180-254- 100  
 \*WFDF—Frank D. Fallain, Flint, Mich. .... 1280-234- 100  
 WFI—Strawbridge & Clothier, Philadelphia, Pa. .... 760-395- 500  
 WFKB—Francis K. Bridgman, Chicago, Ill. .... 1380-217- 100  
 WGAQ—W. G. Paterson, Shreveport, La. .... 1110-273- 250  
 WGAZ—Jones Bend Tribune, South Bend, Ind. .... 1090-275- 250  
 WGBA—South Electric & Radio Mfg. Co., Baltimore, Md. 1180-254- 100  
 WGBB—Harry H. Carman, Freeport, N. Y. .... 1240-244- 100  
 WGBF—Finke Furniture Co., Evansville, Ill. .... 1270-236- 100  
 WGBQ—Stout Institute, Menomonie, Wis. .... 1280-234- 100  
 WGBS—Gimbel Bros., New York .... 950-316- 500  
 \*WGBU—Florida Cities Fin. Co., Fulford By-The-Sea, Fla. 1080-278- 500  
 WGHX—University of Maine, Orono, Me. .... 1190-252- 100  
 WGPC—D. W. May, Newark, N. J. .... 1190-252- 500  
 WGES—Coyne Electrical School, Oak Park, Ill. .... 1200-250- 500  
 WGHF—Geo. H. Phelps, Detroit, Mich. .... 1110-270- 500  
 WGMU—A. H. Grebe & Co., Inc. (portable), Richmond Hill, N.Y. 1270-236- 100  
 WGFH—George Harrison Phelps, Inc., Detroit, Mich. .... 1110-270- 500  
 WGN—The Tribune, Chicago, Ill. .... 810-370-1000  
 WGR—Federal Telephone Mfg. Corp., Buffalo, N. Y. .... 940-319- 750  
 WGS—Georgia School of Technology, Atlanta, Ga. .... 1110 270- 500  
 WGY—General Electric Co., Schenectady, N. Y. .... 790-380-2000  
 WHA—University of Wisconsin, Madison, Wis. .... 560-535- 750  
 \*WHAD—Marquette Univ. and Mil. Jour., Mil., Wis. .... 1000-275- 500  
 WHAG—University of Cincinnati, Cincinnati, O. .... 1290-233- 100  
 WHAM—University of Rochester, Rochester, N. Y. .... 1080-278- 100  
 WHAP—William H. Taylor Finance Corp., Brooklyn, N. Y. 1250-250- 100  
 WHAR—Seaside Hotel, Atlantic City, N. J. .... 1090-275- 500  
 WHAS—Courier Journal & Louisville Times. .... 750-400- 500  
 \*WHAT—George W. Young, Minneapolis, Minn. .... 1140-263- 500  
 WHAV—Wilmington Electric Specity Co., Wilmington, Del. 1130-266- 100  
 WHAZ—Rensselaer Polytechnic Institute, Troy, N. Y. .... 790-380- 500  
 WHB—Sweeney School Co., Kansas City, Mo. .... 820-366- 500  
 WHBF—Beardsley Specialty Co., Rock Island, Ill. .... 1350-222- 100  
 WHBH—Culver Military Academy, Culver, Ind. .... 1350-222- 100  
 WHBP—Johnstown Automobile Co., Johnstown, Pa. .... 1170-256- 100  
 WHBW—D. R. Kienzie, Philadelphia, Pa. .... 1390-216- 100  
 WHDI—Wm. Hood Dunwoody I. Inst., Minneapolis, Minn. 1080-278- 500  
 WHEC—Hickson Electric Co., Inc., Rochester, N. Y. .... 1160-258- 100  
 WHK—Radiovox Co., Cleveland, O. .... 1100-273- 250  
 WHN—George Schubel, New York, N. Y. .... 830-361- 500  
 WHO—Bankers Life Co., Des Moines, Iowa. .... 570-526- 500  
 WHT—Radiophones Broadcasting Corporation, Deerfield, Ill. 1260-238-1500  
 WIAD—Howard R. Miller, Philadelphia, Pa. .... 1200-250- 100  
 WIAS—Home Electric Co., Burlington, Iowa. .... 1180-254- 100  
 WIBA—The Capital Times Studio, Madison, Wisc. .... 1270-236- 100  
 WIBC—L. M. Tate Post No. 39, V.F.W., St. Petersburg, Fla. 1350-222- 100  
 WIBK—University of the City of Toledo, Toledo, O. .... 1460-205- 100  
 WIBL—McDonald Radio Co., Joliet, Ill. (Portable) .... 1390-215- 250  
 WIBO—Nelson Brothers, Chicago, Ill. .... 1330-226- 500  
 \*WIBT—O. E. Miller, New York, N. Y. .... 1420-211- 100  
 \*WIBW—L. L. Dill, Logansport, Ind. .... 1360-220- 100  
 WIL—St. Louis Star, Benson Radio Co., St. Louis, Mo. .... 1100-273- 250  
 WIP—Gimbel Bros., Philadelphia, Pa. .... 590-508- 500  
 WJAD—Jackson's Radio Eng. Laboratories, Waco, Texas. .... 850-353- 500  
 WJAG—Norfolk Daily News, Norfolk, Nebr. .... 1110-270- 250  
 WJAK—Clifford L. White, Greentown, Ind. .... 1180-254- 100  
 WJAM—D. M. Perham, Cedar Rapids, Ia. .... 1120-268- 100  
 WJAR—The Outlet Co., Providence, R. I. .... 980-306- 500  
 WJAS—Pittsburgh Radio Supply House, Pittsburgh, Pa. .... 1090-275- 500  
 WJAZ—Zenith Radio Corp., Chicago, Ill. (portable) .... 1120-268- 100  
 WJBC—Hummer Furniture Co., La Salle, Ill. .... 1280-234- 100  
 WJBD—Ashland Broadcasting Committee, Ashland, Wisc. 1290-233- 100  
 WJJ—Supreme Lodge L. O. Moose, Mooseheart, Ill. .... 990-303- 500  
 WJY—Radio Corporation of America, New York, N. Y. .... 740-405-1000  
 WJZ—Radio Corporation of America, New York, N. Y. .... 660-454-1000  
 \*WKAF—WKAF Broadcasting Co., Milwaukee, Wis. .... 1150-261- 250  
 \*WKAQ—Radio Corporation of Porto Rico, San Juan, P. R. 880-341- 500  
 \*WKAR—Michigan Agric. Col., E. Lansing, Mich. .... 1050-286-1000  
 WKBG—C. L. Carrell (portable), Chicago, Ill. .... 1390-216- 100  
 WKRC—Kodel Radio Corp., Cincinnati, O. .... 710-422-1000  
 \*WKY—E. C. Hull and H. S. Richards, Oklahoma, Okla. 1090-275- 100  
 WLAL—First Christian Church, Tulsa, Okla. .... 1200-250- 150  
 WLB—University of Minnesota, Minneapolis, Minn. .... 1080-278- 500  
 WLBL—Wisconsin Dept. of Markets, Stevens Point, Wis. 1080-278- 500  
 WLIT—Lit Bros., Philadelphia, Pa. .... 760-395- 500  
 WLS—Sears, Roebuck Co., Chicago, Ill. .... 870-345- 500

K.C. W.L. W.P.

WLTS—Lane Technical High School, Chicago, Ill. .... 1160-258- 100  
 WLW—Crosley Radio Corp., Harrison, O. .... 710-422 } 5000  
 \*WLWL—Mis. Soc. of St. Paul the Apostle, New York. .... 1040-288-1000  
 \*WLMC—Clive B. Meredith, Cazenovia, N. Y. .... 1090-275- 1000  
 \*WMAF—Round Hills Radio Corp., Dartmouth, Mass. .... 680-441-1000  
 \*WMAF—Round Hills Radio Corp., Dartmouth, Mass. .... 833-360- 100  
 WMAK—Norton Laboratories, Lockport, N. Y. .... 1130-466- 500  
 WMAQ—Chicago Daily News, Chicago, Ill. .... 670-448- 500  
 WMAZ—Kingshighway Presbyterian Church, St. Louis, Mo. 1210-248- 100  
 WMAZ—Mercer University, Macon, Ga. .... 1150-261- 500  
 WMBB—American Bond & Mortgage Co., Chicago, Ill. .... 1200-250- 500  
 WMBF—Fleetwood Hotel, Miami Beach, Fla. .... 780-384- 500  
 WMC—Commercial Appeal, Memphis, Tenn. .... 600-500- 500  
 WMC A—Greeley Square Hotel Co., New York, N. Y. .... 880-341- 500  
 WNA B—Shepard Stores, Boston, Mass. .... 1200-250- 100  
 WNA C—Shepard Stores, Boston, Mass. .... 1070-280- 500  
 WNA D—University of Oklahoma, Norman, Okla. .... 1180-254- 250  
 WNA P—Wittenberg College, Springfield, Ohio. .... 1210-248- 100  
 WNA T—Lennig Bros. Co., Philadelphia, Pa. .... 1200-250- 100  
 WNA V—People's Tel. & Tel. Co., Knoxville, Tenn. .... 1290-233- 500  
 WNA X—Dakota Radio Apparatus Co., Yankton, S. Dak. .... 1230-244- 100  
 WNJ J—Radio Shop of Newark, Newark, N. J. .... 1290-233- 100  
 WNY C—City of New York, New York, N. Y. .... 570-526-1000  
 \*WOAI—Southern Equipment Co., San Antonio, Texas. .... 760-395-1500  
 WOAN—James D. Vaughn, Lawrenceburg, Tenn. .... 1060-283- 500  
 WOAW—Woodmen of the World, Omaha, Nebr. .... 570-526-1000  
 WOC—Palmer School of Chiropractic, Davenport, Iowa. .... 620-484-5000  
 WOI—Iowa State College, Ames, Iowa. .... 1110-270- 500  
 WOK—Neutrowound Radio Mfg. Co. Homewood, Ill. .... 1380-217-1500  
 WOO—John Wanamaker, Philadelphia, Pa. .... 590-508- 500  
 WOQ—Unity School of Christianity, Kansas City, Mo. .... 1080-278- 500  
 WOR—L. Bamberger & Co., Newark, N. J. .... 740-405- 500  
 WORD—People's Pulpit Association, Batavia, Ill. .... 1090-275-2000  
 WOS—Missouri State Marketing Bureau, Jefferson City, Mo. 680-441- 500  
 WOWL—Owl Battery Co., New Orleans, La. .... 1110-270- 100  
 WOWO—Main Auto Supply Co., Fort Wayne, Ind. .... 1320-227- 500  
 WPAJ—Doolittle Radio Corporation, New Haven, Conn. .... 1120-268- 100  
 WPAK—Municipality of Atlantic City, Atlantic City, N. J. 1000-300- 500  
 WPSC—Pennsylvania State College, State College, Pa. .... 1150-261- 500  
 WQAC—Horace A. Beale, Jr., Parkersburg, Pa. .... 1360-220- 500  
 WQAC—Gish Radio Service, Amarillo, Tex. .... 1280-234- 100  
 WQAM—Electrical Equipment Co., Miami, Fla. .... 1120-268- 100  
 WQAN—Scranton Times, Scranton, Pa. .... 1200-250- 100  
 WQAO—Calvary Baptist Church, New York, N. Y. .... 833-360- 100  
 WQJ—Calumet Rainbow Broadcasting Co., Chicago, Ill. .... 670-448- 500  
 WRAF—The Radio Club, Laporte, Ind. .... 1340-224- 100  
 WRAK—Economy Light Co., Escanaba, Mich. .... 1170-256- 100  
 WRAM—Lombard College, Galesburg, Ill. .... 1230-244- 100  
 WRAV—Antioch College, Yellow Springs, Ohio. .... 1140-263- 100  
 WRAX—Flexon's Garage, Gloucester City, N. J. .... 1120-268- 250  
 WRBC—Immanuel Lutheran Church, Valparaiso, Ind. .... 1080-278- 500  
 WRC—Radio Corporation of America, Washington, D. C. .... 640-469-1000  
 WREO—Reo Motor Car Co., Lansing, Mich. .... 1050-286- 500  
 WRK—Doron Bros. Electrical Co., Hamilton, O. .... 1110-270- 200  
 WRM—University of Illinois, Urbana, Ill. .... 1100-273- 500  
 \*WRMU—A. H. Grebe & Co., Richmond Hill, N. Y. .... 1270-236- 100  
 WRNY—Experimenter Publishing Co., New York, N. Y. .... 1160-258- 500  
 WRR—Dallas Police & Fire Dept., Dallas, Tex. .... 1150-261- 350  
 WRW—Tarrytown Radio Research Labs., Tarrytown, N. Y. 1100-273- 500  
 WSAC—Clemson Agric. Col., Clemson College, S. C. .... 890-337- 500  
 WSAG—Gospel Tabernacle, St. Petersburg, Fla. .... 1130-266- 250  
 WSAI—United States Playing Card Co., Mason, O. .... 920-326- 500  
 WSAJ—Grove City College, Grove City, Pa. .... 1310-229- 250  
 WSAK—Allentown Call Publishing Co., Allentown, Pa. .... 1310-229- 100  
 WSAR—Doughty & Welch Electric Co., Fall River, Mass. 1180-254- 100  
 \*WSAV—Clifford W. Vick Radio Const. Co., Houston, Tex. 1210-248- 100  
 WSB—Atlanta Journal, Atlanta, Ga. .... 700-428- 500  
 WSB C—World Battery Co., Chicago, Ill. .... 1430-210- 200  
 \*WSBF—Stix, Baer & Fuller, St. Louis, Mo. .... 1100-273- 250  
 WSDA—The City Temple, New York, N. Y. .... 1140-263- 250  
 WSKC—World's Star Knitting Co., Bay City Mich. .... 1150-261- 100  
 WSMB—Saenger A'm'h Co. & Maison Blanche N. O. La. 940-319- 500  
 WSMK—S. M. K. Radio Corp., Dayton, Ohio. .... 1090-275- 500  
 \*WSOE—School of Eng'ng of Milwaukee, Milwaukee, Wis. 1220-246- 500  
 WSRO—Radio Co., Hamilton, Ohio. .... 620-483- 100  
 WSU—State University of Iowa, Iowa City, Iowa. .... 620-484- 500  
 WSY—Alabama Polytechnic Institute, Auburn, Ala. .... 1200-250- 500  
 WTAB—Fall River Daily Herald Pub. Co., Fall R'vr, Mass. 1130-266- 100  
 WTAC—Penn. Traffic Co., Johnstown, Pa. .... 1430-210- 100  
 WTAM—Willard Storage Battery Co., Cleveland O. .... 770-389-2500  
 WTAQ—S. H. Van Gorden & Son, Osseo, Wis. .... 1180-254- 100  
 WTAR—Reliance Electric Co., Norfolk, Va. .... 1150-261- 100  
 WTAS—Charles E. Erbsstein, Elgin Ill. .... 990-302-1500  
 WTAT—Edison Illum'ing Co., Boston, Mass. (portable). 1230-302- 100  
 WTAW—Agric. & Mech. Col. of Texas, Col. Station, Tex. 1110-270- 250  
 WTHS—Flint Senior High School, Flint, Mich. .... 1370-219- 250  
 WTTIC—Travelers Insurance Co., Hartford, Conn. .... 860-349- 500  
 WWAD—Wright & Wright, Philadelphia, Pa. .... 1200-250- 100  
 WWAE—Lawrence J. Crowley, Plainfield, Ill. .... 1240-242- 500  
 WWAO—Michigan College of Mines, Houghton, Mich. .... 1140-263- 250  
 \*WWI—Ford Motor Co., Dearborn, Mich. .... 1130-266- 500  
 \*WWJ—Detroit News, Detroit, Mich. .... 850-353-1000  
 WWL—Loyala University, New Orleans, La. .... 1090-275- 100

\*Additions and corrections.



## STATIC ELIMINATION

WITH the approach of summer, every radio fan looks with a certain amount of dread to the Enigma of Radio—Static. For more than a quarter of a century, scientists in many parts of the world have applied their knowledge and skill to the problem of eliminating Static. Most of their attempts have resulted in failure.

Science recognizes but one device capable of curbing the annoying electrical disturbances, and that is the loop antenna. Electrical storms, like other weather disturbances, find their origin in various points of the compass. It is obvious, then, that by the use of a directional loop turned to a direction away from the disturbance, the disagreeable static noises may be tuned out.

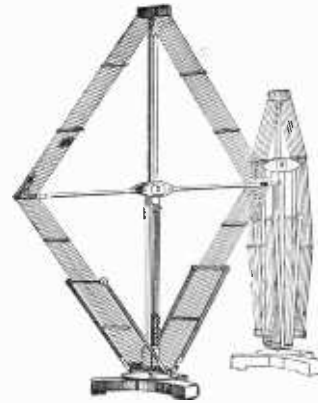

The superior construction of the DTW IMPORTED COLLAPSIBLE LOOP enables it to perform this function to much better advantage than other loop antenna devices. Forty-two inches high by forty inches wide, its inductance consists of fourteen turns of genuine Litzendraht cable, made up of sixty individual strands, insulated, twisted and covered with double green silk.

The woodwork is mahogany and all metal parts are highly nicked. A graduated metal table at the base accurately gives the station direction. The turns are sectionized and by unique design all "dead end" effect is absolutely eliminated. The center tap permits its use without modification for all types of Super Heterodynes. The loop is collapsible and by means of the adjustable slide it may be actually used as the tuning unit of the set. No other loop incorporates such perfection of design, and no other loop can give such marvelous results.

**Price, \$25.00**

CUT OUT

I am interested in the DTW loop advertised in RADIO PROGRESS.

Please send me literature descriptive of the loop.

(Name) .....

(Street) .....

(City) ..... (State) .....



# How To Clean A Crystal

There is only one good way to clean a crystal from your receiving set. If you follow directions carefully, you will not only get reception as good as formerly, but ten to one it will be better than you ever brought in the music before.

Here is the way to do it. Take a 25c piece or 25c in stamps and send it to us with the request that we ship you an Audion Crystal. When you get it through the mail throw your old one on the dump. The result will be that you do not have to hunt for a sensitive spot on the crystal any longer, but by dropping the cat whisker anywhere you will get the music in as loud as you did on the best spot of your old crystal.

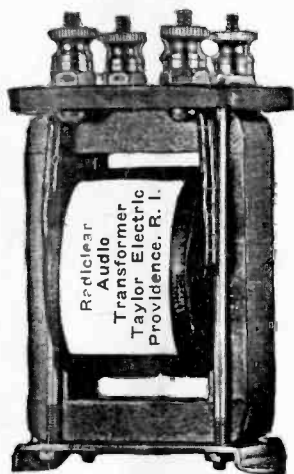

Perhaps you do not know that by combining a crystal with a single tube and using one of our RADICLEAR audio frequency transformers you can get loud speaker volume from the crystal detector. Of course, you will not be able to get more than fifteen or twenty miles range with the normal set but a local station is loud enough for dancing.

The particular advantage of the crystal is its clear tone. There is no distortion at all. If you combine this with an ordinary transformer which distorts, it is like getting a wonderful singer and then listening with cotton stuffed in your ears.

One reason for the clearness of the RADICLEAR transformer outfit is in the grade of Silicon steel used in the core. This is expensive, but we find that it pays dividends in the smoothness of the tone produced. The price of the transformer is \$3.95. If you wish the rest of the kit consisting of socket, rheostat, "B" battery terminal, jack and wiring, then \$6.00 covers the entire equipment.

Use the coupon in the corner.

The Taylor Electric Company,  
1206 Broad Street,  
Providence, R. I.

Please send me the following by parcel post. (Mark which one you want.)

Radiclear Audio Transformer @ \$3.95

Amplifier set complete @ \$6.00

(Socket to fit.....tube)

Audion Crystal @ 25c.

Gold Plated Cat Whisker @ 15c.

I enclose \$.... to pay for these.

(These above prices include the postage.)

Send them to me C. O. D. I will pay the above price plus postage.

(Indicate which way you wish to pay.)

Name.....

Address.....

## TAYLOR ELECTRIC CO.

1206 Broad Street

Providence, R. I.