

A NEW APPROACH TO HI-FI STEREOPHONICS

RADIO & TELEVISION NEWS

AUGUST

1956

35 CENTS

in U. S. and Canada

World's Leading Electronics Magazine

IN THIS ISSUE

COLOR TEST EQUIPMENT

**DESIGN AND CONSTRUCTION
OF R. F. COILS**

**SOUND EFFECTS ADD
REALISM TO DISNEYLAND**

**METHODS OF
MEASURING AND SPECIFYING
AUDIO DISTORTION**

ANTENNA ROTATORS

**ELIMINATING NOISE
IN AUTO RADIOS**

**REALISTIC HIGH FIDELITY
The Dual-Cone Loudspeaker**

**A SIMPLE PREAMPLIFIER
FOR THE HOME BUILDER**

**TRANSISTORIZED
BEACH PHONOGRAPH** ➔
(See Page 45)



X-74-3367-67
SAMUEL TABSHY
6727 N YALE ST
PORTLAND 3 OREG

ANOTHER **FIRST** FOR 

BONDED ELECTRONIC TECHNICIANS



CUSTOMER



RAYTHEON BONDED SERVICE DEALER

WESTERN UNION
"Operator 25"



will recommend them to more customers

Something new — and very important — has been added to the sales force of Raytheon Bonded Electronic Technicians. It's "Operator 25". Customers seeking Radio-TV Service simply call Western Union by number and ask for "Operator 25". In answer to their request for a reliable source of bonded service, "Operator 25" gives them the name and phone number of the nearest Raytheon Bonded Dealer. That means more business — exclusive business — for Raytheon Bonded Electronic Technicians.

This customer producing new sales advantage, plus the cash-protection of the Raytheon Bond,

the Raytheon Bonded Certificate, ID Cards, Decals, Raytheon Creed Displays, the Raytheon Code of Ethics, Classified Telephone Directory listings, all backed by sound, hard-hitting national advertising in LIFE, TIME, NEWSWEEK and TV GUIDE — make the Raytheon Bonded Electronic Technician Program the most powerful sales force a service dealer can have.

Call your sponsoring Raytheon Tube Distributor and ask him if you can qualify as a Raytheon Bonded Dealer.

If you can, you're well on your way to more volume and profit.



RAYTHEON MANUFACTURING COMPANY

Receiving and Cathode Ray Tube Operations

Newton, Mass. • Chicago, Ill. • Atlanta, Ga. • Los Angeles, Calif.

Raytheon makes all these { Receiving and Picture Tubes, Reliable Subminiature and Miniature Tubes, Semiconductor Diodes and Transistors, Nucleonic Tubes, Microwave Tubes



Excellence in Electronics

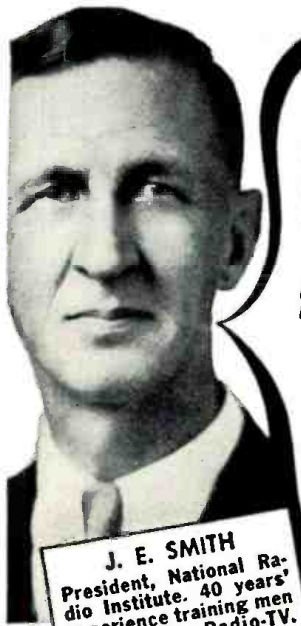

J. E. SMITH
President, National Radio Institute. 40 years' experience training men at home for Radio-TV.

I Will Send You A
SAMPLE LESSON FREE
to show you how easy, practical it is to
Train at Home for Good Radio-Television Jobs



Make \$10, \$15 a Week Extra
Many men I train fix neighbors' Radios, make extra money, soon after they enroll. Actual equipment you build gives you practical experience.

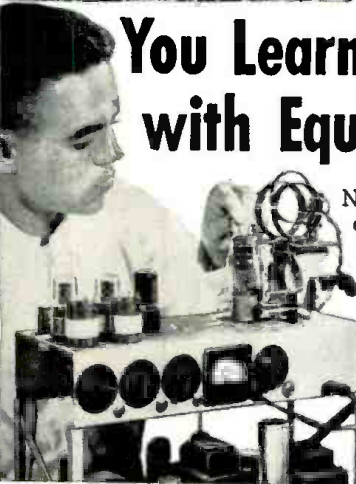
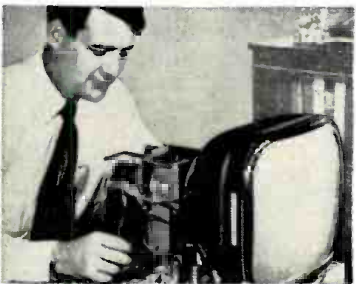

America's Fast Growing Industry Offers You Good Pay Plus a Bright Future

TRAINING plus OPPORTUNITY is the PERFECT combination for ambitious men. Let me send you a sample lesson from my course to prove you can keep your job while TRAINING at home in your spare time for better pay and a brighter future. I will also send my 64-page book to show you that Radio-Television is today's field of OPPORTUNITY for properly trained men.

Television's Growth is Making More Jobs, Prosperity

Radio is bigger than ever and television is growing fast. Government, Aviation, Police, Ship, Microwave Relay, Two Way Communications for buses, taxis, railroads are other growing fields for Radio-Television trained men.

Mail Coupon—Find Out About This Tested Way to Better Pay

Take NRI training for as little as \$5 a month. Many NRI graduates make more in two weeks than the total cost of my training. Mail coupon today for Actual Lesson and 64-page Book—Both FREE. J. E. SMITH, National Radio Institute, Dept. 6HE, Washington 9, D. C. Our 40th Year.

You Learn by Practicing with Equipment I Send

Nothing takes the place of practical experience. That's why NRI training is based on LEARNING BY DOING. My training includes kits of parts which you use to build equipment and get practical experience on circuits common to both Radio and Television. Shown at left is the low-power Broadcasting Transmitter you build as part of my Communications Course.



I Trained These Men



"I have a regular job as a police captain and also have a good spare time Radio and Television service business. Just opened my new showrooms and shop."—C. W. LEWIS, Pensacola, Florida.

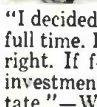

"I decided to quit my job and do TV work full time. I love my work and am doing all right. If fellows knew what a wonderful investment NRI is, they would not hesitate."—W. F. KLINE, Cincinnati, Ohio.



"Thanks to NRI, I operated a successful Radio repair shop. Then I got a job with WPAQ, later WBOB and now am an engineer for WHPE."—VAN W. WORKMAN, High Point, N. Carolina.



AVAILABLE TO **VETERANS** UNDER G.I. BILLS

Good for Both—FREE

Mr. J. E. Smith, President, Dept. 6HE
National Radio Institute, Washington 9, D. C.
Mail me Sample Lesson and 64-page Book, FREE.
(No salesman will call. Please write plainly.)

Name _____ Age _____
Address _____
City _____ Zone _____ State _____
VETS write in date of discharge _____
Approved Member, National Home Study Council

RADIO & TELEVISION NEWS is published monthly by Ziff-Davis Publishing Company, William B. Ziff, Chairman of the Board (1946-1953), at 64 E. Lake St., Chicago 1, Ill. Entered as second-class matter July 31, 1948, at the Post Office, Chicago, Ill., under the act of March 3, 1879. Authorized by Post Office Department, Ottawa, Canada, as second-class matter. SUBSCRIPTION RATES: Radio & Television News—one Year U. S. and Possessions, and Canada \$4.00; Pan-American Union countries \$4.50; all other foreign countries \$5.00.

Publisher
OLIVER READ, D.Sc., WIETI
 Editor
WM. A. STOCKLIN, B. S.
 Technical Editor
MILTON S. SNITZER
 Service Editor
CHARLES TEPFER
 Associate Editor
P. B. HOEFER
 Assistant Editor
J. JUSTER
 Television Consultant
WALTER H. BUCHSBAUM
 Art Editor
FRANK SAYLES
 Art Department
J. A. GOLANEK
W. K. VAHLING
JAMES A. ROTH
 Advertising Director
L. L. OSTEN
 Advertising Manager
MURRAY GOLDMAN
 Midwest Adv. Manager
JOHN A. RONAN, JR.
 Western Adv. Manager
JOHN E. PAYNE

*First in radio-
 television-audio-electronics*



Average Net Paid Circulation 229,357

Radio News Trademark Reg. U. S. Pat. Office • Television News Trademark Reg. U. S. Pat. Off.

CONTENTS

AUGUST, 1956

EDITORIAL—INDUSTRY NEWS

For the Record.....O. Read 8
 Spot Radio News.....Washington Correspondent 16
 New TV Grants Since Freeze Lift..... 16

HIGH FIDELITY AND AUDIO

A New Approach to Hi-Fi Stereophonics.....Norman H. Crowhurst 35
 Realistic High Fidelity—The Dual-Cone Loudspeaker
 (Part 5).....H. A. Hartley 42
 Sound Effects Add Realism to Disneyland..... 52
 Certified Record Revue.....Bert Whyte 62
 A Simple Preamp for the Home Builder.....
Charles P. Boegli & Raymond H. Willis 66
 Methods of Measuring and Specifying Audio Distortion.....W. Philbrook 68
 New Hi-Fi—Audio Equipment..... 94

SERVICING

Television-Radio

Antenna Rotators.....Walter H. Buchsbaum 39
 Eliminating Noise in Auto Radios.....Ralph Sappe 50
 Don't Knock Your Competitor.....Art Margolis 54
 What's New in Flyback Circuits.....Jesse Dines 60
 Mac's Service Shop.....John T. Frye 72
 Antenna News 107
 Service Industry News..... 133

Test Equipment

The "Injecto-cal".....Carl D. Todd 48
 A New Intermittent Localizer.....E. A. Bramsen 59
 Test Equipment for Color.....Robert G. Middleton 63

AMATEUR AND COMMUNICATIONS

The Design and Construction of R.F. Coils.....Herbert S. Brier 56

ELECTRONIC THEORY AND CONSTRUCTION

Transistorized Beach Phonograph.....Paul Penfield, Jr. 45
 Stabilizing Transistors.....L. Fleming 86
 Tunable 500 to 1000 Cycle Bandpass Filter.....Rufus P. Turner 106

DEPARTMENTS

Within the Industry..... 24 What's New in Radio..... 100
 Technical Books 90 Manufacturers' Literature 110
 Sales Aids..... 130



COVER PHOTO: Take your music with you on your vacation. An inexpensive hand-wound portable phonograph, with a transistorized amplifier added, provides adequate reproduction of discs. Construction details on page 45. (Ektachrome by Paul Penfield, Jr.)

ZIFF-DAVIS PUBLISHING COMPANY

President
B. G. DAVIS
 Vice-President
H. J. MORGANROTH
 Vice-President
M. H. FROELICH
 Vice-President & Circulation Dir.
M. MICHAELSON
 Secretary-Treasurer
G. E. CARNEY
 Art Director
AL GRUEN

BRANCH OFFICES:

CHICAGO (11)
 64 E. Lake St., AN 3-3200
 LOS ANGELES (14)
 215 W. 7th St., (Room 412) TRinity 8043



ZIFF-DAVIS PUBLISHING COMPANY
 WILLIAM B. ZIFF (1898-1953) FOUNDER
 Editorial and Executive Offices
 366 Madison Ave., New York 17, N. Y.
 MU 7-8080
VOLUME 56 • NUMBER 2



Member
 Audit Bureau of
 Circulations

© 1956 by Ziff-Davis Publishing Company. All rights reserved.

SUBSCRIPTION SERVICE: All communications concerning subscriptions should be addressed to Circulation Dept., 64 E. Lake St., Chicago 1, Ill. Subscribers should allow at least four weeks for change of address. Include your old address as well as new—enclosure. If possible, an address label from a recent issue of this magazine.

CONTRIBUTIONS: Contributors are advised to retain a copy of their manuscripts and illustrations. Contributions should be mailed to the New York Editorial Office and must be accompanied by return postage. Contributions will be handled with reasonable care, but this magazine assumes no responsibility for their safety. Any copy accepted is subject to whatever adaptations and revisions are necessary to meet the requirements of this publication. Payment covers all author's, contributor's, and contestant's rights, title, and interest in and to the material accepted and will be made at our current rates upon acceptance. All photos and drawings will be considered as part of the material purchased.

RADIO & TELEVISION NEWS



Maybe It's Easier Than You Think...

...To prepare for a profitable future in the big opportunity fields of

TELEVISION RADIO • ELECTRONICS

"DO-IT-YOURSELF" TRAINING

You get many shipments of high-quality parts. You perform over 300 PRACTICAL projects, including building your own test equipment: A Vacuum Tube Voltmeter and a 5 inch Oscilloscope. You KEEP these high-quality, commercial-type instruments to help you earn money during your training and you can use them later on your job. No need to buy such costly equipment when you start out in this field.

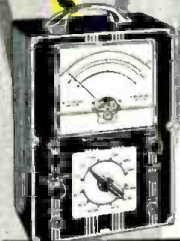

VACUUM TUBE
VOLTMETER

YOU GET CLEAR INSTRUCTIONS

You just ought to read the text of DTI lessons! The words are easy to understand. The directions make everything clear. There are lots of pictures and diagrams, many placed on handy "fold-out" sheets that stay alongside the explanations. You read it, you see diagrams without a lot of flipping back and forth.



5 INCH
"SCOPE"
OSCILLOSCOPE

NOTHING LIKE DTI—HERE'S WHY

Only DTI provides you with training movies and the "ELECTRO-LAB." You run off the movies yourself, and check your reading and "doing" by seeing many basic principles in action on a screen. You can repeat any film several times until you are sure you "get it."

With the "ELECTRO-LAB" you copy a hookup like tracing a picture on tissue paper! The diagrams you follow show through a sheet of clear plastic. You mount the parts, using spring clip connectors to save soldering time as you go from one circuit to another. This cuts mechanical work to a minimum!

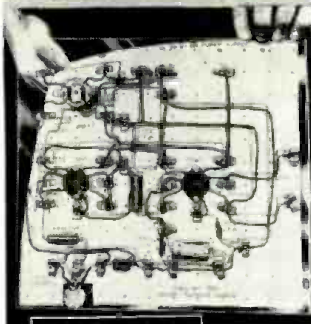

ELECTRO-LAB*

*Trademark

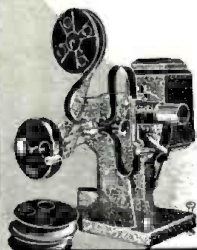

MOVIE PROJECTOR



One of America's Foremost Electronics Training Centers

Member National Home Study Council



DEVRY TECHNICAL INSTITUTE

CHICAGO 41, ILLINOIS

FORMERLY

DEFOREST'S TRAINING, INC.

Read these simple ABC's on how you can get started

Maybe you have been envying the man with a good future in Television-Radio-Electronics—and thinking that's not for you. But, if you are 17 to 55, maybe it is! You don't need previous technical training nor advanced education. You don't have to quit your job and leave home. A lot of men are taking our program, getting ready for good jobs or to start their own business. Many are married. Quite a few are over 40. Many of them never finished high school. What is holding you back? All you have to do is fill out the coupon, send it in to us and we will tell you how we have trained many men like yourself and helped them get started toward real jobs with good money and a fine future.

25 YEARS PROOF

For 25 years we have trained men for better jobs right in their own homes. This first-hand experience in helping thousands of men brings a great advantage to men like you:—training KNOW-HOW designed for REAL RESULTS!

TRAIN IN WELL-EQUIPPED LABORATORIES

If you can come to Chicago, you can get all your training in our big, modern training laboratories where friendly instructors work closely with you as you use much valuable equipment similar to that found in the industry—even including our Television and Radio studio cameras, monitors, microphones, etc. Send the coupon for details.

WE HELP YOU GET STARTED IN THE FIELD

DeVry Tech training in Television-Radio-Electronics turns out a man that knows his business! Many employers all over the United States and Canada are aware of that. Our EMPLOYMENT SERVICE is in close contact with many men who do the hiring. The help we give you in getting started in a new job is one of the most valuable features of DeVry Tech. What's more, if you're interested in STARTING YOUR OWN BUSINESS we'll be able to give you help there too.

IS MILITARY SERVICE AHEAD OF YOU?

If you're soon to enter the ARMED FORCES, we have special information that will be of real value to you. Don't delay. Your future in Television-Radio-Electronics may be nearer than you think. Send that coupon now.

GET THIS BOOKLET FREE!

DEVRY TECHNICAL INSTITUTE

4141 Belmont Ave., Chicago 41, Ill., Dept. RN-8-M

I would like a copy of "Electronics and YOU" showing many opportunities in Television-Radio-Electronics, and how DTI may prepare me for a start in this billion dollar field.

Name _____ Age _____

PLEASE PRINT

Street _____ Apt. _____

City _____ Zone _____ State _____

1041

DTI's training is also available in Canada



THE NEW ISOPHASE SOUND!

Isophase Speakers, an entirely new means for recreating sound
 ... utilizing the electrostatic principle, they produce music
 with a "window-on-the-studio" quality never before attained.

MODEL 580, 1000-CYCLE CROSSOVER / MODEL 581, 400-CYCLE CROSSOVER

THE PICKERING ISOPHASE is a revolutionary new speaker with a single diaphragm that is curved and virtually massless. This diaphragm is moved or driven as a unit by an electrostatic field. It re-introduces an audio signal into the air at a low velocity to closely approximate the unit area energy of the sound at the microphone in a concert hall or studio, thereby creating a "window-on-the-studio" quality that is breathtakingly realistic. Conventional cone or dynamic type loudspeakers reproduce sound by moving only small amounts of air at high velocities. The ISOPHASE, with its large sound-generating surface, is a radical departure from the older concept.

The ISOPHASE is available in two models. Model 581 covers the musical range from 400 cycles per second

up to well beyond the limits of human hearing. The response over this range is consistent and absolutely uniform—without the slightest bump, peak, or resonance of any kind. This in itself is an unprecedented characteristic for a loudspeaker.

Model 580 has the same uniform response and clarity starting at 1000 cycles per second and similarly going out to supersonic frequencies.

Using an ISOPHASE SPEAKER with a FLUXVALVE PICKUP, recorded sound is reproduced for the first time *without distortion caused by the frequency characteristics of the transducers* . . . the middle and higher frequencies are recreated with a smoothness, definition, and degree of balance never before achieved with any speaker.



PICKERING & CO., INC. OCEANSIDE, N. Y.

Professional Audio Components

"For those who can hear the difference"

Demonstrated and sold by Leading Radio Parts Distributors everywhere. For the one nearest you and for detailed literature: write Dept. C-11
 EXPORT: AD. AURIEMA, INC., 89 BROAD ST., NEW YORK / CANADA: CHARLES W. POINTON LTD., 6 ALCINA AVE., TORONTO

An Invitation...

To men who want to "go places" in TV SERVICING

*Find out about this NEW,
ALL-PRACTICE WAY
of becoming a Professional
TV SERVICEMAN*

If you have some Radio or Television experience, or if you know basic Radio-Television principles but lack experience—NRI's new Professional Television Servicing course can train you to *go places* in TV servicing. This advertisement is your personal invitation to get a free copy of our booklet describing this training in detail.

Learn-by-Doing "All the Way"

This is 100% learn-by-doing, practical training. We supply *all* components, *all* tubes, *including* a 17-inch picture tube, and comprehensive manuals covering a thorough program of practice. You learn how experts diagnose TV defects quickly. You see how various defects affect receiver performance—picture and sound; learn causes of defects, accurately, easily, and how to fix them. You do more than just build circuits. You get practice recognizing, isolating, and fixing innumerable troubles.

You get actual experience aligning TV receivers, diagnosing the causes of complaints from scope patterns, eliminating interference, using germanium crystals to rectify the TV picture signal, obtaining maximum brightness and definition by properly adjusting the ion trap and centering magnets, etc. There isn't room on this or even several pages of this magazine to list all the servicing experience you get.

UHF & COLOR TV Making New Boom

Installing front-end channel selector strips in modern UHF-VHF Television receivers and learning UHF servicing problems and their solution is part of the practice you get. To cash in on the coming color TV boom you'll need the kind of foundation in knowledge and experience this training gives.

Get Details of New Course Free

Once again—if you want to go places in TV servicing, we invite you to find out what you get, what you practice, what you learn from NRI's new course in Professional Television Servicing. See pictures of equipment supplied, read what you practice. Judge for yourself whether this training will further your ambition to reach the top in TV servicing. We believe it will. We believe many of tomorrow's top TV servicemen will be graduates of this training. Mailing the coupon involves no obligation.

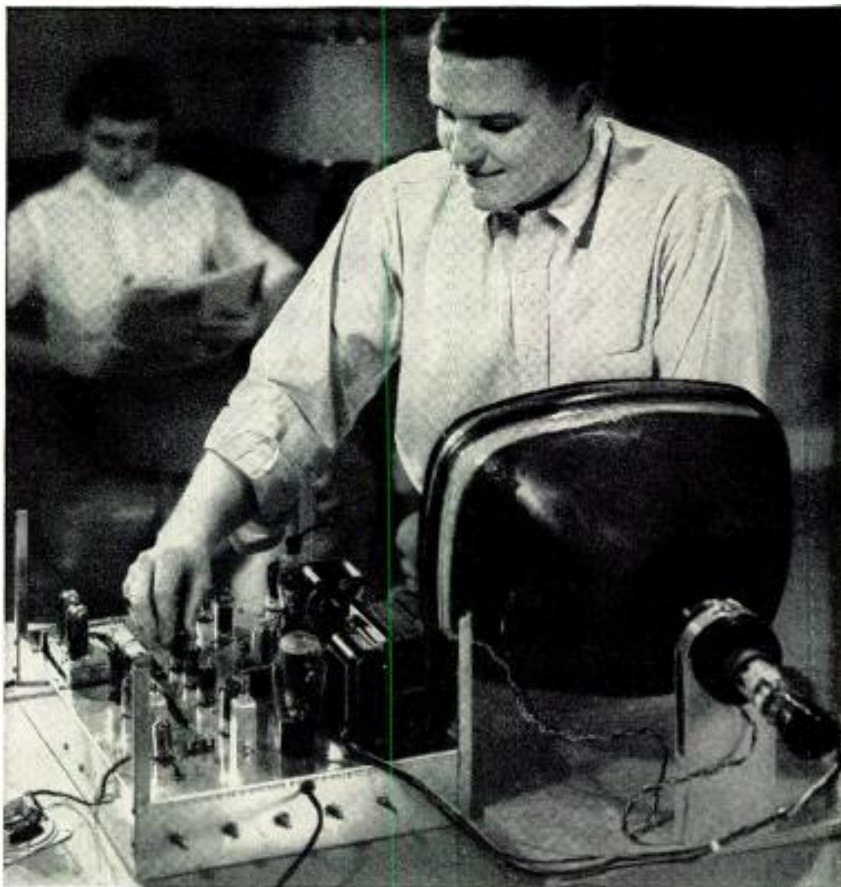

Train at home easily, quickly, for TV's top servicing jobs. NRI's Professional Television Servicing course includes a 17-inch picture tube and all other tubes and components to build a complete TV Receiver, Oscilloscope, Signal Generator, H.F. Probe. Complete training, including all equipment, available now for a low introductory price—under \$200 on easy terms.



National Radio Institute, Dept. 6HET
16th and U Sts., N.W., Washington 9, D. C.

Please send my FREE copy of "How to Reach the Top in TV Servicing." I understand no salesman will call.

Name.....Age.....

Address.....

City.....Zone...State.....

APPROVED MEMBER NATIONAL HOME STUDY COUNCIL

For the RECORD.

SERVICE SHOPS BEING UPGRADED

EACH year at this time we like to descend from our editorial chair, hop in our jalopy and go a-visiting. It has been our custom for many years to drop in for personal and informal visits with technicians at radio and TV service shops scattered throughout the country in order to discuss and observe their operations.

A recent trip resulted in 37 visits in 21 towns on our way to Chicago to attend the Annual Parts Show.

Many of these establishments had been visited prior to this current trip. In contrast with past observations, we found a general improvement in the over-all operations of the service shops. During our discussions, we learned that most of these technicians, because of keener competition, have made a real effort to improve their facilities and to clean up their shops for better appearance. It was indeed gratifying to note that a great deal of brand new test equipment was being used and that obsolete types had been or were being discarded. Most shops were found to have a minimum array of equipment designed specifically for the maintenance of color TV sets. As was expected, such equipment was concentrated in areas of greatest population.

Despite the fact that the average shop had augmented its test equipment, we found that the oscilloscope (still one of the most useful tools of the trade) was not as widely used as would be expected. There are still many service technicians who frown upon its use simply because they do not know how to use it. In such cases, we attempted to revitalize their interest in the oscilloscope especially in view of the fact that when they are faced with color TV maintenance problems, they will be greatly handicapped if they fail or neglect to use this instrument.

As far as business methods are concerned, we discussed the matter of competition within the areas in which they were operating. In sharp contrast to discussions held in past years, we found far less criticism of competitors and an apparent respect for their competition. Only two individuals had any unkind remarks to offer about other technicians operating in their area.

Several technicians complained about the slow service they were getting from suppliers of tubes and component parts. Generally these were operators of small one-man shops. Others, with more capital, were found to have more substantial inventories of essential parts having discovered that, in the long run, they were able

to provide far better service to their customers and maintain a greater volume of business by having a well-stocked parts shelf. It was gratifying to find far less quantities of off-brand tubes than were seen on the shelves of the average service shop during earlier visits. Service technicians are becoming more and more aware of the prestige resulting from stocking and selling known brands made by reputable manufacturers.

Several shops were found to have been completely remodeled and modernized for better eye appeal to the customer. They had developed a more practical arrangement of their service benches which, in most cases, were found to be free from surplus junk and were in orderly condition. There has been a definite trend on the part of the service technician to plan his facilities more carefully in order to obtain maximum workability. For example, the old technique of grouping and mounting all test equipment on wood, Masonite, and other type panels was being discarded in favor of multi-shelf installations which permit the quick removal of test equipment for use when making home service calls.

In the case of larger establishments and where this technique is not practical, there was still some indication that specialized test equipment was mounted flexibly so that it could be removed if and when necessary. Generally, however, the larger shops were found to use permanent shop installations, and outside personnel were equipped with their own portable test instruments.

There was one outstanding negative impression during our visits. This was the failure on the part of many individuals to dress neatly and "professionally." We'd like to reiterate that which has been said many times before: that any technician dealing with the public must "look and dress like a professional." He cannot expect Mrs. Smith to be favorably impressed if he appears at her door to service her home receiver wearing dungarees and a T-shirt. We know several highly qualified technicians who are most careless and sloppy when it comes to their personal appearance. Any of them can certainly afford to buy an inexpensive suit or uniform. Automotive dealers have long recognized the necessity for neatness on the part of their technical employees, but too many electronic personnel still fail to recognize the importance of neatness and good appearance in their work. Both are essential to win the approval of present and future service customers. O. R.



**Combines
Best Features
of ALL
pickups!**

Electro-Voice®

**NEW IMPROVED 80 SERIES
ULTRA-LINEAR CERAMIC CARTRIDGE**

Two Basic Series, fit any arm or plug-in head, combine best features of all cartridges. Standard Model 80 Series replaces most ceramic or crystal cartridges. Model 80M Series replaces ALL magnetic pickups. No adjustments or modifications required!

SUPERLATIVE RESPONSE: 20 to 20,000 cps.

LOWEST INTERMODULATION DISTORTION! Less than 3% at 18 cm/sec.

HIGH OUTPUT! 80 Series, 500 millivolts. 80M Series, 25 millivolts at 5.5 cm/sec.

NO HUM! Absolutely non-inductive. Not sensitive to motor and transformer fields.

HIGH COMPLIANCE! 3 x 10-6 cm/dyne—several times the average hi-fi pickup compliance.

NO PREAMP REQUIRED! Standard 80 Series works in any amplifier input (3 meg. or higher) not having magnetic cartridge equalization. 80M Series works into any magnetic cartridge input.

NO MODIFICATION NEEDED.



80 Series Turnover Pickup. Two independent cartridges in one! No interaction between styli.

Get the facts! See your E-V distributor or mail this coupon today.

Electro-Voice

Electro-Voice, Inc., Buchanan, Mich.

Please send Technical Specification Sheet N68

NAME _____

ADDRESS _____

CITY _____ STATE _____

ALLIED knight-kits

**FINEST ELECTRONIC EQUIPMENT
IN LOWEST-COST KIT FORM**

- ★ Latest Advanced Design
- ★ Quality Components
- ★ Easiest to Assemble
- ★ Save Up To 50%

BUY DIRECT...YOU SAVE MORE

Free 1956 CATALOG

Send for it! Describes the famous KNIGHT-KITS in detail—shows you how you can easily assemble your own instruments and get performance and appearance equal to equipment selling for several times the KNIGHT-KIT price. The 324-page ALLIED Catalog is the leading buying guide to *everything* in Electronics—write for your copy.



SAVE ON THESE QUALITY knight-kit TEST INSTRUMENTS

 5" Wide-Band Oscilloscope Kit F-144 69.00	 Printed Circuit VTVM Kit F-125 24.95	 Tube Tester Kit F-143 counter type 29.75 F-142 portable type 34.75	 VOM Kit 1000 Ohms/Volt F-128 15.95	 VOM Kit 20,000 Ohms/Volt F-140 28.50	 In-Circuit Capacitor Checker Kit F-119 11.65
 Audio Generator Kit F-137 31.50	 Resistance-Capacitance Tester Kit F-124 18.75	 High-Gain Signal Tracer Kit F-135 23.75	 RF Signal Generator Kit F-145 19.75	 Resistance Substitution Box Kit F-139 5.95	 Capacitance Substitution Box Kit F-138 5.50

FAMOUS knight-kits FOR THE HOBBYIST

 "Space Spanner" 2-Band Receiver Kit S-243 13.95 S-247 cabinet, 2.85	 "10-in-1" Lab Kit S-265 12.45	 "Ranger" Superhet Receiver Kit S-735 14.85
 "Ocean Hopper" Receiver Kit S-740 10.75	 Transistor Radio Kit S-765 3.95	 Geiger Counter Kit S-242 15.95
 3-Way Portable Radio Kit S-730 19.95	 Photoflash Kit S-244 28.50 S-246 AC supply, 3.40	 Wireless Broadcaster Kit S-705 8.75

TOP QUALITY HIGH FIDELITY knight-kits

 Basic 25-Watt Deluxe Amplifier Kit S-755 41.50	 10-Watt Hi-Fi Amplifier Kit S-234 22.95	 20-Watt Hi-Fi Amplifier Kit S-750 35.75
--	--	--

LOW-COST knight-kits FOR THE AMATEUR

 50-Watt CW Transmitter Kit S-255 42.50	 Self-Powered VFO Kit S-725 27.50	 Code Practice Oscillator Kit S-239 3.95
---	---	--

All Prices Net F.O.B. Chicago
ORDER FROM

ALLIED RADIO

100 N. Western Ave., Chicago 80, Ill.

August, 1956



Send for the 324-page ALLIED Catalog describing all KNIGHT-KITS—and your buying guide to everything in Electronics.

ALLIED RADIO CORP., Dept. 1-H-6
100 N. Western Ave., Chicago 80, Ill.

Please ship the following Knight-Kits: _____

My check , money order for \$..... enclosed.
 Please send FREE 1956 Catalog.

Name _____

Address _____

City _____ Zone _____ State _____



the fastest selling

ROTORS

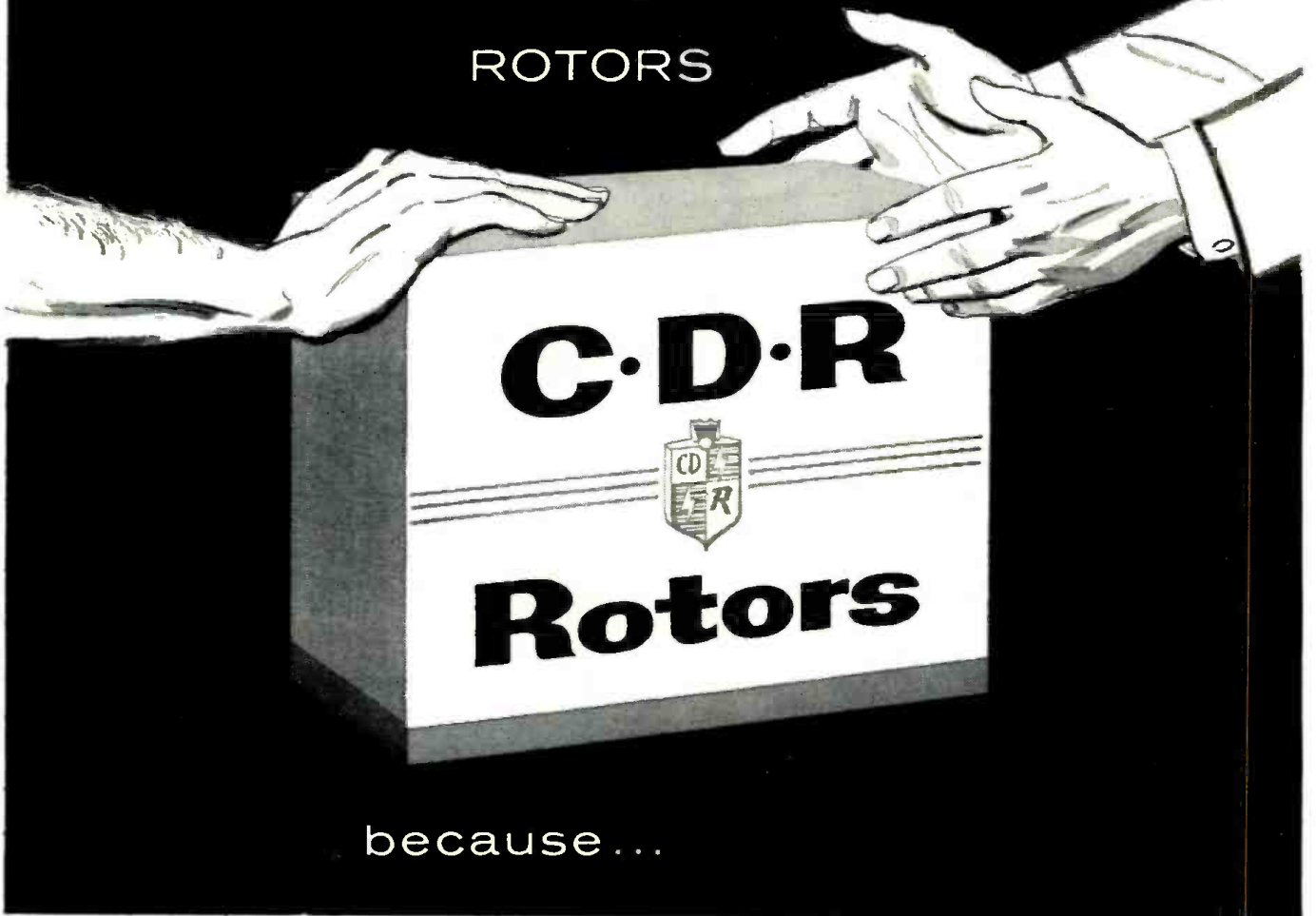

because...

- ✓ Pre-Sold to millions every week on TV
- ✓ The Most Complete Line... A Model for Every Need
- ✓ Superior Engineering... they're Tried-Tested-Proven

<p>AR-22</p>	<p>AR-1</p>	<p>AR-2</p>	<p>TR-2</p>	<p>TR-4</p>	<p>TR-12</p>	<p>TR-11</p>
<p>Completely AUTO-MATIC version of the TR-2 with all the powerful features that made it famous.</p>	<p>Completely AUTO-MATIC rotor, powerful and dependable. Modern design cabinet. 4 wire cable.</p>	<p>Completely AUTO-MATIC rotor with thrust bearing. Handsome cabinet, 4 wire cable.</p>	<p>Heavy-duty rotor with plastic cabinet, "compass control" illuminated perfect pattern dial, 8 wire cable.</p>	<p>Heavy-duty rotor, modern cabinet with METER control dial, 4 wire cable.</p>	<p>Combination value... complete rotor with thrust bearing. Modern cabinet with meter control dial, uses 4 wire cable.</p>	<p>Ideal budget all-purpose rotor, new modern cabinet featuring meter control dial, 4 wire cable.</p>



CORNELL-DUBILIER
SOUTH PLAINFIELD, N. J.



THE RADIART CORP.
CLEVELAND 13, OHIO



The data that Launched Thousands of Careers is yours *FREE*

Tells how you can be successful in **RADIO-TV-ELECTRONICS**

Send for Your Free Copy Today!

This is a brand new edition of the book which has launched thousands of men on good-paying careers in radio-tv-electronics.

It brings you completely up to date—answers important questions on newest career developments in electronics, including Radar, Guided Missiles, Servomechanisms, Computers, as well as Aeronautical Electronics, Broadcasting (AM, FM, TV), Military, Navy and CAA Electronics, Communications and Electronics Manufacturing.

This book, "Your Future in the New World of Electronics," also shows you how CREI Home Study leads the way to greater earnings in the booming electronics world.

However, CREI does not promise you a "snap." With an accredited technical school such as this you must study to convert your ambition into technical knowledge you can sell in the fabulous Electronics market.

Since its founding in 1927, CREI has provided thousands of professional electronics men with technical educations. During World War II, CREI trained thousands for the Armed Services. Leading firms choose CREI courses for group training in electronics, at company expense, among them United Air Lines, Canadian Broadcasting Corporation, Trans-Canada Airlines, Douglas Aircraft Co., Glenn L. Martin Co., Columbia Broadcasting System, All-American Cables and Radio, Inc., Gates Radio Co., Canadair Ltd., Federal Electric Corp., and U. S. Information Agency. CREI courses are prepared by recognized experts, in a practical, easily understood manner. You get the benefit of time-tested study assignments under the personal supervision of a CREI staff instructor. This is accomplished on your own time, during hours selected by you, and controlled by your own will power. This com-

plete training is the reason that graduates find their CREI diplomas key-to-success in radio, TV and Electronics. CREI alumni hold top positions in America's leading firms. At your service is the CREI Placement Bureau, which finds positions for advanced students and graduates. Although CREI does not guarantee jobs, requests for personnel far exceed current supply. Now is the time of decision for you. Luck will not

propel you forward unless it finds you trained. Contacts won't budge you an inch unless you have the skill to back them up. The answer is: Technical Training . . . and willingness to learn. Together they will bring you increased earnings in this new Age of Electronics. Fill out the coupon below and mail it now. We'll promptly send you your free copy of "Your Future in the New World of Electronics." The rest—your future—is up to you!



Industry Calls for CREI Training By Name . . .

SO SHOULD YOU

Here you see an actual help wanted ad from the *San Francisco Examiner*, April 1, 1956, one of many which specify "CREI or equal" training. This shows that industry approves CREI training, even insists on it.

FILL OUT AND MAIL TODAY—BEFORE YOU FORGET IT!

CAPITOL RADIO ENGINEERING INSTITUTE

Dept. 118-C, 3224 16th St., N.W., Washington 10, D. C.

Accredited Technical Institute Curricula

Please send me your course outline and FREE Illustrated Booklet "Your Future in the New World of Electronics" . . . describing opportunities and CREI home study courses in Practical Electronics Engineering.

- CHECK FIELD OF GREATEST INTEREST
- Practical Radio Electronics Engineering
 - Broadcast Radio Engineering (AM, FM, TV)
 - Practical Television Engineering
 - Practical Aeronautical Electronics Engineering

Name Age.....

Street

City..... Zone..... State.....

CHECK: Home Study Residence School Veteran

To help us answer your request intelligently, please give the following information:

EMPLOYED BY.....

TYPE OF PRESENT WORK.....

SCHOOL BACKGROUND.....

ELECTRONICS EXPERIENCE.....

IN WHAT BRANCH OF ELECTRONICS ARE YOU MOST INTERESTED?

TRANSISTORS—first family of electronics

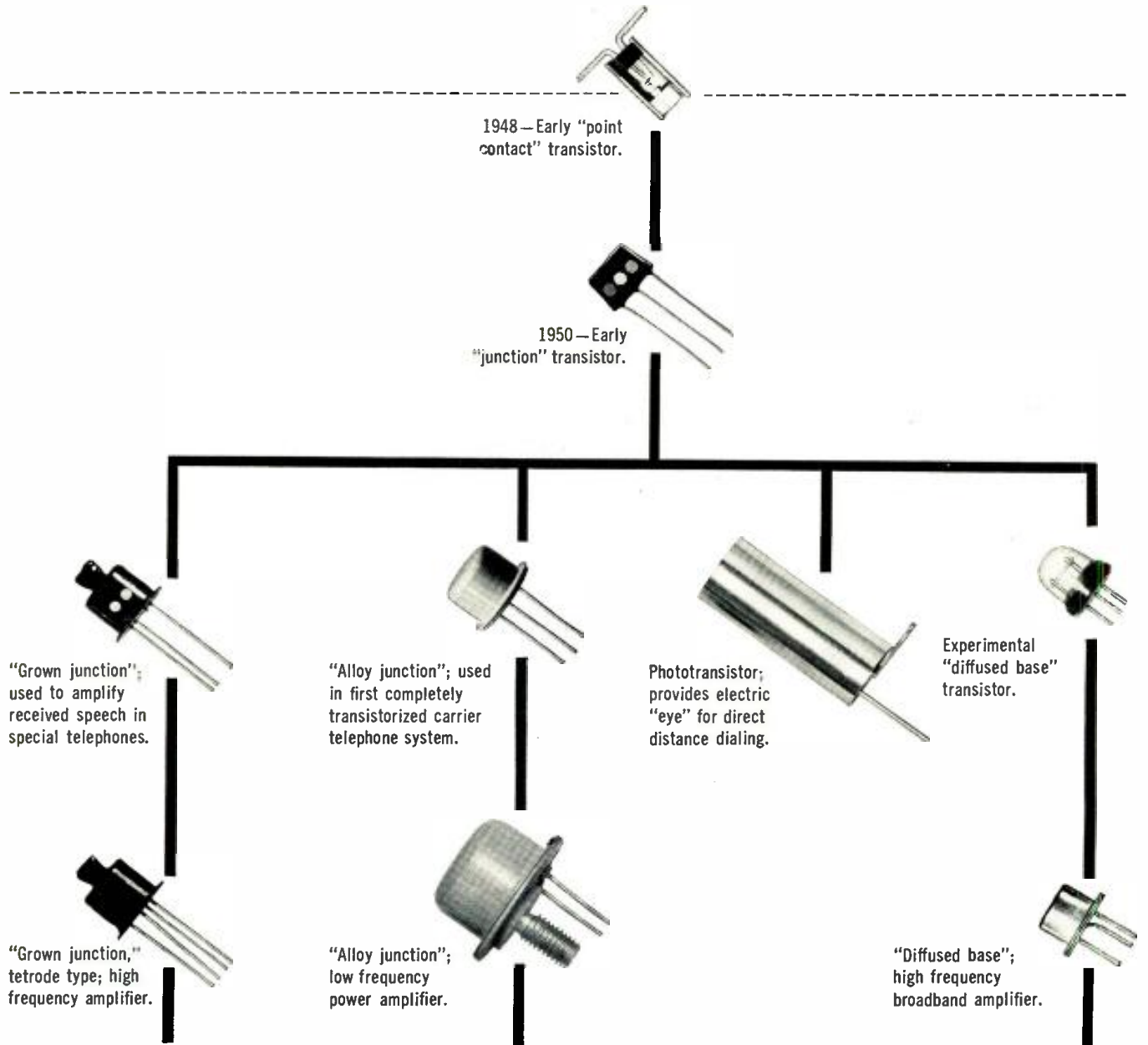

In 1948 Bell scientists announced their invention of the transistor—a tiny device able to amplify signals a hundred thousand times using a small fraction of the power of an electron tube.

From this original “point contact” transistor has grown a distinguished family of immense usefulness to electronics. Some of its leading

members are shown here, in approximate actual size, with their scientific type names.

For telephony the transistor has opened the way for notable advances in instruments, transmission and switching. Elsewhere it has opened the way to advances in hearing aids,

television, computers, portable radios and numerous military applications.

Bell’s transistor family is typical of the Bell Laboratories research that helps keep your telephone service the world’s best—and at the same time contributes importantly to other fields of technology.

BELL TELEPHONE LABORATORIES

WORLD CENTER OF COMMUNICATIONS RESEARCH AND DEVELOPMENT



RADIO & TELEVISION NEWS

DO IT YOURSELF!

BUILD AN AUTHENTIC

Electro-Voice

SPEAKER ENCLOSURE

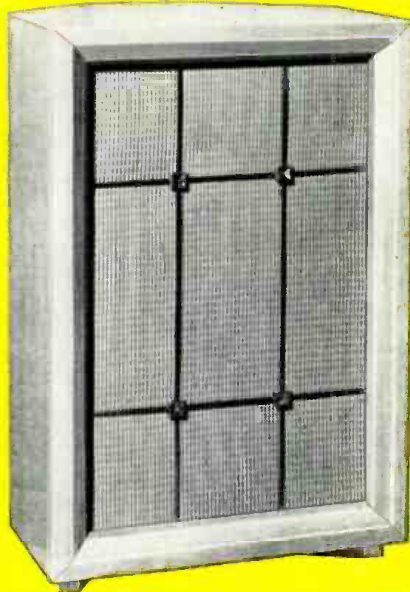
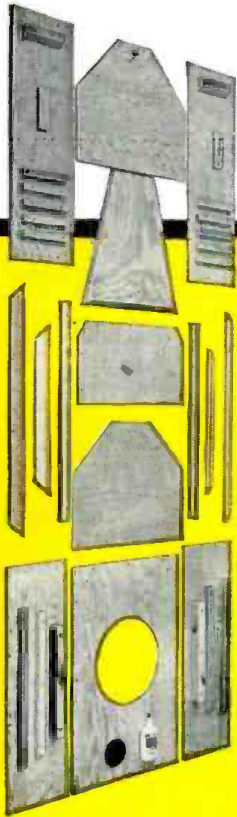

THE ARISTOCRAT KIT

ELECTRO-VOICE KD KITS let you build any of 7 authentic research-engineered Electro-Voice speaker housings at half the cost of comparable factory-built models.

Electro-Voice building block plan lets you expand from a single speaker to a multi-speaker high-fidelity system one economical step at a time.

TWO WAYS TO DO IT

Get the kit—pre-cut, shaped, drilled and marked parts and hardware plus illustrated, step-by-step instruction book.

Buy the book only, order supplies from your lumber dealer. Priced from 75c (the Baronet Kit) to \$1.50 (the Patrician Kit).

Electro-Voice Finishing kits add the professional touch to your enclosure. Walnut, mahogany, fruitwood, cherry, golden oak or ebony. Everything's included—even the brushes. \$5.

42"
36"
30"
24"
18"
12"
6"

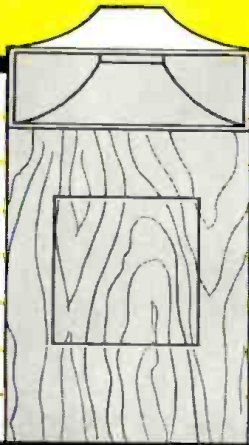

THE PATRICIAN IV KIT

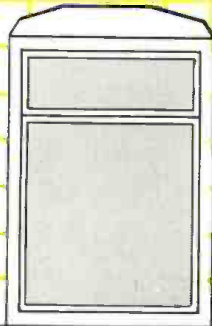

THE CENTURION KIT



THE GEORGIAN KIT

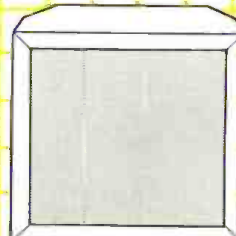

THE REGENCY KIT

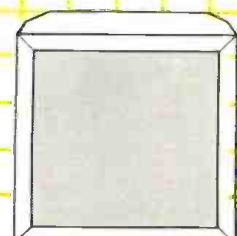

THE EMPIRE KIT



THE BARONET KIT

THE PATRICIAN IV KIT. The interior working horn assembly kit for those desiring the finest. This augmented design of the corner folded-horn bass section for 18-inch, 4-way speaker systems delivers widest bass response of any loudspeaker system. Designed for use with E-V Model 103C Patrician IV four-way driver components. For built-in installations or to be decorated as you choose. Finished size: 57½ in. high, 34½ in. wide, 26¼ in. deep. Shpg. wt. 150 lbs.

Model KD-1.....Net, \$118.00

THE GEORGIAN KIT. The interior working horn assembly kit that creates authentic indirect radiator type corner folded-horn bass section for 15 in. 4-way speaker system. Exceeded in range only by the Patrician IV. For use with deluxe E-V Model 105 or standard Model 117 package of 4-way driver components. For built-in installations or to be decorated as you choose. Finished size: 38½ in. high, 26¼ in. wide, 22½ in. deep. Shpg. wt. 88 lbs.

Model KD-2.....Net, \$65.00

THE CENTURION KIT. Four-way system folded-horn, corner enclosure. Uses exclusive E-V "W" type single-path indirect

radiator for propagation of extended bass. Sealed cavity behind 15 in. low-frequency driver cone prompts superlative transient response, subdues cone excursions, lowers distortion. For use with E-V Model 105 or Model 117 package of driver components. Finished size: 42¼ in. high, 29 in. wide, 22½ in. deep. Shpg. wt. 75 lbs.

Model KD-3.....Net, \$87.00

THE REGENCY KIT. Most popular low-boy style folded-horn enclosure that can be used in corner or flat against one wall. Improves the bass range and response of any 15-in. speaker. Makes an outstandingly efficient reproducer when used with E-V SP15 coaxial speaker, 15TRX triaxial reproducer or 114A 2-way or 114B 3-way system. Finished size: 29¼ in. high, 33½ in. wide, 19 in. deep. Shpg. wt. 70 lbs.

Model KD-4.....Net, \$73.00

THE EMPIRE KIT. Economical enclosure for use in a corner or flat against one wall. Designed for 15-in. speakers and separate 2- and 3-way systems. Particularly effective when used with SP15B coaxial speaker, 15TRXB triaxial reproducer, or 116

2-way or 116A 3-way system. Recommended components for Regency kit may also be employed. Finished size: 29¼ in. high, 32 in. wide, 16 in. deep. Shpg. wt. 45 lbs.

Model KD-5.....Net, \$51.00

THE ARISTOCRAT KIT. Folded-horn corner enclosure designed for 12-in. speakers and separate 2- and 3-way systems. For use with Electro-Voice SP12 or SP12B coaxial speakers, 12TRX or 12TRXB triaxial reproducers, and 108, 111 2-way and 108A, 111A 3-way systems. Smooth reproduction down to 35 cps, with remarkable purity and efficiency. Finished size: 29¼ in. high, 19 in. wide, 15¼ in. deep. Shpg. wt. 37 lbs.

Model KD-6.....Net, \$39.00

THE BARONET KIT. Phenomenal reproducer in very small size. This folded-horn corner enclosure is designed for use with E-V Model SP8B 8-in. Radax speaker. E-V T35 or T35B Super Sonax UHF driver can be added for a 3-way system. Finished size: 23 in. high, 14 in. wide, 13 in. deep. Shpg. wt. 24 lbs.

Model KD-7.....Net, \$26.00

Electro-Voice®

ELECTRO-VOICE, INC.
BUCHANAN, MICHIGAN

Send for Bulletin No. 211-N68. Folders describing Electro-Voice high-fidelity speakers, systems and components, amplifiers, tuners and cartridges available on request from your Electro-Voice distributor or write.

EXPORT: 13 EAST 40TH STREET, NEW YORK 16, U. S. A. CABLES: ARLAB

www.americanradiohistory.com

Master TV Systems by JERROLD

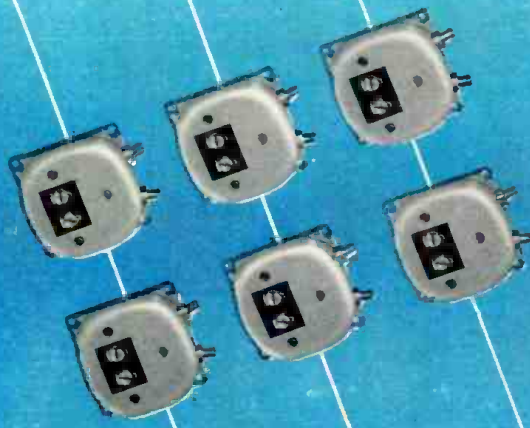

*World's Largest Manufacturer of
Amplified Master Television Equipment*

1. **Antenna-Top UHF CONVERTERS**—Convert any UHF channel to any VHF channel right at the antenna . . . avoid losses of long UHF lead-ins. Have voltage regulated oscillators and Teflon trimmers for drift-free performance.
2. **Lo-Noise PRE-AMPLIFIERS**—Mount at the antenna to amplify the signals, not the snow. Models for all-channel (2-13), low-band (2-6), or single-channel operation. Amazingly low noise level and high gain for perfect pictures where conventional "boosters" fail.
3. **Hi-Gain DISTRIBUTION AMPLIFIERS**—Sensitive, 5-tube cascode circuit distributes snow-free all-channel VHF signals to 5, 10, 20, or more receivers. Noise figure approaches theoretical minimum—only 6 db.
4. **Passive LINE SPLITTERS**—Simplify complicated building layouts. Divide amplifier output 2 or 4 ways to feed low-noise coax distribution lines in various wings. No tubes, cannot overload.
5. **Line Tap IMPEDANCE MATCHERS**—Quick, easy way to connect TV sets to distribution lines. Match 300 ohm receivers to coax line, suppress interaction between sets, compensate for line response tilt.

PLUS Powerful sales aids to help you sell, install, and service any Jerrold system more profitably.

See your nearest Electronic Parts Distributor or write direct to:

**JERROLD
ELECTRONICS
CORP.**

JERROLD

23rd & Chestnut Streets, Philadelphia 3, Pa.

In Canada: Jerrold Electronics (Canada) Ltd., 50 Wingold Ave., Toronto 10, Ont.

Note the space-saving compact design of this 150 volt DC 5 amperes Sola power supply far computer circuits. Panel height is only 7".

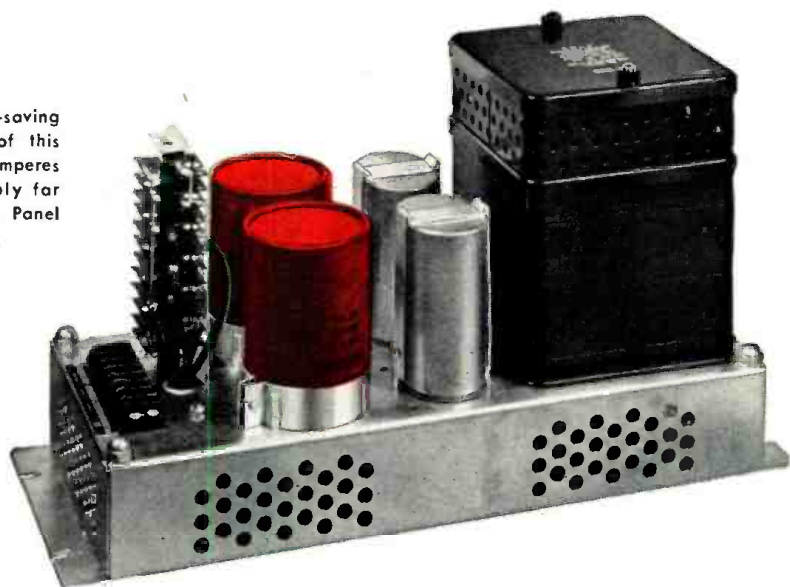

SO LA

chooses Sangamo Capacitors for Germanium Power Supplies

Space-saving compactness and light weight... features assured by the exacting demands of Sola engineers... are among the many advantages of Sola Constant Voltage DC Power Supplies for intermittent, variable, pulse or high current loads. That's why they specify Sangamo Type DCM Electrolytic Capacitors for the high-capacitance filter section of these power supplies.

Besides contributing to the space-saving, weight-reducing design of the "Sola CV DC," Sangamo Capacitors minimize ripple voltage and insure steady, stable DC voltage. No further need for heavy, bulky choke components with their substantial and often-varying load voltage drops.

Just as Sangamo Capacitors meet the exacting specifications of Sola design engineers, they can meet yours... no matter how demanding—regardless of how specialized.

Sangamo DCM Electrolytic Capacitors provide excellent capacity stability with long life... exceptionally low equivalent series resistance... extremely high capacity for case size in low voltage ranges. Special design permits high ripple current without overheating. Can be supplied in maximum energy content rating of 80-watt seconds with maximum voltage rating of 450 VDC. Maximum capacity value of 33,000 mfd. can be supplied at 15 WVDC.



The Sangamo DCM Electrolytic Capacitor is housed in a seamless, drawn aluminum container with gasket-sealed molded alkyd resin base thermosetting plastic cover. Detail of cover construction insures minimum contact resistance in current carrying members and provides an adequate safety vent in case of heavy overload.

SANGAMO ELECTRIC COMPANY
CAPACITOR DIVISION • SPRINGFIELD, ILLINOIS

ATTENTION MEN 17 to 55

HERE'S A NEW OPPORTUNITY FOR YOU!



PREPARE AT HOME FOR A PROFITABLE CAREER IN

AUTOMATION ELECTRONICS

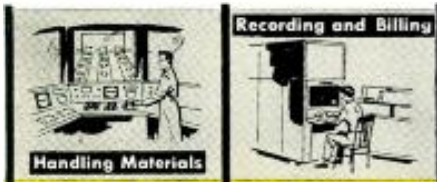

Get in on the Ground Floor of this Fast-Moving Field

Get the right training, and you'll "get places" —with opportunity for money, security and advancement—in Automation Electronics. Automation is already established in many plants. More factories and offices are adding electronic equipment right along. Who's to install, operate and maintain it? You — with the correct training!

HOME MOVIES PRAISED

"The Congressional Record" records how DTI was praised in Congress for its method of training thousands of men for careers in Television—Radio—Electronics by using movies, experiments, and other valuable aids—a method we've successfully followed for the past 25 years. And now for Automation Electronics, too, you train at home in spare time, or at our big laboratories in Chicago, among America's finest. No previous technical experience or advanced education required.

MILITARY SERVICE—If you are subject to Military Service, we have valuable information for you.

A REAL EMPLOYMENT SERVICE! We help you get started when your training is completed.

GET FREE BOOKLET!

MAIL COUPON TODAY!

DeVry Technical Institute, Dept. RN-BA-M
4141 Belmont Ave., Chicago 41, Ill.
Please give me information about Automation Electronics, and how you may help me.

Name _____ Age _____
PLEASE PRINT

Street _____ Apt. _____

City _____ Zone _____ State _____

1042A DTI's training is also available in Canada

DeVRY TECHNICAL INSTITUTE
Formerly DeForest's Training, Inc.
Chicago 41, Illinois

(Member National Home Study Council)



Spot Radio News

* Presenting latest information on the Radio Industry.

By RADIO & TELEVISION NEWS' WASHINGTON EDITOR

THE TWO-YEAR ALLOCATION turmoil will, it appears at this writing, soon be over. The Commission has developed a program that it feels will eventually resolve the channel puzzle.

The key to the solution, FCC spokesmen said, lies in a changeover of part or perhaps all of the country to the ultra-highs, as soon as all of the propagation and equipment problems are solved; and that prospect is not too distant. Most of the Commissioners feel that if industry knows that this thinking represents the positive views of officialdom, concerted action towards speedy u.h.f. receiving and transmitting equipment improvements will result. The performance goal should be, Washington feels, more reliability and gain at both transmission and reception points, to match that now available from the very-highs.

A \$500,000 RADOME TEST range that will provide the Air Force with a central location where they can study the effects of radomes on aircraft radar performance is nearing completion at the Air Research and Development's Wright Air Development Center.

The most complete facility in the country, the range will assist the WADC electronic components lab in solving problems in transmission-reflection, beam-pattern distortion and bore sight error.

The test range will consist of three different and independent units, the last to be completed by late summer. Each unit will hold a radome on a

mount, tilting and rotating it around a radar test antenna. This will permit the microwaves to pass through all portions of the radome. The new facility will thus enable the Air Force to study all types of airborne radome design.

The transmission-reflection unit will be used to determine the percentage of microwave energy transmitted for effective use and the percentage reflected because of the radome. In this test, a microwave beam is transmitted through the moving radome to a fixed receiving antenna fifty feet away. The amount of energy reaching the receiving antenna is then compared with the amount that reaches the antenna when no radome is used. Also, the amount of energy reflected by the radome is recorded. This test shows which portions of the radome permit maximum transmission and which portions must be modified to improve transmission.

Beam pattern distortion, experienced by search, navigation, and bombing radar systems, will be studied by the second unit. In this study microwaves are transmitted 1900 feet across a shadow valley to a test tower where the radome is mounted over a receiving antenna. As the waves pass through the moving radome, their beam pattern is recorded by the receiving antenna which moves in unison with the radome. This test enables distortions in the beam pattern (which ideally is shaped like a giant tear drop) to be pin-pointed and studied,

NEW TV GRANTS SINCE FREEZE LIFT

Continuing the listing of construction permits granted by FCC since lifting of freeze. Additional stations will be carried next month.

STATE	CITY	CALL	CHANNEL	FREQUENCY	POWER*
Arizona	Flagstaff	_____	9	186-192	.35
North Dakota	Dickinson	KDIX-TV	2	84-60	25.88
Puerto Rico	Ponce	_____	9	186-192	832 w.
Texas	San Antonio	_____	12	204-210	316

NEW CALL LETTER ASSIGNMENTS

Idaho	Pocatello	KSEI-TV	6	82-88
Puerto Rico	Caguas	WKBM-TV	11	198-204

CALL LETTER CHANGES

Hawaii	Honolulu	KTCA (formerly KULA-TV)	4	66-72
--------	----------	-------------------------	---	-------

*ERP=(effective radiated power, kw.)

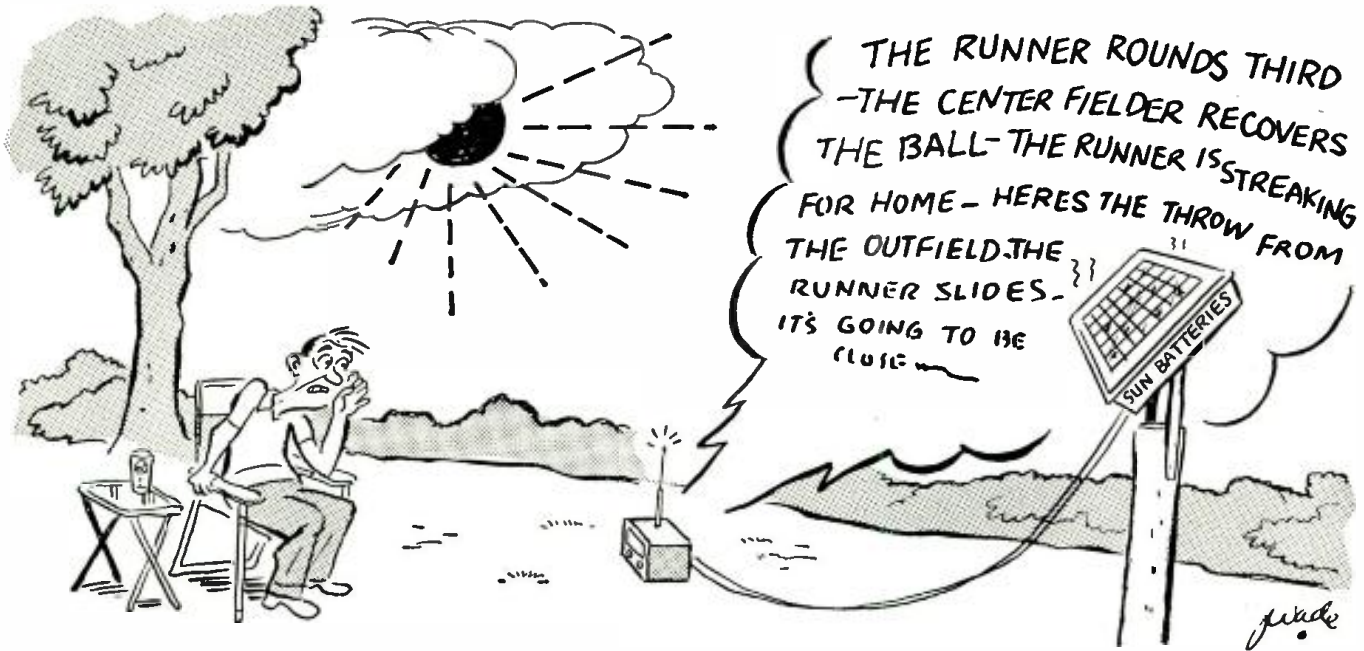

NEW SENSATIONAL

Whatever your transmitter needs may be, there's a Johnson Viking to fill the bill. You already know about the unsurpassed quality and the outstanding performance of the Viking II, Ranger, Adventurer, and the Kilowatt. The four NEW transmitters allow us to offer the most complete line of transmitters ever made available to the amateur. Walter Ashe makes it easy for you to be a proud owner of a new Viking by making one of his famous "Surprise" trade-in offers on your used (factory-built) communications gear. Some of the new Viking transmitters will not be available immediately, so don't wait and be disappointed. Be at the top of the list for early delivery by getting your trade-in deal working today. Wire, write, phone, or use the handy coupon.

Delivery dates indicated are factory estimates and are subject to revision.

JOHNSON Vikings



"6N2"



Bandswitching transmitter for 6 and 2 meters. 150 watts input on CW, 100 AM. Used with crystal or external VFO. Derives power from Viking I, Viking II, or similar power supply-modulator combinations. Complete kit w/tubes. (Available late August.) Net \$99.50
Wired and tested..... 129.50



"FIVE HUNDRED"

600 watts input CW, 500 AM, 500 SSB P.E.P. (with SSB exciter). Built-in VFO. 80 thru 10 meters. Complete kit w/tubes. (Available late September.) Net..\$ 649.50
Wired and tested..... 799.50
Subject to price revision at time of delivery.

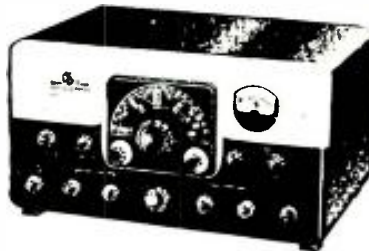

"PACEMAKER"

SSB transmitter-exciter. 90 watts input SSB, CW, 35 AM. Upper and lower sideband selection. Built-in VFO. 80 thru 10 meters. With tubes. (Available from our stock.) Wired, tested only. Net \$ 495.00

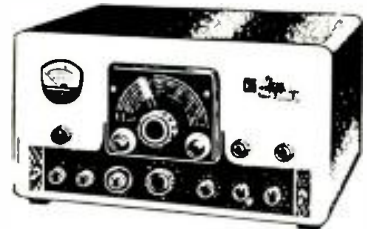

"VALIANT"

275 watts input CW, SSB (with SSB exciter), 200 AM. Built-in VFO. 160 thru 10 meters. Complete kit w/tubes. (Available late August). Net.....\$ 349.50
Wired and tested..... 439.50

All prices f. o. b. St. Louis • Phone Chestnut 1-1125

WRITE FOR FULL INFORMATION ABOUT OUR TIME PAYMENT PLAN

Walter Ashe
RADIO CO.
1125 PINE ST. • ST. LOUIS 1, MO.
Our 34th Year

RN-8-56

WALTER ASHE RADIO COMPANY
1125 Pine Street, St. Louis, Mo.

Rush "Surprise" Trade-In Offer on my.....
for.....
(show make and model of new equipment desired)

Rush FREE 1956 Walter Ashe catalog.

Name.....
Address.....
City..... Zone..... State.....

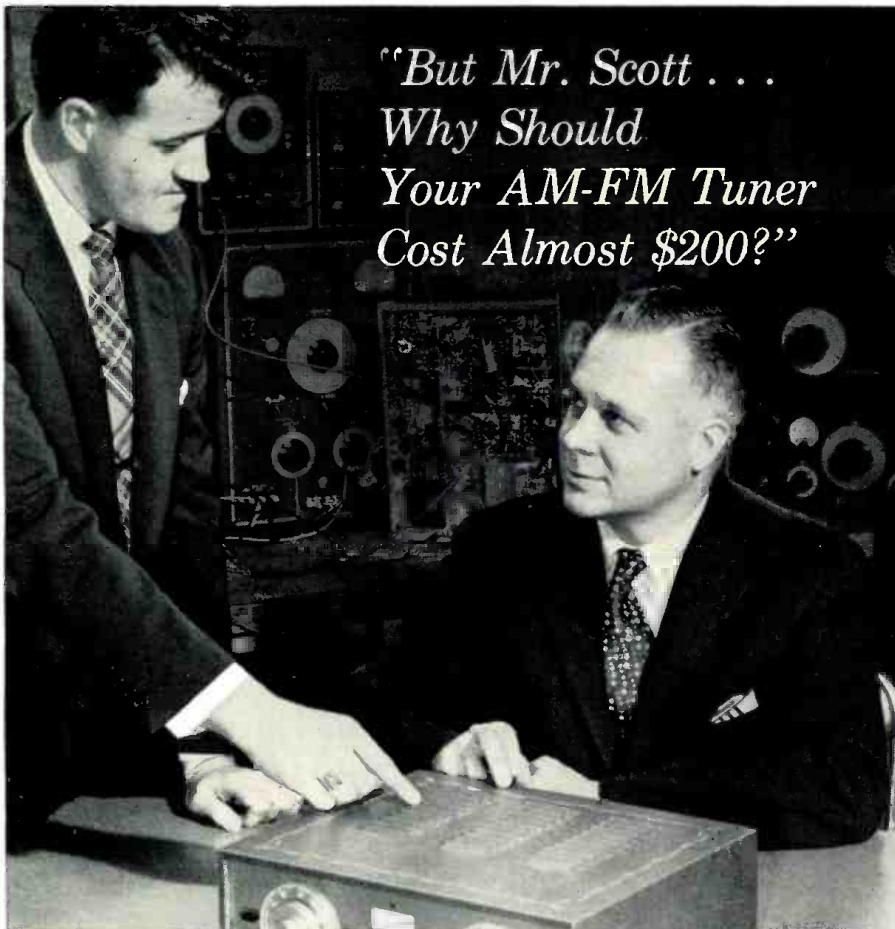

A discussion with Hermon Hosmer Scott in the H. H. Scott acoustic instrumentation laboratories.

*"But Mr. Scott . . .
Why Should
Your AM-FM Tuner
Cost Almost \$200?"*

"At this price you get advanced technical features found only in the H. H. Scott Model 330.

"Actually, the 330 is only slightly more expensive than ordinary tuners, yet it's engineered so far ahead of its time that it will keep up to date long after conventional tuners have become obsolete.

"For example, the 330 has a unique AM circuit designed to meet the growing trend to better AM broadcasting. Now you can hear audio frequencies beyond 10 kc., far above what has heretofore been practical. With Scott's new detector design, there's no distortion even on the extreme high frequencies. Another exceptional feature is the 3-position AM selector switch for optimum AM reception under any signal condition.

"The FM section features new 2-megacycle wide-band circuitry. This innovation insures completely drift-free reception and virtually eliminates co-channel interference. This tuner is so selective you can separate stations so close together conventional tuners would pass them by. The 330 is so sensitive (3 microvolts) you find stations you never knew were there.

"The 330 also has completely separate AM and FM sections for increasingly popular stereo (binaural) operation. Any tuner not equipped for stereo will shortly become obsolete.

"Enthusiastic owners consider the 330 the most advanced tuner ever developed. At \$199.95* it is an outstanding value."

* West coast price slightly higher.

ADDITIONAL TECHNICAL SPECIFICATIONS

FM Section: 3 uv. sensitivity for 20 db quieting — automatic gain control assures optimum adjustment under all signal conditions. AM Section: 1 uv. sensitivity — 10 kc whistle filter — beautiful accessory case \$9.95*. Dimensions in case: 15 1/4" x 4 3/4" x 12 1/2".

FREE! New H. H. Scott Hi-Fi Guide and Catalog. Just off the press. Write for booklet R-8



and permits modification of future radome design to reduce distortion.

The third unit will be used to study bore sight (directional) error; a problem in streamlined radomes for armament fire control and missile guidance systems. In this test, a narrow pencil beam of microwave energy is transmitted through the moving radome to a tracking target antenna that is forty feet distant. As the beam passes through the radome, it is deflected, much as light rays are deflected when passed through curved glass. The target antenna then seeks out the point to which the beam has been deflected. The movement of this antenna serves to chart the magnitude, direction, and rate of change of the deflection; as a result future radome designers will know what direction to take to reduce deflection.

THE LARGEST REMOTELY CONTROLLED planes in history, known as QB-17's, actually the famous World War II Boeing B-17's, are now performing an invaluable service as guided missiles down at the Air Force missile test center in Florida.

First used by the Air Force in the late thirties, the now obsolete "Flying Fortresses" have been equipped to fly pilotless missions in support of the missile programs.

Filling the need for a large, bomber-type aircraft that can carry bulky equipment and instruments capable of recording explosion and shock stress and destruction potential, these old-timers now perform flying missions that would be extremely hazardous to human life.

Completely radio-controlled from the ground or another aircraft, the planes are able to maneuver in evasive action, making them ideal targets for ground-to-air and air-to-air missiles.

As used in typical missions at the test center, the radio-controlled planes (also known as drones) are piloted from nearby Patrick Air Force Base to the launch site at Cape Canaveral. The engines are left running and the ground crew mans the radio controls.

Signals from the ground activate the control and the QB-17 becomes airborne. When the drone is far out to sea, a missile is launched on a course leading to the bomber. A camera in the nose of the drone relays the action to the ground crew via a special television channel, and additional equipment record the data.

The missiles used in these tests are armed with small explosive charges instead of regular warheads, but the charges are enough to cripple the drone. As the QB-17 plummets seaward, the cameras and recording gear are parachuted slowly to the water in floatable wing pods, where they are retrieved by swift crash boats.

If the missile fails to find its mark or only simulates a hit, the drone is brought back by radio controls.

A HISTORIC report on the unusual TV setups employed at the Winter
(Continued on page 88)

RADIO & TELEVISION NEWS

As Garry Moore tells over five million women on the CBS Television Network...

**"A TV network
can't afford
to take chances
on tube quality"**

"CBS tubes are made by the tube manufacturing division of Columbia Broadcasting System. So we *know* how dependable they are. That's why we use them here in our own cameras and other equipment."

Garry also points out that CBS tubes have the Good Housekeeping Guaranty Seal. That means a lot to women . . . and women are your customers.

In fact, if you're like most service technicians, more and more women are asking you for CBS tubes. Because Garry Moore has convinced them that there are no better tubes made. Yes, you'll find it's easy to build customer satisfaction when you use and recommend the tubes you can always depend upon . . . CBS tubes.

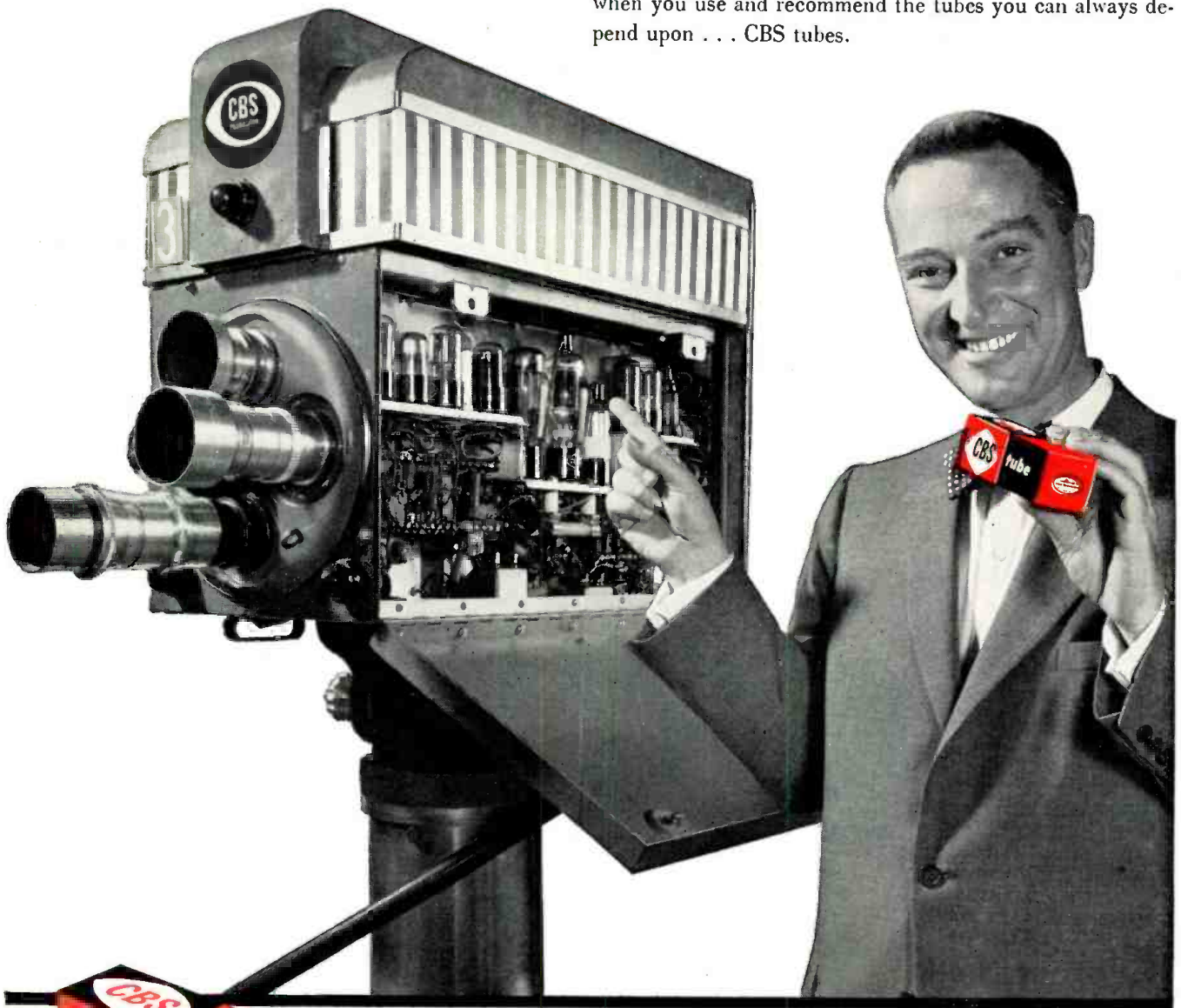

Garry Moore sells you and your expert service, too. Have you seen him?

CBS-HYTRON, Danvers, Massachusetts
A Division of Columbia Broadcasting System, Inc.

OH! MISTER...
WONDERFUL!

new, exciting

WARD
Silveramic
®

**CHROME
FIBERGLAS**



AUTO AERIAL

THE MOST AMAZING NEW DEVELOPMENT IN THE AUTO AERIAL INDUSTRY

WARD again leads the way with another new product. A Fiberglas auto aerial with a chrome finish — LOOKS like chrome, FEELS like chrome, SOUNDS like chrome and has all the revolutionary characteristics of fiberglas. Proved resistant to chemicals and water.

This finish is not a surface paint, but an exclusive method developed only by Ward.

SILVERAMIC PASSED THESE THREE SEVERE TESTS:

1. 30 DAYS EXPOSURE to sea water, gasoline, acids, alkalis, toluene and ethyl alcohol.
2. 3000 HOURS of salt spray at 98° F. This is equivalent to over 20 YEARS OF DRIVING.
3. IMPACT RESISTANT to 160 inch-pounds.

Model TGF-1 CHROME

38" long—54" lead cable. Famous "8-Ball" mounting. Individual shipping weight: 1 lb. List price—\$5.95.

also—Dura-ramic IN FULL COLOR!

Six complementary colors to mix or match—with the same flexible, indestructible fiberglas features.

YELLOW • RED • BLUE • GREEN • BROWN • WHITE

WARD

**PRODUCTS CORPORATION
DIVISION OF THE GABRIEL CO.**

1148 EUCLID AVE. • CLEVELAND 15, OHIO

Electronics Boom Seen

Need For Television Technicians To Rise

Industry Warned About Shortage Of Trained Men

TV SALES SET NEW RECORD

Sylvania Head Expects Huge Electronic Gains

Transistor Radios Developed

RCA HEAD PREDICTS SALES BOOM FOR COLOR TV SETS

VETERANS - - NON-VETERANS

Get Into The Field That's Making Headlines



L. C. Lane, B.S., M.A.
President, Radio-Television Training Association,
Executive Director, Pierce School of Radio & Television.

All over the nation the Television-Radio-Electronics industry is making News — News that means opportunity for YOU. You can cash in on the headlines. **I WILL TRAIN YOU AT HOME FOR A TOP-PAY JOB IN TELEVISION**

I will prepare you for a spot in America's fastest-growing industry. You can become a trained technician in your spare time without giving up your present job or social life. No experience needed.

LEARN BY DOING

As part of your training I give you the equipment you need to set up your own home laboratory and prepare for a top-pay job or set up your own business. You build and keep an Electromagnetic TV RECEIVER designed and engineered to take any size picture tube up to 21-inch. (10-inch tube furnished. Slight extra cost for larger sizes.) . . . also a Super-Het Radio Receiver, AF-RF Signal Generator, Combination Voltmeter-Ammeter-Ohmmeter, C-W Telephone Transmitter, Public Address System, AC-DC Power Supply. Everything supplied, including all tubes.



STUDY NEWEST DEVELOPMENTS

My training covers all the latest developments in the fast-growing Television-Radio-Electronics industry. You learn about FM — RADAR — COLOR TV — TRANSISTORS — PRINTED CIRCUITS, etc.

CHOOSE FROM THREE COMPLETE COURSES covering all phases of Radio, FM and TV

1. Radio, FM and Television Technician Course — no previous experience needed.
2. FM-TV Technician Course — previous training or experience in radio required.
3. TV Cameraman and Studio Technician Course — advanced training for men with Radio or TV training or experience.

EXTRA TRAINING IN NEW YORK CITY AT NO EXTRA COST!

After you finish your home study training in Course 1 or 2 you can have two weeks, 50 hours, of intensive Lab work on modern electronic equipment at our associate resident school, Pierce School of Radio & Television. THIS EXTRA TRAINING IS YOURS AT NO EXTRA COST WHATSOEVER!

FCC COACHING COURSE

Important for BETTER-PAY JOBS requiring FCC License! You get this training AT NO EXTRA COST! Top TV jobs go to FCC-licensed technicians.

VETERANS

My School fully approved to train Veterans under new Korean G. I. Bill. Don't lose your school benefits by waiting too long. Write discharge date on coupon.

EARN WHILE YOU LEARN

Almost from the very start of your course you can earn extra money by repairing sets for friends and neighbors. Many of my students earn up to \$25 a week . . . pay for their entire training with spare time earnings . . . start their own profitable service business.

FREE I'll send you my new 40-page book, "How to Make Money in Television-Radio-Electronics," a **FREE** sample lesson, and other literature showing how and where you can get a top-pay job in Television.

MAIL THIS COUPON TODAY!

Mr. Leonard C. Lane, President
RTTA
Dept. T-8C, 52 East 19th Street, New York 3, N. Y.

Dear Mr. Lane: Send me your NEW FREE BOOK, FREE SAMPLE LESSON, and FREE aids that will show me how I can make TOP MONEY IN TELEVISION. I understand I am under no obligation.

(PLEASE PRINT PLAINLY)

Name _____ Age _____

Address _____

City _____ Zone _____ State _____

I AM INTERESTED IN:

Radio-FM-TV Technician Course

FM-TV Technician Course

TV Cameraman & Studio Technician Course

VETERANS!
Write discharge date

Radio-Television Training Association

52 EAST 19th STREET • NEW YORK 3, N. Y.

Licensed by the State of New York • Approved for Veteran Training

NO OBLIGATION!

John Winegard says:

**30,000,000 TV antennas
can be replaced in the next 5 years.
8,000,000 worn out or antiquated antennas
are spoiling TV reception now when
Republican and Democratic conventions
are the greatest drawing cards of all TV history.**

At WINEGARD we are quadrupling our manufacturing capacity because we absolutely believe that our new Color'ceptor, Color Beam and Minute Mount are the antennas that will create a new standard of TV reception and make good color reception a reality for everybody.

Let me tell you about these new antennas:



The Color'ceptor is the first high gain, fringe area antenna particularly engineered for color reception. Based on world-famous WINEGARD Interceptor design, the Color'ceptor (18 elements) with "Power-Pack" has up to 47% more gain than the Interceptor and the highest front-to-back ratio of any single-bay, all-channel antenna in the industry.

The two Color Beams are the world's first fully assembled and boxed complete antenna installations. Mast, lead-in, insulators, mounts, clothespin on lead-in clip are all assembled (in box). Not a kit. Foolproof to install, the Color Beam can even be sold like an appliance for Do-It-Yourself customers. The Color Beam is intended for 50-mile reception radius. The DeLuxe Color Beam has an average reception radius of 100 miles and is equipped with the "Jigger Mount," the only universal mount for all types of roofs and buildings.

A brand new approach, the Minute-Mount is a completely factory-assembled tripod tower with high-gain antenna for extremely rugged fringe area service—particularly suited for terrain with high winds. The complete package consists of 10-foot non-corrosive all aluminum fold-out assembly mast with high gain antenna incorporating the patented WINEGARD Electro-Lens focusing, attached high-quality lead-in, 7 insulators (3' attached on mount), lightning arrester, ground-wire and ground-rod.

We design every WINEGARD ANTENNA to make you, Servicemen of America, more money, more easily, with more satisfied customers. Ask any leading Electronic Parts Distributor for complete information or write me.

John R. Winegard

**FAMOUS WINEGARD ANTENNAS FOR ONE-MAN SEVEN-MINUTE
INSTALLATION FOR BLACK AND WHITE OR COLOR.**



WINEGARD COMPANY
Burlington, Iowa

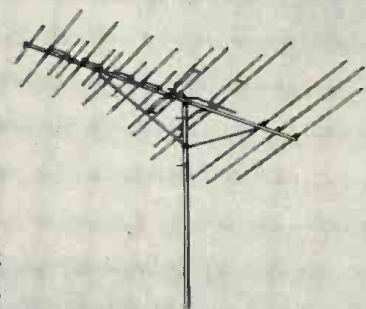

COLOR CEPTOR CL-4X \$39.95

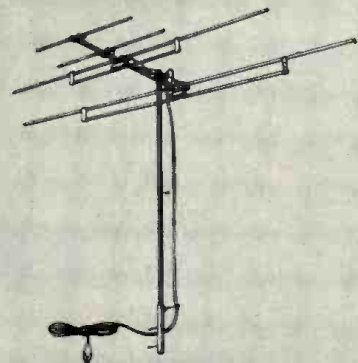

COLOR BEAM TCB-300 (STANDARD) \$14.95

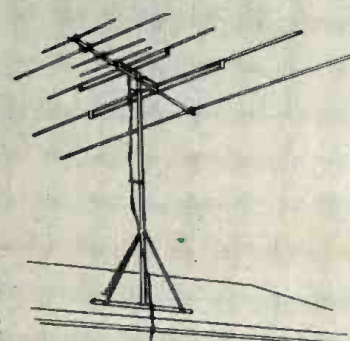

COLOR BEAM TCB-310 (DELUXE) \$29.95

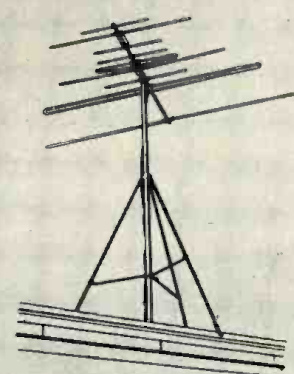

MINUTE-MOUNT M-1 \$37.50 LIST

RADIO & TELEVISION NEWS

BURTON BROWNE ADVERTISING

YOU PUT THIS TUBE IN AND...
 YAP... YAP... YAP... BLAH... BLAH... BLAH
 ... AND I MISSED MY FAVORITE PROGRAM



... IT'S **YOUR** REPUTATION!

Serviceman, at this point you are on your own! Your customer holds only you responsible if the picture tube goes bad because it was your selection. If your selection for replacement was a high quality brand, chances are your reputation for quality work wouldn't be under the gun like this.

When you use Du Mont picture tubes your reputation is backed by the pioneer commercial cathode-ray tube manufacturer of the country. The Twin-Screen Hi-Lite* alumi-

nized picture tube is a product of the finest engineering, design, and production features assembled in 25 years of commercial manufacturing. Your confidence is definitely assured because you know that the guarantee on Du Mont picture tubes is good—as it has always been.

Your reputation for high quality work is established when you use high quality products. You have a reliable partner when you use Du Mont picture tubes.

*The ultimate in aluminized picture tubes

IT'S DEALERS CHOICE

make it...

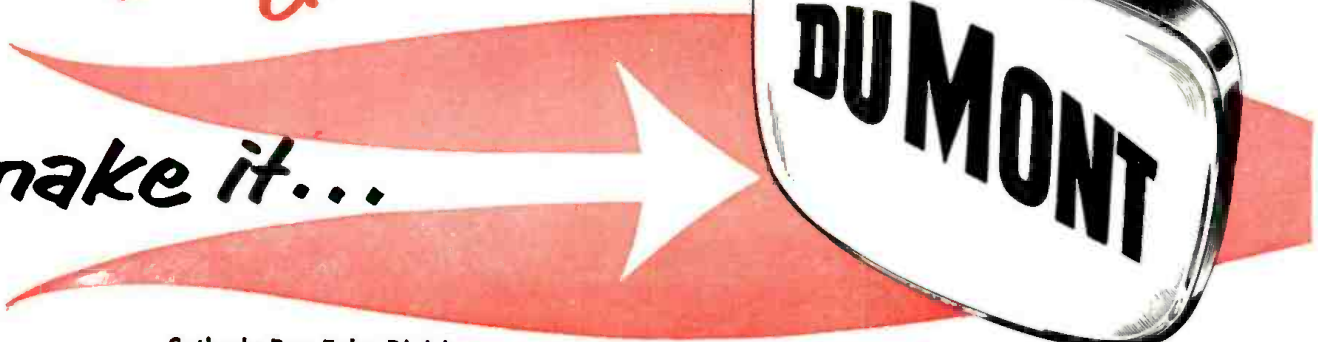

Cathode-Ray Tube Division

ALLEN B. DU MONT LABORATORIES, Inc., 750 Bloomfield Avenue, Clifton, N. J.

Within the Industry

HAROLD S. RENNE has resigned his post as technical editor of **RADIO & TELEVISION NEWS** and **POPULAR ELECTRONICS** to join **Bell Telephone Laboratories** as Technical Information Supervisor.



In his new post, Mr. Renne will serve the technical and trade press, providing information on the *Laboratories'* research and development activities. He was graduated from Kalamazoo College with a B.A. in physics in 1934 and took his M.S. degree in physics at Syracuse University in 1938. Following graduation he was employed by *Underwriters' Laboratories* in Chicago and in 1942 he joined the Illinois Institute of Technology as an instructor and supervisor in the pre-radar program, becoming a physics instructor on the regular staff in 1943.

He joined the *Ziff-Davis Publishing Company* electronics group early in 1944.

Mr. Renne is active in the Institute of Radio Engineers and is currently vice-chairman of the New York Section and has been nominated for the post of chairman for the coming year. He is a member of AIEE, an associate member of Sigma Xi, and a member of Sigma Pi Sigma.

DAYSTROM, INC. has established an export sales organization which will handle the products of all of the firm's electronic companies. The **DAYSTROM INTERNATIONAL DIVISION** will be located temporarily in Newark, N.J. under the managership of William H. Westphal . . . **AIRBORNE INSTRUMENT LABORATORY, INC.** and **COMPAGNIE GENERALE DE TELEGRAPHIE SANS FIL** of Paris, France have announced the formation of an American firm which will manufacture and market electronic products developed in France. The new company, **INTERCONTINENTAL ELECTRONICS CORPORATION**, has established headquarters at 1551 Franklin Avenue in Garden City, Long Island, N.Y. . . . **BURR-BROWN RESEARCH CORPORATION** has been established at Cold Spring Harbor, New York and will specialize in the design, development, and manufacture of transistorized electronic circuits and equipment. A second office will be maintained at Tucson. R. Page Burr and Thomas R. Brown, Jr. are principals in this new firm . . . **DYNAMICS CORPORATION OF AMERICA** has acquired **ELDICO CORPORATION** of Mineola, New York and will operate the firm as a wholly-owned subsidiary . . . **PENTRON CORPORATION**

of Chicago has merged with **ACE INDUSTRIES** of that city as part of a program designed to expand the tape recorder manufacturer's completely vertical operation . . . Sales and distribution of the "Klipzon" line of servicing aids has been acquired by **GENERAL CEMENT MFG. CO.** of Rockford, Illinois from **UNITED TECHNICAL LABORATORIES** of Morristown, N.J. . . . Acquisition of **LOU-BAR PRODUCTS**, manufacturer of precision components for automatic control systems, has been announced by **BECKMAN INSTRUMENTS, INC.** The subsidiary's plant in Santa Monica will remain in operation.

CHARLES W. HOSTERMAN has been named general manager of the electronics division of *Sylvania Electric Products Inc.*



Assistant general manager of the division since 1954, Mr. Hosterman will continue to maintain his office at the electronic division's headquarters, Woburn, Massachusetts.

He joined the firm in 1943 and served in supervisory personnel capacities at various plant locations until 1947 when he was appointed manufacturing superintendent at the radio tube plant in Huntington, West Virginia. In 1950 he became manager of the tube division's plant in Shawnee, Oklahoma, and four years later moved to the electronics division in Woburn.

CBS-HYTRON has expanded its facilities at 4722 West Jefferson Blvd. in Los Angeles and is now offering complete sales and service to its distributors and equipment customers in the West Coast area . . . **TRIO LABORATORIES, INC.** has moved its plant and offices to new and larger quarters at 4025 Merrick Road, Seaford, Long Island, New York . . . The cornerstone has been laid by **MINNESOTA MINING & MANUFACTURING CO.** of St. Paul, Minnesota for a new electrical products research laboratory . . . **GENERAL ELECTRIC COMPANY** is establishing a new electronics plant in the St. Petersburg-Clearwater area of Florida. Employing between 600 to 700 men and women, the new plant will be in operation by December 30th of this year . . . **BURROUGHS CORPORATION** has opened two new laboratories in suburban Philadelphia. The new buildings will increase by 84,000 square feet the work space available to the corporation's research activity . . . **MAGNETIC AMPLIFIERS, INC.**, New York, N.Y. has opened a West Coast division at 136

How many of these NEW RIDER BOOKS do YOU have ... ?



HI-FI LOUDSPEAKERS & ENCLOSURES

by Abraham B. Cohen

A long-needed book, destined to become a classic volume in hi-fi literature. Completely covers the subject. Answers all your questions about loudspeakers and enclosures, design, cross-over networks, construction of own networks, etc. Leather Finish MARCO Cover, 5½ x 8½", illus. #176 . . . Only \$4.60 #176-H, Cloth Bound . . . Only \$5.50



HOW TO SELECT AND USE YOUR TAPE RECORDER

by David Mark

Written for the USER: music lovers, businessmen, lawyers, engineers, teachers, etc. Step-by-step instructions on set-up and using procedures for all applications in the home, office, and professional activities. Also a buyer's guide in selecting a machine to suit individual requirements. Soft cover, 148 pp., 5½ x 8½", illus. #179 . . . Only \$2.95

PICTURE BOOK OF TV TROUBLES

by Rider Lab. Staff

VOL. 5: HORIZONTAL OUTPUT & H-V CIRCUITS
#168-5, 108 pp. . . . Only \$1.80
VOL. 6: HORIZONTAL & VERTICAL SYNC CIRCUITS
#168-6, 120 pp. . . . Only \$1.80

TV MFRS' RECEIVER TROUBLE CURES

edited by M. Snitzer

VOL. 8: Just published. New coverage, from RCA to Zenith.
#143-8 . . . Only \$1.80

TV REPAIR QUESTIONS & ANSWERS

by Sidney Platt

#173-5, SOUND & L-V CIRCUITS:
128 pp. . . . Only \$2.10

ELECTRONICS TECHNOLOGY SERIES

edited by Alex. Schure, Ph.D., Ed.D.

An economically priced series. Each thoroughly and clearly explains the basic concepts of an individual phase of electronics technology principles. Review questions at the end of each chapter. Soft covers, 5½ x 8½", illustrated.

MULTIVIBRATORS

#166-7 . . . Only \$.90

R-F TRANSMISSION LINES

#166-8 . . . Only \$1.25

AMPLITUDE MODULATION

#166-9 . . . Only \$1.25

BLOCKING OSCILLATORS

#166-10 . . . Only \$1.25

WAVE PROPAGATION

#166-11 . . . Only \$.90

SUPERHETERODYNE CONVERTERS & I-F AMPLIFIERS

#166-12 . . . Only \$.90

INVERSE FEEDBACK

#166-15 . . . Only \$1.25

RESONANT CIRCUITS

#166-16 . . . Only \$1.25

**RIDER BOOKS HELP YOU
DO MORE,
LEARN MORE,
EARN MORE . .**

RADIO & TELEVISION NEWS

SUMMERTIME is READING TIME



for all who want to benefit from **INCREASED KNOWLEDGE!**

FUNDAMENTALS OF TRANSISTORS

by Leonard Krugman
Explains the BIG thing in electronics, today—the transistor! Written by one of the pioneers in transistor development, this book tells you all you need to know about this electronic miracle: basic operation, characteristics, performance, and application. Soft Cover, 144 pp., 5½ x 8½", illus. #160.....Only \$2.70

BASIC VACUUM TUBES & THEIR USES

by Rider & Jacobowitz
Basic information relating to vacuum tubes, with a minimum of mathematics, from the behavior of the elementary electron to the specialized types of tubes. A must book for technicians, engineers, students. 208 pp., 5½ x 8½", illus. #171, Soft Cover.....Only \$3.00 #171-H, Cloth Bound.....Only \$4.50

RADIO OPERATOR'S LICENSE Q & A MANUAL

(5th Edition)
by M. Kaufman
Revised and enlarged 5th edition contains the latest revisions in Elements 1 and 2 (Basic Law and Basic Operating Practice). Lists questions and answers of past FCC exams, plus discussions of each answer. An indispensable reference volume for the student and operator. Cloth Bound, 766 pp., 5½ x 8½", illus. #130.....Only \$6.60

ENCYCLOPEDIA ON CATHODE-RAY OSCILLOSCOPES & THEIR USES

by Rider & Usan
Fully and clearly describes the oscilloscope, its construction and capabilities. Covers a wide variety of scopes, including present day models. Profusely (3,000) illustrated. Cloth Bound, 1008 pp., 8½ x 11". #133.....Only \$11.50

HOW TO LOCATE & ELIMINATE RADIO & TV INTERFERENCE

by Fred D. Rowe
An expertly written text which tells you how to locate and eliminate interference. The approach is not theoretical, but direct and practical. Soft Cover, 128 pp., 5½ x 8½", illus. #158.....Only \$1.80



TELEVISION—HOW IT WORKS

(2nd Edition)
by J. Richard Johnson

A completely rewritten, up-to-the-minute edition of an authoritative and informative book. It is the newest and most comprehensive text on the subject, and follows the progress of the received signal from the antenna to the picture tube and loudspeaker. Leather Finish MARCO Cover, 352 pp., 5½ x 8½", illus. #101.....Only \$4.60 #101-H, Cloth Bound.....Only \$5.50

HANDBOOK OF 630-TYPE TV RECEIVERS

by Miller & Bierman
Deals with all versions of the famous 630-type receivers made up to 1955. Explains modifications and circuit improvements made by various manufacturers, and includes 26 pages of troubleshooting charts. A book every technician can use to major advantage! Soft Cover, 200 pp., 5½ x 8½", illus. #174.....Only \$3.50

HOW TO USE SIGNAL & SWEEP GENERATORS

by J. Richard Johnson
Discusses all types of signal and sweep generators, and their applications in AM, FM radio, and TV. Soft Cover, 144 pp., 5½ x 8½", illus. #147.....Only \$2.10

HOW TO USE TEST PROBES

by A. Ghirardi & R. Middleton
The only book of its kind, it covers all types of test probes used with VOM's, VTVM's, and scopes. Complete step-by-step explanations, with practical examples of results and effects. Soft Cover, 176 pp., 5½ x 8½", illus. #165.....Only \$2.90



PICTURE BOOK OF TV TROUBLES

by Rider Lab. Staff

A series of books, each covering a different part of the TV receiver, and showing typical troubles, their symptoms and causes. All material is from actual case histories. These books do your troubleshooting for you! Soft Covers, 5½ x 8½", illus.

- VOL. 1: HORIZONTAL AFC-OSCILLATOR CIRCUITS #168, 80 pp.....Only \$1.35
- VOL. 2: VERTICAL SWEEP-DEFLECTION CIRCUITS #168-2, 96 pp.....Only \$1.80
- VOL. 3: VIDEO I-F & VIDEO AMPLIFIER CIRCUITS #168-3, 96 pp.....Only \$1.80
- VOL. 4: AUTOMATIC GAIN CONTROL CIRCUITS #168-4, 96 pp.....Only \$1.80
- VOL. 5: HORIZONTAL OUTPUT & H-V CIRCUITS #168-5, 108 pp.....Only \$1.80
- VOL. 6: HORIZONTAL & VERTICAL SYNC CIRCUITS #168-6, 120 pp.....Only \$1.80

TV REPAIR QUESTIONS & ANSWERS

by Sidney Platt
A very practical series of questions and answer books on the repair of TV receivers. Each covers a separate section of the receiver, and the series follows the same sequence that the signal itself travels. Soft Covers, 5½ x 8½", illus.

- #173, FRONT ENDS: 128 pp.....Only \$2.10
- #173-2, VIDEO CIRCUITS: 128 pp.....Only \$2.10
- #173-3, SYNC & SWEEP CIRCUITS: 140 pp.....Only \$2.10
- #173-4, DEFLECTION & H-V CIRCUITS: 128 pp.....Only \$2.10
- #173-5, SOUND & L-V CIRCUITS: 128 pp.....Only \$2.10

HOW TO TROUBLESHOOT A TV RECEIVER

by J. Richard Johnson
A book written for the newcomer, to aid in a systematic procedure for troubleshooting. An easily understandable, step-by-step guide. Soft Cover, 128 pp., 5½ x 8½", illus. #152.....Only \$1.80

FM TRANSMISSION & RECEPTION

(2nd Edition)
by Rider & Usan
Covers FM broadcasting of all kinds, and explains the theory, functioning and servicing of various types of FM receivers, including TV receivers. Cloth Bound, 460 pp., 5½ x 8½", illus. #102.....Only \$4.95

OBTAINING & INTERPRETING TEST SCOPE TRACES

by John F. Rider
Explains oscilloscope screen traces in clear, non-mathematical language. Contains over 800 scope traces, and complete instructions on the use of scopes and interpretation of traces. Soft Cover, 190 pp., 5½ x 8½", illus. #146.....Only \$2.40

TV MFGRS' RECEIVER TROUBLE CURES

edited by M. Snitzer
Gives you specific TV receiver troubles, and the cures specified by the set manufacturer. Listings are by manufacturer, model and chassis number. Saves you time, helps you earn more! Soft Cover, 5½ x 8½", illus., each volume over 116 pp.

- VOL. 1: Covers complete details on sets produced by mfgs (listed in alphabetical order) from Admiral to Dumont. #143.....Only \$1.80
- VOL. 2: Covers mfgs from Emerson to Jackson. #143-2.....Only \$1.80
- VOL. 3: Covers mfgs from Kaye-Halbert to Philco. #143-3.....Only \$1.80
- VOL. 4: Covers mfgs from Philharmonic to Shaw. #143-4.....Only \$1.80
- VOL. 5: Covers mfgs from Sparton to Zenith. #143-5.....Only \$1.80
- VOL. 6: All new coverage, through 1954, no duplications . . . Admiral to Firestone. #143-6.....Only \$1.80
- VOL. 7: New coverage, from General Electric to Raytheon. #143-7.....Only \$1.80
- VOL. 8: Just published. New coverage, from RCA to Zenith. #143-8.....Only \$1.80



INTRODUCTION TO COLOR TV

(2nd Edition)
by Kaufman & Thomas

A revised, up-to-date edition of a best seller in books on TV. New edition contains full information on the latest and larger screen picture tubes, simplified receiver circuitry, etc. Most up-to-date introduction to color television available. Soft Cover, 160 pp., 5½ x 8½", illus. #156.....Only \$2.70

COLOR TELEVISION RECEIVER PRACTICES

by Hazeltine Corp. Lab. Staff
Prepared by experts, this book covers every major aspect of color TV receivers, including the latest 21" picture tube and its required circuitry. For anyone who wishes a solid grounding in color television, this volume is ideal. Destined to become a standard reference work on the subject. Soft Cover, 208 pp., 5½ x 8½", illus. #162.....Only \$4.50 #162-H, Cloth Bound.....Only \$6.00

THESE AND MANY OTHER RIDER BOOKS ARE AVAILABLE AT YOUR BOOKSTORE OR PARTS JOBBER—LOOK FOR THE RIDER DISPLAY RACK!



WRITE FOR OUR CATALOG OF RIDER BOOKS

JOHN F. RIDER PUBLISHER, INC.
480 Canal Street, New York 13, N. Y.

In Canada:
Charles W. Pointon, Ltd.
6 Alcina Ave., Toronto, Ontario
In Canada, all prices approximately 5% higher.

Sonotone's 2-model line simplifies cartridge replacement!

JUST 2 SONOTONES (1P, 2T)
TAKE THE PLACE OF...

UP TO 12 MODELS IN OTHER
CARTRIDGE LINES!

*You finish jobs faster, please customers more,
when you standardize on Sonotone Ceramics*

Why juggle a handful of different cartridges, when it's so much easier and faster to stick to just *two*? Sonotone single-needle 1P and turnover type 2T are all you need for over 90% of quality replacement jobs.

These two Sonotone cartridges fit practically any arm. They're quick to install. And remember, Sonotone cartridges are *more* than replacements. They'll give *better* response than original equipment...enhancing your reputation for quality work.

New standard of the phono industry

In more than half the quality phonographs made today by leading manufacturers, you'll find one of these Sonotone cartridges. All the more reason why you should standardize on Sonotone.

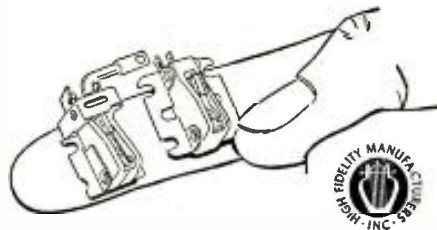

SONOTONE CERAMIC CARTRIDGES

ELMSFORD, N. Y.

In Canada, contact Atlas Radio Corp., Ltd., 50 Wingold Avenue, Toronto

Washington Street, El Segundo, California . . . **CLAREMONT TUBE CORPORATION** has opened an Atlanta, Georgia warehouse at 780 Ponce de Leon Place, N.E. to service customers for the Long Island City firm's TV picture tube line . . . **ELECTRO ENGINEERING WORKS, INC.** has moved to a new 20,000 square foot building at 401 Preda Street, San Leandro, California. The firm was formerly in Oakland . . . **RAYTHEON MANUFACTURING COMPANY** has exercised its option to lease, with a further option to buy, the Shawsheen Mill properties in Andover, Mass. from **TEXTRON, INC.** The facilities will be used for the production of military equipment . . . **MAGNAVOX COMPANY OF TENNESSEE** is building two new buildings at its Greeneville headquarters which will add approximately 70,000 square feet to the company's facilities . . . **DONNER SCIENTIFIC COMPANY** has broken ground for the first plant in its projected "instrument park" to be located in Concord, California . . . **NATIONAL CASH REGISTER COMPANY** has opened a 52,000 square foot structure in Hawthorne, California which will house its electronics division. The facilities will be used for research and design activity in advanced electronic computers and auxiliary equipment for business systems.

DAVID J. MUNROE has been named president of the *Webster Electric Company*, succeeding Preston G. Crewe, who was elevated to the newly created post of vice-chairman of the board of the Racine, Wisconsin firm.



Mr. Munroe has been associated with the company 14 years as chief engineer. A graduate of Cooper Union College, New York City, he was assigned by the *Sperry Gyroscope Co.* to work with *Webster* on army equipment and subsequently joined the company as chief engineer in August 1942.

He also served with the marine division of *Bendix Corp.* Prior to his election to the presidency, he was executive vice-president of the firm.

LEONARD GILLON, manager of manufacturing in the television picture tube section of the *RCA* plant in Marion, Indiana has been appointed plant manager. He has been with the firm since 1929 . . . *Kay Lab* of San Diego has named **GEORGE D. RICE** to the post of production manager. He was formerly with *Stromberg-Carlson* in Rochester . . . **CHARLES E. BALZ** has been upped to the post of vice-president for sales for *Burgess Battery Company*. He has been associated with the Freeport, Ill. firm for 16 years . . . **JAMES HASTIN** has been appointed sales manager of *Brenna & Browne*, Honolulu manufacturers' representative firm . . . **J. R. NELSON**, veteran *Raytheon* engineer and tube specialist, died recently fol-

(Continued on page 125)

RCA offers you the finest training at home in **Radio-TV electronics, TV servicing, Color TV**

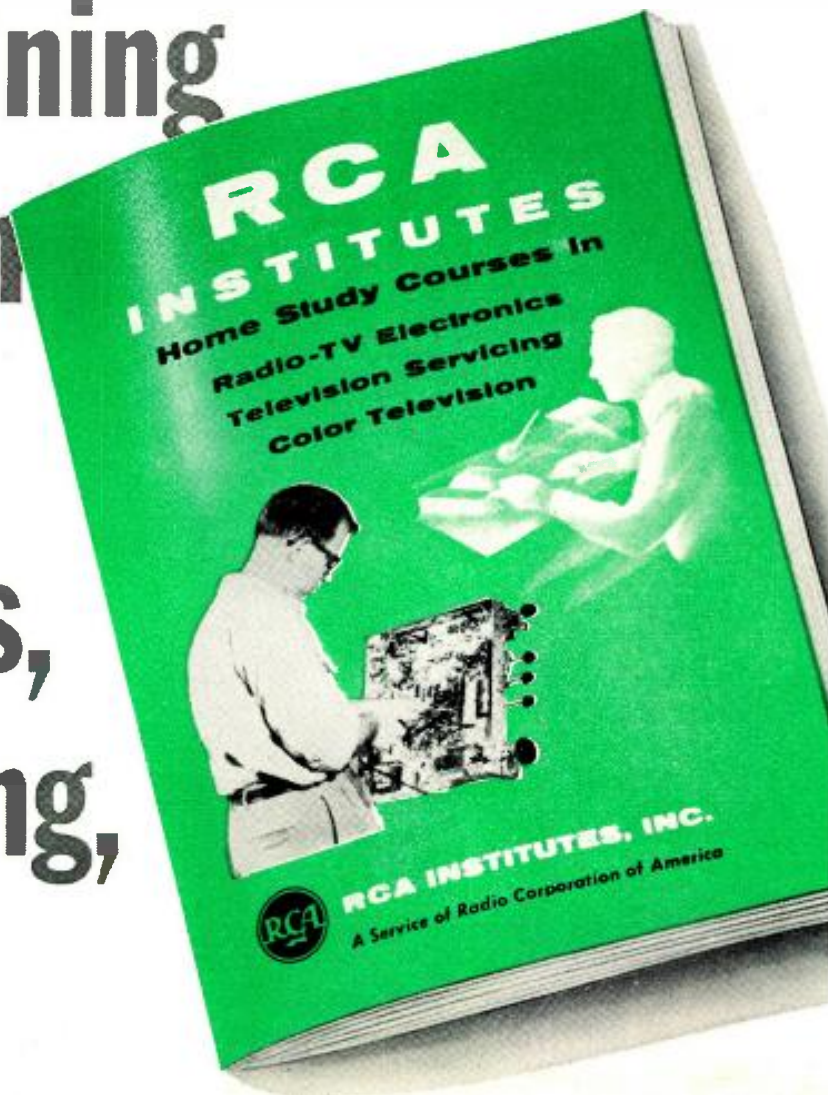

SEND FOR THIS FREE BOOK NOW!

The instruction you receive and equipment you get (and keep) will start you on your way. Pay-as-you-learn. You pay for only one study group at a time. This 52 page book contains complete information on Home Study Courses for the beginner and the advanced student.



RCA INSTITUTES, INC.
A SERVICE OF RADIO CORPORATION OF AMERICA
350 WEST FOURTH STREET, NEW YORK 14, N.Y.

RCA Institutes, Inc., Home Study N-86.
 350 West Fourth Street New York 14, N. Y.
 Without obligation, send me FREE CATALOG on Home Study Courses in Radio, Television and Color TV. No salesman will call.

Name Please Print
 Address
 City Zone State

IMPORTANT
 Be sure to write for RCA Institutes catalog before signing up for any Radio-TV course

THOUSANDS OF SERVICE DEALERS

SATISFY CUSTOMERS
SAVE REPEAT CALLS

MAKE MONEY EVERY DAY with **B&K**



DYNA-QUIK MODEL 500
DYNAMIC MUTUAL CONDUCTANCE TUBE TESTER

Tests over 95%

OF ALL POPULAR TV TUBES*— IN SECONDS

It's easy and profitable to check all the tubes in a TV set with DYNA-QUIK—on every service call. Cuts servicing time. Creates more on-the-spot tube sales. Saves repeat calls, protects service guarantee.

DYNA-QUIK 500 measures true dynamic mutual conductance, completely checks tubes with laboratory accuracy under actual operating conditions right in the home.

Tests each tube for shorts, grid emission, gas content, leakage, dynamic mutual conductance and life expectancy. One switch tests everything. No roll charts. No multiple switching. Makes complete tube test in as little as 12 seconds. Large 4½-inch plastic meter shows tube condition on "Good-Bad" scale or in micromhos on scales calibrated 0-6,000 and 0-18,000. Used in home or shop, DYNA-QUIK is a proved money-maker!

*Including new 600 mil series tubes.

NET \$109⁹⁵

Dyna-Quik 500. Easily portable in luggage-style carrying case. Size: 15¼ x 14¼ x 5½ in. Weighs only 12 lbs. Has 7-pin and 9-pin straighteners on panel.

DELUXE—PORTABLE
CRT MODEL 400
Tests and repairs
TV Picture Tubes



NET \$54⁹⁵

Deluxe CRT 400. With 4½-in. plastic meter. Weighs only 5 lbs. Luggage style carrying case. Size: 11 x 7½ x 5".

Also available in economy model CRT 200 with 3-in. meter at \$39.95 net.

Quickly spots and corrects picture tube troubles right in the home, without removing tube from set. Restores emission, stops leakage, repairs inter-element shorts and open circuits. Life test checks gas content and predicts remaining useful life. Grid cut-off reading indicates picture quality customer can expect. Eliminates tube transportation, cuts service-operating costs. Also saves money on TV set trade-in reconditioning. Earns dollars in minutes—pays for itself over and over again.

Proved In Use by Servicemen Everywhere.

See your B & K Distributor or send for facts on "Profitable TV Servicing In the Home" and Informative Bulletins 500-104-N.



B & K MANUFACTURING CO.
3726 N. Southport Ave. • Chicago 13, Illinois

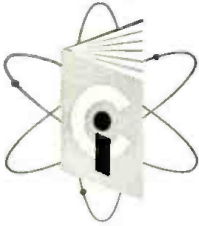

WHERE WILL YOU BE IN ELECTRONICS 6 MONTHS FROM TODAY?

Get this
valuable booklet

FREE



TELLS HOW...

Add Technical Training to your
practical experience...

GET YOUR FCC LICENSE IN A HURRY!

Then use our amazingly effective
JOB FINDING SERVICE

WE GUARANTEE

To Train and Coach You at Home
in Spare time Until You Get

YOUR FCC LICENSE

If you have had any practical experience—
Amateur, Army, Navy, Air Force Radio repair,
experimenting, etc.

HERE IS YOUR GUARANTEE

If you fail to pass your Commercial License
exam after completing our course, we guarantee
to continue your training without additional cost
of any kind, until you successfully obtain your
Commercial license.

TELLS HOW—

Our Amazingly Effective JOB-FINDING
SERVICE Helps CIRE Trainees
Get Better Jobs. Here are a few recent
examples of Job-Finding results:

ELECTRONICS TECHNICIAN

"I am now employed by the Collins Radio Company as a Lab Technician.
(This job was listed in your bulletin). I have used the information gathered
from your course in so many ways and I know that my training with CIRE
helped me a great deal to obtain the job."
Charles D. Sindelar, Cedar Rapids, Iowa.

AIRLINES

"I replied to the Job Opportunities you sent me and I am now a radio operator
with American Airlines. You have my hearty recommendation for your train-
ing and your Job-Finding Service."
James A. Wright, Beltsville, Md.

INDUSTRIAL ELECTRONICS

"Upon my discharge from the Navy I used your Job-Finding Service and as a
result I was employed by North American Aviation in electronic assembly (final
checkout)."
Glen A. Furlong, Fresno, Calif.

MOBILE SERVICING

"I am now employed by the Permian Basin Communications, Inc. and now
manage the service shop in Odessa, Texas for Motorola 2-way communication
equipment. I got the job through your Job Finding Services. My sincere
thanks."
Robert W. Cook, Odessa, Texas.

Employers make job offers like these to our trainees every month. . . .

TRANSCONTINENTAL AIRLINE:

"American Airlines is very much interested
in receiving applications from CIRE trainees.
We have immediate need for technicians in
many cities."

WEST COAST MANUFACTURER:

"We are currently in need of men with elec-
tronics training or experience in radar main-
tenance, and we would appreciate if you will
refer interested persons to us."

Name and Address	License	Time
A/1C Ronald H. Person, St. Louis 20, Mo.	1st Class	25 weeks
Milton L. Geisler, ET3, FPO, San Francisco, Calif.	1st Class	26 weeks
Marvin F. Kimball, Lafayette, Ind.	2nd Class	21 weeks
L. M. Bonino, Harlington AFB, Tex.	2nd Class	16 weeks
John E. Hutchison, Bluefield, W. Va.	1st Class	27 weeks

CIRE IS THE ONLY HOME STUDY SCHOOL WHICH SUPPLIES FCC-TYPE EXAMINATIONS
WITH ALL LESSONS AND FINAL TESTS. Your FCC Ticket is recognized by employers as
proof of your technical ability.



Get All 3 FREE

MAIL COUPON NOW

Member National
Home Study
Council



Cleveland Institute of Radio Electronics

Desk RN-93, 4900 Euclid Ave., Cleveland 3, O.

Please send Free Booklets prepared to help me
get ahead in Electronics. I have had training or
experience in Electronics as indicated below:

- | | |
|---|---|
| <input type="checkbox"/> Military | <input type="checkbox"/> Broadcasting |
| <input type="checkbox"/> Radio-TV Servicing | <input type="checkbox"/> Home Experimenting |
| <input type="checkbox"/> Manufacturing | <input type="checkbox"/> Telephone Company |
| <input type="checkbox"/> Amateur Radio | <input type="checkbox"/> Other _____ |

In what kind of work are you
now engaged? _____

In what branch of Electronics
are you interested? _____

Name _____ Age _____

Address _____

City _____ Zone _____ State _____

Special Tuition Rates to Members of Armed Forces



only complete line of

TV and COMMUNICATION TOWERS

proven in Profits and Customer Satisfaction

• • • • HIGHLIGHTS OF THE ROHN LINE • • • •



● HOT DIPPED GALVANIZED

The finest, most durable finish is available for ROHN Towers and accessories . . . all done entirely on the ROHN premises under careful ROHN supervision.

● UNEQUALLED DESIGN AND ENGINEERING

ROHN is the only design that has stood up over the years. ROHN has been first and foremost . . . and always the leader in new products to meet the changing demands.

● MASS PRODUCTION FOR LOW COSTS

ROHN was the first to utilize mass production techniques to build a superior tower at the most competitive prices. This means no sacrifice in quality yet far greater profits for you.

● UNIVERSAL CUSTOMER ACCEPTANCE

Thousands and thousands of installations prove the ROHN line first in customer satisfaction.

● PIONEER MANUFACTURERS

Pioneers in tower manufacturing—and today one of the world's largest manufacturers of this type equipment. The ROHN Company was built on satisfaction on the part of distributor, dealer and customer alike.

● COMPLETE LINE

Only ROHN offers a full line—one dependable one-stop source for all TV installation equipment. Save headaches, save shipping costs, save time . . . use ROHN unequalled service *exclusively*.



no. 6 tower

"All-Purpose" tower-

Fulfills 75% of your general tower needs—is structurally as sturdy—yet costs less than the well-known Rohn No. 10 Tower. Ideal for home and industrial installations, communication requirements . . . eliminates stocking many different tower models. *Self-supporting to 50 ft. or guyed to 120 ft.!* Easy to climb for fast, efficient servicing. Utilizes "Magic Triangle" which insures far greater strength and stability. Permanent hot-dipped galvanized coating. Dependability—a feature customers demand—is assured with the Rohn No. 6 Tower . . . designed to "stand up" for years to the rigors of weather and climatic conditions.

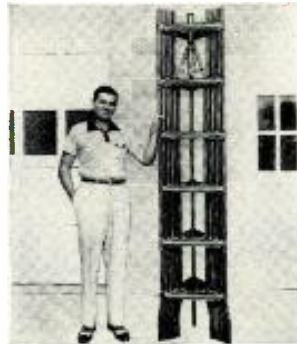

Package Tower*

"Space Saver"—cuts storage space 300% or more!

Popular PT-48 has almost 50' of sturdy tower within a compact 8' x 20" package! "Magic Triangle" design is adapted to a pyramid shape using a wide 19" base with progressively decreasing size upward. Decreases your overhead . . . easy to transport and assemble—cuts shipping costs. Galvanized throughout. Available in heights of 24, 32, 40, 48, 56 and 64 feet!

COMMUNICATIONS TOWER

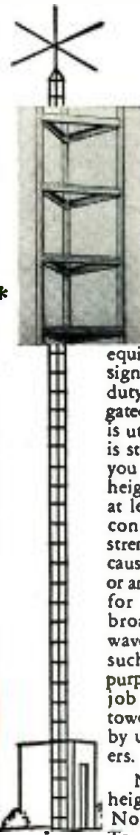

For extreme heights and communication purposes of all kinds, the Rohn No. 40 gives you strength and durability on which you can depend. The time tested and proven

equilateral triangle design using extra heavy duty tubing and corrugated steel cross-bracing is utilized. The No. 40 is structurally sound so you can install it for heights up to 300'; or at lesser heights when considerably greater strength is required because of excessive wind or antenna loading. Use for radio telephone, broadcasting, microwave relay and all other such communication purposes. If a particular job calls for this type tower, save real money by using ROHN towers.

Note: For lesser heights, use the Rohn No. 20 or No. 30 Tower.



Both Towers Feature THE ROHN MAGIC TRIANGLE*

For structural superiority, famed wrap-around "magic triangle" design is featured in these all-steel towers. Towers have full 2 1/2" wide corrugated cross-bracing welded to tubular steel legs. The exclusive design assures dependable strength and permanence.



Telescoping Masts

Heavy-duty hot-dipped galvanized steel tubing and rigid joints give extraordinary strength. *Quick installation* . . . mast attached to base—antenna fixed, then mast hoisted quickly to desired height. Utilizes special clamp and guy ring arrangement. Flanged interior section; crimped exterior section gives most stability that can't be beat. Complete with guy rings and necessary erection parts. In 20, 30, 40 and 50 ft. sizes. Bases and ground mounts available.

ROHN FOLD-OVER TOWERS

These unique fold-over towers are perfect for experimentation, TV service departments, amateur use, and special purposes. Uses regular ROHN tower sections with kit. Now available in standard No. 10 tower to 50', and in ROHN No. 30 & No. 40 towers for heavy-duty use.



ALSO a full line of ROHN ACCESSORIES

Rotor posts, house brackets, eave brackets, peak and flat roof mounts, instant drive-in bases, hinged base sections, telescoping mast bases, guying brackets, UHF antenna mounts, erection fixtures, variety of mounts and supports for masts or tubing,

tower installation accessories, TV service tables, mast and TV hot-dipped galvanized tubing, guy rings, "twister-anchors", rubber tower grommets, insulator sections, hinged rotor platform, accessory shelf and platform and dozens of other items. Get the complete catalog TODAY!

ROHN Manufacturing Company

116 LIMESTONE, BELLEVUE
PEORIA, ILLINOIS

MAIL THIS COUPON FOR FREE LITERATURE!

Rohn Manufacturing Company
116 Limestone, Bellevue
Peoria, Illinois

Gentlemen: Please rush me complete details on the full line of Rohn Towers and Accessories.

Firm _____

Name _____ Title _____

Address _____

City _____ State _____

NATIONAL SCHOOLS

proudly presents

FOR MEN WHO WANT TO EARN MORE MONEY

TELERAMA • ALL 8 BRANCHES OF TELEVISION • ELECTRONICS • RADIO IN ONE DYNAMIC, MODERN SHOP METHOD, HOME TRAINING COURSE

*Registration applied for

Another great advance in **HOME STUDY TRAINING**. Let National Schools, of Los Angeles, a practical Technical Resident Trade School for over 50 years, train you at home by Shop-Method, for today's unlimited opportunities in **ALL 8 BRANCHES** of the Television, Electronics, Radio Industry.

Check all you receive in *One Master Course* at One Low Tuition

1. Television — Including Color TV
2. Radio — FM and AM
3. Industrial Electronics
4. Sound Recording and Hi-Fidelity
5. Preparation for FCC License
6. Automation
7. Radar and Sonar
8. Communications

ALL OF THIS MODERN, NEWEST, PRACTICAL EQUIPMENT IS YOURS TO KEEP!

- Parts to Build a modern TV set, including large screen Picture Tube.
- Parts to build a powerful Superhet Receiver, standard broadcast and short wave.
- Parts to conduct many experiments and build Continuity Checker, RF Oscillator, TV Circuits, Audio Oscillator, TRF Receiver, Signal Generator.
- Professional Multimeter
- These are a MUST for all technicians.

YOU DO MANY PRACTICAL JOBS.

You do servicing, circuit analysis and many other down-to-earth experiments. You build a modern TV set from the ground up... with equipment kits we give you, including a new large screen picture tube and professional Multimeter, at no additional charge.

EARN AS YOU LEARN! Many of our students earn their entire tuition and more in Spare Time jobs we show them how to do while learning. **YOU GET GRADUATE ADVISORY SERVICE, TOO.**

ALL YOURS TO KEEP

L. J. ROSENKRANZ

President of NATIONAL SCHOOLS



This Master-Shop-Method course is completely up-to-date. Here in Los Angeles, the TV and Electronics center of the world, we are able to keep in constant touch with the industries' latest developments. As a student, you will quickly master all phases at home... in your spare time. Your earning power will grow with every lesson. Just as thousands of National Schools graduates do every day, you can handle servicing, manufacturing, repairing, hundreds of other jobs, or make good money in your own business. **SECURE YOUR FUTURE—NOW. SEND COUPON BELOW.**



IN THESE MODERN TV STUDIOS, SHOPS AND LABORATORIES, your Shop Method Home Study Course was developed by experienced instructors and engineers. What an advantage that is to you at home — each lesson is tested, proved, easy to understand. You can master the most up-to-date projects, such as color TV set repair, printed circuits — even prepare for F.C.C. License and industrial electronics without taking a special course. **TAKE YOUR FIRST STEP NOW TO A TOP-PAY JOB IN TV, ELECTRONICS, RADIO. SEND COUPON BELOW TODAY**

APPROVED FOR VETERANS AND NON-VETERANS



NATIONAL SCHOOLS

4000 S. FIGUEROA ST., LOS ANGELES 37, CALIF.

187 N. LA SALLE ST., CHICAGO 1, ILL.

IN CANADA: 811 W. Hastings St., Vancouver, B. C.

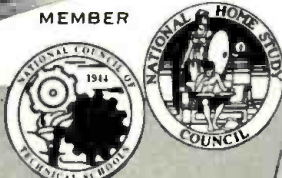

FREE!

Fully illustrated "CAREER" BOOK in TV, Radio, Electronics. AND actual Sample Lesson—yours at no cost, no obligation **SEND COUPON NOW—TODAY!**

NATIONAL SCHOOLS

TECHNICAL TRADE TRAINING SINCE 1905
Los Angeles, California

GET FAST SERVICE — MAIL NOW TO OFFICE NEAREST YOU!

NATIONAL SCHOOLS, DEPT. RH-86
4000 S. FIGUEROA ST. OR 187 N. LA SALLE ST.
LOS ANGELES 37, CALIF. CHICAGO 1, ILL.
Rush free TV-Radio "Opportunity" Book and sample lesson. No salesman will call.

NAME _____ BIRTHDAY _____ 19__

ADDRESS _____

CITY _____ ZONE _____ STATE _____

VETERANS: Give Date of Discharge _____

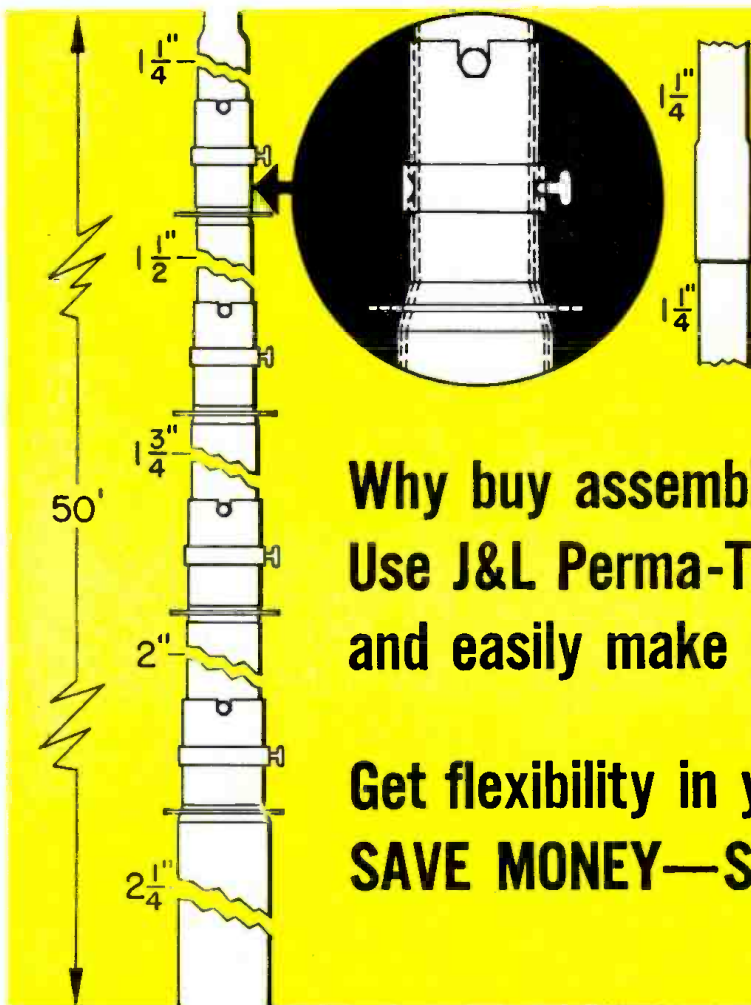

Same 1 1/4-inch piece of Perma-Tube can be used for telescoping masts or with another 1 1/4-inch piece to make smaller 2-piece masts.

**Why buy assembled telescoping masts?
Use J&L Perma-Tube in 10-foot lengths
and easily make your own**

**Get flexibility in your stock
SAVE MONEY—SAVE SPACE**

Only J&L Perma-Tube offers :

- Joint design which provides instant field assembly.
- Machine-fitted joints that insure close tolerance for high strength and rigidity.
- Guy wire ring position that eliminates all binding and guy wire interference.

Buy only a carton each of five different sizes of Perma-Tube (1 1/4 to 2 1/4-inch) and make any telescoping TV mast up to 50 feet in height. Hardware—cotter keys or bolts, clamps and guy rings—may also be secured from your distributor.

You can now “tailor-make” your own TV masts up to 50 feet high by using standard 10-foot lengths of 16-gage Perma-Tube—and save money. Five diameters are available in easily-handled cartons from your local distributor. Largest base section OD is 2 1/4 inches and each telescoping section is 1/4-inch smaller, the smallest section having an OD of 1 1/4 inches.

Corrosion-resistant Perma-Tube is treated with Vinsynite—then coated both inside and outside with a metallic vinyl resin base. It’s made of a special, high-strength, J&L steel tubing. A 10-foot section of 1 1/4 inch diameter by 16 gage is capable of supporting a weight at its center point of 200 pounds with a minimum of deflection and permanent set.

J&L Perma-Tube — best for strength and rust protection

Jones & Laughlin
STEEL CORPORATION · PITTSBURGH

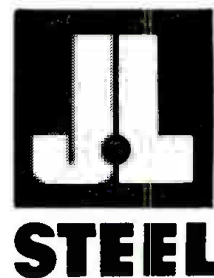

RADIO & TELEVISION NEWS

**NEW! COLOR and Black-&-White
LAB & TV 5" OSCILLOSCOPE #460
KIT \$79.95. Wired \$129.50**

The **FINEST** professional 5 mc wide-band scope value. Ideal for research, h-f & complex waves, plus Color & Monochrome TV servicing. Flat from DC to 3.58 mc ± 1 db (color burst freq.), flat DC to 4.5 mc $+1, -3$ db. Vert. sens. 25 rms mv/in. Vert. Z 3 megs. Has the following outstanding features not found in scopes up to several times its price, kit or wired:

VERTICAL AMPLIFIER: direct-coupled (DC) thruout to eliminate l-f phase shift; push-pull thruout for negligible distortion; K-follower coupling between push-pull pentode stages for extended h-f resp. (minimizes h-f phase shift, extends useful resp. to 10 mc); full-screen undistorted vert. defl; 4-step freq-compensated decade step attenuator up to 1000:1. **SWEEP CIRCUIT:** perfectly linear sweeps, 10 cps - 100 kc (ext. cap. for down to 1 cps); pre-set TV vert. & hor. positions (30 & 7875 cps); automatic sync. ampl. & limiter eliminates sync amplitude adj. **PLUS:** direct or cap. coupling; bal. or unbal. inputs; edge-lit engraved lucite graph screen; dimmer; anti-glare filter; bezel fits std photo equipt. **OTHER IMPORTANT FEATURES:** High intensity trace CRT. Finest sq. wave resp. (.06 usec rise time). Push-pull hor. ampl., flat to 400 kc, sens. 0.6 rms mv/in. Built-in voltage calibration. Intensity mod. Sawtooth & 60 cps outputs. Astigmatism control. Retrace blank-

ing. Instant, drift-free full-screen vert. positioning & 2X full-screen hor. positioning. Bal., cal., astig. adj. externally accessible. 5U1P CRT, 2-6AU8, 2-6CB6, 1-12AU7A, 2-6J6, 1-6AX5, 1-1V2. Deep-etched satin aluminum panel, rugged grey wrinkle steel cabinet. Designed for easy building at home with no special equipment. 13" x 8 1/2" x 16". 30 lbs.

SCOPE DIRECT PROBE* = PD: KIT \$2.75. Wired \$3.95. Eliminates stray-pick-up & signal re-radiation.

SCOPE DEMODULATOR PROBE* = PSD: KIT \$3.75. Wired \$5.75. Demodulates AM carriers between 150 kc and 250 mc.

SCOPE LOW CAPACITY PROBE* = PLC: KIT \$3.75. Wired \$5.75. For signal tracing in high frequency, high impedance & wide-band circuits (as in TV) without distortion from overloading or frequency discrimination.

for **COLOR** and Monochrome TV servicing

**New! PEAK-to-PEAK VTVM #232
& UNI-PROBE (pat. pend.)
KIT \$29.95. Wired \$49.95**

UNI-PROBE: exclusive with EICO! Terrific time-saver! Only 1 probe performs all functions—a half-turn of probe-tip selects DC or AC-Ohms.

The new leader in professional peak-to-peak VTVMs. Latest circuitry, high sensitivity & precision, wide ranges & versatility. Calibration without removing from cabinet. New balanced bridge circuit. High Z input for negligible loading. 4 1/2" meter, can't burn-out circuit. 7 non-skip ranges on every function. 4 functions: +DC Volts, -DC Volts, AC Volts, Ohms.

Uniform 3 to 1 scale ratio for extreme wide-range accuracy. Zero center. One zero-adj. for all functions & ranges. 1% precision ceramic multiplier resistors. Measure directly peak-to-peak voltage of complex & sine waves: 0-1, 14, 42, 140, 420, 1400, 4200. DC/RMS sine volts: 0-1.5, 5, 15, 50, 150, 500, 1500 (up to 30,000 v. with HVP probe, & 250 mc with PRF probe). Ohms: 0.2 ohms to 1000 megs. 12AU7, 6AL5, selenium rectifier; xfmr-operated. 8 1/2" x 5" x 5". Deep-etched satin aluminum panel, rugged grey wrinkle steel cabinet. 7 lbs.

**New! DELUXE PEAK-to-PEAK VTVM #249
with 7 1/2" METER & UNI-PROBE (pat. pend.)
KIT \$39.95. Wired \$59.95**

All the advanced & exclusive features of #232—PLUS the extra convenience and readability of its big 7 1/2" meter. Your ideal bench instrument.

VTVM RF PROBES* #PRF-11 or PRF-25: KIT \$3.75. Wired \$4.95. Accuracy $\pm 10\%$. Use with any 11 or 25 megohm VTVM.

VTVM HV PROBE #HVP-2: Wired \$4.95. Complete with multiplier resistor. Measures up to 30 kv with any VTVM or 20,000 ohms/volt VOM.



Calibration without removing from cabinet.

Only EICO Probes have all these features: fully shielded; rugged terminal board parts mounting; shock-mounted floating construction; swivel-action; color-coding; easy parts accessibility.



150 kc to 435 mc
with ONE generator!

**New! RF SIGNAL GENERATOR #324
KIT \$26.95. Wired \$39.95**

for **COLOR** and Monochrome TV servicing

New wide-range, stable generator - better value than generators selling at 2 or 3 times its cost! Ideal for: IF-RF alignment, signal tracing & trouble-shooting of TV, FM & AM sets; marker gen.; 400 cps audio testing; lab. work. **6 fund. ranges:** 150-400 kc, 400-1200 kc, 1.2-3.5 mc, 3.5-11 mc, 11-37 mc, 37-145 mc; 1 harmonic band 111-435 mc. Freq. accurate to $\pm 1.5\%$; 6:1 vernier tuning & excellent spread at most important alignment freqs. Etched tuning dial, plexiglass windows, edge-lit hairlines. Colpitts RF osc., directly plate-modulated by K-follower for improved mod. Variable depth of int. mod. 0-50% by 400 cps Colpitts osc. Variable gain ext. mod. amplifier: only 3.0 volts needed for 30% mod. Turret-mounted coils slug-tuned for max. accuracy. Fine & Coarse (3-step) RF attenuators. RF output 100,000 uv; AF sine wave output to 10 volts. 50-ohm output Z. 5-way jack-top binding posts for AF in/out; coaxial connector & shielded cable for RF out. Tubes: 12AU7, 12AV7, selenium rectifier; xfmr-operated. Deep-etched satin aluminum panel, rugged grey wrinkle steel cabinet. 8" x 10" x 4 3/4". 10 lbs.

The specs are the proof...

4 NEW BEST BUYS
by **EICO**

**COMPLETE
with Preamplifier, Equalizer and Control Section
New! 20-WATT Ultra-Linear Williamson-
type HIGH FIDELITY AMPLIFIER #HF20
KIT \$49.95. Wired \$79.95**

A low-cost, complete-facility amplifier of the highest quality that sets a new standard of performance at the price, kit or wired. Every detail, down to the etched, brushed solid brass control plate, is of the fine quality EICO is famous for.

Rated power output: 20 watts (34 w peak). IM distortion (60 cps: 6 kc/4:1) at rated power: 1.3%. Mid-band harmonic distortion at rated power: 0.3%. Maximum harmonic distortion between 20 and 20,000 cps at 1 db under rated power: approx. 1%. Power response (20w): ± 0.5 db 20-20,000 cps; ± 1.5 db 10-40,000 cps. Frequency response (1/4w): ± 0.5 db 13-35,000 cps; ± 1.5 db 7-50,000 cps.

5 feedback equalizations for LP's & 78's including RIAA. Variable turnover feedback tone controls do not affect volume & permit large boosts or cuts at either end of audio spectrum with mid-freqs. unaffected. Loudness control & separate level set control on front panel. Low Z output to tape recorder. 4 hi-level switched inputs: tuner, tv, tape, auxiliary (stl/ceramic phono or 2nd tuner); 2 low-level inputs for proper loading with all leading magnetic, FM & quality stal cartidges. Hum bal. control. Extremely fine output transformer has interleaved windings, tight coupling, careful balancing & grain-oriented steel. 8 1/2" x 15" x 10". 24 lbs.

These amazing EICO values are NOW IN STOCK at your nearest distributor. Examine them side-by-side with ANY competitor. You'll see for yourself why indeed EICO is your BEST BUY. Fill out coupon on reverse page.



TURN PAGE FOR MORE EICO VALUES...

**the specs are
the test that tells
who's best!**

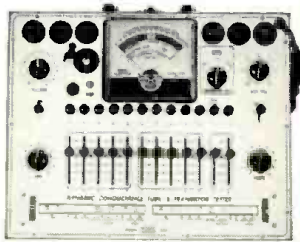

for COLOR & Monochrome
TV servicing
**NEW! DYNAMIC
CONDUCTANCE TUBE &
TRANSISTOR TESTER #666**
KIT \$69.95 WIRED \$109.95

Unexcelled testing thoroughness & accuracy. Checks transistor collector current & Beta using internal dc power supply. Tests all receiving tubes including subminiatures (& Color & Monochrome tv pic tubes with accessory adapter). Composite indication of mutual conductance, plate conductance, & peak emission. Simultaneous sel. of any 1 of 4 combinations of 3 plate, 3 screen, & 3 ranges of control grid voltage. Grid voltage variable over 3 ranges with 5% accurate pot. New series-string voltages for 600, 450 & 300 ma types. 5 ranges meter sens. with 1% precision shunts & 5% accurate pot. 10 SIX-position lever switches for free-point connection of every tube pin or cap. 10 pushbuttons for rapid insert of any tube element in leakage circuit & speedy sel. of individual tube sections. Direct reading of inter-element leakage in ohms. New gear-driven rollchart. Steel case with cover & handle. Sensitive 200 ua meter.

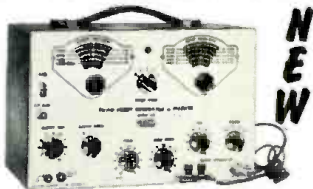

for COLOR & Monochrome
TV servicing
**TV-FM SWEEP GENERATOR
& MARKER #368**
KIT \$69.95 WIRED \$119.95

The FINEST service instrument of this type ever offered in either kit or wired form at ANY price! Outstanding ease & accuracy in FM & TV (including Color) alignment. Entirely electronic sweep circuit with accurately biased inductor: superb linearity on both sides of selected center freq. Newly-designed AGC circuit automatically adjusts osc. for max. output on each band with min. amplitude variations. Sweep gen. range 3-216 mc in 5 OVERLAPPING FUND. BANDS. Sweep width continuously variable from 0.3 mc lowest max. deviation to 0.30 mc highest max. deviation. Variable marker gen. range from 2-75 mc in 3 FUND. BANDS plus a calibrated harmonic band (60-225 mc). Variable marker calibrated with int. xtal marker gen. 4.5 mc xtal included. Ext. marker provision. Double pi line filter. Edge-lit hairlines eliminate parallax.

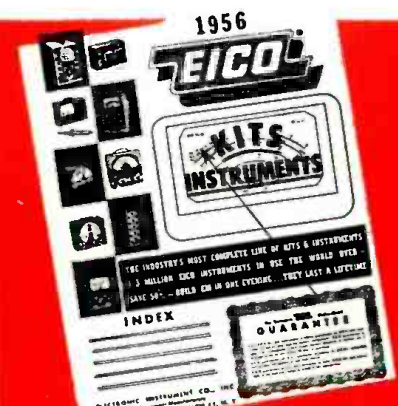

**FREE 1956
EICO CATALOG!**
Tells you how to SAVE 50% on
your test equipment costs!

TUBE TESTER #625
KIT \$34.95
Wired \$49.95
• tests 600 mil series string type tubes
• illuminated roll-chart

Pix Tube Test Adapter\$4.50

New! GEIGER COUNTER #803
KIT \$19.95
Wired \$29.95

(less batteries)
Professional, all-electronic, sensitive, rugged—at lowest cost! Indicates by neon lamp & headphone clicks.

5" PUSH-PULL OSCILLOSCOPE #425
KIT \$44.95
Wired \$79.95

7" PUSH-PULL OSCILLOSCOPE #470
KIT \$79.95
Wired \$129.50

VACUUM TUBE VOLTMETER #221
KIT \$25.95
Wired \$39.95

DELUXE VTVM : 214 (7 1/2" METER)
KIT \$34.95
Wired \$54.95

RF SIGNAL GENERATOR #320
KIT \$19.95
Wired \$29.95

150 kc-34 mc, calibrated harmonics to 102 mc. Pure or mod. RF, & Colpitts osc. 400 cps sine outputs.

NEW! UTILITY TESTER #540
KIT \$12.95
Wired \$15.95

Multi-range ac/dc voltmeter, ammeter, ohmmeter, wattmeter, leakage checker for home & auto repairs.

#944 FLYBACK TRANSFORMER & YOKE TESTER
KIT \$23.95
Wired \$34.95

• fast check all flybacks & yokes in or out of set.
• spots even 1 shorted turn!

Range 500 kc-228 mc on fund. Cont. sweep width control, 0-30 mc.

KIT \$34.95
Wired \$49.95

TV/FM SWEEP GENERATOR #360
5MC-4.5MC CRYSTAL\$3.95 ea.

1% accuracy on all 7 ranges. Range 75 kc-150 mc. Volt reg.

KIT \$39.95
Wired \$59.95

DELUXE RF SIGNAL GENERATOR #315

Sep. volt-meter & ammeter

KIT \$29.95
Wired \$38.95

6V & 12V BATTERY ELIMINATOR & CHARGER #1050

Sep. hi-gain RF & lo-gain audio inputs. Special noise locator. Calibrated wattmeter.

KIT \$24.95
Wired \$39.95

DELUXE MULTI-SIGNAL TRACER #147

Reads 0.5 ohms -500 megohms, 10 mmfd-5000 mfd power factor.

KIT \$19.95
Wired \$29.95

R-C BRIDGE & R-C-L COMPARATOR #950B

HI-FI PREAMPLIFIER #HF-6
KIT \$24.95 Wired \$37.95. With Power Supply: KIT \$29.95. Wired \$44.95

Feedback circuitry thruout! Preamp-equalizer, tone controls, scratch & rumble filters, K-follower output.

20,000 Ohms/Volt MULTIMETER #565
KIT \$24.95
Wired \$29.95

1000 Ohms/Volt MULTIMETER #536
KIT \$12.90
Wired \$14.90

VTVM PROBES KIT Wired
Peak-to-Peak\$4.95 \$6.95
RF\$3.75 \$4.95
High Voltage Probe-1\$6.95
High Voltage Probe-2\$4.95

SCOPE PROBES
Demodulator\$3.75 \$5.75
Direct\$2.75 \$3.95
Low Capacity\$3.75 \$5.75

For FREE 1956 catalog, mail coupon NOW!

EICO

84 Withers St. • Brooklyn 11, N. Y.

Prices 5% higher on West coast and subject to change without notice.

EICO, 84 Withers Street R-8
Brooklyn 11, New York

Send FREE 1956 Catalog and name of neighborhood EICO jobber.

Name.....
Home Address.....
City.....Zone.....State.....
Occupation.....

Turn page for other EICO ad

1945 to 1955: a decade of Know-How & Value Leadership in Kits & Instruments—over 1/2 million sold to date!

A New Approach to Hi-Fi Stereophonics

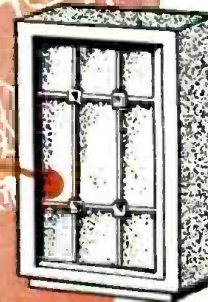
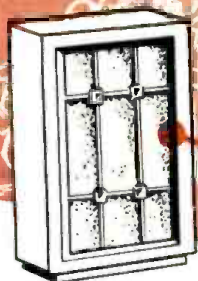

By **NORMAN H. CROWHURST**

THE IDEA of stereophonic reproduction has had time, since it was first introduced, to get arranged, re-arranged, and tried in all kinds of variations. Many types of program material can be enhanced by good stereophonic presentation but some kinds, particularly solo voices and solo instruments, do not sound quite natural in this medium. So let us consider what we really want a stereophonic system to do for us and how various approaches to the problem achieve or fall short of the objectives.

What Should Stereo Do?

The arguments leading to the introduction of stereophonic sound are well known by now: the fact that we have two-ear or binaural perception whereas a microphone or loudspeaker system using only one channel can only convey monaural perception. In making listening comparisons between live program material and reproduced sound, a big difference can be noted between the original sound in live program material and the reverberant sound in the building. However, as soon as the same program material is recorded and reproduced, this difference disappears and the reverberant sound becomes confused with the original sound.

The fact that our binaural perception enables us to detect separately the direction of the original sound and the direction of the reverberant echo in the original production is quickly understood. The problem is to overcome this deficiency in reproduced sound. Another thing, related to this, that we expect stereophonic sound to do for us, is to enable us to pinpoint solo sources of sound, such as a singer's voice or a solo violin, and at the same time to appreciate a widespread source of sound, such as a full orchestra.

Some even claim that stereophonic sound should enable us to pinpoint the

Details on a new system for recording and reproducing tape which provides a spatial effect by filtering.

individual instruments in a full orchestra. People who expect this of stereophonic reproduction should try sitting in an average concert hall and attempting the same thing with a live performance. They will find that this particular requirement is not as simple as it seems. You certainly get an impression of a widespread source of sound but, while the whole orchestra is playing, it is difficult to locate the precise position of the violins and wind instruments by ear alone. This being the case, it seems somewhat unreasonable to expect a stereophonic system to do for us what the live performance fails to do.

Two methods of attacking this problem are already well known, the stereophonic system and the binaural system. In the binaural system a dummy head, with two microphones in the positions normally occupied by human ears, is placed in the auditorium at a position which is intended to represent the listener's head. The program material picked up by these two microphones is then recorded on separate channels and, in due course, is played

to the listener who hears the sound in headphones connected to these separate channels.

Limitations of Binaural

The limitations of this system are obvious. In the first place listening with headphones is quite unlike listening with one's ears free, whatever the quality of the headphone reproduction, and quite apart from the discomfort of wearing headphones for long periods of time. It is true that a remarkable sense of direction is achieved this way because the phasing of sound presented to the two ears is identical with the phasing and intensity of sound received at the microphones in the dummy's head. So the impression of direction, and various other effects such as reverberation coming from different walls of the building, are accurately conveyed.

A further limitation exists in the fact that the dummy's head remains still during the recording, whereas the listener may wish to turn his head slightly, as he would during a live performance, to concentrate his at-

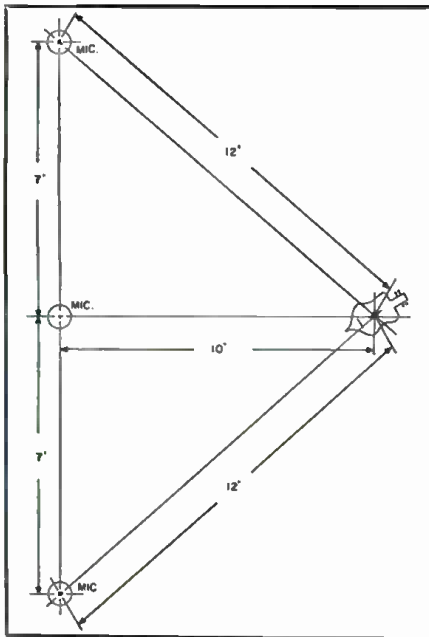

Fig. 1. How multi-microphone pickup of a solo instrument produces an unnatural effect. The side microphone, being only a little farther from the source, will pick up almost the same level. When the effect of studio reverberation is taken into account, the difference in level is negligible.

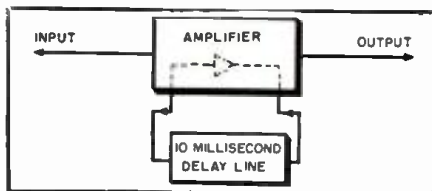

Fig. 2. Block diagram of electronic "artificial reverberation" that has been claimed to produce the same effect as stereophonic reproduction with a single channel. See article for a discussion of technique.

tention on a particular instrument or a particular source of sound. When he turns his head, of course, the dummy does not, and so the sound field rotates with his head instead of remaining as it was, which is quite an unnatural experience.

Broadly speaking, the stereophonic approach appears to have more practical potentialities although it may lack some of the capability of realism possessed by binaural approach. The stereophonic approach aims at recreating a directional sound field so the listener is free to move his head or occupy different positions just the same as he was in the original production. The weaknesses of the stereophonic system appear in the problems imposed to recreate the original sound field.

The classic presentation of the idea represents the recording studio with a line of microphones all along one wall, each microphone picking up sound at that position on the wall and recording it on a separate channel. The playback end then reproduces through a line of loudspeakers on a corresponding wall of the auditorium and the theory is that the sound wave incident at the wall of the studio will

be reproduced at the corresponding wall of the auditorium. Having made this assumption, which is not quite correct as we shall see in a moment, the theory then goes on to say that we don't need a large number because, in fact, a smaller number produces quite a good approximation. The usual number is three. The latter fact has been experimentally verified.

Limitations of Classic Stereo

The fallacy in this multiple channel approach rests in the fact that the incident sound wave at each microphone possesses directionality, but the microphone must be either omnidirectional or directional. Whichever is used, it cannot be sensible to the *direction* in which the incident sound wave strikes. Similarly the corresponding loudspeaker on the wall of the auditorium cannot reproduce the wave with directional discrimination. This means that the directional properties of the original sound waves are not reproduced, only the relative phase differences at selected points along the wall. Pursuing this argument, it is readily seen that complete reproduction of the directional characteristics of the original sound field is quite impossible. This is why stereophonic reproduction fails to satisfy on some kinds of program material.

Suppose, for example, a violin is playing in a studio with three microphones spaced at 7-foot intervals, making a distance between the left and right microphone of 14 feet. If the violin is immediately in front of the center microphone and, say, 10 feet away from it, then it will be about 12 feet from each of the side microphones. (See Fig. 1). This is quite normal proportioning of a studio in which such a recording will be made. Disregarding for a moment any reverberation in the studio, which adds further complications, the intensity of sound recorded on the two side channels will only be some 2 db lower than that recorded on the center channel. When it is reproduced in the auditorium the *intensity* difference is not sufficient to pinpoint the source of sound as being opposite the center loudspeaker. Whatever directional effect is produced is caused by the phase, or time, difference which "fa-

vors" the center speaker. But despite this, the unnatural similarity in level from three sources gives the impression of a larger-than-normal violin.

An expanded solo human voice sounds even more unrealistic and it is this property of the conventional stereophonic presentation that seriously mars its realism.

It has been shown that the apparent *breadth* of stereophonic presentation is due principally to the presence of multiple sound sources. On more than one occasion, during a demonstration of stereophonic sound, the loudspeakers have been changed over so as to operate from a single channel and on at least one occasion the demonstrator was oblivious to this fact! He went on discussing the merits of reproducing sound in its correct intensity and phase relationships, quite unaware that each loudspeaker was, in effect, reproducing the same intensity and phase relation.

It should be noted, however, that changing from a single channel presented over three speakers, to proper stereophonic over the same speakers, makes an audible difference and that the change is undoubtedly an improvement. It gives an illusion that more closely resembles the original, especially in its directional effects.

Past experience has taught us that much of our appreciation is psychological: the first radio transmission was "almost lifelike", because we *could* recognize the voice. When something better came along, we realized the deficiency of what we had hitherto thought good. That story has been repeated over and over. But meanwhile, our ears do a very good job of overlooking the deficiencies!

Besides comparing single channel with stereophonic, over the same speaker grouping, some have experimented with dividing the frequency spectrum and delivering either different parts of the spectrum or different response characteristics to each speaker. This too can improve realism *in some instances*. The snag with this idea is that an arrangement that improves the presentation of one segment of the program material is detrimental to another.

Besides pointing up the weakness of multiple channel reproduction, the comparisons just discussed also reveal a possibility for improvement in two directions—cost and realism. With regard to cost, since a single channel reproduced over multiple sources *can* sound almost as realistic as separate channels reproduced over the same loudspeakers, there appears to be little point in using multiple channel recording.

How, then, shall we improve realism? The principal thing we want stereophonic sound to do is to discriminate between different kinds of sound and sound coming from different directions. With the aid of multiple loudspeakers, I suggest—and I am aware that this will sound like heresy—this can best be achieved by varying the

Fig. 3. Block diagram of system for playback of program for "Perspecta" sound coded stereophonic presentation. See text.

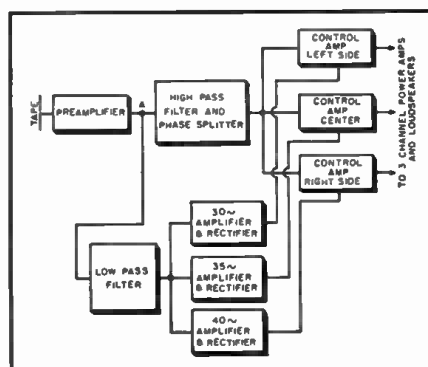

Antenna Rotators

By **WALTER H. BUCHSBAUM**

Television Consultant
RADIO & TELEVISION NEWS

A SURVEY of the commercially available antenna rotators indicates that there are a few basic types, each of which requires a somewhat different approach for installation and servicing. Mechanically, there are two different rotor constructions. In one type, the rotor unit is clamped onto the main mast by offset pipe clamps; this type is referred to as the offset type. Such a unit is shown in Fig. 1.

The second type is the inline rotor. Here, the main mast and rotated mast are directly in line, with the rotor unit interposed between. The latter type is illustrated in Fig. 2.

Most commercial rotators are capable of handling different size loads. When the antenna is a large array, especially for community TV systems, etc., a heavier-than-normal rotor may be required, such as the one shown in Fig. 3. Most manufacturers state the load handling capacity of the rotator as the maximum weight of the rotated assembly; these vary from about 100 to about 200 pounds.

In electrical characteristics, the major difference between rotators is the manner in which the control unit actuates the rotor and the system used to report rotor position to the indicator. The circuit diagram of the system used by many rotor-control box combinations is shown in Fig. 4. In this scheme, the rotor motor is actuated by a double-pole, double-throw switch which determines the direction of rotation. A gear train reduces the speed of the motor down to the actual mast rotation speed and, on the last reduction shaft, a potentiometer is mounted. This potentiometer is connected to the motor and ground and supplies a voltage to the meter to indicate the relative shaft position. As the rotor moves the an-

Fig. 1. The rotator shown here is of the offset type. Note that the mast supporting the rotator is not in a line with the mast holding the antenna proper. Note also how the lead-in is secured to masts.

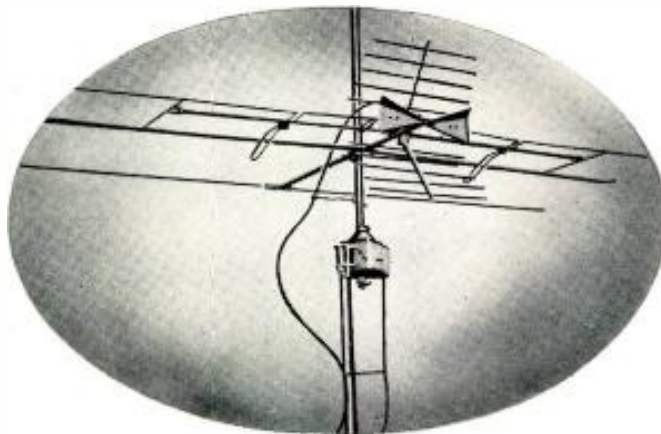

This is the time to inspect old rotators and to install new ones. This article describes proper installation, repair, and lubrication procedures.

tenna through its range, the potentiometer varies the voltage to the meter from zero to its maximum value. The meter is calibrated in direction rather than voltage and thus indicates the direction of the antenna. The appearance of a meter indicator control unit is shown in Fig. 5.

In operation, this system requires that the switch be depressed and held that way until the desired direction is reached, then the switch is quickly released and the antenna stops. This type of control system is simple and straightforward. The control box contains no moving parts except for the switch, consequently there is little occasion for repair. Of course, different manufacturers use variations of this basic concept to make their products original. Some rotators feature a special brake which reduces coasting and which is also helpful in

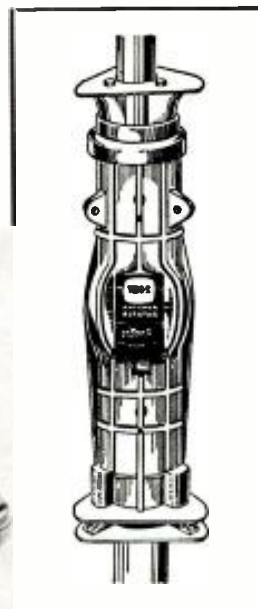

Fig. 2. Two different versions of inline antenna rotators are shown here. In these, the mast sections are lined up.



Fig. 3. This is an extra-heavy duty rotator designed for extremely heavy loads.

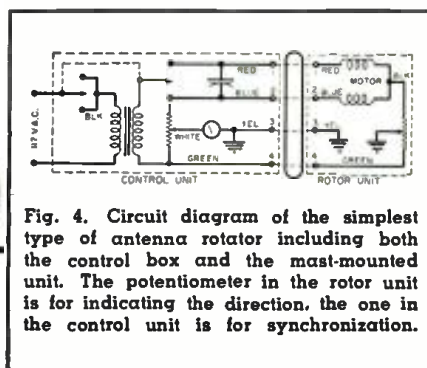

Fig. 4. Circuit diagram of the simplest type of antenna rotator including both the control box and the mast-mounted unit. The potentiometer in the rotor unit is for indicating the direction, the one in the control unit is for synchronization.



Fig. 5. A control box of the type whose schematic diagram is shown in Fig. 4.

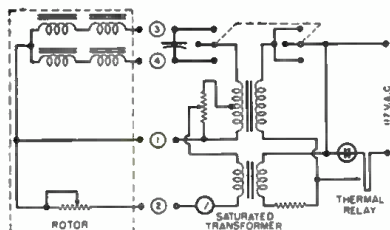

Fig. 6. The complete rotator shown here features a thermal switch for automatically turning on the rotator when the TV set is turned on. The saturated transformer minimizes line fluctuation effects.

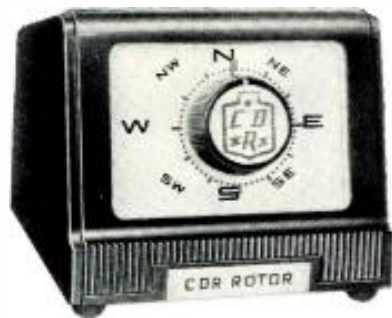

Fig. 7. The control box shown here is calibrated in 6-degree steps. The operator selects the direction desired; the rotor turns the antenna to it and stops.

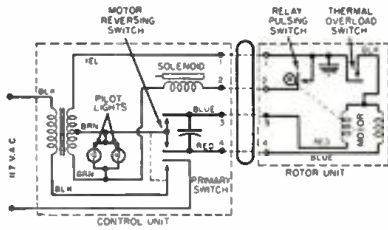
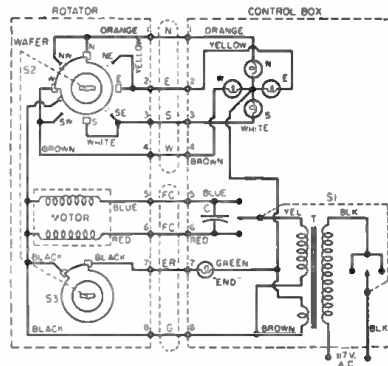

Fig. 8. Schematic diagram of the rotator system using the control box of Fig. 7.

Fig. 9. This rotator uses a wafer switch ganged to the gear train of the motor. One switch section operates a pilot light which indicates the end of rotation; the other section indicates the direction.



curately orient the antenna for each station and then label the indicator accordingly.

Installation

Installing a TV antenna rotator requires the same sort of planned effort as for an elaborate antenna system, but certain special considerations must be made. For one thing, the weight of the entire assembly will be considerably greater than that of an ordinary antenna. For that reason, the supporting base must be strong enough to carry not only the additional weight in a downward direction, but must also withstand the moment of bending or swaying that will be due to the rotator and its brackets. Guy wires which may have been sufficient for a simple antenna may be too weakly anchored when a rotator is added. It is also important to make sure that the antenna will not face towards any obstructions when pointed at the desired TV stations.

The location of the rotor unit itself should be as close to the antenna as possible, but never closer than 0.1 wavelength to the active elements. Putting the rotor close to the antenna keeps the rotated mast short and thereby minimizes the load the rotor has to move and simplifies the guying problem. The stationary part of the mast should be guyed as close to the rotor mounting brackets as possible to minimize swaying of the rotor. Where the rotating mast length exceeds about 6 feet, a second guy ring, preferably one using ball bearings, should be used to guy the upper mast as shown in Fig. 10. With the addition of the guy ring, special care must be taken in adjusting the tension on all guy wires to avoid putting an uneven stress on the rotor or actually bending the upper mast.

Unique among the rotators currently on the market is the *Crown Control Co.* unit which the manufacturer specifi-

Fig. 10. Rotator and antenna installation in which the antenna mast is longer than 6 feet. Here the upper mast should be guyed using a ball-bearing guy ring.

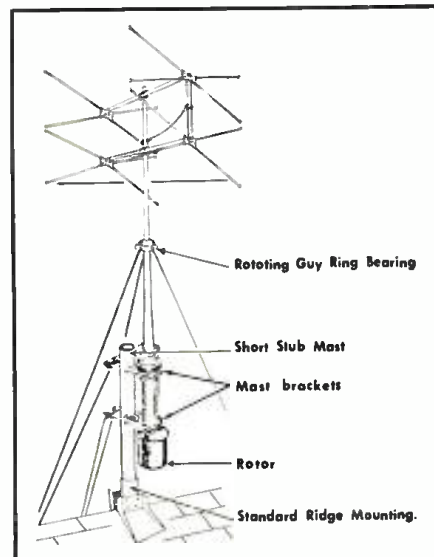

maintaining correct position against the twisting force of strong winds. Other special features are furnished by commercial rotators and these will now be inspected.

The *JFD "Roto King"* shown in the circuit diagram of Fig. 6, supplies power to the TV receiver through a socket in series with a thermal relay. This automatically puts power onto the rotator after the TV set has been turned on. Depending on the power requirements of the TV set, the thermal switch will require a few seconds to warm up before it closes the power contact to the rotator unit, but an adjustment on the thermal switch allows the technician to set this time delay. The use of a saturated transformer in this rotator minimizes the effect of line voltage fluctuations on the indicator.

A completely different indicating system is used in the *Cornell-Dubilier (Radiart)* unit shown in Fig. 7. Here, the operator sets the control knob to the desired position and then the rotor moves the antenna until that position is reached. The control knob incorporates the primary power switch and motor reversing switch (see Fig. 8). When this knob is set to the desired position, power is supplied to the motor which starts to turn and, as it moves, actuates an interrupter wheel which pulses a solenoid at the indicator for every 6 degrees of rotation. The solenoid drives a pointer (not shown in the diagram), and lights a set of pilot lights, until the pointer position coincides with the desired position. At that point, power to the motor is interrupted and the unit is deactivated.

In this system there is no possibility

of coasting or overshooting since the rotor moves the antenna in discrete 6-degree steps. For almost all TV antennas, the 6-degree steps are sufficiently fine.

The third type of indicator uses rotating switch wafers like those used in remote-controlled TV tuners which have recently become so popular. The *Radiart* model "TR-2" is typical of this type; its circuit diagram is shown in Fig. 9. Actual operation of this system is by means of a double-pole, double-throw switch which powers the rotator motor and determines its direction of rotation. Ganged to the gear train of the motor is a set of wafer switches. One indicates the end of the rotation angle by switching on a light marked "end" in the center of the indicator display. The other wafer connects 6-volt power to a set of four pilot lights representing the four major directions. By using eight contacts it is possible to indicate northwest, for example, by lighting up both the north and the west light. While this system is quite simple it requires a total of eight wires to the mast-mounted rotator unit as compared to the usual four-wire cable used in other systems.

Putting aside the technical consideration, the important operating features for the set owner are the ease and accuracy with which he can rotate the antenna to the desired stations. In this respect it is advantageous to have the indicator calibrated by TV channel number rather than azimuth and several manufacturers have taken this into account. They furnish decals or adhesive labels with their units so that the service technician-installer can ac-

cally emphasizes is suitable for use with long mast installations. The manufacturer suggests that the rotator be mounted as low as possible and that the entire long mast and array be rotated. One typical installation is shown in Fig. 11 where the rotator is mounted over the porch of a home with a long tower and the antenna on top of it. There is a rotating guide ring at the top of the tower and another guy ring a little below the antenna crossarm.

The antenna lead-in line should be clamped in a standard polyethylene clamp right on the rotating mast and, after leaving a sufficient amount of free line to account for a complete rotation, the lead-in should again be clamped on the stationary mast. Be absolutely sure that rotating the antenna does not put any strain on the transmission line. The rotator cable should be formed into a drip loop at the rotor unit and then brought down on separate stand-offs.

When possible, all electrical connections for the rotator and antenna should be carefully soldered before mounting and weatherproofed with the usual materials.

Before anchoring the entire assembly on the roof, tower, or other supporting structure, rotate the antenna through the full 360 degrees (or more) and observe where the stop is located. Point the antenna in the direction indicated. In practically all rotators, due north is the location of one stop on the indicator unit. (Most rotators turn through more than 360 degrees to provide overlap.)

Lightning arresters should be installed at the antenna lead-in and separate, different, arresters should be used with the power leads of the rotator cable. Most rotators are supplied with either a 50- or 100-foot length of control cable, but where greater lengths are required, the size of the conductors becomes important. For proper operation, one manufacturer, for example, advises that at least No. 20 wire (7 x 28 stranded) be used for lengths up to 100 feet and No. 18 (doubled 16 x 30) be used for lengths of 400 feet. Some models use less current than others and can, therefore, be operated with smaller gauge wire, but, in general, wire size will be important only in installations exceeding 100 feet.

Before tightening the guy wires and mounting clamps, it is a good idea to check the mast alignment with a plumb line. After the guy wires are tightened, the plumb line should be used again to make certain that the mast assembly is not bent. Straight-line installation is the first requisite for a trouble-free rotator installation. If a guy ring is used on the upper mast, check for any binding or uneven mast loading as the antenna is rotated. Weatherproofing of all points where guys or brackets are anchored completes the mast installation.

Once the antenna mast and rotor assembly have been mounted firmly at their outdoor location, the control box indicator must be synchronized with

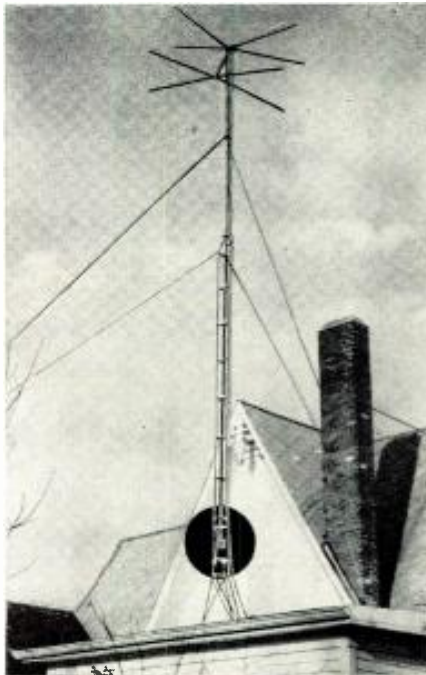

Fig. 11. The installation shown here is unusual in that the rotator is not mounted close to the antenna. However, the manufacturer recommends this installation.

the rotor. Depending on the type of electrical system used, the synchronization will be either electrical, by means of a trimming potentiometer adjustment, or mechanical, by lifting or depressing gears or detents. For example, in the case of the *Cornell-Dubilier* control unit whose circuit is shown in Fig. 8, synchronization is accomplished as follows:

1. Turn the control knob fully counterclockwise. If the light remains on, the rotor has followed but the indicator contact has not. Trip the synchronizing lever accessible under the control box until the light goes out.
2. Repeat for the full clockwise position of the control knob.
3. Knowing the direction in which the antenna is facing, remove the control knob and move the red pointer to a position corresponding to the true antenna direction.

The synchronization of rotating units using the potentiometer system, such as shown in Fig. 6, involves the repeated adjustment of the potentiometer located at the control box to obtain correct readings at both ends of the scale

Repair Procedures

To the television service technician accustomed to troubleshooting the complex electronic circuits of the modern TV receiver, the electrical system of most antenna rotators will appear quite elementary. Electrically, they are usually very simple, but there are still a host of defects that can occur. In most instances these can be separated into defects due to the control and indicating unit, and those occurring in the rotor assembly.

If the antenna turns but the indicator fails to light or the meter fails to show any voltage, the defect obviously

is not in the motor circuit but in the signal path. Ohmmeter circuit tracing will show up any electrical defects but often the trouble is mechanical and only the symptoms are electrical. For example, if the shaft coupling from the potentiometer to the gear drive in the rotor unit gets loose and slips, the indicating system will be either erratic or fail to show any rotation at all.

Troubles in the control and indicator unit are relatively easy to repair since they involve either the replacement of some component or else the adjustment, cleaning, and lubrication of some mechanical part such as a gear, plunger, switch contact, etc. When the rotor unit requires servicing, it usually entails taking down the entire antenna assembly and this, in turn, is a time consuming job. In this respect, those rotators which feature detachable power drive, as shown in Fig. 12, are a real help, since this permits exchanging the motor and gear train without removing the antenna or disturbing the installation in any way. It is seldom, however, that the motor will be the cause of trouble.

When the defect has definitely been traced to the rotor or external antenna system, the nature of the defect often indicates clearly what is really wrong. Of course, if the rotor motor fails to go on at all, the first suspect is the power line and it should be checked for continuity with an ohmmeter. If the motor seems to turn but gets overheated quickly, excessive friction is probably the cause. In this event be sure to check manually whether the antenna assembly is free to rotate or whether uneven guying, bending of the mast, or corrosion in the moving parts of the rotor unit itself is the trouble.

Whenever binding or excessive friction requires that the rotor assembly be taken down it is a good idea to also clean and lubricate the entire gear train, when this is easily accessible. Fig. 13 shows a typical gear train and its relative complexity. Lubrication of the moving parts of the control and in-

(Continued on page 116)

Fig. 12. Some rotators have an easily removable motor and gear train assembly as shown here. The units are factory sealed and usually "lifetime" lubricated.



REPRODUCTION of frequencies up to about 2000 cps is a matter of getting the cone size, shape, and material right, as has been explained in Part 4 of this series. Provided sufficient freedom of movement is incorporated in the design of the cone suspension to give the necessary bass output at low frequencies and the cone is stiff enough to counteract the tendency to develop nodes, no further attention need be paid to the material of the cone and the method of making the voice-coil. Cone break-up will give an output above 2000 cps, but the response will be uneven and certainly deficient above 5000 cps. The difference between an ordinary speaker, such as is produced by the millions for commercial radios and TV receivers, and an alleged high-fidelity speaker is in the attention that has been paid to the matter of reproducing frequencies above this figure and at the extreme low end.

Some designers maintain it is impossible to get a wide smooth response up to 10,000 or 15,000 cps from a single speaker unit, and confine their attention to tweeter-woofer combinations; others, including your present author, do not accept this. They maintain that the disadvantages of the multi-channel speaker outweigh its advantages and that the desired results can be secured with only one magnet system, although it is generally agreed that something special has to be done to the cone, and I insist that something special has to be done to the voice-coil as well. Assessing the merits of a complex diaphragm speaker as compared with a tweeter-woofer combination *by looking at it* involves some knowledge of the merits of the various methods used by designers.

The first step forward in extending the response of a diaphragm was made by P.G.A.H. Voigt in, I think, 1934, when he patented and produced a composite diaphragm consisting of a main cone to which was firmly cemented a "tweeter" cone of smaller diameter and narrower angle. Voigt's idea was that the main cone was too massive to reproduce the extreme highs; it was better that these should emanate from a smaller lighter cone. It was of little consequence that the two were driven by the same voice-coil, since cones break up in any case; using a subsidiary treble cone simply meant that the break up came within controlled limits.

This invention has been widely copied both in the U. S. and Britain. One application of Voigt's invention resulted in a commercial version which incorporated a twin cone. Admittedly, this improved the treble response considerably, but it should be remembered that at the time Voigt's speakers were introduced they were intended for use with logarithmic or exponential curved horns. A speaker working into a properly designed horn has a much greater electro-acoustic efficiency than a speaker working in a flat or box baffle owing to the better loading of the dia-

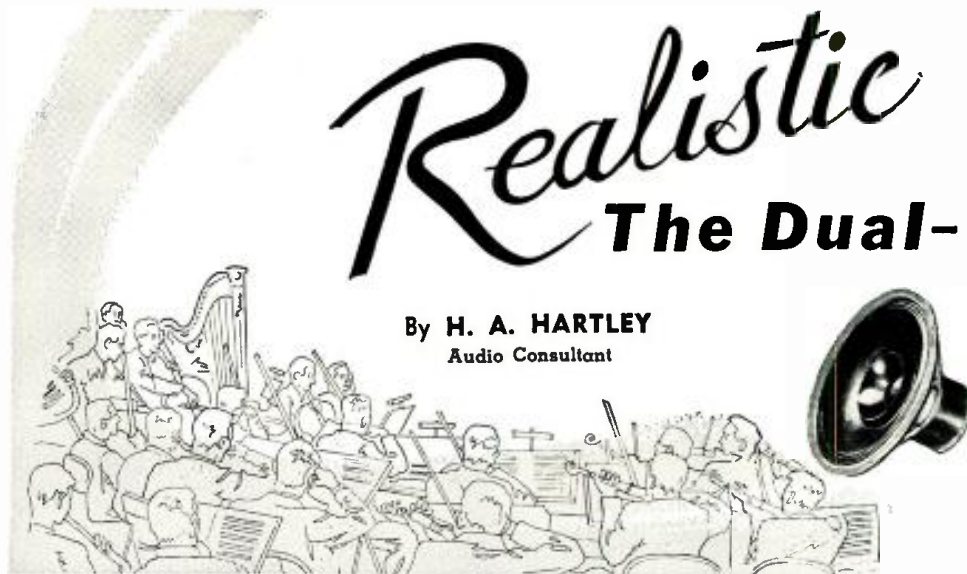

By **H. A. HARTLEY**
Audio Consultant

Part 5. The personal opinions of a noted speaker designer on the advantages and disadvantages of the dual-cone unit.

phragm. For a given acoustic output, a horn-loaded speaker requires much less electrical input and the Voigt speakers produced a very healthy noise with inputs of only 1 or 2 watts. Even more was achieved in the celebrated *Western Electric 555* theater speaker, whose efficiency was considered by some to be phenomenal.

I was so impressed with the results Voigt obtained with horn-loaded speakers that I supposed, incorrectly as it turned out, it would work equally well with baffle speakers, and I obtained permission under license to use the idea in my own loudspeakers. I then discovered the limitations of the idea. The outer edge of the tweeter cone is quite undamped, except for the stiffness of the material of which it is made. If you flip the edge of the small cone of any double-cone speaker with your fingernail, in a direction towards the center of the speaker, you will hear the same sort of noise as if you flipped the edge of an ordinary sheet of paper, but probably sharper, because these small subsidiary cones are usually treated with Bakelite varnish and pressed in dies (this being shown by the much smoother surface of the paper as compared with the main cone's surface). This same buzzy sound is created when the whole assembly is driven hard with big inputs, the frequency of the emitted note being a function of the size of the small cone and the material of which it is made. This spurious note has nothing to do with the frequency of the applied signal, it is merely a resonance generated by sudden impacts of energy from the voice-coil. If an attempt is made to kill this resonance by applying damping material to the edge of the small cone, the mass of the cone is so increased that the extra treble response is lost. The only way to avoid this distortion is to limit the input to the speaker.

Unless the speaker is sufficiently sensitive, that is, efficient, the output may not be adequate; as I have pointed out, loading the diaphragm by using a horn is the certain way of achieving high efficiency, but for a baffle speaker improvement can be gained by using small magnetic gaps and high flux density in the gap. This, however, introduces trouble at the bass end, for freedom from bass resonance can only result from freedom of cone movement, and this implies generous gap clearances and special attention to the design of the magnetic field so that at no point of its excursion does the voice-coil pass into a less intense field. These considerations impose a limit to what can be done by stepping up sensitivity in a baffle speaker. If the speaker is sufficiently sensitive to produce a respectable acoustic output without generating buzzes from an improperly designed tweeter cone, it is almost certain that the magnetic circuit will be of a type that will introduce bass distortion unless the input is limited. The design engineer is faced with a serious problem. The ultimate in treble performance results in poor bass and *vice versa*. As a result, most careful design is needed to effect a suitable compromise.

With this in mind, therefore, it is possible to formulate a few simple rules when assessing twin-cone speakers. Measurement in a laboratory with small constant inputs of varying frequency show that the use of a subsidiary tweeter cone gives more treble than a speaker with a simple diaphragm. When such a speaker is used in a cabinet or flat baffle, the power necessary to produce adequate acoustic output will set up a spurious resonance in the free edge of the small cone unless special steps are taken to prevent this. Twin-cone speakers are, accordingly, better with horn loading as this gives better elec-

High Fidelity cone Loudspeaker...



tro-acoustic efficiency. I would estimate that an efficiency of 15% would be necessary to put the tweeter cone beyond suspicion, and this figure of efficiency is not easily reached except with a large and very carefully designed horn.

The failure of the Voigt twin-cone idea when applied to baffle speakers kept nagging at me for some years. I felt that the basic principle was right—that a small cone should be used for the treble, but there seemed no way of stopping the buzzing of the free edge when driven hard. As I have said, loading this edge to kill the resonance was no remedy, for the mass of the loading neutralized the lightness of the small cone. It finally occurred to me that if the loading weight could be taken away from the tweeter cone the desired results would be obtained, and then I had my brainwave. Fig. 14A shows a section of the typical twin-cone speaker; while my solution of the problem is shown in Fig. 14B, where the apex of the large cone has virtually been removed and the small cone put in its place. The two parts of the cone are joined by a small zone of flexible material to form a compliance. The idea behind this innovation was that the weight of the flexible material damping the erstwhile free edge of the tweeter cone was supported by the main cone, but if sufficient flexibility existed in the compliance, the small cone would still be free to oscillate at the higher frequencies. At the same time it would have to be sufficiently stiff to transmit substantial movements set up at lower frequencies so that the whole cone moved at those frequencies. It called for a considerable amount of experimenting to find just the right degree of flexibility for the compliance, but tabulated results finally enabled a schedule to be compiled for any frequency response desired, within the limits of a two-cone speaker.

The other part of the diaphragm assembly that naturally restricts extreme treble output because of its mass is the voice-coil itself. It is not possible to reduce the weight of this component beyond the point where it loses rigidity; the coil is subjected to

heavy a.c. current impulses and must, therefore, be quite strong. The coil and its former (coil form) usually consist of a paper tube on which is wound two layers of copper wire, the whole firmly cemented together. The method by which the voice-coil former is cemented to the apex of the cone is vitally important, for any weakness here will result in a peak in the response curve, usually at about 3000 cps. This effect is made use of in cheap mass-produced speakers to provide a spurious treble output to compensate for the top cut-off in cheap radios, but is quite out of place in high-fidelity work. The weight of the coil can be reduced by using aluminum wire and this provides some small increase of response at the higher frequencies. The problem is to reduce the weight of the coil-former assembly as much as possible.

The first original approach to solving this problem was that of H. F. Olson ("A New Cone Loud Speaker for High Fidelity Sound Reproduction," *Proceedings of I.R.E.*, January, 1934) who described a voice-coil in two parts connected by a compliance. Fig. 15A shows the arrangement of two voice-coils in series but separated by a flexible compliance in the former; the bass coil is heavier than the treble and is bypassed by a capacitor of such size as to act as a short-circuit at high frequencies. At low frequencies the whole moves together; at high frequencies the flexibility of the compliance permits the treble coil to move

Fig. 14. (A) Cross-sectional view of a typical twin-cone speaker. (B) The Hartley design whereby the apex of the large cone has virtually been removed and replaced by a small cone. The two parts are joined by a small zone of flexible material.

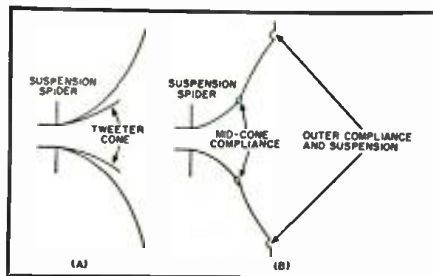

independently (the required movement is really very small). The idea works all right, but the compliant former is a troublesome thing to make with any consistency and the separate leads for the bypassing capacitor difficult to provide; but, like so many things in loudspeaker design, it seemed to set up trains of thought in two minds in Britain.

Of my own case I can speak with authority. It seemed to me that the logical thing to do was to have the treble coil inside the bass coil, concentric with it and separated by a plastic film. In the other case I have no justification in linking the Olsen idea with the "Duode" idea of A. C. Barker. It was a case of two independent workers hitting on much the same idea at the same time, as has happened often enough in the history of human thought. Barker's invention, patented in Britain and described in the *Wireless World* in about 1938 described a composite voice-coil consisting of the regular winding separated from a secondary "winding" by a flexible compliance, but the secondary winding was of only one turn, being an aluminum tube carrying the plastic film and the primary winding; the aluminum tube was the only part of the assembly fastened to the cone. This arrangement is shown in Fig. 15B.

Electromagnetic connection to the secondary of the "transformer" thus formed is purely inductive. The coupling is negligible at low frequencies and the whole assembly moves as a solid entity; at high frequencies currents are induced in the tube which moves independently of the winding proper, so response in the upper register is very good. I haven't had a chance to dissect a Barker speaker so I am unacquainted with the minutiae of his design; but in the case of my own speakers I can say that the degree of compression of the compliance has a decided influence on the response. I have found that winding the coil straight onto the plastic is useless, because the tension of the wire cannot be maintained with great accuracy. I wind the voice-coil onto a very thin paper former, slip the wound former over the plastic which is already fitted to the aluminum tube, and then expand the tube to a predetermined amount. The combination of this compliance with the mid-cone compliance already described gives a response not more than 4 db down at 20,000 cps over an approximate cone of radiation of 120°.

Field Magnet Design

It seems fairly obvious that the greater the magnetic flux in the gap in which the voice-coil works the more sensitive the speaker and the equally obvious way to get more flux is to use a big magnet. In the case of high-fidelity speakers it isn't as simple as that since flux alone is not all that matters; it is just as important that the field of flux should have certain characteristics. Cheap mass-produced

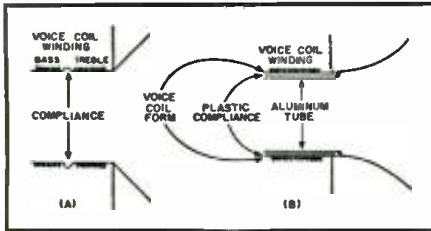

Fig. 15. (A) How two voice coils are connected in series, separated by a flexible compliance. (B) A composite voice coil, developed by A. C. Barker, which consists of a regular winding separated from a secondary "winding" by a flexible compliance. The secondary is an aluminum tube. See text.

speakers have small magnets because permanent magnet steel is very costly; the efficiency of such speakers is secured by having the smallest possible gap and this involves the smallest possible clearances between the voice-coil and the walls of the gap. Such small clearances are only practicable when the permissible movement of the voice-coil is small, since it is almost impossible to preserve absolutely true axial movement with the materials of which the coil, cone, and suspension system are made. Limitation of the axial movement of the voice-coil, through tight suspension, results in a bass resonance of comparatively high frequency. Some such speakers are incapable of reproducing any frequency below 120 cps.

The high-fidelity speaker is required to reproduce very low frequencies and this demands much greater freedom of movement; as I explained earlier, the amount of movement required to reproduce a certain bass frequency depends on the size of the cone, but large cones have certain acoustical disadvantages; they also have the physical disadvantage that, being heavy, they are difficult to start moving and difficult to stop moving. The former property takes the sharp edge off transients; the latter spoils the damping. The attributes of high flux density, apart from improved sensitivity, are good "attack" (immediate response to transients) and good damping. To use a large cone to reduce requisite movement to reduce clearance to improve flux density thus destroys the whole purpose of obtaining high flux density.

Skilled loudspeaker designers know this and have compromised on cones having diameters of from 10 to 12 inches, but reproduction of very low frequencies with such diaphragms involves appreciable coil movement, and this results in further difficulties. Fig. 16A shows a section of a typical magnetic gap with the voice-coil the same length as the gap. The lines of flux are shown dotted, and are closest together when the flux is most intense. Obviously the greatest flux is right inside the gap and when the coil is centered in the gap it is cut by the maximum lines of flux. The speaker is then in its most sensitive condition. When an alternating current is applied to the coil it will oscillate to and fro; at the limits of movement it will cut

fewer lines of flux simply because the field is weaker outside the gap than inside it. Under these conditions the speaker will be less sensitive, but as the signal input is constant the acoustic output will be less when the coil is partly outside the gap; the result will be a wobble of twice the frequency of the applied signal.

Someone once called this the "Doppler" effect in speakers, apparently under the impression that the wobble tone was due to the diaphragm approaching and receding from the listener's ear. It is nothing of the sort and despite the audio pundits I maintain there is no Doppler effect with speakers, a fact I have demonstrated to many electronics societies by the simple experiment of demonstrating one of my own speakers moved to the limit of the cone excursion by an applied 50-cycle signal with the addition of a 1000 cps signal. The two frequencies are heard separate and distinct, with no variation in the pitch of the 1000-cycle note.

In Fig. 16B the voice-coil is seen to be twice as long as the gap. Provided either end of the voice-coil winding does not at any point of its excursion pass within the gap itself, then, to a great extent, the number of lines of flux cut will be equal and the phenomenon of the bass modulating the treble will not occur. Even then, however, the magnetic field is not symmetrical about the gap, because of the natural cussedness of things. There is no need to embark on an exposition of magnetic theory; I need only explain that there are magnetic characteristics of materials resembling the units of electricity.

An electrical conductor can carry just so much current and if this is exceeded the conductor gets hot and finally melts, as when you blow a fuse. A magnetic conductor has *permeability* which represents its flux carrying capacity, just like an electrical conductor, depending on the area of cross-section and the nature of the metal. But in a magnetic circuit you can't blow a fuse, the conductor simply refuses to pass any more flux; it is said to be *saturated*. An electrical conductor has resistance; similarly a magnetic conductor has *reluctance*. A current passing through a conductor does not spray the moving electrons out-

side the limits of the conductor, but it creates an external magnetic field. The magnet in a speaker not only creates flux in the pole-pieces but it also creates an external magnetic field (as you can demonstrate with the old school-boy experiment of sprinkling iron filings on a sheet of paper placed on a horseshoe magnet). These lines of flux outside the magnetic circuit proper are called *leakage flux*.

A given size and design of electro-magnet or permanent magnet has a *magnetomotive force* which provides the flux in the magnetic circuit. The permeability of the center pole of the magnet system determines the maximum flux that can be created in the gap, but the reluctance of the pole-piece tries to stop it. In addition some of the flux is lost as leakage flux between the center-pole and various parts of the whole magnet system. Reluctance is reduced by increasing the diameter of most of the center-pole, as shown in Fig. 16, for by doing so an improvement of something like 50% in useful flux in the gap can be obtained as compared with a pole-piece having the same diameter throughout. But the presence of this extra mass of metal near the front plate, which is the other pole-piece, results in an increase of leakage flux, for the flux naturally takes the line of least resistance. My sketch (Fig. 16A) therefore shows flux lines which have avoided the actual gap completely and it will be obvious that the leakage flux behind the front plate is greater than in front of it, simply because of the unavoidable presence of the center-pole. The field must therefore be asymmetrical about the gap with such an arrangement as that shown in Figs. 16A and 16B.

This sets up a condition of strain in the loudspeaker. Let us assume that the first half cycle of an applied signal drives the voice-coil inwards. The repulsion of the magnetic field in and behind the gap drives the coil forward on the second half cycle, and into a magnetic field which is weaker. On the next half cycle this weaker field has not the same repulsive effect as that behind the front plate, so the tendency of the voice-coil is to stay outside the gap. If the cone is aperiodically suspended on threads, it will be driven out of the gap and stay there. This effect I originally christened electro-mechanical rectification (in 1926 when I first noticed it). In practice, of course, the cone is returned to its normal position by the action of the outer surround and the rear suspension spider, but this only tends to neutralize the effect, the basic cause is still there. Hence the condition of strain, which I have observed, helps to create the phenomenon of cross-modulation.

In my search for a method of producing a symmetrical field, I had no alternative but that of making up a large number of experimental magnets and exploring their fields with a very

(Continued on page 114)

Fig. 16. (A) A section of a magnetic gap with the voice-coil the same length as the gap. (B) The voice-coil in this case is twice as long as the gap. (C) Method for obtaining field symmetry by extending the center pole to stick out beyond the front plate which must be modified as shown in diagram. Refer to article.

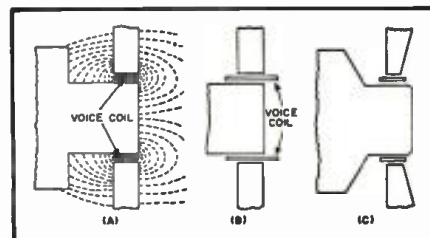

Transistorized Beach Phonograph

By
PAUL PENFIELD, JR.

PROBABLY the best-known and most widely-used piece of electronic equipment, outside of a common radio, is the phonograph. Acoustical phonographs were in common use before the crystal set and today electronic phonographs are used extensively. It is only natural, then, that the latest electronic techniques should be applied to the reproduction of phonograph records. The beach phonograph to be described was developed around one of the recently-released power transistors, the *Sylvania* 2N68.

One limitation generally inherent in the design of a truly portable electric phonograph is that of power. The turntable and amplifier are generally run by 117 volts from the power line. Even the inexpensive acoustical phonographs designed for children generally have electric turntable motors. To make a truly portable phonograph, we must provide not only for amplification but for powering the turntable as well.

Some phonographs have recently come on the market with transistorized amplifiers and with small six-volt motors, powered by several small mercury batteries. However, this design still represents a waste of power. Because of the difficulties of powering the turntable, portable phonographs have never been as popular as portable radios.

Using a hand-wound phonograph, in conjunction with a transistorized amplifier, seems a natural way to get a truly portable phonograph. Hand wound phonographs are not common items, but are still made in small quantity for children's use, or for use where there is no power available. The unit used by the author is a "Silver-tone" #3256, handled coast-to-coast by *Sears, Roebuck and Co.* Since it is a relatively uncommon piece of merchandise, it may not be carried in stock

Fig. 1. Exterior view of the "converted" record player. Note the clips to hold the crank and the tone arm lock which have been added by author to protect phonograph.



Build a transistorized amplifier for your spring-wound, 78 rpm portable phono for carefree, power-free operation.

at your nearby *Sears* store, but is available by mail order. Consult your nearest *Sears* store for details, or else order direct from the *Sears* catalogue.

Besides the phonograph proper, which comes in an attractive imitation-leather case, all parts required for building the phonograph are common enough and are readily available. In many cases most of the parts can be found in the typical experimenter's "junk box." In this category is the phonograph arm, which can be salvaged from any old electric phonograph. An acoustical arm is supplied with the phonograph, but adapting it for use with an electric cartridge would be difficult.

An old cartridge can be salvaged and put to use in the beach phonograph providing it is checked out first to insure operation.

Four transistors are required, three of them *Raytheon* transistors, CK721 or CK722, and one of them, the output stage, a *Sylvania* 2N68 power transistor. All are available at the mail order supply houses. The speakers used (and two were used, as can be seen in Fig. 4) happened to be *RCA* 12-ohm, 2½-inch units, although tests made with other, 4-ohm, loudspeakers indicated that two or three 4-ohm speakers in series would do just as well.

The other components, as noted in the parts list accompanying Fig. 2, are

standard radio parts, which the reader should have no trouble obtaining. The cost of the items is surprisingly small and the experimenter can construct the unit in one or two evenings, and enjoy his favorite records at the beach this summer.

Circuitry

The output stage of the amplifier (see Fig. 2) is a grounded-emitter class A 2N68. Although the 2N68 can, under ideal conditions, put out over half a watt in class A service, the requirements for the beach phonograph are less severe, and the "ideal" conditions of perfectly-matched loads, correct power supply voltages, etc., could not be easily met, so the stage was conservatively designed to put out a quarter of a watt. One blessing of this design is that the power dissipation within the transistor is moderate, and so the danger of thermal "runaway" and of damaging the transistor by operating the phonograph under the hot sun is eliminated.

For general operating conditions of class A output stages using transistors, the reader is referred to an article in the February 1956 issue of *RADIO & TELEVISION NEWS*, entitled "Power Transistors."

The loudspeakers, connected in series and properly phased, serve as the load. Because of the low output impedance of the power transistors, use

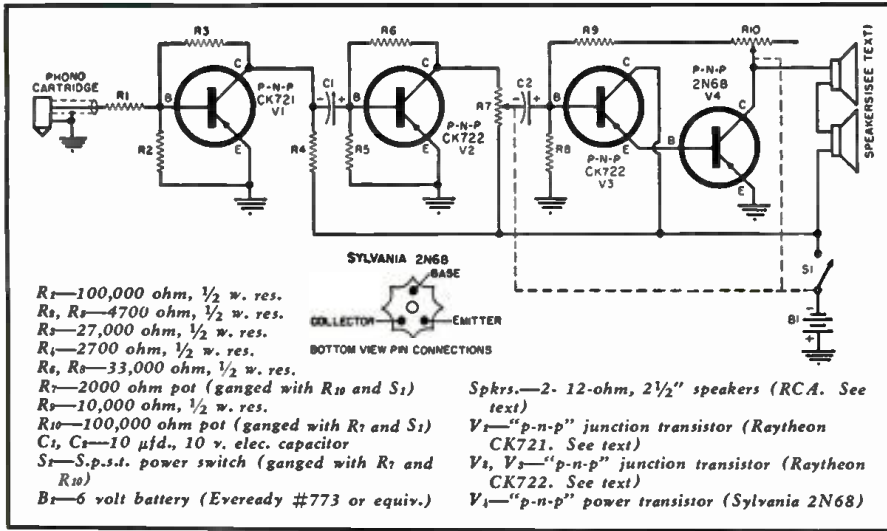

Fig. 2. Complete schematic of transistorized amplifier for the "beach phonograph."

of the normal output transformer can be eliminated entirely in some cases. The beach phonograph is a case in point—the cost and weight of the unit are reduced because of this feature.

One CK722 serves as a driver for the output stage. It is connected in a grounded-collector configuration, to meet the low input impedance of the final stage. Note that the entire emitter current from the CK722 flows through the base of the 2N68—this method of direct coupling reduces power losses to a minimum. As a consequence of this, the quiescent point of operation for the final stage can be determined by biasing the driver stage properly. This is done in the amplifier by the control *R₁₀*.

This control is ganged to the volume control in such a fashion that at low volume levels the quiescent current is cut down to a low value. It should be wired so that when the volume control is turned all the way "on," the resistance of *R₁₀* is minimum. That way, the quiescent current, which is about 100 ma. at full volume, is cut down when it is not needed, that is, when the volume output is small.

The previous two stages comprise the preamplifier. Both operate grounded-emitter, for highest gain. From the standpoint of power gain, transformer coupling would be preferable, but present transistor transformers are not high quality, and the added cost and complication in circuitry were sufficiently troublesome to dictate the use of resistance coupling. Although there is some power gain lost, the over-all gain of the amplifier is still adequate. The coupling capacitors are of a rather large value—10 μfd.—because of the low impedance levels involved in transistor operation. Good low-frequency response dictates use of capacitors of at least this size.

The crystal cartridge is presented with a high impedance by means of *R₁*, the input resistor. This resistor does not reduce the gain as much as might be expected, and improves the frequency response, which tends to be a bit lacking in the bass if the crystal is

loaded down too severely. A value of 100,000 ohms represents a good compromise between high and low resistance, giving flat response from the crystal, without sacrificing more than a few decibels of gain.

Because of the fact that grounded-emitter configurations were used throughout (with the exception of the driver stage) only one battery is necessary. Because this battery supplies only 100 ma. at most, a relatively lightweight, small battery can be used. As noted in the parts list, the Eveready type 773 was used.

Construction

Upon receiving the wind-up phonograph from Sears, the acoustical arm should be carefully removed, taking care not to rip the imitation leather covering. After this is done, the arm to be used may be mounted, using standard procedure for determining the best mounting position. Probably a small platform will have to be built to accommodate the arm mounting in the rather large hole left when the acoustic arm was removed. Details of mounting are left to the reader, since this will differ from case to case. In any event, the arm and cartridge as finally mounted should track properly on the record. A locking-type arm rest is necessary to prevent the arm from being damaged when the phonograph is being carried. The author solved this problem by building a spring-loaded clamp to fit entirely over the arm to hold it down. This clamp can be seen in Fig. 1 and again in Fig. 3. A simple inexpensive locking-type arm rest will do just as well.

The wind-up crank supplied with the phonograph can be secured when it is not in use very easily (as can be seen in Fig. 1) with two ordinary fuse clips.

Since the phonograph is a "consumer item" in a sense, the reader may want to apply a good decorative scheme to the visible parts which he mounts on the phonograph. One convenient decorating material, as used by the author on his unit, is the so-

called "Plastic Veneer." This is merely a photograph made into the form of a decalcomania. The photographs are made of good specimens of various types of wood, and various other objects, such as marble, leather, etc. The inexpensive decal can then be applied to any object or surface with special glue provided for the purpose. This "Plastic Veneer" then provides a tough, good-looking covering. Available to the public in hardware stores, the product, made by the *Meyercord Co.* of Chicago, is used commercially on such items as station wagons and television sets (where the deep mahogany exterior sometimes turns out to be second-grade white pine inside).

To match the imitation leather exterior of the phonograph the author used "English Cowhide" veneer to cover the arm and its mounting plate. The reader of course should use whatever decorating scheme suits his fancy, but the use of "Plastic Veneer" is recommended for its simplicity and good looks.

The next step in construction of the beach phonograph is to mount the loudspeakers. Depending on what type of speakers are used, this can be either a minor or major problem. If the speakers cannot be mounted by screws into the case, they can be mounted by using an angle bracket, as the author did (see Fig. 4). In wiring the speakers, they must be in-phase, that is, avoid wiring them so that one is pushing while the other one is pulling. They should be phased so that they are working together.

The power transistor, clearly visible in the upper left hand corner of Fig. 3 and recognizable by its radial fins, is mounted on a little heat sink. This heat sink is made out of a 3" x 4" piece of aluminum, formed as shown. The dimensions of the heat sink are not at all critical and often a convenient piece of metal lying around in the junk box may be used. Aluminum or copper are the best materials.

The Raytheon transistors are mounted in sockets, the same type used for subminiature hearing aid tubes. Use of these sockets, besides providing the safety features already well-known, permit substitution of higher-gain transistors without any re-wiring necessary, in case this should be desired.

The Sylvania power transistor may be either wired in permanently, or else adapted to plug into the same type of socket. However, in this case, the socket should be movable, since the transistor itself is firmly bolted down to the heat sink.

Mounting the subminiature sockets can be quite a problem, particularly if the supplier happens to forget to send the small retaining rings, which sometimes happens. One method of mounting them is to use the retaining rings to hold the sockets in a universal mounting bracket of one sort or another, or else, the socket may be glued in place with *Duco* cement. Alternately, the socket may be mounted, as it was in the author's unit, by using

the two unused terminals. These may be bent away from the other three terminals, and then soldered into a regular lug of a soldering strip. In any event, one end of the socket should be painted red, to correspond to the red dot next to the collector of the transistor. This will help prevent the transistors from being plugged in backwards.

Mounting the three-bank (two potentiometers and a switch) volume control is a bit difficult, because the panel board is quite thick. However, one ply of the plywood may be removed from the bottom to allow the control to slide up in its hole, at which point it will be possible to tighten a nut down on it.

Wiring the electronic parts is not at all difficult. The polarity of the coupling capacitors, as shown in Fig. 2, *must* be observed. In the author's model, the input stage was wired grouped around the mounting of the arm (in the lower right-hand corner of Fig. 3) and the other stages were mounted forward, nearer the volume control, which was itself mounted toward the front of the turntable board. Variations may be made in the physical layout to suit the reader. For example, the preamp could be mounted in the arm itself, if desired. The battery may be, similarly, mounted any place, although in the author's phonograph it was strapped to the side of the box (see Fig. 4). Actual construction should not take more than two evenings' spare time at the most, even if you work at a leisurely pace.

Performance

Although the beach phonograph was not designed around high-fidelity principles, it does compare performance-wise with small, cheap commercial phonographs (except, of course, for the unique portability feature). The fidelity to be obtained is limited by the quality of the speakers and the size and construction of their enclosures. It

sounds good, which is all that can be asked of a unit designed for such purposes. It also puts out a surprising amount of volume.

If for any reason the reader desires more volume out of the phonograph than it gives at present, he can get more by substituting a CK721 for the CK722 in the second stage (V_2) without any other circuit changes being required.

If noise should turn out to be a problem, or if the reader desires to reduce the noise to its absolute minimum, a CK727 or a 2N106 may be used in place of the CK721 in the first stage (V_1). Again, no other circuit changes are necessary.

The direct current which flows through the loudspeakers causes no deterioration in performance, as might at first be expected.

The phonograph, as it comes from *Sears*, is accompanied by an instruction sheet, which should of course be read before operating the instrument, although certain portions, pertaining to the acoustical arm, will not be of interest. The crank, which comes loose, is inserted into a hole in the side of the cabinet and turned to wind up the motor. The turntable is governor-controlled and the speed can be varied by means of a speed lever next to the turntable. This can be set by using a stroboscope, or, alternately, by merely listening and adjusting to taste. This feature can be useful if it is desired to "tune" the phonograph to a piano, or guitar, or other instrument. Once wound, the phonograph, which operates on 78 rpm only, will run for over 7 minutes, allowing the longest 12" record to be played without re-winding.

Variations

A number of changes can be made in the beach phonograph which may increase its usefulness. In its present state, it is completely appropriate for use on picnics, on the beach, or for

children, for whom the 6-volt power supply holds no electrical shock danger.

However, the limited, although long, battery life may prompt the builder to try his hand at using it with a filtered 6-volt power supply for use around the house. Also, the experimenter may wish to build the amplifier separately, and use it with a 117-volt turntable, and a 6-volt power supply, as a substitute for commercial vacuum-tube phonographs. Even in its full-volume conditions, it consumes less than one-twenty-fifth of the power required for the heaters alone of normal 3-tube phonograph amplifiers.

For use where the battery consumption must be kept to a minimum, the builder might want to incorporate a mechanical interlock to prevent the cover of the unit from closing when the power is turned on. Or, he may want to switch the battery current by means of contacts on the arm rest, so that the power is automatically off when the arm is on the arm rest and automatically on whenever the arm is lifted. The fact that no warm-up period is required by the amplifier makes this feature particularly advantageous in this application.

The experienced experimenter may want to build a device to hold a stack of 78 rpm records inside the cover of the instrument. There is plenty of room in the cover (built large to accommodate the acoustic arm) to carry a number of records, and this added feature may appeal to some builders.

In any event, whether the builder wishes to "spruce up" his beach phonograph with accessories such as these or not, when he has his phonograph done he will have a good, practical, portable phonograph suitable for all sorts of outings, picnics, camping trips, and the like. In addition, he will gain experience working with transistors, and will undoubtedly get satisfaction out of constructing this transistorized phonograph.

-30-

Fig. 3. Bottom of motorboard showing power transistor (top left).

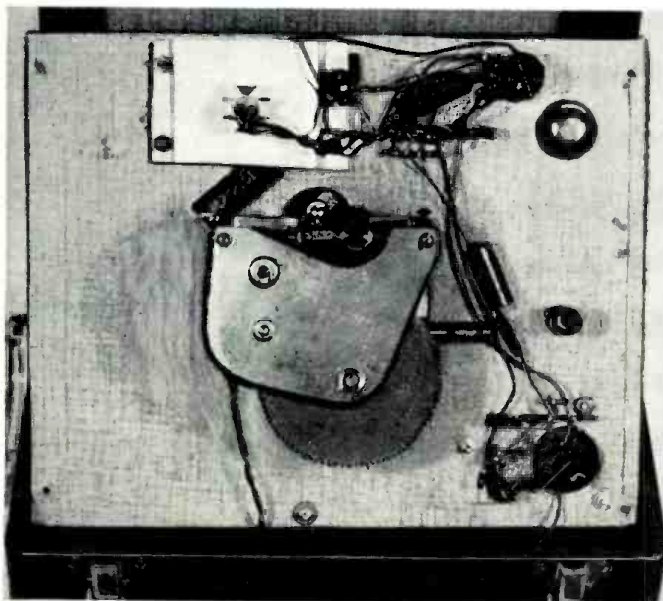
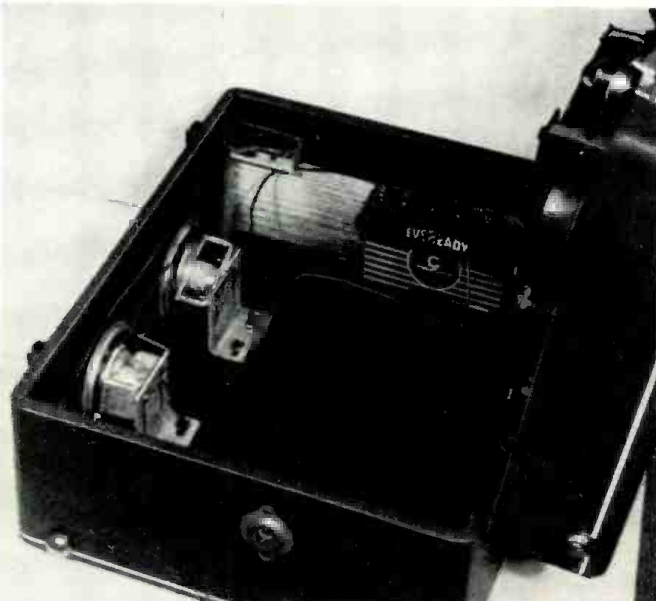

Fig. 4. Interior view showing mounting of speakers and battery.



The "Injecto-cal"

By **CARL D. TODD**
General Electric Company

Build this yourself and you will have one of the handiest instruments devised for checking audio and other circuits, and for calibrating meters.

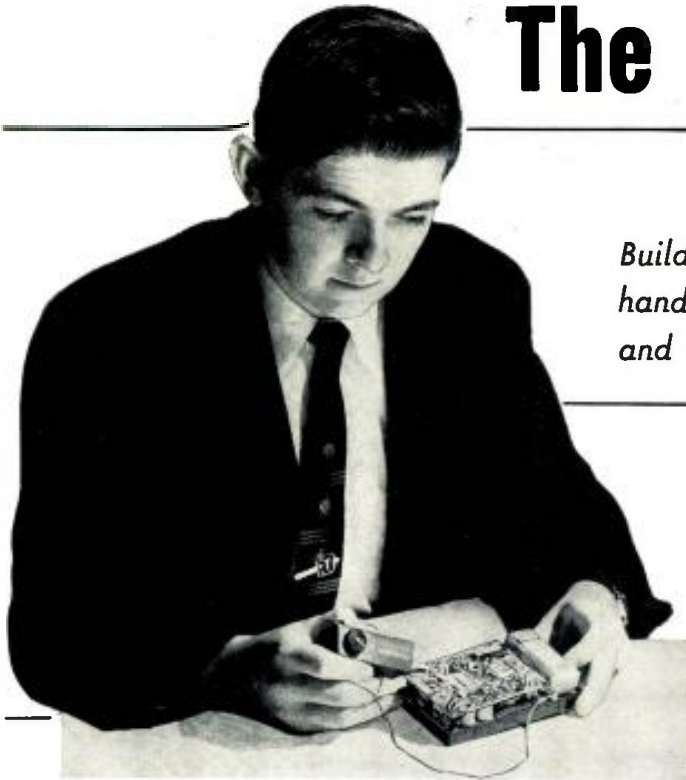

Fig. 1. The "Injecto-cal" is here being used to check the audio section of a transistor radio set. This device has a fundamental frequency of 800 cps.

frequency. Thus, if the "Injecto-cal" is used at any signal point in a radio receiver, phonograph, or audio amplifier, there will be an audio output at the speaker, providing all stages between the point of signal injection and speaker are operating.

The actual signal generating circuit is a free-running multivibrator in which two transistors are alternately driven from cut-off to saturation. The voltage from collector to emitter, while the transistor is in the saturated state for a typical 2N107 in the circuit, is approximately 35 millivolts. When the transistor is in the cut-off state, only a small current flows. This is approximately equal to the collector cut-off current and produces very little voltage across the load resistor. Therefore, the output voltage is very nearly equal to the supply voltage. Thus, the peak-to-peak voltage at the output of the "Injecto-cal" is very close to the battery voltage. By using a mercury battery as the power supply, an accurate voltage is available at the output.

The complete schematic of the "Injecto-cal" is given in Fig. 4. The output of the free-running transistor multivibrator is fed into a resistive voltage divider which allows a peak-to-peak voltage of 0.1, 1.0, or 5.0 volts to be selected by means of a miniature switch. A potentiometer allows the selection of 0 to 6.7 volts peak-to-peak output. The mercury battery serves as a d.c. calibration source.

The fundamental frequency of the "Injecto-cal" output with the component values given in Fig. 4 is approximately 800 cps. The frequency is dependent on the precise values of the components as well as the individual transistors used. The frequency of the multivibrator is also a function of the temperature and battery voltage because of variations in transistor parameters with temperature and operating point.

The rise time of the output waveform for the unit constructed by the author was less than a microsecond with 2N107 transistors. With optimum components and high-frequency transistors, such as the *General Electric* 2N135, 2N136, or 2N137, even better rise times could be obtained.

Construction Hints

The case used, formerly a container

RADIO & TELEVISION NEWS

IT IS well known that the faster a service technician can repair a radio, TV set, or other piece of electronic equipment, the more money he can earn. Therefore, any test equipment which will speed up the servicing process will soon pay for itself many times. Such a device is described here.

The "Injecto-cal," shown in use in Fig. 1, is a dual-function test instrument. It may be used as a signal source for the signal injection method of troubleshooting in r.f., i.f., or audio circuits. It also serves as an accurate calibration reference for the oscilloscope and for many types of vacuum-tube voltmeters. Because of its very small size (less than three cubic inches in the author's model), the "Injecto-cal" may be carried in the service technician's shirt pocket or in the tube caddy for use on home service calls. By injecting the signal at several points in a dead receiver, the faulty stage may be quickly located. The trouble in a non-operative phonograph system may be rapidly isolated to the phono cartridge, preamplifier, or main amplifier by successive application of the output signal from the "Injecto-cal" to the proper signal points in the system. This means that only the defective equipment need be taken to the service shop for repair.

How It Works

The mathematical representation of a true square wave indicates clearly that there are many frequencies present in addition to the fundamental. Even in a waveform which is only partially square, there is a fair amount of harmonic content. The strength of the higher frequency harmonics determines the rise and fall times of the

waveform as well as the sharpness of the corners of the waveform.

Fig. 2 shows the waveform of the output voltage of the "Injecto-cal." Notice the very sharp rise time of the pulse as well as the rather sharp corner at the top of the leading edge. The output is actually a wide-band signal voltage which covers the frequency range from audio to about 40 mc. If this signal is injected into the input of an audio amplifier, the fundamental and the harmonics still within the audio range will be heard in the speaker, or a modification of the waveform shown in Fig. 2 may be seen on an oscilloscope connected to the output. The sharpness of the output waveform as compared to the input will give a relative indication of the high-frequency response of the amplifier.

If the output of the "Injecto-cal" is fed into the input of an r.f. or i.f. amplifier, those harmonics which fall within the passband of the amplifier will be amplified. At the output of the detector there will be an audio tone since successive harmonics passed by the amplifier all differ by an audio

Fig. 2. Output waveform of "Injecto-cal." Note short rise time and sharp leading corner, indicating high harmonic content. This is good for the testing of response.

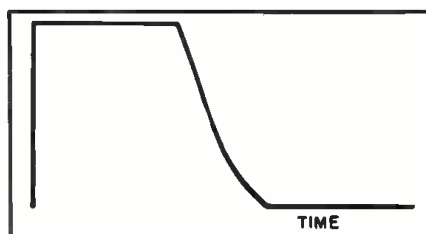

for a miniature transistor transformer, was chosen because its convenient size of 1" x 1" x 3" lent itself to easy placement of the component parts as well as resulting in a very compact piece of test equipment. See Fig. 3. The finished device looks like a small probe and fits very comfortably in the palm of the hand.

The small potentiometer used for the variable output control, R_2 , is ganged with the "on-off" switch; the potentiometer shaft is used as the output probe for the device. A ground wire is provided. The switch used to select the voltage output desired, S_2 , was intended for use as a tone control switch in a hearing aid. In its original form, it is a shorting-type switch in which either one, two, three, or all four of the contacts may be connected to the center terminal. Before this switch may be used in the "Injecto-cal" circuit, it must be modified by breaking off three of the four wiper arms as shown in Fig. 5. The end result is a simple four-pole, single-throw switch.

In order to conserve space and because there was no real necessity for easy removal, the battery was soldered into the circuit rather than mounted in a battery holder. The entire battery current drain of the "Injecto-cal" is less than 500 microamperes, thus allowing almost two thousand hours of continuous operating time. This means that even if the "Injecto-cal" were never turned off, the device would perform faithfully for about three months or more. Because mercury cells maintain constant voltage output almost throughout their life, the accuracy of the calibrator function is retained up until the last few hours of the life of the battery.

In the author's model, the multivibrator was made up and then molded in plastic. This gives a very neat and sturdy assembly but it is not necessary if such material is not readily available.

The accuracy of the output voltage depends, to a great extent, on the accuracy of the resistors which make up the voltage divider. Choose carefully the resistors which make up the values given in the parts list of Fig. 4.

A d.c. blocking capacitor was placed



Fig. 3. Top view of the "Injecto-cal" showing the location of parts and compactness.

in the output circuit of the "Injecto-cal" to protect the transistors from possible damage if the probe were placed on a test point which carries a d.c. potential. The particular capacitor used, C_3 , was of the metalized foil miniature type, allowing rather high capacity and high voltage ratings without excessive physical size. A capacitor of much smaller value could be used although the tendency for hum pickup is increased. If necessary, the capacitor could be used external to the device in the form of an attachment for the probe. In either case, caution should be used to insure that the voltage applied to the tip of the probe is not in excess of the voltage rating of the capacitor.

If it is desired to have a fundamental frequency other than the 800 cps obtained using the given values of components, the easiest method is to change the value of the coupling capacitors from base to collector. If the values of these capacitors are decreased, then the repetition rate would be increased. The upper limit for the 2N107 transistor is about 100 kc., depending on the individual characteristics of the transistors used. A higher repetition rate can be obtained by using high-frequency transistors.

Application

In checking a phonograph system, set the selector knob to 0.1 volt peak-to-peak, turn the "Injecto-cal" on, and clip the ground lead to the phono cartridge ground. Touch the probe to

the signal terminal of the phono cartridge. If no sound is heard in the speaker of the system, the fault is either in the cable from the phono arm to the amplifier or in the amplifier itself. If the sound can be heard in the speaker which is otherwise silent when a record is played, then a defective cartridge is indicated.

The audio system of TV receivers which incorporate a phono input may be quickly checked by turning the TV set to "phono" and plugging the probe of the "Injecto-cal" into the phono jack on the rear of the chassis.

To check the relative high-frequency response of an amplifier, feed the signal into the amplifier and observe the waveform of the output signal with a wide-band oscilloscope. If the short rise time and the sharp corner at the leading edge are retained, then the frequency response is good at the high end.

To calibrate an oscilloscope, connect the probe of the "Injecto-cal" to the vertical input terminal, the ground lead going to the scope ground terminal. Set the selector knob on the "Injecto-cal" to the voltage which is nearest to the voltage measurement desired, and set the gain control of the oscilloscope so that a vertical deflection of one inch or so is obtained.

Knowing the peak-to-peak voltage that is required to produce a given deflection, the amplitude of an unknown waveform may be determined. If the oscilloscope is provided with a decade (Continued on page 122)

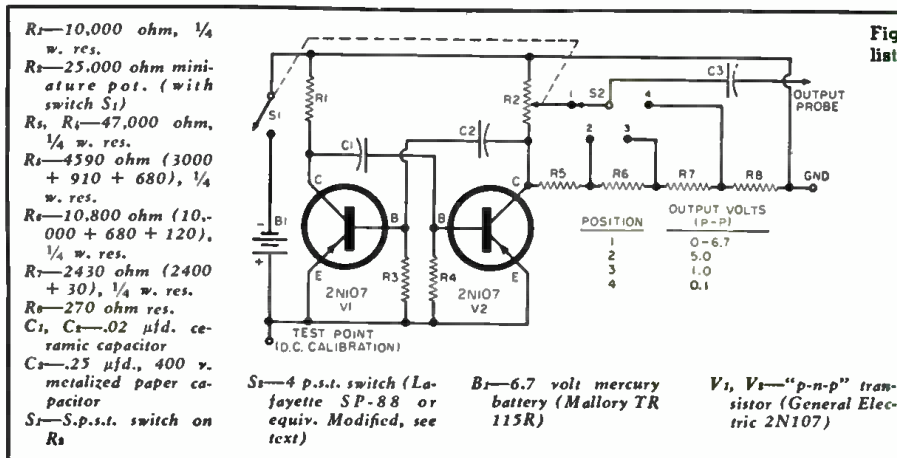

Fig. 4. Schematic diagram and parts list for the transistorized oscillator.

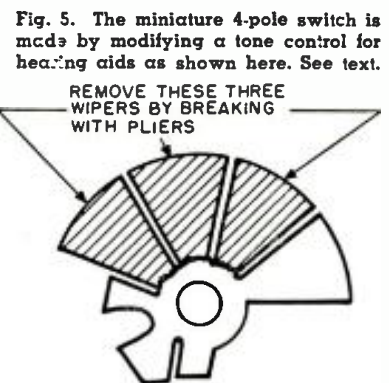

Fig. 5. The miniature 4-pole switch is made by modifying a tone control for hearing aids as shown here. See text.

Eliminating Noise in Auto Radios

By RALPH SAPPE

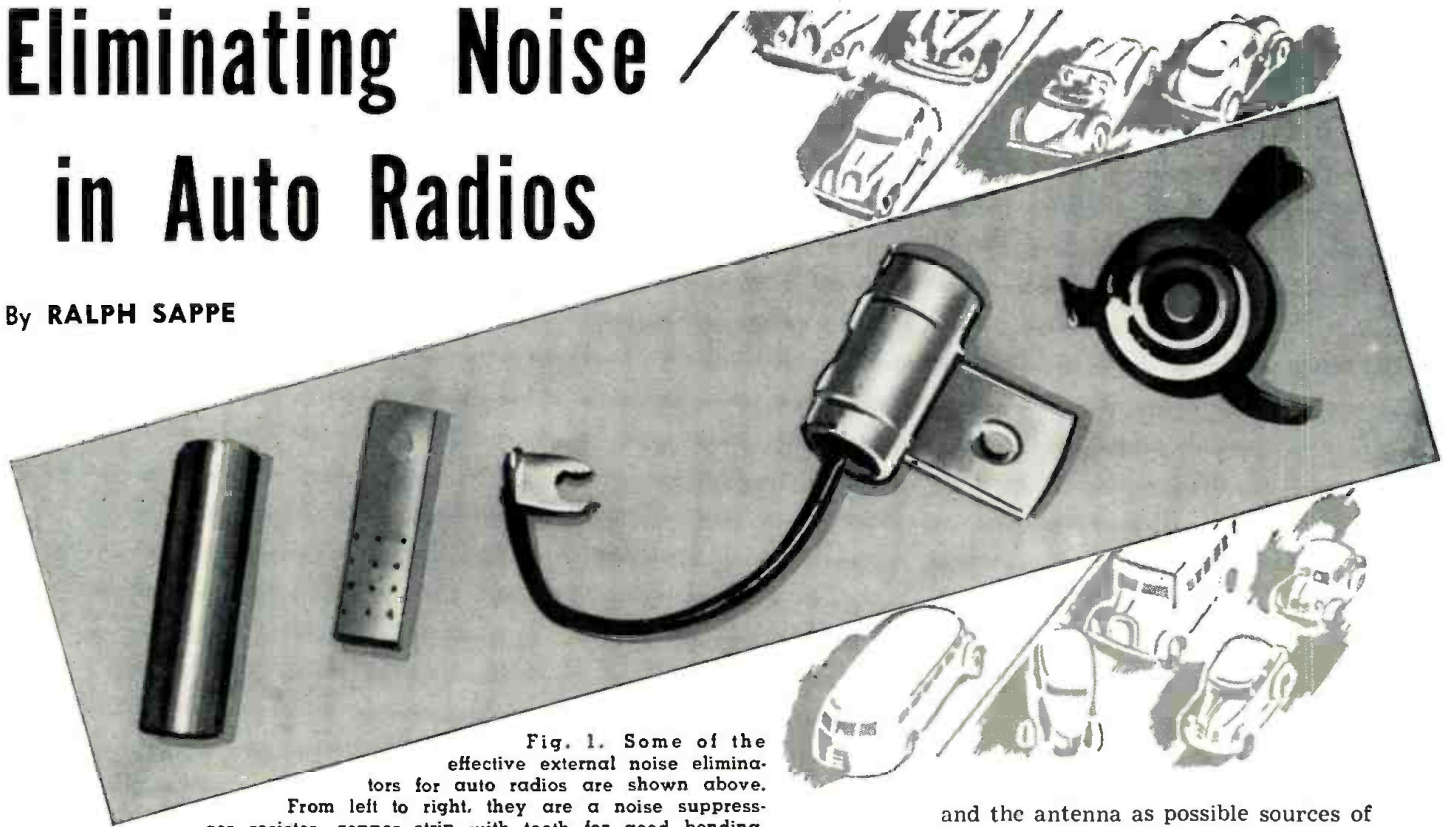

Fig. 1. Some of the effective external noise eliminators for auto radios are shown above. From left to right, they are a noise suppressor resistor, copper strip with teeth for good bonding, a bypass capacitor, and a hub spring for the front wheels.

Auto radio noisy? — use one or all of the noise eliminators described here. They are easy to apply.

SERVICE shops daily come up against auto radios which are noisy due to some defect not in the receiver itself. This article will deal only with such noises.

The first thing to determine in servicing a noisy auto radio is whether the noise is originating inside the receiver or externally. Disconnect the antenna with the set turned on. If the noise remains, try connecting a bypass capacitor from the ammeter to ground. Use any of the special metal-cased capacitors made for the purpose of eliminating auto radio noise (see Fig. 1). If a separate speaker is used, make sure that the speaker is bonded to the chassis or that it makes good ground contact. Also, check to see if the housing of the receiver is well grounded to the dashboard. If the noise remains after these checks, the receiver is probably faulty and ordinary troubleshooting methods will have to be used on it to isolate the guilty component or components.

If, however, the noise stops when the antenna plug is removed, then the noise is entering the set through the antenna. The shield on the antenna cable must be grounded at both the antenna end and at the radio chassis otherwise the shield will be useless and noise will be picked up by the lead-in. A badly rusted antenna should be replaced. Using an ohmmeter, measure the resistance from the

antenna itself to the tip of the antenna plug; this should give a reading of less than five ohms. Check from the ground connection of the antenna plug to the dashboard; this should show a short. The antenna itself must be insulated from ground and should so indicate on an ohmmeter. An excellent check is to substitute another antenna that is known to be good for a suspected one. If good results are obtained with the substitute antenna, especially when the auto is driven, replace the old antenna permanently.

Having eliminated the receiver itself

Fig. 2. A suppressor resistor is shown here connected in series with the lead from the ignition coil to the distributor.

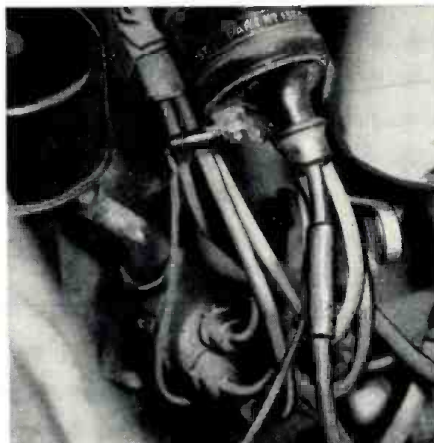

and the antenna as possible sources of noise, the next most likely sources can be pursued.

Probably the most common source of auto radio noise is the ignition system. Such noise is identified by a popping sound in the speaker and varies in frequency with the speed of the motor. When the engine is turned off, the noise disappears. It is caused by high voltage radiation from the distributor lines running to the spark plugs. (The ignition coil steps up the battery voltage to approximately 18,000 volts.)

A suppressor resistor inserted in series with the center lead of the distributor, as shown in Fig. 2, will damp the high voltage pulses from the ignition coil and thus reduce interference from this source. This resistor is on the order of 10,000 ohms and is available at parts distributors. If this fails to remove the noise, additional resistors may have to be inserted at the spark plugs, or better yet, use resistor-type spark plugs with the resistor built right into the body of the plug. Suppressor resistors or resistor-type spark plugs will not impair the efficiency of the motor in the least.

Should both of these remedies fail to suppress the noise, the trouble is probably due to the fact that the hood of the car is not making good electrical contact with the car body. This sometimes occurs after an automobile is two or three years old. Since the hood shields the antenna from all the noise which is generated in the engine compartment, the hood must make good contact with the car body, otherwise it will act as a floating radiator of noise. Small copper strips like those shown in Fig. 1 are available to insure good ground contact between the hood

and car body. They are simply screwed to the body of the car in a place where the teeth on the strip will contact the hood when it is closed. Scrape this spot on the hood to insure good contact. If these strips are not readily available, battery cable or other heavy braided wire may be used to connect the hood to the firewall. Be sure to make good electrical connections.

Generator noise is also a common trouble. The frequency of this noise also increases with the speed of the motor. However, it can be distinguished from ignition noise in that generator noise is much higher pitched and resembles a whine or howl. To eliminate this noise, connect a bypass capacitor to the armature terminal of the generator—be certain not to connect the capacitor to the field terminal. The metal case of the bypass capacitor is grounded to the housing of the generator by means of any available screw or bolt, as shown in Fig. 3.

If the noise persists after the addition of this capacitor, but is decreased in amplitude, the generator itself will have to be checked. A capacitor will not stop completely any noise caused by worn out brushes or a bad commutator. If these are found to be at fault, the generator will have to be repaired.

The voltage regulator is a potential source of interference. Voltage regulator noise is similar to ignition noise and is caused by sparking at the points inside the regulator. A bypass capacitor connected to the battery terminal of the regulator should correct this condition. See Fig. 4. Never connect a bypass capacitor to the field terminal, as this will increase the noise and impair the regulator's action. The battery terminal can be located in many autos quite easily since the wire connected to this terminal is usually quite a bit larger than the rest of the wires connected to the voltage regulator.

Fig. 4. Voltage regulator with bypass capacitor connected to the battery lead.

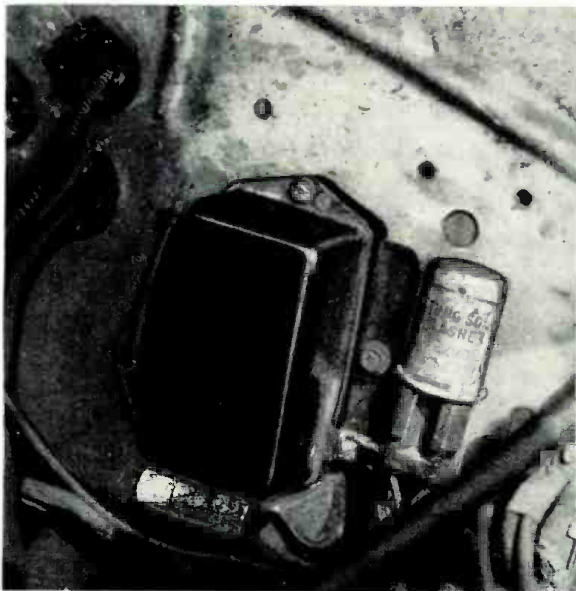

Misadjusted brakes or a "high spot" on the brake lining may cause a "rushing" noise in the radio. This is due to an intermittent rubbing of the brake lining against the brake drum. The remedy for this is simply to have the brakes adjusted by a reliable mechanic.

The front wheels may cause a type of noise commonly called "wheel static." It is a "rushing" noise which increases in frequency as the wheels rotate faster and is caused by a charge which builds up on the wheels by friction. To identify this type of noise, drive the car on a smooth highway and apply the brakes. If the noise stops, it is caused by the front wheels. Applying the brakes grounds the wheels to the frame of the car. Special springs which are inserted into the grease caps on the front wheels will eliminate this type of noise. See Fig. 5. The springs are spiral shaped and give the front wheels good contact with the car body at all times, thus preventing the buildup of a static charge on the front wheels.

If these springs fail to remove the noise, the cause is probably the tires themselves. This condition is called "tire static." A special graphite powder is made for the purpose of eliminating this noise. Deflate all four tires, remove the valve stems, squeeze a tube of graphite into each tire, and inflate the tires again.

Accessories may also cause noise. Electric windshield wipers and turn signals are some of the most frequent offenders. Try connecting a bypass capacitor from the ignition switch or the ammeter to ground to eliminate such noise.

Fuel gauges, temperature gauges, and electric oil pressure indicators can also cause noise when the car is in motion. Oil pressure and temperature gauge noise can be eliminated by connecting a bypass capacitor to the lead going to these instruments on the en-

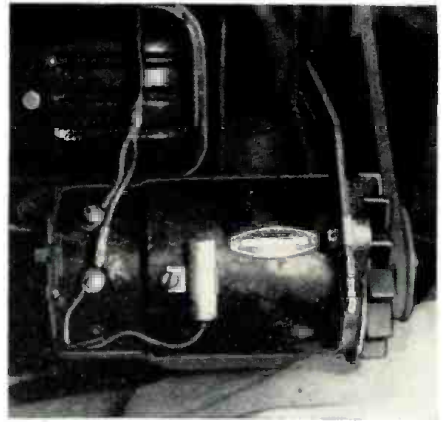

Fig. 3. Bypass capacitor on a generator. The center lead of the capacitor is connected to the armature terminal. The metal body of the capacitor must be grounded.

gine side. Fuel gauge noise can be eliminated by installing a bypass capacitor at the level indicator at the gas tank. The lead of the capacitor should go to the center terminal of the tank unit.

If a two-chassis radio is encountered, make sure that all cables between the chassis are well connected and make good contact.

Noise eliminating devices such as the suppressor resistor, bypass capacitor, front wheel hub springs, and static eliminating powder are a blessing to the auto radio service technician. A large majority of cars will be found to need only one or two of these devices, the most common ones being an ignition suppressor and generator capacitor. A few cars will need more. Very rarely will one of these devices have to be replaced because it is faulty, but don't overlook this possibility.

A good knowledge of car radio noises and the correct application of noise eliminating devices will result in a greater number of satisfied auto radio customers leaving your shop. —30—



Fig. 5. To eliminate "front wheel static," place a spring made for this purpose under the grease cap on the front wheel.

Sound Effects

add

Realism

to

Disneyland

Jim Hervey of the Ralke Company is shown with the continuous automatic fader he designed for feeding the continuous over-all sound effects from one set of loudspeakers to another.

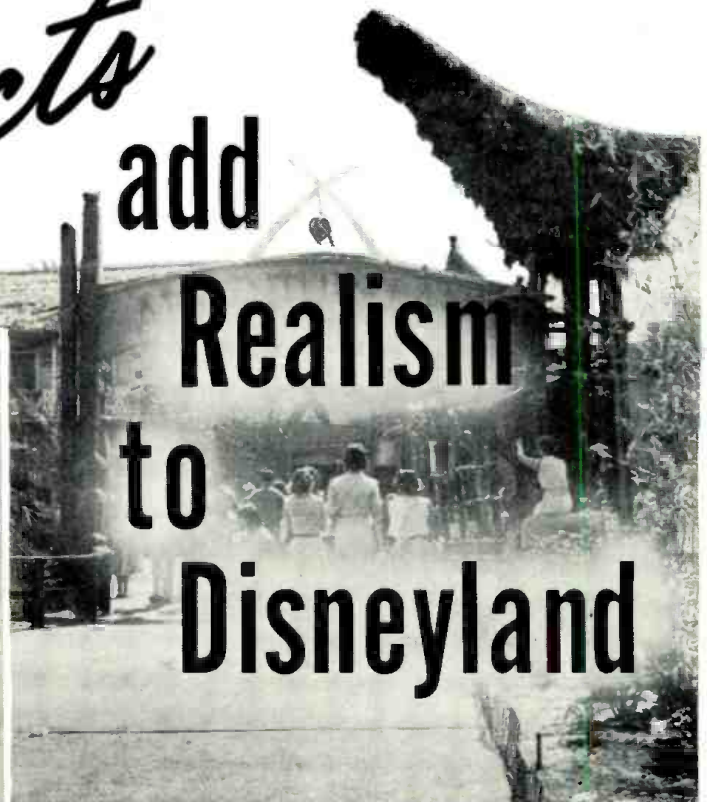
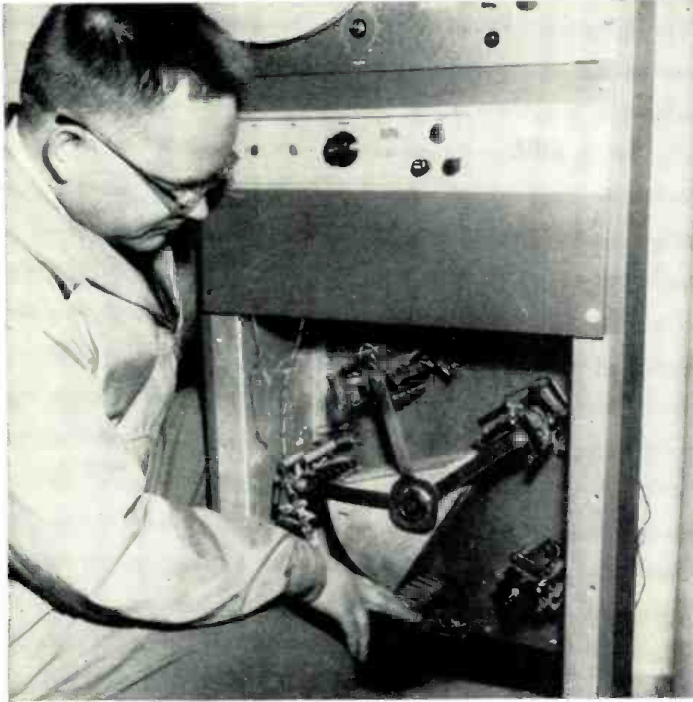

The true-to-life sound effects provided at "Disneyland" lend note of realism to a simulated trip to an adventurous land.

REALISTIC sound effects provide a great deal of the realism at Walt Disney's 160-acre "Disneyland" park at Anaheim, California, thus heightening the illusion of a simulated trip to the moon or a river cruise through the African jungle, hence the extensive array of audio equipment.

A full-time service crew consisting of six technicians is required to maintain 290 loudspeakers, more than 40 miles of wiring, 13 long-playing magnetic tape playback units, and some 150 cartridge-type tape program repeaters. In addition, associated timers, amplifiers, and other equipment is spread over the lot. All in all, there are seven control centers on the grounds at "Disneyland."

One entire section of the park is a simulated African jungle in which three types of sound effects are required. They are: intermittent localized effects which must come in "on cue" such as the trumpeting of a mechanical elephant as visitors approach on one of the five-eighth scale riverboats; continuous localized effects such as a constant chattering of monkeys in one area of the "jungle"; and, continuous over-all effects which would be heard virtually anywhere in the jungle at all times such as the

roar of lions, bird sounds, and the noises of crickets and frogs at night.

All sound effects are on magnetic tape and various types of control devices such as photoelectric cells, timers, and the magnetic tapes themselves turn the effects on and off automatically. One particular device, especially devised for the "Disneyland" project, "moves" the background noises from one section of the jungle to another quite realistically. This is a "continuous automatic fader."

How the sound effects are handled in this section of the park, called "Adventureland," are of particular interest, especially the various effects that come in on a specific cue. For example, a typical sequence of events producing an intermittent localized effect goes something like this: as the riverboat nears the "rhino land" area of the jungle tour it interrupts a photocell beam reaching across the river. Infrared filters keep the beam invisible.

The signal from the photocell trips relays which are located in the mechanical rhinos, thus setting them in motion, and also starting the tape in one of the 150 cartridge-type repeating tape players in the control room for the jungle area.

Sound from this continuous-loop tape is fed into a 30-watt amplifier and in turn to a camouflaged loudspeaker at the rhinos' location.

When the rhino tape has run its sequence (this takes but a matter of seconds) the tape player automatically stops. However, when the rhino tape player had originally started, it also activated a relay for the next sound effect, thus providing a specific delay during which time the boat moved farther down the river. After the delay a second tape player producing sound for a mechanical elephant located on one side of the river is started as soon as the elephant begins to move.

A motor driven timer plugged into the tape player for the elephant is used as a switching device which then switches the tape player output to a loudspeaker located near another elephant across the river. When the loop tape has completed its cycle, it automatically shuts off until another boat breaks the photocell beam to initiate the entire sequence all over again.

The repeater units provide continuous local sound effects, but here there is no control or switching involved. The tape loops, quarter-inch *Scotch* brand magnetic tape with a polyester film backing, manufactured by *Minne-*

sota Mining & Manufacturing Company, simply run continuously. Although these tapes are usually replaced every four or five months, one tape has been running continuously, 12 hours a day, since the park first opened on July 17, 1955. During that time it has been played more than a quarter of a million times.

The third type of sound effect used in the park is the continuous over-all effect providing typical jungle sounds for the entire area. This is recorded on a portion of a 4800 foot reel of one-quarter inch "High Output" magnetic tape, again on polyester film backing. Used on a self-reversing tape player, it is fed into a 50-watt amplifier and then, sequentially, to five groups of loudspeakers (eight speakers to a group) by means of the "continuous automatic fader" designed for that purpose.

This device was developed especially for use at "Disneyland" by Mr. James Hervey, general manager of the project for the *Ralke Company*, Los Angeles, Calif., contractors for audio visual effects at the park.

What it does is to automatically feed the over-all sound track to each set of speakers in turn by means of a rotating unit which makes contact at each of the five positions. So smoothly and realistically is this accomplished that the sounds actually seem to move through the jungle.

To further heighten the illusion, a different sound track on the same 4800 foot tape is used during the evening.

A service technician is shown inspecting one of the 290 loudspeakers which are used to spread the sound effects over the park. The instrument shown here is an Altec-Lansing unit.

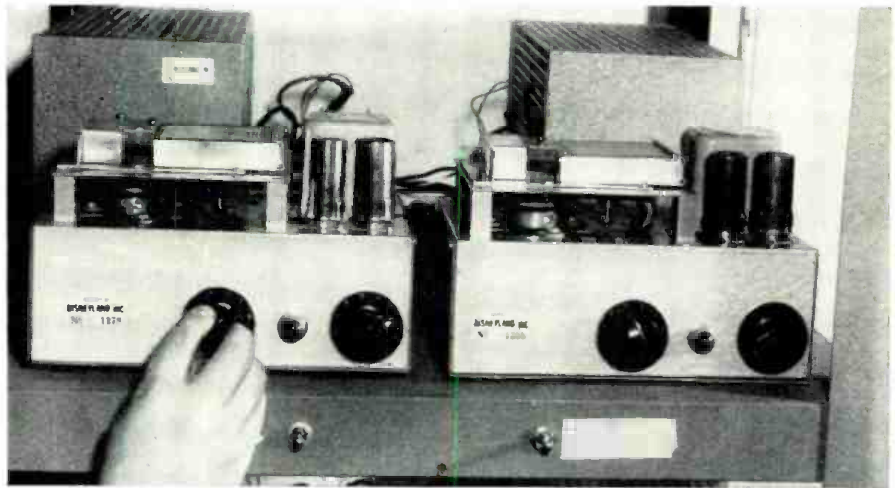

A closeup view of two of the 150 cartridge-type tape players, called McKenzie repeaters, used for intermittent sound effects. Units start and stop automatically.

This second track was actually taped in the African jungle at night and brings authentic evening sounds to the listener.

All of the equipment for reproducing the sound effects for the park is housed in the various control rooms. Seven *Ampex* Model 450-R and six *Presto* Model PB-16 dual track tape players are used. The 150 *McKenzie* program repeater tape players complete the tape equipment. These cartridge-type players are used for intermittent sound effects and they can be started and stopped automatically. The continuous loop of tape runs at a speed of 7½ inches per second.

There is one behind-the-scenes note which may be of interest to the millions of people who have visited the park and also to those who plan to see it in the future. While the authentic jungle noises are indeed captivating, the average tourist has no conception of the "hazards" attached to the maintenance of the audio equipment. After a year of operation, the jungle has become more real than simulated and the camouflaged loudspeakers are almost completely covered with undergrowth. Thus, the "Disneyland" sound technician holds the distinction of being the only technician who must service equipment armed with a machete!

-30-

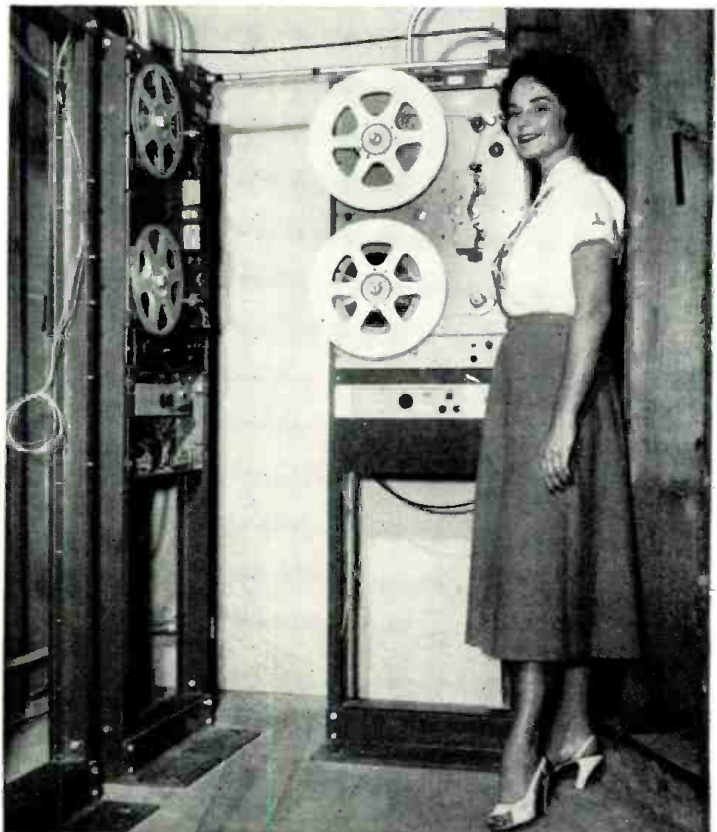

Two *Presto* long-playing players are shown; *Ampex* units are also used. Tapes are dual track and reverse themselves automatically by means of a strip of aluminum foil on the tape.

Don't Knock



YOU walk in on a new service customer and the first words out of the set owner's mouth are, "The last repairman who was here didn't know the back of that set from first base!" Then you learn that the so-called stupid one is your prime competitor.

A rush of pleasure flashes through your nervous system for you are only human. The most delightful kick possible can now be yours. You can join the customer and agree that your competitor has an obnoxious personality and possesses inferior service capabilities. You can also put across your superiority to him. It is a terribly hard temptation to resist.

But human weakness or not, is blasting the safe thing to do, the ethical thing to do, or even the business-like thing to do? Do you think the set owner will think highly of you if you "knock"?

You appear on the TV service scene after your competitor because somehow he messed up the job. Are his "fluffs" always real or could they sometimes exist only in the set owner's mind? Are you, in turn, perfect and do you never offend? Do your tubes and components always hold up 100%? Do your intermittents and other "dog" jobs always turn out satisfactorily to the customer in performance and price? Are your diagnoses always absolutely correct down to the last detail? I wish I could say "yes" to the last four questions, but I can't.

When a customer calls you after one of your friendly competitors has been there first, it's because that service technician has somehow appeared to "goof." In a technically uninformed customer's mind, appearances are all that count. The set owner has all kinds of half-formed wishes and wild expectations as to what a TV technician can do. Lots of times a so-called mistake has nothing at all to do with technical competence.

I knocked on the door of a new service customer one morning. A loud "Come in!" was my response. I opened the door. Sprawled in an armchair drinking coffee was a paunchy woman. Before I could say a word my ears resounded with "I had another serviceman here about three weeks ago. He was no good at all!"

I tuned in a fairly new 21" RCA. There was insufficient vertical sweep and the vertical frequency was running way too fast. I asked what had

Is every repair job you do perfect? Do you never have a callback? Beware, your competitor may defame you too!

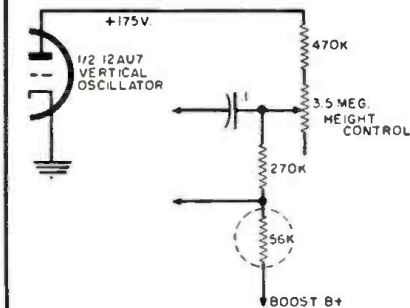

Fig. 1. The 56,000 ohm resistor shown circled in this vertical oscillator circuit of an RCA 21" receiver was bad and had to be replaced to obtain vertical stability.

Your Competitor

By ART MARGOLIS

been wrong before. The reply was, "There wasn't any sound. But if he was any good he should have been able to see this was going to happen." I couldn't think of a thing to say except, we're TV service technicians, not fortune tellers, so I remained silent.

It turned out to be a bench job. Here is the repair she would have liked my ill-fated predecessor to predict was going to happen. I checked voltages in the vertical oscillator—all seemed correct except the plate, it was about forty volts low. I went back into the plate's "B+" line component by component. All resistors and capacitors were perfect. Then I spotted a blue wire coming from the damper boost circuit with some additional "B+" for the tube, see Fig. 1. Between the wire and the supply was a 56,000-ohm, ½-watt resistor. It read open. Replacing it restored the missing forty volts to the oscillator plate. This corrected the sweep and vertical instability troubles.

I delivered the chassis with crossed fingers for I knew if any other trouble should occur it would now be my fault because my prophetic powers are nil.

Quite often TV sets have the nasty habit of playing games with a technician, causing him to technically "fluff" and bringing down the set-owner's wrath upon him. I followed such an unlucky service technician on a 12" *Hallicrafters*. The symptoms were raster and sound but no video. I looked into the back of the set and noticed that the 12AU7 video amplifier was running like a motorcycle, only one little light. I pulled it out and inserted a new one. Some not too good video gradually showed up on the screen.

The set owner moaned, "Why that's the same tube the other fellow changed." The 12AU7 I replaced did have a brand new code date. Then the story came out. A technician from another outfit had been there only the day before. The set had been doing exactly the same thing, loss of video. The previous technician had performed the same repair that I had.

I double checked my tube to be sure it wasn't going to burn out too when I noticed that one of the plates was glowing a pretty cherry red. I shut off the set and pulled it to the shop. On the bench, the 6800-ohm plate resistor was found to short down to about 100 ohms after a few minutes in use. This put excessive "B+" on the 9-pin minia-

ture's plate causing it to draw too much current, thus lighting up.

A new resistor not only killed the unwanted glowing but restored the picture as it should have been. I delivered the set and was, for the present, considered the fair-haired boy. But for the tricks of fate, I could have been the one called first and named the "goon."

I've not always been so lucky. I once serviced a 16" *RCA* to my sorrow. I had to pull it into the shop. It had no horizontal sweep, just a thick, jagged, white vertical line down the center of the screen. My first thought was the yoke but it turned out to be good. Then I scoured through the horizontal oscillator circuit. The culprit turned out to be a 180 μ fd. capacitor from the oscillator grid to the horizontal oscillator transformer (see Fig. 2). It had so changed in value that it threw the 15,750 cps frequency so far off that it ruined the bias to the output stage and severely affected the sweep. A new capacitor corrected the trouble.

The receiver was delivered and forgotten till I bumped into a friendly competitor in a parts house. He told me that a couple of weeks after my repair the set began to act up again in a similar manner. The customer figured she had had enough of my bungling and called my buddy.

He uncovered the rare instance where the same capacitor I had installed had gone bad. Since I didn't manufacture the part I felt exonerated, but clear conscience or not, the customer still has the same lowly opinion of me and let my competitor know it.

Although that time I was technically not at fault, it's not always that way. I have discovered to my great

consternation that I am not perfect. I have been forced to admit that I occasionally make an incorrect diagnosis. I made one yesterday but fortunately I was able to cover it up. I was out looking at an elderly 16" *Motorola*. The symptoms couldn't be more clear cut. No vertical sweep. I checked the vertical tubes and easily available components. They were all good.

The customer, an electrician and a hopeful electronics student, wanted an exact diagnosis before letting me pull the chassis. I described the vertical circuit to him and allowed that the trouble lay only in there. On the bench I sweated out that same vertical circuit from integrator to yoke. To my bewilderment the test equipment very definitely declared that the circuit was perfect. The screen face disagreed, however, for only a thin white horizontal line glowed across the center.

Then I noticed something. Coming off the twin 6BQ6 horizontal output amplifier plate caps were two 47-ohm resistors. (See Fig. 3.) One of them looked a bit burnt. I checked their values and they were both too high. I changed them on general principles and "presto," the vertical sweep spread wide.

The high value resistors had caused the 6BQ6's to draw insufficient current. That hurt the boost "B+" voltage from the damper just enough to kill the vertical oscillator it was feeding but not enough to stop the horizontal oscillator. Even though there was no vertical sweep, enough high voltage still was generated to cause screen brilliance.

My original diagnosis had been theoretically incorrect. In the shelter of the shop I was able to cover it up. Un-
(Continued on page 84)

Fig. 2. Lack of horizontal sweep on a 16" *RCA* set was due to a defective capacitor (shown circled) in the horizontal oscillator circuit. The replacement went bad too.

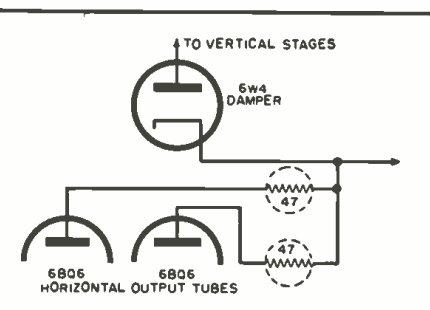
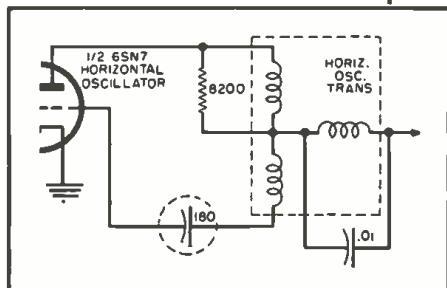

Fig. 3. Partial schematic of the horizontal output amplifier circuit of a *Motorola* 16" receiver. The two indicated resistors increased in value, causing vertical fault.

The Design and Construction of R. F. Coils

FOR obvious reasons, the electronic experimenter seldom constructs the tubes, capacitors, resistors, and similar components used in the equipment he builds. However, he must frequently wind or modify radio-frequency coils to obtain the inductance and other characteristics required for a specific task. Fortunately, doing so is not difficult, once the over-all problem is understood.

The three most important properties of a coil are its inductance, its size, and its losses. Although almost any amount of inductance can be crammed into a given space, losses go up as size goes down; therefore, the three must be considered together. Let us consider inductance first.

Calculating Inductance

There are many formulas available for calculating inductance. Some give high accuracy but require many calculations or the consultation of graphs to determine the value of certain constants. Others are somewhat less accurate, but are more convenient to use. Equations (1) and (2) are of the latter type but give results sufficiently accurate for all but the most precise requirements.

$$L_s = \frac{R^2 N^2}{9R + 10L + 11D} \dots\dots(1)$$

which may also be written:

$$N = \frac{\sqrt{L_s (9R + 10L + 11D)}}{R} \dots\dots(2)$$

where:

L_s = inductance in μ hy.

N = number of turns

R = radius of the form, plus half the thickness of the winding (D)

D = depth of winding (Omit for single-layer coils)

L = length of winding

All dimensions are in inches. Refer to Fig. 1 for more details.

The formulas are accurate to about one per-cent when the inductance is not too low; L/R is not less than about 0.8; the spacing between turns is not too great; and D , L , and R are approximately equal in multi-layer solenoids. For inductance values of less than about one μ hy., the calculated values are five to ten per-cent low.

Coil Efficiency

Coil efficiency or "Q" is determined by the ratio of its inductive reactance (X_L) to its losses (R). It is difficult to predict beforehand. However, experimental work by many investigators has established the factors that produce a high-"Q" coil.

It will be fairly large in diameter and will contain a minimum of insula-

A group of coils and various forms including a core-tuned, snap-in TV, plug-in, shielded polystyrene, and commercially-available coil units.

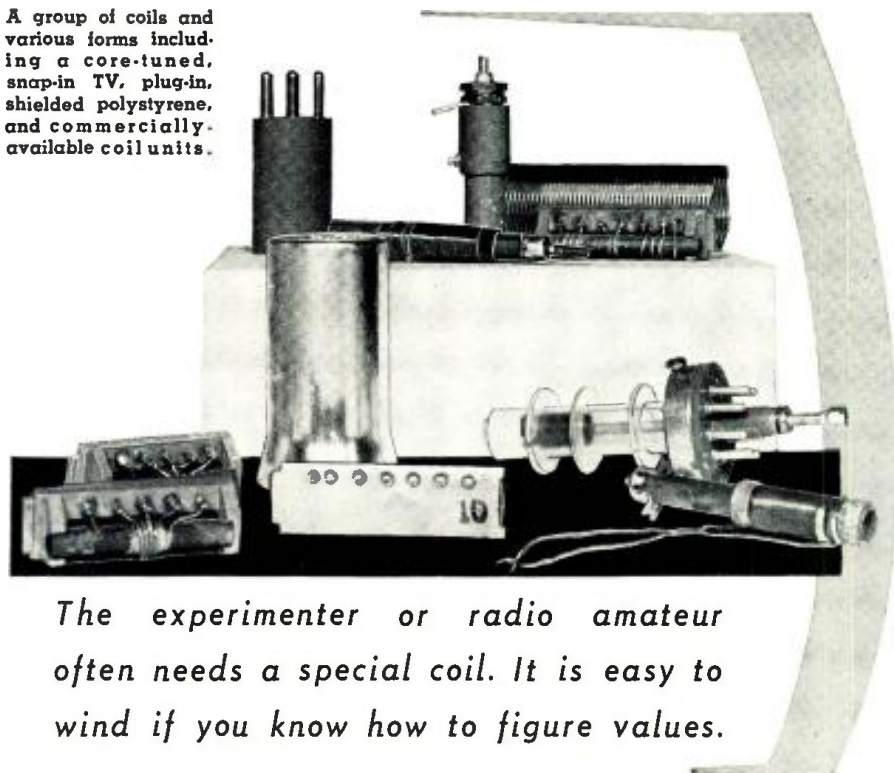

The experimenter or radio amateur often needs a special coil. It is easy to wind if you know how to figure values.

By HERBERT S. BRIER

tion other than air within its field. Its length will not be appreciably less than half its diameter (best), nor much over twice its diameter. Furthermore, it will be wound with the largest size wire that will permit accommodating the required number of turns in the specified winding length when wound with a spacing slightly less than the wire diameter between turns. When wire size, spacing, etc., are kept optimum, coil "Q" varies approximately as the square of the diameter.

Solid wire is preferred for high-frequency coils. It may be enamelled or bare for spacewound coils, but d.c.c. wire will usually produce a slightly more-efficient closewound coil than will enamel wire, because the thickness of the cotton effectively spaces the turns slightly.

Litz wire is preferred for frequencies below about 1500 kc. However, the difference between it and solid wire is so slight at frequencies above 500 kc., it is seldom used above about 500 kc. Layer-wound coils are usually used for coils below 500 kc. to conserve space, although doing so reduces "Q" somewhat.

It is important to protect coils wound upon forms that might absorb moisture with a coating of low-loss coil dope, if highest efficiency is to be retained. This is especially important with coils wound of d.c.c. wire.

Normally, coils with high "Q's" are

desired, although this is not always true. The bandwidth of a resonant circuit is defined as the frequency range over which the voltage across the tuning capacitor does not drop below 70.7% of its resonant value. It is determined by the "Q" of the circuit, according to the relationships:

$$Q = \frac{F_r}{F_u - F_l} \dots\dots\dots(3)$$

$$\text{Bandwidth} = \frac{F_r}{Q} \dots\dots\dots(4)$$

where:

F_r = resonant frequency

F_l = amount frequency must be lowered to reduce signal voltage to 70.7% of its F_r value

F_u = amount frequency must be raised to reduce signal voltage to 70.7% of its F_r value

$$\text{Bandwidth} = F_u - F_l$$

Being connected into an actual circuit reduces the effective "Q" of a resonant combination, usually at least 50%; therefore, coils with "Q's" up to about 100 can be used in the r.f. stages of broadcast receivers without excessive sideband cutting. In double-tuned transformers, the desired bandwidth, the amount of coupling between coils, the number of stages, and other variables all affect the optimum coil "Q." As a rough guide, 455-kc. i.f. trans-

formers often use coils with "Q's" of around 50.

At frequencies above the broadcast band, the "Q" of coils used in receivers and low-power stages of transmitters is often controlled by the space available. But, large, high-"Q" coils are required in the output tank circuits of transmitters, otherwise, they will over-heat, sometimes enough to melt solder out of connections or to damage the coil form.

Another place where very high "Q" is desired is in the loading coils used in mobile antennas, because losses in them largely determine the efficiency of the antennas.

Table 1 lists some representative coils and their "Q's" as a guide to what can be expected.

Core Tuned Coils

It is well known that a coil wound on a powdered-iron core will have a higher inductance than one of the same dimensions wound on "air," because of the core's high permeability. At low frequencies, powdered-iron cores help obtain high inductance in a restricted space. At these frequencies, it is also possible to slip a powdered-iron ring over the coil, to increase the inductance further and to reduce coupling to other components in a circuit.

Unfortunately, all powdered-iron cores have losses, which increase with frequency; consequently, there is always a frequency beyond which a core inserted in a coil increases losses more than it increases inductance. Thus, for high-frequency use, it is necessary to reduce the ratio of iron to insulating binder in the core to decrease losses. Doing so reduces core permeability from over 100 for low-frequency cores to less than five for cores designed for use at frequencies of 100 mc. and higher. This limits the increase in inductance that may be obtained at high frequencies with powdered-iron cores.

Adjustable cores are often used to vary the inductance of coils. This feature is used in permeability-tuned i.f. transformers, TV linearity coils, and even to replace variable capacitors in the tuning systems of short-wave and broadcast receivers.

For high-frequency work, the ability to adjust inductance to exact desired values represents the most valuable feature of variable-core forms. Commercially available ones permit varying inductance 10 to 50 per-cent. The exact percentage depends upon the ratio of core-to-coil diameter, ratio of length to diameter, and core permeability. Formulas are available for calculating it, but it is usually more satisfactory to calculate the number of turns for slightly less than the desired inductance with the core as far out of the coil as possible. Then it can be screwed in to give exactly the desired amount of inductance.

Up to about 100 mc., the "Q" of coils wound on such forms is little affected by the position of the core, although it usually increases slightly as the core is inserted in the coil. This assumes

that the coil is being operated within the frequency range for which the core was designed. At the high-frequency end of a range, inserting the core may decrease "Q" slightly.

It must be stressed that the foregoing is true only when low-loss cores designed for the frequency range involved are used. For example, the standard cores supplied by the *National Company* and the *James Millen Company* with their adjustable-core forms give optimum results up to 10 mc. However, interchangeable cores for frequencies up to 150 mc. are available on order. An exception is the *Millen 74001*, shielded, plug-in form which has a core usable up to 35 mc. Interchangeable cores are undoubtedly available for the forms of other manufacturers as well.

At frequencies above 100 mc., any powdered-iron core becomes quite lossy. Also, the inductance required is usually so small that any increase in it may be an unnecessary evil; hence, copper or brass cores are often used in their place. Such cores reduce inductance about as much as an iron core of similar dimensions increases it. They always reduce coil "Q" somewhat, but the loss is minimized by silver plating the core. Copper and brass cores may be used at any frequency, but they have their greatest usefulness at the higher frequencies.

As an indication of what can be expected from core-tuned coils of different dimensions at various frequencies, Mr. Theodore B. Robinson, Engineer in Charge of Coils, *The National Co.*, Malden, Mass., prepared the information contained in the second part of Table 1. The figures refer specifically to coils wound on *National* forms, but should apply closely to similar forms of other manufacturers.

The table can also be used as an approximate indication of the "Q's" of conventional coils of these dimensions, because the units are designed to permit a moderate change in inductance,

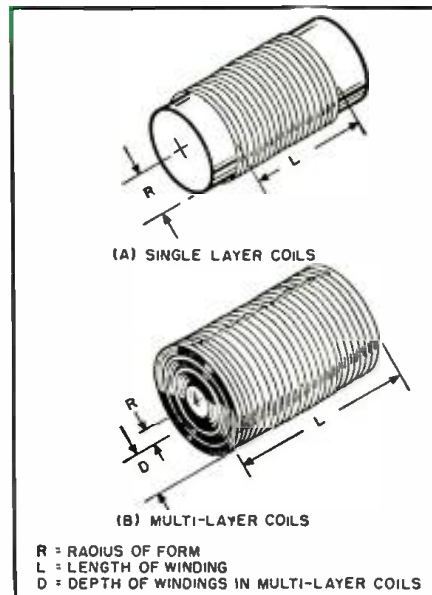

Fig. 1. Single- and multi-layer coil data.

without materially affecting other coil characteristics.

Shielding

Practically speaking, whenever two resonant inductances tuned to the same frequency are in different circuits but within close proximity of each other, it is necessary to shield at least one of the inductances involved, to avoid coupling between them. Minimum shielding losses are introduced by placing the coil inside an aluminum or copper can large enough that no part of the coil comes closer than one-half of its diameter to the shield. Under these conditions, coil inductance will be reduced approximately 10% when $L/D = 0.5$; 13% when $L/D = 1$; and 17% when $L/D = 2$. $L =$ coil length. $D =$ coil diameter.

A smaller shield will increase losses and reduce inductance unduly. As an extreme example, a shield only 10% larger than the coil diameter will de-

Table 1. Approximate "Q's" of typical coils at different frequencies. The numbers in parentheses (lower table) are National Co. stock designations for the cored forms used in compiling this data. Forms of equal quality should give similar results.

DIA.	LENGTH	NO. TURNS	WIRE SIZE	INDUCTANCE (Approx.)	FREQ. (in mc.)	"Q"
3"	3"	60	No. 20	185 μ hy.	1	230
1 1/2"	4"	123	No. 28	185 μ hy.	1	140
3/4"	1 1/8"	130	No. 30	100 μ hy.	2	125
4"	1 5/8"	8	1/8"	10 μ hy.	4	525
4"	1 5/8"	8	No. 18	10 μ hy.	4	300
1 3/4"	4 1/2"	70	No. 18	70 μ hy.	4	160*-350**
*Solid maple form		**Polystyrene rod				
1"	1 3/8"	9	No. 18	1 μ hy.	15	250†
1/2"	5/8"	13	No. 18	1 μ hy.	15	130†
†Bakelite form						
"Q" FOR LOW-LOSS, POWDERED-IRON CORES DESIGNED FOR FREQUENCY OF OPERATION. CORE IN MID-POSITION						
COIL DIA.	FREQ.	"Q"	FREQ.	"Q"	FREQ.	"Q"
1/2" (XR 50)	5 mc.	130	10 mc.	160	20 mc.	200
1" (XR 62)	2 mc.	160	10 mc.	300	20 mc.	310
3/4" (XR 72)	2 mc.	120	10 mc.	240	20 mc.	260
.264" (XR 81 & XR 83)	5 mc.	90	20 mc.	120	50 mc.	120
.375" (XR 91 & XR 93)	5 mc.	110	20 mc.	140	30 mc.	150
Resonating capacity: 100 μ fd. up to 20 mc.; 30 μ fd. for 30 and 50 mc.						

crease inductance 70 to 85 per-cent.

The first step in winding a coil is to determine the inductance required. In a resonant circuit, this is controlled by the frequency and the capacity, according to the formula:

$$F_{kc} = \frac{1,000,000}{2\pi \sqrt{LC}} \dots\dots\dots(5)$$

where:

- $2\pi = 6.28$
- $L =$ inductance in μ hy.
- $C =$ capacity in μ fd.

A coil for the broadcast band must tune to 1650 kc. with the tuning capacity at minimum. Under these conditions, capacity approximates 50 μ fd. Solving Equation (5) on the basis of these figures, $L = 185 \mu$ hy. (approx.).

To calculate the dimensions of a 185- μ hy. coil, let us arbitrarily select a diameter of 1½" and a length of 2" and then solve Equation (2):

$$N = \frac{\sqrt{L_r(9R + 10L)}}{R} = \frac{\sqrt{185(9 \times .75 + 10 \times 2)}}{.75} = 94 \text{ turns.}$$

From Table 2, we see that 94 turns of No. 28 enamelled wire spaced about two-thirds of the wire diameter or 94 turns of No. 28 d.c.c. wire, closewound, will fill the specified coil length.

There is seldom much difference in results from a small change in wire size, if the number of turns and the winding length remain unchanged. But with closewound coils, even a small change in wire size can make a fairly large change in inductance. Then, when it is necessary to use a different wire size or it is necessary to use a different diameter form than is specified in a coil table, it is advisable to calculate the inductance of the original coil and then design a new one of the same inductance with the aid of Equations (1) and (2).

Other things being equal, spacewound, air-insulated coils are the most efficient. However, they become quite fragile when wound of fine wire. Polystyrene has losses only slightly greater than air, and a coil wound on a thin, polystyrene form will compare favorably in efficiency with an airwound coil of the same dimensions. *Teflon* would probably be even better than

polystyrene, but it is quite expensive and, as far as is known, is not available in coil forms. Unfortunately, polystyrene cannot be used where temperatures go much above 150 degrees F. In addition, it is not mechanically stable enough for coils in critical, frequency-determining circuits.

Ceramic forms are recommended where highest electrical and mechanical stability is required and where high temperatures would damage other types of insulation.

Coil forms constructed of other materials will have somewhat higher losses than those just mentioned, but the difference in efficiency between a coil wound on an extremely low-loss form and one wound on a medium-loss form is seldom great on frequencies up to 15 mc. or so. This is true, because losses in the form seldom contribute more than 20% to the total coil losses.

Bases from old tubes make convenient small coil forms. They have reasonably low losses, especially the brown (*Micanol*) bases used on some special-purpose and small transmitting tubes (5R4GY, 807, 811, etc.).

A conventional method of anchoring the ends of small coils wound on forms is to drill rows of small holes in the form and thread the ends of the wire in and out of them. Or in plug-in forms, sometimes only a single hole is drilled, and the end of the wire is brought directly to the base pin and soldered.

A method the author favors is to insert a short length of fairly heavy wire between the hole and the base pin, to which it is soldered. The end of the wire is allowed to protrude from the side of the form for about ¼", so that the end of the winding can be wrapped around it a few times and soldered. This arrangement is especially convenient when the number of turns is frequently varied in experimental setups.

Coils of large diameter wire are most easily terminated in brass screws put through the form from the inside. Whatever the method used, drill the holes in the form before starting to wind the turns.

Probably the best way to wind coils by hand is to measure off the required length of wire from the wire spool and

clamp the spool in a vise. Wrap a piece of cloth around your hand and, starting at the vise, pull the wire through the cloth to straighten the wire.

Fasten the wire to the coil form, back away from the vise until the wire is taut. Start winding by turning the form towards yourself. Keep tension on the wire and gradually walk towards the vise as it is used up. Count the turns while winding.

When the coil is to be spacewound, space the turns approximately while winding. If you first close wind and then space the turns, the entire winding will loosen up. After the required number of turns are in place and the ends of the winding are anchored, the spacing can be equalized by temporarily winding another piece of wire or cord between the turns.

Removing the insulation from the terminating end of wire of a coil while attempting to keep the winding tight can be a frustrating experience. But the job is much simplified, if you stop winding with about a half turn to go and remove the insulation from the wire with a bit of fine sandpaper or emery cloth.

Airwound Coils

Airwound coils may be constructed in the following manner. Wrap a layer of waxed paper around the form and lay three to five strips of polystyrene or other plastic, cut from sheet stock, slightly longer than the length of the coil and equally spaced from each other. Hold them in place with a wrap of *Scotch* tape at each end. After the winding is in place, run a bead of *Duco* household cement or polystyrene cement over each strip. Allow to harden for a few hours, apply another bead of dope, allow it to harden, and remove the coil from the form. Then trim off excess lengths of the strips.

Another strip of heavier polystyrene may be cemented outside the turns opposite one of the inner strips to permit fastening the coil to a plug-in base or to mount it.

When only a single coil is to be wound, a cardboard form that may be destroyed in removing the finished coil from the form may be used. But if a better form is desired, one can be made from a wooden round of the right dimensions, turned down on a lathe.

Saw it apart diagonally the length of the form. Put machine screws through each end of the form to hold the halves together and to anchor the ends of wire during coil construction. To keep the coil round and easier to remove from the coil, insert a piece of smooth metal approximately equal to the thickness of the material removed by the saw between the two halves. Pulling this strip out first makes it easy to get the form out of the coil.

Bulk, airwound coils are available commercially from *Barker & Williamson Co.* They vary in diameter from one-half inch to two and one-half inches and are wound four to 32 turns per inch. The smaller ones ("Mini-

(Continued on page 87)

Table 2. Abbreviated wire table. Use this data in connection with formulas in text.

WIRE SIZE	TURNS PER INCH WHEN ENAMELED	D. C. C.	FEET PER POUND (D. C. C.*)
10	9.6	8.9	31
12	12	10.9	49
14	15	13.8	77
16	18.9	16.4	119
18	23.6	19.8	188
20	29.4	27	298
22	37	30	461
24	46.3	35.6	795
26	58	41.8	1118
28	72.7	48.5	1760
30	100.5	55.5	2530
32	113	62.6	3130
34	143	70	6170

*Note: Enameled wire will run up to 25% more feet per pound in the smaller sizes listed.

A New Intermittent Localizer

By **E. A. BRAMSEN**
President, Seco Manufacturing Co.

FINDING the cause of intermittent troubles in television and radio receivers is often difficult and time consuming. It is a common occurrence to have a receiver perform perfectly in the customer's home when the technician is present and fail again as soon as he steps out of the door. Thus, shop repair is generally indicated. There are so many possible causes of intermittent performance that diagnosis is seldom easy. The problem is further compounded by the fact that the failure, such as fading, abrupt or gradual cessation of operation, instability, recurring distortion or other phenomena, may occur only for brief periods at a time. After considerable experience with a specific type of receiver, a technician may be able to guess at the root of the trouble by leaning on past history. In some cases, all suspicious parts and tubes are replaced on the premise that material costs less than labor.

There is a scientific way to diagnose intermittent troubles and that is by employing a signal tracer. An oscilloscope or a vacuum-tube voltmeter with a suitable demodulator probe may be used for tracing signals from antenna to loudspeaker or picture tube. With this technique the troublesome circuit can often be localized—provided that the defect occurs and continues during the period of testing.

A new test instrument, developed specifically to troubleshoot intermittents, is the *Seco Model SL-10 "Monitron."* With it, a technician may localize the circuit where intermittent operation occurs whether caused by an open or shorted capacitor, cold solder joint, erratic tube, defective resistor, or other electrical or mechanical failure.

The "Monitron" is a dual-channel instrument designed to permit monitoring two circuits or pieces of apparatus simultaneously or for making comparisons between one circuit and another as when making gain measurements. However, it is not necessary to use both channels. For purposes of analysis, the operation of one channel can be viewed.

The probe is connected to any signal-carrying circuit, such as r.f., i.f., a.f., video, or sync circuits, sweep oscillators, high-frequency amplifiers, or sweep amplifiers. The level control is set to a desired value as indicated by an electronic eye. The alarm circuit is set to monitor. If the signal fails or drops to a low value, the alarm circuit is tripped, causing operation of both visible and audible indicators.

For example, the probe can be connected to the input of the second detector or demodulator of a radio receiver or discriminator of a TV sound

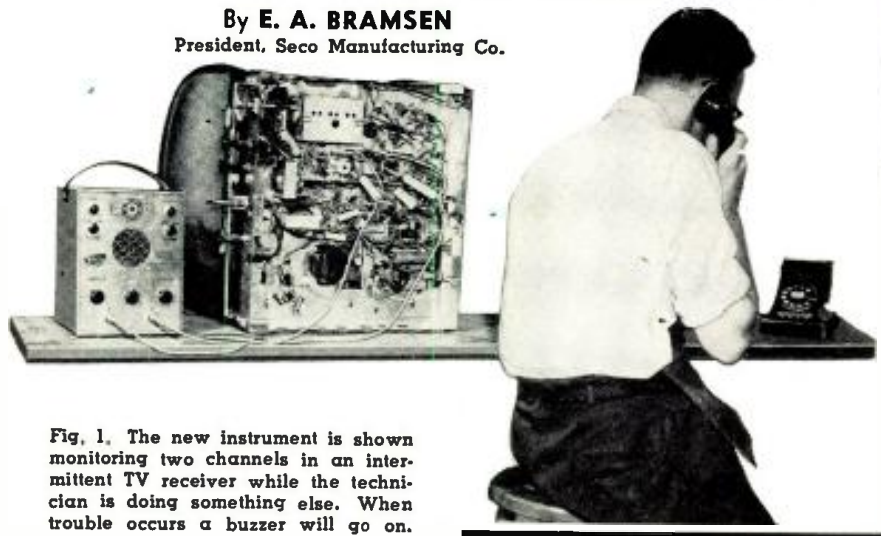

Fig. 1. The new instrument is shown monitoring two channels in an intermittent TV receiver while the technician is doing something else. When trouble occurs a buzzer will go on.

This instrument can save valuable time in the service shop as well as spot hard-to-locate intermittents.

circuit. With a continuous signal present at that point, whether from a broadcasting station or a signal generator, the electronic eye of the "Monitron" indicates the presence of signal and the alarm does not operate. However, if the signal is interrupted or drops in magnitude momentarily or stays off continuously, the electronic eye indicates either the absence of, or diminution of the signal and the alarm is tripped.

Now the second channel can be brought into play. It has been determined that the signal has been cut off or attenuated somewhere between the antenna and the input of the demodulator. The second channel of the "Mon-

itron" can be used to check the presence of signal at other points in the receiver. If the probe for this other channel is connected to the input of the first i.f. stage and a signal is found there but not at the demodulator, it is then known that the trouble is somewhere in the i.f. amplifier. By moving the probes it is possible to find the specific circuit where the trouble is occurring.

The alarm feature is the real time-saver since the technician can connect the probes and then work on other sets or do something else in the shop. See Fig. 1. When a failure occurs, he is apprised of the fact by the visible

(Continued on page 124)

Fig. 2. Schematic diagram of the "Monitron" signal tracer and intermittent locator.

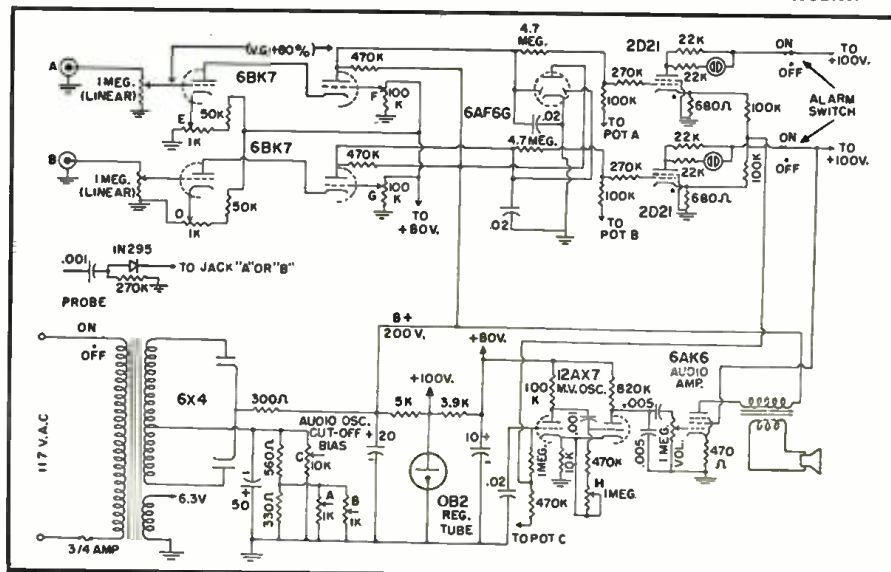

What's New in Flyback Circuits

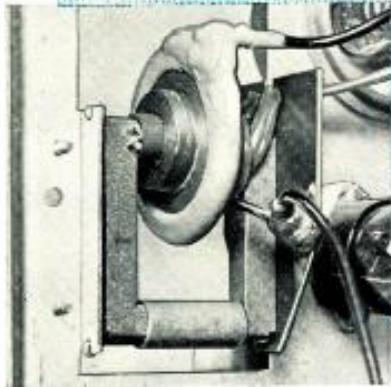
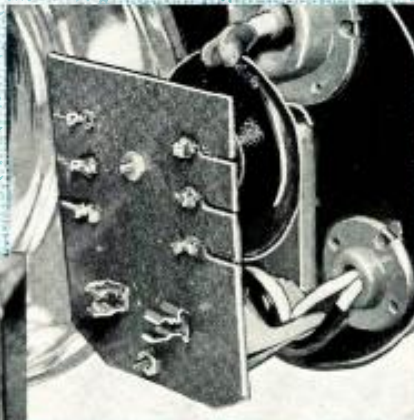
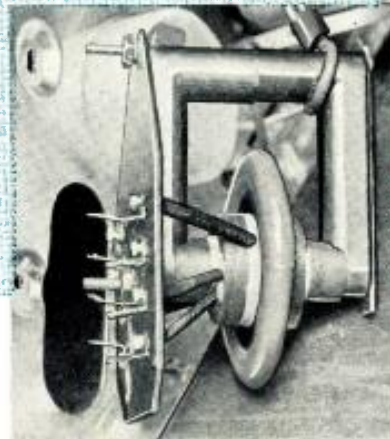

Fig. 1. Three new flyback transformers are shown here. Note their relatively small size and mechanical similarities.



By **JESSE DINES**
Author of "Servicing TV Sweep Systems"

The new smaller and cheaper TV sets require new sweep and high-voltage circuits. Here they are!

SINCE the advent of 90-degree deflection angle picture tubes, the horizontal sweep circuit and its components have changed considerably, both electrically and mechanically. The flyback transformer, in particular, has changed the most. Whereas 10 to 14 kilovolts was generally the high voltage requirement for 70-degree picture tubes (up to 21 inches), up to 19 kilovolts are now used for 90-degree picture tubes. This higher voltage requirement has forced set manufacturers to utilize autotransformers which afford closer coupling between all windings and an increased turns ratio than was provided by conventional transformers with an equal number of turns. These autotransformers are also smaller in size than their predecessors and cost less. Some are shown in Fig. 1.

Aside from a higher voltage output, what are some other features of the newer flyback systems? Besides supplying boosted "B+" voltage to several stages in the receiver, the newer systems now supply as much as 500 or more volts to the focusing electrode of the picture tube. The picture tube with a 90-degree deflection angle requires a special yoke with a wider flare. This draws more sweep current than the older models. Width and linearity controls are not furnished in most of the new receivers, and many do not include a horizontal drive control either.

The high-voltage system used in the *Admiral 17XP3* and *17XS3* chassis is typical of the new trend. The flyback transformer is an autotransformer-type as is indicated in Fig. 2. Circuit simplicity is indicated by the fact that

only two flyback transformer taps are used and there are no width and linearity controls and high-voltage filter.

The .1- μ fd. capacitor connected to terminal 1 of the flyback transformer is the boost capacitor. The 12AX4 damper tube charges this capacitor to 300 volts. The 550 volts which appears from terminal 4 to ground is formed by the 300-volt charge across the boost capacitor in series with the 250-volt "B+" supply. This boosted "B+" is supplied to the plates of the vertical oscillator and output stages, as well as to the picture tube focusing anode.

A 90-degree deflection yoke with a 20-millihenry horizontal coil is used in this receiver. The horizontal coils of 70-degree yokes usually have less than 20 millihenrys of inductance. The 90-degree yoke requires more inductance because it must have more magnetic energy to move the electron beam through a wider angle. A typical 90-degree yoke is shown in Fig. 3.

Whereas 70-degree yokes use a 47- μ fd. or 56- μ fd. capacitor to balance (or compensate for) the distributed capacity of the horizontal coils, 90-degree yokes use capacitors on the order of 100 μ fd. or more. The higher capacitance value is needed to offset the greater distributed capacitance of the horizontal coils because of the wider flare and greater number of turns. Unbalanced yoke coils produce ringing.

In the yoke circuit of Fig. 2, a 230- μ fd. and a 150- μ fd. capacitor are connected across the high and low sides of the yoke horizontal section respectively. Actually, to balance this yoke, an 80- μ fd. capacitor could be connected across the high side of the horizontal section. The advantage of using an additional 150 μ fd. of capacitance across each coil is that in this way more picture width is obtained.

The 2200-ohm resistor in Fig. 2, which connects from the junction of the horizontal coils to the junction of the 150- μ fd. and 230- μ fd. capacitors, is a damping resistor which helps to provide better yoke balancing. A horizontal sweep pulse developed across

Fig. 2. Schematic diagram of the horizontal sweep and high voltage circuits of the *Admiral 17XP3* and *17XS3* chassis. Note the lack of width and linearity coils.

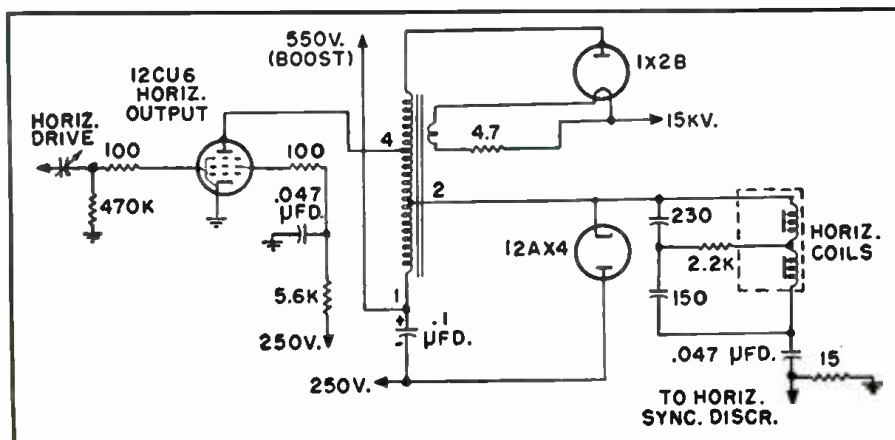



Fig. 3. Typical 90-degree deflection yoke used with 90-degree deflection angle picture tubes. Notice the wide flare of the yoke's horizontal windings.

the 15-ohm resistor, is fed to the horizontal sync discriminator circuit for the purpose of keeping the horizontal oscillator in sync.

Fig. 4 is a schematic diagram of the horizontal sweep and high-voltage circuit of the *Magnavox 650* series chassis. It supplies 15 kilovolts for both 21- and 24-inch picture tubes. Here, there are no drive and linearity controls, nor high-voltage filter. The interesting features in this circuit are the horizontal section of the deflection yoke, width coil, and a.f.c. pulse circuits. The yoke high side, together with the cathode of the 6AX4 damper tube, connect to terminal 5 of the flyback transformer. A pulse developed across the a.f.c. coil, and in part across the yoke, is taken off across the 18-ohm resistor and fed to the 6AL5 horizontal sync discriminator. The .1- μ f.d. capacitor in series with the yoke is for d.c. blocking.

The horizontal yoke windings do not require balancing capacitors because the junction of the two windings is connected to the flyback transformer through a 6800-ohm resistor. The windings are so designed as to balance each other and the transformer windings. The 6800-ohm resistor serves to help yoke balancing and minimize ringing effects. The 15,000-ohm resistor across the a.f.c. coil loads down the secondary and prevents the coil from breaking into oscillation.

The boost voltage is taken from terminal 1 of the flyback transformer via a 1500-ohm dropping resistor. The flow of the damper current *I* is indicated to show how the boost voltage is obtained. A 270-volt charge appears across the .047 μ f.d. capacitor with the polarity shown. The boost voltage from terminal 1 to ground, therefore, is 270 volts plus the 280-volt "B+" or 550 volts.

The horizontal sweep and high-voltage circuit used in the *G-E "M"* series chassis is unique in that the 12BQ6 horizontal output tube cathode is connected in series with an isolated winding on the flyback transformer. See Fig. 5. This isolated winding furnishes

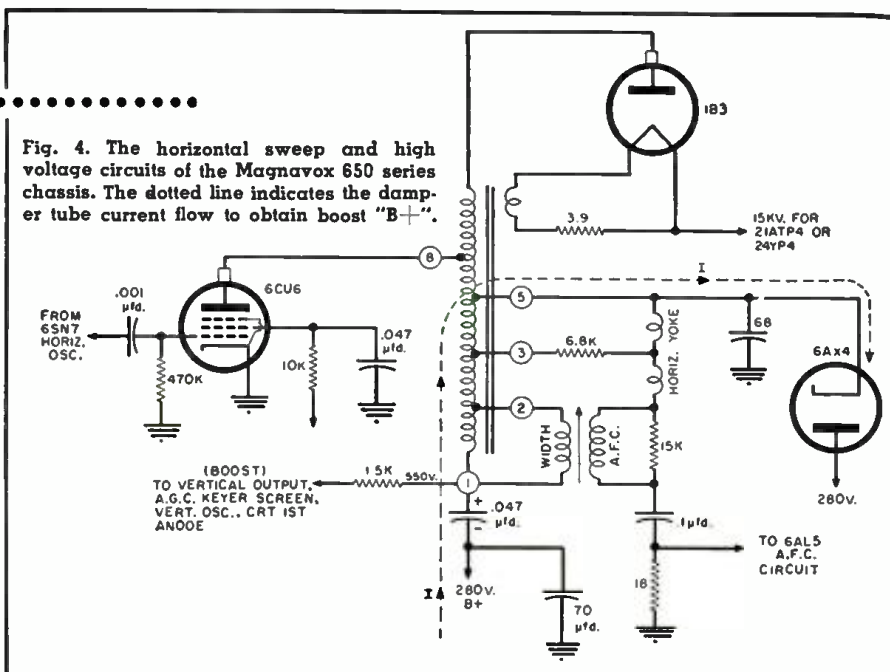

Fig. 4. The horizontal sweep and high voltage circuits of the *Magnavox 650* series chassis. The dotted line indicates the damper tube current flow to obtain boost "B+".

positive feedback to the output tube for maximum operating efficiency.

The negative "spike" of the horizontal drive signal fed to the 12BQ6 cuts off this tube, permitting the flyback circuit to oscillate at about 70 to 90 kilocycles. The first positive half oscillation appears across the flyback transformer and is rectified by the 1X2A to produce 12,000 volts. This positive pulse also appears across the isolated winding which is so wound as to make the 12BQ6 cathode positive, keeping the 12BQ6 cut off during retrace time. The bias provided by the isolated winding actually serves to make the retrace time about 7 microseconds.

The two horizontal deflection yoke windings (20 millihenrys each) are connected in parallel across terminals 1 and 4 of the flyback transformer. This arrangement eliminates the need for a yoke balancing capacitor, since the two windings have equal stray and distributed capacitances. The disad-

vantage of this arrangement is that about four times as much sweep current is needed for proper horizontal deflection than for a similar yoke connected in the conventional way.

The 12AX4 damper and boost "B+" circuits are fairly straightforward. Two capacitors, both 260 μ f.d., are connected across the damper and help to obtain the required sweep width. The horizontal output tube grid circuit is unusual in that the grid-leak network (consisting of an 820,000-ohm and a 100,000-ohm resistor) forms a voltage divider for obtaining a grid bias voltage of -2.7 volts for the 6AU6 video output tube. The 5000- μ f.d. capacitor in parallel with the 100,000-ohm resistor bypasses the 15,750 cps signal to prevent pickup by the video output tube.

The circuit simplifications explained here as well as those in other sections of the TV receiver have, in part, been responsible for the smaller and lighter chassis so popular now. -30-

Fig. 5. The horizontal deflection coils of this *G-E* series "M" TV chassis are in parallel, eliminating the need for a balancing capacitor, however, more yoke current is required. Note the absence of width, linearity, and horizontal drive controls.

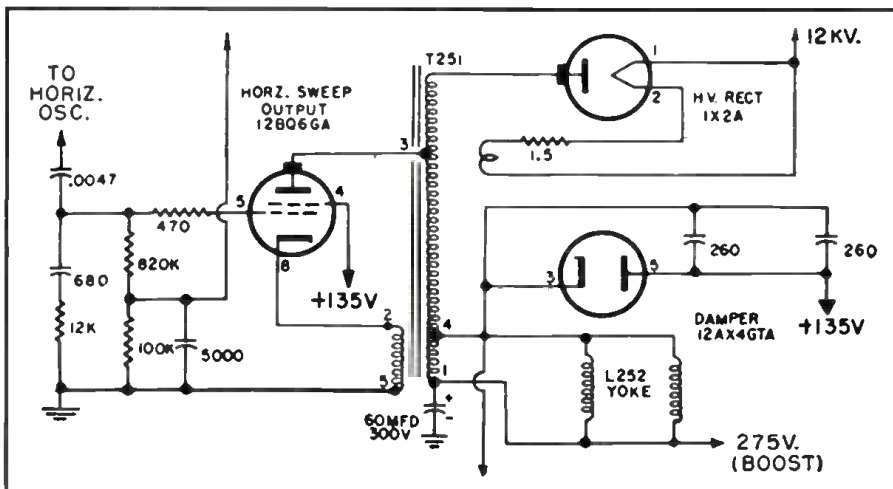



By **BERT WHYTE**

ONE of the perils of writing a column two months in advance of its publication is that any information which is offered in good faith, may be quite inaccurate by the time it reaches the newsstand. A case in point is this month's column which was supposed to bring you a "scoop" on some startling new developments concerning three-channel stereophonic sound. Circumstances have conspired to make this "scoop" an impossibility at this time. There are many aspects of this stereophonic problem which have been solved, but unfortunately, there is still some ways to go, before I can give you a completely integrated and intelligent report. However, in some ways this may be a blessing in disguise because I will have much more space available to me in the September issue and this will allow for even better coverage of the story. Within the bounds of what I have written in the first sentence of this column, I think I can safely say that the stereo report will appear in the September issue!

By the time you will be reading this, it will be sizzling hot summertime and everybody will be concerned with keeping cool! For the music lover, this problem can be solved in many ways . . . there are outdoor music festivals all over the country, usually held in shady parks. For the really affluent there are the wonderful music festivals of Europe and the cool sea breezes encountered getting to and from them. But for many music lovers there is only one out . . . a good hi-fi system, a stack of interesting new records, a comfortable room with a fan or perhaps a modest air-conditioner and, of course, . . . a tall tinkling glass. For the benefit of this group, I'll try to review as many "interesting discs" as possible.

Many readers have noted that I frequently have used the *Weathers* FM phono pickup in my reviews and have inquired about it in their letters. Most of the writers wanted confirmation of reports that this is a very tricky and delicate pickup, difficult to use, and easy to get out of kilter. Very frankly, there is a certain amount of truth in these reports, although most were highly exaggerated. It is true that the oscillator is subject to drift and many people just don't have the facility or patience to "tune" the device correctly. It is also true that the stylus and stylus plate assembly is not for the heavy-handed and that the spacing between stylus and stylus plate is very critical. Like many other things, a fine sports car for example, the performance depends very much on the user. Many people are willing to put up with the idiosyncrasies of this pickup in return for such obvious advantages as 1 gram stylus pressure, fantastic tracking ability due to low mass and tremendous compliance, superb over-all sound. Like practically everything else in audio, whether or not one likes the *Weathers* is strictly a matter of opinion, and I don't have to tell you that what is golden to one ear is

grit to another. Of course the odd thing is that there are plenty of people who like the pickup, but felt that it was not for them due to the aforementioned difficulties. And it goes without saying that there were a number of these people who took the plunge anyway and for some the device worked fine and for others they had the expected troubles.

All this is by way of telling you that those who like this pickup will find the new model just released free from the earlier "bugs," but even more important, those who now own the *Weathers* pickup can send the units to the factory where they will be completely modernized. Instead of spring-loading, the arm will be supplied with viscous damping, there is a new specially ruggedized stylus assembly, and the oscillators are now tuned inductively with a "dead on" or focus point good through several turns of the adjusting screw. There have been so many letters on this subject and so much general contention that I took the matter to the *Weathers* factory and the dope they gave me is what I thought would be of interest to present owners of this pickup. No one should infer that this is an endorsement of this pickup over other fine units on the market.

One more item before we get on to the reviews. Many the letter I have received from people interested in learning about high fidelity. They want to know if there is a school they can attend, a course of study, *some way* they can learn the technical rudiments of the subject, the do's and don't's of assembling systems, and a thousand other pertinent facts. Up to now, I've had no answer for these folks, but maybe this will work. I've been asked by the adult education section of my local high school to lecture one night a week on the subject of high fidelity. In fifteen weeks I hope to be able to impart enough hi-fi "know how," to enable my students to at least avoid the more obvious hi-fi pitfalls and to further their enjoyment of music. It would seem to me that other communities could follow suit, there surely must be some sufficiently knowledgeable hi-fi enthusiasts who would be willing to teach adult education classes once a week. It's certainly an idea worth trying!

Equipment used this month: *New Weathers* arm, cartridge, and oscillator; *Components Corp.* turntable, *Marantz* preamp, 2-60 watt *McIntosh* amplifiers, *Jensen* "Imperial" speaker, *Electro-Voice* "Georgian" speaker, *Ampex* tape equipment.

BLOCH
SCHELOMO
TCHAIKOVSKY
VARIATIONS ON A ROCOCO
THEME FOR CELLO AND OR-
CHESTRA

The opinions expressed in this column are those of the reviewer and do not necessarily reflect the views or opinions of the editors or the publishers of this magazine.

Andre Navarra, cellist with London Symphony Orchestra conducted by Richard Austin. Capitol P18012. RIAA curve. Price \$3.98.

This is the sixth version of Bloch's beautiful work and in many ways the best. Navarra does not have the smooth poetry of a Feuermann nor the passion of Zara Nelsova, but he is not entirely laggard in these respects and in his technical proficiency he need bow to no one. Above all his cello sings, a beautiful cantabile with a fat gorgeous tone, made still more obvious by the superb recording. The old Nelsova/*London* disc of "Schelomo" was a hi-fi stunner, and still is better than most, but it is eclipsed by this version. Here you will find some of the most lush darkly rich cello sound on record, and with excellent wide-range support from the orchestra as well. The Tchiakovsky work receives an equally admirable performance, but the real treasure on this disc is "Schelomo." Highly recommended.

STRAVINSKY
LE ROSSIGNOL (THE NIGHTINGALE) (COMPLETE OPERA)

Janine Micheau, soprano; Genevieve Moizan, soprano; Jean Girardeau, tenor; Lucien Lovao, baritone; Michel Roux, bass; and other soloists with chorus and Orchestre National de la Radiodiffusion Francaise conducted by Andre Cluytens. Angel 35204/L. RIAA curve. Price \$4.98.

This is a notable premiere on LP of one of Stravinsky's most unusual scores. A lyric opera in three acts, it is based on Hans Christian Andersen's charming tale of the "Emperor and the Nightingale." Although written during Stravinsky's "Firebird-Le Sacre" period, it bears little resemblance to these scores except possibly the pungent atonal writing at the beginning of the second act. This recording was awarded the Grand Prix du Disque 1956, and it is not hard to understand why, it is a perfect gem. The soloists are uniformly excellent with Janine Micheau outstanding as the Nightingale. The choral work is first rate considering the difficulty of the score and the orchestra turns in a splendid job and does honor to the complex orchestration. Much credit must accrue to Cluytens for this success. Cluytens is a conductor who has been given some unhappy choices of repertoire in his discal chores, but when he is given something suited to his talents as with this score, he is very, very good indeed! Most notable feature of his conducting here is the sensible pacing and outstanding balance of the various elements. Engineering wise, this is one of *Angel's* very top jobs. All vocal elements are perfectly articulate, the sound is ultra-wide range in frequency and dynamics. Recorded rather close up, which is right for the Stravinsky scoring, there is still enough acoustic perspective for a nice full liveness. Some exciting percussives and exotic scoring in the 2nd and 3rd acts give the work a suitably oriental flavor. Admittedly, this work is for the more advanced music lover, but should find favor with others of an inquiring mind. The usual superb *Angel* packaging is an added plus, with colored drawings of the costumes used in the first performance in 1914, adorning the cover of the album.

TCHAIKOVSKY
SYMPHONY #4
Boston Symphony Orchestra conducted by Charles Munch. Victor LM1953. RIAA curve. Price \$3.98.

Foregoing the shattering thoughts of seventeen previous versions of this valiant war-horse, I am bound to say that this 18th edition must be given serious consideration. I care not that other critics may condemn some
(Continued on page 117)

Test Equipment for Color

What test equipment do you need to install a color TV set? What are the differences among the various types?

COLOR TV servicing and installation requires several new types of test equipment and field experience shows that the characteristics and capabilities of the new instruments are not completely understood in all cases. It is the purpose of this article to indicate what test instruments are needed and how they should be used.

At this time, the service technician is more concerned with the installation of color TV receivers than with their maintenance. Installation men are not concerned with repair procedures, and assume that the receiver is capable of providing proper performance when the controls are correctly adjusted, otherwise the installation man will return the receiver for repair or replacement.

The really essential new instrument for the color TV installation man is the white-dot generator. This instrument is required to provide the necessary information regarding misconvergence of the color picture tube. Although other types of pattern generators can be used, it is generally recognized that the white-dot generator gives the most useful data.

White-dot generators may supply either large dots or small dots; they may provide numerous dots in the pattern, or a small number of dots; they may generate their own horizontal or vertical sync pulses, or it may be necessary to "borrow" sync from the receiver under test; they may provide modulated r.f. output which can be applied directly to the antenna input terminals of the receiver, or they may only provide a video-frequency output which must be injected into the receiver circuits at some point after the picture detector. Retrace blanking may or may not be provided.

Fig. 1 shows the difference in appearance of the pattern when large dots are used and when small dots are used. White-dot generators are available which provide front-panel control of dot size, so that the operator can use a dot size of his own choice. Some receiver manufacturers recommend large dots, while others recommend

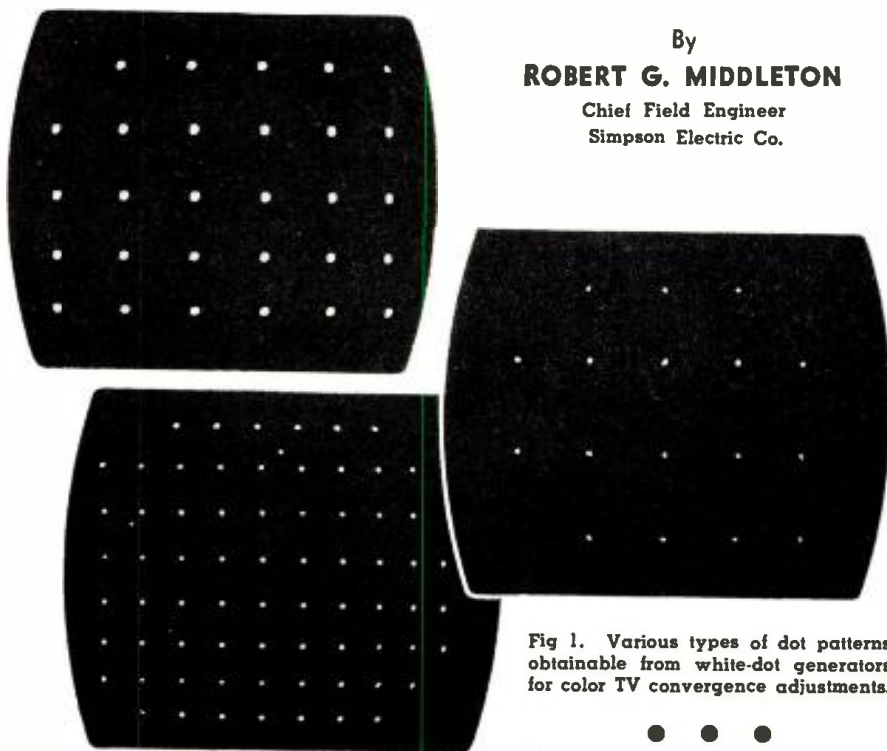

By
ROBERT G. MIDDLETON
Chief Field Engineer
Simpson Electric Co.

Fig. 1. Various types of dot patterns obtainable from white-dot generators for color TV convergence adjustments.

medium or small-sized dots. Individual preferences of operators also differ, and the same operator may prefer large dots when the room lighting is bright or when he must utilize a mirror for viewing the screen, while he may prefer small dots when he can work directly in front of the picture tube, and when the room lighting is dim.

It is a fact that very small dots show up small misconvergences to better advantage than large dots, although the small dots are dimmer and more difficult to observe. Some receiver manufacturers discourage the use of very small dots on the basis that the operator may attempt to obtain impossibly accurate convergence, and thereby waste his time.

Questions often arise as to whether

round dots or square dots are better. Actually, the dot shape provided by service generators is a square or rectangular dot, which only appears round when the picture tube is defocused by setting the contrast and/or brightness control too high. It is hardly necessary to point out the error of such adjustment of these controls.

The difference in appearance of the dot pattern when a small number of dots are utilized, as compared with a large number of dots, is shown in Fig. 1. Although it is usually desirable to use a large number of dots to check convergence at different parts of the CRT screen, difficulties may be encountered in the early stages of convergence when a large number of dots are used. The difficulty comes about from the fact that some large-screen

Fig. 2. Output from a keyed rainbow generator as seen on the screen of a wide-band scope. Note horizontal sync pulses.

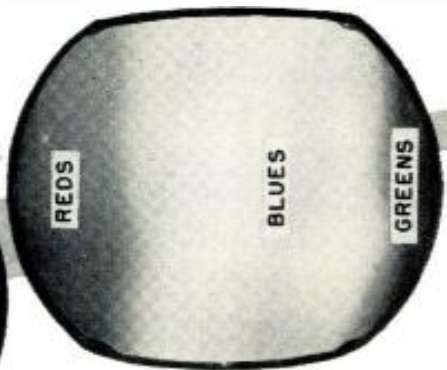
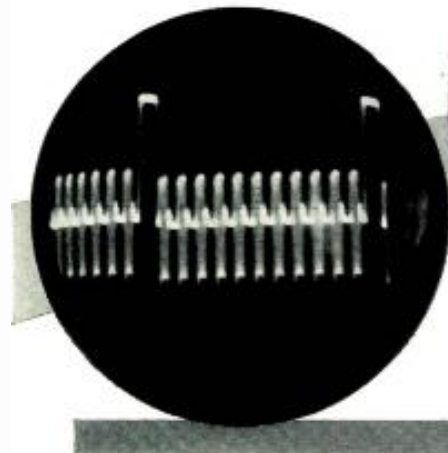

Fig. 3. Typical rainbow display on a color TV tube. The actual display, of course, is in color. Absence of a hue indicates trouble in the associated chrominance channel of the color TV set.

picture tubes may go far out of convergence when the convergence controls are badly misadjusted; in such a case, the red-green-blue triads may be so widely spaced that adjacent triads overlap and cause confusion in a pattern having a large number of dots. Hence, the operator may need to start convergence procedures with a relatively small number of dots, and to make the final convergence with a larger number of dots.

It is convenient to have sync pulses furnished by the generator, as an additional lead does not then need to be run from the generator to tap off sync from the receiver sweep circuits. Unless blanking is provided, horizontal smear will appear in the white-dot pattern, due to dot pulses being caught and stretched on retrace. While background smear is not serious from the standpoint of convergence procedure, the smear is a distraction and annoyance.

Remember that convergence of the three-gun picture tube is a tedious and time-consuming procedure, and that the operator needs every bit of assistance possible from his generator. Experienced installation men do not need to be told of the demands placed on time and tempers by convergence procedures—the newer color TV receivers provide as many as 17 convergence controls, all of which interact to some extent.

Color-Bar Generators

In the event that the technician cannot time his installation so that it coincides with a color TV program transmission, he must utilize some source of color-signal generation, or make a "callback" to set up the color phase and color intensity controls when a color program is available. Hence, the color signal generator is frequently a "must" for installation work.

The simplest source for obtaining a color pattern is to use a modulator output cable, such as the "Chromatic Probe." This is used in conjunction with conventional signal generators and will cause a rainbow pattern to

be displayed on the screen of the color picture tube. Although it leaves something to be desired in the direction of accuracy, saturation, etc., the rainbow pattern does give the installation man sufficient data that he can "get by." To generate a rainbow pattern, the FM and AM generators which feed the probe (see Fig. 4), are adjusted as follows: The AM generator is tuned to 3.58 mc. (the color subcarrier frequency) and the FM generator is tuned to the picture carrier frequency of the channel to which the receiver is set (this should be a vacant channel, to avoid beat interference). The FM generator is operated as a conventional signal generator by reducing the sweep-width control to zero and by turning off the blanking switch.

The output of the probe is fed to the antenna input terminals of the color set. It will be observed that the setting of the contrast control has no effect on the rainbow pattern, but that the pattern becomes bright or dim as the color intensity and brightness controls are varied in the color TV receiver—these latter controls are usually operated approximately three-fourths of maximum for the rainbow display. When the AM generator is set exactly to 3.579545 mc., a single hue appears on the screen of the color picture tube, since the rainbow signal is then zero-beating with the color subcarrier oscillator in the receiver. Next, as the frequency of the AM generator is reduced by one horizontal scan (15,750 cps), one complete rainbow appears on the picture tube. The rainbow pattern is characterized by

Fig. 4. Circuit diagram of a "Chromatic Probe" used with conventional AM and FM signal generators to produce a rainbow pattern on the screen of a color tube.

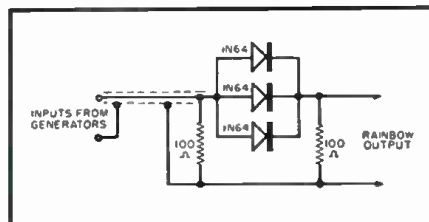

reds, blues, and greens, but lacks the brighter colors, such as yellow; rainbow colors are always dim and bluish, as compared with true color displays, obtained from specialized generators.

Proper setting of the color phasing control of the TV set is indicated when the color sweep is shifted to the standard position on the screen of the picture tube—as the color phasing control is varied, the spectrum moves left or right. The standard position is that which displays a dim orange at the extreme left-hand edge of the screen, merging rightward into the reds, then into the blues to the right of center-screen, and finally into greens at the extreme right-hand edge of the screen.

Note that a standard rainbow is obtained only when the AM generator is operated below the color subcarrier frequency. A rainbow also appears when the AM generator is tuned 15,750 cps above 3.579545 mc., but this display is reversed, i.e., the reds appear at the right-hand side of the screen, and greens appear at the left-hand side. Any number of rainbows up to 30 or 40 can be obtained by tuning the AM generator farther away from the color subcarrier frequency. Standard practice is to utilize a single rainbow with the signal set one horizontal scan below the subcarrier.

Compact rainbow generators for installation work are available, and they avoid the bulkiness of conventional alignment equipment. These contain the necessary signal generators and connectors, and operate in much the same manner as described for the "Chromatic Probe."

Some more elaborate rainbow generators contain sync and burst signals in the chrominance output, as illustrated in Fig. 2. In this arrangement, the rainbow signal is keyed into groups by means of a multivibrator contained in the generator. This type of signal displays rainbow stripes, instead of a continuous chrominance sweep, and is easier to interpret. The first group following the horizontal sync pulse is utilized by the color sync circuits in the receiver, while subsequent groups appear on the screen of the picture tube as rainbow stripes. The horizontal sync pulse provided in the signal stabilizes the pattern, and crystal control of the chrominance signal and the picture carrier signal greatly increases the accuracy of indication.

When a sound carrier is also provided in the output signal from the generator, additional operating facility is obtained, since the operator may then adjust the fine-tuning control accurately to eliminate the 920-kc. beat between sound and chroma. Many color TV receivers are sensitive to adjustment of the fine-tuning control and do not provide true color reproduction unless proper adjustment is made.

Note in Fig. 2 that the simpler types of keyed rainbow generators provide the chrominance signal at black level; for this reason, the hues obtained are

not standard. Standard hues are obtained only when the chrominance signal is combined with suitable values of *Y* (black-and-white video) signal. More elaborate keyed rainbow generators provide a single *Y* output with the chrominance signal, and this *Y* signal can be varied in level by means of a front-panel control. In generators which have no *Y* signal available, the brightness control of the receiver must be advanced to a suitable position to provide an artificial equivalent of a *Y* signal. Of course, it is possible to find some setting which will provide a standard color for one stripe, such as blue or red.

A rainbow generator is useful, not only for adjustment of the color phasing control during installation procedures, but also for troubleshooting the chrominance circuits. For example, consider the rainbow display illustrated in Fig. 3. The display is characterized by reds, blues, and greens, as indicated. In case the *R-Y* detector channel in the color TV receiver is faulty, the reds disappear from the pattern, being replaced by blank raster. Likewise, if the *B-Y* detector channel is faulty, the blues disappear from the pattern, leaving the reds and greens. Lack of input signal to the *G-Y* matrix causes the greens to disappear from the pattern, leaving the reds and blues only. Of course, more complex indications are obtained from other types of chrominance circuit faults and familiarity with these symptoms is gained by experience in service work.

In summary, a rainbow generator will show whether a color TV receiver is capable of reproducing a color signal (no pattern is obtained if the chrominance circuits are "dead"), serve as a guide in adjusting the color phasing control properly, and indicate the nature of major faults in the chrominance circuitry.

The NTSC color-bar generator is the most elaborate and expensive form of color signal generator and provides an output which is essentially the same as transmitted by a color TV transmitter during test pattern time. Varied outputs are generally available from the NTSC type of generator to facilitate different types of tests. The proportions of the signal output from an NTSC color-bar generator are illustrated in Fig. 5. Note carefully that the chrominance signals are not centered on black level, but are superimposed upon definite values of *Y* signal.

This type of signal provides fully saturated and true colors on the screen of the picture tube. Yellow and white bars are available, for example, and the operation of the receiver chrominance circuits is fully indicated. An NTSC color-bar generator may provide both modulated r.f. output and video-frequency output.

Fig. 6 illustrates the appearance of an *R-Y* signal from an NTSC color-bar generator. The output contains horizontal sync, burst, and a crystal-con-

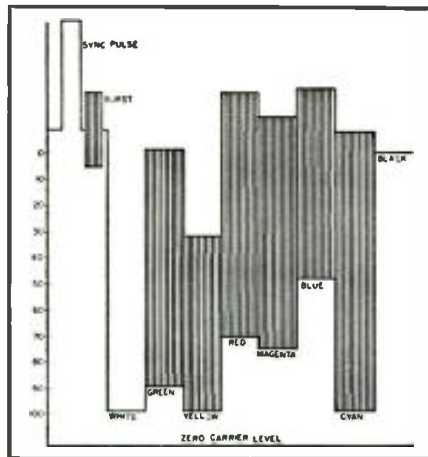

Fig. 5. Composite video signal output of one NTSC color-bar generator. The color tube display resulting from this signal has distinct vertical color bars.

trolled chrominance signal properly phased for *R-Y* response. Since most present-day color TV receivers incorporate *R-Y* and *B-Y* detectors, the advantage of having individual *R-Y* and *B-Y* outputs for bench tests is apparent. An NTSC generator may also provide individual *G-Y* signals for matrix tests; they all provide *I* and *Q* signals.

An NTSC color-bar generator produces standard colors, which appear in a regular sequence when the color phasing control is properly adjusted, as shown in Fig. 7. If the color phasing control is incorrectly adjusted, the entire color spectrum shifts, so that the bars do not appear in proper color sequence. The NTSC color signal is considerably more useful than a rainbow signal for troubleshooting work, because it gives more direct information concerning circuit action.

If the *R-Y* detector channel is inoperative, the red bar appears as a gray, the yellow bar appears green, the magenta bar appears blue, and the white bar appears cyan. Or, if the *B-Y* detector channel is inoperative, the blue bar appears gray, the cyan

Fig. 6. Appearance of an *R-Y* signal from a color-bar generator, as seen on a scope.

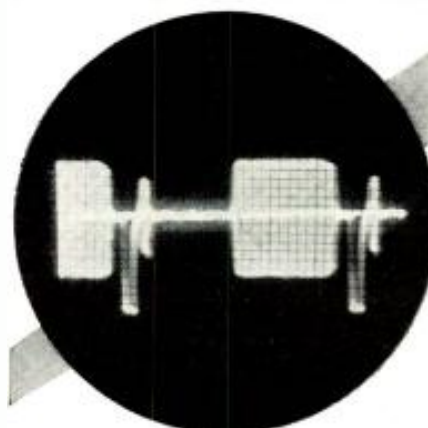

Fig. 7. Typical color sequence provided by one NTSC color-bar generator when the color phasing control is set correctly.

bar appears green, the white bar appears magenta, and the magenta bar appears red. If the *G-Y* matrix channel is inoperative, the green bar appears gray, the yellow bar appears red, the white bar appears magenta, and the cyan bar appears blue.

The *R-Y* and *B-Y* outputs of an NTSC color-bar generator tests the color circuits of a TV set in the following manner. When the color detectors are operating properly, the *R-Y* detector circuit develops maximum output on an *R-Y* signal from the generator and zero output on a *B-Y* signal; the *B-Y* detector will develop maximum output on a *B-Y* signal and zero output on an *R-Y* signal. The color picture tube will display only the *R-Y* bar for the first case and only the *B-Y* bar for the second case. If these conditions are not obtained, the trouble is usually due to misadjustment of the quadrature transformer, or to capacitor failure in the color subcarrier circuits.

When the operator views the output from an NTSC generator on the screen of a wide-band scope, he cannot distinguish the difference between an *R-Y*, *B-Y*, or *G-Y* signal when sawtooth sweep is used. However, if the output from the *R-Y* detector is applied to the vertical channel of the scope, and the output from the *B-Y* detector is applied to the horizontal input of the scope, a chrominance phase display is obtained, as shown in Fig. 8. The transient distortion in the pattern is due to inaccuracies of receiver response and will differ from one receiver to another. Of course, transient distortion in the scope amplifiers can mislead the operator in this regard.

(Continued on page 123)



Fig. 8. Vector phase display obtained on an oscilloscope connected to a color TV set. A color-bar generator furnishes the input to the set. See text.

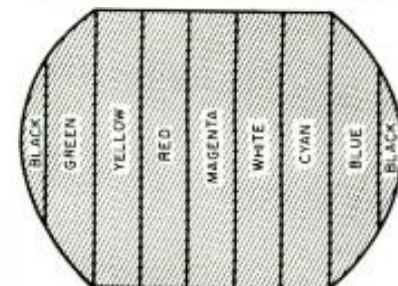

A Simple Preamplifier

By **CHARLES P. BOEGLI**
Cincinnati Research Company
and
RAYMOND H. WILLIS



Fig. 1. Front panel view of the preamplifier. It is housed in a wood case to permit its use on a table top but could, just as easily, be used in its chassis form.

Construction details on a compact, versatile unit that provides an equalized low-impedance output of 0.5 volt and includes a highly effective tone-control circuit.

A NUMBER of power amplifiers are now available which require considerably less than one volt r.m.s. to drive them to full output. One such amplifier was recently described in this magazine.² The majority of preamplifiers, however, are usually designed to provide an output of one to two volts r.m.s., which would overload such amplifiers and lead to excessive distortion by driving them into the clipping region.

It is possible, of course, to adjust the output level of a preamplifier by means of a volume control or voltage divider so that it will not introduce an overloaded condition. Such an expedient, though, is wasteful of gain and may lead to a poorer signal-to-noise ratio. Also, designing a preamplifier for high output may lead to more distortion than would be the case in a low-output unit. Although such distortion could be reduced by means of inverse feedback, it seems silly to design a preamp capable of delivering two or three volts or more when less than one volt is required.

Shown in Fig. 1 is a preamplifier designed specifically for those amplifiers requiring about .5 volt of drive for full output. It can, of course, be used with lower sensitivity amplifiers, but cannot drive them to full output. It is ideally suited for the 13-watt "in-

finite-feedback" amplifier referred to previously.²

The output impedance of this preamplifier is quite low—comparable, in fact, to that of a cathode-follower. However, it should not be used with a power amplifier having a very low input impedance (less than 1000 ohms) such as the 35-watt "infinite-feedback" amplifier described some time ago in this magazine.³ It would be better to revamp the input circuit of such an amplifier so that it can be used with conventional preamps having a high output impedance.

Circuit Design

Earlier preamplifiers designed by one of the authors have always used a dual triode with a passive equalizer between the two sections, and have had a gain (at 1000 cps) of about 14. If a 10-millivolt cartridge is connected to such a preamplifier, the output signal will be around 0.14 volt. This is a rather inconvenient figure; it is too low to be used directly, and if it is passed through even a low- μ triode with a gain of 15, it attains the value of 2.1 volts, which is too high for the present purpose.

On the other hand, a 5879 low-noise pentode has, when properly connected, a gain of about 150, and when it is followed by an equalizer of the type to

be shown, the over-all gain is 2.4. The output from a 10-millivolt cartridge is 0.024 volt, which can be passed through a medium- μ triode like a 12AY7 (gain around 25) to obtain a signal of 0.6 volt.

With input signals as small as those delivered by a magnetic cartridge, there is little to choose between two triodes and one pentode as far as distortion is concerned; both will be found negligibly small. The pentode has the advantage of low input capacity, an important consideration where the cartridge to be used has a high inductance. The pentode also permits simplification of the power-supply filtering requirements, since the signal from the cartridge is raised to a level high enough to be non-critical before anything in the way of equalizing is done to it.

Fig. 2 shows the circuit diagram of the complete preamplifier. The first stage is a 5879; the second, one-half of a 12AY7. Between these two stages is an equalizer switch essentially the same as that previously developed³ and considerably improved by Howell⁴. The high output resistance of the first stage, however, permits the elimination of the large equalizer input resistor. The first two stages are used only when the input-selector switch is turned to one of the two available phono positions. When the switch is turned to a low-gain input position the grid of the first stage is grounded.

Tuners and other sources of signal to be connected to the low-gain inputs must be able to deliver at least 0.6 volt. The last two stages of the preamp have no gain; the first is a cathode-fol-

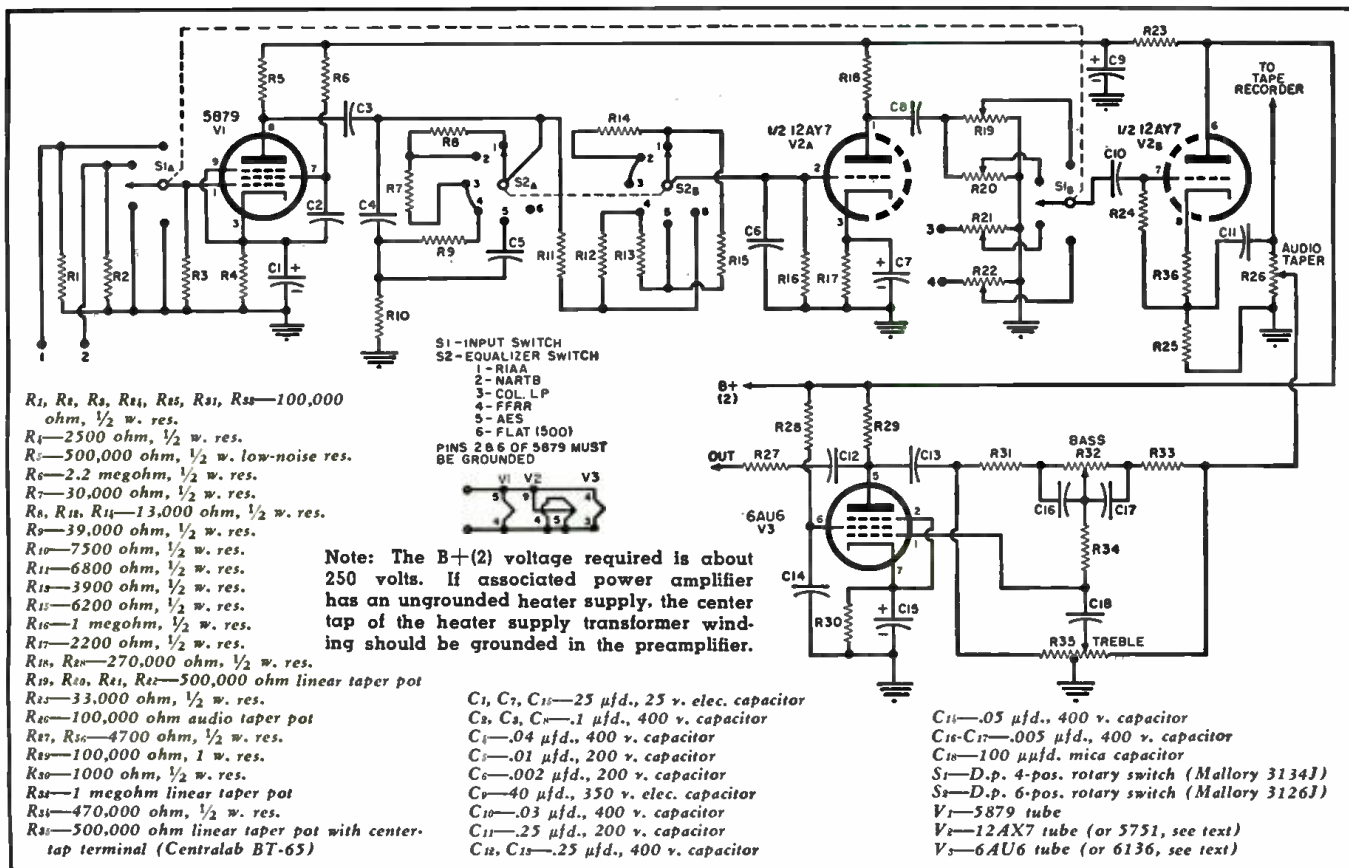

lower to which the tape-recorder output is directly connected. A volume control of low resistance also follows this stage, and the slider of the control is attached directly to the tone-control circuit. It has been found that with a low-resistance volume control like the one used here, there is no interaction of tone- and volume-control functions.

The excellent tone-control circuit devised by Baxandall⁸ is used in exactly the form he recommended, including the high-gain pentode. The original article details the advantages of a pentode over a triode in this circuit. The gain of the tone-control stage is about 1.0 irrespective of the type of tube used in it but the distortion with the pentode is less than that resulting from the employment of a triode. It should be noted that the center tap of the treble control is connected directly to ground. Inserting a resistor here causes considerable loss of performance and is not recommended.

The output resistance of the preamplifier with tone controls in flat position is about 5000 ohms. The frequency response consequently remains unaffected even though very long cables are used to connect preamplifier to amplifier. As a matter of fact, a capacity of 800 μfd. may be shunted across the output terminals before the response drops as much as 1 db at 20,000 cps.

Construction and Performance

The preamplifier was constructed on a 5x10x3-inch chassis in such a manner that it could be slipped into a finished

wood case and used on a table top. Wiring was done mainly on 13-point Cinch-Jones terminal strips. Fig. 3 is an under-chassis view of the finished preamplifier. Except for the equalizer, parts tolerances are not critical. For the equalizer, resistors should be of 5% tolerance and capacitors should be checked with a bridge if at all possible.

Rotating either the input or equalizer switch causes no audible clicks in the

output even with the volume control fully open and with one phono input unterminated. With the input selector on a low-gain position, the hum level of the preamp-amplifier combined is no greater than that of the amplifier alone. On a high-gain position, tube noise becomes audible when the volume control is wide open, but at normal settings it cannot be heard, and

(Continued on page 128)

Fig. 3. Under chassis view. Terminal strips make for neat construction.

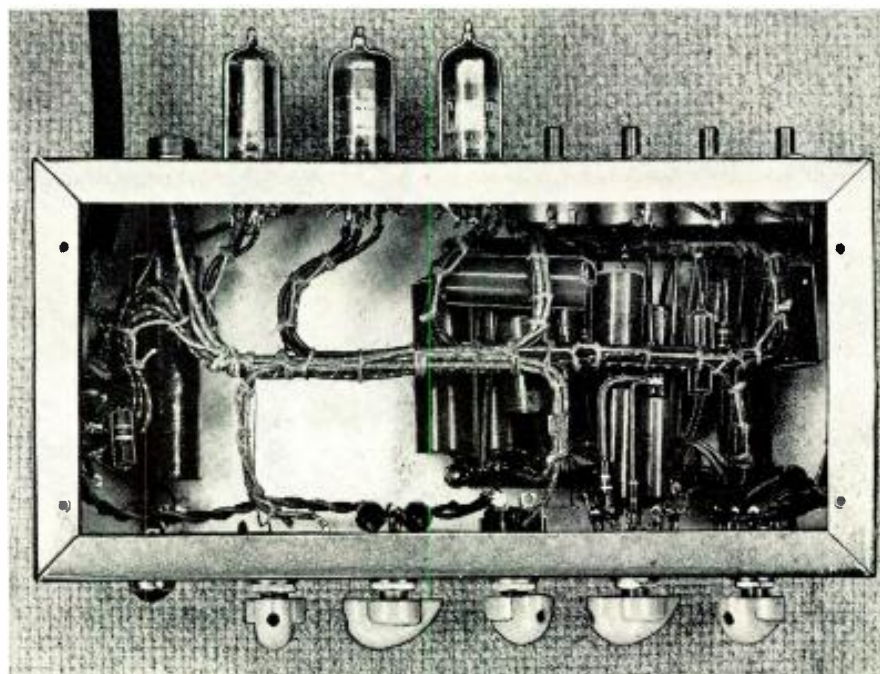

Methods of Measuring and Specifying

AUDIO

Distortion

By W. PHILBROOK

The different methods of measurement as applied to various kinds of distortion encountered in current audio practice.

FOR several decades now the question of measuring and specifying distortion has presented a problem. It is obviously desirable that a value, measured or specified, should have some significance in terms of the listening quality of an audio amplifier. The difficulty in correlating the divergent figures obtained from various tests, with listening experience, has led to the development of a variety of methods of both measuring and specifying distortion. But still the methods used are difficult to correlate with listening experience—in fact the measurements themselves are difficult to correlate with one another under some circumstances. The purpose of this article is to assess the value of different methods of measurement applied to different kinds of distortion met in practice, and to offer some suggestions that may provide the basis for the development of better techniques in measuring and specifying distortion.

Historical

The first method of measuring distortion, and one still widely used, consists of determining the total harmonic content in the output when a pure sine wave input is applied. A strict definition of the system specifies that the harmonic figure given shall be the r.m.s. value of the residual waveform when the fundamental has been removed. There are three reasons for dissatisfaction with this method of measurement.

First, on the basis of evaluating the effects of distortion on a pure tone, the audible effect is dependent on the order of harmonic present. It has been proved that a much larger percentage of pure second is tolerable before it becomes audible than any higher order harmonic. In fact the higher-order harmonics become extremely easy to detect aurally in comparison. This means that a simple specification of total r.m.s. value of the residual har-

monic waveform gives no indication of its relative audibility against the fundamental as a masking tone.

Second, measurement of the effect of distortion on a pure sine tone is no indication of its effect on musical program material, in which there are many different frequencies present at the same time. An amplifier that introduces a quantity of pure second harmonic, which is inaudible on a single tone, can produce quite noticeable distortion due to the intermodulation effects that arise from the same kind of distortion when several tones are present together.

Third, to measure an accurate r.m.s. value of the residual harmonic waveform requires an instrument that gives true r.m.s. reading. The majority of instruments designed for measuring distortion eliminate the fundamental and then measure the residual harmonic with a mean reading instrument calibrated in r.m.s. (See Fig. 1). If the residual harmonic is of sinusoidal waveform, or has a strong single component compared to the remaining components, the error is not great. But with some types of residual waveform—as we shall see presently—the error can be considerable.

On the basis of the second point just discussed, forms of intermodulation test were devised as an alternative to harmonic measurement. These fall into two principal groups, both of which consist of applying two different frequencies to the input of an amplifier simultaneously and looking for spurious components in the output.

One variety applies a low frequency and a high frequency simultaneously, for example 60 cycles and 2000 cycles. The 60 cycles is applied at an amplitude several times as great as that of the 2000 cycles—usually a ratio of 4 to 1, and the higher frequency (2000 cycles) can be regarded as a kind of monitor to check the amplification at different points on the larger low-

frequency waveform. If the amplification is not uniform throughout this waveform, the 2000-cycle tone will become modulated by the change in amplification and this modulation is detectable as a form of distortion.

On the basis of this simple explanation it would appear that this method of checking intermodulation is simply a refined form of harmonic measurement, and that there must be a basic relation between the figure obtained by harmonic measurement and that obtained by intermodulation test, dependent upon the relationship between the high-level, low-frequency signal and the monitoring high-frequency signal.

There is another relationship to consider. This is the fact that the peak waveform is the sum of the amplitudes of the individual waveforms and hence distortion must be related to this value rather than to r.m.s. value of the combined waveform. This complicates correlation of results.

The other kind of intermodulation measurement employs two higher frequencies fairly close together and exploration is then made for spurious tones well away from these high frequencies. For example, if two frequencies of 3000 and 3200 cycles are used for the test, frequencies on the order of 200 cycles and multiples will be expected as distortion products.

This method of intermodulation distortion suffers from the disadvantage that the production of a difference tone is dependent upon an asymmetrical or even-order of distortion. Most modern amplifiers employ push-pull in the stages most likely to cause distortion, so they neutralize second and even-order components, leaving a residual consisting, basically, of odd-order components. Odd-order forms of distortion do not give any asymmetry and hence only produce, as intermodulation products, higher frequency tones than the original ones. Few amplifiers are, of course, completely free from some even-order distortion, due to the earlier single-ended stages, or residual unbalance of the push-pull stages. But a modern amplifier possesses higher components of odd-order harmonics

than of even-order harmonics as a rule. And hence this method of intermodulation measurement gives a completely unreliable value because the major components present in most modern forms of distortion are completely overlooked.

Both these forms of intermodulation have practical significance in musical program material. A high-amplitude low frequency can modulate a higher frequency present in the same composite signal and the result is a dithery kind of effect on the reproduction of the high-frequency tone. This can be particularly noticeable on organ music.

The other combination can cause low-frequency tones to be created when two high-frequency tones of small diatonic interval are played simultaneously. It has been proved that the ear generates such tones subjectively, if the levels are sufficiently intense. However, it is desirable for electronic equipment to be free from this kind of distortion.

The first mentioned method of intermodulation measurement detects most of the varieties of curvature distortion that also show up on harmonic measurement. However, discrepancy appears with the kind of distortion which produces high-order harmonic components, such as feedback amplifiers of the multi-loop variety and changeover distortion in push-pull stages, where the tubes are not correctly biased.

Amplifiers driven to the point of clipping, where clipping occurs very suddenly, also fail to give consistent results by both methods of measurement.

A reason for this can be seen by examining the equipment necessary for making the measurements, and considering the component frequencies that will appear due to the higher order distortion effects. See Fig. 2. The distortion is measured by first filtering off the 60-cycle high amplitude wave. After this the 2000-cycle tone is demodulated by rectifying and filtering so as to eliminate all of the 2000-cycle component.

Provided the intermodulation products are of low order, the low-pass filtering needs only to pass components of 60 cycles and low-order multiples of 60 cycles. However, if high-order distortion is present, some of the higher multiples of 60 cycles can be present, and a filter that will successfully remove 2000 cycles completely will probably remove, or at least reduce, some of the high-order components present in the composite modulation waveform. This fact probably accounts for the discrepancy between the two methods of measurement on this kind of distortion.

Problem Types of Distortion

Next, we should consider the two varieties of distortion that are most common in modern amplifier waveforms and what effect these forms of distortion will have on the methods of measuring we have so far discussed.

There are two cases to be considered.

(1) The form of distortion that appears when an amplifier is operated well within its overload point, so as not to introduce any clipping.

(2) The form of distortion due to clipping at maximum output.

In the first case the distortion is entirely due to curvature of various nonlinear components, and has no appreciable discontinuity-contributing elements. An amplifier operating under this condition, without feedback, will normally contribute a major component of second and/or third harmonic, with rapidly converging terms of higher order. For convenience it may be assumed that higher-order terms may be neglected. But when feedback is applied, the major components are reduced in amplitude to a greater extent than the higher-order components. The result often is that the higher-order components become the major ones in the residual harmonic waveform.

If all the components capable of introducing nonlinear characteristics have been carefully operated under optimum conditions to produce minimum nonlinearity, the amplifier will have a low-order of harmonic before feedback is applied. Unfortunately however, what frequently occurs in the design of a feedback amplifier is that the distortion without feedback is increased to obtain a higher degree of gain, so as to obtain more feedback. This can result in reduction of the ultimate *measurable* distortion. But it can also result in the dominant residue being of high order.

Let's take some figures to illustrate this. Suppose, to get sufficient gain to apply, say, 26 db of feedback, circuit values have been modified so that, without feedback, the amplifier would produce 5% of third harmonic distortion, due to curvature of tube characteristic. The 26 db of feedback will reduce this third harmonic component from 5% to .25%. However, in doing so, the amplifier now receives an input, not of pure fundamental, but fundamental with almost 5% of third harmonic, in anti-phase to the third harmonic that the fundamental will generate in transit through the amplifier.

The nonlinear elements in the amplifier will now generate both harmonic components of this artificially injected third harmonic and also intermodulation products of the fundamen-

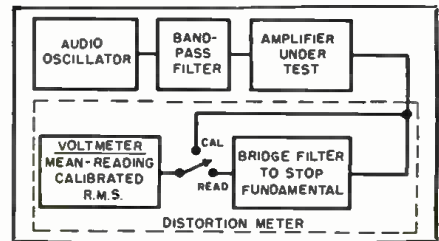

Fig. 1. Block diagram of the usual arrangement for measuring harmonic distortion. The v.t.v.m. in the distortion meter usually reads a rectified mean value, calibrated in r.m.s., assuming a sinusoidal waveform.

tal with its third harmonic since both are now present at the input. Probably the strongest component generated in this case would be the ninth harmonic, due to the third harmonic of the re-injected third of the original. In a first transit through the amplifier this would produce an amplitude of 5% of 5% or .25%.

Of course, if there is no phase shift in this 9 to 1 frequency range, there will be further reduction of this ninth harmonic due to successive feedback around the same loop, and a further multiplication of the order, up to 27th harmonic. But somewhere the phase shift at upper frequencies will begin to throw out the cancellation due to feedback and, consequently, one is left with a residue of frequencies near the upper limit of the passband, produced by a process of successive multiplication of the order of distortion.

If an intermodulation method is applied for the measurement of distortion in an amplifier producing these high-order components, the result is quite similar, although the measurement will be somewhat invalidated due to the reason given previously. However the intermodulation products that will be heard will be of high-order, and tend to make the reproduced sound harsh or gritty.

The third point, mentioned in the criticism of harmonic distortion measurement—that of the relation between mean and r.m.s. value of the residual waveform—does not specifically apply to this kind of distortion, because all the components present in the residual waveform are satisfactorily resolved into a Fourier series with the fundamental as the common factor. This means that the r.m.s. and mean values of the residual waveform will never differ too widely, not by a factor, for

Fig. 2. The more usual method of IM measurement, showing the frequency components present at various points, assuming only first- and second-order products (wave envelopes show first-order only); high-order components will not be adequately measured by this method, for the reason explained in accompanying text material.

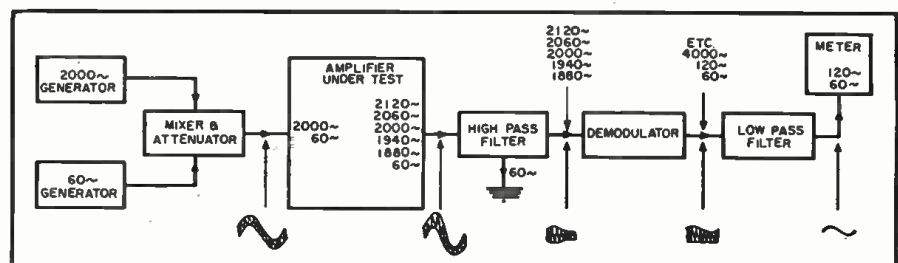

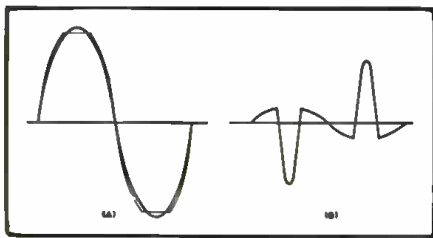

Fig. 3. The waveforms produced in measuring the distortion of a "clipped" wave, due to overload condition in a power stage. (A) The clipped wave, together with sine wave that meter will remove to give residual harmonic (clipped wave is also sinusoidal up to clipping points), and (B) the residual harmonic, amplified. Refer to the article.

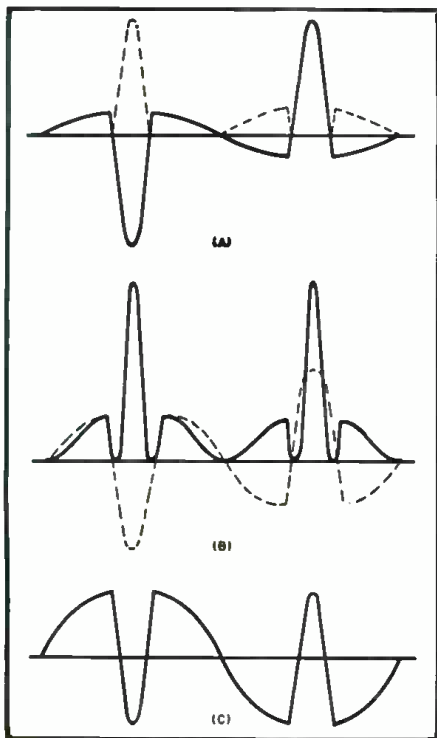

Fig. 4. Comparison of the three methods of metering for balance and harmonic estimation. (A) Using mean reading meter, solid curve shows waveform at input to meter, dotted is rectified portions of wave to give unilateral current. (B) Using r.m.s. instrument, solid curve shows the instantaneous square values, on which reading is based, dotted is the residual input wave to produce the solid curve. (C) Using a peak-to-peak reading instrument. See article.

example, of more than 2 to 1 from the form factor of a single sine wave, which is 1.11.

The other variety of distortion with which we are concerned in modern feedback amplifiers occurs at the overload point or maximum output of the amplifier. When the amplifier runs into a form of distortion that introduces curvature, the feedback has the effect of reducing the distortion successfully. But when the amplifier runs into clipping, at which point on the waveform amplification ceases momentarily, feedback ceases to have effect, and the resultant waveform has the corners of the clipped wave much sharper than an amplifier of the same basic design without feedback.

The waveform of an amplifier operating under this condition can be regarded as following a very close approximation to true sinusoidal over the portion between clipping of successive opposite peaks, at which point it meets a definite discontinuity, which will appear as a pulse on the residual distortion waveform. This is illustrated in Fig. 3.

According to mathematical theory this waveform, being periodic, can be reduced to a harmonic series by Fourier analysis. However it is evident from an examination of the waveform that its properties will differ considerably from those produced by a more regular series.

At this point we should inject a question as to what this kind of distortion will sound like? At this stage we may leave out the question of the sensitivity of the ear to different component frequencies, as this will be affected by the frequency at which the test is made, and also the level, because the Fletcher-Munson curves change their slope with both frequency and level. It will be fairly evident from an examination of the waveform that its effect on the reproduced sound will be precisely similar to an abrupt stopping of the travel of the loudspeaker diaphragm, just short of its maximum excursion. This would sound as if the voice coil were knocking against some obstruction at each end of its travel. From experience we can recognize that this knocking sound will be readily discriminated from the fundamental frequency at which the voice coil is traveling.

So it would appear that a better estimate of the amplitude of the distortion component introduced, will be obtained by comparing the peak value of the "knock" component with the peak value of the fundamental, rather than comparing average values. A third possible basis of comparison would be to use the true r.m.s. values of both waveforms, rather than the mean-value-calibrated-in-r.m.s. which most practical meters read.

Fig. 4 shows a comparison of a balance obtained by each method of reading. At A the mean reading instrument has been used to adjust the balance of fundamental for a minimum reading of residuals. This means that the area above and below the zero line is equal—the condition for giving a minimum reading when the lower half is inverted by rectification and the area is measured by a mean reading instrument. The mean reading instru-

Fig. 5. Theoretical waveform at output from high-pass filter in intermodulation meter. The following demodulator and low-pass filter to remove the "carrier" will not be capable of faithfully measuring this envelope.



ment is calibrated in r.m.s. on the basis of a form factor of 1.11 assumed for a sinusoidal waveform.

On this basis the distortion produced by increasing the signal amplitude by 15% from the point where clipping commences, will give a distortion reading of 3% assumed r.m.s. value.

If a true r.m.s. instrument is used for setting the balance, the residual waveform measured by the r.m.s. instrument will be somewhat different from that shown at Fig. 4A. Here each ordinate is squared, and the minimum reading will occur when the area under the squared value curve, due to the positive-going original wave, is equal to the area under the curve for the negative-going original wave.

As the higher, peaked part of the waveform will produce a larger area by the squaring effect, this means that balance will occur when the peak is pulled down somewhat and the broader areas are pushed out in the opposite direction, as shown in Fig. 4B. On the particular waveform just mentioned the reading obtained by a true r.m.s. instrument would be about 4.5%.

The third possibility would balance for minimum using a peak-reading instrument. In this case a small fraction of the fundamental would be inserted so as to bring the peaks down level with the shoulders as shown in Fig. 4C. Using this as a basis for measurement the same waveform, with a 15% overdrive, will show a distortion of almost 7%.

These examples represent a fairly large amount of distortion and certainly one which will be extremely audible. The figures usually quoted are of much lower order and, at these orders, the discrepancy between the different methods of measurement increases. A value giving a nominal r.m.s. (based on a mean reading instrument) of 1% will give a peak reading of about 2.5%. Going down to a reading obtained with the mean/r.m.s. instrument as .1% the peak value method of measurement will give a reading of .4%. If the distortion is carried down, using the same type of circuit, to the point where the mean/r.m.s. measurement gives a reading of .05%, the peak value would then read .25%.

In theory, application of the same method of final measurement to the intermodulation arrangement would increase the difference between the methods of reading still further. This can be appreciated from Fig. 5, which shows the waveform envelope of the intermodulation signal, after the lower frequency has been filtered out and before demodulation takes place.

On the envelope the indents due to clipping will be 5 times the amplitude (assuming a 4 to 1 ratio) that they show on the simple harmonic measurement, and hence it would appear that the discrepancy between the mean and peak method of taking measurement of the modulation waveform would be even greater, because the pulse ampli-

(Continued on page 113)



FROM DELCO RADIO come the **speakers** with highest performance. You trust them...so do your customers!

Engineering skills of Delco Radio and General Motors combine to offer a full line of speakers for home and auto radios, phonographs, TV, and Hi-Fi. National advertising behind the Delco Wonder Bar Radio develops a bigger service market for you! For fast service call your UMS-Delco Electronics Parts Distributor.

14 Standard Models: Designed and built to R.E.T.M.A. standards with heavily plated metal parts and Alnico-V magnets. Precision felted cones give uniform response over full operating frequency range. All are fully dustproof and dependable.

Dual-Purpose Hi-Fi Model 8007: A superior speaker for custom-built audio systems and for replacements in AM, FM, TV and phonograph sets. Size 8", 50 to 12,500 CPS frequency range; Alnico-V magnet; 10-watt power rating; 4.1 v.c. impedance; 1 $\frac{3}{16}$ " voice coil.

DELCO

W O N D E R B A R

RADIO

DIVISION OF GENERAL MOTORS, KOKOMO, INDIANA



A GENERAL MOTORS PRODUCT—A UNITED MOTORS LINE
Distributed by Electronics Distributors Everywhere

A complete line of original equipment service parts from the

W O R L D L E A D E R I N A U T O R A D I O

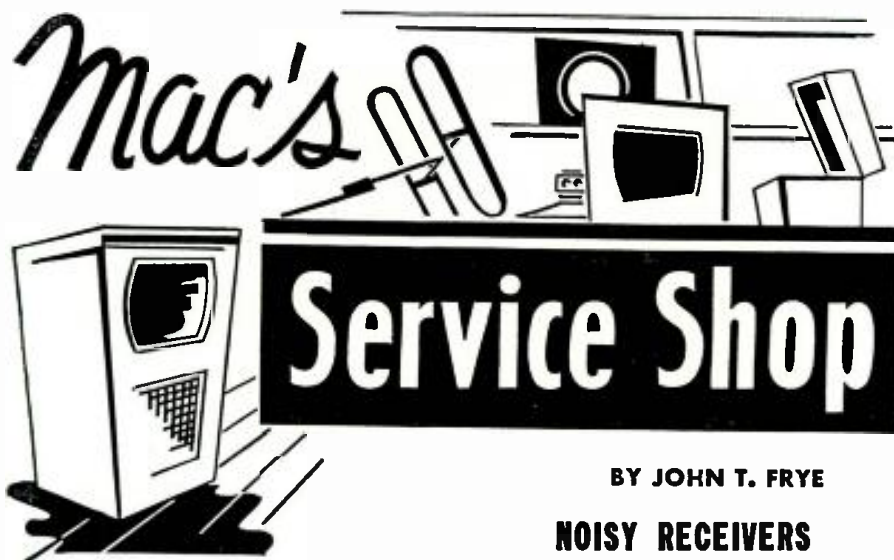

BY JOHN T. FRYE

NOISY RECEIVERS

A BREAK had finally come in the long heat wave, and the August morning was pleasantly cool and invigorating as Barney, whistling cheerfully, came swinging through the front door of the service shop. Mac, his employer, was checking in a small radio because Miss Perkins, the office force of the shop, had not arrived yet.

"You say the set is noisy," Mac noted as he filled out the complaint portion of the job ticket. "Is it noisy all the time or just occasionally?"

"Practically all the time, Buster," the little man in the gaudy sport shirt replied. "Sometimes you can make the noise stop for a little while by pounding on top of the radio, but it soon comes back again."

"What kind of noise is it? hum? whistle? buzz? crackling sound?"

"You just name it, Dad, and that set's got it!" the little man said familiarly.

Barney grinned to himself as he saw Mac wince at being called "Dad," but the shop owner went on with his questions:

"Are other sets in the house noisy, too?"

"The kitchen radio is quiet as you please, even when it is plugged into the same socket with this one that's setting your teeth on edge."

"Suppose you come on back to the service department and let's take a listen to this while you're still here," Mac suggested as he carried the receiver to the service bench and plugged it in.

In a few seconds the radio began to play. At first the reception was good, but after a minute or two a rasping noise could be heard whenever the speaker gave forth with a loud note or whenever the cabinet was tapped lightly with the fingers. Worse yet, when either the volume control or the tone control was varied, the set gave forth with a grating sound. To cap the climax, every time the set was tuned there was a continuous crackling sound from the speaker while the dial pointer was in motion.

"Well, you certainly aren't kidding

about the set's being noisy," Mac admitted. "It's almost a classic example of a noisy receiver. Without checking any further, I can tell you that cleaning up all the different sources of noise in that set will not be cheap."

"Who wants to be cheap?" the little man said cockily. "I want that static jive out of there no matter what it costs. After all, this is the first time that receiver has been in the shop in the five years I've had it; so I'm not hurting. Just clean it up and give me a buzz, Guz, when it's ready."

As the dapper little man stepped jauntily out of the shop, Mac began removing the set from the cabinet. When he had it out on the bench, the first thing he did was to remove the 35W4 at the rear of the chassis and replace it with a new one. Now when the set was turned on, the noise produced by vibrations from the speaker or by tapping on the chassis were gone.

"Scratch one noise source: a noisy rectifier tube," Barney tallied. "It seems that nineteen times out of twenty a noise produced by jarring one of these little sets can be traced to the rectifier, no matter if it is a 35Z5, 35Y4, or 35W4. I've noticed that the sets that mount the rectifier close to the loop antenna, as this one does, are very likely to have this trouble."

"That's right. The noise field generated by the defective rectifier actually radiates into the antenna. You can put a shield on the rectifier and stop the noise, but such a shield makes the rectifier overheat and shortens its life. A new rectifier is the best solution. Now let's see about the volume control."

Mac used a hypo needle to inject a few drops of control cleaner fluid down into the inside of the volume control and rotated the shaft briskly a few times. The noise that had accompanied any movement of this control and the erratic changes of volume that had been present before disappeared like magic.

"So a corroded sliding contact was at fault there," Barney commented,

glad of the opportunity to show off his knowledge. "Are you going to leave that control in or change it?"

"I'm going to change it. After five years, the set deserves a new control. Quite likely the corrosion-resisting plating on the sliding contact is worn though, and cleaning up the bare metal with the cleaning solution would only be a temporary repair. You gotta remember the guy will probably expect the set to hold up another five years when we give it back to him."

"I suppose the tone control is the same way."

"We'll soon see," Mac said as he squirted the cleaner down into the tone control and rotated its shaft back and forth. This time, though, the application of the cleaner did not help a bit. Moving the control knob produced as much noise as before.

"Guess that sliding contact is so bad it won't clean up," Barney offered.

"Maybe," Mac grunted noncommittally as he flipped on the v.t.v.m. As soon as it had warmed up, he placed the negative lead on a line switch terminal and the positive test lead on the tone control lug to which a capacitor coming from the plate of the output tube was soldered. A reading of fifteen volts was indicated, and changing the setting of the tone control caused this voltage to vary widely.

"Leaky capacitor, huh?" Barney questioned.

"Right. Since this capacitor and the variable resistance of the tone control are connected in series between the plate of the output tube and 'B-minus,' this allows current to flow through the sliding contact of the control. Variations in this current produced by moving the control generates the noise."

While he was talking, Mac had swiftly snipped out the bad capacitor and soldered a new one into place. Changing the tone control no longer produced the slightest noise.

"That just leaves the noisy tuning capacitor," Barney prodded. "I suppose dust between the plates or possibly a dirty wiper contact on the rotor is causing the trouble there."

"You might say dust is a 'secondary' cause," Mac said as he used a probe light to peer down between the plates of the closed capacitor; "but I have found that usually the 'primary' cause is poor spacing between the plates. If the rotor plates are evenly spaced between the stator plates, a usual amount of ordinary dust will not cause trouble; but if those plates pass too close together, just a trifle of dust will cause noise. And," he concluded, "I see that is the trouble here."

"Why do the plates get out of line?"

"The capacitor frame warps; the bearing on the end of the rotor shaft wears slightly or works loose if it is of the adjustable type; the plates are bent out of shape by rough handling—there are many reasons. In any case, the first thing to do is restore the proper alignment as nearly as you can.

(Continued on page 131)

how long would it take you to solve this service problem?

SYMPTOM:

Loss of horizontal hold. Hold control will not pull the picture into synchronization. Sound is normal.

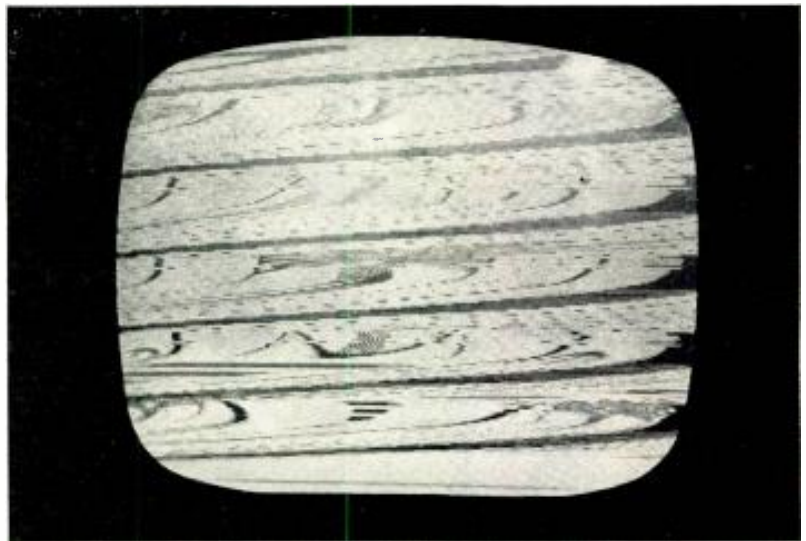

There's no telling how long it might take to solve this problem with hit-or-miss methods—it's been known to take hours. With a PHOTOFACT Folder by your side, the job takes just minutes. Here's why:

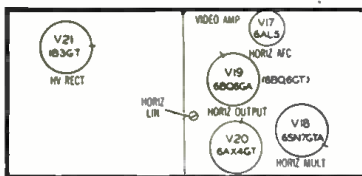

In just seconds, you locate the tubes most likely to cause this symptom by referring to the Tube Placement Chart* and Tube Failure Check Chart* you'll always find in the same place in each PHOTOFACT Folder.

In this case the trouble wasn't caused by tube failure, so...

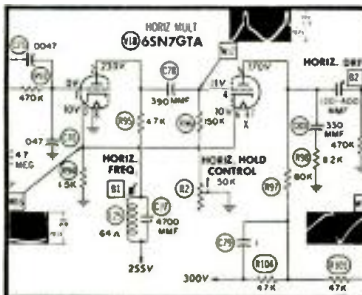

In just seconds you refer to the Horizontal Circuit on the Standard Notation Schematic* featured exclusively in all PHOTOFACT Folders. Circuits are always laid out in the same uniform manner. The Horizontal Circuit is always located in the lower center of the schematic. In a matter of minutes you check waveforms and voltages—they're right on the schematic. And in those same few minutes you find the answer to the problem in this case history. The waveform at W17 and the voltage reading at Pin 4 show a leaky coupling capacitor C78. Yes, you have your answer in just minutes!

C74	270	500	RCM20A271K	S1270	D6-271
C75	.0047	400	RCP10M4472M	SI4700	D6-472
C76	.047	200	RCP10M2473M	BPD-05	DF-50
C77	4700	500	47X543	1464-0047	
C78	390	500	RCM20B391J	1469-00039	D6-391
C79	.1	400	RCP10M4104M	P488N-1	DF-104
C80	330	500	47X570	1469-00033	D6-333

And PHOTOFACT, through its accurate Parts Listings*, instantly gives you a choice of the proper replacement required to accomplish the repair. You save even more time!

From start to finish, you solve your service problems in just minutes...you service more sets and earn more dally with PHOTOFACT by your side!

*One of 32 features found exclusively in PHOTOFACT—the world's finest service data

free



HOWARD W. SAMS & CO., INC.

Howard W. Sams & Co., Inc.
2203 E. 46th St., Indianapolis 5, Ind.

- Send FREE Index to PHOTOFACT Folders
 I am a Service Technician

Name _____

Address _____

City _____ Zone _____ State _____

Send for Sams' INDEX TO PHOTOFACT FOLDERS—your guide to virtually any receiver model ever to come into your shop; helps you locate the proper PHOTOFACT Folder you need to solve any service problem on any model. You'll want this valuable reference guide. Send coupon now.



MONEY BACK GUARANTEE!

Got a tough repair? Try this—at Howard W. Sams' own risk: see your Parts Distributor and buy the proper PHOTOFACT Folder Set covering the receiver. Then use it on the actual repair. If PHOTOFACT doesn't save you time, doesn't make the job easier and more profitable for you, Howard W. Sams wants you to return the complete Folder Set direct to him and he'll refund your purchase price promptly. **GET THE PROOF FOR YOURSELF—TRY PHOTOFACT NOW!**

HEATHKIT®

... world's finest
electronic equipment
in kit form



A MODEL O-10



B MODEL OM-1



C MODEL OL-1



MODEL MM-1
VOM



MODEL M-1
HANDITESTER



MODEL V-7A
VTVM

A Heathkit ETCHED CIRCUIT

COLOR TV

5" OSCILLOSCOPE KIT

Amplifier response essentially flat (+2 db -5 db) from 5 mc down to 2 cps without extra switching. Sweep oscillator allows single-cycle observation up to 500,000 cps, and even higher. Uses etched metal circuit boards. Push-pull vertical and horizontal amplifiers—built in peak-to-peak calibrating source—step attenuated input—preformed and cabled wiring harness. A professional scope ideal for color TV work in the lab or service shop. 11-tube circuit features 5UP1 CRT.

MODEL O-10
\$69.50

Shpg. Wt.
21 lbs.

B Heathkit ETCHED CIRCUIT

5" OSCILLOSCOPE KIT

The OM-1 has many big scope features, including 5", 5BP1 cathode ray tube, and yet it is priced reasonably. Features etched metal circuit boards. Incorporates 3 step input attenuator—phasing control—built-in peak-to-peak voltage calibrator—and push-pull vertical and horizontal amplifiers. Vertical amplifier flat within ±3 db from 2 cps to 200 kc. Sweep circuit functions from 20 cps to 100,000 cps. An excellent general purpose scope for service shop or lab.

MODEL OM-1
\$49.50

Shpg. Wt.
21 lbs.

C Heathkit ETCHED CIRCUIT

3" OSCILLOSCOPE KIT

Has many of the features of the Model OM-1, yet is smaller in physical size for portability, and for use in the home workshop. Employs etched metal circuit boards. Vertical frequency response within ±3 db from 2 cps to 200 kc. Sweep generator operates from 20 to 100,000 cps. The 8-tube circuit features a type 3GP1 cathode ray tube. Measures only 9½" h. x 6½" w. x 11¼" d.

MODEL OL-1
\$29.50

Shpg. Wt.
14 lbs.

Heathkit 20,000 OHMS/VOLT VOM KIT

Requires no external power. Sensitivity is 20,000 ohms/v. DC and 5,000 ohms/v. AC. Black Bakelite case—4½" 50 ua. meter—1% precision resistors. AC and DC ranges are 0-1.5, 5, 50, 150, 500, 1500, and 5000 volts. Direct current ranges are 0-150 ua., 15 ma., 150 ma., 500 ma., and 15 a. Resistance multipliers are X1, X100, and X10,000. DB range from -10 db to +65 db. Especially valuable in portable applications.

MODEL MM-1
\$29.50

Shpg. Wt.
6 lbs.

Heathkit HANDITESTER KIT

This compact model easily slips into tool box, glove compartment, or coat pocket. Valuable as "extra" instrument in service shop, and ideal for the home experimenter. Very popular with appliance repairmen, and electricians. Measures AC or DC voltage at 0-10, 30, 300, 100, and 5000 volts. Direct current ranges are 0-10 ma., and 0-100 ma. Attractive black Bakelite case.

MODEL M-1
\$14.50

Shpg. Wt.
3 lbs.

Heathkit ETCHED CIRCUIT VACUUM TUBE VOLTMETER KIT

The V-7A is used in scientific laboratories, technical schools, service shops, ham shacks, and in the home workshop. Features 200 ua. meter, 1% precision resistors, and etched metal circuit board. Measures DC voltage, ACV (rms), AVC (peak-to-peak), and resistance. AC (rms) and DC voltage ranges are 0-1.5, 5, 15, 50, 150, 500, and 1500 volts. Peak-to-peak ranges are 4, 14, 40, 140, 400, 1400, and 4000 volts. Ohmmeter ranges provide multipliers of X1, X10, X100, X1000, X10K, X100K, and X1 megohm. DB scale also provided. 11 megohm input impedance.

MODEL V-7A
\$24.50

Shpg. Wt.
7 lbs.

NEW

Heathkit PROFESSIONAL RADIATION COUNTER KIT



- ▶ Modern circuit design for maximum sensitivity and reliability.
- ▶ Employs 900 volt Bismuth tube in beta/gamma sensitive probe.
- ▶ Both visual and aural indicators for radiation level.

This radiation counter features ranges of 0-100, 600, 6000, and 60,000 counts per minute and 0-.02, .1, 1, and 10 milliroentgens per hour. The probe uses a 6306 Bismuth tube. The 5-tube circuit employs a 4½", 200 ua. meter, calibrated in cpm, and mR/hr. Also aural signal provided from panel-mounted speaker. Simple to build from the instructions supplied, even for a beginner.

MODEL RC-1
\$79.50

Shpg. Wt.
8 lbs.



HEATH COMPANY A Subsidiary of Daystrom, Inc. **BENTON HARBOR 15, MICH.**



ETCHED CIRCUIT RF

No. 309-C. \$3.50
Shpg. Wt. 1 Lb.

Use with any 11 megohm VTVM for RF measurements up to 250 mc with $\pm 10\%$ accuracy. Employs etched circuit.

Heathkit PROBE KITS



30,000 VOLT D.C. HIGH VOLTAGE

No. 336. \$4.50
Shpg. Wt. 2 Lbs.

Use to measure high DC voltage with VTVM. Precision multiplier resistor mounted inside plastic probe. Multiplication factor of 100 on Heathkit 11-megohm VTVM.

ETCHED CIRCUIT PEAK-TO-PEAK

No. 338-C. \$5.50
Shpg. Wt. 2 Lbs.

Use to read peak-to-peak voltages on DC scale of 11-megohm VTVM. Read direct on VTVM scales from 5 kc to 5 mc.

PROBES FOR VTVM

PROBES FOR SCOPE



LOW CAPACITY

No. 342. \$3.50
Shpg. Wt. 1 Lb.

Low capacity probe prevents circuit loading. Features variable capacitor for correct impedance matching. Ratio of attenuation can be controlled.



SCOPE DEMODULATOR

No. 337-C. \$3.50
Shpg. Wt. 1 Lb.

This probe functions like detector to pass only modulation of signal, and not signal itself. Applied voltage limits are 30 volts rms, and 500 VDC.



MODEL S-3
ELECTRONIC SWITCH KIT



MODEL PS-3
VARIABLE VOLTAGE
REGULATED
POWER SUPPLY KIT

Heathkit ELECTRONIC SWITCH KIT

This instrument allows simultaneous oscilloscope observation of two input signals by producing both signals, alternately, at its output. All-electronic circuit provides 4 switching rates, selected by panel switch. Provides gain for input signals, and features frequency response of ± 1 db 0-100 kc. Employs seven miniature tubes. Sync output provided to control scope sweep. Functions at signal levels as low as 0.1 volt.

MODEL S-3

\$21⁹⁵

Shpg. Wt. 8 Lbs.

Heathkit VARIABLE VOLTAGE REGULATED POWER SUPPLY KIT

This power supply provides regulated DC output that can be manually controlled from 0 to 500 volts. Supplies up to 130 ma at 200 VDC, and up to 10 ma at 450 VDC. Large panel meter monitors output voltage or current. Supplies filament voltage at 6.3 volts AC (4 amperes). Filament and B+ circuits isolated from ground. Ideal lab power supply for use in experimental work.

MODEL PS-3

\$35⁵⁰

Shpg. Wt. 17 Lbs.

MODEL IT-1
ISOLATION
TRANSFORMER KIT



Heathkit ISOLATION TRANSFORMER KIT

Provides isolation between the power line and equipment under test. No direct connection between primary and secondary. Keeps chassis of AC-DC sets "cold." Fused in the primary circuit. Also provides manual voltage control from 90 volts to 130 volts for test purposes. Rated at 100 volt-amperes continuously. Panel meter monitors output voltage.

MODEL IT-1

\$16⁵⁰

Shpg. Wt. 9 Lbs.

Heathkit DIRECT READING CAPACITY METER KIT

This unique instrument indicates capacity in mmf, or mfd, directly on a $4\frac{1}{2}$ " 50 ua. meter. Ranges are 0 to 100 mmf, 0-1000 mmf, 0-0.1 mfd, and 0-1 mfd. Residual capacity less than 1 mmf. Scales are linear. Instrument not susceptible to hand capacity effects. Will measure even small value trimmers or variable air capacitors.

MODEL CM-1

\$29⁵⁰

Shpg. Wt. 7 Lbs.

MODEL CM-1
CAPACITY
METER KIT



Heathkit VIBRATOR TESTER KIT

Checks condition of vibrators under operating conditions. Tests 6-volt vibrators only. Use in conjunction with BE-4 battery eliminator, or similar variable power source. Indicates vibrator quality on large "good-bad" scale. Tests both interrupter and self-rectifier types. 5 different sockets.

MODEL VT-1

\$14⁵⁰

Shpg. Wt. 6 Lbs.

MODEL VT-1
VIBRATOR TESTER KIT



Photographers! Heathkit ENLARGER TIMER KIT

Use to time photographic enlarger. "Time" dial allows settings of from 5 to 60 seconds. Will also control safe-light "on" when enlarger is "off." Enlarger and safelight plug into receptacles on front panel. Handles up to 350 watts. Ideal device to free operator for other operations, and very simple to build. Compact plastic case.

MODEL ET-1

\$11⁵⁰

Shpg. Wt. 3 Lbs.



HEATH COMPANY A Subsidiary of Daystrom, Inc. BENTON HARBOR 15, MICH.



MODEL TS-4
TV SWEEP GENERATOR KIT



MODEL LG-1
LABORATORY GENERATOR KIT

HEATHKIT®

instruments

CONTAIN HIGH QUALITY
COMPONENTS THROUGHOUT.
EACH AN OUTSTANDING DOLLAR
VALUE IN TEST EQUIPMENT.



MODEL LP-2
LINEARITY PATTERN
GENERATOR KIT



MODEL
SG-8
RF SIGNAL
GENERATOR
KIT



MODEL BE-4
6-12 VOLT BATTERY ELIMINATOR
KIT

Heathkit TV SWEEP GENERATOR KIT

All-electronic sweep circuit eliminates mechanical hum and vibration. Features improved linearity—effective AGC—flat output—0 to 40 mc sweep. Covers all frequencies for black and white or color TV work, as well as FM. High output for alignment of tuners, IF strips, boosters, etc. Fundamental output from 4 to 220 mc in four bands. Has crystal oscillator (4.5 mc and multiples thereof), and variable marker covering 19 to 60 mc—up to 180 mc on harmonics. Provision for external marker. Effective two-way blanking.

MODEL TS-4

\$495⁰⁰

Shpg. Wt.
16 Lbs.

Heathkit LABORATORY GENERATOR KIT

This signal generator covers from 100 kc to 30 mc on fundamentals in 5 bands. 400 cycle modulation variable from 0 to 50%. RF output up to 100,000 microvolts. Meter reads RF output or percentage of modulation. Fixed step and variable output attenuation. Voltage regulation, double copper-plated shielding for stability, and other "extras." Provision for external modulation. Output impedance 50 ohms.

MODEL LG-1

\$395⁰⁰

Shpg. Wt.
16 Lbs.

Heathkit LINEARITY PATTERN GENERATOR KIT

Supplies information for white dots, cross-hatch pattern, horizontal bar pattern, or vertical bar pattern. Use for adjustment of vertical and horizontal linearity, picture size, aspect ratio, and focus. Dot pattern is a *must* for color convergence adjustments. Clip merely connects to antenna terminals of TV set. Panel provision for external sync if desired. Covers channels 2 to 13. 5 to 6 vert. bars and 4 to 5 hor. bars.

MODEL LP-2

\$225⁰⁰

Shpg. Wt.
7 Lbs.

Heathkit SIGNAL GENERATOR KIT

This tried and proven generator covers 160 kc to 110 mc on fundamentals in five bands, and calibrated harmonics extend to 220 mc. Very popular in service shops, laboratories, and home workshops. RF output is in excess of 100,000 microvolts, controlled by a variable and a fixed-step attenuator. Output is pure RF, RF modulated at 400 cps, or 400 cps audio for amplifier testing.

MODEL SG-8

\$195⁰⁰

Shpg. Wt.
8 Lbs.

Heathkit BATTERY ELIMINATOR KIT 6-12 volt

This up-to-date battery eliminator will supply either 6 or 12-volt output to take care of auto radios from even the most modern automobiles. Output voltage is variable 0-8 volts DC or 0-16 volts DC. Will deliver up to 15 amperes at 6 volts or up to 7 amperes at 12 volts. Two 10,000 microfarad output filter capacitors insure smooth DC output. Panel meters monitor output current. Will double as a battery charger. Definitely required for automobile radio service work.

MODEL BE-4

\$315⁰⁰

Shpg. Wt.
17 Lbs.

Heathkit CONDENSER CHECKER KIT



Measures paper, mica, ceramic, and electrolytic capacitors in 4 ranges from .00001 to 1,000 microfarads. Indicates condenser value and quality. Also measures resistance from 100 ohms to 5 megohms. All values indicated directly on panel scale, after adjusting for null on electron beam "eye" tube. No calculations necessary. A valuable instrument in service or laboratory applications.

MODEL C-3

\$195⁰⁰

Shpg. Wt.
7 Lbs.

Heathkit SUBSTITUTION BOX KITS



Model CS-1 **\$55⁰⁰** Shpg. Wt.
2 Lbs.

This unit provides switch selection of capacitor values from .001 mfd. to .22 mfd, in 18 RTMA standard values. Kit includes 18" flexible leads with alligator clips.

Model RS-1 **\$55⁰⁰** Shpg. Wt.
2 Lbs.

Provides switch selection of resistances from 15 ohms to 10 megohms, in 36 RTMA values. Resistors are 1 watt, 10%. Extremely valuable in all types of electronic activity.



HEATH COMPANY A Subsidiary of Daystrom, Inc. **BENTON HARBOR 15, MICH.**



MODEL QM-1
"Q" METER KIT



MODEL TC-2
TUBE
CHECKER
KIT



MODEL CC-1
CATHODE RAY TUBE CHECKER KIT



MODEL DR-1
DECADE RESISTANCE
KIT



MODEL DC-1
DECADE CONDENSER
KIT



MODEL IB-2
IMPEDANCE BRIDGE KIT



MODEL TC-2P
PORTABLE
TUBE CHECKER
KIT

Heathkit "Q" METER KIT

The model QM-1 measures the Q of inductances and the RF resistance and distributed capacity of coils. Employs a 4½" 50 microampere meter for direct indication. Features built-in signal source for tests at frequencies of 150 kc to 18 mc in four ranges. Measures capacity from 40 mmf to 450 mmf within ±3 mmf. Indispensable for coil winding, and determining unknown capacitor values. A worthwhile addition to the laboratory or ham shack at a very low price.

MODEL QM-1
\$44.50

Shpg. Wt.
14 lbs.

Heathkit DECADE RESISTANCE KIT

Provides 20 1% precision resistors that are switched to provide values from 1 to 99,999 ohms, in 1-ohm steps. High quality components for precision lab work.

MODEL DR-1
\$19.50

Shpg. Wt.
4 lbs.

Heathkit DECADE CONDENSER KIT

Employs high precision 1% silver-mica capacitors for switch selection of values from 100 mmf to 0.111 mfd. in steps of 100 mmf. Employs ceramic switches for reduced leakage. Invaluable in the laboratory.

MODEL DC-1
\$16.50

Shpg. Wt.
3 lbs.

Heathkit IMPEDANCE BRIDGE KIT

This bridge features built-in oscillator and amplifier. Measures resistance, capacitance, inductance, dissipation factors of condensers, and storage factor of inductance. D, Q, and DQ functions combined in one control. Employs ½% resistors and ½% silver-mica capacitors. 100-0-100 ua. meter indicates null. Two-section CRL dial provides ten separate "units" with accuracy of .5%. Fractions of units read on variable control.

MODEL IB-2
\$59.50

Shpg. Wt.
12 lbs.

Heathkit TUBE CHECKER KIT

You can afford your own tube tester, even if you are an experimenter, or only do part time service work. Uses a 4½" meter with 3-color meter face for simple "good-bad" indications of tube

quality, on the basis of emission. Will test all tubes commonly encountered in radio and TV service work. 14 different filament voltage values provided. Built-in roll chart—ten 3 position lever switches for open or short tests on each tube element. Space provided for future socket addition.

MODEL TC-2
\$29.50

Shpg. Wt.
12 lbs.

Heathkit PORTABLE TUBE CHECKER KIT

The Model TC-2P is identical to the Model TC-2 except that it is housed in a rugged carrying case. This two-tone case is finished in proxylin impregnated fabric. The cover is detachable, and the hardware is brass plated. Ideal for home service calls.

MODEL TC-2P
\$34.50

Shpg. Wt.
15 lbs.



Heathkit TV PICTURE TUBE TESTER ADAPTER

MODEL 355
Shpg. Wt. **\$4.50**
1 lb.

Use with TC-2. Tests picture tubes for emission and shorts. 12-pin socket, 4 ft. cable, octal connector, and technical data. Not a kit.

Heathkit CATHODE RAY TUBE CHECKER KIT

Indicates condition of CRT on large "good-bad" scale. Spring-loaded switches protect operator. Checks all electro-magnetic deflection picture tubes normally encountered in TV servicing. Housed in portable case for service calls. Supplies all operating potentials. Tests for shorts, leakage, and emission. Checks tubes on the work bench, in the carton, or in the set. Features shadowgraph test (spot of light on the screen).

MODEL CC-1
\$22.50

Shpg. Wt.
10 lbs.

Heathkit AC VACUUM TUBE VOLTMETER KIT

Here is a VTVM designed especially for audio work. Combines high impedance, wide frequency range, and high sensitivity. Frequency response, substantially flat from 10 cps to 50 kc. Sensitivity allows measurements as low as 1 mv at high impedance. Ranges are .01, .03, .1, .3, 1, 3, 10, 30, 100, and 300 volts rms. Total db range -52 to +52 db. 1 megohm input impedance at 1 kc.

MODEL AV-2
\$29.50

Shpg. Wt.
5 lbs.



HEATH COMPANY A Subsidiary of Daystrom, Inc. **BENTON HARBOR 15, MICH.**



MODEL HD-1
HARMONIC DISTORTION METER KIT



MODEL CR-1
CRYSTAL RECEIVER KIT



MODEL AG-9
AUDIO GENERATOR KIT



MODEL AG-8
AUDIO GENERATOR KIT



MODEL AO-1
AUDIO OSCILLATOR KIT



MODEL AA-1
AUDIO ANALYZER KIT



MODEL BR-2
BROADCAST BAND RECEIVER KIT



MODEL T-3
SIGNAL TRACER KIT

Heathkit HARMONIC DISTORTION METER KIT

Designed for use with low distortion audio generator, (such as the Model AG-9). Measures harmonic distortion of audio amplifiers under a variety of conditions. Reads distortion on meter as percentage of input signal. Operates between 20 and 20,000 cps. High impedance VTVM built in for initial reference settings and final distortion readings. VTVM ranges are 0-1, 3, 10, and 30 volts full scale. 1% precision resistors employed. Distortion scales are 0-1, 3, 10, 30, and 100% full scale.

MODEL HD-1
\$49⁵⁰
Shpg. Wt.
13 lbs.

Heathkit AUDIO OSCILLATOR KIT (Sine Wave—Square Wave)

Produces sine wave or square wave signals from 20 to 20,000 cps in 3 ranges. Designed for use in service shop, or home workshop. Employs thermistor for output regulation. Features high level output, low distortion, and low impedance output. Produces sine waves for audio testing, or will produce good clean square waves with a rise time of only 2 microseconds. Very simple to build from complete instructions supplied.

MODEL AO-1
\$24⁵⁰
Shpg. Wt.
10 lbs.

Heathkit CRYSTAL RECEIVER KIT

This crystal radio covers standard broadcast band (540 to 1600 kc). Employs two high-Q tank circuits. A sealed germanium diode is used for detection—no critical "cat's whisker" adjustment. Kit includes pair of high impedance headsets, and is easy to build, even for a beginner. Requires no external power.

MODEL CR-1
\$7⁹⁵
Shpg. Wt.
3 lbs.

Heathkit AUDIO ANALYZER KIT

Combines AC VTVM, audio wattmeter, and intermodulation distortion analyzer in one instrument. Includes built-in high and low frequency oscillators for IM tests. VTVM ranges are .01, .03, .1, .3, 1, 3, 10, 30, 100, and 300 volts rms. Wattmeter ranges are .15 mw, 1.5 mw, 15 mw, 150 mw, 1.5 w, 15 w, and 150 w. IM scales are 1%, 3%, 10%, 30%, and 100%. Provides internal loads of 4, 8, 16, or 600 ohms. An extremely valuable instrument for the audio engineer, or for the serious audiophile.

MODEL AA-1
\$59⁵⁰
Shpg. Wt.
13 lbs.

Heathkit AUDIO GENERATOR KIT

Low distortion audio generator (less than .1%). Ideal for use with Model HD-1, or in other applications requiring low signal distortion. Frequency accuracy within $\pm 5\%$. Features step-type tuning from 10 cps to 100 kc, with three rotary switches that provide two significant figures and a multiplier. Output monitored on large 4½" meter. Meter calibrated for output voltage or db. Output ranges are 0-.003, .01, .03, .1, .3, 1, 3, and 10 volts.

MODEL AG-9
\$34⁵⁰
Shpg. Wt.
8 lbs.

Heathkit BROADCAST BAND RECEIVER KIT

Build your own radio with confidence, even if you are a beginner. Features transformer power supply, miniature tubes, built-in antenna, 5½" PM speaker, and planetary tuning from 550 kc to 1600 kc. Complete step-by-step instructions supplied.

Cabinet, as shown, available separately.

MODEL BR-2
\$17⁵⁰
(less cabinet)
Shpg. Wt.
10 lbs.

Heathkit AUDIO GENERATOR KIT

This generator covers from 20 cps to 1 mc in 5 ranges. Output constant within ± 1 db from 20 cps to 400 kc, and down only 3 db at 600 kc. Produces good sine wave with distortion percentage below .4% from 100 cps through the audio range. Provides 10 volts output under no load conditions. Has continuously variable and step-type attenuator with settings of 1 millivolt, 100 millivolts, 1 volt, and 10 volts. Cathode follower output.

MODEL AG-8
\$29⁵⁰
Shpg. Wt.
11 lbs.

Heathkit VISUAL-AURAL SIGNAL TRACER KIT

Features a high-gain RF input channel for signal tracing and troubleshooting from the receiver antenna input clear through all RF and IF stages. Separate low-gain channel for audio circuit exploration. Built-in loudspeaker provides audio response, while electron beam "eye" tube gives visual indication. Ideal for signal tracing in AM, FM, and TV receivers. Built-in wattmeter and noise locating circuit.

MODEL T-3
\$23⁵⁰
Shpg. Wt.
9 lbs.

**Heathkit DX-100
PHONE & CW TRANSMITTER KIT**

This transmitter is rapidly becoming the accepted standard in its price class. 100 watts RF output—built-in power supplies—built-in VFO and modulator—bandswitching on 160, 80, 40, 20, 15, 11, and 10 meters—phone or CW operation. 100 watts output on phone, and 120 watts on CW. TVI suppressed—pi network output coupling—extensive shielding—matches 50 to 600 ohms—high quality components. Uses 1625 tubes in push-pull to modulate 6146 tubes in parallel. Schematic and specifications available on request.

MODEL
DX-100
\$189⁵⁰

Shpg. Wt.
107 Lbs.

**Heathkit DX-35
PHONE & CW TRANSMITTER KIT**

This exciting new kit features bandswitching phone and CW operation on 80, 40, 20, 15, 11, and 10 meters. Plate power input to 65 watts on CW, with controlled-carrier modulation peaks to 50 watts on phone. Features built-in modulator, power supplies, pi network output circuit. Panel meter reads grid or plate current for 6146 final. Schematic and specifications on request.

MODEL DX-35
\$56⁹⁵

Shpg. Wt.
24 Lbs.

Heathkit CW AMATEUR TRANSMITTER KIT

Outstanding dollar-per-watt value! 30-35 watts plate power input, bandswitching for 80, 40, 20, 15, 11, and 10 meters. Crystal or external VFO excitation. 52 ohm output—key click filter—copper-plated chassis—pre-wound coils. Uses 6AG7 oscillator, 6L6 final.

MODEL AT-1
\$29⁵⁰

Shpg. Wt.
15 Lbs.

Heathkit VFO KIT

Go VFO for added convenience and flexibility. Covers 160-80-40-20-15-11 and 10 meters. Three basic oscillator frequencies provide better than 10 volt average RF output. Plug for crystal socket of transmitter. VR tube for stability. Requires only 250 VDC at 20 ma, and 6.3 VAC at 0.45 A.

MODEL VF-1
\$19⁵⁰

Shpg. Wt.
7 Lbs.

Heathkit ANTENNA COUPLER KIT

Matches between transmitter and a long-wire, end-fed antenna. Incorporates an L-type filter to attenuate signals above 36 mc and reduce TVI. 52-ohm coaxial input. Tapped inductor and variable capacitor. Neon RF indicator—simple to build. Handles up to 75 watts, 10 through 80 meters. Use with AT-1 or DX-35.

MODEL AC-1
\$14⁵⁰

Shpg. Wt.
4 Lbs.

Heathkit "Q" MULTIPLIER KIT

Tunes any signal within 1F of receiver, with effective Q of approximately 4,000. Sharp "peak" or "null" surpasses crystal filter in operation. Use with 450-460 kc IF. Will not function with AC-DC receivers. Requires 6.3 VAC at 300 ma, and 150-250 VDC at 2 ma. Cable and plugs supplied.

MODEL QF-1
\$9⁹⁵

Shpg. Wt.
3 Lbs.

**Heathkit COMMUNICATIONS TYPE
ALL BAND RECEIVER KIT**

Unusual sensitivity and selectivity for price. Covers 550 kc to 30 mc in 4 bands. AC power supply—electrical bandspread—antenna trimmer—separate RF and AF gain controls—noise limiter—hear phone jacks—AGC—BFO. Cabinet available separately as shown. Part 91-15A, shipping weight 5 lbs. \$4.50.

MODEL AR-3
\$27⁹⁵

(Less Cabinet)
Shpg. Wt.
12 Lbs.

Heathkit GRID DIP METER KIT

Use for determining unknown frequency, for checking resonance of tuned circuits, or for adjusting wave traps. Equally valuable in ham shack, service shop, or laboratory. Features 500 ua. meter with sensitivity control. Covers 2 mc to 250 mc with five coils, supplied with kit. Coils pre-wound, dial scale pre-calibrated.



MODEL
GD-1B
\$19⁵⁰

Shpg. Wt.
4 Lbs.

**Heathkit
ANTENNA IMPEDANCE METER KIT**

Use this instrument, with a source of RF signal, to determine antenna impedance, line impedance, and to solve impedance matching problems with fixed or mobile antennas or transmission lines. Also, will double as a field strength indicator, or phone monitor. Uses 100 ua. meter. Covers 0 to 600 ohms.

MODEL AM-1
\$14⁵⁰ Shpg. Wt.
2 Lbs.



MODEL DX-100
PHONE & CW TRANSMITTER KIT



MODEL DX-35
PHONE & CW TRANSMITTER KIT



MODEL AT-1
CW AMATEUR TRANSMITTER KIT



MODEL VF-1
VFO KIT



MODEL AC-1
ANTENNA
COUPLER KIT



MODEL QF-1
"Q" MULTIPLIER
KIT



MODEL AR-3
ALL BAND RECEIVER KIT

HEATH COMPANY A Subsidiary of Daystrom, Inc. BENTON HARBOR 15, MICH.



MODEL W-5M

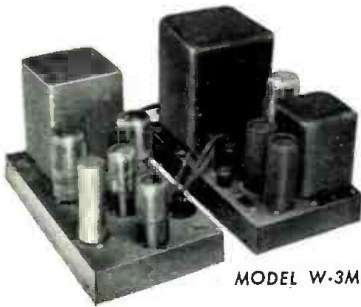

MODEL W-3M



MODEL W-4M

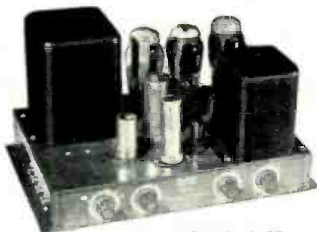

MODEL A-9B



MODEL A-7D

Heathkit ADVANCE-DESIGN HIGH FIDELITY AMPLIFIER KIT

This 25 watt amplifier incorporates the "extra" features required for really outstanding performance, and yet is priced within the range of the average audiophile. Employs KT66 output tubes in push-pull, and features the famous Peerless output transformer. Response is within ± 1 db from 5 cps to 160 kc at 1 watt. Harmonic distortion only 1% at 25 watts. 20 to 20,000 cps. IM distortion only 1% at 20 watts. Output impedance is 4, 8, or 16 ohms. Hum and noise are 99 db below rated output. Features "tweeter saver," and unique balancing circuit. Handles power peaks up to 42 watts.

KIT COMBINATIONS:

W-5M Amplifier Kit: Consists of main amplifier and power supply, all on one chassis. Complete with all necessary parts, tubes, and comprehensive manual.

W-5 Combination Amplifier Kit: Consists of W-5M Amplifier Kit listed above plus Heathkit Model WA-P2 Pre-amplifier Kit. Complete with all necessary parts, tubes, and construction manuals.

Express only—Shipping weight 38 lbs. **\$79.50**

Express only

\$59.75

Shpg. Wt.
31 Lbs.

Heathkit DUAL-CHASSIS HIGH FIDELITY AMPLIFIER KIT

The Model W-3M features the famous Acrosound TO-300 "ultra linear" output transformer. It uses 5881 tubes and has a frequency response within ± 1 db from 6 cps to 150 kc at 1 watt. Harmonic distortion only 1% at 21 watts. IM distortion at 20 watts only 1.3% at 60 and 3,000 cps. Power output is 20 watts. Output impedance is 4, 8, or 16 ohms. Hum and noise is 88 db below 20 watts. A very popular high fidelity unit. Main amplifier and power supply on separate chassis.

KIT COMBINATIONS:

W-3M: Consists of main amplifier and power supply for separate chassis construction. Includes all tubes and components necessary for assembly.

W-3: Consists of W-3M Kit listed above plus Heathkit Model WA-P2 Pre-amplifier described on opposite page.

Express only—Shipping weight 37 lbs. **\$69.50**

Express only

\$49.75

Shpg. Wt.
29 Lbs.

Heathkit SINGLE-CHASSIS HIGH FIDELITY AMPLIFIER KIT

Model W-4A is the original low-priced Williamson Amplifier Kit. A Chicago output transformer and 5881 output tubes are featured. Frequency response is ± 1 db from 10 cps to 100 kc at 1 watt. Harmonic distortion only 1.5% at 20 watts. IM distortion only 2.7%. 20 watts output at 4, 8, or 16 ohms. Hum and noise 95 db below 20 watts. A tried and proven unit featuring a "polished" circuit that may be depended on for reliable high fidelity performance.

KIT COMBINATIONS:

W-4AM: Consists of main amplifier and power supply for single chassis construction. Includes all tubes and components necessary for assembly.

W-4A: Consists of W-4AM Kit listed above plus Heathkit Model WA-P2 Pre-amplifier described on opposite page.

Express only—Shipping weight 35 lbs. **\$59.50**

Express only

\$39.75

Shpg. Wt.
28 Lbs.

Heathkit 20-WATT HIGH FIDELITY AMPLIFIER KIT

This amplifier can provide you with high fidelity at a surprisingly low price. Pre-amplifier built into same chassis as main amplifier. Four switch selected, compensated inputs are available, as are bass and treble tone controls, providing necessary flexibility for home or public address installations at a minimum investment. Features full 20-watt output using push-pull 6L6 tubes. Employs miniature tube types in preamp for low hum and noise. Frequency response is ± 1 db from 20 to 20,000 cps. Harmonic distortion only 1% at full output. Shop and compare—a real "best buy" for you.

MODEL A-9B

\$35.50

Shpg. Wt.
23 Lbs.

Heathkit 7-WATT AMPLIFIER KIT

The 7-watt output of this amazing little amplifier is more than adequate for normal home installations. Using a tapped-screen output transformer of new design, its frequency response is $\pm 1\frac{1}{2}$ db from 20 to 20,000 cps. It provides good sensitivity, with surprisingly low distortion. Transformer tapped at 4, 8, and 16 ohms. Push-pull output. Separate bass and treble tone controls are provided.

MODEL A-7E: Same as Model A-7D, but with stage of pre-amplification. Extra gain for low level cartridges. RIAA compensation.

Shipping weight 10 lbs. **\$18.50**

MODEL A-7D

\$16.95

Shpg. Wt.
10 Lbs.

SPECIAL NOTE: Don't overlook the possibilities of a hi-fi system consisting of the FM-3, the Model A-7E, and the Model SS-1 Speaker System. For only \$82.95, you can have high fidelity in your home.

HEATH COMPANY A Subsidiary of Daystrom, Inc. BENTON HARBOR 15, MICH.

Heathkit HIGH FIDELITY PREAMPLIFIER KIT

Designed specifically for use with Heathkit main amplifiers. Features five separate switch-selected input channels, each with its own input level control. Four-position turnover and roll-off controls for record equalization. Separate bass and treble tone controls. Special hum control to insure minimum hum level. Will do justice to finest program sources. Beautiful satin-gold finish.



MODEL WA-P2
\$197⁵ (with cabinet)
 Shpg. Wt. 7 lbs.

Heathkit AM TUNER KIT

Designed for use with high fidelity systems. Low distortion voltage-doubler detector. Covers 550 to 1600 kc. 20 kc IF bandwidth. Audio response ± 1 db from 20 cps to 2 kc. 6 db signal-to-noise ratio at 2.5 microvolts. RF and IF coils pre-aligned. Power supply built-in. Efficient, modern circuit. Matches WA-P2 and FM-3 in color and style.



MODEL BC-1
\$245⁰ (with cabinet)
 Shpg. Wt. 8 lbs.

Heathkit HIGH FIDELITY FM TUNER KIT

This FM tuner offers sensitivity, selectivity, and stability, not expected at this price level. Efficient 7-tube circuit is entirely new, and incorporates AGC, cascode front end, temperature compensated oscillator, built-in power supply, and other outstanding design features. Only minimum adjustments required after assembly with pre-aligned IF and ratio transformers. Sensitivity is better than 10 microvolts for 20 db of quieting. Covers 88 to 108 mc.



MODEL FM-3
\$245⁰ (with cabinet)
 Shpg. Wt. 7 lbs.

Heathkit ELECTRONIC CROSS-OVER KIT



MODEL XO-1
\$189⁵ Shpg. Wt. 6 lbs.

The XO-1 separates high and low frequencies at selectable crossover points, to feed two separate power amplifiers, one for high frequencies and one for low frequencies. Speakers are then connected to the amplifiers directly, without the usual LC crossover. Separate level controls provided for both outputs. The XO-1 consumes no audio power. Crossover frequencies are 100, 200, 400, 700, 1200, 2000, and 3500 cps. Attenuation is 12 db per octave.

HEATHKIT[®]

HIGH FIDELITY SPEAKER SYSTEM

The Models SS-1 and SS-1B are matched so that when the smaller unit is placed on top of the larger unit, the appearance of a single piece of furniture is achieved. They form an integrated 4-speaker system.



Heathkit HIGH FIDELITY SS-1 SPEAKER SYSTEM KIT



MODEL SS-1
\$399⁵ Shpg. Wt. 30 lbs.

This speaker system employs two Jensen speakers to cover the frequency range from 50 to 12,000 cps. Response is within ± 5 db through this range. Built-in crossover functions at 1600 cps. System rated at 25 watts, with nominal impedance of 16 ohms. Enclosure is a ducted-port bass reflex type. The attractive "picture frame" molding blends with any decorating scheme. You merely assemble the cabinet, wire the speakers and crossover network, and treat the furniture-grade plywood in the finish of your choice.

Heathkit HIGH FIDELITY SS-1B SPEAKER SYSTEM KIT

This Range Extending Speaker System employs a 15" woofer and a super tweeter to cover the frequencies between 35 and 600 cps, and between 4000 and 16,000 cps. When used with the Model SS-1, it extends the frequency range at both ends of the spectrum for a total coverage of ± 5 db from 35 to 16,000 cps. Provides unbelievably rich sound over the audio range.

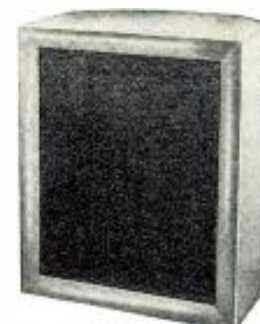

MODEL SS-1B
\$999⁵ Shpg. Wt. 80 lbs.

Exposed panels are furniture grade plywood, suitable for light or dark finish of your choice. All parts are pre-cut and ready for assembly. The kit includes necessary crossover circuits and balance control. Crossover frequencies are 600, 1600, and 4,000. Power rating is 35 watts for speech and music. Nominal impedance is 16 ohms.

The SS-1B, alone, measures 29" high by 23" wide by 17½" deep.

ORDER BLANK

NOTE: All prices subject to change without notice.

Enclosed find () check () money order for _____
 Please ship C.O.D. () postage enclosed for _____ pounds.

On Express orders do not include transportation charge — they will be collected by the express agency at time of delivery.

ON PARCEL POST ORDERS include postage for weight shown. ORDERS FROM CANADA and APO's must include full remittance.

Name _____
 Address _____
 City & Zone _____ State _____
(PLEASE PRINT)

SHIP VIA
 Parcel Post
 Express
 Freight
 Best Way

QUANTITY	ITEM	MODEL NO.	PRICE

HEATH COMPANY A Subsidiary of Daystrom, Inc. BENTON HARBOR 15, MICH.

AMERICA'S FINEST VALUES IN "LOW COST" HIGH FIDELITY

ECONOMY 20 WATT AMPLIFIER \$22.95

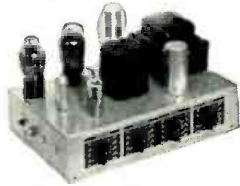

NEW 1957 MODEL
 Push-Pull 6L6 Output Tubes
 Response 30-15,000 CPS
 Bass and Treble Tone Controls
 Input for Xtal or Dynamic Mike
 Input for Xtal or V.R. Phone

With CU-14Y, 12" Coax Speaker... \$32.95
 With P15-CR, 15" Coax Speaker... \$42.95
 With Imperial IV System... \$39.95
 With SP-12125CR... \$44.95
 With HF-33GE... \$69.95

Model HF-20

A tremendous High Fidelity amplifier value. Response 30 to 15,000 cps. Electronic bass and treble boost by separate tone controls. Use this amplifier with any record changer having crystal or variable reluctance cartridge, radio tuner or high impedance crystal or dynamic microphone. 20 watts power output. Use with any 4 or 8 ohm speaker or 250 ohm line. Chassis size, 7 3/4" x 10 1/2" x 7 3/4" high. Complete with tubes: 2-6L6, 2-6C4, 12AX7 and 5U4G. This is a terrific value. A ready to go high fidelity amplifier at less than the cost of a kit. Ship. wt. 17 lbs. Model HF-20. 20 Watt Hi-Fi amplifier. McGee's sale price, \$22.95.

25 WATT HI-FI SPEAKER SYSTEM



2-12" Woofers
 2-5" Tweeters
 Power Supply
 and L-C Crossover Network

SALE PRICE \$24.95

25 watt, High-Fidelity Dynamic Speaker System, complete with 2000 cycle genuine inductance-capacitance cross-over network, two 12" woofer speakers, two 5" high frequency tweeter speakers and separate 110 volt AC power supply for only \$24.95. Frequency response 20 to 18,000 cps. Both the woofers and the tweeters are fine quality dynamic speakers with fields excited to saturation by the power supply. Tweeters are specially made with cones designed to respond only to the high frequencies of the audio spectrum. The 2000 cycle cross-over network is of the high quality inductance-capacitance type which prevents frequencies below 2000 cps from reaching the tweeters and eliminates frequencies above 2000 cps from the woofer circuit. The cross-over network system is simple to connect to any 4 or 8 ohm output of your high fidelity audio amplifier or radio. No. SP-12125CR, High Fidelity Dynamic Speaker System. Ship. wt. 15 lbs. Sale price, \$24.95. No. SP-12125, High Fidelity Dynamic Speaker System, as described above, but less the 2000 cycle cross-over network and with a separate attenuator control. Sale price, \$14.95. Ideal for use with HF-20 and IMP-30 amplifiers described above.



THEATER QUALITY HIGH FIDELITY SPEAKER SYSTEM \$39.95

15" WOOFER PLUS—ELECTROVOICE MODEL 847
 MID-HIGH RANGE SPEAKER—600 CYCLE LC CROSSOVER.

A theatre quality, powerful speaker system for homes and sound demonstration rooms. This speaker arrangement will connect to any high fidelity audio amplifier (8 ohms impedance). Features a 15" electro-dynamic heavy duty woofer with a 600 cycle LC crossover network. Reproduces the low audio register from 600 cycles down to 20 cps. An Electro-Voice Model 847 horn type speaker is used for the middle range and high range of audio. These two speakers are connected to a 600 cycle inductive-capacity crossover network. Built in the network is the field exciter for the 15" woofer. You could spend over \$100 for a speaker system and not beat this one. Stock No. EV-15847X, McGee's sale price, \$39.95.

NEW "LOW-BOY" 3-WAY SPEAKER SYSTEM

15" COAXIAL SPEAKER
 6" SPEAKER-CROSSOVER
 30 to 17,000 CPS
 CHOICE OF BLOND OR MAHOGANY

SALE PRICE \$29.95

Low-Boy, 3-way High Fidelity speaker system. Designed expressly for apartment size high fidelity. Features choice of blond or mahogany cabinet. Use with any high fidelity amplifier. Matches 8 ohm impedance. Equipped with a top quality 15" coaxial speaker and a 6" speaker on one side for augmented mid-range audio dispersion. Size, approx. 25" high, 24" wide and 21" front to back. A tremendous high fidelity speaker system with response from 30 to 17,000 cps. Built in the network is the field exciter for the 15" woofer. You could spend over \$100 for a speaker system and not beat this one. Stock No. GM-415. Ship. wt. 40 lbs. McGee's sale price, \$29.95. (Specify cabinet finish desired when ordering.)

IMPERIAL 30 WATT AMPLIFIER \$29.95

NEW 1957 MODEL
 Push-Pull 6L6 Output Tubes
 Response 15-20,000 CPS
 Bass and Treble Tone Controls
 Compensated Gain for G.E. Cart.
 Input for Xtal or Dynamic Mike

With CU-14Y, 12" Coax Speaker... \$39.95
 With P15-CR, 15" Coax Speaker... \$49.95
 With Imperial IV Speaker System... \$49.95



Model IMP-30

With SP12125CR... \$51.95
 With HF-33GE... \$76.95

New 1957 Model, tube Imperial 30 watt High Fidelity audio amplifier. A \$100.00 list value for only \$29.95. Features a heavy 4 lb. specially wound high fidelity output transformer with 150% inverse feed-back; push-pull 6L6 output tubes and frequency response from 15 to 20,000 cps. Matches 8 or 16 ohm speakers. You can center your entire custom music system around this low cost 30 watt amplifier. This Imperial 30, 30 watt amplifier may be used with any radio tuner or record player. It will drive any speaker system that you may have. Use from one to ten 8 speakers or one 12" or 15" coaxial speaker or any 3-way speaker system. Tone compensated input for either a crystal phono pickup or a General Electric variable reluctance pickup. Also, has input for crystal or high impedance dynamic microphone. 4 controls are made for bass, phono, treble tone and bass boost tone control. This amplifier weighs 21 lbs. net. Full size transformer components would cost you up to \$15.00 if purchased separately. Gold color chassis is 12 1/2" x 7 3/4" x 7 3/4" high. Complete with tubes: 6AT6, 12AX7, 6C4, 12AU7, 2-6L6A, plus 5U4G rectifier. Stock No. IMP-30, 30 watt Imperial High-Fidelity amplifier complete with tubes and diagram. Ship. wt. 23 lbs.. Sale price only \$29.95.

CONSOLE HI-FI SPEAKER SYSTEM \$49.95

12" G.E. PM WOOFER—10" PM MID-RANGE—
 8" G.E. MODEL 850 MID-HIGH RANGE SPEAKER
 AND 600 CYCLE L-C CROSSOVER NETWORK.



Have Juke Box tone quality in your own home. Strictly High Fidelity. Three speakers all connected to a 600 cycle frequency dividing network so that only 2 wires feed the system from any 4 or 8 ohm radio or amplifier. A variable tone compensating control incorporated in the circuit makes brilliant highs or boomy lows to your own taste. Any amplifier that you now have will give you a much wider selection of acoustical arrangements with this speaker system. The 3-way system is shipped ready to connect to your amplifier or hi-fi radio. Equipped with a General Electric 12" woofer, an 8" famous G.E. mid-range speaker and a 10" middle range speaker. Frequency response 30 to 15,000 cps. Take your choice of cabinets: blonde or mahogany. (Specify finish desired when ordering) 37" high, 24" wide and 20" deep. Ship. wt. 75 lbs. Stock No. HF-33GE. Sale price, \$49.95.

Model HF-44GE, console speaker system, same as above except has a heavy duty 12" G.E. PM Model 1201, plus 8" G.E. PM Model 850, 10" mid-range speaker and 5" hard cone tweeter. Sale price, \$54.95. (Specify cabinet finish.)

Model HF-55GE, super deluxe quality console speaker system, same as HF-33GE described above, except has 15", 21 oz. Alnico V magnet woofer, 10" mid-range speaker and Model 4401 Uni-trumpet type tweeter. All 3 speakers incorporate 600 cycle L-C type crossover network with variable tone compensating control. Model HF-55GE. Sale price \$69.95 (specify cabinet finish).

DELUXE CONSOLE SPEAKER SYSTEM \$89.50

15" UTAH WOOFER—10" MID-RANGE—2—5" TWEETERS—CROSSOVER

New, deluxe quality High-Fidelity speaker system, housed in a beautiful blond oak console cabinet, wood, full 4401 Uni-trumpet type tweeter, all 3 speakers incorporate only two wires to connect to any 4 or 8 ohm output of your radio or amplifier. Has variable tone compensating control built-in. Cabinet size: 43" tall, 31" wide and 23 1/2" deep. McGee's sale price, \$89.50.

NEW IMPERIAL SPEAKER SYSTEMS

Imperial IV with 8" G.E. High Fidelity Speaker **\$19.95**

3-Way Imperial VI with 12" G.E. Speaker **\$29.95**

New 1957 Model IMPERIAL IV, High fidelity speaker system with General Electric 8" speaker and 1" tweeter. Housed in a high quality mahogany covered plywood cabinet 10" x 10" x 24" long. Fully enclosed; covered on all sides except back. Use as an auxiliary speaker or with any high fidelity radio, amplifier or home music system. The IMPERIAL IV contains a General Electric Model 850 extended range high fidelity 8" PM speaker with 6.8 ohm, Alnico V magnet and curvilinear cone with 8 ohm voice coil and a 5" tweeter. Response 50 to 15,000 cps. Model IV Imperial \$19.95.

1957 Model Imperial VI, 3-way speaker system. Baffle is of heavy wood, leatherette covered. Similar in appearance to the Imperial IV pictured above, except 4" taller and 1" deeper. Equipped with 2 excellent speakers, a 12" G.E. Model 1203 with 9 oz. Alnico V magnet, plus 5 1/2" PM for middle range and 3" tweeter. Simple to connect to any high fidelity amplifier. (8 ohms impedance). Stock No. IMP-VI, Sale price, \$29.95. Ideal for use with HF-20 and IMP-30 amplifiers described above.

25 WATT, 6-110 VOLT \$69.95 AMPLIFIER ONLY...



COMPLETE 25 WATT, 6-110 VOLT P. A. SYSTEM \$149.95

AMPLIFIER, MICROPHONE 2-TRUMPETS (AS ILLUSTRATED)

MG-6255, complete 25-watt, 6 volt DC and 110 volt AC sound system. Includes 2 Model 848 Electro-Voice CDP coaxial horn projectors with drivers, a 25 watt push-pull 6L6, 6-110 volt amplifier, plus a \$24.50 list Turner high impedance dynamic hand mike with off-on switch. McGee's special sale price, \$149.95. Amplifier is not a kit, but our latest 1957 model, 25 watt 6-110 volt amplifier that operates equally well on a 6 volt storage battery or 110 volts AC. Amplifier features push-pull 6L6 output tubes, inputs for two high impedance mikes, 3 Electro-Voice CDP coaxial horn projectors for shipping. Photo top is packed separately for shipment. Plug-in phono and attach top cover to amplifier. Amplifier size, 13 1/2 x 10 x 9 1/2" high. Stock No. MG-6255 amplifier only. A \$100.00 net value. Sale price, \$69.95. Complete P.A. system, MG-6255 complete with 2 Model 848 Electro-Voice speakers and Turner mike. Sale price, \$149.95.

Speed phono with crystal pickup built-in. Only a few minutes required to assemble. Amplifier size, 13 1/2 x 10 x 9 1/2" high. Stock No. MG-6255 amplifier only. A \$100.00 net value. Sale price, \$69.95. Complete P.A. system, MG-6255 complete with 2 Model 848 Electro-Voice speakers and Turner mike. Sale price, \$149.95.

NEW 30 WATT AMPLIFIER \$39.95 FOR 110 VOLT AC ONLY...

COMPLETE 30 WATT, 110 VOLT PUBLIC ADDRESS SYSTEM WITH 30 WATT AMPLIFIER, MICROPHONE AND 2-TRUMPETS \$109.95

(As Illustrated)

50 Watt P. A. System... \$129.95

New 1957 Model GPA-30X, 30 watt amplifier for 110 volt operation with 2 Electro-Voice Model 848, 30 watt hi-fi outdoor-indoor speakers and a Turner high impedance dynamic hand mike with off-on switch. A \$150.00 dealer net value on sale at McGee for only \$109.95. Amplifier features push-pull 6L6 output tubes, output matches 4, 8, 16 and 500 ohm line. High fidelity response, separate bass and treble tone controls, inputs for two crystal or dynamic high impedance mikes, plus crystal phono pickup. Chassis size, 7 1/2 x 12 x 8" high. Use for all public address needs. Priced with tubes: 2-6L6GB, 5U4G, 2-6C4, 12AX7 and 6AU6. Full 200 mill power supply components. This amplifier compares with amps selling for \$60.00 to \$80.00 dealers net. System furnished with two Electro-Voice Model 848, 30 watt trumpets and drivers, plus a regular \$24.50 list Turner dynamic hand mike. McGee offers you this \$150.00 value for only \$109.95. Stock No. GPA30-848 complete P.A. system. Sale price, \$109.95.

Model GPA-30X, 30 watt amplifier only. Sale price, \$39.95.

Stock No. GPA50-848, complete 50 watt P.A. system similar to above, but with 50 watt amplifier and 2 Electro-Voice Model 848, 30 watt drivers and \$24.50 list Turner dynamic hand mike with off-on switch. Sale price, \$129.95.

Model GPA-50X, 50 watt amplifier only. Sale price, \$59.95.

McGEE RADIO COMPANY PRICES F.O.B. KANSAS CITY TELEPHONE VICTOR 2-5092
 SEND 25% OR FULL REMITTANCE WITH ORDER. 1903 MCGEE ST., KANSAS CITY, MISSOURI
 BAL. SENT C.O.D.

NEW 3-WAY HI-FI CONSOLE SPEAKER SYSTEM

14 TUBE ESPEY HI-FI CUSTOM FM-AM CHASSIS

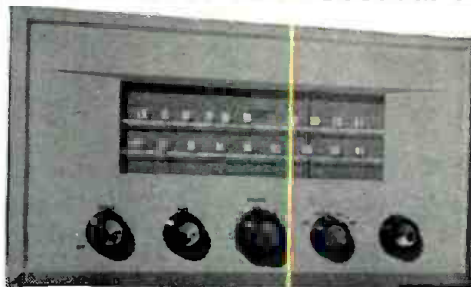

ESPEY MODEL HF-250C WITH MONARCH UA6U CHANGER \$107.95

New 1956 model, 14 tube FM-AM chassis. A true Hi-Fidelity receiver built by a nationally famous maker of fine custom chassis. Espey Model HF-250C, 14 tube FM-AM chassis with push-pull 6V6, 10 watt audio. You could spend \$200 to \$250 for a separate tuner and amplifier and not have the quality of this receiver. Ultra-Linear output used in Williamson type circuit gives frequency response of 10 to 22,000 cps. Output taps of 4, 8 and 16 ohms. Separate RF stages for FM and AM assure high sensitivity. Temperature compensated FM front end for minimum drift. Separate bass and treble tone controls. Pre-amp for all types of magnetic cartridges. 2nd input for crystal phono, tape recorder or TV. 3 position equalizer for accurate reproduction of all records. Built-in antennas for both FM and AM. Response plus or minus 1 db from 10 to 22,000 cps. Harmonic distortion less than 1%. Sensitivity: FM, 8 mv for 30 db quieting; AM, 75 mv for 6 db signal to noise ratio. On-on-volume and equalizer are combined on a concentric control. Has 2 AC outlets on rear of chassis. Beautiful edge lighted flywheel inertia slide rate dial. Size: 7 3/4" x 13 1/2" x 10". Deep. Ship. wt. 24 lbs. (not mailable). Model HF-250C. Sale price, \$79.95. With heavy duty Ulan 15" coaxial PM speaker, both for only \$159.95. Buy either of these new Phillips "Norelco" speakers with your Espey chassis. Made by Phillips of Holland. Features Tri-conal magnet, improved cone design, built-in mechanical cross-over and copper ring fitted into air gap keeps voice coil impedance independent of frequency. Model 9760M, \$54.95 list 12" Phillips speaker, response 30 to 20,000 cps, rated at 20 watts with Model HF-250C Espey chassis, both for only \$99.95. Model 9762M, \$99.95 list 12" Phillips speaker, response 22 to 20,000 cps, rated at 20 watts with Model HF-250C Espey chassis, both for only \$114.95.

RESPONSE FROM 10-22,000 CPS—
PUSH-PULL 6V6'S—
TWIN TONE CONTROLS—
WILLIAMSON TYPE CIRCUIT—INPUTS FOR V.R., CRYSTAL, TAPE, RADIO OR TV
SALE PRICE **\$79.95**
LESS SPEAKER

BLOND OAK 3-WAY HI-FI SPEAKER SYSTEM

HEAVY ELECTRO-VOICE SALE PRICE

15W-15" WOOFER
E-V 847 MID-RANGE
4401 HORN TWEETER
BUILT-IN CROSSOVER—
30-15,000 CPS

\$179.95

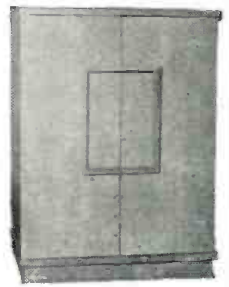

A new 3-Way High Fidelity console speaker system which features a beautiful blond oak cabinet, an Electro-Voice \$78.00 net 15" woofer and mid-range horn, University 4401 tweeter and 3-way crossover network. Electro-Voice 15W, 15" woofer has a frequency response from 30 to 1200 cps, essentially flat. Woofer has a net weight of 37 lbs. Mammouth 5 1/2 lb. Alnico V magnet measures 8" in diameter and is 4 1/2" deep. Has 2 1/2" voice coil, will take up to 30 watts. Electro-Voice 847, 2-way driver horn is used as the mid-range speaker with response of 300 to 10,000 cps. University 4401 tweeter is of the horn type and responds to frequencies up to 15,000 cps. 3-way crossover network is of the inductance-capacitance type which presents a constant resistance type load to your audio system. Equipped with an L-pad to vary loudness of the middle-high ranges. This crossover blends all three speakers into a practical system with only two wires to connect to any 8 ohm output of your high fidelity amplifier. Special coaxially suspended cone. This cabinet cost the manufacturer over \$100.00. We have converted it to a speaker cabinet, adding a full acoustical lining and back. This saving makes our low price possible. Model EVB4-15W, complete speaker system. Ship. wt. 150 lbs. Sale price, \$179.95.

NEW 1957 MODEL

25 WATT 12" COAXIAL SPEAKER

- ★ 14 1/2 oz. G.E. 12" WOOFER—
- ★ 3/2" COAXIALLY SUSPENDED TWEETER—
- ★ BUILT-IN CROSSOVER—
- ★ ALUMINUM VOICE COIL WOOFER— **\$189.95**



McGee's new 1957 model, GE-120XT, 12" 25 watt high fidelity coaxial PM speaker. No frills or dummy pot cover, it's all speaker value. Special coaxially suspended cone. The tweeter is a specially made 1.47 oz. Alnico V, 3 1/2" speaker which extends upper register of audio. Only two wires connect to any 8 ohm amplifier. Ship. wt. 8 lbs. Stock No. GE-120XT. McGee Sale price, \$189.95.

NEW IMPORTED MONARCH HIGH FIDELITY AUTOMATIC CHANGER



WITH GOLDRING #500 VAR. REL. CARTRIDGE
SALE PRICE **\$29.95**

Monarch Model UA6U—new, imported high fidelity 3 speed automatic record changer. Plays 7 1/2", 10" and 12" records automatically. Interlocks records of the same speed in any order. Features a 4 pole high fidelity motor eliminating rumble and wow. Pickup automatically returns to rest and motor turns off after last record has played. Full size 10" turntable has molded rubber patter for better record cushioning. Base size, 10 7/8" x 12 3/4". Tone arm is counter balanced to assure minimum record wear. The changer features, at no added cost, the regular \$9.90 net value Goldring #500 variable reluctance cartridge for the finest hi fidelity record reproduction. Output 10 millivolts. Response, 20 to 16,500 cps. It requires the same input gain as popular American made variable reluctance cartridges. Model UA6U, Monarch automatic changer with Goldring cartridge, ship. wt. 15 lbs. Sale price, \$29.95. Large spindle for 45 RPM records, \$1.88 extra.

NEW CHROME WEBCOR CHANGER WITH RPX-050 G.E. VAR. REL. CART. \$34.95

New Webcor model 1121-270, chrome plated, 3 speed automatic record changer with RPX-050 General Electric variable reluctance cartridge. Has heavy 4 pole motor. Plays all 3 speeds and has 3 sizes. Shuts off automatically after last record. Has neutral position to prevent damaging of drive wheels. Chrome plated. Size 12x13 1/2". Requires 2 1/2" below and 6" above mounting board. Shipping wt. 15 lbs. Only a few to sell at this low price of \$34.95.

G.E. VR CARTRIDGE WITH DIAMOND 1 MIL STYLUS; SIMILAR TO RPX-052A \$15.95



Stock No. VR-52A, genuine General Electric variable reluctance cartridge similar to RPX-052A Golden Treasure model. Has new turnabout baton stylus with plug-in 1 mil diamond and 3 mil sapphire stylus. This is the model that GE furnishes to the changer manufacturers, and it has a stainless steel case instead of the gold plated case. We made a terrific purchase and pass the sav on to you. Only a few hundred to sell. A regular \$23.00 value on sale at McGee for only \$15.95.

STANDARD COIL, PENTODE \$7.95

SC-948, Standard Coil, 21 mc Pentode tuner with 6BC5 or 6AG5 and 6V6 tubes. Popular 12 channel, 2 thru 13, used in millions of TV sets. Why, spend time repairing an old tuner when it may be easier to just replace it. Shaft can be cut to desired length. Available with 2 7/8", 3", 4 1/4" or 4 1/2" shaft. Specify length. Sale price, \$7.95 ea., 2 for \$15.00. Matched knob set \$9c extra. Type 3, 3 tube 21 mc Sarkes-Tarzian tuner with tubes, Rotary switch type complete with 6C4, 6BM6 and 6AQ5 tubes. Regular cost is several times our new low price of only \$4.95. Wired, ready to hook-up to video and sound I.F. strip. Use with either separate sound or inter-carrier. Built-in fine tuning. 2 7/8" shaft. Net, \$4.95.



TWO-TUBE SARKES-TARZIAN TV TUNER WITH TUBES 21MC OR 41MC \$7.95



No. TT-3A, 2 tube Sarkes-Tarzian 12 channel TV tuner for 21mc. Used in CBS, Arvin, Crosley, etc. Ideal for general replacement. Smallest cascade tuner made. Popular in many sets. \$7.95 each, 2 for \$15.00. Either of the above tuners with 9" shaft, \$1.00 extra.

MINIATURE BROADCASTING STATION FOR MICROPHONE AND PHONO WITH CRYSTAL MICROPHONE SALE PRICE \$9.95



Sensational new model MCL-E3 miniature broadcasting station for microphone and Phono. Can be received on any broadcast radio in the home. No wires to connect, tunes in just like a radio station. Has input jacks for crystal mike or record Player. Complete with 12KB and 70L7 tubes and instructions. Operates on 110 volts AC. Simple to operate; one control fades from microphone to record. Frequency can be adjusted so as not to interfere with local radio stations. Miniature broadcasting station, complete with crystal hand mike and instructions. Ship. wt. 4 lbs. Net price \$9.95.



McGee's Famous 12 AND 15 INCH COAXIAL P.M. HIGH FIDELITY SPEAKERS



\$12.95 12-Inch Model CU-14Y
\$23.95 15-Inch Model P15-CR

Model CU-14Y, 12" high fidelity coaxial PM speaker. Response from 30 to 17,500 cps. Full 6.8 oz. Alnico V magnet in the woofer. Special coaxially suspended high frequency tweeter. Built-in crossover network. Only two wires to connect to your radio or amplifier. Matches 3.2 to 8 ohm output. Don't confuse this speaker with many cheap speakers that are ordered. This is a fine quality speaker. Stock No. CU-14Y. Sale price \$12.95 each, two for \$25.00. Model P15-CR, 15" high fidelity coaxial PM speaker. Response down to 20 cps, and up to 17,500 cps. Full 2 1/2" oz. Alnico V magnet in the 15" woofer. Specially made, coaxially suspended 5" high frequency tweeter. Built-in crossover network. Only two wires to connect. Matches 3.2 to 8 ohm output transformer. A regular \$62.50 list speaker. Model P15-CR. McGee's Sale Price, \$23.95. McGee's new 15" Junior coaxial PM speaker. Full 6.8 oz. Alnico V magnet. 5" coaxially suspended tweeter with crossover. Only two wires to connect to any 8 ohm radio or amplifier. Frequency response from 40 to 15,000 cps. Model No. M15-CR, 15" Junior coax PM speaker. Sale price, \$16.95.

3-STATION MASTER SUB-STATIONS \$3.95 EACH \$16.95



Powerful 3 station master. Chrome plated metal case 7 1/2" x 6" x 5". 3 tube AC-DC amp. Press-to-talk switch on top. Volume control, switch and station selector on side. Master is quiet except when call switch is pressed at sub. Use with one to 3 subs. Model MPM-A3, Ship. wt. 10 lbs., \$16.95. Matching sub-station PM-A5, with 5" PM and call-back switch, \$3.95 ea.; 3 for \$10.00. Requires 3 wire intercom cable, \$1.95 per 100 ft.; 500 ft. for \$8.95.

NEW 8-TUBE, 6-VOLT PUSH-BUTTON AUTO RADIO

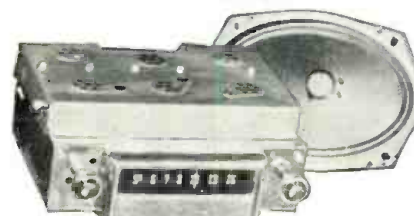

WITH 6" x 9" SPEAKER **\$37.95**
WITH 2-5" x 7" SPEAKERS **\$39.95**

New model SM78555, 8 tube, 6 volt universal mounting auto radio with push-buttons and 2-5x7" PM speakers. These sets were made for Hudson, but due to their small compact construction they can be fit into the dash of many cars. Also, ideal for underdash mounting. Extends only 2 3/4" below dash when underdash mounted. Requires dial cut-out 5 1/2" long and 2 1/2" high with two controls on 7" centers for dash mounting. Minimum depth 6 1/4" behind dash. Overall size: 9" wide, 4 3/4" high and 10" deep. Not intended for an exact custom fit, but it lends itself very well to your custom installation ideas. Has no built-in speaker but is furnished with 2-5x7" PM speakers. 8 tubes with Push-Pull 6AQ5 output tubes. Ship. wt. 14 lbs. Model SM78555, 8 tube, 6 volt auto radio with 2-5x7" speakers, Sale price, \$39.95. Model SM78569, 8 tube, 6 volt auto radio with one 6x9" speaker. Same radio as model listed above, except has one 6x9" speaker, Sale price, \$37.95.

12-VOLT, 6-TUBE MODEL—SALE PRICE \$29.99

Model AM-1259, 6 tube, 12 volt universal mounting auto radio, available with either 6x9" or 5x7" speaker. Similar to 8 tube set described above, except that it has no push-buttons and it is a 6 tube set for 12 volt operation in late model 1955 and 1956 cars. Overall size: 9" wide, 4 1/4" high and 7 3/4" deep. Requires a minimum depth of 6 3/4" behind dash or extends 2 1/4" below dash if underdash mounted. Tubes: 6BE6, 2-6BD6, 6AV6, 6AQ5 and 6X4. Dial requires cut-out 5 1/2" long x 2 1/2" high, 2 controls on 7" centers. Available with either 5x7" or 6x9" speaker. (Specify when ordering.) Model AM-1259, 6 tube, 12 volt universal auto radio with speaker. Ship. wt. 12 lbs. Sale price, \$29.99. 3 section top cow antenna \$2.29 extra. RP-232X rear seat speaker kit, \$4.95 extra.

McGEE RADIO COMPANY PRICES F.O.B. KANSAS CITY
SEND 25% OR FULL REMITTANCE WITH ORDER. TELEPHONE VICTOR 2-5092
BAL. SENT C.O.D. 1903 MCGEE ST., KANSAS CITY, MISSOURI

Your Competitors

(Continued from page 55)

der less advantageous circumstances I could have been designated a "know nothing."

Frank, one of our service technicians, and a real fast-talking top-notch was not so lucky a couple of weeks ago. He was servicing a 21" RCA. He found the video somewhat washed out and some retrace lines showing. Also, the picture was unstable with an annoying flop and roll. The customer, a tough downtown traffic cop, started off by saying, "Another repairman was here yesterday. He said I have a bad picture tube. I don't think it is the picture tube."

Frank smiled and had to agree. How could sync trouble come from a defective CRT? He told the proud set owner, his picture tube seemed fine. Then he checked sync, video, and a.g.c. circuits, found nothing, and pulled the set. What did we find on the bench? Right—a bad picture tube. There was a high resistance short between the control and screen grids. The CRT's screen voltage arrived *via* the sync circuits. The short was tapping off some of the correct voltages of the sync separator, causing the queer symptoms. Our poor Frank had an unpleasant forty-five minute telephone conversation until he finally straightened that one out.

We have decided it's bad business to blast anyone. Even the next door neighbor who, armed with a screwdriver and hammer, attacks your customer's TV, or the part-time service technician who is not yet equipped to do an A to Z servicing job.

Stature in skill, know-how, and experience speaks fluently as you work. If you do a better job than someone else, the comparison sticks out loudly as soon as you open your tube caddy.

Joe, who is one of our smoother technicians was examining a 17" Westinghouse set. The set owner confessed that a good neighbor who knew a little about TV tried to fix it first. Joe found a bad case of a.g.c. trouble. All local stations were completely overloaded and washed out with the outdoor antenna connected. However, the nearby "Mr. Fixit" had taken off the outdoor antenna, shorted the 300-

Fig. 4. Improper a.g.c. action in a Westinghouse 17" set was caused by the defective cathode resistor shown circled here.

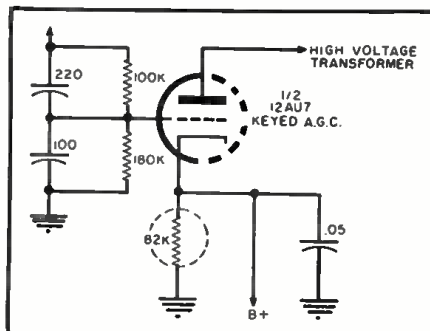

ohm impedance leads together, and then connected the lead-in to one terminal. The sound and video had returned. They were hard on the eyes and ears, but they had returned.

Joe commented without sarcasm as only he can do, "That was a clever idea to temporarily give you some entertainment." Then he pulled the chassis. A load resistor in the cathode of the keyed a.g.c. tube was open (see Fig. 4). A new resistor improved the picture considerably. The set owner needed no sales talk to compare the two jobs on her set.

Fast talking Frank followed up a part-time repairman on a history teacher's 17" RCA. The receiver had horizontal instability. Only a hair-trigger setting of the horizontal hold control would lock the picture in. The customer related to Frank how the other fellow had literally spent hours on the set to no avail.

This set too was pulled. A 5600-ohm resistor in the plate of the sync amplifier had changed in value to practically zero ohms. Only a slight sync pulse was being developed and this slight pulse had little control over the horizontal oscillator. A new resistor enabled the now joyful customer to sweep the hold control over its entire range without any loss of sync. Frank spoke smartly of world politics and weather for he had no need to tell the customer that his repair was superior.

While knocking your competitor at every opportunity is the easy thing to do, that practice serves no useful purpose. It starts a bad feeling that nullifies any attempt at cooperation that may exist. A 95% average in college will win you top honors quite easily; a 95% average in your normal TV service functions can win you a lot of heartache unless we all try to work together.

The American Medical Association recognizes this. You will never find one doctor knocking another. They set a good example to follow. Blasting another service technician behind his back doesn't endow you with a halo. If you actually reverse form, like physicians, and defend your electronic brethren, your few spoken sentences will gain you more respect than 24 hours worth of telling how good you are.

This whole subject was brought home to me in a case I ran into about two weeks ago. I wear glasses for close work. I should take them off between jobs, but sometimes I forget. And the way my face is set up, I look entirely different with glasses.

I walked in on a "callback" of mine a week after I did the original call. This time I was wearing my glasses. The customer disgustedly put her hands on her hips, "Oh, I see they sent another fellow." Then as I crouched behind her set peeling the back off, she said, "I'm glad you came instead, I can see you know what you are doing. The other man was absolutely the worst TV man I've ever had." —30—

MERIT, first in exact and universal replacement transformers, yokes, coils—the only manufacturer of transformers, yokes and coils who has complete production facilities for all parts sold under their brand name.

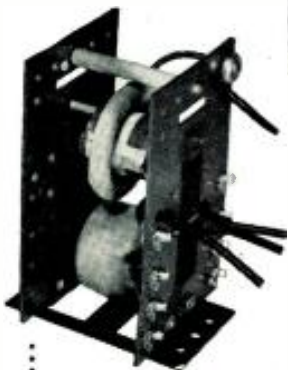

HVO-41 FOR EXACT REPLACEMENT IN AIRLINE, CORONADO, TRUETONE, ARLINGTON, FIRESTONE, WELLS-GARDNER, SILVERTONE, WARWICK. Another in the complete MERIT line of exact and universal replacements—the only single source for all your transformer and coil requirements.

Merit

MERIT COIL & TRANSFORMER CORP.
4427 NORTH CLARK STREET
CHICAGO 40, ILLINOIS



LIFETIME GUARANTEED TUBES

SAVE

BRAND NEW PICTURE TUBES

- RCA Licensed
- One Year Unconditional Guarantee

Type	Price	Type	Price
10BP4	\$11.90	17BP4	\$20.63
12LP4	\$14.38	19AP4	\$24.81
14BP4	\$16.86	21AP4	\$28.79
16RP4	\$19.38	21EP4	\$28.79
16LP4	\$19.38	24AP4	\$42.50

Picture Tubes shipped F.O.B. Harrison, N. J. Above types are most popular, however, you may order any equivalent size at the same price.

HERE'S HOW LIFETIME GUARANTEED TUBES SAVE YOU MONEY!

- We Guarantee to Replace Tubes Labeled MAJOR BRAND Forever
- Each Tube Individually Boxed and Guaranteed
- Over A Half Million Tubes Always in Stock
- Immediate Shipment
- Free Postage On All Orders With Full Remittance
- There are fewer "call backs"
- There are no "out of date" tubes
- "Peak Performance" testing in our fully equipped Testing Department before shipment guarantees quality

SAVE

USED TV SETS

Picture Tube Guaranteed To Work!

- Emerson
- RCA
- Philco
- GE
- Motorola
- Zenith
- Capehart
- Others

10" SET Table Model	\$16.95	16" SET Table Model	\$32.00
10" SET Console	\$19.95	16" SET Console	\$34.95
12" SET Table Model	\$22.95	17" SET Table Model	\$37.00
12" SET Console	\$24.95	17" SET Console	\$39.00
14" SET Table Model	\$27.95		
14" SET Console	\$31.00		

All prices F.O.B. Harrison, N. J. Prices on request for 19", 20", 21" and 24" sets.

OZ4	.43	3BN6	.70	6AV6	.39	6K8	.65	7C6	.43	14B6	.38
1A7GT	.43	3CB6	.52	6AX4GT	.60	6L6	.68	7C7	.45	14Q7	.50
1A7G7	.43	3Q4	.46	6AX5GT	.57	6L7	.42	7E5	.45	19BG6G	1.15
1B3GT	.65	3Q5GT	.57	6B4G	.52	6N7	.60	7E6	.55	19T8	.65
1C5GT	.41	3S4	.47	6B8	.69	6Q7	.40	7E7	.70	24A	.39
1D5GP	.43	3V4	.47	6BA6	.47	6S4	.40	7F7	.59	25AV5GT	.78
1E7GT	.41	4BQ7	.89	6BA7	.58	6SA7	.45	7F8	.70	25BQ6GT	.78
1G6GT	.41	4BZ7	.95	6BC5	.47	6SC7	.48	7G7	.75	25L6GT	.47
1H4G	.43	5AW4	.75	6BC7	.80	6SG7	.41	7H7	.50	25W4GT	.43
1H5GT	.47	5BG6G	1.15	6BE6	.45	6SH7	.43	7J7	.75	25Z5	.37
1J6GT	.47	5J6	.63	6BF5	.40	6SJ7	.43	7K7	.75	25Z6	.37
1L4	.45	5T4	.49	6BF6	.50	6SK7	.45	7L7	.75	27	.25
1L6	.55	5U4G	.63	6BH6	.50	6SL7GT	.55	7N7	.50	35A5	.46
1LA4	.57	5U8	.74	6BJ6	.47	6SN7GT	.55	12AT6	.37	35B5	.50
1LA6	.47	5V4G	.59	6BK5	.68	6SQ7	.39	12AU6	.41	35C5	.50
1LB4	.57	5Y3	.31	6BK7	.76	6SR7	.42	12AU7	.53	35L6GT	.47
1LC5	.49	5Y4G	.36	6BL7GT	.75	6SS7	.41	12AV6	.65	35W4	.34
1LC6	.47	5Z3	.41	6BN6	.58	6T4	.95	12AV7	.37	35Y4	.34
1LD5	.57	6A7	.57	6BQ6GT	.78	6T8	.68	12AX4GT	.65	35Z3GT	.34
1LE3	.57	6A8	.45	6BQ7	.78	6U8	.75	12AX7	.58	37	.29
1LG5	.57	6AB4	.48	6BY5G	.58	6V3	.80	12A27	.63	50A5	.46
1LH4	.64	6AC7	.67	6BZ7	.88	6V6GT	.46	12BA6	.46	50B5	.50
1LN5	.57	6AF4	.79	6C4	.37	6W4GT	.39	12BD6	.48	50C5	.50
1N5GT	.40	6AG5	.50	6C5	.35	6W6GT	.53	12BE6	.46	50L6GT	.42
1R5	.50	6AG7	.69	6CB6	.49	6X4	.34	12BH7	.60	75	.75
1S5	.42	6AH6	.69	6CD6G	1.15	6X5	.34	12BU6	.95	76	.42
1T4	.50	6AJ5	.70	6D6	.48	6X8	.73	12CJ7	.45	77	.38
1U4	.47	6AK5	.54	6E5	.44	6Y6G	.55	12S7	.45	78	.38
1U5	.42	6AL5	.39	6F5	.37	7A4	.45	12SK7	.45	80	.34
1V2	.65	6AQ5	.46	6F6	.38	7A5	.53	12SN7GT	.56	84/6Z4	.44
1X2	.61	6AR5	.46	6G6	.40	7A6	.45	12SQ7	.37	117L7GT	1.09
2A3	.55	6AS5	.48	6H6	.38	7A7	.43	12SR7	.45	117N7GT	1.09
2A5	.57	6AS6	1.70	6I4	1.79	7A8	.45	12V6GT	.45	117P7GT	1.09
2A7	.55	6AS7G	2.19	6J5	.39	7B5	.39	12X4	.37	117Z3	.35
3A4	.31	6AT6	.39	6J6	.47	7B6	.42	14A7	.42		
3A5	.50	6AU4GT	.65	6J7	.43	7B7	.41				
3AL5	.45	6AU5GT	.59	6J8G	.85	7B8	.45				
3AU6	.46	6AU6	.42	6K6GT	.37	7C4	.39				
3BC5	.54	6AV5GT	.65	6K7	.39	7C5	.42				

SAVE

NEW INDOOR ANTENNA

Both UHF and VHF. Brings better reception than most outdoor antennas. Use on top of TV.

List Price \$9.95

YOUR PRICE

Lots of 3 **\$329**

\$3.99 each

ALL PARTS SHIPPED F.O.B. FROM HARRISON, N. J.

WE PAY ALL POSTAGE on orders shipped in USA, Territories and APO's. Send only purchase price of merchandise. Please include approximate postage on foreign shipments. All orders subject to prior sale. Add 25c handling on orders under \$5.00. Quantity users write for special discount.

Write for FREE Tube List—Order Blank—and FREE Sample Tube Carton. We want Y-O-U on Our Mailing List!

SPECIAL SURPRISE
Mention where you saw our ad and we will send you FREE three 6SNGT's with any order of \$10 or more.

FREE GIFT CERTIFICATE*
worth \$5 toward the purchase of any of our merchandise on future orders will be sent with any order of \$50 or more.
* Free Gift Certificate cannot be used to obtain another certificate unless order is \$55 or more.

LOOK WHAT YOU GET FREE!

- 1 RCA Checker Box
- 10 Assorted Resistors
- 10 Assorted 2 color "blank" tube cartons

FREE CLOCK RADIO

With Every \$25 Order

- 1 6BQ6GT tube
- 1 6AU6 tube
- 1 6C5B tube

Wakemaster clock radio with famous Sessions' clock movement wakes you to music or alarm. May be purchased outright from MAJOR BRAND for \$17.95. In ivory or rust.

MAJOR BRAND TUBE CO.

Romano Bldg.

Harrison, N. J.
ESsex 4-1106

WRITE DEPT. RN-D

LOOK TO TRIAD

to fill your TV replacement needs

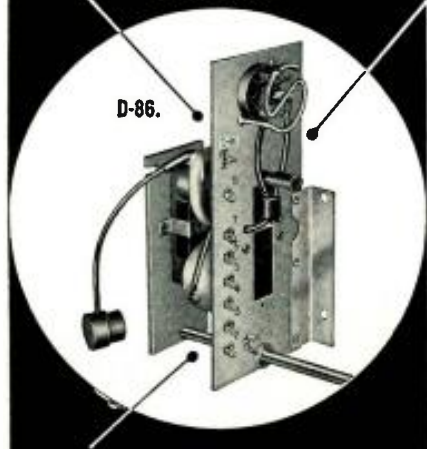

With the addition of the 8 new flybacks (Horizontal Output transformers) listed below, you can depend on TRIAD to supply all your Television replacement transformer requirements.

- D-78. List Price \$11.60. Correct Replacement for Sylvania 241-0011.
- D-79. List Price \$12.35. Correct Replacement for CBS and Firestone PC-10137.
- D-80. List Price \$12.35. Correct Replacement for CBS and Firestone PC-10147, G.
- D-83. List Price \$11.80. Correct Replacement for Raytheon 12E-24612, 12E-24612-1 and 12E-25040.
- D-84. List Price \$13.90. Correct Replacement for Raytheon and Airline C201-22396B, 201-22396-1.
- D-85. List Price \$12.70. Correct Replacement for Airline MW22E67 and Sentinel 22E67.
- D-86. List Price \$15.50. Correct Replacement for Airline MW22E75 and Sentinel 22E75.
- D-87. List Price \$12.70. Correct Replacement for Airline and Sentinel 20E947, B.

Write for Catalog TV-56



4055 Redwood Ave., Venice, California



Stabilizing Transistors

By L. FLEMING

A VERY important circuit technique that has emerged from the mass of engineering literature on transistors, is that of bias stabilization. It is not only necessary, but fortunately it is simple, consisting essentially of a base voltage divider and a resistor in the emitter circuit. The action is quite analogous to that of the cathode resistor in a vacuum tube circuit.

A better name for the transistor circuit scheme outlined here might be current stabilization, since that is what it really is. It applies to the most common and efficient type of transistor amplifier circuit, that using a junction transistor with grounded emitter.

First, Fig. 1A shows such a stage without the stabilization. To get enough "bias current" to flow between base and emitter, the base is pulled upwards, as it were, by means of resistor R_1 connected between the base and "B plus." (The transistors are assumed to be $n-p-n$ types, which operate with their collectors positive. The more common $p-n-p$ types work exactly the same, but with the battery polarity reversed.) The circuit of Fig. 1A is, however, poorly stabilized. This is basically because most of the emitter-base current does not come from the resistor R_1 , like we would like it to do. Most of it comes down from the collector. And if the collector current decides to increase, for some reason, the emitter-base current will increase too. This results in more collector current, which results in more emitter current, and so on, until the collector voltage "hits bottom" or the transistor overheats and goes bad.

There is a reason why the collector current may decide to start climbing. It lies in the cut-off current, defined as the collector current at some normal voltage when the emitter current is zero. This cut-off current is generally on the order of 10 microamperes or more at room temperature and increases rapidly with temperature—around 9 per-cent per degree Centigrade. So, once the transistor starts to warm up, the current will rise, and initiate the vicious circle.

Fig. 1B shows how to get around this trouble with a stabilization circuit. Typical values and voltages are given for purposes of illustration. First item is the emitter resistor R_3 and second is the base voltage divider R_2, R_4 . This divider should be as "stiff," i.e., have as good regulation, as possible without causing loading and power drain difficulties. Load current on the divider tap runs from around 2 to 10 per-cent of the collector current, depending on α . Now, if the base voltage is thus held constant, the emitter-base current will stay the same whatever the collector current might decide to do.

With the divider R_2, R_4 controlling the base potential, something has to be done to limit and control the value of

the emitter-base current. This "something" is the emitter resistor R_3 . There is, incidentally, a fair parallel here to the action of a cathode follower, in the base-emitter circuit. The emitter voltage will follow the base pretty closely. So, to establish the value of the emitter resistor R_3 , we take the voltage across it as being practically the same as the divider voltage across R_4 , and the current as whatever value of collector current we want to have; then apply Ohm's law. In the case of Fig. 1B here, the voltage is 0.6 volt (not much is needed) and the current was picked arbitrarily as 0.6 milliamperes. The emitter resistor then comes out as 1000 ohms. To increase the current, we can either change the divider ratio or reduce the value of R_3 . Bypass capacitor C_2 is optional.

In general, the divider resistors should be as low as possible without loading down the input or drawing too much bleeder current. Practical values for the bottom resistor R_4 run around 3000 to 20,000 ohms. Input impedance of a stage like this is around 500 to 1000 ohms. A 1 μ f. unit is satisfactory for the coupling capacitor C_1 for voice frequency work; larger values when bass is required.

The collector dissipation rating, usually 50 milliwatts for ordinary junction transistors, is rather easy to exceed accidentally. Maximum current ratings are commonly 10 or 20 milliamperes and maximum voltage 20 to 40 volts. But the maximum current and voltage cannot be used at the same time; e.g., 20 volts at 10 milliamperes equals 200 milliwatts.

Credit for development of transistor stabilization circuits belongs to Richard F. Shea of *General Electric*, editor of the authoritative book "Transistor Circuits" (Wiley, 1953). -30-

Fig. 1. (A) A transistor amplifier circuit without stabilization. (B) A suitable stabilization circuit. See text on values.

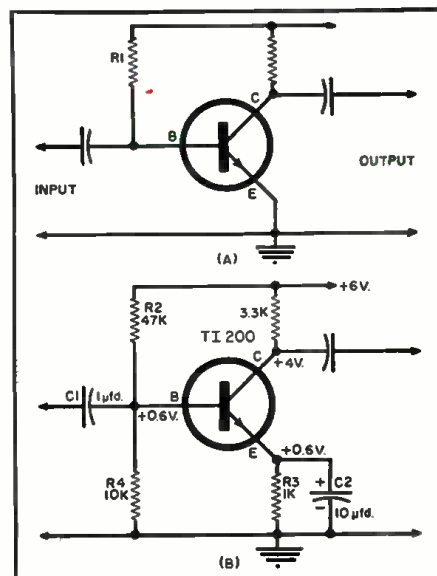

R.F. Coil Design

(Continued from page 58)

ductors") are two or three inches long, and the larger ones are ten inches long. These coils may easily be cut to the desired length.

This company and several others also offer ceramic plug and jack bars of various sizes, which take standard banana plugs and jacks for use with home-constructed coils.

Tapped Coils

The tapped coils often used in amateur transmitters introduce a few special problems. First, taps always reduce coil efficiency somewhat, but not unduly so when compared to the convenience in bandswitching and space conservation that tapped coils offer.

Losses can be minimized by considering the following. At the higher frequencies, the shorted turns act as a capacity in parallel with the active turns. This reduces the number of active turns required to reach a given frequency. Also, when most of the coil is shorted out, the form factor of the remainder is likely to be quite poor.

For such reasons, a single tapped coil is seldom used to cover a frequency range in excess of about six to one. Common amateur practice is to use a separate coil for the 28 mc. band, in series with a larger tapped coil for the 21 to 3.5 mc. bands, plus a third one for the 2 mc. band. Unused taps are connected together.

Occasionally, a shorted portion of a tapped coil will self resonate in one of the higher frequency ranges, to absorb much of the power generated at this frequency. Moving the offending tap slightly will move the resonance to a frequency where it will cause no damage.

Taps on coils wound on forms can be made while winding them by doubling the wire back on itself a few inches and twisting a few times, after which the winding is continued. Or a hole can be drilled in the form, and when the correct number of turns is wound, the wire is cut and threaded through the hole and terminated at the proper point. Then another wire is threaded through the same hole to the same terminal and the winding continued.

Airwound coils are easily tapped by hooking the end of a wire around the turn to be tapped and soldering. The turns on either side of the tapped turn may be pressed inward slightly to increase the clearance around the tap. A bit of aluminum foil may be tucked under it while soldering, to eliminate the possibility of soldering a couple of turns together.

General information included in this article was obtained from so many sources that it would be difficult to credit them all. However, the data on core-tuned coils was correlated from information supplied by the *Stackpole Carbon Co.*, the *James Millen Co.*, and *The National Co.*

—30—

August, 1956

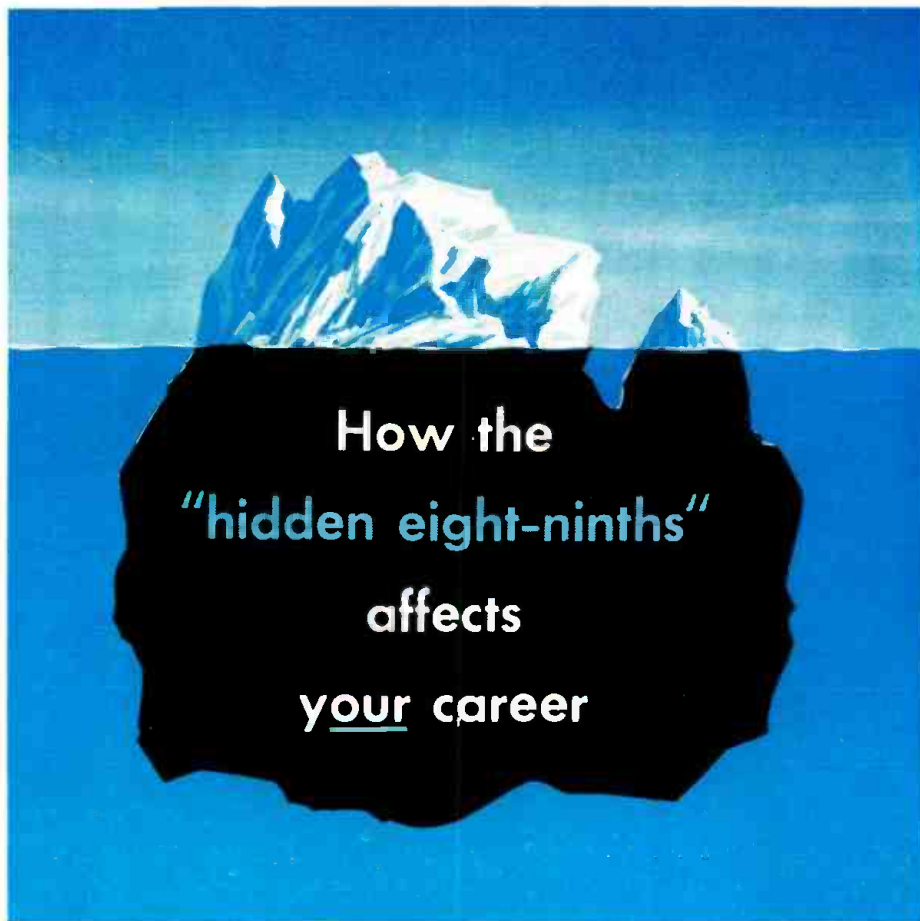

How the
"hidden eight-ninths"
affects
your career

If you look at only the more evident facts of an engineering or technical position, it is like judging the size of an iceberg merely by what shows above water.

The "hidden eight-ninths" may well determine the correctness of your choice.

Consider IBM's leadership in the most exciting, most rapidly expanding, perhaps the most *unlimited* field in electronics: digital computer development, manufacture and new maintenance techniques.

IBM is taking a leading role in the design, construction and installation of Project SAGE—the electronic "nerve center" of America's continental air defense warning system.

Greater responsibilities await the ambitious man at IBM. Advancement is based solely on individual performance. Capability, talent and creative ideas are quickly recognized and rewarded.

Excellent salaries prevail—along with extensive training, liberal benefits, good working conditions, facilities among the finest.

Stability is assured by a 42-year record of solid growth through di-

versified service to all industry, plus government and education.

Immediate, permanent assignments in: Portland, Me., Richmond, Va., Syracuse, N. Y., and other desirable locations.

Liberal relocation expense allowance. IBM and Project SAGE offer opportunities to challenge your ability:

FIELD ENGINEERS

You will be responsible for the performance, evaluation, reliability testing, and maintenance of the entire system containing the world's largest computer.

Requirement: Degree or equivalent with emphasis in electronics.

FIELD ENGINEERING TECHNICIANS

Actual maintenance and component analysis. Assume high-level responsibility. Requirement: Two-year technical school training in electronics, or equivalent.

You are invited to "sound out" IBM potential by writing, giving details of education and experience, to: Nelson O. Heyer, IBM, Room 4308, Military Products Division, Kingston, New York.

DATA PROCESSING
ELECTRIC TYPEWRITERS
TIME EQUIPMENT
MILITARY PRODUCTS

IBM
®

INTERNATIONAL
BUSINESS MACHINES
CORPORATION

ATLAS SOUND CORP.

1446—39 St., Brooklyn 18, N. Y.

Send FREE Buyer's Guide to save me money on public address Loudspeakers, Microphone Stands and accessories.

Name _____ Title _____

Firm _____

Type of Business _____

Address _____

City _____ Zone _____ State _____

HOW to SAVE MONEY on LOUDSPEAKERS and MIKE STANDS

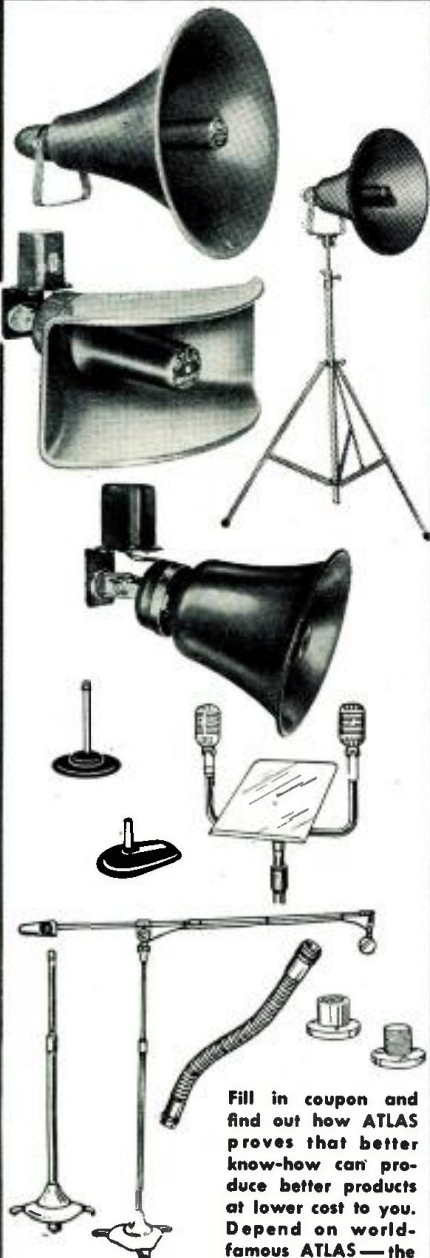

Fill in coupon and find out how ATLAS proves that better know-how can produce better products at lower cost to you. Depend on world-famous ATLAS—the complete quality line with specialist know-how since 1930.



ATLAS SOUND CORP.

1446-39th Street, Brooklyn 18, New York
In Canada: Atlas Radio Corp., Ltd., Toronto, Ont.

Spot Radio News

(Continued from page 18)

Olympic games at Cortina d'Ampezzo, Italy, released by the technical directorate of *Radiotelevisione Italiana*, has revealed that the operation was one of the most complex and expensive ever undertaken. Seventy technicians, three TV remote-broadcast cars, eleven cameras for video and fifteen for films, fifteen mobile radio links, and five fixed lines were required to handle the operations.

To carry TV signals from Cortina for continental transmission, it was necessary to install extensive mobile and fixed radio links, plus long distance coax cable lines.

At the games, three mobile camera units comprising nine television cameras were in use. In addition, a tenth camera was placed in permanent service; this was mounted in a small studio situated in the lower ground floor of the Ice Stadium. At the Ice Palace, a complete 16-mm film scanner was installed.

To insure speedy transmission of films, which were taken by a dozen operators equipped with sound-on-film cameras and pilot-tone cameras, a lab was installed on the grounds for developing and printing reversible 16-mm film. The camera work often presented considerable difficulties, in view of the distances which separated the avenues of the various competitions and particularly the unfavorable cold weather; at times the temperatures dropped to -20° C.

The opening ceremony represented quite a problem, for it was necessary to televise from a mountain over a mile up. Two cameras were carried to the summit. Here, too, were set up the receivers of the Cortina radio relays and transmitters for a relay. This mountain top also served as the home of the Cortina television broadcasting station.

During the course of the games, 42 filmed programs were processed for Italian TV and other countries. Approximately ten copies of a filmed summary were sent abroad every day; these summaries were also transmitted every evening in an Italian TV newsreel. The copies were printed immediately following the first transmission of the film and developed during the night, so that they could be delivered early in the morning by special car to the Treviso airport, and then sent to Rome for continental and overseas air shipment.

AN ELECTRONIC MAID (Monrobot Automatic Internal Diagnosis), a device which constantly monitors the operations and parts of an electronic computer to insure correct answers, will soon be operating within the U. S. Air Force's Air Research and Development Command.

The new device, it is said, will provide a high degree of reliability, so important in reconnaissance work, in

which the electronic computers play a key role. *Maid* will keep an electronic eye on the machine at all times to make certain that there are no failures in the vacuum tubes or germanium diodes which might cause error in computation. In 30 seconds, the unit can pinpoint any malfunction in the 3000 items that are in the computer; location of faulty parts is indicated by means of illuminated electronic indicators. It is then only necessary to replace the malfunctioning package with a spare one and the computer can continue to operate.

The computer, in which this ingenious control will be placed, has 3000 plug-in packages; fifteen-hundred of these packets contain tubes, the remainder semiconductors. The computer's magnetic memory drum whirls around at the rate of a mile a minute. It can retain 100 numbers, each containing twenty decimal digits and 200 instructions, making human intervention unnecessary during the course of a calculation. The computer can whip off 100 multiplications or division problems per minute.

THE LATE MONTHS OF SPRING found a marked slow-down in grants, motivated, most felt, by the forthcoming allocation decision.

The few authorizations and changes approved appear on page 16 of this issue.

ELECTRONICS HAS COME to the rescue once again, this time in the technical race between this country and Russia, with an information storage (photoscopic) unit, which can automatically translate languages, such as Russian, into English.

Information from the storage machine is held on a transparent disc that has been coated with a photographic emulsion. The data appears coded on this disc as microscopic black and white squares arranged in concentric tracks. To read the information, the disc is rotated while a light beam shines through these information tracks of black and white squares. A phototube picks up the light that goes through the disc and converts the sequence of light and dark to electrical signals. The squares on the disc are only .0003 inch on a side, or 6-million per square inch.

The reading station consists of a cathode-ray tube, a lens that projects an image of the spot on the tube onto the information track, and a photomultiplier tube behind the disc. Deflection of the electron beam in the CRT moves the light spot radially, so that it illuminates any one of 600 tracks.

The disc, which will be used in an Air Force machine, will be able to store 30-million bits, equivalent to five-million characters or several books. All of this will be done with the disc spinning at a rate of 1200 rpm, so that information can be read at the rate of 1-million bits per second. The access time to any item chosen at random is the time of one revolution, or 50 milliseconds. . . . L. W.

RADIO & TELEVISION NEWS

APN/4 OSCILLOSCOPE



Easily converted for use on radio-TV Service Bench!

BRAND NEW
Completely Assembled

Supplied only with 5" Scope type 5CP1 and RCA Crystal Unit... **\$14.95**

TS-100/AP OSCILLOSCOPE

BRAND NEW
(worth \$750)

OUR LOW PRICE **\$34.50**

Can be used with linear sweep or general purpose test scope. Cables included. Also used with circular sweep as precision range calculator. Self-contained in metal case 8" x 12 1/2" x 18" deep. For 110V 50 to 1200 cycles AC. Demilitarized, New, with all tubes including crystals and C. R. Tube.

GE WAVEMETER TS-111/CP. BRAND NEW. With Carrying Case. \$39.50

AIRCRAFT "ABC" POWER SUPPLY
Made by Setchell-Carlson. Input 24V DC .8 amps. Output 1.5V @ 3A; 65V @ .010A; -6V. BRAND NEW, metal case 4 1/4 x 4 1/2 x 7 1/4". Only **\$4.24**

BC-375 TRANSMITTER

200-500 Kc, 1500-12500 Kc using plug-in units. 100 watts. Voice & CW. **\$22.50**
Excel. Used, complete with all tubes. All Tuning Units for Above. \$2.25 and up.

AIRCRAFT RADIO TRANSMITTER-RECEIVER

RADIO SET SCR-AR-283. Consists of: RE-CEIVER, 201 to 398 Kc and 2500 to 7850 Kc. TRANSMITTER, 2500 to 7700 Kc. for unmodulated, tone-modulated, or voice. Here's what you get, at this fantastically low price: Receiver complete with 6 tubes; transmitter complete with 4 tubes, Dynamotor for 21 V DC operation, with 4 coils sets, 2 control boxes, antenna switching relay, operating manual. ALL BRAND NEW—and All Yours, for only. **\$15.95**

BC-221 FREQ. METER. \$129.50

BC-221 FREQ. METER CASE

Aluminum case for BC-221 or TS-160 Freq. Meters. With volt. reg. supply using VR105, 2 ballast tubes, relay, cable, etc. Inside front: 9 3/4 x 7 1/2 x 7 3/8". Inside rear: 2" deep. Shock-mounted. **\$3.99**
(Add 50c for packing)

Original Crystal for BC-221 1000 Kc BRAND NEW. **\$8.45**

COMPLETE OPERATING MANUAL for BC-221 Freq. Meter **\$1.95**

BENDIX DIRECTION FINDER

MN-26-C, 12-tube remote control Navigation Direction Finder and communications receiver. 150 to 1500 Kc in 3 bands. 28 V. DC Input. Ideal for commercial navigation on boats and planes. Complete installation comprises:
MN-26-C Receiver, used, with 12 tubes. **\$16.50**
MN-26-C With 12 Tubes, BRAND NEW. **\$22.50**
MN-20-E Rotatable Loop. **2.25**
MN-52 Azimuth Control Box. **2.95**

MN26Y BENDIX DIRECTION FINDER
150 Kc. to 7 Mc. Complete with tubes, motor. BRAND NEW. **\$26.95**
Used, like new, incl. tubes and dynamotor. \$18.95

MICROPHONES

Model	Description	Excellent Used	BRAND NEW
T-17	Carbon Hand Mike.	\$5.45	\$7.95
T-30	Carbon Throat Mike.	.33	.69
T-45	Navy Lip Mike.	.99	1.95
RS-38	Navy Type	2.45	4.95
T-24	Carbon Mike	3.95	4.95
TS-9	Handset	4.95	4.95

HEADPHONES

Model	Description	Excellent Used	BRAND NEW
HS-23	High Impedance	\$2.25	\$4.35
HS-33	Low Impedance	1.95	4.65
HS-30	Low Imp. (featherwt.)	1.49	2.25
H-16/U	High Imp. (2 units)	2.75	7.95
CD-307A	Cords, with PL55 plug and JK26 Jack.	.99	

HI-FI DYNAMIC HEADSET with Cushions
Freq. Range: 40-14000 CPS. No Distortion. BRAND NEW. **\$5.95**

EE-8 FIELD PHONES
OUR PRICE, EACH. **\$16.66**
SOUND POWER Headphone w th Dynamic Mike, BRAND NEW. **\$3.95**

BC-442 ANTENNA RELAY UNIT

Wonderful Value! Consists of 3/4 amp 2" RF Ammeter (antenna current indicator), G-10 scale, Transmitter-Receiver Switching relay, in aluminum case with associated components. BRAND NEW. **\$2.24**

Ham Special! Famous BC-645 XMITTER-RECEIVER



With **DIAGRAM** for Easy Conversion to **CITIZENS' BAND!**
Makes wonderful mobile rig for 420-500 Mc. Easy to convert for phone or CW 2-way communication. **CONVERSION DIAGRAM INCLUDED.** This swell rig originally cost over \$1000—yours for practically a song! You get it all, in original factory carton, BRAND NEW, complete with 17 tubes, less power supply. Conversion Instructions Included. **\$29.50**
Shpg. wt. 25 lbs.

PE-101C DYNAMOTOR for BC-645, has 12-24V input (easy to convert for 6V Battery operation) **\$7.95**
For dynamotor operation. Easily converted to 110 or 32 Volt, 2-1F stages, 3-range tuning cond. Complete with all tubes, in original sealed carton. BRAND NEW. **\$7.95**

UNF ANTENNA ASSEMBLY, for BC-645. **\$2.45**
Complete set of 10 Plugs for BC-645. **\$5.50**

CONTROL BOX for above. **\$2.25**
SNOCK MOUNT for above. **1.25**
CONVERSION BOOKLET, Instructions for most useful surplus rigs. **\$2.50**

TG-34A CODE KEYER

Self-contained automatic unit, reproduces code Practice signal recorded on paper tape. By use of built-in speaker, provides code-practice signals to one or more Persons at speeds from 5 to 25 WPM. BRAND NEW, in original carton. **\$19.95**
TAPES FOR ABOVE AVAILABLE

BC-906-C FREQ. METER—SPECIAL!

Cavity type, 144 to 235 Mc. BRAND NEW in original factory packing, complete with antenna & operating manual. **OUR LOW PRICE. \$12.95**

BC-946B BROADCAST RECEIVER

520 to 1500 Kc. 6 tubes: 3-12SK7, 12SR7, 12A6, 12K8. For dynamotor operation. Easily converted to 110 or 32 Volt, 2-1F stages, 3-range tuning cond. Complete with all tubes, in original sealed carton. BRAND NEW. **\$19.95**
BC-457 TRANSMITTER—5.3 Mc. complete with all tubes and crystal. BRAND NEW. **\$7.68**
BC-458 TRANSMITTER—5.3 to 7 Mc. Complete with all tubes and crystal. BRAND NEW. **\$7.88**
BC-459 TRANSMITTER—7 to 9 Mc. complete with all tubes and crystal. BRAND NEW. **\$11.95**
BC-696 TRANSMITTER—3 to 4 Mc. BRAND NEW, complete with all tubes & crystal. **\$6.88**

SCR-274 COMMAND EQUIPMENT

Type	Description	Used	Excellent Used	BRAND NEW
BC-453	Receiver 190-550 Kc.	\$9.95	\$11.95	\$14.95
BC-454	Receiver 3-6 Mc.	7.19	8.29	11.95
BC-455	Receiver 6-9 Mc.	5.25	7.55	9.95
BC-456	Modulator	2.24	2.75	4.24
BC-450	3-Receiver Control Box	1.49	1.49	1.95
BC-451	Transmitter Control Box	1.25	1.49	1.95
BC-456	Xmitr 3-4-Mc (like set)	6.95	8.88	8.88

110 VOLT AC POWER SUPPLY KIT

FOR ALL 274-N and ARC-5 RECEIVERS
Can be assembled quickly and easily, on pre-drilled chassis. Plugs into the rear of any model 274-N receiver and delivers 24 volts as well as "B" voltage. No wiring changes needed. Complete kit of parts with metal case, instructions. **\$7.95**
SPRING TUNING KNOB for 274-N RECEIVERS. 49c
Fits BC-453, BC-454 and others. Only.

ARC-5/R-2B RECEIVER

2 Meter superhet, 100 to 156 Mc in 4 xtal channels. Louvred alum. cabinet 7 3/8 x 4 7/8 x 14". Complete with 10 tubes and 4 xtals. **\$12.95**
Excel. Cond.

ARC-5/T-23 TRANSMITTER

Companion for above, incl. 2-832A, 2-162N tubes and 4 xtals. BRAND NEW. **\$14.95**
Less Tubes. **\$6.95**

ARC-5 MARINE RECEIVER-TRANSMITTER
Navy Type Comm. Receiver 1.5 to 3 Mc BRAND NEW with 6 tubes. **\$16.95**
Navy Type Comm. Transmitter 2.1-3 Mc BRAND NEW with 4 tubes and Xtal. **\$12.45**

CATHODE RAY TUBES

All Brand New in Original Packing

3CP1	.88	5BP4	\$2.22
3FP7	.68	5CP1	2.45
5BP1	2.22	6LP7	1.88



BUBBLE SEXTANT

Made for U. S. Armed Forces, by AGFA ANSCO. Actually worth \$150 or more! Has illuminated averaging disc for nighttime use. Complete with carrying case. **\$9.95**
Only.

WRITE FOR FREE CATALOG!

Please include 25% deposit with order—Balance C.O.D. MINIMUM ORDER \$3.00. All Shipments F.O.B. Our Warehouse N.Y.C.

G & G Radio Supply Co.

Dept. N-8
51 Vesey St., New York 7, N. Y., CO 7-4605
Branch: 5009 N. Neva Ave., Chicago 31, Ill.

SCR-522 FINEST 2-METER RIG!

Terrific buy! VHF Transmitter-Receiver, complete with all components. 100-156 Mc. 4 channels. Xtal-controlled, Amplitude modulated voice. They're going fast! Excellent condition.
SCR-522 Transmitter-Receiver, complete with all 18 tubes. Special \$33.33
COMBINATION. \$19.50
Receiver Only, with all tubes. **\$22.25**
Transmitter Only, with all tubes. **\$22.25**



LORAN APN-4

FINE QUALITY NAVIGATIONAL EQUIPMENT

Determine exact geographic position of your boat or plane! Complete, BRAND NEW installation consists of: 1D-6B/APN-4 Indicator; R-9B/APN-4 Receiver; PE-206 inverter; Set of Plugs; Vior for Indicator; Operation manual; Brand New, Export packed. **COMPLETE. \$129.50**

R65/APN-9 LORAN Receiver-Indicator, complete with tubes and operating manual, BRAND NEW, export packed. **\$295.00**

SPECIAL APN-9A LORAN Receiver Indicator, less tubes, NEW (demilitarized) \$29.50

BC1206-C BEACON RECEIVER

195 to 420 Kc. made by Setchell-Carlson. Works on 24. 28 volts DC. 135 Kc. IF. Complete with 5 tubes. Size 4" x 4" x 6". Wt. 4 lbs. BRAND NEW. **\$8.88**
Brand New, less tubes. \$5.95
USED, with tubes. \$5.95
USED, less tubes. 2.95



TS-16/APN TEST SET

Very Special at this low price. BRAND NEW. Complete with all cables. **\$12.95**

Type 2J1F1 SELSYNS

Operates from 57 1/2 volts, 400 cycles. New tested. Conversion diagram for 110 volts AC included. BRAND NEW, each. **\$2.95**
CAPS FOR ABOVE. 50c

TYPE APN/1 ALTIMETER

Complete with all tubes. Limited quantity at this special low price! **\$8.95**

NAVY RECEIVER TYPE ARB

Four Band. 105 to 9050 kc. Low Freq., Ship. Broadcast—40 to 80 meters. Includes tubes and dynamotor, for 24 volt operation. Easily converted for 110 V., 12 V, or 6 V. Schematic included. Excellent Condition. Overall: 8 1/4" x 7 1/4" x 15 1/4". Wt. 30 lbs. **COMPLETE WITH ALL TUBES, Special. \$21.50**



MOBILE TRANSCEIVER DYNAMOTOR

Special Buy! Output 625 Volts DC @ 225 Ma. Input 12 1/2 V @ 18.7 Amps. AC. Size 8x 4 1/4 x 4". BRAND NEW. **\$10.95**
Excellent Used \$8.95

OTHER DYNAMOTOR VALUES:

Type	Input	Output	Excellent Used	BRAND NEW
DM-28	28V	224V .07A	\$1.95	\$4.95
DM-32A	28V 1.1A	250V .05A	2.95	5.95
DM-33A	28V 5A	575V .16A	1.95	3.95
DM-38	28V 7A	540V .25A	1.95	3.95
DM-34D	12V 2A	220V .080A	4.25	5.50
DM-37	25.5V 9.2A	625V .225A	5.95	8.95
DM-40	14V 3.4A	172V .138A	1.75	3.45
DM-53A	28V 1.4A	220V .080A	3.95	5.95
DM-64A	12V 5.1A	275V .150A	7.95	7.95
PE-73C	28V 20A	1000V .350A	8.50	11.50
PE-86	28V 1.25A	250V .050A	2.95	5.24
PE-103	6V	500V .160A		
	12V	500V .160A	19.50	34.50
PE-186	28V 11A	400V .400A		6.95

SPECIAL G.E. DYNAMOTOR

INPUT: 28 V. D.C. @ 19 A.
OUTPUT: 1000 V. D.C. @ .350 A. **\$4.95**
Model 5D48B9A. BRAND NEW.

2-VOLT BATTERY "PACKAGE!"

1—2V. 20 Amp. Hr. Willard Storage Battery. **\$2.45**
1—2V. 7 prong Synchronous Plug-in Vibrator. **1.49**
1—Quart Bottle Electrolyte (for 2 cells) **1.45**
ALL BRAND NEW!
Combination Price **\$4.99**

Willard 6-Volt Midget Storage Battery
3 Amp. Hour. BRAND NEW. 3 3/4" x 1-13/16" x 2 3/8". Uses Standard Electrolyte. Only **\$2.22**

KLEIN

THE THRILL THAT
ONLY GOOD TOOLS
CAN GIVE



The radio ham, serviceman or designer knows that the most important tools in his kit are Klein Pliers—long nose, oblique cutters, side cutters.

The quality of the work you do depends in no small measure on the quality of the tools you use. Your reputation as a craftsman is protected when your pliers carry the Klein trademark.



Write for your FREE copy of the Klein Pocket Tool Guide listing Klein equipment and giving valuable information.

Mathias **KLEIN** & Sons
Established 1857 Chicago, Ill., U.S.A.
7200 McCORMICK ROAD • CHICAGO 45, ILLINOIS

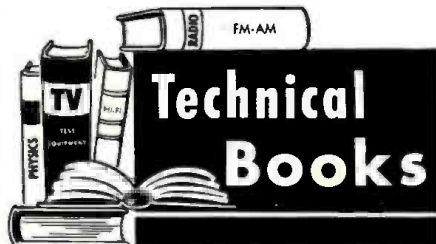

Technical Books

"SERVICING TV SWEEP SYSTEMS" by Jesse Dines. Published by Howard W. Sams & Co., Inc., Indianapolis. 212 pages. Price \$2.75. Paper bound.

The current trend toward large-screen receivers for the home has all but eliminated the deflection-plate/separate transformer type of horizontal sweep system in favor of the flyback system using a flyback transformer, yoke, and horizontal width and linearity coils.

This new and almost universally accepted system has given technicians headaches simply through a lack of understanding of the multiplicity of functions handled by this single section. The author contends that a thorough understanding of flyback circuitry will eliminate the problem and make for faster, more accurate troubleshooting.

The book itself is divided into six chapters which cover the fundamentals of sweep system operation, the sweep system circuit functions, horizontal and vertical sweep-circuit variations, the construction of sweep component parts, troubleshooting this section, and servicing hints.

The text material is written in clear down-to-earth style, with generous helpings of line drawings and photographs. Service technicians will find this book both instructive and time-saving.

* * *

"R-F TRANSMISSION LINES" by Dr. Alexander Schure. Published by John F. Rider Publisher, Inc., New York. 61 pages. Price \$1.25. Paper bound.

The author has managed to pack a tremendous amount of basic information on r.f. transmission lines between the covers of this slim volume.

Because of the minimal use of mathematics, this book could be used either as a classroom text or as a home-study volume. The author discusses the various types of lines in common use, the problem of lumped and distributed constants, variations of constants, characteristic impedance, line termination, standing waves and standing wave ratios, input impedance, line losses, resonant lines, etc.

Charts, graphs, tables, and sketches are used lavishly throughout to forward the student's understanding of the text material.

* * *

"PICTURE BOOK OF TV TROUBLES" by the Rider Staff. Published by John F. Rider Publisher, Inc., New York. 100 pages. Price \$1.80. Paper bound. Vol. 5 ("Horizontal Output and H-V Circuits").

This is the fifth volume in the current "Tell-a-Fault" series covering cir-

Almo
OFFERS THE BEST
FOR LESS!

RADIO craftsmen
THE FINEST IN
HIGH FIDELITY



CONCERTO AMPLIFIER-PREAMP
The "Concerto" Model CA-11 produces 10 watts of clean power over an extremely wide range. Its versatility of controls and more than adequate power make it an ideal amplifier for home high fidelity use.
NOW ONLY \$57.50



SYMPHONY AM-FM TUNER
The "Symphony" Model CT-4 Tuner represents the latest developments in advanced circuitry with a built-in Q-Bar AM antenna, built-in FM antenna and cathode follower output.
NOW ONLY \$89.50

AT ALL *Almo*
RADIO CO. STORES

509 ARCH STREET
Downtown Philadelphia

Branches: Camden, N. J.; Trenton, N. J.; Atlantic City, N. J.; Norristown, Pa.; Wilmington, Del.; Solisbury, Md.



BARGAIN HUNTING?

RADIO SERVICEMEN!

Write for SENSATIONAL CATALOG
HENSHAW RADIO SUPPLY
3619 TROOST KANSAS CITY, MO.

SCHEMATICS—CONVERSIONS
FOR SURPLUS GEAR

NEW LIST DI! MANY ADDITIONS!

Send stamped, self addressed envelope for List D. Add 25c for chart explaining AN nomenclature. DO IT TODAY!

R. E. BOX 1220
GOODHEART BEVERLY HILLS, CAL.

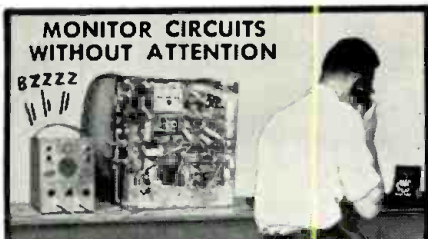

NEW ...The Solution to Your Troublesome **INTERMITTENT** problems!

New! For Television & Industrial Use!



Model SL10
SECO
MONITRON

SIGNAL TRACER AND INTERMITTENT LOCALIZER

In servicing TV receivers, transmitters, and similar electronic equipment where the output signal does not energize a sound producing indicator, a device is needed to actuate visible and audible alarm in case of a break in the signal path. The Seco MONITRON does just that and more!

Performs 4 basic functions:

1. Monitors without attention.
2. Monitors 2 circuits at once (on same or separate chassis.)
3. Operates as a signal tracer.
4. Makes point to point gain measurements.

Another Serviceman's Time-saver joining these indispensable Seco Testers.

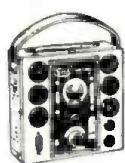

Model GCT-5
GRID CIRCUIT TUBE TESTER

NOW IN KIT FORM!
Model GCT-5 Kit Tester



Model FB-4
FLYBACK CIRCUIT AND INDUCTANCE ANALYZER

Your jobber has 'em or write for information



SECO MFG. CO.
5015 PENN AVENUE S.
MINNEAPOLIS, MINN.

circuit malfunctions that can be diagnosed by means of the pattern on the picture tube.

This manual covers the separate secondary horizontal output circuit, the direct-drive horizontal output circuit, the autotransformer horizontal output circuit, general yoke and width coil faults, flyback high-voltage power supply circuits, and the flyback high-voltage tripler power supply.

The various circuit faults that beset these sections of a television receiver are discussed as the basis of picture tube evidence with scope patterns used lavishly to cover the subject matter.

"HANDBOOK PREFERRED CIRCUITS" by J. H. Muncy. Published by the National Bureau of Standards. Available from the Government Printing Office, Washington 25, D. C. NAVER 16-1-519. Price \$1.75. Looseleaf, paper bound.

This handbook has been prepared by the National Bureau of Standards and the Navy Bureau of Aeronautics and is designed to encourage the standardization of electronic circuits. Its main purpose is to encourage voluntary reduction of unnecessary circuit variations in military equipment.

The manual presents thirty-two preferred circuits, including voltage regulators, multivibrators, blocking oscillators, video detectors, and amplifiers. Schematics of each circuit are provided along with characteristics and other information permitting duplication if desired.

The NBS plans to issue supplements to this handbook from time to time and will make such material available through the Government Printing Office.

"ANALYSIS OF ELECTRIC CIRCUITS" by William H. Middendorf. Published by John Wiley & Sons, Inc., New York. 298 pages. Price \$6.00.

This volume was designed as a college textbook for undergraduate electrical engineering students. A working knowledge of differential and integral calculus plus a college-level course in physics are prerequisites for an understanding of the material presented.

The organization of the text material is novel but, as the author points out, the emphasis is on getting the student to think for himself rather than to just learn formulas and rules by rote.

The book is divided into three main sections covering basic circuit analysis, an extension of basic circuit analysis, and, finally, polyphase power and communications circuits. Each section is divided into various chapters, each accompanied by suitable problems with which the student can check his grasp of the subject. Since some 40 per-cent of the problems have been solved, advanced students may find this text suitable for home study and self-instruction. This book will find its widest application, however, as a college text.

3+3=410



when you use the *new*

SHURE RK-56

REPLACEMENT CARTRIDGE KIT

as a companion to the RK-54

The 3 CARTRIDGES in the RK-56 Kit provide dependable, quickly-installed replacements for 218 cartridges of seven manufacturers.

When used with the RK-54 Kit (where 3 cartridges replace 192) you will have profitable replacements for 410 of the most frequently used phono cartridges!

LIST PRICE **\$22⁹⁵**

Including technical data, replacement chart and 5" x 3" x 1 1/4" plastic box.

Here is broadest coverage for the lowest investment. The RK-56 Kit contains:

Cartridge	Application	OUTPUT LEVEL		Response To
		MG	78	
WC10 Ceramic	Extended range, Improvement- Replacement cartridge for 132 3-speed, plastic-case cartridges, crystal or ceramic, single needle or turnover.	78v	1.0v	12,000 cps
W70 Crystal	All-Purpose Single-Needle cartridge. For Webster C and CX series.	3.0v	3.8v	5,000 cps
W72 Crystal	Dual-Voltage 3-speed Turnover cartridge for Webster FX and Astatic LQD series cartridges.	4v or 2v*		5,000 cps

*Model W72 has a slip-on capacitor furnished as an accessory. With the capacitor, output is 2v for 78 RPM, 1.5v for 33 1/2, 45 RPM. Without the capacitor, output is 4v for 78 RPM, 3v for 33 1/2, 45 RPM.

Available at your Shure Distributor . . . or write to Shure for complete information on this new profitable replacement kit.

SHURE BROTHERS, INC.
Microphones ~ Electronic Components

210 Hartrey Avenue • Evanston, Illinois

Superior's New Model TC-55



New! Streamlined TUBE TESTERS

FOR

The Experimenter or Part-time Serviceman, who has delayed purchasing a higher priced Tube Tester. The Professional Serviceman, who needs an extra Tube Tester for outside calls. The busy TV Service Organization, which needs extra Tube Testers for its field men.

Speedy, yet efficient operation is accomplished by: Elimination of old style sockets used for testing obsolete tubes (26, 27, 57, 59, etc.) and providing sockets and circuits for efficiently testing the new Noval and Sub-Minar types.

Model TC-55 comes complete with operating instructions and charts and streamlined carrying case.

- You can't insert a tube in wrong socket. Separate sockets are used, one for each type of tube base. • "Free-point" element switching system Any pin may be used as a filament pin and the voltage applied between that pin and any other pin, or even the "top-cap". • Checks for shorts and leakages between all elements. Provides a super sensitive method of checking for shorts and leakages up to 5 Megohms between any and all of the terminals. Continuity between various sections is individually indicated. • Elemental switches are numbered in strict accordance with R.M.A. specification. The 4 position fast-action snap switches are all numbered in exact accordance with the standard R.M.A. numbering system.

\$26⁹⁵
NET

PICTURE TUBE TESTER



Superior's New Model TV-40



- Tests all magnetically deflected tubes . . . in the set . . . out of the set . . . in the carton!!
- A complete picture tube tester for little more than the price of a "make-shift" adapter!!

The Model TV-40 is absolutely complete! Self-contained, including built-in power supply, it tests picture tubes in the only practical way to efficiently test such tubes; that is by the use of a separate instrument which is designed exclusively to test the ever increasing number of picture tubes!

SPECIFICATIONS

Tests all magnetically deflected picture tubes from 7 inch to 30 inch types. • Tests for quality by the well established emission method. All readings on "Good-Bad" scale. • Tests for inter-element shorts and leakages up to 5 megohms. • Test for open elements.

Model TV-40 comes absolutely complete — nothing else to buy. Housed in round cornered, molded bakelite case. Only . . .

\$15⁸⁵
NET



Superior's New Model TV-11

Standard Professional TUBE TESTER

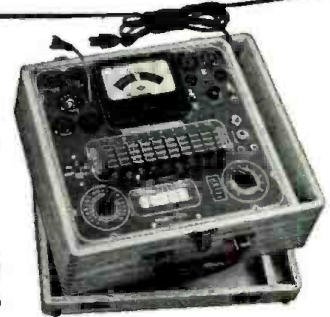

- ★ Uses the new self-cleaning Lever Action Switches for individual element testing. Because all elements are numbered according to pin-number in the RMA base numbering system, the user can instantly identify which element is under test. Tubes having tapped filaments and tubes with filaments terminating in more than one pin are truly tested with the Model TV-11 as any of the pins may be placed in the neutral position when necessary.

- ★ The Model TV-11 does not use any combination type sockets. Instead individual sockets are used for each type of tube. Thus it is impossible to damage a tube by inserting it in the wrong socket.

- ★ Free-moving built-in roll chart provides complete data for all tubes.

- ★ NOISE TEST: Phono-jack on front panel for plugging in either phones or external amplifier will detect microphonic tubes or noise due to faulty elements and loose internal connections.

EXTRA SERVICE — The Model TV-11 may be used as an extremely sensitive Condenser Leakage Checker. A relaxation type oscillator incorporated in this model will detect leakages even when the frequency is one per minute.

The model TV-11 operates on 105-130 Volt 60 Cycles A.C. Comes housed in a beautiful hand-rubbed oak cabinet complete with portable cover.

\$47⁵⁰
NET



TRANS-CONDUCTANCE TUBE TESTER

Superior's New Model TV-12



TESTING TUBES

- ★ Employs improved TRANS-CONDUCTANCE circuit. An in-phase signal is impressed on the input section of a tube and the resultant plate current change is measured. This provides the most suitable method of simulating the manner in which tubes actually operate in Radio & TV receivers, amplifiers and other circuits. Amplification factor, plate resistance and cathode emission are all correlated in one meter reading.

- ★ NEW LINE VOLTAGE ADJUSTING SYSTEM. A tapped transformer makes it possible to compensate for line voltage variations to a tolerance of better than 2%.

- ★ SAFETY BUTTON—protects both the tube under test and the instrument meter against damage due to overload or other form of improper switching.

- ★ NEWLY DESIGNED FIVE POSITION LEVER SWITCH ASSEMBLY. Permits application of separate voltages as required for both plate and grid of tube under test, resulting in improved Trans-Conductance circuit.

TESTING TRANSISTORS

A transistor can be safely and adequately tested only under dynamic conditions. The Model TV-12 will test all transistors in that approved manner, and quality is read directly on a special "transistor only" meter scale.

Model TV-12 housed in handsome rugged portable cabinet sells for only

\$72⁵⁰
NET

ALSO TESTS TRANSISTORS!

EXAMINE BEFORE YOU BUY!
USE APPROVAL FORM ON NEXT PAGE

New!



Superior's New Model 670-A SUPER-METER



SPECIFICATIONS

D.C. VOLTS: 0 to 7.5/15/75/150/750/1,500/7,500 Volts
 A.C. VOLTS: 0 to 15/30/150/300/1,500/3,000 Volts
 OUTPUT VOLTS: 0 to 15/30/150/300/1,500/3,000 Volts
 D.C. CURRENT: 0 to 1.5/15/150 Ma. 0 to 1.5/15 Amperes
 RESISTANCE: 0 to 1,000/100,000 Ohms 0 to 10 Megohms
 CAPACITY: .001 to 1 Mfd. 1 to 50 Mfd. (Good-Bad scale for checking quality of electrolytic condensers.)
 REACTANCE: 50 to 2,500 Ohms 2,500 Ohms to 2.5 Megohms
 INDUCTANCE: .15 to 7 Henries 7 to 7,000 Henries
 DECIBELS: -6 to +18 +14 to +38 +34 to +58

ADDED FEATURE:

Built-in ISOLATION TRANSFORMER reduces possibility of burning out meter through misuse.

The Model 670-A comes housed, in a rugged crackle-finished steel cabinet complete with test leads and operating instructions.

\$28⁴⁰
NET



Superior's New Model TV-60 20,000 OHMS PER VOLT ALLMETER



Includes services never before provided by an instrument of this type. Read and compare features and specifications below!

FEATURES

- Giant recessed 6 1/2 inch 40 Microampere meter with mirrored scale.

- Built-in Isolation Transformer.
- Use of the latest type printed circuit and 1% multipliers assure unchanging accurate readings.

SPECIFICATIONS

8 D.C. VOLTAGE RANGES: (At a sensitivity of 20,000 Ohms per Volt) 0 to 15/75/150/300/750/1500/7500/30,000 Volts.
 7 A.C. VOLTAGE RANGES: (At a sensitivity of 5,000 Ohms per Volt) 0 to 15/75/150/300/750/1500/7500 Volts.
 3 RESISTANCE RANGES: 0 to 2,000/200,000 Ohms, 0-20 Megohms
 2 CAPACITY RANGES: .0025 Mfd. to 30 Mfd.
 5 D.C. CURRENT RANGES: 0-75 Microamperes, 0 to 7.5/75/750 Milliampere, 0 to 15 Amperes.
 3 DECIBEL RANGES: -6 db to +58 db

RF SIGNAL TRACER SERVICE: Enables following the R.F. signal from the antenna to speaker of any radio or TV receiver and using that signal as a basis of measurement to first isolate the faulty stage and finally the component or circuit condition causing the trouble.

AUDIO SIGNAL TRACER SERVICE: Functions in the same manner as the R.F. Signal Tracing service specified above except that it is used for the location of cause of trouble in all audio and amplifier systems.

Model TV-60 comes complete with book of instructions; pair of standard test leads; high-voltage probe; detachable line cord; R.F. Signal Tracer Probe and Audio Signal Tracer Probe. Pliofilm bag for all above accessories is also included. Price complete. Nothing else to buy. ONLY

\$52⁵⁰



Superior's New Model TV-50 GENOMETER



A versatile all-inclusive GENERATOR which provides ALL the outputs for servicing:
A.M. Radio • F.M. Radio • Amplifiers • Black and White TV • Color TV

R. F. SIGNAL GENERATOR: Provides complete coverage for A.M. and F.M. alignment. Generates Radio Frequencies from 100 Kilocycles to 60 Megacycles on fundamentals and from 60 Megacycles to 180 Megacycles on powerful harmonics. • **VARIABLE AUDIO FREQUENCY GENERATOR:** In addition to a fixed 400 cycle sine-wave audio, the Genometer provides a variable 300 cycle to 20,000 cycle peaked wave audio signal. • **BAR GENERATOR:** Projects an actual Bar Pattern on any TV Receiver Screen. Pattern will consist of 4 to 16 horizontal bars or 7 to 20 vertical bars. • **CROSS HATCH GENERATOR:** Genometer will project a cross-hatch pattern on any TV picture tube. The pattern will consist of non-shifting horizontal and vertical lines interlaced to provide a stable cross-hatch effect. • **DOT PATTERN GENERATOR (FOR COLOR TV):** The Dot Pattern projected on any color TV Receiver tube by the Model TV-50 will enable you to adjust for proper color convergence. • **MARKER GENERATOR:** The following markers are provided: 189 Kc., 262.5 Kc., 456 Kc., 600 Kc., 1000 Kc., 1400 Kc., 1600 Kc., 2000 Kc., 2500 Kc., 3579 Kc., 4.5 Mc., 5 Mc., 10.7 Mc., (3579 Kc. is the color burst frequency.)

MODEL TV-50 comes absolutely complete with shielded leads and operating instructions.

\$47⁵⁰
NET

Only

SHIPPED ON APPROVAL NO MONEY WITH ORDER - NO C.O.D.

TRY ANY of the

instruments on this page, for 10 days before you buy. If completely satisfied then send down payment and pay balance as indicated on coupon. No Interest or Finance Charges added! If not completely satisfied return unit to us, no explanation necessary.

MOSS ELECTRONIC DISTRIBUTING CO., INC.
 Dept. D-262, 3849 Tenth Ave. New York 34, N. Y.

Please send me the units checked. I agree to pay down payment within 10 days and to pay the monthly balance as shown. It is understood there will be no finance or interest charges added. It is further understood that should I fail to make payment when due, the full unpaid balance shall become immediately due and payable.

Name _____
 Address _____
 City _____ Zone _____ State _____

All prices net, F.O.B., N.Y.C.

- Model TC-55.....Total Price \$26.95
\$6.95 within 10 days. Balance \$5.00
monthly for 4 months.
- Model TV-12.....Total Price \$72.50
\$22.50 within 10 days. Balance \$10.00
monthly for 5 months.
- Model 670-A.....Total Price \$28.40
\$7.40 within 10 days. Balance \$3.50
monthly for 6 months.
- Model TV-11.....Total Price \$47.50
\$11.50 within 10 days. Balance \$6.00
monthly for 6 months.
- Model TV-40.....Total Price \$15.85
\$3.85 within 10 days. Balance \$4.00
monthly for 3 months.
- Model TV-50.....Total Price \$47.50
\$11.50 within 10 days. Balance \$6.00
monthly for 6 months.
- Model TV-60.....Total Price \$52.50
\$12.50 within 10 days. Balance \$8.00
monthly for 5 months.

You Can Now Afford
**Top Quality
 Test Equipment!**

THE NEW AND VERSATILE

Advance
 LABORATORY-PRECISION

Electronic Instruments

■ Designed for you—and at a price you can afford to pay—precision service instruments made by world-famous ADVANCE Components, Ltd. ADVANCE instruments, functionally designed and laboratory engineered, will provide many years of reliable, trouble-free performance.



Sine and Square Wave
AUDIO GENERATOR

■ ADVANCE Model H-1 Audio Generator covers, in three ranges, 15 cps to 50 Kc, both sine and square waves. On sine waves, accurate to $\pm 1\%$, ± 1 cycle; less than 1% distortion at 1 Kc. Output ± 2 db, 200 uv to 20 volts. On square waves, less than 3 microseconds rise time; output 400 uv to 40 volts. Only \$82.50



RF SIGNAL GENERATOR

■ ADVANCE Model P-1 RF Generator covers 100 Kc to 100 Mc on fundamentals in six ranges, calibrated to 1%. Output variable from 1 uv to 100 mv, ± 6 db, ± 3 uv. 3 Outputs: 75 ohms, 37 ohms, 10 ohms. Audio modulation 30% at 400 cycles; AF output 0-8 volts. Only \$69.50

WRITE TODAY FOR COMPLETE SPECIFICATIONS
 Sole United States Agents

FISHER RADIO SALES Co., Inc.
 21-23 44th DRIVE • Long Island City 1, L. I.



New Hi-Fi-Audio

Equipment

MULTIPLEX FM RECEIVER

Collins Audio Products, P. O. Box 368, Westfield, New Jersey has begun the pilot production of a special FM

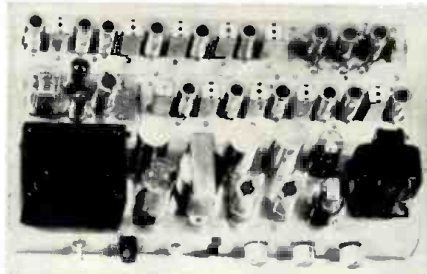

receiver for the reception of FM multiplexed subcarriers.

Features of the new unit include a highly sensitive cascode crystal-controlled front end, extremely wideband i.f. amplifier and discriminator, six-watt push-pull audio circuit, provision for selective muting of either main carrier or subcarrier, automatic background squelch, and oversize power components.

Another special feature of the set is the unique provision for checking both main carrier and subcarrier circuits with one v.t.v.m. plugged into the front of the chassis. Circuits are checked by rotating a tap switch on the front apron. All other controls are on the front and easily accessible.

Full details on this new multiplex receiver are available from the company on request.

AM-FM TUNER KIT

Quality Electronics, 319 Church Street, New York, N. Y. has recently introduced a new AM-FM tuner kit which offers many of the features embodied in higher priced units at moderate cost.

The "Qual-Kit" incorporates an Armstrong FM circuit with Foster-

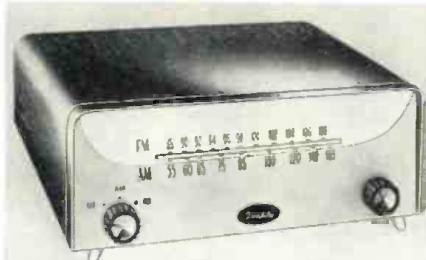

Seeley discriminator, with a 20 to 20,000 cps response. The tuner has excellent signal-to-noise ratio and provides maximum sensitivity and selectivity. A special temperature-compensated oscillator circuit eliminates drift. This kit utilizes seven tubes plus selenium rectifier.

Accompanying the kit is a 28-page, fully illustrated, foolproof booklet of assembly instructions along with four pictorial diagrams showing wiring and assembly in four steps. The AM section of the unit features a superheterodyne circuit with a.v.c. and a ferrite core loop antenna.

Free literature on this and other units in the company's kit line may be obtained by writing the firm direct.

TUNER-AMP-PREAMP

Newcomb Audio Products Company, 6824 Lexington Avenue, Hollywood, California has added a new combination tuner-amplifier-preamp to its "Compact" line of audio components.

Known as the Royal 712, the new unit is only 5 1/8" high, 14 5/8" wide, and 10" deep, yet it embodies all tuner and amplifier functions in a single decorator-styled cabinet.

The amplifier section of the new unit is rated at 12 watts with response



within ± 1 db from 20 to 20,000 cps. Total harmonic distortion is below 1% at 12 watts. Output impedances are 8 and 16 ohms.

Inputs are provided for magnetic pickups, crystal pickups, tape, and auxiliary equipment. An input impedance selector matches input requirements of all magnetic pickups. A special multiple output jack simplifies adaption to the reception of stereophonic or binaural broadcasts using the new FM multiplex system. A tape output jack permits the recording of programs while listening.

The company will supply complete specifications on the Royal 712 on request.

NEW "FERRO-SHEEN" TAPE

ORRadio Industries, Inc. of Opelika, Alabama is now offering its popularly priced "Green Band" recording tape made with the "Ferro-Sheen" process which heretofore was used only on its premium tapes. This upgrading in quality is being offered without any increase of price to the consumer.

The new Irish "Green Band" Ferro-Sheen tape is now available to all tape users for the standard price of all

SPACE MAN...

with a
Brief Case

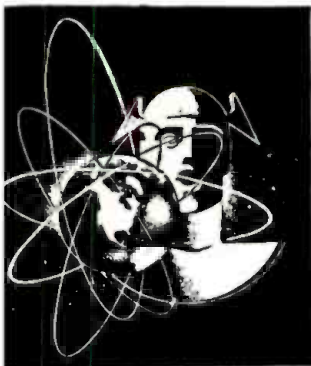

Science has a new kind of space man these days. He carries a brief case.

His mission is as new, as exciting and as challenging as a trip to the moon. In many cases you'll find him on the team at Remington Rand Univac, one of the engineers or technicians who have given UNIVAC the title,

"First in Electronic Computing Systems."

Futures at UNIVAC are as unlimited as the space above. New facilities, fresh working conditions are being born each day at Remington Rand Univac. New members are needed for the team. This is your chance to establish the career every man wants. Write today.

IMMEDIATE OPENINGS FOR:

ELECTRONIC ENGINEERS —

Must have degree and be experienced in pulse circuitry, digital computers, or data processing equipment.

SALES ENGINEERS —

Must have scientific, engineering or mathematical degree and be qualified to combine systems analysis, application and sales function.

PRODUCTION CONTROL —

Engineering degree preferred with 5 years' experience in Production Control Planning. To develop product program schedules and long range production plans.

ALSO OPENINGS FOR —

Physicists... Programmers... Mathematicians... Contract Administrators... and many others.

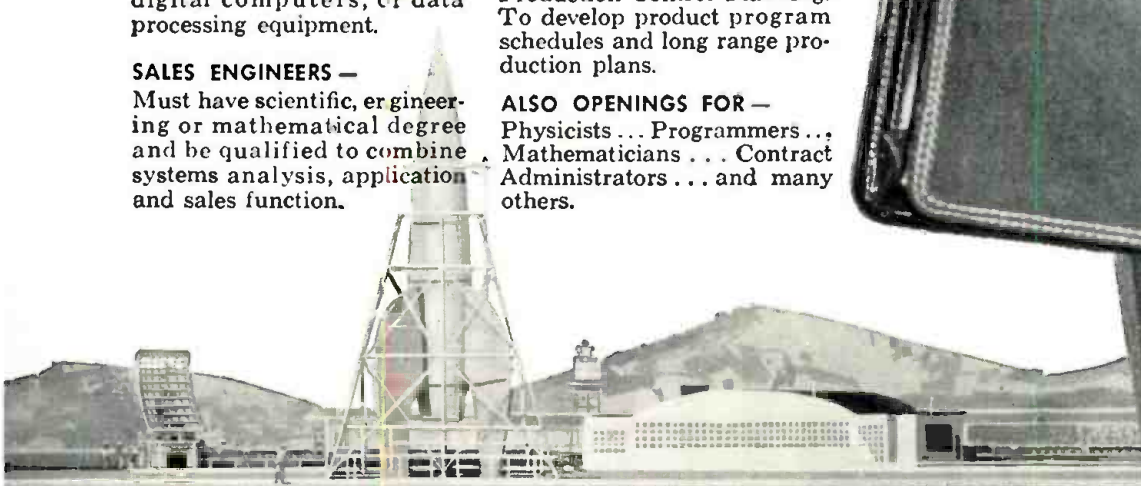

Send Complete Resume to —

Remington Rand Univac

DIVISION OF SPERRY RAND CORPORATION

at any one of these four plant locations

D. A. BOWDOIN

Dept. PA-9

2300 W. Allegheny Ave.

Philadelphia, Pa.

FRANK KING

Dept. NA-9

Wilson Avenue

South Norwalk, Conn.

J. N. WOODBURY

Dept. SA-9

1902 W. Minnehaha Ave.

St. Paul W4, Minnesota

CAL BOSIN

Dept. YA-9

315 Fourth Ave.

New York City

As easy to use as a pencil

WALL
INDUSTRIAL
SOLDERING IRONS
give you

More
BTU's...
Faster
HEAT...
Higher HEAT
CONTINUITY

than ANY OTHER
soldering irons of equal tip size

Proved 4 times faster on the production lines of America's leading electronics firms. Complete range of sizes... scientifically designed... individually tested... for easier, surer precision work or heavy duty soldering. Operate on 110-120 volts, AC or DC! Model 18T illustrated, \$6.25 list.

Exclusive
THERMOSTATIC ACTION...

Guaranteed for the life of the iron!
Prevents excessive tip burning!

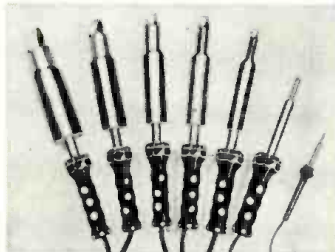

Write for FREE Catalog

WALL MANUFACTURING CO.
Grove City, Pennsylvania
OVER 20,000,000 SOLDERING PRODUCTS SINCE 1864

AUDEL'S TV TELLS HOW TO ANSWER RADIO T.V. QUESTIONS SERVICE LIBRARY

HERE IS LATE INFORMATION IN A HANDY FORM FOR TELEVISION AND RADIO REPAIRMEN, SERVICEMEN AND STUDENTS

AUDEL'S T.V. RADIO SERVICE LIBRARY—Highly Endorsed—Over 1500 Pages—1048 Illustrations & Diagrams. 1001 Important Facts & Figures on Modern Television, Radio, Electronic Devices at your finger ends.

INCLUDES TRANSISTORS & Transistor Circuits, Record Changers, Rectifiers, P.A. Systems, Tape Recorders, Phonograph Pick-ups, F.M., Auto Radio; Radio Compass, Short Wave, Radar, etc.

ASK TO SEE IT! IT WILL PAY TO KNOW—The Basic Principles—Construction—Installation—Operation—Repairs—Trouble Shooting. Shows How to get Sharp, Clear T.V. Pictures. Install Aerials—How to Test. Explains Color Systems, Methods of Conversion, Terms, etc. Includes Ultra High Frequency—Valuable for Quick Ready Reference and Home Study.

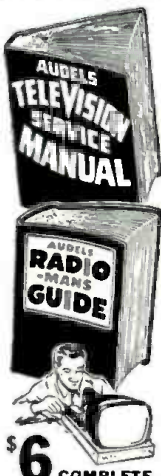

6 COMPLETE 2 VOLUMES Get this Information for Yourself.
7 DAY TEST—PAY ONLY \$1 A Month

MAIL ORDER
AUDEL Publishers, 49 W. 23 St., N.Y. 10, N.Y.
Mail AUDEL'S T.V. RADIO SERVICE LIBRARY (2 Volumes) \$6 on 7 days free trial. If O. K. I will remit \$1 in 7 days and \$1 monthly until \$6 is paid. Otherwise I will return them.

Name _____
Address _____
Occupation _____
Employed by _____ RN

NEW Senco
TRANSISTOR CHECKER
NOW WANTED and NEEDED by EVERY SERVICEMAN!
Quickly and accurately checks all transistors and crystal diodes.
Provides these 4 important checks on transistors:
OPEN • SHORT CURRENT GAIN • LEAKAGE
Checks forward to backward resistance of diodes
★ Complete set-up chart and instruction booklet attached to back
★ Will never become obsolete, with test leads, replaceable up-to-date set-up chart and gain control to vary battery voltage
★ Accurate and simple to operate—takes less than 30 seconds to test either TRANSISTORS or crystal diodes
★ Uses test leads which eliminates need of completely removing transistor from circuit
At leading distributors everywhere

Only \$15.95
DEALER NET Approved by leading manufacturers

SERVICE INSTRUMENTS CO.
171 OFFICIAL RD • ADDISON, ILL.



coated tapes in 7" reels holding 1200 feet, 600 feet, or 150 feet.

A catalogue sheet on the entire line is available from the manufacturer. Ask for Data Sheet CS-2.

NEW PHONO CARTRIDGES

The Astatic Corporation of Conneaut, Ohio is now offering a new series of phono cartridges which have been designated as the "Climatite" series.

Designed to meet all requirements and applications of the phonograph industry, the cartridges are "weather-

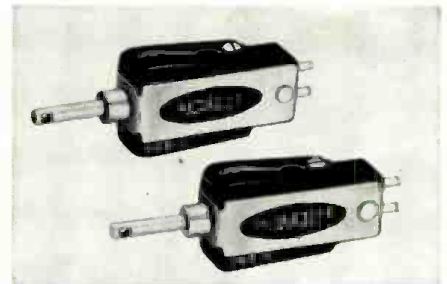

proofed" by the company's "Super MF" process making them ideal for use in areas of extreme cold, heat, or humidity.

The Model 420ts is a high output, high compliance, wide-range turnover containing separate, removable, one and three mil synthetic sapphire needles. A unique needle design simplifies needle replacement and quick replacement of the cartridge can be done without use of special tools,

TRANSISTORIZED TUNER

Scott Radio Laboratories, Inc., 1020 N. Rush Street, Chicago 11, Illinois has developed a transistorized AM-FM tuner and power amplifier for audio applications.

The "Silver Phantom" circuitry offers lower hum level and virtual elim-



ination of background noise. The tuner also features the company's exclusive "gated-beam" FM detector. The circuit provides noise limiting and AM rejection at less than 1.5 volt input.

Write the manufacturer for full details on this new instrument.

PILOT "3-IN-1" UNIT

Pilot Radio Corporation, 37-06 36th Street, Long Island City 1, New York is now offering a "3-in-1" unit which incorporates an FM-AM tuner, preamplifier, and 20-watt amplifier on a single chassis.

Known as the Model HF-41, the new unit requires only the addition of a loudspeaker and record player or tape deck to form a complete home music

system. The unit features a built-in rumble filter, variable loudness control, tape head playback, tape output, tape equalizer, a four-position record

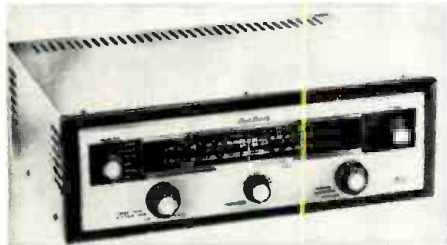

equalizer, flywheel tuning, a.f.c. and a.f.c. defeat, variable phono load, four inputs, d.c. on the filaments of the preamplifier tube, and a Williamson-type amplifier with 20-watts output.

The Model HF-41 is housed in a deep burgundy and brushed brass cabinet measuring 4 3/4" x 14 9/16" x 12 1/8". Write the manufacturer for full details on this equipment.

HEATHKIT SPEAKER SYSTEM

Heath Company, Benton Harbor, Michigan has designed a range-extending speaker system which is being made available as the Model SS-1B kit.

Designed to provide a complete 4-way speaker system when used in conjunction with the company's Model

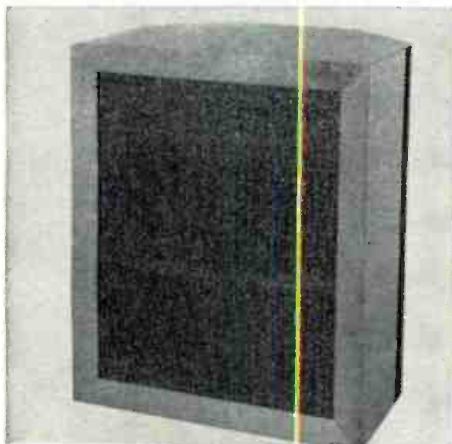

SS-1, the unit employs a supertweeter and a 15" woofer. It functions between 35 and 600 cps and between 4000 and 16,000 cps. Combined frequency response of the two units is ± 5 db from 35 to 16,000 cps. Using four separate speakers minimizes intermodulation distortion problems.

The Model SS-1B is designed to match the Model SS-1. The exposed cabinet panels are furniture-grade plywood suitable for light or dark finish.

50-WATT AMPLIFIER

A new 50-watt amplifier characterized by exceptional stability is now being offered by Gray Research & Development Co., Inc. of Manchester, Conn.

The unit provides 50 watts at less than 1% IM distortion, transients controlled through critical damping which prevents oscillatory surges from pulse-type signals, full frequency range from 6 to 100,000 cps with response outside the audio band smooth and controlled, wide bandpass characteristics to prevent square-wave distortion, and 100

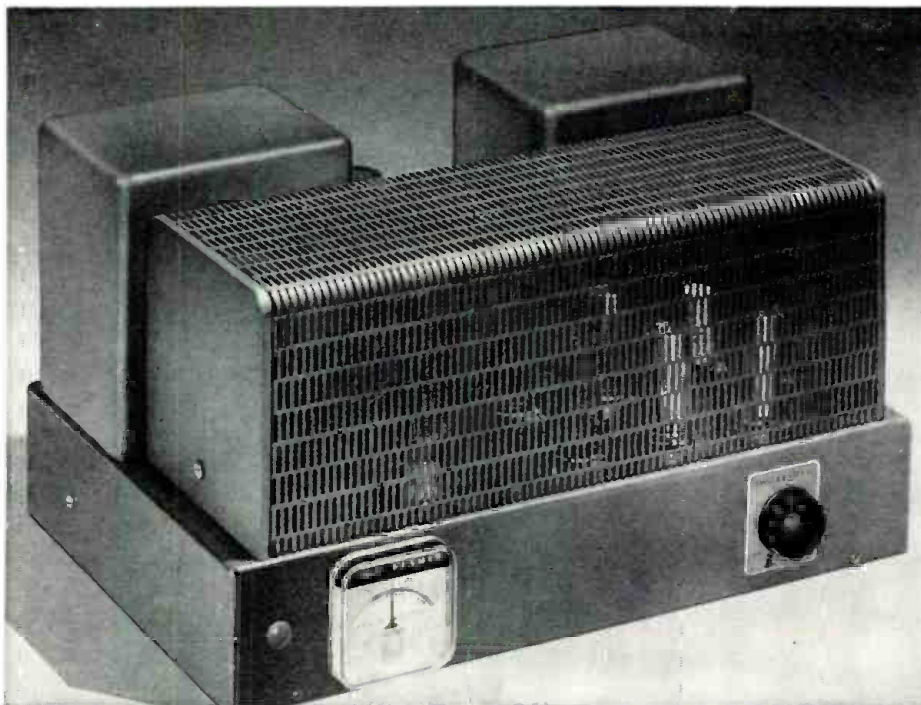

WORLD'S FINEST ALL-TRIODE AMPLIFIER • EQUIPPED WITH POWER MONITOR AND Z-MATIC

New!

THE 
FISHER

55 Watt Amplifier

PLENTY OF POWER for your present — and any possible *future* needs. The new Model 55-A is a laboratory instrument designed for home use. Delivers 55 watts at less than 1% distortion — and handles 110-watt power peaks! Drives even the lowest efficiency loudspeaker system to full output. Exclusive FISHER POWER MONITOR, a full-size, illuminated Power Output Meter, makes possible correct adjustment of output tube bias. It also indicates average audio power. Completely new Z-MATIC Variable Damping Factor Control. Has *three times* the range of ordinary controls. Massive transformers, laced cable wiring, terminal board construction — all are in the FISHER tradition. **\$169.50**

Outstanding Features of THE FISHER 55-A

- Less than 1% harmonic distortion at 55 watts (0.05% at 5 watts, 0.08% at 10 watts.) ■ Handles 110 watts peak. ■ IM distortion below 0.4% at 10 watts (0.8% at 45 watts, 2% at 50 watts.) ■ Uniform response ± 0.1 db 20 to 20,000 cps. (within 1 db, 5 to 100,000 cps.) ■ Power output constant within 1 db at 50 watts, 15 to 60,000 cps. ■ Hum and noise better than 92 db below full output! ■ Bias Control to balance output tubes. ■ Z-MATIC provides variable damping, from 32 to 0.08. ■ Less than 1 volt input produces full output. ■ Input Level Control. ■ 8 and 16-ohm output impedances. ■ Auxiliary AC receptacle. SIZE: 14 1/4" w. x 9 3/8" d. x 8 3/8" high. SHIPPING WEIGHT: 50 lbs.

Price Slightly Higher In The West

WRITE TODAY FOR COMPLETE SPECIFICATIONS

FISHER RADIO CORP. • 21-23 44th DRIVE • L. I. CITY 1, N. Y.

SPECIFY NORELCO
F.R.S.
 for Top Performance
 speaker replacements

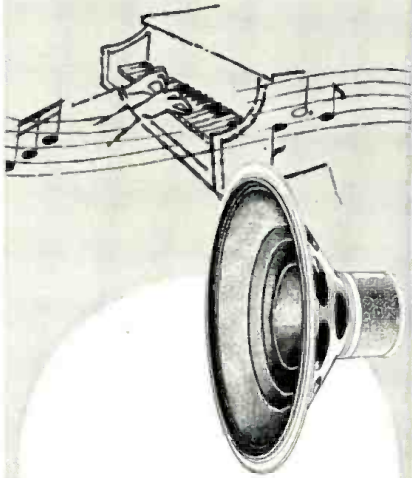

Based on economy alone, any one of the Norelco FRS twin-cone speakers is your best choice.

Aside from price, these speakers have been designed and manufactured by audio craftsmen—to produce unexcelled sound qualities. In a single FRS speaker, sound is reproduced so perfectly that listeners have difficulty in distinguishing recorded performance from those which are live.

FRS Twin Cones are both operated by the same magnet and voice coil. The smaller cone radiates frequencies above 10,000 c/s and diffuses lower frequencies. Frequencies below 10,000 c/s are generated by the larger cone while reflecting frequencies above this frequency.

Price from \$59.98 to \$6.75 in all standard impedances and sizes from 12 inches to 5 inches.

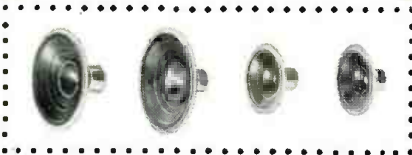

ADD TO... and improve any
 sound system with *Norelco*[®]
 *FULL RESONANCE SPEAKERS



Send to Dept. G8 today
 for more details.

North American Philips Co., Inc.
 100 East 42nd Street
 New York 17, N. Y.

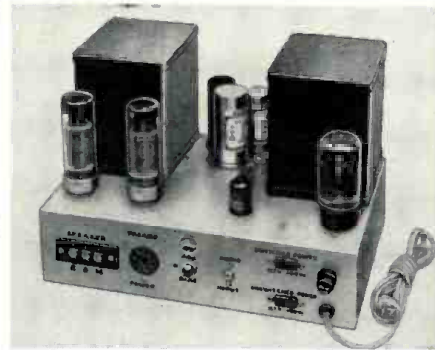

watts of peak power with distortion due to overloading eliminated dynamically.

Complete information on this new amplifier is available from the manufacturer.

HEATH AM TUNER KIT

Heath Company, Benton Harbor, Michigan has come up with a new AM tuner kit which has been especially designed for use with high-fidelity systems.

The BC-1 provides broad bandwidth while maintaining good sensitivity and selectivity. In addition, a special volt-



age doubler detector employing crystal diodes is used for low distortion even at high modulation levels.

Audio response of the unit is ± 1 db from 20 to 20,000 cps with 5 db of pre-emphasis at 10 kc. to compensate for station roll-off above 5 kc. Frequency coverage is from 550 to 1600 kc. and the i.f. bandwidth is 20 kc.

In addition the tuner incorporates a 10 kc. whistle filter, 6 db signal-to-noise ratio at 2.5 μ v., pre-aligned r.f. and i.f. coils, and the need for only three minor trimmer adjustments.

The physical dimensions and color styling of the BC-1 match the company's models WA-P2 and FM-3.

ALTEC P.A. AMPLIFIER

Altec Lansing Corp., 9356 Santa Monica Blvd., Beverly Hills, California is currently marketing a new 20-watt p.a. amplifier which has been designated as the 342A.

The new unit will mix four inputs

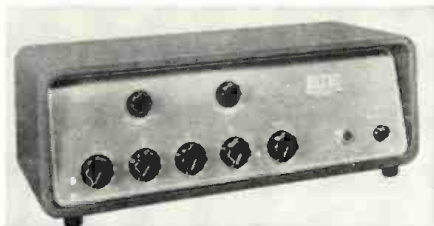

simultaneously and incorporates an "input-matcher" for maximum flexibility. Any combination of four sources can be plugged in and with the "input-matcher" the unit is matched exactly

to the specific needs of each source.

The amplifier can handle any high- or low-impedance microphone, crystal or magnetic phono pickup, tuner, or tape recorder. The d.c. operation of the input tube heaters insures hum-free performance and eliminates the need for hand picking the tubes. It also provides individual volume control for each of the four inputs, a master volume control, and separate bass and treble tone controls, all mounted on a slanted panel for easy operation and visibility.

Write Dept. RV-4 for full details on this unit.

PACKAGED TRANSISTOR AMPS

Centralab, a division of Globe-Union Inc., 900 E. Keefe Avenue, Milwaukee 1, Wisconsin has developed a new packaged transistor amplifier which has been designed especially for use in hearing aids, pocket-sized radios or recorders, computers, etc., or wherever an ultraminiature, high-gain audio amplifier is required.

Both three- and four-stage packages are currently available. The three-stage unit measures .890" x .670" x .250" while the four-stage version measures 1.175" x .665" x .250". The base plate is of grade L-5A low-loss steatite as per JAN-1-10.

A data sheet giving complete specifications, frequency response, and a schematic is available upon request to the company.

TRANSISTORS FOR AUDIO

The Lansdale Tube Co., a division of Philco Corporation, Lansdale, Pa. is now offering three new medium power

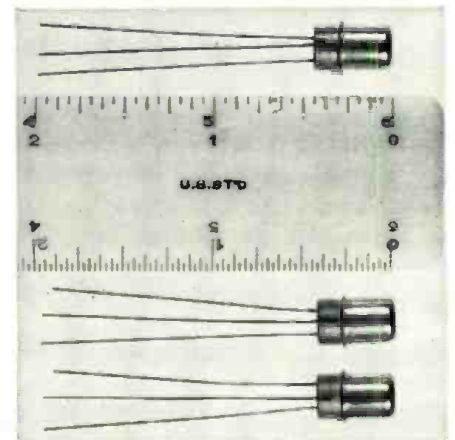

transistors which have been especially designed for use in the audio stages of transistorized radios.

Designated as the 2N233, 2N226, and 2N224, these new hermetically sealed, p-n-p transistors provide up to 300 mw. audio output at battery supply voltages of 3 to 12 volts in driver and class B push-pull operation.

FISHER AMPLIFIER

Fisher Radio Corporation, 21-23 44th Drive, Long Island City 1, New York has added a new master control amplifier to its line of high-fidelity components.

The Model CA-40 combines on a single chassis a 25-watt amplifier and

an advanced-design preamp. The unit features six inputs, six equalization facilities, the firm's "ToneScope" to provide a graphic indication of tone control settings, a four-position loudness contour control, and rumble and noise filters to suppress turntable rumble, FM hiss, or extreme record scratch.

Frequency response of the amplifier

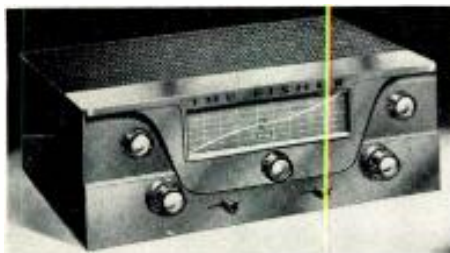

is constant within ± 5 db from 10 to 90,000 cps, with hum and noise virtually inaudible 90 db below full output. Balanced spectrum bass and treble controls provide 15 db boost or cut. The unit has 4, 8, and 16 ohm speaker outputs, plus a cathode-follower output for a tape recorder.

AMPLIFIER-PREAMP KIT

Radio Kits Incorporated, 120 Cedar Street, New York is now marketing a linear Williamson-type amplifier-pre-amplifier kit, the Model FL-10.

Frequency response is 40 to 15,000 cps with a power output of 12 watts $\pm 1\%$ IM distortion. Peak power output is 18 watts. Output impedances of 4, 8, and 16 ohms are provided.

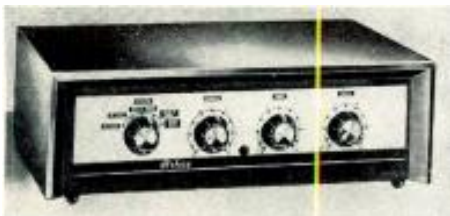

Record equalization for LP, RIAA, and Eur. records is provided. A pink gold panel and black cabinet makes the finished unit decorative enough to be used in any home. The entire unit measures 12½" wide, 4" tall, and 8½" deep.

Complete instructions for assembling this kit are included with the unit and are explicit enough to make the assembly easy even for the layman.

SLIDE FOR CHANGERS

Steel Slides, Inc., 1 Lawton Street, Yonkers, New York has developed a new sliding device for record changers and tape recorders which makes it possible to pull these units out to their full depth, providing easy access for proper operation.

The slide is supplied with a newly-developed neoprene mounting for cushioning the transmission of vibration and shock. These cushion-mounted guides also help to maintain a level position of the phono drawer for its full length of travel.

Dept. SS310-12 will supply full details, delivery data, and prices on these slides.

-30-

August, 1956

ENGINEERED

for those who expect much

PRICED

for those who must buy many

the
PRECISION
model

68
VTVM

METAL CASED

RUGGED



- **Peak-to-Peak Voltage Ranges**

up to 3200 volts peak-to-peak

- **Extra-Large 5¼" Wide-Angle Meter**

easy-reading, long scales

- **High-Impedance Voltage Ranges (AC and DC)**

up to 1200 volts

- **Measures Resistance up to 1000 Megohms**

in 5 overlapping ranges

- **Zero-Center Reference Ranges**

simplify FM discriminator balancing

Model 68: In rugged, blue-gray ripple-finished steel cabinet. Size 5⅞" x 7¾" x 3½". Complete with tubes, internal ohmmeter battery and detailed instruction manual. Net Price.....\$54.50

Accessories Available for Models 68 & 78

RF-12 High Freq. Probe.....Net Price: \$10.95

TV-4 High Volt. Probe.....Net Price: 14.75

Send for free 1956 catalog with detailed descriptions and specifications of the entire PRECISION line of test instruments for industry and electronic service-maintenance.



Model 78

Battery-Operated
VTVM

A must where power line is not available or where power line connection is undesirable. Provides every modern VTVM function. Metal cased. Rugged.

Net Price \$62.50
(including Batteries)



PRECISION Apparatus Company, Inc.

70-31 84th Street, Glendale 27, L. I., N. Y.

Export: 458 Broadway, New York 13, N.Y., U.S.A. • Cables: MORHANEX
Canada: Atlas Radio Corp. Ltd. • 50 Wingold Ave., Toronto 10, Ontario



Europe's Largest Selling
Electronic Tubes
Now Available
to the discriminating
American tube buyer
—at standard prices.



not just a
replacement—
but an
improvement



TELEFUNKEN

PIONEER IN ELECTRONICS
SINCE 1903

Write for your Telefunken Tube
Manual and for the name of your
nearest jobber.

Imported exclusively by

**AMERICAN
ELITE, INC.**

Dept. 3
7 Park Avenue
New York 16, N. Y.

What's

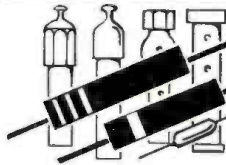

New in Radio

TI SILICON RECTIFIERS

Texas Instruments Incorporated,
6000 Lemmon Avenue, Dallas 9, Texas
has announced five production types

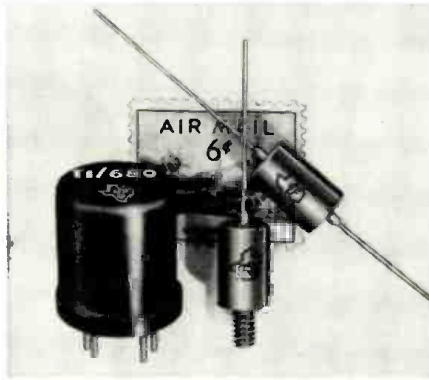

of silicon rectifiers featuring a single
grown junction element with 1500 volt
breakdown voltage.

The new design eliminates the ne-
cessity of using several lower voltage
cells connected in series. Available in
two types of axial and stud half-wave
models and a full-wave plug-in model.
These hermetically sealed rectifiers
eliminate the need for filament power.
The axial models, 1N543 and 1N543A,
allow point-to-point wiring; the Types
1N544 and 1N544A are stud-mounted
for maximum heat dissipation. The
plug-in model, TI/680 can be used in
many applications to replace the JAN
6X4 rectifier tube.

Bulletins on these new units are
available on request. Specify the type
of unit required.

POLARITY-REVERSING PROBE

Futuramic Company, 2500 West 23rd
Street, Chicago, Illinois has announced
the availability of a polarity-reversing
probe for v.o.m.'s.

The Model 263 provides fingertip
control of signal polarity at the flip of

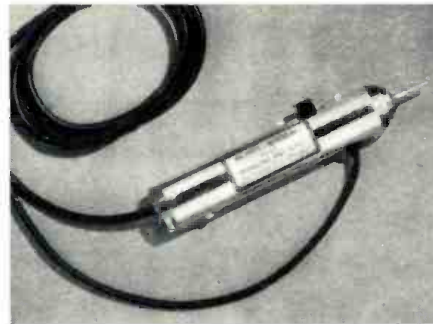

a switch. The miniature switch of slide
construction is mounted in the probe
housing and feeds the signal to the
v.o.m. via a high-flex small diameter
coax cable. The probe housing "floats"

electrically to avoid possibility of
shock to the operator.

It can be used with a 1000, 20,000,
or 100,000 ohms-per-volt meter. Liter-
ature on this and other probes in the
company's line is available on request.

TRANSISTORIZED INTERCOM

The Goldak Company, 1544 West
Glenoaks Blvd., Glendale 1, California
has entered a new field with the de-
velopment of a transistorized intercom
designed for instructor-student use in
light aircraft where noise level is high.

Housed in a laminated-phenolic tube
6½" long and 1" in diameter, the de-
vice consists of a high-gain, low-im-
pedance microphone, a transistor-bat-
tery-operated amplifier, and highly
sensitive rubber-cushioned earphones.
A printed circuit board is used to hold
all the amplifier components including
the battery which is small, inexpen-
sive, and good for over 100 hours. The



printed circuit makes extreme minia-
turization possible and insures trouble-
free performance.

Full details on the "Plane-Talk" will
be supplied by the company on re-
quest.

NIBBLING TOOL

Harrison Radio Corporation, 225
Greenwich St., New York 7, N. Y. is
handling the distribution of a compact,
hand-operated nibbling tool which is
especially suited to the requirements of
service technicians, hobbyists, and ex-
perimenters.

This single tool will cut any shape of
opening in sheet metal, will cut round
or square holes in formed sheet metal
without distortion, and will cut tem-
plates and model parts from thin metal.

The instrument will handle steel up
to 18 gauge and aluminum, copper, or
plastic materials up to 1/16".

D.C. POWER SUPPLY

Electro Products Laboratories, 4500
N. Ravenswood Avenue, Chicago 40,
Ill. has developed a d.c. power supply

RADIO & TELEVISION NEWS

LAFAYETTE SENSATIONAL VALUES! IN COMPLETELY WIRED TEST EQUIPMENT at LESS than the PRICE of KITS!

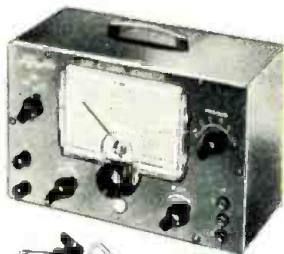

LAFAYETTE SIGNAL GENERATOR
NEVER BEFORE HAS A COMPLETELY WIRED AND TESTED INSTRUMENT OF SUCH ACCURACY AND QUALITY BEEN OFFERED AT SUCH A PRICE!

- FREQUENCY 120 KC TO 260 MC
- 120 KC TO 130 MC ON FUNDAMENTALS
- LABORATORY ACCURACY AND QUALITY

A completely wired and tested instrument not to be confused with units sold in kit form at almost the same price, but with a quality and accuracy of instruments 3 to 4 times its price. Six overlapping ranges generate signals of 120KC - 320KC, 320KC - 1000KC, 1MC - 3.2MC - 11MC, 11MC - 38MC and 37MC - 130MC all on fundamentals with calibrated harmonics from 120MC to 260MC. Selector switch gives instant choice of ranges. Switch gives choice of internal modulation of 400 CPS or use of any external source at other frequencies. For audio testing the 400 cycle signal can be used separately.

22.50

Outputs are unmodulated RF, modulated RF and 400 CPS audio. RF output is in excess of 100,000 microvolts and jacks are provided for choice of either high or low RF output. Stability is insured by special circuit design. Has a fine adjustment RF control. AF output is 2-3 volts, AF input is 4 volts across 1 megohm. Large clear 5 inch etched dial plate and pointer are protected by transparent plastic bezel. Common AF terminals for EXT-MOD input and INT-AF for audio tests eliminate need for special AF output connecto's. Machine engraved panel lettering. Handsome gray metal case with carrying handle. Measures $6\frac{1}{2}'' \times 10'' \times 4\frac{1}{2}''$. Comes complete with pair of leads. AC line cord and plug. Operates on 105-125 750-60 cycle AC. Shpg. wt., 8 lbs.

LAFAYETTE LSG-10 SIGNAL GENERATOR **22.50**

NEW POCKET AC-DC VOM MULTITESTER

2,000 ohm per volt Sensitivity on both DC and AC

160 ua 3" METER
1% PRECISION RESISTORS
SILVER CONTACT SELECTOR SWITCH

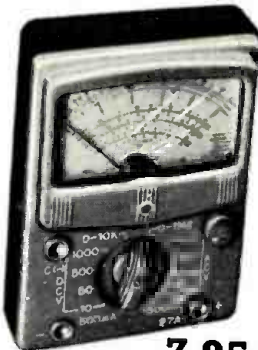

FULL SCALE RANGES
DC Volts: 0-10; 0-50; 0-500; 0-1000 Volts - AC
Volts: 0-10; 0-50; 0-500; 0-1000 Volts-DC Current:
500 ua and 500 ma
Resistance: 0-10K; 0-1 Meg
Decibels: -20 to +22;
+20 to 36 db (0 db - 0.775 V) - Capacity: 250 mmfd to .2 mfd - .005 mfd to 1 mfd - Output Ranges:
0-10; 0-50; 0-500; 0-1000 volts

7.95

Best Buy in America! A very accurate and sensitive VOM. This Multitester is a complete instrument (not a kit) with high quality and sensitive 160 microamp meter; 2000 ohm per volt on both AC and DC. Single selector switch, 1% accuracy resistors, 3" meter. Features extreme versatility, with metal bottom for ruggedness and shielding. Front panel, city range requires 50 volt AC source. Second capacity range requires 10 volt AC source. Size $4\frac{1}{4}'' \times 3\frac{1}{2}'' \times 1\frac{1}{8}''$. Complete with test leads and batteries. Shipping weight, 4 lbs.

RW-27A Complete **7.95**

NEW!

LAFAYETTE CAPACITANCE-RESISTANCE TESTER WITH "IN-SET QUICK CHECK"

COMPLETELY WIRED AND TESTED



- TWO INSTRUMENTS IN ONE
- CHECKS ELECTROLYTIC, PAPER, MICA AND CERAMIC CONDENSERS
- 4 DIRECT READING CAPACITY SCALES FROM .00001 MFD TO 1000 MFD
- CHECK FOR OPEN SHORTS, LEAKAGE AND INTERMITTENTS
- 2 RESISTANCE RANGES FROM 100 TO 5 MEGOHM

Here is a "must" for servicemen and lab technicians. A completely self-contained AC operated capacitance and resistance bridge, plus a quick check for in the set testing. Large 5 direct reading scale has 4 ranges of .00001 - .005 MFD, .001 - .5 MFD, 1 - 50 MFD and 20 - 1000 MFD. Resistance ranges are 100-50,000 OHMS and 10,000 to 5 megohm. Quick check feature enables you to check capacitors for shorts, open or intermittent while in circuit - no need to remove them from the set till you're sure they need replacement. Leakage test switch gives

34.50

you choice of 25, 150, 250, 350 or 450 volts for checking leakage under correct potential. Separate power factor control with continuous settings from 0 to 50%. Operation is simple and accurate, using a magic-eye tube as the null detector. Attractively finished steel case with etched panel and rounded corners, measures $14\frac{1}{2}'' \times 8\frac{1}{4}'' \times 5''$ D. Shpg wt. 19 lbs.

MODEL LC-4 NET **34.50**

NEW!

LAFAYETTE CAPACITOR-RESISTANCE TESTER

COMPLETELY WIRED AND TESTED



21.50

- COMPLETELY WIRED AND TESTED
- CHECKS ALL TYPES OF CONDENSERS FOR CAPACITY, LEAKAGE, OPEN SHORTS OR INTERMITTENT CONDITION
- DIRECT READING SCALES FROM .00001 TO 1000 MFD AND 100 TO 5 MEGOHMS

A stable and accurate bridge type circuit measures capacitance in 4 ranges of .00001-.005 MFD, .001 to .5 MFD, .1 to 50 MFD and 20 to 1000 MFD. Two resistance ranges of 100-50,000 and 10,000 to 5 megohms. Check leakage under actual load with choice of 25, 150, 250, 350 or 450 volts available by selector switch. Power factor control from 0 to 50%. Checks for leakage, open short, or intermittent operation. All readings taken directly off scales after setting magic eye to maximum. Completely self-contained power supply. Attractively finished steel case with rounded corners and etched panel. Operates from 110V AC. Size $9\frac{3}{8}'' \times 7\frac{1}{8}'' \times 5\frac{1}{4}''$ D. Shpg. wt. 10 lbs.

MODEL LC-15 NET **21.50**

HIGH SENSITIVITY 20,000 OHM PER VOLT DC 10,000 OHM PER VOLT AC MULTITESTER

LOOK AT THESE FULL SCALE RANGES!



D.C. Volts: 0-6; 0-30; 0-120; 0-600; 0-1200; 0-6000 Volts - A.C. VOLTS: 0-6; 0-30; 0-120; 0-600; 0-1200 Volts - RESISTANCE: 0-10K; 0-100K; 0-1 Meg; 0-10 Megohms - D.C. CURRENT: 0-60 Microamp; 0-6; 0-60; 0-600 Milliamps - DECIBEL: -20 to +17 db (0 db - 0.774V) - CAPACITY: .0001-.01; .005-.15 mfd - INDUCTANCE: 20-2000 millihenry - OUTPUT RANGES: 0-6; 0-30; 0-120; 0-600; 0-1200 Volts

The new Lafayette high sensitivity Multitester is a complete instrument (not a kit). In addition to its unusual sensitivity of 20,000 OHMS PER VOLT ON D.C. AND 10,000 OHMS PER VOLT ON A.C., and the extraordinary number and scope of its ranges, it is packed with features that would make it

cost at least twice as much if made in this country. Uses 35 ua 3" meter. Dependable, rugged and accurate. Even the test leads are heavy duty with high voltage insulation. Voltage source required for low capacity range is 120V A.C. for high range capacity and inductance scale is 6V A.C. Attractive plastic front with metal bottom. Size $6\frac{1}{4}'' \times 4\frac{3}{4}'' \times 2\frac{1}{2}''$. Complete with batteries and leads. Shipping weight $4\frac{1}{2}$ lbs.

RW-30A Singly, Each **19.95**
In lots of 3, Each **19.25**

PROFESSIONAL TRANSCRIPTION TURNTABLE AND VISCOUS-DAMPED TONE ARM

THE FINEST TRANSCRIPTION TURNTABLE AND TONE ARM FOR THE PROFESSIONAL USER AND THE AUDIOPHILE



COMBINATION DEAL
TURNABLE AND TONE ARM
59.50

TAX ABOVE WITH GE RPX, OSTA DIAMOND and SAP. PRICE Col-age
72.50

PK-100 TRANSCRIPTION TURNTABLE

New 3-speed instrument to delight the connoisseur, is precision engineered to provide dynamic balance and "wow-free" operation. A heavy-duty, constant speed 4-pole induction motor has a variable speed control to permit instant adjustment of the individual speeds to within $\pm 7\%$ to compensate for power source voltage variations. The motor is freely suspended and isolated by shock-mountings to eliminate vibration transfer. The heavy, cast aluminum turntable is rim-driven and has an extra-heavy rim for smooth, effective flywheel action. Idler disengaged in "off" position. Meets professional standards for wow, flutter content, etc. Size: $13\frac{1}{2}'' \times 14''$ and requires $2\frac{3}{4}''$ clearance above and $3\frac{3}{4}''$ below motorboard. For 110-130V 60/50 cycle AC. Supplied with removable 3-speed stroboscopic disc and 45 rpm adapter. Handsome hammertone gray finish. Shpg. wt., 20 lbs.

Net **49.50**

PK-90 VISCOUS-DAMPED TONE ARM

This transcription arm assures dependable and stable operation, utilizing the "floating action" principle of "viscous-damping." The arm is supported at a single point by a jewel bearing having negligible friction. Damping is accomplished by a silicone fluid occupying the gap between a ball and socket. This damping control permits high compliance and negligible tracking error, and prevents damage to either record or stylus should the tone arm be accidentally dropped. Low frequency resonance, skidding and groove-jumping are likewise minimized. The tone arm accepts all records up to 16" and accommodates virtually all hi-fi cartridges by means of precisely engineered adapters which simplify installation and provide proper stylus pressure.

This tone arm is a quality companion to the PK-100 with matching finish. Shpg. wt., $2\frac{1}{2}$ lbs. Net **19.50**

LAFAYETTE RADIO DEPT RH

100 SIXTH AVE., NEW YORK, N. Y.

Write for FREE Bargain Packed Catalog!

BOSTON, MASS., 110 Federal St.
PLAINFIELD, N. J., 139 West 2nd St.
NEWARK, N. J., 24 Central Ave.
BRONX, N. Y., 542 E. Fordham Rd.

**All Tubes Unconditionally Guaranteed
For 1 Year**

PRETESTED TUBES			INDIVIDUALLY BOXED		
024	6AC7	6BK5	6SK7GT	12AL5	12SQ7
1B3GT	6AG5	6BK7	6SL7GT	12AT7	12SR7
1H5GT	6AG7	6BL7GT	6SN7GT	12AU6	19B6GG
1LC5	6AF4	6BQ6GT	6S07	12A07	25BQ6GT
1LN5	6AK5	6BQ7	6SR7	12AV6	25L6GT
1N5GT	6AL5	6BY5G	6T8	12AV7	25W4GT
1Q5GT	6A05	6BZ7	6U8	12AX4GT	25Z5
1R5	6AS5	6C4	6V3	12AX7	25Z6GT
1S4	6AT6	6CB6	6V6GT	12BA6	35B5
1S5	6AUG	6CD6G	6W4GT	12BA6	35C5
1T4	6AU5GT	6F6	6W6GT	12BE6	35L6GT
1T5GT	6AV5	6H6GT	6X4	12A27	35L6GT
1U4	6AV6	6J5GT	6X5GT	12BH7	35W4
1U5	6AX4GT	6J6	6Y6G	12BY7	35Y4
1X2	6AT6	6K6GT	7C5	12SA7	35Z5GT
3Q4	6AM4GT	6L6	7C6	12SG7	50A5
3S4	6BA6	6S4	7E7	12SJ7GT	50B5
3V4	6BC5	6S8GT	7F7	12SK7	50C5
5U4G	6BE6	6SA7	7F8	12SL7GT	50L6GT
5V4G	6BG6G	6SH7	7N7	12SN7GT	11Z23
5Y3	6BJ6	6SJ7GT			
6AB4					

Now Get Up to \$5 For Your Old TV Tube!



upon the purchase of a
**BRAND NEW
DUMONT or RCA lic.
PICTURE TUBE**

Ship dud freight prepaid . . . If you supply dud, deduct from the list prices as follows:

10"-14"—\$2 | 15"—\$2.50 | 16"-17"—\$3.50 | 19"—\$4 | 20"—\$4.50 | 21"—\$5

Prices indicated below are without trade-in.

10BP4	\$10.95	15DP4	\$16.95	16RP4	\$17.00	19AP4	\$23.00
12LP4	12.95	16DP4	18.50	17PB4	19.00	20CP4	24.00
12QP4	12.95	16GP4	18.95	17GP4	21.00	21ALP4	24.00
14CP4	14.95	16KP4	17.00	17LP4	18.00	21EP4	24.00

Picture Tubes Shipped F.O.B. Passaic, N. J.
Shipped Via Railway Express Dept. MR-7 PRescott 3-0330

TUBE MART

The Lokpet Bldg. Passaic, N. J.

**NEW QUICK
24 HOUR
SERVICE
AVAILABLE!**

**ANY
ASSORTMENT
RECEIVING
TUBES
41¢
ea.**

Quantity Buyers!

100 Tubes — \$38.00

FREE POSTAGE on all prepaid Continental U. S. A. orders. 25c handling charge on all orders under \$5.00. 25% Deposit on all C.O.D.'s. Subject to prior sale. Write for FREE TUBE LIST!

which has been especially designed to operate, test, and service transistor auto radios.

The Model D612T operates on a.c. input and handles 6/12 volt tube radios as well as the transistor models. The circuit incorporates a new filter that keeps the a.c. ripple below the critical level for testing of transistor auto radios. Heavy-duty components and a patented conduction cooling system combine to provide a greater current carrying capacity and many more times the cooling surface of standard selenium plates. The new unit can also be used to service or operate aircraft and marine radios, phone circuits, and relays.

Full details are available from R. C. Crossley, sales manager of the company.

PRECISE TUBE TESTER

Precise Development Corporation of Oceanside, Long Island, New York is now in production on an ultra-fast tube checker which is capable of performing both emission and mutual conductance tests for most tubes.

According to the company, it is possible to check five tubes in four sec-



onds merely by rotating a switch. The five tubes can be plugged in at once and tested separately.

The Model 116 will also check transistors, gas, life, and even the individual sections of multi-purpose tubes. The checker is available in either kit or factory-wired form.

IN-CIRCUIT CAPACITOR CHECKER

Simpson Electric Company, 5200 W. Kinzie Street, Chicago 44, Illinois is now in production on a new in-circuit capacitor tester which is designed to cut the servicing time involving this component by as much as 75 per-cent.

The Model 383-A "Capacohmeter" allows radio and TV technicians to locate seven out of ten faulty capacitors without removing them from the circuit. Capable of testing both shunted and coupling capacitors, the new unit can be used with paper, mica, and ceramic capacitors. Capacitance is indicated directly on the meter scale over a range of 10 μ fd. to 10 μ f.

A unique pulse test provides a sharp-fronted a.c. pulse across the capacitor and its associated resistance. Any substantial d.c. leakage is indicated directly on the meter dial. Leakage up

The **NEW YEATS "Shorty"**
**STATION WAGON & PANEL
PICK-UP APPLIANCE DOLLY**



Only 47" tall, this new Yeats dolly is designed for TV and appliance men who make deliveries by station wagon or panel delivery. No need to detach appliance for loading... the YEATS "Shorty" will slide into your vehicle with ease. Has same aluminum alloy frame, 30 second strap ratchet and caterpillar step glide as the standard size YEATS dolly! See your dealer today!

YEATS "Everlast" COVERS & PADS



SEND postcard for full information on our complete line TODAY!

YEATS appliance
dolly sales co.
2101 N. 12th St. Milwaukee 3, Wis.

REPEAT SALE

General Electric Clip-in Golden Treasure
RPX-052A, Boxed.....\$17.95 prepaid

SUMMER SPECIAL

LATEST MODEL VM 710 Dual speed, Dual Track
TAPE RECORDER. REG. PRICE \$189.50.

NOW \$135.50
PREPAID IN U.S.A.

STOP... 6 TRANSISTOR PORTABLE RADIO...

Complete with batteries, in leather case.

AMERICAN MADE.....ONLY **\$46.50**

NOT A KIT

Will play in the most difficult locations

THOUSANDS SOLD

"Understanding High Fidelity"

By L. Biancolli and L. H. Bogen

A MUST for the Hi-Fi enthusiast, novice or expert. 3rd Edition only 35c incl. postage and handling.

NOW—learn any of these languages . . .

SPANISH, ITALIAN, FRENCH OR GERMAN. Includes 4 LP Records with Dictionary and Conversation Book. . . . If you are studying any of these languages or want a refresher course, this \$29.95 Bargain is a SUPER BUY AT **\$9.95** per Set. (Allow for Postage . . . Please.)

COMPLETE LINE OF HI-FI COMPONENTS

Write us your requirements today. Shipments prepaid and insured.

SOUNDMART UNLIMITED, Inc.

63-03 39th Ave. Woodside 77, N. Y.
Retail Store, 169 West 57th St., New York 19, New York

to 400 megohms can be detected in coupling capacitors by means of the instrument's "three-lead" test.

Write the manufacturer direct for full details on this test instrument.

"ROBOTAPE"

Oakton Engineering Corporation, 725 Oakton Street, Evanston, Illinois has developed an endless tape-playing device which has been designed for use as an automatic demonstrator, teacher, or salesman.

Housed in a functional steel box which measure 10" x 8" x 7", the "Robotape" incorporates five controls (a locking volume control, separate selector switch with power "on-off," standby, manual operation, and automatic operation). The tape speed is 3 3/4 ips providing a maximum playing time of 17 minutes. A subsonic signal on the tape can be used to trigger any synchronous action.

Write the manufacturer for full details on this point-of-sale and demonstration device.

TRIODE-PENTODE CONVERTERS

The Tube Department of Radio Corporation of America, Harrison, N. J. has released two new 9-pin miniature type receiving tubes, each containing a medium- μ triode and a sharp cut-off pentode in one envelope.

The tubes have been designed especially for use as a combined oscillator and mixer tube in TV receivers utilizing an i.f. on the order of 40 mc.

The Types 5CG8 and 6CG8 can also be used with AM-FM receivers. The pentode unit may be used in the AM section as a pentode mixer to provide high gain and in the FM section either as a pentode mixer or as a triode-connected mixer depending on signal-to-noise considerations. The triode unit of these tubes makes a satisfactory oscillator for either the AM or FM section.

COLOR TV SCOPE

Electronic Measurements Corporation, 280 Lafayette Street, New York, N. Y. has added a new color television



oscilloscope to its line of service test equipment.

The Model 601 is available in either kit or assembled form and features a full 5 mc. bandwidth for color TV serv-

icing. The d.c. positioning controls provide instantaneous trace positioning without bounce or overshoot. The push-pull vertical amplifier has a sensitivity of .02 volt per inch. A retrace blanking amplifier eliminates confusion and gives clearer pictures. This model uses a two-step compensated attenuator input.

Full details and prices on the two versions of the Model 601 are available from the manufacturer on request.

MICROWAVE RELAY SYSTEM

A new and compact 2000 mc. microwave relay system for TV broadcasters has been put on the market by the Broadcast Equipment Section of General Electric Company, Syracuse, New York.

The new relay unit combines, for the first time, outputs of separate aural and visual transmitters into a common antenna.

Designed to be used at program-point-of-origin, either remote or studio operation, the complete system weighs less than 200 pounds. It comprises two transmitting and two receiving units and two parabolic antennas. The new system can be used for either black-and-white or color transmissions.

DARK TRACE TUBE

Skiatron Electronics & Television Corporation, 180 Varick Street, New York, New York has announced the development of a dark trace tube which is said to retain an image in-

Newest



each. Includes all data needed for quicker TV servicing. Factory service material simplifies repairs. Practically tells you how to find each fault and make the repair. More pages, more diagrams, more information per dollar of cost. Get the best for less. Get SUPREME.



TELEVISION SERVICING COURSE

Let this new course help you in TV servicing. Amazing bargain, complete, only \$3, full price for all lessons. Giant in size, mammoth in scope, topics just like a \$200.00 correspondence course. Lessons on picture faults, circuits, adjustments, short-cuts, UHF, alignment facts, hints, antenna problems, trouble-shooting, test equipment, picture analysis. Special, only **\$3**

Companion RADIO COURSE, Introduction to TV

Here is your complete radio training in 21 easy-to-follow lessons. Covers fundamentals, fault finding, use of test equipment. Everything in radio. Introduction to TV. Self-test questions. New edition. Special, only... **\$2.50**

Just Out



RADIO DIAGRAMS

Here is your complete source of all needed RADIO diagrams and service data. Covers everything from the most recent 1956 radios to pre-war old-timers: home radios, auto sets, combinations, changers, FM, and portables. Sensational values. Only \$2 for most volumes. Every manual has extra large schematics, all needed alignment facts, parts lists, voltage values, trimmers, dial stringing, and helpful hints. Volumes are large in size, 8 1/2 x 11 inches, about 100 pages. See coupon at right for a complete list of these radio manuals. ->

New SUPREME 1956 TV Manual

AMAZING BARGAIN

COVERS ALL POPULAR SETS

Here is your service data for faster, easier TV repairs. Lowest priced. Best by comparison. *Supreme TV* manuals have all needed service material on every popular TV set. Helpful, practical, factory-prepared data that will really make TV servicing and adjustment easy for you. Benefit and save with these amazing values in service manuals. Only \$3 per mammoth volume. The choice of wise servicemen.

SIMPLIFIES TV REPAIRS

These giant TV manuals have complete circuits, alignment facts, response curves, service hints, factory production changes, voltage charts, waveforms, and double-page schematics. Here are your authentic service instructions to help you do expert work quicker; and priced at only \$3 per large yearly manual. Repair any TV model ever made by having in your shop all 10 volumes as listed in coupon. Your special price for all, only \$30. Or try the new 1956 TV manual to see what an amazing bargain you get for \$3. Send no-risk trail coupon today.



The repair of any television set is really simple with *Supreme TV* service manuals. Every set is covered in a practical manner that will simplify troubleshooting and repair. This is the help you need to find toughest faults in a jiffy. Each \$3 TV volume covers a whole year of service material. New *Television Servicing Course* will aid you in learning TV. Be wise, buy *Supreme Manuals* only once each year instead of spending dollars every week.

NO-RISK TRIAL ORDER COUPON

SUPREME PUBLICATIONS, 1760 Balsam Rd., Highland Park, ILL.

- Radio Servicing Manuals**
 Most-Often-Needed Series
 1956 Radio Manual, \$2.50
 1955 Radio Manual, only \$2
 1954
 1953
 1952
 1951
 1950
 1949
 1948
 1947
 1946
 1942
 1941
 1940
 1939
 1926-1938 Manual, \$2.50
 Radio and TV Master Index, 25c

- Rush today TV manuals checked below and Radio manuals at left. Satisfaction guaranteed.
 New 1956 Television Servicing Manual, only . \$3.
 Early 1955 TV, \$3 Additional 1955 TV, \$3.
 1954 TV Manual, \$3. 1953 TV Manual, \$3.
 1952 Television Manual, \$3. 1951 TV, \$3.
 1950 Television Manual, \$3. 1949 TV, \$3.
 1948 TV, \$3. UHF Converters & Tuners, \$1.50
 New Television Servicing Course, complete... \$3.
 Companion Radio Course (all 21 lessons) . \$2.50

RADIO VOLUMES
 specially priced
 at only
\$2.50
 each.
(THIS GROUP ONLY)
\$2
 EACH

- I am enclosing \$..... Send postpaid.
 Send C.O.D. I am enclosing \$..... deposit.

Name:
 Address:

Supreme Publications
 Sold by All Leading Parts Jobbers

Have you had the Chassis Touching JITTERS Lately?



Adjust-A-Volt

LR-5 VARIABLE TRANSFORMER

with isolated primary winding lets you service any TV or radio set made without a chance of a "bite" no more chassis touching jitters.



\$29.50

Delivery from stock of your favorite jobber.

This husky 1/2 KVA electro-statically shielded unit is "Must" test equipment for thousands of service men. Intermittent operating TV or radio sets are checked by dropping line voltage to 105 V or lower to detect a faulty oscillator. Also used to cook a set at 130-140 V to break down intermittent part. On any application where either isolation or a variable transformer is needed Adjust-A-Volt will do the job. Black wrinkle finish, jeweled pilot light and convenient fuse. Write for new 18-page catalog listing all types and sizes.

**STANDARD
ELECTRICAL PRODUCTS CO.**

2238 E. THIRD ST. • DAYTON, OHIO

definitely or until deliberately erased electronically.

With it a moving television image can be "frozen" and held as a "still" for study. Image retention applies even when the tube is disconnected from all circuitry and stored.

The new tube can be used with the company's specially developed projector which will throw an enlarged radar or television image on a screen up to 16 by 16 feet square. With the dark trace tube, virtually any size group study of a still radar projection is feasible. Although the tube was originally developed for radar, it is now being used at many airports throughout the country in air traffic control systems.

RAM FLYBACK

Ram Electronics Sales Co., South Buckhout Street, Irvington-on-Hudson, New York is now marketing a new flyback transformer, the X128.

This unit is a composite transformer which is an exact replacement for

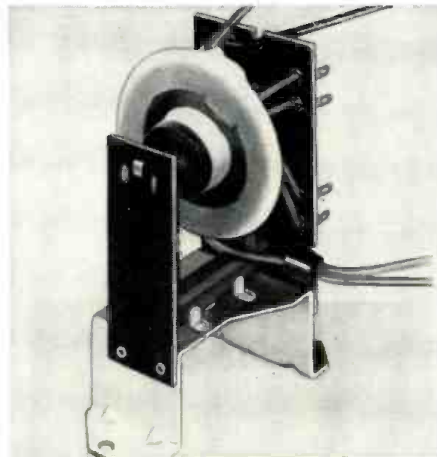

RCA flybacks 78201, 78810, 79145, 79736, 79870, and 100860. This covers 82 chassis and 194 models.

The flyback operates in both 66-70 and 90 degree horizontal output sweep systems and will deliver anywhere from 13 to 17 kilovolts, depending upon its specific application, under normal load conditions. It is characterized by a U-type mounting bracket.

UTILITY CABINET LINE

Perfect Manufacturing Company, 102 Westport Ave., Norwalk, Conn. is offering a new and improved utility cabinet which has been designed espe-

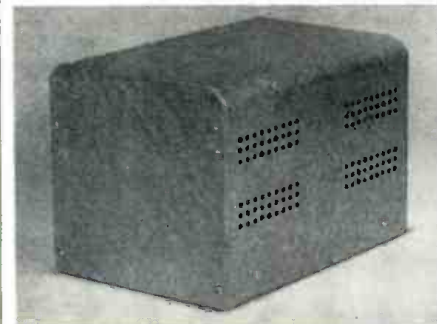

cially for amateurs for housing converters, power supplies, mobile units,

AMATEUR CRYSTAL Headquarters

CRYSTAL HOLDER DATA

FT-243 and FT-241-A holders have 1/2" pin spacing (2 of either of these crystals will plug into any standard octal tube socket). DC-34 holders have 3/4" pin spacing-sockets available when ordered with crystals, each at **25¢**

NOVICEBAND

80 meters within 1 kc of specified frequency—3701 to 3749 kc in DC-34 or FT-243 holders—(specify holder wanted) **79¢**

40 METERS

From 7152 to 7198 kc within 1 kc of specified frequency in FT-243 holders only **79¢**

2-6-10-15-20-40-80 Meter Ham Bands in DC-34 or FT-243 holders (specify holder wanted) **79¢**

STOCK CRYSTALS

Send postcard for free list of frequencies. FT-241, DC-34, FT-243, FT-171, each **50¢**

SPECIAL CRYSTALS

Crystals ground and etched to exact frequency, using electronic counter, in FT-243 holders with 1/2" pin spacing. From 3000 kc to 9000 kc.

.05% tolerance \$1.35 ea., .01% tolerance \$1.50 ea.
.005% tolerance \$2.50 ea.

Crystals ground and etched to exact frequencies in DC-34 holders with 3/4" pin spacing. From 1691 kc to 4600 kc.

.05% tolerance \$1.35 ea., .01% tolerance \$1.50 ea.
.005% tolerance \$2.50 ea.

STOCK CRYSTALS

In FT-243 holders—5675 kc to 8650 kc in 25 kc steps each, **50¢**

FT-241 LATTICE CRYSTALS

In all frequencies from 370 kc to 540 kc—50¢
500 kc Crystals—\$1.00 455 kc Crystals—\$1.00

Texas Crystals

The Biggest Buy in the U.S.

8538 W. GRAND AVENUE • RIVER GROVE, ILL.
ALL PHONES—GLADSTONE 3-3555

Terms: All items subject to prior sale and change of price without notice. All crystal orders MUST be accompanied by check, cash or M.O. WITH PAYMENT IN FULL. NO C.O.D.s. Postpaid shipments: made in U.S. and possessions only. Add 5¢ per crystal for postage and handling charge.

monitors, v.f.o.'s, TVI filters, oscillators, etc.

Tradenamed "The Hamcab," the new line is available in seven standard sizes ranging from 5" x 5" x 7" up to 11" x 7 1/4" x 9". The housing is a combination cabinet and chassis which is constructed of sturdy aluminum and finished in silver gray hammertone. Components can be mounted permanently on the back panel if desired. All inside surfaces of the chassis are unfinished to insure proper electrical contact for good grounding.

Literature on this new line is available upon request to the company.

SYLVANIA TV CHECK TUBE

Sylvania Electric Products Inc. recently introduced a second television receiver check tube which is designed to be used with virtually any television receiver or picture tube from 10 to 27 inches.

Designated as the 8XP4, the new tube is an 8 1/2 inch rectangular type

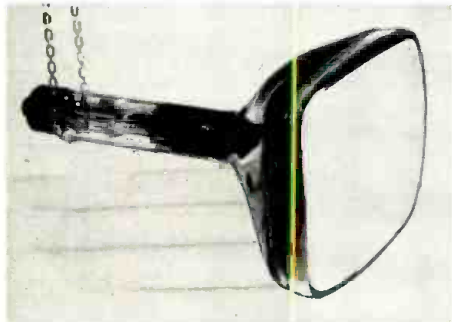

featuring automatic self-focusing and parallel-mounted electron gun, thereby eliminating the need for an ion trap magnet assembly.

As a safety feature, no external conductive coating is used. This eliminates the necessity for "discharging" the tube before handling and is a timesaver in a tube which is to be repeatedly installed and removed in its application as a receiver check tube.

The tube's rated deflection angle is 90 degrees, but when employed in 53 or 70 degree deflection circuits a smaller raster will be obtained.

VIBRATOR TRANSFORMERS

Chicago Standard Transformer Corporation, 3501 West Addison Street, Chicago 18, Illinois has added three new auto radio vibrator transformers to its line, thus raising the total to 34 units, practically all of them exact replacements.

The Stancor P-6490 replaces the Bendix C291787 used in various Ford models while the Stancor P-6494 replaces the Philco 32-8592-1 in new 12-volt radios. These are exact replacement vibrator transformers and require no chassis or circuit alterations when employed in the power supply.

The new P-6491 is a general usage replacement unit for 6-volt primary application. Complete specifications on all of these units are listed in the company's Bulletin No. 514 which is available direct from the firm and from all Stancor distributors.

NEW

PHAOSTRON PROBE-LITE

**ILLUMINATED TEST PROBE
SELF-CONTAINED
SEE WHAT YOU ARE TESTING!**

\$250
LIST

It is just like having an extra hand. Simply insert the probe from your tester into the jack of the Probe-lite and the Probe-lite becomes alive to instantly give you a brilliant, pre-focus spotlight on the area that you are testing plus a long, extra slender, probe tip for making electrical contact in difficult places which previously were inaccessible. It could pay for itself the first time you use it.

GET A FREE PROBE-LITE

If you are the fortunate owner of a Phaostron "555" or "555A" VOM, we will send you a Probe-lite free. Mail us the warranty page you will find in your instruction manual. We will send you a new Probe-lite and return your warranty. Be sure you include your correct name and address.

This offer is good until October 1, 1956.



PHAOSTRON

PHAOSTRON INSTRUMENT & ELECTRONIC CO., 151 Pasadena Avenue, South Pasadena, Calif.

**HARVEY has 'em
...IN STOCK!**

**NEW
REGENCY ATC-1**

**Transistorized
AMATEUR
BAND
CONVERTER**



First and only transistorized amateur band converter available! World's lightest — weighs only 30 ounces! World's smallest — only 4 1/4 by 3 1/4 by 4 1/8 inches! Instantly connects to any receiver — home, mobile car, boat, etc. — to convert it to AM, CW and SSB reception on the 80, 40, 20, 15 and 10 meter amateur bands. Only connections are to an antenna and the receiver's antenna input. When used with a receiver of reasonable sensitivity at 1200 to 1300 Kc, performance is comparable to that of bulky vacuum-tube converters. A simplified "Q" multiplier circuit improves sensitivity and selectivity for AM phone operation. Self-powered by three tiny "Penlight" cells — does not use receiver power. Current drain of only 450 to 600 microamperes gives cells a life expectancy approaching shelf life. Transistor complement: 1—SB-100, 1—2N172, 1—CK 706 diode.

ATC-1, complete with batteries..... **\$79.50**

HARVEY SPECIAL!

**RCA
GEIGER
COUNTER
at 1/2 Price!
BRAND NEW
in Factory-Sealed
Carton**



3-way radiation detection (by meter, neon light and headphone) • Full-vision, easy-to-read meter • Three counting ranges • Handy zero-reset button • Self-contained battery operation (portable radio and flashlight types) • Weather-proof aluminum case (easy to decontaminate in field with damp cloth) • Rugged • Dependable in any climate • Size 8" x 3 1/2" x 7 1/2" • Wt. 5 lbs. inc. batteries
Model WF-10A — Regularly..... **\$119.50**

Harvey Special..... **\$59.75**

VOCALINE

**RADIO
TRANSCIVER
Model
JRC-400**

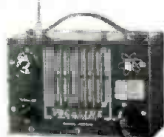

First really low-priced 2-way radio available. Provides satisfactory communication at a distance of up to 10 miles — depending on location and terrain. Amplitude modulated radio telephone operates on fixed frequency of 465 megacycles (Citizens Radio Band). RF power input is 2 watts; power output is 1/3 watt. Self-contained power supply operates on any 115 volt AC outlet or a 6 volt DC power source. Tubes: 6AV6, 6AF4, 6AS5. Weight: 4 lbs. Dimensions: 9" x 6" x 5". FCC approved. **\$69.75**

Single unit, complete with mike..... **\$139.50**

Also available for 12 volt DC (plus 115 volt AC) at same price.

Mail orders shipped same day received. Add estimated shipping charges for total weight, F.O.B., New York, N.Y. Excess, if any, will be promptly refunded.

ESTABLISHED 1927
THRE HARVEY RADIO CO., INC.
103 W. 43rd St., N. Y. 36, N. Y. • JU 2-1500

**Tunable 500 to 1000 Cycle
Bandpass
Filter**

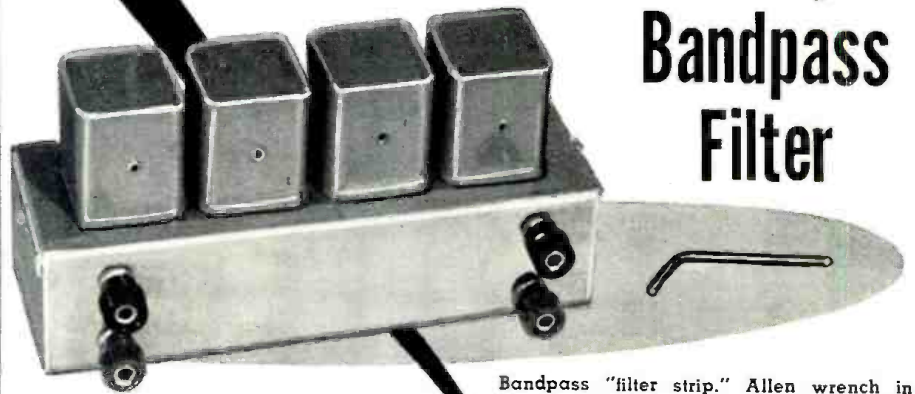

By **RUFUS P. TURNER**

A compact, useful circuit which can be used alone or built into an instrument.

Bandpass "filter strip." Allen wrench in foreground is for pretuning four inductors. Tuning screw access is through cases.

BANDPASS filters find wide application in communications, control processes, bridge measurements, etc., where a single frequency or narrow band of frequencies must be transmitted to the exclusion of adjacent frequencies. Inductance-capacitance filters give the sharpest response but ordinarily are not tunable because of the high-inductance, iron-cored coils required at audio frequencies.

Fig. 1 shows a simple LC-type bandpass filter which may be pretuned to any frequency between 500 and 1000 cycles. The circuit consists of four cascaded parallel LC circuits, each embodying a UTC Type VIC-15 5.4 henry variable inductor shunted by a .005 μ fd. mica capacitor. For maximum selectivity, the tuned circuits are separated by isolating resistors. Other frequency ranges may be obtained by changing the values of C_1 to C_4 . The filter has high input and output impedances and can be d.c.-isolated, if required, by means of 1 to 2 μ fd. capacitors at the input and output.

Insertion loss of the filter is -16 db at the peak of the passband. Fig. 2 shows the frequency response when each of the circuits is peaked to 1000 cycles. Note that the response at one

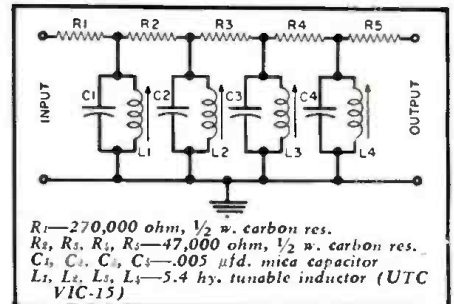

Fig. 1. Circuit of tunable bandpass filter.

octave on either side of maximum transmission is more than 40 db down. If this sharp response is not needed, various amounts of flat-topping may be secured by stagger-tuning the four circuits.

The inductors are tuned by means of an Allen wrench. The tuning screws can be reached through the holes in the front of the inductor cases as shown in the top photo. Built on a 6 1/2" x 2 1/8" x 1 5/8" chassis box, the "filter strip" is small and compact enough to be included in other instruments when desired. Its simplicity can be seen from the underchassis view. The thick metal cans of the inductors shield them effectively against hum pickup and interaction.

When changing the operating frequency, it is a fairly simple matter to peak up the four inductors. The technique is similar to aligning an i.f. amplifier.

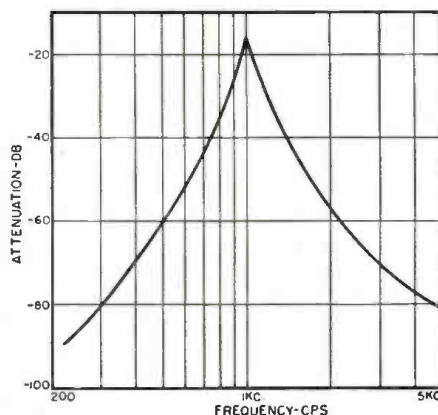
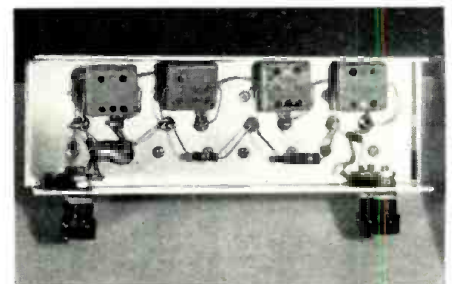

Fig. 2. Frequency response of the bandpass filter tuned to 1000 cycles. See article.

Underchassis wiring of the filter unit.



Antenna News

GIANT DISH

Shown here is a giant dish antenna on its way up to its resting post atop two 100-foot towers. This 3500 pound paraboloidal structure was built by the *Jervold Electronics Corp.* of Philadelphia, Pa., to experiment in pickup of New York channels. It is located in Ventnor, New Jersey, 100 miles from New York City. This is the largest such antenna known to have been built for use in a community TV antenna system. Experimentation is being carried on in conjunction with the *South Jersey TV Cable Co.*, the community system in Ventnor.

The 3500 pound dish, which is as tall and as wide as a 2½-story house, hangs on two hinge pins from the upper brackets of the 100-foot supporting towers. The dish can be angled for pickup of maximum signal. Its di-

ameter is 26 feet and the parabolic curves were cut from ½-inch thick marine plywood and mounted to a



rigidly-braced steel structure. Reflecting wire mesh covers its surface.

NEW WAREHOUSE

Snyder Mfg. Co. of Philadelphia, Pa., through its export division, *Roburn Agencies, Inc.*, announces that it will ship all *Snyder* products destined for the Hawaiian Islands and the Far

East through their new warehouse in the industrial area of Los Angeles. The warehouse, located at 2724 Leonis Blvd., is operated by *Snyder Antengineers, Inc.* of Los Angeles, an affiliate of the parent company. Use of the warehouse will speed up deliveries into the Pacific area and even permit many orders to be delivered by air, if necessary.

8 MILLIONTH ANTENNA

The eight millionth auto radio antenna produced by *Ward Products Corp.*, Div. of the *Gabriel Co.*, 1148 Euclid Ave., Cleveland 15, Ohio, was presented recently to President John Briggs of the parent firm. The gold-plated telescopic antenna mounted on a mahogany base was presented by Donald Blech, the sales manager; Robert Hood, plant manager; Muggs Pugh, sales representative; Pat Leone, vice-president of manufacturing, and William Rickards, director of engineering.

At the same time, the antenna firm reported that it was going into quantity production on coaxial cable with a shield of aluminum foil in place of conventional braided copper wire. The foil is securely wrapped with rayon threads and crisscross strands of wire.

BC-1158 TRANS. & MODULATOR:

Frequency coverage 53.3 to 95 MC 50 Watt. RF Doubler. Amplifier, and Modulator Sections, using 4/815 and 10/12SM7 Tubes. Can be converted to 2-6-10- or 20 Meters. Complete with Tubes, Meter, Blower. NEW: \$39.95 Used: \$29.95

DYNAMOTORS & GENERATORS:

INPUT VOLTS:	OUTPUT VOLTS:	MA.	STOCK No.	PRICES USED:	NEW:
12 VDC	220	80	DM-34	\$2.95	\$ 4.95
12	625	225	DM-35	9.95	12.95
12	230	90	PE-133	4.95	6.95
12 or 24	540	450	DA-12		14.95
12 or 24	230	100	DA-13		8.95
14	220	70	DM-24	4.95	7.95
14	1030	260			
	515	215	DM-42	4.95	9.95
14	375	150	BD-83	3.95	4.95
14 VDC	330	150	BD-87	3.95	5.95
14	250	50	DM-25	6.95	8.95
14	1000	350	BD-77	14.95	20.95
24	250	60	PE-86		8.95
28	1000	350	PE-73	8.95	

12 to 24 VDC PM Dynamotor—Supplies 24 VDC 2 A. from 12 VDC, also 500 V 50 MA. @ 6 VDC will supply 12 VDC & 250 V 50 MA. NEW: \$4.95

METERS:

WESTON AC AMMETER:

(Pictured) In portable leather case, with Test Leads, 2½", 0-15 AC and 0-3 AC Scale. NEW: \$5.95



DC AMMETER HOYT: In portable metal case, with Test Leads, 4½", Fan Mirrored Scale 0-15 ADC. DB METER—10 to Plus 6, Westinghouse 3". NC-35 Imp. 600 ohms @ 1000 cycle 4.95
0-1 MA Weston 506: 2½" Rd. 3.95
0-3 RF AMMETER IS-128: 2½" Rd. NEW: 2.95
0-8 Amp RF w/ Thermocouple IS-85: 2½" Rd. 4.95
0-15 AC-DC—2½" Rd.: IS-122 4.95
0-500 MA DC—2½" Rd.: IS-22 4.95
0-150 V, 60 cycle: Simpson: 3½" R.I. 3.95
0-250 MA DC—DeJur. 3" Sq. 3.95
OUTPUT—5 Ranges, 4000 ohm Imp.—Used: 4.95

COMMAND EQUIPMENT:

(NAVY—274)	USED:	NEW:
520—1500 KC Receiver	\$14.95	19.95
1-3.0 MC Receiver	9.95	
6-9 MC Receiver	4.95	
100-156 MC Receiver (R-28)	10.95	
2.1-3 MC Transmitter	5.95	7.05
3-1 MC Transmitter	6.95	
4-5.3 MC Transmitter	4.95	
7-9 MC Transmitter	4.95	7.05
100-156 MC Transmitter	14.95	
BC-456 Modulator	2.95	

WRITE US YOUR REQUIREMENTS:

Whatever your needs in Generators, Blowers, Inverters, Motors, etc.—write us. Chances are we have it!

Address Dept. RN • \$5.00 Order Minimum, & 25% Deposit on C.O.D.'s • Prices are F.O.B. Lima, Ohio

PRACTICE CODE TAPE SETS

INKED PAPER TAPES—For code practice and training—for radio operators, Hams, amateurs, beginners, and telegraphers. 15 lessons to a set on 16 mm 400 ft. reels that can be reproduced on TG-34A and TG-10 Keyers. SET OF 15 REELS IN WOOD CASE... \$18.95

TG-34A KEYSER: Automatic unit for reproducing audible code practice signals previously recorded in ink on paper tapes—with speaker and phone jack for plugging in headset. Variable speed motor control to 25 WPM, keying oscillator for use with hand key—Complete portable unit with Tubes and Manual... NEW: \$16.95

CLASSIFIED ITEMS:

BC-212G Amplifier—2/6C5 tubes	NEW: \$ 1.95
BC-216 Amplifier—6F7 & 39/44	USED: 1.50
BC-229/429 Receiver—2500-7700 KC w/Coils.	U: 6.95
BC-230 Transmitter—2500-7700 KC w/Coils.	U: 8.95
BC-347 Amplifier—1/6F8G tube	N: 8.95; U: 1.95
BC-357 Beacon Rec.—75 MC	N: \$4.95; U: 2.95
BC-367 Amplifier—2/6V6 tubes	N: \$4.95; U: 2.95
BC-375 Transmitter	Used: 29.95
Tuning Units 1/BC-375; TU-5-6-7-8-9-10-26.	U: Ea. 3.95
Cables 1/BC-375/BC-191, PL-61, 64 or 59.	each end: Ea. 2.75
BC-442 Antenna Relay Box—w/Cond.	New: 2.95
BC-463 Trans.: 67-74 MC, 20 Watt, 16 Tubes.	U: 16.95
BC-603 Receiver FM—20-28 MC	Used: 29.95
BC-604 Trans.: FM—30 Watt, 20-28 MC	Used: 18.95
BC-500 Trans. & Rec.: 25 Watt, 20-28 MC	New: 59.50
BC-617 Receiver Only, 30-40 MC w/Dyn.	Used: 24.95
BC-654 Transceiver: 3800 to 5800 KC	Used: 34.95
BC-709 Amplifier—Battery Operated	New: 1.95
BC-745 Transceiver: 3 to 6 MC	Used: 14.95
BC-924 Trans. FM—30 Watt, 27-38.9 MC	New: 24.95
BC-966 IFF—160-211 MC, 13 tubes	Used: 5.95
BC-1158 Trans.: 50 Watt, 53.3-95 MC	New: 39.95
RM-12 Radio-Telephone, Remote Control	Used: 19.95
RM-13 Telephone, Remote Control	N: \$24.95; U: 19.95
RM-21 Remote Control Box for BC-669	4.95
SCR-625 Mine Detector—Reconditioned	39.95

SCR-522 Transceiver: 100-156 MC	Used: \$34.95
Rec. Chassis only	w/Tubes: 19.95
Trans. Chassis only	w/Tubes: 22.50
	Less Tubes: 9.95
Schematic & Conversion Information only	2.50

ID-60/APA-10 Panoramic Oscilloscope	New: 49.50
TBY Transceiver: 20-80 MC, 4 Bands, w/Tubes	U: 19.95
R1/ARR-1 Receiver—Converts to 2 or 6 Meters	2.95
RT-7/APN-1 Altimeter—440 MC	Used: 9.95
RT-34/APN-13 Transcvr. Comp. less tubes	U: 3.95
R-74/CRW-2 Receiver—53-88 MC—6 Tubes	N: 9.95
TG-34A Keyer: 115/230 V 50-60 cy. w/Tubes	N: 16.95
TG-10 Keyer: Complete w/Tubes	Tested U: 14.95
T-121 Transmitter—3-4 MC with Coder	7.95
Range Beam Filter, Navy Type \$1.95; FL-8 Used	1.49
EE-8 Field Telephones—Checked	Used: 14.95
BD-72 Portable 12 Line Switchboard	Used: 39.95
Sound Powered Head & Chest Set—Checked	3.95
Sound Powered Head & Headset 1/Mark II	Used: 2.95

TS-9 Handset w/Switch—No Plugs	N: \$6.95—U: \$ 3.95
TS-13 Handset w/Switch, PL-68 & PL-55	Used: 5.95
TS-15 Handset w/Switch, PL-68 & PL-55	New: 7.95
T-17 Microphone—Used, Checked	3.95
HS-30 Headset—Hearing Aid Type—L.N.	1.50

BC-1206 Receiver: 200 to 400 KC	New: \$9.95
BC-1206 Receiver/Less Tubes (200-400 KC)	U: 3.95
12 Volt Dynamotor for BC-1206	4.95

CD-874 Cord—1/HS-30—Low Imp., w/PL-55	U: .59
CD-515 Cable for BC-669	2.75
CD-505 Cord—F/HS-30—High Imp., w/PL-54	N: .79
CD-307 Cord—w/PL-55 & JK-26	U: .59
CD-318 Cord—1/PL-68, JK-48, & SW-141	U: .89
GN-45 Handcrank Generator w/Leads & Seat	9.95
R-4/ARR-2 Receiver—234—258 MC, w/Tubes	U: 4.95

BLOWERS—115 VOLT 60 CYCLE:

100 CFM—Single outlet, size: 5" x 6"	\$ 8.95
100 CFM—Dual outlet, size: 8" x 6"	13.95
200 CFM—1" intake, Size: 8" x 7" x 6"	14.95
100 CFM—Flange and Flap Director	6.95

TRANSFORMERS—115 V. 60 CYCLE PRI:

600 VCT/100 MA—6.3 V/5 A; 5 V/3 A	\$4.95
350 VCT/40 MA—6.3 V/2.4 A; 6.3 V/6	1.75
1300 VCT/350 MA—5 inches Sq.	6.95
700 VCT/150 MA—5 V, 3 A; 6.3 V/4.5 A. CSD	3.95
2500 V/015 A; 2.5 V/175 A; 6.3 V/6 A	5.95
1890 V/12.6 MA—Tapped 2.5 V 2 A	5.95
1100 V/80 MA—7.5 VCT/3.25 A	5.95
720 VCT/50 MA—6.3V/2.5 A—5V/2 A	2.50
662 VCT/110 MA—6.3V/2 A—5V/2 A	3.95
800 VCT/300 MA—12.6V/10 A—5V/3 A	6.95
16 Volt 35 Amp. 115/230... \$24.95; 24V—1 Amp	1.50
9 Volt CT—35 Amp.—Tapped 4.5 V	7.95
12 Volt—Two separate windings—4 amp each	5.95
5 V/2 A; 5 V/2 A; 5 V/2 A; & 5 V/6 A	2.95
600-0-600 VAC—200 MA, 12.5 V 2 A; 12.5 V @ 2 A; 5 V @ 3 A.—H-108—Price	8.95
250-0-250 VAC—50 MA, 24 V, 1 A; and 6.3 V 1 A.—H-109—Price	4.95

Choke—12.5 Hy/100 MA	\$1.95
Choke—8 Hy/150 MA—200 Ohm—Open Frame	1.35
Choke—5 Hy/150 MA—85 Ohm	1.50
Choke—10 Hy/250 MA—2½" x 2" x 3" Potted	4.95
Choke—5 Hy/400 MA—1½" x 4" x 5½"	4.95
18.4 Hy. 1 Amp 100 Ohm—7½" x 5½" x 6¾"	6.95

FAIR RADIO SALES 132 SOUTH MAIN ST. LIMA, OHIO

NEW-NEW-NEW

Get your copy of the

ERIE

D-56 CATALOG

Now Available at
ERIE DISTRIBUTORS
Everywhere



More complete than ever, the new ERIE D-56 Catalog not only describes and illustrates the complete line of ERIE Electronic Components but also includes CORNING GLASS and ERIE-

TEFLON items, that are available through ERIE Distributors. Get your copy of the ERIE D-56 Catalog now at your ERIE Distributor; if he cannot supply it, write us, giving his name.

The wire serves not only to bind the foil, but also supplements the shielding function.

A colorful new illustrated catalogue devoted to the complete line of the firm's auto antennas has just been is-



sued by the company. The booklet contains 8 pages and gives specifications on front, rear, and side mounts. Both chrome and "Fiberglas" antennas are described. A section of the catalogue shows the company's up-to-date selection of dealer displays. Inquiries relating to the catalogue should be directed to Dept. 56 of the company.

ALL-CHANNEL YAGI

Clear Beam Antenna Corp., 21341 Roscoe Blvd., Canoga Park, Calif., is introducing a new low-priced, all-channel yagi antenna, its model MY600, called the "San Franciscan." The an-

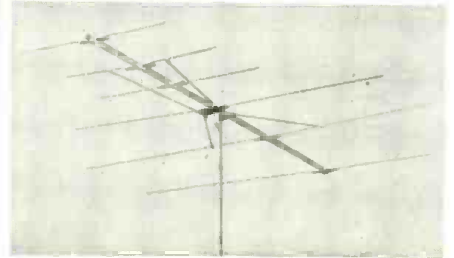

tenna incorporates two arrays of elements, one for channels 7 through 13 and the other to cover channels 2 through 6. A dual delta match is used to phase both sections correctly.

Installation is rapid since all elements unfold readily without the need for tightening of nuts and bolts. Special phasing bars are furnished for stacking purposes, if desired.

Literature on this antenna is available on request.

U.H.F.-V.H.F. FILTER

Channel Master Corp., Ellenville, N. Y., is introducing a completely redesigned model of its u.h.f.-v.h.f. interaction filter, the "Ultra-Tie." This filter joins together u.h.f. and v.h.f. antennas of all types for use with a single transmission line to the TV set. The new model performs this function with leads of any length instead of requiring wires that have to be cut specifically to prescribed lengths for optimum efficiency, as was necessary previously. The improved model also features a new U-type mast clamp.

Like the earlier design, the new "Ultra-Tie" may be used to separate u.h.f. and v.h.f. signals at a TV set or converter where separate u.h.f. and v.h.f. terminals are provided.

Descriptive literature on this new



ERIE ELECTRONICS DISTRIBUTOR DIVISION

ERIE RESISTOR CORPORATION
Main Offices ERIE, PA.

Factories ERIE, PA. • LONDON, ENGLAND • TRENTON, ONTARIO

~~384,000~~ ~~650,000~~ **767,000***
MOBILE-RADIO RIGS NEED MAINTENANCE

You can have a specialized, high-paying business in this fast-growing field—on contract terms! Send for booklet "HOW TO MAKE MONEY IN MOBILE-RADIO MAINTENANCE".

LAMPKIN METERS are the preferred test equipment!

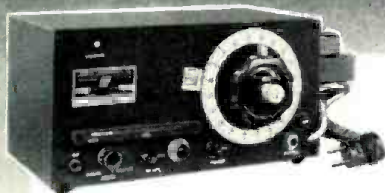

LAMPKIN 105-B MICROMETER FREQUENCY METER

Heterodyne type. Range 0.1 to 175 MC. (crystal-controlled transmitters to 500 MC.), all channels. Pinpoint VHF CW signal source. Weight 13 lbs. Width 13". Price \$220.00 net.

*Annual FCC figures for last three years!

MAIL
COUPON
TODAY!



LAMPKIN 205-A FM MODULATION METER

Indicates FM voice deviation, ± 25 KC. Tunes 25-500 MC. in one band. Has speaker, oscilloscope output. Easy to carry. Weight 13 lbs. Width 12". Price \$240.00 net.

LAMPKIN LABORATORIES, INC.
MFM Division, Bradenton, Florida
At no obligation to me, please send
 Free booklet Data on Lampkin meters

Name _____
Address _____
City _____ State _____

LAMPKIN LABORATORIES, INC.
MFM Division
BRADENTON, FLORIDA

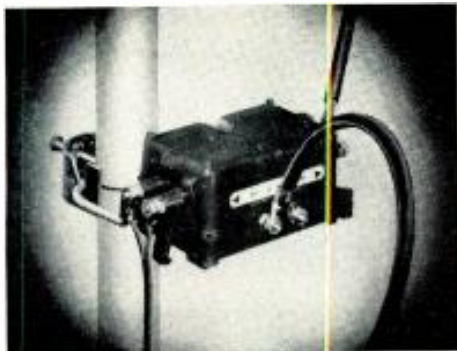

product is available from the manufacturer. The model number on the "Ultra-Tie" is 9034-A and supersedes the model 9034.

INDOOR ANTENNA

Telco Electronics Mfg. Co., Div. of General Cement—Textron American, 919 Taylor Ave., Rockford, Ill., announces a new high-gain, indoor TV antenna, the "Switch-O-Matic." This antenna features 6-phase tuning and a slide adjustment, which is used to obtain the antenna circuit resonance. The 6-phase switch on the front of the antenna base allows the viewer to cancel out ghosts and interference without necessarily having to rotate the antenna itself.

The company also added recently a 2-set TV coupler designed to make it easier to operate a pair of TV sets from a single antenna. This coupler can be used on both u.h.f. and v.h.f. According to the manufacturer, the impedance match for each set is maintained with a minimum of interference or insertion loss.

Further information on both products is available from the manufacturer.

INDOOR TV ANTENNA

Dynamic Electronics-New York, Inc., 73-39 Woodhaven Blvd., Forest Hills, N. Y., announces a new indoor antenna featuring a built-in, high-pass filter. Called the "Filter-Tenna," the unit uses two precision, high-gain phasing elements and a variable 12-position attenuator for tuning out ghosts and fuzz.

Also available from the company is a new accessory display for the parts jobber and distributor trade. The 4-color display panel holds one each of the firm's three new TV and FM accessories—the model T115 audio-video signal attenuator, the model T121 interference suppression high-pass filter, and the model T130 TV and FM tri-set coupler.

The display is designed for either counter or wall use and measures 15" x 19". Both list price and special introductory prices are quoted for each item.

-30-



HELPS YOU MASTER
COLOR TV PRINCIPLES
AND PRACTICES

only \$6.95

ORDER BELOW

SAMS BOOKS
keep you ahead in
ELECTRONICS

"COLOR TV TRAINING MANUAL"

THE NEW BOOK THAT PREPARES YOU FOR SUCCESSFUL COLOR TV SERVICING

Written by C. P. Oliphant and Verne M. Ray, of the Howard W. Sams editorial staff, in practical, down-to-earth language you can understand. Presented in 3 comprehensive sections. SECTION I: Principles of the Color TV System (includes chapters on Colorimetry; Requirements of the Composite Signal; Make-Up of the Color Picture Signal). SECTION II: Color Receiver Circuits (chapters on RF and IF Circuits; Video, Sync and Voltage Supply Circuits; Bandpass-Amplifier, Color-Sync and Color-Killer Circuits; Color Demodulation; Matrix and Output Circuits). SECTION III: Servicing the Color Receiver (chapters on Setting Up the Color Picture Tube; Aligning the Color Receiver; Trouble-Shooting; Test Equipment Required). Appendices include Equations, Vectors, Color-blocks, Colorplates, Glossary. A comprehensive training course that helps you qualify for Color TV servicing. 260 pages, 8½ x 11"; profusely illustrated.

Postpaid, only... \$6.95

Sams books cover every phase of Electronics for the service technician, engineer, student or experimenter. Listed below are a few of the many valuable Sams books available at electronic parts distributors and leading book stores.

USE THIS ORDER FORM

COLOR TELEVISION TRAINING MANUAL.....\$6.95

- Analyzing and Tracing TV Circuits. Presents a new approach to TV servicing. 168 pages, 8½ x 11".....\$3.00
- TV Service Data Handbook. Most frequently needed charts, tables and formulas required in TV servicing and installation. 112 pages, 5½ x 8½".....\$1.50
- Principles & Practices of Telecasting Operations. Discusses equipment and techniques. Covers such subjects as: TV Cameras; Control Rooms; Fundamentals of Studio Lighting; Relay Systems; Maintenance Practices; Technical Production; etc. 600 pages; 6 x 9"; illustrated.....\$7.95
- Radio Receiver Servicing. Covers the basic receiver types—gives time-saving hints for solving basic troubles, such as dead set, weak set, noisy set, etc. 192 pages; 5½ x 8½".....\$2.50
- So You Want to Be a Ham. Tells you what you need to know about getting your license and acquiring equipment. Covers such subjects as: Conquering the Code; Getting Your Ticket; Going on the Air; Electronics as a Career; etc. 196 pages; 5½ x 8½"; illustrated.....\$2.50
- Servicing TV Sweep Systems. Describes the operation, circuit function and circuit variations of vertical and horizontal sweep systems common to most TV receivers. Tells how to analyze circuits; trouble-shoots for you. 212 pages; 5½ x 8½"; illustrated.....\$2.75
- The Recording and Reproduction of Sound. Widely used by Audio engineers, Hi-Fi enthusiasts, broadcasting stations and recording studios. Authoritative chapters cover: behavior of sound waves; basic recording methods; lateral disc recording; micro-groove recording; phono reproducers; microphones; home music systems; P.A. systems; amplifiers; tuners; etc. 810 pages; 6 x 9"; illustrated.....\$7.95

HOW TO UNDERSTAND AND USE TV TEST INSTRUMENTS

- Completely revised and enlarged to include latest data on instruments used for Color TV Servicing. Covers use of VTVM's Signal Generators, Sweep Signal Generators, Scopes, Video Signal Generators, Field Intensity Meters and Voltage Calibrators. 208 pages, 8½ x 11".....\$3.50
- Photofact Television Course. Gives a clear complete understanding of TV principles, operation, practice. Used by thousands of students. 208 pages, 8½ x 11".....\$3.00
- Atomic Radiation, Detection and Measurement. Provides basic understanding of nuclear science and its applications. Thoroughly covers and illustrates circuitry and operation of the many types of detection devices. 200 pages; 5½ x 8½".....\$3.00
- Basic Radio Manual. Provides all the basic facts on theory, definitions, components. Includes section devoted to actual projects that translate theory into practice. 248 pages; 8½ x 11"; illustrated.....\$5.00
- Attenuators, Equalizers and Filters. Describes design, application and theory of operation of every type of Attenuator, Equalizer and Wave Filter. Used in audio recording and reproducing systems, both professional and home-type. Includes chapters on Hi-Fi crossover networks. Provides time-saving charts which permit easy determination of component values required in designing equalizers and filters. 176 pages; 5½x8½"; fully illustrated. Deluxe hard binding.....\$4.00
Paper-bound edition.....\$2.75

There is an authoritative Sams book on virtually any Electronic subject in which you're interested. Check below for FREE Book List describing all Sams books.

Send Book List



Look for
SAMS BOOKS
on the
"Book Tree"
at your Parts
Distributor

HOWARD W. SAMS & CO., INC.

Order from your Parts Jobber today, or mail to Howard W. Sams & Co., Inc., Dept. 1-116 2201 East 46th St., Indianapolis 5, Indiana.

Send books checked above. My (check) (money order) for \$..... is enclosed.

Name.....

Address.....

City..... Zone..... State.....

(outside U.S.A. priced slightly higher)

SAVE!... BARGAINS GALORE!... SAVE!

NEW LOW PRICES!—EFFECTIVE MAY 1st

COMMAND TRANSMITTERS & RECEIVERS—



ARC-5 and SCR-214
as available
FAMOUS "Q" 5'rs
EXG. **\$1095**
CONDITION

Receivers, w/o dynamotors

- R-23 ea BC-453, 100-550 Kc Exit. \$10.95
- R-25 Marine, used \$5.95, new 6.95
- R-26 or BC-454, 3-6 Mc, used Exit. 6.95
- R-27 or BC-455, 6-9.1 Mc, used Exit. \$4.95
- New 5.95
- R-4/ARR-2, 234-258 Mc, as is w/o tubes, 3.95, used w/tubes. 4.95

Transmitters, w/o modulator or dynamotor

- T-18 Marine, 2.1-3 Mc, as is, w/tubes, 3.95, used 4.95, boxed. \$ 5.95
- T-19 or BC-696, 3-4 Mc, as is w/tubes, 6.05 used, 7.95 boxed. 8.95
- T-20 or BC-457, 4-5.3 Mc, as is w/tubes 2.95, used 3.95, boxed. 5.95
- T-21 or BC-458, 5.3-7 Mc, as is w/tubes 2.95, used 3.95, boxed by depot. 4.95
- T-22 or BC-459, 7-9.1 Mc, as is w/tubes, 2.95, used 3.95, boxed. 5.95
- T-23, 100-156 Mc, as is, w/o tubes, 7.95, used, 9.95, new w/tals. 34.95

Misc. Command Equipment as available

- Receiver dynamotors 28v, 1.00, 1lw used 3.95 new 4.95
- BC-456 Sp, Mod w/tubes, new 4.95, used. 3.95
- MD-7/ARC-5 Pl Mod w/tubes Xint. 8.95
- 28 v dynamotors inc w/above mod.
- Separately, w/o mod. 3.00
- Mounting Racks, used, 1.49, new. 2.49
- Receiver spinner knobs 69¢ 3/1.50
- New 24 V Trans. et al 12v, 2A. 3.50
- Plugs for rear of receiver. 1.00
- BC-442 Ant. Relay, cont, vacuum cap.50
- MMFD 5KV Send-Receive relax, RF ammeter, new. 2.95

- 110 VAC power supply for Receiver, cont. above trans & Selenium Rect. kit 8.95
- Wired & Tested 12.95
- Receiver Conversion kit: cont. schematic, BFO Sw, 25 K Pnt. phone Jack, and sBluner knob, with instructions 1.95
- 1625 Tubes, for trans & mod, 50¢ 3/1.00
- 832A for VHF trans. 8.00

- 100 VAC power supply for Receiver, cont. above trans & Selenium Rect. kit 8.95
- Wired & Tested 12.95
- Receiver Conversion kit: cont. schematic, BFO Sw, 25 K Pnt. phone Jack, and sBluner knob, with instructions 1.95
- 1625 Tubes, for trans & mod, 50¢ 3/1.00
- 832A for VHF trans. 8.00

Popular Dynamotor Specials

- DM-34 Recvr. Dyna. 12 V in 220 @ 80 ma Out, new. \$ 4.95
- DM-36 Same as above, 28 V, new. 4.95
- either of above, used. 3.95
- PE-101C, Transmitter, 12 or 24 v input, 500 v at 200 Ma out, (300 w 6 v in) new 7.95
- DM-42, 12 V in, out 1000 and 500, ea at 215 Ma, used. 12.95
- DM-35, 12 V in, 600 at 200 Ma out, New, 12.95 Used 12.95
- Wincharger Dyna. 12 V in. 440 @ 220 MA Out, New 12.95
- BD-69 Rec. Dyna. 14 v in. 220 at 80 Ma out, new 9.95
- PE-73, 24 v in, 1000 at 350 Ma out, New 8.95, used 6.95
- PE-94, 28 v. in., for 522, 300 at 250 Ma, 150 bias, and 12 V 10 A, new. 4.95

2.00 Minimum Order. All prices Subject to Change without Notice. Canada & Mexico minimum 10.00. Cash with Order. Sorry, no COD. California Orders include 4% tax. Prices FOB Los Angeles.

SAM'S SURPLUS, 1306 Bond St., Los Angeles 15, California

WESTON—SANGAMO—YOUR CHOICE

- Meters. All New. 2" Square
- 0-2 Ma 0-200 Ma
- 0-5 Ma 0-300 Ma
- 0-15 Ma 0-500 Ma
- 0-50 Ma 0-20 VDC
- 0-100 Ma 0-300 VDC



- 3.29 each, Special, 3 for 9.00
- Filament Transformer—240 VAC, Primary 5 VAC, 30 A, 15 KV insulation when used on 120 VAC, gives 2 1/2 VAC for 806's or 249's, Brand New. \$ 7.95
- Heavy Duty Collins choke, 300 Ma, can take 500 Ma peak, new. 3.95
- 249C, 5000 volts, new, each. 1.95
- Bleeder resistors, 50 K 100 W, new. 1.95
- Transmitter Power Supply Kit contains chassis, 2 transformers, 2 tubes, 2 sets filters and bleeders, gives 500 VDC and 250 VDC, value of parts 23.34 Special. 15.95
- Weight 22 lbs.

- Brand New Headphones, your choice of HS-23, 2000 ohms, or HS-33, 600 ohms, complete with brand new rubber cushions. \$3.95
- Used HS-23, w/o cushions. 1.95
- New small cushions, Pr. .49
- Used chamois cushions, Pr. .49
- New lg rubber cushions, Pr. .29



- Brand New Impedance matching transformer, plug in, 2000 ohms to 600 ohms, takes std plug, boxed 69¢
- Used 3 for. \$1.95
- CD-307A cords, has JK-26 on one end for phones, std plug other end, brand new, boxed .97



- Brand New J-38 Code Keys, for sending CW with your transmitter. 1.45
- Build your Modulator, Input trans., 1.50, driver, 2.50, mod. trans. 2.95, 2 new 1625 tubes, value 7.70, all for. 1.95
- Stewart Warner Ammeter, 0-0.60 Amps, brand new, 95¢, 6 for. 5.00
- Phone-CW Filters, 1020 cycles, new, FL-5, 69¢ FL-R with switch. 1.89
- GP-7 transmitter with all tubes and 80 meter coil unit only. 13.95
- Leas tubes and coil unit. 7.95
- BC-375, 100 CW or phone transmitter, less tuning units, contains modulator, w/o tuning work anal. w/o tuning units, but with 12.95

- TU-7, 4.5-6.2 Mc; TU-8, 6.2-7.7 Mc; TU-9, 7.7-10 Mc; TU-10, 10-12.5 Mc; TU-26, 200-500 choice, used. 2.29
- T-30 Throat Mikes, each. 1.00
- 3 Mast Sections, MS-49 thru 52, 50¢ each, 52 and above, 75¢ each, Special, 1 each MS-49 thru 54, makes 18' vertical. 2.95

- Variable Antenna Matcher, 100 w. rating in the BC-375, ok for 1 Kw in a Pi network. 8.95
- MN-26C direction finding equipment
- Receiver w. dyna. 10.95
- MN-20E Loop. 4.95
- MN-52H Az Cont Box. 2.95
- All above new, special, 12.95

- Antenna Insulators, Bendix MT-49C, plated end caps, new, 15¢ each, 10 for. 1.25
- Control Box w/5 Ma S meter. 1.98
- Antenna Gear, new 28VDC. 2.95
- Hp. w/Gear box. 2.95
- SCR-522, exc. condition, tubes. 34.50
- Contains Receiver, Transmitter and control panel covers range 100-156 Cm, easily put on 2 meters. \$34.50
- New transmitters, GP-11 for 12 volts, or GP-12 for 24 volts, with tubes and built in modulator—less tuning unit. 5.95
- Tuning Unit for above. 1.95
- New Mfg. surplus wire wound flat strip resistors. Some contain 3 separate resistors. Ranges from 20,000 ohms. Wholesale Value 9.27 All yours, 12 assorted for. 1.00
- 1 1/2" Sub miniature speakers, Dynamic, white they last, ea. 4.95
- 12V Solenoid for Mikes, 100 Amp. Capacity. 1.49



FERRITE CORED INDUCTORS

Alladin Radio Industries, Inc., Nashville 2, Tennessee has recently released an 8-page engineering bulletin covering its line of ferrite cored inductors.

The publication provides details on several new product lines, including the "Tiny-L" inductors which cover the range from .33 to 6.8 microhenrys. Specifications on four of the company's lines are given in tabular form for ready reference. General application notes are also included.

Write the company direct for a copy of this bulletin.

SUBMINIATURE CONNECTORS

The Catalogue Department of Cannon Electric Company, 3208 Humboldt St., Los Angeles 31, California has announced the availability of a new engineering bulletin covering its Type "D" subminiature connectors.

These units are designed for miniature equipment and components requiring rack and panel chassis construction in electronics, radio, aviation, automation, instruments, and other fields.

The 8-page, 2-color bulletin contains actual size photographs of the units; dimensional data; soldering, mounting, and shell deviations; standard assemblies and variations, in addition to several application photos.

NEW TRIAD CATALOGUES

Triad Transformer Corporation, 4055 Redwood Ave., Venice, California has just issued two new catalogues of interest to the industry.

The first is the company's 1956 television replacement guide which lists the firm's correct television replacement transformers for more than 100 set manufacturers and over 6000 models.

The second publication is the 1956 edition of the company's general catalogue and covers nearly 700 items, 76 of which are new to the line. The catalogue illustrates and describes these products in some detail.

When writing for copies of these catalogues, please specify TV-56 for the replacement guide and TR-56 for the general catalogue. The company's jobbers will also supply copies on request.

"PRESSURE GAGE"

George Scherr Co., Inc., 200 Lafayette Street, New York 12, New York is currently offering copies of a four-page brochure covering its line of precision dynamometers.

Of particular interest to the electronics industry are the "Gram Gages" or "Spring Tension Gages" which are

WANTED



WANT Coronet (illustrated), Double Bell Wonder, Victor Types A, D, E, and O. Monarch Special and Improved Monarch. Also Edison Tin-foil (replica) machine, his Idelia, Excelsior and Treadle Phonographs. Want early Bell-Tainter, American Gramophones, Multiphone, Multinola, Scott Magazine Phonograph, Peerless, Sovereign, Wizard Phonograph, Regina Hexaphone, and Graphophones. Also catalogues or old literature on phonos made prior to 1906. Want unusual machines and coin-in-slot cylinder phonographs. Need a few early reproducers (sound boxes) for Victor, Columbia, and Edison.

A few duplicate Edisons and graphophones are now available for sale or trade.

Send clear snapshot and full information to

Box 50

RADIO & TELEVISION NEWS

366 Madison Ave., New York 17, N. Y.

Willing to pay cash for Early Phonographs with outside horns

suitable for measuring minute pressures having a range of .5 to 5 grams. Write the company direct for a free copy of this fully illustrated brochure.

PRINTED CIRCUIT DATA

Cronume, Incorporated, 3701 Ravenswood Avenue, Chicago 13, Illinois has just issued a colorful four-page brochure, entitled "An Introduction to Printed Circuitry," which describes the firm's new printed circuitry process.

The publication outlines the company's facilities for producing printed circuits by the *UL*-approved process and offers recommendations on the basic steps necessary for exact circuit duplication.

Copies of this brochure will be forwarded without charge upon written request to the manufacturer.

NEW RETMA STANDARDS

The Engineering Department of the Radio-Electronics-Television Manufacturers Association, 11 West 42nd Street, New York 36, New York has just released five new RETMA standards covering a variety of products and procedures in the radio and electronics industry.

The new publications include packing tests for radio, radio-phonographs, high-fidelity equipment and recorders (RETMA RS-151, 25 cents); minimum standards for land-mobile communication FM or PM transmitters for 25 to 470 mc. (RETMA RS-152, 60 cents); molded mica capacitors (RS-153, revised, \$1.60); polarized dry electrolytic capacitors for general use (RS-154, revised, 90 cents); and fixed wire-wound power resistors (RS-155, revised, 80 cents).

Any or all of these publications are available from the Engineering Department. Enclose payment with all orders.

RELAY SPECIFICATIONS

American Machine & Foundry Company, 261 Madison Ave., New York 16, N. Y. has prepared a 12-page brochure entitled "Specifying Relays" which is being offered without charge to engineers and other interested persons.

Prepared by James F. Rinke, director of engineering of the corporation's relay subsidiary, *Potter & Brumfield Manufacturing Co., Inc.*, the article covers in some detail the various factors that should be considered in selecting an electrical relay for a given application. These factors include circuit characteristics, type of switching, actuation power, operating speed, duty cycle, life expectancy, environmental conditions, physical requirements, and cost.

The brochure is available on letter-head request to the Public Relations Department of the firm.

TAPE DATA BOOK

Minnesota Mining and Manufacturing Co., 900 Fauquier St., St. Paul 6, Minn. has issued a new technical data booklet covering the important physical and magnetic properties of twelve

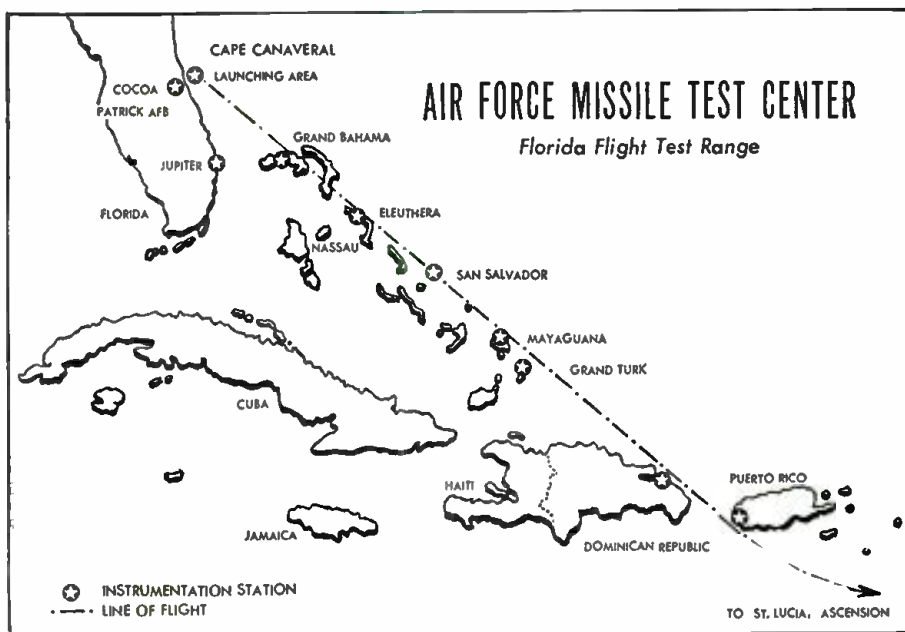

RCA

ANNOUNCES OPPORTUNITIES

**In Guided Missile Test Instrumentation
For Electronic Technicians**

At the following locations

PATRICK AIR FORCE BASE, FLORIDA	CAPE CANAVERAL	
Engineering development technicians	Radar	Timing
Radar	Radio	Telephone
Communications	Telemetry	Optics
Test Equipment		

*Enjoy pleasant Florida living and working at these locations.
Liberal company benefits. Relocation assistance.*

INTERESTING DOWN-RANGE ASSIGNMENTS

Radar	Telemetry	Telephone
Radio	Timing	Optics

These positions are located on the Islands shown on the map above. Salary, 30% differential, meals and lodging furnished. Return to U.S. every 3 months.



For information and arrangements for personal interview, send complete resume to:

Mr. H. C. Laur
Technical Employment, Dept. N-16H
Missile Test Project
RCA Service Co., Inc.
P.O. Box 1226, Melbourne, Florida



RADIO CORPORATION of AMERICA

TUBES FOR THE FINEST IN HI-FI



Almost without exception, makers of the finest high-fidelity sets depend upon Tung-Sol Audio Amplifier Tubes to help deliver the performance expected of their products.

Through these tubes—the "5881" and the "6550"—Tung-Sol clearly demonstrates its ability to meet and maintain high-fidelity's critical design requirements in volume production.

This achievement is indicative of the quality and dependability of Tung-Sol Hi-Fi, Radio and TV Tubes . . . products of America's largest independent electron tube manufacturer, Tung-Sol Electric Inc. Newark 4, N. J.



TUNG-SOL
ELECTRON TUBES

Tung-Sol Automotive & Electronic Products

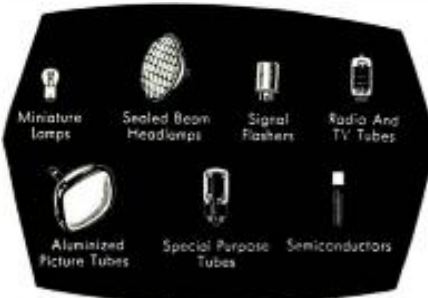

"Scotch" brand magnetic tapes and films.

The 12-page booklet covers such physical properties as backing thickness, ultimate tensile strength, yield strength, elongation at break, residual elongation, tear and impact strength, and coefficient of expansion.

Magnetic properties include coercivity, retentivity, coating thickness, erasure characteristics, bias current requirements, relative low-frequency output, and relative high- and low-frequency sensitivity.

Copies of this new publication are available from Dept. A6-114 of the company.

TV TEST EQUIPMENT

The Technical Products Department, *General Electric Company*, Electronics Park, Syracuse, New York has recently issued an elaborate 12-page booklet covering its precision, laboratory-type television test equipment.

The brochure (ECL-37) pictures and describes in detail the Type ST-2A oscilloscope, the ST-4A sweep generator, the ST-5A marker generator, and the ST-16A color alignment generator in addition to a balanced output adapter (ST-8A), a color compensator (ST-17A), a chroma probe (ST-18A), and a matrix filter (ST-19A).

Write the department on your company letterhead for a copy of this publication.

CERRO ALLOYS

Cerro de Pasco Corporation, 300 Park Avenue, New York 5, New York has prepared a compact folder listing some 63 applications of its group of low-temperature-melting alloys.

The new folder is accompanied by a handy business reply card for obtaining more complete data on the products listed in the tables. Address your requests for copies of this publication ("63 Jobs You Can Do Better with Cerro Alloys") to O. J. Seeds, manager of the Alloy Sales Department of the firm.

TUBE INVENTORY GUIDE

An easy check on inventories and the movements of all types of tubes is facilitated with the new Tube Inventory Guide being offered by all *Westinghouse* tube distributors.

Available to all dealers, the tube guide is designed to aid in keeping track of tube stocks and movements. All types of radio and TV tubes as well as picture tubes are listed in the guide.

Visit your local *Westinghouse* distributor for a copy of this handy inventory control.

"TEFLON" CATALOGUE

Continental-Diamond Fibre Division, Newark, Delaware has published a new sixteen-page catalogue covering its "Teflon" line of tapes, sheets, rods, tubes, gaskets, and fabricated specialties.

The data is presented in easy to use tabular form with all pertinent infor-

mation provided. Photographs and text material discuss applications and other special features.

When writing for a copy of this brochure, please specify "Teflon" catalogue T-55.

PRECISION WIREWOUNDS

International Resistance Company, 401 N. Broad Street, Philadelphia 8, Pa. has published a four-page bulletin containing comprehensive data on winding technique, testing, tolerance, inductance, insulation, terminals, temperature coefficient, etc., for its MIL-type precision wirewound resistor line.

Charts and graphs are also included in Bulletin D-1a which is available without charge on request.

G-E TELEVISION BOOKLETS

General Electric Company, Electronics Park, Syracuse, New York has two 4-page brochures available on its new closed-circuit color television system (Type TE-1-B) and its monochrome industrial TV system (Type TE-3-A).

Each of the publications lists the component units in the system, suggests possible applications for the equipment, and points out the salient features. Both mechanical and electrical specifications are provided on both systems.

Write the company for copies of either or both of the brochures.

ANALOGUE COMPUTERS

The *Berkeley Division of Beckman Instruments, Inc.*, 2200 Wright Ave., Richmond 3, California has released a simplified "short course" in the basic theory and practice of analogue computers.

Entitled "An Introduction to the Application of Electronic Analog Computers," this publication originally was presented in the form of a paper before the National Conference on Industrial Hydraulics by Hugo Martinez, *Berkeley* consultant.

The data file explores the various aspect of simulation and describes its convenient implementation with analogue computers for solving great varieties of problems in systems design, engineering, and industry.

Free copies of Data File 121 are available from Department 1141 of the company.

COLOR TV COURSE AT HOME

RCA's Tube Division, Harrison, N. J. has announced the availability of a "Color-TV Home Study Course" comprising a basic course prepared by *RCA Institutes* plus advanced data and servicing techniques prepared by John R. Meagher, the company's authority on television servicing.

The 11-lesson course, successfully completed, will entitle the technician to an *RCA Institutes'* "Advanced Color-TV Home Study Course Certificate."

Contact the company's tube distributors or write the Tube Division direct for full details on this course, its cost, and the system by which the instruction will be given.

Distortion Measurements
(Continued from page 70)

tude is relatively greater, while the pulse time duration on the waveform is the same.

However, in practice, demodulation of the carrier renders it impossible to get a faithful measurement of the peak amplitude of the pulse indent because the indent time may be less than 1 cycle of "carrier." This means that the regular intermodulation method of detecting this form of distortion tends to minimize the reading much more than the harmonic method of measuring the same distortion.

The foregoing discussion has not produced a satisfactory answer as to the best method of measuring high-order distortion at levels well within the maximum handling capacity of the amplifier. We are still faced with the discrepancy in audibility of the different order components. It would seem that some weighting network with say, 6 db-per-octave upward slope might provide an answer, but here comes the difficulty of standardization in interpretation of the readings obtained.

For measuring the distortion in the region of maximum output there does seem to be a possibility which is somewhat simpler than the case for lower levels. This consists of comparing, not the mean or r.m.s. readings of the fundamental and the residual harmonic,

but rather the peak reading of these two component waveforms.

It seems from the foregoing discussion that this will give a much better indication of the relative audibility of the distortion produced. The only factor not being taken into account in this case being the shape of the Fletcher-Munson curve, which obviously will make the audibility of the distortion different at all frequencies.

It is therefore suggested that at least an improvement in the significance of distortion measurements will be made if peak reading of the residual harmonic is compared with the peak reading of the fundamental for all kinds of measurements. This will not introduce a serious variation in the reading obtained for low-level, high-order harmonic types of distortion, but in the case where clipping is introduced—which is quite a serious one, as it enables apparently low values of harmonic distortion to be quoted when quite audible distortion is present—it should help matters in getting a specification of distortion that is more consistent with the effect it produces.

As a method it involves a comparatively minor modification to the test instrument, in which the instrument manufacturers will undoubtedly be pleased to cooperate. The specification should be given some distinctive title, to avoid unfavorable comparison with the other method of measurement. The term "peak-to-peak distortion" is suggested.

New! RCA Victor acetate tape with full High Fidelity response!



Now—professional tape—you can sell at no extra cost! It's RCA Victor's new acetate tape with full High Fidelity response! Also available: new RCA Victor acetate tape with full frequency performance that you can sell at a special low introductory price. And new RCA Victor "Mylar"* tape—super-strength—plays 50% longer! Call your RCA Victor distributor now for full details on these 3 great new tapes.

*"Mylar" is a registered Dupont trademark for its polyester film.

RCA VICTOR
RADIO CORPORATION OF AMERICA

CAMDEN 8, NEW JERSEY

If you're buying price alone DON'T BUY HERE!

If you want the BEST QUALITY at the LOWEST PRICE BUY FROM



STANLEY
ELECTRONICS CORP
935 MAIN AVE., PASSAIC, N. J.
Department MR-2

ALL TUBES "CIRCUIT TESTED" FOR TOP PERFORMANCE

Individually boxed • One year RTMA guarantee • Best Brands Available

0Z4	1P5GT	5Z4	6B8G	6J7	6S57	7N7	12Z3
1A3	1Q5GT	6A3	6BA6	6J7GT	6T8	7Q7	14A5
1A5GT	1R5	6A5G	6BA7	6J8G	6U8	7X6	14A7
1A6	1S4	6A7	6BC5	6K5GT	6V6GT	7Y4	14Q7
1A7GT	155	6A8	6BD5GT	6K6GT	6W4GT	7Z4	19B6G
1A85	1T4	6A8CT	6BCT	6K7	6W6GT	12A6	19J6
1A8	1T5GT	6A84	6BF5	6K7GT	6X4	12AT6	19T8
133GT	1U4	6A87	6B6G	6K8G	6X5GT	12AT7	24A
184P	1V	6AC5GT	6BH6	6K8GT	6Y6G	12AU6	25A5GT
185	1V2	6AC7	6BJ6	6L6CA	7A4-XXL	12AU7	25BQ6GT
137GT	1V5	6AF4	6BK5	6L7C	7A5	12AV6	25L6GT
1C3	1X2A	6AC5	6BK7A	6N7	7A6	12AV7	25Y5
1C5GT	2A5	6AG7	6BL7GT	6P5GT	7A7	12AX7	25Z3
1C6	2A6	6AH4	6BN6	6Q7	7A8	12AY7	27
1C7G	2A7	6AH6	6BQ6GT	6Q7GT	7AC7	12BA6	32L7GT
1C8	2B7	6AJ5	6BQ7A	6R7	7AH7	12BA7	35A5
1D5GP	3A4	6AK5	6BY5G	654	7AJ7	12B4	35B5
1E5GP	3A5	6AL5	6BZ7	657G	7B4	12BE6	35C5
1E8	3A8C1	6AL7GT	6C4	658GT	7B5	12BH7	35L6GT
1F7G	3B7	6AQ5	6C5GT	65A7	7B6	12BY7	35W4
1H4C	3D6	6AQ6	6CF6	65A7GT	7B7	12J5GT	35Z3
1H5GT	3Q4	6A97GT	6C6	6C7	7B8	12K8	35Z5GT
1H6GT	3Q5GT	6AS5	6C6G	6C7GT	7C4	12SA7	45Z5GT
1I6GT	354	6AT6	6CD6G	65H7GT	7C5	12SA7GT	50A5
1L4	3V4	6AU4	6C56	65J7	7C7	12S7GT	50B5
1L6	5AX4	6AUSGT	6D6	65J7GT	7E5	12S7	50C5
1LA6	5T4	6AU6	6E5	65K7	7E6	12SH7	50L6GT
1LC5	5U4C	6AV5GT	6F5GT	65K7GT	7F7	12S7GT	70L7GT
1LC6	5V4C	6AV6	6F6GT	65L7GT	7F7	12SK7GT	75
1LD5	5X4C	6AX4	6F7	65N7GT	7F8	12SK7GT	77
1LE3	5Y3C	6AX5GT	6G6G	6S07	7G7	12SL7GT	78
1LG5	5Y3CT	6B5	6H6GT	6S07GT	7J7	12SN7GT	80
1LNS	5Y4C	6B6G	6J5	6SR7	7K7	12S7GT	
1NSGT	5Z3	6B7	6J6	6SR7GT			

BRAND NEW DUMONT and RCA Lic. PICTURE TUBES

No Replacement Dud Required! • All Brand New • Full One Year Guarantee

Discounts for the Quantity Purchaser • Partial Listing
F.O.B. Passaic, N. J. Shipped via Railway Express

30BP4	\$10.95	15DP4	\$16.95	16RP4	\$17.00	19AP4	\$23.00
32LP4	12.95	16DP4	18.50	17BP4	19.00	20CP4	24.00
34CP4	15.25	16GP4	19.25	17GP4	21.00	21ALP4A	24.00
		16KP4	17.00	17LP4	18.00	21EP4	24.00

WRITE FOR STANLEY'S NEW FREE PARTS CATALOG.

Repeated by Popular Demand!
UTAH 12" COAXIAL SPEAKER with built-in cross over network... \$11.50

TERMS: FREE POSTAGE on all prepaid continental U.S.A. orders on receiving tubes only. All picture tubes F.O.B. Passaic, N. J. 50¢ handling charge on all orders under \$5.00. 25% deposit on all C.O.D.'s. Subject to prior sale.

TAKE YOUR CHOICE! ANY ASSORTMENT RECEIVING TUBES 47¢ EACH

Unconditionally Guaranteed for one year.

FREE POSTAGE on all prepaid continental U.S.A. orders.

BUILD 16 RADIO CIRCUITS AT HOME

With the New Improved 1956 Progressive Radio "Edu-Kit" only **\$19.95**

A PRACTICAL HOME RADIO COURSE

Now Includes **SOLDERING IRON, TESTER, HIGH FIDELITY, SIGNAL TRACER, CODE OSCILLATOR, PRINTED CIRCUITRY**



FREE TOOLS

- No Knowledge of Radio Necessary
- No Additional Parts or Tools Needed
- Excellent Background for TV
- Unconditional Money-Back Guarantee

FREE Hi-Fi, Radio & TV Servicing Manuals on Request. (See Coupon Below).

WHAT THE "EDU-KIT" OFFERS YOU

The "Edu-Kit" offers you an outstanding PRACTICAL HOME RADIO COURSE at a rock-bottom price. You will learn radio theory, construction and servicing. You will learn how to build radios, using regular schematics; how to solder and wire in a professional manner; how to service and trouble-shoot radios. You will learn how to work with punched metal chassis as well as the new Printed Circuit chassis. You will learn the principles of IFF and AF amplifiers and oscillators, detectors, rectifiers, test equipment. You will learn and practice code, using the Progressive Code Oscillator. You will build 16 Receiver, Transmitter, Code Oscillator, Signal Tracer and Signal Injector circuits, and learn how to operate them. You will receive an excellent background for TV. In brief, you will receive a basic education in Electronics and Radio, worth many times the small price you pay.

PROGRESSIVE TEACHING METHOD

The Progressive Radio "Edu-Kit" is the foremost educational radio kit in the world, and is universally accepted as the standard in the field of electronics training. The "Edu-Kit" uses the modern educational principle of "Learn by Doing." You begin by building a simple radio, gradually, in a progressive manner, and at your own rate, you construct more advanced multi-tube radio circuits, learn more advanced theory and techniques, and do work like a professional radio technician.

THE KIT FOR EVERYONE

You do not need the slightest background in radio or science. The "Edu-Kit" is used by young and old, schools and clubs, by Armed Forces Personnel and Veterans Adm. for training and rehabilitation. The "Edu-Kit" is used in 79 countries throughout the world. Designed for universal use, the "Edu-Kit" operates on any voltage from 105 to 125 volts, AC and DC. For use in countries employing higher line voltages, a 210-250 Volt AC/DC model is available.

THE "EDU-KIT" IS COMPLETE

You will receive all parts and instructions necessary to build 16 different radio and electronics circuits, each guaranteed to operate. Our kits contain tubes, tube sockets, variable, electrolytic and paper dielectric condensers, resistors, tie strips, coils, hardware, tubing, punched metal chassis, Instruction Manuals, etc. In addition, you receive Printed Circuit materials, including Printed Circuit chassis, special tube sockets, hardware and instructions. You also receive a useful set of tools, a professional, electric soldering iron, and a self-powered, dynamic Radio and Electronics Tester. The "Edu-Kit" also includes Code instructions and the Progressive Code Oscillator. You will also receive lessons for servicing with the Progressive Signal Tracer and the Progressive Signal Injector, a High Fidelity Tester, FCC Amateur License Training Book, and a Quiz Book. All parts, components, etc. of the "Edu-Kit" are 100% unconditionally guaranteed, brand new, carefully selected, tested and matched. Everything is yours to keep. The complete price of this practical home Radio and Electronics course is only \$19.95.

TROUBLE-SHOOTING LESSONS

You will learn to trouble-shoot and service radios, using the professional Signal Tracer, the unique Signal Injector, and the dynamic Radio and Electronics Tester. Our Consultation Service will help you with any technical problems.

J. Stassatlis, of 25 Popular Pl., Waterbury, Conn., writes: "I have repaired several sets for my friends, and made money. The 'Edu-Kit' paid for itself. I was ready to spend \$240 for a course, but I found your ad and sent for your kit."

FREE EXTRAS

- Radio and Electronics Tester • Electric Soldering Iron • Set of Tools • Tester Instruction Book • Hi-Fi Book • TV Book • Quiz Book • Membership in Radio-TV Club • Consultation Service • FCC Amateur Lic. Training • Printed Circuitry
- UNCONDITIONAL MONEY-BACK GUARANTEE

ORDER FROM AD—RECEIVE FREE BONUS RESISTOR KIT WORTH \$5

- "Edu-Kit" Postpaid. Enclose full payment of \$19.95.
- "Edu-Kit" C.O.D. I will pay \$19.95 plus postage.
- Send me FREE additional information describing "Edu-Kit." Include FREE valuable Hi-Fi, Radio & TV Servicing Manuals. No obligation. (Outside U.S.A.—No C.O.D.'s. "Edu-Kit" for 105-125 V. AC/DC \$20.95; 210-250 V. AC/DC \$23.45.)

Name _____
Address _____

PROGRESSIVE "EDU-KITS" INC.
497 Union Ave., Room 56E, Brooklyn 11, N. Y.

Realistic High-Fidelity (Continued from page 44)

shallow search coil connected to a flux-meter. I do not think there is any other way of doing it, and it is extremely tedious. Owing to the bulk of the center-pole behind the front plate some extension of the pole is necessary and this must be supplemented by chamfering the front plate itself. Fig. 16C shows the magnet system I finally determined as a result of many experiments and it does give a truly symmetrical field, but at some loss of sensitivity. If the center-pole is saturated (as it would be in the most economical design) the total flux behind the front plate has to be transferred to the front and this lessens the actual flux in the gap. Since I insisted on a freely suspended diaphragm, I had to choose between good sensitivity with bass cross-modulation or lower sensitivity with distortionless bass—one more instance of loudspeaker design always being a compromise.

If the speaker is not fitted with a dustcover and has a suspension spider of the open type, you can see if the voice-coil winding sticks out of the gap. Then you can grasp the cone between forefingers and thumbs and pull it towards you to the limit of its movement (taking great care not to overstrain the suspension). If there still seems to be plenty of winding in the gap, then the coil is longer than the gap and the risk of cross-modulation is reduced. However, many speakers are fitted with dustcaps and closed rear suspensions, making visual examination of the coil and magnet system almost impossible. The properties of the speaker must then be tested electrically (if the dealer will allow you to do so!)

Apply, from an audio oscillator or from the a.c. power line through a "Variac" or other variable transformer, an alternating current (anything between 40 and 60 cps) of such magnitude as to move the cone to its limits. This point is determined by gradually increasing the input to the speaker until there is a suggestion of the voice-coil former or the rear suspension hitting on the center pole or front plate, then reducing the input slightly. Now, from another signal source, apply a 1000-cycle signal and listen carefully. If the 1000-cycle note is modulated in strength by the low frequency note, usually having a sort of burbling effect, cross-modulation is present. You may think that this wouldn't be heard on ordinary music, but it will. One bang on the drum will affect the sound from the rest of the orchestra and one held pedal note of the organ will make all the higher frequencies sound dreadful.

Next month we will take up the matter of multi-channel speakers. At that time we will go into those loudspeaker systems having two or more units working in conjunction with some sort of filter circuit.

(To be continued)

Always Buy Columbia

SPEAKIN' OF SPEAKERS
Here's a batch of the best! New, boxed NORELCO—Hi-Fi, twin-cone, co-axial: 20 W. & ohm. 12". Frequency: 35-18,000 cps. New. Lists at \$54.95. Your price... **\$24.95**
EIGHT INCH—8 W. 4 ohm. 8". 1,000 c/s. New. This honey lists at \$36.95. Now... **\$19.95**
Save 25 bucks! New. This honey lists at \$49.50. Now... **\$24.95**
Your net, at a great saving, only \$24.95
NATIONAL Co-ax. 21.5 oz. magnet. 6.5 oz. magnet. A top quality top name speaker. Lists at \$39.95. Now... **\$14.95**
NATIONAL MAKE-12" 6.8 oz. magnet. Lists at \$19.95. Look at this low net! Only... **\$6.95**
HEAVY MAGNET SPEAKER—Big 12" speaker. National brand. Basement bargain! Lists at \$39.95. Now... **\$3.98**
STANDARD BRAND—9" speaker. 1.47 oz. magnet. Lists at \$11.00. Now... **\$1.44**
6 x 9 INCH—1.47 oz. magnet. Exceptional quality for the price. Only... **\$1.99**
UTAH 8". With whizzer. 3.10 oz. magnet. 2 for \$11.00. Each... **\$5.95**

SONOTONE CARTRIDGE Model 2TS: Brand new and terrific! Lists at \$9.50. Your **\$3.95** get it for...

THE BEST-BEST BUYS IN BATTERIES!
NY-6. Miniature. Wet cell. 6 V. @ 3 amp. Brand new. Each... **\$1.95**
6 V. @ 15 AH: Wet cell. 4 1/2 x 4 1/4 x 5 1/2". Brand new. Special. Only... **\$3.95**
WILLARD 25-2: Wet cell. New... **\$2.95**
WILLARD 20-2: Brand new. Hot buy! **\$1.95**

IT'S TUBE TIME @ COLUMBIA! ALL NEW!
2D21 \$.99 70L7 \$.95
6AG5 \$.50 807W \$.95
6CA \$.50 825 \$.50
6J6 \$.50 872A \$ 1.50
6V6 \$.50 958A \$.49

BRAND NEW CO-AX CONNECTORS
BARREL TYPE, feed-through, extension connectors, 4 for \$2.89. Each... **50c**
SO-239 FEMALE CONNECTORS, Ea.... **25c**
PL-259 MALE CONNECTORS, Ea.... **20c**

19" OPEN PANEL RACK: New, open face, 32 high, with double the price! 36" high & 15" deep. 3 sides enclosed. With door. New... **\$12.95**
NEW CABINET: 10" high & 14" deep. This one has top lid. 3 sides enclosed. New... **\$9.95**

All orders FOB Los Angeles. 25% deposit required. All items subject to prior sale. MINIMUM ORDER \$3.00. OPEN FRIDAY NITE TILL 10 P.M.

Columbia ELECTRONICS
2251 W. WASHINGTON BLVD.
LOS ANGELES 18, CALIFORNIA

TUNERS CONVERTERS

LOW COST CRYSTAL CONTROLLED

A practical low cost converter suitable for 30-50 or 6 meter band. Net \$11.88.

POLICE • FIRE • CIVIL DEFENSE



- ✓ Precision
 - ✓ Stability
 - ✓ Sensitivity
 - ✓ Easy Installation
- only \$29.50 net

• A compact converter supplied with commercial tolerance crystals, made to your exact frequency requirements. Furnished with tubes and crystal.

Crystal controlled converters can be supplied for other frequencies. Other converters with squelch.

VARIABLE TUNERS

Improved AM-FM now available for 20-30, 30-50, 50-54 88-108, 108-170 MC from \$18.75



Write for free information today

Kuhn ELECTRONIC PRODUCTS
20 Glenwood • Cincinnati 17, Ohio

Hi-Fi Stereophonics (Continued from page 38)

"panned" to emphasize the desired effect and the impression received is not just due to simple simultaneous three-channel communication.

If you carefully analyze your sense of direction, you will find that it is extremely difficult to tell the direction of a continuous tone, whether it be organ music, orchestral music at full volume, or an oscillator, when reproduced over a loudspeaker. Any form of continuous tone, or group of continuous tones reproduced in music, sets up a whole pattern of standing waves in the room, as shown in Fig. 11. This means that the intensity pattern throughout the room is extremely complicated, and you will find that, if you move your head in a room where a loudspeaker is reproducing a tone from an oscillator, the apparent direction of the sound source changes quite quickly with a small head movement. It is difficult to identify the sound with the loudspeaker emitting it.

However, as soon as you put some form of more live program material through the same loudspeaker you are much more conscious of its position. You will find, by careful analysis, that this is due to the transient nature of the program material. It is with the sharp wavefronts that you identify directions and not the continuous tones which follow them. This fact is what enables the *Perspecta* principle to operate so effectively to produce what proves to be, in fact, a more satisfactory illusion of stereophonic sound than the classic method employing three or more channels.

It would seem likely that this system, or one using a similar principle, will ultimately be accepted as providing the best and most economical approach to realism in reproduced sound. As it will be some time before such a system is developed commercially and recorded material is available, doubtless some readers will want to try it for themselves, following the method outlined.

-30-

Fig. 11. Standing wave pattern set up by single tone reproduced from a loudspeaker in a room. At the positions marked "X," the dotted lines indicate the apparent direction of source which can be adjudged by the points of maximum and minimum instantaneous pressure, indicated by solid and open circles. See the article.

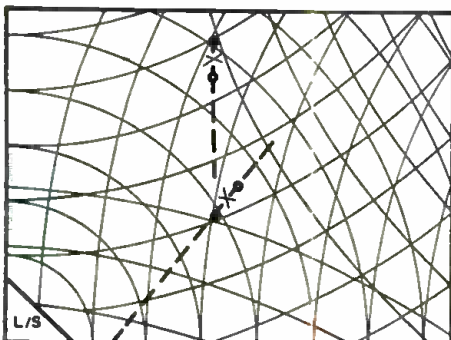

TECHNICIANS: ARE YOU NOW QUALIFIED FOR ENGINEERING WORK?

THEN HERE IS YOUR OPPORTUNITY FOR
AN ENGINEERING ASSIGNMENT WITH
THE RCA SERVICE COMPANY!

... And you'll be eligible for educational benefits through RCA's liberal Tuition Refund Plan, a real boost toward that actual engineering education you're interested in! Many other company-paid benefits, of course. Excellent starting salaries • pleasant suburban locations • relocation expenses paid.

Which of these engineering fields do you prefer?

- Missile Electronics
- Navigational Aids Planning & Design
- Naval Electronic Systems Installations Planning
- Specifications Engineering Writing

ARRANGE FOR CONFIDENTIAL INTERVIEW WITH
REPRESENTATIVES OF RCA ENGINEERING MANAGEMENT
AT A LOCATION CONVENIENT TO YOU

Please send complete resume to:

Mr. John R. Weld
Employment Manager, Dept. Y-2H
Radio Corporation of America
Camden 2, New Jersey



RCA SERVICE CO., INC.



**GUARANTEED
PERFORMANCE**

CROWN

Professional Tape Recorder

CROWN PRINCE



Easily Portable. 10 1/2" Reels. Rack mounting tape transport.

IDEAL FOR HI-FI INSTALLATIONS!

IPS	DUAL TRACK		Flutter WOW	Noise Ratio
	Frequency Response Record and Playback	CPS		
15	±2 DB 20-18000	CPS	.10%	55 DB
7 1/2	±2 DB 20-15000	CPS	.15%	52 DB
3 3/8	±3 DB 40-8000	CPS	.25%	44 DB

Less Case **\$349⁵⁰**

Write for literature.
Address Dept. RN-7

Specifications . . .

- "MICRO-LINEAR" HEADS • THREE SPEEDS • THREE MOTORS • MEETS NARTB STANDARDS •
- "MICRO-SYNC" TIMING • STRAIGHT LINE THREADING • 4" DUAL LIGHTED METER
- MAGNETISM BRAKING • PERFECT ERASURE • CATHODE FOLLOWER OUTPUT

INTERNATIONAL RADIO & ELECTRONICS CORP.

ELKHART, INDIANA

new!



Arkay Model Hi-Fi FL-10 Amp-PreAmp Kit
Williamson type super-linear amplifier with built-in pre-amp. Pushpull 12 watt output frequency response ±1 db, 10 to 40,000 cps with extremely low IM and harmonic distortion. An amplifier to be proud of. **\$28.95**

Visit your local distributor for these wonderful kits and write today for the special FREE Radio Kits Catalogue and list of dealers. Your copy will be sent by return mail with no obligation. Write to . . .

twins by **ARKAY**



Matching tuner which offers less than 1% distortion and a -70db hum level. Sensitivity is 6 uv for 20 db quieting on FM and 20 uv on AM.

With AFC control and defeat **\$29.95**
Available in FM only **\$23.95**
Less Cover

Radio Kits Inc., Dept. 10 120 Cedar Street, New York City

Antenna Rotators (Continued from page 41)

indicator unit should also be done whenever the unit has seen more than a year of service and requires some other repair. One of the most important factors in good lubrication is the removal of old, sticky, deteriorated grease. This is best done by wiping contacts, bearing surfaces, and similar parts with a clean cloth, cotton preferred, dipped in carbon tetrachloride or similar cleaning solution.

Most antenna rotators require two different types of grease. The electrical switch contacts at the indicator and interrupter contacts at the rotor, when such are present, are best lubricated with "Lubriplate" or a similar light lubricant. The gears, mast bearings, and support bearings, as well as other moving parts, should be lubricated with a light grade of automotive grease or Vaseline. The latter has a tendency to run at even moderate heat and should be avoided in warm climates.

When remounting the antenna be sure to check all brackets and other hardware for corrosion and excessive wear. Weatherproofing all anchoring points and tightening up all clamps completes the repair.

If a rotator does not work properly, its effect on television reception in the receiver is often the same as a defect in the TV set itself. Servicing the rotator then becomes as important as receiver servicing and the technician will have to possess the technical knowledge to carry out this work. As has been shown, installing and servicing antenna rotators should not present any great technical problems to the practicing technician. However, this type of work can be an extra source of profit to the technician who goes after it aggressively. One idea is to offer a "Summer Special" on their tuneup and repair, if needed. -50-

Fig. 13. Cutaway view of a rotator showing the gear train for reducing the speed of the motor to that required for proper operation, which is usually about 2 rpm.

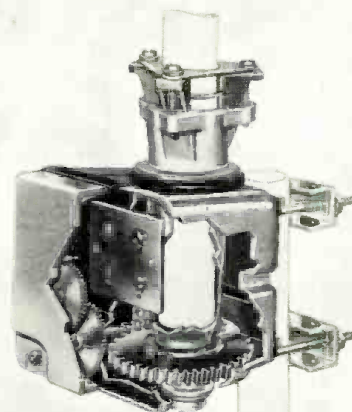

Certified Record Revue
(Continued from page 62)

of the Munch mannerisms and his headlong pace. I like the reading because it's exciting and at least it's different! And even if the Munch reading were less satisfactory than it is, the playing he elicits from the Boston men would more than offset this fall from grace. There is a fine bravura spirit in their playing coupled with a sumptuousness of tone and gratifying precision. Truly Munch has come a long way with this orchestra. Not the least of the attractions of this disc is the splendid sound. The fine sonority of the strings, the soul-satisfying power of the tympani and the bass drum in the last movement, the bright brazen blare of the trumpets and trombones, all are captured with outstanding realism. The Kubelik/Mercury disc still has the edge in sheer overwhelming sound, mostly due to the incomparable acoustics of Chicago's Orchestra Hall, but this has attractions of its own and many may prefer the different character of the sound imparted by the Boston acoustics. One of the nicer things to con-

template is that this was undoubtedly recorded in stereo and the tape should be along soon for our aural delectation.

STRAVINSKY
CONCERTO FOR PIANO AND WIND INSTRUMENTS
CAPRICCIO FOR PIANO AND ORCHESTRA

Nikita Magaloff, pianist with L' Orchestre de la Suisse Romande conducted by Ernest Ansermet. London LLI392. RIAA curve. Price \$3.98.

A regular rash of Stravinsky this month and I, for one, couldn't feel happier about it! It would seem that after the great deal of attention recently given to his larger works, the companies are turning to his shorter and lesser known compositions which have either not been recorded previously, or are in need of upgrading and refurbishing from the standpoint of technical and artistic quality. The "Concerto" has been recorded once previously on the Concert Hall label and left much to be desired especially from the aspects of sound quality. No problem like that exists in this present recording where the piano of Magaloff is heard with superb clarity and definition. The London engineers have

provided a crystal sharp mirror of the orchestra to complement the piano and have recorded all quite "close-up" which is appropriate for the dry, almost astringent scoring. The "Capriccio" is similarly treated to sharply etched, highly detailed sound. Magaloff has an appreciation and the talent necessary to cope with the difficulties of the score, which is especially demanding of phrasing. Needless to say, his task of synchronizing with the orchestra is made much easier by the presence of old Stravinsky-specialist Ernest Ansermet. As is usual, Ansermet's grasp of the essential problems of the work makes for a nicely balanced, well integrated reading. The "Capriccio" has fared better in previous recordings (2) than the "Concerto" but it, too, submits to the special talents of Magaloff and Ansermet and emerges shiny bright in sound and ever more interesting in concept. For Stravinsky lovers, this is a must.

BARTOK
CONCERTO FOR ORCHESTRA
Chicago Symphony Orchestra conducted by Fritz Reiner. Victor LM1934. RIAA curve. Price \$3.98.

This is a real puzzler! Take a wonderful work, have it played by a virtuoso orchestra,

40¢ for any TUBE

\$37.00 per hundred

we will not be undersold

DON'T PAY MORE FOR SET TESTED LONG LIFE DEPENDABLE RADIO & TV TUBES • BUY VIDEO INDIVIDUALLY BOXED • ALL GUARANTEED FOR ONE YEAR OR YOUR MONEY BACK

Some Standard Brand—Others With Famous VIDEO Brand

0A2	2X2	6AC7	6BK5	6SG7	7F8	12V6GT
0A3	3A4	6AG5	6BK7	6SH7	7N7	12X4
0A4	3A5	6AF4	6BL7GT	6SJ7GT	7Q7	14A7
0B2	3AL5	6AH4GT	6BN6	6SK7GT	7Y4	14B6
0C3	3AU6	6AK5	6BQ6GT	6SL7GT	7Z4	14Q7
0Z4	3BC5	6AL5	6BQ7	6SN7GT	12A6	19B6G
1A7GT	3C86	6AM8	6BY5G	6SQ7	12AH7GT	19T8
1B3GT	3Q4	6AN4	6BZ7	6SS7	12AT6	24A
1C7G	3Q5GT	6N8	6C4	6SV7	12AT7	25AV5GT
1F4	3S4	6AQ5	6C86	6T8	12AU6	25BQ6GT
1H4	3V4	6AQ7GT	6CD6G	6U4GT	12AU7	25C06G
1H5GT	4B27	6A55	6CF6	6U7G	12AV6	25C06
1J6GT	4B97	6A57G	6C56	6U8	12AV7	25L6GT
1L4	5AM8	6AT6	6CU6GT	6V3	12AX4GT	25W4GT
1L6	5AN8	6AU4GT	6E5	6V6GT	12AX7	25Z6GT
1LAG	5AQ5	6AU5GT	6H6GT	6W4GT	12AZ7	35L6GT
1LCS	5AT8	6AU6	6J4	6W6GT	12B4	35W4
1LH4	5AW4	6BU5GT	6J5GT	6X4	12BA6	35Y4
1LMS	5AZ4	6AV6	6J6	6X5GT	12BE6	35Z3
1NSGT	5J6	6AX4GT	6K6GT	6X8	12BH7	35Z5GT
1S4	5T4	6AK5GT	6L6	6Y6G	12BY7	50A5
1S5	5T8	6BAG	6N7GT	7A5	12C06	50B5
1T4	5U4G	6BC5	6S4	7A7	12S47	50C5
1U4	5U8	6BC7	6S7G	7B5	12S7	50L6GT
1U5	5V4G	6B6G	6S7	7B7	12SH7	80
1V2	5V6GT	6BF5	6S7Y	7C5	12SJ7GT	117N7GT
1X2	5Y3	6BG6G	6SC7	7C6	12SK7	117P7GT
2A7	5Y4G	6BH6	6SF5	7C7	18SN7GT	117Z3
2D21	6A84	6BJ6	6SF7	7F7	12SQ7	

REMEMBER, MR. CUSTOMER!

Over 30,000 satisfied TV servicemen can't be wrong. You can buy with confidence from VIDEO, a reputable firm with over 10 years experience. We are the sole distributor of Video Brand tubes.

FREE POSTAGE in U.S.A. and Territories on orders over \$5.00. 25¢ handling charge on orders under \$5.00. 25% deposit required on C.O.D.s. Please send approximate postage or freight on Canadian and foreign orders. Subject to prior sale.

SEND for our **FREE** complete **TUBE & PARTS LIST** and order blank.

We Have OVER 1000 USED TV SETS

At All Times In Our Huge Warehouse Buy one or more of these WORKING TVs to sell or use as your own second set! All Sets in GOOD WORKING condition! Your Choice—Console or Table Model

10".....	\$23.00	19".....	\$58.00
12".....	\$28.00	20".....	\$64.00
14".....	\$33.00	21".....	\$72.00
16".....	\$40.00	24".....	\$99.00
17".....	\$46.00		

When ordering TVs, state whether table model or console is desired. Also preference on make of set. All TVs sent railway express F.O.B. Newark. On any quantity WIRE or CALL today!

FREE BONUS ANTENNA GIVEN WITH ANY TV SET ORDER!!

Also On Hand . . . ANY MAKE OR MODEL BRAND NEW TV OR APPLIANCE

Prices on request! We will beat any quoted price!

FREE RCA "CHEATER" CORD GIVEN WITH ANY TUBE ORDER OF \$7.00 OR MORE!!

VIDEO

SAME DAY SHIPMENT OF ALL ORDERS!

Phone **HUMboldt 4-9848**

ELECTRIC COMPANY
79 CLINTON PL. NEWARK, N. J.

for All RECORD SPEEDS

The Collaro High Fidelity



4-Speed

Record Changer

Model RC-456
for 78, 45, 33 $\frac{1}{3}$ and
16 $\frac{2}{3}$ rpm records

ROCKBAR CORPORATION

650 Halstead Avenue, Mamaroneck, N.Y.

Tell me all about the COLLARO
RC-456

Name _____

Address _____

City _____ Zone _____ State _____

MH-4

with fine performance by an authoritative conductor, and record the work with splendid modern sound. This should certainly give you a winner, but oddly it doesn't quite "come-off." I've tried to analyze the reasons why and it all boils down to one . . . it's strictly a matter of scoring and acoustics. For once the wonderful spacious acoustics of Chicago's Orchestra Hall have backfired! The "Concerto for Orchestra" is an intricate score with almost an infinitude of inner detail. In fact, it is so "loaded" with detail that it requires virtuoso orchestras to cope with the complexities, and for this reason the work is not generally found in the programs of the lesser orchestras. Obscure this detail and you have lost the essence of the work. This is a score where spacious acoustics must be tamed, where all recording must be done very "close-up" almost razor sharp in its merciless delineation, the edge dulled by just the tiniest smidgin of reverb to lend a little roundness. Alas, *Victor* used the technique ordinarily so successful in Orchestra Hall and so out of place in this work. There is only one way this technique could have been successful and I venture to say, even though I have not yet heard it, that the stereo tape sounds all right. The wonderful ability of the stereo to separate and discriminate between the various instruments will probably save the day. Well, this is just my opinion. Could be that many people won't mind the out-of-place reverb, and still others will prefer the fine Reiner performance whatever the acoustics. Ignoring acoustics for now, it is pleasant to report that the sound is very good, quite wide in frequency and dynamics, with good string tone, the famous Chicago brass sound clean and resonant, percussion clean and accurate.

DEBUSSY CHILDREN'S CORNER SUITE PETITE SUITE

Concert Arts Orchestra conducted by Felix Slatkin. Capitol P8328. RIAA curve. Price \$3.98.

This is a delectable little record, with understanding and ingratiating performances of these charming works. The "Petite Suite" at the hands of Slatkin is newly interesting and with the superb *Capitol* sound this is the recording of choice. The "Children's Corner" fares equally well, but there is more grace and poetry in the recent Cluytens reading on *Angel*. Soundwise, the *Angel* version is softer hued, this recording more sharply detailed, both very good indeed. Many may prefer this disc for the coupling and the over-all excellence. As usual, the quiet *Capitol* surfaces contribute to the illusion of presence. Hi-fi fans should have a field day testing their speakers with the extraordinary low-frequency power of the contrabass in the "Jimbo's Lullaby" section.

RAVEL VALES NOBLES ET SENTIMENTALES MA MERE L'OYE MENUET ANTIQUE

Orchestre National de la Radiodiffusion Francaise conducted by Andre Cluytens.

RAVEL INTRODUCTION AND ALLEGRO FOR FLUTE, HARP AND STRINGS

The Pascal Quartet, L. Laskine, harpist, J. P. Rampal, flutist, U. Delecluse, clarinetist. *Angel* 35173. RIAA curve. Price \$4.98.

Here are some choice Ravel items, served up in fine fashion by Cluytens with an assist from the Pascal Quartet and soloists. Cluytens has a good feeling for the music and doesn't oversentimentalize like so many with this music. His tempi are reasonable, his balances excellent, and he manages some fine playing from his orchestra. His reading of the

"Mother Goose" is certainly the best since the old Koussevitsky and with the fine new sound this would be the choice to replace aging copies of the work. The "Introduction and Allegro" is excellent in sound and performance but has stiff competition from the recent Hollywood Quartet version on *Capitol*. All in all, with the justness of the coupling, the strength of the performances, and the clean wide range sound, this is a most desirable disc and is highly recommended.

ELGAR THREE BAVARIAN DANCES CHANSON DE NUIT CHANSON DE MATIN ARNOLD ENGLISH DANCES

London Philharmonic Orchestra conducted by Sir Adrian Boult. London LL1335. RIAA curve. Price \$3.98.

This is a 12" coupling of these works which were originally issued on 10" discs. All are light fare and make good summer listening. The Elgar dances are entertaining in their way and give a foretaste of the Elgar of sterner stuff that is to come. His skill at orchestration is already much in evidence in this early work. The Arnold "English Dances" is the most interesting on this disc. Gay and spritely, they are quite infectious in their unalloyed merriment. Perhaps the most remarkable thing about these dances is the sound. *London* made no fanfare when the original 10" was issued and they haven't here with the 12", yet in many respects, this is one of the finest recordings ever issued by *London*. I heard the 10" original and it was very good, but unless my ears are deceiving me, the 12" is far, far better. I suspect the 12" was recut with some new cutter or new techniques. At any rate, the sound is magnificent. This is a real hi-fi spectacular with all the pyrotechnics you could want! Great robust french horn sound, sharp bright trumpets, clean yet incisive strings, woodwinds mellow and woodwinds piercingly stratospheric, and pungent percussion of great clarity and weight. There is a bass drum whumping away in several parts of the score that is simply fabulous. Not only is it really way, way down in the low frequencies, but it has tremendous power and, withal, a most naturally live sound. I do not know the reason for the modesty on the part of *London*, and could be I'm just hearing things, but everything being normal (and I think it is) this is something for you to look into. It's a real ding dong dilly!

BRAHMS SYMPHONY #3 TRAGIC OVERTURE ACADEMIC FESTIVAL OVERTURE Minneapolis Symphony Orchestra conducted by Antal Dorati. Mercury MG-50072. RIAA curve. Price \$3.98.

Usually Antal Dorati is given the spectacular repertoire by *Mercury*. He's either shooting off cannon in the "1812 Overture," or shaking foundations with a "Feste Romane," or fighting battles in "Ein Heldenleben," or some such thing. And you can't blame *Mercury* for this. Dorati is about as good a master of the pyrotechnical as exists today. But on occasion he has been entrusted with the reading of less athletic repertoire and has shown that he has skill and facility here too, as witness this disc of Brahms 3rd symphony. It is not a reading in the classic vein of a Koussevitsky or a Bohm or Szell. Yet he manages as much warmth, permits grace where it is necessary, and can summon more strength than any of these conductors. In fact this facet of strength is perhaps the most important aspect of his reading. He brings a vigor and spirit to the work that is refreshing after a surfeit of "gemutlichkeit" and it-must-be-done-this-way tradition. Which is not to

RADIO & TELEVISION NEWS

infer or imply that his reading is in any way "revolutionary." His tempi are reasonable if a little on the brisk side, his few mannerisms subsidiary to the score as a whole. Perhaps this enthusiasm for Dorati is heightened by the magnificent sound he is afforded. Even if his reading were far less satisfying than it is, one would be hard put to reject a disc with such splendor of sound. Here *Mercury* proves that the less spectacular repertoire can sound every bit as thrilling as the most bombastic works. The sumptuous strings of the Minneapolis are here a thing of clean unsullied beauty, no screech nor raspy edge mars their smooth precision. The darker colors of the cello and contrabassi, substantial in their weighty sonority, merge in balanced harmony with their light-voiced brethren. There is brass, imperious and demancing, brass soft-voiced and mellow, woodwinds of velvet persuasion, percussion that is big and authoritative. Balance all these choirs to perfection, enrobe them in spacious acoustics that make for a huge, "big-hall" liveness, yet do not mask the myriad details of the score, endow them with the widest of frequency and dynamic ranges, excise all distortions, groove or otherwise, and you have a recording pristine in its sonic contour, superior to all that has gone before. Truly this is a Brahms 3rd, the sound of which should remain exalted for a long time. The "Tragic Overture" gets a good straightforward performance and is also much in the debt of the wonderful sound and the "Academic Festival" overture at the hands of Dorati is a rousing inspired thing, perhaps a mite bumptious in its unrestrained enthusiasm, but appealing for its honest joyfulness. All in all, a superior recording that is highly recommended.

STRAUSS, J.-DESORMIERE
LE BEAU DANUBE (COMPLETE BALLET)

ROSSINI
WILLIAM TELL. BALLET MUSIC
London Philharmonic Orchestra conducted by Jean Martinon. London LL-1383. RIAA curve. Price \$3.98.

Here is an LP premiere that is sure to delight the legions of Strauss lovers. Old ballet master Roger Desormiere has collected a number of familiar Strauss melodies and orchestrated them into the form of a ballet, with choreography by the great Leonide Massine. In typical Graustarkian surroundings, the scene is set on a Holiday and the familiar Boy-Girl-Rival-Trouble-Happy-Ending routine is enacted. As you might expect this is music all bubble and froth, unrestrained gaiety, lilting, whirling, quite irresistible. The performance by Martinon can best be described as ebullient. He gives the excellent orchestra its head and it is obvious everyone is having a great deal of fun. The London engineers have entered into the spirit with a recording which is a sparkling little gem. The instrumentation is well defined, no distortions were noted, acoustic perspective was appropriate to the score. The ballet music from "William Tell" serves as an adequate filler on the second side. A happier choice for summer listening than this disc would be hard to imagine.

BOSTON POPS PICNIC
Boston Pops Orchestra conducted by Arthur Fiedler. Victor LM1985. RIAA curve. Price \$3.98.

Another fine disc to accompany that tall cool glass on a summer day! Fiedler conducts his always superb group in a program varying from "Jalousie," "Malaguena" and LeRoy Anderson's "Waltzing Cat," to the thunderous snortin' warhorse "Poet and Peasant Overture" of Von Suppe. Other numbers make up a pleasant and well balanced program. As usual with this group the engineers have

AN UNPRECEDENTED OFFER!
by the famous **NEL-KAYE Record Club**

JOIN NOW and get
38% off
on ANY LP RECORD
(Any Label—No Exceptions)



Plus **Free** with your membership:
any 10" or 12" record of your choice

If you are a true record collector be it classical, Pop or Jazz—and if you usually buy more than just a few records a year, this club was designed for you.

The membership fee is \$10. per year and entitles you to the following advantages available only to Nel-Kaye members:

- 1 For the \$10. fee we will send you one 10" or 12" LP record absolutely FREE, ANY record—ANY label—the choice is entirely up to you. (The value of this Free record alone is actually worth the greater part of your \$10. membership fee).
- 2 Throughout the year (for a full 12 month period) you may purchase as many LP records as you wish, and receive 38% off the current list price. That's a saving of \$1.50 on each record you buy. If you purchase as few as one record a week, you save more than \$75. a year.
- 3 There are no restrictions of any kind. You may order any LP record—any label, major or

minor—RCA, Decca, Columbia, Capital, Mercury, London, Westminster, Urania, Vox, Hayden Society, etc., any LP listed in any record Catalog. No exceptions—in short, any LP ever recorded.

During the 12 month period of your membership, you may order as many or as few records as you wish, the amount is entirely up to you.

4 Each month you will receive, absolutely FREE, a new record catalog worth 25c, listing every LP ever recorded.

5 All records are guaranteed factory-new and in perfect condition assuring the highest standards of Hi Fidelity recording. Exchanges on any defective records are made immediately without charge.

The fact that we buy records in tremendous volume and work on a minimum mark-up makes this unique club possible. We have thousands of satisfied members all over the world.

JOIN TODAY
and save
many, many dollars
throughout the year.

Note: There is a few cents postage and handling charge on all orders.

COMPLETE SATISFACTION GUARANTEED

Make checks payable to Dept. RT 8
NEL-KAYE RECORDS, Inc., 1604 Yark Ave.
N. Y. 28, N. Y.

I am enclosing \$10 check or money order covering one year membership in the "Nel-Kaye Record Club of the Year." This does not obligate me in any way. I may order as many or as few records of my choice as I wish.

My free L.P. record choice is.....

NAME.....

ADDRESS.....

CITY.....ZONE.....STATE.....

XCELITE Hand Tools
PREFERRED BY THE EXPERTS

No. 99 Junior Kit



NOW!

OFF-THE-SHELF DELIVERY
ON THIS POPULAR KIT!

Here's good news for those of you who haven't been able to get this new 99 Junior kit. Our new plant addition is turning it out full tilt and it's on distributors' shelves. ASK YOUR SUPPLIER to show you this pocket-size roll plastic kit with all its tools (3/16, 7/32, 1/4, 5/32, 3/16, 11/32 and 3/8" nut driver bits—Nos. 1 and 2 Phillips screwdrivers—3/16 and 5/32 slotted screwdrivers). Also ask about the new 1/2" reamer with 3/16" hole for T-handle leverage. It fits the 99 Junior handle.

XCELITE, INCORPORATED
Dept. E
Orchard Park, N. Y.

For Originality
LOOK TO **XCELITE**

don't
be
vague...

insist on
SPRAGUE
BLACK
BEAUTY®
TELECAP®
tubulars

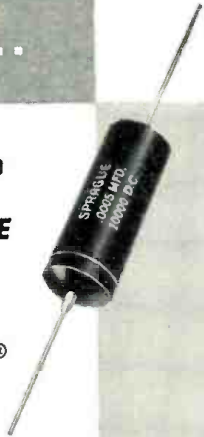

SPRAGUE

NORTH ADAMS, MASS.

ELECTRIC BRAIN KIT
Can you think faster than this Machine?

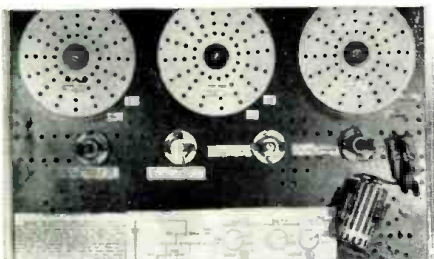

Control Panel of GENIAC set up to do a problem in check valve research.

Be careful before you answer. GENIAC the first electrical brain construction kit is equipped to play tic-tac-toe, cipher and enclipher codes, convert from binary to decimal, reason (in syllogisms) as well as add, subtract, multiply and divide. Specific Problems in a variety of fields—actuarial, policy claim settlement, physics, etc., can be set up and solved with the components. Connections are solderless and are completely explained with templates in the manual. This covers 33 circuits and shows how new ones can be designed.

You will find building and using GENIACs a wonderful experience: one kit user wrote us, "this kit has opened up a new world of thinking to me." You actually see how computing, problem solving, and game play (Tic-tac-toe, nim, etc.) can be analyzed with Boolean Algebra and the algebraic solutions transformed directly into circuit diagrams. You create from over 400 specially designed and manufactured components a machine that solves problems faster than you can express them.

Schools and colleges, teachers of science or math, engineering, philosophy or psychology will find these excellent demonstrators of circuitry, solutions in symbolic logic, theory of numbers, cybernetics, and automation.

Note: Teachers take advantage of our 10% discount to educational institutions and for group purchases.

SEND for your GENIAC kit now. Only \$19.95 with over four hundred components and parts, fully illustrated manual and wiring diagrams. We guarantee that if you do not want to keep GENIAC after one week you can return it for full refund plus shipping costs.

— MAIL THIS COUPON —

SCIENCE KITS, Dept. RT-86, Oliver Garfield Co.
126 Lexington Ave., N.Y. 16, N.Y.

Please send me:

- 1 GENIAC Electric Brain Construction Kit and Manual.
- \$19.95 (East of Mississippi)
- \$20.95 (Elsewhere in United States)
- \$21.95 (Outside the United States)

Returnable in seven days for full refund if not satisfied. I enclose \$..... in full payment. My name and address are attached.

120

captured their fine playing with splendid realism.

BELL, DRUM, AND CYMBAL
Saul Goodman, percussionist. Angel 35269. RIAA curve. Price \$4.98.

This is Angel's contribution to the ever growing list of special percussion recordings. Angel astutely chose Saul Goodman to do its disc, a most happy choice inasmuch as Mr. Goodman is just about the most famous percussionist extant. With Leonard Sterling aiding him in narration Mr. Goodman leads you through the various divisions of the percussion battery and then, through the now familiar medium of multiple track recording, does a virtual one-man-band stint with his Theme and Variations on "My Country 'Tis of Thee," and Saint-Saens, "Danse Macabre." While not as complete a survey as the recent Vox disc on percussion, this disc has the virtue of more sparkle and spontaneity, and avoids the dullness of extended documentation. Soundwise it is excellent with all the various instruments miked "close-up" as they should be, and all come through with sharp crisp definition. Particularly outstanding is the huge bass drum sound and the various snare drums.

I honestly believe that most of you will get a bang out of the solo rendition of "Danse Macabre." It's a real "one-man band."

BEETHOVEN

SYMPHONY #9
SYMPHONY #8

Elisabeth Schwarzkopf, Marga Hoffgen, Ernst Hafliger, Otto Edelmann, soloists and chorus of the Gesellschaft der Musikfreunde, Vienna, with Philharmonia Orchestra conducted by Herbert von Karajan. Angel 3544B. RIAA curve. Price \$9.96. Two discs.

Ever since von Karajan began to record the Beethoven symphonies for Angel, his 9th has been eagerly awaited. A listen to this version indicates that the patience of his devotees will not have been wasted. Like any version of the 9th it must inevitably be compared with Toscanini's tremendous performance. It is inconceivable to me that anyone can say about the recorded performances of the 9th that they do or don't like a given performance, in much the same manner as one would choose vanilla rather than chocolate. Each has its own particular virtues and this blind rejection of any version except the Toscanini is unwarranted and, if I may say, seems to be indulged in mainly by pseudo-intellectuals who don't know any better. That the Toscanini performance still seems to have more heart and spirit, more vitality than this version is beside the point. Von Karajan is somewhat more deliberate, his dynamic expression somewhat more restrained but, all in all, his is a superb performance, with the best first movement of any existing version. The second movement is a little draggy, generally the score is well integrated and does not leave the impression of disjointedness as do some versions. As for plus virtues. I like the Angel soloists better than any others, for the simple reason that they make an attempt to sing this almost unsingable music... they don't shout and bellow and strain as do so many others. The choral work is definitely a cut higher than in the other editions and last, but by no means least, this is the best sounding and most intelligible 9th. Recorded at surprisingly high level, this has tremendous dynamics, very wide frequency response, little choral "blur" or "fusion," generally low distortion even in the big climaxes. Strings were smooth and clean, brass big and noble sounding, percussion sharp and accurate except that a little more weight in the finale would have been welcome. Summing up, if you want a

DON'T JUST SAY CAPACITORS

DON'T JUST SAY CAPACITORS

DON'T JUST SAY CAPACITORS

Ask For Sprague By
Catalog Number

Know what you're getting
get exactly what you
want. Don't be vague
insist on Sprague. Use Complete radio-TV service catalog C-610. Write Sprague Products Company, 51 Marshall Street, North Adams, Massachusetts.

SPRAGUE

WORLD'S LARGEST

CAPACITOR MANUFACTURER

always buy
RAD-TEL
for HIGHEST QUALITY
TUBES
at lowest prices



SAME DAY SERVICE—FULL 1 YEAR GUARANTEE—INDIVIDUALLY BOXED

Another Rad-Tel Super-Special!
5F7 RCA
CATHODE RAY TUBE

Magnetic focus and deflection. 53° deflection angle, neck diameter 1 3/8 inch. Base shell octal 8-pin. Special features: long persistence for either low speed non-recurring signals or high speed recurring signals; two or more signals can be observed with suitable switching. single 95¢ ea.



Lots of 3 **79¢ ea.**

SPEAKERS

6" PM with filter choke, 10 W., 20 ohm resistor and 5 prong female socket. \$2.35 ea.

Lots of 3 **\$1.95 ea.**

AUTO SPEAKER

7 1/2" heavy duty dynamic. \$1.19 ea.

Lots of 3 **99¢ ea.**



FREE TUBE & PARTS CATALOG listing 400 high quality tube types. WRITE DEPT. RN-8.

EXPORT INQUIRIES INVITED
TERMS: 25% deposit must accompany all orders—balance C.O.D. All shipments F.O.B. Irvington warehouse.

Rad Tel
TUBE CO.
Not Aml. With Any Other Tube Mail Order Co.

Orders under \$5.00—50¢ handling charge. PLEASE: Send full remittance. Allow for postage and save C.O.D. charges. Unused money refunded. Subject to prior sale.

115 COIT ST., IRVINGTON II, N. J.

first rate performance with the best sound now available, you won't go wrong on this. The 8th gets a good performance, too, if at a somewhat hurried pace.

Tape Review

BEETHOVEN PIANO CONCERTO #4 MOONLIGHT SONATA

Guionar Novaes, pianist with Pro Musica Symphony, Vienna, conducted by Hans Swarowsky. Phonotapes-Sonore-Vox PM121. 7" reel, 7½ ips, dual-track. NARTB curve. Price \$7.95.

This is the first of the new *Phonotapes* I have heard and if this is any indication, the future bodes well for this new company. Using for the most part *Vox* masters and the masters of a few other smaller companies, they have already built up quite a formidable catalogue. The Novaes performance of the 4th is too well known to document further than saying it has all the sensitivity, restraint, and intelligent phrasing we have come to expect of this gifted artist. Above all else she makes her piano sing in broad lovely cascades of sound. Technically this is better than the disc by quite a bit. Dynamics of course are superior, but the extra cleanness of the piano sound is an unexpected plus. I could detect no harshness or transient ringing in the piano, no audible wcv or flutter. Hammer action was discernible the only mar in an otherwise fine recording. The orchestral accompaniment is full and wide ranged and entirely complementary to the piano. At a good comfortable room-filling level, tape hiss was so low as to be quite unnoticable. Whoever is doing the duplicating is doing a darn good job. The famous "Moonlight" fares equally well as the concerto both technically and artistically, except for a slight increase in tape hiss. All in all an auspicious start and I'm looking forward to future issues. It is also a happy thing to note that stereo will be produced on a regular basis by this company in the near future! As played on my *Ampex* 600, tape equalization was no problem whatever.

Next month I'll try to keep the stream of reviews rolling in your direction so that while you still have vacation time to listen to discs you may want to add to your permanent collection.

-30-

TV SETS IN USE

AN ESTIMATED three out of four households in the United States now have television receivers, according to the results of a sample survey conducted this spring by the U.S. Department of Commerce's Bureau of the Census.

About 35 million, or 73 per-cent of the households enumerated, had one or more television receivers. This represents a 10 per-cent increase over the 32 million households with television sets in June 1955 when the last survey of TV receivers was made by the Bureau. The June 1955 figure represented 67 per-cent of the households.

In 1950, the first time a question on television ownership was included in the census, there were about 5 million households with television sets, or 12 per-cent of the total.

The new figures were obtained in conjunction with the Census Bureau's Current Population Survey. The information was obtained at the request of the Advertising Research Foundation. A more detailed analysis of the results of this survey, including a breakdown of the figures into various categories, will be released in the near future, according to the Department of Commerce spokesman.

-30-

August, 1956

Foremost in RADIO and ELECTRONIC Books

RADIO HANDBOOK, GIANT 14th EDITION. A one-volume library of radio information, with extensive, simplified theory. Detailed how-to-build-it data on dozens of items of practical radio equipment\$7.50*

WORLD'S RADIO TUBES (Brans' Radio Tubes Vade Mecum) World's most authoritative tube book.....\$5.00*

WORLD'S EQUIVALENT TUBES (Brans' Equivalent Tubes Vade Mecum) Over 32,900 comparisons\$5.00*

WORLD'S TELEVISION TUBES (Brans' Television Tubes Vade Mecum) Covers all TV and special purpose tubes \$5.00*

BETTER TV RECEPTION (in fringe and low signal areas) Second edition. The standard guide for fringe-area installation technicians and enthusiasts..\$2.50*

RADIOTELEPHONE LICENSE MANUAL. Typical study questions with concise answers for any U.S.A. commercial radiotelephone operator's license..\$3.75*

FOR MORE DATA, SEND STAMP FOR CIRCULAR

*Plus any tax.



BUY FROM YOUR DISTRIBUTOR
Add 10% on direct mail orders to
EDITORS and ENGINEERS, Ltd.
Summerland 2, California



big reasons why QUIETROLE
Reg. U. S. Pat. Off.

is "The Choice of Better Service Dealers Everywhere"

- 1 MERIT
- 2 QUALITY
- 3 RELIABILITY

The original product for quieting noisy controls and switches . . . the universal lubri-cleaner for TV and radio . . .

Say "QUIETROLE" to your distributor . . . be sure you get it.

NO GUM! NO GOO! NO GRIME!

Carried by recognized jobbers . . . everywhere!

manufactured by

QUIETROLE COMPANY INC.
Spartanburg, South Carolina

IN CANADA: Active Radio & TV Distributors
38 Spadina Ave., Toronto 2B, Ont.

THE MUSICAL MASTERPIECE SOCIETY INVITES YOU TO ACCEPT

FREE

BEETHOVEN'S 9th SYMPHONY

(The Choral)

Plus Beethoven's 1st and 8th Symphonies

Netherlands Philharmonic Orchestra and Chorus Under the Baton of Walter Goehr

All Three Symphonies Complete
To The Last Note! The Most
Astounding Record Offer Ever Made!



To demonstrate the amazing value, the magnificent artistry of the Society's recordings take this majestic new album of BEETHOVEN'S NINTH . . . plus Beethoven's 1st and 8th symphonies—as a FREE GIFT! No obligation to buy another record ever. We simply want to introduce you to the enjoyment awaiting you in all the new releases listed below. Great masterpieces performed by world renowned artists and orchestras . . . reproduced on high-fidelity discs encompassing the entire range of human hearing.

Save Over 40% off usual cost
When you send for your FREE GIFT Recordings, you also become eligible to audition FREE any or all of these 30 additional discs at the rate of two a month. Pay only \$1.89, plus shipping, for each you keep. Pay nothing for those you don't want after 5 day trial. FREE GIFT is yours in any case. Mail coupon now!

THE MUSICAL MASTERPIECE SOCIETY, Dept. RT-8
43 W. 61st St., New York 23, N. Y.

Rush my FREE GIFT album of Beethoven's 9th, 1st and 8th symphonies. Also deliver for a 5 day free home trial the long-playing selections I have NOT crossed off at the right, about two a month. I will be billed only for those I keep — at only \$1.89 plus shipping, per long-playing disc. I may return any recording, and pay nothing. I may cancel my Trial Membership at any time. Free Gift is mine to keep in any case.

Name

Address

City..... Zone.. State.....
Canada: 105 Bond Street, Toronto 2, Ont.

Just Imagine the Fabulous Record Collection You Can Build From This List!

(Cross out only those you do not want to audition free)

1. DVORAK: Symph. No. 5
2. TCHAIKOVSKY: Violin Con.
3. MOZART: Piano Con. No. 24
4. BACH: Magnificat in D
5. BEETHOVEN: "Emperor" Concerto
6. BIZET: Symph. in C
7. VIVALDI: Four Seasons
8. SCHUMANN: Piano Concerto
9. HAYDN: Trumpet-Concerto, and Flute-Concerto
10. SCHUBERT: "Trout" Quintet
11. MOZART: "Jupiter" and 17th Symph.
12. CHOPIN: Piano Con. No. 1
13. BACH: Violin Con. No. 2
14. RIMSKY-KORSAKOFF: Capriccio Espagnol; Mussorgsky: Intro. to "Khorovantchina"
15. DEBUSSY: Quartet in G; and Sonata for Cello and Piano
16. BEETHOVEN: "Appassionata" and "Moonlight" Sonatas
17. BRUCH: Violin Concerto; PAGANINI: La Campanella
18. MOZART: Clarinet Quint. in A
19. SAINT-SAENS: Violin Concerto No. 3
20. MOZART: Symph. Nos. 40 & 34
21. GOLDMARK: Rustic Symph.
22. BEETHOVEN: Symph. No. 7
23. CHOPIN: Sonata No. 2
24. HAYDN: "Surprise" and "Military" Symphs.
25. FRANCK: Symph. in D
26. STRAVINSKY: Firebird, and Piano Con.
27. SCHUBERT: Symph. No. 3
28. PROKOFIEFF: Violin Con. No. 1 and Piano Con. No. 1
29. MENDELSSOHN: "Scottish" Symph.
30. DVORAK: "American" Quar.

COMPLETE TRAINING FOR BETTER RADIO-TV SERVICE JOBS

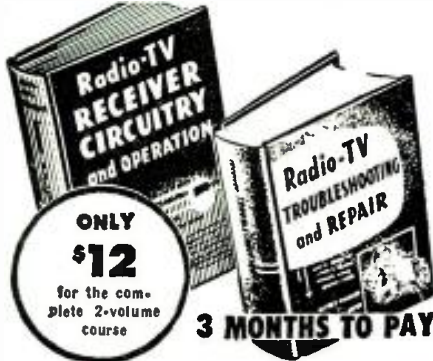

Let these two great new Ghirardi training books teach you to handle all types of A.M., F.M. and TV service jobs by approved professional methods—and watch your efficiency and earnings soar!

Completely modern, profusely illustrated and written so you can easily understand every word, these books gave the way to fast, accurate service on any type of home radio-TV-electronic equipment ever made. Each book is brand new. Each contains the latest data on the latest methods and equipment—NOT a re-hash of old, out-of-date material. Each is co-authored by A. A. Ghirardi whose famous RADIO PHYSICS COURSE and MODERN RADIO SERVICING were, for 20 years, more widely used for military, school and home study training than any other books of their type!

THE NEW Ghirardi RADIO-TV SERVICE LIBRARY

Almost 1500 pages and over 800 clear illustrations show step-by-step how to handle every phase of modern troubleshooting and servicing.

1—Radio and Television Receiver TROUBLESHOOTING AND REPAIR

A complete guide to profitable professional methods. For the beginner, it is a comprehensive training course. For the experienced serviceman, it is a quick way to "brush up" on specific jobs, to develop improved techniques or to find fast answers to puzzling service problems. Includes invaluable "step-by-step" service charts. 320 pages, 417 illus., price \$6.75 separately. (Outside U.S.A. \$7.25)

2—Radio and Television Receiver CIRCUITRY AND OPERATION

This 669-page volume is the ideal guide for servicemen who realize it pays to know what really makes modern radio-TV receivers "tick" and why. Gives a complete understanding of basic circuits and circuit variations; how to recognize them at a glance; how to eliminate guesswork and useless testing in servicing them. 417 illus. Price separately \$6.50 (outside U.S.A. \$7.00).

New low price...you save \$1.25!

If broken into lesson form and sent to you as a "course," you'd regard these two great books as a bargain at \$50 or more! Together, they form a complete modern servicing library to help you work faster, more efficiently and more profitably. Completely indexed so you can look up needed facts in a jiffy.

Under this new offer, you save \$1.25 on the price of the two books—and have the privilege of paying in easy installments while you use them! No lessons to wait for. You learn fast—and you learn right!

STUDY 10 DAYS FREE!

Dept. RN-86, RINEHART & CO., Inc.
232 Madison Ave., New York 16, N. Y.

Send books below for 10-day FREE EXAMINATION. In 10 days, I will either remit price indicated or return books postpaid and owe you nothing.

- Radio & TV Receiver TROUBLESHOOTING & REPAIR (Price \$6.75 separately)
- Radio & TV Receiver CIRCUITRY & OPERATION (Price \$6.50 separately)

Check here for MONEY-SAVING COMBINATION OFFER... Save \$1.25. Send both of above big books at special price of only \$12.00 for the two. (Regular price \$13.25... you save \$1.25). Payable at rate of \$3 after 10 days if you decide to keep books and \$3 a month for 3 months until the total of \$12 has been paid.

Name

Address

City, Zone, State

Outside U.S.A.—\$7.25 for TROUBLESHOOTING & REPAIR; \$7.00 for CIRCUITRY & OPERATION; \$13.00 for both books. Cash with order, but money refunded if you return books in 10 days.

The "Injecto-cal"

(Continued from page 49)

step attenuator, the calibration may be made at one of the lower voltage levels, thus allowing large voltages to be measured.

Most of the a.c. vacuum-tube voltmeters measuring from 1 volt r.m.s. and up are actually dependent on the peak-to-peak voltage for their readings although the scales are calibrated in r.m.s. volts. The scale reading is actually .354 of the peak-to-peak voltage; keeping this in mind, the calibration of the v.t.v.m. may be checked with the "Injecto-cal."

For calibrating d.c. voltmeters, the internal mercury battery is used. With the "Injecto-cal" turned on, 6.7 volts is available between the ground lead (negative terminal) and the test point shown in Fig. 4. A small hole should be provided in the rear of the case for access to this positive point.

Altogether, the "Injecto-cal," when properly used, can be a very useful instrument in the hands of a radio-TV service technician or experimenter.

—50—

KARLSON CABINET MODIFICATION

AS THE result of a series of comprehensive tests in cooperation with Southeast Electronics, Karlson Associates has just announced a further improvement in its popular 15-inch loudspeaker enclosure.

Although it did not show up in earlier tests because of the test method employed and the type of testing gear then available, all of the previous enclosures exhibited peaks in the mid-frequency range. With minor modifications, this problem has been eliminated, resulting in more uniform performance.

The changes are minor and simple to make. In the diagram below note that the horizontal shelf is now positioned $5\frac{3}{4}$ " in front and its over-all size from front to rear is $10\frac{1}{2}$ ". The port opening should be decreased in size to a new dimension of $3\frac{1}{2}$ ". In order to adopt these new dimensions it will be necessary to add on four strips of wood. These should be secured with wood screws and glue.

With the addition of the horizontal shelf, as mentioned, it is more important than ever that the entire front chamber of the enclosure have a very hard and glossy finish. If necessary, brush on at least three coats of clear lacquer. If this is not done there will be considerable loss at the high-frequency end of the spectrum.

—50—

Modifications on the Karlson 15" speaker enclosure adopted after special testing.

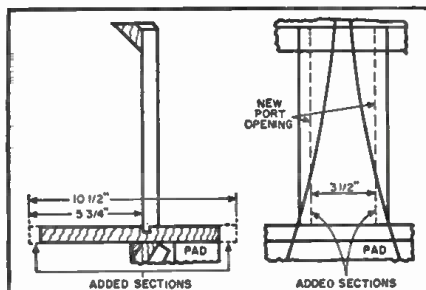

OSCILLOSCOPE

Model 830
Mfd. for U.S. NAVY

This scope is a combination of a highly efficient conventional 3" oscillograph, with a thyratron linear sweep and a synchronized sweep frequency modulator or wobulator. Operates from 115VAC-60 cycles. The perfect instrument for service, labs, schools, industry, experimenter. All features of high priced lab scopes available to you at less than the price of a kit.

SIZE: 10" x 7 $\frac{1}{8}$ " x 14"
wt. 23 lbs.

\$29.95

All tested. All in perfect operating condition. All made to rigid Navy specs. A complete "scope with instruction book for less than the price of a kit. (We ship by express.)

complete F.O.B. N. Y.

TELESCOPING MAST SECTION, MS-53. Threaded on both ends to permit telescoping to any desired length. Each rod is 1 meter (33 $\frac{3}{4}$ "). Sturdy flexible steel with brass ends. Unlimited possibilities: mobile, verticals, and planes, etc.

—New—Sold only in lots of 6..... **6/\$2.75**

COMMAND SERIES IN STOCK

Rcvrs. All Excellent Condition. All with tubes and Crystals.

3-6 MC—w/dyn. Black Wrinkle Finish..... \$6.95

6-9 MC—w/dyn. Black Wrinkle Finish..... 6.95

XMTRS. ALL EXCELLENT COND. ALL WITH TUBES.

2-1.3 Mc. Black Wrinkle Finish..... \$5.95

3-4 Mc. Black Wrinkle Finish..... 6.95

4-5.3 Mc. Black Wrinkle Finish..... 5.95

5-3.7 Mc. Black Wrinkle Finish..... **\$6.95**

S.S.B. These Brand New

7-9.1 Mc \$6.95

SPECIAL

BC-458, 5.4-7 Mc transmitter, used condition. Perfect for conversion to SSB at an **2 for \$5.00** all time low.....

MODULATION XFORMER, 20 watt. Mfd. for TCN transceiver, Stancor 95A10. Also used as 1:1 isolation..... \$ 1.95

FILA XFORMER, 24t, 1.5A, compact FB all surplus gear..... 1.95

FILA XFORMER, 5v, 15A, new..... 2.95

TUBE TYPE 1625 (SSB) types—Dozen..... 2.25

SENSITIVE MICRO-AMMETER—0-50 Micro Amp DC 2 $\frac{1}{2}$ "—New, St.—New..... 5.95

DUMONT OSCILLOSCOPE 224A—Exc. Cond. 79.95

VIBRAPACK PE 104—Exc. Cond..... 4.95

WESTON ANALYZER 772, Exc. Cond..... 39.95

HANDY TALKY BC 611, Matched prs. New Ben. Operating cond.—Pair..... 149.95

HAND SET 78-13 (w/cables). Like New..... 5.95

REX RADIO SUPPLY 88 Cortlandt St. New York 7, N. Y.

SELF SELECTING

ELSCO

NOISE REDUCING ANTENNAS

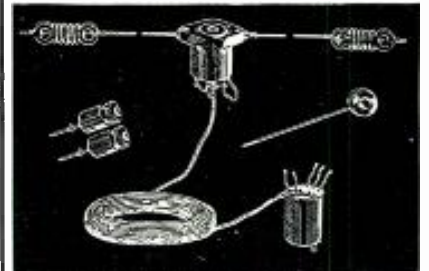

- Wide-band reception with correct impedance matching.
- Cancels all noise picked up by transmission line.
- Used by Government laboratories, Hams, SWLS, and service institutions.
- Recommended for installations where noise pickup is a problem.
- Antenna always automatically tuned to frequency.
- Sold complete with insulators, pre-measured flat-top, transmission line, and couplers.

\$14.25

- Also available as MASTER ANTENNA system for apartment houses, hospitals, etc.

Write for further information and price.

ELECTRONIC SPECIALTIES MFG. CORP.
76 Irving Street Worcester 10, Mass.

Color Test Equipment
(Continued from page 65)

The chrominance phase display corresponding to an NTSC color-bar signal for the case of distortionless receiver circuits and scope amplifiers is diagrammed in Fig. 9. This diagram deserves some attention, inasmuch as it provides the bench man with a wealth of direct data concerning chrominance circuit operation. As the color phasing control is turned, the vector display rotates on the scope screen. As the color intensity control is turned, the display expands or contracts accordingly. The length of each vector from the center (black) is proportional to the chrominance voltage for that color. The angle of each vector with respect to the horizontal axis is equal to the phase of the chrominance voltage for that particular color.

If the angles do not appear correctly in the vector display, the phase of one or both of the color subcarriers is incorrect—this latter point is determined by observing which color phases appear correctly and which do not. If the lengths of the vectors do not appear in proper ratios, the output voltages from the color detectors (either or both) are incorrect, or the output voltage from the G-Y matrix is incorrect. Again, this localization is made by observing which vector lengths are out of proportion.

Which color test instruments will be required by your shop depends upon how much color TV service work you are anticipating. While the amount of color TV servicing and installation is limited at present, those who are prepared to handle such jobs will get the lion's share when the market opens up.

Fig. 9. The vector display shown here corresponds to the bar pattern above it. This is a correct display; if the receiver circuits were faulty, the display would be different. See Fig. 8.

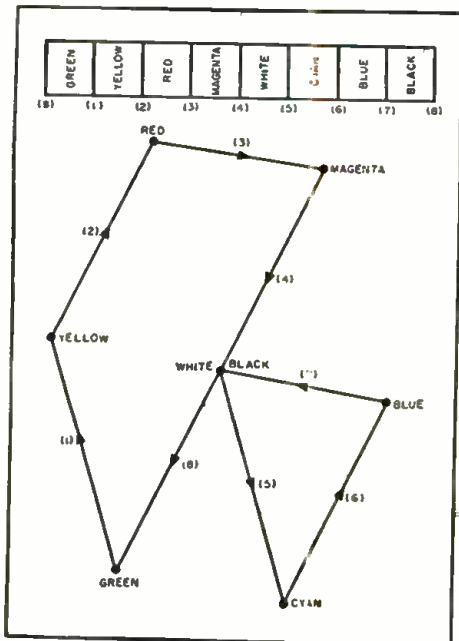

INDEPENDENT SCIENTIFIC SURVEY
AND LAB TESTS PROVE
PRECISE MODEL #111---"BEST
COMMERCIAL TUBE TESTER
AT ANY PRICE"...



Now You Can Check Tubes
The Manufacturer's Way

- Checks both emission and mutual conductance
- Checks all tubes including hearing aid, miniatures
- Six different plate voltages
- Different grid signals
- Simplified Short check
- Gas check
- New type switches
- Deeply etched aluminum panel
- Three different screen voltages
- Latest roll chart
- Measures filament current
- Measures grid bias

precise
Model #111

111K (kit form) **NOW ONLY \$79.95**
111W (factory wired) \$139.95
incl. carrying case and cover

Mutual Conductance and Emission TUBE TESTER

An independent scientific survey conducted by an impartial testing laboratory confirms what purchasers already know: "The most advanced, the most complete tube tester and the best priced is made by PRECISE DEVELOPMENT CORP., Oceanside, N. Y."

CHECK THESE ADDITIONAL 'specs' ... TALK TO YOUR JOBBER AND TO ANYONE WHO HAS THIS OUTSTANDING TUBE TESTER...

The Model 111 is the only single commercial tube tester that checks all tubes for both EMISSION and MUTUAL CONDUCTANCE separately. Filament current is measured directly on large meter when checking a VOLTAGE SAPPER tube. NEW, MODERN DESIGNED ROTARY SWITCHES allow you to check each tube element individually. NEW TYPE Single Rotary switch for complete short checks. The 111 makes all BIAS,

FILAMENT VOLTAGE, GAS, LIFE checks visually on large meter ... 5 individually calibrated ranges and scales for mutual conductance tests. NEWLY DESIGNED "NO BACKLASH" ROLL CHART lists all tubes including the new type 600 mil series tubes. Provisions are made for testing many color tubes. All CRT's can be checked with accessory adaptor, Model PTA.

ASK YOUR DISTRIBUTOR ABOUT THE FAMOUS MODEL #116 QUICK-TEST VERSION OF THE MODEL #111 ... TESTS 5 TUBES IN 4 SECONDS EACH ... ACCURATELY

precise DEVELOPMENT CORP., OCEANSIDE, NEW YORK

THE NEW No-Noise TUNER-TONIC

Volume Control and Contact Restorer with Perma-Film



Cleans, lubricates, protects ... not a carbon-tet solution. Still available in the new 6 oz. spray can. Net to servicemen—\$2.25

with **PERMA-FILM**

Cleans, lubricates, restores all tuners including wafer type. Won't change or affect capacities, inductance or resistance. Won't harm insulations or precious metals, nor attack plastics. For television, radio and FM. Eliminates all noise, oxidation and dirt indelibly. Non-toxic. Net to non-inflammable, insures trouble-free performance. Extra economical because a small amount does the job!



2 oz. bottle. Net to servicemen **1.00**

Also available in 8 oz. bottles and quart cans. At your nearest distributor.

\$3.25

ELECTRONIC CHEMICAL CORP.

813 Communipaw Avenue

Jersey City 4, N. J.

Your choice of school
is highly important
to your career in



**INDUSTRIAL
ELECTRONICS**



RADIO



TELEVISION

Become an
**ELECTRICAL
ENGINEER**
or an
**ENGINEERING
TECHNICIAN**
at

MSOE in Milwaukee

Choose from courses in:

ELECTRICAL ENGINEERING
Bachelor of Science degree in 36 to 42
months with a major in electronics or
electrical power.

ELECTRICAL TECHNOLOGY
Engineering Technician certificate
in 12 months in electronics, radio, or
electrical power;

Associate in Applied Science degree
in 18 months in radio and television.

TECHNICAL SERVICE
Service certificate in 6 months in electro-
nicity; in 12 months in radio and television.

MSOE — located in Milwaukee,
one of America's largest indus-
trial centers — is a national
leader in electronics instruction
— with complete facilities,
including the latest laboratory
equipment, visual aid theater,
amateur radio transmitter —
offers 93 subjects in electrical
engineering, electronics, radio,
television, electrical power,
and electricity.

Advisory committee of lead-
ing industrialists. Courses
approved for veterans. Over
50,000 former students.
Excellent placement record.

TERMS OPEN SEPTEMBER,
JANUARY, APRIL, JULY

Choose wisely — your
future depends on it. Write
for more information today!



MILWAUKEE
SCHOOL OF ENGINEERING
Dept. RN-856 1025 N. Milwaukee St.
Milwaukee 1, Wisconsin

Send FREE career booklets on:

Electrical Engineering Radio-Television

I am interested in..... (Name of course)

Name..... Age.....

Address.....

City..... Zone..... State.....

If veteran, give discharge date.....

MS-31

Intermittent Localizer

(Continued from page 59)

and audible alarms. With one probe connected to the output of the r.f. mixer and the other to the input of the video amplifier, for example, tripping of the alarms of both channels would indicate that the trouble is in the front end of the TV set. However, if the alarm circuit of the channel connected to the mixer does not trip, the trouble is obviously after the mixer stage.

The "Monitron" consists of two individual signal tracer circuits, each with an electronic alarm circuit and both making use of a common audible alarm. See Fig. 2. Each channel is provided with a probe which contains a diode to permit rectification of a sample of almost any type of continuous signal of sufficient amplitude. The d.c. output of the probe is fed through a linear level control to the input of a cascode type d.c. amplifier. The output of the amplifier is measured by one section of a type 6AF6G electronic eye tube. The one dual electronic eye tube serves both channels. The output of the d.c. amplifier also affects the bias on a thyratron tube. Failure or a sharp drop in applied signal voltage

changes the bias on the thyratron, causing it to fire and permit plate current to flow. This causes the neon indicator lamp for that particular channel to glow and simultaneously turns on an audio frequency oscillator, common to both channels, whose output is amplified and heard through the built-in loudspeaker. Thus both visible and audible alarms are provided. The alarm response time is about 1/200th of one second so that very short breaks in signal may be detected.

In addition to monitoring and signal tracing, the instrument can be used to measure the relative gain or loss in a circuit by noting the difference in level setting to obtain the same amount of electronic eye deflection as the probe is moved from one point to another. Besides its use in servicing TV sets and home radio receivers, it has many industrial applications, particularly in the servicing of mobile radio equipment. In microwave relay systems, this type of instrument can prove very valuable for checking i.f. circuits in repeater and terminal equipment as well as circuits carrying signals in the video spectrum. It can also be useful in "debugging" many types of electronic control systems where continuous signals are employed. The technique is similar to that used in locating receiver intermittents. —30—

LOW-COST TRANSISTORIZED POCKET RECEIVER

THOSE willing to part with a five-dollar bill in the interests of learning more about transistor circuitry and at the same time make something useful will undoubtedly want to try building this one-transistor pocket receiver, as shown in the diagram below.

The entire circuit may be built into a plastic box which measures just 3" x 2" x 1". The type of box that opens in the center should be purchased since in this circuit the batteries are housed in the lid while the balance of the components fit neatly into the base of the box.

The circuit itself is a combination crystal diode and transistor one which will provide excellent local reception using an earphone. Incidentally, if a dynamic earphone is used in place of the crystal unit shown in the diagram, the 4700-ohm resistor across the phones should be removed.

An unusual feature of this circuit is the double-tuned antenna stage. A "High-Q" ferrite core antenna is used to select the station while the specially designed miniaturized 365- μ fd. variable capacitor peaks the response of the station selected.

The IN34A crystal diode is used as a detector and the transistor (a G-E Type 2N107 "p-n-p" junction unit) is connected as a grounded-emitter amplifier in this particular circuit.

All of the parts required to build this receiver are standard and may be purchased at most of the larger parts jobbers. If the builder wishes to purchase the entire unit in kit form for convenience, Lafayette Radio, 100 Sixth Ave., New York 13, N. Y., offers the receiver as the KT-80 for \$4.95 without earphone. A miniature crystal earphone is available for \$1.49 extra. —30—

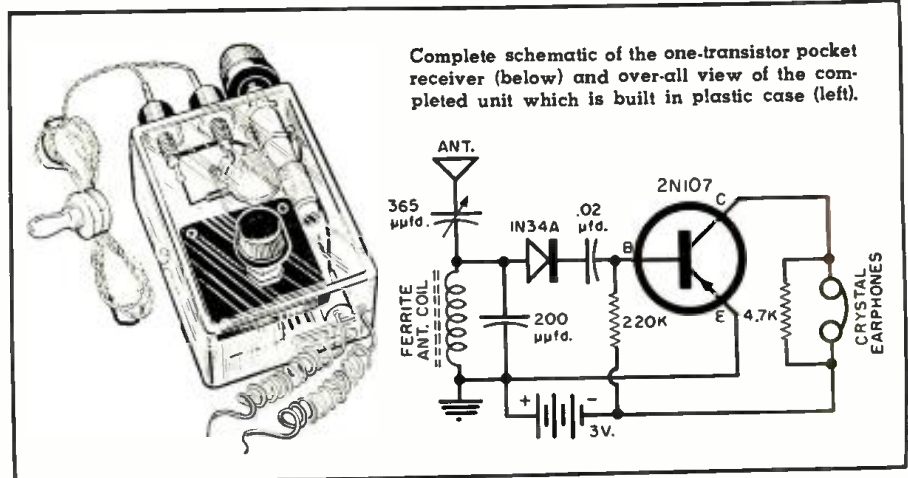

Complete schematic of the one-transistor pocket receiver (below) and over-all view of the completed unit which is built in plastic case (left).

illness. He was 56 years old. **IRVING KAUFMAN** is the new president in charge of engineering at *Audio-Video Recording Co. Inc.* He will supervise all engineering personnel and facilities for the New York firm. . . . **EARL H. KIRK** has been appointed distributor sales manager of the *Regency Division of I.D.E.A., Inc.* He has been with the firm since 1951 and has over 35 years' experience in the radio and electronic field. . . . **DR. BENNETT S. ELLEFSON** and **MARION E. PETTEGREW** were named vice-president in charge of engineering and research and vice-president of tungsten-chemical and parts operations, respectively, by *Sylvania Electric Products Inc.* . . . **BILL ATKINS** is the new industrial sales manager of the *Mellotone Division of Wendell Plastic Fabric Corp.* of New York. . . . *National Company, Inc.* of Malden and Melrose, Mass. has appointed **GEORGE E. MAGRATH** to the post of eastern manager of industrial sales. . . . *Bradley Laboratories* has named **HAROLD B. ROSENBERG** to the post of production manager of its selenium division. He has been with the firm since 1950. . . . **DONOVAN H. TYSON** has been elected vice-president and controller of *Allen B. Du Mont Laboratories, Inc.* . . . **FRANK ADAMS**, eastern sales manager of *ORRadio Industries, Inc.*, passed away in Philadelphia after a long illness. He was 59. . . . **ARTHUR L. CHAPMAN** is the new vice-president, manufacturing, for *Sylvania Electric Products Inc.* He will make his headquarters at the company's New York City offices. . . . The appointment of **THOMAS B. KALBFUS** to the post of general sales manager has been announced by the television-radio division of *Westinghouse*. . . . **DR. ROBERT J. JEFFRIES** is the new assistant to the president of *Daystrom, Inc.* His responsibilities will include executive development, education, and training at all levels of the organization. . . . **DR. WENDELL B. SELL** has been appointed general manager of the Electronics Division of *American Machine & Foundry Company*. He will make his headquarters in Boston. . . . **DAVE COLE** is the new national sales manager of commercial products for *Dynamic Electronics-New York, Inc.* of Forest Hills, Long Island. . . . *Armour Research Foundation of Illinois Institute of Technology* has named **DR. ROBERT W. BENSON**, an acoustic specialist, to the post of assistant manager of the physics research department. . . . **CHARLES W. KLEIDERER** is the new vice-president for sales of *Penn-Plastics Corporation*. He was also elected to the firm's board of directors. . . . **CLAUDE D. VANNOY** has been elected assistant treasurer of *International Resistance Company* of Philadelphia. . . . The appointment of **ROBERT D. WICK** to the post of manager, government sales, Semiconductor Division has been an-

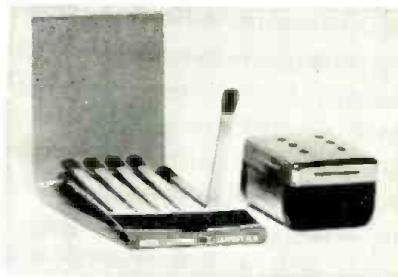

TELEX Mini-Mike®

- Tiny, precision speaker-microphone.
 - Quality, dynamic performance.
 - For use in dictating machines, transceivers, other electronic equipment where "ruggedness" is important.
- Model 100 PRECISION DESIGN Wt. approx. 1 1/4 oz.; Size 1" x 1" x 3/4"; Impedance 10 ohms

TELEX Boom-Type Headset

NEW! For airline reservation boards, telephone operators, television floormen.

- Lightweight, adjustable tone arms, no ear muffs.
- Available with single, double receivers, split phones.



TELEX TV "Listener"

For TV or radio enjoyment where INDIVIDUAL listening is desired. Allows children to watch "westerns" while Dad reads the paper. Two persons may use at same time. 4' cord from Earset to control unit, 10' cord from unit to TV or radio set.

We'd like to send you additional information! Write Dept. EA-3.

TELEX, INC.

Electro-Acoustic Division, Telex Park, St. Paul 1, Minn.

Manufacturers of the World's Finest Precision Miniature Electronic Equipment.

FREE 1956 CATALOG

WORLD RADIO LABORATORIES
"The World's Largest Distributor of Amateur Radio Equipment"

Jam packed with bargains — everything in Radio, TV, and Hi-Fi — for Handyman, Ham, Experimenter or Serviceman!

- Pay Only 10% Down
- Easy Terms
- Liberal Trade-Ins
- Save Over 50% on Recond. Eqp't.
- Over 800 Guaranteed Recond. Items



WORLD RADIO LABORATORIES
3415 WEST BROADWAY
COUNCIL BLUFFS, IOWA



Lgo I. Meyerson

PERSONALIZED SERVICE

MAIL HANDY COUPON

WORLD RADIO LABORATORIES, INC. R-8
 3415 W. Broadway — Council Bluffs, Iowa
 Free 1956 Catalog New Beam Manual
 Wall-Sized Radio Map 25c
 NAME _____
 ADDRESS _____
 CITY _____ STATE _____

LEARN

Television RADIO-COLOR-TV Electricity ELECTRONICS IN THE GREAT SHOPS OF COYNE

TRAIN QUICKLY! OLDEST, BEST EQUIPPED SCHOOL of ITS KIND in U.S.

Veterans and Non-Veterans—Get practical training in top opportunity fields. Prepare now for a better job and a real future. Advanced education or previous experience not needed. Employment service to graduates.

Enroll NOW—Pay Later

Finance Plan and Easy Payment Plan. Also Part Time Employment help for students. Training in Refrigeration and Electric Appliances can be included.

FREE BOOK Clip coupon for Big Free Illustrated Book. No obligation and No Salesman Will Call. Act NOW.

B. W. Cooke, President

A TECHNICAL TRADE INSTITUTE OPERATED NOT FOR PROFIT Established 1899 500 S. Paulina, Chicago

COYNE ELECTRICAL SCHOOL

B. W. COOKE, Pres.
COYNE Electrical School
500 S. Paulina St., Chicago 12, Ill. Dept. C6-85H

Send FREE BOOK and full details on:

- TELEVISION-RADIO
- ELECTRICITY-ELECTRONICS

NAME _____
 ADDRESS _____
 CITY _____ STATE _____

EXPAND YOUR PORTABLE TV SALES

WITH



INVERTERS

for changing your storage battery current to A. C. HOUSEHOLD ELECTRICITY

Anywhere... in your own car!

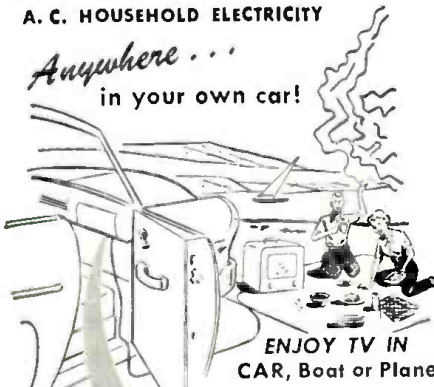

mounted out of sight under dash or in trunk compartment!

ENJOY TV IN CAR, Boat or Plane



EASY TO INSTALL EASY TO OPERATE

ATR INVERTERS

especially designed for operating standard 110 volt A.C. portable TV sets

also

- TAPE RECORDERS
- WIRE RECORDERS
- DICTATING MACHINES
- ELECTRIC RAZORS

for

- EXECUTIVES
- SALESMEN
- PUBLIC OFFICIALS
- POLICEMEN
- FIREMEN
- OUTDOOR MEN
- REPORTERS
- FIELD INSPECTORS
- DOCTORS
- LAWYERS, ETC.

See your jobber or write factory

- ✓ NEW MODELS
- ✓ NEW DESIGNS
- ✓ NEW LITERATURE
- 11" A Battery Eliminators,
- DC-AC Inverters,
- Auto Radio Vibrators



AMERICAN TELEVISION & RADIO CO.

Quality Products Since 1931

SAINT PAUL 1, MINNESOTA, U. S. A.

nounced by Radio Corporation of America. He will make his headquarters at Somerville, N.J. . . . **ALFRED B. ROSSIP** has been named staff engineer and assistant to the president of *General Transistor Corp.*, Richmond Hill, N.Y. . . . **DR. HERBERT S. BENNETT** has been appointed to the engineering staff of *Allen B. Du Mont Laboratories, Inc.* He was formerly director of research and development at *Dynamic Electronics Corp.*

HERBERT O. WILSON has been appointed works manager of the *Astatic Corporation* of Conneaut, Ohio.

He formerly held similar positions at the *Fada Radio & Electronics Co.* of Belleville, N. J., and the *Radiart Corporation* of Cleveland. His background of diversified mechanical development and manufacturing experience was acquired through his association with these firms as well as with *Western Electric, RCA,* and *Thomas A. Edison Co.*



A graduate of Bucknell University, Mr. Wilson served during World War II as officer in charge of the Marine Corps Radio Section, Electronic Design Branch of the Navy's Bureau of Ships, in Washington, D. C.

RAYTHEON MANUFACTURING COMPANY has sold the assets of its television and radio operations in Chicago to *Admiral Corporation* of that city.

The new acquisition will be operated as the Belmont Division of *Admiral*. Included in the transaction are two plants in Chicago, the inventory of finished television and radio receivers, and plant equipment. The two plants include a total of approximately 430,000 square feet of space.

Raytheon's major operations, which are concentrated in the greater Boston area, will not be affected.

Henry F. Argento, a vice-president of *Raytheon* and manager of the TV and radio operations, will join *Admiral* in a similar capacity with its Belmont Division.

Terms of the transaction were not disclosed by the principals.

DONALD E. GARR has been named manager of *General Electric Company's* newly established Industrial Electronics Laboratory in Syracuse, New York.

He has been with the company since 1936 when he entered the firm's test course following graduation from Kansas State College with a B.S. degree in electrical engineering. For the past 16 years he has been employed in the company's general engineering laboratory in a number of managerial positions.



Within the Industry
 (Continued from page 1)
 Having a Short
 Vice-President
 Engineering

PHOTO ELECTRIC
 95¢
 CE Vac use
 1-1 Mfg. ing
 New. remove
 equip. 4 1/2" x 4 1/2"

GE Pyronol Oil CONDENSER
 12 MFD. 330 VAC. 50 CY. 95¢
 Removed from equip. NEW.

30 TUBE SOCKETS. Subminiature, 7 & 9 pin miniature; 4 to 8-pin. Alca-nibed & ceramic shield base (type 100)

2000 PCS. HARDWARE. Radio, TV, shop, wood-working screws, springs, grommets, etc.

40 MOULDED CONDENSERS. Best known makes .0005 to 0.1 mf to 1000V.

30 CERAMIC DISC CONDENSERS. .01 mmf to 1000V. TV repairmen note!

8 TUBULAR ELECTROLYTICS. Popular values to 450V. Top makes, axial leads.

60 KNOBS. Instrument, radio, TV types. Push-on & set screw types. Some 35c ea.

10 PANEL SWITCHES. Momentary, push & rotary. Wide variety.

50 TUBULAR CONDENSERS. 23 values! .00035 to 1 mf., up to 6000V. Oil, 100.

10 PP & TWIST ELECTROLYTICS. Ass'd. to 1000 mfd. to 450V. Some multiples.

100 COIL FORMS. Experimenters, note! Wide variety of shapes & sizes. Ceramic and bakelite.

60 CARBON RESISTORS. Insulated; 35 values. 15 ohms to 10 megs. 1/2, 1 & 2W; 5% & 10% incl. famous Allen Bradley!

CHOICE KIT 97c
 LISTED THIS

50 MF. CONDENSERS. Rare 5 values. .0001 to 1200 W/DC. Silver. 57¢

10 CARBON RESISTORS. 30 values; 100 ohm to 1 meg; 1/2, 1 & 2W. Many 5%. Uninsulated.

30 POPULAR BULBS. Special! Wide variety standard, miniature, screw and bayonet types. 1.1 thru 6V.

12 LINE CORDS. AC/DC cords; molded plugs. For all electrical eqpt. Stock up now!

50 CERAMIC CONDENSERS. Tubular, disc, button & standard! 5 to .01 mmf to 1000V.

12 VOLUME CONTROLS. Handy, shop asst. of radio, TV, lab units. Some 1W.

50 RF COILS & CHOKES and short-tuned coils for TV, radio, lab. 20 types.

20 POWER RESISTORS. Wirewound, 20 values. 5 ohms to 12,000. 5 to 50 watts. Candohm & tubular types.

All New MYSTERY PACKAGE of ELECTRONIC PARTS

It's the surprise of your life! 20 pounds of BRAND NEW usable GOVT. surplus. The ideal gift for hams, etc.

Worth \$40.00
 Our Price **\$395**
 Ship Wt. 20 lbs.

PICTURE TUBE BRIGHTENER 94¢

TERMS: Cash with order or 25% DOWN—BALANCE C.O.D.
 ALL PRICES NET F.O.B. DETROIT MINIMUM ORDER \$2.00

TYler 8-9400
HERSHEL RADIO CO.
 5249 GRAND RIVER Detroit 8, Michigan

Assortments for One Buck

100 1/2 W Resistors
 75 1 W Resistors
 50 2 W Resistors
 10 W.W. Resistors
 50 TUB Condensers
 30 CER. Condensers
 30 MICA Condensers
 3 TV Elect. Cond.
 5 Radio Elect. Cond.

20 Pilot Lights
 50 Sockets
 50 Radio Knobs
 50 Term. Strips
 10 Vol. Cont. L/SW
 5 Vol. Cont. N/SW
 10 TV Coils
 Wire and Solder Kit
 Hardware Kit

CAPITAL ELECTRONICS, 222 Fulton St., N. Y. C.

RADIO and TELEVISION ELECTRONICS

RCA in all Technical Phases
 New Classes (Day and Evening) Start 1st of Dec., Mar., June, Sept.

Free Placement Service for Graduates
 For Free Catalog write Dept. RN56
RCA INSTITUTES, INC.
 A Service of Radio Corporation of America
 350 WEST 4TH ST., NEW YORK 14, N. Y.

EXPAND YOUR PORTABLE TV SALES

WITH



INVERTERS

for changing your storage battery current to A. C. HOUSEHOLD ELECTRICITY

Anywhere... in your own car!

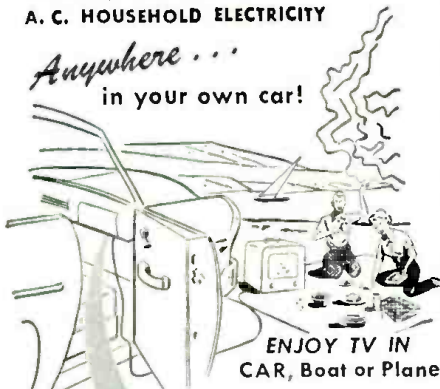

ENJOY TV IN CAR, Boat or Plane

mounted out of sight under dash or in trunk compartment!



EASY TO INSTALL EASY TO OPERATE

ATR INVERTERS

especially designed for operating standard 110 volt A.C. portable TV sets also

- TAPE RECORDERS
 - DICTATING MACHINES
 - WIRE RECORDERS
 - ELECTRIC RAZORS
- for
- EXECUTIVES
 - OUTDOOR MEN
 - SALESMEN
 - REPORTERS
 - PUBLIC OFFICIALS
 - FIELD INSPECTORS
 - POLICEMEN
 - DOCTORS
 - FIREMEN
 - LAWYERS, ETC.

See your jobber or write factory

✓ NEW MODELS ✓ NEW DESIGNS ✓ NEW LITERATURE
"A" Battery Eliminators, DC-AC Inverters, Auto Radio Vibrators

ATR AMERICAN TELEVISION & RADIO CO.
Quality Products Since 1931
SAINT PAUL 1, MINNESOTA, U. S. A.

nounced by Radio Corporation of America. He will make his headquarters at Somerville, N.J. . . . **ALFRED B. ROSSIP** has been named staff engineer and assistant to the president of *General Transistor Corp.*, Richmond Hill, N.Y. . . . **DR. HERBERT S. BENNETT** has been appointed to the engineering staff of *Allen B. Du Mont Laboratories, Inc.* He was formerly director of research and development at *Dynamic Electronics Corp.*

HERBERT O. WILSON has been appointed works manager of the *Astatic Corporation* of Conneaut, Ohio.



He formerly held similar positions at the *Fada Radio & Electronics Co.* of Belleville, N. J., and the *Radiart Corporation* of Cleveland. His background of diversified mechanical development and manufacturing experience was acquired through his association with these firms as well as with *Western Electric, RCA,* and *Thomas A. Edison Co.*

A graduate of Bucknell University, Mr. Wilson served during World War II as officer in charge of the Marine Corps Radio Section, Electronic Design Branch of the Navy's Bureau of Ships, in Washington, D. C.

RAYTHEON MANUFACTURING COMPANY has sold the assets of its television and radio operations in Chicago to *Admiral Corporation* of that city.

The new acquisition will be operated as the Belmont Division of *Admiral*. Included in the transaction are two plants in Chicago, the inventory of finished television and radio receivers, and plant equipment. The two plants include a total of approximately 430,000 square feet of space.

Raytheon's major operations, which are concentrated in the greater Boston area, will not be affected.

Henry F. Argento, a vice-president of *Raytheon* and manager of the TV and radio operations, will join *Admiral* in a similar capacity with its Belmont Division.

Terms of the transaction were not disclosed by the principals.

DONALD E. GARR has been named manager of *General Electric Company's* newly established Industrial Electronics Laboratory in Syracuse, New York.



He has been with the company since 1936 when he entered the firm's test course following graduation from Kansas State College with a B.S. degree in electrical engineering. For the past 16 years he has been employed in the company's general engineering laboratory in a number of managerial positions.

SPECIAL SUMMER

OIL COND. \$1.65
2 MFD. 3000 VDC. Pyranol Oil. W/Mounting brackets. 2-1 Mfd. 3000 VDC. New. Also useful for equip. 4 1/2" x 4 1/4" x 2 1/2"

PHOTO ELECTRIC CELL 95¢
95¢ Vacuum Cell used in A.M. P.R.O. Sound Projector. Also useful for opening garage doors and Alarm Systems.

GE Pyranol Oil CONDENSER 95¢
12 MFD. 350 VAC. 60 Cy. Removed from equip. NEW.

30 TUBE SOCKETS. Subminiatures, 7 & 9 pin miniatures, 4 to 8 pins. Alnico-milled & ceramic shield base type. tool

2000 PCS. HARDWARE. Radio, TV, shop, wood-working screws, springs, grommets, etc.

40 MOULDED CON. DENERS. Best known makes. .0005 to .01 mf to 1000V.

30 CERAMIC DISC CON. DENERS. 5 mmf to .01 mf. to 3000V. TV repairmen note!

8 TUBULAR ELECTROLYTICS. Popular values to 450V. Top makes. axial leads.

60 KNOBS. Instrument, Radio, TV types. Push-on & set screw types. Some 35c ea.

10 PANEL SWITCHES. Micro. car. momentary. push & rotary. Wide variety.

80 TUBULAR CON. DENERS. 23 values! .00025 to .10 mf. up to 8000V. Oil, too.

10 PP & TWIST ELEC. TROLTYCS. Ass'd. to 1000 mfd. to 450V. Some multiples.

100 COIL FORMS. Experimenters, note! Wide variety of shapes & sizes. Ceramic and bakelite.

60 CARBON RESISTORS. Insulated. 35 values. 15 ohms to 10 megs. 1/2, 1 & 2W. 5¢ to 100¢ incl. famous Allen Bradley!

60 MICA CONDENSERS. Rare offer! Postage stamp types. 25 values. .0001 to .01. to 1200 VDC. Many silver. 5¢ to 10¢.

125 CARBON RESISTORS. 30 values. 100 ohms to 1 meg. 1/2, 1/2, 1 & 2W. Many 5¢. Uninsulated.

30 POPULAR BULBS. Special! Wide variety standard miniature, screw and bayonet types. 1-1

12 LINE CORDS. AC/DC con'ts. molded plugs. For all electrical Equip. Stock up now!

50 CERAMIC CONDENSERS. Tubular, disc, button & stand-off. 5 to .01 mmf to 1000V.

12 VOLUME CONTROLS. Handy, shop asst. of radio, TV, lab units. Some 5W.

20 RF COILS & SHIMES and slug-tuned coils for TV, radio, lab. 20 types.

50 POWER RESISTORS. Wirewound. 20 values. 5 ohms to 12,000. 5 to 50 watts. Candohm & tubular types.

All New MYSTERY PACKAGE
of ELECTRONIC PARTS

It's the surprise of your life! 20 pounds of BRAND NEW usable GOVT. surplus. The ideal gift for hams, etc.

Worth \$40.00
Our Price **\$3.95** Ship Wt. 20 lbs.

7/17/52 11?

PICTURE TUBE BRIGHTENER 94¢

TERMS: Cash with order or 25% DOWN—BALANCE C.O.D.
ALL PRICES NET F.O.B. DETROIT MINIMUM ORDER \$2.00

HERSHEL RADIO CO.
5249 GRAND RIVER Detroit 8, Michigan

Assortments for One Buck

100 1/2 W Resistors	20 Pilot Lights
75 1 W Resistors	50 Sockets
50 2 W Resistors	50 Radio Knobs
10 W.W. Resistors	50 Term. Strips
50 TUB Condensers	10 Vol. Cont. L/SW
30 CER. Condensers	5 Vol. Cont. N/SW
30 MICA Condensers	10 TV Coils
3 TV Elect. Cond.	Wire and Solder Kit
5 Radio Elect. Cond.	Hardware Kit

CAPITAL ELECTRONICS, 222 Fulton St., N. Y. C.

RADIO and TELEVISION ELECTRONICS

RCA in all Technical Phases
New Classes (Day and Evening) Start 1st of Dec., Mar., June, Sept.

Free Placement Service for Graduates
For Free Catalog write Dept. RN56
RCA INSTITUTES, INC.
A Service of Radio Corporation of America
350 WEST 4TH ST., NEW YORK 14, N. Y.

Within the Industry
(Continued from page 1)

56 years the new engineering Co. Inc. engineering per- the New York
 lowing a sales manager of I.D.E.A., Inc. the firm since 1951
 old son of I.D.E.A., Inc. the firm since 1951
 vig years' experience in electronic field . . . DR.
 LLEFSON and MARION E. were named vice-presi-
 large of engineering and re-
 and vice-president of tungsten-
 chemical and parts operations, respec-
 tively, by Sylvania Electric Products
 Inc. . . . BILL ATKINS is the new in-
 dustrial sales manager of the Mellotone
 Division of Wendell Plastic Fabric
 Corp. of New York . . . National Com-
 pany, Inc. of Malden and Melrose, Mass.
 has appointed GEORGE E. MAGRATH to
 the post of eastern manager of indus-
 trial sales . . . Bradley Laboratories
 has named HAROLD B. ROSENBERG to
 the post of production manager of its
 selenium division. He has been with
 the firm since 1950 . . . DONOVAN H.
 TYSON has been elected vice-president
 and controller of Allen B. Du Mont
 Laboratories, Inc. . . . FRANK ADAMS,
 eastern sales manager of ORRadio In-
 dustries, Inc., passed away in Philadel-
 phia after a long illness. He was 59
 . . . ARTHUR L. CHAPMAN is the new
 vice-president, manufacturing, for Syl-
 vania Electric Products Inc. He will
 make his headquarters at the com-
 pany's New York City offices . . . The
 appointment of THOMAS B. KALBFUS to
 the post of general sales manager has
 been announced by the television-radio
 division of Westinghouse . . . DR. RO-
 BERT J. JEFFRIES is the new assistant to
 the president of Daystrom, Inc. His
 responsibilities will include executive
 development, education, and training
 at all levels of the organization . . .
 DR. WENDELL B. SELL has been ap-
 pointed general manager of the Elec-
 tronics Division of American Machine
 & Foundry Company. He will make
 his headquarters in Boston . . . DAVE
 COLE is the new national sales man-
 ager of commercial products for Dy-
 namic Electronics-New York, Inc. of
 Forest Hills, Long Island . . . Armour
 Research Foundation of Illinois Insti-
 tute of Technology has named DR. RO-
 BERT W. BENSON, an acoustic specialist,
 to the post of assistant manager of
 the physics research department . . .
 CHARLES W. KLEIDERER is the new vice-
 president for sales of Penn-Plastics
 Corporation. He was also elected to the
 firm's board of directors . . . CLAUDE
 D. VANNOY has been elected assistant
 treasurer of International Resistance
 Company of Philadelphia . . . The ap-
 pointment of ROBERT D. WICK to the
 post of manager, government sales,
 Semiconductor Division has been an-



TELEX Mini-Mike®

- Tiny, precision speaker-microphone.
- Quality, dynamic performance.
- For use in dictating machines, transceivers, other electronic equipment where "ruggedness" is important.

Model 100 PRECISION DESIGN Wt. approx. 1 1/3 oz.; Size 1" x 1" x 3/4"; Impedance 10 ohms

TELEX Boom-Type Headset

NEW! For airline reservation boards, telephone operators, television floormen.

- Lightweight, adjustable tone arms, no ear muffs.
- Available with single, double receivers, split phones.



TELEX TV "Listener"

For TV or radio enjoyment where INDIVIDUAL listening is desired. Allows children to watch "westerns" while Dad reads the paper. Two persons may use at same time. 4' cord from Earset to control unit, 10' cord from unit to TV or radio set.

We'd like to send you additional information! Write Dept. EA-3.

TELEX, INC.

Electro-Acoustic Division, Telex Park, St. Paul 1, Minn.

Manufacturers of the World's Finest Precision Miniature Electronic Equipment

FREE 1956 CATALOG

WORLD RADIO LABORATORIES
 "The World's Largest Distributor of Amateur Radio Equipment"

Jam packed with bargains — everything in Radio, TV, and Hi-Fi — for Handyman, Ham, Experimenter or Serviceman!

- Pay Only 10% Down
- Easy Terms
- Liberal Trade-Ins
- Save Over 50% on Recond. Equpt.
- Over 800 Guaranteed Recond. Items



WORLD RADIO LABORATORIES
 3415 WEST BROADWAY
 COUNCIL BLUFFS, IOWA



Leo I. Meyerson

PERSONALIZED SERVICE

MAIL HANDY COUPON

WORLD RADIO LABORATORIES, INC. R-8
 3415 W. Broadway — Council Bluffs, Iowa

Free 1956 Catalog New Beam Manual
 Wall-Sized Radio Map 25c

NAME _____
 ADDRESS _____
 CITY _____ STATE _____

LEARN

Television RADIO-COLOR-TV Electricity ELECTRONICS

IN THE GREAT SHOPS OF **COYNE**

TRAIN QUICKLY! OLDEST, BEST EQUIPPED SCHOOL OF ITS KIND IN U.S.

Veterans and Non-Veterans—Get practical training in top opportunity fields. Prepare now for a better job and a real future. Advanced education or previous experience not needed. Employment service to graduates.

Enroll NOW—Pay Later
 Finance Plan and Easy Payment Plan. Also Part Time Employment help for students. Training in Refrigeration and Electric Appliances can be included.

FREE BOOK Clip coupon for Big Free Illustrated Book. No obligation and No Salesman Will Call. Act NOW.

B. W. Cooke, President
COYNE ELECTRICAL SCHOOL
 A TECHNICAL TRADE INSTITUTE OPERATED NOT FOR PROFIT Established 1899
 500 S. Paulina, Chicago

B. W. COOKE, Pres.
 COYNE Electrical School
 500 S. Paulina St., Chicago 12, Ill. Dept. C6-85H

Send FREE BOOK and full details on:

TELEVISION-RADIO
 ELECTRICITY-ELECTRONICS

NAME _____
 ADDRESS _____
 CITY _____ STATE _____

The new laboratory which seems to concentrate on the SW AND new products, tech. August 21. for the industry Auditorium for and the Ambassador convention.

W5N show is co-sponsored by Coast Electronic Manufacturers Association and the Los Angeles and San Francisco sections of the Institute of Radio Engineers.

Last year's attendance of 20,000 scientists, engineers, educators, and industry leaders is expected to be exceeded this year.

ANTHONY SCALA, formerly vice-president and general manager of *Chatham Electronics Division of Gera Corporation*, has been elected president of the division, succeeding W. L. Meier, who has been appointed director of research.



Mr. Scala retains his post of vice-president of *Gera Corporation* and that of director of the parent company, *RKO Industries Corp.*

SOUTHERN ARIZONA HAMFEST
THE Fort Huachuca Amateur Radio Club will sponsor this year's Southern Arizona Hamfest which will be held at Fort Huachuca, Arizona over the Labor Day weekend, September 1 through 3rd.

The meet will be held in the picnic area of scenic Garden Canyon in the heart of the Huachuca Mountains. There will be two and one-half days of contests and entertainment. Features of the meet will be a real western-style chuckwagon dinner, a guided tour of the Army Electronic Proving Ground, and lots of contests.

Entertainment for XYL's and junior ops has been lavishly scheduled.

Register with the secretary, Fort Huachuca Amateur Radio Club, P.O. Box 903, Fort Huachuca, Arizona. Accommodations are limited, so register early. Tickets are \$2.00 for adults and \$1.00 for children under 12 years.

PRIZES FOR READERS

A SPECIAL giveaway drawing especially for readers of this magazine will be held by Wholesale Radio Parts Co., Inc. on August 31, 1956. The three winners will have their choice of a Harmon-Kardon AM-FM tuner/amplifier combination, a Precise Model 111 tube checker, or a Hallicrafters S-85 communications receiver.

The occasion is the distributor's 25th Anniversary which is being celebrated by giving presents rather than receiving them as is usual with "birthday" fetes.

Readers can become eligible for this drawing by forwarding a postcard with their names and addresses to "Free RADIO & TELEVISION NEWS Drawing," in care of the company at 311 W. Baltimore St., Baltimore 1, Md.

Always Specify **Stancor** the most complete line in the industry

When you need a flyback or any other transformer for TV, radio or any electronic application

JUST RELEASED... 11 NEW EXACT REPLACEMENT FLYBACKS FOR ZENITH - G.E. - ARVIN

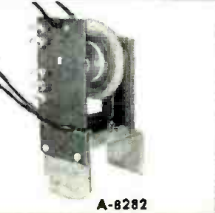
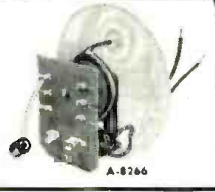

Stancor Part No.	Replaces Part No.
A-8266	G. E. RTO-161
A-8273	Zenith S-19408
	Zenith S-20099
A-8274	Zenith S-21317
A-8275	Zenith S-22130
A-8276	Zenith S-22154

Stancor Part No.	Replaces Part No.
A-8277	Zenith S-21219
A-8278	Arvin E-40117
A-8279	Arvin E-41024
A-8280	Arvin E-42721
A-8281	Arvin E-24681
A-8282	Arvin E-41852



FREE: The latest up-to-date Stancor TV Transformer Replacement Guide and Catalog—from your distributor or write us for your copy.

CHICAGO STANDARD TRANSFORMER CORPORATION

3505 ADDISON ST. • CHICAGO 18, ILL.

Export Sales: Roburn Agencies, Inc., 431 Greenwich St., New York 13, N. Y.

MUST HAVE FOR CURRENT ORDERS
PHONE COLLECT
BC-312 9C-314 BC-610
BC-342 BC-344 T-47/ART-13
R-5/ARN-7 ARC-3 ATC/ART-13
SEMLER INDUSTRIES INC. STanley 7-1554
6853 Lankershim Blvd. North Hollywood, Calif.

HI FI CORRECT OFFSET ANGLE FOR LP RECORDS
This Tone Arm gives TOP PERFORMANCE!!
Available at better HI FI dealers or write: **\$14.95**
Volpar
4404 W. 22 ST. PANAMA CITY, FLA.

GET INTO ELECTRONICS

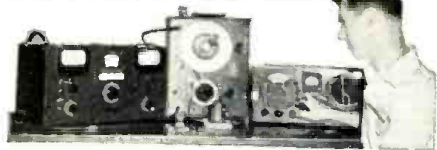

You can enter this uncrowded, interesting field. Defense expansion, new developments demand trained specialists. Study all phases radio & electronics theory and practice; TV; FM; broadcasting; servicing; aviation, marine, police radio. 18-month course. Prepare for good pay. Graduates in demand by major companies. High School or equivalent required. Begin January, March, June, September. Campus life. Write for catalog. **VALPARAISO TECHNICAL INSTITUTE** Dept. RD Valparaiso, Indiana

Hermetically Sealed Relay
Coil 110V AC 60 cy SPDT Con-
tacts 10 Amps. . . . \$1.85 ea.

SPECIAL VOLTMETER
BRAND NEW ROLLER SMITH 2 1/2" **\$1.95**
18-36 VDC.

SMALL PIONEER GENEMOTORS
Ideal for Amateur or Commercial Service 5.5 to 6
volt DC input—output 400 volts at 175 MA cont.
or 275 MA intermittent duty. Comes complete with
A & B filters, RF hash filter & internal cooling fan.
Same as above—with 11.5 to 12 volt
DC input. . . . each **\$19.95**
each **\$12.95**

DYNAMOTOR STARTING RELAY
12V DC coil. Solenoid type fully enclosed. Will
easily handle 50 amps. Contacts and winding isolated from ground. . . . 2 for **\$3.00**

CRYSTAL MICROPHONE ELEMENT
Crystal element mfd. by Brush Development Co. Ex-
cellent fidelity. Each element indiv. tested. Suitable
for Ham use, PA systems, home recorders or any
sound recording or transmission. Size: 1 1/8" Sq. Make your own
microphone. . . . ea. **98c**

MS 1" Miniature Meter \$3.95
Filament Transformer
Pri. 110V, 60 cy. Sec.
Secondary 6.3V @ 10 amps.
Good quality. . . . \$1.65

TELEPHONE HANDSET ELEMENTS
Receiving and carbon microphone elements fits
standard W.E. or Conn. Tel. handsets, 65¢ ea. or
\$1.10 pr.

G. E. RELAY CONTROL
(Ideal for Model Controls, Etc.)
Contains a sigma midgeet 8,000 ohm, relay
(trips at less than 2 MA), high impedance
choke, bi-metal strip, neon pilot and many
useful parts. The sensitive relay alone is
worth much more
than the total
low price of . . . **\$1.25 ea.** 10 for **\$9.90**

SENSITIVE RELAY
5000 ohm coil operates on 1 ma. adjustable con-
tacts, adjustable armature tension. SPDT-Bakelite
base. Ideal for model work. Can also be
used on AC. Draws . . . ea. **\$1.75**
4 mil AC 110 V. Ideal for . . . ea. **\$1.50**
burglar alarm 5 for

UNIVERSITY MM2 SPEAKER
Weatherproof and waterproof reflex type speaker.
Many industrial and commercial applications. Ca-
pacity 15 Watts, impedance 16 ohms. **\$15.95**
List \$40.00. OUR PRICE. . . .

OIL CONDENSER SPECIALS
BRAND NEW

2 MFD 600 VDC .50	1 MFD 3000 VDC 1.85
4 MFD 600 VDC .75	10 MFD 7500 VDC 45.00
6 MFD 600 VDC .85	1 MFD 10,000 VDC 22.00
8 MFD 600 VDC .95	2 MFD 10,000 VDC 39.95
10 MFD 600 VDC 1.19	1 MFD 15,000 VDC 29.50
12 MFD 600 VDC 1.50	1 MFD 25,000 VDC 49.50
2 MFD 1000 VDC 1.85	1 MFD 330 AC .95
4 MFD 1000 VDC 1.35	5 MFD 330 AC 2.90
8 MFD 1000 VDC 1.50	20 MFD 330 AC 2.90
1 MFD 1200 VDC 1.10	8 MFD 660 AC 2.35
1 MFD 1500 VDC 1.95	10 MFD 660 AC 2.75
1 MFD 1400 VDC 2.50	
1 MFD 2000 VDC .85	
2 MFD 2000 VDC 1.50	
4 MFD 2000 VDC 1.50	
10 MFD 2000 VDC 6.95	

NEW PANEL METERS
G.E., WESTINGHOUSE, W.E. SIMPSON, etc.

1" METERS	0-150 MA RF
1 1/2" 0-5 Amps	Int. Thermo. . . 3.40
RF with ext.	0-4 Amps R.F. . . 3.40
Thermocouple 3.95	0-8 Amps R.F. . . 2.95
2" METERS	0-1 1/2 Milli
0-50 Microamp \$5.95	amps . . . 3.95
0-100 Microamp 4.95	15-0-15 Milli . . . 3.95
0-5 Amps DC 2.95	amps . . . 3.95
0-10 Amps AC 2.85	0-50 Milliamp
0-35 Mil 2.95	(1 Mil Base) . . . 3.95
0-200 Mil AC . . . 2.95	0-300 Milliamps 3.95
10-0-10 Amps . . . 2.95	0-15 Amps DC . . . 2.95
DC 2.95	50-0-50 Amps . . . 4.50
0-130 Volts AC . . . 2.95	0-10 Mil AC . . . 3.95
0-300 Volt AC . . . 3.95	0-5 Amps AC . . . 3.95
	0-50 Microamp . . . 6.95

BUD C2008
Variable Condenser. Insulantite insulation. Air
gap .03 Capacity 300 MMF. Reg. net \$4.65 ea.
OUR PRICE **\$1.65**

TURNER DYNAMIC MICROPHONE
Model 22D—200 ohm imp. Freq. response 75-
9000 cy. Complete with desk stand & shielded cord. BRAND NEW. . . . **\$14.95**

METER SPECIAL
3 1/2" Sq. Bakelite cased meter. Scale 0-150 MA.
Basic 0-1.5 MA. We supply shunt
wire. . . . ea. **\$3.45**

Read 'n' Save Bargains

9 Pin tube pin aligner89c
Precision Meter Multiplier—1 Megohm
1 1/2" tolerance \$1.49 ea.
500 MMF CERAMIC CONDENSERS . . . 10 for 5.50
NAT. EMC VAR. COND. 250 MMF . . . 1.25 ea.
SANGAMO F2L .001 5000 VOLTS WORKING
TRANSMITTING MICA CONDENSER . . . 75
HEINEMANN CHOC. BREAKER
110 V. 60 cy. 20 amps. Curve 4. . . . 1.25
.01 MMF 1000 VDC MICAS 5 for .95
.01 MMF 2500 VDC 5 for 1.50
.0004 2500 VDC MICAS 5 for .95
.025 600 V. MICAS 5 for .95
100.00 OHM. 100 WATT RESIST. 75c ea.
RELAY 6 VOLT DC DPDT \$1.25 ea.
1 MFD Oil Condenser 400 VDC. 20c ea.
10 for 1.50

All merchandise sold on a 10 day money back guarantee basis
Min. Order \$3.00—25% with Order—F.O.B. New York

PEAK
ELECTRONICS COMPANY
66 W. Broadway, New York 7, N.Y., WO-2-5439

Preamplifier Unit
(Continued from page 67)

it is at any setting far less than the surface noise of the best LP discs. The r.m.s. sum IM distortion of the last two stages is, under any circumstances, entirely negligible, being on the order of 0.2% at three volts output with the tone controls in flat position, the volume control wide open, and a 27,000-ohm resistor shunted across the output terminals. The IM distortion of the entire preamp on phono position is difficult to measure because of the impossibility of leveling the response without affecting other factors, but it appears to be well under 0.6% with an input of about 30 mv. All IM distortions measured at 60 and 7000 cps, 4:1.

The response of the entire system consisting of a Pickering "Fluxvalve" cartridge, the preamp just described, and a modified 35-watt "infinite-feedback" amplifier was measured by connecting a v.t.v.m. to the output terminals of the amplifier (to which a speaker was also attached) and playing an RCA 12-5-49 test record with the equalizer in RIAA position. The response was flat and smooth within ± 1 db from 30 to 18,000 cps and extended to 37,000 cps. Critical listeners have been impressed by the cleanliness of reproduction.

Precautions

The circuit is unusually free from trouble and lead dress is not particularly critical. The 5879 and 12AY7 tubes were designed especially for this type of service and are neither microphonic nor apt to pick up hum. On the other hand, some care must be exercised in the selection of the 6AU6 since some of them are microphonic.

For some purposes a somewhat higher gain on the phono inputs may be desirable, and this may be had by substituting a 12AX7 for the 12AY7. The substitution does not involve any compromise whatever, and the only result is to approximately double the gain of the unit on the high-gain input position. A very careful selection must, however, be made since many 12AX7's are quite microphonic. During the experimental work one case was observed in which mechanical feedback from the speaker to the 12AX7 was sufficient to cause singing at 500 cps even though the speaker cabinet was ten feet from the preamplifier! It is probably wise to obtain premium tubes (6136 for 6AU6, and 5751 for 12AX7) for particularly critical applications. Shock-mounting the tubes may also prove helpful.

The preamplifier described here may appear somewhat plain beside the glittering arrays currently available. An inspection of the circuits of most commercial units reveals very little in the way of magical tube circuitry, however, and most of the complexity lies in the switching functions. The individual designer, because he must make

Demand for Effective plan classes. Well-equipped. Approved for June.

Bach, Sci. degree
Complete Radio Eng. courses Electronics. Also Mech., Civil, Eng. 36-month B.S. in Bus. Adm. Acctg., Motor Transport Mgt.)
Students faster. Prep courses. McCarthy, Dir. Adm., for cat. "Your Career in Engineering & merce."

TRI-STATE COLLEGE
1686 College Avenue, Angola, Indiana

LMB BOX CHASSIS OFFERS FREE inside LMB boxes

10 tested kit diagram projects for the builder. Each kit projects are complete in every detail. Circuit diagram, photo of project both front and rear photo. Rear photo shows wiring and parts. Detailed instructions for building, complete parts list and approximate cost. Complete to build except parts and your distributor can supply the parts. Ask your distributor for the list of LMB kit Diagram Projects. If he does not have them, write to

LMB 1011 Venice Blvd. Los Angeles, 15, Calif.

EXAMINE FREE! Profit NOW with the latest on successful transistor design, application, operation —in ONE COMPLETE VOLUME!

TRANSISTOR ELECTRONICS

by Arthur W. Lo, Richard O. Endres, Jakob Zawels, Fred D. Waldhauer, Chung-Chih Cheng; all RCA engineers.

At last, here's an authoritative, practical book which rounds up all available information, ideas and techniques on transistors and presents this useful data to you in 520 illustrated, easy-to-follow pages! These RCA experts cover the whole field, from design and operation of transistors to their application. Much material is just released, printed here for the first time. Whether you're a beginner or seasoned vet . . . working in radar, TV, radio, computing, or allied fields . . . this complete, new book will give you mastery of transistors and show you how to use this knowledge profitably and successfully!

Gives Complete Coverage. Including:

Physical concepts (36 pages) . . . characteristics, parameters, equiv. circuits (14 pages) . . . basic amplifier configurations (50 pages) . . . low freq. amplifiers (42 pages) . . . hi-freq. amplifiers (39 pages) . . . power amplifiers (28 pages) . . . hi-freq. operation (47 pages) . . . physical interpretation of transistor parameters (38 pages) . . . oscillators (38 pages) . . . modulation & demod. (48 pages) . . . pulse circuits (76 pages) . . . tabular-analyses of fundamental transistor networks & circuits . . . shows parallels, contrasts between transistor and vac. tube circuits . . . features practical circuits . . . plus much more valuable material and workable, useful techniques.

MAIL NOW—FREE TRIAL OFFER

Prentice-Hall, Inc., Dept. 5741-K1
Englewood Cliffs, New Jersey

Please send me a copy of TRANSISTOR ELECTRONICS for 10 days' FREE use. Within 10 days I'll either return book and owe nothing, or will keep it and remit \$4 down (plus small postage charge) and then \$4 a month for two months in full payment.

Name
Address
City Zone State

Save! Send \$12.00 with this coupon and we pay postage. Same return and refund guarantee.

use of readily available components, finds it difficult or impossible to duplicate this complexity.

Whether numerous knobs, push-buttons, and meters are desirable or not on a preamplifier depends, of course, upon whether preference is to be given to pleasing the eye or the ear. The writers feel that once the essential electronic requirements have been met, beauty lies in simplicity of control. It is true that separate bass and treble equalizers could be provided to permit 25 different combinations, but 19 of them would be for characteristics never used by any company and would furnish exact equalization for no records. A "loudness" control could easily be installed but the writers have never heard a satisfactory one unless auxiliary means were provided for standardizing the input level.

This preamplifier was designed to fill the needs of the person who may have one or two record players, and an AM-FM tuner, or two separate tuners. In simplicity of design and construction it can hardly be exceeded, while the quality of the output, in the opinion of many critical listeners, leaves little to be desired.

REFERENCES

1. Bocgli, Charles P.: "A 35-Watt 'Infinite-Feedback' Audio Amplifier," RADIO & TELEVISION NEWS, July 1954.
2. ———: "A 13-Watt All-Triode 'Infinite-Feedback' Amplifier," RADIO & TELEVISION NEWS, November 1955.
3. ———: "New Developments in Phono Equalizers," RADIO & TELEVISION NEWS, April 1953.
4. Howell, John J., Jr.: "Miniature Equalizer," RADIO & TELEVISION NEWS, October, 1954.
5. Barandall, P. J.: "Negative-Feedback Tone Control," Wireless World, October, 1952.

-30-

SERVICING SHORTCUT

By CHARLES GARRETT

HERE's a suggestion for the quicker servicing of TV sets whose pictures narrow or go out completely after being on for awhile.

In such cases most often the horizontal output tube (6BQ6, 6BG6, 6CD6, 6AV5, and 6AU5) is at fault, and less often the power rectifier (5U4 or selenium unit). Most technicians, however, want to be positive a tube is defective before replacing it. Because the tubes responsible for this condition will test OK at first, valuable time is wasted waiting for them to act up.

On TV sets which give trouble only when hot and where the horizontal output and/or power rectifier tubes are suspect, try this to speed up the repair (parallel heaters only).

With set on and operating normally, remove the horizontal oscillator tube. This removes much of the bias from the horizontal tube, causing it to draw extra current. The same is true of the power rectifier tube. They will both heat up very rapidly. Leave the horizontal oscillator out for one or two minutes—less if the output tube plate shows signs of turning red—re-install it.

If either tube is at fault, the condition will show up immediately and suspected tubes can be substituted one by one.

The normal tube will stand this temporary overload if the plates are not allowed to become cherry red.

-30-

August, 1956



FIELD TECHNICIANS

Broaden the scope of your career with Bendix Radio!

Get these BIG ADVANTAGES!

- Professional status
- The prestige of representing the leader in its field.
- Top salaries
- Liberal field allowances

If you have 5 or more years of electronics experience, you benefit many ways as a Bendix Radio Field Engineer. You will receive full pay while you go to our company-sponsored school in Baltimore. Then, you will be given a key assignment in the United States or overseas with responsibility of maintaining search and surveillance radar equipment made by Bendix Radio.

Write, call or wire EMPLOYMENT SUPERVISOR Dept. R

Bendix Radio

DIVISION OF BENDIX AVIATION CORP
Towson 4, Maryland
(Phone Valley 3-2200)

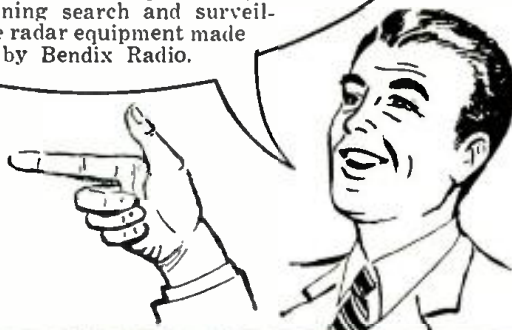

HOUSE CURRENT Anywhere

NOW, WHILE FISHING, CAMPING, BUSINESS TRIPS, ANYWHERE YOU DRIVE YOU CAN ENJOY MANY OF THE CONVENIENCES USUALLY AVAILABLE ONLY AT HOME, SHOP, OR OFFICE:



- Electric Shavers
- Car Polishers
- Radios-Lights
- Phonographs
- Dictation Machines
- Tape Recorders
- Hand Vacuum Cleaners
- Small Do-It-Yourself Tools
- Heating Pads "101" USES



Trav-Electric CONVERTERS

No installations. Just plug into cigar lighter. That is all. Priced as low as \$11.95



See your Electronic Parts Jobber or Dealer; or write direct to us.

TERADO COMPANY
1058 RAYMOND AVE., ST. PAUL 14, MINN.



Only from famous COYNE do you get this modern up-to-the minute TV Home Training. Easy to follow instructions—fully illustrated with 2150 photos and diagrams. Not an old Radio Course with Television tacked on. Includes UHF and COLOR TV. Personal guidance by Coyne Staff. Practical Job Guides to help you EARN MONEY QUICKLY IN A TV-RADIO SALES AND SERVICE BUSINESS—part time or full time. COSTS MUCH LESS—pay only for training—no costly "put together kits."

SEND COUPON FOR FREE BOOK

SEND COUPON BELOW for Free Book and full details including EASY PAYMENT PLAN. NO COST OR OBLIGATION—NO SALESMAN WILL CALL.



D. W. COOKE, Pres. **COYNE ELECTRICAL SCHOOL** FOUNDED 1899
A TECHNICAL TRADE INSTITUTE OPERATED NOT FOR PROFIT
500 S. Paulina Dept. C6-HT5 Chicago 12, Illinois

COYNE ELECTRICAL SCHOOL
Television Home Training Div.
500 S. Paulina St., Chicago 12, Ill., Dept. C6-HT5

Send FREE BOOK and details of your Television Home Training offer.

Name _____
Address _____
City _____ State _____

STAN-BURN

EDDARKE

CATHODE RAY TUBE SPECIALS

ONE YEAR GUARANTEE

G.E.	Type	STAN-BURN	G.E.	Type	STAN-BURN	
\$13.25	10BP4	\$10.20	\$28.15	17CP4	\$19.50	
18.00	10FP4	14.00	31.25	17GP4	20.75	
16.25	12LP4A	13.95	32.25	19AP4	22.50	
28.95	12UP4	10.50	27.40	20CP4	18.95	
18.15	14CP4	13.40	33.00	21AP4	22.25	
	15DP4	14.50	33.25	21MP4	23.50	
31.25	16AP4A	18.50	27.40	21EP4	20.15	
26.25	16KP4	15.75	90.75	21FP4	42.00	
31.25	16GP4	18.50	DUMONT TUBES			
29.00	16LP4	15.25	120PA	23.75	16FP4	26.00
29.00	16WP4	15.25	150PA	15.25	17KP4	25.00
22.50	17BP4	15.75	160PA	31.00	19AP4	33.25
					21KP4	38.50

STAN-BURN CRT TUBES RCA LICENSED—MFG. BY LINCOLN
PRICES SUBJECT TO CHANGE WITHOUT NOTICE

\$20 WORTH OF ELECTRONIC PARTS IN GRAB-BAG consisting of: Porcelain sockets, coils, speaker, transformers, resistors, condensers, etc. ONLY \$1.98 (plus 50¢ postage).

TAPE RECORDERS—Famous Brand

Special	Special
List Pr. \$249.95 \$169.00	List Pr. \$129.95 \$79.95
List Pr. 199.95 129.00	List Pr. 79.95 59.95

Write for complete illustrated details.

WINDOW FANS

VORNADO—18" Blade—Reversible—list \$89.95
SPECIAL \$47.95 net
FRIGID—20" Blade—6 speed—Reversible with
Thermostat control—list \$89.95, SPECIAL \$47.95 net
Westinghouse in stock—write for full details

KITS!

We stock the following manufacturers complete line of kits—see Advertisers Index

EICO QUALITY ARKAY PRECISE

All domestic orders will be shipped prepaid for a limited time. Send us your list. Order by Manufacturer and Model Number of item.

TRANS-ATOMIC TRANSISTOR RADIO...KIT	\$6.95
Same as above WIRED Ready to play...	\$7.95
SENSIPHONE EARPHONES—Single Phone...	\$1.50
Double Phone...	\$2.50
GERMANIUM DIODE Loopstick Radio Kit...	\$3.25

AM-FM-SW AUTO RADIO

Drift Free FM—World's Finest—Becker LeMans
For PUSH BUTTON... \$179.95
For SIGNAL SEEKER... \$239.95
Includes: GE SPEAKER with GRILLE and AUTOMATIC
ELECTRIC ANTENNA. Simple installation for all cars.
Specify 6 or 12 Volt system.

VM 4 SPEED HI-FI CHANGER—Model 1210 with
Ronette, Sonotone or Astatic flip-over cartridge. \$22.95

RC456-4 SPEED COLLARO—BRAND NEW.
SPECIAL \$29.95
45 RPM SPINDLE for above... \$2.98

3 SPEED PORTABLE RECORD PLAYER with MONARCH
CHANGER—Ronette cartridge—Portable Two Tone Car-
rying Case... \$34.95

WEBSTER Model 140—3 SPEED Automatic with
Ronette Sonotone or Astatic flip-over cartridge... \$22.49

MONARCH 3 SPEED AUTO. INTERMIX
CHANGER with crystal cartridge... \$21.95

Same with British variable reluctance... 24.95

45 RPM SPINDLE... \$1.88

TUB MONARCH 3 Speed MOTOR & TURN-
TABLE UNIT (less arm)... 4.95

PEARLESS PORTABLE BATTERY OPERATED RADIO—
Colors: Green, White, Red or Blue—5 TUBE IMPORT.

BATTERY KIT for above... \$2.00

JEWEL—Model 5200—5 TUBE AC-DC RADIO... \$12.50

RECORDING TAPE—Top quality—1200 Feet—Famous
brand—BOXED—1 to 5—\$1.69 ea. 6 to 11—\$1.59 ea.
12 or more... \$1.49 ea.

HALLICRAFTERS TV

17" PORTABLE TV... Dealer net	\$103.95
Model 17T5700M—Table Model... Dealer net	91.95
Model 21T5460M—Table Model... Dealer net	129.46

SETCHELL CARLSON—17" PORTABLE TV... \$119.95

HI-FI PACKAGE DEAL

Includes: JENSEN K210 SPEAKER. MONARCH AUTO-
MATIC CHANGER with GE RPX 050. 12" SPEAKER
ENCLOSURE in BLOOD or MAHOGANY WOOD (Specify
color). MATCHING BASE FOR CHANGER. Also many other
10 WATT HF10 BOGEN AMPLIFIER. **\$9950**

Complete, ready to play. A \$135.00

Value for Only... not

or your choice of similar units at relative package
price. Write for Prices.

DEALERS: Write for low cost prices and
catalogs on 156 models—HALLI-
CRAFTERS, SUPERIOR, NATIONAL, PRECISION,
HICKOK, TECHMASTER, G.E., WESTINGHOUSE,
TUNG-SOL, MAJESTIC, GRUNDIG, ARKAY KITS,
DELCO, GEN. MOTORS. Address all inquiries to
Dept. RN-8.

COMPLETE HI-FI DEPT. SEND US YOUR LIST FOR LOWEST QUOTATIONS ON ANY ITEM.

We invite export inquiries and offers. Our export de-
partment will give special attention to expediting
foreign orders at minimum commissions. We are
authorized distributors for United Motors, all Geico
and Gen. Motors Auto Radio parts in stock.
We also carry a complete line of popular makes of
Radio Tubes at 50/40 discount. Also many other
special purpose and transmitting types, and all elec-
tronic parts and equipment at lowest prices. Send us
a list of your requirements for prompt quotations.
Terms: 20% with order. Balance C.O.D. All prices
F.O.B., NEW YORK Warehouse. Minimum order \$5.00.
Write for our latest price list and Hi-Fi Catalog RN-8.

STAN-BURN RADIO and
ELECTRONICS CO.
558 CONEY ISLAND AVE. • B'KLYN 18, N. Y.

Sales Aids

WESTINGHOUSE HOUSE ADS

As part of an intensive campaign to make its corporate name a household and industry word, Westinghouse Electric Corporation has launched a heavy schedule of institutional ads which will be carried in business and trade papers and over CBS radio and television network stations during the political conventions in August.

Spreads are being used to dramatize the company's recent achievements in atomic energy, engineering, research, and product development.

This newest phase is supplemental to the firm's heavy merchandising of its complete home appliance and radio-TV line in all media.

ELECTRONIC TOOL DISPLAY

A full assortment of the most popular tools for radio, television, electronics, and general electrical work is now

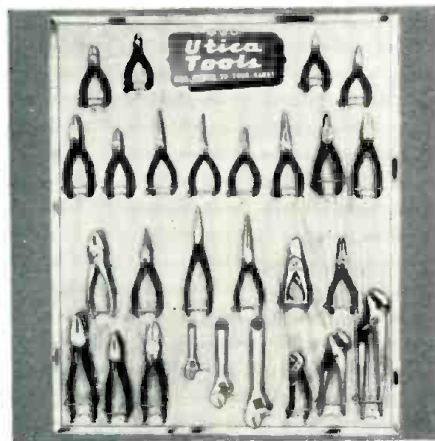

being offered by Utica Drop Forge & Tool Corp., Utica 4, New York.

The display, a natural wood panel 25" wide and 31" high with chrome stripping, is equipped to handle stocking of tools in three different ways. The unit may be had with one, two, or three of each tool.

The basic assortment includes mid-gut diagonals, long chain nose pliers with cutters, needle nose pliers, and chain nose pliers without cutters. All of these have red plastisol handles. The balance of the display carries three sizes of rib-joint pliers, slip joints, duck bills, side cutters, heavy duty diagonals, adjustable wrenches, and printed circuit pliers.

MERCURY BATTERIES

A compact, economical kit of mercury batteries which enables radio dealers and service engineers to capitalize on the growing market for replacement batteries for miniature transistorized portable radios is being

offered by P. R. Mallory & Co., Inc., Indianapolis 6, Indiana.

Included in the kit are 20 mercury batteries in 6 different voltages and sizes to fit popular makes of miniature transistorized portables.

The kit is factory-packed, with all batteries mounted in place on an attractive, two-color display panel. The dealer can set the display up in seconds. It has an easel back, for mount-



ing on a counter, or it can be hung from a wall. Each kit is individually packed in a shipping container. Supplied with each kit is complete cross reference information for battery types used in popular portables.

For information on this merchandiser, contact any Mallory distributor or the company's Distributor Division.

FILAMENT CHECKER DISPLAY

Precision Apparatus Company, Inc., 70-31 84th Street, Glendale 27, Long Island, New York is currently offering a striking counter display for merchandising its all-new Model SS-10 series-string filament checker.

The attractive merchandiser, with its brilliant poster colors, displays two units horizontally while an actual unit in its standup background dramatizes the many selling points of the device—the checking of receiver tube filament continuity, picture tube continuity,



television and radio set fuse continuity, and the straightening of bent tube pins.

Write the company direct for full details on both the new series-string filament checker and on the counter display for merchandising the unit. The company will handle such requests promptly.

Mac's Service Shop
(Continued from page 72)

Usually this can be done by resetting the rotor shaft thrust bearing, if an adjustable one is provided; or you may have to move a whole stator section slightly by prying carefully against the insulating mountings at the ends. Seldom is it a good idea, or necessary, to try to bend all the plates of a rotor or stator section one at a time.

"At any rate, *after* you have set the plates in alignment, if there is still noise when the capacitor is rotated, then you can try blowing any foreign matter from between the plates with the air hose, washing it out with a cleaning fluid, or even burning it out—after the leads have been disconnected from the capacitor, of course—by connecting the high tension leads from that old neon transformer of ours across it and rotating the tuning shaft while the arc sizzles between the plates."

Mac stopped with a reminiscent chuckle and then went on: "Real old-timers in this game will still remember with cold sweat a popular make of set that came out several years ago with plated tuning capacitor plates. After one of these sets was in use a few months, the plating would start to crack and peel away in little curls that would short out a tuning capacitor section and produce the darndest noise when the set was tuned. About time you had one section cleaned up, the same thing would develop in another section. That was a real dog."

By this time he had the capacitor plates aligned, and the dial pointer could be swung from one end of the scale to the other without the least hint of the rasping sound that had been present before. He next checked all the tubes and replaced a weak output tube, aligned the i.f., r.f., and oscillator trimmers, and was just preparing to put the chassis back into the cabinet when suddenly the speaker gave forth with a crackling sound that gradually worsened and changed into a motorboating howl.

"I'll be a monkey's uncle if the filter capacitors aren't bad, too!" Mac exclaimed. "No doubt they have been contributing to the noise he was hearing. A filter capacitor with a poor connection between a lead and the foil can produce an intermittent static-like noise that is very hard to locate, unless it opens all the way, as this one obligingly did."

A fresh capacitor was installed, and the set was again quiet. Mac put it back into the cabinet and then plugged it in and turned it on for a final check. As it started to play, a crackling, popping noise issued from the speaker! He glowered grimly at it for a few minutes and then suddenly reached over and twisted the line plug in the socket. The noise stopped at once.

"I *thought* I saw that dial lamp flickering a bit," Mac said triumphant-



Only planned high fidelity can give you true high fidelity!

Putting together a hi-fi system for your home *can be simple*—and it probably will cost a lot less than you think! Here at MusiCraft we offer the kind of information and guidance that will help you get started right and avoid mistakes.

As you may know, possible combinations of components are practically

limitless. We're happy to help you choose what will best suit your home and your budget. You can start small and add as you wish.

Stop in at MusiCraft soon or write us for further information. Let us help you plan the *kind* of high fidelity system that will give you *true* high fidelity.

Send your name and address if you would like to be on our mailing list for our announcements. Would you like a free copy of "Understanding High Fidelity"?



If you want to "build-it-yourself" and save—MusiCraft has a complete line of component parts in stock. The step-by-step directions are easy to follow—and you can feel free to call on us for any technical assistance you may need.

MusiCraft

48 East Oak Street • Chicago 11, Illinois • Delaware 7-4150

Lowest Prices • Largest Component Selections • Complete Custom Installation Service

LEARN TV SERVICING UHF—COLOR—VHF

Master the latest, up-to-the-minute TV and Color TV developments.

You can Earn to \$5,000-\$10,000 a year in TV servicing after a few short months. Education or age is no barrier. Find out how you can EARN WHILE YOU LEARN in our big Shops and Laboratories. You work with the latest equipment. Waste no time with Non-Essentials, Math or Design Theory. Complete information in our new FREE booklet. Address Dept. 8-56-R. Approved for veterans. Free Placement Service.

WESTERN TELEVISION INSTITUTE
341 W. 18th St. Los Angeles, Calif.

Dept. 8-56-R
Mail me information about training.
Name
Address

BE QUALITY WISE

Hi-Fi AM-FM Tuner Kit \$28.95
Every kit complete with 28 page fully illustrated, instruction and assembly manual.
Write today for FREE catalogue and name of nearest dealer carrying these remarkable units.



COVER AND LEGS OPTIONAL
Quality-Electronics Dept. T-8
319 Church Street New York 13, N. Y.

CODE SENDING SPEED

Be a "key" man. Learn how to send and receive messages in code by telegraph and radio. Commerce needs thousands of men for jobs. Good pay, adventure, interesting work. Learn at home quickly through famous Candler System. Qualify for Amateur or Commercial License. Write for FREE BOOK
CANDLER SYSTEM CO.
Dept. 2-J, Box 928, Denver 1, Colo., U.S.A.

YEAR'S 39 BIGGEST ONE-DOLLAR BUYS!

\$1 FAMOUS "KIT KING" \$1 DOLLARKITS

PLUS—Any Item in This Ad Free with Each \$10 Order!

WRITE FOR OUR FREE SUMMER FLYER!

- 16 PRINTED CIRCUITS.** Scoop! On 9x18" board. Eliminates wiring. Hobbyists take note! New! Reg. \$8. Wt. 1 lb. **\$1**
- 10 "POLY" BOXES.** Ass'd. sizes, hinged & snap lock clear plastic boxes for pocket radios, parts, etc. Hundreds of uses! Reg. \$2.50. **\$1**
- TEN 110 VAC SWITCHES.** Panel type, SPDT solder lug terminals, bakelite handles. Transistor model, testers. Wt. 1/2 lb. **\$1**
- 20 PRECISION KNOBS.** "Hi-Fi." instrument, eqpt. types. Knurled, skirted. Some 65c ea. Brass inserts & set screws. Wt. 1 lb. Reg. \$9. **\$1**
- 7 ROLLS HOOKUP WIRE.** 25-ft. rolls, #18 to #24. Ass'd. strains, insulation, colors. Wt. 1/2 lb. **\$1**
- 12 AC-DC LINE CORDS.** For chassis, clocks, eqpt. 14" l. w/molded plugs. Stock up now! Wt. 1 lb. **\$1**
- 10 PANEL SWITCHES.** Micro, AC, rotary, push, monie types. Wonderful assortment. Wt. 2 lbs. **\$1**
- 2000 PCS. HARDWARE.** Radio-TV, shop screws, springs, hundreds of other items. Wt. 3 lbs. Reg. \$15. **\$1**
- FOUR SILICON DIODES.** 1N21, 1N22 and two 1N23s. Most used **\$1**
- 6 PANEL LITES.** Amber jewels, for standard bayonet bulbs. Wt. 1/2 lb. **\$1**
- 10 TRANSISTOR SOCKETS.** For 4, 5-pin subminiatures, 3-pin transistors. Reg. \$3. **\$1**
- 60 TUBULAR CONDENSERS.** 25 values: .00035 to 0.5 mf to 1000V. Oils, tool. Wt. 2 lbs. **\$1**
- 50 COILS & CHOKES.** RF, ant., osc., coils & chokes. 20 1/2 lbs. **\$1**
- 30 DISC CONDENSERS.** Ceramic. 5mm. 100V. 10 mf up to 1000V. Ass'd. values. TV repairman's **\$1**
- 20 WIREWOUND RESISTORS.** All different values, 5 ohms to 12,000; 5 to 50 W. Candohm, coated, vitreous. Wt. 2 lbs. Reg. \$10. **\$1**
- 20 PRECISION RESISTORS.** Top makes. 50 values. Carbonfilm & WW. 1/2 to 2 w; 50 ohms to 1 meg. 17" tol. Wt. 1/2 lb. **\$1**
- 8 PC. NUTDRIVER KIT.** Plastic handle; 3/16, 7/32, 1/2, 5/16, 11/32, 3/4, 7/16" steel socket wrenches; plastic case. **\$1**
- 40 MOLDED CONDENSERS.** ERS. Top makes. .001 to 1 mf up to 1000V. Black, brown ceramic cases. **\$1**
- 150 ASST. PARTS.** Biggest parts buy ever! Large ass't. resistors, ceramic, paper & oil condensers, shields and more! **\$1**
- "KIT KING" RADIO KIT.** Germanium crystal set, complete w/pre-drilled table case, pictorial instructions. Wt. 1/2 lb. **\$1**
- 16 PRINTED CIRCUITS.** Scoop! On 9x18" board. Eliminates wiring. Hobbyists take note! New! Reg. \$8. Wt. 1 lb. **\$1**
- TUBE SCOOP! ANY SIX FOR \$1.** 46; 954; 39/44; 9000; 7E5; 7C20; 39; 34; 35; 71. **\$1**
- G-E R/C EXCLUSIVE.** Includes r/c xfmr. 115 to 0.3 @ 1.5A (alone worth total price), 3000 ohm inductor, condensers, resistors, sockets. Wt. 2 lbs. **\$1**
- 12 VOLUME CONTROLS.** Wide variety up to 0.5 meg. incl. WW. For radio, TV, lab. Wt. 1 lb. Reg. \$8. **\$1**
- 60 ASST. KNOBS.** Push-on and screw types for radio, TV, lab. applications. Some 35c ea. **\$1**
- 30 STANDARD BULBS.** Handy ass't. min. bayonet types. 1.1 to 6V. **\$1**
- 15 CERAMIC VARIABLE CONDENSERS.** Poplar type, trimmer type. 10 values; singles & duals. **\$1**
- 125 RESISTORS.** Insulated & uninsulated. Values: 25 ohms to 1 meg. 1/2 to 2 w. 5%, too. **\$1**
- 3 CRYSTAL DIODES.** Hughes subminiature and 1N51 diodes. Reg. \$4. **\$1**
- 60 TERMINAL STRIPS.** Wide variety, solder lug tip strips, clips, boards 1 to 10 terminals. Wt. 1 lb. Reg. \$4. **\$1**
- 50 CERAMIC CONDENSERS.** ERS, tubular, disc, button, stand-off types. 30 values, 5mm to .01 **\$1**
- 10 ELECTROLYTICS.** Metal & paper types; singles, duals, triples, some 125. Wt. 3 lbs. Reg. \$15. **\$1**
- 60 CARBON RESISTORS.** Insulated, incl. famous 35 values, 1/2, 1 & 2W; 1 & 5%, too. **\$1**
- 25 TUBE SOCKETS.** Subminiature, 9, octals, loctals; mica & ceramic; shield base types also. 10 types. Wt. 1 lb. **\$1**
- 40 SUBMINIATURE RESISTORS.** Carbon; 1/5 W. For model, transistor projects. 10 to 4.7 megs, 10 values. Reg. \$1 **\$1**
- 30 OIL CONDENSERS.** Bathtubs, rectangular, tubular types. Long life. Wide variety; .02 to 1 mf to 600 V. Wt. 3 lbs. **\$1**
- 100 COIL FORMS.** Bakelite, compressed, hermetically sealed types. Many choke styles. Wt. 2 lbs. **\$1**
- WIRE BY THE POUND.** Hundreds of pre-cut lengths from 3" to 8" long. Stranded; tinned ends. Ass'd. colors, sizes. Wt. 2 1/2 lbs. **\$1**
- G-E PRE-AMP KIT.** Chassis, condensers, resistors, wire, socket, schematic for famous equalizer. (Uses 6BC7-88c extra). **\$1**
- 60 MICA CONDENSERS.** Precision stamp type. 30 values: .0001 to .01 mf to 1200 V. Silver, 5% tool **\$1**

HOW TO ORDER

Check items wanted. Return entire ad with check or M. O. Incl. sufficient postage, excess returned. C.O.D. orders, 25% down. Rated, net 30 days. RN-8

NAME
STREET
CITY ZONE STATE

Enclosed \$..... for kits; \$..... for postage.

LEKTRON SPECIALTIES

28 GARDNER STREET CHELSEA 50, MASS.
Visit our salesroom at 131 Everett Ave., Chelsea

ly as he began sandpapering the prongs of the line plug and spreading them so they would make better contact with the outlet socket contacts. After this treatment, the radio played perfectly once more.

"The only thing I can think of to console you," Barney remarked, "is to say nothing else to cause noise can happen to that set. All the noise-producers have already reared their ugly heads."

"Sh-h-h-h! Don't say that! It may hear you," Mac admonished in a hoarse whisper. "There're literally dozens of things that can still happen. An i.f., r.f., or oscillator coil may develop a poor connection in a winding, especially one carrying d.c. current, that will result in a very noisy set. A mica coupling capacitor between an r.f. stage plate and a mixer grid makes a Jim-dandy noise producer when it becomes leaky. So does the mica capacitor usually found from the first audio stage plate to ground. We've both seen a line bypass capacitor with a poor connection between a wire lead and the foil produce a noise every time the chassis is jarred, just as happened with the noisy rectifier. Even a line switch that makes poor contact will occasionally be found producing the same kind of noise you heard when the line plug was not making good contact with the outlet socket. Poor tube socket contacts that make noise are very common, especially in the loctal series. And don't forget those noisy mixer and second detector tubes that produce a rushing sound that may stop when you tap them once and start again when you flip them a second time. Those little rascals are a real headache."

"Okay, Dad, I'll not forget," Barney said with a teasing grin, ducking his head in mock terror.

Major General J. D. O'Connell, Chief Signal Officer, explains the operation of the U. S. Army's new transceiver unit to WAC PFC Vivian K. Hudgins. This equipment is part of the Logistical Reporting Network now in operation between four key signal depots and the Army Signal Supply Agency in Philadelphia. Punch cards are used to transmit data on supply requirements among four signal depots in the net. If none is able to fill the order, the order goes to the procurement depot in Philadelphia. Data of this type is transmitted at night.



ASK FOR FREE FLYER!
New, interesting bargains!

TOO HOT?
Then Go Fishing!

But first send for our terrific, new bargain flyer to read in the boat!

Guaranteed best for man, beast or fish.

Free prizes, too!

ARROW SALES, INC.

Box 3007-R No. Hollywood, Cal.

A TERRIFIC BARGAIN in a

SOLA CONSTANT-VOLTAGE TRANSFORMER
Ends fluctuating line voltage!
OVER 60% OFF...



the factory price at a 1-input 2,000 VA unit! And here's another bonus! This Air Forces 2,000 VA overstock, Sola Cat. No. 30788, has 4 inputs! 90-125 V., 190-250 V., 60 cy. or 50 cy. Isolated secondary is constant 115.0 V., ±1% from no-load to full-load of 17.4 amp. So, if you choose, use it as a 220:115 V. step-down. And slash \$147.50 off the factory 1-input price!

Brand new in original wood box, 4 cu. ft. Ship. wt. 254 lbs. P.O. No. 2700 Pasco, Wash. Only **\$97.50**

THE M. R. COMPANY
Beverly Hills, Calif.
P. O. Box 1220-A

NEW CATALOG!

- INDUSTRIALS!
- ENGINEERS!
- EXPERIMENTERS!
- LABS!
- HAMS!
- NOVICES!

Are You on Our Mailing List?
If not, write us today for free copy!

MINIATURE HAND CRANK GENERATOR

Latest type, light weight. From recent model field phone. Many uses. Brand new. **\$1.49**

Terrific buy! **49¢**

HI-FI PERMA-FLUX HEADSET: Annular grooved plastic fibre cones with voice coil as in speakers. Chamotte car pads. Gives finest music reproduction. **\$7.95**

Brand new in original carton. Special. Only \$7.95
All items F.O.B. L.A. Prices subj. to change without notice. Calif. buyers add tax. Send 25¢ deposit with C.O.D. orders.

NEW CATALOGUE NO. 110 IS OFF THE PRESS!

Get your free copy today!

J. J. GLASS ELECTRONICS CO.
1615 S. Main St. Los Angeles 15, Calif.

LAM FLUX

ALUMINUM SOLDERING FLUX

The miracle you have been waiting for. Throw away your nuts, bolts and rivets. With this flux you solder Aluminum the same as other metals. Send \$2.00 Cash, Check or M.O.—No C.O.D. Postpaid in U.S.A.

E. Lampe, P.O. Box 371, Lindenhurst, L. I., N. Y.

ENGINEERING



B.S. DEGREE in 27 MONTHS

Prepare for unlimited opportunities of the Electron Age! Earn your B.S. degree in 27 months at Indiana Technical College. Intensive, specialized course. Comprehensive training in math and electrical engineering, advanced radio theory and design, television, electronics. Modern laboratories. Low rate. Also B.S. DEGREE IN 27 MONTHS in Aeronautical, Chemical, Civil, Electrical and Mechanical Engineering. G.I. approved. Enter September, December, March, June. Earn part of your expenses in Fort Wayne while studying. Write for catalog.

INDIANA TECHNICAL COLLEGE

986 E. Washington Blvd., Fort Wayne 2, Indiana

Please send me free information on B.S. ENGINEERING DEGREE IN 27 MONTHS as checked.

- Electronics
- Chemical
- Aeronautical
- Civil
- Mechanical
- Electrical

Name

Address

RADIO & TELEVISION NEWS

Service Industry

News

WHEN we speak of maintaining good relations with individual customers, it is known as customer relations. When we deal with better relations with the public *en masse*, it is called public relations. It is in the field of public relations that the independent service industry has been woefully weak. The failure to create a strong, national service association has kept the independent service industry from taking advantage of opportunities to promote itself.

We are living in an age in which public opinion in the mass can be influenced only by extensive national campaigns. These campaigns do not necessarily require the use of expensive consumer magazines. The greatest requirement is the active, aggressive cooperation of ethically operated service shops in every city, town, and village in the country.

Since the first of the year the press wires carried two news stories that could have helped the cause of ethically operated, independent service shops, if local associations and individual shops had taken advantage of the opportunity they afforded.

During February, most of the metropolitan area daily newspapers carried a story by William Ewald, a *United Press* reporter, under the headline, "Mystery of TV Makes Lush Field for Rackets." This news story was based on information supplied by the National Association of Better Business Bureaus, which estimate that the public is being swindled out of \$15 million per year for phony TV repairs. The article stated that during 1955, 107 Better Business Bureaus reported 107,732 inquiries and complaints from rankled set owners.

All operators of ethically operated service businesses should have welcomed the information it contained about service pricing. The news account stated: "The abuses take various guises. One of the most common is the 'flat rate' repair deal. In this one, the repairman offers to fix a set for an absurd price—usually \$1.00 or \$2.00. The customer winds up paying \$20, \$50, even \$100. The Bureau likes to point out that it costs a qualified technician almost \$5 to visit your home in terms of time and overhead."

In March, the national press wires carried another news story which was run by most metropolitan dailies in a boxed enclosure under the caption, "How to Get Hooked." This story listed the "ten worst buys" from advertising claims as reported by the Federal Trade Commission. Numbered among these ten worst buys was "Television Repair Come-ons."

August, 1956

NEW!



Altec's sensational 260A amplifier *delivers the most undistorted power per dollar!*

Altec Lansing engineers invite you to check carefully the amazing specifications of the new 260A amplifier. They believe you will agree that 260 watts of power available throughout the extended frequency range of 40 to 15,000 cycles sets the 260A apart as an outstanding development in the field of heavy duty amplifiers for public address, industrial and laboratory use. The fact that this entire power output is available at less than 2% distortion also indicates the high quality of this highest power Altec amplifier.

Regardless of whether your amplifier needs dictate a power output of 10 watts or 260 watts, an Altec Lansing amplifier is your best choice to deliver the most undistorted power per dollar.

Altec Lansing also manufactures a complete line of high quality microphones, control consoles, loudspeakers, horns, tuners, scientific instruments, theatre systems, public address systems, high fidelity systems and transformers.

SPECIFICATIONS:

Gain: 50 db: 30 db bridging 600 ohm line
 Input Sensitivity: 1.2 v rms: 600 ohms
 Power Output: 260 watts @ less than 2%
 thd, 45 cycles-15 KC
 Frequency Response: \pm 10 watts, \pm 0.5
 db, 20-20,000 cps; \pm 3 db, 5-70,000
 cps
 Source Impedance: 500/600 ohms and
 5,000 ohms bridging
 Load Impedance: 9, 19 (70 v line), 65
 (130 v line) ohms
 Output Impedance: Less than 12% of
 nominal load impedance
 Noise Level: -16 dbm; 70 db below
 rated output
 Controls: Meter switch—Plate current
 balance
 Power Supply: 105/117/125 volts, 60
 cycles, 600 watts
 Tubes: 2-6AU6, 2-613, 2-3B2B,
 1-5R4GYA
 Dimensions: 18" H x 19" W x 14-1/4" D
 Color: Blue gray
 Weight: 186 lbs.
 Accessories: #12156 wall mounting
 assembly



loudspeakers • amplifiers • preamplifiers • tuners • enclosures

Dept. 8T

9356 Santa Monica Blvd., Beverly Hills, Calif.

161 Sixth Avenue, New York 13, N. Y.

MUST MOVE OUR WAREHOUSE

Set Builders—Experimenters

GIANT SURPRISE KIT \$4.95

25-30 lbs. of brand new RADIO PARTS . . . no junk . . . Transformers, Filter and Bypass Condensers, Resistors; Wirewound, Carbon, Volume Controls, Sockets, Wire, Variables, Chassis and Gang Switches. Parts that every Service Man, Experimenter or Ham needs. Express or Freight Shipments Only. No C.O.D.

NEWARK SURPLUS MATERIALS CO.
324 PLANE ST., Newark, N. J.



110V, AC POWER SUPPLY FOR 274N RECEIVERS

Just plug it into the rear of your 274-N RECEIVER . . . any model. Complete kit and black metal case, with ALL parts and diagrams. Simple and easy to build in a jiffy. Delivers 24 volts plus B voltage. No wiring changes to be made. Designed especially for the 274-N receiver. Only \$8.95. Filament trans. for 274N receivers. Pri. 110V, 60 cy. AC. Sec. 24V @ .6A. An excellent buy at . . . \$1.95 ea.

SPLINED TUNING KNOB FOR 274N RECEIVERS

An exclusive O-R item manufactured for us. Fits BC-453, BC-454 and other 274N receivers. This is a really hard-to-obtain item. Only . . . 89c ea.



OFFENBACH-REIMUS

1564 Market Street, San Francisco, Calif.

COMMAND ARC-5 TRANSMITTER

T-20... 4 to 5.3 MC
T-21... 5.3 to 7 MC



Brand New... \$495
3 to 4 mc. like new... \$5.95

RECEIVERS	Leas Tubes As Is	Excellent Used	Brand New
520-1500 KC ...		\$14.95	\$19.95
1.5-3.0 MC ...		7.95	9.95
3-6 MC ...			\$2.95

TRANSMITTERS
T-23 ARC-5 UHF 2 METER TRANSMITTER—This terrific command transmitter has turret switching coils for all stages. Uses 1025 Osc., 1025 Tripler, coils for all stages. 832A Final. Range 100-150 mc. 4 832A Tripler. 832A Final. Range 100-150 mc. 4 automatic turret using 12 or 24 motor or 2 manually operated system. These coils can very easily be re-wound for 6 and 10 meters. Complete with all Tubes. Excellent condition \$9.95. Brand New ... \$11.95
R28—Companion receiver for above. Used Exc. \$11.95

TWO METER VHF TRANSCEIVER
RT-19/ARC-4 Transceiver complete with all tubes in excellent like new condition. Each \$19.50

BC 906 Cavity type freq. meter. 144 mc to 235 Mc. Complete with antenna and operating manual. Brand new—Orig. factory pack... \$14.95 ea.

SURPRISE PACKAGE
20 lbs. of MISCELLANEOUS ELECTRONIC EQUIPMENT—WORTH MUCH MORE than this low price of ONLY... \$1.95

DYNAMOTORS

Type	Input	Output	Used	New
BD-77	12 VDC	1000 VDC	350 MA.	\$14.95
BD-83	12 VDC	375 VDC	150 MA.	1.95 \$4.95
DM-64	12 VDC	275 VDC	150 MA.	3.95 5.95
DM-34	12 VDC	220 V	80 MA.	2.95 4.95
DM-35	12 VDC	625 VDC	225 MA. Exc. Cond.	9.95

PHONES—Sound Powered, Reconditioned... ea. \$ 5.95 and Tested... pr. 11.00

MOBILE HEAVY DUTY DYNAMOTOR: 14 V. INPUT-output: 1030 VDC 200 MA. Tapped 515 V. 215 MA. use of 6 V DC INPUT-500 V. 175 MA. While they last—DM-42-Excel. Condition. \$4.95 Brand New ... \$9.95

APG 5 or 15 CAVITY
10 Cm. 2C43 osc Xmitter, 2C40 Loc. Osc. Rec. 1B27 TR; tunes 2400 to 3000 MCS, less tubes. Price ... \$4.95

Navy Shipboard Receiver-Radio
300KC to 23MC. Designed for optimum performance for the reception of pure modulated or interrupted CW. Used Exc. ... \$49.50

CRYSTAL—100 KC. ... \$2.95
MG-149F—110V AC, 400 cycle-750 VA Inverter. Used. ... each \$9.95

LORAN EQUIPMENT
Marine or Airborne Long Range Navigational equipment. Determine the exact geographic position of your boat or airplane.
AN/APN-4 Loran set. Frequency range 1700-2000 KC. complete with 10dB/APN-4 Indicator. R92/APN-4 receiver. crystal and plug. ... Brand New \$129.50 Complete ... Brand New \$295.00 (Quantity prices available—write)

\$450 HI-FI Headset for only \$7.95

Uses annular grooved plastic fibre comes with voice coils as in speakers, and brand new chamois ear pads to obtain spacing for correct acoustical load. GIVES FINEST MUSIC REPRODUCTIONS! Each capsule wired separately, with plug for binaural sound. Imp.: 300 Ohms per unit or 600 Ohms when wire in \$7.95 series. Brand new in original carton. ... \$4.95 USED EXC COND. ... \$14.95

RT-24/APX-2 IFF EQUIPMENT—44 tube transceiver. 11-0AG5, 19-6C4, 7-518, 2-9006, 1-VR150, 1-3Y3, 1-2021, 2-2C26 with usable parts, tube sockets, relays, coax fittings, condensers, resistors, etc. 24 volt Blower motor, 24V gear train motor. Power transformer 400 to 2400 cycles. Original govt. cost \$750.00. Brand New. Complete with tubes... ea. \$14.95

A Sweet Oscilloscope Deal
INDICATOR. With 5CP1, mounted and shielded, with high-voltage divider network, focusing, intensity, horizontal & vertical positioning controls, and double-deck chassis with ota sockets for up to 27 tubes, plus 22 potentiometers, and resistors. New \$9.95 Light all aluminum 9", 9.12", 13". New \$9.95 with 5CP1. Leas tubes and crystal. Only \$24.50
Freq. Meter—Cavity tuned—absorption type—110 VAC 60 cycle 150 to 240 Mc. ... \$24.50 Like New ... \$24.50 100 to 127 Mc—Like New ... \$24.50

PE-109 Inverter 12VDC input, 115V, 1.5 amps., single phase, 400 cycle output. Brand New ... \$39.50 ea. MS-33 600 Ohm—New. ... ea. \$5.45

MS-23 Ill-Imp. headphones—Brand New... \$5.45
TS-9 Handset—Complete with cord & Butterfly switch. Brand New Original Cartons... \$6.95
10 for ... \$60.00
T-26 Mobile Chest Mike. Brand new... \$1.29

WRITE FOR NEW BULLETIN AND PRICES.

ALL ITEMS F.O.B. CHICAGO
25% Deposit required with orders
R W ELECTRONICS
Dept. N, 2430 S. Michigan Ave., Chicago 16, Ill.
PHONE: CAIumet 5-1281-2-3

While these articles, read by millions of people, warned the public about what to avoid when buying TV service, they did not give the set owners any help in determining the honest, competent, ethically operated shops. The tendency of the public is to be suspicious of all independent service shops when they read newspaper stories like these.

If you operate an honest, competent service business, put yourself in the shoes of the TV set owner who does not know you and is looking for a good, reliable man to fix his TV set. What is there about your business that distinguishes it from the "gyps" and "fast-dollar" boys in your town? Since, by normal business attrition, you lose 35% of your old customers each year, you must be continually adding new customers just to make up for this high loss percentage.

The independent service business is "low man on the customer's totem pole" when he looks for someone to service his TV set. His first inclination is to call the dealer from whom he bought the set. If the dealer provides TV service and has treated the customer fairly, the set owner will continue to patronize his facilities.

Second choice of the average person is to patronize services listed under the brand name of the product. The third choice is an independent shop, and the set owner is apt to turn to the independent with some misgivings.

Through consistent promotion, service associations in many areas are succeeding in focusing set owner attention on their members as shops that give competent, honest service. Some associations advertise a "double guarantee" of satisfactory service. All service work performed by members is guaranteed by the member who handled the service and by the association. Many set owners like the assurance of this type of a performance guarantee.

The great need of independent electronic service shops is for ethically operated shops in all communities, large, medium, and small, to join together in cooperative programs to make themselves known to the set-owning public. Cooperatively, they can carry out effective public relations programs that are too costly for an individual shop to handle alone.

A mailing piece titled "Don't Get Hooked," based upon the information supplied by the National Association of Better Business Bureaus and the FTC has been prepared. Readers who would like to have a copy of the mailer may obtain one by sending a stamped and addressed envelope to TTLB Special Service, P. O. Box 1321, Indianapolis 6, Indiana. Ask for the "Don't Get Hooked" mailer.

New National Group
Delegates from associations located in ten states met recently in Kansas City where they formed the American Electronic Service Council and approved its incorporation as a nonprofit national association.

Crystals
BUY NOW AND SAVE UP TO 90%
NEW LOW PRICES! NEW SAVINGS!
Get the dope!
NOVICE, FT-243
FT-171, FT-241,
FT-249, DC-34/35
SHIP BAND, MISC.
SAME DAY SERVICE!
SATISFACTION GUARANTEED!
OVER 5,000 FREQUENCIES!
SEND FOR FREE CATALOG
"The House of Crystals"
U. S. CRYSTALS, Inc.
1342 S. La Brea Ave. Los Angeles 19, Cal.

TOO HOT? Then Go Fishing!
But first, send for our terrific, new, bargain flyer to read in the boat!
Guaranteed best for man, beast or fish! Free prizes, too!
ARROW SALES, INC.
Box 3007-R North Hollywood, Cal.

TELEVISION
PREPARE FOR A GOOD JOB!
BROADCAST ENGINEER
ELECTRONICS RADIO SERVICING
Television Servicing
(Approved for Veterans)
BUILDING AIRCONDITIONED
SEND FOR FREE LITERATURE
BALTIMORE TECHNICAL INSTITUTE
1425 EUTAW PLACE, BALT. 17, MD.

CONALERT MONITORS CONELRAD

• Fail-Safe • Meets FCC Requirements
• 5 Channels • FCDA Approved
• Low Cost Effective as of Jan. 2nd, 1957—
MANDATORY FOR OPERATORS OF ALL RADIO TRANSMITTERS!
For complete information write:
ENGINEERING CORP.
2981 Middlefield Road
Palo Alto, California

The delegates, who represented associations with a combined total of more than two thousand member service shops, named the following officers to serve until May 1957: Forrest L. Baker of San Antonio, Texas, chairman; B. A. Bregenzer of Pittsburgh, Pa., vice-chairman; Howard Wolfson of Chicago, Ill., secretary; and Murray Barlowe of Bethpage, L. I., treasurer.

Regional officers elected by the delegates from associations in their regions were John Wheaton of Mineola, N. Y., first region vice-president; Alexander Weiss of Detroit, Mich., second region vice-president; and Harold Garten of Wichita, Kansas, third region vice-president. Action on a regional officer for the fourth region, consisting of the Rocky Mountain and Pacific Coast States, was deferred pending a regional meeting of associations in that area in the near future.

C. D. "Jack" Hughes of Wichita, Kansas, was named executive secretary of the new national association. National offices have been set up at 815 Central Building, Wichita, Kansas.

Association officers and shop owners who are interested in the aims and objectives of the new association should write to Mr. C. D. Hughes at the Wichita, Kansas, address.

PHOTO CREDITS

Page	Credit
39 (Fig. 1)	Alliance Mfg. Corp.
39 (Fig. 2, left), 40 (Fig. 7) Cornell-Dubilier
39 (Fig. 2, right) LaPointe Electronics Corp.
39 (Fig. 3) Telrex, Inc.
39 (Fig. 5) Channel Master Corp.
40 (Fig. 10), 41 (Fig. 11) Crown Control Co.
41 (Fig. 12) JFD Manufacturing Co.
48, 49, 60 (right), 61 (Fig. 5) General Electric Company
52, 53 Minnesota Mining & Manufacturing Co.
59 Seco Manufacturing Co.
60 (left) CBS-Columbia, Inc.
60 (center) Howard W. Sams & Co., Inc.
61 (top left) Ram Electronics Sales Co.
63, 64, 65 Simpson Electric Co.
66, 67 Cincinnati Research Co.
116 Thompson Products
124 Lafayette Radio
132 Official U. S. Army Photograph

ERRATA

The article "New TV Antenna Roundup" (May 1956) contained an error on page 64. It was stated that "a 6 db voltage gain relative to a simple dipole is equivalent to a 3 db power gain, and merely means that twice as much signal is received—not six times as much." Actually, a 6 db voltage gain is equivalent to a 6 db power gain, but the voltage ratio for 6 db gain is 2 and the power ratio for 6 db gain is 4. If a manufacturer specifies that his antenna is four times stronger than another, for example, it is important to know whether this is four times the voltage or four times the power. If it is power, then the signal received will be only twice as strong.

The schematic diagram of the radio paging pocket receiver (page 36, June 1956) in the article "Person-to-Person Communications" contains an incorrect connection between the plate and grid of V₁. The direct connection between the plate and control grid should be removed, leaving the 4.7 megohm resistor and the 91 μ fd. capacitor connected between the plate (through tuned circuit L₁C₁) and the control grid.

In the parts list accompanying Fig. 4 ("A No-Load Signal Probe," page 69, June 1956) the descriptions of transformers T₁ and T₂ were inadvertently interchanged.

GRAND OPENING SALE

TO introduce you to our large new home
4 floors of QUALITY MERCHANDISE
at ROCK BOTTOM PRICES . . .

AIREX
THE ELECTRONICS
SUPERMARKET

RECORD CHANGER BARGAINS

COLLARO RCS4: 3 speed intermix, automatic shut-off, weighted turntable, plug-in head with Shure ceramic cart. Reg. \$48.75.	\$29.95
WEBSTER MDL 140: 3 speed intermix, automatic shut off, dual styli cart. 2 pole motor. Reg. \$37.50.	\$21.95
WEBSTER MDL 140 GE: 3 speed intermix, with GE reluctance RPX 050-A cart., dual sapphire styl, automatic shut off. Reg. \$40.	\$25.95
MONARCH MDL UAG: British made, 3 speed, weighted turntable, intermix, automatic stop and shut off, heavy duty 4 pole motor, rubber turntable mat. Reg. \$49.95.	\$22.95
GARRARD RC 121: New, 3 speed, auto-manual changer; heavy duty turntable, 4 pole motor, plug-in head.	\$42.50
GARRARD RC 88: Latest model, 3 speed, deluxe; weighted turntable mat, automatic shut off, plug in head.	\$54.50
GARRARD RC 98: 3 speed (variable) super auto-manual changer with 45 RPM adapter spindle.	\$67.50

RECORD CHANGER BASES & BOARDS

for the changers listed
BASES . . . \$3.89 MOUNTING BOARDS . . . \$1.95
12" Ball Bearing Phono Slides . . . Pr. \$1.95

GENERAL ELECT GOLDEN TREASURE RELUCTANCE CARTRIDGE RPX 052A. Triple play .003 mill sapphire & .001 mill diamond. Clip-in Stylus. Stylus pressure 1/2 gram.	\$22.90
RECOTON - GOLDRING MAGNETIC TURNOVER CART. "500." Triple play. .003 mill sapphire & .001 diamond. Response 20-18000 cycles. Stylus pressure 6-7 grams. Mounts in any tone arm with 1/2" hole centers.	\$22.93
RONETTE HI-FI CARTRIDGE: with dual sapphire styl. For use with any of changers listed.	\$3.95
45 RPM SPINDLES GARRARD \$3.49 WEBSTER \$2.95 MONARCH \$2.95 COLLARO \$2.95	

Standard Coil Cascade TV Tuner

Replacement for any type TV set. 41 MC. 1". Shaft length 3 3/4". Knobs to match—69c.

5 WATT, 3 TUBE AUDIO AMPLIFIER
TONE & VOLUME CONTROL With 12AU6; 35Z5; 50L6 & output transformer & extra AC receptacle. Phono jack input. 7 1/2"x3" with mtg. brackets

WESTERN ELECTRIC POWER AMPLIFIER
Complete with Ruggedized tubes 6587, 68CT, 6L6—condensers, chokes, resistors. Many uses. Original cartons. From radar equip. Gov't cost \$95. Tubes worth \$7.75 Complete

All merchandise is brand new, factory fresh & guaranteed. Mail & phone orders filled on receipt of certified check or MO of 20% of items as a deposit. Balance C.O.D., F.O.B. Factory N. Y. Prices & specifications subject to change without notice.

AIREX RADIO CORP. 64 Cortlandt St., N.Y. 7, N.Y.
Phone CO 7-2137

KIT FANCIERS! Now You Can Have...

- PROFESSIONAL CONSTRUCTION
- ACCURATE PERFORMANCE DATA
- CONVENIENCE

The Miami Instrument Company now offers expert construction of electronic kits where this service is not available from the supplier. ORDER THROUGH US! Your completed kit will be sent to you postpaid, accompanied by accurate performance data, guaranteeing confidence in the equipment. Specify manufacturer, model and send only cost of kit plus 60%. This offer does not include receivers.

MIAMI INSTRUMENT COMPANY
Dept. K, P.O. Box 384, Miami 44, Florida

LEARN TV

Work on late model sets—using modern equipment and service techniques: under qualified technician instructors. Short resident and correspondence courses—no unnecessary math or theory—also UHF and Color TV. APPROVED FOR VETERANS . . . day and night classes.

Write for free literature. Dept. IA for residence—Dept. IAC for correspondence.
V.S.I. TELEVISION SCHOOL 4570 Firestone Blvd., Box 359
South Gate, California



FAMOUS UTAH 12" COAXIAL SPEAKER

Latest Design
Parabolic Woofer with
3 1/2" Parabolic Tweeter

This Utah 12" dual range reproducer compares in every respect with highly advertised \$50.00 units—yet COSTS LESS than most speakers. Exclusive built-in cross-over network ensures a frequency response from 35 to 15,000 cycles. The handling capacity is a full 12 watts. Ideal for any custom installation. Voice Coil impedance—8 ohms. Shipped in factory sealed cartons. SHPG. wt. 0 lbs.

\$12.88

MULLARD HI-FIDELITY TUBES

Type	Replaces	Description	Price
EL34	KT66; 6CA7	For amplifiers up to 100 watts	\$4.35
EL37	6L6; 5881; KT66	Increases power output 10-25% while reducing distortion level	\$3.50
EL84	68Q5	2 in push-pull drivers up to 20 w.	\$2.40
ECC81	12AT7	Eliminates microphonics & reduces noise levels.	\$2.60
ECC82	12AU7	Eliminates microphonics & reduces noise levels.	\$2.20
ECC83	12AX7	Eliminates microphonics & reduces noise levels.	\$2.50
EF86	Z729; 6267	Reduces hum, noises & microphonics	\$2.75
GZ32	5V4; 5U4	Delivers currents up to 300 MA. Sep cathode construction	\$2.95



FM-AM TUNER KIT

Easy to assemble. Professional quality performance. 3 double tuned IF stages. Foster-Seely discriminator for automatic frequency control & defeat. 7 tubes —70DB. Sensitivity 6 microvolts for automatic on FM & 20 microvolts on AM. FM selectivity 20KC band width 8 DB down; AM 8KC band width 5 DB down. 5 1/4" high x 9 1/2" wide x 8" deep. Complete with step-by-step instructions. **\$29.95**
FM TUNER ONLY—\$23.95 • COVER—\$3.95
These units are ideal in combination with the Grommes Hi-Fi Amplifier.

Grommes Hi-Fi Amplifier Kit

10 Watts, 18 watts peak. Resp. 20-20,000 cps ±1 db. Preamp., 4 inputs. Hum—80 mt. 2% Harm. Dist at 10 watts. Complete with detailed step by step instruction manual, all resistors, condensers, tubes, wire & solder. Easy to make. 2-12AX7, 2-6V6, & \$24.95

Send for our complete Hi-Fi Audio Catalog. When in showroom with a full line of amplifiers, speakers, tuners and enclosures. Send card to be put on mailing list.

All merchandise is brand new, factory fresh & guaranteed. Mail & phone orders filled on receipt of certified check or MO of 20% of items as a deposit. Balance C.O.D., F.O.B. Factory N. Y. Prices & specifications subject to change without notice.

EASY TO LEARN CODE

It is easy to learn or increase speed with an Instructograph Code Teacher. Affords the quickest and most practical method yet developed. For beginners or advanced students. Available tapes from beginner's alphabet to typical messages on all subjects. Speed range 5 to 40 WPM. Always ready—no QRM.

ENDORSED BY THOUSANDS!

The Instructograph Code Teacher literally takes the place of an operator-instructor and enables anyone to learn and master code without further assistance. Thousands of successful operators have "acquired the code" with the Instructograph System. Write today for convenient rental and purchase plans.



INSTRUCTOGRAPH COMPANY

4711 SHERIDAN ROAD, CHICAGO 40, ILLINOIS

WRITE FOR BONUS BARGAIN CATALOG

KITS! KITS!

All Kits Contain Most Popular Values & Sizes
EXTRA! FREE KIT WITH EACH \$10 KIT ORDER
 15 Volume Controls
 250 Ft Hookup Wire
 25 Wirewound Resistors
 50 Paper Condensers
 10 Condensers, Sattubs
 60 Inductors & Coils
 75 Carbon Resistors*
 * In Plastic Box

10 Rotary Switches
 10 Toggle Switches
 25 1/2" Resistors
 25 Tube Sockets
 5 Crystal Diodes

99c

FAMOUS BRAND PHONO CARTRIDGES

Original Boxed, Money Back Gtd.



RPX050A .001 & .003 (SS) \$6.75
 RPX052A Golden Treasure (DS) \$19.25
 RPX053A Golden Treasure (DD) \$28.00

Replacement Needles "TETRAD" Diamond
 RPJ013A Dual (DS) .001 & .003 "TETRAD" \$11.10
 RPJ01D or RPJ03D Single (D) "TETRAD" \$9.55
 RPJ01S or RPJ03S Single (S) \$1.35
 RPJ003 or RPJ004 Single (D) "TETRAD" \$9.85
 MG or 78 Single (D) "TETRAD" \$9.85

NEW COLLARD RC-54 RECORD CHANGER @ \$27.95;
 With RPX050A @ \$34.90; With RPX052A @ \$44.95

FINEST HI-FI RECORDING TAPE

1200 Ft.—7" Reel **\$1.45** Lots
 Money Back Gtd.

Highest quality controlled plastic base
 tape made by new Ferro-Sheen process.
 Precision coated & Silt. Gtd. Consist.
 output. Splice Free. Freq. 7 1/2 IPS
 40-15KC Oxide Wnd In. 3 FOR \$1.50
 EACH; SINGLY @ \$1.59 EA.



NEW IMPROVED "TAB" HI-FI SPEAKERS

With Inbuilt Network Ticonal Alnico 5 Plus
 Magnet, 4 to 8 Ohm V.C.
 15" TRIAX, 25 Watt/20-20,000 Cycles.
 MODEL F15H3X \$36
 12" TRIAX, 20 Watt/40-20,000 Cycles.
 MODEL F12H3X \$27
 8" COAX, 6 to 10 Watt/75-19,000 Cycles.
 MODEL P8H2X \$8



NEW "TABTRON" SELENIUM BRIDGE

Gtd. RECTIFIERS One Yr.
 FOLLOWING LIST, FULL WAVE BRIDGE

Cont.	Volts	Volts	Volts	Volts
1AMP	\$1.40	\$2.80	\$3.70	\$4.40
2AMP	2.40	3.40	5.00	10.25
3AMP	2.90	4.10	5.75	12.70
4AMP	3.50	6.40	11.25	29.65
6AMP	3.95	7.90	12.75	29.65
10AMP	5.85	11.35	19.40	41.25
12AMP	7.20	14.25	22.00	43.85



"TABTRON" HI CURRENT PWR SUPPLIES

ONE YEAR GUARANTEE
 Variable 0-28VDC. Completely Built.
 Incis: Full Wave Selenium Rectifier,
 Transformer, Variac, Volt & Amp
 Meters, Switch, Terminals & Fuse. In
 heavy duty Steel Cabinet. Standard
 115V/60cy Input or 220V and 3 phase

Stk. No.	Cont. Rating	W-Meters
T28V5A	0-28 VDC at 5 Amp	\$50.00
T28V12A	0-28 VDC at 12 Amp	\$125.00
T28V24A	0-28 VDC at 24 Amp	\$155.00
T28V50A	0-28 VDC at 50 Amp	\$285.00



VARIABLE 0 TO 6 & 12 VOLT/12 AMP DC Power Supply

Battery Eliminator, Charger, Model RR,
 Plater, Aircraft, Marine or any other
 Extra heavy duty Selenium Rectifier, 2
 meters V & A. Designed for continuous
 service & up to 20 Amps intermittent
 overload.
 MODEL T612V12AC @ \$33.00



INFRARED SNOOPSCOPE

See In Dark Tube
 Selected G.D. Image Converter Tube. Hi-
 sensitivity, simplified design 2" dia.
 Willamite screen. Hi Resolution. Tube &
 Data @ \$4.90; 2/57.50
Snooperscope Power Supply
 Model PS2001-4500VDC/35MA. Using Dual Doubler
 Ckt. In Metal Cabinet \$21.95
 KIT, Same as above, Less Cabinet \$13.95

New, Unused • Individually Boxed FULL RETMA TUBES WARRANTY

No Electrical or Mechanical Rejects

0Z4	.45	6AV5	.80	6K6	.45	12AX7	.33
1AX2	.95	6AV6	.45	6SA	.45	12BA6	.50
1B3	.65	6AX4	.85	6T7	.55	12BH7	.65
1R5	.50	6B7	.75	6J5J7	.65	12BY7	.97
1T4	.50	6BA6	.45	6SK7	.50	12CV7	.64
1U5	.45	6BC5	.60	6SN7	.55	12SK7	.45
1X2	.85	6BE6	.45	6X4	.55	12SN7	.56
3V4	.75	6BG6	1.15	6SQ7	.55	12SV7	.50
5U4	.45	6BK7A	1.1	6T8	1.15	25Z6	.90
5V4	.60	6BL7	.90	6T8	1.15	25Z6	.90
5Y3	.65	6BN6	1.19	6V6	.55	25L6	.42
6AC7	.65	6BQ5	1.90	6W4	.35	25W4	.45
6AG3	.45	6BQ7A	1.90	6W4	.35	35Z5	.45
6AK5	.60	6C4	.35	6X5	.40	35L6	.60
6AL5	.40	6CB6	.50	6X8	.85	35W4	.59
6AQ5	.45	6C6	1.08	12AT6	.60	50B5	.70
6AT6	.45	6CF6	1.25	12AT7	.65	50C5	.52
6AU4	.95	6CL6	1.65	12AU6	.41	50L6	.83
6AU5	.60	12AU7	.40	83V	.68	83V	1.22
6AU6	.45	6J6	.45	12AX4	.68	83V	1.22

"TABLITE" ELECTRONIC FLASH KITS

AC & Battery Inbuilt
 All in One Camera Case
 Uses new to cost low voltage super
 circuit constant bright lightoutput.
 Light duration 1/600 sec'd; color
 & 6000; cost per flash less than
 1/4c. 1000 to 2000 flashes per set
 of batteries. All kits with inbuilt
 AC Pack. (Kits less batteries.)
 MODEL 400B, 60W sec'd color 75+; B & W 225+.
 Recycles 2 sec'ds, less than 4 lbs. \$29.95
 MODEL 600B, 120W sec'd color 100+; B & W 300+.
 Recycles 5 sec'ds, less than 5 lbs. \$44.95
 2-240V Batteries. @ \$10
SOLD WITH "TAB" MONEY BACK GUARANTEE
 Photoflash Cond. 525MFD/450V/53W 5EC. NEW LOW
 leakage, Famous mfg. @ \$8; 2/51.5



"TAB"

DEPT. BRNG, 111 LIBERTY ST., N. Y. G. N. Y.
 PHONE RECTOR 2-6245-CABLE "TABPARTS"

INDEX OF Advertisers

AUGUST 1956

While every precaution is taken to insure accuracy, we cannot guarantee against the possibility of an occasional change or omission in the preparation of this index.

ADVERTISER	PAGE	ADVERTISER	PAGE
Airex Radio Corp.	135	Nel-Kaye Record, Inc.	119
Allied Radio Corp.	9	Newark Surplus Materials Co.	133
Almo Radio Co.	90	North American Phillips Co., Inc.	98
Altec Lansing Corporation	133	Offenbach-Reimus	133
American Elite, Inc.	100	Pacific State University	133
American Television & Radio Co.	126	Peak Electronics Company	128
Arrow Sales, Inc.	132, 134	Phoastron Instrument and Electronic Company	105
Ashe Radio Company, Walter	17	Pickering & Co., Inc.	6
Atlas Sound Corp.	88	Precision Apparatus Company, Inc.	99
Audel Publishers	96	Prentice-Hall, Inc.	128
B & K Manufacturing Co.	28	Precise Development Corp.	123
Baltimore Technical Institute	134	Progressive "Edu-Kits," Inc.	114
Barry Electronics Corp.	137	Quality Electronics	131
Bell Telephone Laboratories	12	Quietrolle Company, Inc.	121
Bendix Radio	129	R.C.A. Institutes, Inc.	27, 126
CBS-Hytron	19	RW Electronics	134
Candler System Co.	131	Radiart Corporation, The	10
Capital Electronics	11	Radio Corporation of America	111, 113, 115
Capital Radio Engineering Institute	11	Radio Ham Shack, Inc.	116
Chicago Standard Transformer Corporation	29	Radio Kits, Inc.	21
Cleveland Institute of Radio Electronics	27	Radio-Television Training Association	120
Columbia Electronics	114	Rad-Tel Tube Co.	120
Cornell-Dubilier	10	Raytheon Manufacturing Company, 2nd Cover	95
Coyne Electrical School	125, 129	Remington Rand, Inc.	122
Delco Radio	71	Rex Radio Supply	25
DeVry Technical Institute	5, 16	Rider, Publisher, Inc., John F.	24, 25
Dressner	136	Rinehart & Co., Inc.	30
DuMont Laboratories, Inc., Allen B.	23	Rohn Manufacturing Company	118
Editors and Engineers, Ltd.	121	Rockbar Corporation	118
Electro-Voice, Inc.	8, 13	Sams & Co., Inc., Howard W.	73, 109
Electronic Chemical Corp.	123	Sangamo Electric Company	15
Electronic Instrument Co., Inc. (EICO)	33, 34	Science Kits	120
Electronic Specialties Mfg. Corp.	122	Scott, Inc., H. H.	91
Erie Resistor Corporation	108	Seco Mfg. Co.	127
Fair Radio Sales	107	Semler Industries, Inc.	96
Fisher Radio Corp.	94, 97	Service Instrument Co.	91
G & G Radio Supply Co.	89	Shure Brothers, Inc.	26
Goodheart, R. E.	90	Sonotone Corporation	102
Harvey Radio Co., Inc.	106	Soundmart Unlimited	120, 120
Heath Company	74, 75, 76, 77, 78, 79, 80, 81	Sprague Products Company	130
Henshaw Radio Supply	90	Stan-Burn Radio & Electronics Co.	104
Hershel Radio Co.	126	Standard Electrical Products	113
Indiana Technical College	132	Stanley Electronics Corp.	103
Instructograph Company	135	Supreme Publications	103
International Business Machines Corp.	87	"TAB"	136
International Radio & Electronics Corp.	116	Telex, Inc.	125
J. J. Glass Electronics Co.	132	Terado Company	109
Jerrold Electronics Corp.	14	Texas Crystals	124
Jones & Laughlin Steel Corporation	32	Texas College	86
Kaar Engineering Corp.	134	Triad Transformer Corp.	102
Klein & Sons, Mathias	90	Tube Mart	102
Kuhn Electronics	114	Tung-Sol Electric, Inc.	112
LMB Box Chassis	128	U. S. Crystals, Inc.	134
Lafayette Radio	101	V.S.I. Television School	135
Lampe, E.	132	Valparaiso Technical Institute	127
Lampkin Laboratories, Inc.	108	Video Electric Company	117
Lektron Specialties	132	Viking of Minneapolis	3rd Cover
McGee Radio Company	82, 83	Volpar	127
M. R. Company, The	132	Walt Manufacturing Co.	96
Major Brand Tube Co.	85	Ward Products Corporation	20
Mallory & Co., Inc., P. R.	Fourth Cover	Western Television Institute	131
Merit Coil & Transformer Corp.	84	Winegard Company	22
Miami Instrument Company	135	World Radio Laboratories, Inc.	125
Milwaukee School of Engineering	124	Xcelite, Incorporated	119
Moss Electronic Distributing Co., Inc.	92, 93	Yeats Appliance Dolly Sales Co.	102
Musical Masterpiece Society, The	121		
MusiCraft	131		
National Radio Institute	3, 7		
National Schools	31		

WANT A BETTER JOB? BECOME AN ELECTRONIC ENGINEER
 ONLY 32 MONTHS TO EARN A BACHELOR OF SCIENCE DEGREE IN ELECTRONIC ENGINEERING
 Class enrollment limited to allow for individual instructions. Chartered by state of California. Nonprofit-educational—established 26 years.
APPROVED FOR VETS—ENROLL NOW!
 SEND FOR FREE CATALOG
PACIFIC STATES UNIVERSITY
 1516 S. Western Ave., Dept. O, LOS ANGELES, CALIF.

TAPE RECORDERS
 Tapes—Accessories
 Nationally Advertised Brands
UNUSUAL VALUES
 Send for Free Catalog
DRESSNER
 69-02 RA-174 St.
 Flushing 65, N. Y.

MERITAPE
 Low Cost, High Quality Recording Tape—in boxes or cans.

Classified

RATE: 50c per word. Minimum 10 words. October issue closes August 10th. Send order and remittance to: RADIO & TELEVISION NEWS, 366 Madison Ave., N. Y. C. 17.

RADIO ENGINEERING

COMPLETE radio, electronics theory & practice; television; broadcasting; servicing; aviation, marine, police radio. 18 or 21 months. Catalog. Valparaiso Technical Institute, Dept. N, Valparaiso, Ind.

FOR SALE

DIAGRAMS for repairing radios \$1.00. Television \$2.00. Give make, model. Diagram Service, Box 672-RN, Hartford 1, Conn.

TV Trade-In sets. Philco, R.C.A., Emerson, others. List available. 10"—\$12. 12" to 17"—\$15. up. Washtek Service Co., Dept. R, 956 Southern Blvd., Bronx, N. Y.

TUBES—TV, Radio, Transmitting And Industrial Types At Sensibly Low Prices. New, Guaranteed, 1st Quality, Top Name Brands Only. Write For Free Catalog or Call Walker 5-7000, Barry Electronics Corp., 512 Broadway, New York 12N, N. Y.

TRADE-IN Television Sets \$14. Jones Radio, 1115 Rambler, Pottstown, Pa.

DIAGRAMS—Radios, Amplifiers, Changers, \$1.00 Each. Television Service Data \$2.00. Unknown Models, Give Tube Layout and Part Numbers. Kramer's Radio Service, Dept. 656, 36 Columbus Ave., New York 23, N. Y.

BUY Surplus Electronics; Instruments; Test Equipment; Sonar; Radar; Tubes; Transceivers—Direct From U. S. Government Surplus Depots—List & Procedure \$1.00—Brody, Box 8-RTA, Sunnyside 4, New York.

MINIATURIZED reference voltage device calibrated against standard cell. 1.0193 volts d.c.—\$9.50.—Transistor Thermocouples Co., South Pasadena, Calif.

NAVY Surplus-used, complete with tubes—Receiver, R 28, 100 to 156 MC \$8.00, Transmitters, T-19, BC 696-3 to 4 MC, \$5.00, T-20, BC 457-4, to 5.3 MC \$3.95, T-21, BC 458-5.3 to 7 MC, \$3.95. Jack Box New BC 1366 M, \$1.00. Prices F.O.B. B'ham, Ala. Rogers Trading Co. 2401 Second Ave., North, Birmingham 3, Ala.

1-CLOUGH Bregle Company Vacuum Tube Voltmeter, Type 88. 1-Cathode Ray Oscilloscope, Type 1550. 2-Single Corp. Oscillator VO-3-B, Mfg. by Amplifier Co. of America. Box 552 % RADIO & TELEVISION NEWS.

DIAGRAMS! Repair Information! Radios—amplifiers—recorders \$1.00. Televisions \$1.50. Give make, model, chassis.—Norelco-Philips and Ampex tubes in stock! TV Mittie, Box 101 RA, Hicksville, New York.

HIGH Fidelity—New, special Collaro RC-54; mounting board; specify Ronette Cartridge or Blank Plug-in Head. \$29.95 Prepaid. Full line of Hi Fi equipment. Write today. Prompt reply. Soundmart, Unlimited, 63-03 39th Street, Woodside 77, N. Y.

HI-FI Preamp: Having hum problems in your HI-FI system? The Hiard Model 57 all transistor booster preamp is what you need. The 57 raises the signal level from your pickup above the hum level of your preamplifier-equalizer. It introduces no hum; frequency response \pm 5db from 10 to 55,000 cycles; included battery lasts for years; price \$9.95. Pre-paid orders sent post-paid. Additional information sent on request. The Hiard Company, Box 1363, Alamogordo, New Mexico.

MANUFACTURING Building For Sale—56,600 square feet located central North Carolina. High pressure boiler and partially air conditioned. Contact Robins & Weill, Inc., Greensboro, N. C.

TECHNICIANS. Novices: 6 meter 5-element beam antenna, \$14.95 ppd. 2 meter 6-element, \$6.95 ppd. Wholesale Supply Co., Lunenburg, Mass.

WANTED

WANTED, For Parts, Damaged, Hickok 533 Tube Tester. Please Give Condition And Price. John H. Stephens, Wickes, Arkansas.

TUBES and equipment bought, sold, and exchanged. For action and a fair deal write B. F. Gensler, W2LN1, 56 Crosby St., N. Y. 12N, N. Y.

WANTED: ART-13 transmitters and parts—also ARC-1, ARC-3 and ARN-7. Have requirement for ARN-6 material. Iron Core Loops, need all types Collins and Bendix Aircraft Radio equipment. Florida Aircraft Radio & Marine, Inc. P. O. Box 205, International Airport Branch, Miami 48, Florida.

CYLINDER and old disc phonographs. Edison Concert, Balmoral, Conqueror, Opera, and Oratorio models. Berliner Gramophones and Zono-ophones, Columbia disc and cylinder (graphophones, Bettini micro-reproducer. Want old catalogues and literature on early phonos prior to 1919. Will pay cash or trade late hi-fi components. Box 50 % RADIO & TELEVISION NEWS.

AN/APR-4, AN/APR-9, other "APR," "ARR," "TS," ARC-1, ARC-3, ART-13, everything surplus; Tubes, Manuals, Laboratory equipment. Describe, price in first letter. Engineering Associates, 434 1stterson Rd., Dayton 9, Ohio.

ART-13/T47A Transmitters, \$175.00; ART-13/T47 Transmitters, \$125.00; BC-788 C Airmeters, \$175.00; ARC-3 Transceiver Complete, \$325.00; R5/ARN-7 Radio Compass, \$175.00; BC-348 Rec'r Modified, \$25.00; BC-348 Rec'r Unmodified, \$50.00; ARC-1 Transceiver, \$300.00; BC-342 Rec'r, \$50.00; BC-312 Rec'r, \$40.00; I-152-C Indicator, \$50.00. Ship Via Express, C.O.D. Subject To Inspection To H. Finnegan, 49 Washington Ave., Little Ferry, N. J.

WANTED: Receiver R5/ARN-7, MN-62A Transceivers, RT18/ARC-1, AN/ARC-3, BC-788C, I-152C, Collins, Bendix equipment, Test Sets, Dynamometers, Inverters. We pay highest prices. Advise quantity, condition, price first letter. Aircraft Radio Industries, Inc., 15 East 40th St., New York City, telephone LEXington 2-6254.

AIRCRAFT Electronics Needed: BC-788, I-152, ARN-7, ARC-3, ARC-1—or any type airborne electronics. Electronic Tubes Needed: Broadcast (water and air cooled), transmitting, receiving (in quantity only), Magnetrons, Klystrons, etc. Top Prices Paid! Write or phone description for immediate action. Bob Sannet, W6REX, 1524 S. Edris Dr., Los Angeles 35, Cal. Phone: CRestview 1-3856.

RC221's WANTED—Highest cash price for RC-221's paid even more if the unit has modulation and hasn't been tampered with. Original Book needed. Write giving Model No. to Weston Laboratories, Inc., Bolton, Mass.

REPAIRS AND SERVICING

HIGH Fidelity Speakers Repaired. Amprite Speaker Service, 70 Vesey St., N. Y. 7, N. Y. Ba. 7-2580.

TAPE RECORDERS

PRE-recorded Tape Music, recording tape accessories, Discounts. Catalogue, Elasco Sales, 270 E. Concord, West Hempstead, N. Y.

TAPE Recorders, Tape, Unusual Values. Free catalog. Dressner 69-02 R, 174 St., Flushing 65, N. Y.

CANADIANS! Let us quote on your tape recorder needs. Soundscription Service, 5239 Park Ave., Montreal, Que.

CORRESPONDENCE COURSES

USED Correspondence Courses and Books sold and rented. Money back guarantee. Catalog free. (Courses bought.) Lee Mountain, Pisgah, Ala.

USED Correspondence Courses and Books Bought, Sold, Rented. Catalog Free. Myrtle Vernon, Henagar, Ala.

RECORDS

PHONOGRAPH Records Cheap. Catalogue. Paramount, ND-313 East Market, Wilkes-Barre, Penna.

KITS assembled and wired. M. Vincek, 117 Center St., Clifton, N. J.

Only the 5 TOP QUALITY brands of

STANDARD BRAND TUBES

AT SENSIBLE PRICES!

- 90-Day RETMA guarantee
- Individually boxed • First quality only
- Brand New
- No private brands • No rejects
- No rebrands or rewashed bargains

Write for complete price list.
Over 1000 tube types in stock.

SPECIAL-PURPOSE TUBES

Write for our complete listing on Transmitting, Industrial, Special-Purpose Tubes, and Crystal Diodes. We STOCK over 1000 types at excellent prices.

TRANSMITTING TUBE SPECIALS

(SURPLUS-NEW ORIG. BOXED)

4PR60A	\$50.00	750T	\$50.00
304TH	8.75	803	2.00
307A	47.50	807W/5933	2.85
450TH	47.50	812	1.25

EQUIPMENT SPECIALS!

LM-15 NAV. FREQ. METER W/orig. book. \$150.00
XTAL. AMPLIFIER SPLY. Excl. 35.00
LM POWER SUPPLY. 2ely. 35.00
KAY MEGA-MARKER SR. 13 channel xtal 35.00
free. TV marker. 35.00
HICKOK combo. CNE gen. ANALYZER model 49.50
550X mut. cond. type. Used, cases worn but in good oper. condx. W/latest tube data book. Special 39.50
PRECISION MODEL 912 portable. Used; in good oper. condx. W/instr. book & role chart 33.50
PRECISION CHECKER ANALYZER MODEL 920 used, worn, but in good oper. condx. W/instr. book & role chart. Special 37.50

2 COLOR TUBE CARTONS

Keeps your tube stock neat. New safety partition prevents tube breakage. Distinctively lithographed in glossy red and black. The most distinctive tube carton available today. Minimum quantity: 100 of any one size. Write for case list prices.

SIZE FOR TUBE PER 100
Miniature \$1.00
Large GT. 1.25
Large C. 1.85
Large C. 2.50

WHITE GLOSSY BOXES
Completely blank. No printing or color. Otherwise same as above. Same high quality, same low prices. Specify "WHITE" when ordering. When color is not stated, 2 color cartons will be shipped.

TUBE STACKERS
White glossy only. Ministacker holds 10 Mini tube cartons; "GT" stacker holds 10 "GT" cartons. SIZE PER EACH
Ministacker 1 1/2c
GT 2c

DIRECTRON SELENIUM RECTIFIERS

Max. Amps.	18 VAC 14 VDC	36 VAC 28 VDC	54 VAC 42 VDC	72 VAC 56 VDC	130 VAC 100 VDC
1	\$1.35	\$2.30	\$3.70	\$4.50	\$7.40
2	2.00	2.75	5.30	5.90	9.15
3	3.50	4.10	5.75	7.85	12.70
4	4.50	6.40	11.30	14.30	29.85
6	3.95	7.70	12.75	17.30	21.70
12	9.20	11.35	19.40	24.80	41.25
16	12.00	22.00	24.40	32.80	43.85
20	13.05	25.05	37.25	48.75	56.50
24	14.25	28.75	44.50	57.65	81.00

We build other selenium rectifiers. Transformers and chokes to your specifications. Complete line of new rectifier transformers, chokes and capacitors in stock at all times. May be ordered at same time as selenium rectifiers above for immediate delivery. Write for complete price list.

TRANSFORMER SPECIALS!

VIBRATOR TRANSFORMER
PRIMARY: 6 volts—100 ohms DC
SECONDARY: 310 volts DC @ 150 ma. (Cond. Input)
1500 volt insulation RMS
Made by Electric Trans. Co. to MIL-T-27, Grade 1, Class A specs. (Spec. No. 2570-1) Meas. 3 1/2" x 4 1/2" hermetically sealed. **\$1.95**

MODULATION TRANSFORMER
PRIMARY: Z-6000 @ 170 ohms DC
SECONDARY: Z-6000 @ 215 ohms DC
Freq. resp.: 200-5000 CPS. 3000 volts test. Rated at 20 watts but will actually handle 40 watts with case. (PP 616's, 815, etc.) **\$2.50**
Special each (TWO FOR \$4.00)

EXTRA SPECIAL!
Husky, Heavy Duty, Plate Transformer.
PRIMARY: 115 or 230 volts, 50/60 cy.
SECONDARY: 350 volts CT @ Husky 1 Amp plus 10,000 volts insulation RMS. Mfg'd by Amstron. Meas. 14 3/4" x 10 3/4" high. Brand new, guaranteed, in original wood crates. Worth over \$175. OUR SPECIAL PRICE **\$49.50**

KILOWATT PLATE TRANSFORMER
PRIMARY: 115 volts, 60 Cy.
SECONDARY: 3000 volts DC @ 350 Ma. High voltage insulation. Wire leads, open frame. Meas. 12 1/2" x 6" x 7". SPECIAL \$17.95

COMPANION CHOKES FOR ABOVE
10 Henry @ 500 ma. 180 ohms DC resistance. High voltage insulation. SPECIAL \$5.50

WRITE FOR "BARRY'S GREEN SHEET"
ISSUED MONTHLY. FREE!

TERMS: 25% deposit with order, balance C.O.D. All merchandise guaranteed, F.O.B. N.Y.C.

BARRY ELECTRONICS CORP.

512 Broadway, Dept. RN, N.Y. 12, N.Y.

Call Day or Night—24 Hour Phone Service
Phone: Walker 5-7000

When you order by mail . . .

please print your name and address clearly, be specific in your order, enclose proper amount, allow ample time for delivery.

TUBE SPECIALISTS to the WORLD

SELECT THE TUBES YOU NEED FROM ONE OF THE MOST COMPLETE TUBE INVENTORIES IN THE WORLD



RECEIVING TUBES

0A2	.69	GAD7G	1.50	6L6G	.98
0A4B	.95	GAFY	1.23	6L7	.95
0B2	.65	GAF6G	.85	6N7	.89
0Z4	.49	GAG5	.72	6Q7	.85
1A3	.68	GAG7	.98	6Q7GT	.79
1A7	.52	GAH4	.85	6R7	.68
1AD4	1.20	GAH6	.85	6R7GT	.68
1AE4	.92	GAI5	.69	6S4	.57
1AX2	.79	GAJ5	.75	6S4GT	1.05
1B3GT	.79	GAK6	.69	6SA7	.79
1C5GT	.52	6AL5	.58	6SA7GT	.79
1G4	.65	6AL7	.95	6SB7Y	.87
1G6GT	.49	6AM4	1.50	6SC7	.72
1H5GT	.58	6AM8	1.10	6SF5	.62
1J6GT	.65	6AN4	1.50	6SF5GT	.72
1L6	.74	6AN5	2.75	6SF7	.92
1LA4	.79	6AN8	1.15	6SG7	.65
1LA6	.85	6AQ5	.57	6SH7	.74
1LB4	.85	6AQ6	.57	6SH7GT	.69
1LC5	.79	6AR5	1.15	6S17	.59
1LCE	.69	6AR6	2.15	6SK7	.64
1LD5	.85	6A55	.70	6SK7GT	.59
1LE3	.79	6A56	1.95	6SL7GT	.75
1LG5	.85	6A57G	2.35	6SN7GT	.75
1LH4	.85	6A58	1.15	6SQ7	.59
1LN5	.79	6AT6	.52	6S17GT	.69
1NSGT	.59	6AT8	1.05	6SR7	.55
1Q5GT	.95	6A14	1.05	6SS7	.75
1R4	.65	6A15	1.10	6ST7	.95
1R5	.65	6A16	.65	6T8	.95
1S4	.65	6A17	.85	6U5	.95
1S5	.65	6A18	1.20	6U5GT	.95
1T4	.65	6A19	.53	6V3	1.10
1T5	.69	6A20	.79	6V6	.59
1U4	.59	6B4G	.95	6W6GT	.65
1V	.65	6B8	.67	6W6GT	.79
1V2	.59	6BA6	.63	6X4	.49
1V6	1.49	6BA7	.85	6X5GT	.95
1X2A	.85	6BC4	1.50	6X8	.89
2A6	.59	6BC5	.68	6Y6G	.79
2X2	.49	6BD5	1.35	7A4	.69
2X2A	1.35	6BD6	.73	7A6	.75
3A3	1.05	6BE6	.65	7A7	.75
3A4	.50	6BF5	.82	7AB	1.65
3A5	.64	6BF6	.68	7AD7	.89
3AL5	.65	6BG6G	1.75	7AF7	.95
3AU6	.70	6BH6	.79	7AG7	.95
3AV6	.60	6BJ6	.69	7AH7	.95
3B7	.39	6BK5	.95	7B4	.65
3BC5	.80	6BK7	1.05	7B5	.75
3BN6	1.05	6BN6	1.10	7B7	.75
3BY6	.75	6BQ6GT	1.15	7B8	.85
3CB6	.80	6BQ7A	1.15	7C5	.75
3CF6	.85	6BX7	1.20	7C6	.75
3D6	.39	6BY5G	1.25	7C7	1.15
3FL4	.85	6BZ7	1.20	7E7	.85
3QY	.65	6C4	.38	7F7	1.10
3Q5	.75	6C5	.48	7F8	1.10
3S7	.65	6C5GT	.46	7G7	1.10
3V4	.69	6C6	.49	7H7	.79
4BQ7A	1.30	6C8G	.85	7J7	1.15
4BZ7	1.35	6CB5	4.40	7K7	1.10
5AM8	1.05	6CD6G	1.75	7N7	.85
5AN8	1.10	6CF6	.90	7Q7	.95
5AQ5	.75	6CF6	.85	7R7	.95
5AS8	1.10	6CG7	.85	7V7	.95
5AT8	1.10	6CL6	1.10	7W7	.95
5AY8	1.15	6CM6	.85	7X7	.90
5AW4	1.10	6C56	.75	7Y4	.85
5AZ4	.60	6C16	1.30	7Z4	.65
5J6	.90	6D6	.59	12A4	.85
5R4GY	1.45	6DC6	.95	12A4G	.79
574	.90	6E5	.75	12A5GT	1.05
5U4G	.58	6F5	.59	12AL5	.65
5U8	1.10	6F6	.85	12AQ5	.70
5V4G	.88	6F7	.85	12AT6	.48
5V6GT	.70	6F8G	.72	12AT7	.92
5W4GT	.65	6GG6	.72	12A7G	.75
5X8	1.05	6H6	.59	12AV6	.52
5Y3GT	.49	6HG7	.49	12AV7	.95
5Y4G	.65	6J4	2.55	12AW6	.95
5Z3	.69	6J5	.47	12AX4	.85
5Z4	.89	6J5GT	.47	12AX7	.78
6A3	.95	6J6	.68	12AY7	1.15
6A6	.82	6J7	.82	12AZ7	.85
6A7	1.09	6J7GT	.65	12B4	.85
6A8	.85	6K6GT	.74	12BA6	.60
6ABGT	.95	6K7	.59	12BA7	.89
6ABY	.59	6K8	1.10	12BD6	.70
6AM7	.69	6K8GT	.65	12BE6	.65
6AC5	1.05	6L6	1.69		
6AC7	.85				

12BF6	.60	14B6	.69	35W4	.44
12BH7	.89	14C7	.95	35Y4	.65
12BK5	.95	14E6	1.05	35Z3	.65
12BQ6GT	1.35	14E7	1.15	35Z5	.44
12BY7	.90	14F7	.85	41	.75
12BZ7	.95	14F8	.85	43	.69
12C8	.69	14H7	.85	42	.79
12CU6	1.35	14N7	.85	50A5	.68
12H6	.59	14Q7	.85	50B5	.68
12J5GT	.65	14R7	1.20	50C5	.68
12K7GT	.85	14S7	1.10	50L6	.62
12K8	.69	14W7	1.25	60X6	.85
12Q7GT	.75	25BQ6G	1.89	50Y6	.78
12SA7	.69	19T8	.95	50Y7	.78
12SA7GT	.69	25AV5	1.25	53	.92
12SC7	.75	25AX4	1.05	70L7	1.15
12SG7	.79	25BK5	.95	75	.65
12SH7	.65	25BQ6GT	1.25	77	.47
12S17	.65	25CD6G	1.75	78	.57
12SK7	.69	25CU6	1.75	80	.59
12SN7	.75	25L6GT	.65	81	1.85
12SQ7	.59	25W4GT	.72	83	.95
12SR7	.59	25Z5	.25	83V	.95
12SV7	.59	25Z6	.62	84/6Z4	.49
12SVGT	.73	30	.65	117L/M7	1.95
12W6GT	.87	32L7	.85	117N/P7	1.85
14A4	.95	35A5	.68	117Z3	.68
14A5	1.30	35B5	.68	117Z4	1.05
14A7	.75	35C5	.68	117Z6	.95
14AF7	.95	35L6	.65		

100TL	8.25	885	.95	5829	1.35
211	2.45	902	2.45	5840	4.40
2498	2.95	918	1.65	5841	7.40
249C	1.95	923	1.25	5844	.95
250TH	18.95	925	1.50	5851	3.45
250TL	14.75	927	.95	5876	12.50
262B	4.95	930	1.19	5879	1.25
274A	1.95	931A	2.45	5881	2.95
274B	.85	954	.25	5886	2.75
304TH	7.95	955	.35	5894	15.95
304TL	9.95	956	.35	5896	4.45
307A	1.10	957	.35	5899	3.95
350A	2.65	958A	.35	5902	5.95
350B	2.35	959	1.32	5905	8.75
371B	.85	981	.29	5906	14.95
393A	4.50	1603	2.95	5908	7.85
417A/5842	12.45	1619	.50	5923	3.95
417A/5842	12.45	1622	1.45	5933	2.25
434A	2.95	1624	.95	5963	5.45
450TH	47.50	1625	.29	608DWA	2.95
450TL	35.00	1626	.19	6096	1.45
705A	.68	1633	.85	6097	1.45
707A	4.95	1635	1.48	6098	1.85
707B	3.95	1641	1.35	6099	1.35
715B	2.95	1654	1.75	6101	1.45
715C	10.95	2050	.65	6113	1.25
717A	.35	5316	6.45	6147	4.75
721A	.65	5517	1.65	6161	69.50
723A/B	8.45	5634	6.95	6187	3.95
725A	2.95	5636	2.90	6189	2.25
726A	4.95	5637	4.95	8013A	3.75
726C	32.50	5638	7.45	8014	67.50
750TL	65.00	5641	5.95	8020	1.25
801A	.38	5642	.95	8025	1.45
802	2.45	5643	5.95	9001	.82
803	1.40	5647	3.95	9002	.60
804	8.85	5651	1.35	9003	1.20
805	4.85	5654	1.25	9004	.35
806	4.85	5658	7.90	9005	1.39
807	1.18	5670	1.10	9006	.25
808	1.25	5675	10.95	C11A	10.95
809	2.20	5676	1.25	CK1005	.22
810	9.50	5678	1.95	CK1006	3.25
811	2.75	5686	2.65	CK1007	.65
811A	2.75	5687	5.10	CK1038	4.70
812A	3.25	5693	4.65	CK1039	4.70
813	10.50	5696	.90	F123A	2.75
814	1.50	5702	1.95	F127A	22.50
815	1.75	5703	1.85	F128A	14.95
816	1.15	5704	1.85	FG17	3.50
816	1.15	5718	2.75	FG27A	10.90
818	7.42	5718A	4.75	FG32	3.95
829B	7.95	5719	2.15	FG95	17.50
830B	.65	5725	1.45	FG105	12.95
832	5.75	5727	1.25	FG172	17.95
832A	7.95	5732	2.95	HF100	6.95
832A	37.50	5744	1.75	HF300	17.50
836	2.45	5742	1.45	WL616	47.50
837	1.25	5751	1.45	RK65	7.50
838	.69	5762	99.50	RK72	.50
845	4.85	5763	1.25	RK21	5.50
851	8.95	5783	4.45	TZ40	3.50
860	2.95	5787CK	4.95		
861	12.95	5794	5.95		
866A	.98	5812	2.70		
872A	1.25	5814	.95		
876	.72	5819	32.50		
878	.48	5820	495.00		
884	.95	5823	1.35		

CASH for YOU!

We urgently need for government contracts military electronic equipment, such as: BC312, BC342, BC348, ART13, APR4, ARC1, ARC3, ARN6, ARN7, BC221, BC788, BC610, and many others. State conditions, type and best price.

TRANSMITTING TUBES

0A3/VR75	.86	2D21W	1.95	4X150A	22.45
0B3/VR90	.73	2E22	3.15	4X150G	31.95
0C3/VR105	.68	2E24	1.95	5BP1	2.35
0D3/VR150	.68	2E26	3.25	5BP4	1.95
1B22	1.25	2E30	1.55	5C22	27.50
1B23	2.68	2E31	2.45	5CP1	1.95
1B24	4.85	2J31	14.00	5CP1A	8.45
1B27	12.95	2J32	12.50	5CP7	7.95
1B35	3.45	2J33	14.00	5D21	7.45
1B38	33.50	2J34	14.00	5FP7	1.20
1B40	3.45	2J36	14.95	5J29	29.50
1B41	3.75	2J51	97.50	5J30	17.25
1C21	1.89	2J55	39.50	5J33	6.95
1N21	.39	2J61	12.95	5J31	12.45
1N21B	1.45	2J62	12.95	5J32	6.35
1N23	.68	2K23	15.25	5J35	9.95
1N23B	1.40	2K25	11.95	5LP1	7.40
1N34	.42	2K28	27.50	5NP1	4.95
1N34A	.48	2K35A	56.90	6AC7W	1.45
1P21	29.50	3AP1	2.90	6AK5W	1.45
1P22	13.25	3B24	.95	6AL5W	.95
1P23	1.85	3B24W	4.95	6AQ5W	1.70
1P25	64.50	3B25	4.95	6AS6W	2.69
1P28	8.95	3B26	7.45	6BF7W	3.45
1P32	.95	3B29	8.95	6C4W	

This is the
year of the...

Viking

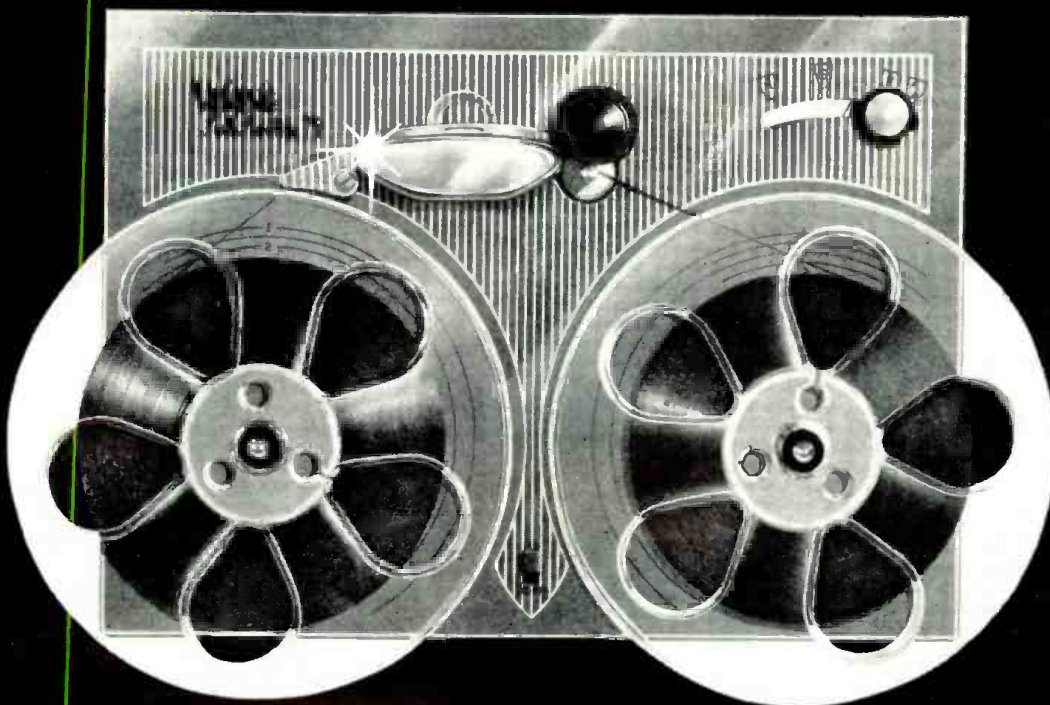

In this year . . . only one thing in the audio field is new: the complete acceptance of tape equipment as an essential part of the high fidelity home music system.

Viking of Minneapolis, recognized leader in the manufacture of tape system components, takes time out to thank our 400 Viking dealers and the customers who "pioneered" in tape, for the acceptance that made this leadership a fact.

In this coming '56-57 season we will continue to offer the 75 Series Decks, thoroughly tested and thoroughly proven by thousands of home users.

Viking offers as well, new and even finer PB60 and RP61 Tape Preamplifiers, featuring newly available low-noise tubes, and with circuit and assembly refinements dictated by this past year's evaluation.

New this year . . . smartly styled furniture cabinets providing for integrated monaural record-playback units, stereo players and stereo recorders.

Viking OF MINNEAPOLIS

9600 Aldrich Avenue South, Minneapolis 20, Minnesota

EXPORT DIVISION: 26 Warren Street, New York City 7, New York

www.americanradiohistory.com

... another
MALLORY
service-engineered
product

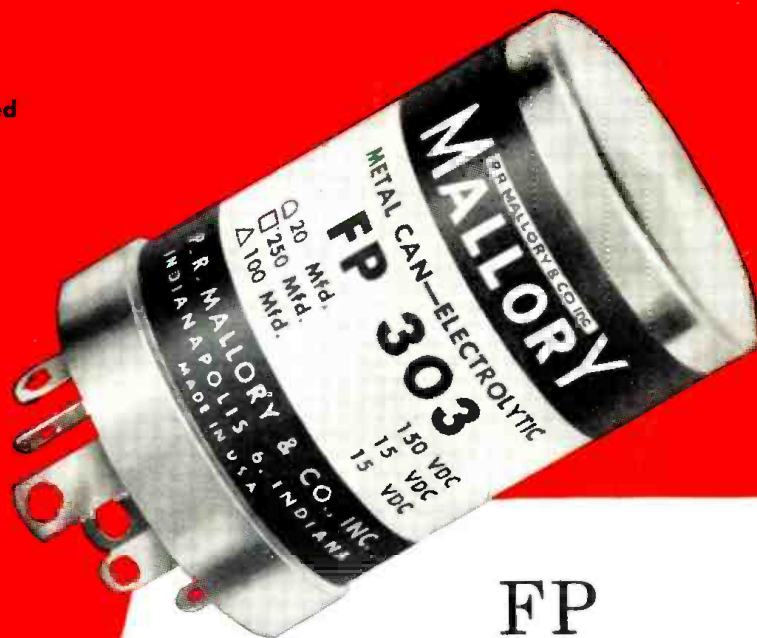

FP CAPACITORS take high ripple currents

(all FP's are Mallory)

No need to worry about ripple currents, when you choose Mallory FP (fabricated plate) capacitors for replacement. They're built to handle the toughest ripple . . . even the values you find in the latest color TV sets.

FP's, in fact, will stand 50 to 100% higher ripple current than usual industry expectation for a given rating. And this superior performance . . . proved by tests at 85° C ambient . . . can be expected of *all* FP capacitors, for they are manufactured to highest standards of uniformity. Mallory's unique FP construction makes this possible. It puts more electrolyte and more anode area into a smaller case . . . to give better heat dissipating qualities.

Be sure to specify Mallory FP's by name, not only for high ripple applications, but for all your electrolytic capacitor replacements. See your local Mallory distributor today!

P. R. MALLORY & CO. Inc.
MALLORY

• Capacitors • Vibrators • Resistors • Controls • Switches
• Rectifiers • Power Supplies • Filters • Mercury Batteries

P. R. MALLORY & CO. Inc., INDIANAPOLIS 6, INDIANA

www.americanradiohistory.com