

# RADIO & TELEVISION NEWS

NOV 1954  
35 CENTS  
In Canada 40¢



## IN THIS ISSUE

COMMUNITY TV

"LINEAR STANDARD"  
AMPLIFIER

CHECKING  
YOUR AUDIO SYSTEM

THE GROUND PLANE  
GROWS UP

FUNDAMENTALS OF COLOR TV

A TRANSISTORIZED  
LIGHT-BEAM COMMUNICATIONS  
SYSTEM

TVI TROUBLESHOOTING

HOW TO CHECK  
YOUR SWEEP GENERATOR

EQUALIZER FOR FM PICKUPS

COMPACT 2-METER RIG

(See Page 63)



# NEW **RAYTHEON** GUN WITH CROSSOVER CONTROL

Helps RAYTHEON PICTURE TUBES  
Set New Standards of Picture Quality

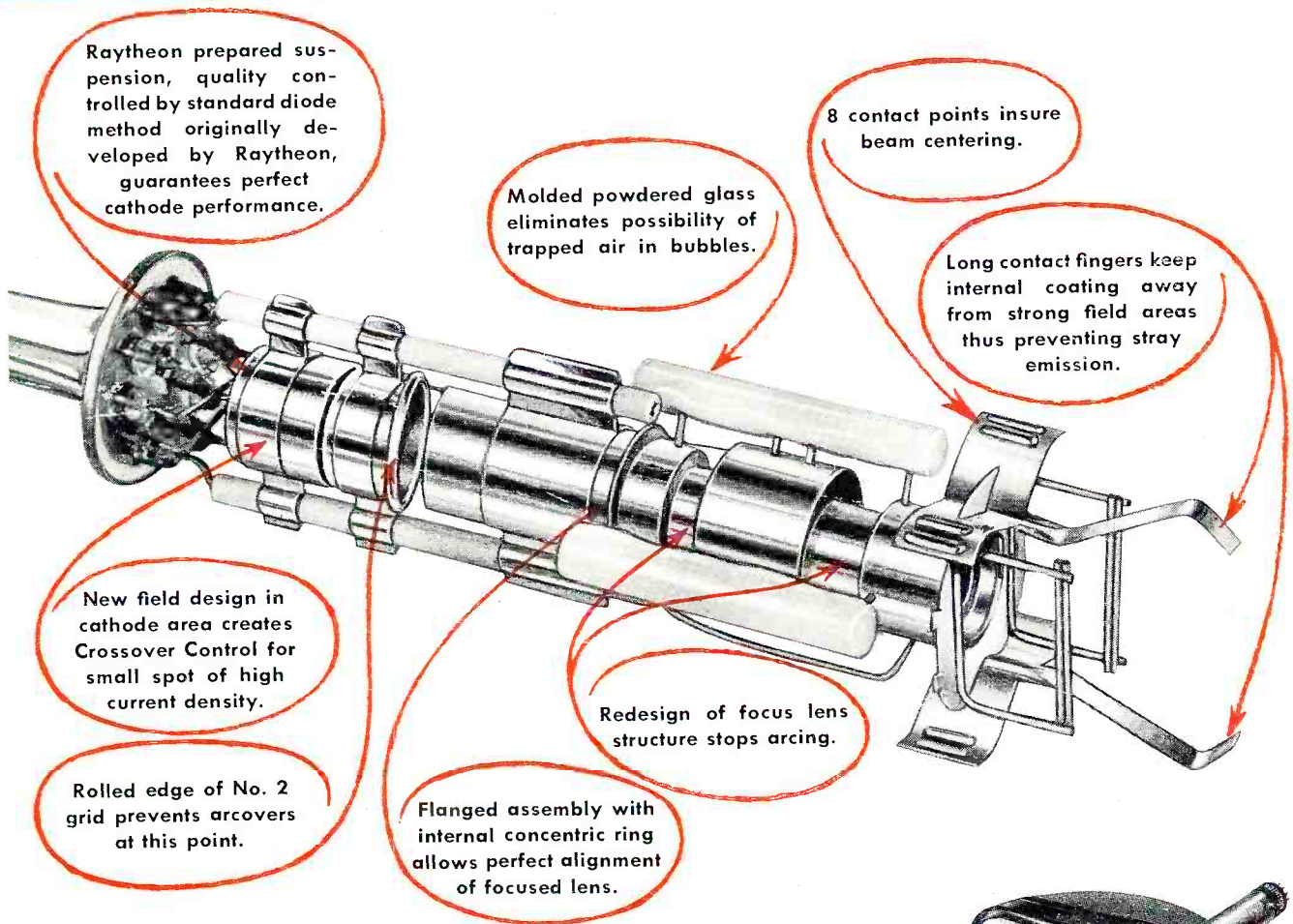

For crisp, clean, high definition pictures, you can't beat Raytheon Picture Tubes with the new *Crossover Control Gun*. This new gun has a specially shaped grid designed to keep the electrostatic field undisturbed. Emission from the center of the cathode is vastly improved eliminating slow electrons from the edges which overshoot and smear. These design improvements do away with tailings and halos, lines and spots won't blur even under highlight conditions.

You owe it to your customers and yourself to *replace with Raytheon*. Ask your Raytheon Tube Distributor for complete information.



*Excellence in Electronics*

**RAYTHEON MANUFACTURING COMPANY**

Tube Division  
Atlanta, Ga., Los Angeles, Cal.

RAYTHEON MAKES ALL THESE:

INDUCTOR DIODES AND TRANSISTORS • NUCLEONIC TUBES • MICROWAVE TUBES • RECEIVING AND PICTURE TUBES

# I'll Train You For Your FCC License

Training plus opportunity is the perfect combination for job security, good pay, advancement. A Federal Communications Commission Commercial Operator's License puts you in line for a good job in Radio or Television Broadcasting, Police, Marine, Aviation, Mobile or Micro-Wave Relay Radio. Mail Coupon for 64-page book free. It will give complete facts about my Communications Course.

## You Build This Transmitter

with parts I send. Use it to get practical experience. Put this station "on the air." Perform procedures required of broadcasting station operators, conduct many experiments, make practical tests.

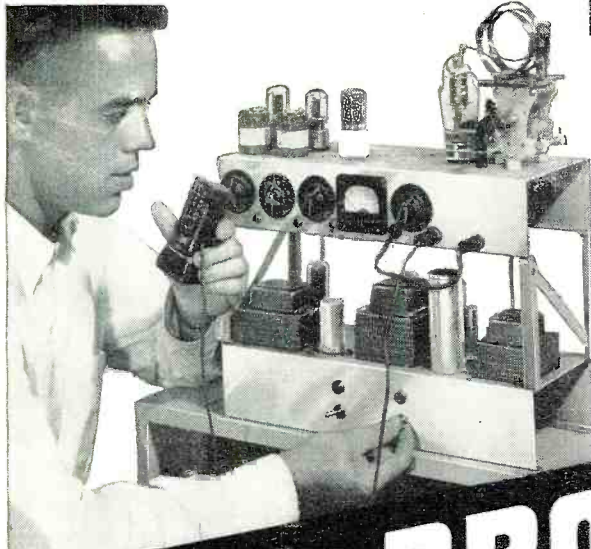

# LEARN BROADCASTING by PRACTICING at Home in Spare Time

## Get Practical Experience on Circuits Common to Radio & TV

Ever think HOW FAST Radio-Television Communications is changing, developing, growing? Have you considered what this amazing progress can mean to you? Even without Television the industry is bigger than ever before. Over 115 million home and auto radios, 3000 radio stations, about 200 TV stations with hundreds more being built. Expanding use of Aviation and Police Radio, Micro-Wave Relay, Two-Way Radio for buses, taxis, etc. makes opportunities for Communications Technicians and FCC licensed operators. New jobs, more jobs for beginners! Better jobs, better pay for experienced men!

## Television Is Today's Good Job Maker

Over 25 million television sets are in use. Thousands more being sold every week. Good TV jobs opening for Technicians, Operators everywhere. The time to act is NOW! Start learning Radio-TV communications. America's fast growing industry offers good pay, a bright future, security. If you are a beginner, my course can help you get FCC License, prepare for the job

J. E. SMITH, President National Radio Institute Washington, D. C. has trained more men for Radio-Television than any other man. OUR 40TH YEAR.



## MY COURSE INCLUDES TELEVISION

you want. If you've had some training in Radio or Radar, or as a Licensed Operator, my course modernizes—increases the value of your knowledge.

## Includes New Developments

Mail coupon now for facts about my practical course in Radio-Television Communications. Let me send you my FREE book. See the nine big Kits of Parts I send that "bring to life" theory you learn. You get practical experience by working on circuits common to both Radio and Television; also lessons on TV principles. Read about the Transmitter you build and operate, about the Electronic Multitester you get. All equipment is yours to keep. My graduates are filling jobs, making good money in both Radio and Television. Remember, the way to a successful career in Television is through experience in Radio.

## Mail Coupon for Book FREE

Send today! See what my Communications course is like. Find out how I get you ready for a brighter future, better earnings, more security in Radio-Television. Send coupon now in envelope or paste on postal. NO OBLIGATION, NO SALESMAN WILL CALL! My book, sent to you FREE, tells the full story. J. E. SMITH, President, Dept. 4EE, National Radio Institute, Washington 9, D. C. Our 40th year.

**YOU BUILD** this Transmitter Power Supply used in the basic experiments in RF and AF amplifiers, frequency multipliers, buffers, etc.



**YOU PRACTICE** setting up code, amplitude and frequency modulation circuits (put voice, music, etc.) on "carrier signals" you produce. You learn how to get best performance.

**YOU MEASURE** current, voltage (AC, DC and RF), resistance and impedance in circuits with Electronic Multitester you build. Shows how basic transmitter circuits behave; needed to maintain station operation.



**YOU BUILD** this Wavemeter and use it to determine frequency of operation, make other tests on transmitter currents.

## Training Leads to Jobs Like These

- |   |  |   |
|---|--|---|
| <p><b>BROADCASTING</b><br/>Chief Technician<br/>Chief Operator<br/>Power Monitor<br/>Recording Operator<br/>Remote Control Operator</p> <p><b>SHIP AND HARBOR RADIO</b><br/>Chief Operator<br/>Assistant Operator<br/>Radiotelephone Operator</p> | <p><b>GOVERNMENT RADIO</b><br/>Operator in Army, Navy, Marine Corps, Coast Guard<br/>Forest Service<br/>Dispatcher<br/>Airways Radio Operator</p> <p><b>POLICE RADIO</b><br/>Transmitter Operator<br/>Service Technician</p> | <p><b>AVIATION RADIO</b><br/>Plane Radio Operator<br/>Airport Transmitter Operator</p> <p><b>TELEVISION</b><br/>Pick-Up Operator<br/>Voice Transmitter Operator<br/>TV Technician<br/>Remote Control Operator</p> |
|---|--|---|

## I TRAINED THESE MEN

"My position with WNBT is video control engineer on the RCA color project. I owe a lot of my success to your textbooks."—Warren Deem, Malverne, N. Y.

"I am a technician at WTOP in Washington and I like it very much. Most of my radio knowledge was from N.R.I."—John Britto, Hyattsville, Md.

"A former employer recommended N.R.I. training. Now employed as transmitter operator at WKBO."—Albert Herr, New Cumberland, Pa.

AVAILABLE TO **VETERANS** UNDER G.I. BILLS

## SERVICING TRAINING ALSO AVAILABLE

If you prefer a good-pay job in Radio-Television Servicing... or your own money-making Radio-Television Sales and Service Shop, I'll train you at home. My famous Servicing Course also includes many Kits of Parts. You use them to get PRACTICAL EXPERIENCE with circuits common to Radio and Television. I also show you how to make \$10, \$15 a week or more EXTRA MONEY fixing neighbors' Radios while training. Full information in my 64-page book... Mail coupon.

## MAIL NOW-BOOK FREE

MR. J. E. SMITH, President, Dept. 4EE, National Radio Institute, Washington 9, D. C. Mail me your 64-page Book, FREE. (No salesman will call. Please write plainly.)

Name..... Age.....  
Address.....  
City..... Zone..... State.....

**VETS** write in date of discharge

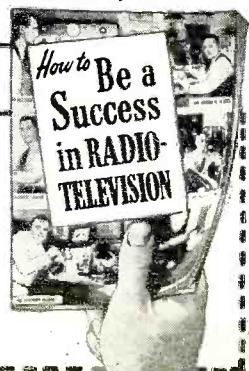

RADIO & TELEVISION NEWS is published monthly by Ziff-Davis Publishing Company, William B. Ziff, Chairman of the Board (1946-1953), at 64 E. Lake St., Chicago 1, Ill. Entered as second-class matter July 21, 1948, at the Post Office, Chicago, Ill., under the act of March 3, 1879. Authorized by Post Office Department, Ottawa, Canada, as second-class matter. SUBSCRIPTION RATES: Radio & Television News—one year U. S. and possessions, and Canada \$4.00; Pan-American Union countries \$4.50; all other foreign countries \$5.00. Radio-Electronic Engineering Edition—one year U. S. and possessions, and Canada \$6.00; Pan-American Union countries \$6.50; all other foreign countries \$7.00. Postmaster—Please return undelivered copies under form 3589 to 64 E. Lake St. Chicago 1, Ill.

Editor and Asst. Publisher  
**OLIVER READ, D.Sc., WIETI**

Managing Editor  
**WM. A. STOCKLIN, B. S.**

Technical Editor  
**H. S. RENNE, M. S.**

Service Editor  
**CHARLES TEPFER**

Assistant Editors  
**P. B. HOEFER**  
**M. C. MAGNA**

Television Consultant  
**WALTER H. BUCHSBAUM**

Short-Wave Editor  
**KENNETH R. BOORD**

Art Editor  
**FRANK SAYLES**

Draftsmen  
**A. A. GANS, W2TSP**  
**J. A. GOLANEK**

Advertising Manager  
**L. L. OSTEN**

Midwest Adv. Manager  
**JOHN A. RONAN, JR.**

Western Adv. Manager  
**JOHN E. PAYNE**



*First in radio-  
television-audio-electronics*

Average Paid Circulation over 230,000

Radio News Trademark Reg. U. S. Pat. Office • Television News Trademark Reg. U. S. Pat. Office.

**MAY, 1954**

**CONTENTS**

Community TV.....*Walter H. Buchsbaum* 35  
 Quartz Crystal Etching.....*Gene Brizendine, W4ATE* 38  
 Transistor Tester.....*H. L. Armstrong* 39  
 Fundamentals of Color TV—The Tri-Gun Receiver (Part 3)....*Milton S. Kiver* 40  
 The "Linear Standard" Amplifier.....*Julius Z. Knapp* 43  
 Half-Wave Rectifier Circuit.....*J. T. Cataldo* 47  
 Certified Record Revue.....*Bert Whyte* 48  
 The Ground Plane Grows Up.....*William H. Harrison, W6ULD* 49  
 A Transistorized Light-Beam Communications System.....  
 .....*Vladimir Kenn & Nathan Sokal* 52  
 An Equalizer for FM Pickups.....*James A. Mitchell* 54  
 How to Check Your Sweep Generator.....*Louis E. Garner, Jr.* 56  
 1954 TV Receiver Specifications..... 58  
 Checking Your Audio System.....*Julius A. Konins* 59  
 Simplified Cross-Coupled Amplifier.....*Charles P. Boegli* 62  
 Compact 2-Meter Rig.....*Woodrow Smith* 63  
 The Continuous Evolution in TV Antennas..*Edward M. Noll & Matthew Mandl* 64  
 TVI Troubleshooting (Part I).....*Carl J. Quirk* 66  
 Using the D.C. Scope to Measure Amplitude Modulation.....  
 .....*R. M. Cohen & J. W. Owens* 68  
 Mac's Radio Service Shop.....*John T. Frye* 74  
 New Approach to Conical Antenna Design.....*Roy J. Wade* 76  
 New TV Grants Since Freeze Lift..... 100  
 New TV Stations on the Air..... 110  
 Radio-TV Service Industry News..... 136  
 Parts Show Exhibitors..... 157

**DEPARTMENTS**

For the Record.....*The Editor* 8      Technical Books ..... 86  
 Spot Radio News..... 16      What's New in Radio..... 92  
 Within the Industry..... 26      New Audio Equipment..... 116  
 Short-Wave.....*K. R. Boord* 70      New TV Products..... 148  
 Manufacturers' Literature ..... 152

COPYRIGHT 1954  
 (All Rights Reserved)

**ZIFF-DAVIS PUBLISHING COMPANY**  
 WILLIAM B. ZIFF (1898-1953) FOUNDER  
 Editorial and Executive Offices  
 366 Madison Ave., New York 17, N. Y.  
 VOLUME 51 • NUMBER 5



Member  
 Audit Bureau of  
 Circulations

**SUBSCRIPTION SERVICE:** All communications concerning subscriptions should be addressed to Circulation Dept., 64 E. Lake St., Chicago 1, Ill. Subscribers should allow at least four weeks for change of address.

**CONTRIBUTIONS:** Contributors are advised to retain a copy of their manuscripts and illustrations. Contributions should be mailed to the New York Editorial Office and must be accompanied by return postage. Contributions will be handled with reasonable care, but this magazine assumes no responsibility for their safety. Any copy accepted is subject to whatever adaptations and revisions are necessary to meet the requirements of this publication. Payment covers all author's, contributor's, and contestant's rights, title, and interest in and to the material accepted and will be made at our current rates upon acceptance. All photos and drawings will be considered as part of the material purchased.

**RADIO & TELEVISION NEWS**



COVER PHOTO: Gonset's "Communicator," a compact 2-meter rig, goes with the family in the car, on picnics, or to the beach. It operates on both 6 volts d.c. and 117 volts a.c. (Ektachrome by Peter J. Samerjan)

**ZIFF-DAVIS PUBLISHING COMPANY**

President  
**B. G. DAVIS**

Vice-Presidents  
**H. J. MORGANROTH**  
**M. H. FROELICH**

Secretary-Treasurer  
**G. E. CARNEY**

Circulation Manager  
**M. MICHAELSON**

**BRANCH OFFICES**

CHICAGO (1)  
 64 E. Lake St., AN 3-5200

LOS ANGELES (14)

Strotter Center, 900 Wilshire Blvd., Mich. 9836

Now IN YOUR OWN HOME Learn

# TELEVISION

## RADIO-ELECTRONICS

*the Amazingly Effective*

### D. T. I. WAY

—with the aid of BOTH HOME EQUIPMENT and HOME MOVIES

NO PREVIOUS EXPERIENCE NEEDED

NOW... get EVERYTHING YOU NEED

for real Laboratory-type training AT HOME

Above: Work over 300 fascinating experiments with this equipment

1. Build over 300 fascinating experiments from 16 BIG SHIPMENTS of Electronic-Radio parts which you KEEP.

2. Build valuable commercial-type test equipment—as shown to the left—which you KEEP. This includes a quality 5 INCH oscilloscope and jewel bearing Multi-Meter—both highly useful for Television work.

3. Build and keep a big 21 INCH TV Set. (D.T.I. offers another home training in Television-Radio-Electronics, but without the TV set.)

4. Use a 16 mm. movie projector and new series of highly instructive movies—a wonderful aid to help you grasp important fundamentals faster... easier... better.

5. Enjoy well-illustrated, easy-to-read lessons with handy FOLD-OUT diagrams.

6. Get an honest-to-goodness EMPLOYMENT SERVICE to help you get a good job after graduating—or assistance in starting your OWN SALES AND SERVICE BUSINESS. Mail coupon today for the complete details.

What will mailing the coupon below do for YOU? Just this! You'll find out about one of today's most remarkable... practical ways to prepare to get into America's amazing billion dollar opportunity field of TELEVISION-RADIO-ELECTRONICS. You'll see how to get into fascinating work that pays well... that offers one of America's most promising futures... that enables you to start your own business almost "on a shoe string," if you prefer this to a job opportunity.

And above all, you'll get some GOOD NEWS especially welcomed by men anxious to earn REAL MONEY in this thrilling field. For you'll see that NOW you can get the kind of practical, laboratory-type training so desirable for making real progress in Television-Radio-Electronics AND WITHOUT LEAVING HOME.

You'll see that DeVry Technical Institute sends everything needed to set up your own HOME LABORATORY.

You get and keep the same type of basic electronic equipment used in our modern Chicago Training Laboratories. You get home training that includes the knowledge and experience gained from training thousands of students first hand in Chicago.

And to top it all, you use DTI's amazingly effective and exclusive home training aid—INSTRUCTIVE MOVIES. But why not get the complete story? Mail coupon today for information-packed literature.

#### MODERN LABORATORIES

If you prefer, get all your preparation in our new Chicago Training Laboratories—one of the finest of its kind. Ample instructors, modern equipment. Write for details!

#### MILITARY SERVICE!

If you're subject to military service, the information we have for you should prove very helpful. Mail coupon today.

Get this information-packed publication

FREE!

Mail Coupon Today

89 WAYS TO EARN MONEY IN TELEVISION RADIO-ELECTRONICS

DEVRY TECHNICAL INSTITUTE  
4141 BELMONT AVE., CHICAGO 41, ILL. Dept. RN-5-K

I would like your valuable information-packed publication showing how I can get started toward a good job or my own business in Television-Radio-Electronics.

Name..... Age.....  
Street..... Apt.....  
City..... Zone..... State.....



"ONE OF AMERICA'S FOREMOST TELEVISION TRAINING CENTERS"

**DEVRY TECHNICAL INSTITUTE**

AFFILIATED WITH  
**DEFOREST'S TRAINING, INC.**  
CHICAGO 41, ILLINOIS

Quality is an elusive thing. Engineers measure it... copywriters glorify it... salesmen describe it. But the final test is actual performance. If a product is the best in its field, those who know quality will accept no other.

That is the story of Pickering's new 260 Turnover Cartridge.

Introduced only months ago, it is already a leader among magnetic cartridges. It has won that position because it is the nearest thing to perfection yet produced. Here are the combined advantages it offers:

## The nearest Thing to Perfection

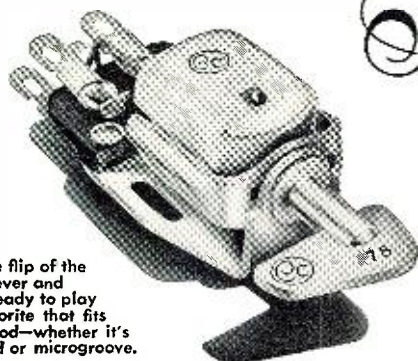

A simple flip of the handy lever and you're ready to play any favorite that fits your mood—whether it's standard or microgroove.

1. HIGHER OUTPUT—Better overall signal-to-noise ratio.
2. LOWER OVERALL DISTORTION—Less intermodulation distortion with wider frequency response.
3. MINIMUM TRACKING FORCE—Lowest practical tracking force for both microgroove and standard recordings.
4. HIGHER COMPLIANCE—Compliance of moving elements is the highest practical, consistent with best-quality transcription arms and changers.
5. LOWER MOVING MASS—Lowest of any comparable magnetic cartridge.
6. TWO DIAMOND STYLI—For longer record and stylus life and greatest economy.

These design features have real meaning to those who understand that quality reproduction depends on components which meet professional standards. If you want the best that high fidelity can offer, ask your dealer to demonstrate the new 260 Turnover Cartridge. You, too, will hear the difference!

**PICKERING and company incorporated • Oceanside, L. I., New York**



**PICKERING PROFESSIONAL AUDIO COMPONENTS**

*“For those who can hear the difference”*

... Demonstrated and sold by Leading Radio Parts Distributors everywhere. For the one nearest you and for detailed literature: write Dept. C-4

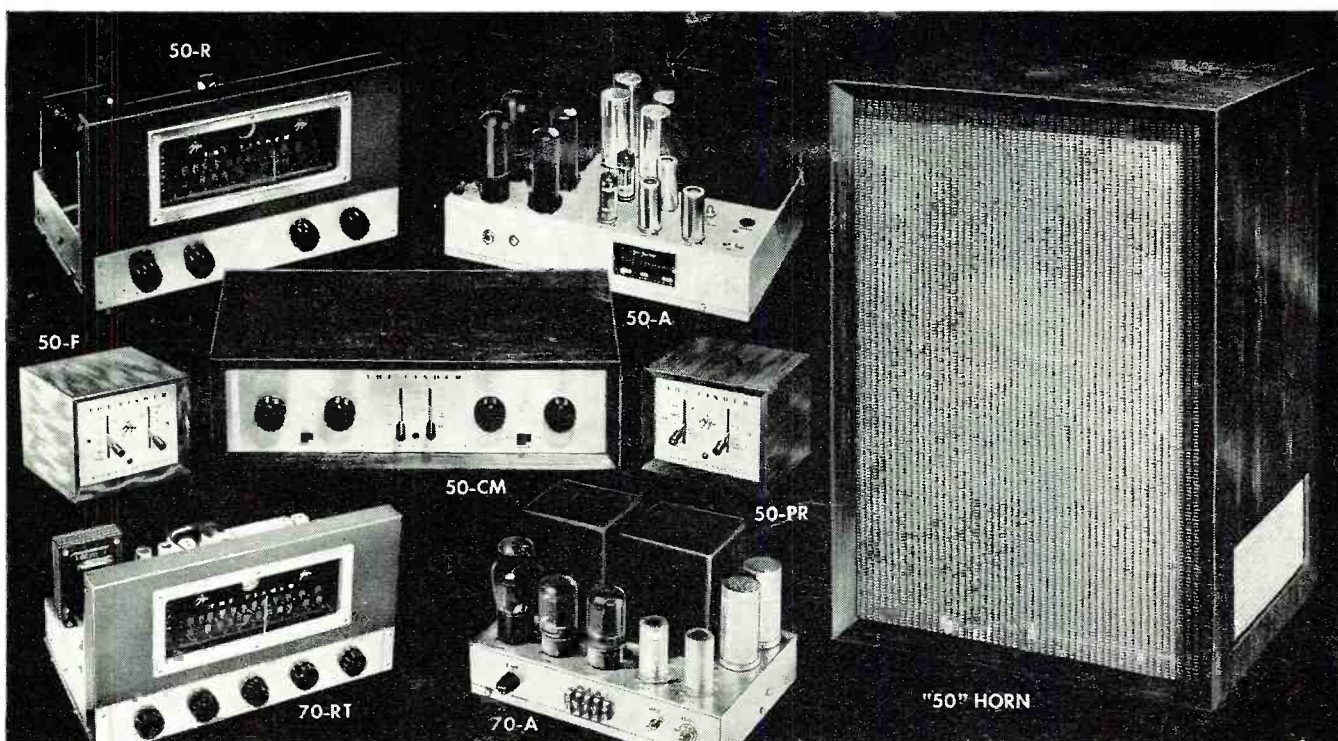

*The Best Costs Less When You Buy*

# THE FISHER

## Custom Audio Components

■ If you are buying 'for keeps' buy the best *first!* Buy FISHER, *quality leader* for seventeen years. Engineered for the professional, functionally designed for home use. "Of the very best!"—*High Fidelity*.

### FM-AM TUNER, Model 70-RT

Features extreme sensitivity, low distortion and low hum. Armstrong system, *adjustable* FM-AFC and AM selectivity. Preamplifier-equalizer, 2 inputs, 2 cathode follower outputs. Six controls. Self-powered. **\$184.50**

### FM-AM TUNER, Model 50-R

Same features as 70-RT above, but designed for use with external preamplifier-equalizer such as 50-C. Hum level better than 100 db below 2 volts output. Fully shielded and shock-mounted. Self-powered. **\$164.50**

### MASTER AUDIO CONTROL, Series 50-C

16 choices of record equalization, plus separate bass and treble tone controls, loudness balance control. Five inputs and input level controls, two cathode follower outputs. Chassis only, **\$89.50** • With cabinet, **\$97.50**

### 25-WATT AMPLIFIER, Model 70-A

50-watts peak! More *clean* watts per dollar. Less than ½% distortion at 25 watts (0.05% at 10 watts.) Response ±0.1 db, 20-20,000 cycles; 1 db, 10 to 50,000 cycles. Hum and noise virtually non-measurable! **\$99.50**

### 50-WATT AMPLIFIER, Model 50-A

100-watts peak! World's *finest* all-triode amplifier. Uniform within 1 db, 5 to 100,000 cycles. Hum and noise 96 db below full output. 1M distortion below 2% at 50 watts. Highest quality components thruout. **\$159.50**

### "50" HORN, SPEAKER ENCLOSURE

NEW! Regardless of the speaker or enclosure you are now using, the "50" Horn marks a revolution in performance. Can be used with any 12" or 15" single, coaxial, dual or triaxial speaker system. **\$129.50**

### PREAMPLIFIER-EQUALIZER, Model 50-PR

*Professional* phono equalization facilities at low cost! Independent switches for LF turn-over and HF roll-off. Output lead up to 50 feet. Can accommodate any low-level, magnetic pickup. Self-powered. **\$22.95**

### HI-LO FILTER SYSTEM, Model 50-F

Does what ordinary *tone* controls cannot do, for it suppresses all types of noise with an *absolute minimum* loss of tonal range. High impedance input; cathode follower output. Use with any equipment. **\$29.95**

*Prices slightly higher west of the Rockies*

WRITE TODAY FOR COMPLETE SPECIFICATIONS

**FISHER RADIO CORPORATION • 39 EAST 47th STREET • NEW YORK, N. Y.**

**for PA  
LIKE ON TV**

**636  
Slimair  
DYNAMIC  
MICROPHONE**

Gives you features similar to those in the famous E-V Slim-Trim TV Microphones. That's why it is so outstanding for Public Address, Recording and other general-purpose use.

List Price . . . . . \$70

**SMOOTH RESPONSE  
60-13,000 CPS  
HIGH OUTPUT  
OMNIDIRECTIONAL  
ACOUSTALLOY  
DIAPHRAGM  
BUILT-IN  
BLAST FILTER**

Can be used in the hand, on a stand, or overhead

SEND FOR BULLETIN

**Electro-Voice**  
410 CARROLL ST. • BUCHANAN, MICH.  
Export: 13 E. 40th St., N. Y. 16, U. S. A.

*For the* **RECORD.**  
BY THE EDITOR

WHAT'S AHEAD IN COLOR TV?

THIS is a question everyone is asking and has been asking as a result of the widespread publicity following the go-ahead from the FCC on a compatible color system. It may surprise you to know that YOU hold the answers. Those of you who are reading this editorial are, in all probability, dealers, distributors, or independent service technicians vitally interested in the television industry, in its future and what it will mean to you personally now and in the years to come. In analyzing the problems besetting the color TV industry, it is our opinion that when color comes into its own it will have as great, if not greater, impact on our business than monochrome TV had when it first took its place in the living room alongside the radio.

There is no doubt in our minds that monochrome, or so-called black and white television, will always remain an important factor in the industry just as radio did when television made its entrance—but, just as the radio receiver is no longer the central piece of furniture in the living room, so monochrome television will relinquish that place to the color TV receiver and just as a table model radio is now an accepted complement to the furnishings of other rooms, so will table model monochrome television sets become a complement to color. Thus, black and white television sales should continue to hold up in a seemingly saturated market just as radio sales have continued to mount right along with television set sales.

Now as to color *per se*. Anyone who has looked at a color receiver realizes the service maintenance problem color will bring. You saw it when black and white first came into the picture. There were opportunists (to use a less offensive term) who tried to take advantage of the public's lack of knowledge of things electronic and many set owners suffered at their inexperienced hands.

This past experience will put the public on guard. There has also been enough publicity on color to warn people that they will want access to *reliable* service. People will no longer buy from anyone who can get them a set. The same situation of scarcity will not prevail as it did when black and white TV was first made available. People will be more cautious and discerning than they were at that time. They will be able to pick and choose.

This is a blessing in disguise. It means that the dealer and distributor that does a sound merchandising job, who has qualified men to install and

demonstrate color TV, and competent service facilities will get the business; that is as it should be. The laws of economics and of cause and effect are as immutable and inexorable as the law of gravity. They cannot be escaped; they cannot be ignored without serious consequences.

In our opinion, those dealers who have tried to ride along by selling TV receivers with no provision for service will fall by the wayside. They won't be able to "get by with it" with color. We do not say that every dealer needs to be an expert on color TV maintenance but he *must* make some organized connection with a recognized authorized service agency that is qualified to maintain a color set. If he does not, he will find the set back on his doorstep, and you can't blame the customer for such action.

TV manufacturers know from bitter experience that customer satisfaction depends almost solely upon the ability of the dealer to provide prompt service on their products.

Many of the fine trade schools in the U.S. are now offering specialized courses in TV service. Some have recently added color TV even though manufacturers have not reached any degree of production. There is no better way for a technician today to spend his spare time more profitably than by learning the rudiments of color TV circuits.

So—what's ahead in color? As a dealer you hold the answer. If you are *not* organized to give adequate service when color breaks there is nothing but trouble ahead for you; you might as well get out while you can. But, if you make adequate provision for service maintenance yourself or through a recognized, authorized, qualified independent (and there are many) you will experience the biggest boom you have ever known.

It's up to you, but don't wait until you're in trouble and make no mistake, when color starts to grow, it will grow fast! It's too late to begin thinking about making a reservation when you hear "All Aboard." *Now* is the time to prepare. There are thousands of good, qualified technicians preparing to service color television. Make *your* plans now and *you* will be on the band wagon that will produce sweet music to your ears. Remember, a color television receiver is a big ticket item. There is a lot of money involved—it deserves proportionate attention. It's up to you to make the most of it. But start *NOW*. It's later than you think!  
..... O. R.



always in stock  
at ALLIED

# RCP QUALITY TEST INSTRUMENTS

RADIO CITY PRODUCTS CO.

Choose this reliable equipment for your service bench, lab or field work—and save! Order RCP instruments from ALLIED—for top value and accurate, dependable service.

## Model 808A Do-All TV-Radio-CR Tube Tester, Reactivator & VTVM

Consists of RCP Model 324P Tube Tester and a new CRT tester-reactivator, plus a VTVM. Checks all tubes including miniatures, sub-miniatures and magnetically deflected TV picture tubes. Easy-to-read 4 1/2" meter. Has fast-operating double Roll-index. 17-range VTVM uses balanced bridge type push-pull circuit. Input impedance of 25 megs for minimum current drain. Zero center scale for discriminator alignment. Ranges: AC and DC volts, 0-5-25-100-250-1000; resistance, 0.2 ohm to 1000 megohms in 5 ranges; db—20 to -62 in 5 ranges. Accuracy: AC, 5%; DC, 3%. Also checks capacitors for shorts and leakages. Oak carrying case, 12 1/2 x 12 3/4 x 4 3/4". With test leads, isolation probe and batteries. For 105-125 volts, 60 cycle AC. Shpg. wt., 12 1/2 lbs. **84 FX 333. Net. . . . . \$97.95**

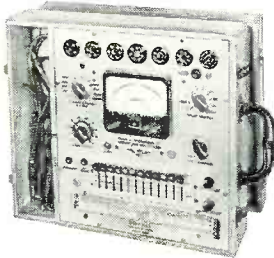

**Model HVMP-1. High Voltage Probe.** Extends DC range of VTVM in Model 808A above, to 30,000 volts. **84 F 334. Net. . . . . \$8.77**

## Model 750 UHF-VHF Do-All Signal Generator

New, combination signal, marker and pattern generator. Covers all UHF-VHF channels for FM and TV receiver servicing. Checks and aligns front ends, sound IF's and picture traps, linearity, sync circuits, sweep circuits, focus and deflection. Inductuner and special anti-backlash drive assure accuracy of 0.5%. All VHF frequencies covered on fundamental. Ranges: 9-11, 21-47, 54-220, 465-690 and 650-900 mc. RF's and IF's clearly calibrated on large etched dial. Provides steady horizontal or vertical bars or cross-hatch pattern on all channels. Internal modulation: 360 cps and 141.75 kc. Also provides unmodulated carrier signal. Complete with leads. Size, 10 1/4 x 6 1/2 x 5 3/8". For 105-125 volts, 60 cycle AC. Shpg. wt., 10 lbs. **84 F 338. Net. . . . . \$77.91**



## Model 655 Do-All VTVM

New, peak-to-peak type VTVM provides accurate measurements of complex waveshapes. Reads RMS and peak to peak simultaneously of wave-forms in video, sync and deflection circuits. Industrial applications include servicing of vibrator type power supplies and AC generators. 7 ranges on all functions. Reads peak to peak AC from 0.2 to 2000 volts; AC RMS 0.1 to 1500 volts; DC 0.02 to 1500 volts. Measures resistances from 0.2 ohms to 1000 megohms. High impedance input. Balanced bridge-type push-pull circuit and peak-to-peak rectification result in absence of circuit loading, wave-form error and frequency distortion. Supplied with test leads. Size: 10x6x5". For 105-125 volt 50-60 cycle AC. Shpg. wt., 8 lbs. **84 F 324. Net. . . . . \$58.31**



**NEW**

## SENSATIONAL MODEL 123 "FLYBACKER"

Tests Flyback Transformers and Yokes—Trouble Shoots Horizontal TV Circuits in Shop or Home

Now available for accurate and speedy testing. Extremely sensitive—shows up a single shorted turn in a flyback transformer or yoke. Makes tests with components in place in the receiver. Checks all flyback transformers and yokes for opens or shorts. Tests are applicable to induction windings on any transformer, speaker choke, solenoid, relays, etc., where impedance is not relatively low; acts virtually as a proportional AC ohmmeter.

Oscillator circuit operates at 1500 cycle frequency; interruption frequency 60 cycle. Slightest induction change caused by a shorted turn or intermittent effects shows up instantly on meter as "Bad." Has 3 "Good-Bad" scales; scale for yokes; direct-reading numbered scale; illuminated meter dial. In compact grey steel case with aluminum finish steel panel; 9 3/8 x 6 x 4 3/4". Complete with test leads. For 105-125 volts, 60 cycle AC. Shpg. wt., 8 lbs. **84 F 620. Net. . . . . \$39.15**



## ALLIED STOCKS ALL RCP INSTRUMENTS

84 FX 364. Model 8873A Servishop. Net. . . . .	\$137.15
84 FX 368. Model 324P Tube Tester. Net. . . . .	77.91
84 F 332. Model 730 "Signaliner" Signal Generator. Net. . . . .	32.29
84 F 336. Model 740A VHF Signal Generator. Net. . . . .	68.11
84 FX 365. Model 8020 FM-TV Servishop. Net. . . . .	303.80
84 FX 366. Model 8023 AM-FM-TV Servishop. Net. . . . .	334.18
84 FX 367. Model 324C Tube Tester. Net. . . . .	68.55
84 F 335. Model 533M Midgetscope. Net. . . . .	97.51
84 F 340. Model 453C Master Multitester. Net. . . . .	35.77
84 F 274. Model 447B AC-DC Multitester. Net. . . . .	17.59

All RCP instruments priced over \$45, are available on Easy Payments; only 10% down, 12 months to pay. Write for details.

## FREE 268-PAGE BUYING GUIDE

Make your selection from the world's largest stocks of electronic tubes, parts, test instruments, audio equipment, amateur gear, industrial components—get everything in electronics at lowest prices. Send for your FREE copy today.



**ALLIED RADIO**

ALLIED RADIO CORP., Dept. 1-E-4  
100 N. Western Ave., Chicago 80, Ill.

Send FREE 1954 Allied Catalog.  
 Ship the following RCP instruments. . . . .  
\$ . . . . . enclosed

Name . . . . .

Address . . . . .

City . . . . . Zone . . . . . State . . . . .

**INTERNATIONAL RECTIFIER**

C O R P O R A T I O N



EL SEGUNDO  
CALIFORNIA

*Selenium  
Rectifiers*

for  
direct **TV-RADIO**  
replacement

**WIDEST RANGE IN THE INDUSTRY**

The type you need...  
when you need it!

AVAILABLE FROM YOUR FAVORITE JOBBER

Available  
with  
universal  
mounting  
for  
universal  
replacement.

For more  
information  
write Dept. A  
for Bulletin JRP-2

**INTERNATIONAL RECTIFIER**

C O R P O R A T I O N

Executive Offices: 1521 E. Grand Ave., El Segundo, Calif. • Phone: ORegon 8-6281  
Chicago Branch Office: 205 West Wacker Drive • Phone: Franklin 2-3889  
New York Branch Office: 501 Madison Avenue • Phone: Plaza 5-8665

When the profile of the Cadillac looked like this



It was understandable that the profile of a V.O.M. might look like this



But this is the profile of today's Cadillac

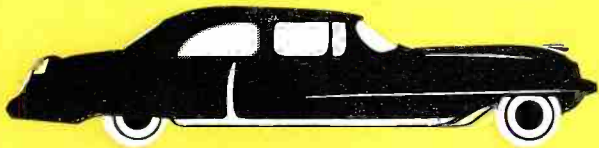

And if you buy a V.O.M. that is truly of today it will have a profile like this

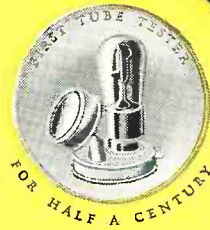

## STREAMLINING signifies the difference!

In cars, streamlining symbolizes the tremendous advances in automotive engineering and performance. In fine test equipment, too, streamlining signifies the difference.

The flush switches, dials and jacks of the Smoothie make it easy to slip in your pocket, carrying case or tool kit, eliminate snag hazards on your bench.

But even more—the streamlining expresses externally the advanced internal design which makes the Triplett Model 630 as superior to the obsolete knobby bumpy-faced testers as the Cadillac of today is to the Cadillac of fifty years ago. These internal design features include such developments as selector switch of molded construction, completely enclosed; elimination of harness wiring, etc. Your most frequently used tester—your V.O.M.—should be the best—the one of which many thousands are in use in laboratories today—the Smoothie, Triplett Model 630 Volt-Ohm-Mil-Ammeter, \$39.50 net. Ask your parts jobber or write Triplett Electrical Instrument Company, Bluffton, Ohio.

Only Triplett offers you a ten day free trial on all test equipment.

# the SMOOTHIE

the only streamlined V.O.M. with a smooth face

# TRIPLETT

## 630

Volt-Ohm-Mil-Ammeter

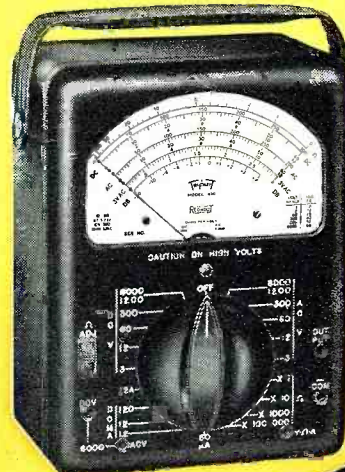

Burton Browne Advertising

# NEW!

# G E SERVICE OUT-PERFORM

Here's what G.E.'s new **SERVICE-DESIGNED Tubes** mean to you:



- ✓ They cut callbacks on TV repairwork, by doing a far more dependable job than their prototypes.
- ✓ Your tube-inventory requirements are lower. **SERVICE-DESIGNED Tubes** give top performance in *all* chassis.
- ✓ Your customers get more hours of trouble-free TV enjoyment . . . because **SERVICE-DESIGNED Tubes** have longer average life.
- ✓ They cost the same as their prototypes, despite improved performance and long life. You get higher tube value than ever before!



**SERVICE-DESIGNED 5U4-GA**

*You can SEE the Difference!*

Here, for the first time, is a line of tubes developed specially for television servicing! These 6 new G-E **SERVICE-DESIGNED Tubes** soon will be followed by others designed from the ground up to meet the practical requirements of your work.

• Where greater sturdiness or higher voltage capacity were found desirable, these qualities have been *designed into* the new types. You can install G-E **SERVICE-DESIGNED Tubes** in any circuit with confidence, knowing they have the safety margin to stand up!

• See your G-E tube distributor today! He will be glad to show you the new **SERVICE-DESIGNED Tubes**—explain how they will save you time, trouble, and costs, and increase your list of satisfied TV customers. *Tube Department, General Electric Company, Schenectady 5, New York.*

The 5U4-G prototype (left) was a tube that did a good electrical job, but was subject to damage from shocks and vibration. In the new **SERVICE-DESIGNED 5U4-GA**, you have a rectifier that can withstand hard usage. Note the arrowed reasons why:

(1) Substantial mica supports brace the tube structure at both top and bottom, instead of at the top only. Also, double-fin plate construction gives better heat dissipation.

(2) Glass bulb now is straight-side, compact, and strong. It is

specially "necked down" at bottom, so the base can be the same diameter as the 5U4-G—enabling the same ring-clamps to be used when installing the tube.

(3) Base construction has been changed to button-stem, with the leads passing through widely spaced individual seals at the bottom of the glass envelope, the same as with miniature tubes. This gives greater strength, also shorter leads and better lead separation. Another advantage is improved heat conduction. This, in turn, materially reduces electrolysis and air-leakage.

## Ready Now: 3 MORE G-E SERVICE-DESIGNED TUBES THAT DO OUTSTANDING JOBS . . . AND WHY!

### SERVICE-DESIGNED 5Y3-GT

A sturdier tube, with longer life! Mica supports now brace the tube structure both top and bottom. . . new button-stem base adds strength, separates the leads. . . double-fin plate construction gives the **SERVICE-DESIGNED 5Y3-GT** much improved heat dissipation.

### SERVICE-DESIGNED 25BQ6-GA

Cut callbacks with this new tube that runs cooler than its prototype! All the improved features of the 6BQ6-GA. Larger bulb gives ample cooling. Tube handles higher pulse plate voltages. High-melting-point solder protects plate cap-terminal.

### SERVICE-DESIGNED 1B3-GT

Install and forget! This new tube does a superior job far longer! Special lead glass wards off electrolysis and air-leakage. There is a new ring around the filament which stops "bowing" and the filament burn-outs that frequently result.

# -DESIGNED TUBES ALL OTHERS!

**Specially developed for the TV service industry.  
Cost the same as types they replace.**



● Type 6SN7-GTA has been redesigned to give top performance in all synchro-guide and other TV circuits. Among measures taken to assure this result, is a special factory "chopper" pulse test. The test is made at voltages equal to the lowest line voltages that will be encountered in TV chassis of any make.

In all respects and in all circuits, the SERVICE-DESIGNED 6SN7-GTA now will replace Type 6SN7-GT. Capacity of the new tube is much superior to the old, as proved by this cross-tabulation of ratings:

	Old 6SN7-GT	New 6SN7-GTA
Max plate voltage	300 v	500 v
Max plate dissip., per plate	2½ w	5 w
Max heater-cathode voltage	90 v	200 v

"Running hot" shortened the life of many prototype 6BQ6-GT's (left). G-E designers went to the heart of the problem, and, retaining the same basing layout for interchangeability, gave this tube a king-size bulb that means cooler operation under all normal conditions.

Also, because of special mica design and new processing techniques, the new SERVICE-DESIGNED 6BQ6-GA will handle higher pulse plate voltages. Internal

tube arcing is cut 'way down.

In many TV chassis, Type 6BQ6-GT now is pushed to the limit. Replacing with 6BQ6-GA's means far fewer service callbacks due to early tube failures.

A further important improvement in the SERVICE-DESIGNED 6BQ6-GA, is use of a special high-melting-point solder for the plate cap-terminal. This prevents loosening of the terminal when the tube is removed for testing.

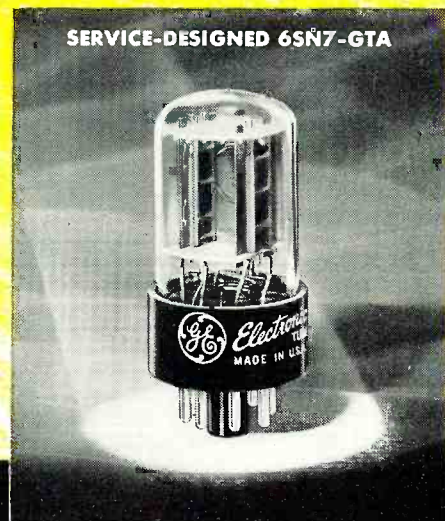

GENERAL



ELECTRIC

161-1A3

the kind of things servicemen

dream about

All servicemen dream about the ultimate in fine testing equipment—the kind of instruments engineered by Simpson that make the dream of perfect servicing a reality.

Recommended by well-known service managers of 17 leading television manufacturers, the 480 GENESCOPE has effectively conquered the problem of checking both UHF and VHF signals.

For proven accuracy and proven profits, sell your cus-

tomers Simpson instruments for your UHF-VHF TV servicing needs.

Available to servicemen are two complimentary booklets. One tells how to use Simpson Models 479 and 480 in UHF areas. The other describes "A 1001 Uses For The Simpson Model 260"...50 pages.

These booklets are typical of one of the many Simpson services for Simpson distributors.

**Simpson** ELECTRIC COMPANY

5200 W. Kinzie St., Chicago 44, Illinois

Phone: EStebrook 9-1121

In Canada: Bach-Simpson, Ltd. London, Ontario

**NEW**



\$197.00

**Model 476 Mirroscope**

A fine 5" oscilloscope that will save you up to 60% bench space.

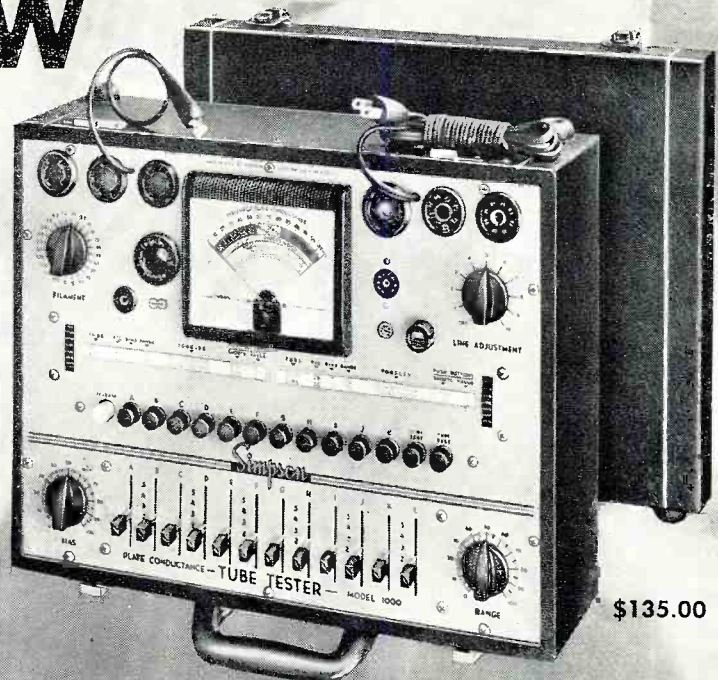

\$135.00

**Model 1000 Plate Conductance Tube Tester**

Features fast testing in convenient ohms readings for leakage and shorts

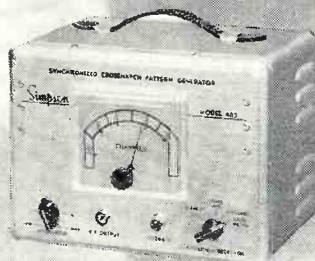

\$147.50

**Model 485 Synchronized Crosshatch Pattern Generator**

For adjusting deflection circuits in TV receivers.

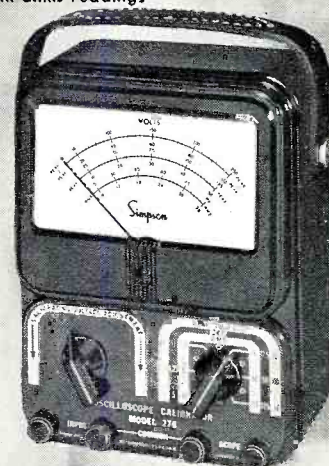

\$29.50

**Model 276 Oscilloscope Calibrator**

To determine the voltage in an oscilloscope waveform.

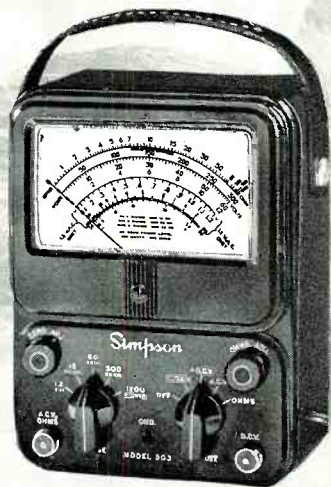

\$68.00

**Model 303 Vacuum Tube Volt-Ohmmeter**

Low current consumption...wide resistance ranges.

**NEW**

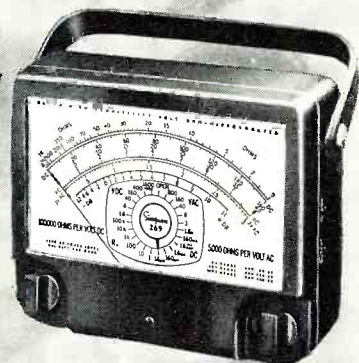

\$88.00

**Model 269 Volt-Ohm Microammeter**

100,000 ohms per volt. 7 inch dial—7 inch case

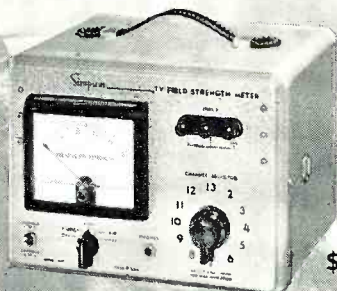

\$115.00

**Model 488 Field Strength Meter**

Town or Country use...ideal in fringe areas.



\$38.95

**Model 260**

Outsells all other high sensitivity volt-ohm-milliammeters combined.

**NEW**

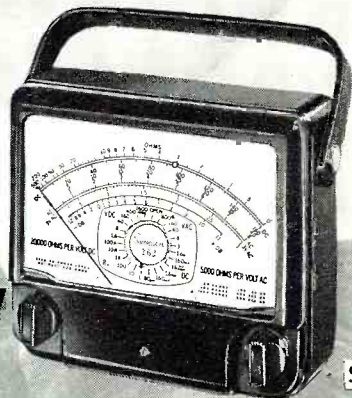

\$59.50

**Model 262 Volt-Ohm-Milliammeter**

33 ranges 20,000 ohms per volt



**Model 479 TV-FM Signal Generator**

For aligning all of today's UHF-VHF TV-FM Receivers

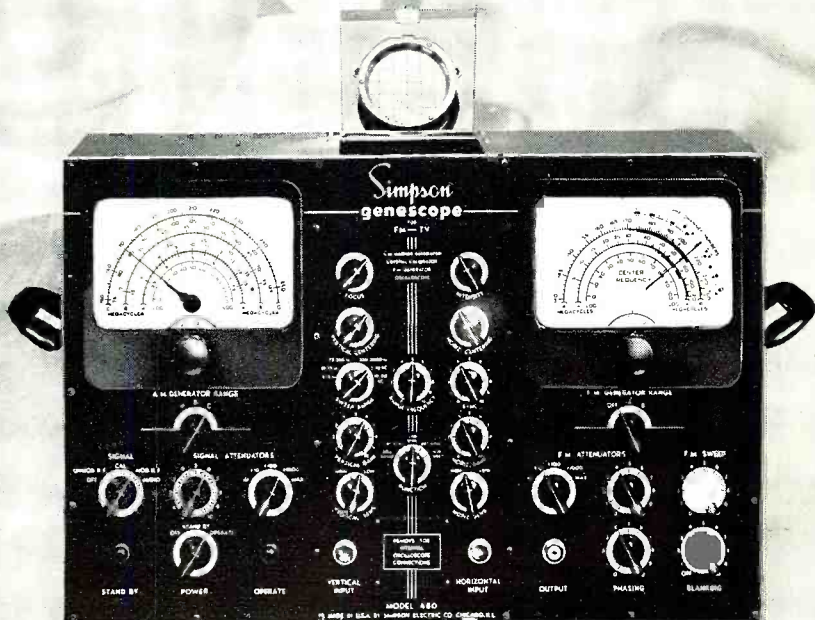

**Model 480 TV-FM Genescope \$475.00**

Ideal signal generator and oscilloscope combination for servicing ultra sensitive UHF-VHF TV receivers.

\$325.00

**Dictate Reports  
Accurately-Promptly!**  
make your car, boat or plane  
a "rolling office"

with

**ATR**

**INVERTERS**

for changing your storage  
battery current to

A.C. Household  
ELECTRICITY  
Anywhere

... in your  
own car!



mounted  
out of sight  
under dash  
or in trunk  
compartment!

**EASY TO INSTALL  
EASY TO OPERATE**

**ATR INVERTERS**

especially designed for operating  
standard 110 volt A. C. . . .

- TAPE RECORDERS
- WIRE RECORDERS
- EXECUTIVES
- SALESMEN
- PUBLIC OFFICIALS
- POLICEMEN
- FIREMEN
- DICTATING MACHINES
- ELECTRIC RAZORS
- OUTDOOR MEN
- REPORTERS
- FIELD INSPECTORS
- DOCTORS
- LAWYERS, ETC.

See your jobber or write factory

✓ NEW MODELS    ✓ NEW DESIGNS    ✓ NEW LITERATURE  
"A" Battery Eliminators,    DC-AC Inverters,    Auto Radio Vibrators



**AMERICAN TELEVISION & RADIO Co.**

Quality Products Since 1931

SAINT PAUL 1, MINNESOTA, U. S. A.

# Spot Radio News

\* Presenting latest information on the Radio Industry.

By RADIO & TELEVISION NEWS'  
WASHINGTON EDITOR

**AERONAUTICS AND RADIO**, strongly linked since the earliest days of key-clicking, have now become more firmly allied than ever via a constant stream of brilliant ground-air developments.

In Washington, through the active cooperation of the Radio Technical Commission for Aeronautics, bold progress has been recorded. Aviation has been aided by intensive research programs and earthy results. To illustrate, in one investigation of the feasibility of remote control operation of field lights via radio at airports which are unattended at night, a number of important problems have been resolved.

In tests that have been conducted, a radio receiver, to which a suitable switching mechanism had been connected, was installed at a small airport. The approaching pilot turned on the airport lights by pressing the microphone switch of his aircraft transmitter a predetermined number of times. And after takeoff, the lights were extinguished by a similar operation in the plane. The use of such a system, it was said, could become a key factor in safety, by increasing the number of landing fields available during emergencies.

A special committee, including representatives of the Air Transport Association, Aeronautical Radio, Inc., Air Line Pilots Association, Aircraft Owners and Pilots Association, Navy, Air Force, Coast Guard, FCC, and the CAA, is evaluating the advantages and problems inherent in a radio-controlled automatic airport lighting system.

Another RTCA project has produced an interesting report analyzing the features of a single-sideband aeronautical radiotelephone system for air-ground communication in the 2 to 24-megacycle radio-frequency band. Such a system, it was noted, would increase the number of usable channels and maintain the reliability of air-ground contact with decreased transmitter power output.

Two specific advantages of the new technique were cited by the commission: Efficiency of over-all signal transmission would be improved as a result of the reduction in interference effects and the greater utilization of transmitter capability. And the new method would also make available approximately twice as many channels in the aero radio-frequency spectrum as can

be realized with double-sideband techniques.

Stressing the latter feature of the new approach, the commission added that a rapid increase in the number of channels required for air-ground communication is anticipated within the next few years, and the economical frequency-spectrum requirements of the ssc method can well be the deciding factor in its future implementation.

As the result of still another aeroradio study, RTCA has developed procedures for calibrating audio- and radio-frequency signal generators to produce signals acceptable for testing and adjusting airborne vor and ils receivers. Noting that the procedures were developed primarily to aid the operators of aircraft radio service stations, the commission said that while the methods were prepared for the more commonly used types of signal generators, they may also be used to determine whether signals produced by other types of gear are within acceptable tolerances.

In addition to signal generators, standard omni-bearing selectors are also used in testing vor receivers at bearing settings other than the zero indexing position. Calibration procedures for such omni-bearing selectors are now being prepared by RTCA.

**COLOR TV's** official technical family has disbanded. After several years of round-the-clock conferences and field surveys, the NTSC, composed of the nation's color specialists, has closed its books, filed its records, and bowed out of the picture. The final step was instituted by the group's chairman, Dr. Baker, who issued a formal notice announcing the dissolution of the committee. All members received a letter of thanks for their sincere service in helping to establish a sound, practical, compatible system for color TV.

For his distinguished contribution as chairman, Dr. Baker received an award, the "Emmy" statuette, from the Academy of Television Arts and Sciences, at a special ceremony over which H. L. Hoffman, a director of RETMA, presided.

In an acceptance commentary, Baker said that this was an award to be shared by all of the members of NTSC who strove so hard to reach a practical

(Continued on page 99)

**RADIO & TELEVISION NEWS**





# HERE'S YOUR BIG OPPORTUNITY!

# TELEVISION

## TECHNICIANS EARN BIG PAY!

L. C. Lane, B.S., M.A.  
President: Radio-Television Training Association  
Executive Director:  
Pierce School of  
Radio & Television



**NO**  
experience  
needed... I'll  
train you **AT**  
**HOME** in your  
**SPARE TIME!**  
Earn while  
you learn!

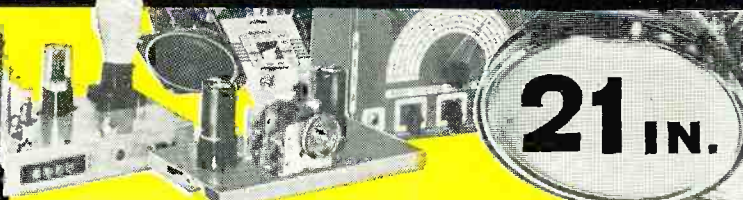

**21 IN.**

### CIVILIANS! VETERANS!

#### PREPARE FOR A BRIGHTER FUTURE AS A TV TECHNICIAN

Keep your present job while I prepare you **AT HOME**, using the same successful methods that have helped hundreds of men—many with no more than grammar school training—master television!

#### ENOUGH EQUIPMENT TO SET UP YOUR HOME LABORATORY!

As part of your training, I give you **ALL** the above equipment you need and more to prepare for a **BETTER PAY TV** job. You build and keep a professional **GIANT SCREEN TV RECEIVER** complete with big picture tube, takes any size up to 21-inch... also a Super-Het Radio Receiver, RF Signal Generator, Combination Voltmeter-Ammeter-Ohmmeter, C-W Telephone Transmitter, Public Address System, AC-DC Power Supply. Everything supplied including all tubes!

**EXPERT FM-TV TECHNICIAN TRAINING!** My FM-TV Technician Course can save you months of training if you have previous Armed Forces or civilian radio experience! Train at home with kits of parts, plus equipment to build **BIG SCREEN TV RECEIVER**, and **FREE FCC Coaching Course!** **ALL FURNISHED AT NO EXTRA COST!**

**FREE FCC COACHING COURSE!** Important for **BETTER PAY JOBS** requiring FCC License. You get this training **AT HOME** and **AT NO EXTRA COST.** Top TV jobs go to FCC licensed technicians.

**NEW! PRACTICAL TV CAMERAMAN & STUDIO COURSE!** (For men with previous radio and TV training) I train you at home for an exciting high pay job as the man behind the TV camera. Work with TV stars in TV studios or "on location" at remote pick-ups! A special one-week course of practical work on TV studio equipment at Pierce School of Radio & TV, our associate resident school in New York City, is offered upon your graduation.

**LEARN ALL ABOUT COLOR TV!** I give you the latest principles and practical training in **TV COLOR!**

## VETERANS!

**MY SCHOOLS FULLY APPROVED TO TRAIN VETERANS** under new G.I. bill! If discharged after June 27, 1950 — **CHECK COUPON!** Also approved for **RESIDENT TRAINING** in New York City at Pierce School of Radio and Television... qualifies you for full subsistence allowance up to \$160 per month. Write for details.

## WARNING!

**ALL VETERANS DISCHARGED BEFORE AUGUST 20, 1952** must be enrolled and **IN TRAINING** by August 20, 1954. Otherwise you lose your G.I. rights to a free education under **NEW G.I. BILL!** Don't put it off... it takes several months to get your papers processed! **RUSH COUPON BELOW.** Tell your ex-G.I. friends!

## YOU GET ALL 4 FREE!

**GOOD SPARE TIME EARNINGS!** Almost from the very start you can earn extra money while learning, repairing Radio-TV sets for friends and neighbors. Many of my students earn up to \$25 a week... pay their entire training from spare time earnings... start their own profitable service business. *Act now! Mail coupon and find out for yourself what a TV career can do for you!*

**OPTIONAL: TWO WEEKS TRAINING IN NEW YORK CITY AT NO EXTRA COST!** You get two weeks, 50 hours, of intensive Laboratory work on modern electronic equipment at our associated school in New York City—Pierce School of Radio and Television. And I give you all this **AT NO EXTRA COST** whatsoever, after you finish your home study training in the Radio-FM-TV Technician Course and FM-TV Technician Course.

### RADIO-TELEVISION TRAINING ASSOCIATION

52 EAST 19th STREET, NEW YORK 3, N. Y.

Licensed by the State of New York • Approved by the VA



**MAIL THIS COUPON NOW! No Salesman Will Call!**

Mr. Leonard C. Lane, President  
RADIO-TELEVISION TRAINING ASSOCIATION  
52 East 19th Street, New York 3, N. Y. Dept. T-58

Dear Mr. Lane: Mail me your **NEW FREE BOOK, FREE SAMPLE LESSON**, and **FREE** aids that will show me how I can make **BIG MONEY IN TELEVISION.** I understand I am under no obligation and no salesman will call.

(PLEASE PRINT PLAINLY)

NAME \_\_\_\_\_ AGE \_\_\_\_\_

ADDRESS \_\_\_\_\_

CITY \_\_\_\_\_ ZONE \_\_\_\_\_ STATE \_\_\_\_\_

#### I AM INTERESTED IN:

- Radio-FM-TV Technician Course
- FM-TV Technician Course
- TV Cameraman & Studio Course

**VETERANS!**  
Check here for  
Training under  
NEW G.I. Bill



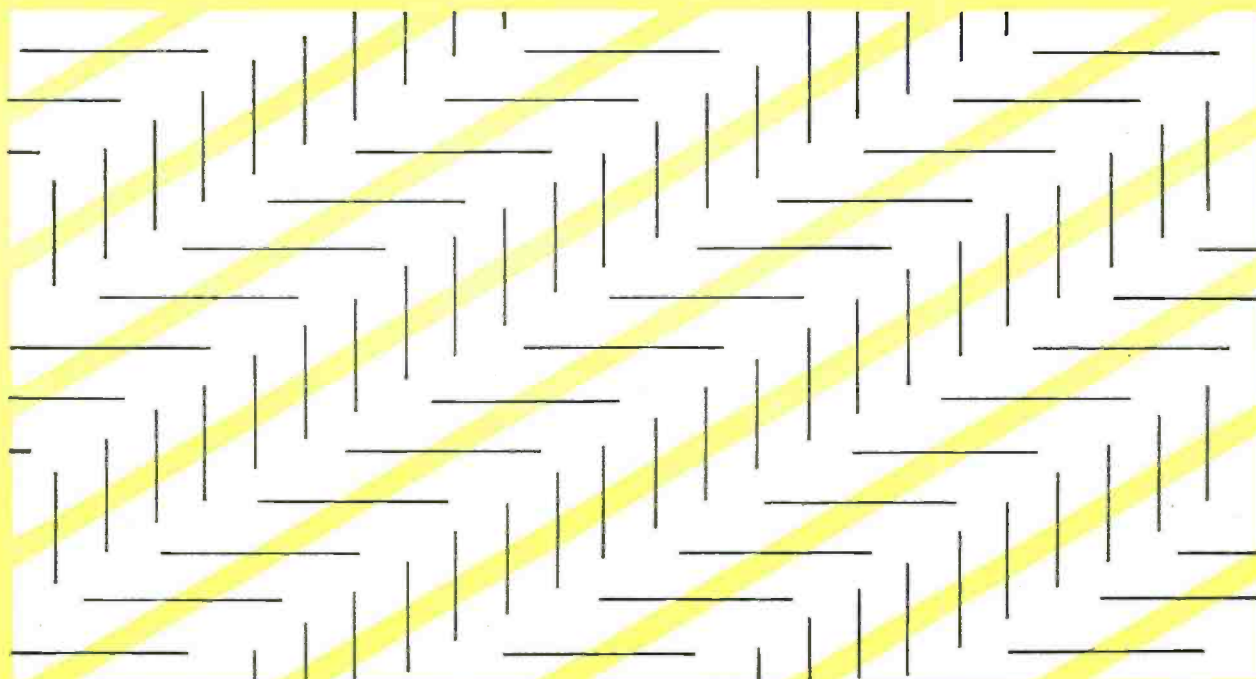

# THINGS ARE **NOT** AS THEY SEEM...

The long lines are strictly parallel—  
that they appear otherwise is an optical illusion.

This fuse merely has the metal caps cemented to the  
glass.

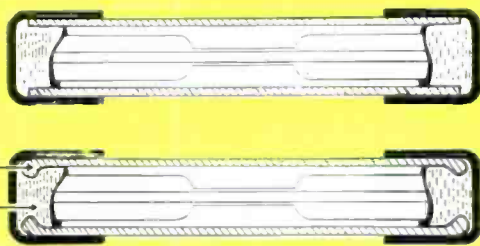
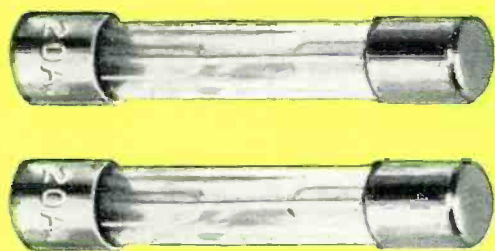

The difference between these two  
fuses is no illusion...

This Littelfuse has the caps locked to glass like this.  
The ends of the glass are formed<sup>A</sup>. The solder which  
is bonded in a separate operation to the cap reflows  
through the small aperture and spreads out to form a  
permanent collar-button lock<sup>B</sup> between cap and glass—  
impervious to moisture and vibration. The exclusive  
Littelfuse feature eliminates fuse failure due to loose caps.

*Littelfuse leads all other fuse manufacturers in design  
patents on fuses. Lock-cap assembly patent no. 1922642*

# LITTELFUSE

DES PLAINES, ILLINOIS



**TRAIN *FASTER*—TRAIN *BETTER*—TRAIN *EASIER*  
IN 10 MONTHS—OR LESS—FOR  
**RADIO-TELEVISION****

**Our 21st Year Training Men for Greater Incomes and Security in Radio-Television**

**I SEND YOU  
18 BIG KITS**

of Radio Television parts and equipment. Much of your training will be actual construction and experimentation . . . the kind of truly PRACTICAL instruction that prepares you for your Radio-Television career.



Frank L. Sprayberry  
President  
Sprayberry Academy  
of Radio

**NEW! NO OBLIGATION PLAN**

**You Have No Monthly Payment Contract to Sign  
Pay For Your Training as You Earn and Learn**

You can get into Radio-Television, today's fastest growing big money opportunity field, in *months* instead of years! My completely new "package unit" training plan prepares you in as little as 10 months or even less! *No monthly payment contract to sign—thus NO RISK to you!* This is America's finest, most complete, practical training—gets you ready to handle any practical job in the booming Radio-Television industry. Start your own profitable Radio-Television shop . . . or accept a good paying job. I have trained hundreds of successful Radio-Television technicians during the past 21 years—and stand ready to train you, even if you have no previous experience! Mail coupon and get all the facts—FREE!

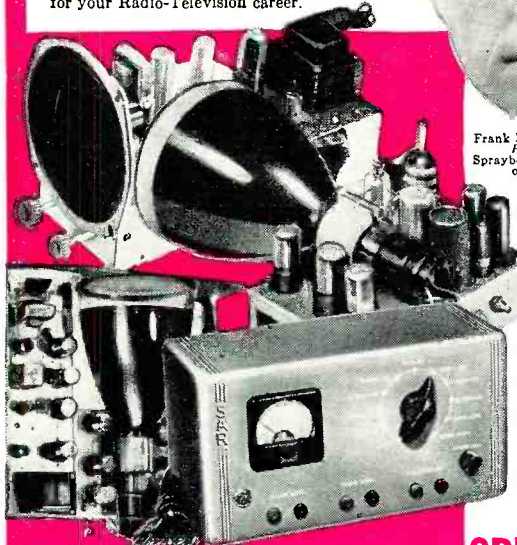

**Valuable Equipment Included  
With Training**

The new Sprayberry "package" plan includes many big kits of genuine, professional Radio-Television equipment. You perform over 300 demonstrations, experiments and construction projects. You build a powerful 6-tube 2-band radio set, multi-range test meter, signal generator, signal tracer, many other projects. All equipment and lessons are *yours to keep* . . . you have practically everything you need to set up your own profitable Radio-Television service shop.

**Earn Extra Money While You Learn!**

All your 10 months of training is IN YOUR HOME in spare hours. Keep on with your present job and income while learning. With each training "package" unit, you receive extra plans and "Business Builder" ideas for spare time Radio-Television jobs. New television stations everywhere, open vast new opportunities for trained Radio-Television Technicians—and those in training. If you expect to be in the armed forces later, there is no better preparation than practical Sprayberry Radio-Television training.

**YOU BUILD** the Television set and the powerful superhet radio receiver shown above. IN ADDITION to the other test units shown here (many are not shown because of lack of space). All equipment I send you is **YOURS TO KEEP.**

**SPRAYBERRY ACADEMY OF RADIO 111 NORTH CANAL ST.  
Dept. 25-J, Chicago 6, Ill.**

**MAIL COUPON  
TODAY!  
NO OBLIGATION**

**SPRAYBERRY ACADEMY OF RADIO, Dept. 25-J,  
111 North Canal St., Chicago 6, Ill.**

Please rush to me all information on your 10-MONTH Radio-Television Training Plan. I understand this does not obligate me and that no salesman will call upon me. Be sure to include 3 books FREE.

Name..... Age.....

Address.....

City..... Zone..... State.....

I invite you to get all the facts—

**FREE TO YOU 3 BIG  
RADIO-TELEVISION BOOKS**

I want you to have ALL the facts about my new 10-MONTH Radio-Television Training—without cost! Rush coupon for my three big Radio-Television books: "How to Make Money in Radio-Television," PLUS my new Illustrated Television Bulletin PLUS an actual sample Sprayberry Lesson—ALL FREE. No obligation and no salesman will call. Mail coupon NOW!



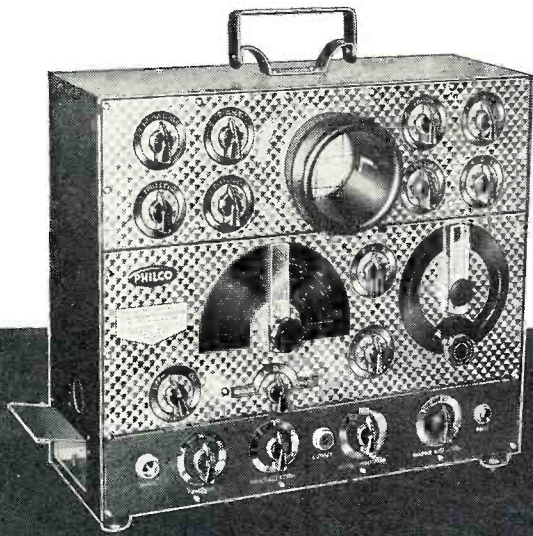

*Your Own Portable  
"Service Bench" for  
IF-RF Alignment!*

# PHILCO

## VISUAL ALIGNMENT GENERATOR

### Oscilloscope, Sweep and Marker Generator

*All in One Instrument!*

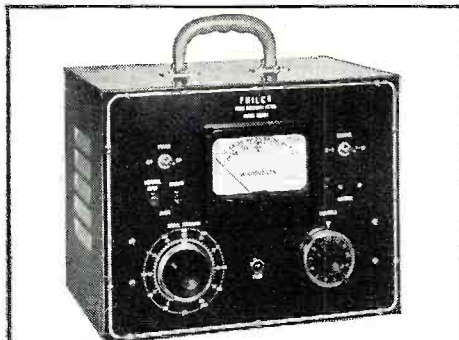

### **NEW! PHILCO** **FIELD STRENGTH METER**

Here's more than an antenna signal checker. The new Philco Field Strength Meter provides direct readings of RF signal level. It has built-in electronic sensitivity control. Signal levels above 100 microvolts are read directly on the calibrated dial. Read 10 to 100 microvolt levels on the high sensitivity meter. High gain, low noise TV tuner provides exceptional wide range of sensitivity. Now, measure both strong and weak signals with the Philco reference calibration method. It's the same type found in expensive laboratory equipment. MODEL M-8104.

The Philco Model 7008 Visual Alignment Generator is a completely self-contained "service bench" for all alignment and trouble shooting problems in the field. It is specifically designed to permit rapid servicing of the IF amplifier and front end of TV and FM receivers. The sweep section furnishes a high output signal with uniform sweep level throughout the FM and television bands, as well as the intermediate frequencies used. The marker system, with its associated crystal calibrator, has an accuracy of .005%. The built-in oscilloscope greatly simplifies test set-up. Furnished complete with high frequency detector probe, output and input cables and AC cord.

#### **Look at these PHILCO features:**

1. Only two external cable connections necessary...minimizes regeneration and feed-back.
2. Shielded multiplier attenuator provides accurate control
- of RF output from a few microvolts up to .1 volt.
3. RF output increases with frequency to offset the fall off in gain which normally occurs on the higher frequencies.

**AVAILABLE THROUGH YOUR PHILCO DISTRIBUTOR  
ON A NEW SPECIAL PAYMENT PLAN**



Take advantage of the great  
**SHARE and PROFIT Program**  
on Philco Receiving Tubes  
Parts and Accessories  
**NOW AT YOUR PHILCO DISTRIBUTOR**

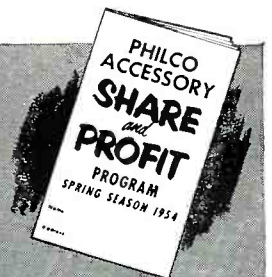

Now a

# COLOR

## TELEVISION HOME STUDY COURSE

by RCA Institutes



"Color Television is here—not around the corner, or in the developmental labs, but here! The big question now is . . . Are You ready for Color TV?"

"You may now have a successful TV servicing business. When color sets come to your bench for servicing, will you be able to handle them?"

"Color Television is a vast new field, embodying entirely new concepts . . . principles of light and vision, radically new circuitry."

### First Home Study Course in Color TV

Now is the time to prepare. Now, for the first time, you can train yourself for the

opportunities in this brand-new field. The just-announced RCA Institutes Home Study Course is the *first* home study course covering all phases of color television. Offered only to those already experienced in radio-television servicing, it explains the "why" of basic theory, as well as the "how-to-do-it" of servicing techniques.

Planned and written by RCA instructors, the entire course is based on the practical experience of RCA engineers—the men who have pioneered in the research and development of color television since the very first color experiments, many years ago.

Remember when black-and-white television first became a reality? Overnight, the demand for men who knew television grew. Even now, a shortage of qualified servicemen exists. Think, then—of the even greater demand for servicemen who will understand the many additional problems of color reception!

### Costs so little to gain so much

RCA Institutes makes it easy for you to prepare yourself now for color television. Not only is the cost of the home study course for qualified servicemen extremely low, but you pay for the course on a pay-as-you-learn basis.

RCA Institutes conducts a resident school in New York City offering day and evening courses in Radio and TV Servicing, Radio Code and Radio Operating, Radio Broadcasting, Advanced Technology. Write for free catalog on resident courses.

Send for **FREE Booklet**—Mail the coupon, today. Get complete information on the RCA INSTITUTES Home Study Course in Color Television. Booklet gives you a general outline of the course lesson by lesson. See how thoroughly you can learn Color TV. Mail coupon in envelope or paste on postal card.



### MAIL COUPON NOW!

RCA INSTITUTES, INC., Home Study Dept. RN554  
350 West Fourth Street, New York 14, N. Y.

Without obligation on my part, please send me copy of booklet "RCA INSTITUTES Home Study Course in COLOR TELEVISION." (No salesman will call.)

Name \_\_\_\_\_ (please print)  
Address \_\_\_\_\_  
City \_\_\_\_\_ Zone \_\_\_\_\_ State \_\_\_\_\_



**RCA INSTITUTES, INC.**  
A SERVICE OF RADIO CORPORATION of AMERICA  
350 WEST FOURTH STREET, NEW YORK 14, N.Y.

May, 1954

# They're Hot Packed



## DELCO RADIO CANS ITS POWER TRANSFORMERS TO PROTECT THEIR QUALITY AND PERFORMANCE

If you want a part made *right*, you've got to be able to control all phases of its production. That's why Delco Radio exercises strict quality control over all its parts—for service use as well as for original equipment.

Let's look at some new power transformers for auto radios: The laminated core inserts are stamped out of low-loss silicon steel, then heat treated to insure retention of desired magnetic properties. Skilled operators use special machines to wind the primary and secondary coils. On the production line, laminations and coils are assembled and, with other parts, placed in a metal can. Finally, a hot asphalt compound is poured into the shield can. On cooling, it becomes a solid mass that holds all components in position, transfers heat and protects the transformer's quality and performance.

Satisfied customers are the basis of a good service business, and Delco Radio service parts assure customer satisfaction. Delco Radio service parts are available through your UMS Delco Electronic Parts Distributor.



*Potting power transformers. The transformer can is filled with an asphalt compound which helps to protect the transformer and transfer heat from the transformer to the can for better heat dissipation.*



A GENERAL MOTORS PRODUCT  A UNITED MOTORS LINE 

DISTRIBUTED BY ELECTRONICS WHOLESALERS EVERYWHERE

# DELCO RADIO

DIVISION OF GENERAL MOTORS CORPORATION, KOKOMO, INDIANA



# Where Will You Be in **ELECTRONICS** 6 Months from Today?

**ADD TECHNICAL TRAINING to your practical experience**  
**Get Your FCC License In A Hurry!**

**Then Use Our Amazingly Effective  
JOB FINDING SERVICE**

**Get This Valuable Booklet FREE**



**TELLS HOW—**

**HERE IS YOUR GUARANTEE**

If you fail to pass your Commercial License exam after completing our course, we guarantee to continue your training without additional cost of any kind, until you successfully obtain your Commercial license, provided you first sit for this examination within 90 days after completing our course.

**WE GUARANTEE**

**TO TRAIN AND COACH YOU AT HOME IN SPARE TIME UNTIL YOU GET YOUR FCC LICENSE**

If you have had any practical experience—Amateur, Army, Navy, Radio repair, or experimenting.

**TELLS HOW—**

**TV ENGINEERING INCLUDED IN OUR TRAINING & COACHING**

**Our Amazingly Effective JOB-FINDING SERVICE Helps CIRE Students Get Better Jobs**  
 Here are a few recent examples of Job-Finding results:

**GETS AIRLINES JOB**

"Due to your Job-Finding Service, I have been getting many offers from all over the country, and I have taken a job with Capital Airlines in Chicago, as a Radio Mechanic."  
 Harry Clare, 4537 S. Drexel Blvd., Chicago, Ill.

**GETS FIVE JOB-OFFERS FROM BROADCAST STATIONS**

"Your 'Chief Engineer's Bulletin' is a grand way of obtaining employment for your graduates who have obtained their 1st class license. Since my name has been on the list I have received calls or letters from five stations in the southern states, and am now employed as Transmitter Engineer at WMMT."  
 Elmer Powell, Box 274, Sparta, Tenn.

**GETS CIVIL SERVICE JOB**

"I have obtained a position at Wright-Patterson Air Force Base, Dayton, Ohio, as Junior Electronic Equipment Repairman. The Employment Application you prepared for me had a lot to do with me landing this desirable position."  
 Charles E. Loomis, 4516 Genesee Ave., Dayton, Ohio.

Your FCC Ticket is recognized in all radio fields as proof of your technical ability.

**TELLS HOW— Employers make JOB OFFERS Like These to Our Graduates Every Month**

Letter from nationally-known Airlines, "We would also appreciate if you would place the following additional advertisement in your bulletin—Wanted—Superintendent of Communications . . . Salary \$666.66 per month."  
 Letter from nationally known manufacturer of high quality AM and FM transmitters, "We are very much in need at the present time of radio-electronics technicians and would appreciate any helpful suggestions that you may be able to offer. Salary up to \$412 per month to start."

These are just a few examples of the job offers that come to our office periodically. Some licensed radioman filled each of these jobs . . . it might have been you!

**HERE'S PROOF FCC LICENSES ARE OFTEN SECURED IN A FEW HOURS OF STUDY WITH OUR COACHING AT HOME in Spare Time.**

Name and Address	License	Lessons
Lee Worthy 2210 1/2 Wilshire St., Bakersfield, Calif.	2nd Phone	16
Clifford E. Vogt, Box 1016, Dania, Fla.	1st Phone	20
Francis X. Faerth, 38 Beuler Pl., Bergenfield, N. J.	1st Phone	38
S/Sgt. Ben H. Davis, 317 North Roosevelt, Lebanon, Ill.	1st Phone	28
Albert Schoell, 110 West 11th St., Escondido, Calif.	2nd Phone	23

**CLEVELAND INSTITUTE OF RADIO ELECTRONICS**  
 CARL E. SMITH, E.E., Consulting Engineer, President  
 Desk RN-58, 4900 Euclid Bldg., Cleveland 3, Ohio

**OURS IS THE ONLY HOME STUDY COURSE WHICH SUPPLIES FCC-TYPE EXAMINATIONS WITH ALL LESSONS AND FINAL TESTS.**



**GET ALL 3 FREE! MAIL COUPON NOW**

**CLEVELAND INSTITUTE OF RADIO ELECTRONICS**  
 Desk RN-58, 4900 Euclid Bldg., Cleveland 3, Ohio  
 (Address to Desk No. to avoid delay)

**B** I want to know how I can get my FCC ticket in a minimum of time. Send me your FREE booklet, "How to Pass FCC License Examinations" (does not cover exams for Amateur License), as well as a sample FCC-type exam and the amazing new booklet, "Money-Making FCC License Information."

Be sure to tell me about your television engineering course.

Name.....  
 Address.....  
 City..... Zone..... State.....

Paste on 2-cent postcard or send air mail.

# HERE'S **WHY** IRC EXACT DUPLICATES ARE DOUBLE-MONEY-BACK **GUARANTEED**

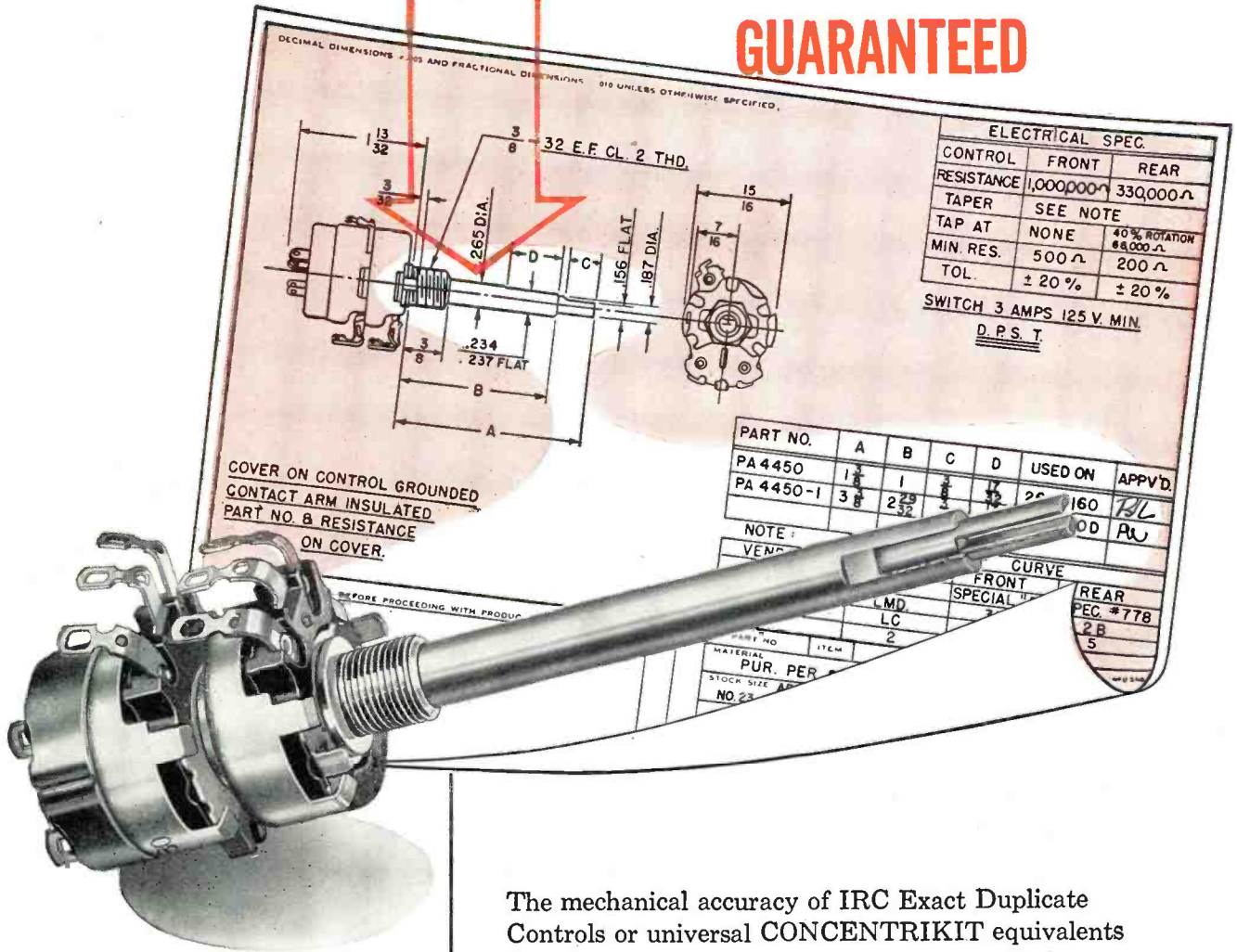

**ONLY IRC GUARANTEES**  
**SATISFACTORY MECHANICAL FIT**  
**AND ELECTRICAL OPERATION**  
**OR DOUBLE-YOUR-MONEY-BACK**

The typical manufacturer's specifications shown here are exactly duplicated by IRC QJ-180 control. CONCENTRIKIT assembly includes P1-229 and R1-312 shafts with B11-137 and B18-132X Base Elements, and 76-2 Switch.



*Wherever the Circuit Says* 

The mechanical accuracy of IRC Exact Duplicate Controls or universal CONCENTRIKIT equivalents is based on set manufacturers' procurement prints. Specifications on those prints are closely followed.

Shaft lengths are *never less* than the set manufacturer's nominal length—*never more* than  $\frac{3}{32}$ " longer.

Shaft ends are precisely tooled for solid fit.

Inner shaft protrusion is accurately duplicated for perfect knob fit.

Alterations are never needed.

For Exact Duplicate Controls, specify IRC. Most Service Technicians do.

## INTERNATIONAL RESISTANCE CO.

415 N. Broad Street, Philadelphia 8, Pa.

In Canada: International Resistance Co., Ltd., Toronto, Licensee



# \$8000<sup>00</sup> PRIZES

## WESTINGHOUSE LEAGUE LEADERS

### AND DEALER AID CONTEST

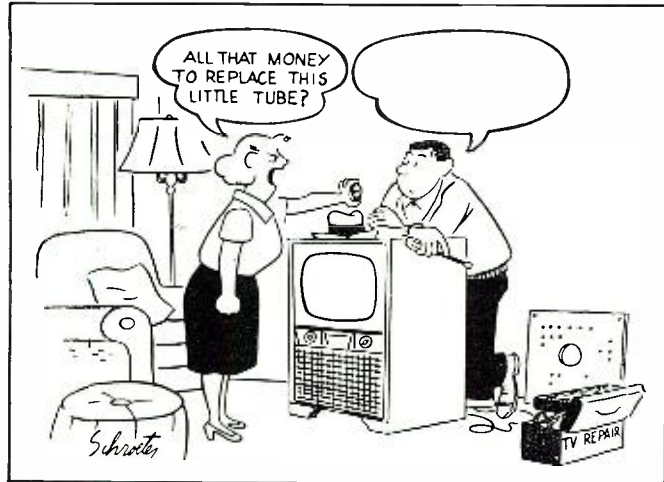

How would YOU Answer This Service Customer?

Your solution to this cartoon—and your careful selection of American and National League Leaders, as of August 1, 1953—can win \$1000.00 CASH for you. Send in your entry now, for one of the 209 big, valuable prizes in the Westinghouse League Leaders and Dealer Aid Contest. It's easy to qualify.

Just buy 25 Westinghouse Receiving Tubes or 1 Westinghouse Picture Tube for each entry you submit. Winning entries will be judged on the basis of correctness of team selection, and aptness, originality and effectiveness of cartoon solution.

Your Westinghouse distributor salesman will certify your Entry Blank when he takes your tube order. Ask him for additional Entry Blanks.

ET-95051



**208 MORE BIG PRIZES  
FOR TV SERVICE MEN**

**2nd PRIZE \$700** in YOUR Choice of Merchandise

**3rd PRIZE \$400** in Merchandise YOU Select

**4th PRIZE \$300** YOU Select the Merchandise

FIRST, SECOND, THIRD AND FOURTH PRIZE WINNERS WILL MEET MICKEY MANTLE OR STAN MUSIAL IN THE BIG PRIZE AWARD DINNER WESTINGHOUSE HAS PLANNED FOR YOU IN NEW YORK

- 5 Fifth Prizes of \$140 Each in Merchandise
- 20 Sixth Prizes of \$70 Each in Merchandise
- 30 Seventh Prizes of \$35 Each in Merchandise
- 50 Eighth Prizes of \$20 Each in Merchandise
- 100 Ninth Prizes of \$15 Each in Merchandise

YOU CAN BE SURE...IF IT'S **Westinghouse**

**RELIATRON® TUBES**

WESTINGHOUSE ELECTRIC CORPORATION

Electronic Tube Division

Box 284

Elmira, N. Y.

**USE THIS OFFICIAL LEAGUE LEADERS ENTRY BLANK**

1. League Leaders on August 1st, 1953 were:

AMERICAN LEAGUE

NATIONAL LEAGUE



MY NAME .....

SHOP NAME .....

STREET .....

CITY..... STATE.....

**SEND ALL ENTRIES TO:  
WESTINGHOUSE TUBE CONTEST**

P. O. Box 610, Grand Central Station

New York 17, New York

2. Here is what I would say to the Lady in the Cartoon:

---

---

---

---

---

---

---

---

(Attach additional sheet of paper if necessary. 100 words maximum.)

**THIS SPACE FOR DISTRIBUTOR'S SALESMAN'S CERTIFICATION**

I certify this Entry Blank has been qualified by the purchase of (25 Westinghouse Receiving Tubes) (1 Westinghouse Picture Tube)

Salesman's Signature.....

Company Name.....

City..... State.....

# ANNOUNCING THE NEW

and most complete  
standard  
stock line . . .

## ERIE

TEMPERATURE COMPENSATING  
TUBULAR CERAMICONS

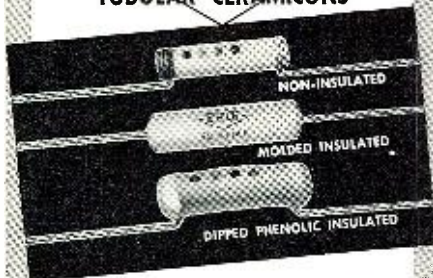

**Three Temperature Coefficients:** NPO, N330, N750: Close tolerance on all temperature coefficients.

**Non-insulated, Molded insulated, Dipped Phenolic Insulated.**

**Wide range of capacity values, close tolerance on all capacity values.**

**Provide commercial equivalents of many often used JAN types.**

One purpose of the three temperature coefficients is to provide the means of combining in parallel, various combinations of NPO and N330; and NPO and N750 to obtain intermediate temperature coefficients. Formulae for computing these values as well as a simple nomograph for quick computations will be afforded in service information.

The range of capacity values is the most complete offered as standard stock by any ceramic capacitor manufacturer. Servicemen and engineers . . . your distributor has these capacitors to meet your requirements for TV replacements, laboratory work, and prototype development.

Write for complete list of capacity values available JAN equivalent table, and nomograph.

ERIE components are stocked at leading electronic distributors everywhere.

**ELECTRONICS DISTRIBUTOR DIVISION  
ERIE RESISTOR CORPORATION**

Main Offices: ERIE, PA.

Factories: ERIE, PA. • LONDON, ENGLAND  
TRENTON, ONTARIO

# Within the

# INDUSTRY

**JOHN E. NELSON** has been named central regional manager for *General Electric* equipment tube sales. He will direct all of the equipment tube sales and commercial engineering activities in the region which includes 21 midwestern states and part of Pa.



He will make his headquarters at the company's new warehouse at 3800 N. Milwaukee Ave. in Chicago.

For the past year he has been product manager for the company's industrial and transmitting tubes at the Tube Department headquarters in Schenectady. He joined the company in 1942 after serving the U. S. Department of Agriculture for nine years.

\* \* \*

**JETRON MANUFACTURING COMPANY** of Chicago is re-entering the television antenna field. J. Tunkl who was formerly associated with *Tricraft Products Company* is a principal of the firm . . . **JOE MURPHY**, formerly associated with *Cunningham and Mitchell Company* of Indianapolis, has organized his own representative firm with offices at 2505 East 39th St. in Indianapolis . . . **Wally B. Swank** has formed the **ELECTRO SALES COMPANY** to serve distributors in the upper New York state area . . . **INSULATED CIRCUITS, INC.** a manufacturer of printed circuits and sub-assemblies, has been established at 115 Roosevelt Ave. in Belleville, N. J.

\* \* \*

**AL E. DANIELSON**, formerly sales-service coordinator for the western division of *Admiral Corporation*, has been appointed general manager of *Pioneer Electronics Corp.*, West Los Angeles manufacturer of TV picture tubes.

He joined *Admiral* in 1945 and was transferred to the West Coast in 1947. Prior to this affiliation he was with *P. R. Mallory & Co., Inc.* and *Stewart-Warner*.



In his new post he will be in charge of product scheduling and expediting and procurement and contracts.

\* \* \*

**RUSS DIERTHER** of Chicago has been named chairman of the newly-established Conference Coordinating Committee set up by the five trade associations in the electronics industry. S. L. Baraf is serving as co-chairman of the group.

The purpose of the new committee

is to coordinate regional conferences run by sales representatives and eliminate duplication of time, effort, and expense.

The five associations cooperating in this new committee include the West Coast Electronic Manufacturers Association; the Radio-Electronics-Television Manufacturers Association; the Sales Managers Club, Eastern Group; the Association of Electronic Parts and Equipment Manufacturers; and "The Representatives" of Electronic Products Manufacturers, Inc.

\* \* \*

**RETMA** has recently released figures on television receiver sales for 1953. According to the Association, 6,375,279 television sets and 7,064,485 radios (excluding auto radios) were sold at retail during the year.

These figures compare with 6,144,988 television sets and 7,689,701 radios, excluding auto sets, sold in 1952. Auto radio production totaled 5,182,934 units during 1953.

\* \* \*

**B. F. VALLIERE** has been named vice-president and general manager of the *F. W. Sickles Division of General Instrument Corporation*.



In his new capacity he will have over-all responsibility for the division's three plants in Chicopee, Mass., Dan-ielson, Conn., and Joliet, Ill. He joined the firm in 1946 after serving in an executive capacity with *Sylvania* and *American Bosch*.

He will make his headquarters at the plant in Chicopee, Mass.

\* \* \*

**RAYTHEON MANUFACTURING COMPANY** is planning to build an electronic engineering and research laboratory in Wayland, Mass., 20 miles from Boston. Plans are conditioned upon the completion of satisfactory arrangements with city officials and suitable financing . . . A new regional sales office and warehouse has been established at 4056 W. Armitage Ave., Chicago 39, by **FEDERAL ELECTRIC CORPORATION**. The new outlet is the third in an expanding network of warehouse facilities established by the company . . .

**ADMIRAL DISTRIBUTORS, INC.** has moved to new headquarters at 6565 E. Washington Blvd. in Los Angeles. The single-story concrete building contains 62,000 square feet of floor space . . . **RADIO CORPORATION OF AMERICA** has established a new office at 522 N. Pitt St. in Alexandria, Va. to provide consulting and engineering services for

RADIO & TELEVISION NEWS

# ADVANCE! Raise your earning power—learn RADIO-TELEVISION-ELECTRONICS by SHOP-METHOD HOME TRAINING

## GOOD JOBS AWAIT THE TRAINED RADIO-TV TECHNICIAN

There is a place for you in the great Radio-Television-Electronics industry when you are trained as National Schools will train you at home!

Trained technicians are in growing demand at good pay—in manufacturing, broadcasting, television, communications, radar, research laboratories, home Radio-TV service, and other branches of the field. National Schools Master Shop-Method Home Training, with newly added lessons and equipment, trains you in your spare time, right in your own home, for these fascinating opportunities. OUR METHOD IS PROVED BY THE SUCCESS OF NATIONAL SCHOOLS TRAINED MEN, ALL OVER THE WORLD, SINCE 1905.

## EARN WHILE YOU LEARN

Many National students pay for all or part of their training with spare time earnings. We'll show you how you can do the same! Early in your training, you receive "Spare-time Work" Lessons which will enable you to earn extra money servicing neighbors' and friends' Radio and Television receivers, appliances, etc.



Signal Generator

Audio Oscillator

T. R. F. Receiver

## National Schools Training is All-Embracing

National Schools prepares you for your choice of many job opportunities. Thousands of home, portable, and auto radios are being sold daily—more than ever before. Television is sweeping the country, too. Co-axial cables are now bringing Television to more cities, towns, and farms every day! National Schools' complete training program qualifies you in all fields. Read this partial list of opportunities for trained technicians:

Business of Your Own • Broadcasting  
Radio Manufacturing, Sales, Service • Telecasting  
Television Manufacturing, Sales, Service  
Laboratories: Installation, Maintenance of Electronic Equipment  
Electrolysis, Call Systems  
Garages: Auto Radio Sales, Service  
Sound Systems and Telephone Companies, Engineering Firms  
Theatre Sound Systems, Police Radio  
And scores of other good jobs in many related fields.

## TELEVISION TRAINING

You get a complete series of up-to-the-minute lessons covering all phases of repairing, servicing and construction. The same lesson texts used by resident students in our modern and complete Television broadcast studios, laboratories and classrooms!



## MASTER ALL PHASES!

Get Master Shop-Method Home Training from an Established Practical Resident School with its own Training — almost 50 Years of Successful Experience in Training Ambitious Men.  
**We Bring National Schools To You!**



You also receive this Multitester

Superheterodyne Receiver

## LEARN BY DOING

You receive and keep all the modern equipment shown above, including tubes and valuable, professional quality Multitester. No extra charges.

## FREE! RADIO-TV BOOK AND SAMPLE LESSON!

Send today for National Schools' new, illustrated Book of Opportunity in Radio-Television-Electronics, and an actual Sample Lesson. No cost—no obligation. Use the coupon now—we'll answer by return airmail.

APPROVED FOR  
VETERANS  
AND  
NON-VETERANS  
Check coupon below

Both  
Resident and  
Home Study  
Courses Offered!

## NATIONAL SCHOOLS

LOS ANGELES 37, CALIFORNIA • ESTABLISHED 1905  
IN CANADA: 811 W. HASTINGS STREET, VANCOUVER, B.C.



## GET FACTS FASTEST! MAIL TO OFFICE NEAREST YOU!

(mail in envelope or paste on postal card)

NATIONAL SCHOOLS, Dept. RH-54

4000 S. Figueroa Street Los Angeles 37, Calif. or 323 West Polk Street Chicago 7, Ill.

Send FREE Radio-TV Electronics book and FREE sample lesson. No obligation, no salesman will call.

NAME \_\_\_\_\_ BIRTHDAY \_\_\_\_\_ 19 \_\_\_\_\_

ADDRESS \_\_\_\_\_

CITY \_\_\_\_\_ ZONE \_\_\_\_\_ STATE \_\_\_\_\_

Check if interested ONLY in Resident Training at Los Angeles.  
VETERANS: Give Date of Discharge \_\_\_\_\_

# everything needed . . .

## FOR THE QUALITY INSTALLATION

# antennas

A complete line of VHF and UHF antennas, designed for high gain and top performance, is made by the antenna-wise craftsmen of AMPHENOL. The color-tested INLINE\* and its new partner the Conical are superior VHF antennas. The Corner Reflector, Yagi, Rhombic and re-designed Bo-Ty are the sturdiest, most efficient UHF antennas offered today. For VHF, UHF or combined VHF/UHF installations the AMPHENOL Stacked-V is the first choice of distributors, dealers and the public.

\*Reissue U.S. Patent 23,273

# accessories

AMPHENOL accessories for the quality tv installation include Stand-off Insulators, mast sections and hardware, the UHF/VHF ISONET, new UHF/VHF Lightning Arrestor with lowest measurable loss, and the new TELE-COUPPLERS for effective coupling of two to four television sets to one antenna. The TRISONET couples high and low band VHF antennas and UHF antenna to one TV set.

# lead-in

Unique AIR-CORE Tubular Twin-Lead (U.S. Pat. No. 2,543,696) is a truly efficient transmission line with lowest signal loss of any lead-in. AIR-CORE is a must for UHF television. AMPHENOL Flat Twin-Lead has been proved through years of effective transmission as a superior VHF lead-in.

the famous trade mark

**AMPHENOL**

AMERICAN PHENOLIC CORPORATION

www.americanradiohistory.com

the Armed Forces . . . **SPECIFIC PRODUCTS** is now located in new and larger quarters at 14515 Dickens Street, Sherman Oaks, California . . . A new one-story factory building is now being built by the Central Manufacturing District for **THE HALLICRAFTERS COMPANY** at Kostner Avenue and 45th Street in Chicago. The plant will be used for TV manufacturing, warehousing, and shipping . . . **TEXAS HOME EQUIPMENT COMPANY** has moved to a new building at 1012 McKinney Ave. in Dallas. The new site boasts its own railway spur and truck dock . . . **MESA PLASTICS COMPANY** is now occupying its new and enlarged plant at 11751 Mississippi Ave., Los Angeles 25 . . . **DEAN ELECTRONICS CO., INC.** has moved from Brooklyn to 425 Devoe Ave., Bronx 60, N. Y. The company makes phonographs.

**C. BYRON FARMER** is the regional sales manager for the newly-created southeastern sales region for *General Electric* replacement tubes. He will have headquarters in Atlanta, Ga.

Mr. Farmer is a native of Atlanta and studied electrical engineering at Georgia Tech and industrial management at the University of Georgia. He joined *General Electric* in 1936 in the apparatus group and served from 1940 to 1945 in the Navy.

He returned to the apparatus group after the war and in 1947 joined the electronics division on its marketing training program. From 1948 until his present appointment, he served as sales manager for replacement tube sales in the Georgia-Alabama-Florida district.

**OSCAR JAEGER** has been named application engineer for the midwest division of the *Westinghouse* tube division with headquarters in Chicago. He was formerly with *Crosley* . . . **EDMOND I. EGER** is the new vice-president of advertising for *Admiral Corporation*. He replaces **SEYMOUR MINTZ** . . . **THOMAS A. MARSHALL** has joined *Miller Television Company* as development engineer . . . **J. P. SMITH, JR.**, formerly chief engineer of the *Daven Co.*, has been promoted to the post of director of engineering . . . *Micamold Radio Corporation* has named **ALFRED GARTNER** sales manager of the firm. He was formerly associated with *Cornell-Dubilier* and *Solar* . . . **ROBERT L. UNGER** is the new director of industrial relations for *Hoffman Radio Corp.*'s television division . . . *Washington Technological Associates* has named **E. WILLARD JENSEN** to the post of government contract manager . . . **HAROLD N. BEVERIDGE** has been named manager of *Raytheon's* equipment division operations in Chicago. He will be responsible for all development and production work at the plant located at

(Continued on page 141)



## TELEPHONE SCIENCE GUIDES A **PUNCH** NO ENEMY CAN DODGE

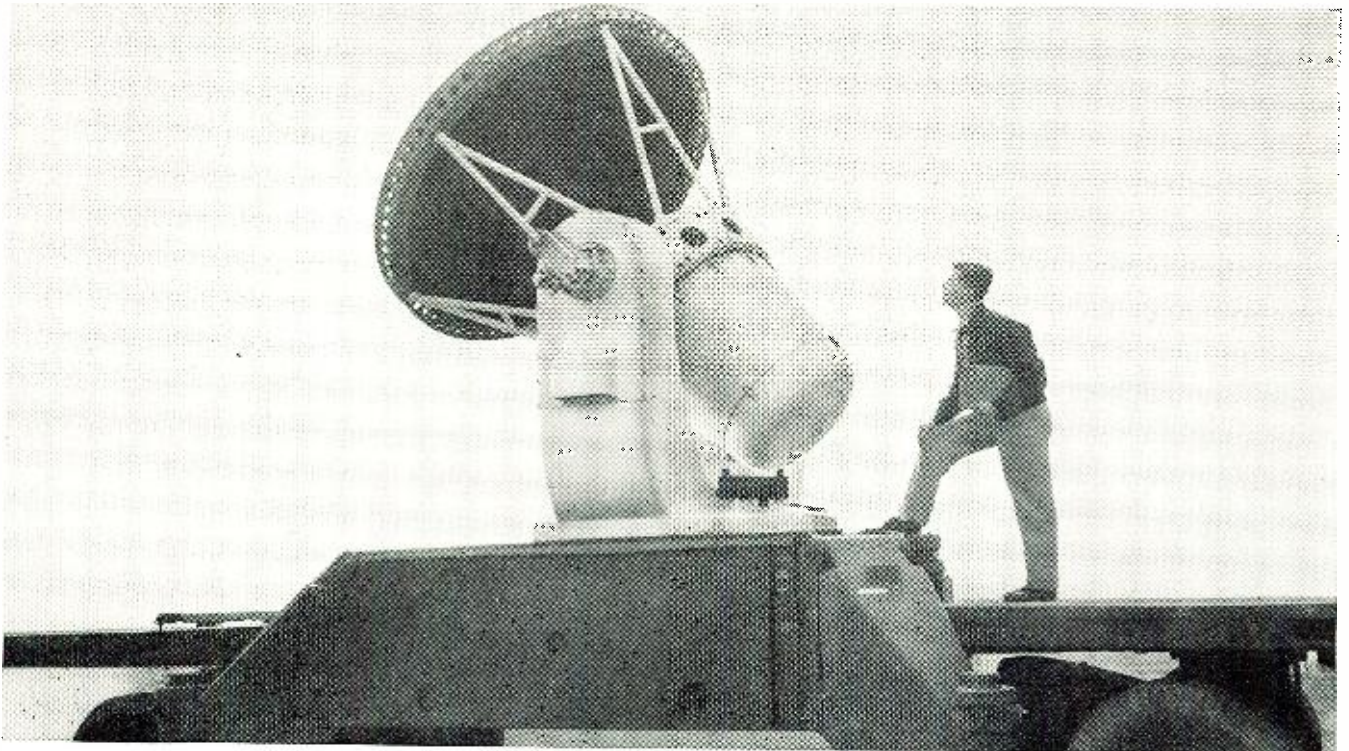

(Upper left) — Nike's missile climbs to destroy an enemy, under guidance of complex electronic controls. A radar is shown at right. Nike (pronounced Ny'kee) is named after the Greek goddess of Victory.



BELL TELEPHONE  
LABORATORIES

Is it possible to guide an anti-aircraft missile so that it will track down and destroy a rapidly maneuvering target? No one knew the answer for sure when the U. S. Army put this question to Bell Telephone Laboratories in 1945.

The special skills and techniques developed to create the nation's communications network uniquely fitted Bell scientists to answer this question. They recommended a new system, Nike, and then worked to bring it into being with

engineers from Army Ordnance, Western Electric Company and Douglas Aircraft Company.

The first Nike installation has been made, and more will follow. Thus, America's defenses grow stronger through a new extension of frontiers in the communications art. It is a proud achievement of the knowledge and skills first developed at Bell Telephone Laboratories to make the nation's telephone service ever better.

*Improving telephone service for America provides careers for creative men in scientific and technical fields*

There's never been a rotator like it!

# JFD ROTENNA

The **CUSTOMER** will **LOVE** the **STYLING** and **EASE** of **TUNING**.  
YOU will **LOVE** the **CARTRIDGE SERVICING** and tuning **ACCURACY**.

**Piano keyboard tuning!**

**Cartridge servicing!**

**Stop watch accuracy!**

Never before have there been so many outstanding engineering developments combined in one great rotator! One year in development. Destined to set new standards in rotator performance.

**Finger tip piano control tuning** with outstanding position indicator. Finely calibrated. Easy to read. "Panoramic" dial face indicates precise antenna position at all times. Magnificently styled console enhances beauty of modern or period decor.

Cartridge type detachable power drive unit can be removed in seconds **without dismantling antenna**. Simply unloosen two screws.

**Stop-watch tuning accuracy.** Ultra-sensitive system accurate within 1/2 degree of rotation. Brakes to an instant stop. No drift or error.

390° continuous rotation in either direction, today's **widest** traverse range. Permits station selection beyond normal 360° traverse—allows perfect tuning in all directions.

Powerful balanced inline construction supports direct dead weight load of as many as 10 element channel 2 yagis as can be stacked on mast.

**JFD antennas—your key to sharper, steadier, brighter UHF and VHF pictures in your area, black and white or color.**

Burton Browne advertising



**JFD MANUFACTURING CO., INC.,**  
Brooklyn 4, New York, BEnsonhurst 6-9200  
World's Largest Manufacturers of  
TV Antennas and Accessories.

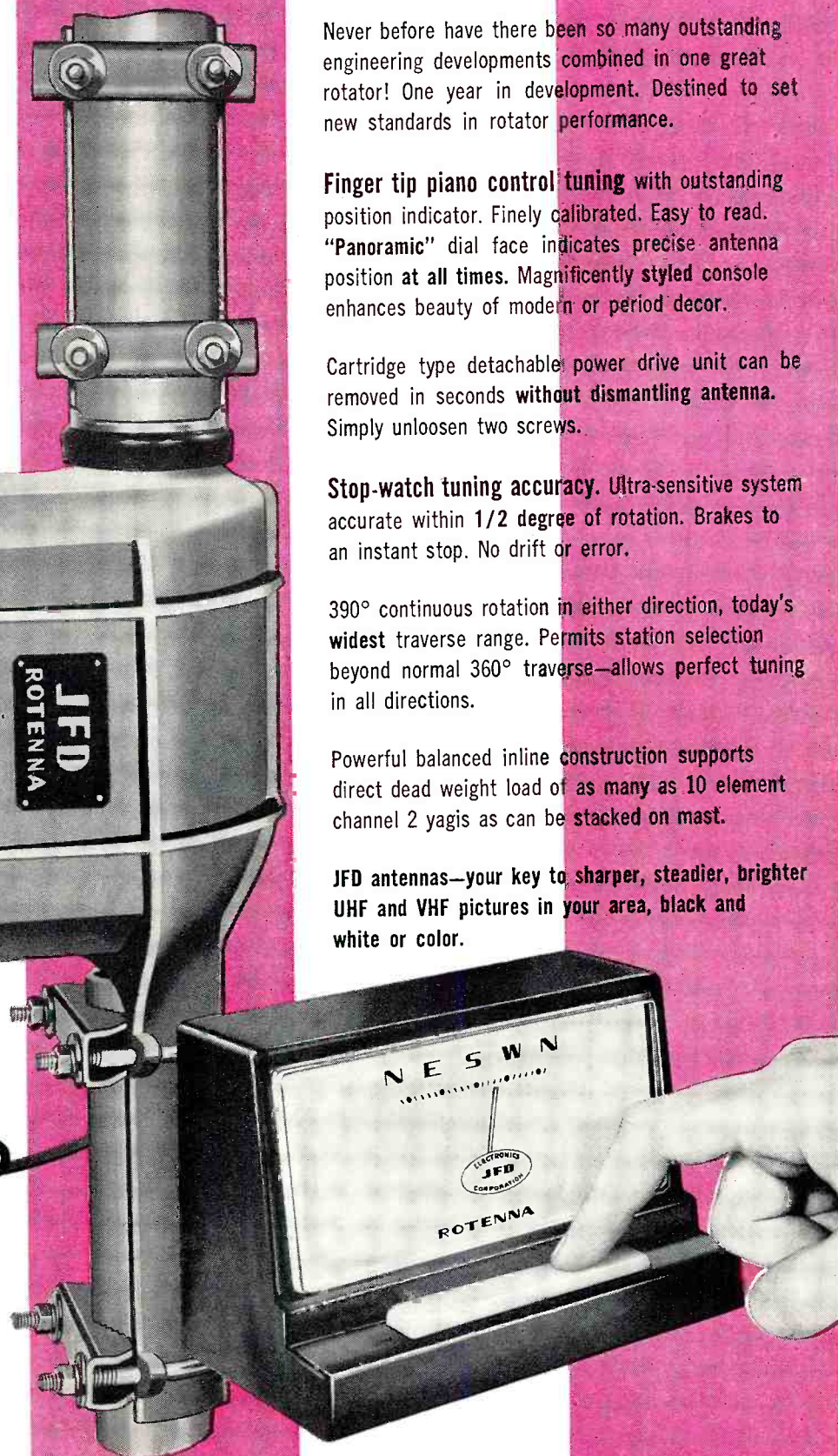

# Here's your Opportunity

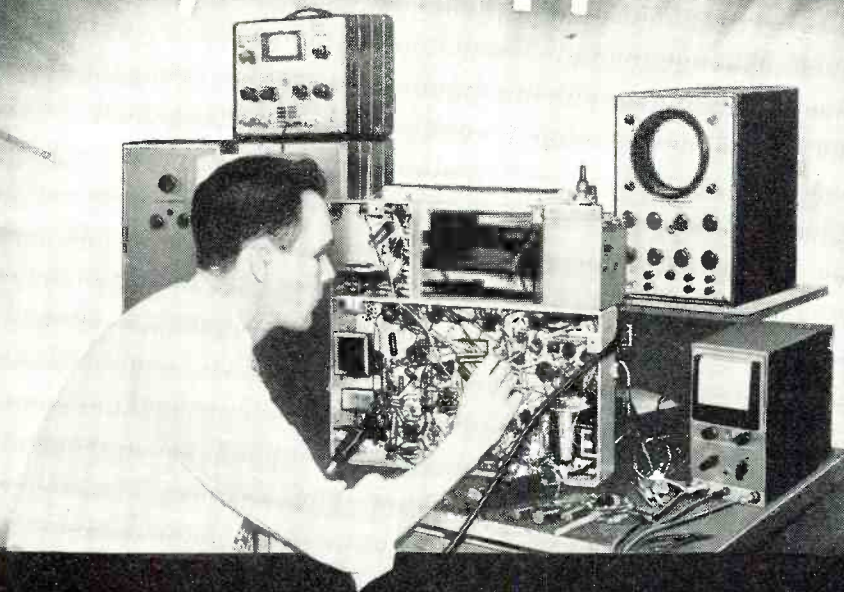

## to prepare for a good job or a business of your own in TV SERVICING

ARE YOU SATISFIED with the position you now hold? Do you feel you're worth more money? Are you pleased with yourself, your work, your associates . . . and your future? What does the next year hold for you . . . and the year after that?

Are you content merely to plod along through the best years of your life . . . or do you want to get into more pleasant work . . . hold a well-paid job . . . perhaps establish your own business?

If you are looking for a REAL opportunity . . . If you want to GROW with a GROWING INDUSTRY . . . If you want to grasp the success that should be yours, then we say to you, study TV Servicing.

Everyone knows that Television is the fastest growing industry today. Opportunities are going begging for men who have

the training and ability to grasp them. *Now is the time to start on the road to success in TV Servicing.*

### Study at Home in your spare time

The RCA Institutes Home Study Course in TV Servicing is easy to learn. You progress rapidly, step by step, as you learn the procedure of servicing and trouble-shooting TV receivers and installing TV antennas. Hundreds of pictures and diagrams help you understand the how-it-works information and the how-to-do-it techniques.

### A Service of

### Radio Corporation of America

The RCA Institutes TV Servicing course was written and planned by instructors with years of specialized experience in training men. You get up-to-the-minute information, too, because you study right at the source

of the latest developments in Television. Your lessons are carefully examined and accurately graded by competent teachers who are interested in helping YOU to succeed.

RCA Institutes is licensed by the University of the State of New York . . . an affiliate member of the American Society for Engineering Education . . . approved by leading Radio-TV Service Organizations . . . approved by Veterans Administration.

### It costs so little to gain so much

RCA Institutes makes it easy for you to take advantage of the big opportunities in TV Servicing. The cost of the TV Servicing Home Study Course has been cut to a minimum. You pay for the course on a pay-as-you-learn unit lesson basis. *No other home study course in TV Servicing offers so much for so little cost to you.*

RCA Institutes conducts a resident school in New York City offering day and evening courses in Radio and TV Servicing, Radio Code and Radio Operating, Radio Broadcasting, Advanced Technology. Write for free catalog on resident courses.

**SEND FOR FREE BOOKLET**—Mail the coupon—today. Get complete information on the RCA INSTITUTES Home Study Course in Television Servicing. Booklet gives you a general outline of the course by units. See how this practical home study course trains you quickly, easily. Mail coupon in envelope or paste on postal card.



### MAIL COUPON NOW!

RCA INSTITUTES, INC., Home Study Dept. RN554  
350 West Fourth Street, New York 14, N. Y.

Without obligation on my part, please send me copy of booklet "RCA INSTITUTES Home Study Course in TELEVISION SERVICING." (No salesman will call.)

Name \_\_\_\_\_ (please print)

Address \_\_\_\_\_

City \_\_\_\_\_ Zone \_\_\_\_\_ State \_\_\_\_\_



## RCA INSTITUTES, INC.

A SERVICE OF RADIO CORPORATION OF AMERICA  
350 WEST FOURTH STREET, NEW YORK 14, N. Y.

May, 1954

# The best TV set is only as good as its antenna!

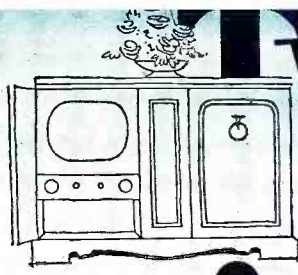

FROM A SELLING AND SERVICING STANDPOINT . . .

*Why* CONSIDER LESS THAN THE BEST ANTENNAS?



*truly deserve your most careful consideration!*

From every standpoint, they are the finest, farthest-reaching all-channel "fringe" area antennas ever designed. No other antennas, regardless of type or number of bays can match their performance . . . for photo-clear reception and consistent, trouble-free service.

2 YEARS OF DEVELOPMENT have gone into research, design, engineering and development of the KAY-TOWNES SUPER "KATYS." Right at this very moment our own exhaustive tests are being substantiated at dealer installations all over the country. These dealers are convinced . . . you will be, when you test the SUPER "KATYS" yourself . . . that these amazing antennas are the answer to complete customer satisfaction!



*Now!*  
LONG DISTANCE  
*Plus*  
PHOTO-CLEAR  
RECEPTION!



*Guaranteed TO OUT-PERFORM ANY OTHER ALL-CHANNEL TV ANTENNA Ever Made!*

KAY-TOWNES unique and exclusive "Snow-Filter" design eliminates cloudy and spotty pictures . . . and will open markets for TV Set sales in many areas now considered "impossible." Think of the tremendous profit-possibilities the SUPER "KATYS" offer to the Television Industry!

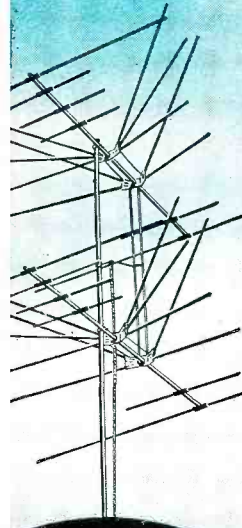

Manufactured and Distributed in CANADA By DELHI METAL PRODUCTS, LTD., DELHI, ONTARIO

**KAY-TOWNES  
ANTENNA COMPANY  
ROME, GEORGIA**

LEADERS IN THE FIELD OF FRINGE AREA ANTENNA DESIGN



# NEXT MOVE'S UP TO YOU!



## CHEMICALS

### ... Everything You Need!



**G-C Pli-O-BOND CEMENT**  
No. 43-2 2 oz. List \$0.65



**G-C ELECTRONIC CONTACT CLEANER**  
No. 210-2 2 oz. List \$0.55



**G-C RUBBER-TO-METAL & PHONO DRIVE CEMENT**  
No. 35-2 2 oz. List \$0.65



**G-C VINYLITE CEMENT**  
No. 58-2 2 oz. List \$0.65



**G-C RADIO-TV SERVICE CEMENT**  
No. 30-2 2 oz. List \$0.65



**G-C TV HIGH VOLTAGE CORONA DOPE**  
No. 47-2 2 oz. List \$1.20



**G-C TELEVISION TUBE KOAT**  
No. 49-2 2 oz. List \$0.95



**G-C MAG-NETIK RECORDING HEAD CLEANER**  
No. 53-2 2 oz. List \$1.60



**G-C ELECTRICAL & RESISTOR CEMENT**  
No. 27-2 2 oz. List \$0.65



**G-C PLASTIC CEMENT**  
No. 32-2A 2 oz. List \$0.65



**G-C DE-OX-ID**  
No. 19-2 2 oz. List \$1.60

## 90 CHEMICALS FOR... BETTER TV-RADIO SERVICING

With the largest, most complete line of quality chemicals in the industry, G-C is the name you should remember whenever you need cement, solvent, cleaners, lubricants and all the rest. Yes, with close to a hundred different G-C Chemicals now available—everything you need—the next move's up to you!



**G-C RADIO SERVICE SOLVENT**  
No. 31-2 2 oz. List \$0.55



FREE CATALOG... big, 64-page illustrated G-C Catalog No. 156. Get it at your jobber... or send postcard direct.



**GENERAL CEMENT MFG. CO.**

904 Taylor Avenue

Rockford, Illinois

# NOW! 1200+ 2000+ SENSATIONAL EICO SCOPE VALUES!

NEW AMAZING FEATURE PACKED  
7" PUSH-PULL OSCILLOSCOPE

Only **EICO** Has All These Features

- VERTICAL FREQ. RESPONSE: flat  $\pm 2$  db 10 cps - 1 mc
- VERTICAL SENS.: .01 volts rms/inch
- HOR. FREQ. RESP.: flat  $\pm 0$  db 10 cps - 200 kc, -4 db at 500 kc
- HOR. SENS.: .3 volts rms/inch
- SWEEP RANGE: 15 cps-100 kc
- 3-STEP FREQ.-COMPENSATED ATTENUATOR eliminates freq. distortion, overloading.
- CATHODE FOLLOWER inputs to both amplifiers
- PUSH-PULL outputs in both amplifiers
- RETURN TRACE BLANKING
- INT. VOLTAGE CALIBRATOR
- V & H TRACE EXPANSION & CENTERING: 1.5X full screen without distortion.
- DIRECT CONNECTION to vert. CRT plates.
- PHASING CONTROL of internal 60 cps sine wave sweep.
- AT FRONT PANEL: Intensity mod. input; 60 cps, sawtooth outputs.

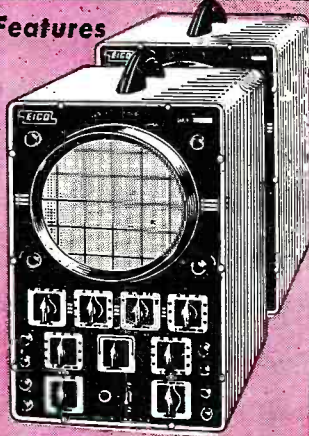

MODEL 470K  
KIT \$79.95. WIRED \$129.50.

0-5 10, 100, 500, 1000 V (30 KV with HVP-1 probe).  
 • 5 ohm ranges from .2 ohm to 1000 megs.  
 • DC input Z 26 megs.  
 • 4 1/2" meter movement in can't-burn-out circuit.  
 • 1% mult. resistors.

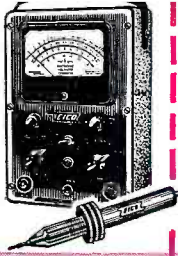

HIGH VOLTAGE PROBE \$6.95  
 • Extends range of VTVMs & voltmeters to 30 KV.

360K SWEEP GEN. KIT \$34.95. WIRED \$49.95.

- Continuous coverage of all TV & FM freqs. from 500 kc to 225 mc.
- Sweep width variable 0-30 mc.
- Crystal marker oscillator, variable amplitude.



CATHODE RAY TUBE CHECKER  
630K, WIRED \$24.95 KIT \$17.95



- Checks all types of TV picture and C.R. tubes in the set or carton. Bridge measurement of peak beam current (proportional to screen brightness).
- Detects shorted & open elements.

214K VTVM KIT \$34.95. WIRED \$54.95.  
249 K P-P KIT \$39.95 WIRED \$59.95

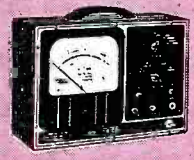

- Large 7 1/2" meter, can't-burn-out circuit.
- AC/DC volts: 0-5, 10, 100, 500, 1000 (30 KV with HV Probe).
- 5 ohms ranges from .2 ohm to 1000 megs.
- DC input Z 26 megs.
- 1% mult. resistors.

Large 7 1/2" meter

950A-K R-C BRIDGE & R-C-L COMP. KIT \$19.95. WIRED \$29.95.

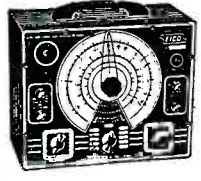

- Measures & tests all resistors; .5 ohm to 500 megohms
- Every type condenser, 10 mmf to 5000 mfd.
- 0-500 DC voltage source for capacitor leakage testing.

EICO EXCLUSIVE! 5" PUSH-PULL SCOPE, 425K, Amazing feature-packed economy-priced

Wired, \$79.95. KIT, \$44.95.

PUSH-PULL V & H amplifiers. Sens: 0.5-1 rms v/in. Useful to 2.5 mc. SWEEP: 15 cps-76 kc. Z-axis intensity modulation. Dual trace positioning controls.



SCOPE VOLTAGE CALIBRATOR KIT 495K KIT \$12.95. WIRED \$17.95.  
 • Sq. wave output at power-line freq. with full-scale readings of .1, 1, 10 or 100 V. peak-to-peak  
 • Accuracy  $\pm 5\%$  of full-scale on each range.

1/2 & 12V BATTERY ELIMINATOR KIT 1050K KIT \$29.95. WIRED \$38.95.

- DC output: 0-8 V or 0-16 V.
- Continuous current rating: 10 A at 6 V, 6 A at 12 V.
- Intermittent current rating: 20 A at 6 V, 12 A at 12 V.
- Separate Voltmeter & Ammeter.



**NOW! ONLY EICO KITS & WIRED INSTRUMENTS Gives You LIFETIME SERVICE & CALIBRATION GUARANTEE\***

\*at less than our cost of handling (See EICO Guarantee Card enclosed with each Kit & Instrument).

BAR GENERATOR 352K, WIRED \$19.95 KIT, \$14.95

- Enables rapid adjustment of TV picture V&H linearity without hard-to-find station transmitted test pattern.
- Produces .16 V or 12 H bars. Operates on TV channels 3, 4, or 5-

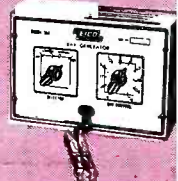

Prices 5% higher on West Coast. Specifications and prices subject to change without notice.

## New! EICO SCOOPS!

232K PEAK-to-PEAK VTVM with DUAL-PURPOSE AC/DC *Uni-Probe* \*  
KIT \$29.95 WIRED \$49.95



Measures directly p-p voltage of complex and sine waves: 0-4, 14, 42, 420, 1400, 4200 V p-p. DC/RMS sine voltage range: 0-1.5, 5, 15, 50, 150, 500, 1500 V. Ohms: 0-1000 megs. 7 non-skip ranges on every function. Calibration without removing from cabinet. Zero center. Freq. Resp. 30 cps-3mc. 1% precision ceramic multipliers. Exceptional stability and accuracy. Compact, portable (7x5x4), smart, rugged.

NEW! UNI-PROBE! Terrific time-saver! Only 1 probe for all functions—a half-turn of probe-tip selects DC or AC-OHMS!

249 K PEAK-to-PEAK VTVM with 7 1/2" METER KIT \$39.95, WIRED \$59.95

944 K FLYBACK TRANSFORMER AND YOKE TESTER  
Kit \$23.95 Wired \$34.95

Tests all flybacks and yokes, in or out of TV set—in just seconds! Detects even 1 shorted turn! Exclusive separate calibration for air—and iron-core flybacks assures utmost accuracy. Large 4 1/2" meter, 3 colored scales. Compact, portable (7 x 5 x 4"), smart, rugged.

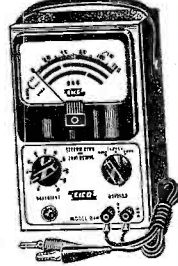

1171K RES. DECADE BOX KIT \$19.95 WIRED \$24.95  
 DECADE CONDENSER BOX KIT 1180K KIT \$14.95 WIRED \$19.95  
 RTMA RESISTANCE SUBSTITUTION BOX 1100K WIRED \$9.95 KIT \$5.50

315K DELUXE SIG. GEN. KIT \$39.95. WIRED \$59.95.

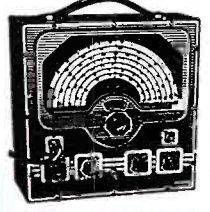

- Covers range of 75 kc to 150 mc.
- 7 calibrated scales: accuracy better than 1%.
- Bandsread vernier tuning.
- 4-step RF shielded output multiplier: constant output Z.

377K SINE & SQUARE WAVE AUDIO GEN. KIT \$31.95. WIRED \$49.95.

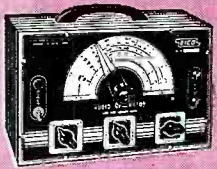

- Complete sine wave coverage, 20-200,000 cps in 4 direct-reading ranges.
- Complete square wave coverage, 60-50,000 cps.
- Cathode follower output circuit.

536K MULTIMETER KIT \$12.90. WIRED \$14.90.  
526K MULTIMETER KIT \$13.90. WIRED \$16.90.



- 1000  $\Omega$ /V; 31 ranges
- DC/AC volts: Zero to 1, 5, 10, 50, 100, 500, 5000.
- DC/AC Current: 0-1, 10 ma; 0.1, 1 A.
- Ohms: 0-500, 100 K, 1 meg.

565K MULTIMETER KIT \$24.95 WIRED \$29.95.  
555K MULTIMETER KIT \$29.95 WIRED \$34.95 (1% precision resistors)



- 20,000  $\Omega$ /V; 31 ranges.
- DC/AC/Output volts: 0-2.5, 10, 50, 250, 1000, 5000.
- DC Current: 0-100 ua; 10, 100, 500 ma; 10 A.
- Ohms: 0-2K, 200K, 20 meg.

145K SIG. TRACER KIT \$19.95. WIRED \$28.95.



- Audibly signal traces all IF, RF, Video & Audio circuits from ANT to SPKR or CRT in all TV, FM, AM, etc. without switching.
- Germanium crystal diode probe responsive to over 200 mc.
- Integral test speaker.

320K SIG. GEN. KIT \$19.95. WIRED \$29.95.  
322K SIG. GEN. KIT \$23.95. WIRED \$34.95.



- Fundamentals 150 kc to 34 mc, harmonics to 102 mc.
- 5-step band switching.
- Colpitts audio oscillator generates 400 cps pure sine wave voltage.
- Permits pure RF, modulated RF, or pure AF.

Write NOW for FREE latest Catalog R-5

Ask your jobber for FREE EICO business building decals.

Separate Assembly & Operating Manuals supplied with each EICO KIT!

You build EICO Kits in one evening, but... they last a lifetime!

SAVE OVER 50%! See the famous EICO line TODAY, at your local jobber.

ELECTRONIC INSTRUMENT CO., Inc., 84 Withers Street, Brooklyn 11, N. Y.



© 1954

By **WALTER H. BUCHSBAUM**

Television Consultant  
RADIO & TELEVISION NEWS

# COMMUNITY TV

*These systems have a potential of 16 million viewers. Here are the cost and other factors involved in their organization and operation.*

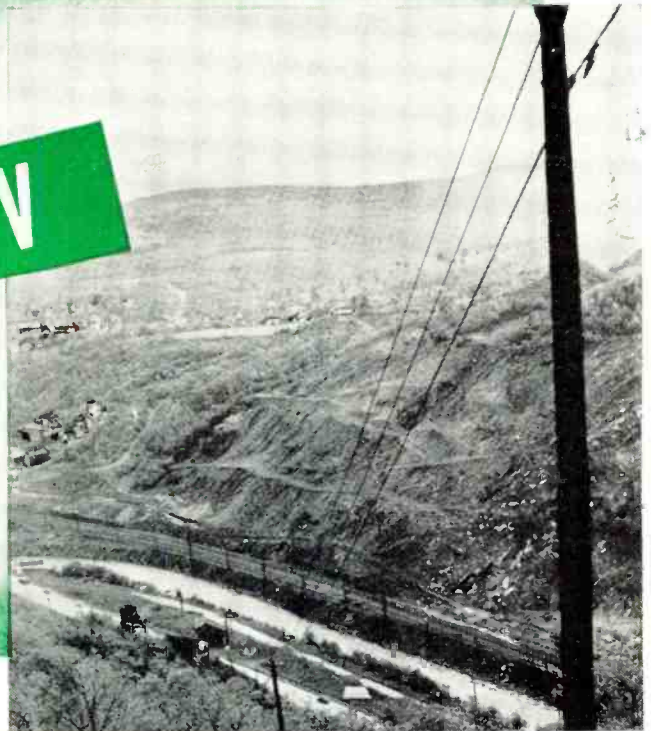

Fig. 1. Above (left), community TV antenna tower with yagi arrays for five channels. (Above) Pole mounted cable from antenna to town.

**W**ARREN, PENNSYLVANIA was a typical small town nestled at the foot of a mountain and unable to receive any TV signals because of this mountain. A little over a year ago a group of enterprising citizens formed the *Warren Community TV Corporation* and soon thereafter over 1000 homes in Warren had the cultural and entertainment benefits from three different TV stations. They can now choose programs from channel 4 in Buffalo, N. Y., channel 6 in Johnstown and channel 10 in Altoona, Pa.

Warren is one of the almost 300 towns and cities currently using a community TV system to bring television reception to over 170,000 Americans. While the growth of community TV was speeded and often caused directly by the long TV station freeze, the thawing out of this freeze since 1952 has not stunted the growth of community TV. As more stations open up, additional small communities have TV reception almost within their grasp and often only a mountain stands between good TV reception and a deadspot. It is estimated that the eventual total of over 2000 TV stations will reach only 90% of our population, leaving over 16 million Americans without TV reception. Obviously this neglected 10% will be a good market for community TV installations and a potential 16 million customers is quite a powerful stimulus for the ever alert electronics industry.

It is no wonder then that there are a dozen firms currently engaged in manufacturing, installing, and servicing community TV equipment. See Table 1. There is even a strong and articulate National Community Television Association, Inc. in Palmerton, Pennsylvania, which is made up of the operators of the various TV systems. The fact that so many of our readers



have inquired about community TV systems and that it has become such an important part of the TV industry prompted us to make a survey of this field. Rather than give detailed technical data on a particular installation, we shall discuss the technical, financial, and legal problems involved in most systems.

Fig. 2 illustrates a typical small town lying at the base of a hill, so far away from TV transmitters or so located that only very poor reception is possible in the town. By locating a tall tower at the top of the obstructing hill, reception from three different TV stations is possible. All that is needed now is to bring the three signals down to the community. The little boxes on the poles are line amplifiers as shown in Fig. 5, and the cable down the mountain may actually look like the installation in Fig. 1. Simple as this may appear, considerable engineering and design time is involved. As a matter of fact, a typical community TV system requires months of calculation, design, and installation. After most installations are completed, additional time is required for optimizing various sections and adjusting the over-all system for satisfactory performance.

Before an installation is considered, both economic and technical factors which determine the feasibility of the project must be known. The following technical data should be available:

1. Number of stations to be received.
2. Frequencies of these stations, their distances, and signal strengths.
3. Antenna location. Usually one location is satisfactory for all antennas,

but occasionally several receiving locations must be used and the signals combined later.

4. Distance from the antenna to the locality served; the availability of power poles from one point to the other.

5. Number and distance of prospective subscribers—distance from each other; number that are ready at once; number of potential subscribers.

6. Future TV station assignments.

7. Availability of power to run amplifiers at various points.

It will be noted that some of these questions also reflect on the economic aspect of an installation since they will determine cost as well as revenue. Other financial problems to be explored concern local licensing, right-of-way for cable locations, cost of the real estate connected with the antenna location, insurance, power, cost of renting phone or power-line poles, local taxes, etc. Compared with the original installation cost of the system, these expenses are rather small and usually do not materially affect the success of an installation.

Expected revenue varies with the number of subscribers and various local factors but, in general, subscribers pay between \$125 and \$150 for the initial installation, and a rental fee of from \$2.00 to \$4.00 per month. Although this may seem high to the average TV audience, the people living in such remote towns would expect to pay at least that for a barely satisfactory tower installation, with subsequent service calls for storm damage, corrosion, etc.

The block diagram of one commu-

Amplitel, Inc.  
362 W. 57th St.  
New York 19, N. Y.

A.R.F. Products, Inc.  
7627 Lake St.  
River Forest, Ill.

Blonder-Tongue Laboratories Inc.  
526 North Ave., Westfield, N. J.  
Community Engineering Corp.  
418 W. College Ave.  
State College, Pa.

Entron Company  
2500 "Q" St., N. W., Washington, D. C.  
Industrial Television Inc.  
369 Lexington Ave., Clifton, N. J.

International Telemeter Corp.  
2000 Stoner Ave., Los Angeles, Cal.

Jerrold Electronics Corp.  
26th & Dickinson Sts.  
Philadelphia 46, Pa.

RCA-Victor Division, RCA  
Camden, New Jersey

Spencer-Kennedy Laboratories Inc.  
186 Massachusetts Ave.  
Cambridge 39, Mass.

Television Transmission Co.  
301 Peru St., Peru, Ill.

Transvision Inc.  
460 North Ave.  
New Rochelle, N. Y.

Table 1. Manufacturers of community television systems and/or equipment.

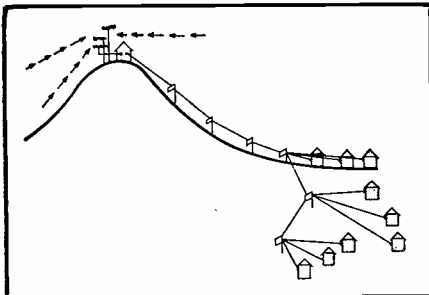

Fig. 2. Simplified diagram of basic community TV system receiving three channels and using pole-mounted line amplifiers.

community TV system is shown in Fig. 3. Three stations can be received here; channel 4, channel 6, and channel 68. Each of these stations is picked up by a double-stacked array (yagis for v.h.f., bow tie and reflector for u.h.f.) tuned and oriented for best signal. The two low-band signals go into channel preamplifiers having five 6AK5 tubes, tuned to provide up to 64-db gain with 6-mc. bandpass. A 6AN5 cathode follower provides the necessary 75-ohm output impedance to match the rest of the installation.

Since cable losses at u.h.f. are quite high and there are no economical and satisfactory r.f. amplifier tubes available for u.h.f., the signal from channel 68 is mixed with a local oscillator signal and converted down to channel 2. At that frequency it is amplified and passed through a cathode follower just like the other signals. All three signals are combined and carried down from the antenna to the town. The cable used is Federal type K-111, which is similar to RG-11/U and is about 5/8 inches in diameter, double-shielded, and has an approximate attenuation of about 20 db per 1000 feet at the low TV band. As a result of this attenuation, the system described here uses a set of line amplifiers every 2000 feet. Each set consists of three separate tuned channel amplifiers having up to 64-db gain. To compensate for variations in signal strength, variations in cable losses, and atmospheric changes, every third amplifier set contains a.g.c. A total of 13 amplifiers are used in cascade between the antenna and the distribution amplifiers.

After the signal reaches the community proper, a series of distribution amplifiers is used to get it to the individual subscribers. To avoid interference with each other, each TV antenna outlet, as well as the branch-off point, contains some attenuation in the form of a resistive pad. While heavy coaxial cable is used to bring the signal down from the antenna, the individual customer's lead-in is regular RG-59/U, and a simple stub-type impedance transformer is used in the home to match 75-ohm cable impedance to the usual 300-ohm receiver input.

The preceding system is just one of the over 300 different ones now in use and while it is typical in its general operation, there are many other types. One variation is the *Blonder-Tongue* system which allows both 75- or 300-ohm connections at the distribution amplifiers and outlet boxes. Fig. 4 shows the model DA8-1 amplifier which has 8 outlets, four on each side, each one of which can be used for 75 or 300 ohms. This amplifier incorporates variable gain control, has over 35-db isolation between outlets, and does not use tuned channel strips but is broadly tuned over the entire v.h.f. TV band. The *Jerrold Electronics* system uses 75-ohm customer outlets and then uses a matching stub of 300-ohm line at the TV set.

Another feature of some installations is the method of compensating for the different cable losses at different channels. In the *Amplitel* sys-

Fig. 3. Block diagram of system receiving two v.h.f. and one u.h.f. channels.

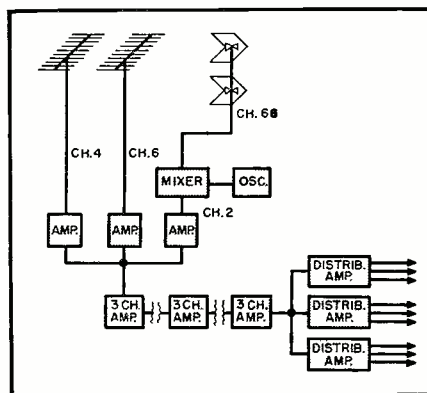

tem used in Warren, the individually-tuned channel amplifiers along the line were so adjusted in gain as to equalize the cable losses. Thus, channel 4 signals were amplified less than channel 6 and much less than channel 10, which has the highest losses. This gain adjustment at each amplifier is quite cumbersome, especially in installations requiring a large number of amplifiers. To avoid this, a line equalizer can be used. This unit contains fixed attenuation and is designed to equalize the losses of 1000 feet of RG-11/U cable.

Other specialized items required for community TV systems are high "Q" interference traps, line splitters, tap-off connections, and line matching transformers. The community TV equipment manufacturers listed in Table 1 supply a complete line of every item needed and while some provide primarily engineering advice, others will plan and supervise an entire installation.

One of the difficulties in long distance antenna installations is the great loss at the higher v.h.f. channels. If at all possible, the first three channels received will be converted to channels 2, 4, and 6 for transmission down the mountain. Channels 3 and 5 are avoided because of the likelihood of adjacent channel interference. When more than three channels are received *Jerrold Electronics* uses a system of lower frequency subcarriers which require much less amplification. Called the "W" and "K" system, the equipment consists of the regular channel 2, 4, and 6 amplifier plus a special oscillator and mixer to convert the additional two channels down to 24-30 mc. and 40-46 mc. This system permits fewer amplifiers for these two channels between the antenna and the town but then requires reconversion up to unused normal channel frequencies before distribution.

One major advantage of this system is its flexibility for existing installations where broadband distribution amplifiers are used and where the addition of a new station can be handled with relatively minor changes in existing facilities. Fig. 6 shows the equipment in a typical 3-channel amplifier shack at the antenna site. By merely adding converter-amplifier strips, a fourth and a fifth channel can be relayed to the subscribers. The four cases at the right contain high "Q" interference traps.

In addition to using channelized amplifiers, some community TV systems employ wide-band line and distribution amplifiers capable of amplifying all TV frequencies in the v.h.f. band. The most recent and most unique installation of this type provides reception on eight v.h.f. channels. Located in the Poconos mountains, the community of Buck Hill Falls, Pa., was within reach of both New York and Philadelphia, but the hilly terrain made reception difficult. The wide-band system installed there by *Spencer-Kennedy Laboratories*, in cooperation with *Philco*, has its anten-

na site on a nearby mountain and receives channels 2, 4, 5, 7, 9, 11, and 13 from New York and channel 6 from Philadelphia. Over five miles of cable have been installed to date and connection of this system to include other nearby communities is planned for the near future.

The Buck Hill Falls installation is unique in that it is the first instance where as many as eight channels are received. Technically this was accomplished by use of wide-band amplifiers which, in a single amplifier assembly, can amplify all twelve v.h.f. channels. A detailed description of this technique appeared in the *Radio-Electronic Engineering* Edition of RADIO & TELEVISION NEWS in April 1950, and the chain amplifiers described therein are in use, with some modifications, in the Buck Hill Falls community TV system.

Because of the difficulties and expense involved in the transmission of signals from the antenna tower down to the distribution network, it would seem that a microwave link might be more economical and convenient. In locations where such distances are appreciable, microwave links are actually used. A typical case is the town of Casper, Wyoming. The nearest TV station is in Denver, Colorado, 240 air miles away. Obviously a cable installation would have been too expensive, especially since the nearest usable signal was received at Laramie, Wyoming, 110 miles from Casper. The solution was a receiving antenna at Laramie and a series of five relay links to bring the signal to the heart of Casper. On January 8th, this year, the people of Casper got their first TV reception thanks to combined efforts and facilities of the *American Telephone and Telegraph Company*, which furnishes and rents the microwave link, and the *Jerrold Electronics Corporation*, which planned the antenna installation and the cable distribution system. Although these facilities are considerable and the distance from Denver far beyond the fringe area, subscribers pay only \$150 for installation and \$7.50 a month rental.

Another instance of microwave relay operation is the installation in Reno, Nevada, which receives San Francisco stations through a single-hop microwave chain. Again *A. T. & T.* furnishes and rents the microwave link, while *Jerrold Electronics* supplied the distribution system and plans. In the case of Reno, the microwave link carries all San Francisco's TV channels and the distribution system employs broadband amplifiers throughout.

Each installation generally requires some individual design, irrespective of the type of equipment used. Local interference, excessive receiver radiation, and many other problems require the close attention of experienced personnel. Once the installation is completed, however, maintenance and troubleshooting are relatively minor problems. There are always defective parts, bad tubes, etc., which can keep



Fig. 4. An eight-outlet distribution amplifier of the type used between the cable and the homes of the various subscribers.

a service technician busy. A typical system contains about 40 separate amplifiers, each having three channel strips of 5 tubes each. This alone adds up to 600 tubes. Since each of the 40 units must also have a power supply, usually regulated, and using about 5 more tubes, there is a grand total of 800 tubes which are potential sources of defects.

Since many of these amplifiers are located away from the town, on poles and in weatherproof housings, their service is time consuming. Although in some smaller installations, local TV service technicians often maintain all or part of the installation, the usual procedure is to employ one or more technicians for maintenance and repair of the entire system.

#### Financial Aspects

One of the outstanding economic facts about community TV is that it is definitely good business. The secondary benefits to the community, especially as concerns the sale and servicing of TV receivers, are quite obvious, but it is not so obvious that community TV is a money-making proposition for the operating group. A typical example of this is the Williamsport, Pa., community TV system. The initial installation costs were \$31,000 of which \$7000 went for a good antenna tower and location. Within a few months of operation, over 1400 subscribers had paid the \$125 connection fee, bringing the income of the community system operators to over \$175,000. So far, most of the operators have been able to claim the connection fee as capital investment and not as income, and therefore as non-taxable. Add to this initial return the \$3.50 monthly rental per subscriber, and it's plain that community TV is really a good, substantial business.

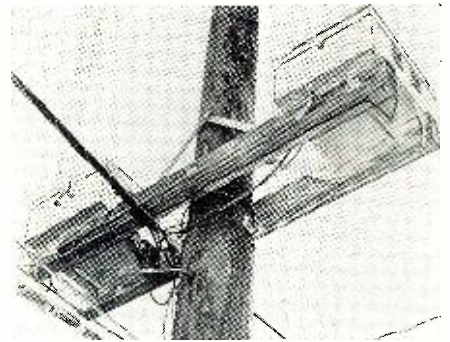

Fig. 5. Pole-mounted line amplifiers used to boost the signal along the cable from the antenna to compensate for line losses.

Needless to say, the equipment manufacturers also charge a legitimate cost plus profit for all engineering work, labor, and material.

The initial investment required will vary greatly with the many different conditions of each installation, but certain rough estimates can be given as to the cost of community TV. The cost of certain fixed assets for the organization, and the cost of the antenna tower and cable must be financed in advance. The fixed assets consist of local office space, engineering survey costs, secretarial, legal, and transportation fees. This may include a truck, some test equipment, and one or more full-time employees. Up to about \$10,000 is usually expended on these items before income is produced.

The cost of the tower and the line to town depends, of course, on many local factors. In general, the major expense at the antenna site is the purchase or long-term lease of the land and the erection of a suitable tower. If it is possible to buy only a small plot at the desired location and also obtain the right-of-way to this site, this item may run as low as a few hundred dollars. The tower itself may cost between \$1000 and \$5000 depending on height and type of construction. Antennas and cables to the amplifier shack cost only a few hundred dollars at most. The amplifier shack and the equipment it contains can vary so greatly in price that this item is frequently an unknown factor until the detailed plans are made. In any event, the antenna amplifier and mixer set up should not exceed about \$5000.

The really expensive item is the cable down the mountain. The cost depends not only on the length of cable required, but also on whether poles belonging to some local utility can be

(Continued on page 122)

Fig. 6. Three-channel amplifier setup in equipment shack of a typical system.

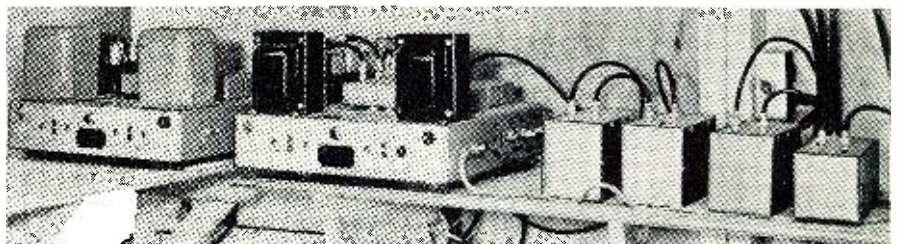

# QUARTZ CRYSTAL ETCHING

By GENE BRIZENDINE, W4ATE



*Non-standard or unusual frequencies can be obtained by etching standard or surplus crystals to desired range.*

**F**REQUENTLY, in experimental and research work, it is found that a crystal of an odd or unusual frequency is required. Placing an order and waiting for the plate to be specially processed is often expensive and time-consuming.

The crystal etching process to be described solves this difficulty nicely, enabling anyone to adjust plates to the desired frequency quickly, and at very little expense.

To explore these possibilities, the author successfully processed five surplus plates which were required to be spaced exactly 100 kilocycles apart in frequency. The crystals used were the type which fit the popular FT-243 holder and are suspended at each cor-

ner by "lands" or raised portions on the holder electrodes. Previous experience in changing the frequency of this type of crystal by grinding, had resulted in decreased activity and, in some cases, output had dropped to zero, in spite of all measures taken to restore activity. In almost all cases crystal operation was unsatisfactory. One cause for this appears to be that the crystals do not receive equal treatment over their surfaces. Another is that particles of both the grinding material and quartz may become embedded in the surface, hampering operation. The etching process removes material uniformly over all surfaces of a good-quality plate, including the edges, which are tedious to finish by

other methods. When taken from the etching solution and rinsed, the plate is very clean. Items required for processing are pictured in Fig. 2.

Before removing the crystals from their holders, they were plugged into a grid-dip meter, instead of the usual coil, to obtain an indication of their original activity. This reading, along with the frequency, was recorded for each plate. The empty holders were immediately closed again, protecting the electrodes from any dust or corroding effect of the air.

Ammonium bifluoride, CP grade, was used for the processing. This material is inexpensive, costing about one dollar per pound, and may be obtained from a chemical supply house. The material should not contact any part of the body and although not highly toxic, the fumes should not be breathed. For these reasons, rubber gloves were used and the actual etching was done out-of-doors. The chemical attacks glass also, and for this reason, the usual container in which it is supplied is wax-lined.

A saturated solution was prepared in a plastic dish, by dissolving all the ammonium bifluoride which would dissolve in one pint of water. The saturation point may be noted when particles no longer will dissolve and sink to the bottom of the container. Preparation of the solution may be speeded up somewhat by stirring and crushing the larger lumps. Etching is possible with a more dilute solution, however the rate will be proportionately slower.

For a "test run", one plate was submerged in the solution, timing being done with an ordinary clock. This means was used to determine the speed of etching to be expected with the particular solution and crystal being processed. After exactly 60 minutes, the plate was removed and immediately rinsed in clean water. After drying, the frequency and activity were measured, again using the grid-dip meter and BC-221 frequency meter. The activity had actually improved and the frequency had increased from the original 4600 to 4603 kilocycles indicating an etching rate of 3 kilocycles per hour. With this figure established, the crystal was brought to the desired frequency easily, by appropriate timing.

It was observed that different crystals of the same original frequency may exhibit widely differing etch rates. For this reason, each crystal was etched "privately," occupying one compartment of the plastic ice cube

*(Continued on page 84)*

Fig. 1. Checking the approximate frequency of plate with BC-221 frequency meter.

Fig. 2. Equipment needed to etch crystals. Ammonium bifluoride, a plastic ice cube tray, rubber gloves, and a frequency meter are needed to perform this operation.

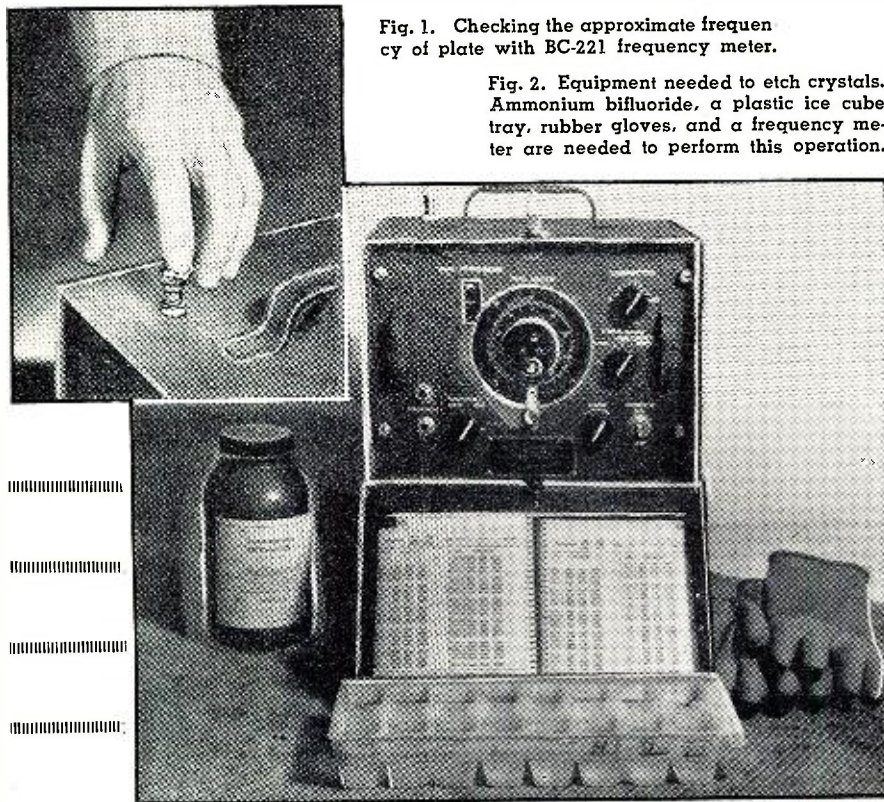

# TRANSISTOR TESTER

By

**H. L. ARMSTRONG**  
Clevite-Brush Development Co.

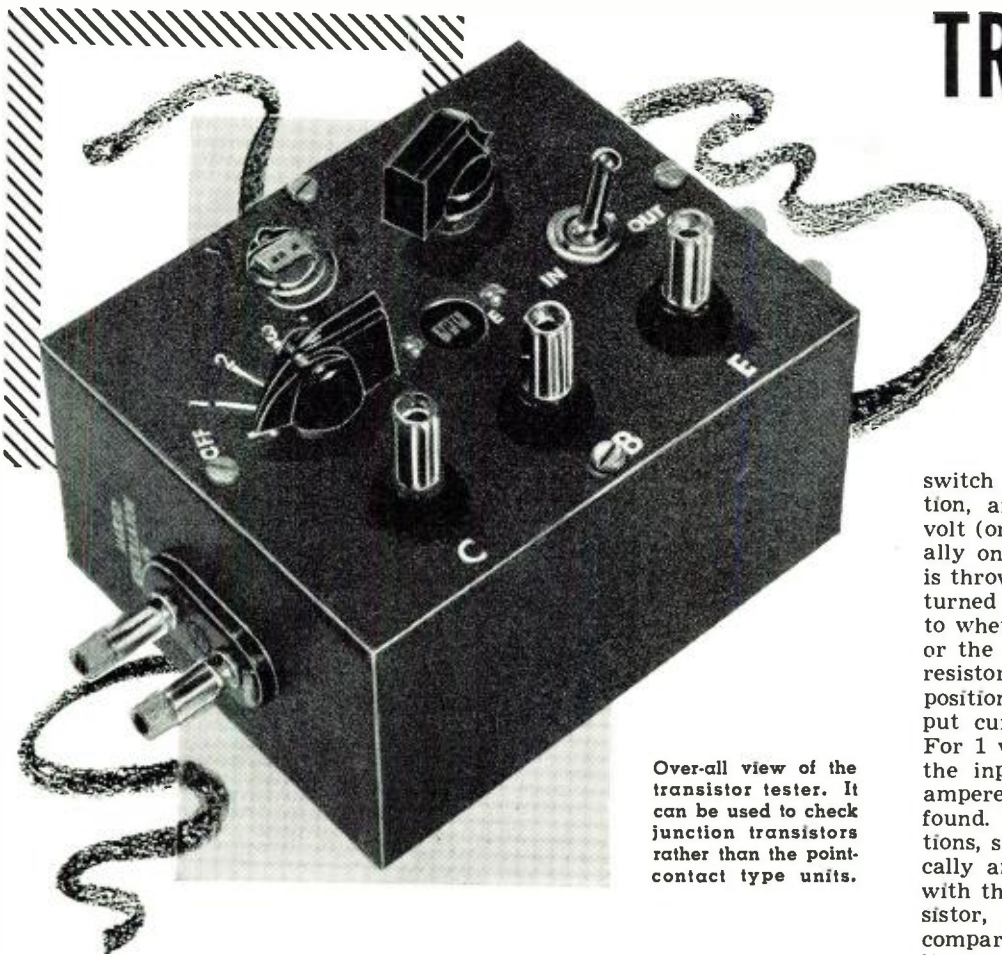

Over-all view of the transistor tester. It can be used to check junction transistors rather than the point-contact type units.

*A simple device for checking transistor current gain.*

*An external signal generator and v.t.v.m. are required.*

switch  $S_2$  is thrown to the "in" position, and the input adjusted to one volt (or some other suitable level, usually one volt is convenient). Then  $S_2$  is thrown to the "out" position, and  $S_1$  turned to position 1 or 3 (according to whether it is desired to use the 1.5 or the 6 volt supply). Since the load resistor is 1000 ohms in either of these positions, the meter will read the output current in milliamperes directly. For 1 volt from the signal generator, the input current will be 10 microamperes; thus the current gain can be found. This fulfills the desired conditions, since the 100,000 ohms is practically an infinite impedance compared with the input impedance of the transistor, while 1000 ohms is negligible compared to the output impedance. The base bias current can be adjusted by  $R_6$ ; it will usually be found that there is some setting for which the gain will be a maximum. When the transistor is to be used in another circuit, the bias current may be chosen so the value is that which gives maximum gain.

Positions 2, 4, and 5 on  $S_1$  do not measure the current gain directly, since the load resistance will no longer be negligible. They were added, however, for checking the behavior when large load resistors are desirable; if, for example, the voltage gain is important.

This circuit has been used only with *p-n-p* transistors. For use with *n-p-n* transistors, it would merely be necessary to change the polarity of the supply.

**N**OW that transistors are coming into more common use, it is to be expected that many will wish to experiment with them in various circuits. It was found useful, at this laboratory, to build a simple circuit for checking transistors before using them.

Since the junction transistor is proving to be most useful in low frequency, audio, and general applications, this circuit is designed for it, rather than the point-contact type. Usually, the transistor will operate in the grounded emitter configuration.<sup>1,2</sup> Then the parameter of most interest is the current gain, defined as the ratio of output current, into a zero impedance load, to input current, from an infinite impedance source. Typical values of this parameter range from ten to fifty. The currents referred to are the alternating signal currents; the direct bias currents are not taken into account. This current gain is the parameter to be measured.

Fig. 1 shows the diagram of the circuit used. Only the actual circuitry associated with the transistor was constructed, and this was used with a signal generator and a high impedance voltmeter, which were readily available.

Either a 1.5 volt or a 6 volt supply can be used; these voltages were

chosen because they are often desirable in transistor applications.

Three ways of connecting the transistor were provided; two sockets (one with equal spacings, one with the collector position widely spaced), also three binding posts for use when a socket is not convenient.

To test a transistor, it is connected in the circuit, a signal generator to the input terminals and a high impedance voltmeter to the output terminals. The signal generator is set at some convenient frequency, say 1000 cycles,

Fig. 1. Complete schematic diagram of the transistor tester. It is battery powered.

- $R_1, R_7$ —100,000 ohm,  $\frac{1}{2}$  w. res.  $\pm 5\%$
- $R_2, R_4$ —10,000 ohm,  $\frac{1}{2}$  w. res.  $\pm 5\%$
- $R_3, R_5$ —1000 ohm,  $\frac{1}{2}$  w. res.  $\pm 5\%$
- $R_6$ —500,000 ohm, 2 w. pot. (with switch  $S_2$ )
- $C_1, C_2$ —1  $\mu$ d., 100 v. cond.
- $S_1$ —S.p. 6-pos. switch (Centralab #1401)
- $S_2$ —S.p.d.t. toggle switch
- $S_3$ —S.p.s.t. switch (on  $R_6$ )
- $B_1$ —Penlight cell (1  $\frac{1}{2}$  v.)
- $B_2$ —4 penlight cells in series (6 v.)
- 2—5-pin in-line subminiature socket (Cinch-Jones 2H5. This type is recommended although different types were used originally. Unused holes can be plugged, if desired, to make these do either for transistors with the RETMA pin arrangement or with equally-spaced pins)

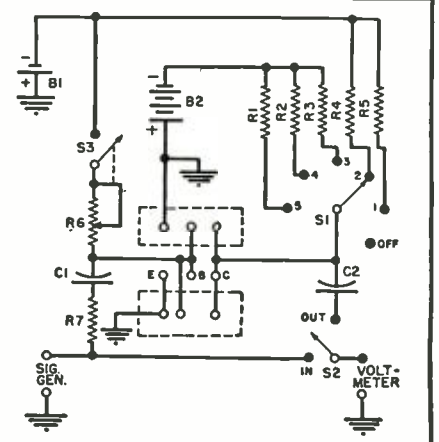

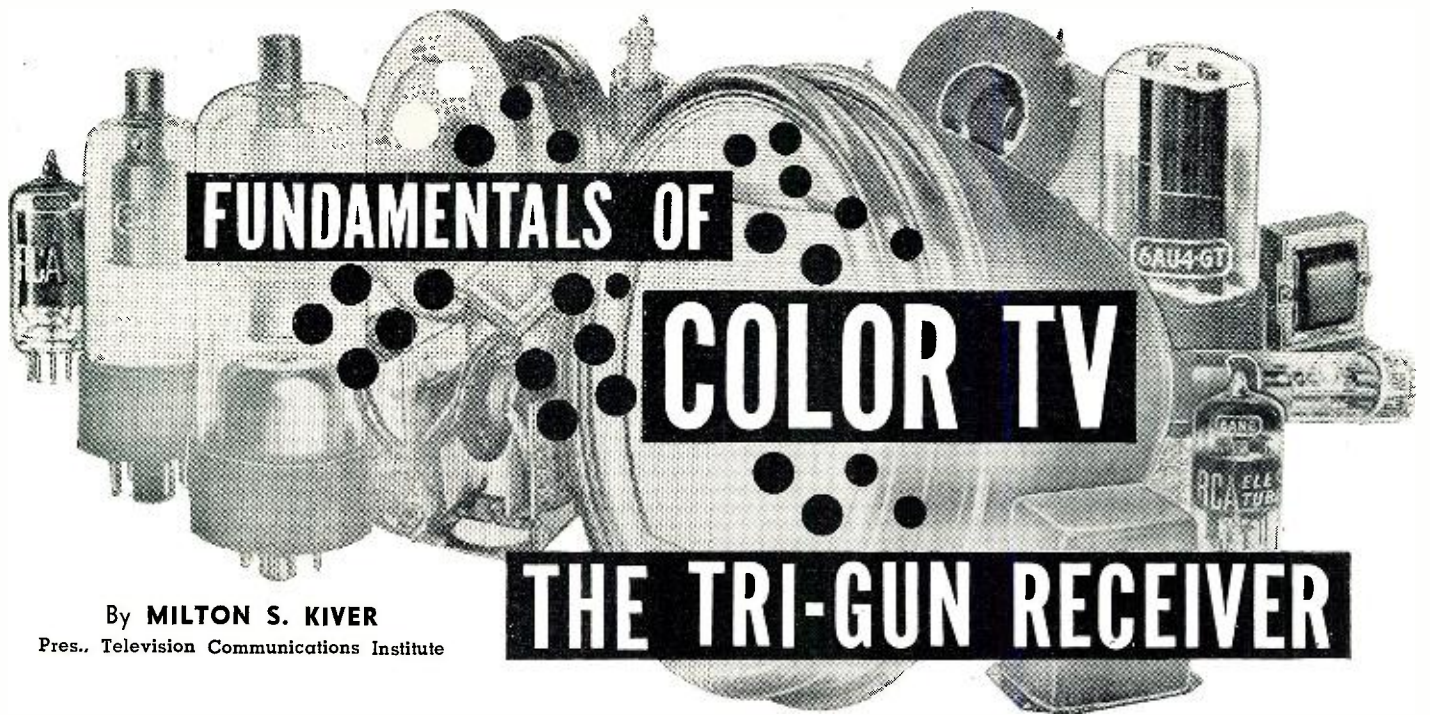

# FUNDAMENTALS OF

# COLOR TV

# THE TRI-GUN RECEIVER

By **MILTON S. KIVER**

Pres., Television Communications Institute

## *Part 3. A general analysis of a color receiver based on the NTSC system. Specific circuitry will be covered later.*

**I**N last month's article we developed the principles of the NTSC color television system. In this and succeeding articles we will examine first the general form of a suitable receiver and then delve more deeply into it, replacing each of the block sections by specific circuits.

Much of the internal circuitry of color television receivers depends upon the type of picture tube used. Thus, you would find circuits in sets using the tri-gun picture tube that would not be found in receivers utilizing a single-gun tube. Of course, the reverse situation would also be true, *i.e.*, there would be stages in a single-gun receiver that have no actual counterpart in the tri-gun set. Since the tri-gun tube is the one that set manufacturers are turning to first, let us start our receiver analysis with it.

An over-all block diagram of an NTSC color television receiver using a tri-gun display device is shown in Fig. 1. The signals captured by the antenna are received by an r.f. tuner which is similar in all respects to the tuners employed in black-and-white receivers. That is, it is capable of receiving v.h.f. signals on channels 2 to 13 and perhaps u.h.f. signals from channels 14 to 82. In the v.h.f. band, an r.f. amplifier is present, together with an oscillator and mixer. For u.h.f. reception, the signal is either converted down to v.h.f. (and then treated as any other v.h.f. signal), or the video i.f. signal is produced directly.

The tuner is followed by a video i.f. system which is somewhat more extensive than the video i.f. systems of monochrome sets in that it usually contains

more stages and its bandpass is somewhat wider. Also, more care must be taken in alignment to see that the response curve possesses the proper shape. However, the layout of the stages, their circuitry, and the use of traps follow the practice established in monochrome receivers.

An a.g.c. voltage is applied to the first few video i.f. amplifiers, as well as to the r.f. amplifier.

The sound take-off point in Fig. 1 is shown as coming from the end of the video i.f. system rather than from the second detector or beyond. This might lead you to believe that a split-sound system is employed rather than an intercarrier system. Such is not the case. An intercarrier system is employed and the reason for positioning the sound take-off in the video i.f. system stems from a desire to prevent undesirable interaction between the sound carrier and the color subcarrier. The two are separated by 920 kc. and unless the sound carrier is kept properly attenuated, a 920 kc. beat will appear on the picture tube screen. To minimize such interaction, the sound carrier is removed at the plate of the last video i.f. stage. This permits the set designer to adjust all of the following circuits so that the response to the sound carrier or to any 4.5 mc. beat which it may produce (after detection) is as low as possible.

In the sound system, the sound and monochrome video carriers are mixed in a germanium crystal diode, producing a 4.5-mc. beat note that contains the sound intelligence of the broadcast. This is followed by several sound i.f. amplifiers, an FM detector, and then

the usual audio amplifiers. See Fig. 2. Again, this follows the practice established in monochrome receivers.

Returning to the video channel, both the black-and-white and the color signals are extracted from the picture carrier at the video detector. (Remember that while the color sidebands have their own subcarrier, they still form part of the over-all video signal. As far as the picture carrier is concerned, color signals occupy the same relative position as any monochrome frequency.) The combined signals, after the detector, are applied to a video amplifier. At the plate of this stage, portions of the signal are shunted to the sync and a.g.c. stages and to a color sync section. See Fig. 3. At the same time, another portion of the signal is taken from the cathode circuit of this tube and applied to the chrominance or color section of the receiver. Still remaining is the luminance or black-and-white signal and this is taken from the plate of the 1st video amplifier and applied to the grid of the 2nd video amplifier through a 1.0 microsecond time-delay network. This is done so that when the luminance and color signals meet again later in the adder or matrix section, they will be in time step with each other. The color signals pass through narrow bandpass filters in the chrominance system and this serves to delay them. By inserting an equivalent delay line in the path of the luminance signal, we keep all segments of the video signal in step with each other.

Two contrast controls are shown in Fig. 3, one in the cathode leg of the 1st video amplifier, the other at the input to the 2nd video amplifier. The units are mechanically ganged together so that the proper relationship is maintained between the monochrome and color signals for all settings of the contrast controls.

The video signal is amplified by the



2nd video amplifier and then fed to the adder (or matrix) section. Here it combines with the various *I* and *Q* (or color-minus-brightness) signals to produce the proper amounts of red, green, and blue voltages.

### Chrominance Section

The function of the color or chrominance section is, first, to extract the color sidebands, second, to attenuate all the remaining sections of the signal and third, to demodulate the color signals so that the original color "intelligence" or voltages are obtained. Here is how this is accomplished. Refer to Fig. 4.

A portion of the total video signal is obtained from the cathode of the 1st video amplifier and fed to a bandpass amplifier. Beyond this stage is a bandpass filter which permits signals from approximately 2.1 to 5.0 mc. to pass, while other frequencies are attenuated. This tends to eliminate all monochrome signals below 2.1 mc. The color information, of course, lies between 2.1 mc. and 4.2 mc. of the video signal.

The bandpass amplifier receives other voltages in addition to the video signal. The screen grid of the tube, for example, receives a negative pulse from the horizontal deflection transformer. This is designed to key the tube off while the color burst signal (on the back porch of each horizontal sync pulse) is passing through the circuit. This prevents the color burst voltage from reaching the d.c. restorers at the output of the chrominance channel and incorrectly shading the background of the color picture. The color burst signal is designed principally for the color synchronization section of the receiver, as will be pointed out presently.

The control grid circuit of the bandpass amplifier also operates in conjunction with a color killer tube. This killer tube biases the bandpass amplifier to cut-off when a black-and-white signal alone is being received. However, when a color signal is present, the color burst just mentioned keeps the color killer tube cut off and this, in turn, releases the bandpass amplifier so that it will pass color signals to the following color demodulators.

The end of the bandpass filter is terminated in a chroma control potentiometer. This control regulates the

amount of color signal reaching the picture tube and, hence, determines the saturation with which the colors will appear. In action it may be compared to the contrast control although there is a master contrast control that regulates the intensity of both the monochrome and color portions of the image simultaneously. The chroma control might be considered as an adjunct to the master contrast control, concerned only with the color portion of the picture.

Beyond the bandpass filter and chroma control, the color signal is fed in equal measure to two demodulators (i.e., detectors). One is called the *Q* demodulator, the other the *I* demodulator. The incoming signal goes to the No. 1 grids of these tubes. At the same time, color subcarrier voltages of about 30 volts peak-to-peak are applied to the No. 3 grids (the suppressor grids). The color subcarrier voltages both possess the same frequency, but one is 90° out-of-phase with the other. This is in accordance with the formation of the *I* and *Q* signals at the transmitter. The beating of this inserted carrier with the *I* and *Q* sidebands recreates the original signals at the demodulator outputs.

The signals from the demodulators now pass through low-pass filters designed, first, to remove the color subcarrier frequency (3.579545 mc.) and the sideband frequencies and, second, to limit the *I* and *Q* signal bandwidths to the values assigned to them at the transmitter. Thus, the output of the *Q* demodulator goes through a 0.5 mc. low-pass filter while the output of the *I* demodulator passes through a 0.15 mc. low-pass filter. The *Q* signal is applied to an amplifier from which positive and negative output voltages are available. The *I* signal goes first to one amplifier which provides one polarity output and then to a second amplifier from which the opposite polarity output voltage is obtained. (The reader will recognize that one tube could provide both positive and negative *I* voltages, if desired.)

All the *I* and *Q* voltages, in proper amplitude and polarity, together with the luminance signal, combine in a series of fixed resistive networks to produce the desired red, green, and blue color signals. After this, each signal is passed through one more ampli-

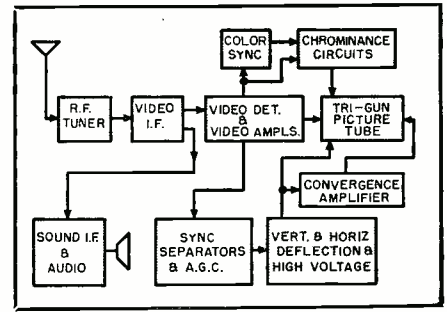

Fig. 1. Block diagram of a tri-gun color set.

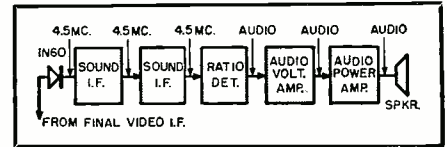

Fig. 2. Sound system of a color TV receiver.

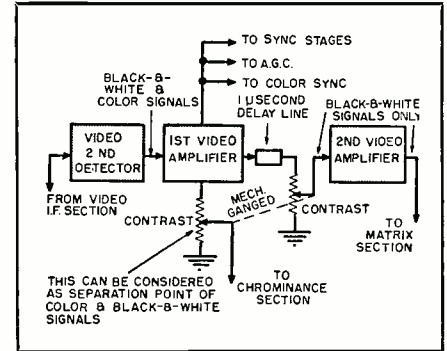

Fig. 3. Block diagram of the video section.

fier and then each is applied to a separate control grid of a tri-gun color tube. Included, too, in this final arrangement, are three d.c. restorers, one each for the red, green, and blue signals.

At the end of this article is a mathematical proof showing how the red, green, and blue signals are obtained by combining the *I*, *Q*, and *Y* (luminance) signals. We suggest at this point, that the reader simply accept the statements previously given.

### Color Sync Section

A portion of the signal at the plate of the 1st video amplifier goes to a stage known as a burst amplifier. This stage is the input amplifier for a special section of the receiver known as

Fig. 4. The chrominance section of a color television receiver. See text for an analysis of block functions.

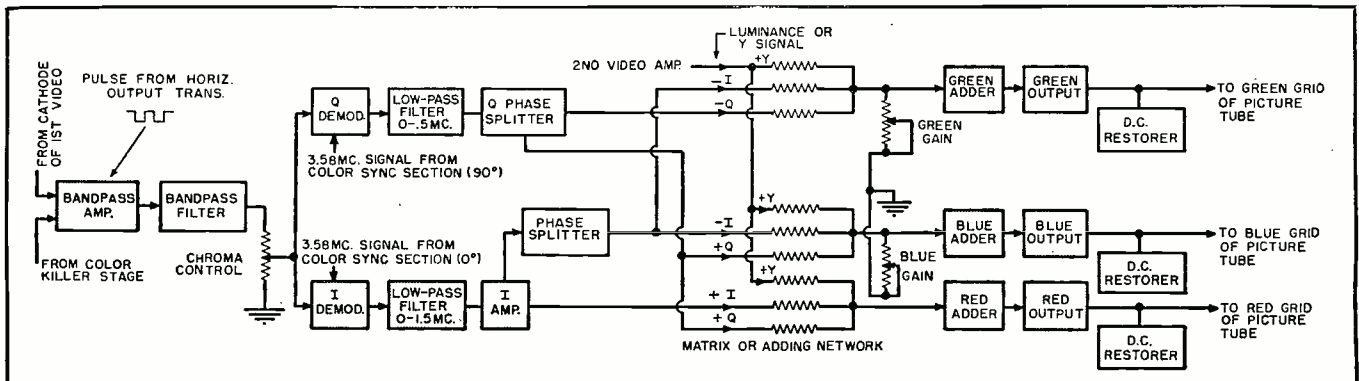

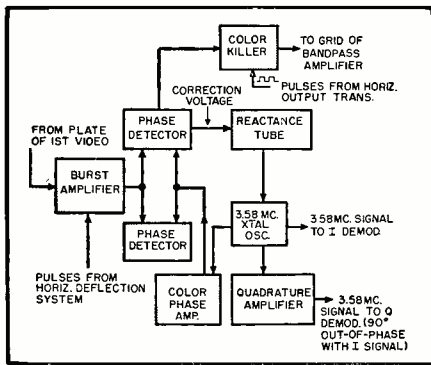

Fig. 5. Block diagram of color sync channel.

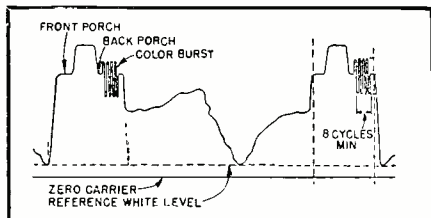

Fig. 6. The color burst on the back porch of each horizontal sync pulse. Refer to text.

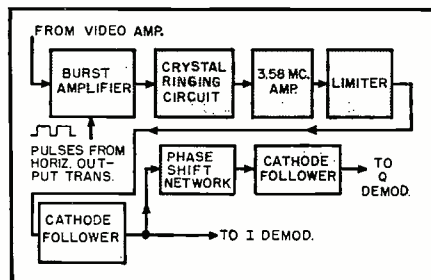

Fig. 7. A crystal ringing circuit for developing a 3.58 mc. signal for use in the I and Q demodulation steps in color receiver.

the color synchronization section. See Fig. 5. The purpose of this section is to utilize the color burst, which is sent along with the horizontal sync pulses, to develop in the receiver a local subcarrier possessing the proper frequency and phase. This is necessary because the color signal, when broadcast from the transmitter, does not possess a color subcarrier. All it possesses are the color sidebands. To properly demodulate the color signal, the carrier must be reinserted and this is one of the principal functions of the color synchronization section.

In order to reinsert the missing carrier properly, the receiver must be given some information concerning the frequency and phase of the missing carrier. This information is provided in the form of a burst of approximately 8 cycles of the color subcarrier which appears on the back porch of each horizontal synchronizing pulse in the composite signal. See Fig. 6.

The burst amplifier is normally kept cut off except during horizontal retrace when it is keyed or triggered into conduction. In this way, all but the desired burst are prevented from passing through this tube. The signal at the output of the burst amplifier is fed to a phase detector. The phase detector also receives a sample of

the signal generated by a 3.58 mc. crystal oscillator. The two signals are compared with each other and any difference in frequency and phase leads to the development of a correction voltage which is applied to a reactance tube. The latter stage, being connected across the oscillator tuning circuit, causes its frequency and phase to change enough to bring the oscillator in line with the received burst.

Output from the I demodulator is obtained directly from the oscillator while a succeeding quadrature amplifier supplies a signal 90° out-of-phase with the I signal. This is fed to the Q demodulator. This quadrature relationship is required because the I and Q signals were originally 90° out-of-phase with each other when the color subcarrier was modulated at the transmitter.

An alternate approach to the development of a suitable 3.58 mc. subcarrier can be achieved by means of a crystal ringing circuit. This system uses a quartz crystal which, when excited by the color burst at the start of each horizontal line, will continue to "ring" or oscillate at its natural frequency (here 3.58 mc.) for the duration of one horizontal line, at least. The burst from the burst amplifier activates the quartz crystal which, because of its extremely high "Q," continues to oscillate with very little decrease in amplitude until the next burst arrives. A trimmer condenser in series with the crystal can change its resonant frequency by several hundred cycles and thus compensate for normal crystal tolerances.

The stage following the crystal is an amplifier stage and the stage beyond that is generally a limiter to smooth out variations in output of the ringing circuit. See Fig. 7. Output from the limiter may be used as one of the 3.58 mc. driving voltages for the I or Q demodulators, while the same output passed through a 90° phase-shift network will provide the reference voltage for the other demodulator.

Note this distinction between these

Fig. 8. Arrangement of the vertical and horizontal stages and the high-voltage system.

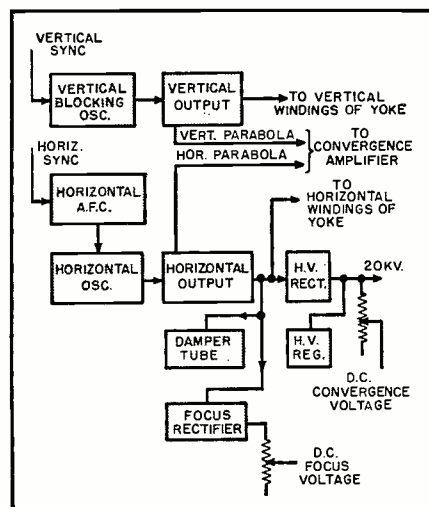

two circuits: In the crystal ringing circuit, no oscillations are generated when no color bursts are being received (*i.e.*, when a black-and-white signal is reaching the receiver). On the other hand, in the automatic phase detector system, a 3.58 mc. voltage is always being developed, even when the color burst is not present.

A color killer tube is included in both types of color sync systems. Its purpose is to prevent signals from passing through the chrominance section when no color signal is being received. This is done to prevent the appearance of spurious color specks on a black-and-white picture.

Much of the remaining section of the color television receiver is similar to the circuits in black-and-white television receivers. The a.g.c. stage, for example, is generally of the keyed variety, receiving a suitable video signal at its control grid and a positive triggering pulse from the horizontal output transformer. The a.g.c. voltage that develops, then, is governed by the amplitude of the sync pulses in the incoming signal.

The sync separator system receives a portion of the composite video signal and then acts to divorce the sync pulses from the rest of the signal. At the output of the sync separator section, the sync pulses are fed to the vertical and horizontal deflection systems through appropriate integrating and differentiating networks.

A block diagram of the two deflection systems and the high voltage section is shown in Fig. 8. For the most part the vertical and horizontal oscillators and output amplifiers follow established practice. Thus, the vertical system uses a blocking oscillator and an output amplifier. The horizontal system possesses an a.f.c. network, a controlled horizontal oscillator, an output amplifier, and a damper tube. A special focus rectifier operates off the horizontal output transformer to develop 4000 volts which are required by the focus electrode on the tri-gun color picture tube.

The accelerating voltage for the picture tube is 20,000 volts and this is obtained by employing one or more high-voltage rectifiers. In addition, regulation of this voltage is desirable to prevent variations in scanning linearity, brightness, and most important of all, picture color. A gaseous shunt regulator tube is one common method employed to stabilize the high voltage. During an all-black picture the regulator absorbs the entire load; during an all-white picture the picture tube takes the load and the regulator does very little.

There is one additional feature of this receiver that requires some explanation and that concerns the horizontal and vertical parabolic waveforms that are sent to a convergence amplifier. These voltages are combined and then placed in series with the d.c. focus and convergence voltages which are required by the tri-

(Continued on page 146)

# THE "LINEAR STANDARD" AMPLIFIER

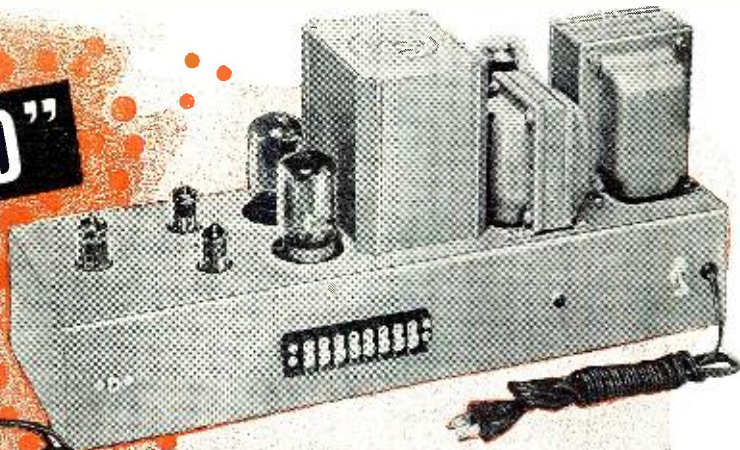
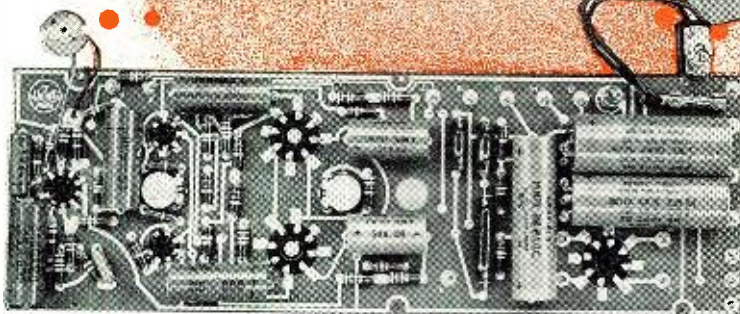

Fig. 1. Top and under chassis views of the UTC "Linear Standard" amplifier kit. Printed circuits are used for easy assembly.

By **JULIUS Z. KNAPP**  
Audio Application Engineer  
United Transformer Company

**A**BOUT a year ago our audio lab was given a project . . . to design an ideal audio amplifier for high-fidelity use. Before we were through, an entirely new concept of high-fidelity amplifier design had emerged.

At the start, we felt that practically all of the distortion in a well-designed, high-fidelity system would be found in things external to the amplifier . . . the recording or pickup distortion that occurs before the point at which signal enters the amplifier, and the distortion that occurs in the loudspeaker system after the signal leaves the amplifier. With this assumption, all that is required is an amplifier with high power handling ability, low distortion, and a frequency response extending four octaves on each side of the audio band. Unfortunately, a thorough investigation brought to light the fact that this did not provide an adequate means for obtaining full high fidelity. Additional requirements had to be placed upon the amplifier to assure excellent over-all performance.

An intensive laboratory program was then started to determine the nature of various distortions. Many tests were made and, after a careful analysis, we were able to find both cause and cure. We found, for example, that extension of an amplifier's bandwidth four octaves below the audio band did not guarantee good low-frequency transient response.

High-frequency oscillation was found to be a second problem. The capacitance in the test speaker leads and speaker system was sufficient to cause high-frequency oscillations in many quality audio amplifiers. These oscillations did not occur when the amplifiers were checked with a dummy resistor load, and being far above the audio range, could not be heard, but their

*A 20-watt multiple loop feedback amplifier that uses standard power and output transformers in its circuitry.*

effect in actual use was substantial, one of the peculiar characteristics of this oscillation being the fact that it would vary from zero to maximum under different signal conditions.

It was realized that a new amplifier circuit would have to be developed to provide the ideal high-fidelity amplifier called for in this project. Incidentally, between the start of this investigation and its completion, over a year's work was involved. Fig. 1 shows two views of the final amplifier design. In Figs. 2 and 3, the circuit diagram and the equivalent block diagram indicate the details of the final design. The evolution of this design and the data showing its characteristics as compared to previous circuitry follow.

We started with the fact that a very high amount of feedback would be required to reach the extremely low distortion levels desired for ultimate high fidelity. In the basic Williamson amplifier the feedback is provided in one step from the output to the input. This approach, in a multi-stage amplifier, results in a peaked response at both ends of the audio spectrum and a narrow margin of stability (Fig. 8). A basic design requirement of our amplifier was to correct this condition and, thus, obtain a much higher order of stability. This was accomplished through the use of multiple feedback loops. In Fig. 3 it can be seen that there are three feedback loops. The first is a local loop within the output stage. The second is a push-pull loop from driver

stage to output stage. The third is an overloop from the output to the input. Twelve db of negative feedback is provided in each loop, thus effecting a total 36 db negative feedback around the output stage. The combined effect of the two inner feedback loops and the phase correcting network in the first interstage, all within the single over-all feedback loop, is to produce an amplifier free from response peaks and positive feedback at either end of the spectrum.

Fig. 4 shows the extremely low intermodulation distortion at all power levels resulting from the large amount of feedback. In Fig. 5 the frequency response curve of this amplifier is shown. The band trimming effect of the phase correction network in the first interstage is evident. Fig. 6, the curve of maximum power output versus frequency, shows the high power levels (0 db = 21.7 watts) that are obtained in a small package using all the component parts and tubes within their specified ratings. Incidentally, the hum level is 80 db below rated output.

Amplifiers with high amounts of feedback are sometimes critical as to components. However, in this circuit the stability is high enough to permit replacing one of the 5881 output tubes with a 6V6 with negligible effect, even though we had simulated extreme unbalance conditions. We also substituted a 6CB6 for one of the 6AU6's to simulate extreme driver unbalance with similar results. Resistors in all por-

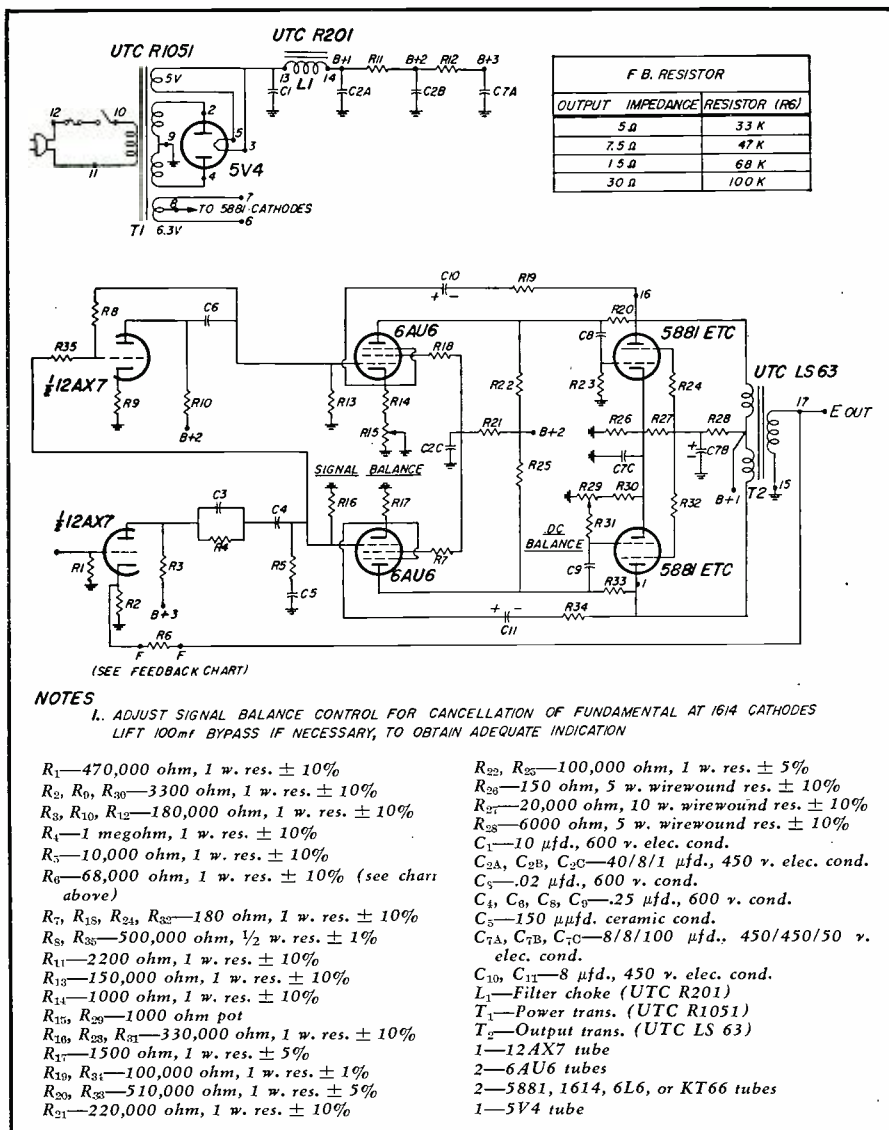
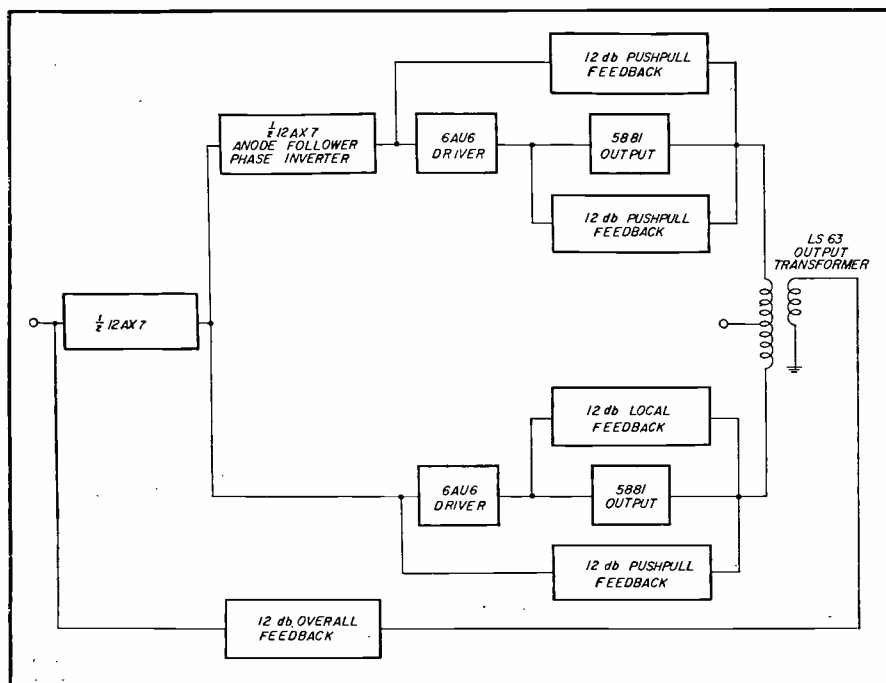

Fig. 2. Complete schematic and parts list covering the UTC Model MLF amplifier.

Fig. 3. Block diagram of amplifier. Other output tubes may be used. See Fig. 2.



tions of the circuit, except the few where precision resistors are employed, were changed by 30%, with no substantial effect on circuit performance.

The flaw in the single feedback system used in the Williamson type amplifier is well illustrated by the curve in Fig. 8. We made circuit variations and substituted transformers made by three manufacturers to assure ourselves that this was a general condition. In Fig. 8 the type and amount of feedback can be read as the difference in level between the curves of raw and net amplifier gain. From the basic definition of feedback, whenever the net amplification is less than the raw amplification, we have negative feedback with its attendant benefits. Whenever the net amplification is greater than the raw amplification, we have positive feedback with its many problems.

The low-frequency positive feedback peak is within the turntable rumble frequency band. For the majority of high-fidelity users who do not employ weighted transcription turntables with hysteresis synchronous motors, this is an important consideration. The positive feedback in the rumble range results in a loudspeaker damping factor fifty times worse than midband with twice the gain for rumble frequencies as compared to music signals. Because rumble has a high energy content, its signal can readily push the loudspeaker cone into a nonlinear portion of its operating characteristic. The result is that the program content suffers serious distortion. This was one of the points which made it necessary to evaluate the over-all system rather than measuring an amplifier on the lab bench.

To measure an amplifier's characteristic under steady state conditions alone is insufficient. However, with step function testing steady state and transient response can be accurately checked. Step function testing is simple, and with its response from d.c. to infinite frequency can be tested. Fig. 7A illustrates the simple apparatus employed. Essentially it consists of applying a sudden, constantly maintained, d.c. voltage. A clock is started at the instant the switch is closed and the graph of Fig. 7B records the result. The leading edge of the step, which is essentially a change in input voltage in zero time, would require an amplifier with an infinite high-frequency limit to reproduce exactly. The amount of time required for the amplifier to respond to this type of signal is called its "rise time." If the amplifier could amplify low frequencies down to d.c., its output waveshape would rise to its final value and stay there until the input step was removed. With an amplifier that cannot amplify d.c., the amount of time the output remains at the flat top of the step is an accurate indication of its amplification at low frequencies. From this we can see that a proper reading of the amplifier's response to the step function will give an accurate picture of the frequency

response of our amplifier to a steady-state signal. Even more important, however, is the fact that this type of testing will show us what the amplifier is doing in the transient period *until* it comes to its final output. In the transient response we can see the relative stability of the amplifier against oscillation, and can deduce the direct and indirect effects on the total music producing system.

Fig. 11A shows the response of the "Linear Standard" power amplifier to a unit step. The faint dot visible on the zero axis is the time at which the step function was applied. It can be seen that there are two distinctly different rates of output signal decay. A glance at the schematic will show that we have a low frequency stabilizing phase lead network ( $C_2$  and  $R_4$  in the first coupling circuit) that is partially responsible for this. The overshoot, that portion of the response below the zero axis, is a basic part of RC coupling circuit pulse response. As is evident, the input pulse is equivalent to closing and opening a switch in the typical interstage circuit of Fig. 10. There would be an initial flow of current after the closing of the switch while the condenser acts as a short circuit. As the charge builds up on the condenser, the voltage across it will reduce the current flow through  $R_0$ , and so reduce the output voltage. The time constant is determined by  $R_0$  and  $C_0$ . When the switch is opened, the charge stored in the condenser will discharge through the circuit resistance ( $R$  and  $R_0$ ) to produce the overshoot. This discharge time constant is determined by  $R_{total}$  and  $C_0$ . We can see that while there is overshoot in Fig. 11A, there is no low frequency oscillation.

Fig. 11A can be compared with Fig. 11B which shows the corresponding step function response of one Williamson-type circuit. By counting the timing cycle peaks, it can be seen that a low frequency damped oscillation occurs, which lasts 3.5 times the length of the overshoot shown in Fig. 11A, and whose initial value is 250% of the maximum value reached in overshoot. This low frequency oscillation (roughly one cycle-per-second) can be induced by commonly encountered phenomena as well as the step function. Sharp volume level changes which occur in program material having large dynamic range will cause this oscillation. The a.c. line voltage variations with their attendant "B+" level changes, switching of preamp or station tuning circuits, and many other transient impulses will produce this type of oscillation. The seriousness of this effect has already been described, and hinges on the fact that at this low frequency oscillation point we have peak-positive feedback, which not only increases the effect of amplifier gain, but the damping factor of the amplifier is more than fifty times worse than at mid-band. It is evident that any substantial amount of low frequency power (this oscillation represents considera-

ble low frequency power) will drive the cone to its mechanical limit. Audio signals superimposed on top of this condition will be radically distorted, since in this displaced position the speaker can no longer duplicate an incoming signal. In other words, while our amplifier in a steady-state resistive load test circuit might show 1% distortion, under this condition of operating use 50% distortion is readily understandable. To minimize this distortion condition, the amplifier must be as free as possible from ringing or overshoot. Only in this way can high-fidelity performance result and listener fatigue be minimized.

Since the birth of high fidelity, there has been a constant movement to provide increased realism in program material. This improvement is represented by a decreased distortion content and an increased dynamic range, further increase of dynamic range being provided through the use of loudness controls that boost high and low frequencies. This results in a strong possibility of amplifier overload at certain passages even when the average loudness is at comfortable level. Under these conditions, we found that amplifier recovery from overload was an important factor to consider in the amplifier design. Fig. 11C illustrates the recovery from overload of the "Linear Standard" power amplifier. The bright line at the top and bottom of the left-hand portion of the oscillogram indicates that clipping is taking place. It is readily seen that the recovery is smooth and free from transient disturbances. Fig. 11D is the same picture with an expanded sweep, to re-examine the time interval close to the signal reduction point, the same 5 cycle timing wave is employed, and it is self-evident that recovery is smooth. Fig. 11E is a comparable oscillogram using a well-known amplifier. In this instance, the recovery from overload shows a low-frequency transient in the output envelope, which is illustrative of the condition producing the large voice-coil movement. This is why there are many comments that the

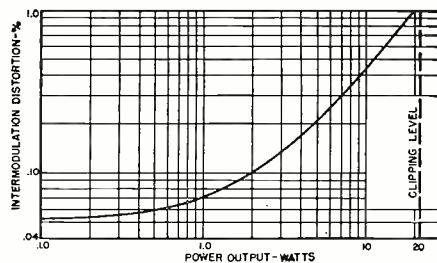

Fig. 4. IM distortion versus power output at 40 cps and 7 kc., mixed 4:1.16 ohms.

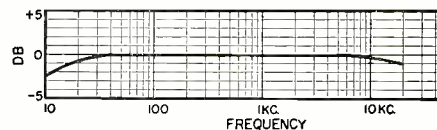

Fig. 5. Frequency response of the Model MLF at 1/2 watt output, 16 ohm connection.

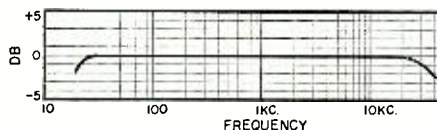

Fig. 6. Maximum power output of amplifier 0 db=21.7 watts, 16 ohm connection. Input is 1.1 volts for maximum output.

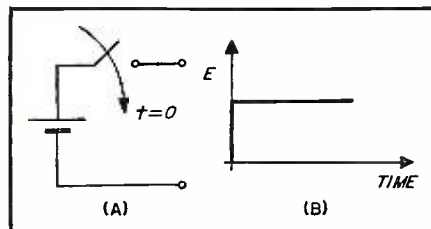
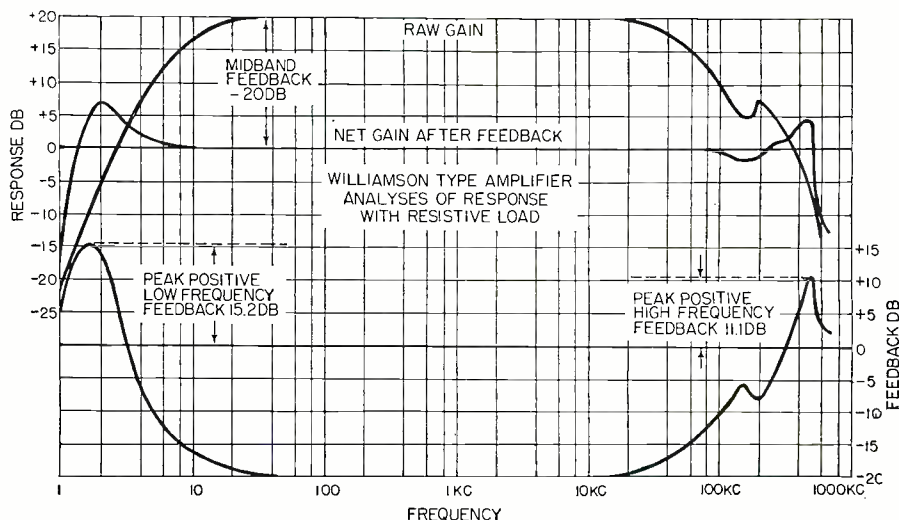

Fig. 7. Step function production and graph.

single-loop feedback amplifier sounds "muddy" on orchestral crescendos.

To investigate amplifier response at high frequencies, we found it necessary to expand the region near the start of the step function. This was accomplished by using square waves in lieu of the step, and adjusting the horizontal scale to exactly 10 microseconds per box with a 10 kc. square-wave input (precisely 10 kc., set with an events-per-unit-time-meter). Using the standard rise time as the time it

Fig. 8. A typical response pattern for a basic Williamson-type amplifier.



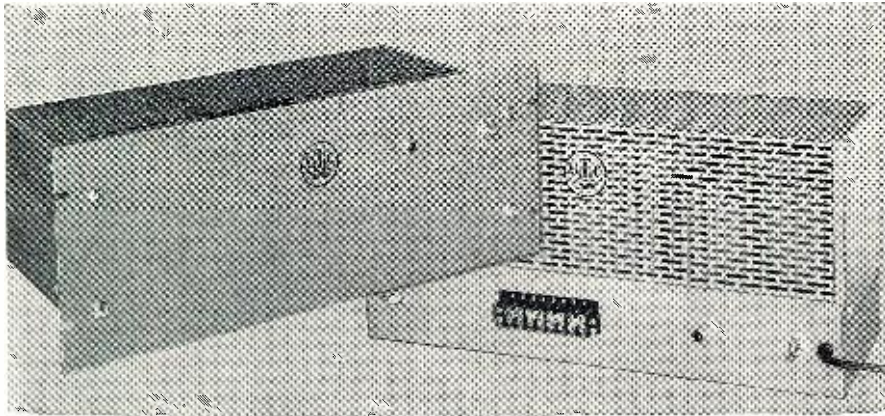

Fig. 9. The commercial version of the "Linear Standard" amplifier comes complete with dust cover as shown. If desired, it can be easily adapted for rack mounting.

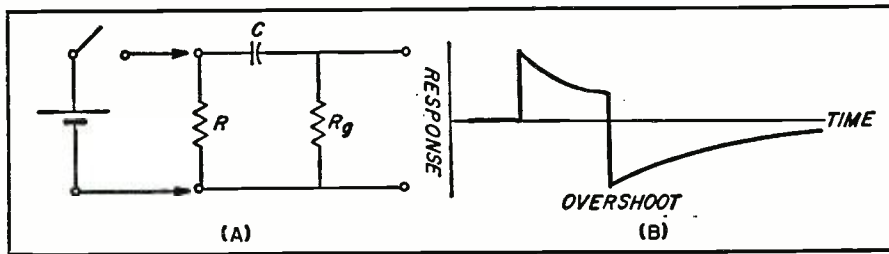

Fig. 10. Typical interstage and its pulse response for any RC amplifier.

takes to go from 10% to 90% response, we can see from Fig. 11F that the "Linear Standard" power amplifier has a rise time of 6.6 microseconds, which is adequate for any acoustic waveforms that can be encountered. Reading the flat top of the wave, we find a transient oscillation, but of very small magnitude and highly damped. This rise time has been set in the design of the phase lag network ( $R_g$ - $C_s$ ) so that with the 36 db multiple feedback system, stability against oscillation with any type of load has been effected. Fig. 11G shows a similar square-wave oscillogram with a widely used hi-fi amplifier. Here the rise time is unnecessarily shorter, since it is not required for audio fidelity, but the increased bandwidth results in

poor stability. A close inspection of the flat top in this figure shows a persistent r.f. oscillation. Fig. 11H is an expansion of this flat top showing the extent and seriousness of this ringing. The lead and speaker system capacity of a typical high-fidelity amplifier load was measured and found to be on the order of .0025  $\mu$ fd. and greater. Fig. 11I was obtained by loading the amplifier with this amount of capacity in addition to its resistive load, and it can be seen that the amplifier is close to ultrasonic oscillation. Under test it was found that the actual frequency of oscillation depended, in addition, on circuit capacities and the output transformer used. Over the range of tests tried, this oscillation frequency was found to be anywhere from 25 kc. to

490 kc. Further tests were run to determine the effect of this oscillation. As shown in Fig. 11J (signal freq. here is 1 kc. and the oscillation freq. is 485 kc.), if the oscillation is not too great the waveform distortion is comparable to that found in table model radios at peak output. Further investigation indicated that the basic Williamson amplifier could oscillate on zero audio signal, and then as audio signal was injected, oscillation amplitude would decrease on negative peaks and finally disappeared at peak signal input. This is shown in Fig. 12, where the audio signal input was raised from zero to maximum in four steps until the r.f. oscillation disappeared. A possible explanation for this variable stability may lie in the fact that the output tube  $g_m$  cannot be considered constant at high signals, but must be considered as varying through the signal cycle.

We have indicated that loudspeaker systems, as used, represent loads with substantial capacity. While at first thought this would not seem so, in practice we find this to be true, particularly with the remote multiple speaker installations so commonly used. Cable capacities run from 40 to 80  $\mu$ fd./ft. and the shunt capacities per speaker range from 50 to 150  $\mu$ fd. With the "Linear Standard" amplifier this is of no particular consequence because of the excellent stability that it provides.

It is easy to sum up the radical step that this new amplifier provides in high-fidelity design. For quite some time, it has been realized that good transient response is an essential for high-fidelity reproduction. The approach heretofore was to extend the amplifier bandwidth far beyond the region of audio use, with the feeling that an amplifier whose bandwidth is so much greater than the audio band must have good transient response at the center of the band. In other words, the center of the band repre-

(Continued on page 113)

Fig. 11. (A) Step function response of the Model MLF and (B) a Williamson amplifier. (C) Overload recovery of the Model MLF and (D) with expanded time scale. (E) Overload recovery of a Williamson-type unit. (F) 10 kc. square-wave response and rise time of Model MLF and (G) Williamson-type. (H) Expanded scale square-wave top Williamson-type amplifier. (I) Square-wave ringing with capacitive load Williamson-type. (J) A Williamson-type amplifier in high-frequency oscillation.

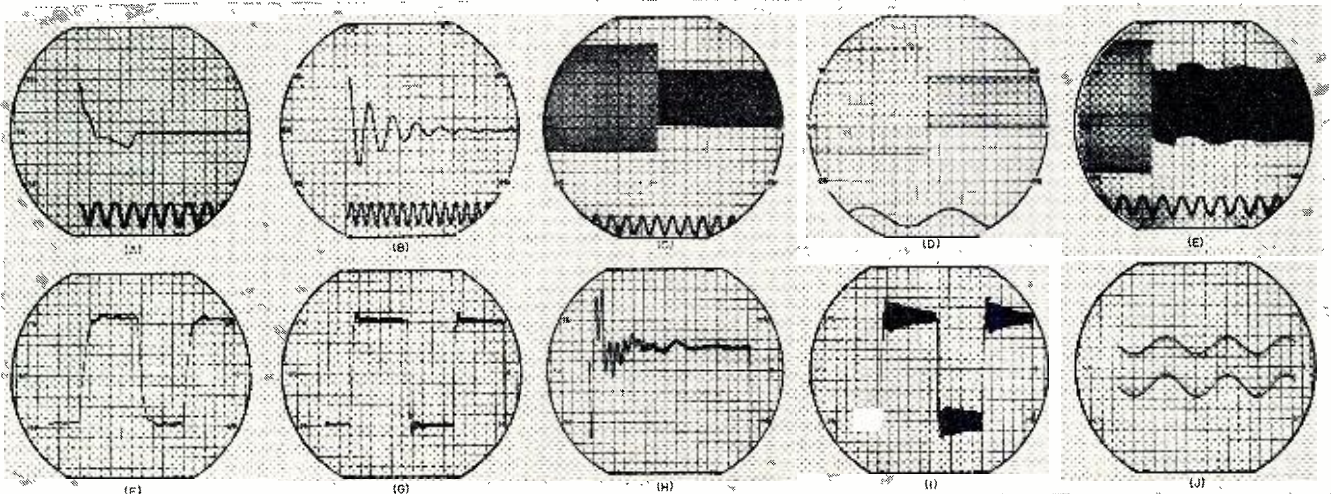

# HALF-WAVE RECTIFIER CIRCUIT

By  
J. T. CATALDO

International Rectifier Corporation

*How to calculate inverse peak voltages in half-wave rectifiers. The method described is fast and simple.*

THE simplest arrangement for rectification of a.c. is the single-phase, half-wave circuit. In the simple half-wave circuit, only one-half cycle of the input voltage is utilized for rectification. The other half-cycle is blocked by the high reverse resistance of the rectifier. In order to maintain current flow during the non-conducting half cycle, an electrolytic condenser is generally employed across the output terminals of this circuit. This condenser serves to increase the available d.c. output voltage and also results in decreased ripple voltage. The most popular circuit, using a selenium rectifier, is shown in Fig. 1A.

While the theory of half-wave rectification has received some analysis in standard radio textbooks, such discussions either treat the subject in a general descriptive manner or present mathematical formulas whose application to the practical case is involved and tedious. In such cases, the assumption is made that the resistance of the rectifier and the supply line are negligible compared with the load resistance. This is not the case under some conditions of use and it is felt that the following graphical presentation with simple formulas will aid the average persons confronted with this problem.

Some electronic engineers and technicians do not appreciate the special consideration required in the design of a selenium rectifier for operation in a half-wave circuit using a condenser as a filter. It is believed that this condition was probably brought about by the rating system used for radio and TV selenium rectifier stacks. These rectifier stacks are usually referred to as having a voltage rating of 130 volts r.m.s. maximum. This voltage rating, however, is predicated on the use of the selenium rectifier with a capacitive filter. The condenser, when charged, imposes a higher reverse voltage on the selenium rectifier.

It is believed that a simple analysis of the operation of a half-wave circuit will aid the reader. Accordingly, when the upper terminal in Fig. 1A is positive (during the conducting half cycle), the condenser, *C*, charges to near the peak voltage. The magnitude of this peak voltage is:

$$E_c = 1.41 (E_L - E_D)$$

where:  $E_L$  = r.m.s. line voltage (117 volts)

$E_D$  = r.m.s. voltage drop across resistor and rectifier

The voltage drop across the resistor and rectifier,  $E_D$ , equals zero on open circuit conditions. Therefore, condenser *C* will charge to the peak value of the input voltage, or 165 volts. When the lower terminal is positive (on the non-conducting half-cycle), the rectifier has to block the full peak line voltage. In considering the polarity of the condenser voltage and the line voltage, it can be seen that these two voltages are in series with the rectifier. It is considered advisable to add the peak voltages, since one voltage is d.c. and the other is an r.m.s. voltage. Then, for open circuit conditions, the rectifier has to block the sum of these two voltages, or twice the line voltage, shown as *A* in Fig. 1B. This summation is:

$$E_p = E_c + E_L$$

where:  $E_p$  = total peak voltage, *A*

$E_c$  = condenser voltage

$$E_p = 1.41 \times 117 + 1.41 \times 117$$

$$E_p = 330 \text{ volts peak}$$

The standard radio and TV selenium rectifier stacks are rated for 380 volts peak and, consequently, they will adequately block this reverse voltage of

330 volts. An equivalent circuit demonstrating this condition is given in Fig. 1C. In this circuit, both the peak line voltage and the no-load capacitive voltage are replaced by batteries.

It should be noted that under load conditions, the condenser starts to discharge through the load during the non-conducting half cycle. This condition is graphically shown in Fig. 1D. The waveform shown was duplicated from an oscillogram taken with an *International Rectifier* Type RS75E connected in the circuit shown in Fig. 1A. With load current flowing, a voltage drop exists across both the resistor *R* and the selenium rectifier. This voltage drop is approximately 7 volts r.m.s., making the voltage available after rectification 110 volts r.m.s. The condenser will then charge to  $110 \times 1.41$  or 155 volts. During the non-conducting half cycle, no voltage drop exists across the rectifier or resistor. Consequently, the magnitude of the total peak reverse voltage can be determined as follows:

$$E_p = E_c + E_p$$

(Continued on page 106)

Fig. 1. (A) A simple half-wave condenser input rectifier circuit. (B) Waveform of the output voltage under open-circuit conditions. (C) Equivalent circuit showing peak voltages across rectifier during non-conducting half cycle. (D) Waveform of the output voltage under load condition. See text for discussion.

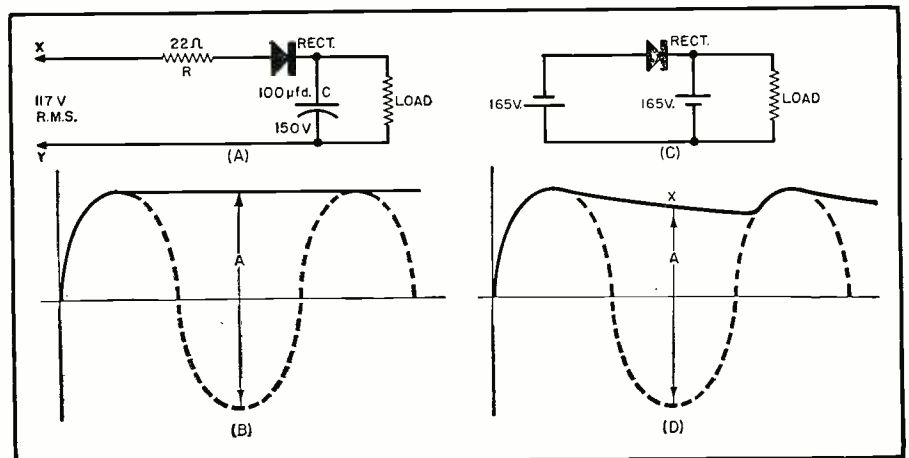

# Certified RECORD REVUE

By BERT WHYTE

ONCE upon a time there was a music lover (of sorts) named Joe Dolt. Now Joe was just like any other red-blooded American male, except that he was one of the most determined cusses who ever lived. Joe's living room was equipped with an imposing model of a "Magna-Squeak Mahogany Monstrosity," combination AM-FM-TV-Phono, with triple-track, heat-hardened aluminum screen and storm doors. Joe was happy with this boon companion of his, and would while away the hours, indulging in his passion of listening to old English madrigals. One day he visited a friend of his who had just acquired a *high-fidelity phonograph*. This was the turning point in Joe's life. *Never*, no never, had he heard quality like this. He was stunned. He plied his friend with eager questions. How long has this been going on? Where did you get this marvel? How much did it cost?

Armed with the answers, Joe hocked his wife's jewels and a couple of his mother's old glass eyes, and hied himself to the nearest audio emporium. Joe's unhappiness and the beginning of his psychosis had its roots here. The clever salesman let Joe listen to the same outfit that his friend had, and then casually called Joe's attention to a complex instrument panel that looked like it had been swiped from a B-36. Full of mysterious flashing lights and push-buttons and toggle switches. "You see," the salesman glibly explained, "with these buttons and switches you can put together any number of different amplifiers and speakers and pickups and you might hear something you like better." Well, Joe bit for this and soon was punchy from punching buttons. Enraptured, he would shout, "Wow! Listen to the *highs* from this tweeter!" Or, "Man, you hear that triangle?" (The use of a question mark after this last statement is rather superfluous, since the triangle was sounding off like the bells of the Kremlin.) After being led quietly but firmly away from the magic punch-board, Joe plunked down his dough for a *hi-fi* outfit a few notches above the one owned by his friend, but not quite the outfit Joe really wanted, but couldn't afford. In a burst of feverish activity, Joe assembled his pride and joy and then the

*great moment* came when he put the pickup on an organ record someone had recommended, and *high-fidelity sound* filled the house and heart of Joe Dolt! Ecstatically Joe listened, but gradually a frown crept across his face. Something was wrong! Joe was puzzled, but not for long. Of course! How stupid of him. There simply wasn't enough gain. Suiting words to actions, in a few moments a stupendous roar filled the house and a mighty organ, ten times larger than life, was born. The rafters quivered and shook, the termites surrendered and took off, local seismographs were oscillating wildly. Inevitably there was hue and alarm, and the fire engines and the police arrived. Joe and these assorted visitors had a real hoe-down. Joe was adamant, he was. "Man's home is his castle and concert hall and that is that."

It wasn't too long before Joe realized that he had made a mistake when he bought this particular hi-fi outfit. "Just not good enough, that's all. It's the intermodulation that's annoying the neighbors, not the volume." So after spending the morning at the bank arranging a mortgage on his house, Joe was again ensconced before the magic punch-board, and this time he shot the works and bought the *very best* hi-fi set in existence. And bedlam reigned in Joe Dolt's neighborhood. The very air thrummed and throbbled with the mighty power of the Philharmonic, grown gargantuan by 200 watts, "full out!" Joe gave up his madrigals and discovered Stravinsky. One nerve shattering day he brought home a copy of Varese's "Ionization," and from then on you couldn't tell whether the fire engines were coming to Joe's house or had taken up permanent residence there. You would think by this time that Joe was finally satisfied. But no. The highs were bothering him, or rather the lack of them. Told that he had the most advanced tweeter the art had yet produced, this stopped him—for awhile. As I said before, Joe was a very determined cuss. He started to study electronics and machine shop practice. He learned all the intricacies of music and acoustics. And he built

tweeter after tweeter. Still nothing satisfied him, and the nights were made hideous with the roar of his experiments. He discovered that a human being cannot hear high frequencies above a top limit of 20,000 cycles, but that dogs could hear much higher than this. As I said, Joe was a determined cuss. He went to one of those islands in the South Pacific populated exclusively by wild dogs, and lived among them for some time to acclimate himself to their way of life and to learn the secret of their superior hearing. By the time Joe left the dogs, he had not only learned to hear like them, but he could converse with them as well. Joe was getting near his goal, but he wasn't finished yet. He went to medical school and studied anatomy and physiology and histology, paying particular attention to the mechanism of the inner ear, the auditory nerve, the connecting ganglia, and the audio-sensory sections of the brain. Armed with this imposing fund of knowledge, he began to dissect the hearing apparatus of dogs, thereby calling down the wrath of the anti-vivisectionists on his head. Nothing daunted, Joe plunged ahead in his pioneer work. Finally, Joe knew success. Some magic amalgam of all his vast knowledge of electronics and engineering and music and medicine, had produced at last—the perfect tweeter!

You wouldn't know Joe Dolt's neighborhood these days. The sun smiles brightly, children play in the streets once again, all is quiet and serene. Joe? He is as happy as a pup. You see, he invites in a group of the local wags (Ouch!) and records them in original compositions of his own, such as "Concerto for Canine Chorus." Then man and dog, they sit back happily and listen to the playback over the perfect tweeter which they alone can hear, and all is quiet without.

The moral of this fable is that you can have too much of a good thing!

Equipment used this month: *Pickering* arm and cartridge, *Rek-O-Kut* T12H turntable, *Fisher* "Master Audio Control," *McIntosh* 30-watt amplifier, *Jensen* G-610 "Triaxial" speaker in *Jensen* corner folded horn enclosure.

## STRAUSS, RICHARD SALOME

Malburga Wegner, soprano; Georgine von Milinkovic, mezzo-soprano; Laszlo Szemere, tenor; Josef Metternich, baritone; and Waldemar Kmentt, tenor; with Vienna Symphony Orchestra conducted by Rudolph Moralt. Columbia SL-126, NARTB curve, Price \$11.90, two discs.

This recording came as something of a surprise to me, since I had heard that Dimitri Mitropoulos was to conduct "Salome" at the Metropolitan next season, and I naturally assumed that *Columbia* would issue a recording of the event. Well, whatever the reason, this recording is indeed welcome. The only other recording available is on the *Oceanic* label and while it has its good moments, leaves much to be desired. This is an altogether

(Continued on page 129)

The opinions expressed in this column are those of the reviewer and do not necessarily reflect the views or opinions of the editors or the publisher of this magazine.



# THE GROUND PLANE GROWS UP

By WILLIAM H. HARRISON, W6ULD

*A new slant on a ground plane antenna that increases efficiency on higher frequencies.*

**D**URING the past few years a great deal of interest has been centered on the quarter-wave ground-plane antenna. As many know, the important advantages of this type of antenna are low-angle radiation, ease of feeding, small space requirements, and relatively low cost. The purpose of this article is to show how it is possible to further improve the antenna by doing nothing more than going straight up a few more feet.

We will first consider the angle of radiation. Most transmissions on 20 meters take place at angles between 6 and 17 degrees, 15 meters between 4 and 14 degrees, and 10 meters at angles below 10 degrees. Anything above these angles is useful only for short skip contacts. How many of you have had difficulty working those DX stations but find that you have obtained excellent reports during short skip sessions? The reason is that the antenna is radiating a good portion of the power at the higher angles. The quarter-wave vertical antenna radiation pattern follows quite closely a cosine curve from the horizon and concentrates much of the energy at the low angles; however, at angles over 20 degrees there is still a great deal of energy radiated that is of little value. The antenna to be described is non-directional and tends to concentrate practically all of the radiation below 20 degrees. The vertical plane pattern is quite similar to that of a well designed rhombic. As the height of a quarter-wave antenna is increased, the energy radiated becomes more concentrated at the lower angles. This continues with increased height to  $\frac{5}{8}$  wavelength ( $.625\lambda$ ), as may be seen in Fig. 2. If the length is further increased, some of the energy in the low angle lobe begins to form in a lobe at a much higher angle, and power at the desired angle is lost. With the  $\frac{5}{8}$  wave radiator a small high-angle lobe is present, however it is a relatively small portion of the total radiated energy. Information taken from the "FCC Standards of Good Engineering Practice" indicates that maximum radiation along the horizontal takes place with a  $\frac{5}{8}$  wave radiator.

Let us now consider feeding the  $\frac{5}{8}$  wave radiator. The quarter-wave vertical antenna may be fed directly with

Fig. 1. The six-foot parabolic reflector, mounted on the side of the building, is used to illuminate an antenna under measurement. A  $\frac{5}{8}$  wave vertical is mounted in center of ground plane. The complete assembly is rotated from inside the building where pattern is recorded. The antenna laboratory is located on top of Mt. Lee in Hollywood, 1900 feet above sea level from which level it is possible to make radiation measurements with minimum disturbance due to surrounding terrain or structures. See text for discussion of the results obtained during antenna tests.

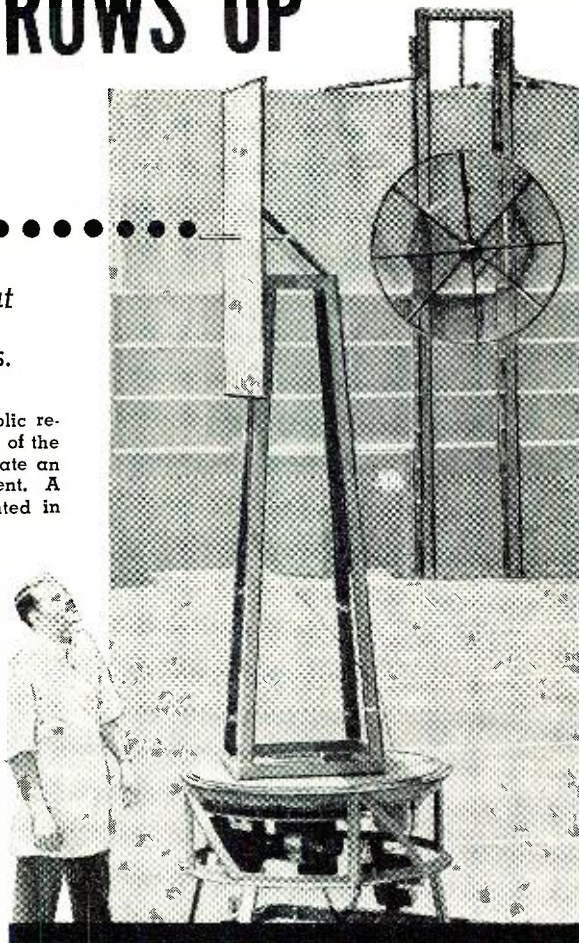

52-ohm coax because it has a base resistance of 40 to 50 ohms and a fairly low reactance. Measurements made on several such quarter-wave antennas indicate that they can be fed directly and will maintain a standing wave ratio on 52-ohm coax of about 1.5. As the height is increased the base resistance of the antenna increases to a point around  $.42$  wavelength where it reaches a maximum and then decreases with a further increase in height. At a height of  $\frac{5}{8}$  wavelength the base resistance is again near 52 ohms, which makes it simple to feed. The resistance and reactance curves shown in Fig. 3 indicate the impedance for various heights of radiators and points of actual measurement.

The  $\frac{5}{8}$  wave antenna on 20 meters is approximately 44 feet and measurements were taken on either side of this value. It was found that the base impedance is slightly higher than indicated in various texts possibly because of a difference in base capacities or antenna cross-section dimensions. The height was increased to 47 feet where the resistive component is 50 ohms, making this a desirable height. The measured reactance is low at this height (60 ohms capacitive) which can be tuned out by a small series coil as indicated in Fig. 6. If the coil is not used the system will still work favor-

ably as the measured standing wave ratio is only 1.5 to 1. By using the little coil, in series with the coax feeding the base of the antenna, the v.s.w.r. was reduced to approximately 1.05 to 1.

When working an antenna against ground, the ground system is very important. Broadcast stations are required to install a ground system of at least 120 radials  $\frac{1}{4}$  wavelength or greater. The main reason is to provide maximum radiation at the ground level. Without the extensive ground system much of the energy radiated at the extremely low angles is lost in absorption. In this case low angles are meant to represent those below 5 degrees. While we as hams are not particularly interested in such low radiation angles, yet it is necessary to work the antenna system against ground, and the better the ground system the less energy will be lost. At our former home in Tempe, Arizona, I installed a ground system in the back yard before the grass was sown. It consisted of 120 radials 35 feet long, using #16 galvanized iron wire.

The wires were buried 1 to 2 inches. This task wore out two hoes and the neighbors' curiosity. The coax line was buried at the same time making a neat installation with only the vertical antenna and mount showing above the

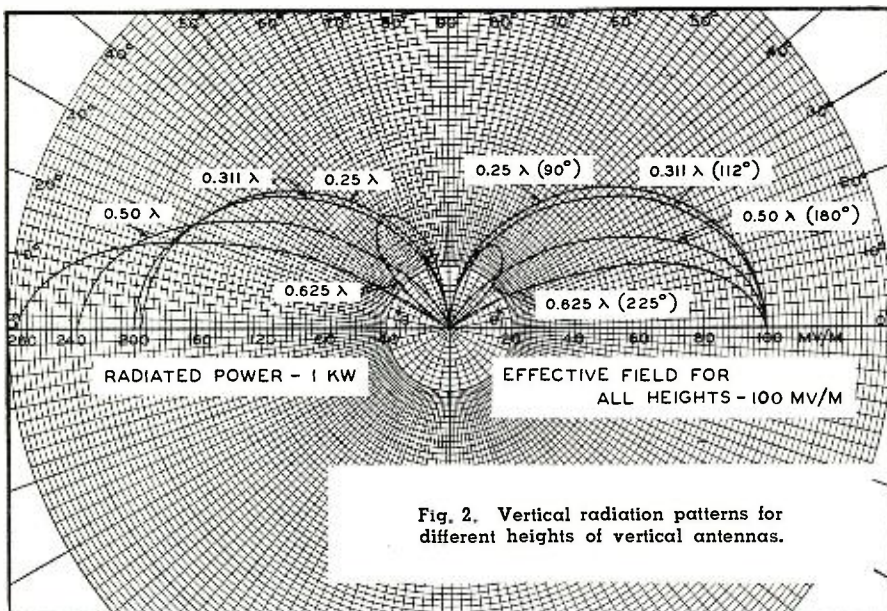

ground. Two sets of guy wires were used. I would like to mention that I have found it desirable to use two egg insulators at the point where each guy is attached to the tower as well as breaking up the guys every tenth wavelength with another egg insulator. This gives assurance the guys are not connected to the tower electrically which would detune the system. The ground system used with my present antenna consists of 16 radials ranging from 25 to 45 feet running out in all directions from the base of the tower. One may plant as many as the wife will permit; however, make certain to use at least 4 radials.

Information available in various texts verifies the fact that added low angle radiation is obtained with the  $\frac{5}{8}$  wave radiator; however it was desired to construct a miniature  $\frac{5}{8}$  wave radiator as well as a quarter-wave vertical antenna system and actually

make radiation measurements. If the frequency is increased to 1000 mc. the radiators become 7.4 and 2.96 inches respectively, making them easy to mount and rotate so that a radiation pattern may be obtained. The two antennas (individually) were originally mounted in a ground-plane which consisted of sheet iron approximately a yard square. The whole assembly was then rotated and patterns taken to determine the directivity of the antennas in the vertical plane. Due to the small size of the ground-plane the results did not resemble the desired patterns. The major lobes were forced up away from the ground-plane and minor lobes developed off the back.

The data we are interested in is based on an infinite ground-plane. It was, however, possible to use this same ground-plane to make patterns of horizontal antennas (mounted parallel to the ground-plane) because the

voltage vector cannot be supported on the ground-plane and the radiation is driven up away from the ground, as indicated by the patterns shown in Figs. 7C and 7D for horizontal antenna mounted a quarter wavelength and a half wavelength above ground respectively. The final patterns for the  $\frac{5}{8}$  and  $\frac{3}{4}$  wave vertical antennas, shown in Figs. 7A and 7B, were taken by using duplicate elements working against one another instead of against the ground-plane, that is, a complete dipole was used (see Fig. 5) so that the pattern would not be dependent upon a ground-plane of finite size. The image antenna in this case is not a mere image but the real thing and radiates equally well, thus duplicating the pattern of the top half of the antenna below the imaginary horizon. The results are identical to the published patterns of broadcast engineering firms, except of course in duplicate.

It would be interesting to make a study of the effects of the size of a ground-plane with respect to the antenna height and also the effect of tapering the ground-plane wires to form different sizes of conic ground-planes as are used by many hams. All of these features affect the angle of radiation, and of course the height of the system above the actual ground will also make some difference. In the case of 10 and 15 meters, due to the small height, it might be desirable to place the antenna in a ground-plane located above ground (depending on the individual circumstances) so that the antenna system will be in the clear.

Now we get down to the facts of how much improvement can be expected. The relative merits of the two antennas may be compared by comparing their field intensities at the desired radiation angles. This information is available in the FCC publication men-

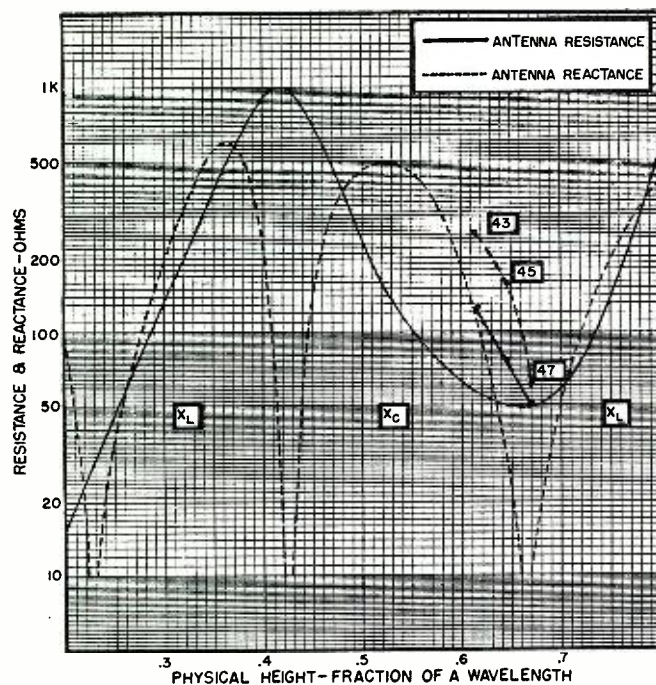
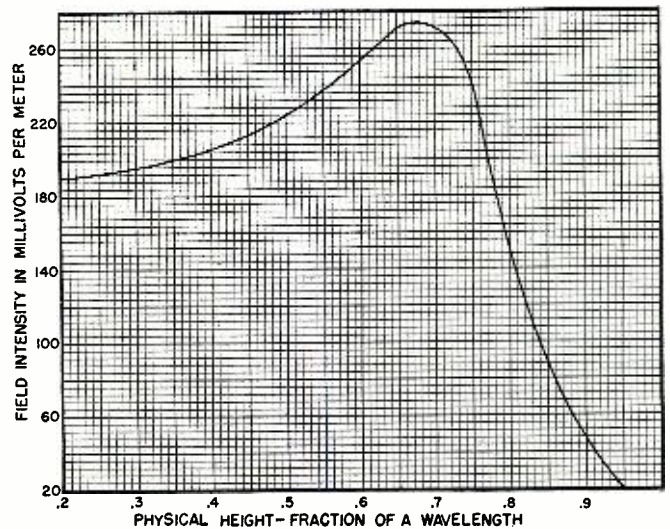

Fig. 3. Resistance and reactance components of impedance between tower base and ground system of a vertical tube mast.

Fig. 4. Unattenuated field intensity for various heights of vertical antenna measured at a distance of one mile from a one kilowatt transmitter. See text for complete details.



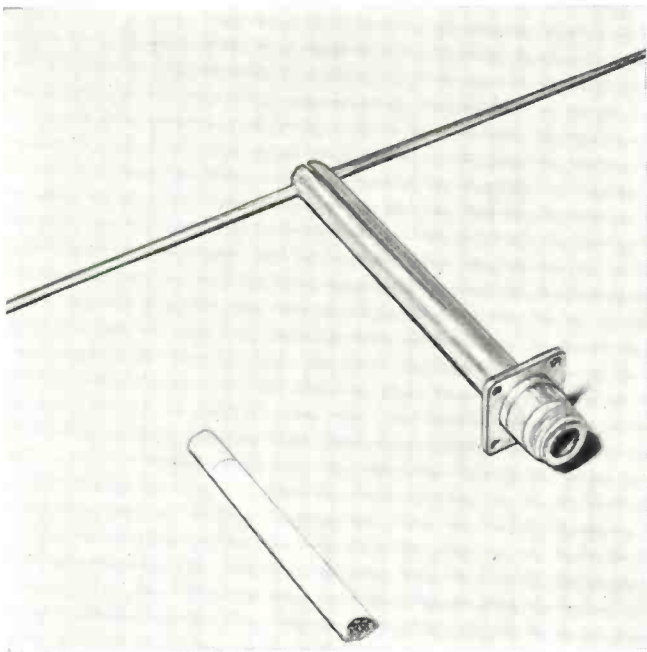

Fig. 5. Photo shows the antenna which was used to make the pattern measurements shown in Fig. 7A. This unit has an element length of  $\frac{5}{8}$  wavelength on either side of the feedpoint.

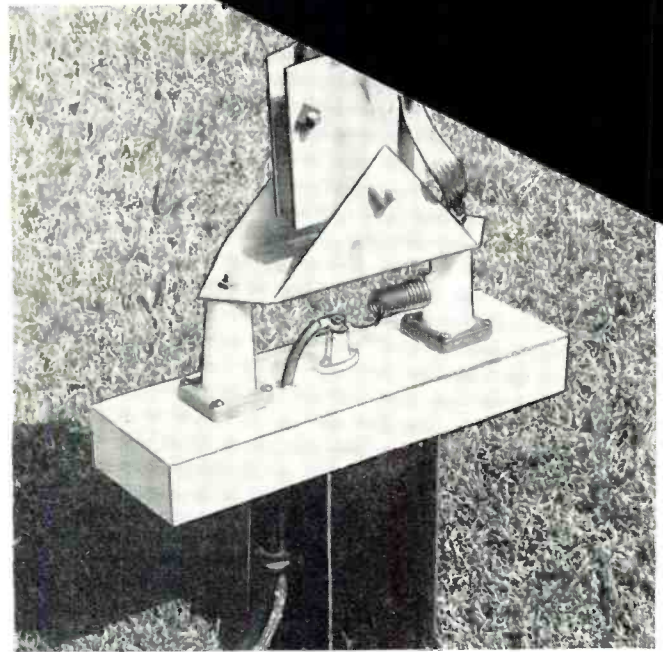

Fig. 6. Antenna base and mount used to support the 20-meter, 47-foot vertical antenna. Bonding strap is used to insure good electrical connection between components. Note grounded coax.

tioned previously. Based on 1 kilowatt input to each antenna, the quarter-wave element produces a field of approximately 195 millivolts per meter at one mile, while the  $\frac{5}{8}$  wave radiator under the same conditions provides about 275 millivolts per meter. (See Fig. 4.) This is the field produced at

zero degrees. The difference in the two fields is reduced as the angle is increased, as can be seen by the patterns in Figs. 7A and 7B. They become equal in magnitude at about 20 degrees but, as mentioned earlier, long distance communications on 20 meters takes place at an average angle of 12 de-

grees, 9 degrees on 15 meters, and about 5 degrees on 10 meters.

Based on the field strengths just given, we get a power gain of  $(275/195)^2 = 2.0$  (power gain is proportional to the square of the voltage ratio). However, because the antenna

(Continued on page 155)

Fig. 7. Vertical plane radiation patterns. (A) Pattern measured with antenna shown in Fig. 5. (B) Same antenna as shown in Fig. 5, except element length reduced to  $\frac{1}{4}$  wavelength on either side of the feedpoint. (C) Horizontal dipole antenna mounted  $\frac{1}{4}$  wavelength above ground, and (D) mounted  $\frac{1}{2}$  wavelength above ground. (E) Comparison of  $\frac{1}{4}$  and  $\frac{5}{8}$  wave vertical antenna patterns. Pattern details and measuring techniques are discussed in text.

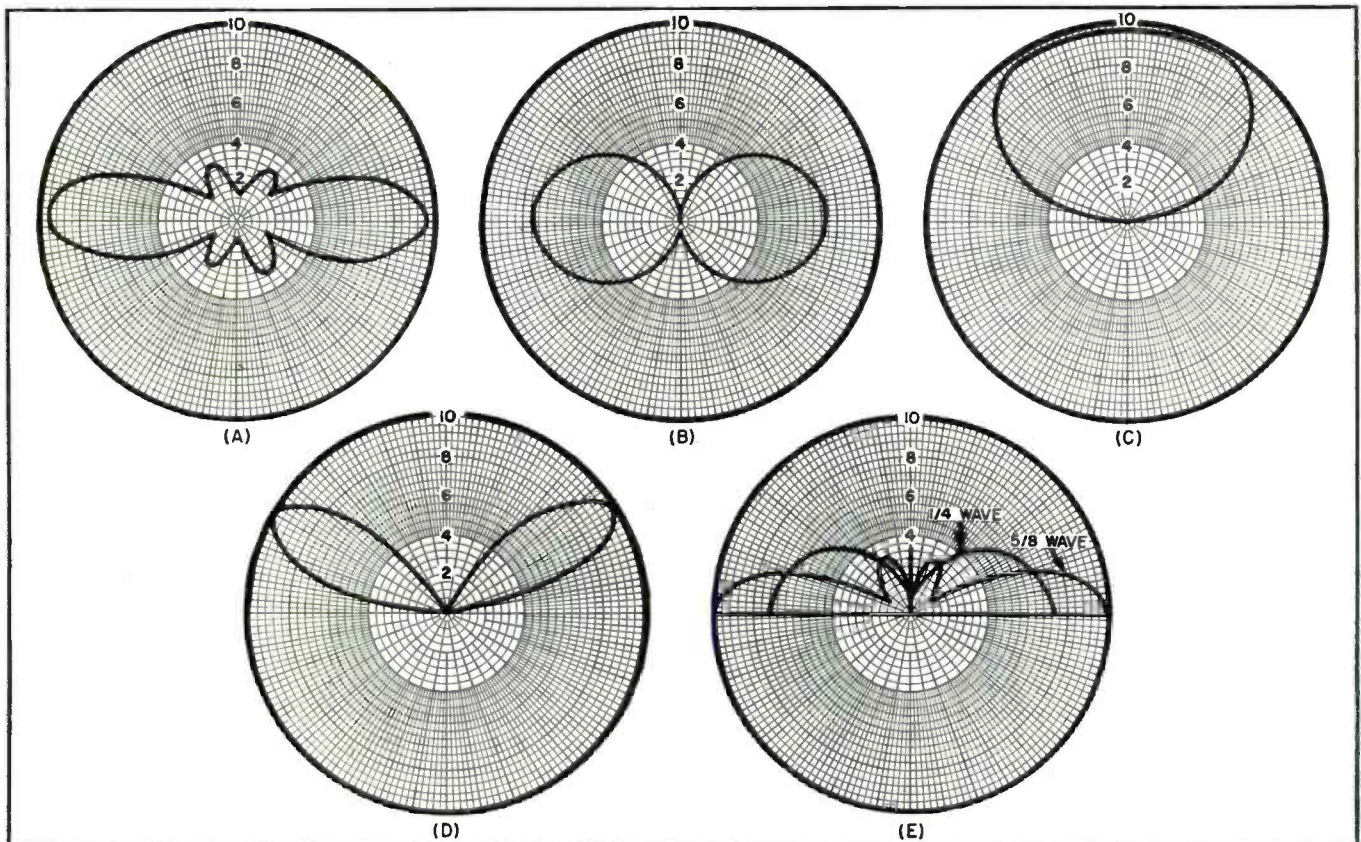

# AUTHORIZED LIGHT-BEAM COMMUNICATIONS SYSTEM

The receiver used with the light beam communications system. It is compact and easy to build.

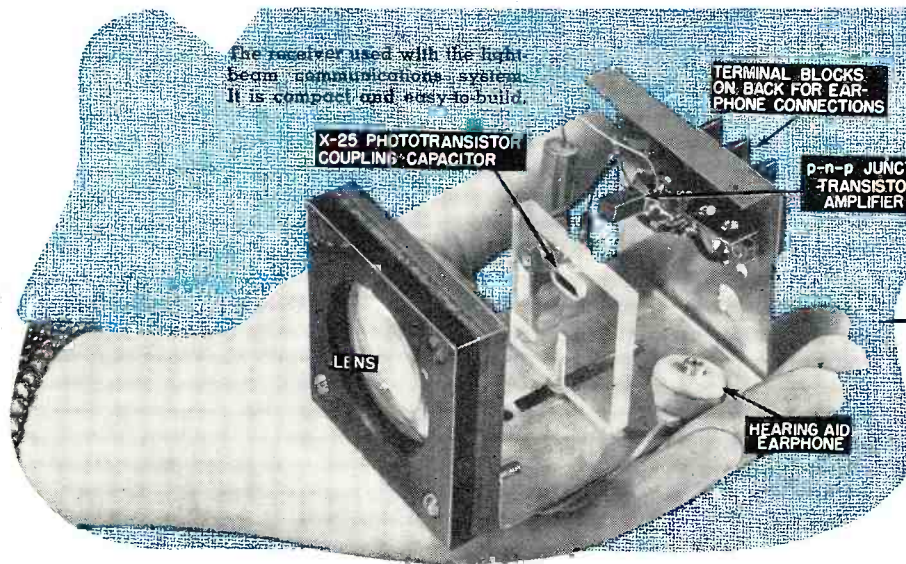

A simple system which can provide communications over a distance of 30 feet and more. A phototransistor is used.

ONE of the newer developments in the transistor field is the phototransistor, <sup>1, 2, 3, 4</sup> a small, rugged, sensitive semiconductor photocell with built-in transistor amplifier. Many devices can be built using this unit; one of the more interesting ones is a light-beam audio communications system.

The unit built by the authors used a glow modulator light source at the transmitter. The receiver had a phototransistor with a transistor amplifier, and operated from a 3-volt dry-cell. Excellent transmission was obtained along a 30-foot hall using ordinary condensing lenses for the optics. Methods of improving this performance will be discussed later in the article.

## Principle of Operation

The light-beam communicator works as follows:

The brightness of a lamp is varied by the audio signal. Light from this lamp is beamed to the receiver. A phototransistor in the receiver draws a current proportional to the brightness of the lamp; the current waveform is then a replica of the original audio signal. This current is amplified and applied to an earphone which makes the signal audible.

The system is similar to ordinary AM broadcasting, except that light waves are used instead of radio waves. Since light has a much shorter wavelength than radio waves, it can be beamed much more easily. Beamwidths of only a few degrees can easily be obtained; this means that most of the transmitted power is directed towards the receiver instead of being radiated in all directions. This gives power efficiency in point-to-point communication, and also helps keep the transmission secret, since only those in the direct path of the beam can detect the transmission.

## Receiver

The heart of the receiver is the phototransistor, a transistor which is light-sensitive. Typical characteristic curves are given in Fig. 6; it can be seen that this unit is similar to a triode vacuum tube with a plate resistance of about 20,000 ohms and a transconductance of about 1 milliamperere per millilumen of light. (The input signal here is light, instead of grid voltage as in a vacuum tube.)

The phototransistor current is amplified by a transistor amplifier, the output of which goes to an earphone.



The transmitter. The extra 12AX7 tube is a preamplifier added to handle low-level pickup.

By  
**VLADIMIR KENN**  
The Photocontrols Co.  
and  
**NATHAN SOKAL**

The schematic diagram is shown in Fig. 5.

Resistance-capacitance coupling is shown in Fig. 5 because it is usually simpler and cheaper for the experimenter. However, if the proper audio transformers are available, higher gain can be obtained by matching the output impedance of the phototransistor to the input impedance of the transistor amplifier, and by matching the output impedance of the transistor amplifier to the earphone. The headphones can be placed directly in the phototransistor circuit without an amplifier. Satisfactory operation can be obtained this way over a distance of about 20 feet.

If a transistor amplifier is used satisfactory operation can be obtained at 100 feet.

A schematic for a transformer-coupled amplifier is given in Fig. 1. The transformer impedances are not critical; about 20,000 ohms primary to 50 ohms secondary should be good for  $T_1$  and  $T_2$  should match the earphone (usually about 1000 ohms) to about 500,000 ohms. If the transformers have tapped windings, the experimenter can choose the taps which give the best match for his particular transistors.

The reader should be warned that some transistors may not work well in the grounded-emitter circuit of Fig. 5; the authors found that three of their four transistors would work satisfactorily in this circuit. All transistors

should be satisfactory in the grounded-base circuit of Fig. 1.

### Light Source

Previous experimenters<sup>5</sup> have used battery-operated lanterns as light sources. The lamp brightness is modulated by a transformer-coupled power amplifier in series with the lantern battery, as shown in Fig. 2. The voice-coil winding in series with the battery alternately bucks and aids the battery on alternate half-cycles of a.c. voltage.

Other experimenters have used electromechanical shutters to modulate the output of a constant-intensity light source.

The light source used in the authors' equipment was a *Sylvania* R1131C glow modulator tube. The R1131C is a gas-tube similar to the familiar VR types except that the glow is much brighter, and is confined to a small area, about 0.1 inch in diameter. A small source of light is required to collimate the light into a narrow beam; the glow modulator tube is ideally suited to this purpose. In addition, the light output is very nearly linear with current, giving linear modulation. A circuit using this tube is shown in Fig. 4. One volt peak-to-peak audio input gives maximum modulation.

### Optics

The optics of the unit are shown in Fig. 3. The glow modulator tube is placed at the focus of the transmitter lens (a 50-cent condensing lens is satisfactory), giving a narrow focused beam. The phototransistor is placed at the focus of a receiver lens similar to the transmitter lens. When the two units are carefully aimed at each other, the system is ready to operate. The necessity for careful aiming is a result of the directional efficiency of the transmitter and the high angular sensitivity of the receiver. The transmitted energy is channelled into a beam only a few degrees wide, while the receiver accepts signals only from within a cone a few degrees wide. Thus ambient light or interfering signals are rejected by the receiver unless they come almost exactly from the direction of the transmitter. Therefore the system works perfectly well in bright sunshine.

The reader should remember that the optics work as described only if the light source and the phototransistor are each placed accurately at the focal points of their respective lenses. The transmitter focus can be set by projecting the beam onto a screen or wall about 20 feet away, and adjusting the lens for the smallest spot on the screen. The focus at the receiver can be checked visually by focusing the image of a bright light onto the germanium bar of the phototransistor. This bar is about  $\frac{1}{16}$  inch below the surface of the transparent plastic of the phototransistor.

### Possible Improvements

The maximum distance over which the system can communicate is set by the signal-to-noise ratio of the receiver.

The internal noise of transistors decreases inversely with frequency. Thus at 16 kc., the noise power would be about  $\frac{1}{20}$  of that at 800 cps, which is roughly the center of the speech band. If the audio signal were modulated on a carrier of about 16 kc., and if the transistor amplifier were tuned to 16 kc. and followed by a detector, then the signal-to-noise ratio should be improved by about 20 times. The separation between transmitter and receiver could then be increased about four times without increasing transmitter power, still maintaining the same signal-to-noise ratio. The glow modulator tube works up to about 16 kc.

In addition, if the diameter of the receiver lens were doubled or tripled, the distance could also be doubled or tripled, because of the more efficient light collection at the receiver.

### Special Components

The phototransistor used in the receiver was an X-25, manufactured by *Transistor Products, Inc.*, Boston 35, Mass. The transistor amplifier was a p-n-p junction type available from *Raytheon, RCA*, or *Sylvania* (CK721, CK722, or 2N34).

The lenses were 2-inch diameter, 2.75-inch focal length condensing lenses available on the surplus market for about 50 cents each. The glow modulator was a *Sylvania* R1131C.

This light-beam device gives reliable communication in a small, low-power package. It is useful if directional wireless communication is desired without radio transmission. It also makes an instructive project for the experimenter interested in transistor circuits.

The authors wish to thank Mr. G. B. Tiffany for constructing the transmitter.

### REFERENCES

1. Shive, J. N.: "Properties of the M-1740 P-N Junction Photoelect." *Proceedings of the IRE*, November, 1952.
2. Shive, J. N.: "A New Germanium Photoresistance Cell." *Physical Review*, April 1959.
3. Morton, J. A.: "Present Status of Transistor Development." *Proceedings of the IRE*, November, 1952.
4. Seel, R. G. and Holt, R. B.: "Photodiodes and Phototransistors." *Electronic Design*, September and November 1953.
5. Blanchard, T. A.: "Talking on a Light Beam." *Radio-TV Experimenter*, Vol. 2, 1952.
6. Leslie, Eric: "Experimental Communication with Light Beams." *Radio-Electronics*, October 1953.

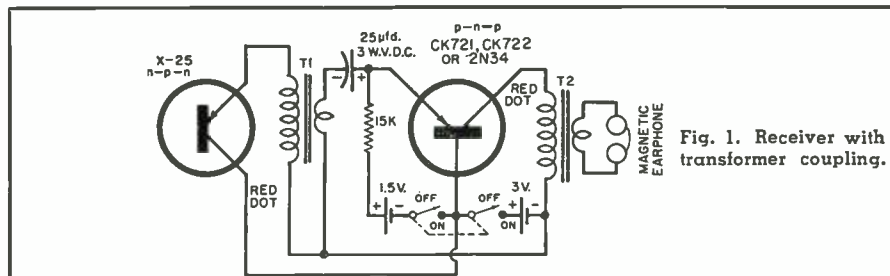

Fig. 1. Receiver with transformer coupling.

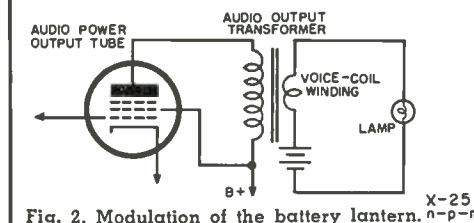

Fig. 2. Modulation of the battery lantern.

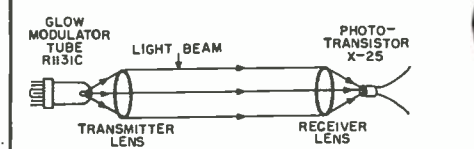

Fig. 3. The optical setup for the system.

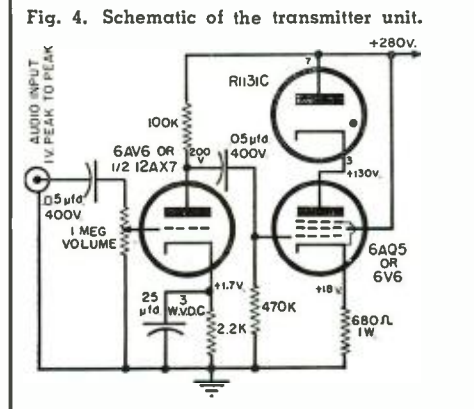

Fig. 4. Schematic of the transmitter unit.

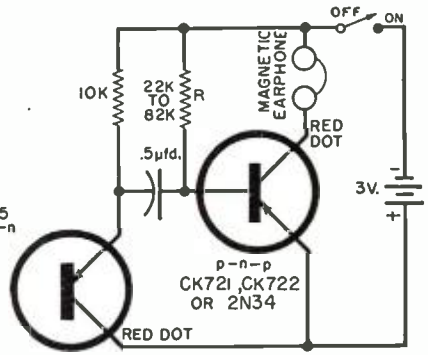

Fig. 5. Receiver with RC coupling. The value of R must be chosen to provide  $\frac{3}{2}R_1$  ma. through the earphone where  $R_1$  is the earphone resistance in kilohms. See text.

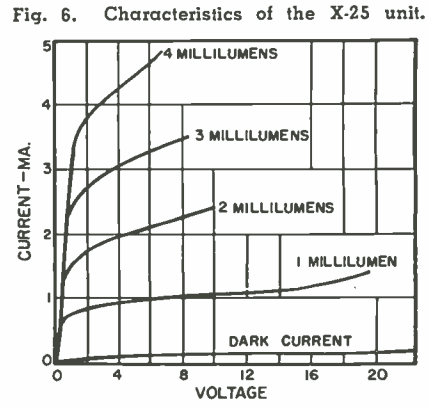

Fig. 6. Characteristics of the X-25 unit.

# AN EQUALIZER FOR FM PICKUPS

By

JAMES A. MITCHELL

A simple and versatile equalizing circuit which provides correct record compensation for all makes of capacitance FM pickups.



Over-all view of the FM cartridge oscillator and the constant-amplitude equalizer.

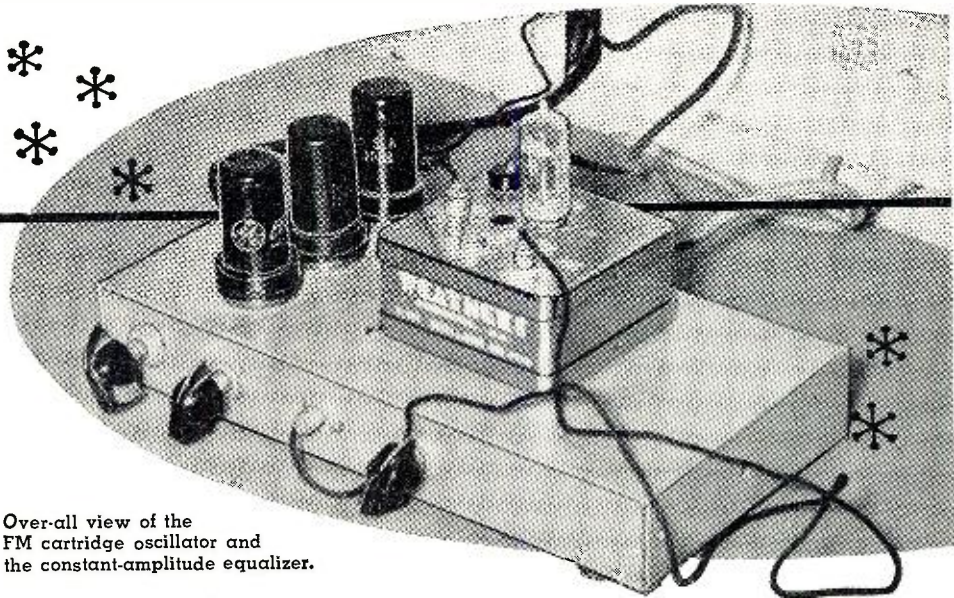

A NEW TYPE of phonograph pickup cartridge which has been growing in popularity among hi-fi fans is the *Weathers* FM pickup. The electrical properties of this type of pickup make possible a new equalizing circuit which has many advantages over the circuits generally used in preamps designed for magnetic cartridges. The principles and practical construction of such an equalizer will be described.

First let us consider how the FM pickup generates a voltage in comparison with the magnetic type pickups. All of the magnetic cartridges create a voltage in a coil by changing the magnetic flux through it. The magnetic field is varied through the coil by the movement of the stylus in any of several arrangements. Since the voltage in the coil is determined by the rate of change of the magnetic flux, the voltage is proportional to the rate of movement of the stylus. This system

produces a frequency response which is referred to as constant velocity. In the FM capacitance pickup the movement of the stylus creates a change in capacitance between the stylus and a nearby plate. This capacitance is part of the circuit of a radio-frequency oscillator. As the capacitance changes so does the frequency of oscillation. This frequency-modulated signal is converted to an audio frequency by a simple detector. Since the capacitance of the stylus and plate is a function of the distance between them, the voltage produced in the detector is proportional to the distance or amplitude of the stylus movement. The frequency response of this system is termed constant amplitude.

Constant amplitude response differs from constant velocity response in that it has greater output as the frequency is decreased and conversely lower relative output as the frequency is in-

creased. There is no fundamental advantage to either system of response if the preamplifier correctly equalizes the response curve. Actually records are made with a recording curve which is a composite of constant amplitude and constant velocity recording methods. Variations in the recording curves make an adjustable equalizer desirable.

Almost all existing preamplifiers with adjustable controls have been designed for magnetic pickups. If it is desired to use an FM pickup with these preamplifiers the response of the FM pickup must be changed to constant velocity before feeding it into the unit. This is easily done by inserting a small condenser, 50 or 100  $\mu\text{fd.}$ , between the oscillator output and the preamplifier input. *Weathers* and most preamp manufacturers show how to do this. However certain inherent advantages of the FM pickup are not fully utilized with this method. First, the FM oscillator has an output of about 500 mv. which, since it has a constant amplitude response, is also the approximate output of the very low frequencies. This should be compared with magnetics which have an output of 15 to 60 mv. at 1000 cycles but only 1 to 5 mv. at the very low frequencies. This makes it possible to obtain an excellent signal-to-noise and hum ratio with the FM pickup. When a condenser is used to convert the response to constant velocity the bass frequencies are reduced to about the same level as the magnetics and the usual elaborate precautions to minimize hum and noise are required in the preamp. Second, it is difficult to design a magnetic-type preamp with the full 6 db-per-octave bass boost. With constant amplitude response available directly from the FM pickup, there is no need to boost the bass at all. So why convert it to constant velocity and then have to

Fig. 1. Required equalization curves for a constant-amplitude pickup to provide flat response for various recording methods. See text for details.

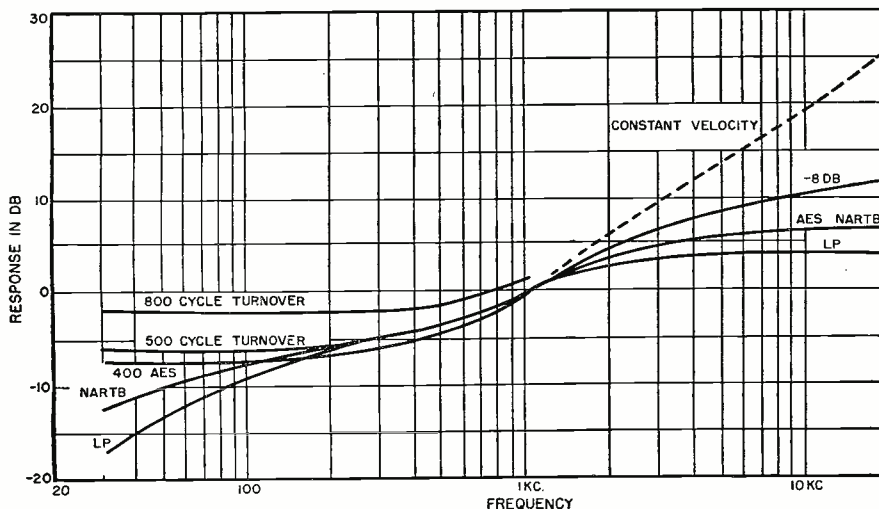

boost the bass back to constant amplitude.

Fig. 1 shows the response curves a preamp should have to provide the proper equalization for a constant amplitude pickup such as the FM type. Fig. 2 shows, for comparison, the same equalization curves as they are required in a preamp for magnetic pickups with constant velocity response. Note that actually less correction is required for the most used recording methods with the constant amplitude pickup. Also that while the usual constant velocity preamp boosts the bass and cuts the treble, the constant amplitude preamp cuts the bass slightly and boosts the highs. With modern high-frequency pre-emphasized recordings little additional boost in the preamp is necessary.

The fundamental RC circuit to produce the equalization needed in the constant amplitude preamp is shown in Fig. 3.  $C_1$  is a small condenser which, in conjunction with  $R_3$ , provides the high-frequency boost.  $R_1$  is a resistor which bypasses  $C_1$  at the low frequencies and controls the turnover to constant amplitude response in the bass.  $R_2$  is a resistor which, depending on its value, limits the high-frequency boost and allows a variable high-frequency control.  $C_2$  is a larger condenser which, if present, restricts the very low frequencies to provide the low bass attenuation required for LP and RCA "Orthophonic" recording curves.

One interesting feature of this circuit in comparison with ordinary preamps is that the elements which are to be varied to control the bass turnover and the high-frequency pre-emphasis are the two resistors  $R_1$  and  $R_2$ . In nearly all magnetic preamps it is the condensers which must be varied. This requires a switching arrangement with many components. With this constant-amplitude equalizer two variable resistors can provide all the turnover and treble control necessary. A switch cutting in  $C_2$  can modify the low bass for the LP pre-emphasis.

Fig. 4 shows a practical set of values for this equalizing circuit. This network can be used either directly connected to the FM detector and before the first amplification stage or it may be used following a triode amplification stage. It provides nearly exact equalization for all the standard recording curves. Fig. 6 shows curves actually obtained at the various settings of the controls. Remember that since the controls are continuous any intermediate high-frequency pre-emphasis correction or bass turnover can be obtained. The only equalization setting which is somewhat short of theoretical is when  $R_3$  is set at zero resistance for the flat constant-velocity curve. The circuit shown is 1.3 db below theoretical at 10,000 cycles and 3.5 db below 20,000 cycles. Since this curve is used only for playing frequency test records or old 78's with no highs anyway this is of little practical consequence. Halving all of the condenser values and doubling the size of all the resistors

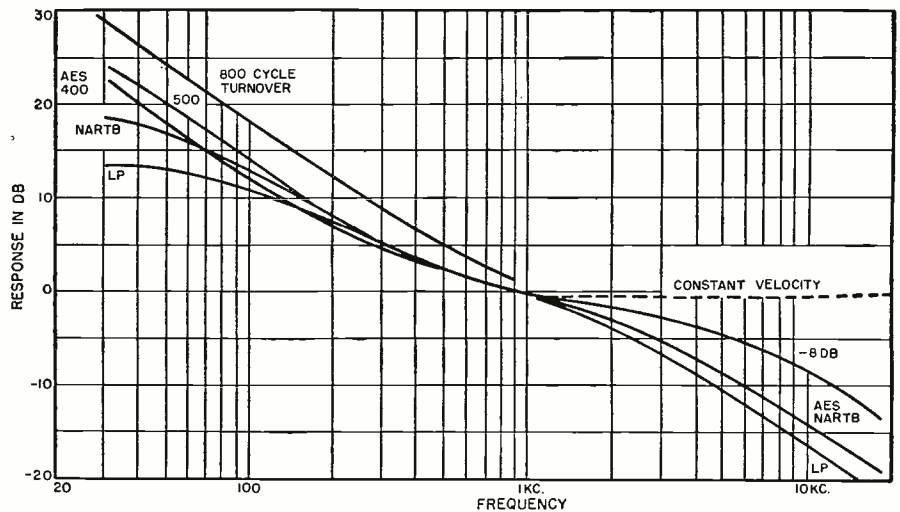

Fig. 2. Required equalization curves for the conventional constant-velocity (magnetic) pickups. Compare this curve with that shown in Fig. 1.

in the circuit (except  $R_4$  which should not be changed) will make the flat position correct to within 1.3 db at 20,000 cycles but will double the voltage loss in the equalizer. Since the equalization is nearly exact on all the lower settings of the high-frequency control the values given were preferred.

The size of variable resistor  $R_2$  and fixed resistor  $R_1$  have been selected to provide a variable bass turnover of from 280 to 1000 cycles, with a complete swing of the control knob. The value of variable resistor  $R_3$  will provide a correction for records made with no high-frequency pre-emphasis to those made with 20 db pre-emphasis at 10,000 cycles. Switch  $S_1$  has three positions for exact adjustment of low bass pre-emphasis. Position 1, with no condenser, is flat for all constant-amplitude turnovers. Position 2 provides the correct NARTB and RCA "Orthophonic" bass. The bass turnover should be set for 500 cycles on these records. Position 3 matches the LP recording

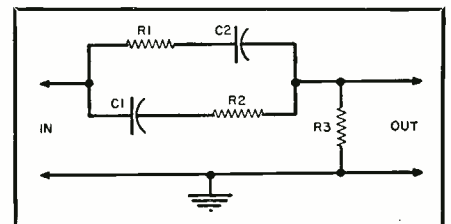

Fig. 3. The fundamental RC circuit for constant-amplitude equalization.

curve with the turnover also set at 500 cycles.

This equalizing circuit has a loss of 24 db at 1000 cycles. The equalized output is about 30 mv. at all frequencies if the circuit is connected directly to the oscillator. This is still about 20 db above the signal level of magnetic pickups in the 30 to 60 cycle range. Hum pickup in the amplification stage following the equalizer is, therefore, 20 db less than when the same tube is used as a magnetic-type equalizer. Fig. 4B

(Continued on page 83)

Fig. 4. (A) Circuit of adjustable equalizer and (B) the voltage amplifier circuit.

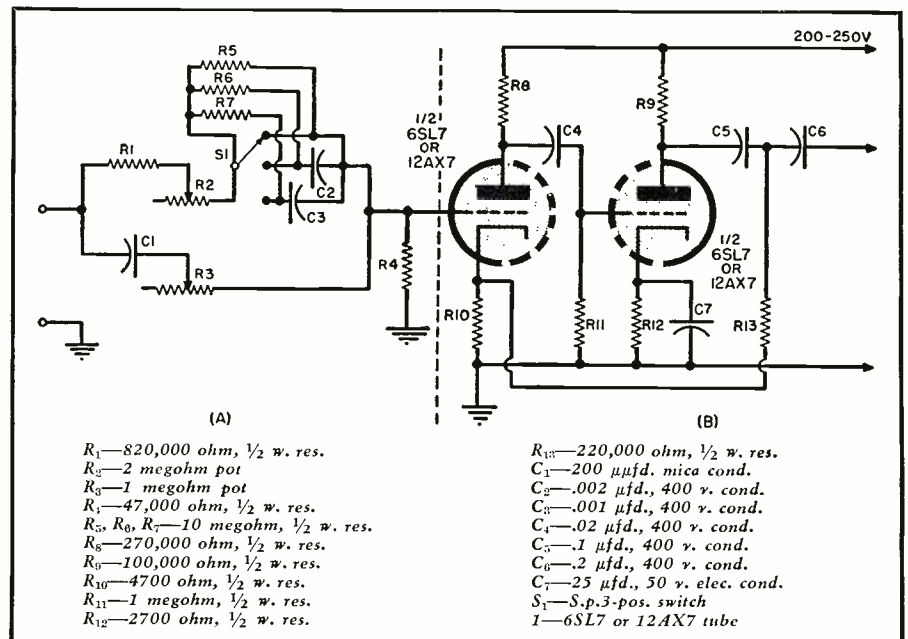

- (A)
- $R_1$ —820,000 ohm,  $\frac{1}{2}$  w. res.
  - $R_2$ —2 megohm pot
  - $R_3$ —1 megohm pot
  - $R_4$ —47,000 ohm,  $\frac{1}{2}$  w. res.
  - $R_5, R_6, R_7$ —10 megohm,  $\frac{1}{2}$  w. res.
  - $R_8$ —270,000 ohm,  $\frac{1}{2}$  w. res.
  - $R_9$ —100,000 ohm,  $\frac{1}{2}$  w. res.
  - $R_{10}$ —4700 ohm,  $\frac{1}{2}$  w. res.
  - $R_{11}$ —1 megohm,  $\frac{1}{2}$  w. res.
  - $R_{12}$ —2700 ohm,  $\frac{1}{2}$  w. res.

- (B)
- $R_{13}$ —220,000 ohm,  $\frac{1}{2}$  w. res.
  - $C_1$ —200  $\mu$ fd. mica cond.
  - $C_2$ —.002  $\mu$ fd., 400 v. cond.
  - $C_3$ —.001  $\mu$ fd., 400 v. cond.
  - $C_4$ —.02  $\mu$ fd., 400 v. cond.
  - $C_5$ —.1  $\mu$ fd., 400 v. cond.
  - $C_6$ —.2  $\mu$ fd., 400 v. cond.
  - $C_7$ —25  $\mu$ fd., 50 v. elec. cond.
  - $S_1$ —S.p.3-pos. switch
  - 1—6SL7 or 12AX7 tube

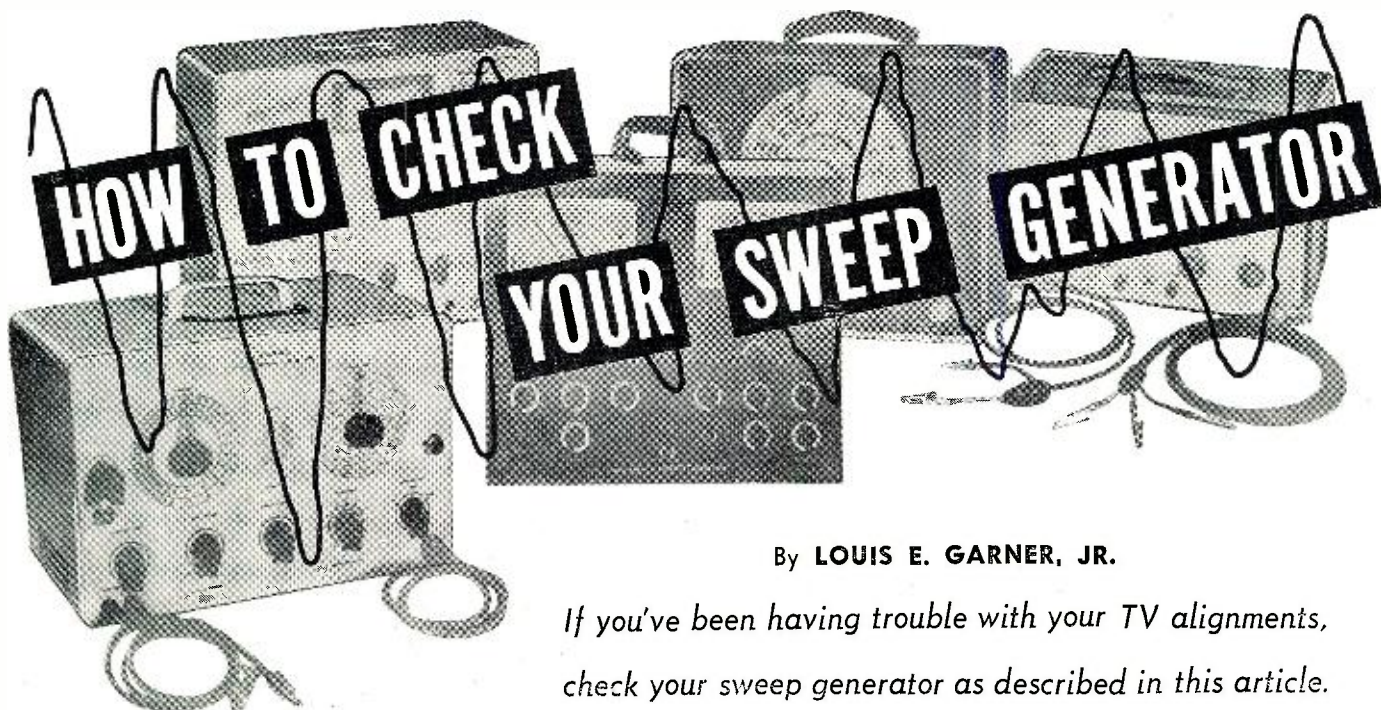

By LOUIS E. GARNER, JR.

*If you've been having trouble with your TV alignments, check your sweep generator as described in this article.*

IT WOULD be difficult to estimate the number of times that television service technicians have carefully aligned the video i.f. stages of a TV receiver, carefully checked the response of the video amplifier, and then, when trying out the receiver on a station, found that a poor quality picture was obtained. In some cases the "aligned" receiver has severe phase shift and smearing, or its sensitivity is greatly reduced, or it has become unstable, the i.f. stages regenerating and breaking into oscillation at almost any moment.

Some service technicians have had such a situation happen to them often enough that they have lost faith in the sweep generator - marker - oscilloscope method of alignment. In almost every case, however, the difficulty lies not with the method, or even its technique of application, but rather, with the equipment used. Most often, the sweep generator is found to be at fault, and these faults can generally be resolved into two general types of improper operation—a nonlinear sweep, or an output that is not flat over the swept range.

As an experiment, the author checked the operation of a number of commercially built sweep generators. The selection of instruments was made at random, and no effort was made to test several instruments of each model to arrive at an average. However, the results of even a limited test of this type are interesting. Of the approximately six instruments checked, only one, a laboratory-type instrument costing over four hundred dollars, was found to have a really linear sweep, adequate sweep width, and a flat (within 10% over the swept range) output.

This does not mean that the other instruments were unusable, that their design or manufacture were lacking,

or that they were defective. It is difficult to design and manufacture a wide-band sweep generator to sell at a low or moderate price, which will also have all the necessary and desirable features important to the busy service technician, together with a perfectly linear sweep, flat output, high output, adequate frequency coverage, and sweep width. All of the instruments tested were satisfactory for TV alignment, *provided their characteristics were known and taken into account in the alignment procedure.* The author worked out an extremely simple and easy-to-apply technique for checking the operation of the sweep generator at the frequency at which it was being used.

#### Effects of Nonlinear Sweep

A typical "ideal" TV i.f. response curve is shown in Fig. 1A. The gradual slope may appear on either the left-hand or the right-hand side of the response curve, depending on the sweep generator and oscilloscope used.

Suppose, now, that the sweep generator used for aligning the receiver has a nonlinear sweep. Even with such a condition present, it may still be possible to adjust the i.f. stages until the response curve shown in Fig. 1A appears on the screen of the CRO. The true response curve will be considerably different, however.

If the sweep generator was nonlinear such that the left-hand half of the sweep was expanded compared to the right-hand portion, alignment for the pattern shown in Fig. 1A would result in a true response curve with the general shape shown in Fig. 1B. If, on the other hand, the right-hand portion of the sweep were compressed compared to the left-hand half, alignment for the response of Fig. 1A would result in the true response shown in Fig. 1C.

Other conditions of nonlinear sweep would result in other unsatisfactory response curves.

Although, with some receivers, it may still be possible to obtain a passable picture with response curves similar to those shown in Figs. 1B and 1C, far from optimum results would be obtained. In critical sets, it might be found impossible to obtain even a satisfactory picture.

#### Effects of Varying Output

A flat output over the swept frequency range is, in most cases, just as important (if not more important) as a linear sweep. The effect of a varying sweep generator output on the video i.f. response curve can be seen by referring again to Figs. 1A, 1D, and 1E.

If the output of the sweep generator dropped over the right-hand portion of the sweep, but the i.f. stages were adjusted to give the desired pattern (Fig. 1A), the true response curve would appear as in Fig. 1D. With a drop in signal output over the left-hand portion of the sweep, the true response curve would appear as in Fig. 1E when the i.f. stages were adjusted for the pattern in Fig. 1A. In both cases, the pattern for which the adjustments are made is far different from that actually obtained.

With a response similar to that shown in Fig. 1D, the receiver may appear to lack sensitivity (poor contrast), there might be an excessive amount of grain present, and sound bars might appear in the image. With a response similar to that shown in Fig. 1E, the picture may lack definition. In addition, with some sets there might be a definite tendency towards oscillation in the i.f. stages.

#### Checking the Sweep Generator

The only equipment needed for the



checking procedure is that normally used in alignment. The interconnections of the equipment are identical to those used for alignment (see Fig. 2). The TV receiver (or FM or AM receiver if another type sweep is being checked) should be in good working condition. For the purpose of the check procedure, it is unimportant whether the receiver is perfectly aligned, however.

Although our discussion has been primarily concerned with TV receivers and sweep generators, the technique described may be used with any sweep used for alignment purposes.

Adjust the sweep generator for maximum sweep width. Next, adjust the receiver, oscilloscope, and sweep center frequency until a centered response curve appears on the screen of the CRO. (See Fig. 3A.) The exact shape and size of the response curve are unimportant; it is the *change* which occurs in the shape and amplitude of the response curve as the sweep generator is adjusted that indicates its condition.

Shift the center frequency of the sweep generator first in one direction, then in the other. This will cause the response curve to shift across the screen of the CRO as shown in positions "1," "2," and "3" (Fig. 3A). If the sweep is linear, and varies as does the horizontal sweep signal supplied to the CRO (assuming a linear horizontal amplifier in the CRO), and if the output of the generator is flat over the swept range, then the shape and amplitude of the response curve will remain constant as it moves across the screen.

Should the sweep be nonlinear, the slope of the sides of the response curve will change, as will the bandwidth. See Fig. 3B. In this case the sweep is more rapid on the left-hand side, resulting in a squeezed response curve (curve "2"). An expanded response (curve "3") results when the frequency deviation decreases.

If the output of the sweep generator varies, the amplitude of the response curve will change as the center frequency is shifted. In Fig. 3C is illustrated the variation in amplitude that may occur if the output of the sweep generator is greater on the left-hand side and less on the right-hand side than in the middle. The relative changes in amplitude may be noted by using the graph scale of the CRO. A good sweep generator will not have an amplitude variation exceeding 5% (plus or minus) over its swept range.

Of course, some variation in output amplitude is to be expected because of the change in L/C ratio of the fixed oscillator for various center frequencies. The experienced technician will know when this is excessive.

To determine the relative frequency variation where the sweep is nonlinear, use the marker generator. First, re-adjust the center frequency of the sweep until the response curve is again centered on the CRO.

When the marker generator is tuned

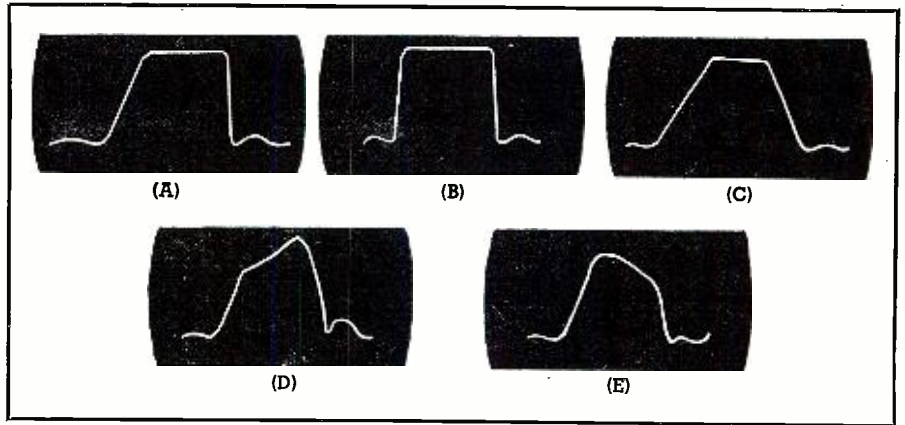

Fig. 1. (A), Ideal TV i.f. response curve; (B) and (C), faulty circuit response due to nonlinear sweep generator; (D) and (E), actual response of a circuit which is aligned for a flat curve using a generator whose output varies over its range.

to the center frequency of the sweep, the marker should fall in the center of the sweep and the response curve (see Fig. 3D). If the indicated sweep width is 10 mc., adjusting the marker to 5 mc. on either side of the center frequency will cause the marker to move first to one end of the pattern, then to the other. Noting the movement of the marker on the pattern with equal variations in frequency permits an estimate of relative sweep linearity.

In some cases it may be found that the center frequency of the sweep is not exactly as indicated. This results from the difficulty of keeping a sweep generator on calibration. However, this is unimportant as long as the sweep is linear and the output flat. The marker should always be used for positive frequency identification, and for "spotting" the video and audio i.f. carriers.

### Corrective Steps

While the technique just described permits checking the sweep generator output over only a comparatively narrow range, it may be used whenever the generator is connected to a receiver and scope. With the equipment set up for alignment, checking the sweep generator before starting the alignment procedure takes only a minute or so.

If the sweep output does not vary more than 10% maximum over the

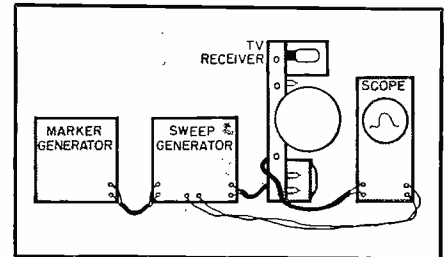

Fig. 2. Test equipment setup for checking the condition of a sweep generator.

swept range (or plus or minus 5%), and the linearity is not excessively bad, the alignment of the receiver may be carried out exactly as recommended by the receiver manufacturer.

If it is found that any nonlinearity occurs at the extreme limits of sweep (or if the output drops appreciably only at the limits), then reducing the sweep width to the minimum absolutely required for the alignment procedure will often permit normal response curves to be obtained. In general, the smaller the sweep width used, the more linear the sweep, and the flatter the output.

Should the test technique indicate a variation in linearity only at one extreme (or a similar change in output), then normal alignment may be carried out in many cases by shifting the center frequency of the sweep generator in the opposite direction.

(Continued on page 156)

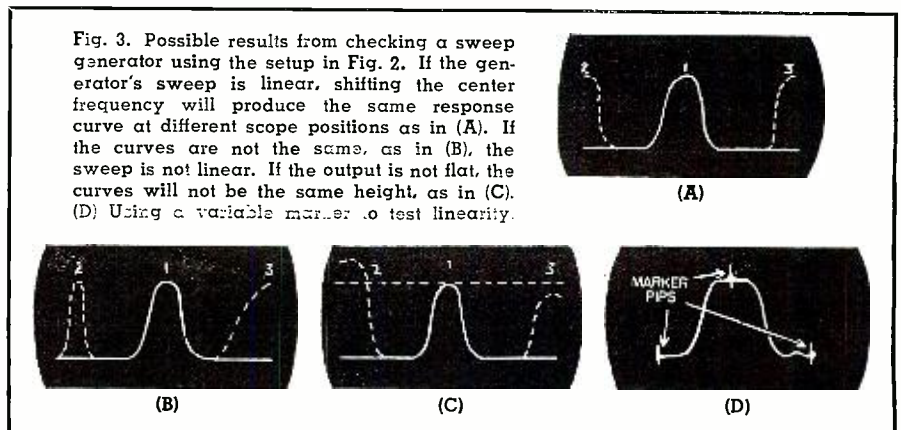

Fig. 3. Possible results from checking a sweep generator using the setup in Fig. 2. If the generator's sweep is linear, shifting the center frequency will produce the same response curve at different scope positions as in (A). If the curves are not the same, as in (B), the sweep is not linear. If the output is not flat, the curves will not be the same height, as in (C). (D) Using a variable marker to test linearity.

# 1954 TV RECEIVER SPECIFICATIONS

Continuation of the list of mechanical and electrical specifications on new TV sets for service technicians. See next issue for additional listings.

MFR.	CHASSIS	TUBES							VIDEO I.F. FREQ. (MC.)	H.V. <sup>4</sup> (KV.)	U.H.F. PROVISION	POWER (WATTS)	SPECIAL FEATURES	
		TUNER	I.F. <sup>1</sup>	VIDEO <sup>2</sup>	AUDIO	SWEEP <sup>3</sup>	P.S.	CRT						
EMERSON	120180-D	6BQ7 or 6CB6	6CB6	6AL5	6AU6	12AU7, 6SN7	5U4	17LP4A	45.75	14.5	11	190	6	
		6BK7 or 6CB6	6CB6	6CB6	6AU6	6BQ6, 6W6	1X2A							
		6BZ7	6CB6		6AL5	6SN7, 12AU7	6W4							
		6J6			6AV6	12AU7	5U4							
				6V6										
	120196-B	6BQ7 or 6CB6	6CB6	6AL5	6V6	12AX7*, 12AU7	5U4	21MP4	45.75	15.5	Strips	180		
	120182-D	6BK7 or 6CB6	6CB6	6CB6	12AX7*	6SN7, 6BQ6	5U4	17LP4A	45.75	15.5	Strips	180	6	
	120206-D	6BZ7	6CB6		6AL5	6W6	1X2A	21YP4	45.75	15.5	Strips	180		
	120195-D	6J6			6AU6		6AX4	17LP4A	45.75	15.5	11	180		
	120197-B	6J6			6CB6			21MP4	45.75	15.5	11	180		
	120197-D							21YP4	45.75	15.5	11	180		
	120185-D	6BQ7 or 6CB6	6CB6	6AL5	6AU6	12AU7, 6SN7	5U4	21MP4	45.5	15.5	Strips	190	6	
	120192-F	6BK7 or 6CB6	6CB6	6CB6	6AL5	6BQ6, 6W6	1B3	21MP4	45.5	15.5	Strips	190	9	
	120190-D	6BZ7	6CB6		6AV6	12AU7, 12AU7	6W4	17LP4A	45.5	14.5	Strips	190	6	
	120192-B	6J6			6V6	6SN7	5U4	21YP4 or 21MP4	45.5	15	Strips	190	6	
	120192-D				6AU6				45.5	15	Strips	190	6	
	120209-F	6BQ7 or 6CB6	6CB6	6AL5	6AU6	12AU7, 12AU7	5U4	21YP4	45.75	15.5	11	190		
		6BK7 or 6CB6	6CB6	6CB6	6AU6	12AU7, 6SN7	5U4							
		6BZ7	6CB6		6AL5	6SN7, 6BQ6	1B3							
		6AF4			6AV6	6W6	6W4							
	6J6			6V6										
120211-D	6BQ7 or 6CB6	6CB6	6AL5	6V6	12AX7*, 12AU7	5U4	21YP4	45.75	15.5	11	180			
120211-F	6BK7 or 6CB6	6CB6	6CB6	6AL5	6SN7, 6BQ6	1B3	21YP4	45.75	15.5	11	180			
	6BZ7	6CB6		12AX7*	6W6	6AX4								
	6J6			6AU6		5U4								
	6J6			6CB6										
HALLICRAFTERS	A1300D	6BZ7 or 6CB6	6CB6	12BY7	6AU6	6SN7, 12BH7	1B3	17HP4	45.75	16		180	5, 10	
	C1300D	6BK7A	6CB6		6AL5	6AL5, 6SN7	6AX4	17HP4	45.75	16		180	5, 10	
	E1300D	6J6 or 6X8	6CB6		6C4	6BQ6		21AP4	45.75	16		180	5, 10	
					6W6									
	B1300D	6BZ7	6CB6	12BY7	6AU6	6SN7, 12BH7	1B3	17HP4	45.75	16	11	190	5, 10	
	D1300D	6J6 or 6X8	6CB6		6AL5	6AL5, 6SN7	6AX4	17HP4	45.75	16	11	190	5, 10	
	F1300D	6X8	6CB6		6C4	6BQ6		21AP4	45.75	16	11	190	5, 10	
					6W6									
	A1400D	6BZ7	6CB6	12BY7	6AU6	6BE6, 6SN7	5U4C	21ZP4A	45.75	17	11	255	5, 10, 12	
	B1400D	6J6	6CB6	6AU6	6AU6	6S4, 6AQ7	5U4C	21ZP4A	45.75	17		255	5, 10, 12	
		6CB6		6AL5	6SN7, 6BQ6	1B3								
		6CB6		6AV6		6W4								
				6AQ5										

1. Video i.f. tubes only. 2. Includes detector and a.g.c. 3. Includes sync section and a.f.c. 4. CRT 2nd anode voltage. 5. Removable safety glass. 6. Local-fringe a.g.c. adjustment. 7. High-fidelity sound. 8. Aluminized picture tube. 9. TV-radio-phono combination. 10. Built-in antenna. 11. 82-channel tuner. 12. Adjustable dial light. \*Part of tube is used in another section.

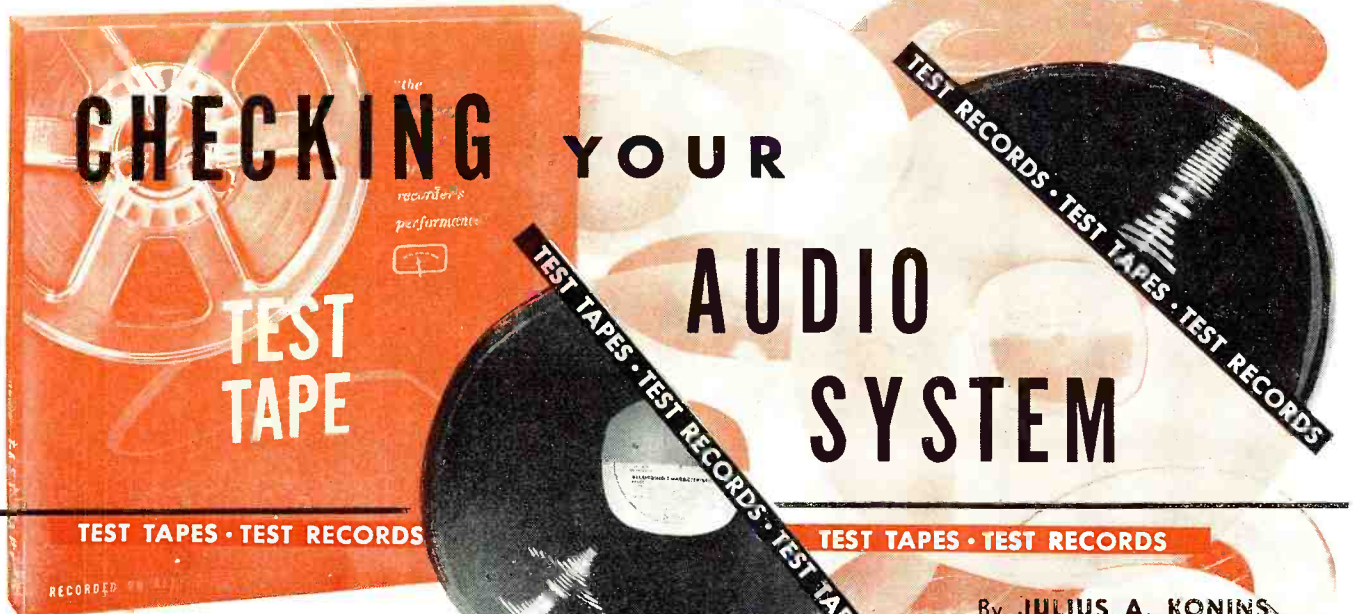

# CHECKING YOUR AUDIO SYSTEM

TEST TAPES • TEST RECORDS

TEST TAPES • TEST RECORDS

By JULIUS A. KONINS  
The Dubbings Co., Inc.

**D**URING the past few years audio equipment and test methods have been developed which allow any owner of a high-fidelity sound system to obtain excellent performance at moderate cost. To insure that the sound reproducing equipment is performing at the highest level of quality of which it is capable, a group of inexpensive easy-to-use test devices have been made available. For the music lover, technician, hi-fi "bug," and audio engineer, these test instruments are a "must" for maintaining top quality performance. After all, there isn't much sense in buying \$500 worth of audio components and having them perform like a cheap record player just because proper adjustments were not made.

Not too long ago, when 78 rpm shellac records were the only ones on the market, it didn't really matter very much whether or not the audio enthusiast had a method of measuring the quality of his reproducing system. The limited frequency response, and high surface noise, obviated the need for home test facilities. Few people worried about intermodulation distortion, transient response, and the like.

Of course, the professional sound man had his tools for evaluating equipment performance. There was the signal generator for testing an amplifier, and some prewar 78 rpm frequency records (selling for as high as \$25 per set) to be used in conjunction with an oscilloscope, still only for professional use.

About the only thing that the average owner was concerned about was turntable speed. The simplest way of checking this was to use a stop watch and marked turntable or a stroboscopic disc. The more meticulous listeners of 78 rpm records also employed a weight gauge to determine the pressure of the stylus on the record. In order for the stylus to stay in the record groove and track the lateral undulations which produce the sound, about 15 grams or

more were used. If the weight was off, a coin (a penny weighs 3 grams) could be taped to the pickup arm.

For the novice or professional—a relatively inexpensive method of checking performance of your audio equipment. Especially recorded test tapes or discs and output level indicator are all that is required to make these checks.

## Introduction of LP Records

For a number of years, it was recognized that the limited performance and short playing time of 78 rpm records had to be overcome, and it was, with the introduction of the 33 1/3 rpm microgroove record. However, it was not accomplished simply by reducing turntable speed, decreasing groove width, and cutting at a finer pitch. A large number of problems accompanying the introduction of the long-playing record had to be solved.

Through the use of better plastic record materials and improved manufacturing processes, the record makers were able to press discs with good response from 30 to over 12,000 cycles-per-second, and equipment manufacturers came up with designs which could reproduce this frequency range.

To check the frequency response of the pickup and amplifiers, *Clarkston* and other companies developed sweep-frequency test records. On such a record, a signal starting at 70 cycles was rapidly increased to 10,000 cycles or so, thereby sweeping most of the audio band. But an oscilloscope was necessary to display the frequency response, so the sweep-frequency test record was still restricted to the professional audio man. Other companies also produced frequency records, including *Columbia*, *Cook*, *RCA*, and *Universal*.

Perhaps more serious than the fre-

quency response was the combination of distortions and noise that became more pronounced in the new LP records. Since the turntable speed had been reduced, the ear was now more aware of slight variations in speed. A non-constant rotational speed has a modulating effect, called "wow" for low-frequency speed variations, and "flutter" for higher ones and the ear can detect changes in speed as small as 0.5%. Other factors which became apparent were background noise, 60-cycle hum, and turntable rumble—all capable of making themselves quite evident because the LP's, with their quieter record material, use a lower recording level and wider dynamic range. Also, since the newer record materials are softer than shellac, stylus pressure had to be made small to reduce record wear. The lighter stylus pressure, in turn, required improved styli, transducers, and pickup arms to insure faithful tracking.

## Performance Test Record

In order to test all of these things—frequency response, wow and flutter, background noise, hum and rumble, and tracking—test records of various types were made available commercially. One of the first test records offered that would enable the hobbyist and technician, as well as the professional, to measure the performance of his phonograph was *The Dubbings Co. D-100*. Both sides of this record are identical and serve to check against one another. Bands 1 through 13 de-

## COOK NA BEAM TEST FOR INTERMODULATION DISTORTION

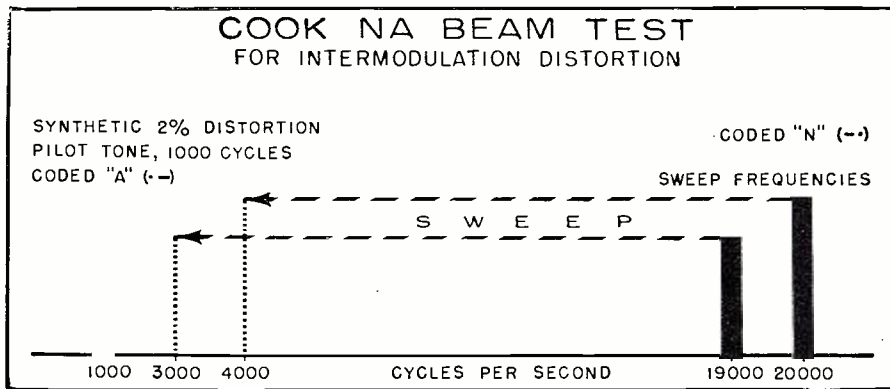

termine the frequency response of the equipment and are in steps from 30 to 12,000 cycles. Approximate response can be checked by ear; exact measurement requires a vacuum-tube voltmeter, calibrated oscilloscope, or an inexpensive test level indicator.

Band 14 on the D-100 is a 45-second unmodulated or quiet band. Anyone who has ever searched a musical recording for a few seconds of quiet grooves can really appreciate how useful this band is. With the volume turned up and the pickup on the arm rest, hum due to stray magnetic fields, a.c. on the tube filaments, power supply ripple, etc., is readily discernible. With the turntable stationary and the stylus in a groove, noise from an external or background source is easily detected. Proper shock mounting of the phonograph should eliminate it. With the stylus in the quiet grooves and the turntable rotating, detection of further rumble would indicate that the motor mounting or drive mechanism is causing the turntable rumble.

Band 15 on the D-100 is a 45-second, 3000-cycle tone at constant volume. The human ear is most sensitive at this frequency and any wow or flutter will show up instantly as a variation in volume or pitch. If these effects are pronounced, they may indicate a dirty phonograph drive mechanism, worn idler wheel, or wobbly turntable.

Bands 16 through 20 on the test record contain a 400-cycle tone, each one representing a 3 db volume increase over the preceding one. The ability of the pickup cartridge and

arm to track can be tested on these bands by listening for the fuzziness which indicates that the needle is jumping around in the groove. Besides being a test of cartridge compliance, these grooves permit the stylus force and pickup arm damping to be properly adjusted.

### Intermodulation Distortion

With the extension of the frequency range of home sound systems to over 12,000 cycles, the problem of intermodulation distortion became serious. That is, when two or more frequencies and their harmonics are simultaneously introduced into the system, they can heterodyne or beat with one another to produce sum and difference frequencies not present in the original. Although the original frequencies may have been pleasing musical notes, the new frequencies generated may be decidedly non-musical and displeasing. The source of intermodulation may be in high-mass cartridges, loudspeakers with undamped metallic cones, high frequency horn drivers with voice coil rub, and, of course, amplifier electron tube circuits, particularly at high powers where the tubes operate on the nonlinear portion of their characteristic curves.

Until a year ago, the only way intermodulation distortion could be measured was by feeding two pure tone frequencies into a system from two signal generators, and then measuring the resulting intermodulation products individually. This is a prac-

tical procedure in a laboratory, but not in a home with limited test instruments.

Recently *Cook Laboratories* made available a record, called the "NA Beam Test Record for Intermodulation Distortion," which enables the listener to detect, by ear, distortion over 2%. This value can be achieved with readily available high-fidelity components and may, arbitrarily, be considered the maximum allowable for top quality reproduction. Upon playing the record, if the listener hears dot-dash (A), his system has less than 2% intermodulation distortion. If the distortion is greater than 2%, he hears dash-dot (N).

This test record accomplishes the N-A indication by having two frequencies, 1000 cycles apart, sweep the audio band. One uncoded signal sweeps from 20,000 cycles to 4000 cycles, while simultaneously a second signal, coded dash-dot, sweeps from 19,000 cycles to 3000 cycles. While these two frequencies are sweeping, a third signal, a 1000-cycle constant pilot tone coded dot-dash is also recorded. The amplitude of the pilot tone corresponds to 2% of the average carrier envelope and furnishes a sensitive reference comparison for the 1000-cycle difference between the two sweep frequencies. Thus, if the intermodulation distortion in the playback system is 2%, the 1000-cycle pilot tone (A) is dominant; if the 1000-cycle intermodulation between the sweep frequencies is over 2%, it overrides the 1000-cycle pilot tone and reads out N. One side of this record is for monaural and the other side for binaural systems.

### Styli and Record Wear

The introduction of microgroove records necessitated a reduction in the radius of the stylus tip from 0.003 in. for 78 rpm to 0.001 in. This means the stylus contact area is reduced to 1/9 of what it used to be. Despite decreased weights for pickup arms, the stylus pressure on the record runs to several tons per-square-inch. As records are played, they tend to wear the stylus tip to the shape of the groove, particularly if the stylus is made of soft material. Not only does this cause

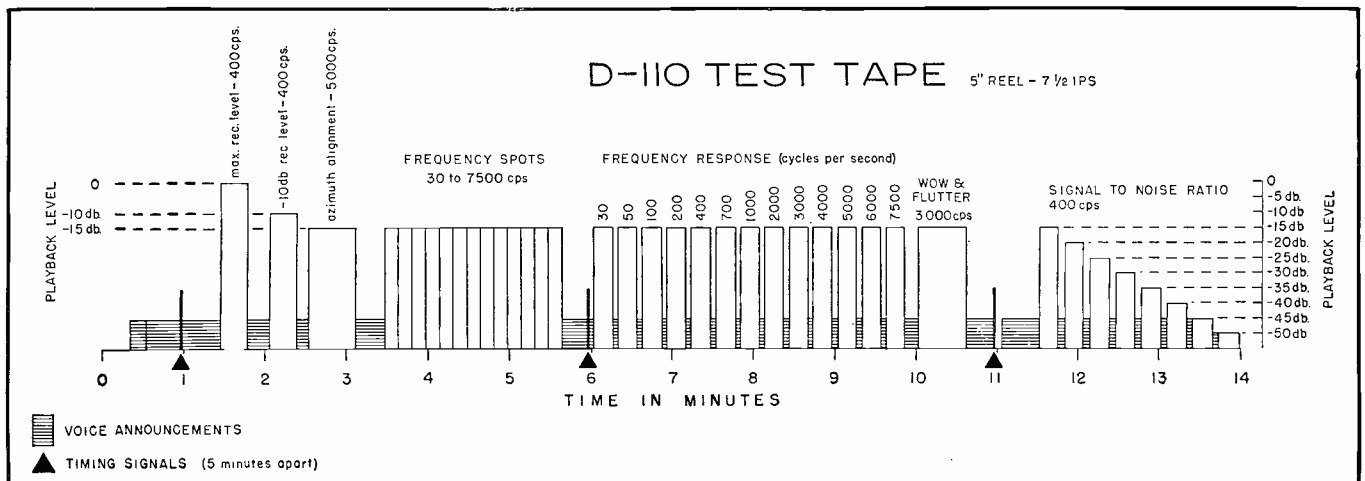

the record grooves to wear out, but noise, distortion, and lack of high frequency response results.

When fiber or soft steel needles were in vogue, after one or two playings they were rejected as worn and replaced, if the music lover knew what was good for his records. Considering that the needle covers a distance of about  $\frac{1}{8}$  mile for a 12-inch 78 rpm disc, it was no wonder that the soft steel wore out quickly. People then started to fit their pickups with sapphire styli (usually made synthetically) or diamond styli (generally natural stones). Sapphire is a considerable improvement over steel. It is easily polished and not very expensive, but it is not a permanent needle. To safeguard records properly, sapphire styli often must be replaced after about seventy playings. Such replacement is costly enough to pay for a diamond stylus, which, if carefully made, can last for over a thousand playings, which is just about "permanent" for most practical considerations.

To check stylus wear, it can be examined under a microscope. Since this is not always convenient, *Audak* has developed a stylus test record which accelerates the rate of record wear. By employing a soft record material, extra weight on the pickup arm, and an eccentric center hole, the record enables the listener to detect a worn stylus by observing a change in the color of the test grooves after they have been played with a defective stylus.

### Equalization

In recording music on a record with a flat recording characteristic, if the stylus velocity is to remain constant, it is necessary that the amplitude of the lateral wiggles of the groove increases as the recorded frequency is decreased. If the stylus were adjusted to make efficient use of the groove width at a low frequency, the amplitude of the stylus movement would be exceedingly small at the higher frequencies; so much so that the high frequency sound would be lost in the inherent surface noise of the record.

To overcome these two limitations, instead of recording with a flat characteristic, the low frequencies are attenuated to restrict stylus amplitude, and the high frequencies are boosted during recording to obtain an advantage over the record's inherent noise. To compensate for this non-uniform recording characteristic, the playback system should employ some form of tone control or equalization to boost the lows and attenuate the highs and thus bring about reproduction equivalent to the original sound.

The choice of exact turnover frequencies, where the bass and treble are respectively attenuated and boosted during recording, is somewhat arbitrary. To the dismay of audio enthusiasts, the various record manufacturers and professional associations, which usually establish standards, did not agree on a single characteristic

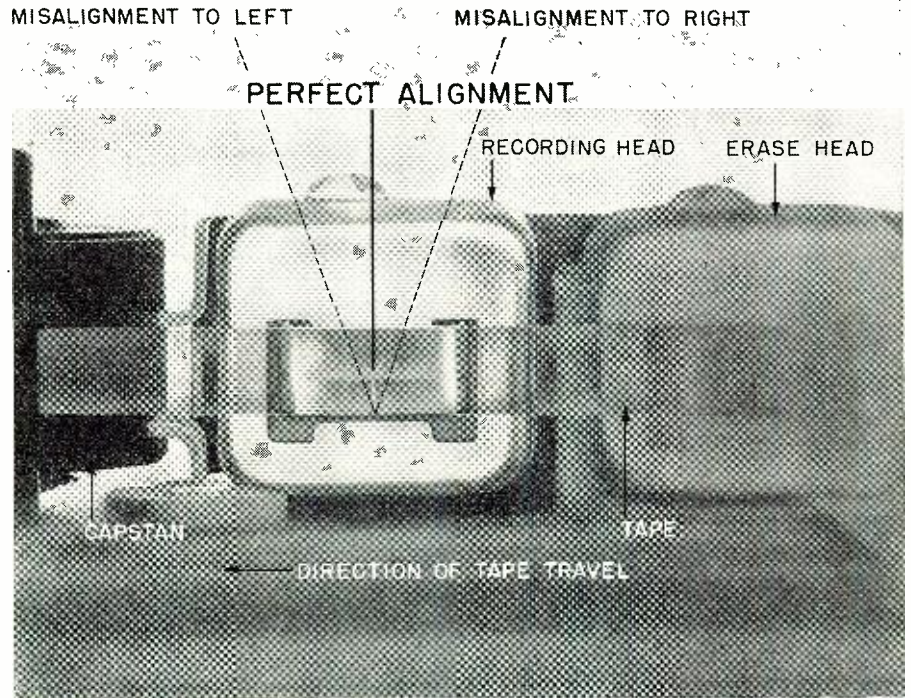

Perfect alignment of the recording head can be determined by using a special test tape. Correct alignment is indicated when maximum output is obtained. This is assuming, of course, that the test tape was recorded on a perfectly aligned machine.

curve. There are four curves in widespread use in the United States today. They differ in detail, but all employ the compensation principle just described.

The simplest systems employ bass and treble controls to compensate for the recording characteristic curves. But how much for each curve? How is the more advanced method of using an equalizer with preset electronic circuits which compensate for the different curves at the flick of a switch to be checked and adjusted to maintain efficiency?

To overcome the equalization bugaboo, *The Dubbings Company* has made a 12-inch, 33 $\frac{1}{3}$  rpm test record available, the D-101—"The Measure of Your Phonograph's Equalization." On it are

recorded four identical frequency runs ranging from 30 to 12,000 cycles in 13 steps, and cut according to four different recording curves: AES (Audio Engineering Society), NARTB (National Association of Radio and Television Broadcasters), *Columbia LP*, and *RCA's "New Orthophonic."* With this record and a vacuum-tube voltmeter or the simple test-level indicator to be described, the phonograph system can be adjusted for optimum performance.

When this record is used to test a system without an equalizer, approximate equalization can be obtained by adjusting the amplifier tone controls. These calibrations can then be used permanently to compensate for any of

(Continued on page 142)

A simple gadget that can be used in place of a v.t.v.m. to check output of an audio system. Circuit (A) is a three-bulb arrangement which will indicate a variation of  $\pm 3$  db. In actual use the output level is increased until the center bulb barely glows. Then as output is varied and either one of the other bulbs lights it indicates a 3 db variation. Circuit (B) is similar to (A) with the exception that a wider output range can be measured with a 2 db variation between bulbs. In use, it is connected across any speaker having a voice-coil impedance from 4 to 16 ohms. Photo at right is a commercial version of three-bulb unit of Circuit (A).

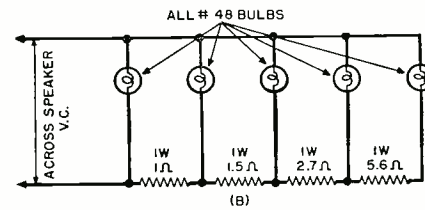
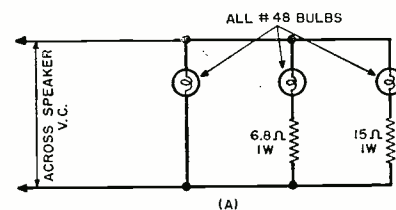
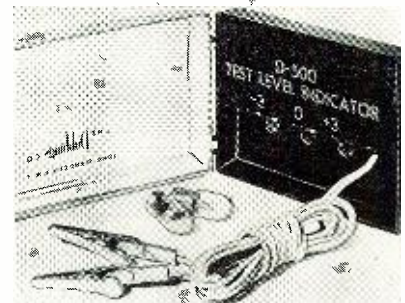

# Simplified

## CROSS-COUPLED AMPLIFIER

By  
**CHARLES P. BOEGLI**  
Cincinnati Research Company

Revised version of a 1948 circuit. It could be used as an input stage to an amplifier fed by a preamp terminating in a cathode follower. Standard components are used throughout.

SEVERAL years ago a rather unusual cross-coupled amplifier was described by Van Scoyoc.<sup>1</sup> This stage, Fig. 1, has a large number of interesting characteristics; it can, for example, serve as a phase inverter in which the push-pull output is perfectly balanced at all frequencies. The amplifier can also be supplied with a push-pull input; the push-pull output is then perfectly balanced irrespective of the unbalance that may exist in the input signals. The original article described a number of applications of this noteworthy circuit, which might be considered the vacuum-tube equivalent of a single or push-pull plate to push-pull grid interstage transformer.

This circuit can be simplified into the vacuum-tube equivalent of a line

to push-pull grid transformer, Fig. 4, by eliminating the input tubes of the original circuit which functioned as cathode followers and feeding the signal directly into the cathodes and grids of the amplifier tubes. Since the cathode resistors of these tubes can be made quite small, a balanced impedance of 600 ohms is easily obtained. The outputs from the plates are balanced irrespective of the manner in which the input signal is applied, that is, whether the signal is applied between the two outside terminals (push-pull input) or one of the outside terminals is grounded for a.c. and the input is applied between the outer outside terminal and ground, as with single-ended input. The analogy of this circuit to its transformer equivalent

is quite complete, even to the cancellation of second-harmonic distortion when two-phase input is used.

To investigate the distortion and other characteristics of the circuit, stages utilizing a 6SN7 and 6SL7 connected as in Fig. 4, were used. The "B+" voltage was 400 and the load resistors  $R_L$  were 100,000 ohms each. The cathode resistors  $R_c$ , which determine the input impedance of the stage, were 300 ohms each. The grid-bias resistors  $R_g$  were 680 ohms for the 6SN7 and 1600 ohms for the 6SL7, producing in each case a grid bias of about -2 volts. A balanced input was furnished to the two terminals by means of a high-quality line-to-line transformer (Triad HS-56) and the intermodulation distortion in the output was measured for frequencies of 60 and 3000 cps in the ratio of 4:1. The gain of the 6SN7 stage was 25 and that of the 6SL7 stage was 40.

Fig. 3 shows the intermodulation distortion measured for the stages utilizing the two tubes mentioned previously. It is worthy of note that the 6SL7 stage has much less distortion than the circuit using the lower- $\mu$  6SN7. There is a certain amount of degeneration caused by the unby-passed cathode resistors and this reduces distortion in proportion to the amplification of the tubes. In addition, the 6SL7 requires a smaller input signal to produce the same output, which tends to reduce the distortion.

The effect of the bias-resistor size ( $R_g$ ) on the performance of the 6SL7 stage was investigated by measuring the intermodulation distortion at a fixed output of 15 volts r.m.s. as the bias resistors were varied. Fig. 2 shows the result; the distortion is not greatly affected by the values of the bias resistors (as long as the grids are not driven positive) but there is a

(Continued on page 81)

Fig. 1. The original cross-coupled circuit as described by J. N. Van Scoyoc in 1948. Fig. 2. The influence of the bias resistors on intermodulation distortion of 6SL7 stage. The output is 15 volts. Fig. 3. Intermodulation distortion for the simplified cross-coupled stage, under the conditions described in the article. See text for data. Fig. 4. The author's simplified version of the cross-coupled amplifier circuit.

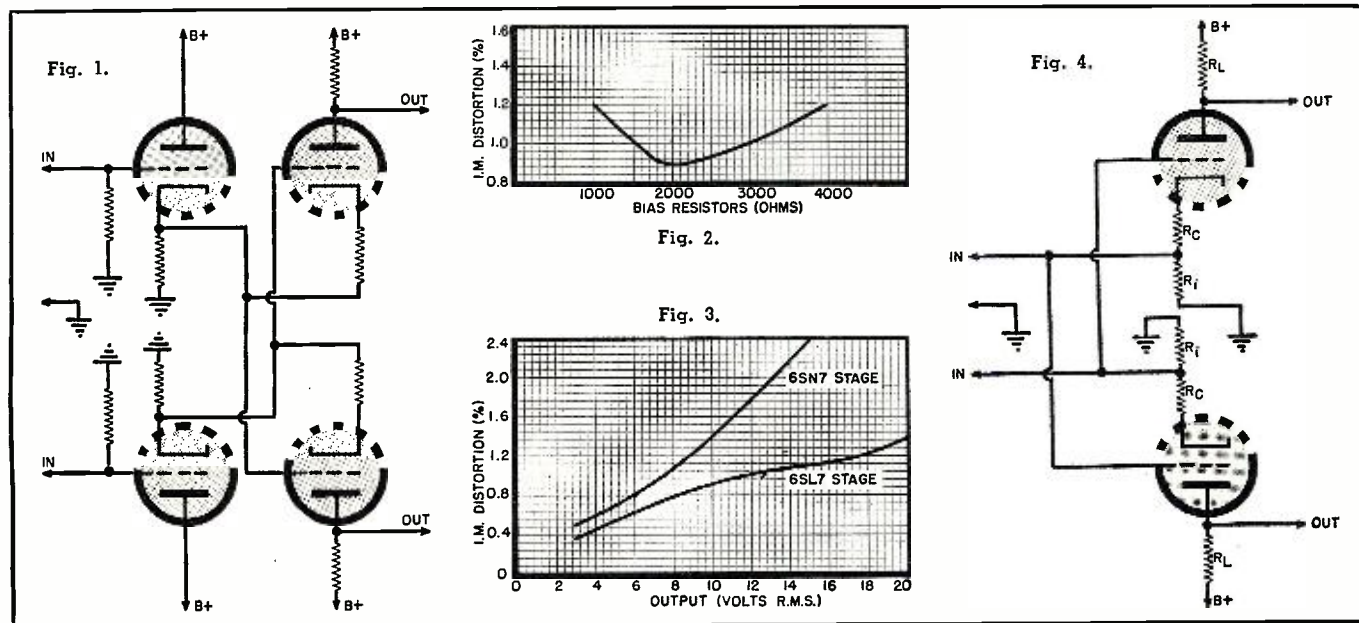

# COMPACT 2-METER RIG

By **WOODROW SMITH**  
Chief Engr., Gonset Company

Front panel view of the Gonset "Communicator II" 2-meter transmitter-receiver.

Details on a compact unit which can be used by amateurs, the CAP, airports, and as a "unicom" for small landing fields.

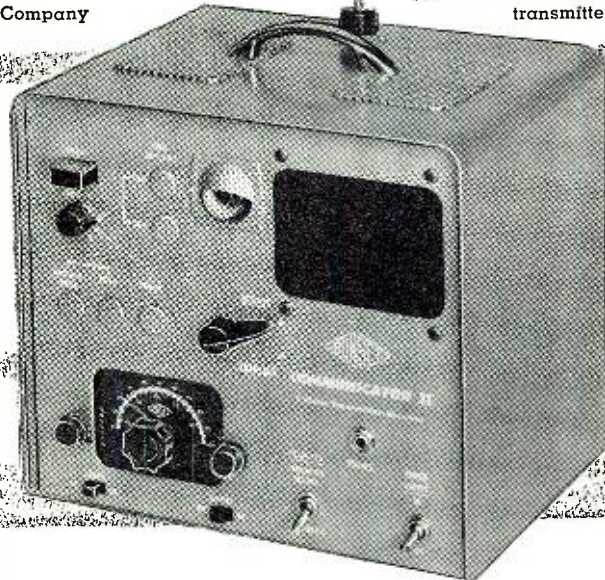

**B**ECAUSE it happens so frequently, few people are surprised when history repeats itself. Back in the mid-thirties a happy bedlam usually reigned on the old 5-meter band, at amateur conventions, as a result of the high incidence of portable and mobile transceivers. Activity in general on the 5-meter band (referred to as "u.h.f." in those days) was high and weekends during good weather saw devotees taking off for the hills in droves to work a little "extended DX," distances not usually possible from the average city location.

Later, in the years just before World War II, substantially the same cycle was repeated on the old 2½-meter band. There were some serious workers using high power crystal control and superhet receivers, but the bulk of activity was still represented by the simple transceiver of two or three tubes, using a superregenerative receiver with the oscillator doubling up for transmitter service.

The war brought an end to such activity and afterwards it was not immediately resumed. It was generally conceded that the simple modulated oscillator and superregenerative receiver were outdated and the tightening up of the regulations regarding transmitter stability on the 2-meter band was an added deterrent. The non-selective, radiating receiver and the "wobulated oscillator" transmitter went out the window in the interest of greater band utilization. This would make it possible for more stations to operate at the same time before QRM reached intolerable proportions. There was only one trouble: except during an "opening" or a special "field day," occupancy of the band usually was much less than during the old prewar peak of 2½-meter operation.

There could be but one reason. A 2-meter station "with a handle on it" meeting the new requirements was not within the construction capabilities of a large number of potential users and

no such factory-built gear was on the market. Gambling that a piece of factory-built gear which would take the place of the old *Abbott*, *Haigis*, and other then-popular transceivers would find a wide market, a transmitter-receiver unit meeting present day stability and selectivity requirements was developed and put in production.

The complexity of such equipment, as exemplified by the Gonset "Communicator," contrasted with that of a typical "prewar" transceiver is readily apparent from a comparison of the block diagrams of Figs. 1 and 2. However, it seems that complexity of equipment does not bother even the  
(Continued on page 88)

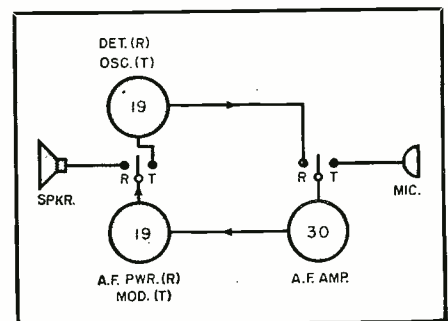
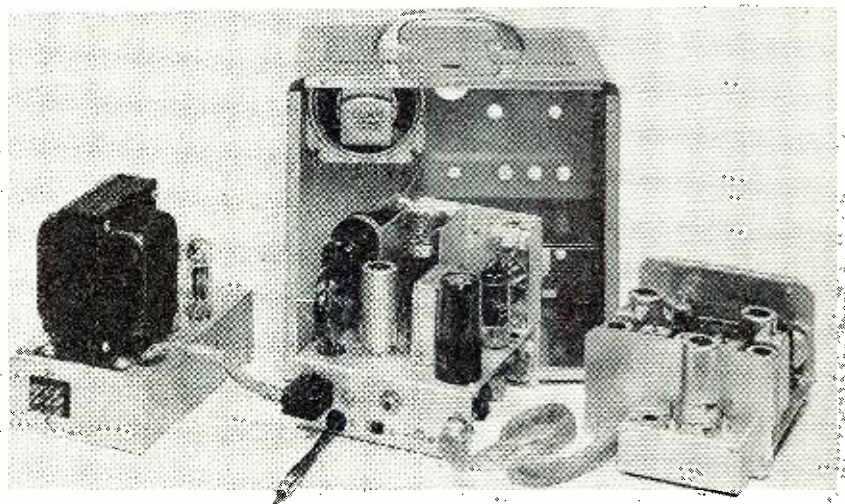

Fig. 1. Block diagram of an amateur transceiver popular in the 1930's. Actually, this was a "deluxe" job as many such units used only two tubes. Simple but effective, its chief drawback was that it was very uneconomical of the spectrum space.

The modern transceiver has from five to ten times the number of components as its prewar prototype. Shown here are the three basic units of the "Communicator": universal power pack (left), transmitter r.f. and composite audio (center), and the receiver (right). The cabinet and speaker are shown at the rear of the photo.



# THE CONTINUOUS EVOLUTION IN TV ANTENNAS

By  
**EDWARD M. NOLL and MATTHEW MANDL**

*Technical progress and changing reception conditions have led to the development of many new types of TV antennas. Some of these new ones are described here.*

THE antenna remains a most important element in TV reception. In fact, more and more is expected of antennas nowadays—there are more multi-station areas than formerly, more channels, and more fringe-area viewers. These variables, plus competitive hypertension, lead to an endless parade of new antenna models reaching the market. This article will describe some of these new models and the problems which they are designed to overcome.

One of the most perplexing problems of antenna evolution today is the development of a basic type that can offer all-band performance of a sufficient quality to approach the per-

formance of a dual v.h.f.-u.h.f. installation. The common approach has been to modify a v.h.f. type to a combination v.h.f. and u.h.f. type.

Although these antennas do the job for which they are intended, namely, to receive v.h.f. and u.h.f. signals of sufficient strength to operate a TV receiver, many of them do not give the relatively high gain we have come to expect from v.h.f. antennas. To some extent, this is due to a loss of efficiency of the v.h.f. antenna because of the structural changes needed to convert it for u.h.f. reception. In some cases the reception pattern may become narrow and difficult to orient, with side lobes susceptible to reflections; or poor standing-wave conditions may result giving erratic reception and deterioration of gain.

Another approach to the combination v.h.f.-u.h.f. antenna is to redesign a good u.h.f. antenna to permit v.h.f. reception. In this technique, one need make little or no compromise with the antenna performance on the u.h.f. band. Thus, the gain and reception of the u.h.f. antenna is not disturbed an alarming amount, and the performance on the u.h.f. band (where performance is at present most critical because of limited propagation range and prevalence of dead spots) is at peak efficiency. The v.h.f. performance need be

sacrificed just slightly with respect to the higher gain v.h.f. antennas.

A typical v.h.f.-u.h.f. antenna evolved from a good u.h.f. antenna is illustrated in Fig. 1. In this antenna a standard corner reflector with a bow-tie driven element is used for u.h.f. reception. By properly positioning a single and longer v.h.f. dipole in the corner reflector, v.h.f. reception can be added without sacrificing u.h.f. performance. The addition of other v.h.f. elements, or metallic or insulated supports into the center of the corner reflector or near the point of transmission line attachment, results in an increasing deterioration of u.h.f. performance. The simple dipole addition does, however, introduce some minor lobes to the u.h.f. antenna pattern.

## U.H.F. Antennas Without Insulators

Most insulators lose some of their insulating qualities at u.h.f., and leakage currents through the insulator or through deposits that form on the insulators can cause substantial signal losses. Inasmuch as a quarter wavelength is a short dimension in terms of inches for u.h.f. band operation, it is possible to use metallic stubs to function as insulators for a u.h.f. antenna.

Fundamental knowledge of transmission line characteristics tells us that a shorted quarter-wave section of line has a high and maximum impedance at its open end. A quarter-wave stub (see Fig. 2A) is such a device. When connected across any low impedance, such as an antenna or low-impedance transmission line, it has no adverse effect upon the operation of that antenna or line. Consequently, no insulator, as such, is required and the separation between dipole elements of the u.h.f. antenna is strictly an air dielectric separation which is better than any practical insulating material. In fact, the presence of the quarter-wave stub can also improve the bandwidth of the driven element to which it is attached.

The quarter-wave stub has a maximum impedance that is resistive at its resonant frequency and, likewise, the antenna is resistive at resonance. However, an antenna is considered to be a series-resonant circuit, and off of the

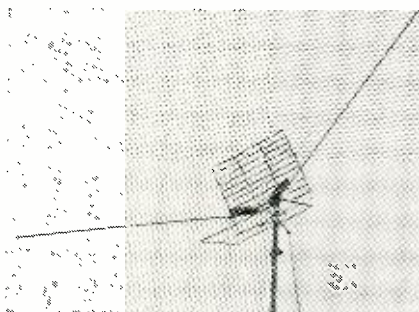
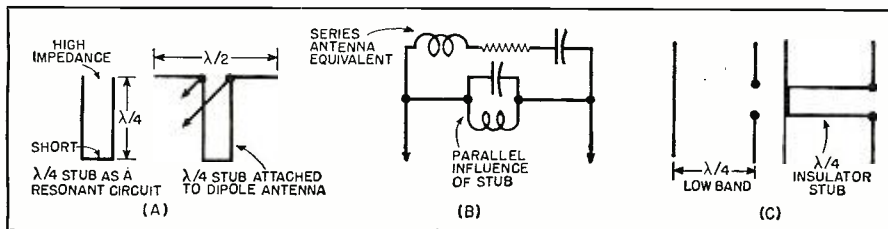

Fig. 1. Modifying a u.h.f. antenna results in the v.h.f.-u.h.f. type shown here, designed for primary TV areas.

Fig. 2. (A) A quarter-wave stub attached to a dipole antenna, (B) the influence of a stub on antenna bandwidth, and (C) method of attaching stub to u.h.f. antenna.





resonant frequency it has reactance as well as resistance. Thus, the impedance of the driven element rises above and below its resonant frequency. At a signal frequency above resonance a series-resonant circuit becomes inductive because of the limiting influence on current flow by the rising inductive reactance; below the resonant frequency, the antenna becomes capacitive because of the limiting influence of rising capacitive reactance on current flow. This rising impedance limits the bandwidth over which an antenna is sensitive and can transfer signal to the low-impedance transmission line. However, the presence of a parallel resonant circuit (quarter-wave insulator stub) can increase the effective bandwidth of the antenna because of its opposite reactance change with respect to frequency. Above resonance, a parallel resonant circuit becomes capacitive because current flow in the parallel resonant circuit is determined by the lowest reactance. Below the resonant frequency, a parallel resonant circuit becomes inductive (lower inductive reactance below resonance). The net result of having the two resonant circuits (series antenna circuit and parallel stub circuit) in parallel, as in Fig. 2B, is to cancel the reactive effect and maintain a purely resistive antenna impedance over a wider band of frequencies.

A simple method of incorporating a shorted quarter-wave stub on a u.h.f. antenna is illustrated in Fig. 2C. In this arrangement, the transmission line is connected to the front of the antenna, and two connecting lines are shorted together and attached to the rear element. Thus, the connecting lines between the two sections of the antenna act as a quarter-wave stub with relation to the point of attachment of the transmission line, while the back section of the antenna functions as a conventional reflector. This arrangement improves the performance of the basic antenna. In fact, the band-widening influence of the stub makes this antenna comparable to the higher-gain conical type.

One of the first such antennas for u.h.f. service is shown in Fig. 4A. In this antenna, consisting of a bow-tie and reflector, metallic spacers are used to attach the bow-tie to the screen reflector without the use of an insulator. The quarter-wave separation between bow-tie and reflector (four to five inches near the center of the u.h.f. band) permits the metallic supports to function as a stub and prevents shunting of the bow-tie elements. The point of mechanical attachment of the metallic spacers to the bow-tie elements is positioned away from the point of transmission line attachment, minimizing leakage currents and permitting greater uniformity of response over the u.h.f. band.

A corner reflector u.h.f. antenna, using metallic supports between the bow-tie and the apex of the corner reflector, is shown in Fig. 4B. Here the dimension between the corner reflector

apex and the bow-tie had to be chosen as an optimum between proper focus position for the bow-tie in the screen, and the quarter-wave dimension required by the insulator stub arrangement. However, the stub arrangement does permit a corner reflector design with a higher gain and more uniform response than one employing an insulator.

Another major advantage of the metallic support plan is the ease with which the antenna design can be made into a single preassembled unit, permitting ease in packing, storage, and installation.

### New V.H.F. Antennas

The problem facing v.h.f. antenna designers the past few months has been how to obtain high-gain reception on more v.h.f. channels and a better reception pattern on all v.h.f. channels.

For some time now the yagi antenna has predominated in weak signal areas. However, into these very same areas have moved new v.h.f. channels, more sensitive receivers, and transmitters with higher v.h.f. powers. This has introduced co-channel and adjacent channel interference problems in many areas where they did not exist before. Consequently, the accent in present v.h.f. antenna design is more toward improving the antenna pattern rather than the gain. It is a fact that, in many areas where co-channel interference or other types of interference exist, an improved antenna pattern on a modern sensitive television receiver results in an apparent gain improvement because of the added clarity and stability of the picture.

Constant v.h.f. antenna improvements led to the development of yagi types that covered two or three adjacent television channels and, finally, the low-band yagi and the high-band yagi. For v.h.f. all-channel reception this requires two separate transmission lines and a switch at the receiver input, or the use of a high-band-low-band isolation filter which introduces some signal losses. The next logical step to obtain v.h.f. all-channel reception is to compromise reflector, driven element, and director lengths to permit operation over this greater span of v.h.f. frequencies. The modification necessary, however, makes the antenna look so different that it can only loosely be considered as a modified yagi.

The requirements of a v.h.f. all-channel antenna in terms of electrical performance are that there must be effective reflector action for each channel, a uniform impedance and sensitivity for driven element or driven element grouping for all channels and, wherever possible, effective director action as well. In one new antenna (see Fig. 3), effective reflector action is obtained by using a large screen-type reflector with varying reflector lengths. This type of construction permits peak reflector gain for the various channels as well as good shielding action in the rear for a good front-to-back ratio and minimum co-channel

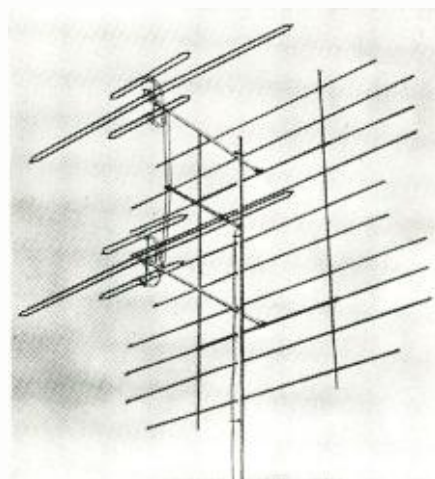

Fig. 3. An all v.h.f. band TV antenna, two-bay array, with reflector screen.

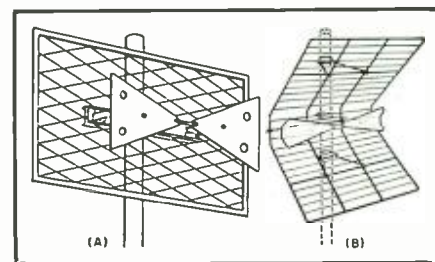

Fig. 4. Two commercial u.h.f. antennas using quarter-wave stubs as insulators.

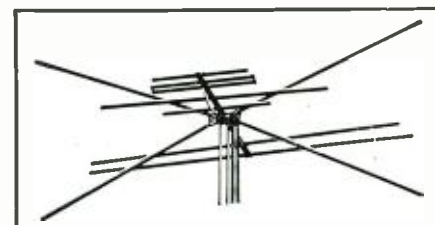

Fig. 5. Single-bay all-channel v.h.f. antenna with directors for high and low bands and multiple reflectors.

interference. The driven elements form a long folded dipole for the low band, and three smaller dipoles for the high band, with a central feeding point.

Still another approach is the antenna shown in Fig. 5 which uses directors. This antenna also contains dual reflectors for the low band, and combina-

(Continued on page 145)

Fig. 6. All v.h.f. band antenna with adjustable tilt conical for high band.

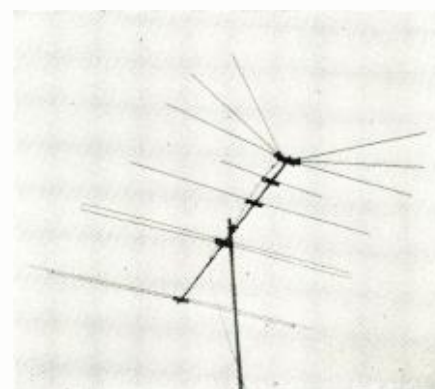



# TROUBLESHOOTING

By **CARL J. QUIRK**

Allen B. Du Mont Laboratories  
Author, "A Handbook of Television Interference"

*Part 1. A comprehensive survey of the causes, cures, and types of TV interference for service technicians.*

**S**INCE the advent of postwar commercial TV, the average service technician has been doing a better-than-average job of maintaining the nation's millions of TV receivers. Despite adverse publicity, most customers are given fair treatment and honest service. When a service technician fails to satisfy a customer it is usually a case of insufficient knowledge rather than a lack of interest or a desire to do well.

The working knowledge of service technicians doing everyday service work should include a clear cut picture of TV interference (TVI) problems and their solutions. In the material to follow, we will spell out all the rules necessary to identify and cure the vast majority of interference problems encountered.

Any good service technician, upon approaching a TV set that requires his attention, immediately analyzes the effects that he sees and hears as part of his procedure to quickly solve the problem. He is interested in establishing what section of the receiver is faulty before he starts his tests. In this article, a similar approach will be made to interference problems. The first step is to very carefully examine the interference pattern on the CRT to place it into one of five TVI classifications. Once classified, the technician can then proceed to make tests and effect a cure.

Most types of interference can be broken down into five general categories. Each classification is tabbed according to the appearance of the interference superimposed on the desired picture on the face of the CRT. These classifications are: 1, Unmodulated; 2, Frequency Modulated (FM); 3, Video Modulated; 4, Burst Modulated; and 5, Mixed Modulated.

Before any misunderstanding arises, the assignments in terms of modulation apply specifically and directly to the appearance of the interference and are not necessarily applicable to the source of the interference. For exam-

ple, the fact that an interference is classified as belonging in the unmodulated group does not mean that its source transmits an unmodulated signal. As we discuss each classification, we will point out those cases where the type of modulation of the source may not produce the same type interference modulation.

## Unmodulated Interference

The interference pattern presented in Fig. 1 illustrates one form of unmodulated interference. The effect produced by this type of TVI is a pattern of straight lines completely covering the picture. These lines usually run diagonally across the picture as in Fig. 1, however, in certain unusual cases they may be vertical or, more frequently, horizontal.

The number of lines depends on the frequency difference between the effective frequency of the interference and the video carrier frequency of the channel affected. This visual effect in TV is analogous to the squeals or whistles that are often heard in radios and technically referred to as heterodynes. Any change in frequency will result in either a change in the direction of the lines or a change in the number of lines, depending upon the amount of the frequency change, as will be discussed later.

The term "unmodulated" as used here, therefore, refers to this diagonal-line type of interference whose pattern does not change with modulation. Some of the unmodulated sources of this type of interference are:

1. Local oscillator radiation from another TV receiver
2. Local oscillator radiation from an FM receiver
3. An amateur radio station

The following sources of modulated signals can also cause this type interference:

1. Another TV station operating on the same channel
2. A strong high channel TV station related to a lower one through an i.f.

response, causing interference on the lower channel

3. Radiation of harmonics of the video i.f. of the receiver in question

4. A standard radio broadcast station

## Frequency Modulated TVI

Fig. 2 illustrates the pattern that will mask the desired program when FM interference is received. Unlike the unmodulated type, this interference is always caused either directly or indirectly by a source of frequency-modulated signals. A direct cause is when an FM signal beats against the video carrier of the desired station. An indirect, and much less frequent, cause is when an unmodulated signal falling into the desired channel beats against the FM sound carrier of the desired station. Normal procedure on the part of the viewer to eliminate the latter is to detune the set slightly so that the sound carrier drops and thus reduces or eliminates the beat.

For the benefit of those who have never had the questionable pleasure of witnessing FM interference, there are several characteristics that must be recognized by the observer.

If you were to watch the interfering pattern on the TV screen while listening to the FM broadcast causing the interference, you would notice that small segments of the beat lines would shift direction in accordance with the modulation. With music this is not too apparent except to an experienced observer. In the case of voice modulation however, recognition is immediate because when the person who is talking pauses, the pattern reverts to the unmodulated form. As a matter of fact, an aid to solving a case of FM interference is to determine the source of the interference, and using an FM radio is one of the best methods for identifying the culprit, as will be discussed in greater detail later.

When the frequency of the beat is low (under 100 kc.), see Fig. 3, the pattern is not as distinct as when the



Fig. 1. Picture on CRT with unmodulated type interference. The number of bars is the key to the frequency of the TVI.

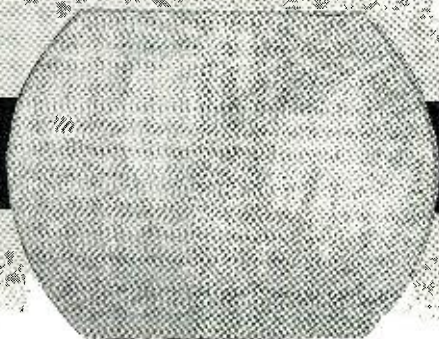

Fig. 2. A typical case of FM interference on the picture tube of a TV set. The interference lines move constantly.



Fig. 3. A case of low-frequency FM interference. The TVI is not as apparent here as in Fig. 2, note the background.

beat frequency is higher. However, little difficulty will be experienced in recognizing the changes in the pattern with modulation.

FM interference can be caused by one of the following:

1. Standard FM broadcasts
2. The sound carrier of a TV station occupying the channel immediately below that to which the set is tuned (adjacent channel sound interference)
3. The sound carrier of a high channel TV station which beats with the video carrier of a low channel TV station to which the set is tuned
4. Radiation from the sound i.f. strip of the receiver
5. The 4.5 mc. difference between the sound and video in the TV set
6. Police radio stations, both fixed and mobile

#### Video Modulation

Video modulated interference, as shown in Fig. 4, usually takes the form of a superimposed picture which swings back and forth across the desired program. When the interfering signal is strong, recognition poses no particular problem as the undesired signal must come from another TV station. However, when the interference is weak, only the higher amplitude sync and blanking signal will be seen in the form of a vertical bar swinging across the picture. In such cases, identification will involve mathematical relationships between neighboring stations and the interfered with station.

Incidentally, because of this side-to-side movement of the interfering signal, this type of interference is often referred to as the "windshield wiper" effect.

Unlike the previous types of interference discussed, the only possible source of such interfering signals is other TV stations. Interference-causing stations are confined to the following:

1. Adjacent channel—video carrier of TV station on next higher channel
2. Co-channel—signal of TV station occupying the same channel as the desired station
3. Strong nearby stations—cross modulation
4. A high-channel TV station which

interferes with a low-channel station due to a "beat"

#### Burst Modulation

The term burst modulation merely signifies that the interference effect, instead of appearing as a superimposition over the entire picture area, is superimposed on a section of the picture. Such bursts may appear as a vertical bar interference, as shown in Fig. 5, which illustrates the well known Barkhausen effect, commonly associated with the horizontal output circuit. In Fig. 6 is an example of a horizontal burst which was caused by an electric light bulb.

The interference band may remain stationary or, as in some cases of horizontal bursts, such as light bulb interference, the band may slowly drift upward or downward.

The more common sources of this type of interference are: diathermy equipment, sweep generators, incandescent light bulbs, fluorescent light bulbs, Barkhausen oscillations, defective motors, and automobile ignition systems.

#### Mixed Modulation

This interference consists of the pattern resulting when two or more signals react on the desired one. The mere existence of two or more interfering signals seen at one time on a channel does not necessarily place the condition in this classification. If, however, the two signals heterodyne together in some mathematical relationship to produce a resultant interfering signal in a superhet response for the channel affected, then the condition would belong in this classification. For example, if an FM signal beat with a video signal and produced an interference on a high-channel TV station, both the video modulation and the FM pattern would be visible. Furthermore, if one of the signals was sufficiently attenuated, then the interference would be eliminated.

The main reason for assigning a separate classification for such conditions is to alert the observer to carefully scrutinize each interference effect he sees and to account for all the beats that are present. In many cases, more

(Continued on page 128)

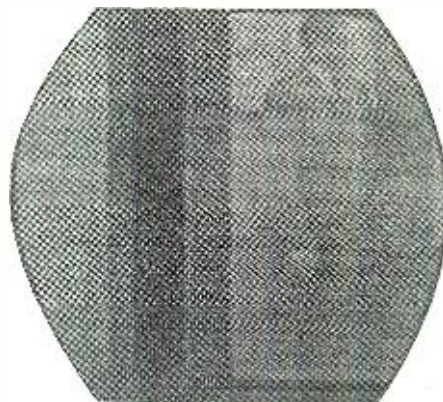

Fig. 4. Typical example of video modulated TV interference. The black bar moves across the tube and reappears.

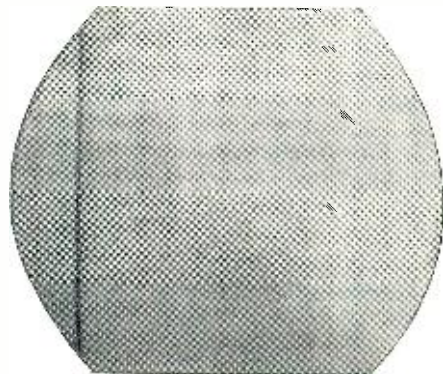

Fig. 5. The interference shown here is due to Barkhausen oscillations in horizontal output circuit of TV receiver.



Fig. 6. The interference bar shown on the lower portion of the pattern is due to radiation from an electric light bulb.

# USING THE D.C. SCOPE

# TO MEASURE

# AMPLITUDE MODULATION

By  
**R. M. COHEN and J. H. OWENS**  
Tube Dept., Radio Corporation of America

*Simple and accurate method, for use at 2 meters as well as 75, for measuring and observing amplitude modulation.*

**T**HIS article describes a simple and accurate method for the measurement and observation of amplitude modulation which may be used at 2 meters or 1 $\frac{1}{4}$  meters as well as on 75. The only special equipment required in this method is a d.c. scope. Because the vertical amplifier of such a scope is direct-coupled all the way from the input terminal to the deflection plates on the cathode-ray tube, the frequency response is flat down to zero cycles (d.c.), and the d.c. sensitivity is equal to the peak-to-peak a.c. sensitivity.

## Description of Method

In the method to be described, direct connection or tight coupling to the high-voltage and high-power circuits in the transmitter is avoided. When direct coupling is used, connections are made to the r.f. output transmission line; when loop coupling is used, the loop is very loosely coupled to the output tank circuit. The required r.f. voltage in the loop-coupled arrangement is only two or three volts.

Fig. 1A shows a suitable arrangement of test equipment for measuring and observing amplitude modulation. The pickup loop is loosely coupled to the output of the radio transmitter, the output is rectified by the detector, and the resultant d.c. output voltage is supplied through a low-pass r.f. filter to the vertical input of the d.c. scope. The audio frequencies are not filtered from the output of the rectifier. No physical connection is made to the transmitter or modulating circuits.

The pickup loop is placed inside the transmitter cabinet and is loosely coupled to the final tank. The 270  $\mu$ fd. coupling condenser, the 0.12-megohm diode load resistor, and the 1N34A diode form a linear detector, the output of which is coupled to the d.c. scope through the low-pass filter

consisting of the 0.22-megohm resistor and a capacitance. The filter capacitance consists of the capacitance of the diode probe and cable, approximately 35  $\mu$ fd., and the input capacitance of the scope, which is approximately 35  $\mu$ fd. Because these capacitances are effectively in parallel, the filter capacitance is the sum of the two, or 70  $\mu$ fd. This value is high enough to short-circuit the r.f. effectively without removing audio modulation.

Fig. 1B shows an alternate arrangement of test equipment which is equally satisfactory and may be more desirable in some cases. In this arrangement,  $C_1$  and  $C_2$  comprise a capacitance voltage divider which acts as an attenuator.  $C_1$  is a small fixed condenser and  $C_2$  is a compression mica padder. The ratio of capacitance between  $C_1$  and  $C_2$  determines the attenuation ratio, i.e.,  $E_{crystal}/E_{total} = C_1/(C_1 + C_2)$ . If for example, the total r.f. voltage on the line were 100 volts,  $C_1$  were 10

$\mu$ fd., and  $C_2$  were 100  $\mu$ fd., then the voltage applied to the crystal would be 9 volts.

## Operation

1. The coupling between the pickup loop and the output of the transmitter is adjusted to provide an r.f. input signal to the detector of at least two but not more than twenty volts r.m.s. so that the detector will have satisfactory linearity. This adjustment is very important as will be explained later. The adjustment should be made at full unmodulated carrier output. The approximate r.f. level can be determined by measurement of the d.c. output of the low-pass filter with a high-impedance voltmeter such as a "VoltOhm-yst." If the deflection sensitivity of the scope is calibrated, as in the RCA WO-88A, or if the scope has an internal calibration meter, the auxiliary voltmeter is not required.

2. The transmitter is turned off and the horizontal-gain control of the scope adjusted for no horizontal deflection. The horizontal- and vertical-centering controls are then adjusted to center the spot on the face of the scope, as shown in Fig. 2A.

3. The carrier is turned on, unmodulated, and the vertical-gain control is adjusted until the spot moves exactly one major division on the face of the scope, as shown in Fig. 2B. The spot may move either up or down depending on the polarity of the circuit connections. The spot moves because the application of r.f. carrier causes d.c. voltage to appear at the output of the rectifier, deflecting the beam of the d.c. scope an amount proportional to the carrier amplitude.

4. The modulation is turned "on" and an audio signal is applied. Although it is not necessary that a sine-wave source be used for the audio signal, the use of such a source facilitates the interpretation of the information displayed on the scope because both the frequency and the output of the signal remain constant. The pattern now appears as shown in Fig. 2C. The spot travels up and down following the instantaneous value of the modulated voltage. Fig. 2C shows the excursion of the spot during 100 per-cent modulation, in which the no-signal value of

Fig. 1. Suggested arrangement of equipment for observing and measuring AM.

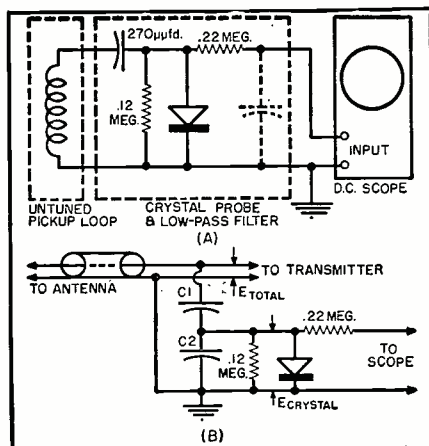

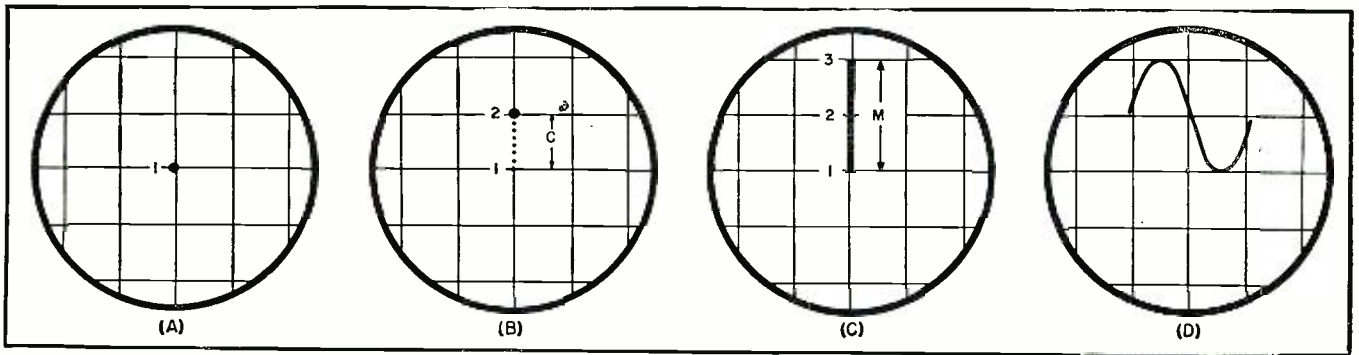

Fig. 2. (A) Spot centered on face of scope, no carrier, no modulation. (B) Spot moved vertically one major division on the face of the scope, carrier "on," modulation "off." (C) Vertical excursion of spot during 100 per-cent modulation from a sine-wave source. (D) Pattern observed for 100 per-cent sinusoidal modulation when horizontal sweep voltage is applied.

the carrier is doubled on positive peaks and is reduced to zero on negative peaks. The percentage of total modulation, both positive and negative, at any instant is equal to  $100M/2C$  where  $C$  equals the linear displacement in scope divisions of the spot caused by the application of the unmodulated carrier, and  $M$  equals the peak-to-peak length of the line in scope divisions resulting from the modulation of the carrier. If the modulation is symmetrical, the vertical line extends an equal distance above and below point 2, as shown in Fig. 2C.

5. If it is desired to observe the shape of the audio modulation, the horizontal-gain control of the scope is adjusted until the pattern extends across the desired width on the face of the scope. The sweep oscillator of the scope must be synchronized with the modulation frequency. Fig. 2D shows the pattern observed on the face of the scope in cases of 100 per-cent sinusoidal modulation.

Various types of transmitter distortion may be observed in the pattern on

the face of the scope as a result of overmodulation, unsymmetrical modulation, or audio nonlinearity. Figs. 3 and 4 show typical patterns which result under various conditions of transmitter misadjustment. In Figs. 3A, 3C, 4A, and 4C the patterns were obtained with the horizontal-gain control adjusted for no deflection, and the others were obtained with the gain control adjusted as in step 5.

#### Precautions

If this method of measuring and observing amplitude modulation is to be used successfully, some general precautions must be taken. In most cases, crystal-diode rectifiers or diode-type electron-tube rectifiers are not linear unless a sufficiently strong signal is impressed across their input. In crystal-diode rectifiers, linearity usually begins at an input voltage upwards of about 0.5 volt. In electron-tube diodes, linearity usually occurs at an input voltage of approximately 1.0 volt. Because the operation of this test method depends on the linearity

of the detector, input voltages of several times previously mentioned values are required. A crystal-diode detector, however, can be overloaded rather easily. It is advisable, therefore, to keep a check on the input signal to the crystal. Because the d.c. output of a diode detector is almost equal to the peak value of the a.c. input signal when the diode operates into a high-impedance load in shunt with a condenser, as shown in Fig. 1, it is possible to determine the magnitude of the r.f. input signal by measuring the d.c. output voltage. This measurement should be made when the carrier is unmodulated. The desired input signal can usually be obtained by adjusting the coupling of the pickup loop to the transmitter.

When this method of measurement is used with very-high-power transmitters, or high-frequency transmitters, problems may occur as a result of the presence of stray r.f. fields. If the probe cable is the correct length to resonate at the carrier frequency, the

(Continued on page 123)

Fig. 3. (A & B) Patterns showing unsymmetrical modulation due to distortion in a.f. system. (C & D) Unsymmetrical modulation due to insufficient r.f. excitation to final stage or to a.f. system distortion. See article for a complete discussion.

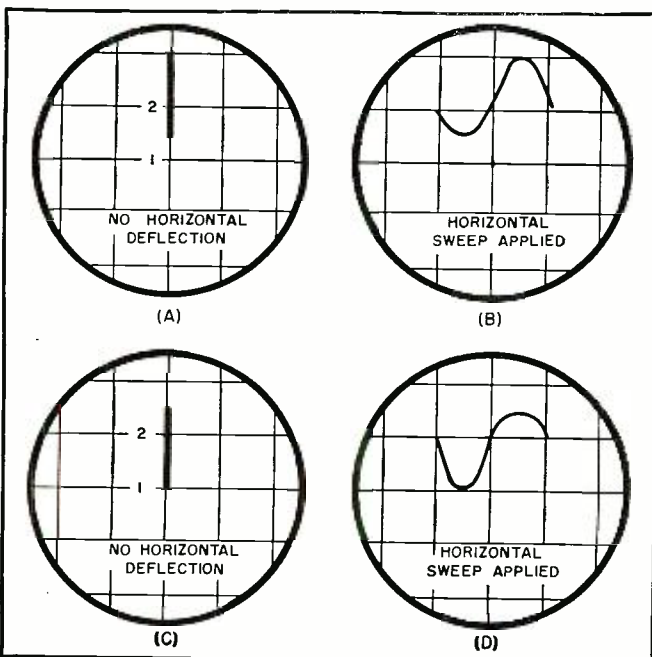
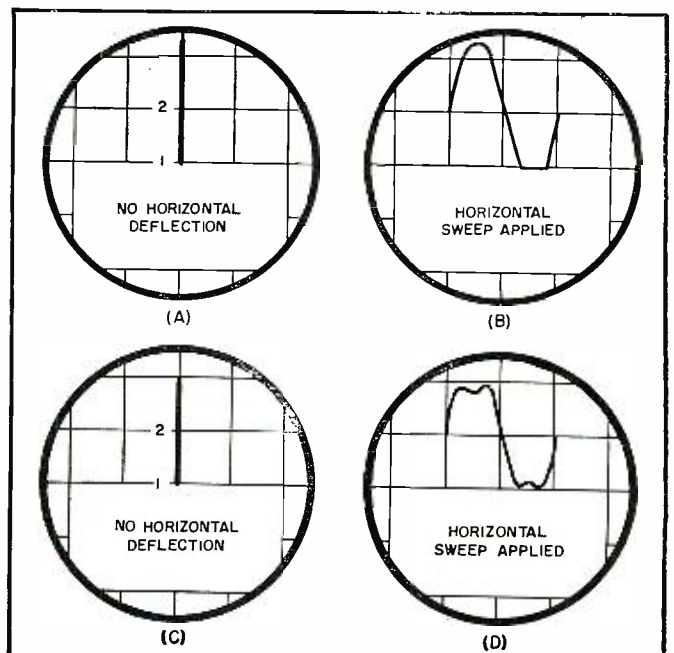

Fig. 4. (A & B) Patterns showing distortion due to over-modulation. (C & D) Patterns showing distortion in audio signal. All of the patterns shown were taken with the RCA WO-88A oscilloscope, a sufficiently linear and stable unit for this work.





# International SHORT-WAVE

Compiled by **KENNETH R. BOORD**

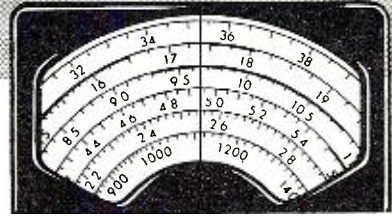

**T**HE North American Section, World Friendship Society of Radio Amateurs, with headquarters at 214 Delaware Ave., Toronto 4, Ontario, Canada, is eager to get members on the North American Continent. The organization, founded in 1935 and with general headquarters in England, is especially well-known for its "Bedfast Club" and its "Junior Section." Inquiries should go to Bob Kenny, c/o Mark Northcott, Route 2, King, Ontario, Canada, the Hon. Secy. for the North American continent, or to the American representative, Gary Ripton, 47 Lake St., Le Roy, N. Y., USA.

### Around the World

(Note: By the time you read this, some stations will have gone on *summer* schedules; in such cases, you may find programs *one hour earlier* than listed herein.—K. R. B.)

**Alaska**—ALF, 5.980, Juneau, noted 0715 with *test* transmission of the Alaskan Communications System. (Carlos, Calif.)

**Albania**—Radio Tirana, 7.852A, has *English* 1400. (Pearce, England)

**Algeria**—Radio Algerie, 6.160, heard 1635-1658 in Arabic when closed with "La Marseillaise." (Roberts, Conn.)

**Andorra**—Radio Andorra, measured 5.990, noted 1830 with recordings at poor level in heavy QRM. (Ferguson, N. C.) Heard in France 0600-0900, 1630-1900; announces 5.980 although actually uses 5.990. ("La Radio Mondiale," France)

**Angola**—Luanda, 11.862, noted 1530 with chimes, call in Portuguese, then light music. (Pearce, England) Heard regularly 1330-1530 on 6.355; once noted parallel on 6.678. (Fairs, England, *via* Radio Sweden) Heard on CR6RN, 9.632, at 1530-1600. (*Etersvep*, Sweden)

**Argentina**—LRS, 9.310, Buenos Aires, closes 2300 in Spanish. (Kahan, Calif.) The International Service (SIRA) has not been reported lately; most former SIRA transmitters now announce "Radio del Estado;" heard opening 0825 over LRA, 15.345, good level. Is on LRU, 15.29, earlier than that. (Ferguson, N. C., others) LRY, 9.76, *Radio Belgrano*, heard closing in Spanish 2300. (McPhadden, Calif.)

**Australia**—Correct frequency of VLW11, Perth, is 11.840, *not* 11.830, scheduled 2130-0500 Sun.-Fri., 2130-0530 Sat. (Radio Australia) VLI6, 6.090, Sydney, N.S.W., noted 0600 with ABC news relay, fair level in N. Y. (Chatfield)

**Azores**—CSA93, 4.865, Ponta Delgada, noted closing 1902. (ISWL, England)

**Balearic Islands**—Radio Menorca,

(Note: Unless otherwise indicated, all time is expressed in American EST; add 5 hours for GCT. "News" refers to newscasts in the English language. In order to avoid confusion, the 24 hour clock has been used in designating the times of broadcasts. The hours from midnight until noon are shown as 0000 to 1200 while from 1 p.m. to midnight are shown as 1300 to 2400.)  
The symbol "V" following a listed frequency indicates "varying." The station may operate either above or below the frequency given. "A" means frequency is approximate.

7.410A, noted 1430, music. (Harris, Mass.)

**Bechuanaland**—ZNB, 8.230, Mafeking, heard with SABC news relay 1400, then recordings. (Pearce, England)

**Belgian Congo**—OTH, 9.210, Leopoldville, noted 1230-1330 closedown. (JSWC)

**Belgium**—ORU, 6.000, Brussels, some days is noted in Sweden 1300 with music. (Landen)

**Brazil**—Radio Cultura, 6.165A, Sao Paulo, noted to 0100 or later; often has "Starlight Music" with announcements in *English*, Portuguese; this one noted at 1817 with Japanese session in progress. (Smith, Ga.; Bellington, N. Y., others) Radio Gazeta, 9.685, has *tested* 1700-2100. (*N. Z. DX Times*) Heard still on air *after* 2230. (Bellington) PSL, 7.935, Rio de Janeiro, noted 1730-1800 sign-off, strong level. (Chatfield, N. Y.) Radio Bandeirantes, ZYR78, 11.925, noted at good level 1930. (Bernard, Calif.)

**British Guiana**—ZFY, 3.257, measured, Georgetown, noted 1945 at fair level; is listed 3.255. (Ferguson, N. C.; Chatfield, N. Y.) Closes around 2115A. Heard in Britain *after* 1900, plenty of CWQRM. (Patrick) Was heard some weeks ago on *announced* 7.945 at 1705-1759 closedown, in *test* to Barbados, good level. (Huttemeyer, N. J.)

**British Honduras**—Radio Belize, 3.300, noted at fair level 2000 with news, weather. (Welch, Mass., others)

**British New Guinea**—VLT6, 6.130A, has news 0400. (URDXC)

**Bulgaria**—Sofia, 9.700 now has *English* for North America 1745-1800, 1930-1945 (*except* Sun.), 2000-2030, 2300-2330; for Europe 1500-1515, 1615-1645-1715-1730 on 7.255, 7.671A. (Pearce, England)

**Burma**—Radio Rangoon, 4.777A, noted 0905 in Burmese; 0915-1015 closedown in *English*, including talks, personal messages, news (1000); reception has improved lately. (Morgan, Balbi, Calif.)

**Canada**—CFVP, 6.030, Calgary, Alta., noted 2000. (Callarman, Ore.) CBRX, 6.160, Vancouver, British Columbia, heard 1238 with music, fair level in Calif. (Morgan) CHNX, 6.130, Halifax, N. S., good 1700. (Wilhelm, N. Y.)

**Canary Islands**—Tenerife, 7.515A, has been heard in Spanish with talk, music 1530-1600. (Perssen, Sweden, *via* "On the Air")

**Cape Verde Islands**—CR4AA, Praia,

From the new, high-powered equipment at Horby, Radio Sweden is sending improved signals to all parts of the world. See schedule listed under "Around the World."

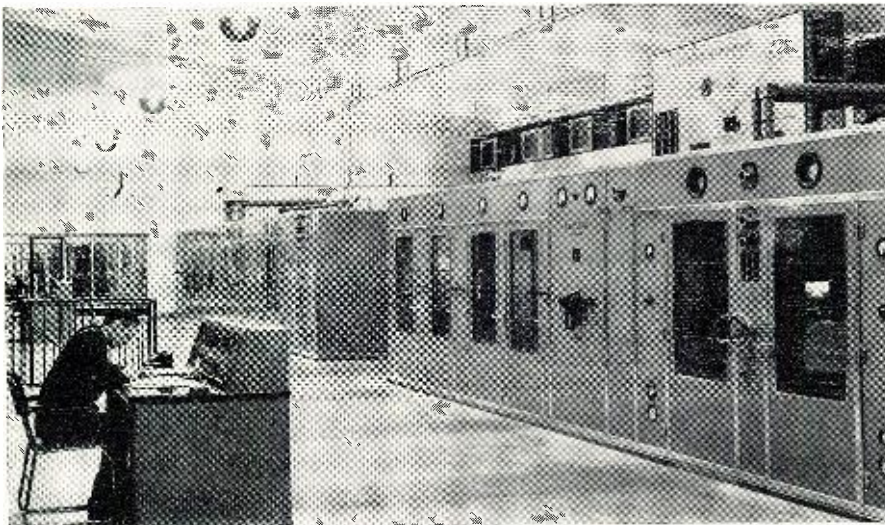

# NEW! PEAK-to-PEAK VTVM

complete with NEW DUAL-PURPOSE AC/DC

**Uni-Probe** (Pat. Pend.)

EICO's revolutionary new engineering design!  
The professional peak-to-peak VTVM that beats 'em all  
— in laboratory precision features and low price!

Model 232 **KIT \$29.95** WIRED \$49.95

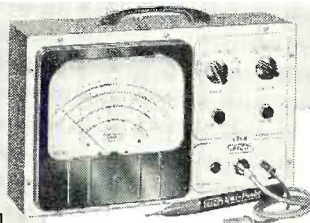
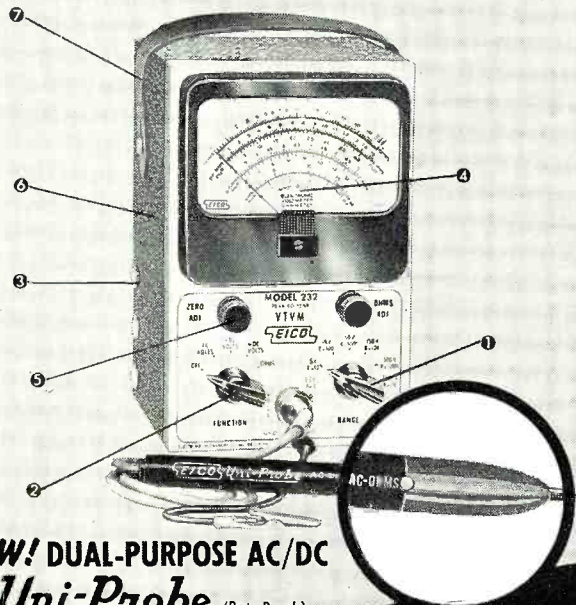

Model 249  
**KIT \$39.95**  
WIRED \$59.95

**New**  
**DELUXE PEAK-to-PEAK VTVM**  
with 7½" METER  
& exclusive **Uni-Probe** (Pat. Pend.)

All the outstanding & exclusive features of Model 232—plus the extra convenience and readability of its big 7½" meter. An ideal bench instrument.

- Measures directly p-p voltage of complex & sine waves: 0-4, 14, 42, 420, 1400, 4200 volts p-p.
- DC/RMS sine voltage ranges: 0-1.5, 5, 15, 50, 150, 500, 1500 volts. Reads up to 30,000 V. with HVP probe.
- Resistance ranges: 0.2 ohms to 1000 megs in 7 ranges.
- ① 7 non-skip ranges on every function.
- ② 4 functions: +DC Volts, -DC Volts, AC Volts, Ohms.
- Uniform 3 to 1 scale ratio for extreme wide-range accuracy.
- Large 4½" meter in can't-burn-out circuit.
- ③ Calibration without removing from cabinet.
- ④ Zero-center for TV-FM discriminator alignment.
- ⑤ One zero-adjustment for all functions and ranges.
- Frequency Response: 30 cps-3 mc (up to 250 mc with PRF probe).
- 1% precision ceramic multiplier resistors.
- Exceptional circuit stability and accuracy.
- ⑥ New compact size for extra-easy portability (7"x5"x4").
- Smart professional styling — new satin finish etched panel with contrasting knobs and meter and grey wrinkle steel case.
- ⑦ Leather handle.

## NEW! DUAL-PURPOSE AC/DC

**Uni-Probe** (Pat. Pend.)

Terrific time-saver! Only 1 probe performs all functions—a half-turn of probe-tip selects DC or AC-OHMS!

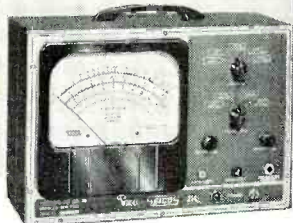

**DELUXE VTVM with 7½" METER**

Model 214 **KIT \$34.95** WIRED \$54.95

All the versatility and performance-proven features of Model 221—plus the extra convenience and legibility of its big 7½" meter. An excellent bench instrument.

**Now!** **4 EICO VTVM KITS**  
to choose from!

## VACUUM TUBE VOLTMETER

The reliable, performance-proved EICO VTVM—ever-popular universal instrument for all TV/radio/electronics servicing.

Model 221 Over 50,000 in use!

**KIT \$25.95**  
**WIRED \$39.95**

- ① Large 4½" meter in can't-burn-out circuit.
- ② Zero-center for TV/FM discriminator alignment.
- ③ 4 functions: +DC Volts, -DC Volts, AC Volts, Ohms.
- Electronic AC/DC ranges: 0-5, 10, 100, 500, 1000 volts.
- Reads up to 30,000 volts with HVP accessory probe.
- Reads peak-to-peak with PTP accessory probe.
- Reads up to 250 mc with PRF accessory probe.
- 5 Resistance ranges: 0.2 ohms to 1000 megs.
- 5 DB ranges: -20 to +55.
- DC input resistance: 25 megs.
- 1% precision ceramic multiplier resistors.
- Double-triode bridge circuit for extra stability and accuracy.
- ④ Rugged grey wrinkle steel case.
- ⑤ 3-color etched rubproof panel.
- Complete with AC/DC and common leads.
- ⑥ Leather handle.

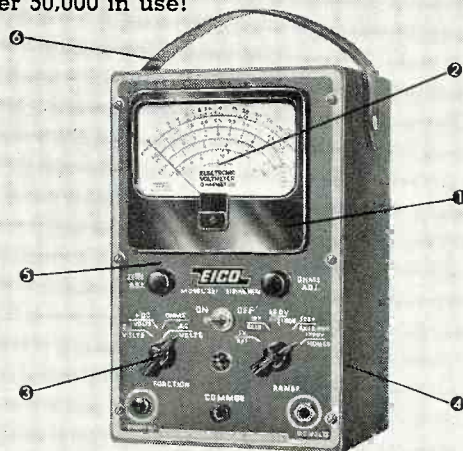

**EICO**<sup>®</sup>  
Laboratory Precision at Lowest Cost

See these sensational VTVM values at your local jobber today.  
Write for FREE Catalog RV-5. Read EICO's other ads in this issue—See Advertiser's Index

ELECTRONIC INSTRUMENT CO., Inc., 84 Withers Street, Brooklyn 11, N. Y.

Prices 5% higher on West Coast.

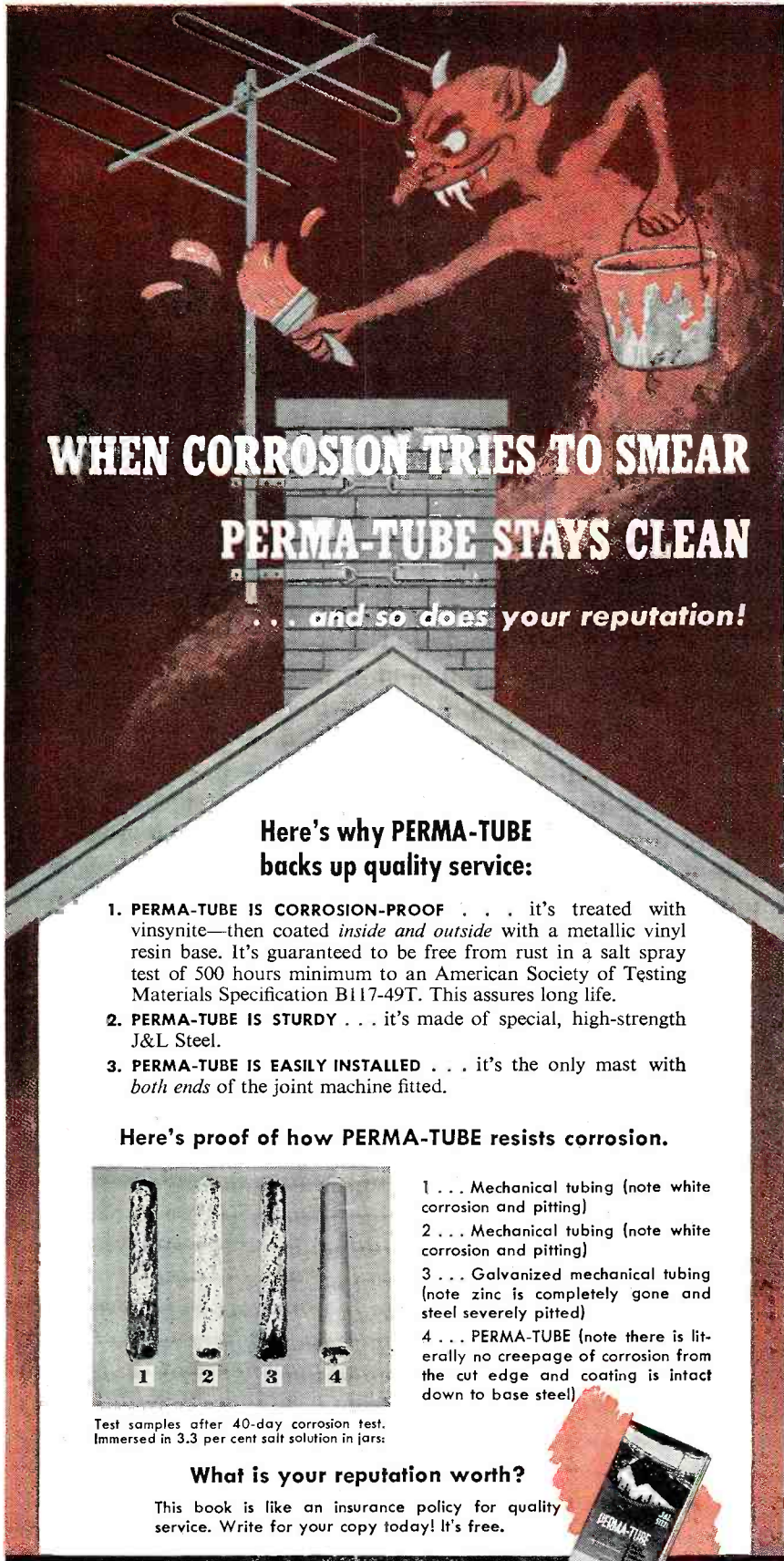

**WHEN CORROSION TRIES TO SMEAR  
PERMA-TUBE STAYS CLEAN**  
... and so does your reputation!

**Here's why PERMA-TUBE  
backs up quality service:**

1. **PERMA-TUBE IS CORROSION-PROOF** . . . it's treated with vinsynite—then coated *inside and outside* with a metallic vinyl resin base. It's guaranteed to be free from rust in a salt spray test of 500 hours minimum to an American Society of Testing Materials Specification B117-49T. This assures long life.
2. **PERMA-TUBE IS STURDY** . . . it's made of special, high-strength J&L Steel.
3. **PERMA-TUBE IS EASILY INSTALLED** . . . it's the only mast with *both ends* of the joint machine fitted.

**Here's proof of how PERMA-TUBE resists corrosion.**

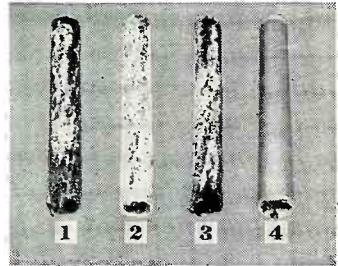

Test samples after 40-day corrosion test. Immersed in 3.3 per cent salt solution in jars.

- 1 . . . Mechanical tubing (note white corrosion and pitting)
- 2 . . . Mechanical tubing (note white corrosion and pitting)
- 3 . . . Galvanized mechanical tubing (note zinc is completely gone and steel severely pitted)
- 4 . . . PERMA-TUBE (note there is literally no creepage of corrosion from the cut edge and coating is intact down to base steel)

**What is your reputation worth?**

This book is like an insurance policy for quality service. Write for your copy today! It's free.



Jones & Laughlin Steel Corporation  
Dept. 495, 3 Gateway Center, Pittsburgh 30, Pa.  
Please forward a copy of your "PERMA-TUBE" booklet.

Name \_\_\_\_\_  
Company \_\_\_\_\_  
Address \_\_\_\_\_

still noted near 7.398 from 1500 sign-on. (Pearce, England)

*Ceylon*—Radio Ceylon, 9.520, noted with American popular songs, commercials 0823-0845. (Morris, O.) Is good in the Philippines on 17.820 around 0500-0600. (Navarro) Heard with news on this channel 0430; noted opening 2030 on 11.870, announcing 7.190 in parallel; VOA relay from Colombo 1130-1200 is now noted over 11.875, 7.230; at 1300 has Commercial Service's dance music program on 5.020. (Collett, N. Z., via Radio Australia) Heard on 9.520 at 1103-1130, good signal. (Tandrow, Calif.; Roberts, Conn.) This outlet opens 0730.

*China*—Radio Peking, 6.201A, noted 1038 in Chinese, music; strongest of the Peking transmitters; often heard with dictation-speed Chinese to around 1300 fade-out. Noted on 11.690A in Chinese 0955 when is scheduled to have *English*. (Morgan, Calif.) The 0930 news from Peking is heard on 6.065V rather than on announced 6.040. (Balbi, Calif.)

*Colombia*—Radiodifusora de Occidente, 4.766, measured, Cali, noted in clear 2328-2333 closing, is HJEF.

*Costa Rica*—TIFC, 9.647A, San Jose, noted at fair level 2155 with news in *English*, signs off 2300. (Bigley, Pa.) Has new 2 kw. transmitter with pair of 833's in final; antenna is quad without reflector, directed N-S. Lists news 2255. (Niblack, Ind.; Bellington, N. Y., others) *Radio Cristal*, 6.006, has sports news in Spanish from the entire continent on Sat. 1900-1930, followed by selections from the "Hit Parade." Gives QRA as Box 348, San Jose. (Kahan, Calif.)

*Cuba*—Radio Alvarez, 12.06AV, Havana, noted around 1500, good signal. (Bellington, N. Y.) In verifying, listed 12.000, COBX, 2 kw. (Niblack, Ind.)

*Denmark*—Copenhagen, 15.165, noted opening 0400. (JSWC)

*Dominican Republic*—H11A, 4.996 Santiago, *Radio Caribe*, noted at weak level closing 2105 in Spanish. (Roberts, Conn.)

*Ecuador*—HCJB, 17.890, heard 1315 with religious broadcast for Europe. (Weaver, Va.) And 1600-1715 at good level in Mass. (Dodge) *Radio Quinta Piedad*, 6.635, noted past 2230 on *Tue.* only with classical music or opera. (Stark, Texas)

*Egypt*—Radio Cairo, 15.315, noted 0950 with Arabic vocal music; on 11.815 in Arabic around 1345. (Pearce, England, others) With Arabic around 1500 on 7.045A. (Bellington, N. Y.; Pearce, others) Heard on 9.475 at good level with news 1330, off around 1700. (Gates, Conn.)

*El Salvador*—Radio Nacional, 9.550A, noted in Spanish with classical music 2230-2312A closedown. (Smith, Ga.) YSS, 6.010A, noted with "English by Radio" at 2000 on Thur.; YSAXA, 11.950, heard on a Sun. with *English* program 1755-1825 check. (Niblack, Ind.)

*England*—BBC noted opening 1800 in German on 3.955A. (Pearce, England) (Continued on page 106)



# A Brief Survey of COLOR TV

... how its  
complex character  
means job opportunity  
for you



—by E. H. RIETZKE,  
President, Capitol Radio Engineering Institute

A GOOD MANY YEARS AGO, when he was a young fellow, my Dad was one of the country's fastest typesetters. He could go anywhere and get a highly paid job with any newspaper in the country. Then came the linotype machine! Before he knew it, my Dad's job was obsolete. He had to start all over in another line of work.

How will you get along in the age of Color TV that has already arrived? Will you have to start all over? Or will you be prepared? The choice is a matter of black-and-white—or color. As you may know, color tv involves handling an understandably much more complicated signal than for black-and-white; the components must be in perfect balance; the margin for error is practically zero. Technical personnel need new skills in working to closer tolerances. Microwave relays and coaxial cables require added equipment and special adjustments. Before a station can originate color it needs a great deal of additional equipment, much more expensive and vastly more complicated than that for black-and-white. Slide and film equipment also require additional components and maintenance. Color camera chains are much more complex, requiring more highly skilled adjustments and care. Reports of network experiments indicate that live telecasting in color increases technical man-hours required by 30 to 50%. Lighting personnel need more skill in handling new—and delicate—problems. That's a very quick run-down from the

transmitter end. Every step is a technical opportunity.

What about color receivers? They'll be bigger—with roughly twice as many receiver tubes as black-and-white. There is at least one more tuning knob—the chroma control for color saturation. Maintenance is complicated, to say the least, with three highly critical video channels to trouble-shoot instead of one. Service contracts for color receivers will cost considerably more than for black-and-white, according to one highly qualified source—which should give you an idea of servicing complexity—and earnings possibilities. So much for transmission and reception. Manufacture of color equipment is another field for trained technicians.

Most well-informed sources agree that color television will be spread all over the U.S. by 1956 at the latest. The years between now and then are crucial. If you are interested in an honest-to-goodness career in this booming part of the booming electronics industry, here's how you can step ahead of competition, move up to a better job, earn more money, and be sure of a well-paid job: Study radio-television-electronics via CREI. You don't have to be a college graduate. You do have to be willing to invest some of your spare time—at home. You can do it while holding down a full-time job. Thousands have.

Since 1927 CREI has provided men

with the technical knowledge that leads to more job security—and more money. CREI starts with fundamentals and takes you along at your own speed, not held back by a class, not pushed to keep up with others who have more experience. You master the fundamentals, then get into more advanced phases of electronics engineering principles and practice. Finally you may elect training at career level in high specialized applications of radio or television engineering, or aeronautical radio.

The coupon below, properly filled out, will bring you—without cost—a fact-packed booklet, "Your Future in the New World of Electronics," which includes outlines of courses offered, a resume of career opportunities, full details about the school, our Placement Bureau (with more requests for trained men currently on file than we can fill), and the names of some of the organizations using CREI training (like All American Cables & Radio, Inc., Canadian Broadcasting Corp., Columbia Broadcasting System, RCA Victor Division, United Air Lines, to name a few). I urge you—for your own good—to send for this free booklet immediately.

**NOTE:** CREI also offers Resident School instruction, day or evening, in Washington, D. C. New classes start once a month. If you are a veteran discharged after June 27, 1950, let the new GI Bill help you obtain resident (or home study) instruction. Check the coupon for more data.

## CAPITOL RADIO ENGINEERING INSTITUTE

An Accredited Technical Institute. Founded in 1927

3224 16th Street, N.W.

Dept. RN 115A

Washington 10, D. C.

Send booklet "Your Future in the New World of Electronics" and course outline.

CHECK  
FIELD OF  
GREATEST  
INTEREST

- TV, FM & Advanced AM Servicing
- Practical Radio Engineering
- Broadcast Radio Engineering (AM, FM, TV)
- Practical Television Engineering
- Aeronautical Radio Engineering

Name.....  
Street.....  
City..... Zone..... State.....

Check:  
 Residence School  
 Veteran

# Mac's RADIO SERVICE SHOP

By JOHN T. FRYE



## BARNEY'S DOG SHOW

FOR three whole days Barney had been operating Mac's Radio Service Shop all by himself while his boss took a brief vacation, and he was so swollen with self-importance that he could hardly stand himself. On this morning that Mac was due back, he had come to work a whole hour early to make sure that all tools and instruments were in their proper places, that the place was swept out and dusted, and, above all, that Mac would find it open and ready for business when he came down to open up. It was well that he did, for Mac himself showed up a half hour early.

"Good morning, Flamingo Top," Mac saluted his helper. "I see we are still in business, anyway."

"Natch!" Barney replied with a grin. "Your public never missed you. Have a good time?"

"Swell, but I noticed a kind of funny thing. There are times here when I feel I'd be blissfully happy if I never saw the innards of another radio or TV set; but I hadn't been away twenty-four hours until my hand began to sort of ache for the feel of a solder gun. The wife almost had to use her whip to keep me away from a TV set with a bad case of vertical jitter in one of the motels where we stayed. I'm sure I could have fixed it if she would have stopped mumbling, 'Remember, you're on vacation!'"

"I was sure that would be the case," Barney said smoothly; "so that is why I saved this dog show for you." As he said this, he waved to a side bench on which several sets were piled. "You know you told me not to waste too much time on any 'dogs' that showed up; so any set that I couldn't make fly right within an hour, I put over there. Of course, I could have fixed them if I had taken the time, but I

knew you were right about keeping up with the work."

"Of course you could," Mac agreed without the sign of a grin. "Let's have at them."

"Well first is this little 45 rpm record player with a funny case of hum. It's bad enough to be really annoying when a record is playing; yet it stops when the motor is switched off. My guess is that the a.c. from the motor field must be getting into the amplifier some way. Listen to it."

Mac cocked a critical ear for a minute and then remarked: "I don't hear the hum when the changer cycle is operating."

"No, but I supposed that was because it might have a muting switch that shorted out the amplifier input while the records were being changed. Some of the changers have that arrangement, you know."

"Not this one," Mac said as he picked up the compact little changer and started taking screws out of the Bakelite case so he could lift off the changer mechanism.

"I've checked the filters, changed all tubes, looked to make sure the shielded lead to the cartridge is not shorting out or developing a poor grounding connection of the shield," Barney offered.

By this time Mac had the changer mechanism off and was peering at the turntable drive mechanism. Suddenly he switched on the motor and carefully inserted a screwdriver bit against the revolving side of the motor shaft that drove a rubber-tired idler pulley. Then he replaced the changer on the case and set the pickup arm down on a record. There was not the least trace of the annoying hum.

"The trouble was mechanical," Mac answered the questioning look in Bar-

ney's eyes. "There was a bit of hard dirt or gum on one side of the motor shaft, and every time this came around it gave the idler pulley a bump. The motor travels at a speed that does make the frequency of these bumps sound about like 60 cycle a.c. when the vibration is picked up by the needle resting on a record. When the change cycle picked the needle off the record, the vibration no longer reached the pickup and so the 'hum' stopped. I scraped off the gummy substance with the screwdriver bit held against the revolving shaft. Trot out your next dog."

"Here's one that just won't align," Barney explained as he set a small a.c.-d.c. chassis on the bench. "Something is apparently wrong with the oscillator coil. Since it has 456 kc. i.f., I figure the oscillator ought to be setting on 2056 kilocycles when the set is tuned to 1600 kc.; but I've checked with the grid dip meter, and it only goes up to about 1800 kc. with the oscillator trimmer screwed clear out. By screwing this trimmer clear in, you can actually throw the oscillator over on the low side of the signal at the high end of the band; but then it won't track, of course."

"Where does the oscillator sit at the low end of the band?"

"Still a little low, but not nearly as bad as at the high end."

"That sounds more like too high minimum capacity rather than inductance trouble," Mac suggested as he carefully examined the tuning condenser gang. Suddenly he picked up a small screwdriver and worked with it on the back side of the stator of the oscillator section, the opposite end from where the trimmer was mounted.

"Now let's see if we can align it," he said as he switched on the signal generator. When the generator was set to 1600 kc., the oscillator was easily brought into line with its trimmer. The r.f. trimmer was adjusted at 1400 kc., and then the generator was moved to 600 kc. When the dial pointer was set at the 600 kilocycle mark, there was the generator signal.

"What the heck did you do?" Barney demanded.

"The oscillator section of the tuning condenser has two trimmers, one on each end of the stator," Mac explained. "You find that situation every now and then. The rear trimmer is set before the condenser is mounted and is not intended to need adjustment after that, for the front trimmer is supposed to take care of all ordinary conditions. That is why this back trimmer is practically inaccessible and easy to overlook. In this case, however, something made that back trimmer increase in capacity. Perhaps a trimmer plate was caught on a thread and suddenly slipped off; or maybe a little wax was between the plates and gradually softened and let the plates come closer together. Anyway, after this back trimmer increased in capacity, you could not get the minimum

*(Continued on page 124)*

NOW FROM P. R. MALLORY & CO. Inc. **MALLORY...**

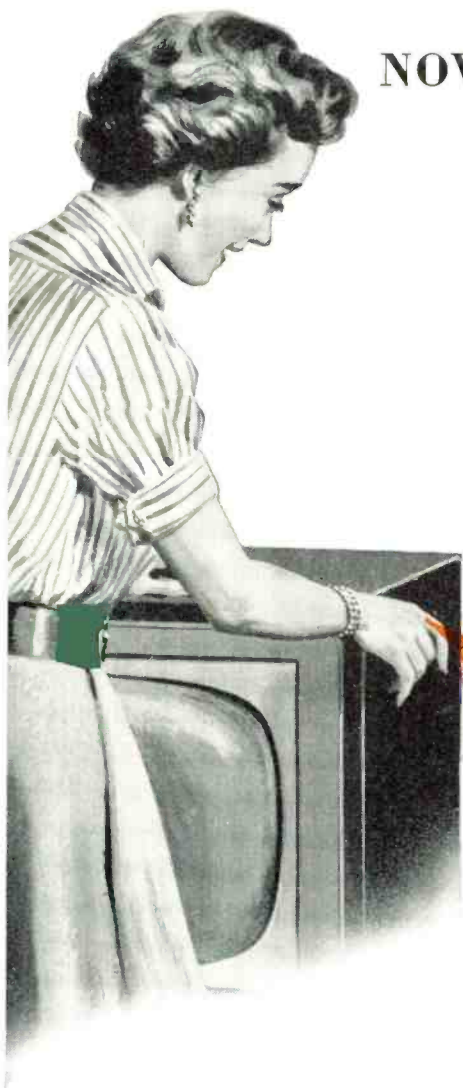

the **1**st... All-Channel  
UHF Converter  
Designed to fit  
*Inside ANY VHF Set*

Here's another first from Mallory... The Mallory Model '188' Concealed UHF Converter. It fits inside any VHF set to make it an all-channel receiver. And it's a sure-fire salesbuilder for you.

**Look at these features of the Mallory '188'.**

**OUT OF SIGHT...** The entire unit is mounted inside the cabinet. All that shows is a clear plastic selector dial and switch lever.

**EASY TO INSTALL...** No alteration in the set chassis is required and the '188' has its own power supply. Can be mounted inside the cabinet on either side or at the top. A bracket and four screws do the job on wood cabinets. On plastic or metal cabinets, the converter may be mounted on the fiber-board rear enclosure.

**PROVED PERFORMANCE...** The '188' offers you the same proved performance... the same high quality reception... as the Mallory '88' Cabinet Converter which has given outstanding performance in UHF areas across the Nation.



*Mallory Concealed Converter  
—first on the market*



*Mallory Cabinet Converter  
—first on the market*

*Give Yourself Greater Converter Sales...  
By Giving Your Customers Their Choice  
of Mallory Converter Styles.*

.....  
**NO RADIATION PROBLEM!**

Both Mallory Converters contain specially designed components to prevent troublesome interference from radiation—a problem common to low quality converters which ruin TV reception over a wide area.

P. R. MALLORY & CO. Inc.  
**MALLORY**

CAPACITORS • CONTROLS • VIBRATORS • SWITCHES • RESISTORS  
RECTIFIERS • POWER SUPPLIES • CONVERTERS • MERCURY BATTERIES

**APPROVED PRECISION PRODUCTS**

**P. R. MALLORY & CO. Inc., INDIANAPOLIS 6, INDIANA**

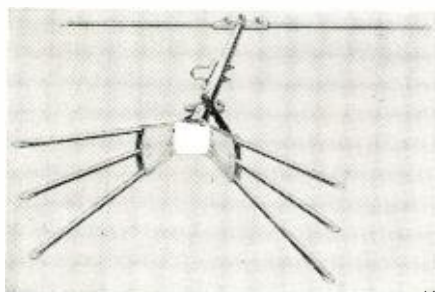

Fig. 1. Adjustable conical TV antenna described in this article. The forward angle of the elements is adjusted by loosening the wing nut and sliding the collar to the desired boom position.

THE popularity of the conical TV antenna is deserved. It has many desirable features such as: broadband coverage, excellent line match, simplicity of construction, and moderate price. However, it has certain disadvantages. These are a broad horizontal pattern; a multi-lobed pattern, especially on the higher channels; and the necessity of using different forward angles for the active elements to provide optimum performance on the low channels or the high channels.

Since the conical antenna does have so many desirable characteristics, a natural line of investigation is toward eliminating the undesirable features.

Experimental work along this line has brought about a new development which eliminates most of these disadvantages and, in some cases, utilizes those characteristics which had been thought to be disadvantageous.

It will be noted that the main disadvantages of the conical are connected with its horizontal pattern. In order to provide the minimum number of minor lobes on channels 7-13 it is necessary to "vee" the active elements forward. This results in a combining of the minor lobes into a single major lobe, as shown in Fig. 2. However, when this is done, the horizontal aperture pre-

Fig. 2. Polar TV reception patterns for two different angular settings of driven elements of the conical.

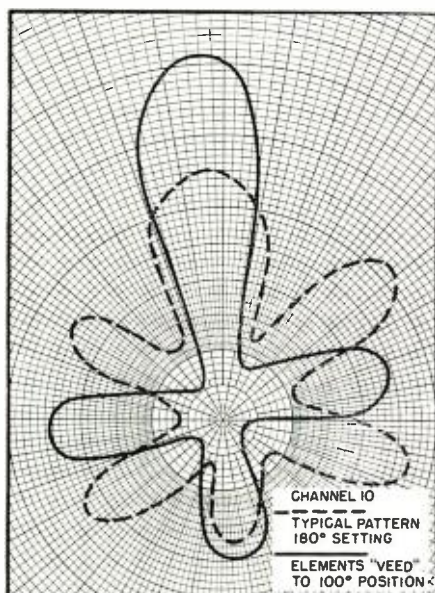

# NEW APPROACH TO CONICAL ANTENNA DESIGN

By ROY J. WADE  
Trio Manufacturing Co.

*A new type of conical TV antenna, adjustable for the weakest station and the elimination of ghosts.*

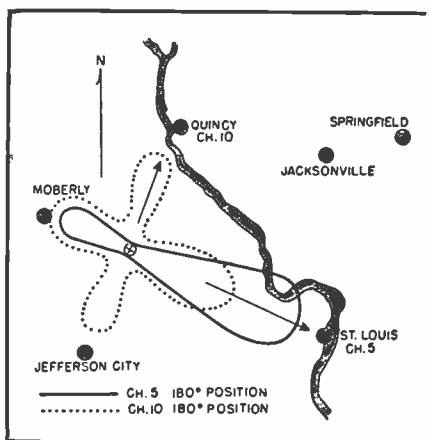

Fig. 3. Example of the change in reception pattern that occurs for different signal frequencies at one setting of the conical antenna. The adjustable conical may be varied to take advantage of the most useful change in the pattern for different stations.

sented by the antenna to an incoming signal is decreased, with some sacrifice of gain on the lower channels. Usually, in multi-channel areas, one channel will provide a much weaker signal than the others. In order to use the desirable characteristics of the conical most effectively and at the same time provide flexibility, a design which involves a variable "veeing" of the active elements has been worked out. This makes it possible to adjust the conical for optimum performance on the weakest station.

In the experimental work which led to the final form of the antenna shown in Fig. 1, it was found that the minor lobes which exist on channels 14 to 83 could be combined into an essentially single-lobed horizontal pattern by using a 60° included angle between the active elements.

To illustrate the flexibility of operation of this new development in conical antenna design, refer to Fig. 3, showing two of the stations available with reasonable consistency in eastern Missouri. These are channel 5 from St. Louis and channel 10 from Quincy, Illinois. Fig. 3 shows the horizontal pattern of the antenna having the elements set in the 180° position. It will

be noted that the minor lobes which exist on channel 10 provide high signal pickup from Quincy when the antenna is pointed toward St. Louis. These minor lobes can be shifted through a considerable range by adjusting the position of the active elements. In other words, in many areas, a little experimental work will determine a position for the active elements which will provide gain on several channels in several different directions.

An additional feature which has proved highly valuable in actual installations is the fact that the nulls can also be shifted by varying the position of the active elements. Fig. 4A shows a typical situation which produces a ghost signal, due to the minor lobe which provides signal pickup from the reflecting surface. By slight readjustment of the position of the active elements, a null can be made to appear at that point rather than the minor lobe which had caused the ghost signal, as is shown in Fig. 4B. In other words, this antenna provides two methods for ghost elimination—orientation of antenna, and placement of the nulls by varying the horizontal pattern. It is obvious that this same principle is helpful in cases of co-channel interference.

In most u.h.f.-v.h.f. areas where it is necessary to orient and adjust the antenna for maximum u.h.f. signal reception, it is suggested that the elements of this antenna be adjusted to the maximum "vee" position (smallest angle between forward elements) for highest gain.

Fig. 4. As the element angle of the conical is adjusted, the lobes and nulls shift to different points, making it possible to change a lobe (with its ghost pickup) to a null, thus helping to eliminate the ghost problem.

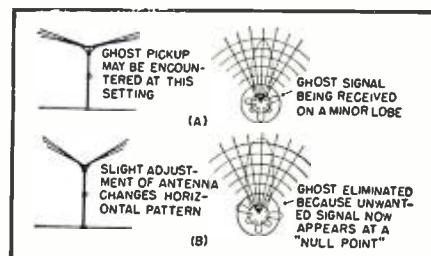

BUILD YOUR OWN

# Heathkits

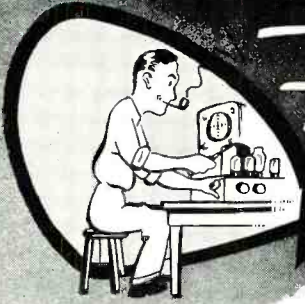

- TEST INSTRUMENTS
- AMPLIFIERS
- RECEIVERS, etc.

- ① Save by ordering direct from manufacturer.
- ② All high quality standard brand components.
- ③ Increased knowledge through actual construction.
- ④ Sound engineering insures excellent performance.
- ⑤ Kit construction is fascinating and enjoyable.



MODEL  
O-9

**\$59.50**

Shipping  
Wt. 28 lbs.

## Heathkit MODEL O-9 OSCILLOSCOPE KIT

New features unheard of in a kit oscilloscope have been added to the already popular Heathkit series. All top quality components are used including a brand new RCA 5U1 CRT. Ten other first line tubes complete the lineup. Voltage regulation provides a rock steady pattern regardless of normal line voltage variations. A built-in blanking amplifier eliminates the retrace line entirely. Other important advantages are a phasing control, Z axis input, direct connections to the deflection plates, 1 volt peak-to-peak calibration voltage and a calibrated grid screen.

Wiring is simplified by the use of the harness technique which also results in a neat professional appearance. Extremely wide vertical bandwidth allows accurate reproduction of even a 500 KC square wave. Excellent focusing characteristics are made possible by the use of the new RCA 5U1 CRT and a spot shape control. One of the most versatile of test instruments, the Heathkit O-9 Oscilloscope will be invaluable in the radio and TV service shop, as a work project in schools and for all types of circuit investigation work in the laboratory. Its new features make Model O-9 comparable in every way to many commercially built oscilloscopes selling for as much as \$400. Don't pass up this opportunity to add a really fine instrument to your service or experimental lab.

Heathkit

### VOLTAGE CALIBRATOR KIT

The use of a Voltage Calibrator will greatly increase oscilloscope usefulness. Provides a convenient method of making peak to peak voltage measurements by establishing a relationship between the unknown wave shape and the Voltage Calibrator. Voltage ranges .01-100 volts peak to peak. The Voltage Calibrator features direct reading scales and a regulated power supply system.



MODEL VC-2

**\$11.50**

Shipping Wt. 4 lbs.

Heathkit

### ELECTRONIC SWITCH KIT

The Heathkit Electronic Switch Kit will further extend scope usefulness by permitting simultaneous observation of two individually controlled traces. Continuously variable switching rates 10 cps to 2,000 cps in three ranges. Will also serve as a square wave generator over the range of switching frequencies.



MODEL  
S-2

**\$23.50**

Shipping  
Wt. 11 lbs.

## Heathkit VACUUM TUBE VOLTMETER KIT

The beautiful new 1953 Heathkit Model V-6 VTVM, the world's most popular kit instrument, now offers many outstanding new features in addition to retaining all of the refinements developed and proven through the production of over 70,000 VTVM kits. The Heathkit VTVM now features extended voltage ranges with 50% greater coverage on the DC range. New 1 1/2 volt low scale provides well over 2 1/2 inches of scale length per volt permitting faster measurements with greater accuracy. AC and DC ranges are 0-1.5-5-15-50-150-500-1500 volts (1,000 volts maximum on AC). Ohmmeter ranges are X1, X10, X100, X1,000, X10K, X100K X1 meg. Measures .1 ohm to 1,000 megohms. Other features are db scale, center scale zero adjust and polarity reversal switch. High 11 megohm input resistance virtually eliminates circuit loading.

The low anti-inflation price of this tremendously popular kit includes all tubes, necessary constructional material, test leads and the construction manual.

MODEL V-6

**\$24.50**

Shipping  
Wt. 6 lbs.



### Heathkit AC VACUUM TUBE VOLTMETER KIT

MODEL AV-2

**\$29.50**

Shipping  
Wt. 5 lbs.

A new amplifier type AC VTVM that makes possible those sensitive measurements so essential in laboratory or audio work. Ten voltage ranges covering from .01 RMS full scale to 300 volts RMS full scale. Input impedance 1 megohm with frequency response 20-50,000 cycles. Ten DB ranges from -52 to +52 DB. Four diodes in meter bridge circuit for maximum linearity.



Heathkit

### HANDITESTER KIT

MODEL M-1

**\$14.50**

Shipping  
Wt. 3 lbs.

The ever popular Handitester is now supplied with a Simpson 400 microampere meter movement. Provides AC and DC voltage ranges 0-10-30-300-1,000-5,000 volts. Ohmmeter ranges 0-3,000 and 0-300,000 ohms. DC current measurements 0-10 and 0-100 milliamperes. A completely self contained portable instrument.



**HEATH COMPANY • Benton Harbor 15, Mich.**

# HEATHKITS for the ENGINEER

## Heathkit VISUAL AURAL SIGNAL TRACER KIT

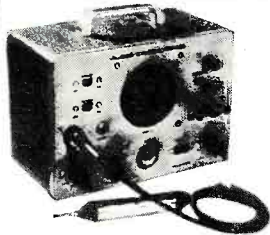

MODEL T-3 **\$23<sup>50</sup>**

Shipping  
Wt. 10 lbs.

Designed especially for service applications in AM-SW-FM-TV repair work. RF and audio two channel input. More than adequate sensitivity—new noise locator circuit—calibrated wattmeter—substitution speaker—visual signal indication. Can be used with scope and VTVM, checks phono cartridges, phono mechanisms, microphones, tuners, etc. Let the Heathkit Visual Aural Signal Tracer help you.

## Heathkit CONDENSER CHECKER KIT

An instrument designed solely for its particular job. Not a "sideline" or a multiple function instrument. Measures value and quality of unknown condensers and resistors. Capacity range .00001 mfd to 1,000 mfd. Resistance range 100 ohms to 5 megohms. Sensitive electron beam indicator—five polarizing test voltages—safety spring return leakage test switch. An amazingly accurate instrument at this low price.

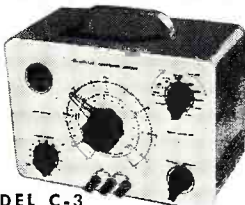

MODEL C-3  
**\$19<sup>50</sup>** Shipping  
Wt. 8 lbs.

## Heathkit SIGNAL GENERATOR KIT



MODEL SG-8  
**\$19<sup>50</sup>**

Ship. Wt. 8 lbs.

The standard service instrument for alignment work. .1 volts output from 160 KC to 110 MC. Calibrates harmonics up to 220 MC. Internal (400 CPS) and external modulation. Pre-calibrated coils for all 5 bands. Good stability and accuracy. All test leads included.

## Heathkit GRID DIP METER KIT

One hand operation. 5 pre-wound coils cover 2—250 MC. Controlled sensitivity. Usable as an oscillator or an absorption wavemeter. Extra low frequency coils available.



MODEL GD-1B  
**\$19<sup>50</sup>**

Ship. Wt. 4 lbs.

## Heathkit LABORATORY REGULATED POWER SUPPLY KIT



MODEL PS-2  
**\$33<sup>50</sup>**

Ship. Wt. 20 lbs.

A regulated variable 160-450 volt DC output power supply for the lab or service shop. Accurate voltage and current measurements with large Simpson meter. AC supply 6.3 volts at 4 amperes—standby switch eliminates warmup time. Low hum content—5 tube circuit. AC and DC output voltages isolated from panel for maximum operational flexibility.

## Heathkit RESISTANCE SUBSTITUTION BOX KIT

MODEL RS-1

Ship. Wt. **\$5<sup>50</sup>**  
2 lbs.

Choice of 36 switch selected resistance values 15 ohms to 10 megohms. All standard RTMA 1 watt 10% resistors. Buy several for those lab and service applications.



## NEW Heathkit 20,000 OHMS PER VOLT MULTIMETER KIT

Here is the solution to all service problems requiring a portable measuring device of high accuracy. 20,000 ohms/volt sensitivity on DC and 5000 ohms/volt on AC. Full scale voltage ranges of 1.5, 5, 50, 150, 500, 1500 and 5000. DC current ranges of 150 microamperes; 15, 150 and 500 milliamperes; and 15 amperes. Resistances are measured from .2 ohms to 20 megohms in 3 ranges and decibels from -10 to +65 db.

Model MM-1 uses standard commercially available batteries and is not affected by strong RF fields as encountered in and near transmitting equipment. 1% precision resistors on a very easily wired ring type range switch and a highly accurate Simpson 50 microampere meter fully qualifies the Heathkit Multimeter for close tolerance laboratory and service work. The meter movement is placed in a recessed position for maximum non-glare readability. The kit includes the attractive black bakelite cabinet, 2 color meter scales, test leads, batteries and all other necessary components. Overall cabinet size is 5 1/4" wide x 4" deep x 7 1/2" high.

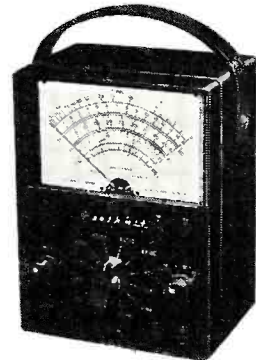

MODEL MM-1

**\$26<sup>50</sup>**

Ship. Wt. 6 lbs.

## Heathkit TUBE CHECKER KIT

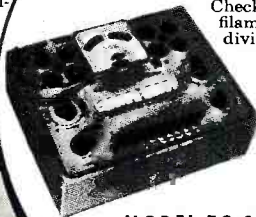

MODEL TC-2  
**\$29<sup>50</sup>**

Shipping Wt. 12 lbs.

Checks overall tube quality, filament continuity, and individual elements for shorts and opens. Features chart illumination, harness type wiring, and large 3-color meter scale.

Portable Model TC-2P at \$34.50. Wt. 14 lbs. No. 91-8 Cabinet only at \$7.50. Wt. 7 lbs. No. 355 TV Picture Tube Adapter at \$4.50. Wt. 1 lb.

## Heathkit LABORATORY GENERATOR KIT



MODEL LG-1

Ship. Wt. **\$39<sup>50</sup>**  
16 lbs.

A professional laboratory instrument designed for extreme accuracy in frequency and output level. Colpitts oscillator operates in 5 ranges from 150 KC to 30 MC. Panel meter calibrated in output voltage and percent of modulation. Output in excess of .1 volts. Features complete shielding of oscillator, buffer and attenuator sections; regulated power supply and 50 ohm output cable. Comparable instruments priced many times higher than the cost of this new kit.

## Heathkit AUDIO WATTMETER KIT



MODEL AW-1  
Ship. Wt. **\$29<sup>50</sup>**  
6 lbs.

Measure output power levels directly with the Heathkit Audio Wattmeter. Flat response to frequencies from 10 CPS to 250 KC. Full scale ranges of 5 MW, 50 MW, 500 MW, 5 W and 50 W. Db calibration from -10 to +48. Uses non-inductive built-in load resistors providing impedances of 4, 8, 16 and 600 ohms. Meter bridge uses 4 germanium diodes.

HEATH COMPANY • Benton Harbor 15, Mich.

# SERVICEMAN • AMATEUR • STUDENT

## Heathkit IMPEDANCE BRIDGE KIT



MODEL IB-2  
**\$59<sup>50</sup>**  
Ship. Wt. 15 lbs.

Modern design with built-in 1 KC generator for AC measurements. A choice of the Wheatstone, Maxwell, Hay or capacitance comparison bridges for measuring resistance, capacitance, inductance, dissipation factor and storage factor. 1/2% resistors and precision mica condensers provide maximum accuracy. Completely AC operated.

## Heathkit DECADE RESISTANCE KIT



MODEL DR-1  
**\$19<sup>50</sup>**

Ship. Wt. 4 lbs.

Individual switch selection of twenty 1% precision resistors in 1 ohm steps from 1 to 99,999 ohms. Sturdy ceramic wafer switches featuring silver plated contacts and smooth, positive detent action.

## Heathkit COMMUNICATIONS RECEIVER KIT



MODEL AR-2  
Ship. Wt. 12 lbs. **\$25<sup>50</sup>**  
(Less Cabinet)

Full coverage from 550 KC to 35 MC on 4 bands, with good sensitivity and selectivity. Features electrical bandspread, BFO, headphone jack, slide rule dial with ham band identification, RF gain control, noise limiter and phone-standby-CW switch. Top quality, high gain components used throughout. Pre-wound coils in a shielded turret assembly and a transformer operated power supply assure trouble-free performance.

Cabinet available separately. No. 91-10. Shipping wt. 5 lbs. Price \$4.50.

## Heathkit AUDIO OSCILLATOR KIT

MODEL AO-1  
**\$24<sup>50</sup>**  
Ship. Wt. 11 lbs.



Features sine or square wave coverage from 20-20,000 cycles in 3 ranges. Variable 10 volt output level at 600 ohms impedance. Thermistor controlled linearity—precision multiplier resistors—distortion less than .6%. An outstanding instrument value at this amazing low price.

## Heathkit Q METER KIT



MODEL QM-1  
**\$44<sup>50</sup>** Ship. Wt. 14 lbs.

A typical Heathkit invasion of the laboratory instrument field. Here is the first successful low priced Q meter ever offered in kit form. Oscillator supplies RF in the range of 150 KC to 18 mc. Reads Q directly on calibrated meter scales. Measures Q of condensers, RF resistance and distributed capacity of coils. Calibrate capacitor with range of 40 mmf to 450 mmf with vernier ±3 mmf. All measurements made at the operating frequency.

## Heathkit AMATEUR TRANSMITTER KIT

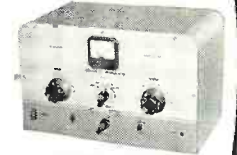

MODEL AT-1  
**\$29<sup>50</sup>**

Ship. Wt. 16 lbs.

Power input up to 35 watts on 30, 40, 20, 15, 11 and 10 meters. Can be crystal or VFO excited. Complete with modulator input socket and VFO power output provisions. Other desirable features are good shielding, AC line filter, key click filter, standby switch and a 52 ohm coaxial output. Model AT-1 is AC operated and is suitable as an exciter for a higher powered rig. Complete with full instructions for construction and use.

## Heathkit TELEVISION SWEEP GENERATOR KIT

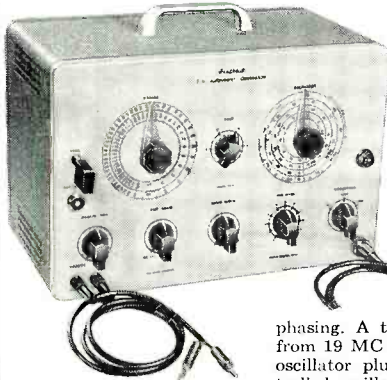

MODEL TS-3  
**\$44<sup>50</sup>**  
Ship. Wt. 18 lbs.

Simplify your TV alignment jobs with the new Heathkit TS-3. Full coverage on fundamentals from 4 MC to 220 MC at an output of well over 100,000 microvolts... Automatic blanking and wide range phasing. A triple marker system ranges from 19 MC to 180 MC using a Colpitts oscillator plus the 4.5 MC crystal controlled oscillator for check points (crystal furnished). Provisions are also made for using an external marker.

Featured is the new sweep system, using an \*INCREDUCTOR controllable inductor. Sweep width is variable from 0 to 12 MC at the lower RF frequencies and increases to 0-50 MC at the highest... Other advantages are power supply regulation, constant RF output level, independent marker and RF output control circuits, low impedance output and properly terminated output cables. The construction manual is complete in all detail and with a reasonable amount of care, Model TS-3 will serve faithfully for many years to come.

\*Trademark, C.G.S. Laboratories, Stamford, Connecticut

## Heathkit DECADE CONDENSER KIT

Switch selected 1% silver mica precision condensers providing capacity range of 100 mmf. to 0.111 mfd. in steps of 100 mmf.

MODEL DC-1  
**\$16<sup>50</sup>**

Shipping Wt. 4 lbs.



## Heathkit AUDIO GENERATOR KIT

A new extended range 18 cycles—1 megacycle audio instrument at a remarkably low price. Five continuously variable output ranges—600 ohm output impedance—low distortion figure, less than .4% from 100 cps through audible range.



MODEL AG-8  
**\$29<sup>50</sup>**

Ship. Wt. 11 lbs.

## Heathkit BAR GENERATOR KIT



Small, compact and easy to use, Model BG-1 supplies horizontal or vertical bars for TV linearity adjustments. Output cable clips directly to the TV receiver antenna terminals.

MODEL BG-1  
Ship. Wt. 6 lbs. **\$14<sup>50</sup>**

## Heathkit BATTERY ELIMINATOR KIT

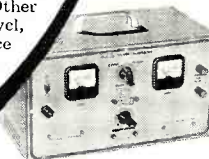

MODEL BE-4  
Ship. Wt. 18 lbs. **\$31<sup>50</sup>**

6 or 12 volt operation with current and voltage constantly monitored. Double protection with a fused transformer and automatic overload relay. Well filtered output and all heavy duty components. Designed for auto radio repair and as a storage battery charger.

## WRITE FOR *Free* CATALOG

New 40 page 1954 Catalog lists all kits, specifications, schematics and latest price information.

# HEATH COMPANY • Benton Harbor 15, Mich.

## Heathkit FM TUNER KIT



MODEL FM-2  
\$22.50

Shipping Wt. 9 lbs.

Sensitive transformer operated 8 tube circuit. Frequency coverage 88-108 mc. Pre-assembled and tuned "front end." Vernier tuning with slide rule type dial.

## NEW Heathkit BROADCAST BAND RECEIVER KIT



MODEL BR-2  
\$17.50

(Less Cabinet)  
Ship. Wt. 11 lbs.

Complete receiver with chassis mounted 5 1/4" PM Speaker and new rod type antenna. Covers the full broadcast band (550 KC-1600 KC) with excellent sensitivity and selectivity. Operates as a receiver, tuner or a phono amplifier. High gain miniature tubes and IF transformers. Easy tuning with direct planetary drive.

Cabinet available separately. Part No. 91-9. Ship. wt. 5 lbs. Price \$4.50.

## LOW PRICED Single UNIT WILLIAMSON TYPE

### AMPLIFIER KIT

MODEL W-4M  
\$39.75

Ship. Wt. 28 lbs.

The famous Heathkit Williamson Type Amplifier is now available in a single chassis. Includes power supply and power amplifier. Enjoy the same high quality reproduction at less cost by eliminating the second chassis, connecting cables, etc. Size 15 1/4" wide—7" high—9" deep. Model W-4 includes W-4M and preamplifier WA-P2. Shipping weight 35 lbs. Price \$59.50.

## NEW HEATHKIT WILLIAMSON TYPE AMPLIFIER KIT

The ideal amplifier for custom high fidelity audio installations. Tops in performance, value and flexibility of operation. Either Altec Lansing Peerless or Acrosound output transformers available. Frequency response  $\pm 1$  db 10 CPS to 100 KC, negligible hum and noise levels and plenty of reserve power for complete listening pleasure. First Williamson Type Amplifier supplied with matching preamplifier.

### PRICES OF VARIOUS COMBINATIONS:

W-2 Amplifier Kit (Includes Main Amplifier with Peerless Output Transformer, Power Supply and WA-P2 Preamplifier.) Shipping weight 38 lbs. Shipped express only ..... \$69.50

W-2M Amplifier Kit (Includes Main Amplifier with Peerless Output Transformer and Power Supply.) Shipping weight 30 lbs. Shipped express only..... \$49.75

W-3 Amplifier Kit (Includes Main Amplifier with Acrosound Output Transformer, Power Supply and WA-P2 Preamplifier.) Shipping weight 38 lbs. Shipped express only ..... \$69.50

W-3M Amplifier Kit (Includes Main Amplifier with Acrosound Output Transformer and Power Supply.) Shipping weight 30 lbs. Shipped express only..... \$49.75

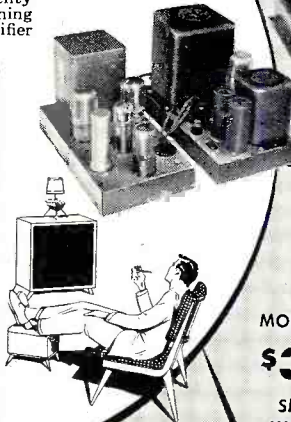

## Heathkit ECONOMY 6 WATT AMPLIFIER KIT



MODEL A-7B  
\$15.50

Ship. Wt. 10 lbs.

Dual inputs—separate bass and treble tone controls—output impedances of 4, 8, and 15 ohms. Performance far beyond that normally expected for the price.

A-7C: Includes preamplifier for low level input devices. Price \$17.50

## Heathkit HIGH FIDELITY 20 WATT AMPLIFIER KIT

MODEL A-9B  
\$35.50

Shipping Wt. 23 lbs.



Outstanding features of the Heathkit 20 Watt Amplifier include a frequency response of  $\pm 1$  db from 20 CPS to 20 KC. less than 1% harmonic distortion at rated output. separate (boost and cut) bass and treble tone controls, 4 selected input jacks, hum balancing control and output impedances of 4, 8, 16 and 500 ohms. Flexibility is emphasized in the input circuits with built-in preamplifier and proper equalization.

## HEATHKIT HIGH FIDELITY PREAMPLIFIER KIT

MODEL WA-P2  
\$19.75

Ship. Wt. 7 lbs.



Complete compensation for LP, NARTB, AES and early 78 recording characteristics. An ideal control unit for the custom Hi-Fi system. 5 individually controlled inputs, 4 turnover and roll-off switch positions, 3 twin triode tubes, cathode follower output, monitored recorder output, shock mounted tube chassis and proper shielding. All condensers are of the molded plastic type. Critical input circuits feature low noise deposited carbon resistors. Use it with any conventional high fidelity amplifier.

**HEATH COMPANY • Benton Harbor 15, Mich.**

## ORDER BLANK

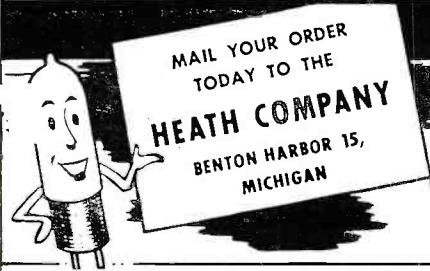

From \_\_\_\_\_

SHIP VIA  
 Parcel Post  
 Express  
 Freight  
 Best Way

QUANTITY	ITEM	MODEL NO.	PRICE

Enclosed find ( ) check ( ) money order for \_\_\_\_\_ pounds. On Express orders do not include transportation charges—they will be collected by the express agency at time of delivery.

ON PARCEL POST ORDERS insure postage for weight shown. ORDERS FROM CANADA and APO's must include full remittance.



## Cross-Coupled Amplifier

(Continued from page 62)

minimum at a cathode-resistor value of 2000 ohms. At this point the IM distortion is 0.9%. When it is realized that the IM distortion is almost always considerably greater than the harmonic distortion the value of this circuit can be fully appreciated.

To a large extent, the IM distortion is independent of the size of the cathode resistors  $R_c$ , but if they are made too large in value the effective plate voltage is reduced. Under normal conditions the IM distortion of the circuit is inversely proportional to the plate supply; that is, reduction of the plate supply to 200 volts approximately doubled the IM distortion. For this reason it is not desirable to make the cathode resistors too large.

The outputs are always perfectly balanced irrespective of the method of connecting the input. The frequency response for both stages was flat to over 200 kc.

Since the input terminals are at a small d.c. potential above ground, coupling condensers must be used to isolate them from d.c. The input resistance is so low that electrolytic condensers are indicated. For the circuit shown in Fig. 4, a response down 3 db at 10 cps is obtained by using 50- $\mu$ fd. condensers.

Among other applications, this circuit could presently be used as an input stage to an amplifier fed by a pre-amplifier terminating in a cathode follower.

### REFERENCE

1. Van Scoyoc, J. N.; "A Cross Coupled Input and Phase Inverter Circuit," *Radio-Electronic Engineering Edition, Radio & Television News*, November, 1948. —30—

## CONNECTOR IDEAS

By ARTHUR TRAUFFER

AS shown at the left of the photo below, there are still many of the old-fashioned removable-top types of binding posts in use, but it's hard to make phone tips, or the tips of test prods, hold in them.

The problem is easily solved by slipping a Fahnestock clip on the post. Now you can connect a wire, a test prod, or a phone tip as shown. Bend the finger tab on the Fahnestock clip back a little so it won't hit the knob of the binding post when you press on it.

Another problem is to connect an alligator clip to a phone-tip jack. Simply buy a few extra phone tips and keep them handy near your equipment. When you want to connect an alligator clip to a tip jack, simply grip one of the tips in the clip and shove the tip in the jack, as shown at the right of the photograph.

—30—

Connecting a phone tip to a binding post (left) and alligator clip to jack (right).

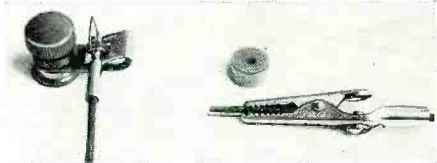

May, 1954

Thousands of engineers and audio enthusiasts have improved Hi-Fi performance with DUBBINGS' tests.

Here is what Audio Experts are saying about our latest development:

HAROLD D. WEILER, author of "Hi-Fidelity Simplified" in his forthcoming book states:

"The Dubbings' Test Tapes are an absolute must for anyone interested in obtaining and maintaining peak performance from his tape recorder . . ."

ROBERT J. MARSHALL, Chief Engineer, Fairchild Recording Equipment Co.:

"Dubbings' new Test Tapes are welcome companions to that company's series of fine Test Records . . . Getting all the important tests on a single reel is a tribute to advanced engineering know-how."

*the first and only comprehensive*

ON ONE REEL — ALL MAJOR TESTS FOR PERFECT ADJUSTMENT OF:

WOW AND FLUTTER

HEAD ALIGNMENT

FREQUENCY RESPONSE

30 to 7,500 cps at 7½ ips

30 to 15,000 cps at 15 ips

SIGNAL LEVEL

SIGNAL TO NOISE RATIO

TAPE SPEED

A complete instruction book, "Tape Recorder Maintenance", is enclosed



D-110, 5" REEL 7½ IPS

D-111, 7" REEL 15 IPS

*individually recorded*  
on REEVES SOUNDRAFT

**LIFETIME**  
*professional tape!*

*no costly voltmeter needed . . . the simplified D-500 TEST LEVEL INDICATOR is noted for accuracy (use with both test tape and records) . . . only \$3.95*

the accepted standard in audio tests  
**DUBBINGS' TEST RECORDS**

ORDER WITH CONFIDENCE . . . UNCONDITIONAL MONEY BACK GUARANTEE

### D-100 TEST RECORD

"Measure of Your Phonograph's Performance." The test record for:

FREQUENCY RESPONSE RUMBLE AND HUM WOW AND FLUTTER TRACKING STYLUS COMPLIANCE

### D-101 TEST RECORD

"Measure of Your Phonograph's Equalization." The only record with each of these response curves:

COLUMBIA LP AES NARTB  
RCA's "New Orthophonic"

Enclosed find  CHECK  MONEY ORDER

NAME \_\_\_\_\_

ADDRESS \_\_\_\_\_

CITY \_\_\_\_\_ ZONE \_\_\_\_\_ STATE \_\_\_\_\_

The DUBBINGS CO., Inc. Dept. 45  
41-10 45th St., L.I.C. 4, N.Y.

Quantity	Amt.
<input type="checkbox"/> D-110 5" Reel 7½ ips @ \$12.50	_____
INTRODUCTORY TILL MAY 15 @ \$10.95	\$ _____
<input type="checkbox"/> D-111 7" Reel 15 ips @ \$17.50	_____
INTRODUCTORY TILL MAY 15 @ \$15.95	_____
<input type="checkbox"/> D-500 TEST INDICATOR @ \$3.95	_____
<input type="checkbox"/> D-100 TEST RECORD @ \$3.50	_____
<input type="checkbox"/> D-101 TEST RECORD @ \$4.95	_____
Postage & Handling \$ .50	_____
Please Print TOTAL	\$ _____



# MORE DEALERS ARE INSTALLING

## CHANNEL MASTER'S CHAMPION THAN ANY OTHER ANTENNA IN TELEVISION HISTORY!



model no.  
325-2

All-channel reception: VHF & UHF

HORIZONTAL POLAR PATTERNS  
(Relative Voltage)

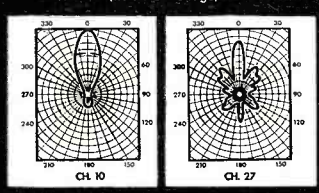

Gain  
(above tuned reference dipole)

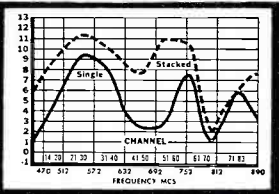
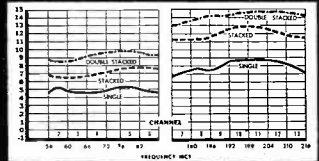

**ONLY THE CHAMPION** enjoys this overwhelming acceptance: over 300,000 already sold!

**ONLY THE CHAMPION** is powered by the unique "Tri-Pole," the triple-powered dipole system that provides fabulous VHF-UHF fringe area performance. 100% aluminum; rugged, exclusive alloy. Installs in a flash!

**ONLY THE CHAMPION** gives you this four-star promotion program:

- ★ **FREE newspaper ads**
- ★ **FREE TV film commercials**
- ★ **FREE colorful display material**
- ★ **FREE consumer literature**

See your Channel Master distributor for full details.

### The antenna America knows best!

Introduced to millions through the editorial pages of their favorite magazines and newspapers, and on TV.

**DON'T BE MISLED BY "LOOK-ALIKES" . . .  
THERE'S ONLY ONE REAL CHAMPION!**

Model no. 325, Single bay; Model no. 325-4, Four bay; Model no. 325-6, Super Champ



**CHANNEL MASTER CORP.** ELLENVILLE, N. Y.

The World's Largest Manufacturer of Television Antennas

Copyright 1954 Channel Master Corp.

## Equalizer for FM Pickups

(Continued from page 55)

shows a simple two-stage voltage amplifier which is suitable for bringing the voltage up to about 1.3 volts, ample for any high-level input. It is outstanding for flat frequency response, low distortion, and low output impedance due to a high ratio of feedback.

The continuous controls should be calibrated and marked in the manner of Fig. 5. Calibration can be accomplished in one of several ways. If an audio oscillator and an a.c. vacuum-tube voltmeter are available it is possible to trace the frequency response at a number of settings. It is more direct to use the following scheme. Set the high frequency control on maximum high-frequency boost and the low-frequency pre-emphasis switch on flat (no condenser). Adjust the audio oscillator and vacuum-tube voltmeter to get a standard reading at 1000 cycles. Then lower the frequency of the oscillator to 100 cycles. Adjust the bass turnover control (see Table 1) to get output in terms of db below the standard 1000 cycle reading and mark the controls with corresponding turnover.

The high-frequency control is adjusted in the same general manner and marked in terms of correction for high-frequency pre-emphasis. The oscillator is turned to 10,000 cycles and the readings of Table 2 relative to the standard 1000 cycle tone correspond to the given marking of the high-frequency control.

The response curves obtained by switching in  $C_2$  and  $C_3$  should be checked against the curves of Fig. 6. Some selection of condensers may be required to accurately match the de-

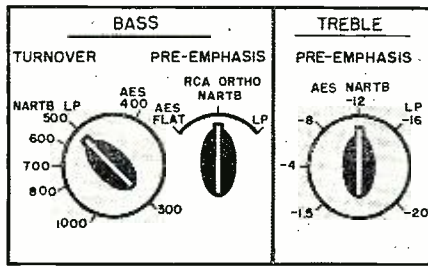

Fig. 5. Sample control panel for the constant-amplitude equalizer unit.

OUTPUT (100 vs 1000-)	BASS TURNOVER
-10 db	300
-8 db	400 (AES)
-6 db	500 (NARTB, LP)
-2 db	800

Table 1. Bass turnover frequency adjustment with 100-cycle output vs 1000 cycles.

OUTPUT (10,000 vs 1000-)	H.F. CORRECTION
+18 db	-2 db
+16 db	-4 db
+12 db	-8 db
+8 db	-12 db (AES, NARTB)
+4 db	-16 db (LP)
+0 db	-20 db

Table 2. High-frequency pre-emphasis control settings (10,000 cycles vs 1000 cycles).

sired response with your FM equalizer.

The controls can also be calibrated quite well if only an ohmmeter is available. In this case  $C_1$  should be selected within  $\pm 5\%$  of the correct value. The various markings for the controls can then be found from the measured resistances of the variable resistors according to Table 3. Since both  $R_1$  and  $R_2$  comprise the bass turnover control, the resistance measurement should include these two in series for proper calibration.

-30-

BASS TURNOVER CONTROL		H.F. PRE-EMPHASIS CONTROL	
$R_1 + R_2$ (in megohms)	Turnover (cycles)	$R_3$ (in ohms)	Correction (1000-)
.8	1000	0	-1.5 db
1.0	800	120,000	-4 db
1.6	500	200,000	-8 db
2.0	400	300,000	-12 db
2.7	300	500,000	-16 db
		800,000	-20 db

Table 3. How the control can be calibrated using an ohmmeter exclusively.

Fig. 6. Response curves obtained with the constant-amplitude equalizer.

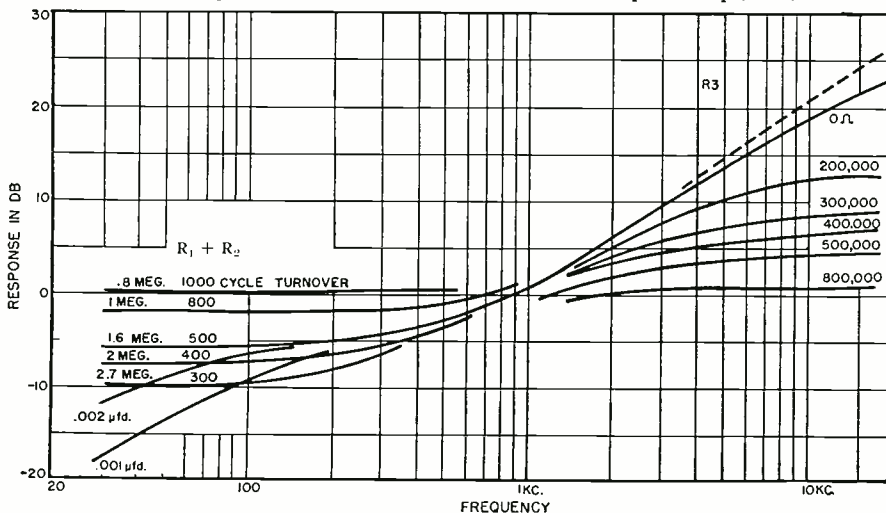

**They're small in size!**  
**They provide flexibility!**  
**They offer positive protection!**

Dependability that gives you confidence. Flexibility that helps you do a better job! These are things you can count on getting in Centralab's new PA-1000 Series. See for yourself:

**You get** high-strength, high-resin, laminated phenolic insulation that exceeds Phenolic Standards Grade XXX.

**You get** one-piece shaft construction for accurate indexing. Adjustable stop permits selection of positions or continuous rotation (11 active positions, 1 off-position).

**You get** steatite spacers with nickel-plated brass shafts, bushings, tierods, and nuts. All other metal parts are treated to pass 50-hour salt-spray test — a must for applications in a humid or salt atmosphere.

**You can get** complete switches or separate miniature phenolic sections, index assemblies, hardware, and accessories.

That's only part of the PA-1000 story. Get it all — send coupon for Centralab catalog sheet 28-1.

Then order Centralab Miniature Phenolic Rotary Switches from your Centralab distributor.

SEE US AT BOOTH 790.

1954 MAY 17-20 • CHICAGO  
ELECTRONIC PARTS SHOW

CENTRALAB, A Division of Globe-Union Inc., 910 E. Keefe Ave., Milwaukee, Wisconsin  
Send me Centralab catalog sheet 28-1.

Name.....  
Company.....  
Address.....  
City..... Zone..... State.....

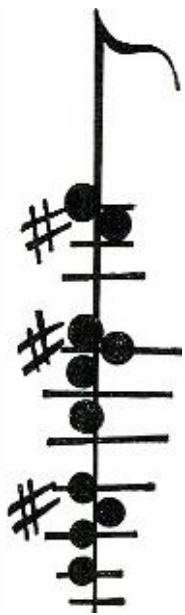

# 6 REASONS WHY HI-FI FANS DEMAND THE FAIRCHILD SERIES 215 DIAMOND CARTRIDGE WITH HIGH COMPLIANCE

Instantly — there's a startling improvement in sound when record collectors switch to the FAIRCHILD Series 215. Listeners who have just discovered high-fidelity — and seasoned audiophiles both hear a new presence in recordings.

Only FAIRCHILD's moving coil design can give such unequalled performance. Compare — and you too will agree that the start of any high-fidelity system must be the high Compliance FAIRCHILD Series 215.

- 1 — Brings true-to-life color to high piano chords.
- 2 — Releases new low frequency tones.
- 3 — Smooth linearity — lower apparent surface noise.
- 4 — Reduces tone arm resonance greatly.
- 5 — Preserves record quality — reduces stylus wear.
- 6 — Eliminates — completely — listening fatigue caused by tracking distortion.

All of this at an unbelievably low price — **\$3750**

And investigate these FAIRCHILD products, too!



The NEW Model 240 Balanced-Bar Preamplifier-Equalizer offers typical FAIRCHILD quality, a wide latitude of control, extreme operating simplicity, correct record equalization and decorator styling. Net to user — \$98.50

The NEW Model 280 Plug-In Type Pickup Arm brings professional quality into the home with minimum size, unusual pivoting method, low bearing friction and accepts all standard makes of cartridges. Net to user — \$29.50



SEE YOUR AUDIO DEALER or for free folder write:  
**FAIRCHILD RECORDING EQUIPMENT**  
8th Ave. & 154th STREET, WHITESTONE, L. I., N. Y.

**Crown**  
BROADCASTER  
PORTABLE  
TAPE  
RECORDER

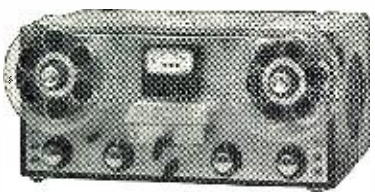

**NOW for the first time—true broadcasting quality priced low enough for all to enjoy.** Six years development has resulted in the only recorder of its price meeting NARTB broadcasting standards.

- 3 speeds—15", 7½", 3¾"
- ± 2 db 30-11000 cps at 7½"/sec.
- 3 motor mechanism. 2 inputs
- less than .25% flutter and wow
- 20 watt hi-fi amp. built in
- 8" 10 watt speaker built in

Write today for free brochure to Dept. R5  
Dealer Inquiries Invited

**INTERNATIONAL RADIO & ELECTRONICS CORP. • ELKHART, INDIANA**  
Builders of Broadcast Equipment Since 1938

tray shown in Fig. 2. The etch rate, the predicted date, and time the goal frequency would be reached, were penciled on strips of masking tape placed along the tray sides.

The etching rate will be more constant by maintaining the solution at a recommended 60° centigrade, however, perfectly satisfactory results were obtained without this refinement.

A rapid means of checking the approximate frequency of a plate was found, using the BC-221 frequency meter. As shown in Fig. 1, the plate is simply placed on the meter output binding post. The crystal is excited mechanically, by lightly tapping its center, while exploring with the main dial. At the general frequency of the crystal, loud plops are heard in the headphones. As the crystal neared the desired frequency, all measurements were made with the crystal operating in the equipment and holder to be used.

Usual precautions in handling the finished blank should be observed to prevent oil from the hands reaching the surfaces. Should the electrodes appear soiled, they may be washed, using castile soap and a toothbrush. The writer prefers to dry the plate and electrodes in tissue, such as is used to clean optical lens, and then "pour" the plate into the holder, without actually touching either crystal or electrodes.

The finished plate was installed between electrodes intended for operation near the desired frequency. This is necessary, since the height of the supporting corners varies with frequency. It is possible for the center of the plate to strike the electrode plate, if sufficient clearance is not provided by the "lands". On the other extreme, efficiency decreases if the corner supports are too high for a given frequency.

With the crystal operating in the grid-dip meter, the position of the plate for best output was located, by making slight changes in its position between the electrodes, until the highest meter reading was obtained. The cover was then tightened and the activity again checked, to see that the same alignment was in effect.

Crystals which failed to respond to the process were noted to have some visible flaw such as excessive air bubbles or chipped surfaces. Some plates ceased to oscillate because their composition was not uniform, developing a wood-grained appearance as the softer portions were etched away.

Appreciation is expressed to Mr. R. B. Belsor of the Georgia Institute of Technology staff for outlining the basic elements of this process.

**REFERENCE**

Heising, Raymond A.: "Quartz Crystals for Electrical Circuits," D. Van Nostrand Company, Inc., New York.

# 7,168 Service-Dealers Cashing in on CQS

**SURVEY SHOWS 78% OF SERVICE-DEALERS  
REPLYING REPORT ENTHUSIASTIC  
SUPPORT OF CQS PLAN!\***

Using the *Certified Quality Service* plan? If not, you may be losing business to your competitor across the street. If you *are* using the CQS tags and all the sales aids available to you, you're all set. . .

**AND HERE'S GOOD NEWS!**

\*Survey conducted January, 1954

**Your NATIONAL ADVERTISING continues to sell  
for you in LIFE during May and June.**

## BE SURE YOU HAVE YOUR CERTIFICATION TAGS



Your national advertising says, "Ask your Service-Dealer for this CQS Tag." Tie in. All you have to do is:

1. Use your improved, colorful, multi-use CQS Tags to build more business and greater customer confidence . . . *in you.*
2. Use your CQS signs, posters, decals, and other sales aids. Make it easy for customers to find you.

CQS Tags are available: 250 for \$2.25, 500 for \$3.50, 1000 for \$6.00, with your 3-line imprint. Ask your distributor salesman for special offer . . . or use coupon to order direct.

## GET YOUR CQS CBS-STAR KIT

Contains 6 smashing, big, colorful, magnetic CBS-Star streamers. Each features a different CBS-TV star: Benny . . . Burns and Allen . . . Gleason . . . Godfrey . . . Murrow . . . and Marie Wilson. Each is a different size and shape. Each sells the Star Performance of your *Certified Quality Service*. Kit also includes a new inside/outside CQS decal and a Business Builder's Catalog showing the many sales aids available to you. CBS-Star Kit is *free* with CQS Tags . . . Kit alone, 25¢.

Let folks know you're the Service-Dealer they read about in the national magazines. Ask your distributor salesman for special offer . . . or use coupon. Order your Tags and CBS-Star Kit today.

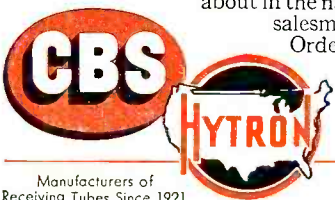

**CBS-HYTRON** Main Office: Danvers, Mass.

Manufacturers of Receiving Tubes Since 1921

A Division of Columbia Broadcasting System, Inc.

A member of the CBS family: CBS Radio • CBS Television  
Columbia Records, Inc. • CBS Laboratories • CBS-Columbia • and CBS-Hytron

May, 1954

**Want Reliable TV and Radio Repairs . . . fair charges?**

Ask your service-dealer for this **CERTIFICATION Tag!**

**Certified QUALITY SERVICE**

The service that parts don't do in service shops. We use the best and most reliable parts and work to the highest standards.

**Fact-about your TV set**

Time is not the enemy of your TV set. It is the quality of the parts and the skill of the repairman. The best way to get the most out of your TV set is to have it repaired by a Certified Quality Service Dealer. These dealers are trained to use the best parts and to work to the highest standards. They are also equipped to handle all types of TV sets and radio receivers. They are also equipped to handle all types of TV sets and radio receivers. They are also equipped to handle all types of TV sets and radio receivers.

**Certified QUALITY SERVICE**

ASK YOUR SERVICE-DEALER FOR THIS TAG

**Building New Tube Business for You!**

CQS dealers themselves help you sell CBS-Hytron Mirror-Back and CTS-Rated tubes.



## CBS-HYTRON, Danvers, Mass.

Please rush me:

A CBS-Star Kit free with . . . CQS Tags  
(quantity)  
@ \$2.25, 250; \$3.50, 500; \$6.00, 1000

A CBS-Star Kit *only*  
@ 25¢ (for handling and mailing)

I enclose \$ . . . to cover Tags and/or Kit.  
(Please send cash, check, m.o. . . no C.O.D.'s.)

HERE IS MY 3-LINE IMPRINT FOR TAGS  
(please print name and address)

Name . . . . .

Street . . . . .

City . . . . . State . . . . .

Signed . . . . .

# Quality Features OF TUNG-SOL PICTURE TUBES



**Gun** made of best grade non-magnetic steel.

**Glass bead** type assembly is stronger both mechanically and electrically—gives greater protection against electrical leakage.

**Rolled edges** in gun minimize corona.

**Custom built stem** with greater spacing between leads assures minimum leakage.

**Low resistance** of outside conductive coating minimizes radiation of horizontal oscillator sweep frequency.

**Double cathode tab** provides double protection against cathode circuit failure.

**Selected screen composition** resists burning (X pattern).

**Rigid control** of internal conductive coating provides utmost service reliability.

**Designed** for use with single or double field ion trap designs.

**One-piece construction** of parts assures better alignment.

**Maximum dispersion** of screen coating assures uniform screen distribution.

Tung-Sol makes All-Glass Sealed Beam Lamps, Miniature Lamps, Signal Flashers, Picture Tubes, Radio, TV and Special Purpose Electron Tubes and Semiconductor Products.

TUNG-SOL ELECTRIC INC., Newark 4, N. J. Sales Offices: Atlanta, Chicago, Columbus, Culver City (Los Angeles), Dallas, Denver, Detroit, Newark, Seattle.

## TUNG-SOL®

RADIO AND TV TUBES



You Can Build A Reputation On Tung-Sol Quality

## Technical BOOKS

"THE ELECTRONIC MUSICAL INSTRUMENT MANUAL" by Alan Douglas. Published by *Pitman Publishing Corp.*, New York. 215 pages. Price \$6.00. Second edition.

This practical handbook has been designed for electronic engineers, musicians, and the manufacturers of musical instruments. Since the author's contention is that fundamentally all electronic musical instruments employ the same basic circuits, much space has been devoted to a careful analysis of the production and mixing of electrical oscillations, amplifiers, tone controls, and loudspeakers.

Three introductory chapters cover sound, music and noise, and conventional multi-note instruments. The balance of the book covers commercial electronic instruments and experimental methods. A complete schematic of the "Solovox" and a partial diagram of the "Novachord" are also included with the text. In addition, the author has used partial schematics, photographs, and wiring diagrams to illustrate his material.

The text is meaty, well-written, and concise. For the reader with a solid technical background in audio, this book provides a handy reference tool of inestimable value.

\* \* \*

"THE RADIO AMATEUR'S HANDBOOK" compiled by the ARRL Staff. Published by *American Radio Relay League*, West Hartford, Conn. 800 pages including catalogue section. Price \$3.00. Thirty-first edition. Paper bound.

Like the first crocus or robin, the new edition of the "Handbook" arrives in the Spring—and is almost as welcome as Spring itself.

Following the time-honored and wholly acceptable formula of the previous editions, the new volume has been carefully revised to reflect the progress made by the industry and in the art during the past year. There are new sections on semiconductor devices, high-frequency transmitter designs for the Novice, up-to-date high-powered equipment for the experienced ham, new data on v.h.f. reception and equipment for this portion of the spectrum, new information on mobile gear, and BCI and TVI data. Over 150 new tube types and transistors have been added to the vacuum-tube table and the base-diagram sections of the book.

This newest edition is up to the customary high standards of these publications and readers will find that they have received their money's worth and more in this volume.

\* \* \*

"HOW TO USE METERS" by John F. Rider. Published by *John F. Rider, Publisher, Inc.*, New York. 154 pages. Price \$2.40. Paper bound.

There has long been a need for a practical handbook on meters and their uses and this one seems to fill the void nicely.

The text material covers the application of all kinds of panel meters, v.o.m.'s, v.t.v.m.'s, etc. for radio and television service work, transmitter installations and repairs, laboratory practice, and industrial applications.

The author tells what meter to use where and how to use it. He also explains the differences between meter type measuring equipment of all kinds and outlines their limitations.

The book is well illustrated with photographs and schematics of various commercially-available instruments. The text would be equally suitable for home study, reference, and as a teaching aid.

\* \* \*

"RECEIVING TUBE SUBSTITUTION GUIDEBOOK" by H. A. Middleton. Published by *John F. Rider, Publisher, Inc.*, New York. 42 pages. Price \$99. Paper bound. Second Supplement.

This is the second supplement to the original guidebook which was published some years ago.

This particular volume is devoted almost entirely to television receiver tube substitutions and alternate picture tubes which may be employed. Each tube is listed along with its substitute, its performance rating, and the circuit changes that are required when the tube is not directly interchangeable.

All this information is provided in tabular form for maximum utility. The book also contains a cumulative index of the previous volumes.

\* \* \*

"ON THE AIR" by Roger Manvell. Published in the U. S. by *The British Book Centre Inc.*, New York. 196 pages. Price \$3.50.

This slim volume is a "study of broadcasting in sound and television" written by one of the well-known personalities on the roster of the *British Broadcasting Corporation*.

It is a non-technical book slanted for the general reader. It is concerned primarily with the programming end of the radio and television industry and covers the historical background of the *BBC* system as compared to systems in the United States and elsewhere.

The author also delves into such touchy subjects as control, monopoly, sponsoring, minorities, freedom of speech, and good taste. Comparisons are made between *BBC* programming and air fare offered listeners and viewers in the United States.

Those interested in the entertainment and/or educational aspects of radio and TV broadcasting should enjoy this work.

\* \* \*

"TV TROUBLESHOOTING AND REPAIR GUIDEBOOK" by Robert G. Middleton. Published by *John F. Rider, Publisher, Inc.*, New York. 152 pages. Price \$3.30. Paper bound. Volume 2.

Like its predecessor volume, this is



**"SURPRISE" Trade-Ins Help Make Both Ends Meet!**

Keeping your eyes open for bargains, pays off in big savings. And a bargain is just what you get when you take advantage of our "Surprise" Trade-In Allowance on used test and communication equipment. So get your trade-in deal working today. Wire, write, phone or use the handy coupon below.

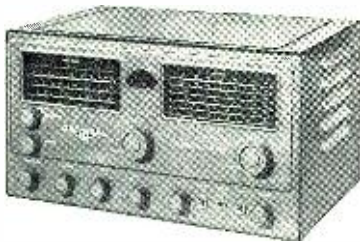

**NEW NATIONAL NC-98.**  
Covers 550 KC to 40 MC. 9 tubes.  
Lowest priced receiver having crystal filter. Less speaker. Net \$149.95



**HALLCRAFTERS SX-88.**  
Dual conversion, high selectivity.  
Less speaker. Net \$595.00

**MORROW 5BR Five Band Converter.**  
Net \$74.95

**GONSET "Super 6" Converter.**  
Net \$52.50

**GONSET Super-Ceiver.** Net \$119.50

**CARTER GENEMOTORS.** Furnish "B" power for mobile transmitters.

**Model 450 AS.** 6 VDC input. 400 VDC at 250 MA output. Net \$49.25

**Model 520 AS.** 6 VDC input. 500 VDC at 200 MA output. Net \$49.25

12 VDC Models also available at slight additional cost.

**HARVEY WELLS BANDMASTER TRANSMITTERS.**

**Model TBS-50C** Net \$111.50  
**Model TBS-50D** Net \$137.50

**MOBILE GEAR**

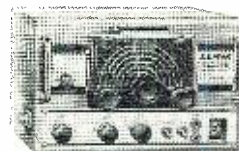

**ELMAC AF-67 TRANS-CITER.**  
Net \$177.00

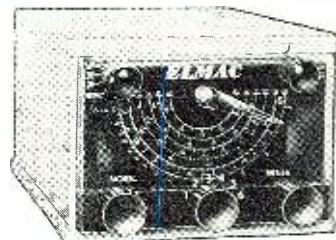

**ELMAC MOBILE RECEIVER.**  
Dual conversion, 10 tubes.  
**Model PMR-6A** For 6 volts Net \$134.50  
**Model PMR-12A** For 12 volts Net \$134.50

**ELMAC PS-2V.** 115 VAC power supply for AF-67. Net \$49.50

All prices f. o. b. St. Louis • Phone Chestnut 1125



**FREE CATALOG!** R-54-5

WALTER ASHE RADIO COMPANY  
1125 Pine Street, St. Louis 1, Missouri

Rush "Surprise" Trade-In Offer on my \_\_\_\_\_  
for \_\_\_\_\_  
(show make and model number of new equipment desired)

Send new FREE 1954 Catalog.

Name \_\_\_\_\_  
Address \_\_\_\_\_  
City \_\_\_\_\_ Zone \_\_\_\_\_ State \_\_\_\_\_



# 3 NEW RIDER BOOKS FOR MAY

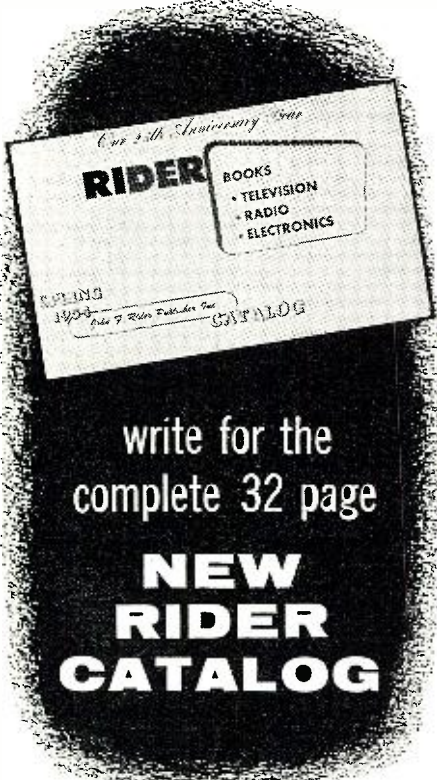

## HOW TO LOCATE AND ELIMINATE RADIO & TV INTERFERENCE

by Fred D. Rowe,  
Northern California Electricity Bureau

An expert from the Northern California Electricity Bureau tells how he located sources of radio and TV interference—and the things he did to eliminate them. This is not a theory or a “perhaps” book. The content is direct to the point and tells what to do. 128 (5½ x 8½”) pages, illus.....\$1.80

## TECHNICIAN'S GUIDE TO TV PICTURE TUBES

by Ira Remer

A picture tube servicing guide for the television installation and repair man. Covers the care, methods of handling, replacement maintenance and repair of the picture tube. It is written for the technician who desires basic and specific information on the picture tube and its accessories (including conversion) without wading through reams of technical data, complicated circuit explanations. 140 (5½ x 8½”) pages, illus.....\$2.40

## FUNDAMENTALS OF TRANSISTORS

by Leonard Krugman

The transistor is now evolved to a point where it is suitable for many applications, both as a direct replacement and as a supplement to electron tubes. An expert has consolidated in practical form for the repair man, the engineer, the hobbyist and the engineering student the explanation and application of the transistor. Basic transistor operation, characteristics, performance and applications are explained. 160 (5½ x 8½”) pages, illus.....\$2.70

Buy these books now from your jobber, bookstore—if not available from these sources, write to:

**JOHN F. RIDER PUBLISHER, INC.**  
460 Canal Street, New York 13, N. Y.

**Canada:**  
Mr. Charles W. Fenton  
1826 Central Street, East  
Toronto, Ontario

**Eastern Agents:**  
Robert A. Green, Inc.  
39 Murray Street  
New York 7, New York

**West Coast Office:**  
2218 20th W. Jefferson Blvd.  
Los Angeles, California

**Cable Address:**  
RIDER PUBLISHER, N. Y.

a thoroughly practical handbook for the working technician.

Without frills or theoretical digressions, the text material presents how-to-do-it information on troubleshooting front ends, servicing video i.f. strips, locating faults in video amplifiers, analyzing trouble in sound i.f. and detector systems, how to service audio amplifiers, and tracing troubles in horizontal circuits.

The text is amplified and clarified by the use of many circuit diagrams, scope patterns, and graphs.

Those who have studied the first volume will find this expanded and extended text a real addition to their reference shelves.

\* \* \*

## "RADIO TROUBLESHOOTING GUIDEBOOK" by John F. Rider & J.

Richard Johnson. Published by *John F. Rider, Publisher, Inc.*, New York. 152 pages. Price \$2.40. Paper bound. Volume 1.

This is the first volume in a new series of handbooks that will, eventually, cover every phase of radio receiver servicing. Designed for the technician, student, or the hobbyist, the text is written in easy-to-understand form.

This first book covers AM and FM superheterodynes, the fundamentals of troubleshooting, and such common symptoms and remedies as undesired signals, weak signals, distortion, noise, and the dead receiver.

The judicious use of block diagrams, schematics, scope patterns, etc. throughout the text enhances the practical value of this work. —50—

## Compact 2-Meter Rig

(Continued from page 63)

less technically-minded present-day amateur as long as the equipment is easy to tune up, reliable in operation, and not priced outside the range of his pocketbook.

While originally designed for amateur use, the “Communicator” (with frequency range modified when necessary) is finding wide use for Civil Air Patrol ground service, ground control at large airports, flight test communication at aircraft factories, and “unicom” ground station use at small airports not equipped with control towers. The universal dual-input power supply (6 volts d.c. or 117 volts a.c.) allows fixed-station, mobile, or portable operation under a wide variety of conditions and many a unit which is used for fixed station work one day is used for portable or mobile work the next.

Other features sufficiently unconventional or uncommon to be of interest are: the provision for using the modulator as a public address amplifier with external “bull horn” speaker;

tuning-eye metering in which all tunable circuits in the transmitter are adjusted by tuning for maximum eye closure; an antenna circuit rectifier to facilitate tuning for maximum power in the load; a series diode squelch which is gated by a d.c. amplifier actuated from the a.v.c. voltage; and a “spotting switch” to permit spotting of the transmitter frequency on the receiver dial. The 6E5 tuning eye is actuated by the a.v.c. under “receive” conditions, and serves as a relative-indicating “S” meter to facilitate beam orientation, peaking of the r.f. and i.f. trimmers, etc.

To make operating techniques now common on the lower frequency phone bands possible with the “Communicator,” a variable frequency oscillator unit has just been released. It employs a 6CB6 combination Clapp-type oscillator and tripler, feeding a 6CL6 class A amplifier. The unit also contains a stage of audio preamplification and a voltage-regulated 117 volt a.c. power supply. Three tuned circuits at 24 mc. insure freedom from spurious multiplication of the 8 mc. oscillator, the relatively low oscillator frequency being used for reasons of stability. —50—

Fig. 2. Block diagram of the Gonset “Communicator”. The integral universal power supply which works from either 6 volts d.c. or 117 volts a.c. is not diagrammed.

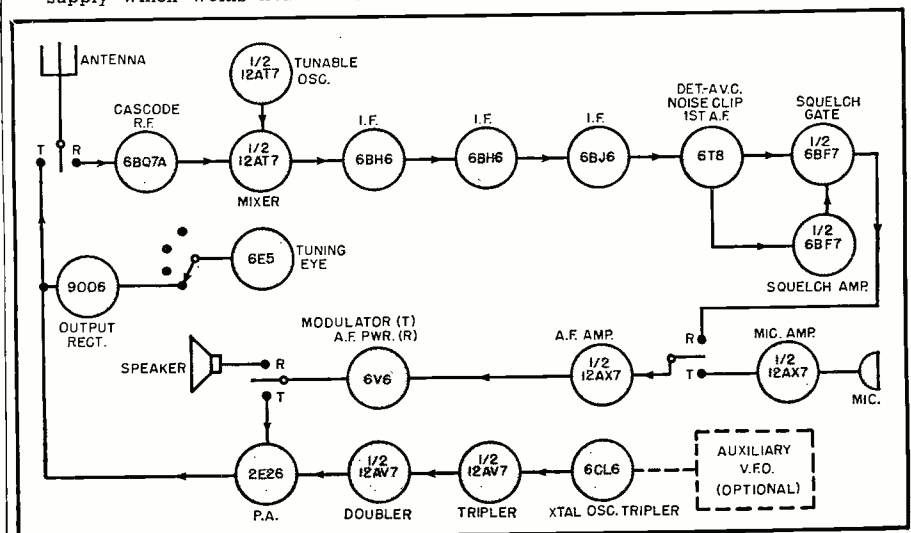



RCA PIONEERED AND DEVELOPED COMPATIBLE COLOR TELEVISION

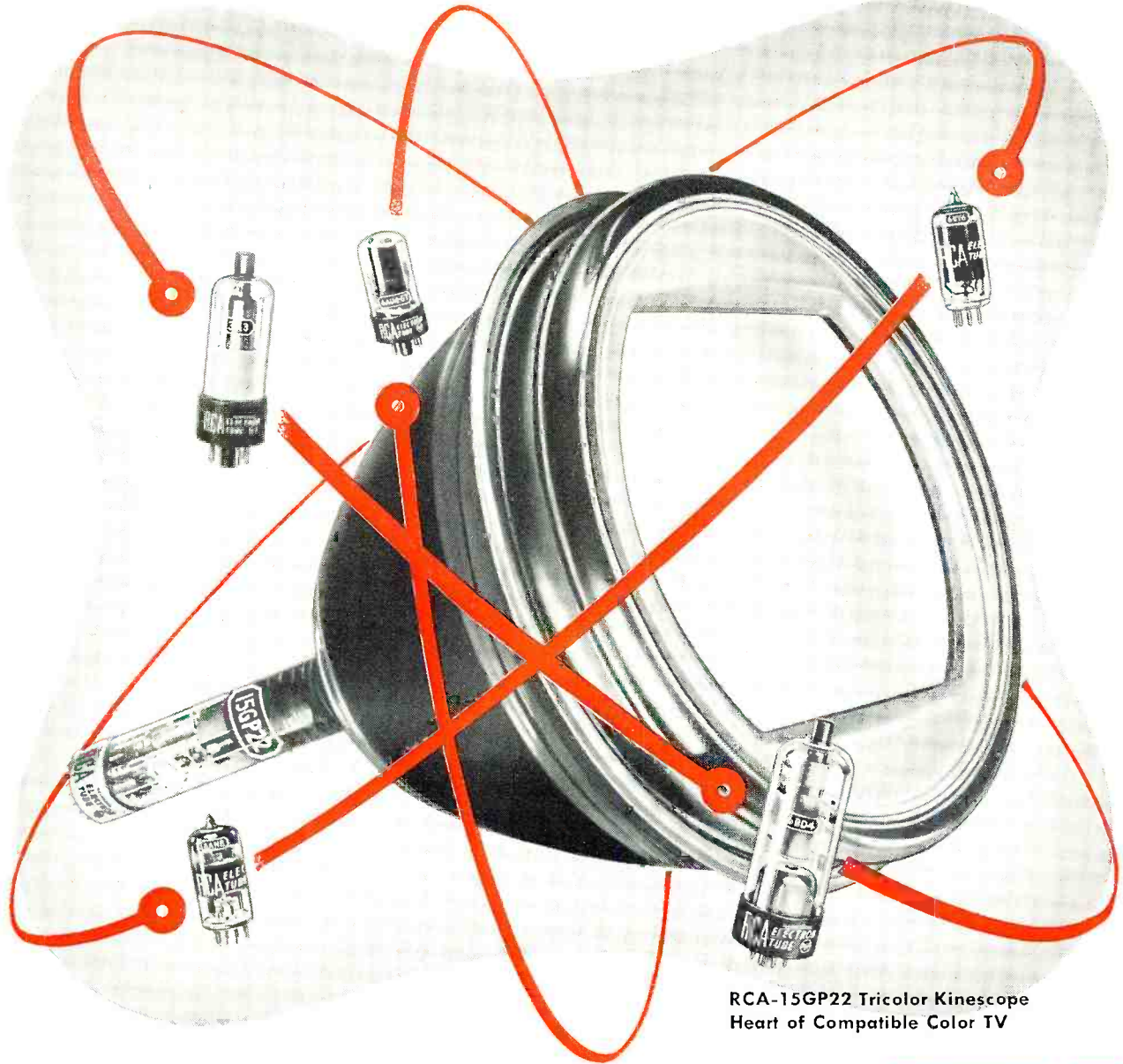

RCA-15GP22 Tricolor Kinescope  
Heart of Compatible Color TV

You're ready for **COLOR TV**  
...because RCA is ready for you

RCA—pioneer in the development of compatible color television—is ready now to supply you with the replacement receiving tubes and kinescopes you will need when color TV comes to your town.

Engineered for color by RCA, these tubes are designed to work together for superior performance.

RCA announces with pride the

new 15GP22 Tricolor Kinescope . . . heart of compatible color television. To supplement its other receiving tubes applicable to color television, including the RCA 6BY6 Pentagrid Amplifier and the RCA 6AU4-GT Damper Diode, RCA has developed three new types specifically for color circuits: RCA-6BD4 Sharp-Cutoff Beam Triode for regulation of high-

voltage dc power supply; RCA-3A3 Half-Wave Vacuum Rectifier for pulsed rectifier scanning service; and RCA-6AN8 Medium-Mu Triode Sharp-Cutoff Pentode for general-purpose use.

To restore the original performance of color TV sets, play safe . . . use genuine RCA tubes for color TV.

Be posted on Color TV . . . keep in touch with your RCA Distributor.



**RADIO CORPORATION of AMERICA**

**ELECTRON TUBES**

**HARRISON, N. J.**

**NORTH, EAST, SOUTH, WEST...**

# Federal has a lead-in

Whatever the area or atmosphere... city or fringe... rain, snow ice, heat, dust, salt spray, polluted air or radiation... you'll find the answer in these quality-controlled cables by Federal —

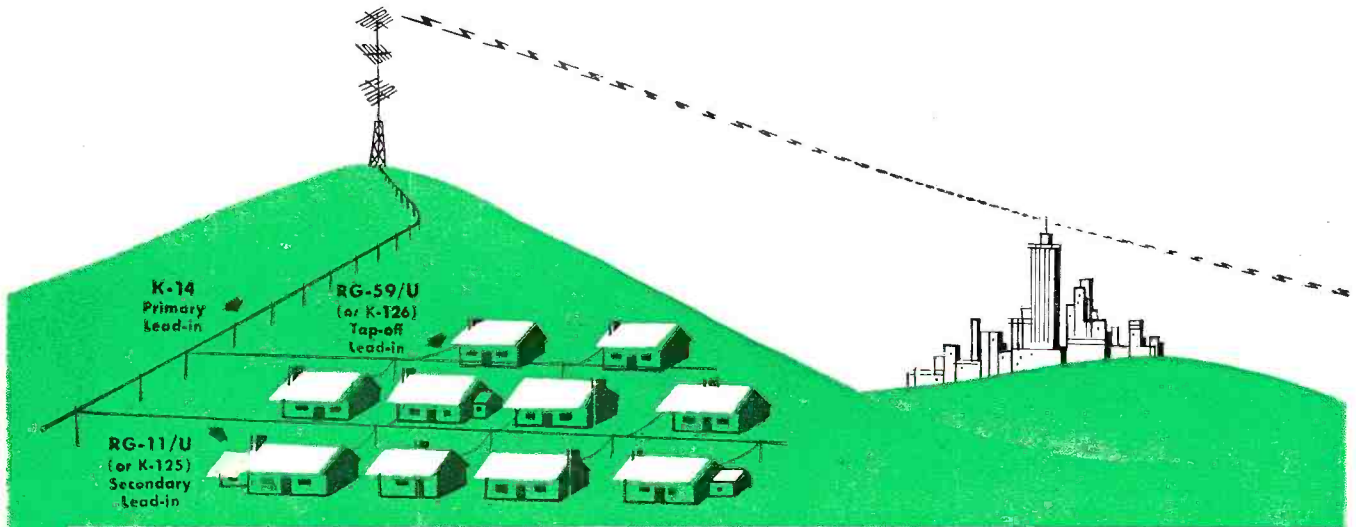

## FOR COMMUNITY TV IT'S *Federal's* "BIG 5"

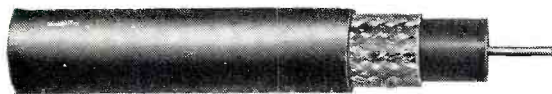

**K-14**—71-ohm shielded primary transmission line for community distribution systems. Famous for lowest line loss, long cable runs and fewer amplifiers required. Capacitance: 21.5 mmf/ft. Attenuation DB 100/ft: .57–50 Mc; .90–100 Mc; 1.42–200 Mc; 2.3–400 Mc.



**RG-11/U**—75-ohm shielded low-loss coaxial. One of the best small-diameter cables. Tops as a community TV secondary lead-in. Seven strands #26 tinned copper. Capacitance: 20.5 mmf/ft. Attenuation DB 100/ft: 1.5–50 Mc; 2.15–100 Mc; 3.2–200 Mc; 4.7–400 Mc.



**RG-59/U**—73-ohm coaxial TV lead-in cable. Highly efficient as a community system pole-to-house tap-off. Meets all needs wherever a high-grade installation is a must. Capacitance: 21 mmf/ft. Attenuation DB 100/ft: 2.7–50 Mc; 4.0–100 Mc; 5.7–200 Mc; 8.5–400 Mc.

**Use these 2 for Community TV radiation:**

## FOR URBAN CENTERS



**K-111**—300-ohm shielded, balanced TV lead-in developed by FTR. Minimizes noise, snow, ghosts due to transmission line pick-ups. Ideal for many areas where good TV was impossible before. Capacitance: 4.2 mmf/ft. Attenuation DB 100/ft: 3.4–100 Mc; 6.6–400 Mc.



**TV-1184**—300-ohm dumbbell-shaped TV lead-in. A standard low-cost lead-in for areas without unusual conditions. Cinnamon-brown color is highly resistant to ultraviolet. Two conductors: 7/#28. Capacitance: 4 mmf/ft. Attenuation DB 100/ft: 1.28–100 Mc; 3.0–400 Mc.



**TV-1182**—300-ohm deluxe type heavy-duty TV lead-in with 90 mil. web. Insulated with "silver" polyethylene, Federal development that provides maximum weather protection and long life. Capacitance: 4 mmf/ft. Attenuation DB 100/ft: 1.22–100 Mc; 2.85–400 Mc.

## Non-Radiating Lead-ins for MULTIPLEX TV SYSTEMS



**K-125**—75-ohm coaxial TV lead-in cable. Double-shielded and jacketed. Formerly listed as SP-75.



**K-126**—73-ohm coaxial TV lead-in cable. Double-shielded and jacketed. Formerly listed as SP-76.

**K-125** alternates for RG-11/U as secondary lead-in  
**K-126** alternates for RG-59/U as tap-off lead-in

Wherever there are **V** customers...

# for the finest **VHF-UHF**

**Federal's TV-1185** \*

...**"PIPELINE"** of the Air!

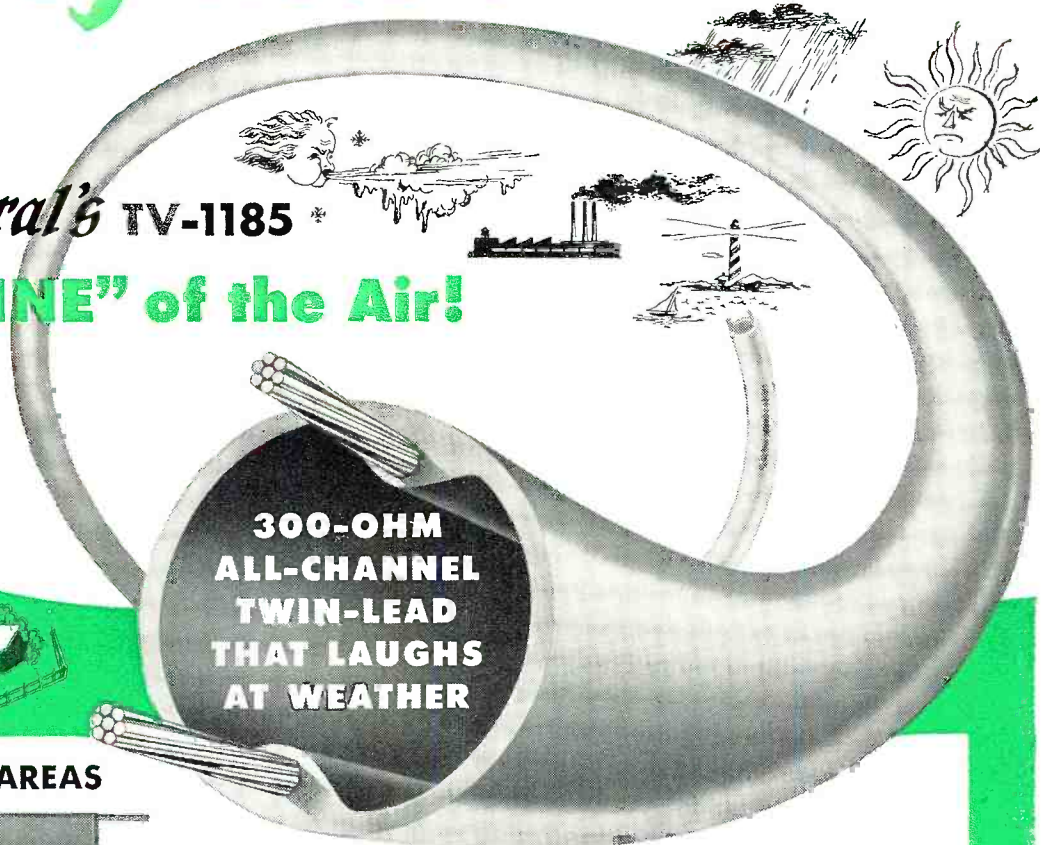

**300-OHM  
ALL-CHANNEL  
TWIN-LEAD  
THAT LAUGHS  
AT WEATHER**

## FOR FRINGE AREAS



**TV-1182**—Provides remarkably low line loss in fringe areas. Outstanding for resistance to weather and sunlight. Silver-colored insulation blends with any color scheme in home decoration.



**K-200 (RG-86/U)**—200-ohm heavy-duty ultra low-loss lead-in. Particularly adaptable to remote-area installations — especially long runs and multi-stack antennas. Also used with rombsics.

**See your local  
Federal Distributor  
or write to  
Federal direct  
Dept. D-959A**

**Re-designed — Re-engineered!**

## **NOW BETTER THAN EVER!**

FEDERAL'S TV-1185—the famous "Pipeline" of the Air—has been greatly improved. It's *more durable, more flexible and more efficient* . . . a better cable to work with!

This *new* TV-1185 is smaller in O.D. . . . with conductors consisting of seven strands of #28 stranded copper. It fits all stand-off brackets and lightning arresters . . . holds its shape while going around sharp-angle edges. And there's greater protection against oxidization in damp, salty areas. TV-1185 leads in Weatherometer tests, due to its Federal-developed "silver" polyethylene insulation.

TV-1185 keeps the energy field inside the weather-proof sheath . . . providing exceptionally low loss . . . more constant impedance. It's absolutely tops in tubular lead-ins!

Capacitance: 4 mmf/ft. Attenuation DB 100/ft:  
0.5–10 Mc; 0.95–50 Mc; 1.25–100 Mc; 1.7–200 Mc;  
2.6–400 Mc; 3.0–500 Mc; 4.5–1000 Mc.

Product of America's leading producer of solid dielectric coaxial cables



# Federal Telephone and Radio Company

SELENIUM-INTELIN DEPARTMENT

100 KINGSLAND ROAD, CLIFTON, N. J.

In Canada: Federal Electric Manufacturing Company, Ltd., Montreal, P. Q.

Export Distributors: International Standard Electric Corp., 67 Broad St., N. Y.

# THE New SUPER-ROYAL

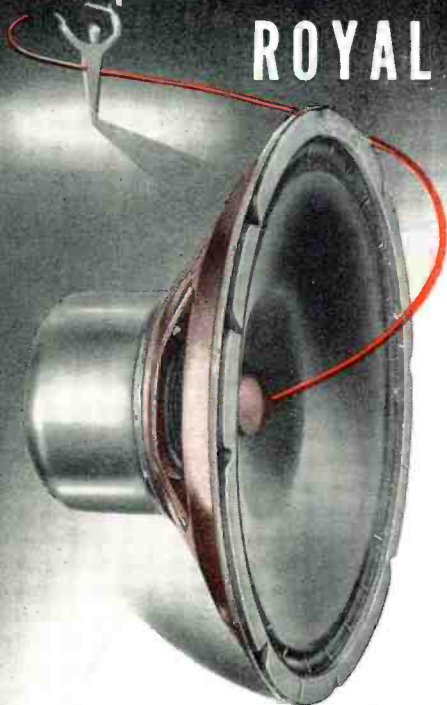

## High Fidelity Speakers

BY  
*Permoflux*

WITH THE  
**Famous Treated Slotted Cone  
FOR LOW RESONANCE**

This exclusive Permoflux feature, plus New design in magnetic structure, utilizing heavy Alnico 5 ring magnet, results in extended distortion free, low frequency response.

The specially designed single cone radiator reproduces both high and low frequencies with exceptional clearness, and avoids the inherent distortion of coaxial or 2 way systems.

See and hear the Super Royal at your High Fidelity Dealer

Available in 3 sizes  
8, 12 and 15 inch.

For descriptive literature write to . . .

**Permoflux CORPORATION**  
4918 Grand Ave., Chicago 36, Ill.  
West Coast Plant  
236 S. Verdugo Rd., Glendale 5, Cal.

## WHAT'S

# New in Radio

The products described in this column are for your convenience in keeping up-to-date on the new equipment being offered by manufacturers. For more complete information on any of these products, write direct to the company involved.

### NATIONAL RECEIVER

National Company, Inc., 61 Sherman St., Malden 48, Mass. has added another new receiver to its line of amateur and s.w. sets.

Known as the NC-98, the receiver is equipped with a crystal filter, "S" meter, accessory socket, and is calibrated for either ham or short-wave



bands. The NC-98 provides coverage from 500 kc. to 40 mc. It uses 8 miniature tubes plus a rectifier and has one r.f. stage, two i.f. stages, slide-rule dials, antenna trimmer, noise limiter, provision for NBFM, and a separate h.f. oscillator.

For further information on this new "anniversary" receiver write Dept. 19AR-98 of the company.

### PHONE-C.W. TRANSMITTER

A new medium-power ham transmitter featuring v.f.o. or crystal operation on six amateur bands has been announced by Barker & Williamson, Inc., 237 Fairfield Ave., Upper Darby, Pa.

The Model 5100 transmitter provides input powers of 150 watts c.w. and 135 watts phone. Either v.f.o. or crystal control may be selected for any amateur band, 80, 40, 20, 15, 11, or 10 meters. The output frequency is read directly on the face of the slide-rule dial which is accurately calibrated for each band.

The tube line-up for the r.f. section includes three 6BJ6's as the v.f.o., crys-



tal oscillator, and keyer circuit. For the multiplier section four 6AQ5's are used in broadband circuitry. The output of the multiplier feeds a pair of 6146's in the final amplifier.

The speech amplifier-modulator uses a 6U8 voltage amplifier feeding a 6AQ5 driver. A pair of 6146's operating in class AB2 provides more than adequate audio power to fully modulate the transmitter carrier. Power for both the r.f. and modulator sections is supplied by two 5R4GY's and one 5Z4 rectifier. Critical voltages for v.f.o. and screen circuits are stabilized by a VR105 and VR150 respectively.

Full details on the Model 5100 are available from the company.

### SUBMINIATURE VIBRATOR

American Television & Radio Company, St. Paul, Minn. is now offering a miniature vibrator which has been specially designed for miniature flashlight cell-operated power supplies in conjunction with radiation measuring devices, photomultiplier cells, and infrared detection equipment.

Developed by ATR in cooperation with the Squier Signal Laboratory, Signal Corps Engineering Laboratories at Ft. Monmouth, N. J., the vibrator has a driving coil voltage of 1.5, 3, or 6 volts d.c. and operates on coil power

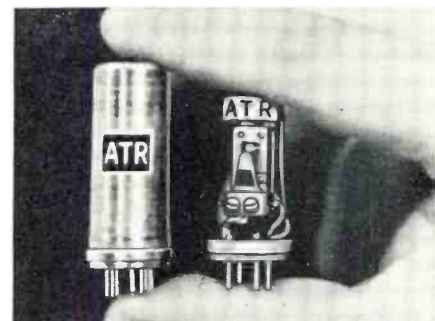

of less than 45 milliwatts. The vibrator is of full-wave, non-synchronous, driver-type construction, having a frequency of 100 cycles and a total time efficiency of 80 per-cent.

The seated height is 1 3/4", the diameter is 5/8", and the total volume is .675 cubic inches. The weight of the vibrator assembly is .3 ounce while the total weight of the complete structure in the container is .6 ounce. It is designed to fit a 7-pin miniature tube base.

### HEAT-DISSIPATING SHIELD

International Electronic Research Corporation, 175 W. Magnolia Blvd., Burbank, Cal. is in production on a new type of heat-dissipating miniature tube shield which is designed to dissipate tube-generated heat by rapid conduction of the heat from the tube envelope to the chassis or heat sink.

The improved cooling offered by these shields is due to contact between the tube and the shield and the chassis.

# NEW INVENTION OUTMODES ALL PRESENT ANTENNAS!

**53 CLAIMS GRANTED IN 5 U.S. PATENTS ON NEW REVOLUTIONARY ANTENNA INVENTION!**

**NEW!**

**SUPER 60**

#2,585,670 #2,609,503 #2,625,655 #2,644,091 #2,661,423 others pending

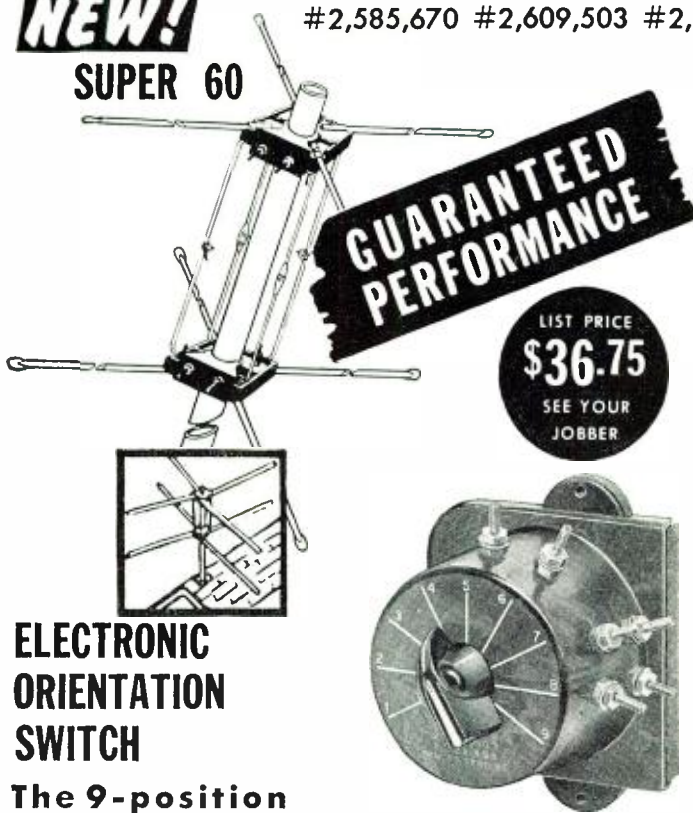

## ELECTRONIC ORIENTATION SWITCH

The 9-position selector switch electronically rotates the antenna in a stationary position.

### THIS IS ALL YOU NEED!

The price includes the complete antenna and the 9-position electronic orientation switch. The Air Dielectric Polymicalene Transmission Line is purchased as required for the individual installation.

- ★ **GUARANTEED TO POSITIVELY OUTPERFORM ALL OTHER ANTENNAS** (with or without rotor motors) on ALL UHF, and ALL VHF stations 2 thru 83 from ALL directions.
- ★ **GUARANTEED** to positively give you the **CLEAREST, SHARPEST, most PERFECT GHOST-FREE** pictures possible in both **COLOR** and black-white.

**MONEY BACK GUARANTEED TO RECEIVE *All* CHANNELS 2-83 FROM *All* DIRECTIONS AND POSITIVELY OUTPERFORM *All* OTHER ANTENNAS WITH OR WITHOUT A ROTORMOTOR**

## UP TO 10 TIMES MORE POWERFUL THAN ALL PRESENT CONVENTIONAL ANTENNAS!

New, revolutionary antenna, while being up to 10 times more powerful than conventional antennas, is still able to receive all television and FM stations from all directions without a rotor motor of any kind. The electronic orientation switch used with a new type transmission line developed specifically for this extra powerful antenna now makes it possible to clearly receive stations heretofore considered out of range. It is now possible to put up just one antenna, use just one transmission line, pay for just one installation and receive the finest possible reception from the stations in and coming to your area regardless of their direction.

**NEW POLYMICALENE 4 CONDUCTOR TRANSMISSION LINE**

- Low Loss External Air Dielectric
- Matched Impedance
- Eliminates End Sealing
- Eliminates Condensation
- Up to 50% Less Loss Than Tubular When Wet
- Easily Spiraled
- No Breaking or Shorting
- Patents Pending - T. M. Reg

*If your Distributor or Dealer can't supply you... Contact us for the name of one who can*

**NOW!! SOLVE YOUR ANTENNA PROBLEM ONCE AND FOR ALL.**

**ALL CHANNEL ANTENNA CORP.**  
70-07 Queens Blvd., Woodside 77, N. Y. Hlckory 6-2304

**SEE US IN CHICAGO—  
BOOTH NO. 3**

# PRACTICE CODE TAPES

• Code Training and Practice Inked Paper Tapes on 16 MM 400 ft. Reels for telegraph and radio operation. 15 Reels to a Set, in wood case—for use with TG-34A and TG-10 Keyers **\$12.95**  
Set of 15 Reels.....

Separate Tapes for the following lessons:  
Tape #11—Traffic      Tape #8—Code Groups  
Tape #12—Traffic      Tape #2—Receiving  
Each Tape on 16 MM Reel, in metal container: \$1.25 Ea.

**TG-34A KEYSER:** 115 or 230 V. @ 50 to 60 cycle  
—KEYER TG-34A is an automatic unit for reproducing audible code practice signals previously recorded in ink on paper tape. By use of the self contained speaker, the unit will provide code practice signals to one or more persons (variable speed, 5 to 25 WPM) or provide a keying oscillator for use with a hand key. The unit is compact, in portable carrying case, complete with tubes, photo cell, and operating manual. Size: 10<sup>1</sup>/<sub>16</sub>" x 10<sup>1</sup>/<sub>2</sub>" x 15<sup>1</sup>/<sub>16</sub>". Shipping weight: 45 lbs. Prices—While They Last:

In Original Box, **\$14.95**  
BRAND NEW: \$24.95 • USED:

**TG-10 KEYSER:** Same function as TG-34A, only larger, using 2/6N7—2/6L6—2/6SJ7—1/5U4G Tubes and 1/923 Photo Cell. Housed in standard Metal Cabinet, can be removed for 19" rack mtg. Size: 11" H x 24" W x 18<sup>1</sup>/<sub>2</sub>" D.  
NEW: \$29.95 • USED: \$19.95

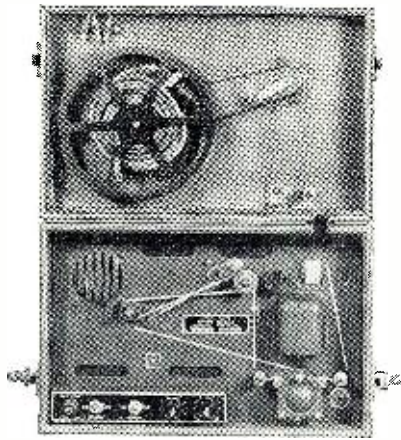

## ANTENNA EQUIPMENT

### MAST BASES—INSULATED:

MP-132 BASE—Illustrated at left—1" heavy coil spring, 2" insulator. Overall length: 11<sup>1</sup>/<sub>2</sub>". Weight: 2<sup>3</sup>/<sub>4</sub> lbs. Price.....\$3.95  
MP-S-33 BASE—Insulated type with heavy coil spring and 5" dia. insulator. Requires 2" hole for mounting. Weight: 9 lbs. ....\$5.95  
MP-48 BASE—Insulated type base with heavy coil spring. Requires 1<sup>3</sup>/<sub>8</sub>" mounting hole. Weight: 11 lbs. ....\$6.95  
MP-37 BASE—Insulated type with heavy coil spring; 7" dia. insulator; requires 1<sup>3</sup>/<sub>8</sub>" hole for mounting. Weight: approx. 10 lbs. ....\$8.95

**MAST SECTIONS FOR ABOVE BASES:**  
Tubular steel, copper coated, painted in 3 ft. sections, screw-in type. MS-53 can be used to make any length with MS-52-51-50-49 for taper. Any section, @ 50c each.  
Larger Diameter Section: MS-54.....75c

## NEW—LOW—LOW PRICES

### ARC-5 COMMAND EQUIPMENT:

R-25/ARC-5 Rec. 1.5 to 3 MC. No Tubes. Used: \$14.95  
R-26/ARC-5 Rec. 3 to 6 MC. No Tubes. Used: 7.95  
R-27/ARC-5 Rec. 6 to 9 MC. No Tubes. Used: 6.95  
R-28/ARC-5 Rec. 100 to 156 MC. No Tubes. Used: 12.95  
T-20/ARC-5 Trans. 4 to 5.3 MC. ....New: 16.95  
T-22/ARC-5 Trans. 7 to 9 MC. ....Used: 14.95

### 274-N COMMAND EQUIPMENT:

BC-454 Rec. 3 to 6 MC. ....Used: \$10.95  
BC-455 Rec. 6 to 9 MC. ....Used: 9.95  
BC-456 Trans. 5.3 to 7 MC. ....Used: 9.95  
BC-459 Trans. 7 to 9 MC. ....Used: 14.95  
BC-456 Modulator .....Used: 2.95  
FT-225 Mtg. F/BC-456 .....Used: .50c .....New: .95  
FT-220 3 Rec. Rack .....Used: \$1.50 .....New: 2.50  
FT-221 3 Rec. Shock .....Used: .50c .....New: .95  
BC-450 3 Rec. Cont. Box. ....Used: \$1.50 .....New: 2.00  
BC-451 Trans. Cont. Box. ....Used: \$1.00 .....New: 1.50  
PLUG—Male for rear of Rec. or Trans. .... .55  
DM-32 Dynamtr F/Rec. 24V. Used: \$2.95. New: 6.95  
DM-33 Dynamtr F/Modulator & Trans. ....Used: 2.95

### TRANSFORMERS FOR COMMAND REC. & TRANS.:

600-0-600 VAC—200 MA. 12.5 V. 2 A.; 12.5 V. @ 2 A.; 5 V. @ 3 A. 115 Volt Primary, H-108 Price.....\$8.95  
250-0-250 VAC—50 MA. 24 V. 1 A., & 6.3 V. 1 A.; 115 Volt Primary, H-109—Price.....\$3.95

## FREE CATALOG

LISTING HUNDREDS OF TRULY EXCEPTIONAL "BUYS"!—WRITE FOR YOUR FREE COPY NOW!

# FAIR RADIO SALES

132 SOUTH MAIN ST.  
LIMA, OHIO

## DYNAMOTORS

### HEAVY DUTY MOBILE DYNAMOTOR:

14 V. INPUT—Output: 1030 VDC 260 MA. Tapped 515 V. 215 MA. use @  
6 V DC INPUT—500 V. 175 MA. While they last—DM-42.....Excel. Cond.: \$14.95.....New: \$20.95

INPUT VOLTS:	OUTPUT: VDC	MA.	STOCK No.	PRICES: USED: NEW:
14	230	90	DM-21	\$9.95
14	330	150	BD-87	6.95 \$8.95
14	250	50	DM-25	6.95 8.95
14	1000	350	BD-77	14.95 29.95
28	230	100	DA-1A	3.95 5.95
24	250	60	DM-32	2.95 6.95
24	575	160	DM-33	2.95
28	210	125	DY-22	7.95
28	1000	350	PE-73	8.95
12 or 24	500	50	USA/0515	4.95
12 or 24	275	110	USA/0516	4.95
6 or 12	500	160	PE-103	29.95 39.95
12	230	90	PE-133	6.95 8.95

PE-101 DYNAMOTOR—6 or 12 Volt. (Reprints of original CQ conversion articles—Oct. & Dec., '52 issues—furnished.) This is the Dynamotor the Hams have been talking about! Easily adapted to supply 625 V. @ 150 MA. and 325 V. 125 MA. @ 12 Volts— or 300 V. 90 MA. and 160 V. 110 MA.  
@ 6 Volts .....NEW: \$4.95

**TRANSFORMERS—110 V. 60 CYCLE PRI.:**  
5 Volt CT-25A—10,000 V. Ins. OPEN FRAME—6" x 5" x 4<sup>1</sup>/<sub>2</sub>".....\$7.95  
6.3 V. 1 Amp.....1.25      24 V. 1 Amp..... 1.95  
24 V. 1/2 Amp.....1.50      24 V. 6.5 Amp..... 5.95  
6—24—or 30 Volt 8 Amp.....5.95

## COAXIAL CABLES:

**RG-8/U** (SPECIAL) 51.5 ohms. Same size as RG-8/U. Prices: 1 to 100 ft. @ 8c per ft.—100 to 500 ft. @ 7<sup>1</sup>/<sub>2</sub>c per ft.—500 to 1000 ft. @ 7c per ft.—1000 ft. Rolls @ 6<sup>1</sup>/<sub>2</sub>c per ft.  
RG-34/U—71 ohms, 145 ft. length.....\$15.00

## SOUND POWERED HEAD AND CHEST SET

Navy Type—No Batteries Required—Ideal for TV Antenna Installations and many other uses. 20 Ft. Cord. Used.  
Tested: .....\$5.95 EA.



**TELEPHONE WIRE FOR THE ABOVE**  
COMBAT TYPE—2 Cond. Twisted, Rubber Covered, Medium Weight, W-130.....@ .01c per Ft.  
FIELD WIRE—2 Cond. Twisted, Weather-proof, Heavy Duty, W-110—525 Ft. Roll.....\$4.75

Address Dept. RN • Minimum Order \$5.00  
Prices F.O.B., Lima, Ohio • 25% Deposit on C.O.D. Orders

Metal spring fingers which rest on the tube make the contact. Convection is aided through the use of windows and an open top in the shield for creating a chimney effect. The base assists in transferring the heat from the shield to the chassis or heat sink.

Currently, shields are available for all sizes of seven- and nine-pin miniature tubes. Literature and specifications are available from the company.

## BEAM ANTENNAS

Gotham Hobby Corp. of 107 E. 126th Street, New York 35, N. Y. is now offering a complete line of beam antennas for the 2, 6, 10, 15, and 20 meter amateur bands.

There are 38 different models in the line. All booms and elements are made of 61ST6 aluminum alloy. The elements are easily adjusted for spacing and length. The two-element beams are said to produce a power gain of 4 and a front-to-back ratio of 17 db while the three-element beams give a power gain of 7 and a front-to-back ratio of 29 db.

Complete details on this antenna line are available from the company.

## MINIATURE RELAY

The Terado Company, 1068 Raymond Ave., St. Paul 14, Minn., is in production on the Series 6000 micro relay which combines small size with positive action.

The unit has a single-pole, double-throw switch rated at 1 ampere. Oper-

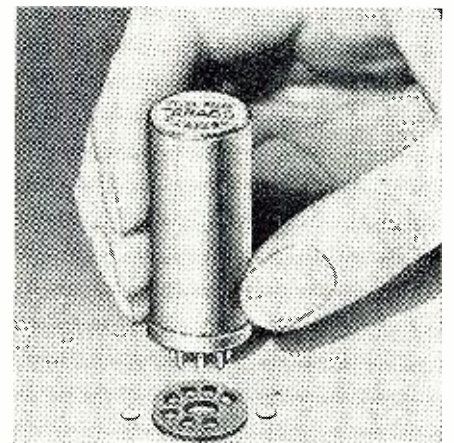

ating power is 60 milliwatts. The contacts are of solid coin silver and coil resistance is a maximum of 10,000 ohms.

Insulation is rated at 500 volts to ground and the whole unit is hermetically sealed. A standard 7-pin miniature ceramic base is used. The temperature range is from + 85 degrees C to -55 degree C.

The company will supply a data sheet giving full details upon request.

## DELUXE INTERCOMS

Mark Simpson Manufacturing Co., Long Island City 3, N. Y. has added the deluxe 12 and 24 station "President" series to its line of intercoms.

Housed in metal cabinets with decorative metal grilles, the a.c.-powered series offers flexible and versatile in-

## Get Your F.C.C. LICENSE Quickly!

We are specialists in preparing you, IN A MINIMUM OF TIME, to pass F.C.C. examinations for all classes of operator licenses. Both correspondence and resident training is available. Results guaranteed. Write for free brochure.  
**GRANTHAM SCHOOL OF ELECTRONICS**  
Dept. 103, 6064 Hollywood Blvd., Hollywood 28, Calif.

## World's Only Recorder of its Kind WALKIE-RECORDALL 8-LB SELF-POWERED BATTERY RECORDER

• AUTOMATIC UNDETECTED RECORDING up to 4 hrs  
• PICKS UP WITHIN 60 FT. RADIIUS  
• VOICE ACTIVATED "SELF START STOP"  
• NO WIRES OR PLUGS.  
Records noiselessly in or out of closed briefcase, containing hidden mike while walking, riding, flying. Conferences, lectures, dictation, 2-way phone. Permanent, unalterable, indexed recording at only 3c per hr.  
MILES REPRODUCER CO., INC.  
812 Broadway, N. Y. 3, N. Y. Dept. RN-5

**RADIART**  
**Seal-Vent**  
**VIBRATORS**

are **TOPS**

The complete rugged service line of vibrators that has dominated the field for years. Exclusive design plus controlled manufacture guarantees long-life performance! Built to "take it", they work under the most adverse conditions. You too will agree RADIART VIBRATORS are the STANDARD of COMPARISON!

the Complete  
Replacement Line



THE **RADIART** CORPORATION  
CLEVELAND 13, OHIO

TV ANTENNAS • AUTO AERIALS • VIBRATORS • ROTORS • POWER SUPPLIES

# COMPLETE TRAINING FOR BETTER RADIO-TV SERVICE JOBS



Let these two great new Ghirardi training books teach you to handle all types of AM, FM and TV service jobs by approved professional methods—and watch your efficiency and earnings soar!

Completely modern, profusely illustrated and written so you can easily understand every word, these books pave the way to fast, accurate service on any type of home radio-TV-electronic equipment ever made. Each book is brand new. Each contains the latest data on the latest methods and equipment—NOT a re-hash of old, out-of-date material. Each is co-authored by A. A. Ghirardi, whose famous RADIO PHYSICS COURSE and MODERN RADIO SERVICING were, for 20 years, more widely used for military, school and home study training than any other books of their type!

## THE NEW Ghirardi RADIO-TV SERVICE LIBRARY

Almost 1500 pages and over 800 clear illustrations show step-by-step how to handle every phase of modern troubleshooting and servicing.

### 1—Radio and Television Receiver TROUBLESHOOTING AND REPAIR

A complete guide to profitable professional methods. For the beginner, it is a comprehensive training course. For the experienced serviceman, it is a quick way to "brush up" on specific jobs, to develop improved techniques or to find fast answers to puzzling service problems. Includes invaluable "step-by-step" service charts. 417 pages, 417 illus., price \$6.75 separately. (Outside U.S.A. \$7.25)

### 2—Radio and Television Receiver CIRCUITRY AND OPERATION

This 669-page volume is the ideal guide for servicemen who realize it pays to know what really makes modern radio-TV receivers "tick" and why. Gives a complete understanding of basic circuits and circuit variations; how to recognize them at a glance; how to eliminate guesswork and useless testing in servicing them. 417 illus. Price separately \$6.50 (outside U.S.A. \$7.00).

### New low price...you save \$1.25!

If broken into lesson form and sent to you as a "course," you'd regard these two great books as a bargain at \$50 or more! Together, they form a complete modern servicing library to help you work faster, more efficiently and more profitably. Completely indexed so you can look up needed facts in a jiffy.

Under this new offer, you save \$1.25 on the price of the two books—and have the privilege of paying in easy installments while you use them! No lessons to wait for. You learn fast—and you learn right!

### STUDY 10 DAYS FREE!

Dept. RN-4, RINEHART & CO., Inc.  
232 Madison Ave., New York 10, N. Y.

Send books below for 10-day FREE EXAMINATION. In 10 days, I will either remit price indicated or return books postpaid and owe you nothing.

- Radio & TV Receiver CIRCUITRY & OPERATION (Price \$6.50 separately)
- Radio & TV Receiver TROUBLESHOOTING & REPAIR (Price \$6.75 separately)

Check here for MONEY-SAVING COMBINATION OFFER... Save \$1.25. Send both of above big books at special price of only \$12.00 for the two. (Regular price \$13.25... you save \$1.25.) Payable at rate of \$3 after 10 days if you decide to keep books and \$3 a month for 3 months until the total of \$12 has been paid.

Name .....

Address .....

City, Zone, State.....

Outside U.S.A.—\$7.25 for TROUBLESHOOTING & REPAIR; \$7.00 for CIRCUITRY & OPERATION; \$13.00 for both books. Cash with order, but money refunded if you return books in 10 days.

tercommunications facilities for industrial, institutional, and office installations.

One basic system can be adapted to any type intercom setup desired. A single master can be used with up to 24 remote stations. An executive system of up to 25 masters may be used in a completely private intercom system or masters and remotes may be intermixed. A telephone-type handset can be plugged into any master for privacy in communication with other master stations.

The company will supply complete specifications on request.

### HAND-HELD MICROPHONES

American Microphone Company, 370 South Fair Oaks, Pasadena 1, Cali-

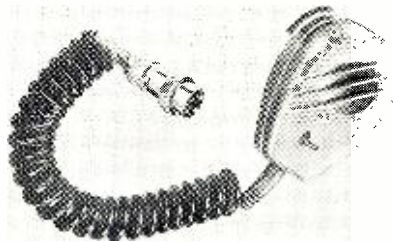

fornia has announced a new line of hand-held microphones known as the "501" series.

The new series provides a complete line of dynamic and carbon units for mobile, police, ship-to-shore, aircraft, and amateur radio applications. The "501" line features an exclusive die-cast aluminum cantilever-action switch, a gray hammertone finish, and light weight (10 ounces without cable or plug).

The company will supply full details on the line upon request.

### "BEAMED POWER" ROTARIES

Telrex Inc., Asbury Park, N. J. is now offering a new line of "Beamed Power" rotary antennas for the 2, 6, 10, 15, and 20 meter bands.

Each array features the company's "perfect match" balun with a "T" transformer for optimum coaxial line coupling, broadband resistive match, balanced pattern, no matching problem, and minimum TVI.

Laboratory-controlled precision tuning assures broadband resistive unity match, peak gain, and high signal-to-interference pattern with all cut-and-try eliminated.

### "GRIP-SPINTITE"

Stevens Walden, Inc., 450 Shrewsbury St., Worcester 4, Mass. is currently marketing a new tool for service technicians, the "Grip-Spintite."

The new tool securely holds either nuts or bolts. It is designed for use in general repair and assembly work and eliminates the possibility of these pieces dropping into the equipment. Utilizing a precision machined and finished taper lock construction, this wrench holds or releases the nut or bolt with a simple push or pull on the locking sleeve.

The "Grip-Spintite" is manufac-

tured in twelve sizes from  $\frac{3}{16}$ " to  $1\frac{1}{16}$ ". Descriptive catalogue sheets and specifications are available from the company.

### RADIO COMPONENTS

Superelex Electronics Corp., 23 Ather-ton St., Yonkers, N. Y. has announced the addition of two items to its line, the "Vari-Tenna" and the "Energized Ferri-Loopstick."

The "Vari-Tenna" is a coil with an extremely high "Q" winding and a ferrite core which is especially designed to replace the antenna coil and long hank of wire. The "Energized Ferri-Loopstick" is a miniaturized "bar loop" for use where space is a factor. Because of the high "Q" of the ferrite rod, a core length of only  $2\frac{3}{4}$ " is required. A quick-lock vinyl collar is used to maintain the core in its ad-justed position.

### REGULATING TRANSFORMER

United Transformer Company, 150 Varick St., New York, N. Y. is in production on a new type regulating transformer which has been specifically designed for TV receivers and various home appliances.

The R-49 will handle any load up to 350 watts. It comes complete with a cord and plug input and standard receptacle output. A locking switch provides settings for 115 volt output with input line voltages of 85, 90, 95, 100, 105, 110, 120, or 125 volts, 50-60 cycles.

### POCKET PORTABLE RADIO

Privat-Ear Corporation of Blacks-burg, Va. is now marketing a new pocket portable radio which offers day-time reception of nearly 50 miles.

The little set uses subminiature tubes with a diode crystal detector in a unique circuit. Housed in a plastic case, the "Privat-Ear" comes complete with a chrome-plate telescopic antenna. Over-all dimensions are  $2\frac{1}{4}$ "



wide,  $5\frac{3}{4}$ " long, and  $\frac{7}{8}$ " thick. Weight with batteries and built-in antenna is 8 ounces. Cases are available either in red or maroon.

### TAPERED REAMER

Master Manufacturing Company, 42 Virginia Place, Buffalo, N. Y. is now offering a new tapered reamer which



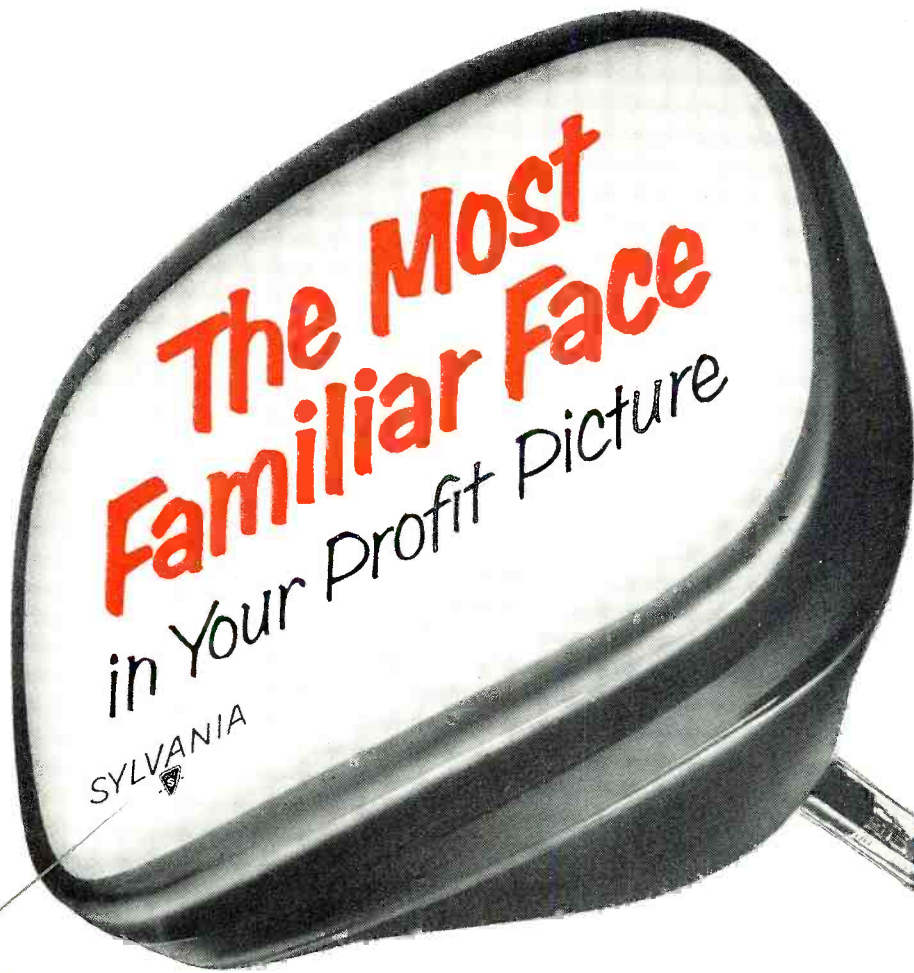

**The Name SYLVANIA etched on the face is assurance of RECOGNIZED QUALITY**

When your customers "replace the face," show them this picture tube etched SYLVANIA! They know it's the name that means leadership and dependable performance!

Your customers will appreciate the favor of being offered the top value for their investment . . . and, to most people, a new TV Picture Tube is *definitely* an investment.

**Backed by Nation-wide TV Show** – The story of Sylvania Picture Tubes' quality and the facts about their winning exhaustive tests is being told again and again to millions on the high-ranking, weekly TV show, "Beat the Clock."

There's a Sylvania Picture Tube Distributor near you who offers excellent service, cooperation and a full range of available tubes. You'll find it profitable to do business with your Sylvania Distributor and to push the full Sylvania line.

Make sure your customers know all the facts about picture tubes. Ask your Sylvania Distributor for a free supply of these booklets to give to your prospects.



# SYLVANIA

Sylvania Electric Products Inc., Dept. 4R-3505, 1740 Broadway, New York 19, N. Y.

In Canada: Sylvania Electric (Canada) Ltd., University Tower Bldg., St. Catherine Street, Montreal, P. Q.

**LIGHTING • RADIO • ELECTRONICS • TELEVISION**

**NEW!**

**NICHOLS NEVER-STAIN**

**Aluminum TV AND RADIO GROUND WIRE**

**RUST PROOF**



- ★ High Electrical Conductivity
- ★ Inconspicuous — Low Reflectivity
- ★ Pliable — Specially Tempered
- ★ Etched finish — clean
- ★ STD. No. 8 B & S Ga. (.128" dia.)

**Aluminum TV ANTENNA GUY CABLE**

**RUST PROOF**



- ★ Seven — 18 Ga. Stranded Wires
- ★ Flexible — Specially Tempered
- ★ High Strength Aluminum Alloy for all Types of Antennas.
- ★ Approx. break strength — 500 lbs.



\*Packed 2-500 ft. continuous coils per carton marked every 100 ft. with bright red tape.



**PACKAGING DATA**

ITEM	PKG. NO.	DESCRIPTION
TV Grd. Wire	8	100 ft. coil per box, 10 boxes per ctn.
TV Grd. Wire	9*	2-500 ft. continuous coils.
TV Cable	50	100 ft. coil per box, 10 boxes per ctn.
TV Cable	60*	2-500 ft. continuous coils.

Order from your jobber or write us direct. Address Dept. TVN-3

**NICHOLS WIRE & ALUMINUM CO.**  
DAVENPORT, IOWA  
World's Largest Manufacturer of Aluminum Nails

is of interest to the radio and television service field.

The new tool, which is made from a high alloy steel, will ream an under-sized hole from 1/8" to 5/16" in metal, wood, plastic, etc. The reamer is securely fastened in an unbreakable plastic handle.

For additional information on this service item write Gerald N. Abt, *The Hana Company*, Jackson Building, Buffalo, New York, the firm handling the distribution of the reamer.

**V.T.V.M.**

*Beckman Instruments Inc.*, P. O. Box 296, Station A, Richmond, California is currently marketing a new vacuum-tube voltmeter in its "Shasta" line of miniature test instruments.

The Model 201 which is designed as a general purpose laboratory or service instrument covers d.c. voltages in



seven full-scale ranges of 1.5 to 1500 volts at an impedance of 11 megohms. The a.c. ranges are calibrated both in r.m.s. values and peak-to-peak values. Separate scales are provided for 0-4 peak-to-peak and the 0-1.5 r.m.s. ranges for greater accuracy. Resistance values from 1000 ohms to 1000 megohms, full scale, are covered in seven ranges. Maximum accuracy is at midscale which is calibrated in multiples of 10 ohms for convenience.

Standard probes include the company's "Illumi-probe" with a miniature lamp built into the plastic end of the probe and a set of "Klipzon" probes for resistance measurements. High voltage and high frequency probes are available as accessories.

**REAR-SEAT SPEAKER KIT**

*Quam-Nichols Company*, Marquette Rd. and Prairie Ave., Chicago 37, Illinois has introduced a rear-seat auto speaker kit, the AS-3.

A new 5 x 7 inch model with a 1.47 oz. *Alnico V* magnet, the AS-3 has a 3/4" voice coil and will handle the undivided output of any conventional auto receiver.

*Ford, Chrysler, Studebaker, Hudson*, and other models have baffle openings for the AS-3 size unit.

The kit is popularly priced and is ready for immediate delivery, according to the company.

WORLD'S LARGEST MANUFACTURER OF CUSTOM BUILT TELEVISION

**MATTISON**

**SILVER ROCKET 630 CHASSIS**

Featuring Syncromatic Tuning

**NO DRIFT UHF-VHF-DX**

ONLY THE MATTISON 630 ELIMINATES DRIFTING APART OF PICTURE AND SOUND ON UHF, VHF and DX RECEPTION. SELECT YOUR CHANNEL . . . SOUND IS AUTOMATIC. (Syncromatic tuning is an exclusive Mattison 630 Circuit)

Tube Complement:  
29 tubes  
3 rectifiers  
1 CRT

**SILVER ROCKET**  
630 Chassis with built in UHF Tuner

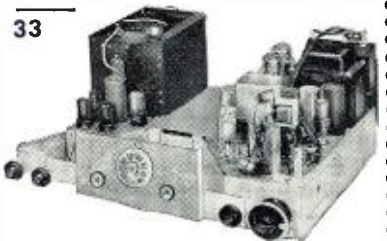

**All Channel UHF Tuner**

• UHF Cascode I.F. amplifier adds additional I.F. stage. Very important because UHF transmitters operate with moderate power and RECEIVER must be sensitive to give top notch UHF performance.

**SILVER ROCKET 630 CHASSIS**

• with TUNEABLE •

**BUILT-IN BOOSTER for Better DX Reception**

Tube Complement:  
28 tubes  
3 rectifiers  
1 CRT

Select Your Channel . . . SOUND IS AUTOMATIC!



**Tuneable Booster**

• Broad band single knob control pre-amplifier built in to eliminate long leads which may cause regeneration and attenuation of signal.  
• ONLY THE MATTISON 630 CHASSIS HAS AN ALL CHANNEL TUNEABLE BUILT-IN BOOSTER THAT INCREASES SIGNAL STRENGTH UP TO 10 TIMES.

ALL CABINETS MADE IN MATTISON'S OWN CABINET FACTORY. AVAILABLE IN EVERY FINISH AND STYLE. WRITE FOR COMPLETE CATALOG.

**DEALERS! SERVICE MEN!** Here is your opportunity to become the "important" TV Dealer in your area for THE FINEST CUSTOM-BUILT LINE OF TV RECEIVERS. FREE! Write for Mattison's merchandising portfolio explaining the "UNASSEMBLED PLAN" and "\$1,000,000 FLOOR PLAN."



When you buy from Mattison you need only one source of supply! You can buy a Mattison Chassis, a Mattison Cabinet or a complete Mattison TV Set!

Manufactured with integrity

**Mattison Television & Radio Corp.**  
10 West 181st St., Dept. RN, N. Y. 53, N. Y.

**Spot Radio News**  
(Continued from page 16)

solution, and he was truly grateful for the tribute and genuine appreciation of the committee's work.

The entire electronics industry is indebted to this selfless group which made such an important contribution to the advancement of color TV.

**THE HISTORIC DISCOVERY** of two radio nebulae (sources of intense radio waves in our galaxy) by a team of scientists at the Naval Research Lab, was made, NRL authorities have revealed, through the use of a 600-inch radio telescope. Measurements were taken at a wavelength of 9 centimeters (approximately 4 inches), corresponding to a frequency of 3200 megacycles.

One of the new radio nebulae was described as the Great Nebula of Orion, about 1000 light years from the earth, and the other as the Swan Nebula, about 3000 light years away. Measurements were also made of several of the brighter radio sources in our galaxy, and also one in the constellation of Cygnus, which is about 30-million light years distant. (A light year is a common unit of measurement for astronomers; it represents the distance that light would travel in a year, or six-million-million miles.)

The foregoing measurements represent the first successful investigation at shorter wavelengths. In recent years, astronomers have been able to detect several sources of radiation in space which have not been observable with optical telescopes, even the 200-inch telescope at Mount Palomar. However, until the NRL study, these measurements have been limited to wavelengths longer than 21 centimeters.

**CHANNEL SPLITTING** on a broad scale for the mobile-radio industry, the subject of a recent lengthy special-committee report now under scrutiny by the FCC, involves more than just the purchase of narrow-band equipment. So reported Edwin L. White, chief of the FCC safety and special services bureau, during a recent talk before the Chicago Section of the IRE. He noted that since the report had appeared, the Commission has received many proposals that a channel-splitting decision be postponed until an across-the-board set of rules and regulations can be established. Other proposals have revolved about the installation of narrow-band equipment by a certain date, and still others have asked that the Commission initiate international agreements so that the rest of the world would go on split channels, while stations here stay on the present channels, thus . . . "relieving the stations of this country from international interference, which they now receive or which may be received in the future."

May, 1954

**OUTSTANDING for HIGH FIDELITY!**  
**COLLINS TUNERS and RECEIVERS**  
AUDIO PRODUCTS CO.  
**NOW! ... with AFC**

Each Collins Tuner Kit is complete with punched chassis, tubes, power transformer, power supply components, hardware, dial assembly, tuning eye, knobs, wire, etc., as well as the completed sub-assemblies: FM tuning units, AM tuning units, IF amplifiers, etc., where applicable. All sub-assemblies wired, tested and aligned at the factory make Collins Pre-Fab Kits easy to assemble even without technical knowledge. The end result is a fine, high quality, high fidelity instrument at often less than half the cost—because you helped make it and bought it direct from the factory.

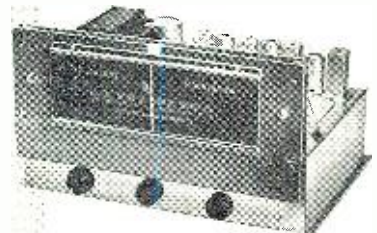

FM Tuner Kit

**\$55**

with AFC \$58.50

The FM-11 tuner is available in kit form with the IF Amplifier mounted in the chassis, wired and tested by us. You mount the completed RF Tuning Unit and power supply, then after some simple wiring, it's all set to operate. 11 tubes: 6J6 RF amp, 6AG5 converter, 6C4 oscillator, 6BA6 1st IF, (2) 6AU6 2nd and 3rd IF, (2) 6AU6 limiters, 6AL5 discriminator, 6AL7-GT double tuning eye, 5Y3-GT rectifier. Sensitivity 6 to 10 microvolts, less than 1/2 of 1% distortion, 20 to 20,000 cycle response with 2DB variation. Chassis dimensions: 12 1/2" wide, 8" deep, 7" high. Illustrated manual supplied. Shipping weight 14 lbs.

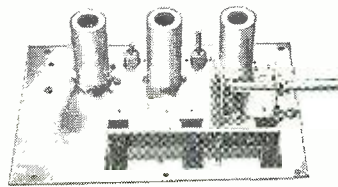

FMF-3 Tuning Unit

**\$15.25**

with AFC \$18.75

The best for FM. The most sensitive and most selective type of "front end" on the market. 6 to 10 microvolts sensitivity. Image ratio 500 to 1. 6J6 tuned RF stage, 6AG5 converter, 6C4 oscillator. Permeability tuned, stable and drift-free. Chassis plate measures 6 1/2" x 4 1/2". In combination with the IF-6 amplifier, the highest order of sensitivity on FM can be attained. Tubes included as well as schematic and instructions. Draws 30 ma. Shipping weight FMF-3: 2 1/2 lbs. Dial available @ \$3.85.

IF-6 Amplifier

6 Tubes. Shipping Wgt. 3 lbs.

**\$19.75**

**FOR USERS OF COLLINS TUNERS**

Receive \$5.00 credit toward the new FMF-3A front end! Mail us your old front end with \$13.75 and we will send you the new, improved FMF-3A with A.F.C., or, remit the full amount of \$18.75 and when we receive your old unit in return a check will be mailed you for \$5.00.



AM-4 Tuning Unit

**\$24.50**

Tops in AM superhet performance! A 3-gang tuning condenser gives 3 tuned stages with high sensitivity and selectivity. Assembly is completely wired, tested and aligned ready for immediate use. Frequency coverage 540 KC to 1650 KC at a sensitivity of 5 microvolts. Tubes 6BA6 RF amplifier; 6BE6 converter; 6BA6 IF amplifier and 6AT6 detector. Draws 30 ma @ 220 volts. Mounts on a chassis plate measuring 4" x 7 3/8". Shipping weight 2 1/2 lbs. Dial available at \$3.85.

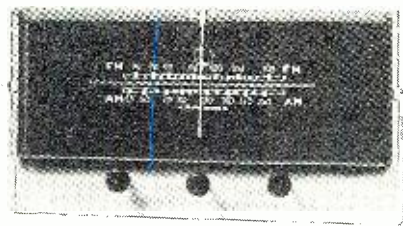

FM/AM Tuner Kit

**\$77.50**

with AFC \$81.00

The original 15 tube deluxe FM/AM pre-fab kit redesigned on a smaller chassis. The tuner now measures 14" wide by 12" deep by 7 1/2" high. This attractive new front and dial assembly opens up new applications where space is at a premium. Kit includes everything necessary to put it into operation—punched chassis, tubes, wired and aligned components, power supply, hardware, etc. Kit comprises FMF-3 tuning unit, IF-6 amplifier, AM-4 AM tuning unit, magic eye assembly and complete instructions. All tubes included. Shipping weight 19 lbs.

**MAIL COUPON TODAY**

To: Collins Audio Products Co. Inc. RN-5  
P.O. Box 268, Westfield, N. J.  
Tel. Westfield 2-4390

- FM Tuner Kit    FM/AM Tuner Kit    FMF-3 Tuning Unit  
 with AFC    with AFC    with AFC  
 IF-6 Amplifier    AM-4 Tuning Unit

NAME .....

ADDRESS .....

CITY ..... STATE .....

Amount for Kit \$ ..... See weights, add shipping cost \$ .....

Total amount enclosed \$      Check  Money Order

**WHEN YOU THINK OF TUNERS, THINK OF COLLINS AUDIO PRODUCTS**

# REAL SAVINGS!

AT PART-MART

3 SPEED "INTERMIX"

## RECORD CHANGER



LOTS OF 3  
\$23.95 EA.

Famous-make latest design, fully automatic changer at record low price! This peerless performer plays all 7", 10" and 12" records in any sequence. "Free-Floating" featherweight tone arm has Webster turn-over cartridge and dual needles for 33 1/3, 45 and 78 rpm; balanced for excellent tonal reproduction. Automatic shut-off after last record. Direct rim drive turntable action and constant speed motor for "wow"-free operation. Easily installed. Will not jam. Dim: 13" x 11 1/4" with 5 1/4" clearance required above and 2 1/8" below mtg. board. Complete with Phono and AC Cords. Fresh stock. Quantity limited at this low price. Wt. 10 lbs. No. LE 122. EA. \$24.95

## CHECK-MATIC PEN

ANYONE WITH A CHECKING ACCOUNT needs this famous 2-in-1 Check-Matic Pen! You get a durable Ball-Point Pen (worth the price alone) that writes over 75,000 words PLUS the amazing Check-Matic Check Protector! Prevents forgery by embossing and printing indelible lines over amount. NOBODY can write over it without detection. Protects thousands of checks. Black with Gold-colored caps. Fully Guaranteed. WE PAY POSTAGE. Stock No. GE123.



PPD. \$1.69

## STANDARD TV BOOSTER



LOTS OF 3  
\$6.95 EA.

Limited quantity of this precision TV Tuner at a rock-bottom price! One knob continuous tuning, ptd circuits, iron core output transformer, and one tube oper. Hi-gain and Lo-noise on all channels. 4-purpose switch with fine tuner. Shielded 300 ohm oper. Compl. in handsome brown plastic cabinet. Dim: 8" x 4 1/2" x 4 1/4". 117 V., AC. only. Wt.: 6 lbs. No. LFE 124. \$7.45 EA.

## HS-33 HEADSETS

Only a limited quantity of these famous Army-Navy Headsets available at the best price in a good long time. Complete with Headband, Headpiece control, Sponge Rubber Cushion Pads for quiet, and 5 ft. Cord with PL-55 Plug. Impedance: 600 ohms. Wt. 1 lb. Stock No. LFE 125. Less Adapter. ADAPTER for 4000 ohms impedance. . . . . 79c EA.



\$3.95 EA.

## TRIPLE-PLAY CARTRIDGE

G. E. RPX-050. Only a limited quantity left at this price! Popular variable reluctance cartridge. Plays all records. Complete with dual sapphire-tipped needle: .001" tip for 33 1/3 and 45 rpm; .003 tip for 78 rpm. Wt. 6 oz. No. LE 120. \$4.39 EA.

## LINE VOLTAGE TESTER

New! Accurate line voltage meter giving you instantaneous readings right at the receptacle. JUST PLUG IN! Swivel head. Easy reading. AC only. Reads 0-150 Volts. ±5%. Precision-made. Wt. 8 \$3.00 EA.



Write for Additional Listings  
INCLUDE POSTAGE—Excess Promptly Returned  
TERMS: F.O.B.—N.Y.C.—MIN. ORDER \$3.00—  
25% Deposit on C.O.D. Orders. SAVE C.O.D.  
CHARGES—REMIT IN FULL PLUS POSTAGE. Ex-  
cess Promptly Returned. SUBJECT PRIOR SALE.

White reported that many said the latter step would be unwise since long-range interference from the stations here is . . . "as serious, if not more serious, than the long-range international interference; thus we should take international interference in our stride, embark on a program of channel splitting, and reap, as much as possible, the benefits of having fewer stations on individual channels."

Pointing out that the frequency-allocation problem is extremely complicated, the special-service expert declared that should all the frequencies available to the mobile services be made available to all of the mobile users, without some form of subdivision, confusion would exist. The potential user, he said, would be faced with an almost impossible task in conducting a study to determine which frequencies in his particular area would be most suitable for his proposed use. It would be necessary, White said, to give attention to the requirements, both existing and potential, of those in the particular field involved, as well as of all the mobile services in the neighborhood.

The so-called geographical assignment of frequencies has also been suggested as a solution, the government's specialist added. To a certain extent this type of assignment is now being

conducted, it was shown, and it's probable, that as time goes on, there will be more geographical sharing.

"But this type of assignment is not all peaches and cream, as some would have everyone believe," White said. He noted that on many occasions the Commission has been urged to adopt this type of sharing, on the grounds . . . "that the industry with which the sharing is proposed . . . 'couldn't possibly be interested in radio here.'"

"No one is infallible," White said. "A few years ago, the consensus was that there was no oil in Montana and North Dakota, and therefore the petroleum frequencies could well be shared by other services operating in the great northwest. However, it looks today as though the Williston Oil Basin in this area will be as important as the oil basins in the Texas-Oklahoma area. It is fortunate that this basin is not in a forested area, as forest products and petroleum are now sharing part of their frequencies, and not only would the existing situation cause trouble, but also proposals for additional sharing now being considered by those two industries would have to have been dropped."

Continuing his appraisal of frequency sharing, White declared that many have said that sharing between large industries would be practical. How-

# NEW TV GRANTS SINCE FREEZE LIFT

Continuing the listing of construction permits granted by FCC since lifting of freeze. Additional stations will be carried next month.

STATE	CITY	CALL	CHANNEL	FREQUENCY (mc.)	POWER* (Video)
Alabama	Selma	WBAM†	8	180-186	2.51
Arkansas	El Dorado	.....	10	192-198	2.82
California	El Centro	.....	16	482-488	21.9
"	Modesto	KRTB-TV	14	470-476	20.4
"	Stockton	.....	13	210-216	158
D.C.	Washington	WWOK-TV	50	686-692	22.9
Florida	West Palm Beach	WEAT-TV†	12	204-210	50.12
Illinois	Chicago	WOPA-TV†	44	650-656	204
Indiana	Indianapolis	WISH-TV	8	180-186	316
Kansas	Great Bend	.....	2	54-60	100
Louisiana	Baton Rouge	.....	2	54-60	55.8
New York	Carthage	.....	7	174-180	191
New Jersey	Camden	WKDN-TV	17	488-494	112
North Carolina	Wilmington	WTHT	3	60-65	6.03
Oklahoma	Tulsa	.....	31	572-578	96
Ohio	Elyria	WEOL-TV	7	174-180	11.2
South Dakota	Rapid City	.....	12	204-210	105.2
Tennessee	Chattanooga	WDEF-TV	13	210-216	316
Texas	Houston	.....	12	204-210	4.36
West Virginia	Clarksburg	WBLK-TV	12	204-210	316
"	Charleston	WCGS-TV	8	180-86	316

## NEW CALL LETTER ASSIGNMENTS

California	Bakersfield	KBAK-TV	29	560-566
"	San Diego	KUSH	21	512-518
"	Tulare	KVVG	27	548-554
Florida	Miami	WMFL	33	584-590
Iowa	Sioux City	KTIV	4	66-72
Kentucky	Lexington	WLAP-TV	27	548-554
"	Louisville	WOXL-TV	41	632-638
Louisiana	Baton Rouge	WBRZ	2	60-66
Maryland	Baltimore	WTFL	18	494-500
Missouri	Kirksville	KTVO	3	60-66
Ohio	Cincinnati	WOXN-TV	54	710-716
"	Cleveland	WHK-TV	19	500-506
Oklahoma	Ada	KTEN	10	192-198
"	Enid	KGEO-TV	5	76-82
Tennessee	Knoxville	WATE	6	82-88
Texas	Corpus Christi	KLTG	43	644-650
"	Corpus Christi	KVDO	22	518-524
"	Tyler	KGKB-TV	7	174-180

\*ERP = (effective radiated power, kw.). . . = Call letters to be announced † = Temporary call letters.

**PART-MART**  
ROCKVILLE CENTER L. I., N. Y.

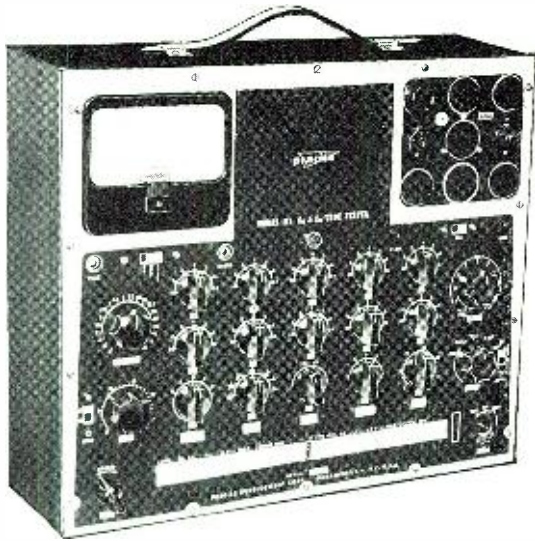

**NOW AVAILABLE . . .**

# precise No. 111 TUBE TESTER

*Checks Both Emission & GM Separately*

1. Allows filament current to be measured directly on the meter.
2. Checks AC-DC tubes and indicates "Voltage Sapping."
3. Tests horizontal sweep tubes by pulse emission.
4. Tests all tubes for emission and GM at the flick of a switch.
5. Short tests simply made without complicated switch manipulation.
6. Measures tube bias directly.
7. Tests all types of tubes, including latest styles and cathode ray tubes.

No. 111K—Kit . . . **\$69.95** No. 111W—Wired . . . **\$139.95**

## NO. 9071 VOLTAGE REGULATED V.T.V.M.



- FULL BRIDGE VTVM
- Rugged 7" meter
- Deposited carbon, 1% ceramic resistors
- Amphenol connector
- Coax DC connector
- Burn-out proof circuit
- DC input 25 meg.
- Power transformer used. (No Selenium Rectifier)
- 4 tube circuit
- Etched panel
- Measures 8"x11"x5"

No. 9071K—Kit . . . **\$35.95**  
No. 9071W—Wired . . . **\$49.95**

## NO. 760 VOLTAGE REGULATED POWER SUPPLY



**INVALUABLE  
FOR REPAIR  
AND  
LABORATORY  
WORK**

- Range +140 volts to over 450 volts regulated
- % Regulation—within 1% at specified current deviations
- % Ripple .01% at specified currents
- Rugged 4 1/2" meter movement
- Shunt & multiplier resistors within 1% accuracy
- — 1200v to 1200v—unregulated

No. 760K—Kit . . . **\$39.95**  
No. 760W—Wired . . . **\$59.95**

## *Famous* precise **SCOPES**

### MODEL 308B

- Full 8 1/2" tube designed specially for this model.
- Voltage regulation.
- High frequency—Low frequency—Normal frequency—Synchronization circuit.
- Separate intensifier anode.
- Deluxe version of Model 300B

No. 308BK—Kit . . . **\$129.95** No. 308BW—Wired . . . **\$239.50**

Model 300B—Full 7 1/2" scope with many deluxe features:

No. 300BK—Kit . . . **\$94.95** No. 300BW—Wired . . . **\$199.50**

New No. 303 3" Scope for TV & Industrial Use Now Available—Write for catalog & Prices.  
Send for Catalog on the Complete Line of Precise Test Equipment

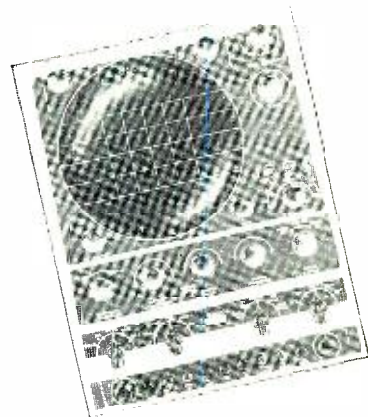

SEND FOR COMPLETE CATALOG

Send 20% deposit with order, balance C.O.D., or, check or money order in advance.

**T**EE-VEE  
Supply Co.

All orders are shipped on the same day received

**3211-13 Washington Street  
Jamaica Plain 30, Mass.**

# C.R.T. TUBE TESTER

SUPERIOR'S NEW MODEL TV-40



★ A complete picture tube tester for little more than the price of a "make-shift" adapter!!

★ Tests all magnetically deflected tubes . . . in the set . . . out of the set . . . in the carton!!

**SPECIFICATIONS:**

- Tests all magnetically deflected picture tubes from 7 inch to 30 inch types
- Tests for quality by the well established emission method. All readings on "Good-Bad" scale.
- Tests for interelement shorts and leakages up to 5 megohms.
- Test for open elements.

**EASY TO USE:**

Simply insert line cord into any 110 volt A.C. outlet, then attach tester socket to tube base (Ion trap need not be on tube). Throw switch up for quality test . . . read direct on Good-Bad scale. Throw switch down for all leakage tests.

Model TV-40 C.R.T. Tube Tester comes absolutely complete—nothing else to buy. Housed in round cornered, molded bakelite case.

**\$15<sup>85</sup>** NET

AT YOUR RADIO PARTS JOBBER

Write Dept. RN-5 for catalog of complete line.



**SUPERIOR INSTRUMENTS CO.**  
2435 White Plains Road New York 67, N. Y.

ever, it has been found that sharing on a local basis to satisfy individual applicants is not too practical. As an example of such a problem, the need for an additional frequency in New York City, using a forest-products channel could well be proposed by someone, believing that since this channel is not being used in the east, it should be assigned. Of course, he said, such an assignment could never be made, for as soon as others heard that such a channel was being made available, everyone would start screaming that their need for that channel was greater than that of the applicant who entered the original plea. And the yells would not only come from the metropolitan area but surrounding communities, too.

Reviewing the geographical-sharing situation, White said that it is probable that if the current and the future, including the unforeseen, needs . . . of each locality could be given individual study, and the frequencies parceled out to that locality in proportion to its individual needs, and if the staff were large enough and far-seeing enough to anticipate all developments, the most efficient use of radio could be made." But, as a practical matter, the IRE audience was told, it does not seem probable . . . "that such a staff will ever be assembled, so that this end will never be achieved. And in the interim, a compromise must satisfy."

The most promising source for major channel expansion, White indicated, is through . . . "the utilization of new portions of the frequency spectrum and through improved technology in the use of those portions which are now occupied."

FCC's proposal to legalize functional

## MOVING?

Please Advise Our Circulation Dept., 64 E. Lake St., Chicago I, Ill.  
Please Allow 30 Days for Change of Address

# ELECTRON TUBE WHOLESALERS, INC.

RECEIVING TRANSMITTING SPECIAL PURPOSE  
140 DUANE STREET • NEW YORK 13, N. Y. • Phone: Barclay 7-7616

**RECEIVING TUBES**

Type	Price	Type	Price
0A2	.89	3A5	.93
0A3/VR75	.99	3A8	.60
0A4G	.65	3B7	.39
0B2	.74	3D6	.39
0B3/VR90	.95	3LF4	.79
0C3/VR105	.98	3Q4	.48
0D3/VR150	.89	3Q5GT	.55
0Z4	.54	3S4	.48
1A5GT	.39	3V4	.51
1A7	.49	5T4	1.28
1AB5	.39	5U4G	.53
1AX2	.61	5W4	.50
1B3	.67	5X4	.50
1D8GT	.77	5Y3GT	.36
1G6GT	.25	5Z3	.44
1H5GT	.48	6A6	.47
1J6G	.59	6A7	.82
1L4	.45	6A8	.69
1LA6	.79	6AB4	.49
1LB4	.79	6AB7	.75
1LC5	.69	6AC5GT	.99
1LC6	.79	6AC7	.89
1LD5	.77	6AF6	.89
1LE3	.78	6AG5	.46
1LG5	.77	6AG7	.60
1LH4	.78	6AJ5	.89
1LN5	.59	6AK5	.73
1N5	.61	6AL5	.36
1P5GT	.57	6AQ5	.37
1Q5GT	.57	6AR5	.39
1R4	.89	6AS5	.56
1R5	.48	6AT6	.37
1S4	.58	6AU6	.40
1S5	.42	6AV5	.79
1SA6	.48	6AV6	.37
1T4	.48	6AX6GT	.55
1U4	.48	6B7	.55
1U5	.48	6B8	.85
1X2A	.63	6BB	.53
2A3	.95	6B8B	.53
2A4G	.99	6BA7	.40
2A5	.59	6BA7	.56
2A6	.49	6BC5	.49
2A7	.64	6BD6	.44
2B7	.62	6BE6	.37
2X2	.39	6BG6G	1.18
2X2A	1.15	6BH6	.45
3A4	.44	6BJ6	.42

**THIS MONTH'S SPECIALS**  
6AL5 .31c  
6AL6 .55c  
6B27 .83c  
6B7 .48c  
6LN5  
We must limit quantities to not more than 25 per type, for each order—at these Smashingly Low Prices!

## SENSATIONAL DISCOUNTS!

We specialize exclusively in TUBES—of every kind and description—serving the industry for years. More than 3000 different types in stock for IMMEDIATE DELIVERY—including hard-to-get and discontinued numbers. All tubes exhaustively tested in our fully equipped laboratories, and re-tested at time of shipment.

## FULL ONE YEAR GUARANTEE

All tubes individually boxed and code-dated.

Type	Price	Type	Price	Type	Price	Type	Price
6BK7	.95	6L7G	.59	6V6GT	.39	7L7	.59
6BN6	.79	6N7	.48	6W4	.45	7N7	.75
6BQ6	.79	6O7	.49	6W6	.46	7Q7	.85
6BQ7A	.88	6R7	.48	6X4	.36	7R7	.65
6BZ7	.89	6S4	.42	6X5GT	.35	7S7	.85
6C4	.37	6S7G	.59	6X8	.74	7T7	.91
6C5	.39	6SA7	.40	6Z7G	.79	7Z7	.83
6C6G	.57	6SC7	.79	7A5	.59	7W7	.85
6C8G	.85	6SD7GT	.38	7A6	.69	7X7	.70
6C8B	.45	6SF5	.45	7A7	.69	7Y4	.44
6C9B	1.10	6SF7	.59	7AD7	.95	7Z4	.49
6D6	.69	6SG7GT	.40	7AG7	.55	7Z7	.85
6D8G	.68	6SH7	.60	7AH7	.56	10Y7	.69
6E5	.48	6SH7GT	.50	7B4	.44	12A6	.59
6E6	.39	6SJ7	.50	7B5	.59	12AH7	.89
6F5	.45	6SK7	.40	7B6	.59	12AT6	.39
6F7	.33	6SL7GT	.49	7C4	.58	12AT7	.64
6F8G	.39	6SN7GT	.49	7C5	.59	12AU6	.39
6G6G	.65	6SQ7	.41	7C7	.65	12AU7	.58
6H6	.49	6SR7	.45	7E5	.59	12AV6	.49
6H6G	.40	6ST7	.49	7F7	.65	12AV7	.69
6J6	.49	6T8	.59	7H7	.59	12AX4GT	.59
6J6G	.49	6U7G	.45	7J7	.75	12AX7	.59
6K7	.39	6U8	.59	7K7	.79	12AY7	.79

**FREE! SEND FOR OUR LATEST LISTING**  
Minimum Order \$10. Please include 25% deposit with order. Prices subject to change without notice. All prices F.O.B. our Warehouse, N.Y.C. Write for types not listed.

Type	Price	INDUSTRIAL	Type	Price	INDUSTRIAL	
32L7GT	.98	1B22	.41	2D21	1.09	
35C5	.37	1B24	.55	2I26	26.95	
35W4	.47	1B32	.42	3Q24	1.75	
35Y4	.35	1N23	.46	4Y21	2.21	
35Z3	.43	2C40	.47	.89	304TL	7.50
35Z5GT	.48	2C44	.49	.44	307A	4.80
42	.41	2D21	.55	.40	316A	2.50
43	.37	2I26	.42	.44	446A	3.40
45Z3	.42	3Q24	.46	.62	705A	1.50
46	.49	4Y21	.59	.64	715B	6.50
47	.89	304TL	.49	.59	717A	.58
49	.44	307A	.57	.55	721A	2.50
50B5	.40	316A	.57	.58	726A	9.50
50C5	.44	446A	.58	.80	801A	.39
50L6GT	.62	705A	.64	1.00	70L7GT	1.80
50X6	.64	715B	.64	.815	803	2.90
50Y6GT	.59	717A	.49	.815	815	3.90
56	.49	721A	.55	.826	826	.89
57	.58	726A	.58	.836	836	3.95
58	.58	801A	.81	.837	837	1.40
59	.65	CATHODE RAY	.81	.842	842	1.30
.65	.65	3EPI	5.50	.842	842	.60
.69	.69	5BP1	3.95	.842	842	6.85
.83	.83	5BP4	5.95	.854	854	.85
.85	.85	5BP7	5.95	.864	864	1.30
.88	.88	5C10P1	7.45	.954	954	.34
.91	.91	5D2P7	10.50	.955	955	.54
.93	.93	6H4P4A	24.95	.955	955	.60
.95	.95	6D4P4	24.95	.960	960	.60
.98	.98	16D5	.59	.962	962	.49
.99	.99	89/Y	.49	.962	962	.44
.99	.99	11Z23	.38	.963	963	1.10
.44	.44	11Z4GT	.75	.963	963	1.40
.84	.84	807	1.39	.963	963	.65
.75	.75	25B06GT	.95	.963	963	.89
.64	.64	9001	1.48	.963	963	1.10
.25	.25	9002	.98	.963	963	.55
.44	.44	9003	.98	.963	963	2.50
.26	.26	9004	.97	.963	963	3.80
.27	.27	9006	.68	.963	963	2.90

FM operation (grant special licenses authorizing transmission of programs for stores, banks, etc.), has found staunch support in some quarters and severe criticism elsewhere.

Fearing that the rule will pave the way for a "pay-as-you-listen-or-see" trend, *Storer Broadcasting* spokesmen declared that they were not in favor of any proposal which would tend to . . . "undermine the traditional foundations of broadcasting in the United States, namely that no charge is made to any listener for the right to receive any broadcast program, and that broadcast stations must serve the general public interest, not the specialized interests of small segments of the public." They also felt that broadcast stations were not common carriers and that the business practices and rate schedules of broadcasters should not be subject to regulation by the Commission. In addition, they pointed out, the adoption of such a plan could well be . . . "the opening wedge for conversion of all broadcast bands to non-broadcast uses." Noting that the only justification for the proposal is to . . . "enable FM licensees, in part, to alleviate their financial difficulties . . ." the broadcaster warned that the same argument, if accepted . . . "would furnish an equally strong argument for conversion of the AM band, the v.h.f. TV band, and the u.h.f. TV band to non-broadcast uses, such as pay-as-you-listen radio or TV services or theater TV."

(There are several petitions before the Commission asking approval of a subscription-TV service for ultra-high operators.)

The National Association of Radio-Television Broadcasters applauded the FCC plan, declaring that the proposed extension would . . . "facilitate more complete utilization of the 88-108 megacycle band than is possible under current rules." Association spokesmen felt that the change could . . . "contribute to the development of a more secure financial base of operations for FM broadcast stations."

OVER 1200 applications for new TV stations have been filed with the Commission since freeze-lift day according to a recently-released report.

Analyzing the status of present and potential stations, the FCC said that 482 post-freeze grants have been authorized, and at this writing there were 157 applications pending.

Continuing their detailed review, the Commission pointed out that the nation had 223 TV communities (when the report was issued), which included 120 with very-high operators, 71 using the ultra-highs, and 32 with both u.h.f. and v.h.f. stations. In addition, there were 129 areas in which authorization to operate on the low bands had been granted; 118 to use the higher channels; and 77 zones to use eventually both the *u* and *v* type of TV stations.

THE ENLARGED staff of hearing examiners has begun to dive into the

# Brilliant Response

...for **PROFESSIONAL**  
or **HOME SYSTEMS**

RCA's new, extended-range speaker, SL-12—a true, high-fidelity, 12-inch speaker priced under \$25.  
8 ohms, 10 watts, 50 to 16,000 cycles

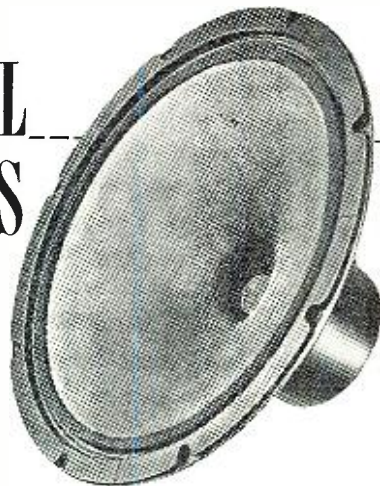

**For brilliance and realism**—for crisp, clear reproduction—listen to RCA's High-Fidelity speaker, Type SL-12.

You'll find it hard to believe such honest reproduction—such brilliant presence—can be achieved with a speaker priced so low. It's truly professional

reproduction at a price the hobbyist can well afford.

Hear it . . . see it . . . price it . . . and compare it with other speakers costing considerably more. Listen to all the professional-grade RCA *Intermatched* High-Fidelity components at your local RCA ELECTRONICS DISTRIBUTOR'S.

—FOR UNEQUALLED PERFORMANCE AT ANY PRICE—



RCA's famed LC-1A speaker, with acoustic domes for ideal sound distribution.

DeLuxe RCA 20-watt amplifier intermatched for perfect performance with all RCA components.

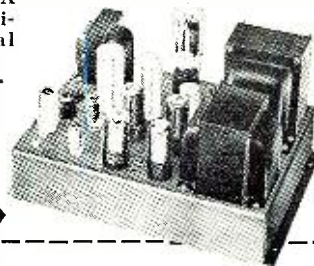

—professional-grade components of

**RCA INTERMATCHED**  
**High Fidelity**

Radio Corporation of America, Dept. E99, Building 15-1, Camden, N. J.  
Please send me information on:

- RCA Intermatched High-Fidelity components
- RCA's complete High-Fidelity "Victrola"® phonographs

Name \_\_\_\_\_

Address \_\_\_\_\_

City \_\_\_\_\_ Zone \_\_\_\_\_ State \_\_\_\_\_



**RADIO CORPORATION of AMERICA**

# Windsor TUBES

RADIO & TV RECEIVING

TESTED and  
GUARANTEED  
for **PEAK**  
PERFORMANCE

We've EARNED your Confidence . . . and we mean to KEEP it! Thousands of Service Organizations and Dealers throughout America send us REPEAT orders month after month—they now KNOW you can **DEPEND** upon the WINDSOR promise of **PEAK PERFORMANCE!**

And here's why: Every tube we ship is first carefully tested in our laboratories, for maximum functioning characteristics, right in a radio or TV set—under actual operating conditions! That's why we unconditionally guarantee every Windsor Tube in accordance with the Standard Warranty: Full replacement of any defective tube within 90 days of purchase, excepting only burnouts and breakages. Each tube attractively packaged in individual carton.

**BUY—AND SELL—WINDSOR TUBES WITH CONFIDENCE!**

Type	Each	Type	Each	Type	Each	Type	Each
IA7GT	\$.67	3Q5GT	\$.72	6B8G	\$.93	6J7	\$.70
IB3GT	\$.69	3S4	\$.61	6B8A6	\$.50	6K6GT	\$.45
IH5GT	\$.51	3V4	\$.62	6B7A	\$.66	6K7	\$.70
IJ6	\$.93	5R4GY	1.00	6B8C5	\$.58	6L6G	\$.88
IL4	\$.63	5U4G	\$.44	6B5D5GT	\$.98	6L6GA	\$.88
IL6	\$.66	5V4G	\$.83	6B6	\$.54	6Q7GT	\$.55
ILA4	\$.82	5Y3G	\$.37	6B6E	\$.51	6S4	\$.51
ILA6	\$.80	5Y3GT	\$.32	6B6F5	\$.66	6S8GT	\$.70
ILB4	\$.82	5Y4G	\$.43	6B6F6	\$.43	6SA7GT	\$.57
ILC5	\$.80	6AB2T	\$.68	6B6GG	1.47	6SC7	\$.63
ILC6	\$.80	6AB4	\$.51	6BH6	\$.63	6SD7	\$.55
ILD5	\$.80	6AC5GT	\$.82	6B07	\$.53	6SF5GT	\$.66
ILE3	\$.80	6AG5	\$.59	6BK5	\$.76	6SH7GT	\$.52
ILG5	\$.80	6AH4	\$.68	6BK7	\$.97	6SJ7GT	\$.52
ILH4	\$.80	6AH6	\$.89	6BL7GT	\$.94	6SK7GT	\$.55
ILN5	\$.80	6AK5	1.05	6BN6	\$.98	6SL7GT	\$.68
IN5GT	\$.63	6AL5	\$.44	6B06GT	\$.98	6SN7GT	\$.59
IR4	\$.85	6AQ5	\$.51	6B07	\$.92	6SQ7GT	\$.46
IR5	\$.62	6AQ6	\$.47	6C4	\$.41	6T8	\$.85
IS4	\$.67	6AQ7	\$.75	6C5GT	\$.60	6U4GT	\$.60
IS5	\$.52	6AR5	\$.42	6C6B	\$.58	6U8	\$.86
IT4	\$.62	6AS5	\$.55	6C6DG	2.04	6V3	1.09
IU4	\$.61	6AT6	\$.42	6D5	\$.63	6V6GT	\$.51
IU5	\$.51	6AUSGT	\$.85	6E6	\$.72	6W4GT	\$.50
IX2A	\$.74	6AU6	\$.47	6F5GT	\$.54	6W6GT	\$.63
2X2	1.43	6AV5	\$.85	6HG6T	\$.55	6X4	\$.37
3LF4	\$.76	6AV6	\$.41	6JS5GT	\$.44	6X5GT	\$.36
3Q4	\$.66	6AX4	\$.72			6Y6G	\$.64



Type	Each	Type	Each
7A4/XXL	\$.57	12AD6	\$.51
7A5	\$.70	12BE6	\$.51
7A6	\$.58	12BH7	\$.69
7A7	\$.58	12BY7	\$.77
7A8	\$.58	12J5GT	\$.48
7AD7	1.05	12SA7GT	\$.57
7AF7	\$.63	12SH7GT	\$.67
7AG7	\$.65	12SK7GT	\$.55
7AH7	\$.65	12SL7GT	\$.67
7AJ7	\$.70	12SN7GT	\$.59
7B4	\$.54	12SQ7GT	\$.46
7B5	\$.51	14A7	\$.58
7B6	\$.52	14AF7	\$.68
7B7	\$.58	14B6	\$.50
7C4	1.05	14C5	\$.85
7C5	\$.56	14D5	\$.70
7C6	\$.50	14E6	\$.70
7C7	\$.58	14E7	\$.85
7E5	\$.93	14F8	\$.69
7E6	\$.68	14J7	\$.85
7E7	\$.85	14N7	\$.75
7F7	\$.69	14Q7	\$.62
7F8	\$.87	14R7	\$.85
7G7	\$.85	14S7	\$.80
7H7	\$.61	19B6GG	1.53
7J7	\$.85	19T8	\$.87
7K7	\$.85	25BQ6GT	\$.98
7L7	\$.85	25L6GT	\$.53
7M7	\$.62	25W4GT	\$.53
7N7	\$.62	25Z6GT	\$.46
7Q7	\$.62	35A5	\$.55
7R7	\$.70	35B5	\$.53
7S7	\$.90	35C5	\$.53
7V7	\$.92	35L6GT	\$.52
7W7	\$.99	35W4	\$.33
7X6	\$.62	35Z5GT	\$.33
7Y4	\$.45	50A5	\$.55
7Z4	\$.50	50B5	\$.52
12AT6	\$.53	50C5	\$.52
12AT7	\$.75	50L6GT	\$.52
12A6	\$.47	50P5	\$.43
12A7	\$.58	117Z3	\$.43
12A8	\$.87	117Z6GT	\$.75
12AX4	\$.72		
12AX7	\$.67		
12AY7	2.15		
12B4	\$.66		
12BA6	\$.50		
12BA7	\$.66		

25% Deposit with Order. All merchandise F.O.B. NYC. For orders less than \$10. Add \$1 handling cost. Deduct 2% if full remittance accompanies order. All merchandise subject to prior sale and price changes without notice.

Note to our Latin-American Friends: SE HABLE ESPANOL!

WRITE FOR ADDITIONAL TUBE TYPES AND PRICES. We also stock Special Purpose and Transmitting Tubes at similar savings! Dept. N-5

processing baskets and with notable results. It has become possible to issue the largest number of new grants in months, and also solve scores of competitive issues. A listing of the grants authorized and new call letters assigned, at this writing, appears on page 100 of this issue.

RADIO's grand old man, Lee de Forest, often called the father of radio, is still at it, and he's 80 years of age now. Today, he is trying to find a solution to an age-old problem: the conversion of heat into electrical power through the adaptation of thermopile principles. He hopes that soon he may be able to announce that he can operate a TV receiver with current created by gas flames striking copper strips, joined together with pieces of constantan (copper-nickel alloy) kept cool. The pile, producing a low voltage and high amperage current, requires a special motor with husky magnets to operate at the low voltage, high current available. . . . A hardy project for anyone, but apparently not too rugged for this resourceful genius. Good luck Doc. Everyone knows that eventually you will find the answer to this old puzzler. . . . L.W.

## AUTO RADIO HINT

By A. L. ALBRIGHT

RECENTLY I encountered a case of trouble in an auto receiver that I had not seen before in all my thirty years of repairing sets.

Since no signal would go through, voltage measurements were made and found to be very low. Bypass condenser checking, pulling out tubes (which may have been shorted), etc. indicated the possibility of a shorted fixed tuning condenser across the primary of the midget i.f. transformers but this was not the trouble. Ohmmeter tests showed 40 ohms between point "A" on the portion of the circuit shown in the diagram and ground.

The only remaining component to be examined was the spark plate suppressor assembly which was, of course, riveted to the chassis. As I believe in repairing sets instead of just making replacements, the rivets were removed after unsoldering the wires attached to the six terminals of the assembly and the assembly was then taken apart.

The varnished cambric insulation between plates 5 and 6 was burned. "Polyken" 4" wide plastic tape was used to effect a repair. The assembly was then restacked and attached to the chassis with 6/32 bolts. —30—

Partial schematic of the tuning unit from a Motorola auto receiver. The varnished cambric "B" between plates 5 and 6 had broken down causing fault described above.

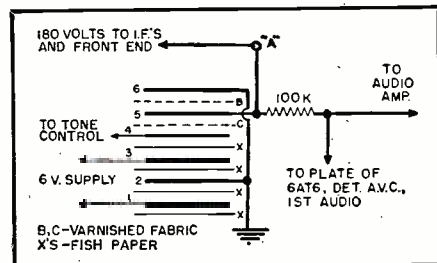

## FREE! WINDSOR TUBE CADDY

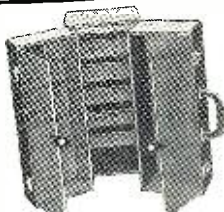

The most practical Service-Aid ever designed for the radio and TV repairman. This ideal television carry-all now offered free with every purchase of \$160.00 or accumulated purchases totaling \$160.00 within 90 days. (You get caddy credit memo with each purchase).

Windsor Tube Caddy may also be purchased outright for \$14.95.

DON'T MISS THIS SENSATIONAL OFFER!

**Windsor ELECTRONIC TUBE CO.**  
2612-N NOSTRAND AVENUE, BROOKLYN 10, N. Y.

## SAVE! CLOSEOUT SAVE! COMMAND SETS

274N and ARC-5 EQUIPMENT

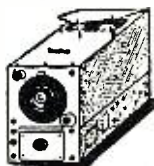

TYPE			
BC-453 Rcvr.	190-550 Kc.	Used, with tubes.	\$14.95
		As is, less tubes.	12.95
BC-454 Rcvr.	3-6 Mc.	Used, with tubes.	8.95
		As is, less tubes.	4.95
BC-455 Rcvr.	6-9 Mc.	Used, with tubes.	7.95
		As is, less tubes.	4.95
BC-456 Modulator		Used, with tubes.	3.95
		As is, less tubes.	2.95
BC-696 Xmtr.	3-4 Mc.	Used, with tubes.	14.95
		As is, less tubes.	8.95
BC-457 Xmtr.	4-5.3 Mc.	Used, with tubes.	6.95
		As is, less tubes.	3.95
BC-458 Xmtr.	5.3-7 Mc.	Used, with tubes.	6.95
		As is, less tubes.	3.95
BC-459 Xmtr.	7-9.1 Mc.	Used, with tubes.	9.95
		As is, less tubes.	5.95
BC-450 3 Rcvr. control box		Used	1.49
BC-451 Xmtr. control box		Used	1.49
3 Receiver rack		Used	1.49
2 Transmitter rack		Used	1.49

Specify first and second choice—274N or ARC-5 Equipment.  
CASH WITH ORDER. Include 3 1/2% sales tax with California orders—plus approximate Postage. Excess will be refunded. Approximate shipping weight per unit: 15 lbs.

**SAM'S SURPLUS**

1306-B BOND STREET LOS ANGELES 15, CALIF.

ONLY \$495

Yr. Ppd. or C.O.D. + Chgs.



## THE NEW TV DYNATRACER

- TRACES TV SIGNALS AND VOLTAGES
- LOCATES DEFECTIVE COMPONENTS
- REQUIRES NO ADDITIONAL EQUIPMENT

This sensationally new piece of test equipment is ideal for trouble-shooting television sets in the home or in the shop. The "DYNATRACER" will out-perform more expensive testers and should pay for itself on the very first repair.

**A Must for Every TV Technician SPECIFICATIONS:** The "DYNATRACER" is a self-powered quality test instrument designed to trace TV signals through any Video, Sound, Sync. AFC, Horizontal or Vertical Sweep Circuit—will isolate trouble to a stage or component.

**ADDED FEATURE:** The "DYNATRACER" will also trace voltages (50/500 V. AC/DC) and instantly locate open, shorted, intermittent or leaky (up to 20 MEGOHMS) condensers, resistors, coils, X-Formers, etc. Instruction and Trouble-Shooting Book Enclosed

**10 DAY MONEY-BACK GUARANTEE**  
Cut out advertisement, attach name and address with \$5.00 bill, check or money order and mail to

**Century ELECTRONICS CO.**

211-04 99th Ave Dept. 213 Queens Village, N. Y.



**F** You have never ordered by mail because you did not want to buy anything "sight unseen" or —  
 You have ordered by mail but with disappointing results or —  
 You have never purchased anything on time payments because of excessive finance charges, then —

— **HERE** —

is your opportunity to examine what you want under our "Seller not Buyer, takes all the risk" plan. We invite you to order any item on this page and examine it in the privacy of your own home. If you decide to keep it, you

can then pay the balance in easy monthly payments with no interest or finance charges added. Otherwise, you may return the merchandise for prompt refund of your down-payment.



Measures 6 1/4" x 9 1/2" x 4 1/2"

Superior's new  
 Model 670-A **SUPER METER**  
 A COMBINATION VOLT-OHM MILLIAMMETER PLUS  
 CAPACITY REACTANCE INDUCTANCE AND DECIBEL MEASUREMENTS

**SPECIFICATIONS:**

D.C. VOLTS: 0 to 7.5/15/75/150/750/1,500/7,500 Volts  
 A.C. VOLTS: 0 to 15/30/150/300/1,500/3,000 Volts  
 OUTPUT VOLTS: 0 to 15/30/150/300/1,500/3,000 Volts  
 D.C. CURRENT: 0 to 1.5/15/150 Ma. 0 to 1.5/15 Amperes  
 RESISTANCE: 0 to 1,000/100,000 Ohms 0 to 10 Megohms  
 CAPACITY: .001 to 1 Mfd. 1 to 50 Mfd. (Quality test for electrolytics)  
 REACTANCE: 50 to 2,500 Ohms, 2,500 Ohms to 2.5 Megohms  
 INDUCTANCE: .15 to 7 Henrys 7 to 7,000 Henrys  
 DECIBELS: -6 to +18 +14 to +38 +34 to +58

**ADDED FEATURE:**

The Model 670-A includes a special **GOOD-BAD** scale for checking the quality of electrolytic condensers at a test potential of 150 Volts.

The Model 670-A comes housed in a rugged, crackle-finished steel cabinet complete with test leads and operating instructions.

**\$28<sup>40</sup>**  
 NET



Superior's new  
 Model TV-11 **TUBE TESTER**

**SPECIFICATIONS:**

- ★ Tests all tubes including 4, 5, 6, 7, Octal, Lock-in, Peanut, Bantam, Hearing Aid, Thyatron, Miniatures, Sub-Miniatures, Novals, Sub-minars, Proximity fuse types, etc.
- ★ Uses the new self-cleaning Lever Action Switches for individual element testing. Because all elements are numbered according to pin-number in the RMA base numbering system, the user can instantly identify which element is under test. Tubes having tapped filaments and tubes with filaments terminating in more than one pin are truly tested with the Model TV-11 as any of the pins may be placed in the neutral position when necessary.
- ★ The Model TV-11 does not use any combination type sockets. Instead individual sockets are used for each type of tube. Thus it is impossible

- to damage a tube by inserting it in the wrong socket.
- ★ Free-moving built-in roll chart provides complete data for all tubes.
- ★ Newly designed Line Voltage Control compensates for variation of any Line Voltage between 105 Volts and 130 Volts.
- ★ **NOISE TEST:** Phono-jack on front panel for plugging in either phones or external amplifier will detect microphonic tubes or noise due to faulty elements and loose internal connections.

The model TV-11 operates on 105-130 Volt 60 Cycles A.C. Comes housed in a beautiful hand-rubbed oak cabinet complete with portable cover. . . . .

**\$47<sup>50</sup>**  
 NET

**EXTRA SERVICE**—The Model TV-11 may be used as an extremely sensitive Condenser Leakage Checker. A relaxation type oscil-

lator incorporated in this model will detect leakages even when the frequency is one per minute.

**SUPERIOR'S NEW MODEL TV-40**

**C.R.T. TUBE TESTER**

★ **A complete picture tube tester for little more than the price of a "make-shiff" adapter!!**

★ **Tests all magnetically deflected tubes . . . in the set . . . out of the set . . . in the carton!!**

The Model TV-40 is absolutely complete! Self-contained, including built-in power supply, it tests picture tubes in the only practical way to efficiently test such tubes: that is by the use of a separate instrument which is designed exclusively to test the ever increasing number of picture tubes!

**EASY TO USE:**

Simply insert line cord into any 110 volt A.C. outlet, then attach tester socket to tube base (Ion trap need not be on tube). Throw switch up for quality test . . . read direct on Good-Bad scale. Throw switch down for all leakage tests.

Model TV-40 C.R.T. Tube Tester comes absolutely complete—nothing else to buy. Housed in round cornered, molded bakelite case. Only . . . . .

**SPECIFICATIONS:**

- Test all magnetically deflected picture tubes from 7 inch to 30 inch types.
- Tests for quality by the well established emission method. All readings on "Good-Bad" scale.
- Tests for inter-element shorts and leakages up to 5 megohms.
- Test for open elements.

**\$15<sup>85</sup>**  
 NET



**MOSS ELECTRONIC DISTRIBUTING CO., INC.**  
 Dept. E-98, 3849 Tenth Ave., New York 34, N. Y.

Please send me the units checked. I am enclosing the down payment with order and agree to pay the monthly balance as shown. It is understood there will be no carrying interest or any other charges provided I send my monthly payments when due. It is further understood that should I fail to make payment when due, the full unpaid balance shall become immediately due and payable.

Name . . . . .  
 Address . . . . .  
 City . . . . . Zone . . . . . State . . . . .

- MODEL 670-A . . . . . Total Price \$28.40 \$7.40 down payment. Balance \$3.50 monthly for 6 months.
- MODEL TV-11 . . . . . Total Price \$47.50 \$11.50 down payment. Balance \$6.00 monthly for 6 months
- MODEL TV-40 . . . . . Total Price \$15.85 \$3.85 down payment. Balance \$4.00 monthly for 3 months.
- I enclose \$ . . . . . as down payment.
- Ship C.O.D. for the down payment.

# H B G

is here!

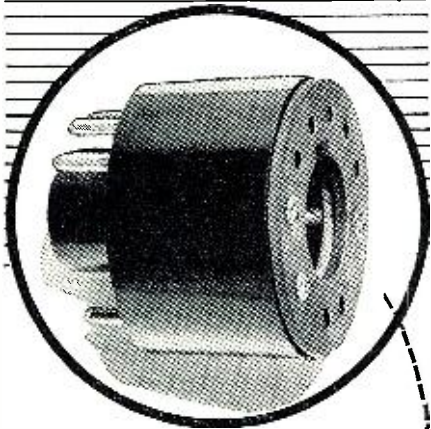

for Quick TV Set  
Adjustment and  
Alignment!

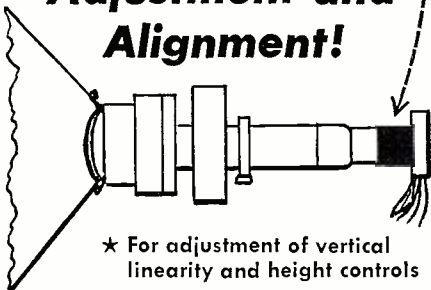

- ★ For adjustment of vertical linearity and height controls
- ★ Accurate positioning of focus coil or magnet
- ★ Precise setting of yoke
- ★ Complete with instructions

Perma-Power

\*HORIZONTAL BAR GENERATOR

Dealer Net \$195

See Your Jobber Today!

manufactured by

Chicago 25, Ill.

Manufacturers of Electronic Equipment Since 1922

EXPORT: SCHEEL INTERNATIONAL  
4237 N. Lincoln, Chicago 13, Ill.

## Half-Wave Rectifiers

(Continued from page 47)

where:  $E_c = 128$  at point X in Fig. 1D  
 $E_p$  = peak line voltage  
 $E_v = 128 + 1.41 \times 117$  or 293  
 volts peak (A in Fig. 1D)

These calculations are often misleading in regard to the peak voltage impressed across the rectifier. If this peak voltage of 293 volts is used for the design of a rectifier, short life is inevitable. In practice, the selenium rectifier sees the full peak voltage (330 volts) as shown in Fig. 1B when the equipment switch is turned on. Therefore, irrespective of calculated peak voltages at full load conditions, the design of the rectifier must be based on no-load peak voltages.

When the expected life of electronic equipment using selenium rectifiers is on the order of 20,000 hours or more, industrial selenium rectifier stacks should be used. The number of series plates required can be determined by dividing 330 volts peak by the peak rating of the selenium rectifier plate to be used. For example, a 26 volt r.m.s. plate has a peak rating of 36.5 volts, and a 33 volt plate has a rating of 46.2 volts peak. Consequently, a stack with 26 volt plates should have 9 plates in series while 7 series plates are sufficient if 33 volt plates are used for this application. This same analysis can be used for other half-wave capacitive circuits having a different input voltage.



This young SWL, Theodore Harris, of Ferndale, Michigan, uses a National NC-125 receiver with a 9 mc. doublet, 30 ft. high, and a 12 mc. center-fed vertical in addition to a straight wire for 6 mc. Harris is now an engineering student at Wayne U.

has Portuguese for Portuguese colonies in Africa. (Pearce, England) Asks for reports. (Leake, N. J.) Morgan, Calif., notes deteriorated signal from this one when opens 0330 with French, musical session.

Germany—NWDR, Hamburg, noted on 6.075 at 0630 with orchestral concert. (Pearce, England) This is a 5 kw. transmitter, heard in clear 0245; scheduled 2300-1900 (Sun. from 0000). (Cushen, N. Z., others) Cologne, 11.795, noted opening 1130 at good level with announcements in German, *English*; parallel on 7.29 at weaker level. (Chatfield, N. Y.) MDR, 9.728, Leipzig, noted 2000 with news in German. (de Neuf, N. Y.)

Greece—Jannina, near 7.088, noted 1545 with Greek vocals, closing 1602 with National Anthem after call in Greek; Greek Forces Station, 7.420A, Athens, noted 1540 with light music. (Pearce, England)

Guatemala—TGNE, 9.668, TGNC, 11.850, noted at excellent level in *English* 2200-2345. (Callarman, Ore., others)

Haiti—4VEH, 9.656A, noted on a Mon. at 2110, good level, slight QSB. (Church, Calif.) 4VC, 9.485, is good level in French 1300-1500. (Roennau, Ont.) Good on 4VB, 6.091A, to 2300 closedown. (Smith, Ga.)

Holland—Hilversum, 15.22, noted with news in Dutch 1000. (Roennau, Ont.) Heard on 6.025 at 2145 in *English* for North America, fair, some QSB. (Delatore, O.; Parsons, Pa.)

Honduras—HRLP, 6.050AV, Tegucigalpa, noted at excellent level 2215. (Niblack, Ind.)

Hungary—Budapest has *English* for Europe daily 1500-1530, 1700-1730 on 7.220, 6.248. (Pearce, England)

Iceland—TFJ, 12.175, Reykjavik, noted *Sun. only* 1115-1130 with music, news in Icelandic; no signature tune. (Pearce, England)

India—Madras, 4.920, noted with news relay from Delhi 1030; and on 6.075, presumably Delhi, with same broadcast. (Morgan, Calif.) AIR, 17.740, 15.380, noted opening *English* for Europe 0230, news 0235, closing 0330. (Pearce, England)

Indo-China (Vietnam)—Latest sched-

## International Short-Wave

(Continued from page 72)

Fiji Islands—ZJV3, 3.980A, Suva, heard with music 0515, bad QRM, poor level. (Morgan, Calif.) Has news 0400. (*DX-Radio*, Sweden)

Finland—Helsinki, 17.800, noted with news 0430. (Collett, N. Z., via Radio Australia) Repeat for USA-Canada is 0600, 17.800, 15.190. (Pearce, England)

France—Paris, 7.105, noted ending French transmission to Balkans 1550-1557 at good level in Ohio. (Morris) Heard on 5.955 at fair to moderate level in Spanish 1615-1645 when closes with "La Marseillaise."

French Equatorial Africa—Brazzaville, 15.595, noted 1440 with recordings, closing 1502 with "La Marseillaise." (Ferguson, N. C.) Heard at good level with news 1745 on 11.970. (Eversley, N. Y.) Announces news for 0015, 0515, 1400, 1545, 1745. (Leake, N. J.)

French Guiana—Radio Cayenne is heard daily 1730-1830 on 6.232AV; widely reported.

French West Africa—Radio Dakar, 9.560, noted with *English* session 1715-1730 (when closes with "La Marseillaise") on Mon., Wed., Fri., Sat. (Roemer, Ky.; McKee, O.) On Tue., Thur.

ule for *English* for India, Southeast Asia, is 0900-1100, 7.230. (Catch, England) Heard on 9.755 opening *English* period 1103 with "Knightsbridge March," followed by news; closes 1120, announces next *English* for 1830 on 7.230. (Pearce, England) Heard on 6.116 with French news 1026, closing 1029 with "La Marseillaise," good level in Calif. (Morgan) *Radio Dalat*, 7.265, noted 0600 in Vietnamese, 0635 with French; signs off 0745-0750 with playing of interval signal. (JSWC)

*Iran—Radio Teheran*, 3.786A, noted 1445 with news in German; 1515 news in *English*, closing 1530. (Pearce, England)

*Iraq—Radio Baghdad*, 6.135, is heard in Sweden 1415-1500. (*Nattugglan*, Sweden)

*Israel—Tel Aviv*, 9.010A, noted with "Voice of Zion" session in *English* 1615-1700 sign-off, poor level. (Welch, Mass.; Bishop, O.) Extends to 1730 *Sat.* when has translations from Talmud. (Bellington, N. Y.) At press time, news was still 1515. (Pearce, England)

*Italy—Rome*, 11.81, 15.400, heard with news for South Africa 1045-1100 (*except Sun.*); signing on to Britain, Ireland 1330 on 11.810, 15.400, 7.290, opening with news. (Pearce, England) Heard on 7.29 opening to North America 1915 with news; for Western North America 2130. (Welch, Mass.; Leake, N. J.; Chapman, Pa.) And parallel on 9.575A. (Saylor, Va., others) ISWL, England, says the Third Program is heard from Milan, 6.240, at 1600 at strong level in Britain.

*Jamaica—Radio Jamaica*, 3.360, noted 2230 with UN news report. (de Neuf, N. Y.)

*Japan—Ishikawa*, Japan, flashes that the "first commercial" short-wave station licensed is JOZ, 3.925, JOZ-2, 6.095, both to be 5 kw.; program will be news, music, and so on in Japanese; should be on the air in June or July; QRA is The Nippon Keizai Press, 2-1 Kayabacho, Nihonbashi, Chuo-Ku, Tokyo, Japan. Ishikawa says that by now *Radio Japan* should be beamed in 12 directions (including to Middle and Far East and to South China), using 18 languages (Cantonese, Fukenesse, Arabic, Persian added).

AFRS, Tokyo, noted over 11.92 with news 1700; at 0940 tune-in on 4.860. (Cooper, Calif.) JOB6, 11.725, Tokyo, is good level some days in Latin American beam 1700-1800. (Huttemeyer, N. J., others)

*Kenya Colony—Nairobi*, 4.855, is scheduled Mon.-Fri. 0500-0600, 1000-1500; Sat. 0500-0610, 1000-1500; Sun. 0200-0600, 1000-1400. (ISWC, London)

*Lebanon—Radio Beirut*, 8.036, now has its daily *English* session 0900-1000 instead of 1000-1100 as formerly. (Pearce, England)

*Liberia—ELBC*, 6.024A, Monrovia, is fair 1715-1845 sign-off. (Saylor, Va.)

*Libya—FBS*, Benghazi, should be testing soon with 7.5 kw.; is scheduled 0000-1600, 4.782, 4.965. (JSWC)

*Luxembourg—Radio Luxembourg*, 6.090, has an *experimental English* ses-

# THE NEW *Utah* Chordette

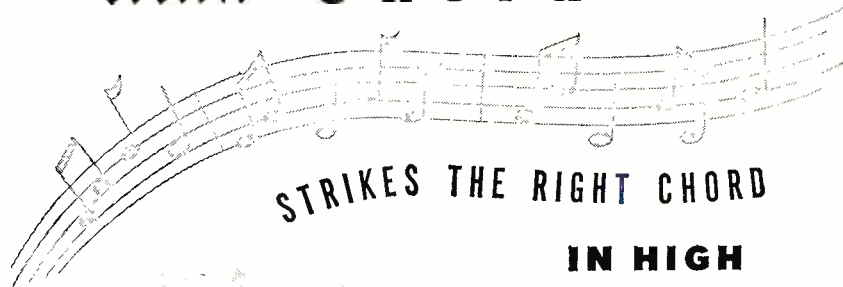

STRIKES THE RIGHT CHORD

IN HIGH FIDELITY

BEAUTY  
STYLING  
RESPONSE  
PRESENCE



Blond Chordette—  
Model HF 500 B  
Complete with two  
speaker system  
Audiophile Net—\$54.95

At a price  
**YOU CAN AFFORD**

Something new has happened in high fidelity—the Utah Chordette. A fine piece of functional furniture with a beauty and styling as modern as tomorrow combined with a two-way high fidelity sound system designed for those who demand fine reproduction. The new Chordette is truly a space saver—it can be used as a chair side or end table, bookshelf—or without the leg assembly—be mounted vertically. The fine woods and tasteful design of the Chordette—whether you select a model in blonde korina, mahogany or rich cherry will complement and grace your decor—excite the envy and admiration of your friends. The new Chordette is truly a master achievement in the art of woodworking and sound engineering—and at a price you can afford.

See and Hear the New Chordette at Your Local Hi Fi Headquarters

ASK FOR A DEMONSTRATION OF ALL THE HIGH FIDELITY MODELS IN THE UTAH PERSONALITY SERIES

TRIO ★ BRILLANTE ★ CONCERTO ★ QUARTETE  
★ SQUIRE AND MATCHING ESQUIRE

In the Squire you can enclose your tuner, amplifier and record changer—all in one cabinet.



**RADIO PRODUCTS CO., INC.**

1350 MONROE STREET  
HUNTINGTON, INDIANA

# YOU Get More Listening Pleasure from any record with the **McIntosh C-108** PROFESSIONAL AUDIO COMPENSATOR

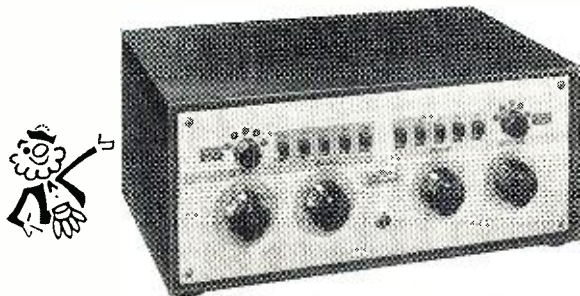

Amazing flexibility of the new McIntosh C-108 guarantees the most listening pleasure from all of your records.

Five bass turnover switches, five treble attenuation positions, variable bass and treble controls compensate for all recording curves.

Rumble filter diminishes or completely eliminates turntable rumble.

Aural Compensator Control maintains proper bass and treble loudness when system plays at low volume level. The

McIntosh C-108 combines, for the first time, beauty and abundant flexibility with ease of operation.

## FREE BOOKLET

Send for illustrated brochure on record company compensation curves.



### DON'T THROW OLD RADIOS AWAY!

Here's the data you need to fix them FAST and r-i-g-h-t!

There's a "secret" to repairing old radios fast and profitably... and this big RADIO TROUBLESHOOTER'S HANDBOOK is it!

Just look up the old make and model you want to fix. This manual-size, 3 1/2 pound, 744-page Ghirardi handbook tells what the trouble is likely to be... and shows you exactly how to fix it. No useless testing! No wasted time! Even beginners can handle jobs "slick as a whistle."

## THE ONLY GUIDE OF ITS KIND!

Cuts service time in half!

Included are common trouble symptoms and their remedies for over 4,800 models of home and auto radios and record changers. Actual case histories cover practically every model made by 202 manufacturers between 1925 and 1942—Airline, Apex, Arvin, Atwater Kent, Belmont, Bosch, Brunswick, Clarion, Crosley, Emerson, Fada, G-E, Kolster, Majestic, Motorola, Philco, Pilot, RCA, Silvertone, Spartan, Stromberg and dozens more. Gives how-to-do-it data on SPECIFIC jobs—NOT general theory. Includes hundreds of pages of invaluable tube and component data, service short cuts, etc.

---TRY IT 10 DAYS... at our risk!---

Dept. RN-54, RINEHART & CO., Inc.  
232 Madison Ave., New York 16, N. Y.

Send Ghirardi's RADIO TROUBLESHOOTER'S HANDBOOK for 10-day free examination. If I decide to keep book, I will then remit the full price of only \$6.50 plus a few cents postage. Otherwise, I will return book postpaid and owe you nothing.

NAME.....  
ADDRESS.....  
CITY, ZONE, STATE.....

## McIntosh LABORATORY, INC.

326 Water Street, Binghamton, N. Y.  
Export Division: 25 Warren St., New York 17, N. Y.

### QUARTZ CRYSTALS

FT-243-.093" PIN DIA.—.486" PIN SPC

FOR HAM AND GENERAL USE • GUARANTEED

4035 5385 5880 6373 6900 7625 7900	1015 6175 7025 7340 8380
4080 5485 5900 6375 6906 7640 7906	2125 6200 7040 7350 8400
4110 5500 5906 6400 6925 7641 7925	3500 6440 7050 7375 8425
4165 5675 5925 6406 6940 7650 7940	3640 6450 7073 7400 8430
4190 5677 5940 6425 6950 7673 7950	3680 6473 7075 7425 8450
4255 5700 5950 6673 6973 7675 7973	3735 6475 7100 7440 8460
4280 5706 5973 6675 6975 7700 7975	3760 6500 7106 8006 8475
4300 5725 5975 6700 7450 7706 8206	3800 6506 7125 8025 8483
4397 5740 6225 6706 7473 7720 8225	3840 6525 7140 8050 8500
4490 5750 6240 6725 7475 7725 8240	3885 6540 7150 8073 8525
4495 5773 6250 6740 7500 7740 8250	6000 6550 7173 8075 8550
4780 5775 6255 6750 7506 7750 8273	6025 6573 7175 8100 8575
4845 5800 6273 6773 7525 7773 8275	6050 6575 7200 8125 8583
4930 5806 6275 6775 7540 7775 8300	6075 6600 7206 8150 8600
5030 5825 6300 6800 7550 7800 8306	6100 6606 7225 8173 8625
5205 5840 6306 6806 7573 7825 8325	6106 6625 7273 8175 8650
5250 5850 6325 6825 7575 7840	6125 6640 7275 8200 8700
5300 5852 6335 6840 7600 7850	6140 6650 7300 8340 8733
5305 5873 6340 6850 7606 7873	6150 7000 7306 8350
5333 5875 6350 6875 7610 7875	6173 7006 7325 8375

49c each - 10 for \$4.00 | 99c each - 10 for \$8.00

Low Frequency—FT-241A for SSB, Lattice Filter etc., .093" Pins, .486" SPC, marked in Channel Nos. 0 to 79, 54th Harmonic and 270 to 389, 72nd Harmonic. Listed below by Fundamental Frequencies, fractions omitted.	CR-1A SCR 522 1/4" P 1/2" S	FT171B BC-610 2 Banana Plugs 3/4" SPC
370 393 414 436 498 520 400 459	5910	2030 2220 2390 3202 3580
372 394 415 437 501 522 440 461	6370	2045 2258 2415 3215 3945
374 395 416 438 502 523 441 462	6450	2052 2260 2436 3232 3955
375 396 418 481 503 525 442 463	6470	2065 2280 2442 3237 3995
376 397 419 483 504 526 444 464	6497	2082 2282 2532 3250
377 398 420 484 505 527 445 465	6522	2105 2290 2545 3222
379 401 422 485 506 529 446 466	6547	2125 2300 2557 3510
380 402 423 486 507 530 447 468	6610	2131 2305 3035 3520
381 403 424 487 508 531 448 469	7350	2145 2320 3120 3550
383 404 425 488 509 533 450 470	7380	2155 2360 3155 3570
384 405 426 490 511 534 451 472	7390	
385 406 427 491 512 536 452 473	7480	
386 407 428 492 513 537 453 474	7580	
387 408 430 493 514 538 454 475	7810	
388 409 431 494 515 455 476	7930	
390 411 433 495 516 456 477		
391 412 434 496 518 457 479		
392 413 435 497 519 458 480		

49c each - 10 for \$4.00 | 99c each - 10 for \$8.00

Spec.—200 KC or 500 KC in FT241A Holder, \$1.95 ea.

# SUN

PARTS DISTRIBUTORS, LTD.

520 TENTH ST. N. W.—WASH. D. C., DEPT. N

sion 0300; wants reports on it. (ISWL, England)

**Malaya**—BFEB, Singapore, noted opening 0600 on new 9.625 at powerful level in Calif.; program is different from on 9.690, 7.12, 11.82; on 6.135 is weak 0630 with Indian-type program. **Radio Malaya**, 7.200, Singapore, noted with *English* 0645; Kuala Lumpur, 6.025, has news 0630, weak to fair. (Balbi) **Radio Malaya**, 4.780, Chinese network, fair to good around 0930-1030 closedown; on 4.820 with *English* service, poor to good to 1030 sign-off.

**Monaco**—**Radio Monte Carlo**, 7.349, noted to 1730 or later (some days), good level. (Chatfield, N. Y.)

**Mozambique**—The *English* outlet on 4.916A is heard as early as 1015, as late as 1215. And on 11.724A at 2334 with popular music, *English* announcements, fair level. (Morgan, Calif.)

**New Caledonia**—**Radio Noumea**, 6.033A, noted 0159 in French. (Morgan, Calif.)

**New Zealand**—ZL4, 15.280, Wellington, noted 1600 with weather report, then recordings. (Ferguson, N. C.) Still audible to fair in Eastern USA around 2100.

**Nicaragua**—YNWW, 7.849, Managua, noted at good level 2043, music, still on at 2302. (Harris, Mass.)

**Nigeria**—Lagos, 4.800, is heard in Germany with *English* 1300-1700. (ISWC, London) Noted at fair level to 1710 closedown. (Huttemeyer, N. J.)

**North Korea**—**Radio Pyongyang** noted on 6.250 at good level at 0425 tune-in to 1000 closedown, all-Korean. (Morgan, Calif.)

**Northern Rhodesia**—Lusaka is scheduled now 1115-1400, 3.346; 0700-1400, 4.826; 0700-1000, 7.220. (ISWL, England)

**Norway**—**Radio Norway**, 11.735, Oslo, heard opening 1100, fine level. (Saylor, Va.)

**Pakistan**—**Radio Pakistan**, 5.990, noted in clear with news by man 1015-1030, fair level. (Morgan, Calif.) And parallel over 7.010. Noted to British Isles on 7.010, 6.235 at 1530-1615. (Pearce, England)

**Panama**—HP5J, 9.607A, noted strong some days around 1830-1900. (Bellington, N. Y.)

**Philippines**—Manila, 9.64, noted closing 1000. (JSWC) DZH7, 9.730, Manila, heard with news 1200, closing 1221A ending with prayer, hymn, National Anthem. (Cooper, McPhadden, Calif.; Koch, Ore.)

**Pitcairn Island**—ZBP, 500 kc., 12.110, 500 watts, has *English* 1100-1300, 0000-0100, 0700-0800 "over one transmitter used on both frequencies," station officials inform Scheiner, N. J.

**Poland**—**Radio Warsaw** noted with *English* 1430-1500 on 7.170; 1500-1530, audible on 6.025, 7.125; at 1730-1800 near 5.93, 5.98, 6.04. (Pearce, England) Good in W. Va. 0745-0815 over 11.74 in *English* for North America.

**Portugal**—Lisbon noted from 1135 on announced 15.040, good level in Britain; all-Portuguese. (Brown, ISWL, England) Like a local at 1000. (Bishop, O.) Heard on 9.790A well around 1300-

RADIO & TELEVISION NEWS

1400. (Smith, Ga., others) *Radio Renasença, Emissora Católica Portuguesa*, 6.154A, Lisbon, noted 1815 with piano music; 1900 clock chimes, closed with singing by choir. (Pearce, England)

*Portuguese India—Radio Goa*, 9.610, noted on Sun. 1130 with *English* session of request numbers and commercials; at 1200 has recorded musical concert. (Pearce, England)

*Roumania—Bucharest*, 6.145A, 9.570, noted with *English* 1730. (Pearce, England) With news for North America 2200. (Ferguson, N. C., others)

*Sao Tome—CR5SC*, 4.807, noted closing 1600, poor level. (URDXC)

*South Africa—SABC's "Springbok Radio"*, commercial service, noted in Japan at good strength on 7.295 to 1045 closedown; 4.945 is sometimes audible after 1045. (JSWC)

*Johannesburg*, 4.895, can be heard from 2345 when opens with setting-up exercises in Afrikaans; signal is good some days in Eastern USA. (Niblack, Ind.) Scheiner, N. J., has received SABC schedules which show *experimental* transmitter to Southwest Africa from Johannesburg with *English* on 9.680 at 2345-1605 (from 0055 on Sat., and to 1645 on Sat.).

*South Korea—HLKA*, Seoul, 3.8925, 1 kw., and 2.510, 10 kw., operate in Korean 1530-1900, 2100-2400, 0300-1000; *except Sat., Sun.*, has *English* 0430-0445 ("Voice of Free Korea"); at 0730-0745, *except Sun.*, has *English* lesson. (Scheiner, N. J.)

*Spain—Valladolid*, 7.006, noted with music 1505; *Radio Mediterraneo*, 6.995A, Valencia, heard 1510 with talks in Spanish, music. Puerto de Santa Maria, 7.210, heard closing with anthem 1800. (Pearce, England) Madrid, 9.363, noted to Europe in *English* daily 1515-1545. (Bjornert, Sweden) Good level 2215 in *English* to North America; also 1805A. (Black, N. C.)

*Surinam—Paramaribo*, 15.405A, noted good level around 1830. (Gay, Calif.) Heard on 5.752 ending *English* on a Tue. 2055, then with Dutch to 2105 sign-off. (Morris, O.)

*Sweden—Radio Sweden*, 6.065, weak in news to North America 2100-2110. (Crowell, Pa.) And to Western North America 2300 on 6.095. (Koch, Ore.)

*Switzerland—HER5*, 11.865, Berne, noted 1145 with news, heavy QRM. (Jones, N. C.) Noted closing European Service on 9.535 at 1730. (Roennau, Ont.) United Nations Radio is noted over HBQ, 6.675, Geneva, 1330-1400. (*DX-Radio*, Sweden)

*Tahiti—Radio Tahiti*, 6.135, Papeete, noted from around 2230, best after 2330, talk in French and has music of South Seas, closes usually 2400A. (Balbi, McPhadden, Calif.) At times plays "jazzy" American tunes, sometimes pauses between numbers; closes with vocal theme piece, native, and chimes as background for announcements. Heard on 7.105A from 0100 tune-in to 0200 close, music. (Morgan, Gay, Calif.)

*Taiwan (Formosa)—Taipeh*, 11.735, noted with news 2300, 0030. (Collett, N. Z.) BED7, 7.130A, is good some

# Tested

## AGAIN and AGAIN

45 times by factory experts to provide and insure consistent HIGH FIDELITY PERFORMANCE

# Only craftsmen

does this . . . each and every tuner must perform with less than 1/2% intermodulation distortion at 100% frequency modulation when tested from antenna to audio output.

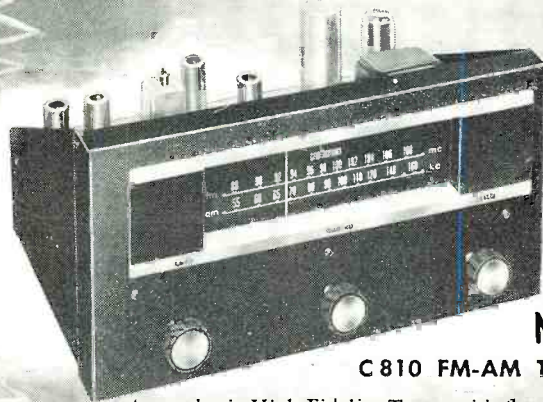

**New!**

**C 810 FM-AM Tuner**

A new basic High Fidelity Tuner with flat audio output response. Featuring: Sensitive FM, 4 $\mu$ v for 30 db quieting. Automatic Frequency Control (no drift) on FM simplifies tuning. Frequency response,  $\pm 1/2$ db, 20 to 20,000 cps. Distortion — FM, 1/3% at 100% modulation. Cathode-follower audio output for remote installations.

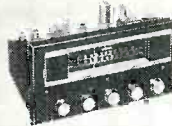

**New C 800A FM-AM Tuner**

(same as C 810 with additional features)

Built-in phono preamplifier and record equalizer. Front-panel selected equalization for AES, LP or EUROpean recording characteristics. Double-shadow tuning eye. Bass and treble controls continuously variable up to 15 db attenuation or boost.

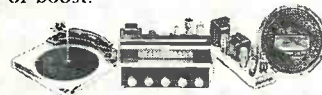

**Craftsmen CA1 Assembly**—a complete HiFi home music system. Ready to install with all cables, hardware, escutcheons and detailed plans. \$275 net.



Get new booklet on High Fidelity by DEEMS TAYLOR. Ask your Supplier or write to us . . . enclose 10c to cover handling and mailing.

Department R5

THE RADIO **craftsmen** INCORPORATED

4403 North Ravenswood Ave., Chicago 40, Ill.



## Centralab Steatite Ceramic Insulators

Protected in packages...  
their quality is guaranteed

Every item lives up to your  
expectations — and it's clean!



Feed-through  
insulators

What do you need in steatite ceramic insulators? Spreader-strain insulators? Standoff or pillar insulators? Feed-through insulators? Fish-spine beads? Through-panel bushings? Your Centralab distributor has them all — in JAN grade L-5.

All items are packaged, so you get them in the same high-quality condition they were in when they left the factory.

Centralab steatite ceramic is harder than the hardest quartz. And it has other desirable characteristics:

- It has a uniform white appearance.
- It has high dielectric strength (240 volts per mil), exceedingly low loss at high frequencies (at 1 m.c. — .007).
- It has high mechanical strength. (18,000 psi, modulus of rupture)
- It is impervious to moisture and common acids. (0 to .02% absorption)
- It does not warp in use.
- It withstands high temperature. (up to 1600°C.)

All these characteristics remain stable with age.

Order Centralab Steatite Ceramic Insulators from your Centralab distributor. You get higher quality—but pay less! Send coupon for catalog material.

SEE US AT BOOTH 790.



**CENTRALAB**,  
A Division of Globe-Union Inc.  
910 E. Keefe Avenue, Milwaukee 1, Wisconsin  
Send me catalog material on Centralab  
Steatite Ceramic Insulators.

Name .....

Company .....

Address .....

City..... Zone..... State.....

X-2954

days around 0630-0800 in Chinese. (Saylor, Va.)

**Tangier**—Radio Africa noted back on old frequency of 7.125A at 1510 with varied recordings, announcements in French; at 1730 announced in Spanish. (Pearce, England) Heard in Spain around 1635. (Diez)

The "Radio Voice of International Evangelization," Box 219, Tangier, has been heard in Sweden *testing* on 7.250 weekdays 1500-1600, Sundays from 0800; calls in *English*, Spanish noted; reception reports requested. (Radio Sweden)

**Trinidad**—VP4RD noted up to 6.096 from (listed) 6.085, going past 0600. (Stark, Texas)

**Turkey**—Radio Ankara, TAS, 7.285, is excellent in *English* 1615-1645, to Western Europe. (Hill, Mass.; Long, N. J.) Still strong 1815-1900 to North America over TAT, 9.515. (Crowell, Pa.; Levy, Koral, N. Y.) Technical University of Istanbul, 7.030, noted 1500 with classical piano music; signed off with orchestral music 1507. (Pearce, England)

**USI (Indonesia)** — YDF6, 9.685A, noted in *English* for Europe-New Zealand 1400-1500; 11.770 should parallel. (Pearce, England) YDF6, 9.710, heard ending *English* session 0658. (Ferguson, N. C.) This one noted closing 1100. (Navarro, Philippines) YDK1, 4.855, Palembang, Sumatra, heard at poor level. native music around 1000; YDR, 4.865, Ambon, Moluccas, fair closing with interval signal 0945; YDB2, 4.910, Djakarta, Java, is good occasionally with Arabic 0800; YDP, 4.930, Tjirebon relay station, is fair 0900-1115 fade-out with Indonesian language, native music; YDJ, 5.060, Jogjakarta, Java, noted at fair to good strength from 0800-1030 closedown, some days to

1130; YDJ2, 7.100, Jogjakarta, fair with Indonesian music 1027, closing 1030 with Hawaiian guitar interval signal; an unidentified Indonesian is noted on 5.995 with interval signal at 1000 closedown, fair level. (Morgan, Calif.)

**USSR**—Moscow, 11.900, is good level in Manila around 0935-0945 with news, in beam to Southeast Asia. (Navarro) Can be heard well in USA on 11.740 in parallel. Yervan, Armenian SSR, 5.740, *measured*, noted by Fairs, England, at 1445. (URDXC)

**Venezuela**—YVME, 4.800, Maracaibo, noted closing in Spanish 2225, nice level; requests reports. (Wilder, N. Y.) Lists 7.5 kw. at 6030-2330. (Hardwick, N. Z.) YVQI, 3.470, Barcelona, heard 1115-1130, music. (Tandrow, Calif.)

**Yugoslavia**—*English* periods from Radio Yugoslavia, Belgrade, now are 1330-1345, 1745-1800 on 6.100, 7.200. (Pearce, England, others)

\* \* \*

### Press Time Flashes

Niblack, Ind., has received word from Deborah Landman, English Section, "Voice of Zion," Jerusalem, that it is hoped the Israel Post Office's new 50 kw. transmitter will be in operation this month (May). *Watch for tests*. At press time, ORU, Brussels, Belgium, had announced it was moving from 6.085 to 9.767 for North American beam 1900-2200. *English* from around 2000; OTC, 9.655, was to continue as relay of ORU.

Germany plans to build a 100 kw. transmitter for its Overseas Service from Cologne, but it will not be completed before 1956, according to station officials. (Roennau, Ont.) Probably beginning in May, broadcasts will include *English*, French, Spanish, and Portuguese, in addition to German.

## NEW TV STATIONS ON THE AIR

(As of April 25, 1954)

The following new stations bring the lists published in previous issues up to date.

STATE, CITY	STATION	CHANNEL	FREQUENCY RANGE (IN MC.)	VIDEO WAVELENGTH (IN FT.)	VIDEO POWER* (IN KW.)
Georgia Albany	WALB-TV	10	192-198	5.08	100
Iowa Des Moines	WHO-TV	13	210-216	4.65	316
Mason City	KGLO-TV	3	60-66	16.06	100
Maryland Salisbury	WBOC-TV	16	482-488	2.04	15.1
Massachusetts Worcester	WAAB-TV	20	596-602	1.65	66
Oregon Eugene	KVAL-TV	13	210-216	4.65	56
Pennsylvania Erie	WSEE-TV	35	596-602	1.65	66
Territories Honolulu, Hawaii	KULA-TV	4	66-72	14.61	30
San Juan, P.R.	WAPA-TV	4	66-72	14.61	56.5
Canada St. John, N.E.	CHSJ-TV	4	66-72	14.61	27.8
Sudbury, Ont.	CKSO-TV	5	76-82	12.74	1.74

KRTV, channel 17, Little Rock, Arkansas; KFOR-TV, channel 10, Lincoln, Nebraska; and WIFE, channel 22, Dayton, Ohio, have gone off the air.

The frequency of the video carrier = 1.25 + channel lower freq. limit. Total number of TV stations now on the air in U.S.: 381 (135 of which are u.h.f.).

\*From Station CP application.

ALL TUBES are guaranteed for one year! Individually boxed. Very BEST BRANDS available for immediate delivery!

0A46	.119	2A6	89c	6AH6	.189	6BH6	69c	6K5GT	.69	6S07	.89	7C5	.89	12AU7	.79	12SN7GT	.95	26	59c	57	79c
024	59c	2A7	89c	6AK5	.89	6BJ6	69c	6K6GT	.59	6S07GT	.59	7C6	.79	12AV6	.59	12SQ7	.95	27	79c	58	79c
0240	59c	2B3	89c	6AK6	.119	6BK7	1.19	6K7GT	.69	6S7GT	.69	7C7	79c	12AV7	.89	12SQ7GT	69c	35A5	95	70L7	1.49
1A5GT	.79	2B7	.89	6AL5	.79	6BL7	.79	6K8GT	1.19	6SS7	.99	7E5	79c	12AV8	1.19	1223	95	35B5	95	71A	79c
1A7GT	.79	2E5	.89	6AQ5	.69c	6BN6	.119	6L6	.69	6T8	.89	7E6	79c	12AX4	.69	1447	95	35C5	95	71A	79c
1B3GT	.95	2X2/879	.79	6AQ6	.79	6BO6GT	1.19	6L6GA	1.39	6U5	.69	7F7	.89	12AX7	.69	14A7	95c	35D4	.59	77	.69
1B5	29c	3Q1	.129	6A07	.119	6B07	.79	6L7	1.19	6U6	.69	7F8	.89	12B7	.89	14B6	89c	35E4	.59	78/6D6	.95
1H4	59c	3Q4	.69	6A08	.69	6B08	.69	6L8	.69	6U7	.69	7G7	.79	12B7A	1.19	14B8	89c	35F5	.69	80	.69
1H5GT	.59	3Q5	.89	6A09	.89	6B09	.89	6L9	.69	6U8	.89	7H7	.79	12B7B	.69c	14C5	1.19	35G5	.79	84/6Z4	.69
1J6GT	59c	3S1	.69	6A10	.69	6B10	.69	6M6	.69	6U9	.69	7J7	1.19	12B7C	.89	14C7	95c	35H5	.79	85	.79
1L4	1.19	3S4	.69	6A11	.69	6B11	.69	6N6	1.29	6V8	.89	7K7	.79	12B7D	.89	14F8	1.29	35I5	.79	85	.79
1L6	1.19	3V4	.69	6A12	.69	6B12	.69	6O6	.69	6V9	.89	7L7	.69	12B7E	.69c	14H7	1.29	35J5	.79	85	.79
1L6A	1.19	3V4	.69	6A13	.69	6B13	.69	6P6	.69	6W6	.69	7M7	.69	12B7F	.69c	14I7	1.29	35K5	.79	85	.79
1L6B	1.19	3V4	.69	6A14	.69	6B14	.69	6Q6	.69	6X6	.69	7N7	.69	12B7G	.69c	14J7	1.29	35L5	.79	85	.79
1L6C	1.19	3V4	.69	6A15	.69	6B15	.69	6R6	.69	6Y6	.69	7P7	.69	12B7H	.69c	14K7	1.29	35M5	.79	85	.79
1L6D	1.19	3V4	.69	6A16	.69	6B16	.69	6S6	.69	6Z6	.69	7Q7	.69	12B7I	.69c	14L7	1.29	35N5	.79	85	.79
1L6E	1.19	3V4	.69	6A17	.69	6B17	.69	6T6	.69	6A7	.69	7R7	.69	12B7J	.69c	14M7	1.29	35O5	.79	85	.79
1L6F	1.19	3V4	.69	6A18	.69	6B18	.69	6U6	.69	6B7	.69	7S7	.69	12B7K	.69c	14N7	1.29	35P5	.79	85	.79
1L6G	1.19	3V4	.69	6A19	.69	6B19	.69	6V6	.69	6C7	.69	7T7	.69	12B7L	.69c	14O7	1.29	35Q5	.79	85	.79
1L6H	1.19	3V4	.69	6A20	.69	6B20	.69	6W6	.69	6D7	.69	7U7	.69	12B7M	.69c	14P7	1.29	35R5	.79	85	.79
1L6I	1.19	3V4	.69	6A21	.69	6B21	.69	6X6	.69	6E7	.69	7V7	.69	12B7N	.69c	14Q7	1.29	35S5	.79	85	.79
1L6J	1.19	3V4	.69	6A22	.69	6B22	.69	6Y6	.69	6F7	.69	7W7	.69	12B7O	.69c	14R7	1.29	35T5	.79	85	.79
1L6K	1.19	3V4	.69	6A23	.69	6B23	.69	6Z6	.69	6G7	.69	7X7	.69	12B7P	.69c	14S7	1.29	35U5	.79	85	.79
1L6L	1.19	3V4	.69	6A24	.69	6B24	.69	6A7	.69	6H7	.69	7Y7	.69	12B7Q	.69c	14T7	1.29	35V5	.79	85	.79
1L6M	1.19	3V4	.69	6A25	.69	6B25	.69	6B7	.69	6I7	.69	7Z7	.69	12B7R	.69c	14U7	1.29	35W5	.79	85	.79
1L6N	1.19	3V4	.69	6A26	.69	6B26	.69	6C7	.69	6J7	.69	7A7	.69	12B7S	.69c	14V7	1.29	35X5	.79	85	.79
1L6O	1.19	3V4	.69	6A27	.69	6B27	.69	6D7	.69	6K7	.69	7B7	.69	12B7T	.69c	14W7	1.29	35Y5	.79	85	.79
1L6P	1.19	3V4	.69	6A28	.69	6B28	.69	6E7	.69	6L7	.69	7C7	.69	12B7U	.69c	14X7	1.29	35Z5	.79	85	.79
1L6Q	1.19	3V4	.69	6A29	.69	6B29	.69	6F7	.69	6M7	.69	7D7	.69	12B7V	.69c	14Y7	1.29	35A6	.79	85	.79
1L6R	1.19	3V4	.69	6A30	.69	6B30	.69	6G7	.69	6N7	.69	7E7	.69	12B7W	.69c	14Z7	1.29	35B6	.79	85	.79
1L6S	1.19	3V4	.69	6A31	.69	6B31	.69	6H7	.69	6O7	.69	7F7	.69	12B7X	.69c	15A7	1.29	35C6	.79	85	.79
1L6T	1.19	3V4	.69	6A32	.69	6B32	.69	6I7	.69	6P7	.69	7G7	.69	12B7Y	.69c	15B7	1.29	35D6	.79	85	.79
1L6U	1.19	3V4	.69	6A33	.69	6B33	.69	6J7	.69	6Q7	.69	7H7	.69	12B7Z	.69c	15C7	1.29	35E6	.79	85	.79
1L6V	1.19	3V4	.69	6A34	.69	6B34	.69	6K7	.69	6R7	.69	7I7	.69	12B7A	.69c	15D7	1.29	35F6	.79	85	.79
1L6W	1.19	3V4	.69	6A35	.69	6B35	.69	6L7	.69	6S7	.69	7J7	.69	12B7B	.69c	15E7	1.29	35G6	.79	85	.79
1L6X	1.19	3V4	.69	6A36	.69	6B36	.69	6M7	.69	6T7	.69	7K7	.69	12B7C	.69c	15F7	1.29	35H6	.79	85	.79
1L6Y	1.19	3V4	.69	6A37	.69	6B37	.69	6N7	.69	6U7	.69	7L7	.69	12B7D	.69c	15G7	1.29	35I6	.79	85	.79
1L6Z	1.19	3V4	.69	6A38	.69	6B38	.69	6O7	.69	6V7	.69	7M7	.69	12B7E	.69c	15H7	1.29	35J6	.79	85	.79

**10%** discount on orders of 100 tubes or more.

**5%** discount on 50 tube orders.

**FREE** with every order. 11" screw driver. 1/2" chrome vanadium blade. Insulated handle. Everybody can use another screw driver.

Regency All channel UHF Converter. Hottest news in UHF history. The Cadillac of UHF converters NOW \$14.96 net

Picture tube brightener 5.95 list dealer cost \$1.95

TV Arrow antenna to receive UHF, VHF, or UHF-VHF \$2.95

Midget Radar Outdoor UHF antenna \$4.77

TELERON TV WAVE TRAP For VHF Channels 2 to 13. Clears VHF picture, stops interference at once, 30 seconds to attach. ea. net \$1.75 All UHF Channels \$2.75

TV 2-set antenna couplers \$1.17 ea.

Flyback Transformer TV Horizontal output, universal replacement, 14,500 V. \$2.49 ea.

70 degree cosine yoke with 4 leads and network \$2.95 ea.

### FILTER CONDENSERS

FP Type or Tubular with Leads—Fresh Stocks Always

8 mfd.	450 V.	.35	10 mfd.	50 V.	.19
8-8	450 V.	.45	20.	50 V.	.19
10.	450 V.	.39	25.	50 V.	.19
10-10	450 V.	.45	50.	50 V.	.25
20.	450 V.	.45	100.	50 V.	.29
20-20	450 V.	.49			
30	450 V.	.45	20 mfd.	150 V.	.35
30-30	450 V.	.59	20-20	150 V.	.45
40	450 V.	.49	30	150 V.	.45
40-40	450 V.	.69	30-30	150 V.	.49
60	450 V.	.69	40	150 V.	.49
60-40	450 V.	.69	40-20	150 V.	.49
80	450 V.	.69	40-40	150 V.	.49
80-40	450 V.	1.29	50-30	150 V.	.49

### P. M. SPEAKERS

12" COAXIAL PM SPEAKERS. High Fidelity with Crossover filter attached. 20 watts; 40-19,000 cps. response; 8 ohm Voice-coil. ea. **\$12.95**

15" COAXIAL SPEAKER 20-17,500 cps. ea. **\$19.95**

Very best quality—NATIONAL BRANDS. Individually Packed.

3"	ea.	\$1.39
4"	ea.	1.59
5"	ea.	1.79
6"	ea.	1.99
8"	ea.	3.23
10"	ea.	5.10
12"	ea.	5.95

**SPECIAL PRICE**

### SPECIAL PURCHASE PICTURE TUBES

	With Dud	Without Dud	List Price
16AP4 metal	\$15.95	\$18.95	\$46.00
16DP4 glass			40.00
17CP4A metal	17.95	20.95	36.00
21AP4A metal	21.95	26.95	55.00

PLEASE SHIP DUDS EXPRESS PREPAID

### MISCELLANEOUS BUYS

I. F. TRANSFORMER—456 Kc. .29c  
PILOT LIGHTS, Type No. 47  
10 for 39c. 25 for 52.95  
VOLUME CONTROLS FOR SWITCH, 2" shaft, 1 meg, 1/2 meg, 1/4 meg  
SINGLE ION TRAPS .34c  
DOUBLE ION TRAPS .29c  
OUTPUT TRANSFORMER—1 meg for 50L5, 29c; for 6V6, 39c  
6-root LINE CORD UL 10 for \$1.95  
TV INTERLOCK CORDS .ea. 49c

### SELENIUM RECTIFIERS

60 mil.	.69
75 mil.	.79
100 mil.	.89
150 mil.	1.29
200 mil.	1.59
300 mil.	1.75
350 mil.	1.95
400 mil.	2.45
450 mil.	2.49
500 mil.	2.55

### BRAND NEW TV PICTURE TUBES

Rectangular Tubes Are Supplied With Daylight Type Dark Face

SIZE	PRICE	SIZE	PRICE
7JP4	\$17.95	17HP4	25.10
8BP4	23.00	17TP4	
10BP4	15.95	19AP4	
12JP4	18.60	19DP4	28.70
12LP4		19FP4	
12UP4	19.95	21AP4	
14BP4	21.20	21CP4	29.95
15AP4	23.50	21EP4	
16AP4	23.90	21FP4	
16DP4	23.80	21GP4	32.30
16EP4	26.95	21MP4	
16GP4		24AP4	67.95
16KP4	23.80	24CP4	77.30
16LP4		24EP4	
16RP4		27GP4	98.50
17BP4		27LP4	
17CP4	25.10	27NP4	89.95
17DP4		27RP4	99.95

THESE ARE GUARANTEE ON ALL TYPES SEND US YOUR ORDER AND WE WILL SHIP FROM STOCK IMMEDIATELY

**TERMS:** 25% DEPOSIT with order, balance C.O.D. ALL shipments F.O.B. Chicago. CHARGE. CABLE ADDRESS: CONTULAB. These prices supersede all previously advertised prices, subject to change

### RADAR TYPE TV ANTENNA

For UHF and VHF RECEIVES ALL CHANNELS

212 miles reception recorded, 125 miles common. This unbeatable antenna has been reinforced to withstand 150 mile winds. Satisfaction guaranteed or your money back. Less Mast, List Price... \$49.95

Your Cost... **\$19.95**

5 ft. DURABLE MAST heavy gauge 1 1/4 diam. with interlocking end. Slip two sections together for a ten-footer. 5 sections = 25 ft. Each section... \$1.25

### MOLDED TUBULAR BY-PASS CONDENSERS

50 Condensers assorted in package \$4.95

600 VOLT	.05	12c
.001	.9c	1
.002	.9c	1
.005	.9c	1
.01	1.2c	25 mfd.
.02	1.2c	.5 mfd.

### THE DUAL LAZY H

Pre-Assembled Co-Lateral Array \$2935

The dual LAZY H. Only 6 connections instead of 40. A snap open Lazy H is the serviceman's desire for the UHF-VHF band. One lead in for high gain UHF-VHF. Strictly for the fringes.

### 21" TV CONVERSION KIT COMPLETE WITH CABINET

Now you can make that conversion. This table model cabinet eliminates your bottle neck. Supplied complete with 21" picture tube, 70 degree yoke, gold mask and safety plate, fly back transformer and width coil, very easy to install and all for \$50.00.

### TV CONVERSION KITS

Easily Installed consisting of rectangular tube, 70 degree yoke, beautiful mask, flyback transformer and width coil.

17" Conversion Kit, as above, complete.	\$25.95
20" Conversion Kit, as above, complete.	38.95
21" Conversion Kit, as above, complete.	39.95
24" Conversion Kit, as above, complete.	89.95
24" Conversion Kit, Round	69.95
27" Conversion Kit, as above, complete.	99.95
24" & 27" Rectangular Kits Contain 90° yoke.	

### CONICAL TV ANTENNA KIT

Complete 20-Piece Kit Contains Everything You Need For A Professional Installation.

For all around good reception on ALL CHANNELS. List price \$31.95. Elements are made of GENUINE AIRCRAFT ALUMINUM tubing. Contains everything you need: 2 Six Element Conical Bays, 1 pair "Q" Bars, 2 Five Ft. 1 1/4" Mast Sections, 60 Ft. 300 Ohm Twin Line, 3 Standoff Insulators, 2 Screw-eye Standoffs, 1 Mounting Base, 1 Guy Ring, 1 Clamp Assy, 1 Pipe Strap, 4 Lag Bolts and Complete Instructions.

10 Element conical rugged throughout. Only... **\$3.95**

Double bay array, with stacking bars... \$7.25

4 Bay array, with harness and stacking bars... \$14.95

6 Element Conical. Only... \$2.95

Stock No. RK902 \$12.99 Complete

### DOUBLE CONYAGI

The equivalent of 40 dipoles

Newest development for long distance TV reception.

MONEY BACK GUARANTEE **\$15.95**

### RESISTOR KITS

Insulated 1/2, 1 and 2-watt assortment of most used values. I.R.C. Ohmite, Stackpole, Speer. 100 for... **\$2.95**

### 300 OHM TWIN LEAD

55 Mil. 100 ft.	\$1.59
1,000 ft.	13.95



**Free!**  
**New, revised edition**  
**Centralab**  
**PRINTED ELECTRONIC CIRCUIT**  
**GUIDE NO. 3**

**Gives you facts that save you time and money while trouble-shooting — help eliminate call-backs**

Here's a handy working tool. It puts practical service dope right at your fingertips where you can always find it.

It gives you information you can't afford to be without today. Over 35,000,000 Centralab Printed Electronic Circuits (PEC's) are now in use in today's radio and television sets.

Just look at the "meat and potatoes" between the covers of Guide No. 3:

- Lists 127 radio and TV manufacturers and their PEC applications—showing part identification number, manufacturer's part number, and Centralab catalog number.
- Shows circuit schematics that guide you in using PEC's to replace standard components.
- Tells how you can easily check Centralab PEC's with a VOM and simple 60-cycle capacitor bridge.

It's easy to get your free copy of the Centralab Printed Electronic Circuit Guide No. 3. Just fill in and mail the coupon below today. \*Trademark



CENTRALAB, A Division of Globe-Union Inc., 910 E. Keefe Avenue, Milwaukee 1, Wisconsin  
 Send me a free copy of the new 1954 edition of the Centralab Printed Electronic Circuit Guide No. 3.

Name.....  
 Company.....  
 Address.....  
 City..... Zone..... State.....  
 Y-2354

(ISWC, England) *Radio Athens*, 9.607, has news in French 1230, in *English* 1245. (Pearce, England) Forces Broadcasting Service, 5.010, Singapore, Malaya, has been heard in native 0800-0900, poor level but should get better now. (Morgan, Calif.) Kempala, Uganda, will operate on 3.340, 5.026, 7.110 with 7.5 kw. (*N. Z. DX Times*)

Morgan, Calif., has noted a Spanish-speaker on 11.959A around 1000 that announces as in Mexico. At press time, he had received this over-all revised schedule of *Radio Japan*—0000-0100, 9.695, 11.780; 0200-0300, 15.135, 11.780; 0400-0500, 15.135, 11.725; 0600-0800, 9.695, 7.180; 0830-0930, 9.695, 11.725; 0945-1045, 9.695, 11.725; 1100-1200, 9.695, 11.725; 1400-1500, 9.695, 7.180; 1700-1800, 15.135, 11.725. Transmitters are listed 50 kw.

A Brazilian noted on 6.125A around 2200-2300 and at other times seems to announce as *Radio Nacional*, Sao Paulo. (Niblack, Ind.; Bellington, N. Y.) The new commercial "Danish" station, 7.310, is heard around 1400-1500, 1700-1800, asking for reports to Rosenorms Alle 58, Copenhagen, Denmark. (Pearce, England) However, according to *WRH*, location is Tangiers, not Denmark. (Radio Australia) According to data from *Radio Maroc*, Rabat, Fr. Morocco, the session widely heard in USA on 15.205 around 0730-0930, asking for reports, and announcing in *English*, French, is a relay by a 50 kw. VOA station at Tangier. (Scheiner, N. J.) A new station at Ambato, Ecuador, has been noted on 6.204, announcing "Radio Cosmopolita," heard 2200 tune-in to 2300 sign-off, weak to fair. (Rastorfer, N. Y.)

*Radio Omdurman*, Anglo-Egyptian Sudan, now lists 5.000 (new), 6 kw., and 6.410, 350 watts, in Arabic 2315-2345 daily, 1130-1430 daily, 0300-0400 Sun., 0300-0430 and 0900-1000 Fri.; in *English* 1115-1130 Sun., Wed., and 1230-1300 Fri. (Scheiner, N. J.) A Japanese government station at Wakkanai, Hokkaido Island, is testing on 9.175, according to *Nippon Hoso Kyokai*, Tokyo; probably is one audible in Sweden 0450-0520 testing on approximately 9.200. (Radio Sweden) Spring schedule of *Radio Sweden* includes *English* to Western North America 1600 and 2300, 9.535; to Eastern North America 0700 on 15.155, 1930 and 2100 to Middle East 2300, 15.155, and 0930, 15.155; to Africa 0000 and 1300. 11.705; to Middle East 2300, 15.155, 0930, 11.880; to Far East 2300, 9.620, and 0800 on 11.880. (Saylor, Va.)

*Sharq-al-Adna*, 11.720, Cyprus, is heard in Australia 0900-0943. (*Malmo DX-aren*, Sweden) Heard in Sweden on 6.790 at 1300-1400. (*DX-Radio*, Sweden) Prague, 9.504, Czechoslovakia, has *English* 0715 and 1400. (Pearce, England)

**Acknowledgment**

Thanks for the FB reports—keep them coming to Kenneth R. Boord, 948 Stewartstown Road, Morgantown, West Virginia, USA. Good DX-ing, fellows! . . . . . K. R. B.

**Communication Engineers**

*with experience in the fields of*

- Systems Engineering**
- Information Theory**
- Circuit Development**
- Electro-mechanical Development**
- Equipment Engineering**

THE OPENINGS

Advancements in the fields of wave propagation, translation of information, communication theory, circuit techniques and equipment miniaturization have created a number of new openings for qualified engineers in the Hughes Advanced Electronics Laboratory.

AREAS OF WORK

The communication group is concerned with the design and development of unique radio communication systems and with exploiting new radio communication techniques. Specialists in propagation phenomena, antenna systems, network theory, magnetic recording, wide-band amplification, and intricate electromechanical devices are active in this program.

*Assurance is required that relocation of applicant will not cause disruption of an urgent military project.*

**Hughes**

RESEARCH AND DEVELOPMENT LABORATORIES

*Scientific and Engineering Staff*

CULVER CITY, LOS ANGELES COUNTY, CALIFORNIA



**"Linear Standard" Amplifier**  
(Continued from page 46)

senting the audio range would have small phase shift and a musical wave-shape coming through this region would be undistorted. The concept in this new amplifier circuitry involves a realization that a linear phase condition required for optimum *transient* response actually involves a smaller bandwidth than can be obtained if *amplitude* response is considered alone. The "Linear Standard" circuit designed by J. M. Diamond of our laboratories and discussed in the article "Multiple Feedback Audio Amplifier" (Electronics, November 1953) is a big step in this direction. It actually provides bandwidth for optimum *transient* response, and recognizes the necessity for a rugged, stable structure that can give long, trouble-free service. Components and tubes are conservatively used within their specified ratings.

It was required that the amplifier be easy to assemble—there would have to be uniformity between the lab models and those sold—and long term trouble-free stability was essential. To meet these requirements the amplifier ended up with an etched circuit design requiring for assembly merely the making of 17 numbered screw-type connections.

The etched circuit with all components in place is shown in Fig. 1. Etched circuit soldering technique is used, making total soldering time in manufacture somewhat less than 10 seconds per amplifier. Tube sockets, pilot lamp, fuse clips, etc. are all incorporated directly into the etched circuit board. A simple suspension method, illustrated in Fig. 13, protects both sides of the etched circuit board and maintains low, pre-determined, ground capacities. The layout is such that the vacuum-tube filaments are kept above the top surface of the metal chassis, so that their heat radiates into the surrounding air.

Fig. 12. Multiple oscillogram of Williamson-type amplifier output with capacitive loading as input audio signal is varied, showing the conditional stability obtained. See text for the complete discussion.

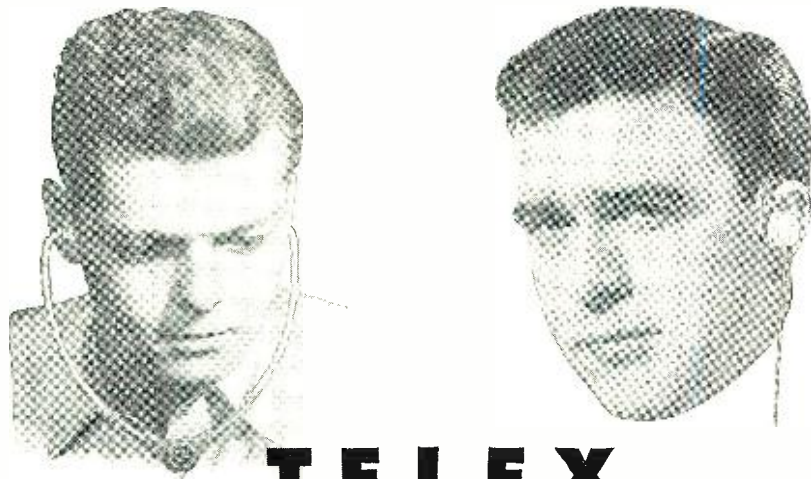
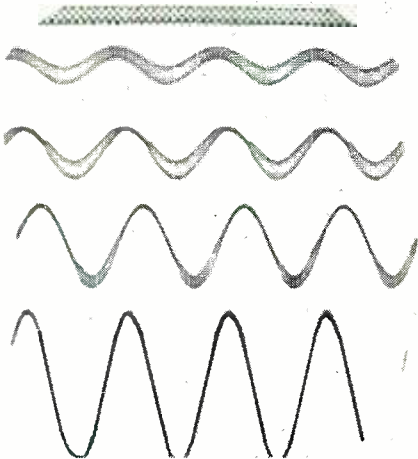

**TELEX**  
*headsets...*



*modern... lightweight... comfortable...*

Telex Headsets—designed for constant use, constant comfort, constant fidelity. Easy to wear... makes wide range of sound easy to hear... gives exceptional performance where finest sound reproduction is needed the most—DIRECTLY IN THE EAR!

**TELEX**—Standard of The World for Quality Headsets!



**DYNASET\*** New, under-chin headset. Weighs only 1.25 oz.—permits freedom of head movement. High fidelity range delights radio-TV monitors. Ruggedly constructed for longer life, greater dependability.



**TWINSET\*** Pipes pure signal directly into ears blocking out background noises. Weighs only 1.6 oz. Easily adjustable—rests lightly on temples—uses only one cord—magnetic.



**EARSET\*** Sensitive single-phone headset leaves other ear free for phone calls or conversation. Fits either ear, holds securely. Single cord stays out of way. Excellent fidelity. Weighs only 1/2 oz.



**MONOSET\*** Replaces heavy, old-style headsets—gives superior performance without encumbering head. High fidelity, lightweight—1.6 oz.—banishes listening fatigue. Accepted by the most particular of users. Magnetic.

For complete information on  
Telex Headsets, write today to

**TELEX**  
TELEX PARK  
ST. PAUL, MINNESOTA

ELECTRO ACOUSTIC DIVISION  
DEPARTMENT 1-G

®TRADE MARK

IN CANADA, ATLAS RADIO CORPORATION, TORONTO.

Easy, fast way to cut "Key" and "D" openings in chassis

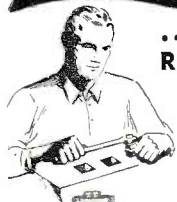

**...with new GREENLEE Radio Chassis Punches**

Now, in 1½ minutes or less make perfect "Key" or "D" holes for sockets and other equipment. Simply insert GREENLEE Punch and turn with an ordinary wrench . . . get a "clean" opening in a hurry! Write today for details on these as well as GREENLEE Radio Chassis Punches for round and square openings. Greenlee Tool Co., 1885 Columbia Ave., Rockford, Illinois

No. 732 "Key" Punch



No. 733 "D" Punch



**PREMAX**

**Built To Do Any Important Job Better!**

**Mobile Antennas**

The finest low-cost mobile you can buy! Center-loaded coil can be used for 75 or 20-meter operation or variations secured by jumpering. Also available for special Civil Defense uses such as 2000-3000 kcs., 2374 kcs., and the 3105, 4325 and 4585 kcs. marine bands.

Get special Bulletin from your jobber or write direct.

**Premax Products**  
Division of Chisholm-Ryder Co., Inc.

5423 HIGHLAND AVE., NIAGARA FALLS, N. Y.

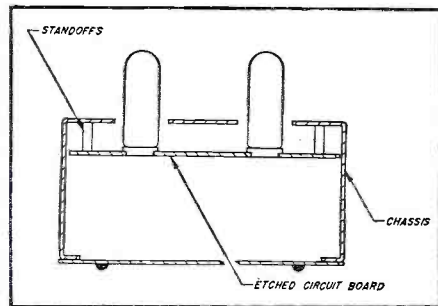

Fig. 13. Cross-section drawing of amplifier.

The heavy magnetic components are mounted to the metal chassis, and make connection to the amplifier circuit through screw terminals located on the etched circuit board. While this amplifier is sold as a kit, the etched circuit construction makes it possible to pre-check each kit with its own set of tubes prior to shipment, to assure optimum performance to the purchaser. The user merely has to wire up the 17 screw connections, and if he has an 8 or 16 ohm speaker, he is finished. For other speakers and matching problems, all the transformer secondary connections are brought out to a barrier terminal strip and connections for impedances from 1.2 to 30 ohms are readily available. To get optimum transformer efficiency, the secondary of a high-fidelity output transformer must be sectionalized for series-parallel arrangements which will permit the use of all the secondary copper in any of the widely used impedance values.

The UTC LS-63 transformer employed has exceptionally wide frequency response with minimum phase shift in the passband. If line impedances are required, type LS-61 is available. With the terminal strip arrangement provided, it is possible to cover a wide range of impedance values with a minimum of effort. However, for loads other than 8 or 16 ohms the feedback resistor (see chart on schematic Fig. 2) must be changed. This resistor is held between two screw connectors for easy change. The values of feedback resistors required for additional output impedance values are listed in Fig. 2.

With the realization that size is an important factor in many high-fidelity installations, this unit has been designed to remarkably small dimensions (5¼"x17½"x8") for its performance. The bottom is protected by a cover plate equipped with bumper feet to prevent the marring of furniture. These dimensions also allow the mounting of the amplifier on a 7" relay rack panel for studio use. No resoldering is required, it merely being necessary to prepare the panel for the mounting of the amplifier and mount the unit on it.

The "Linear Standard" power amplifier, while a universal amplifier, provides new standards of performance. Its technical qualifications are of professional caliber, yet its constructional requirements through the use of modern technology are in the province of the music lover. -30-

Let MILTON S. KIVER Help You Prepare For U.H.F.-TV, Color And...

**TELEVISION SERVICING**

**Easy to TRAIN AT HOME This Practical Way!**

Men with the right training in Television Servicing are in big demand . . . pull down big pay. T.C.I. TRAINS YOU RIGHT with easy-to-follow technical training designed by servicemen, for servicemen! You learn practical, professional type Television Servicing without leaving your present job. Included are money-making extras such as set conversion, master antenna installation, U.H.F.-TV NTSC Color System and field servicing short cuts. You can start earning Television money after the first few lessons. You learn to test, trouble shoot and repair all types of TV sets the proven, practical way!

**HERE'S HOW YOU GET EXPERIENCE!**

You train on your own large screen modern television receiver, furnished as part of your course. This set is yours to keep! As an optional feature you can get two weeks of actual field experience out on service jobs and on the repair bench for Chicago's largest independent servicing organization. You learn Television Servicing by actually doing Television Servicing . . . you get the practical know-how you need to qualify for BIG MONEY in this fast-growing field! Age is no barrier, Many TCI students are over 40!

**VETERANS!** T.C.I. is approved for G.I. training under Public Law 580. Check coupon.

**ACT NOW!** Mail coupon for FREE Catalog and SAMPLE LESSON. Write TODAY!

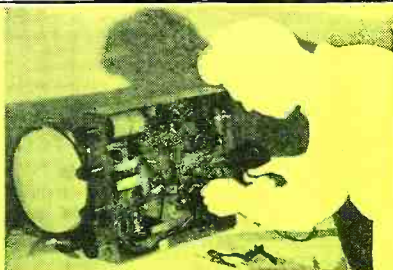

**YOU GET** and keep modern large screen Television receiver.

**YOU DO** actual testing, servicing, trouble shooting and repairing

**BEGINNERS! LEARN ABOUT NEW BASIC TV COURSE!**

You don't need radio experience for practical, home-study training in Basic Television. Start earning money in TV after first few easy lessons. Check coupon for details.

**MAIL NOW FOR FREE BOOKLET**

MILTON S. KIVER, President  
TELEVISION COMMUNICATIONS INSTITUTE  
605 W. Washington Blvd., Dept. BA,  
Chicago 6, Ill.

Flush full facts on practical TV training. I am not obligated. Salesman will not call.

Name .....  Veterans: check here  
Address .....  
City ..... Zone ..... State .....

BEGINNERS check here for information on Basic Television Course.

**TELEVISION COMMUNICATIONS INSTITUTE**

605 W. Washington Blvd., Dept. BA, Chicago 6, Ill.



**CHECK These Terrific RAD-TEL Tubes and Parts SAVINGS!**

**70% to 90% OFF on TUBES INDIVIDUALLY BOXED FULL YEAR GUARANTEE!**

**SAME DAY SERVICE . . . OVER 300 TYPES IN STOCK AT ALL TIMES**

Type	Price	Type	Price	Type	Price	Type	Price	Type	Price	Type	Price	Type	Price	Type	Price		
OA2	.74	1T4	.49	6AK5	.55	6BQ7	.90	6SH7GT	.49	7C5	.69	12BE6	.39	14AF7	.59	42	.42
OA4	.68	1U4	.49	6AK6	.59	6BZ7	.90	6S7GT	.41	7C6	.59	12BF6	.39	14H7	.59	43	.55
OB2	.81	1U5	.43	6AL5	.38	6C4	.37	6SK7GT	.41	7E5	.59	12BH7	.63	14J7	.30	45	.55
OC3	.72	1V	.53	6AQ5	.39	6C5	.39	6SL7GT	.48	7E6	.30	12BY7	.65	14N7	.84	45Z3	.44
OD3	.70	1X2A	.63	6AQ6	.37	6C6	.58	6SN7GT	.52	7E7	.59	12BZ7	.65	14W7	.30	45Z5	.49
OZ4M	.55	2A3	.30	6AR5	.37	6CB6	.44	6SQ7GT	.37	7F7	.79	12C8M	.34	19B6G	.95	50A5	.55
1A5	.30	2A4G	.24	6AS5	.50	6CD6	1.11	6SR7GT	.45	7G7	.89	12H6	.56	19C8	.70	50B5	.43
1A7GT	.47	2W3	.38	6AT6	.37	6D6	.59	6SS7GT	.42	7H7	.59	12SC7M	.63	19T8	.69	50C5	.39
1AX2	.62	2X2	.59	6AU4GT	.68	6E5	.48	6T4	.99	7J7	.79	12J5	.42	19V8	.79	50L6GT	.61
1B3GT	.68	3A4	.45	6AU5GT	.82	6F5GT	.39	6T8	.56	7L7	.59	12J7	.49	24A	.39	50Y6	.49
1C5	.43	3E5	.46	6AU6	.36	6F6	.59	6U4	.60	7N7	.69	12K8	.59	25AV5GT	.83	50Y7	.50
1E7	.29	3Q4	.48	6AV5GT	.83	6G6	.52	6U6	.59	7X7	.70	12Q7	.59	25BQ6GT	.79	55	.49
1G6	.24	3Q5GT	.49	6AV6	.37	6H6GT	.41	6U8	.61	7Y4	.69	12S8GT	.62	25L6GT	.39	57	.58
1H4	.30	3S4	.49	6AX4GT	.53	6J5GT	.43	6V6GT	.39	7Z4	.59	12SA7GT	.65	25W4GT	.59	58	.60
1H5GT	.49	3V4	.51	6B4	.64	6J6	.52	6W4GT	.44	12A6	.54	12SF5	.50	25Z5	.66	70L7	.97
1L4	.46	5U4G	.50	6BA6	.39	6J7	.43	6W6GT	.44	12A8GT	.61	12SG7	.51	25Z6	.49	75	.49
1L6	.59	5W4GT	.50	6BA7	.57	6K5	.47	6X4	.37	12AL5	.37	12SJ7M	.67	26	.45	76	.44
1LA4	.59	5Y3GT	.37	6BC5	.49	6K6GT	.37	6X5GT	.37	12AQ5	.52	12SK7GT	.63	27	.39	77	.57
1LC5	.59	5Z3	.45	6BD5	.59	6K7	.44	6X8	.75	12AT6	.37	12SK7M	.63	32L7	.89	78	.47
1LC6	.79	5Z4	.59	6BD6	.45	6L6	.64	6Y6G	.48	12AT7	.66	12SL7GT	.47	35	.58	80	.35
1LD5	.59	6A6	.51	6BE6	.39	6L7M	.68	7A4	.47	12AU6	.38	12SN7GT	.52	35B5	.40	83V	.68
1LE3	.59	6AB4	.44	6BF5	.41	6Q7	.45	7A5	.59	12AU7	.54	12SQ7GT	.56	35C5	.39	84/6Z4	.46
1LH4	.69	6A7	.69	6BF6	.37	6R7	.69	7A6	.69	12AV6	.39	12SR7M	.49	35L6GT	.41	85	.59
1LN5	.59	6AC7M	.86	6BG6G	1.25	6S4	.38	7A7	.69	12AV7	.63	12V6GT	.46	35W4	.37	117L7	.99
1N5GT	.67	6AF4	.90	6BH6	.46	6S7M	.79	7A8	.68	12AX4	.56	12X4	.38	35Y4	.54	117P7	.99
1P5GT	.57	6AG5	.48	6BJ6	.43	6S8GT	.53	7AF7	.53	12AX7	.56	14A5	.59	35Z3	.59	117Z3	.37
1Q5GT	.58	6AG7M	.99	6BK7	.80	6SA7GT	.43	7B4	.44	12AY7	.99	14A7	.63	35Z4	.47	117Z6	.69
1R5	.49	6AH4	.57	6BL7GT	.83	6SD7GT	.41	7B6	.69	12BA6	.38	14B6	.63	35Z5GT	.47	807	.99
1S4	.59	6AH6	.73	6BN6	.59	6SF5GT	.46	7B7	.49	12BA7	.60	14B8	.63	36	.39	866A	1.39
1S5	.43	6AJ5	.65	6BQ6GT	.79	6SG7GT	.41	7C4	.59	12BD6	.45	14C7	.79	41	.42	Hi-Po 567	1.39

**RAD-TEL Parts - TOPS in Quality - LOW LOW in Price!**

**Philco TV BOOSTER**  
 Made by PHILCO, famed for quality and precision communications equipment. Completely self-contained, including 2 tubes—1 for High Channels and 1 for Low Channels and selenium rectifier plastic cabinet. In factory sealed cartons, complete with instructions.  
**\$10.95** each  
 In Lots of 3 \$9.95



**STANDARD BOOSTER**  
 12 channel RF Amplifier with self-contained AC power supply. Hand-some plastic cabinet. List price \$23.00  
**\$7.95** each  
 Lots of 3 each **\$7.45**



**Granco "Star" UHF CONVERTER**  
 Brand new! Latest model! Unit is highly engineered, receives all UHF channels. Coaxial tuned cavity elements complete with 6AF4 oscillator, 6CB6 I-F and crystal in line. Shipped ready to install and operate.  
 List Price \$20.95  
 . . . \$22.45  
 De-luxe model Five Star  
 UHF Converter, Pre-selector 1N82-6BQ7 catcode and 6AF4 oscillator.  
 List price \$30.95. . . . . \$29.97



**The New WEN SANDER-POLISHER**  
 Enables you to sand wood satin smooth in seconds, sand rust off furniture, shoes, your car! Anything! Even gives a good massage. Weighs only 2 1/2 lbs.  
 List Price \$13.95  
**\$10.46** ea.  
 Lots of 3 \$9.30 Ea.



**Cathode Ray TUBE REJUVENATOR**  
 Fits all makes of picture tubes. Completely automatic. Easy to install, no tools needed. For A.C. parallel circuits. Your Old Picture Tubes Are Still Useful. List price—\$5.95.  
 Lots of 10 **\$1.09** each  
**1.39** each



**SELENIUM RECTIFIERS**  
 Mfd. by FEDERAL

MA	PRICE
65	59¢
75	69¢
100	79¢
150	84¢
200	1.25
250-1010A	1.75
250-1028A	1.75
300	1.39
350-1238A	1.59
350-1023A	1.59
400	1.59
500	1.99

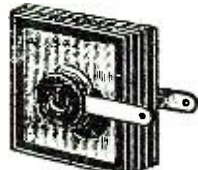

**WEN SOLDERING GUN**  
 3 seconds on 120 Volt AC readies it for any soldering requirement. 250 Watt size. Also List Price \$12.95  
**\$9.71** Each  
 Lots of 3 . . . . . \$8.64 Each  
**TIPS** Feraloy Long Life. 35c ea. Standard Tip. . . . . 11c ea.



**UNIVERSAL FLYBACK**  
 High efficiency FERRITE core horizontal transformer . . . supplies 14,000 Volts. For all 63 to 70 kinescopes. Famous Type. In constant demand. List price \$11.50.  
**1.95** each  
 Lots of 3 **1.85** each



**VOLUME CONTROL KIT**  
 Kit of 10 includes wire-wound, dual and carbon  
 The price of one (1) for the quantity of ten (10). Short and long shaft.  
 Lots of 3 kits **\$1.59** ea.  
**\$1.79** PER KIT



**Famous Make CLOCK RADIO**  
 With Telechron luminous clock, automatic shut-off and wake-up features. Starts coffee perking; switches on appliances, 5 tubes including rectifier. Built-in antenna, 60 cycles AC. UL-approved.  
 Ebony \$22.95  
 Lots of 5 \$22. ea.  
 Walnut \$23.95  
 Lots of 5 \$23. ea.  
 Ivory \$24.95  
 Lots of 5 \$24. ea.



**Famous Make Personal Portable BATTERY RADIO**  
 4 Tubes (2 Dual-Purpose) Has extra long life hundred hour batteries. Long distance reception. Large dynamic speaker. Thumb wheel tuning. All stations, plastic case, with collapsible handle. Rich gold finish trim. Red, brown or grey. Complete with batteries and leather case.  
**\$19.95** each  
 complete Lots of 3 \$19. ea.



**Sensational! New! INDOOR ANTENNA**  
 Famous 3-Way  
 For UHF, VHF and FM radio. Delta-beam. 50% increase in pulling power by extending dipoles. For average, fringe and UHF areas. For movie-clear pictures.  
 Single Antenna **\$3.95**  
 Lots of 6 \$3.69  
**RESISTORS** (Asst. of 200) Uninsulated, 1/2 Watt, 1 Watt, 2 Watt, and some 10 Watt. List Price \$1.39 ea. \$1.01 ea.



**TERMS:** A 25% deposit must accompany all orders—balance C.O.D. All shipments F.O.B. Irvington warehouse. Orders under \$10—\$1.00 Handling Charge. Subject to prior sale.  
**PLEASE:** send full remittance . . . allow for postage and save C.O.D. charges! We refund all unused money!  
 Phone: Essex 5-2947

**RAD-TEL TUBE CO.**  
**"INTEGRITY IS OUR CHIEF ASSET"**  
 Write to Dept. RN-5 115 Coit St. Irvington 1, N. J.

# 'SCOPES ARE "GOLD MINES"

... when you know how  
to use them fully on all  
types of service jobs

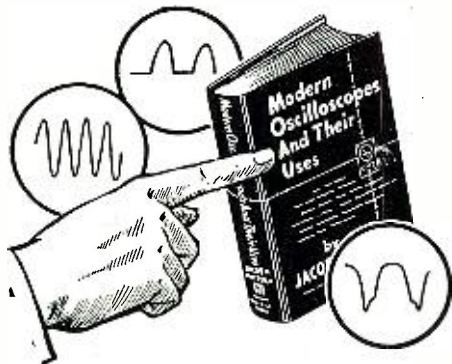

... AND THIS BOOK  
MAKES IT EASY TO LEARN  
ALL ABOUT THEM!

No question about it! The cathode ray oscilloscope is the handiest, most useful instrument in radio-TV servicing today. Servicemen who master it get the best jobs—make the most money—work lots faster—and are headed for even bigger things in the future!

## MODERN OSCILLOSCOPES AND THEIR USES

By Jacob H. Ruiter, Jr.  
of Allen B. DuMont Laboratories, Inc.  
326 pages. 370 Illustrations. \$6.00

- ✓ When, where, why and exactly how to use them
- ✓ How to interpret patterns
- ✓ How to handle tough jobs easier and faster

Now the oscilloscope won't "stump" you—not when you have the clear explanations given by this famous book! It contains no involved mathematics—no puzzling and complicated discussions. Instead, it goes right to work explaining oscilloscopes fully and showing you exactly how to use them in lab work and on AM, FM and TV service work—from locating troubles to handling tough realignment jobs. Each operation is carefully explained including determining where and how to use the 'scope; making connections, adjusting circuit components, setting the controls and analyzing patterns fast and accurately. About 370 illustrations including pattern photos make things doubly clear.

No other type of specific service method training can mean so much to you in terms of efficiency and greater earning power! Send for it today. See for yourself how this book can help you—before you buy!

**READ IT 10 DAYS... at our risk!**

Dept. RN-54 RINEHART BOOKS, Inc.,  
Technical Division,  
232 Madison Ave., New York 16, N. Y.

Send MODERN OSCILLOSCOPES AND THEIR USES for 10-DAY EXAMINATION. If I decide to keep the book, I will then remit \$6.00 plus a few cents postage in full payment. If not, I will return book postpaid and owe you nothing.

Name.....

Address.....

City, Zone, State.....

Employer's Name & Address.....

OUTSIDE U.S.A.—Price \$6.50 cash only.  
Money back if book is returned in 10 days.

# NEW EQUIPMENT FOR THE AUDIO TECHNICIAN

## NEW AM-FM TUNER

Altec Lansing Corporation, 161 Sixth Avenue, New York 13, N. Y. has added a new AM-FM tuner to its line of audio products.

The Model 303C offers increased sensitivity, operating simplicity, a.f.c.,

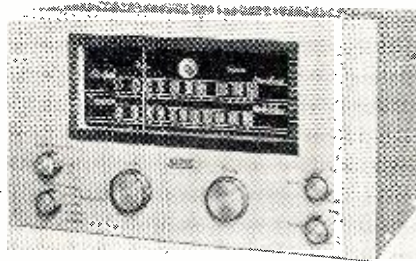

and the elimination of tuning complexities. It is housed in a satin brass cabinet with burnished panel, dials, and controls, thus eliminating the necessity for housing it in a furniture piece unless desired.

Both AM and FM circuits are included, together with complete facilities for phonograph reproduction and a simplified crossover control for playing tapes. Spare inputs are available for TV, tape recording, etc.

The company will supply additional details to those making their requests direct to the firm.

## AMPLIFIER-PREAMP

British Industries Corporation, 164 Duane St., New York 13, N. Y. is currently merchandising the new Leak TL/10 amplifier-preamplifier combination which incorporates a master control unit.

The four master controls include an input selector with six positions for tuner, tape, AES, NARTB, frrr, and Columbia LP a treble control with eight indicated stages covering a 25 db range; bass control with eight



stages covering a 25 db range; and a volume control with continuously variable gain and an "on-off" switch.

The amplifier incorporates the new-

est ultra-linear 10-watt circuit and includes two of the latest type KT-61 beam power output tetrodes in push-pull. All components are mounted on a terminal board for easy servicing.

Literature and complete information are available from Dept. LP-2 of the firm.

## THREE-SPEAKER RECORDER

Pentron Corporation, 221 E. Cullerton, Chicago 16, Ill. is now offering a new magnetic tape recorder which incorporates three speakers.

Two of the speakers are for middle and bass coverage and are contained in the recorder case. The tweeter is mobile. It is mounted on the recorder's lid and is removable to any part of the room. The tweeter features an individual volume control.

Other features of the recorder include a complete LC crossover network at 1000 cycles, push-button speed change, a special editing key,



and magic-eye level indicator. Frequency range is 50 to 10,000 cps at 7½ ips.

The Model HT 225 is portable and weighs 33 pounds. It is housed in a two-tone Saran plastic simulated leather case. The lid can be closed and operated with 7" reels.

## NEW SPEAKER SYSTEM

Stephens Manufacturing Corporation of Culver City, California has added a new loudspeaker system to its line of "Tru-Sonic" components.

Featuring a fully expanding exponential rear horn and incorporating many new improvements, this new three-way system uses two 103 LX low-frequency drivers, a 600 cycle crossover and a 625 H high-frequency multicellular horn with the P30 high-frequency driver. In addition, the system includes an ultra-high frequency model 214 driver and its associated network.

The "Continental" is housed in a

**RADIO & TELEVISION NEWS**

cabinet measuring 48 inches high, 38 inches wide, and 21 inches deep. It is available in either blonde or mahogany finishes.

### NEW SPEAKER ENCLOSURE

Fisher Radio Corporation, 41 E. 47th Street, New York 17, N. Y. has recently announced the new Model 50 horn speaker enclosure.

The cabinet is designed for use with 12 or 15 inch speaker systems. Smooth

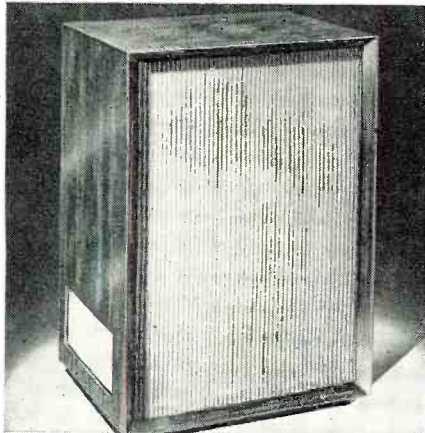

response to below 30 cycles is claimed by the maker. The cabinet will house single, dual, or triaxial speaker systems. Air loading of the bass region results in an output of four times that of an infinite baffle enclosure, thus reducing speaker distortion and increasing the speaker's power handling capacity.

The cabinet measures 37" high, 25" wide, and 20 1/2" deep. It is available in dark mahogany (Model 50-HM) or blonde (Model 50-HB). Further data may be obtained by writing the manufacturer direct.

### BINAURAL EQUIPMENT

Eder Engineering Company, 1568 South First St., Milwaukee 4, Wisconsin has announced the availability of the first four units of its new series of binaural equipment.

The four new units are playback

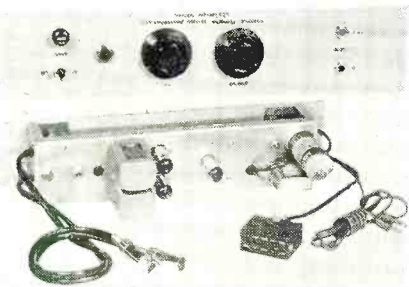

preamplifiers, two for tape and two for discs. All of the units feature balance and gain control with proper equalization being provided. The equipment is self contained and all are housed in identical cabinets.

The company will supply full technical details on these units on request.

### "AUDIO HAILER"

Audio Equipment Co., Inc., 805 Middle Neck Road, Great Neck, N. Y. is in production on a single-unit elec-

# Lafayette Greatest Tape Buy Ever!



1200 FT. REEL  
Genuine Plastic Base  
**\$1.89** RECORDING TAPE  
C.O.D. accepted per roll plus postage

LAFAYETTE made a terrific deal with one of the leading manufacturers of recording tape to supply us with their regular tape which sells for almost twice our price. WE GUARANTEE ABSOLUTE SATISFACTION OR YOUR MONEY BACK. The finest, professional-quality recording tape obtainable. Highest performance for thousands of playings. Red Oxide Base in a smooth, uniform coating; greater signal strength; with maximum fidelity; uniform frequency response from 40-15,000 cps at 7 1/2" per second; and freedom from background noise and distortion. Each reel is individually boxed. Shipping weight 10 oz.

**SALE!**  
**MASCODE BOOSTER**  
5.95 ea.  
in lots of 3,  
singly, ea. 6.25



**Great Buy**

**MASCODE MODEL ABV AUTO. ALL CHANNEL VHF 3 TUBE TV BOOSTER**  
Features a new low noise cascade circuit. Fully automatic — no tuning. Best for all TV receivers, old or new. Boosts all channels 2 to 13 — automatically! Brings up station strength an average of 13 times on all channels 2 through 13. Low noise factor (approximately 6). Automatically turned on and off by the TV set. Concealed behind TV receiver. Mount it and forget it. Employs new 6BE7-A tube for snow-free reception with new high gain-low noise TV receivers. 3-tube circuit includes two 6J6 tubes in push-pull, cross-neutralized RF amplifier circuit. All-metal cabinet, brown hammertone finish. U/L approved. Undistorted sound and picture on all 12 channels. Engineered for maximum performance. Size 9" x 5" x 3". Shine, wt. 4 lbs. **MODEL ABV VHF-TV BOOSTER.** List \$39.50

**TELEPHONE INTERCOM**  
• Self Contained Battery • Buzzer Signal  
• Ideal For TV Installers  
• Operates Up To 2 Miles



You can now have a complete 2-station telephone type intercom system at an amazingly low cost. Simply lift the receiver from its hanger and press the button to signal the other party. It operates on self-contained #1 flashlight cell for as much as a mile. You may use Mallory 4 volt Mercury cell for longer distances. Batteries are easily replaceable. The Alnico 5 magnet gives loud and clear reproduction. Molded high impact case resists breaking. Installation is extremely simple and consists of merely attaching the clips provided to the ends of the wire. Ideal not only for ordinary intercom use as a telephone set, but perfect for TV installers where the antenna lead can be used as the connecting wire. Complete set consists of 2 phones, hangers for mounting on wall, batteries and 50 feet of 2-conductor wire.  
Stock # ML-39, Complete Set.....NET 5.98

Talk about tuners!  
**THE STANDARD CASCADE TUNER TOPS 'EM ALL!**

**BRAND NEW! GUARANTEED!**  
The No. 1 Tuner in the trade. Lafayette is out front with this red-hot **STANDARD COIL CASCADE TUNER** deal. Lafayette made a buy—we paid cash—and you get the saving! Regular dealer price \$24.50. Servicemen, now is the time to stock up and save! Size: 4 3/4" x 3 1/4" x 6 1/4" supplied with 6J6 and 6BQ7. Stock No. TL-11. Shpg. wt. 4 lbs.

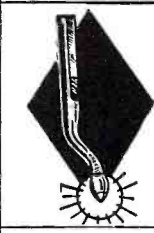

**DIAMOND NEEDLES AT RHINESTONE PRICES**  
Diamonds maintain optimum performance and give longer life to both records and stylus. This is a genuine whole diamond precision polished to .002 point. Plays all 3 speeds. Fits all single needle cartridges having thumbscrew or set-screw. For the life of your records —Buy Diamonds!  
PK-26.....Net 2.89



**NOW! PHILCO BOOSTER**  
The Philco Television Booster Model TB-3 is a high quality, push-pull, wide-band radio-frequency amplifier designed to amplify r-f signals in the television bands. This unit employs two 6J6 tubes as r-f amplifiers, uses a selenium rectifier in a self contained power supply. Channels 2 through 13.  
**MODEL TB-3** in original factory sealed cartons. Money back guaranteed! Shpg. Wt. 5 lbs. ea.

**WESTERN ELECTRIC HEARING AID**

Reg. price ~~\$185.00~~  
Our price **\$14.95**  
Brand new, in original Western Electric's jeweler's case. Supplied with receiver, receiver cord, battery cord and plug (less batteries). Money back guarantee. Act now while they last! Uses Burgess XK30E and 6R batteries at \$1.55 per set.



**ROTO AUTOMATIC HACKSAW**  
Fits any 3/4" Electric Drill. Cuts any wood, metal or plastic up to 3/4". There are no gears or bearings to wear out! Saw blade is only exposed moving part. Folds to 1 1/2" x 1 1/2" — fits any tool box. Uses standard hacksaw blades. Handle covers and protects saw blade when not in use. Shpg. wt. 1 lb.  
HD-60.....NET 3.72



**TIMER-SWITCH SALE**  
This "almost human" timer will switch your radio, television, or any other appliance on or off, fully automatically. Will turn them on at any desired pre-set time. Can be pre-set up to 12 hours. Full-vue crystal dial, 3 knob front, 3/2" diameter. With mtg. ring and bracket.  
MS-62, for 110V/60 Cy AC  
in lots of 6, ea. 3.45  
singly, ea. 3.69



**PRECISION DRAFTING SET**  
11 Pieces—Fitted Felt-Lined Case. Made in Germany, of heavy brass, nickel plated and polished. Instruments include 5/16" Compass with pencil and pen points and lengthening bar. 5/16" Divider, three 3/4" sidewheel bow dividers with needle point, pen point and pencil point. 5" Ruling pen, extra handle for pen or pencil, capsule with extra leads. Interchangeability of these many parts makes this an exceptionally versatile set. Your money back if this set is not worth twice our price!  
F-13.....Not 2.75

**\$2.75**

**Lafayette Radio**  
DEPT. RE  
Write for free catalog.  
NEW YORK, N.Y. 100 Sixth Ave.  
BRONX, N.Y. 542 E. Fordham Rd  
NEWARK, N.J. 24 Central Ave.  
PLAINFIELD, N.J. 139 West 2nd St.  
BOSTON, MASS. 110 Federal St.

# FOR THOSE WHO SEEK THE ULTIMATE IN HIGH FIDELITY CABINETS

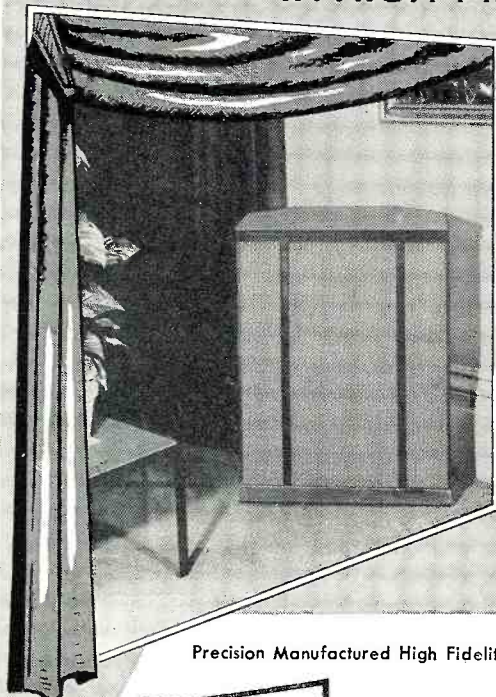

## Klipsch REBEL IV by Cabinart

A Klipsch Corner Horn Enclosure designed especially for manufacture by Cabinart.

- Two-way system performance. So flexible in design so as to provide you wide latitude in determining your listening requirements. Removable panel allows for a variety of speaker combinations. For example, in the 12" Klipsch you can install a single 12", two 12" speakers or a tweeter-woofer combination.

- Attractively styled to blend with any interior decor, the Klipsch Rebel IV by Cabinart comes in Lined Oak, Honey Walnut, French Mahogany and Black Lacquer.

### "Popularly Priced"

\*\$69.00 Net for 12" model

\*\$87.00 Net for 15" model

\*Net prices, slightly higher West and South.

Precision Manufactured High Fidelity Cabinets of Character



**G & H WOOD PRODUCTS CO.**

75 NORTH 11th STREET, BROOKLYN 11, N.Y.

Pioneers in radio furniture for high fidelity equipment

tronic megaphone which provides an acoustic level of 112 to 115 db at 5 feet.

The new "Audio Hailer" permits effective speech transmission up to 3000 feet depending on atmospheric and surrounding noise conditions. The unit is completely self-contained with batteries and a three-stage amplifier in the main housing which weighs slightly over five pounds. The form fitting handle incorporates a press-to-talk trigger switch.

### TAPE PREAMPLIFIER

A new professional tape preamplifier, the Model HFP-1, has been introduced by *Pentron Corporation* of 211 E. Cullerton, Chicago 16, Ill.

The unit offers frequency response of 50 to 12,000 cps  $\pm$  3 db with a minimum of distortion. It includes an illuminated vu meter, centered in the brushed-copper front panel. Used with the company's intermatching 9T-3M tape transport mechanism, the preamplifier offers a tape recording and playback system which is said to be comparable to professional equipment.

The controls on the HFP-1 are the recording vu meter, gain control and power switch, a "record-play" switch, and a compensation switch.

### BINAURAL CONVERSION

*Cook Laboratories*, 114 Manhattan St., Stamford, Conn. has introduced an

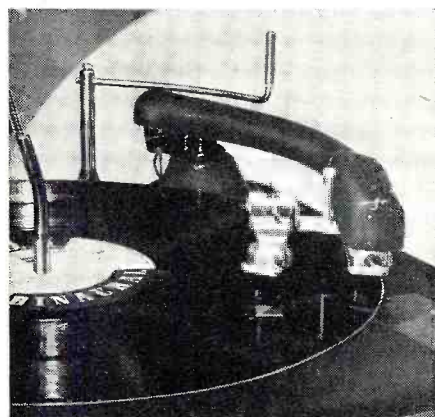

inexpensive "Clip-On" which converts any home phonograph into a binaural unit.

The "Clip-On" provides a "side-car" type arrangement with  $\frac{1}{2}$ " mounting holes for any two standard cartridges. The expense of a special binaural arm has thus been eliminated. With the new unit ordinary arms, including changers, are provided with mountings which track the twin grooves of the company's binaural records.

Regular single-track LP's may also be played. Further information on the "Clip-On" is available from the company on request.

### SOUND LEVEL METER

*Industrial Television, Inc.*, 369 Lexington Avenue, Clifton, N. J. has added the IT-140M sound level meter to its line of electronic equipment.

The new unit is portable, lightweight, and pocket-sized. It can be used to check the frequency response

## TREMENDOUS BARGAIN!

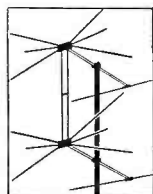

### IN CONICALS 2-BAY 16-ELEMENT CONICAL ARRAY With Hi-Band Adapters Sturdy $\frac{3}{8}$ " Elements

**\$499 EACH IN LOTS OF 3**      **SINGLE LOTS \$5.30 EACH**

Never before has National Electronics had a BARGAIN like this. We made a special purchase in order to get these sensational prices. And this array has everything. This conical 2-bay 16-element array provides ultra-fine fringe reception. Includes sixteen  $\frac{3}{8}$ " inch airplane type aluminum elements, including hi-band adapters for greater gain on the high channels and is complete with one pair of stacking bars to each array. These are packed in cartons of three 16-element arrays per carton, with the rods, at \$14.95 per carton.

When purchased in single 16-element arrays, separately boxed—your cost is: \$ 5.30 each  
3 Two-Bay Arrays per carton without Tie Rods . . . . . 13.50 carton  
4 Bay Ultra-Fringe Stacking Assembly for Above—Model 4B . . . . . \$1.95 set



### UHF Corner Reflector EACH IN LOTS OF 6 ONLY \$299

This hi-gain UHF Corner Reflector can only be offered you at this low price for a short time. 8 to 11 db gain across UHF band. Order Model F-6.

Low-loss UHF Tubular Twin lead—100' coil . . . \$4.95  
UHF-VHF antenna Matching Transformer—permits use of 1 lead from VHF & UHF antennas . . . . 2.75

Ask for new Spring & Summer catalog—Contains New Profit-Sharing Plan.

ALL PRICES F.O.B. CLEVELAND, OHIO  
Do not remit more than complete purchase price. Pay shipping charges on receipt of goods, 25% deposit on all C.O.D. orders, please. Money-back guarantee. Prices Subject to Change Without Notice.

**National Electronics**  
OF CLEVELAND  
**THE HOUSE OF TV VALUES**  
105 Delco Building Cleveland 3, Ohio

## New EICO PROBES\*



### SCOPE PROBES

SCOPE DEMODULATOR PROBE  
KIT \$3.75      WIRED \$5.75

LOW CAPACITY PROBE  
KIT \$3.75      WIRED \$5.75

DIRECT PROBE  
KIT \$2.75      WIRED \$3.95

**SPECIAL**  
ALL 3  
SCOPE  
PROBES  
Kit . . . \$9.95  
Wired \$14.95

## VTVM PROBES

VTVM RF PROBES  
KIT \$3.75      WIRED \$4.95

PEAK-TO-PEAK PROBES  
KIT \$4.95      WIRED \$6.95



SENSATIONAL HIGH VOLTAGE PROBE  
Model HVP-2  
ONLY . . . \$4.95

See these amazing probe values at your jobber today. Write now for FREE catalog RP 5. Read EICO'S other ads in this issue—turn to Advertisers Index!

**EICO**® \*PAT. APP. FOR  
ELECTRONIC INSTRUMENT CO., Inc.  
84 WITHERS STREET, BROOKLYN, NEW YORK

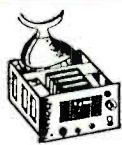

### BROADCAST BAND and AERO

Ideal for Use in Boats, etc.

MN-26-C Remote Controlled Navigational Direction finder and communications receiver. Manual DF in any one of three freq. bands. 150 to 1500 KC. 24 V. Self contained dynamotor supply. Complete installation, including receiver, control box, loop, azimuth control, Left-Right Indicator, plugs, loop transmission line and flex. shafts, oper. & main, manual.

- ALL UNITS BRAND NEW EXCEPT CONTROL BOX \$69.50
- MN-26-Y 150 to 325 KC. 325 to 695 KC. 3.4 to 7 megacycles, comp. installation. 49.50
- MN-26-C alone, like new. 24.95
- MN-26-Y as is less tubes. 4.95
- MN-20-E Loop. Brand New. 6.95
- MN-52 Crank drive, New. 2.50
- MN-26LB Receiver exc. freq. 150-1230 KC. 2.9-6mc. 59.50

Low Freq. Crystals—FT 241 A for SSB, lattice filter, 1/2" spc. 54th harm channels listed by fund. Fractions omitted. See previous Radio-TV News issues for frequencies 49c each 10 for \$3.00

**BC-433 RADIO COMPASS RECEIVER** 200 to 1700 KC, used, excellent condition less tubes. \$14.95

used, as is, less tubes and cover, excellent for parts only \$6.95

BC-434 Control box for above. Brand new...\$4.65 Used 1.79

TG-5 Portable Telegraph set—used...\$3.95 Complete with key 2 for 7.00 J-41 and headphones. 2 for 11.00

### BEAM-ROTATOR

Reversible beam rotator motor 8500 rpm, attached to gear reduction box which drops speed to 120 rpm—used \$1.95 3 for \$5.50

BEAM ANTENNA SELSYN TRANSMITTER and indicator, per set. \$12.00

BC-684 FM Transmitter, 27-38 mc, used, exc. \$14.95

BC-604 FM Transmitter, 20-27 mc, used, exc. \$11.95

### NEW TG-34A PORTABLE KEYS

115 or 230 V; 50 to 60 cycle, complete with tubes, photocell and carrying case...\$24.95 Used, exc. \$14.95

### BC-929-A

Contains power supply 110 V. 400 cycles, has 7 tubes such as 3CP1, brand new, complete with tubes. Each \$14.95

### BC-746 TUNING UNIT

Plug-in transmitter tuning unit from Army Walkie-Talkie. Contains antenna and tank coils, tuning condenser, transmitting and receiving crystals. \$1.29 Ideal transmitter foundation. ONLY

### HAND SET

Western Electric, Used, exc. cond. \$2.95 ea.

### ID6/APN4

Made to operate in conjunction with Radio Receiver R-9(1)/APN-4. Unit includes 10 tubes, one 5" scope tube, crystal controlled standard oscillator, sweep circuits, marker pulses. \$39.50 Excellent cond.

TS-184/AP Test Set. \$19.95

IE 19A-SCR522 Test Unit. 295.00

T-222-Signal Generator. Used, exc. 95.00

### II TUBE UHF TUNABLE RECEIVER

234-258 mc. less tubes. \$7.95 With conversion diagram to 220.

I-83—Dynamotor testing panel, complete with all meters. Used, exc. \$39.50 Brand new \$49.50

EE65 Test set-Telephone for testing and locating trouble on magnetic type line. Complete in carrying case. New \$14.95

RM29 For field phone use includes talk, listen and ringing crkts. Wonderful sub. for EES less handsets—new \$6.95

Hundreds of items in stock. WRITE FOR NEW BULLETIN AND PRICES. Shipments F.O.B. warehouse. 20% Deposit on orders. Minimum order \$5.00. Illinois residents, add regular sales tax remittance. Prices subject to change without notice.

### Mikes, Headsets & Microphones

- T-26 Telephone chest unit with F-1 Western Electric Transmitter \$2.39
- HS-33 Low Impedance Headset exc. \$2.95 new \$5.45
- HS-23 Headset, used \$1.89 new 4.50
- CD-307 Ext. cord for HS-23-33 Like new \$79. new 1.29
- Throat Mike—T-30...new .98
- Lip Mike—Navy Type...new .98
- CW-49505 High Impedance Headset Complete with headband...Used 98c
- T-45 Lip Mike. New \$1.75
- HS-30, miniature headset. Used \$1.49, new 2.49
- RS38 Navy type carbon mike—exc. \$3.95 4 for \$12.00



### SCOOP OF THE MONTH

#### BC-454—3 to 6 MC

Aircraft Re. has 1415 kc. I. F. channel. Easy to convert to a hot 10 meter receiver. \$995

WITH TUBES. Exc. condition... The Army Aircraft Receiver BC-454 covers 3 to 6 MC. Has 3 gang tuning condenser and two stages of 1414 KC. intermediate frequency. By removing plates from the gang and re-winding the Ant., R. F. and osc. coils you can have a red hot 10 meter receiver. We have plenty of these. Priced less the 28 volt dynamotor.

ONLY BC-453 190 to 550 KC. With tubes. Exc. cond. \$1495 AT THE OLD PRICES

	As Is	Less Tubes	With Tubes	New
BC-455 Receiver, 6 to 9 mc.			\$9.95	
BC-456 Modulator	\$2.95	4.95	\$7.95	

Control Boxes, racks, mounts, connectors for above in stock—write.

### ARC-5/R-28

Two Meter Receiver, exc. cond. Complete with tube. \$17.95

Here is the 2-meter superhet you have been looking for! Absolutely one of the BEST available today! Tunes from 100 to 156 Mcs. in four crystal channels. (Easily converted to continuous tuning.)

### NAVY ARB RECEIVER

195 Kc thru 9 Mc. Includes broadcast band. Can be converted easily to a good ham receiver. 25V. DC input. Covers 4 bands. This is a deluxe type super-het receiver. Note: The frequency coverage includes the standard broadcast band. Has 4-gang tuning condenser; can be converted to 110 V. AC receiver. Complete with tubes: 12SF7, 12SA7, 3-12SP7 and 12 A 6. Dial is built on front of chassis. Electric driven or manual band change switch. Weight 25 lbs. Size 6" x 7" x 15". Complete with tubes \$39.95 and dynamotor.

### MARKER BEACON RECEIVER—AIRCRAFT

Complete sensitive relay to control external circuits from received signals. The receiver to control models, open doors from a distance, etc. \$4.95

### OIL CONDENSERS

8 mfd. oil condensers @ 600 VDC. 98c

10 for—\$9.00 Oil Filled—1 mfd. at 3600v. \$1.95 ea. 2.22 at 4000v. 1.75 ea.

MG-149F excellent condition...\$ 89.50

MG-153 Inverter (3 phase)...Used 89.50

PE-206. inverter, like new...\$ 7.95

PE-218. inverter, excellent condition... 24.95

### CRYSTAL SETS

100 ea. type DC 34 transmitting crystals and 100 ea. DC 35 receiving crystals—complete with carrying case CH-219-1690 KC to 4440 KC. Government acquisition cost...\$1,000.00 BRAND NEW. \$49.50 Your Cost... per set of 200

### MARK II TRANSMITTER & RECEIVER

Ideal for mobile or stationary use. 15 tube set transmits and receives 2 to 8 MC. Phone, CW and MCVW 25 Watt Master Oscillator Control. Transmits and receives 240 MC. Phone. Also an intercommunicating set. Comes complete with 15 tubes, Headset, Micro., Antennas, Control Box. 12/24 Volt Power Supply and instructions—ready to operate. Set size: 27" x 10" x 13 3/4". Price \$59.50 Available—All Parts and Accessories for Mark II Sets!

**For Your Convenience!**  
New "RW" West Coast Representative!  
**ELECTRONICS TRADING POST**  
1632 Venice Blvd.  
Phone: Richmond 7-4104  
Los Angeles, Calif.

### BC1267 TRANSMITTER AND RECEIVER

154 to 186 Mcs., 1KW pulse oscillator, superhet circuit, 2 RF stages, and 5 stagger tuned IF's, includes 21 tubes; 2C26(2), 3E29/829B (1), 6AG5(7), 6C4(1), 6E5(1), 6H6 (1), 6AK5(3), 6J5(2), 6SN7(1), 6V6 (1), 9006(1); can be easily converted to 2 meter converter and outboard amplifier, ship. wt. 75 lbs., complete with conversion instructions (NOTE: 3E29/829B is worth \$10.00 alone) 3" meter... excellent condition (less tubes) \$1495

good condition...\$9.95 with 21 tubes...\$24.95

**RA-105 HIGH VOLTAGE POWER SUPPLY FOR ABOVE** 117.5 v AC—Single Phase 60 cyc.—Power Supply. Complete with 7 rect. Tubes and Filter capable of supplying all NU, bias v and Fil. v of sig. C xmt'r and rec. \$16.95 F.O.B. California

### NATIONALLY ADVERTISED TUBES

5BP1	\$239 ea.	304TL	\$3.95	
3BP1		10 for...	3.00	
5AP1		808	.95	
		4 for \$8.00	720BY	\$19.95

QUANTITY PRICES AVAILABLE 1G25, 1G26, 33, 34, 95A, CK1005, 6Z7G, 9002, 9006, 1610, 955, 9004, 12A3, 1F4, 1F5, 211, 6F5, 1629, 19, 50, 12L8.

10 for \$30.00

RT/34 APS 13 TRANSCEIVER—Used as a tail warning radar on 415 MC. Containing a 30MC 1F Strip and various other parts, these units have been stripped of RF sections and all tubes, but are an excellent buy if only for parts \$3.95 and 1F Strip. Used... R-1/ARR-1—220 MC converted with minor alterations becomes a high gain converter with 10 stages of RF amplification—(complete with diagram). New \$3.95

BC 347 Interphone Amplifier... \$2.95  
1-70 Tuning Meter... .89  
APS 13 UHF Antenna, Pair... .98  
1-97 Bias Meter... \$3.95 4.95  
One Tube Interphone Amplifier—Small compact aluminum case fully enclosed. 2 1/4" x 3 1/4" x 5 3/4". .79  
EC 709 Battery operated lightweight interphone amplifier. Complete with tube and shock mount, but less battery...New \$3.95

### DYNAMOTORS

DYNAMOTORS: The best dynamotor for conversion to 6v. Multiple windings! After conversion you get choice of 100 or 350 v. at 50 MA or 250 v. at 100 MA. Complete dope sheet furnished. \$4.65 BRAND NEW (See "CQ" Aug. Issue)...

DM-28—Dynamotor for BC-348—28V DC at 1.25 amps in 220 V at 70 MA output Good \$4.95

DM-32A—Dynamotor for Command Receiver 28V at 1.1 input 250V at 60 MA output...Used 2.95 New 7.50

DM-33—Dynamotor for Command Transmitters—Used \$2.95

D-101 Imp. 27V 1.75 Amp. output 285 VC .075 amp 3 for \$5.00

PE-94...each \$1.95

PE103—6V Dynamotor...Used \$2.95 Pioneer 5.6 V. input. 425 V., .375 amp. output, like new \$14.95

BC-1033 62-80mc recvr. Like new, less tubes, ea. \$5.95  
BC375, exc. \$49.50  
BC191, exc. \$49.50  
BD77, used, exc. \$14.95  
BC-620 with P. E. 117...\$39.50

**BUY NOW! RW ELECTRONICS**

Dept. N, 2430 S. Michigan Ave., Chicago 16, Ill.

PHONE: Calumet 5-1281-2-3

**BUY NOW!**

# Check THESE N. J. R. T. TUBE PRICES 70% to 90% OFF LIST

Type	Price	Type	Price	Type	Price
1A7GT	.45	6AK5	.75	6L6	.62
1B3GT	.67	6AL5	.37	6R7	.49
1H5GT	.38	6AQ5	.37	6S4	.38
1L4	.50	6AQ6	.36	6S8GT	.51
1N5GT	.62	6AT6	.37	6SA7GT	.41
1R5	.48	6AU4GT	.70	6S07GT	.39
1S5	.40	6AU6	.40	6SK7GT	.39
1T4	.48	6AV6	.37	6SL7GT	.49
1U4	.48	6AX4GT	.55	6SN7GT	.50
1U5	.40	6BA6	.40	6SQ7GT	.37
1X2	.65	6BA7	.57	6T8	.57
3A4	.43	6BC5	.49	6U8	.59
3LF4	.49	6B06	.45	6V6GT	.38
3Q4	.48	6BE6	.37	6W4GT	.42
3Q5GT	.48	6BG6G	1.20	6W6GT	.45
3S4	.48	6BH6	.45	6X4	.35
3V4	.50	6BJ6	.41	6X5GT	.35
5A24	.50	6BK7	.89	7E6	.35
5U4G	.55	6BL7GT	.65	7F8	.63
5Y3GT	.39	6BQ6GT	.70	12AL5	.40
5Z3	.45	6BQ7A	.92	12AT6	.35
5Y4G	.39	6BZ7	.95	12AT7	.65
6A3	.57	6C4	.39	12AU6	.38
6A6	.49	6CB6	.45	12AU7	.55
6AB4	.42	6C06G	1.15	12AV6	.50
6AF4	.92	6F6	.45	12AV7	.60
6AF6	.75	6J5	.40	12AX4GT	.55
6AG5	.47	6J6	.50	12AX7	.55
6AJ5	.73	6K6GT	.37	12BA6	.40

**Guarantee**  
ALL NJRT TUBES ARE BRAND NEW AND FULLY GUARANTEED FOR ONE YEAR

Type	Price	Type	Price
12BA7	.57	35A5	.49
12BE6	.41	35B5	.38
12BH7	.65	35C5	.38
12BY7	.65	35L6GT	.45
12BZ7	.65	35W4	.37
12SA7	.58	35Z3	.43
12SK7	.58	35Z5GT	.45
12SL7GT	.49	42	.40
12SN7GT	.50	43	.53
12SQ7	.55	45	.53
12SR7met	.55	50B5	.41
12V6GT	.50	50C5	.41
19BG6G	1.15	50L6GT	.59
19T8	.75	70L7GT	1.07
25BQ6GT	.75	76	.42
25L6GT	.40	117Z3	.39
25W4GT	.45	117L7GT	1.19
25Z6	.37	807	1.25

and dynamic range of high-fidelity sound systems and is suitable for soundmen and hi-fi enthusiasts. Other applications include checking individ-

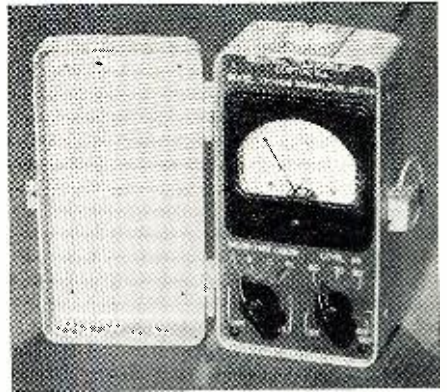

ual loudspeakers, record players, recorders, etc. Acoustical level can be checked for recording and noise level can be measured in buildings, homes, factories, subways, etc.

The IT-140M comes complete with carrying case, batteries, and microphone.

### MATCHED CABINETS

River Edge Industries, River Edge, New Jersey is now offering a new line of popularly-priced matched cabinets for custom audio installations.

Currently there are three cabinets in the set, a chair-side remote control step table, a television cabinet, and a speaker enclosure. The controls for the TV set and speaker are contained in the step table.

Each cabinet is so styled that it will fit in with any living room decor. The cabinets may be finished to suit the homeowner. Catalogue W-1-54 contains full information on the new line and is available on request.

-30-

The purest substances in the world—99.99999999 per cent pure—are being made at Bell Labs by means of a new and simple refining method developed there. These substances have only one atom of impurity in ten billion atoms of the material—about the same as a pinch of salt in 35 freight cars of sugar. The new process is being used in refining germanium for transistors. W. G. Piann, left, inventor of the "zone-melting" process, is shown operating the equipment while J. H. Scaff holds single crystal of purified germanium.



**FREE FIVE 1L4 TUBES INDIVIDUALLY CARTONED LIST \$11.25 WITH EVERY ORDER OF \$25.00 OR MORE.**

Many 7 volt types not listed. All tubes individually boxed. For orders under \$10 add \$1 handling charge. Tubes offered subject to prior sale. Prices subject to change. All orders shipped F.O.B. 2% discount if full remittance accompanies order. 25% deposit on c.o.d. shipments.

SEND FOR FREE TUBE LISTING.

**T.V. PIX TUBE BRIGHTENER \$1.39**  
For T.V. sets where voltage supply is low AC LINE BOOSTER with safety fuse and switch **\$5.95**



## NEW JERSEY TELEVISION SUPPLY CO.

Sole Distributor of NJRT Tubes

906B WESTFIELD AVE., ELIZABETH, N. J. EL. 3-6166

**NOW COYNE TRAINS YOU IN SPARE TIME AT HOME**

**TELEVISION RADIO-ELECTRONICS**

Only from famous COYNE do you get this modern up-to-the-minute TV Home Training. Easy to follow Step-by-Step instructions—fully illustrated with 2150 photos and diagrams. Not an old Radio Course with Television tacked on. Personal guidance by Coyne Staff. So practical you can quickly EARN MONEY in a TV-RADIO SALES AND SERVICE BUSINESS—part time or full time. Not only FINEST TRAINING but COSTS MUCH LESS—pay only for training—No costly extras.

**SEND COUPON for DETAILS FREE**  
SEND COUPON BELOW for Picture Folder and full details including EASY PAYMENT PLAN. NO COST OR OBLIGATION—NO SALESMAN WILL CALL.

B. W. COOKE, Pres. **COYNE** FOUNDED 1899  
**ELECTRICAL SCHOOL**  
A TECHNICAL TRADE INSTITUTE CHARTERED NOT FOR PROFIT  
500 S. Paulina Dept. 54-HT5 Chicago 12, Illinois

B. W. COOKE, President  
COYNE ELECTRICAL SCHOOL  
500 S. Paulina St., Chicago 12, Ill., Dept. 54-H15  
Send FREE Picture Folder and details of your Television-Radio-Electronics Home Training offer.

Name.....  
Address.....  
City..... State.....

**BA SAVE 67% ON THIS FAMOUS Telechron CLOCK-TIMER MECHANISM**

AN ELECTRIC CLOCK! A DEPENDABLE TIMER!

AT LEAST A \$10.00 VALUE  
**\$3.27**

Turns "off" automatically anything rated up to 660 watts at any preset time from a minimum of 15 minutes to a maximum of 11 hours and 45 minutes. Also has self-contained manual "off" switch. Experimenters, hams, laboratories, dealers, home makers—just about everybody will find lots and lots of uses for this genuine "Telechron" clock with timer mechanism. Attractive 3 1/2" diameter round face clock with easy to read red numerals inset on a bright finished chrome bezel. Front time set control. Metal base plate with mtr. holes measures 4" wide x 3 1/4" high. Mechanism requires 1 1/4" behind plate. Operates on 115 V. 60 cycles AC only Switch rating 660 watts. Complete with template and wiring diagram. Shpg. wt. 1 1/2 lbs.

No. 37A316 Special Each **\$3.27** 6 Lots Each **\$2.97**

**BURSTEIN-APPLEBEE CO.**  
1012-14 McGee St., Kansas City 6, Mo.

Send me Clock-Timers. \$..... enclosed.  
 Send Free B-A Catalog

Name.....  
Address.....  
City..... State.....  
include postage for parcel post shipments.



# 1954 PHOTOGRAPHY DIRECTORY & BUYING GUIDE

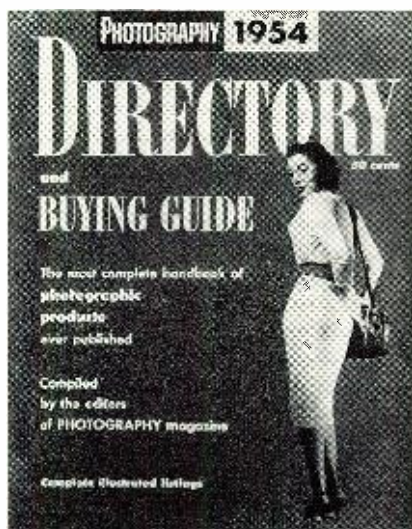

- the first *complete* photographic consumer buying guide ever published.
- easy to use . . . easy to understand . . .
- lists and describes virtually every photographic product, every piece of photographic equipment, available in the United States . . .
- provides expert advice on the selection of equipment and materials best suited to your particular needs . . .
- a money-saving, time-saving buying aid for everyone interested in photography.

**ON SALE APRIL 27th**

**AT NEWSSTANDS AND CAMERA STORES ONLY**





SH!

SH!

SH!

**QUIETROLE**  
 TRADE MARK REG. U.S. PAT. OFF.  
**ELIMINATES NOISE**  
**THE SAFE\*CLEAN WAY!**

**"The ORIGINAL  
 NON-INFLAMMABLE  
 NON-CONDUCTIVE  
 LUBRICANT CLEANER"**

Available in  
 2 oz., 4 oz., 8 oz.



QUIETROLE . . . the original and most reliable lubricant cleaner quiets noisy television and radio controls, switches\* and other moving parts. Why take less . . . avoid imitations . . . order QUIETROLE, developed after years of research.

**NO GUM! NO GOO!  
 NO GRIME!**

Carried by recognized jobbers . . . everywhere!

\*Unequaled for TV front end switches. Contains no "thinner".



manufactured by  
**QUIETROLE  
 COMPANY**  
 Spartanburg, South Carolina

**Community TV**  
 (Continued from page 37)

used, power is available at these poles, and many other factors. In Montpelier, Vermont, for example, the cost-per-mile was \$3000 for a total of about 6 miles, but in other locations cable has been put up at considerably less expense. It is important to add to the cost of the cable and its installation the cost of line amplifiers, about \$100 per channel, which are installed about every 2000 feet. Another item is the cost of power connection for each amplifier and the rental fee for each pole. Various local telephone and light companies charge between \$1.00 and \$2.00 per-month-per-pole as rental.

Once the signal is carried into the town, the remaining expenses of distribution and home installation can be covered as work progresses since each subscriber pays at the time of connection. This means that for the average connection cost of about \$20.00 per subscriber, the community TV operator receives about \$125 which can be applied to the cost of the main distribution system and finally pays back the total investment as the work progresses. Recent experience indicates that at the beginning about 20% of the homes or more will sign up at once. After a few years of operation, as many as 70% of the homes can be expected to join the local community TV service.

As concerns the FCC, the only limitation on community TV systems to date is the minimum r.f. radiation regulations applying in general to all TV receiving equipment. The equipment supplier can be expected to fulfill these requirements and in many cases the installation may have to pass FCC inspection. Other legal considerations will depend greatly on local regulations, but certain basic problems exist in most instances.

To fix the status of the new enterprise, the first step will usually be to obtain a local franchise as a public utility such as the telephone, gas, and electric companies have. This will establish such things as real estate taxes for the antenna site, easement rights for installation of poles and cable, easement rights for use of poles belonging to other utilities, and various waivers of local ordinances concerning wiring in the town limits. A local law firm, preferably one with experience in the utility field, will be able to give a more detailed picture of the various legal hurdles which must be overcome. To date we know of no instance where legal restriction has prevented an otherwise feasible community TV system from operating.

Community TV is one of the fastest growing children of the big TV family and promises both the subscriber and the operator substantial benefits. The subscriber gets dependable TV reception which otherwise would be either impossible or else only marginal. —30—

**NO BROKEN  
 LEADS**



when you use  
*The New*  
**MOSLEY**

*"Y-Ty"*



LIST PRICE \$ .80

PATENT APPLIED FOR

- Low Loss, Permanent Connections Of Transmission Line and Phasing Strips To TV Antenna Elements!
- For UHF and VHF Antennas!
- For All Types Transmission Line!
- Eliminates Roof-top Soldering Jobs!
- Quick — Easy to Install!
- Available In Two Sizes To Fit All Antennas!

**CATALOG 263-S** For all UHF Antennas and most VHF Yagis, Conicals, Inline, and other type antennas where distances between terminals is 4" or less.

**CATALOG 263-L** For TRIO Zig-Zag, and other antennas where distance between terminals is 6" or less.

Your reputation hangs on fine threads of copper. Use the MOSLEY "Y-TY" on Every Installation Job To Stop Antenna Call-backs!

The NEW MOSLEY "Y-TY" now available at Radio and Television Parts Distributors — Coast-to-Coast!

WRITE FOR FREE COPY  
 OF THIS CATALOG

**Mosley**  
 Electronics, Inc.

8622 ST. CHARLES ROCK ROAD  
 ST. LOUIS 14, MISSOURI

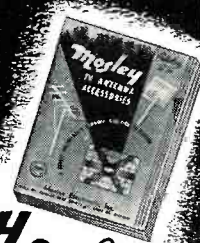

## Measuring AM (Continued from page 69)

magnitude of the r.f. energy on the probe becomes a critical function of the position of the cable, and may even be affected by the operator's position in the room. This problem can be avoided by a change in the length of the cable or in the operating frequency. A change in frequency is usually the most practical solution because the modulation characteristics of a transmitter are not a critical function of frequency.

When a rig is transmitting "California Kilowatts," the main power line usually picks up sufficient energy to cause difficulties in scope operation. The use of r.f. filtering in the scope supply leads is the recommended solution to this problem. This situation, incidentally, exists when any method of modulation indication employing a scope as an indicating device is used. The method of modulation indication described in this article is probably easier to use with high-power transmitters than methods which require direct connection to the modulation circuits of the transmitter because satisfactory operation may be obtained when the probe is connected to the shield (outer conductor) of the transmission line at a distance of a foot or more from the cabinet and the ground lead is connected to the transmitter cabinet.

The accuracy of this method of modulation is also dependent on the linearity of the direct-coupled amplifiers in the oscilloscope. Scopes which have a tendency to drift in centering or a lack of balance are not satisfactory for accurate modulation measurements. The direct-coupled amplifier system of the RCA WO-88A oscilloscope is sufficiently linear and stable to be used successfully with this system of measuring modulation. The RCA demodulator probe WG-291 is satisfactory and convenient for use as a crystal-diode detector and low-pass filter.

-30-

## Transistor Tester

(Continued from page 39)

sary to reverse the batteries. A switch could be added for this purpose, if desired; however, this was not felt to be worthwhile here.

For convenience, this circuit was built in a small metal chassis, which contained the batteries (penlight cells) as well as the various components. It is merely necessary to plug in the generator and voltmeter, and proceed with the test.

## REFERENCES

1. Shea, R. F., et al.: "Principles of Transistor Circuits," John R. Wiley & Sons, Chapter 4
2. Sulzer, P. G.: "Junction Transistor Circuit Applications," Electronics, August 1953

-30-

# COME SEE... COME SAVE AT PLATT'S NEW SUPERMARKET OF VALUES!

Here's really sensational news for all you fellows who like to shop to display ALL of our terrific, hard-to-get equipment. Unfortunately, this ad permits us to list only a few of our many, many sale items, so why not come down now and browse around.

## SPECIAL!

45 Henry 60 ma 625 ohm. LIMITED QUANTITY OF THESE CHOKES..... \$1.25



## LP-21-A LOOP

Used with BC-433 & R5-ARN-7 Army Compass Receivers. Excellent, used..... \$19.95



## MN-26C INSTALLATION

A 12 tube remote control manual direction finder desirable for commercial type navigation on boats and planes. Has a frequency range of 130 kc to 1500 kc in 3 bands. This frequency covers the beacon and standard broadcast bands. Operates on 28 VDC input. Complete installation consists of:

MN26C Receiver—Brand New.....\$39.95  
MN20E Rotable Loop..... 9.95  
MN2S Remote Control Box..... 19.95  
2 Flex Shaftings..... 5.75  
1 Antenna Cable..... 2.95  
2 Plugs..... 2.00  
1 MN-2 Azimuth Control Box..... 3.95  
SPECIAL! Complete Installation.....\$74.95  
(You Save \$10.55)

## ELECTRIC MEGAPHONE SYSTEM



## For Rural Areas, Hotels, Commercial Steamers, Ball Parks, Etc.

U. S. NAVY type PA-1 Electric Megaphone equipment is designed for voice reinforcement in much the same manner as, but to a greater degree than, the familiar acoustic megaphone. Consists of Megaphone Unit (which combines a microphone and reproducer in a single assembly), Portable Amplifier which electrically amplifies the output signal of the microphone section of the megaphone and feeds this amplified signal to the reproducer section. Charging Rack for recharging the self-contained storage battery of the portable amplifier. BRAND NEW—A TREMENDOUS VALUE! DEMONSTRATION GIVEN AT PLATT'S STORE..... \$149.50



## SCR-274N COMMAND and ARC-5 EQUIPMENT



RECEIVERS	EXCELLENT USED	NEW
BC-453—180-550 KC.....	13.95	\$49.95
BC-454—3 to 6 MC.....		24.95
BC-455—6 to 9 MC.....		19.95
1.5 to 3.....		29.95

TRANSMITTERS	EXCELLENT USED	NEW
A-958—2.1 to 3 MC.....		29.95
BC-457—4 to 5.3 MC.....	\$9.95	14.95
BC-458—5.3 to 7 MC.....		29.95
BC-459—7 to 9.1 MC.....		24.95
T-15 ARC 5—500 to 800 KC.....		29.95

ADDITIONAL EQUIPMENT	EXCELLENT USED	NEW
BC-456 Modulator.....	1.29	7.29
BC-450 Control Box (3 Receiver).....		2.98
BC-451 Control Box (Transmitter).....		1.79
BC-442 Relay Unit (ANT).....		2.49
Flexible Shafting with gear to fit receivers.....		5.69
3 Receiver Rack.....	1.79	1.95
2 Transmitter Rack.....		2.98
Single Transmitter Rack.....		3.95
DM-33 Dynamotor for Command Set.....		3.49
Mounts for Above Racks.....	1.95	3.95

**TUNING UNITS—BRAND NEW**  
TU-25 and TU-18 Tuning Units from the BC-223 Transmitter. Freq. range of TU-25: 3,500 to 5,250 KC. Freq. range of TU-18: 3,000 to 4,500 KC. ONLY \$5.50 each. BRAND NEW..... \$1.00 ea. METAL CASES to hold above Tuning Units.....

**TAKE YOUR PICK FROM THESE BARGAINS!**  
CRYSTALS for the BC-438 Command Transmitter, plug-in type, 6200 KC, BRAND NEW..... \$1.95  
Complete set of COILS for BC-438 Command Trans..... 3.95

**RADIO CONTROL BOX BC-732-A**  
used with R-47/ARN-5 also R-57 and R-89/ARN-5..... \$1.49

**MICROPHONE SUPER-SALE**  
T-44 MIKE—magnetic type consisting of Mike Unit MC-259, Cord CG-257, Plug PL-179 and Jack JK-26..... \$1.29  
T-45 MIKE—Carbon Lip Mike..... 1.95  
T-17 MIKE—Carbon—HAND NEW..... 3.75  
T5-13 HANDSET—BRAND NEW..... 7.95

**MINIMUM ORDER \$2.00**  
Immediate Delivery. Send 25% deposit on C.O.D. orders. All shipments F.O.B., N.Y.C. (N.Y.C. residents add sales tax to your remittance.)

**SAVE! SAVE! SAVE!**  
SCR-522 RECEIVERS  
less oscillator assembly, frequency shifter and tubes. Contains all Coils, Transformers, Resistors, Condensers and other valuable parts. SPECIALLY PRICED each \$7.95

**CHECK THESE GREAT SAVINGS!**  
SA-1/APN-1 ALTITUDE LIMIT SWITCH, excellent used condition.....\$3.45  
1D-14B/APN-1 ALTITUDE INDICATOR, excellent, used..... 5.45  
1-65B COMPASS LEFT TO RIGHT INDICATOR, excellent, used..... 5.45  
1-82A 360 degree Selsco oriented NAVIGATOR'S INDICATOR, part of ARN-7. BRAND NEW..... 8.95



FL-30 RADIO FILTER (identical to PL-81), excellent, used.....\$1.49  
F-21/ARA-9 RADIO FILTER, excellent condition..... 1.29  
FL-5 RADIO FILTER..... .99

**BC-221 Frequency Meter**  
Real Value! QUANTITY IS LIMITED—so first come, first served. They are just like new, with original calibration charts. Range 125-20,000 KC with crystal check points in all ranges. Complete with AC crystal and tubes..... \$139.50  
MODULATED TYPE..... \$169.50  
MODULATED TYPE with AC Power Supply..... 189.50  
These Frequency Meters at factory treated, checked for frequency alignment and GUARANTEED.



TUBES	BRAND NEW!	TUBES
1B22..... 69c	215A..... 09c	843..... 17c
2B22..... 49c	221A..... 29c	864..... 19c
2C26..... 09c	316A..... 29c	1626..... 19c
2C26A..... 09c	388A..... 59c	7193..... 19c
3B22..... \$1.19	471A..... \$1.19	9002..... 69c
3D6..... 39c	432A..... 39c	8K34..... 99c
7C4..... 39c	722A..... 99c	E1148..... 49c
15R..... 39c	801A..... 39c	VR2..... 14c
39/46..... 29c	826..... 29c	VT127..... 15c
144B..... 29c	841..... 29c	

**BEST VALUES IN PLUGS!**  
PL-114, used..... \$1.00  
PL-152, used..... 1.00  
PL-153, used..... 1.00  
PL-154, used..... 1.00  
PL-156, used..... 1.00  
PL-172..... 1.25  
PL-259..... .45  
PLP-166..... 1.25  
PLQ-103..... \$2.00  
PLQ-169..... 1.50  
PLQ-171..... 1.25  
PLQ-173..... 2.25  
M-359..... .50  
S0-104..... 2.50  
PLP-166 receptacles..... .75

## HEADSETS

HS-23 high impedance, BRAND NEW with ear pads.....\$4.65  
HS-33 low impedance, BRAND NEW with ear pads, cord and PL54 plug..... 5.65  
HS-33, used..... \$1.89  
CD-307A Corps. 6 H. NEW..... 1.49  
HS-16 high impedance—used..... .98



**Field Telephones**  
Army surplus, completely reconditioned and electrically tested, using flashlight cells and a pair of interconnecting wires, GUARANTEED LIKE NEW.  
\$21.95  
**TELEGRAPH KEYS**  
J37..... \$1.50  
J38..... 1.50  
J41..... .98  
J45..... 3.95

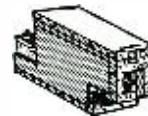

**SENSATIONAL SALE!**  
ARG-5/R-28 2 MTR RCVR  
\$19.95

Here is the 2-meter superhet you have been looking for! Absolutely one of the BEST available today! Tunes from 100 to 156 Mcs. in four crystal channels. (Easily converted to continuous tuning.) Tube lineup is as follows:  
717A—R.F. 717A—Mixer. 2-12SH7—1st and 2nd I.F. 16-9 Mc. 12SL7—Det. AVC Spuehler, 12SL7—1st audio-spuehler amplifier. 12A6—2nd audio. 12SH7—R.F. Osc.—4th Harmonic Gen. 717A—Tripl. 12th Harmonic Gen. 717A—Dblr.—12th Harmonic.



**PRE-AMPLIFIER MODEL K-1**  
The K-1 is used to amplify output level for microphones and phonographs. Operates on 24-28 VDC, can be converted to 110 AC. Comes complete with PL 55 plug and 2-600 119-B cord. 2 terminal blocks and instruction book.  
BRAND NEW.....SPECIAL! \$3.95

**PLATT ELECTRONICS CORP.**  
DEPT. A, 489 BROOME ST., NEW YORK 13, N. Y.  
PHONES: WO 4-0827 and WO 4-0828

# Amplifier SENSATION OF THE YEAR

## the H. H. SCOTT "99"

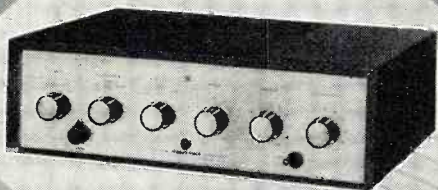

\$99.95 net

"best amplifier for the money I've ever owned"

Other owners say: (owner's comments on returned guarantee tags)

"amazed at its performance—idea of fully encasing the amplifier is brilliant—a group of twelve persons, upon hearing this amplifier, judged it the best dollar for dollar buy on the market — more than satisfied — I am sure every owner is as proud as I am of his 99-A amplifier."

FREE BOOKLET

### An Expert Says:

"the little Scott, amusingly designed to resemble a control unit alone, has few rivals in the feature of flexibility, regardless of price."

C. G. Burke, NEW TRENDS IN AUDIO  
"Saturday Review" Dec. 26, 1953

HERMON HOSMER SCOTT, INC. 385 PUTNAM AVENUE, CAMBRIDGE 39, MASSACHUSETTS

First And Only Book With

# COLOR TV CIRCUITS & SERVICING

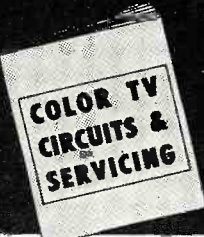

- See Actual Circuits Used In Color Sets
- Color TV Principles
- Simplified Color TV Servicing

**JUST OFF THE PRESS!**  
Everything You Want To Know About Color TV!

Down-to-earth explanations of color TV circuits with actual diagrams of various manufacturers. Basic principles told in everyday language. NTSC system explained in detail. Trouble-shooting and servicing simplified. Detailed explanation of color TV theory. Over 100 pages packed with all the answers on color TV. Profusely illustrated. \$2.95 postpaid. ORDER BY MAIL TODAY . . . NOW!

**BEECO**

Dept. P3  
Mathieson Building  
Baltimore 2, Md.

## RECEIVING TUBES

Only The Top Brands Such As RCA, GE, SYL, CBS.

**AT TREMENDOUS SAVINGS OVER REGULAR WHOLESALE**

Other Tubes Available At Same Low, Low Prices

**Brand New Pix Tubes Full One Year Guarantee**

	With Old Tube	With Old Tube	
10BP4	10.50 10.00	16RP4	18.50 16.00
12LP4	12.50 12.00	17BP4	19.50 17.00
12LP4A	13.50 12.00	17CP4	21.00 18.00
16AP4	19.00 17.00	19AP4	24.00 20.00
16AP4A	24.00 17.00	19AP4A	25.00 20.00
16DP4/A	17.50 16.00	20CP4	25.00 21.00
16GP4	20.50 17.00	21EP4	27.00 20.00

Latest Code Dates • Boxed • Fully RTMA Guaranteed

0Z4	.62 6AL5	.63 6CB6	.76 12AV7	1.13
1B3	.93 6AQ5	.76 6CD6	1.98 12BA6	.73
1X2	1.08 6AU6	.67 6J6	.92 12BE6	.78
5U4	.63 6AV6	.60 6K6	.65 12BH7	1.07
5Y3	.48 6BA6	.71 6SN7	.85 12SA7	.80
6AB4	.80 6BG6	1.98 6S4	.73 12SK7	.77
6AC7	1.25 6BK7	1.28 6V6GT	.75 12SQ7	.67
6AG5	.85 6BQ6	1.42 6W4	.70 35W4	.49
6AH6	1.40 6BZ7	1.42 12AV7	1.03 3Z5	.51
6AK5	1.30 6BZ7	1.52 12AU7	.85 50L6	.75

Special Pix Tube Brightener Each. . . \$1.59  
Lots 3 . . . \$1.29  
RCA 630 Type Chassis, Cascode Tuner, 12" Speaker . . . \$149.00  
Double V Ant. . . \$2.39 each Lots 6, . . \$1.98  
1,000 Ft. 300 Twin Lead . . . \$10.95

## STUART ELECTRONIC DISTRIBUTORS

Dept. R-4, 149-09 Union Turnpike  
Flushing 67, N. Y. OL 8-3553

TERMS: 25% check or money order. Bal. C.O.D.  
P.O.B. New York. Min. Order \$10.00.  
Satisfaction Guaranteed or Money Back.

## Mac's Service Shop

(Continued from page 74)

capacity low enough, even with the front trimmer screwed clear out. I managed to back the adjusting screw of the rear trimmer off a couple of turns, and then everything was all right. What are you looking for on that set?" he broke off as Barney scrutinized another little set he picked off the bench.

"I'm just making sure this one has no trick trimmers," Barney muttered. "I can't make it track, either. In this case, though, the oscillator tracks with the dial all right, but the r.f. section will not track with the oscillator. If I peak up the r.f. at 1400 kc., it is way off at 600 kc., and I have to back the trimmer clear out there to get any sensitivity at all. The i.f.'s are right on the nose, and I can't see a thing wrong with the loop antenna. What do you make of that?"

"Hm-m-m-m, it sounds as though you have too much capacity on the low end of the band, doesn't it?" Mac reflected. "Apparently when you tune from the high end to the low, the capacity of the loop-tuning portion of the condenser increases faster than it should. I see you've bent the outside rotor plates out as far as you could."

As he talked, Mac was carefully looking at the tuning condenser. Once more he picked up a screwdriver and carefully pried sideways on the end of the stator section of the r.f. tuning condenser. The set instantly came to life on the low end of the band. The bent-out rotor plates were returned to their normal position and the r.f. trimmer was adjusted at 1400 kc. Then the set was tuned to 600 kc. Moving the r.f. trimmer screw in either direction now made the output fall off, indicating that the r.f. circuit was tracking perfectly with the oscillator.

"The stator section of the r.f. tuning condenser had shifted," Mac explained, "so that the rotor plates no longer were centered between the stator plates. In fact, when I looked at the closed condenser, it looked as though the plates were nearly rubbing. This reduced spacing will produce a whopping increase in the condenser's maximum capacity. I simply pried the stator plate mountings over until the rotor plates looked evenly spaced between the stator plates, as they should be. Incidentally, I might mention this happens pretty often. In fact, whenever the r.f. section refuses to track with the oscillator, the first thing to do, even before you start bending plates is to see if something like this has not happened."

"Well, so far you've straightened out every one of my puzzlers with nothing more than your little old screwdriver," Barney answered; "but here's one I'll bet will make you use something else. When this set came in, it had a very bad case of home-talentitis. A screen bypass had gone out, and then the

"...and all I did was install a  
**WALSCO** antenna"

Buyers are getting wiser. The quality of *their* TV reception is *your* responsibility . . . and they'll hold you to it! For *your* protection, sell and install **WALSCO**, the finest antennas ever built for VHF and UHF.

**WALSCO IMPERIAL CONICAL (all-channel VHF)**

Featuring the new, exclusive "Barrier Disc" Insulator to prevent shorts and maintain lasting high gain performance anywhere. Designed for color as well as black and white. Not affected by dirt, moisture, salt . . . will not rust. Stainless steel hardware prevents corrosion losses *permanently*. Pre-assembled . . . guaranteed 3 years!  
Single Bay . . . only \$9.95 List. Also available in Dual and 4 Bay Stacks.

**WALSCO CORNER REFLECTOR (UHF)**

No other UHF antenna so effectively combines all three . . . (1) extra high gain; (2) all-channel reception; (3) sharp vertical and horizontal directivity. Features the hollow, unbreakable X-77 Insulator . . . silicone treated to shed dirt and moisture . . . not affected by extreme heat, cold or wind.  
Single Bay . . . \$10.95 List. Also available in 2 and 4 Bay Stacks.

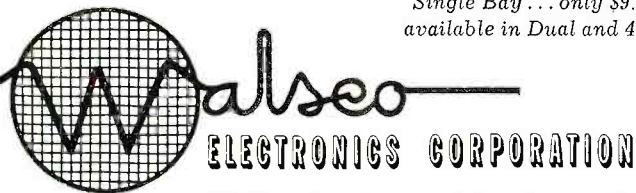

3602 Crenshaw Boulevard, Los Angeles 36, California

Branch: 315 West Walton, Chicago, Illinois

Overseas Distributor: Ad Auriema, Inc., 89 Broad St., New York 4, N.Y.

Canadian Factory Distributor: Atlas Radio Corp., Ltd., 560 King St. West, Toronto 2-B.

**ALL RADIO AND TV TYPES**

# TUBES

**CLOSE OUT!**  
SET MANUFACTURERS  
**CLOSE OUT!**

- STANDARD BRAND WARRANTY
- BRANDED
- BULK PACKED OR INDIVIDUALLY BOXED

ONE OF AMERICA'S LARGEST WHOLESALERS

044G	\$.50	6AK5	\$.75	6K7G	\$.49	12SA7GT	\$.58
0Z4	.49	6AL5	.34	6L6GA	.99	12SG7	.61
183GT	.65	6AQ5	.37	6SA7	.59	12SH7	.49
18Z4	4.95	6AQ6	.35	6SA7GT	.61	12SK7G	.48
185GT	.39	6AS5	.62	6SC7	.81	12SN7GT	.46
1F5G	.47	6AT6	.35	6SF5	.58	12SQ7GT	.49
1L4	.40	6AU6	.38	6SC7	.59	12SR7	.49
1Q5GT	.39	6AV5GT	.79	6S17	.67	1233	.39
1R5	.46	6AV6	.38	6S17	.54	198G6G	1.15
1S4	.40	6BA6	.33	6SK7	.39	1978	.81
1S5	.38	6BA7	.37	6SL7GT	.49	25AV5GT	1.05
1T4	.46	6BC5	.35	6SN7GT	.46	25BQ6GT	.75
1U4	.48	6BE6	.37	6SQ7GT	.37	2516GT	.40
1U5	.38	6BF5	.69	6SR7	.49	25Z6GT	.37
1X2A	.83	6BG6G	1.16	6TB	.57	3217	.34
2A5	.39	6BH6	.45	6U7	.49	33	.29
2E22	1.45	6BJ6	.48	6U8	.38	34	.29
2E24	.33	6BL7	.85	6V6GT	.38	35B5	.38
3A8	.33	6BN6	.72	6W4GT	.41	35C5	.38
3B24W	2.95	6BQ6	.70	6W6GT	.41	35LEGT	.42
3D6	.25	6BQ7	.76	6X4	.35	35M4	.46
3D2G	1.95	6C4	.31	6X5GT	.35	35Z5GT	.46
3Q4	.48	6CS	.41	6X5GT	.35	50B5	.41
3Q5GT	.48	6CSGT	.41	6R7	.39	50C5	.41
354	.46	6C6	.49	12A6	.39	50L6GT	.59
3V4	.46	6C8G	.42	12AT6	.31	117Z3	.39
4C35	24.95	6CD6G	1.08	12AT7	.57	801A	.19
5FP14	9.95	6E5	.76	12AUG	.34	803	2.95
5U40	.49	6FGGT	.45	12AU6	.52	814	2.95
5Y3G	.36	6HG	.49	12AV7	.60	832A	7.95
6A6	.35	6H4	.49	12AY7	.72	838	2.95
6AB7	.89	6J5GT	.34	12BA6	.52	9016GT	4.49
6AC7	.68	6J6	.50	12B86	.49	5670	1.45
6AG5	.46	6J7G	.49	12BH7	.41	5718	4.95
6AH6	.85	6K6GT	.35	12H6	.49	6101CT	4.95
				12J7	.29	9003	1.10

MINIMUM ORDER: \$10.00. Terms: 25% with order, balance C. O. D. Please include postage. All prices subject to change without notice. F. O. B. New York City. Mail Order Division:

## TRANSAMERICA ELECTRONICS CORP.

120 LIBERTY ST., NEW YORK 6, N. Y., Corlandt 7-4307

### The COMPLETE line



DR Double-Reentrant Projectors



Paging & Talk-Back Speakers



ALNICO-V-PLUS Driver Units



Dual Speakers

### for EVERY

### Public Address need!



Tweeters



FULL-GRIP, VELVET-ACTION Mike Stands

WRITE NOW for FREE Catalog 553



## ATLAS SOUND CORP.

1446 39th St., Brooklyn 18, N. Y.  
In Canada: Atlas Radio Corp., Ltd., Toronto, Ont.

### POLYSTYRENE

#### ROD—12" or 48" lengths.

Dia.	12"	48"	Dia.	12"	48"
1/8"	\$.03	\$.12	3/4"	\$.80	\$ 3.20
3/16"	.06	.24	1"	1.55	6.00
1/4"	.10	.40	1-1/8"	2.00	8.00
5/16"	.16	.64	1-1/4"	2.30	9.20
3/8"	.21	.84	1-3/8"	3.00	12.00
7/16"	.30	1.20	1-1/2"	3.30	13.20
1/2"	.40	1.60	1-3/4"	4.50	18.00
5/8"	.57	2.28	2"	5.90	23.60

#### SHEET—masking paper both sides.

Thickness	Size	Price
1/16"	12" x 12"	\$ 2.50
3/32"	12" x 12"	2.75
1/8"	12" x 12"	3.00
3/16"	12" x 12"	3.75
1/4"	12" x 12"	4.60
1/16"	12" x 24"	4.90
3/32"	12" x 24"	5.25
1/8"	12" x 24"	5.90
3/16"	12" x 24"	7.25
1/4"	12" x 24"	8.25
1/32"	20" x 20"	7.75
1/16"	24" x 24"	9.50
3/32"	24" x 24"	10.25
1/8"	24" x 24"	11.75
3/16"	24" x 24"	14.00
1/4"	24" x 24"	16.00
5/16"	20" x 20"	14.50
3/8"	20" x 20"	16.00
3/8"	24" x 24"	23.75
1/2"	20" x 20"	21.50
1/2"	24" x 24"	31.88
5/8"	20" x 20"	34.50
3/4"	20" x 20"	41.00
1"	20" x 20"	55.50

#### TUBING — 12" or 48" lengths.

O.D.	I.D.	12" lgth.	48" lgth.
1/4"	1/8"	\$.07	\$.28
5/16"	3/16"	.10	.40
3/8"	1/4"	.13	.52
1/2"	3/8"	.18	.72
5/8"	1/2"	.23	.92
3/4"	5/8"	.29	1.16
1"	7/8"	.38	1.52
1-1/2"	1-1/4"	1.13	4.52
2"	1-3/4"	1.50	6.00

All prices F.O.B. our warehouse New York!

## LEEDS RADIO CO.

75 Vesey St. Dept. A New York City 7

owner proceeded to turn every trimmer he could find before giving up and bringing it in. There are a lot of trimmers, too, for the set is an AM-FM combination. I quickly located the bypass and replaced it, and then I realigned the set. Had a heck of a time doing it, too, for the trimmers were so far out that the generator would not shove a signal through until I fussed around with the adjustments quite a bit. Finally I got it aligned, and it seemed to be working all right until I tuned in a strong station. Then it distorted pretty badly. It does the same thing on every strong station, although it sounds OK on all FM stations and on weak AM stations."

"What checks have you made?"

"Naturally I decided something was overloading. Since the setting of the volume control had no effect on the distortion, I reasoned the overloading must be taking place in an r.f. or i.f. stage. That sounded like something was wrong with the a.v.c. circuit; so I checked the a.v.c. bus, and there are no leaky condensers anywhere along it. Thinking one of the tubes might be gassy, I tried all new ones without this making any difference. Next I got out the signal tracer and went through the set. The distortion definitely begins in the last i.f. stage. This stage, since it doubles in brass as a limiter on FM, does not have any a.v.c. applied to its grid; so it would be easy to overload with a strong signal. Listen to how it acts."

Barney ran the signal generator into the antenna connections of the receiver. As he gradually increased the output of the generator, the 400 cycle tone coming from the speaker rapidly rose in volume to a certain level; then it actually decreased as the generator output kept on going up.

"What does the a.v.c. voltage measure?" Mac wanted to know.

"It comes up to about three or four volts on a strong station, which does not seem like enough to me," Barney replied. "Still, there's nothing wrong with any part of the a.v.c. circuit that I can find. Here's one peculiar thing that might be a clue: when I take the r.f. probe of the v.t.v.m. and go down through the set, the r.f. voltage keeps increasing steadily until I come to the secondary of the last AM i.f. transformer, and there it takes a big dip. I'd expect some step-down, but when I have fifteen volts across the primary of this transformer, there are only about two or three volts across the secondary. Do you suppose something's wrong with the transformer?"

Without answering, Mac picked up an alignment screwdriver.

"Oh no, not that again!" Barney groaned.

Mac hooked the signal generator across the input of the i.f. amplifier and set it to the 456 kc. frequency specified in the service data pasted on the chassis. Then he began to turn an i.f. alignment slug with his screwdriver. At first the signal heard in the speaker took a slight dip and then began to rise

# New TELEVISION COURSE

Amazing Bargain, Complete, Only \$3

Compiled by  
M. N. Beitman,  
radio engineer,  
teacher, author,  
& serviceman.

## Television Servicing Course

PRACTICAL TELEVISION TRAINING FOR HOME-STUDY

Compiled by  
M. N. BEITMAN

SUPREME PUBLICATIONS

COMPLETE \$3  
ONLY

### PRACTICAL, NEW, LARGE

Here is your complete training in television servicing. These new lessons cover every fact, adjustment and repair of every type and make of TV receivers. Giant in size, mammoth in scope, just like other correspondence courses selling for over \$150. Our amazing offer permits you to obtain the course complete for only \$3, nothing else to pay. Easy-to-follow, well illustrated lessons on circuits, picture faults, adjustments, short cuts, about UHF, alignment, antenna problems, trouble-shooting, service hints, how to use test equipment, and many practical sections prepared by leading manufacturers. Just published. Send trial coupon today and use the complete TV course at our risk. Satisfaction guaranteed. Your price for all lessons in large manual form, complete, postpaid, only \$3. Send trial-coupon now.

### COVERS EVERYTHING IN TV

Let these lessons take you into TV servicing the easy way. The very first lesson of this sensational course tells how to do simple repairs. You start earning money immediately. Second lesson tells you what is wrong, by just looking at the picture—no instruments used. Lesson 4 has 32 large, 8½ x 11" pages and 28 large illustrations on practical antenna installations and improvements. Another 12 lessons deal with trouble-shooting, stagger-tuned alignment, inter-carrier sets, UHF converters, use of TV test equipment, picture analysis, new circuits. TV facts that puzzled you will be quickly cleared up. Yes, you will find yourself doing TV repairs in minutes—instantly finding faults or making all needed adjustments. Examine this course for 10 days in your own home. Look over this collection of material, read a few lessons, apply some of the hints. Then decide to keep the lessons at the bargain cost of \$3 (full price), or return the material.

### RADIO & TV Manuals

Your complete source of all needed RADIO and TV diagrams and service data. Most amazing values. Still sold at pre-Korean prices. Only \$2 to \$3 per volume. Every Radio manual contains large schematics, all needed alignment facts, parts lists, voltage values, trimmers, dial stringing, and service hints. Each TV manual is a practical treatise on servicing a full year's sets, with giant blueprints, waveforms, hints, alignment and voltage charts, production changes. See coupon at right for a complete list of these low-priced Supreme service manuals.

### NO-RISK TRIAL ORDER COUPON

SUPREME PUBLICATIONS, 1760 Balsam Rd., Highland Park, ILL.

#### Radio Diagram Manuals

- 1953 Radio Manual, \$2.50
- 1952 Radio
- 1951 Diagrams } EACH
- 1950 Manual } \$2.50
- 1949 Radio
- 1948
- 1947
- 1946
- 1942
- 1941
- 1940
- 1939
- 1926-1938 Manual, \$2.50
- Master INDEX only 25¢

PRICED  
AT ONLY  
**\$2**  
EACH

Send TV manuals checked  below and Radio manuals at left. Satisfaction guaranteed or your money back.

- New Television Servicing Course, complete... \$3.
- Latest 1954 Television Servicing Manual, only... \$3.
- 1953 TV Manual, \$3.      1953 UHF Units, \$1.50
- 1952 Television Manual, \$3.      1951 TV, \$3.
- 1950 Television Manual, \$3.      1949 TV, \$3.
- 1948 TV, \$3.      1947 TV & FM, only \$2.

- I am enclosing \$..... Send postpaid.
- Send C.O.D. I am enclosing \$..... deposit.

Name: \_\_\_\_\_  
Address: \_\_\_\_\_

## Supreme Publications

Sold by All Leading Parts Jobbers



Everything you need in quality nut drivers!

"I said,  
**ALL XCELITE  
NUT DRIVERS  
NOW HAVE  
COLOR-CODED  
HANDLES!**"

(color flashes you the size)

3" to 6" Overall Regular in  
3/16", 7/32", 1/4", 9/32", 5/16",  
11/32", 3/8", 7/16" and 1/2".



Hollow shaft, in 1/4", 5/16",  
11/32", 3/8", 7/16", 1/2", 9/16"  
and 5/8".



Stubby 3/4" overall in 1/4", 5/16"  
and 3/8".

Color Handle	Hex Nut
black	3/16"
brown	7/32" and 7/16"
red	1/4" and 1/2"
orange	9/32" and 9/16"
yellow	5/16" and 5/8"
green	11/32"
blue	3/8"

**JOBBERS!** You have a date at Booth 592, Chicago Show, to see the top sellers in screwdrivers, nut drivers, pliers and other radio-TV tools. See you there!

Your supplier has 'em!  
Ask him, or write:

### XCELITE, INCORPORATED

(Formerly Park  
Metalware Co., Inc.)  
Dept. E  
Orchard Park,  
New York

For Originality  
LOOK TO XCELITE

## NEW SUPER POST TOWERS FOR TELEVISION ANTENNAS IN FRINGE AREAS

### TOWERS OF STRENGTH TO LAST A LIFETIME

Self-supporting tower built up of galvanized steel sections. No guy wires necessary. Easy to erect. Safe and resistant to high wind. Available in heights 47 ft., 60 ft., 73 ft., 87 ft., and 100 ft., with bases in proportion.

### FRINGE AREA TV BUYERS MUST HAVE SPECIALLY BUILT TOWERS FOR CLEAR RECEPTION

Tower and the TV set go hand in hand as a package sale to rural TV buyers. Provides an extra sale and profit to dealers. An excellent fast selling accessory for jobbers and dealers.

### TERRITORIES OPEN FOR JOBBER DEALER FRANCHISE

Write for complete structural details, packing, prices, discounts, and territorial assignment.

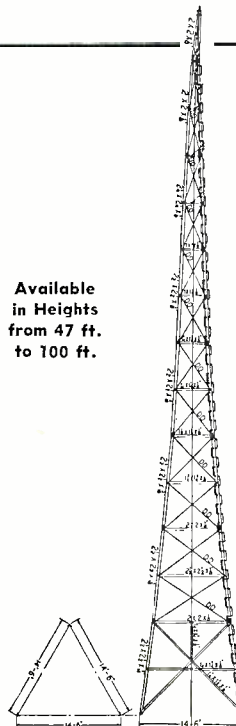

Available in Heights from 47 ft. to 100 ft.

MANUFACTURED BY

## AERMOTOR CO.

Dept. 6105, 2500 Roosevelt Road, Chicago 8, Illinois  
BUILDERS OF STEEL TOWERS SINCE 1888

In

# CANNON "UA" Audio PLUGS

gold-plated  
contacts  
really  
pan out!

UA-3-11 Plug



UA-3-14 Wall  
Mounting  
Receptacle

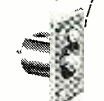

UA-3-32 Wall  
Mounting  
Receptacle



UA-3-42 Microphone  
or Panel Mounting  
Receptacle



UA-3-13 Wall  
Mounting  
Receptacle



UA-3-31 Wall  
Mounting  
Receptacle

UA-3-12 Plug



Yes! You get immense satisfaction from gold in any form... and particularly from the performance of the gold-plated contacts in Cannon's modern "UA" audio Series connectors.

Contacts are heavily gold-plated over silver plate... not just "flashed" with a light coating of gold. You get maximum protection from oxidation and deterioration... maximum protection to vital audio circuits... absolute reliability.

Cannon's thumb-pressure LATCH-LOCK prevents accidental disconnect. Available through Cannon distributors.

**WRITE FOR  
RJC BULLETIN!**

Refer to Dept. 145

**CANNON ELECTRIC  
COMPANY, 3209  
Humboldt St., Los  
Angeles 31, Calif.**  
Factories in Los Angeles; New Haven; Toronto, Canada; London, England. Representatives and distributors in all principal cities.

**CANNON ELECTRIC**

Since 1915



steadily. He reduced the generator output, peaked the trimmer, and disconnected the generator cable. Now when the set was tuned to a strong local station, not a bit of distortion was present.

"That was a peculiar one," Mac conceded, "and it all came from the set's being so far out of alignment in the beginning. As you were trying to force a signal through it, you probably happened to align from the front end back — almost always a bad practice. By the time you reached the last adjustment, the final i.f. stage was badly overloaded and operating in a non-linear fashion. Because of changes produced in the badly distorted modulated envelope delivered by this stage to the detector and a.v.c. rectifier, tuning the final slug in the proper direction produced more a.v.c. voltage and so decreased the signal fed to the overloaded stage, but it also actually caused the audio signal delivered by the detector to decrease. This led you to set the tuning slug far out of alignment, and so the set could not produce sufficient a.v.c. voltage to keep the final i.f. amplifier from overloading. Don't take it too much to heart, though; that could have happened to anyone."

"I don't mind that so much," Barney muttered darkly; "but I'm just wondering whether or not I like the idea of working for a screwdriver mechanic!"

## TVI Troubleshooting

(Continued from page 67)

than one interference is present but they are not interdependent and therefore, can be treated as individual cases of interference and classified as stated in the previous paragraphs. The possibilities of mixed modulation combinations are very numerous and more often than not, an interference problem that defies solution winds up in this classification.

The following represent such cases:

1. The video carrier of channel 5 (77.25 mc.) beating against an FM station at 100 mc. and their sum frequency falling into the response of channel 7 (174-180 mc.)
2. The video carrier of channel 6 (83.25 mc.) beating against an FM station at 103 mc. and their sum frequency falling into the response of channel 9 (186-192 mc.)
3. The video carrier of channel 7 (175.25 mc.) beating against an FM station at 97.5 mc. and the difference frequency falling into channel 5 (76-82 mc.)

Thus far we have attempted to classify the various types of interference as the first step in our procedure to minimize or eliminate these effects. Our next step is to further break down these classifications by certain tests which will enable us to establish how an interfering signal is entering the set. We will then be ready to apply necessary corrective measures.

(To be continued)

**Positive  
connections  
every time**



with  
new  
Centralab  
Precision

## Attachable Terminal HI-VO-KAPS®

When it comes to high-voltage capacitors, you just can't beat CRL Precision Attachable Terminal Hi-Vo-Kaps for dependability. Here's why:

They are 100% factory-tested at twice rated working voltage — withstand continuous overload up to 40,000 v.d.c.

Terminals and taps have heavy 8-32 thread — cannot strip or break off, when terminals are tightened.

Terminals seat flat at bottom of tap. No gaps between terminals and capacitor body — no possibility of corona.

Positive mechanical bond between stub terminals and internal electrodes prevents loosening, when terminals are attached.

Keep a stock of CRL Precision Attachable Terminal Hi-Vo-Kaps on hand. Separate packaging of terminals and capacitor body lets you buy only the terminals you need. See your Centralab distributor.

Send coupon for bulletin 28-2  
on CRL Precision Attachable  
Terminal Hi-Vo-Kaps.  
SEE US AT BOOTH 790.



**CENTRALAB,**  
A Division of Globe-Union Inc.  
910E E. Keefe Avenue, Milwaukee 1, Wisconsin  
Send bulletin 28-2 on CRL Precision  
Attachable Terminal Hi-Vo-Kaps.

Name.....

Company.....

Address.....

City..... Zone..... State.....

D-1954

**RADIO & TELEVISION NEWS**





# Make your Math EASY



You'll find those time-saving equations easy to use, easy to solve with the aid of

## Elements of Mathematics for Radio, TV & Electronics

By Bernhard Fischer & Herbert Jacobs

If you've ever hesitated to use a time-saving equation because you were not quite sure how to set it up; or had moments of doubt about decimals or percentages; or wanted a quick check on your figuring—THIS IS THE BOOK FOR YOU. It makes crystal clear each step in the reasoning and each procedure in the arithmetic, geometry, and algebra needed by radio and TV technicians. You'll find it EASY to work out frequency resolutions, voltage drops, inductive reactances, decibels and the many other radio and TV problems in which accurate use of math is essential. Hundreds of sample problems, with answers, give you thorough practice.

## Radio & TV Mathematics

by Bernhard Fischer

A handbook of step-by-step solutions for 409 problems in radio, TV, and industrial electronics. Whatever YOUR problem—whether it is to correct the power factor of a motor, find the impedance and length of a matching stub between antenna and transmission line, or any of hundreds of other problems—here is the clear, exact solution.

Have you got your copy of "The most helpful" service guide?

## Mandl's TV Servicing

The book that is eagerly bought by servicemen throughout the country as the most practical and helpful guide to quick, accurate trouble-shooting on today's receivers.

## Mandl's TV Service Course Laboratory Manual

46 experiments, with exact what-to-do and what-to-look-for directions, show how each part of a typical receiver operates and what causes trouble.

### SEE THEM ON APPROVAL

The Macmillan Co., 60 Fifth Ave., New York 11

Please send me the books checked below. I will remit full price plus small delivery charge, or return books in 10 days. (Save: Send check or money order and we pay delivery charge)

- Elem. of Math. \$7.20     TV Servicing, \$5.50  
 Radio & TV Math. \$6.75     TV Serv. Lab. Man. \$3.90

Signed .....

Address .....

This offer good only within continental limits of U.S.A.

scale with consummate ease, her strength is phenomenal. It is unfortunate that *Columbia* did not record "Salome" in its entirety with Welitch. All that we have is a 10" disc (*Columbia* ML12048) of the final scene. Listening to it in comparison with this later effort, one is impressed anew with Welitch's performance. Of course, the sound is far better in this newer version and it must be admitted that the final scene is not the whole opera. All in all, this new complete "Salome" has much to recommend itself. As I said, the sound is good, if not extraordinary. Good string tone, especially in cello and contrabass, excellent woodwinds, percussion variable from clean sharp cymbals to tympani which are occasionally muddy. The rest of the vocal forces involved do a competent job and a German-English libretto helps considerably. NARTB curve needed a few db bass boost which unfortunately at times made the tympani still "muddier." A matter of taste here.

### SCHUMANN

#### SYMPHONY #2 IN C MAJOR

The Cleveland Orchestra conducted by George Szell. *Columbia* ML-4817, NARTB curve. Price \$5.95.

The record companies are still trotting out the war horses. Sometimes a new "champion" is crowned; most of the time the new entry is an "also ran," far back with the pack. I don't know whether to put this new Schumann 2nd in Win, Place, or Show! On the quality of its sound it is a sure winner. On the merits of performance, this is something else again. Szell is a good conductor for this type of repertoire. His reading is straightforward, beautifully balanced, a model of good taste. I dare say that the disc will find favor with the majority of "Schumannites." I do feel, however, that Szell displays a little stolidity, a leanness of expression not in keeping with this particular Schumann symphony. The reading by Stokowski on *Victor* is a much more effective effort. Stokowski brings to this symphony more of Schumann's feelings when he composed the work in 1846. He conveys the inner turmoil and the real physical pain afflicting Schumann when he wrote the first movement, and later in the scherzo, effectively portrays Schumann's strange change of mood to almost light-hearted capriciousness. Throughout the rest of the symphony, Stokowski maintains a more personal liaison with Schumann's ideas, than does Szell. The sound on the Stokowski disc is good, but it is in this department that the Szell disc shines. An extremely bright recording, with clean incisive strings, very articulate woodwinds, and solid authoritative percussion. The acoustical environment is ideal; just enough reverberation for this type of music. I may get some arguments on this score, for strange as it may seem, I know a great many people who feel that a "dry and dead" type of sound is more suitable to Schumann's music! Why they should feel this way I don't know. I don't know

**NEW LOW PRICES!**  
**MANUFACTURERS ATTENTION!**  
 We have large quantity of OIL-FILLED CAPACITORS! All voltages and capacities. Special prices for quantity orders. WHAT DO YOU NEED?

**24-HOUR TIME SWITCH—90% DISCOUNT!**  
**HEAVY DUTY SANGAMO MECHANISM:** 115 or 24 VDC, 60 cycles. Up to 3 "ON" and "OFF" cycles. Skip "OFF" any one or two days you wish. 30A DPST Switch. Controls lawn sprinklers, 80A neon signs, hen-house lights, etc. With instructions. Guaranteed. **\$4.95**  
 (Dealers: Write for quantity discounts.)  
**HALF-INCH PIPE SIZE SOLENOID VALVE,** 18 to 24 VDC, 1/2 A. Controls lawn sprinkler with above mechanism. **\$2.95**  
**TRANSFORMER,** 115 V., 60 cycles to 24 V., 1A, for above solenoid & many other uses. **\$1.39**  
**HELIUM RECTIFIER,** 30 V. full wave, for above transformer & solenoid. **\$1.50**

**MODEL 27-Z TESTER**  
 (Made in Japan)  
**\$10.95**  
 (Plus 25c shipping)  
 RANGES: AC and DC volts 0-5/25/250  
 0-10 DC MA 0-1/10/100/250. Ohms 0-10K, 100K. Black bakelite panel, motor for correct acoustical load. Gives all case. Manufacturer claims extreme accuracy and our spot checks show them to be within 1%!

**FILTER-CAPACITOR STEALS!**  
 1) Dual 6 MFD, 600 VDC, oil-filled, hermetically sealed, gives you 2 ladder sections, or parallel for 12 MFD. Only \$1.29, two for \$2.49.  
 2) 1 mfd, 600 VDC, oil, hermetically sealed. Ea. 13c. 10 for \$1.49  
 3) 8 mfd. @ 600 VDC, oil filled. Ea. 98c. 10 for \$9.80

**\$45.00 HI-FI HEADSET AT \$7.95**  
 Uses annular grooved plastic fibre cones with voice coils as in speakers, and padded charcoal ear muffs to obtain spacing for correct acoustical load. Gives fine musical reproduction, 600 ohms. Checked out with freshly laundered ear pads and long flexible fabric cord with phone tips. (Shpg. wt. 3 lbs.) **\$7.95**

**MARINE RADIO**  
 6 V. RADIO TELEPHONE, Jefferson-Travis. (Emerson Radio Corp.) 5 W. This is their Brand new NOT SUPPLUS. The latest thing for emergency standby by or small boat. Covers 2-3 mcs. x-tal controlled, ship-to-ship and ship-to-shore. Has 6 V. input or will run 8-10 hours on its own self-charging 6 V. battery pack. Needs no special installation. A kid can operate. Has built-in speaker. Unit comes in small metal case with carrying handle. Size: 10 1/2" x 8 1/2" x 3 1/2" inches. Wt. 30 lbs. Complete with mike, instructions, and 90-day factory warranty. Ready to go, less xtals and battery. **\$69.50**  
**CRYSTALS—2 pr. needed, specify frequency. Ea. \$18.00. Set of 4. \$16.00**  
 100 W. RADIOPHONE, SMALL RECEIVERS, DIRECTION FINDERS, ANTENNAS, ETC. WRITE FOR INFORMATION AND PRICES

**12 V. RECEIVER DYNAMOTOR**  
 Same as the 24V dynamotors on the back of your 274-N or ARC-3 command receiver except that these are made for 9 to 14 volts. Same base plate and plug connections. Output 250V, 60 ma. **\$4.95**  
 DY-1/ARR-2X, like new, checked out. .... **\$7.95**

**GENERATOR-ALTERNATOR SPECIAL**  
 120V AC PLUS 28.5 V DC  
 Two units in one package, each complete in itself: the removable centrifugal slip clutch and the generator-alternator. Clutch maintains armature speed of 2400 rpm for drive speeds varying between 100 and 4200 rpm. Outputs 120V, 800 cy, 1 ph., 1080 VA plus 28.5 v, 25 A DC. Drive it from engine or electric motor. With diagram and instructions. **\$9.95**  
 Excellent condition. VOLTAGE REGULATOR (Carbon pile) for above. **\$2.95**  
 New

**200 AMP 24 V. GENERATOR**  
 For marine-aircraft-farm-amateur-summer home-battery charging-welding-etc. Heavy Duty 24-30 VDC R400-800 RPM. G.P. type 2CM-81B2 (Air Forces P1). Excellent condition. A \$47.50 **\$9.95**  
 value for only

**SIX-INCH MAGNETIC COMPASS**  
 Bendix #1801-1-A, beautifully damped, easily read to 1 degree. Rotatable azimuth dial. Luminous, 3" deep fore-aft line-up sighting meters. Rotation type jewel bearing. Contains corrector. 5" high, 3 mts. holes 6 5/8" apart. Fits your binnacle. **\$12.95**  
 Used, wood

**12 V. DYNAMOTOR**  
 (D. W. Thomas Engineering, Inc.) Ready to use. Continuous duty ratings. Gray finish. 10 1/2" lg. 2 1/2" dia. 1400V, 350 ma. #1224-2 600V, 200 ma. Either. **\$9.95**  
 (Less base.) ... **\$6.00**  
 Add \$6.00 for base box containing starting relays & filters as shown. Shipping wt. 11 lbs.; with base, 15 lbs.

**B'CAST, LIGHTHOUSE, AERO**  
 MN-26C Remote controlled navigational direction finder and communications receiver. Manual DF from 150 to 1500 kcs. 25 v self-contained dynamotor supply. Complete installation, including receiver, control box, loop, azimuth control, left-right indicator, plus loop transmission line, flex shafts, and schematics. Easily converted to 12 v. Receiver & Loop Brand New, with tubes. **\$69.50**  
 (Accessories may be slightly used.) ... (Shipping wt. 7.5 lbs.)

**G. L. ELECTRONICS, INC.**  
 905 E. Vermont Ave., Los Angeles 6, Calif.  
 Minimum Order \$5.00 Total, 25% Deposit Required  
 All Prices F.O.B. Los Angeles, Calif. Buyers Add Sales Tax  
 GET ON OUR MAILING LIST!  
 "OPEN MONDAY BITES THE NINE"

either, if many of you are aware that nowadays the reverb in a recording is largely a controlled factor. In other words recording engineers are no longer completely at the mercy of existing acoustics in a given concert hall. If there is too long a decay period in a certain hall, the engineers have methods of suppressing it; and conversely, the reverb can be enhanced if it is felt necessary. Nine times out of ten, a recording is given a "test run" to determine whether the hall where the recording was made has suitable natural acoustics; this "test take" can be "doctored" with more or less reverb and the proper balance decided upon. Of course, this method has limitations. All the "doctoring" in the world won't make a good concert hall out of one that is really bad! It's just another new and occasionally very useful tool in the art of recording.

I see I have digressed. To sum up this disc of the Schumann 2nd, I would say that its virtue of superior sound will weigh heavily with many a music lover, offsetting the small discrepancies of the Szell performance. The disc reproduced well from the NARTB curve, bass and treble controls set flat. Surfaces were quiet in my copy.

**SAEVERUD, HARALD**  
**RONDO AMOROSO, GALDRESLATTAN, SINFONIA DOLOROSA**  
**VALEN, FARTEIN**  
**THE CEMETERY BY THE SEA, MICHELANGELO SONNET, THE SILENT ISLAND**

Oslo Philharmonic Orchestra conducted by Oivin Fjeldstad. Mercury MG 10149, AES curve, Price \$4.85.

Here is an unexpected tid-bit from *Mercury*, sure cure for the "war horse blues." Usually any music of Norwegian origin immediately brings to mind gay, dance-like tunes full of the peasant idiom that dominates much of the music of Grieg. This is a somewhat different dish of tea. Harald Saeverud is one of Norway's most celebrated composers, and the works herein recorded are but a tiny sampling of a prodigious musical talent. The score he composed for Ibsen's "Peer Gynt" in 1948 took Norway by storm. It is to be hoped that someone will take the trouble to record this masterpiece and soon! Saeverud's writing is "modern," but not in the usually accepted sense of atonality or dissonance. If there is an awareness of a peasant or folk-tune motif in his works, it is not truly derivative, but rather inspirational in nature. Of the three works on this disc by Saeverud, the "Sinfonia Dolorosa" is easily the most outstanding. Written during the Nazi occupation of Norway, it is an intensely dramatic work, and is a rather stark portrayal of the composer's feeling for his stricken country. The "Rondo Amoro" is a pleasant little work, well played, and the "Galdreslatten" is very clever, energetic, and always interesting.

Fartein Valen, in contradistinction to Saeverud, is an out-and-out atonalist and disciple of Schoenberg. For

# Now! get the NEW **EICO**<sup>®</sup> FLYBACK TRANSFORMER & YOKE TESTER

Model 944

**KIT \$23.95**

WIRED \$34.95

**QUICK,  
 POSITIVE  
 TESTING OF  
 FLYBACK  
 AND  
 YOKES**

in or out  
 of set



Now one of  
 the most  
 difficult TV  
 service jobs  
 becomes  
 quick and  
 easy as  
**A-B-C!**



- Positive check of all types flyback & yokes, in or out of set—in just seconds!
- Operates on the extremely sensitive grid-dip principle—shows up even 1 shorted turn!
- Exclusive separate calibration for air core and iron core flybacks for accurate testing of all types
- Checks any inductance whose impedance is not too low.
- Large easy-to-read 4½" meter.
- 3 separate colored scales.
- Tests continuity of yokes, coils, speakers, switches, etc.
- New compact size for extra-easy portability (7"x5"x4").
- Smart professional styling—New satin finish etched panel with contrasting knobs and meter and grey wrinkle steel case.
- Kit comes complete with easy-to-follow INSTRUCTIONS.

**BE SURE!  
 SAVE TIME!**

BEFORE you install or remove a flyback or yoke—CHECK it with EICO's Model 944!

Compare this new EICO instrument at your parts jobber today.



Write for FREE Catalog RF-5.  
 Read EICO's other ads in this issue  
 —see Advertiser's Index.

Prices 5% higher on West Coast.

**ELECTRONIC INSTRUMENT CO., Inc.,**  
 84 Withers Street, Brooklyn 11, N. Y.

**SAVE \$\$\$**  
**THOUSANDS OF BARGAINS**  
 Send Stamp for our  
**GIANT CATALOG**  
**UNITED RADIO CO.**  
 58A MARKET ST. NEWARK, N. J.

**BARGAIN HUNTING?**  
**RADIO SERVICEMEN!**  
 Write for SENSATIONAL CATALOG  
**HENSHAW RADIO SUPPLY**  
 3619 TROOST KANSAS CITY, MO.

**GET INTO  
 ELECTRONICS**



You can enter this uncrowded, interesting field. Defense expansion, new developments demand trained specialists. Study all phases radio & electronics theory and practice: TV; FM; broadcasting; servicing; aviation, marine, police radio. 18-month course. Graduates in demand by major companies. H.S. or equivalent required. Begin Jan., March, June, Sept. Campus life. Write for catalog.

**VALPARAISO TECHNICAL INSTITUTE**  
 Dept. RD Valparaiso, Indiana

# Bargain in Broadcast Quality TAPE RECORDER MECHANISM

# 38.75



Model 90 "Ultra-Audio" tape transport mechanism complete with high quality record-erase-playback dual track head, 110 volt, 60 cycle induction motor, rewind, accessories and hi-quality plastic base recording tape.

## USE WITH ANY HI-GAIN AMPLIFIER

The "Ultra-Audio" tape transport mechanism comes complete with convenient terminals and full instructions which permit its application to your present amplifier, phono-radio, or other audio unit, for the making, reproduction and erase of tapes, just as any standard tape recorder. This machine is ideal for the hi-fi enthusiast, the experimenter, the radio ham, or commercial user. It is identical to that provided for our commercial outlets. Little experience is required to follow simple instructions and comprehensive circuit diagrams to connect to almost any radio or audio unit for full life-like performance.

## Records—Reproduces—Erases, At Two Speeds

Simple change over parts furnished permit operation at either 7 1/2 or 3 3/4 inches per second speeds. A number of circuit diagrams with clear instructions are provided to enable even the novice to construct special amplifiers, etc., at minimum cost to obtain results comparable to that of recorders selling for many hundreds of dollars. Machine will operate with any amplifier capable of being excited by crystal mike or magnetic phono, and with most radios. Unit comes complete, ready to connect and use. Provided with convenient mounting lugs. The fine professional appearance of this unit will make any user proud to display his "Ultra-Audio" Model 90. **MONEY BACK GUARANTEE.**

The Model 90 tape transport mechanism was initially developed by the engineers of the Ultra-Audio Broadcasting System for our own use to provide an extremely rugged and simple unit with sufficient mechanical stability to meet commercial and broadcast requirements. It was felt that such design could be achieved by following a careful program of simplicity and removing many of the "frills" at a cost much lower than we were compelled to pay for so-called "professional" units and eliminate a great deal of the constant servicing, repair, and adjustment expense of such units as were available to us.

Available at no cost to the purchasers and users of Ultra-Audio Broadcasting System equipment are the full facilities and services of our engineering staff.

## FIRST COME—FIRST SERVED

(Shipped pre-paid on cash with order—otherwise charges collect. 1/2 cash with order on all C.O.D.'s.) All orders subject to possible two weeks' delay.

ORDER FROM  
EQUIPMENT-SERVICE DIVISION

**Ultra-Audio Broadcasting System**  
BOX 243, SAN DIEGO (12), CALIFORNIA

those of you who immediately shy away from the atonal, don't run too fast in this instance! These pieces are highly listenable with a minimum of "shock effect." In fact throughout all of these works is a sort of pervading mysticism, which could hardly have been expressed better through any other musical means than in the twelve-tone system. This mysticism has its roots in the long lonely winters Valen would spend on the family farm in the west of Norway. In spite of the highly suggestive titles of these three pieces, they are not too introspective, but rather are powerful statements of personal belief from a composer who is intensely human. The sound on this disc is good, but cannot bear comparison with the famous "Olympian" series of *Mercury* records. String tone is a little edgy at times, otherwise quite acceptable, and there is some surprisingly clean percussion. Excellent acoustic perspective. Since I am unfamiliar with these works, I cannot give too much of a critique on the conducting of Øivin Fjeldstad. Suffice it to say that a good orchestral balance seemed to be maintained in all of these works and the orchestra was well disciplined and played extremely well. Mr. Fjeldstad was co-conductor with Leopold Stokowski and his orchestra at Carnegie Hall during March in a program of Norwegian works. Disc conformed to the AES curve, controls set flat. Quiet surfaces.

**REUBKE, JULIUS**  
SONATA IN C MINOR FOR ORGAN  
ON THE 94TH PSALM

**LISZT**  
FANTASIA AND FUGUE ON B.A.C.H.  
E. Power Biggs on the Old Boston Music Hall Organ at Methuen Memorial Hall. Columbia ML 4820, NARTB curve. Price \$5.95.

Calling all hi-fi fans! Man, this is it! One of the most rip-snortin' demonstration records of the new year! I can't remember when I've liked an organ record so much. This one has everything to recommend it. Fabulous reproduction of the wonderful old Boston Music Hall organ, coupled with splendid performance by E. Power Biggs of some of the most florid and romantic organ music ever written. This is the pioneer effort by *Columbia* in recording this fabulous old organ. The story of this great organ on the back of the jacket is truly fascinating. The organ now reposes in the Methuen Memorial Music Hall, at Methuen, Mass. This is a case where a building was specially constructed to house an organ, rather than *vice versa*, which is the usual case. Because of this there are particularly good acoustics to do justice to this famous instrument. Reubke only lived to be 24, but he lives today in his "Sonata in C Minor on the 94th Psalm." This is organ in the grand manner. Frankly, many people consider this a very overblown and fustian piece of music. Be that as it may, this is highly exciting music, and music which calls for prodigious talent in the organist and absolute

**RADIO & TELEVISION NEWS**

# AUDELS T.V. RADIO SERVICE LIBRARY

HERE IS LATE INFORMATION IN A HANDY FORM FOR RADIO AND TELEVISION REPAIRMEN, SERVICEMEN AND STUDENTS



2 VOLS. \$6 COMPLETE 1 MO. PAY ONLY \$1

AUDELS T.V. RADIO SERVICE LIBRARY—Highly Endorsed—1001 Facts—Over 1552 Pages—625 Illustrations, Diagrams of Parts. Presents Important Subjects of Modern Radio, Television, Industrial Electronics, F.M., Public Address Systems, Auto, Marine & Aircraft Radio, Phonograph Pick-Ups, etc.

**IT PAYS TO KNOW!**  
The Basic Principles—Construction—Installation—Operation—Repairs—Trouble Shooting. Shows How to get Sharp, Clear T.V. Pictures. Install Aerials—How to Test. Explains Color Systems, Methods of Conversion, Terms, etc. Includes Ultra High Frequency (U.H.F.)—Valuable for Quick Ready Reference & Home Study. Tells How to Solve T.V. & Radio Troubles—Answers Your Questions.

Get this Information for Yourself.  
7 DAY TEST—ASK TO SEE IT!

## MAIL ORDER

AUDELS, Publishers, 49 W. 23 St., N.Y. 10, N.Y.  
Mail AUDELS T.V. RADIO SERVICE LIBRARY 2 Vols. \$6 on 7 days free trial. If O. K. I will remit \$1 in 7 days and \$1 monthly until \$6 is paid. Otherwise I will return them.

Name \_\_\_\_\_  
Address \_\_\_\_\_  
Occupation \_\_\_\_\_  
Employed by \_\_\_\_\_ RN

## New Guaranteed TUBES Standard Brands

PRICES SLASHED  
FAR BELOW WHOLESALE!

Standard brands only! One of largest stocks in U.S. We sell—buy—trade. WRITE FOR FREE CATALOG JUST OFF PRESSES.

1A3	.70	654	.70	25L6GT	.69
1A4	1.20	65A7	.80	31	.39
1A7	.85	65C7	.95	33	.39
1C5	.80	65F5	.70	34	.39
1C6	1.10	65F7	1.00	48S5	.69
1C7	1.00	65G7	.75	50L6GT	.69
1C21	1.00	65H7	.85	83	.99
1E5	1.20	65N7GT	.85	0A2	.95
1F7	1.20	65P7	.70	0B2	.99
1LA4	.90	65L7GT	.85	1D21	4.50
1LC6	.90	65N7GT	.85	2AP1	6.95
1LW6	.90	65Q7	.55	2C51	3.85
1NSGT	.65	65R7	.70	2D21	1.15
1R4	.90	65S7	.90	2E26	3.25
1R5	.75	65T7	.65	2E28	3.25
1X2A	.90	678	.95	3A1	5.00
3A4	.80	8U5	1.90	3B1	3.50
3B6	.49	6V6GT	.70	3F7	1.95
3C4	.65	6W4GT	.70	3GP1	2.95
3Q5GT	.80	GX4	.60	3HP7	2.95
354	.75	8V6G	.85	3AP1	3.25
6T4	1.40	7C4	.90	3B1	3.25
5U4G	.70	7C7	.90	58P4	3.25
5V4	1.00	7J7	1.50	5F7	1.95
5X4	.65	7N7	.90	52AY7	1.65
5Y3GT	.55	12A6	.85	11A8	.49
5Y4G	.55	12A7T	.95	304TL	6.95
6A7	1.00	12AU7	.95	701A	4.50
6C6	.85	12C8	1.10	807	1.59
6D6	.85	12H6	.62	811A	3.49
6F6	.45	12J6	.60	813	8.95
6F7	1.25	12K7	.80	820	5.50
6F8G	1.25	12K8	.59	8308	2.50
6G8G	.85	12S7GT	.92	866A	1.30
6K7	.75	12S7GT	.89	872A	2.75
6J5	.65	12SH7	.87	935	5.50
6J8G	1.20	12S7GT	.92	955	4.49
6K7	.75	12SQ7	.65	966	.49
6L6	1.50	12SR7	.49	957	.49
6L7	.95	1486	.75	958A	3.89
6N7	.95				

Thousands of other types of Transmitting and Receiving Tubes. Prices subject to change without notice. Californians add sales tax. Add postage to order. Minimum order \$5.00.

## VEEDER ROOT COUNTER

5 figure. Adds ten for each revolution of shaft in one direction; subtracts ten for each revolution in opposite direction. Size 3/4"x3/4"x1" dovetail mounting; lever arm removable. Each \$1.25



**Jsh**  
SALES CO.

**ELECTRONICS**  
Dept. R-D  
7552 Melrose Ave.  
Los Angeles 46,  
California

clarity in the recording. In fantasia form, Reubke's sonata is an inspired co-mingling of the contrapuntal greatness of the 18th century, and the newer, more dynamic elements of 19th century writing. If you want fire and fury in your organ music, this piece has it to spare. You people with the big speaker systems are going to have a field day with this one! The registration of this organ includes a 32' Principal and 32' Contra-bombarde as well as other bass ranks. The reproduction of these great pipes is wonderfully clean and sonorous. I wouldn't go so far as to say that the recording has captured the 16 cycle fundamental of the big pipes, but the upper harmonics are there and, believe me, this disc will test the low frequency efficiency of any system! The Liszt works are not too familiar to most people, but I can assure you they are most worthy of recording. In fact, music of this stature coming from Liszt who wrote many obvious and trite pieces of music is a pleasant surprise. Here again, is music very demanding of the performer and Mr. Biggs is at home with this as he is with the Reubke Sonata. The reproduction here is on a par with the Reubke and the sonorities achieved are truly wondrous. High-frequency reproduction is equal to the competition of the pedals and *Columbia* has kept the whole in splendid balance. The NARTB curve will do nicely here and I leave to your own good taste and discretion the question of bass boost. In my acoustic set-up I found about 4 db of boost made for a more realistic result. Be careful! (Now don't be like friend Joe Dolt in the story which begins this column and terrorize your neighbors by cutting loose on this disc with 50 watts!)

**GRIEG  
PEER GYNT**

Oslo Philharmonic Orchestra conducted by Odd Gruner-Hegge, Mercury MG 10148, AES curve, Price \$4.85.

More Norwegian material from *Mercury*, this time the famous "Peer Gynt." This is not the 1st and 2nd suites to which you are accustomed, but is the music as presented in the original stage version and contains much that is not in the suites. Particularly interesting and effective are the "Prelude" and "Norwegian Bridal Procession" music and the song of the "Saeter" girls. At the end of the disc is the famous "Solvejg's Song" beautifully sung by Eva Prytz as Solvejg and with Alfred Maurstad doing nobly as Peer Gynt. All the more familiar sections are heard too, and are given authentic and spirited performances. This Oslo Philharmonic is a very good orchestra and the sound on this disc does them justice. As I said of the other Norwegian disc, this is still not "Olympian" sound, but nevertheless has its merits. String tone about on a par with the other disc and percussion still better and in certain sections, outstanding. The inclusion of original material and the authenticity of performance make this an invaluable, 1954

**WE'RE IN OUR NEW BUILDING!**



Leo I. Meyerson  
WØGFQ



We are now operating from our new ultra-modern electronics building — geared for greater efficiency and faster, more complete PERSONALIZED service than ever before!

**HALLICRAFTERS S-40B \$119.95**



**\$9.54 Per Month**  
(12 months)

**\$12.00 CASH DOWN**

Communication receiver with built in speaker covering 540-Kc to 44 Mc in four bands. One RF stage, 2 IF stages.

**HALLICRAFTERS SX-88 \$595.00**



**\$47.30 Per Month**  
(12 months)  
**\$59.95 CASH DOWN**  
**\$32.42 18 MONTHS**

Dual Conversion Receiver 535-33.3-Kc in 6 bands. 2 RF stages, variable 6 position band width selectivity, 250 cycles to 10 Kc. 10 watt audio output, 17 tubes plus voltage regulator, ballast tube and rectifier.

**HALLICRAFTERS RECEIVERS AVAILABLE FOR IMMEDIATE SHIPMENT**

MODEL NUMBER	12 MONTHLY PAYMENTS	DOWN PAYMENT	CASH PRICE	MODEL NUMBER	18 MONTHLY PAYMENTS	DOWN PAYMENT	CASH PRICE
S-38C	\$3.97	\$ 5.00	\$ 49.95	S-76	\$10.90	\$20.00	\$199.95
S-53A	\$7.95	\$10.00	\$ 99.95	SX-62	\$19.07	\$35.00	\$349.95
S-72 Port	\$8.74	\$11.00	\$109.95	SX-71	\$13.62	\$25.00	\$249.95
S-77A	\$9.54	\$12.00	\$119.95	HT-20XMTR	\$24.50	\$44.95	\$449.50



**FREE  
1954  
CATALOG**

WRITE—WIRE  
PHONE 2-0277

Get your BIG NEW 1954 WRL CATALOG, offering the greatest selection of radio and television equipment, parts and supplies for the Novice, Experimenters, Hams and Professionals.

WORLD RADIO LABORATORIES R-5  
3415-27 W. Broadway  
Council Bluffs, Iowa

Please send me:

- 3' x 4' U.S. Radio Map 25c
- New Catalog
- Used Equipment List
- WRL XMTR Info
- SX-88 Info
- S-40B Info
- NEW LOG BOOK 25c

Name \_\_\_\_\_

Address \_\_\_\_\_

City \_\_\_\_\_

State \_\_\_\_\_



**RADIO and TELEVISION ELECTRONICS**



in all Technical Phases  
New Classes (Day and Evening) Start 1st of Dec., Mar., June, Sept.

Free Placement Service for Graduates  
For Free Catalog write Dept. RN-54

RCA INSTITUTES, INC.  
A Service of Radio Corporation of America  
350 WEST 4TH ST., NEW YORK 14, N. Y.



*Free!*

Get More Service Calls with

**EICO DECALS**

For Store Windows & Cars.

Write EICO

Brooklyn 11, N.Y. Dept. DR-5

**CORONA RADIO KITS**

EASY TO BUILD • EDUCATIONAL  
EXCELLENT RECEPTION

Broadcast  
Superhet  
Kit

**\$14.75**

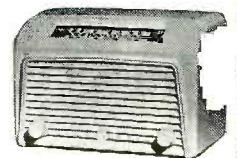

ROCKET 115K—Latest Single Band superhet circuit for ultimate in sensitive reception and tonal quality. Kit includes all necessary parts, punched chassis, attractive bakelite mahogany cabinet, built-in loop antenna, iron core IFs, big Alnico V spkr.; tubes: 12SK7, 12SA7, 12SQ7, 50L6, 35Z5. Automatic vol. control, beam power output. Tunes 540 to 1700 Kc. Simple step-by-step instructions included.

Plaza 812K 2-Band AC-DC Super Kit...net \$20.75  
Globemaster 814K 3-Band Super Kit...net \$24.75  
All kits supplied less wire and solder. Please include 25% deposit with C.O.D. orders. Dept. N-5.

CORONA RADIO & TV CO.  
136 LIBERTY ST., NEW YORK 6, N. Y.

# BUILD 15 RADIOS

**AT HOME ONLY**

With the New Improved 1954 **\$19<sup>95</sup>**

Progressive Radio "EDU-KIT"

NOW INCLUDES

**SIGNAL TRACER  
and  
CODE OSCILLATOR**

- ABSOLUTELY NO KNOWLEDGE OF RADIO NECESSARY
- NO ADDITIONAL PARTS NEEDED
- EXCELLENT BACKGROUND FOR TELEVISION
- SCHOOL INQUIRIES INVITED
- 10-DAY MONEY-BACK GUARANTEE

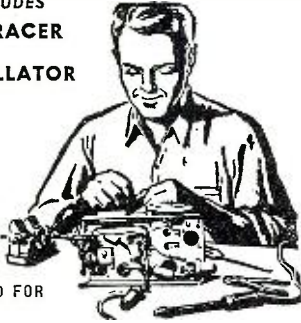

## WHAT THE PROGRESSIVE RADIO "EDU-KIT" OFFERS YOU

The "Edu-kit" offers you a Home Radio Technician Course at a rock-bottom price. You will learn how to identify Radio Symbols and Diagrams; how to build radios, using regular radio schematics; how to wire and solder in a professional manner. You will learn how to operate Receivers, Transmitters, and Audio Amplifiers. You will learn how to service and trouble-shoot radios. You will learn code. You will receive training for F.C.C. license. In brief, you will receive a basic education in Radio exactly like the kind you would expect to receive in a Radio Course costing several hundred dollars.

### THE KIT FOR EVERYONE

It is not necessary that you have even the slightest background in science or radio. The "Edu-Kit" is used by young and old; by radio schools and clubs; by Armed Forces personnel and veterans for training and rehabilitation. No instructor is required. Instructions are complete, simple and clear. You cannot make a mistake.

### PROGRESSIVE TEACHING METHOD

The "Edu-Kit" uses the principle of "Learn by Doing." Therefore you will build radios, perform jobs, and conduct experiments to illustrate the principles which you learn. You begin by learning the function and theory of each of the radio parts. Then you build a simple radio. Gradually in a progressive manner, you will find yourself constructing more advanced multi-tube radio sets, and doing work like a professional Radio Technician. The "Edu-Kit" Instruction Books are exceedingly clear in their explanations, photographs and diagrams. These sets operate on 105-125 V. AC-DC.

### The Progressive Radio "EDU-KIT" Is Complete

You will receive every part necessary to build fifteen different radio sets. Our kits contain tubes, tube sockets, chassis, variable condensers, electrolytic condensers, mica condensers, paper condensers, resistors, line cords, selenium rectifiers, tie strips, coils, hardware, tubing, etc. An Electrical and Radio Tester is included. Complete, easy-to-follow instructions are provided. In addition, the "Edu-Kit" now contains lessons for servicing with the Progressive Signal Tracer, F.C.C. instructions, quizzes. The "Edu-Kit" is a complete radio course, down to the smallest detail.

### TROUBLE-SHOOTING LESSONS

Trouble-shooting and servicing are included. You will be taught to recognize and repair troubles. You will build and learn to operate a professional Signal Tracer. You receive an Electrical and Radio Tester, and learn to use it for radio repairs. While you are learning in this practical way, you will be able to do many a repair job for your neighbors and friends and charge fees which will far exceed the cost of the "Edu-Kit." Our Consultation Service will help you with any technical problems which you may have.

### FREE EXTRAS

- Electrical & Radio Tester • Electric Soldering Iron • Book on Television • Radio Trouble-Shooting Guide • Consultation Service • Quizzes • F. C. C. Training

### ATTRACTIVELY GIFT PACKED

**PROGRESSIVE "EDU-KITS" INC.**

497 UNION AVE. DEPT. RN-29  
BROOKLYN 11, N. Y.

MAIL TODAY—Order shipped same day received. 10-Day Money-Back Guarantee. Include ALL FREE EXTRAS.

- Send "Edu-Kit" Postpaid. I enclose full payment of \$19.95 (U.S.A. only).
- Send "Edu-Kit" Postpaid. I enclose full payment of \$20.95 (Outside U.S.A.).
- 210-250 V. Adaptor for "Edu-Kit"—\$2.50.
- Send "Edu-Kit" C.O.D. I will pay \$19.95 plus postage. (U.S. only).
- I wish additional information describing "Edu-Kit". No Obligation.
- Send me FREE Radio-TV Servicing Literature.

Name .....  
Address .....

**PROGRESSIVE "EDU-KITS" INC.**  
497 Union Ave., Dept. RN-29, Brooklyn 11, N.Y.

ble disc for students and musicologists. AES curve needed slight treble cut. Moderately quiet surfaces.

### SALZEDO, CARLOS

**EIGHT DANCES FOR HARP, TRANSCRIPTIONS FOR TWO HARPS**

Carlos Salzedo and Lucille Lawrence, harpists. Mercury MG10144, AES curve, Price \$4.85.

Lovers of the harp will go for this one. Here is a great big dose of the harp by Carlos Salzedo, one of the greatest harp virtuosos extant. The eight dances were written by Salzedo in 1943 and vary in mood from French rococo to "Bolero" and "Seguidilla." All are very expertly played by Mr. Salzedo and are interesting little vignettes. Mr. Salzedo teams up with Lucille Lawrence in some fascinating transcriptions of pieces you are familiar with in other musical guises. Heard on the disc are such favorites as "Clair de Lune," Granados' "Spanish Dance #5," and Mendelssohn's "Spinning Wheel." The reproduction of the harp is first rate throughout. Remember, the harp is full of its own intermodulation, which is faithfully captured here. So don't start worrying about the record or your equipment being out of kilter. AES curve was perfect, set flat. Surfaces were moderately quiet. A "different" kind of record you might like.

### RACHMANINOFF

**SONATA IN G MINOR FOR CELLO AND PIANO**

Joseph Schuster, cello and Leonard Pennario, piano. Capitol P8248, NARTB curve. Price \$5.70.

This beautiful sonata is available in several other editions on LP, with names of much greater stature as soloists. At the risk of incurring much wrath, I must say that this lack of "stature" does not in the least detract from this performance. I really feel that this collaboration between these two artists who are friends "off-stage" is the best on discs. The sound alone would make this version superior to the others. The cello is richly sonorous, and silken smooth, the piano clean and waver-free, the balance between them is ideal and is maintained throughout the performance. I don't pretend to say that this is a perfect, flawless performance, but a missed note here and there, a slip of technique are not enough to destroy the wonderful rapport that exists between these two musicians. The music is very lyrical with that distinctive thread of melancholy running through it that is so characteristic of Rachmaninoff. Not for you lovers of the bang and the bang, but just as telling and effective in its own way. Highly recommended. NARTB curve was adequate with controls set flat. Typical dead quiet *Capitol* surfaces.

### SIBELIUS

**FOUR LEGENDS FOR ORCHESTRA**  
Danish State Radio Symphony Orchestra conducted by Thomas Jensen. London LL843, frr curve. Price \$5.95.

Here is the other side of the record-

## LEADING TELEVISION DEALER TELLS YOU THE VALUE OF KRYLON

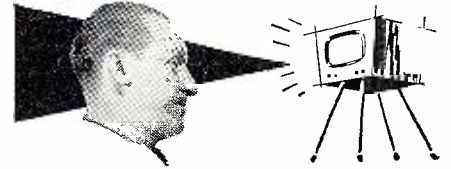

● "I use Krylon on the high voltage sections of TV receivers, and on the antennas as well. It does a good job, cuts down contract calls, and I know it gets the word around about my servicing reliability."—Edwin G. Schaffer, President, Edwin G. Schaffer Company, 7920 Frankford Avenue, Phila., one of the Quaker City's most progressive television organizations.

KRYLON 100% Acrylic Spray is a crystal clear, high dielectric strength coating in a push-button dispenser. For all high voltage sections and component parts of television receivers. Because of its weather-proofing qualities, it is ideal for coating antennas, lead-ins, etc.



"The most important handyman in the TV industry."

## KRYLON, INC.

2038 Washington Ave., Phila. 46, Pa.

Krylon also available in Bright Aluminum, Flat Black, Glossy Black, Touch-Up White and Bright Gold

At TV Jobbers Everywhere

It *PAYS* to  
ADVERTISE  
RADIO & TELEVISION NEWS  
has the  
LARGEST CIRCULATION  
of any magazine  
in its field

RADIO & TELEVISION NEWS

ing picture, as different from the previous remarks on duplication. There is a duplication here, yes. But there are only two versions available and the music is well off the beaten track. About the only reason for a commercial venture in this work is the fact that the 2nd legend is the famous "Swan of Tuonela". This "tone poem" has long enjoyed popularity in the concert hall. It is only fair to report however, that if you will take the time to listen to the other "Legends" you will be surprised and enchanted with this interesting music. The first legend has some very lyrical and warm passages, surprising from Sibelius, and the other two legends have some very sinister and exciting writing. The sound and the performance here are both to be preferred to the recent Columbia effort. While the Columbia sound was good, this has gone a step further and is outstanding. Some wonderful percussion, with players of unusual alertness and precision, and some very lush string tone. Brass is bright and close-to. Mr. Jensen seems to have a better grasp of the score than his colleague on Columbia, perhaps due to the Scandinavian influence and more familiarity with the music. I needed a db or two of bass boost to make this sound right with the *frr* curve. Quiet surfaces.

### HAM CLUB DOINGS

**T**HE Fresno Amateur Radio Club, Inc. will hold its 12th annual hamfest on May 1st and 2nd. Daytime activities will be centered at the Fresno Motel on Highway 99 and will include hidden transmitter hunts, an open forum, mobile judging, a ladies' program, and technical speeches. The banquet, entertainment, and a drawing for prizes will be held at the Fresno Memorial Auditorium. The event begins at 9 a.m. with the banquet scheduled for 7:30 p.m.

Tickets are \$4.50 each and reservations may be made with Grant Storey, W6NTK, 908 West Pico, Fresno, California.

\* \* \*

**R**OCHESTER, N. Y. will again be headquarters for the Western New York Hamfest on Saturday, May 15th at the Doud American Legion Post on Buffalo Road. The program includes a mobile contest, DX forum, hi-fi recording demonstration, etc. The main speaker will be Oliver Read, W1ETI, Editor and Asst. Publisher of RADIO & TELEVISION NEWS. Make reservations with R.A.R.A., P.O. Box 1388, Rochester, N. Y.

\* \* \*

**T**HE "Ham Butchers" 40-meter radio net picnic will be held at the Eldon city park in Eldon, Missouri on May 30th and 31st.

All hams, XYL's, and YL's are invited. Special entertainment will be provided. Those requiring cabin reservations may contact Paul M. Cooper, WØTGG, Eldon, Missouri.

\* \* \*

**T**HE Eighth Annual Missouri Emergency Net picnic will be held at Kansas City's Swope Park in the Shelter House on June 6th. Basket lunch, free refreshments, prizes, and entertainment are planned.

Standby mobiles will be used to guide hams to the picnic grounds. Registration fee is \$1.00.

# SAVE!...SURPLUS BARGAINS...SAVE!

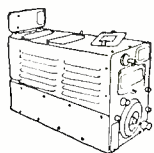

## CLOSE OUT COMMAND SETS 274N and ARC 5 EQUIPMENT

Type	Rev.	Me.	Used.	tubes	Price
BC-453	Revr.	190-550	Kc.	Used, with tubes	\$14.95
As is, No return, Less tubes					12.95
BC-454	Revr.	3-6	Mc.	Used, with tubes	8.95
Sold as is, Less tubes					4.95
BC-455	Revr.	6-9	Mc.	Used, with tubes	7.95
Sold as is, Less tubes					4.95
BC-456	Modulator			Used, with tubes	3.95
Sold as is, Less tubes					2.95
BC-696	Xmtr.	As is,	No return,	Less tubes	9.95
BC-457	Xmtr.	4-5.3	Mc.	Used, with tubes	6.95
Sold as is, Less tubes					3.95
BC-458	Xmtr.	5.3-7	Mc.	Used, with tubes	6.95
Sold as is, Less tubes					3.95
BC-459	Xmtr.	7-9.1	Mc.	Used, with tubes	9.95
Sold as is, Less tubes					5.95
BC-450	3 Revr.	Control Box		Used	1.49
BC-451	Xmtr.	Control Box		Used	1.49
3 Receiver	Rack			Used	1.49
2 Xmtr.	Rack			Used	1.49

## METERS— WESTON • SANGAMO

All New. All D.C. 2" Square.

0-5 Ma	
0-15 Ma	
0-50 Ma	\$3.29 each
0-100 Ma	
0-200 Ma	
0-300 Ma	
0-500 Ma	



0-2 Ma		\$1.95
Voltmeter, 2" Sq.	0-20 Volts	3.29
DC Voltmeter, 2" Sq.	0-300 Volts W/Ext. resistance, Complete	\$3.95; 3 for 9.95
RF Amppmeter, 2" Sq.	0 to 5 Amp.	2.29
Ammeter 2" Sq.	0 to 50 Amp.	\$3.29; 3 for 9.00
3" Rd. Meters, DC, All New,	0-15, 0-30, 0-100 Mills.	Each \$3.95; 3 for 9.00
2 1/2" Rd. 0-30 Mills. Ea.		\$2.95; 3 for 8.00
Each		3.29
Terminal couple, 2" Sq.	0 to 300 Mill. H. F.	2.95
Amp. Meter, No. 100-0-60		.97c
"S" Meter		Used 2.49

## OIL CONDENSERS

3mfd	400V	\$8.95
4mfd	1000V	1.49
2mfd	2500V	3.95
1mfd	3600V	1.95
10mfd	60V	2.49
2mfd	60V-Rd.	39c
2mfd	60V-Rect.	58c
4mfd	600V	1.19



## RELAYS

6V-2.5 Amp.	2 Contacts DT	\$2.49
12V-1.5 Amp.		
24V-1.0 Amp.		

## IDEAL FOR MOBILE

32V Time Delay Relay	\$1.98
Latching Relay 24VDC	2.49
24VAC Relay SUST	2.49
12VDC Relay DPDT	1.39
6VDC, 12 Ohms Keying Relay	New 1.39

## TRANSFORMERS & CHOKES

225 Mi, 110V in. Fil 1-5V 3 ohm, 2-5V #2A, 3-6.4V 10.4A, 4-6.4V 1.2A, 2-412V, 11.5V 710	New \$5.95
250 mi, 1.8 Ohm, 40 Ohm	49c
6000V Fil, 3.5V Sec, 10 Watts	49c
10000 3.2 Ohms, 4V, 6K, 7.15, 6X6	49c
Pron Pitch Transformer only	5.95
12V 24V 2 amp, 110V primary, Fil Xformer.	2.95
BC 375 Mod. Transformer	3.95

TUNING UNIT BC-746 W/PT243 Ntal. Socket, RIF & Ant. coil 140 mmfd, midset coil forms, sockets, resistors, etc. in wrinkle finished fiber case, Size 4" x 2 3/4" x 1 1/4". See CQ March '54 for VFO .97c

5" PM Speaker	New \$1.95
FL 8 Filters	1.49
FL 5 Filters	.95
BL 42B Antenna Reel Assy.—Less Wire	New 8.95
TG-10 Code Keyer	22.50
Code Practice tapes for TG-10 & TG-14, 15 Rolls	14.95
Hand Keys J-38	.95c
Mobile Gen. Noise Filter, 55A-30VDC	1.00

## ALL NOVICE BAND XTALS AVAILABLE—\$1.49 Each

Cash with order. Prices subject to change without notice. California orders please include 3 1/2% Sales Tax. Please include approximate postage—Excess will be refunded.

**ESEGE SALES COMPANY, INC.** 1306 BOND ST. at PICO LOS ANGELES 15, CALIFORNIA

## TUNING UNITS FOR BC 375 OR 191 TRANS.

TU-7	4500-6200 Kc	New \$2.29
TU-8	6200-7700 Kc	2.29
TU-9	7700-10000 Kc	2.29
TU-10	10000-12500 Kc	2.29
TU-26	200-500 Kc	2.29

## TUBES

6AK5		3 for \$1.19
211		.49c
3047A		\$1.95
5114		3 for .97c
31P1		.97c

## DYNAMOTORS

PE-103	6 or 12VDC input	500VDC 160Ma output	New \$34.95
PE-73	28V @ 20Amps. output	1000V @ .350 Amps.	New \$8.95
PE-77	14V @ 40Amps output	1000V @ .350 Amps.	New \$19.95
PE-94	or Ser-522	24V.	New \$9.95
PE-94	Dyn. only.		Used \$5.95
DM-32A	Output 250VDC .06.		New \$2.95
ARC-1 DY-9/ARC-1			Used \$14.50
12V Input—11 Amps.	4 1/2" High, 7 1/4" Long.		440V Output—200 Amps (TCS)

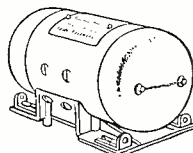

## LOOP ANTENNAS

LP-21A		New \$39.50
Rotatable Loop Unit—Type XM-20-E		
8" Diameter—used with MX-26 Compass		
and RA to DR. By Bendix		New \$4.95
MN-26C Compass Receiver		New 19.95
MN-26Y Compass Receiver		New 49.50
Radio Compass 433 G W/tubes		Used 17.95
BC-357 Marker Beacon Rec. W.O. Tube		New 5.95
BC-1206 Beacon Recv		New 12.95



## C.A.P. OR 2 METERS

Arc-4 W/tubes, Good, used	\$29.95
522 Trans.-Receiver. W/tubes, Good, used	59.50



**BC-223 TRANSMITTER.** 20 watt. Ideal for ship-to-shore or ham rig. Crystal or MFC control on four pre-selected channels. 2000 to 2550 KC. Used of 5 plug-in coils, five tubes: 2-50L and 2-56, with one tuning unit. Used \$19.95 New 39.95

**GP-7 NAVY XMITTER.** 100 watt master os. can use on any freq. from 350-9050 Kc. by using proper plug-in. With 1 tuning unit. \$13.95

**RAX Receiver—Separate superhet has 8 tubes, 1 antenna and 2 R.F. Sections. Frequency range of set No. 1 200-1500 Kcs. Set No. 2 7000-27000 Kcs. Used, As Is, No Return \$7.95**

HS-18 Headset, High Imp.	New \$2.45
HS-23 Headset, High Imp.	Used 1.95
HS-33 Headset, Low Imp.	New 4.95
Lip Mike Navy Type M1419	New .49
CD-507 Ext. cord for HS-23-23	New .97
Throat Mike T-30	Used .6 for 1.00
RS-83 Aircraft Microphone, W/4H. Cord, plug, push to talk switch.	New 2.95
Desk Hand Phone & Stand	Used \$2.95
Matching Transformer for HS-30	.49



Antenna Mast AN 75 or 104	\$1.49
Antenna A 62 Phantom	4.95
Interphone Amplifier Type CMX 50128	
12VDC W/O Tubes	6.49
Headset Adapter MC385 High to Low Impedance	New .49
Antenna Switch SPDT	New 1.00
BC 1066 Recv. in canvas carrying case	New 9.95
BC 434 Control Box (Lots of good parts & an "S" Meter	New 3.49

Surprise Kit of Pots—25 Asst. \$2.95

I-82A Indicator	New \$9.95
BC-929-A Indicator	Good Used 9.95
PE-120 Vibrator Power Supply for BC 620-630, 6, 12, 24V	New 19.95
Vibrator Transformer 6, 12, 24 VDC W/200—1.75V RMS HYPOT Pri, 1500V RMX 60CPS	SEC 2500V RMX 60CPS
Vibrator 4 Phon 6 Volts	(Nat. Mfg.) New 97c
BC-306 Antenna Tuning Unit	New \$3.95
Speaker Grill cloth 10 1/2 x 10 1/2—8 3/4	As is \$6.95
RT-7APN I Tranceiver, Tubes & Dyn.	As is \$6.95
BC-430 Xmitter W/1.5 R.F. Ampmeter	5.95

**NEW** Training Course

**"BASIC RADIO MANUAL"**



Developed with the cooperation of the Electronics Industry and the help and advice of hundreds of Radio Shop Instructors and educators.

The **BASIC RADIO MANUAL** is a comprehensive 248-page training guide, outlining step-by-step a 36-Lesson Course on Basic Radio, accompanied by a practical Shop Project section demonstrating theories in action (learning by actual doing). The table of contents which follows is the best index to the value of this planned guide for maximum effectiveness in Radio training...

**36-LESSON SECTION:** Basic Electricity • Technical Terms • Circuits & Symbols • Parts Identification • Ohm's Law • Kirchhoff's Voltage Law • Kirchhoff's Current Law • Watt's Law • Cells and Batteries • Magnetism • Electro-Magnetism • Relays • Meters • Meter Construction & Use • Use of Volt-Ohmmeter • Soldering Techniques • Capacitor Construction • Alternating Current • The Capacitor • Resistance-Capacitance • Electro-Magnetic Induction • Inductance, Impedance, etc. • Transformers • Pulsating DC • Vacuum Tube Construction • Vacuum Tube Characteristics • Grid Bias • Voltage & Current Measurements • Power Sources • Rectifiers • AC-DC Power Supply • Voltage Doublers • Transformer Type Power Supplies • Resonance • Oscillators • Principles of Radio Transmission and Reception.

**13-PROJECT SECTION:** Color Code • Circuit Symbols and Technical Terms • Ohm's Law Applications • Kirchhoff's Laws in Application • Soldering Practice • Capacitor Construction & Capacitive Reactance • Inductive Reactance • Vacuum Tube Construction • Tube Characteristics Curves • Crystal Receiver • Construction of AC-DC Power Supply • Construction AC Power Supply • Construction Audio Amplifier.

If you're interested in Radio self-study, or if you instruct in the subject, you'll want the **BASIC RADIO MANUAL**—the complete guide to effective Radio training.

ONLY \$5.00

**ORDER TODAY!**

**HOWARD W. SAMS & CO., INC.**

Order from your Parts Jobber today, or write to Howard W. Sams & Co., Inc., 2203 E. 46th St., Indianapolis 5, Ind.  
 My (check) (money order) for \$..... enclosed. Send ..... copy(ies) of the "BASIC RADIO MANUAL" (\$5 per copy).  
 Name.....  
 Address.....  
 City..... Zone... State.....  
 (outside U. S. A. priced slightly higher)

**RADIO-TV Service Industry News**

AS REPORTED BY THE TELEVISION TECHNICIANS LECTURE BUREAU

ONE of the interesting things your editors have observed at every one of the Bureau's lectures is the relatively small percentage of men interested in electronic circuitry who have any interest in the science of making money out of their training and skill. It requires one type of knowledge to understand how to repair electronic devices; it requires another type of knowledge to make money out of that know-how.

It is extremely unfortunate that so many good technicians attempt to develop service businesses of their own without first acquiring some understanding of the simple economic fundamentals that control the success or failure of any business—big or little. The worst piece of advice that could be handed to anyone entering business in this era is that old adage, "Build a better mousetrap and the world will beat a path to your door." That saying should have been buried with buggies as the regular means of transportation. Thousands of expert technicians lacking an understanding of simple business fundamentals have failed dismally in their attempts to establish their own businesses while less skillful technicians possessed of some business know-how have built substantial companies.

**Selling Service**

The biggest problem of a small business is to keep itself prominently known to enough people so that it will get a sufficient volume of service business regularly to pay all of its operating expenses and give the owner a better-than-average income. If a man can't make a better-than-average income by assuming all of the responsibilities of running an independent business then he owes it to himself and his family to get a job and let someone else carry the heavy responsibilities of business management.

In their studies of successful and unsuccessful service businesses your editors have reached the conclusion that the difference in the degree of success of one service business over another depends upon the extent and professional character of their service sales promotional programs. Most fail-

ures in the service business occur with shops that have no planned promotional program. Their advertising is usually confined to a listing in the advertising section of the telephone directory and an occasional ad in the business services of the want ad section of a daily or weekly newspaper. Neither of these methods of advertising sell anything—neither the service nor the business. They merely catalogue the business as being able to perform TV or radio service if the readers need it.

On the other hand, some small shops have very effective direct-mail service selling programs. They use seasonal copy in their direct mail cards and letters to solicit the type of service business the set owner may be most apt to need at the time the mailing is made. Some small businesses have these mail promotions handled regularly by a mimeographing shop that has mailing facilities while others follow a system of mailing twenty-five to thirty letters per day regularly.

Some of the most effective sales promotion is accomplished by riding on the coattails of local or national events that are of interest to a large segment of the population. For instance, some important sports or political event is widely publicized to be broadcast over a weekend when the weather is good and at a time when most people prefer to spend their weekends out-of-doors. Promotional material dealing with the pleasure of hearing these broadcasts over a portable, battery-operated radio would impel the reader to try out his set to see if it needs batteries or service.

The service business is double-tough during the summer months largely because few radio or TV service shops plan promotions far enough in advance for them to be effective when the shops need the business. Summertime "service special" promotions should be started early in June and continued on through July and early August. Fall service promotions should be started by the middle of August.

One of the selling tools used by auto repair shops to stimulate business during "off-months" is to offer specials that imply that the customer is



going to get a lot of work for the money he spends in having his car serviced. However, a careful study of the detailed list of the services performed for the special price reveals that more than half of them are done anyway on any similar service job. They are mostly those things a mechanic checks visually when he works on a car. But they make good reading for a customer interested in a bargain.

Most of the major independent service companies have developed special service selling programs that they start using early in June. These programs along with air conditioning installations which most of them have taken on to level out their volume, help them to maintain a sufficient volume of business to keep their field service organizations intact during the summer months.

### Antenna Maintenance

A very badly neglected phase of service business is the maintenance of TV antenna systems. All parts of an outdoor antenna system take a terrific beating during the winter months. However, if you wait until July to try to sell antenna maintenance you will find your campaigns falling flat. The time to start your sales promotion programs to develop business from antenna maintenance is late in April or early in May. Set owners are still staying indoors most of the time and observing their regular TV viewing schedules. A good antenna maintenance program started late in April or early in May will make readers conscious of deficiencies in the quality of the pictures on their sets. However, if you offer an antenna-system maintenance check to set owners, be sure you have a fixed plan for checking all elements of the antenna system thoroughly. An antenna maintenance check should include the following:

1. The transmission line—closely observe its quality, condition, and appearance. Ask the set owner if the high-band signals are weaker when it rains. If they are it is an indication of severe line loss through moisture absorption. Remember that transmission line deterioration is far more detrimental on u.h.f. band signal levels than it is on v.h.f.

2. Antenna connection terminals—check them carefully. Solder on new lugs if the present ones are not soldered.

3. Antenna elements—check for loose and weak elements. Look closely for rust and wear at all points where electrical contact must be maintained. Antennas have been improved so much that in many cases, replacing the old antenna with a new one will improve TV performance considerably.

4. Check the antenna for correct orientation. In particular, check the U-bolt assembly to make sure there is no play and possible shift in orientation with high winds.

5. Transmission line clearance—carefully observe whether the transmission line stands clear of the roof



# Irish BRAND OFFERS YOU A SOUND RECORDING TAPE TO FIT THE PERFORMANCE REQUIREMENTS OF YOUR TAPE RECORDER . . . . .

Not all tape recorders are alike. A professional instrument intended for high quality music reproduction will perform differently than a portable unit intended for home or office use. Whereas one will record and reproduce from 30 to beyond 15,000 cycles per second, the less costly unit may be limited to a range from 100 to 7000 cps. or less.

Obviously, there is no advantage in using a wide response tape with a limited-response recorder! And there is a definite disadvantage . . .

## WHY PAY MORE FOR WIDER RESPONSE WITHOUT GETTING ANYTHING IN RETURN?

Until the development of IRISH Brown Band, users of sub-professional tape recorders had no choice! But IRISH Brown Band was designed specifically for such recorders. THERE HAS BEEN NO SACRIFICE IN QUALITY . . . IRISH Brown Band has been specially developed to reproduce with true fidelity the frequency range between 100 and 8000 cycles.

The considerable savings in production costs now enables you to buy high quality, plastic tape at a price, which up to now, could only buy ordinary paper tape!

1200 feet, plastic tape, on plastic reel **\$2.50 NET**

For professional recording on equipment with wide frequency response, your best tape buy is IRISH GREEN BAND NO. 211, the professional super-sensitive, wide-range recording tape that is used in broadcast stations and recording studios throughout the industry.

1200 feet on plastic reel . . . . . **\$3.30 NET**

2400 feet on metal reel . . . . . **\$7.71 NET**

One day you will surely use IRISH . . . write direct to factory for a free sample test reel today.



At all leading radio parts distributors

**ORRADIO INDUSTRIES, INC.**

OPELIKA 5, ALABAMA

EXPORT DIVISION: Morhan Exporting Corp., New York, N. Y.

**Quick-Wedge SCREW HOLDING SCREWDRIVER**

**Holds the Screw!**

**Drives it, too!**

Unconditionally Guaranteed

**ASK FOR IT AT YOUR DEALER**

KEDMAN COMPANY - 233 SO. 5th WEST - SALT LAKE CITY 1, UTAH

### RADIO ENGINEERING DEGREE IN 27 MONTHS

Radio engineering is a big field. There's room for you in it—if you're cool. Get first-class training at Indiana Tech. Intensive, specialized course, including strong basis in mathematics and electrical engineering, advanced radio theory and design, television, electronics. Modern laboratories. Low rate. Also B.S. DEGREE IN 27 MONTHS in Aeronautical, Chemical, Civil, Electrical and Mechanical Engineering. U.S. Government approved. Enter June, September, December, March. You can earn part of your expenses right here in Fort Wayne while you are studying.

### INDIANA TECHNICAL COLLEGE

934 E. Washington Blvd., Fort Wayne 2, Indiana

Please send me free information on B.S. Engineering Degree in 27 months as checked.

Radio-Television  Aeronautical  
 Civil  Mechanical  Electrical

Name \_\_\_\_\_  
Address \_\_\_\_\_

# POWER ELECTRONICS

JACK L. LEVINSON  
534 Market St. San Diego, Calif.  
BEImont 2-7234

## APS-13 TRANSCEIVER

Incomplete but Excellent Condition **\$2.95**

## BC-367—INTERPHONE AMPLIFIER

Has 12 volt Dynamotor and spare tubes Brand New **\$9.95**

## 3CP1—CATHODE RAY TUBE

Brand New in Original Cartons **\$1.95**

## RU RECEIVER

With any Coil, Brand New **\$3.95**

## TCS-XMTR DYNAMOTOR

12 Volt Input, 440 Volt Output, 200 MA. Brand New **\$19.95**

## BD-77 DYNAMOTOR

12 Volts Input, 1000 Volts Output, 350 MA Brand New with Spares **\$34.95**

## HI-FI HEADSET

Navy Type with large ear pads. Exc. Cond. **\$3.95**

## APN-1 METER

Has Basic Movement. Excellent **\$1.95**

## RS-38 HAND MICROPHONE

Aircraft or Mobile Mike. Excellent Condition **\$2.95**

## AIR FORCE BOOM MICROPHONE

Fits on Head Set. Excellent Condition **\$1.95**

## SCR-625 MINE DETECTOR

Complete in Carrying Case. New **\$55.00**

## 24 V. LATCHING RELAY

Excellent Condition **\$1.25**

## 24 V. SIGNAL LIGHTS

Seal Beam Type. New With Carrying Case & Filters **\$5.95**

## BC-348 RECEIVER—24 VOLTS \$95.00

BC-224 Receiver 12 Volts Excellent Condition **\$95.00**

## SELSYN DIFFERENTIAL

110 Volts A. C., 60 Cycle Bendix. Excellent **\$5.95**

## SPERRY SERVO UNIT—TYPE A-3

New in Boxes **\$5.95**

## APX-2 IFF

Has Motor and Blower. Also Thousands of Parts. Excellent Condition **\$19.95**

# POWER ELECTRONICS

JACK L. LEVINSON  
534 Market St. San Diego, Calif.  
BEImont 2-7234

and metallic objects. A u.h.f. line that touches a metallic surface at the right spot can kill a u.h.f. signal. The same thing can happen with a poor quality lightning arrester. Be sure to replace broken and weak insulators.

6. Guy wire system—inspect the guy wire system and mounting brackets for signs of wear and weakness.

7. Placement of antenna—the positioning of the antenna is many times more important on u.h.f. than it is on v.h.f. Check other spots on the roof for relocating the antenna if u.h.f. performance is poor. Above all, *know* what is normal and abnormal performance in your area so you can give your customer more than mere restoration of former results. By installing the latest improved products and top quality accessories you can many times give your customer improved performance over the initial installation.

It is unfortunate for television that so many set owners are content to watch inferior pictures with indoor antennas when in many cases a good outdoor antenna system would give them better reception. This situation is largely the fault of the independent servicing industry because antenna systems are an accessory item from which the service industry gets a high percentage of the income produced from their sale.

The primary function of set manufacturers, set distributors, and set retailers is to sell new sets. If a purchaser is satisfied with the picture from an indoor antenna to purchase a set, all industry elements concerned with the set's production and distribution have completed their primary objective in that particular case. Of course, many indoor antennas are serving to bring excellent pictures to sets, especially in areas close to the transmitter. But where reception will be improved with an outside antenna this should be pointed out to the set owner.

The one industry element that has been derelict in its responsibilities to its employers (advertisers) and its customers (set owners) has been the broadcasters. Every TV and radio broadcast station should be working closely with its local servicing forces in creating a consciousness among set owners about the high quality of sound and pictures they would get if their sets were properly installed and maintained. Set manufacturers, distributors, and dealers can profit only once out of the sale of a radio or TV set. They make that profit (or try to) at the time the set is sold. The broadcaster, however, has an opportunity to make a continuous profit from every set sold as long as it is in use.

As the TV industry competes with other entertainment industries for the public's attention, maintaining public interest in TV programs may revolve around the quality of the picture the average set owner sees on his own TV set. As a matter of selfish self-interest every TV broadcaster should work hand-in-glove with the established and

# STAN-BURN RADIO and ELECTRONICS CO.

## \*CATHODE RAY TUBE SPECIALS\*

One Year Guarantee		STAN-BURN	
G. E.			
*7JP4	\$17.10	10BP4	\$10.50
*10BP4A	19.25	12LP4	12.50
*10FP4A	24.00	12LP4A	14.50
*12KP4A	27.10	12QP4	12.50
*12LP4A	21.70	12JP4	12.50
*12QP4/B1014		12UP4A	15.00
Dumont	21.00	14CP4	17.00
*12UP4B	28.75	15DP4	18.50
*14CP4	24.50	16KP4	18.50
*15DP4/B1014		16DP4 or A	18.50
Dumont	23.75	16JP4 or A	18.50
*16AP4A	30.95	16CP4 or A	18.50
*16DP4A (N.U.)	25.25	16FP4	18.50
*16GP4 or B	31.25	16WP4	18.50
*16KP4/16RP4	24.20	16AP4	19.00
*16KP4A		16AP4A	23.00
(Aluminum)	28.75	16EP4	19.00
*16JP4A (N.U.)	25.25	16EP4A	23.50
*16LP4A	28.50	16BP4 or A	21.00
*16WP4A	26.50	17BP4	19.50
*16GP4B	31.25	17CP4A	21.60
*17BP4A	24.00	17GP4B	22.60
*17CP4	23.90	19FP4	23.00
*17CP4B	29.00	19FP4A	24.00
(Aluminum)	29.00	19AP4	22.90
*19AP4A	41.50	19AP4A	24.90
*20CP4	34.50	20CP4	26.00
*20LP4	37.50	21EP4	26.50
*21AP4	42.00	21AP4	26.50
*17EP4A	36.30	24AP4	49.00
*24AP4A	78.50		

\*QUANTITY CRT USERS\*  
\*We will give you DUD allowances if you ship them to us Prepaid. 10 CRT's minimum shipment. WRITE FOR DETAILS.\*

## \*ANTENNA SPECIALS

*RED DOUBLE "V" Antenna	1-5	6 or more
*10 ELEMENT CONICAL	\$2.19	\$1.98
*DOWELED INSERTS	2.98	2.79
*Folded Hi Straight Low Quick Rpt.		
1/2" elements	4.25	3.25
*WINDOW CONICALS	4.95	3.75
*MASTS		
10 FOOT SWEEP	1.79	1.29
NEPCO MASTS	1.69	1.49
*TV WIRE		
42 MFT. 300 OHM	\$ 9.95	11.95 M Ft.
55 MFT. 300 OHM	11.95	11.95 M Ft.
72 OHM COAXIAL	35.00	35.00 M Ft.

## \*CHASSIS 630 TECH-MASTER \$149.50\*

Model C-30 with Cascade Tuner. . . . . \$42.00  
\*OPEN FACE CABINET . . . . . \$42.00\*

## \*TAPE RECORDERS IN STOCK

\*PENTRON — Model 9T3C — 2-speed Tape Recorder . . . . . Write for Price.

## \*RADIO CRAFTSMAN

Model C400—Hi-Fi Amplifier . . . . . Net 42.90

Model C10—AM-PM Tuner . . . . . Net 131.50

Model C500—Williamson Amplifier . . . . . Net 93.50

We also carry MASCO—BOGEN—PILOT, etc., Amplifiers, Pre-Amps, FM Tuners and WEBSTER Tape Recorders.

\*6x9 PM Speaker . . . \$ 3.98

\*7" PM Speaker . . . 3.98

\*70" Yoke . . . . . 1.98

\*630 Vert. output . . . 1.98

\*upright . . . . . 1.98

\*630 Vert. output . . . 1.29

\*potted . . . . . 1.29

\*630 Vert. Blocking . . . . . 17.95

\*OSC. XForm . . . . . 89

\*Cascade Tuner . . . . . 23.95

\*Dumont 21.25 mc. 14.95

\*Famous Inputuner. 10.00

\*TV Permanent Magnet . . . . . 1.98

\*Focus Assembly. 1.98

## \*THREE SPEED RECORD PLAYER \$39.95\*

in Portable Carrying Case. . . . . Special

## \*20CP4 Progressive . . . . . Special \$23.95\*

## \*AUTHORIZED DISTRIBUTORS for Gen-eral Electric, Kenrad, Tung-Sol, National Union, De Wald, Regal, Automatic and General Motors.\*

\*Automatic Custom-Built Radios for Plymouth, Ford, Chevrolet and many others, always in stock.

\*We carry a Complete line of HI-FIDELITY and sound equipment. Send us your requests.

\*We also carry a complete line of popular makes of Radio Tubes at 50/10 discount. Also many other special purpose transmitting types, and all electronic parts and equipment, at lowest prices. Send us a list of your requirements for prompt quotations.

\*Terms: 20% with order. Balance C.O.D. All prices F.O.B. NEW YORK Warehouse. Minimum order \$5.00.

\*Write for our latest price list and Hi-Fi catalog to Dept. RN-5.

# STAN-BURN RADIO and ELECTRONICS CO.

(C.B.S. THEATRE BLDG.)  
1697 BROADWAY • NEW YORK 19, N.Y.

## GET INTO TV SERVICING

Send for free 24-page illustrated booklet which tells you how to become a successful TV technician. America's leading TV servicing school offers you a specialized training program that omits non-essential math & design theory. You concentrate on radio & TV servicing only. You get professional training experience right in our fully-equipped shops & laboratories. Send for this booklet today. Write Dept. R-73. No obligation—no salesman will call.

Approved for Veterans

## WESTERN TELEVISION INSTITUTE

341 W. 18th St. Los Angeles 15, Calif.

competent elements in TV servicing to educate the TV set-owning public on why their sets should be properly installed and maintained—and not merely serviced when they go out of commission.

One of the best outdoor antenna sales programs we have ever examined is the one developed by the *Central Television Service Company* of Chicago. The key promotion piece in this selling program is an attractive eight page booklet titled "Why Television Antennas?" This booklet starts with a brief discussion on how TV signals are dispersed from the broadcast station and picked up for reproduction by the receiver. Then follows well-written sections on antenna height and size; antenna direction; types of antennas, both roof and indoor; and ghosts.

When a *Central TV* field service technician reports that an outdoor antenna should be installed in a home where he has repaired a set with an indoor antenna, a letter from the service manager together with a copy of the booklet is sent to the set owner. This letter reads:

"Our serviceman who visited your home reports that your reception can be greatly improved if you have an outside antenna installed. You realize, of course, that the picture on your television screen can only be as good as the television signal delivered to your receiver by your antenna. Even a properly operating television set cannot produce ghost-free pictures unless a strong television signal is delivered by the antenna.

"Our normal charges for a complete roof installation (including materials and labor) is \$35.00.

"Since you have just paid us a charge for a service call, we are offering you a credit of this amount which you may apply toward your antenna work. This credit certificate may only be used if you order an antenna installation within thirty days.

"I am sure that you will want to take advantage of this chance to get the best possible pictures on your set."

The maximum service credit allowed on the price of an outdoor antenna installation is ten dollars. A credit certificate which carries the amount of the credit that will be allowed is sent along with the letter and booklet.

If you would like to examine a copy of this booklet send twenty-five cents in coin or stamps to *TTLB Special Services Dept.*, P. O. Box 1321, Indianapolis 6, Ind., and ask for a copy of the booklet "Why Television Antennas?"

Every service businessman who hopes to get a share of the color television business when it starts rolling would do well to start sharpening up his understanding of TV antennas and acquiring a knowledge of how to promote the sale and maintenance of TV antenna systems. At this time it seems apparent that an outdoor antenna system will be a "must" with every color set installation.

May, 1954

# EICO

TEST EQUIPMENT  
for AM, FM, and TV

## New EICO Instruments BAR GENERATOR

Easy to use. Connects to antenna terminals of TV set. Tests picture linearity, picture size, and vertical and horizontal synch circuit stability.

Model 352-K Complete Kit ..... \$14.95  
Model 352 Factory Wired ..... 19.95

- Operates on channels 3, 4 or 5
- Provides 16 vertical and 12 horizontal bars
- Switch permits selection of 'vertical', 'horizontal' or 'stand-by'
- Output Voltage: 100,000 microvolts
- Dimensions: 7 1/2 x 5 x 4 1/2"
- Weight: 6 lbs.

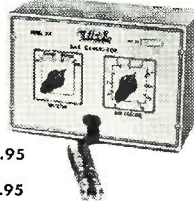

## CATHODE RAY TUBE CHECKER



An easy, fast and fully reliable instrument for testing oscilloscope and TV picture tubes without removing from the scope or the set.

Model 630-K Complete Kit ..... \$17.95  
Model 630 Factory Wired ..... 24.95

- Provides bridge measurement of peak beam current
- Indicates shorts and open elements in electronic gun
- Tests sockets and cables used with picture tubes
- 2 1/2-foot cables permit testing of tube directly in set or in carton.

## VACUUM TUBE VOLTMETER



A rugged, accurate VTVM with 4 1/2" meter. Has 15 different ranges, plus zero-center adjustment for TV and FM alignment.

Model 221-K Kit.....\$25.95  
Model 221 Wired..... 49.95

- 1% multiplier resistors for extreme accuracy
- AC and DC ranges: 0-5, 10, 100, 500, and 1000 volts
- Measures up to 30 Kilovolts with HVP-2
- Input DC impedance: 25 megohms
- Measures up to 200 mc with P-75 Probe
- .2 to 1000 megohms in 5 ranges

Prices Net, F.O.B. N. Y. C. Subject to change without notice. \*PAT. APP. FOR

# HARVEY

ALWAYS HAS IT... IN STOCK  
for IMMEDIATE DELIVERY

## 5-inch PUSH-PULL OSCILLOSCOPE

A laboratory precision instrument at lowest cost. Has extra sensitivity, range, and other plus features for fast accurate servicing. Steel chassis and cabinet minimize external interference.

Model 425-K Complete Kit.....\$44.95

Model 425 Factory Wired... 79.95

- Push-pull vertical and horizontal amplifiers
- Vertical sensitivity: .05 to .1 rms volts/inch
- Useful response from 5 cps to 500 kc
- TV-type multivibrator sweep generator
- Stable, accurate sweep range: 15 cps to 75 kc
- Direct connection terminals to CRT plates for measuring % modulation and voltage amplitude
- Dual controls for positioning trace on screen
- Dimensions: 8 1/2 x 17 x 13", Ship. Wgt. 29 lbs.

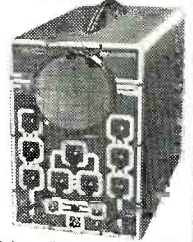

## New EICO PROBES



### SCOPE DEMODULATOR PROBE

Model PSD Complete Kit ..... \$3.75  
Factory Wired ..... 5.75

### LOW CAPACITY PROBE

Model PLC Complete Kit ..... \$3.75  
Factory Wired ..... 5.75

### DIRECT PROBE Model PD

Complete Kit ..... \$2.75  
Factory Wired ..... 3.95

**SPECIAL**  
ALL 3  
SCOPE  
PROBES  
Kit ... \$9.95  
Wired \$14.95

### VTVM RF PROBES

Model PRF-11 or 25

For any 11 or 25 megohm VTVM

Complete Kit ..... \$3.75  
Factory Wired ..... 4.95

### PEAK-to-PEAK PROBES

Model PTP-11 or 25

For any 11 or 25 megohm VTVM

Complete Kit ..... \$4.95  
Factory Wired ..... 6.95



### SENSATIONAL HIGH VOLTAGE PROBE

Model HVP-2

Factory Wired Only ..... \$4.95

# HARVEY RADIO CO., INC.

103 W. 43rd Street, New York 36, N. Y. • JUDSON 2-1500

# TUBES 1 YEAR GUARANTEE

1B3GT \$ .69	6AU5 \$ .84	6BG6G \$1.29	6K6 \$ .45	6V3 \$1.10	12AV6 \$ .41	12SA7 \$ .63	2516 \$ .52
1X2A .74	6AU6 .46	6BH6 .63	6S4 .51	6V6 .51	12AV7 .85	12SK7 .60	25W4 .52
5U4G .49	6AV5 .85	6BL7 .94	6SA7 .57	6W4 .50	12AX4 .70	12SL7 .65	35B5 .50
5Y3GT .37	6AV6 .41	6BQ5 .93	6SC7 .63	6W6 .60	12AX7 .66	12SQ7 .59	35L6 .51
6AB4 .51	6AX4 .72	6BQ7 .92	6SK7 .53	6X4 .37	12AY7 1.29	12SQ7 .54	39W4 .37
6AG5 .59	6BA6 .49	6C4 .41	6SL7 .67	6X5 .37	12BA6 .50	14AF7 .68	35Z5 .47
6AK5 .79	6BA7 .65	6CB6 .58	6SN7 .59	6Y6G .63	12BA7 .66	14N7 .75	50A5 .55
6AL5 .44	6BC5 .58	6CD6G 1.49	6SQ7 .45	12AT6 .53	12BE6 .52	198BGG 1.20	50B5 .51
6AQ5 .51	6BE6 .51	6J5 .44	6T8 .83	12AT7 .75	12BH7 .69	19T8 .86	50C5 .51
6AT6 .42	6BF5 .66	6J6 .68	6U8 .85	12AU7 .59	12BY7 .77	25BQ6 .95	50L6 .59

Many Other Types Available

Deduct 5% on orders of \$25. or more

25% deposit must accompany all orders—balance C.O.D., F.O.B. Irvington. If full amount is sent with order, we will pay freight charges. On orders under \$10., add \$1. handling charge. All tubes subject to prior sale.

# HI-LITE

ELECTRONIC SALES CO.  
837A 18th Avenue • Irvington 11, N. J.

# TE TRON TUBES

**GUARANTEED! . . . LOWEST PRICES EVER!**

All tubes individually boxed . . . unconditionally guaranteed for one year.

TYPE	PRICE	TYPE	PRICE	TYPE	PRICE	TYPE	PRICE	TYPE	PRICE	TYPE	PRICE
0Z1	.45	6A8	.40	6BE6	.46	6K6GT	.38	12AT6	.37	12SN7GT	.36
1A7GT	.53	6AB4	.43	6BF5	.48	6K7	.40	12AT7	.47	12SN7GT	.38
1B3GT	.62	6A07	.63	6BF6	.48	6L6	.78	12AU6	.43	19B6GG	1.48
1H5GT	.51	6AF4	1.02	6BG6G	1.18	6Q7	.40	12AU7	.58	19T8	.71
1L4	.51	6AG5	.52	6BH6	.51	6S4	.41	12AV6	.42	25B06GT	.82
1N5GT	.51	6AH1GT	.65	6BJ6	.51	6S8GT	.65	12AV7	.73	25L6GT	.41
1R5	.51	6AJ5	.96	6BK7	.78	6SA7GT	.45	12AX4GT	.80	25W4GT	.43
1S5	.43	6AK5	.96	6BL7GT	.78	6SK7GT	.45	12AZ7	.61	25Z6GT	.36
1T4	.51	6AL5	.43	6BN6	.90	6SL7GT	.60	12BA6	.46	35B5	.48
1U	.43	6A05	.48	6BQ6GT	.76	6SN7GT	.60	12BA7	.58	35C5	.48
1U5	.43	6AR5	.48	6BQ7	.85	6SQ7G	.71	12BE6	.46	35L6GT	.41
1X2	.65	6AT6	.37	6BY5G	.60	6T8	.38	12B7	.65	35W4	.33
2A3	.35	6AU6	.43	6BZ7	.95	6U8	.76	12B7Y	.61	35Z5GT	.33
3Q4	.33	6AV5GT	.60	6C1	.41	6V6GT	.48	12BH7	.61	50B5	.48
3S1	.48	6AV6	.37	6CB6	.51	6W4GT	.43	12BZ7	.63	50C5	.48
3V4	.48	6AX1GT	.60	6CD6G	1.63	6W6GT	.53	12K7	.40	50L6GT	.50
5U4G	.43	6AX5GT	.60	6CU6	.95	6X4	.37	12SA7GT	.45	Type 80	.40
5V4G	.49	6BA6	.56	6F6	.42	6X5GT	.38	12SK7GT	.45	117Z3	.33
5Y3GT	.30	6BA7	.58	6J5GT	.49	12AL5	.43	12SL7GT	.60	117L7GT	1.20
5Z3	.42	6BC5	.48	6J6	.61						

**FREE** \$5.00 list value Bonus Box of Radio & TV components including resistors, condensers—controls, and many other items with each order of \$25.00 or more.

**FREE GIFT OFFER** One 6BG6 tube will be shipped FREE with any order accompanying this ad.

We now have a complete line of special purpose and transmitting tubes in stock.

Write for quotations on your requirements—Dept. T.

We guarantee your orders to be shipped the same day they are received!

Minimum order \$10.00. 25% deposit on C.O.D. orders—save parcel post charges. Orders accompanied with full remittance will be shipped prepaid anywhere in continental U.S.A. All orders subject to prior sale.

**SPECIAL!**

while they last **39¢** each 10 for **\$3.50**

Type	Type	Type	Type	Type
1A4P	1E7GT	19	34	37
1C6	1F4	19B29	25	39/44
1C7G	1H4G	22	35/51	46
1D5CP	2A7	33	36	49
1D7G				1F5G

These specials are new Sylvania's individually boxed. Order now.

## TELTRON ELECTRIC COMPANY

428 Harrison Ave., Dept. RN5, Harrison, N. J. Phone: WAverly 6-1338

**STOP VOLUME CONTROL NOISE!**

**"NO NOISE"**

New 6 oz. Spray Can

Net to Servicemen **\$2.25**

CONTAINS AMAZING NEW **PERMA-FILM**

- ★ CLEANS! . . . dirt and oxidation immediately on contact.
- ★ LUBRICATES! . . . one drop eliminates scratch, hum and noise.
- ★ PROTECTS! . . . assures continued top performance.

Perfect Contact Restorer—cleans & restores volume controls, band switches, push button assemblies, electrical contacts. NO NOISE is not a carbon tet solution.

2 oz. bottle. Net to Service-men **\$1.00**

Available in 8 oz. bottles and quart cans. Nearest distributor—or write

**ELECTRONIC CHEMICAL CORP.**  
813 Communipaw Ave., Jersey City 4, N. J.

**WHILE THEY LAST!**

**10" TV REMOTE "SLAVE" SETS**

**HERE'S YOUR CHANCE TO GET THAT EXTRA SET FOR PLAYROOM, BED ROOM, KITCHEN, ETC.!!**

These are COMPLETE, OPERATING slave units. Hook up to any standard TV receiver (only 4 soldered connections) to reproduce any tuned TV channel. COMPLETE SCHEMATIC & HOOK-UP DATA SUPPLIED. Operates on 110V. DC. AC conversion data included.

**FEATURES:**

- H.V. OSC. POWER SUPPLY . . . detachable unit.
- 4" HORN DUTY SPEAKER
- MAJOR STANDARD PARTS INCLUDE: Def. Yoke, Focus Coil, Horiz. & Vert. Outputs, two 10H—100ma Chokes, 150ma Sel. Rect., Electrolytics, Controls, etc.
- HANDSOME WALNUT VENEER & LEATHERETTE CABINET (20 1/2" x 17" x 14 1/2")

!! PARTS ALONE WORTH SEVERAL TIMES THE PRICE !! Perfect condition

—used. Shipped Railway Exp. (Sorry No. C.O.D.'s).

**\$23.95**

**SCOPE PARTS!**—3" CR TUBE SHELD (3BP1, etc.) 1.29  
5" CR TUBE FRONT BEZEL . . . . . .98  
5" SCOPE VISOR—moulded vinyl . . . . .98  
5 1/2" GLASS LENS—round, convex—ca.39c 6/1.98  
TIMER MOTORS—30 RPM A.C. MOTOR (115V). Dble. 1/4" shaft. 5"x2 1/2"x1 1/4". Shpg. wt. 2 lbs. 2.95  
5 RPM A.C. MOTOR (Bristol). 115V. 2 W. O.D. 2 1/2" Mod. 200C. . . . .2.49  
CRYSTAL HAND MIKE—rugged all-purpose unit complete with shielded cable, moulded bakelite. 3.95  
MIDGET CRYSTAL MIKE CARTRIDGE—1" sq x 3/16". High imped., hi-gain (Brush). . . . .1.98

**2" PANEL METERS.** (Round) 0-5 MA DC level output, 1/4" range, 1" deep, for recording  
= 30. P.E. MAGNET WIRE—400 ft. roll—ca.23c 5/1.00  
= 32 P.E. Magnet Wire—12 oz. spool. . . . .98  
HOOK-UP WIRE—Red, Yel., Blue or Black. 100 ft. . . . .89  
W.110B FIELD WIRE—coils 100-400 ft. . . . .1 1/2c ft.  
1" ACOUSTICAL FIBREGLASS CABINET LINING 36" Wide. Per Sq. Ft. . . . .39

**OVER 5000 KITS SOLD!!**

AND STILL GOING STRONG!! That's our "JUMBO RADIO ELECTRONICS PARTS KIT". A "grab-bag" of inventory odds & ends worth several times its price. 17 lbs. of SWITCHES, SOCKETS, WIRE, RESISTORS, CONDENSERS, TV PARTS & DIAGRAMS, PHOTOFACTS, COILS, CONTROLS, ETC., **\$3.95**

ALL FOR . . . . .

G-E TUNGAR BULBS (2 amp)—#206501, 12X825 or 105928. . . . .ea. 1.49  
ROTARY SOLENOID (24VDC). 1 1/2" dia. . . . .ea. .89  
7/8" x 3/8" . . . . .ea. .89

"DIRECT FACTORY SPEAKER REPAIRS SINCE 1927"  
Min. Order \$3.00. 20% deposit req. on all C.O.D.'s.  
Please add sufficient postage—excess refunded.

**Edione Radio Corp.**  
67 Dey Street  
New York 7, N. Y.

For those who scoff at that statement and say "That's what they said about black-and-white TV, and look at how many people are using built-in and indoor antennas," just consider carefully how many of these set owners are watching degraded pictures because they do not have a proper antenna installation. When you degrade the color signal with an inferior antenna system you not only lose definition—you lose the color control signals as well.

The outdoor antenna that you will install with a color receiver will have to meet the requirement of broadband reception with a minimum of lobes. Be careful not to make any promises about reception of color programs on TV antennas you are installing now for monochrome receivers.

### Service Aids

Several programs are under way to find ways and means of curbing radiation from TV sets, and extraneous signals from other electronic services that affect TV reception. The Federal Communications Commission has been alert to the problems imposed by controllable TVI and is starting to apply strong measures to correct the situation.

The most exhaustive study of the sources of TVI has been conducted over the past three years by the Washington Television Interference Committee, a research project set up by the Electric Institute of Washington and the Radio-Electronics-Television Manufacturers Association. The first report on the findings of the Committee was released in 1952. This report, edited by P. S. Rand of Remington Rand, Inc., dealt exhaustively with the possible sources of TVI and included suggestions for counteracting interference from most known sources.

Recently, the Washington TVI Committee published a TVI aid dealing with the circuitry involved in the rectification of undesired r.f. signals in the audio stages of television and other receivers. This bulletin includes schematics and detailed descriptions of circuit modifications that will eliminate rectification of undesired r.f. signals. Service organizations may obtain a copy of this Television Interference Aid by sending ten cents in coin or stamps to: Editor, Washington TVI Committee Aids, 1110 Lake Boulevard, Annandale, Va.

The National Appliance & Radio-Television Dealers Association recently announced the publication of the 1954 edition of the official "NARDA TV Trade-in Blue Book." This book features suggested trade-in values on more than 4000 television sets—the products of more than 50 manufacturers. Most sets produced from 1946 through 1953 are included.

The 1954 "NARDA TV Blue Book" sells for \$5.00 per copy. It includes "A Look at the Market in 1954," "How to Sell More in 1954," and "How to Service and Sell Trade-ins" as added features. Information on this book

# OUT THEY GO!

for less dough—**Harjo** from

## Just Out! And They'll Go Fast!

**2-METER TRANSMITTER KIT**  
Famous APO 15 tuning unit—makes a beautiful 2-meter mobile transmitter. 4 1/2" x 4 1/2" x 1 1/2". Tuning unit contains 2 6CF's, driving an 832 Bnal, and 646 modulator tube. Comes with tuned circuits, many components, schematic diagram and conversion sheet. Don't pass this up! Brand New! \$35 value. **\$14.95** POSTPAID

**701A Transmitting Tube**  
Why Pay More! **\$4.95**

A surplus radar tube which duplicates many of the features of the 4-250 at far less cost. Send for complete data sheet—A pair will surprise you!

**DuMont 3GP1 Cathode Ray Tubes**

**\$1.79—3 for \$5**

Same tube used in the famed Dumont 22A oscilloscope. New, original boxes.

## METER BARGAINS!

**O-1 MA Full Scale 3" Aircraft Instrument Type Tops** for "S" meters, VOM, experimental use. Read "Building a Multimeter" on page 71, March issue, Radio & TV News... **\$1.49 ppd.** 3 for **\$4 ppd.**  
**WESTON FREQ. METER** #814, 350 to 450 cycles, 100 to 125 V. Read. Ideal for TV antenna installations, etc. 20" cord, new... **\$9.95**  
**RC1206 BEACON MVR**, Brand new, with tubes, 500-400KC... **\$9.95**  
**VARIABLE CONDENSER**, broadcast type, Cardwell PK 544, OD1, split stator, 50-540 MC per section, .250 spacing. Dimensions 2 1/4" x 8 3/4" x 7 1/4"... **\$49.50**  
**COAXIAL CABLE SPECIAL**, Similar to RG-47, 51 ohms, 100'... **\$4.95**  
**COMMAND SET TUNING KNOBS**, Fits RC-453, IC-154 and other 2748 Revers... **\$59 ppd.**

**CERAMIC CONDENSERS** \$1 ppd.  
Kit of 100 asstd. Brand new, standard brands. \$10 value.

## APS 13 Complete 420 MC Radiophone

When converted with our easy-to-follow schematics and instructions, it can range in most cases equal to 2 meters. Fine for communication, ranches, farms, etc. .... **\$4.95**

**\$14.75 VALUE**

Complete with 10 sections, conversion booklet, and 30 MC I.P. strip, less tubes, dynamotor.

**MICRO SWITCHES**, new... **4 for \$1**  
**SOUND POWERED HEAD & CHEST SET**, Navy type, no batteries required. Ideal for TV antenna installations, etc. 20" cord, new... **\$9.95**  
**PL6B PLUGS**, brand new... **.69c**  
**RC1206 BEACON MVR**, Brand new, with tubes, 500-400KC... **\$9.95**  
**VARIABLE CONDENSER**, broadcast type, Cardwell PK 544, OD1, split stator, 50-540 MC per section, .250 spacing. Dimensions 2 1/4" x 8 3/4" x 7 1/4"... **\$49.50**  
**COAXIAL CABLE SPECIAL**, Similar to RG-47, 51 ohms, 100'... **\$4.95**  
**COMMAND SET TUNING KNOBS**, Fits RC-453, IC-154 and other 2748 Revers... **\$59 ppd.**

## Make Harjo Your Headquarters for TRANSFORMERS

**HI-VOLTAGE FILAMENT TRANSFORMER**, Primary 110 V, 60-cy. Secondary 5V @ 10 amps, 20 KV insulation. With mounted socket for 872 rectifier tube. Famed donut type, practically extinct. FB for labs, transmitters. Shpg. wt. 15 lbs. New... **\$17.95**  
**110-V, 60-CYCLE FILAMENT TRANSFORMER**, Primary, Secondary 21 4-V, 16 amps. Secondary 2-216V @ 1.75 amps... **\$1.95**  
**PRIMARY 120V**, 4000 VA. Secondary is 20,000 V FT. 7.50 MA, 17.5 KV insulation. Shpg. wt. 100 lbs. New... **\$49.50**  
**CLASS B DRIVER**, Primary 500/125, Secondary 6800/1700, Amertrans... **\$7.50**  
**AUTOMATIC VOLTAGE REGULATOR**, Thordarson, Primary 95, 135, 190, 270 Volts. Secondary 115 V, 60 cycles @ 350 VA... **\$24.95**  
**NEW POWER TRANSFORMER**, 110 V, 60 cy. primary, 150V, 30MA secondary 0.3-1 amp. Full FB for test dln kits, test equip. 79c or 4 for \$3  
**Save On** 13H 250MA, Brand new, **\$3.95**  
**CHOKES** 20H 300MA, 5KV ins., **4.95**  
7H 420MA, 90 ohms, **5.95**  
50H 580MA, 17.5KV ins. Brand new, Shpg. wt. 300 lbs. .... **\$85.00**

## TELESCOPIC ANTENNA

7' long, 3 sections for portable or mobile. All new, packaged... **95c**

## RCA Surplus TV CAMERA!

Only **\$295**



With 1848 iconoscope and 6-stage video amplifier and clipper. For use in movie pickup chains and training and experimental work. **UNBEATABLE BARGAIN!** Write for complete info!

Attn: Schools, Labs, Hams! **WE PAY MORE** for Radio Parts, Equipment! Cash in Surplus—or trade! Write now!

Write for **FREE Surplus Catalog**. Thousands of items not listed. If you don't see it, write. All shipments F.O.B. warehouse.

**Harjo Sales Co.**  
Dept. RD  
4109 Burbank Blvd., Burbank, Calif.  
P.O. Box 1187, Magnolia Park Sta.  
Cable: Harjo Phone: Victoria 9-2411

may be obtained by writing the National Trade-in Guide Company, Madison, Wis.

Results of the Bureau's national survey of standard charges for radio and phonograph service have been tabulated in the form of a chart for easy reference. These charts are printed on 11x14-inch bristol board suitable for use as wall or desk charts and are available from the Bureau at \$1.00 for two copies. To obtain copies of these charts of standard service charges for radio and phonograph service, send one dollar to TTLB, P. O. Box 1321, Indianapolis, Ind. —50—

## Within the Industry

(Continued from page 28)

4132 W. Belmont Ave., Chicago . . . **JOHN LACKMAN** has been appointed executive technical director of *Chester Cable Corp.* . . . **FRED AYLESWORTH** of *Chicago Standard Transformer Corporation's* sales staff died at his Hollywood, California, home recently. He was formerly purchasing director of *Gilfillan Bros.* . . . *Pentron Corporation* has appointed **MARTIN MANN** to the post of advertising manager. He was formerly with *Permoflux Corp.* . . . **JOHN G. THOMPSON** is the new midwestern regional sales manager for *Westinghouse's* electronic tube division. He will direct the sales activities of the division in eighteen states in the Midwest . . . **ROBERT L. PARRISH** has been named manager of the new *Sprague Electric* plant now under construction at West Jefferson, N. C. . . . **C. RUSSELL FELDMAN** has been elected president of *National Union Radio Corp.*, succeeding **KENNETH C. MEINKEN** who has resigned. The new president will continue his post of chairman of the board, a position he has held since 1946 . . . **BILL RABIN** is the new general manager of *Ferricore, Inc.* He was formerly with *RCA* and *General Ceramics* . . . The television and broadcast receiver division of *Bendix* has named **W. C. LEDERER** sales promotion manager . . . **JOSEPH M. COLEMAN** is merchandising assistant for *Sylvania's* radio tube and TV picture tube divisions . . . **THOMAS J. MERSON** has been elected vice-president of *Audio & Video Products Corporation*. He will continue as vice-president in charge of engineering of the *Audio-Video Recording Company* . . . *Krylon, Inc.*, has named **ELMORE E. KAYSER** advertising and sales promotion manager . . . **RALPH C. POWELL** has been named product manager by *American Screen Products Company*. He will have charge of sales of television antennas and associated equipment . . . **HARRIS O. WOOD** is the new chief engineer of the *Philco's* television division . . . The board of directors of *Radio Receptor Co., Inc.* has elected **RALPH MENDEL** to the post of vice-president in charge of the engineering products division. He joined the firm in 1948 and has been manager of the division for the past few years. —50—

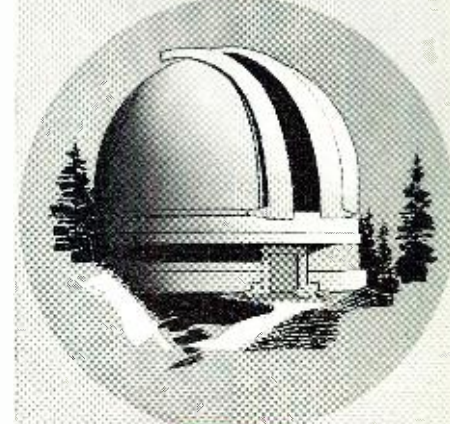

**"To find and follow the better way"** . . . Out of the vision of Dr. George Ellery Hale came the great "American Idea" that resulted in the creation of the "Glass Giant of Palomar"—world's largest telescope—to gather new light from the farthest stars for the searching eye of science.

With us, the "American Idea" is, by directed effort and applied know-how, to continue to lead in bringing you electronic products of the highest quality.

**INSIST ON AMERICAN REPLACEMENT CRYSTAL CARTRIDGES**

Send for **FREE** catalog 46

**American microphone co.**  
370 South Fair Oaks Ave. • Pasadena, 1, Calif.

**Saves service time!  
Reduces your  
investment in parts!**



**One Single  
Centralab  
Printed Electronic  
Circuit\***

replaces several old-style  
individual components

**And its stability assures long  
life . . . happier set-owners**

When you run up against one of the millions of old radio and TV sets that were built before PEC's were used, do you waste costly time trying to locate a shorted or intermittent component?

You don't have to—you can replace an entire section of an old-style circuit with a single PEC. And you can do it at a part-cost of as little as 36¢ to 81¢ net!

For example, if the trouble is in the vertical integrator of a TV set, you can replace the whole section with a vertical-integrator PEC plate. If the trouble is in the audio detector of a radio set, you can replace the entire section with an audio-detector PEC plate.

Why risk service "call-backs", by replacing only one old-style component? All the other parts are the same age—replace 'em all with one PEC.

New, revised Centralab Printed Electronic Circuit Guide No. 3 tells the whole story—and shows circuit schematics that help you install PEC's. Send coupon for free copy.

SEE US AT BOOTH 790. \*Trademark



CENTRALAB, A Division of Globe-Union Inc.  
910E E. Keefe Avenue, Milwaukee 1, Wisconsin  
Send me a free copy of the 1954 edition of  
the Centralab Printed Electronic  
Circuit Guide No. 3.

Name.....  
Company.....  
Address.....  
City..... Zone..... State.....

## Checking Your Audio System

(Continued from page 61)

the four popular recording characteristics.

When the record is used with an equalizer set for one of the four recording curves and that characteristic is played with the tone controls flat, the voltage readings should be constant for the complete run, if the equalizer is perfectly adjusted. Any variations from the reference level can be compensated for by the bass and treble controls to bring about proper equalization.

At this point, it is worth noting that unusual deviations in the system's frequency response, which may be discovered with either the D-100 or D-101 test records, should be recognized as a symptom. For example, peaks in the 4000 to 12,000 cycle range may indicate cartridge resonance. When peaks at the low end are discovered, arm resonance may be suspected. A sharp cut-off may be blamed on the cartridge.

Test records may serve to awaken that segment of the audio fraternity not yet aware of how components are rated. For example, a fellow who bought a 20-watt amplifier tabbed "flat from 20 cycles to 20,000 cycles" may be a bit taken aback when he finds out that the amplifier will produce 20 watts output at 1000 cycles, but will only be flat from 20 cycles to 20,000 cycles when the output is 1/4 watt!

### Test Level Indicator

If a vacuum-tube voltmeter is used to make some of the measurements described, it should be a good one, and good v.t.v.m.'s are expensive. Cheap voltmeters are inaccurate. *The Dubbing's Company* has developed the D-500 test level indicator which is diagrammed and pictured on page 61.

### Magnetic Tape Recorders

The growing popularity of magnetic tape recorders may be attributed, in large degree, to certain inherent advantages over record players. Tape recorders eliminate needle scratch, record wear, tracking error, moving parts in pickup, and critical cutting methods. Tape also makes possible re-use of the recording medium, easy editing, and excellent frequency response with wide dynamic range.

On the other hand, tape recorders introduce new problems such as critical head alignment and tape stretch, while still being subject to wow and flutter, noise level, timing and frequency response considerations.

A satisfactory means of checking these functions is necessary to obtain best performance and to troubleshoot mechanical difficulties. Also, every owner of a tape recorder should have a simple way of periodically evaluating the quality of his equipment to maintain optimum performance.

With this in mind, *Ampey* has de-

## COMMUNICATIONS RECEIVERS



Contains  
All Components

### FEATURES:

- 2 Watt P. P. Audio
- Amplified AVC
- Voltage Regulated Oscillator Supply
- Noise Limiter
- Beat Oscillator
- Air Tuned R.F. Trimmers
- 2 Stage Permeability Tuned 455 KC I.F. Plus Crystal Filter
- Phone Jack — Built-in Stand-by Relay
- Operates on 105 to 125 Volts AC or DC Power Source
- Frequency Range 200 KC to 400 KC and 450 KC to 13 MC in Six Bands
- 40:1 Geared Ratio Dial Drive
- 11 Tubes Plus Selenium Rectifier
- 6SG7 RF Amp.
- 6SB7Y Mixer
- 2-6SG7 I.F.
- 6H6 2nd Det & N. L.
- 6SF7 AVC Amp.
- 6SL7 RFO & 1st Audio
- 6SL7 Phase Inverter
- P.P. 25L6GT Audio
- VR-75 Voltage Regulator
- Full Vision Calibrated Dial
- Cabinet 10 1/2" high x 12 1/2" deep
- Finished in fine grain black wrinkle
- Front panel silk screened to identify each control

### FRONT PANEL CONTROLS

- Tuning
- R.F. Gain
- Audio Gain
- BFO-AVC Switch
- Power On-Off
- Stand-by
- Noise Limiter On-Off and Control
- Antenna Trimmer
- Crystal Filter On-Off
- Crystal Phasing
- Selectivity
- Band Change Switch
- Calibrated Dial Face

**COMPLETE KIT**—This kit is complete with every part necessary to assemble into a finished receiver, including tubes and cabinet. Chassis is punched and marked. Mount the parts, wire it, align it and you have a fine receiver of commercial appearance, that can't be beat for 3 or 4 times the price. Parts layout, schematic diagram and alignment instructions are supplied.

Shpg. weight 45 lbs. Shipped express only. F.O.B. Chicago and subject to change without notice.

**SPECIAL Complete Kit**

**59.50**  
KIT PRICE EACH

### 300 OHM TWIN LEAD

55 mil—22 ga—virgin polyethylene—individually boxed—1000 ft. spools, special @ \$12.95 per spool. Shipped wt. 12 lbs. per spool. 10 spools @ \$10.00 per spool.

### WIRE KIT

Ten hundred ft. rolls of hook-up wire in assorted sizes, colors and insulations—\$15.00 value, attractively boxed for only **\$5.95**

### POWER TRANSFORMER

150V, 60 CPS. primary, HV secondary 720 volt C.T. @ 270 mils. Filament: 6.3v @ 6 amps 6.3v @ 1.2 amps and 5v @ 3 amps. 3"x3 3/4" mounting centers, double horizontal half-shell mounting, ship. wt. 12 lbs. **\$6.95**

Price each. All prices F.O.B. Chicago; remittance in full or 25% deposit with order.

## BOULEVARD ELECTRONICS, INC.

Mail Order Address:  
1229 W. Washington Blvd., Chicago, Ill.  
Store Address: 4054 W. Belmont Ave., Chicago, Ill.  
**RADIO AND TELEVISION SUPPLIES**

## EASY TO LEARN CODE

It is **EASY** to learn or increase speed with an Instructograph Code Teacher. Affords the quickest and most practical method yet developed. For beginners or advanced students. Available to beginner's alphabet to typical messages on all subjects. Speed range 5 to 40 WPM. Always ready—no QRM.



### ENDORSED BY THOUSANDS!

The Instructograph Code Teacher literally takes the place of an operator-instructor and enables anyone to learn and master code without further assistance. Thousands of successful operators have "acquired the code" with the Instructograph System. Write today for convenient rental and purchase plans.

## INSTRUCTOGRAPH COMPANY

4711 SHERIDAN ROAD, CHICAGO 40, ILLINOIS

**RADIO & TELEVISION NEWS**

veloped a test tape with a frequency run of 50 to 15,000 cycles, which is essentially similar to the frequency records described.

The vertical alignment of the record and playback head must be exact; otherwise a loss of high-frequency response will result. Naturally, if a tape is recorded and played back on the same misaligned head, this signal loss will not be present. But as soon as a tape properly recorded elsewhere is played, or if the machine has separate record and playback heads, the difference in quality will become quite evident.

Amper and Audio Devices have devised vertical alignment tapes recorded by heads in perfectly vertical position. The user is required to adjust the head of his recorder for maximum output, which occurs at vertical alignment.

Another available test tape made by Dubbings can test wow and flutter, head azimuth alignment, frequency response, signal-to-noise ratio, volume-level setting, and tape speed.

This D-110 test tape, "The Measure of Your Tape Recorder's Performance," consists of a 5-inch reel providing about 15 minutes' playing time at 7½ inches-per-second. On it, wow and flutter may be checked by a steady 3000 cycle tone. At this frequency the ear is very sensitive to changes in pitch, detecting as little as 0.5%. One trick of the trade is to create wow by touching the reel lightly during operation. If this induced wow does not materially increase the total amount of wow, chances are that the wow was excessive in the first place, and should be a clue for tracing uneven tape tension, wobbly capstan, or worn idlers.

The test for vertical head alignment employs a 5000 cycle tone originally recorded by a head in a precise vertical position. Head alignment is checked by skewing the tape by gently touching the top or bottom of the moving tape with a pencil or similar object, thus twisting the tape and changing the relative azimuths of the tape and head a slight amount. If the output of the machine falls off then the head is properly aligned because output is at maximum when the tape is untouched. Conversely, if skewing the tape in either direction increases the output, then the head is misaligned and should be adjusted until maximum output is achieved.

If the machine has a separate record head, it too may be aligned after the playback head has been adjusted by recording a 5000 cycle tone on a piece of scrap tape, and playing it back. If the record head is in vertical alignment, skewing the tape will cause a drop in output. The source for the 5000 cycle tone may be a signal generator or a test record.

To set the proper volume level for measuring the frequency response with the D-110 test tape, the entire frequency range of 30 to 7500 cycles is first covered rapidly allowing a few seconds for each of the 13 steps. Any

# TECH MASTER

MANUFACTURERS OF THE WORLD'S  
FINEST CUSTOM-BUILT TV CHASSIS

NOW OFFERS New Horizons  
of TV Enjoyment in the  
**UHF Field**

with a  
**Full 70-Channel  
UHF Selector**

available in all  
**TECH-MASTER  
630-type chassis!**



**UHF or VHF -  
THE 630 BY TECH-MASTER  
IS STILL THE FINEST  
TV CHASSIS EVER PRODUCED**

**MODEL 2430:** For picture tubes up to 24". Audio connection for optional use of external amplifier.

**UHF/VHF.....\$249.50 VHF.....\$189.50**

**MODEL 2431:** Same as 2430, but with True Fidelity Push-Pull audio amplifier.

**UHF/VHF.....259.59 VHF.....199.50**

**MODEL 2430-9:** For new 90° kinescopes. (24" rectangular, 27" and 30").

**UHF/VHF.....299.50 VHF.....252.50**

**MODEL 1930:** Similar to 2430 with slight modifications including area control switch at rear of chassis and cadmium plated finish instead of nickel.

**UHF/VHF.....224.95 VHF.....179.50**

**MODEL C-30:** Designed for the utmost in Quality at an Economical price.

**UHF/VHF.....209.95 VHF.....149.50**

(All prices NET. Picture Tube not included.)

Tube M't'g Brackets with 2400 Models



**UHF SELECTOR,  
MODEL TV 101U:**

Fits into recess of any 630-type chassis. Brings in all available UHF stations. Factory assembled, wired and aligned.....\$36.95 net

AT ALL LEADING RADIO PARTS DISTRIBUTORS

Write For Detailed Literature



**TECH-MASTER CORPORATION**  
Radio & Television  
445 BROADWAY, NEW YORK 13, N. Y.

**MAKERS OF CUSTOM-BUILT  
TV CHASSIS, TV KITS  
AND HIGH FIDELITY  
AUDIO EQUIPMENT**

## BASIC MULTIMETER KIT

- 3 COLOR METER SCALE
- 2 COLOR SWITCH PLATE
- COMPLETE BUILDERS AND USERS MANUAL

Instrument has 15 Ranges of Volts, Ohms, Mills and Output A.C. and D.C.

When Ordering Specify if Meter to Be Used Is 3 or 4½ Inch

**\$1** POSTPAID IN U.S.A.  
No C.O.D. or Stamps

**makit** Products

ROBERT HILLIARD CO.  
Inglewood, California

Box 549

## MORE JOBS than graduates

Electronic Engineers  
Excellent opportunity for professional growth and advancement in engineering and electronics.  
Demand for our engineering graduates exceeds supply.  
Effective placement. Study in this world-famed college established 1884. Quarters start June, Sept., Jan., March. Approved for Korean Vets.

### Bach. Sci. degree in 27 months

Complete Radio Eng. courses . . . TV, UHF and FM. Also Mech., Civil, Elec., Chem., Aero. and Adm. Eng.; Bus. Adm., Acct. Small classes. Well-equipped labs. Modest costs. Prep. courses. Write Jean McCarthy, Director of Admissions for Catalog and Campus View Book.



**TRI-STATE COLLEGE**

1654 College Avenue, Angola, Indiana

# KESTER

Since the most important single step in Radio-Television Servicing is soldering . . . it's just plain good sense to use the best — KESTER SOLDER . . . Key Name in Solder for More Than 50 Years.

KESTER SOLDER COMPANY  
4235 Wrightwood Avenue • Chicago 39, Illinois  
Newark 5, New Jersey • Brantford, Canada

# SOLDER

**New Flyweight Magnemite\***

**Electric-Motor Battery-Operated Portable Recorder**

The ideal recorder for newspaper reporting, recording lectures, telephone monitoring, field reports traveling secretary, on-the-spot interviews, reference recording, customer interviews, salesmen reports and secret recordings. Combines, for the first time, ease and efficiency of operation with maximum reduction of weight. Performs anywhere, producing professional results under adverse conditions. Fly-ball governor-controlled electric motor plus triple shielding assures constant speed and freedom from hash. Weather-tight, satin-finished, aluminum alloy case gives complete protection to recorder. Three models available in speeds of 15/16, 1/8 and 3/4 ips.

- Check these unusual features:**
- ★ Records for 4 full hours (Model 310-A)
  - ★ Operates from self-contained dry cells
  - ★ Immediate playback
  - ★ Size: 5 1/2 x 9 x 12 inches
  - ★ Weight: only 8 pounds

Write for complete technical literature and direct factory prices to Dept. RT

**AMPLIFIER CORP. of AMERICA**  
398 Broadway, N. Y. 13, N. Y.  
U.S. Pat. Reg. U.S. Pat. Off.

## EXPERIMENTERS!



HERE IS YOUR OPPORTUNITY TO BUY A COMPLETE PROTELGRAM PHILIPS TV SYSTEM AT A REMARKABLE PRICE... THIS OFFER INCLUDES . . .

**89<sup>50</sup>**

PLUS ONLY \$10.00 extra for cabinet

- 1) Chassis complete with 23 tubes plus 1 diode wired and ready for use.
- 2) Protelgram projection unit including picture tube.
- 3) 25,000 volt power supply ready for use.
- 4) 8" dynamic speaker on large baffle.
- 5) 23" flat viewing screen and full size reflecting mirror.

NOTE: Chassis includes . . . Automatic beam suppressor . . . High Fidelity sound system . . . Automatic gain control . . . "Standard Coil" Tuner, etc.

## THE GOLDSTAR CO.

58 Walker Street, New York 13, N. Y.

peaks in the playback characteristic are immediately evident and appropriate precautions can be taken to protect the sensitive output test instrument. The response characteristic may then be plotted by noting the output level for each of the voice-announced tone steps from 30 to 7500 cycles.

A companion tape, the D-111, is available for checking high-fidelity and professional machines. It is on a 7" reel for 15 ips machines. It runs to 15,000 cycles but otherwise is the same as the D-110 tape.

A simple, yet interesting test for signal-to-noise ratio from 15 to 50 db is provided on the D-110 and D-111. A 400-cycle tone is diminished in volume in steps of 5 db. At each interval, the gain of the tape player should be increased to maintain constant output volume, as shown by a voltmeter or test level indicator across the external speaker. The noise level of the player increases simultaneously with the upward adjustments of the volume control. Finally, a point is reached where the noise during the few seconds between tones is as loud as the last tone itself. The level at which this occurs is the machine's signal-to-noise ratio, relative to a standard zero level which produces about 3% total harmonic distortion in a professional machine. The maximum of 50 db is about the best achieved on top quality home recorders, although 40 db is not uncommon.

A section of these test tapes provides an excellent means of calibrating the tape recorder's recording level indicator for the optimum level at which all future tapes should be recorded in order to keep the distortion below about 3% on peaks. If the playback volume control is set to give a convenient output while playing this section of the tape, a 400-cycle recording made on the machine should be made at a level which will produce the same output with the playback volume set at the same position. It should be noted that "zero level" establishes the maximum recording level, and, for complex material, such as music, should be considered the peak amplitude.

Accurate tape speed is a prerequisite for high-quality reproduction. Interestingly enough, some recorders tested showed an error of over two minutes in 15 minutes of playing.

For the given tape speed of 7 1/2 or 15 ips, the linear distance is a measure of tape speed. Therefore, at three locations on the tape, near the beginning and after 5 and 10 minutes, timing beeps are recorded. Since the tapes are recorded on machines with synchronous motors, the accuracy is within one second. If it is just five minutes, the tape speed is correct; if it takes longer than five minutes, the speed is too slow. The third beep should be heard 10 minutes after the first one if the machine is operating as it should.

Several new developments in audio test instruments are needed for use



In DETROIT it's  
**AARON ELECTRONICS**  
6025 Mt. Elliott, Detroit 11, Michigan

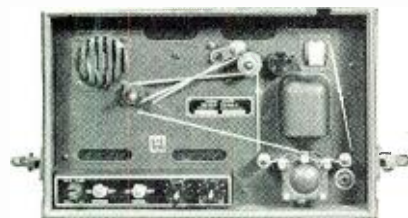

**TG-34-A CODE KEYS**—115/230 V 50-60 cycle. Auto-matic Unit reproduces code practice signals recorded on paper tape. This unit will provide code signals to one or more persons by use of self-contained speaker. Keying oscillator for use with a hand key. Compact in portable carrying case—complete with tubes, photo-cell & operating manual. Size: 10 1/2" x 10 1/2" x 15 1/2" 16". Shipping Wt. 4.5 lbs. BRAND NEW in original box. . . . . **\$24.95**

**TG-10 CODE KEYS**—115 V 50-60 cycle. Similar in operation to TG-34 but with higher audio output (push-pull 6L6's) to 4, 8, 15 ohm spk., not supplied. Fine for P.A. system. Size: 11x24x18 1/2". Wt. 6.5 lbs. with tubes & photo-cell. See April ad for picture . . . . . **UNFD \$19.95**

**CODE PRACTICE & TRAINING TAPE**—for use with the TG-34 & TG-10 Keyers. Inked on 16 mm paper on 300 ft. reel. Complete set of 15 Reels. New in sound carrying case. . . . . **\$12.95**

**INDIVIDUAL TAPES** for the following lessons—2, 2, 2, 8, 11, 12. New in metal containers. ea. **\$1.25**

**PROP PITCH MOTOR**—24-33 VAC or DC. Reversible—3 volts required. 7000 in 1 gear reduction—appr. 3/4 RPM—1/2 hp motor—rugged gear train and sturdy thrust bearing. Wt. 6.5 lbs. . . . . **\$15.50**

**PE-128 BATTERY CHARGER**—Vibrator Type—charging equip. operates from 6 or 12 V storage batt.—maintains trickle charge on 6 V or 2-6 V batt. or charges those batt. simultaneously. Has 1 DCMA & 1 DC Volt meter . . . . . **\$12.50**

**RM-20-A CONTROL UNIT**—self contained incl. ringer. 4kt. 3 pos. Locking type selector for monitor, direct or radio control or use as telephone. . . . . **\$6.95 ea.**

**BC-1141 AMPLIFIER**—used with the DC-625 Amino-Detector—with 2-1N5, 1-1G4 tubes—in metal case. Used but good. . . . . **\$5.95**

**CARDWELL 7 GANG TUNING CONDENSER**—Type CA-215 30 to 2 Dual Gear Ratio—out of the TS-225 Xmtr. which tunes 2 to 5.2 mc. \$2.95 ea. 2/\$5.00

**PERMEABILITY TUNER**—has osc. coil-ant. coil—ideal for 5 tube superhet—schematic diagram enclosed. New. . . . . **\$2.00**

**SUPREME VOLT-OUT-PUT METER**—Model #5918—40 ua movement—25,000 ohms per volt. OHM SCALE: 0-500 to 0-50 meg in 6 steps. VOLTS SCALE: 0-140, 0-15, 0-1.5. 3 steps. . . . . **\$6.95**

**COPPER OXIDE METER RECTIFIER**—1 prong plug-in Type B-2 01-Triplett #T-2250-0-500 ua AC—100 na DC—100 mw DC . . . . . **\$1.25**

**TRIUMPH SWITCH AS5-Y**—Model C-30-27-5. 8 pos.—comp. wired w/ all volt multipliers & current shunt resistors—w/ copper oxide rectifier—knob & mtg. hdwy. . . . . **\$2.95**

**SOUND-POWERED PHONOGRAPH INSERTS**—out of the TS-110 handset and head-set cost no the same thing for ONLY a fraction of costs of compl. units. . . . . **\$1.25 each, 10 for \$9.95**

**CERAMIC CHANGE-OVER RELAY**—A.P.D.T. 2. Load 1177. Cont. rating 115 V 6 amp. Single wound coil 220 VAC 60 cycle, 25 ma. 3000 ohm DC res. Fast acting . . . . . **\$1.50**

**PHONETTE**

Made by Personal Music Corp. 24V operated. Hayden Timer Motor. 5" Dyn. Spk. 2 pilot lights. Coin inserts 1 to 5 pennies. Chromed metal and grill. Wt. 6 1/2 lbs. Size: 4 1/4 x 7 1/2 x 6". Used

**\$1.95**

Only . . . . .

TECH. MANUAL FOR BC-221 FREQ. METER. . . \$1.25  
M-14 MOTOR—24 VDC 5a—8500 rpm—1/13hp. \$2.95  
110 VAC—4 rpm motor—2 3/8x2x2 1/4. Wt. 6 oz. \$2.95

**Very Stable 2 Meter Coated Xtals.**  
CR-1/AR Type 1/8" P 1/2" S

8001.43	8036.36	8082.	8146.15	8180.
8007.69	8060.	8104.62	8155.71	8201.54
8020.	8063.08	8120.	8160.	8220.
	75c each		10 for \$6.50	

7270 KC XTAL—CR-1 Type. Boxed. 75c ea. 10/\$6.50  
115 VAC 60 cycle BLOWER—1525 RPM. Type L—Model 3571—approx. 100 cu. ft. dis.—3/4" intake 2" outlet. Motor size 4 1/2x3 1/2". Has mounting bracket with detachable heating element. \$9.95 with heating element. \$8.95 less heating element. . . . .

PE-133 Dynamotor. for use with above revr. Input: 12 V @ 3 amps. Output: 230 VDC @ 90 ma. New. . . . . **\$5.95**

ANTENNA AN-75—7 ft. long in 7 sections—used for portable or mobile antenna . . . . . **\$1.25**

J-47 TELEGRAPH KEYS—New . . . . . **\$0.97**

**TUBE SPECIALS**

3054	.....	\$125.00	531	.....	\$4.95
728FY	.....		305	.....	\$2.50
706-C	.....		3821	.....	\$2.50
5J33	.....		702B	.....	\$1.95
2J29	.....		1836	.....	\$1.95
204A	.....		TZ-20	.....	\$1.25

1E7	ANY	39/44
12L8	10	EF-51
23D4	FOR	215-A
34	10	1629
37	\$3.00	89

25¢ WITH ORDER—BALANCE INCLUDING POSTAGE  
C.O.D. MICHIGAN RESIDENTS ADD 3% SALES TAX  
MINIMUM ORDER \$3.00.

May, 1954

by hobbyists and technicians to round out the already fine assortment now available. For one, a simple method of measuring transient response would be welcome. Also, if some genius (he'd have to be) could devise an inexpensive means of measuring speaker output, thereby eliminating costly calibrated microphones and free-field test areas, high fidelity would forever be indebted to him.

But more urgently needed, and more easily achieved, is a fully systematized series of musical test records, permitting systems to be tested by ear. Musical instruments, one by one and in groups, for different frequencies and sound levels, could be recorded, and the listener instructed on what he should and should not hear. Capitol, Cook, and Weathers are among the companies which have come out with such records. These are important starts, but are yet to be systematized. Here is a tremendous horizon for audio test techniques—one that is virtually untouched—and one which will truly complement all the devices described. —30—

**TV Antenna Evolution**

(Continued from page 65)

tion low-band conical driven element and high-band folded dipole. Thus, on the low band, the antenna consists of a dual reflector, conical driven element, and single director; on the high band; a single reflector, folded dipole driven element, and single director. The section of line between the high-band folded dipole and low-band conical driven element is of proper length to minimize interaction between the high- and low-band segments of the antenna.

Another antenna using this basic approach is shown in Fig. 6. Here, a folded dipole and dual low-band reflector and a conical, each element of which is adjustable for the optimum tilt angle for the high band, insures all-band performance.

In all of these types, the presence of the low-band driven element will contribute to some multiple-lobing of the high-band pattern. However, the screening action of the multiple-reflector-director combination reduces these lobes substantially below those present with basic conicals and other standard v.h.f. types. —30—

**SEMINARS PLANNED**

**THE School of Engineering of The Pennsylvania State College, State College, Pa., has announced a series of summer seminars in the electronic field, which are open to the public.**

Transistors will be covered June 9-18; color television, June 21-July 2; analogue computers, June 21-July 2; electrical contacts, June 28-July 2; and electrostatic precipitation, June 21-25.

Details on these seminars are available from R. L. Riddle, chairman of the Short-Course Committee at the college.

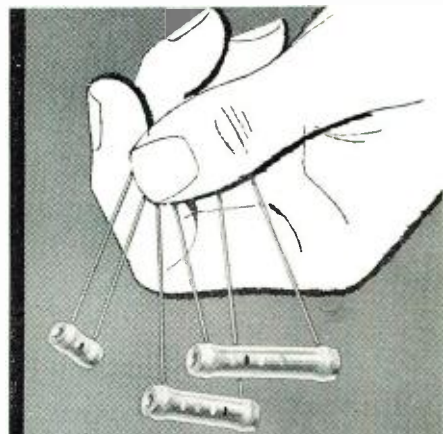

Your most  
trouble-free  
replacements

for old-style mica and  
ordinary tubular capacitors

**Centralab**  
Standard Tubular

**BC HI-KAPS®**

600 V.D.C.W.—1600 V.D.C.W.—3000 V.D.C.W.  
For bypass, coupling, and general use

Any way you look at it, BC Hi-Kaps are "just what the doctor ordered."

- They're small in size — have convenient radial leads.
- They fit easily, without tricky bending.
- They let you make close-coupled low-inductance connections — and fast.
- They operate at temperatures where ordinary tubulars fail — up to 85° C.
- They withstand extreme humidity.
- They're color-coded per RETMA and JAN specifications.
- They're conveniently packaged—5 or 25.

Have plenty of BC Hi-Kaps on hand to replace old-fashioned capacitors. Your Centralab distributor has complete stocks — see him soon.

Send coupon  
for Centralab  
Catalog 28.



SEE US AT BOOTH 790.



**CENTRALAB,**  
A Division of Globe-Union Inc.  
910E E. Keefe Avenue, Milwaukee 1, Wisconsin

Send Centralab Catalog 28.

Name \_\_\_\_\_  
Company \_\_\_\_\_  
Address \_\_\_\_\_  
City \_\_\_\_\_ Zone \_\_\_\_\_ State \_\_\_\_\_

D-854

# Trav-Electric

DC to AC

**CURRENT CONVERTERS**  
for Land... Sea... Air

**JUST PLUG INTO CIGAR LIGHTER ON DASH**  
Change 6 or 12 Volt D. C.  
to 110 Volt A. C. - 60 cycle



Operates Test Equipment,  
All Electric Shavers

SIZE: 2"x2"x3 1/2"  
**Trav-Electric MIDGET** \$11.95  
Model 6-11160, 60 Cycle, 10-15 Watts List



- OPERATES
- Test Equipment
  - Turntables
  - Lights
  - Short, long Wave Radios
  - Portable Phonographs
  - Electric Shavers, etc.

SIZE: 2 1/2"x2 1/2"x4 1/2"  
**Trav-Electric SENIOR** \$15.95  
Model 6-11160, 60 Cycle, 35-40 Watts List



- OPERATES
- Curling Irons
  - Radios
  - Turntables
  - Small Dictating Machines
  - Test Equipment,
  - Electric Shaver
  - Portable Phonographs

SIZE: 4"x5"x6"  
**Trav-Electric MASTER** \$24.95  
Model 6-51160, 60 Cycle, 40-50 Watts List



- OPERATES
- Wire Recorders
  - Amplifiers
  - Soldering Iron
  - Radios
  - Dictating Machines
  - Turntables
  - Small Electric Drill
  - Electric Shaver

SIZE: 4"x5"x6"  
**Trav-Electric SUPER** \$37.95  
Model 6-71160, 60 Cycle, 60-75 Watts List

**FULLY GUARANTEED**  
See your Jobber or Dealer

## Terado COMPANY

1058 RAYMOND AVENUE  
ST. PAUL 14, MINNESOTA

In Canada Write: Atlas Radio Corp., Ltd.  
560 King St. West, Toronto 28, Ont.

Export Sales Division: Scheel International, Inc.  
4237 N. Lincoln Ave., Chicago 18, Ill. U.S.A.  
Cable Address—Harsheel

## Basic Color TV

(Continued from page 42)

gun picture tube. The need for these additional voltages stems from the fact that the phosphor plate and the shadow mask of the picture tube are flat surfaces. Hence, if the three electron scanning beams are made to converge at the center of the screen, they will not converge at the screen at other points away from the center. The result would be a misregistered picture. To keep this from occurring, special parabolic waves are combined with the d.c. voltage on the convergence electrode of the color picture tube as the beams swing across the screen.

To maintain good focus over the entire screen, a similar parabolic voltage is inserted in series with the fixed d.c. focus voltage.

Following is the proof, mentioned earlier, showing how the red, green, and blue signals are obtained by combining *I*, *Q*, and *Y* signals.

The *I* signal, from NTSC specifications, is defined as:

$I = -.27(B-Y) + .74(R-Y)$  where *B* stands for blue, *R* stands for red, and *Y* stands for the monochrome signal.

The *Q* signal is similarly defined as consisting of:

$$Q = .41(B-Y) + .48(R-Y)$$

These may be looked upon as two simultaneous equations that we wish to solve for (*B-Y*) and (*R-Y*). To solve for (*R-Y*), simply multiply the entire *Q* equation by .27 and multiply the entire *I* equation by .41, then add them together. Doing this gives us:

$$.27Q = (.27)(.41)(B-Y) + (.27)(.48)(R-Y)$$

plus

$$.41I = -.27(.41)(B-Y) + (.41)(.74)(R-Y)$$

or

$$.27Q + .41I = (.27)(.48)(R-Y) + (.41)(.74)(R-Y)$$

simplifying:

$$.27Q + .41I = (.13)(R-Y) + (.30)(R-Y) = .43(R-Y)$$

$$\text{Hence } (R-Y) = \frac{.27}{.43}Q + \frac{.41}{.43}I$$

$$\text{or } R-Y = .62Q + .96I$$

Thus, if we take .62 of the *Q* signal (with positive polarity) and .96 of the *I* signal (with positive polarity) and mix them together, we obtain a red-minus-brightness signal, (*R-Y*).

By taking the same *I* and *Q* equations, and solving for *B-Y* instead of *R-Y*, we obtain the following result:

$$B-Y = -1.1I + 1.7Q$$

Still to be obtained is a *G-Y* signal and this was shown in the previous article to equal:

$$G-Y = -.51(R-Y) -.19(B-Y)$$

or, substituting the equivalent *I* and *Q* expressions just given,

$$G-Y = -.51(.62Q + .96I) -.19(-1.1I + 1.7Q)$$

or

$$G-Y = -.64Q -.28I$$

## CRYSTAL GRINDING KIT!

- ★ Grind your own crystals to desired frequency for ham bands.
- ★ No elaborate frequency measuring equipment needed. Your receiver is sufficient.
- ★ It's easy - simple as A, B, C!

### CONTENTS OF BASIC KIT

- 9 good, commercially-made crystals for re-grinding. Mounted in original holders with fundamental frequencies indicated on holders.
- 1 master crystal for calibration purposes.
- Crystal grinding components.
- Easy-to-follow instructions.
- Material to re-mark holders to your new frequency.

### Kit No. 1-80 Meters

Includes Basic Kit and crystals mounted in DC-34 & DC-35 type holders. Pin spacing: 9/4". Crystal holder dim.: 1 3/8" x 1 3/8" x 1/2". Pins will fit into banana plug sockets. Price per COMPLETE KIT... \$7.95 postpaid

### Kit No. 2-40 Meters

Includes Basic Kit and crystals mounted in FT-243 holders. Pin diam.: .093". Pin spacing: .486". Holder dim.: 1 3/16" x 1 1/4" x 7/16". Will fit into any standard octal tube socket. Price per COMPLETE KIT..... \$6.95 postpaid

### Kit No. 3 - 2 Meters

Includes Basic Kit and crystals mounted in FT-243 holders. Same physical dimensions as those in Kit No. 2. MULTIPLY FREQUENCY 18 TIMES. Price per COMPLETE KIT..... \$6.95 postpaid

### Kit No. 4 - 2 Meters

Includes Basic Kit and crystals mounted in FT-243 holders. Same physical dimensions as those in Kit No. 2. MULTIPLY FREQUENCY 24 TIMES. Price per COMPLETE KIT..... \$6.95 postpaid

CRYSTAL BUYERS! WE HAVE LARGEST STOCK OF CRYSTALS IN THE WORLD! SEE OUR APRIL '54 ADS IN RADIO & TV NEWS AND C.Q. FOR COMPLETE LIST.

NOTE: Check, cash or M.O. IN FULL MUST ACCOMPANY ORDERS. NO C.O.D. Items subject to prior sale and change of price without notice.

## U.S. CRYSTALS, INC.

805 S. UNION AVE., LOS ANGELES 17, CALIF.  
Phonas: DUmkirk 1-3020 - DUmkirk 1-3029

## TV TRADE-IN SETS

- Philco • Emerson • GE • Admiral
  - Motorola • Tele-King • Others
- 10" — \$17; 12" to 17" — \$20 up

Send check or money order now!  
List available—Add \$5 for packing  
**WASHTEK SERVICE CO.**  
1501 Boston Road, Bronx, N. Y. DA 3-9281

Please mention

## RADIO & TELEVISION NEWS

when answering Advertisements

To each of these color-minus-brightness quantities ( $R-Y$ ,  $B-Y$ , and  $G-Y$ ) we add  $Y$  from the luminance channel (*i.e.*, the second video amplifier) to obtain  $R$ ,  $B$ , and  $G$ . These are the three color signals we seek. These are then amplified and fed to their respective grids of the tri-gun picture tube. (To be continued)

### D.C. VOLTMETER FOR R.F.

By JOSEPH ZELLE  
Tech. Staff, WERE-AM, FM, TV

**O**FTEN enough the technician, in troubleshooting or experimenting, wants to know the actual d.c. voltage existing on the grid or plate of receiver or transmitter r.f. stages. The v.t.v.m. may not only be expensive and unavailable but actually useless for the high frequencies under investigation.

A very simple voltmeter can be made up from the ordinary v.o.m. by using an r.f. choke as the probe. The choke acts to prevent loading on the r.f. circuit. It also prevents bypassing the r.f. through stray capacitance. At the same time, though, it allows the d.c. to flow to the meter and register the actual d.c. voltage appearing across the circuit in question.

Any run-of-the-mill r.f. chokes lying about the shop will serve for ordinary low- and high-frequencies. For v.h.f. and u.h.f., it may be necessary to use special r.f. chokes for the particular frequencies. In many cases only the "hot" lead will have to have a choke, Fig. 1B. More exacting requirements will call for an r.f. choke in the "cold" or r.f. ground lead as well, Fig. 1A. Then, too, if the measuring leads are rather long and the frequency high so that the leads approach a half-wave or more, it may be safer to use a meter with r.f. choking and condenser bypassing at the meter as well, Fig. 1C. The chokes should be at the very tips of the probes to provide the shortest possible leads. Among the common pi-wound chokes, the pig-tail will serve admirably. The pig-tail can also be covered with spaghetti tubing so that the probe point can go deep into the wiring of the circuit, Fig. 1D.

The nature of the measurements, the desired accuracy, and the ingenuity of the technician will determine the combination to be used. Even an ordinary d.c. voltmeter could be pressed into service providing it has the proper seal for the voltages to be encountered.

Basically, the r.f. probe will give the d.c. voltage readings for bias and drive conditions as well as the output supply voltages with negligible effect on the circuits being measured.

-30-

Fig. 1.

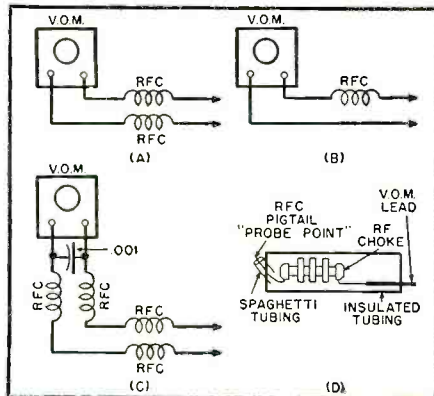

**BAKER STREET**

YOU can now enjoy the world-famous

**LONDON MYSTERY MAGAZINE**

Remember how you thrilled to the daring exploits of Raffles, the master criminal; of Cleek, man of a thousand faces; of the incomparable Sherlock Holmes? Or how your heart pounded as you were led along London's crooked streets, with the dense fog closing in and a murderer lurking in some alley bordering the Thames?

If you long for the good old days, if you're weary of private eyes, if you prefer the Agatha Christie or Graham Greene type of mystery and intrigue, then you won't want to miss a single issue of this great magazine—exactly as it appears in the famous British edition.

Published in America by the  
**ZIFF-DAVIS PUBLISHING COMPANY**

On Sale May 11 At leading newsstands 35¢

**SCOTLAND YARD**

**CHARING CROSS**

**WATERLOO BRIDGE**

SPEECH AMPLIFIER—3 Trans., 4 tubes	\$ 9.50
RADIO-MARINE—65 watt with dyn.	195.00
CRYSTALS—7010-7140-7300-8007.69	
8155.71-8528.57 KC	1.50
DYNAMOTOR—(6V.) 425 V-375 ma.	18.50
VIBRAPACK—(6 or 12V.) 375 V. 200 ma less vibrator	9.50
DYNAMOTOR—PE 101-C	3.95
TRANSFORMER—Tap 8-9-10-11-12V. 5 amp.	4.95
5000 MFD-50V.—Elec. cond.	2.75
<b>ALGERADIO ELECTRONICS CO.</b>	
147 Front Street	Hempstead, N. Y.

### ENJOY 3 COLOR TELEVISION FILTER SCREEN NOW

Changes dull eye-straining black and white pictures into beautiful color tones. Seconds to attach. No tools used. Helps eliminate glare. Order direct. Send \$1 for screen size up to 16", \$1.25 size 17", \$1.50 size 20", \$2 size 21", \$2.50 size 24", \$3 size 27". (Also available are single solid color screens in blue, green, or amber.) Prices on solid color screens are 30% less. We pay postage except on C.O.D. orders. Satisfaction guaranteed. Inquiries from dealers also welcomed.

Zingo Products, Johnstown 19, New York

### RCA MI-2475 SOUND POWERED PHONES NEW EXPORT PACKED

complete with 22' rubber covered cable press to talk switch are light weight, the mic is on a swivel boom that can be moved to any position in front of face. Press to talk switch clips on jacket front can be locked in on position.

NO BATTERIES or other volt-just connect to two conductor wires—good over mile or longer.

Brand New, \$1395 Ea.

Gov't Cost, \$62



Include postage with order. Shipping weight 4 lbs. New Address: BARTO, PA. Phone: BALLY 5-3621

**McCONNELL'S**

**CODE SENDING SPEED**

Be a "key" man. Learn how to send and receive messages in code by telegraph and radio. Commerce needs thousands of men for jobs. Good pay, adventure, interesting work. Learn at home quickly through famous Candler System. Quality for Amateur or Commercial License. Write for FREE BOOK.

**CANDLER SYSTEM CO.**  
Dept. 2-E, Box 928, Denver 1, Colo., U.S.A.

Here's a **TERRIFIC BUY** for  
**MOBIL HAMS!**



**FAMOUS BC-645**  
Transmitter-Receiver

Makes wonderful mobile rig for 420-500 Mc. Easy to convert for phone or CW 2-way communication. CONVERSION DIAGRAM INCLUDED. This swell rig originally cost over \$1000—

**BRAND NEW!**  
yours for practically a song! You get it all, in original factory carton, **BRAND NEW**, complete with 17 tubes, less power supply. Shpg. wt. 25 lbs. **\$29.50**

**PE-101C DYNAMOTOR** for BC-645, has 12-24V input (easy to convert for 6V Battery operation, instructions included).....only **\$4.85**

**UHF ANTENNA ASSEMBLY**, for BC-645 ..... **\$2.45**

**CONVERSION BOOKLET**, Instructions for most useful surplus rigs..... **\$2.50**

**HEADSETS**

	Excellent USED	BRAND NEW
H5-23 high impedance .....	\$2.95	\$4.75
H5-33 low impedance .....	1.45	5.75
H5-30 low imp (featherw).....	1.49	2.45
H-16/U high imp (2 units).....	—	4.95
CD-307A cords, with PL55 plug and JK26 jack, 8' long.....	—	1.19

**SCR-522 BARGAIN OFFER!**

**SCR-522 Xmitter** less tubes \$22.50 with tubes..... **\$32.50**  
**SCR-522 Rcvr** less tubes \$19.50 with tubes..... **\$24.50**

**BC 605 INTERPHONE AMPLIFIER**

Can be easily converted to an intercom, set—ideal for office, home or factory. New .....\$4.45 Like New .....\$2.95



**PRICES SLASHED!**

Type	USED	Excellent USED	BRAND NEW
BC-453 Rcvr. 190-550 Kc. ....	\$18.50	\$24.50	\$44.50
BC-454 Rcvr. 3-6 Mc. ....	9.25	11.25	21.95
BC-455 Rcvr. 6-9 Mc. ....	8.95	10.95	16.50
BC-456 Modulator .....	—	7.75	5.75
BC-457 Xmtr. 4-5.3 Mc. ....	12.50	16.50	24.50
BC-458 Xmtr. 5-3.7 Mc. ....	7.95	9.75	23.50
BC-459 Xmtr. 7-9.1 Mc. ....	12.95	14.25	22.50
BC-450 3-Rcvr. Control Box .....	—	1.49	1.95
BC-451 Xmtr. Control Box .....	—	1.25	1.49
3-Receiver Rack .....	—	1.79	2.95
2-Transmitter Rack .....	—	1.59	3.25
Single Transmitter Rack .....	—	1.59	3.25

**ARC-5 T-23 Transmtr.**, with tubes. Brand New..... **\$49.50**

**ARMY FIELD PHONES**

Type EEB—Talk as far as 17 miles. Dependable 2-way communication. Each phone complete with ringer and handset. Excellent Condition. Your cost..... **\$22.25**

**BRAND NEW MODULATED BC-221-AK FREQ. METER**

125 to 20,000 Kc. with xtal check points in all ranges. Complete with tubes, xtal, calibration charts. Limited quantity each ..... **\$210.00**  
**UNMODULATED BC-221 Freq. Meter**, with tubes, xtal, charts; factory treated, checked for alignment, GUARANTEED. Terrific low price..... **\$129.50**

**BEACON RECEIVER BC-1206-C**

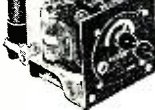

Complete with 5 tubes. Tunes 150 Kc. to 150 Kc. 15 Frequency—13.5 KC. Receiver Sensitivity—3 Microvolts for 10 Milliwatts output. Output Impedance—300 Ohms and 4000 Ohms. Volume Control—RF Gain Control. Power Supply—24-28 Volts Aeroplane Battery. Current—7.5 Amperes.

**BRAND NEW** ..... **\$12.95**  
Used, as is, special..... **\$6.95**

**WILLARD 6-VOLT MIDGET STORAGE BATTERY**

3-amp hr. **BRAND NEW**. 3 3/8" x 1-13/16" x 2 3/8". Uses standard electrolyte..... **\$2.65**

**WILLARD 2-VOLT STORAGE BATTERY**

20 AMP. HR. **BRAND NEW**..... **\$2.69**

**DYNAMOTORS**

Type	Input	Output	Exc. Used	Brand New
DM-32A	28V 1.1A.	250V .05A.	\$4.90	\$7.50
DM-33A	28V 7 A.	275V .66A.	2.25	3.95
	28V 7 A.	540V .25A.		
DM-40	14V 3.4A.	172V .138A.	7.40	9.50
DM-23	28V	224V .07A.	3.95	6.95
PE-73	28V 20A.	1000V .350A.	9.50	12.50

Please include 25% Deposit with order—Balance C.O.D. MINIMUM ORDER \$3.00. All Shipments F.O.B. Our Warehouse N.Y.C.

**G & G Radio Supply Co.**  
Dept. N-5  
51 Vesey St., New York 7, N. Y., CO 7-4605  
Branch: 16 W. Kinzie St., Chicago, Ill.

# NEW TV PRODUCTS on the Market

**INDUSTRIAL TV SYSTEM**

*Kalbfell Laboratories, Inc.*, P. O. Box 1578, San Diego 10, California is now offering a small, lightweight television camera for industrial applications.

The equipment is designed to be used either as an industrial intercom or in commercial telecasting for remote, studio, or film pickup. The camera can be held in the palm of the hand. It consists of a vidicon pickup tube operated with an 8 mc. cascode preamplifier. All electrical adjustments on the camera can be controlled remotely at the camera control. Up to 500 feet of cable can be used between

each section, serving as a brace and locked joint to prevent slippage. Extra security is provided with large thumb bolts that actuate internal concave pressure nuts against the tube sections.

The guy rings included with the units have a unique key-notched slot enabling the installer to slip the guy ring over bolts and to hook in individual anchor eyes after erecting the tubing.

Currently available units range between two sections extending to 20 feet and five sections extending to 50 feet. A brochure, form #248, is available from the company.

**U.H.F. SET COUPLERS**

*Radio Merchandise Sales Inc.*, 2016 Bronxdale Ave., New York 60, N. Y. has developed a two-set u.h.f. coupler, the Model AC-2U.

The coupler incorporates a printed circuit and comes complete with installation instructions and mounting screws. According to the company there is no interaction between the receivers. The coupler also provides the necessary 300-ohm impedance required for the input and output circuits.

The coupler is housed in a high-impact plastic cabinet which can be mounted on the wall or baseboard.

A data sheet on this u.h.f. coupler is available on request.

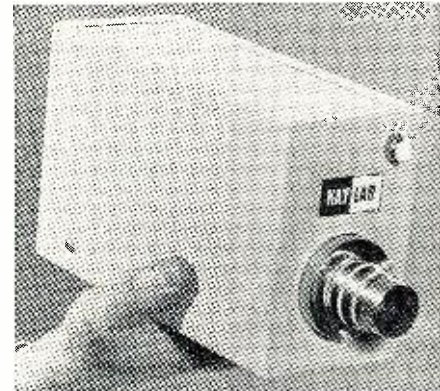

the camera and camera control unit. The control unit consists of three basic subassemblies—an 8 mc. video amplifier, horizontal and vertical deflection chassis, and a power supply.

The company will forward a 4-page brochure on this system upon request.

**NEW "LO-LOSS" LINE**

*Imperial Radar & Wire Corp.*, 820 East 233rd St., New York 66, N. Y. is in production on a new type of high-gain, low-loss wire which has been tradenamed "Spongee."

The line uses a special polyethylene with a sponge feature, allowing many air holes, and 7-strand #28 copper wire, 20 gauge. It is said to be suitable for v.h.f., u.h.f., and color antenna installations. The wire has been tested under all climatic conditions with especially good results being obtained in the salt water test.

The wire comes on 1000 foot, non-returnable reels.

**TRIAD REPLACEMENTS**

*Triad Transformer Corporation*, 4055 Redwood Ave., Venice, Cal. has added six new flybacks to its line of replacement parts.

The new units comprise four universal types and two coil replacements. The complete line of replacement components is covered in Catalogue TV-54 while information on the company's line of transformers is contained in Catalogue TR-54. Either or both of these catalogues are available on request.

**U.H.F. MIXER DIODES**

*International Rectifier Corporation*, El Segundo, California is in production on the Type G02 germanium mixer diode for u.h.f. applications.

Each unit is manufactured from specially treated, single-crystal germanium to assure maximum uniformity of characteristics. They are designed for circuit frequencies up to 3000 mc. with a low noise figure of 10-14 db at 500 mc.

The Type G02 is designed for solder-in applications where space is limited. Dimensions are 5/12" in diameter and 3/8" in length. It is provided with #24 tinned copper leads .02" in diameter.

**TELESCOPIC TUBING**

*JFD Manufacturing Company, Inc.*, 6101 Sixteenth Ave., Brooklyn 4, New York is now offering a new series of telescopic tubing.

The "Sky-Lok" line features flared bottoms and curled-in tops for all sections to prevent pulling out. In addition, a heavy-duty bolt goes completely through the tubing at the bottom of

# INTERCOM SPECIAL!

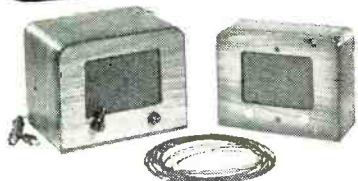

Now you can own an intercom that has a thousand uses at a price you would normally pay for a kit. This intercom comes housed in wooden cabinets completely wired and ready to operate. Outfit consists of one master, one sub station and fifty feet of two wire cable. Ideal for home as baby sitter. Perfect for office or factory. Order now as quantities are limited. YOUR COST **\$16<sup>65</sup>** COMPLETE only.

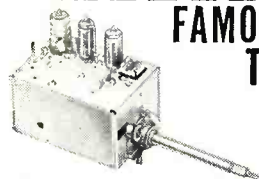

## FAMOUS G. I. TUNER

YOUR CHOICE  
**\$4<sup>99</sup>**

WITH TUBES

These tuners are brand new and guaranteed. Your choice of two or three tube tuner. 2-tube has 6CB6, 6J6. 3-tube has 3-6J6.

FREE BARGAIN CATALOG • WRITE DEPT. RN-5

**STEVE-EL Electronics Corp.**  
61 Reade St. New York 7, N. Y.

## CONCORD'S BUY OF THE MONTH

Sensational

SELF POWERED

2 WAY

PHONE SYSTEM



**\$4<sup>50</sup>** PAIR

Sensitive 2 way phone system Operate with telephone like clarity over distances of up to one mile. Phones made of rugged, shockproof Dow Styron with self-contained 1½ Volt flashlight battery. Has full size carbon mike 24 carat gold plated. Complete with push to talk switch, spring clip-on and wall brackets. Without a doubt, one of the most sensational service, office or home items ever offered. Complete with batteries. Two conductor twisted pair weatherproof wire for above. . . . 2e per ft 100 ft. \$1.50

**FREE! NEW 1954 CATALOG!**

A complete, comprehensive listing of all your electronic requirements. Bursting with SPECIAL VALUES



CONCORD RADIO, 53 Vesey St., N. Y. 7, Dept. NS

- Please send . . . sets of phones at \$4.50 ea.
- Enclosed find \$ . . . . in complete payment. Minimum 20% deposit with C.O.D.
- Send new 1954 CONCORD CATALOG!

NAME \_\_\_\_\_

ADDRESS \_\_\_\_\_

CITY \_\_\_\_\_ ZONE \_\_\_\_\_ STATE \_\_\_\_\_

**CONCORD RADIO • 53 VESEY ST. NEW YORK 7, N. Y. • Dlgby 9-1132**

The Type G02A may be used either as a clip-in or solder-in unit. Its dimensions are the same but it includes 3/16" clip pins.

The G02A is a direct replacement for any u.h.f. diode now being employed as a mixer in TV tuners and converters. Dept. 1A of the company will provide a copy of Bulletin ER-190 upon letterhead request.

### REMOTE CONTROL UNIT

Mercury Marine Electric Co., Inc. of 2905 Jones Street, San Francisco, Cal. is now offering an easily-installed

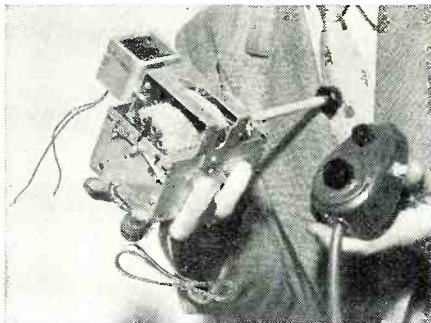

remote television control unit which is designed for trouble-free service and simplicity.

The control turns the set on or off, operates the picture contrast control and volume control, and operates the channel selector. It does not impair simultaneous use of existing controls. Twenty-five feet of plastic covered cable is furnished, with longer lengths available on special order.

A data sheet covering the "Control-master" is available on request.

### SMALL TV CAMERA

Diamond Power Specialty Corp., Lancaster, Ohio is now offering a small camera for industrial TV installations, the Model 300-BV.

The new camera is interchangeable with the company's standard "Utiliscope," Model 300-B, and compares favorably with it in simplicity of operation. All circuits are easily accessible for servicing.

Complete information on this new

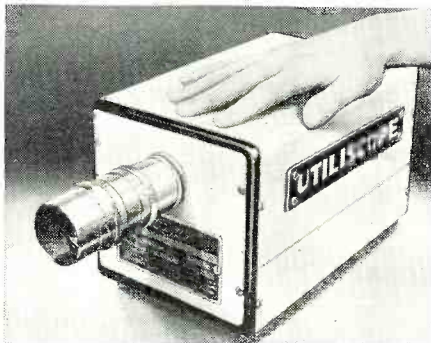

camera is included in Bulletin 1136A which is available from the company on request.

### ANTENNA ROTATOR

The Radiart Corporation, Cleveland, Ohio is now marketing a new television antenna rotator, the Model TR-4 "CDR-Rotor."

The new rotator is a redesigned ver-

## You Can Become an ELECTRICAL ENGINEER with a Bachelor of Science Degree IN 36 MONTHS

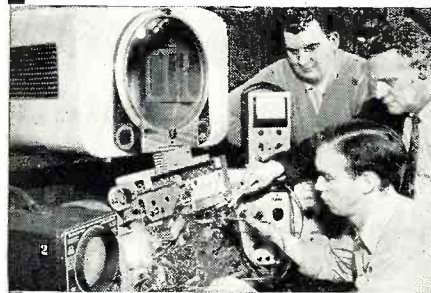

Major in Electronics or Power at Milwaukee School of Engineering

Everyone knows the tremendous opportunities ahead in electrical engineering. The expanding field of color television alone is one example. In addition to the demand for engineers, thousands of engineering technicians are needed. The Milwaukee School of Engineering can prepare you to become an engineer in 36 months or an engineering technician in 12 to 18 months. It'll pay you to look into it today. No obligation.

### Technician and Service Courses — 12 to 18 months

In 12 months you can be a radio technician. An additional 6-month course qualifies you as a radio-television technician with an Associate in Applied Science degree. Or you can earn an industrial electronic technician certificate in 12 months.

These technician courses form the first third of the program leading to a B. S. Degree in Electrical Engineering. Twenty-one subjects studied include electronics, electronic engineering, and electronic design.

Also offered are: radio-television service course (12 mos.); electrical service course (6 mos.); general preparatory and refresher course (3 mos.).



Terms open July, September, January and April

Faculty of specialists — 50,000 former students — Annual enrollment from 48 states and 23 foreign countries — Non-profit institution — 51st year of service — Course approved for veterans — Residence courses only.

## MILWAUKEE SCHOOL OF ENGINEERING

TEAR OUT AND MAIL TODAY  
MILWAUKEE SCHOOL OF ENGINEERING  
Dept. RN-554, 1025 N. Milwaukee Street  
Milwaukee 1, Wisconsin

Send me  Free illustrated booklet on opportunities in Electrical Engineering or  Free illustrated booklet on careers in Radio-TV.

I am interested in \_\_\_\_\_ (name of course)

Name \_\_\_\_\_ Age \_\_\_\_\_

Address \_\_\_\_\_

City \_\_\_\_\_ Zone \_\_\_\_\_ State \_\_\_\_\_

If veteran, indicate date of discharge \_\_\_\_\_



## V.O.M. GRIEF

By JOSEPH D. AMOROSE

"TAKE nothing for granted when servicing radios—never be too sure."

Failure to observe this little precept can result in costly multimeter damage—it happened to the writer recently. An RCA model 85T1 radio receiver came in for repairs. The owner said it was serviced in another shop, but it still didn't play. A glance showed that a rectifier tube and filter condenser had been newly installed. The set was plugged in cautiously; the tubes lit up, pilot light burned normally, and all seemed favorable for a more extended test. Voltages on all plates and screens were measured next. These were practically nonexistent—less than 10 volts registered where a potential of 250 volts should have existed. The test prods were then placed on the second (output) filter condenser. Same thing here—less than 10 volts.

"Just a routine job," it was assumed, "the 1300-ohm dynamic speaker field is probably open." To check this, the test leads were moved to the first (input) filter, and since 340 volts was the top voltage listed on the schematic for this set, the v.o.m. was set on the 500-volt scale. Surely this range was enough.

But here tragedy struck!

Upon touching the test leads to the input filter condenser terminals, the needle shot up to the opposite pin with terrific force. The pointer bent and calibration was ruined. A careful check of the wiring at the input filter was made (after the tears had been wiped away) and the trouble was quickly located. The technician (?) who had previously installed the new input filter condenser had replaced the wires incorrectly. He had removed the speaker field's lead from the plus side of the input filter condenser and attached it to the negative lead of this condenser, as shown by the dotted line in the diagram. To make matters worse, he also failed to reconnect the minus leg of the input filter to the "B—" leg of the power supply where it normally belonged. As a result of this incorrect wiring, the full voltage of the transformer's high-voltage secondary was impressed across the input filter condenser causing it to store over 700 volts.

After the wires were connected properly, the set performed perfectly. It turned out that the owner was the "technician" who had made the previous "repair." The oft-repeated warning: "Always use a higher v.o.m. scale than you anticipate you will need," should bear repeating once again. It can never be quoted too often—if it will save a multimeter.

Original diagram and the service fault introduced by a "technician" which resulted in a burned out meter for author.

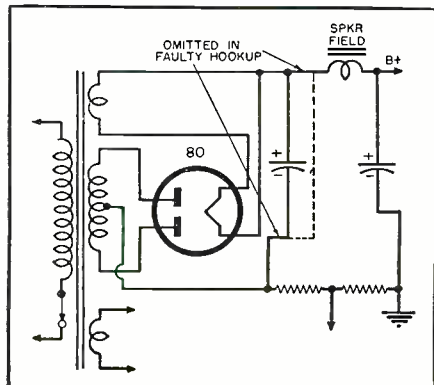

May, 1954

# NEW Grammes CUSTOM HI-FI COMPONENTS

**216BA Professional Amplifier**—New 2 in 1 Tri-Linear Triode amplifier. Wider frequency range. Higher power. Lower distortion. Improved version of two popular amplifier circuits. Switch selects either: 1—in Triode position it operates as an advanced Williamson circuit 2—in Tri-Linear position, it becomes a super-powered tapped screen circuit. **\$.99.50**

**210PA Professional Pre-Amplifier**—New equalizer pre-amplifier control in period styled cabinet. Full frequency range. Lowest distortion. Negative feedback around each stage. Exact equalization for any record by individual turnover and roll-off controls. Step-type bass, treble controls. Ideal remote control for finest amplifiers, **\$.99.50**. Cabinet extra.

**206PA De Luxe Pre-Amplifier**—New complete equalizer pre-amplifier 4-knob control. Record compensator switch with 3-channel input selector for correct playback curves. Feedback magnetic pick-up equalization, cathode follower output. **\$.55.00**

**50PG3 De Luxe Amplifier**—New advanced version of famous 50PG2. Peak power: 20 watts. Wider range, lower distortion. New pickup pre-amp. Cathode coupled tone controls. Removable panel. **\$.55.00**

**100BA De Luxe Amplifier**—A basic unit for the average hi-fi home system. Full range reproduction with low distortion and reserve power with tonal quality to rival costlier amplifiers. **\$.41.25**

**LJ2 Economy Amplifier**—Popular, low cost, good fidelity unit. Peak power: 18 watts. Built-in pre-amp. **\$.41.75**

**5PA Pre-Amplifier**—Economical, self-powered unit. Adapts any amplifier or radio for use with magnetic pick-up. Input for G. E., Audak and Pickering. **\$.11.50**

**RC1 Record Compensator**—Provides correct playback curve for all records. Designed for amplifiers without compensator controls. **\$.10.00**

Write today for FREE detailed information!



**PRECISION  
ELECTRONICS, INC.**  
9101-RC KING AVENUE FRANKLIN PARK, ILL.

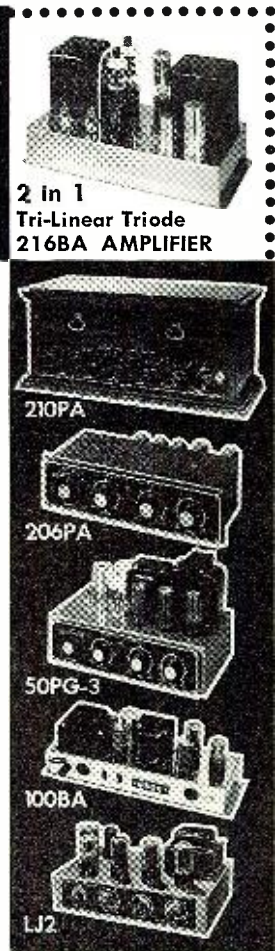

HiFi

ONE OF THE GREAT NAMES IN RADIO SINCE 1922

Pioneers and specialists in AM and FM, the name Freed-Eisemann has provided the highest quality performance in radio and television. This experience over the years assures you of the highest standards of sound reproduction... guarantees High-Fidelity!

The new Freed-Eisemann single chassis hi-fi unit is based upon the most advanced concepts of the art. No "one" assembly can match its excellence!

Beautifully styled, the Freed-Eisemann chassis may recline on an open shelf or table or may be readily dismantled for console installation. Complete, ready to operate, by merely connecting a High-Fidelity speaker.

Fine AM-FM Tuner of superior performance

High Fidelity 10 watt amplifier of low distortion response and wide frequency range.

... on one chassis

for ease of installation and operation

- Tuned RF on both AM and FM for maximum sensitivity and selectivity.
- Audio frequency Response: 20 cycles to 20,000 ± 1db. at full output.
- Audio output 10 watts at less than 1.5% distortion.
- Record compensation—Treble and Bass Controls.
- Jack for Tape Recorder.
- Electronic Tuning Eye.

... a product of

Write Department RN5 for illustrated literature

**Freed Electronics & Controls Corp.** • 200 Hudson St. • New York 13, N. Y.

# High Fidelity



at moderate cost

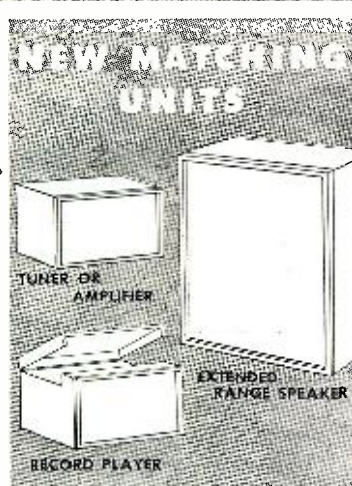

A complete ensemble of 3 cabinets—now only a fraction of previous cost. Handsome mahogany or blonde leatherette (same price). Sleek modern design with extended top and slanted sides. Carefully built with "Craftsmanship in Cabinets."

**DBR-2 Speaker Cabinet**—for use as two-way, infinite baffle, or bass reflex system .....Net \$34.80

**UC-1** Takes most any tuner or amplifier on the market.....Net \$14.40

**UC-2** For Record Player. Inside space 16½" W. x 9½" H. x 14" D. Net \$15.90

*Craftsmanship in Cabinets*



# MANUFACTURERS' LITERATURE

The various listings presented in this section are for your convenience. The bulletins, unless otherwise indicated, are available to all our readers. For prompt attention write directly to the manufacturer for this literature.

## PROMOTIONAL MATERIAL

The Home Instrument Department of *Radio Corporation of America* is now distributing an elaborate kit of display material, mailing pieces, and other promotional aids for the company's high-fidelity phonograph line.

The kit includes a special high-fidelity demonstration record with excerpts from various *RCA Victor* records and a commentary by Deems Taylor explaining the advantages of high fidelity.

## INDUSTRIAL IRONS

*Hexacon Electric Co.*, 119 W. Clay Ave., Roselle Park, N. J. is now offering copies of its new catalogue covering industrial electric soldering irons.

Catalogue No. 106 features many new additions to the company's line and lists a total of forty models in seven distinct types from 25 to 700 watts, ¼" to 1½" tips.

## CONTROLS AND RESISTORS

*Clarostat Mfg. Co., Inc.* of Dover, N. H. has announced the availability of its Catalogue No. 54 which features standard controls and resistors for radio and electronic equipment as well as industrial components.

Printed in two colors, the catalogue includes concise descriptions of the products, photographs, dimensional drawings, listings, prices, and standard packings. Copies are available from the company's distributors or the company direct.

## COLOR TV EQUIPMENT

*Radio Corporation of America*, Camden, N. J. has released its first catalogue of standard color broadcast equipment.

Included in the publication are all of the items required for transmitting network color programs including requisite test equipment. All of the equipment listed is currently in production by the company.

## "SECOND OP"

A handy new operating aid for amateurs is now being produced by *Electro-Voice, Inc.* of Buchanan, Michigan.

Known as the "Second Op," the new unit is a 10½" circular computer that puts complete DX operating information at the fingertips and speeds QSO's. On the single computer it is possible to read data on every country and amateur-recognized subdivision covering prefix; great circle beam heading; time and date at the DX location; air mail, first class, and QSL card postage rates; IRC exchange

table; continent; DX zone; prefix-to-country translation; and QSL bureau addresses. Also included is a log to indicate date of contact and receipt of QSL card for each country.

"Second Op" is available from the company for \$1.00 prepaid.

## MAGNECORD CATALOGUES

*Magnecord, Inc.*, 225 W. Ohio Street, Chicago 10, Ill. has just issued two comprehensive catalogues—one a general full-line listing of products available for professional use and the other a complete catalogue of equipment for the hi-fi market.

The general catalogue describes all professional equipment in detail and includes specifications on the company's binaural recorder. A comparative chart lists all specifications for each type of recording mechanism and each available amplifier.

Copies of these publications are available on request.

## "TEMPLES OF TONE"

A comprehensive 16-page brochure on high-fidelity has been published by *Electro-Voice, Inc.* of Buchanan, Michigan.

Entitled "Tools for Building Temples of Tone," the new publication explains the three basic types of equipment needed for hi-fi reproduction. It also shows the character and effects of audible sound in relation to octaves and frequencies and explains the important subjective effects of various portions of the audible spectrum.

The brochure goes on to explain how to choose components comprising a hi-fi system. A copy of Bulletin No. 216 is available from the company for ten cents in coin or stamps to cover postage and handling.

## PARTS CATALOGUE

*Clum Manufacturing Company's* Electronics Division, 601 W. National Ave., Milwaukee 4, Wis. is now offering a copy of its 1954 catalogue to interested persons.

This 8-page publication lists ferrite antennas, TV coils, TV filters, r.f. chokes, oscillator coils, terminal strips, and lock switches. A copy of this electronics parts catalogue will be forwarded upon request.

## PICTURE TUBE SELECTOR

A pocket-size, slide-rule picture tube selector which solves most picture tube replacement problems is now being offered by the cathode ray tube division of *Allen B. Du Mont Labs, Inc.*

The selector gives complete electri-



## UHF TRANSMITTER-RECEIVER APS-13

**\$495**

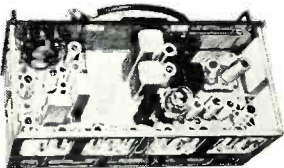

Freq. range 415-429 MC. 5 stages of 30 MC. IF amplifier. Complete with R.F. and I.F. sections. Less dynamotor and tubes. With schematic. Excel. cond.

### ARC-5/R-28 2-METER RECEIVER

Here is the 2-meter superhet you have been looking for! Absolutely one of the BEST available today. Tunes from 100 to 156 Mc. in four crystal channels. (Easily converted to continuous tuning.) Tube lineup is as follows: 717A—R.F., 717A—Mixer, 2—12SH7—1st and 2nd I.F. 16.9 Mc. EXCEL. COND. ....\$24.50

BC-604 30 W. FM TRANSMITTER. For 20-27 MC. band. Ideal for 10-11 meters. Complete with tubes, temperature controlled crystal oven and technical manual with all instructions for BC-603 and BC-604. Less dynamotor and crystals. Excel. cond. .... **\$12.95**

### TG-10 CODE KEYS

Self-Contained Automatic unit for code practice signals from an inked type recording. Complete with 7 tubes and electric eye. Audio freq. output of 800 CPS. Size: 11 x 24 x 18 1/2"—110-220 VAC 60 cy.—78 RPM motor can be used for a turntable—Power unit can be used for a P.A. system—wt. 65 lbs. Excellent cond. ....\$22.50



### C.A.P. SPECIAL BC-625 VHF TRANSMITTER

Freq. range 100-156 MC. With modulation section and speech amplifier. Less tubes & crystals, with conversion dope. Used, good condition. (See Nov/53 CQ.) **\$9.95**

### ARB NAVY RECEIVER

105 to 9050 KC. Four Bands. Calibrated Dial. LF-Ship-BC-80 & 40 Meter—Complete with Tubes and Dynamotor. For 24 Volt operation: easily converted to 110 V.—12 or 6 Volt. Size: 8 1/4" x 7 1/4" x 15 1/2". Excellent cond. ....\$32.50  
DU-I. DIRECTION FINDER LOOP AMPLIFIER for ARB receiver. With tubes and loop. Excellent condition ....\$19.95



### ID6/APN4

Made to operate in conjunction with Radio Receiver R-9 ( )/APN-4. Unit includes 19 tubes, one 5" scope tube, crystal controlled standard oscillator, sweep circuits, marker pulses. Excellent cond. Less tubes but with 5" scope tube. .... **\$29.50**

WITH TUBES & CRYSTAL. ....\$39.50  
DYNAMOTOR SPECIAL: 9 V. input, Output 450 V. 75 mls. With extended shaft and drive gear on one end. New ....\$7.95

### BEST HEADSET & MIKE BUYS

H-160 HEADSET. 8,000 ohms ....\$3.95  
HS-18 HEADSET. New ....2.45  
HS-23 HEADSET. High imp. New. ....4.95  
HS-30 HEADSET. Featherweight type. Low imp. New. ....\$2.49 USED. ....1.49  
HS-33 HEADSET. Low imp. New. ....5.50  
HS-38 HEADSET. USED. excel. cond. ....1.49  
NEW ....3.50  
RS-38 MIKE. NEW. \$4.95 USED. ....2.75

PE-125 POWER SUPPLY: Operates on 12 or 24 V. battery. NEW. ....\$17.95

T9—MODULATION TRANSFORMER. For BC-610 Transmitter. Pri. 16-000 Ohms CT. sec. 8,330 ohms @ 250 ma. Fully shielded steel case. New. \$34.50



### Sound Powered Handset TS-10

Uses no batteries or external power source. Ideal for TV installation work, farms, construction projects, connecting outbuildings, extensions, etc., includes 5 ft. cord. **\$14.50**  
Used, Excel. cond. PER PR. ....\$18.50  
NEW. Ea. ....\$9.95 NEW Per Pr. ....\$18.50

LM. METER. Frequency meter with modulation. Freq. range: 125-20,000 Kc. With calibration book. Excel. cond. ....\$49.50

### FREE HAM FLYER!

Featuring Loads of Special Values  
SEND FOR YOUR COPY TODAY!

All shpts. F.O.B. whse. Calif. residents add sales tax, 25% deposit required. Specify shipping instructions and ADD SHIPPING COSTS TO EACH ORDER. All items subject to prior sale and change of price without notice.

### ARROW SALES INC.

Mailing Address: P.O. Box 3878-Q, N. Hollywood, Calif.  
Office-Warehouse: 7460 Varna Ave., N. Hollywood, Calif.

cal values, basing, and important physical features for 36 major replacement picture tube types. Over 100 other tube type listings are indexed according to interchangeability with the basic types.

The selector is being made available through the company's picture tube distributors.

### CABINET FOLDER

James B. Lansing Sound, Inc., 2439 Fletcher Drive, Los Angeles 26, Cal. has issued a 4-page instructional folder on its rear-loaded folded horn corner console enclosure which is available on request.

Booklet No. 34 is designed primarily for hobbyists and experimenters who wish to develop their own instrument in built-in format. The booklet provides a basic formula which may be adapted to specific conditions with additions to be made at a later date.

The folder is illustrated with photographs and schematics and depicts eight separate and distinct constructional steps from raw material to the finished product.

### B-T SERVICE MANUAL

A sixteen-page booklet containing schematic diagrams and service data for all of its home and master TV units is now being offered by *Blonder-Tongue Laboratories, Inc.*, 526-536 North Avenue, Westfield, N. J.

Complete circuit information, parts lists, and typical voltage readings are supplied for each electronic unit. Master TV installation and maintenance notes and a dealer list of replacement parts are also featured.

The publication is available from the company's distributors for 25 cents a copy.

### TECHNICAL MONOGRAPH

*Helipot Corporation*, South Pasadena, California has made available a copy of a paper presented by Irving J. Hogan at the 1952 West Coast IRE Convention.

Entitled "Electrical Noise in Wire-Wound Potentiometers," the twelve-page illustrated monograph describes the kinds of noise which can originate in a precision potentiometer, methods of observing and measuring noise, and sets up a system of units in which such noise can be expressed.

Copies of this publication are available from the Technical Information Service of the company without charge.

### THORDARSON BOOKLETS

*Thordarson-Meissner*, Mt. Carmel, Illinois is offering two new publications of interest to the industry.

Catalogue 54-A includes 83 schematics covering approximately 300 coils, cross references to competitors' numbers, 62 new TV coils, and a new r.f. heater supply, and complete listings of the *Meissner* hi-fi components and kits.

The second publication, TV-21, consists of 32 pages featuring schematics, diagrams, catalogue material, and re-

## You save more... ...service better with EMC PRECISION INSTRUMENTS

The top quality of EMC precision instruments has been proven by years of coast-to-coast tests performed both in the field and on the bench covering every servicing condition.

Exceptionally low prices on these quality instruments are made possible by combining every new engineering advance with EMC large volume production.

Convince yourself... check the features and prices of the two outstanding examples quoted below...

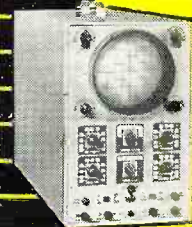

### NEW MODEL 600 OSCILLOSCOPE

Compare these high quality features with scopes selling up to twice the price of the new model 600.

- Uses new 5 U1 - 5" scope tube for sharp focusing and good intensity.
- Retrace blanking amplifier to eliminate confusion and give clearer pictures.
- Has built-in 60 cycle phasing control and sweep for TV servicing.
- Uses astigmatism control for better focusing.
- Provision for Z axis input or intensity modulation.
- Synchronization available on position or negative phase of input voltage or from external source.
- Uses a 2 step compensated attenuator input.
- Has a 2 stage push-pull vertical amplifier with sensitivity of .02 volts per inch.
- Multivibrator swap from 15 cycles to over 75 kilocycles.
- Direct connections to scope plates available.

New Model 600 (completely wired and tested).....\$99.50

### MODEL 106 VACUUM TUBE VOLTMETER

Compare these high quality features with meters selling up to twice the price of Model 106.

- Completely electronic—meter cannot burn out
  - Dual triodes balanced bridge circuit
  - Zero center adjustment for TV and Fm alignment
  - Uses 1% precision resistors for voltage multipliers
  - Full scale deflection of 1 1/2 volts for both AC-DC volts
  - 1 meg. isolating resistor in probe
  - Measures resistance in 5 ranges from 2 ohm to 1000 megs.
  - Space saving portable Bakelite case — 4 1/4" x 5 1/4" x 2 7/8"
- New Cost-Saving Prices... Lowest on market for wired and kit form.

Model 106, illustrated (Complete with all leads).....\$35.90

Model 106, in kit form..... 23.90

RF and high voltage accessory probes available.

## EMC ELECTRONIC MEASUREMENTS CORPORATION

280 Lafayette Street, New York 12, New York  
Export Dept., 303 W. 42nd St., N. Y. C.

Write department RTN-5 for complete catalog.

Buy PEERLESS  
and you buy  
the BEST!

Insist on Peerless 20-20  
And 20-20 Plus transformers.

Consistent quality.  
Uniform response.

Smooth roll-off.  
High efficiency.

Low distortion.  
No dips, no peaks.

When your amplifier is equipped with a Peerless 20-20 Transformer (20-20, 600 cycles) you can be confident of high quality performance. Rigid adherence to stringent specifications and tight quality control are reflected in the outstanding performance of Peerless 20-20 transformers surpassed only by the 20-20 PLUS line.

When superlative performance is desired, the Peerless 20-20 PLUS is the answer. The 20-20 PLUS has all the famous features of the 20-20 line PLUS wider frequency range, PLUS improved efficiency, PLUS smaller size, PLUS increased power rating, PLUS greater value. You can depend on Peerless for the best.

Write today for the Peerless Catalog

 **PEERLESS**  
Electrical Products

A DIVISION OF



9356 Santa Monica Blvd., Beverly Hills, Calif.  
161 Sixth Avenue, New York 13, New York

placement listings for approximately 6000 TV models.

Either or both of these catalogues are available without charge from Dept. C of the company.

#### EBY CATALOGUE

*Eby Sales Co.*, 130 Lafayette St., New York 13, N. Y. is currently distributing copies of its new Catalogue No. 54.

This 24-page bulletin lists sockets and shields, terminal strips, battery plugs, binding posts, connectors, tip jacks, radio and TV accessories and components, and wiring harnesses.

The catalogue is lavishly illustrated and contains complete specifications on the offerings.

#### AEROLITE CATALOGUE

*Aerolite Electronics Corporation*, 507 26th Street, Union City, N. J. has issued a 32-page catalogue for manufacturers.

The items listed in the catalogue are pictured and diagrammed and in most cases complete specifications are provided. The line includes all types of assembly hardware and components, alignment tools, wire, panel indicators, patchcords, etc.

Requests for this catalogue will be honored only on letterhead request from manufacturers.

#### CONDENSED AUDIO DATA

*Audio & Video Products Corporation*, 730 Fifth Ave., New York 19, N. Y. has published a tape recording accessories catalogue which is free on request.

The six-page publication has been designed to provide the answers to such questions as which equalizer should be used, what about filters, which microphone for which application, which power amplifier is suitable, etc.

The various pieces of equipment selected to answer the questions are fully described and pictured in this folder.

#### REPLACEMENT PARTS

*Rogers Electronic Corp.*, 43-49 Bleecker Street, New York, N. Y. has published a 16-page replacement catalogue which is being made available to TV distributors and service technicians without charge.

The catalogue includes a complete list of TV set models with their full-focus deflection yoke and flyback transformer replacements. The publication also includes diagrams and other useful data.

#### PROMOTION KIT

*Burgess Battery Company*, Freeport, Ill. is now offering a sales promotion kit for portable radio battery dealers.

The kit contains a battery selection chart, window streamers, replacement guide, door decal, cross reference chart, replacement stickers, and retail price chart. It is available from the company's distributors.

Editors and Engineers

PUBLICATIONS

#### RADIOTELEPHONE LICENSE MANUAL

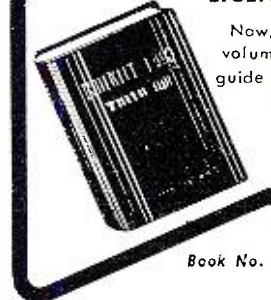

Now, in one convenient volume, complete study-guide questions with clear concise answers for preparation for all U.S.A. commercial radio-telephone operator's license examinations

Book No. E&E-RL1

\$3.75\*

WORLD'S EQUIVALENT TUBES (Equivalents Vade Mecum) NEW 10TH EDITION. A guide for substitutions of radio tubes, indicating direct or near equivalents.  
Book No. E&E-VM10. . . . . \$5.00\*

WORLD'S RADIO TUBES (Brans' Vade Mecum) 9TH EDITION. Lists over 15,000 tubes from every tube making country. Printed in 16 languages.  
Book No. E&E-VM9... . . . . \$5.00\*

ANTENNA MANUAL. A practical, comprehensive book on antennas, for everyone interested in transmission and reception. Over 300 pages.  
Book No. E&E-AM1..... \$3.50\*

SURPLUS RADIO CONVERSION MANUAL. VOL. 1. Practical conversions. Write for list of contents. Book No. E&E-SM1..... \$2.50\*

SURPLUS RADIO CONVERSION MANUAL. VOL. 2. Companion to Volume 1.  
Book No. E&E-SM2..... \$2.50\*

\*Plus any tax.

**BUY FROM YOUR DISTRIBUTOR**  
ADD 10% ON DIRECT MAIL ORDERS TO  
EDITORS and ENGINEERS, Ltd.  
BOX 689A, SANTA BARBARA, CALIF.  
Established order from BAKER & TAYLOR, Millis, N. J.

Special for QUICK Action  
The "BUY" of the Century

FIRST COME—FIRST SERVED



only \$12<sup>95</sup>

#### G.E. SR2A FM BUS RECEIVER

COMPLETE WITH ANTENNA & SPEAKER

Crystal Controlled, BUT easily converted to full FM band coverage or Police Bands.  
(Instructions Included)

12 volt input—Built-in Mallory Vibrapak worth more than the full price.

Complete with 12 good tubes.

Add Packing & Shipping Charge of \$1.00  
(No packing charge if you buy 3)

DON'T DELAY—ORDER TODAY

CRAMER ELECTRONICS INC.  
811 Boylston St., Boston, Mass.

RADIO & TELEVISION NEWS

**Ground Plane Antenna**  
(Continued from page 51)

length was increased slightly beyond  $\frac{5}{8}$  wavelength (47 feet) to improve the impedance match to the coax line, the field strength is reduced to approximately 263 millivolts per meter. This value gives a gain over a quarter-wave vertical of 1.8 on the horizon and at a vertical angle of 10 degrees, 1.6. In terms of db, the two gains are respectively 2.56 db and 2 db.

The  $\frac{5}{8}$  wave radiator has another advantage of producing maximum radiation at a height of  $\frac{5}{8}$  wavelength above the ground which reduces loss due to absorption of energy by house, garage, trees, etc. Maximum radiation from an antenna takes place at the current maximums, and in this case we have a current maximum located at a considerable height; i.e., one-quarter wavelength from the top. On 20 meters, this amounts to a height of 30 feet.

If you have the opportunity of comparing the vertical  $\frac{5}{8}$  wave antenna with another antenna, do so with a station which is located a considerable distance. I recall an instance several years ago when a friend informed me that his ground-plane on 40 meters was not as good as his little low horizontal job. He had made checks with a station located about 60 or 70 miles away. Further checks were made from my location under similar conditions and what he had said proved to be true. After studying the matter it was seen that the ground wave in either case has long since been attenuated so ground-wave communications between the two stations was not possible. Communications therefore were via sky wave, which in the case of the ground-plane was not possible because of the low radiation angles causing the signal to skip right over the receiving station. The energy from the horizontal, however, was concentrated at very high angles (see Fig. 7C) so that some of the energy was hitting the ionosphere at the proper angle and returning to the receiving station. Comparing the same two antennas at 2000 miles, the ground-plane was found to be far superior to the horizontal.

I have found that a thirty-foot telescoping pole, normally used to support TV antennas, makes an excellent bottom portion of the  $\frac{5}{8}$  wave radiator for twenty meters. This pole is available for approximately fifteen dollars. Several lengths of thin wall steel conduit that telescope inside the smallest section of the 30 footer can be added to bring the total length to 47 feet. The complete assembly is light (40 pounds) and can be put up by two people, first figuring what the length of the guy wires should be and installing two of them while the antenna is on the ground. While one fellow holds the base down the other fellow can



**PIX-O-FIX**  
**TV TROUBLE**  
**FINDING GUIDES**

by Ghirardi and Middleton

Don't guess . . . don't waste time on television receiver repairs! Cut service time in half on 2 jobs out of 3!

**PIX-O-FIX No. 1**—Identifies 24 of the more common television receiver troubles by actual TV screen photos. Gives 194 causes and 253 remedies for these troubles. Price separately \$1.25.

**PIX-O-FIX No. 2 (Just out!)**—Covers 23 additional troubles not included in No. 1 with accurate repair instructions. Together, the 2 volumes are a practical guide to "picture analysis" servicing of any TV set. Price \$1.25 separately.

**SPECIAL!** Get both at only \$2.00 for the two. Use coupon.

**RECOGNIZE TELEVISION TROUBLES At A Glance!**  
**... FIX 'EM TWICE AS FAST!**

**HANDLE 90% OF TV TROUBLES BY EASY PICTURE ANALYSIS**

The looks of the picture on a bad television receiver . . . or the lack of any picture at all . . . can usually tell you in a jiffy what is wrong. PIX-O-FIX Troubleshooting Guides not only make this easy, but also show just where and how to make repairs.

Just turn the PIX-O-FIX dial until the picture appearing in its "window" shows the same trouble symptoms as the picture in the set you're repairing. PIX-O-FIX then tells what is likely to cause this trouble and gives step by step repair instructions. Testing time is cut

to minutes. Repairs are made fast and easy and right!

**WORK BETTER AND FASTER!**

The two PIX-O-FIX Guides cover 47 different kinds of TV trouble . . . just about anything you're likely to be called on to fix. Operation is simple and easy.

Remember! PIX-O-FIX Guides are NOT "gadgets." They're practical professional servicing devices by two of America's best-known servicing authorities. Our money-back guarantee protects you fully!

**10-DAY MONEY-BACK GUARANTEE**

Dept. RN-54, Rinehart & Company, Inc.  
232 Madison Ave., New York 16, N. Y.

Enclosed find \$ . . . . . for which please rush the following:

PIX-O-FIX No. 1 (\$1.25)  PIX-O-FIX No. 2 (\$1.25)

BOTH PIX-O-FIX No. 1 and No. 2 at the special price of only \$2.00 for two plus postage

If not satisfactory, I will return PIX-O-FIX postpaid in 10 days and you guarantee to refund the purchase price.

Name . . . . .

Street . . . . .

City, Zone, State . . . . .

OUTSIDE U.S.A. \$1.50 each, \$2.50 for both. Same return privilege.

**POWER TRANSFORMERS**

Comb. Transformers	115V/50-60 cps. Input	
CT-479	7000V/.018A (2 X Ind. V. Test) 2.5V 5A/17,800 V. Test.	\$37.50
CT-138	520-0-520V/500MA, 6.3V/3A, 6.3V/1A	14.75
CT-013	450-0-450V @ 200 MA, 10V/1.5A, 2.5V 3.5A 5V/3A	6.95
CT-341	1050 100W, -625V @ 5MA, 26V @ 4.5A 2x2.5V/3A, 6.3V @ 3A	9.95
CT-071	110V .200A 33/.200, 8V/10, 2.5/10	4.95
CT-403	350VCT .026 A 5V/3A	2.75
CT-931	585VCT .086 A 5V/3A, 6.3V/6A	4.25
CT-442	525VCT 75 MA 5V/2A, 1 CT/2A, 50V/200 MA	3.85
CT-7501	650VCT/200MA, 6.3V/8A, 6.3V/5A	6.49
CT-444	230-0-230V/.085A, 5V/3A, 6V/2.5A	3.49

**"SEA-DOG" CONVERTER**

Designed for Buships, this rugged, compact dynamotor is rated as follows:

INPUT: 115 VDC—6 AMPS  
OUTPUT: 13 VDC at 40 AMPS  
—OR—26 VDC at 20 AMPS

Brand New, with Switchbox and Spare Parts. . . . . **\$89.50**

**DYNAMOTORS**

TYPE	INPUT VOLTS	AMPS	VOLTS	OUTPUT AMPS	PRICE
DM 416	14	6.2	330	.170	56.75
BD 63A	24	3.25	375	.150	7.50
BD AR 93	28	1.75	285	.075	3.95
23350	12	9.4	275	.110	8.95
B-19 Pack			500	.050	
DA-3A*	28	10	300	.260	6.95
			150	.010	
			14.5	5.	
PE 73 CM	28	19	1000	.350	22.50
D-402†	14	2.8	220	.08	12.95
	13.5	12.2	300	.200	
			8.8VAC		12.50
SP 175	18	3.2	450	.06	4.49
DM 25†	12	2.3	250	.05	6.95

† Less Filter  
‡ Used, Excellent

**INVERTERS**  
PE-218-H: Input: 25/28 vdc, 92 amp. Output: 115v. 350/500 cy 1500 volt-amperes. NEW. . . . \$37.50  
PE-206: Input: 28 vdc, 36 amps. Output: 80 v 800 cy, 500 volt-amps. Dim: 13"x5½"x10½". New . . . . . \$22.50

Send M.O. or Check, Shipping Chgs. C.O.D.  
**COMMUNICATIONS EQUIPMENT CO.**  
131 Liberty St., Dept. N.5 New York City 7, N. Y.

**FREE!**  
**THE HOTTEST VALUE-PACKED BULLETIN IN THE MAILS!**

Over 153,000 subscribers buy and save through

**WHOLESALE RADIO'S**

**F.Y.I. BULLETIN**

**EVERYTHING IN RADIO • TV HI-FI SOUND**

Write For Issue #130

**WHOLESALE**

**RADIO PARTS CO., INC.**

371 W. Baltimore St., Baltimore-1, Md.

**AIREX'S HI-FIDELITY**  
**1954 CO-CHANNEL 630FA-2A**  
 GENUINE FM ARMSTRONG SOUND SYSTEM  
 READY FOR COLOR CONVERTER

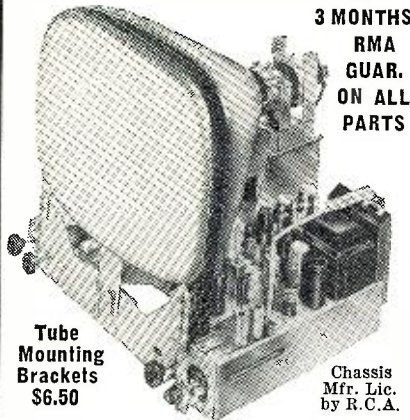

**Tube Mounting Brackets \$6.50**

**3 MONTHS RMA GUAR. ON ALL PARTS**

Chassis Mfr. Lic. by R.C.A.

**CHECK THESE EXCLUSIVE FEATURES**

- 10 WATT push-pull audio output. Frequency range from 40 to 12,000 cycles • 3 position fringe area switch • Delayed gated AGC system • Standard Coil Cascade Tuner prevents radiation • Retrace Blanking Circuit allows you to raise the brightness without the annoying vertical retrace lines • Heavy duty front focus control • Automatic gain control potentiometer allows you to adjust the threshold sensitivity as low as 4 microvolts & still keep the full 4 MC band width • Improved sync amplifier • Improved automatic brightness control • Set aligned for 21.9 MC. New Ham band will not interfere • Improved fused high voltage power supply gives full 14.5 KV under load. Will handle all picture tubes up to 24 inch round with full sweep • Improved video amplifier has a gain of 40 • All moulded plastic condensers give long life & trouble-free operation • Easily adapted to new UHF stations in 2 minutes by just changing a strip in the tuner • Extra heavy duty power transformer with large safety factor • 6CB6 tubes in Video IF to give full gain • Extra filtering in power supply for hum & ripple-free operation • Phono Connection & switch on chassis allows you to play your phonograph or tuner through the built-in 10 watt hi-fidelity amplifier • Extra heavy duty focus coil, which runs cool • Full focus cosine yoke.

**THE ONLY CHASSIS WITH 10 WATT PUSH-PULL HI-FI AUDIO SYSTEM AT**

**\$169<sup>95</sup>**

Fed. Tax Included Less C.R. Tube and Brackets

Complete with Two Speakers—12" Hi-Fi Woofer and Tweeter

With UHF 83 Channel Converter—\$211.90

Detailed Service Manual & Schematic—\$1

**COMBINATION SAVING!**

- 630 FA-2A Chassis
- 21" Picture Tube
- Mah. Console Cabinet

**\$244<sup>95</sup>**

With mask, glass, tube mtg brackets FOR THE 3 UNITS

**TV PICTURE TUBE SALE**

Standard Brands, Factory New. Guar. 1 year.

- 17" Tube . . . \$27.95
- 20" Tube . . . \$34.95
- 21" Tube . . . \$39.95
- 24" Tube Round (Guar. 6 Mos.) \$79.95
- 24" Tube Rect. \$59.95
- 27" Tube Rect. \$79.95
- Ring and Sleeve for 24" Round, \$ 7.50

**630 CHASSIS FOR 24" & 27" RECT. OPERATION \$189<sup>95</sup>**

PRICE . . . . . Not push pull audio

**TV GOLD PLASTIC MASKS**

- 16" and 17" . . . \$ 4.95
- 20" and 21" . . . \$ 7.95
- 24" . . . . . \$14.95
- 27" . . . . . \$17.95

630 UHF converter . . \$34.95

**BARGAIN CABINET BUY**

Beautiful mahogany console cabinet cut for 630 FA-2A Chassis. Complete with mask, glass & tube mounting brackets. **\$49.95**

In Blond . . . . . \$59.95

Send for complete cabinet brochure

SEND POSTCARD TO BE PUT ON FREE MAILING LIST

All merchandise brand new, factory fresh, guaranteed. Mail & phone orders filled upon receipt of certified check or money order for \$25 as deposit on TV chassis. 20% on other items. Balance C.O.D. F.O.B. factory N. Y. Prices & specifications subject to change without notice. NO FED. TAXES TO PAY.

**AIREX RADIO CORP.**

SHOWROOM: 171 Washington St., N. Y. 7  
 Cortlandt 7-5218

walk it up into position. Once in position the base is secured so that the base man is free to pull up on the third guy.

The coil is made with an inside diameter of 1/2 inch, #12 wire, wound 8 turns per inch. For the 20-meter band, the antenna should be 47 feet high and the coil should consist of 12 turns. A coil of 10 turns should be used with a 31-foot antenna for the 15-meter band. For the 10 meter band, use a coil of 8 turns with a 23-foot antenna.

The 47-foot vertical was used during the field day contest producing good reports from the east coast while running only 30 watts. A 579X report was received from Australia. The 3/4 wave radiator is nothing new but definitely something that has been overlooked by the hams. It adds that extra punch you've been looking for at a very reasonable cost.

Appreciation is extended to *Micro-wave Engineering Company* for granting permission to photograph and use their equipment to make the pattern measurements.

**Check Your Sweep Generator**

(Continued from page 57)

Excessive nonlinearity, or an excessive variation in output over the swept range, may indicate an actual defect in the sweep generator. In such a case, it may prove worthwhile to turn the instrument over to one of the laboratories specializing in instrument repair, or to contact the manufacturer. Unless adequate calibration equipment is available, and the service technician is familiar with its use, he should not undertake the repair of his own instruments (other than tube replacement and similar minor defects).

On the other hand, if the instrument is needed badly for day-to-day work, and can not be spared immediately, it is possible to obtain satisfactory alignment by noting the variation in linearity and output, and adjusting the i.f. stages accordingly. Thus, the final response curve as seen on the CRO may appear quite different from that recommended by the receiver manufacturer. However, the true response curve of the set, taking the limitations of the sweep into account, may be the one desired. To use this last mentioned technique effectively, it is necessary to experiment somewhat with the sweep generator and the alignment procedure. When doing this, use the station test pattern as a standard check on definition and over-all response until the necessary skill is developed.

To sum up, it is necessary that the service technician be thoroughly familiar with the accuracy and limitations of his sweep generator if his alignments are to be effective. Following the procedure outlined in this article, the technician can check his generator and discover what allowances he must make during alignment to compensate for any generator nonlinearity or attenuation over the swept range.

**GET THIS NEW SPRAGUE T-C RULE**

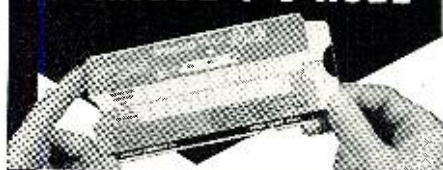

Save time . . . avoid mistakes . . . in finding the values of stock N750 and NPO type ceramic capacitors to connect in parallel to equal a capacitor of desired intermediate temperature coefficient of the required capacitance. Just slide this handy, pocket-size rule to the proper values and you'll come up with the right answer quick as a wink every time. On back are complete color codes on all types of ceramic capacitors. Ask your Sprague Distributor for one, or write to Sprague Products Co., 51 Marshall Street, North Adams, Mass. It's only 15c.

**SPRAGUE PRODUCTS COMPANY**

Distributors' Division of the Sprague Electric Co.  
 NORTH ADAMS, MASS.

1000 miles received at night!

**SKYMASTER PALM SIZE RADIO**

Vacuum tube miniature kit covers standard broadcast band 550 to 1600 KC. Hearing aid battery powered. A PERSONAL radio for home, office, camp, etc. This ideal beginner's kit includes photo diagram for easy assembling. ALL PARTS GUARANTEED. Batteries plus EXTRA "A" BATTERY, \$1.50. 1500 OHM ALNICO MAGNET powered earphone \$1.45. Flesh color 1900 ohm HEARING AID EARSET AVAILABLE AT \$4.95. C.O.D. orders acceptable with \$1 deposit within U.S. and possessions.



**\$6<sup>75</sup>** PostPaid

FACTORY-ASSEMBLED \$8.95 (SET ONLY)

PRECISION RADIO ELECTRONICS  
 Placerville, Calif.

**SPEAKER RECONING**

Complete line Cones, Spiders, Rings and Voice Coils. Custom Built Voice Coils. Low prices. Write for Parts List and Reconing information.

WESTERN ELECTRONICS CO.

3164 West Colfax Denver 4, Colo.



**\$2.95 EACH OR 2 FOR \$5.00!**

Genuine Telephone Company Upright Telephone complete with cords, in tested and guaranteed condition with 50 ft. of wire, roll of tape, inter-communication instructions. Tape and wire offer for this month only. Complete line of telephones, dial, magneto, inter-communication, etc. Write for free list. All shipments F.O.B.

TELEPHONE ENGINEERING CO.  
 Dept. 5X4 Simpson, Pa.

**SCHEMATICS—CONVERSIONS FOR SURPLUS GEAR**

NEW LIST! MANY ADDITIONS!

Send stamped, self addressed envelope for List C. Add 25c for chart explaining AN nomenclature.

R. E. BOX 1220  
 GOODHEART BEVERLY HILLS, CAL.

# PARTS SHOW EXHIBITORS

May 17-20, Conrad Hilton Hotel, Chicago, Illinois

Acro Products Co.  
Advance Electric & Relay Co.  
Aerolite Electronics Corp.  
Aerovox Corporation  
All Channel Antenna  
Alliance Manufacturing Co.  
Alpha Metals Co.  
Alpha Wire Corp.  
Alproco, Inc.  
Altec Lansing Corp.  
American Microphone Co.  
American Phenolic Corp.  
American Radio Hardware Co.  
American Screen Products  
American Television & Radio  
Amperite Co., Inc.  
Anchor Radio Company  
Argos Products Co., Inc.  
Astatic Corporation  
Astron Corporation  
Atlantic Wire & Cable Co.  
Atlas Sound Corp.  
Audio Devices, Inc.

Baker Manufacturing Co.  
Barker & Williamson, Inc.  
Baumker Manufacturing Co.  
Belden Manufacturing Co.  
Bell Sound Systems  
Berlant Associates  
Blonder-Tongue Laboratories  
David Bogen Co., Inc.  
Brach Manufacturing Co.  
British Industries Corp.  
Brook Electronics Division  
Bud Radio, Inc.  
Burgess Battery Company  
Bussmann Manufacturing Co.

Cannon Electric Co.  
Allen D. Cardwell Mfg. Co.  
Carter Motor Company  
CBC Electronics  
CBS-Hytron  
Centralab Division  
Channel Master Corp.  
Chicago Standard Transformer Corp.  
Clarostat Manufacturing Co.  
Clear Beam TV Antenna  
Cleveland Electronics  
Collins Radio Co.  
Columbia Wire & Supply Co.  
Conrac, Inc.  
Continental Carbon, Inc.  
Consolidated Wire & Assoc. Companies  
Copperweld Steel Products  
Cornish Wire Company  
Cowan Publishing Company  
Crescent Industries  
Crestwood Recorder Division  
Crown Controls Company

Davis Electronics Co.  
Delco Radio Division  
Drake Electric Works  
Dukane Corporation  
Allen B. Du Mont Labs., Inc.  
Duotone Company, Inc.

Easy Up Tower Co.  
Hugh H. Eby Co. (Eby Sales Co.)  
Eicor, Inc.  
Elco Corporation  
Eldico of New York, Inc.  
Electronic Instrument Co.  
Electronic Measurements Corp.  
Electronic Publishing Co.  
Electro Products Laboratories  
Electro-Voice, Inc.

Electrovox Company  
Equipto Division  
Erie Resistor Corp.

Federal Telephone & Radio Corp.  
Feiler Engineering Co.  
Fenton Company  
The Finney Company  
Fisher Radio Corp.  
Freed Electronics & Controls  
Freed Transformer Co.  
Fretco, Incorporated

Gabriel Electronics Div.  
Gee Lar Manufacturing Co.  
General Cement Mfg. Co.  
General Electric Co.  
General Industries Co.  
General Instrument Corp.  
G & H Wood Products Co.  
Gonset Company  
Gramer Transformer  
Granco Products  
Grayhill  
Great Eastern Mfg. Co.  
Guardian Electric Mfg. Co.

Haldorson Transformer Co.  
Hallcrafters Company  
Hammarlund Manufacturing Co.  
Hardwick, Hindle, Inc.  
Harman-Kardon, Inc.  
Haydon Products Co.  
Hickok Electrical Instrument Co.  
Hi-Lo TV Antenna Co.  
Hy-Lite Antenna

IE Manufacturing  
Illinois Condenser Co.  
Imperial Radar & Wire  
Industrial Television  
Insuline Corp. of America  
International Rectifier Corp.  
International Resistance Co.

Jackson Electrical Instr. Co.  
James Vibrapowr Company  
J-B-T Instruments, Inc.  
J. F. D. Manufacturing Co.  
Jensen Industries, Inc.  
Jensen Manufacturing Co.  
Jerrold Electronics Corp.  
Jersey Specialty Co., Inc.  
E. F. Johnson Company  
Jontz Manufacturing Co.

Kay-Townes Antenna Co.  
Kester Solder Company  
K G Electronics Co.  
Kleer Vue Manufacturing Co.  
Kuehne Mfg. Co.

James B. Lansing Sound Co.  
Lapointe Electronics, Inc.  
Leader Electronics  
Lenz Electric Mfg. Co.  
Littelfuse, Inc.  
Lowell Manufacturing Co.

P. R. Mallory & Company  
Master Mobile Mounts  
Merit Coil & Transformer Corp.  
James Millen Mfg. Co., Inc.  
J. W. Miller Company  
M. A. Miller Manufacturing Co.  
Miller Television Co.  
Model Engineering & Mfg., Inc.  
Modern-Aire Mfg. Co.  
Mosley Electronics

# NOW! BECOME EXPERT AT RADIO- TELEVISION

## IN 4 EASY STEPS!

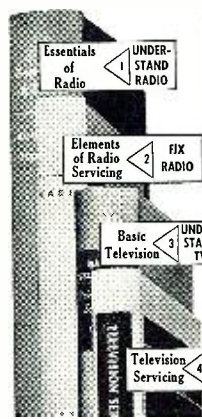

Complete Self-Training Library in RADIO and TV by Famous Experts — Takes You BY SIMPLE STEPS From Basic Theory to Problems of Repair, Installation, Color TV, etc.

Now you can do ANY Radio-TV installation, service, or repair job like an expert; operate field-testing equipment; understand problems of TV, FM-AM transmission, etc. Step into a good-paying job—or start your own service business. Train yourself AT HOME . . . IN SPARE TIME . . . with the McGraw-Hill Radio and Television Servicing Library.

2296 Pages—  
1611 Illustrations

The men who wrote this complete 4-volume Library are among the outstanding radio and TV instructors in America today. Every detail is clearly explained in over TWO THOUSAND PAGES of step-by-step instruction and over SIXTEEN HUNDRED "how-to-do-it" illustrations, cross-section diagrams, etc. The review questions and answers "nail down" everything you learn. At-a-glance "trouble-shooting" charts show how to diagnose instantly any radio or TV breakdown . . . and how to repair it expertly and quickly. The Library will pay for itself many times over. It gives all you need to know for FM and TV in the FCC's 1st-class license exam; gives an experienced technician more confidence and skill.

### SEND NO MONEY

Mail coupon below to examine complete four-volume Library FREE for 10 days. No obligation. Or you may examine individual books FREE for 10 days by checking the proper boxes in coupon.

### PARTIAL CONTENTS ESSENTIALS OF RADIO.

800 pages, 433 illus.  
Circuit Analysis • Vacuum Tubes • Circuits: Detector • Amplifier • Tube Oscillator • Power Supply • Transmitting, Receiving • Etc.

### ELEMENTS OF RADIO SERVICING.

475 pages, 375 illus.  
Multimeters • AC Power Supply • Speakers • Antennas • Auto Radios • Push-Pull Output Stage

### BASIC TELEVISION.

592 pages, 415 illus.  
Scanning • Synchronizing • Video Signal • Brightness Control • DC Reinsertion • Picture • FM Alignment • Picture Tubes • VHF and UHF transmission • Reception

### TELEVISION SERVICING

429 pages, 338 illus.  
Antennas • Transmission Lines • Test-pattern and Picture Analysis • Localizing Reception Troubles • Interference Remedies • Deflection Circuits  
AND MUCH MORE!

### FREE 10-DAY TRIAL COUPON

McGraw-Hill Book Co., Inc., Dept. RTN-5  
327 West 41st St., New York 18, N. Y.

Send me for 10 day free examination the Radio and TV Servicing Library, 4 Vols. (Regular retail price is \$27.25; Special Course Price only \$21.95 in easy installments.) If not satisfied with Course, I will return it, pay nothing. Otherwise, I'll send \$1.95 plus delivery then and only \$4.00 in monthly installments. If you wish to examine any of these books individually, check below the ones you wish us to send you for 10 Days' FREE EXAMINATION:

Essentials of Radio,  Elements of Radio Servicing, \$5.25  
 Basic Television,  Television Servicing, \$7.00

For any book I keep, I'll send \$2.00 plus delivery in 10 days, balance in easy monthly installments.

Name .....  
Address .....  
City ..... Zone ..... State .....  
Position .....  
Company ..... RTN-5

WE PAY FOR DELIVERY if you send first payment of \$1.95 when ordering Library or full price when ordering individual books (prices above). Same return privilege. (Offer applies to U.S.A. only.)

**GO MOBILE FOR MAY!  
GO COLUMBIA FOR VALUES!**

**40-METER RECEIVER:** 6 tubes with 3 I.F. stages. Good cond. **\$5.95**  
Less tubes  
**ARC-4 VIB. TRANSCIEVER:** For novices. 2-meter, CD or CAP. ALL TUBES included. Excellent cond. **\$27.50**

**12 AND 6 VOLT DYNAMOTORS—**

- 12 V. input, 1000 V. @ 350 ma. out. Has starting relay and fuse block. Like new. Tested. **\$19.95**
- 12 V. input, 625 V. @ 225 ma. out. Dim.: 7 1/2" x 3 3/4". Excellent cond. A little beauty. **\$19.95**
- 12 V. input, 260 V. @ 70 ma. out. For Command Receiver. New. **\$12.95**
- 12 V. input, 375 V. @ 150 ma. With filter base. Excellent condition. **\$5.95**
- 12 or 24 V. input **VIBRATOR POWER SUPPLY.** 475 V., 200 ma. out. New. **\$17.50**
- 6 V. input, 350 V. @ 130 ma. out. Completely filtered with starting relay. New. **\$17.95**

**SCR-183 12V. RECEIVER & TRANSMITTER:** Covers marine, as well as aircraft and ham bands with proper coil. Has 2 coils, 2 control boxes, tuning head, flex cable. 12 V. dynamotor. PARTS ALONE WORTH \$25.35! Approx. 25 W. output. Plus schematic. **\$12.95**

**NEW LOW PRICE**  
12 V. 25 AMP DELCO-REMY MOBILE GENERATOR: Fair, used condition. Best price at lowest in many a month. **\$3.95**

**CRYSTALS! HAM BANDS! ALL FREQS. FT-243 HOLDER, 10 or more. Ea. 69c**  
5 or more. Ea. 89c Individually. Ea. 99c

**AMATEUR CRYSTAL KITS!**

**GRIND YOUR OWN CRYSTALS!** Kit consists of 1) One master crystal for calibration purposes plus 9 additional commercial crystals in original holders with fundamentals on holders. 2) All necessary crystal grinding components. 3) Easy to follow instructions. 4) Material to re-work holders. No expensive lab equipment needed. Simple as A-B-C!

80 METER KIT **\$7.95**  
40 METER KIT **6.95**  
2 METER KIT using 18th harmonic **6.95**  
2 METER KIT using 24th harmonic **6.95**

**NOVICES! Here's the kit for YOU!**

1 American Beauty 100 W. SOLDERING IRON  
1 Pair LONG NOSED PLIERS  
1 Pair DIAGONAL CUTTER  
100 NEW, MISCELLANEOUS RECEIVER PARTS. Tube sockets, chassis, resistors, condensers, etc. COMPLETE KIT. REGULAR \$10.95 value. Only **\$4.95**

**MARINE MEN—A-HOY!**

**BC-223 25 W. MARINE TRANSMITTER:** Pipe the specs, mate! 12 or 24 V. input. 4-channel crystal controlled. Complete with ALL tubes, power supply, cable, mike and 4 crystals ground to YOUR frequency in the 2-3 Mc. marine band. Schematic included. New! COMPLETE! A **\$89.50** spankin' good value.

**JEFFERSON-TRAVIS MARINE 5 W. RADIO-PHONE:** 2-channel crystal controlled TRANSCIEVER. Complete with tubes and instructions but less crystal. **\$99.50**

**ARB RECEIVERS:** Look at its range: 195 Kc. to 9.05 MC! Terrific for DF work. Excellent cond. ONLY **\$49.50**

**MARINE CRYSTALS:** Any marine frequency, any type holder. Ground to your specs. FCC approved. **NEW!** Set of 4 **\$19.95**

**NEW SIG. CORPS RELEASE**

**LATEST FIELD TELEPHONES:** made of lite-weight aluminum. Waterproof. Long range. Has bell or neon indicator for call signal. Uses a handset with F-1 button. Easily converted to terrific phone patch. Complete with bats. BRAND NEW. PER PAIR. **\$19.50**

**APS-13 "Tail End Charley" TRANSCIEVER** 420 MC. UHF. 3 stages of 30 MC. IF amplifier. Complete with RF & IF section & schematic less tubes and dynamotor. Good cond. **\$4.95**

**TUBE BUYS! LOWEST PRICES!**

5BP4 .. \$2.95 6AC7 .. 62c 813 .. \$6.95  
6SN7 .. .75 829-B .. 7.95 832-A .. 4.95

**METER: TRIPLETT.** 3" Rd. 0-100 microampere. New **\$5.95**  
**METER:** 0-15 V. AC. 2" rd. Westinghouse. New **\$2.95**  
**METER:** 0-9 amps RF 2" rd. Westinghouse. New **\$3.49**

**DUAL METER INDICATOR:** Has 2 individual movements each perpendicular to the other. One has 110 microamperes movement; other —210 microampere movement. Makes terrific "S" meter or field-strength meter. Dim.: 3 1/4 x 3 in. New, with cracked lens. **\$3.49**

**WRITE FOR FREE CATALOGUE!**

GET OUR COMMAND GEAR PRICES!  
MINIMUM ORDER \$3.00  
All orders F.O.B. Los Angeles. 25% deposit required. All items subject to prior sale. Note New Address. Dealer Inquiries Invited.

**COLUMBIA ELECTRONIC SALES**

2251-53 W. Washington Blvd., Los Angeles 18, Calif. Come in and visit our new, larger centrally located warehouse-store!

**TELEVISION**

**PREPARE FOR A GOOD JOB!**  
BROADCAST ENGINEER  
COMMERCIAL OPERATOR (CODE)  
RADIO SERVICING

**Television Servicing**

(Approved for Veterans)  
SEND FOR FREE LITERATURE  
**BALTIMORE TECHNICAL INSTITUTE**  
1425 EUTAW PLACE, BALT. 17, MD.

Don McGohan, Inc.

National Carbon Co.  
National Company  
National Electric Products  
National Teletable Corp.  
National Union Radio Corp.  
National Video Corp.  
Newcomb Audio Products

Ohmite Manufacturing Co.  
Orradio Industries  
Oxford Electric Corp.

Par-Metal Products Corp.  
Peerless Products Div.  
Penn Television Products  
Pentron Corporation  
Perma-Power Company  
Permoflux Corporation  
Permo, Inc.

Philmore Manufacturing Co.  
Pickering & Company  
Plastoid Corporation  
Potter & Brumfield  
Precise Development Corp.  
Precision Apparatus Co.  
Premier Metal Products  
Presto Recording Corp.  
Pyramid Electric Company

Quam-Nichols Company  
Quietrole Co.  
Q-Line Mfg. Corp.

Racon Electric Co.  
Radelco Manufacturing Co.  
Radiart Corporation  
Radio City Products Co.  
Radio Corporation of America  
Radio Craftsmen, Inc.  
\*Radio-Electronics  
\*Radio-Electronic Jobber News  
Radio Materials Corp.  
Radio Merchandise Sales  
Radion Corporation  
Radio Receptor Co., Inc.  
\*Radio & TV Journal  
\*Radio & Television News  
\*Radio & TV Weekly  
Ram Electronics Co.  
Rauland-Borg Corp.  
Raytheon Manufacturing Co.  
Recoton Corporation  
Reeves Soundcraft Corp.  
Regency Division  
Rego Insulated Wire Co.  
Rek-O-Kut Company  
John F. Rider Publisher, Inc.  
River Edge Industries  
Rockbar Corporation  
Rohn Manufacturing Co.  
Rytel Electronics Mfg. Co.

Howard W. Sams & Co.  
San Fernando Elec. Mfg.  
Sangamo Electric Co.  
\*Service Magazine  
\*Service Management Magazine  
Shure Brothers, Inc.  
Simpson Electric Co.  
Mark Simpson Mfg. Co.  
Skyline Manufacturing Co.  
Herman H. Smith, Inc.  
Snyder Manufacturing Co.  
Sola Electric Co.  
Sonar Radio Corp.  
Sonotone Corp.  
South River Metal Products  
Spirling Products Co.  
Sprague Products Co.  
Standard Coil Products  
Standard Electrical Products  
Stephens Manufacturing Co.  
Stevens Walden, Inc.  
Stewart Warner Company  
Stromberg-Carlson Co.  
Sutton Electronics Co.  
Switchcraft, Inc.

THE WORLD'S FIRST  
**BUILD-IT-YOURSELF  
ELECTRONIC ORGAN**



TONE GENERATORS  
KEYBOARDS  
POWER SUPPLIES  
STOPS  
AMPLIFIERS  
TONE CABINETS  
CONSOLES

SAVE HUNDREDS OF DOLLARS  
WITH OUR COMPLETE KITS AND  
STEP-BY-STEP INSTRUCTIONS

You can assemble one octave at a time. Build a one to three-manual organ. You order only materials you need. Send for FREE catalog.

**ELECTRONIC ORGAN ARTS**

DEPT. N  
BOX 16454 VINE STATION  
Los Angeles 38, Calif.

**CRYSTALS!**

**COMPLETE SET—80 CRYSTALS**  
Ranging from 370-516 Kc., 54th Harmonic. INCLUDING 500 Kc. & 455 Kc. crystals. **\$6.95**  
Only **Per set**

**COMPLETE SET—120 CRYSTALS**  
Ranging from 370-540 Kc., 72nd Harmonic. INCLUDING 500 Kc. & 455 Kc. crystals. **\$9.95**  
Only **Per set**

200 KC. CRYSTAL **1.75**  
500 KC. CRYSTAL **2.25**  
1,000 KC. CRYSTAL **2.75**

GENERATOR: 12 V. 35 A. Used cond. **Ea. \$3.95**

**EXTRA!** See Our Ad in April '54 Radio News. Loads of Hot Buys. No Change in Prices!

ALL MERCHANDISE **SEND FOR**  
SOLD AS IS **FREE CATALOGUE**  
**J. J. GLASS ELECTRONICS CO.**  
1615 S. MAIN ST. LOS ANGELES 15, CALIF.

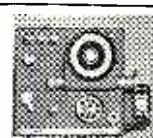

**RECEIVER FOR HAM  
NOVICE AIRCRAFT  
BOAT & MOBILE**

U.S. Navy RU-18 6 tube sensitive receiver with straight wire and loop input, closeout sale only 100 available, with this special price choice of any 2 of the below coil sets with ea. set some coils are dual freq. a HJ & low W/ a switch others are single (195-435) (540-830 & 2040-3000) (540-830 & 3000-4525) (540-830 & 5200-7700) (2040-3000) (400-600 & 6000-9050) (4000-6000) and a few 830-1330 all freq. is KC extra coils \$2.50 each order early send P.P. charges W/order **\$8.95** shipping WT. packed 25 lbs. **ea.**  
**McCONNELL'S** New Address: BARTO, PA. Phone: BALLY 3-3621

**TEST EQUIPMENT REPAIRED**

Contractors to U. S. Government  
Repairs and calibration by skilled craftsmen on all makes of Meters, Testers, Sig. Gen's., V.T.V.M.'s, Scopes, etc. Prompt service. All work guaranteed. For immediate estimate send instrument by P.P. Ins. to

**DOUGLAS INSTRUMENT LABORATORY**  
Electronic Instrument Repairers  
176 Norfolk Avenue Boston 19, Mass.

**ARKAY** WORLD'S FINEST  
**KITS**

RADIOS PHONOGRAPHS TV  
TEST EQUIPMENT HI-FI  
Write for FREE Brochure

RADIO KITS, INC. • 120 Cedar St., N. Y. 6

RADIO & TELEVISION NEWS

Sylvania Electric Products

- Talk-A-Phone Company
- Sarkes Tarzian, Inc.
- Tech-Master Products
- Technical Appliance Corp.
- Technician
- Tel-A-Ray Enterprises
- Electrosonic Corp.
- Tele-Ex-Pand Products
- Tele-Matic Industries
- Telex, Inc.
- Telrex, Inc.
- Thomas Electronics
- Thordarson-Meissner
- Transistor Products
- Triad Transformer Corp.
- Tricraft Products
- Trimm, Inc.
- Trio Manufacturing Co.
- Triplett Electrical Instr. Co.
- Tung Sol Electric
- TV Products
- Turner Company

- Ungar Electric Tools
- United Catalog Publishers
- United Transformer Co.
- University Loudspeakers
- Utah Radio Products

- Vaco Products Co.
- Van Cleef Brothers, Inc.
- Vidaire Electronics
- V-M Corporation

- Waldom Electronics
- P. Wall Manufacturing Co.
- Wallace's Telaides
- Walsco Electronics Corp.
- Ward Leonard Electric Co.
- Ward Products Corp.
- Webster-Chicago Corp.
- Webster Electric Co.
- Weller Electric Corp.
- Wen Products, Inc.
- Westinghouse Electric
- Weston Electrical Instr. Co.
- Wilcox-Gay Corp.
- G. F. Wright Steel Corp.

Xcelite, Inc.  
\*Trade Papers

**PHOTO CREDITS**

Page	Credit
35, 37 (Figs. 5 & 6)	Jerrold Electronics Corp.
37 (Fig. 4)	Blonder-Tongue Laboratories Inc.
43, 44, 45, 46, 113, 114	United Transformer Company
47	International Rectifier Corporation
59, 61	The Dubbings Company
63	Gonset Company
64 (Fig. 1), 65 (Fig. 6)	Snyder Mfg. Co.
65 (Fig. 3)	Channel Master Corporation
67	Allen B. Du Mont Laboratories
70	Radiojant, Stockholm
76	Trio Manufacturing Co.
120	Bell Telephone Laboratories

**ERRATUM**

There is an omission in the diagram accompanying the article "Rumble Filter" (page 147, March 1954 issue). A 470,000 ohm resistor should be connected between a point immediately following C<sub>1</sub> and ground. It is further suggested that a shorting-type switch be used rather than the ordinary d.p.d.t. specified to eliminate a momentarily open ground when switching.

**384,000 MOBILE-RADIO RIGS NEED MAINTENANCE!**

Make frequency and FM deviation checks on unlimited numbers of channels with just these 2 meters!



**LAMPKIN 105-B MICROMETER FREQUENCY METER**

Uses one crystal to measure all transmitters from 0.1 to 175 mc. Gives readings of percent error from assigned frequencies. Acts as precision CW signal generator for receiver final alignment.

**PORTABLE**—Width less than 13" . . . weight less than 14 lbs., each.

**MEET FCC REQUIREMENTS**—for mobile-service checks.

For technical data . . . mail coupon today!



**LAMPKIN 205 FM MODULATION METER**

Direct indication of peak voice deviation, 0-25 kc positive or negative. Tunable 25-200 mc. in one band. Doubles as relative field-strength meter. Built-in speaker. Jack for oscilloscope.

LAMPKIN LABORATORIES, INC.  
MFM DIVISION  
BRADENTON, FLORIDA  
Without obligation, please send me data on Lampkin meters.

Name \_\_\_\_\_  
Street \_\_\_\_\_  
City \_\_\_\_\_ State \_\_\_\_\_

**LAMPKIN LABORATORIES, INC.**  
Bradenton, Florida

**ARROW . . . First Again!**

**ARROW APPROVED Universal FM Tuner and Amplifier**



UNIVERSAL—"Golden" 5 Watt Amplifier      UNIVERSAL "Golden" FM Tuner

The new UNIVERSAL "Golden Series" of custom designed high fidelity audio equipment brings you the finest in quality systems components at the lowest possible cost.

**"Golden" 5 Watt Amplifier**

- Built-in Pre-Amplifier for Magnetic Pickups
- Four Inputs . . . all front panel controlled!
- Separate Bass and Treble Boost Controls Attenuation

Net price . . . . . \$27.95

"Golden" FM Tuner, Model 711. FM Tuner, "drift compensated" without bass and treble controls or pre-amplifier. It is designed primarily for use with an amplifier that has its own controls and pre-amp such as the UNIVERSAL "GOLDEN CUSTOM FIVE." A front panel switch is provided for Phono OFF-ON control.

Net price less cabinet . . . . . \$39.50

With mahogany cabinet . . . . . 44.75

(Mail Orders Accepted:  
25% Deposit, Balance C.O.D.)

**FREE!**

New 1954 Audio Handbook 104 pages of down-to-earth Hi-Fi information the Audiophile should know. Plus illustrations and specifications of all quality Hi-Fi equipment. Write to Dept. R, or visit our Sound Studios for your Free copy.



**ARROW Audio Center**  
ALWAYS AN AUDIO FAIR  
65 CORTLANDT ST., NEW YORK 7, N. Y.

**LEARN**

**Television-Radio Electricity REFRIGERATION-ELECTRONICS IN THE GREAT SHOPS OF COYNE**

**TRAIN QUICKLY! OLDEST, BEST EQUIPPED SCHOOL OF ITS KIND IN U.S.**

Come to the Great Shops of Coyne in Chicago. Get practical training in opportunity fields—TELEVISION-RADIO—ELECTRICITY—ELECTRONICS—vital in Defense Program. Prepare now for a better job in industry or better service rating.

**Approved for Veterans**  
Finance Plan—Enroll now, pay most of tuition later. If you need part-time work to help out with living expenses while at Coyne, we'll help you get it. **Special tuition plan for men of Draft Age.**

**FREE BOOK** Clip coupon for Big Free Illustrated Book. No salesman will call. Act NOW.

B. W. Cooke, President  
**COYNE SCHOOL** A TECHNICAL TRADE INSTITUTE CHARTERED NOT FOR PROFIT Established 1895 500 S. Paulina, Chicago

**ELECTRICITY ★ TELEVISION RADIO ★ REFRIGERATION ★ ELECTRONICS**

B. W. COOKE, Pres. (COYNE School) 500 S. Paulina St., Chicago 12, Ill. Dept. 54-H5

Send FREE BOOK and full details on:  
 TELEVISION-RADIO       ELECTRICITY

NAME \_\_\_\_\_  
ADDRESS \_\_\_\_\_  
CITY \_\_\_\_\_ STATE \_\_\_\_\_

FIVE TOP NAME BRANDS

STANDARD BRAND TUBES

at Sensational Savings!

- FULLY GUARANTEED
- INDIVIDUALLY BOXED

NO SECONDS... NO REHASHED "BARGAINS" NO REACTIVATED TUBES. YOU CAN PLACE YOUR CONFIDENCE IN OUR DEPENDABLE, NEW TUBES.

Tube Orders Over \$25.00, with full remittance, PREPAID to you in U.S.A.

RECEIVING TUBES

Type	Net	Type	Net	Type	Net
0A2	.95	6AV5GT	1.10	7A7	.75
0B2	.85	6AV6	1.57	7AB7	.69
0B3		6AX4GT	.84	7B6	.75
VR90	.82	6AX5GT	.80	7B7	.76
0C3		6BAG	.75	7BA7	.78
1R10S	.80	6BAE	.70	7C4	.29
0D3		6BC5	.74	7C5	.69
VR150	.89	6BE6	.72	7E5	.59
0Z4	.55	6BG6G	1.85	7F8G	1.55
0Z4A	.55	6BH6	.85	7H7	.70
1A7GT	.77	6BJ6	.85	7J7	.98
1B3GT	.90	6BK6	1.15	7K7	.90
1B2T	1.15	6BK7A	1.15	7X7	.90
1M5GT	.77	6BL7GT	1.20	12A7G	1.05
1L4	.50	6BN6	1.20	12A7T	1.05
1L6	.95	6BG6GT	1.20	12AU7	.84
1L4S	1.10	6BQ7A	1.23	12AV7	1.00
1L2S	1.10	6BY5G	1.75	12AW6	.88
1L5S	1.10	6C7	.95	12AX7	.80
1N5GT	.95	6C4	.56	12AY7	1.90
1R4	.95	6C6	.50	12B4	.98
1R4S	.95	6C8	.75	12B6	.70
1S5	.70	6C6DG	1.80	12B6E	.75
1T4	.75	6CU6	2.10	12BE6	.72
1U4	.75	6D7	1.80	12BH7	1.00
1U5	.70	6D5	3.50	12B7	1.05
1V	1.03	6F5	.68	12B7Z	1.10
1V2	.90	6F5GT	.68	12C6	.65
1X2	.90	6F6G	.80	12C7	.65
1X2B	3.25	6F6G	.80	12C7Z	.65
1X2C	.90	6F8G	.85	12D6	.70
3A4	.59	6G6	.85	12D6E	.70
3B7	.39	6H6	.52	12E6GT	.70
3B7S	.39	6H6	.52	12F6GT	.70
3CG5T	.90	6J4(RCA)	5.75	12G7	.63
3S4	.75	6J6	.80	12K7	.55
3L4	.75	6J7	.75	12L7GT	.65
3V4	.75	6K4		12M7GT	.85
5AW4	1.55	6K4A	2.25	12Q7GT	.63
5V4G	1.50	6K6GT	.65	12R7	.69
5U4G	.59	6K7	.60	12X7GT	1.11
5V4G	.97	6L6	1.10	12Y7	.50
5W4G	.80	6L6GA	1.10	19B6G6	2.05
5X4G	.75	6L6M	1.25	19T8	1.10
5Y3GT	.48	6L6M	1.25	25G6GT	1.35
6A8GT	1.10	6N7M	.70	25L6GT	.70
6A8	.70	6Q7GT	.80	25W4GT	.70
6A8T	.95	6S4	.63	25X6GT	.64
6AC7	1.14	6S4M	.63	25Z6GT	.64
6AF4	1.19	6S7	.69	28B7	1.55
6AG5	.78	6S7	.88	35A5	.72
6AG7	1.10	6S7GT	.88	35B5	.72
6AH4GT	.89	6S7GT	.88	35C5	.72
6AH6	1.23	6S7GT	.88	35D5	.72
6AJ5	1.30	6S7H	.98	35L6GT	.70
6AKS	.80	6S7H	.98	35M6GT	.70
6AKS-W	1.00	6SK7	.69	35Z6GT	.70
6AK6	.98	6SL7GT	.65	35Z6GT	.70
6AL5	.60	6SN7GT	.63	50B5	.48
6AN4	1.55	6S07	.63	50B5	.48
6AQ5	.72	6T8	.99	50C5	.72
6AQ6	.72	6U8	1.05	50L6GT	.70
6AS5	.75	6V6	.81	50L6GT	.70
6AS6	2.65	6V6GT	.67	81	.75
6AS7G	3.75	6W4GT	.65	83V	1.15
6AT6	.58	6W4	1.30	6Z4	1.40
6AU4GT	1.00	6X5GT	.52	11Z73	.75
6AUG	.65	6X8	1.00	11Z76	1.00

SPECIAL PURPOSE TUBES

Type	Net	Type	Net	Type	Net
1N21B	1.88	304TH	7.75	955	.45
1N23B	2.20	(Surplus)	7.75	CK1005	.85
1N34A	.55	310	1.85	1619	.33
1N48	.75	(WE)	3.75	1622	1.95
1N54	.75	407A	4.95	1626	.20
2C51	4.85	408A	3.00	1629	.25
2E26	3.40	(WE)	3.00	1632	.25
2E30		805	2.95	5516	7.65
(Hy)	2.20	805	2.95	5528	5.00
2J19	.22	807	1.55	5654	10.00
2J61	.29	809	1.55	5670	3.25
2J62	.25	812A	3.65	5687	2.95
2K28	.25	816	1.40	5691	7.00
3BP11	7.00	818B	1.40	5693	6.20
3B28	4.95	851	39.95	5814	7.75
3C23(GE)	6.75	866A	1.25	6096	1.85
3C24/24G	1.00			9003	1.45
4B24	4.50			9006	.25
5C22	44.95				
5D21	11.90				
7C25	110.00				
7C30	85.00				
211 WT4C	.88				

Above is only a partial listing of our huge stock. Types not listed may be ordered at approx. the same savings. Many new special purpose types in stock.

DE LUXE TUBE CADDY

This newly designed Tube Caddy is light weight and compact. It is ruggedly constructed, reinforced throughout. Holds approx. 150 tubes plus meters and tools.

SPECIAL AT \$12.95

TWO-COLORED TUBE CARTONS, with new Safety Partitions. Prevents Tube Breakage. This Super-Gloss Red and Black Carton is the Most Distinctive Box Available Today! Minimum: 100 any one size. Quantity prices on request.

SIZE	EACH
Miniature... (6AU6, 6AL5, etc.)	\$5.01
GT... (6SN7, 6W4, etc.)	.0125
LARGE GT... (1A3, 6BQ6GT, etc.)	.015
LARGE G... (5U4G, 6BG6G, etc.)	.02

Terms: 25% with order, balance C.O.D. Minimum Order \$5.00 All merchandise guaranteed. F.O.B., N.Y.C. PHONE: RECTOR 2-2562

**BARRY ELECTRONICS CORP.**  
136-F LIBERTY ST. N. Y. 6, N. Y.

INDEX OF Advertisers

MAY 1954

While every precaution is taken to insure accuracy, we cannot guarantee against the possibility of an occasional change or omission in the preparation of this index.

ADVERTISER	PAGE	ADVERTISER	PAGE
Aaron Electronics	145	Leotone Radio Corp.	140
Aermotor Co.	127	Littelfuse, Inc.	18
Airex Radio Corp.	156	London Mystery Magazine	147
Algeradio Electronics Co.	147	MacMillen Company, The	130
All Channel Antenna Corp.	93	Mallory & Co., Inc., P. R.	4th Cover, 75
Allied Radio Corp.	9	Mattison Television & Radio Corp.	98
Altee Lansing Corporation	154	McConnell's	147, 158
American Microphone Co.	141	McGraw-Hill Book Co.	157
American Phenolic Corporation	28	McIntosh Laboratory, Inc.	108
American Television & Radio Co.	16	Miles Reproducer Co., Inc.	94
Amplifier Corp. of America	144	Milwaukee School of Engineering	149
Argos Products Company	152	Mosley Electronics, Inc.	122
Arkay Radio Kits, Inc.	158	Moss Electronic Distributing Co., Inc.	105
Arrow Electronics	159	National Electronics of Cleveland	118
Arrow Sales, Inc.	153	National Radio Institute	3
Ashe Radio Co., Walter	87	National Schools	27
Atlas Sound Corp.	126	New Jersey Television Supply Co.	120
Audel Publishers	132	Nichols Wire & Aluminum Co.	98
Baltimore Technical Institute	158	Onan & Sons, Inc., D. W.	161
Barry Electronics Corp.	160	Orradio Industries, Inc.	137
Beeco Company	124	Part Mart	100
Bell Telephone Laboratories	29	Peak Electronics Co.	150
Boulevard Electronics, Inc.	142	Perma Power Company	106
Burstein-Applebee Co.	120	Permoflux Corporation	92
CBS-Hytron	85	Philco Corporation	20
Candler System Co.	147	Photography	121
Cannon Electric Company	128	Pickering & Company, Incorporated	6
Capitol Radio Engineering Institute	73	Platt Electronics Corp.	123
Centralab	83, 110, 112, 128, 142, 145	Power Electronics	138
Century Electronics Co.	104	Precision Electronics	151
Channel Master Corp.	82	Precision Radio Electronics	156
Cleveland Institute of Radio Electronics	23	Premax Products	114
Collins Audio Products Co., Inc.	99	Premier Radio-TV Supply	111
Columbia Electronic Sales	158	Progressive "Edu-Kits," Inc.	134
Communication Equipment Co.	155	Quietrol Company	122
Concord Radio	149	RCA Institutes, Inc.	21, 31, 133
Corona Radio & T.V. Co.	133	R W Electronics	119
Coyne Electrical School	120, 159	Radiart Corporation, The	95
Cramer Electronics, Inc.	154	Radio Corporation of America	89, 103
DeForest's Training, Inc.	5	Radio Craftmen, Inc., The	109
Delco Radio Corporation	22	Radio-Television Training Association	17
Douglas Instrument Laboratory	158	Rad-Tel Tube Co.	115
Dubbings Co., Inc., The	81	Raytheon Manufacturing Company	2nd Cover
Editors & Engineers, Ltd.	154	Rider Publishers, Inc., John F.	88
Electron Tube Wholesalers, Inc.	102	Rinehart & Co., Inc.	96, 108, 116, 155
Electronic Chemical Corp.	140	Sams & Co., Inc., Howard W.	136, 161
Electronic Instrument Co., Inc. (EICO)	34, 71, 118, 131, 133	Sam's Surplus	104
Electronic Measurements Corporation	153	Sangamo Electric Company	3rd Cover
Electronic Organ Arts	158	Scott, Inc., Herman Hosmer	124
Electro-Voice	8	Simpson Electric Company	14, 15
Erie Resistor Corporation	26	Sprague Products Company	156
Esge Sales Co.	135	Sprayberry Academy of Radio	19
Fair Radio Sales	94	Stan Burn Radio & Electronics Co.	138
Fairchild Recording Equipment Corp.	84	Standard Surplus	129
Federal Telephone and Radio Company	90, 91	Steve-El Electronics Corp.	149
Fisher Radio Corporation	7	Stuart Electronic Distributors	124
Freed Electronics & Control Co.	151	Sun Parts Distributors, Ltd.	108
G & G Radio Supply Co.	148	Superec Electronics Corp.	161
G & H Wood Products Co.	118	Superior Instruments Co.	102
G. L. Electronics, Inc.	130	Supreme Publications	127
General Cement Mfg. Co.	33	Sylvania Electric Products, Inc.	97
General Electric Co.	12, 13	"TAB"	162
Goldstar Co., The	144	Tech-Master Products Co.	143
Goodhart, R. E.	156	Tee Vee Supply Co.	101
Grantham School of Electronics	94	Telephone Engineering Co.	116
Greenlee Tool Co.	114	Telecommunication Institute	114
Harjo Sales Co.	141	Transamerica Electronics Corp.	126
Harvey Radio Company, Inc.	139	Telex, Inc.	113
Heath Company	77, 78, 79, 80	Teltron Electronics Co.	140
Henshaw Radio Supply	131	Terado Company	146
Hilliard Co., Robert	143	Tri-State College	143
Hi-Lite Electronic Sales Co.	139	Triplet	11
Hughes Research and Development Laboratories	112	Tung-Sol Electric, Inc.	86
Indiana Technical College	137	Ultra-Audio Broadcasting System	132
Instructograph Company	142	United Radio Co.	131
International Radio & Electronics Corp.	84	U. S. Crystals, Inc.	146
International Rectifier Corporation	10	Utah Radio Products Co.	107
International Resistance Company	24	Valparaiso Technical Institute	131
JFD Manufacturing Co.	30	Waldom Electronics, Inc.	146, 159
J. J. Glass Electronics Co.	158	Walseo Electronics Corporation	125
JSH Sales Co.	132	Washtek Service Co.	150
Jones & Laughlin Steel Corporation	72	Western Electronics Co.	156
Kay-Townes Antenna Company	32	Western Radio & Television Institute	138
Kedma Co.	137	Westinghouse Electric Corporation	25
Kester Solder Company	144	Wholesale Radio Parts Co., Inc.	155
Krylon, Inc.	134	Windor Electronic Tube Co.	104
Lafayette Radio	117	World Radio Laboratories	133
Lampkin Laboratories, Inc.	159	Xcelite, Inc.	127
Leeds Radio Co.	126	Zingo Products	147



# STAY ON THE AIR WHEN POWER FAILS...with an ONAN Electric Plant



**AUTOMATIC  
START & STOP**

Model 10EL, 10KW A.C.

When storms, floods, or fires interrupt electricity and force you off the air, you lose listeners and income. Guard against loss, assure vital public service during emergencies by installing an Onan Electric Plant. Onan Standby Electric plants serve many network and private stations. Gasoline driven automatic models to 50,000 watts.

**PORTABLE ELECTRIC PLANTS  
FOR MOBILE RADIO USES**



Supply A.C. power for broadcasting at scene of events. Light in weight. Can be carried by hand or in trunk of car. A.C. models: 400 to 3,500 watts.

Write for **FREE Folder**



**D. W. ONAN & SONS INC.**  
7902 University Avenue  
Minneapolis 14, Minnesota



## RUB AWAY NOISE FROM TV TUNER!

with

Superex

# NEW TUNERASER

STICK **98¢**  
NET

Removes tarnish and corrosion  
from all electrical contacts

Specially compounded to make turret contacts glow like new, this efficient Superex TUNERASER stick quickly, easily eliminates noise and intermittents from TV tuner. Simply rub on and watch tarnish and corrosion disappear. It's economical too! One stick lasts a year under normal use.



23 Atherton St., Yonkers, N. Y.

May, 1954

# Classified

Rate 50c per word. Minimum 10 words

## RADIO ENGINEERING

COMPLETE radio, electronics theory & practice: television; broadcasting; servicing; aviation, marine, police radio. 12 or 18 months. Catalog. Valparaiso Technical Institute, Dept. N, Valparaiso, Ind.

## FOR SALE

CIRCUIT Diagrams will save your precious time. Radio \$1.00. Television \$2.00. Give make and model. Carleton Radio, 39 Daniel, East Hartford 8, Conn.

TV-FM antennas. All types including UHF. Mounts, accessories. Lowest prices. Wholesale Supply Co., Dept. H, Lunenburg, Mass.

SPECIALS! 5" PM Speakers \$1.05, 3/\$2.95; 0-1Ma Meters \$3.65; 6V. Dynamotors 200V./130Ma \$8.95; 67 1/2 V. Good Surplus batteries 65c; Hearing aid pots 85c; Sectional Whip Antennas—16 ft. \$2.45, 32 ft. \$5.75; Radio Control 27 1/4 Mc Transmitter & Receiver kit \$9.95; New pocket TV high volts tester 3—15Kv. \$3.95. Free catalog. Gyro Electronics, 325 Canal Street, New York City 13.

RESISTORS, condensers, micas, electrolytics, tubulars, latest pigtail types, new, every piece usable, some short leads. 5 lbs.—\$5.00, 10 lbs.—\$8.50. Prepaid. Cagan, Box 1152, Rochester, N. Y.

DIAGRAMS—Radio \$1.00; record changers, recorders \$1.25. Television with service data \$2.00. Where model unknown, give part numbers. Kramer's Radio Service, Dept. S53, 36 Columbus Ave., New York 23, N. Y.

TAPE Recorders, Tapes, Accessories. Unusual Values. Dressner, 624-R East 20th St., N.Y.C. 9.

ALUMINUM tubing, angle and channel, plain and perforated sheet. Willard Radcliff, Fostoria, Ohio. FREE: Get our monthly electronic lists. Dick Rose, Everett, Wash.

TELEVISION Sets, \$30 up. W4API, 1420 South Randolph, Arlington, Virginia.

MANUFACTURERS Surplus. 60 note-triple stacked shunt keying mechanisms. Octave wired isolating resistor to each palladium contact. 2 types, Great. 16' -8' -4'. Swell, 8' -4' -2 1/2'. Make your own electronic organ with these basic units. \$10.00 each. Minshall-Estey Organ, Inc., P.O. Box 537, Brattleboro, Vermont.

## WANTED

WILL buy all ART-13/type T-47A \$200.00; ART-13/type T-47, \$150.00; BC-348 unmodified \$65.00; BC-348 modified \$50.00; APN-9 \$200.00; ARC-3 complete \$600.00; R77 Receivers \$300.00; ARC-1 \$300.00; BC-312 \$60.00; BC-342 \$60.00. Ship via Express C.O.D., subject to inspection to: H. Finnegan, 49 Washington Avenue, Little Ferry, N. J.

WANTED—surplus selsyns, synchros, torque units, autosyns, amplidyne, aircraft radio equipment, tubes, etc. Highest prices. Lectronic Research, 715 Arch St., Philadelphia.

## BUSINESS OPPORTUNITIES

RADIO Ser. shop. 4 rental units on acre. Income \$550 p. m. Furnished stock. Del. wagon. Fine rep. No T.V. Any trial. Retir. to Eng. June. \$12,000. 1/2 cash. 1728 G Street, Sacramento, California.

## CORRESPONDENCE COURSES

USED correspondence Courses and Books sold and rented. Money back guarantee. Catalog free. (Courses bought.) Lee Mountain, Pisgah, Ala.

USED Correspondence courses and educational books bought, sold, rented. Catalog free. Educational Exchange, Summerville, Ga.

## MISCELLANEOUS

SPEAKER repairs on all makes. Jobbers wanted. Amprite Speaker Service, 70 Vesey St., New York 7, N. Y.

USED Radio Vibrators rejuvenated \$1.25 each; 30 day guarantee. Radio Products Service, Box 591, Springfield, Ohio.

FREE money saving bargain list. 10 MFD/600WV Oil Capacitor 98c; RCA 3A1A \$5.95; add postage. Mark Electronic, 1888 Randell Ave., Bronx 72, N. Y.

COMPLETE Speaker Repair Service. Quality Workmanship and Parts. Charles B. Albright, 12373 Pierce St., Pacoima, Calif.

BUILD your own electronic organ or miniature electronic brain. Jim Kirk, W6DEG, 1552 Church St., San Francisco 14, Calif.

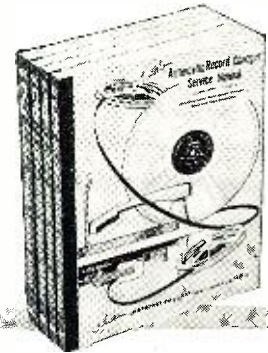

## be an expert on RECORD CHANGER SERVICING

with the HOWARD W. SAMS  
"AUTOMATIC RECORD CHANGER  
SERVICE MANUALS"

Get the only authoritative compilation of its kind—complete coverage of virtually all Automatic Record Changers produced since 1948—in 4 great PHOTOFACT Manuals. All data complete, accurate, uniform—based on first-hand lab analysis of the actual changers. Helps you service any model quicker, easier—for greater profits. Own and use the complete Library!

**NEW VOLUME 5.** Complete electrical and mechanical data on 22 record changers and tape recorders produced in 1952 and 1953. Features exclusive "exploded view" diagrams, "all-view" photos, full change cycle data, adjustments, service hints, complete replacement parts lists. Shows methods used for record support, record selection, pickup arm handling, needle setdown point determination, tripping, etc. Tape recorder coverage includes full head-adjustment, cleaning and operation details. All data is authoritative and accurate, obtained directly from lab analysis of the actual equipment. Makes you an expert on changer and recorder repairs. 288 pages, 8 1/2 x 11".

ORDER CM-5. Only.....\$3.00

**VOLUME 4.** Covers 38 changers and recorders produced during 1951.

ORDER CM-4. Only.....\$3.00

**VOLUME 3.** Covers 44 changers and recorders produced during 1949 and 1950.

ORDER CM-3. Only.....\$3.00

**VOLUME 2.** Covers 45 changers and recorders produced in 1948 and early 1949.

ORDER CM-2. Only.....\$4.95

Get into profitable Changer Repair work—  
ORDER THE COMPLETE "CHANGER LIBRARY"

## HOWARD W. SAMS & CO. INC.

Order from your Parts Jobber today, or write to Howard W. Sams & Co., Inc., 2203 East 46th St., Indianapolis 5, Ind.

My (check) (money order) for \$..... enclosed. Send the following books:

- CM-5 (\$3.00)       CM-3 (\$3.00)  
 CM-4 (\$3.00)       CM-2 (\$4.95)

Name.....

Address.....

City.....Zone.....State.....

(outside U.S.A. priced slightly higher)

INDUSTRIALS WRITE ON YOUR LETTER-HEAD FOR POWER SUPPLY CATALOG

SELENIUM RECTIFIERS. We specialize in Rectifiers and Power supplies to specifications. Immediate delivery.

Full Wave Rectifier & Transformer. All 115V/60 cy inputs. up to 14VDC at 12 amps. \$19.98

RECTIFIER XFMR. PRIMARY 115V/0-120V. SECONDARY 0-9-12-18-24-36V

RECTIFIER CHOKES. 4 Amp .07 Hy. 6 Ohm \$7.95

BATTERY CHARGER RECTIFIER. 12-30V (CT) 100 Amp. fan cooled.

HIGH CURRENT PWR SUPPLIES. Variable 0-28VDC. Completely Built, Ready to Go.

DC POWER SUPPLY. Variable DC Power supply, full wave rectification.

NEW RHEOSTAT LIST. 15 ohm 25W w/knob. \$1.10; 10 for \$7.00

SOLDERING GUNS & TORCHES-FAMOUS MAKE. LEAK-LESS LP. No flame. No soot or odor.

TWINE & COAX CABLE. 300 OHM Twine 65' \$1.39. Mil Hvy Dty 100 Ft.

PHOTOFLASH LAMPS. Replaces W-56. TLW FA104/U5W 150 \$5.98

100 WATT SEC PHOTOFLASH KIT. Includes 50 Flash Lamp. Rated 150 Watt Sec.

PRECISION LABORATORY POTENTIOMETER. Wirewound 2000 Ohm 25Watt

THAT'S A BUY. WATCH THIS SECTION EVERY MONTH. IRC HI-MEG HI-VOLT RESISTORS

VARIABLE VOLTAGE TRANSFORMERS. VARIAC-GR-STACCO. 0-135V/3A \$11.25

866A KIT and XFORMER. 2 Tubes, Sects, xmfr. 115V/60Vc inpt.

DIODE PROBE TUBE. UNEXCITED FOR NO-LOSS HYV TESTING.

INFRARED SNOOPERSCOPE. Image-Converter Tube. Hi-sensitivity.

TRANSFORMER. Const. Dty 115VAC Inpt. Size 2 1/8" Hx 1 1/2" W

TACHOMETER GENERATOR. MARK V STUD MFG. GENERAL ELECTRIC

"TAB" TESTED & GUARANTEED. PRICES SUBJECT TO CHANGE

Table with columns for part numbers (e.g., OA2, OA3, OA4) and prices. Includes various electronic components like resistors, capacitors, and tubes.

FILAMENT TRANS. 2.5VCT/10A 12.5Vctns \$5.50; 3 for \$14

TRANSFORMERS. All 115 V 60 Cye Inpt. TV CT Pwr Xmfr up to 20"

TELEVISION ANTENNA. CONICAL Broad response, all channel, powerful for fringe areas.

FILTER CHOKES. Check These Reduced Low Prices. 12Hy/80MA/Hsld/3KVs \$2.25

TACHOMETER GENERATOR. MARK V STUD MFG. GENERAL ELECTRIC. Part #2CMS-AAK-20

"TAB" TESTED & GUARANTEED. PRICES SUBJECT TO CHANGE. WRITE FOR COMPLETE LISTING

Table with columns for part numbers (e.g., 82, 83, 84) and prices. Lists various electronic components and their current prices.

Table with columns for part numbers (e.g., 1N21A, 1N21B) and prices. Lists various electronic components and their current prices.

MIKES & HEADSETS. Crystal Mike Cartridge \$1.25; 5 for \$5

OIL CONDENSERS. NEW WAREHOUSE LISTING. 00025MFD/25KV \$6.00; 2 for \$10.00

OIL CONDENSER SPECIAL. 10 MFD \$1.75 ea. lots of 3

Audio Amplifier. Ready to Go. MODEL TUSP Ultra Hi-Fi

"TAB" STYL SPECIALISTS. ELECTROVOICE Triplay \$1.98

COAXIAL SPEAKERS. All 8 Ohm V.C. Alnico V Magnets. Inbuilt net work, 2 wires

NEW RELAY LIST. Tremendous Price Reductions. R1T1 Stevens Arnold Resonant

CRYSTAL DIODES. KEMTRON-W.E. SYLVANIA. 1N21 .49c; 10 for \$ 3.98

Radio & Television News. Money Back Guarantee. (Cost of Mfg. Only) \$5

Visit Booth 776  
at the May Parts  
Show and see ...

Not only  
these fine  
Electrolytics  
but also ...

Sangamo's  
complete  
line of high  
quality mica,  
paper, molded  
tubular, and  
button type  
capacitors.

8C64-7

# Sangamo Dry Electrolytics

Live many seasons  
for heap good  
reasons

these wire lead  
tubular capacitors  
will not deteriorate  
with age



Use Sangamo dry tubular electrolytics for trouble-free replacements. You don't have to worry about premature failure. Long life is really built into these capacitors. They have exceptional staying power because:

- 1 A super-seal keeps the electrolyte from evaporating even under the toughest conditions of heat and humidity.
- 2 All these capacitors are aged at 85° C to build a tough dielectric film that will stand up under high heat.
- 3 All aluminum container prevents the "creeping" corrosion that occurs in capacitors when any other metal is permitted to contact the electrolyte.
- 4 Sangamo electrolyte is really pure. Continuous laboratory control of every batch keeps the chlorine ion concentration to less than 10 parts per million. That's 99.999% pure, or better!
- 5 No lead breakage. Sangamo uses a special wire that resists bend fatigue. A specially designed rivet that "cradles" the lead gives additional protection.

**P. S.** These wire lead tubulars fit those tight corners— Their compact design gives maximum capacity in minimum space. See your Sangamo Distributor for all your capacitor replacement needs.

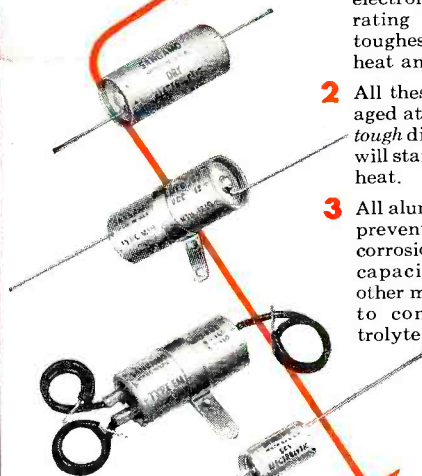

Those who know



choose Sangamo

## SANGAMO ELECTRIC COMPANY

MARION, ILLINOIS

The easy way  
is the right way . . .  
when you use *Mallory Midgetrols*®

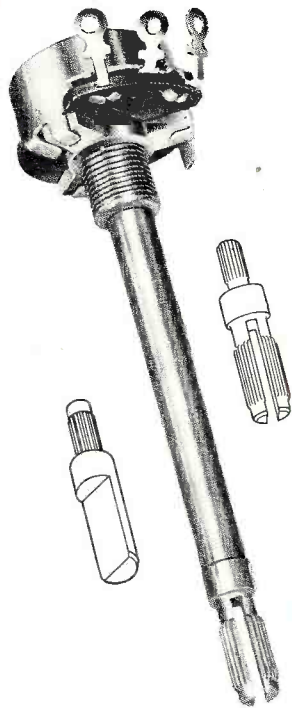

*Easy*

because the round, tubular shaft of the Mallory Midgetrol can be cut accurately and quickly. Easily adapted to split-knurl, flatted, or set screw type knobs. And you save additional time because AC switches can be attached instantly without control disassembly.

*Right*

because Mallory Midgetrols are engineered to match the electrical characteristics of original equipment of any radio or TV set . . . give equal, often better, performance than the original control.

*For Jobs*

done right the easy way, always use Mallory Midgetrols. You'll save time and trouble. And, equally important, you can depend on Mallory Midgetrols for performance that makes satisfied customers.

*To make your auto radio repair work easier . . .*



The new Mallory Auto Radio Control Guide speeds selection of the proper control for every job that comes your way. Ask your Mallory Distributor for a copy . . . or write to P. O. Box 1558, Indianapolis, Ind.

P. R. MALLORY & CO. Inc.  
**MALLORY**

CAPACITORS • CONTROLS • VIBRATORS • SWITCHES • RESISTORS  
RECTIFIERS • POWER SUPPLIES • CONVERTERS • MERCURY BATTERIES

**APPROVED PRECISION PRODUCTS**

**P. R. MALLORY & CO. Inc., INDIANAPOLIS 6, INDIANA**