

RADIO & TELEVISION NEWS

APRIL

1954

35 CENTS
In Canada 40¢



INCLUDING
*Communication
Engineering*

IN THIS ISSUE

U. H. F. FRINGE INSTALLATIONS

THE UNIVERSAL VIBRATO

FUNDAMENTALS OF COLOR TV

IMPEDANCE MATCHING OF
MULTIPLE SPEAKERS

HORNS FOR THE
P. A. TECHNICIAN

A 146 MC.
CIVIL DEFENSE STATION

THE AUTO-TONE

TV BOOSTER FOR U. H. F.

THE SIGNAL BOUNCER

THE U. H. F.
CORNER REFLECTOR

(See Page 63)

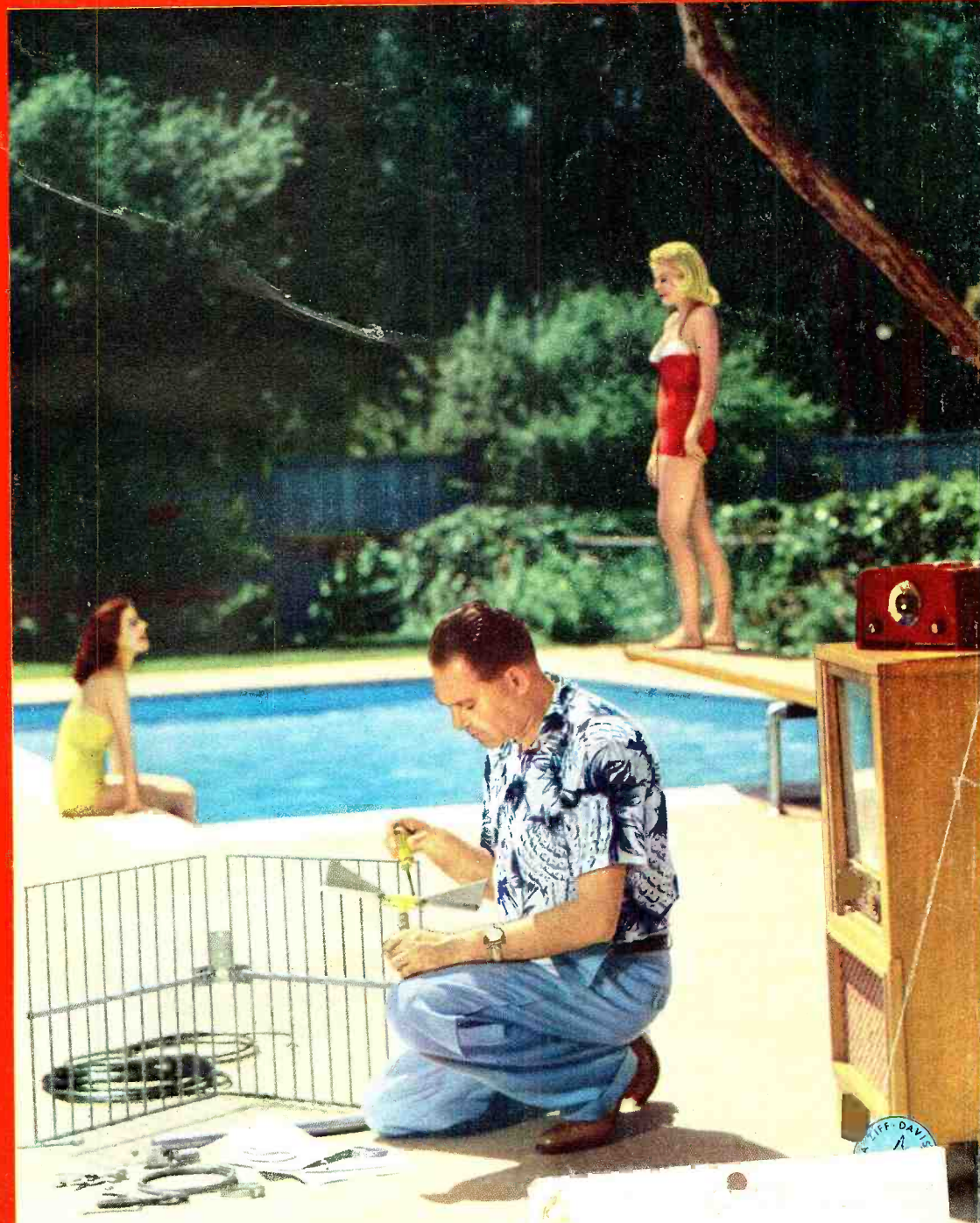

GRAND RAPIDS 8 MICH
102 RIDGEWOOD ST SE
GLENN LEDGER
MRS C-4-30-40-00

PEOPLE WON'T LOOK FOR YOU TO GIVE YOU RADIO AND TELEVISION SERVICE BUSINESS...

because YOU'RE PRETTIER  THAN YOUR COMPETITOR OR

because YOU EMPLOY MORE MEN  OR

because YOU HAVE FLASHIER TRUCKS 

BUT... THEY WILL LOOK FOR YOU AND GIVE YOU

MORE BUSINESS* IF YOU ARE A



BONDED ELECTRONIC TECHNICIAN



and YOU'LL KEEP THE BUSINESS IF YOU USE



QUALITY RADIO AND TELEVISION TUBES



because THEY ARE **RIGHT...FOR SOUND AND SIGHT!**

**BETTER ASK YOUR RAYTHEON TUBE DISTRIBUTOR IF YOU CAN
QUALIFY FOR THIS EXCLUSIVE SALES STIMULATOR**

*In a recent survey Raytheon Bonded Electronic Technicians indicated that the *Raytheon Bonded Program* boosts their volume and profit at least 10 per cent.

RAYTHEON MANUFACTURING COMPANY

Receiving Tube Division
Newton, Mass., Chicago, Ill., Atlanta, Ga., Los Angeles, Cal.

RAYTHEON MAKES ALL THESE:

RECEIVING AND PICTURE TUBES • RELIABLE SUBMINIATURE AND MINIATURE TUBES • SEMICONDUCTOR DIODES AND TRANSISTORS • NUCLEONIC TUBES • MICROWAVE TUBES



Excellence in Electronics



You Build THIS TRANSMITTER
with Parts I Send

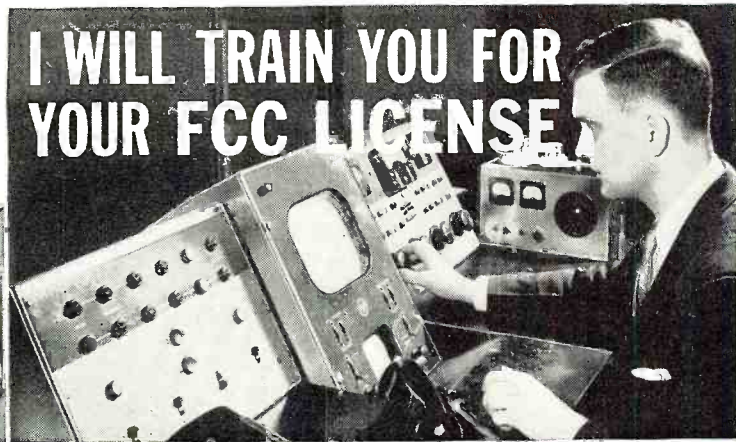

I WILL TRAIN YOU FOR YOUR FCC LICENSE

LEARN COMMUNICATIONS by Practicing at Home in Spare Time

Use parts I send for Actual Experience

My Training Leads to Jobs Like These

BROADCASTING: Chief Technician, Chief Operator, Power Monitor, Remote Control Operator, **SHIP AND HARBOR RADIO:** Chief Operator, Radiotelephone Operator, **GOVERNMENT RADIO:** Operator in Army, Navy, Coast Guard, Forestry Service Dispatcher, **POLICE RADIO:** Transmitter Operator, Service Technician, **AVIATION RADIO:** Plane Radio Operator, Airport Transmitter Operator, **TELEVISION:** Pickup Operator, Voice Transmitter Operator, TV Technician.

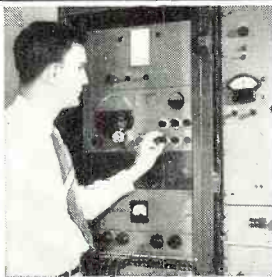

The Communication Course I offer you is backed by NRI's 40 year record of training men at home. My well-illustrated lessons give you the basic principles you must have to assure success. My skillfully developed kits "bring to life" what you learn from my lessons, give you practical experience on circuits common to BOTH Radio and Television. You build the low-power Broadcasting Transmitter shown above (at left). You put this station "on the air," and conduct procedures required of Broadcasting Station operators. My book shows other valuable equipment you build and keep.

mitter Operators, Remote Control Operators, Service and Maintenance Technicians, etc. Mail Coupon. Find out, without obligation, what I offer. NRI training can assure you more of the better things of life; can help you qualify for high pay and promotion when times are good, enjoy greater security when jobs are scarce. Progressive, ambitious men consider Radio-TV an outstanding field for their life's work. My 64-page book, "How to Be a Success in Radio-Television," gives important facts about America's fast growing industry, details of job opportunities, tells about kits I furnish for practical experience, shows what my graduates are doing and earning. You don't have to leave home or give up your job to take NRI courses. You learn at home in your spare time, at low cost, on terms as low as \$5 a month. Many of my graduates make more than the total cost of my training in just two weeks. Mail coupon now. J. E. SMITH, President, National Radio Institute, Dept. 4DE, Washington 9, D. C. OUR 40th YEAR.



J. E. SMITH
PRESIDENT,
National Radio Institute
For 40 years, the leader in training men at home.

I TRAINED THESE MEN AT HOME



"Am employed as transmitter engineer-studio operator at KPAT. Most important day of my life was when I enrolled with NRI." — Elmer Frewaldt, Madison, S. Dak.



"I did not know a thing about Radio before I enrolled for your training. Now I have a job as Studio Engineer at Radio Station KMMJ." — Bill Delzell, Central City, Nebr.

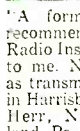

"A former employer recommended National Radio Institute training to me. Now employed as transmitter operator in Harrisburg." — Albert Herr, New Cumberland, Pa.

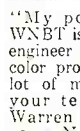

"My position with WNET is video control engineer on the RCA color project. I owe a lot of my success to your textbooks." — Warren Deem, Malverne, N. Y.



"Am with WCOG. Happy with my job. NRI course can't be beat. Passed exam for 1st class Radio-phone license with no trouble." — Jesse W. Parker, Meridian, Miss.

AVAILABLE TO VETERANS UNDER G. I. BILLS



I Also Have a Course in Radio-TV SERVICING

If you prefer a career in Radio-Television Servicing, I'll train you at home for it. Course includes many kits of parts. My book shows that many make \$10, \$15 a week EXTRA fixing sets while training.

Television's Rapid Growth Making Good Jobs, Prosperity

Radio is bigger than ever with over 3000 Broadcasting Stations on the air making good jobs for Chief Operators, Recording and Remote Control Operators, Power Monitors, Technicians, etc. Now there's Television, too. About 200 TV Stations are on the air with many more being built, construction of hundreds of additional stations authorized, and new TV Station applications being filed every month. Think of the demand this is creating from coast to coast for Pickup and Voice Trans-

Send for FREE 64Pg. Book

How to Be a Success in RADIO-TELEVISION

Mr. J. E. SMITH, President, Dept. 4DE
National Radio Institute, Washington 9, D. C.

Mail me 64-page Book FREE. (No salesman will call. Please write plainly.)

Name..... Age.....

Address.....

City..... Zone..... State.....

VETS write in date of discharge

RADIO & TELEVISION NEWS is published monthly by Ziff-Davis Publishing Company, William B. Ziff, Chairman of the Board (1946-1953), at 64 E. Lake St., Chicago 1, Ill. Entered as second-class matter July 21, 1948, at the Post Office, Chicago, Ill., under the act of March 3, 1879. Authorized by Post Office Department, Ottawa, Canada, as second-class matter. **SUBSCRIPTION RATES:** Radio & Television News—one year U. S. and possessions, and Canada \$4.00; Pan-American Union countries \$4.50; all other foreign countries \$5.00. Radio-Electronic Engineering Edition—One year U. S. and possessions, and Canada \$6.00; Pan-American Union countries \$6.50; all other foreign countries \$7.00. Postmaster—Please return undelivered copies under form 3589 to 64 E. Lake St., Chicago 1, Ill.

Editor and Asst. Publisher
OLIVER READ, D.Sc. W1ETI

Managing Editor
WM. A. STOCKLIN, B. S.

Technical Editor
H. S. RENNE, M. S.

Service Editor
CHARLES TEPFER

Assistant Editors
P. B. HOEFER
M. C. MAGNA

Television Consultant
WALTER H. BUCHSBAUM

Short-Wave Editor
KENNETH R. BOORD

Art Editor
FRANK SAYLES

Draftsmen
A. A. GANS, W7TSP
J. A. GOLANEK

Advertising Manager
L. L. OSTEN

Midwest Adv. Manager
JOHN A. RONAN, JR.

Western Adv. Manager
JOHN E. PAYNE



*First in radio-
television-audio-electronics*

Average Paid Circulation over 230,000

Radio News Trademark Reg. U. S. Pat. Office • Television News Trademark Reg. U. S. Pat. Off.

CONTENTS

APRIL, 1954

A 146 mc. Civil Defense Station.....	<i>H. S. Pustarfi, W2HDQ, & I. W. Daly, W2YBZ</i>	35
U.H.F. Fringe Installations.....	<i>Walter H. Buchsbaum</i>	40
Horns for the P.A. Technician.....	<i>Abraham B. Cohen</i>	43
1954 TV Receiver Specifications.....		46
The Signal Bouncer.....	<i>Elbert Robberson</i>	47
The Audio Cathode Follower.....	<i>Newton Nelson</i>	50
The Universal Vibrato.....	<i>Richard H. Dorf</i>	52
The Auto-Tone.....	<i>Ed. C. Miller</i>	54
Impedance Matching of Multiple Speakers.....	<i>Sherman H. Hubelbank</i>	56
Fundamentals of Color TV—The NTSC System (Part 2).....	<i>Milton S. Kiver</i>	59
TV Test Equipment—How To Choose, How To Use (Part 2).....	<i>Robert G. Middleton</i>	62
The U.H.F. Corner Reflector.....	<i>Frank D. Hurd & Jan K. Kobler</i>	63
A Serviceman's Sweep Generator.....	<i>E. C. Fiebich & G. Russell</i>	64
TV Booster for U.H.F.....	<i>J. R. Lange</i>	66
Certified Record Revue.....	<i>Bert Whyte</i>	68
Mac's Radio Service Shop.....	<i>John T. Frye</i>	74
New TV Grants Since Freeze Lift.....		88
New TV Stations on the Air.....		136
Radio-TV Service Industry News.....		156

DEPARTMENTS

For the Record.....	<i>The Editor</i>	8	What's New in Radio.....	78
Spot Radio News.....		16	New TV Products.....	94
Within the Industry.....		24	Manufacturers' Literature.....	103
Short-Wave.....	<i>K. R. Boord</i>	73	Technical Books.....	138
New Audio Equipment.....		142		

COPYRIGHT 1954

(All Rights Reserved)

ZIFF-DAVIS PUBLISHING COMPANY

Editorial and Executive Offices

366 Madison Ave., New York 17, N. Y.

VOLUME 51 • NUMBER 4



Member
Audit Bureau of
Circulations

SUBSCRIPTION SERVICE: All communications concerning subscriptions should be addressed to Circulation Dept., 64 E. Lake St., Chicago 1, Ill. Subscribers should allow at least four weeks for change of address.

CONTRIBUTIONS: Contributors are advised to retain a copy of their manuscripts and illustrations. Contributions should be mailed to the New York Editorial Office and must be accompanied by return postage. Contributions will be handled with reasonable care, but this magazine assumes no responsibility for their safety. Any copy accepted is subject to whatever adaptations and revisions are necessary to meet the requirements of this publication. Payment covers all author's, contributor's, and contestant's rights, title, and interest in and to the material accepted and will be made at our current rates upon acceptance. All photos and drawings will be considered as part of the material purchased.

RADIO & TELEVISION NEWS

ZIFF-DAVIS PUBLISHING COMPANY

President
R. G. DAVIS

Vice-Presidents
H. J. MORGANROTH
M. H. FROELICH

Secretary-Treasurer
G. E. CARNEY

Circulation Manager
M. MICHAELSON

BRANCH OFFICES

CHICAGO 111
417 Loop 31, AN 7-9200

LOS ANGELES 1111
Staffer Center, 900 Wilshire Blvd., AN 4-9534



COVER PHOTO: Walter Schott assembles the Walsco Model 4450 u.h.f. corner reflector out in sunny California. Company's u.h.f. converter is shown atop the television set in foreground. (Ektachrome by Peter J. Samerjan)

NOW... from one of the foremost Electronic training centers of its kind...

Learn TELEVISION RADIO-ELECTRONICS

at home

89 WAYS TO EARN MONEY IN TELEVISION RADIO ELECTRONICS

MAIL COUPON TODAY for valuable free publication showing how and where real money is being made in Television—and how you may prepare to break into this promising field.

ABOVE: Build and operate scores of interesting circuits from these parts for real Learn-By-Doing experience.

16 shipments of electronic parts. Over 300 projects

Looking for a chance to earn REAL MONEY... to get a really interesting job or your own business... to enjoy the satisfaction that comes from knowing your future is tied in with one of America's promising opportunity fields? Then mail the coupon at once. Find out about a training method that thousands of graduates PROVE is one of today's most EFFECTIVE WAYS to learn Television-Radio-Electronics—America's great, billion dollar opportunity field.

Now you can have your own HOME LABORATORY

Using the D.T.I. Way, no previous technical experience is needed. You can get (1) laboratory type training at home in your spare time—or (2) full time training in one of the nation's finest TV-Radio-Electronic training laboratories. The home method includes EVERYTHING YOU NEED to Learn-By-Doing. You work over 300 experiments from 16 shipments of quality parts which you keep. This even includes building and keeping the valuable commercial-type test equipment shown to the right—ideal for helping you earn while you learn. You also get easy-to-read, well-illustrated lessons. And to help you master important fundamentals faster, easier, better, you get D.T.I.'s remarkable and exclusive home training advantage—Learn-By-Seeing HOME MOVIES.

Mail Coupon TODAY!

Why not get ALL the facts about D.T.I.'s wonderful training program... about the effective Employment Service available to all graduates... about the special advantages that may be yours if called to military service? Mail coupon today. We believe the late facts we have for you are really going to surprise you.

BELOW: New Home of D.T.I.

D.T.I. has purchased and now occupies this large, modern, daylight building devoted exclusively to one of the finest TV-Radio-Electronic Training Centers of its kind. This now locates all of our training operations under one roof—to serve you even better.

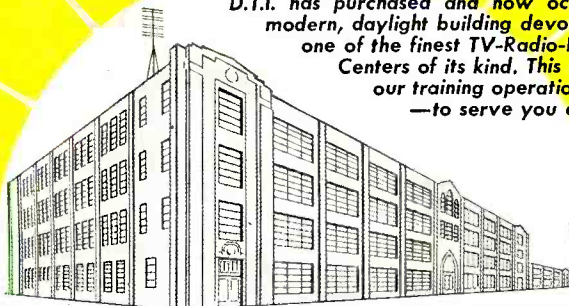

Jewel Bearing MULTI-METER



High Quality OSCILLOSCOPE a "must" for TV service



Learn by Seeing MOTION PICTURES at home



21 INCH

Build and keep this BIG DTI Engineered TV set—easily converted to U.H.F. (DTI offers another home training, but without the TV set.)



DEVRY TECHNICAL INSTITUTE
4141 BELMONT AVE., CHICAGO 41, ILL. Dept. RN-4-K

I would like your Opportunity News Bulletin showing "89 Ways To Earn Money in Television-Radio-Electronics"; also, complete facts about the training opportunity made possible by your organization.

Name _____ Age _____

Address _____ Apt. _____

City _____ Zone _____ State _____

DEVRY TECHNICAL INSTITUTE
AFFILIATED WITH
DEFOREST'S TRAINING, INC.
CHICAGO 41, ILLINOIS

WIN \$8,000⁰⁰

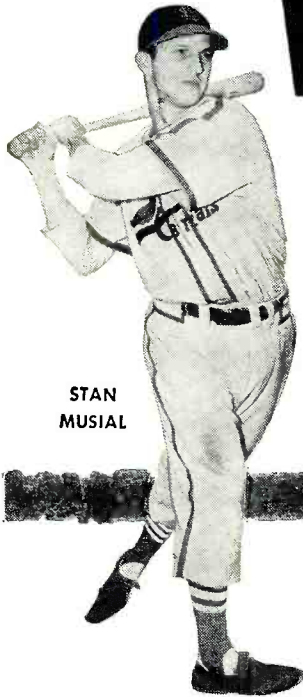

STAN MUSIAL

1ST PRIZE ~~ⓧ~~
\$1,000⁰⁰ \$
CASH \$

MICKEY MANTLE



Westinghouse EAGUE LEADERS

AND DEALERS AID CONTEST

You never saw such an easy contest! Just fill in the names of the teams which were leading each major league on August 1, 1953. Then you have the first leg on the \$1,000 CASH First Prize in the exciting League Leaders and Dealer Aid Contest.

Fill in the Entry Blank on the opposite page. Have your distributor salesman certify that you have purchased 25 Westinghouse Receiving Tubes OR 1 Westinghouse Picture Tube. And mail your Entry Blank

NOW! An early entry can win one of the big prizes for you.

After naming League Leaders on August 1, 1953, write your answer to the cartoon situation pictured on the Entry Blank. Winners will be judged on the basis of correctness of team selection, and aptness, originality and effectiveness of cartoon solution.

Enter as often as you wish. The more entries you submit, the better chance you have at the 209 Big Cash and Merchandise Prizes. Ask your distributor salesman for additional entry blanks. He will be glad to sign them when he takes your tube order.

ET-95049

YOU CAN BE SURE...IF IT'S
Westinghouse

RELIATRON[®] TUBES

WESTINGHOUSE ELECTRIC CORPORATION, ELECTRONIC TUBE DIVISION, ELMIRA, N. Y.

IN PRIZES...

209 PRIZES FOR SMART SERVICE MEN

2ND PRIZE— \$700 in YOUR Choice of Merchandise

3RD PRIZE— \$400 in Merchandise YOU Select

4TH PRIZE— \$300 YOU Choose the Merchandise

FIRST, SECOND, THIRD AND FOURTH PRIZE WINNERS WILL MEET MICKEY MANTLE OR STAN MUSIAL IN THE BIG PRIZE AWARD DINNER WESTINGHOUSE HAS PLANNED FOR YOU IN NEW YORK

- 5 Fifth Prizes of \$140 Each in Merchandise
- 20 Sixth Prizes of \$70 Each in Merchandise
- 100 Ninth Prizes of \$15 Each in Merchandise
- 30 Seventh Prizes of \$35 Each in Merchandise
- 50 Eighth Prizes of \$20 Each in Merchandise

FILL IN THIS ENTRY BLANK TODAY!

1. League Leaders on August 1st, 1953, were:

AMERICAN LEAGUE

NATIONAL LEAGUE

2. Here is what I would say to the lady in the Cartoon:

.....
.....
.....

(ATTACH AN ADDITIONAL SHEET OF PAPER IF NECESSARY—100 WORDS MAXIMUM)

MY NAME

SHOP NAME

STREET

CITY.....STATE.....



THIS SPACE FOR DISTRIBUTOR SALESMAN'S CERTIFICATION

I certify this Entry Blank has been qualified by the purchase of (25 Westinghouse Receiving Tubes) (1 Westinghouse Picture Tube)

SALESMAN'S SIGNATURE

COMPANY NAME

CITY.....STATE.....

SEND ALL ENTRIES TO:

WESTINGHOUSE TUBE CONTEST

Box 610, Grand Central Station, New York 17, New York

**NEWEST
FASTEST SELLER
in the field!**

**CDP
COMPOUND
DIFFRACTION
PROJECTOR**

**Public Address
Loudspeaker System**
setting new standards for
**VOICE PENETRATION
AND MUSICASTING**

- Greatly outperforms comparably sized reentrant horns
- Tremendous penetrating power and coverage at very low unit energy cost
- Exclusive E-V coaxial design and diffraction principle
- Peak-free response ± 5 db to 10,000 cps
- Delivers $2\frac{1}{2}$ octaves more musical range
- Weather-proof, blast-proof, splash-proof Virtually indestructible

Model 848 CDP. 25 watts. 16 ohms.
List Price, \$65.00 Net, \$39.00

**COMPARE
POLAR PATTERN**
Sound distribution of CDP exceeds 120° at all frequencies up to 10,000 cps.

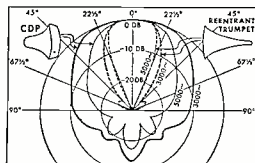

**COMPARE
RESPONSE AND
EFFICIENCY**
Note extended high frequency range of CDP. Response is smooth, peak-free ± 5 db to 10,000 cps.

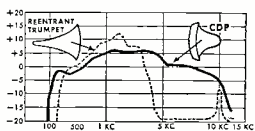

Write for Free
Bulletin No. 197

Pat. Pend.

Electro-Voice

410 CARROL ST. • BUCHANAN, MICHIGAN
Export: 13 E. 40th St., New York 16, U.S.A. Cables: Arlab

For the **RECORD.**
BY THE EDITOR

HOW LOW WILL HI-FI GO?

IN OUR September, 1953 issue we commented on the misuse of the term "hi-fi" and the attendant confusion that certainly exists in the minds of the high-fidelity purchaser. We recently attended the Los Angeles Audio Fiesta and were among some 25,000 who put in an appearance at this highly successful audio show. We came away with a mixed feeling of frustration and satisfaction. For the most part, high-fidelity was properly demonstrated to the audiophile but in too many cases noise supplanted music to a great degree. In fact, there were some exhibitors who delighted in blasting their prospects from their very doors. Broken glass replaced music in too many cases and the beat of the tomtom was reproduced through various loudspeaker systems as being representative of true high-fidelity.

Perhaps the most shocking misuse of claims to high-fidelity was found in some literature which stated, "Here are the features a true high-fidelity instrument must have. Only when you have all of these features, balanced electronically, acoustically, and harmonically, will you achieve the full richness of high-fidelity reproduction of your records."

The literature displayed a block table on which were compared the features of recorder "X" with six other similar record players. The following are the so-called features claimed by the manufacturer to be essential to true high-fidelity reproduction:

1. Reasonably priced.
2. Magnetic cartridge pickup.
3. Sapphire styli.
4. Compensated preamplifier for high-fidelity magnetic cartridges.
5. Minimum five-watt amplifier.
6. Three or more speakers.
7. Frequency response at least 50 to 15,000 cps.
8. Four-pole motor.
9. "X" high-fidelity automatic three-speed changer.

For the sake of clarification and in fairness to the gullible audiophile, we will take each of these "features" and analyze them for what they are worth.

1. Reasonably priced: Since when does a record player (\$149.50) have to be reasonably priced in order to be a true high-fidelity instrument? Does this mean that the purchaser should not wisely spend more money to obtain really fine equipment?

2. Magnetic cartridge pickup: In spite of the fact that magnetic cartridges have earned an enviable reputation, one cannot claim that they are essential, as does this advertiser,

for a high-fidelity instrument. Several capacitive, crystal, and ceramic type cartridges are capable of producing high-fidelity.

3. Sapphire styli: What a ridiculous claim this is. Since when is a record player limited to sapphire styli? Perhaps the manufacturer has never heard of the advantage of using the diamond?

4. Compensated preamplifier for high-fidelity magnetic cartridges: Shades of amplitude! Of course this would be required for any magnetic cartridge. The table shows this as a "feature" and lists only one other competitor as having this feature but startlingly we see that manufacturer "X" and the competitor are the only ones listing magnetic cartridges.

5. Minimum five-watt amplifier: This "feature" just squeezes by the bare requirements of power for an audio amplifier capable of giving satisfactory dynamic performance. We'd much prefer the ad to state that they had an eight-watt amplifier (if they did) rather than to ballyhoo the rating as a feature.

6. Three or more speakers: This claim, of course, is utterly ridiculous and any high-fidelity fan who has been properly informed knows full well that a single wide-range loudspeaker having a large enough cone to properly reproduce clean bass is certainly far more effective than an assortment of small speakers clustered in a small box. How about any good coaxial?

7. Frequency response at least 50 to 15,000 cps: This "feature" has been so widely misused that for all practical purposes it has become useless. The audio man well knows that even very inexpensive audio amplifiers today, using proper amounts of feedback and using cheap output transformers, can, as far as the amplifier itself is concerned, give a frequency range of 50 to 15,000 cps. The "feature" implies that the entire chain of components comprising the instrument is capable of this response. There is no reference, however, to the amount of distortion, etc. and without these there can be no measure of high-fidelity.

8. Four-pole motor: This certainly will come as a revelation to the audiophile. This new "feature" deserves but one word of comment—phew!

9. "X" high-fidelity automatic three-speed changer: Since when does a high-fidelity instrument require a changer?

We must conclude, therefore, that only one of the nine "features" (as stated by manufacturer "X") is essential to a true high-fidelity instrument. Do you agree? O. R.

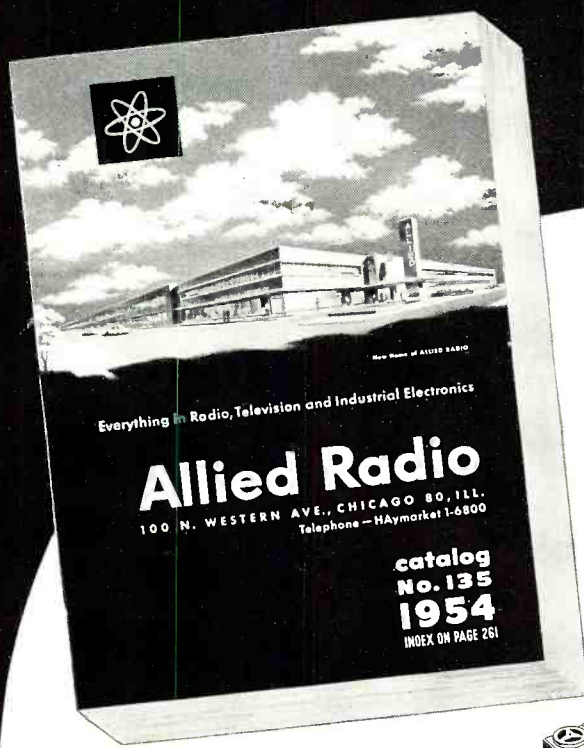

the only **COMPLETE** catalog
for **Everything in TV, Radio**
and **Industrial Electronics**

FREE value-packed

1954 ALLIED 268-PAGE CATALOG

The World's Largest Stocks

- TV and Radio Parts
- Test Instruments
- High-Fidelity Equipment
- Custom TV Chassis
- AM, FM Tuners and Radios
- Recorders and Supplies
- P.A. Systems, Accessories
- Amateur Station Gear
- Builders' Kits, Supplies
- Equipment for Industry

Fastest Service in Electronic Supply

SEND FOR THE LEADING
ELECTRONIC
BUYING GUIDE
FREE!



NEW HOME OF
ALLIED RADIO
ultra-modern facilities
TO SERVE YOU BEST



EASY PAY TERMS

Use **ALLIED'S** liberal Easy Payment Plan—only 10% down, 12 months to pay—no carrying charge if you pay in 60 days. Available on Hi-Fi and P.A. units, recorders, TV chassis, test instruments, Amateur gear.

TV and HI-FI SPECIALISTS

To keep up with developments in High-Fidelity and TV, look to **ALLIED**. Count on us for all the latest releases and largest stocks of equipment in these important fields. If it's anything in High-Fidelity or Television—we have it *in stock!*



SEND FOR IT TODAY

Get **ALLIED'S** latest catalog—268 pages packed with the world's largest selection of quality equipment at lowest, money-saving prices. See all the latest releases in custom TV chassis, TV antennas and accessories; AM and FM tuners and radios; *everything* in High-Fidelity custom components; latest P. A. Systems and accessories; recorders and supplies; Amateur receivers, transmitters and station gear; specialized industrial electronic equipment; test instruments; builders' kits; huge listings of parts, tubes, tools, books—your choice of the world's most complete stocks of quality equipment. **ALLIED** gives you every buying advantage: speedy shipment, expert personal help, lowest prices, assured satisfaction. Get the big 1954 **ALLIED** Catalog. Keep it handy—and save time and money. Send for your **FREE** copy today.

**SAVE ON EVERYTHING
IN ELECTRONICS**

ALLIED RADIO
World's Largest Electronic Supply House

ALLIED RADIO CORP., Dept. 1-D-4
100 N. Western Ave., Chicago 80, Illinois

Send **FREE** 268-Page 1954 **ALLIED** Catalog

Name _____

Address _____

City _____ Zone _____ State _____

Your Own Portable "TV Station" For Receiver Adjustment

NEW!

PHILCO

TELEVISION PATTERN GENERATOR

**DEVELOPS BOTH RF
AND VIDEO OUTPUT**

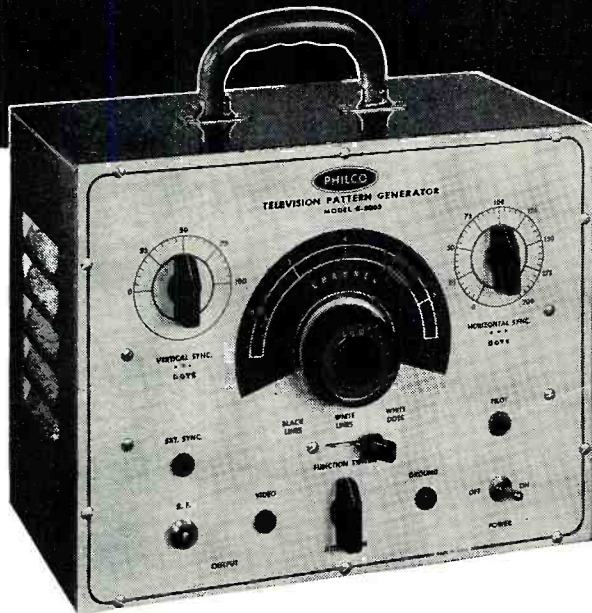

A Must for Areas Where Continuous Station Broadcasts are Not Available

Now use the dot and line patterns from the new PHILCO Model G-8005 to check linearity, focus, astigmatism, blooming and high voltage regulation. Trouble shoot receivers on any channel, 2 through 6, or with video output. The PHILCO G-8005 Television Pattern Generator is an instrument especially adapted for service work . . . designed to save you time.

Look at These Philco Features . . .

1. Provides new white dot pattern and either white or black vertical lines for *all* cathode ray tube circuits.
2. Easy to operate: connect Pattern Generator output to TV set. Select proper test pattern. Accurately check both the vertical and horizontal sweep circuit performance.
3. External Sync. Jack improves stabilization in many special cases. Provides wide range operation.
4. A custom type instrument with new and novel circuits designed to reduce service time in both laboratories and service shops.

**AVAILABLE THROUGH YOUR PHILCO DISTRIBUTOR
ON A NEW SPECIAL PAYMENT PLAN**

PHILCO MODEL S-8200 3" OSCILLOSCOPE

A sensitive, portable unit adaptable to either bench or field service. **VERTICAL AMPLIFIER:** DC coupled, Sensitivity—0.05V rms/inch. Frequency Response—0-1 mc/s within 6DB. DC coupled Vert. Amplifier circuits and low capacity probes facilitate video circuit trouble shooting. Built-in voltage calibrator permits use as high sensitivity vacuum tube voltmeter. **HORIZONTAL AMPLIFIER:** Sensitivity—0.5V rms/inch. Frequency Response—10 cps to 125 KC/s within 6DB. Sweep Circuit Frequency—Variable 15 to 30,000 cps . . . preset frequencies at vertical and horizontal sweep rates.



Take advantage of the great
SHARE and PROFIT Program
on Philco Receiving Tubes
Parts and Accessories
NOW AT YOUR PHILCO DISTRIBUTOR



ADVANCE! Raise your earning power—learn RADIO-TELEVISION-ELECTRONICS by SHOP-METHOD HOME TRAINING

GOOD JOBS AWAIT THE TRAINED RADIO-TV TECHNICIAN

There is a place for *you* in the great Radio-Television-Electronics industry when you are trained as National Schools will train you at home!

Trained technicians are in growing demand at good pay—in manufacturing, broadcasting, television, communications, radar, research laboratories, home Radio-TV service, and other branches of the field. National Schools Master Shop-Method Home Training, with newly added lessons and equipment, trains you in your spare time, right in your own home, for these fascinating opportunities. **OUR METHOD IS PROVED BY THE SUCCESS OF NATIONAL SCHOOLS TRAINED MEN, ALL OVER THE WORLD, SINCE 1905.**

EARN WHILE YOU LEARN

Many National students pay for all or part of their training with spare time earnings. We'll show you how you can do the same! Early in your training, you receive "Spare-time Work" Lessons which will enable you to earn extra money servicing neighbors' and friends' Radio and Television receivers, appliances, etc.



Signal Generator

Audio Oscillator

T. R. F. Receiver

National Schools Training is All-Embracing

National Schools prepares you for your choice of many job opportunities. Thousands of home, portable, and auto radios are being sold daily—more than ever before. Television is sweeping the country, too. Co-axial cables are now bringing Television to more cities, towns, and farms every day! National Schools' *complete* training program qualifies you in all fields. Read this partial list of opportunities for trained technicians:

- Business of Your Own • Broadcasting
- Radio Manufacturing, Sales, Service • Telecasting
- Television Manufacturing, Sales, Service
- Laboratories: Installation, Maintenance of Electronic Equipment
- Electrolysis, Call Systems
- Garages: Auto Radio Sales, Service
- Sound Systems and Telephone Companies, Engineering Firms
- Theatre Sound Systems, Police Radio
- And scores of other good jobs in many related fields.

TELEVISION TRAINING

You get a complete series of up-to-the-minute lessons covering all phases of repairing, servicing and construction. The same lesson texts used by resident students in our modern and complete Television broadcast studios, laboratories and classrooms!



MASTER ALL PHASES!

Get Master Shop-Method Home Training from an Established Practical Resident School with its own Training Shops, Laboratories, Studios—almost 50 Years of Successful Experience in Training Ambitious Men.



We Bring National Schools To You!



You also receive this Multitester

Superheterodyne Receiver

LEARN BY DOING

You receive and keep all the modern equipment shown above, including tubes and valuable, professional quality Multitester. *No extra charges.*

FREE! RADIO-TV BOOK AND SAMPLE LESSON!

Send today for National Schools' new, illustrated Book of Opportunity in Radio-Television-Electronics, and an actual Sample Lesson. No cost—no obligation. Use the coupon now—we'll answer by return airmail.

APPROVED FOR VETERANS AND NON-VETERANS
Check coupon below

Both Resident and Home Study Courses Offered!

NATIONAL SCHOOLS

LOS ANGELES 37, CALIFORNIA • ESTABLISHED 1905
IN CANADA: 811 W. HASTINGS STREET, VANCOUVER, B. C.



GET FACTS FASTEST! MAIL TO OFFICE NEAREST YOU!

(mail in envelope or paste on postal card)

NATIONAL SCHOOLS, Dept. RH-44

4000 S. Figueroa Street Los Angeles 37, Calif. or 323 West Polk Street Chicago 7, Ill.

Send FREE Radio-TV Electronics book and FREE sample lesson. No obligation, no salesman will call.

NAME _____ BIRTHDAY _____ 19 _____

ADDRESS _____

CITY _____ ZONE _____ STATE _____

Check if interested **ONLY** in Resident Training at Los Angeles.
VETERANS: Give Date of Discharge.



**yours is a
serious business** ■ ■ ■

If TV service is your chosen profession, you have a serious stake in it. It's your way of life and it serves a vital role in man's newest and most powerful means of communication. The man who takes his service seriously will enjoy the benefits of a successful business career. Customers turn to the serviceman who believes that only quality components are worthy of quality workmanship.

You can depend on Du Mont quality picture tubes to do more for your service.



Photography Magazine Contest Winning Photo by Cornelius E. Westveer

Replacement Sales, Cathode Ray Tube Division
Allen B. Du Mont Laboratories, Inc., Clifton, N. J.

PIONEER IN BIG PICTURE TUBES • ORIGINATOR OF THE FAMOUS BENT-GUN AND SELFOCUS •
LEADER IN HIGH-RESOLUTION • MAJOR SUPPLIER TO MOST FINE TELEVISION RECEIVER MANUFACTURERS

*Trade-Mark

it's new
it's new
it's new

It's What You've Been Asking For!

it's new

it's new
it's new
it's new
it's new
it's new
it's new
it's new

the TR-4 CDR Rotor

still the most powerful TV rotor, enough power to turn any array.

NOW... With Meter Cabinet Using 4-Wire Cable

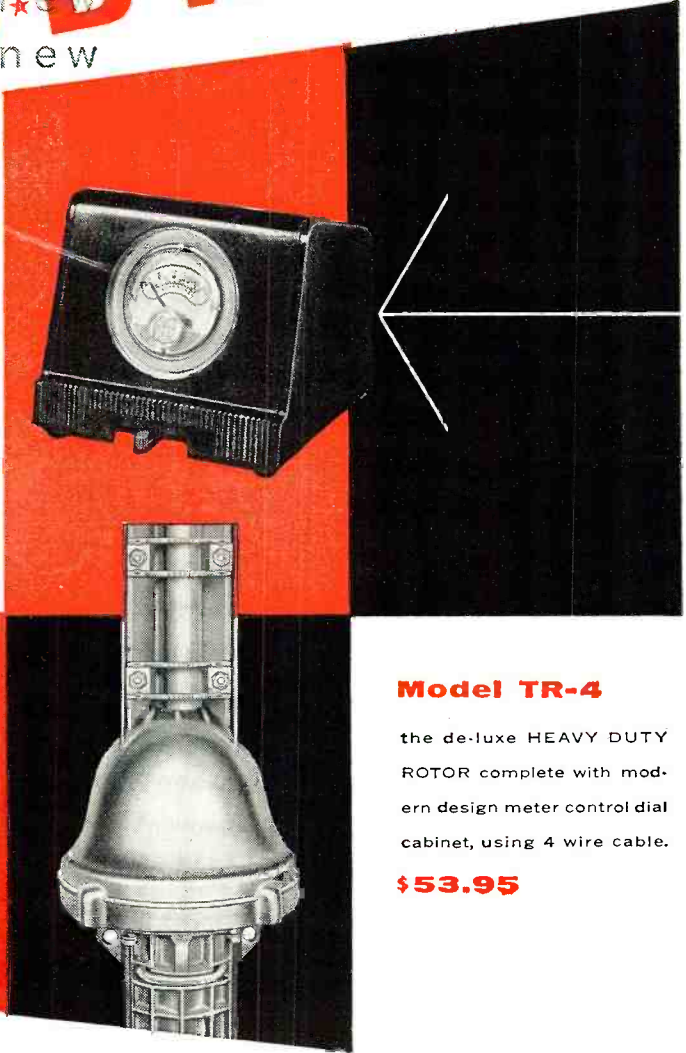

Model TR-4
the de-luxe HEAVY DUTY ROTOR complete with modern design meter control dial cabinet, using 4 wire cable.
\$53.95

also these models **TR-2 • TR-11 • TR-12**

CORNELL-DUBILIER
SOUTH PLAINFIELD, N. J.



THE RADIART CORP.
CLEVELAND 13, OHIO

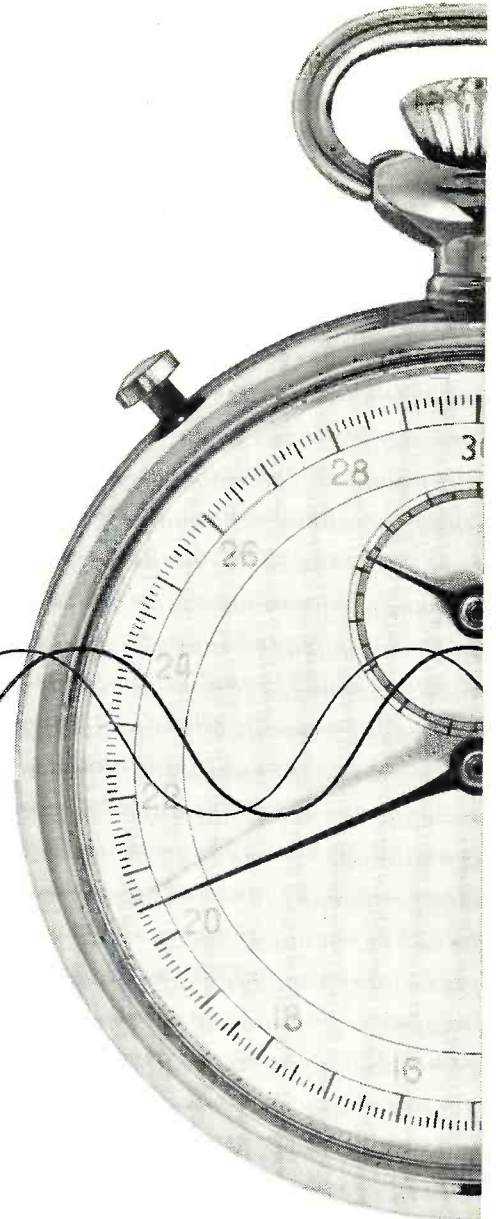

WHAT TIME IS GREEN?

In color television, the colors on the screen are determined in a special way. A reference signal is sent and then the color signals are matched against it. For example, when the second signal is out of step by 50-billionths of a second, the color is green; 130-billionths means blue.

For colors to be true, the timing must be exact. An error of unbelievably small size can throw the entire picture off color. A delay of only a few billionths of a second can make a yellow dress appear green or a pale complexion look red.

To ready the Bell System's television network for color transmission, scientists at Bell Telephone Laboratories developed equipment which measures wave delay to one-billionth of a second. If the waves are off, as they wing their way across the country, they are corrected by equalizers placed at key points on the circuit.

This important contribution to color television is another example of the pioneer work done by Bell Telephone Laboratories to give America the finest communications in the world.

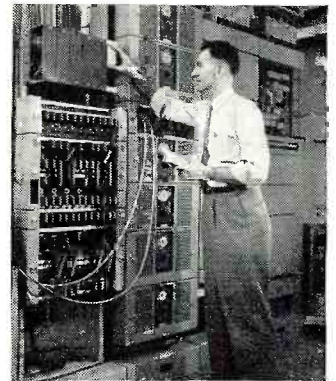

To keep colors true in television, signals must be kept on one of the world's strictest timetables. Equalizers that correct off-schedule waves are put into place at main repeater stations of the transcontinental radio-relay system.

BELL TELEPHONE LABORATORIES

IMPROVING TELEPHONE SERVICE FOR AMERICA PROVIDES CAREERS FOR
CREATIVE MEN IN SCIENTIFIC AND TECHNICAL FIELDS.





Speaking of Speakers...

DELCO RADIO CAREFULLY CONTROLS THE MANUFACTURING OF ITS SPEAKERS TO ASSURE HIGHEST POSSIBLE QUALITY

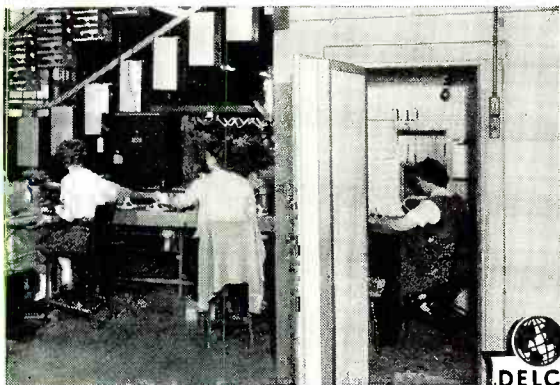

In the audio test booth, the speaker is checked for its ability to deliver good listening. In the background you can see a small section of the speaker production line.



High quality in the final product can be had only through rigid quality control. Take speakers, for example. Speaker baskets are formed in our stamping department. Special machines wind the voice coils. On the assembly line the cones are secured to the voice coils and then assembled with the basket. All along the line inspectors have been checking and rechecking. Then, the speaker is magnetized and goes into a specially designed sound booth for a final check.

This continuing quality control is one important reason why Delco Radio replacement parts assure customer satisfaction. Made by the world's largest manufacturer of auto radios, they are available from your UMS Delco Electronic Parts Distributor.

**DISTRIBUTED BY
ELECTRONICS
WHOLESALE
EVERYWHERE**

DELCO RADIO

DIVISION OF GENERAL MOTORS CORPORATION, KOKOMO, INDIANA

A GENERAL MOTORS PRODUCT   A UNITED MOTORS LINE

by itself

IN A CLASS

NC-98 \$149⁹⁵

National

THE NEW

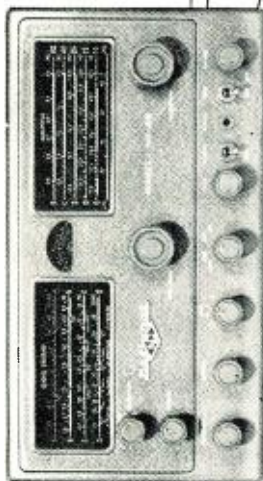

RADIO WIRE TELEVISION, INC.

100 SIXTH AVE., NEW YORK CITY

48 W 48th ST., NEW YORK CITY

212 FULTON ST., NEW YORK CITY

35 WILLIAM ST., NEWARK, N. J.

110 FEDERAL ST., BOSTON, MASS.

Spot Radio News

* Presenting latest information on the Radio Industry.

By RADIO & TELEVISION NEWS'
WASHINGTON EDITOR

RADIO, stripped of its dazzling glamour during recent years by the television surge, has begun to recapture the hearts of not only those at home, but industry, too, the Commission has found. Declaring that actually radio usage now extends from cradle to grave, the nation's space chiefs pointed out that there are now radio facilities for calling and speeding doctors and ambulances to the homes of expectant mothers, and after the baby arrives radio-equipped vehicles can deliver milk, pick up and return diapers and generally perform other chores in the interest of the newcomer. And at the other extreme, radio is also being used for the dispatching and movement of funeral corteges.

Specifically, it was said, there are now more than 60 different classes of radio stations which hold over a quarter-of-a-million authorizations covering the use of some 600,000 fixed and mobile transmitters. The authorizations range from A (aeronautical) to X (symbol for experimental) operations.

The diversification of radio's uses at present was illustrated in the report by a host of fascinating examples: Control of city and highway traffic systems. . . . Direction of the movement of crews cleaning city streets, water mains, and so on. . . . Expedition of the delivery of food, fuel, building material, etc. . . . Speeding of repairs for home and business fixtures and appliances. . . . Dispatching of trucks to pick up garbage, dead animals, and other refuse. . . . Routing of rural school buses. . . . Aiding of beach and other recreational area patrols. . . . Contacting workers on isolated ranches. . . . Direction of the movement of machinery on large farms. . . . Searching for oil on land and under off-shore waters. . . . Spotting of schools of fish from moving planes so that their locations can be radioed to fishing boats. . . . Directing motion picture crews on location. . . . Aiding bank and business protective-patrol systems. . . . Relaying of news between reporters on assignment and their newspaper offices. . . . Control of model airplanes. . . . Sending of fingerprints and other information from one police department to another. . . . Helping to train bloodhounds to serve with police agencies. . . . Timing and photographing of the finish of track-racing events. . . . Communication between engine and caboose of long freight trains; between

moving trains and wayside stations; and in yard operations. . . . Controlling railroad track switches by the engineer on a moving train. . . . Picking up and delivering telegrams by auto. . . . Relaying telephone and telegraph messages; also TV programs. . . . Bridging gaps in disrupted wire lines. . . . Transmitting pictures and facsimile. . . . Controlling crowds at large regattas, horse shows, golf matches, and other big outdoor events. . . . Transmitting orders from "car hops" to kitchens of drive-in restaurants. . . . Controlling the movement of ships in harbors. . . . Paging of doctors and other persons. . . . Determining the position of ships and aircraft, also the proximity of objects. . . . Directing of firefighters at the scene of a blaze. . . . Providing emergency road services operated by garage and automobile associations. . . . Sending of weather and market reports. . . . Supervising and controlling of valves, pressures, and fluid levels along pipe lines. . . . Recording of sunspot cycles. . . . Measurement of radio propagation, and the study of planetary reflection. . . . The establishment of emergency communication lines in time of local, regional, and national disaster. . . . And the ever-popular broadcasting to millions and millions at home or in automobiles, seacraft, airplanes, buses, department stores, restaurants, and places of business.

Television, the driving youngster, was, of course, still a dynamic factor, the account added. Reviewing a growing new use of TV, closed-circuit operation, the Commission said that this intriguing phase would eventually become a major means of sight communication in the nation. Currently, closed-circuit video is being used to demonstrate surgery and other medical techniques to doctors and students; link classes of schools or colleges for instructional purposes; check signatures between branches of a bank; watch babies in large nurseries; guard prisoners in jails; relay church, concert, entertainment and other programs to overflow or supplemental audiences; demonstrate new products to scattered groups of salesmen; observe plane takeoff and landing at airports; supervise freight-car movements; detect unnecessary chimney smoke; and check documents in different parts of a large filing system. In addition, tieline telecasting has been found effective in in-

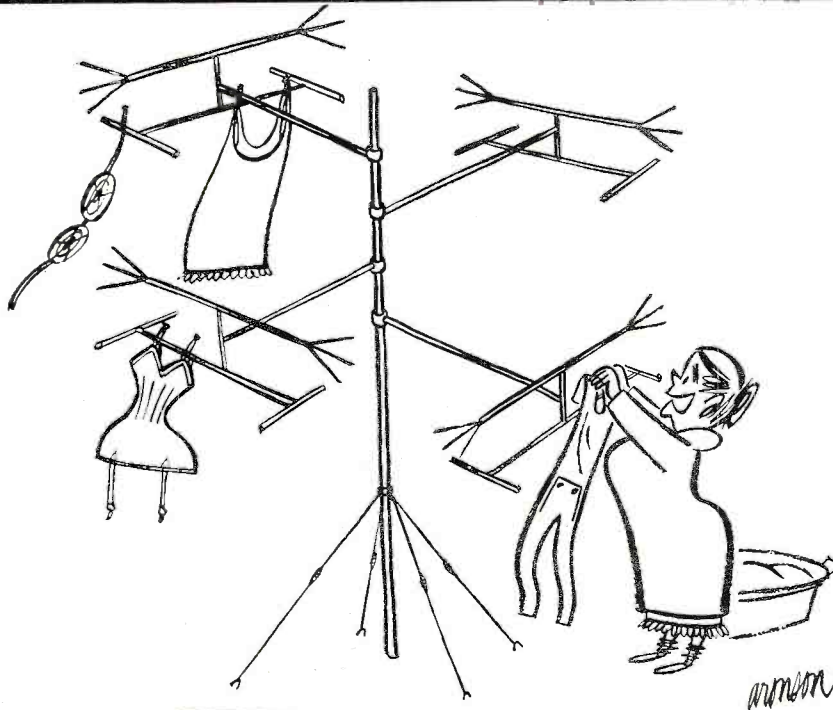

DAD THOUGHT THIS ANTENNA
WOULD HELP, BUT ALL WE NEEDED
WERE SPRAGUE CAPACITORS!

Don't Be Vague... Insist on SPRAGUE

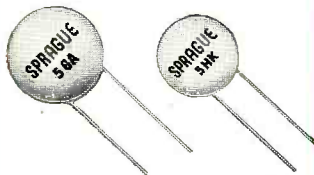

Insist on Sprague CERAMICS

Tiny, tough, dependable . . . in every application . . . whether discs, plates, buttons, or door knobs. And there's a Sprague ceramic capacitor to meet every service need. You give your customers dependable service, guard yourself against costly call-backs, when you use only Sprague Ceramic capacitors.



Insist on Sprague TWIST-LOK* 'LYTICS

Sprague TVL's fill the top performance bill in the toughest TV circuits. High temperatures, surge voltages, ripple currents won't faze them. Like all Sprague capacitors, Twist-Lok 'Lytics are your first line of defense against expensive call-backs.

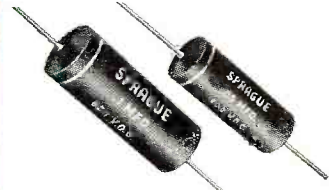

Insist on Sprague BLACK BEAUTY® TELECAPS®

The most imitated capacitor Sprague ever introduced. But you get Sprague *performance* only when you insist on Sprague Telecaps. Hundreds of millions are in use today as first choice of quality conscious manufacturers and servicemen. It's the *premium* molded tubular *at no extra cost*.

Accept no substitutes. There is a Sprague Distributor in every sales area in the United States. Write for the name of your nearest source of supply today.

☆ Trademark

SPRAGUE

Get your copy of Sprague's latest radio and TV service catalog C-609. Write Sprague Products Company*, 51 Marshall St., North Adams, Mass.

*Distributors' Division of Sprague Electric Company

**WORLD'S LARGEST
CAPACITOR MANUFACTURER**

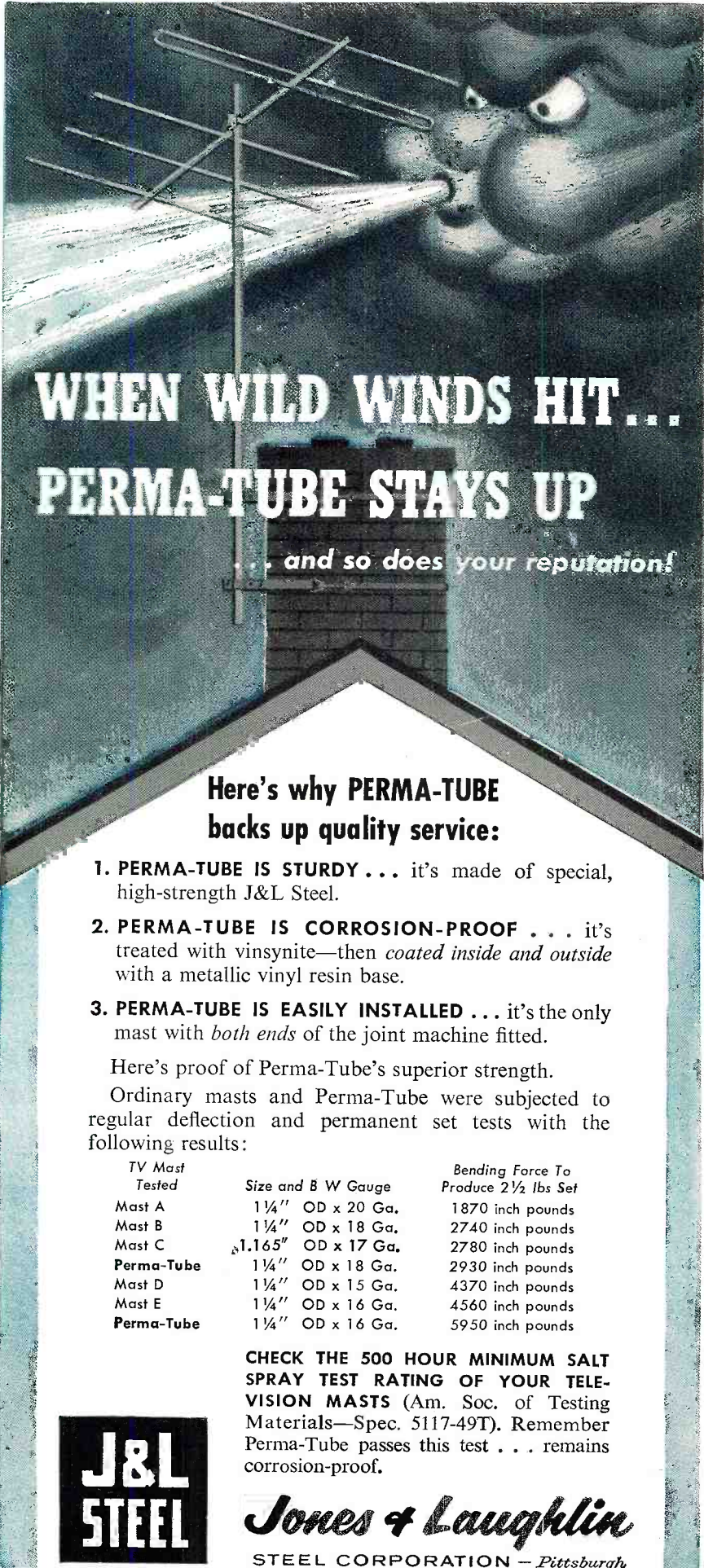

**WHEN WILD WINDS HIT...
PERMA-TUBE STAYS UP**
... and so does your reputation!

**Here's why PERMA-TUBE
backs up quality service:**

- 1. PERMA-TUBE IS STURDY . . .** it's made of special, high-strength J&L Steel.
- 2. PERMA-TUBE IS CORROSION-PROOF . . .** it's treated with vinsynite—then *coated inside and outside* with a metallic vinyl resin base.
- 3. PERMA-TUBE IS EASILY INSTALLED . . .** it's the only mast with *both ends* of the joint machine fitted.

Here's proof of Perma-Tube's superior strength.

Ordinary masts and Perma-Tube were subjected to regular deflection and permanent set tests with the following results:

TV Mast Tested	Size and B W Gauge	Bending Force To Produce 2 1/2 lbs Set
Mast A	1 1/4" OD x 20 Ga.	1870 inch pounds
Mast B	1 1/4" OD x 18 Ga.	2740 inch pounds
Mast C	1.165" OD x 17 Ga.	2780 inch pounds
Perma-Tube	1 1/4" OD x 18 Ga.	2930 inch pounds
Mast D	1 1/4" OD x 15 Ga.	4370 inch pounds
Mast E	1 1/4" OD x 16 Ga.	4560 inch pounds
Perma-Tube	1 1/4" OD x 16 Ga.	5950 inch pounds

CHECK THE 500 HOUR MINIMUM SALT SPRAY TEST RATING OF YOUR TELEVISION MASTS (Am. Soc. of Testing Materials—Spec. 5117-49T). Remember Perma-Tube passes this test . . . remains corrosion-proof.



Jones & Laughlin
STEEL CORPORATION — Pittsburgh

dustry serving as a robot eye to follow production and handling processes, such as watching boiler, water-level, and other gauges from the main control room, detecting delays in the movement of material; and otherwise enabling supervisors to see into several places at the same time. The teletine has also been used to watch dangerous operations from a safe distance, such as those involving the use of atomic energy, furnace combustion, detonation of explosives by the military, and metal firing.

A BATTLE-ROYAL raged in room G-16 in the Senate wing of the Capitol, during the early part of the year, when Robert E. Lee faced the Senate Interstate and Foreign Commerce Committee seeking approval of his appointment to the Commission. He was needed, buffeted, and spanked by several Democratic Senators who felt that he was not the man for the job. But when the fiery debates ended, the majority of the Committee voted him into office.

The argument against Lee's confirmation was led by Senator Mike Monroney, who said that he was not debating the integrity of the nominee, but his background. The Senator declared that in his opinion Lee did not appear to have sufficient experience as a real fighter for freedom of speech. Commenting on this key requirement, the Senator said: "No longer is freedom of the press the solitary means of preserving liberty. Important as it is, the . . . nationwide resources of hundreds of broadcasting and TV stations now have as great an impact, or an even greater impact on the public mind, as the printed word."

Continuing his criticism of Lee, the Senator then pointed out that oddly a . . . "strange silence has been hanging over this appointment . . . particularly in the radio and TV field." Noting that to the best of his knowledge but one broadcaster had spoken in behalf of the appointee. Monroney added: "For the most part . . . the industry that could receive a life or death sentence at the hands of the Commission . . . has maintained a stony silence."

Lee was defended by Senator John W. Bricker, chairman of the committee, who praised him as an . . . "able, straightforward and honest man . . ." who would do a . . . "constructive job" on the Commission. Others pointed out that Lee had performed valuable service during his tenure with the FBI. In '41, the new Commissioner had been named administrative assistant to J. Edgar Hoover, FBI director. In this post he was responsible for building up of the FBI staff. Subsequently Lee became chief clerk of the Bureau.

Commissioner Lee, who succeeds Paul A. Walker who retired last Summer, will serve for a seven-year term.

A REVIVED EFFORT to place the Commission on a self-sustaining basis has
(Continued on page 84)

Here's your Opportunity

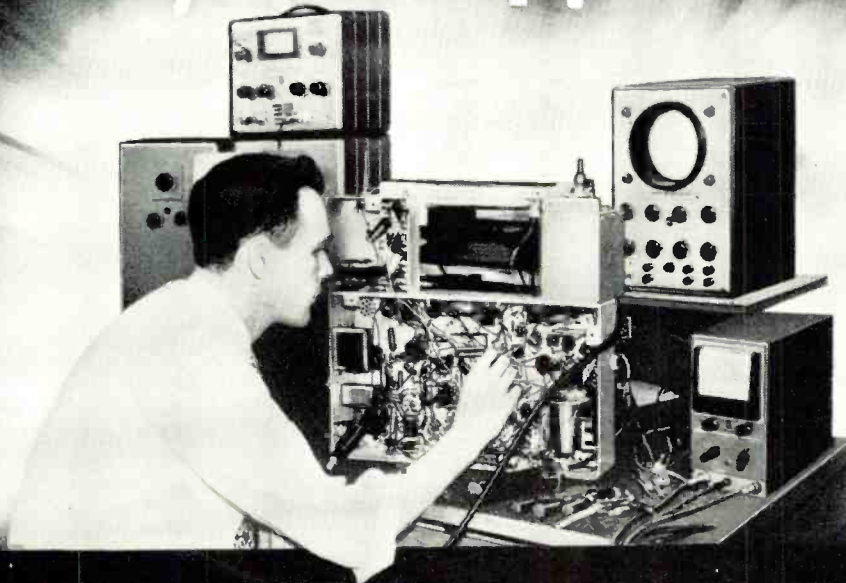

to prepare for a good job or a business of your own in TV SERVICING

ARE YOU SATISFIED with the position you now hold? Do you feel you're worth more money? Are you pleased with yourself, your work, your associates . . . and your future? What does the next year hold for you . . . and the year after that?

Are you content merely to plod along through the best years of your life . . . or do you want to get into more pleasant work . . . hold a well-paid job . . . perhaps establish your own business?

If you are looking for a REAL opportunity . . . If you want to GROW with a GROWING INDUSTRY . . . If you want to grasp the success that should be yours, then we say to you, study TV Servicing.

Everyone knows that Television is the fastest growing industry today. Opportunities are going begging for men who have

the training and ability to grasp them. Now is the time to start on the road to success in TV Servicing.

Study at Home in your spare time

The RCA Institutes Home Study Course in TV Servicing is easy to learn. You progress rapidly, step by step, as you learn the procedure of servicing and trouble-shooting TV receivers and installing TV antennas. Hundreds of pictures and diagrams help you understand the how-it-works information and the how-to-do-it techniques.

A Service of

Radio Corporation of America

The RCA Institutes TV Servicing course was written and planned by instructors with years of specialized experience in training men. You get up-to-the-minute information, too, because you study right at the source

of the latest developments in Television. Your lessons are carefully examined and accurately graded by competent teachers who are interested in helping YOU to succeed.

RCA Institutes is licensed by the University of the State of New York . . . an affiliate member of the American Society for Engineering Education . . . approved by leading Radio-TV Service Organizations . . . approved by Veterans Administration.

It costs so little to gain so much

RCA Institutes makes it easy for you to take advantage of the big opportunities in TV Servicing. The cost of the TV Servicing Home Study Course has been cut to a minimum. You pay for the course on a pay-as-you-learn unit lesson basis. No other home study course in TV Servicing offers so much for so little cost to you.

RCA Institutes conducts a resident school in New York City offering day and evening courses in Radio and TV Servicing, Radio Code and Radio Operating, Radio Broadcasting, Advanced Technology. Write for free catalog on resident courses.



RCA INSTITUTES, INC.
A SERVICE OF RADIO CORPORATION OF AMERICA
350 WEST FOURTH STREET, NEW YORK 14, N.Y.

SEND FOR FREE BOOKLET—Mail the coupon—today. Get complete information on the RCA INSTITUTES Home Study Course in Television Servicing. Booklet gives you a general outline of the course by units. See how this practical home study course trains you quickly, easily. Mail coupon in envelope or paste on postal card.



MAIL COUPON NOW!

RCA INSTITUTES, INC., Home Study Dept. RN354
350 West Fourth Street, New York 14, N. Y.

Without obligation on my part, please send me copy of booklet "RCA INSTITUTES Home Study Course in TELEVISION SERVICING." (No salesman will call.)

Name _____ (please print)

Address _____

City _____ Zone _____ State _____

Now... SOLDERING MADE TWICE AS EASY!

FIRST, the Soldering Aid.
Now, the **NEW CBS-HYTRON
SOLDER DISPENSER**
makes soldering *twice as easy.*

No more tangling with haywire coils of solder. Your thumb on knurled control wheel of unique Solder Dispenser feeds solder . . . retracts it neatly when job is done . . . without waste. A one-hand tool, Dispenser eliminates time out to unroll and straighten solder. Holds 72 inches of solder . . . a month's supply. It's compact . . . light . . . convenient . . . pencil-like . . . with handy pocket clip. Soldering becomes a pleasure with this time-and-money saver. Servicemen say, "Wouldn't be without it."



HOW TO USE. Your CBS-Hytron Solder Dispenser comes ready to use . . . with 20 lengths of 0.050-inch, 40/60 activated rosin core solder.

To start: Point Dispenser vertically downward. Shake a length of solder into position . . . at the same time rotating the knurled wheel toward you to begin the feed. Roll out an inch of solder and go ahead with the job. Need more solder? Just rotate the wheel with your thumb. When through, turn wheel away from you to draw unused solder back into Dispenser.

Knurled cap of Dispenser unscrews for refilling. Your package of 80 specially cut and sealed Refills gives you four months' supply. Plus the month's supply already loaded in the Dispenser.

Your new Solder Dispenser is fun to use . . . a natural companion to your Soldering Aid. And your Dispenser saves you time and money, too. Get yours today!

FREE . . . APRIL 15
THROUGH MAY 31

You can get this complete package free from April 15 through May 31. Your CBS-Hytron distributor will give you a free Solder Dispenser (loaded with 20 Refills) . . . and a plastic tube of 80 additional Refills. Enough to last 5 months.



WITH YOUR ORDER FOR CBS-HYTRON TUBES . . . ONLY 75 RECEIVING OR 3 PICTURE TUBES

Just order 75 CBS-Hytron receiving tubes . . . or 3 CBS-Hytron picture tubes. Your CBS-Hytron distributor will give you this valuable, time-and-money saver . . . *free*. Remember, offer is limited to April 15 through May 31. And the unique Solder Dispenser and Refills are available *only* on this special offer.

ACT NOW!

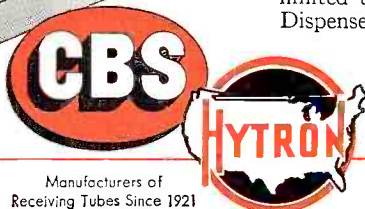

Manufacturers of
Receiving Tubes Since 1921

CBS-HYTRON Main Office: Danvers, Mass.

A Division of Columbia Broadcasting System, Inc.

A member of the CBS family: CBS Radio • CBS Television
Columbia Records, Inc. • CBS Laboratories • CBS-Columbia • and CBS-Hytron

RECEIVING • TRANSMITTING • SPECIAL-PURPOSE • TV PICTURE TUBES • CRYSTAL DIODES AND TRANSISTORS
RADIO & TELEVISION NEWS

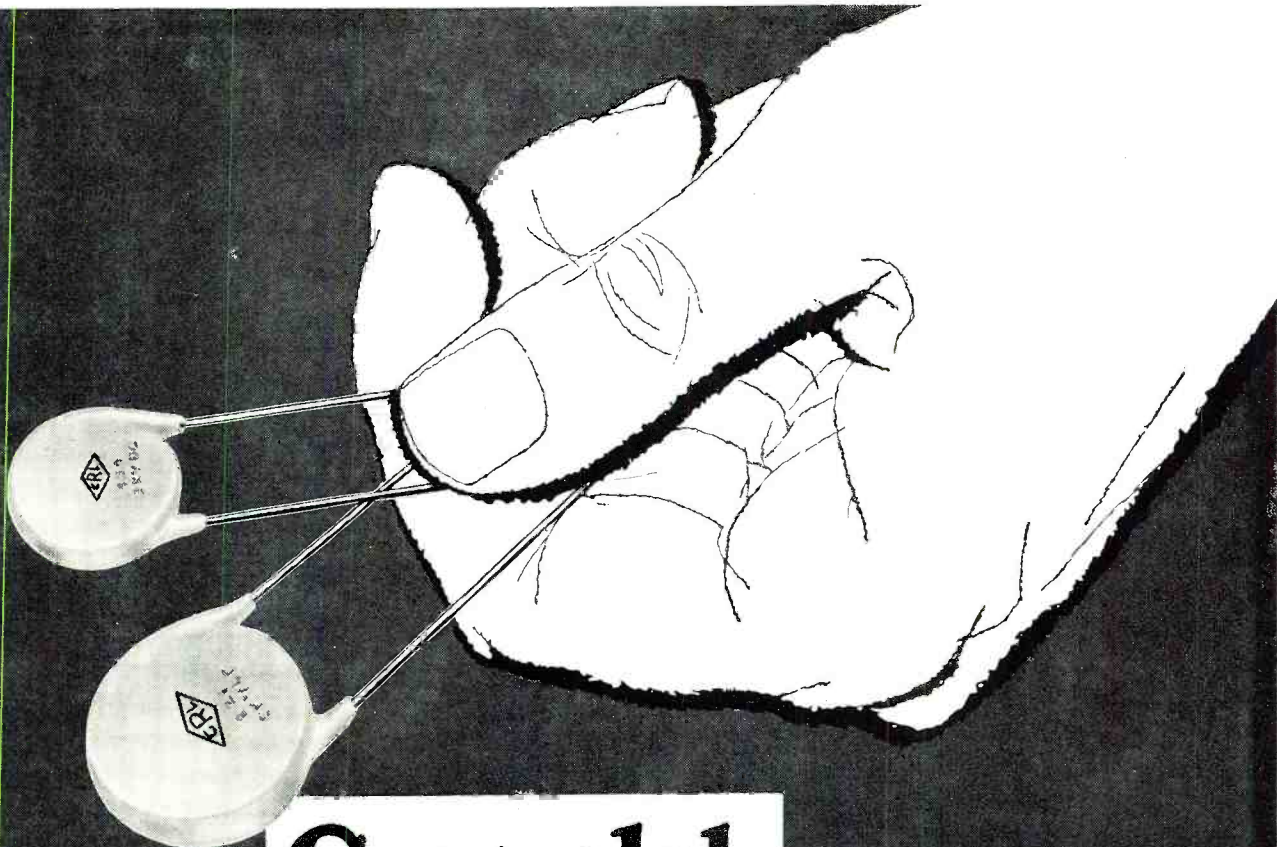

Centralab announces

new HI-VO-DISC* capacitors



DD30

DD60

3000-VDCW and 6000-VDCW discs that are highly efficient as bypass and coupling capacitors in high-frequency circuits under conditions of extreme humidity or temperature

Centralab does it again — gives you and your customers more for your money in two new series of high-voltage disc capacitors. You'll agree that they're tip-top additions to the world's greatest line of ceramic capacitors.

Every unit in both the DD30 and DD60 series is tested at twice rated working voltage. So you know you can count on them for high capacity

and performance up to 85° C.

There are other reasons why these CRL Hi-Vo-Discs help end profit-robbing call-backs: The heavy, special phenolic insulation has triple-high-temperature wax impregnation. Tolerances are held to ± 20%.

Send coupon for catalog sheet 28-2 —for complete information on these new CRL capacitors for bypass, coupling, and general applications.

Centralab

A DIVISION OF GLOBE-UNION INC.
Milwaukee 1, Wisconsin
In Canada
804 Mt. Pleasant Rd., Toronto 12, Ontario

CENTRALAB, A Division of Globe-Union Inc.
910D E. Keefe Avenue, Milwaukee 1, Wisconsin

Send me catalog sheet 28-2 describing Centralab's new HI-VO-DISC capacitors.

Name.....
Company.....
Address.....
City.....Zone.....State.....

D-2154

Now you can say "NUTS" to the usual TV summer sales slump!

REVOLUTIONARY NEW CROSLEY SUPER-V MEANS SALES ACTION *NOW!*

Here's the set the industry said couldn't be built. Crosley's gone ahead and built it!

CROSLEY SUPER-V IS DIFFERENT OUTSIDE!

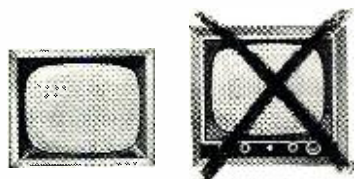

It's the most compact TV set ever designed. Fits in places you couldn't think of putting other sets, makes it possible to have TV in any room!

CROSLEY SUPER-V IS DIFFERENT INSIDE!

The chassis is designed so you can replace every tube from the back. Or you can easily slide the cabinet off to expose the whole works.

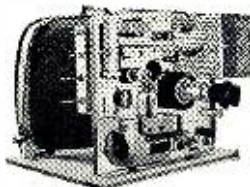

- Portable—light enough to carry, small enough to handle. Take it anywhere.
- Takes up to $\frac{1}{3}$ less space than other 17" TVs—fits where other sets won't.
- Super-Vertical Circuit pulls in brilliant picture—is easier to service.
- Front all screen—controls on the side.
- Choice of 3 finishes (mahogany, walnut, blond).
- Full-Year Warranty on picture tube—90 days on chassis parts.
- Rolling off Crosley production line in volume—priced for profit and action now!



A triumph of Crosley's 33 years' electronic research

Featured on
"YOUR HIT PARADE"
starting in March
on NBC-TV Network

17-INCH
Super-V

Retail prices start at
\$ **139** ⁹⁵
Coast to Coast
(walnut-finished)

YOU MAKE A GOOD PROFIT ON EVERY ONE—AND YOU CAN HAVE ALL YOU WANT! CALL YOUR CROSLEY DISTRIBUTOR NOW!

You can **SELL** them better on a **CROSLEY**

IN A CLASS

by itself...

THE NEW

NC-98

No need to write a book about the new NC-98
One quick comparison proves it's in a class
by itself — in performance and price!
For only \$149.95, what other receiver offers you all
the "high-priced" features listed below?

CRYSTAL FILTER

S-METER

550 KCS. TO 40 MCS. RANGE

CALIBRATED AMATEUR BANDSPREAD

OR

CALIBRATED SWL BANDSPREAD*

NEW MINIATURE TUBES

AN RF STAGE

ACCESSORY SOCKET

TWO IF STAGES

EDGE-LIGHTED LUCITE DIALS

NOISE LIMITER

SEPARATE HF OSCILLATOR

3-POSITION SELECTIVITY

ANTENNA TRIMMER

PHASING CONTROL

SENSITIVITY CONTROL

*Model NC-98SW (for shortwave listeners)

Write for complete specifications
today to Dept. RN 454

tuned to tomorrow

\$149.95

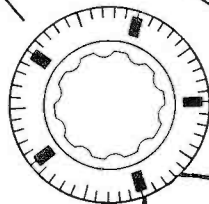
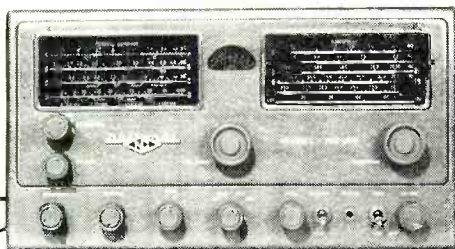

National



NATIONAL COMPANY, INC., MALDEN & MELROSE, MASS.

April, 1954

23

by
every
test



is BEST!



ATR AUTO
RADIO
VIBRATORS

Have Ceramic Stack Spacers
A COMPLETE LINE
OF VIBRATORS

Designed for Use in Standard
Vibrator-Operated Auto Radio
Receivers. Built with Precision
Construction, featuring Ceram-
ic Stack Spacers for longer
lasting life. Backed by more
than 22 years of experience in
Vibrator Design, Develop-
ment, and Manufacturing.

Free

"A" Battery Eliminators, DC-AC
Inverters, Auto Radio Vibrators



NEW MODELS NEW DESIGNS NEW LITERATURE

See your jobber or write factory

AMERICAN TELEVISION & RADIO CO.

Quality Products Since 1931

SAINT PAUL 1, MINNESOTA—U. S. A.

Within the
INDUSTRY

JAMES M. EARLY is the new sales service engineer for the radio and television picture tube division of *Sylvania Electric Products Inc.*

In his new post he will conduct the company's service meetings across the country on all phases of radio and television test equipment and on technical subjects pertaining to the radio-TV field.



He has been associated with the company since 1952, is a member of the American Institute of Physics, a member of the Association for the Advancement of Science, and an associate member of the IRE. He is a veteran of World War II.

* * *

DR. W. R. G. BAKER was one of three prominent electrical engineers recently inducted into Eminent Membership of Eta Kappa Nu, honorary electrical engineering fraternity.

Dr. Baker was chosen in recognition of "his technical achievements and administrative leadership in the field of electronics."

Also honored were Dr. Marvin J. Kelly, president of *Bell Telephone Laboratories* and Dr. Reinhold Rudenberg, the Gordon McKay professor of electrical engineering at Harvard University.

Only eight electrical engineers have been so honored previous to these latest awards.

* * *

JOSEPH H. QUICK has been elected president of *National Company, Inc.*, succeeding Charles C. Hornbostel.

Mr. Quick has been associated with such firms as *RCA, Philco,* and *Sylvania* and since 1946 has been the senior partner of *Work-Factor Company*, management engineering firm. He was most recently president of *Harrington & Richardson Arms Company* of Worcester, Mass.



* * *

ORRADIO INDUSTRIES, INC. of Opelika, Alabama, maker of "Irish" recording tape, has opened a New York office at 458 Broadway. James F. Kenney will be in charge of the new office . . .

GRANCO PRODUCTS, INC. has broken ground for a new addition to its Long Island City, N. Y. plant. The new building will double the company's present space . . . **SOLA ELECTRIC CO.** of Chicago has opened a branch office for specialty transformer sales at 2025

Sunset Boulevard in Los Angeles. Richard S. Smith who has been with the company since 1947 will be in charge . . . The third major plant expansion in four years has been completed by **JOHN VOLKERT METAL STAMPINGS, INC.** of Queens Village, N. Y. The 12,000 square foot building will be used for the production of precision stampings and assemblies for the electronics industry . . .

VITRO CORPORATION OF AMERICA has opened an office at 726 Jackson Place, N.W., Washington 6, D. C. . . . **BURROUGHS CORPORATION** has set up an electronic instruments division as a separate manufacturing and marketing division of the company. The new division will occupy an entire building at 1209 Vine Street, Philadelphia . . .

NATIONAL COMPANY, INC. has established a Washington sales office to handle government contract work . . . **CHROMATIC TELEVISION LABORATORIES, INC.** has added new grid-producing facilities in Emeryville, California, to help step up production of color tubes.

* * *

MICHAEL F. CALLAHAN has been named vice-president in charge of manufacturing for all of the *CBS-Hytron* plants.

He started with the company's Salem factory 24 years ago as a tube tester.



The company also announced the appointment of Edgar K. Wimpy as director of general engineering and Dr. Russell R. Law as director of research and development. Dr. Law was formerly associated with *RCA* for 18 years.

* * *

G. W. DeSOUSA, formerly manager of *General Electric's* tube department marketing administration, has been named manager of equipment tube sales for the company . . . **E. B. CONLEY** has been appointed vice-president and general manager of *Allied International, Inc.'s* manufacturing plant, known as the *Allied Engineering Division* . . . *Sylvania Electric Products Inc.* has named **COLE H. PILCHER** to the post of director of industrial relations. He has been with the firm since 1941 . . .

JOHN P. KEARNEY, manager of the industrial and electronics sales division of *Kimble Glass Co.*, has been promoted to the post of manager of new product development. He will be principally engaged in the development of the company's color television bulb program . . . **GARDINER G. GREENE** has become president and principal stockholder of *Browning Laboratories, Inc.* of Winchester, Mass. **DR. GLENN H.**

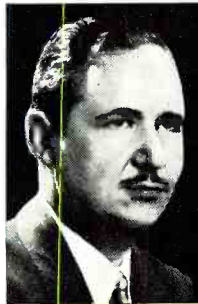

NO EXPERIENCE NECESSARY! LEARN TELEVISION AT HOME IN YOUR SPARE TIME!

L. C. Lane, B.S., M.A.
President: Radio-Television Training Association
Executive Director: Pierce School of Radio & Television

Super-Het Radio Receiver

Public Address System

C-W Telephone Transmitter

AC-DC Power Supply

Giant Screen TV Receiver

Combination Voltmeter-Ammeter-Ohmmeter

RF Signal Generator



You build all this equipment and more! Everything yours to keep.

VETERANS! CIVILIANS!

BE A SUCCESS AS A TRAINED TV TECHNICIAN!

Keep your present job while I prepare you AT HOME, using the same successful methods that have helped hundreds of men—many with no more than grammar school training—master television!

WARNING! state place s in- dusty ways home You ent I helped grammar
ALL VETERANS DISCHARGED BEFORE AUGUST 20, 1952 must be enrolled and IN TRAINING by August 20, 1954. Otherwise you lose your G.I. rights to a free education under NEW G.I. BILL! Don't put it off... it takes several months to get your papers processed! RUSH send COUPON BELOW. Tell your ex-G.I. friends!

VETERANS!

MY SCHOOLS FULLY APPROVED TO TRAIN VETERANS UNDER NEW G.I. BILL! If discharged after June 27, 1950 — CHECK COUPON! Also approved for RESIDENT TRAINING in New York City... qualifies you for full subsistence allowance up to \$160 per month.

EXPERT FM-TV TECHNICIAN TRAINING!

My FM-TV Technician Course can save you months of training if you have previous Armed Forces or civilian radio experience! Train at home with kits of parts, plus equipment to build BIG SCREEN TV RECEIVER, and FREE FCC Coaching Course! ALL FURNISHED AT NO EXTRA COST!

NEW! PRACTICAL TV CAMERAMAN & STUDIO COURSE!



I train you at home for an exciting big pay job as the man behind the TV camera. Work with TV stars in TV studios or "on location" at remote pick-ups! A special one-week course of practical work on TV studio equipment at Pierce School of Radio & TV, our associated resident school in New York City, is offered upon your graduation.

FREE FCC COACHING COURSE!

QUALIFIES YOU FOR HIGHER PAY! Given to all my students AT NO EXTRA COST after TV Theory and Practice is completed. Helps you qualify for the TOP JOBS in Radio-TV that demand an FCC License! Full training and preparation at home for your FCC License.

OPTIONAL: TWO WEEKS TRAINING IN NEW YORK CITY AT NO EXTRA COST

You get two weeks, 50 hours, of intensive Laboratory work on modern electronic equipment at our associated school in New York City—Pierce School of Radio and Television. And I give you all this AT NO EXTRA COST whatsoever, after you finish your home study training in the Radio-FM-TV Technician course and FM-TV Technician Course.

RADIO-TELEVISION TRAINING ASSOCIATION

52 East 19th Street, New York 3, N. Y.

Licensed by the State of New York

Approved by the VA

ENOUGH EQUIPMENT TO SET UP YOUR HOME LABORATORY!

As part of your training, I give you ALL the equipment you need to prepare for a BETTER PAY TV job. You build and keep a professional GIANT SCREEN TV RECEIVER complete with big picture tube (designed and engineered to take any size up to 21-inch)... also a Super-Het Radio Receiver, RF Signal Generator, Combination Voltmeter-Ammeter-Ohmmeter, C-W Telephone Transmitter, Public Address System, AC-DC Power Supply. Everything supplied including all tubes.

GOOD SPARE TIME EARNINGS!

Almost from the very start you can earn extra money while learning, repairing Radio-TV sets for friends and neighbors. Many of my students earn up to \$25 a week... pay their entire training from spare time earnings... start their own profitable service business. Act now! Mail coupon and find out for yourself what a TV career can do for you!

MAIL COUPON TODAY!

MY 4 FREE AIDS SHOW YOU HOW AND WHERE TO GET A BETTER PAY JOB IN TELEVISION!

See for yourself how my simple, practical methods make success easy.



NO SALESMAN WILL CALL!

Mr. Leonard C. Lane, President
RADIO-TELEVISION TRAINING ASSOCIATION
52 East 19th Street, New York 3, N. Y. Dept. T-4B

Dear Mr. Lane: Mail me your NEW FREE BOOK, FREE SAMPLE LESSON, and FREE aids that will show me how I can make BIG MONEY IN TELEVISION. I understand I am under no obligation and no salesman will call.

(PLEASE PRINT PLAINLY)

NAME _____ AGE _____

ADDRESS _____

CITY _____ ZONE _____ STATE _____

I AM INTERESTED IN:

- Radio-FM-TV Technician Course **VETERANS! Check here**
 FM-TV Technician Course **for Training under NEW**
 TV Cameraman & Studio Course **G.I. Bill**

The *FIRST STEP* in

HIGH FIDELITY

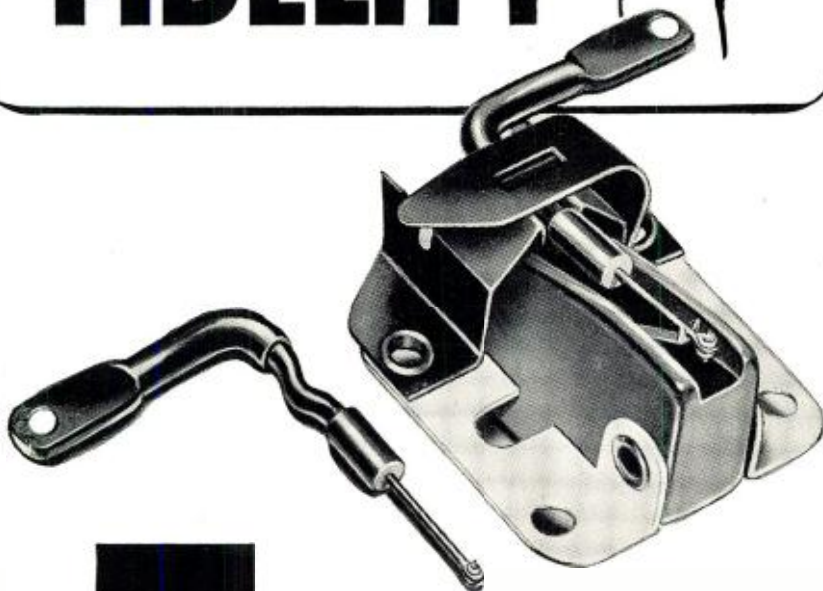

TITONE

CERAMIC CARTRIDGE

There is no wiser investment a phonograph owner can make than a TITONE ceramic cartridge.

Costing no more than ordinary "replacement" cartridges, TITONE gives a world of difference in results — an entirely new experience in true high-fidelity sound, no matter what the make of phonograph.

And only *two models* will replace most present-day installations!

No other cartridge gives all these features!

No preamplifier or equalizer needed • Unaffected by moisture or temperature • Wide frequency range • Outstanding response • High sensitivity • Low distortion • High compliance • No hum pickup • Superior tracking ability • Wide adaptability • Proper groove fit • Only needle rotates • Simple to replace

(Used by America's foremost manufacturers of high-fidelity phonographs, TITONE is an original discovery and development of the Sonotone laboratories. Literature available.)

ELECTRONIC APPLICATIONS DIVISION

SONOTONE CORPORATION

Elmsford, New York

BROWNING, former president, was named chairman of the board . . . **JOE CHAPMAN LANE, JR.** is the new manager of advertising and sales promotion for the *Westinghouse* electronic tube division . . . *Fairchild Recording Equipment Co.* has named **ROBERT G. BACH** to the post of assistant sales and advertising manager . . . **JOHN J. CORCORAN** is the new sales representative and commercial engineer for *Tung-Sol Electric Inc.*'s west coast office. He will make his headquarters in Culver City . . . *Raytheon Manufacturing Company's* radio and television division has appointed **JOHN H. KELLY** general manager. He will be located at the Chicago plant . . . **GEORGE D. NEWMAN, JR.** is the new general sales manager for *Hitemp Wires, Inc.* . . . The appointment of **DAVID H. KUTNER** as director of advertising has been announced by *Motorola Inc.* . . . *Pilot Radio Corporation* has named **EDWIN CORNFIELD** sales manager . . . **HARRY OEDEKERK**, president of *Hycon Mfg. Company*, has been elevated to the post of chairman of the board while **ALDEN E. ACKER** has been elected president . . . The home instruments division of *Freed Electronics & Controls Corp.* has appointed **W. WALTER JABLON** sales manager . . . **IRA LANDIS**, former treasurer of the *Herman H. Smith* concern, has been elected president of the firm succeeding the late Mr. Smith . . . *Channel Master Corp.* has added two engineers to its electrical and mechanical engineering staffs. **DR. WILLIAM OSBORN** was named project engineer in the development of new v.h.f. and u.h.f. antennas while **DR. MIAO YUNG-MIAO** was appointed project engineer in the development of mechanical test equipment for antennas . . . **JACK KUFELD** has been named manager of *Arrow Electronics Inc.*'s sound division at the "Audio Center" located at 65 Cortlandt St., New York City . . . **M. J. McNICHOLAS** is the new director of *Andrea Radio Corporation's* electronic division . . . *V-M Corporation* has named **MERLE CAIN** distributor sales manager.

* * *

BRON KUTNY has been named field engineer for *Channel Master Corporation*, Ellenville, N. Y. antenna manufacturer.

In his new post, Mr. Kutny will supplement the company's expanding field engineering program which includes education of distributor salesmen and dealers, in-the-field testing of new antennas, and on-the-spot troubleshooting in problem areas.

He was formerly educational director of *Emerson Radio and Phonograph Corporation*.

* * *

FRANK H. SHEPARD, JR. has been elected president of The Radio Club of America, Inc. for 1954.

Serving with Mr. Shepard are Frank
(Continued on page 163)



THINGS ARE **NOT** AS THEY SEEM...

This *is* a perfect square.
It is an optical illusion that the sides bend.



3 amps fuse will not blow at 3 amps.

Fuses are not rated by the current at which they blow. Fuses are rated by the maximum current they should carry indefinitely.

Each type of fuse blows according to the requirements of the equipment it was designed to protect.

Littelfuse has cooperated with NEC, Underwriters, Armed Forces MIL Specs Committees in establishing the characteristics of the various fuse types.

Littelfuse holds more design patents on fuses than all other manufacturers combined.

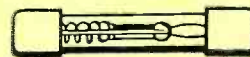

3 AG "SLO-BLO"



3 AB



8 AG U/L



1 AG



4 AG ANTI-VIBRATION

LITTELFUSE

DES PLAINES, ILLINOIS

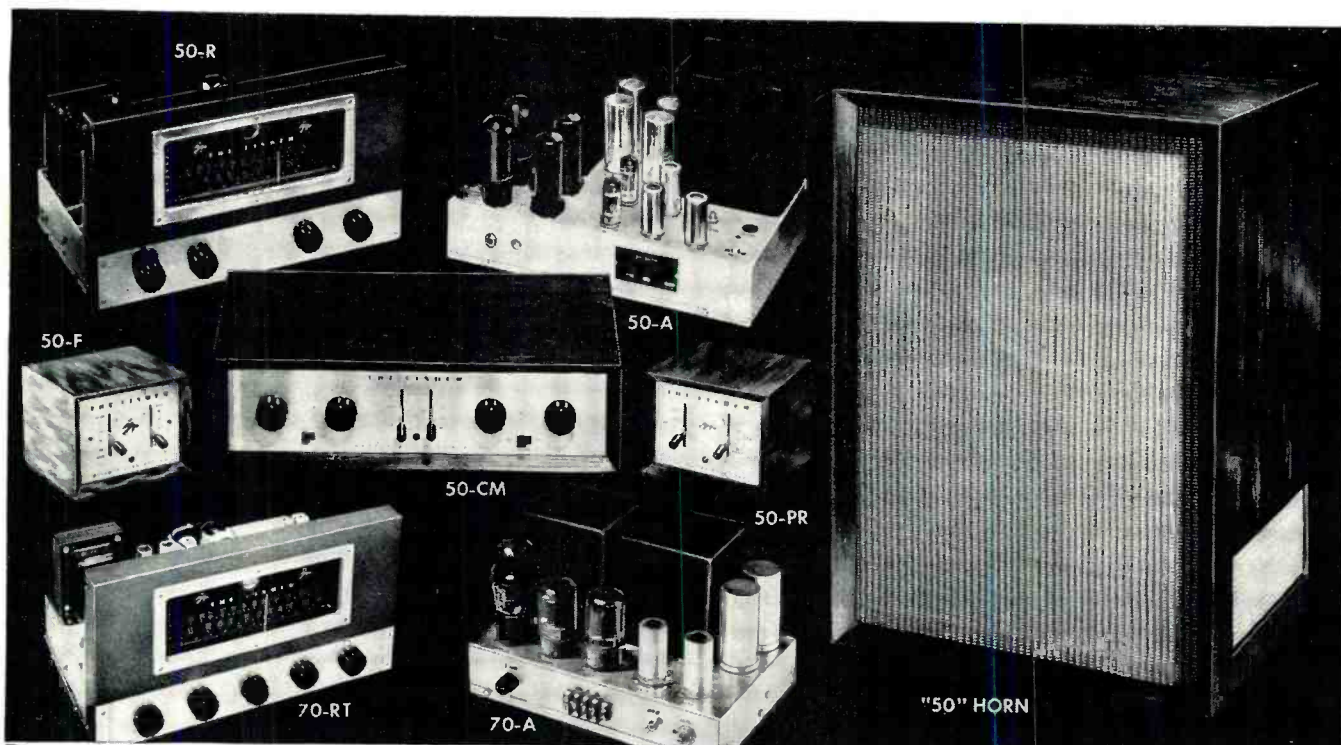

The Best Costs Less When You Buy

THE FISHER

Custom Audio Components

■ If you are buying 'for keeps' buy the best *first!* Buy FISHER, *quality leader* for seventeen years. Engineered for the professional, functionally designed for home use. "Of the very best!"—*High Fidelity.*

FM-AM TUNER, Model 70-RT

Features extreme sensitivity, low distortion and low hum. Armstrong system, *adjustable* FM-AFC and AM selectivity. Preamplifier-equalizer, 2 inputs, 2 cathode follower outputs. Six controls. Self-powered. \$184.50

FM-AM TUNER, Model 50-R

Same features as 70-RT above, but designed for use with external preamplifier-equalizer such as 50-C. Hum level better than 100 db below 2 volts output. Fully shielded and shock-mounted. Self-powered. \$164.50

MASTER AUDIO CONTROL, Series 50-C

16 choices of record equalization, plus separate bass and treble tone controls, loudness balance control. Five inputs and input level controls, two cathode follower outputs. Chassis only, \$89.50 • With cabinet, \$97.50

25-WATT AMPLIFIER, Model 70-A

50-watts peak! More *clean* watts per dollar. Less than ½% distortion at 25 watts (0.05% at 10 watts.) Response ±0.1 db, 20-20,000 cycles; 1 db, 10 to 50,000 cycles. Hum and noise virtually non-measurable! \$99.50

50-WATT AMPLIFIER, Model 50-A

100-watts peak! World's *finest* all-triode amplifier. Uniform within 1 db, 5 to 100,000 cycles. Hum and noise 96 db below full output. IM distortion below 2% at 50 watts. Highest quality components thruout. \$159.50

"50" HORN, SPEAKER ENCLOSURE

NEW! Regardless of the speaker or enclosure you are now using, the "50" Horn marks a revolution in performance. Can be used with any 12" or 15" single, coaxial, dual or triaxial speaker system. \$129.50

PREAMPLIFIER-EQUALIZER, Model 50-PR

Professional phono equalization facilities at low cost! Independent switches for LF turn-over and HF roll-off. Output lead up to 50 feet. Can accommodate any low-level, magnetic pickup. Self-powered. \$22.95

HI-LO FILTER SYSTEM, Model 50-F

Does what ordinary *tone* controls cannot do, for it suppresses all types of noise with an *absolute minimum* loss of tonal range. High impedance input; cathode follower output. Use with any equipment. \$29.95

Prices slightly higher west of the Rockies

WRITE TODAY FOR COMPLETE SPECIFICATIONS

FISHER RADIO CORPORATION • 39 EAST 47th STREET • NEW YORK, N. Y.

"LOCAL" UHF BOW TIE KIT
For local and in-town installations,
in strong signal areas. Kit complete.

- LIST
No. 9030* (Series 1 accessories) \$13.95
No. 9034 (Series 2 accessories) 13.95
No. 9038 (Series 3 accessories) 13.95
No. 9042 (Series 4 accessories) 13.95

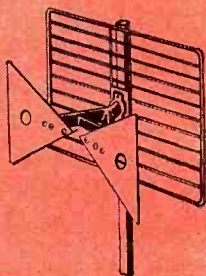

"FRINGE" UHF TWO STACK BOW TIE KIT

For fringe areas up to 30 miles
(depending on local conditions). Kit
complete.

- LIST
No. 9031* (Series 1 accessories).....\$16.75
No. 9035 (Series 2 accessories)..... 16.75
No. 9039 (Series 3 accessories)..... 16.75
No. 9043 (Series 4 accessories)..... 16.75

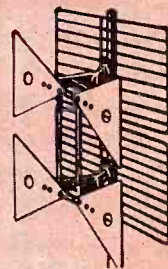

SERIES NO. 1 HARDWARE



SERIES NO. 2 HARDWARE



SERIES NO. 3 HARDWARE

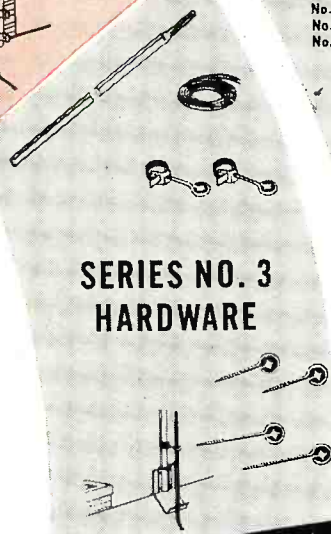

SERIES NO. 4 HARDWARE



"DELUXE" UHF CORNER REFLECTOR KIT
For troublesome areas, or where
extra high gain is required. Kit
complete.

- LIST
No. 9032* (Series 1 accessories) \$19.50
No. 9036 (Series 2 accessories) 19.50
No. 9040 (Series 3 accessories) 19.50
No. 9044 (Series 4 accessories) 19.50

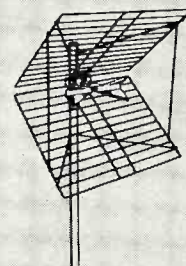

"DOUBLE V" UHF & VHF ANTENNA KIT

Highly directional and very satisfac-
tory where both UHF & VHF
signals are to be received on
same antenna. Complete.

- LIST
No. 9033* (Series 1 accessories) \$14.95
No. 9037 (Series 2 accessories) 14.95
No. 9041 (Series 3 accessories) 14.95
No. 9045 (Series 4 accessories) 14.95

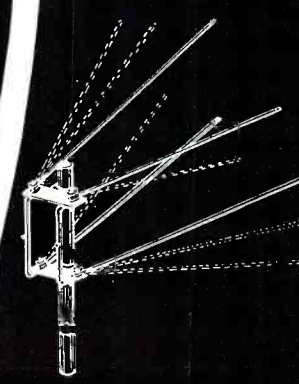

UHF

"DO IT YOURSELF"

ANTENNA KITS

CHOICE OF 4 DIFFERENT SETS OF MOUNTING
HARDWARE FOR EACH ANTENNA

16 COMBINATIONS TO CHOOSE FROM!

These new TELCO Antenna Kits are just what you need for profitable selling to the "do-it-yourself" market. There's a wide range of styles to meet every requirement . . . with four choices in hardware components for each kit. Your favorite distributor's got them . . . or can get them for you!

***WHAT EACH TELCO KIT CONTAINS**

SERIES 1 ACCESSORIES

- Complete Antenna, as shown
- 1-6 ft. 1 1/4" Mast
- 50 ft. Guy Wire
- 50 ft. UHF Low Loss Line
- 1-Guy Wire Clamp
- 4-Screw Eyes
- 2-Universal Mast Stand-Offs
- 2-3" Wood Screw Stand-Offs
- 2-7" Wood Screw Stand-Offs
- 1-Mast Base

SERIES 3 ACCESSORIES

- Complete Antenna, as shown
- 1-5 ft. 1 1/4" Mast
- 50 ft. UHF Low Loss Line
- 2-Universal Mast Stand-Offs
- 2-3" Wood Screw Stand-Offs
- 2-7" Wood Screw Stand-Offs
- 1-All-Purpose Antenna Mast Bracket

SERIES 2 ACCESSORIES

- Complete Antenna, as shown
- 1-6 ft. 1 1/4" Mast
- 50 ft. UHF Low Loss Line
- 2-Universal Mast Stand-Offs
- 2-3" Wood Screw Stand-Offs
- 2-7" Wood Screw Stand-Offs
- 1-Chimney Mount

SERIES 4 ACCESSORIES

- Complete Antenna, as shown
- 1-5 ft. 1 1/4" Mast
- 50 ft. UHF Low Loss Line
- 2-Universal Mast Stand-Offs
- 2-3" Wood Screw Stand-Offs
- 2-7" Wood Screw Stand-Offs
- 1-Snap-In Wall Mount

AN ANTENNA STYLE AND HARDWARE SELECTION FOR EVERY INSTALLATION — 16 KITS IN ALL!

NOTE — Special kits for particular areas
made to order. Write for details!



FREE!
Your new TELCO Cata-
log. Ask your jobber
. . . or write direct,



TELEVISION HARDWARE MFG. CO.
DIVISION OF GENERAL CEMENT MFG. CO.
904 Taylor Avenue Rockford, Illinois

Here it is! DRAMATIC DEVELOPMENT IN TV INSTALLATIONS! LESS METAL ...LOWEST LOSS IN AN ALL-PURPOSE STAND-OFF INSULATOR



PA *
Stand-off Insulator
*Pivot-Action-Lock

PAL* stand-off insulator is the serviceman's PAL for all UHF and VHF installations—takes tubular, open and flat transmission lines more quickly and simply.

No metal surrounds the PAL insulator. PAL eliminates standing waves and voltage losses on UHF or VHF. Produces sharper, clearer pictures.

The PAL* positive lock—pressure button exerts extra locking tension when insulator is in closed position.

PAL* is easy to work with—even in the open position
PAL* is always in one piece because of the exclusive JFD hinge design. No threading of insert. No crimping.

PAL* is plated to a special military spec which safeguards against rust. Exclusive BRONZ-IDITE plating.

PAL* cam type latch is for quicker, easier, better installations.

Write for PAL Brochure No. 243
JFD MANUFACTURING CO., INC.
Brooklyn 4, N. Y.

World's largest manufacturers of TV Antennas and Accessories

Burton Browne Advertising



1. Simply hinge insulator—slip lead-in into place—(any type fits tightly inside insulator).

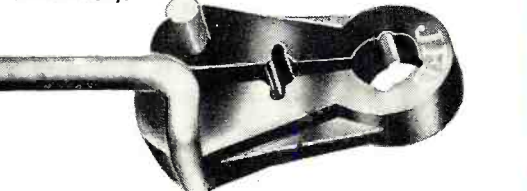

2. Swing polyethylene insulator into place—click that's it.

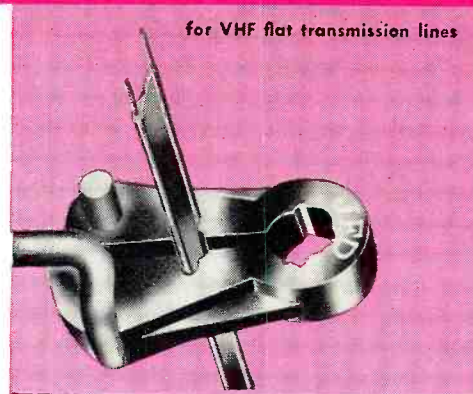

for VHF flat transmission lines

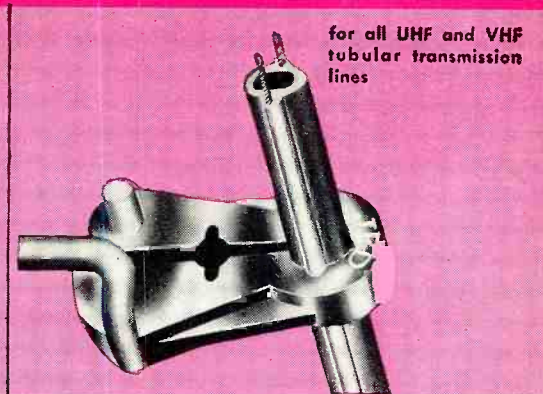

for all UHF and VHF tubular transmission lines

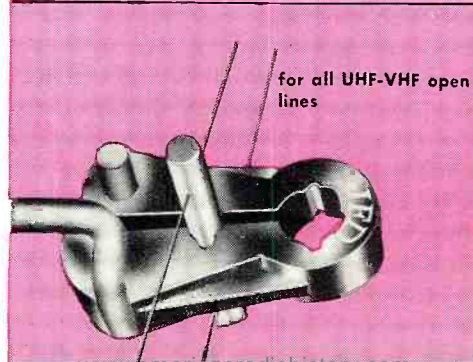

for all UHF-VHF open lines

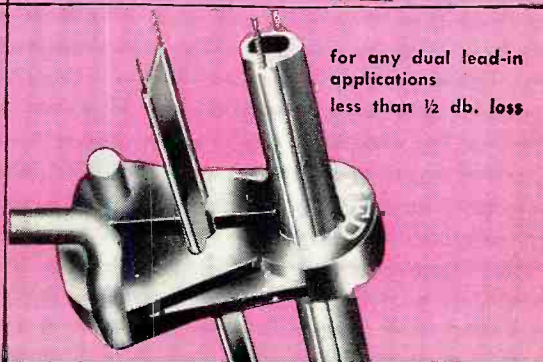

for any dual lead-in applications less than 1/2 db. loss

EVERYTHING IN PERFORMANCE
 ... AT A PRICE
 YOUR
 CUSTOMERS
 WILL LIKE!

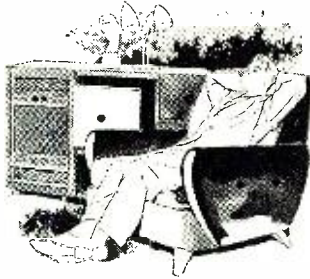

THE INDUSTRY'S MOST
 COMPATIBLE LINE...
 BEST ODDS GOING FOR
 SATISFIED CUSTOMERS!



SIMPLE TO SELL...
 THEY LISTEN ONCE... LOOK AT
 THE PRICE TAG
 ... AND BUY!



**HIGH-FIDELITY,
 the G-E way,
 MAKES SENSE!**

THOSE seven simple words tell the complete story. Your customers may spend a lot more money for equipment, but they'll never buy better performance than the General Electric Custom Music Ensemble delivers! Here, in *one integrated sound system*, lies the answer to widest high-fidelity customer interest... your greatest potential for profit and sales.

To go places in the high-fidelity business, go all the way with General Electric! Get aboard early... mail the coupon below for complete information today.



CUSTOM
 INSTALLATIONS
 WITH MATCHED EQUIPMENT

HAVE
 BONUS APPEAL!



UNEQUALLED REPUTATION FOR
 QUALITY... G-E's FAMOUS
 VARIABLE RELUCTANCE
 CARTRIDGE PROVES IT!

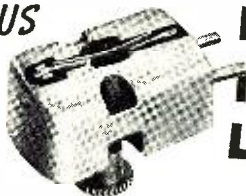

General Electric Company, Section R944
 Electronics Park, Syracuse, New York.

Send me information on all units in the G-E high-fidelity equipment line.

NAME.....
 ADDRESS.....
 CITY..... STATE.....

GENERAL  ELECTRIC

To build a healthy, growing service business...

YOU NEED THESE 6 NEW

WALSCO

SERVICE ITEMS



NEW WALSCO CLEAN-O-MATIC...

Covers contacts on "Standard Coil" tuners and keeps them clean, silent, oxidation-free. Very easy to install. Tube of "Tunerlub" and crocus cloth included.

Cat. No. 1200

\$1.50 net

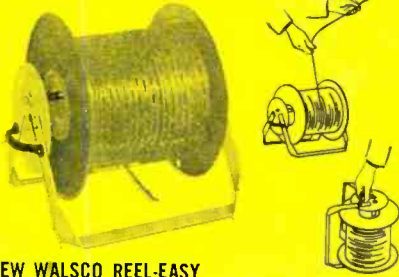

NEW WALSCO REEL-EASY

Portable wire reel holder. Light, durable, compact—weighs only 1 1/2 lbs. Handy to carry, easy to dispense lead-in wires. Eliminates tangled cables.

Cat. No. 503

\$3.60 net



NEW WALSCO VIEW BINS

Keeps small parts handy, sorted, visible and dust-free. Sturdy, tilt-type, spill-proof drawers reveal contents. No hidden corners. Silver hammer-tone finish. Welded steel.

Cat. No. 1010-6 bin

\$4.95 net

Cat. No. 1010-12 bin

9.50 net

Cat. No. 1010-24 bin

16.95 net

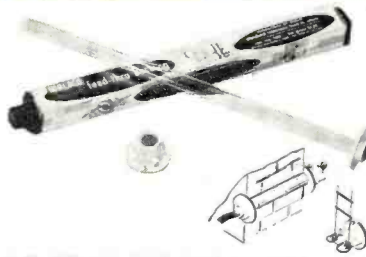

NEW WALSCO FEED-THRU BUSHING

Bring antenna cables into the house the professional way. This bushing fits all lead-in and rotator cables. Terminate "open line" outside... bring flat line through bushing to set. Fits walls up to 16". Requires 3/4" hole.

Cat. No. 1551

\$1.17 net



NEW WALSCO TOOLS

New I.F. alignment tool for all UHF RCA, Zenith and other sets.

Cat. No. 2527

\$0.42 net

"Slug Saver" front end alignment tool for all "Standard Coil" tuners. Impossible to lose slugs with this patented tool.

Cat. No. 2528

\$0.63 net

Solder-ease tool. Bristles of brush and prongs of stainless steel. Solder will not stick.

Cat. No. 2529

\$0.99 net



NEW WALSCO GUY-TITE

Tighten guy wires faster and better with this new WalSCO tool. Does the job of a turnbuckle at a fraction of its cost.

Cat. No. 1568 Box of 100

\$3.60 net

Cat. No. 1566 Tool and 18 tites

4.95 net

WALSCO ELECTRONICS CORPORATION

3602 Crenshaw Blvd. • Los Angeles 16, Calif.

Canadian Factory Distributor: Atlas Radio Corp., Ltd., 560 King St. West, Toronto 2-B.
Overseas Distributor: Ad Auriema, Inc., 89 Broad St., New York 4, N.Y.

Quality is an elusive thing. Engineers measure it . . . copywriters glorify it . . . salesmen describe it. But the final test is actual performance. If a product is the best in its field, those who know quality will accept no other.

That is the story of Pickering's new 260 Turnover Cartridge.

Introduced only months ago, it is already a leader among magnetic cartridges. It has won that position because it is the nearest thing to perfection yet produced. Here are the combined advantages it offers:

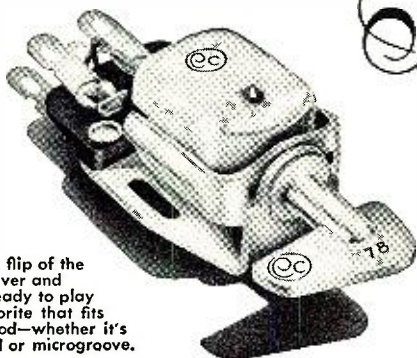

A simple flip of the handy lever and you're ready to play any favorite that fits your mood—whether it's standard or microgroove.

The nearest Thing to Perfection

1. HIGHER OUTPUT—Better overall signal-to-noise ratio.
2. LOWER OVERALL DISTORTION—Less intermodulation distortion with wider frequency response.
3. MINIMUM TRACKING FORCE—Lowest practical tracking force for both microgroove and standard recordings.
4. HIGHER COMPLIANCE—Compliance of moving elements is the highest practical, consistent with best-quality transcription arms and changers.
5. LOWER MOVING MASS—Lowest of any comparable magnetic cartridge.
6. TWO DIAMOND STYLI—For longer record and stylus life and greatest economy.

These design features have real meaning to those who understand that quality reproduction depends on components which meet professional standards. If you want the best that high fidelity can offer, ask your dealer to demonstrate the new 260 Turnover Cartridge. You, too, will hear the difference!

PICKERING and company incorporated • Oceanside, L. I., New York



PICKERING PROFESSIONAL AUDIO COMPONENTS

“For those who can hear the difference”

NOW... 2 SENSATIONAL EICO SCOPE VALUES!

NEW AMAZING FEATURE PACKED
7" PUSH-PULL OSCILLOSCOPE

Only EICO Has All These Features

- VERTICAL FREQ. RESPONSE: flat ± 2 db 10 cps - 1 mc
- VERTICAL SENS.: .01 volts rms/inch
- HOR. FREQ. RESP.: flat ± 0 db 10 cps - 200 kc, -4 db at 500 kc
- HOR. SENS.: 3 volts rms/inch
- SWEEP RANGE: 15 cps-100 kc
- 3-STEP FREQ.-COMPENSATED ATTENUATOR eliminates freq. distortion, overloading.
- CATHODE FOLLOWER inputs to both amplifiers
- PUSH-PULL outputs in both amplifiers
- RETURN TRACE BLANKING
- INT. VOLTAGE CALIBRATOR
- V & H TRACE EXPANSION & CENTERING: 1.5X full screen without distortion.
- DIRECT CONNECTION to vert. CRT plates.
- PHASING CONTROL of internal 60 cps sine wave sweep.
- AT FRONT PANEL: intensity mod. input; 60 cps, sawtooth outputs.

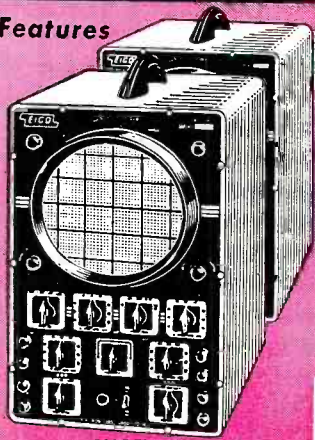

MODEL 470K
KIT \$79.95. WIRED \$129.50.

EICO EXCLUSIVE! 5" PUSH-PULL SCOPE, 425K, Amazing feature-packed economy-priced
Wired, \$79.95. KIT, \$44.95.

PUSH-PULL V & H amplifiers. Sens: 0.5-1 rms v/in. Useful to 2.5 mc. SWEEP: 15 cps-76 kc. Z-axis intensity modulation. Dual trace positioning controls.



SCOPE VOLTAGE CALIBRATOR KIT 495K KIT \$12.95. WIRED \$17.95.

- Sq. wave output at power-line freq. with full-scale readings of .1, 1, 10 or 100 V, peak-to-peak.
- Accuracy $\pm 5\%$ of full-scale on each range.

12V BATTERY ELIMINATOR KIT D50K KIT \$29.95. WIRED \$38.95.

- DC output: 0-8 V or 0-16 V.
- Continuous current rating: 10 A at 6 V, 6 A at 12 V.
- Intermittent current rating: 20 A at 6 V, 12 A at 12 V.
- Separate Voltmeter & Ammeter.



221K VTVM KIT \$25.95. WIRED \$49.95.

- AC & DC volts: 0-5, 10, 100, 500, 1000 V (30 KV with HVP-1 probe).
- 5 ohm ranges from .2 ohm to 1000 megohms.
- DC input Z 26 megohms.
- 4 1/2" meter movement in can't-burn-out circuit.
- 1% mult. resistors.



360K SWEEP GEN. KIT \$34.95. WIRED \$49.95.

- Continuous coverage of all TV & FM freqs. from 500 kc to 228 mc.
- Sweep width variable 0-30 mc.
- Crystal marker oscillator, variable amplitude.

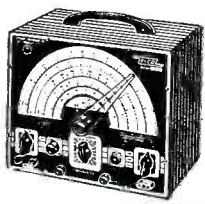

HIGH VOLTAGE PROBE \$6.95

- Extends range of VTVMs & voltmeters to 30 KV.



PIX TUBE ADAPTER for Tube Testers \$4.50. Checks TV picture tubes while in set.



214K VTVM KIT \$34.95. WIRED \$54.95.

- Large 7 1/2" meter, can't-burn-out circuit.
- AC/DC volts: 0-5, 10, 100, 500, 1000 (30 KV with HV Probe).
- 5 ohms ranges from .2 ohm to 1000 megohms.
- DC input Z 26 megohms.
- 1% mult. resistors.

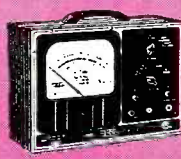

625K TUBE TESTER KIT \$34.95. WIRED \$49.95.



- Illum. gear-driven "Speed Rolchart."
- New lever-action switches for individual testing of every element.
- Tests all conventional & TV tubes.

950A-K R-C BRIDGE & R-C-L COMP. KIT \$19.95. WIRED \$29.95.



- Measures & tests all resistors; .5 ohm to 500 megohms.
- Every type condenser, 10 mfd to 5000 mfd.
- 0-500 DC voltage source for capacitor leakage testing.

COUNTER CABINET for above: add \$10.00 to Kit or Wired Prices.

NOW! ONLY EICO KITS & WIRED INSTRUMENTS Gives You LIFETIME SERVICE & CALIBRATION GUARANTEE*

*at less than our cost of handling (See EICO Guarantee Card enclosed with each Kit & Instrument).

171K RES. DECADE BOX KIT \$19.95. WIRED \$24.95.

- Resistance values from 0 to 99,999 ohms with 0.5% precision.
- All resistors have 0.5% accuracy

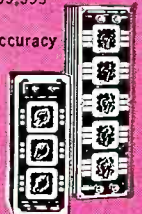

DECADE CONDENSER BOX KIT 1180K KIT \$14.95. WIRED \$19.95.

- All capacitors precision silver mica, accuracy $\pm 1\%$.
- Range from 100 mfd - 0.111 mfd in steps of 100 mmf.
- Smooth-action positive detent ceramic switches.

Prices 5% higher on West Coast. Specifications and prices subject to change without notice.

New! EICO SCOOPS!

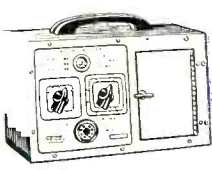

CATHODE RAY TUBE CHECKER 630K, WIRED \$24.95 KIT, \$17.95.

- Checks all types of TV picture and C.R. tubes in the set or carton. Bridge measurement of peak beam current (proportional to screen brightness).
- Detects shorted & open elements.

315K DELUXE SIG. GEN. KIT \$39.95. WIRED \$59.95.



- Covers range of 75 kc to 150 mc.
- 7 calibrated scales: accuracy better than 1%.
- Bandspread vernier tuning.
- 4-step RF shielded output multiplier: constant output Z.

BAR GENERATOR 352K, WIRED \$19.95 KIT, \$14.95

- Enables rapid adjustment of TV picture V & H linearity without hard-to-find station-transmitted test pattern.
- Produces 16 V or 12 H bars. Operates on TV channels 3, 4, or 5.

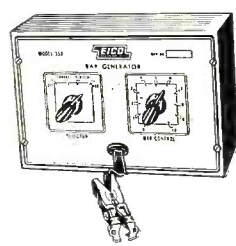

377K SINE & SQUARE WAVE AUDIO GEN. KIT \$31.95. WIRED \$49.95.



- Complete sine wave coverage, 20-200,000 cps in 4 direct-reading ranges.
- Complete square wave coverage, 60-50,000 cps.
- Cathode follower output circuit.

565K MULTIMETER KIT \$24.95 WIRED \$29.95.



- 555K MULTIMETER KIT \$29.95 WIRED \$34.95. (1% precision resistors)
- 20,000 Ω/V ; 31 ranges.
 - DC/AC/Output volts: 0-2.5, 10, 50, 250, 1000, 5000.
 - DC Current: 0-100 ua; 10, 100, 500 ma; 10 A.
 - Ohms: 0-2K, 200K, 20 meg.

145K SIG. TRACER KIT \$19.95. WIRED \$28.95.



- Audibly signal traces all IF, RF, Video & Audio circuits from ANT to SPKR or CRT in all TV, FM, AM, etc. without switching.
- Germanium crystal diode probe responsive to over 200 mc.
- Integral test speaker.

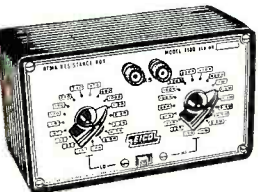

RTMA RESISTANCE SUBSTITUTION BOX 1100K WIRED \$9.95 KIT, \$5.50.

- Enables rapid substitution of resistances from 15 ohms to 10 megohms in decade multiples of 15, 22, 33, 47, 68, 100 ohms.
- Uses 36 standard 1 watt, $\pm 10\%$ RTMA resistors.

536K MULTIMETER KIT \$12.90. WIRED \$14.90. 526K MULTIMETER KIT \$13.90. WIRED \$16.90.



- 1000 Ω/V ; 31 ranges
- DC/AC volts: Zero to 1, 5, 10, 50, 100, 500, 5000.
- DC/AC Current: 0-1, 10 ma; 0.1, 1 A.
- Ohms: 0-500, 100 K, 1 meg.

320K SIG. GEN. KIT \$19.95. WIRED \$29.95. 322K SIG. GEN. KIT \$23.95. WIRED \$34.95.



- Fundamentals 150 kc to 34 mc, harmonics to 102 mc.
- 5-step band switching.
- Colpitts audio oscillator generates 400 cps pure sine wave voltage.
- Permits pure RF, modulated RF, or pure AF.

Write NOW for FREE latest Catalog R-4 showing entire EICO line. Ask your jobber for FREE EICO business building decals.



Separate Assembly & Operating Manuals supplied with each EICO KIT!

You build EICO Kits in one evening, but... they last a lifetime!

SAVE OVER 50%! See the famous EICO line TODAY, at your local jobber.

ELECTRONIC INSTRUMENT CO., Inc., 84 Withers Street, Brooklyn 11, N. Y.

Fig. 1. Panel view of the 146 mc. transmitter-receiver which is built in a compact, portable case. The various panel controls are identified in the text.



A 146 MC. CIVIL DEFENSE STATION

By
HENRY S. PUSTARFI, W2HDQ and **IRENAEUS W. DALY, W2YBZ**

A carefully-engineered station for fixed, portable, or mobile use which provides reliable radio communications.

IN THE past few years many municipalities have become aware of the need for preparedness for civil emergencies. The group most active in civil defense organizations is the communications division, not only because of its relative importance, but for many years its backbone has been stiffened by eager amateurs in the art of radio communications.

Most of the equipment for civil defense radio communications has, in the past, been built, owned, operated, and maintained by licensed radio amateurs. Today with the realization that civil preparedness is a necessity in peace as well as war, municipalities have allocated funds for the purchase, operation, and maintenance of radio as well as other equipment.

About eighteen months ago *Measurements Corporation* of Boonton, N. J., with a branch located in Parsippany Troy Hills Township, offered through the "*Measurements Radio Association*," a club of radio amateurs, to build ten transmitter-receiver units for Parsippany Troy Hills Township, which at that time was organizing its radio facilities and training operators. One additional unit was offered to the West Morris Chapter of the American Red Cross, located at Denville, N. J. Field tests were conducted to determine which frequencies would provide the most reliable coverage of the Township's ten civil defense districts, which cover an area of approximately 30 square miles. These tests indicated that two-meter operation would provide the desired communications. Several of *Measurements'* employees, familiar with the mobile work being done with the Livingston Amateur Radio Club's two-meter equipment, managed through the kindness of the club members to obtain one unit as a basic design model, along with associated wiring diagrams. An agree-

ment was made between "*Measurements Radio Association*" and the communications officer of Parsippany Troy Hills Township that any design changes could be made by *Measurements* who were supplying the labor and small parts gratis. Several association members volunteered to work Saturdays and Sundays until the job was completed.

This equipment, in order to be of general usefulness to the public, had to be completely portable so that it could be used at any location, on any vehicle, or for fixed station service.

EDITOR'S NOTE: *The authors of this article supervised the engineering and manufacturing of the equipment described as employees of Measurements Corporation of Boonton, N. J. The information contained in the article was taken as laboratory data on this gear.*

The equipment had to be designed to operate in continuous service, for long periods of time, without component failure, and be so constructed that unqualified personnel could not make adjustments on the transmitter. It was not considered advisable to exceed commercial continuous ratings on tubes or components. Because of the portability requirements, efficiency had to be as high as possible. Complete circuit and test data had to be available to facilitate maintenance and servicing.

After exhaustive tests and redesign, the v.h.f. equipment herein described

is believed by the authors to meet the stated requirements for reliable civil defense equipment.

General Description

The v.h.f. station consists of a transmitter-receiver, antenna, microphone, and power source. See Figs. 2 and 4.

The transmitter-receiver consists of three basic sub-assemblies; r.f., modulator, and receiver. The modulator is common to both transmitter r.f. and receiver r.f., serving as an audio amplifier in the "receive" position and a modulator in the "transmit" position. The sub-assemblies are mounted directly on the inside front half of the case which also serves as the front panel and speaker enclosure. The exterior is finished with black crackle enamel and, to provide a maximum of thermal transfer, the interior is finished in flat black. Adequate air circulation is provided by case vents on top, bottom, sides, and in the front panel. See Figs. 3 and 7.

The antenna input and output have been designed to match an unbalanced resistive load of 75 ohms.

The transmitter frequency is fixed within the range 144 mc. to 148 mc. The receiver frequency is continuously variable within the range of 143 mc. to 149 mc. This range covers the 2-meter amateur band and the civil air patrol frequency at its high end.

High level plate-modulated radio telephony is available.

The antenna is a commercial 75-ohm

Fig. 2. Complete schematic and parts list for the 146 mc. transmitter-receiver for civil defense applications.

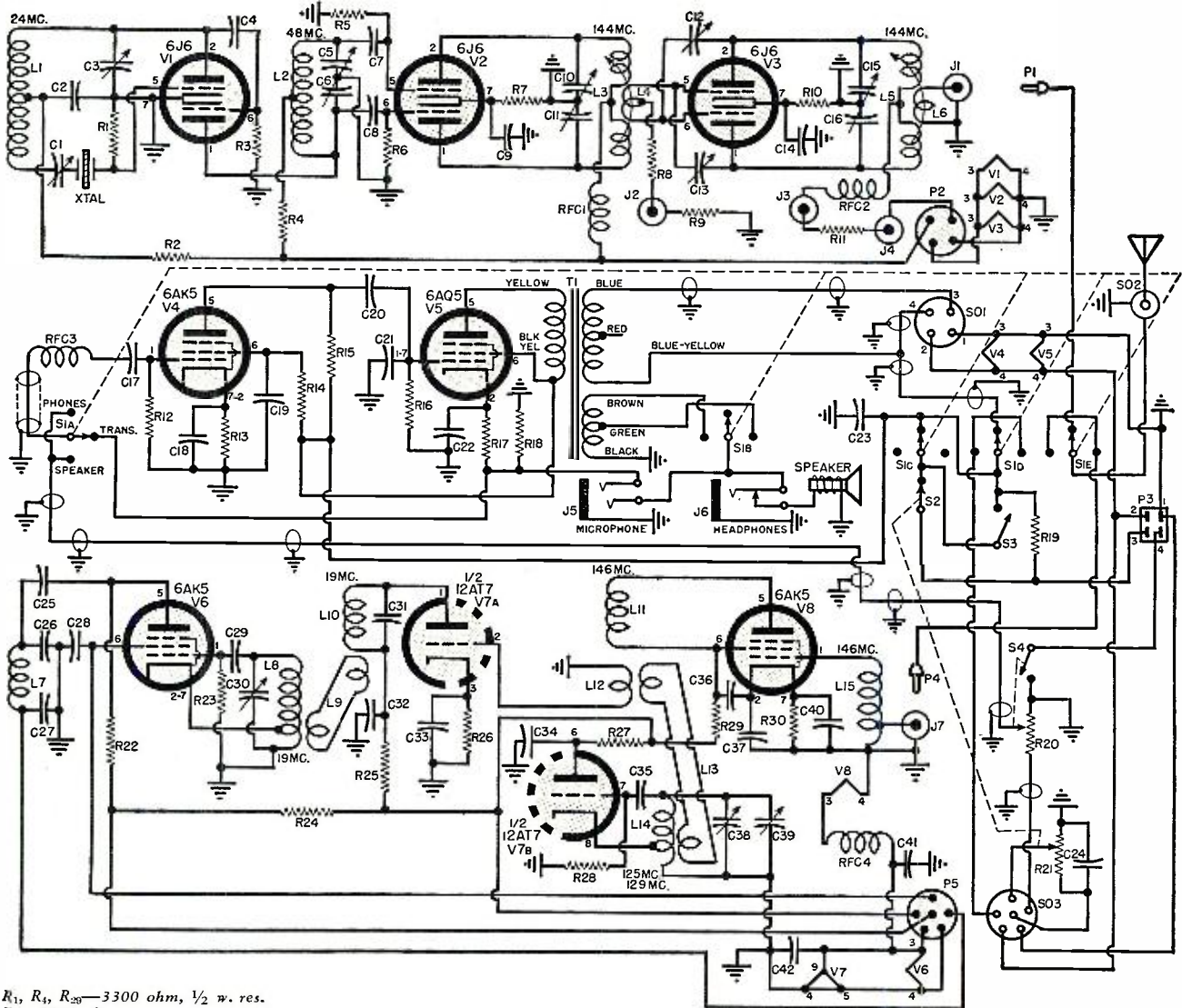

- R_{13}, R_{14}, R_{20} —3300 ohm, $\frac{1}{2}$ w. res.
 R_2 —5000 ohm, 1 w. res.
 R_3 —10,000 ohm, $\frac{1}{2}$ w. res.
 R_{53}, R_8 —33,000 ohm, $\frac{1}{2}$ w. res.
 R_7 —470 ohm, $\frac{1}{2}$ w. res.
 R_6, R_{13} —2000 ohm, $\frac{1}{2}$ w. res.
 R_{10}, R_{11} —47 ohm, $\frac{1}{2}$ w. res.
 R_{10} —200 ohm, $\frac{1}{2}$ w. res.
 R_{12}, R_{10} —510,000 ohm, $\frac{1}{2}$ w. res.
 R_{14} —200,000 ohm, $\frac{1}{2}$ w. res.
 R_{15}, R_{24} —51,000 ohm, $\frac{1}{2}$ w. res.
 R_{17} —90 ohm, 3 w. wirewound res.
 R_{18} —60 ohm, 2 w. res.
 R_{19} —1000 ohm, 10 w. wirewound res.
 R_{20} —500,000 ohm vol. control (IRC Type Q-13-133, taper C with s.p.s.t. switch)
 R_{21} —50,000 ohm vol. control (IRC Type Q-11-123, taper A with s.p.s.t. switch)
 R_{22} —100,000 ohm, $\frac{1}{2}$ w. res.
 R_{23} —1 megohm, $\frac{1}{2}$ w. res.
 R_{25}, R_{26}, R_{27} —1000 ohm, $\frac{1}{2}$ w. res.
 R_{28} —22,000 ohm, $\frac{1}{2}$ w. res.
 R_{30} —150 ohm, $\frac{1}{2}$ w. res.
 C_1 —25 μ fd. var. cond. (Hammarlund Type APC)
 $C_2, C_9, C_{14}, C_{17}, C_{20}, C_{25}, C_{26}, C_{27}, C_{28}, C_{33}, C_{33}, C_{34}, C_{37}, C_{10}, C_{13}, C_{42}$ —005 μ fd. disc ceramic cond. (Erie Type 811)
 C_3 —50 μ fd. var. cond. (Hammarlund Type APC)
 C_4 —47 μ fd. ceramic cond. (Erie Type GP1A or GP1K)
 C_5, C_6 —50 μ fd. var. cond. (Hammarlund Type APC modified to split stator)
 C_7, C_8 —27 μ fd. ceramic cond. (Erie Type GP1A or GP1K)
 $C_{10}, C_{13}, C_{15}, C_{18}$ —25 μ fd. var. cond. (Hammarlund Type APC modified to split stator)
 C_{12}, C_{15} —75.2 μ fd. glass trimmer cond.

- C_{15} —10 μ fd., 25 v. elec. cond.
 C_{16} —1 μ fd., 400 v. cond. (Solar XTIM or equiv.)
 C_{21} —47 μ fd. ceramic cond.
 C_{22} —50 μ fd., 25 v. elec. cond.
 C_{23}, C_{24} —8 μ fd., 450 v. elec. cond.
 C_{29}, C_{33}, C_{35} —20 μ fd. zero temp. coeff. cond. (Erie NPO, Style A)
 C_{30}, C_{35} —7.45 μ fd. zero temp. coeff. trimmer cond. (Erie NPO, Style TS2A)
 C_{36} —100 μ fd. mica cond. (Underwood)
 C_{37} —Variable cond. (Hammarlund Type HFA151 modified, see text)
 L_1 —18 t. B & W "Miniductor" #3003, tap 4 t. from crystal end
 L_2 —13 t. B & W "Miniductor" #3003, center-tapped
 L_3, L_5 —6 t. #18 silver wire, 1" long, $\frac{3}{8}$ " dia., space $\frac{3}{8}$ " in center, center-tapped
 L_4 —4 t. #18 silver wire, $\frac{3}{8}$ " dia., center-tapped
 L_6 —3 t. #18 silver wire, $\frac{3}{8}$ " dia.
 L_7 —Two 50 mhy. chokes in series (Measurements Corp. #A-2325-A)
 L_5 —19 $\frac{1}{2}$ t. #22 Formex wire wound on $\frac{1}{2}$ " dia., 1" long polystyrene rod, tap 4 t. from gnd. end
 L_9 —1.5 link, single t. #22 Formex wire, each end
 L_{10} —17 $\frac{1}{2}$ t. #22 Formex wire wound on $\frac{1}{2}$ " dia., 1" polystyrene rod
 L_{11} —6 t. #18 silver wire, $\frac{3}{8}$ " dia.
 L_{12} —5 t. #18 silver wire, $\frac{3}{8}$ " dia.
 L_{13} —Injection link, single t. #22 Formex wire, each end
 L_{14} —2 t. #18 silver wire, $\frac{3}{8}$ " dia., tapped $\frac{3}{4}$ t. from gnd. end

- L_{15} —5 t. #18 silver wire, $\frac{3}{8}$ " dia., tapped $1\frac{1}{2}$ t. from gnd. end
 $RFC_1, RFC_2, RFC_3, RFC_4$ —22 t. #28 Formex wire wound on 36,000 ohm ABGB form
 T_1 —Mod. and output trans. 6000, 8000, 200 ohm and v.c. winding. 6000 ohms to mod. plate, 8000 ohms to class C load (Harvey Wells Co. Cat. No. 9D1003)
 $Xtal.$ —8 mc. crystal for overtone operation with Millen No. 33202 socket, .125" pin dia., $\frac{1}{2}$ " spacing. (A 24 mc. overtone type crystal, Biley type AX3 can be used)
 J_1, J_2 —RCA type phono-jack
 J_3 —Pin jack (yellow)
 J_4 —Pin jack (blue)
 J_5 —Pin jack (red)
 J_6 —Dual-circuit phone jack
 J_7 —Closed-circuit jack (Utah)
 P_1, P_2 —RCA type phono plug
 P_3 —4-pin plug (Amphenol #7145)
 P_4 —4-pin plug (Jones P-304-AB)
 P_5 —6-pin plug
 SO_1 —4-pin socket (Amphenol 78-S4S)
 SO_2 —Coaxial connector (AN type SO239)
 SO_3 —6-pin socket (Amphenol 78-S6S)
 S_1 —3-pos., 3-gang switch (Mallory Type 178C)
 S_2 —S.p.s.t. sw. (ganged to R_{21})
 S_3 —S.p.s.t. toggle sw.
 S_4 —S.p.s.t. sw. (ganged to R_{20})
 $Speaker$ —4 x 6-inch PM oval speaker with 4 ohm v.c.
 V_1, V_2, V_3 —6J6 tube
 V_4, V_5, V_8 —6AK5 tube
 V_6 —6AQ5 tube
 V_7 —12AT7 tube
 All resistors to be $\pm 10\%$ tolerance

coax, modified for *one minute* installation. The mount was designed by David M. Ruggles, W2LOF. See Fig. 4.

The microphone is a surplus T17B, which has been modified to hold a *Western Electric* F1 single-button microphone (see Fig. 5). Any good single-button carbon microphone may be used.

The power source is a modified PE101C or CWD-21AAX dynamotor or an equivalent power supply. This is done by removing the center set of brushes marked "LV+" and "LV-" under the long dust cover. The gear train and coding contact assembly should also be removed. (See Fig. 6 for dynamotor connections).

Circuit Data

The modulator-audio amplifier unit utilizes a 6AK5 (V_4) class A voltage amplifier and a 6AQ5 (V_5) class A power amplifier. The input circuit, when being used as a modulator, has been designed for a single-button F1 carbon microphone. The microphone excitation current, 23-35 ma., is derived from the 6AQ5 cathode. See Fig. 2.

The over-all gain of the modulator is fixed and is sufficient to fully modulate the radio-frequency unit when speaking into the microphone with slightly less than normal telephone volume.

The frequency characteristics of the modulator will be determined primarily by the microphone and will have a flat response with frequency, $\pm 10\%$, 400 cps to 10 kc.

Power output of the modulator is 2 watts into the class C load of 9550 ohms and is fully capable of modulating the class C final amplifier 100% with less than 5% modulator distortion at 1 kc.

When being used as the receiver audio amplifier, the audio gain may be varied by means of potentiometer R_{20} .

The undistorted power output into the self-contained, 4-ohm PM loudspeaker is 1.3 watts and into the 200-ohm headset is 1.6 watts.

The frequency response of the audio amplifier in the loudspeaker "receive" position is flat within $\pm 10\%$, 600 cps to 10 kc.

When headphones are used the loudspeaker is *muted*. J_5 is a dual-circuit jack for use with a microphone or telephone set.

The switch on the gain control potentiometer provides remote relay control of the dynamotor primary cir-

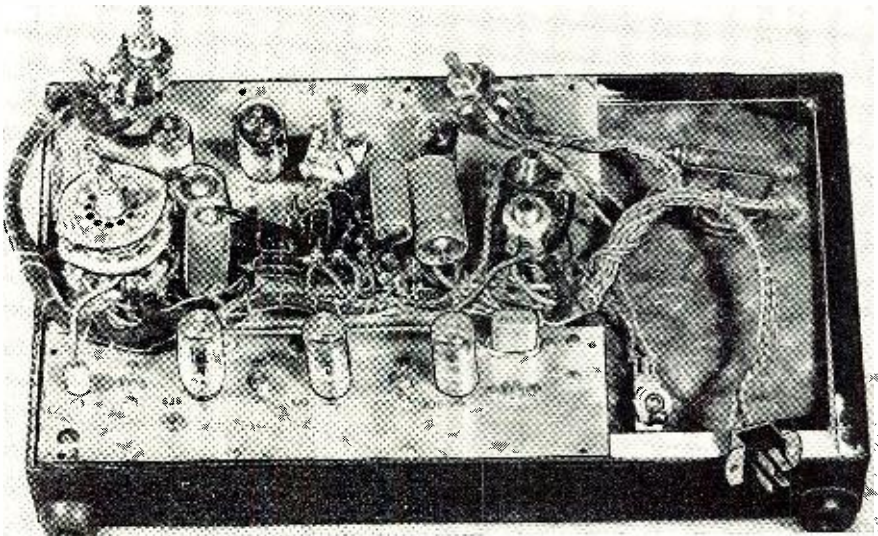

Fig. 3. Top view of transmitter-receiver showing the three sub-chassis used.

uits and the transmitter-receiver heaters ("on-off" power switch S_1).

When switching from the "transmit" to the "receive" position a series-dropping resistor (R_{19}) is inserted in the high-voltage line to compensate for the change in load on the PE101C or CWD-21AAX dynamotor and thus reduce the high voltage to the operating level for the receiver.

Note: A toggle switch (S_2) is installed just behind the front panel air vent to provide operation on a fused PE101C or CWD-21AAX dynamotor and battery or a fixed power supply. The switch removes the high-voltage dropping resistor from the high-voltage line when in the "fixed supply" position and inserts it in the "dynamotor" position. The high-voltage dropping resistor is the same one used for tune-up operations in the "transmit" position.

The fixed power supply requirements are 200 volts at approximately 150 milliamperes and 6.3 volts at 2.5 amperes a.c. or d.c.

Radio Frequency Unit

The radio-frequency unit consists of $\frac{1}{2}$ 6J6 (V_1) 24 megacycle overtone crystal oscillator (utilizing an 8 megacycle crystal operating at its third harmonic.) The crystal oscillator feeds $\frac{1}{2}$ 6J6 (V_1) doubler which, in turn, excites a single push-pull 6J6 (V_2) tripler. The tripler is link-coupled to a 6J6 (V_3) neutralized class C amplifier operating at 4 watts input with a measured plate circuit efficiency at 146

megacycles of approximately 45%. With the radio-frequency drive available, the modulation capability of the final amplifier is 100% with no indication of non-linearity until the 100% level is reached. The demodulated distortion is less than 10% at 1000 cps, 100% modulation.

The incidental frequency modulation at 146 megacycles is approximately 55 kilocycles with 1000 cps, 100% modulation.

Labeled phone tip jacks are provided to meter the final amplifier grid and plate currents. Because 47-ohm metering shunts are used to provide circuit continuity only low resistance milliammeters should be used for metering. If 400-ohm movements must be used the shunt resistance should be taken into account. Plate current is read on J_3 and J_4 while grid current to ground is read on J_2 .

Switch S_3 , provided on the superregeneration potentiometer R_{21} , places lower plate voltage on the radio-frequency unit when set full counter-clockwise. This provision has been made for tune-up purposes only.

The final tank circuit is link coupled to the 75-ohm antenna system.

Receiver Unit

The receiver consists of a variable frequency 143 to 149.0 megacycle superheterodyne with unbalanced 75-ohm input. A 6AK5 (V_5) broadband radio-frequency amplifier at 146 megacycles provides the necessary isolation and rejection required in this type

Table 1. Tube socket voltage chart. This data is needed for making the modulation measurements on the transmitter-receiver unit.

FUNCTION SW. POSITION	TUBE	PIN	PLATE	PIN	SCREEN	PIN	CATHODE
Receive	6AK5 (V_4)	5	140 v.	6	140 v.	2-7	2.4 v.
Receive	12AT7 (V_1)	1	196 v.			3	3.5 v.
Receive	12AT7	6	193 v.			8	
Receive	6AK5 (V_5)	5	85*-55**v.	6	38*-95**v.	2	
Receive	6AK5 (V_1)	5	133 v.	6	127 v.	2-7	3.6 v.
Receive	6AQ7 (V_1)	5	193 v.	6	200 v.	2	6 v.
Transmit	6J6 (V_1)	2	200 v.			7	10 v.
		1	Junction R_1 -RFC ₁				
FUNCTION SW. POSITION	TUBE	PIN	PLATE	PIN	SCREEN	PIN	CATHODE
Transmit	6J6 (V_3)	2	192 v.			7	5.8 v.
		1	Junction J_1 -RFC ₁				
Transmit	6J6 (V_1)	2	135 v.				
		1	Tap on L_1				

*Threshold and **full clockwise positions of superregeneration control
 Notes: All readings taken with 20,000 ohms-per-volt d.c. meter
 72 ohm, 2 watt non-inductive dummy load across antenna connector.
 All readings with R_{19} shorted (S_2 in fixed position)
 Source voltage of 200 volts d.c. and 6.3 volts a.c. or d.c.

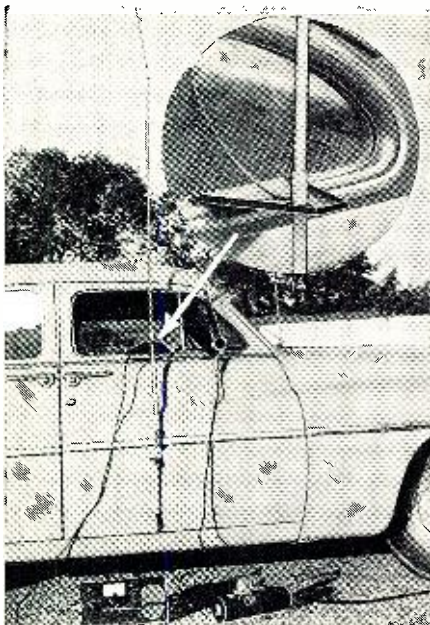

Fig. 4. The 146 mc. station ready for operation. The setup includes the transmitter-receiver, dynamotor, and an antenna. The inset is a close-up of antenna mount.

service. A 12AT7 (V_1) dual triode serves as the local oscillator operating on the low frequency side, 19 megacycles removed from the signal frequency and as a mixer with an output frequency of 19 megacycles. The 6AK5 (V_2) second detector is of the self-quenching superregenerative type operating at 19 megacycles with a quench frequency of 26 kilocycles. Superregeneration is controlled by the screen voltage adjust potentiometer R_{21} .

This receiver, in conjunction with the audio unit, will deliver clearly audible output with a 1 microvolt, 1000 cps, 30% modulated carrier at the antenna input. At the superregenerative threshold level a 3-microvolt un-

modulated carrier will provide a 6 db decrease in the no signal noise level. The signal-to-image ratio is approximately 20 db.

The selectivity of the superregenerative detector is inherently poor and depends on both quench level and strength of the received signal. The skirt response of the receiver is down 6 db at ± 0.15 megacycle removed from carrier and down 10 db at ± 0.2 megacycle removed from carrier (at the threshold level with 10 microvolt carrier).

The superregenerative type detector has excellent a.v.c. qualities and all signals between approximately 30 and 50,000 microvolts will produce small changes in output.

A filter, consisting of L_1 , C_{26} , and C_{27} , has been included in the second detector plate circuit to reduce the 26 kilocycle quench voltage at the grid of the first audio tube to a negligible value.

The receiver frequency stability is sufficient for its intended civil defense service.

Mechanical Construction

The receiver-transmitter is fully enclosed in two aluminum chassis 7" x 13" x 2". As seen in Fig. 1 the antenna connection is mounted on the left side of the case—the Jones power receptacle is on the right side. Rubber feet have been provided on the bottom and back sides for protection of the case and to insure proper ventilation. A leather handle has been installed on the top side for ease in carrying the equipment.

The front panel controls (see Fig. 1) and jacks are: left top, receiver audio volume (R_{20}), this control in its full counterclockwise position operates the power switch (S_1); right top, superregeneration control (R_{21}), this control in its full counterclockwise position operates a tune switch (S_2) for

the transmitter; left center, transmitter-receiver control switch (S_1); right top jack (J_6), phone jacks providing 200-ohm or 4-ohm output into external load; right lower jack (J_5), mike jack wired to provide audio for a handset earpiece; center panel control is receiver tuning (C_{28}). The bottom front has a removable panel to permit authorized personnel to make adjustments of the transmitter tuning condensers (C_3 , C_5 - C_6 , C_{10} - C_{11} , C_{15} - C_{16}). C_1 , the crystal padder used in the transmitter, C_{38} local oscillator trimmer, and C_{30} detector frequency trimmer are accessible through holes in the sides of the case. C_{12} and C_{13} neutralizing condensers are accessible through holes in the rear cover.

The receiver, r.f., and modulator sections are constructed on a strip sub-chassis approximately two inches wide and nine inches long. Tuning condensers used in the transmitter are the "APC" type, some modified to provide split-stator condensers for the balanced circuits. The tuning condenser used in the receiver local oscillator tuning is a modified Hammarlund HFA 15, two stators and one rotor remain to provide bandspread. All coils are wound on polystyrene forms and cemented with Amphenol 912 cement after adjustment to provide a rugged assembly.

Transmitter Alignment

Equipment Required:

1. Power supply, 100 and 200 v. at 100 ma., 6.3 v. at 2.5 amp.
2. 75-ohm, 2 watt dummy load—pure resistance.
3. Absorption type wavemeter—range 20-150 mc. Measurements Corporation Model #59.
4. Low resistance d.c. milliammeter, 0-15 ma.
5. Low resistance d.c. milliammeter, 0-50 ma.
6. D.c. voltmeter, 0-200 v.
7. Insulated screwdriver.

Procedure:

1. Connect power supply directly to transmitter unit plug—not through modulator—and set to 100 volts d.c.
2. Connect 75 ohm load to J_1 .
3. Set crystal padder C_1 to one-half maximum capacity. (C_1 is bracket mounted.)
4. Loosely couple the wavemeter tuned to 24 mc. to L_1 and tune C_3 slowly from the maximum capacity position to the point where the oscillator just kicks sharply into oscillation. The most stable setting will be found a fraction of a turn past this point.
5. Loosely couple the wavemeter tuned to 48 mc. to L_2 and tune C_5 - C_6 for maximum output as indicated on the wavemeter.
6. Unsolder the ground side of R_9 and insert the 0-15 ma. milliammeter to read final grid current.
7. Increase power supply voltage to 200 volts d.c.
8. Tune C_{10} - C_{11} for maximum final grid current as indicated on milliammeter.

Table 2. Specifications on both the transmitter and receiver portions of unit.

TRANSMITTER		RECEIVER	
Antenna:	75 ohm unbalanced resistive load	Antenna:	75 ohm unbalanced resistive load
Freq. Range:	Crystal controlled 144-148 mc. band	Freq. Range:	Variable 143 to 149 mc.
Emission:	A3, high-level plate mod. (Incidental FM approx. 55 kc. with 1 kc., 100% AM)	Sensitivity:	A 3 μ v. unmodulated carrier will provide a 6 db reduction in noise output from the "no signal" noise level. A 1 μ v. 30% mod. carrier will provide a clearly audible signal.
Power		Selectivity:	Skirt response down 6 db at ± 0.15 mc. removed from carrier and down 10 db at ± 0.2 mc. removed from carrier (at threshold level with a 10 μ v. carrier)
Output:	1.8 watts unmodulated with nominal plate power input of 4 watts	A.V.C.:	Inherent to 2nd detector—flat 30 to 50,000 μ v.
Efficiency:	Final plate circuit—45%	Image Ratio:	Approx. 20 db
Distortion:	144 mc. demodulated distortion less than 10% at 1 kc. 99% modulation (Final amplifier non-linearity and residual carrier noise negligible)	I.F.:	19 mc.
Audio Input:	Carbon mike using W.E. Fl button	Audio Gain:	V.G. variable at approx. 2000
Mod. Gain:	V.G. fixed at approx. 2000	Audio Fid.:	$\pm 10\%$, 600 cps to 10 kc.
Mod. Fidelity:	$\pm 10\%$, 400 cps to 10 kc.	Audio Output:	1.3 watts undistorted into speaker (4 ohms) at 1 kc. and 1.6 watts into low impedance headphones (200 ohms)
Mod. Power:	2 watts into class C load of approx. 10,000 ohms		
Mod. Distortion:	Less than 5% at 1 kc.		
Over-all Fidelity:	Limited by microphone		
POWER SUPPLY			
This unit has been designed for operation from a fused, modified PE101C or CWD-21AAX dynamotor and storage battery or from an external fixed power source that will provide 200 volts d.c. at approximately 150 ma. and 6.3 volts at 2.5 amps.		Dynamotor drain is 3.5 amps at no load; 9.5 amps in the "receive" position; 13.5 amps in the "transmit" position. The approximate starting surge is 25 amps.	

9. Rotate C_{15} - C_{16} and note if sharp grid current dip is present.

10. If present, adjust neutralizing condensers C_{12} and C_{13} in small increments, keeping them balanced, until all indication of dip disappears as C_{15} - C_{16} is rotated.

11. Loosen L_4 with *Amphenol* thinner and adjust for maximum final grid current as indicated on milliammeter (grid current should fall between 10 and 13 ma.).

12. Connect 0-50 milliammeter from the "B+" side of RFC_1 to J_3 thus applying plate voltage to the 6J6 final amplifier. Final amplifier grid current should fall to 8 or 9 ma. with application of plate voltage.

13. Immediately tune C_{15} - C_{16} for a sharp dip as read on the 0-50 ma. plate milliammeter. This dip should fall to 21 ma.

14. If the dip is more or less than 21 ma. loosen L_6 with *Amphenol* thinner and adjust the link for the requisite 21 ma., keeping the final tank condenser C_{15} - C_{16} at resonance as indicated by the dip.

15. At this point rotate C_{15} - C_{16} and note whether the minimum plate current dip (21 ma.) falls at exactly the same place as maximum grid current. This is a better indication of neutralization than Step 9. This unit *must* be properly neutralized. Adjust C_{12} and C_{13} until plate current minimum and grid current maximum fall at exactly the same place as C_{15} - C_{16} is rotated. The unit will then be neutralized.

16. Repeat C_5 - C_6 and C_{10} - C_{11} as indicated by final grid current. Final grid current should now fall between 8-9 ma., never lower. If 8 ma. cannot be reached recheck this procedure from the beginning. Keep circuits resonated and final neutralized. If the 6J6 final amplifier tube is changed, the final will have to be reneutralized.

17. If coils are replaced they should be adjusted to approximate frequency as indicated on the schematic with condensers one-quarter meshed.

18. When adjusting links L_4 and L_6 care should be taken to see that they maintain their positions while the *Amphenol* coil cement is drying.

19. Resolder R_9 to the ground lug and remove dummy load. The unit is now aligned and ready for installation. The final plate current should be checked, when cased, with the unit's antenna system connected. The final should load to 21 ma. at resonance. L_6 can be touched up if necessary to reach rated input.

20. After replacing the back of the case adjust crystal padder C_1 through the end of the case to correct frequency. Meters can be connected to the meter jacks visible through the front panel air vent and all circuits resonated for maximum final grid current and rated final power input of 4 watts.

21. Transmitter pin jack code: blue, final 6J6 plate; red "B+"; yellow, final grid. If using dynamotor supply after back cover is replaced make sure

dynamotor fixed supply toggle switch is in dynamotor position. A rough output frequency check can be made with the wavemeter.

22. Note that neutralization and transmitter tuning will have to be checked and usually readjusted with the rear cover in place. The two neutralizing condensers can be reached through the two plug buttoned holes in the rear cover.

Modulator Measurements

Equipment Required:

1. Power supply, 200 v. d.c. at 100 ma., 6.3 v. at 2.5 amp.
2. Vacuum tube voltmeter, *Measurements Corporation*, Model 67 or equivalent.
3. Audio frequency oscillator, *Measurements Corporation*, Model #82, or equivalent.
4. 50 ohm non-inductive load.
5. 4 ohm non-inductive load, 2 watts.
6. 200 ohm non-inductive load, 2 watts.
7. 9550 ohm non-inductive load, 2 watts.

Procedure:

Gain: "Transmit Position." For the following modulator measurements short out R_{10} :

Approximately 0.07 volt of 1 kc. sinusoidal input into the microphone jack will produce 139 volts of undistorted output across the 9550-ohm dummy load (modulation winding). For this check isolate the a.f. oscillator and place the 50-ohm dummy load across the microphone jack. Distortion at full output will be less than 4%. Frequency response is $\pm 10\%$ from 400 cycles to 10 kc.

Gain: "Receive" and "Phones" positions. For the following modulator measurements short out R_{10} :

In the "receive" position approximately 0.07 volt of 1 kc. sinusoidal input at pin 5 of P_5 , with R_{20} full clockwise will produce 2.3 volts of undistorted output across the 4-ohm speaker winding load and 19 volts across the 200-ohm phone winding load in the "phones" position.



Fig. 5. Close-up of the modified T17B microphone, changed for W.E. F1 button.

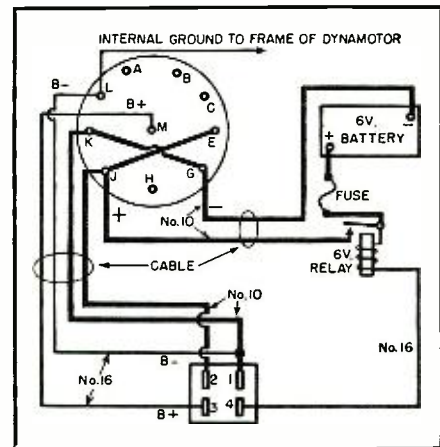

Fig. 6. Connections for mobile operation. See text for dynamotor modification data.

If the modulator gain requirements are not met and voltages check as per the tube voltage chart (Table 1), it may be necessary to select 6AK5's for maximum gain and/or 6AQ5's for minimum distortion.

Receiver Alignment

Equipment Required:

1. Power supply, 200 v. d.c. at 100 ma., 6.3 v. at 2.5 amp.

(Continued on page 82)

Fig. 7. Rear view of front panel showing sub-chassis and loudspeaker in place.

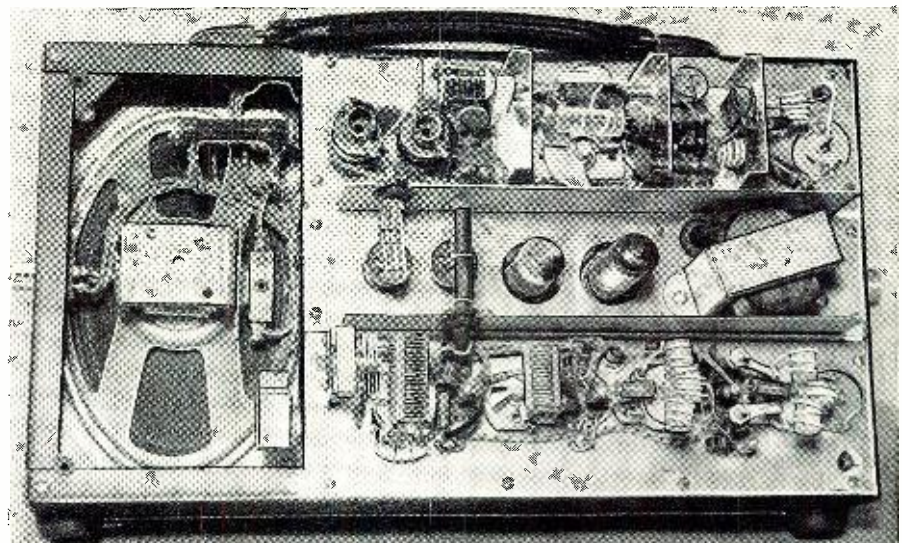



By
WALTER H. BUCHSBAUM
Television Consultant
RADIO & TELEVISION NEWS

Down-to-earth hints on how to squeeze every possible db of signal out of u.h.f. in the difficult fringe areas.

AFTER the first rash of new local u.h.f. installations, many service technicians find that additional customers are available, often in much greater numbers, in the u.h.f. fringe areas. This type of area differs from the familiar v.h.f. fringe area in many ways and requires a somewhat different approach and new service procedures.

In most cases, the u.h.f. fringe area is much closer to the transmitter than its v.h.f. counterpart. Most locations more than 50 miles from any u.h.f. station will receive only weak signals and many spots much closer have reception troubles due to obstacles and reflections. All the disturbing aspects of v.h.f. wave propagation, such as multiple path transmission, diffraction around obstacles, absorption by foliage, and reflection from moving objects, occur in u.h.f., but their damage is greater. A good example is the well known diffraction phenomenon, where an intervening hill blocks TV waves, but enough energy is bent around the crest of the hill to permit some kind of reception behind it. The amount of energy diffracted in u.h.f. is less than half of that normally expected from a v.h.f. station. To make matters worse, trees near the top of the hill will absorb much more of the diffracted u.h.f. signal than of any v.h.f. signal.

Fig. 1 illustrates some of the causes of weak u.h.f. signals and although they are also present in v.h.f. fringe areas, their effects are much more marked in the u.h.f. TV band.

This article describes the various factors in a typical u.h.f. fringe installation which can be adjusted for better reception. When the signal at the re-

ceiver is so weak that "snow" appears, every change which will improve the signal strength is worthwhile. Getting every possible db of signal requires careful consideration of all the factors which can cause losses and the major portion of this article is devoted to pointing out these "signal sinks" and methods of avoiding them. Starting at the antenna we shall show how each portion of the installation can be designed for minimum loss and optimum signal.

Antenna Installation

The popular argument as to which antenna is best will probably never be settled, but for practical reasons, gain and directivity are the most important characteristics in the fringe area.

Bandwidth, cost, and ease of installation are certainly secondary when a single station is received weakly and the acquisition of a new customer is at stake. For the typical fringe installation, therefore, a yagi antenna as in Fig. 2, a corner reflector, or a rhombic is recommended. Above all, when using a yagi, be sure that the antenna is cut for the channel to be received.

In planning the installation it is well to remember that, optimizing all other factors, the actual signal which the antenna picks up represents the best possible reception. Therefore the type of antenna, location, mounting, and orientation can be considered as at least 50% of the job. This should be pointed out to the customer and the resulting installation charges can be based on the signal strength with which the technician must work.

Recent advertising stresses the fact that some antennas use gold or some

other type of plating, special dielectric spacers, or air dielectric to operate well in the u.h.f. fringe area. The boon of gold or silver plating is somewhat dubious since the surface resistivity of the antenna elements is normally quite low compared to the characteristic impedance. However, such plating does help to prevent rusting and deterioration.

Dielectric losses at the antenna terminals can be considerable, especially if the dielectric used has a tendency to absorb moisture. One limitation of most antenna terminal arrangements is that they do not keep dust and moisture out. In this respect, the antennas which require no dielectric spacers are preferable. Where a dielectric spacer is used, the antenna terminals can be weatherproofed with special tape. Polyethylene, polystyrene, or vinyl tape can be used, provided the tape is pressed tight to keep water and air out and is not used so profusely that its thickness results in impedance mismatch. No more than two layers should normally be used and never, but never, use electrical friction tape or any kind of cellophane or paper-based tape.

Having made a good connection, preferably soldered without flux, we are now ready to hoist the antenna into place for a trial orientation. Fig. 2 shows a simple six-element yagi and the direction of rotation and motion for optimum performance. Because of the appearance of so-called "space nodes," the antenna should be moved up and down, forward and backward as well as rotated to point towards the station. The up and down motion should be done slowly and extended for at least half a wavelength or about one foot at the lowest u.h.f. channel. It will be found frequently that maximum and minimum signal locations exist both in the vertical and horizontal plane, spaced half a wavelength apart. For the same reason the forward and backward motion is recommended. In addition to all these ma-

neuers, it is often helpful to vary the angle between the antenna beam and the mast, indicated by the 30 degree tilting at the left of Fig. 2.

It may be necessary to repeat this procedure for several locations until the strongest signal is obtained. Since foliage absorbs u.h.f. waves to a great extent, be sure during the winter season that the antenna will not be blocked by trees or brush when spring comes along.

Once the best location and directional position have been determined, the installation is made permanent. In addition to the normal rigidity and sturdiness required for v.h.f. antennas, the u.h.f. fringe installation must be guyed sufficiently to prevent swaying in the wind. A wind displacement of one foot, while tolerable at v.h.f. will often cause "picture breathing" or excessive fading on u.h.f. channels.

On one u.h.f. fringe installation, good pictures were obtained at the time of installation, but when the customer's husband came home the picture fluttered until dinner time. Then a stable picture was obtained again. When the service technician came the next day, the fluttering was gone. In the late afternoon fluttering occurred again until dinner time. The cause for this vanishing flutter was apparently the reflections coming from a nearby highway where traffic was only substantial during the morning and evening rush hours. The reflection from passing automobiles was alternately in phase and out of phase with the main signal, causing flutter. Unfortunately there was no practical solution possible since the location of the home and the u.h.f. station required that the antenna be oriented towards the highway.

Transmission Lines

The flat 300-ohm twin-lead used for v.h.f. installations is quite lossy at u.h.f. and should never be used in weak signal areas. The author measured as much as 10 db loss at 800 mc. in a 50 foot length of flat twin-lead. By comparison, it was found that the same length of tubular twin-lead had less than 2 db loss.

There are many different kinds of low-loss u.h.f. transmission line on the market and most of them are quite good. Open-wire line is theoretically the least lossy and therefore most suitable for fringe installations. In actual practice, however, the open-wire line has some distinct drawbacks. Near industrial centers the air pollution is often quite bad and causes soot and grease deposits on the dielectric spacers. After a while the sum total of many coated spacers is sufficient to change the characteristic impedance of the line, resulting in standing wave and dissipation losses in the transmission line. Completely covered twin-leads do not suffer so much from dust and dirt because the insulation always keeps the grime away from the conductors themselves.

More lossy than the transmission

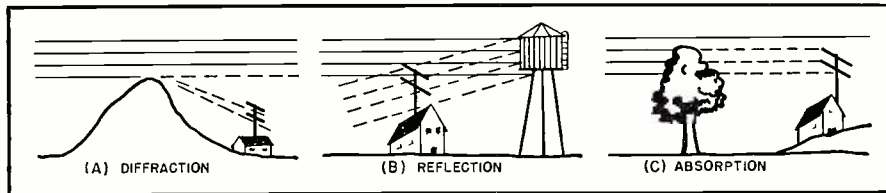

Fig. 1. Some of the causes for weak u.h.f. reception. (A) Hills and obstructions do not diffract as much signal at u.h.f. as at v.h.f.; (B) reflections are more troublesome at u.h.f., especially from relatively small sized structures; (C) trees and foliage absorb signal energy at u.h.f. leaving less for the antenna and set. See discussion in text.

line itself are some of the indispensable accessories such as the standoffs, v.h.f.-u.h.f. couplers, and lightning arresters. The latter, especially, can be quite a trap for u.h.f. signals. There are basically two types of arresters on the market, one using resistive elements, the other using condensers. For u.h.f. the resistive models are not recommended since they cause not only a poor impedance match, but also unbalance the line. Some of the older style v.h.f. lightning arresters are unsuitable because their capacities are too large and, in many instances, the plastic case material has such poor dielectric qualities in the u.h.f.-TV band that impedance mismatch is considerable. The author checked the v.s.w.r. of several lines with lightning arresters and found those using "v.h.f. only" models have more than a 2.5:1 standing wave ratio. The latest u.h.f. or v.h.f.-u.h.f. models introduce less than 1.5:1 v.s.w.r. Thus, the selection of a good lightning arrester is another important factor in squeezing every db of gain out of the antenna in a fringe area.

When a u.h.f. fringe installation also requires a v.h.f. antenna, care should be taken about using a v.h.f.-u.h.f. antenna coupler. All of the commercially available crossover networks have some insertion loss at u.h.f. In a fringe area, every db of signal strength is important. The best solution for fringe locations where both u.h.f. and v.h.f. antennas are needed is to run separate transmission lines to a suitable low-loss switch at the receiver. In many instances it is possible to simply connect each transmission line to its respective tuner input and depend on the u.h.f. converter or tuner to select the desired signal.

Transmission line standoffs and supports are another potential signal trap. This is especially true in most fringe installations where the transmission line is quite long and is supported in many spots. The ideal standoff, or at least the best possible, is the type consisting entirely of polystyrene or some other low-loss dielectric. For rigidity, however, as well as for mounting purposes, steel is usually required. The most popular types of standoffs use a metal loop with a polyethylene grommet inside which supports the transmission line. At u.h.f., the metal loop together with the dielectric forms a condenser which effectively shunts the two wires of the transmission line. This capacity is quite small and by itself has little effect on the transmission line characteristic. When a great num-

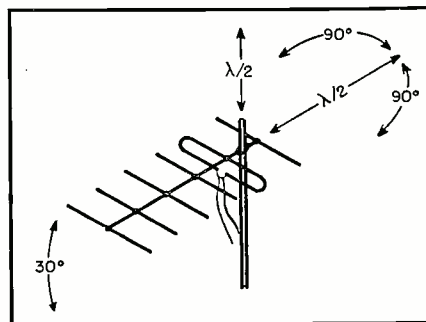

Fig. 2. Directions in which an antenna should be tested before the installation is definitely made for u.h.f. receiver.

ber of standoffs is used, however, their total capacity may seriously upset the impedance of the line. This is especially true when the standoffs are placed at equal distances resembling multiples of $\frac{1}{2}$ wavelength at the channel being received. In this event considerable losses, as much as 6 db for 12 standoffs, can be encountered.

For u.h.f. fringe installations, therefore, it is recommended that as few standoffs as possible be used while still maintaining good mechanical support for the line and, whenever possible, use standoffs without metal rings. Where a large number of standoffs is essential, try to space them at different distances from each other to avoid multiple $\frac{1}{2}$ wave spacing effects.

Needless to say, such poor v.h.f. practices as simply laying the transmission line on top of a metal roof, dropping sections into gutters, or taping it to metal supports are even more detrimental at u.h.f.

All the measures discussed so far are aimed at avoiding signal losses, but there is one important step, the addition of a booster amplifier, that can actually increase the signal amplitude.

U.H.F. Boosters

In v.h.f. fringe installations the use of a booster is now almost standard practice and many different boosters are available. However, such u.h.f.-r.f. amplifiers are complex and u.h.f. boosters are still somewhat of a problem. The limiting factor in any booster is its noise figure as compared to the noise figure of the receiver. If the u.h.f. tuner or converter has a noise figure of 12 db at the channel used and the booster has a 16 db noise figure, then the addition of the booster will actually result in a snowier picture.

Most continuous tuners have a noise figure of 14 db at optimized channels,

and 24 db at poorly tracked channels. Turret tuners have a noise figure of 12 db at optimized channels, and 18 db at average alignment. Converter strips for turret tuners result in a 16 to 24 db noise figure with little chance of optimizing at any channel.

Most u.h.f. boosters have a noise figure of 11 to 15 db, with a gain of 7 to 13 db.

We can see from this data that the greatest advantage of the booster is an increase in gain. In other words, where the over-all receiver gain is low, a booster will help. Where it is possible to get a snowy picture with plenty of contrast, the over-all gain is sufficient and only a better noise figure can improve reception. In many cases for both continuous and turret-type tuners or converters it is possible to optimize at least one channel so that the noise figure is about as good as that of a booster. The real utility of the booster comes with the use of u.h.f. conversion strips in v.h.f. tuners. In these cases, the noise figure of the booster is superior and the over-all gain of the receiver is usually sufficient, so that the booster can really improve reception.

In addition to the currently available u.h.f. boosters, new models will soon appear having noise figures below 8 db and stage gains of 10 and 12 db. This will be possible by the development of inexpensive u.h.f.-r.f. amplifiers. Improved versions of the 6AF4 and 6AJ4 are now in pilot production at RCA and G-E and these tubes will operate satisfactorily over the u.h.f. band, in grounded-grid circuits, and in regular 7-pin miniature sockets. These tubes will, of course, be used in most new v.h.f.-u.h.f. tuners, but their application in u.h.f. boosters will help overcome the limitations of many older u.h.f. converters and tuners.

Optimizing the Receiver

The final destination of the u.h.f. signal is the input circuit of the TV receiver and at that point further improvements can be made to get the best possible picture from a weak u.h.f. signal. First of all, the various approved and time tested v.h.f. fringe receiver modifications should be tried. These include reducing a.g.c. bias, adding an a.g.c. delay circuit, re-aligning the i.f. section for a narrower response curve and similar measures. In receivers where double conversion is used, be sure the v.h.f. channel acting as first i.f. for the u.h.f. signal is tuned

up for optimum response. It is possible to adjust v.h.f. input and mixer networks to less than 6 db noise figure if a cascode circuit is used and less than 9 db for a pentode r.f. amplifier. Checking the bandpass and over-all gain of the v.h.f. section will make the optimizing of the u.h.f. portion much easier.

In many instances where an external converter is used, the output stage of the converter, usually a cascode, and the input of the v.h.f. tuner should also be aligned for best sensitivity and noise figure. The connecting cable should be as short as possible and its length should be trimmed for best picture. After all i.f. and v.h.f. adjustments have been checked, the u.h.f. networks can be tuned up. Most u.h.f. tuners and converters now in use are of the continuous-tuning type. Whether capacity tuned transmission lines, coaxially tuned lines, shorted rings, or other systems are employed, the problems of tracking the r.f. network with the mixer and oscillator networks and of impedance matching the input are always present. In continuously-tuned devices it is usually possible to get best tracking at the highest and lowest frequency and some sort of compromise at the center. For a typical u.h.f. fringe installation only one channel need be optimized and this makes the alignment process easier.

Before adjusting anything it might be well to try different mixer crystals. Most tuners and converters use either a 1N72 or 1N82 in this circuit and performance of different crystals can vary considerably. Since the crystal usually is in a clip-type holder it is a simple matter to switch crystals, but it is also necessary to retune the mixer trimmer or touch up the r.f. bandpass network. The better equipped service technician can try improving crystal performance by putting a 1N21B crystal into the tuner. This is a more expensive crystal, usually used for government work, and requires a different mounting clip. Its performance is decidedly better than the 1N72 or 1N82. Again retuning is required.

To align the r.f. network of most u.h.f. tuners and converters requires a u.h.f. sweep generator and oscilloscope and this operation can be performed in the shop, prior to the installation. Tune the main tuning control for the desired channel, then check the response curve, leaving the local u.h.f. oscillator on. The oscillator should produce a pip

on the flat portion of the response curve, and the r.f. network is then tuned for the most even, narrow, and highest bandpass possible. To check the antenna input circuit, the u.h.f. sweep generator impedance should be 300 ohms and the coupling network should be adjusted for maximum response curve height.

For detailed instructions on optimizing a turret tuner refer to the September, 1953, issue of RADIO & TELEVISION NEWS, which gives this data for the Standard Coil 82-channel tuner. The steps for adjusting the various circuits are the same as outlined previously, but the range of each adjustment is more limited since the turret tuning itself permits tracking for many more than the three usual spots.

Many u.h.f. converters and tuners use hi-pass filters at the u.h.f. input and occasionally these filters are lossy or cause slight mismatch. Where adjustment is provided, try optimizing it, otherwise it may be possible to bring the u.h.f. antenna line directly to the r.f. network without going through the hi-pass filter. Another problem is the mismatch of the antenna line to the receiver input. Try cutting the transmission line $\frac{1}{2}$ inch at a time until the best picture is obtained. Occasionally it is possible to improve picture performance by folding a 6 inch length of tinfoil over the transmission line near the receiver and sliding it up and down until the best picture is observed. Tape the tinfoil onto the line at the best spot.

Fig. 3 shows the sum total of signal losses and the nature of each drop in signal. In order to get the best possible performance from a u.h.f. fringe installation it is essential that each of these losses be minimized or compensated. As an example, the antenna matching losses can be avoided by correct impedance match, i.e., using the right kind of antenna for the right type of transmission line. The losses due to the transmission line can often be overcome by the addition of a u.h.f. booster, provided that the noise figure of the booster is at least as good as that of the tuner. Standoff losses due to impedance mismatch can be minimized by using as few standoffs as consistent with mechanical support and avoiding the use of the type that uses a metal ring around the dielectric.

The type of loss easiest to compensate occurs at the input to the u.h.f. tuner or converter. To avoid this loss it is essential for almost every fringe installation that the u.h.f. networks be re-aligned and tuned up for the weakest channel. This is especially important for continuously-tuned systems where mistracking can introduce losses of 10 db or more. In addition to tracking, the use of a selected crystal mixer diode is also recommended and the r.f. input circuit should be adjusted whenever possible.

As a last step to insuring good u.h.f. reception, weatherproofing the entire outdoor portion of the installation is essential. Under weatherproofing we

(Continued on page 149)

Fig. 3. Various steps between the antenna and set in a typical installation, showing the major sources of signal loss and their causes in each section.

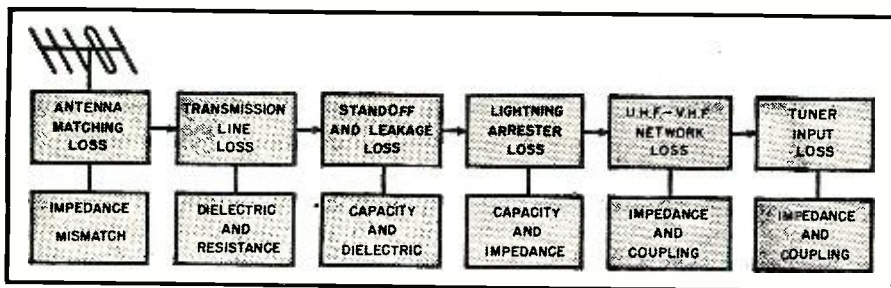

HORNS FOR THE P.A. TECHNICIAN

By

ABRAHAM B. COHEN

University Loudspeakers, Inc.

Fig. 1. A versatile sound truck installation using "Cobreflex" horns.



The selection of the correct horn for the job involves factors which must be carefully evaluated by soundmen.

IN THE development of the commercial sound field, one of the first great advances was the conversion of the long straight horn into a folded or "reflexed" type of horn. The portability and smaller size of the reflex horn, as compared to the long straight horn, was reason enough for its widespread acceptance. It is only natural, then, that the application of the reflex principle should lead to further specialization in horn design.

Offshoots from the standard round horn type of reflex projector have been on the increase and the man whose livelihood depends on keeping up with these advances finds himself on the "horns of a dilemma." He knows that the old standbys do a good job yet here are new horns that apparently will do some specialized job better. How can he be sure? And in the face of these developments how shall he plan his capital investments and how shall he engineer his jobs?

To enable the sound engineer to follow the general trend of these specialized developments, this discussion will present the pertinent facts the soundman should know. We will analyze the conditions which will determine the choice of one type of horn over another for a given application, and we will describe the engineering principles of the specialized horns which may be peculiarly adaptable to specialized sound applications. In the understanding of these principles and their application, the soundman will profit from more effective public address applications and maximum utilization of his investment. In a similar fashion the high-fidelity enthusiast will obtain a more satisfying musical performance from these specialized projectors with high-fidelity attributes. It should be readily understood at the very beginning that the purpose of specialization in horn design is not to obsolete the standard reflex round horn, but rather to add new and valuable members to its family. The end product of such specialization will result in a family of horns which fall into two categories. There will be all the ramifications of the round mouth horn of the type shown in Fig. 2A, and then there will be all the variations of the special purpose horns of other than round contour, a typical example of which is shown in Fig. 2B.

All horns are sound projectors. The

efficiency with which the sound is projected, the direction in which it is projected, and the quality of the projected sound will depend upon the size of the horn, the general shape of the horn, and the driver unit which feeds the horn. Although these three factors do not function independently of each other, it is possible to generalize the degree to which each one of them contributes to the final projected sound field. The generalization runs briefly as follows:

A. The longer the acoustic length of the horn, the more powerful will be the sound field on the horn axis (if the horn flare remains unchanged), because the longer horn has a better chance to mold the sound pulses traveling through it into a more axially controlled contour so that these pulses emerge more confined to the axis areas; and furthermore the larger mouth which results from the longer horn permits less off-axis diffraction of the wavefront as it emerges from the horn. The end result is more on-axis diffraction for the longer horn.

B. The slower the horn expansion, the lower will be the theoretical cut-off frequency of the horn.

C. The larger the mouth area, the more smoothly (with minimum of valleys and peaks) will the low frequencies be reproduced.

D. For round mouthed horns, the higher frequencies are beamed more sharply on the axis, the lower frequencies are refracted more uniformly over a hemispherical surface.

From an inspection of these performance generalizations from which specific performance characteristics may be selected, it is fairly easy to match the horn to the job. This is one reason for the almost universal acceptance of the acoustic horn for professional sound projection. The following illustrations, treated briefly, will show how these generalizations may be put to specific use.

If the job specifications call for reproduction of a rather full range of music, the sound projector should, among other things, be able to handle those low frequencies that add body and

substance to the music. The projector that will best transmit these low frequencies will be one that tapers gradually, that has a slow flare. It may be shown mathematically that the more gradual the flare, the lower the "cut-off" frequency. If commercial specifications on horns are examined, it will be found that as the specified cut-off frequency is lowered, the acoustic length of the horn increases; it has to "open up" more slowly, and so occupies more space. If two horns having the same length are compared, the one which has the more gradual flare will have the lower frequency coverage. The smoothness of this low-frequency response and the over-all efficiency with which these low frequencies will be reproduced will, however, be determined by the size of the horn mouth.

In the case of two horns which flare at the same rate, the longer with its larger mouth will reproduce the same low frequencies as the shorter one, but with smoother and more efficient output. Thus, to get back to the job of reproducing full range music, the horn for the job will be the long, slowly flaring, large horn.

There are occasions, of course, where the low, low frequencies may be dispensed with, where the music to be transmitted is narrow range material, comparatively speaking. Under these conditions, and under those economically imposed circumstances where some loss in low frequencies must be accepted as an alternative to high equipment costs, then one of the somewhat smaller horns may be selected.

There are applications, of course, where low frequencies are not necessarily required at all, such as paging systems, street corner rally setups, police jaywalker "waker-uppers" on street corners; or where the associated equipment which will feed the horn system is frequency limited as in such devices as tubeless amplifiers, then the small horn may be used.

Of course, combinations of large and small horns may also be devised to provide adequate sound coverage. Let us suppose that a soundman is called upon to set up a sound re-enforcement



Fig. 2. (A) The Model PH reflex trumpet. (B) The Model "Cobreflex-2" reproducer.

system for a single concert in the town's recreation park. This setup may take the form of a single, long, large horn facing directly into the audience, plus two smaller horns angled out toward the sides. The large horn will provide good low-frequency projection at high levels over a wide circular area covering the entire audience, but the higher frequencies will be beamed and concentrated on the central section of the audience. This loss of high frequencies on the side areas will then be overcome by the sound projected from the smaller high frequency horns into these side areas.

Now this is just one obvious example of how the soundman can utilize the well-known characteristics of a family of horns to properly engineer a sound re-enforcement job. For this reason, such a group of horns, judiciously selected, may provide the basis of a wide variety of applications which would be impossible were the soundman to limit himself to a single type of horn.

This is one of the objectives that the acoustic design engineer sets for himself when he initiates a new horn design. His aim is to provide an addition to the horn family so that more flexible combinations of sound projectors may be made available.

Today especially does the horn designer have a "field day" for new design. The high-fidelity technique has taken the horn to its bosom. Horns are extremely helpful for the proper

low-frequency loading of woofers and properly designed high-frequency horns may control the angular dispersion of the high frequencies. Horns are here to stay, both in the public address field and in the high-fidelity field. And, more and more, these fields will cross. The public address field needs the hi-fi know-how of getting a message across with clarity and realism, while the hi-fi field can use the high-efficiency techniques of the public address field.

What, then, may be designed into a horn that will add to the horn family and expand it and make it more flexible? One of the big problems in the projection of sound is the control and manipulation of the directivity or the dispersion, as the case may be. In the evolution of horn designs toward this end, there have been developed the "cobra" types of horns. One will realize, of course, the significance of "cobra" as a term descriptive of something flat and wide (as the business end of the actual thing whose name it bears). These cobra projectors are then, in essence, wide-angle projectors, and they may differ considerably in appearance from the conventional round mouth horn, as Fig. 2A would indicate. We must realize, however, at the very beginning that although the new wide-angle projectors are quite different in appearance from the round mouth horn, they are not mutually exclusive in application.

They are, rather, independent personalities within the horn family,

where they exert their individual influences on a particular sound operation; or they may act in concert, in a complementary manner. Being members of the same horn family, it is only natural that some of the characteristic traits of one member of the family should show up in the other. Thus it is not surprising to find that the new cobra designs are built upon the sturdy body skeleton of the reflex horn.

What can we expect from a cobra-reflex type of horn that we cannot obtain from a single sound horn?

Let us return to our town concert example for we have, in part, touched on the problem, namely, the dispersion of the higher frequencies over a much wider angle than is possible with the comparatively tightly-beamed round horn. But, and this is a real big "but," this dispersion must be accomplished without losing any of the low frequencies normally expected from a horn of the same comparable acoustic length. Essentially, then, our prime concern, acoustically speaking, in the horn variation is "wide-angle projection" plus over-all high efficiency at all frequencies compatible with horn length. It is taken for granted that such a design must be accomplished in a mechanical construction which will commend itself to rugged outdoor and mobile use as well as indoor hi-fi applications.

Now we have the desired specifications that should enable the engineer to grab his slide rule, go into his laboratory, closet himself in his anechoic sound chambers, and come out with a new specialized horn. While he is thus laboriously struggling in his private chambers, let us turn the calendar ahead a few weeks, and take a look at what our talented engineer will present to us on a silver platter. Let us examine what the new horn will do, and how we may use the properties built into it. After we have explored these application angles, perhaps our engineering staff will be kind enough to let us in on the engineering secrets of how, generally speaking, they go about the design of a horn for specialized performance.

While our engineer has been busy making his final tests and comparisons in the sound room, we have taken the liberty of pilfering a few representative curve sheets which come out in an endless stream from his automatic sound level recorder.

These curves are only sample comparisons of the performance of the reflex-cobra horn versus a round-mouth horn where the comparisons are made directly on the axis for both horns, and then made off at an angle of 45 degrees from the axis in the "horizontal plane," that is, the plane in which wide-angle dispersion is required.

With the desire to be objective, however, we must caution against casual inspection of curves. Curves are completely objective in nature. But in listening to sound there is subjective quality which our own conscience feels

Fig. 3. Comparison of operating principles between (A) reflex and (B) cobra horn.

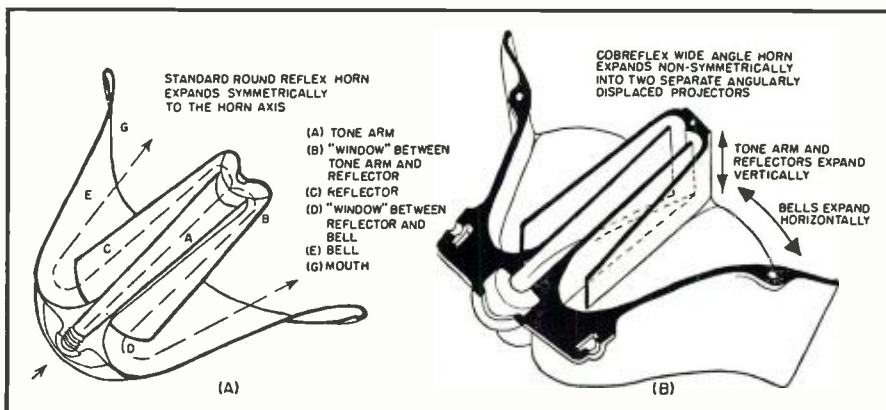

and which cannot be put on paper. We must make field tests and listen to all the symptoms, both *indoors* and outdoors, at high level and at low level, in quiet areas and in noisy areas, and to one type of program and then to another. This is really a big directive to give the soundman when he goes out shopping and it is doubtful whether he could actually accomplish such an all-out comparison. So to a great degree we still have to consult objective information such as that shown in Fig. 4A, with the knowledge that those units which demonstrate the greatest over-all efficiency in those characteristics in which we are most interested will no doubt come out on top in subsequent field tests.

Coming back to Fig. 4A, it is interesting to note that the round reflex horn has better low-frequency efficiency than the somewhat smaller reflex-cobra horn and that this higher efficiency in the low-frequency area is but little affected by the angle of measurement. These effects are readily prophesied from the horn theory generalizations that were previously outlined, because the round horn is somewhat longer and larger than the reflex-cobra with which it was compared.

The extra efficiency of the round horn over the reflex-cobra does not extend, however, over the entire spectrum. Examining the zero axis curve we see that the two horns become of equal efficiency in the 2 to 3 kc. region and that, if anything, the reflex-cobra has just a slight edge over the round horn, but not enough to make any critical difference in listening to these higher frequencies if we were standing directly in front of the two horns. However, at 45 degrees off the central axis we would soon notice an outstanding difference in the sound fields as shown in curve B of Fig. 4.

Whereas there is hardly any loss in acoustic output of the cobra-reflex out in these sideline areas, there is a drop of about 25 db in the round horn response between 3 and 15 kc. In terms of actual sound power thrown into this 45 degree axis, the cobra-reflex puts out 315 times the power of the round horn. Here, then, is a horn designed for wide-angle dispersion which has an over-all high efficiency compatible with its acoustic length, and equal to what a round horn of the same size would produce in the low-frequency area, but which shows remarkably uniform high-frequency efficiency over a wide horizontal angle. The applications of this type of horn, whereby we may put these interesting characteristics to work, are of considerable importance. Therefore in order to maintain an unbroken discussion of these applications in the next section, we will digress but briefly at this point to illustrate the engineering principles whereby these characteristics were developed.

The operating principles of this type of horn are practically told in Fig. 3. The round horn, for example, is a

symmetrically expanding sound duct; that is, it expands in the "vertical" direction as well as the "horizontal" direction. On top of this symmetrical expansion we have a round mouth from which the sound radiation takes place. This combined symmetry of horn expansion which molds the wavefront and horn mouth which radiates that wavefront, can obviously produce nothing but a sound field symmetrical in all respects between the "vertical" and "horizontal" planes. It would then be natural to assume that if we wanted a non-symmetrical sound field, we could accomplish the result by molding the wavefront in a non-symmetrical fashion within the horn itself and propagate the sound field into space from a mouth whose radiation characteristics were likewise non-symmetrical. Examination of the structure of this wide-angle horn (Fig. 3B) will reveal just such asymmetrical expansion within the horn. The tone arm and reflector sections of the wide-angle horn first expand in the *vertical* direction, the direction opposite that in which we desire maximum spread. This reverse expansion conserves the pressure of the sound wavefront in the horizontal direction until it is almost ready to emerge into space. Thus we find that the bell sections of the horn reverse the direction of the expansion, not restricting the vertical expansion but giving free play to the horizontal expansion. This allows the wavefront to spill out in the horizontal direction under the impulse of the pressure which has been held in constraint in this direction by the previous horn sections. Wide-angle horizontal dispersion ensues from each of the individual mouths of the two horns which, lying side by side, are likewise angularly orientated, a factor enhancing the wide-angle dispersion characteristics of this type of horn.

With this brief analysis of the principles upon which the horn is designed, we may now center our attention on the application of the horn alone or in combination with other horns of the family.

Let us backtrack to our previous example of the concert in the village park. Instead of a combination of one large horn which will disperse the

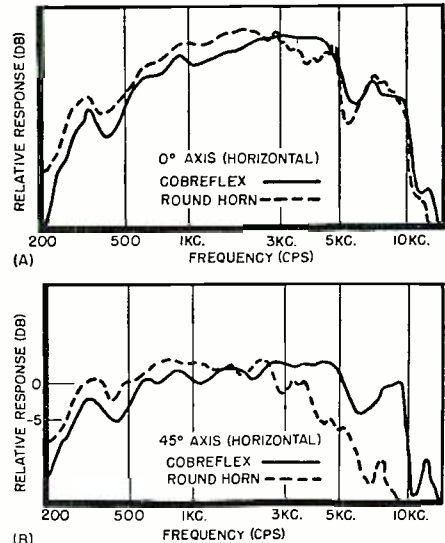
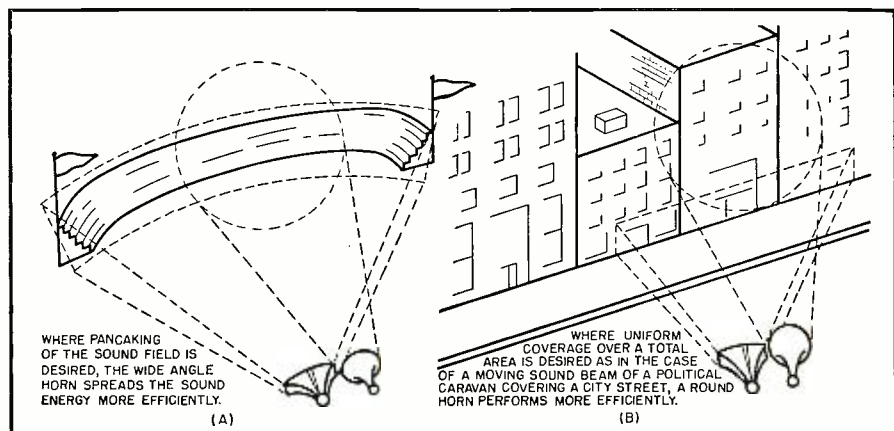

Fig. 4. Comparison of the responses of a round horn and a "cobra" type (A) directly in front of speaker (B) at an angle of 45 degrees from the horizontal axis.

lows over the whole area, and the two smaller horns to re-enforce the highs on the side areas, we may use the same low-frequency horn and a single "Cobreflex." The latter wide-angle horn will cover the entire area with the upper lows, the middle, and the high frequencies with uniform intensities. To the discriminating soundman there will immediately come to mind the possibility of converting this simple two-unit outdoor system into a real high-fidelity system worthy of "concert hall" use. This may be accomplished by the addition of a crossover network that will channel only the lows to the large round horn unit, and simultaneously channel the middle- and high-frequencies to the cobra-reflex. The advantages of an arrangement of this nature, in addition to the uniformly wide area coverage, include more intermodulation-free reproduction (which means cleaner and more satisfying sound reproduction) and an added factor of safety in the life of the high-frequency driver unit through the elimination of low-frequency power.

In other quality reproduction systems it may be possible to sacrifice
 (Continued on page 150)

Fig. 5. Comparative performance of the two types of horns for different p.a. usage.



954 TV RECEIVER SPECIFICATIONS

Continuation of the list of mechanical and electrical specifications on new TV sets for service technicians. See next issue for additional listings.

MFR.	CHASSIS	TUBES							VIDEO I.F. FREQ. (MC.)	H.V. ⁴ (KV.)	U.H.F. PRO-VISION	POWER (WATTS)	SPECIAL FEATURES
		TUNER	I.F. ¹	VIDEO ²	AUDIO	SWEEP ³	P.S.	CRT					
CAPEHART	CX-37-1	6BZ7	6CB6	6AU6	6BK5	6W4GT, 6BE6	1B3GT	21ZP4A	40	14	11	210	5, 10
		6X8	6CB6	1N64	6X8*	12AU7, 6BF6	5U4G	17LP4					
		6AF4	6CB6	6X8*	6BN6	6V6GT, 12AU7		21EP4A					
		1N82	6CB6	6AQ5		6BQ6GT		21EP4B 21ZP4B					
	CX-37 90°	6BQ7	6CB6	6AU6	6X8*	6CS6, 12AU7	5U4G	24CP4	40	20	Strips	270	5, 10
		6J6	6CB6	1N64	6BN6	12AU7, 6BF6	5U4G	or 27GP4					
			6CB6	6X8*	6AV6	6AV5GT, 6CD6G	1B3GT						
			6CB6	6AQ5	6AQ5	6AX4GT, 6AX4GT							
	CX-37-1 90°	6BZ7	6CB6	6AU6	6AQ5	6AX4GT, 6AX4GT	1B3GT	27GP4	40	20	11	270	5, 10
		6X8	6CB6	1N64	6X8*	6CS6, 12AU7	5U4G	or					
		6AF4	6CB6	6X8*	6BN6	12AU7, 6BF6	5U4G	24CP4					
		1N82	6CB6	6AQ5	6AV6	6AV5GT, 6CD6G							
DU MONT	RA-301	6BQ7	6CB6	6C4	6AU6	6BE6, 6AB4	5U4G	24DP4A	41.25 45.75	18	Strips or 11	270	5, 6, 10
		or	6CB6	6AU6	6AL5	6AL5, 6SN7GT	5U4G						
		6BK7	6CB6	12BY7	6AT6	6CD6G, 6AU4GT	1B3GT						
		6J6			6V6GT	12AU7, 6AU5GT							
	RA-302	6BK7	6CB6	6C4	6AU6	6BE6, 6AB4	5U4G	24DP4A	41.25 45.75	18	11	290	5, 6, 10
		6J6	6CB6	6AU6	6AL5	6AL5, 6SN7GT	5U4G						
		6J6	6CB6	12BY7	6AT6	6CD6G, 6AU4GT	1B3GT						
		12AU7			6V6GT	12AU7, 6AU5GT							
	RA-306	6BQ7	6CB6	6C4	6AU6	6BE6, 12AT7	5U4G	17HP4	41.25 45.75	14.5	Strips or 11	200	5, 6, 10
		or	6CB6	6AU6	6AL5	6AL5, 6SN7GT	1B3GT	21FP4A					
		6BK7	6CB6	12BY7	6AT6	6BQ6GT, 6AX4GT							
		6J6			6W6GT	6S4							
RA-307	6BK7	6CB6	6C4	6AU6	6BE6, 12AT7	5Y3GT	17HP4	41.25 45.75	14.5	11	220	5, 6, 10	
	6J6	6CB6	6AU6	6AL5	6AL5, 6SN7GT	5Y3GT	21FP4A						
	6J6	6CB6	12BY7	6AT6	6BQ6GT, 6AX4GT	1B3GT							
				6W6GT	6S4								
EMERSON	120166-D	6BQ7 or	6CB6	6AL5	6AU6	12AU7, 6SN7	5U4	17LP4A	45.75	14.5	Strips	190	6
	120171-B	6BK7 or	6CB6	6CB6	6AU6	6BQ6, 6W6	1B3	21MP4	45.75	15.5	Strips	190	6
	120173-D	6BZ7	6CB6		6AL5	12AU7, 6SN7	6W4	21FP4	45.75	15	Strips	190	6
		6J6			6AV6		5U4						
		6V6											
	120209-D	6BQ7 or	6CB6	6AL5	6AU6	12AU7, 6SN7	5U4	21YP4	45.75	15.5	11	190	
	120174-D	6BK7 or	6CB6	6CB6	6AU6	6BQ6, 6W6	1B3	21MP4	45.75	15	11	190	6
	120193-F	6BZ7	6CB6		6AL5	6SN7, 12AU7	6W4	21MP4	45.75	15	11	190	9
	120198-D	6J6			6AV6	12AU7	5U4	17LP4A	45.75	14.5	11	190	6
	120210-D	6J6			6V6			21YP4	45.75	15	Strips	190	
	120179-B	6BQ7 or	6CB6	6AL5	6AU6	12AU7, 6SN7	5U4	27EP4 or 27RP4	45.75	18	11	210	6
	120203-B	6BK7 or	6CB6	6CB6	6AU6	6BQ6, 6W6	1B3		45.75	18	11	210	6
	120204-B	6BZ7	6CB6		6AL5	6SN7, 12AU7	6AX4		45.75	18	11	210	6
	120205-B	6J6			6AV6	12AU7	5U4		45.75	18	11	210	6
		6J6			6V6		6AX4						

1. Video i.f. tubes only. 2. Includes detector and a.g.c. 3. Includes sync section and a.f.c. 4. CRT 2nd anode voltage. 5. Removable safety glass. 6. Local-fringe a.g.c. adjustment. 7. High-fidelity sound. 8. Aluminized picture tube. 9. TV-radio-phonograph combination. 10. Built-in antenna. 11. 82-channel tuner. 12. Adjustable dial light. *Part of tube is used in another section.

THE SIGNAL BOUNCER

By ELBERT ROBBERSON

ANYONE who has ever tuned a transmitter, whether novice, amateur, or professional engineer, has wondered about the field strength and how the signal sounds at a distance. A number of different systems have been developed to give this information, ranging from simple adaptations of a portable v.o.m. to shielded monitors and remote receivers. All of these procedures have disadvantages, ranging from high cost, or excessive complication in the case of sensitive remote measuring and monitoring gear, to hopeless inaccuracy, and even not being able to get a report when wanted, if other stations are relied upon for signal information.

How would you like to have a distant station with a good receiver and operator always on tap to give you more accurate field strength reports than you have ever gotten before?

The "Signal Bouncer" turns the trick. With it, distant field measurements are uniformly reliable because you read them yourself—and on your own receiver. And what is the "Signal Bouncer"? One tube, three tuned circuits, and a box. It won't set you back much and it will give a million dollars' worth of information. Here is how it goes.

In the transmitting game, the important thing is the power that is radiated from the antenna. If you try to gauge by the antenna current, you are measuring power which is being lost as well as the part going toward radiation. If you sample the air in the same room as the transmitter, you get not only a piece of the power that has come from the antenna, but also some that has come directly from the field around the transmitter, or the house wiring. The only accurate way to measure the over-all transmitter and antenna effectiveness is to sample what is in the air. The sampling must be done far enough away so that it is not influenced by induction or conduction. Observations at a distance of 50 or 100 feet, if the instruments are in a fairly clear area, will give the right picture.

The usual procedure is to put a detector and meter at this distance, which is fine except for one thing. It is out there and you are here at the transmitter.

"Signal Bouncer" in operation. Antenna is extended and the box grounded by means of clip lead and ground rod. Antenna adjustments may be touched up by watching for meter jog at resonance.

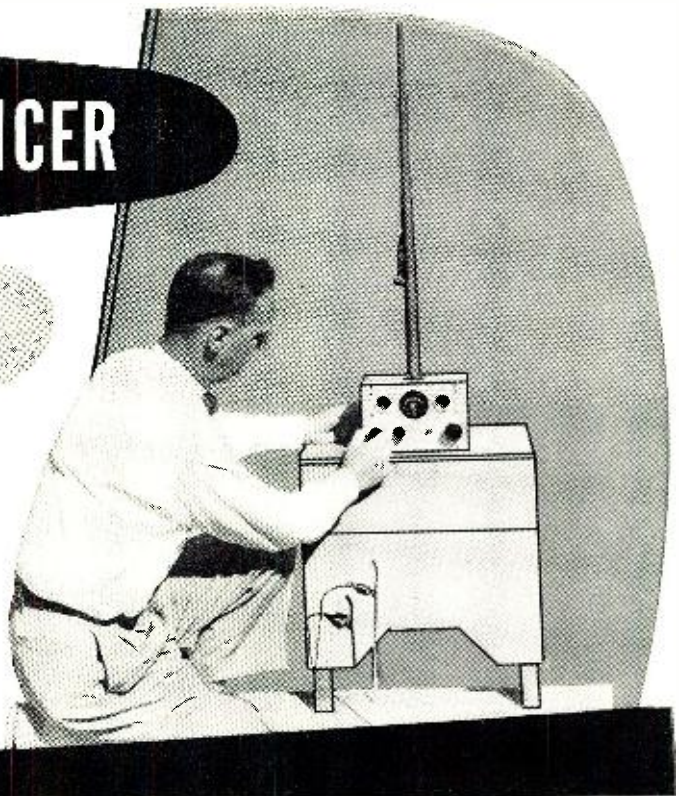

A novel device for use during transmitter adjustments. It provides data on signal strength via station's receiver.

You can look at the response on the distant meter with a pair of binoculars, or you can run a cable between the remote detector and the transmitter to operate a local meter. But radio was invented to do away with such wire links—why not use radio to get the information from the detector to the operator!

Fig. 1 shows such a system. The signal picked up by the remote receiver controls the output amplitude of the remote transmitter, so its strength varies in proportion to the main-transmitter signal strength. The only requirement is that the remote transmitter be on a different frequency than the station transmitter, in order not to be masked. S-meter indications on the main station receiver will then indicate the relative strength of the main transmitter's signal at the remote point.

Fig. 1. Simplified diagram showing how the principle of "Signal Bouncer" is employed.

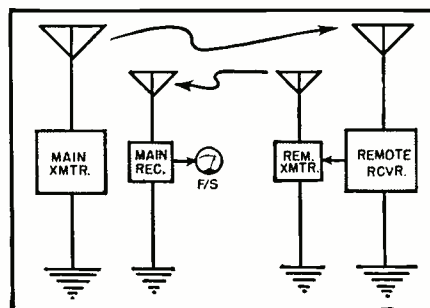

In practice, it is not necessary to have an actual transmitter in the remote unit—a simple frequency changer is all that is required. The signal is picked up, shifted over to another frequency, and sent back to the main station, to actuate the main receiver. The means by which this can be accomplished are familiar to everyone. All the system need amount to is a "mixer," such as is employed in the superheterodyne receiver. The signal is tuned in on this superhet "front end." Then, instead of running the i.f. signal through an amplifier and detector, it is put back into the antenna, and radiated as a new signal.

It is not necessary to have separate antennas at the remote station for receiving and transmitting, since an antenna may perform two or more functions simultaneously. Therefore, the remote antenna can be used to pick up the signal from the main station and at the same time radiate another signal on a different frequency.

The most common demonstration of this is the well-known phenomenon of "re-radiation" in the simple regenerative receiver, where at the same time a signal is being received, the oscillating detector puts a strong signal back on the air over the same antenna.

Fig. 2 shows the circuit of the simplest setup. A grid-dip meter is used as the local oscillator and a diode as the mixer. The tuned circuit, L_2-C_2 , is resonant at the main-station signal frequency, F_1 . Closely coupled to it is L_3 ,

Required metalwork can be accomplished with hand tools. Socket holes may be made with chassis punch or rotary hacksaw. Insulator arrangement will depend on the type of antenna employed.

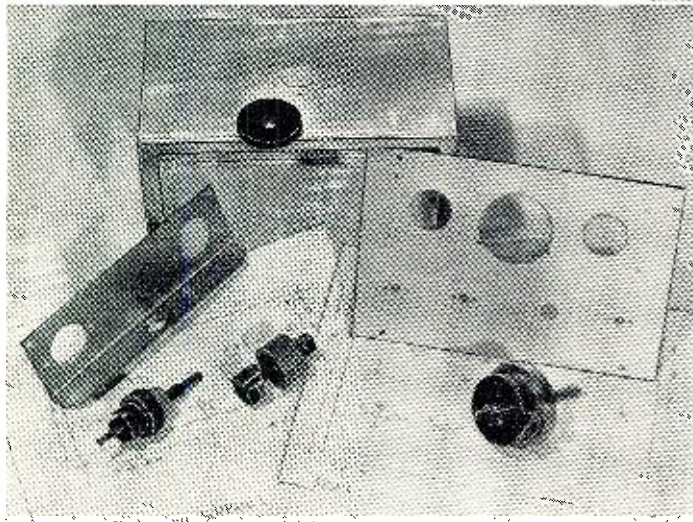

Chassis is secured to panel by four aluminum or brass spacers, 2" long, drilled and tapped for 6/32 machine screws. The panel holes for coils should be filed to clear forms without scraping.

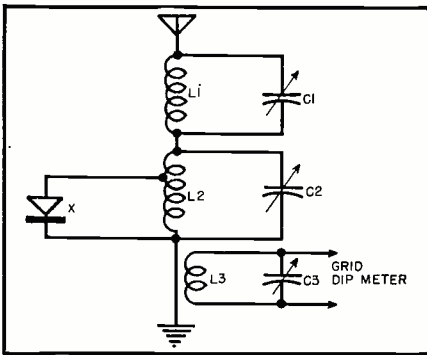

Fig. 2. Circuit of the simplest possible setup with grid-dip meter used as the local oscillator and a diode as the mixer.

which is the coil of a grid-dip meter on a frequency, F_2 , which is 2000 kc. removed from the signal frequency. In

the diode, X, the two currents mix to form the third, or difference frequency, F_3 . The circuit, L_1-C_1 , is resonant to this frequency so, in conjunction with the diode, it has the effect of a generator operating on frequency F_3 , and the antenna is thus re-excited.

As in the case of the familiar "wave trap" the main transmitter signal passes without opposition through the circuit, L_1-C_1 ; and likewise the circuit, L_2-C_2 , allows passage of the returning signal frequency. Hence, the antenna circuit is effectively resonant at both frequencies, and the currents are "sorted out" and routed to the proper place by the tuned circuits. Surprisingly enough, even a haywire lashup of this type will operate as a "signal bouncer" over a short distance.

A serious adaptation of the principle is the circuit shown in Fig. 3. Except

for one rather startling difference, it will instantly be recognized as the 1R5 tube in the conventional pentagrid-converter circuit. L_2-C_2 is tuned to the frequency of the main transmitter; and L_3 generates local oscillations at a frequency above or below the signal frequency by the number of kilocycles on which the return signal is desired. The plate then feeds this resultant frequency back into the antenna, which is resonated to the new frequency by the circuit, L_1-C_1 .

The power output of the "Signal Bouncer" on this resultant frequency is so small that there is no possibility of it causing interference to other services. However, transmitters in other services will interfere with the signal from the "Signal Bouncer," so a quiet spot, in which sky waves are minimum, such as the 160-meter ham band, is chosen for the frequency, F_3 . For purposes of illustration, the frequency 2000 kilocycles will be used here.

Then, to check the output of a transmitter on 3600 kilocycles, the grid circuit of the "Signal Bouncer" is tuned to this frequency. The oscillator is tuned to 5600 kc., so a 2000-kc. heterodyne appears at the 1R5 plate. L_1-C_1 is resonated at this frequency, and if the main station receiver is tuned to 2000 kc., a facsimile of the main-station signal can be heard.

With the "Signal Bouncer" at the far corner of the back yard, the signal facsimile heard is indicative of the field strength at that distance. Relative strength of the radiated field can thus be taken from the station-receiver S-meter.

By keeping the frequency, F_3 , in the 1800 to 2000-kc. range, a fixed coil can be used in the mixer plate. Plug-in grid and oscillator coils are used to spread the signal-frequency coverage through the 14-mc. amateur band. At higher frequencies than this, the conventional measuring setup with observations made directly by eye is perfectly practical, because a separation

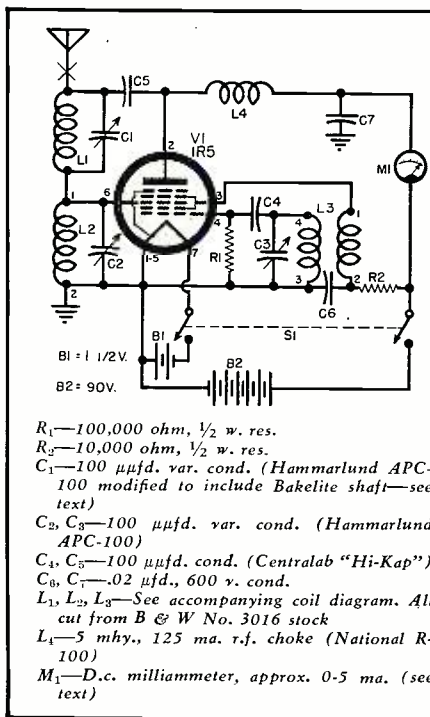
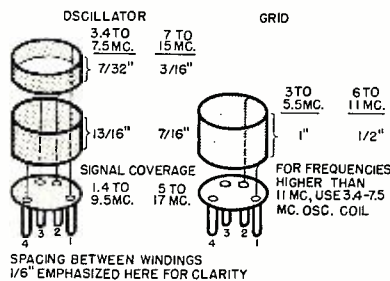
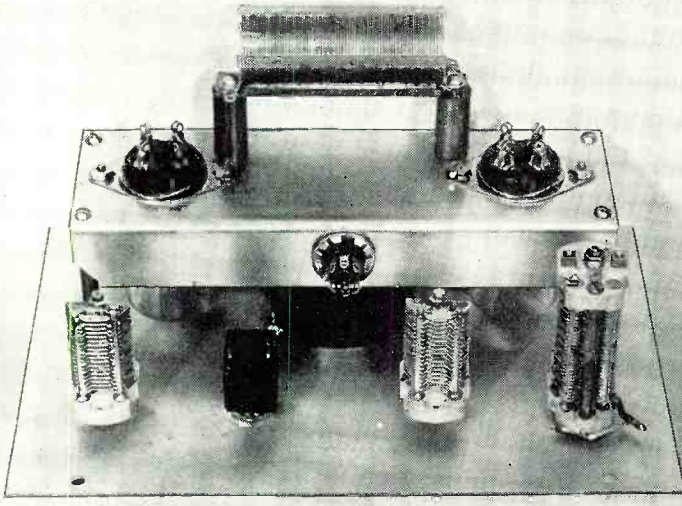

Fig. 3. Schematic of "Signal Bouncer" and details for winding coils L_1 , L_2 , and L_3 . See text for full coil data.



- S_1 —D.p.s.t. toggle switch
- B_1 —1 1/2 volt battery (Burgess 2F)
- B_2 —Two 45 volt batteries in series (90 volts total—Burgess Z30)
- V_1 —1R5 tube
- 1—9" x 5" x 6" aluminum cabinet (ICA No. 29844)
- 1—Surplus telescopic mobile antenna, 18" to 18' with required hardware and insulators
- 4—1/4" aluminum rods, 2" long, drilled and tapped 6-32 each end
- 2—1" Bakelite spacers, drilled and tapped 6-32 each end
- 1—1/8" x 1/2" x 3 1/2" polystyrene strip
- 4—Coil forms (Amphenol No. 24-4P)
- 1—Subchassis panel 7 1/2" x 2 1/4", 1" flange

Start of wiring operation. Before subpanel is secured, make connections to meter. Parts wired in are battery plugs, choke L_1 , C_7 , and S_1 . Hanging end of L_1 connects to pin 2 of V_1 .



Mechanical assembly of unit. Although the variable condenser at the far right is larger than the others, the parts list is correct in specifying all three as 100 μfd . See text on this.

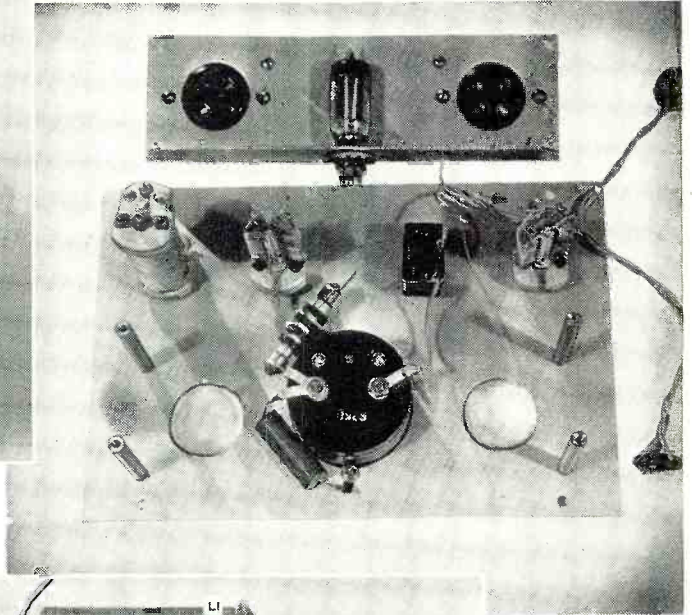

of only a few feet amounts to the wavelength or so of isolating distance usually required.

Panel controls are thereby held to the minimum of an "on-off" switch and tuning condensers for the three circuits. A set of two grid and two oscillator coils is sufficient to cover this frequency range. Conventional parts are used throughout, with one slight exception. In order to permit the direct connection of the input- and output-antenna "tanks," the plate-tuning condenser must have an insulated rotor and shaft. The type of condenser specified has insulated mounting bosses and requires only an insulated shaft. The pin holding the original shaft onto the end of the rotor was driven out and a shaft made of a $\frac{1}{2}$ " length of $\frac{1}{4}$ "-diameter Bakelite substituted.

The meter used is from a surplus antenna-tuning unit. All it amounts to is a low-range milliammeter in the plate circuit. This may be omitted if desired, or any meter having about a 5-ma. movement can be used if one of the surplus instruments is not on hand. Normal current will read around 4 on this meter, corresponding to somewhat over 1 ma., and will indicate that both batteries and the tube are functioning. In addition, a slight "peak" will be obtained when the incoming signal is strong enough and all circuits are in resonance, so fine tuning may be done by the meter in the field.

Construction is shown by the drawings and photographs and is perfectly straightforward. The unit is housed in an aluminum cabinet which measures 9"x5"x6". The subchassis is 7 $\frac{1}{2}$ "x2 $\frac{1}{4}$ " and has a 1" flange. The only thing the least bit out of the ordinary is the coils, which are adaptations of the B & W "Miniductors."

The plate coil, which is fixed, is B & W type No. 3016. Because this coil has no provision for mounting, it is cemented to a strip of $\frac{1}{2}$ "x $\frac{1}{8}$ " poly-
(Continued on page 140)

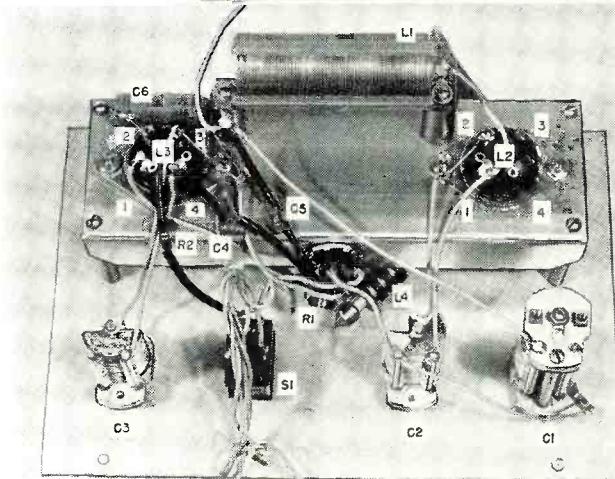

Unit completely wired. Wire at top connects to antenna. Coil socket terminals are flattened to afford clearance for batteries. L_1 should be examined carefully for short-circuited turns.

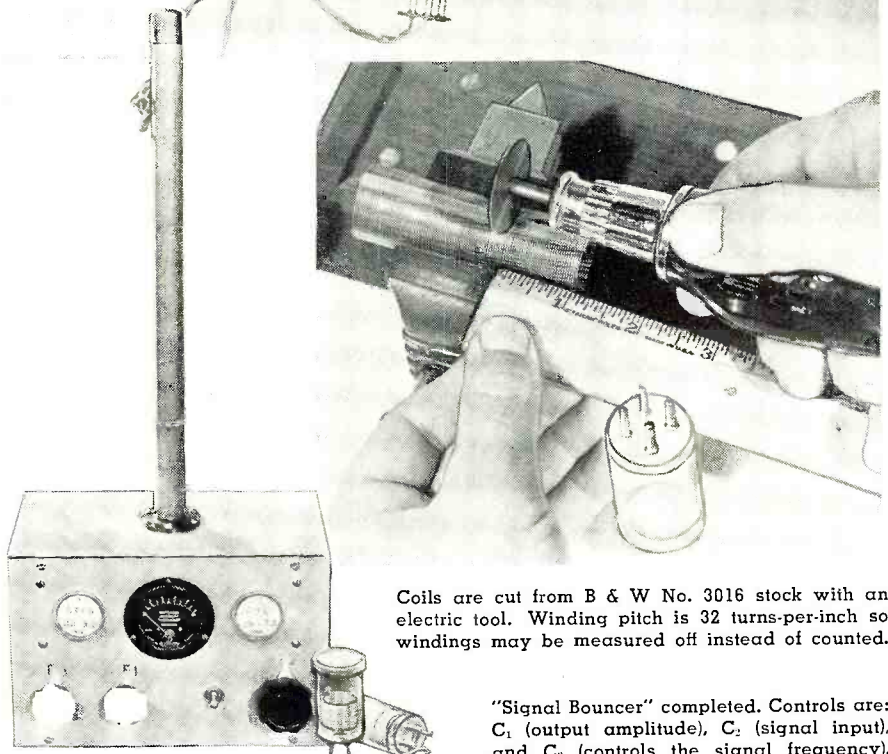

Coils are cut from B & W No. 3016 stock with an electric tool. Winding pitch is 32 turns-per-inch so windings may be measured off instead of counted.

"Signal Bouncer" completed. Controls are: C_1 (output amplitude), C_2 (signal input), and C_3 (controls the signal frequency).

THE AUDIO CATHODE FOLLOWER

By

NEWTON NELSON

How a cathode follower can be used in driver and output circuits.

AFTER spending a few minutes riffling through the pages of an audio catalogue, almost everyone will admit that flat frequency response corresponds to a flat pocketbook. The group of high-fidelity enthusiasts who insists on high peak powers, that are actually used once a month, coupled with ultrasonic frequency response seem limited to persons whose income figures correspond to cycles of high-frequency cut-offs. Recent common sense treatments^{1, 2} show that for those who live near children and dogs and are satisfied with "slight effect upon tone quality" as compared to ideal, a frequency range of 60 to 10,000 cycles and a power output of five watts at two to three per-cent distortion are wholly justified. With these criteria in mind the search for a suitable amplifier begins. If the cost of the amplifier is to remain reasonable the necessarily expensive wide-range output transformer must be avoided. Flat frequency response can be obtained by heavy application of inverse feedback, but in using cheaper transformers the builder is immediately faced with the twin bugbears of instability and oscillation caused by excessive phase shift and the inability to deliver anything near rated power at the ends of the audio

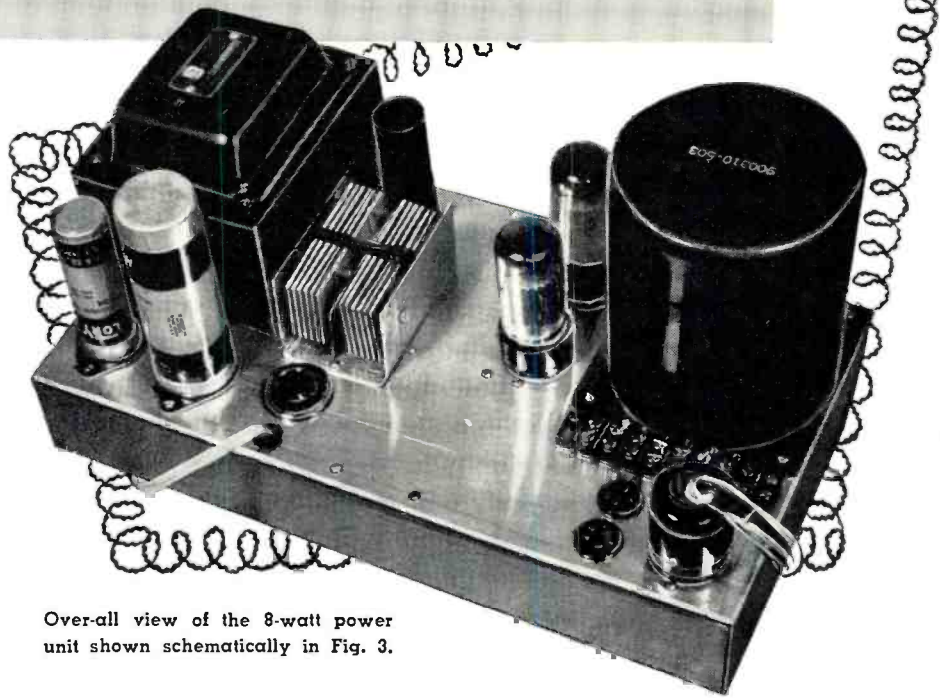

Over-all view of the 8-watt power unit shown schematically in Fig. 3.

spectrum. This is particularly important at low frequencies where a large portion of the power is concentrated in normal speech and music and where compensation for ear and equipment deficiencies is greatest. Frequency response curves are usually given for low power levels, because the more revealing frequency-maximum power curve would show serious inadequacy in the low-frequency region. These evils can be avoided if the output transformer is removed from the feedback loop and is, instead, driven by a very-low-impedance generator. This will also produce good loudspeaker damping, another "must" for good reproduction.³ A circuit ideally suited to these requirements is the cathode follower. Here, output stage feedback produces hump-free response and low

distortion without including the transformer in the feedback loop, and low driving impedance provides rated power at low frequencies. Using a low-cost output transformer (Stancor A-3830), two cathode follower 6V6's produced 50% more power at forty cycles than a similar triode circuit could produce.⁴ Distortion characteristics are excellent, remaining low until overload is reached and then rising sharply. These advantages, coupled with good damping and stability, produce an excellent amplifier.

But it is not all free. On the debit side, the main disadvantage of the cathode follower is the large driving voltage required for appreciable output power. Low cost and wide frequency range preclude a voltage step up with transformer coupling to the

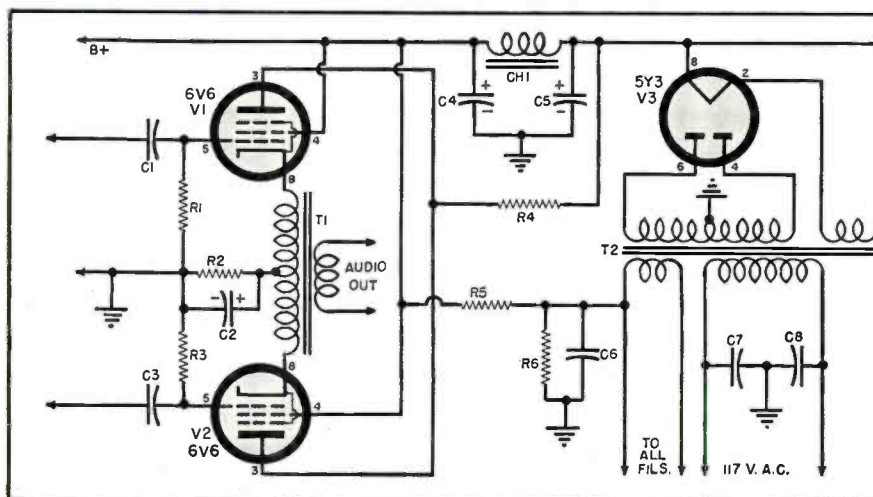

Fig. 1. Schematic of 5-watt power unit. The efficiency of this unit falls in the triode bracket and its over-all cost is only a little more than that of a wide-range output transformer. Although the output transformer used is a low-cost unit, it provides good performance in this circuit.

- R₁, R₅—220,000 ohm, 1/2 w. res.
- R₂—270 ohm, 5 w. wirewound res.
- R₃—2000 ohm, 20 w. wirewound res.
- R₄—560,000 ohm, 1/2 w. res.
- R₆—100,000 ohm, 1/2 w. res.
- C₁, C₃, C₇, C₈—.1 μfd., 600 v. cond.
- C₂—50 μfd., 50 v. elec. cond.
- C₄, C₅—40 μfd., 450 v. elec. cond.
- C₆—.01 μfd., 600 v. cond.
- CH₁—25 hy., 50 ma. filter choke
- T₁—Output trans., 3500 ohms to v.c. (Stancor A-3830)
- T₂—Power trans. 375-0-375 v. @ 120 ma.; 6.3 v. @ 3.5 amps

power stage grids. Thus maximum output voltage from RC-coupled stages is a necessity. Since power is a product of $E \times I$, large peak current capabilities are also desirable in the output stage. It is difficult to obtain large powers with readily available receiving tubes without resorting to parallel operation and large current drain. Powers in the ten-watt range are readily available using common tubes however. With low-cost transformers the damping is best at low frequencies and becomes poor at high frequencies if the leakage inductance is large. Both high-frequency damping and high-frequency response are dependent on the transformer so the circuit is not a cure-all for defective units.

The resistance-coupled driver developed for this application will deliver high peak voltages at low distortion. A cross-coupled phase inverter, Fig. 2, was chosen because of the flexibility of the two inputs that will enable it to handle almost any kind of signal, and the good balance which permits the easy application of negative feedback from the output cathodes. It was found that by matching cathode resistors R_3, R_4 and feedback resistors R_7, R_9 most 12AU7's would give outputs balanced to within a few per-cent so that a balancing pot was not deemed necessary. The high audio voltages are developed by the 6AU6's which have excellent output voltage capabilities. This stage is followed by a cathode follower in order to present a high impedance to the 6AU6's thus getting maximum voltage output and also permitting the use of low grid resistance in the power stage to minimize grid overload and gas current flow, particularly in view of the high electrode voltages used in some applications. Since it was desired to mount the preamplifier remotely, the entire driver was built on a small chassis and a cable was run from this low-impedance output. About thirty decibels of feedback in unbypassed cathodes and the over-all feedback loop enable the driver to deliver 165 volts peak audio ± 1 db from 20 to

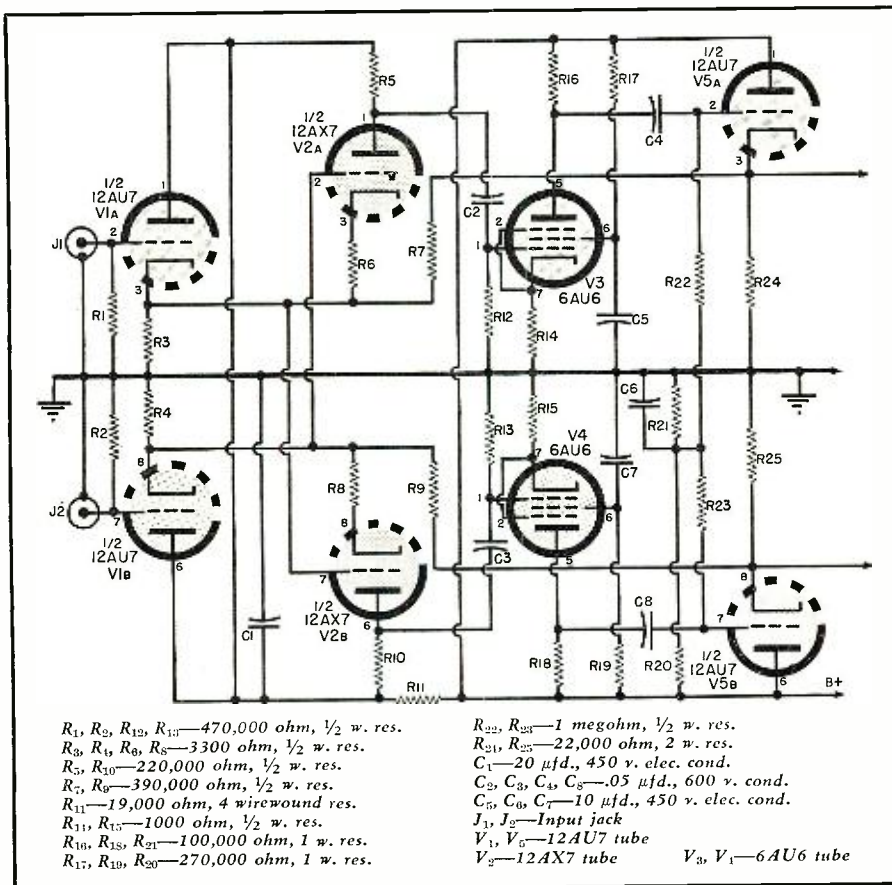

Fig. 2. Schematic of a cathode-follower driver unit. See text for full details.

60,000 cycles with 400 volts of "B+." At 50 volts peak the response is flat to over 100 kc. Distortion is negligible until it rises sharply at overload. In fact, the driver alone will deliver a watt of audio to a loudspeaker.

The ideal power tube should have high mu and large current capabilities at low plate voltages. Regular triodes of this breed are hard to find. The choice would then lie with the tetrodes and pentodes. The problem of what to do with the screen grid can be solved in two ways.

One way is to use a tube normally operating at high screen voltages and

triode connect it. Two 6V6's were connected as shown in Fig. 1. The 350 volt screen-to-cathode voltage exceeds the normal ratings but screen dissipation is well below rated. At zero bias the cathode has risen to a point where the zero bias screen-to-cathode voltage is within normal rating and the screens do not suffer. Plate voltage can be reduced by a dropping resistor to keep the plate dissipation down. Plate voltage has little effect as long as it stays more than 75 volts above peak cathode voltage. This mode of operation will deliver
(Continued on page 110)

Top view of the driver unit. The tone controls and preamp are built on this compact 5" x 9½" chassis. See Fig. 2 for diagram.

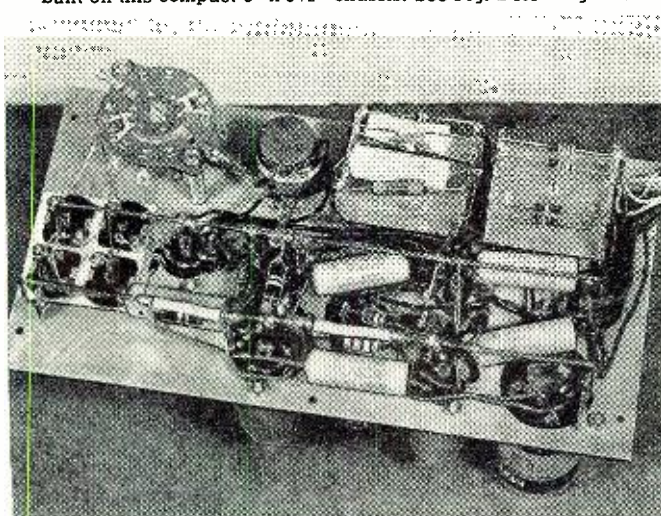

Bottom view. Compact construction is possible because direct wiring, and parallel ground and high-voltage busses are used.

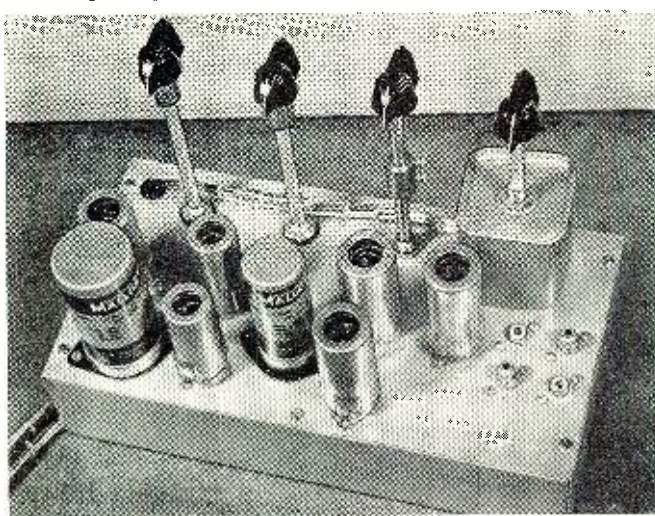

Fig. 1. Front view of "universal vibrato" unit showing location of above-chassis parts and the various controls on the chassis apron.



THE UNIVERSAL Vibrato

By
RICHARD H. DORF
Audio Consultant

A phase modulator circuit which can be used with guitars, organs, pianos, etc., to produce a realistic vibrato effect.

IN THE course of a great deal of investigation into the electronic production and control of music and publication of the results, the writer has received quite a number of requests for a vibrato circuit from guitarists and others. Until recently the only circuit capable of imparting vibrato to music originating from fixed-frequency sources was the elaborate electro-mechanical scanner used in some *Hammond* organs, and it is impractical for individuals to construct. Now, however, an entirely practical, easily constructed all-electronic circuit does exist. The writer has employed it in somewhat modified form in the "universal vibrato," a completely self-contained device.

Either vibrato or tremolo is an important factor in music of almost every kind. To note its effect, hum a single tone, keeping the pitch perfectly constant as far as possible. Whether you are a crow-voiced musical duffer or a Metropolitan tenor, you will note that the tone is musically uninteresting. Now listen to a professional singer on the radio or from a record and note that when he sings a single tone he does *not* keep the pitch or frequency constant. He varies it up and down slightly at a rate somewhere between about 5 and 8 cycles-per-second. This pitch variation is known as "vibrato." It makes a tone interesting.

The violinist or other stringed-instrument player does the same thing by moving the finger with which he is pressing down a string. This varies the effective length of the string between 5 and 8 times per second and gives the vibrato frequency variation. Everyone who has seen a violinist play remembers that the left hand is always in

vibratory motion; it is kept so to produce vibrato.

A few instruments have tone sources whose pitch cannot be varied. One of these is the pipe organ, whose pitch depends on the dimensions of the pipes. Another is the harmonica, whose pitch depends on the dimensions and mass of the reeds. In those instruments vibrato is impossible and the substitute is tremolo. Tremolo is a periodic variation in volume. In the organ it is produced by alternately blocking and unblocking the orifice in the chamber containing the pipes by mechanical means. In the harmonica tremolo can be produced by the vibratory movement of a hand at the rear of the instrument, closing and opening a path between the reeds and the outer air.

Players of instruments capable of vibrato must be fairly skillful to produce it. Many amateur guitarists do not have that skill. They employ contact microphones and amplifiers to give their instruments Hawaiian guitar effects. To provide the desired periodic variation some of these amplifiers contain tremolo circuits. Such circuits consist of a low-frequency oscillator, the output of which varies the gain of an amplifier stage at the oscillator frequency.

Fig. 2. The "Doppler effect" applied to the "universal vibrato" circuit. See text.

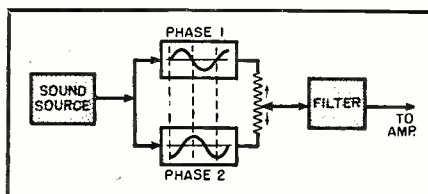

Unfortunately, however, tremolo—volume variation—is not nearly as pleasing as vibrato—frequency variation. But while it is easy to vary the volume of music, it is not as easy to vary its pitch electrically.

The "universal vibrato" does this seemingly impossible job. It can take music from any source whatever—any instrument, from a contact microphone, radio, records, tape—and vary its pitch up and down at a rate 5 to 8 times per second to produce the same effect as if the player had himself produced the vibrato. This means not only that the guitar player can have vibrato without working at it, but also that other instrumentalists can do the same. Of equal interest is the fact that instruments on which vibrato cannot be produced at all—pipe and reed organs, some *Hammond* organs, piano, etc.—can now have it, and some very interesting new effects are possible.

How It Works

The "universal vibrato" is a phase modulator. Its principle has been thought of before, but an embodiment of it was recently designed in detail and brought out commercially in a spinet electronic organ made by *Wurlitzer*, the Model 44. This organ has reeds as tone sources. The designers were dissatisfied with the tremolo which was produced by rotating vanes in front of the speaker on previous models and designed this circuit to provide a genuine tremolo.

To visualize how the principle works, remember the old illustration of the Doppler effect. A train is approaching you, blowing its whistle. As the train gets closer the pitch of the whistle seems to rise, reaching a maximum as the train reaches you. Then, as the train goes away the whistle pitch descends again.

The vibrato is like the moving train whistle. But instead of approaching and passing the listener, it travels on a reciprocating path—moving forward

and backward, approaching, backing away, approaching, and backing away. Thus we hear the whistle pitch rise and fall, rise and fall. All this despite the fact that the whistle itself—steam blown against a mechanical whistle device—really remains at quite constant pitch as far as the train engineer (who remains at a constant distance from it) is concerned.

What is really happening, from the viewpoint of the trackside listener, is phase modulation. If the train remains a constant distance away, the pitch is constant. It takes a certain amount of time for the sound to reach the listener's ears; and all parts of the wave take the same amount of time, so that the ear hears each part of the wave in the proper order and with the same time separation as at the source.

When the train is moving toward the listener, however, that is not true. As the train gets nearer, the time required for the sound to get to the ear constantly decreases. As a result, the second half of the wave, for instance, gets to the listener before it ought to. And since the two parts of the wave are closer together at the ear than at the whistle, the ear assumes that the frequency is higher.

This Doppler effect is simply a case of advancing phase. The principle is used commonly in phase-modulated r.f. transmitters to produce frequency modulation. And this is exactly what happens in the "universal vibrato."

The idea is block-diagrammed in Fig. 2. The sound source, whatever it may be, is converted to audio by a microphone, tuner, pickup, or whatever it may be. From it two separate audio signals are derived. Each signal is an exact replica of the original, but they are displaced from each other in phase by approximately 90 degrees. In Fig. 2 phase 2 lags phase 1.

The two phase-displaced signals are connected (for illustration purposes only) by a potentiometer. The arm of the potentiometer is constantly moving up and down 5 to 8 times per second. At each end of the potentiometer the arm picks up maximum signal from one phase and minimum from the other. At medium positions it picks up a proportional amount of each. Thus the signal on the potentiometer arm is constantly varying in phase. As it travels toward the phase-1 signal, the signal it picks up is advancing in phase and the frequency apparently rises; as it moves toward phase 2, the phase is retarded and the frequency decreases.

Note that if the arm stops in a single position, the frequency remains constant. The two signals simply mix at the arm and produce a single signal and with a phase which is the resultant of the two, according to the proportion in which they are mixed. Since the ear is not sensitive to phase as such, the result, amplified and radiated from a loudspeaker, will sound just like any ordinary signal.

The faster the arm travels up and
(Continued on page 90)

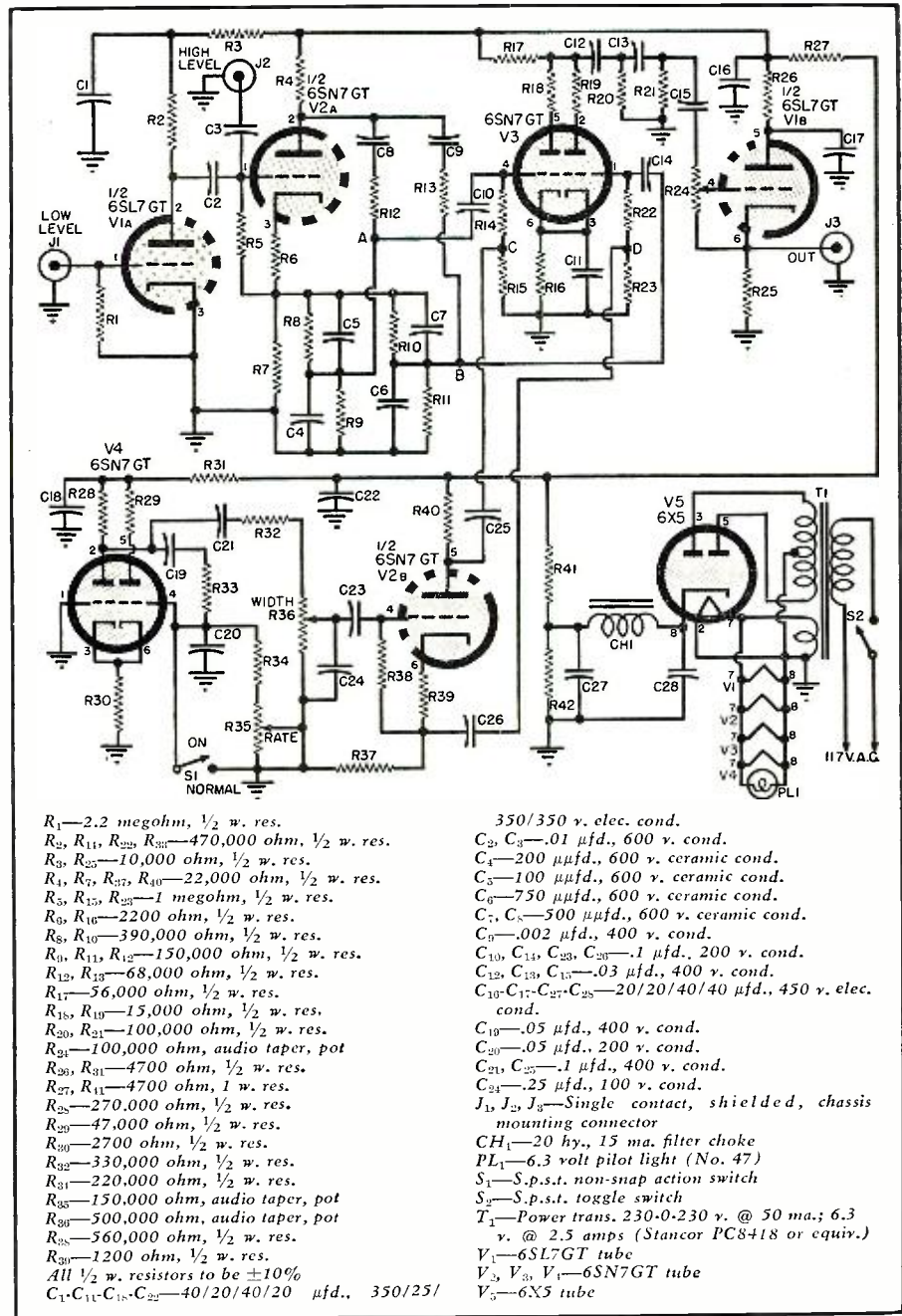
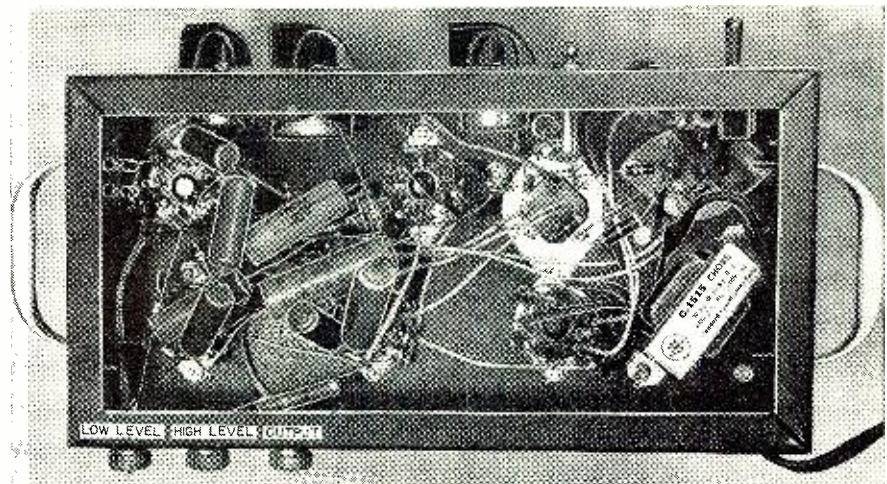

Fig. 3. Complete schematic diagram of the "universal vibrato" unit.

Fig. 4. Underchassis view. A smaller chassis may be used if desired.





Front panel view of the "Auto-Tone." Three 7F7's are used although almost any twin-triode can be substituted if desired.

In effect a loudness control—uses three tubes in a single circuit. Provides automatic bass and treble control to compensate for the Fletcher-Munson effect.

NEARLY everyone is aware that the effective response of the human ear is not the same at all volume levels, it being more nearly flat at high volume levels, and having less sensitivity to the lower and higher ends of the audio spectrum on low intensity sounds. Because the design engineers were aware of this fact they introduced the tapped volume control which compensates for the reduced sensitivity of the ear to the lower frequencies at low volume control settings by boosting the bass. The volume control, in some cases, has combined a treble-boost control with a bass-boost on the same shaft as the volume potentiometer. Obviously, a sound of constant volume

could be handled satisfactorily by one of these arrangements, but speech or music, or any of the sounds normally encountered in audio amplifiers do not have constant volume, but may, and do, have passages, words or syllables of much lower than average level. The need, therefore, is for some automatic method of response control: An amplifier that would introduce considerable bass and treble boost at low inputs, and some method of automatically reducing the amount of boost as the volume increases.

In the simple bass-boost circuit shown in Fig. 1A, the setting of R determines whether the full capabilities of boost are used or not. When this resistor is at its maximum (assuming its maximum resistance is equal to, or greater than, the reactance of C at the lowest frequency to be amplified) the boost will also be greatest. When R equals zero, C is shorted and the purely resistive network of R_1 and R_2 does not discriminate frequencies and the response will be essentially flat. If R is replaced by the plate-to-ground resistance of a vacuum tube, varying the d.c. bias will vary the plate current and likewise its effective resistance. It is possible, then, to control the bass boost by varying the bias on the grid of such a control tube. If the bias is obtained by rectifying the incoming audio voltage, the amount of bass boost can be controlled by the sound level.

If control of the bass was all that was desired, the basic circuit of Fig.

Fig. 1. (A) A simple bass-boost circuit. (B) Simplified bass control circuit using a tube. (C) Basic treble-boost control circuit. (D) Curve for the circuit of (B). See text for details on these circuits.

1B would suffice. Because the plate voltage on V_1 , and hence its plate resistance will not, in practice, drop to zero, and its effective maximum resistance can not exceed the value of its plate resistor, the ratio of maximum to minimum resistance across C will not be nearly as high as R in Fig. 1A. This means that with the circuit designed to provide a nearly flat frequency response with V_1 conducting its maximum (the plate resistance of V_1 at minimum), the maximum bass boost that can be expected will be just slightly more than 6 db at 100 cycles over the response at 1000 cycles. If no corresponding treble boost is incorporated, that amount will do. But if treble boost is also used, a boost of both treble and bass of about 12 db above the 1000 cycle level should be available at low volume levels. This can be obtained, as will be explained later. Fig. 1D shows a typical curve for the circuit of Fig. 1B, with the control tube, V_1 , inoperative (low volume input). Fig. 1C is a basic treble-boost control circuit, wherein the amount of boost is controlled by the components C and R , and the control tube attenuates all frequencies in the same proportion, instead of leaving frequencies that are not boosted unchanged while varying the amount of boost, as was done in the bass circuit just described. For that reason it could not be used alone, but must be used in conjunction with the bass booster or linear attenuator. This method of control for the high frequencies was chosen because the control tube can be operated in the same fashion as the bass control tube with its cathode grounded, and because it makes it possible to obtain the desired 12 db boost for both the highs and the lows. This is accomplished by applying the output of the low boost and the high boost to a mixer tube in such a manner that they will be in a ratio of 2:1 in amplitude and 180 degrees out-of-phase at 1000 cycles, with the control tubes inoperative. This gives us an additional 6 db attenuation at 1000 cycles which, added to the 6 db boost at 100 cycles, results in an effective boost of the lows and highs of about 12 db.

The output of Fig. 1B is approximately 3% of the input amplitude, with a phase shift of minus 40 degrees at 1000 cycles, when the plate resistance of V_1 is 12,000 ohms, which it is when there is no output from the rec-

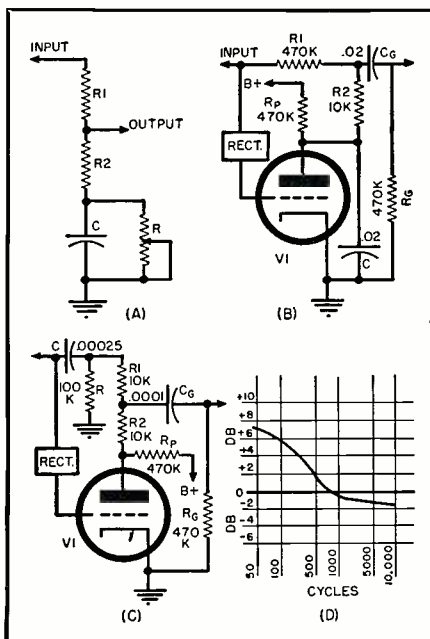

tifier. A single condenser-resistor network such as RC in Fig. 1B cannot produce more than a positive phase shift approaching 90 degrees. In fact the phase of the voltage at the junction of R_1 and R_2 is slightly less than 80 degrees at 1000 cycles. It is necessary to use another RC combination, namely C_6-R_6 , to provide the additional 60 degree shift to make the output of Fig. 1C directly out-of-phase with the output of Fig. 1B. The output phases of these two circuits do not change correspondingly with frequency, so that at some frequency above 1000 cycles, where the voltage outputs are equal in amplitude, they are no longer out-of-phase, so there is no frequency where the resultant output is less than the output at 1000 cycles.

In the "Auto-Tone" amplifier pictured, three type 7F7 tubes were used. If octal types are preferred by the constructor, type 6SL7GT tubes may be substituted with no circuit or parts value changes. Almost any twin-triodes can be used with this circuit, but the values of R_{22} , R_{23} , R_{11} , and R_{15} would have to be changed if the characteristics of the desired tube types differ much from the 7F7. In the complete schematic of Fig. 2, the first section of V_{3A} is used as a straight "class A" amplifier, the output of which is fed to the bass-boost network, the treble-boost network, and the control rectifier. The rectifier is the second section of V_{3B} , and is of the high-impedance, cathode-follower type. The static conditions of this tube are such that it has cathode bias slightly higher than if the tube were operating as a "class A" amplifier. Audio signals of small amplitude, i.e., whose negative peaks do not cut off plate current in the tube, will cause no change in the d.c. voltage at the cathode. As the applied signal strength increases beyond cut-off, the negative portion of the audio will have less and less of a nullifying effect, and the voltage on the cathode will increase in a positive direction. C_{11} is merely a filter condenser; R_{22} limits the grid current in the control tubes, and R_{23} determines the voltage on the grids of the control tubes at minimum signal level. V_{1B} is the bass-

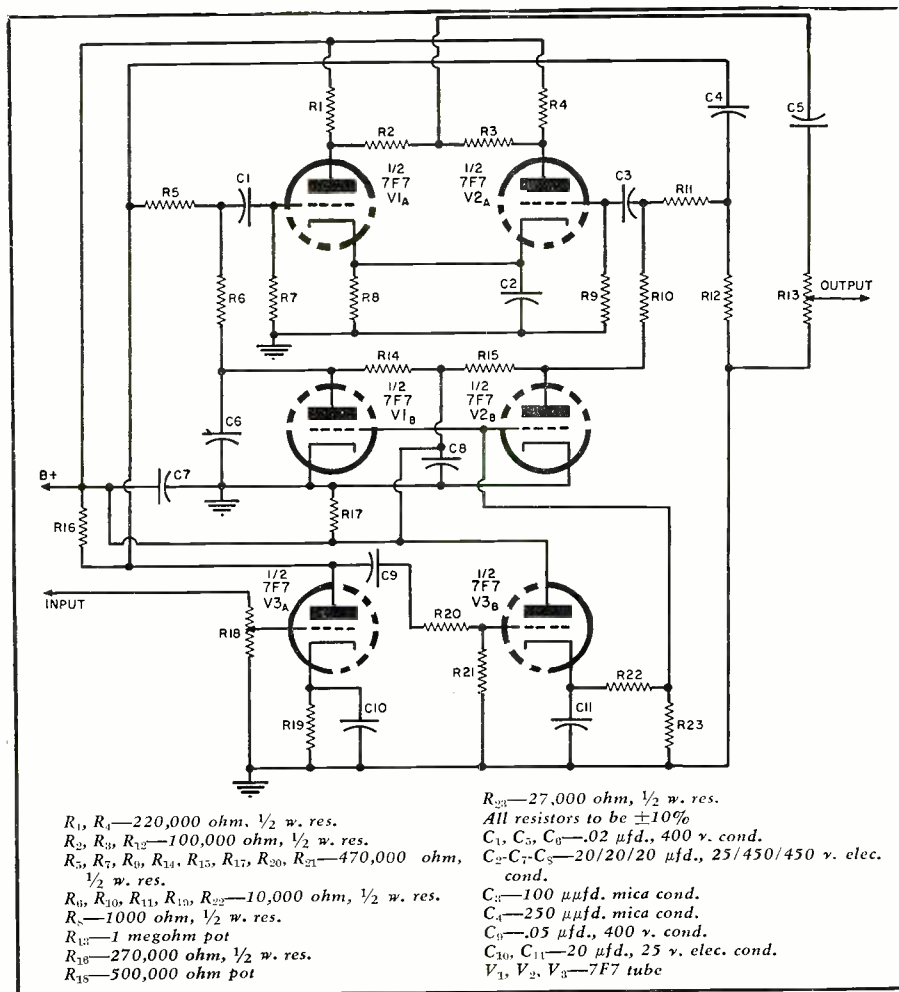

Fig. 2. Complete schematic of the "Auto-Tone." See text for possible alterations.

boost control tube and V_{1A} is the bass mixer. The treble-boost control and mixer are V_{2B} and V_{2A} , respectively.

Power requirements are not critical. The heater drain is .9 amp at 6.3 volts, and the plate current drain is less than 5 ma. at any voltage from 250 to 400 volts. 300 volts is about optimum. Terminal board construction, such as is pictured makes construction, easy and is to be recommended. As long as the usual care in wiring is observed, no

(Continued on page 106)

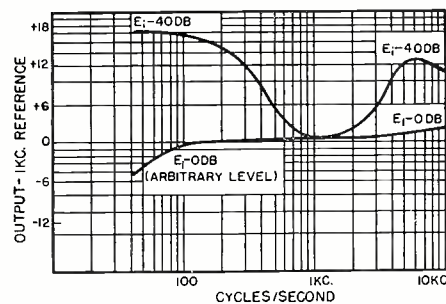
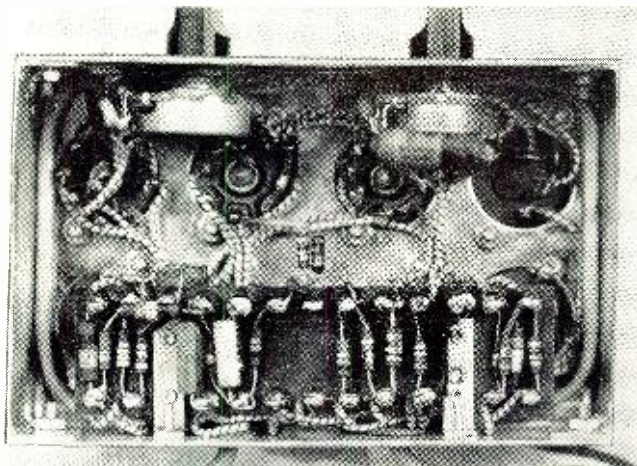
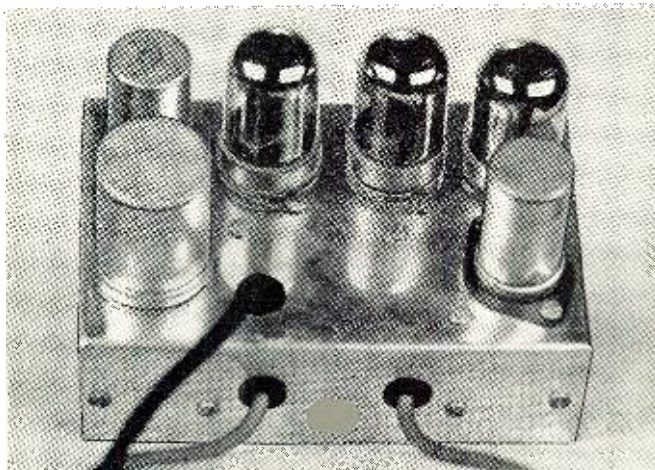

Fig. 3. Measured curves of the "Auto-Tone."

Under chassis view. Terminal board construction is used.



Rear view showing how chassis is laid out for compactness.



IMPEDANCE MATCHING OF MULTIPLE SPEAKERS

By

SHERMAN H. HUBELBANK
Connecticut Telephone & Electric Corp.

Performance of multiple speaker installations can be improved if voice-coil impedances are matched.

IN SETTING up multiple speakers, the problem of impedance matching is a most important one. All the speakers must be matched to the output impedance of the audio amplifier to secure a maximum transfer of energy from the amplifier to each speaker and to minimize the undesirable effects of distortion which are prevalent when the system is mismatched.

Since the distribution of audio energy from the amplifier to multiple speakers is a power distribution problem, the power desired at each speaker location must be individually considered for proper impedance matching.

The simplest type of multiple speaker installation would be a type similar to Fig. 1, where each speaker draws the same amount of power and is wired in parallel without the use of matching transformers.

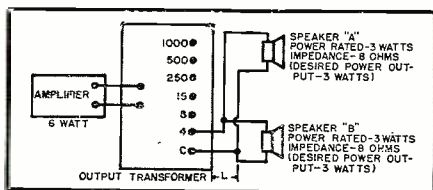

Fig. 1. Simplest type of multiple speaker installation where each speaker draws the same amount of power and is parallel wired.

This type of installation, using only two speakers that have low power ratings, works well for short distances. However, since this is a low impedance line (4 ohms terminating resistance) it has a high current and low voltage, and since the line loss is proportional to the square of the current, the length L (distance from amplifier to speakers) cannot be long. In general a 15% power loss in the line is the maximum acceptable loss. Using #22 AWG size wire for the 4-ohm example of Fig. 1, the maximum distance of L is 18 feet for this 15% line power loss. Of course, a larger size wire would reduce the line loss and, consequently, extend the distance of the run. A run of 30 feet may be made for this example using #20 AWG size wire. In general, for long runs and for speakers of larger power, it becomes increasingly more economical and efficient to use a high impedance line to obtain low current and high voltage. The use of matching transformers or line transformers provides the necessary high voltage.

If conditions are such that one area needs 15 watts of power for coverage, yet another area needs only 3 watts of power for adequate coverage, connecting a 15-watt speaker and a 3-watt speaker in parallel will not give the desired results.

Table 1. Maximum permissible high-impedance line lengths for various installations.

WIRE SIZE AWG (B & S)	LOAD IMPEDANCE			
	100 OHMS	250 OHMS	500 OHMS	1000 OHMS
18	400'	1000'	2000'	4000'
20	250'	750'	1500'	3000'
22	150'	400'	800'	1600'
12	1500'	4000'	8000'	16,000'
14	1000'	2500'	5000'	10,000'
16	750'	1500'	3000'	6000'

NOTE: Lengths beyond those shown above for specific impedances and wire sizes will exceed the maximum allowable power loss of 5%.

As shown in Fig. 1, with both speakers rated at 3 watts and an impedance of 8 ohms, the voltage developed across each speaker is the same, approximately 4.9 volts. Now, since the wattage rating of a loudspeaker is only the rating of the maximum input power that the speaker can safely handle and not necessarily the power developed across it, two dissimilar speakers with the same impedance will develop the same voltage and consequently the same power. To develop different power levels from each speaker, the system should be wired as shown in either Fig. 2A or 2B, or different speaker impedances should be used.

In Fig. 2A both speakers "A" and "B" are rated at 15 watts, however, it is desired that the coverage of speaker "A" be 15 watts and that of speaker "B" be 3 watts. By placing an attenuator rated at 15 watts across speaker "B" this is accomplished. The output of the amplifier must be 30 watts to allow speaker "A" to utilize 15 watts, speaker "B" to utilize 3 watts, and the attenuator to waste 12 watts. Speaker "B" must be rated at 15 watts even though only 3 watts output is desired, since it is possible for the attenuator to be at an extreme position, allowing the full 15 watts to enter the speaker. The maximum distance L is still 18 feet using #22 AWG size wire.

The advantages of using the matching transformers shown in Fig. 2B to accomplish the same end result as the circuit of Fig. 2A are evident from the following comparison: Fig. 2A, audio amplifier—30 watts; speakers "A" and "B"—15 watts each; maximum distance using #22 wire—18 feet; Fig. 2B, audio amplifier—18 watts; speakers "A" and "B"—15 and 3 watts respectively; maximum distance using #22 wire—400 feet.

Therefore, as the multiple speaker requirements become more complex, i.e., different wattages, voice coil impedances, longer runs of line, etc., it becomes much more economical to use matching transformers.

The problem of how to properly match the various speakers of different output loads and voice coils with

the amplifier can be approached using the formula: $Z_t = (W_a Z_a) / W_s$

where:

Z_t = matching transformer primary impedance, in ohms

W_a = total amplifier power required, in watts

Z_a = amplifier output transformer secondary impedance (line impedance), in ohms

W_s = desired input power to speaker, in watts

Note: This formula will only give the matching impedance of a single speaker in a group of parallel speakers. In using this formula it should be remembered that the sum of all the desired speaker input powers must equal that of the output power of the amplifier.

Since the formula is a proportional type it can be transposed to a simple graph (see Fig. 3).

In using either the formula or the graph, the value of Z_a , the impedance of the secondary of the amplifier's output transformer, must be arbitrarily chosen. If upon computing the values of the matching transformers they are either not readily available types or odd values, try another output transformer tap value.

To use the graph, the following steps should be taken:

1. Assume a value for Z_a , the impedance of the secondary of the output transformer.

2. Using the value decided upon for the desired speaker power, W_s (Fig. 3 —15 watts or 3 watts) draw a vertical line to the intersection of the horizontal line from the transformer impedance Z_a .

3. Draw a diagonal line from the origin of the graph (point "0") to the point of intersection of the transformer impedance line and the individual speaker watts line.

4. Continue this diagonal line until it intersects a vertical line drawn from W_a , the amplifier output in watts.

5. The impedance value of the primary of the matching transformer is at this intersection point.

6. Repeat the procedure for each speaker until the total watts to be dissipated equals the total available at the amplifier.

The following example (see Fig. 4) covers a more complex installation, one that is fairly typical for a small factory which uses voice paging and intermission music.

It has been decided that 30 watts will adequately cover the machine shop, 15 watts the general factory, 10 watts the shipping room, and 3 watts each of the two offices. The total power needed is 61 watts. A 70 watt or larger amplifier should be chosen not only to allow for future expansion, but also to allow for losses in the lines, speakers, transformers, etc. However, in using the formula or graph to compute the matching transformer impedances, the amplifier wattage should be 61 in the formula to balance the total needed to cover the necessary factory departments.

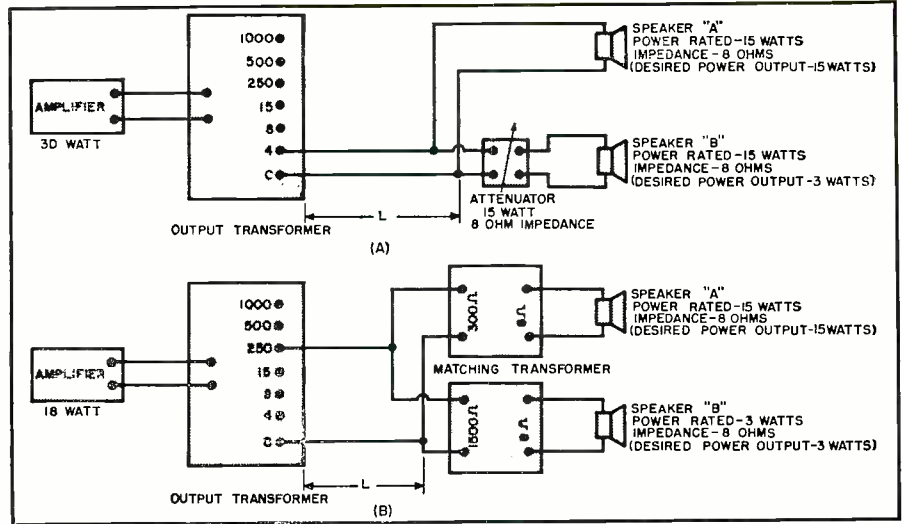

Fig. 2. To develop different power levels from each speaker, the system should be wired as shown. (A) If speakers "A" and "B" are both rated the same but the coverage is to be different, an attenuator is used. (B) The use of matching transformers is an improvement over the circuit of (A). See text for discussion.

Where individual volume level must be controlled at each speaker area, "T" pad attenuators should be used. These present a constant source impedance as well as a constant load at all settings. The attenuator should be chosen to match the impedance of the speaker and should be rated to dissipate the entire wattage of the speaker. In the example shown in Fig. 4 the volume level of the speaker in one office needed to be individually controlled as did the speaker in the general factory. Consequently, a "T" pad attenuator was inserted in front of each of the two speakers.

Since the two offices were located close to each other and they each had low wattage requirements, it was decided they should be parallel connected to one matching transformer. If they were individually connected to the line each would require a matching transformer with an impedance ratio of 5000 to 8 ohms. However, by wiring the speakers in parallel the total watt-

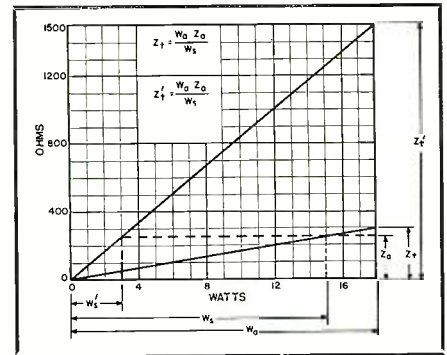

Fig. 3. Graphical representation of the formula for matching various speakers of different output loads and voice coils with an amplifier of a certain output.

age is 6 watts, therefore the matching transformer needed requires an impedance ratio of 2500 to 4 ohms. The reason that the impedance ratio for the two cases remains the same is that the ratio is determined by the com-

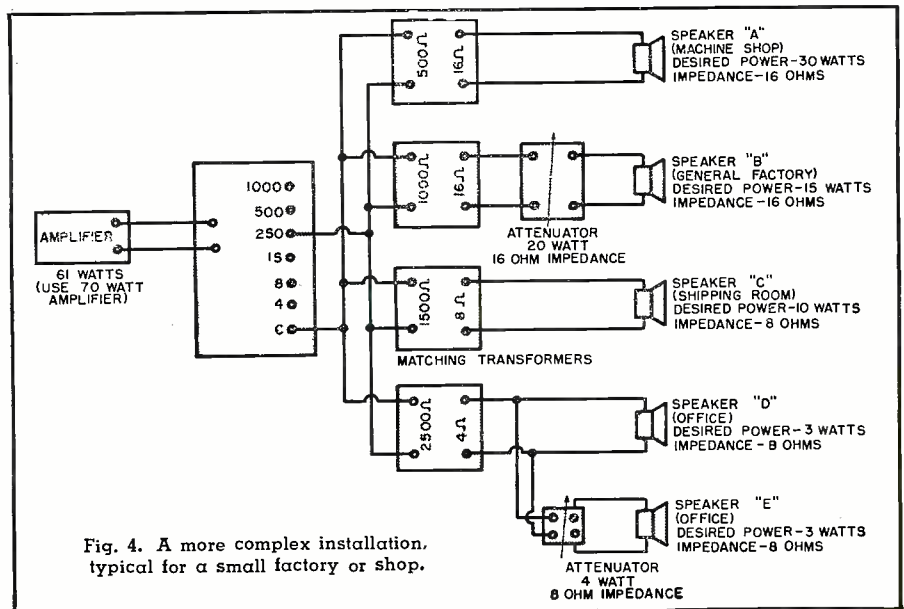

Fig. 4. A more complex installation, typical for a small factory or shop.

puted primary value and the impedance of the voice coils of the loudspeakers for the secondary. Therefore, one less transformer was needed when the two 3-watt speakers were wired directly in parallel.

It should be noted that in Fig. 4, the maximum distance of "L" using #20 AWG size wire, for a line power loss of 5% is 750 feet. Five percent is the maximum allowable line loss for high impedance lines for maximum efficiency, since there are other losses in the matching transformers. See Table 1.

The output impedance of many amplifiers will be found to be rated in ohms and also have either a 70 volt (70.7 constant voltage) tap or a 140 volt (141.4 constant voltage) tap. The 70-volt tap will be found on audio amplifiers that are rated under 100 watts; the 140 volt tap on those rated over 100 watts. This is the new RETMA method for multiple loudspeaker matching to allow multiple loudspeakers to be connected with the same ease as electric lights are connected across a 117-volt a.c. system. The same requirement that holds for electric lights, that the total power consumed must be less than or equal to the total power available, also holds for loudspeakers.

This 70.7 volt rating allows the speaker transmission line to conform to the National Electric Code and the Underwriter's standard and not require the use of "BX" cable.

It should be pointed out that this condition of 70 or 140 constant voltage exists only when the amplifier is delivering its exact rated output. At lower signal levels, the output voltage is less than 70 or 140 volts and if the amplifier is driven beyond the rated output, the voltage is higher than 70 or 140 volts. This standardization method means that the amplifier output voltage is the same for a low power amplifier as for a high power amplifier if the output of both ampli-

fiers is rated under or above the dividing line of 100 watts.

Fig. 5 shows the same installation as Fig. 4 using the constant voltage tap on the output transformer of the amplifier. The desired power at each speaker site is the same as the previous example, however the amplifier now has a 70 volt tap.

To calculate the needed primary impedance of the matching transformer the following formula should be used:

$$Z_i = E^2/W_s$$

where:

Z_i = matching transformer primary impedance, in ohms

E^2 = output voltage 70² or 140²

W_s = desired input power to speaker, in watts

For simplification, the value of E^2 for a 70 volt tap is rounded off to 5000. Since the amplifier power does not enter into the calculations, it must be remembered that the desired power of all the loudspeakers can not exceed the total amplifier power available.

The primary impedance for speaker "A" should be 166 ohms. Since this is not a conventional value, a transformer having a primary of 150 ohms and the proper secondary was chosen. In the event no substitute can be found, any transformer having the correct primary-to-secondary impedance ratio may be used.

For speaker "B," 333 ohms was computed and a transformer with a primary of 333 ohms and secondary of 16 ohms was found. An alternate method would be to consider the attenuator dissipating an extra 5 watts and therefore allow 20 watts to be the desired wattage. Then the transformer would require a primary of 250 ohms.

Speaker "C" did not require any manipulation in matching transformers.

Speakers "D" and "E" require a matching transformer of approximately 833 ohms. A transformer having a 1000 ohm primary and a secondary of 4 ohms would not present too great a mismatch.

How much of a mismatch is permissible depends upon whether or not the speaker will be overdriven, whether there is still adequate power to give sufficient coverage, and whether the increase in power level at each speaker (if any) exceeds the total power available.

Before using an alternate matching transformer, substitute the new transformer primary value in the formula and solve for the desired power. If this figure satisfies the requirements, a permissible substitution has been found.

In general, a transformer of $\pm 10\%$ mismatch may be chosen without any appreciable disruption of power levels. However, if there is no matching transformer available with a tap within tolerance use the larger value tap, especially if the speaker is rated exactly or close to the desired wattage, so that the speaker will not be overdriven. In all cases the figures should be recomputed to check that the speaker will not be overdriven.

Another important consideration in proper loudspeaker matching is that each speaker be properly phased with respect to each other. If the speakers are not properly phased, the sound from one may cancel the sound from the other, resulting in "dead" spots when two or more speakers are used in the same room. When the speakers are wired in-phase, the sound from one speaker will reinforce the other and provide maximum coverage with a minimum output.

Phasing may be checked by placing a flashlight battery (1.5 volts) across the speaker. Mark the polarity of the battery on the speaker terminals when the cone goes inward. Repeat for all the speakers. When wiring, connect the like terminals together, except when wiring a series circuit, then connect the positive terminal of one speaker to the negative terminal of the other speaker. If a hum-bucking coil is used in a speaker, it should be temporarily shorted out for this phasing check.

Where the speakers are connected in parallel, if one breaks down the power is distributed over the others. This could cause the remaining speakers to break down shortly thereafter especially if all the speakers are operating close to their maximum power ratings. However, this disadvantage can readily be overcome by operating the speakers at about 75% of their continuous load rating.

The major disadvantages of connecting the speakers in series are similar to the general objections to series circuits; that is, if the voice coil of one speaker opens up, all the speakers are out of service and the fact that surge voltages become greater, hastening breakdowns. In the event that a series connection is required, it is advisable to electrically insulate the speaker cluster, by insulating each speaker mounting bracket individually.

If a choice is available in amplifiers
(Continued on page 106)

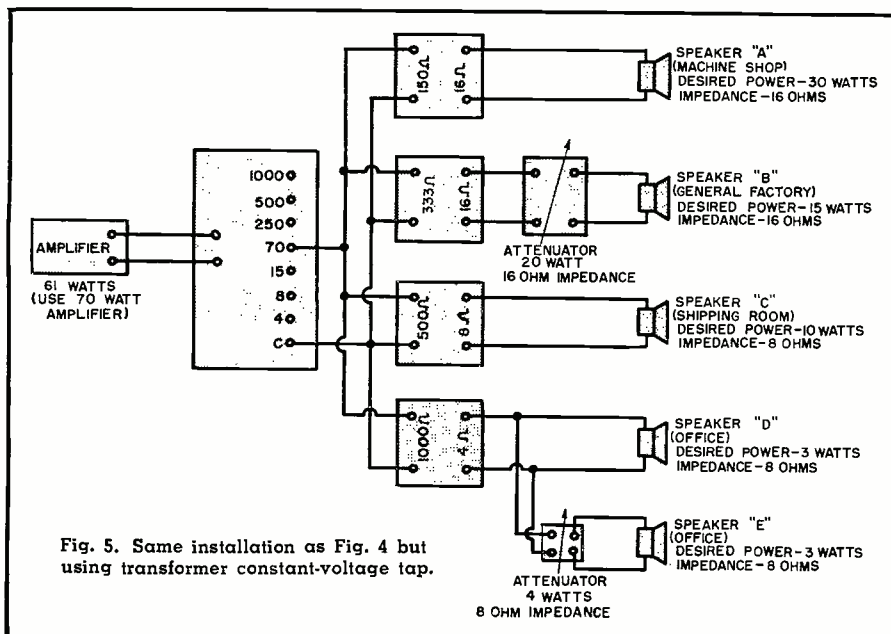

Fig. 5. Same installation as Fig. 4 but using transformer constant-voltage tap.

FUNDAMENTALS

OF COLOR TV

THE NTSC SYSTEM



By

MILTON S. KIVER

Pres., Television Communications
Institute

RCA's developmental 19-inch tri-color tube shown with the 15-inch version which is in production for color sets.

PERHAPS the most striking feature of the compatible color television system to the service technician is the fact that a high quality color television signal can be fitted into the same spectrum space now occupied by a black-and-white (or monochrome) signal. To make this feat even more astounding, we not only have the color signal, but we have in no way disturbed the existing monochrome signal.

How is all this possible? It is all possible because of the nature of a television signal. When we say that a television signal extends from 0 up to 4 mc., we do not mean that it occupies every cycle of that 4 mc. In other words, the energy is not spread continuously from one end of the band to the other; rather, it exists in the form of bundles of energy each separated from the group above and below it by a frequency of 15,750 cycles. This is illustrated in Fig. 1, where a section of the spectrum of a video signal is shown. Note that each bundle or cluster of energy is distinct from its neighbors, with relatively wide, empty spaces in between. It is into these empty spaces that the color signal is fitted. This process of fitting one video signal in among the empty spaces of another video signal is known as interleaving. The two signals thus can be said to occupy the same general band, although they never come in contact with each other and hence do not, within limits, interfere with each other.

The Monochrome Signal

The black-and-white or monochrome portion of the total color signal is equivalent in all respects to present black-and-white signals. It is formed by combining the red, green, and blue signals from their respective color cameras in the proportions of:

$$Y = .59G + .30R + .11B$$

where Y is a mathematical symbol representing the monochrome signal, G is the green signal, R is the red signal, and B is the blue signal.

Part 2. Explanation of the NTSC color TV signal, how it was developed, and why it is compatible with black-and-white.

This particular combination was chosen because it closely follows the color sensitivity of the human eye. That is, if you take an equal amount of green light, and an equal amount of red light, and an equal amount of blue light and superimpose the rays from these lights on a screen, you will see white. However, if you then look at each light separately, the green would appear to be twice as bright as the red, and six to ten times as bright as the blue. This is because the eye is more sensitive to green than to red, and more sensitive to red than to blue. It is in recognition of this fact that the proportions given in the formula were chosen.

Thus, the monochrome signal is composed of 59 per-cent green, 30 per-cent red, and 11 per-cent blue, and contains frequencies from 0 to 4 mc. (The use of the letter Y to denote the monochrome portion of the color signal is a common practice and should become familiar to the reader.)

Other names for this monochrome signal are luminance and brightness signal. The function of this signal is to reproduce, at the picture tube, the changes in brightness of the picture.

The Color Signal

The second component of the television signal is the color signal itself. This, we have just seen, is interleaved

with the black-and-white signal. To determine what information this portion of the total signal must carry, let us first see how the eye reacts to color, since it is the eye, after all, for which the color image is formed.

A number of men have investigated the color characteristics of the human eye, and they found that to reproduce essentially all of the colors which the eye normally sees, we require only three so-called primary colors of light. These are red, blue, and green. The proportion in which these colors are mixed will determine the color produced; when all three are used, white will be produced.

The average human eye requires these three primaries only for relatively large colored areas or objects. When the size of the area or object decreases, several things happen. Probably the most important change that takes place is that it becomes more difficult for the eye to distinguish between various colors. For example, blue and green are often confused with each other, as are brown and crimson. Also, blue tends to look like grey and yellow likewise becomes indistinguishable from grey. Reds remain fairly distinct, but all colors tend to lose some of their vividness. Thus, where the eye formerly required three primary colors, now it finds that it can get by very well with only two. That is, these

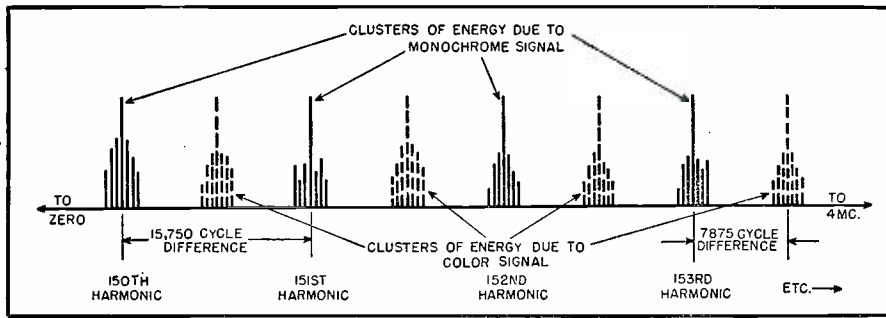

Fig. 1. Representation of the signal energy distribution of a 4 mc. video signal showing how the color information is inserted in the gaps between the monochrome.

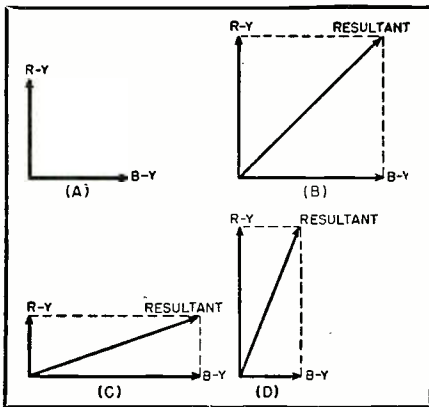

Fig. 2. The angular position and amplitude of the resultant carrier for various amplitudes of B-Y and R-Y. (A) The B-Y and R-Y vectors. (B) The resultant when B-Y and R-Y are equal. (C) when B-Y is stronger than R-Y, and (D) when the R-Y signal is stronger than B-Y signal.

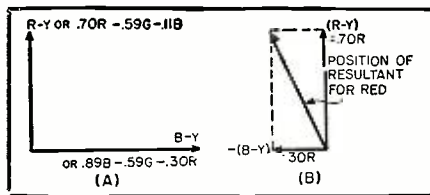

Fig. 3. How color determines the position of a resultant vector. (A) Equations showing compositions of B-Y and R-Y. (B) Position of resultant vector when red field only is being scanned. See text for details.

two will, in different combinations with each other, provide the range of colors that the eye needs or can see.

Finally, when the detail becomes very small, all that the eye can discern are changes in brightness; colors cannot be distinguished from grey and to all intents and purposes, the eye is color blind.

These properties of the eye are utilized in the NTSC color system. For example, only the larger detail is colored; the fine detail is rendered in black-and-white. Secondly, as we shall see later, even the color information sent is regulated according to bandwidth. That is, the larger objects receive more of the green, red, and blue than the medium sized objects.

The color signal takes the form of a subcarrier and an associated set of sidebands. The subcarrier frequency is approximately 3.58 mc. This represents a figure which is the product

(approximately) of 7875 cycles multiplied by 455. 7875 is one half of 15,750, and if we use an odd multiple (i.e., 1, 3, 5, etc.) of 7875 as a carrier, then it will fall midway between the harmonics of 15,750 cycles. If we used even multiples of 7875, we would end up with 15,750 or one of its harmonics and this would place the color signal at the same points (throughout the band) as those occupied by the black-and-white signal. Refer back to Fig. 1. By taking an odd multiple of 7875, we cause the second signal to fall in between the bundles of energy produced by the first signal, and the two do not interfere.

Now that we have a color carrier (or subcarrier, as it is known), the next step is to provide it with enough modulation to enable the receiver to develop a color picture. Ordinarily, the information required would consist of R, G, and B since these are the three primary colors of light from which all of the other colors are derived. This means modulating the color subcarrier with three different quantities. Actually, however, we can do exactly the same job using only two quantities if we resort to the following modification. Take the R, G, and B voltages and combine them with a portion of the monochrome signal after the latter has been inverted 180°. This produces R-Y, G-Y, and B-Y signals. We can do this by taking a portion of the brightness signal (Y signal) and passing it first through a low-pass filter. This permits only the low-frequency components to get through which is satisfactory since the color signals are also concerned only with the low frequencies. Then the brightness signal is passed through an amplifier and inverted. If we call the brightness signal Y, then after the inversion it becomes -Y. This is then added to each of the three color signals or voltages to produce a G-Y, a R-Y, and a B-Y signal.

At the receiver, the original R, G, and B can be re-obtained by adding Y to G-Y to obtain G, by adding Y to R-Y to get R, and by combining Y with B-Y to get B.

Thus far, it would seem that we have only exchanged R, G, and B for R-Y, G-Y, and B-Y. However, once this is done, it turns out that instead of requiring all three color-difference signals, all we really need are two, say

R-Y and B-Y. This is so because G information is already present in the Y or brightness signal since the latter contains voltages from all three colors (i.e., $Y = .59G + .30R + .11B$). Hence, if we send along only R - Y and B - Y in the color signal to the receiver, we can use these to obtain the G-Y information we need. For those who would like to see proof of this, a simple analysis is given at the end of the article.

Thus, we now have only two pieces of color information to send and somehow the 3.58 mc. color subcarrier must be modulated by R - Y and B - Y voltages without conflict to each other.

The best solution to this problem, designers found, was to take the B-Y and R-Y signals and apply each to a separate modulator. At the same time, 3.58 mc. carriers were also applied to each modulator, but with this difference. Their frequencies were the same, but one carrier was 90° out-of-phase with the other. After the carriers were amplitude modulated, they were then combined to form a resultant carrier. This is best illustrated by means of vectors. In Fig. 2A, the B-Y vector represents the B-Y modulated carrier; the R-Y vector represents the carrier modulated by the R-Y voltage. When these voltages or signals are combined, a resultant is formed. If the R-Y and B-Y signals are equally strong, the resultant will occupy the position shown in Fig. 2B. If the B-Y signal is predominant, the resultant will be drawn closer to it. See Fig. 2C. On the other hand, if the R-Y signal is the stronger, the position of the resultant vector will shift toward it. See Fig. 2D. Thus, we can see that the phase angle of the resultant will be governed by the coloring of the picture while the amplitude (or length) of the vector will determine how saturated the colors are.

This particular fact is of great importance in the receiver because if we somehow change the phase of the resultant with respect to B-Y or R-Y, then the colors reproduced on the screen will be incorrect. Hence, present circuit designs incorporate a special phasing control which enables us to compensate for any phase shift that may occur. The position of this control in the circuit will be covered in a later article.

Note that the B-Y and R-Y signals amplitude modulate their separate carriers prior to the addition and so each modulated signal possesses a 3.58 mc. carrier and a series of sidebands (like every AM signal). When the resultant is formed, the sidebands are brought along with it.

If we were to pause now and reconstruct our total color signal, here is what we would find. First, there would be the Y or monochrome signal and it would extend over the entire video frequency range from 0 to 4 mc. Second, there would be a color subcarrier, with a frequency of 3.58 mc. This carrier is modulated by the R-Y and B-Y sig-

nals and the modulation intelligence is contained in a series of sidebands that stretch above and below 3.58 mc. Just how far above and below is dependent on the band of frequencies contained in the $R-Y$ and $B-Y$ modulating voltages. It was discovered that the eye is perfectly satisfied with the color image that is produced if we include color information only up to 1.5 mc., while the portion of the image from 1.5 mc. to 4 mc. is rendered in black-and-white. Hence, the sideband frequencies of the color modulating voltages (so far called $R-Y$ and $B-Y$) need extend only from 0 to 1.5 mc. Furthermore, we can even modify this set of conditions somewhat because the three primary colors are required only for large objects or areas, say those produced by video frequencies up to .5 mc. For medium sized objects, say those produced by video frequencies from .5 to 1.5 mc., only two primary colors need be employed.

In other words, to take advantage of this situation, we need two color signals, one of which has a bandpass only up to .5 mc., while the other has a bandpass from 0 to 1.5 mc. The next problem, then, is to determine what the composition of these two color signals is.

To appreciate the answer to this, let us return to the vector diagram showing the $R-Y$ and $B-Y$ signals. This is redrawn in Fig. 3A and to this diagram we have added the equivalent equation for Y , namely, $.59G + .30R + .11B$. For $R-Y$, then, we have $R - .59G - .30R - .11B$ or $.70R - .59G - .11B$ and, for $B-Y$ we obtain $B - .59G - .30R - .11B$ or $.89B - .59G - .30R$. This means that the $R-Y$ and $B-Y$ vectors contain R , G , and B voltages in the proportions shown.

Now, let us suppose that the color camera is scanning a scene containing only red. Then, no green or blue voltages would be present and the $R-Y$ signal becomes simply $.70R$, while the $B-Y$ signal is reduced to $-.30R$. This set of conditions is shown in Fig. 3B, with the position, too, of the resultant vector. In other words, this is the position the vector would occupy when red only was being sent.

By following the same process, we can obtain the position that the resultant vector occupies when only green is being sent, or blue, or any other color formed by uniting these three colors in any combination. A number of colors are shown in Fig. 4 and we see, perhaps more clearly than before, how the phase of the color subcarrier changes as the color to be transmitted varies. This, of course, brings us back to a statement previously made, namely: the phase angle of the resultant will be governed by the coloring of the picture while the amplitude (or length) of the vector will determine how intense (i.e., saturated) the colors are.

The designers of the NTSC system found that while they could use $R-Y$ and $B-Y$ for the color signals, better system operation would result if they

chose two other signals situated not far from the $R-Y$ and $B-Y$ signals. These two other signals were labeled I and Q signals and their position with respect to $R-Y$ and $B-Y$ is shown in Fig. 7.

Thus, where before we had $R-Y$ and $B-Y$ voltages modulating the 3.58 mc. color subcarrier, we now substitute I and Q signals. Furthermore, the Q signal possesses frequencies up to .5 mc. while the I signal is permitted to have signals up to 1.5 mc.

Now, what do we gain from this? For all color signal frequencies up to .5 mc., both I and Q are active and since they are 90° apart as were $R-Y$ and $B-Y$, they will act just the way $R-Y$ and $B-Y$ acted. That is, they will, in combination with each other, produce all of the colors shown in Fig. 4. Hence, whether we use I and Q or $R-Y$ and $B-Y$ as our modulating voltages for color frequencies up to .5 mc., we get precisely the same results.

Now consider the situation for color frequencies from .5 mc. to 1.5 mc. The Q signal drops out and only the I signal remains to produce color on the picture tube screen. From Fig. 7 we see that positive values of the I signal will produce colors between yellow and red or actually a reddish orange. On the other hand, negative values of I will produce colors between blue and cyan or, in general, in the bluish-green range. Hence, when only the I signal is active, the colors produced on the screen will run the gamut from reddish-orange to bluish-green.

But why do we want this? If you go back to an earlier section of this article you will see that for medium-sized objects (say those produced by video signals from .5 mc. to 1.5 mc.) the eye is sensitive only to bluish-green or reddish-orange. Since this is so, the NTSC signal (via its I component) is fashioned to take advantage of this fact.

We are now in a position to consider the color signal in all its aspects.

1. There is a monochrome signal with components that extend from 0 to 4 mc. This is the Y signal.

2. The color subcarrier frequency is set at 3.58 mc. (actually it is 3.579545 mc.).

Fig. 4. The phase of the color subcarrier depends upon the color to be sent.

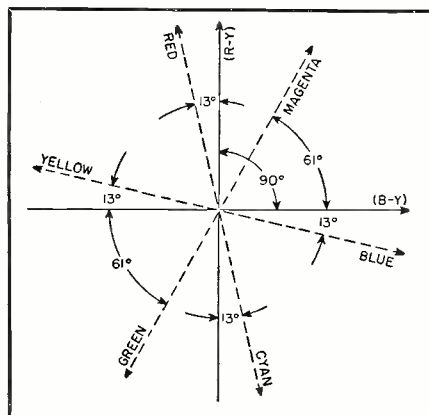

3. This color subcarrier is modulated by two color signals called the I and Q signals.

4. The Q signal has color frequencies that extend from 0 to 500 kc. or .5 mc. This means that the upper Q sideband extends from 3.58 mc. up to $3.58 + .5$ or 4.08 mc. The lower Q sideband goes from 3.58 mc. down to $3.58 - .5$ or 3.08 mc.

5. The I signal has color frequencies that extend from 0 to 1.5 mc. When this modulates the color subcarrier, upper and lower sidebands are formed. The lower sideband extends from 3.58 mc. down to $3.58 - 1.5$ or 2.08 mc. If the full upper sideband were permitted

(Continued on page 148)

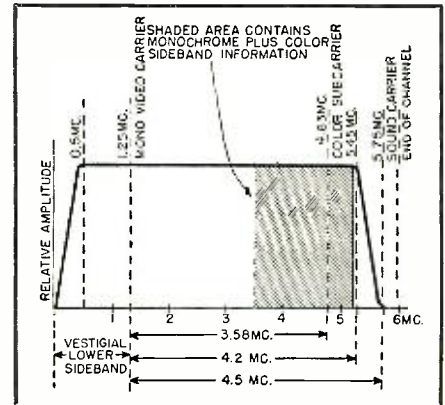

Fig. 5. The distribution of the full color signal within its allotted band.

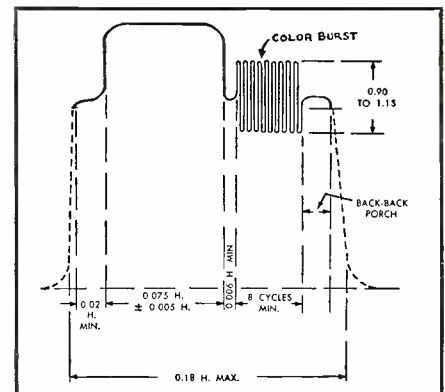
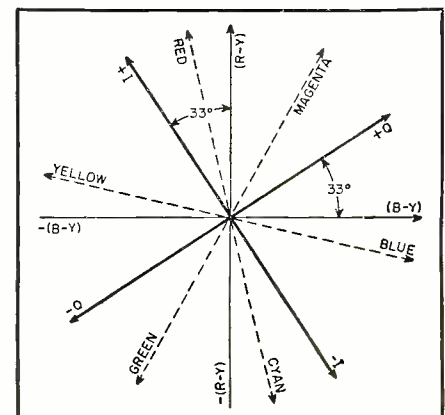

Fig. 6. The position of the color burst for subcarrier oscillator sync on the back porch of a horizontal sync pulse.

Fig. 7. The positions of the I and Q signals with respect to $R-Y$ and $B-Y$.



TV TEST EQUIPMENT

HOW TO CHOOSE

By

ROBERT G. MIDDLETON

Author, "TV Troubleshooting Guide"

HOW TO USE

Part 2. Description of two useful TV service instruments and methods for using them to test television circuits.

IN LAST month's article we discussed the test equipment required for service work and mentioned some of the applications for each. This article will continue with some of the additional types of equipment frequently used in service work.

Video amplifiers are checked out by means of square-wave generators. Square-wave generators are used to test the response of a circuit to transients (among other applications), and the transient response of a video amplifier is quite as important as its frequency response. The ability of a video amplifier to reproduce low and high frequencies is a critical test of its transient response. These transients can be conveniently furnished by a square-wave generator.

The output of a square-wave generator is shown in Fig. 1. This output can be applied directly to the video amplifier or passed through a high-frequency modulator and applied to the r.f. or i.f. circuits of the receiver. A typical reproduced square wave from a video amplifier in average condition is shown in Fig. 2. This waveform indicates that the video amplifier under test has a very poor low-frequency response. Other forms of severe square-wave distortion are illustrated in Fig. 3.

The chief requirement for a square-wave generator is that the rise time of the generator must be faster than the rise time of the video amplifier. Since the rise time of the usual video amplifier is on the order of 0.08 microsecond, the square-wave generator used to test the amplifier should have a rise time of approximately 0.05 microsecond, to provide a safe margin. The frequency ranges used in testing video amplifiers extend from 50 or 60 cps to 100 kc., or higher. Useful information is obtained if square-wave tests can be conducted up to .5 mc.

The scope which is used to check the square-wave output of the video amplifier must have better frequency response than the video amplifier, to provide a useful test. The scope can be checked by applying the output from the square-wave generator directly to the vertical-input terminals. A 60-cycle square wave should be reproduced without appreciable tilt, and a 500-kc. square wave should be reproduced without severe corner rounding, overshoot, or ringing. Otherwise, it will be necessary to bypass the vertical amplifier of the scope in such tests, and to apply the output from the video amplifier directly to the vertical-deflection plates of the scope. The latter

method avoids distortion, but has the disadvantage of low sensitivity.

It is apparent that the requirements of a scope used in square-wave testing are quite the opposite of a scope used for visual-alignment work. For this reason, some service shops have a high-sensitivity, narrow-band scope for alignment work, and a medium or low-sensitivity wide-band scope for square-wave checking. In addition to providing satisfactory square-wave testing, a wide-band scope also permits the viewing of voltage and current waveforms in sync and sweep circuits, as illustrated in Fig. 4. If the scope can be conveniently calibrated in terms of peak-to-peak voltage, the peak-to-peak values of such waveforms can also be accurately and rapidly measured.

Pattern Generators

Closely related to square-wave generators are pattern generators, which provide a dot or bar pattern on the screen of the picture tube, as illustrated in Fig. 5. Pattern generators are utilized primarily to check the linearity of horizontal and vertical sweeps, although it should be recognized that they provide much additional information. The dots are formed by pulses, and the clarity and definition with which these pulses are reproduced tell the experienced eye whether the signal circuits are functioning properly, or not.

The more elaborate pattern generators also provide horizontal, vertical, and equalizing pulses, from which the centering of the picture and the operation of the sync circuits can be accurately checked.

Two types of pattern generators can be used: the first type provides a modulated r.f. output, which is applied at the input terminals of the receiver. This is the most convenient type of signal to use. The second type of pattern generator provides a video output, which must be applied at the input of the video-amplifier circuit. However, if the service technician's marker generator provides internal high-frequency modulating facilities (as is sometimes the case), the output from a video pattern generator can be used to modulate the output from the marker generator, which is applied in turn to the input terminals of the receiver.

(Continued on page 149)

→ Fig. 1. Generator's square-wave output.

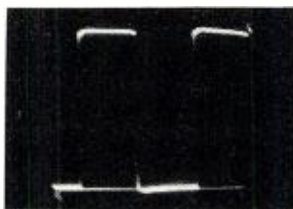

↓ Fig. 2. A typical video response to a square-wave input; notice the poor low-frequency response of this video circuit.



→ Fig. 3. The square-wave distortion developed by faulty signal circuits. (A) Shows a form of overload distortion; (B) Phase shift and loss of the high frequencies.

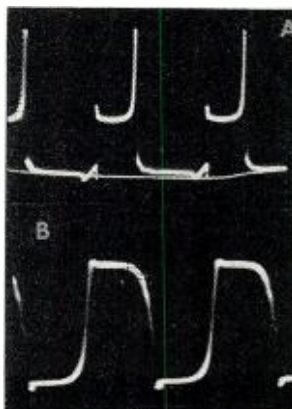

↓ Fig. 5. The sweep linearity can be checked with a pattern generator. Shown here is a dot pattern on the face of a CRT.

↑ Fig. 4. Sweep circuits can be checked for voltage and current waveforms by means of a wide-band oscilloscope and test probes. Shown here is the deflection coil current of a conventional television receiver circuit.

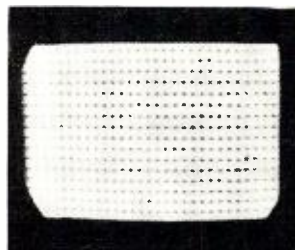

THE U.H.F.

Corner Reflector

By
FRANK D. HURD and JAN K. KOBLER
Walsco Electronics Corp.

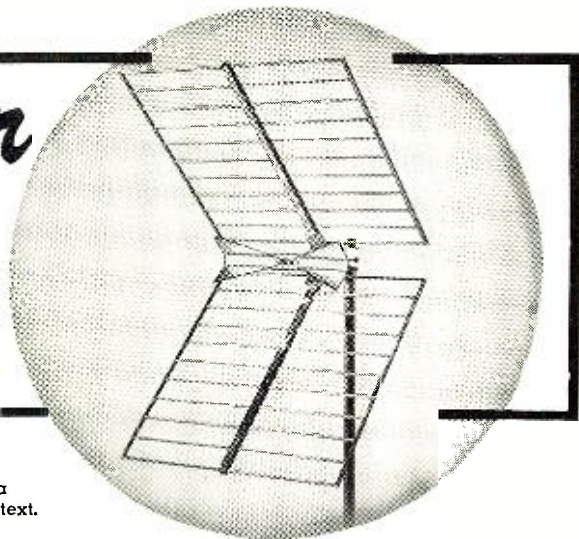

Fig. 1. The Walsco corner reflector u.h.f. TV antenna using a fan dipole driven element. See text.

THE corner reflector-type antenna (see Fig. 1), with its excellent electrical characteristics, has been known for over twenty years. The reason this high-gain antenna has not been used for v.h.f. on a broad commercial basis is that on frequencies below 250 mc., the large physical dimensions necessary would make production, shipping, and installation difficult and costly. The short wavelengths of the u.h.f. band, however, make it possible to use the corner reflector antenna to excellent advantage. Not only is a u.h.f. corner reflector reasonably small and easy to install, it also combines all the features desirable in a u.h.f. antenna, namely, coverage of the whole u.h.f. band, high gain, good vertical and horizontal directivity, close impedance match, and outstanding front-to-back ratio.

Whereas with most other antennas the unavoidable compromise between gain and frequency coverage is not always satisfactory, the corner reflector can be made nearly perfect in this respect. Fig. 2 shows a comparison of gain *versus* frequency for a corner reflector and a 10-element yagi antenna designed for channels 40 through 54.

For all its apparent simplicity, this antenna presents a number of highly intricate problems in design because improving one element of the configuration does not necessarily mean better performance. The complicated interaction of all parts often entails changes in several shapes and dimensions when *one* element is modified. The most critical factors are the following (See Fig. 3):

1. Size and shape of driven element
2. Distance of driven element from apex, "S"
3. Corner angle "α"
4. Length of reflector halves, "L"
5. Width of reflector halves, "H"
6. Spacing of reflector bars, "G"

Two triangles, each 6 inches long, bent parallel to the reflector sides and with a flat space $\frac{3}{4}$ inches wide in the center, are used as the driven element in the antenna shown in Fig. 1. The spacing of the driven element "S", expressed in fractions or multiples of the wavelength, λ , is interrelated with the corner angle "α" and the reflector length "L". Fig. 4 is a graph of gain *versus* "S" for 60° and 90° corner angles. At first glance, it would seem that

The corner reflector antenna, popular for u.h.f. TV reception, is not as simple to design as it appears. Here is a discussion of some problems encountered.

when "α" is 60° and "S" is 1.5λ the highest gain would result. However, when "α" is 90°, "L" can be held down to as low as 1.25λ without a noticeable deterioration of the directivity pattern, but when "α" is 60°, "L" must be at least 2λ . With an antenna designed to operate on a center frequency of 680 mc. for channel 49 (wavelength 17.3 inches), this would mean a reflector length of nearly 3 feet. The disadvantages of such a large reflector (high cost, awkward in shipping and installing, great weight, high wind resistance) are not compensated for by the higher gain.

The reflector length is not only related to the wavelength but also to "S". The corner reflector antenna works much the same as a parabolic headlight reflector. In this case, TV signal waves which hit the front of the reflectors are "focused" in upon the driven element. Signal waves hit the reflectors at various angles, and are "reflected" to the driven element at the same angles. The reflector length

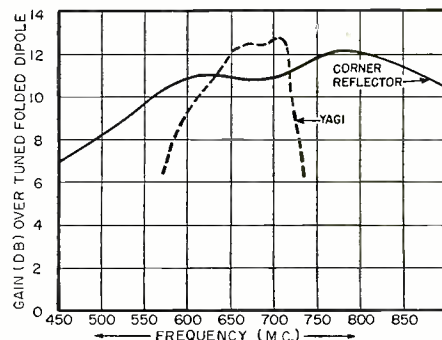

Fig. 2. Comparison of gain vs. frequency for the Walsco u.h.f. broadband yagi and their Model 4450 corner reflector antenna.

must be at least two times "S" to allow the driven element to receive as much of this reflected signal energy as possible. The dimensions used for the antenna shown in Fig. 1 are: "S" = 5.5 inches, "L" = 20 inches, and "α" = 90°. Under these conditions, "S" is 0.2λ at the low end and 0.4λ at the high end of the u.h.f. band. In other words, the

(Continued on page 116)

Fig. 3. Typical corner reflector antenna showing the important dimensions as discussed in the accompanying text.

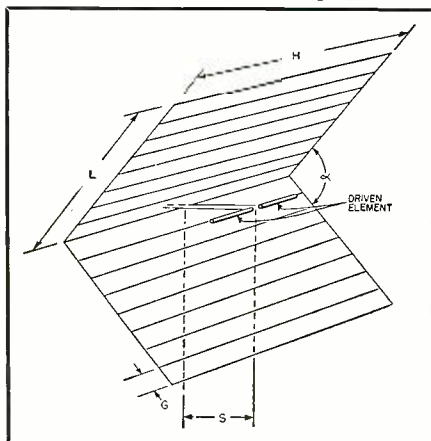
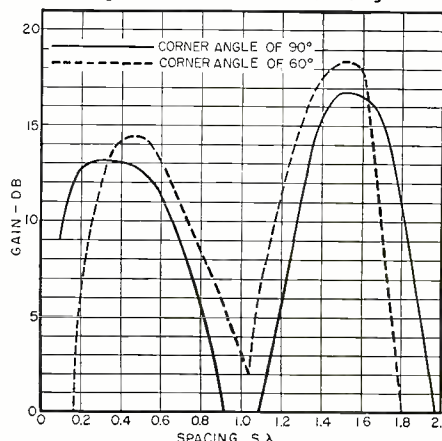
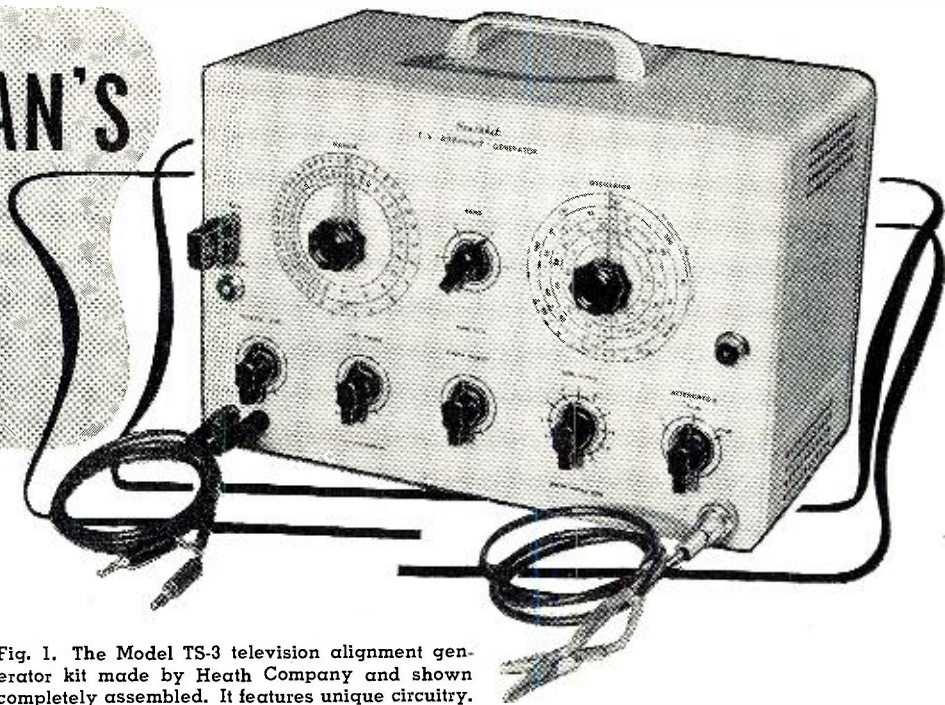

Fig. 4. Variation in gain for various spacings between driven element and the apex, for two reflector angles.



A SERVICEMAN'S SWEEP GENERATOR



By

E. C. FIEBICH and G. RUSSELL
Heath Company

Fig. 1. The Model TS-3 television alignment generator kit made by Heath Company and shown completely assembled. It features unique circuitry.

Details on a low-cost service instrument that provides a flexible sweep circuit and variety of control circuits.

DURING the past few years, many excellent service articles have appeared in various publications discussing the relative merits of a variety of sweep generators and their application to actual TV circuit alignment problems. Through a gradual process of instrument development and a better understanding of alignment techniques, a theoretically reasonable standard of desirable sweep generator operation has been established. This theoretical standard represented the usual compromise between the performance the technician expected of an instrument and what the instrument manufacturer was able to supply in a reasonably priced, production model sweep generator.

The *Heath Company* after many months of cooperative effort with the *C. G. S. Laboratories* of Stamford, Conn., released an improved sweep generator incorporating the latest high-frequency design techniques. This new instrument design negated the previously accepted arbitrary standards by overcoming some of the shortcomings inherent in many sweep generators available to the TV technician.

Perhaps a brief review from the technician's viewpoint would be helpful in providing a better understanding of the entire situation. The true radio technician has always been a rather unusual, rugged individualist. He was primarily engaged in service work because he liked radio and was happiest when working with circuits. He kept abreast of the latest releases and new circuits as they made their appearance, developed his own "pet" technique for

troubleshooting and operating procedure. He had to be a combination of technician, business manager, credit manager, collection man, and diplomat. Of course, all these personalities are seldom present in any single individual. Usually, after the repair battle had been won, interest in the balance of the transaction waned and, in many cases, there was a genuine feeling of reluctance to actually charge the customer for the full value of the repair job. The fun and the satisfaction was in doing the job, not in collecting for it. (As a group, radio technicians were notoriously poor businessmen.) Although the life of a radio technician was far from monotonous, he did enjoy a fairly definite pattern of existence. He had his own way of doing things and always had a pretty good idea of what to expect from every new service job he tackled.

Suddenly, the relative security of his life was upset by the explosion of the TV bomb that had been threatening him. Soon his customers called upon him to repair their TV sets instead of their radios. Successful TV service required rapid absorption of the complex circuits involved, the peculiarities and characteristics of their operation and, most important of all, the new test equipment required. It is to the everlasting credit of the entire radio service fraternity that they successfully met and conquered the TV service challenge even though the path was mighty rocky in spots.

One of the most difficult and puzzling procedure changes demanded was the technique of tuned-circuit alignment.

The signal generator and output meter formerly used were of little assistance as the entire picture was drastically altered. Now, instead of aligning radio i.f.'s for a 10 kc. bandpass, television i.f. stage alignment required a 4.5 mc. bandpass, or three times the width of the entire radio broadcast band. TV picture quality was directly dependent upon the skill and care used in i.f. alignment. Obviously, new equipment was needed and this fact was painfully demonstrated to the technician who attempted to "touch up" trimmer adjustments without using suitable test equipment.

About the easiest way to determine signal action through a television i.f. stage is to actually view the waveform with an oscilloscope. The majority of radio service shops did not use this instrument and its acquisition meant an additional major expenditure. A vital companion piece for the scope was a sweep generator, another "foreign" equipment item. Selection of these items was based entirely upon manufacturers' claims and the size of the technician's pocketbook. These sweep generators were not only new equipment items, but they demanded an entirely new operating technique. Mere possession of such an instrument did not necessarily insure ability to align TV circuits properly.

The design of sweep generators went through the usual growing pains, finally arriving at the arbitrarily accepted standard previously mentioned. The major shortcomings of a number of the early sweepers were: Operation too complex; output signal unstable and weak; non-linear sweep; ineffective attenuation; waveform susceptible to external loading or distortion through marker action; questionable calibration accuracy of either generator or marker systems; and a diminishing succession of similar defi-

ciencies. In spite of these apparent weaknesses test instrument manufacturers are to be praised for their successful efforts in producing low cost, reasonably useful equipment.

Some of the early sweep generators offered to the technician made use of the reactance tube circuit principle of operation. Objections were mainly insufficient sweep action and non-linear output. The next significant forward step was the application of the still commonly used method of obtaining sweep action through electromechanical means. This was accomplished by the use of a speaker-like device with an attached metal disc or cup so positioned with respect to the oscillator coil as to have a capacitive effect on the coil inductance. As an a.c. control voltage was applied to the speaker-like sweep motor, the disc or cup vibrated at a fixed rate, thereby causing a proportional variation in the frequency characteristics of the oscillator coil. As the control voltage was increased, the sweep action also increased.

Because of circuit limitations imposed by the electromechanical sweep motor, it was not feasible to sweep the entire instrument frequency range in a similar manner. This, in turn, resulted in the use of the well-known beat frequency oscillator system in which the output of the swept variable oscillator was beat against a fixed oscillator and the resultant frequency represented the useful instrument output. The necessity of using a b.f.o. system further increased complexity of instrument operation and introduced new problems, mainly instability, spurious oscillation, and attenuation difficulties. Another major objection to the sweep motor was the definite mechanical limitation as to the degree of sweep obtainable and the wear or fatigue of the paper fabric propulsion system.

In addition to these two basic principles of sweep generator operation, there were several very successful generator developments in which sweep action was obtained through the use of a variable permeability device or some form of saturable r.f. reactor. While these instruments were capable of good performance, the price range was beyond the reach of the average TV technician. (Continued on page 112)

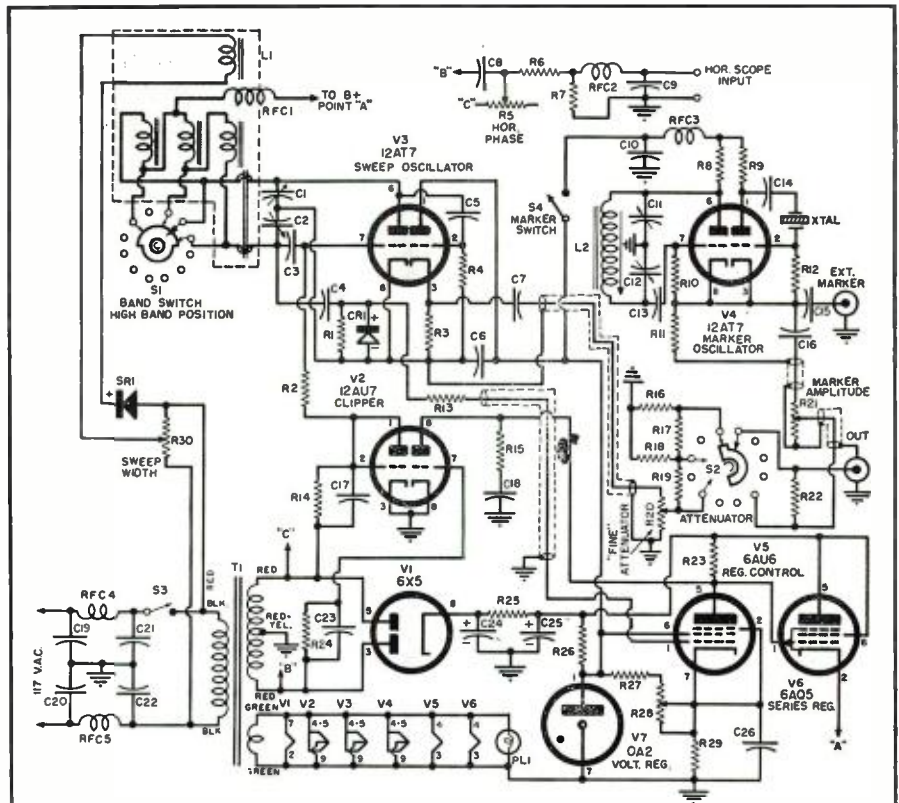

- R_1 —3.3 megohm, $\frac{1}{2}$ w. res.
- R_2, R_4 —4700 ohm, $\frac{1}{2}$ w. res.
- R_3, R_{22} —270 ohm, $\frac{1}{2}$ w. res.
- R_7 —68,000 ohm, $\frac{1}{2}$ w. res.
- R_8 —1 megohm pot (with s.p.s.t. switch, S_3)
- R_6, R_{24} —1 megohm, $\frac{1}{2}$ w. res.
- R_9 —10,000 ohm, $\frac{1}{2}$ w. res.
- R_{10} —47,000 ohm, $\frac{1}{2}$ w. res.
- R_{10} —22,000 ohm, $\frac{1}{2}$ w. res.
- R_{11} —150 ohm, $\frac{1}{2}$ w. res.
- R_{12}, R_{23} —100,000 ohm, $\frac{1}{2}$ w. res.
- R_{13} —56,000 ohm, $\frac{1}{2}$ w. res.
- R_{14} —47,000 ohm, 1 w. res.
- R_{15} —3300 ohm, $\frac{1}{2}$ w. res.
- R_{16}, R_{17} —47 ohm, $\frac{1}{2}$ w. res.
- R_{17}, R_{18} —680 ohm, $\frac{1}{2}$ w. res.
- R_{20} —200 ohm pot ("Fine Atten.")
- R_{21} —200 ohm pot (with s.p.s.t. switch, S_4 , "Marker Amp.")
- R_{25} —470 ohm, 1 w. res.
- R_{26} —3000 ohm, 10 w. wirewound res.
- R_{27} —22,000 ohm, 1 w. res.
- R_{28} —100,000 ohm pot ("Level Set")
- R_{29} —1000 ohm, $\frac{1}{2}$ w. res.
- R_{30} —500 ohm, 25 w. wirewound pot ("Sweep Width")
- C_1, C_2, C_{11}, C_{12} —Tuning cond. (Heath Part No. 26-10)
- C_8 —200 μ fd. ceramic cond.
- C_1, C_{15}, C_{16} —100 μ fd. ceramic cond.
- C_3 —4.7 μ fd. ceramic cond.
- C_{10}, C_{14} —270 μ fd. ceramic cond.
- C_7, C_9, C_{13}, C_{23} —1000 μ fd. ceramic cond.
- C_5 —.01 μ fd., 1000 v. cond.
- C_{15} —150 μ fd. ceramic cond.
- C_{17} —.02 μ fd., 600 v. cond.
- C_{18} —680 μ fd. ceramic cond.
- $C_{19}, C_{20}, C_{21}, C_{22}$ —5000 μ fd. ceramic cond.
- C_{24}, C_{25}, C_{26} —20/20/20 μ fd., 450/450/25 v. elec. cond.
- S_1 —4-pos. bandswitch (Heath Part No. 63-72)
- S_2 —3-pos. attenuator switch (Heath Part No. 63-70)
- S_3 —S.p.s.t. switch (on R_8)
- S_4 —S.p.s.t. switch (on R_{21})
- RFC_1, RFC_2, RFC_3 —R-f. choke (Heath Part No. 45-2)
- RFC_4, RFC_5 —Line choke (Heath Part No. 45-6)
- L_1 —Controllable inductor (Heath Part No. 403-1)
- L_2 —Marker oscillator coil (Heath Part No. 40-52)
- T_1 —Power trans. (Heath Part No. 54-5)
- PL_1 —#47 pilot lamp
- CR_1 —1N48, 1N34, or CK705 crystal diode
- SR_1 —Selenium rectifier (Heath Part No. 57-2)
- $Xtal.$ —4.5 mc. crystal

Fig. 2. Schematic diagram of the Heathkit TS-3 television sweep generator.

Fig. 3. Under chassis view of the TS-3. The use of several sub-assemblies facilitates construction of this sweep generator.

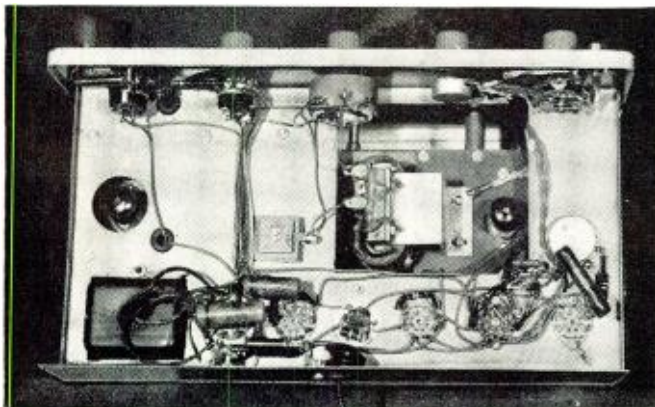
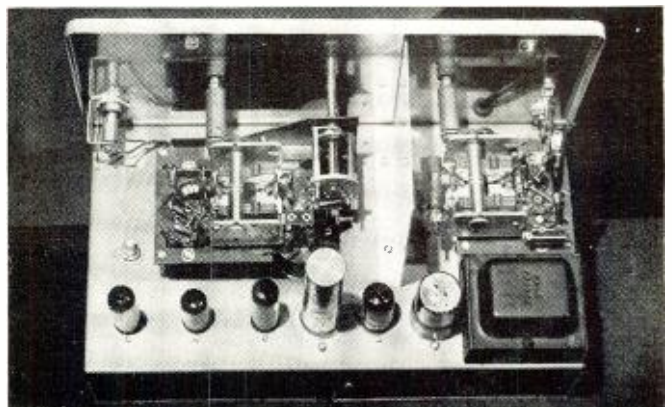
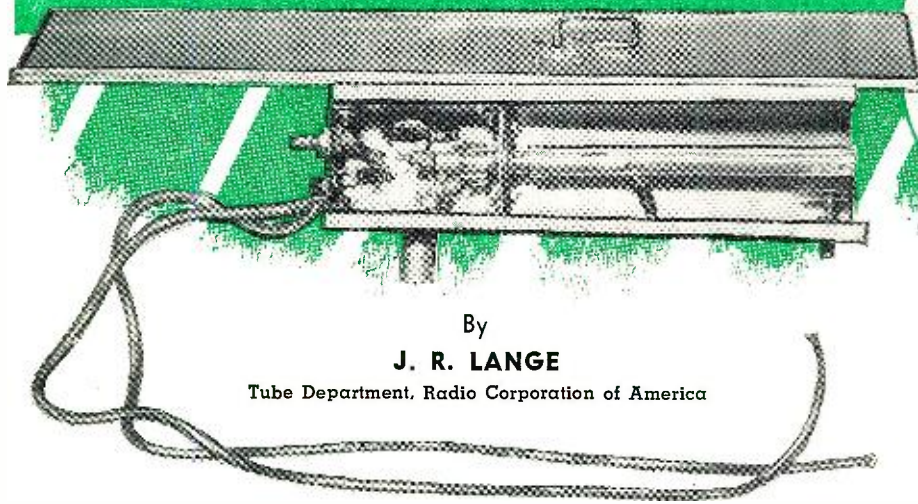

Fig. 4. Top chassis view of instrument showing the location of the major components, sub-assemblies, and the shield plate.



TV BOOSTER FOR U.H.F.



By

J. R. LANGE

Tube Department, Radio Corporation of America

Construction data on a grounded-grid booster amplifier for u.h.f. television receivers using a "pencil" tube.

THE new u.h.f. television stations opening up all over the country have revived the old questions "How far does a fringe area extend?" and "How good a picture can you get in a fringe area?" The answer to both questions is the same for u.h.f. as it has been for v.h.f.—*add a good booster.*

But this answer simply brings up another question: Is there a commercial tube that can amplify effectively at frequencies as high as 890 megacycles? The answer to this one is definitely *yes.*

The grounded-grid u.h.f. booster described in this article was built around a commercially-available tube and a type of tuned circuit popular with amateurs for work in the 420-megacycle band. While the tube itself and the tuned circuit that goes with it may look a little unusual to some service technicians and experimenters, the combination makes an effective low-noise u.h.f. amplifier, with a gain of 7 db (a voltage gain of slightly over 2.2) and a bandwidth of 8 to 10 megacycles at the high end of the u.h.f. television band. The cost is moderate and the construction involves only some simple sheet-metal work.

The heart of the booster is the RCA 5876 "pencil" triode shown in Fig. 1. "Pencil" tubes have been used for several years in military and civil-aeronautic electronic equipment and have been popular with amateurs for ultra-high-frequency work. Their unusual construction blends beautifully into the relatively simple high-"Q" coaxial circuitry used at ultra-high and microwave frequencies. The low-inductance cylindrical plate and cathode termi-

nals are at opposite ends of the tube, with the grounded flange-type grid terminal acting as a highly effective shield between them. In addition, their negligible grid-lead inductance and low plate-to-cathode capacitance give "pencil" tubes a freedom from frequency "suckouts" and regeneration not possible with conventional miniature-tube construction.

Coaxial-Line Tuning

The circuit of the booster is given in Fig. 2. The diagram is presented in semi-pictorial form because of the close relationship between physical structure and electrical performance in circuits of this type. The resonant circuit is a section of coaxial line or "cavity." The "cold" outer conductor also forms the housing for the tube and other circuit components.

The inner conductor, which connects directly to the anode terminal of the 5876, is approximately one half-wavelength long at the desired center frequency. The inner conductor will have maximum impedance and r.f. voltage at its ends, and a point of practically zero impedance at its electrical center. This makes it possible to feed in the plate-supply voltage for the 5876 at the approximate mid-point "A," where the impedance to ground and r.f. voltage are very low, and thus avoid grounding out the amplified signal through the power supply. The single-turn, inductively-coupled output loop can be adjusted to a position between the mid-point and either end of the inner conductor that gives the correct impedance match for maximum output.

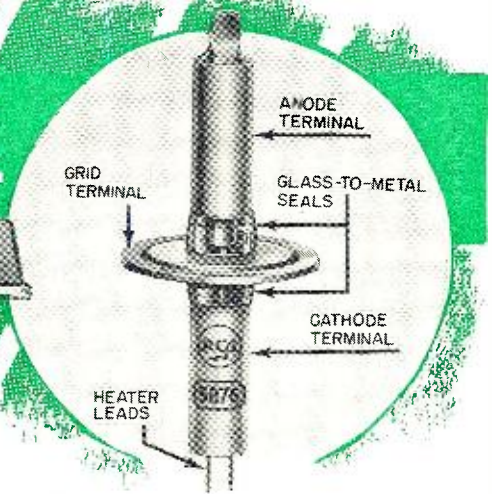

Fig. 1. The "pencil" triode used in the booster described in this article and interior view of the channel 83 booster showing details for mounting the tube.

Although the physical length of the cavity and inner conductor determine the center frequency, a limited range of adjustment is provided by the trimmer condenser at the open end of the line. This range varies from about 30 megacycles at the low end of the u.h.f. television band to about 80 megacycles at the high end. Because the FCC usually allocates u.h.f. channels in one area at 36-megacycle (6-channel) intervals, one booster can be used to receive two local u.h.f. stations. For example, a booster built for channel 30 will tune from channel 27 to channel 33 with no difficulty.

The improvement in reception with the booster is due, in part, to the following:

1. The noise factor or "snow factor" of your TV set depends mainly on the noise originating in the front end where the initial signal amplification takes place. This booster is capable of reducing the noise factor of a TV set from 18 to 15 db, which in some cases nearly doubles the "picture to snow" ratio of the receiver.

2. The added gain provided by the booster compensates for the normal signal loss in the crystal converter and materially increases the contrast and sync stability of the TV set. This is especially valuable in cases where the set gain is on the low side.

3. The additional selectivity obtained by inserting the booster between the antenna and the converter reduces the effects of harmonic, image, and intermediate-frequency interference which may enter the receiver through the antenna circuit. The boosters shown in the photographs were particularly effective in reducing interference from a strong channel 5 television signal and an 88.3-megacycle FM station on a u.h.f. converter with channel 6 output. This interference occurred when the converter was used with rhombic and V-type antennas that had good sensitivity on both the v.h.f. and u.h.f. television bands.

RADIO & TELEVISION NEWS

4. The isolating effect of the booster between the converter and the antenna also provides a substantial reduction in local-oscillator radiation through the antenna circuit.

Construction Details

The cavity of the booster can be made of brass, stiff roofing copper, or even tin-plated steel (if the tinned face is on the inside of the cavity.) The channel 43 and channel 83 boosters shown in Fig. 4 were bent out of .035-inch sheet brass. If facilities are not available for bending the U-shaped cavity out of a single sheet of metal, the sides and bottom can be formed separately and bolted together. The bolts should not be more than one inch apart along the length of the cavity. The cavity length "L" for any desired center frequency in the u.h.f. television band can be found from the graph in Fig. 3. All cavities have the same 1 1/4-inch square cross section.

Flanges are bent on the top edges of the cavity so that the lid containing the output loop can be moved back and forth to find the point of optimum coupling. Make the lid several inches longer than the cavity so that there is enough overlap at each end to allow for coupling adjustments. Fold down the long sides of the lid to fit over the cavity flanges. They should grip the flanges with enough pressure to hold a setting, but not tightly enough to prevent changing the position of the lid in small increments when desired. The extra metal at the lid ends can be cut off after alignment without affecting the tuning. The channel 54 booster shown in Fig. 4 was made from brass plate. A milling machine was required for machining parts.

Fig. 1 shows how the 5876 is mounted on the cavity partition. A 7/16-inch mounting hole will clear the 5876, and will accommodate later "pencil"-type tubes having larger diameter glass seals. The tube is clamped to the partition with three #2-56 screws and the bent sheet-metal washers shown in Fig. 4. Tighten the screws carefully and uniformly just enough to hold the tube firmly against the partition. Excessive or unequal pressures on the clamping washers may crack the glass-to-metal seal.

The cathode contact is a fuse clip, connected to the type UG-290/U coaxial input jack through a button-type coupling condenser with the shortest possible leads. A Cinch type 54A11953 or 54A16325 socket, or a subminiature tube socket is used to connect the heater chokes to the tube. *Do not solder to the tube heater leads, as this may crack the glass seal.*

The anode connector can be made of 3/16-inch o.d. brass or copper tubing. (Most refrigerator-supply houses carry copper tubing this size.) Saw four equally-spaced slots about one inch deep at one end of the connector to form contact fingers (see Fig. 1), and file out the inside of the tubing at this end so that it fits snugly (but not too tightly) on the anode terminal of the

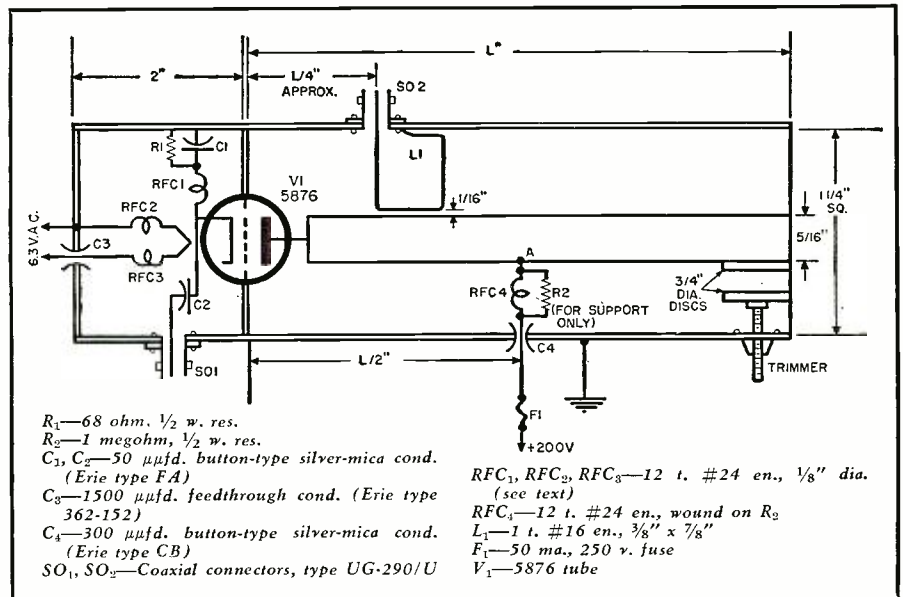

Fig. 2. Pictorial diagram of the "pencil" triode u.h.f. booster. The cavity length, "L", for the desired center frequency is given in the graph of Fig. 3.

5876. Avoid undue strain on the glass-to-metal tube seals when sliding the anode connector on the tube. The one-megohm resistor on which the plate choke is wound will provide adequate support for the anode connector if the booster is not bumped around excessively.

The rotor of the fine-tuning condenser shown in Fig. 2 was made from a dismantled 0.5-7 μfd. concentric trimmer. The mounting clip was installed in the 1/4-inch hole 3/8-inch from the open end of the cavity. The inner brass plunger at the end of the adjusting screw was cut down to a length of 1/16-inch and soldered to the center of a 3/4-inch copper disc. An identical disc soldered to the anode connector forms the stator. The adjusting screw should fit the spring fingers on the mounting clip snugly for smooth tuning. If you don't feel like dismantling a perfectly good high-frequency trimmer for this purpose, you can make the rotor section from the mounting clip and adjusting screw of an old snap-in i.f. coil.

The coupling and cathode resistor

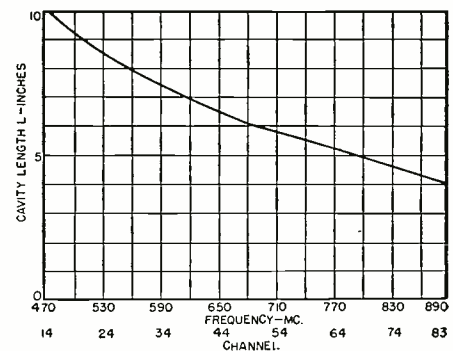

Fig. 3. Graph for finding booster cavity length, "L", for any u.h.f. TV channel.

bypass condensers should be good quality "button-type" micas. (Many ceramic and mica types have enough inductance to act like chokes at ultra-high frequencies.) Values from 50 to 100 μfd. may be used. Higher values may give undesirable resonance effects with lead inductances. The r.f. chokes are wound close-spaced at one end, with the turns spaced out gradually to about a three-turn separation at

(Continued on page 108)

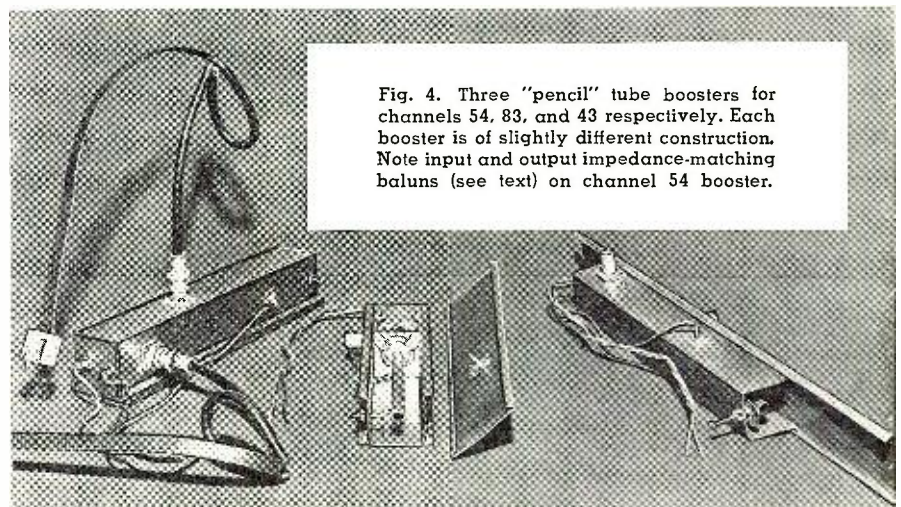

Fig. 4. Three "pencil" tube boosters for channels 54, 83, and 43 respectively. Each booster is of slightly different construction. Note input and output impedance-matching baluns (see text) on channel 54 booster.

Certified RECORD REVUE

By BERT WHYTE

AS MOST of the readers of this column are aware, the author has been beating the drums for binaural and multi-channel sound for quite some time. I must freely admit that so far, the results have not been altogether world-shaking. Oh, we've had *some* progress. A stirring of interest among several of the major phonograph record companies (I can't say just who!), and the actual marketing of some very estimable pre-recorded binaural tapes (known as "Concertapes") by some friends of mine, the Fine Arts Quartet. That is about as far as any concrete evidence of binaural activity goes. On the other hand, as far as *interest* in binaural sound is concerned there has been a steady increase and it seems likely to continue as more and more hi-fi fans (and just plain music lovers!) are exposed to it.

Certainly this is borne out by the amount of mail I receive on this controversial subject. Of late, there has been quite a number of letters from readers who all seemed to have had the same brain wave at the same time. These worthy people say in essence: "Why don't you try to make *three channel* stereosound a reality, instead of just *two channel* stuff?" Now I know that they all mean well, and it's just that they haven't taken the time to sit down and think about the problems involved and how completely impractical is their suggestion. Sure, I'd

like three-channel sound. In fact if you'll let me know how to do it, I'd like 50 or 100 channels of sound.

You may have heard it stated that if you had a screen with an infinite number of microphones and an infinite number of loudspeakers, you would hear the orchestra behind the screen as well as if no screen existed at all! This is perfectly true, the only trouble being that the cost of the equipment in this nifty experiment would be so astronomical, it would be far simpler to buy yourself several orchestras and forget about the electrical nonsense. Now some bright boy is going to shout at me "Don't you know *Ampex* has a three-channel tape machine?" Sure I do, friend, and *Magnecord* or *Fairchild* or even *Webcor* or *Revere* can give you one; that is if you are willing to pay the price and then try to figure out where to get material to play on your brainchild. Taking a long, hard look (or listen) at the multi-channel music situation, I am bound to say that the difference between two-channel and three-channel stereosound is greatly exaggerated. Yes, to a person who has a highly developed sense of audio discrimination, there most certainly is a difference. But let me assure you, the number of people who are capable of such discernment are very few and far between. The so-called "hole" that is supposed to be evident between the two-channel stuff is more imagined than real. Actually, many of

the "off-axis" effects are the result of incorrect mike placement coupled with the wrong type of mike.

You are surprised to learn that there is such a thing as a criterion for the placement of mikes in multi-channel sound? Well, nobody wrote any laws concerning the subject and there is precious little precedent to draw upon other than this: if widely separated loudspeakers are going to be used in the reproduction of multi-channel sound, then some departure must be made from the rigid discipline of "six inches apart." Conversely, you can't go whole hog the other way and use mike placements of 30-40 and even 50 feet and still have a reasonable facsimile of stereosound. Consider several other aspects of obtaining "trinaural" sound.

I am presuming you will want your stereosound in the form of tapes which of course means you will need a machine to play these tapes. This means adherence to a standard tape ($\frac{1}{4}$ inch) for reasons of economy in the cost of the tape itself and in design factors in the machine. While it is very true that three and even four channels can be accommodated on $\frac{1}{4}$ inch tape, it is equally true that every channel you add to the tape above the original full track width causes a significant deterioration of the signal-to-noise ratio as well as undesirable cross modulation between closely spaced channels.

O.K. So these problems can and have been solved—but only at great expense. When we come to the tape machine itself, the following problems present themselves: triple heads—difficult to make and align properly and—expensive. Three, instead of two pre-amplifiers, three meters, three power amplifiers, and so on down the line to the ultimate need for three loudspeakers. All this can be done, but at the present state of the art, difficult and again—terribly expensive. Even two-channel sound is not without these problems. Indeed, it is just these factors which are responsible for the cautious approach to stereosound. Even presupposing the existence of a moderately priced three-channel tape machine, this is only the beginning. For the hi-fi enthusiast could not be very well envisioned playing his "trinaural" through three 89-cent replacement speakers driven by single-ended amplifiers. All right—I agree that even through such highly unsatisfactory gear as just described the over-all effect would be pretty good. *But*, you know how hi-fi nuts are. They wouldn't be satisfied with less than the best their overstrained budgets would allow. Many hi-fi boys already own high quality gear. For all the advantages of two-channel reproduction, they will scratch and scrounge another amplifier and speaker from their protesting pocketbooks. For the very slight increment of improvement in a three-channel system they'll think twice before taking the plunge for still another amplifier and speaker.

In many cases, lack of space in small
(Continued on page 121)

We recently received a letter from Mrs. Edwin Meredith of Ridgewood, Bolton, Ontario that so cogently expresses the role of high-fidelity music that we would like to share parts of Mrs. Meredith's letter with our other readers.

"Last night we sat before a roaring fire and listened to 'Macbeth' over our high-fidelity set.

"We live in the country about thirty miles from Toronto and far enough away to have most of the wonderful things a Canadian winter can offer. It offered quite a severe sample last night. Sparkling snow outside and a hard crescent moon. But that was all closed away because we wanted to find out if the recording of 'Macbeth' was as fine as you had suggested. So the curtains were pulled, there was one soft light near the record player.

"We are so fortunate to have a daughter who is an engineer. She landed in a Toronto station on Christmas morning with two very heavy suitcases which contained our long-awaited Christmas present. Much of Christmas morning was spent in my husband and daughter assembling the present—it was a high-fidelity set. Beverly was especially excited to get it all together since she had not been able to try it out beforehand. Well it worked—and works beautifully. Hence RADIO & TELEVISION NEWS being in our house. And hence my husband reading your column and being fascinated with all you dangled before our willing eyes.

"When my husband came in last night with the records we could hardly wait to get started.

"Well, it was even beyond our hopes. Not a pin dropped from beginning to end. We had read 'Macbeth' last year some time but the actual sequence of the plot was not clear. We just listened to see how we felt about a play coming to us from some records turning on a turntable. It was as clear as a seen play and almost more exciting.

"I don't know whether we fell more in love with Shakespeare or with the actors, or even with the recording. It was all so beyond anyone's wildest hopes. So here I am writing to thank you for a magnificent evening and many more since Shakespeare and that recording deserve repetition.

"We will look forward to our daughter's RADIO & TELEVISION NEWS with your column. I shall read it, too, now!

"Many thanks for the stage you have set for us."

BUILD YOUR OWN

Heathkits

- TEST INSTRUMENTS
- AMPLIFIERS
- RECEIVERS, etc.

- ① Save by ordering direct from manufacturer.
- ② All high quality standard brand components.
- ③ Increased knowledge through actual construction.
- ④ Sound engineering insures excellent performance.
- ⑤ Kit construction is fascinating and enjoyable.



MODEL O-9
\$59.50
Shipping
Wt. 28 lbs.

Heathkit MODEL O-9 OSCILLOSCOPE KIT

New features unheard of in a kit oscilloscope have been added to the already popular Heathkit series. All top quality components are used including a brand new RCA 5U1 CRT. Ten other first line tubes complete the lineup. Voltage regulation provides a rock steady pattern regardless of normal line voltage variations. A built-in blanking amplifier eliminates the retrace line entirely. Other important advantages are a phasing control, Z axis input, direct connections to the deflection plates, 1 volt peak-to-peak calibration voltage and a calibrated grid screen.

Wiring is simplified by the use of the harness technique which also results in a neat professional appearance. Extremely wide vertical bandwidth allows accurate reproduction of even a 500 KC square wave. Excellent focusing characteristics are made possible by the use of the new RCA 5U1 CRT and a spot shape control. One of the most versatile of test instruments, the Heathkit O-9 Oscilloscope will be invaluable in the radio and TV service shop, as a work project in schools and for all types of circuit investigation work in the laboratory. Its new features make Model O-9 comparable in every way to many commercially built oscilloscopes selling for as much as \$400. Don't pass up this opportunity to add a really fine instrument to your service or experimental lab.

Heathkit

VOLTAGE CALIBRATOR KIT

The use of a Voltage Calibrator will greatly increase oscilloscope usefulness. Provides a convenient method of making peak to peak voltage measurements by establishing a relationship between the unknown wave shape and the Voltage Calibrator. Voltage ranges .01-100 volts peak to peak. The Voltage Calibrator features direct reading scales and a regulated power supply system.



MODEL VC-2
\$11.50
Shipping Wt. 4 lbs.

Heathkit

ELECTRONIC SWITCH KIT

The Heathkit Electronic Switch Kit will further extend scope usefulness by permitting simultaneous observation of two individually controlled traces. Continuously variable switching rates 10 cps to 2,000 cps in three ranges. Will also serve as a square wave generator over the range of switching frequencies.



MODEL S-2
\$23.50
Shipping
Wt. 11 lbs.

Heathkit VACUUM TUBE VOLTMETER KIT

The beautiful new 1953 Heathkit Model V-6 VTVM, the world's most popular kit instrument, now offers many outstanding new features in addition to retaining all of the refinements developed and proven through the production of over 70,000 VTVM kits. The Heathkit VTVM now features extended voltage ranges with 50% greater coverage on the DC range. New 1 1/2 volt low scale provides well over 2 1/2 inches of scale length per volt permitting faster measurements with greater accuracy. AC and DC ranges are 0-1.5-5-15-50-150-500-1500 volts (1,000 volts maximum on AC). Ohmmeter ranges are X1, X10, X100, X1,000, X10K, X100K X1 meg. Measures .1 ohm to 1,000 megohms. Other features are db scale, center scale zero adjust and polarity reversal switch. High 11 megohm input resistance virtually eliminates circuit loading.

The low anti-inflation price of this tremendously popular kit includes all tubes, necessary constructional material, test leads and the construction manual.



MODEL V-6
\$24.50
Shipping
Wt. 6 lbs.

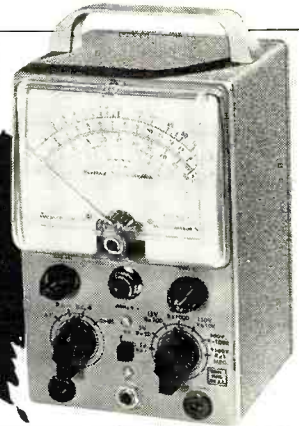

Heathkit AC VACUUM TUBE VOLTMETER KIT

MODEL AV-2
\$29.50
Shipping
Wt. 5 lbs.



A new amplifier type AC VTVM that makes possible those sensitive measurements so essential in laboratory or audio work. Ten voltage ranges covering from .01 RMS full scale to 300 volts RMS full scale. Input impedance 1 megohm with frequency response 20-50,000 cycles. Ten DB ranges from -52 to +52 DB. Four diodes in meter bridge circuit for maximum linearity.

Heathkit

HANDITESTER KIT

MODEL M-1
\$14.50
Shipping
Wt. 3 lbs.



The ever popular Handitester is now supplied with a Simpson 400 microampere meter movement. Provides AC and DC voltage ranges 0-10-30-300-1,000-5,000 volts. Ohmmeter ranges 0-3,000 and 0-300,000 ohms. DC current measurements 0-10 and 0-100 milliamperes. A completely self contained portable instrument.

HEATH COMPANY • Benton Harbor 15, Mich.

HEATHKITS for the ENGINEER

Heathkit VISUAL AURAL SIGNAL TRACER KIT



MODEL T-3 \$23⁵⁰

Shipping
Wt. 10 lbs.

Designed especially for service applications in AM-SW-FM-TV repair work. RF and audio two channel input. More than adequate sensitivity—new noise locator circuit—calibrated wattmeter—substitution speaker—visual signal indication. Can be used with scope and VTVM, checks phono cartridges, phono mechanisms, microphones, tuners, etc. Let the Heathkit Visual Aural Signal Tracer help you.

Heathkit CONDENSER CHECKER KIT

An instrument designed solely for its particular job. Not a "sideline" or a multiple function instrument. Measures value and quality of unknown condensers and resistors. Capacity range .00001 mfd to 1,000 mfd. Resistance range 100 ohms to 5 megohms. Sensitive electron beam indicator—five polarizing test voltages—safety spring return leakage test switch. An amazingly accurate instrument at this low price.



MODEL C-3
\$19⁵⁰ Shipping
Wt. 8 lbs.

Heathkit SIGNAL GENERATOR KIT



MODEL SG-8
\$19⁵⁰

Ship. Wt. 8 lbs.

The standard service instrument for alignment work. 1 volt output from 160 KC to 110 MC. Calibrated harmonics up to 220 MC. Internal (400 CPS) and external modulation. Pre-calibrated coils for all 5 bands. Good stability and accuracy. All test leads included.

Heathkit GRID DIP METER KIT

One hand operation. 5 pre-wound coils cover 2—250 MC. Controlled sensitivity. Usable as an oscillator or an absorption wavemeter. Extra low frequency coils available.



MODEL GD-1B
\$19⁵⁰
Ship. Wt. 4 lbs.

Heathkit LABORATORY REGULATED POWER SUPPLY KIT



MODEL PS-2
\$33⁵⁰

Ship. Wt. 20 lbs.

A regulated variable 160-450 volt DC output power supply for the lab or service shop. Accurate voltage and current measurements with large Simpson meter. AC supply 6.3 volts at 4 amperes—standby switch eliminates warmup time. Low hum content—5 tube circuit. AC and DC output voltages isolated from panel for maximum operational flexibility.

Heathkit RESISTANCE SUBSTITUTION BOX KIT

MODEL RS-1

Ship. Wt. \$5⁵⁰
2 lbs.



Choice of 36 switch selected resistance values 15 ohms to 10 megohms. All standard RTMA 1 watt 10% resistors. Buy several for those lab and service applications.

NEW Heathkit 20,000 OHMS PER VOLT MULTIMETER KIT

Here is the solution to all service problems requiring a portable measuring device of high accuracy. 20,000 ohms/volt sensitivity on DC and 5000 ohms/volt on AC. Full scale voltage ranges of 1.5, 5, 50, 150, 500, 1500 and 5000. DC current ranges of 150 microamperes; 15, 150 and 500 milliamperes; and 15 amperes. Resistances are measured from .2 ohms to 20 megohms in 3 ranges and decibels from -10 to +65 db.

Model MM-1 uses standard commercially available batteries and is not affected by strong RF fields as encountered in and near transmitting equipment. 1% precision resistors on a very easily wired ring type range switch and a highly accurate Simpson 50 microampere meter fully qualifies the Heathkit Multimeter for close tolerance laboratory and service work. The meter movement is placed in a recessed position for maximum non-glare readability. The kit includes the attractive black bakelite cabinet, 2 color meter scales, test leads, batteries and all other necessary components. Overall cabinet size is 5 1/2" wide x 4" deep x 7 1/2" high.

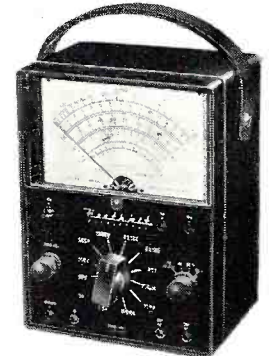

MODEL MM-1

\$26⁵⁰

Ship. Wt. 6 lbs.

Heathkit TUBE CHECKER KIT



MODEL TC-2
\$29⁵⁰

Shipping Wt. 12 lbs.

Checks overall tube quality, filament continuity, and individual elements for shorts and opens. Features chart illumination, harness type wiring, and large 3-color meter scale.

Portable Model TC-2P at \$34.50. Wt. 14 lbs. No. 91-8 Cabinet only at \$7.50. Wt. 7 lbs. No. 355 TV Picture Tube Adapter at \$4.50. Wt. 1 lb.

Heathkit LABORATORY GENERATOR KIT



MODEL LG-1
Ship. Wt. \$39⁵⁰
16 lbs.

A professional laboratory instrument designed for extreme accuracy in frequency and output level. Colpitts oscillator operates in 5 ranges from 150 KC to 30 MC. Panel meter calibrated in output voltage and percent of modulation. Output in excess of .1 volts. Features complete shielding of oscillator, buffer and attenuator sections; regulated power supply and 50 ohm output cable. Comparable instruments priced many times higher than the cost of this new kit.

Heathkit AUDIO WATTMETER KIT



MODEL AW-1
Ship. Wt. \$29⁵⁰
6 lbs.

Measure output power levels directly with the Heathkit Audio Wattmeter. Flat response to frequencies from 10 CPS to 250 KC. Full scale ranges of 5 MW, 50 MW, 500 MW, 5 W and 50 W. Db calibration from -10 to +48. Uses non-inductive built-in load resistors providing impedances of 4, 8, 16 and 600 ohms. Meter bridge uses 4 germanium diodes.

HEATH COMPANY • Benton Harbor 15, Mich.

SERVICEMAN • AMATEUR • STUDENT

Heathkit IMPEDANCE BRIDGE KIT



MODEL IB-2
\$59.50

Ship. Wt. 15 lbs.

Modern design with built-in 1 KC generator for AC measurements. A choice of the Wheatstone, Maxwell, Hay or capacitance comparison bridges for measuring resistance, capacitance, inductance, dissipation factor and storage factor. 1/2% resistors and precision mica condensers provide maximum accuracy. Completely AC operated.

Heathkit DECADE RESISTANCE KIT



MODEL DR-1
\$19.50

Ship. Wt.
4 lbs.

Individual switch selection of twenty 1% precision resistors in 1 ohm steps from 1 to 99,999 ohms. Sturdy ceramic wafer switches featuring silver plated contacts and smooth, positive detent action.

Heathkit TELEVISION SWEEP GENERATOR KIT

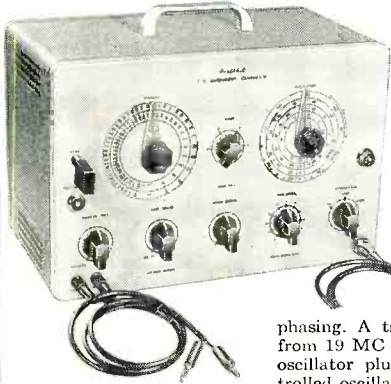

MODEL TS-3
\$44.50

Ship. Wt. 18 lbs.

Simplify your TV alignment jobs with the new Heathkit TS-3. Full coverage on fundamentals from 4 MC to 220 MC at an output of well over 100,000 microvolts. . . . Automatic blanking and wide range phasing. A triple marker system ranges from 19 MC to 180 MC using a Colpitts oscillator plus the 4.5 MC crystal controlled oscillator for check points (crystal furnished). Provisions are also made for using an external marker. Featured is the new sweep system, using an *INCREDUCTOR controllable inductor. Sweep width is variable from 0 to 12 MC at the lower RF frequencies and increases to 0-50 MC at the highest. . . . Other advantages are power supply regulation, constant RF output level, independent marker and RF output control circuits, low impedance output and properly terminated output cables. The construction manual is complete in all detail and with a reasonable amount of care, Model TS-3 will serve faithfully for many years to come.

*Trademark, C.G.S. Laboratories, Stamford, Connecticut

Heathkit COMMUNICATIONS RECEIVER KIT

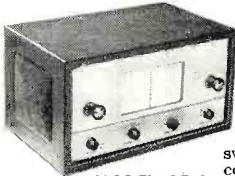

MODEL AR-2
Ship. Wt. **\$25.50**
12 lbs.
(Less Cabinet)

Full coverage from 550 KG to 35 MC on 4 bands, with good sensitivity and selectivity. Features electrical bandspread, BFO, headphone jack, slide rule dial with ham band identification, RF gain control, noise limiter and phone-standby-CW switch. Top quality, high gain components used throughout. Pre-wound coils in a shielded turret assembly and a transformer operated power supply assure trouble-free performance.

Cabinet available separately. No. 9I-10. Shipping wt. 5 lbs. Price \$4.50.

Heathkit Q METER KIT

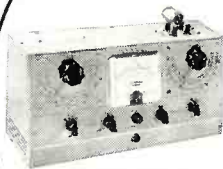

MODEL QM-1
\$44.50 Ship. Wt.
14 lbs.

A typical Heathkit invasion of the laboratory instrument field. Here is the first successful low priced Q meter ever offered in kit form. Oscillator supplies RF in the range of 150 KC to 18 mc. Reads Q directly on calibrated meter scales. Measures Q of condensers, RF resistance and distributed capacity of coils. Calibrate capacitor with range of 40 mmf to 450 mmf with vernier ±3 mmf. All measurements made at the operating frequency.

Heathkit AUDIO OSCILLATOR KIT

MODEL AO-1
\$24.50

Ship. Wt.
11 lbs.

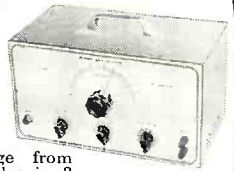

Features sine or square wave coverage from 20-20,000 cycles in 3 ranges. Variable 10 volt output level at 600 ohms impedance. Thermistor controlled linearity—precision multiplier resistors—distortion less than .6%. An outstanding instrument value at this amazing low price.

Heathkit AMATEUR TRANSMITTER KIT

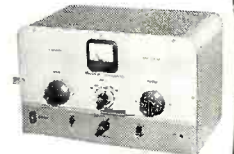

MODEL AT-1
\$29.50

Ship. Wt. 16 lbs.

Power input up to 35 watts on 80, 40, 20, 15, 11 and 10 meters. Can be crystal or VFO excited. Complete with modulator input socket and VFO power output provisions. Other desirable features are good shielding, AC line filter, key click filter, standby switch and a 52 ohm coaxial output. Model AT-1 is AC operated and is suitable as an exciter for a higher powered rig. Complete with full instructions for construction and use.

Heathkit DECADE CONDENSER KIT



Switch selected 1% silver mica precision condensers providing capacity range of 100 mmf. to 0.111 mfd. in steps of 100 mmf.

MODEL DC-1
\$16.50

Shipping Wt. 4 lbs.

Heathkit AUDIO GENERATOR KIT



MODEL AG-8
\$29.50

Ship. Wt. 11 lbs.

A new extended range 18 cycles—1 megacycle audio instrument at a remarkably low price. Five continuously variable output ranges—600 ohm output impedance—low distortion figure, less than .4% from 100 cps through audible range.

Heathkit BAR GENERATOR KIT



Small, compact and easy to use, Model BG-1 supplies horizontal or vertical bars for TV linearity adjustments. Output cable clips directly to the TV receiver antenna terminals.

MODEL BG-1

Ship. Wt. **\$14.50**
6 lbs.

Heathkit BATTERY ELIMINATOR KIT



MODEL BE-4
Ship. Wt. **\$31.50**
18 lbs.

6 or 12 volt operation with current and voltage constantly monitored. Double protection with a fused transformer and automatic overload relay. Well filtered output and all heavy duty components. Designed for auto radio repair and as a storage battery charger.

WRITE FOR Free CATALOG

New 40 page 1954 Catalog lists all kits, specifications, schematics and latest price information.

HEATH COMPANY • Benton Harbor 15, Mich.



International SHORT-WAVE

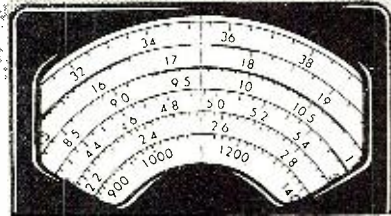

Compiled by **KENNETH R. BOORD**

THE story of HJKH, *Accion Cultural Popular*, Sutatenza, Colombia, is an interesting one. *Accion Cultural Popular*, a Catholic church organization dedicated to the reduction of illiteracy in Colombia by means of radio broadcasting, was founded approximately six years ago by The Rev. Father J. J. Salcedo who was then vicar of Sutatenza and an active radio amateur. Father Salcedo first used a low-powered amateur radio transmitter which was received on battery-operated receivers located at "schools" in the nearby towns and countryside. At these receivers a group of "campesinos" gathered to listen to the broadcast lessons which were explained to them by an instructor with the help of a blackboard.

Encouraged by the results obtained with these limited facilities, *Accion Cultural Popular* steadily expanded its operations, and in April 1953, a Maurice I. Parisier & Company 25 kw. short-wave transmitter was inaugurated at Sutatenza. With this transmitter—most powerful in Colombia—and 5000 new, specially-designed, battery-operated receivers, tens of thousands of "students" throughout the Republic are now being taught not only how to read and write but other subjects such as farming, homemaking, hygiene, and religion.

Because of its relatively small population (300), the town of Sutatenza presently appears on only the most detailed maps of Colombia. It is located approximately 60 miles northwest of the capital, Bogota, in the Andean Valley of Tenza at an altitude of about 6000 feet.

Accion Cultural Popular, which has an irregular schedule, operates on 5.070, usually at 0600-0700, 1600-1700, and 1830-2000 (sometimes runs later); irregularly, on Sat. may open about 10 minutes earlier (0550A) with *English* for listeners in Australia-New Zealand. For a while, in response to requests from "Down Under," the station had a 30-minute *English* session each Sat. 0530-0600. QRA is HJKH, *Accion Cultural Popular*, Sutatenza, Colombia.

* * *

DX Broadcast

Arrangements have been completed for your short-wave editor, Ken Boord, to present a program of Passion Week and Easter organ melodies in a special DX broadcast dedicated to short-wave listeners throughout the world. This

program will be aired from TGNA ("Telling the Good News Abroad"), the radio voice of the Central American Mission, Box 601, Guatemala City, Guatemala, Central America, at 2315-2345 EST on Sat., April 17 (Easter Sun. 0415-0445 GMT), over TGNB, 9.668, and TGNC, 11.850. Harold Van Broekhoven, director of TGNA, says all correct reports will be verified by QSL card and a mimeographed letter which tells of the work of TGNA, sent airmail. "We appreciate it when the listener encloses an International Reply Coupon, but we will not make this a requirement," Director Van Broekhoven points out.

* * *

"On the Air" is the title of a mimeographed short-wave DX bulletin now issued by Bruce Cushman, 133 Summer St., Kingston, Mass., USA. Details and a sample copy of the bulletin can be had direct from Mr. Cushman.

* * *

Around the World

Albania—ZAA, 7.852A, Tirana, noted with *English* 1600-1620; later had French. (Sutton, O.) Heard opening in *English* 1400. (Pearce, England) Is fair some days with *English* 1700-1730, has CWQRM at times. (Jannis, S. C.)

Andorra—Radio Andorra, 5.990, noted in Spanish 1700-1745, QRK4. (Saffle Radio Club, Sweden)

Anglo-Egyptian Sudan—Radio Omdurman, 7.078A, noted in Arabic, musical program 2310-2350A. (Sutton, O.)

Angola—Bluman, Israel, says *Radio Clube de Angola*, Luanda, is noted 1330 on 9.045, 11.840. (Radio Sweden) CR6RB, 9.165, Benguela, is heard in Sweden 1335-1542; CR6AA, 5.033, Lobito, is noted with music 1315, CWQRM. (*Nattugglan*, Sweden) CR6RJ, 10.040A, Sa da Bandeira, noted 1419-1532 at poor level, QSB. (Huttemeyer, N. J.)

Australia—VLQ9, 9.660, Brisbane, Queensland, is heard in Sweden to 0830 closedown. (*Etersvep*, Sweden) VLA15, 15.200, noted fair level 2245 during West Coast transmission, news 2245, signing off 2315. (Bigley, Pa.) VLA9,

9.58, noted 0145-0400, good level. (Vokral, N. Y.) VLC9, 9.615, noted at excellent level to West Coast 1000-1115 daily. (Nicholls, Calif.)

Balearic Islands—Radio Menorca, 7.410A, noted 1330; with Spanish news and native music 1400-1430. (Sutton, O.) ISWL, England, reports this one heard on 7.406 by Patrick, England, around 1430.

Bechuanaland—ZNB, 8.230, Mafeking, has SABC news relay 1400, closes 1430 with "God Save the Queen."

Belgian Congo—OTC, 9.655, Leopoldville, noted at fine level relaying ORU, Brussels, to North America in *English* 2000-2200 closedown. (Bigley, Pa.; Winch, Calif., others)

Belgium—ORU, 6.085, Brussels, is good to North America during *English* 2000-2200 closedown. (Esser, Pa.; Foster, Ill., others)

Brazil—Strong Brazilian on 9.685 at (Continued on page 129)

HJKH, *Accion Cultural Popular*, Sutatenza, Colombia, although located in a town of only 300, is the most powerful transmitter (25 kw.) in the country. Shown are two of the three antenna supporting towers and the buildings which house the transmitter and a diesel-driven generator. *Accion Cultural Popular* was started about six years ago by The Rev. Father J. J. Salcedo, who first used a low-powered amateur transmitter which was received on battery-operated receivers located in "schools" in the nearby towns and at centers throughout area.

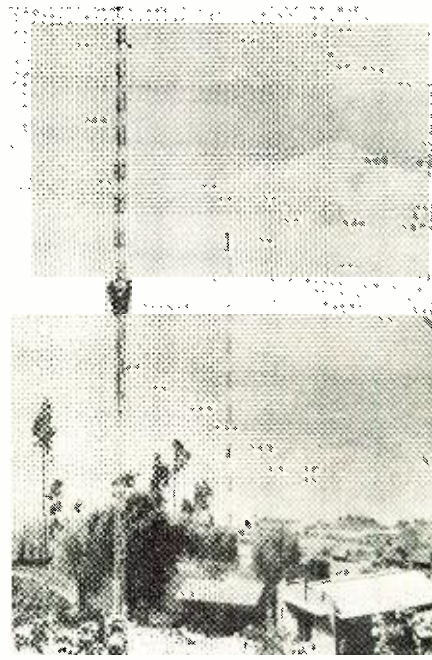

(Note: Unless otherwise indicated, all time is expressed in American EST; add 5 hours for GCT. "News" refers to newscasts in the English language. In order to avoid confusion, the 24 hour clock has been used in designating the times of broadcasts. The hours from midnight until noon are shown as 0000 to 1200 while from 1 p.m. to midnight are shown as 1300 to 2400.)

The symbol "V" following a listed frequency indicates "varying." The station may operate either above or below the frequency given. "A" means frequency is approximate.

Mac's RADIO SERVICE SHOP

By JOHN T. FRYE

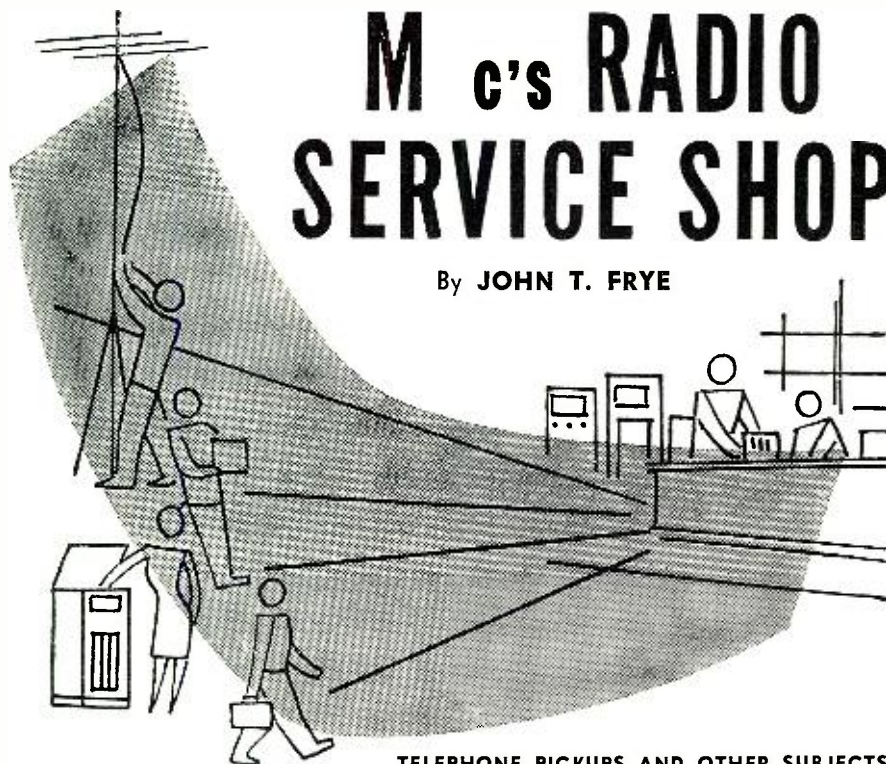

TELEPHONE PICKUPS AND OTHER SUBJECTS

THE calendar said April, but the drifting snowflakes outside the service shop window looked more like the middle of January. Barney turned away from the depressing sight and went back to join his boss at the service bench.

"One of the few advantages of growing older," Mac murmured, "is that you learn to take the weather as it comes instead of fretting about it."

"Don't talk to me about weather," Barney growled. "Talk about anything else. Even give me one of your long-winded technical lectures."

"Ignoring that 'long-winded' adjective," Mac said with a grin, "I might chatter away a bit. The other day you asked me whether or not it was legal to use inductive-type pickups for recording telephone conversations. You argued, as I remember, that since no direct connection was made to the telephone wires, 'it was nobody's business,' as you put it, if you wanted to use one of these gadgets."

"So?" Barney questioned.

"So I wrote to the FCC for an opinion. They sent me back copies of pertinent reports and orders, together with a letter. It all boils down to about this: (1) You cannot use a recording device in connection with interstate and foreign message toll telephone service without all parties to the telephone conversation being notified that telephone recording devices are being used. (2) Only one form of such notification is acceptable. (3) This is the notification produced by a recurring signal of certain specified characteristics. (4) The specifications for this signal, produced by an automatic warning device, are as follows: The signal consists of a single tone having a pitch of 1400 cycles per sec-

ond, plus or minus 10%. This tone is injected into the telephone line in the form of 'beeps' having a length of 20/100 of a second, plus or minus 20%. These beeps must occur at intervals not less than 12 seconds nor more than 18 seconds apart. The signal strength level of the beeps must equal the average telephone talking level."

"You mean I can't just say to the guy on the other end, 'Joe, I'm recording this,' and let it go at that?"

"That's right. Only the automatic tone signal can do the notifying that a recording is being made. When the recorder is directly connected to the line, the telephone company furnishes an automatic signaling device that produces the beep signal whenever the recorder is working; but when you use an inductive type of pickup, the problem is different. The FCC says that as far as it knows, no automatic tone warning has yet been developed to operate with a recorder employing an induction-type pickup.

"Of course the FCC's order only applies to interstate and foreign telephone conversations. It does not apply to local and intrastate calls. However, the FCC says it understands similar tariff regulations have been filed by local and intrastate telephone companies with their regulatory agencies. I know our telephone book has a statement that the recording of a telephone conversation without introducing the 'beep' signal is unlawful. I notice on the box in which one of these induction pickups is packed that there is a warning that it cannot be used for recording interstate calls without the beep. It goes on to say that the FCC ruling does not apply to intrastate calls and that some states require a warning tone while others do not."

"It looks like the thing for me to do is to get busy on inventing a gadget for producing the beep signal without having to make a connection to the line," Barney commented. "Really, though, I'm not sure I'll have time. Since I read where color television had been recorded on tape, I'm concentrating on my TeleTapeCamera."

"How will that work? if I may be so foolish as to ask," Mac quizzed.

"Without giving away too many secrets, I can tell you it is a sort of movie camera, complete with sound, that uses magnetic tape for film. I simply load up the camera with a roll of tape and go out and shoot a few shots of bathing beauties gamboling on the beach. Their merry shrieks of girlish laughter are recorded on one track of the tape. The rest of the tape is used to record the light images that have been transformed to magnetic pulses in the various transistorized circuits of my camera. Then I take the tape home and put it on a playback device plugged into the TV set. Right away the girls, in full color, mind you, start gamboling on the screen of the TV receiver, and the before-mentioned girlish laughter comes from the speaker. If I should ever grow tired of this entertainment—may that never happen!—I can simply erase the tape and put it back into the camera for taking other pictures."

"How far are you along with this invention?" Mac asked.

"Well, I bought a transistor yesterday," Barney replied.

"That's about what I thought," Mac remarked dryly; "but the basic idea may not be as wacky as you suppose. Really, almost all of the know-how for such a camera has been uncovered. Now, though, suppose we quit daydreaming and do a little work, just for kicks. What is the matter with that little set? You've been on it since yesterday."

"If I knew what was wrong, I'd fix it," Barney replied tartly. "The little cuss has a strong a.c. hum that appears only when a station is tuned in. At first I thought that would be a snap. Usually this happens when the condenser across the line opens up; but in this case, that condenser was all right. I tried a new one to be sure. Then I decided that possibly the tuning condenser frame was shorting to the chassis. No dice there, either. Next I substituted new filter condensers, for I have seen cases where a fault there will produce that condition, although usually a poor filter condenser results in a hum that is present all the time instead of just being present when a station is being received. That was no good either. I did not expect it to help because it looks as though new filters had been put in not long ago. Right now I'm fresh out of ideas. You got any?"

Mac turned the little chassis upside down and did some wire tracing in the vicinity of the filter condenser

(Continued on page 154)

A Brief Survey of COLOR TV

... how its
complex character
means job opportunity
for you



—by E. H. RIETZKE,
President, Capitol Radio Engineering Institute

A GOOD MANY YEARS AGO, when he was a young fellow, my Dad was one of the country's fastest typesetters. He could go anywhere and get a highly paid job with any newspaper in the country. Then came the linotype machine! Before he knew it, my Dad's job was obsolete. He had to start all over in another line of work.

How will you get along in the age of Color TV that has already arrived? Will you have to start all over? Or will you be prepared? The choice is a matter of black-and-white—or color. As you may know, color tv involves handling an understandably much more complicated signal than for black-and-white; the components must be in perfect balance; the margin for error is practically zero. Technical personnel need new skills in working to closer tolerances. Microwave relays and coaxial cables require added equipment and special adjustments. Before a station can originate color it needs a great deal of additional equipment, much more expensive and vastly more complicated than that for black-and-white. Slide and film equipment also require additional components and maintenance. Color camera chains are much more complex, requiring more highly skilled adjustments and care. Reports of network experiments indicate that live telecasting in color increases technical man-hours required by 30 to 50%. Lighting personnel need more skill in handling new—and delicate—problems. That's a very quick run-down from the

transmitter end. Every step is a technical opportunity.

What about color receivers? They'll be bigger—with roughly twice as many receiver tubes as black-and-white. There is at least one more tuning knob—the chroma control for color saturation. Maintenance is complicated, to say the least, with three highly critical video channels to trouble-shoot instead of one. Service contracts for color receivers will cost considerably more than for black-and-white, according to one highly qualified source—which should give you an idea of servicing complexity—and earnings possibilities. So much for transmission and reception. Manufacture of color equipment is another field for trained technicians.

Most well-informed sources agree that color television will be spread all over the U.S. by 1956 at the latest. The years between now and then are crucial. If you are interested in an honest-to-goodness career in this booming part of the booming electronics industry, here's how you can step ahead of competition, move up to a better job, earn more money, and be sure of a well-paid job: Study radio-television-electronics via CREI. You don't have to be a college graduate. You do have to be willing to invest some of your spare time—at home. You can do it while holding down a full-time job. Thousands have.

Since 1927 CREI has provided men

with the technical knowledge that leads to more job security—and more money. CREI starts with fundamentals and takes you along at your own speed, not held back by a class, not pushed to keep up with others who have more experience. You master the fundamentals, then get into more advanced phases of electronics engineering principles and practice. Finally you may elect training at career level in high specialized applications of radio or television engineering, or aeronautical radio.

The coupon below, properly filled out, will bring you—without cost—a fact-packed booklet, "Your Future in the New World of Electronics," which includes outlines of courses offered, a resume of career opportunities, full details about the school, our Placement Bureau (with more requests for trained men currently on file than we can fill), and the names of some of the organizations using CREI training (like All American Cables & Radio, Inc., Canadian Broadcasting Corp., Columbia Broadcasting System, RCA Victor Division, United Air Lines, to name a few). I urge you—for your own good—to send for this free booklet immediately.

NOTE: CREI also offers Resident School instruction, day or evening, in Washington, D. C. New classes start once a month. If you are a veteran discharged after June 27, 1950, let the new GI Bill help you obtain resident (or home study) instruction. Check the coupon for more data.

CAPITOL RADIO ENGINEERING INSTITUTE

An Accredited Technical Institute. Founded in 1927

3224 16th Street, N.W.

Dept. RN

Washington 10, D. C.

Send booklet "Your Future in the New World of Electronics" and course outline.

CHECK
FIELD OF
GREATEST
INTEREST

- TV, FM & Advanced AM Servicing
- Practical Radio Engineering
- Broadcast Radio Engineering (AM, FM, TV)
- Practical Television Engineering
- Aeronautical Radio Engineering

Name.....
Street.....
City..... Zone..... State.....

Check:
 Residence School
 Veteran

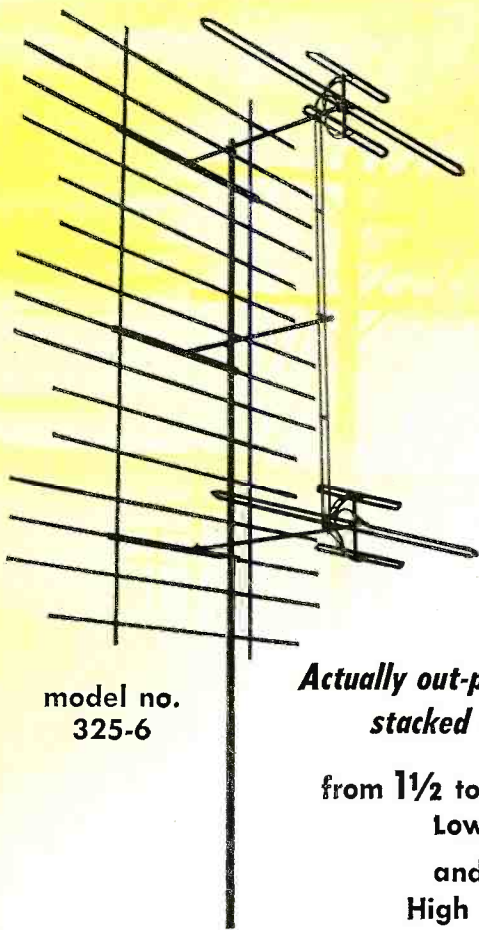

model no.
325-6

**Actually out-performs the
stacked CHAMPION**

**from 1½ to 3 DB more
Low Band gain
and 1 DB more
High Band gain!**

Channel Master proudly introduces the SUPER CHAMP — the newest addition to the Champion antenna family. The Super Champ is a super-powerful antenna that provides extraordinary VHF-UHF reception at greater distances than has ever before been possible.

How it Works:

The Tri-Pole assemblies of the stacked Champion have been wider-spaced by the addition of a third reflecting screen between the antennas. These antennas are joined with a newly-designed half-wave stacking harness. The result: Tri-Pole assemblies are spaced a full half-wave on the Low Band, increasing both Low and High Band gain.

Champion Performance on UHF

In addition to its sensational VHF performance, Channel Master's entire Champion series — including the Super Champ — has been carefully designed to provide excellent reception on the UHF band. Write for complete technical details.

AVAILABLE TWO WAYS:

1. As a complete antenna, model no. 325-6

Consists of two Tri-Pole assemblies, three reflecting screen assemblies and a special stacking harness for wide-spaced Tri-Pole. **\$54¹⁷**
list

2. As a Conversion Kit, model no. 325-7

For converting standard 2-bay Champions into Super Champs. Consists of reflecting screen and specially-designed stacking harness. **\$14⁵⁸**
list

CHANNEL MASTER'S *new*
***SUPER* CHAMP**

featuring wide-spaced stacking of Tri-Pole assemblies

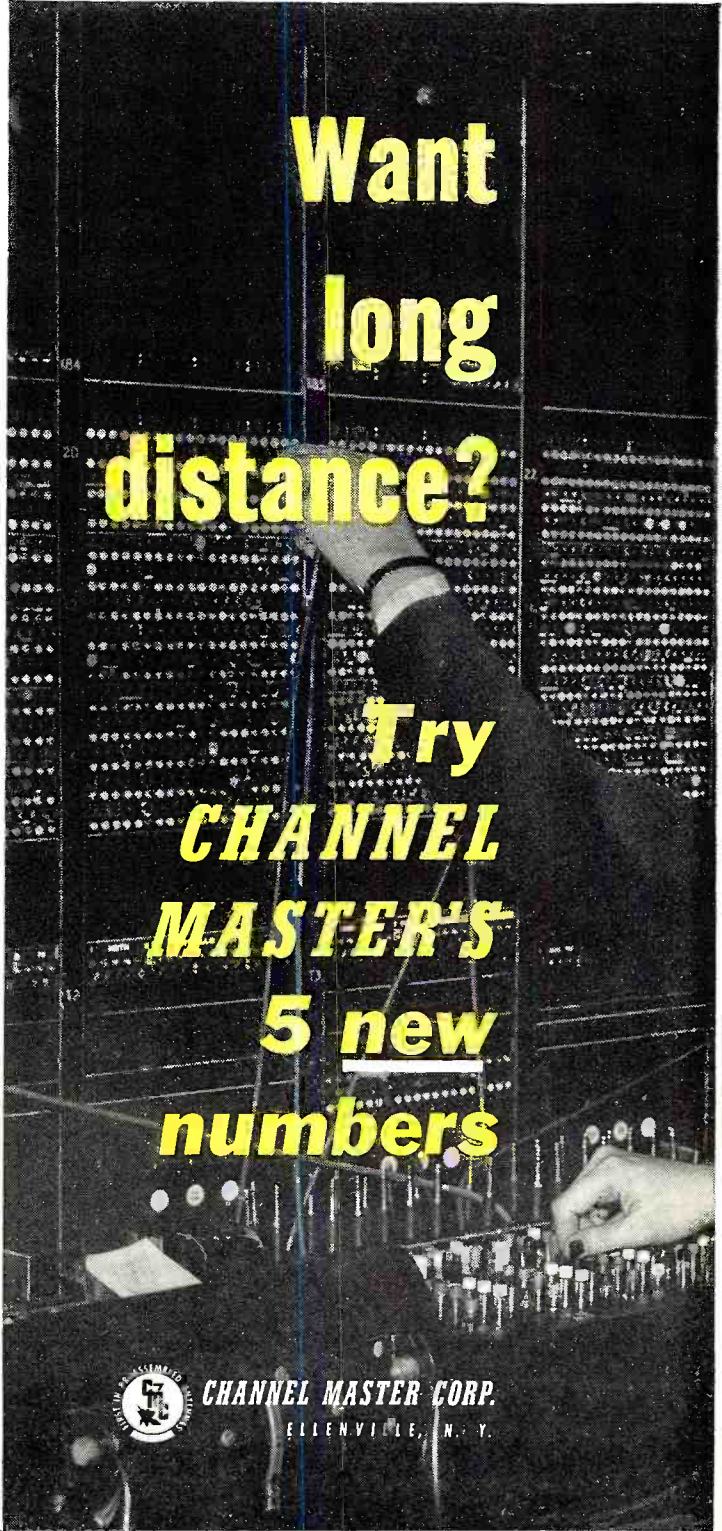

**Want
long
distance?**

**Try
CHANNEL
MASTER'S
5 new
numbers**



CHANNEL MASTER CORP.
ELLENVILLE, N. Y.

Designed for **POWER!**

Low Priced for **ACTION!**

These new antennas are the most sensitive of their type — feature Channel Master's famous built-in quality at remarkable low prices, to help you meet competition on any level.

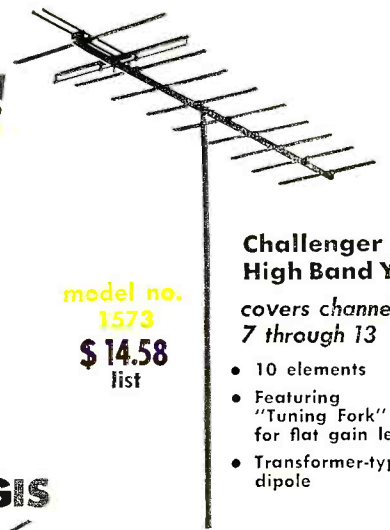

model no.
1573
\$ 14.58
list

Challenger High Band Yagi

covers channels 7 through 13

- 10 elements
- Featuring "Tuning Fork" for flat gain level
- Transformer-type dipole

CHALLENGER BROAD BAND YAGIS

Here's Broad Band coverage with the high gain and directivity of the Yagi. Ideal for areas served at present by two or more VHF stations on the same band and areas where new VHF stations are being added to present ones, on the same band. Feature 100% aluminum construction; are completely preassembled. They give high gain across the band; high front-to-back ratio. Can be stacked for extra sensitivity.

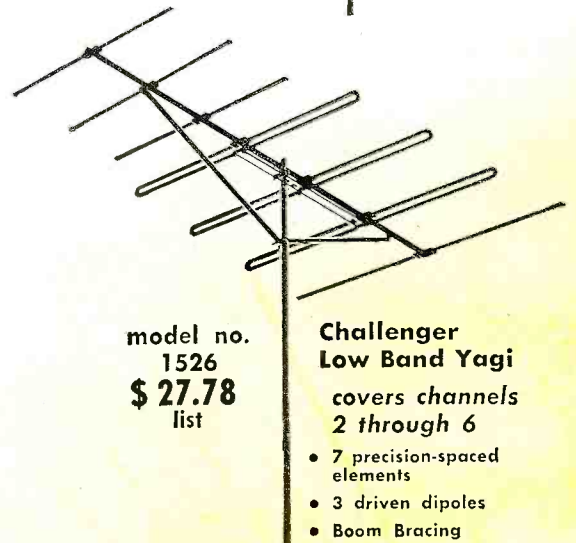

model no.
1526
\$ 27.78
list

Challenger Low Band Yagi

covers channels 2 through 6

- 7 precision-spaced elements
- 3 driven dipoles
- Boom Bracing

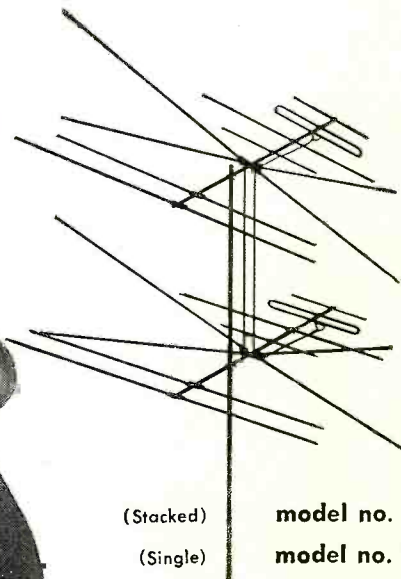

(Stacked)

model no. 321-2 \$ 25.97 list

(Single)

model no. 321 \$ 12.64 list

GLOBE TROTTER

- All-channel VHF fringe area coverage.
- All-channel UHF primary area coverage.
- 100% aluminum construction.
- Completely preassembled — no loose hardware.

MULTI-BOW

covers channels 14 through 83

- Outstanding fringe area reception.
- All-aluminum, solid sheet elements.
- "Free-Space" terminals.
- Heavy-duty welded wire screen, bright zinc electroplated.

model no.
410
\$ 11.11
list

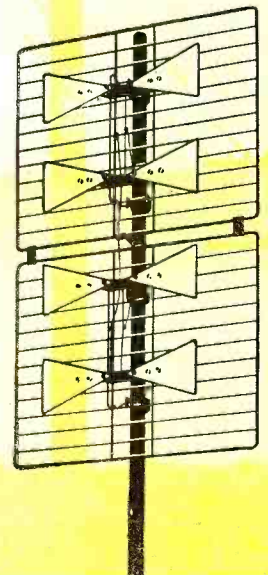

The World's Largest Manufacturer of Television Antennas

Copyright 1954 Channel Master Corp.

There's a future for you as an ELECTRICAL ENGINEER



Bachelor of Science Degree in 36 Months. Major in Elec- tronics or Power

Everyone knows the tremendous opportunities ahead in electrical engineering. The expanding field of color television alone is one example. In addition to the demand for engineers, thousands of engineering technicians are needed. The Milwaukee School of Engineering can prepare you to become an engineer in 36 months or an engineering technician in 12 to 18 months.

It takes only 12 months to become a radio technician. An additional 6-month course qualifies you to become a radio-television technician with the degree of Associate in Applied Science. Or you can earn an industrial electronic technician certificate in 12 months.

These technician courses form the first third of the program leading to a Bachelor of Science degree in Electrical Engineering with a major in electronics. Twenty-one subjects in electronics, electronic engineering and electronic design are studied in this course.

Also offered are a 12-month radio-television service course; a 6-month electrical service course; and a 3-month general preparatory and refresher course.

Terms open July, Sept., January and April
Faculty of specialists — 50,000 former students — Annual enrollment from 48 states and 23 foreign countries — Non-profit institution — 51st year of service — Course approved for veterans — Residence courses only.



MILWAUKEE SCHOOL OF ENGINEERING

MILWAUKEE SCHOOL OF ENGINEERING
Dept. RN-454, 1025 N. Milwaukee St.
Milwaukee 1, Wisconsin

Send me Free bulletin on opportunities on
Electrical Engineering or Free bulletin on
careers in Radio-TV.

I am interested in _____
(name of course)

Name _____ Age _____

Address _____

City _____ Zone _____ State _____

If veteran, indicate date of discharge _____

WHAT'S NEW IN RADIO

The products described in this column are for your convenience in keeping up-to-date on the new equipment being offered by manufacturers. For more complete information on any of these products, write direct to the company involved.

SEMI-AUTOMATIC KEY

The *E. F. Johnson Company* of Waseca, Minnesota is now marketing a new "Special Model" semi-automatic key.

According to the company, the new design enables amateurs and telegraphers to obtain a professional quality

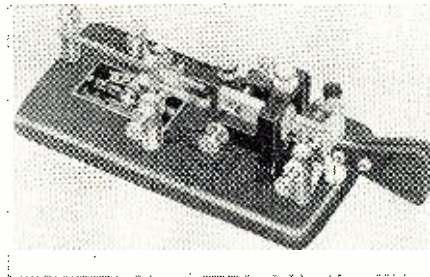

semi-automatic key at moderate cost. The key has a heavily chrome plated vibrator arm assembly and seven separate adjustments permitting operation at virtually any keying speed.

Additional features include an auxiliary circuit closing switch, extra heavy cast metal base with rubber bumpers, and the company's adjustment keying lever.

ROTARY ANTENNA

A highly directional, high-gain antenna for amateur, commercial, and military communications systems has been announced by *Trylon Tower Division, Wind Turbine Co.*, West Chester, Pa.

The new rotary beam is available as either a single- or dual-band unit for operation on any band between 12 and 50 mc. Each array can be supplied with either 3 or 4 elements consisting of adjustable telescoping aluminum tubes, plus adjustable element stubs, and adjustable "T" match for the low-band driver.

Complete specifications and prices on the kit are available on request.

VARISTOR KITS

General Electric Company's Distribution Transformer Department, Dept. 42-211, Pittsfield, Mass. is now offering two new "Thyrite" varistor kits which provide a variety of miniature disc- and rod-type varistors for experimental applications in electronics, communications, power control, and allied fields.

Kit 1 (Catalogue No. 108L338G1) is of the miniature disc type and contains 12 varistors, two each of six ratings, color-coded with connecting leads. Kit 2 (Catalogue No. 108L338G2) contains rod-type units, 10 varistors with two each of five ratings, also color-coded with connecting leads.

Both kits contain data tables of physical and electrical properties and log-log volt-ampere characteristics graphs.

Bulletin GEA-4138C, containing complete information, is available on request.

SEALED TOGGLE SWITCH

A d.p.d.t. toggle switch that is miniaturized and tested for a load of 10 amperes at 250 volts has been announced by *Krautter-Weber Tool Company*, 69-77 Twelfth Avenue, Newark 3, N.J.

The new switch is sealed in a bushing for panel mounting by means of a bonded silicone rubber diaphragm. The sealed bushing is threaded on the $\frac{15}{32}$ " outside diameter that is .420 inch high. Provision has also been made for "O" ring sealing against a chassis or panel. The switch measures .625 x .407 x 1.140 inches.

TINY ELECTROLYTICS

Cornell-Dubilier Electric Corp., South Plainfield, N.J. has developed a compact subminiature tantalum electrolytic condenser which measures $\frac{9}{16}$ " long and $\frac{3}{16}$ " in diameter.

Specially adapted for transistor circuitry, the new electrolytics cover an operating temperature range from -55 to +85 degrees C, have low leakage current and extended service life.

Thirty-five units are now available in the new series ranging in capacity from .01 μ fd. to 8 μ fd. and from 3 to

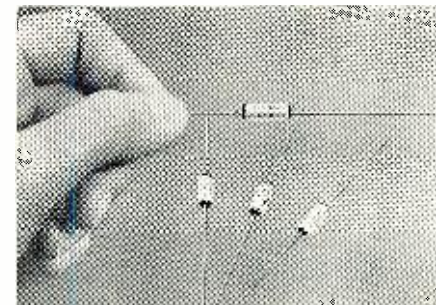

150 working volts in both polarized and nonpolarized types.

Bulletin No. 525 contains complete data on these units and is available on request.

COIL LINE

North Hills Electric Company, P.O. Box 427, Great Neck, New York has announced the availability of a new series of coils.

The new Series 120 variable inductance units cover the range from 2 μ hy. to 2 mhy. with eleven coils. Each coil is adjustable by means of a low-loss core. This series is designed especially

Telrex offers more in '54!

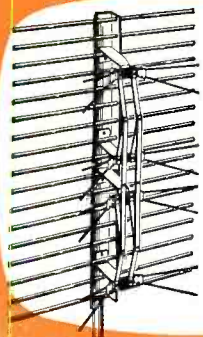

FOR ULTRA-HI GAIN ON UHF
MODEL 84
"CONICAL-V-BEAM"

- Four bay unidirectional array
- All in-phase signal addition at all frequencies with no lobe splitting
- All-aluminum light weight and rugged

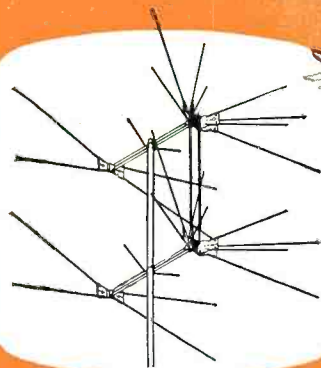

FOR UNIFORMLY HI-GAIN CHANNELS 2 to 83
DUO-BAND "CONICAL-V-BEAM"

- Uniformly Hi-Gain
- Excellent Directivity
- Automatic Transition From UHF to VHF
- High Signal-To-Noise Ratio

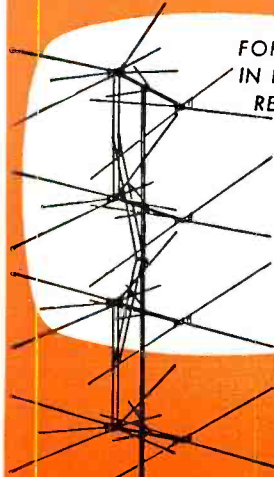

FOR THE ULTIMATE IN LONG DISTANCE RECEPTION THE

TELREX 4 BAY "CONICAL-V-BEAM" SERIES

The ultimate in long distance arrays. Guaranteed to out-perform any antenna or combination of cut-to-frequency antennas. When used with Duo-Band splines, it comprises the ultimate from Ch. 2 to 83. Unequaled for reception to 200 miles.

"Conical-V-Beams" are produced under Re-Issue Patent Number 23,346 and sold only thru authorized distributors

1. SUPERIOR QUALITY— All Aluminum, All-Weather Construction

—Quality first is the Telrex pledge. Extra rugged construction includes all-aluminum design with precision parts fabrication for lasting installations. Wherever feasible, Telrex pre-assemblies at the factory to save you time and money at the site.

2. SUPERIOR RECEPTION —

"Better By Design"...

Rain or Shine—For UHF or VHF you can depend on Telrex for clearer, sharper pictures... finer sound reception. Near or far—city, suburb or rural area—there's a Telrex model engineered for your particular locality. Over 60 antenna types are included in the new Telrex catalog. Write for your copy, today!

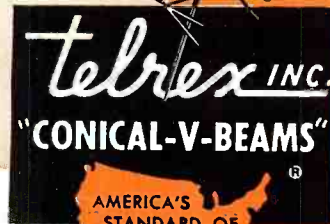

ASBURY PARK 7
NEW JERSEY

By the MAKERS of the FAMOUS "BEAMED POWER" COMMUNICATION ROTARIES

TG-34A KEYER PORTABLE

• 115 or 230 V. @ 50 to 60 cycle—KEYER TG-34A is an automatic unit for reproducing audible code practice signals previously recorded in ink on paper tape. By use of the self contained speaker, the unit will provide code practice signals to one or more persons or provide a keying oscillator for use with a hand key. The unit is compact, in portable carrying case, complete with tubes, photo cell, and operating manual. Size: 10 1/8" x 10 1/2" x 15 3/16". Shipping weight: 45 lbs.

While They Last—

Brand NEW: \$24.95 • USED \$14.95
in original box

TG-10 KEYER: Same function as TG-34A, only larger, using 2/6N7-2/6L6-2/6S17-1/5U4G Tubes and 1/923 Photo Cell. Housed in standard Metal Cabinet, can be removed for 19" rack mtg. Size: 11" H x 24" W x 18 1/2" D.
NEW: \$29.95 • USED: \$19.95

DYNAMOTORS

HEAVY DUTY MOBILE DYNAMOTOR:

14 V. INPUT—Output: 1030 VDC 260 MA. Tapped 515 V. 215 MA. use @
6 V DC INPUT—500 V. 175 MA. While they last—
DM-42—Excel. Cond.: \$14.95...New: \$29.95

INPUT VOLTS:	OUTPUT VOLTS:	STOCK MA.	PRICE:	NEW:
14 VDC	230	90	DM-21	\$9.95
14	330	150	BD-87	6.95
14	250	50	DM-25	6.95
14	1000	350	BD-77	11.95
28	230	100	DA-1A	3.95
24	250	60	DM-32	2.95
24	375	150	DM-33	2.95
28	110	125	DY-22	7.95
28	1000	350	PE-73	8.95
12 or 24	500	50	USA/0515	4.95
12 or 24	275	110	USA/0516	4.95
6 or 12	500	160	PE-103	29.95
12	250	90	PE-133	6.95

PE-101 DYNAMOTOR—6 or 12 Volt. (Reprints of original CO conversion articles—Oct., Dec., '52 issues—furnished.) This is the Dynamotor the Hams have been talking about! Easily adapted to supply 625 V. @ 150 MA. and 325 V. 125 MA. @ 12 Volts— or 300 V. 90 MA. and 160 V. 110 MA.
@ 6 VoltsNEW: \$4.95

SOUND POWERED HEAD AND CHEST SET

Many Type—No Batteries Required—
Ideal for TV Antenna Installations
and many other uses. 20 Ft. Cord.
Used
Tested:\$5.95 EA.



TELEPHONE WIRE FOR THE ABOVE

COMBAT TYPE—2 Cond. Twisted, Rubber Covered,
Medium Weight, W-130.....@.01c per Ft.
FIELD WIRE—2 Cond. Twisted, Weather-
proof, Heavy Duty, W-110—325 Ft. Roll.....\$4.75

TRANSFORMERS—110 V. 60 CYCLE PRI.:
5 Volt CT-25A—10,000 V. Ins. OPEN FRAME—6" x
5" x 4 1/2".....\$7.95
6.3 V. 1 Amp.....1.25 24 V. 1 Amp.....1.95
24 V. 1/2 Amp.....1.50 24 V. 6.5 Amp.....5.95
6-24—or 30 Volt 8 Amp.....5.95

COAXIAL CABLES:

RG-8/U (SPECIAL) 51.5 ohms. Same size as
RG-8/U. Prices: 1 to 100 ft. @ \$c
per ft.—100 to 500 ft. @ 7 1/2c per ft.—500 to 1000 ft.
@ 7c per ft.—1000 ft. Rolls @ 6 1/2c per ft.
RG-34/U—71 ohms, 145 ft. length.....\$15.00

Address Dept. RN • Minimum Order \$5.00
Prices F.O.B., Lima, Ohio • 25% Deposit on
C.O.D. Orders

FAIR RADIO SALES 132 SOUTH MAIN ST. LIMA, OHIO



NEW—LOW—LOW PRICES ARC-5 COMMAND EQUIPMENT:

R-25/ARC-5 Rec. 1.5 to 3 MC. No Tubes. Used: \$14.95
R-26/ARC-5 Rec. 3 to 6 MC. No Tubes. Used: 7.95
R-27/ARC-5 Rec. 6 to 9 MC. No Tubes. Used: 6.95
R-28/ARC-5 Rec. 100 to 156 MC. No Tubes. Used: 12.95
T-20/ARC-5 Trans. 4 to 5.3 MC.....New: 16.95
T-22/ARC-5 Trans. 7 to 9 MC.....Used: 14.95

274-N COMMAND EQUIPMENT:

BC-454 Rec. 3 to 6 MC.....Used: \$10.95
BC-455 Rec. 6 to 9 MC.....Used: 9.95
BC-458 Trans. 5.3 to 7 MC.....Used: 9.95
BC-459 Trans. 7 to 9 MC.....Used: 14.95
BC-456 Modulator.....Used: 2.95
FT-225 Mtg. F/BC-456.....Used: 50c.....New: .95
FT-220 3 Rec. Rack.....Used: \$1.50.....New: 2.50
FT-221 3 Rec. Shock.....Used: 50c.....New: .95
BC-450 3 Rec. Cont. Box.....Used: \$1.50.....New: 2.00
BC-451 Trans. Cont. Box.....Used: \$1.00.....New: 1.50
PLUG—Male for rear of Rec. or Trans......55
DM-32 Dynamtr F/Rec. 24V. Used: \$2.95.....New: 6.95
DM-33 Dynamtr F/Modulator & Trans.....Used: 2.95

TRANSFORMERS FOR COMMAND REC. & TRANS.:

600-0-600 VAC—200 MA. 12.5 V. 2 A.; 12.5
V. @ 2 A.; 5 V. @ 3 A. 115 Volt Primary, H-105
Price.....\$8.95
250-0-250 VAC—50 MA. 24 V. 1 A., & 6.3 V.
1 A.; 115 Volt Primary, H-109—Price.....\$3.95

ANTENNA EQUIPMENT

MAST BASES—INSULATED:

MP-132 BASE—Illustrated at left—"1"
heavy coil spring, 2" insulator. Overall
length: 11 1/2". Weight: 2 3/4 lbs.
Price.....\$3.95
MP-S-33 BASE—Insulated type with heavy
coil spring and 5" dia. insulator. Re-
quires 2" hole for mounting. Weight:
9 lbs.\$5.95
MP-48 BASE—Insulated type base with
heavy coil spring. Requires 1 3/8" mount-
ing hole. Weight: 11 lbs.....\$6.95
MP-37 BASE—Insulated type with heavy
coil spring; 7" dia. insulator; requires 1 3/8" hole for
mounting. Weight: approx. 10 lbs.....\$8.95
MAST SECTIONS FOR ABOVE BASES:
Tubular steel, copper coated, painted in 3 ft. sec-
tions, screw-in type. MS-53 can be used to make
any length with MS-52-51-50-49 for taper. Any sec-
tion, @ 50c each. Larger Diameter Section:
MS-54.....\$1.25

FREE CATALOG

LISTING HUNDREDS OF TRULY EXCEPTIONAL
"BUYS"!—WRITE FOR YOUR FREE COPY NOW!

for color TV circuits, filter network applications, video peaking, r.f. and i.f. amplifiers, adjustable delay lines, and marker circuits.

The company is also equipped to handle special coil orders on a custom basis.

TEST EQUIPMENT

Tektronix, Inc., P.O. Box 831, Port-land 7, Oregon has introduced two new pieces of test equipment, the Type 190 constant-amplitude signal generator and Type 130 LC Meter.

The Type 190 generates sine waves in the frequency range of 350 kc. to 50

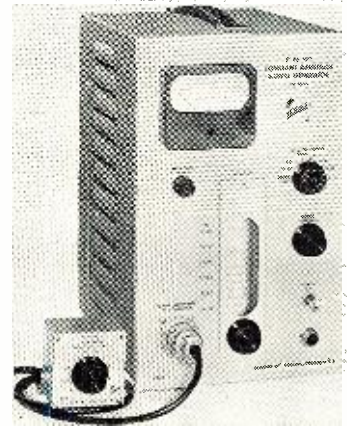

mc. Output amplitude varies less than 2 per-cent from 350 kc. to 30 mc. and less than 4 per-cent from 30 to 50 mc. Frequency is continuously variable in six ranges with frequency indication accurate within 2 per-cent.

The Type 130 is a direct reading meter for small values of inductance and capacitance in components and circuits. The instrument has five ranges, 0-3, 0-10, 0-30, 0-100, and 0 to 300 μ hy. or μ fd. Accuracy is within 5 per-cent at full scale. It has coarse and fine zero-adjust controls and an illuminated 4" meter.

GUY WIRE

Fenton Company, 15 Moore Street, New York 4, N.Y. has introduced a new guy wire which is packaged in a flat handi-pack.

Tradenamed "Tuf-Guy Ten Spot," the new guy wire is spotmarked every 10 feet for easy measuring. A 7" circle on the top of the box is perforated and the wire is unwound through this hole from the center of the reel.

According to the company, since the box rests firmly on the rooftop, the guy wire is easy to handle on installation jobs.

SINGLE-UNIT MOBILE COIL

Vaaro Electronic Engineering Co., Box 5035, Long Beach, California is now marketing a new variable single-unit mobile coil for use in the 75, 40, 20, 15, 11, and 10 meter band range.

The coil is so designed that a slider can be moved up or down until the transmitter loading is obtained and then locked into place by a special shaft lock. The coil is built in two models, the Model V-102 for rigs de-
(Continued on page 118)

URGENT! URGENT!
ELECTRONIC TUBES
We Pay Spot Cash for:
RADIO, TV -all types
Slate type, condition
of merchandise, quantities and price.
TELEVISION MATERIALS CORP.
120 Liberty St., New York 6, N. Y.
CO 7-4307

**RECEIVER FOR HAM
NOVICE AIRCRAFT
BOAT & MOBILE**
U.S. Navy RU-18 6 tube sensitive receiver with straight wire and loop input, closeout sale only 100 available, with this special price choice of any 2 of the below coil sets with ea. rec. Some coils are dual freq. a hi & low W/ a switch others are single (195-435) (540-830 & 2040-3000) (540-830 & 3000-4525) (540-830 & 5200-7700) (2040-3000) (400-600 & 6000-9050) (4000-6000) and a few 830-1330 all freq. is KC extra coils \$2.50 each order early send P.P. charges W/order shipping WT. packed 25 lbs. ea. **\$8.95**
McCONNELL'S New Address: BARTO, PA. Phone: BALLY 5-3621



Edward H. Guilford
Executive Vice President

Want To DOUBLE YOUR PAY?

How To Pass FCC COMMERCIAL RADIO OPERATOR EXAMINATIONS LICENSE



**TELEVISION
ENGINEERING**
included in our
Training and coaching

GET THIS AMAZING NEW BOOKLET FREE!

TELLS HOW ...

WE GUARANTEE

TO TRAIN AND COACH YOU AT
HOME IN SPARE TIME UNTIL YOU GET

YOUR FCC LICENSE

If you have had any practical experience—Amateur, Army, Navy, radio repair, or experimenting.

HERE IS YOUR GUARANTEE

If you fail to pass your Commercial License exam after completing our course, we guarantee to continue your training without additional cost of any kind, until you successfully obtain your Commercial license, provided you first sit for this examination within 90 days after completing your course.

TELLS HOW ...

Our Amazingly Effective JOB-FINDING SERVICE

Helps CIRE Students Get Better Jobs

Here are a few recent examples of Job-Finding results:

GETS CIVIL SERVICE JOB

"Thanks to your course I obtained my 2nd phone license, and am now employed by Civil Service at Great Lakes Naval Training Station as an Equipment Specialist." Kenneth R. Leiser, Fair Oaks, Md. Del., McHenry, Ill.

GETS STATE POLICE JOB

"I have obtained my 1st class ticket (thanks to your school) and since receiving same I have held good jobs at all times. I am now Chief Radio Operator with the Kentucky State Police." Edwin P. Healy, 264 E. 3rd St., London, Ky.

GETS BROADCAST JOB

"I wish to thank your Job-Finding Service for the help in securing for me the position of transmitter operator here at WGAE in Pittsburgh." Walter Kosechik, 1442 Ridge Ave., N. Braddock, Pa.

GETS AIRLINES JOB

"Due to your Job-Finding Service, I have been getting many offers from all over the country, and I have taken a job with Capital Airlines in Chicago, as a Radio Mechanic." Harry Clare, 4537 S. Drexel Blvd., Chicago, Ill.

TELLS HOW ...

Employers Make JOB OFFERS Like These to Our Graduates Every Month!

Letter from nationally-known Airlines, "We would also appreciate if you would place the following additional advertisement in your bulletin—Wanted—Superintendent of Communications . . . Salary \$666.66 per month."

Letter from nationally-known airplane manufacturer, "We need men with electronic training or experience in radar maintenance to perform operational check-out of radar and other electronics systems . . . starting salary . . . amounting to \$329.33 per month."

Letter from nationally-known Airlines, "We are contemplating placing . . . an Airline Ground Radio Engineer." Starting salary \$385 per month.

These are just a few examples of the job offers that come to our office periodically. Some licensed radioman filled each of these jobs . . . it might have been you!

HERE'S PROOF FCC LICENSES ARE OFTEN SECURED IN A FEW HOURS OF STUDY WITH OUR COACHING AT HOME IN SPARE TIME

Name and Address	License	Lessons
Lee Worthy 2210 1/2 Wilshire St., Bakersfield, Calif.	2nd Phone	16
Clifford E. Vogt Box 1016, Dania, Fla.	1st Phone	20
Francis X. Foeckel 38 Beuler Pl., Bergenfield, N. J.	1st Phone	38
S/Sgt. Ben H. Davis 317 North Roosevelt, Lebanon, Ill.	1st Phone	28
Albert Schell 110 West 11th St., Escondido, Calif.	2nd Phone	23

CLEVELAND INSTITUTE OF RADIO ELECTRONICS

Carl E. Smith, E. E., Consulting Engineer, President
Desk RN-63, 4900 Euclid Bldg., Cleveland 3, Ohio

OURS IS THE
ONLY HOME
STUDY COURSE
WHICH SUP-
PLIES FCC-TYPE
EXAMINATIONS
WITH ALL LES-
SONS AND FINAL
TESTS.



Your FCC Ticket is required by most employers as proof of your technical ability.

MAIL COUPON NOW

CLEVELAND INSTITUTE OF RADIO ELECTRONICS
Desk RN-63—4900 Euclid Bldg.
Cleveland 3, Ohio
(Address to Desk No. to avoid delay.)

B I want to know how I can get my FCC ticket in a minimum of time. Send me your FREE booklet: "How to Pass FCC License Examinations" (does not cover exams for Amateur License), as well as a sample FCC-type exam and the amazing new booklet, "Money-Making FCC License Information." Be sure to tell me about your Television Engineering Course.

Name.....
Address.....
City..... Zone..... State.....

Paste on two cent postcard or send air mail.

Here's a TERRIFIC BUY for MOBILE HAMS!



FAMOUS BC-645 Transmitter-Receiver

Makes wonderful mobile rig for 420-500 Mc. Easy to convert for phone or CW 2-way communication. CONVERSION DIAGRAM INCLUDED. This swell rig originally cost over \$1000—yours for practically a song! You get it all in original factory carton, BRAND NEW, complete with 17 tubes, less power supply.

- Shpg. wt. 25 lbs. **\$39.50**
- PE-101C Dynamotor for BC-645, has 12-24V input (easy to convert for 6V Battery operation, instructions included).....only **\$4.85**
- UHF Antenna Assembly, for BC-645..... **\$2.45**
- CONVERSION BOOKLET, Instructions for most useful surplus rigs..... **\$2.50**

HEADSETS

	Excellent USED	BRAND NEW
HS-23 high impedance	\$2.95	\$4.75
HS-33 low impedance	2.45	5.75
HS-30 low imp (featherw).....	1.49	2.45
H-16 U high imp (2 units).....	—	4.95
CD-307A cords, with PL55 plug and JK26 jack, 8' long.....	—	1.19

SCR-522 BARGAIN OFFER!

- SCR-522 Xmitter less tubes \$22.50 with tubes..... **\$32.50**
- SCR-522 Recvr less tubes \$19.50 with tubes..... **\$24.50**

BC 605 INTERPHONE AMPLIFIER

Can be easily converted to an intercom, set—ideal for office, home or factory. New..... **\$5.25** Like New..... **\$3.95**



SCR-274N COMMAND and ARC-5 EQUIPMENT

Type	USED	BRAND NEW
BC-453 Revr. 190-550 Kc. \$21.50	\$28.50	\$44.50
BC-454 Revr. 3-5 Mc.	12.50	24.95
BC-455 Revr. 6-9 Mc.	10.95	12.95
BC-456 Modulator	2.75	5.75
BC-457 Xmtr. 4-5.2 Mc.	13.50	28.50
BC-458 Xmtr. 5-3.7 Mc.	8.50	9.75
BC-459 Xmtr. 7-9.1 Mc.	14.95	16.50
BC-450 3 Revr. control box.....	1.49	1.95
BC-451 Xmtr. control box.....	1.25	1.49
3 Receiver rack	1.79	2.95
2 Transmitter rack	1.59	3.25
Single Transmitter rack	1.59	3.25
ARC-5/T-23 Transmtr, with tubes. Brand New.....	—	\$49.50

ARMY FIELD PHONES

Type EEB—Talk as far as 17 miles. Dependable 2-way communication. Each phone complete with ringer and handset. Excellent Condition. Your cost..... **\$22.25**

DC AMMETER 0-15 Amps

A terrific buy! 3 1/2" easy reading scale. 75 divisions. Black plastic case 4 1/2" x 2 1/2" x 2 1/2" covered with hinged cover. Brand New. Wonderful for automotive, battery charging, general test work. Value **\$4.59** \$25. All yours for only.....

Sensational BC-221 FREQUENCY METER

Buy! JUST LIKE NEW! Limited quantity, first come, first served! Range 125 to 20,000 Kc. with crystal check points in all ranges. Complete with tubes, crystal, calibration charts. **\$129.50**

YOUR COST: These Frequency Meters are factory treated, checked for frequency alignment and GUARANTEED. Modulated BC-221-AK BRAND NEW. Complete..... **\$210.00**



BEACON RECEIVER BC-1206-C

Complete with 5 tubes. Tunes 195 KC to 420 KC. 1F Frequency—135 KC. Receiver Sensitivity—5 Microvolts for 10 Milliwatts output. Output Impedance—300 Ohms and 4000 Ohms. Volume Control—RF Gain Control. Power Supply—24-28 Volts. Airplane Battery. Current—.75 amperes.

BRAND NEW **\$12.95** Used, as is, special..... **\$6.95**

WILLARD 6-VOLT MIDGET STORAGE BATTERY

3-amp hr. BRAND NEW. 3 3/8" x 1-13/16" x 2 3/8". Uses standard electrolyte. **\$2.65**

WILLARD 2-VOLT STORAGE BATTERY. 20 AMP. HR. BRAND NEW..... **\$2.69**

DYNAMOTORS

Type	Input	Output	Exc. Used	Brand New
DM-32A	28V 1.1A.	250V .05A.	\$4.95	\$7.50
DM-33A	28V 5 A.	575V .16A.	2.25	3.95
DM-40	28V 7 A.	540V .25A.	—	—
DM-41	14V 3.4A.	172V .138A.	7.40	9.50
DM-28	28V	224V .07A.	3.95	6.95
PE-73	28V 20A.	1000V .350A.	9.50	12.50

Please include 25% deposit with order—Balance C.O.D. MINIMUM ORDER \$3.00. All Shipments F.O.B. Our Warehouse N.Y.C.

G & G Radio Supply Co.
Dept. N-4
51 Vesey St., New York 7, N. Y. CO 7-4605
Branch: 16 W. Kinzie St., Chicago, Ill.

Civil Defense Station

(Continued from page 39)

2. Signal generator covering both 19 mc. and 144 to 148 mc. with provisions for 1 kc. internal modulation at 30% (Measurements Corporation, Model 80).
3. Pad, 50:70 ohm, 6 db.
4. Grid dip and absorption type wavemeter covering both 19 mc. and 144 to 148 mc. (Measurements Corporation, Model 59, megacycle meter).
5. Vacuum-tube voltmeter (Measurements Corporation, Model 62 or equivalent).
6. Modulator audio unit from v.h.f. transmitter-receiver.
7. 4-ohm, 2-watt resistor.
8. Loudspeaker with 4-ohm voice coil.
9. Insulated probe and screwdriver.
10. Amphenol coil cement and thinner.

Procedure:

1. Short out R_{10} with switch S_1 .
2. Set function switch to "receive" position, full clockwise.
3. Gain control to full clockwise.
4. Connect 4-ohm load and vacuum tube voltmeter to speaker leads.
5. Connect signal generator through 50:70 ohm pad to antenna input jack of receiver.
6. With signal generator off and with proper voltages applied to the receiver adjust first i.f. coil, L_{10} , to 19 mc., by spreading or compressing turns, as indicated on the grid dip meter. Make sure that the observed dip is not being reflected through the i.f. link from the second detector grid coil.
7. Shut off power supply and tune C_{30} - L_8 to 19 mc. as indicated on grid dip meter.
8. Turn power supply on and set superregeneration control to approximately 50% of maximum rush level as indicated on vacuum-tube voltmeter. Turn signal generator on, frequency at 19 mc., 1 kc. modulation at 30%, output, 2000 microvolts, and carefully peak C_{30} for maximum output on vacuum-tube voltmeter.
9. Shut signal generator off and set C_{30} to maximum capacity; utilizing insulated screwdriver tune oscillator bandset condenser C_{33} so that L_{14} resonates at 123.5 mc. as indicated by grid dip method.
10. Set C_{30} to minimum capacity and note whether L_{11} resonates at 130.5 mc.
11. For proper bandspread characteristics adjust variable condenser C_{39} by bending stator plate and bandset condenser C_{33} to produce a local oscillator frequency range 123.5 to 130.5 mc.
12. Remove 6AK5 (V_5) r.f. tube from socket and resonate mixer coil L_{12} to 146 mc. using the conventional grid dip method.
13. Replace 6AK5, shut off power supply, and resonate input coil L_{13} to 146 mc. by grid dip method.
14. Remove 12AT7 (V_7) from socket

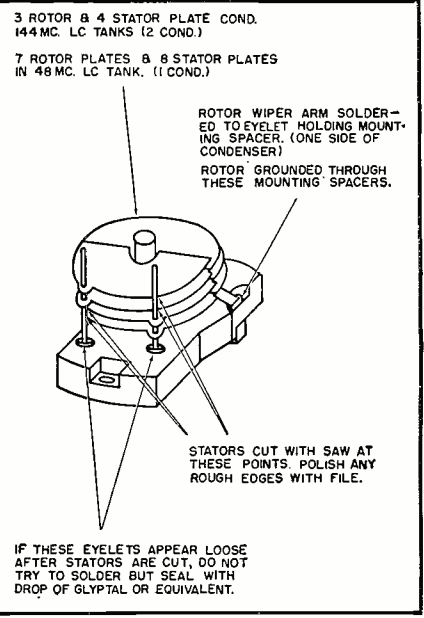

Fig. 8. Mechanical changes for the Hammarlund Type APC condensers to provide split-stator operation. The units, as modified, have proven extremely stable even after several months' operation. The LC combinations will hold resonant settings.

and short out L_{13} r.f. input coil with short jumper.

15. Turn on power supply and resonate L_{11} r.f. output coil to 146 mc. using grid dip method.
 16. Replace 12AT7 (V_7), connect speaker and remove load. Turn on signal generator, frequency 146 mc., 1 kc. 30% modulation, 10 microvolt output and tune receiver until signal is audible, check superregeneration control for smoothness and note whether multiple beats are in evidence at the regenerative level while tuning through the 146 mc. signal. If there are multiple beats and/or rough superregeneration control adjust link L_{13} until there is a single beat at the regenerative level and smooth superregeneration.
 17. Check for possible detuning of second detector and repeat if necessary.
 18. In a properly adjusted and aligned receiver a 3 microvolt unmodulated signal will produce a 6 db drop in noise level throughout the 2-meter band as measured on the vacuum-tube voltmeter across the 4-ohm dummy load. (Noise level just past the superregenerative threshold is approximately 2.9 volts). A one microvolt, 1 kc. 30% modulated carrier will produce a clearly audible signal throughout the band. Seal all coils after adjustment.
- This equipment in conjunction with a modified 522 transmitter-receiver using a stacked coax antenna fifty feet above ground provides a system that has been in active use since its presentation to Parsippany Troy Hills Township by Measurements Corp. and has proved itself to be outstanding both from an operational and reliability viewpoint. See Table 2 for complete specs on the unit.



I'll Train **YOU** at Home in Your Spare Hours for Big Pay Job • Your Own Business • Exceptional Opportunity in

RADIO-TELEVISION

ON *New* NO-OBLIGATION PLAN!

**I Send You
18 BIG
KITS
OF RADIO-
TELEVISION
EQUIPMENT**

You Have NO MONTHLY PAYMENT CONTRACT

to sign . . . you pay for your training as you learn and earn... **ENROLL NOW!**
Be Ready in Little as 10 MONTHS!

Now you can get into Radio-Television, today's fastest growing big money opportunity field, in months instead of years! My completely new "package unit" training plan prepares you to qualify as a Radio-Television Technician in as short a time as 10 months, or even less! I offer you my training with no monthly payment contract to sign—thus NO RISK and NO OBLIGATION for you! This is America's finest, most modern and really practical training. Includes FM . . . UHF Television and all the most recent developments. My training gets you ready to handle any practical job in the booming Radio-Television industry. Start your own profitable Radio-Television Service Shop . . . or accept a fine paying job. I have trained hundreds of successful Radio-Television technicians—and I can train you regardless of lack of previous experience. Mail coupon and get all the facts—FREE!

VALUABLE EQUIPMENT INCLUDED WITH TRAINING

Much of your Sprayberry Training is actual construction, demonstration and experimentation. You get priceless practical experience this way. You build the 6 tube Sprayberry Short Wave and Broadcast Training Radio Receiver, the Sprayberry Television set, multi-range test meter, signal generator, signal tracer, cathode ray oscilloscope and many other projects. All this equipment is yours to keep. You have practically everything you need to set up your own profitable Radio-Television shop. All lessons and books I send you remain your own property.

OUR 21st YEAR TRAINING MEN FOR RADIO-TELEVISION Earn Extra Money While You Learn

All your Sprayberry Training is given IN YOUR OWN HOME during your free time. Keep on with your present job and income while learning Radio-Television. With each Sprayberry "Package Training Unit" I include money-making plans and special "Business Builders" for spare time Radio-Television service jobs. New Television stations opening everywhere open big money opportunity for men to install UHF antennas—I tell you how! If you expect to be in the Armed Forces later, there is no better preparation than Radio-Television. Mail coupon below . . . get facts FREE. *No salesman will call.*

FREE TO YOU 3 BIG RADIO-TELEVISION BOOKS

I invite you to get all the facts—
I want you to have ALL the facts—without cost! Rush coupon for my three big Radio-Television books! "How to Make Money in Radio-Television" PLUS my new illustrated Television Bulletin PLUS an actual sample Sprayberry Lesson—ALL FREE. No obligation and no salesman will call. Mail coupon NOW!

SPRAYBERRY ACADEMY OF RADIO
111 NORTH CANAL STREET, DEPT. 25-H
CHICAGO 6, ILLINOIS

Train at Home in Spare Hours!

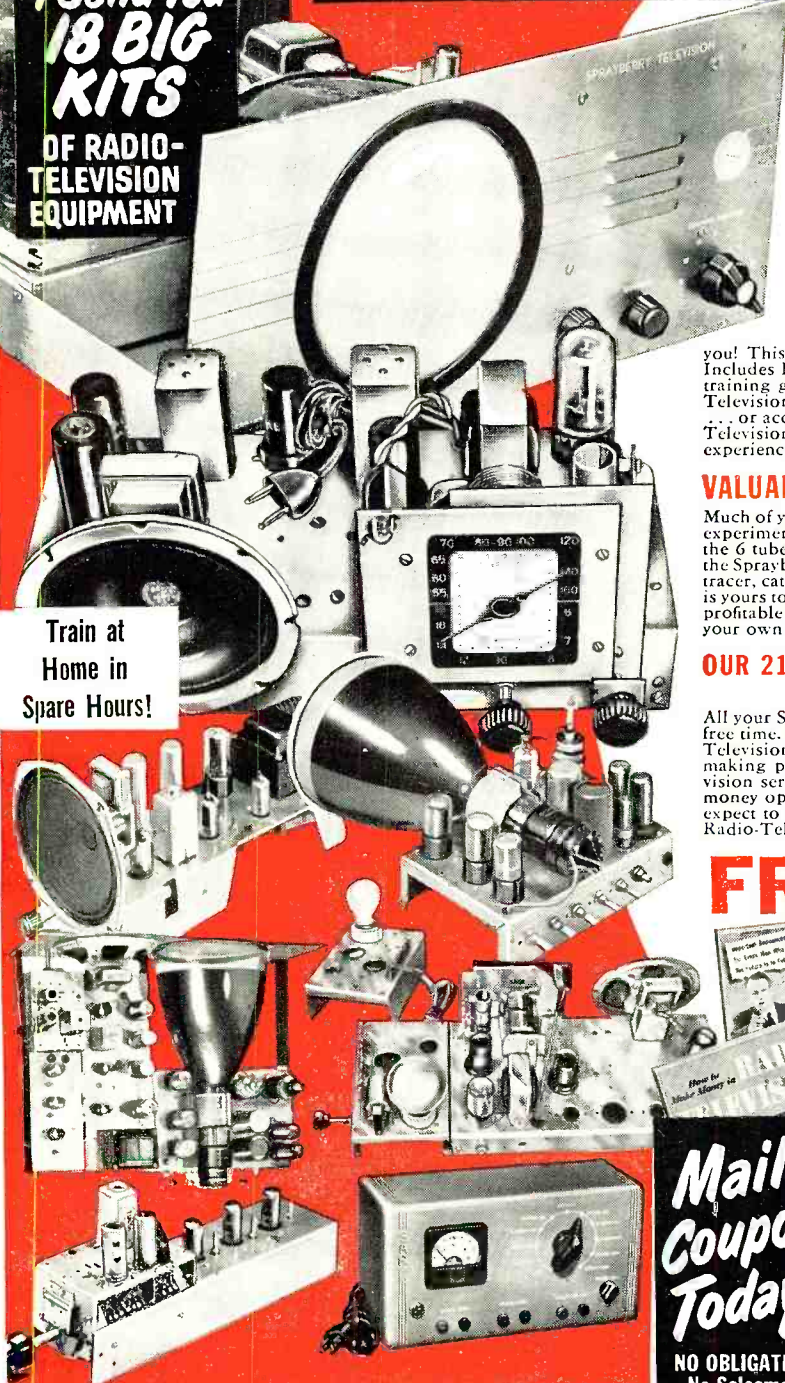

IF YOU ARE EXPERIENCED IN RADIO

Men already in Radio who seek a short intensive 100% TELEVISION Training with FULL EQUIPMENT INCLUDED are invited to check and mail the coupon at the right.

Mail Coupon Today!
NO OBLIGATION
No Salesman Will Call

SPRAYBERRY ACADEMY OF RADIO, Dept. 25-H
111 North Canal St., Chicago 6, Illinois

Please rush to me all information on your 10-MONTH Radio-Television Training Plan. I understand this does not obligate me and that no salesman will call upon me. Be sure to include 3 books FREE.

Name Age

Address

City Zone State

Are you Experienced? No Experience

HARVEY



AUTHORIZED DISTRIBUTOR

presents

2 NEW RCA PORTABLE SIGNAL GENERATORS

Especially suited to the requirements of the Service Technician, the Audio Experimenter, the Factory and the Laboratory.

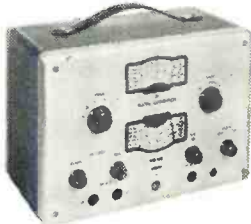

RF SIGNAL GENERATOR

Model WR-49A — Has DC isolated, cathode-follower outputs so that signals can be injected into any point in the circuit. New dial design facilitates accurate readings. Thorough shielding minimizes radiation, and hum pickup. Other outstanding features include:

- Frequency Range: 85 kc to 30 mc.
- Calibration accuracy on all bands $\pm 1\%$.
- Built-in 400-cycle oscillator for internal modulation or external use.
- Modulation continuously variable up to 70%.
- Attenuator Range: 65 db.
- Weighs only 8 lbs.

Complete with tubes, shielded cable, and instructions. **\$59.50**

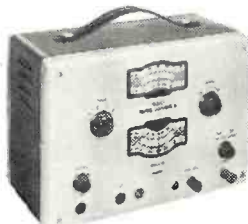

AUDIO SIGNAL GENERATOR

Model WA-44A—Extremely valuable for measuring performance of amplifiers, tone controls, equalizers, loudspeakers, and other audio circuits and components. Has DC isolated cathode-follower outputs so that signals can be injected into any point without loading the circuit or reflecting any reactance. Other outstanding features include:

- Frequency Range: 11 cps to 100 kc.
- Response ± 1 db.
- Additional 60-cycle signal for Intermodulation Distortion tests.
- Regulated oscillator power supply.
- Weighs only 10 lbs.

Complete with tubes, shielded cable, and instructions. **\$87.50**

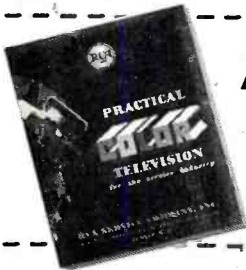

ORDER YOUR COPY OF RCA'S "PRACTICAL COLOR TELEVISION for the Service Industry"

58 pages of explanatory data, color illustrations, schematics, and charts, fully explaining the RCA Compatible Color Television System. This is an absolute must for any serviceman who plans to profit from this new opportunity. Price, only **\$2.00**

HARVEY Is Ready With A Complete Line of RCA Color Television Components

Harvey is always looking ahead . . . with an eye on latest developments. Whether you need equipment, components or other electronic parts, you can be quite certain to find them in Harvey's extensive stocks . . . ready for immediate 'off-the-shelf' delivery to you, anywhere.

Prices Net, F.O.B. N. Y. C. Subject to change without notice.

HARVEY RADIO CO., INC.

103 W. 43rd Street, New York 36, N. Y. • JUdson 2-1500

CUSTOM CABINETS *Elegance*

for TV and Hi-Fi at LOW COST!



FRENCH PROVINCIAL Closed View

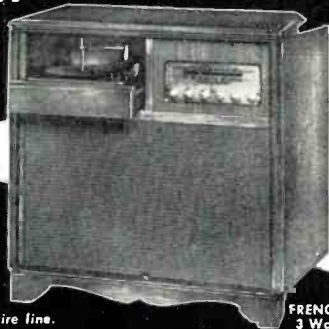

FRENCH PROVINCIAL 3 Way Combination

You get far more for your cabinet dollar when you buy *Standard*. Beautiful fidelity styling, choice select-grain woods, careful construction, functional design, acoustical correctness — all to the acknowledged *finest standards* of the industry.

Compare — Write now for FREE Catalog **T-4** showing our entire line.

Standard Wood Products Corp. / 47 West 63rd Street, New York 23, N. Y.

Spot Radio News (Continued from page 18)

appeared in a proposal calling for the establishment of fees to cover costs of licensing and allied activities. Based on provisions of the Independent Offices Appropriation Act of 1952, the proposed plan calls for a sliding-scale of charges for AM, FM, and TV applications for construction permits; modifications of construction permits or modifications of licenses involving change in power, frequency, location, and operation; licenses for new stations; renewals of licenses; assignment or transfer of permits or licenses, and special service authorizations.

Specifically, it is proposed to divide all applications for authorizations in the broadcast service into categories. For the first of these categories, involving major analysis and action by the Commission, a fee of \$325 is proposed. For all other applications in the broadcast services, the fee would be \$50.

A fee of \$10 would be charged, it was also noted, for the processing of all applications in the safety and special radio service bracket, with the exception of applications in the amateur, disaster, and RACES services, for which a \$3.00 charge would be made.

Other proposed fees would cover applications for experimental services (\$20); and approvals and type specifications of diathermy and other r.f. gear, for which \$100, \$600, and \$1500 charges would be made.

In supporting its request, the Commission reported that it had been determined that during '53 approximately 45% of the body's entire expenditures were directly or indirectly related to licensing, and this percentage was utilized as a full-cost recovery base from which the fees were derived.

The fee proposal was viewed by Madame Commissioner Frieda Hennock as a particularly important document, which should be discussed at a public hearing. She felt that the decision to license broadcasters was an especially delicate issue. For example, she said, in the broadcast field, the . . . "public policy or interest served . . ." might be shown to . . . "far outweigh all other factors and justify no fee, or at the most, only a nominal application fee to emphasize the overwhelming public interest consideration and to impress upon the applicants the importance of the public responsibility that goes with a broadcast license."

Continuing, Miss Hennock added that the value of . . . "broadcast license and the public policy and interest served might require a graduated scale of fees rather than a uniform fee determined on the basis of a formula which does not seem to take into account either the size, type, or location of a station, of the relative importance of the applications." Analyzing this problem, she said that the fee proposed would be . . . "the same for every

the same for every

RADIO & TELEVISION NEWS

Now a

COLOR

TELEVISION HOME STUDY COURSE

by RCA Institutes



"Color Television is here—not around the corner, or in the developmental labs, but here! The big question now is . . . Are You ready for Color TV?"

"You may now have a successful TV servicing business. When color sets come to your bench for servicing, will you be able to handle them?"

"Color Television is a vast new field, embodying entirely new concepts . . . principles of light and vision, radically new circuitry."

First Home Study Course in Color TV

Now is the time to prepare. Now, for the first time, you can train yourself for the

opportunities in this brand-new field. The just-announced RCA Institutes Home Study Course is the *first* home study course covering all phases of color television. Offered only to those already experienced in radio-television servicing, it explains the "why" of basic theory, as well as the "how-to-do-it" of servicing techniques.

Planned and written by RCA instructors, the entire course is based on the practical experience of RCA engineers—the men who have pioneered in the research and development of color television since the very first color experiments, many years ago.

Remember when black-and-white television first became a reality? Overnight, the demand for men who knew television grew. Even now, a shortage of qualified servicemen exists. Think, then—of the even greater demand for servicemen who will understand the many additional problems of color reception!

Costs so little to gain so much

RCA Institutes makes it easy for you to prepare yourself now for color television. Not only is the cost of the home study course for qualified servicemen extremely low, but you pay for the course on a pay-as-you-learn basis.

RCA Institutes conducts a resident school in New York City offering day and evening courses in Radio and TV Servicing, Radio Code and Radio Operating, Radio Broadcasting, Advanced Technology. Write for free catalog on resident courses.

Send for **FREE Booklet**—Mail the coupon, today. Get complete information on the RCA INSTITUTES Home Study Course in Color Television. Booklet gives you a general outline of the course lesson by lesson. See how thoroughly you can learn Color TV. Mail coupon in envelope or paste on postal card.



MAIL COUPON NOW!

RCA INSTITUTES, INC., Home Study Dept. RM154
350 West Fourth Street, New York 14, N. Y.

Without obligation on my part, please send me copy of booklet "RCA INSTITUTES Home Study Course in COLOR TELEVISION" (No salesman will call.)

Name _____ (please print)

Address _____

City _____ Zone _____ State _____



RCA INSTITUTES, INC.

A SERVICE OF RADIO CORPORATION of AMERICA
350 WEST FOURTH STREET, NEW YORK 14, N.Y.

April, 1954

THE TEST OF TIME

Has proven
ROHN TOWERS
Superior!

IN CONSTRUCTION

Rohn Towers are built of heavy duty tubular steel electrically welded throughout by skilled workmen exactly to specifications. Proof of Rohn construction lies in the fact that thousands of towers have been sold in the past several years and have successfully withstood the rigors of time in all climates and under the severest of conditions!

IN PERFORMANCE

Rohn Towers assure you of trouble-free performance and once installed give unquestioned satisfaction year in and year out! You are free of complaints because over the years Rohn Towers have proved themselves from the serviceman, dealer and customer point of view!

IN SALES

Sales acceptance has been phenomenal — thousands have been sold coast-to-coast — and the design has been one which has withstood every test known! Why "experiment" with an unproved tower design when you can sell Rohn?

So we ask you, "Why take chances with an untried tower? Be sure — sell Rohn — the only tower of its kind to withstand every test!"

Rohn Fold-Over Tower
 only one of its kind
 exclusive with
 Rohn —
 patent
 pending.

Rohn Telescoping
 Mast — complete
 line in a proven
 structural
 design in 20'
 —30'—40'—
 50' models.

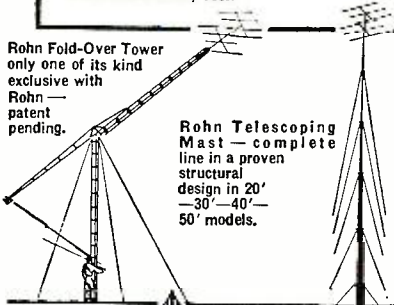

MANUFACTURING CO.
 DEPT. RTN 116 LIMESTONE BELLEVUE
 PEORIA, ILL.

3 Self Supporting Rohn Towers To Fit Your Every Need

The No. 5 — The self-supporting tower for use up to 40', or guyed to 80'. An economical, yet sturdy, permanent tower!

The No. 10 — The standard 12' design that is self-supporting to 50' and can be installed to 120' when guyed!

The No. 20 — The heavy duty Rohn Tower, ideal for communication and where great height is required — self-supporting to 60', or guyed to 150'!

All Rohn Towers are in 10' sections — easily erected, transported and stored!

A COMPLETE LINE OF TOWER ACCESSORIES AND HARDWARE

A full line of Superior Designing Tower accessories is available including guying brackets, house brackets, wall mounts for towers and masts, special tower bases such as peak and flat roof mounts, etc.

Contact your Rohn authorized representative or your distributor for FREE CATALOG or write . . .

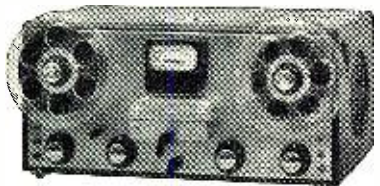

NOW for the first time—true broadcasting quality priced low enough for all to enjoy. Six years development has resulted in the only recorder of its price meeting NARTB broadcasting standards.

- 3 speeds—15", 7½", 3¾"
- ± 2 db 30-11000 cps at 7½"/sec.
- 3 motor mechanism. 2 inputs
- less than .25% flutter and wow
- 20 watt hi-fi amp. built in
- 8" 10 watt speaker built in

Write today for free brochure to Dept. R4
 Dealer Inquiries Invited

INTERNATIONAL RADIO & ELECTRONICS CORP. • ELKHART, INDIANA

Builders of Broadcast Equipment Since 1938

broadcast application and for many different types of applications; an applicant for a standard broadcast station and an applicant for a v.h.f. TV station in a large metropolitan area; a struggling FM operator seeking a change in location or modification of his license, as well as a prosperous licensee of a TV station."

Discussing a similar drawback in the safety and special service fee proposal, the Commissioner said that a graduated scale should obtain here too, based on types of service and purposes for which the services were to be used.

A UNIQUE ALTIMETER using frequency shifting, that can measure altitudes as low as two feet, has been developed by a trio of experts at the Bureau of Standards. Called the non-quantized frequency-modulated altimeter, the instrument now makes it possible for a helicopter pilot to know when his craft is within several feet of the landing surface, whereas conventional altimeters give information only to the closest 10 to 20 feet. The device operates in the X band or at 10,000 megacycles.

Analyzing the design of this development, the Bureau pointed out that most frequency-modulated altimeters for aircraft generate high-frequency signals and direct the radio energy along a narrow path. When the radiated energy strikes a reflecting surface, as the deck of a ship, it returns to the transmitter-receiver location essentially along the same path. Then electronic circuits translate into feet or miles the period elapsed between the time the signal left the transmitter and the time it returned to the receiver. Under ideal conditions, the frequency of such an altimeter should be continuously variable, starting at zero frequency and continuing to higher and higher frequencies. The distance between the transmitter and the ground would then be computed electronically from the frequency difference between the received signal at one instant and the transmitted signal at that same instant. With such a continuously-variable generator, the frequency of the received signals would always be lower than the transmitted signal by an amount dependent on the instantaneous distance from the ground.

However, it was noted, since transmitters cannot be continuously varied between zero and an infinitely high frequency, altimeters in actual practice generate a relatively narrow band of frequencies and transmit this range at a recurring rate. Thus the distance-dependent time delay between the transmitted and received signals still forms the basis for measuring altitude, but in conventional models the recurrence of like frequencies within short intervals introduces an error that prohibits the accurate detection of altitudes less than 10 or 20 feet. In addition, it has been found, conventional altimeters operate under a quantized system, in which integral distances,

Push the tube that PROTECTS YOU TWO WAYS!

**SYLVANIA
PICTURE TUBES
GUARD YOUR
REPUTATION
AND PROFITS!**



Be sure to show your customers the name SYLVANIA now etched on the lower left face of every Sylvania Picture Tube.

These letters are small in size (imperceptible when the tube is lighted), but they're mighty big in importance! For, they identify a genuine Sylvania Picture Tube... the tube found best in exhaustive tests conducted by an independent laboratory on tubes of 9 different makes.

Naturally, this high performance record helps maintain your reputation. It

also helps protect your profits... eliminates customer complaints and costly call-backs.

Remember, most customers regard a picture tube as an important investment. So, you're doing them a valuable service when you sell them the best their money can buy... a SYLVANIA! For new characteristics booklet covering all the latest Sylvania Picture Tubes, call your regular Sylvania Distributor or write direct to Dept. 4R-3504 Sylvania today!

Sylvania Television Program telling millions!

Most of your customers have seen and heard about Sylvania's high quality during the big popular show "Beat the Clock" on CBS-TV. Week after week, from coast to coast, the facts about Sylvania quality are being demonstrated to millions.



Get this new booklet for your files!

SYLVANIA

Sylvania Electric Products Inc.  1740 Broadway, New York 19, N. Y.

In Canada: Sylvania Electric (Canada) Ltd.
University Tower Bldg., St. Catherine Street, Montreal, P. Q.

LIGHTING • RADIO • ELECTRONICS • TELEVISION

April, 1954

87

The C-800 is here
to bring you new
record performance!



the new
craftsmen 800
FM-AM TUNER
with built-in phono
preamplifier and
record equalizer

Now—Craftsmen brings you a tuner that matches all your finest records . . . is setting new records for versatility, too. The C-800 is further evidence that Craftsman leadership in high fidelity is something you can put your finger on, something you can hear.

- Front-panel-selected equalization for AES, LP or EUROpean recording characteristics. Inverse feedback compensated dual-triode phono preamp for correct turnover and roll-off characteristics.
- Improved AM reception. Wider bandwidth for better fidelity, and sharper IF bandpass "skirts" for greater selectivity.
- Double-shadow tuning eye and AFC (no drift) on FM simplifies tuning. Front-panel AFC cut-out for tuning weak stations.
- Efficient new layout. Bottom plate, completely shielded chassis minimize oscillator radiation, assure tuner isolation.
- Cathode follower audio output for remote installations; 2 volts at less than 1/2% dist. Detector output also has cathode follower for recording applications.
- Bass and treble controls continuously variable from attenuation to boost—flat position clearly marked. Selector positions: FM, FM with AFC, AM, TV, LP, AES, EUR, and SPare.
- Mahogany-finish wood cabinet available.

HIGH FIDELITY — LOW COST! C-400 audio amplifier offers 10 watts ± 1 db., 15 — 20,000 cps., less than 1% distortion. New streamlined chassis design.

Write today for information

THE RADIO

craftsmen INC.

Dept. 4-R, 4401 N. Ravenswood Ave.
Chicago 40, Ill.



such as 10, 20, or 30 feet, are added, and the average over a period of time is a measure of the altitude of the transmitter. This system has been found efficient and accurate in the measurement of higher altitudes, but it does not provide accurate values of very low altitudes.

In the new altimeter, a small portion of the transmitted signal is fed through a frequency shifter and is then combined with the signal received from the ground. The frequency shifter may be either an electrical or mechanical device designed to produce a new signal with a frequency displaced by a constant amount (about 100 cycles) from the frequency of the transmitted signal. The combined signals, from the frequency shifter and the ground, are rectified, amplified, and then fed into a counting-averaging mechanism.

PLAGUED by a backlog of petitions, application amendments, deletion requests, and assorted legal problems, new station grants continued to be slow during the early months of the year. Undoubtedly with the expanded hearing force in full swing now, authorizations will soon step up.

Notwithstanding the return of about 40 applications for new stations, mostly in the ultra-high bands, a stream of applicants have continued to request assignments on the ultra high bands throughout the country. The interest, Washington reports, is as keen as ever.

At this writing, those listed in box below, received construction permits,

and a number also received official calls for their new stations.

INDUSTRY WAS SHOCKED to hear of the death of its most colorful scientist, Major Edwin Howard Armstrong, whose bold inventions played so vital a role in the development of modern broadcasting and AM and FM receivers.

Responsible for the famous superhet, the improved regenerative circuit, and the perfection of the FM system, the Major (as he preferred to be known even though he had been a professor of electrical engineering at Columbia and a holder of doctorate degrees) had devoted his entire life to research and invention. His eagerness and fervid interest in searching for the ultimate in reception and transmission will never be forgotten . . . L.W.

SPRING TV MEET

PLANS have been finalized for the Eighth Annual Spring Television Conference being held April 24th at the Engineering Society Building in Cincinnati.

Sponsored by the Cincinnati Section of the IRE in cooperation with The Professional Group on Broadcast and TV Receivers, the one-day session will include nine technical papers and a banquet at which Axel G. Jensen, director of TV research, Bell Telephone Laboratories, will be the speaker.

Clyde G. Haehle, c/o Crosley Broadcasting Corp., 140 W. Ninth St., Cincinnati 2, Ohio, is publicity chairman of the meet.

—30—

NEW TV GRANTS SINCE FREEZE LIFT

Continuing the listing of construction permits granted by FCC since lifting of freeze. Additional stations will be carried next month.

STATE	CITY	CALL	CHANNEL	FREQUENCY (mc.)	POWER* (Video)
Arkansas	Hot Springs	9	186-192	12.6
Georgia	Albany	WALB-TV	10	192-198	50.1
Iowa	Sioux City	KCOM†	4	66-72	46.18
Louisiana	Alexandria	KALB-TV†	5	76-82	5
Minnesota	Hibbing	10	192-198	10.5
North Carolina	Durham	WTIK-TV	11	198-204	316
Pennsylvania	Erie	66	782-788	30
	Sharon	39	620-626	1.7
Texas	Corpus Christi	22	518-524	20.5
	Tyler	KGKB†	7	174-180	20.4











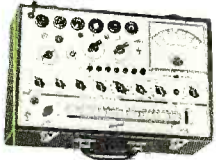

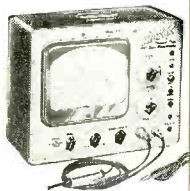
NEW CALL LETTER ASSIGNMENTS

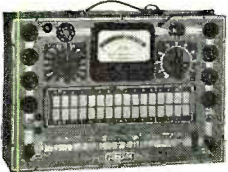
California	Fresno	KBID-TV	53	704-710
	Sacramento	KBIE-TV	46	662-668
Florida	West Palm Beach	WMIE-TV	27	548-554
Georgia	Alexandria	KALB-TV	5	76-82
	Thomasville	WCTV	6	82-88
Kansas	Topeka	KTKA	42	638-644
Kentucky	Newport	WNOP-TV	74	830-836
Michigan	Detroit	WCIO-TV	62	758-764
Mississippi	Jackson	WLBT	3	60-66
Missouri	Joplin	KSWM-TV	12	204-210
Pennsylvania	Erie	WLEU-TV	66	782-788
South Carolina	Greenville	WFBC-TV	4	66-72
Virginia	Richmond	WOTV	29	560-566
Wisconsin	Marinette	WMGB-TV	11	198-204

*ERP = (effective radiated power, kw.). . . = Call letters to be announced
† = Temporary call letters.

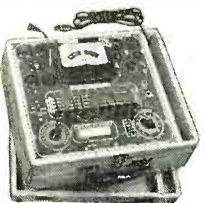

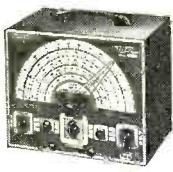
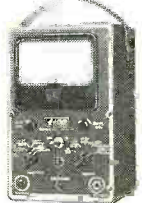
You Will Never Be Fooled With A Walter Ashe "SURPRISE" Trade-In

TUBE TESTERS	OSCILLOSCOPES	TV GENERATORS	VACUUM TUBE VOLTMETERS	NEW ITEMS
 <p>HICKOK 600A Net \$164.00</p>	 <p>RCA WO-88A Net \$149.50</p>	 <p>HICKOK 610A Net \$219.00</p>	 <p>HICKOK 209-A Net \$132.50</p>	 <p>RADION UHF-VHF TV Field Strength Meter, Battery Operated. Net \$97.50</p>
 <p>JACKSON 648B Net \$102.41</p>	 <p>HICKOK 665 Net \$129.50</p>	 <p>PRECISION E-400 Net \$136.95</p>	 <p>RCA WV-97A Net \$67.50</p>	 <p>SPRAGUE KT-1 Kwik Test Capacitor Checker Net \$33.81</p>
 <p>SUPERIOR TV-11 Net \$46.55</p>	 <p>EICO 470 Kit Net \$79.95 Wired and Tested Net \$129.50</p>	 <p>EICO 360 Kit Net \$34.95 Wired and Tested Net \$49.95</p>	 <p>EICO 221 Kit Net \$25.95 Wired and Tested Net \$49.95</p>	 <p>SUPERIOR TV-40 CRT Tube Tester Net \$15.53</p>

All prices f. o. b. St. Louis • Phone Chestnut 1125

Walter Ashe
RADIO CO.
1125 PINE ST. • ST. LOUIS 1, MO.

FREE CATALOG!

R-4-54

WALTER ASHE RADIO COMPANY
1125 Pine Street, St. Louis 1, Missouri

Rush "Surprise" Trade-In Offer on my _____

for _____
(show make and model number of new equipment desired)

Send new FREE 1954 Catalog.

Name _____

Address _____

City _____ Zone _____ State _____

**Send
for
your
copy
today**

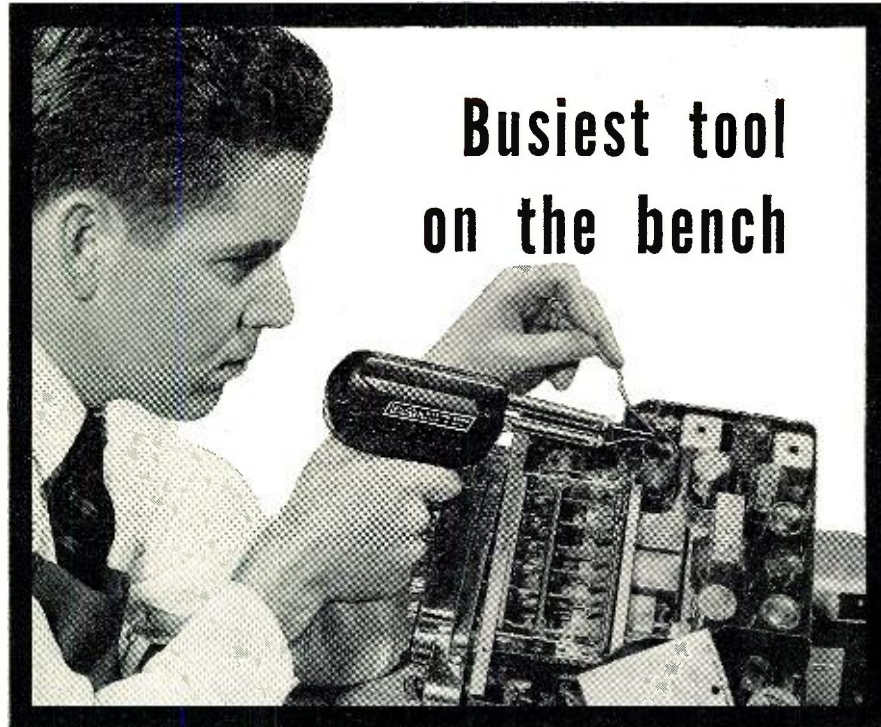

Busiest tool on the bench

**The new Weller Soldering Gun—the tool that finishes
the job before ordinary soldering tools warm up!**

Weller's newest models—

Go anywhere inside circuit-jammed chassis of smallest portables and table models. Slim streamlining and longer reach makes tight spots a cinch—in a fraction of the normal time.

Get hot instantly with click of trigger. Another click and—power is instantly boosted—up to 275 watts!

Give wide selection of power for every job—100, 135, 200, 250, and now—275 watts! Light and heavy duty models, either single or dual heats.

You'll like the perfect balance and slim lines, too—on all latest Weller models. Ask your distributor for a demonstration, or write direct for bulletin.

Weller

**Better from Grip to Tip
SOLDERING GUNS**

810 Packer Street, Easton, Pa.

**... FIRST CHOICE with
servicemen because
Fenwire is BEST by TEST**

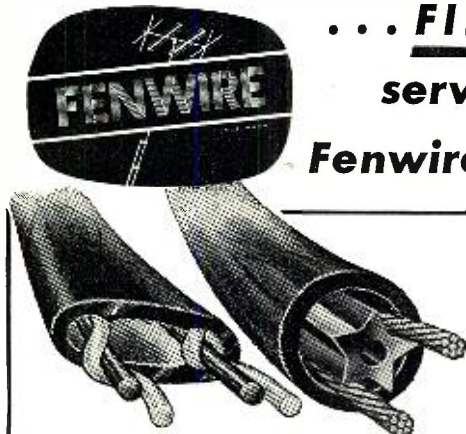

*FENTUBE-AIRSPACED and *TWISTUBE are outstanding for high performance—low loss—stable characteristics under all atmospheric conditions—reduced interference pick up—reasonable price.

Write Dept. RN-4 for literature on complete FENWIRE line including "TUF-GUY" . . . finest guywire made.

(Sold through jobbers only.)

*U.S. & British Pat. Pending

FENTON COMPANY • 15 Moore Street, N. Y. 4, N. Y. Tel. Bowling Green 9-3445

The Vibrato

(Continued from page 53)

down the higher will be the rate of frequency change. (Also, to a minor extent in practice, the greater will be the apparent total frequency variation.) If the arm travels all the way to the ends of the pot the frequency will vary to its greatest extent; but if it moves only a little way each side of center the amount of frequency change will be small. Obviously then, the vibrato rate and width (or depth) can both be controlled.

The filter which follows the potentiometer is there to remove the frequency component representing the movement of the pot arm itself, which is below 10 cycles.

Electronic Circuits

In the actual device there are no moving parts; the whole job is done by invisible electrons. The entire circuit is diagrammed in Fig. 3.

In the "universal vibrato" pre- and post-amplification have been added to the vibrato circuit itself to make it more versatile. V_{3A} is a preamplifier for low-level inputs. The high-level input is satisfactory for most purposes. When it is used with the volume control at maximum the device has approximately unity gain, and the output voltage is practically identical to the input. V_{1B} is the output amplifier, a cathode-follower, allowing a long line to the main amplifier.

The first tube of the vibrato circuit itself is V_{2A} , the phase splitter. It looks like an ordinary "long-tailed" phase splitter, with equal loads in cathode and plate circuits to produce two outputs 180 degrees apart. And this is just what it is.

The requirement for the vibrato circuit is to obtain two voltages which are about 90 degrees apart at all frequencies. Phase-shifting circuits are quite common, but the amount of phase shift, as well as the amplitude of the output, in any single circuit is entirely dependent on frequency. To make the phase separation fairly independent of frequency it is possible to take two voltages 180 degrees apart and pass them through phase-shift networks so designed that as one signal shifts in phase due to frequency the other also shifts in such a manner as to keep the angle between the two at about 90 degrees. The angle of either changes with frequency with respect to the original signal entering the phase splitter. But this does not matter as long as we can derive two signals whose separation in phase remains constant. An article, "Phase Angle Measurements at A.F.", in the *Radio-Electronic Engineering* Edition of this magazine for July, 1953, explains this in detail and gives the calculations, though for a different purpose.

In Fig 3 the result is produced by the networks R_8-C_5 , C_4-R_9 , $R_{10}-C_7$, C_6-R_{11} , C_5-R_{12} , and C_6-R_{13} . The two signals

RADIO & TELEVISION NEWS

NO INTEREST!!

Buy on our radically new
Time Payment Plan

NO CARRYING CHARGES!!



Measures 6 1/4" x 9 1/2" x 4 1/2"

Superior's new
Model 670-A

SUPER METER

A COMBINATION VOLT-OHM MILLIAMMETER PLUS
CAPACITY REACTANCE INDUCTANCE AND DECIBEL MEASUREMENTS

SPECIFICATIONS:

D.C. VOLTS: 0 to 7.5/15/75/150/750/1,500/7,500 Volts
A.C. VOLTS: 0 to 15/30/150/300/1,500/3,000 Volts
OUTPUT VOLTS: 0 to 15/30/150/300/1,500/3,000 Volts
D.C. CURRENT: 0 to 1.5/15/150 Ma. 0 to 1.5/15 Amperes
RESISTANCE: 0 to 1,000/100,000 Ohms 0 to 10 Megohms
CAPACITY: .001 to 1 Mfd. 1 to 50 Mfd. (Quality test for electrolytics)
REACTANCE: 50 to 2,500 Ohms, 2,500 Ohms to 2.5 Megohms
INDUCTANCE: .15 to 7 Henrys 7 to 7,000 Henrys
DECIBELS: -6 to +18 +14 to +38 +34 to +58

ADDED FEATURE:

The Model 670-A includes a special **GOOD-BAD** scale for checking the quality of electrolytic condensers at a test potential of 150 Volts.

The Model 670-A comes housed in a rugged, crackle-finished steel cabinet complete with test leads and operating instructions.

\$28⁴⁰
NET



Superior's new
Model TV-11

TUBE TESTER

SPECIFICATIONS:

- ★ Tests all tubes including 4, 5, 6, 7, Octal, Lock-in, Peanut, Bantam, Hearing Aid, Thyatron, Miniatures, Sub-Miniatures, Novals, Sub-minars, Proximity fuse types, etc.
- ★ Uses the new self-cleaning Lever Action Switches for individual element testing. Because all elements are numbered according to pin-number in the RMA base numbering system, the user can instantly identify which element is under test. Tubes having tapped filaments and tubes with filaments terminating in more than one pin are truly tested with the Model TV-11 as any of the pins may be placed in the neutral position when necessary.
- ★ The Model TV-11 does not use any combination type sockets. Instead individual sockets are used for each type of tube. Thus it is impossible

to damage a tube by inserting it in the wrong socket.

- ★ Free-moving built-in roll chart provides complete data for all tubes.
- ★ Newly designed Line Voltage Control compensates for variation of any Line Voltage between 105 Volts and 130 Volts.
- ★ **NOISE TEST:** Phono-jack on front panel for plugging in either phones or external amplifier will detect microphonic tubes or noise due to faulty elements and loose internal connections.

The model TV-11 operates on 105-130 Volt 60 Cycles A.C. Comes housed in a beautiful hand-rubbed oak cabinet complete with portable cover.

\$47⁵⁰
NET

EXTRA SERVICE—The Model TV-11 may be used as an extremely sensitive Condenser Leakage Checker. A relaxation type oscil-

lator incorporated in this model will detect leakages even when the frequency is one per minute.

SUPERIOR'S NEW MODEL TV-40



C.R.T. TUBE TESTER

A complete picture tube tester
★ for little more than the price of a "make-shift" adapter!!

★ Tests all magnetically deflected tubes . . . in the set . . . out of the set . . . in the carton!!

SPECIFICATIONS:

- Test all magnetically deflected picture tubes from 7 inch to 30 inch types.
- Tests for quality by the well established emission method. All readings on "Good-Bad" scale.
- Tests for inter-element shorts and leakages up to 5 megohms.
- Test for open elements.

EASY TO USE:

Simply insert line cord into any 110 volt A.C. outlet, then attach tester socket to tube base (Ion trap need not be on tube). Throw switch up for quality test . . . read direct on Good-Bad scale. Throw switch down for all leakage tests.

Model TV-40 C.R.T. Tube Tester comes absolutely complete—nothing else to buy. Housed in round cornered, molded bakelite case. Only

\$15⁸⁵
NET

MOSS ELECTRONIC DISTRIBUTING CO., INC.
Dept. B-97, 3849 Tenth Ave., New York 34, N. Y.

Please send me the units checked. I am enclosing the down payment with order and agree to pay the monthly balance as shown. It is understood there will be no carrying interest or any other charges provided I send my monthly payments when due. It is further understood that should I fail to make payment when due, the full unpaid balance shall become immediately due and payable.

Name
Address
City Zone State

- MODEL 670-A Total Price \$28.40 \$7.40 down payment. Balance \$3.50 monthly for 6 months.
- MODEL TV-11 Total Price \$47.50 \$11.50 down payment. Balance \$6.00 monthly for 6 months.
- MODEL TV-40 Total Price \$15.85 \$3.85 down payment. Balance \$4.00 monthly for 3 months.
- I enclose \$ as down payment.
- Ship C. O. D. for the down payment.

**HUDSON RADIO & TELEVISION
CORP.**

48 W 48th ST., NEW YORK 36, N. Y.
212 FULTON ST., NEW YORK 7, N. Y.
35 WILLIAM ST., NEWARK 2, N. J.

by itself

IN A CLASS

NC-98 \$149⁹⁵

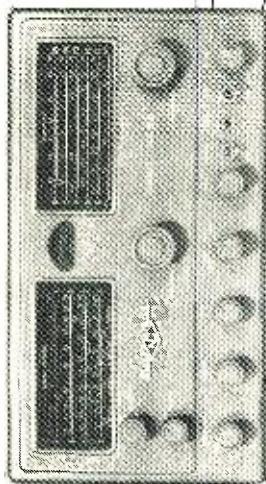

National



THE NEW

present at points *A* and *B* are sufficiently close to 90 degrees apart at all audio frequencies to give the needed result.

Each of these signals is fed through a 0.1- μ fd. blocking condenser to one grid of V_3 . The plates of V_3 are connected through separate 15,000-ohm resistors (for isolation) to a common load resistor R_{17} . At this point, assuming the tube operates normally, we would have a single signal of the same waveshape as the input with phase halfway between those of the signals at *A* and *B*.

The tube is actually operating as an electronic switch, however. To points *C* and *D* is connected a locally generated signal of a frequency between 5 and 8 cycles. When this signal makes point *C* most negative and point *D* most positive, the left triode of V_3 is cut off and the right triode has maximum gain; the reverse is true as well. Thus at one time the signal from point *A* appears at the output and at another the signal from point *B* appears. This means that the output of V_3 is constantly changing in phase, which will appear as a constant change in frequency. We have thus frequency-modulated the audio input signal and imparted a genuine vibrato to it.

The network C_{12} - C_{13} - C_{15} - R_{20} - R_{21} - R_{24} is a high-pass filter, of which R_{24} also acts as a volume control. The filter prevents the switching action of V_3 from appearing in the output as amplitude modulation of the signal. Some AM may appear but it contributes to the pleasantness of the effect. The filter also reduces the low-frequency response of the system somewhat, but this is unimportant for most musical instruments, which do not generate tones low enough to be affected. If necessary a sharp-cut-off LC filter can be substituted, tuning for a cut-off just below the lowest musical note to be passed.

The switching signal is generated by V_1 , which is a simple RC sub-audio oscillator. The frequency is determined by C_{19} , R_{23} , C_{20} , and the series value of R_{21} and R_{23} . R_{23} is the vibrato rate control which varies the oscillator frequency to determine how fast the vibrato should be. S_1 stops oscillation when it is closed, removing the vibrato.

The oscillator output is carried through C_{21} and R_{22} to a potentiometer R_{26} . The arm of this pot goes to the grid of V_{2B} , the vibrato phase splitter. R_{26} is the width control, which determines how much frequency change there will be on each vibrato cycle.

While V_{2B} is a phase splitter of the same type as V_{2A} , no further phase-shifting networks are added. The two 180-degree-separated low-frequency signals are fed to the two grids of V_3 in push-pull as the switching signals.

Construction

In the case of this particular gadget it is impossible to claim that the neatest possible layout was made.

AIREX'S HI-FIDELITY 1954 CO-CHANNEL 630FA-2A GENUINE FM ARMSTRONG SOUND SYSTEM READY FOR COLOR CONVERTER

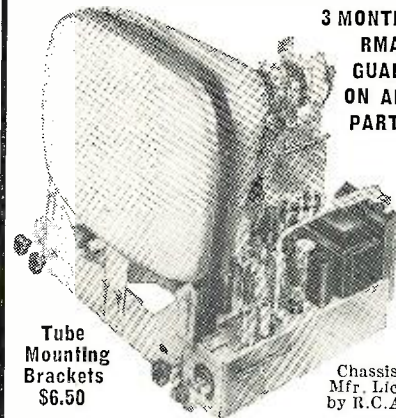

**3 MONTHS
RMA
GUAR.
ON ALL
PARTS**

Tube
Mounting
Brackets
\$6.50

Chassis
Mfr. Lic.
by R.C.A.

CHECK THESE EXCLUSIVE FEATURES

- 10 WATT push-pull audio output. Frequency range from 40 to 12,000 cycles • 3 position fringe area switch • Delayed gated AGC system • Standard Coil Cascade Tuner prevents radiation • Retrace Blanking Circuit allows you to raise the brightness without the annoying vertical retrace lines • Heavy duty front focus control • Automatic gain control potentiometer allows you to adjust the threshold sensitivity as low as 4 microvolts & still keep the full 4 MC band width • Improved sync amplifier • Improved automatic brightness control • Set aligned for 21.9 MC. New Ham band will not interfere • Improved fused high voltage power supply gives full 14.5 KV under load. Will handle all picture tubes up to 24 inch round with full sweep • Improved video amplifier has a gain of 40 • All moulded plastic condensers give long life & trouble-free operation • Easily adapted to new UHF stations in 2 minutes by just changing a strip in the tuner
- Extra heavy duty power transformer with large safety factor • 6CB6 tubes in Video IF to give full gain • Extra filtering in power supply for hum & ripple-free operation • Phono Connection & switch on chassis allows you to play your phonograph or tuner through the built-in 10 watt hi-fidelity amplifier • Extra heavy duty focus coil, which runs cool • Full focus cosine yoke.

THE ONLY CHASSIS WITH 10 WATT PUSH-PULL HI-FI AUDIO SYSTEM AT

\$169⁹⁵

Fed. Tax Included Less C.R. Tube and Brackets

Complete with Two Speakers—12" Hi-Fi
Woofer and Tweeter

With UHF 83 Channel Converter—\$211.90
Detailed Service Manual & Schematic—\$1

COMBINATION SAVING!

• 630 FA-2A Chassis
• 21" Picture Tube
• Mah. Console Cabinet
With mask, glass, tube mtg brackets
FOR THE 3 UNITS

This Month
Only

\$244⁹⁵

Fed. Tax
Incl.

TV PICTURE TUBE SALE

Standard Brands, Factory
New, Guar. 1 year.

- 17" Tube...\$27.95
- 20" Tube...\$34.95
- 21" Tube...\$39.95
- 24" Tube Round
(Guar. 6 Mos.)...\$79.95
- 24" Rect...\$59.95
- 27" Tube Rect...\$79.95
- Ring and Sleeve
for 24" Round...\$ 7.50

**630 CHASSIS
FOR 24" & 27" RECT.
OPERATION \$189⁹⁵**

PRICE
Not push pull audio

**TV GOLD
PLASTIC MASKS**

- 16" and 17" \$ 4.95
- 20" and 21" \$ 7.95
- 24" \$14.95

630 UHF
converter . . . \$34.95

BARGAIN CABINET BUY

Beautiful mahogany console cabinet cut
for 630 FA-2A Chassis. Complete with
mask, glass & tube mounting brackets..

\$49.95

In Blond \$59.95

Send for complete cabinet brochure

FREE—New TV—Hi-Fi PARTS CATALOG

All merchandise brand new, factory fresh, guaranteed.
Mail & phone orders filled upon receipt of certified
check or money order for \$25 as deposit on TV chassis.
20% on other items. Balance C.O.D., F.O.B.
factory N. Y. Prices & specifications subject to change
without notice. NO FED. TAXES TO PAY.

AIREX RADIO CORP.

SHOWROOM: 171 Washington St., N. Y. 7
Gramercy 7-9245

Probably not enough time was spent figuring out on paper exactly what underchassis room had to be made available where. However, the model was not really too far off and readers can do a better job by noting where the crowding occurs and acting accordingly.

The basic unit is an "amplifier foundation" 10 1/4" long and 5" wide. The circuit could probably be built on a slightly smaller chassis but this size seems about the best. The chassis-cover "foundation" unit is more useful than a chassis-and-cabinet setup because all controls can be on the chassis apron without looking incongruous. Where there is a cabinet the controls ought to be on the front panel, which would require long leads coming through the chassis.

Fig. 1 shows the chassis top with the cover removed. At lower left is V₁, with V₂ to its right. The tubes at the rear are, left to right, V₄, V₃, and V₅. The underchassis view of Fig. 4 shows that the filter choke is mounted under the power transformer by two of the same screws that hold the transformer down. Switch S₁, the vibrato "on-off" switch, is a surplus item taken from an SCR-274-N antenna junction box, but any kind can be used.

The reader with a vibrato requirement need not, of course, build his unit just as this one was designed. If it is convenient it can be built into an amplifier between any two stages that do not handle more than 10 volts of audio. In that case it can use the amplifier's power supply. The "B" requirements are only about 15 ma., although the existing filament transformer should be looked over to be sure that it will stand an additional 900 ma. drag required by the vibrato-circuit tubes, V₂, V₃, and V₄ in Fig. 3.

In using the "universal vibrato" with instruments which are primarily acoustic (where amplification need not be used or where the acoustic sound will be louder than the amplified sound) the way to add the vibrato is to make a recording, placing the vibrato between microphone and amplifier or between two amplifier stages. Instruments of this kind include pianos, pipe organs, and the like.

-30-

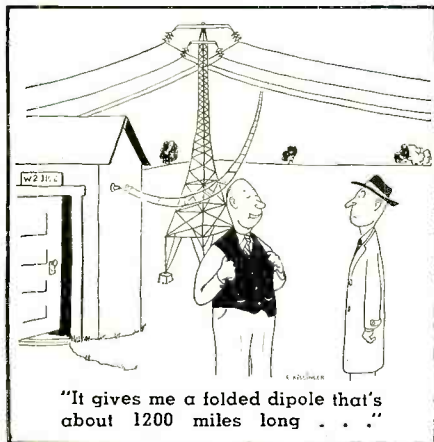

"It gives me a folded dipole that's about 1200 miles long . . ."

April, 1954

Here's how RCA INTERMATCHED COMPONENTS take the mystery out of High Fidelity

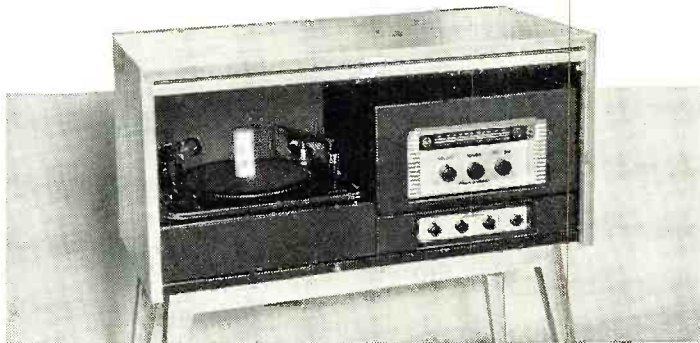

RCA Intermatched High-Fidelity cabinet and enclosures
house any selection of components you may choose.

If you're interested in high fidelity . . . interested in the beauty of music, beautifully reproduced, but confused about how to select the system you want . . . here's how you can have everything you want in high fidelity *plus the assurance of the RCA name on every component in your system.*

Here is professional-grade equipment—bearing the best known name in professional sound—designed to bring the concert hall and the recording studio into your home. Here is RCA's broad background in acoustics and profes-

sional sound reproduction in equipment selected to meet your needs, your taste in high fidelity, and your budget.

In RCA's broad line you can find an almost limitless number of combinations—and the *one* combination you want. Because these units are all *intermatched*, you can develop your own system without a technical background—without fear of mismatch at any stage. It's the easy way to choose . . . it's the sure way to get what you want in high fidelity.

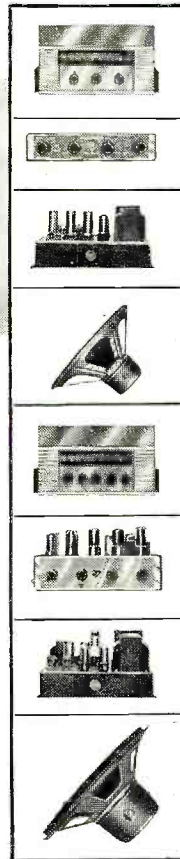

Work out any system you want—Select from
these typical combinations—or plan your own
HEAR THEM AT YOUR RCA ELECTRONICS DISTRIBUTOR'S

	TUNERS		AMPLIFIERS			SPEAKERS				
	Record Changer (SRC-51)	Pre-Amplifier (SV-1)	ST-1	SVT-1	SVP-10 (10-watt)	SP-10 (DeLuxe 10-watt)	SP-20 (DeLuxe 20-watt)	SL-8	SL-12	LC-1A
Quality record reproduction at low cost	X				X			X		
Quality record and radio reproduction at low cost	X		X		X			X		
Extended range record reproduction, medium price	X	X				X			X	
Extended range record and radio reproduction, medium price	X			X		X			X	
DeLuxe quality record reproduction	X	X					X			X
DeLuxe quality record and radio reproduction	X			X			X			X

"Professional-Grade"
High Fidelity
from RCA—
LEADER IN SOUND



RADIO CORPORATION of AMERICA

RCA Engineering Products
Dept. B222, Building 15-1, Camden, N. J.

- Please send me your new, free booklet on RCA Intermatched high-fidelity equipment.
- Please send me information on the new complete RCA high-fidelity "Victrola"® phonographs.

Name _____
Address _____
City _____ Zone _____ State _____

Read
the news
on
page 21?



Centralab

announces

new

ceramic
high-voltage
disc capacitors

Turn to the
Centralab

announcement

now

NEW TV PRODUCTS on the Market.....

TV TEST EQUIPMENT

The Hickok Electrical Instrument Company, 10524 Dupont Ave., Cleveland 8, Ohio is now offering two new test instruments for TV service applications.

The Model 695 television sweep generator features a sweep signal which is absolutely linear and without amplitude modulations. The instrument fea-



tures continuous tuning and an easy-to-read scale which is marked off in channels to provide a foolproof method of tuning. Three r.f. oscillators provide complete v.h.f. coverage on fundamentals with a high .3 volt output and heterodyned output i.f. frequencies of 0-50 mc.

The second item is a universal video generator which has been redesigned to incorporate a feature providing accurate registration adjustment of the three color guns in new TV color sets.

The Model 650C is simple to operate and can be used for the accurate adjustment of focus, convergence, centering of individual beams, purity yoke, etc. It can also be used for troubleshooting black-and-white receivers.

Full details on either or both of these instruments is available from the company on request.

SELF-SUPPORTING TOWER

The Walnut Machine Company, 1525 S. Walnut St., South Bend, Indiana is in production on a new 60-foot, self-supporting steel television antenna tower.

The new tower, which can be erected by one person, can be completely installed without climbing above 27 feet. It requires no guy wires or house supports and it is counterbalanced so that it can be lowered easily.

The company will forward complete details on request.

COLOR TV PARTS

Electrometric, Inc., Woodstock, Illinois has just announced a new color TV coil kit which contains 32 items for use with shadow mask tubes.

Included in the kit are a new dis-

tributed constant delay line, a new horizontal output transformer, horizontal dynamic-converging and dynamic-focusing transformer, a horizontal dynamic-convergence phase control, width control, linearity control, and a complete set of i.f., video, and color information circuit coils.

The company is also offering a new color TV horizontal output transformer designed for use with a single 6DC6 driver tube and to work into a 11.8 mhy. yoke. Known as the CTV515, the new transformer comes complete with four filament windings.

Details on both the kit and the transformer are available on request.

GRID CIRCUIT CHECKER

Seco Manufacturing Company, 5015 Penn Ave., S, Minneapolis, Minn. has developed a tester for vacuum tube grid circuits which isolates a.g.c. tube malfunctions.

An "electronic eye" on the device is used to reveal such tube faults as control grid emission, high resistance cathode-grid or cathode-to-heater shorts. The checker will also test tubes in audio, i.f., and sync circuits. It is



not designed to replace present tube testers but to supplement them by performing additional services.

RAYTHEON "BROW-LITE"

The Receiving Tube Division of Raytheon Manufacturing Company, Newton, Mass. is now offering a unique servicing aid for technicians, the "Brow-Lite."

The new product is a different kind of flashlight that makes servicing faster and easier by directing the light automatically to the point wanted while leaving the technician's hands free to work on the set. It has a "snorkel" socket which adjusts the light to any angle. Using standard parts, the light is pocket size, easy to carry, and is constructed of durable plastic.

RADIO & TELEVISION NEWS

New
**UHF & VHF
 LEAD-IN**

Thousands of separately sealed tiny cells, filled with inert gas, make this waterproof cable stable and efficient electrically.

ADVANTAGES:

- 1 Lowest losses at UHF and VHF frequencies.
- 2 Great abrasion resistance and mechanical strength.
- 3 No time-consuming end seal required; easy to install.
- 4 No internal moisture to cause signal loss.
- 5 No kinking when used with antenna rotors.
- 6 Resistant to snow, ice, rain, and wind.
- 7 Resistant to ultraviolet rays from the sun.
- 8 Uses Belden Weldoohm conductor for long conductor life.
- 9 Can be clamped tightly in stand-off insulators without crushing. No special fittings required.
- 10 Conductor spacing is constant even when the lead-in is transposed.
- 11 No stripping problem for attaching the conductor.

This heavy wall of brown virgin polyethylene protects the cable against mechanical abuse and damage from ultraviolet sun rays.

...Cuts
SIGNAL LOSS

This completely new 300-ohm line results from the development of a new cellular plastic core where each separate cell is filled with an inert gas to make an efficient cable with the lowest possible losses at both UHF and VHF frequencies. With this absolutely waterproof cable, no sealing of the ends is necessary. Celluline cable can be fixed in stand-off insulators without crushing. The thick outer wall of polyethylene serves to protect the cable from abrasion and sun damage.

By fusing *only* virgin polyethylene, the wall can be made smooth—absolutely free from rough spots—to prevent the adherence of dust and other impurities which would increase the losses.

The copper-covered steel strands, which make up the conductors, assure 49% greater resistance to breaking from flexing or stretching than any all-copper conductor.

8275 CELLULINE[®]
 TRANSMISSION LINE

by **Belden**
 WIREMAKER FOR INDUSTRY

WE'RE IN OUR NEW BUILDING!



Leo I. Meyerson
WØGFQ



We are now operating from our new ultra-modern electronics building — geared for greater efficiency and faster, more complete PERSONALIZED service than ever before!

HALLICRAFTERS S-40B \$119.95



\$954 Per Month
(12 months)

\$12.00 CASH DOWN

Communication receiver with built in speaker covering 540-Kc to 44 Mc in four bands. One RF stage, 2 IF stages.

HALLICRAFTERS SX-88 \$595.00

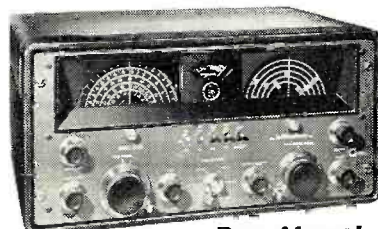

\$4730 Per Month
(12 months)
\$59.95 CASH DOWN
\$32.42 18 MONTHS

Dual Conversion Receiver 535-33.3-Kc in 6 bands. 2 RF stages, variable 6 position band width selectivity, 250 cycles to 10 Kc. 10 watt audio output. 17 tubes plus voltage regulator, ballast tube and rectifier.

HALLICRAFTERS RECEIVERS AVAILABLE FOR IMMEDIATE SHIPMENT

MODEL NUMBER	12 MONTHLY PAYMENTS	DOWN PAYMENT	CASH PRICE	MODEL NUMBER	18 MONTHLY PAYMENTS	DOWN PAYMENT	CASH PRICE
S-38C	\$3.97	\$ 5.00	\$ 49.95	S-76	\$10.90	\$20.00	\$199.95
S-53A	\$7.95	\$10.00	\$ 99.95	SX-62	\$19.07	\$35.00	\$349.95
S-72 Port	\$8.74	\$11.00	\$109.95	SX-71	\$13.62	\$25.00	\$249.95
S-77A	\$9.54	\$12.00	\$119.95	HT-20XMTR	\$24.50	\$44.95	\$449.50



FREE 1954 CATALOG

WRITE—WIRE
PHONE 2-0277

Get your BIG NEW 1954 WRL CATALOG, offering the greatest selection of radio and television equipment, parts and supplies for the Novice, Experimenters, Hams and Professionals.

WORLD RADIO LABORATORIES R-4
3415-27 W. Broadway
Council Bluffs, Iowa

Please send me:

- 3' x 4' U.S. Radio Map 25c
 New Catalog
 Used Equipment List
- WRL XMTR Info
 SX-88 Info
 S-408 Info
 NEW LOG BOOK 25c

Name _____

Address _____

City _____

State _____



110V. AC POWER SUPPLY FOR ANY 274-N RECEIVER



Just plug it into the rear of your 274-N RECEIVER . . . any model. Complete kit and black metal case, with ALL parts and diagrams. Simple and easy to build in a jiffy. Delivers 24 volts plus B voltage. No wiring changes to be made. Designed especially for the 274-N receiver. Only \$8.95.

Filament trans. for 274N receivers. Pri. 110V, 60 cy. AC. Sec. 24V @ .6A. An excellent buy at \$1.95 ea.

SPLINED TUNING KNOB FOR 274N RECEIVERS

An exclusive O-R item manufactured for us. Fits BC-453, BC-454 and other 274N receivers. This is a really hard-to-obtain item. Only .89c ea.



OFFENBACH-REIMUS

1564 Market Street, San Francisco, Calif.

SPEAKER RECONING

Complete line Cones, Spiders, Rings and Voice Coils. Custom Built Voice Coils. Low prices. Write for Parts List and Reconing information.

WESTERN ELECTRONICS CO.

3164 West Colfax Denver 4, Colo.

SCHEMATICS—CONVERSIONS FOR SURPLUS GEAR

NEW LIST! MANY ADDITIONS!

Send stamped, self addressed envelope for List C. Add 25c for chart explaining AN nomenclature.

R. E.

BOX 1220

GOODHEART

BEVERLY HILLS, CAL.

It is currently available from the company's tube distributors.

CRT CHECKER KIT

Electronic Instrument Co., Inc., 84 Withers St., Brooklyn 11, N.Y. has just announced a new cathode-ray tube

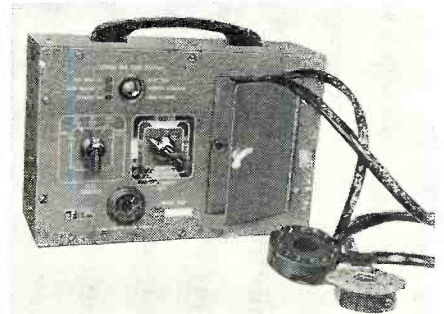

checker which is available in both kit and wired form.

Known as the *Eico* Model 630, the new instrument is portable, easy to operate, and will handle all sizes of TV picture tubes and oscilloscope tubes whether electrostatic or electromagnetic. Tubes can be tested in the set or carton by using the test sockets connected to the tester by 2½ foot cables.

A catalogue on this and other instruments in the company's line is available on request.

19" TRI-COLOR TUBE

Radio Corporation of America has announced the design and pilot production of a 19" shadow mask tri-color kinescope which has nearly double the picture area and the same brightness as the company's 15" tube.

The developmental 19" tube, which is enclosed in a glass envelope, is expected to be commercially available in limited quantity later this year. Further details on this new color tube will be available at a later date.

CAMERA CONVERSION

General Electric Company, Syracuse, N.Y. has announced plans to modify existing black-and-white television cameras for live color program origination.

The converted cameras will be used with a device known as a "Chromacoder," developed by CBS. The unit translates field sequential color signals from the cameras into compatible NTSC color signals.

The company will build field sequential cameras as well as the "Chromacoder" for present or future stations.

"ROTOR-SECTION"

R. J. Buchan Company, P.O. Box 9, Bricelyn, Minn. is now offering its LL300 "Rotor-Section" which is designed to be used with rotatable antennas.

The new product consists of a six-foot length of LL300, 300-ohm, open-wire line with each conductor insulated with Fiberglass tubing. Equipped with Nicopress sleeve solderless connectors, it can be quickly and easily



CONICAL
* PAT. PEND.



* PAT. PEND.

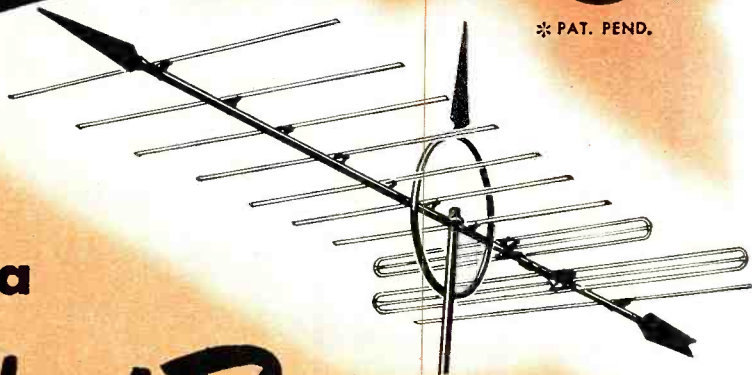

NEW TELE-VANE ANTENNAS BY WARD

backed by a

Power Packed Promotion

Here they are . . . the newest idea in TV antenna design — opening an entirely new field for you with vastly increased profits. Tell the 69 million readers of the Tele-vane national consumer magazine ads that YOU sell Tele-vanes! Use Ward's local tie-in advertising aids . . . all featured and shown in this Tele-vane Kit.

It's yours FREE for the asking.



Complete in one kit, all the dope on window streamers . . . mailing piece . . . newspaper ads and mats . . . full color counter display . . . radio commercials . . . TV slides and announcements.



THE WARD PRODUCTS CORP.

DIVISION OF THE GABRIEL COMPANY

1148 Euclid Ave., Cleveland 15, Ohio

Canadian Distributor: ATLAS RADIO CO., LTD., TORONTO, CANADA





**be an expert on
AUTO RADIO
SERVICING!**

Get the only authoritative compilation of its kind—complete Auto Radio Service Data coverage of all important models since 1946—in 3 great PHOTOFACT Manuals! All data complete, accurate, uniform—based on lab analysis of the actual auto radios covered. Helps you service any model quicker, easier—for greater profits. Get the complete Library!



VOL. 1. AUTO RADIO SERVICE MANUAL

Covers over 100 models made from 1946 to 1949 by 24 manufacturers. Each receiver is completely covered in uniform format; includes schematics, chassis photo views, replacement parts data, service hints, etc. All data based on actual lab analysis. 396 pages, 8½ x 11".

ORDER AR-1. Only\$4.95



VOL. 2. AUTO RADIO SERVICE MANUAL

Covers 60 different chassis (40 models) used in 1948, 1949 and 1950 auto radio receivers. Authoritative, complete service data that makes your work quicker, easier and more profitable. 288 pages, 8½ x 11".

ORDER AR-2. Only\$3.00



VOL. 3. AUTO RADIO SERVICE MANUAL

Covers 47 different chassis (80 models) used in 1950, 1951 and 1952 auto radio receivers. Absolutely the most complete, accurate and easy-to-use data available—uniform and practically presented to make you an expert on the repair of any auto radio. 288 pages, 8½ x 11".

ORDER AR-3. Only\$3.00

SPECIAL OFFER!
All 3 Volumes, Yours for Only \$9.95
Save on the Complete Library—see your PHOTOFACT Distributor

HOWARD W. SAMS & CO., INC.

Order from your Parts Jobber today, or write direct to HOWARD W. SAMS & CO., Inc. 2203 E. 46th Street, Indianapolis 5, Ind.

My (check) (money order) for \$.... encl. Send:
 AR-1 \$4.95 AR-2 \$3.00 AR-3 \$3.00
 Complete 3-Volume Library \$9.95

Name

Address

City State

attached to 300-ohm open wire line so that it can be used with a rotator without danger of shorting, yet maintain the low-loss, long-life features of the open-wire line.

REPLACEMENT FLYBACKS

Chicago Standard Transformer Corporation, Addison and Elston, Chicago 18, Illinois has added three exact replacement flyback transformers to its line.

The A-8230, A-8231, and A-8232 are used in *Air King*, *CBS-Columbia*, *Emerson*, *Firestone*, and *Silvertone* receivers. Exact duplicates, both physically and electrically, they cover 88 chassis and 194 models.

Stancor Bulletin 480 describes the flyback applications and lists the chassis and models. It is available without charge from the company's *Standard Division*.

MERIT REPLACEMENT

Merit Coil & Transformer Corp., 4427 N. Clark St., Chicago 40, Ill. is now offering an exact universal flyback replacement for *Sylvania* receivers that replaces four of the present units and covers 39 different chassis and over 160 different models.

The HVO-13 is supplied as a core and coil only since the original mounting bracket which is part of the chassis must be used. A new filament lead wire for use by technicians, in the event original filament leads are cracked, is enclosed with the flyback as well as detailed instructions for making the replacement.

"ULTRA-SWEEP"

Kay Electric Company, 14 Maple Avenue, Pine Brook, N.J. is now offering a u.h.f. sweep generator known as the "Ultra-Sweep."

The instrument features accurate dial calibration, continuously variable sweep width, a built-in detector, and zero level baseline. The unit's front panel dial, calibrated in both channel number and 10 mc. steps, permits instant frequency selection within the 450 and 900 mc. range. Calibration accuracy is approximately ± 1 mc.

The unit, with its regulated power

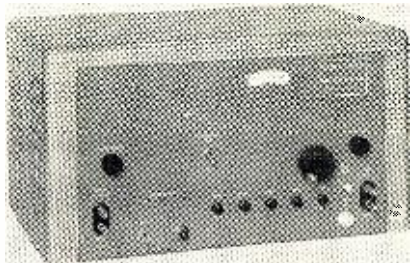

supply, is enclosed in a functionally-designed steel cabinet with all operational controls conveniently located on the front panel.

U.H.F. ARRESTERS

The Tube Department of *Radio Corporation of America* has developed two quick-service types of u.h.f. light-

ning arresters for protection against damage from lightning and static charges.

The screw type, 234A1, is designed for direct mounting to baseboards or windowsills while the strap type, 235A1, can be attached to antenna masts and cold-water pipes. Both are UL approved.

Both of the arresters can be used with virtually all types of 300-ohm u.h.f. transmission lines—tubular, oval, foam, and jacketed—without affecting the electrical characteristics of the line.

DISTRIBUTION AMPLIFIER

Waldom Electronics Inc., 911 Larrabee St., Chicago 10, Ill. has entered the television accessory field with the



introduction of an electronic distribution amplifier which permits the operation of two TV sets from a single antenna and acts as a booster to improve reception on both receivers.

The "Duo-tenna" is said to minimize noise and snow due to weak signals. The amplification and isolation design of the unit precludes radiation interference between the sets, according to the company.

COUPLER LINE

Industrial Television, Inc., 369 Lexington Ave., Clifton, N. J., is now offering a complete line of indoor-outdoor multiple receiver couplers.

Newly-added units include the IT-131A and IT-132A v.h.f. "Autocouplers." These couplers use individual r.f. transformers in a unique arrangement to feed up to eight receivers with low insertion loss and good receiver isolation. The new IT-135A u.h.f. "Autocoupler" uses wideband hybrid ring principles to feed two u.h.f. sets.

"THRU-THE-WALL" TUBING

Javex, P. O. Box 646, Redlands, Cal., is in production on a new "Thru-the-Wall Tenna-Tube" which is constructed entirely of polystyrene.

The new tube will handle any antenna line including coax, ladder, round or flat and is easily installed in any wall by drilling a ¾" hole. It is solderless in design and comes complete with mounting hardware.

It also features the company's new "Mini-Plate," a miniature wall plate, and patented self-aligning contacts. The tubing itself is available in ivory or clear polystyrene.

now you can easily...

IMPROVE

AUDIO

PERFORMANCE

Use the famous
DUBBINGS' TEST RECORDS
which have enabled thousands of
Hi-Fi enthusiasts to calibrate phono
equipment without voltmeters.

**D-100—"THE MEASURE OF
YOUR PHONOGRAPH'S PERFORMANCE"**

**D-101—"THE MEASURE OF
YOUR PHONOGRAPH'S EQUALIZATION"**

with Dubbings' simplified methods

now the latest in DUBBINGS' Co.
devices — engineered to help you
adjust for peak performance...

THE FIRST COMPREHENSIVE

**TEST
TAPE**

ONLY D-110 AND D-111 TAPES

*"The Measure of Your Tape
Recorder's Performance"*

CAN TEST FOR:

- *Wow and Flutter*
- *Head Azimuth Alignment*
- *Frequency Response*
- *Signal to Noise Ratio*
- *Signal Level*
- *Tape Speed*

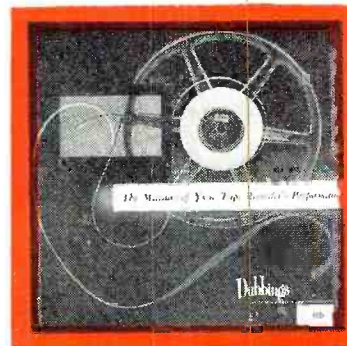

...recorded
exclusively on stretch-
proof, REEVES
SOUNDCRAFT
LIFETIME
professional tape!

READ DETAILED DATA AND SPECIAL IN-
TRODUCTORY OFFER ON NEXT 3 PAGES 

TEST TAPE

Now, for the first time, you can calibrate, service and adjust your tape recorder completely for maximum performance by using *one* test tape—everything from setting proper volume level to aligning recording head.

These tapes are expected to serve you for many years to come, so they have been recorded on REEVES SOUNDCRAFT LIFETIME tape, the most durable ever developed... It is stretch-proof, moisture proof, exceedingly strong... and the highest quality professional tape available anywhere. Recorded with the finest available professional tape machines—produced by the FAIRCHILD Recording Company.



*the first and
ly comprehensive
test tapes*

HAROLD D. WEILER, author of "High Fidelity Simplified," in his forthcoming book, "Tape Recorders and Tape Recording," states: "The DUBBINGS' Test Tapes are an absolute must for anyone interested in obtaining and maintaining peak performance from his tape recorder. Their use insures better tapes. They are more than just test tapes..."

TO ORDER, SIMPLY DETACH CONVENIENT STAMPED, ADDRESS'D ENVELOPE AT RIGHT ▶

TEST RECORDS

*the most widely
accepted
standard of
performance*

These highly acclaimed test records permit *every* owner of a Hi-Fi phonograph to make his sytem perform to the limit of its capability. No more questionable performance with expensive equipment. These records are also the best trouble shooting tools conceived. How much weight should the pickup arm have for proper tracking? What are the best tone control settings?... And the solution to almost any other problem for attaining peak performance... these records will do it for you.



TEST INDICATOR

*proven accuracy
at modest cost*

For many years the only way to check an audio system's output was with a good vacuum tube voltmeter. Since voltmeters are expensive and complex, DUBBINGS has developed a very inexpensive, simple test level indicator for the audiophile. It is the only real substitute for a voltmeter, and can be used with ANY TEST TAPE OR TEST RECORDS.

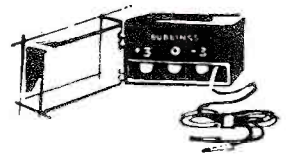

AUDIO SALES

*select lines of
quality components*

The DUBBINGS Company, Inc. is an authorized agent for the leading audio manufacturers. Rather than list all these tested and proven components, just ask for our catalog, which describes the best quality-for-your-money equipment—on the order form at the right...

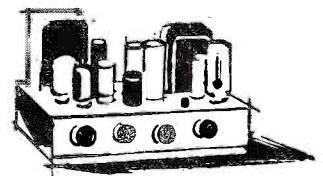

AUDIO SERVICES

Our other services include disc recording, tape duplication, off-the-air monitoring, master recording and many more. You can receive a bulletin describing these services by checking order form at the right...

The DUBBINGS Co., Inc., Dept. 44RT, 41-10 45th Street, Long Island City 4, New York

TEST TAPES

"THE MEASURE OF YOUR TAPE RECORDER'S PERFORMANCE"

D-110 — 5" reel, 7½ ips

D-111 — 7" reel, 15 ips

Recorded on REEVES SOUNDCRAFT LIFETIME magnetic tape made of DuPont "Mylar" Polyester film.

The only tape for indicating:

- Wow and Flutter
- Head Azimuth Alignment
- Frequency Response
- Signal to Noise Ratio
- Signal Level
- Tape Speed

For technical data see following page

TEST INDICATOR

D-500 TEST LEVEL INDICATOR

For use with any test tapes and test records....

The only accurate, yet inexpensive substitute for a good voltmeter. Consists of three bulbs calibrated to light up at 3 db intervals when connected across speaker leads.

TEST RECORDS

"THE MEASURE OF YOUR PHONOGRAPH'S PERFORMANCE"

D-100—12" vinyl disc, 33⅓ rpm

The only record for measuring:

- Frequency Response
- Rumble and Hum
- Wow and Flutter
- Tracking

"THE MEASURE OF YOUR PHONOGRAPH'S EQUALIZATION"

D-101—12" vinyl disc, 33⅓ rpm

The only record with these response curves:

- Columbia LP
- AES
- NARTB
- RCA's "New Orthophonic"

IN ADDITION... **AUDIO EQUIPMENT**
OF TESTED QUALITY IS FULLY STOCKED
at the **DUBBINGS co., inc.**

FOR YOUR CONVENIENCE...
AN ADDRESSED, POSTAGE FREE
ORDER ENVELOPE IS AT RIGHT

Simply detach along perforated
lines, fill out and mail today

To Calibrate for
Peak Hi-Fidelity.
Performance use

AUDIO TESTS

exclusively engineered by
the **DUBBINGS co., inc.**

ORDER NOW WITH THIS CONVENIENT
POST-FREE, ADDRESSED ENVELOPE

FOLD

*FIRST FOLD HERE

Enclosed find CHECK MONEY ORDER

Quantity	Amount
<input type="checkbox"/> D-110 TEST TAPE 5" reel 7½ ips INTRODUCTORY OFFER @ \$10.95 (For Orders Received After May 15, 1954, cost is \$12.50)	\$.....
<input type="checkbox"/> D-111 TEST TAPE 7" reel 15 ips INTRODUCTORY OFFER @ \$15.95 (For Orders Received After May 15, 1954, cost is \$17.50)	\$.....
<input type="checkbox"/> D-500 TEST INDICATOR @ \$3.95 For use with any test tapes or records	\$.....
<input type="checkbox"/> D-100 TEST RECORD @ \$3.50 "The Measure of Your Phonograph's Performance"	\$.....
<input type="checkbox"/> D-101 TEST RECORD @ \$4.95 "The Measure of Your Phonograph's Equalization"	\$.....

Simple, complete instructions
enclosed with all the above.

FOLD

*SECOND FOLD HERE

<input type="checkbox"/> Fresh 7" Reel of REEVES SOUNDCRAFT LIFETIME Tape (\$9.75 list) @ \$6.50	\$.....
<input type="checkbox"/> Fresh 10½" Reel of REEVES SOUND- CRAFT LIFETIME Tape (\$19.80 list) @ \$13.20	\$.....

Postage & Handling \$.50

(*Enclose Remittance Between
First and Second Folds) **TOTAL** \$.....

New 1954 Audio Catalog Recording Service Bulletin

UNCONDITIONAL MONEY BACK GUARANTEE!

NAME _____

ADDRESS _____

CITY _____ ZONE _____ STATE _____

I am a: PROFESSIONAL IN ELECTRONICS AUDIOPHILE

Please Print

**LISTEN...
TO
WHAT
AUDIO EXPERTS
ARE
SAYING...**

*comprehensive
technical specifications
on*

DUBBINGS':

**AUDIO
TESTS**

SEE PRECEDING PAGE FOR VITAL FACTS

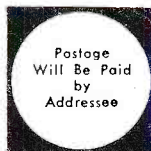

BUSINESS REPLY ENVELOPE

First Class Permit No. 1851, Sec. 34.9, P.L.&R., Long Island City, N. Y.

The DUBBINGS Co., Inc.

41-10 45th STREET

LONG ISLAND CITY 4, N. Y.

DEPT. 44RT

GEORGE MAERKLE, Chief Engineer, Fisher Radio Corporation.

"The DUBBINGS' D-110 and D-111 Test Tapes are the first to fill the long standing need for accurate and easily used means of evaluating and improving performance of magnetic recording equipment..."

ROBERT J. MARSHALL, Chief Engineer, Fairchild Recording Equipment.

"DUBBINGS' new Test Tapes are welcome companions to this company's series of fine test records. They demonstrate the same high calibre and are the only practical means for truly measuring the high fidelity tape recorder's performance. Getting all the important tests on a single reel is a tribute to advanced engineering know-how."

HAROLD D. WEILER, author of "High Fidelity Simplified," in his forthcoming book,

"Tape Recorders and Tape Recording," states: "The DUBBINGS' Test Tapes are an absolute must for anyone interested in obtaining and maintaining peak performance from his tape recorder. Their use insures better tapes. They are more than just test tape..."

D-110 TEST TAPE—"The Measure of Your Tape Recorder's

Performance" 5" reel 7½ ips, REEVES SOUNDCRAFT LIFETIME Tape

WOW AND FLUTTER—3,000 cps tone • HEAD AZIMUTH ALIGNMENT—5,000 cps tone • FREQUENCY RESPONSE—30 to 7,500 cps in 13 steps 30, 50, 100, 200, 400, 700, 1 kc, 2, 3, 4, 5, 6, 7.5 kc. Recorded with standard NAB characteristic for 7½ inches per second. • SIGNAL TO NOISE RATIO—400 cps tone, 15 to 50 db in 5 db steps with announcements • MAXIMUM SIGNAL LEVEL—zero level, 400 cps, 3% total harmonic distortion • TAPE SPEED—timing beeps at 0, 5 and 10 minutes. Detailed instruction book enclosed.

D-111 TEST TAPE—"The Measure of Your Tape Recorder's

Performance" 7" reel, 15 ips, REEVES SOUNDCRAFT LIFETIME Tape

WOW AND FLUTTER—3,000 cps tone • HEAD AZIMUTH ALIGNMENT—10,000 cps tone • FREQUENCY RESPONSE—30 to 15,000 cps in 14 steps 30, 50, 100, 200, 400, 700, 1 kc, 2, 4, 6, 8, 10, 12, 15 kc. Recorded with standard NAB characteristic for 15 inches per second. • SIGNAL TO NOISE RATIO—400 cps tone, 15 to 50 db in 5 db steps with announcements • MAXIMUM SIGNAL LEVEL—zero level, 400 cps, 3% total harmonic distortion. • TAPE SPEED—timing beeps at 0, 5 and 10 minutes. Detailed instruction book enclosed.

D-500 TEST LEVEL INDICATOR

RANGE—Calibrated for 3 db increments in level; 1 db increments can be judged easily • SENSITIVITY—Indicates at listening volume level when connected across 3 to 16 ohm loudspeaker terminals • FREQUENCY RESPONSE—Non-frequency discriminating; equally accurate at any frequency. Precision made, durable construction. Leads and alligator clips supplied. Detailed, easy to use instruction book enclosed.

D-100 TEST RECORD—"The Measure of Your Phonograph's

Performance" 12" pure vinylite disc, 33½ rpm microgroove.

FREQUENCY BANDS—30, 50, 100, 250, 400, 700, 1 kc, 2, 4, 6, 8, 10, 12 kc., 4½ db/oct. attenuation below 500 cps. Constant velocity above 1 kc at 6 cm/sec level • ACCURACY—Within 1 db • WOW AND FLUTTER—3,000 cps tone • TRACKING TEST—5 bands of 400 cps tone at increasing levels; 2.5, 4, 6, 8½, 11 cm/sec. • UNMODULATED GROOVE—to check rumble, noise and hum. Both sides of record identical. Detailed, easy to use instructions on record cover.

D-101 TEST RECORD—"The Measure of Your Phonograph's

Equalization" 12" pure vinylite disc, 33½ rpm microgroove.

FREQUENCY BANDS—30, 50, 100, 250, 400, 700, 1 kc, 2, 4, 6, 8, 10, 12 kc for each of the following recording curves; Columbia LP, NARTB, AES, and the RCA "New Orthophonic." An additional 1 kc reference band before each frequency run • ACCURACY—within 1 db Detailed, easy to use instructions on record cover.

Manufacturers' Literature

The bulletins reviewed in this section are for your convenience; unless otherwise indicated they are available to all our readers. For prompt attention write directly to the manufacturer for literature described.

CRYSTAL DATA

A handbook of crystal and oscillator theory has been compiled and published by the *James Knights Company*, Sandwich, Ill.

The booklet is intended as a handy reference for the design engineer using crystals. It outlines important factors that should be considered in equipment design if maximum crystal performance is to be realized.

The "Crystal Handbook" is available at \$1.00 per copy from the company.

RESISTOR CATALOGUE

Sprague Electric Company, North Adams, Mass. has issued a 36-page catalogue on power-type fixed wire-wound resistors manufactured in accordance with MIL specifications R-26B.

Catalogue 101 illustrates and describes the resistors in great detail with line drawings and photographs being used lavishly to facilitate selection of the correct unit.

MUELLER CLIPS

Mueller Electric Co., 1583 East 31st Street, Cleveland 14, Ohio has published a single-page catalogue sheet which lists its complete line of battery and test clips, antenna clampers, ground clamps, and insulated test clips.

The products listed cover a wide range of radio and television applications and copies of this data sheet may be obtained without charge on request.

DEFLECTION YOKE

Syntronic Instruments, Inc., 100 Industrial Road, Addison, Ill. is now offering a catalogue page which pictures and describes its new Type Y16-6 high-speed, 60 degree, push-pull magnetic deflection yoke.

Complete data includes dimensional drawings and tables of electrical and mechanical characteristics with full explanations to assist design engineers. A table listing a wide variety of horizontal-vertical coil inductance combinations is also provided.

BBB COLOR TV BOOKLET

General Electric Company is making the widest possible distribution of the new Better Business Bureau booklet on color television.

The company, which has distributed 50,000 copies of the booklet through the company's dealers and distribu-

tors, is advocating the use of the booklet as a tool with which dealers can clarify for themselves and the public some of the rumors, misinformation, and wishful thinking which has been stimulated by the advent of color TV.

CABINET DATA

River Edge Industries, River Edge, N.J. has issued a 12-page catalogue, W-54, which describes the company's line of hi-fi speaker and television cabinets.

The publication is complete with diagrams, photographs, and general information and covers the company's entire line of custom cabinets.

"ULTRA-LINEAR" AMPLIFIER

Chicago Standard Transformer Corporation's Standard Division, Addison and Elston, Chicago 18, Illinois is now offering a copy of Bulletin 479 which describes the construction of *Stancor's* "ultra-linear" high-fidelity amplifier.

The 4-page booklet includes chassis drawings, a schematic, and complete parts list. Owners of the company's original *Stancor-Williamson* amplifier can convert to "ultra-linear" operation by making the changes outlined in this same bulletin.

The booklet is available without charge from any of the company's distributors or from the company itself.

SIMPSON BROCHURE

A new 4-page brochure describing five of the company's volt-ohm-milliammeters and volt-ohm-microammeters is now available from *Simpson Electric Co.*, 5200 W. Kinzie Street, Chicago 44, Ill.

The publication contains complete descriptive data about the company's new Model 269, 100,000-ohms-per-volt sensitivity volt-ohm-microammeter.

When writing for a copy of the brochure, please specify Form "A-4 RCS."

WIRE SAMPLES

Imperial Radar & Wire Corp., 820 East 233rd Street, Bronx 66, N.Y. is currently offering a sample card containing all of the different sizes of wire manufactured, the gauge, the weight per thousand feet, breaking strength, diameter of each type of wire, etc.

This card, which is being offered free of charge, is available to dealers who write the factory direct or contact their nearest distributors.

MOTOR REPAIR

How the company's "Scotch" brand electrical tapes can be used to speed electric motor construction and repair is the subject of a new 12-page booklet being offered by *Minnesota Mining and Manufacturing Co.*, 900 Fauquier St., St. Paul 6, Minn.

Included in the illustrated booklet are specifications for 10 different electrical tapes for a wide variety of insulation and holding applications in motor work. It also includes information on the company's electrical insulation resin for complete encapsula-

SAVE ON INSTRUMENTS!

- do better testing with fewer instruments
- avoid buying costly equipment you don't really need
- discover new uses for old instruments
- learn all about ALL instrument types; how to use them more efficiently; how to interpret their readings



BASIC ELECTRONIC TEST INSTRUMENTS

by Rufus P. Turner

254 pages, 171 illus. Price only \$4

Get the real "low-down" on

Current and voltage meters
TV pattern generators
Grid-dip oscillators
Oscilloscopes
Ohmmeters
Volt-Ohm-Milliammeters
V-T voltmeters
Power meters
Capacitor checkers
Impedance meters
Special bridges
Tube testers
TV sweep and marker generators
Distortion meters
TV linearity pattern generators
Square-wave generators
Signal tracers
R-F test oscillators
Inductance checkers
R-F and A-F measuring devices

... and over 30 other standard instrument types!

This book can save you hundreds of dollars by avoiding unnecessary instrument purchases! And it can help you handle all kinds of testing faster and more accurately in the bargain by putting your present instruments to better use.

Actually, **BASIC ELECTRONIC TEST INSTRUMENTS** is a complete training course covering over 60 instrument types for TV and radio service, ham and experimental use. The author's whole object is to help you do better work; choose instruments intelligently and use them fully. Dozens of work-saving short-cuts are outlined. New uses for old instruments are clearly explained.

Practically all present day instrument types—including the latest television types—are impartially discussed. You learn exactly how to use each type and to know exactly what it can and cannot do.

Learn These MONEY-SAVING INSTRUMENT "TRICKS"!

You discover new uses for VOM's, oscilloscopes, signal generators, etc. You see how to extend the range of many old instruments; how to use power drain measurements for fast TV troubleshooting; how a bridge can be built from old instruments; how to measure i-f impedance the easy ways; how to measure inductance and capacitance with a grid-dip oscillator and dozens of other money-saving "tricks." Use coupon!

10 DAY FREE TRIAL

Dept. RN-44, RINEHART & CO., Inc.,
232 Madison Ave., New York 16, N. Y.

Send Turner's BASIC ELECTRONIC TEST INSTRUMENTS for 10-day FREE examination. If I decide to keep book, I will remit \$4.00 plus postage. Otherwise, I will return book postpaid promptly and owe you nothing.

Name

Address

City Zone State

OUTSIDE U.S.A.—Price \$4.50 cash only. Money back if book is returned in 10 days

Windsor TUBES

RADIO & TV RECEIVING

TESTED and
GUARANTEED
for **PEAK**
PERFORMANCE

WHAT EVERY SERVICEMAN SHOULD KNOW. . . . No tube checker reading of "Good" can positively insure that a specific tube will function perfectly in a TV set. . . . only a substitution test in an actual set will do that! This is particularly true of tubes used in power and sweep circuits, deflection amplifiers, oscillators, reactance modulators, etc.

YOU PLAY IT SAFE when you buy Windsor tubes—because every tube we ship has been carefully pre-tested in a radio or TV set for **PEAK PERFORMANCE** under actual operating conditions. So we unconditionally guarantee every Windsor tube in accordance with the Standard Warranty: full replacement of any defective tube within 90 days of purchase, excepting only burnouts and breakages. Each tube is attractively packaged in individual carton.

BUY—AND SELL—WINDSOR TUBES, WITH CONFIDENCE

Type	Each	Type	Each	Type	Each	Type	Each
1A7GT	\$.87	3Q5GT	\$.72	6B8G	\$.93	6J7	\$.70
1B3GT	\$.69	3S4	\$.61	6BA6	\$.50	6K6GT	\$.45
1H5GT	\$.51	3V4	\$.62	6BA7	\$.66	6K7	\$.70
1J6	\$.93	5R4GY	1.00	6BC5	\$.59	6L6G	\$.88
1L4	\$.63	5U4G	\$.44	6BD5GT	\$.98	6L6GA	\$.88
1L6	\$.66	5V4G	\$.83	6BD6	\$.54	6Q7GT	\$.55
1LA4	\$.60	5Y3GT	\$.37	6BE6	\$.51	6S4	\$.51
1LA6	\$.82	5Y4G	\$.43	6BF5	\$.66	6S6GT	\$.75
1LC5	\$.80	6A8GT	\$.68	6BF6	\$.43	6SA7GT	\$.57
1LC6	\$.80	6A8GT	\$.68	6BG6G	1.47	6SC7	\$.63
1LD5	\$.80	6A8GT	\$.68	6BH6	\$.63	6SD7	\$.55
1LE3	\$.80	6A8GT	\$.68	6BJ6	\$.53	6SF5GT	\$.86
1LG5	\$.80	6A8GT	\$.68	6BK5	\$.76	6SH7GT	\$.52
1LH4	\$.80	6A8GT	\$.68	6BK7	\$.97	6SJ7GT	\$.52
1LN5	\$.80	6AK5	1.05	6BL7GT	\$.94	6SK7GT	\$.55
1NS6GT	\$.63	6AL5	\$.44	6BN6	\$.98	6SL7GT	\$.59
1R4	\$.85	6AQ5	\$.51	6BQ6GT	\$.98	6SN7GT	\$.68
1R5	\$.62	6AQ6	\$.75	6BQ7	\$.92	6SQ7GT	\$.46
1S4	\$.67	6AQ7	\$.47	6C27	1.09	6T8	\$.85
1S5	\$.52	6AR5	\$.52	6C4	\$.41	6U4GT	\$.60
1T4	\$.62	6AS5	\$.45	6C5GT	\$.60	6U8	\$.86
1U4	\$.61	6AT6	\$.82	6CB6	\$.58	6V3	1.09
1U5	\$.51	6AU5GT	\$.46	6CDBG	2.04	6V6GT	\$.51
1X2A	\$.74	6AU6	\$.47	6D5	\$.63	6W4GT	\$.50
2X2	1.43	6AV5	\$.85	6E5	\$.72	6W6GT	\$.63
3L4	\$.76	6AV6	\$.41	6F5GT	\$.54	6X4	\$.37
3Q4	\$.66	6AX4	\$.72	6H6GT	\$.55	6X5GT	\$.36
				6J5GT	\$.44	6Y6G	\$.64
				6J6	\$.46		

Type	Each	Type	Each
7A4/XXL	\$.57	7B4	\$.54
7A5	\$.70	7B5	\$.52
7A6	\$.57	7B6	\$.58
7A7	\$.58	7C5	\$.56
7A8	\$.56	7C6	\$.50
7AD7	1.05	7C7	\$.58
7AF7	\$.63	7E5	\$.85
7AG7	\$.65	7E6	\$.65
7AH7	\$.65	7E7	\$.85
7AJ7	\$.70	7F7	\$.69
		7G8	\$.97
		7H7	\$.81
		7J7	\$.85
		7K7	\$.85
		7L7	\$.85
		7M7	\$.62
		7N7	\$.62
		7P7	\$.92
		7Q7	\$.62
		7R7	\$.70
		7S7	\$.90
		7V7	\$.99
		7X6	\$.62
		7Y4	\$.45
		7Z4	\$.50
		12AT6	\$.53
		12AT7	\$.75
		12AU6	\$.47
		12AU7	\$.58
		12AV6	\$.41
		12AW7	\$.37
		12AX4	\$.62
		12AX7	\$.77
		12AY7	2.15
		12B4	\$.66
		12BA6	\$.50
		11Z23	\$.43
		11Z26GT	\$.75



FREE! WINDSOR TUBE CADDY



The most practical Service-Aid ever designed for the radio and TV repairman. This ideal television carry-all now offered free with every purchase of \$100.00 or accumulated purchases totaling \$100.00 within 90 days. (You get caddy credit memo with each purchase).

Windsor Tube Caddy may also be purchased outright for \$14.95.

DON'T MISS THIS SENSATIONAL OFFER!

- Carries approximately 125 tubes including meters and sockets.
- 16 3/4 inches long x 8 1/4 inches wide x 1 3/4 inches high.
- Weighs only nine pounds.
- Ruggedly constructed with heavy leatherette covering, strong plastic handle, nickel plated hardware, and reinforced with metal clamps.

25% Deposit with Order. All merchandise F.O.B. NYC. For orders less than \$10. Add \$1 handling cost. Deduct 2% if full remittance accompanies order. All merchandise subject to prior sale and price changes without notice.

WRITE FOR ADDITIONAL TUBE TYPES AND PRICES. We also stock Special Purpose and Transmitting Tubes at similar savings! Dept. N-4

Windsor ELECTRONIC TUBE CO.
2612-N NOSTRAND AVENUE, BROOKLYN 10, N. Y.

ONLY \$495
Ppd.
or C.O.D.
+ Chgs.

THE NEW TV DYNATRACER

- TRACES TV SIGNALS AND VOLTAGES
- LOCATES DEFECTIVE COMPONENTS
- REQUIRES NO ADDITIONAL EQUIPMENT

This seasonally new piece of test equipment is ideal for trouble-shooting television sets in the home or in the shop. The "DYNATRACER" will out-perform more expensive testers and should pay for itself on the very first repair.

A Must for Every TV Technician

SPECIFICATIONS: The "DYNATRACER" is a self-powered quality test instrument designed to trace TV signals through any Video, Sound, Sync, A.F.C., Horizontal or Vertical Sweep Circuit—will isolate trouble to a stage or component.

ADDED FEATURE: The "DYNATRACER" will also trace voltages (50/500 V. AC/DC) and instantly locate open, shorted, intermittent or leaky (up to 20 MEGOHMS) condensers, resistors, coils, X-Formers, etc.

Instruction and Trouble-Shooting Book Enclosed

10 DAY MONEY-BACK GUARANTEE

Cut out advertisement . . . attach name and address with \$5.00 bill, check or money order and mail to

Century ELECTRONICS CO.
8509-21st Ave., Dept. 212, Brooklyn 14, N. Y.

TEST EQUIPMENT REPAIRED

Contractors to U. S. Government

Repairs and calibration by skilled craftsmen on all makes of Meters, Testers, Sig. Gens., V.T.V.M.'s, Scopes, etc. Prompt service. All work guaranteed. For immediate estimate send instrument by P.P. Ins. to

DOUGLAS INSTRUMENT LABORATORY
Electronic Instrument Repairers
176 Norfolk Avenue Boston 19, Mass.

TELEVISION

PREPARE FOR A GOOD JOB!
BROADCAST ENGINEER
COMMERCIAL OPERATOR (CODE)
RADIO SERVICING

Television Servicing

(Approved for Veterans)
SEND FOR FREE LITERATURE
BALTIMORE TECHNICAL INSTITUTE
1425 EUTAW PLACE, BALT. 17, MD.

tion of motor coils against corrosive vapors, moisture, oils, and shock.

WESTINGHOUSE SERVICE DATA.
Westinghouse Electric Corporation is now offering a 127-page service manual covering all television receivers made by the company from 1947 through 1954.

The outsized 12x 15 inch pages are bound in plastic so the manual will lie flat on the bench. Pages covering new models can be added as issued. The manual includes a photograph of each model and a complete schematic of the set. Alignment data, response curves, and other pertinent data is also included.

The manual, priced at \$1.75, is available from the company's radio-television distributors.

POINT-CONTACT TRANSISTORS
Amperex Electronic Corporation, 230 Duffy Ave., Hicksville, N.Y. has recently issued an elaborate 32-page bulletin on its 0C50 and 0C51 point-contact transistors.

Included in the booklet is information on the operation of a point-contact transistor, characteristic curves, basic amplifier circuits, typical oscillator and switching circuits, and tentative data and curves on the company's two types of transistors.

Write the company for details on how to obtain this bulletin.

GEE-LAR CATALOGUE
Gee-Lar Manufacturing Company, 1330 10th Avenue, Rockford, Illinois has published a 16-page catalogue of radio-television products which is available on request.

Fully illustrated and featuring list prices as well as complete product descriptions, Catalogue 56 covers a wide variety of molded plastic knobs for radio, television, instrument, and experimental work.

RECORDER HEAD DATA
The problems of tape recorder head alignment and head wear are covered in a new technical bulletin now being offered by Minnesota Mining and Manufacturing Co., 900 Fauquier St., St. Paul 6, Minn.

Designated "Sound Talk" Bulletin No. 27, the three page publication covers azimuth alignment and tape skewing, importance of head contact, and the effects of head wear on magnetic tape recording and reproduction. In addition, it includes an eight-step check list for locating high-frequency response loss caused by head problems.

SUN BULLETIN
Sun Radio & Electronics Co., Inc., 650 6th Avenue, New York 11, N.Y. has issued a four-page news bulletin covering industrial sound and recording equipment.

The pamphlet describes tape, tape splicers, microphones, recorders, turntables, and accessory units.

Write the company direct for a copy of this publication.

NEW INVENTION ON OUTMODES ALL PRESENT ANTENNAS.

53 CLAIMS GRANTED IN 5 U.S. PATENTS ON NEW REVOLUTIONARY ANTENNA INVENTION!

NEW!

SUPER 60

#2,585,670 #2,609,503 #2,625,655 #2,644,091 #2,661,423 others pending

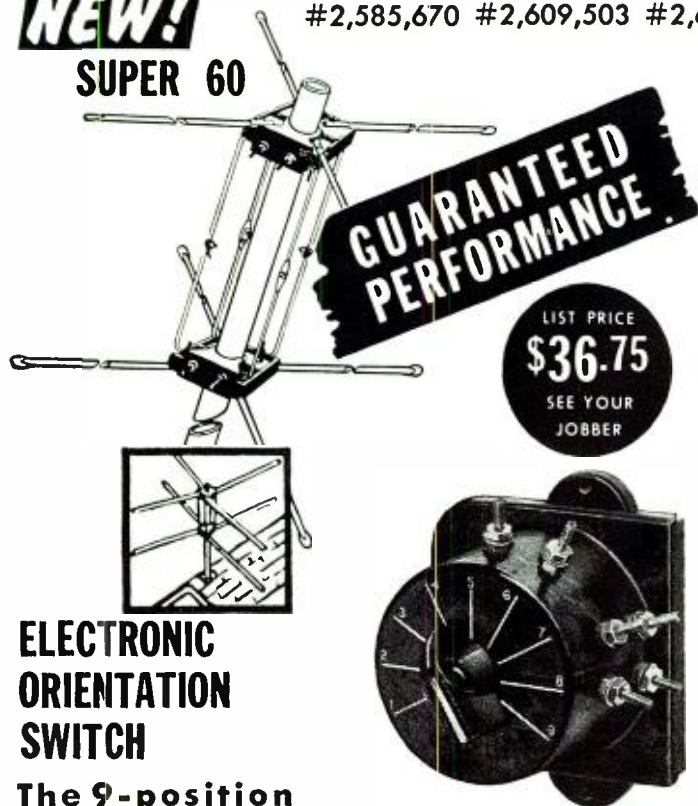

ELECTRONIC ORIENTATION SWITCH

The 9-position selector switch electronically rotates the antenna in a stationary position.

THIS IS ALL YOU NEED!

The price includes the complete antenna and the 9-position electronic orientation switch. The Air Dielectric Polymicalene Transmission Line is purchased as required for the individual installation.

- ★ GUARANTEED TO POSITIVELY OUTPERFORM ALL OTHER ANTENNAS (with or without rotor motors) on ALL UHF, and ALL VHF stations 2 thru 83 from ALL directions.
- ★ GUARANTEED to positively give you the **CLEAREST, SHARPEST, most PERFECT GHOST-FREE** pictures possible in both **COLOR** and **black-white**.

MONEY BACK GUARANTEED TO RECEIVE *All* CHANNELS 2-83 FROM *All* DIRECTIONS AND POSITIVELY OUTPERFORM *All* OTHER ANTENNAS WITH OR WITHOUT A ROTORMOTOR

UP TO 10 TIMES MORE POWERFUL THAN ALL PRESENT CONVENTIONAL ANTENNAS!

New, revolutionary antenna, while being up to 10 times more powerful than conventional antennas, is still able to receive all television and FM stations from all directions without a rotor motor of any kind. The electronic orientation switch used with a new type transmission line developed specifically for this extra powerful antenna now makes it possible to clearly receive stations heretofore considered out of range. It is now possible to put up just one antenna, use just one transmission line, pay for just one installation and receive the finest possible reception from the stations in and coming to your area regardless of their direction.

NEW POLYMICALENE 4 CONDUCTOR TRANSMISSION LINE

- Low Loss External Air Dielectric
- Matched Impedance
- Eliminates End Sealing
- Eliminates Condensation
- Up to 50% Less Loss Than Tubular When Wet
- Easily Spiraled
- No Breaking or Shorting
- Patents Pending - T. M. Reg

If your Distributor or Dealer can't supply you... Contact us for the name of one who can

NOW!! SOLVE YOUR ANTENNA PROBLEM

ALL CHANNEL ANTENNA CORP.
 70-07 Queens Blvd., Woodside 77, N. Y. Hickory 6-2304

ONCE AND FOR ALL.

Check THESE N. J. R. T. TUBE PRICES 70% to 90% OFF LIST

Type	Price	Type	Price	Type	Price
1A7GT	.45	6AK5	.75	6L6	.62
1B3GT	.67	6AL5	.37	6R7	.49
1H5GT	.38	6AQ5	.37	6S4	.38
1L4	.50	6A06	.36	6SBGT	.51
1NSGT	.62	6AT6	.37	6SA7GT	.41
1R5	.48	6AU4GT	.70	6SD7GT	.39
1S5	.40	6AU6	.40	6SK7GT	.39
1T4	.48	6AV6	.37	6SL7GT	.49
1U4	.48	6AX4GT	.55	6SN7GT	.50
1U5	.40	6BA6	.40	6SQ7GT	.37
1X2	.65	6BA7	.57	6T8	.57
3A4	.43	6BC5	.49	6U8	.59
3LF4	.49	6BD6	.45	6V6GT	.38
3Q4	.48	6BE6	.37	6W4GT	.42
3Q5GT	.48	6BG6G	1.20	6W6GT	.45
3S4	.48	6BH6	.45	6X4	.35
3V4	.50	6BJ6	.41	6X5GT	.35
5A24	.50	6BK7	.89	7E6	.35
5U4G	.55	6BL7GT	.65	7F8	.63
5Y3GT	.39	6BQ6GT	.70	12AL5	.40
5Z3	.45	6BQ7A	.92	12AT6	.35
5Y4G	.39	6BZ7	.95	12AT7	.65
6A3	.57	6C4	.39	12AU6	.38
6A6	.49	6CB6	.45	12AU7	.55
6AB4	.42	6CD6G	1.15	12AV6	.50
6AF4	.92	6CF6	.45	12AV7	.60
6AF6	.75	6J5	.50	12AX4GT	.55
6AG5	.47	6J6	.50	12AX7	.55
6AJ5	.73	6K6GT	.37	12BA6	.40

Guarantee
ALL NJRT TUBES ARE BRAND NEW AND FULLY GUARANTEED FOR ONE YEAR

Type	Price	Type	Price
12BA7	.57	35A5	.49
12BE6	.41	35B5	.38
12BH7	.65	35C5	.38
12BY7	.65	35L6GT	.45
12BZ7	.65	35W4	.37
12SA7	.58	35Z3	.43
12SK7	.58	35Z5GT	.45
12SL7GT	.49	42	.40
12SN7GT	.50	43	.53
12SQ7	.55	45	.53
12SR7met	.55	50B5	.41
12V6GT	.50	50C5	.41
19BG6G	1.15	50L6GT	.59
19T8	.75	70L7GT	1.07
25B6GT	.75	76	.42
25L6GT	.40	117Z3	.39
25W4GT	.45	117L7GT	1.19
25Z6	.37	807	1.25

T.V. PIX TUBE BRIGHTENER \$1.39
For T.V. sets where voltage supply is low AC LINE BOOSTER with safety fuse and switch \$5.95

FREE FIVE 1L4 TUBES INDIVIDUALLY CARTONED LIST \$11.25 WITH EVERY ORDER OF \$25.00 OR MORE.
Many 7 volt types not listed. All tubes individually boxed. For orders under \$10 add \$1 handling charge. Tubes offered subject to prior sale. Prices subject to change. All orders shipped F.O.B. 2% discount if full remittance accompanies order. 25% deposit on c.o.d. shipments.

SEND FOR FREE TUBE LISTING.

NJRT TUBE CO.
NEW JERSEY TELEVISION SUPPLY CO.
Sole Distributor of NJRT Tubes
906B WESTFIELD AVE., ELIZABETH, N. J. EL. 3-6166

Editors and Engineers PUBLICATIONS

BETTER TV RECEPTION
New 2nd Edition
IT COVERS ALL YOU WANT TO KNOW ABOUT fringe and low-signal areas

BETTER TV RECEPTION has become the standard guide for the installation technician and a popular text for TV enthusiasts.

Book No. E&E-TR2
\$2.50 per copy* (paperbound) at our store

For Additional Coverage

RADIOTELEPHONE LICENSE MANUAL. Typical study questions with concise answers for any commercial U.S.A. radiotelephone operators license. Book No. E&E-RL1.....\$3.75*

RADIO HANDBOOK. GIANT 13TH EDITION. A one-volume library of radio information with extensive, simplified theory. Detailed how-to-build-it data on dozens of items of practical radio equipment. Book No. E&E-RH13 . \$6.00*

SURPLUS RADIO CONVERSION MANUA. VOL. 1. Practical conversions. Write for list of contents. Book No. E&E-SM1.....\$2.50*

SURPLUS RADIO CONVERSION MANUAL. VOL. 2. Companion to Volume 1. Book No. E&E-SM2.....\$2.50*

*Plus any tax.

BUY FROM YOUR DISTRIBUTOR
300 10th, ON DIRECT MAIL ORDERS TO
EDITORS and ENGINEERS, L.I.C.
BOX 489A SANTA BARBARA, CALIF.
Booksellers and: from BAKER & TAYLOR, Hillside, N. J.

SAVE MONEY... MAKE MONEY...
LEARN TV
the practical way--

17" to 21" ASSEMBLE A TRANSVISION TV KIT

Pay as You Wire \$39 Down Payment

I WILL HELP YOU to start learning TV the practical way -- by assembling a TRANSVISION TV KIT in EASY STAGES. For only \$39 you get PACKAGE #1 (standard first pkg. for all of our kits). This package gives you the BASIC CHASSIS and over 450 TV COMPONENTS with complete Instructions, Drawings, Photos, Service Booklet, and a year's subscription to my "TV and Electronics Notes". When ready, you order the next stage (pkg. #2), etc. Low prices make your complete kit a terrific buy!

FREE CATALOG Shows 6 Great TV Kits:

EXCLUSIVE: Only Transvision TV Kits are adaptable to UHF. Ideal for FRINGE AREAS. No Previous Technical Knowledge required. Write now!

TRANSVISION, INC., Dept. N4
NEW ROCHELLE, N. Y.

--- MAIL THIS COUPON TODAY ---

Educational Director
TRANSVISION, INC., NEW ROCHELLE, N. Y. Dept. N4

I'm enclosing \$_____ deposit. Send standard kit PACKAGE #1, with all Instruction Material. Balance C.O.D.

Send FREE copy of your new TV Kit Catalog.

Name _____
Address _____
City _____ State _____

Multiple Speaker Matching (Continued from page 58)

it would be advisable to choose one with a 70-volt constant voltage output tap, to allow for ease in expansion. Under the conventional method if additional speakers are desired it is necessary to recompute the values of all the matching transformers, because the total power has changed. The RETMA 70-volt tap allows for continued expansion until the output of the amplifier is reached, without re-computing any transformer values; since the formula is not dependent upon the total power in use.

By carefully matching the various loudspeakers using either the RETMA method or the conventional method a judicious saving of necessary power will be obtained allowing for a more flexible and inexpensive amplifier.

REFERENCES

"Impedance Matching and Power Distribution in Loud Speaker Systems," Jensen Technical Monograph No. 2, Jensen Mfg. Co.
Read, Oliver: "The Recording and Reproduction of Sound," Howard W. Sams & Co., Inc.

The "Auto-Tone" (Continued from page 55)

troubles should develop. As it actually makes little difference whether the minimum boost frequency is exactly 1000 cycles or not, all components need have no better tolerance than 10%. If this frequency is not as close to 1000 cycles as the constructor would desire when the unit is tested, changes in C_3 and/or R_9 may be made up to 50% of their value to correct it.

The "Auto-Tone" was designed primarily for use with record players, and when so used the output of the cartridge or preamp is connected across R_{15} , and the arm of R_{13} is connected to the amplifier input. It should be noted here, perhaps, that this circuit does not replace the tone control circuits in the amplifier or preamp. With full input, the "Auto-Tone's" response is essentially flat from 100 cycles to 10,000 cycles and more, and at that input the tone controls on the main amplifier should be adjusted for the most pleasing results at full room volume. The main amplifier controls may be left at those settings, and R_{13} used to control the volume. The amount of bass and treble boost will then be controlled directly by the amount of sound coming from the speakers, being maximum when the level is lowest. Fig. 3 shows the measured curves of the "Auto-Tone" pictured.

The preceding information, along with the schematic, should explain the operation. The curves show the measured results. Hearing it in use is the only real way to appreciate the added listening pleasure the "Auto-Tone" can contribute.



BOOKS

Servicemen for Amateurs Experimenters

New!

201. PRACTICAL TV ENGINEERING. By Scott Helt, New 2nd Ed. A definitive work with new chapters on color, u.h.f., and v.h.f. Mfg. and sales engineers, broadcast engineers, students, and tech workers will all find this book an invaluable aid to a thorough understanding of this booming medium. 730 pages. **\$7.50**

202. NOLL'S TV for RADIOMEN. By Edward M. Noll. One of the most widely used of all books on TV theory and construction, book is in simple non-mathematical terms and gives practical instruction on installation, alignment and adjustment. **\$8.00**

203. PRINCIPLES AND PRACTICES OF TELECASTING OPERATIONS. By Harold E. Ennes. 600 pages, 450 illus. **\$7.95**

204. BASIC TELEVISION ENGINEERING. By Bernard Grob. 592 pages with 415 illustrations covering scanning, synchronizing, video signal, brightness control, DC Reinsertion, Picture, Tube Alignment, picture tubes, VHF and UHF transmission and reception. **\$7.50**

200. HOW TO USE SIGNAL AND SWEEP GENERATORS. By J. Richard Johnson. A practical handbook for the service technician, the radio amateur and the experimenter. Emphasis is on how to use the equipment, not on why it works. Lavishly illustrated, it gives test uses and discusses problems and their solutions in using this equipment. **\$2.00**

215. ELECTRONIC MEASUREMENT. By Terman and Pettit. New, completely revised edition of "Measurements in Radio Engineering". Tells how to solve measurement problems in radio and electronic engineering. Covers measurement of audio frequencies, determining tube co-efficients, measurement of noise figures on the oscilloscope, measuring line parameters, making time interval measurements, measuring power using bolometer and calorimeter methods, measuring field patterns of antennas. **\$10.00**

205. HOW TO TROUBLESHOOT A TV RECEIVER. By J. Richard Johnson. A step by step guide for newcomers. **\$1.80**



206. UHF TELEVISION ANTENNAS AND CONVERTERS. By A. Lytel. Latest information on all types, covers latest UHF installation techniques. **\$1.80**

207. AUDELS TV-RADIO SERVICE LIBRARY, 2 vols. **\$6.00**

208. MODERN OSCILLOSCOPES AND THEIR USES. By Jacob H. Ruiter, Jr., 360 pages, 370 illus. **\$6.00**

209. ESSENTIALS OF RADIO. By Sturzberg & Osterheld. **\$6.75**

210. TELEVISION ENGINEERING. By Fink, 2nd Ed. **\$8.50**

211. INDUSTRIAL ELECTRONICS: An Introduction to Modern Industrial Electronic Practice. By Dr. R. Kretzman. **\$5.50**

212. TELEVISION: The Electronics of Image Transmission. By Zworykin and Morton. Television in all its technical aspects. Includes valuable information for installing TV stations. 646 pages. **\$8.50**

213. ELECTRICAL ENGINEERS HANDBOOK, Vol. 2. By Pender and McIlwain, 4th Ed. Covers the field of communications, including facsimile, TV, FM and pulse techniques. Contains information on optics, 1,618 pages. **\$8.50**

224. RADIO DATA CHARTS. By R. T. Beatty. Charts required in the design of radio receivers cover such items as frequency, wavelength, inductance, capacity, frequency, self-inductance, r.f. coil windings, reactance of coils or condensers, transformer design, choke and transformer design. The only equipment necessary to utilize any of the nomograms is a straightedge. **\$1.75**

(See *Technical Books* section for editors comments.)

New!

4th EDITION

225. TELEVISION SIMPLIFIED. By Milton S. Kiver. The most up-to-date, complete, and practical television handbook now available for repair men, radio workers and all who are interested in the practical opportunities a working knowledge affords. Basic principles are explained in language free of involved theory or mathematics—from the analysis of circuits and operating fundamentals of frequency modulation to the repairing of television sets and the explanation of an actual troubleshooting system. **\$6.75**

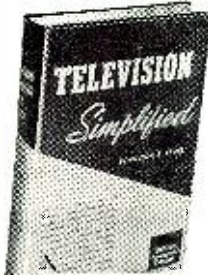

226. TELEVISION AND FM RECEIVER SERVICING. By Milton S. Kiver. New, third edition of this famous definitive text. Explanatory material is offered freely so that the student or novice technician may derive maximum benefit from this text. Eighteen chapters cover antennas, TV receiver installation, TV test equipment, r.f. stages, video i.f. and detector stages, video amplifiers, and a.g.c. systems, CR picture tubes, servicing intercarrier receivers, using TV test patterns, deflection systems, etc. Service technicians who have come to depend on Kiver as reference will welcome this new volume. **\$4.20**

A GREAT BARGAIN

227. TELEVISION REPAIR MAN'S TUBE LOCATION GUIDE. By William Prior, Jr. Almost every known make of set including over 4000 models are covered with tube location diagrams. Put it in your service kit, in your shop, in the home. Up to date 1954 edition. **Only \$1.00**

New!

216. A GUIDE TO AUDIO REPRODUCTION. By David Fidelman. An A to Z explanation of the reproduction of sound. Discusses all phases of systems and requirements plus design, construction, assembly, and testing of systems and components. Explains in detail the circuitry of preamplifiers and amplifiers; complete discussion of phono cartridges, tuners, microphones, loudspeakers and enclosures. For the radio and TV service technician, engineer and experimenter. Companion volume to Weiler's *High Fidelity Simplified*. 250 pages. **\$3.50**



217. HIGH FIDELITY TECHNIQUES. By John H. Newitt. For the engineer, home builder of audio gear, service technician, studio personnel and professionals in the audio field. 12 chpts. in easy to read language. **\$7.50**

218. RECORDING AND REPRODUCTION OF SOUND, 2nd Ed. By Oliver Read. A complete presentation of the entire subject of sound. Discusses modern theory and methods used in the recording and reproduction of sound, based upon years of experience and research. Includes charts and Appendix. 810 pages. **\$7.95**

219. AUDIO AMPLIFIER MANUALS. Produced by Howard W. Sams. Four volumes from 1948 to 1952 covering a wide variety of amplifiers, tuners, and recorders, plus associated equipment used in high-fidelity systems. Includes circuit diagrams, parts lists, etc. (Specify year desired when ordering.) **Each \$3.95**

220. ELEMENTS OF SOUND RECORDING. By Frayne and Wolfe. Covers everything in sound recording from the nature of sound to stereophonic recording. **\$9.50**

221. HIGH FIDELITY SIMPLIFIED, 4th Ed. By Harold D. Weiler. A non-technical explanation of hi-fi techniques and the necessary components which constitute a hi-fi system. Covers the latest tape recorders and the newest types of enclosures and speaker systems. 208 plates. **\$2.50**

222. HOME MUSIC SYSTEMS. By Edward T. Canby. How to assemble parts at greatest savings. **\$4.00**

223. HIGH FIDELITY HANDBOOK. By Greene, Radcliffe and Scharff. A virtual encyclopedia of step by step instructions, hundreds of diagrams that make it easy, inexpensive to select, install, assemble, and enjoy your own HI-FI system for records, tape, FM, AM, TV. Expert guidance in layman's language. **\$4.50**

When You Want a Book



Your Radio & TV News Book Service will attempt to procure any book in this field for you. Just send title, author and price.

MAIL THIS COUPON NOW

RADIO & TELEVISION NEWS BOOK SERVICE, Dept. R4
201 East 57th Street, New York 22, N. Y.

I enclose \$..... for which please ship postpaid books circled or indicated below. If not satisfied I can return them within 5 days for refund.

200 201 202 203 204 205 206 207 208 209 210 211 212 213
215 216 217 218 219 220 221 222 223 224 225 226 227

Any book not listed..... \$.....

Name.....

Address.....

City..... Zone..... State.....

ALL ORDERS SHIPPED POSTPAID. Sorry, no COD's. Add 3% sales tax with orders for N. Y. C. delivery; add 25¢ per title for delivery outside U.S.A., except for APO's.

NEVER BEFORE AT THIS PRICE



Frequency
125 - 20,000 kc
Input
12 or 24V DC .6 or
.3 Amp and
120-475V 5-20 MA

LM FREQUENCY METER

HETERODYNE MODULATED
Complete With Calibration Book
While They Last **\$49.50**
ONLY

TG-10 KEYER



Automatic Code Training Keyer, originally
used for class instruction. Includes a push-
pull 6L6 amplifier, variable speed synchro-
nous drive motor and rewind. Tube comple-
ment 3-6SJ7, 1-6SN7, 1-5Y3.
Dimensions: 25"x19"x11" **\$24.50**
Limited Quantity



FREQUENCY STANDARD

Input: 110v 60cy - AC
Intervals: 10kc & 200kc
Tube Complement: 1-5U4, 2-6SJ7,
2-6N7, 2-6L6. An accurate crystal
controlled, multi-vibrator test set
for checking frequencies up to 30mc
BRAND NEW **\$29.50**

Precision Test Equipment

FROM THE
World's Largest Stock
IMMEDIATE DELIVERY

SIGNAL GENERATORS

TS 13-AP	1-72	I-196
TS 35-AP	1-96	I-208
TS 45-AP	1-122	LAF
TS 120-UP	1-130	804C

Measurements No. 78 Ferris No. 18B

RANGE CALIBRATORS

TS 5-AP	TS 19-AP	TS 102-AP
---------	----------	-----------

FREQUENCY METERS

BC 221	LM	TS 174
--------	----	--------

POWER METERS

TS 33	TS 36	TS 125	I 203
-------	-------	--------	-------

ECHO BOXES

TS 61	TS 62	TS 110	TS 207
-------	-------	--------	--------

DELAY LINES

TS 10 A-B-C	TS 59 AP
-------------	----------

OSCILLATORS

TS 170	BC 376	BC 638
--------	--------	--------

Hewlett Packard 200 B D

OSCILLOSCOPES

TS 34	Dumont	TS 100
-------	--------	--------

208-224-241

SPECTRUM ANALYZERS

TS 148	Marconi TF 890-1
--------	------------------

MISCELLANEOUS

TS 12-AP	TS 89-AP	IE 21
----------	----------	-------

TS 16-APN	TS 118-AP	IE 36
-----------	-----------	-------

TS 32-TRC-1	TS 184A-AP	I 56
-------------	------------	------

TS 51-APG	TS 251	I 95
-----------	--------	------

TS 56-AP	TS 268-U	I 100
----------	----------	-------

TS 78-U	IE 19	I 139A	AN-UPM-1
---------	-------	--------	----------

ASSOCIATED INDUSTRIES
CABLE ADDRESS *Amis* LOS ANGELES
6855 TUNJUNGA AVENUE
NORTH HOLLYWOOD, CALIF.

Television Booster (Continued from page 67)

the other end to reduce shunt-capacitance effects.

Since the input and output impedances of the booster are close to 75 ohms, a "balun" of the type shown in Fig. 5 will be needed to match the 300-ohm u.h.f. lead-in from the antenna. A similar "balun" will be needed at the booster output unless the u.h.f. receiver or converter has provision for 75-ohm input. In any case, the power loss is small and the increase in noise factor is negligible even with two "baluns." The "balun" loop length in inches is $3900/f$, where f is the center frequency in megacycles of the u.h.f.

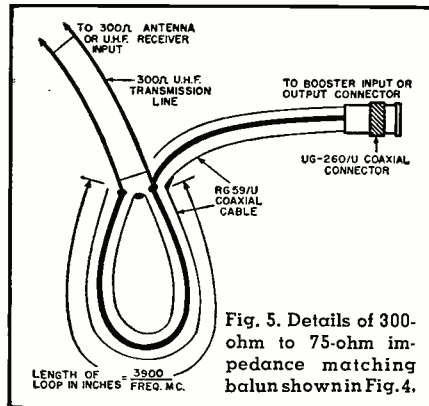

Fig. 5. Details of 300-ohm to 75-ohm impedance matching balun shown in Fig. 4.

channel to be received. Note that this is *not* the frequency for which the cavity is cut, except in the case of a single-channel booster. Where two or more channels are to be received, best results will be obtained with separate "baluns" for each channel, especially for those near the low end of the u.h.f. band.

Booster Alignment

If you have access to one, a u.h.f. sweep and marker generator is the best instrument for aligning the booster.

The alignment setup with a u.h.f. sweep generator is shown in Fig. 6. The only additional equipment required is an oscilloscope for viewing the demodulated sweep waveform, a demodulator network, if such is not included in the sweep generator, and a pair of pads (where necessary) for matching the 75-ohm booster input and output impedance to the terminal

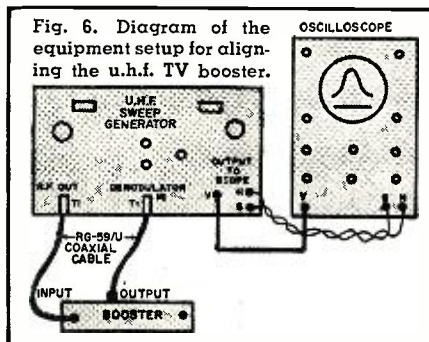

Fig. 6. Diagram of the equipment setup for aligning the u.h.f. TV booster.

TO THE

E. E.

OR

PHYSICS GRADUATE

WITH EXPERIENCE IN

RADAR

OR

ELECTRONICS

HUGHES RESEARCH AND DEVELOPMENT LABORATORIES ARE ENGAGED IN A CONTINUING PROGRAM FOR DESIGN AND MANUFACTURE OF ADVANCED RADAR AND FIRE CONTROL SYSTEMS IN MILITARY ALL-WEATHER FIGHTERS AND INTERCEPTORS.

YOU WILL serve as technical advisor in the field to companies and government agencies using Hughes equipment.

TO BROADEN your field of experience in radar and electronics you will receive additional training at full pay in the Laboratories to become thoroughly familiar with Hughes radar and fire control equipment.

AFTER TRAINING you will be the Hughes representative at a company where our equipment is installed; or you will direct operation of Hughes equipment at a military base.

THE GREATEST advancements in electronics are being made in this sphere because of military emphasis. Men now under 35 years of age will find this activity can fit them for future application of highly advanced electronic equipment.

HUGHES

RESEARCH AND DEVELOPMENT
LABORATORIES

SCIENTIFIC AND
ENGINEERING STAFF

Culver City, Los Angeles County, Calif.

Assurance is required that relocation of the applicant will not cause disruption of an urgent military project.

impedances of the generator or demodulator. Operating voltages for the booster can be obtained from a small power supply or from the TV set.

With the coupling loop in the position shown in Fig. 2, check the frequency range of the fine-tuning control. The cavity length "L" may have to be lengthened or shortened to accommodate the desired frequencies. The booster will have slightly better gain if the length "L" is such that the desired range can be covered with the smallest possible amount of fine-tuning capacitance. Next, set the fine-tuning control to the desired mid-frequency, and adjust the coupling for maximum gain by sliding the lid back and forth.

If no alignment equipment is available, you can do a good job with a u.h.f. station signal and a TV set. Disable the receiver's a.g.c. and substitute fixed battery bias as in normal alignment procedure to make booster-tuning effects more noticeable. An old 630-type set is ideal for this purpose as it has no a.g.c. A v.h.f. field strength meter in conjunction with a u.h.f. converter may be used in place of a TV set.

First, tune in the desired channel for maximum contrast and sound with the u.h.f. converter or channel selector. Then, transfer the antenna lead-in to the booster input "balun," and connect the booster output (through another "balun" if necessary) to the antenna terminals of the converter or tuner. Set the booster output-coupling loop at the position shown in Fig. 2. Watch the picture contrast and tune the trimmer. (Be careful not to turn the trimmer in far enough to touch the anode connector and short the plate voltage to ground.) With a cavity of the correct length, you should be able to tune through a definite peak in contrast and a corresponding reduction in snow with the trimmer. If there is such a peak, it may be possible to get even more gain and less snow by readjusting the coupling loop and the trimmer. If no definite peak can be reached at all, the length of the cavity may have to be changed.

With either method of alignment, do not use the coupling loop to vary the tuning, but only to find the maximum output point once the correct frequency range has been found with the fine-tuning control.

If the booster does not give the desired results, check the following:

1. If a black picture results from overloading, increase the substitute battery bias on the TV set. This is equivalent to turning back the a.g.c. threshold control. (One set which required little a.g.c. voltage for sufficient contrast was "blacked out" when a pre-aligned channel 54 booster was added. Increasing the a.g.c. voltage gave a good sharp picture.)

2. Check the "pencil" tube plate current. This should run around 16 to 18 ma. A slowly slumping lower value may indicate a cracked glass seal on the tube.

April, 1954

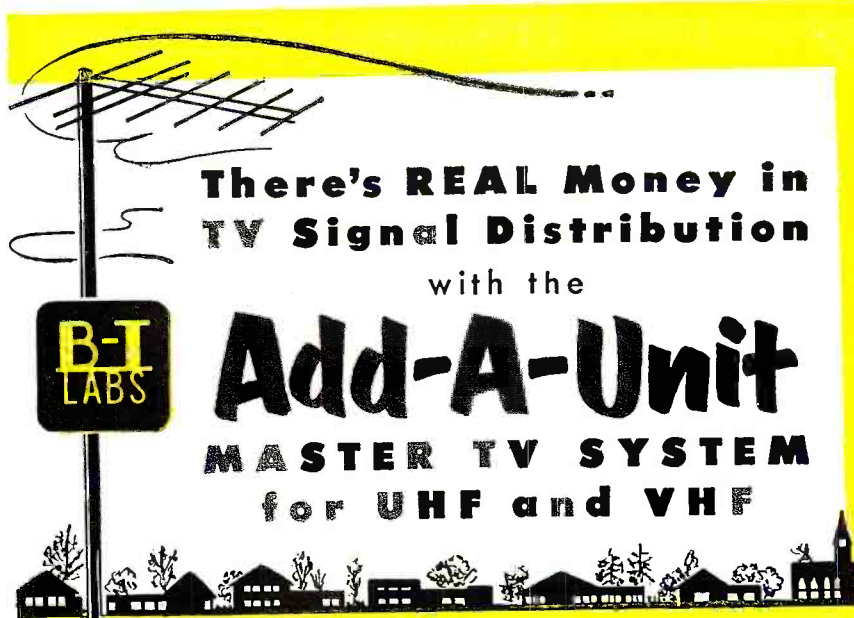

There's REAL Money in TV Signal Distribution

with the

Add-A-Unit

MASTER TV SYSTEM

for UHF and VHF

The B-T Add-A-Unit System is a new tool. It is your 'open sesame' to the biggest boom that has ever hit the TV servicing industry.

Hotels, motels, schools, apartment houses, community developments, hospitals, and hundreds of others with multi-receiver problems are clamoring for low cost, easy-maintenance, efficient TV distribution systems.

This is YOUR BIG MARKET... your real money market

The B-T Add-A-Unit System offers you these advantages:

1. It is the lowest cost amplified distribution system ever designed.
2. It is the easiest system to install under all conditions... requires no special tools and no outside engineering assistance.
3. Its flexibility is practically unlimited and it can serve 2000 TV receivers as effectively as it can serve 2.
4. It has no 'bugs' and requires little or no maintenance.
5. It permits complete control of signal strength: amplification or attenuation, as may be required, assuring high quality reception at all TV outlets from all available channels.
6. Every B-T Master System installed by you is a sure fire 'clincher' for additional business.

Let the B-T System Work for You.

The B-T Add-A-Unit Master TV System consists of the following B-T units:

- MIXER AMPLIFIER
- DISTRIBUTION AMPLIFIERS
- COMMERCIAL ANTENSIFIER
- RESISTOR OUTLET BOX
- TV SYSTEM ACCESSORIES

Attenuator Matching Transformer
Remote Control Line Splitters
Line Loss Equalizer
Weather-Proof Housing



Write to Dept. NO-4 for Free Installation Manual and Complete Specification Data.

BLONDER-TONGUE LABORATORIES, INC.
Westfield, New Jersey

TRAIN FOR TELEVISION

in 3 easy steps!



ONLY \$15.50

for the complete training (all 3 books)

5 Months to Pay!
.. earn while you learn



These three easily understood books make it easy for you to train for television—at absolute minimum cost. No lessons to wait for! No wasted time! Read singly, each book is an authentic, easy-to-understand guide to an essential phase of modern TV. Add all three together and you have a specialized training that can help you win better pay in TV service, a good job as a studio technician, or even a business of your own in the fastest-growing industry of all!

The famous

RINEHART TV LIBRARY

① FREQUENCY MODULATION

This great, 448-page book with over 300 illustrations provides complete training in F-M—the subject so often neglected in TV training and which so frequently “stumps” service technicians. F-M, of course, is used for TV sound and many other important developments. Book covers F-M control circuits, receivers, transmitters, mobile equipment, detectors, antennas, test equipment, service problems, etc. **Price \$5.00 separately. (Outside U.S.A. \$5.50).**

② TELEVISION SERVICING

After studying this great book, you'll find even the most puzzling TV service problems greatly simplified. You'll work better, faster—more profitably! Actual service case histories make things amazingly clear. Illustrations explain details step by step. Subjects range from testing, repair and component replacement, antennas, testing, improving picture linearity to fringe area reception, vital service data, and many others. **Price \$4.00 separately. (\$4.50 outside U.S.A.)**

③ TELEVISION ENGINEERING (TELECASTING)

This 700-page book can help you forge quickly ahead of the average TV student! In particular, it takes you right into the TV station and shows how the work is done . . . from camera chains to lighting . . . from ordinary transmission and reception to the latest UHF, VHF and color television developments. Ideal for general TV training . . . a “MUST” for those who want to get into studio work. 385 illus. **Price \$7.50 separately. (Outside U.S.A. \$8.00.)**

YOU CAN'T LOSE on this offer!

Read this famous RINEHART TV LIBRARY for 10 full days before you decide! Bought singly, these 3 fact-packed books cost \$16.50. Under this offer you save \$1 and have the privilege of paying in easy monthly installments while you use the books. Use coupon!

10-DAY FREE EXAMINATION

Dept. RN-44, RINEHART & CO., Inc.,
232 Madison Ave., New York 16, N. Y.

Send me the famous RINEHART TV LIBRARY (3 books) for 10-DAY FREE EXAMINATION. If the books are not what I want, I will return them postpaid in good condition at the end of 10 days and owe you nothing. If I decide to keep them, I will then enclose \$3.50 as my first payment and will send you \$3 a month for 4 months until the total special price of \$15.50 is paid.

NOTE: Any of these books may be bought separately at prices indicated for each.

Name

Address

City, Zone, State

(Outside U.S.A. price of set \$16.50, cash only, with same 10-day return privilege.)

3. Slide a small piece of tinfoil along the 300-ohm line about a foot away from the input “balun” while watching the picture. This works best if there are several feet of flat 300-ohm line between the “balun” and the tubular line from the antenna.

4. Vary the size of the coupling and cathode-resistor bypass condensers. Spread or compress the turns of the input choke if the desired coverage is near the high or low end of the u.h.f. band. A 56-ohm or 75-ohm cathode bias resistor, instead of the 68-ohm unit shown in the parts list of Fig. 2, may give a better input impedance match at your frequency.

5. Be sure you can tune through a definite peak with the trimmer.

Two of these boosters fed by corner-reflector or stacked-rhombic antennas through about one-hundred feet of tubular 300-ohm line have given good performance at Harrison, N. J. The channel 43 amplifier has provided a picture from WICC-TV, Bridgeport, Conn., where only blanking bars could be seen without it. The channel 54 amplifier provides snow-free NTSC color test patterns from KE2XDR in New York City, even though this station radiates only about 5 kw. and the transmission path is blocked by the RCA building in Rockefeller Center. Two boosters in series seem to offer some improvement in noise characteristics as well as more gain. —30—

Audio Cathode Follower

(Continued from page 51)

five watts of audio into a 3500-ohm load.

Another alternative is to use a tube

normally operating at low screen potentials and driving the screens along with control grids. Two 6AV5's can deliver eight watts of audio under the conditions of Fig. 3. R_{14} and R_{15} , Fig. 2, are increased to 100,000 ohms to keep the plate dissipation of the 12AU7 within ratings.

The impedance of the load is not at all critical and can vary over wide limits if maximum power is not required. Both damping and distortion can be improved by reflecting a higher load impedance into the cathode circuit but at the expense of power output. This feature lends itself admirably to a multiple speaker arrangement in which it is desirable to switch off speakers; for once the maximum load has been matched the load can be switched off with a s.p.s.t. switch with no attendant matching-distortion problems and the power is automatically reduced with the number of speakers, preventing overload or burnout.

The ability to deliver clean, distortion-free audio over a wide range of frequencies, highlighted by excellent response where it is needed—at low frequencies—even with the less expensive transformers, gives the cathode follower a definite place in the audio picture. It can be the long sought answer to those pocketbook blues. Build one—your ears will be glad, too.

REFERENCES

1. Olson, H. F. & Morgan, A. R.: “A High-Quality Sound System for the Home,” *RADIO & TELEVISION NEWS*, November 1950
2. Mitchell, James A.: “Loudness and Power in Audio Systems,” *RADIO & TELEVISION NEWS*, February 1951
3. Matthews, Herb.: “Design Considerations for High-Quality Reproducing Systems,” *RADIO & TELEVISION NEWS*, April 1950
4. Fleming, Lawrence: “Quality Amplifier for TV Sound,” *RADIO & TELEVISION NEWS*, May 1951

Fig. 3. Circuit diagram of a cathode follower providing 8 watts power output. The filament winding at 60 volts positive stays within maximum heater-to-cathode ratings on all tubes. If additional features are desired, a Stancor P-8168 power transformer can be used which would supply current for tuners, preamps, etc. The extra 260-volt, center-tapped winding can be used to supply d.c. heater current. A bridge rectifier lends itself to this dual-voltage application.

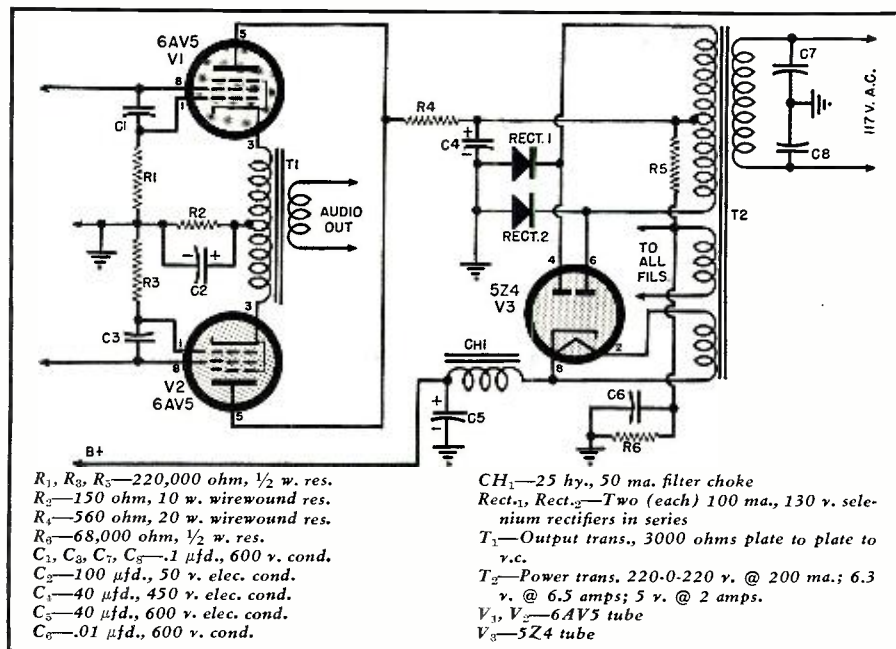

CRYSTALS

Guaranteed to oscillate!
Your choice of frequencies!
Largest selection in the world!

HAM BANDS

FT-243 HOLDER. Fundamental frequencies. .093" Pin. Dia. .486" Pin. SPC



1015	2390	3215	3995	6473	7025	7273	8073	8430
1110	2415	3237	6000	6475	7040	7275	8075	8450
1150	2430	3245	6025	6500	7050	7300	8100	8460
1525	2442	3250	6050	6506	7073	7306	8106	8475
1915	2460	3460	6073	6525	7075	7325	8125	8483
1930	2532	3500	6075	6540	7100	7340	8140	8500
1940	2545	3540	6100	6550	7106	7350	8150	8525
1950	2557	3590	6106	6573	7125	7375	8173	8550
2065	2605	3640	6125	6575	7140	7400	8175	8575
2105	2738	3680	6140	6600	7150	7425	8200	8583
2118	2785	3720	6150	6606	7173	7440	8240	8600
2125	2835	3735	6173	6625	7175	8000	8350	8625
2140	2940	3760	6175	6640	7200	8006	8375	8650
2145	3005	3800	6200	6650	7206	8025	8380	8700
2305	3010	3840	6440	7000	7225	8040	8400	8733
2320	3202	3885	6450	7006	7240	8050	8425	

Lots of 10 or more 69c
 Each 79c
 Lots of 5 or more 79c
 Each 99c
 Individually 99c
 Each

FREE! With every order for 50 or more of these crystals, 1 crystal storage case. Type BX-40. Capacity: 120 crystals.

LOW FREQUENCIES

FT-241-A HOLDER For Single Side Band

400	459
440	461
441	462
442	463
443	464
444	465
445	465
446	466
447	468
448	469
450	470
451	472
452	473
453	474
454	475
455	476
456	477
457	479
458	480



Lots of 10 or more 79c
 Each 89c
 Lots of 5 or more 89c
 Each 99c
 Individually 99c
 Each

FREE! With every order for 40 or more of these crystals, 1 crystal storage case. Capacity: 40 crystals.

200 KC Crystal \$1.99
500 KC Crystal 1.99
1,000 KC Crystal 2.49
1,000 KC Crystal 3.45

(For LM & BC-221—Octal Base)

CR-1A HOLDERS & DC-11A HOLDERS



5910	6522	7390
6370	6547	7480
6450	6610	7580
6470	7350	7810
6497	7380	7930

Lots of 10 or more 69c
 Each 74c
 Lots of 5 or more 74c
 Each 79c
 Individually 79c
 Each

SCR-522—1/8" Pin. 1/2" XX SP.

ASSORTED CRYSTALS. Ea. \$1.99

WRITE TODAY FOR QUANTITY DISCOUNTS

Indicate Frequencies and Quantities Desired

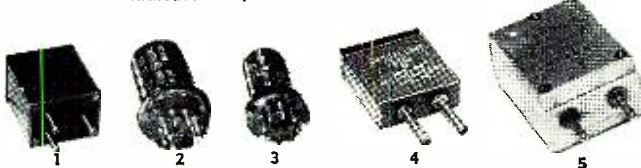

1. FT-249.
2. Octal Base Type. 81.95 Kc.
3. DC-15-A Octal Base Type. 200 Kc.
4. SR-5, 10,000 Kc.
5. BSD 180-G.

COMPLETE SETS

ARC-1	BC-452	BC-659	BC-1000	SCR-300	SCR-522	SCR-610
ARC-3	BC-604	BC-669	LM	SCR-508	SCR-536	SCR-619
ARC-5	BC-610	BC-684	SCR-211	SCR-509	SCR-608	TRC-1
ART-15	BC-620	BC-745	SCR-274N	SCR-510	SCR-609	TRC-2

AND MANY OTHERS. INQUIRIES INVITED. WRITE TODAY!

NOTE: All items subject to prior sale and change of price without notice. **MINIMUM ORDER \$2.50.** All orders **MUST** be accompanied by check, cash or M.O. California buyers add sales tax. INCLUDE APPROXIMATELY 5c PER CRYSTAL FOR POSTAGE. We solicit quantity inquiries from manufacturers.

FUNDAMENTAL FREQUENCIES FT-243 HOLDER



4035	5205	5760	5950	6375	6940	7525	7720	7950
4110	5250	5775	5973	6400	6850	7540	7725	7873
4165	5300	5800	6225	6425	6875	7550	7740	7975
4190	5305	5806	6240	6673	6900	7575	7773	8206
4255	5333	5825	6250	6675	6906	7600	7775	8240
4280	5385	5840	6255	6700	6925	7606	7800	8250
4300	5485	5850	6273	6706	6940	7610	7825	8273
4397	5500	5852	6275	6725	6950	7625	7840	8275
4450	5675	5873	6300	6740	6973	7640	7850	8300
4490	5677	5875	6306	6750	6975	7641	7873	8306
4495	5700	5880	6325	6773	7450	7650	7875	8325
4780	5706	5900	6335	6775	7473	7673	7906	8350
4845	5725	5906	6340	6800	7475	7675	7906	8683
4930	5740	5925	6350	6806	7500	7700	7925	8690
5030	5750	5940	6373	6825	7506	7706	7940	

Lots of 10 or more 34c
 Each 39c
 Lots of 5 or more 39c
 Each 49c
 Individually 49c
 Each

LOW FREQUENCIES

FT-241-A HOLDER. For single side band. Channel Numbers 0-79. 54th harmonic & 270-389. 72nd harmonic. Fractions omitted.



370	386	401	414	429	485	498	513	529
372	387	402	415	430	486	501	514	530
374	388	403	416	431	487	502	515	531
375	390	404	418	433	488	503	516	533
376	391	405	419	434	490	504	518	534
377	392	406	420	435	491	505	519	536
379	393	407	422	436	492	506	520	537
380	394	408	423	437	493	507	522	538
381	395	409	424	438	494	508	523	
383	396	411	425	441	495	509	525	
384	397	412	426	443	496	511	526	
385	398	413	427	444	497	512	527	

Lots of 10 or more 39c
 Each 44c
 Lots of 5 or more 44c
 Each 49c
 Individually 49c
 Each

FREE! With every order for 50 or more of these crystals, 1 crystal storage case. Capacity: 40 crystals.

FT-171 HOLDER

BC-610. Banana Plugs. 3/4" SPC.



2030	2145	2300	2532	3155	3520
2045	2155	2305	2545	3202	3550
2052	2220	2320	2557	3215	3570
2065	2258	2360	2660	3232	3580
2082	2260	2390	2940	3237	3945
2105	2280	2415	3055	3250	3955
2125	2282	2435	3120	3222	3970
2131	2290	2442	3150	3510	3995

Lots of 10 or more 79c
 Each 89c
 Lots of 5 or more 89c
 Each 99c
 Individually 99c
 Each

ON CRYSTALS BELOW WRITE TODAY FOR SPECIAL PRICES INDICATE QUANTITY AND FREQUENCIES DESIRED

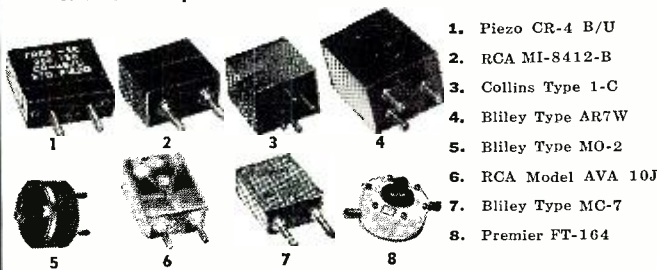

1. Piezo CR-4 B/U
2. RCA MI-8412-B
3. Collins Type 1-C
4. Bliley Type AR7W
5. Bliley Type MO-2
6. RCA Model AVA 10J
7. Bliley Type MC-7
8. Premier FT-164

DC-34 & DC-35 CRYSTALS. Spacing 3/4"



SHIP BAND FREQUENCIES Ea. \$2.99
 2142 2174 2638 2670



FREQUENCIES LISTED BELOW, YOUR CHOICE. EA. ONLY 99¢

1690	1870	2082	2220	2326	2435	2527	2685	2807	2960	3149	3345	3695	3807.5	3925	4030	4210
1705	1890	2090	2235	2335	2440	2540	2710	2816	2980	3161	3365	3702.5	3825	3935	4035	4215
1720	1910	2105	2240	2340	2446	2586	2711	2831	3000	3190	3395	3705	3830	3940	4050	4240
1738	1930	2106	2255	2355	2466	2587	2725	2851	3010	3201	3412	3730	3855	3960	4065	4305
1746	1970	2131	2258	2360	2467	2599	2732	2863	3023	3227.5	3442.5	3765	3870	3965	4065	4325
1770	1990	2155	2275	2375	2478	2605	2745	2894	3027.5	3270	3462	3769	3885	3985	4085	4345
1790	2010	2175	2280	2390	2491	2625	2764	2935	3055	3279	3540	3770	3890	3995	4090	4380
1810	2030	2195	2295	2395	2500	2643	2775	2899	3077.5	3297	3575	3775	3895	4012.5	4150	4440
1830	2050	2202	2300	2415	2510	2665	2776	2925	3095	3311	3655	3790	3905	4015	4175	4745
1850	2075	2215	2315	2422	2514	2670	2926	3117	3317	3665	3792.5	3920	4020	4177.5		

U. S. CRYSTALS, INC.,

805 S. UNION AVE.,
 LOS ANGELES 17, CALIF.

**INTERNATIONAL
RECTIFIER
CORPORATION**

EL SEGUNDO
CALIFORNIA

**RADIO TV
TYPE
SELENIUM
RECTIFIERS**



**NOW
AVAILABLE
AT
YOUR
FAVORITE
JOBBER**

**Widest Range
in the Industry**

Ask for Bulletin JRP-2

**INTERNATIONAL RECTIFIER
CORPORATION**

1521 E. Grand Ave., El Segundo, Calif. - Phone: ORegon 8-5281
CHICAGO: 205 W. Wacker Drive - Phone: Franklin 2-3889
NEW YORK: 501 Madison Avenue - Phone: Plaza 5-8865

Sweep Generator
(Continued from page 65)

In the Fall of 1953, a radically improved sweep generator, Model TS-3, was announced by the *Heath Company*. See Fig. 1. This new generator offered an entirely new, flexible sweep circuit and a combination of control circuits which, to the best of our knowledge, have not been incorporated in a single instrument of this type or in this low price range.

The Circuit

The most outstanding improvement in this instrument was the method used to obtain necessary sweep deviation. Sweep oscillator action is obtained in an extremely interesting manner through the use of an "Inductor" (Trademark, *C. G. S. Laboratories*) controllable inductor. This transformer-like device is constructed of U-shaped laminated steel with a pair of series-connected, current-control windings on each leg. Across the top lamination gap are placed fixed oscillator coils wound on ferrite cores which make actual electrical connection with the structural lamination. With no exciting current applied to the control windings, the oscillator coils operate at their nominal inductance. As an adjustable amount of control current (sweep width control) is applied to the control windings, a magnetic field is set up which completes itself through the oscillator coil ferrite cores. This action, in turn, causes the oscillator cores to vary their characteristics to a degree dependent upon the amount of excitation current and the subsequent magnetic field strength. In effect, the oscillator coils lose inductance as the exciting current increases and the frequency of the oscillator increases proportionately with the highest possible frequency deviation obtained when the cores are saturated. Visualize this action taking place at a fixed 60-cycle rate and the principle of sweep generator action is obvious. The selenium rectifier and the control winding circuit (see Fig. 2) maintain sweep linearity by permitting the primary current to flow in one direction only.

The sweep oscillator circuit utilizes one half of a 12AT7 tube in a standard Colpitts oscillator circuit. Frequency coverage is determined by a 4-position range switch which, in effect, shorts out coils as the frequency range is increased. On the highest frequency range, the connecting straps and switch circuit comprise the oscillator tuned circuit. Oscillator operation is continuous from 4 mc. to 220 mc., includes FM band coverage, and is entirely on fundamentals, thereby assuring high output level and efficient attenuation.

The remaining half of the 12AT7 oscillator tube is connected as a voltage-regulated, cathode-follower output stage. This circuit arrangement provides the dual function of a low im-

**In DETROIT it's
AARON ELECTRONICS**
6025 Mt. Elliott, Detroit 11, Michigan

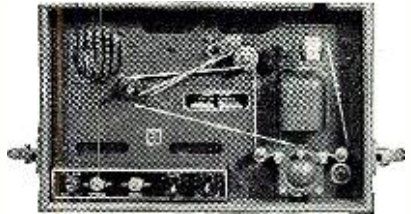

TG-34-A CODE KEYS—115/230 V @ 50-60 cycle—Automatic unit reproduces code practice signals recorded on paper tape—This unit will provide code signals to one or more persons by use of self-contained speaker—Keying oscillator for use with a hand key—Compact in portable carrying case—complete with tubes, photocell & operating manual—Size: 10 1/8 x 10 1/2 x 15 1/16" — Shipping wt. 45 lbs.—**BRAND-NEW in original box \$24.95**

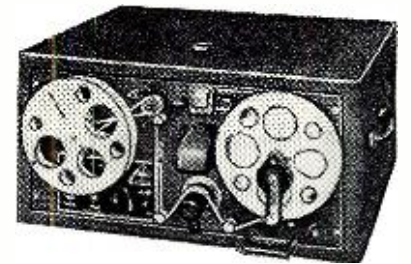

TG-10 CODE KEYS—115 V @ 50-60 cycle—Similar in operation to TG-34-A but with higher audio output (Push-Pull 6L6's) to 4, 8, 15 ohm speaker, not supplied—Fine for P.A. system—Size: 11 x 24 x 1 1/2" —Wt. 65 lbs. with tubes and photocell—**NEW \$29.95**
USED \$19.95

- PE-128 BATTERY CHARGER**—Vibrator type—charging equip. operates from 6 or 12 V storage battery—maintains trickle charge on 6 V & 2-26 V batt. or charges these batt. simultaneously—has 1 DC Millamp & 1 DC Volt meter \$12.95
UHF 180-200 MC TRANSMITTER—Type T-3074 British made—see Feb. Adv. for details—New . . . \$14.95
BRITISH ENGINE DRIVEN ALTERNATOR—Type R—Model SU1271—separately excited at 24 VDC—Output: 30 VAC, 1500-2600 cycles—500 Watts—New . . . \$14.95
PROP PITCH MOTOR—24-33 VAC or DC—Reversible—3 wires required—7000 to 1 gear reduction—approx. 3/4 RPM—out H.P. motor—rugged gear train and sturdy thrust bearing—wt. 65 lbs. \$15.50
RM-29-A CONTROL UNIT—self contained incl. ringor Ckt. 10 for coding type selector for monitor, direct or radio control, or use as telephone. \$6.95 each or 2 for \$12.00
115 VAC 60 cy. BLOWER—1525 RPM—Type L—Model 3571—App. 100 cu. ft. dis.—3/4" intake—2" outlet—motor size 3 1/2x3"—Has mounting bracket and heat ins. element \$7.95
BC-1141 AMPLIFIER—used with the BC-625 Mine-Detector—with 2-1N5, 1-1G4 tubes—in metal case . . . \$5.95
CARDWELL 7 GANG TUNING CONDENSER—Type CA-233—30 to 100 pF. Dual gear ratio—out of the Box \$23.00
Xtal. \$2.95 ea. 2 for \$5.00
PERMEABILITY TUNER—has osc. coil—ant. coil—ideal for 5 tube superhet—schematic diagram enclosed—New 45c ea. 6 for \$2.00
METER RECTIFIER—Copper Oxide—4 prong plug in Type B-27 H—Triplet T-2250-9—500 ua AC—100 ua DC—100 ma DC—New \$1.25
TRIUMPH SWITCH ASSY—Model G-30-27—5 pole 8 pos.—compl. wired w/all volt multipliers & current shunt resistors—w/copper output knob & ins. hdw.—New \$2.95
WIRE KIT—each individually packaged on one carton with a pr. wt. 4 lbs.—consists of 25 ft. power cord (2 cond. #18 AWG str. copper wire rubber covered)—5 rolls, 25' per roll #30, 10 str. hook up wire, glass ins. 3 env. of 1 doz. per env. shakerproof washers—New \$1.95
SOUND-POWERED PHONE INSERTS—out of the TS-10 handset and Head-Chest set—Do the same thing for ONLY a fraction of costs of compl. models. \$1.25 ea.; 10 for \$9.95
HS-23 HEADSET—Hi-Imp—practically new. \$2.95 ea.; 2 for \$5.00
H-18U Headset—800 ohms. \$2.95 ea. 2 for \$5.00
PHONE SPEAKER BOX—contains 5" dyn. spk.—24 V Hayden Timer Motor—(see Feb. ad for picture and compl. description). \$1.95 2 for \$3.50
TECH. MANUAL FOR BC-221 FREQ. METER. \$1.25
ASSORTMENT OF HOME, AUTO, RCVR. KNOBS. \$1.75
TRANSISTOR VOLTAGE REGULATOR—Type RH-115 VAC 400 cy.—72 KW—output 75 to 120 V @ 6 amp—black wrinkle finish metal case—wt. 11 lbs. New \$5.95
BATTERY CHARGER METER—New \$4.95
110 VAC—4 rpm Motor—2 1/2x2 1/4"—wt. 6 oz. \$2.95
FW-16 HALF WAVE RECTIFIERS— \$5.00
Input: 72 VAC. Output: 56 VDC @ 75 ma.
Input: 26 VAC. Output: 10.5 VRC @ 40 ma.
Either Rectifier 50c ea.; 10 for \$4.00

Very Stable 2 Meter Coated Xtals.
CR-1 AR Type 1 1/2" 1/2" power cord.
8001.43 8036.36 8082. \$146.15 8180.
8007.69 8060. \$104.62 \$53.71 8201.54
8020. 8063.08 8120. \$160.
NEW. 75c ea. 10 for \$6.50

7270 KC Xtal.—CR-1 Type—New, boxed. 75c ea.; 10 for \$6.50

TUBE SPECIALS

1B36 \$ 1.95	EF-50 \$ 0.51
1E7G51	204-A 11.95
2J29 11.95	215-A 1.18
3B21 2.50	205 2.50
5J33 11.95	531 4.95
TZ-20 1.25	702-B 1.95
23D451	702-B 1.95
3451	728FY 11.95

BRITISH TYPE TUBES
VR-57 \$1c ea.
VR-136 \$1c ea.
VR-91-A \$1c ea.
VU-113 \$1c ea.
VT-75-A \$1c ea.
VR-505 \$1c ea.

pedance output source and isolation of the swept oscillator from external circuit loads. The output of the cathode follower is connected to the attenuator network consisting of a three step "coarse" attenuator and a variable "fine" control. The maximum output of this oscillator circuit is a measurable .1 volt at 50 ohms, more than required for individual r.f. or i.f. stage alignment.

A very important feature of the sweep oscillator operation is that sweep action is in one direction only from the starting or base frequency. This characteristic, in conjunction with the extreme sweep width available, from zero to 50 mc. depending upon base frequency, permits some startling service observations. For example, to check an i.f. picture carrier of 25.75 mc., the sweep generator oscillator can be set to about 16 mc. and the sweep width control advanced to 30 mc. The 14 mc. sweep width displayed on a scope will then show response curve information such as adjacent channel picture trap at 19.75 mc., sound trap at 21.25 mc., video carrier at 25.75 mc., and adjacent channel sound trap at 27.25 mc. Obviously, this display could be easily duplicated at other frequencies with either more or less sweep as required. The important point is that this generator will easily provide necessary information because of the good, smooth control of full range sweep deviation, high signal level, full frequency coverage, and good attenuation.

Return trace blanking is desirable to eliminate the return trace when the oscillator comes back to its starting frequency. Without blanking, a double trace is present that could cause unnecessary confusion. Since there is no output from the oscillator during the return 180 degrees of the line a.c. cycle, a straight line will appear on the scope and this makes an excellent reference base for easier judgment of pattern symmetry. Elimination of the return trace is accomplished by effectively removing the plate voltage from the oscillator and, at the same time, driving the oscillator grid negative by approximately 100 volts. Plate supply voltage is removed by tying the grid of the 6AQ5 series regulator tube to ground through the 12AU7 clipper tube which cuts the tube off. At the same time, the opposite side of the 12AU7 tube stops conducting and the oscillator grid swings negative with the associated side of the power transformer secondary. This occurs during 180 degrees of the a.c. cycle. During the remaining 180 degrees the grid is clamped to ground through the 12AU7 and plate supply voltage is restored to the oscillator due to the removal of the short from the 6AQ5 grid.

Good regulation of the oscillator r.f. output voltage is obtained by an electronically regulated power supply. This is the system which maintains the oscillator output level flat ± 1 db throughout its sweep frequency range. A portion of the r.f. voltage developed

TECH-MASTER *High Fidelity* Amplifier and Preamplifier KITS

- Tech Master audio amplifier kits are made with the same "custom-quality" attention that has made Tech-Master the first name in TV chassis. They are built to a standard, not to the price. There have been no compromises . . . every component is the finest obtainable . . . workmanship is meticulous.

UL* WILLIAMSON TYPE AMPLIFIER KIT:

(with power supply.) Famous Williamson circuit with modifications for increased, undistorted power output. Uses specially wound quality output transformer.

Model TM-15A, Kit of Parts . . . Net Price . . . \$49.95

Model TMD-15A, DELUXE KIT: Factory assembled, all major components mounted, ready to wire. Net Price . . . \$59.95

*Ultra linear operation through use of screen-tapped primary output transformer

4 CHANNEL PREAMPLIFIER-EQUALIZER KIT:

Provides complete equalization for virtually all recording characteristics now employed. Extra flexibility provided by independent bass and treble boost and attenuation controls.

Model TM-15P, Kit of Parts . . . Net Price . . . \$19.95

Model TMD-15P, DELUXE KIT: Factory assembled, all major components mounted, ready to wire. Net Price . . . \$29.65

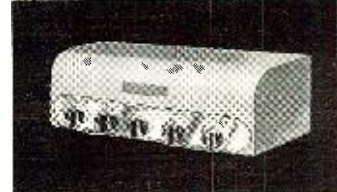
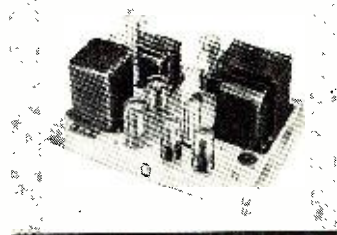

AT ALL LEADING RADIO PARTS DISTRIBUTORS



TECH-MASTER CORPORATION
443-445 BROADWAY, NEW YORK 13, N. Y.

TECH-MASTER, MAKERS OF CUSTOM-BUILT TV CHASSIS,
QUALITY TV KITS & HIGH FIDELITY AUDIO EQUIPMENT.

Literature
Upon Request

First And Only Book With

COLOR TV CIRCUITS & SERVICING



- See Actual Circuits Used In Color Sets
- Color TV Principles
- Simplified Color TV Servicing

JUST OFF THE PRESS!
Everything You Want To Know
About Color TV!

Down-to-earth explanations of color TV circuits with actual diagrams of various manufacturers. Basic principles told in everyday language. NTSC system explained in detail. Trouble-shooting and servicing simplified. Detailed explanation of color TV theory. Over 100 pages packed with all the answers on color TV. Profusely illustrated. \$2.95 postpaid. ORDER BY MAIL TODAY . . . NOW!

BEECO

Dept. P1
Mathieson Building
Baltimore 2, Md.

Guy TV Antenna this New Easy Way!

the fastest, easiest,
neatest, and least
expensive way of
guying TV Antenna
securely. No holes,
just screw them
into the ground.

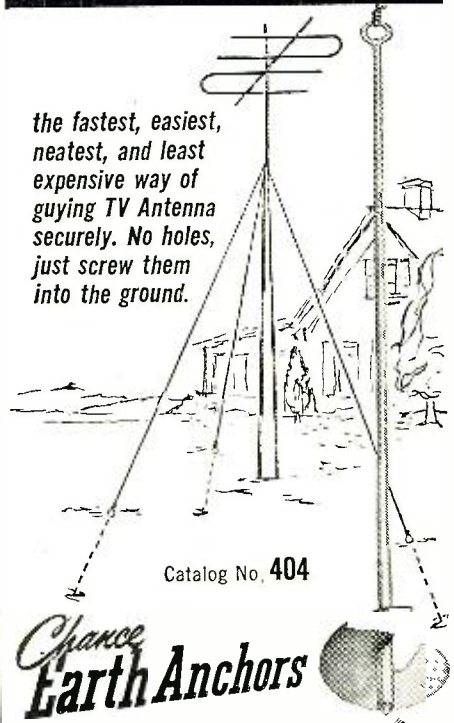

Catalog No. 404

Chance
Earth Anchors

Ask your TV Supplier, or write

A-B-CHANCE CO. CENTRALIA, MO.

COLUMBIA'S SPRING SENSATIONAL SALES!

MARINE MEN—A-HOY!

BC-223 25 W. MARINE TRANSMITTER: Pipe the specs. mikes! 20 or 24 V. input. 4-manual, crystal controlled. Complete with ALL tubes, power supply, cable, mike and 4 crystals ground to YOUR frequency in the 2-3 Mc. marine band. Schematic included. New! COMPLETE! A **\$89.50** spunkin' good.

JEFFERSON-TRAVIS MARINE'S 5 W. RADIO-PHONE: 2-channel crystal controlled TRANSMITTER. Complete with tubes and instruments but less crystal. **\$99.50**

ARB RECEIVER: Look at its range: 195 Kc. to 9.05 MC! Terrific for DF work. Excellent cond. ONLY. **\$49.50**

MARINE CRYSTALS: Any marine frequency, any type holder. Ground to your specs. FCC approved. **\$5.50**
Set of 4 **\$19.95**

75 MC CRYSTAL CONTROLLED RECEIVER
Uses 10 tubes—6AG5's and 6J6's. COMPLETE with tubes and dynamotor. Excel. cond. **\$14.95**

WESTON MODEL 95 TUBE TESTER: Excellent cond. Ea. **\$12.95**

RS-38 HAND MIKE: With coiled cable. Excellent cond. **\$2.79**

TS-102/AP RANGE CALIBRATOR: This is a crystal controlled pulse generator producing a square-topped, 50 V. synchronizing pulse of 3 microseconds at a p.r.f. of 400, 800, 1600 or 2,000 c.p.s. and a triangular marker pulse of .4 microseconds duration at a p.r.f. corresponding to a pulse-echo distance of 1,500 ft. The phase between the marker and sync pulses is continuously variable from a -180 to +180°. Like new condition. PRICE ON REQUEST.

NEW! BOXED! SLASH-PRICED!

500,000 ohm AUDIO POTENTIOMETER. **\$0.35**
Ea.

I.C.A. ALIGNMENT & NEUTRALIZING TOOLS. Ea. **.09**

HS-30 HEAD SET. Ea. **1.50**

ROGERS LIQUID FISH GLUES. Holds over 3,500 lbs. per sq. in. 12 bottles per case. **.99**

48 INCH DIAM. SIG. CORPS' BALLOONS. Ea. **1.95**

SPECIAL! ITEMS \$1.00 OR LESS!!!

BA-38: Same as XX-69. Late mfr. Worth \$3.75. Terrific 103 1/2 V. "B" battery. NEW. Ea. only **25¢** (Write today for special quantity discount.)

RESISTOR ASSORTMENT: NEW! Many gold bands. 100 for **.98¢**

POTENTIOMETER ASSORTMENT: New & used. Excel. cond. 10 for **.98¢**

CERAMIC TUBE SOCKETS: For 872, 211, 832 or 832-A. Most new, some used. Excel. cond. Ea. **25¢**

CRYSTALS! HAM BANDS!

Specify Frequencies

All frequencies. FT-243 Holder, 10 or more. **.89¢**
5 or more. Ea. **.89¢**
Individually. Ea. **.99¢**

12 AND 6 VOLT DYNAMOTORS— F. B. for Mobile!

- 12 V. input, 1000 V. @ 350 ma. out. Has starting relay and fuse block. Like new. Tested. **\$19.95**
- 12 V. input, 625 @ 225 ma. out. Dim. 7 1/2 x 3 1/4 x 3 1/4. Excellent cond. A like new. **\$17.50**
- 12 V. input, 260 V. @ 70 ma. out. For Command Receiver. New. **\$12.95**
- 12 V. input, 375 V. @ 150 ma. With slide case. Excellent condition. **\$5.95**
- 12 or 24 V. input VIBRATOR POWER SUPPLY. 475 V. @ 200 ma. **\$17.50**
- 6 V. input, 350 V. @ 150 ma. out. Completely filtered with starting relay. New. **\$17.95**

12 V. 25 AMP. DELCO-REMY MOBILE GENERATOR

Fair, used cond. Never before sold at this sensationally low price. **\$3.95**
Stock up!

SCR-518 UHF ELECTRONIC ABSOLUTE ALTIMETER. Terrific for conversion to 420 MC and citizen's bands. Consists of transmitter, receiver, indicator, power supply, control boxes, cables with plugs, mounts, etc. Less tubes. BRAND NEW. **\$19.95**
Never before priced so low. ONLY.

APS-13 "Tail End Charley" TRANSMITTER

420 MC. UHF. 5 stages of 30 MC. IF amplifier. Complete with RF 81F section & schematic. Less tubes and dynamotor. Good cond. **\$4.95**

TUBE BUYS! LOWEST PRICES!

5BP4. \$2.95 6AC7. 62¢ 813. \$6.95 6Z5. \$5.59
6SN7. .75 6AK5. 49¢ 832-A. 4.95 6V6. .65
SCR-183 12 V. RECEIVER & TRANSMITTER: Covers 12 V. dynamotor. Parts alone worth \$25.35! Approx. 25 V. output. Plus schematic. New low price. **\$12.95**

METER: 0-25 ma. 2" rd. Weston New. Down to ONLY. **\$9.99**

METER: 0-15 V. "A.C." 2" rd. Westinghouse. New. **\$2.95**

METER: 0-9 amp. RF 2" rd. Westinghouse. New. **\$3.49**

WESTERN ELECTRIC METER: 100-0-100 scale. 0-1 ma. each side of zero. 3" rd. New. **\$2.95**

DUAL METER INDICATOR: Has 2 individual movements each perpendicular to the other. One has 110 microampere movement, other —210 microampere movement. Makes terrific "m" meter or field-strength meter. Dim.: 3 1/4 x 3 in. New. **\$3.95**

ARC-5 OR 274-N TRANSMITTERS

All pre-tested & guaranteed.

- 1-3 mcs. Brand new **\$19.95**
- 3-4 mcs. With tubes **25.00**
- 4-5.3 mcs. With tubes **8.25**
- 5-7 mcs. With tubes **12.50**
- 7-9.1 With tubes **14.50**

274/ARC-5 VHF TRANSMITTER. For C.A.P. with tubes 100-155 MC. Crystal control. **29.95**

ARC-5 OR 274-N RECEIVERS

Equipped with Tuning Knobs

- 19-55 kc. **\$19.95**
- 1-5.3 mcs. Like new. **24.50**
- 3-6 mcs. Brand new. **12.00**
- 3-6 mcs. With tubes. **12.50**
- 6-9.1 mcs. With tubes. Used. **21.95**
- New. **8.25**
- 6-9.1 mcs. Used. Less tubes. **8.25**
- BC-458 274-N Modulator. Less dynamotor. Excel. cond. **3.95**

Plus All Accessories Needed for Above. Conversion dope available on request.

Write Today—and ask for FREE CATALOGUE!

All orders F.O.B. Los Angeles. 25% deposit required. All items subject to prior sale. Note New Arrivals. Minimum order \$10.00. Inquiries Invited.

COLUMBIA ELECTRONIC SALES

2251-53 W. Washington Blvd., Los Angeles 18, Calif.
Come in and visit our new, larger centrally located warehouse-store!

by the oscillator is fed to a crystal diode and rectified. The d.c. voltage, at this point, is connected to the grid of the 6AU6 control tube. If the output of the swept oscillator should fall off at any point, the voltage developed across the diode will also drop off. This change of potential applied to the 6AU6 grid will cause the high voltage to be increased which, in turn, increases the activity of the oscillator. An opposite reaction occurs if the output of the oscillator should increase. The efficiency of this circuit operation is demonstrated through automatic oscillator plate voltage variation from 40 to 180 volts.

Another very important feature of the TS-3 sweep generator is a built-in marker system which allows two or more markers to be simultaneously evident on a trace. One half of the 12AT7 marker oscillator tube functions as a variable frequency Colpitts oscillator, 19 to 60 mc. on fundamentals and 57 to 180 mc. on calibrated harmonics. The other half of the 12AT7 operates as a Pierce crystal-controlled oscillator. The cathodes of both oscillators are tied to a common resistor causing all frequencies generated to be present at one point. The plate supply of the marker oscillator is voltage regulated to insure a high degree of operating stability. An additional feature of this type of circuit is that the sum and difference frequencies of the two oscillators will be present as well as the main operating frequencies. Thus, when a 4.5 mc. crystal is used, markers spaced 4.5 mc. apart will be evident on the trace. Output of the marker oscillator is fed through a control to the output of the generator. Marker and sweep oscillator outputs are attenuated separately to allow more flexible control. A 4.5 mc. crystal is supplied with the kit and is panel mounted so that it can be removed at any time in order to help identify the marker pip present on the trace. Its panel location is also convenient for changing marker crystal frequencies.

Since both the marker and sweep oscillator portions of the instrument use identical variable condensers, it was decided to further standardize the construction assembly of these units through a "unitized" assembly. Therefore, identical, laminated phenolic base plates are used for the actual sub-chassis and all ground return points are carefully brought out to a common ground terminal at the panel mounting of the output cable connector. This method completely eliminates problems caused by ground eddy currents in the chassis. Variable condenser control shafts are also of laminated phenolic construction to remove r.f. from the front panel.

The power supply system employs a 6X5 full-wave rectifier with well filtered d.c. output. Plate voltage for the rectifier tube and heater voltage for all tubes as well as voltage for the phasing and blanking circuits is furnished by the power transformer. Phasing is accomplished by connecting a con-

denser and variable resistor across the high-voltage plate winding. Changing the amount of resistance changes the phase shift in the network which is connected to the horizontal output terminals.

The attenuation network is basically simple and operates effectively through the range of operation demanded for service work. The sweep generator can be set for minimum output and no discernible radiation will be observed on nearby operating TV receivers tuned to actual transmitted programs. This is true even when the oscillator portion of the sweep generator is tuned through the transmitted frequency. An efficient, two-section r.f. filter in each leg of the a.c. supply line is a contributing factor in the control of r.f. radiation.

Calibration of this new sweep generator is easily accomplished with an oscilloscope and the instrument can be described as self-calibrating.

Marker dial calibration requires using the harmonics generated by the 4.5 mc. crystal in the fixed marker circuit. These harmonics calibrate the variable frequency marker oscillator at several points on the dial. Adjustment of pointer settings and the marker oscillator slug effectively trims and pads the entire dial range. The sweep oscillator dial needs only to be indexed, with the condenser fully marked, because accuracy is not required from the sweep portion of the instrument. The marker system (and not the sweep system) is always considered to be the accurate reference. Frequency markings on the sweep oscillator dial are for reference only. It is obvious, therefore, that the over-all accuracy of the entire generator is limited only by the accuracy of the crystal marker itself, thereby providing a higher degree of calibrating accuracy than ever before obtainable in kit constructed instruments.

Multiple markers can be obtained by feeding the output of an external signal generator into the external marker connection provided. The generator can be tuned to beat against the fixed or variable oscillator at a frequency difference designed to give marker pips spaced at desired frequency intervals. An additional advantage of this marker system is that the crystal or variable oscillator energy can be taken directly from the external marker connector for fixed frequency alignment of sound and video i.f. stages, traps, discriminators, etc. Use of the marker generator in this manner keeps all alignment consistent from a common source insuring peak performance when alignment is completed.

Some of the actual service set-ups outlined in the instruction booklet accompanying the sweep generator kit are alignment of stagger-tuned, over-coupled and intercarrier i.f. systems; oscillator, r.f., and sound alignment. The broad frequency coverage of the instrument permits its use on the FM broadcast frequencies as well as the

TUBES & PARTS

Write for our free BARGAIN CATALOG

ALL TUBES are guaranteed for one year . . . individually boxed. Very BEST BRANDS available for immediate delivery!

DA46	1.89	2A6	89c	6AH6	1.89	6BH6	69c	6K5GT	.69	6S07	.79	7C5	.89	12A07	.79	12SN7GT	.99	26	59c	57	79c
D24	.79	2A7	.89	6AK5	.89	6BJ6	.69	6K6GT	.59	6S07GT	.59	7C6	.79	12A07	.79	12SQ7	.99	27	59c	58	79c
1A5GT	.79	2B3	.89	6A6K6	1.08	6BK7	1.19	6K7GT	.69	6S7GT	.69	7C7	.79	12A07	.79	12SQ7GT	.99	28	59c	59	79c
1A7GT	.79	2C3	.89	6AL5	.69	6BL7	.79	6K8GT	.69	6S7GT	.69	7C8	.79	12A07	.79	12SQ7GT	.99	29	59c	60	79c
1B3GT	.35	2E5	.89	6A0G5	.89	6BN6	1.19	6L5G	.69	6S7GT	.69	7C9	.79	12A07	.79	12SQ7GT	.99	30	59c	61	79c
1B5	.79	2K2/879	.74	6A0T7	.89	6B0G6	1.19	6L6GA	1.39	6S7GT	.69	7D	.79	12A07	.79	12SQ7GT	.99	31	59c	62	79c
1H5GT	.39	3F4	1.25	6AR5	.79	6B0T7	.79	6L7	.69	6S7GT	.69	7E	.79	12A07	.79	12SQ7GT	.99	32	59c	63	79c
1J6GT	.69	30F4	.69	6AT6	.59	6B27	1.29	6N6G	1.40	6S7GT	.69	7F	.79	12A07	.79	12SQ7GT	.99	33	59c	64	79c
1L4	.79	30GT	.89	6AS5	.69	6C4	.69	6N7GT	1.19	6S7GT	.69	7G	.79	12A07	.79	12SQ7GT	.99	34	59c	65	79c
1L6	1.19	35A	.69	6AU5GT	1.29	6C5GT	.69	6P5GT	.69	6S7GT	.69	7H	.79	12A07	.79	12SQ7GT	.99	35	59c	66	79c
1L4A	1.19	5T4	.35	6AU6	.59	6C6	.69	6Q7GT	.69	6S7GT	.69	7I	.79	12A07	.79	12SQ7GT	.99	36	59c	67	79c
1L5	.39	5V4	1.40	6AV5GT	.89	6C6G	.69	6R7GT	.69	6S7GT	.69	7J	.79	12A07	.79	12SQ7GT	.99	37	59c	68	79c
1L5C	.39	5W4	.87	6AX4	.69	6C6D	1.89	6S7GT	1.15	6S7GT	.69	7K	.79	12A07	.79	12SQ7GT	.99	38	59c	69	79c
1L6C	.39	5W4	.87	6AX5	.69	6C6D6	1.89	6S8GT	1.25	6S7GT	.69	7L	.79	12A07	.79	12SQ7GT	.99	39	59c	70	79c
1L5D	1.19	5W4GT	.59	6AX6	.69	6C6F6	1.19	6SA7GT	1.29	6S7GT	.69	7M	.79	12A07	.79	12SQ7GT	.99	40	59c	71	79c
1L6D	1.19	5Y3GT	.45	6AY5GT	.89	6D6/78	1.19	6S7GT	.69	6S7GT	.69	7N	.79	12A07	.79	12SQ7GT	.99	41	59c	72	79c
1L8	1.19	5Y4	.54	6BAQ	1.44	6D9G	1.15	6S7GT	.69	6S7GT	.69	7O	.79	12A07	.79	12SQ7GT	.99	42	59c	73	79c
1L8C	.39	5X4G	.81c	6BR6T	1.15	6E5	.69	6S7GT	.69	6S7GT	.69	7P	.79	12A07	.79	12SQ7GT	.99	43	59c	74	79c
1L8D	.39	5Z3	.81c	6BR6T	1.15	6E5	.69	6S7GT	.69	6S7GT	.69	7Q	.79	12A07	.79	12SQ7GT	.99	44	59c	75	79c
1N5GT	.39	6A3	1.68	6BA7	.69	6F6GT	.59	6S7GT	.69	6S7GT	.69	7R	.79	12A07	.79	12SQ7GT	.99	45	59c	76	79c
1P5GT	.79	6A7	.89c	6BC5	.69	6F7	.59	6S7GT	.69	6S7GT	.69	7S	.79	12A07	.79	12SQ7GT	.99	46	59c	77	79c
1Q5GT	.79	6A8GT	1.24	6BD7	1.05	6F8G	1.53	6S7GT	.69	6S7GT	.69	7T	.79	12A07	.79	12SQ7GT	.99	47	59c	78	79c
1R5	.39	6A8	.69	6BD5GT	.89	6G6G	.95	6S7GT	.69	6S7GT	.69	7U	.79	12A07	.79	12SQ7GT	.99	48	59c	79	79c
1S5	.39	6A8T	1.15	6BD5GT	.89	6G6G	.95	6S7GT	.69	6S7GT	.69	7V	.79	12A07	.79	12SQ7GT	.99	49	59c	80	79c
1U4	.69	6AC7	1.45	6BF5	.69	6G6G	.95	6S7GT	.69	6S7GT	.69	7W	.79	12A07	.79	12SQ7GT	.99	50	59c	81	79c
1U5	.59	6AF4	1.76	6BF6	.69	6G6G	.95	6S7GT	.69	6S7GT	.69	7X	.79	12A07	.79	12SQ7GT	.99	51	59c	82	79c
1V	.59	6AG5	1.05	6BG6	.69	6G6G	.95	6S7GT	.69	6S7GT	.69	7Y	.79	12A07	.79	12SQ7GT	.99	52	59c	83	79c
X2A	.89c	6AG7	1.49	6BG6G	1.89	6G6G	.95	6S7GT	.69	6S7GT	.69	7Z	.79	12A07	.79	12SQ7GT	.99	53	59c	84	79c

FREE

with every order, 1" screw driver, 1/2" chrome vanadium blade. Insulated handle. Everybody can use another screw driver.

Regency All channel UHF Converter Hottest news in UHF history. The Cadillac of UHF converters NOW \$14.96 net

Picture tube brightener 5.95 list dealer cost \$1.95

TV Arrow antenna to receive UHF, VHF, or UHF-VHF \$2.95

Midget Radar Outdoor UHF antenna \$4.77

TELETRON TV WAVE TRAP For VHF Channels 2 to 13. Clears VHF picture, stops interference all once, 30 seconds to attach. ea. net \$1.75 All UHF Channels \$2.75

TV 2-se antenna coupler \$1.17 ea

Flyback Transformer TV Horizontal output, universal replacement 14,500 V \$2.49 e

70 degree cosine yoke with 4 lead and network \$2.95 ea

FILTER CONDENSERS

FP Type	or Tubular with Leads—Fresh Stocks Always
8 mfd.	450 V. .35 10 mfd. 50 V. .19
10	450 V. .45 20. 50 V. .43
10-10	450 V. .35 25. 50 V. .19
20	450 V. .45 50. 50 V. .25
20-20	450 V. .49 100. 50 V. .29
30	450 V. .45 20 mfd. 150 V. .35
30-30	450 V. .59 20-20 150 V. .45
40	450 V. .49 30 150 V. .49
40-40	450 V. .69 30-30 150 V. .49
60	450 V. .69 40-40 150 V. .49
60-40	450 V. .89 40-20 150 V. .49
80	450 V. .69 40-40 150 V. .49
80-40	450 V. 1.29 50-30 150 V. .49

P. M. SPEAKERS

12" COAXIAL PM SPEAKERS. High Fidelity with Crossover filter attached. 20 watts; 40-19,000 cps. response; 8 ohm coil. ea. **\$12.95**

15" COAXIAL SPEAKER. ea. **\$19.95**

Very best quality—NATIONAL BRANDS. Individually Packed.

3"	ea. \$1.39
3 1/2"	ea. 1.59
4"	ea. 1.59
6"	ea. 1.79
8"	ea. 2.29
10"	ea. \$5.10
12"	ea. 5.95

SPECIAL PURCHASE PICTURE TUBES

	With Dud	Without Dud	List Price
16AP4 metal	\$15.95	\$18.95	\$46.00
16DP4 glass			40.00
17CP4A metal	17.95	20.95	36.00
21AP4A metal	21.95	26.95	55.00

PLEASE SHIP DUDS EXPRESS PREPAID

MISCELLANEOUS BUYS		SELENIUM RECTIFIERS	
1. PILOT TRANSFORMER—456 Kc. .29c		65 mil. .39	
FILAMENT LIGHTS, Type No. 47		75 mil. .79	
10 for 39c; 100 for \$2.95		100 mil. .89	
VOLUME CONTROLS FOR SWITCH, 2" shaft, 1 meg, 1/2 meg, 34c		150 mil. 1.29	
MEG. 100P4 .19c		250 mil. 1.65	
SINGLE ION TRAPS, .19c		300 mil. 1.75	
DOUBLE ION TRAPS, .19c		350 mil. 1.95	
OUTPUT TRANSFORMER, .19c		400 mil. 2.45	
for 50L6, 29c; for 6V6, 39c		450 mil. 2.49	
6-foot LINE CORD UL 10 for \$1.95		500 mil. 2.55	
TV INTERLOCK CORDS, .48c			

BRAND NEW TV PICTURE TUBES

Rectangular Tubes Are Supplied With Daylight Type Dark Face

SIZE	PRICE	SIZE	PRICE
7JP4	\$17.95	17HP4	25.10
8BP4	23.00	17TP4	28.70
10BP4	15.95	19AP4	32.30
12JP4	18.60	19FP4	77.91
12LP4	19.95	20CP4	77.91
14BP4	21.25	21AP4	98.50
15AP4	23.50	21EP4	
16AP4	23.95	22CP4	
16BP4	23.80	22FP4	
16EP4	26.95	21MP4	
16GP4		24AP4	
16JP4		24CP4	
16KP4		24DP4	
16LP4		27EP4	
16WP4		27FP4	
17BP4		27LP4	
17CP4		27NP4	
17CP4		27RP4	

THESE ARE BRAND NEW PICTURE TUBES

ONE FULL YEAR GUARANTEE ON ALL TYPES SEND US YOUR ORDER AND WE WILL SHIP FROM STOCK IMMEDIATELY

TERMS: 25% DEPOSIT with order, balance C.O.D. ALL shipments F.O.B. Chicago. ORDERS LESS THAN \$5.00—\$1.00 SERVICE CHARGE. CABLE ADDRESS: CONTULAB. These prices supersede all previously advertised prices, subject to change

RADAR TYPE TV ANTENNA

For UHF and VHF RECEIVES ALL CHANNELS

212 miles reception recorded. 125 miles common. This unbeatable antenna has been reinforced to withstand 150 mile winds. Satisfaction guaranteed or your money back. Less Mast, List Price. \$19.95

Your Cost. \$19.95

5 ft. DURABLE MAST heavy gauge 1 1/4 diam. with interlocking end. Slip two sections together for a ten-footer. 5 sections = 25 ft. Each section \$1.25

MOLDED TUBULAR BY-PASS CONDENSERS

50 Condensers assorted in package \$4.95

600 VOLT	9c	1.00	12c
.001	9c	1.00	19c
.002	9c	2.00	19c
.005	9c	25 mfd.	19c
.01	9c	.25 mfd.	19c
.02	12c	.5 mfd.	29c

THE LAZY H

Pre-Assembled Go-Lateral Array

\$29.35

The dual LAZY H. Only 6 connections. This table model cabinet eliminates your bottle neck. Supplied complete with 21" picture tube, 70 degree yoke, gold mask and safety plate, fly back transformer and width coil, very easy to install and all for \$50.00.

21" TV CONVERSION KIT COMPLETE WITH CABINET

Now you can make that conversion. This table model cabinet eliminates your bottle neck. Supplied complete with 21" picture tube, 70 degree yoke, gold mask and safety plate, fly back transformer and width coil, very easy to install and all for \$50.00.

TV CONVERSION KITS

Easily installed consisting of rectangular tube, 70 degree yoke, beautiful mask, flyback transformer and width coil.

17" Conversion Kit, as above, complete.	\$25.95
20" Conversion Kit, as above, complete.	38.95
21" Conversion Kit, as above, complete.	39.95
24" Conversion Kit, as above, complete.	89.95
24" Conversion Kit, Round	69.95
27" Conversion Kit, as above, complete.	99.95
24" & 27" Rectangular Kits Contain 90° yoke.	

CONICAL TV ANTENNA

10 Element conical \$3.95

Double bay array, with stacking bars \$7.75

4 Bay array, with harness and stacking bars \$14.95

6 Element Conical. Only \$2.95

CONICAL TV ANTENNA KIT

Complete 20-Piece Kit Contains Everything You Need For A Professional Installation.

For all around good reception on ALL CHANNELS. List price \$31.95. Elements are made of GENUINE AIRCRAFT ALUMINUM tubing. Contains everything you need: 2 Six Element Conical Bays, 1 pair HQ Bars, 2 Five Ft. 1 1/4" Mast Sections, 60 Ft. 300 OHM Twin Line, 3 Standoff Insulators, 2 Screw-eye Standoffs, 1 Mounting Base, 1 Guy Ring, 1 Clamp Assy, 1 Pipe Strap, 4 Lag Bolts and Complete Instructions.

10 Kits only . . . \$100.00

Stock No. RK902 **\$12.99** Complete

UHF Antenna Kit

- Includes everything you need.
- 1) UHF bow tie antenna with reflector.
 - 2) 3 mast sections.
 - 3) Jumbo 300 ohm tubular transmission line.
 - 4) Sealer cap for UHF transmission line.
 - 5) Universal mast base.
 - 6) 50 ft. top quality guy wire.
 - 7) 3 screw eye anchors for guy wire.
 - 8) Guy wire ring.
 - 9) 3 stand off insulators for 300 ohm transmission line.
 - 10) 2 mast stand off insulators for 300 ohm transmission line.
 - 11) Illustrated instructions for quick, easy assembly.
- All in one carton for only \$7.65
- Double bay array complete as above plus 5 mast sections and matching device for proper stacking \$11.77

RESISTOR KITS

Insulated 1/2, 1 and 2-watt assortment of most used values, I.R.C. Ohmite, Stackpole, Spear. 100 for **\$2.95**

300 OHM TWIN LEAD

55 Mil. 100 ft.	\$1.59
1,000 ft.	13.95
20 Ga. 80 Mil. 100 ft.	1.89
1,000 ft.	16.95
UHF TUBULAR 300 OHM LINE	
1,000 ft.	\$34.50
100 ft.	\$4.95

All Channel Foam Line, 100' for \$6.95, 50' for \$3.95

TUBE KITS

BEST BRANDS AT BEST PRICES

3V4, 1T4, 1R5, 155	\$2.19
3Q4, 1T4, 1R5, 155. List Value \$8.00. Tube Kit only.	\$1.98
354, 1T4, 155, 1R5. List Value \$7.80. 4-Tube Kit.	\$1.98
1U4, 354, 155, 1R5. List Value \$7.80.	\$1.98
All Four Tubes for	\$2.49
117Z3, 1U5, 354, 1R5, 1T4. AC-DC Portable Kit. All for	\$2.59
12AT6, 12BA6, 12BE6, 35W4, 50B5, 5 Tubes for	\$3.49
50L6GT, 35Z5GT, 12SQ7GT, 12SA7GT, 5 Tubes for	\$3.49



PREMIER RADIO-TV SUPPLY, division of CONTINENTAL CORPORATION
3239 West North Avenue, Chicago 47, Illinois ARmitage 6-5550

**FOR THOSE WHO SEEK THE ULTIMATE
IN HIGH FIDELITY CABINETS**

*Your Music System
Housed Within A Furniture Setting*

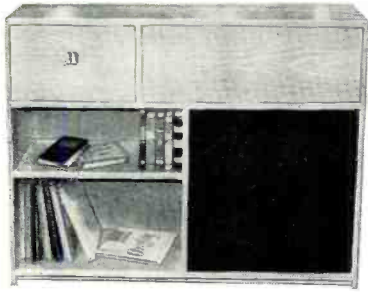

Handsomely styled in the finest woods, both models are available in Mahogany or Birch, Natural Birch or Unfinished Birch.

Here's a bookcase cabinet that provides ample room for the housing of a record changer, tuner, amplifier and speaker... plus a music library.

MODEL 90: Overall dimensions: 35½" H., 48" W., 16" D. Tuner compartment: 11" H., 29" W., 15" D. Baffle area: 5 cu. ft.

MODEL 91: Similar in size to Model 90. Contains adjustable record shelves in place of speaker baffle at no extra charge.

Finished **\$125*** net
White Birch—Unfinished **\$96*** net

*Net prices, slightly higher West and South

Precision Manufactured High Fidelity Cabinets of Character

G & H WOOD PRODUCTS CO.
75 NORTH 11th STREET, BROOKLYN 11, N.Y.



PIONEERS IN RADIO FURNITURE FOR HIGH FIDELITY EQUIPMENT

i.f. frequencies. Operating flexibility permits actual duplication of alignment pattern photos as outlined in TV manufacturers' service bulletins.

An extremely interesting aspect is the possibility of the use of this generator for u.h.f. service. Because of the excellent high level fundamental output, the fourth harmonic will provide frequency coverage up to 880 mc. which is within 10 mc. of the u.h.f. band upper limit (890 mc.). While the instrument was designed specifically for v.h.f. service, it is obvious that the probability of good u.h.f. service application exists.

Through continued use of the instrument, it is quite likely that many additional applications, such as alignment of boosters, remote tuners, checking video amplifiers by beating against another generator, will become evident. With this new sweep generator, the TV technician has an indispensable service tool at his disposal that will really assist him in the accurate and rapid alignment of TV circuits. -30-

U.H.F. Corner Reflector

(Continued from page 63)

whole range is being covered by the peak of the gain curve, as shown in Fig. 4.

The width "H" of the reflector is not critical.

The spacing between reflector elements, "G," should not be greater than 0.2 λ at the highest frequency (890 mc.). When "G" is greater than 0.2 λ, losses through the reflector become a factor and the front-to-back ratio of the antenna is impaired. About two inches seems an effective distance between reflector bars.

For stacking, two corner reflectors may be placed side by side and joined with two 20-inch lengths of 300-ohm line. This will add an average gain of 2.5 db over the entire range. -30-

TAPE HYPERTENSION

By J. W. CLIFTON

FOUR recording improvements result when the 1¾" diameter hub of earlier type 7" reels is increased to the new 2¾" standard:

1. Lessened tape tension, reducing speed variations common at the beginning and end of the reel
2. Greater pitch uniformity throughout recording
3. Reduced vibration and better winding due to lessened speed of rotation
4. Increased life of recording head and recording tape as a result of reduced tension

The simplest means of increasing the hub diameter is to wind inexpensive paper base recording tape onto the empty reel until a diameter of 2¾" has been reached. The tape is then cut and the end taped down securely.

All measuring can be eliminated by transferring the contents of a 3" reel of tape onto an empty 7" reel.

Standard length recordings can still be placed on the larger hub. -30-

RADIO & TELEVISION NEWS

ATLAS RADIALS

FOR CHURCHES

FOR FACTORIES

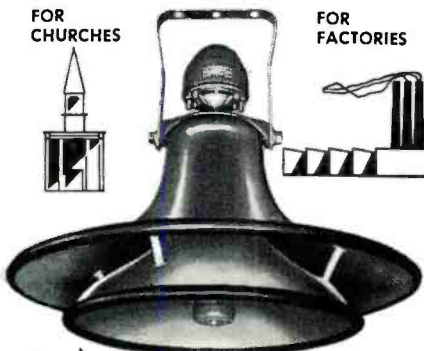

FOR TERMINALS

FOR CARNIVALS

With uniform 360° coverage, non-resonant construction, and 100% storm-proofing, ATLAS Radial Driver Unit Projectors often solve the most difficult sound problems—ore excellent for reproduction of speech, chimes and music. For complete details on Radials and the famous ATLAS line of Public Address and Microphone Stand Equipment...

WRITE NOW for FREE Catalog 553

ATLAS SOUND CORP.
1446 39th St., Brooklyn 18, N. Y.
In Canada: Atlas Radio Corp., Ltd., Toronto, Ont.

WE WANT YOUR BUSINESS...

and low, low prices plus fast service is how we hope to get it!

A typical Steve-El Value!



CASCADE TUNER

Most popular of all tuners. Used in millions of TV sets and chassis. Covers all channels from 2 to 13 with interchangeable coils on strips for UHF work. Each channel has individual oscillator adjustment screw reached from front of panel for alignment of picture brilliance, definition and sound. Balanced 300-ohm input. Supplied with 6J6 and 6BQ7. Price \$14.59 each.

only **\$13⁹⁹** ea. (lots of 3)

FREE!

Write Dept. RN-4 for latest STEVE-EL SUPER-VALUE catalog. Hundreds of values typical to Cascode Tuner bargain.

STEVE-EL Electronics Corp.

61 Reade St.

New York 7, N. Y.

Just Out

AMAZING NEW SUP EME 1954 TV MANUAL FULL YEAR'S TV MATERIAL IN A GIANT VOLUME — \$3

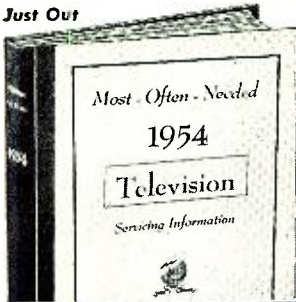

The new 1954 TV manual is the scoop of the year. Covers all important sets of all makes in one giant volume. Your price of this mammoth manual is only \$3. This super-value defies all competition. Other volumes at only \$3 and \$2 each. Each manual has a whole year of service material. Includes all data needed for quicker TV repairs. Get the best for less. Get SUPREME.

COVERS ALL POPULAR SETS

Supreme TV manuals have all needed service material on every popular TV set of every important manufacturer. Here is helpful, practical, factory-prepared data that will really make TV servicing and adjustment easy for you. Benefit and save with these amazing values in service manuals. These giant TV manuals have complete circuits, alignment facts, test patterns, response curves, service hints, all recommended changes, voltage charts, waveforms, and many double-page diagram blueprints. Here is your TV service material to help you do more expert work quicker; and priced at only \$3 and \$2 per manual covering a full year of material. Be ready to repair any TV set by having in your shop all eight TV volumes listed in coupon below. Or try the new 1954 TV MANUAL to see what an amazing bargain you get for only \$3. Send trial coupon for prompt shipment.

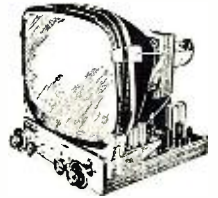

The repair of any television set is really simple with Supreme TV service manuals. Every set is covered in a practical manner that will simplify troubleshooting and repair. This is the help you need to find toughest faults in a jiffy. Each \$3 TV volume covers a whole year of service material. New UHF Units manual at only \$1.50 has everything on UHF. Be wise, buy Supreme Manuals only once each year instead of spending dollars every week for not needed data.

RADIO-ELECTRONICS

NEW AMAZING HOME-STUDY COURSE OFFER



Large, 3-volume course

Here is the most amazing bargain in electronic training. For only \$3.95 (full price), you receive a complete course of 53 large lessons. Covers every topic of radio, electronics, with large lessons on TV, FM, audio, etc. As an extra, every page has teacher-comments to guide you and supply additional help. Lessons include self-testing questions, 427 drawings, pictures, and diagrams. Compares lesson-by-lesson with the best \$200 home-study correspondence courses. Your special price, complete, 3-in-1 volume, 53 lessons, only \$3.95

Newest

RADIO DIAGRAMS



Here is your complete source of all needed RADIO diagrams and service data. Covers everything from most recent radios to pre-war old-timers; home radios, auto sets, combinations, changers, and portables. Sensational values. Still sold at pre-Korean prices. Only \$2 for most volumes. Every Radio manual contains large schematics, all needed alignment facts, parts lists, voltage values, trimmers, dial strapping and helpful service hints. All volumes are large in size, 8 1/2 x 11 inches, about 192 pages. See coupon at right for a complete list of these low-priced manuals.

Supreme Publications

Sold by all Leading Radio Jobbers

NO-RISK TRIAL ORDER COUPON

SUPREME PUBLICATIONS, 1760 Balsam Rd., Highland Park, ILL.

Radio Diagram Manuals

- Latest 1953 Manual, \$2.50
- 1952 Radio
- 1951 Diagrams
- 1950 Manual
- 1949 Radio
- 1948
- 1947
- 1946
- 1942
- 1941
- 1940
- 1939
- 1926-1938 Manual, \$2.50
- Master INDEX only 25c

EACH
\$2.50
PRICED AT ONLY \$2 EACH

Send TV and Radio manuals checked below and at left. You guarantee satisfaction or my money back.

- New 1954 Television Servicing Manual, only \$3.00
- 1953 TV Manual, \$3. 1953 UHF Units, \$1.50
- 1952 Television Manual, \$3. 1951 TV, \$3.
- 1950 Television Manual, \$3. 1949 TV, \$3.
- 1948 TV, \$3. 1947 TV & FM, only \$2.
- Practical Radio & Electronics Course, \$3.95

- I am enclosing \$..... Send postpaid.
- Send C.O.D. I am enclosing \$..... deposit.

Name:

Address:

ORDER BY MAIL TODAY! FROM "WHOLESALE RADIO"

Sensational New High Gain Snyder VHF "TEXAS RANGER"

For Ultra Fringe

All channels 2 to 13. High gain for ultra fringe area. Good front to back ratio and pattern. Rejects co-channel and adjacent channel interference. Gain is better than stacked content on the low band and equal to or better than conical types on the high band. Model AX670.



\$8.50 less mast

Equal to \$50 Aerial Systems All Directional TV AERIAL

360° DIRECTRONIC SYSTEM

Exclusive Snyder Engineering and designs cut cost to \$18.95

COMPLETE with three 3 1/2 ft. masts, 75 ft. 3 cond. cable, beam selector sw., guy rings and mtg. base. Electronically beams complete 360° rotation to give clear pic on all channels. You choose direction with directronic selector sw. mounted on or near TV set. Complete double stacked array with 18 hi-tensil double alloy aluminum elements. AX-599 same as TX-599 less masts, guy rings & mtg. base \$16.95

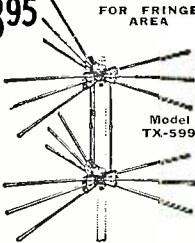

FOR FRINGE AREA Model TX-599

SNYDER BROAD BAND YAGIS

- Higher Gain than Conventional Yagis
- For Fringe and Ultra Fringe

High signal level for sharp, bright pictures. Hi-tensil 3/8" aluminum elements. 7 on low band; 9 on high band. Complete with universal U clamps.

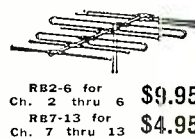

RE-2-6 for Ch. 2 thru 6 \$9.95
RE-7-13 for Ch. 7 thru 13 \$4.95

FREE!

THE HOTTEST VALUE-PACKED BULLETIN IN THE MAILS!

Over 153,000 subscribers buy and save through WHOLESALE RADIO'S F.Y.I. BULLETIN EVERYTHING IN RADIO • TV HI-FI SOUND

IT'S FREE! WRITE FOR YOURS TODAY!

NOW! TEST CONDENSERS WITHOUT REMOVING THEM FROM THE CIRCUIT



SPRAGUE KT-1 KWIK-TEST CAPACITOR CHECKER

Turns trouble-shooting hours into seconds. Checks condensers for opens, shorts, intermittents RIGHT IN THE CIRCUIT. Checks bypass, couplings or filters 300 mmf to 2000 mf. Even when in parallel with resistor. A must for profitable servicing of TV receivers. \$34.50

SPECIAL!

QUICK-TEST, QUICK-SERVICE POCKET SIZE TESTERS AT POCKET SIZE PRICES

HORIZONTAL BAR GENERATOR

Provides equally spaced horizontal lines for precise yoke setting, accurate positioning of focus coil or magnet. Quick linearity and centering adjustments. Inserts between Pic tube and socket.



\$1.95

Check TV Circuits On The Spot With PIX-EYE

Quickly analyzes all video circuits. No more pull-up picture tube.



Model TE-5 \$5.97

TUBE TESTER CRT ADAPTER

Converts Any Tube Tester Into a CRT Tester Tests any picture tube, 10" to 30" magnetic focus or electrostatic for shorts, emissions, etc. No need to remove picture tube from cabinet. 48" adapter lead included.



\$3.45

Checks All TV, Radio & Pic Tubes VISULITE TUBE CHECKER

Quickly checks all tube filaments. Take it everywhere. Operates on 110 V. ac or dc. Complete with test leads. May also be used as continuity checker.



\$3.95

WHOLESALE RADIO PARTS CO., Inc.

311 W. BALTIMORE ST., BALTIMORE 1, MD.

- 8 vertical outputs
- 1 deflection yoke
- 1 filter choke
- 5 width and linearity controls
- 17 exact replacement flybacks
- 23 TV power transformers

55 NEW TV REPLACEMENT COMPONENTS HAVE BEEN ADDED TO THE STANCOR LINE

STANCOR
YOUR MOST COMPLETE SOURCE
OF TV REPLACEMENT
TRANSFORMERS

- 28 flybacks (27 exact duplicates)
- 55 TV power transformers
- 8 deflection yokes
- 9 width and linearity controls
- 15 vertical outputs
- 8 blocking-oscillators
- 3 focus coils
- 5 filament transformers
- 22 filter chokes
- 19 audio outputs

NOW 172 TV REPLACEMENT COMPONENTS ARE IN THE STANCOR LINE



CHICAGO STANDARD
TRANSFORMER CORPORATION

3584 ELSTON AVE. • CHICAGO 18, ILL.

EXPORT SALES: Roburn Agencies, Inc., 39 Warren Street, New York 7, N.Y.

Ask for Stancor's new TV Replacement Guide listing replacement applications for these transformers in 6800 TV models and chassis: FREE from your local Stancor distributor, or from Chicago Standard Transformer Corporation.

Stancor transformers are listed in Sams Photofact Folders and in Counter-facts.

What's New in Radio

(Continued from page 80)

veloping from 0 to 250 watts input and the Model V-103 for rigs developing from 0 to 500 watts input.

New literature covering this coil as well as other items in the company's line is available on request.

ANTENNA ACCESSORIES

Imperial Radio & Wire Corp., 820 East 233rd Street, Bronx 66, N.Y. has introduced two new antenna accessory products.

The first is a new ground rod which features a heavy steel rod $\frac{3}{8}$ " in diameter with heavy double plating and finished with a hand-rubbed oil coat to insure long life. The rod comes in 4 and 6 foot lengths with a fine, turned-down point for easy installation.

The second product is a new type of guy wire made of 7 strands of 18 gauge high-tension pure aluminum with a close knit twist for added strength. The aluminum guy is packaged in a 100 foot continuous coil, 1000 foot carton or on a 1000 foot metal spool.

SUBMINIATURE ROTARY SWITCHES

Micro Switch, Freeport, Illinois has announced a new 17AS series of sub-miniature rotary selector switches which offer a means of switching as

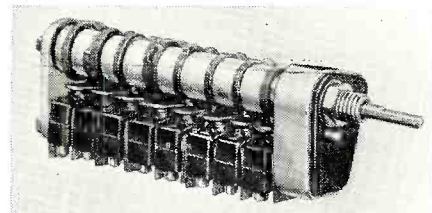

many as eight different circuits with one compact assembly.

The new switch assemblies are available with from two to eight switching units and from two to eight detent positions, with a 45 degree angle between detents. Virtually any switching sequence is possible.

HANDY SLIDE RULE

Helipot Corporation, 916 Meridian Ave., South Pasadena, California is offering, without charge, a handy pocket-size slide rule.

Made of heavy-gauge plastic, with a transparent runner, it carries the most used A, B, C, D, and C1 scales. The slider is also useful as a ruler, as one edge is calibrated in sixteenths while the other edge is in millimeters. The reverse of the slider bears Ohm's law formulas and a Fahrenheit-Centigrade conversion scale.

AXIAL LEAD RESISTORS

Tru-Ohm Products, 2800 N. Milwaukee Ave., Chicago 18, Ill. is now offering a series of axial lead resistors which are wound on fiber glass cord in a continuous length.

During manufacture the cord is cut

GET INTO ELECTRONICS

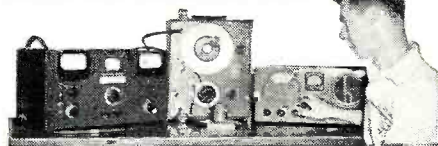

You can enter this uncrowded, interesting field. Defense expansion, new developments demand trained specialists. Study all phases radio & electronics theory and practice: TV; FM; broadcasting; servicing; aviation, marine, police radio. 18-month course. Graduates in demand by major companies. H.S. or equivalent required. Begin Jan., March, June, Sept. Campus life. Write for catalog.

VALPARAISO TECHNICAL INSTITUTE
Dept. RD Valparaiso, Indiana

Opportunity for Large Earnings

Sales Engineers wanted to actually demonstrate, with antenna trailer, a New Patented, Rotorless, All Direction, All Channel, UHF-VHF, TV, FM Antenna. Limited Traveling. Write

ALL CHANNEL ANTENNA CORP.
70-07 Queens Blvd., Woodside 77, N. Y.



Free!
Get More Service Calls with
EICO DECALS
For Store Windows & Cars.
Write EICO
Brooklyn 11, N.Y. Dept. DR-4



It pays to ask for
“RECTIFIER RED”
 the new product-line color for

Federal

MINIATURE SELENIUM RECTIFIERS

FEDERAL—the *original* miniature—has said goodbye to *gray*. The new bloom is “*Rectifier Red*”... a striking color that instantly tells servicemen they’re getting the rectifier efficiency and long life that created tens of millions of profit opportunities for radio-TV servicing... tells them they’re getting the *quality* that keeps Federal miniatures the best-seller in America’s vast and growing rectifier replacement market!

Look for “*Rectifier Red*”... get the performance that *clicks*... the replacement profit that *sticks*! See your

Federal Distributor for Federal miniatures in handy 8-unit kits... in quantity lots... or in individual packages sold through Federal’s self-service rectifier dispenser... on hundreds of counters! See your “FTR” Distributor now, or write to Dept. F-759-A



“America’s first and largest manufacturer of selenium rectifiers”

**DC’S
 PERENNIAL
 PERFORMER**
 —year after year after
 year after year...!

Federal 
 Telephone and Radio Company

100 KINGSLAND ROAD, CLIFTON, N. J.

In Canada: Federal Electric Manufacturing Company, Ltd., Montreal, P. Q.
 Export Distributors: International Standard Electric Corp., 67 Broad St., N. Y.

Read
the news
on
page 21?



Centralab

announces

new

**ceramic
high-voltage
disc capacitors**

Turn to the

Centralab

announcement

now

to the required length and then the leads are securely clamped to each end. The core is then coated with silicone cement and inserted in a ceramic tube which affords mechanical protection and high dielectric strength.

The new resistors are supplied in standard wattage ratings of 5, 7, and 10 watts and to maximum resistance values of 1000 ohms, 5000 ohms, and 7500 ohms respectively.

DECADE RESISTANCE BOX

Stuart F. Louchheim Company, 1229 N. Broad St., Philadelphia 22, Pa. is now offering a new low-cost decade resistance box which has been designed for use by laboratories, radio amateurs, technicians, etc.

The box has a range of 0 to 11 megohms in 1000 ohm steps. The box

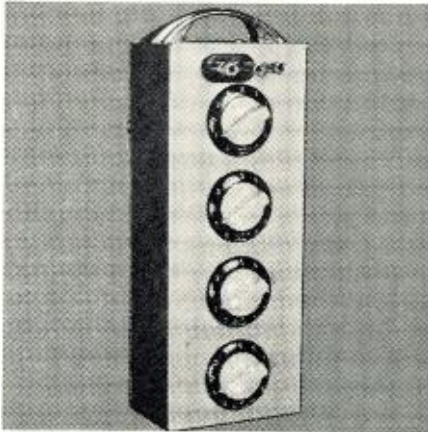

is accurate to $\pm 1\%$. The instrument measures 10" long, 4" wide, and 2½" high.

The company will supply full details on request.

POWER RESISTOR KIT

Clarostat Mfg. Co., Inc., Dover, New Hampshire is now offering a new version of its "Greenohm" fixed wirewound 10-watt power resistor kit.

The new kit consists of 20 fixed wirewound resistors in the most popular ohmage. The resistors are mounted by means of metal clips to a two-color board which serves as an inventory reminder. As resistors are removed, the ohmage of that particular resistor appears on the board. It is thus possible to check resistor needs for re-ordering. The board has two metal eyelets for hanging on a wall.

SQUARE-WAVE GENERATOR

Linear Equipment Laboratories, of Brightwater Place, Massapequa, N. Y. is now offering a wide-range square-wave generator covering a frequency range of 5 cycles to 5 mc.

The Model HF-10's range can be extended by the use of an external condenser. Waveform symmetry is adjustable. Output impedances of 75 and 500 ohms are provided. The rise time is approximately .02 microsecond.

The power supply is regulated and a standby switch and indicator are incorporated for operating convenience. A catalogue sheet on this unit is available.

**BUILD 15 RADIOS
AT HOME ONLY**

With the New Improved 1954 \$19⁹⁵
Progressive Radio "EDU-KIT"

NOW INCLUDES
**SIGNAL TRACER
and
CODE OSCILLATOR**

• ABSOLUTELY
NO KNOWL-
EDGE OF
RADIO NEC-
CESSARY

• NO ADDI-
TIONAL
PARTS
NEEDED

• EXCELLENT
BACKGROUND FOR
TELEVISION

• SCHOOL INQUIRIES INVITED

• 10-DAY MONEY-BACK GUARANTEE



**WHAT THE PROGRESSIVE RADIO
"EDU-KIT" OFFERS YOU**

The "Edu-Kit" offers you a Home Radio Technician Course at a rock-bottom price. You will learn how to identify Radio Symbols and Diagrams; how to build radios using regular radio schematics; how to wire and solder in a professional manner. You will learn how to operate Receivers, Transmitters, and Audio Amplifiers. You will learn how to service and trouble-shoot radios. You will learn code. You will receive training for F.C.C. license. In brief, you will receive a basic education in Radio exactly like the kind you would expect to receive in a Radio Course costing several hundred dollars.

THE KIT FOR EVERYONE

It is not necessary that you have even the slightest background in science or radio. The "Edu-Kit" is used by young and old; by radio schools and clubs; by Armed Forces personnel and veterans for training and rehabilitation. No instructor is required. Instructions are complete, simple and clear. You cannot make a mistake.

PROGRESSIVE TEACHING METHOD

The "Edu-Kit" uses the principle of "Learn by Doing." Therefore you will build radios, perform jobs, and conduct experiments to illustrate the principles which you learn. You begin by learning the function and theory of each of the radio parts. Then you build a simple radio. Gradually in a progressive manner, you will find yourself constructing more advanced multi-tube radio sets, and doing work like a professional Radio Technician. The "Edu-Kit" Instruction Books are exceedingly clear in their explanations, photographs and diagrams. These sets operate on 105-125 V. AC-DC.

The Progressive Radio "EDU-KIT" is Complete

You will receive every part necessary to build fifteen different radio sets. Our kits contain tubes, tube sockets, chassis, variable condensers, electrolytic condensers, mica condensers, paper condensers, resistors, line cords, selenium rectifiers, tie strips, coils, hardware, tubing, etc. An Electrical and Radio Tester is included. Complete, easy-to-follow instructions are provided. In addition, the "Edu-Kit" now contains lessons for servicing with the Progressive Signal Tracer, F.C.C. instructions, Quizzes. The "Edu-Kit" is a complete radio course, down to the smallest detail.

TROUBLE-SHOOTING LESSONS

Trouble-shooting and servicing are included. You will be taught to recognize and repair troubles. You will build and learn to operate a professional Signal Tracer. You receive an Electrical and Radio Tester, and learn to use it for radio repairs. While you are learning in this practical way, you will be able to do many a repair job for your neighbors and friends and charge fees which will far exceed the cost of the "Edu-Kit." Our Consultation Service will help you with any technical problems which you may have.

FREE EXTRAS

• Electrical & Radio Tester • Electric Soldering Iron • Book on Television • Radio Trouble-Shooting Guide • Consultation Service • Quizzes • F. C. C. Training

ATTRACTIVELY GIFT PACKED
PROGRESSIVE "EDU-KITS" INC.
497 UNION AVE. DEPT. RN-28
BROOKLYN 11, N. Y.

MAIL TODAY—Order shipped same day received. 10-Day Money-Back Guarantee. Include ALL FREE EXTRAS.

Send "Edu-Kit" Postpaid. I enclose full payment of \$19.95 (U.S.A. only).

Send "Edu-Kit" Postpaid. I enclose full payment of \$20.95 (Outside U.S.A.).

Send "Edu-Kit" C.O.D. I will pay postage (U.S.A. only).

I wish additional information describing "Edu-Kit." No obligation.

Send me FREE Radio-TV Servicing Literature.

Name

Address

PROGRESSIVE "EDU-KITS" INC.
497 Union Ave., Dept. RN-28, Brooklyn 11, N.Y.

RADIO & TELEVISION NEWS

Certified Record Revue

(Continued from page 68)

apartments (acoustically as well as physically) will be a constraining factor. Yes, three-channel stereosound would be nice to have, and some happy day it may be cheap enough to become a reality. In the meantime, let us not forget that two-channel sound is, for the greater part, just as good as "trinaural" and with just a little more faith and effort on the part of all manufacturers concerned, can and will be the next great step forward in our never-ending quest for audio perfection and musical enjoyment.

Equipment used this month: *Rek-O-Kut* T12H turntable, *Pickering* pickup and arm, *Fisher* Master Audio Control, *McIntosh* 30-watt amplifier, *Jensen* H530 coaxial in a *Jensen* corner horn.

SCHONBERG

DIE GURRE-LIEDER

Chorus and orchestra of the New Symphony Society of Paris conducted by *Rene Leibowitz*. Haydn Society HSL 100, NARTB curve. Price \$17.85 (3 discs).

Here for the first time on LP is one of the most massive musico-dramas ever composed. The orchestral and choral forces employed in this work are tremendous. There is much doubling of instrumentation and the addition of an unusual percussion battery with such diverse and fantastic items as "several large iron chains." The orchestra totals over 150 men and the chorus only slightly smaller. You would probably expect to be blown off your feet with this formidable assemblage. While there are moments of great power, in the main the scoring is not heavy or thick textured. This is, I must admit, rather eclectic music, written when Schonberg was a young man and showing rather clearly his admiration for Wagnerian drama and Mahlerian grotesquerie. In spite of this obvious derivation, it is still all Schonberg, although his atonality and dissonance is hardly in evidence. There is not space to permit telling you more about the story other than it is a North European legend, a sort of Danish "Tristan," and a very bloodthirsty tale. The principal characters are Waldemar, ably sung by tenor Richard Lewis (lately he has been heard as Tom Rakewell in Stravinsky's "The Rake's Progress"); Tove, well represented by soprano Ethel Semser, and Waldtaube, brilliantly portrayed by mezzo-soprano Nell Tangeman. Much of the score is eerie, sensually beautiful, and interlaced with odd and clever little bits of orchestration that give a dim hint of the Schonberg that is to follow in later works. For all the huge scale on which this work is scored, the recording has been very well done indeed. There is a minimum of overload and choral blur you might expect in this kind of thing and each section of the orchestra is clearly delineated. For all this, however, the record is erratic in sound. In



FOLLOW ARROW FOR BIGGEST STOCK AT LOWEST PRICES

- RADAR—TRANSMITTERS
- RECEIVERS — TUBES — PARTS

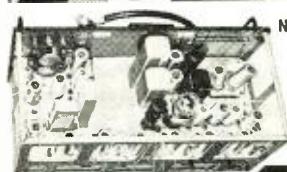

Sensational New Year buy!

UHF TRANSMITTER-RECEIVER

Frequency range 415-420 MC. Receiver uses 13 tubes. 5 Stages of 30 MC. IF amplifier. With schematic. Less dynamotor and tubes. Excellent condition. Never before offered at this money-saving price! Supply limited! BUY NOW!

\$5.95



C.A.P. SPECIAL BC-625 VHF TRANSMITTER

Freq. range 100-156 MC. With modulation section and speech amplifier. Less tubes & crystals, with conversion dope. Used, good condition. (See Nov/53 (Q).)

\$9.95

SCR-283 TRANSMITTER-RECEIVER. Complete with dynamotor and tubes. 40, 80 meter. F.B. for mobile. NEW with service manual. \$24.50

BEST HEADSET & MIKE BUYS

H-16U HEADSET.	8,000 ohms.	\$3.95	
HS-18 HEADSET.	New	2.45	
HS-23 HEADSET.	High imp.	New	4.95	
HS-30 HEADSET.	Featherweight type.	USED	1.49	
HS-33 HEADSET.	Low imp.	USED	1.49	
HS-38 HEADSET.	Low imp.	New	5.50	
HS-38 HEADSET.	USED.	excl. cond.	3.50	
RS-38 MIKE.	NEW.	\$4.95	USED	2.75

Monthly Specials!

ID6/APN4



Made to operate in conjunction with Radio Receiver R-9(1)/APN-4. Unit includes 19 tubes, one 5" scope tube, crystal controlled standard oscillator, sweep circuits, marker pulses. Excellent cond.

\$29.50

Less tubes but with 5" scope tube.

I-83 COMPLETE DYNAMOTOR TESTING PANEL. With meters. Excellent condition. . . . \$19.50
TG-10 TELEGRAPH KEYING AMPLIFIER. Excellent condition. Only **\$22.50**

DYNAMOTOR SPECIAL: 9 V. input. Output 450 V. 75 mils. With extended shaft and drive gear on one end. New. \$7.95
TA-12 TRANSMITTER. 50 W. Excellent cond. . . . \$29.95
MP-28 POWER SUPPLY. Excellent cond. \$14.95

ASB EQUIPMENT

ASB RECEIVER: Freq. range: 510-555 MC. With tubes. New. Reduced to. \$14.50
ASB TRANSMITTER: Freq. range: 510-555 MC. Complete with tubes. Only. 7.95
ASB POWER SUPPLY: New. 4.50
ASB ANTENNA SWITCHING UNIT. New. (Hot Buy!) 4.50
ASB 5" OSCILLOSCOPE INDICATOR. (only) 9.95

CRYSTALS!

FT-243 for:
SCR 509 SCR 510
SCR 536 SCR 609
SCR 610
Many other types of holders in ALL desired frequencies IN STOCK!

CALLING HAMS!

New catalogue just off the press! Loads of hot values!
WRITE TODAY!
Ask for FREE HAM CATALOGUE!

R-28/ARC-5 RECEIVER

100-156 MC. With tubes. Excel. cond. \$32.50

MOTOROLA MODEL TR 20-18 MOBILE 2-WAY RADIO. Used condition. \$150.00

RADAR TEST EQUIPMENT

TS-3, TS-12, TS-13, TS-15, TS-33, TS-34, TS-35, TS-36, TS-45A/MS.

COMMAND EQUIPMENT (SCR-274N)

	Used	New		Used	New
BC-442 ANTENNA RELAY.	Less cond.	\$1.95	BC-458 TRANSMITTER.	5.3-7 MC. With tubes	\$9.95
BC-451 TRANSMITTER CONTROL BOX		\$1.50	MC-211 90° ANGLE COUPLING UNIT.		\$0.95
BC-450 3-RECEIVER REMOTE CONTROL BOX		2.95	FT-234 MOUNTING RACK for single transmitter	2.95	3.50
MC-215 MECHANICAL DRIVE SHAFT. For lever		2.95	FT-226 MOUNTING RACK for 2 Command Xmitters.		3.95
BC-496 2-POSITION RECEIVER CONTROL BOX		2.95	FT-221 MOUNTING PLATE for FT-220		1.50
BC-454 RECEIVER. 3-6 MC. With tubes		12.95	FT-220 MOUNTING RACK for 3 receivers	2.25	3.95
BC-455 6-9 MC RECEIVER. With tubes		9.95 14.95	FT-225 MOUNTING PLATE for BC-456		2.25
BC-457 TRANSMITTER. 4-5.3 MC. With tubes		9.95	BC-456 MODULATOR. For SCR-274.	5.75	1.25
			Complete set of 4 tubes for transmitter		

Miscellaneous Specials!

BC-223 TRANSMITTER. With tubes and one tuning unit. Excel. cond. \$49.50
RM-12 WITH HANDSET. Excellent cond. 35.50
RM-13 LESS HANDSET. Good cond. 24.95
T-48 DESK STAND MIKE. New. 4.95
LIP MIKE. Navy type. New.98

6 V. CARTER DYNAMOTOR POWER SUPPLY. Filtered. Output 3.50 VDC at 150 MA. Complete with 6 V. starting relay. Capacitors and choke. Mounted on 6x4x3" chassis. NEW **\$17.95**

BC-1023 75 MC. MARKER BEACON RECEIVER. Complete with tubes, mtg. rack. NEW. 10.95
PE-125 POWER SUPPLY: Operates on 12 or 24 v. battery. NEW \$17.95

CCT-52232 NAVY COMMAND TRANSMITTER 2.1-3 MC. New, with tubes. \$14.95
250 TL TUBE. Ea. \$9.95 Per Pair \$17.00

\$5.00 MINIMUM ORDER ACCEPTED. All items subject to prior sale. All shipments F.O.B. warehouse. Calif. residents add tax with remittance. 20% deposit required. Please specify shipping instructions with order. EQUIPMENT WANTED! Highest prices paid for all types of Electronic Gear!

HAVE YOU ANY NEW OR USED RADIO GEAR TO SELL? FOLLOW ARROW FOR TOP PRICES!

ARB RECEIVER. Excellent cond. \$32.50
DU-1 LOOP AMPLIFIER UNIT. For ARB. 19.95

T-9 MODULATION TRANSFORMER. For BC-610 transmitter. New. \$34.50
TELEPHONE REPEATER AMPLIFIERS:
EE-99. New, with tubes 17.95
EE-99. New 12.95
FL-8 RANGE FILTER 1.95
PL-68 MIKE PLUG79
IN-4A L/R TUNING METER. Used. 3.95
FL-5 RANGE FILTER95
TS-10 SOUND POWERED HAND SET—Used, excel. cond. Per Pair. 14.50
NEW. Ea. \$9.95 NEW. Per Pair. 18.50
FIELD TELEPHONE. EE-8. Complete HAND NEW. SPECIAL ONLY. 27.50
DC OVERLOAD RELAY. West. 0.2-1.0 amps. 6.50
234-258 MC RECEIVER. 17.95

INDUSTRIAL CORPORATIONS

We carry one of the most complete stocks in U. S. of Military Electronic Equipment, Test Equipment, and Aircraft Electronics. Call or write for NEW catalogue.

ARROW SALES, INC.

Cable Address: ARROWSALES PO Box 5-1810

Mailing Address: P. O. Box 3876-R, N. Hollywood, Calif.
Office-Warehouse: 7460 Varma Ave., N. Hollywood, Calif.

NOW!

**Step ahead faster
as an
INDUSTRIAL
ELECTRONICS
TECHNICIAN**



Turn your experience into a big, new better-paying career!

Day by day industrial plants are adding more electronic devices—for sorting, counting, checking almost any control job you can name. Cash in on industry's great need for men who can keep these devices in top working order. Make more money, feel more secure, doing work that is second nature to you. With what you already know about electronics you have a long head start in a field just beginning to boom. GET INTO IT RIGHT NOW with the help of

**PRACTICAL INDUSTRIAL
ELECTRONICS LIBRARY**

No long sessions on math or theory! These 4 practical volumes show you how to keep the plant's electronic equipment working... how to locate and correct tube and circuit troubles... how to install, service, and maintain even brand new equipment without being stumped by new circuits. **FREE TRIAL—EASY TERMS!**

- 4 volumes (1390 pp., 1050 illus.); Chute's Electronics in Industry
- Miller's Maintenance Manual of Electronic Control
- Mapkus & Zeluff's Handbook of Industrial Electronics Circuits
- Henney & Fahnestock's Electron Tubes in Industry

McGraw-Hill Book Co., 327 W. 41 St., NYC 36
Send me the Practical Industrial Electronics Library for 10 days' examination on approval. In 10 days I will send \$2.50, then \$4.00 a month until \$22.50 is paid. (A saving of \$3.50 under the regular price of \$26.00.) Otherwise I will return books postpaid. (Print)

Name
Address
City Zone State
Company
Position RTN-4

This offer applies in U.S. only.

some sections it is as cleanly wide-range stuff as you could ask for and, inexplicably, in other sections sounds quite restricted. Acoustically it is well done, with just enough reverber to give spaciousness to the whole. In spite of these shortcomings the sound is more than adequate for the enjoyment of this monumental score. Here again we have a work which some people may find hard to digest all at one sitting. But do try it, because it is an interesting work and historically represents a transitional period in Schonberg's composing, and can be well used as a springboard for an introduction to some of his more atonal works. Surfaces in my copy were fair and with the NARTB curve a few db of bass boost sounded better to my ears.

**COPLAND
BILLY THE KID
SCHUMAN
UNDERTOW**

Ballet Theatre Orchestra conducted by Joseph Levine. Capitol FDS, P-8238, NARTB curve. Price \$5.95.

As far as I'm concerned here is one of the finds of the month. Here is a really exciting coupling as far as music goes and the sound is terrific! Both of these works have been committed to LP before, but neither of the previous editions can hold a candle to the brilliance of these new versions. "Billy the Kid" should find great favor among you lovers of clever modern scoring, for this is Copland at his best. Alternately bright and gay, pastorale at times, pseudo-tragic and above all great fun, this is modern music with a very high "listenability index." I thought Levine's interpretation, while in good taste and in splendid balance, was not quite as searching as Leonard Bernstein's earlier effort for Victor. Soundwise this version is far superior

**RECORDING TAPE (Plastic Base)
40% OFF (NEW)**

WASHINGTON, D. C. **WHERE ELSE WOULD THERE BE MORE RED TAPE?**

- 1200 ft. plastic tape with plastic reel included.
- Each reel individually boxed.
- Choice of nationally famous top quality brands such as:
 - Webcor (2806) 3.20; Reeves (SPN-12) 3.20; Audio (1251) 3.25; Scotch (111-A) 3.25; Panacoustic (111-A) 3.25; Irish. Professional grade (211 RPA) 3.30.
- FREE! A 7.95 tape carrying case included with purchase of 12 new tapes!

★ ★ ★ ★ ★
USED RECORDING TAPE (PLASTIC BASE)

1.99 for 7"-1200 foot
.99 for 5"-600 foot
.59 for 4"-300 foot
.29 for 3"-150 foot
Plastic reels included with all above sizes

New empty plastic reels in boxes for easy labeling. 3" 10c; 4" 22c; 5" 24c; 7" 29c; 7" Professional reel (2 1/4" hub) 39c ea. **EMPTY BOXES:** 3" 3c; 4" 5c; 5" 5c; 7" 10c ea.

We carry all brands of new tape, recording blanks, tape recorders, etc. at low prices. PLEASE INCLUDE SUFFICIENT POSTAGE.

COMMISSIONED ELECTRONICS CO.
2503 Champlain St. N.W., Washington 9, D. C.

CORONA RADIO & TV CO.

**EASY TO BUILD • EDUCATIONAL
EXCELLENT RECEPTION**

Broadcast Superhet Kit

\$1475

ROCKET 115K—Latest Single Band superhet circuit for ultimate in sensitive reception and tonal quality. Kit includes all necessary parts, punched chassis, attractive bakelite mahogany cabinet, built-in loop antenna, iron core IFs, big Alnico V spkr.; tubes: 12SK7, 12SA7, 12SQ7, 50L6, 3Z5. Automatic vol. control, beam power output, Tuning 50 to 1700 Kc. Simple step-by-step instructions included.

Plaza 812K 2-Band AC-DC Super Kit...net \$20.75
GlobeMaster 814K 3-Band Super Kit...net \$24.75

All kits supplied less wire and solder. Please include 25% deposit with C.O.D. orders. Dept. N-4.

CORONA RADIO & TV CO.
188 LIBERTY ST., NEW YORK 6, N. Y.

—RECEIVING TUBES—

Type	Price	Type	Price	Type	Price	Type	Price	Type	Price	Type	Price	Type	Price	Type	Price	Type	Price
0A2	.89	2A7	.64	6C4	.37	6K8G	.65	6SQ7	.41	7E5	.59	12BA6	.49	12SL7GT	.49	1822	1.80
0A3 VR75	.89	2B7	.62	6CS	.39	6L5G	.79	6SR7	.45	7F7	.65	12BA7	.59	12SN7GT	.58	1824	8.89
0A4G	.89	2C7	.62	6CSGT	.45	6L6	.72	6SS7	.60	7H7	.59	12BD6	.49	12SQ7GT	.56	1825	1.90
0B2	.74	2X2A	1.15	6G6	.57	6L7	.85	6ST7	.49	7J7	.75	12BE6	.49	12SR7	.49	1N23	1.95
0B3 VR30	.95	3A4	.44	6G8G	.65	6L7G	.59	6T7G	.79	7K7	.79	12BH7	.65	12SY7	1.10	20C40	6.95
0C3 VR105	.95	3B4	.44	6C8B	.45	6N7	.98	6T8	.59	7L7	.59	12BY7	.65	12Z3	.39	2D21	1.09
0D3 VR150	.89	3BA	.60	6D6	.69	6Q7	.49	6U8	.59	7Q7	.61	12C8	.34	14A4	.69	2126	26.95
0Z4	.54	3B7	.39	6D8G	.98	6R7	.49	6V6GT	.39	7R7	.65	12FSGT	.35	14AF7	.59	3D21A	7.95
1A4P	.49	3C4	.48	6E5	1.10	6N7G	.79	6U7G	.45	7N7	.45	12G7	.62	12GZ7	.62	3D21L	2.50
1A5GT	.39	3LF4	.79	6F5	.39	6R7Q	.55	6X4	.36	7T7	.91	12J5GT	.69	14A8	.59	3D22	14.50
1A6	.37	3Q4	.48	6G5G	.48	6R7	.49	6Y6GT	.35	7W7	.91	12J7GT	.58	14C7	.69	3AR6	2.85
1A8	.49	3SGT	.58	6G6	.48	6S7	.45	6Y8	.69	7X7	.79	12K6	.58	14E7	.83	3C21	2.40
1A8S	.39	3S4	.48	6G8	.45	6S7G	.45	6Y8G	.69	7Z7	.79	12K7GT	.69	14F7	.59	3C22	1.75
1AX2	.61	3V4	.51	6G8G	.45	6S7	.45	6Y8	.69	7Z7	.79	12K8	.58	14H7	.59	3C23	2.21
1B5	.26	3T4	1.28	6G8G	.45	6S7	.45	6Y8	.69	7Z7	.79	12K8GT	.58	14I7	.59	3C24	4.49
1C6	.34	5W4	.50	6G8G	.45	6S7	.45	6Y8	.69	7Z7	.79	12K8GT	.58	14J7	.59	3C25	4.80
1C7G	.35	5X4	.50	6G8G	.45	6S7	.45	6Y8	.69	7Z7	.79	12K8GT	.58	14K7	.59	3C26	2.50
1D5	.44	5Z3	.44	6G8G	.45	6S7	.45	6Y8	.69	7Z7	.79	12K8GT	.58	14L7	.59	3C27	3.40
1D5G	.39	5Z4	1.03	6G8G	.45	6S7	.45	6Y8	.69	7Z7	.79	12K8GT	.58	14M7	.59	3C28	3.50
1D7G	.39	5A5	.47	6G8G	.45	6S7	.45	6Y8	.69	7Z7	.79	12K8GT	.58	14N7	.59	3C29	6.50
1D8GT	.77	6A7	.82	6G8G	.45	6S7	.45	6Y8	.69	7Z7	.79	12K8GT	.58	14O7	.59	3C30	5.58
1E4	.29	6A8	.66	6G8G	.45	6S7	.45	6Y8	.69	7Z7	.79	12K8GT	.58	14P7	.59	3C31	1.90
1E6P	.33	6A9	.49	6G8G	.45	6S7	.45	6Y8	.69	7Z7	.79	12K8GT	.58	14Q7	.59	3C32	9.50
1F4	.34	6A8T	.45	6G8G	.45	6S7	.45	6Y8	.69	7Z7	.79	12K8GT	.58	14R7	.59	3C33	2.90
1F5G	.34	6A8SGT	.99	6G8G	.45	6S7	.45	6Y8	.69	7Z7	.79	12K8GT	.58	14S7	.59	3C34	8.89
1G4GT	.34	6A7	.85	6G8G	.45	6S7	.45	6Y8	.69	7Z7	.79	12K8GT	.58	14T7	.59	3C35	10.10
1G6GT	.25	6A7	.85	6G8G	.45	6S7	.45	6Y8	.69	7Z7	.79	12K8GT	.58	14U7	.59	3C36	8.89
1H4G	.25	6AF6	.75	6F5	.39	6R7Q	.55	6X4	.36	7T7	.91	12J5GT	.69	14V7	.59	3C37	1.80
1H5GT	.38	6A25	.46	6F5G	.45	6R7GT	.69	6X5GT	.35	7W7	.91	12J7GT	.58	14W7	.59	3C38	7.50
1H6GT	.38	6A25	.46	6F5G	.45	6R7GT	.69	6X5GT	.35	7W7	.91	12J7GT	.58	14X7	.59	3C39	9.95
1J6G	.59	6A7	1.49	6F7	.49	6S7G	.45	6Y8	.69	7Z7	.79	12K7GT	.69	14Y7	.59	3C40	3.95
1J6T	.59	6A7	1.49	6F7	.49	6S7G	.45	6Y8	.69	7Z7	.79	12K7GT	.69	14Z7	.59	3C41	1.40
1L4	.45	6A4S	.73	6F8G	.99	6S8	.59	6Y7G	.79	7Y4	.44	12K8	.58	14A8	.59	3C42	6.85
1L4A	.79	6A0S	.36	6G6G	.65	6SA7	.40	6Z7G	.75	7Z4	.48	12K8GT	.58	14B7	.59	3C43	1.35
1L4B	.79	6A0S	.36	6G6G	.65	6SA7	.40	6Z7G	.75	7Z4	.48	12K8GT	.58	14C7	.59	3C44	1.40
1L4C	.79	6A0S	.36	6G6G	.65	6SA7	.40	6Z7G	.75	7Z4	.48	12K8GT	.58	14D7	.59	3C45	6.85
1L8S	.69	6A5S	.50	6H6	.49	6S7GT	.45	6Y8	.69	7Z7	.79	12K8GT	.58	14E7	.59	3C46	1.35
1LC6	.79	6A7G	.37	6I7	.49	6S7F	.59	7A7	.55	12A7	.64	19B6G	.64	19B6G	.64	3C47	3.4
1LDS	.78	6A0S	.40	6J7G	.39	6SC7GT	.40	7A7H	.56	12A7T	.64	19C7	.69	19T8	.79	3C48	3.4
1LG5	.77	6AV6	.37	6J7GT	.52	6SH7	.60	7A7	.56	12A7G	.64	19C7	.69	19T8	.79	3C49	3.4
1LH4	.78	6AX4GT	.55	6K6GT	.49	6SH7GT	.50	7B5	.59	12A7U7	.58	12SF7GT	.69	25AC5GT	.75	3C50	8.0
1LNS	.59	6B5	.85	6K7	.43	6S7K7	.49	7C4	.58	12AX4GT	.59	12S7H7	.75	25L6GT	.69	3C51	1.22
1NS	.48	6B6	.75	6K7G	.39	6SL7GT	.49	7C5	.59	12AX7	.59	12S7J7	.75	25L6GT	.69	3C52	1.70
1P5GT	.56	6B7	.95	6K8	.79	6SN7GT	.49	7C7	.65	12A7V7	.59	12S7K7GT	.62	25Z6GT	.36	3C53	1.22
1Q5GT	.57	6B8	.85														
1R4	.89	6B8G	.53														
1R5	.48	6B8	.40														
1S4	.58	6B7A	.56														
1S5	.42	6B8C5	.49														
1SA6	.48	6B8D6	.44														
1T	.48	6B8E6	.37														
1U4	.48	6B8G6	1.13														
1U5	.48	6B8H6	.45														
1X2A	.63	6B8J6	.42														
2A3	.95	6B8K6	.79														
2A5	.48	6B8L6	.79														
2A5	.59	6B8O7A	.88														
2A6	.49	6B8Z7	.89														

ADDITIONAL DISCOUNTS: On orders for \$25 or more, deduct 3%. F.O.B. Our warehouse, New York City. All tubes individually boxed.

Prices subject to change without notice. All prices **FREE: SEND FOR OUR LATEST LISTING.**

ELECTRON TUBE WHOLESALERS, INC.
RECEIVING • TRANSMITTING • SPECIAL PURPOSE

140 DUANE STREET • NEW YORK 13, N. Y. • Phone: BArday 7-7616

CATHODE RAY

3EP1	5.50	1C31	.80
5B1	5.50	1C34	1.10
5B4	5.50	1E44	.80
5CP1	5.25	20B0	1.35
7B7P	7.45	7B7	5.58
12C7	15.50	8012	2.50
16HP4A	24.95	8013A	3.80
16DP4	24.95	8020	2.90

to the older *Victor*. Bright punchy brass, clean string tone, very live woodwinds and some really outstanding percussion, especially the tympani and snares. A real hi-fi and musical treat!

Bill Schuman's "Undertow" I recommended to you once before on a *Mercury* disc and my opinion of this music hasn't changed. This blood-curdling ballet suite is still a terrific listening experience. This new version is superior to the *Mercury* both interpretively and in matter of sound. As a matter of fact even more than "Billy the Kid" do I admire the sound on this side of this disc. *Capitol* has been plugging "Billy" as a really hot item, and while I agree that it is good, I think this "Undertow" is still better. Take for instance the tympani. In "Billy" they are very clean but seem to lack the impact generated by the percussionist in this score. String tone is even more persuasively live. There are some very beautiful passages in "Undertow" along with the tremendously powerful writing in the murder scene whose harsh terror will send a chill down your spine when you hear it!

Acoustically these recordings are very well done with spaciousness, but not so much of it that you think it was recorded in Mammoth Cave. One thing I must mention about this *Capitol* recording is the fabulously quiet surfaces. I have noticed that all of the pressings coming from their Scranton plant have this attribute. Really dead quiet, with only an occasional "tick" to remind you that you are listening to a vinylite record. Recording conformed perfectly with the NARTB curve, everything set flat.

SCHEIDT

TABULATURA NOVA SELECTIONS
Luther Noss, organist, playing the Holtkamp organ, Battel Chapel, Yale University. Overtone LP3, NARTB curve. Price \$5.95.

Here is a brand-new LP company whose activities are worth more than a passing glance. Their avowed purpose is the recording of a whole series of baroque organ works on the magnificent new Holtkamp organ at Yale University. The example here reviewed is strong evidence of their desire to do a good job. This is one of the finest recordings of a baroque-type instrument extant. The typical brightness and articulation of the voicing, the hoarse breathiness of some of the stops is a revelation. No muddy blur here! Scheidt, a pupil of the great Sweelinck, was a composer of considerable inventiveness and used devices which were surely strange for their time and place. A master of embellishment and coloration, his works are not very easy to play. All the more tribute to the artistry of Luther Noss, whose command of his instrument is never in doubt.

The "Tabulatura Nova" is partly secular, partly sacred in its various sections and is extremely interesting pre-Bach music. Many of the sections have a vocal assist from the choir of the Yale Divinity School which does an excellent job. I always tell you when

April, 1954

Sangamo Dry Electrolytics

Live many seasons
for heap good
reasons

these wire lead
tubular capacitors
will not deteriorate
with age



Use Sangamo dry tubular electrolytics for trouble-free replacements. You don't have to worry about premature failure. Long life is really built into these capacitors. They have exceptional staying power because:

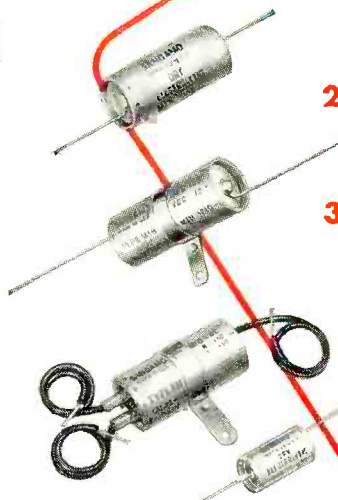

- 1 A super-seal keeps the electrolyte from evaporating even under the toughest conditions of heat and humidity.
- 2 All these capacitors are aged at 85° C to build a tough dielectric film that will stand up under high heat.
- 3 All aluminum container prevents the "creeping" corrosion that occurs in capacitors when any other metal is permitted to contact the electrolyte.
- 4 Sangamo electrolyte is really pure. Continuous laboratory control of every batch keeps the chlorine ion concentration to less than 10 parts per million. That's 99.999% pure, or better!
- 5 No lead breakage. Sangamo uses a special wire that resists bend fatigue. A specially designed rivet that "cradles" the lead gives additional protection.

P. S. These wire lead tubulars fit those tight corners—Their compact design gives maximum capacity in minimum space. See your Sangamo Distributor for all your capacitor replacement needs.



SANGAMO ELECTRIC COMPANY

MARION, ILLINOIS

SC54-4

123

"G" PRESENTING THE *New* GRIP SPINTITE® WRENCHES

PATENTS PENDING

FINEST QUALITY
STEEL SHANK
AND SLEEVE
○
BRIGHT PLATED
FINISH
○
STRONG
PLASTIC HANDLE

WITH THE EASY "FINGER-CONTROL"
GRIP AND RELEASE ACTION
FOR THOSE
HARD-TO-GET-AT PLACES —

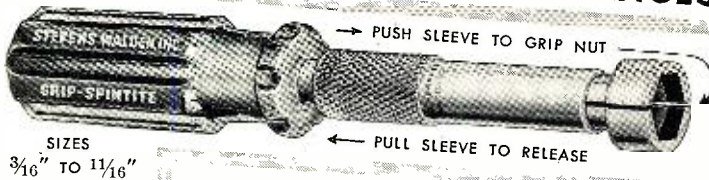

SIZES
3/16" TO 1 1/16"

BY THE MAKERS OF
THE ORIGINAL
SPINTITE
WRENCHES
OVER 150 STYLES
AND SIZES

ONE HAND OPERATION—

- GRIPS nuts or bolts of any material
- HOLDS firmly in any position
- TIGHTENS nut or bolt securely
- RELEASES at the pull of the fingers

4-101

Write for
catalogue

STEVENS WALDEN Inc.

450 SHREWSBURY STREET — WORCESTER, MASSACHUSETTS
MAKERS OF WORLD-FAMOUS HAND TOOLS FOR OVER 50 YEARS

The Magnemite*



Battery-Operated Spring-Motor Portable Recorder

Field recordings can now be made with equivalent quality and with as little effort as studio console recordings. Smaller than a portable typewriter (11 1/2 x 10 x 8 inches) and weighing 15 lbs. including the dry-cell batteries that last 100 operating hours, the Magnemite* is easily carried and operated anywhere.

Here are truly professional specifications:

- Model 610-SD (7 1/2 ips, 50 to 7500 cycles meets NARTB standards.
- Model 610-E (15 ips, 50 to 15,000 cycles) meets primary NARTB standards.
- Dynamic range 50 db.
- Flutter ± 0.1%.
- Constant speed governor-controlled.
- Monitoring and playback facilities.

Write for complete technical literature and direct factory prices to Dept. RT:



AMPLIFIER CORP.
of AMERICA

398 Broadway, N. Y. 13, N. Y.

*Trade Mark Reg. Pat. Pending

2-METER CONVERTER KIT

Now you can receive 2-meters on a conventional Short Wave Receiver. Especially designed Push-Pull 6J6 R. F. Amplifier into 6J6 Oscillator-Mixer. Balanced line input, coaxial output. All slug-tuned adjustments, high quality components. Output frequency is 21 to 25 MC. Highly stable oscillator. The Converter is PRE-WIRED excepting the tuned circuits. Anyone with even the slightest experience can complete in a comparatively short time. . . . SMALL SIZE 5" long, 3 1/4" wide, 3 1/2" deep. . . . AN EXCELLENT BUY OF COMPONENT PARTS ENABLES US TO SELL AT THESE LOW PRICES. . . . WITH PROPER ASSEMBLY, WE GUARANTEE SATISFACTORY RESULTS. . . . COMPLETE SIMPLIFIED INSTRUCTIONS and ALL NECESSARY COMPONENTS ARE SUPPLIED.

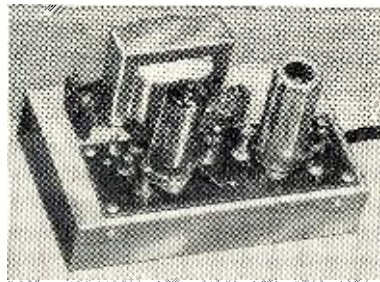

Model 2 (Illustrated) with A. C. Power Supply
FOR ADDITIONAL DETAILS REFER TO CQ MAGAZINE: PAGE 32, DEC., 1953

MODEL 1—Without Power Supply	\$9.95
MODEL 2—With A. C. Power Supply	\$14.45
6J6 TUBES (each unit requires 2)	\$1.25 EA.

WE PAY POSTAGE ANY PLACE IN U. S. Send check or Money Order. No C.O.D.'s. California orders add 3% Sales Tax.

K & L RADIO PARTS CO.

1406 VENICE BLVD. LOS ANGELES 6, CALIF.
• COMING SOON: VFO FOR 2 METERS, HIGHLY STABLE, REASONABLY PRICED.

reviewing organ music, whether or not it is suitable for demonstration hi-fi purposes; and nine times out of ten when it's baroque stuff, I say that it is not suitable. Here is an exception. While there are no really low pedal notes, the rest is very wide range and is a good check for intermodulation distortion. NARTB curve needed a few db bass boost and surfaces were moderately quiet. A new venture and a worthwhile one!

MUSICAL MEMOIRS

Weathers FM recording, MPI, AES curve. Price \$5.95.

MUSICAL GADGETRY

Weathers FM recording, AH1002, AES curve. Price \$5.95.

Kind of hard to list these recordings they are so far off the beaten track compared to the type of record usually reviewed in this column. First of all they are jazz-type discs which, as you know, I have never devoted any space to, and further they are specialized hi-fi recordings which we have not had occasion to review either. However these discs are so unusual I thought you wouldn't mind our leaving the "straight and narrow" for a little while. Produced by Paul Weathers of FM pickup fame, these are out and out demonstration records, designed to test the capabilities of your system. "Musical Memoirs" is a potpourri of popular numbers played by a typical small "night club" group. While the group is composed of particularly good instrumentalists, I am not "knocked out" with the singer involved. The sound is truly excellent. It is very evident that a great deal of care and preparation went into the making of these discs. The guitar and bass viol and the Hammond organ employed are marvels of clarity and cleanness, exceptionally wide range and distortion free. A special "Spectrumax" recording method is used which is best explained on the jacket of the record for you. "Musical Gadgetry," the other disc in this new series, is an incredible one. Consisting of a selection played on restored monstrosities such as a Wurlitzer Carousel Band Organ, Mandolin Piano and Orchestrope, the sounds issuing from these are simply fantastic! I doubt if anyone can take more than ten minutes of this sort of thing, but these first ten minutes are worth the price of the record. Laugh? I thought I'd blow a gasket! Absolutely some of the gold-dinging sound this side of Coney Island. Incredibly corny and more so when it is reproduced with the fabulous accuracy of this recording. Boy, you'll hear every kind of wheeze, groan, thump, bing-bang, bells, and what have you the mind of man ever conceived. It is all great fun and the wide range of reproduction makes the disc invaluable as a test for transients. Very quiet surfaces.

BAXTER, LES

THE PASSIONS

Bas Sheva chorus and orchestra conducted by Les Baxter. Capitol LAL 486. NARTB curve. Price \$4.85.



BROADCAST BAND and AERO

Ideal for Use in Boats, etc.

MIN-26-C Remote Controlled Navigational Direction Finder and communications receiver. Manual DF in any one of three freq. bands, 150 to 1700 KC. 24 V. Self contained dynamo supply. Complete installation including receiver, control box, loop, azimuth control, left-right indicator, plugs, loop transmission line and flex shafts, opp. & main. manual.

box, loop, azimuth control, left-right indicator, plugs, loop transmission line and flex shafts, opp. & main. manual.

MEASUREMENTS CORP.

SIGNAL GENERATOR Model 78-B

Freq. range 15 to 25 mc and 195 to 225 mc; modulated by int. osc. @ freq. of 400 to 8200 cps.; operates from source of 100 to 130 v; 25 to 60 cps AC.

LIKE NEW

\$39.50

MIKES and HEADSETS

- T-26 Telephone chest unit with F-1 Western Electric Transmitter \$2.39
- HS-33 Low Impedance Headset exc. \$2.95 **\$5.45**
- HS-23 Headset, used \$1.89 new 4.50
- CD-307 Ext. cord for HS-23-33 Like new \$7.95 new 1.29
- Throat Mike—T-30 new .98
- Lip Mike—Navy Type new .98
- CW-49505 High Impedance Headset Complete with headband Used **98c**
- T-45 Lip Mike. New **\$1.75**
- HS-30, miniature headset. Used \$1.49, new 2.49
- RS38 Navy type carbon mike—exc. ca. \$3.95
- 4 for \$12.00



SCOOP of the Month

BC1267 TRANSMITTER AND RECEIVER

154 to 186 Mcs., 1KW pulse oscillator, superhet circuit, 2 RF stages, and 5 stagger tuned IF's, includes 21 tubes; 2C26(2), 3E29/829B(1), 6AG5(7), 6C4(1), 6E5(1), 6H6(1), 6AK5(3), 6J5(2), 6SN7(1), 6V6(1), 9006(1); can be easily converted to 2 meter converter and out-board amplifier, ship. wt. 75 lbs., complete with conversion instructions (NOTE: 3E29/829B is worth \$10.00 alone).

excellent condition **\$14.95**

(less tubes) with 21 tubes **\$24.95**

AMPLIFIER can be easily converted to 100w outboard amplifier complete with 3E29/829B and conversion data **\$14.95 ea.**

CONVERTER can be easily converted to 2 meter converter, with conversion data **\$9.95 ea.**

METER 0-1kw 0-10ma 4" Panel Meter **\$3.95 ea.**

POWER YOUR RIG FROM AC

RA-34 RECTIFIER. Makes a ground nutt of BC-191, the 12V version of BC-375-E. Convert BC-375-E to 12V by changing heater link switches and relay connections, power it with RA-34. Input 105-125 or 210-250V, 60 cy. Outputs: For plates, 1900V filtered dc at 350 ma; for relay and mike, 12V filtered dc at 2.4 A; for heaters, 12V ac at 14.25 A.

Used condition. F.O.B. **\$159.75**

LOOK WHAT YOU GET FOR \$14.95

- 350 feet of continuous length of 50 ohm coaxial cable
- 100 feet of same coaxial cable
- Cavity type attenuator
- 6 Short lengths of RGSU with connectors and sockets
- In wooden case—shipping weight 30 lbs.—all for **\$14.95**

Low Freq. Crystals—FT 241 A for SSB, lattice filter, 1/2" spc. 54th harm channels listed by fund. Fractions omitted.

See previous Radio-TV News issues for frequencies 49c each 10 for \$3.00

BC-433 RADIO COMPASS RECEIVER

200 to 1700 KC, used, excellent condition less tubes **\$19.95** used, as is, less tubes and cover, **\$6.95** excellent for parts only **\$4.65** Used **\$1.79**

VHF TRANSCEIVER

Ideal substitute for SCR-522, freq. range 140-144 mc, crystal controlled, 10 watts. The receiver section has two individual IF sections, feeding a common 3 stage 10mc IF amplifier. Both IF sections may be operated simultaneously, or either one individually. The receiver unit has 13 tubes. The transmitter is of straight forward design. Transmitter unit has 7 tubes, one #832 as final modulated by a pair of 6L6 and push-pull. Complete unit in case less tubes, and diagram less dynamo. **\$9.95**

EXCELLENT CONDITION **\$19.95** WITH TUBES **\$19.95**

TG-5 Portable Telegraph set—used **\$3.95**
2 for **7.00**
new **5.95**
2 for **11.00**

BEAM-ROTATOR

Reversible beam rotator motor 8500 rpm, attached to gear reduction box which drops speed to 120 rpm—used **\$1.95**
3 for **\$5.50**

BC-620 TRANSMITTER-RECEIVER UNIT

FM transmitter-receiver, crystal controlled, two channels, freq. range 20-27.9 mc. 13 tubes, dual meter for testing filament and plate circuits. **\$39.25**
PE-117 Power supply for above, complete, like new ca. **\$17.95**

RECEIVER

Battery powered heterodyne receiver, 75-150 mc—brand new **\$10.95**

Hundreds of items in stock. WRITE FOR NEW BULLETIN AND PRICES. Shipments F.O.B. warehouse. 20% Deposit on orders. Minimum order \$5.00. Illinois residents, add regular sales tax remittance. Prices subject to change without notice.

- BEAM ANTENNA SELSYN TRANSMITTER and indicator, per set. **\$12.00**
- BC-684 FM Transmitter, 27-38 mc, used, exc. **\$14.95**
- BC-604 FM Transmitter, 20-27 mc, used, exc. **\$11.95**

TG-34A PORTABLE KEYS

115 or 230 v; 50 to 60 cycle, complete with tubes, photocell and carrying case. **\$24.95**
Used, exc. **\$16.95**

BC-929-A

Contains power supply 110 V, 400 cycles, has 7 tubes such as 3CP1, brand new, complete with tubes. Each **\$14.95**

BC-746 TUNING UNIT

Plug-in transmitter tuning unit from Army Walkie-Talkie. Contains antenna and tank coils, tuning condenser, transmitting and receiving crystals. Ideal transmitter foundation. ONLY **\$1.29**

CONDENSERS

Oil filled—1 mfd at 3600 v. **\$1.95 ea.**
2.22 at 1000 v. **\$1.75 ea.**

ID6/APN4

Made to operate in conjunction with Radio Receiver R-9(1) APN-4. Unit includes 19 tubes, one 5" scope tube, crystal controlled standard oscillator, sweep circuits, marker pulses. **\$42.50**
Excellent cond.

WOBUlator

BUILD TV-FM-AM SWEEP GENERATOR

You can build "Versatile Sweep Frequency Generator" with APN-1 magnetic units. **\$ 5.95**
TS-184/AP Test Set **\$39.50**
IE-194-SCR522 Test Unit **235.00**
T-292-Signal Generator Used, exc. **95.00**

11 TUBE UHF TUNABLE RECEIVER
234-258 mc. less tubes **\$7.95**
With conversion diagram to 220.

- | | As Is | Less Tubes | With Tubes | New |
|--------------------------------------|-------|------------|------------|--------|
| BC-454 3 to 6 mc. | — | — | \$11.95 | — |
| BC-455 Receiver, 6 to 9 mc. | — | — | 9.95 | — |
| BC-456 Modulator \$2.95 | — | — | 4.95 | \$7.95 |
| BC-458 Transmitter, 5.3 to 7 mc 2.95 | — | — | — | — |
| BC-459 Transmitter, 7 to 9 mc 7.95 | — | — | — | — |

Control Boxes, racks, mounts, connectors for above in stock—write.

- MG-149F excellent condition **\$ 89.50**
- MG-149H excellent condition **129.50**
- MG-153 Inverter (3 phase) Used **89.50**

PE-206, inverter, like new **\$11.95**
PE-218, inverter, excellent condition **24.95**

BC-640 **\$695.00**
BC-639 with RA 42 rectifier. **225.00**

I-83—Dynamotor testing panel, complete with all meters. Used, exc. **\$39.50**
Brand new **\$49.50**

EE65 Test set—Telephone for testing and locating trouble on magnetic type line. Complete in carrying case. New **\$14.95**

RM29 For field phone use includes talk, listen and ringing crkts. Wonderful sub. for EES less handsets—new **\$6.95**

NATIONALLY ADVERTISED TUBES

- 5BP1 ..\$3.29 3BP1 ..\$3.29 5AP1 ..\$3.29
- 3 for \$9.00 3 for \$9.00
- All Brand New in Original Cartons
- 304TL **\$5.95** 808 **\$1.95**
- 830-B **\$1.59** 720BY **\$29.50**

QUANTITY PRICES AVAILABLE

1625, 1626, 33, 34, 954, CK1005, 627G, 9002, 9006, 1619, 955, 9004, 12A3, 1F4, 1F5, 211, 6F5, 1629, 19, 50, 12L8.

10 for \$3.00

RT7/APN-1 TRANSCEIVER UNIT—Used as an altimeter. it may be converted for signaling control circuits, etc. Used, less tubes, wobulator dyn. as is. **\$4.95**

RT/34 APS 13 TRANSCEIVER—Used as a rail warning radar on 415 MC. Containing a 30MC IF Strip and various other parts, these units have been stripped of RF sections and all tubes, but are an excellent buy if only for parts **\$4.95** and IF Strip. Used. **\$4.95**

R-1/ARR-1—220 MC converted with minor alterations becomes a high gain converter with two stages of RF amplification—(complete with diagram). New. **\$4.95**

ALL THREE ABOVE ITEMS FOR \$7.50

- BC 347 Interphone Amplifier. **\$2.95**
- I-70 Tuning Meter. **.89**
- APS 13 UHF Antenna, Pair. **.98**
- I-97 Bias Meter **\$3.95** **4.95**
- One Tube Interphone Amplifier—Small compact aluminum case fully enclosed. 24"x3"x3 1/2" **.79**
- Loss Tube **.79**
- BC 709 Battery operated lightweight interphone amplifier. Complete with tube and shock mount, but less battery. New **\$3.95**

DYNAMOTORS

DYNAMOTORS: The best dynamotor for conversion to 6v. Multiple windings! After conversion you get choice of 100 or 350 v. at 50 MA or 250 v. at 10 MA. Complete dope sheet furnished. BRAND NEW (See "CQ" Aug. issue) **\$4.65**

DM-28—Dynamotor for BC-348—28V DC at 1.25 amps in 220 V at 70 MA output Good **\$4.95**

DM-32A—Dynamotor for Command Receiver 28V at 1.1 input 250V at 60 MA output Used **2.95** New **7.50**

DM-33—Dynamotor for Command Transmitters—Used **\$2.95**

D-101 Imp. 27V 1.75 Amp. output 285 VC .075 amp each **\$1.95**
3 for **\$5.00**

PE-94 each **\$1.95**

PE103—6V Dynamotor. Used **\$22.95**

BC-1033 62-80 mc recvr. Like new, less tubes. ea. **\$5.95**
BC-1023 brand new with tubes **9.95**

SCR-625—FAMOUS ARMY MINE-DETECTOR

For Prospectors, Miners, Oil Companies, Plumbers, etc. This unit is being offered now at a considerable reduction in price. Recently advertised at \$79.50 it is now available in the same brand new wrappings in suitcase style carrying case (less batteries). **\$59.50**
New

RU-19—Receiver. Complete control **\$17.95**

box and coils—brand new ca. **\$49.50**

BC375, exc. **\$49.50**

BC191, exc. **49.50**

TU5, exc. **14.95**

BD77, used, exc. **14.95**

BUY NOW! R W ELECTRONICS Dept. N, 2430 S. Michigan Ave., Chicago 16, Ill. **BUY NOW!**
PHONE: Calumet 5-1281-2-3

HBC

is here!

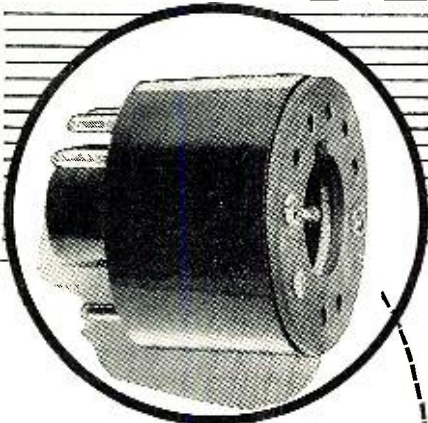

for **Quick TV Set
Adjustment and
Alignment!**

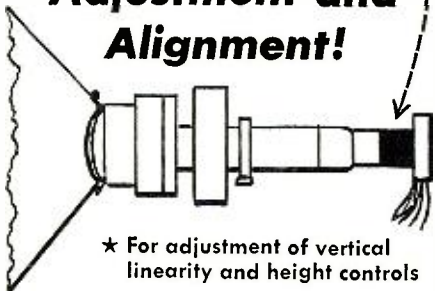

- ★ For adjustment of vertical linearity and height controls
- ★ Accurate positioning of focus coil or magnet
- ★ Precise setting of yoke
- ★ Complete with instructions



See Your Jobber Today!



EXPORT: SCHEEL INTERNATIONAL
4237 N. Lincoln, Chicago 13, Ill.

While we're on this off-beat record and jazz kick, let's review a few more that have come my way. This effort by Les Baxter has to be heard to be believed, and maybe even then you won't. It is called a study in high fidelity and it certainly qualifies as that. This is deliberately artificial music with many effects which are possible only in a recording studio. As far as the sound is concerned I find it very well done with all that the lover of bizarre sounds would want in the way of tricky brass and woodwind effects and ear shattering percussion. All this is very clean and wide range. But the music! Allowing for the intended artificiality in searching for special effects, this is an impossible mish-mash right off the cob! Bas Sheva alternately screams, rages, whimpers, wails, laughs maniacally and otherwise sounds like a bush league Yma Sumac. As a high-fidelity experience it's great. As music just 'taint my dish of tea. Excellent packaging with record enclosed in soft plastic sleeve and good analysis of the musical sections in a special brochure. Again super quiet surfaces. You might like it.

SONGS FOR STRINGS
Members of the Pittsburgh Symphony Orchestra conducted by Richard Jones. Capitol L149. NARTB curve. Price \$4.85.

All right, with this review we'll get off our "pop" kick. Actually this could not be called objectionable by anyone since it consists of some of those popular numbers like "Yesterdays" and "Summertime" and "Long Ago and Far Away" that are really excellent music. The fact that they are still played today in spite of the fiercely competitive attention of contemporary "pops" is evidence of their worth. Richard Jones, the musical director of *Capitol Records*, has dished up some very tasty arrangements of the tunes mentioned and other favorites. The orchestration is lush and full blown, but in good taste nevertheless. He avoids the more obvious devices of the Mantovani school of sentimentality and maintains an excellent balance throughout. The string tone here is really gorgeous, no steely edge to annoy you. Evidence of the good work William Steinberg is doing with the Pittsburgh is found in the splendid playing of the orchestra. All in all, very enjoyable, a good record for day dreaming or cocktailing!

MILHAUD
LE BOEUF SUR LE TOIT
RAVEL
LE TOMBEAU DE COUPERIN
SATIE
THREE GYMNOPEDIES
HONEGGER
PASTORALE D'ETE

Concert Arts Orchestra conducted by Vladimir Golschmann. Capitol P8244, NARTB curve. Price \$5.95.

Another splendid recording from *Capitol* whose work seems to constantly improve. The Milhaud piece, a sassy jazzy type of thing with impudent good humor is most welcome. The only other recording is on *Columbia*

which is now beginning to show its age and cannot be compared with this present version. The genius of Ravel shows here again in his tribute to classicism. I believe this is the finest sounding "Tombeau" yet produced, and one which holds up very well in performance. Let us say that perhaps Golschmann is not the perfect conductor for this work, but his reading is nevertheless most commendable. Very straightforward and with a fine regard for Ravel's indications of tempi. The sound is really clean and well balanced in this recording with some exceptional French horn and woodwind reproduction. The Satie work is interesting as an example of his less strenuous composing and are pleasant little pieces, well performed and with good sound. The Honegger contribution is new to LP and as with Satie, shows the more serene and easy going side of his nature, rather than the fire-breathing for which he is noted. This "Pastorale" is an innocuous work, very finely wrought, a beautiful, sensitive little thing. On the whole this is a very worthwhile disc, especially notable for the Ravel and the Milhaud works. The Concert Arts Orchestra is evidently some sort of hand-picked recording orchestra, and does some fine work and, as noted before, has some excellent solo instrumentalists. The disc conformed to the "T" with the NARTB curve and once again it was a treat with the uncanny silence of the surfaces.

MENDELSSOHN
CONCERTO FOR VIOLIN AND ORCHESTRA IN E MINOR

BRUCH
CONCERTO FOR VIOLIN AND ORCHESTRA IN G MINOR

Nathan Milstein, violinist, with the Pittsburgh Symphony Orchestra conducted by William Steinberg. Capitol P8243. NARTB curve. Price \$5.95.

With this recording Nathan Milstein makes his debut as a *Capitol* artist. The debut is an auspicious one to say the least. For in the framework of his consummate artistry *Capitol* has blessed him with some of the best concerto recording yet heard. There are seemingly countless recordings of the Mendelssohn and Bruch concerti, and no doubt there are many versions which have their adherents. Many of these people might find cause to quibble with Milstein's interpretation or Steinberg's supporting reading. But I doubt that many would argue over the quality of reproduction on this disc. This is so very much better than the recording which has been afforded these concerti heretofore, that this feature alone is worth the price of the disc. Superb balance is maintained between soloist and orchestra and the string tone throughout is complementary rather than competitive. Clean, edgeless, with all the nuances and subtleties of the interpretation shining through. Milstein plays with ardor of old and his Mendelssohn fairly sings. His Bruch is less effective, but still a good clean-cut reading. Steinberg is in full charge

RADIO & TELEVISION NEWS

ADVANCE INFORMATION ON NEW REVOLUTIONARY **precise** INSTRUMENTS

Sensational 3" OSCILLOSCOPE

For TV and Industrial Use
No. 303

Can be supplied with regular or high persistency tubes.

DOZENS OF FEATURES INCLUDING:

- Voltage Regulation
- High Frequency—Low Frequency—Normal Frequency Synchronization Circuit
- Vertical-flat (3db) DC through 5 megacycles with sensitivity of greater than 10 millivolts push-pull (3.94 Millivolts/cm).

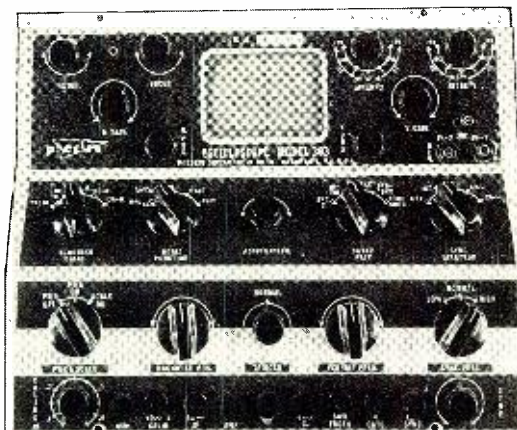

NO. 9071 VOLTAGE REGULATED V.T.V.M.



- FULL BRIDGE VTVM
 - Rugged 7" meter
 - Deposited carbon, 1% ceramic resistors
 - Amphenol Connector
 - Coax DC connector
 - Burn-out proof circuit
 - DC input 25 meg.
 - Power transformer used. (No Selenium Rectifier)
 - 4 tube circuit
 - Etched panel
 - Measures 8" x 11" x 5"
- No. 9071K —Kit \$35.95
No. 9071W—Wired \$49.95

NO. 760 VOLTAGE REGULATED POWER SUPPLY

Invaluable for repair & laboratory work



- Range +140 volts to over 450 volts
- % Regulation—Within 1% at specified current deviations
- % Ripple .01% at specified currents
- Rugged 4 1/2" meter movement
- Shunt & multiplier resistors within 1% accuracy
- -1200v to +1200v—unregulated

IT'S HERE No. 111 precise TUBE TESTER CHECKS BOTH EMISSION & GM SEPARATELY

1. Allows filament current to be measured directly on the meter
2. Checks AC-DC tubes and indicates "Voltage Sapping"
3. Tests horizontal sweep tubes by pulse emission
4. Tests all tubes for emission and GM at the flick of a switch
5. Short tests simply made without complicated switch manipulation
6. Measures tube bias directly
7. Tests all types of tubes including latest styles and cathode ray tubes

SEND FOR COMPLETE CATALOG

Send 20% deposit with order, balance C.O.D., or, check or money order in advance.

TEE-VEE
Supply Co.

All orders are shipped on the same day received

3211-13 Washington Street
Jamaica Plain 30, Mass.

The COLOR TV BOOM will mean... NEW PROFITS for the experts!

INTRODUCTION TO COLOR TV

by Kaufman & Thomas

Here is the complete story about color television—all types of receivers—all types of picture tubes—all types of circuits—written in a clear, understandable language without mathematics. The most complete book on the subject. Easy to understand! A "must" for all technicians, engineers and students.

Over 140 (5 1/4 X 8 1/4") pages, illus.....\$2.10

HIGHLIGHTS OF COLOR TELEVISION

by J. R. Locke, Jr.

A right-to-the-point explanation of the highlights of the NTSC color television system—such as colorimetry—matrixing—the color sub-carrier—synchronous detection—etc. A "quickie" on color TV.

58 (5 1/2 X 8 1/2") pages, illus.....Only \$0.99

HOW TO INSTALL AND SERVICE AUTO RADIO RECEIVERS

by Jack Darr

An expert gives practical, detailed instructions on how to install and service all types of automobile radios. Not a schematic book. Shows where to run lead-ins, how to install antennas, eliminate noise and gives methods for vibrator testing. Furnishes a complete list of tools, spare parts and other equipment and how to set up an auto radio service business.

128 (5 1/2 X 8 1/2") pages, illus.....\$1.80

SERVICING TV VERTICAL AND HORIZONTAL OUTPUT SYSTEMS

by Harry Thomas

Complete. Easy-to-understand. Discusses all types of vertical and horizontal output circuits used in TV receivers—recognition of trouble—how to locate faults and their repairs. No other book in print offers equivalent coverage of the subject or explains details as clearly.

Over 140 (5 1/2 X 8 1/2") pages, illus.....\$2.40

RADIO TROUBLESHOOTING GUIDEBOOK VOL. 1

by Rider and Johnson

A practical guide to radio receiver operation, trouble diagnosis and repair. Detailed instructions on how to shoot trouble. Specify lists of symptoms and the parts and sections that should be checked. Direct approach.

160 (5 1/2 X 8 1/2") pages, illus.....\$2.40

Write for information on all RIDER books.
Buy these books now from your jobber... bookstore
if not available from these sources, write to:

JOHN F. RIDER PUBLISHER, INC.
480 Canal Street, New York 13, N. Y.

of all proceedings and tempi is not subject to any whims or caprices of interpretive meddling. The orchestra responds beautifully to Steinberg's urgings and turns in a top flight support of Mr. Milstein. As I say, there may be better readings extant of these concerti, but it's going to take some doing to beat the sound. A db or three of bass boost helped out the NARTB curve. Super quiet surfaces. (I'd like to know how *Capitol* achieves such noiseless qualities!)

-30-

WIRELESS OPS OF OLD

By C. HOWARD BOWERS

A SUBJECT which might cause some debate is, which section of our country has produced the greater number of pioneer wireless ops? As far as this series of articles on Old Timers is concerned, the West Coast is in the lead, and in this issue we salute Ralph L. Hazleton, of Gooding, Idaho, but who originally hailed from Santa Cruz, California. Ralph Hazleton, wasn't always a big shot with the Civil Aeronautics Administration as he now is, but started like a lot of other old timers with a spark coil, electrolytic detector, and a 75 ohm phone before graduating to a man's sized transformer, rotary spark-gap, plate glass condensers, and a receiver consisting of a loose-coupler, galena detector and other items from the old *Electro Importing Company's* catalogue. All this was in Santa Cruz, California in 1910.

When World War I came along, our subject old timer tells of being in the U. S. National Naval Volunteers and of training aboard the old *USS Oregon*—"Bulldog of the Navy!" In the fall of 1917 he was transferred to the light cruiser *Marblehead* and a tour of chasing German raiders in the Caribbean Sea and Gulf of Mexico. By this time Ralph was a Navy Radioman, 1st class and in charge of the ship's radio shack!

On September 20, 1919, ex-navyman Hazleton passed the Government examination and secured a commercial license. Without delay he sailed on the steam schooner *Willamette* as second operator and a desire to see the world, through a port-hole! By January 1920 our friend was signed for a deep-water voyage aboard the *SS West Kader* bound for Shanghai, China and extended to include Hawaii, Cuba, Ireland, and back to Vancouver, B. C. And then, to quote Ralph himself, "During the next 11 years there were many more ships and many more voyages, mostly to the Orient."

No specific mention is made of a love interest, but Ralph does say that in 1932 he felt the urge to "settle down" and so accepted an appointment as an Assistant Airways Keeper in the Bureau of Air Commerce at Wendover, Utah, where code was ruled out in favor of voice communication to the planes flying that route.

Mr. Hazleton has progressed along with the many systems of dispatching and reporting aircraft until he is now Chief Communicator of the local station at Gooding, Idaho, and concludes by saying, "My many years as an operator, both amateur and professional, have given me much pleasure and at no time have I had a dislike for any phase of it."

Editor's Note: We would like to hear from some East Coast Old-Timers. If your career as a commercial operator started around 1912, please send us a short sketch for publication in this column.

-30-

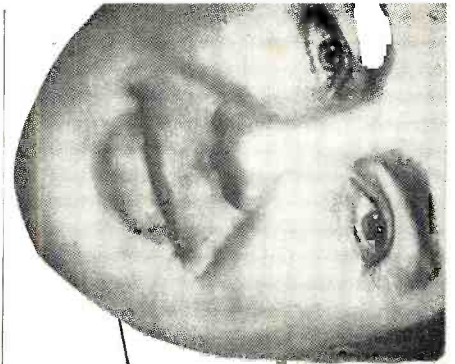

THE NEW

National



IN A CLASS

by itself

NC-98

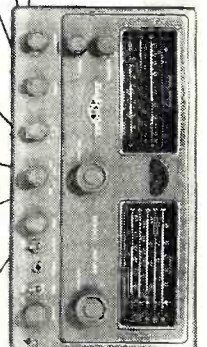

"YOU CAN BET ON
BOB HENRY FOR
THE BEST!"

Bob Henry

TERMS AND TRADE

HENRY RADIO STORES

11240 OLYMPIC BLVD.
LOS ANGELES 64
Phone: 393
"LARGEST DISTRIBUTORS OF SHORT
WAVE RECEIVERS"

BUTLER 1, MISSOURI
Brookshire 2-2917

International Short-Wave

(Continued from page 73)

2130-2300 sign-off is believed to be relay of m.w. PRA6, *Radio Gazeta*. (Niblack, Ind.; Bellington, N. Y.) Location is Sao Paulo. PSH, 10.050A, Rio de Janeiro, noted with North American recordings 1710. ("On the Air") ZYK3, 9.565, Recife, heard Sun. ending "Brazil Calling" (*English*) 1655. (Jacobson, Ill.)

Bulgaria—Radio Sofia, 7.671, noted with news sessions now 1615-1630, 1715-1730 closedown. (Sutton, O., others) Noted on 9.700 with news 1745. (Esser, Pa.; Ferguson, N.C.)

Canada—CBRX, 6.160, Vancouver, Brit. Columbia, heard opening 1045, good level. (Christie, Calif.)

Cape Verde Islands—CR4AB has been heard in Britain on measured 7.090 at 1720; CR4AA, 7.397A, is fairly good in England around 1630. (ISWL, England) Heard opening 1500 with "A Portuguesa," closing with same 1700. (Buggins, England)

Ceylon—Commercial Service of Radio Ceylon, 9.520, noted past 0900. (Hill, Mass.; Stark, Texas) And as late as 1100. (Balbi, Calif.) This outlet is now used from 0630 parallel 6.006. (Radio Australia) Noted on 17.820 with news 0530. (Sanderson, Australia) Heard well on 11.975 to 1140 tune-out. (Boyce, N.J.)

Chile—CE622, measured 6.2225, Santiago, *Sociedad Nacional de Minería*, noted frequently evenings (EST). (Rastorfer, N.Y.) CE1180, 11.998A, Santiago, heard 1315 with Spanish music. (Tandrow, Calif.)

China—Radio Peking, 9.050A noted 1830-1905 with native music, had pips; heard on 6.200 parallel 7.430A with native music and setting-up exercises 1745-1820. (Sutton, O.)

Colombia—HJFW, 5.072, Manizales, is back here from 5.018 after trying to "buck" teletype for a while without success; scheduled 0645-2330. (Stark, Texas) HJEX, 6.054A, Cali, excellent around 2030. (Zahner, Md.)

Costa Rica—Radio Excelsior, 6.50867, noted 0645 at strong level, but only partly readable. (Rastorfer, N.Y.) Although TIFC, San Jose, announces 9.645, seems nearer 9.647 lately. (Stark, Texas; Bellington, N.Y.) Heard in *English* 2330. (Rugal, Kans.)

Cuba—COBC, 9.360A, nice level 1745; *Radio Salus*, COBZ, 9.030, good level 1800. (Morrison, R.I.)

Cyprus—ZJM7, 11.720A, noted 0030 with Arabic session of news, music. (Sanderson, Australia) Is scheduled 2225-0130, 0330-1500 (Sun., Fri. 2225-1500). (Bluman, Israel, via Radio Australia) Noted on 6.12, 6.17, 6.79 with news in Arabic 2300. (Jannis, S.C.)

Czechoslovakia—Prague's listed 7.255 outlet was measured 7.346 recently 1930 when began *English* to North America. (Ferguson, N.C.) Good signal then. (Goodrich, Ind.; Jacobson, Ill., Douglas, Ont.) Noted with *English* 0715-0745, 1400-1425 on 9.504. (Buggins, England)

April, 1954

RCP

Portable Radio Repair Shop

"DO-ALL" SERVISHOP...

Compact, convenient service package to meet your AM-FM, audio test needs—in the home and in the shop. Combination of seven individual instruments housed in a portable carrying case provide the test-efficiency of many more. There is nothing that does the complete job as expertly and professionally as the RCP Servishop.



Model 8873A Servishop
Complete with tubes, batteries, leads, etc. in beautifully finished oak, portable case. **\$1399⁵** NET

- Tube Tester
- Vacuum Tube Voltmeter
- AM Signal Generator
- FM Signal Generator
- AF Signal Generator

Plus a Cathode Ray Tube
Tester and Reactivator

As A Package Buy, The RCP Servishop Means
More Dollar Value For Less Money.

Model 808A
TV-Radio-CR Tube Tester,
Reactivator and VTVM... **\$999⁵** NET

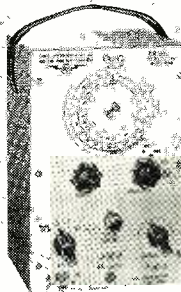

Model 740A
"DO-ALL" Signal,
Marker and Pattern
Generator for VHF
Areas... **\$695⁰** NET



Model 533M
High Sensitivity, Wide
Band Re-
sponse 3"
Midgetscope. **\$995⁰** NET



Model 453C
20,000 Ohms
per Volt Multi-
Tester for AM-
FM-TV. **\$365⁰** NET



Model 123
Tests Flyback
Transformers
and Yokes
Accurately and
Speedily. **\$397⁵** NET

RCP has a complete line of test instruments to meet the expanding requirements of the service industry. Drop in at your local parts distributor and see "the line that's service-designed."

Write Dept. RN-4 for latest RCP Catalog.

RADIO CITY PRODUCTS CO., INC.

152 WEST 25th STREET • NEW YORK 1, N. Y.



NEW!

NICHOLS
NEVER-STAIN
TRADE MARK

Aluminum TV AND RADIO GROUND WIRE

RUST
PROOF



- ★ High Electrical Conductivity
- ★ Inconspicuous — Low Reflectivity
- ★ Pliable — Specially Tempered
- ★ Etched finish — clean
- ★ STD. No. 8 B & S Ga. (.128" dia.)

Aluminum TV ANTENNA GUY CABLE

RUST
PROOF



- ★ Seven — 18 Ga. Stranded Wires
- ★ Flexible — Specially Tempered
- ★ High Strength Aluminum Alloy for all Types of Antennas.
- ★ Approx. break strength — 500 lbs.

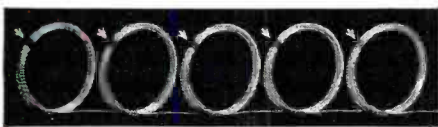

*Packed 2-500 ft. continuous coils per carton marked every 100 ft. with bright red tape.

PACKAGING DATA

ITEM	PKG. NO.	DESCRIPTION
TV Grd. Wire	8	100 ft. coil per box. 10 boxes per ctn.
TV Grd. Wire	9*	2-500 ft. continuous coils.
TV Cable	50	100 ft. coil per box. 10 boxes per ctn.
TV Cable	60*	2-500 ft. continuous coils.

Order from your jobber or write us direct. Address Dept. TVN-3

NICHOLS
WIRE & ALUMINUM CO.
DAVENPORT, IOWA
World's Largest Manufacturer of Aluminum Nails

Ecuador—HCJB, 11.915, noted 0700 parallel 9.743A. (Clarkson, Tenn.) **Radio Ibis**, 6.23457, Esmeralda, heard 1845 to 2331 sign-off, strong; **Radio Manta**, HC4EB, 6.8697, noted 2230-2305 sign-off, fair, readable. (Rastorfer, N.Y.)

Egypt—Cairo noted on 11.965, 6.085 at 1545 with Arabic music; call at 1600; heard on 15.315 at 0800-0900 to India, news 0830. (Pearce, England) Good on 9.475 with news 1330. (Crowell, Pa., others)

El Salvador—**Radio Nacional**, 9.55A, San Salvador, heard in Spanish 2130-2200. (Middleton, O.) Heard opening 1900 in terrific QRM. (Bellington, N.Y.) In verifying, **Radio Nacional** listed channels of 9.555, 6.010. (Riggs, Calif.)

Ethiopia—**Radio Addis Ababa**, ETAA, 15.047A, noted 1300-1430 and had no English during that time. (Sutton, O.) Irregularly, seems to have news 1315A. Noted by Pearce, England, parallel on 9.615A.

Fiji Islands—ZJV3, 3.980, Suva noted 0445 with musical program, news. (Sanderson, Australia)

Finland—OIX5, 17.800, Helsinki, heard 0445 with news, commentary. (Sanderson, Australia) And strong then on OIX4, 15.190; has Home Service program from 0455. (N. Z. DX Times) Has further English now 0600-0615. (Radio Sweden)

France—Paris, 11.830A, noted opening 1100 to Madagascar in French; may be listed 11.845 outlet. (Gay, Calif.) Heard on 5.955 at 1455-1523 in French, in clear. (Roberts, Conn.) Heard on 9.680A at 0115, fair level, with classical music. (Calos, Calif.)

French Equatorial Africa—**Radio Brazzaville**, 11.970, is strong 1550 with news for Europe. (Hill, Mass.) And 1745-1800 on both 11.970, 9.440. (Winch, Calif.; Esser, Pa.)

French Guiana—A Swedish SWL reports **Radio Cayenne** moved to 6.240A, heard with weak signal 1730-1830. (Radio Sweden) Niblack, Ind., places this one currently on 6.232A; opens with short interval of gongs or chimes, plays "La Marseillaise," then woman says "Ici Cayenne, Radiodiffusion Francaise."

French Morocco—**Radio Maroc**, Rabat, has been heard on 15.205 at 0730-0930 in English, French, Arabic; requests reports to P. T. T. Building, Rabat, Fr. Morocco. (ISWC, London)

French West Africa—**Radio Dakar** noted on 4.885A with all-French session 0230-0400 fade-out, had heavy CWQRM; was not parallel with other Dakar channels. (Saylor, Va.)

Gold Coast—Accra, 4.915, noted with Gold Coast news 1245, closing 1300 with "God Save the Queen." (Pearce, England)

CODE SENDING RECEIVING SPEED

Be a "key" man. Learn how to send and receive messages in code by telegraph and radio. Commerce needs thousands of men for jobs. Good pay, adventure, interesting work. Learn at home quickly through famous Candler System. Qualify for Amateur or Commercial License. Write for FREE BOOK.

CANDLER SYSTEM CO.
Dept. 2-D, Box 928, Denver 1, Colo., U.S.A.

CRYSTALS

LARGEST
STOCK

IN THE
WORLD



NOTE!

HUGE PRICE
REDUCTIONS!
FREE GIFT
OFFER BELOW

COMPLETE SET—80 CRYSTALS
Ranging from 370-516 Kc., 54th Harmonic, INCLUDING 500 Kc. & 455 Kc. crystals. Only \$6.95 Per set

COMPLETE SET—120 CRYSTALS
Ranging from 370-540 Kc., 72nd Harmonic, including 500 Kc. & 455 Kc. crystals. Only \$9.95 Per set

200 KC. CRYSTAL.....Ea. \$1.75
500 KC. CRYSTAL.....Ea. .75
1,000 KC. CRYSTAL.....Ea. 2.75

All above crystals in FT-241-A HOLDERS 1/2 in. pin SPC.

FREE WRIST COMPASS—On request with every \$15.00 order for crystals.

MISCELLANEOUS BEST BUYS

3-STAGE UNIT. Will make a terrific 2-meter converter. Consists of: 1 out stage, 1 RF stage & 1 mixer stage. New design. \$2.95
ULTRA-VIOLET COCKPIT LAMP. Used. \$1.95
FILLOW SPEAKER. Used. .95
SOUND POWERED 2-WAY COMMUNICATION SET. With 50 ft. of wire. Palm type. Excel. cond. \$3.35
24V. TRANSFORMER. Pri. 110 V. @ 2 amps New \$1.95

SPECIAL! 12 V. 35 AMP GENERATOR
Ideal for mobile rig. Used. ONLY. \$3.95

SILVER CIRCLE TUNER. Used.
Ea. \$1.25 3 for \$2.95

ARW-2 Remote Control Receiver

10-channel audio-tone receiver. Ideal for radio control, garage door opener, lawn mower, model boat and many other electronic control devices. Here are some of the parts it contains: ten 10,000-ohm resistors, 10 audio filter sections, 14 standard size tubes, 2 crystals, 24 V. power supply, plus many other useful items. ALL NEW. An unbeatable value at ONLY \$27.50

PE-73 DYNAMOTOR. Used. \$3.49

HI-FI HEADSET. For finest reproduction. \$2.95

Excellent condition \$2.95

CHOKER 16 Henry 0.45 amps. New \$6.95

400 ASSORTED SILVER MICA CONDENSERS. New, mounted 10 to a strip. All for \$1.95

SPECIAL COMBINATION!

WILLARD 6 plastic storage battery for model control equipment. Uses standard electrolyte. NEW. (Orig. sold for \$2.49.)
PLUS REVERSIBLE MIDGET MOTOR. Operates on 1 1/2-6 V. at top speed of 10,000 RPM. (Orig. price \$1.95). NEW. BOTH units now only \$2.79

All merchandise sold as is. Prices net F.O.B. Los Angeles. All items subject to prior sale.

J. I. GLASS ELECTRONICS CO.
1615 S. MAIN STREET
LOS ANGELES 15, CALIF.

STOCK CLEARANCE SPECIALS

Vacuum Cond. 20,000 V. 40 and 200 MMFD. \$6.50
Tube Dual 8 MF 600 V. Oil Cond. \$2.75
Small Alligator Clips: only \$2 for 15c
"Bud"-1.45 MMFD. .017 GAP Variable Cond. \$79c
Single & Double ION Traps. \$19c ea.
Peerless 10 H. 85 MA Filter Choke. \$89c
Large Roll Euclyon Tape. \$49c
4200 KC Command IF N-FMRS Input-Interstage Output. Also BFO Coil: All Four \$1.29
6V DC Heavy Duty Starting Relay. \$1.19
Special on Recording Tape—write for information.

TUBE SALE: BOXED—NEW

50c: 1T4-185-354-6AK5-6AL5-6AT6-6AU6-6BA6-6BC3-6BE6-6B6-6C4-6J5-6SA7-6SL7-6W4-6X4-6X3-12A6-12AU6-12BA6-12BE6-12SA7-12SK7-12SN7-12SQ7-25L6-35W4-35Z3-30B5-50L6
60c: 1X2-6AG3-6CB6-6V6-6W6-12BH7
75c: 12AT7-12AU7 \$1.50; 19B6.
MINIMUM TUBE PURCHASE—\$5.00.
STANDARD RMA GUARANTEE

All Merchandise is New and Guaranteed in Perfect Condition. Remit with Order. We Pay Postage.

K. & L. RADIO PARTS CO.

1406 Venice Blvd. Los Angeles 6, Calif.

RADIO and TELEVISION ELECTRONICS



in All Technical Phases
New Classes (Day and Evening) Start 1st of Dec., Mar., June, Sept.

Free Placement Service for Graduates For Free Catalog write Dept. RN-54

RCA INSTITUTES, INC.

A Service of Radio Corporation of America
350 WEST 4TH ST., NEW YORK 14, N. Y.

RADIO & TELEVISION NEWS

Guatemala—TGNA now uses 11.850 (TGNC) instead of 5.9525 (TGNA) in parallel with 9.668 (TGNB) for *English* 2200-2345A. (Esser, Pa.; Sechtman, Pa.; Ferguson, N.C.) TGJA, 5.990, noted 2215-2330 with gospel message and songs. (Tandrow, Calif.)

Haiti—Radio Commerce, 6.140AV, some days around 1820 uses this channel; other days seems to be around 6.085AV; may be alternating between these two channels. (Niblack, Ind.) The 9.485 outlet noted opening in French 0630, strong level in N. C. (Ferguson) 4VEH's current channel has been measured 9.658. (Ferguson, N.C.) 4VRW, 10.074A, *Radio Haiti*, noted 1500 identifying in both French, *English*. (Reidler, Pa.)

Holland—Radio Nederland, 11.73, Hilversum, is excellent level in Dutch around 1330. (Niblack, Ind.) Noted to North America 2130-2210 over 9.59, 6.025. (Bengtsson, Sweden, others) Heard closing in Dutch 2030 on 6.025. (Roberts, Conn.) The new 100 kw. transmitter is expected to be in operation by the end of this year or early 1955; two more 100 kw. s.w. transmitters will be installed later on. (Cody, Ireland)

Honduras—Radio Progreso, 6.18238, noted around 0045 in bad QRM; is listed on 6.185 as San Pedro Sula, 1 kw. (Rastorfer, N. Y.)

Hong-Kong—ZBW3, 9.525, Victoria, noted 0600 with BBC news relay. (Sanderson, Australia; Morgan, Calif.) Heard in Japan 2230-2400 closedown, news 2315. (Ishikawa)

Hungary—Radio Budapest, 6.248A, noted ending *English* to North America 2330; followed by Hungarian session. (Roberts, Conn.; Winch, Calif.) With *English* to North America 1930-2000. (Zerosh, Pa.) Good level on 9.833 then parallel. (Garren, Calif.)

India—Delhi, 9.565, noted at good level with news 0835-0845. (Sutton, O.) With news 1930 on 9.755. (Mast, N. Y.) Heard opening on this channel daily 1830 with usual interval signal and identity, then into language. (Niblack, Ind.) News relayed from Delhi can be heard 1030 over Madras, 4.920. (Pearce, England) Mysore is scheduled 2030-2145, 4.800; 0300-0400, 6.065; 0700-1130, 4.800. (Scheiner, N. J.)

Indo-China (Vietnam)—"Voice of Vietnam," 9.625A, Saigon, noted with *English* 0930-1000 closedown. (Sutton, O.) Has world news 0940A. (Navarro, Philippines) *Radio France-Asie*, Saigon, noted on 7.230 at 1122 with French, closed 1128. (Morgan, Calif.) Heard opening with *English* and French announcements 0900. (Stark, Texas) Some days is "just like a local." (Christie, Calif.) Noted as early as 0300. (Balbi, Calif.) Heard on 9.755A opening for Europe in French 1035; with *English* 1100-1135 closedown. (Pearce, England) Latest schedule for *English* is 1830-1900, 7.230; 2020-2045, 11.935; 0900-1115, 11.935, all to India and Southeast Asia; 15.430 at 0345-0515 to Australia - New Zealand. (Buggins, Catch, England)

Iran—Radio Teheran, 3.780A, noted

IMPORTANT ANNOUNCEMENT

In line with PLATT'S all-important policy of offering top quality, hard-to-get equipment at the lowest possible price, we have seen fit to close our branch at 159 Greenwich St., N. Y. C. and consolidate our two stores into one giant "super market of values" at our main headquarters at 489 Broome St., N. Y. C. This consolidation will result in a lower overhead, whereby we can pass along even greater savings to our many customers who shop in person. Why not drop down now and take advantage of our special buys.

MICROPHONE SUPER-SALE

- T-44 MIKE—magnetic type consisting of Mike Unit MC-233, Cord CO-287, Plug PL-179 and Jack JK-26 \$1.29
- T-45 MIKE—Carbon Lip Mike 1.95
- T-17 MIKE—Carbon—BRAND NEW 9.75
- T-13 HANDESET—BRAND NEW 7.95

Multitester Foundation BIAS METER I-97A

Contains a zero center 3 1/2" round Marion voltmeter calibrated 0-100 volts each side. Movement is one mill each side of center. The unit is mounted in a steel box 7"x5"x1 1/2" and contains 8 contact push button line cord dual 100 MFD at 200 V DC condenser, a potentiometer 6 IRC 1% wire wound non-inductive resistors: one 400 ohm, two 2500 ohm, one 5000 ohm, one 10,000 ohm, one 15,000 ohm. Excellent for building a zero center multitester with ranges of 1, 10, 100, 1000 volt



COMPLETE BRAND NEW \$5.45

FOR THE FIRST TIME!

- 5A-1/APN-1 ALTITUDE LIMIT SWITCH, excellent used \$3.45
- 1D-14B/APN-1 ALTITUDE INDICATOR, excellent used 5.45
- I-65B COMPASS—LEFT TO RIGHT INDICATOR, excellent used 5.45
- I-82A 360 degree Selsol operated NAVIGATOR'S INDICATOR, part of ARN-7, BRAND NEW 8.95

- FL-30 RADIO FILTER (Identical to FL-8), excellent used \$1.49
- F-21/ARA-9 RADIO FILTER, excellent condition 1.29
- FL-5 RADIO FILTER99

HEADSETS

- HS-23 high impedance, BRAND NEW with ear pads \$4.65
- HS-33 low impedance, BRAND NEW with ear pads, cord and PL54 Plug 5.65
- CD-307A Cords, 6 ft. NEW \$1.49
- HS-16 high impedance—used98



HEADSET ADAPTER MC-385

Used with headsets HS-33 or HS-38—raising the impedance from low to high. Comes complete with PL 55 Plug. ONLY 49c

- BC-648-A CONTROL BOX This control box contains many valuable parts including a zero to five DC milliammeter. \$2.95

- RADIO CONTROL BOX BC-732-A used with R-47/ARN-5 also R-57 and R-89/ARN-5 \$1.49

- ## DYNAMOTORS
- DA-1A—input 28 VDC @ 1.6 amps. Output 230 VDC @ 100 amps. BRAND NEW \$8.95
 - BD-AR-93—input 28 VDC @ 3.25 amps. Output 375 VDC @ 150 mills. good used \$7.50
 - DM-33—input 28 VDC @ 5.0 amps. Output 575 VDC @ 160 mills. BRAND NEW \$4.95
 - DM-53—input 24 VDC @ 1.4 amps. Output 220 VDC @ 80 mills. BRAND NEW \$5.50
 - MP-28-A dynamotor power supply unit input 23 to 28 V 14.8 amp DC, output 540 V 450 MA DC. With a transmitter modulation section using 1 6N7, 1 6F6 and a pair of 807 tubes in push-pull. Also includes modulation transformer. Used for Bondix TA-12, excellent used \$14.50
 - PE-94-C—input 28 VDC @ 13 amps. Output 13 VDC @ 3.9 amps. 150 VDC @ 10 mills. 300 VDC @ 260 mills. BRAND NEW \$7.50
 - PE-98—input 12 VDC @ 26 amps. Output 13 VDC @ 3.9 amps. 150 VDC @ 10 mills. 300 VDC @ 260 mills. good used \$22.00

SPECIAL!

20 LBS. of ASSORTED RADIO PARTS A terrific buy at only \$1.99



- ## Field Telephones
- Army surplus, complete receiver, battery and electrically tested, using 2 1/2 inch GM cells and a pair of inter-connecting wires. GUARANTEED LIKE NEW \$28.95
- ## TELEGRAPH KEYS
- J37 \$1.50
 - J38 1.50
 - J4198
 - J45 3.95

GENERAL ELECTRIC MAZDA LAMPS, #623, 24-28 Volts, 6 candle power—sensationally priced at only \$2.50 per hundred.

MINIMUM ORDER \$2.00

Immediate Delivery — Send 25¢ deposit on C.O.D. orders. All shipments F.O.B., N.Y.C. (N.Y.C. residents add sales tax to your remittance.)

SPECIAL-OF-THE-MONTH! SCR-522 RECEIVERS

Less oscillator assembly, frequency shifter and tubes. Contains all Coils, Transformers, Resistors, Condensers and other valuable parts. SPECIALLY PRICED \$7.95 each

- ## BEST VALUES IN PLUGS!
- | | |
|---------------------------|--------------------------|
| PL-114, used \$1.00 | PLQ-103 \$2.00 |
| PL-152, used 1.00 | PLQ-169 1.50 |
| PL-153, used 1.00 | PLQ-171 1.25 |
| PL-154, used 1.00 | PLQ-175 2.25 |
| PL-156, used 1.00 | M-35950 |
| PL-172 1.25 | PS-104 2.50 |
| PLP-166 1.25 | PO-17 receptacles... .75 |

SPECIALS!

- JK-26 JACK 19c ea.
- Length Type PL-55 15c ea.
- SWITCHBOX BC-706, BRAND NEW \$1.95

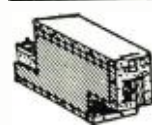

SENSATIONAL SALE! ARC-5/R-28 2 MTR RCVR

\$19.95

Here is the 2-meter superhet you have been looking for! Absolutely one of the BEST available today! Tunes from 100 to 126 Mcs. in four crystal channels. (Easily converted to continuous tuning.) Tube lineup is as follows:
717A—R.F., 717A—Mixer, 2-12SH7—1st and 2nd I.F. 6.9 Mc.
12SL7—Det. AVC Speech, 12SL7—1st audio-speech amplifier.
12A6—2nd audio, 12SH7—R.F. Osc.—4th Harmonic Gen.
717A—Trip. 12th Harmonic Gen. 717A—Dblr.—12th Harmonic.

TAKE YOUR PICK FROM THESE BARGAINS!
CRYSTALS for the BC-458 Command Transmitter, Plug-in type, 6200 KC. BRAND NEW. \$1.95
Complete set of COILS for BC-458 Command Trans. 3.95

- ## PRE-AMPLIFIER MODEL K-1
- The K-1 is used to amplify output level for microphones and phonographs. Operates on 24-28 VDC. can be converted to 110 AC. Comes complete with PL 55 plug and 2-foot, 119-B cord, 2 terminal blocks and instruction book. BRAND NEW SPECIAL! \$3.95

- ## TUNING UNITS—BRAND NEW
- TU-25 and TU-18 Tuning Units from the BC-223 Transmitter. Freq. range of TU-25: 3.500 to 3.250 KC. Freq. range of TU-18: 3.000 to 4.500 KC. ONLY \$5.95 each.
METAL CASES to hold above Tuning Units. . . \$1.00 ea.

- ## BC-221 Frequency Meter
- Real Value! QUANTITY IS LIMITED —so first come, first served. They are just like new, with original calibration charts. Range 125-20,000 KC with crystal check points in all ranges. Complete with crystal and tubes. \$139.50
MODULATED TYPE \$149.50
MODULATED TYPE with AC Power Supply 189.50
These Frequency Meters are factory treated, checked for frequency alignment and GUARANTEED.

- ## SCR-274N COMMAND and ARC-5 EQUIPMENT
- EXCELLENT

- ## RECEIVERS
- | USED | NEW |
|-------------------------------------|---------|
| BC-453—190 to 550 KC. \$29.95 | \$49.95 |
| BC-454—3 to 6 MC. | 24.95 |
| BC-455—6 to 9 MC. 5.95 (as is) | \$13.95 |
| 1.5 to 3. | 34.95 |

- ## TRANSMITTERS
- | | |
|--------------------------------|-------|
| A-958—2.1 to 3 MC. | 29.95 |
| BC-457—4 to 5.3 MC. | 14.95 |
| BC-458—5.3 to 7 MC. 9.95 | 14.95 |
| BC-459—7 to 9.1 MC. | 24.95 |
| T-15 ARC 5—500 to 800 KC. | 29.95 |

- ## ADDITIONAL EQUIPMENT
- | | |
|--|-----------|
| BC-456 Modulator. | 7.29 |
| BC-450 Control Box (3 Receiver) | 1.49 1.95 |
| BC-451 Control Box (Transmitter) | 1.29 1.79 |
| BC-442 Relay Unit (ANT) | 5.69 |
| Flexible Shafting with gear to fit receivers. | 2.69 |
| 3 Receiver Rack. 1.79 | 2.29 2.98 |
| 2 Transmitter Rack. | 2.39 |
| Single Transmitter Rack. | 3.97 |
| DM-33 Dynamotor for Command Set. | 3.95 |
| Mounts for Above Racks. | 1.95 |

- ## TUBES BRAND NEW! JAN! BOXED! TUBES
- | | | |
|-------------------|-------------------|-----------------|
| 1B22 69c | 215A 99c | 843 17c |
| 2B3 29c | 211A 29c | 864 19c |
| 2C26 99c | 316A 29c | 1628 19c |
| 2C26A 99c | 388A 59c | 7193 19c |
| 3B22 \$1.19 | 471A \$1.19 | 9002 69c |
| 3D5 59c | 532A \$1.19 | 9528 19c |
| 7C4 39c | 722A 99c | E1148 49c |
| 15R 39c | 801A 19c | RK34 99c |
| 39-44 29c | 82B 29c | VR02 14c |
| 114B 29c | 841 29c | VT127 15c |

PLATT ELECTRONICS CORP.
DEPT. A, 489 BROOME ST., NEW YORK 13, N. Y.
PHONES: WO 4-0827 and WO 4-0828

As you know...

YOUR HI-FI RECORDING SYSTEM IS ONLY AS GOOD AS YOUR MICROPHONE!

These important features are the reasons why the

SHURE GRADIENT "300"

HIGHER FIDELITY MICROPHONE is used by leading recording artists and Hi-Fi enthusiasts for consistently superlative reproduction:

- ✓ **REDUCES REVERBERATION** and pick-up of unwanted noises by 66%!
- ✓ **SMOOTH FREQUENCY RESPONSE**—40-15,000 c.p.s.
- ✓ **BI-DIRECTIONAL PICKUP PATTERN**—enables you to arrange the artists around microphone to obtain the best balance between the different musical components.
- ✓ **VOICE-MUSIC SWITCH**—for utmost flexibility in achieving highest quality recordings.
- ✓ **HIGH OUTPUT**—eliminates hum problems—by allowing recorder to be operated at normal gain settings.
- ✓ **MULTI-IMPEDANCE SWITCH** for LOW, MEDIUM or HIGH IMPEDANCE—provides added flexibility.

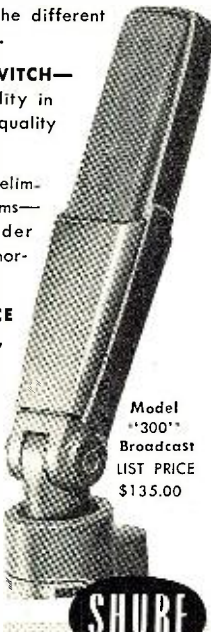

Model "300" Broadcast LIST PRICE \$135.00

Model S33 Desk Stand List Price \$15.00



SHURE BROTHERS, Inc.

Microphones and Acoustic Devices
225 West Huron St., Chicago 10, Illinois
Cable Address: SHUREMICRO

Please send me FREE Microphone Catalog 77A and list of Shure Distributors in my locality.

Name _____
Address _____
City _____ State _____

RNG-4

with *English* 1515, closing 1530. (Pearce, England)

Iraq—Station heard on 11.724A at 0615 in Arabic news and music is believed Baghdad. (Sanderson, Australia)

Israel—Tel Aviv, 9.010A, good level 1515A with news. (Hill, Mass., others) Nice signal with *English* 1615-1700 closedown. (Bishop, O., others)

Ivory Coast—*Radio Abidjan* has moved from 7.210 to 4.945, tests 0145-0230. (ISWC, London) Can not be found there around 1445, but Delhi does use 4.940 then with French; do not confuse. (Pearce, England)

Jamaica—*Radio Jamaica*, 3.360, noted 2300 with world news. (Irvine)

Japan—JKI2, 9.655, Tokyo, heard S8 at 2100-2200, *English* and musical session (Sutton, O.) JOA6, 7.180, noted 2400 with news, very bad QRM seemingly from *Radio Free Europe*. (Morgan, Calif.) And parallel over 9.695. (Tandrow, Calif.) *Radio Japan*, 11.725, comes through well most days in Latin American beam 1700-1800 in Spanish, Portuguese, Japanese. (Roemer, Ky.; Saylor, Va.; Niblack, Ind., others) JOA4, 11.705, Tokyo, noted 2000-2015 with music and news in Japanese. (Tandrow, Calif.)

Kenya Colony—Nairobi, 4.855, noted closing 1500 after time pips. (Pearce, England)

Kuwait—Al Kuwait, 5.000, heard 1410-1430 sign-off, all-Arabic. (Bug-gins, England)

Liberia—ELBC, 6.024A, Monrovia, heard 1745-1800, music, announced in *English*. (Sutton, O.)

Madagascar—*Radio Tananarive*, 9.515, is good strength some days around 2255. (Riggle, O.)

Malaya—*Radio Malaya*, 4.825, Singapore, noted 0630 with news, music. (Sanderson, Australia) Noted closing 1030 in *English*; the 4.78 channel heard with different program, closing also 1030 with "God Save the Queen," fair level in Calif. (Balbi)

Mauritius—QSL was received from Forest Side, with note: "We are always glad to receive such comments and would welcome any further reports from you." Was for report of June 1953, when station was heard 1105 on 15.092. (Harris, Mich.) Not reported as heard lately.

Mexico—Morgan, Calif., reports as new, XEHQ, 9.87A, identifying after chimes around 1545. Roberts, Conn., hears XEKW, 6.030, Morelia, 2100-2154 closedown, all-Spanish.

Monaco—*Radio Monte Carlo*, 7.349, noted 1710 with *English* program (some days). (Johansson, Sweden) Heard closing 1805. (Morris, Pa.)

Mozambique—Lourenco Marques, 4.916AV, more recently has been noted 2255 with interval signal of musical theme, before starting session 2300; heard on 11.742AV in *English* around 1345-1405, and from around 2300. (Niblack, Ind.) The 4.916AV channel noted 1134 with popular requests; at 1145 played 4 chimes, announced "Lourenco Marques for Happy Listening in the 25-, 60-, and 85-meter bands..."

TAKE IT FROM EDWIN SCHAFFER:

"KRYLON TV Acrylic Spray cuts down contract calls, and spreads the word about my servicing reliability!"



Edwin G. Schaffer, President, Edwin G. Schaffer Co., 7920 Frankford Avenue, Phila., sprays hi-dielectric strength KRYLON on the high voltage sections of TV receivers to prevent corona... and he also sprays KRYLON on antennas to weather-proof them. KRYLON TV Acrylic Spray is crystal clear... gives lasting protection. It's the push-button spray coating that's become the TV industry's most useful right-hand man!



KRYLON, INC.

2038 Washington Ave., Phila 46, Pa.

Krylon also available in Bright Aluminum, Flat Black, Glossy Black, Touch-up White, and Bright Gold.

AT TV JOBBERS EVERYWHERE

RADIO ENGINEERING 27 MONTHS DEGREE IN 27 MONTHS

Radio engineering is a big field. There's room for you in it—if you're good. Get first-class training at Indiana Tech. Intensive, specialized course, including strong basis in mathematics and electrical engineering, advanced radio theory and design, television, electronics, Modern laboratories. Low rate. Also B.S. DEGREE IN 27 MONTHS in Aeronautical, Chemical, Civil, Electrical and Mechanical Engineering. G.I. Government approved. Enter June, September, December, March. You can earn part of your expenses right here in Fort Wayne while you are studying.

INDIANA TECHNICAL COLLEGE

934 E. Washington Blvd., Fort Wayne 2, Indiana
please send me free information on B.S. Engineering Degree in 27 months as checked.

Radio-Television Aeronautical
 Civil Mechanical Electrical

Name _____
Address _____

RADIO & TELEVISION NEWS

Faded out 1215, weak. (Morgan, Calif.) The 11.742AV outlet noted 1410 with recordings. (Ferguson, N. C.) Heard in Portuguese on 4.872A closing 1517 with "A Portuguesa," after news in Portuguese at 1500. (Pearce, England)

New Caledonia—Radio Noumea, 6.028, heard in French 0500-0530. (NNRC)

New Zealand—Radio New Zealand noted 1256 with bird (Tui) interval. opening 1300 on 11.78, 11.83 with bad QRM from VOA; at 2230-0030 on 15.28 with 11.83 parallel to 0145; at 0200 opening over 11.83, 11.78. (Morgan, Calif.) Noted on 15.28 at 2330 to around 0030 fade-out. (Cook, Calif.)

Nicaragua—Radio Mil, La Voz de Nicaragua, 6.19905, Managua, noted after 2300 with religious program; weak level in bad spot. (Rastorfer, N. Y.)

Nigeria—Lagos, 4.800, heard 1300, 1500 with BBC news relay. (Pearce, England)

Northern Rhodesia—Lusaka, 4.826, noted 1232 with *English*; schedule is 0700-1400 on 4.826, 7.220. (Pearce, England) Heard closing 1402, fair level using two anthems. (Buggins, England)

Norway—Radio Norway has informed Saylor, Va., that it now can switch the 100 kw. transmitter from 9.610 to 7.210 for more effective use. Heard by Kroll, N. Y., Sun., at 1200 on 11.735 with *English* ("Norway This Week") fairly good level.

Pakistan—Radio Pakistan, 7.010, Karachi, noted with news 1545-1558. (Sutton, O.) Heard on 11.885 with news 2115; on 6.235 with *English* 1530, parallel 7.010; on 17.835 at 0530 with news, music. (Sanderson, Australia) Opens on 9.484 at 0930 with time pips. (*Malmo DX-aren*, Sweden)

Peru—OAX4T, 9.562, Lima, noted at weak level coming on air 1100. (Morgan, Calif.) Heard 2315 with songs in French, had bad QRM. (Zahner, Md.)

Philippines—DZH5, 9.690, Manila, noted 0530 with news. (Sanderson, Australia)

Portugal—Lisbon noted on 11.796A at 0700-0730. (Sutton, O.) Noted closing 1530 on the *new* 9.795A channel. (Pearce, England) Good on 9.740 around 1700. (Morrison, R. I.)

Portuguese Guinea—A Belgium SWL reports Bissau *testing* recently on 9.375 around 1700-1800 closedown; also mentioned a 75-m. channel as in use. (ISWL, England)

Portuguese India—Radio Goa, 9.610, has request session 1130-1200, then musical concert to 1230 closedown on Wed., Fri., Sun. (Pearce, England)

Romania—Bucharest, 6.144A, noted with *English* from 2200. (Stark, Texas; Jannis, S. C., others) Heard with *English* 1745-1800 on 9.57. (Jannis) Heard 1430 in *English* on 9.254A. (Saylor, Va., others)

Saudi-Arabia—Djeddah, 11.950, noted 2300 with Arabic session of news, music. (Sanderson, Australia)

South Africa—Cape Town, 5.890A, is audible some days 2345 with setting-up exercises in Afrikaans; at 0000 has

OUTSTANDING for HIGH FIDELITY!

PRE-FAB COLLINS TUNERS and RECEIVERS

Two ALL NEW Complete Kits for Every High-Fidelity Need

Collins Audio Products Co. is in no way affiliated with Collins Radio Co.

Each Collins Tuner Kit is complete with punched chassis, tubes, power transformer, power supply components, hardware, dial assembly, tuning eye, knobs, wire, etc., as well as the completed sub-assemblies: FM tuning units, AM tuning units, IF amplifiers, etc., where applicable. All sub-assemblies wired, tested and aligned at the factory make Collins Pre-Fab Kits easy to assemble even without technical knowledge. The end result is a fine, high quality, high fidelity instrument at often less than half the cost—because you helped make it and bought it direct from the factory.

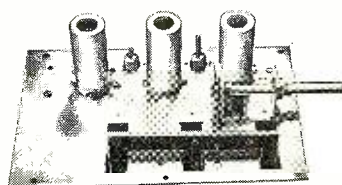

FMF-3 Tuning Unit

\$15²⁵

The best for FM. The most sensitive and most selective type of "front end" on the market. 6 to 10 microvolts sensitivity. Image ratio 500 to 1. 6J6 tuned RF stage, 6AG5 converter, 6C4 oscillator. Permeability tuned, stable and drift-free. Chassis plate measures 6 1/2" x 4 1/2". In combination with the IF-6 amplifier, the highest order of sensitivity on FM can be attained. Tubes included as well as schematic and instructions. Draws 30 ma. Shipping weight FMF-3: 2 1/2 lbs. Dial available @ \$3.85.



IF-6 Amplifier

\$19⁷⁵

A remarkable value! 6 tubes are used in the IF amplifier: 6BA6 1st IF, (2) 6AU6 2nd and 3rd IFs, (2) 6AU6 limiters and 6AL5 discriminator. High gain, wide-band response (200 KC) for highest fidelity. 20 to 20,000 cycles. Distortion less than 1/2 of 1%. Draws 40 ma @ 220 volts. Chassis plate dimensions: 11 1/8" x 2 1/2". Shipping weight: 3 lbs.



AM-4 Tuning Unit

\$24⁵⁰

Tops in AM superhet performance! A 3-gang tuning condenser gives 3 tuned stages with high sensitivity and selectivity. Assembly is completely wired, tested and aligned ready for immediate use. Frequency coverage 540 KC to 1650 KC at a sensitivity of 5 microvolts. Tubes 6BA6 RF amplifier; 6BE6 converter; 6BA6 IF amplifier and 6AT6 detector. Draws 30 ma @ 220 volts. Mounts on a chassis plate measuring 4" x 7 3/8". Shipping weight 2 1/2 lbs. Dial available at \$3.85.

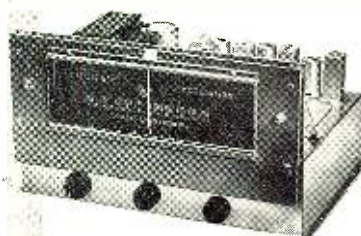

FM Tuner Kit

\$55

The FM-11 tuner is available in kit form with the IF Amplifier mounted in the chassis, wired and tested by us. You mount the completed RF Tuning Unit and power supply, then after some simple wiring, it's all set to operate. 11 tubes: 6J6 RF amp, 6AG5 converter, 6C4 oscillator, 6BA6 1st IF, (2) 6AU6 2nd and 3rd IF, (2) 6AU6 limiters, 6AL5 discriminator, 6AL7-GT double tuning eye, 5Y3-GT rectifier. Sensitivity 6 to 10 microvolts, less than 1/2 of 1% distortion, 20 to 20,000 cycle response with 2DB variation. Chassis dimensions: 12 1/2" wide, 8" deep, 7" high. Illustrated manual supplied. Shipping weight 14 lbs.



FM/AM Tuner Kit

\$77⁵⁰

The original 15 tube deluxe FM/AM pre-fab kit redesigned on a smaller chassis. The tuner now measures 14" wide by 12" deep by 7 1/2" high. This attractive new front and dial assembly opens up new applications where space is at a premium. Kit includes everything necessary to put it into operation—punched chassis, tubes, wired and aligned components, power supply, hardware, etc. Kit comprises FMF-3 tuning unit, IF-6 amplifier, AM-4 AM tuning unit, magic eye assembly and complete instructions. All tubes included. Shipping weight 19 lbs.

To: Collins Audio Products Co. Inc. P.O. Box 368, Westfield, N. J. Tel. Westfield 2-4390. RN-4

FM Tuner Kit FM/AM Tuner Kit Slide Rule Dial Assembly FMF-3 Tuning Unit IF-6 Amplifier AM-4 Tuning Unit

NAME

ADDRESS

CITY STATE

Amount for Kit \$ See weights, add shipping cost \$

Total amount enclosed \$ Check Money Order

WHEN YOU THINK OF TUNERS, THINK OF COLLINS AUDIO PRODUCTS

ERIE 413

HIGH VOLTAGE CERAMICONS®



THE REPLACEMENT for high voltage TV filter applications

The ERIE 413 High Voltage Ceramicon is an innovation in capacitor design and has had wide acceptance by servicemen everywhere.

Now, for even greater convenience, each body is individually packaged with 7 terminals in 5 different styles. With a minimum stock the serviceman is now able to supply the correct replacement terminals for practically any receiver plated at 20 KV or lower. Inventory is reduced, service time is reduced, profits are increased. The illustrations on the left tell the story.

ERIE components are stocked by leading electronic distributors everywhere.



ELECTRONICS DISTRIBUTOR DIVISION
ERIE RESISTOR CORPORATION

Main Office: ERIE, PA.
Factories: ERIE, PA. • LONDON, ENGLAND • TORONTO, CANADA



LIFETIME TAPE

is the ONLY magnetic tape equal to this critical application" ▶



That's what Dubbings Company, Inc., say of Soundcraft's LIFETIME Magnetic Recording tape. These nationally known specialists in the hi-fi field chose LIFETIME Tape for their new 15-minute test reels.

These amazing test reels accurately measure your tape recorder's wow and flutter, head azimuth alignment, frequency response, signal-to-noise ratio, signal level, tape speed. After exhaustive study of every available tape, Dubbings found that only LIFETIME was equal to the job.

And that's why you, too, should choose LIFETIME Tape for your critical

applications. More and more radio, TV and recording studios insist on LIFETIME Tape for its strength; freedom from stretch and shrink despite temperature and humidity, permanence and high fidelity. Remember, LIFETIME Tape is guaranteed for a lifetime! Make your own test today!

REEVES SOUNDRAFT CORP.

Dept. U4

10 East 52nd St., New York 22, N.Y.

news in that language. (Sutton, O.) Johannesburg, 11.937, noted with SABC news some days 1400; other days is in Afrikaans then. (Pearce, England) Closes 1535. (ISWC, England)

South Korea—Collett, N. Z., has logged HLKA, 2.510, Seoul, "Voice of Free Korea," at 0445 in *English*

Spain—*La Emisora del Instituto Laboral de Puerto de Santa Maria*, 7.210, noted closing 1800; *Radio Mediterraneo*, 6.995, Valencia, heard 1455 with dance music, same at 1815 recheck. (Pearce, England) The Santa Maria station, 7.210, heard from as early as 0300. (Cody, Ireland) Madrid, 9.363, good 1800-1840 with *English* to North America. (Sorosiak, Ohio, others) Good level in *English* 1515-1547. (Bishop, O.) Verified with nice card after many months. (Klein, Va.)

Sweden—*Radio Sweden*, 6.095, noted to Western North America 2300 with news. (Morgan, Calif., others) And to Eastern North America 1930 over 6.065, terrific signal. (Roberts, Conn.) Good on this channel in *English* 1600-1610. (Morrison, R.I.)

Switzerland—Berne, 17.784, is usually good around 0815. (Zahner, Md.)

Syria—Damascus has been noted using 9.550A for Spanish, Arabic from 1900 (evidently to Latin America). (ISWL, England) The *English* session 1630-1730 closedown is now noted over 7.235A. (Jannis, S. C., others)

Tahiti—*Radio Tahiti*, Papeete, lately has been on 7.110A closing around 0202 with "La Marseillaise"; mostly French or U. S. popular rather than classical music; heard just before 0100 some days but usually doesn't fade in until around 0130; is weak to fair with heavy QRN. (Gay, Calif.)

Tangier—*DX-Radio*, Sweden, reports *Pan American Radio* on 15.048 heard 1318 with news. *Radio Africa*, 7.193A, noted 1430-1700 in French, *English*, Spanish, Italian, says ISWC, London.

Thailand—HSK9, 11.670, Bangkok, noted ending Overseas Service 0920A and continuing with Home Service. (Pearce, England) At 2315 with *English* for North America; HSK8, 6.240, noted 0700 with *English* announcements, then program in Thai. (Sanderson, Australia) Heard opening on 11.670 at 0500 with news. (Ishikawa, Japan)

Trinidad—VP4RD, 6.085, Port-of-Spain, is fine level from around 0600. (Saylor, Va.)

Turkey—TAT, 9.515, Ankara, still noted at good level in *English* for North America 1815-1900 closedown. (Foster, Ill., others) Heard ending *English* for Western Europe 1645 over 7.285, 9.465. (Scheiner, N. J.)

Uruguay—Montevideo, 11.900A, fair in Spanish, music around 2015. (Jacobson, Ill.)

USA—WRUL broadcasts daily except Sat. 1455-1645 to Europe on 11.78, 9.53; 1800-2035 to Latin America, 11.73, 9.585. (Weisburger, Md.)

USI (Indonesia)—YDF6, 9.710, Djakarta, noted with news 0615-0630, good level in Ohio. (Sutton) Closing 1100. (Navarro, Philippines) Heard on 4.910

RADIO & TELEVISION NEWS



CHECK These Terrific RAD-TEL Tubes and Parts SAVINGS!

70% to 90% OFF on TUBES INDIVIDUALLY BOXED FULL YEAR GUARANTEE!

SAME DAY SERVICE . . . OVER 300 TYPES IN STOCK AT ALL TIMES

Type	Price	Type	Price	Type	Price	Type	Price	Type	Price	Type	Price	Type	Price	Type	Price		
OA2	.74	1T4	.49	6AK5	.55	6BQ7	.90	6SH7GT	.49	7C5	.69	12BE6	.39	14AF7	.59	42	.42
OA4	.68	1U4	.49	6AK6	.59	6BZ7	.90	6SJ7GT	.41	7C6	.59	12BF6	.39	14H7	.59	43	.55
OB2	.81	1U5	.43	6AL5	.38	6C4	.37	6SK7GT	.41	7E5	.59	12BH7	.63	14J7	.30	45	.55
OC3	.72	1V	.53	6AQ5	.39	6C5	.39	6SL7GT	.48	7E6	.30	12BY7	.65	14N7	.84	45Z3	.44
OD3	.70	1X2A	.63	6AQ6	.37	6C6	.58	6SN7GT	.52	7E7	.59	12BZ7	.65	14W7	.30	45Z5	.49
OZ4M	.55	2A3	.30	6AR5	.37	6CB6	.44	6SQ7GT	.37	7F7	.79	12C8M	.34	19BG6	.95	50A5	.55
1A5	.30	2A4G	.24	6AS5	.50	6CD6	1.11	6SR7GT	.45	7G7	.89	12H6	.56	19C8	.70	50B5	.43
1A7GT	.47	2W3	.38	6AT6	.37	6D6	.59	6SS7GT	.42	7H7	.59	12SC7M	.63	19T8	.69	50C5	.39
1AX2	.62	2X2	.59	6AU4GT	.68	6E5	.48	6T4	.99	7J7	.79	12J5	.42	19V8	.79	50L6GT	.61
1B3GT	.68	3A4	.45	6AU5GT	.82	6F5GT	.39	6T8	.56	7L7	.59	12J7	.49	24A	.39	50Y6	.49
1C5	.43	3E5	.46	6AU6	.38	6F6	.59	6U4	.60	7N7	.69	12K8	.59	25AV5GT	.83	50Y7	.50
1E7	.29	3Q4	.48	6AV5GT	.83	6G6	.52	6U6	.59	7X7	.70	12Q7	.59	25BQ6GT	.79	55	.49
1G6	.24	3Q5GT	.49	6AV6	.37	6H6GT	.41	6U8	.61	7Y4	.69	12S8GT	.62	25L6GT	.39	57	.58
1H4	.30	3S4	.49	6AX4GT	.53	6J5GT	.43	6V6GT	.39	7Z4	.59	12SA7GT	.65	25W4GT	.59	58	.60
1H5GT	.49	3V4	.51	6B4	.64	6J6	.52	6W4GT	.44	12A6	.54	12SF5	.50	25Z5	.66	70L7	.97
1L4	.46	5U4G	.50	6BA6	.39	6J7	.43	6W6GT	.44	12A8GT	.61	12SG7	.51	25Z6	.49	75	.49
1L6	.59	5W4GT	.50	6BA7	.57	6K5	.47	6X4	.37	12AL5	.37	12SJ7M	.67	26	.45	76	.44
1LA4	.59	5Y3GT	.37	6BC5	.49	6K6GT	.37	6X5GT	.37	12AQ5	.52	12SK7GT	.63	27	.39	77	.57
1LC5	.59	5Z3	.45	6BD5	.59	6K7	.44	6X8	.75	12AT6	.37	12SK7M	.63	32L7	.89	78	.47
1LC6	.79	5Z4	.59	6BD6	.45	6L6	.64	6Y6G	.48	12AT7	.66	12SL7GT	.47	35	.58	80	.35
1LD5	.59	6A6	.51	6BE6	.39	6L7M	.68	7A4	.47	12AU6	.38	12SN7GT	.52	35B5	.40	83V	.68
1LE3	.59	6AB4	.44	6BF5	.41	6Q7	.45	7A5	.59	12AU7	.54	12SQ7GT	.56	35C5	.39	84/6Z3	.46
1LH4	.69	6A7	.69	6BF6	.37	6R7	.69	7A6	.69	12AV6	.39	12SR7M	.49	35L6GT	.41	85	.59
1LN5	.59	6AC7M	.86	6BG6G	1.25	6S4	.38	7A7	.69	12AV7	.63	12V6GT	.46	35W4	.37	117L7	.99
1N5GT	.67	6AF4	.90	6BH6	.46	6S7M	.79	7A8	.68	12AX4	.56	12X4	.38	35Y4	.54	117P7	.99
1P5GT	.57	6AG5	.48	6BJ6	.43	6S8GT	.53	7AF7	.53	12AX7	.56	14A5	.59	35Z3	.59	117Z3	.37
1Q5GT	.58	6AG7M	.99	6BK7	.80	6SA7GT	.43	7B4	.44	12AY7	.99	14A7	.63	35Z4	.47	117Z6	.69
1R5	.49	6AH4	.57	6BL7GT	.83	6SD7GT	.41	7B6	.69	12BA6	.38	14B6	.63	35Z5GT	.47	807	.99
1S4	.59	6AH6	.73	6BN6	.59	6SF5GT	.46	7B7	.49	12BA7	.60	14B8	.63	36	.39	866A	1.39
1S5	.43	6AJ5	.65	6BQ6GT	.79	6SG7GT	.41	7C4	.59	12BD6	.45	14C7	.79	41	.42	Hi-Po 567	1.39

RAD-TEL Parts - TOPS in Quality - LOW LOW in Price!

Philco TV BOOSTER

Made by PHILCO, famed for quality and precision communications equipment. Completely self-contained, including 2 tubes—1 for High Channels and 1 for Low Channels and selenium recifier plastic cabinet. In factory-sealed cartons, complete with instructions.



\$10.95
In Lots of 3 \$9.95

STANDARD BOOSTER

12 channel RF Amplifier with self-contained AC power supply. Hand-some plastic cabinet. List price \$23.00



\$7.95 each
Lots of 3 each **\$7.45**

UHF CONVERTER

Brand new! Latest model! Unit is highly engineered, receives all UHF channels. Coaxial tuned cavity elements complete with 6AF4 oscillator, 6CH6 I-F and crystal mixer. Shipped ready to install and operate. List price \$29.95. **\$22.45** Deluxe model Five Star UHF Converter. Pre-selector 1N82-6BQ7 cascade and 6AF4 oscillator. List price \$39.95. **\$29.97**



FLYBACK TESTER

A MUST for every Service-Man!

Your Price



39.95
Fast, sure, a 1-turn short. Tested while in receipt. Tests continuity on yokes, coils, speakers, switches, etc. **FREE!** Flyback and yoke with each order.

Cathode Ray TUBE REJUVENATOR

Fits all makes of picture tubes. Completely automatic. Easy to install, no tools needed. For A.C. parallel circuits. Your Old Picture Tubes Are Still Useful. List price—\$5.95.



1.39
Lots of 10 **1.29**

SELENIUM RECTIFIERS

Mfd. by FEDERAL

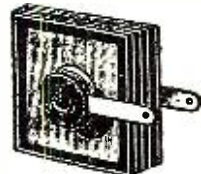

65 59¢
75 69¢
100 79¢
150 84¢
200 1.25
250-1010A 1.75
250-1028A 1.75
300 1.39
350-1238A 1.59
350-1023A 1.59
400 1.59
500 1.99

Hi-Voltage POWER SUPPLY

4500 VOLTS 6 WA. 12AU7 oscillator 1B3 rectifier. Completely enclosed in shielded metal case, removable cover. Improve performance of your scope as R.F. high voltage supply.



BRAND NEW!
\$2.95
Kit of 2 tubes for above \$1.22
Lots of 5 **\$2.75** ea.

UNIVERSAL FLYBACK

High efficiency FERRITE core horizontal transformer . . . supplies 14,000 Volts: For all 65 to 70 kinescopes. Famous Type. In constant demand. List price \$11.50.



1.95 each
Lots of 3 **\$1.85** each

Famous Standard Coil CASCODE TUNER

Famous standard tuner. TV front end. Double the gain with a great reduction in noise. A MUST for fringe area replacement. Includes tubes 6BK7 or 6BQ7 and 6J6. List Price \$34.50 ea.



\$18.95
Lots of 2 ea. **17.95**

Famous Make CLOCK RADIO

With Telechron luminous clock. Automatic shut-off and wake-up features. Starts coffee perking; switches on appliances. 5 tubes including rectifier. Built-in antenna, 60 cycles AC. UL-approved.



Ebony \$22.95
Lots of 5 \$22. ea.
Walnut \$23.95
Lots of 5 \$23. ea.
Ivory \$24.95
Lots of 5 \$24. ea.

Famous Make Personal Portable BATTERY RADIO

Has extra long life hundred hour batteries. Long distance reception. Large dynamic speaker. Thumb wheel tuning. All stations. Plastic case, with collapsible handle. Rich gold finish trim. Red, brown or grey. Complete with batteries and leather case.



\$19.95 each
complete
Lots of 3 \$19. ea.

Sensational! New! INDOOR ANTENNA

Famous 3-Way Delta-beam. 30% increase in pulling power by extending dipoles. For average fringe and UHF areas. For movie-clear pictures. Single antenna. **\$5.95**

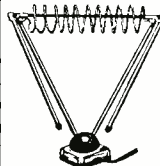

Lots of 6. **\$5.37**
Lots of 12. **\$4.83**
Lots of 24. **\$4.47**



300 OHM TWIN LEAD

TV LEAD-IN WIRE
AWG 20 strand copper. 55 mil. web poly.
2 1/2¢ per foot
\$1.95 per 100 ft.
\$14.50 per 1000 ft.



TERMS: A 25% deposit must accompany all orders—balance C.O.D. All shipments F.O.B. Irvington warehouse. Orders under \$10—\$1.00 Handling Charge. Subject to prior sale.

PLEASE: send full remittance . . . allow for postage and save C.O.D. charges! We refund all unused money!

Send For **FREE** Illustrated PARTS CATALOGUE

RAD-TEL TUBE CO.

"INTEGRITY IS OUR CHIEF ASSET"
Dept. RN-4 Phone: Essex 5-2947
115 Coit St., Irvington 11, N. J.

Tangibly Great Sound Reproduction

IS WHAT YOU'LL HEAR AND FEEL
WHILE LISTENING TO POPULAR OR
CLASSICAL MUSIC THROUGH A

BROOK HIGH QUALITY AUDIO AMPLIFIER



Model
22A

— handsomely compact 10-watt
single-chassis combination.
Quality sound, at cost so low
any music lover can afford it.



Model
12A4

— combining famous BROOK
12A power amplifier, and flexi-
ble 4B pre-amplifier, at moder-
ate cost.



Model
10C4

— 30-watt basic amplifier —
remote control pre-amplifier
combination; higher power for
full-bodied orchestral passages.

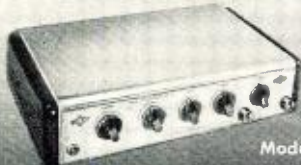

Model 7

— Self-powered pre-amplifier
perfect complement to any good
basic amplifier.

Every BROOK Amplifier is built to the
highest possible standards of quality.

Write for full information on the com-
plete BROOK line; also name of your
nearest dealer. Dept RT-4

BROOK ELECTRONICS, INC.

First in the High Quality Audio Field Since 1934
34 DeHART PLACE, ELIZABETH, N. J.

at 0901 with Arabic music, woman an-
nouncer. (Morgan, Calif.) Lately, Dja-
karta has been using YDF6, 9.685A, to
Europe and New Zealand in *English*
1400-1500 closedown. (Pearce, Eng-
land) *Radio Sweden* lists frequencies
in use then as 9.866, 11.770. Balbi, Mor-
gan, Calif., hear YDJ, 5.060, Dogjakar-
ta, fair to good level 0930-1030 close-
down. *Etersvep*, Sweden, reports YDQ3,
9.550A, Makassar, Celebes, heard in
Sweden 0915-0945; YDP3, 7.240, Bukit-
tinggi, Sumatra, noted 1000-1100.

USSR—Home Service noted on 4.715
at 0226, with songs; 0229 announced
in Russian, then had talk by man.
(Morgan, Calif.) Moscow noted in
English 0900 on 11.740A. (Esser, Pa.)
And with powerful signal on 7.230 at
1900 in *English* to North America.
(Bellington, N. Y.) Heard at strong
level on 6.070V with news 0100. (Calos,
Calif.) Heard on many channels in
popular s.w. bands during *English* to
North America 1800-0100. (Hunteman,
Fla.)

Vatican—HVJ, 11.74, noted with
news 1000-1015. (Zerosh, Pa.) Also
uses 9.55, 11.685, 15.120 then; and
9.550, 7.280, 11.685 at 1315. (Crowell,
Pa.)

Venezuela—Maracaibo, 4.800, defi-
nitely announces YVMF on m.w. and
YVME on s.w. (Niblack, Ind.; Stark,
Texas) This one noted 2130 asking in
English for reception reports. (Roemer,
Ky.) YVLA, 4.780, Valencia, is nice
signal lately by 1730. (Buggins, Eng-
land) YVKO, 6.170, has French *irregu-
larly*, for about 15 minutes, some-
times at 1735, other times around 1815.
YVMA, Maracaibo, *Ecos del Julia*, not-
ed moved from 4.750A to 5.039, best
when opening around 0530. (Stark,
Texas)

Yugoslavia—Belgrade, 6.100, heard
recently 1557 with *English*, played an-

them 1800 and left the air. (Bellington,
N. Y.) Still has *English* 1645-1700. (Ze-
rosh, Parsons, Pa., others)

Press Time Flashes

When this was compiled, *Radio
Sweden* had just replaced 7.210 with
9.620 for beams to Africa in *English*
and Swedish 0000-0045, 1300-1345.
(Radio Sweden) HI4T, 5.970, Domini-
can Republic, has weather report in
Spanish 2030 supplied by Naval HQ, in-
cluding weather forecast for the entire
Caribbean region for the next 24 hours.
(Kahan, Calif.) *Clandestine, Yugoslav
Emigrant Station*, 6.885A, noted 1630,
uses 2-chime interval signal; had mu-
sic; native talk to 1700. (Sutton, O.)
Heard closing 1730 at fairly good level
in N. J. (Huttemeyer) Djakarta, 7.27,
Indonesia (USI), is noted again in clear
1000-1030 sign-off; has QRM from Mos-
cow to around 1000. (Balbi, Calif.)

CKA36 (formerly VONW), North
West River, Labrador, Newfoundland
Province, Canada, operates on 3.420
with 75 watts, with religious sessions
beginning Sun. 1700, Tues. and Fri.
1845; North West River is a village of
approximately 250 people, located on
the river inlet on the western coastline
of Lake Melville, approximately 20
miles north of Goose Bay. (URDXC)

Radio Peking lately has been back
on 7.500 from 7.430, noted 1800. (Ni-
black, Ind.; Balbi, Calif.) A Guatemal-
an station on 6.101, noted as early as
0724, announces "Radio Phillip, La
Emisora Musical de Guatemala"; usu-
ally fades in around 0735 and goes past
0010. (Stark, Texas) Complete list of
Taiwan (Formosa) stations, received
by Scheiner, N. J., is "Voice of Free
China," BED3, 15.235, BED4, 11.920,
BED6, 11.736, BED7, 7.130, BED29,
6.095; Chinese Air Force Station,
6.117.5, 9.775; Tso-Ying Military Sta-

NEW TV STATIONS ON THE AIR

(As of March 25, 1954)

The following new stations bring the lists published in previous issues up to date.

STATE, CITY	STATION	CHANNEL	FREQUENCY RANGE (IN MC.)	VIDEO WAVELENGTH (IN FT.)	VIDEO POWER* (IN KW.)
California Fresno	KBID-TV	53	704-710	1.4	460
Georgia Savannah	WTOC-TV	11	198-204	4.93	60
Indiana South Bend- Elkhart	WSJV	52	698-704	1.41	20.4
Minnesota Duluth	KDAL-TV	3	60-66	16.06	100
Mississippi Jackson	WSLI-TV	12	204-210	4.79	214
Montana Great Falls	KFBB-TV	5	76-82	12.74	25.1
New York Troy	WTRI	35	596-602	1.65	260
Rhode Island Providence	WNET	16	482-488	2.04	210
Wisconsin Superior	WDSM-TV	6	82-88	11.8	100
Canada Kitchener, Ont.	CKCO-TV	13	210-216	4.65	16
KCTY, channel 25, Kansas City, Missouri, has gone off the air.					

The frequency of the video carrier = 1.25 + channel lower freq. limit. Total
number of TV stations now on the air in U.S.: 377 (134 of which are u.h.f.).

*From Station CP application.

tion, 10,200; Tai-pei Armed Forces Radio Station, 7,000; "Voice of Justice," 7,300.

The Armed Forces Radio Service will *not* verify reception reports for listeners in the U. S. ("On the Air," others) ISWC, London, lists *English* from Damascus, Syria, for 0500-0630, 7,145; 0945-1045, 15,395; 1630-1730, 7,235.

4VEH, 9.656, Cap Haitien, Haiti, has switched to this new "morning" channel because of bad QRM on 9.690; now broadcasts from *new* studios, using a 100-foot dipole (vertical) antenna which is non-directional, replacing the temporary V-beam used since last summer; scheduled 0600-0905 on Mon., Tues., Wed., Fri.; 0600-1005 Sat.; 0600-0935 Sun.; Sun. also 1630-2135, and also Mon. (in *English only*) at 1830-2030 on *test* channels—have included 9.690, 9.675, 9.656, 9.664, 9.635; the test channels may be changed from time to time until a satisfactory one is found; the Listeners' Post, mail-answering session, is now 0930-1000 Sat. and 1930-2000 Mon.; no date has yet been set for the 1 kw. or 10 kw. transmitters to go on the air; the 1 kw. one is to come on first, primarily for use in the 49-m. band; there will be a special broadcast when the new transmitters come into use. (West, Va., via NNRC)

AFRS, Far East Network, Tokyo, announces schedule as JKL, 4,860, 1600-2015; JKL2, 9,605, 2030-0215; JKL, 4,860, 0230-1000; JKI4, 11,825, 1600-1000. (Morgan, Balbi, Calif.) When BFEBS, Singapore, Malaya, opens 0415 with news, announces 15.43, 11.82, 7.12, and *new* 6.110; Kuala Lumpur, 6.025, noted with news 0630. *Radio France-Asie*, Saigon, Indo-China (Vietnam) has returned to 6.11 from 6.17, audible *after* 1000 when Moscow leaves channel. (Balbi, Calif.)

Pusan Radio, South Korea, destroyed by fire in November, will be rebuilt. (Scheiner, N. J.) Brown, Wyo., has heard the New Zealand Forest Service at Wellington testing on 9.85A around 1000.

Acknowledgment

Thanks for the fine reports! Keep them coming to Kenneth R. Boord, 948 Stewartstown Road, Morgantown, West Virginia, USA. Good listening, fellows! . . . K. R. B.

Natalie KALMUS Television CABINETS

NOW AT FACTORY PRICES!

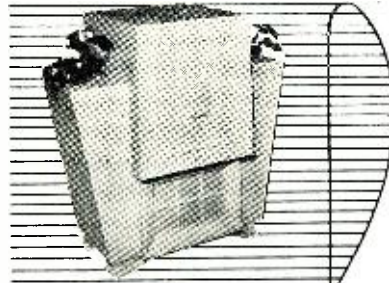

The Student
Prinse

HANDSOMELY DESIGNED IN HAND-RUBBED OAK. INVISIBLE "MAGIC TOUCH" DOOR LOCKS. SIZE: 42" HIGH, 43" WIDE, 24" DEEP. TAKES UP TO 21" TV SET. INDOOR PLANTERS STEP UP DECORATIVE EFFECT. COMPLETE WITH MASK AND POTTERY. **\$6950**

F. O. B. LOS ANGELES. 25% DEPOSIT. BALANCE C. O. D.

The Full
Combination

THE TV CABINET IN OAK OR MAHOGANY THAT'S YEARS AHEAD. INVISIBLE DOOR LOCKS OPEN AT A TOUCH. SIZE: 42" HIGH, 44" WIDE, 24" DEEP. TAKES UP TO 21" TV SET. COMES COMPLETE WITH MASK AND POTTERY. **\$8950**

F. O. B. LOS ANGELES. 25% DEPOSIT. BALANCE C. O. D.

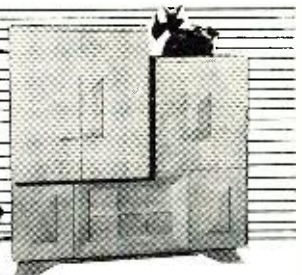

R. S.
ENTERPRISES

7636 Santa Monica Blvd.
Los Angeles 46, Calif.

Save production dollars
with 

**TAPERED
Germanium
Diodes**

*Speed Assembly
In Your Circuitry
Eliminate Errors!*

With a unit as tiny as a germanium diode chances of error in assembly are multiplied . . . but the tapered design of the Radio Receptor diode case works for you to eliminate these problems.

Allowing polarity identification at a glance or touch, the taper and hexagon shape reduce error, assure ease of handling and prevent rolling—Giving you increased production and real dollar savings!

Write us today for further information, without obligation of course. We also manufacture Germanium Transistors and SELETRON Selenium Rectifiers.

Seletron and Germanium Division
RADIO RECEPTOR COMPANY, INC.

In Radio and Electronics Since 1922

Sales Dept.: 251 West 19th Street, New York 11
WAtkins 4-3633 • Factories in Brooklyn, N. Y.

Make Sure to See Our Exhibit at the I.R.E. Show March 22-25,
Kingsbridge Armory, Booth 511 - 513 - Components Avenue.



**LOSE SOME TOOLS,
MISTER?**

**SAVE TOOLS, TEMPER AND TIME
WITH XCELITE NUT DRIVER SETS!**

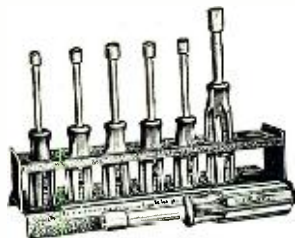

No. 137 BENCH SET

3/16, 1/4, 5/16, 11/32, 3/8 regular; 1/2 and 9/16" hollow shaft nut drivers with COLOR CODED handles. No more fumbling—everything's where you need it. Ask your supplier!

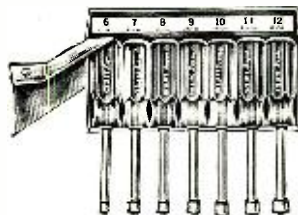

No. 127 LOCKABLE
WALL SET

Tamper-proof. Has 3/16, 7/32, 1/4, 9/32, 5/16, 11/32, 3/8 regular nut drivers with COLOR CODED genuine XCELITE plastic handles. Lifetime tools.

XCELITE, Incorporated

(Formerly Park Metalware Co., Inc.)

Dept. E
Orchard Park,
New York

For Originality
LOOK TO XCELITE

6 NEW TRIAD FLYBACKS

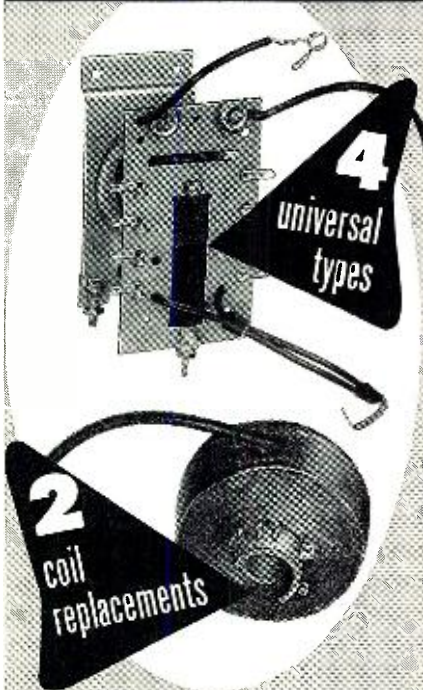

As evidence of Triad's continuing efforts to meet your TV-replacement needs — exactly and completely — 6 new flybacks have been added to the line. A total of 19 are now available, with more being added all the time. These flybacks are precisely engineered for specific replacements and carefully constructed of the finest materials. Their resulting high performance and long life insures satisfied customers and helps you build and hold your service business.

Type No.	List Price	Description
D-31	\$11.00	Universal type. Universal mounting. Replaces RCA 231-T1
D-32	10.75	Has AGC tapped winding. Matches all yokes.
D-33	10.00	Universal type. Universal mounting. Has AGC tapped winding similar to D-32, but low impedance secondaries.
D-35	11.00	Universal type. Universal mounting. Replaces RCA 223-T1, 224-T1, 230-T1 and 232-T1.
DA-36	3.50	Coil only. Replaces coil in Zenith Part No. S-18567.
DA-37	3.50	Coil only. Replaces coil in Zenith Part No. S-19032.

Available from stock. See your jobber for these — and all of your TV replacements.
Write for Catalogs TR-54A and TV-54A



Technical BOOKS

"BASIC RADIO MANUAL" by Sams Staff. Published by *Howard W. Sams & Co., Inc.*, Indianapolis. 239 pages. Price \$5.00. Paper bound. Volume 1.

This is the first volume in the new *Sams Educational Series* of publications and has been planned to meet the demand for a practical syllabus for instructors in basic radio whether they be high school teachers, Boy Scout leaders, ham club Novice program planners, or others charged with planning a truly basic course for the beginning student.

The manual which is designed as both a text book and a project manual is divided into two sections—one covering the lecture portion of the course and the other the laboratory or projects section. There are 36 lessons and 13 projects included. Among the build-it-yourself projects are a.c.-d.c. power supplies, a.c. power supplies, an audio amplifier, and a crystal receiver, and practice sessions in soldering, etc.

A planning guide for instructors, which is also available for use in conjunction with the manual, lists instructional material required as desirable for such courses and details on suitable service or demonstration test benches.

From the number of requests we have received for material of this type, we believe that this new course will find a ready-made audience among instructors.

"DIAL CORD STRINGING GUIDE" by Sams Staff. Published by *Howard W. Sams & Co., Inc.*, Indianapolis. Volumes 3 and 4. \$1.00 each. Paper bound.

These are the third and fourth volumes in the current *Sams* series covering dial cord data for a wide variety of radio and television chassis.

In addition to providing pictorial diagrams of the various dial stringing systems the handbook carries a list of general notes which apply to all such restringing jobs.

Each volume also includes a cumulative index of the previous volumes. Volume 3 covers radios from 1950 through part of 1951 and television receivers from 1946 through part of 1951. Volume 4 covers both radio and television receivers from 1951 to 1953.

Considering the amount of time most dial stringing jobs take, these volumes should be a happy choice for the service bench library.

"ELEMENTS OF ELECTRICAL ENGINEERING" by Arthur L. Cook & Clifford C. Carr. Published by *John Wiley & Sons, Inc.*, New York. 671 pages. Price \$6.75. Sixth Edition.

Although this familiar work made its original appearance in 1924, readers of the sixth edition will find that the text material has been completely revised and more than half of the book has been rewritten.

STAN-BURN EDARKE

CATHODE RAY TUBE SPECIALS

One Year G. E. Guarantee		STAN-BURN	
*7JP4	\$17.10	10BP4	\$10.50
*10BP4A	19.25	12LP4	12.50
*10FP4A	24.00	12LP4A	14.50
*12KP4A	27.10	12QP4	12.50
*12LP4A	21.70	12JP4	12.50
*12QP4A/B1014		12UP4A	15.00
Dumont	21.00	14CP4	17.00
*12UP4B	28.75	15DP4	18.50
*14CP4	24.50	16KP4	18.50
*15DP4/B1014		16DP4 or A.	18.50
Dumont	23.75	16JP4 or A.	18.50
*16AP4A	30.95	16CP4 or A.	18.50
*16DP4A (N.U.)	25.25	16FP4	18.50
*16CP4 or B	31.25	16WP4	18.50
*16RP4/16RP4	24.20	16AP4	19.00
*16KP4A		16BP4A	19.00
(Aluminum)	28.75	16EP4	19.00
*16JP4A (N.U.)	25.25	16EP4A	23.50
*16LP4A	28.50	16GP4 or A.	21.00
*16WP4A	26.50	17BP4	19.50
*16GP4B	31.25	17CP4A	21.60
*17BP4A	24.00	17GP4B	22.60
*17CP4	23.90	19FP4	23.00
*17CP4B		19FP4A	24.00
(Aluminum)	29.00	19AP4	23.90
*19AP4A	41.50	19AP4A	24.90
*20CP4	34.50	20CP4	26.00
*20LP4	37.50	21EP4	26.50
*21AP4	42.00	21AP4	26.50
*21EP4	36.35	24AP4	49.00
*24AP4A	78.50		

QUANTITY CRT USERS
We will give you DUD allowances if you ship them to us Prepaid. 10 CRT's minimum shipment. WRITE FOR DETAILS.

ANTENNAE SPECIALS		1-5	6 or more
RED DOUBLE "V" Antenna	...	\$2.19	\$1.98
10 ELEMENT CONICAL			
DOWELED INSERTS	2.98	2.79	
Folded Hi Straight Low Quick Rig			
1/2" elements	4.25	3.25	
WINDOW CONICALS	4.95	3.75	
MASTS			
10 FOOT SWEGDED	1.39	1.29	
NEPCO MASTS	1.69	1.49	
TV WIRE			
55 Mil. 300 OHM	...	\$ 9.95 M Ft.	
72 OHM COAXIAL	...	35.00 M Ft.	

CHASSIS 630 TECH-MASTER		\$149.50
Model C10 With Cascade Tuner	...	
OPEN FACE CABINET	...	42.00
TAPES RECORDERS IN STOCK		
PENTRON - Model 973C - 2-speed Tape Recorder	...	Write for Price
RADIO CRAFTSMAN		
Model C400-Hi-Fi Amplifier	...	Net 42.90
Model C10-AM-FM Tuner	...	Net 131.50
Model C500-Williamson Amplifier	...	Net 99.50

CONVERSION SPECIAL
21EP4 American Standard Tube ALL FOR ONLY
21" Bevel Mask
Ram Conversion Kit (Mention Set to be converted.) \$43.50
AUTHORIZED DISTRIBUTORS for General Electric, Kenrad, Tung-Sol, National Union, De Wald, Regal, Automatic and General Motors.
Automobile Custom-Built Radios for Plymouth, Ford, Chevrolet and many others — always in stock.
We carry a Complete line of HI-FIDELITY and sound equipment. Send us your requests.
We also carry a complete line of popular makes of Radio Tubes at 50/10 discount. Also many other special purpose and transmitting types, and all electronic parts and equipment at lowest prices. Send us a list of your requirements for prompt quotations.
Terms: 20% with order. Balance C.O.D. All prices F.O.B., NEW YORK Warehouse. Minimum order \$5.00.
Write for our latest price list and Hi-Fi catalog, to Dept. RN-4.

STAN-BURN RADIO and ELECTRONICS CO.
(C.B.S. THEATRE BLDG.)
1697 BROADWAY • NEW YORK 19, N.Y.

Quick-Wedge SCREW HOLDING SCREWDRIVER
Holds the Screw!
Drives it, too!
Unconditionally Guaranteed
ASK FOR IT AT YOUR DEALER
KEDMAN COMPANY • 222 50. St. WEST • SALT LAKE CITY 1, UTAH

The book is divided into six self-contained sections which cover the fundamentals of electric and magnetic circuits; basic relations for electrical machines; d.c. machinery; a.c. circuits; a.c. machinery; and instruments, electronics, and special applications.

Like the earlier volumes, this book has been designed as a text for non-electrical engineering students to give them the fundamentals of the subject. A working knowledge of college algebra is prerequisite for a thorough understanding of this presentation.

The text includes a series of test questions at the end of each chapter as well as examples which accompany the various sections. For the student with the required background, this book could be used as a home-study text or as a reference work for the tyro engineer.

"TELEVISION, A WORLD SURVEY" compiled by UNESCO. Published by Columbia University Press, New York. 184 pages. Price \$1.75. Paper bound.

Those interested in the impact of television throughout the world will welcome this informative and fact-packed publication compiled by UNESCO.

This recent study gives detailed information on the history of television in each country covered by the survey. It includes the structure and form of organization, the source of revenue, technical facilities which are available or projected, programming and reception, the number and type of transmitters, as well as the progress of color television and how personnel is trained for new stations.

A comparative table of countries having regular or experimental broadcasts lists the number of television stations in operation, the estimated number of receivers, the potential audience, date of first broadcasts, and other pertinent data.

One interesting facet of the report is the per capita comparison of sets in use between the various countries. There is now one TV set for every 7.15 persons in the U.S., one for every 24 persons in the United Kingdom, one for every 55 Cubans, one set for every 704 Frenchmen, one for every 2400 in the Soviet Union, and one for every 8000 in the German Federal Republic.

"MOST-OFTEN NEEDED 1954 TELEVISION SERVICING INFORMATION" compiled by M. N. Beitman. Published by Supreme Publications. Chicago. 192 pages. Price \$3.00. Paper bound. Volume TV-8.

This is the eighth volume in the Supreme series of TV service manuals and like the previous volumes covers in concise form information needed to troubleshoot and repair current television receivers.

The material, as furnished by the manufacturers, includes special set features, service adjustments, trouble chart, a complete circuit diagram, and alignment data on each receiver or chassis series.

April, 1954

Guaranteed reception
...most sensitive all-channel antenna
"22 DB GAIN"
"OUTPERFORMS ALL OTHERS"
"Guaranteed reception"
"...most sensitive all-channel antenna"

What can you believe in Antenna Claims?

Every claim for all-channel antenna performance should be supported by facts—not "sales talk." Facts are what you get from DAVIS... proof furnished by Microwave Engineering Company, of Los Angeles, who are recognized experts on antenna research and testing.

Write for this data. It's actually certified... data you can count on.

Remember, it's the picture that pays off in customer satisfaction. A DAVIS picture must please you—it's guaranteed to please or your money is refunded by the factory.

Send the coupon for facts on the DAVIS antenna.

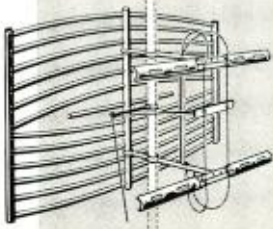

MAIL THIS COUPON TODAY:
 DAVIS ELECTRONICS, Box 1247, Burbank, Calif.
 Gentlemen... send me the following:
 Technical data and complete information on the new SUPER-VISION ANTENNA
 Name and address of NEAREST JOBBER

COMPANY NAME _____
 MY NAME _____
 ADDRESS _____
 CITY _____ STATE _____

DAVIS SUPER-VISION
 COPYRIGHT 1953
DAVIS ELECTRONICS
 P. O. BOX 1247 - BURBANK - CALIF.
 Factories in: BURBANK, CALIF., CHICAGO, ILL., SILVER SPRINGS, MD.

QUARTZ CRYSTALS

GUARANTEED! FT-243—.093" PIN DIA. .486" PIN SPC.—FOR HAM AND GENERAL USE

4035 5437 5950 6800 7610 7900	1015 6000 6573 7200 8125 8600
4080 5485 5973 6806 7625 7906	1930 6025 6575 7250 8140 8225
4165 5500 6240 6825 7640 7925	1940 6050 6600 7300 8150 8650
4190 5660 6250 6850 7641 7940	1950 6075 6606 7306 8173 8700
4280 5675 6273 6875 7650 7950	2065 6100 6625 7325 8175 8733
4300 5700 6275 6900 7673 7973	2125 6125 6640 7340 8200
4330 5706 6300 6925 7675 7975	3500 6140 6650 7350 8340
4397 5725 6325 6950 7700 8206	3640 6150 7000 7375 8350
4490 5740 6350 6975 7706 8225	3680 6175 7025 7400 8380
4495 5750 6373 7450 7720 8250	3735 6200 7050 7425 8400
4535 5773 6375 7473 7725 8273	3760 6440 7073 7440 8425
4735 5780 6400 7475 7740 8275	3800 6450 7075 8000 8450
4840 5806 6406 7500 7750 8300	3840 6473 7100 8025 8475
4930 5840 6425 7506 7773 8325	3885 6475 7125 8050 8500
4950 5852 6673 7525 7775 8630	3940 6500 7140 8073 8525
4980 5873 6675 7540 7800 8683	3955 6506 7150 8075 8550
5030 5875 6700 7550 7825 8690	3990 6550 7175 8100 8575
5205 5880 6706 7573 7840	
5300 5906 6725 7575 7850	
5385 5925 6750 7600 7873	
5379 5940 6775 7606 7875	

49c each—10 for \$4.00

Low Frequency—FT-241A for SSB, Lattice Filter etc., .093" Pins, .486" SPC., marked in Channel Nos. 0 to 79, 54th Harmonic and 270 to 389, 72nd Harmonic. Listed below by Fundamental Frequencies, fractions omitted.

370 393 414 436 498 520 480 459	5910
372 394 415 437 501 522 440 461	6370
374 395 416 438 502 523 441 462	6450
375 396 418 481 503 525 442 463	6470
376 397 419 483 504 526 444 464	6497
377 398 420 484 505 527 445 465	6522
379 401 422 485 506 529 446 466	6547
380 402 423 486 507 530 447 468	6610
381 403 424 487 508 531 448 469	7350
383 404 425 488 509 533 450 470	7380
384 405 426 490 511 534 451 472	7390
385 406 427 491 512 536 452 473	7480
386 407 428 492 513 537 453 474	7580
387 408 430 493 514 538 454 475	7810
388 409 431 494 515 455 476	7930
390 411 433 495 516 456 477	
391 412 434 496 518 457 479	
392 413 435 497 519 458 480	

49c each—10 for \$4.00

CR-1A SCR
 Foundation coils for 50 meter VFO or exciter. Less xtals.98c
SEE ARTICLE BY W3PPQ IN MARCH '54 CQ

BC746 TUNING UNITS
 FT-171B, BC-610
 2 Banana Plugs
 3/4" SPC

99c each—10 for \$8.00
Special—200 KC or 500 KC in FT241A Holder, \$1.79 each

PLEASE ADD 20c POSTAGE FOR EVERY 10 CRYSTALS OR LESS

SUN PARTS DISTRIBUTORS, LTD.
 520 TENTH ST. N. W.—WASH. D. C., DEPT. N

NOW COYNE TRAINS YOU IN SPARE TIME AT HOME

TELEVISION RADIO-ELECTRONICS

Only from famous COYNE do you get this modern up-to-the-minute TV Home Training. Easy to follow Step-by-Step instructions—fully illustrated with 2150 photos and diagrams. Not an old Radio Course with Television tacked on. Personal guidance by Coyne Staff. So practical you can quickly EARN MONEY in a TV-RADIO SALES AND SERVICE BUSINESS—part time or full time. Not only FINEST TRAINING but COSTS MUCH LESS—pay only for training—No costly extras.

SEND COUPON for DETAILS FREE
 SEND COUPON BELOW for Picture Folder and full details including EASY PAYMENT PLAN. NO COST OR OBLIGATION—NO SALESMAN WILL CALL.

B. W. COOKE, Pres. COYNE ELECTRICAL SCHOOL FOUNDED 1899

A TECHNICAL TRADE INSTITUTE CHARTERED NOT FOR PROFIT
 500 S. Paulina Dept. 44-HT5 Chicago 12, Illinois

B. W. COOKE, President
COYNE ELECTRICAL SCHOOL
 500 S. Paulina St., Chicago 12, Ill., Dept. 44-HT5
 Send FREE Picture Folder and details of your Television-Radio-Electronics Home Training offer.

Name.....
 Address.....
 City..... State.....

may be necessary to tune the receiver or the bouncer oscillator slightly, but a return signal should be heard if the dials are set to the right frequencies. All controls should be "peaked" for maximum receiver response, then the bouncer may be taken outside.

At first it should not be taken too far away, because different locations will affect the tuning, and it will be found that some touching up may be required as different spots are tried. The panel meter should jump slightly at the proper settings. Maximum distance will result, of course, with the antenna extended to its greatest length.

Another way to obtain optimum tuning is to open a window so the receiver loudspeaker can be heard at the "Signal Bouncer." Turn off the receiver a.v.c., then turn on the b.f.o. Have someone key the rig, and tune the "Signal Bouncer" for the loudest beat. To be sure operation is in the proper mode, turn off the bouncer and key the transmitter. The receiver should now be quiet.

In the immediate vicinity of powerful broadcast stations, it may be found that random mixing with the broadcast harmonics caused by accidental diodes, such as corroded drain piping, fence wires, power-line guys, etc., may cause spurious responses to appear in the station receiver when the transmitter is keyed. These can be identified by being partially modulated with the broadcast program. While, in a way, they are giving information of the same type as provided by the "Signal Bouncer," these responses should be avoided, since they may be coming from anywhere at all and are usually highly irregular.

The distance at which the "Signal Bouncer" may be used will depend upon transmitter power, frequency, and the antennas. Depending upon specific conditions, the use of all or only a part of the 18 feet of antenna available may be required—and it may be possible to increase the range (if necessary—check first) by use of a small antenna loading coil at the point marked "X" in the schematic. A value of inductance should be used which will bring the antenna tuning closer to resonance on the return-signal frequency. Because of the effect of the other circuits in the antenna it is best to determine the size experimentally.

After a little experience with the "Signal Bouncer," it should be possible to set up standards of distance and adjustment so that comparisons of main-station antennas, matching systems, power, and tuning adjustments may all be positively checked—as they would be by an accurate observer at a distance—even if the band is dead and everyone else is asleep.

This is better than having a slave. If you're seriously interested in how you are getting out from time to time, build a "Signal Bouncer." This is a sure-fire way of checking and one that can be applied day or night, summer or winter. Try it.

Let MILTON S. KIVER Help You Prepare For U.H.F.-TV, Color And...

TELEVISION SERVICING

Easy to TRAIN AT HOME This Practical Way!

Men with the right training in Television Servicing are in big demand . . . pull down big pay. T.C.I. TRAINS YOU RIGHT with easy-to-follow technical training designed by servicemen, for servicemen! You learn practical, professional type Television Servicing without leaving your present job. Included are money-making extras such as set conversion, master antenna installation, U.H.F.-TV NTSC Color System and field servicing short cuts. You can start earning Television money after the first few lessons. You learn to test, trouble shoot and repair all types of TV sets the proven, practical way!

HERE'S HOW YOU GET EXPERIENCE!

You train on your own large screen modern television receiver, furnished as part of your course. This set is yours to keep! As an optional feature you can get two weeks of actual field experience out on service jobs and on the repair bench for Chicago's largest independent servicing organization. You learn Television Servicing by actually doing Television Servicing . . . you get the practical know-how you need to qualify for BIG MONEY in this fast-growing field! Age is no barrier, Many TCI students are over 40!

VETERANS!
T.C.I. is approved for G.I. training under Public Law 550. Check coupon.

ACT NOW! Mail coupon for FREE Catalog and SAMPLE LESSON. Write TODAY!

TELEVISION COMMUNICATIONS INSTITUTE

605 W. Washington Blvd., Dept. AZ, Chicago 6, Ill.

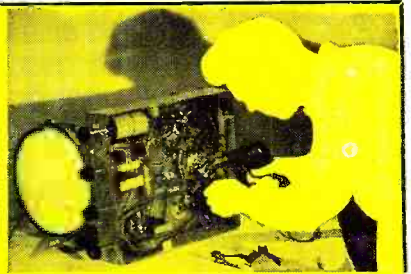

YOU GET and keep modern large screen Television receiver.

YOU DO actual testing, servicing, trouble shooting and repairing

BEGINNERS! LEARN ABOUT NEW BASIC TV COURSE!

You don't need radio experience for practical, home-study training in Basic Television. Start earning money in TV after first few easy lessons. Check coupon for details.

MAIL NOW FOR FREE BOOKLET

MILTON S. KIVER, President
TELEVISION COMMUNICATIONS INSTITUTE
605 W. Washington Blvd., Dept. AZ,
Chicago 6, Ill.

Rush full facts on practical TV training. I am not obligated. Salesman will not call.

Name Veterans: check here

Address

City Zone State

BEGINNERS check here for information on Basic Television Course.

NOW EICO® brings you A LABORATORY SCOPE AT A PRICE YOU CAN AFFORD!

Now you can enjoy all the tremendous advantages of troubleshooting with the greater speed, precision and visual meaning which only an oscilloscope gives you. With the EICO 5" Scope you can:

- Visually align TV, FM and AM sets
- Visually signal trace and trouble-shoot every stage of any electronic device
- Visually analyze complex waveforms

..... All without disturbing circuits

425K 5" Push-Pull Scope KIT \$44.95. Wired \$79.95.

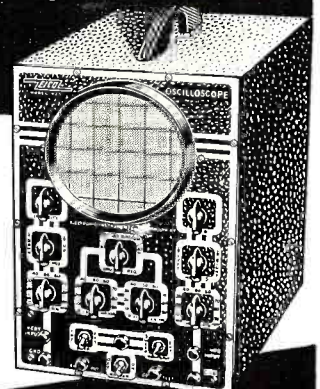

NEW 3 PROBES make 3 INSTRUMENTS of your EICO Scope

DEMODULATOR PROBE KIT \$3.75. Wired \$5.75—For signal tracing every stage of TV, FM and AM sets.
LOW CAPACITY PROBE KIT \$3.75. Wired \$5.75—For broad bandwidth and high impedance circuits.
DIRECT PROBE KIT \$2.75. Wired \$3.95—For voltage and current measurements and general analysis.
Special introductory price, set of three PROBE KITS \$9.95. Wired \$14.95

Compare these specifications with scopes selling at many times the EICO economy price!

- Push-pull Vert. & Hor. amplifiers
- Full-screen V & H centering controls
- Intensity (Z-axis) mod.
- 6.3 volt AC, 60 cps test signal output

- Direct connections to deflection plates
- V & H Freq. Resp: 5 cps — 500 kc; usable to 2.5 mc.
- V Sens: .05 to .1 volts rms/inch
- V & H input imp: 1 megohm
- Multivibrator Sweep Generator Range: 15 cps — 75 kc
- Tubes: 2-5Y3, 2-6J5, 3-6SN7, 1-5" CRT.



See this amazing Scope value at your jobber today. Write NOW for FREE Catalog SR-4 describing the complete EICO line. Turn to our full-page ad on page 34 of this magazine.

ELECTRONIC INSTRUMENT CO., INC.
84 Withers Street, Brooklyn 11, N.Y.

NEW EQUIPMENT FOR THE AUDIO TECHNICIAN

COAX SPEAKER ASSEMBLY

The R. T. Bozak Company, 114 Manhattan St., Stamford, Conn. is now marketing a two-way coaxial speaker designated as the Model B-207.

The speaker comes complete with crossover filter, which is wired, mount-

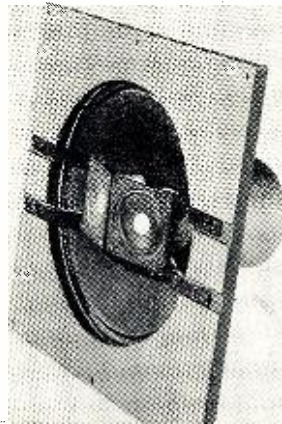

ed, and ready for installation with only two wires to be connected to the 8-ohm tap on the amplifier.

The B-207 consists of the company's B-199A bass speaker with a coaxially mounted B-200X direct-radiating dual tweeter; a 6 db per octave crossover filter; and a terminal board, all mounted on a heavy 15" square plywood panel pre-drilled for attaching screws. The entire unit can thus be mounted as a unit on a suitable baffle behind a cut-out intended for either a 12" or 15" speaker.

A specification sheet on this speaker is available on request.

"LIFETIME" TAPE

Reeves Soundcraft Corp. of New York City has developed a magnetic recording tape which the company unconditionally guarantees will never break or curl when used under normal conditions of recording and playback.

Marketed under the tradename of "Lifetime" tape, the company claims that the tape will not shrink, stretch, or dry out. The tape owes its qualities to the company's newly-developed magnetic oxide coating and its base of Du Pont "Mylar" polyester film.

The new tape is being offered in splice-free reels of 600, 1200, and 2400 feet or 2400 feet on a hub only.

EMERSON PHONOGRAPHS

Emerson Radio and Phonograph Corporation of 111 Eighth Ave., New York 11, N. Y. has introduced three phonographs which have been competitively priced.

Two of the new models are table models, one of which (Model 800) has three six-inch speakers. Both of the

models contain a newly-designed four-tube amplifier that is said to provide undistorted reproduction of the range from 50 to 12,000 cps. A variable control allows tone adjustments by the listener. Both Models 800 and 802 have three-speed changers that will handle 7, 10, and 12 inch records.

A three-speed portable phonograph, the 806, is the third model in the new series. It weighs only 6 pounds in a plastic cabinet and is available in an assortment of colors.

"CINESONE"

Foto Corporation of America, 169 Lexington Ave., New York, N. Y. is now in production on the new "Cinesone" unit which offers sound on film to owners of silent projectors.

The unit which will adapt to any 16 or 8 mm. silent projector or optical sound projector, comes complete with adapter, microphone, 6-tube amplifier, and 6" speaker. It will record both voice and music on any standard magnetic track and offers all regular recording and playback facilities plus a special automatic subducer which enables the user to record a new track over the old without erasure at the flip of a switch. This switch is located on

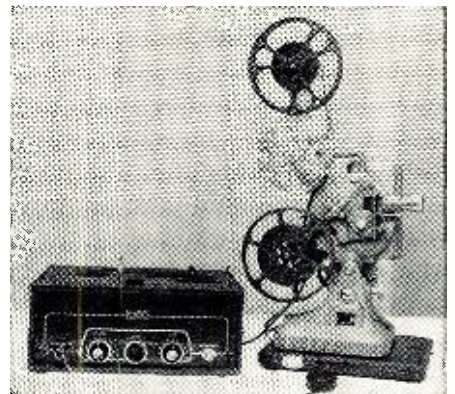

the adapter so that those who own tape recorders and do not have to purchase the amplifier, will still have the automatic subduing feature.

A handy data sheet giving all the pertinent information on the "Cinesone" is available on request.

"WALKIE-RECORDALL"

Miles Reproducer Company, Inc., 812-814 Broadway, New York 3, New York is now offering a self-powered, briefcase recorder-reproducer that weighs only 9 pounds including the built-in batteries.

Designated as the "Walkie-Recordall," the new unit picks up and records audible speech within a radius of 60 feet. The instrument uses "Sona-bands," endless safety film bands,

RADIO & TELEVISION NEWS

A modern
dynamic

at an

"old fashioned"

price

TURNER
ADA 95D



This is a modern dynamic microphone all right . . . with Alnico V Magnets and moving coils for maximum sensitivity to voice and music. Wide response range and outstanding sound characteristics make it ideal for tape recorder, PA, or commercial broadcasting use. Its design is certainly modern, too . . . trim, handsome, functional.

And about that price. We call it "old-fashioned" because it's so much lower than you would expect to pay in these expensive days. Only \$35.00 list.

Frequency response, 70 to 10,000 cps; output level, -58 db; 20 ft. removable grey plastic cable set; standard 3/8"-27 coupler; high impedance wired single ended (single conductor shielded cable); 50, 200, or 500 ohms wired for balanced line (two conductor shielded cable). About 8 1/2" high.

ADA 95D. List Price-----\$35.00

ADAS 95D. List Price
with slide switch-----\$38.50



CANADA: Canadian Marconi Co.,
Toronto, Ont. and Branches

EXPORT: Ad. Auriema, Inc.
89 Broad Street, New York 4, N. Y.



12 V. DYNAMOTOR

(D. W. Thomas Engineering, Inc.)
NEW! Guaranteed. Ready to use. Continuous duty ratings. Gray finish. 10% fr. = 1224-1 400V, 350 ma. = 1224-2 600V, 200 ma. Either... **\$9.95**
Add \$6.00 for base box containing starting relays & filters as shown. Shipping wt.: 11 lbs.; with base, 13 lbs.

12 V. RECEIVER DYNAMOTOR

Same as the 24V dynamotors on the back end of your 274-N or ARC-5 command receivers, except that these are made for 9 to 14 volts. Same base plate and plug connections. Output 250V, 60 ma. **\$5.95**
DY-1/ARR-2X, like new, checked out.

GENERATOR-ALTERNATOR SPECIAL

120V AC PLUS 28.5V DC
Two units in one package—complete in itself: the removable centrifugal slip clutch and the generator-alternator. Clutch maintains armature speed of 2400 rpm for drive speed varying between 2400 and 4200 rpm. Outputs 120V, 800 cy, 1 ph., 1050 VA plus 28.5 v. 25 A DC. Drive it from engine or electric motor. With diagram and instructions. **\$24.50**
New... (Freight prepaid)

VOLTAGE REGULATOR (Carbon pile) for above. **\$2.95**
New

200 AMP 24 V. GENERATOR

For marine—aircraft—farm—amateur—summer home—battery charging—welding—etc. Heavy Duty 24-30 VDC. 4400-8000 RPM. G. E. type 2CX-81B2 (All forces P1). Excellent condition. A \$47.50 value for only... **\$24.50**
(Freight prepaid)

SIX-INCH MAGNETIC COMPASS

Bendix #1801-A, beautifully damped, easily read to 1 degree. Rotatable azimuth dial. Luminous, 3-deep fore-aft line-up sighting markers. Flotation type on jewel bearing. Contains corrector, 5" high, 3 mtg-holes 6 3/8" apart. Fits your binnacle. **\$14.95**
Used, good

MARINE RADIO

- 1.) Our marine division announces the ALL NEW 1954 G.I. SEA KING, a complete FCC-approved 100-watt xmit-receiver in one compact case, one-knob control. Time-tested circuitry in a miniaturized package. Write for info.
- 2.) Command receiver 1.5-3 mc in rack with dynamotor, ready to go, with leads for break-in brought out. Use also as the extra receiver necessary to monitor 2182 KC.
- 3.) Good old reliable unidirectional Direction Finder DU-1 remodeled to lighthouse—beacon—lower half of Broadcast Band—and entire Marine Band. Goes ahead of any receiver. New, with instructions... **\$47.50**
- 4.) Bulkhead speaker in neat compact louvered-metal baffle, with transformer to match headset output jacks. Specially 4K or 600 ohms... **\$5.95**
- 5.) 6 Volt Radiophone! 2 xtal-controlled channels, brand new Jefferson-Travis, 5-watt output, with mike, built-in speaker. Less xials... **\$69.50**

B'CAST, LIGHTHOUSE, AERO

MN-26C Remote controlled navigational direction finder and communications receiver. Manual DF from 150 to 1500 kcs. 24 v self-contained dynamotor supply. Complete installation, including receiver, control box, loop, azimuth control. Left-right indicator, plugs, loop transmission line, box shafts and schematics. Receiver & Loop Brand New, with tubes. (Accessories may be used)... **\$69.50**
(Shipping wt. 75 lbs.)

MINIATURE 6 V. WET BATTERIES

The famous NT-6 Willard 2.1 AH, 6 volt battery. A standard for model control, etc. Plastic case, only 3 5/8" long, 1 1/3 1/8" wide, 2 5/8" high. Uses standard electrolyte. New. Boxed. EA. **\$1.29** 4 for... **\$4.95**
CHARGED... **\$2.45**

FILTER-CAPACITOR STEALS!

- 1.) Dual 6 MFD, 600 VDC, oil-filled, hermetically sealed. Gives you 2 ladder sections, or parallel for 12 MFD. Only **\$1.29**, two for **\$2.49**.
 - 2.) 1 mfd, 600 VDC, oil, hermetically sealed... **19c**
- 10 for \$1.49

\$45.00 HI-FI HEADSET AT \$7.95

Uses annular grooved plastic fibre cones with voice coils as in speakers, and padded chamois ear muffs to obtain spacing for correct acoustical load. Gives finest music reproduction, 600 ohms. Checked out with freshly soldered ear pads and long flexible fabric cord with phone tips. (Shpg. wt. 3 lbs.) **\$7.95**

MODEL 27-Z TESTER

(Made in Japan)

\$10.95

(Plus 25c shipping)

RANGES: AC and DC volts 0-25/250/500, DC MA 0-1/10/100/250, Ohms 0-10K, 100K. Black bakelite panel, metal case. Manufacturer claims extreme accuracy and our spot checks show them to be within 1%! Here is a meter to be proud of!

METERS, 2" rd.; 0-1 ma **\$3.95**, .500-0-500pa **\$3.95**

12-CHANNEL TV FRONT END FOR \$1.19
Famous "Silver Circle" tuner, with original factory instructions. Use for 2-meter converters, receivers, etc. The TV bargain of the year! Factory rejected for minor damage. Less tubes... **\$1.19** each, 3 for **\$2.95** (Shipping wt. each 3 lbs.) Tubes, shields and knobs for above... **\$1.25** set, 3 for **\$3.00**

G. L. ELECTRONICS, INC.

905 S. Vermont Ave., Los Angeles 6, Calif.
Minimum Order \$50 Total. 25% Deposit Required
All Prices F.O.B. Los Angeles, Calif. Buyers Add Sales Tax
GET ON OUR MAILING LIST
"OPEN MONDAY NITES 'TIL NINE"

which have a recording capacity ranging up to 4 hours on each band face or 8 hours of recording on a single tape.

A variety of accessories is available for this recorder. The company will supply a complete data sheet upon request.

HALLICRAFTERS PHONOGRAPHS

The *Hallcrafters Company*, 4401 West Fifth Ave., Chicago 24, Ill. has entered the phonograph field with a low-priced model that covers the frequency range from 30 to 16,000 cps.

The set is designed in contemporary style in either blonde or mahogany



finishes. The speaker grille, which runs the entire front of the unit, is modern gold trim while the detachable iron legs may be removed and the mobile cart (as shown) substituted.

The three-speed record changer features a variable reluctance magnetic pickup with two sapphire needles. Controls include separate bass and treble. A special loudness control is used in place of the usual volume control to provide proper amplifier output compensation. A five-position recording studio compensator adjusts to the record being played.

An 8-watt amplifier and two wide-range speakers are used in the custom acoustic enclosure. Provision is made for connecting extension speakers if desired.

TABLE PHONOGRAPH

Arthur Ansley Manufacturing Company, Doylestown, Pa. is now offering the Model HF-7, a three-speed phonograph.

The heavy mahogany cabinet closes to form a specially designed baffle for the coaxial speakers, a 10" woofer and small tweeter. A wide-range a.c. amplifier with power transformer gives 5 watts output and covers the entire audible tone range.

Tapered round legs that screw into special sockets under the cabinet are furnished with each instrument to enable it to be used as a console table if desired. The HF-7 is available in three finishes.

BOOKCASE CABINET

G & H Wood Products Company, 75 N. 11th Street, Brooklyn 11, New York has added a modern bookcase cabinet to its "Cabinart" line of enclosures.

Read
the news
on
page 21

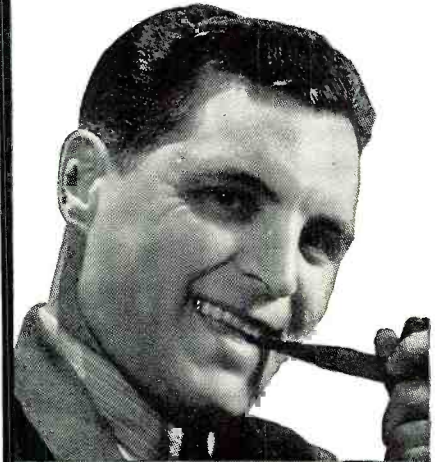

Centralab

announces

new

ceramic high-voltage disc capacitors

Turn to the

Centralab

announcement

now

Federated

OFFERS

precise

KIT AND WIRED
INSTRUMENTS

NOW
IN
STOCK

EXCLUSIVE...

precise

MODEL #308

8 1/2" SCOPE

KIT \$129.50

#308W \$229.50

No other oscilloscope, at any price, can meet all the specifications of this electronic masterpiece

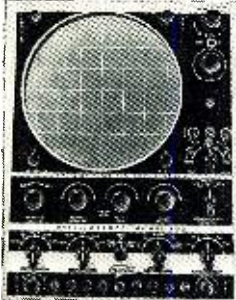

- VERTICAL FREQ. RESPONSE—Flat $\pm 1\frac{1}{2}$ db DC thru 5 MC.
- SENSITIVITY—Greater than 10 millivolts push-pull (3.9 Millivolts/CM)
- BLANKING—60 cycle or 120 cycle Blanking through Blanking amplifier circuit.
- SWEEP RATE—Linear sweeps from 1 cycle to 80 KC in 5 ranges. (1-10 uses Ext. C.) DRIVEN and RECURRENT sweeps.
- MAGNIFIER—Expands and magnifies signal up to 10 times.
- PUSH-PULL—Output in both amplifiers.
- CRT—The latest type 8 1/2" NEW tube a PRECISE EXCLUSIVE.
- VOLTAGE REGULATED.
- ANODE INTENSIFIER—a PRECISE FIRST INTERNAL CALIBRATOR

NEW 7" OSCILLOSCOPE

MODEL #300K \$94.95
MODEL #300W \$199.50

LOWEST PRICED IN ITS FIELD
NEW MODEL #909
VACUUM TUBE VOLTMETER

FACTORY WIRED \$375.00

Model 909 Vacuum Tube Voltmeter. 1% Ceramic precision Resistors; Coax DC connector; FM zero alignment scale; burn-out proof circuit; DC input 25 Meg. Rugged oversize 4 1/2" meter.
MODEL #909 KIT \$25.98



IN STOCK AT ANY OF OUR OUTLETS

Federated Purchaser

66 Day Street New York 7, N. Y. Dlgby 9-3050

- Newark, N. J., 114 Hudson St.
- Allentown, Pa., 1115 Hamilton St.
- Easton, Pa., 925 Northampton St.
- Los Angeles 15, Cal., 911 So. Grand Ave.

The Model 90 is designed to house a complete music system (record changer, tuner, amplifier, and speaker) plus a music library. Over-all dimensions are 35 1/2" high, 48" wide, and 16" deep. The tuner compartment is 11" high, 29" wide, and 15" deep. The baffle area is 5 cubic feet. The changer mounts on ball-bearing slides—in a pull-out drawer. The cabinet is also available with additional shelves instead of the speaker baffle if desired.

The cabinet is finished in mahogany on birch or natural birch or may be obtained in unfinished birch.

BROOKS AM-FM TUNER

Brooks Laboratories, Inc., 751 Main Street, Waltham, Mass. has added a new AM-FM tuner to its line of audio equipment.

Known as the Model ST-15A, the new unit incorporates automatic frequency and tone controls. The FM section employs the company's new temperature-compensated oscillator circuit which is said to eliminate drift problems. Both the AM and FM sections employ inductive tuning.

Measuring only 8" x 15" x 6 3/4", the tuner employs five controls: bass, treble, volume, selector switch, and tuning. A data sheet giving all specifications on the Model ST-15A is available on request.

MARTIN AMPLIFIER

H. S. Martin & Company, 1916 Greenleaf Street, Evanston, Ill. is in production on a basic amplifier, the Model 352-A.

The new amplifier provides less than .5 per-cent harmonic distortion at any frequency, at any power level up to 25 watts and less than .5 per-cent inter-

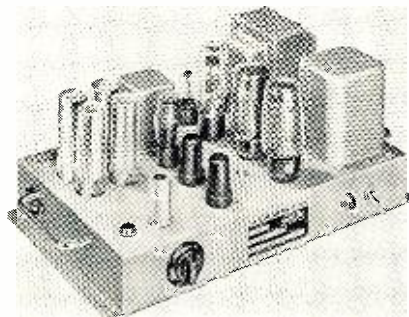

modulation distortion, any combination of frequencies, at any power level up to 22 watts. Hum and noise are reduced to more than 90 db below full output.

A companion control amplifier, the Model 352-CA is also available.

A data sheet on these new instruments is available from the company on request.

NEWCOMB AM-FM TUNER

Newcomb Audio Products Co., 6824 Lexington Ave., Hollywood 38, California is currently offering a self-powered, dual-knob AM-FM tuner which has been especially designed for use with amplifiers having their own controls.

Designated as the "Classic 200," the

COMMUNICATIONS RECEIVERS



Contains All Components

FEATURES:

- 2 Watt P. P. Audio
- Amplified AVC
- Voltage Regulated Oscillator Supply
- Noise Limiter
- Beat Oscillator
- Air Tuned R.F. Trimmers
- 2 Stage Permeability Tuned 455 KC I.F. Plus Crystal Filter
- Phone Jack — Built-in Stand-by Relay
- Operates on 105 to 125 Volts AC or DC Power Source
- Frequency Range 200 KC to 400 KC and 490 KC to 19 MC in Six Bands
- 40:1 Gearing Ratio Dial Drive
- 11 Tubes Plus Selenium Rectifier
- 6SG7 RF Amp.
- 6SB7Y Mixer
- 2-6SG7 I.F.
- 6HG 2nd Det & N. L.
- 6SF7 AVC Amp.
- 6SL7 BFO & 1st Audio
- 6SL7 Phase Inverter
- P. P. 25LGGT Audio
- VR-75 voltage Regulator
- Full Vision Calibrated Dial
- Cabinet 19 1/2" long x 10 1/2" high x 12 1/2" deep
- Finished in fine grain black wrinkle
- Front panel silk screened to identify each control

FRONT PANEL CONTROLS

- Tuning
- R.F. Gain
- Audio Gain
- BFO-AVC Switch
- BFO Pitch On-Off
- Stand-by
- Noise Limiter On-Off and Control
- Antenna Trimmer
- Crystal Filter On-Off
- Crystal Phasing
- Selectivity
- Band Change Switch
- Calibrated Dial Face

COMPLETE KIT—This kit is complete with every part necessary to assemble into a finished receiver, including tubes and cabinet. Chassis is punched and marked. Mount the parts, wire it, align it and you have a fine receiver of commercial appearance, that can't be beat for 3 or 4 times the price. Parts layout, schematic diagram and alignment instructions are supplied.

Shpg. weight 45 lbs. Shipped express only. F.O.B. Chicago and subject to change without notice.

SPECIAL Complete Kit \$59.50 KIT PRICE EACH

HEAD PHONES

Signal Corps HS-18 replacement units, consisting of 2 type R-14 series connected units with PL-54 plug. 8000 ohm impedance. Per set. \$1.00

304TL'S

Eimac, Jan, 304TL's. Individually boxed. Each. \$7.50

HAND MICROPHONE

Replacement for T-17 mike. English make, single button, removable element, press to talk switch, 3 wire unshielded \$1.95 cable. Price each. \$1.95

BOULEVARD ELECTRONICS, INC.

Mail Order Address:
1229 W. Washington Blvd., Chicago, Ill.
Store Address: 4054 W. Belmont Ave., Chicago, Ill.
RADIO AND TELEVISION SUPPLIES

ENJOY 3 COLOR TELEVISION FILTER SCREEN NOW

Changes dull eye-straining black and white pictures into beautiful color tones. Seconds to attach. No tools used. Helps eliminate glare. Order direct. Send \$1 for screen size up to 16", \$1.25 size 17", \$1.50 size 20", \$2 size 21", \$2.50 size 24", \$3 size 27". (Also available are single solid color screens in blue, green, or amber.) Prices on solid color screens are 10% less. We pay postage except on C.O.D. orders. Satisfaction guaranteed. Inquiries from dealers also welcomed.

Zingo Products, Johnstown 19, New York

COURSES OFFERED

- Radio Technician
- Electronic Tech. (Radar)
- Radio Comm. (F.C.C. Lic. Prep)
- F.M. & T.V. Tech.
- Electrical Insp.

Write for Free Booklet

LINCOLN SCHOOL

of Radio & Television, Inc.

1851 B'way, N. Y. C. • CI 6-5300



Bargain in Broadcast Quality TAPE RECORDER MECHANISM

38.75

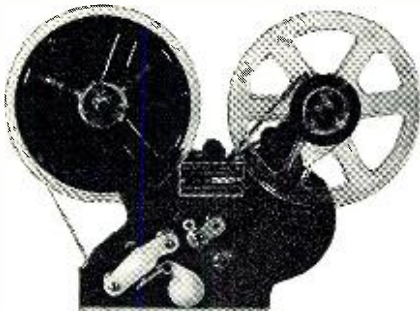

Model 90 "Ultra-Audio" tape transport mechanism complete with high quality record-erase-playback dual track head, 110 volt, 60 cycle induction motor, rewind, accessories and hi-quality plastic base recording tape.

USE WITH ANY HI-GAIN AMPLIFIER

The "Ultra-Audio" tape transport mechanism comes complete with convenient terminals and full instructions which permit its application to your present amplifier, phono-radio, or other audio unit, for the making, reproduction and erase of tapes, just as any standard tape recorder. This machine is ideal for the hi-fi enthusiast, the experimenter, the radio ham, or commercial user. It is identical to that provided for our commercial outlets. Little experience is required to follow simple instructions and comprehensive circuit diagrams to connect to almost any radio or audio unit for full life-like performance.

Records—Reproduces—Erases, At Two Speeds

Simple change over parts furnished permit operation at either 7 1/2 or 3 3/4 inches per second speeds. A number of circuit diagrams with clear instructions are provided to enable even the novice to construct special amplifiers, etc., at minimum cost to obtain results comparable to that of recorders selling for many hundreds of dollars. Machine will operate with any amplifier capable of being excited by crystal mike or magnetic phono, and with most radios. Unit comes complete, ready to connect and use. Provided with convenient mounting lugs. The fine professional appearance of this unit will make any user proud to display his "Ultra-Audio" Model 90. **MONEY BACK GUARANTEE.**

The Model 90 tape transport mechanism was initially developed by the engineers of the Ultra-Audio Broadcasting System for our own use to provide an extremely rugged and simple unit with sufficient mechanical stability to meet commercial and broadcast requirements. It was felt that such design could be achieved by following a careful program of simplicity and removing many of the "frills" at a cost much lower than we were compelled to pay for so-called "professional" units and eliminate a great deal of the constant servicing, repair, and adjustment expense of such units as were available to us.

Available at no cost to the purchasers and users of Ultra-Audio Broadcasting System equipment are the full facilities and services of our engineering staff.

FIRST COME—FIRST SERVED

ORDER FROM
EQUIPMENT-SERVICE DIVISION

Ultra-Audio Broadcasting System
BOX 243, SAN DIEGO (12), CALIFORNIA

(Shipped pre-paid on cash with order—otherwise charges collect. 1/2 cash with order on all C.O.D.'s.) All orders subject to possible two weeks' delay.

STOP VOLUME CONTROL NOISE!



New 6 oz.
Spray Can

Net to Servicemen **\$2.25**

CONTAINS AMAZING NEW PERMA-FILM

- ★ CLEANS! . . . dirt and oxidation immediately on contact.
- ★ LUBRICATES! . . . one drop eliminates scratch, hum and noise.
- ★ PROTECTS! . . . assures continued top performance.



Perfect Contact Restorer—cleans & restores volume controls, band switches, push button assemblies, electrical contacts. **NO NOISE** is not a carbon tet solution.

2 oz. bottle, Net to Servicemen **\$1.00**

Available in 8 oz. bottles and quart cans. Nearest distributor—or write

ELECTRONIC CHEMICAL CORP.
813 Communipaw Ave., Jersey City 4, N. J.

B-A SAVE 70%

ON THESE FAMOUS
WESTON-SANGAMO
HIGH-QUALITY 2-INCH
PANEL METERS!

REGULAR NET PRICE AT LEAST \$7.50!
\$2.48

B-A buyers, always alert for bigger and better dollar-saving buys for you, do it again with this astonishing deal. So out they go at a fraction of their regular cost. Quantities limited — Order Now.

D'Arsonval moving coil type, English precision made. Neat 2 1/4" square black bakelite case mounts in 2 1/16" round hole. All have plainly calibrated scales and insulated zero set.

- No. 18B368. Range 0-5 Milliamperes DC.
 - No. 18B395. Range 0-100 MA DC, with scale calibrated 0-300.
 - No. 18B396. Range 0-5 Amps. RF, with internal thermo-couple.
- CHOICE **\$2.48** Lots of 5* **\$2.25**
EACH EACH
- *Can be assorted.

BURSTEIN-APPLEBEE CO.

1012-14 McGee St., Kansas City 6, Mo.

Send Free B-A Catalog No. 541

Send me..... Meters, \$..... enclosed.

Name.....

Address.....

City.....State.....

include postage for parcel post shipments.

The changer operates at all three speeds and will play 7", 10", and 12" records. The unit stops automatically after the last record is played and a red "tell-tale" light mounted behind the speaker grille shows when the amplifier is on.

The phonograph measures 15 3/4" x 9 1/4" x 19 1/4" and is housed in a luggage-style portable case.

PORTABLE PHONOGRAPH

The Audio-Master Corp., 17 E. 45th Street, New York, N. Y. is currently marketing a compact 3-speed phonograph which has been designated as the Model #36.

The outside grille for the speaker is backed with an acoustic baffle for extra tonal qualities. In addition, the unit includes a high-gain amplifier with variable tone and volume control, a twist crystal pickup arm with two permanent needles, a 5" speaker, and a three-speed motor.

The Model #36 is housed in a decorative carrying case of lock-corner construction. It is covered with washable leatherette and comes in a variety of colors.

RECORDER-PHONO COMBO

Magnetic Recording Industries, 30 Broad Street, New York 4, N. Y. has developed a magnetic disc recorder-phonograph combination which has been designed especially to meet the specialized requirements of educators.

Known as the "Magneticon," the new unit is a three-speed portable phonograph which instantly converts into a complete magnetic recorder-playback

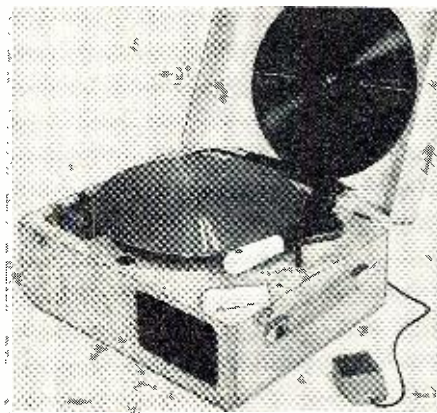

unit whenever the student or teacher desires to make a magnetic recording on a magnetic disc. A special magnetic needle is plugged in in place of the regular phono needle.

The resultant recordings can be played an indefinite number of times or can be erased and reused. Where phonographs are already in use, a variation of the basic "Magneticon," is available to permit such phonographs to make and play the magnetic records.

Several models are currently available and details on any or all of the units are available from the company on request. Ask for a copy of the "Magneticon" folder and the descriptive data sheet, both available from the company direct.

Hi-Fi Music belongs in every home...



MUSIC shows you how to have it!

You will be amazed and delighted at the wealth of handsomely illustrated, easy-to-understand articles in the four unique departments on music from records, tape, FM radio, and the latest hi-fi equipment. Among 16 exclusive feature articles are **MUSIC**: Your Record Shopping Guide lists all LP's issued in the last two months, classified under 15 headings for easy reference. Plan Your Record Concerts shows how to select records for 9 different home concerts. **EQUIPMENT**: First disclosure of a New Type of Speaker, and discussion of Hi-Fi Quality, and Hi-Fi Costs. **INSTALLATION**: How to Plan Your Own Hi-Fi System starts a series for beginners. Other articles include Origin of the Air-Coupler, and What You Should Know About FM. **OPERATION**: Correcting Hi-Fi Troubles tells why and how. Directory of FM Stations shows where and when to tune for FM programs.

Your first copy FREE!

Just as you must hear hi-fi music to discover the pleasure it can give you, your family, and your guests, so you must see MUSIC at HOME Magazine to find out all the things you've never thought of concerning the use of music in your home.

Accordingly, if you will send in your subscription order, using the coupon at the right, I will

send you the current issue with my compliments, and start your paid subscription with the next issue following. When you get your FREE issue, if you are not completely satisfied, let me know promptly, and the ENTIRE amount of your remittance will be refunded.

Milton B. Sleeper

MUSIC at HOME is a large-size magazine, handsomely designed, elaborately illustrated with photographs and drawings, and beautifully printed on fine paper. You'll enjoy it from cover to cover, and you'll be proud to show it to your friends. Mail your order today, so you can be sure of getting it from the very first issue.

MILTON B. SLEEPER, Publisher
207A East 37th Street, New York 16, N. Y.

Please send me the first issue of MUSIC at HOME without charge, and enter my subscription to start with the second issue. My remittance is enclosed for

\$6 for 3 years (18 issues) \$3 for 1 year (6 issues)

If I am not completely satisfied with the first copy, I will notify you within 30 days, and you will return my remittance in full.

Name.....

Address.....

City & Zone.....State.....

You can build a reputation on Tung-Sol[®] Quality

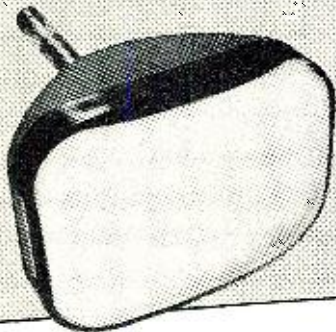

TUNG-SOL makes
All-Glass Sealed Beam Lamps,
Miniature Lamps,
Signal Flashers,
Picture Tubes, Radio, TV,
Special Purpose Electron Tubes,
Semiconductor Products.



TUNG-SOL ELECTRIC INC.
Newark 4, New Jersey

Sales Offices: Atlanta, Chicago, Columbus, Culver City (Los Angeles), Dallas, Denver, Detroit, Newark, Seattle

Basic Color TV (Continued from page 61)

to exist, it would extend all the way up to $3.58 + 1.5$ or 5.08 mc. Obviously this would prevent the use of a 6 mc. overall band for the television signal (video and sound). To avoid this spilling over beyond the limits of the already established channels, the upper sideband of the *I* signal is limited to about .6 of a megacycle. This brings the upper sideband of the *I* signal to 4.2 mc. The video passband then ends rather sharply at 4.5 mc. See Fig. 5.

There is one further fact that is of importance in the make-up of a color television signal and this concerns the color subcarrier. We know that the 3.58 mc. carrier is modulated by the two *I* and *Q* color signals. Now, in conventional modulation methods, both the carrier and the sidebands are present when the signal is finally sent out over the air. The intelligence (or modulation) is contained in the sidebands and that is actually all that we are interested in. However, the carrier is sent along because it is required in the receiver to reverse the modulation process and recreate the original modulating voltages.

In the NTSC color system, the color subcarrier is not sent along with its sidebands (after the latter have been formed). Instead, it is suppressed by using a balanced modulator. This particular practice is followed for two reasons. First, by suppressing the color subcarrier, we reduce the formation of a 920 kc. beat note between it and the 4.5 mc. sound carrier which is also part of every television broadcast. This 920 kc. note would appear as a series of interference lines on the face of the picture tube. Now, it is true that the color sidebands are present and that they can (and do) beat with the 4.5 mc. sound carrier to produce similar low frequency beat notes. However, in any signal, the carrier usually contains far more energy than any of its sidebands and so, when we suppress the carrier, we are, in effect, suppressing the chief source of this interference. Whatever other interference may be produced by some of the stronger sidebands near 3.58 mc. can be more easily dealt with using traps in the i.f. system. This will be seen when we examine the circuitry of a receiver.

The second reason for using this suppressed carrier method is that it leads to an automatic removal of the entire color signal when the scene that is televised is to be sent wholly as a black-and-white signal. For when this occurs, *I* and *Q* drop down to zero and since the balanced modulators suppress the carrier, no color signal at all is developed. After all, why have a useless color carrier when no color information is to be sent?

With these advantages of carrier suppression comes one disadvantage. When the color sidebands reach the

color section of the receiver, a carrier must be reinserted in order to permit detection to take place. Off hand, one might suppose that all we needed to do this is to employ an oscillator operating at 3.58 mc. This is one requirement. A second and vitally important consideration is the phase of this reinserted carrier. Remember that back at the transmitter, attention was given to the phase of *I* and *Q* as they were introduced into the modulator. If the same relative phase were not maintained in the reinserted carrier, the colors obtained at the output of the color circuits would not possess the proper hue.

To provide information concerning the frequency and phase of the missing color subcarrier, a color burst is sent along with the signal. This burst follows each horizontal pulse and is located on the back porch of each blanking pedestal. See Fig. 6. It contains a minimum of 8 cycles of the subcarrier and it is phased in step with the color subcarrier used at the station. In the receiver, this burst is used to lock in the frequency and phase of a 3.58 mc. oscillator, and thus, we are assured at all times that the reinserted carrier will correctly do its job when it recombines with the color sidebands.

The position of the color burst on the back porch of each horizontal sync pulse insures that it will not be seen on the screen of either color or monochrome television receivers since the screen is ordinarily blacked out during this retrace interval. If the burst were to be placed at a lower level, it would produce undesirable spurious picture tube light, especially on those sets which did not contain special horizontal blanking signals.

The burst does not appear during the vertical serrated pulses or after the equalizing pulses. It was found that the 3.58 mc. oscillator in the receiver remains in synchronism during this brief interval when no burst signal is being received. Upon the reappearance of the horizontal sync pulses and the accompanying color burst at the end of the vertical pulse interval, control of the 3.58 mc. receiver oscillator is smoothly resumed.

Following is the proof, mentioned earlier in the article, that we need only *R-Y* and *B-Y* to give us *R-Y*, *B-Y*, and *G-Y*.

Y, the monochrome signal, consists of 59 per-cent green, 30 per-cent red, and 11 per-cent blue. Or, mathematically:

$$Y = .59G + .30R + .11B$$

With this in mind, an *R-Y* signal is:

$$R - Y = R - (.59G + .30R + .11B)$$

or:

$$R - Y = .70R - .59G - .11B$$

By the same method, a *B-Y* signal is:

$$B - Y = B - (.59G + .30R + .11B)$$

or:

$$B - Y = .89B - .59G - .30R$$

Also, a *G-Y* signal is:

$$G - Y = G - (.59G + .30R + .11B)$$

or:

$$G - Y = .41G - .30R - .11B$$

Now, if we take .51 (R-Y), add it to .19 (B-Y), and then invert the resultant signal, we will obtain G-Y. This will prove that with R-Y and B-Y we can get G-Y.

Thus,

$$.51 (R-Y) = .51 (.70R - .59G - .11B) \\ = .36R - .30G - .056B$$

And,

$$.19 (B-Y) = .19 (.89B - .30R - .59G) \\ = .17B - .057R - .11G$$

Adding the two equations together gives us:

$$.36R - .30G - .056B + .17B - .057R - .11G \\ \text{or, combining like terms:}$$

$$.30R - .41G + .11B.$$

This is equal to -(G-Y) as shown above. Hence if we invert the equation, we obtain:

$$.41G - .30R - .11B$$

which is G-Y.

(To be continued)

TV Test Equipment

(Continued from page 62)

ceiver. When the marker generator provides high-frequency modulating facilities, the output from a square-wave generator can be used to modulate the output from the marker generator, to obtain a test of the over-all response of the receiver signal circuits over a wide range of video frequencies.

External high-frequency modulators can be easily devised from germanium crystal diodes and resistors, when required. However, the detailed discussion of such devices is beyond the scope of this article and cannot be covered here.

-30-

U.H.F. Installations

(Continued from page 42)

include the guying of the mast to avoid swaying and the resultant "picture breathing," as well as patching up each hole in the masonry or woodwork with weatherproofing material. The connection of the antenna to the transmission line should be weatherproofed as well as possible, with soldered connections wherever feasible. All tape used should be either polyethylene or vinyl and never should regular friction tape be employed.

If the reader concludes after this article that a u.h.f. fringe installation is a complicated and time-consuming job, he is quite right. Competent service technicians know that such an installation requires a lot of time and equipment and therefore plan accordingly. As far as the customer is concerned, he should understand that because he lives in a u.h.f. fringe area the installation will cost him considerably more than it would in a strong signal location. Usually the entertainment value of TV in such remote areas is so great that set owners are quite willing to pay well in order to obtain television reception.

-30-

Oliver Read* licenses *Angle Genesee* to build FOLD-A-FLEX Speaker Enclosures

Fold-a-Flex principle permits compensation for any speaker characteristic. Optimum setting, possible with any combination of speakers, affords maximum listening pleasure.

In the same general style as other fine Angle Genesee high fidelity equipment cabinets, the new Fold-a-Flex enclosure incorporates the usual quality Angle Genesee construction features. Functions as a corner speaker, or can be placed flush against a side wall.

The Fold-a-Flex may be used as a folded horn, infinite baffle or bass reflex enclosure, and changed from one type enclosure to another almost instantaneously and as often as desired. Settings are possible for every speaker system, room and type of sound. Traditional mahogany or contemporary blonde oak. Other Angle Genesee finishes at modest additional cost. For more information about this and other Angle Genesee cabinets, also name of dealer near you, write **Angle Genesee Corporation, 110 Norris Drive, Rochester 10, New York.**

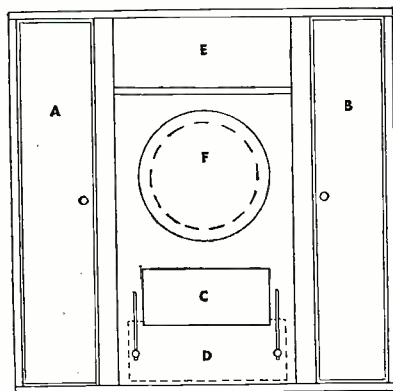

FIGURE 1
(NOT TO SCALE)

Folded Horn. Two hinged doors or ports, A and B, are completely sealed by gaskets against passage of air, in either of two open positions (see figure 2). Pushed inward,

*Author of the basic text, "Recording & Reproduction of Sound".

Patents Pending



ports A and B become extensions of inner horn structure, forming the mouths of the folded horn.

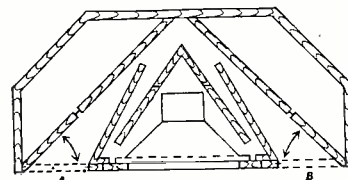

FIGURE 2
(NOT TO SCALE)

Infinite Baffle. Closing ports A, B and C makes the enclosure an air tight infinite baffle, trapping approximately 10 cubic feet of air which is sufficient to properly damp 12" or 15" speakers.

Bass Reflex. Position of slide D (figure 1) is easily adjusted by loosening two knobs. Instructions for accurate setting are furnished with each cabinet.

Compartment E is isolated mechanically and acoustically from cabinet partitions, and is provided with a separate front panel to accommodate mid-range horns and tweeters either at time of initial installation or later as system is expanded. Space is also allowed for mounting crossover networks. Cut out F on main baffle is for mounting a 15" speaker... removable sub baffle is provided for mounting 12" speaker.

— Advertisement —

BASIC MULTIMETER KIT

- 3 COLOR METER SCALE
- 2 COLOR SWITCH PLATE
- COMPLETE BUILDERS AND USERS MANUAL

Instrument has 15 Ranges of Volts, Mills and Output A.C. and D.C.

When Ordering Specify if Meter to Be Used
1s 3 or 4 1/2 Inch

\$1 POSTPAID
No C.O.D. or Stamps

makit Products
ROBERT HILLIARD CO.
Inglewood, California

Box 549

MORE JOBS than graduates

Electronic Engineers

Excellent opportunity for professional growth and advancement in interesting and busy field.

Demand for our engineering graduates exceeds supply. Effective placement. Study in this world-famed college established 1884. Quarters start June, Sept., Jan., March. Approved for Korean Vets.

Bach. Sci. degree in 27 months

Complete Radio Eng. courses... TV, UHF and FM. Also Mech., Civil, Elec., Chem., Aero. and Adm. Eng.; Bus. Adm., Acct. Small classes. Well-equipped labs. Modest costs. Prep. courses. Write **Jean McCarthy, Director of Admissions** for Catalog and Campus View Book.



TRI-STATE COLLEGE

1644 College Avenue, Angola, Indiana

NEW PROBES!

FOR VTVM'S & SCOPES

- FULLY SHIELDED
- SHOCK-MOUNTED TERMINAL BOARD
- SWIVEL ACTION
- ALL PARTS ACCESSIBLE
- COLOR CODED

Only EICO Probes Have All These Features!

SCOPE DEMODULATOR PROBE
MODEL PSD

KIT \$3.75

WIRED \$5.75

LOW CAPACITY PROBE MODEL PLC

KIT \$3.75

WIRED \$5.75

DIRECT PROBE MODEL PD

KIT \$2.75

WIRED \$3.95

VTVM RF PROBES MODEL PRF-11 OR 25
For any 11 or 25 megohm VTVM

KIT \$3.75

WIRED \$4.95

PEAK-TO-PEAK PROBES
MODEL PTP-11 OR 25
For any 11 or 25 megohm VTVM

KIT \$4.95

WIRED \$6.95

SENSATIONAL HIGH VOLTAGE PROBE
MODEL HVP-2

ONLY . . . \$4.95
FOR VTVM'S & VOM'S

See these amazing probe values at your jobber today. Write now for free catalog PR-4. Turn to our full-page ad on page 34 this magazine.

EICO® "All above probes Pat. App. for."
ELECTRONIC INSTRUMENT CO., Inc.
84 WITHERS STREET, BROOKLYN, NEW YORK

Horns for P.A.

(Continued from page 45)

some of the real low-frequency reproduction for the objective of combined maximum wide-angle coverage with maximum portability, then a wide-angle device such as embodied in the specialized design of this horn, may be prescribed.

Wide-angle distribution of a sound field is of great importance in mobile systems because of the coverage expected of it in an outdoor application. What does this signify? It tells us that the areas we want to cover are generally fairly close to the ground and that the sound field must be projected down to this ground zone rather than be lost in the wide open spaces above. For example, as a sound truck moves down a line of parade, or progresses along with a political caravan, or is used to cover track and field events for the local school competition, the cobra-type horn will lay down a uniform sound field over a comparatively flat horizontal sector. We may say that the sound is "pan-caked" down where it is needed most. It will of course be realized that in all these applications, our audience is all down on one comparatively flat plane, the people on the sidewalk watching the parade, the people on the street corners listening to the political gladiators, the spectators circling the athletic field; all these people, spread out over a wide horizontal area, will get the maximum sound coverage. This principle of distribution of the sound energy into those areas which specifically need that distribution is illustrated in Fig. 5A.

Now does this mean that the standard round horn is obsolete for these applications? On the contrary, we may point to the same general applications where the round horn may be preferred. Let us get back to our political caravan once more. If the soundman wants to cover not only the street zone, but wishes to send the political message into the open windows of the upper stories of our modern city apartment houses as well as cover the sidewalk zone, then the round horn would be called for, since this horn has symmetrical horizontal and vertical sound field projection. However, although the sound field from this horn will cover both street zone and elevated areas at the same time, the usable duration of the message carried by this sort of projection will be comparatively short as the sound truck moves along because of the more tightly beamed effect of the round horn. See Fig. 5B. So we see that we may choose between generally uniform coverage for shorter periods of time through the use of the standard round horn, or wide angle coverage in one desired plane for longer periods of time through the use of the "Cobreflex."

Because of the beaming effect of the round horn, we will find that it has

particular advantages over the wide-angle horn in *long range penetration* and for "localized" spotting operations. It is a characteristic of sound propagation over long outdoor distances that the frequencies above 4 to 5 kc. are greatly attenuated by atmospheric fog and mist; are masked by ambient noise of rustling trees, foliage, and shrubbery; are absorbed by grassy and soft terrains and are deflected by wind movements and temperature striations within the atmospheric shell. (It is thus not for purposes of monotony but for reasons of carrying power under adverse conditions that fog horns sound as "low" and "ominous" as they do.)

Thus in applications of long-distance projection we try not to spread out our available energy in such a manner that it will have to fight its way along under adverse conditions, but rather beam it ahead for maximum usability. If we thus consider that the intelligibility of a message over *long* distances is mostly contained in the *middle* frequencies, and that the higher frequencies are buffeted about over large distances by the wind streams which practically destroy any wide-angle dispersion originally built into the sound wave, we might just as well, then, put all our (acoustic) energy into "spot-lighting" techniques and so maximize the probability that the sound will go where we want it to by the judicious use of *round* horns.

There are also outdoor applications of medium range sound projection where the higher frequencies may be absorbed in one area. This may occur in sound coverage over a variable terrain of an outdoor amphitheater, or in parks, where in one section there may be heavy outcroppings of "soft" foliage and other brush, in contrast to an over-all smoothness of terrain. It would be desirable, then, to aid any wide-angle device with a directly beamed sound into this "soft" absorbent area. This would, of course, be accomplished by means of the round horn.

In view of the fact that the mobile use of the horn means that it will be called upon to perform many different functions, as the individual job may specify, provision must be made for the energizing of the horn by whatever driver units seem best fitted for the job. It is another aspect of the successful meeting of job specification through greater specialization of components.

A horn of this type should not be rigidly tied down to one type of integral driver unit, but should be able to form a *system* with several combinations of drivers. Therefore such a horn must have a universal coupling at its throat for any standard screw-on driver unit, the unit chosen at the discretion of the user as he analyzes the job requirements. He is not rigidly bound to a single driver by the horn construction, but has a freedom of choice in what will be best in any given application.



IT CAN'T BE DONE!

Yet many have attempted to try it.

The round hole needs a round peg—custom-fit to meet the need. In the choice of a speaker, just as in the choice of the peg, the point of application should be the governing factor.

So why waste loudspeaker capacity and amplifier power using the wrong speaker for the job? University makes available over 50 different models of speakers, each designed to meet a particular requirement most efficiently. University loudspeakers are *application engineered* to provide optimum performance with maximum economy—technically and cost-wise.

Whether the need is for music or voice, or both—for either indoor or outdoor use; whether in a fixed position in a factory or for mobile use on a vehicle, boat, train or airplane... there's a University speaker that can do the job best. *Don't spend more for more than you need... CHECK UNIVERSITY FIRST!*

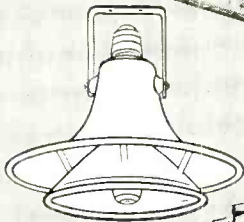

Radial type projectors and paging speakers with 360° dispersion for maximum coverage at lowest cost and ease of installation.

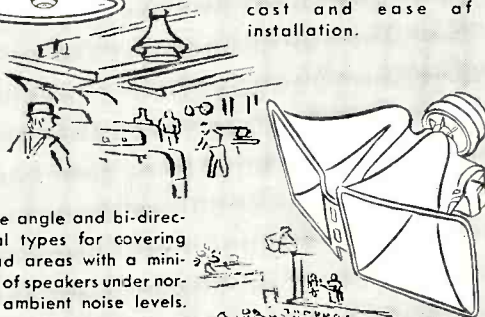

Wide angle and bi-directional types for covering broad areas with a minimum of speakers under normal ambient noise levels.



Reflex trumpets in various sizes for incomparable efficiency, distance and noise penetration.



FREE—new 1953 copy of the University Technilog • Complete up-to-date manual of sound theory, application and installation requirements • SEND for your copy today.



UNIVERSITY LOUDSPEAKERS • INC.
80 SOUTH KENSICO AVENUE WHITE PLAINS, N. Y.

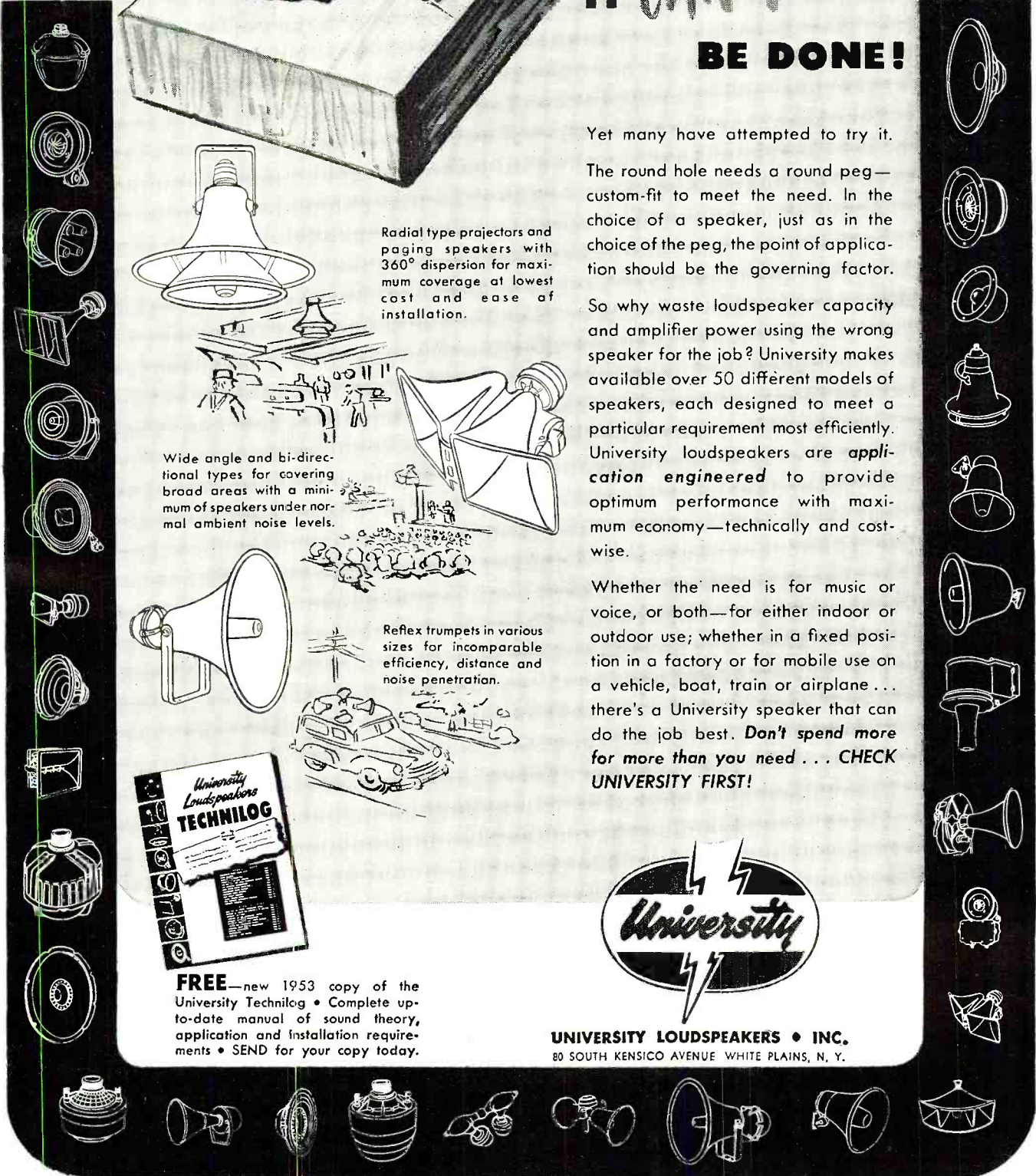



makes this greatest of TV offers—backed by

MONEY-BACK GUARANTEE:

\$88 TV SERVICE INSTRUMENT VALUE FOR— **\$39⁹⁵**

NEW TV Component Tester performs functions you've always wanted. Look what you get:— FLYBACK and YOKE TESTER, value \$39.00 SELENIUM RECTIFIER TESTER, val. 29.00 CRT TESTER and REACTIVATOR, val. 20.00

Total Instrumentation, value..... 88.00 ALL 4 in 1 great instrument, net..... 39.95



NEVER BEFORE SUCH GREAT VALUE. For only \$39.95 you get 4 testing-and-repair instruments all in one! Compact, weighs only 3 lbs. Does things never been done before! Pays for itself quickly. Prove it yourself—

TRY IT for 10 DAYS on Money-Back Guarantee:

10-DAY TRIAL: Try this Transmission TV COMPONENT TESTER for 10 days. Then, if you are not 100% satisfied, you may return it. Your purchase price, less 10% (our cost of handling and re-packing) will be promptly refunded.

TRANSMISSION, INC. • NEW ROCHELLE, N. Y.

RUSH THIS COUPON NOW

TRANSMISSION, INC.

NEW ROCHELLE, N. Y.

- DEPT. RN-44
- Send _____ TV COMPONENT TESTERS @ \$39.95.
 - Enclosed find \$_____ deposit. Balance C.O.D.
 - Enclosed find \$_____ in full.

I accept your 10 Day Trial terms.

Name _____
 Address _____
 City _____ State _____
 My Jobber is _____

JOBBER INQUIRIES INVITED

Because of this flexibility he may, if need be, use a single 15-watt tweeter unit when the "Cobreflex" is to be used as a middle- and high-frequency reproducer in a two-way outdoor hi-fi system; or he may use a standard 30-watt driver unit to cover larger areas with standard commercial sound; or for real heavy-duty work he may couple on two driver units to the one horn with a standard "Y" connector, thus producing a standard 60-watt, wide-angle projector. Increased "public address" efficiency may thus be realized through greater specialization of component parts (various drivers, wide-angle devices, two-way connectors, etc.) and judicious combinations of these components.

Not only is public address work leaning more heavily on horns, but the home high-fidelity field is swinging toward the use of horns as well. This has become especially true of low-frequency and high-frequency projectors. The number one problem in low-frequency reproduction is to provide a high degree of acoustic loading on the driver unit (usually a cone type speaker) so that optimum lows may be generated. Horns provide this optimum in acoustic loading, and are therefore extensively employed for low-frequency reproduction. In the high-frequency domain the horns are used primarily for directivity control, that is, to spread the normally beamed high frequencies out over a wide area in one horizontal plane. To bridge the middle gap in the horn family for high-fidelity reproduction, we would like to have a horn which will combine the high efficiency of horn loading for the upper lows with the wide-angle dispersion characteristics needed for the middles (and highs).

In high-fidelity systems, therefore, this wide-angle cobra horn may be incorporated in either a two-way or three-way system. The lower cut-off frequency of the horn is about 250 cps. This means that the low-frequency section of the system may operate up to 300 cps and then cut off leaving the rest of the reproducible spectrum to the remaining driver section(s). The sharp low-frequency cut-off characteristic of the horn will serve to make the crossover performance more effective. In this area of crossover, the horn will actually perform as a part of the crossover network itself, adding considerable sharpness to the separation of the lows from the highs.

Now if a wide-angle horn is to be used in a two-way system, it may be energized by a wide-range, high-fidelity driver unit of the split-path type, whose frequency response goes out to 12,000 cps. On the other hand, if the horn is to be inserted in the 4 to 6 kc. area, a general purpose type of driver unit which does not employ the split-path principle, may be used because in this type driver the response drops off rather quickly in the 5 kc. area. A regression of this sort will be of considerable effectiveness at the crossover point, in this case materially aiding in

10" TV SETS

Reconditioned by Electronic Experts

Your Choice

- Philco—Motorola—
- G. E.—Emerson—
- Westinghouse—
- Raytheon—
- Olympic—Admiral—
- plus many others.

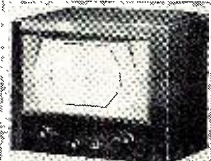

90 Day Guarantee

on all tubes, including picture tube. They're sure to go fast at this price, so please give 2nd and 3rd choice when ordering; or, IF YOU WANT A REAL BUY—JUST LEAVE IT TO US TO SELECT A TOP-NOTCH NAME BRAND SET THAT WILL BE SURE to give every set checked for performance before shipment. Sorry, no C.O.D.'s

WHILE THEY LAST \$4750

- PILOT BULBS: D.C. bayonet base... 6V/15W... 10/75c; 12V/5W... 10/98c; 12V/36W... 10/\$1.10; 60V/7W... 10/89c; 115V/6 CP... 10/\$1.49; 220V/21 CP... 10/\$1.39
- PHILCO TV TURRET TUNER (P1276-3109, less coil, contact strip) For '48 & '49 models... \$1.49
- ABOVE TUNER with 3 socket wired RF strip... 1.98
- PHILCO 3 MIN. SOCKET RF STRIP, containing over \$4.00 worth of Resistors, Condensers, etc... .59

KITS!! KITS!! KITS!!

A BARGAIN FOR EVERYONE!!!

SPEAKER REPLACEMENT CONES

- Popular sizes, 4" to 12", incl. oval. Less voice coils, 12 asstd. \$1.98
- SPEAKER REPAIR KIT... SAVE \$\$\$ with this PROFESSIONAL ASSORTMENT of Rings, Spiders, V.C. forms, Felt, Chamois Lthr., Shim Kit, Cement & Instructions... 2.49
- SPECIAL: BOTH CONE & REPAIR KITS for 2.49

CABINET & CHASSIS FOUNDATION

- 2 tone mahog. veneer; 10"x6 1/2"x5 3/4" inside. Plus ready-punched chassis... 1.89
- MIDGET CABINET & CHASSIS... pol. walnut; 7"x5 1/2"x4" inside. Punched 4 min. tube chassis... 1.49
- ROTARY SELECTOR SWITCHES... incl. multi-contact, multi-deck, 1/4" shafts, Kit 6 asstd... 1.49
- CARBON RESISTORS... 100 asstd... 1.98
- MOULDED BAKELITE CONDENSERS... 50mmf to .2mfd, 200-500V... 30 asstd... \$1.98; 100/2.98
- ALNICO MAGNETS... Powerful Bar, Block, "U" Rod, etc. Kit of 10 assorted... 1.98

(WRITE FOR LATEST "ALNICO" SUPPLEMENT)

JUMBO RADIO-ELECTRONICS PARTS KIT

- Loaded with: COILS, SOCKETS, SWITCHES, WIRE RESISTORS, CONDENSERS, PHOTOFACTS, TV PARTS & DIAGRAMS, PLUS MUCH, MUCH MORE. \$3.95 (Shpg. wt. 20 lbs.)

"DIRECT FACTORY SPEAKER REPAIRS SINCE 1927" Min. Order \$3.00, 20% deposit req. on all C.O.D.'s. Please add sufficient postage—express refunded.

LEOTONE RADIO CORP.
 67 Day Street
 New York 7, N. Y.

Build your OWN McIntosh Amplifier with

the exclusive



PATENTED McINTOSH CIRCUIT

M-106A

Save Money—Enjoy Professional Quality

Less than 1% distortion can be yours at cost plus elbow grease! Buy a McIntosh output Transformer, complete with schematics and parts list. Have money left over!

McIntosh circuit guarantees less than 1% distortion, same as the assembled 30 and 50 watt McIntosh amplifiers... includes 20 watt hermetically sealed output Transformer built to Mil-T-27 standards (4 1/4" wide, 3 5/8" deep, 5 1/16" high, with 1/2" mounting bolts). Transformer No. M-106A only \$55.00.

See your McIntosh dealer, or write McIntosh Laboratory for the name of a dealer near you.

McIntosh LABORATORY, INC.
 326 Water Street • Binghamton, New York
 Exports: 25 Warren Street, New York, N. Y.

RADIO & TELEVISION NEWS

NO BROKEN LEADS

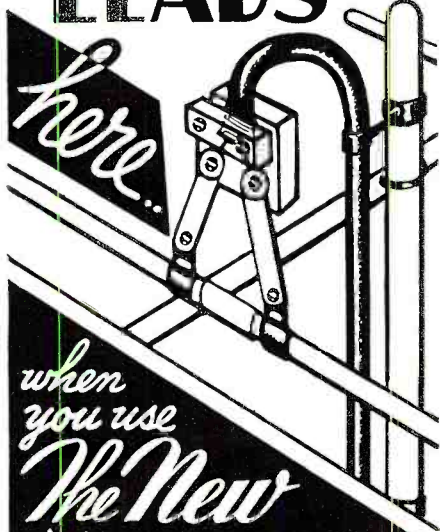

when you use
The New
MOSLEY
"Y-TY"



LIST PRICE \$.80

PATENT APPLIED FOR

- Low Loss, Permanent Connections Of Transmission Line and Phasing Strips To TV Antenna Elements!
- For UHF and VHF Antennas!
- For All Types Transmission Line!
- Eliminates Roof-top Soldering Jobs!
- Quick — Easy to Install!
- Available In Two Sizes To Fit All Antennas!

CATALOG 263-S For all UHF Antennas and most VHF Yagis, Conicals, In-line, and other type antennas where distances between terminals is 4" or less.

CATALOG 263-L For TRIO Zig-Zag, and other antennas where distance between terminals is 6" or less.

Your reputation hangs on fine threads of copper. Use the MOSLEY "Y-TY" on Every Installation Job To Stop Antenna Call-backs!

The NEW MOSLEY "Y-TY" now available at Radio and Television Parts Distributors — Coast-to-Coast!

WRITE FOR FREE COPY OF THIS CATALOG

Mosley
Electronics, Inc.

8622 ST. CHARLES ROCK ROAD
ST. LOUIS 14, MISSOURI

the separation of the middle frequencies from the highs.

Public address should be, and may easily be, taken out of the raucous and merely noise producing field, and made into a legitimate high-fidelity field. This will inevitably result in more effective "public address" coverage and improved intelligibility. Similarly, the high-fidelity field may wisely employ the horn techniques of the p.a. field to provide the necessary high-efficiency, wide-field coverage which is necessary for the equalized distribution of all frequencies in the listening area. We cannot help but conclude this section by remarking that the specialization of the horn family in the form of the wide-angle cobra type has broken the horn family down into finer components and, in the refining process, has created a field of application, in conjunction with the standard units, which is "bigger than both of them."

We have dealt with this horn in all of its acoustical ramifications. But as all good soundmen know, there is more to a loudspeaker than meets the ear, especially if it is intended for outdoor public address work. Outdoor use and/or mobile use connotes rough usage under all weather conditions, operation on rough roads which impart strenuous jars and bumps to equipment, and destructive atmospheric conditions such as smoke and dust. Therefore, it is only proper to give consideration to those factors of mechanical design that insure long and trouble free service under such conditions.

The reflex type of construction provides maximum protection for the driver unit against the entrance of dirt, rain, snow, smoke, smog, or other injurious vapors. The long tortuous path down the bell, around the reflector, and then again down the tone arm provides sufficient "trap" for these foreign particles. What is more, the slope of these sections is such that even if water or rain should be driven into the inner members, the water will automatically drain down and out. The driver unit protection is naturally not obtained in other than reflex type horns, for in the simple straight horn, or in any type of horn where the driver unit diaphragm is directly facing the atmosphere, such channel "trap" conditions do not prevail. While on the matter of wind and weather, of special interest in the case of mobile use is the reduced wind resistance offered by a horn shaped like the "Cobreflex," lying flat against the car top.

Even though the frontal mouth area of this horn may be equal to that of a round horn, its horizontally elongated and swept back curved mouth offers considerably less wind resistance than that of a round symmetrical mouth of the same relative area. This is of practical importance to the soundman who is concerned with the stresses and strains on the car top by a horn being buffeted by a strong wind.

TRANSVISION FIELD STRENGTH METER

Finest
at
Any Price

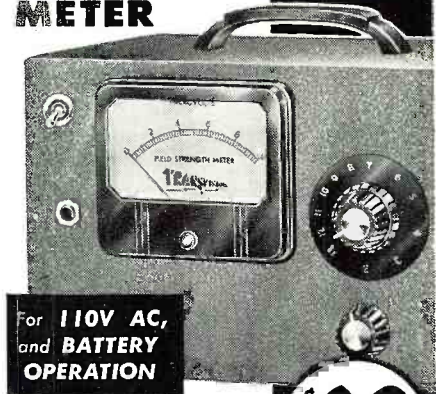

For 110V AC,
and BATTERY
OPERATION

SAVES 50% OF
INSTALLATION COST

Works from antenna
(no TV set needed)

FINEST because: Each Meter is individually calibrated in microvolts on every channel. Widest range—10-50,000 microvolts, 12 channel selector. Multiplier switch for weak signal areas.

Pays for itself on 3 or 4 jobs. Measures relative picture signal strengths directly from antenna. Determines best antenna system and orientation. Checks receiver re-radiation (local oscillator). Identifies signals—TV, FM, TVI. Easy to operate, light, rugged. Many other exclusive features.

*Model FSM-4, for 110V AC only. Complete with tubes. Wt. 13 lbs. net \$69.

Model FSM-4B, for Battery Operation and 110V AC. Wt. 13 lbs. net \$89.

TRANSVISION, INC.
NEW ROCHELLE, N. Y.

\$69
NET*

A MUST IN
FRINGE AREAS

UHF
OR
VHF

10 DAY TRIAL:
Try these fine instruments for 10 DAYS. Then, if you return them, your cost less 10% (our cost of re-packaging) will be refunded.

Test & Repair CRTs

Make BIG PROFITS this EASY way:

Every Service Shop needs these Transvision Instruments. Can be used while picture tubes are in sets or cartons. Choice of 4 types:

TESTER-REACTIVATOR-SPARKER: 3 instruments in 1: Measures cathode emission; locates shorts between elements; locates high resistance shorts (leakage) as high as 3 megohms. Gives rapid check of gas condition of tube.

Reactivates dim tubes—renews brightness and detail. Sparks out electrical leakage. net \$34.95

TESTER-REACTIVATOR: 2 instruments in 1: Similar to the above but without the sparking function. net \$19.95

TESTER-SPARKER: 2 instruments in 1: Sparks out electrical leakage between elements—saves many picture tubes and small tubes. Provides a variable 8,000-volt D.C. supply; useful for analyzing hard-to-solve deflection problems. net \$23.95

SPARKER: Eliminates leakage between elements in C.R.T.'s and small tubes. net \$18.95



Transvision, Inc., New Rochelle, N. Y., Dept. N4

- Send me _____
 Enclosed find \$_____ deposit. Balance C.O.D.
 My JOBBER is _____
 I accept your 10 Day Trial terms.

Name _____
 Address _____
 City _____ State _____

JOBBER INQUIRIES INVITED

Best Recording Tape Buy!



1200 FT. REEL
Genuine Plastic Base
RECORDING TAPE

\$1.89 per roll plus postage
C.O.D. accepted

LAFAYETTE made a terrific deal with one of the leading manufacturers of recording tape to supply us with their regular tape which sells for almost twice our price. **WE GUARANTEE ABSOLUTE SATISFACTION OR YOUR MONEY BACK.** The finest, professional-grade recording tape obtainable. Highest performance for thousands of playings. Red Oxide Base in a smooth, uniform coating; greater signal strength; with maximum fidelity; uniform frequency response from 40-15,000 cps.

Talk about tuners! THE STANDARD CASCADE TUNER TOPS 'EM ALL!

BRAND NEW! GUARANTEED!

The No. 1 Tuner in the trade. Lafayette is out front with this red-hot STANDARD COIL CASCADE TUNER deal. Lafayette made a buy—we paid cash—and you get the saving! Regular dealer price \$24.50. Servicemen, now is the time to stock up and save! Size: 4 3/4" x 3 1/4" x 6 1/4" supplied with 6J6 and 6BQ7. Stock No. TL-11. Shpg. wt. 4 lbs.

\$14.95 ea.
\$14.25 ea.
in lots of 3



NOW! PHILCO BOOSTER

The Philco Television Booster Model TB-3 is a high quality, push-pull, wide-band radio-frequency amplifier designed to amplify r-f signals in the television bands. This unit employs two 6J6 tubes as r-f amplifiers, uses a selenium rectifier in a self contained power supply. Channels 2 through 13.

~~\$39.50~~ list
\$12.50 ea.
\$11.50 ea.
in lots of 3

MODEL TB-3 in original factory sealed cartons. Money back guarantee! Shpg. Wgt. 5 lbs. ea.

TELEPHONE INTERCOM

- Self Contained Battery
- Buzzer Signal
- Ideal For TV Installers
- Operates Up To 2 Miles

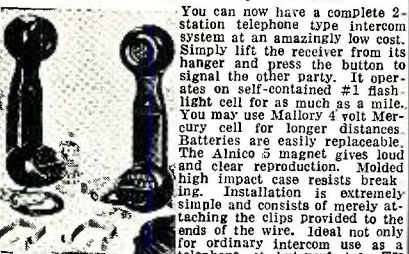

You can now have a complete 2-station telephone type intercom system at an amazingly low cost. Simply lift the receiver from its hanger and press the button to signal the other party. It operates on self-contained #1 flashlight cell for as much as a mile. You may use Mallory 4 volt Mercury cell for longer distances. Batteries are easily replaceable. The Alnico 3 magnet gives loud and clear reproduction. Molded high impact case resists breaking. Installation is extremely simple and consists of merely attaching the clips provided to the ends of the wire. Ideal not only for ordinary intercom use as a telephone set, but perfect for TV installers where the antenna lead can be used as the connecting wire. Complete set consists of 2 phones, hangers for mounting on wall, batteries and 50 feet of 2-conductor wire.

Stock #ML-39, Complete Set.....NET 5.98

ROTO AUTOMATIC HACKSAW

Fits any 1/4" Electric Drill. Cuts any wood, metal or plastic up to 3/4". There are no gears or bearings to wear out! Saw blade is only exposed moving part. Folds to 1 1/2"x1 1/2"x4 1/2"—fits any tool box. Uses standard hacksaw blades. Handle covers and protects saw blade when not in use. Shpg. wt. 1 lb.

HD-60.....NET 3.72



WESTERN ELECTRIC HEARING AID

Reg. price ~~\$185.00~~
Our price **\$14.95**

Brand new, in original Western Electric's jeweler's case. Supplied with receiver, receiver cord, battery cord and plug (less batteries). Money back guarantee. Act now while they last! Uses Burgess 2X30E and 8R batteries at \$1.55 per set.



Write for free catalog.

LAFAYETTE RADIO
DEPT. RD

NEW YORK, N.Y. 100 Sixth Ave.
BRONX, N.Y. 542 E. Fordham Rd.
NEWARK, N.J. 24 Central Ave.
PLAINFIELD, N.J. 139 West 2nd St.
BOSTON, MASS. 110 Federal St.

It is axiomatic that the fewer the parts in a device, the fewer parts there are to come loose and cause trouble. In the "Cobreflex" there is essentially a "one-piece" construction. The horn sections, the tone arm, reflector, and bell, are molded in one piece so that by putting two identical halves together a solid unit construction results. Thus there are no spacers or "stays" to work loose, nor any vital acoustical element of the horn to be jarred out of its critical position. All the acoustic elements are formed into one rigid life-long relationship in the aluminum die casting machine. This "all out" aluminum construction makes for a rust-free and erosion-proof horn construction where rust smears will not deface the equipment nor will erosion-eaten seams affect the acoustic performance of the assembly. —30—

Mac's Service Shop

(Continued from page 74)

connections. Then he cut a lead loose from one tie-point and resoldered it to another. Next he turned the receiver on and tuned it across the band. No hum was heard on any station.

"Oh quit looking like you had just found The Lost Chord," Barney said disgustedly. "Go on and tell me how dumb I was."

"No, I do not think you were dumb," Mac said gently. "As usual, though, you were too busy looking for the trouble to stop and think about it. This kind of hum is always produced by something that modulates the r.f. or i.f. signal at the hum frequency. That is what you should have been looking for. The clue to the cause of the trouble was the fact that the filter condensers had recently been replaced. You will note that a can-type, twist-prong condenser was replaced with a cartridge type. That meant all the leads going to the prongs of the original condenser had to be removed and transferred to the wire leads of the new unit. The technician who did this got a little confused and transferred the plate lead for the i.f. stage from the output of the filter to the input. This placed considerable ripple voltage on the plate and screen of that tube. Since it handled only i.f. frequencies, this ripple produced no hum as long as no carrier signal was being passed by the i.f. stage.

"When a carrier was being received, however, this carrier was modulated by the ripple voltage. When this hum-modulated carrier was detected, the hum voltage appeared in the output. I simply put the plate and screen lead back to the output of the filter, where it belongs, and that cleared up the trouble."

"It sounds so easy when you explain it," Barney said with a sigh.

"If it will make you feel any better, I'll tell you about a case I did not solve so easily," Mac said consolingly. "Last week I went out on a call in which the

	MAST BASE	BC 605 INTERCOM
	Type MP 22. Ideal for all vehicles. New, complete with universal motor & all hardware.	Easily converted to an ideal Inter-Communications set for office, home or factory. Original. New w/conversion data
	\$3.75	\$4.75

DYNAMOTORS

TYPE	INPUT VOLTS	AMPS	VOLTS	AMPS	PRICE
DM #16	14	6.2	170	.170	\$6.75
DM 33A	28	7	340	.250	8.95
BD AR 93	28	3.25	375	.150	7.50
23350	27	1.75	250	.075	3.95
R-19 Pack	12	9.4	275	.110	8.95
DA-3A*	28	10	500	.050	6.95
			300	.250	
			150	.010	
PE 73 CM	28	19	14.5	5.	
BD 69†	14	2.8	1000	.350	22.50
D-402†	13.5	12.2	220	.05	12.95
			300	.200	
SP 175	18	3.2	8.8VAC	.06	12.50
Dm 25†	12	2.3	250	.05	4.49
† Less Filter					6.95
‡ Used, Excellent					* Replacement for PE 94.

INVERTERS

PE-218-H: Input: 25/28 vdc, 82 amp. Output: 115v. 350/500 cy 1500 volt-amperes. NEW.....\$37.50
PE-206: Input: 28 vdc, 36 amps. Output: 80 v 800 cy. 500 volt-amps. Dim: 13"x5 1/2"x10 1/2".
New \$22.50
NAVY COR-211095: Input 22-30 VDC/75-60A.
OUTPUT: 115V/400 CY. 1 KVA/8.7A. RPM: 4800.
With coupling provision for motor. Brand New.
Original packing\$150.00

ARTILLERY MICROPHONES

Microphone, Type T-21, condenser type, used to detect sound of Artillery fire or shell detonation. A number of these units are placed in the ground at various field locations in Geometric patterns at intervals up to 2000 yds. Mike unit comprises a condenser head, acoustic chambers, and a 2-stage Audio Amplifier.
Requires 6 flashlight Batteries and 1-"C" Battery—with all tubes, but less batteries.....\$32.50

MOBILES! C. D. MEN! CAP!!

IDEAL DYNAMOTOR—CONVERTS EASILY TO SUPPLY UNIT DELIVERING

12 Volt Input	150 MA	6 Volt Input	90 MA
325 V @ 125 MA	OR	160 V @ 110 MA	

Brand New with Conversion Data.....\$3.75

Send M.O. or Check, Shipping Chgs. C.O.D.
COMMUNICATIONS EQUIPMENT CO.
131 Liberty St. Dept. N-4 New York City 7, N. Y.

Of Course....

HARRISON HAS IT!

... In Stock!

THE NEW National NC-98

A GREAT RECEIVER!

For Short Wave Listeners, Novices and experienced Amateurs, here's a receiver that tops them all for value!

- Tuned RF stage *only*
- Crystal filter
- "S" Meter

\$149.95

- ✓ See pg. 23 for complete specs.
- ✓ Write HARRISON now for FREE literature.
- ✓ See it demonstrated at both great HARRISON stores.
- One of America's best & oldest factory authorized distributors.
- ✓ ORDER NOW! Immediate delivery from.....

Ham Headquarters Since 1925!

HARRISON RADIO CORPORATION

225 Greenwich St. • N. Y. 7, N. Y.
BArclay 7-7777

JAMAICA BRANCH: Hillside Ave. at 145th St.

complaint was that the sound was causing interference in the picture. Naturally, I decided one of the sound traps was out of adjustment, but no amount of adjusting in the cabinet would cure the condition. Next I decided that possibly something was wrong with one of the traps; so I pulled the chassis and brought it to the shop. It was one of those chrome-plated custom chassis of the 630 type with separate sound and picture. The fellow had bought a cabinet and had done a fine job of installing the chassis and a hi-fi speaker.

"When I put the chassis on the bench and turned it on, the trouble was gone! Not the least trace of sound interference could be seen in the picture. Apparently the ride to the shop had cured whatever was wrong. Naturally I tapped and pounded the set all over in the hope that I could make the trouble show up again, for, like all technicians, I despise a set that seems to cure itself; but nothing I could do would make the trouble come back. The only thing to do was return the chassis, which I did. I put it back into the cabinet and turned it on, and the same old trouble was right there!

"With a very red face I pulled the chassis again, but this time I set it on the floor beside the set and turned it on. The sound bars were gone. It began to dawn upon me that there was something inside the cabinet that caused the trouble. A careful examination revealed that the owner had installed two two-inch-wide tin strips on either side for the feet of the chassis to ride on when he slid the receiver in and out of the cabinet. These rubber-mounted feet had little projections on the bottom that bit into the wood and made the heavy chassis extremely hard to slide until the tin strips were installed. The picture and sound i.f. channels were mounted side by side on the same side of the chassis. One of the strips ran directly beneath the i.f. transformers of both channels. I decided that possibly this tin strip, which was insulated from the chassis, was coupling the sound i.f. back into the picture i.f. The sound traps were up near the tuner, but the coupling might be taking place from the output of the sound i.f.—where the signal strength would be greatest—right over to the picture i.f. at a point where no more sound traps appeared between them and the detector.

"To test the theory, I put the chassis back into the cabinet and shorted the tin strip to the chassis with a screwdriver. Instantly the sound interference almost entirely disappeared. It was only present on one channel. A little figuring revealed that the strip was a quarter wavelength long on that channel. Removing the tin strip cured the trouble completely. Now do you feel better to see how easily I was stumped?"

"I dunno," Barney muttered. "When you have troubles, you solve them; but when I have problems, you have to solve them, too."

April, 1954

Insure Yourself FASTER, EASIER Installations AT LOWEST COST

NEW SUPER-FRinge MOTORLESS DIRECTRONIC

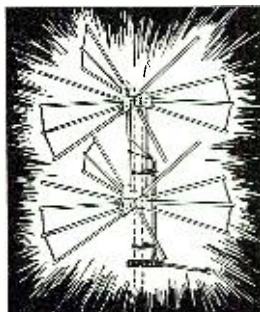

- 24 Elements
- New High Gain
- Clearer, Sharper Pictures
- Electronically Beamed in All Directions
- New Low-Loss Tubular Tri-X Cable
- Eliminates Ghosts—Interference

New improved Hi-gain Super Directronic offers sensational advantages over motorized antennas—less installation cost—less upkeep. The new 24-element Directronic is beamed to any transmitter in fringe range by new 6-position Directronic Switch located at receiver. Twenty-four elements provide high gain in all directions. New Tri-X low-loss tubular cable minimizes attenuation. Serviceman's kit contains 24 hi-tensil aluminum elements, including 6 reflectors, Directronic 6-position switch, 75 ft. Tubular Tri-X, 3 matched stacking bars, Universal U-Clamps.

Model AX-524 as shown \$23.50

FAMOUS ROCKET ZOOM-UP TOWERS

• Sturdy • Reliable • Easiest Installation
Economize with Rocket Zoom-up Towers. Offers quickest, easiest way to make an installation up to 50'. Each section telescopes inside the other—to erect simply slide out each section in its turn—insert bolt thru section below—tighten to keep mast from turning. Each tower complete with ray rings, bolts, and mounting base suitable for peak or flat roof. Handsome and sturdy. Rocket Zoom-ups offer you economy and long life. Order by size.

20' \$ 9.95 30' \$15.95
40' 19.95 50' 29.95

UHF STRIPS Now available for Standard Coil tuners. To order, specify channel No. and series designated by letter, such as F, G, Q, etc., stamped on each strip of your present tuner. (Set consists of osc. & ant.)

\$750
Ea.

- UHF tubular low-loss twin lead 100 coil \$4.95
- Rocket twin lead—7/28 stranded02 ft.
- UHF-VHT Antenna Coupler, permits use of 1 lead for both UHF & VHT Antennas 2.75
- UHF-VHT Antenna Coupler, permits use of 1 lead for both UHF & VHT Antennas69
- Lightning Arrestor—for tubular or flat lead12
- UHF Mast Stand-off Insulators—7"06
- UHF Screw—7"06

NEW SPRING CATALOG AVAILABLE
Includes Sensational Profit Sharing Point Plan

SENSATIONAL SAVINGS 2 BAY—16 ELEMENT CONICAL ARRAY

with High Band Adapters at Rockbottom Prices

SINGLE LOTS \$5.30 EACH IN LOTS OF 3 \$4.99

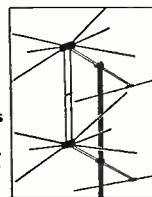

Never before has National Electronics had a BARGAIN like this. We made a special purchase in order to get these sensational prices. And this array has everything. This conical 2-bay 16-element array provides ultra-fine fringe reception. Includes sixteen 3/8 inch airplane type aluminum elements, including hi-band adapters for greater gain on the high channels and is complete with one pair of stacking bars to each array. These are packed in cartons of three 16-element arrays per carton, with tie rods, at \$14.95 per carton.

DEALERS—SERVICEMEN—ATTENTION
Single 16-element Array \$ 5.30 Ea.
1 Carton 6 arrays—No Tie Rods 13.50 Ea.
4 Bay Stacking Assembly—No. 4B 1.95 Ea.

ROCKET BROAD BAND YAGIS

- SENSATIONAL GAIN
- SENSATIONAL PICTURES IN FRINGE AND ULTRA FRINGE AREAS



Switch to Yagi! Broad Band Hi-Gain Antennas! These new Yagis give you Yagi reception on the 5 low-band and 7 hi-band channels—no restriction to one single channel! A two-bay array will outperform even a 10 or 12-element single channel Yagi. Price is sensationally low. Complete serviceman's array includes 1 double reflector, 2 folded dipoles, 3 di-rig construction.

Model RB 26—Ch. 2 thru 6—7-element . . . \$10.95 ea.
Model RB 713—Ch. 7 thru 13—9-element . . . 5.95 ea.
Matched Stacking Bars 1.25 ea.

ALL PRICES F.O.B. CLEVELAND, OHIO

Do not remit more than complete purchase price. Pay shipping charges on receipt of goods. 25% deposit on all C.O.D. orders, please. Money-back guarantee. Prices Subject to Change Without Notice

National Electronics
OF CLEVELAND
THE HOUSE OF TV VALUES
1104 Delco Building Cleveland 3, Ohio

ROUND, SQUARE, KEY and "D" OPENINGS QUICKLY MADE with Greenlee Radio Chassis Punches

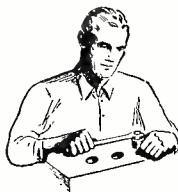

Save hours of hard, tedious work . . . cut accurate holes in chassis for sockets, plugs, controls, meters, panel lights, etc. with GREENLEE Punches. In 1-1/2 minutes or less make a smooth hole in metal, bakelite or hard rubber up to 1/16" thick. Easy to operate . . . simply turn with ordinary wrench. Wide range of sizes. Write for details. Greenlee Tool Co., 1884 Columbia Avenue, Rockford, Ill.



AUDELS TV-RADIO SERVICE LIBRARY

HERE IS LATE INFORMATION IN A HANDY FORM FOR RADIO AND TELEVISION REPAIRMEN, SERVICEMEN AND STUDENTS



2 VOLS. \$6 COMPLETE \$1 A MO. PAY ONLY 1 MO.
AUDELS T.V.-RADIO SERVICE LIBRARY—Highly Endorsed—1001 Facts—Over 1552 Pages—625 Illustrations, Diagrams of Parts. Presents Important Subjects of Modern Radio, Television, Industrial Electronics, P.M., Public Address Systems, Auto, Marine & Aircraft Radio, Phonograph Pick-Ups, etc.

IT PAYS TO KNOW!
The Basic Principles—Construction—Installation—Operation—Repairs—Trouble Shooting. Shows How to get Sharp, Clear T.V. Pictures. Install Aerials—How to Test, Explains Color Systems, Methods of Conversion, Terms, etc. Includes Ultra High Frequency (U.H.F.)—Valuable for Quick Ready Reference & Home Study. Tells How to Solve T.V. & Radio Troubles—Answers Your Questions.

Get this Information for Yourself. 7 DAY TEST—ASK TO SEE IT!

MAIL ORDER
AUDEL, Publishers, 49 W. 23 St., N.Y. 10, N.Y.
Mail AUDELS T.V. RADIO SERVICE LIBRARY 2 Vols. \$6 on 7 days free trial. If O. K. I will remit \$4 in 7 days and \$1 monthly until \$6 is paid. Otherwise I will return them.

Name _____
Address _____
Occupation _____
Employed by _____

NOW IT'S Plug-In SELENIUM RECTIFIERS

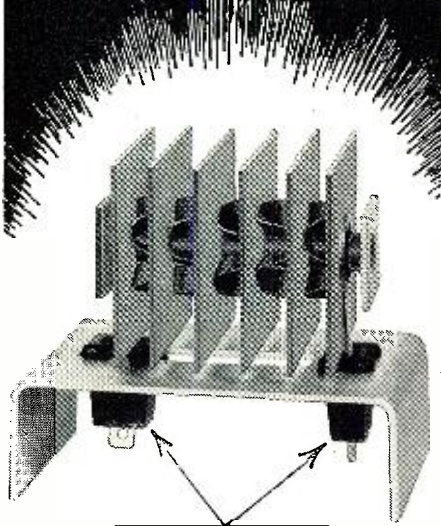

POLARIZED
CINCH SOCKET NO 9221

**Plugged In
for Easy Replacement**

**Polarized
for Correct Positioning**

**Still Can Be
Soldered In The Set**

*Available In All Sizes.
Write for Further Information.*

When buying selenium rectifiers
be sure to specify "PLUG-INS"
... they cost no more.

*Send for your Free copy of "Selenium
Rectifiers for Color Television".*



RECTIFIER DIVISION

Dept. R-2, 415 N. College Ave., Bloomington, Ind
In Canada—50 St Clair Ave. N W., Toronto

RADIO-TV Service Industry News

AS REPORTED BY THE
TELEVISION TECHNICIANS LECTURE BUREAU

FIRST OFF, your editor would like to thank the hundreds of service technicians who have written the Bureau to express their appreciation for the continuing effort of this department to encourage sound pricing of service labor. Hundreds of "Standard TV Labor Charges" charts have been mailed to those who have written in for them and a review of the requests shows that they have come from every state and many foreign countries.

Several service associations are using reprints of this department and the 8½ x 11 reprints of the Standard TV Labor charts in their campaigns to encourage all service shop operators in their areas to adopt sound service labor pricing practices. Some letters tell of very interesting experiences with the use of the charts. These are crystallized in the following excerpt from a long letter received from a reader:

"When I started my service business I assumed that I had to price my work on the same level that part-time technicians charged for it. But I found I barely scratched out an existence and I had to work eighteen hours a day, seven days a week when business was good to build up a little reserve to carry me through the tough months.

"The charts started me to studying the actual time I used in completing service jobs. They also led me to studying the cost of running my little business in relation to the time I gave to bench work and on service calls in the customers' homes.

"It was so obvious that I had to raise my charges if I ever was to make a good living out of my business. So with a few changes to suit my particular situation, I adopted the schedule shown on the charts.

"This is the interesting part: Since I have been getting adequate charges everything about my business has improved. Increased business has made it possible for me to add a man to help me. I feel prouder of my work, my profession; our service has improved and my relations with my customers are better."

Radio-Phono Service Charges

The Bureau has also had some very interesting responses from its national

survey of labor charges for radio and phono service. The plan the Bureau follows in making these national surveys is designed to take into account the pricing practices in every major center in the country.

The plan is not to establish prices but merely to report on recognized standard service operations and what concerns with accurate cost accounting systems have found they must charge for those standard service functions to pay their costs of doing business and to give them a small return on their investments.

In order to obtain an accurate national picture of charges, the Bureau selects a basic schedule used by an individual service company or an organized group. Charges in several other centers are then compared with those on the working chart. From these a tentative average schedule is made up which is checked against charges prevalent in approximately fifty different areas.

In developing the final schedule, preference is given to the higher charges to make the schedule applicable to any area. In those areas where living and operating costs permit a lower schedule of charges, when a customer complains about charges the technician can show that their charges are lower than the national average charges for the same service operations.

Customer Education

Most of the leading service company executives are unanimous in their opinions that service must stand on its own two feet to make the activity of servicing an important segment of the electronics industry.

One of the responsibilities that service must assume in "standing on its own two feet" is that of educating set owners about what they must expect to pay for efficient service performed by competent technicians backed by reliable companies. The second responsibility is to develop some plan or program to help set owners identify honest, reliable servicing companies.

A study of business conditions in the plumbing industry provides a good picture of what can happen in an industry when its service charges become the

RADIO & TELEVISION NEWS

PLATE TRANSFORMER BARGAIN

Made by Chicago Trans. Co. Sec., 3000-0-3000 Volts RMS @ 300 Ma. 115 V., 60 Cy. Primary. Type FS Full case. Pri. tapped to reduce Voltage to 2500 V. RMS. BRAND NEW, BOXED IN ORIGINAL CASES. A TERRIFIC VALUE AT \$29.95 ea.

MOBILE DYNAMOTORS

Made by Pioneer. Input 6 VDC. Output 400 V. @ 175 Ma. Mounting bracket attached. Removed from equipment. All checked and guaranteed. This is your chance to get a small rugged Dynamotor at only \$12.95 ea.

WESTON METERS MODEL 301

0-100 Microamp DC (Spec. Scale).....	\$9.95
0-150 VAC Rectifier type.....	8.95
0-200 Microamps DC.....	8.95
0-10 Volts DC (1000 ohms/v).....	6.95
0-1Ma (KV Scale).....	6.95
0-50 Ma DC.....	6.95
0-1.5 Mills DC.....	6.95

MODEL 731

0-200 Microamps (Spec. Scale).....	8.95
0-1 Ma (0-100 Scale).....	7.95

MODEL 506

0-200 Microamps.....	6.95
0-1 KV with Mult.....	6.95

WESTERN ELECTRIC METERS 3/2 inch round

100-0-100 Microamps DC.....	7.95
0-1.5 Ma DC.....	4.95

WESTINGHOUSE METERS—Model NX35

0-500 Microamps (0-100 Scale).....	5.95
------------------------------------	------

GENERAL ELECTRIC

0-150 Volt AC—Model AO 22.....	6.95
0-3 Amp RF w/thermo—Model D044.....	6.95
0-5 Amp RF w/thermo—Model D044.....	6.95
Running Time, 99,999 Hours, 115 V., 60 cy.....	9.95

MANY OTHER METERS IN STOCK. PLEASE WRITE YOUR REQUIREMENTS.

WESTON FREQUENCY METER

Model 814. 350 to 450 cycles, 100 to 125 Volts. Regular Price \$100.00.

Our Price, **\$39.95 EA.**
Brand New

G. E. RELAY CONTROL (Ideal for Model Controls, Etc.)

Contains a sigma midget 8,000 ohm, relay (trips at less than 2 MA), high impedance choke, bimetal strip, neon pilot and many useful parts. The sensitive relay alone is worth much more than the total **\$1.25** Each 10 for **\$9.90** low price of

Panel Meters

NEW GOVT SURPLUS STANDARD BRANDS

2" METERS

DB meter—10 to	
-20.....	\$3.49
0-80 ma DC.....	3.49

3" METERS

0-200 Microamps.....	\$6.95
0-400 Microamps.....	5.95
0-500 Microamps.....	5.95
0-200 Milliamper.....	4.50
0-250 Milliamper.....	4.50
0-1.5 Volts AC.....	4.95
0-3 Volts AC.....	4.95

OIL CONDENSERS

4 MFD—600 VDC.....	.95
10 MFD—600 VDC.....	1.50
2 MFD—1000 VDC.....	.95
6 MFD—1500 VDC.....	2.95
2 MFD—2000 VDC.....	2.50
2 MFD—2500 VDC.....	3.95
100 MFD—4000VDC.....	47.95
2 MFD—5000 VDC.....	5.95
50 MFD—330 VAC.....	6.95
1 MFD 7500VDC.....	1.75
1 MFD 20 KVDC.....	49.95
15 MFD 5 KVDC.....	49.95
5 mfd 660 VAC.....	2.95

NON-INDUCTIVE RESISTORS

Ohmite, 250 Ohm, 100 Watt.

59¢

Special, 5 for \$2.50

FILTER CHOKES

4 Henry, 500 ma DC, fully cased. Cracked Insulators, but guaranteed O.K. electrically. **\$2.95** Each

SOLA CONSTANT VOLT TRANSFORMERS

Input 95-125 V 60 Cy Output Regulated 115V	
250 VA.....	\$33.65
500 VA.....	48.65

WIRE WOUND RESISTOR KITS

25 assorted 10 Watt.....	\$1.95
25 assorted 20 Watt.....	2.50
50 assorted 5, 10, 20, and 50 Watt.....	4.95

WIRE WOUND RESISTORS

Stock too long to list. We can supply most sizes, so order what you need.

10 Watts. From 1 Ohm to 70K Ohms.....	\$.15
20 Watts. From 4 Ohms to 50K Ohms.....	.20
25 Watts. From 1 Ohm to 100K Ohms.....	.30
50 Watts. From 5 Ohms to 100K Ohms.....	.40
100 Watts. From 50 Ohms to 100K Ohms.....	.50

LEEDS & NORTHRUP WHEATSTONE BRIDGE—Model 5300

Excellent condition—Limited quantity. **\$69.95 ea.**

EIMAC VACUUM CONDENSERS

6 MMF 32 KVDC (VC 6-32).....	\$ 9.95
12 MMF 32 KVDC (VC 6-32).....	10.95
50 MMF 32 KVDC (VC 50-32).....	12.95

Min. Order \$3.00—25% with Order—F.O.B. New York, N. Y.

PEAK ELECTRONICS CO.

66 West Broadway, New York 7, N. Y.
Phone WOrth 2-5439

butt of jokes without counter-publicity to reveal the true costs of giving service.

The plumbing business is a "protected" business. It is severely regulated by municipal ordinances and state and national codes and every activity involved in the operation of a plumbing contracting business is under union regulations and jurisdiction.

When a plumbing contractor needs additional labor to dig a ditch for a sewer or waterline he calls his union local and requests the number of men he needs. The rate for this common labor is \$1.95 per hour. He has a very serious accounting problem on his hands with this transient labor since he is responsible for deducting the various taxes from their pay and reporting the men's correct names, addresses, and social security numbers in his monthly and other state and federal reports.

The overhead costs in a plumbing contract or service business are a substantial factor in the operational costs. Labor costs probably should not exceed 30% of labor income and less in many areas.

Plumbers do not solicit individual service jobs any more. As a matter of fact, most of them avoid these kinds of jobs wherever they can. The reason for it is that they cannot break even on the average service job in the home. In one area checked by the Bureau the established charge for plumbing service is \$4.50 per hour. Held to an inflexible wage scale and with a substantial investment in automotive equipment, tools, and supplies for this type of work, the plumber will lose about two dollars an hour on every home service job he tackles. Yet the average home owner feels he will be gypped if he calls a plumber!

Lack of any type of public relations program plus the inflexible restrictions that are imposed on plumbing as a business have brought about a situation in which the average home owner now does his own plumbing maintenance and calls in a plumber only in a dire emergency.

The moral here for the electronic industry is that every man who is interested in building a business in electronic servicing for himself must personally assume some of the responsibility for educating the set owning public in the wisdom of buying regular set maintenance and what they should expect to pay for honest, competent service.

The Set Owner's Dilemma

How can the owner of a TV set needing service know, when he reads the listings of service companies in the advertising section of the telephone directory, which are reliable, dependable companies? How can a set owner know when he reads ads offering home service at \$2.50 per call that service cannot be performed at that price and that he may be courting trouble if he buys it?

The Better Business Bureau of St.

EST. 1914

National

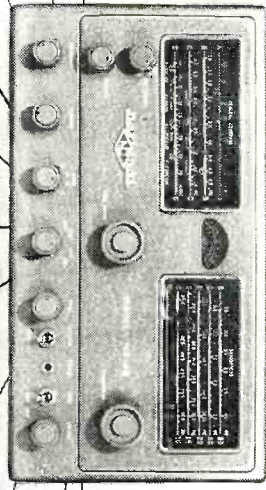

THE NEW

MC-98

\$149.95

IN A CLASS

by itself

hrc

Harvey

RADIO CO., INC.

103 W. 43rd St., New York 36, N. Y. • JUlson 2-1500

WORLD'S LARGEST MANUFACTURER
OF CUSTOM BUILT TELEVISION

MATTISON

SILVER ROCKET 630 CHASSIS

Featuring Syncromatic Tuning

NO DRIFT UHF-VHF-DX

ONLY THE MATTISON 630 ELIMINATES DRIFTING APART OF PICTURE AND SOUND ON UHF, VHF and DX RECEPTION. SELECT YOUR CHANNEL . . . SOUND IS AUTOMATIC. (Syncromatic tuning is an exclusive Mattison 630 Circuit)

Tube Complement:
29 tubes
3 rectifiers
1 CRT

SILVER ROCKET
630 Chassis with
built in UHF Tuner

33

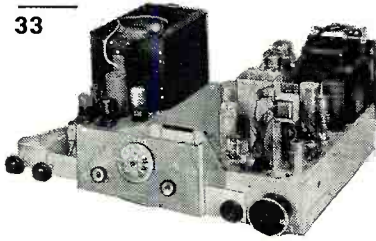

All Channel UHF Tuner

- UHF Cascode I.F. amplifier adds additional I.F. stage. Very important because UHF transmitters operate with moderate power and RECEIVER must be sensitive to give top notch UHF performance.

SILVER ROCKET 630 CHASSIS

• with TUNEABLE •

BUILT-IN BOOSTER for Better DX Reception

Tube Complement:
28 tubes
3 rectifiers
1 CRT

Select Your
Channel . . .
SOUND IS
AUTOMATIC!

32

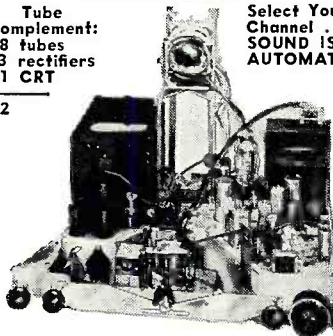

All Channel Booster

- Broad band single knob control pre-amplifier built in to eliminate long leads which may cause regeneration and attenuation of signal.
- ONLY THE MATTISON 630 CHASSIS HAS AN ALL CHANNEL TUNEABLE BUILT-IN BOOSTER THAT INCREASES SIGNAL STRENGTH UP TO 10 TIMES.

ALL CABINETS MADE IN MATTISON'S OWN CABINET FACTORY. AVAILABLE IN EVERY FINISH AND STYLE. WRITE FOR COMPLETE CATALOG.

DEALERS! SERVICE DEALERS! Here is your opportunity to become the "important" TV Dealer in your area for THE FINEST CUSTOM-BUILT LINE OF TV RECEIVERS. FREE!! Write for Mattison's merchandising portfolio explaining the "UNASSEMBLED PLAN" and "\$1,000,000 FLOOR PLAN."



Manufactured with integrity

When you buy from Mattison you need only one source of supply! You can buy a Mattison Chassis, a Mattison Cabinet or a complete Mattison TV Set!

Mattison Television & Radio Corp.
10 West 181st St., Dept. RN, N. Y. 53, N. Y.

Louis is trying to eliminate "price" or "bait" advertising by asking local advertising media to observe a new set of regulations when accepting ads from service companies. These regulations specify:

"Standards of practice to govern television service advertising. Advertisers who offer to service television sets shall make no reference to repairing in the home.

"Advertisers who quote a price for a service call shall state definitely the period of labor time included in that price and rate per hour to be charged for labor time in excess of that period.

"Reference also should be made to the cost of parts. For example: Service call \$5—includes 15 minutes' work; additional work at rate of \$5.00 per hour; plus cost of necessary parts."

In Detroit, where attempts to get newspaper cooperation in curbing bait advertising were unsuccessful, their aggressive Better Business Bureau threw the spotlight of publicity on service frauds by filing complaints against specific companies with the local prosecutor. The BBB submitted case histories on eleven concerns which showed they had made substantial overcharges on 30 out of 33 service jobs they were called in to handle.

Concurrently with the news of the prosecutor's action against these concerns, feature stories in Detroit's leading dailies cautioned set owners to beware of low price service offers and recommended that if the set owner was not familiar with the character of a service firm to check on it before calling for service.

One columnist said:

"There are several ways to check on the firm you call. The Better Business Bureau will tell you if there have been any complaints (against the company).

"Another organization, the Television Service Association of Michigan, is currently setting up a clearing house of information on television repair firms. They will also tell you if there have been any complaints.

"The TSA is a group of independent TV repair firms which is attempting to set a standard of ethics for the TV service industry. They have a code for their members which contains many items TV set owners would be wise to check when calling in a repairman."

In their ads and flyers, which carry the names, addresses, and telephone numbers of all TSA member firms, they urge readers—"For Dependable Television Service . . . Don't be fooled . . . Don't be misled . . . By bargain prices, absurd claims of screwdriver mechanics or neighborhood handymen . . . Call a competent technician. There is a TSA Member in your district."

They succinctly describe the character of TSA member firms in short, easy-to-understand phrases. "The Association as a group guarantees the work of each of its members. Each member has passed a rigid investigation as to . . . his integrity . . . his know-how . . . his equipment. He must maintain these high standards to

5U4G **Outdated!**
Obsolete!
Don't be behind the times! Smart servicemen replace every 5U4G with modern

HI-PO TV RECTIFIER TUBE "B" Plus Booster only 159

Guaranteed

or your
money back

- Increased picture height & width
- Brighter picture
- More gain
- Longer lasting
- More effective

HI-PO TV RECTIFIER TUBE is a "must" for satisfactory, continuous, reliable output in ANY set, especially with 21" or larger tube. HI-PO TV RECTIFIER TUBE is exceptionally valuable in older sets with deteriorated components and tubes.

Bring back life to TV sets with HI-PO TV RECTIFIER TUBE. Helps eliminate "snow" in fringe and weak signal area, simplifies set adjustments, increases picture tube grid #2 voltage and its high voltage. Functions similar to 5U4G, produces greater DC output voltage, increases "B" plus voltage supply by 20 to 30 volts.

SPECIFICATIONS	
Filament Voltage . . .	5.0 Volts
Filament Current . . .	4.0 Amperes
Peak Inverse Voltage . . .	1550 Volts Max.
Peak Plate Current, per plate . . .	750 Ma.
D. C. Output Current. . .	250 Ma. max.

BOOST PRESTIGE!

BOOST PROFITS!

ORDER TODAY!
Check or M.O.
We pay postage.
C.O.D., 25%
with order.

BAY ELECTRONIC DISTRIBUTORS, INC.
1736 Jerome Ave., Bronx, N. Y.

FREE!

ANY ONE OF THESE

HI-FIDELITY RECORDINGS
{50-15000 Cycles}

BEETHOVEN
"Egmont" and
"Coriolanus" Overtures

33 1/3 R.P.M.

OR **BIZET OR BACH** "Brandenburg" Concerto No. 3
"Carmen" Suite

YES! Yours FREE—any one of these magnificent recordings superbly performed by the celebrated British conductor Walter Goehr and the Netherlands Philharmonic Orchestra. Take any one free—OR you may have ALL THREE records for ONLY \$1!

We make this amazing offer to introduce you to our superb High Fidelity recordings. We will also send you our FREE brochure telling how you can get other brilliant recordings of the world's greatest music—for less than ONE THIRD the usual retail price!

There are no "strings" attached to this generous offer. But it may have to be withdrawn soon. So rush coupon right now to Musical Masterpiece Society, Dept. 474, 250 W. 57th St., New York 19, N. Y.

The Musical Masterpiece Society, Inc.
Dept. 474, 250 W. 57th St.
New York 19, N. Y.

Please send L. P. records checked:
 BEETHOVEN BIZET BACH

NOTE: If you check ONE record, it is FREE—simply enclose 25¢ to help cover cost of special packing, shipping. If you check ALL THREE, enclose \$1. (WE pay postage.)

Also send FREE brochure describing your other fine recordings. No obligation.

Name

Address

City..... Zone.... State.....

RADIO & TELEVISION NEWS

keep his membership. Equipment plus know-how . . . equals . . . best possible performance. Integrity . . . equals . . . legitimate parts . . . fair prices."

The Power of United Effort

There is little an individual service operator can do toward correcting unethical service practices in his area just by his own efforts. But in co-operation with other legitimate, high-minded service shop operators he can do a great deal.

It will be a never-ending battle to keep the servicing profession free from racketeers. But their activities can be sharply curbed in any area where honest service operators join together to establish a firm and solid foundation for their businesses. A united service front can be accomplished only through the formation of democratically controlled associations. However, the mere formation of an association will amount to nothing unless the members individually and collectively contribute the time and energy necessary to carry out the association's programs.

The Future of Service

The activity of electronic installation and servicing is standing on the threshold of a period of vast opportunity for men possessed of moral integrity, intestinal fortitude, technical acquaintance with electronic circuitry and devices, and business acumen. Such men will have the chance to build solid, substantial businesses that will be a credit to the industry and return a continuing profit to their founders.

The transition of electronics from radio to television produced the experience and proof that the business of electronic servicing can be both profitable and stable. Through trial and error, many organizations have established the basics of management and operation for independent electronic service businesses. These organizations went through the period of boom and bust in TV and have managed to side-step all of the pitfalls that can quickly swallow up a new type of business in a changing, shifting, fast-growing industry.

The next two years will provide the final proof of stability and longevity of independent service businesses. They will be years of transition, too—transition from monochrome to color TV. They will differ from the period when TV first developed in that the average person of today doesn't have the reckless buying urge that was prevalent for several years after the end of World War II. People will like color TV but they may not buy sets with the same "pioneering" spirit that inspired them to buy their first monochrome TV.

During this period when set manufacturers will be exploiting color sets that the average person cannot buy there is a possibility that the public's interest in TV may drop. Surveys show that we are still basically a radio-minded people and users are not

ALL RADIO AND TV TYPES

CLOSE OUT SET MFR'S SURPLUS TUBES

- STANDARD BRAND WARRANTY
- BRANDED
- BULK PACKED IN ORIGINAL MFR'S NESTED CARTONS OR INDIVIDUALLY BOXED
- EVERY TUBE METER AND CHASSIS TESTED FOR TOP QUALITY

0A4G	\$.50	6AQ5	\$.37	6K6GT	\$.36	12BE6	\$.41
0Z4	.49	6AQ6	.36	6K7G	.49	12BH7	.53
1B3GT	.65	6AS5	.62	6L6GA	.99	12H6	.49
1B24	4.95	6AU6	.36	6S47	.59	12J7	.29
1L4	.47	6AV5GT	.79	6S47GT	.61	12SA7GT	.58
1R5	.46	6AV6	.36	6S7	.81	12S6GT	.61
1S4	.40	6BA6	.33	6S7S	.58	12SH7	.49
1S5	.38	6BA7	.57	6S7GT	.59	12SK7GT	.49
1T4	.46	6BC5	.46	6S7H	.65	12SN7GT	.46
1U4	.46	6BE6	.37	6S7J	.54	12SQ7GT	.49
1U5	.38	6BF5	.69	6SK7	.69	12SR7	.49
1X2A	.65	6BG6G	1.16	6SK7GT	.39	12Z3	.39
2E22	1.45	6BH6	.45	6SL7GT	.49	19BG6G	1.15
2X2A	.33	6BH6	.45	6SN7GT	.46	19T8	.61
3A8	.33	6BJ6	.46	6SQ7GT	.37	25AV5GT	1.05
3B24W	2.95	6BL7	.65	6SR7	.49	25B6GT	.40
3D6	.25	6BN6	.72	6T8	.57	25Z6GT	.37
3B26	1.95	6BQ6	.70	6U7	.49	33	.29
3Q4	.48	6BQ7	.76	6V8	.59	34	.29
3Q5GT	.48	6C4	.31	6V6GT	.38	35B5	.38
3S4	.46	6C5	.41	6W4GT	.41	35L6GT	.42
3V4	.46	6C5GT	.41	6W6GT	.41	35W4	.32
4C35	24.95	6C6	.49	6X4	.35	35Z6GT	.33
5FP14	9.95	6CB6	.42	6X5GT	.35	50B5	.41
5U4G	.49	6CD6G	1.08	7R7	.59	50C5GT	.59
5Y3G	.36	6E5	.76	12A6	.39	117Z3	.39
6A6	.35	6F6GT	.45	12A6G	.31	801A	.19
6AB7	.69	6H6	.49	12A7	.57	803	2.95
6AC7	.68	6HG6T	.49	12A77	.57	814	2.95
6AG5	.46	6J4	.99	12AUG	.34	832A	4.95
6AH6	.88	6J5GT	.34	12AUV	.52	836	1.49
6AK5	.75	6J6	.50	12AV7	.60	866A	1.49
6AL5	.34	6J7G	.49	12BA6	.72	8670	1.45
						8718	4.95
						6101CT	4.95
						9003	1.10

MINIMUM ORDER: \$10.00. Terms: 25% with order, balance C. O. D. Please include postage. All prices subject to change without notice. F. O. B. New York City. Mail Order Division:

TRANSAMERICA ELECTRONICS CORP.

120 LIBERTY ST., NEW YORK 6, N. Y., COntlandt 7-4307

EARN MORE MONEY— BE A PROFESSIONAL TELEVISION SERVICE TECHNICIAN



STEP INTO THE TOP PAY \$5,000—\$10,000 A YEAR CLASS. 7 MONTHS' SHOP TRAINING QUALIFIES YOU.

If you want to reach your goal as a Successful Service Technician you will need plenty of "KNOW HOW" to qualify for the better servicing jobs or profitable shop ownership.

SEND FOR FREE BOOK TODAY!

WESTERN TV offers real experience on live equipment in our **BIG SHOPS AND LABORATORIES** in the shortest practical time under expert instructors. Graduates are in big demand because they have the "field experience" necessary for immediate "bench" or supervisory positions. You learn every phase of Radio and TV servicing (AM, FM, VHF, UHF). WTI men win fast promotion . . . can demand better pay . . . develop highly profitable businesses of their own with the latest and most **PRACTICAL PERSONALIZED TRAINING BEHIND THEM**. You concentrate all your time on being a **PROFESSIONAL TV SERVICE TECHNICIAN**—non-essential math and engineering theory omitted. **YOU CAN EARN WHILE YOU LEARN**. Special Finance Plan. **APPROVED FOR VETERANS**. Find out how you can get into the **TOP PAY GROUP**—Send for this fact-packed book **NOW!**

WESTERN TELEVISION INSTITUTE *America's Leading Television Servicing School*

Western Television Institute Dept. R-44
341 W. 18th St., Los Angeles 15, Calif.
Without obligation, please send FREE fully illustrated booklet. (No salesman will call.)

NAME _____ AGE _____
ADDRESS _____
CITY _____ ZONE _____ STATE _____

PHOTOCON SALES

417 N. Foothill Blvd. SYcamore 2-4131
Pasadena 8, Calif. RYan 1-6751

CABLE: Photocon, Pasadena.

NEW SPRING CATALOG NOW AVAILABLE

Boonton Q-Meter 170A 30mc. to 200mc. Exc. \$350.00

General Radio Type 620A Heterodyne Frequency Meter, Panel Mounting, 300kc. to 300mc.Exc. 425.00

783 Output Power Meter General Radio Like New R101/ARN6 Receiver with 12-80A/ARN6 225.00

Radio Compass AS-313A/ARN6 Antenna, C149/ARN6 Control Box, Cables, and PlugsExc. 300.00

Hazeltine TV Alignment Signal Generator Mods. 1314, 1317, Channel 1-13 Sound & Video, with Power Supplies Mods. 1321, 1322. All rack mounted.Exc. 600.00

BC-221 or LM Freq. Meter.Exc. 99.50

Kay Elec. Mega-Sweep.Exc. 250.00

Kay Elec. Mega Pipper.Exc. 100.00

Model 228X Hickok Universal crystal controlled Signal Generator.Like New 125.00

Model 230 Clough Brønle AC Cap. & Res. Turns Ratio Bridge.Exc. 45.00

Industrial Circuit Tester Weston Model 785 Like NewExc. 125.00

APA-10 Pan Oscilloscope Receiver.Exc. PUR*

A LARGE STOCK OF ARC-1, ARC-2, ART-13, APN4, APN4B, APR4, ARB, BC-312, BC-342, BC-348, BC433G, BC-611, BC-1306, CRT-3, 196A I222, IE-19A, IE-35A, IE-36A, SCR-284, SCR-522, SCR-578, SCR-625, TCS, T10/APQ2, TS-34/317, TS-100/AP, TS-184/AP, 14C, Plugs and SelsynsPUR*

*PUR—Price upon request.

WANTED

All types of radio and electronic surplus. We especially need: AP10, APN9, APR4, ARN4, ARC1, ARC3, ART13, ATC, BC221, BC342, BC348, BC611, BC721, DY12, DY17, I100, LM10 to LM18, MG149E, MG149H, PU14, R5/ARN7, R5A/ARN7, SCR718C, TCS, TN16, TN17, TN19, TN54, TS3, TS13/AP, TS33, TS35, TS43, TS75, TS76, TS102, TS147/OP, TS148/UP, TS173, TS174, TS175, TS250, TS251, TS323, UCT, 1F, 1G, 50T, 50G, 5F, 5G, 6C, 6G, 115V, 60 c.p.s. Selsyns), and all types of Hewlett Packard, General Radio, Co., Measurements Corp., Boonton Radio, Ferris, Leeds & Northrup, and other test equipment.

Please state accurate description, condition, and your lowest price. Explain modification, if any. We pay freight charges.

V-M
BRINGS OUT THE
VIVID MUSIC
IN YOUR RECORDS



V-M 936HF High Fidelity Record Changer Attachment, \$69.95**
Model 935HF Changer, (same less metal pan), \$59.95**

V-M 936HF

HIGH FIDELITY
RECORD CHANGER
ATTACHMENT

The music in your finest records pours out all its beauty . . . clear, complete, unmarred . . . when reproduced on the "custom engineered" V-M 936HF. Your discriminating ears bear witness that here, in truth, is the Voice of Music! Exclusive motor and laminated, balanced turntable assure constant speed. Gentle tri-o-matic® spindle protects records from slap and wear. Resonance-free die cast tone arm and plug-in heads accommodate most cartridges*. Ask your V-M Dealer for a demonstration of all 936HF features. V-M Corporation is the world's largest manufacturer of phonographs and record changers.

V-M HIGH FIDELITY PORTABLE P-A SYSTEM
Powerful 8 watt package, 10" Jensen PM speaker with 25' cord, "slide-out" amplifier stays near automatic record changer. Matching leatherette cases, Model 960 record changer \$64.50**, Model 160 amplifier \$66.50**.



*Pre-amplification stage required with magnetic type pickups
**Slightly higher in the west.

UL APPROVED



PLEASE MAIL COUPON

V-M CORPORATION
Benton Harbor 4, Michigan
Please send me illustrated folder, "Bring Concert Halls Within Your Walls."
Name _____
Address _____
City _____ State _____

wedded to their TV sets as radio owners were to their radio sets "before TV."

Along with the transition in the television industry service businesses will be affected by the general readjustments that are taking place in the over-all economy. There will be lots of money in circulation but people will be more cagey about spending it.

All of this adds up to a big selling job that must be done by every business that deals with the general public. It means a selling job for service businesses, too. It is the responsibility of service to sell the public on the wisdom of keeping their TV sets and radios in good repair.

Selling Service

Every family always has more "wants" than it has money to buy. Service is something they don't like to buy because it calls for spending money they wanted to use to buy something else.

One of the most talked-about developments of the past several months has been the tremendous interest in "do-it-yourself" programs. Every place where these programs have been advertised widely the sponsors have been swamped with registrations. Since these programs have projects to interest every age level in the average family they could seriously change the TV-viewing habits of a lot of families.

They require the expenditure of money for tools and materials which puts them in competition for the funds that might be used for the purchase of a new set or the overhaul of the current set. If they reduce the TV-viewing time in a lot of homes they would reduce the need for service.

These factors in the competition for the consumer's harder-to-get dollars lead to but one conclusion.

Every service shop, big or little, should use a consistent service selling program from now on until it is swamped with work on color TV.

There are many fine service selling campaigns available to any shop that will use them. The tube manufacturers have some honeys and many of the component manufacturers provide mailing pieces that have a good impact on every set owner who gets a copy.

Parts distributors have samples of the campaigns that are available on the lines they carry. This material can be used by shops individually or it can be used as association or group mailing pieces.

One of the enigmas of service as a business is why more service groups haven't pooled their resources to conduct direct mail promotion campaigns to sell electronic service in general. Such campaigns have a good impact because the mailings reach a large percentage of the people in a given area at the same time. The selling message carries a much greater force when promoted by a group of businesses than it does when sent out by an individual business.

POWERSTATE Type No. 1126
VARIABLE VOLTAGE TRANSFORMER
New, Original Boxes
\$3395
Write for Quantity Discounts
Input 115 V. AC, 50/60 cycles. Output voltage 0-135 V. AC. Max. amps output. 1.5 a m p s. 2 KVA. Over 111 sizes. 8 3/16" x 8 1/16" x 1 1/2" With knob & scale. Send 30% deposit with order. Open accts. to rated firms.
V & H RADIO & ELECTRONICS, Dept. R
2033 W. Venice Blvd., L.A. 5, Calif.—Republic 3-1127

1000 miles received at night!
SKYMASTER PALM SIZE RADIO
Vacuum tube miniature kit covers standard broadcast band 550 to 1600 KC. Hearing aid battery powered. A PERSONAL radio for home, office, camp, etc. This ideal beginner's kit includes photo diagram for easy assembling. ALL PARTS GUARANTEED. Battery plus EXTRA "A" BATTERY, \$1.50. 1500 OHM ALNICO MAGNET powered earphone \$1.45. Flesh color 1900 ohm HEARING AID EARSET AVAILABLE AT \$4.95. C.O.D. orders acceptable with \$1 deposit within U.S. and possessions.
\$675 postpaid
Factory-Assembled, \$8.95
PRECISION RADIO ELECTRONICS
Placerville, Calif.

WHAT PRICE FIDELITY \$146.50
HI-FI ENSEMBLE
✓ Collaro 3/532 Intermix changer
✓ G.E. RPX-052 Diamond Cartridge
✓ 12" University Diffusicone
✓ 10 Watt Push-Pull HiFi Amp.
✓ Finished Base Reflex Cabinet
Complete specifications upon request.
FIDELITY UNLIMITED
63-03 39TH AVE DEPT. R
WOODSIDE 77, N. Y.

Get Your F.C.C. LICENSE Quickly!
We are specialists in preparing you, IN A MINIMUM OF TIME, to pass F.C.C. examinations for all classes of operator licenses. Both correspondence and resident training is available. Results guaranteed. Write for free brochure.
GRANTHAM SCHOOL OF ELECTRONICS
Dept. 103, 6064 Hollywood Blvd., Hollywood 28, Calif.

World's Only Recorder of its Kind
WALKIE-RECORDALL
8-LB SELF-POWERED BATTERY RECORDER
• AUTOMATIC UNDETECTED RECORDING up to 4 hrs. Records noiselessly in or out of closed briefcases, containing hidden mike while walking, riding, flying. Conferences, lectures, dictation, 2-way phone. Permanent, unalterable, indexed recording at only 3c per hr.
• PICKS UP WITHIN 60 FT. RADIUS.
• VOICE ACTIVATED "SELF-START-STOP"
• NO WIRES OR PLUGS.
MILES REPRODUCER CO., INC.
812 Broadway, N. Y. 3, N. Y. Dept. RN-2

NEWARK Recommends

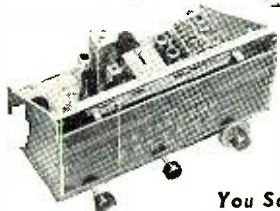

**TERRIFIC
VALUE!
in HI-FI!**

You Save on

NEWARK'S Model 100 AM-FM Radio Chassis

Tunes from 535 to 1720 kc on AM and from 88 to 108 mc on FM. Features include: extra stage of RF gain on FM, built-in preamplifier for reluctance type pickup; tone control; AVC; beam power output; attractive edge-lighted "slide-rule" dial. For 3.2 or 8 ohm speaker voice coils. 3 position equalizer switch to compensate for recording characteristics in LP, AES or European recordings. Tubes: 2-6BA6, 6BE6, 6AU6, 6AL5, 12AT7, 6AV6, 12AX7, 6V6GT, and 5Y3GT rectifier. Complete with tubes, ferrite loopstick antenna for AM and folded dipole for FM. 105-125 volts, 50/60 cycles AC. 13½x7½x10". 18 lbs. **59.50** 96F016. NET.....

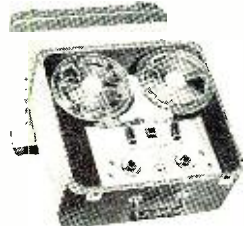

New!
PENTRON
Model
HT-225

3 Speaker High Fidelity Tape Recorder. New and unique three speaker placement assures full reproduction of original music. Two recording and playing speeds at the push of a button: 3¾ ips, for two hours of recording on a 7" reel; or 7½ ips, for one hour. Amplifier equalizes automatically at either speed. Has fast forward and rewind speeds (20-1), 70 seconds for 1200 feet. Editing key permits deleting or adding to record tape. Positive interlock switch prevents accidental erasure and tape spillage. Freq. range: 7½ ips, 50-10,000 cycles; 3¾ ips, 50-5,000 cycles. Speakers: 3-Alnico V; 2-6" woofers in recorder case; 1-4" tweeter in lid, removable to any part of the room for dimensional sound presence effect. Complete LC crossover network at 1000 cycles. Power output: 5 watts. Signal to noise ratio: 50db. Flutter less than 0.5%. Mag:c eye recording level indicator. Input jacks for microphone, radio, TV sound or phonograph. Provision for external amplifier. Case, 15¾x15x11". 105-125 volts, 60 cycles AC. 35 lbs. **168.75** 74F920. NET.....

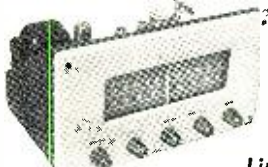

Save!
New Low
Price!

Limited Quantities

ESPEY 512C HI-FI FM-AM Tuner. Completely self-powered chassis. Features full tonal range with increased selectivity and sensitivity. Tuned RF stage and two high-gain IF stages. Built-in preamplifier for all types of magnetic cartridges, with switch for selecting crystal phono cartridge. Circuit is drift compensated. Uses nine tubes, including three dual-purpose types, plus 5Y3GT rectifier. Has six-gang tuning condenser. High and low level audio outputs. Phono input. With tubes, AM & FM antennas, hardware and es-cutcheon. 105-125 volts, 60 cycle AC. 13½" W., 8½" H., 9" D., 16 lbs. **59.50** 96F031. NET.....
F.O.E. Chicago, include shipping and insurance

Order from Dept. R-4

NEWARK
ELECTRIC COMPANY

223 W. Madison Street, Chicago 6, Illinois

April, 1954

Whatever you do, don't be a "sitting duck" in the months ahead. Sell service.

Booklet on Color TV

In the months ahead there will be a lot of confusion among set owners about color TV. Since it is a subject that can be "romanticized" in feature articles you can expect to see a lot of articles about it in the general circulation magazines. A lot of them will build misconceptions about color TV.

Recently the National Better Business Bureau released a consumer booklet titled "The Facts About Color Television," copies of which are being distributed by the *General Electric Company's* radio and television department.

It is an 8-page booklet that opens with the pertinent statement, "Color television, when it becomes a commercial reality, will develop gradually as one more stage in the orderly *evolution* of the television industry. It will not foment a *revolution* which could destroy or impair the value of television receivers now in use. Specifically, it will not obsolete the black-and-white (monochrome) receiving set you now own or contemplate purchasing."

It provides information on the development of color TV, the meaning of compatibility, the facts about conversions, availability of color programming and receivers, prices and picture sizes. -30-

COMPLETE TRAINING FOR BETTER RADIO-TV SERVICE JOBS



Let these two great new Ghirardi training books teach you to handle all types of AM, FM and TV service jobs by approved professional methods—and watch your efficiency and earnings soar!

Completely modern, profusely illustrated and written so you can easily understand every word, these books pave the way to fast, accurate service on any type of home radio-TV electronic equipment ever made. Each book is brand new. Each contains the latest data on the latest methods and equipment—NOT a re-hash of old, out-of-date material. Each is co-authored by A. A. Ghirardi whose famous RADIO PHYSICS COURSE and MODERN RADIO SERVICING were, for 20 years, more widely used for military, school and home study training than any other books of their type!

THE NEW Ghirardi RADIO-TV SERVICE LIBRARY

Almost 1500 pages and over 800 clear illustrations show step-by-step how to handle every phase of modern troubleshooting and servicing.

1—Radio and Television Receiver TROUBLESHOOTING AND REPAIR

A complete guide to profitable professional methods. For the beginner, it is a comprehensive training course. For the experienced serviceman, it is a quick way to "brush up" on specific jobs, to develop improved techniques or to find fast answers to puzzling service problems. Includes invaluable "step-by-step" service charts. 820 pages, 417 illus., price \$6.75 separately. (Outside U.S.A. \$7.25)

2—Radio and Television Receiver CIRCUITRY AND OPERATION

This 669-page volume is the ideal guide for servicemen who realize it pays to know what really makes modern radio-TV receivers "tick" and why. Gives a complete understanding of basic circuits and circuit variations; how to recognize them at a glance; how to eliminate guesswork and useless testing in servicing them. 417 illus. Price separately \$6.50 (outside U.S.A. \$7.00).

New low price...you save \$1.25!

If broken into lesson form and sent to you as a "course," you'd regard these two great books as a bargain at \$30 or more! Together, they form a complete modern servicing library to help you work faster, more efficiently and more profitably. Completely indexed so you can look up needed facts in a jiffy.

Under this new offer, you save \$1.25 on the price of the two books—and have the privilege of paying in easy installments while you use them! No lessons to wait for. You learn fast—and you learn right!

STUDY 10 DAYS FREE!

Dept. RN-44, RINEHART & CO., Inc.
232 Madison Ave., New York 10, N. Y.

Send books below for 10-day FREE EXAMINATION. In 10 days, will either remit price indicated or return books postpaid and owe you nothing.

- Radio & TV Receiver CIRCUITRY & OPERATION (Price \$6.50 separately)
- Radio & TV Receiver TROUBLESHOOTING & REPAIR (Price \$6.75 separately)

Check here for MONEY-SAVING COMBINATION OFFER... Save \$1.25. Send both of above big books at special price of only \$12.00 for the two. (Regular price \$13.25... you save \$1.25.) Payable at rate of \$3 after 10 days if you decide to keep books and \$3 a month for 3 months until the total of \$12 has been paid.

Name

Address

City, Zone, State,

Outside U.S.A.—\$7.25 for TROUBLESHOOTING & REPAIR; \$7.00 for CIRCUITRY & OPERATION; \$13.00 for both books. Cash with order, but money refunded if you return books in 10 days.

New Guaranteed TUBES Standard Brands

Prices Slashed!
Receiving and Transmitting
TUBES

One of the largest stocks in the U. S. Standard brands only! We sell—buy—trade. All inquiries answered promptly.
WRITE FOR FREE CATALOG!

Special! Vacuum Capacitors

50-15	\$ 7.50	12-32	10.00
50-32	12.50	100-20	14.50

VEEDER ROOT COUNTER

5 figure. Adds ten for each revolution of shaft in one direction; subtracts ten for each revolution in opposite direction. Size ¾"x3¼"x1" dovetail mounting; lever arm removable. Each **\$1.25**

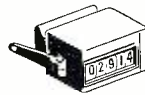

jsh SALES CO.
ELECTRONICS
Dept. R-C
7552 Melrose Ave.
Los Angeles 46,
California

EASY TO LEARN CODE

It is easy to learn or increase speed with an Instructograph Code Teacher. Affords the quickest and most practical method yet developed. For beginners or advanced students. Available tapes from beginner's alphabet to typical messages on all subjects. Speed range 5 to 40 WPM. Always ready—no QRM.

ENDORSED BY THOUSANDS!

The Instructograph Code Teacher literally takes the place of an operator-instructor and enables anyone to learn and master code without further assistance. Thousands of successful operators have "acquired the code" with the Instructograph System. Write today for convenient rental and purchase plans.

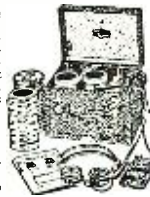

INSTRUCTOGRAPH COMPANY

4711 SHERIDAN ROAD, CHICAGO 40, ILLINOIS

Trav-Electric

DC to AC

CURRENT CONVERTERS
for Land... Sea... Air

JUST PLUG INTO CIGAR LIGHTER ON DASH
Change 6 or 12 Volt D. C.
to 110 Volt A. C. - 60 cycle



Operates Test Equipment,
All Electric Shavers

SIZE: 2 1/2" x 2 1/2" x 3 1/2"

Trav-Electric MIDGET

\$1195

Model 6-11160, 60 Cycle, 10-15 Watts



- OPERATES**
- Test Equipment
 - Turntables
 - Lights
 - Short, Long Wave Radios
 - Portable Phonographs
 - Electric Shavers, etc.

SIZE: 2 1/2" x 2 1/2" x 4 1/2"

Trav-Electric SENIOR

\$1595

Model 6-11160, 60 Cycle, 35-40 Watts



- OPERATES**
- Curling Irons
 - Radios
 - Turntables
 - Small Dictating Machines
 - Test Equipment,
 - Electric Shaver
 - Portable Phonographs

SIZE: 4" x 5" x 6"

Trav-Electric MASTER

\$2495

Model 6-11160, 60 Cycle, 40-50 Watts



- OPERATES**
- Wire Recorders
 - Amplifiers
 - Soldering Iron
 - Radios
 - Dictating Machines
 - Turntables
 - Small Electric Drill
 - Electric Shaver

SIZE: 4" x 5" x 6"

Trav-Electric SUPER

\$3795

Model 6-71160, 60 Cycle, 60-75 Watts

FULLY GUARANTEED
See your Jobber or Dealer

Terado COMPANY
ST. PAUL 14, MINNESOTA

In Canada Write: Atlas Radio Corp., Ltd.
560 King St. West, Toronto 28, Ont.
Export Sales Division: Scheel International, Inc.
4237 N. Lincoln Ave., Chicago 18, Ill. U.S.A.
Cable Address—Harshell

PHOTO CREDITS

Page	Credit
35, 37, 38, 39	Measurements Corporation
40	P. R. Mallory & Co. Inc.
40	Industrial Television Inc.
40	Standard Coil Products Company
40	Anaconda Wire & Cable Co.
43, 44	University Loudspeakers, Inc.
59, 66, 67	Radio Corporation of America
63	Walsco Electronics Corp.
64, 65	Heath Company
73	Accion Cultural Popular

ERRATUM & ADDENDUM

National Company, Inc. has announced that their NC-88 communications receiver, described on page 67 of the March issue, is now available with two differently calibrated dials. In addition to offering the calibration for 10, 11, 15, 20, 40, and 80 meters, a second scale marked for the 17, 19, 25, 31, and 49 meter short-wave bands is available at the option of the purchaser at no extra cost.

In the article "A.C. Fields in TV Receivers" (page 111 of the November 1953 issue) the copper strap shown on the choke coil in Fig. 3 should actually cover only the open part of the windings and should then go around the outside of the end laminations. The strap does not completely encircle the windings, as this would cause a short circuit.

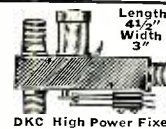

DKC High Power Fixed

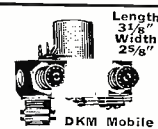

DKM Mobile

FEATURES

1. AC types entirely free of hum and are guaranteed equally as silent as DC. Transmit contact pressure in excess of 100 grams with receive contact approximately 50 grams.
 2. Causes negligible change in SWR up to 100 mc.
 3. Rated at 1000 watts in a flat line.
 4. Special type receiver connector automatically grounds receiver contact inside of connector during transmit and protects receiver from RF—Does not ground receiver. (Optional) Not available for DKM Model.
 5. External SPDT switch available (optional).
 6. Relays supplied with UHF connectors—type "N" on special order.
- AC types (all voltages) Amateur Net. \$10.50
DC types (all voltages) Amateur Net. \$9.50
Add \$1.00 for SPDT external switch add \$1.00
Add \$1.00 for special receiver connector.
Prices F.O.B. Warren—Dealer inquiries invited.
THE DOW-KEY COMPANY, Warren, Minnesota

RCA MI-2475 SOUND POWERED PHONES

NEW EXPORT PACKED
comes with 22' rubber covered cable press to talk switch are light weight, the mic is on a swivel boom that can be moved to any position in front of face. Press to talk switch clips on jacket front can be locked in on position.
NO BATTERIES—or other voltage needed—just connect to two conductor wires—good over mile or longer.



Brand New. \$1395 Ea.

Gov't Cost, \$62
Include postage with order. Shipping weight 4 lbs.
New Address: BARTO, PA.
McCONNELL'S Phone: BALLY 5-3621

Classified

Rate 50c per word. Minimum 10 words

RADIO ENGINEERING

COMPLETE radio, electronics theory & practice: television; broadcasting; servicing; aviation; marine, police radio. 12 or 18 months. Catalog. Valparaiso Technical Institute, Dept. N, Valparaiso, Ind.

FOR SALE

ISOLATION transformer 35w 117v sec. 117 or 135 plus 6.3v .45a tap. 3 lbs. \$1.95 plus postage. Removed from new equipment. Surplus bought. Empire Electronics Co., 409a Ave. L, Brooklyn 30, N. Y.

USED television sets \$25. Jones, 1115 Rambler Ave., Pottstown, Pa.

200 UNMARKED ceramics. Mixed values \$1.00. Schneider, Box 214, Seaford, N. Y.

WILCOX Gay tape recorder 2 speed \$75.00. 20 rolls 1200' magnetic recording tape \$1.50 each. Scott, 1208 First Ave., Columbus, Georgia.

SPECIALS! Police Receivers; 6 volt. mobile, 2-3 Mc., working condition: \$13.50. Sectional Whip Antennas: 16 ft. \$2.45; 32 ft. \$5.75. Radio Control: 27 1/4 Mc. Transmitter & Receiver Kit \$9.95. New Pocket TV Volts Tester 3-15 Kv \$3.95. Free catalog N. Gyro Electronic, 325 Canal St., N.Y.C.

TELEVISION Sets, \$30 up. W4API, 1420 South Randolph, Arlington, Virginia.

SURPLUS Packs: Included are tubes, condensers, resistors, etc. A bargain. \$1.00 ppd. Valen, 905 E. 210 St., Euclid 19, Ohio.

TUBES and equipment bought, sold, and exchanged. For action and a fair deal, write B. N. Gensler, W2LNI, 136-F Liberty, New York 6, N. Y.

TAPE Recorders, Tapes, Accessories. Unusual Values. Dressner, 624-R East 20th St., N.Y.C. 9.

ALUMINUM tubing, angle and channel, plain and perforated sheet. Willard Radcliff, Fostoria, Ohio.

WILLIAMSON Amplifiers—buy direct from manufacturer—\$56.00 up. Write Long Island Sound Co., 19 Bennett Place, Amityville, N. Y.

TAPE Recorders, tuners, amplifiers etc., at unique savings. Write Rand, 84 Cortlandt Street, N. Y. 7, N. Y.

MINIFON recorder, portable, complete, excellent condition. Frederick Stein, Atchison, Kansas.

TAPE Mechanism, new Twin-Trax 808-A. \$90. Foran, 3452 Hackett, Milwaukee, Wisconsin.

GLASS Cartridge Fuses . . . 450,000 type 3 AG. 4 Amp. 500 to box bulk, \$3.00 per M. Minimum order 10,000. 25% deposit, balance C.O.D. Wilco Corp., 2913 N. Pulaski Road, Chicago 51, Ill.

DIAGRAMS with service information Radio \$1.00, Television \$2.00. Give make and model. Diagram Service, Box 672-RN, Hartford, Conn.

WANTED

WILL buy all ART-13/type T-47A \$200.00; ART-13/type T-47, \$150.00; BC-348 unmodified \$65.00. BC-348 modified \$50.00; APN-9 \$200.00; ARC-3 complete \$600.00; R77 Receivers \$300.00; ARC-1 \$300.00; BC-312 \$60.00; BC-342 \$60.00. Ship via Express C.O.D. subject to inspection to: H. Finnegan, 49 Washington Avenue, Little Ferry, N. J.

WANTED—surplus selsyns, synchros, torque units, autosyns, amplidyne, aircraft radio equipment, tubes, etc. Highest prices. Lectronic Research, 715 Arch St., Philadelphia.

BUSINESS OPPORTUNITIES

REVOLUTIONARY new type TV antenna proves superior. Exclusive territory rights available. Derr, 1018 Taylor, Vallejo, California.

CORRESPONDENCE COURSES

USED correspondence Courses and Books sold and rented. Money back guarantee. Catalog free. (Courses bought.) Lee Mountain, Pisgah, Ala.

MISCELLANEOUS

SPEAKERS repaired, wholesale, guaranteed. Jobbers wanted. Amprite Speaker Service, 70 Vesey St., New York City 7.

KITS Assembled. Bridges Electronic Service, 5100 Randolph Rd., Rockville, Md.

USED Radio Vibrators rejuvenated \$1.25 each; 30 day guarantee. Radio Products Service, Box 591, Springfield, Ohio.

DEALERS & Distributors, "New Non-inflammable Line" of accessories. Cement, Tuner Lubricant, Arc Insulation, etc. First of their kind for the Service Man. A. P. Electro Lab., Box 862, Union, New Jersey.

FREE money saving bargain list. 10 MFD/600WV Oil Capacitor 98c; RCA 3APIA \$5.95; add postage. Mark Electronic, 1888 Randell Ave., Bronx 72, N. Y.

COMPLETE Speaker Repair Service. Quality Workmanship and Parts. Charles B. Albright, 12373 Pierce St., Pacoima, Calif.

BUILD your own electronic organ or miniature electronic brain. Details free. Jim Kirk, W6DEG, 1552 Church St., San Francisco 14, Calif.

RADIO & TELEVISION NEWS

Within the Industry
(Continued from page 26)

A. Gunther as vice-president; Joseph J. Stantley as treasurer; O. James Morelock as corresponding secretary; and W. Gordon Russell as recording secretary.

Directors elected for the same period include Ernest V. Amy, Ralph H. Batcher, Harry W. Houck, F. A. Klingenschmitt, Jerry Minter, and Harry Sadenwater.

* * *

VERGAL BOURLAND of *Bourland Home Appliances*, Fort Worth, Texas, has been elected president of the National Appliance and Radio-TV Dealers Association for 1954.

H. B. Price, Jr. of Norfolk, Va. was re-elected vice-president, while Victor P. Joerndt and Ken Stucky were re-elected secretary and treasurer respectively. Don Gabbert and Carl Hagstrom are the newly elected vice-presidents.

* * *

HUMBERT P. PACINI has been named manager of the engineering department of *Du Mont's* television receiver manufacturing division.



Formerly assistant manager of the department he now heads, Mr. Pacini joined the company in October 1951 as a consulting engineer. Prior to that he was a consulting engineer for leading electronics organizations in New York and New Jersey.

From 1946 to 1950 he served as assistant radar chief at the Air Forces Electronic Research Laboratory in Cambridge, Mass. Prior to that he was a project engineer on radar systems for the Evans Signal Laboratory of the Signal Corps.

* * *

CONTINENTAL RADIO CORPORATION has been merged with **INDUSTRIAL SPRING CORPORATION** and will operate under the **CONTINENTAL** name. The firm makes a line of radios and radio-phonograph combinations . . .

CARBORUNDUM COMPANY has acquired all of the capital stock of **STUPAKOFF CERAMIC AND MANUFACTURING COMPANY**, ceramic manufacturer. The firm will continue to operate under the **STUPAKOFF** name and management . . . **LEWIS AND KAUFMAN, LTD.** is the successor company to **LEWIS AND KAUFMAN, INC.**, **PACIFIC ELECTRONICS**, and **LEWIS ELECTRONICS**. The address of the firm is 17320 El Rancho Ave., Los Gatos, California . . .

DOW CORNING SILICONES LIMITED has recently been formed by **DOW CORNING CORPORATION** as a wholly-owned Canadian subsidiary with office and warehouse facilities located on Tippet Road, Wilson Heights, Toronto. D. C. R. Miller has been named general manager of the new firm.

KESTER

SOLDER

POWER TRANSFORMERS FOR SELENIUM RECTIFIERS OR FILAMENTS. PRIMARIES 115V 60 CYCLES.

12.6VCT/2A/2500V INS.	36 3/4 x 19	\$ 2.79
25.2VCT/1A/2500V INS.	42 x 19	2.79
12.6V/7A or 25.2V/3.5A/2500V INS.	61 1/4 x 19	6.17
26VCT/3A/2000V INS.	77 x 19	4.11
104VCT/3A/2000V INS.	8 3/4 x 19	11.76
78V TAP 26V/52V/6A/2000V INS.	14 x 19	22.34
13V/12A/2000V INS.	12 1/4 x 19	7.06
104VCT/6A/2000V INS.	14 x 19	24.69
156V TAP 130V/3A/2000V INS.	17 1/2 x 19	23.52
130V TAP 104V/12A/2000V INS.	26 1/4 x 19	70.56
156V/6A/2000V INS.	35 x 19	41.16
36VCT/10A/2000V INS.	35 x 19	15.87
72VCT/10A/2000V INS.	35 x 19	29.40

RACK PANEL CABINETS BLACK CRACKLE FINISH

Size	Panel Space	Price
#42 42-1/16 x 22 x 17 1/4	36 3/4 x 19	\$27.25
#47 47-5/16 x 22 x 17 1/4	42 x 19	31.20
#66 66-9/16 x 22 x 17 1/4	61 1/4 x 19	40.50
#82 82-5/16 x 22 x 17 1/4	77 x 19	48.75
#10 10 1/2 x 21 1/2 x 15	8 3/4 x 19	9.70
#14 14 x 21 1/2 x 15	12 1/4 x 19	11.88
#15 15 3/4 x 21 1/2 x 15	14 x 19	13.20
#19 19 1/4 x 21 1/2 x 15	17 1/2 x 19	15.70
#28 28 x 21 1/2 x 15	26 1/4 x 19	18.45
#36 36 3/4 x 21 1/2 x 15	35 x 19	20.45

RACK PANELS BLACK CRACKLE FINISH

Size	Steel	Aluminum
1 3/4	\$.63	\$.73
3 1/2	.70	.99
5 1/4	.88	1.50
7	.99	1.80
8 3/4	1.25	2.15
10 1/2	1.48	2.70
12	1.75	3.15
14	1.99	3.63
15 3/4	2.25	3.99
17 1/2	2.48	4.45
19 1/4	2.75	4.88
21	3.05	5.25
26 1/4	on request	
35	on request	

Grey Crackle Furnished on Request—Same Price.

All prices F.O.B. our warehouse New York
LEEDS RADIO CO.
75 Vesey St. Dept. A New York City 7

GET INTO ONE OF THESE GREATER OPPORTUNITY FIELDS

Electricity or Radio-Television

TRAIN IN THE GREAT SHOPS OF COYNE OLDEST, BEST EQUIPPED SCHOOL OF ITS KIND IN U. S.

Prepare for your future NOW. Get practical training in TELEVISION—RADIO—ELECTRICITY—ELECTRONICS—all vital in Industry. Prepare now for a better job that also offers a real future in the years ahead. Learn on real equipment at Coyne—no advanced education or previous experience needed.

Approved for Veterans—finance plan—enroll now, pay most of tuition later. Part time employment service while training if needed.

FREE BOOK Clip coupon for Big Free Illustrated Book. No salesman will call. Act NOW.

B. W. COOKE President
COYNE ELECTRICAL SCHOOL FOUNDED 1899
A TECHNICAL TRADE INSTITUTE CHARTERED NOT FOR PROFIT
500 S. Paulina St., Chicago, Dept. 44-85H
ELECTRICITY • TELEVISION • RADIO • REFRIGERATION • ELECTRONICS

B. W. COOKE, Pres.
COYNE ELECTRICAL School
500 S. Paulina St., Chicago 12, Ill. Dept. 44-85H
Send FREE BOOK and details on:

RADIO-TELEVISION ELECTRICITY

NAME.....

ADDRESS.....

CITY.....STATE.....

FIVE TOP NAME BRAND

STANDARD BRAND TUBES



at Sensational Savings!

- FULLY GUARANTEED
- INDIVIDUALLY BOXED

NO SECONDS OR REHASHED "BARGAINS." YOU CAN PLACE YOUR CONFIDENCE IN OUR DEPENDABLE, NEW TUBES.

Tube Orders Over \$25.00, with full remittance, PREPAID to you in U.S.A.

RECEIVING TUBES

Type	Net	Type	Net	Type	Net
0A2	.95	6AV5GT	1.10	7A7	.75
0B2	.85	6AV6	.48	7A8	.69
0B3	.85	6AX4GT	.72	7B6	.75
VR90	.82	6AX5GT	.85	7B7	.78
0C3	.80	6B8	.75	7B8	.78
VR105	.80	6BAG	.60	7C4	.29
0D3	.80	6BBS	.69	7C5	.69
VR150	.89	6BEG	.63	7E5	.39
024	.55	6BGGG	1.79	7F7	.85
024A	.55	6BHG	.85	7F7G	1.55
1A7GT	.77	6BK5	.95	7N7	1.20
1B3GT	.77	6BK7	1.10	7N7	.98
1B27	11.50	6BKT	1.00	7X7	.90
1H5GT	.77	6BNB	1.20	12A7E	.50
1L4	.95	6BQGGT	1.11	12A7F	.50
1L6	.95	6BQGGT	1.11	12A7G	.79
1LA6	1.10	6BY5G	1.95	12AV6	.50
1LB4	1.10	6BZ7	1.28	12AV6G	.90
1LN5	1.10	6CA	.50	12AW6	.90
1NSGT	.95	6CC	.50	12AX4	.90
1R4	.95	6CBE	.65	12AX7	.70
1R5	.75	6C6G	1.10	12AY7	1.00
1S5	.70	6CU6	2.10	12B4	.98
1T4	.50	6D6	.75	12BA6	.66
1U4	.50	6F4	3.50	12BE6	.75
1U5	.70	6F5	.68	12BE6	.64
1V	1.03	6F5GT	.68	12BH7	.85
1V2	.90	6F6	.75	12BH7	.85
1X2A	.85	6F6G	.80	12BZ7	1.10
1Z2	3.25	6F8C	.85	12SA7	.64
2K2	.35	6GGG	.85	12SA7	.70
3A4	.59	6H6	.52	12SG7	.80
3B7	.59	6J4(RCA)	5.75	12SH7	.63
3Q4	.89	6J5	.75	12SK7	.55
3Q5GT	.90	6J6	.75	12SK7	.61
3S4	.75	6J7	.75	12SL7GT	.75
3Q4	.94	6K4	2.25	12SQ7GT	.55
3V4	.75	6K4A	2.25	12SR7	.69
5W4A	1.55	6K6GT	.59	12SX7GT	1.50
5B4G	1.50	6K7	.60	14F7	.75
5U4G	.56	6L6G	1.10	19B6GG	2.05
5V4G	.82	6L6GA	1.10	19T8	.85
5W4G	.80	6L6M	1.30	25B0GGT	2.44
5X4G	.75	6N7M	.70	25L6GT	.62
5Y3GT	1.10	6N7M	.70	25W4GT	.65
6AR8T	1.10	6Q7GT	.80	25Z6GT	.70
6AB4	.65	6Q7GT	.80	28D7	1.55
6AB7	.95	6S4	.98	35B5	.60
6AC	1.04	6S7M	.98	35C5	.62
6AF4	1.39	6S7M	.98	35D6GT	.65
6AG5	.71	6S7M	.98	35W4	.45
6AG7	1.10	6SD7GT	.80	35Z3GT	.70
6AH4GT	.80	6S7M	.98	50A5	.75
6AH6	.88	6S7M	.98	50B5	.65
6AJS	1.30	6S7M	.98	50L6GT	.65
6AK5	.79	6S7M	.98	80	.65
6AK5-W	1.50	6SL7GT	.65	81	.75
6AK6	.98	6SN7GT	.73	83V	1.15
6ALS	.55	6S7M	.98	84/6Z4	.65
6AN4	1.50	6T8	.89	117Z3	.75
6AQ5	4.55	6U8	.90	117Z6	.98
6AQ6	.73	6V3	1.15		
6AS5	.70	6V6GT	.61		
6AS6	1.95	6W7GT	.75		
6AS7G	3.75	6W6GT	.75		
6AT6	.48	6XS7GT	.50		
6AUG	.59	6X8	.85		

SPECIAL PURPOSE TUBES

Type	Net	Type	Net	Type	Net
1N21B	1.88	304TH		955	.45
1N23B	2.20	(Cu Plus)	7.75	C9005	.65
1N34A	.78	310A		1616	.85
1N48	.55	(WE)	3.75	1619	1.33
1N54	.75	40A		1622	.95
2C51	4.85	(WE)	4.95	1625	.30
2E26	3.40	408A		1626	.20
2E30		(WE)	3.00	1628	.25
(Hy)	2.20	803	3.25	2050	1.40
2J39	12.50	805	2.95	5516	7.65
2J61	2.50	807	1.95	5550	3.25
2J62	25.00	809	3.50	5670	3.25
K28	25.00	812A	3.65	5654	1.75
3DP11	7.00	812B	3.65	5656	10.00
3B28	4.95	830B	2.75	5670	3.25
3C23(CE)	6.75	851	39.95	5687	2.95
3C24/24G	1.00	866A	1.25	5693	7.00
4B24	4.50			5693	6.20
5C22	44.95			5814	1.75
5D21	11.90			6006	1.85
7C25	110.00			9096	1.45
7C30	85.00			9094	.30
211V74C	.88			9096	.25

Above is only a partial listing of our huge stock. Types not listed may be ordered at approx. the same savings. Many new special purpose types in stock.

AUTHORIZED DISTRIBUTORS

CBS-HYTRON EIMAC WESTINGHOUSE

ORIGINAL JOBBERS' BOXED TUBES IN STOCK—LATE DATES, at WHOLESALE PRICE LEVELS!

TWO-COLORED TUBE CARTONS, with new Safety Partitions. Prevents Tube Breakage. This Super-Gloss Red and Black Carton is the Most Distinctive Box Available Today! Minimum: 100 any one size. Quantity prices on request.

SIZE	EACH
Miniature (6AUG, 6ALS, etc.)	.50
GT (6SN7, 6W4, etc.)	.0125
LARGE GT (1B3, 6BQGGT, etc.)	.015
LARGE G (5U4G, 6BGGG, etc.)	.02

Terms: 25% with order, balance C.O.D. All merchandise guaranteed. F.O.B., N.Y.C.

PHONE: RECTOR 2-2562

BARRY ELECTRONICS CORP.

136-F LIBERTY ST. N. Y. 6, N. Y.

INDEX OF Advertisers

APRIL 1954

ADVERTISER	PAGE	ADVERTISER	PAGE
Aaron Electronics	112	Leotone Radio Corp.	152
Airex Radio Corp.	92	Lincoln School of Radio & Television, Inc.	144
All Channel Antenna Corp.	105, 118	Littelfuse, Inc.	27
American Television & Radio Co.	24	Mallory & Co., Inc., P. R.	4th Cover
Amplifier Corp. of America	124	Mattison Television & Radio Corp.	158
Angle Genesee	149	McConnell's	80, 162
Arkay Radio Kits, Inc.	164	McGraw-Hill Book Co.	122
Arrow Sales Inc.	121	McIntosh Laboratory, Inc.	152
Associated Industries	108	Miles Reproducer Co., Inc.	160
Ashe Radio Co., Walter	89	Milwaukee School of Engineering	78
Atlas Sound Corp.	116	Mosley Electronics, Inc.	153
Audel Publishers	155	Moss Electronic Distributing Co., Inc.	91
Baltimore Technical Institute	104	Musical Masterpiece Society, Inc., The	158
Barry Electronics Corp.	164	National Company	16, 33, 92, 120, 157
Bay Electronic Distributors, Inc.	158	National Electronics of Cleveland	155
Beeco Company	113	National Radio Institute	3, 165
Belden Mfg. Co.	95	National Schools	11
Bell Telephone Laboratories, Inc.	14	Newark Electric Company	161
Blonder-Tongue Laboratories, Inc.	109	Newark Surplus Materials Co.	140
Bonica Newsreel Club	149	New Jersey Television Supply Co.	106
Boulevard Electronics, Inc.	144	Nichols Wire & Aluminum Co.	130
Brook Electronics, Inc.	136	Offenbach-Reimus	96
Burstein-Applebee Co.	146	Peak Electronics Co.	157
C B S-Hytron	20	Perma Power Company	126
Candler System Co.	130	Philco Corporation	10
Capitol Radio Engineering Institute	75	Photocon Sales	159
Centralab	21, 94, 120, 143	Pickering & Company, Incorporated	33
Century Electronics Co.	104	Platt Electronics Corp.	131
Chance Company, A. B.	113	Precise Development Co.	144
Channel Master Corp.	76, 77	Precision Radio Electronics	160
Chicago Standard Transformer Corporation	118	Premier Radio-TV Supply	115
Cleveland Institute of Radio Electronics	81	Progressive "Edu-Kits", Inc.	120
Collins Audio Products Co., Inc.	133	RCA Institutes, Inc.	19, 85, 130
Columbia Electronic Sales	114	R. S. Enterprises	137
Commissioned Electronics Co.	122	R W Electronics	125
Communication Equipment Co.	154	Radiart Corporation, The	13
Concord Radio	145	Radio City Products Co., Inc.	129
Corona Radio & T.V. Co.	122	Radio Corporation of America	93
Coyne Electrical School	139, 163	Radio Craftsmen, Inc., The	88
Crosley Division, Avco Mfg. Corp.	22	Radio Receptor Company, Inc.	137
Davis Electronics	139	Radio & Television News Book Service	107
DeForest's Training, Inc.	5	Rad-Tel Tube Co.	135
Delco Radio Corporation	15	Raytheon Manufacturing Company	2nd Cover
Douglas Instrument Laboratory	104	Reeves Soundcraft Corp.	134
Dow-Key Company, The	162	Rider Publishers, Inc., John F.	128
Dubbings Co., Inc., The	99, 100, 101, 102	Rinehart & Co., Inc.	103, 110, 145, 161
Dumont Laboratories Inc., Allen B.	102	Rohn Manufacturing Co.	86
Editors & Engineers, Ltd.	16	Sams & Co., Inc., Howard W.	98, 140
Electronic Chemical Corp.	146	Sangamo Electric Company	123
Electronic Instrument Co., Inc.	34, 118, 141, 150	Sarkes-Tarjian, Inc.	156
Electro-Voice	8	Shure Brothers, Inc.	132
Electron Tube Wholesalers, Inc.	122	Sleeper, Publisher, Milton B.	147
Erie Resistor Corporation	134	Sonotone Corporation	26
Fair Radio Sales	80	Sprague Products Company	17
Federal Telephone and Radio Company	119	Sprayberry Academy of Radio	83
Fenton Company	90	Stan Burn Radio & Electronics Co.	138
Fidelity Unlimited	160	Standard Wood Products Corp.	84
Fisher Radio Corporation	28	Steve-El Electronics Corp.	116
G & G Radio Supply Co.	82	Stevens Walden, Inc.	124
G & H Wood Products Co.	116	Sun Parts Distributors, Ltd.	139
G. L. Electronics, Inc.	143	Supreme Publications	117
General Cement Mfg. Co.	29	Sylvania Electric Products, Inc.	87
General Electric Co.	31	"TAB"	166
Goodhart, R. E.	96	Tech-Master Products Co.	113
Grantham School of Electronics	160	Tee Vee Supply Co.	127
Greenlee Tool Co.	155	Tele-Diagnosis Co.	140
Hario Sales Co.	145	Telephone Engineering Co.	164
Harrison Radio	154	Television Communications Institute	141
Harvey Radio Company, Inc.	84	Television Materials Corp.	80
Heath Company	69, 70, 71, 72	Telrex Inc.	79
Hilliard Co., Robert	149	Terado Company	162
Hughes Research and Development Laboratories	108	Transamerica Electronics Corp.	159
Indiana Technical College	132	Transvision, Inc.	106, 152, 153
Instructograph Company	161	Triad Transformer Corp.	138
International Radio & Electronics Corp.	86	Tri-State College	149
International Rectifier Corporation	112	Tung-Sol Electric, Inc.	148
International Resistance Company	3rd Cover	Turner Company, The	142
J. J. Glass Electronics Co.	130	Ultra-Audio Broadcasting System	146
JFD Manufacturing Co.	30	U.S. Crystals	111
JSH Sales Co.	161	University Loudspeakers, Inc.	151
Jones & Laughlin Steel Corporation	18	V & H Radio & Electronics	160
K & L Radio Parts Co.	124, 130	V-M Corporation	160
Kedman Co.	138	Valparaiso Technical Institute	118
Kester Solder Company	163	Walco Electronics Corporation	32
Krylon, Inc.	132	Ward Products Corp., The	97
Lafayette Radio	154	Weller Electric Corp.	90
Leeds Radio Co.	163	Western Electronics Co.	96
		Western Television Institute	159
		Westinghouse Electric Corporation	6, 7
		Wholesale Radio Parts Co., Inc.	117
		Windsor Electronic Tube Co.	104
		World Radio Laboratories	96
		Xcelite, Inc.	137
		Zingo Products	144

\$2.95 EACH OR 2 FOR \$5.00!



Genuine Telephone Company Upright telephone complete with cord in Tested and Guaranteed condition. For inter-communication or extension. Complete line of telephones and parts, inter-communication systems, switchboards, handsets, magneto and dial telephones, etc. Write for free list. C.O.D. orders accepted. All shipments F.O.B.

TELEPHONE ENGINEERING CO.
Dept. 4C4 Simpson, Pa.

ARKAY KITS WORLD'S FINEST

RADIOS PHONOGRAPHS TV TEST EQUIPMENT HI-FI Write for FREE Brochure

RADIO KITS, INC. • 120 Cedar St., N. Y. 6

Here's a NEW Way to Reach the Top in TV SERVICING

**All-practice method—
professional techniques,
skills, knowledge of
circuits, etc.**

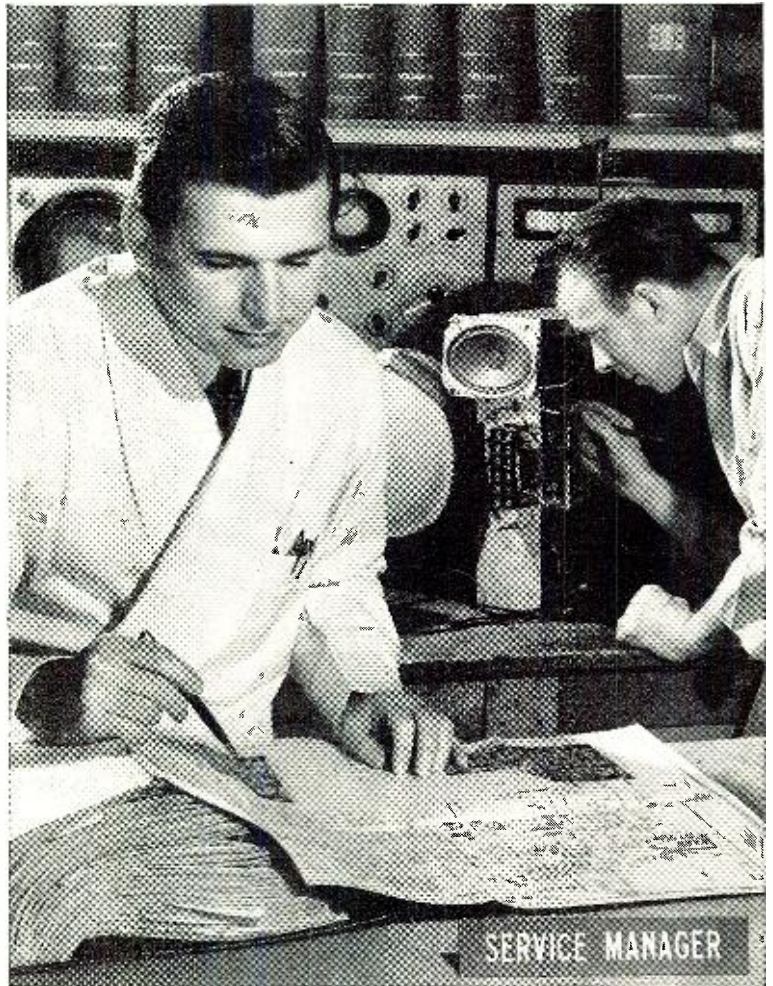

Includes 17" picture tube, all other tubes, components for a TV Receiver, Scope, Signal Generator, HF Probe. Low Introductory price under \$200, on easy terms. Mail Coupon today.

IF YOU HAVE some Radio or Television experience, or if you know basic Radio-Television principles but lack experience—NRI's new Professional Television Servicing course can train you to go places in TV servicing. This advertisement is your personal invitation to get a free copy of our booklet which describes this training in detail.

LEARN-BY-DOING "ALL THE WAY"

This is 100% learn-by-doing, practical training. We supply all the components, all tubes, including a 17-inch picture tube, and comprehensive manuals covering a thoroughly planned program of practice. You learn how experts diagnose TV receiver defects quickly. You see how various defects affect the performance of a TV receiver—picture and sound; learn to know the causes of defects, accurately, easily, and how to fix them. You do more than just build circuits. You get practice recognizing, isolating, and fixing innumerable TV receiver troubles.

You get actual experience aligning TV receivers, diagnosing the causes of complaints from scope patterns, eliminating interference, using germanium crystals to rectify the TV picture signal, obtaining maximum brightness and definition by properly adjusting the ion trap and centering magnets, etc. There isn't room on this or even several pages of this magazine to list all the servicing experience you get.

UHF AND COLOR TV MAKING NEW BOOM

Installing front-end channel selector strips in modern UHF-VHF Television receivers and learning UHF servicing problems and their solution is part of the practice you get if you live in a UHF area. To cash in on the coming color TV boom you'll need the kind of knowledge and experience which this training gives.

GET DETAILS OF NEW COURSE FREE

Once again—if you want to go places in TV servicing, we invite you to find out what you get, what you practice, what you learn from NRI's new course in Professional Television Servicing. See pictures of equipment supplied, read what you practice. Judge for yourself whether this training will further your ambition to reach the top in TV servicing. We believe it will. We believe many of tomorrow's top TV servicemen will be graduates of this training. Mailing the coupon involves no obligation.

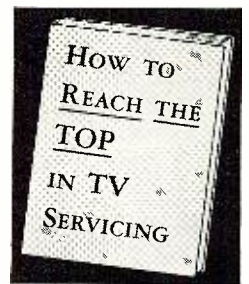

**National Radio Institute, Dept. 4DET
16th and U Sts., N.W., Washington 9, D. C.**

Please send my FREE copy of "How to Reach the Top in TV Servicing." I understand no salesman will call.

Name _____ Age _____

Address _____

City _____ Zone _____ State _____

NO. 1 CHOICE

of **ALL** Fixed Composition Resistors by almost

3 to 1*

**Not Claims! Not Predictions! But Plain Facts!
Unbiased, authoritative, independent surveys (made regularly since 1930) show IRC BT RESISTORS to be the Service Technicians' choice by a continually increasing margin. Today, BT RESISTORS are preferred over the total of all other brands combined!*

**Ask for IRC BT's...
Most Service Technicians Do!**

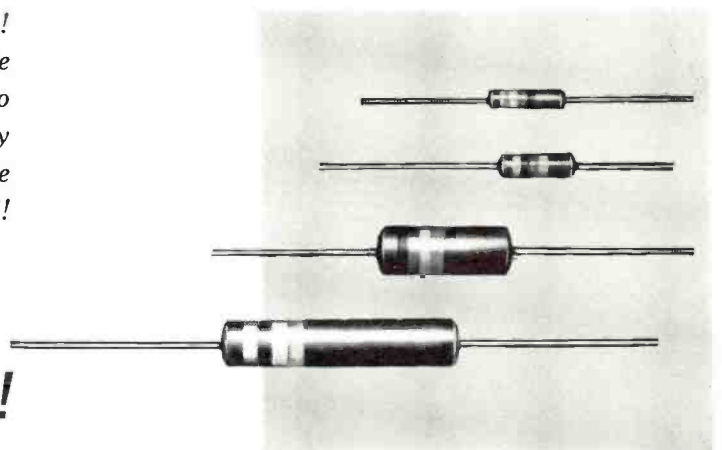

INTERNATIONAL RESISTANCE COMPANY

415 N. Broad Street, Philadelphia 8, Pa.

Wherever the Circuit Says ~~~

In Canada: International Resistance Co., Ltd., Toronto, Licensee

**Do a Lot...
With
a Little**

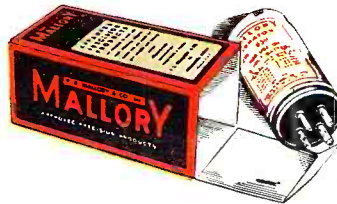

*Cover 75% of Your Replacement Needs
with Just 6 Mallory Vibrators*

You don't need a large inventory when you rely on Mallory Vibrators for your replacement work. A selection of just six Mallory Vibrators gives you coverage of 75% of your jobs.

And you can use Mallory Vibrators with complete confidence that their performance will satisfy you . . . and your customers. Mallory not only made the first commercial vibrator but supplies more to set makers than all other manufacturers combined.

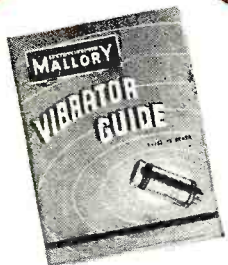

Do It Faster...

You speed selection of the right Vibrator for any job when you use the current Mallory Vibrator Guide. It's your complete cross-reference and service guide. See your Mallory Distributor about this handy book . . . or write P.O. Box 1538, Indianapolis 6, Indiana.

P. R. MALLORY & CO. Inc.
MALLORY

**CAPACITORS • CONTROLS • VIBRATORS • SWITCHES • RESISTORS
RECTIFIERS • POWER SUPPLIES • FILTERS • MERCURY BATTERIES
APPROVED PRECISION PRODUCTS**

P. R. MALLORY & CO. Inc., INDIANAPOLIS 6, INDIANA