

Editor and Asst. Publisher
OLIVER READ, D.Sc., W1ETI

Managing Editor
WM. A. STOCKLIN, B.S.

Technical Editor
H. S. RENNE, M.S.

Service Editor
CHARLES TEPFER

Assistant Editors
P. B. HOEFER
M. C. MAGNA

Television Consultant
WALTER H. BUCHSBAUM

Short-Wave Editor
KENNETH R. BOORD

Art Editor
FRANK SAYLES

Draftsmen
A. A. GANS, W2TSP
J. A. GOLANEK

Advertising Manager
L. L. OSTEN

Midwest Adv. Manager
JOHN A. RONAN, JR.

Western Adv. Manager
JOHN E. PAYNE

RADIO & TELEVISION NEWS

*First in radio-
television-audio-electronics*

Average Paid Circulation over 230,000

Radio News Trademark Reg. U. S. Pat. Office • Television News Trademark Reg. U. S. Pat. Office.

Reg. U. S. Pat. Off.

CONTENTS

NOVEMBER, 1953

A Dual Channel Recording System.....	Oliver Read	43
Pages from a Tape Editor's Notebook (Part I).....	Donald C. Hoefler	46
Increased Profits from Custom Building.....	John B. Ledbetter	48
Counterbalanced Pickup Arms.....	Morris Scott Dollen	50
Railroad Yard Loudspeaker Systems.....	Leo G. Sands	51
High Quality at Low Cost.....	Lothar Stern	54
The "Compleat Fidelity" (Part I).....	Don V. R. Drenner	57
Audio at AFIS.....	Major Eugene F. Coriell, USAF	58
The "Electronorgan" (Part I).....	Richard H. Dorf	60
How Many Watts?.....	R. H. Tanner	65
Feedback Preamp for Low-Impedance Pickups.....	Geoffrey H. Grey	66
Improving the "Fold-a-flex".....		68
Certified Record Revue.....	Bert Whyte	70
Exponential Horn Design.....	Joseph F. Sodaro	71
Transistor Guitar Amplifier.....	Louis E. Garner, Jr.	74
Which Phono Preamp?.....	Allan M. Ferres	76
The "Compentrol"—A Loudness Attenuator.....	R. Wiener & N. E. Nelson	79
Amplifier Features Phase Shift for 3D Effect.....	Alva R. Wilson	80
The Ultrasonic U-25 Enclosure.....	Edwin C. Reynolds	83
Mac's Radio Service Shop.....	John T. Frye	84
Color TV (Part 2).....	William R. Feingold	99
A "Small-Package" Modulator.....	Ed Brauner, W2URF	103
Meet the Snivet.....	M. B. Knight	104
A New V.F.O.....	Alva Wilson, W5DAD	107
A.C. Fields in TV Receivers.....	Walter H. Buchsbaum	111
Know Your 1954 Sylvania TV Receivers.....	William Nelson	115
A Sound-Actuated Electronic Switch.....	Lt. Comdr. Benjamin G. Lewis, USNR	120
An Expanded-Scale Power Line Meter.....	J. H. Mintzer	122
A Simple Versatile Substitution Tester.....	Frederic T. C. Brewer	124
6BQ7A Cascode 10-Meter Preamp.....	Charles A. Lownsbury, Jr., W2QKA	129
An Electronic Home Temperature Control.....	Harry W. Lawson	130
Multi-Voltage Power Supply.....	Glade Wilcox	134
Boeing Electrical Circuits Made by Etching Process.....	Irving Petite	140
Simplified Crystal I.F. Filter.....	William Bruce Cameron, W8IVJ	144
Audio Input Fader.....	L. H. Trent	150
A Potentiometer-Decade Adapter: The "Decapot".....	H. J. Gould	178
TV Receiver for DX.....		184
Radio-TV Service Industry News.....		208
Service Hints on Sylvania TV Sets.....		214



COVER PHOTO: High-fidelity reproduction facilities are only part of this audio-transmission laboratory. It is designed to provide maximum circuit flexibility. (See page 43). (Ektachrome by Jay Seymour)

ZIFF-DAVIS PUBLISHING COMPANY

Chairman of the Board and Publisher
WILLIAM B. ZIFF

President
B. G. DAVIS

Vice-Presidents
H. J. MORGANROTH

M. H. FROELICH

Secretary-Treasurer
G. E. CARNEY

BRANCH OFFICES

CHICAGO (1)
 64 E. Lake St., AN 3-5200
 LOS ANGELES (14)
 Staffer Center, 900 Wilshire Blvd., Mich. 9856

DEPARTMENTS

For The Record.....	The Editor	8	New TV Station Lists.....	160, 162
Spot Radio News.....		16	What's New in Radio.....	194
Within the Industry.....		34	Manufacturers' Literature.....	218
Short-Wave.....	K. R. Boord	132	New TV Products.....	222
New Audio Equipment.....		152	Technical Books.....	230

COPYRIGHT 1953
 (All Rights Reserved)

ZIFF-DAVIS PUBLISHING COMPANY
 Editorial and Executive Offices
 366 Madison Ave., New York 17, N. Y.
VOLUME 50 • NUMBER 5



Member
 Audit Bureau of
 Circulations

SUBSCRIPTION SERVICE: All communications concerning subscriptions should be addressed to Circulation Dept., 64 E. Lake St., Chicago 1, Ill. Subscribers should allow at least four weeks for change of address.
CONTRIBUTIONS: Contributors are advised to retain a copy of their manuscripts and illustrations. Contributions should be mailed to the New York Editorial Office and must be accompanied by return postage. Contributions will be handled with reasonable care, but this magazine assumes no responsibility for their safety. Any copy accepted is subject to whatever adaptations and revisions are necessary to meet the requirements of this publication. Payment covers all author's, contributor's, and contestant's rights, title, and interest in and to the material accepted and will be made at our current rates upon acceptance. All photos and drawings will be considered as part of the material purchased.

RADIO & TELEVISION NEWS

Now IN YOUR OWN HOME Learn

TELEVISION RADIO ELECTRONICS

the Amazingly Effective

D. T. I. WAY

—with the aid of BOTH
HOME EQUIPMENT
and HOME MOVIES

NO PREVIOUS EXPERIENCE NEEDED

NOW... get
**EVERYTHING
YOU NEED**

for real Laboratory-
type training
AT HOME

Above:
Work over
300
fascinating
experiments
with this
equipment

What will mailing the coupon below do for YOU? Just this! You'll find out about one of today's most remarkable... practical ways to prepare to get into America's amazing billion dollar opportunity field of TELEVISION-RADIO-ELECTRONICS. You'll see how to get into fascinating work that pays well... that offers one of America's most promising futures... that enables you to start your own business almost "on a shoe string," if you prefer this to a job opportunity.

And above all, you'll get some GOOD NEWS especially welcomed by men anxious to earn REAL MONEY in this thrilling field. For you'll see that NOW you can get the kind of practical, laboratory-type training so desirable for making real progress in Television-Radio-Electronics AND WITHOUT LEAVING HOME.

You'll see that DeForest's Training, Inc. sends everything needed to set up your own HOME LABORATORY.

You get and keep the same type of basic electronic equipment used in our modern Chicago Training Laboratories. You get home training that includes the knowledge and experience gained from training thousands of students first hand in Chicago.

And to top it all, you use DTI's amazingly effective and exclusive home training aid—**INSTRUCTIVE MOVIES**. But why not get the complete story? Mail coupon today for information-packed literature.

MODERN LABORATORIES

If you prefer, get all your preparation in our new Chicago Training Laboratories—one of the finest of its kind. Ample instructors, modern equipment. Write for details!

MILITARY SERVICE!

If you're subject to military service, the information we have for you should prove very helpful. Mail coupon today.

1. Build over 300 fascinating experiments from 16 BIG SHIPMENTS of Electronic-Radio parts which you KEEP.
2. Build valuable commercial-type test equipment—as shown to the left—which you KEEP. This includes a quality 5 INCH oscilloscope and jewel bearing Multi-Meter—both highly useful for Television work.
3. Build or keep a big 21 INCH TV Set. (D.T.I. offers another home training in Television-Radio-Electronics, but without the TV set.)
4. Use a 16 mm. movie projector and new series of highly instructive movies—a wonderful aid to help you grasp important fundamentals faster... easier... better.
5. Enjoy well-illustrated, easy-to-read lessons with handy FOLD-OUT diagrams.
6. Get an honest-to-goodness EMPLOYMENT SERVICE to help you get a good job after graduating—or assistance in starting your OWN SALES AND SERVICE BUSINESS. Mail coupon today for the complete details.



Get this
information-packed publication



FREE!

Mail Coupon Today

"ONE OF AMERICA'S FOREMOST TELEVISION TRAINING CENTERS"
—Established 1931—



DEFOREST'S TRAINING, INC.
AFFILIATED WITH
DEVEY Technical INSTITUTE
C. AGC

DEFOREST'S TRAINING, INC.

RN-11J

2533 N. Ashland Avenue, Chicago 14, Ill.

I would like your valuable information-packed publication showing how I can get started toward a good job or my own business in Television-Radio-Electronics.

Name..... Age.....
Street..... Apt.....
City..... Zone..... State.....

TRIPLET 630 Volt-Ohm-Mil-Ammeter

"speaks" for itself in any company



ing to desired circuit thru a single 2½" knob flush with the face panel. The molded switch itself embodies the most advanced engineering practices. Fully enclosed, the silvered contacts are kept permanently clean. Its rugged construction means stronger performance and longer life.

These two factors are but samples of the many ways in which on-the-job needs have been anticipated and provided for in a beautiful streamlined tester. It provides A.D-D.C. Volts, D.C. Micro-amperes, Milli-amperes, Amperes, Ohms, Megohms, Decibel and Out Put readings in a no-short design embodying interior construction with all direct connections; no harness cabling. Its fool-proof unit switch construction houses precision resistors in insulated recesses in direct connection with switch contacts.

Study the following Ranges and descriptions and compare them point by point with any similar instrument for conclusive proof that Triplet 630 "speaks" for itself in any company.

Ranges

D.C. Volts: 0-3-12-60-300-1200—at 20,000 Ohms/Volt (For Greater Accuracy on TV and other High Resistance Circuits.)

A.C. Volts: 0-3-12-60-300-1200-6000—at 5,000 Ohms/Volt

(For Greater Accuracy in Audio and other High Impedance A.C. Circuits.)

Decibels: -30, +4, +16, +30, +44, +56, +70. (For Direct Reading of Output Levels.)

D.C. Microamperes: 0-60—at 250 Millivolts.

D.C. Milliamperes: 0-1.2-12-120—at 250 Millivolts.

D.C. Amperes: 0-12—at 250 Millivolts.

*Ohms: 0-1,000-10,000—(4.4-44 at center scale).

*Megohms: 0-1-100—(4,400-440,000 center scale).

Output: Condenser in series with A.C. Volt ranges.

**Resistance ranges are compensated for greatest accuracy over wide battery voltage variations. Series Ohmmeter circuits for all ranges to eliminate possibility of battery drain when leaving switch in Ohms position.*

TRIPLET 630 Volt - Ohm - Mil - Ammeter has many significant advantages and features that make it stand distinctly apart from similar instruments in its price class. Actually in components, in engineering, in minutely accurate performance, Triplet 630 closely approaches laboratory standards.

Since the scales of any VOM comprise the means by which it makes its multiple services most valuable, the legibility and easy-read-ability are of prime importance. Triplet engineers have created in Triplet 630 the longest scales available in this size tester. (The upper arc by actual measurement is four and three-eighths inches.)

This long-scale factor accounts for the ease with which precise readings are easily made. Further legibility is gained by use of black and red scale markings. D.C. and D.B. are black and white. A.C. and Ohm markings are red on white. Ohms from one hundred million to one-tenth ohm mark the range of this amazing scale. On low ohms, center scale reading is 4.5 ohms.

The Single Switch

Further indication of the practical skill and engineering "know-how" behind Triplet 630 is the Single Switch. Its simplicity of operation assures no burn-outs thru momentary memory lapses. There is instant switch-

Get a Triplet 630 into your own hands at your distributor.
U.S.A. Dealer Net \$3950

TRIPLET ELECTRICAL INSTRUMENT COMPANY
BLUFFTON, OHIO

RADIO & TELEVISION NEWS

Check the specs...
Check performance...

Then, They'll Choose Hallicrafters



Model S-76

Double conversion receiver. Broadcast Band 538-1580 kc plus three short-wave bands covering 1720 kc-34 Mc.

Calibrated electrical handspread for easy tuning. Double superhet with 50 kc second i-f and giant 4-inch "S" meter. Five position selectivity, one r-f, two conversion, two i-f stages, temperature compensated. 3.2 or 500 ohm outputs.

Satin black steel cabinet. 18½" x 8⅞" x 9½" deep. Nine tubes, voltage regulator, and rectifier. For 105/125 V. 50/60 cycle AC. Use R-46 speaker. . . . **\$199⁹⁵**

SELECTIVITY CURVES, S-76

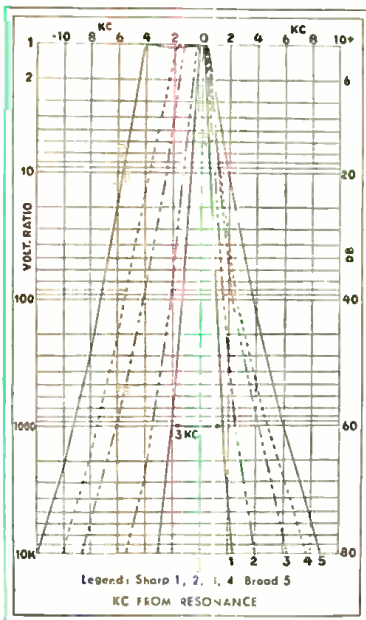

Do you know any better way, any other way, to judge SW equipment than to check the specifications and the performance? Frankly that's the only valid way we can think of to make sure you get your money's worth. Check these specs. Take a look at the selectivity curve for the S-76. It is typical of the outstanding value Hallicrafters offers in every price class.



Model HT-20. T.V.I. suppressed 100 watt AM-CW transmitter with all spurious outputs above 40 Mc at least 90 db. below full rated output.

All stages metered; single meter with eight position meter switch; output tuning indication. Frequency range of 1.7 Mc to 31 Mc continuous on front panel control. Seven tubes plus five rectifiers. For 105/125 V. 50/60 cycle **\$449⁵⁰**

Model SX-71. Covers Broadcast Band 535-1650 kc plus four short-wave bands covering 1650 kc-34 Mc. and 46-56 Mc.

Narrow Band FM one r-f, two conversion, and three i-f stages. Temperature compensated, voltage regulated. Three watt output (terminals for 500 and 3.2 ohms).

Satin black steel cabinet. 18½" x 8⅞" x 12" deep. 11 tubes plus regulator, rectifier. For 105/125 V. 50/60 cycle AC. Use R-46 speaker. **\$249⁹⁵**



Model R-46. Matching 10" PM speaker for use with Hallicrafters communications receivers SX-71, SX-76, SX-73 or SX-62. 80 to 5000 cycle range. Matching transformer with 500-ohm input. Speaker voice coil impedance, 3.2 ohms.

Satin black steel cabinet matches all Hallicrafters receivers. Cloth covered metal grille. 15" x 10⅞" x 10⅞" deep. Ship. wt. 17 lbs. **\$24⁹⁵**



hallicrafters

World's Leading Exclusive Manufacturer of Communications and High Fidelity Equipment, Radio and Television

440 West Fifth Avenue, Chicago 24, Illinois
Hallicrafters Ltd., 51 Camden Street, Toronto, Canada

E-V

for PA
LIKE ON TV

636
Slimair
DYNAMIC MICROPHONE

Gives you features similar to those in the famous E-V Slim-Trim TV Microphones. That's why it is so outstanding for Public Address, Recording and other general-purpose use.

List Price \$70

SMOOTH RESPONSE
60-13,000 CPS
HIGH OUTPUT
OMNIDIRECTIONAL
ACOUSTALLOY
DIAPHRAGM
BUILT-IN
BLAST FILTER

Can be used in the hand, on a stand, or overhead

SEND FOR BULLETIN

Electro-Voice
410 CARROLL ST. • BUCHANAN, MICH.
Export, 13 E. 40th St., N. Y. 16, U.S.A.

For the RECORD.

BY THE EDITOR

AUDIO—1923 VINTAGE

THIS, our Sixth Annual Audio Issue, sets a new high in editorial content, circulation, and in advertising. Never before has the interest in high-fidelity been so keen and it now seems certain that this interest will continue for many years.

Ever since the inception of audio as it relates to electronics this magazine has, for 34 years, published every major development. Old timers in audio will recall attempts early in the vacuum-tube era to obtain amplification by very crude methods compared to present standards. In recalling early experiments we searched back through our bound copies of *RADIO & TELEVISION NEWS* (then *RADIO NEWS*) to the year 1923 to see exactly what was going on at that time. We selected the January, 1923 issue. This particular year was an important one in audio. Engineers were just beginning to regard the advantages of audio amplification in conjunction with "loud talkers" to provide group listening instead of individuals being confined to headset reception. Crystal sets were still popular in 1923 but many of the leading manufacturers of that time were concentrating on headsets, two-step amplifiers, and various types of horns and other reproducers using the headset in conjunction with an adapter for coupling to a horn.

We found several rather interesting articles in the January, 1923 issue, among which was one entitled "A New Radio Loud-Speaker." It describes a device "consisting of a thin leaf-shaped spruce panel supported on pegs and with a little iron armature fastened to the board near the point where a stem would join the leaf. The earcap and diaphragm on an ordinary radio receiver is removed and the phone is laid on the iron armature so that it sticks to it," etc.

One need only attend the demonstrations at our audio fairs to realize that we have gone a long way (db-wise) during 30 years of audio progress. Another interesting article describes "a practical inexpensive loud-speaker." The article states that the "secret of assembling the horn is in the use of surgeon's adhesive tape," etc. and goes on to describe the construction of a horn whose seams are secured by means of the tape. A headphone-type receiver is held by clamps against the bottom of the horn. The author states that "the horn gives considerable amplification and is free from the objectionable 'tinny' sound experienced with sheet iron in horns," etc. Wow!

Another development was covered in an article entitled, "The Electro-

Static Loud-Speaker" describing a device in which the principle of functioning is determined by a peculiar operation of some imperfect dielectrics based on experiments conducted by a Dr. Gray and two Danish scientists, Messrs. Johnson and Rahbeck. It advises that "since this loud-speaker system, which may also be used as a recorder, is operated by tension it is necessary to use some step-up transformers. The polarizing tensions may be obtained from the 'B' battery which is used with the amplifier but an iron core choke coil should be connected in parallel with the device so as to permit the direct current to reach the plate of the vacuum tube. When the signals are sufficiently amplified the electro-static system provides the means for a good loud-speaker arrangement."

This device never achieved any practical use and the horn type loudspeakers dominated the so-called audio field for a long time.

This was the period when various headphones achieved great popularity for connecting to the tone arms of early phonographs. We still have some of these in our own personal collection.

One of the earliest names prominent in audio was *Magnavox*. Many old timers claim one of the earliest of developments dates back to 1913 when the *Magnavox* electro-dynamic receiver was first demonstrated publicly. Their ad, ten years later in 1923, features a 14- and an 18-inch horn using the electro-dynamic receiver.

We ran across an ad showing one of the loudspeaker cabinets. It employed a spiral tone chamber and was sold for \$12.50 and this, mind you, included a "powerful built-in unit," etc. This, of course, referred to a headphone used as the driver. The year 1923 will certainly go down in history as a "headset year." Old timers will readily recall many of the early manufacturers supplying radio headphones to the trade. They included: *Murdock, Frost, Schwarze, Elwood, Manhattan, Connecticut, Stromberg-Carlson, Leich, Holtzer-Cabot, Everett, Coryphone, Brundes, Western-Electric, Dictagraph, Kellogg, Baldwin, Brown*, to name a few. The average price for a pair of phones in 1923 was about \$7.00 and most of them were either 2000 or 3000 ohms. Audio transformers were selling for about \$3.50 and horns, complete with single headphone, at about \$40.00.

Today, 30 years later, audio has become "big business" and a source of real pleasure to millions. We look forward to another 30 years of audio progress O.R.

RADIO & TELEVISION NEWS



NEW HOME OF ALLIED RADIO

ultra-modern facilities TO SERVE YOU BEST

FREE!

get your
value-packed
**1954
ALLIED**
268-PAGE CATALOG

The World's Largest Stocks

- TV and Radio Parts
- Test Instruments
- High-Fidelity Equipment
- Custom TV Chassis
- AM, FM Tuners and Radios
- Recorders and Supplies
- P. A. Systems, Accessories
- Amateur Station Gear
- Builders' Kits, Supplies
- Equipment for Industry

**Fastest Service in
Electronic Supply**

the only
COMPLETE
catalog for
everything in
**TV, Radio and
Industrial
Electronics**

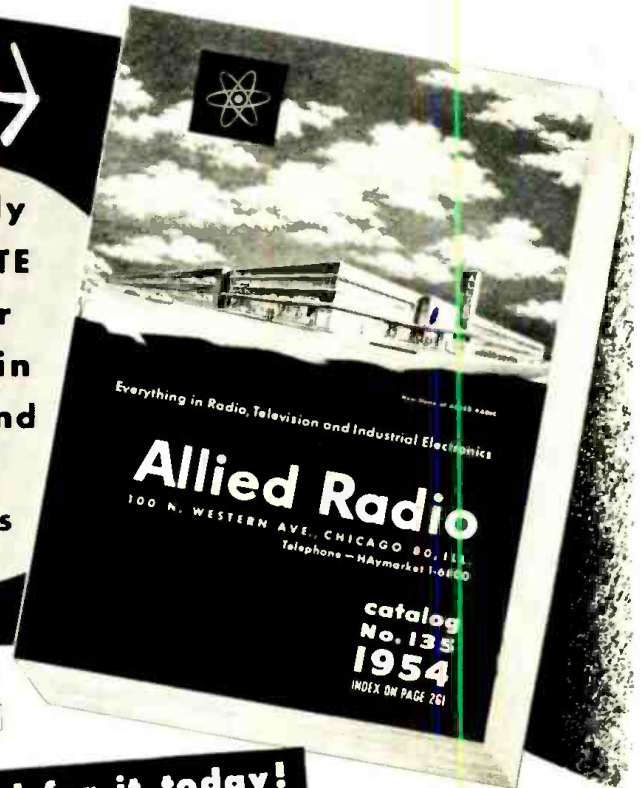

Send for it today!

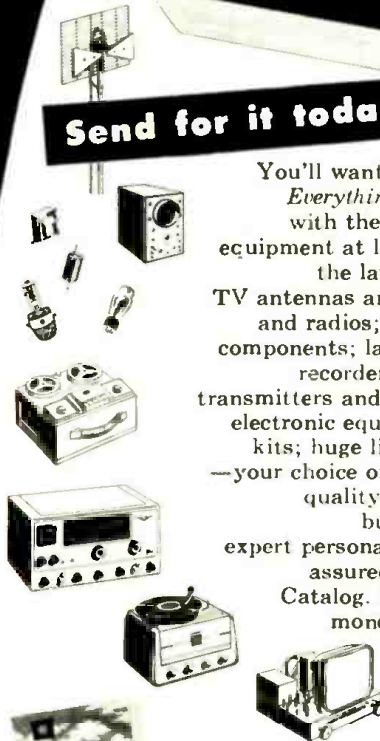

You'll want the *one* complete Buying Guide to *Everything in Electronics*—268 pages packed with the world's largest selection of quality equipment at lowest, money-saving prices. See all the latest releases in custom TV chassis, TV antennas and accessories; AM and FM tuners and radios; *everything* in High-Fidelity custom components; latest P.A. Systems and accessories; recorders and supplies; Amateur receivers, transmitters and station gear; specialized industrial electronic equipment; test instruments; builders' kits; huge listings of parts, tubes, tools, books—your choice of the world's *most complete stocks* of quality equipment. ALLIED gives you *every* buying advantage: speedy shipment, expert personal help, lowest prices, liberal terms, assured satisfaction. Get the 1954 ALLIED Catalog. Keep it handy—and save time and money. Send for your **FREE** copy today.

**SAVE ON EVERYTHING
IN ELECTRONICS**

**SEND FOR THE LEADING
ELECTRONIC BUYING GUIDE**

free

ALLIED RADIO
World's Largest Electronic Supply House

EASY-PAY TERMS

Use ALLIED'S liberal Easy Payment Plan—only 10% down, 12 months to pay—no carrying charge if you pay in 60 days. Available on Hi-Fi and P. A. units, recorders, TV chassis, test instruments, Amateur gear, etc.

TV and HI-FI SPECIALISTS

To keep up with developments in High-Fidelity and TV, look to ALLIED. Count on us for all the latest releases and largest stocks of equipment in these important fields. If it's anything in High-Fidelity or Television—we have it in stock!

ALLIED RADIO CORP., Dept. 1-L-3
100 N. Western Ave., Chicago 80, Illinois

Send FREE 268-Page 1954 ALLIED Catalog.

Name _____

Address _____

City _____ Zone _____ State _____

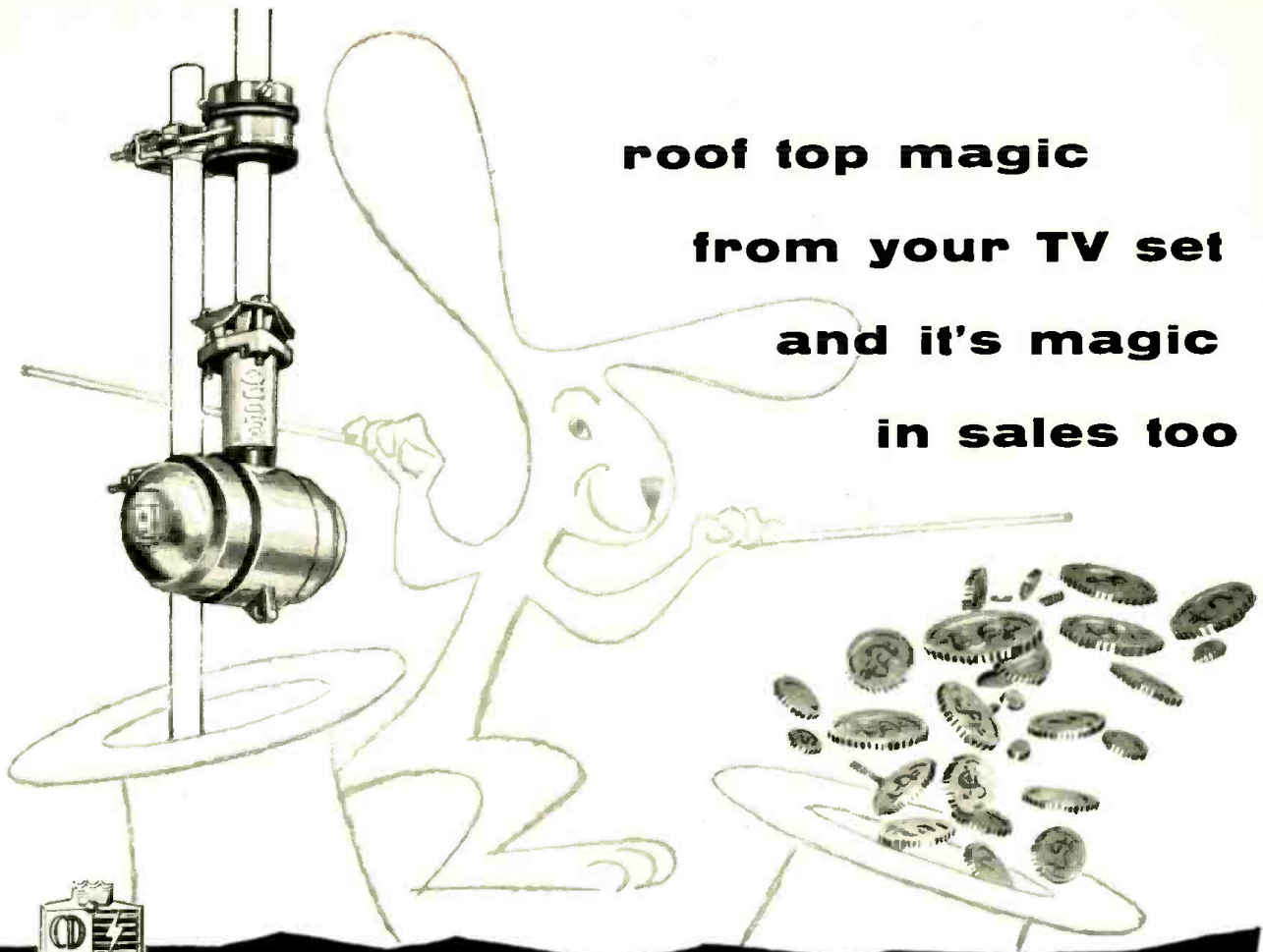

the C·D·R Rotors

NATIONALLY PROMOTED IN TELEVISION

★ There's real MAGIC to the CDR ROTOR!
The way it IMPROVES any TV picture is magic
...the way it sells... is magic! BUT... the real
answer is quality manufacture of a proven design!

That adds up to continued dependable
performance... CDR ROTORS ARE BUILT TO
LAST... built to perform under any conditions!

NOW... MORE IN DEMAND THAN EVER
BEFORE with the BIG consumer advertising
campaign in full swing... if you don't
have your BIG CDR PROMOTION KIT with
selling and advertising aids... write us
for your kit... to help you sell EVEN MORE!

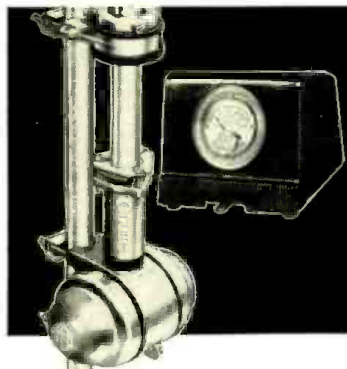

TR-12... a special combination value consisting of complete rotor including thrust bearing... handsome modern design cabinet with meter control dial **\$47.95**

TR-11... same as TR-12 without thrust bearing **\$44.95**

TR-2... the HEAVY DUTY rotor especially suited for special TV antenna installations. Complete rotor with "Compass Control" cabinet having illuminated "perfect pattern" dial. **\$49.95**

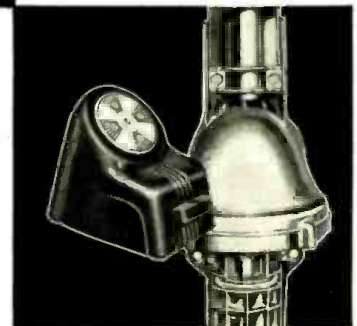

THE RADIART CORPORATION
CLEVELAND 13, OHIO



THE CORNELL-DUBILIER ELECTRIC CORP.
SOUTH PLAINFIELD, N.J.

Quick TV Success can be yours...

if you act now!

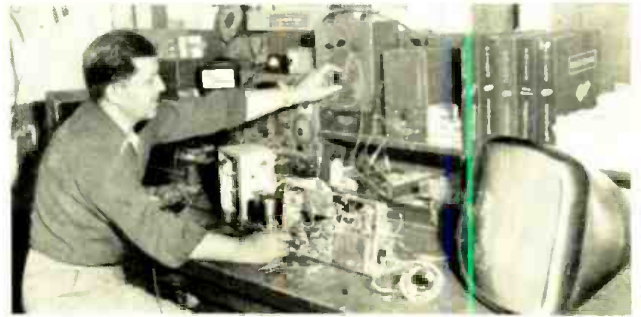

- Prepare now for the new Radio-TV-Electronics boom. Get in on VHF and UHF . . . aviation and mobile radio . . . color TV . . . binaural sound! The International Correspondence Schools can help you!

If you've ever thought about Radio or Television as a career . . . if you have the interest, but not the training . . . if you're waiting for a good time to start . . . NOW'S THE TIME!

No matter what your previous background, I.C.S. can help you. If Radio-TV servicing is your hobby, I.C.S. can make it your own profitable business. If you're interested in the new developments in Electronics, I.C.S. can give you the basic courses of training you need. If you have the job but want faster progress, I.C.S. can qualify you for promotions and pay raises.

I.C.S. training is success-proved training. Hundreds of I.C.S. graduates hold top jobs with top firms like R.C.A., G.E., DUMONT, I.T.&T. Hundreds of others have high ratings in military and civil service. Still others have successful businesses of their own.

With I.C.S., you get the rock-bottom basics and theory as well as the all-important bench practice and experimentation. You learn in your spare time—no interference with business or social life. You set your own pace—progress as rapidly as you wish.

Free career guidance: Send today for the two free success books, the 36-page "How to Succeed" and the informative catalog on the course you check below. No obligation. Just mark and mail the coupon. With so much at stake, you owe it to yourself to act—and act fast!

CHECK THESE SEVEN FAMOUS I. C. S. COURSES—ONE FOR YOU!

- PRACTICAL RADIO-TELEVISION ENGINEERING**—Foundation course for radio-television career. Basic principles plus advanced training. Radio, Sound, TV.
- TELEVISION TECHNICIAN**—To qualify you for high-level technical positions in television. Camera, studio, transmitter techniques. Manufacture, sale and installation of TV equipment.
- TELEVISION RECEIVER SERVICING**—Installation, servicing, conversion. Dealership. For the man who knows about radio and wants TV training.
- RADIO & TELEVISION SERVICING**—Designed to start you repairing, installing and servicing radio and television receivers soon after starting the course.
- RADIO & TELEVISION SERVICING WITH TRAINING EQUIPMENT**—Same as above but with addition of high-grade radio servicing equipment and tools.
- RADIO OPERATING COURSE**—Special course to help you pass the Government examination for operator's licenses Cyde. TV, FM, Radioregulations.
- INDUSTRIAL ELECTRONICS**—Broad, solid background course devoted to the electron tube and to its many applications.

INTERNATIONAL CORRESPONDENCE SCHOOLS



BOX 2251-C, SCRANTON 9, PENNA.

Without cost or obligation, send me "HOW to SUCCEED" and the booklet about the course BEFORE which I have marked X:

- | | | | | |
|---|---|--|--|---|
| <p>ART</p> <ul style="list-style-type: none"> <input type="checkbox"/> Commercial Art <input type="checkbox"/> Magazine and Book Illustrating <input type="checkbox"/> Cartooning <input type="checkbox"/> Show Card and Sign Lettering <input type="checkbox"/> Fashion Illustrating <p>AUTOMOTIVE</p> <ul style="list-style-type: none"> <input type="checkbox"/> Automobile Mechanic <input type="checkbox"/> Auto Elec. Technician <input type="checkbox"/> Auto Body Rebuilding and Refinishing <input type="checkbox"/> Diesel—Gas Engines <p>AVIATION</p> <ul style="list-style-type: none"> <input type="checkbox"/> Aeronautical Engineering Jr. <input type="checkbox"/> Aircraft Engine Mechanic <input type="checkbox"/> Airplane Drafting <p>BUILDING</p> <ul style="list-style-type: none"> <input type="checkbox"/> Architecture <input type="checkbox"/> Arch. Drafting <input type="checkbox"/> Building Contractor <input type="checkbox"/> Estimating <input type="checkbox"/> Carpenter and Mill Work <input type="checkbox"/> Carpenter Foreman <input type="checkbox"/> Reading Blueprints <input type="checkbox"/> House Planning <input type="checkbox"/> Plumbing | <ul style="list-style-type: none"> <input type="checkbox"/> Heating <input type="checkbox"/> Steam Fitting <input type="checkbox"/> Air Conditioning <input type="checkbox"/> Electrician <p>BUSINESS</p> <ul style="list-style-type: none"> <input type="checkbox"/> Business Administration <input type="checkbox"/> Certified Public Accountant <input type="checkbox"/> Accounting <input type="checkbox"/> Bookkeeping <input type="checkbox"/> Stenography and Typing <input type="checkbox"/> Secretarial <input type="checkbox"/> Federal Tax <input type="checkbox"/> Business Correspondence <input type="checkbox"/> Personnel and Labor Relations <input type="checkbox"/> Advertising <input type="checkbox"/> Retail Business Management <input type="checkbox"/> Managing Small Business <input type="checkbox"/> Sales Management <input type="checkbox"/> Salesmanship <input type="checkbox"/> Traffic Management <p>CHEMISTRY</p> <ul style="list-style-type: none"> <input type="checkbox"/> Chemical Engineering <input type="checkbox"/> Chemistry <input type="checkbox"/> Analytical Chemistry <input type="checkbox"/> Petroleum—Nat'l Gas <input type="checkbox"/> Pulp and Paper Making <input type="checkbox"/> Plastics | <p>CIVIL, STRUCTURAL ENGINEERING</p> <ul style="list-style-type: none"> <input type="checkbox"/> Civil Engineering <input type="checkbox"/> Structural Engineering <input type="checkbox"/> Surveying and Mapping <input type="checkbox"/> Structural Drafting <input type="checkbox"/> Highway Engineering <input type="checkbox"/> Reading Blueprints <input type="checkbox"/> Concrete Construction <input type="checkbox"/> Sanitary Engineering <p>DRAFTING</p> <ul style="list-style-type: none"> <input type="checkbox"/> Aircraft Drafting <input type="checkbox"/> Architectural Drafting <input type="checkbox"/> Electrical Drafting <input type="checkbox"/> Mechanical Drafting <input type="checkbox"/> Structural Drafting <input type="checkbox"/> Sheet Metal Drafting <input type="checkbox"/> Mine Surveying and Drafting <p>ELECTRICAL</p> <ul style="list-style-type: none"> <input type="checkbox"/> Electrical Engineering <input type="checkbox"/> Electrician <input type="checkbox"/> Electrical Maintenance <input type="checkbox"/> Electrical Drafting <input type="checkbox"/> Electric Power and Light <input type="checkbox"/> Lineman <p>HIGH SCHOOL</p> <ul style="list-style-type: none"> <input type="checkbox"/> High School Subjects | <ul style="list-style-type: none"> <input type="checkbox"/> College Preparatory <input type="checkbox"/> Mathematics <input type="checkbox"/> Commercial <input type="checkbox"/> Good English <p>MECHANICAL AND SHOP</p> <ul style="list-style-type: none"> <input type="checkbox"/> Mechanical Engineering <input type="checkbox"/> Industrial Engineering <input type="checkbox"/> Industrial Supervision <input type="checkbox"/> Foremanship <input type="checkbox"/> Mechanical Drafting <input type="checkbox"/> Machine Design-Drafting <input type="checkbox"/> Machine Shop Practice <input type="checkbox"/> Tool Design <input type="checkbox"/> Foreman Instrumentation <input type="checkbox"/> Machine Shop Inspection <input type="checkbox"/> Reading Blueprints <input type="checkbox"/> Toolmaking <input type="checkbox"/> Gas—Electric Welding <input type="checkbox"/> Heat Treatment—Metallurgy <input type="checkbox"/> Sheet Metal Work <input type="checkbox"/> Sheet Metal Pattern Drafting <input type="checkbox"/> Refrigeration <p>POWER</p> <ul style="list-style-type: none"> <input type="checkbox"/> Combustion Engineering <input type="checkbox"/> Diesel—Electric <input type="checkbox"/> Electric Light and Power | <ul style="list-style-type: none"> <input type="checkbox"/> Stationary Steam Engineering <input type="checkbox"/> Stationary Fireman <p>RADIO, TELEVISION, COMMUNICATIONS</p> <ul style="list-style-type: none"> <input type="checkbox"/> General Radio <input type="checkbox"/> Radio Operation <input type="checkbox"/> Radio Servicing—FM <input type="checkbox"/> Television <input type="checkbox"/> Electronics <input type="checkbox"/> Telephone Work <p>RAILROAD</p> <ul style="list-style-type: none"> <input type="checkbox"/> Locomotive Engineer <input type="checkbox"/> Diesel Locomotive <input type="checkbox"/> Air Brakes <input type="checkbox"/> Car Inspector <input type="checkbox"/> Railroad Administration <p>TEXTILE</p> <ul style="list-style-type: none"> <input type="checkbox"/> Textile Engineering <input type="checkbox"/> Cotton Manufacture <input type="checkbox"/> Rayon Manufacture <input type="checkbox"/> Woolen Manufacture <input type="checkbox"/> Loom Fixing <input type="checkbox"/> Finishing and Dyeing <input type="checkbox"/> Textile Designing |
|---|---|--|--|---|

Name _____ Age _____ Home Address _____
 City _____ Zone _____ State _____ Working Hours _____ A.M. to _____ P.M.
 Occupation _____

Special tuition rates to members of the U.S. Armed Forces. Canadian residents send coupon to International Correspondence Schools Canadian, Ltd., Montreal, Canada.



Presenting

“RECTIFIER RED”

the new product-line color for

Federal MINIATURE SELENIUM RECTIFIERS

FEDERAL—the *original* miniature—is saying goodbye to *gray*. The new bloom is “*Rectifier Red*” . . . a striking color that instantly tells servicemen they’re getting the rectifier efficiency and long life that created tens of millions of profit opportunities for radio-TV servicing . . . tells them they’re getting the *quality* that keeps Federal miniatures the best-seller in America’s vast and growing rectifier replacement market!

Look for “*Rectifier Red*” . . . get the performance that *clicks* . . . the replacement profit that *sticks*! See your Federal Distributor for Federal miniatures in handy 8-unit kits . . . in quantity lots . . . or in individual packages sold through Federal’s self-service rectifier dispenser . . . on hundreds of counters! See your “FTR” Distributor now, or write to Dept. F-759



“America’s first and largest manufacturer of selenium rectifiers”

Federal 
Telephone and Radio Company

100 KINGSLAND ROAD, CLIFTON, N. J.

In Canada: Federal Electric Manufacturing Company, Ltd., Montreal, P. Q.
Export Distributors: International Standard Electric Corp., 67 Broad St., N. Y.

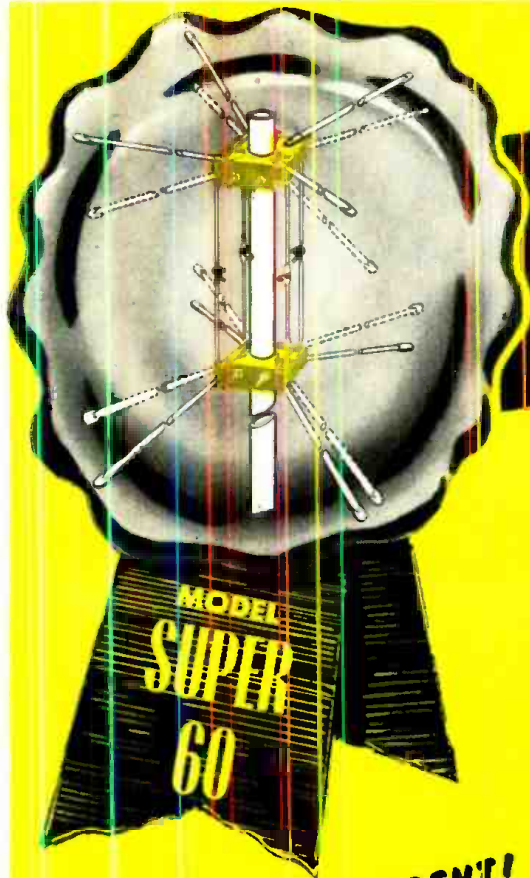

GUARANTEED PERFORMANCE

MONEY BACK GUARANTEED TO RECEIVE *All* UHF and *All* VHF STATIONS IN *All* DIRECTIONS FOR 60 MILES WITHOUT A ROTORMOTOR OF ANY KIND!!

**SO NEW! SO DIFFERENT!
IT'S PATENTED!**

- # 2,585,670
- # 2,609,503
- # 2,625,655
- # 2,644,091

OTHERS PENDING

WORLD'S MOST POWERFUL UHF-VHF TELEVISION ANTENNA

While antenna reception is guaranteed for 60 miles, perfect pictures have been consistently received as far as 160 miles from stations.

NEW POLYMICALENE 4 CONDUCTOR TRANSMISSION LINE

- Low Loss External - Air Dielectric
- Matched Impedance
- Eliminates End Sealing
- Eliminates Condensation
- Up to 50% Less Loss Than Tubular When Wet
- Easily Spiraled
- No Breaking or Shorting
- Patents Pending - T. M. Reg.



All NEW DESIGN FOR '54

- LOW-LOSS SWITCH
- LOW-LOSS PHENOLIC INSULATORS
- USES NEW 4-CONDUCTOR MATCHED IMPEDANCE LINE
- ONLY 10 INCH SPACING BETWEEN ANTENNA BAYS



The 9 position selector switch electronically rotates the antenna in a stationary position.

LIST PRICE
\$36⁷⁵
SEE YOUR LOCAL JOBBER

PRICE INCLUDES

- Complete stacked array • 4 stacking bars • 9 position switch • Switch-to-set coupler • 2 - 7 1/2" stand offs • Individually boxed in mailable carton

Money Back Guarantee IN EVERY AREA
IN ALL LOCATIONS WITH STATIONS IN ALL DIRECTIONS
The new All Channel Model Super 60 is guaranteed to bring in immediately on installation every UHF and every VHF station within 60 miles in any direction, giving clearer and sharper pictures than any antenna or combination of antennas with or without rotor motors.
If, immediately on installation, it fails to do this, we agree to refund to the jobber to whom we sold and shipped it, his full purchase price.

ALL CHANNEL ANTENNA CORP.

70-07 Queens Blvd., Woodside 77, N. Y.

Hickory 6-2304



NEW IMPROVED ZIG-ZAG

with New Re-entrant Network

OUTPERFORMS ON ALL CHANNELS

(Using Single Lead-in)

Re-entrant network
as used on ZZ16H
and 12L

The sensational, radically new TRIO ZIG-ZAG antenna, introduced less than a year ago, has enjoyed the greatest acceptance of any TV antenna ever made!

NOW — TRIO introduces a radically new improvement that makes this great antenna even greater than before! It consists of a new re-entrant type impedance matching network for ZIG-ZAG antennas which now provides an almost perfect impedance match to the feedline on EVERY channel!

UNIFORMLY HIGH GAIN

There is no measurable difference in gain on ANY channel whether operating stacked high-band and low-band ZIG-ZAG antennas from a single feed-line or using them separately. There is no insertion loss such as found in isolation networks. For example, the ZZ12L and ZZ16H now provide 3 to 6 DB. more gain than elaborate, stacked cut-to-channel arrays. This additional gain is often the difference between a good picture and a poor one.

Elaborate tests conducted all over the country under every conceivable type of terrain and in locations where ten out of the thirteen VHF channels were available, proved conclusively that TRIO ZIG-ZAG ANTENNAS OUTPERFORM ANY and EVERY colinear, conical, or broadband multi-element Yagi on the market today — AND ZIG-ZAG

does it on ALL VHF channels. Whether its a new installation or a replacement, INSIST ON TRIO ZIG-ZAG TV ANTENNAS, with their EXTREMELY HIGH GAIN, SHARP DIRECTIVITY, SUPERIOR LINE MATCH, MULTI-CHANNEL COVERAGE and RUGGED-LONG LIFE CONSTRUCTION.

Illustrated above is the NEW re-entrant network developed by TRIO engineers for the model ZZ12L and ZZ16H combination. Current shipments will include the complete network. There is nothing else needed for single feed-line operation!

Used stacked — or separately — TRIO ZIG-ZAG antennas are the hottest ever designed!

New descriptive literature available direct or from your supplier.

New network supplied with all high-gain Zig-Zag models

ANOTHER NEW TRIO PLANT TO SERVE YOU!
This modern, new addition to TRIO's present facilities adds 24,000 sq. ft. of manufacturing space. A new laboratory, not illustrated, has also been added.
Although TRIO has definite commitments for 60 cars of aluminum to meet increased demands, we are not sure we will be able to fill all orders. We suggest you order now!



TRIO

Manufacturing Co.

GRIGGSVILLE, ILLINOIS

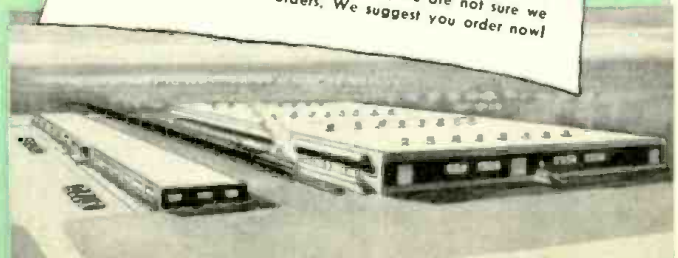

TRIO

AMERICA'S MOST DEPENDABLE TV ROTATOR

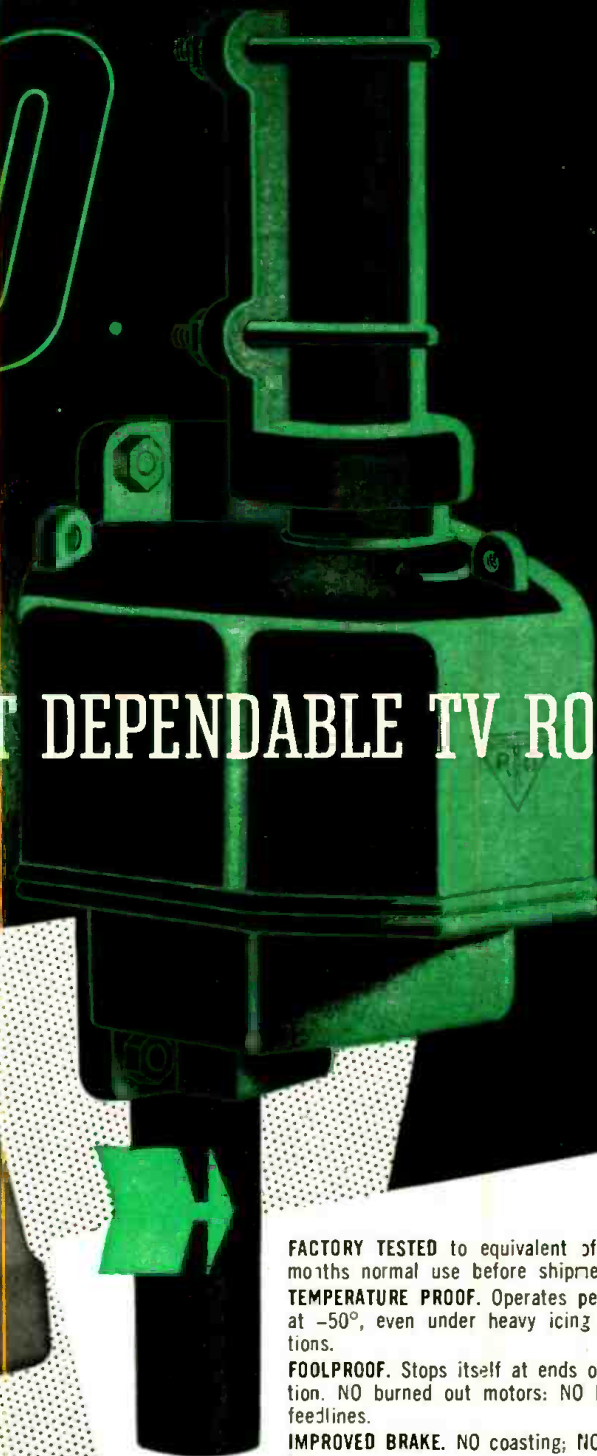

FACTORY TESTED to equivalent of three months normal use before shipment.

TEMPERATURE PROOF. Operates perfectly at -50° , even under heavy icing conditions.

FOOLPROOF. Stops itself at ends of rotation. NO burned out motors; NO broken feedlines.

IMPROVED BRAKE. NO coasting; NO drifting.

TWO MOTORS. Separate motor for each direction of rotation.

SMART—EASY TO USE Control unit. Indicates direction without turning rotator.

TWO YEAR GUARANTEE instead of the usual one.

**Write for literature.*



TRIO Manufacturing Co.

GRIGGSVILLE, ILLINOIS

NEW! 4 P.E.C.* KITS

Right now there are 100,000,000 radio and TV sets — 4 or more years old — in everyday use. These sets do *not* have P.E.C.'s. You'll save service time and parts investment — have greater confidence in your service jobs if you replace old-style components with P.E.C.'s. Centralab P.E.C. kits are your best supply source!



PCK-18

18 P.E.C. units. Replace 42 old-style resistors and 52 old-style capacitors.
Net - - - \$9.00



PCK-110

110 P.E.C. units. Replace 255 old-style resistors and 52 old-style capacitors.
Net - - - \$55.80



PCK-220

220 P.E.C. units. Replace 525 old-style resistors and 620 old-style capacitors.
Net - - - \$115.80



All prices subject to change without notice

PCK-45

45 P.E.C. units. Replace 106 old-style resistors and 133 old-style capacitors.
Net - - - \$24.00

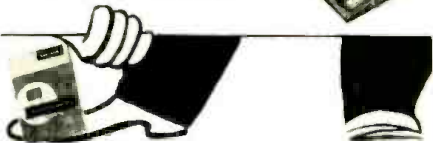

This P.E.C. Guide No. 2 (included with each kit) tells you how and when to use P.E.C.'s. Shows cross indexing — schematics — tells you how to test P.E.C.'s. Get complete details from your CRL distributor or use coupon below.

Centralab

*Trademark — Printed Electronic Circuits

CENTRALAB
A Division of Globe-Union Inc.
910-K E. Keefe Ave., Milwaukee 1, Wis.

Please send name of distributor stocking P.E.C. Kits, also additional technical data.

Name _____

Firm _____

Address _____

City _____ Zone _____ State _____

Spot Radio News

* Presenting latest information on the Radio Industry.

By RADIO & TELEVISION NEWS'
WASHINGTON EDITOR

COMPATIBLE COLOR'S long epic march to the nation's capitol, seeking that golden seal of approval, appears at long last to be drawing to an end, and a mighty grand and glittering end. For at this writing, the records indicate that it seems to be just a matter of technical formality, before the final go-ahead is flashed to the nation.

As the crucial 30-day deadline passed, no serious objections to the Commission's intent to approve came forth. Those who did issue briefs were critical of the high costs quoted for the first output of color sets, and the possible inability of industry to cope with the economic hazards which such prices might introduce; but none objected to the system or its capabilities.

A tip-off on the endorsement that is expected, loomed when NTSC's popular chairman, Dr. Baker, appeared in the office of the Commission's headman, Rosel H. Hyde, with an official 16-volume color-committee report on the final filing day, and posed with the government representative for several photos. In presenting the huge record to Hyde, Baker said: "These documents represent an investment of more than one-million manhours of intensive work by the top engineers of the television industry, in an effort to develop satisfactory standards for commercial color television. . . . If measured in terms of dollars, this represents an investment by industry of nearly ten-million dollars over a period of two-and-a-half years. The result, we feel, has been the creation of technical signal specifications that not only will give the public a good television service, but also will permit keen competition among various companies within the industry."

Accepting the report, the Commissioner noted that this was a notable occasion, for most in industry had approved the work, and the few who did not go along completely, did not offer any truly serious objections.

Actually only four companies filed critical comments with the Commission. Particularly disturbed was U. A. Sanabria, who felt that economists should be consulted first, before a decision is set, to advise whether the nation is really ready for receivers that will cost around a thousand dollars. In his opinion, color TV should

be restricted to a single area for at least three years until there is . . . "positive proof that it answers the question of economy" . . . and there appears . . . "an adequate capacity to supply, so that the television industry can roll smoothly when it is introduced." He also wanted to be sure that the introduction of color at this time will . . . "not foster a monopoly through inadequate distribution of know-how, nor that it will load onto the public the impossibility of getting trained men to service these sets once they are on the market." Noting that the system offered was truly a . . . "masterpiece of electronic science, which may be regarded as a technical miracle. . . .", he asked if the development wasn't a . . . "little premature and too expensive to fit into our economy."

Also striking out at the price problem was *Chromatic*, who urged the Commission to seek adequate assurance that inexpensive chassis will eventually be forthcoming. They were well satisfied with the system and its ability to produce satisfactory color pictures, the brief continued, but the matter of lower costs was also fundamental. Insurance that cheaper sets will be available must obtain, they insisted, and such protection must be supported by demonstrations of actual equipment built to sell at the lower prices, with tests being made under typical home conditions.

Paramount also felt that the Commission should delay final action on any new standards until the cost item has been more fully explored. They believed that it . . . "would be unfortunate, if in the interest of speed, the Commission were to adopt a color system which would be of use only to those who could afford expensive receivers, when by taking a little more time, a complete study could be made of methods which hold forth promise of being able to produce reasonably-priced receivers."

The fourth brief, filed by *CBS*, told the Commission that while they also felt that the NTSC receiving gear did not meet the price criterion, and in addition the equipment did not, in their opinion, satisfy the simplicity-of-operation point, compatible color standards would now be in the public interest, since eventually both the cost



WANT MORE PAY? MORE SECURITY? A JOB WITH FUTURE UNLIMITED?

VETERANS! CIVILIANS! NO EXPERIENCE NECESSARY!

Go Into TELEVISION

I'll train you at home... in your spare time

for better-pay jobs in TV

L. C. Lane, B.S., M.A.
President, Radio-Television Training Association
Executive Director, Pierce School of Radio & Television

LEARN MORE

I give you ALL the practical training you need to qualify for the highest-paid technician jobs in TV.

RADIO-FM-TV TECHNICIAN TRAINING

No experience necessary! You learn by practicing with equipment I send you. It's easy! I give you the same successful guidance that has helped hundreds of men towards a TV career. Many started with only grammar school training.

FM-TV TECHNICIAN TRAINING

Saves you months if you have previous Armed Forces or civilian radio experience! Train at home. I give you kits, plus equipment to build BIG SCREEN TV RECEIVER, and FREE FCC COACHING COURSE! Everything AT NO EXTRA COST!

OPTIONAL: TWO WEEKS TRAINING IN NEW YORK CITY AT NO EXTRA COST!

You get two weeks, 50 hours, of intensive Laboratory work on modern electronic equipment at our associated school in New York City—Pierce School of Radio and Television. And I give you all this AT NO EXTRA COST whatsoever, after you finish your home study training in the Radio-FM-TV Technician course and FM-TV Technician Course.

FREE FCC COACHING COURSE!

Important for BETTER PAY JOBS requiring FCC License. You get this training AT HOME and AT NO EXTRA COST! Top TV jobs go to FCC licensed technicians.

NEW! PRACTICAL TV CAMERAMAN & STUDIO COURSE!

(For men with previous radio and TV training)

I train you at home for an exciting high pay job as the man behind the TV camera. Work with TV stars in TV studios or "on location" at remote pick-ups! A special one-week course of practical work on TV studio equipment at Pierce School of Radio & TV, our associate resident school in New York City, is offered upon your graduation.

VETERANS!

MY SCHOOLS FULLY APPROVED TO TRAIN VETERANS UNDER NEW G.I. BILL! If discharged after June 27, 1950 — CHECK COUPON! Also approved for RESIDENT TRAINING in New York City as Pierce School of Radio and Television... qualifies you for full subsistence allowance up to \$160 per month.

RADIO-TELEVISION TRAINING ASSOCIATION

52 EAST 19th STREET, NEW YORK 3, N. Y.

Licensed by the State of New York • Approved by the VA

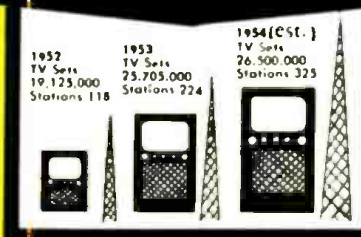

PROOF!

TV NEEDS THOUSANDS OF TECHNICIANS!

TV is coming into practically every community. More than 2,000 new TV stations authorized in this country alone! Thousands of new studios being planned and built. All kinds of new equipment coming on the market. Millions of new TV-set owners will need servicing. It's the rich field of the future with money-making opportunities NOW... if you get in on the ground floor. There just won't be enough TV Technicians to go around. It's your chance of a lifetime for GOOD EARNINGS in a TOP JOB or YOUR OWN BUSINESS!

EARN MORE

MORE MONEY AND A CAREER ARE WAITING FOR YOU HERE!

Earn while you learn by repairing TV sets for friends and neighbors. Many of my students make up to \$25 a week in spare time... pay for their entire training this way... start their own money-making service business. When they complete training and go into TV full time, their earnings zoom into big figures! My graduates are now working at RCA, NBC-TV, CBS-TV, DUMONT TV and numerous other TV studios and plants.

yours to build and keep!

GET MORE

Enough equipment to start your own home Laboratory! You learn by doing. I give you ALL the equipment. You build and keep a professional

GIANT SCREEN TV RECEIVER complete with mammoth picture tube (takes any size up to 21 inch)... also a Super-Het Radio Receiver, RF Signal Generator, Combination Voltmeter-Anmmeter-Ohmmeter, C-W Telephone Transmitter, Public Address System, AC-DC Power Supply, and more! 15 full Kits! All tubes supplied, too!



Public Address System



C-W Telephone Transmitter



Combination Voltmeter-Ammeter-Ohmmeter



Super-Het Radio Receiver



RF Signal Generator

YOU GET ALL 4 FREE!

Just by mailing coupon. Try the Sample Lesson. Read how and where you can make big money in TV... easily!



MAIL THIS COUPON NOW! No Salesman Will Call!

Mr. Leonard C. Lane, President
RADIO-TELEVISION TRAINING ASSOCIATION
52 East 19th Street, New York 3, N. Y. Dept. T-11A

Dear Mr. Lane: Mail me your NEW FREE BOOK, FREE SAMPLE LESSON, and FREE aids that will show me how I can make BIG MONEY IN TELEVISION. I understand I am under no obligation and no salesman will call.

(PLEASE PRINT PLAINLY)

NAME _____ AGE _____

ADDRESS _____

CITY _____ ZONE _____ STATE _____

I AM INTERESTED IN:

- Radio-FM-TV Technician Course
- FM-TV Technician Course
- TV Cameraman & Studio Course

VETERANS!
Check here for Training under NEW G.I. Bill



"Of the very best!"

—HIGH FIDELITY MAGAZINE

FISHER

SERIES "50"

■ It is only natural that more than one manufacturer will claim *his* product is the best. For that reason it remains for *you* to be the judge. We say—*demand the specs.* Then check workmanship, performance and beauty of appearance. If you do all these things, the answer will inevitably be . . . THE FISHER SERIES "50." There is no finer made.

THE FISHER **Master Audio Control** MODEL 50-C

■ "One of the finest units yet offered to the enthusiast or audio engineer."
—*Radio and TV News.* Can be used with *any* amplifier. 1M distortion virtually unmeasurable. Complete, professional equalization settings and tone controls; genuine F-M loudness control; five inputs, five independent input level controls, two cathode follower outputs. Self-powered.

Chassis, \$89.50 • With blonde or dark cabinet, \$97.50

THE FISHER **FM-AM Tuner** MODEL 50-R

■ Features *extreme sensitivity* (1.5 mv for 20 db of quieting); *low distortion* (less than 0.04% for 1 volt output); *low hum* (more than 100 db below 2 volts output.) Armstrong system, *adjustable AFC* with switch, *adjustable AM selectivity*, separate FM and AM front ends (shock-mounted), cathode follower output, fully shielded, aluminum chassis, self-powered.

THE FISHER **50-Watt Amplifier** MODEL 50-A

■ Truly the world's finest all-triode amplifier, yet moderately priced. A man's size unit! Less than 1% distortion at 50 watts (.08% at 10 watts.) 1M distortion below 2% at 50 watts. Uniform response within .1 db from 20 to 20,000 cycles; 1 db, 5 to 100,000 cycles. Hum and noise more than 96 db below full output. Quality components throughout. **\$159.50**

Prices slightly higher west of the Rockies

WRITE TODAY FOR COMPLETE SPECIFICATIONS

FISHER RADIO CORPORATION • 39 EAST 47th STREET • N. Y.

and simplicity factors would be under control. Because of this view, *CBS* continued, the company has set up plans to produce tri-color tubes in the second quarter of next year; and production of receivers will begin in the late spring of '54.

While they approved the NTSC system, *Columbia* added, they still maintained that the field-sequential system remains as the one . . . "which is best capable of producing, on a regular daily basis under normal operating conditions at the station and in the home, the most consistently excellent quality of color pictures on a practical, simple, flexible and economical basis." However, because of the system's incompatibility to the 27-million-odd receivers now in use, they added, it would be best that the electronic method be adopted.

Another healthy sign that color would be with us soon appeared in the announcement that *NBC* has scheduled some of its top-notch shows for color premieres, and will probably also colorcast the Tournament of Roses Parade as well as the Rose Bowl football game from the coast on New Year's day. In addition, the network has converted a 300-seat theater in New York City for projection of color TV on a large size screen; both the public and trade will be invited to special showings here. The broadcaster also reported that it has begun instructing most of its operating personnel on color procedures, and will augment its color facilities at the Colonial Theatre by rebuilding the huge *Warner Brothers* sound stage in Brooklyn for color work.

Color will also be the official springboard for many novel inventions. Magnetic tape, it has been disclosed, will be used to record the first color test programs emanating from Los Angeles. Recording in this fashion, it was claimed, offers a practical answer to color-program distribution, for duplicate tapes can be turned out at a fraction of the costs involved in processing copies of color films. While the technique is still in the experimental phase, it is said to have reached an advanced stage, so that its commercial debut might be announced very soon.

All events thus indicate that, unless some unusual complications arise, the Commission will approve color officially, certainly before the year is out, and possibly sooner.

AIRCRAFT CONTROL, through radar and radio-controlled piloting, are still the most vital projects of the civilian and military.

In Washington, recently, the Joint Communications-Electronics Committee of the Joint Chiefs of Staff revealed that they had proposed a *common system secondary radar safety beacon*, which would improve the reliability of the radar traffic control system, provide positive identification of aircraft by use of coded replies, and

(Continued on page 160)

RADIO-ELECTRONIC *Engineering*

S E C T I O N

**RADIO &
TELEVISION
NEWS**

Reg. U.S. Pat. Off.

TELEVISION • RADIO • ELECTRONICS • RESEARCH • COMMUNICATIONS • MICROWAVES

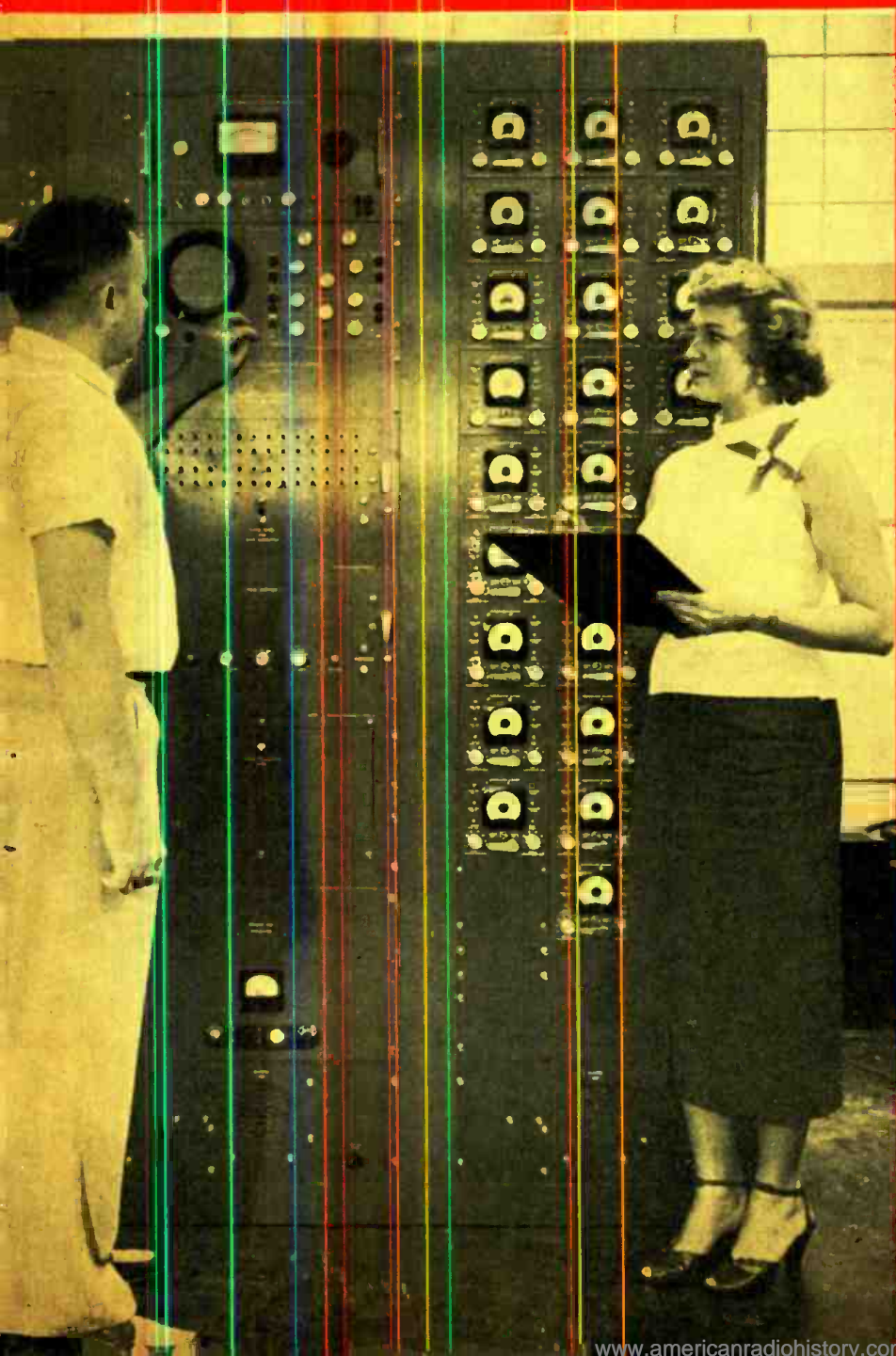

NOVEMBER, 1953

DECOMMUTATING TELEMETERED DATA
3

SINGLE-SIDEBAND TRANSMISSION
6

PRIMARY STANDARD
THERMAL NOISE GENERATOR
10

CARRIER-CONTROLLED RELAY
13

CONSTANT-OUTPUT
BROADCAST AMPLIFIER
14

ELECTRONIC AUDIO
BANDPASS FILTER
16

DEPARTMENTS

NEWS BRIEFS	18
NEW PRODUCTS	20
NEW LITERATURE	22
NEW TUBES	24
LOOKING AT TUBES	26
PERSONALS	28
CALENDAR	29
TECHNICAL BOOKS	30



Copyright, 1953, by Ziff-Davis Publishing Company
RADIO-ELECTRONIC ENGINEERING is published each month as a special section in a limited number of copies of RADIO & TELEVISION NEWS, by the Ziff-Davis Publishing Company, 366 Madison Avenue, New York 17, N. Y.

Edited by H. S. RENNE
and the Radio & Television News Staff

The Parsons electronic telemetering decommutation system undergoing tests at the Air Force Missile Test Center, Florida. James B. Wynn, Jr., co-author of article on page 3, and Mrs. Naomi Cheaney are shown operating the equipment and compiling performance data.



for QUALITY TRANSFORMER COMPONENTS

The bulk of UTC industrial transformer production is to customer's specifications for such organizations as G. E., Westinghouse, RCA, etc. However, a standardized line of approximately 700 stock items for industrial and communication service are available. A few of these types are illustrated here.

STEP DOWN AUTO-TRANSFORMERS

With 6 foot cord and female receptacle 220-240 to 110-120 Volts—50/60 Cycles

Type No.	Application	L	W	H	Wgt. Lbs.
R-41	85 watt capacity	2 $\frac{3}{8}$	2 $\frac{3}{8}$	3 $\frac{1}{8}$	4
R-42	125 watt capacity	3	3	3 $\frac{1}{2}$	5
R-43	175 watt capacity	3 $\frac{1}{4}$	3 $\frac{1}{4}$	3 $\frac{7}{8}$	5 $\frac{1}{2}$
R-44	250 watt capacity	3 $\frac{7}{8}$	3 $\frac{1}{4}$	3 $\frac{7}{8}$	6 $\frac{1}{2}$
R-45	500 watt capacity	4 $\frac{1}{8}$	3 $\frac{7}{8}$	4 $\frac{5}{8}$	12
R-46	1200 watt capacity	6 $\frac{3}{8}$	3 $\frac{7}{8}$	4 $\frac{5}{8}$	18
R-64	2500 watts, no cord	10 $\frac{1}{2}$	4 $\frac{3}{4}$	6 $\frac{3}{4}$	30



ISOLATION TRANSFORMERS

Ideal for isolating line noise, AC-DC sets, etc. Excellent electrostatic shielding. 1500 volt breakdown test. Six foot cord and male receptacle.

Primary 110-120 volts, 50/60 cycles—Secondary 110-120 volts

Type No.	Rating	L	W	H	Wgt. Lbs.
R-72	40 watts	2 $\frac{3}{4}$	2 $\frac{5}{8}$	3 $\frac{1}{8}$	4
R-73	100 watts	3 $\frac{3}{8}$	3 $\frac{1}{4}$	3 $\frac{7}{8}$	6
R-74	250 watts	4 $\frac{3}{8}$	3 $\frac{7}{8}$	4 $\frac{5}{8}$	12
R-75	600 watts	6 $\frac{7}{8}$	3 $\frac{7}{8}$	4 $\frac{5}{8}$	20
R-76	1200 watts	8 $\frac{3}{8}$	4 $\frac{1}{2}$	5 $\frac{7}{8}$	30
R-77	2500 watts (no-cord)	12	7	9	70



LINE VOLTAGE ADJUSTERS WITH METER

The perfect answer to abnormal or fluctuating line voltage. Adjust switch so that meter reads at red line and you know that your equipment is working at correct voltage.

These units combine a tapped auto-transformer with a switch and meter in a compact, rugged assembly. The nine tap switch provides for line voltages of 60 to 140 volts on 115 volt output models and 160 to 240 volts on 230 volt output models.

All units are designed for 50/60 cycle service and come complete with 6 foot input cord and plug and outlet receptacle.

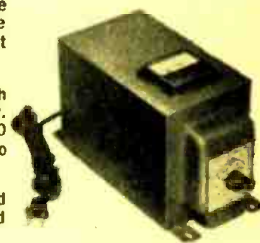

Type No.	Primary Voltages	Sec. Volts	Watts	L	W	H	Wt. Lbs.
R-78	60, 70, 80, 90, 100, 110, 120, 130, 140	115	150	7	4	4 $\frac{3}{4}$	6
R-79	60, 70, 80, 90, 100, 110, 120, 130, 140	115	300	7	4	4 $\frac{3}{4}$	9
R-80	60, 70, 80, 90, 100, 110, 120, 130, 140	115	600	10 $\frac{1}{4}$	4	4 $\frac{3}{4}$	13
R-81	60, 70, 80, 90, 100, 110, 120, 130, 140	115	1200	10 $\frac{1}{4}$	4	4 $\frac{3}{4}$	21
R-83	160, 170, 180, 190, 200, 210, 220, 230, 240	230	150	7	4	4 $\frac{3}{4}$	6
R-84	160, 170, 180, 190, 200, 210, 220, 230, 240	230	300	7	4	4 $\frac{3}{4}$	9
R-85	160, 170, 180, 190, 200, 210, 220, 230, 240	230	600	10 $\frac{1}{4}$	4	4 $\frac{3}{4}$	13
R-86	160, 170, 180, 190, 200, 210, 220, 230, 240	230	1200	10 $\frac{1}{4}$	4	4 $\frac{3}{4}$	21

EXPORT VOLTAGE ADAPTER

Complete with cord and plug and special locking switch providing for line voltages of 105, 115, 125, 135, 150, 210, 230, 250 volts; 42 to 60 cycles. Output voltage 115.

Type No.	Rating	Wgt. Lbs.
R-47	85 watts	4 $\frac{1}{2}$
R-48	150 watts	5 $\frac{1}{2}$

TV VOLTAGE REGULATOR

Complete with cord, plug, and special locking switch. Permits operation of 115 volt 50/60 cycle TV sets on line voltages of 85, 90, 95, 100, 105, 110, 120, 125 V.

Type No.	Rating	Wgt. Lbs.
R-49	350 Watts	5

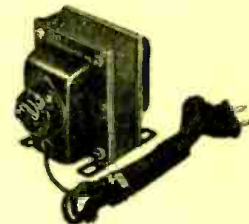

SIGNALLING AND CONTROL TRANSFORMERS

Primary 110-120 volts, 50/60 cycles—Secondary 110-120 volts

High power transformers suitable for operating relays, sirens, horns, gongs, etc. from 115 V. 50/60 cycle line. These units have four secondary terminals providing 4, 8, 12, 16, 20 and 24 volt output. The volt ampere rating is based on the 24 volt secondary tap with corresponding reduction at the lower voltages. Underwriters' approved primary leads are employed, and screw-type binding posts.

TYPE	WATTS	OVERALL DIMENSIONS	MTG. DIM.	WEIGHT LBS.
SC-3	50	3 x 3 $\frac{1}{2}$ x 3-9/16	1 $\frac{7}{8}$ x 2 $\frac{1}{4}$	3
SC-4	100	3 $\frac{1}{4}$ x 4 x 4	2 $\frac{1}{8}$ x 2 $\frac{1}{2}$	5
SC-5	250	4 x 5 x 4 $\frac{3}{4}$	3 $\frac{1}{4}$ x 3	10



United Transformer Co.
150 VARICK STREET NEW YORK 13, N. Y.

EXPORT DIVISION: 13 EAST 40th STREET, NEW YORK 16, N. Y. CABLES: "ARLAB"

www.americanradiohistory.com

DECOMMUTATING

TELEMETERED DATA

By

FOSTER REYNOLDS*

and

JAMES B. WYNN, JR.**



Use of plug-in components, shown above in the gate-triggering unit, permits rapid servicing.

ELECTRONIC development in various fields has been highly stimulated by the Guided Missile Program of the Department of Defense. One such field that is greatly indebted to this program is radio telemetry. Some of the early circuitry was hastily devised under great duress to accomplish top priority rush jobs during World War II. It was most effective for the particular assignments, but was definitely limited in its application and not commensurate with present components and techniques. This article describes an electronic decommutation system which is based upon present operational requirements and which employs new design techniques.

The importance of the radio-telemetry field is evidenced by the fact that the Research and Development Board of the Department of Defense established, through the Committee on Guided Missiles, a Working Group on Telemetering. Through the efforts of this Group, a set of telemetering standards was published. This set of standards was not intended to be a list of detailed specifications but was regarded as a means of setting forth the characteristics of the signals employed by radio-telemetry

*Chief, Telemetry Section, Development & Manufacturing Division, Ralph M. Parsons Company.
**Chief, Telemetry Section, Technical Systems Laboratory, Air Force Missile Test Center, Air Research and Development Command, Patrick Air Force Base, Florida.

Electronic analog low-pass filters are used in a system for decommutating FM / FM telemetered data.

systems, thus making it possible for compatible test facilities to exist at the various test ranges throughout the United States regardless of the Service Branch, and representing an RDB accomplishment towards unification and equipment standardization. With this in mind, detailed equipment specifications were formulated for the decommutation system by engineers of the Air Force Missile Test Center, Patrick Air Force Base, Florida, that would be compatible with the RDB standards as well as the anticipated missile programs and the present state of the art.

Over-All Telemetry System

Before delving into the detailed aspects of separating telemetered information, it would probably be worth while to review briefly an over-all FM/FM radio-telemetry system. Everyone is familiar with telemetry in one of its simplest forms—wire telemetry is used to indicate the amount of fuel in an automobile fuel tank. Remote information presentation is commonplace today, and radio telemetry is one of the specialized techniques in this branch of communications.

For the majority of applications, a radio-telemetry system is divided into

two separate installations—an airborne transmitting package and a ground receiving and recording station. Information from gyros, control surfaces, strain gages, etc., is converted by means of transducers into electrical parameters, such as voltage or inductance changes, which can control the frequency of a subcarrier oscillator. Up to 12 or 14 subcarrier oscillators are used simultaneously to modulate a miniature frequency-modulated transmitter.

Quite often it is necessary to trans-

Preliminary adjustments being made on the remote console unit, which displays separated data on the meters.





Gate units incorporating the filter sections set up for preliminary inspection.

mit a considerable amount of low frequency information such as air speed, altitude, rate of turn, etc. Since many of the subcarrier oscillators are capable of high frequency response, i.e., 300 to 2000 cps, it is practical to commutate mechanically many channels of low frequency data on a single subcarrier oscillator. Most of the commutator plates have 30 segments and, under the system standards, three segments are used for frame synchronization and 27 segments for separate data channels. The separate data channel capacity of 12 continuous channels may be increased to 116 channels of information by commutating four of the subcarrier frequencies.

Commutation adds very little to the cost, complexity, or weight-per-channel-capacity of the airborne package. In considering the ground receiving station, it must be realized that the equipment is not expended with each test as in missile testing, so that the cost of demodulation equipment to separate the commutated data automatically (about \$20,000) can be amortized over many years of operation.

Basic Telemetry Equipment

Basic equipment used in ground radio-telemetry receiving stations consists of an FM receiver, magnetic tape recorders to store the complex subcarrier fre-

quencies, subcarrier discriminators to separate the subcarrier frequencies, demodulators to separate the commutated data, recording oscillographs and pen recorders to display data for analysis.

The salient factors of the demodulation system specifications are accuracy and long-time stability. A survey of commercially available equipment soon made it very evident that no manufacturer would guarantee his standard models as meeting requirements of high accuracy (less than 1% error full scale) with good linearity without adjustment over an eight-hour period of continuous operation. It is appropriate at this time to point out, and it cannot be overstressed, that the basic requirements of telemetry equipment are typical of what is expected of most electronic instrumentation equipment. Some of the more important additional electrical performance requirements are as follows:

1. **Accuracy**—Over-all system error shall not exceed $\pm 0.5\%$ of maximum deviation.
2. **Linearity**—Output linearity shall be within $\pm 0.25\%$ of full output for incremental data changes over full channel deviation.
3. **Stability**—All performance specified is applicable to a minimum of eight hours of continuous operation after a warm-up period which shall not exceed one hour.
4. **Signal Input Voltage**—A minimum of ± 3.75 volts peak-to-peak to a maximum of ± 50 volts peak-to-peak from a balanced line at any quiescent level shall be satisfactory for specified performance.
5. **Input Impedance**—The input impedance shall be 80,000 ohms or greater.

Fig. 1. Schematic diagram of a demodulator channel employing a two-stage electronic analog low-pass filter.

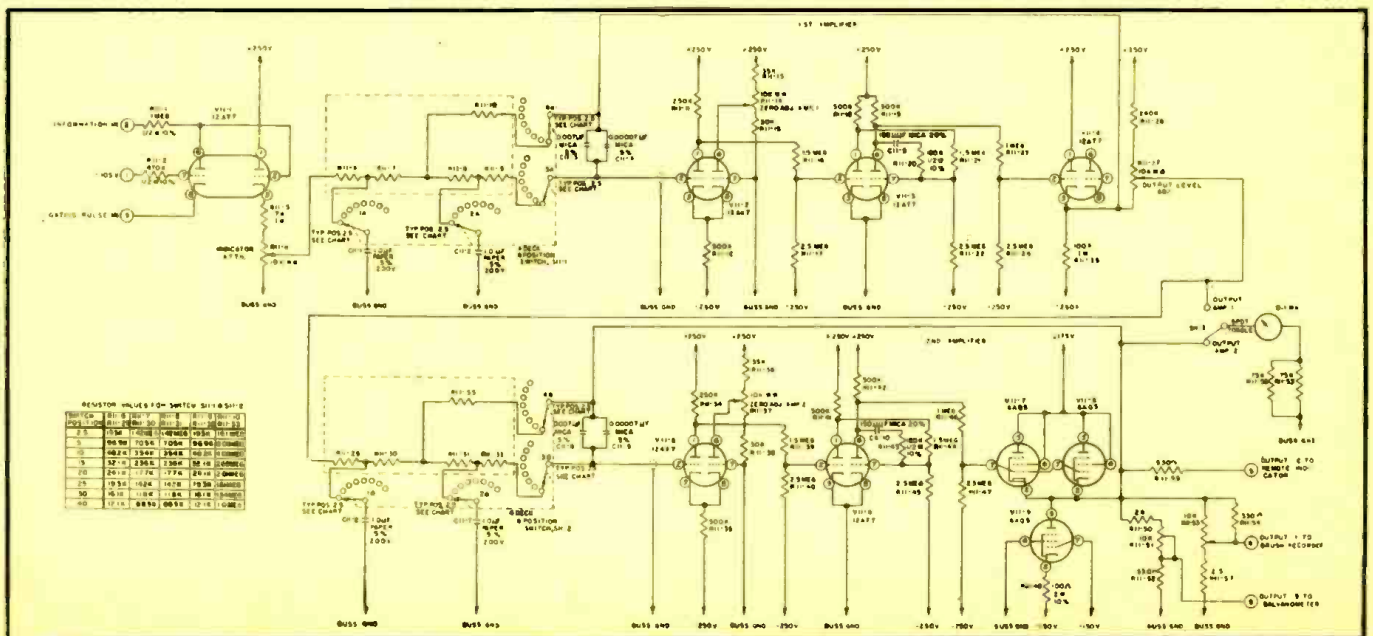

6. **Pen Output**—Output impedance shall be approximately 330 ohms and work into a load impedance of 1400 ohms (*Brush pen motor* Type 920 or equivalent). A maximum driving current of ± 12.5 ma. shall be delivered and balanced at center signal to ground.
7. **Galvanometer Output**—Output impedance shall be approximately 330 ohms and work into a load impedance of 330 ohms (oscillograph galvanometer attenuator pad). A maximum driving current of ± 5 ma. shall be delivered and balanced at center signal to ground.
8. **Remote Indicator Output**—Output impedance shall be approximately 330 ohms and work into a load impedance of 600 ohms (telephone land line). A maximum driving current of ± 2 ma. shall be delivered and balanced at center signal to ground.

Installation on subtropical islands, or along the sea coast, imposes environmental conditions of high humidity and salt content as well as moisture and fungus; for this reason, a tropicalization treatment must be given to all chassis to prevent leakage paths and rapid deterioration.

A common source of error in a great deal of electronic equipment, and a factor which may make the controls overly sensitive or make frequent readjustment of the equipment necessary, is the primary power voltage fluctuation. While elaborate electronically regulated power supplies furnish a constant d.c. source in this system, any variation in the source voltage is carried through to all the vacuum tube heaters and may overtax the power transformers. Therefore, a primary line regulator is included in the equipment—a *Stabiline* voltage regulator Model 300JA, which delivers regulated power at 110 volts, 45 amperes, to the complete system.

The equipment to be described in detail represents the most recent FM/FM decommutation system to become commercially available as a standard item. It was fabricated by the *Ralph M. Parsons Company* under Contract #AF 08(606)-297 with the Air Force Missile Test Center. Electronic analog low-pass filters are employed for smoothing telemetered decommutated data. This circuit application, new to the field of radio telemetry, coupled with the advanced system design should prove a definite step forward in the state of the art. See Fig. 1.

It will probably be easier to consider the operation of the system if a functional description of the information signal and the block diagram of Fig. 2 are followed. For this reason, the first circuitry to be described will be that dealing with the telemetered commutated data and its associated control

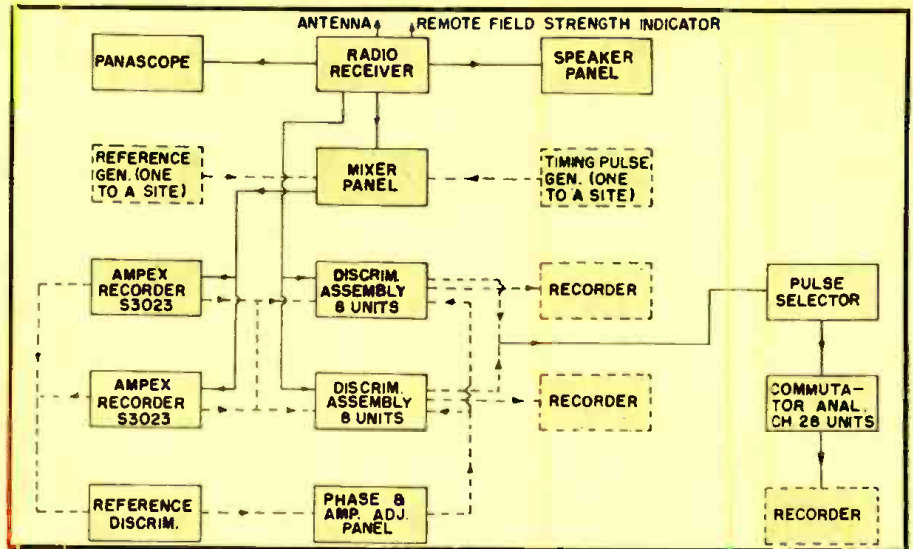

Fig. 2. Block diagram of a class A telemetry receiving station.

functions; then the supplemental circuits, such as power supplies and specialized test instruments, will be discussed.

Pulse Selector

The input time-shared pulse signal applied to the electronic decommutator is derived from a subcarrier discriminator in a radio-telemetry receiving station and is fed to the pulse selector chassis. This portion of the equipment performs many functions. It detects the presence of a master pulse in the commutated signal train and generates a secondary pulse which is transmitted to the first counter circuit of the sequential counter. It also acts as a primary amplifier for raising the voltage of the incoming intelligence to a usable level. This amplifier is of the differential type and it may be used with a balanced line input having practically any quiescent level. The differential junction of the amplifier provides a convenient point at which primary gating may take place to fulfill the requirement of ground gating of the telemetry signal. Normally, a synchronized, free-running multivibrator is used to generate switching pulses; but under conditions where intelligence becomes obliterated by noise, the multivibrator runs at its own natural period, thus generating false switching pulses that maintain counting of the trigger chain until intelligence is regained.

The last major function of the pulse selector is to provide a closed-loop servo system that controls the width at which the ground gating circuit operates. This width must be kept at a constant proportionality with relation to the commutation speed. The servo system senses a change in airborne sampling rate by virtue of a secondary low-pass filter, the output of which—an analog voltage—is compared to a standard reference voltage, and the resulting error-signal

is amplified by a high gain integrating amplifier. In turn, this amplifier controls the clamping point at which a phantastron circuit initiates operation. Since the sweep of the phantastron is linear and the termination of its period is stable, the resulting variation in clamping level produces a corresponding variation in output pulse width. The phantastron then provides the blanking signals for the primary gating circuit, thus completing the closed loop of the system.

Patch Panel and Gate Generator

In terms of flow of information, the second chassis is the patch panel and gate generator, which contains the previously mentioned counting circuits de-

(Continued on page 25)

The "Telemetry Commutator Simulator" is shown being adjusted to provide a pulse train equivalent to a 5-cps 30-segment commutated signal.

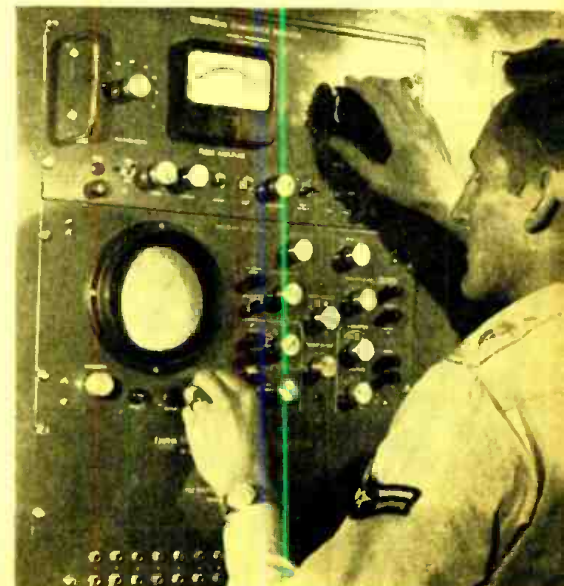

SINGLE-SIDEBAND TRANSMISSION

By **ROBERT C. MOSES**

Lear, Inc.

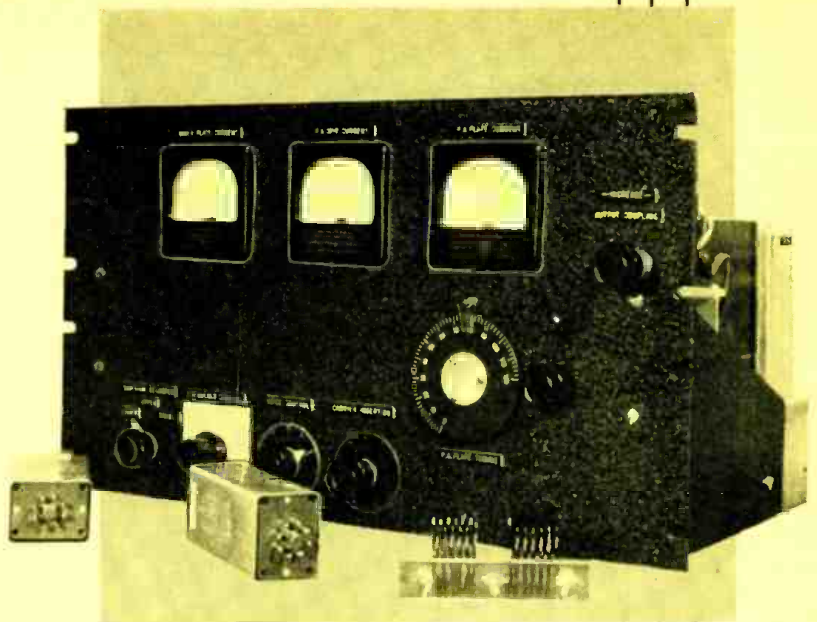

Front view of exciter chassis.

Part II covers the design, construction and performance of an SSSC transmitter having an output of 600 watts.

PART I of this series presented a general discussion of single-sideband, suppressed-carrier transmission techniques, including a comparison with double-sideband AM systems and the basic principles governing generation and amplification of the SSSC signal. Part II deals with practical design considerations of single-sideband transmission systems, with particular reference to the phase-shift method of SSSC generation. In order to illustrate one application of the techniques presented, a complete description of a typical 600-watt phase-shift SSSC transmitter is included.

Among the circuits encountered in single-sideband, suppressed-carrier transmission systems are audio and r.f. phase-shifting networks, balanced modulators, frequency converters, and r.f. linear amplifiers. Space limitations preclude a detailed treatment of all possible configurations of the system elements mentioned; hence the circuits to be presented should be considered as representative of a typical design. By the same token, the discussion has been slanted towards those circuits particularly applicable to the phase-shift system, as the design requirements of the latter are generally more exacting.

Audio Phase-Shift Networks

Audio phase-shift networks may be either of the active or the passive type, i.e., they may or may not include vacuum tubes. Active networks,

in general, are characterized by a fairly wide audio bandwidth over which the amplitude and phase shift remain within usable limits; but at the same time, they involve several tube sections with attendant space and power requirements. Passive networks, on the other hand, contain only resistance and capacitance elements but are good over a relatively narrow portion of the audio range. Both types of networks introduce an insertion loss which may vary from 8 to 12 db, depending upon the particular network design. Figure 2 shows one form of active audio phase-shift network in which the departure from quadrature phase relationship is less than 0.8° and the amplitude is constant within 0.5 db over the frequency range from 75 to 5500 cps.

The network of Fig. 2 accepts single-ended audio input at a peak level of up to 10 volts, and delivers four individual output voltages of equal ampli-

tude having a mutual 90° phase relationship, i.e., 0°, 90°, 180° and 270°. Phase-shifting elements consist of appropriate resistance-capacitance high-pass networks driven with 180° phased output voltages from an associated phase-inverting triode. In any one such phase-shifting stage, it can be shown that the amplitude of the output voltage is constant with frequency within limits, whereas the phase shift varies according to the relation:

$$\theta = 2 \left[\tan^{-1} \frac{1}{\omega CR} \right] \dots (1)$$

In order that the audio phase shifter may maintain a substantially constant 90° phase relationship over a wide frequency range, several cascaded stages in a two-channel arrangement are used, and the individual stages are "stagger-tuned" to the specific frequencies indicated. The individual phase characteristics thus combine to provide the required over-all characteristic. Figure 1 shows the phase curves for the six networks by themselves, and the resulting over-all phase shift vs. frequency is also included.

The passive audio phase shifter of Fig. 3 consists of differential 45° lead-lag networks employing six RC elements in a lattice configuration. Equal-amplitude voltages applied to the inputs in 180° phase relation produce two output voltages having a substantially constant phase difference of 90° over the frequency range from 200 to 2600 cps and amplitude equality within 1 db over a similar frequency band. The insertion loss of this network is approximately 9 db, and maximum phase departure is of the order of 1°. In common with the active network described above, it is necessary

Fig. 1. Phase characteristics of individual elements in the network of Fig. 2, and resulting over-all phase characteristic.

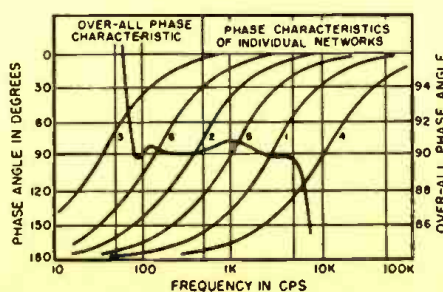

that the individual RC elements be "tuned" to specific frequencies in order to obtain the required over-all phase characteristics; by the same token, the input voltages must maintain amplitude equality and 180° phase relationship over the audio band of interest. Figure 4 shows the over-all amplitude-phase characteristics of this particular audio phase-shift network; other passive network configurations have been devised.

R.F. Phase-Shift Networks

In contrast to the audio phase-shift networks described above, 90° r.f. phase shifters operate at substantially fixed signal frequencies. Consequently, they may be relatively simple affairs consisting either of complementary 45° lead-lag networks employing resistive and reactive elements or double-tuned mutually coupled LC circuits. An example of the first is shown in Fig. 6.

The phase angle attributable to the RL branch of the network is given by:

$$\theta_1 = \tan^{-1} \frac{R}{\omega L} \quad (2)$$

while that for the RC branch is:

$$\theta_2 = -\tan^{-1} \omega CR \quad (3)$$

Insertion loss α in db is:

$$\alpha_1 = 20 \log_{10} \left[\frac{1}{(1 + R^2/\omega^2 L^2)^{1/2}} \right] \quad (4)$$

for the inductive branch, and

$$\alpha_2 = 20 \log_{10} \left[\frac{1}{(1 + R^2/\omega^2 C^2)^{1/2}} \right] \quad (5)$$

for the capacitive branch.

When the inductive and capacitive elements are so proportioned that their reactances at the operating frequency are equal to the series resistance in each branch, $-\theta_1 = \theta_2$, and the differential phase shift between the terminals of the network is the required 90°, the insertion loss is 3 db to each output and the input impedance to both branches in parallel is equal to R.

In a double-tuned transformer where the coefficient of coupling slightly exceeds the critical value ($KQ_c = 1.5$ to 1.8), the phase of the secondary-induced voltage is inherently displaced by very nearly 90° from that of the primary when both circuits are tuned to resonance. In addition, the phase of the secondary voltage varies rapidly through quadrature in the vicinity of secondary resonance. Such a transformer constitutes an excellent r.f. phase shifter since the phase relationship is readily adjustable by secondary tuning and the insertion loss may be made low. Furthermore, the load impedance presented to the driver stage (generally the carrier oscillator) is relatively large; hence, little power is dissipated in the phase-shifting network.

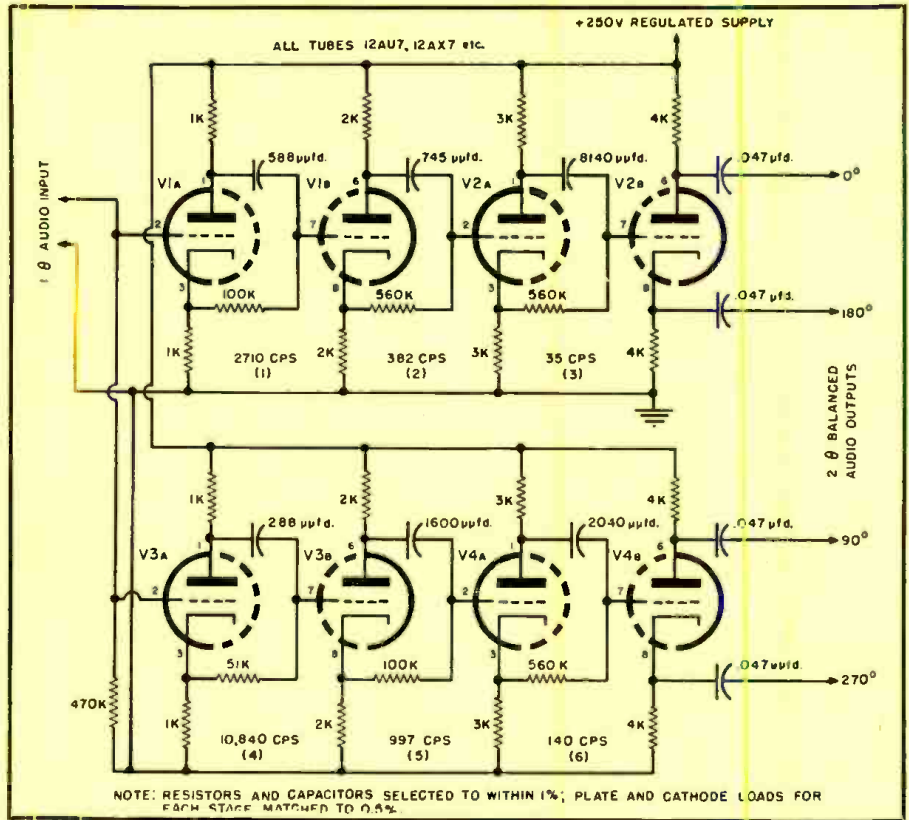

Fig. 2. Circuit diagram and parts values for complete active audio phase-shift network.

Balanced Modulators

Balanced modulators utilize vacuum tubes or other nonlinear circuit elements in a balanced bridge arrangement whereby the carrier and modulating voltages are introduced in such a manner that the carrier is cancelled in the output and the sidebands appear.

In vacuum-tube balanced modulators, any of the conventional forms of modulation, i.e., plate, grid, screen-grid, etc., may be employed, although grid modulation seems to be most applicable because of the very small amount of audio power required. The circuit arrangements of Fig. 5 are typical.

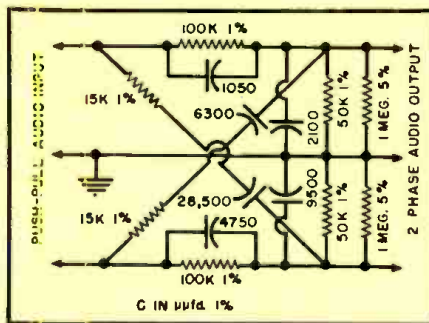

Fig. 3. Passive 90° phase-shift network.

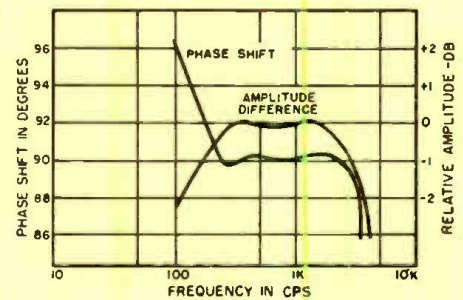
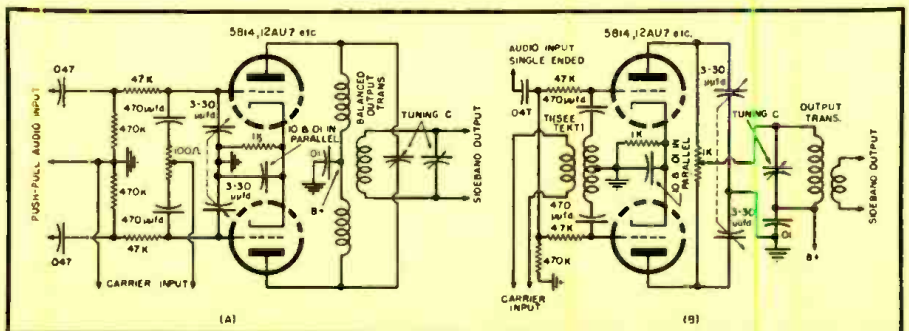
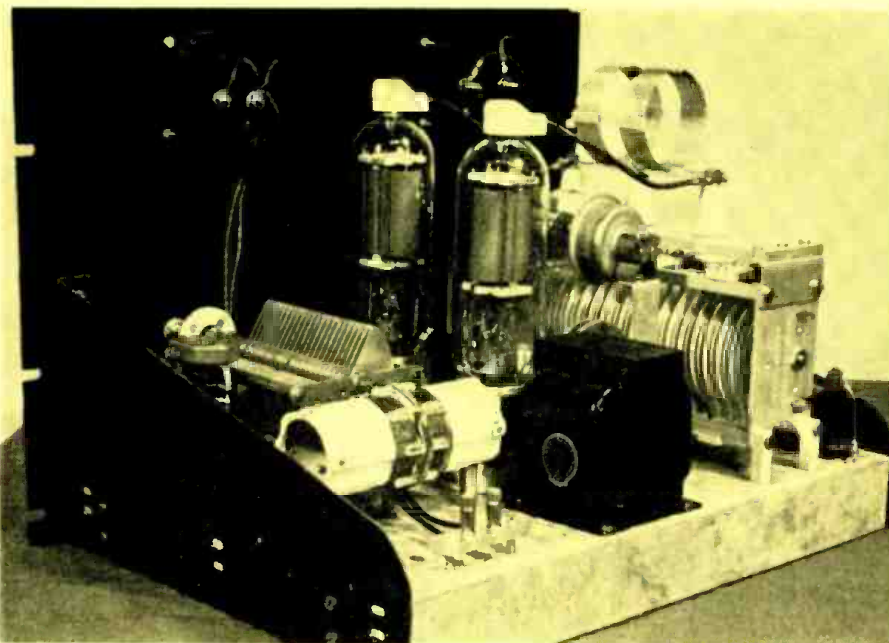

Fig. 4. Amplitude-phase characteristics of passive phase-shift network, Fig. 3.

Fig. 5. Circuit diagrams and parts values for two typical balanced modulators.





Rear view of power amplifier chassis showing location of components.

In Fig. 5A, the audio modulating signal is applied to the grids in 180° phase relationship, while the carrier appears

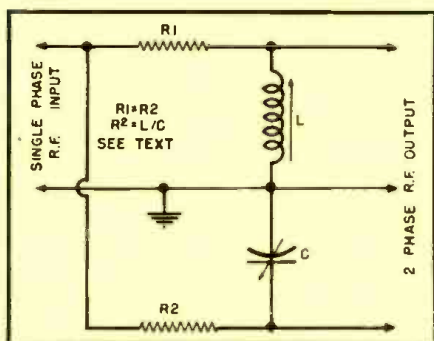

Fig. 6. RLC type of r.f. phase shifter.

in phase at the same grids. The plates are push-pull connected across the primary of a balanced double-tuned transformer in which the equivalent load impedance presented to each tube is equal, as is the coefficient of coupling from the secondary to each half of the primary. Circuit conditions are such that operation takes place largely over the lower bend of the tube characteristics. Sum and difference frequency components resulting from the modulation process are developed across each half of the balanced primary winding; these sideband components have relative phases such that they are additive in the secondary. The carrier, on the other hand, is in phase across the pri-

mary; cancellation will result provided that the system is balanced. Therefore, the voltage across the secondary represents sideband output alone, and is a linear function of the amplitude of the modulating signal to the extent that the peak audio component at each grid does not approach the carrier voltage. The usual design criterion for circuits of this type is to make the carrier at least three to five times larger in amplitude than the peak modulating voltage, thus insuring linearity and low distortion over the entire dynamic operating range.

The circuit of Fig. 5B functions in essentially the same manner as that of Fig. 5A. In this case, the audio signal is applied in phase to the grids while the carrier is in 180° phase relation. Plates are connected together and work into a common tuned load impedance. Out-of-phase carrier voltages cancel across the latter (subject to system balance conditions), whereas the in-phase sideband components are passed on to the following circuits.

Degree of carrier suppression obtained when using two tubes of the same type will be at least 15 to 20 db without auxiliary balancing adjustments. Where a greater degree of suppression is desired, resistance and capacitance balancing at the grids or plates may be necessary. With careful balance adjustments, carrier suppression of the order of 50 to 60 db may be attained; however, slow drifts in tube characteristics or component values may render such adjustments unstable over an extended period of time.

Frequency Converters

Frequency converters are a virtual necessity in filter-type single-sideband equipment since limitations in the sideband filter require that initial generation of the SSSC signal take place at a relatively low radio frequency. In phasing systems designed for operation over a wide range of frequencies, converters are frequently used to eliminate the necessity for readjustment of the r.f. phase-shift networks when the operating frequency is changed. Frequency converters may be either of the single-ended or push-pull type; the single-ended version finds application in cases where the power output requirements are small, and where the frequencies of the input signal and heterodyning oscillator are sufficiently removed from one another so that the latter can be rejected in a simple band-pass filter. Double-ended arrangements, on the other hand, are used where appreciable power is required to drive the following stage, or where a high degree of discrimination against the local oscillator signal is necessary.

In the general case of heterodyne

Fig. 7. Block diagram of the SSSC transmitter shown in the photographs.

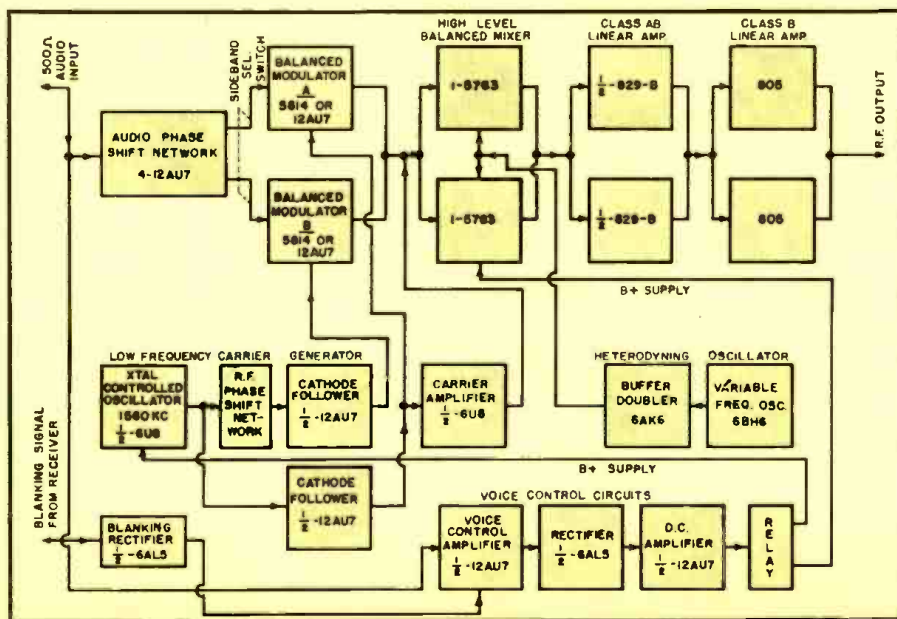

frequency conversion, the amplitude of the sum and difference frequency components representing the desired output will be a linear function of the input signal only if the local oscillator injection voltage is several times greater than the peak signal voltage. This is a similar situation to that existing in the case of the balanced modulators. In high-level frequency converters, use of a relatively large local oscillator signal is implied. At the same time, where both signals are impressed on the same grid, the peak grid voltage cannot usually exceed the fixed grid bias without introducing a secondary form of non-linearity; since the peak grid voltage is represented by the sum of the two signals, the relative levels of the latter must be so selected as to stay within the limits defined above. By the same token, the tube characteristics and operating points affect both linearity and dynamic range, and a general improvement in both is obtained through use of tubes having a long grid-base characteristic, operated at or near projected-cutoff grid bias.

SSSC Transmitter

Practical application of a number of the circuits discussed is illustrated in the typical 600-watt phase-shift SSSC transmitter design shown in the functional block diagram of Fig. 7. The system incorporates the active audio phase-shift network of Fig. 2, and two 12AU7 or 5814 dual-triode balanced modulators similar to that of Fig. 5A. Because

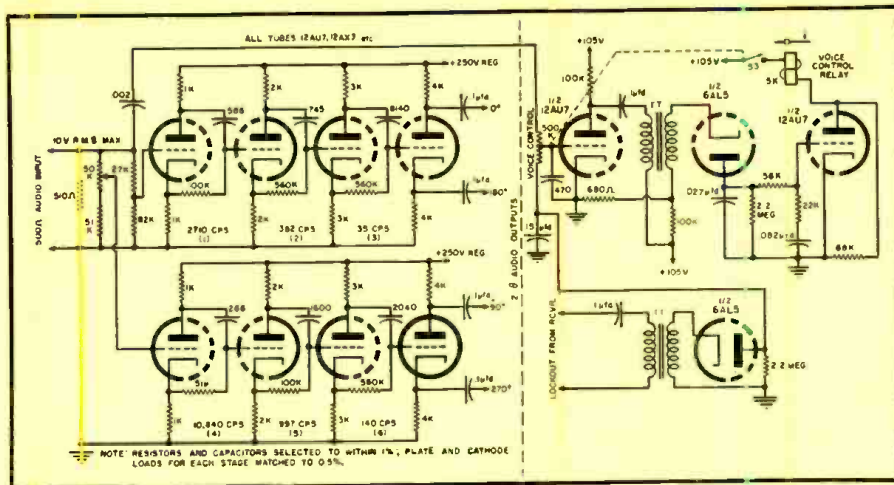
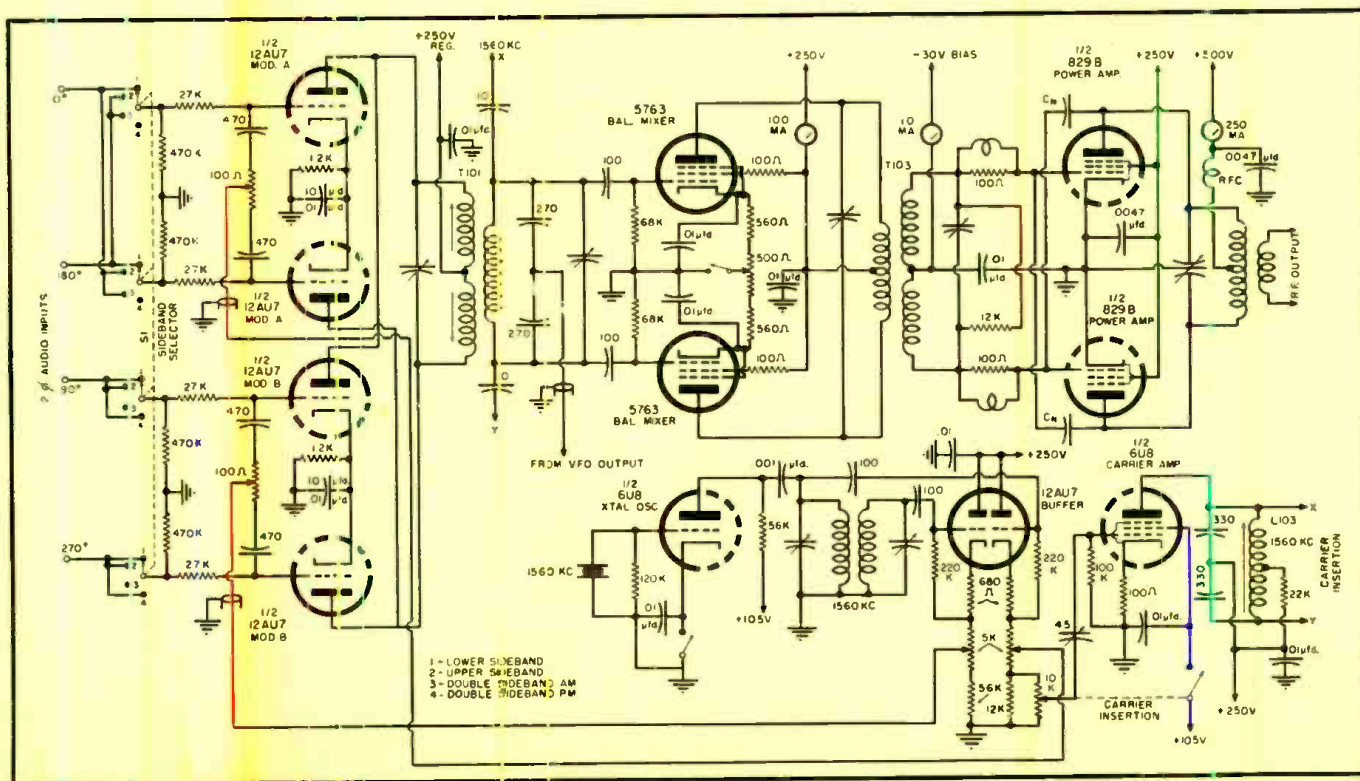

Fig. 8. Circuit diagram of the audio phase-shift network and voice control.

operation over a wide range of output frequencies is required, the SSSC signal is generated at a fixed crystal-controlled frequency of 1560 kc., and is heterodyned to the final operating frequency in a high-level balanced mixer utilizing two type 5763 beam pentodes. The output of the balanced mixer drives a dual tetrode type 829-B push-pull class AB₁ linear amplifier to a peak power input of 130 watts for direct operation into an antenna system; alternatively, the latter is operated class AB₁ at a lower power level to drive a push-pull 805 class B linear amplifier to a peak power of slightly under 600 watts. The 1560-kc. carrier generator comprises a type 6U8 triode crystal oscillator and a 12AU7 dual cathode-fol-

lower isolation amplifier, one section of which is driven directly from the oscillator plate and the other section through a 90° r.f. phase shifter of the coupled tuned-circuit type. A 6U8 pentode amplifier operating into a balanced load circuit is provided for purposes of carrier reinsertion. Additional design features include a built-in v.f.o. heterodyning oscillator and buffer stage, an automatic voice-control system with provisions for blanking by the received signal, and appropriate switching for upper and lower sidebands, double-sideband AM and double-sideband PM. Schematic diagrams of the four sections of the system are shown in Figs. 8 through 11; the system diagram is (Continued on page 30)

Fig. 9. Circuit diagram of balanced modulators, carrier generator and r.f. circuits.



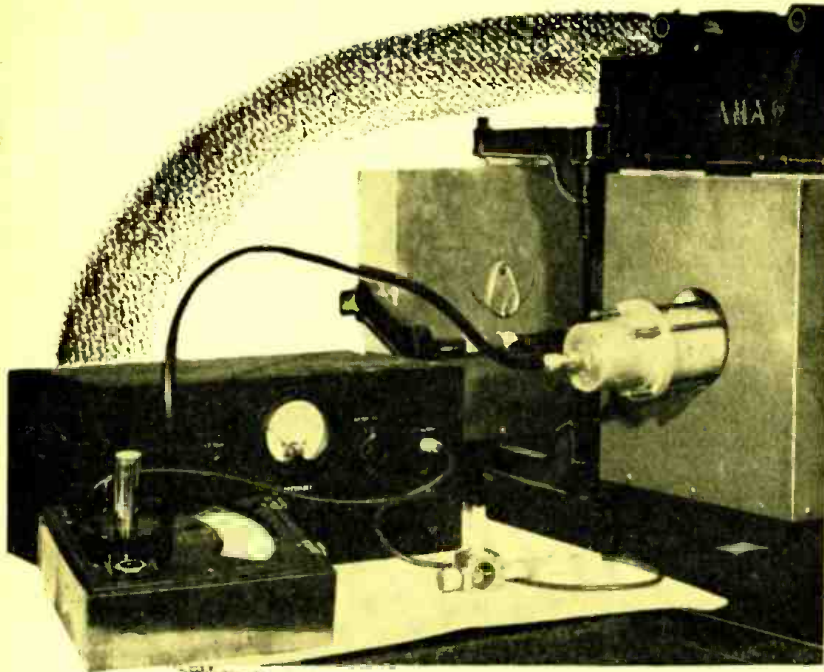

Experimental setup showing the standard noise generator, thermocouple meter, and indicating meter for reading noise output.

PRIMARY STANDARD THERMAL NOISE GENERATOR

By **GERARD LYNCH**

Signal Corps Engineering Laboratories

A heated precision resistor matched to a coaxial line serves as a primary thermal noise standard.

AN ELECTRICAL measurement standard may be established by mutual agreement on a definition of some arbitrary value, system, or technique; or the standard may be measured by determining two or more physical constants, in which case the relationship of these constants to each other will automatically define the electrical standard. Primary electrical standards are generally fixed by the latter method. This article deals with the development of a primary type of thermal noise generator in which the value of noise power is determined by the measurement of the absolute temperature of a coaxial resistor and the electrical resistance value of this resistor. Design data, operational results, and some typical noise figure measurements are included for such a 50-ohm standard thermal noise generator.

Random Noise Analysis

The decrease of atmospherics with increasing frequency has created a demand for random noise generators that will enable the equipment designer to know how closely absolute sensitivity is being approached. Present-day commercial electronic random noise generator outputs not only vary from model

to model but the actual value of output voltage is not known.

Thompson, North and Harris¹ have dealt with the equivalent random noise of a temperature-limited saturated diode; Schottky², Nyquist³ and Johnson⁴ have given detailed analyses of the behavior of random noise due to thermal agitation.

In his work, Johnson has shown that the resistance structure has no measurable effect on the quantity of the noise, this being dependent only on the value of resistance. The square of the thermal noise voltage of a resistor is expressed by the following equation:

$$E^2 = 4KTfR \quad \dots \quad (1)$$

The symbols are defined as follows:

Table 1. Temperatures required to give various noise levels.

x db	T _x (° Kelvin)
3	585
4	736
5	926
6	1167
7	1468
8	1850
9	2340

K = Boltzmann's constant, 1.38×10^{-23} joules per degree absolute

T = absolute temperature, ° Kelvin

KT = kinetic energy of a molecule

R = equivalent resistance, ohms

f = the integrated bandwidth, cps

Inspection shows that R and T are the physical constants to be determined.

If R is the equivalent noise generator resistance at any frequency f , Eq. (1) may be expressed as:

$$E^2_{rms} = 4KTR \int_0^f (f) df \quad \dots \quad (2)$$

indicating that the real part of the generator impedance is the design parameter and that the problem is to measure R and T .

The temperature values required to obtain practical power outputs were determined by using the basic equation:

$$E_o^2 = 4KT_o Rf \quad \dots \quad (3)$$

This may be written as follows:

$$\frac{E_o^2}{E_x^2} = \frac{4KT_o Rf}{4KT_x Rf} = \frac{T_o}{T_x} \quad \dots \quad (4)$$

where E_x^2 is the higher noise voltage and T_o is the unknown temperature. Then:

$$x \text{ db} = 10 \log_{10} T_x - 10 \log_{10} T_o \quad \dots \quad (5)$$

where x db is the desired noise power ratio above ambient temperature. This reduces to:

$$\log_{10} T_x = \frac{x \text{ db}}{10} + \log_{10} T_o \quad \dots \quad (6)$$

If a value for T_o of 293° Kelvin (room ambient 20° C) is assumed:

$$\log_{10} T_x = 0.1 x \text{ db} + 2.4669 \quad \dots \quad (7)$$

Table 1 shows the values of T_x re-

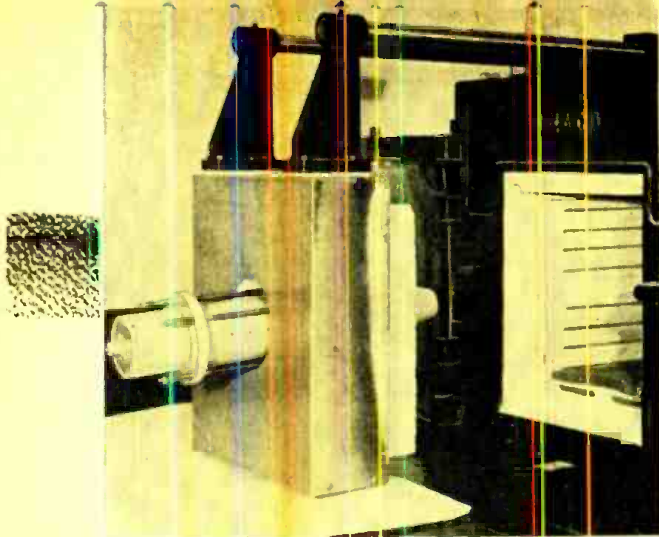

Location of generator in the open oven door.

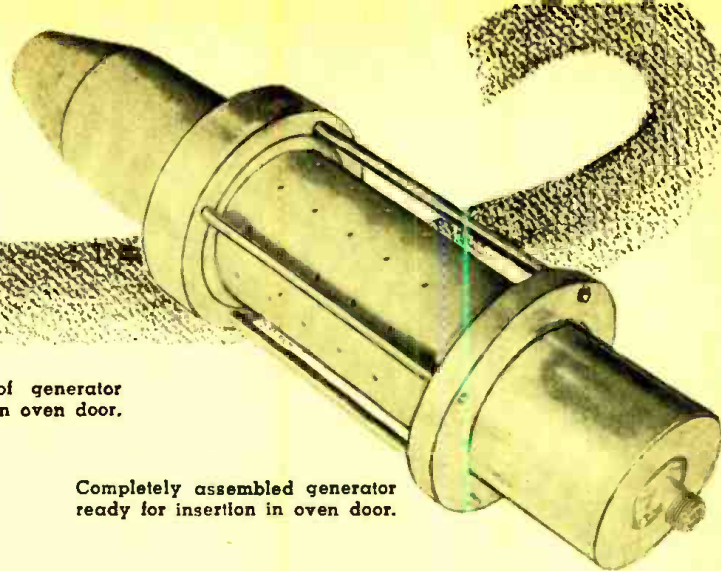

Completely assembled generator ready for insertion in oven door.

quired to give various values of α db, indicating that an oven capable of producing high temperatures is necessary.

Resistor Design

The design of a coaxial resistor capable of a high temperature cycle eliminated the use of most standard materials. Since the resistor should not be affected by small temperature changes in the oven, a large resistor mass was needed. It was decided that a coaxial ceramic form would suffice if a metallic film of the correct resistance could be deposited on the ceramic. Platinum, a nonoxidizing metal having a high melting point, was selected and "Lava A" was used for the ceramic. The photographs and Fig. 1 show in detail the generator which was constructed incorporating this coaxial resistor.

Ceramic Metalizing

There are several known methods for metalizing ceramics, namely, evaporation, sputtering and painting. Extreme difficulties were encountered in trying to evaporate or sputter the platinum on the fired ceramic due to the high melting point of platinum and the porosity of the lava. The platinum paste products of the *Hanovia Chemical Company* were found to be satisfactory in the temperature range up to 900° C.

With the exception of the 50-ohm strip on the resistance, all of the coaxial surfaces were brush-painted with the #12 grade platinum paste after the surfaces had been heat-cleaned at 600° C and cooled to room temperature. (Paint-firing instructions must be followed or flaking and bubbling will occur.) The 50-ohm strip was then painted with a Liquid Bright #05x which has a resistivity of 25 ohm/sq. cm. after firing. Sufficient coats were applied to each of four resistance rods to give 60 ohms at the temperatures shown in Table 1 for 3-db, 4-db, 5-db, and 6-db rods. The platinized ceramic forms were then stabilized by being heated to 1000° C for 16 hours. Continuous heat cycling to 900° C for three months caused no measurable change in resistance.

The kiln selected was an *American Art Clay* model with a special door which allows pull-out operation.

Operation and Use

The assembled generator is placed in the oven and a chromel-alumel thermocouple is inserted in the resistance rod. Temperature readings may be taken on a millivolt bridge or the thermostatically controlled oven can be set to the required temperature and allowed to stabilize. The generator impedance value can be determined with a slotted line or impedance bridge, or may be taken from a calibration chart. This is necessary for accurately determining the noise power transfer constant.

When calibrating a laboratory-type random noise generator against a standard of this type, an amplifier having the desired frequency coverage is required as well as a true r.m.s.-reading voltmeter or ammeter. A direct noise power comparison at a fixed level is possible using this amplifier and voltmeter and a correction may be made on the laboratory noise generator at any one of the four levels mentioned, dependent on the resistance rod selection. Incremental calibration points may be obtained by using an attenuator as shown in Fig. 2 and calculating the power values in accordance with Eq. (8), which will be discussed later. The attenuator system in Fig. 2 allows the use of a noisy amplifier but introduces an error due to attenuator inaccuracy.

Higher noise values of the laboratory type of generator may also be checked by inserting a series of accurate 6-db attenuator pads in series with the laboratory generator output.

If the higher noise level measurements are made in this manner (i.e., 6-db attenuator pads attached to the laboratory noise generator), Eq. (8) must be used to determine the output of the laboratory generator before its output can be compared with that of the standard.

Incremental Measurements

Since resistance rods are not readily changed to allow for various noise outputs, an attenuation system was adopted to allow incremental noise values to be determined. Figures 2A and 2B each show a noise figure test setup. Equivalent circuit analysis of these setups is shown in Figs. 3A and 3B, and Eq. (8) indicates how noise figure calculations are made. Considerable error in the value of the attenuated noise power will be present if this procedure and Eq. (8) are not followed.

The various symbols used in Figs. 2 and 3 have the following meanings:

- $T_{o.}$ = noise power at output terminals of attenuator
- T_g = noise power of generator at T_r °
- T_R = noise power of 50-ohm resistor at room temperature
- α = power ratio of attenuator = output/input
- $R_{g.}$ = resistance of noise generator

Fig. 1. Cross-section drawing of the noise generator showing internal construction.

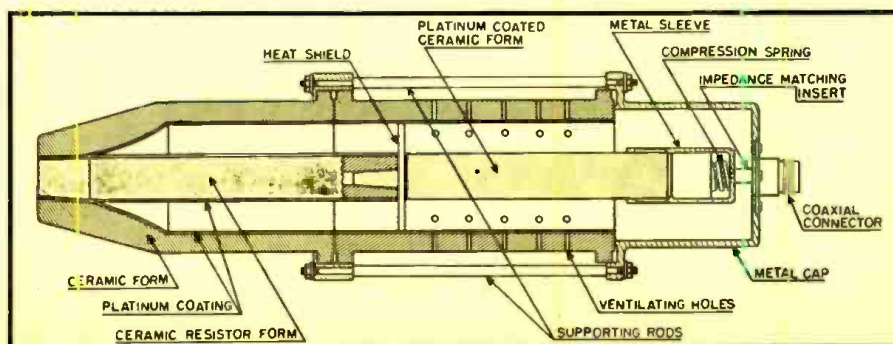

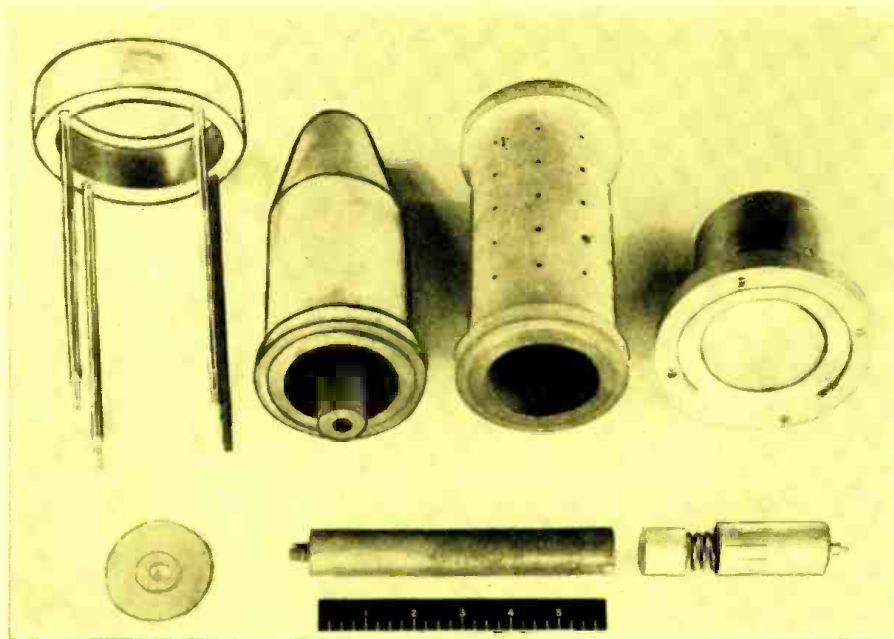

Disassembled view of the noise generator, showing component parts.

For the case where the noise power T_x equals T_R (i.e., generator at ambient temperature) and R_{gen} equals the characteristic impedance of the attenuator, the output power T_{eq} equals T_R since the attenuator output impedance is a constant for all values of α (Fig. 2A). For the case where the noise power T_x is not equal to T_R and R_{gen} equals the characteristic impedance of the attenuator (Fig. 2B), the output power T_{eq} is given by:

$$T_{eq} = T_R + \alpha (T_x - T_R) \\ = T_R \left[1 + \alpha \left(\frac{T_x}{T_R} - 1 \right) \right] \quad (8)$$

In the equivalent circuit A, Fig. 3, T_{eq} is shown as T_R , the noise power of the resistance of the attenuator. In the equivalent circuit B this is also true, but the equivalent of the noise generator

is shown as two generators, $(T_x - T_R)$ and T_R , since T_x is a function of the oven temperature with a minimum value of T_R . T_R is shown ahead of the attenuator; this noise power may be assumed to be due only to the terminating resistance of the attenuator (50 ohms). Since T_R is a constant for all values of attenuation α when the generator is at room temperature, only the differential power $T_x - T_R$ is attenuated.

As an example, suppose that it is desired to determine four values of noise power (T_{eq}) at the output terminals of the attenuator for a fixed temperature and resistance value using Eq. (8) and equivalent circuit B (Fig. 3). For four values of attenuation, when $R = 50$ ohms and $T_x = 1167^\circ$ K (generator noise power 6 db above ambient), the constant α is first determined for the values of attenuation to be used (see Table 2), and the equivalent noise power is then determined for the values of attenuation using Eq. (8). For an attenuation of 6 db, $T_{eq} = 1.75 T_R$.

It should be noted that there is present at the generator terminals, at this temperature of 1167° K, 6 db of noise power above ambient temperature. When using the 6-db attenuator, T_{eq} thus becomes $1.75 T_R$ or 2.4 db above

Attenuator Setting, db	α	T_{eq}
0	1.0	
2	0.632	
4	0.398	
6	0.250	$1.75 T_R$

Table 2. Values of α and T_{eq} for four different attenuator settings.

Fig. 2. Block diagrams of two different noise figure test setups.

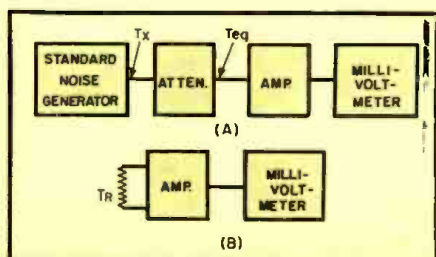
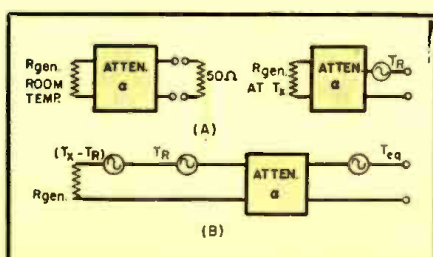

Fig. 3. Equivalent circuits for the test setups shown in Fig. 2.



ambient noise power and not $1.25 T_R$ or 0.9 db above ambient.

Application

The output of this standard generator may be used to calibrate other random generators in a direct comparison test employing thermocouple, millivoltmeter, and coaxial switch; or a more precise measurement may be made with a variation of Dicke's radiometer or Freeman's calibration system⁵. The generator may also be used in noise figure measurements directly by taking two readings with an attenuator, and determining the figure by extrapolation.

As employed here, the term "noise generator" is a misnomer. While it is true that noise generators are designed to produce calibrated levels of random noise, this calibration is generally in terms of noise figure—since the noise generator is actually a noise figure measuring set with a calibration of 0 db, meaning 0-db noise figure.

The thermal noise generator is calibrated in absolute values referenced to the noise voltage from a resistor at room temperature. Although a temperature ratio of $1167/293$ is approximately $4/1$ or 6 db in power, this ratio corresponds to a 3-db noise figure—which must be taken into account in any calibration of noise figure generators.

Conclusions

1. This generator is a primary noise standard since its electrical performance is determined by a quantitative measurement of two physical parameters: temperature and resistance.
2. Daily use for three months has resulted in no measurable change in output power.
3. Impedance measurements indicate a good 50-ohm source.
4. The generator is limited in use since much time is required to make the initial measurement.
5. A desirable feature would be a higher output.
6. A measuring set similar to Freeman's⁵ should be developed to utilize this standard fully.

Considerable credit should be given to Dr. Richard Guenther and Dr. George Goubau, SCEL, for their aid and guidance in this project.

REFERENCES:

1. Thompson, B. J., North, D. O., and Harris, W. A., "Fluctuations in Space-Charge-Limited Currents at Moderately High Frequencies," *RCA Review*, Jan., April, Oct., 1940, and Jan., April, July, 1941.
2. Schottky, W., "Small-shot Effect and Flicker Effect," *Physical Review*, Vol. 28, July, 1926, pp. 74.
3. Nyquist, H., "Thermal Agitation of Electric Charge in Conductors," *Physical Review*, Vol. 32, July, 1928, pp. 110-113.
4. Johnson, J. B., "Thermal Agitation of Electricity in Conductors," *Physical Review*, Vol. 32, July, 1928, pp. 97-109.
5. Freeman, J. J., "Noise Comparator for Microwaves," *RADIO-ELECTRONIC ENGINEERING*, March, 1953.

CARRIER-CONTROLLED RELAY

By

DAVID E. HARRIS

Haller, Raymond and Brown, Inc.



Fig. 1. Rear view of complete unit.

A relay that is actuated by the presence of a signal at the i.f. stages of a receiver.

IT IS frequently desirable to have in operation a control circuit that is actuated by a received radio signal. Such a circuit is incorporated in the carrier-controlled relay to be described here.

This unit was designed for use in conjunction with a radio receiver to develop a control signal coinciding in time with the reception of an r.f. carrier wave. It is particularly useful at airport control towers where recording of all voice traffic is required; it allows the recorder to be turned on only during periods when voice communication is actually taking place, thus permitting a large saving in recording tape.

To actuate the relay, a signal is taken from the i.f. of the receiver. As there are no tuned circuits in the unit, the particular i.f. used is of no consequence and the relay will operate whenever an i.f. signal of sufficient amplitude is present. This signal is rectified, amplified and then fed to the grid of the relay control tube.

An incoming signal is fed through a low impedance coaxial cable to the rectifier circuit consisting of a type 1N34 crystal diode, R_1 , R_2 and C_1 . (See Fig. 2.) R_1C_1 makes up a comparatively long time-constant circuit which filters the rectified voltage. The resulting d.c. voltage, proportional to the strength of the incoming signal, appears on the grid of the direct-coupled amplifier V_1 . C_1 serves to isolate the rectifier from any d.c. potentials which might be present at the receiver i.f. output.

The direct-coupled amplifier consists of one triode section of a 12AX7, V_1 . Operating grid bias for this stage is obtained from the drop across the cathode resistor, R_3 , and the drop across the portion of the threshold control, R_6 , between the negative end and the slider. The threshold control, R_6 , permits adjustment of the bias to V_1 , so that the circuit is in its most sensitive state in the absence of an input signal to the i.f. rectifier. With no input signal, and with the threshold control properly adjusted, plate current in V_1 is such that its anode potential with respect to ground is approximately equal to the potential of the cathode of the relay control tube, V_2 , due to the voltage drop through R_4 . With the application of an input signal, the control grid of V_1 is driven in a negative direction, its anode current decreases and the potential at its anode

rises. Because of the high- μ characteristic of V_1 , a very small amplitude input signal results in a rise of several volts in its anode potential.

The potential at the anode of V_1 is applied to the control grid of the relay control tube, V_2 , which consists of both triode sections of a type 12AU7 connected in parallel. The cathode of V_2 is maintained at a potential of 75 volts above the negative side of the power supply by V_4 , a type VR75. R_5 limits the control grid current of V_2 to a very small value when the anode potential of V_1 is higher than the cathode potential of V_2 . In the absence of an input signal, the anode current of V_2 is too low to operate the relay RL_1 . When an input signal is present, the grid potential of V_2 rises, the anode current increases, and relay RL_1 operates.

Under some conditions, it is desirable to bypass the control circuit temporarily. The switch, S_1 , when thrown to the position in which the negative side of the

(Continued on page 31)

Fig. 2. Circuit diagram and parts values for the carrier-controlled relay.

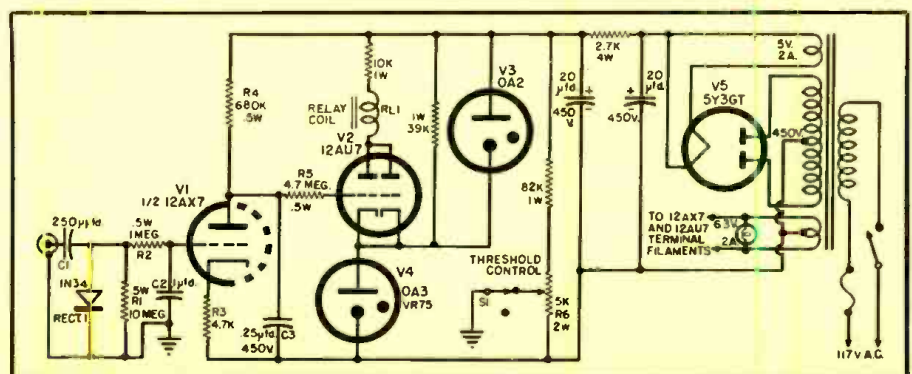

CONSTANT-OUTPUT BROADCAST AMPLIFIER

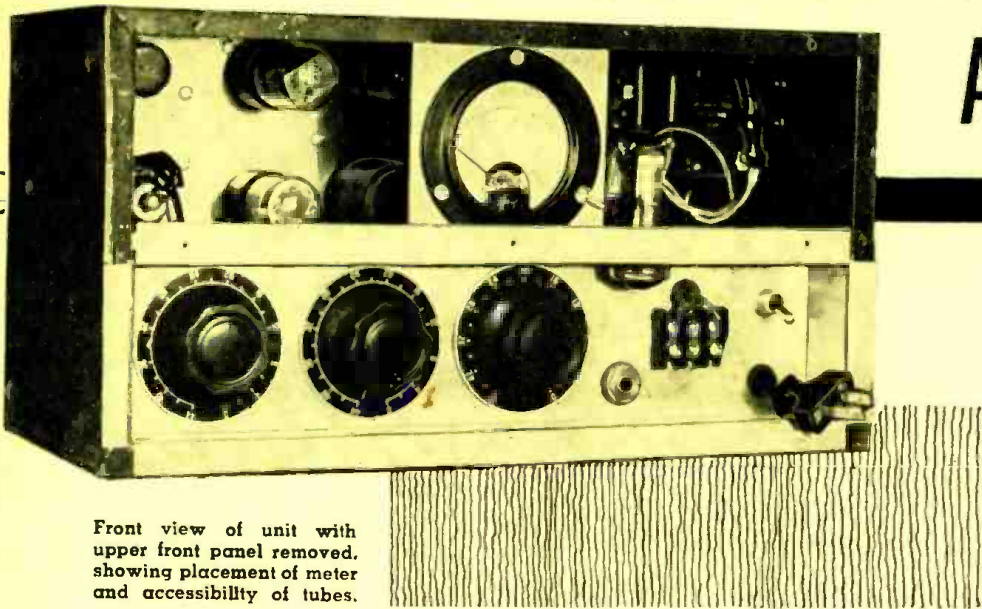

Front view of unit with upper front panel removed, showing placement of meter and accessibility of tubes.

By **ED C. MILLER**

Chief Engineer, Station KWEI

Output level of this amplifier remains constant within 1 db for input variations of up to 20 db.

IN COMMERCIAL radio broadcasting, the factors usually considered in design of equipment are: quality of response, ease of operation, and long life with minimum maintenance. Under the "ease of operation" heading comes another item which could be termed "minimum operational personnel." This is more or less true in all instances and is especially true at smaller stations where the operating margin is small. It has been exemplified over the years by the increasing use of engineers who double as announcers, newscasters, program directors, etc. In studio and control room work it has proved very successful, because the engineer is either doing the announcing or can watch the performers, and can thus anticipate any sudden increase in loudness and adjust the gain controls accordingly.

But remote-pickup broadcasts, and especially sports remotes, have continually presented two problems. The sportscaster cannot do justice to his reporting if he is endeavoring to maintain a near-constant output level from his remote amplifier. This leaves the gain-riding to the studio engineer who cannot see the play and will therefore have difficulty following the changes in incoming signal level. The second problem is electrical rather than physical. It is the possibility of overdriving the telephone line from the remote location to the control room, which may

cause crosstalk in adjacent cable pairs or distortion in the broadcast loop. (The above is predicated on the use of only one man at the remote site. Because of the problems just mentioned, it has been customary to use two men—one to engineer and ride gain, the other to give the play-by-play coverage of the event. Obviously, this means increased overhead.)

The most practical solution to these problems, i.e., the use of some means of automatic volume control or amplitude compression in the remote gear, has not been overlooked. But it conflicts with two of the prerequisites of remote gear: light weight and small size. In order to achieve the quality desired with the customary variable- μ

tubes, a push-pull circuit would be required and would involve at least three more tube envelopes and one more transformer than used at present in commercial remote equipment, increasing considerably its size, weight and cost.

In recent months a circuit has been developed, primarily for communications and amateur use, which is known as the NRCS loss compressor. Shown schematically in Fig. 1, it is a forward-acting, high-impedance compressor, with a loss logarithmically proportional to the applied signal amplitude. It can be designed to produce an output within 1 db of the zero compression output, with an input change of nearly 20 db. Its frequency response is good, and the distortion at all levels of compression very satisfactory, but it does produce a low frequency transient with compression changes—which limits low frequency operation. In the remote equipment built at KWEI, this transient was eliminated by the push-pull arrangement shown in Fig. 2.

Considerable thought was given to the design of the remote amplifier shown in the photographs. It meets all the physical and electrical requirements deemed desirable by the engineers responsible for the quality of the broadcasts and by the sports announcers who have to use it. These include light weight, small size, good frequency response, low distortion, two individually adjustable microphone inputs, and no necessary adjustments after setup in the field.

Normally, when a two-way line is available for use as the broadcast loop, commercial announcements may be read at the main studio and cues for the sportscaster can be fed back down the line. When this is the case, one microphone input is all that is needed. But when a one-way line is used, and this method of feeding cues is not feasible, the sportscaster can allow a prearranged time for the announcer at the studio to read the announcements or be assisted at the field

Fig. 1. Basic compressor unit.

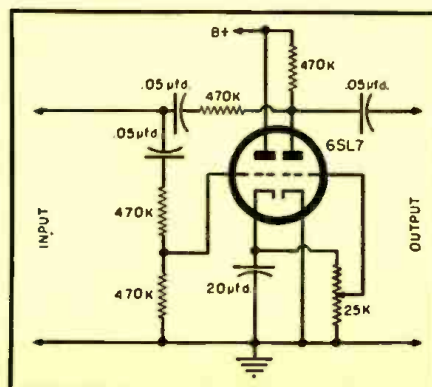

by an announcer. In the latter event, two microphones are highly desirable, and for that reason two inputs were provided. Controls were incorporated for both inputs to accommodate announcers with widely divergent voice strength. The output level control is not absolutely necessary but it increases the flexibility of the unit sufficiently to warrant its use.

Instead of an output meter, a meter showing the degree of compression is much more helpful in setting up the gear. To reduce the setup time for each broadcast, all controls were recessed and the line terminals and power plug were installed on the front. The pilot light is so placed that—by simply slipping out the jewel—it provides light to see the control settings and to read by in poorly lighted locations. The meter is recessed $\frac{3}{8}$ " behind the panel for protection during transportation because no cover is used. And, of course, the power supply was built into the same case.

Almost any good quality amplifier circuit could be used incorporating this type of compression; a simple straight-forward circuit was selected. The main design consideration was to provide 60 volts peak-to-peak of undistorted audio at the input of the compressor, with an average audio level at the microphone. This corresponds to 20 db of compression. It is desirable to have an

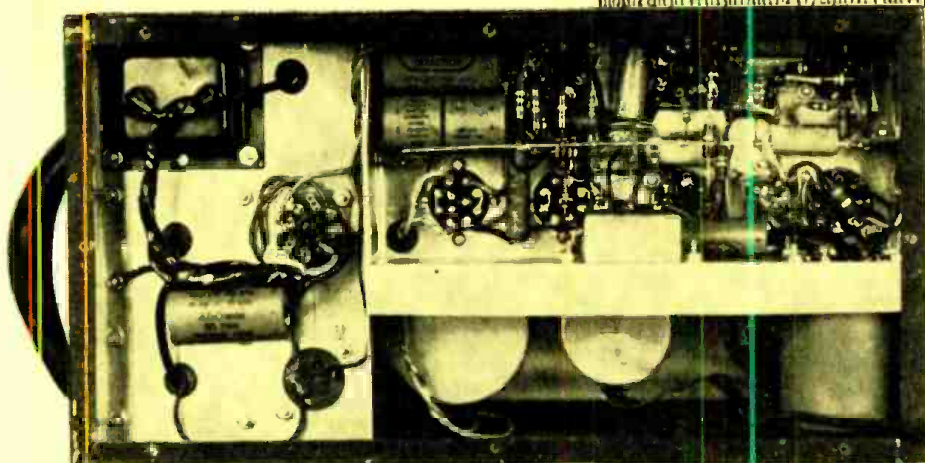

Rear view of unit with back cover plate removed to show dual chassis.

output of about + 15 dbm (1-mw., 600-ohm reference) available from the amplifier.

The finished equipment, shown schematically in Fig. 2, has been in use for several months, and has fulfilled all expectations. Through the use of this unit, it has been possible for an unassisted sportscaster to put out a better regulated remote than an engineer-sportscaster combination with the usual remote amplifier. After connecting the telephone line and power cable and plugging in the microphone, the man setting up the equipment at the remote location adjusts the microphone input

gain control so that the compression meter needle swings to about 2 db of compression (100 μ a.) when he talks into the microphone in his normal voice. He then adjusts the output control to provide the level desired at the control room. Thereafter, he can concentrate entirely on the event to be broadcast. It has been found that the 18-db additional compression is ample for most announcers even in their most excited deliveries.

As mentioned previously, any amplifier that meets a few simple requirements can have this compressor built (Continued on page 29)

Fig. 2. Circuit diagram and parts list for the complete remote broadcast amplifier.

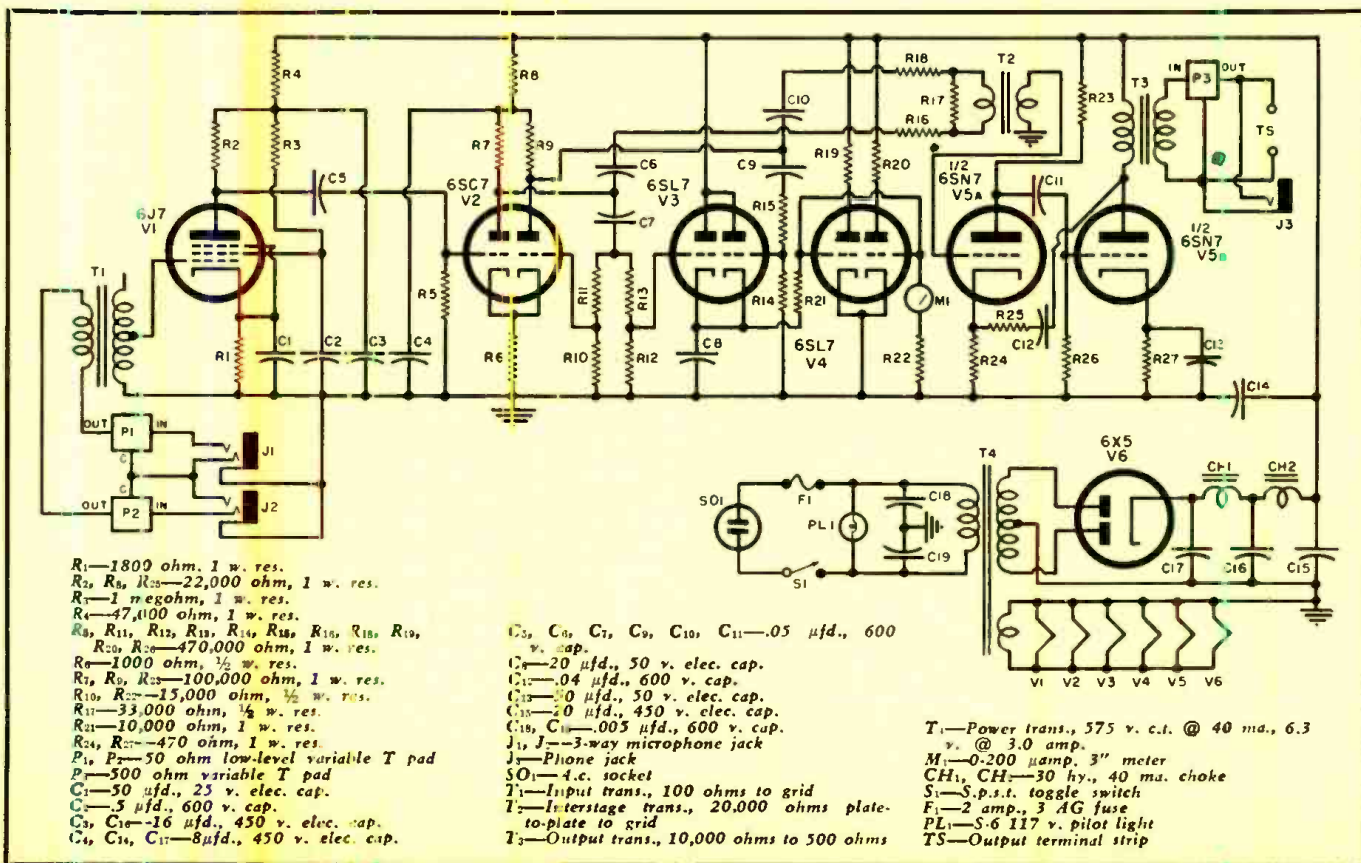

ELECTRONIC AUDIO BANDPASS FILTER

By **ROBERT J. GUNDERMAN**

Designers for Industry, Inc.
Cleveland, Ohio

*Design of narrow-bandpass electronic filter with
center frequency adjustable from 20 to 5000 cps.*

AN ELECTRONIC narrow-bandpass filter system has been developed whereby the center frequency of the passband can be moved in the range from 20 to 5000 cps. This system offers the advantages of simplicity, continuous tuning, light weight and high stability through the use of negative rather than positive feedback. To achieve these advantages, a simple electronic phase-inverter rejection circuit is employed in the negative feedback circuit of an audio amplifier.

The most common RC null networks are the Wien-bridge and the twin-T. Neither were suitable for this low-frequency bandpass filter system; there is no common reference between the input and output terminals in the Wien-bridge, and the twin-T posed a tuning problem. It is not practical to tune a

circuit with capacitors because of the large value of capacitance required.

To simplify the tuning problem, a simple electronic phase-inverter circuit was utilized for driving a half-lattice RC filter of the all-pass type. In addition to the simplification of tuning, such a circuit allows tuning ratios of 100 to 1 without the necessity of band-switching.

The rejection network is shown in Fig. 1. Signal voltage passed through R_1 and V_{1A} is shifted 180° regardless of its frequency, while the main path (V_{3A} and V_{3B}) consists of two cascaded phase-shift amplifier stages—each designed to give a voltage phase shift of 90° when $X_c = R$. The use of two such stages allows adjustment of the null frequency, as a 180° phase shift in any one stage can be obtained only when

$R = 0$. The output from these stages is then passed through an amplifier which acts to isolate them from the network output (V_{4A}).

Once the proper setting of the balancing potentiometer R_1 is found, the output voltages from the two halves of V_1 will be equal in magnitude at all frequencies since the phase-shifter output voltages cannot be altered by varying R_1 . That frequency which causes a phase difference of 180° between these voltages will cause the over-all circuit to have a null output. The frequency at which the null is produced in this manner is determined by the variable resistors, R_2 and R_3 , in the phase-shifting circuit.

Values of C_1 , R_2 and C_2 , R_3 were chosen according to the desired range of null frequencies. When R is maximum, the null frequency is minimum because $X_c = 1/2\pi fC$, and the null is that frequency at which $R = X_c$. Because a range of 20 to 5000 cps was desired, calculations for R and C were made at $f = 20$ cycles, where X_c is minimum. The maximum value of R is limited by the tube characteristics; therefore, a value of 1 megohm was chosen for R . The corresponding value for C to give a reactance of 1 megohm at 20 cps is approximately $0.01 \mu\text{fd}$.

Due to the fact that two phase-shift networks are cascaded, the null frequency will occur for that signal which receives a total phase shift of 180° . Inasmuch as the two phase-shift networks may not be perfectly identical, it is possible that such phase-shift combinations as 85° and 95° might occur to give the total 180° phase shift. For this reason, it is evident that the ganging of the two resistors need not be exact. It was found that standard audio tapers give a relatively linear frequency calibration for the knob rotation.

To keep the output voltage of a phase-shifter stage constant, the magnitude of the signal in the cathode resistor must equal the magnitude of the signal in the plate resistor. This is true in a triode stage where the plate and cathode resistors are matched to the same value. The actual value is not critical.

Response curves, shown in Fig. 2, were made on the filter alone at two different settings of the frequency control. The actual rejection can be seen to drop from 0 to approximately 33 db at the null. The output signal fails to rise all the way to 0 db at the high frequencies because of the falling off in high frequency response of the amplifier stages.

Resistor R_1 , in Fig. 1, is inserted to allow adjustment of the feedback voltage. This control is necessary since transmission at the null frequency is

(Continued on page 23)

Fig. 1. Circuit diagram and component values for the electronic bandpass filter.

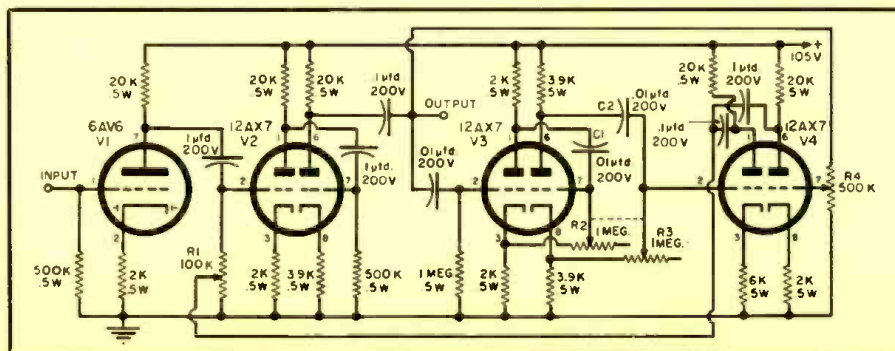



if you use Electronic Parts...

You'll want these specification Sheets from Sylvania

SYLVANIA

LIGHTING • RADIO • ELECTRONICS • TELEVISION



In Canada: Sylvania Electric (Canada) Ltd., University Tower Bldg., St. Catherine St., Montreal, P. Q.

Sylvania makes it simpler for you to specify accurately the electronic components you need. Free Sylvania electronic parts specification sheets are available now.

These data sheets tell you everything you need to know. Included is information on all types of sockets, plugs, receptacles, connectors, fuse holders, and many other electronic component products. Sizes, various materials used, photos and diagrammatic drawings make each of these "spec" sheets complete and easily read.

Send today for your FREE data sheets covering products in which you are most interested. Just check the coupon below or fill in the blank line provided, indicating your specific interest.

SEND THIS COUPON NOW!

Sylvania Electric Products Inc.
Dept. 3A-3511, 1740 Broadway,
New York 19, N. Y.

Please send me FREE electronic
data sheets checked at right.

- | | |
|--|---|
| <input type="checkbox"/> Molded Sockets | <input type="checkbox"/> Plugs |
| <input type="checkbox"/> Special Sockets | <input type="checkbox"/> Receptacles |
| <input type="checkbox"/> Laminated Sockets | <input type="checkbox"/> Miscellaneous Products |
| <input type="checkbox"/> _____ | |

Name _____

Street _____

City _____ Zone _____ State _____

NEWS BRIEFS

TINTED TV SCREEN

Improved clarity of picture and glare reduction can be achieved through the use of the television screen which has



been put on the market by *Libbey-Owens-Ford Glass Company*, Nicholas Building, Toledo, Ohio, for makers of television receivers. A neutral-tint safety glass screen, it was developed as a result of research on the part of *Libbey-Owens-Ford* scientists into methods of controlling the passage of light through laminated glass.

Actually, this screen is neutral in color, but a light filter—which reduces the haze of brightness—gives balance to contrasting shades of light and makes the picture much sharper. The photograph shows a resolution test being made on a sample of the new screen.

"EPOGLAS"

After several months of research and pilot production, *Plastilight, Inc.*, 481 Canal Street, Stamford, Conn., has placed on the market a laminate of epoxy-resin and glass-cloth known as

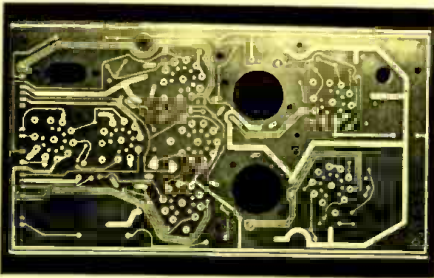

"Epoglas" which exhibits excellent mechanical and electrical properties. Water absorption is very low (0.016%);

dielectric constant, surface resistivity and arc resistance are high; and service temperature is 175° C.

Epoglas sheets can be supplied in two forms and in thicknesses that range from 0.003" through 0.500". They are available (1) copper-clad on one or both sides, ready for etching, or (2) unclad, for use in terminal boards or as bases for plated and printed circuits.

COMPUTER DEMONSTRATION

In this photograph, a *Burroughs Sensimatic* business machine—current automatic office equipment—is compared with a machine of the future, the

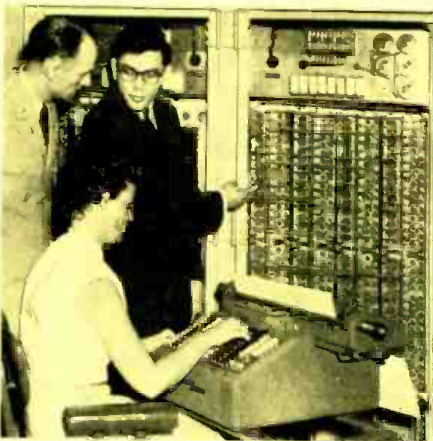

new "memory" for ENIAC (Electronic Numerical Integrator and Computer). ENIAC's new memory, one of the fastest in existence, was recently demonstrated to Army Ordnance officials at *Burroughs Corporation's* Philadelphia Research Center.

Electronic and magnetic techniques used in the memory are under development at this research center, which is located at 511 N. Broad Street, Philadelphia 23, Pa., for application to information-processing equipment for business use. High speed computation services, performed automatically on the *Burroughs* laboratory computer, are now available to business, manufacturing, trade and scientific organizations.

COMPONENT MANUFACTURER

Bradford Components, Inc.—a newly organized electronic component manufacturing firm located at Bradford, Pa.

—is equipped with facilities to develop and produce wire-wound precision resistors of low and medium power, to wind precision coils to customer specification, and to handle component sub-assemblies of all types.

Heading the corporation as president is F. Gordon Schermerhorn (left), who



has had many years of successful executive experience in the electronic component manufacturing industry. Mr. John G. Cumming, Jr. (right), formerly general manager of the *Webb Oil Company*, is vice-president and treasurer.

AIRPORT RADAR SYSTEM

Safer, more efficient traffic control is provided by the airport surveillance radar system now in operation at the Norfolk, Va., municipal airport. Developed and built by *General Electric Company* engineers at Syracuse, N. Y., for the Civil Aeronautics Administration, the new system has also been installed and awaits commissioning by the CAA at many other major airports.

The radar operator at the right observes on the radar screen the flight paths of all planes within a radius of 30 to 60 miles. Only moving aircraft



appear on the screen; map overlays show controllers the exact locations of obstructions dangerous to approaching aircraft. During periods of poor visibility, the new radar helps to space and control the arrival of inbound planes so that they can be "fed" into the precision approach control system at the safest, most efficient rate.

ENGINEERS:

**DOES YOUR
PRESENT JOB
GIVE YOU**

ALL THESE

RCA

CAREER

ADVANTAGES?

**POSITIONS NOW OPEN FOR
SENIOR DEVELOPMENT
AND DESIGN ENGINEERS:**

- ✓ ELECTRONIC . . .
- ✓ COMMUNICATIONS . . .
- ✓ MECHANICAL . . .
- ✓ COMPUTER . . .
- ✓ ELECTRON TUBE . . .

**PERSONAL INTERVIEWS ARRANGED
IN YOUR CITY.** A copy of our booklet
"Challenge and Opportunity," describing the role of the
engineer in RCA, will be mailed upon request. Please
send a complete resume of your education and
experience to:

MR. ROBERT E. McQUISTON, Manager
Specialized Employment Division, Dept. 204-K
Radio Corporation of America
30 Rockefeller Plaza
New York 20, N.Y.

Yes No

CHECK SHEET

- PROFESSIONAL RECOGNITION AND PRESTIGE?
- ADVANCEMENT IN STATUS?
- SECURITY AND STABILITY?
- CHALLENGE AND OPPORTUNITY?
- HIGH SALARY SCALE AND OPPORTUNITIES FOR PROMOTION?
- EXCELLENT SUBURBAN HOUSING AT REASONABLE COST?
- FACILITIES FOR PROFESSIONAL ADVANCEMENT?
- UNEXCELLED TECHNICAL AND LABORATORY FACILITIES?
- ASSOCIATION WITH TOP SCIENTISTS?
- TUITION REFUND PLAN FOR ADVANCED STUDY?
- MILITARY OR COMMERCIAL OPPORTUNITY?
- MODERATE COST OF LIVING?
- MODERN RETIREMENT PLAN?
- COMPANY-PAID LIFE INSURANCE?
- COMPANY-PAID LIBERAL HOSPITAL, SURGICAL AND DISABILITY PLAN (FAMILY BENEFITS)?
- LIBERAL VACATION PLAN?
- LIBERAL HOLIDAY SCHEDULE?
- PROFESSIONAL STATUS AND UTILIZATION OF YOUR EDUCATION AND EXPERIENCE?



RADIO CORPORATION of AMERICA

NEW PRODUCTS

VARIABLE RESISTORS

Two variable composition resistors have been announced by *Chicago Telephone Supply Corporation*, Elkhart,

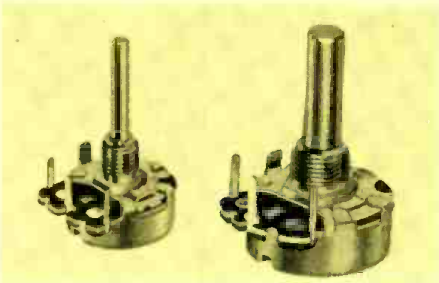

Ind., for use in printed circuit applications—Type U70, having a $\frac{3}{4}$ " diameter, and Type U45, with a $\frac{15}{16}$ " diameter. The latter control is also available with s.p.s.t. or d.p.s.t., 3-ampere, 125-volt switch.

Several unique design features are incorporated in these controls: (1) protection against bending during handling is achieved by recessing each blade-type terminal in a notch in the bakelite base of the control; (2) valuable mounting space is conserved on the printed circuit panel by placing terminals close to the mounting bushing; and (3) adequate clearance for circuit paths is provided by ample spacing between terminals.

ANALOG STIMULUS GENERATOR

The Model CS "Central Signal Component" is an analog stimulus generator manufactured by *George A. Philbrick Researches, Inc.*, 230 Congress Street, Boston 10, Mass., for use in high-speed repetitive analog computing systems. It

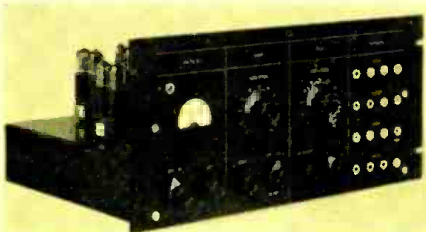

initiates time solutions and assists in the organizing, operating, and calibrating of such systems as well as in the display of their results. A fixed time base of 20 cps is employed, affording a 50-millisecond computing interval.

Three kinds of output signals, design-

ated respectively as "clamp," "ramp," and "step," can be obtained from the Model CS. The clamp holds a system artificially stabilized prior to stimulation; the ramp provides a linear time base—covering the entire 50-millisecond interval—for plotting and scanning purposes; and the step is automatically delayed following removal of the clamp.

DATA-HANDLING SYSTEM

A multichannel data-handling system for use in aircraft and missile testing has been completed by the *Potter Instrument Company, Inc.*, 115 Cutter Mill Road, Great Neck, N. Y., for the

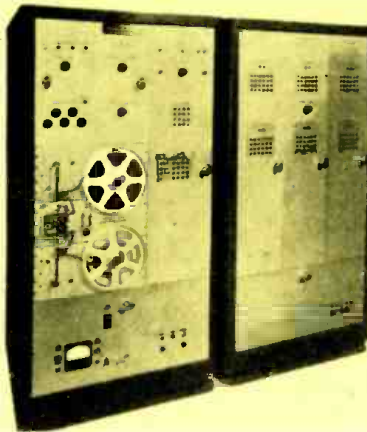

Consolidated Vultee Corporation of San Diego.

This system is designed to digitize, sample, and record information obtained from Doppler frequency effects or pulse code modulation from each of three independent channels, and to provide—through a fourth channel—recorded time marker signals as a data reference. Special decades allow addition or subtraction of counts and indicate the algebraic sign of the total counts.

Individual components or complete systems are now available to provide sampling rates up to 100 per second, and these may be combined with existing or proposed methods employing punched cards, direct data printers, or magnetic tape recorders.

VARIABLE OSCILLATOR

Northern Radio Company's variable master oscillator provides a continuously variable r.f. source with a sta-

bility of approximately 1 cycle per mc., in the range of 2 to 4 mc. It may be used as the basic control oscillator for diversity receivers, high frequency transmitters and other communications devices, or as a laboratory standard for test and measurement functions.

No curves, interpolations or calculations of any kind are required in the

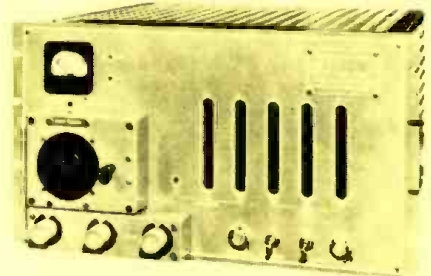

use of this instrument. Frequency is set approximately to the desired value by rotating the oscillator dial. The last three digits of the desired frequency are on the switches; the frequency automatically locks in at this value and holds with an accuracy which exceeds that of most temperature-controlled crystal oscillators. For complete details, write directly to *Northern Radio Co., Inc.*, 147 West 22nd Street, New York, N. Y.

MINIATURE POTENTIOMETER

Only .875" in diameter, the Type 9 *Electro-Mec* ultralow-torque potentiometer will operate with a mechanical torque as low as .015 ounce-inches. It is said to offer an opportunity to designers and manufacturers of computers and servomechanisms to achieve a heretofore unattainable degree of miniaturiza-

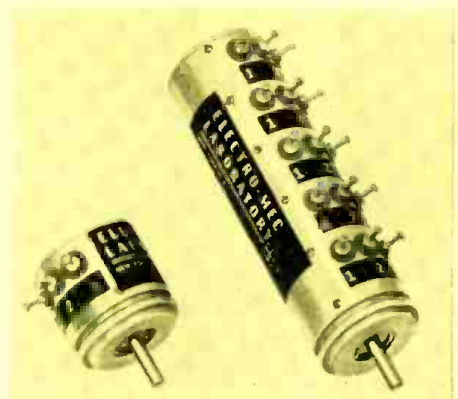

tion without sacrifice of high performance characteristics.

A new structural feature of Type 9 is the use of a precision-machined aluminum housing for the toroidally wound resistance element. Individual potentiometer cups are only .500" long, and the instruments are available in ganged assemblies up to six units. A five-cup assembly, using one shaft to operate all

(Continued on page 27)



TYPE BH6A
FREQ. 210-500 kc -
1000-100,000 kc



TYPE BH8
FREQ. 15-200 kc -
550-2000 kc



TYPE BH9A
FREQ. 90-200 kc



TYPE BH7A
FREQ. 15,000-50,000 kc



THE INSIDE STORY

Top quality means top performance after long service. Bliley quality control far exceeds the perfunctory steps necessary to produce and ship crystals which meet a nominal specification.

Bliley precision process techniques, rigidly followed in orientation, slicing, lapping, and plating guarantee peak crystal performance. That extra touch of engineering and craftsmanship makes the big difference in your equipment.

That's the Bliley inside story!

- # RESEARCH
- # ENGINEERING
- # CRAFTSMANSHIP
- # PRECISION
- # PRODUCTION
- # DELIVERY
- # QUALITY



BLILEY ELECTRIC COMPANY
UNION STATION BUILDING • ERIE, PA.

NEW LITERATURE

CARBON AND GRAPHITE PRODUCTS

Standard and special carbon and graphite components and materials for chemical, electrical, and mechanical applications are described in Catalog 40A, copies of which may be obtained on letterhead request from the *Stackpole Carbon Company*, St. Marys, Pa.

Recently revised and enlarged, the 44-page catalog contains a wealth of data on carbon and graphite as applied to products ranging from battery and welding carbons to tube anodes, electrical contacts, bearing materials, seal rings, rail bonding molds, graphite for spectrographic analysis, and many others.

PRODUCTION ENGINEERING

"Production Engineering" is the title of a four-page bulletin available from *Designers for Industry, Inc.*, 2915 Detroit Avenue, Cleveland 13, Ohio. It discusses the *DFI* production engineering services—which include design an-

alysis, production processing, process specification and work simplification—and tells how these services are applied in the development and testing of prototype production models and special-purpose machinery.

DISPERSIONS

A four-page booklet listing 37 dispersions of colloidal graphite, molybdenum disulfide, vermiculite, and zinc oxide has been issued by the *Acheson Colloids Company*. Typical applications, densities, carriers and other important data are given.

Copies of "A List of 'dag' Dispersions for Industry" may be obtained by writing to *Acheson Colloids Company*, Division of *Acheson Industries, Inc.*, Port Huron, Mich.

SOLDER AND BRAZING ALLOYS

Bulletin FF-1 describes *Fusion Engineering's* line of flux-containing electrical, electronic, and mechanical bond

paste solder and brazing alloys, and discusses a new two-part semiautomatic soldering technique. It may be obtained by writing to *Fusion Engineering*, 4504 Superior Avenue, Cleveland 3, Ohio.

A color-coded chart illustrates the melting ranges of each solder and brazing alloy type, and line drawings of a variety of parts demonstrate the new soldering method which involves pre-application of paste to each part with separate heat application.

ELECTRONIC CONTROLLERS

The Bristol Company, Waterbury 20, Conn., has announced publication of a bulletin on its new line of "Free-Vane" electronic controllers. Known as No. B226, the 16-page bulletin describes the latest additions to the Series 500 instruments, available as indicating or recording controllers for temperature, pressure, flow, liquid level, humidity, and time program.

Information on the unique frequency modulation principle of the control unit, plus data on combinations of indicators or recording pens and control units, and examples of applications are contained in this fully illustrated booklet.

QUARTZ ORIENTATION

Results of measurements made of the relative intensities of x-rays reflected from a large number of planes in quartz are given in NBS Circular 543 together with suggestions for their most effective use in the determination of orientation of crystal blanks. Graphs are presented which indicate the effect of inclined planes on the intensities of the reflected beam, and tables and charts to facilitate the use of the most essential x-ray data are included.

Entitled "Reference Data for Orienting Quartz Plates by X-ray Diffraction," Circular 543 is available from the Superintendent of Documents, U. S. Government Printing Office, Washington 25, D. C., for 15 cents a copy.

JUNCTION PHOTSENSITIVE TRANSISTOR

DEVELOPMENT of a germanium n-p-n junction photo transistor, said to be the first commercially available amplifying photo transistor ever made, has been announced by *Transistor Products, Inc.*, Boston, Mass., an operating unit of *Clevite Corporation*. Its immediate applications will include use in automatic punch card accounting machines, automatic dimmers for automobiles, and automatic brilliance controls on television receivers.

The Type X-25 is an n-p-n junction photosensitive transistor with sufficient power output to operate a relay. Maximum operating power is 60 mw. and

maximum nondestructive power is 400 mw. The X-25 may be considered as being a light-sensitive device with an incorporated amplifier.

This experimental photo transistor can be coupled with an a.c. amplifier provided that a mechanical or electro-mechanical light chopper is used in conjunction with it to supply a pulsed signal for a.c. current flow. The current then will be a function of the light intensity. Experiment has shown this transistor to be responsive to pulse frequencies as high as 25 kc.



The X-25 n-p-n junction photo transistor.

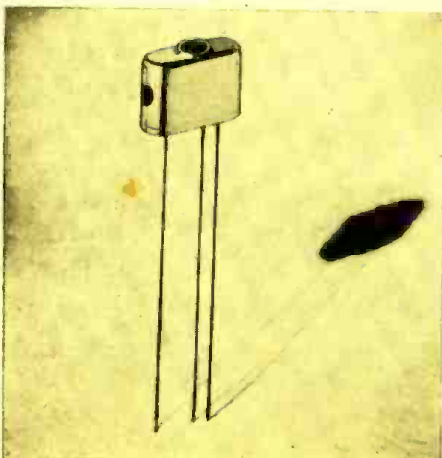

Average estimated characteristics for the experimental X-25 photo transistor.

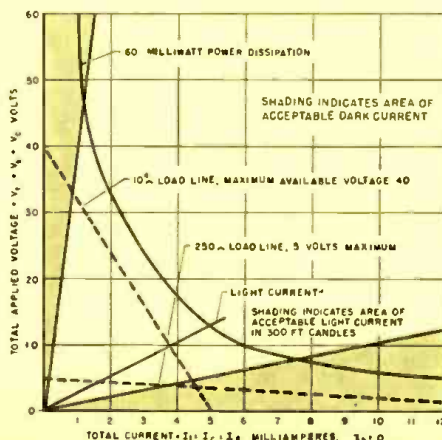

VIBRATION ISOLATORS

Complete engineering data on the Series M44 "All-Met" vibration isolators are given in *Barry Product Bulletin 534*, which provides the first technical description of vibration isolators of the knitted-wire type. The *Barry Series M44* is specifically designed for protection of sensitive equipment in military aircraft at extreme operating temperatures.

Bulletin 534 contains information on: transmissibility in all directions of motion; isolation curves for acceleration and displacement; the effect of load variation, and of extremely high and low temperatures; performance after severe

shock; and other data. It is free on request from *The Barry Corporation*, 870 Pleasant Street, Watertown 72, Mass.

STRAIN GAGES

Specifications for 105 sizes and types of SR-4 strain gages are tabulated in the new price list available on request from *Baldwin-Lima-Hamilton Corporation*, Philadelphia 42, Pa., which also covers instruments and accessories. Factors to be considered in selecting SR-4 gages are given more fully than in the previous edition.

Audio Filter

(Continued from page 16)

only 33 db down from transmission at frequencies far removed from the null. The proper setting is obtained when there is no oscillation at frequencies far removed from the null.

The effects of a 33-db null rather than a perfect null from the rejection filter can be observed in the following calculations. A 33-db loss represents a voltage ratio of 1 to 45.7, or a feedback factor β of 1/45.7. In this case, the amplification A without feedback is 37. The gain with feedback is:

$$G = \frac{A}{1 + \beta A} = 20.4$$

As β approaches zero, the system gain approaches A . The improved response resulting from an increase to 60-db rejection can be calculated in the same way, giving a gain of 35.7.

These calculations do not apply for frequencies removed from the null because the feedback signal is 180° out of phase with the input only at the null frequency—a result of the phase comparison of constant-amplitude voltages in the output of the filter. However, neglecting the slight inaccuracies at a point on the curve where the rejection is 6 db, the gain is found as above. The feedback factor β is 0.5, giving a gain of 1.895.

Another important consideration is the magnitude of the internal imped-

ance of the input signal source. The output of the rejection filter has a high impedance and is coupled into the high impedance amplifier unit. It is necessary that the magnitudes of both the signal source voltage and the feedback voltage be applied to the amplifier input with the same relative values so that proper mixing will result. If such is not the case, the signal input to the amplifier cannot be controlled by the variable voltage out of the filter. This lack of control is prevented by the addition of an isolation amplifier stage.

Figure 3 is a plot of the bandpass filter response for three different settings of the frequency control. A constant over-all gain can be had at any frequency setting within the limits of the amplifier response. Constant gain is particularly useful in analyzing a signal for relative amplitudes of different frequency components.

The results obtained through the use of this system are reproducible without difficulty. Selectivity can be greatly improved, it is believed, by increasing the gain of the RC-coupled amplifier and by lowering the depth of the null in the rejection network through the addition of more phase-shifting stages. Not much can be done to increase the feedback at frequencies removed from the null because the feedback signal at such points is no longer 180° out of phase with the input signal. Any increase in βA at such a point might result in oscillations.

Inability to secure a perfect null is due to the lack of perfect balance of the two voltages mixed in the rejection network output. An increase in amplification of the two out-of-phase signals before mixing takes place would greatly increase the depth of the null.

BIBLIOGRAPHY:

Villard, O. G. "Tunable A-F Amplifier," *Electronics*, July, 1949, pp. 77-79.
 Terman, F. E., "Radio Engineering," McGraw-Hill Book Company, Inc., 1947.
 Vullen, G. E. and Wallman, H., "Vacuum Tube Amplifiers," Radiation Laboratory Series Vol. 18, McGraw-Hill Book Company, Inc., 1948.

WHEN YOU ORDER WELLS COMPONENTS...



HERE'S WHAT YOU GET

- 1 IMMEDIATE DELIVERY FROM STOCK (in any quantity)
- 2 FINEST QUALITY OF FAMOUS BRANDS
- 3 GENERALLY LOWER PRICES
- 4 RETURN PRIVILEGE FOR FULL CREDIT IF NOT SUITED TO YOUR REQUIREMENTS

The valuable service Wells provides to the industry is being used by many of our greatest manufacturers as a matter of course.

Our vast stock (the world's largest) may contain just the components you need to fill urgent orders — at a substantial savings in time and cost.

ADEL CLAMPS • ANTENNAS, Insulators, Mast Sections • BINDING POSTS • BLOWERS • CABLE ASSEMBLIES • CHOKES • COILS • CONDENSERS Oil Filled, Bathtub, Hearing Aid, Transmitting Mic, Silver Mic, Ceramic, Variable, Trimmer • CRYSTALS • FILTERS • FUSES • MOUNTINGS • GENERATORS • GROUND RODS • HEADSETS • i.f. COILS • JACKS • JACK BOXES • KEYS, Telegraph KNOBS • LAMPS • LORD MOUNTS • LUGS MOTORS & BRUSHES • PLUGS • RECTIFIERS Selenium, Copper Oxide, Meter, Diode • RESISTORS—All Types • SELSYNS • SOCKETS • SWITCHES Aircraft, Micro, Switchettes, Toggle • TIMERS • TUNING—Flexible • TUNING SHAFTS • TRANSFORMERS All Types • VIBRATORS • WALKIE TALKIES

DYNAMOTORS

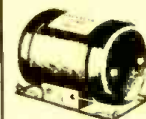

OVER 100,000
NEW DYNAMOTORS
IN STOCK!

DM 32A — DM 53A — PE 36 — PE 101C
DM 33A — D 101 — PE 94, etc.
Large quantities of brushes for all types of dynamotors and motors.

Write us for quotations. Advise us your requirements.

A complete Signal Corps stock number listing of items in our stock. Write for listing No. 5G-200. (For government agencies and contractors only.)

Manufacturers and distributors—write for new Condenser Catalog C-10 now available.

Write, Wire, Phone Your Requirements

all phones: SEELEY 8-4143



833 W. Chicago Ave., Dept. R, Chicago 22, Illinois

Fig. 2. Rejection network response.

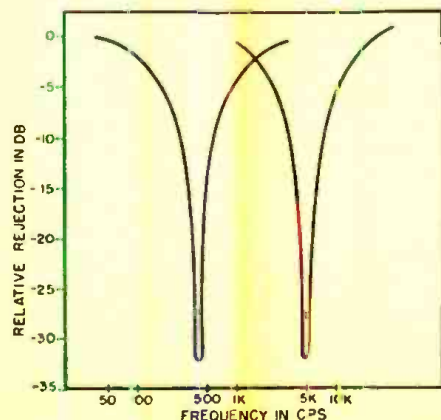
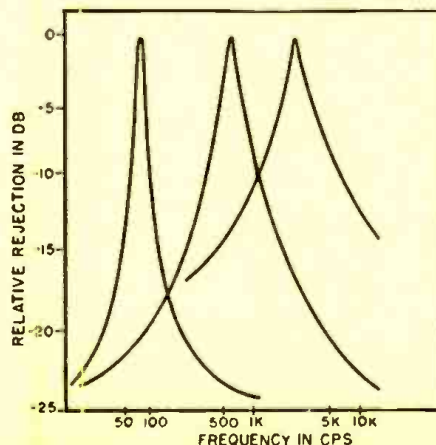

Fig. 3. Bandpass filter response.



NEW TUBES

HIGH VACUUM RECTIFIER

The Los Gatos Brand 705A is a thoriated-tungsten type of high vacuum rectifier. With a half-filament connection, operation is 2.5 volts at 5 amperes; with full-filament connection, operation is 5 volts at 5 amperes. A data sheet illustrating the 705A and containing a dimensional outline drawing is available from *Lewis and Kaufman, Ltd.*, 70 El Rancho Avenue, Los Gatos, Calif.

When used as a rectifier, this tube has a maximum peak inverse voltage rating of 30,000 volts for both connections. Maximum average plate current for a peak inverse voltage not greater than 15,000 volts is 75 ma., half filament, and 150 ma., full filament; for a peak inverse voltage of 30,000 volts, it is 50 and 100 ma. respectively.

TEMPERATURE-LIMITED DIODES

Thermosen, Inc., manufacturer of "Kalotron" diodes, has announced the addition of two new tubes to its line. Designated as the 5DC-5 and the 5DC-5M, they have the following similar

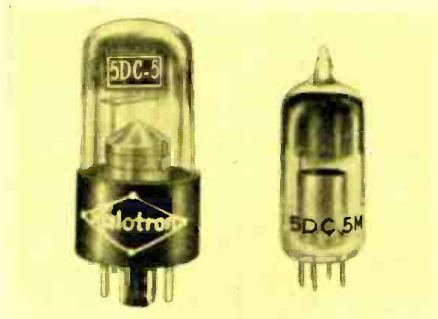

electrical specifications: filament voltage—5.6 a.c./d.c.; cathode current—55-75 ma.; plate voltage—500; plate current—450-575 ma. The 5DC-5 uses a T9F1 bulb and a #8537 8-pin intermediate octal base, while the 5DC-5M uses a T5½ bulb and a T5½ 7-pin miniature button base.

When the anode current is a direct function of filament voltage, these diodes have temperature-limited emission characteristics. Small changes in filament voltage result in relatively large changes in anode current. For further information, write to *Thermosen, Inc.*, 361 West Main Street, Stamford, Conn.

TWIN TETRODE

Having a maximum plate dissipation rating of 20 watts under ICAS condi-

tions, the Type 6252 twin tetrode works efficiently with a power output of 12 watts at 600 mc. It is a lower power version of the *Amperex* Type 5894/AX9903, and has been successfully op-



erated as a frequency multiplier over the entire u.h.f. television band.

Only 3" in over-all height and slightly less than 1¼" in maximum diameter, the Type 6252 is particularly suitable for low-drain mobile transmitters and multiplier chains. For further information, write to *Amperex Electronic Corporation*, 230 Duffy Avenue, Hicksville, L. I., N. Y.

HIGH-RELIABILITY TUBES

Specifically designed for equipment in which extreme electrical and physical dependability is essential, the newest group of "Five-Star" high-reliability tubes to be announced by the Tube Department of the *General Electric Company*, Schenectady, N. Y., includes two twin diodes, one twin triode, and two pentodes.

The GL-6202 is a miniature full-wave high-vacuum rectifier for power supplies in which the d.c. current requirements do not exceed 50 ma.; within the limits of its maximum ratings, it is a replacement for the 6X4. Also a miniature full-wave high-vacuum rectifier, the GL-6203 twin diode is for use in power supplies of a.c. and storage battery-operated equipment.

A subminiature medium-mu twin triode, the GL-6021 is suitable for general-purpose amplifier applications; each section has an individual cathode and is electrically independent.

The semi-remote-cutoff characteristic of the GL-5899 subminiature pentode as a wide-band, high-frequency amplifier makes it suitable for circuits to which it is desired to apply automatic

gain control. Electrically and physically a replacement for the 6AC7, the GL-6134 is a sharp-cutoff pentode intended for service as a wide-band r.f. or i.f. amplifier, or as a video amplifier.

RCA TUBES

Among the latest tubes announced by the Tube Department of the *RCA Victor Division*, Harrison, N. J., are the RCA-5690—a full-wave vacuum rectifier, the RCA-5719—a high-mu triode, and RCA-5840—a sharp-cutoff pentode.

Vacuum Rectifier

The RCA-5690 is a "Special Red" vacuum rectifier tube designed for industrial and aircraft applications where rigid requirements for dependability, stability, and long tube life are of prime importance. It has two separate diode units of the indirectly heated cathode type, and is conservatively rated to withstand a maximum peak inverse plate voltage of 1120 volts, a maximum peak plate current per plate of 375 ma., and a maximum d.c. output current per plate of 75 ma.

Triode and Pentode

Both "premium" tubes of the subminiature type with flexible leads, the 5719 and 5840 are primarily for use in mobile and aircraft receivers where dependable performance under shock and vibration is a major consideration. A pure tungsten heater is incorporated in each of these tubes to give long life under conditions of frequent "on-off" switching.

In audio service as a resistance-coupled amplifier, the 5719 (left) provides high voltage gain; it features a compact structure designed to reduce microphonic output. As a broadband r.f. am-

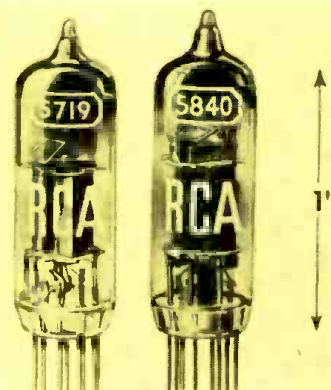

plifier, the 5840 (right) can be used at frequencies up to about 400 mc.; three leads to the cathode permit isolation of the input and output circuit returns.

TV "MEMORY TUBE"

Transatlantic television is being brought ever nearer to reality. At a convention for *Raytheon* TV distribu-

(Continued on page 28)

Decommutating

(Continued from page 5)

signed and mounted in individual plug-in type cans. These cans reduce the down time due to unit failures and increase efficiency in system servicing. Also included on this chassis is a series of cathode followers used to transform the relatively high impedance of the counter plates to a low impedance for driving lines leading to the individual demodulator channels.

Demodulator

Two electronic-analog low-pass filter units are connected in series on the demodulator chassis. The closed loop gain of each is adjusted to a value of 10, giving an over-all voltage gain of 100 for each channel. It can thus be seen that with a channel zero frequency gain of 100 it is possible to realize one volt at the output for every volt change in pulse input amplitude. Frequency of cutoff of the filters may be controlled independently from the front panel of each demodulator chassis; the number of different cutoffs is sufficient for demodulating commutation rates ranging from 2.5 to 40 rps. A linear cathode follower gate drives the first filter unit, and the grid of this cathode follower is controlled so that during the long "off" time of the duty cycle the grid is below cutoff, thus eliminating drifts in input intelligence at the base line due to changes in vacuum tube transconductance and characteristics. During the period of gating, the grid is brought into a region just below cutoff, permitting the intelligence to bring the tube up to its normal operating and linear region.

Each gate has an output sufficient to drive to full scale a *Brush* direct-writing pen motor, a recording oscillograph galvanometer element, and a remote indicating device, all connected in parallel. The output lines of each channel are designed so that one is always grounded, the other having a voltage which ranges above and below ground. When center modulation is applied to a particular channel, both lines are essentially at ground and zero current flows through the recording devices.

Power Supplies

Power supplies provide four voltages: +250, -250, +175, and -150 volts. The latter two are of high current capacity and are used only on the output tubes of the demodulator channels. The other two provide plate power for the channel amplifiers; and since the amplifiers are of a d.c. type, the supplies are highly stabilized and slaved to each other. Two regulating loops are contained in the -250 volt supply: the "A" loop is of the conventional type found in most

regulated power supplies and performs the functions of decreasing hum and compensating for rapid changes in load and line voltage, while the "B" loop is a high gain a.c. amplifier which receives its input signal from a vibrating reed type of vibrator chopper. This chopper, by means of a double-pole, double-throw relay contact, compares the output of the supply to a standard reference voltage. Under conditions of power supply drift, the differential produced in the comparison increases in one of two phases, depending upon the direction in which the supply has drifted. This primary reference is composed of a sub-miniature regulator tube contained with its dropping resistor in a temperature-controlled oven. Stability of reference voltage for long periods of time is of the order of 400 μ v., with a static operating potential of approximately 83 volts. The "E" loop—which has a gain of 1000—amplifies this chopper-produced square wave; and at its output, a second set of contacts on the same solenoid is used to demodulate the amplified signal. A long-time-constant RC integrator then smooths the demodulated square wave and provides a d.c. voltage proportional to the drift or error voltage between the standard reference and the power supply output. The amplified error voltage of the "B" loop is then returned to a control grid of a differential amplifier in the "A" loop, where it performs the function of compensating for slow, long-term drifts within the system. In turn, the +250-volt supply is slaved or stabilized with reference to the -250 volt supply, so that as a drift occurs in the latter, making it more negative, the positive supply will produce a more positive voltage—with the result being, theoretically, a zero drift of the differential voltage between the two. In practice, this drift can be measured to ground and found to be of the order of 700 μ v.

Oscilloscope and Commutator

Remaining chassis in the system are the oscilloscope and electronic commutator simulator. The oscilloscope is connected directly to the pulse selector, and various waveforms throughout the system may be monitored by selecting each individual point with a rotary switch found on the front panel of the pulse selector. The electronic commutator simulator produces a stable and reliable output which duplicates in every respect the waveform generated by an airborne mechanical commutator. Facilitating the initial setup and check-out of the entire ground station is the basic purpose of this unit.

Physical construction of the ground station is such that all major and minor chassis may be serviced in an operative condition. Drawer slides permit the

removal of the large power supply units from the rack to an extended position where they may be completely rotated so that the bottoms of the chassis are accessible for servicing. The demodulator channels are of the plug-in type with the chassis designed so that they are mounted vertically rather than in the conventional horizontal or shelf-like position; such mounting allows all vacuum tubes to extend in a horizontal direction, providing a configuration similar to vertical ducts from top to bottom, and thus permits maximum heat transfer for a given amount of air flow.

The electronic-analog low-pass filter described in this article was constructed from basic circuitry developed by Dr. L. L. Rauch, Professor of Aeronautical Engineering, University of Michigan. Professor Rauch, one of the early pioneers in the field of radio telemetry, served as a consultant to the *Ralph M. Parsons Company*.

BIBLIOGRAPHY:

- Wynn, J. B., and Ackerman, S. L., "Guided Missile Test Center Telemetering System," *Electronics*, May, 1952.
Kiebert, M. V., "Multichannel FM/FM Telemetering System," *Tele-Tech*, March, April, 1952.
Boothe, K. B., "Tape Recording for Telemetering and Data Analysis," *Tele-Tech*, May, June, 1952.
Wynn, J. B., and Ackerman, S. L., "Guided Missile Data Recording," *RADIO ELECTRONIC ENGINEERING*, February, 1953.



Laboratory Engineering
5" OSCILLOSCOPE

- DC amplifiers to 4.5 mc with 17 millivolt sensitivity.
- Calibrating voltages, triggered sweep, Z-axis modulation, light shield provided.
- Write for technical details . . .

THE HICKOK ELECTRICAL INSTRUMENT CO.
10814 DUPONT AVE. CLEVELAND 9, O.

LOOKING at TUBES

By **WILFRID B. WHALLEY**

Adjunct Professor of Electrical Engineering
Brooklyn Polytechnic Institute

The development of large-screen color television.

OVER A period of many years, there has been a great demand for large screen pictures for both monochrome and color television. Until wide-screen projection was developed, satisfactory theater operation required images of the standard 20' x 16' size and comparable in brightness to film projection. Also, it was necessary that the picture detail closely approximate television system standards.

Several methods of reproducing large images have been developed, ranging from high voltage projection tubes to special types of electron beam-controlled light valves.

Projection Tube Development

Intensive effort has gone into the problem of increasing the light output from picture tubes, and into developing an optical lens system to project the light onto a theater screen efficiently.

In the middle 1930's, it was a major step to shift from the then typical 7,000-volt operation of direct-view picture tubes to the 20,000-volt operation of 4"-diameter projection tubes. A long series of experiments with multiple-aperture electron guns resulted, late in 1937, in a tube having fairly good resolution with a beam current of 1.5 ma. at 20 kv. The tube face was accurately processed for optical flatness in order to be suitable for a high quality f1.4 projection lens. Special phosphors were also developed to provide higher light efficiency. Despite the high density beam currents, and the high average phosphor screen power of 30 watts, the illumination was insufficient for a theater screen.

Fig. 1. Diagram of reflective-projection optics showing location of the CR tube.

Courtesy of RCA Review

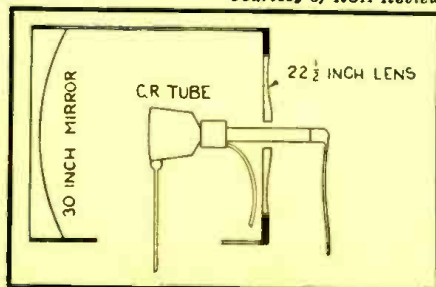

It was noted that a typical transmission-type optical lens had an over-all efficiency of only 3-4%. The light radiating from the face of the picture tube covered a solid angle of nearly 180°, whereas the lens collected the light from an angle of only 40-60°. It became clear that another type of lens would be necessary, and experiments were undertaken with the Schmidt lens which had proved so successful in astronomy.

As shown in Fig. 1, the Schmidt lens is a reflecting type lens having a diameter many times that of the projection tube screen. Since the face of the projection tube was almost flat—to avoid excessive defocusing of the electron beam at the extremes of deflection—while the reflective lens was concave, an aspherical lens was added at the open end for correction. Well-designed optical systems of this type give light efficiencies of 20-25%.

To obtain more light output, projection tubes were designed for still higher voltages. Unfortunately, it was found that all phosphors had some "sticking" potential. Due to the poor electrical conductivity of phosphor screens, the crystals in the phosphor operated at an average equilibrium potential such that the ratio of secondary electron emission was unity. As the second anode voltage was increased, the screen potential would rise slowly.

During the war, satisfactory procedures were developed for placing a thin aluminum film on the back of the phosphor screen, and this solved the "sticking" problem. The vapor-deposited aluminum film was bonded directly to the high voltage terminal, and, because of its good conductivity, held each phosphor particle at the full d.c. voltage.

Progressively, projection kinescopes have been successfully operated at 50 kv., and recently as high as 100 kv. Nearly all have 7" diameters and in a few cases 10" diameters. Each is constructed with a double-walled neck to provide a longer glass insulation path, and utilizes forced air cooling over the glass face.

Demonstrations of theater color television have been made with groups of three of these 100-kv. projection units.

As with early three-unit picture tube assemblies, it was necessary that each of the three tubes operate with as precisely similar characteristics as possible. Each tube was made with a different type of phosphor chosen to give one of the primary colors in the red, green or blue regions, and, when necessary, corrected by a suitable color filter placed in the lens. The three deflection yokes had to be exactly alike, and be supplied from the same horizontal and vertical deflection power amplifiers. Also, the three lens systems had to be similar, have all the components mounted rigidly, yet be adjustable for optical superimposition at the viewing screen.

Light Valves

Many engineers have attempted to produce large screen pictures from a high intensity light source, with some form of intermediate control tube or other device. The *Scophony Company* designed many monochrome theater installations based upon a special form of Kerr cell. The Kerr cell was energized from the receiver video amplifier, and modulated the light from a high-intensity mercury vapor source. As shown in Fig. 2, scanning of the image was obtained by reflecting the light beam in sequence from two rotating multisided mirror drums. The drum for horizontal scanning, while quite small, ran at a very high rpm.

Reasonably bright monochrome theater television pictures have been produced by this equipment, but for color television the decrease in light caused by the necessary color filters has been a real disadvantage.

The "Eidophor"

Intensive work in Switzerland over the past decade has led to a new type of electron beam-controlled light valve called the *Eidophor*, which operates on an entirely new principle. It makes use of the light from a flaming arc source passed through a large transfer mirror system. Hence there is high light output, even for color television operation.

As may be seen in Fig. 3, the light passes in succession through a rotating

Fig. 2. Fundamentals of the Scophony system of ultrasonic light control for TV.

Courtesy of Proceedings of the I.R.E.

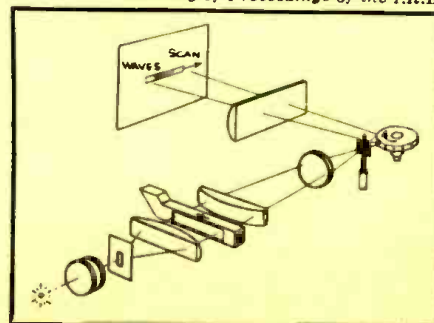

color filter disc and a condensing lens, and is reflected by a special slotted mirror onto a spherical mirror coated with an oil film. A high quality electron gun bombards the surface of the oil. As the electron beam—driven by a typical deflection yoke—scans the oil surface, an electric field pattern corresponding to the television signal is built up. For a dark area of the scene the oil film is not disturbed, while for a bright area the oil film receives maximum field and a corresponding change in refraction. Any change in refraction of the oil film causes light to be reflected back through the spaces in the slotted mirror to the projection lens.

The electron gun operates with a steady beam current of only 60 μ a. at 15 kv., less power than is used in a conventional direct-view picture tube. The electron beam is of a rectangular shape, with the longer dimension vertical to fill exactly the space between adjacent writing lines. In the horizontal direction, it provides from two to three times the horizontal resolution of typical picture tubes while controlling the high intensity light source. As may be expected, the electron gun and the spherical mirror assembly are located in an evacuated chamber connected to a good quality diffusion pump.

This device has many advantages. It can be placed in the same position in a theater as the usual film projector. The light output in color is at least comparable to color film projection, and has high resolution. The video signal power required is negligible. Further, since only one light source and only one electron gun are required, there is no problem of registration in the color image.

Fig. 3. Mechanical drawing of the Eidophor projection system showing: (1) arc light source, (2) aperture plate, (3) color wheel, (4) condenser lens, (5) mirror bar system, (6) electron gun and deflection system, (7) spherical mirror with thin layer of liquid, (8) electron-bombarded liquid area that modulates light beam, (9) knife edge determining thickness of liquid layer, (10) projection lens, (11) directing mirror.

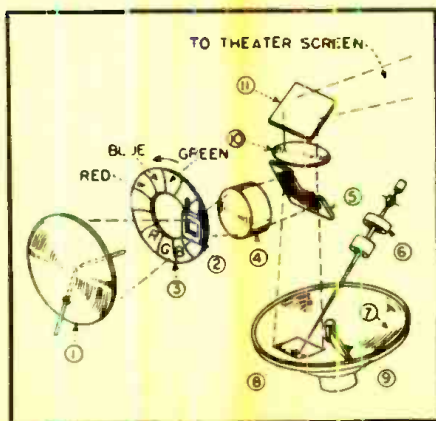

New Products

(Continued from page 20)

five units, is 2.81" in length—including the base and cover.

Full information and data sheets may be obtained on request from *Electro-Mes Laboratory*, 21-09 43rd Avenue, Long Island City, N. Y.

AUTOMATIC CIRCUIT CHECKERS

High-speed, high-reliability automatic checkers that detect and locate wiring discrepancies and reduce test time to a minimum are now available from *Federal Telephone and Radio Corporation*, associate of *International Telephone and Telegraph Corporation*. The standard FTR circuit checkers can automatically test up to 100 circuits; facilities for larger numbers can be provided on request.



The photograph shows a test position

ties for larger numbers can be provided on request.

on the FTR production line; the unit being tested is on the left, with the automatic circuit tester in the center and its associated bridge on the right. This production test equipment has been used for over three years and has resulted in the saving of tens of thousands of hours of skilled labor.

Further information on these automatic circuit checkers may be obtained from the Component Sales Department, *Federal Telephone and Radio Corporation*, 100 Kingsland Road, Clifton, N. J.

COMPLEX PLANE ANALYZER

Vector calculations on the complex frequency plane are speeded up by the complex plane analyzer—a new form of compact analog computer announced by *Technology Instrument Corp.*, Acton, Mass., for the design of networks and feedback control systems. Operation is straightforward and accuracy is better than 1%.

Gain and phase-shift results are computed simultaneously and appear directly on a meter. Frequency response, transient behavior and root locus solutions are easily found for both open and closed-loop systems. Responses to impulse, step, exponential and complex driving functions can be determined by the use of this instrument.

Precision PAPER TUBES

2000 SIZES in any shape ID or OD

The advertisement features a collection of various paper tubes, including rectangular, cylindrical, and spiral-wound types. Some are standing upright, while others are lying flat. The background is dark, making the white tubes stand out. The text is prominently displayed in a bold, sans-serif font.

Whatever your specific needs, depend on PRECISION PAPER TUBES to meet all requirements. Spirally wound under pressure, PRECISION PAPER TUBES are subjected to rigid tolerance control to insure strict adherence to specifications and provide maximum winding space. PRECISION PAPER TUBES possess 15 to 20% greater strength, yet are light in weight.

Made from the finest dielectric kraft or fish paper, phenol impregnated, acetate or combinations, PRECISION PAPER TUBES afford high insulation, heat dissipation and moisture resistance. Available in any size, shape, I.D., or O.D.—any quantity.

Write today for Arbor List of over 2000 sizes. . . . Send specifications for free sample.

PRECISION PAPER TUBE CO.

2063 WEST CHARLESTON STREET • CHICAGO 47 • ILLINOIS

Plant No. 2: 79 Chapel St., Hartford, Conn. — Also Mfrs. of PRECISION Coil Bobbins

Personals



ROBERT C. CHEEK, formerly assistant division sales manager of the Electronics Division of *Westinghouse Electric Corporation*, has been promoted to the newly created post of assistant manager of engineering. After joining *Westinghouse* in 1939, Mr. Cheek acted as a consultant on power system problems, and later, as a specialist on carrier and microwave applications. In 1949, he was named "outstanding young electrical engineer" by the ETA KAPPA NU.



THORNTON W. CHEW, for the past four years vice-president in charge of engineering for Stations KFMB and KFMB-TV in San Diego, has now joined the *John Poole Broadcasting Company*, Hollywood, Calif., as director of engineering and operations. He will supervise the construction and operation of Station KBIC-TV, Sacramento, and Station KPIK-TV, Los Angeles, as well as a third yet unnamed television station to be built in Fresno, California.



G. MILTON EHLERS brings to his appointment as chief research engineer of *Aerovox Corporation*, New Bedford, Mass., over a quarter of a century of experience in the field of electronic components. Holder of various patents for both components and processes, Mr. Ehlers has served in such positions as: director of research, *Globar Corporation*; chief ceramic engineer, *Centralab Division of Globe-Union, Inc.*; and—most recently—president, *Herlec Corporation*.



ELBERT W. MARLOWE, who has been with *Union Switch & Signal*—division of *Westinghouse Air Brake Co.*, Swissvale, Pa., since 1945, has been appointed section engineer, Air Traffic Control and Navigation. He served as supervising engineer, Research Section, during the past year. In World War II, Mr. Marlowe worked as an electronic engineer for both the Naval Ordnance Laboratory in Washington, D. C., and the University of California at Los Alamos.



FRANK J. POWERS has been named head of the Industrial Engineering Department of *CBS-Columbia Inc.*, Long Island City, N. Y., TV/radio receiver manufacturing subsidiary of the *Columbia Broadcasting System*. Mr. Powers held a similar post at the *Burndy Engineering Company*, and also has held managerial posts with *Federal Radio & Telephone Corporation* and the *Sperry Gyroscope Company*. He is a graduate of Union College in electrical engineering.



JOHN A. RANKIN, the director of engineering of *The Magnavox Company*, Fort Wayne, Ind., since 1951, has now been elected vice-president as well. He is in charge of development, design and engineering for the production of all civilian and military equipment. Prior to joining *Magnavox*, Mr. Rankin served as an executive engineer in the radio and electronic industries; he held prominent positions with *Belmont Radio Corporation* and *RCA Industries Labs*.

New Tubes

(Continued from page 24)

tors and dealers held in Chicago's Opera House in July, Mr. C. F. Adams, Jr., president of *Raytheon Manufacturing Company*, described a television "memory tube" that can store a complete television program for two months or more.

The high frequency system by which TV pictures can be shot across the Atlantic Ocean permits the reception of only a small portion of the total image at a time; hence the information is put into the "memory tube" at a relatively slow rate. However, when the tube has been given a complete picture, it can be played back over regular TV stations within a few seconds.

TV PICTURE TUBES

Two cathode-ray tubes for television—Type 24CP4 and Type 24CP4A, its aluminized counterpart—have been placed in production by *The Rauland Corporation*. Both are rectangular, glass, magnetic focus and magnetic deflection, direct-view picture tubes featuring an electron gun which is used with an external single-field ion trap magnet and an external conductive coating that acts as a filter capacitor when grounded. For more information, write *The Rauland Corporation*, 4245 North Knox Avenue, Chicago, Ill.

Broadcast Amplifier

(Continued from page 15)

into it; but, obviously, the best results will be obtained if the complete remote gear is designed as a unit. For those who would like to duplicate the one pictured, or design a similar type of unit, here are some factors to be considered.

The first two stages (6J7 and 6SC7) should be able to amplify the full microphone input—with a normal level of speech—to 60 volts peak-to-peak at the plates of the 6SC7 without distortion and with good linearity. As this is the maximum signal level that can be applied to the compression circuit without introducing distortion, it isn't necessary to have much surplus of distortionless gain in these stages. With the parts values shown, an average of 8-db attenuation is required between the microphone and the input transformer; this allows plenty of latitude for use by various announcers, and has proved more than ample at Station KWEI. The third stage is a push-pull high-impedance cathode follower rectifier with series-limiting resistors in the grids.

In this third stage, the capacitor from the cathode of the first 6SL7GT to ground determines the compression time and, to a certain extent, the re-

lease time. Because the voltage from the cathode is applied to the two grids of the compressor tube (second 6SL7GT) in parallel, it does not have to perform any outstanding filtering job. A value of from 10 μ d. to 20 μ d. will provide reasonably fast compression and recovery. Higher values will produce a correspondingly slower action. The determining factor in choosing this capacitor is to make it as small as possible without making the compression action so fast that it becomes noticeable to the listeners. The value shown is about the optimum for speech. This type of compressor works on the principle of introducing a loss into the circuit which increases as the input increases after a given audio level is reached. In theory, the minimum loss for the service desired is 20 db and the maximum loss is about 40 db. In practice, because of the type of rectification employed, another 5 db should be added to these figures. Maximum output from the transformer T_2 will then be 60 volts minus 45 db, or a little less than .5 volts, times the gain of the transformer. Nominal output impedance is 20,000 ohms. Two triodes in cascade can bring this level up to about +15 dbm using negative feedback.

Because of the low plate current drain of the tubes used, a power supply with resistor-capacitor filtering would no doubt work; but to be sure no ripple will be introduced from the power supply, it incorporates two chokes, with capacitor input. To simplify construction, the ground lead was a bus bar running the length of the amplifier chassis, grounded to the chassis only at the tie point nearest the input transformer. Hum and noise is

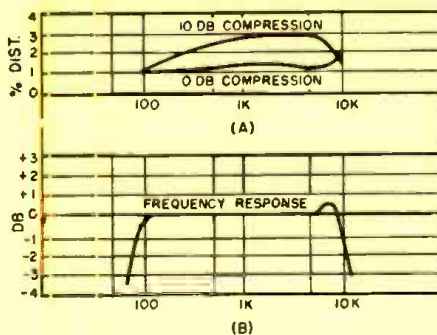

Fig. 2. (A) Distortion at 0 and 10 db compression. (B) Frequency response.

more than 60 db below the maximum signal level.

It will be noted in Fig. 1 that there are no variables other than the attenuators, which are adjusted from the front panel. All tubes were replaced individually by tubes of different manufacturers with no noticeable change in results. That there is no variable resistor in the cathode circuit of V_2 may surprise some who are familiar with the NRCS-type compressor. A potentiometer is generally used here to set the zero compression level, which is controlled in this circuit by the resistor between the plates of V_1 . If R is determined by formula, it is done as follows:

$$R = \frac{.707 (R_{11} + R_{12})}{20}$$

Then, if R_{11} and R_{12} are 470,000 ohms each, the value of R will be 33,229 ohms. This value will provide an almost flat output over the entire compression range. As the other resistors have only a 20% tolerance, a 33,000-ohm resistor was used for R . R is the dominant control over the circuit loss until the plate voltage of V_1 drops, as a result of compressor action, below 10% of the d.c. plate supply voltage. Resistor R_2 in the cathode of V_1 determines the rate of compression.

Not only has this remote equipment been used for sportscasts, but also for dance orchestra remotes with equal success, allowing the announcer to emerge the show without riding gain. The distance the announcer is from the microphone and the loudness of his speech control the amount of compression and permit his voice to reduce the over-all gain of the amplifier (though the output is the same), effecting the same result as would be obtained by fading the music into the background. When the announcer stops talking, the amplifier gain returns to maximum and the music rises to the fore. Though Station KWEI has three commercial standard remote amplifiers, the one built by the engineering staff is used whenever it is available, in preference to the others.

RESISTORS*

- ALL MAKES
- ALL OHMAGES
- ALL TOLERANCES

1/2 WATT—1 WATT—2 WATT

AMERICA'S BEST

EB 1/2 W 10% .03 each
 GB 1 W 10% .06 each
 HB 2 W 10% .09 each
 For 5% add 100%
 Minimum per Item — \$2.00
 Minimum per Order — \$10.00

LEGRI COMPANY

158 West 99 Street, New York, N. Y.

PLANS INTO PLASTICS

PRECISION MACHINING OF ALL THE PLASTICS

including

POLYSTYRENE COPOLYMER 1422
 BUTYRATE TEFLON
 NYLON KEL-F

PLASTIC FABRICATING

Printloid is equipped for the complete production of a wide variety of consumer and industrial items in any quantity. We work with any plastic material in sheets, rods and tubes. Die-cutting, deep drawing, stamping, forming, finishing, and assembling in our own plant.

PLASTIC PRINTING

LETTERPRESS . . . SILK SCREEN

HOT STAMPING

for Containers, Displays, Dials, Charts, Machined Parts, Etc.

Ask for brochure illustrating various plastic products fabricated to specification by Printloid.

PRINTLOID, INC.

95 Mercer St., N. Y. 12, N. Y.

CALENDAR of Coming Events

OCTOBER 28-29—IRE-RTMA Radio Fall Meeting, Toronto, Ontario.

NOVEMBER 9-12—Conference on Radio Meteorology, University of Texas, Austin, Texas.

NOVEMBER 13-14—Annual Electronics Conference, Kansas City Section, IRE, Hotel President, Kansas City, Mo.

NOVEMBER 18-20—Joint IRE-AIEE Sixth Annual Conference on Electronic Instrumentation in Medicine and Nuclear Physics, New York, N. Y.

DECEMBER 8-10—AIEE-IRE-ACM Joint Computer Conference and Exhibition, Statler Hotel, Washington, D. C.

FEBRUARY 4-6, 1954—Sixth Southwestern Conference and Electronics Show, Tulsa, Okla.

MARCH 22-25, 1954—Radio Engineering Show and IRE National Convention, Kingsbridge Armory and Waldorf-Astoria Hotel, New York, N. Y.

TECHNICAL BOOKS

"FIELDS and WAVES in MODERN RADIO" by Simon Ramo and John R. Whinnery. Second Edition. Published by John Wiley & Sons, Inc., 440 Fourth Avenue, New York 16, N. Y. 576 pages. \$8.75.

Expanded by about 10%, the second edition of this well-known, widely used book contains much new material designed to keep it the simplest yet most thorough treatment of the electromagnetic theory essential to a practical understanding of fields and waves in present-day radio. Nearly all of the original material has been revised for additional clarity, with some of the less useful parts being eliminated.

The new material includes: a complete chapter on microwave networks; more simple examples in the chapters on static fields; use of the Smith chart in the simple transmission line treatment; several new aspects of propagating waves, such as the principle of duality and slow-wave circuits; and new features in the chapter on radiation, such as discussions of horns, slot antennas, and receiving antennas.

Many problems have been added in this edition, particularly at the introductory level, and the rational mks system of units is used throughout.

"DIELECTRIC AERIALS" by D. G. Kiely, Royal Naval Scientific Service. Published by John Wiley & Sons, Inc., 440 Fourth Avenue, New York 16, N. Y. 132 pages. \$2.00.

As no complete theory of the operation of dielectric aerials exists, and as methods of theoretical treatment vary in initial assumptions and in obtained results, it has not yet been possible to prepare a textbook giving an authoritative account of the subject. One of Methuen's Monographs on Physical Subjects, this volume provides a critical review of the existing theoretical and experimental work on radiation pattern characteristics and the derivation of mathematical expressions for them. Information useful for practical design has been included.

"Dielectric Aerials" is addressed primarily to physicists and engineers who are not specialists in aerials, although the experienced aerial designer may find the design data useful for future applications. Little attention has been paid to the details of experimental techniques, which are largely standard; the bibliography will assist the reader in obtaining further details of experimental procedure.

SSSC Transmission

(Continued from page 9)

split up in this manner for the sake of clarity of presentation and discussion.

Phase-Shift Network and Voice Control

Shown in the schematic diagram of Fig. 8 are the audio phase-shift network and voice control circuits. The audio phase-shift network is identical to the one shown in Fig. 2. Individual plate and cathode resistors for each phase-shifting stage must be accurately matched to each other within $\pm 0.5\%$, and should be of a type which will retain precise resistance values with aging and environmental variations. By the same token, the phase-shift resistors and capacitors must be selected to like tolerances and have the same high order of stability. Also, because the operation of the phase-shift network as a whole is adversely affected by any appreciable impedance in the plate supply, the latter should be of the electronically regulated type. The operating range of this particular network is 70 to 5800 cps for 30-db or better undesired-sideband rejection, and the insertion loss is about 10 db.

The input of the phase-shift network is designed to operate from a microphone preamplifier through a 500-ohm audio line. Maximum input level is +15 db, and is attenuated through a resistance network to feed each phase-shift channel in phase. A potentiometer in one channel input permits equalization of the audio voltages applied to each balanced modulator. The grid of the voice control amplifier is fed from the common input through a high-pass RC network and gain control, and the output of this stage is coupled through a step-up transformer to a rectifier and d.c. amplifier. The plate circuit of the latter includes a normally closed sensitive relay. Application of an audio signal causes the d.c. amplifier plate current to be cut off, thus opening the relay and applying plate voltage to the appropriate r.f. stages. A time-constant circuit at the grid of the d.c. amplifier delays slightly the reclosing of the relay in order to hold the transmitter "on" during normal pauses in speech. To prevent actuation of the voice control circuits during loudspeaker operation, a "lockout" audio signal is derived from the receiver and applied to the blanking rectifier at a level of about 15 volts. The d.c. output of the latter is filtered and appears as a negative bias at the grid of the voice control amplifier stage, desensitizing it during the time the received signal is present.

Modulators and R.F. Circuits

Balanced modulators, carrier generator, frequency converter, and the first

linear amplifier are shown in Fig. 9. Quadrature output of the audio phase-shift network is applied as two individual balanced audio signals to modulators A and B through the sideband-selector switch S_1 . This switch is so arranged as to reverse the phase of the audio voltage to modulator A, thus permitting selection of upper or lower sideband; additional positions disable either modulator A or B to allow generation of double-sideband phase- or amplitude-modulated signals respectively.

The two balanced modulators themselves use conventional double-triode circuits having cathode resistor bias, and are fitted with individual balancing controls in the grid circuits. Provisions for capacitance-balancing were found to be unnecessary. The plate circuits of the two modulators are connected in parallel, and the combined output is applied to the primary of the balanced transformer T_{101} . This transformer is equipped with a split primary winding, each section of which is inductance-tuned by an appropriate slug to permit balancing of the entire modulator system. The balanced modulators operate at +250 volts, and each draws 11 ma. of plate current; the peak carrier voltage on each modulator is 10 volts, and the peak audio signal is 2.5 volts to each grid. Effective conversion gain is of the order of 7 times for both modulators together, and the carrier suppression exceeds 40 db.

Consisting of a conventional crystal-controlled oscillator at a frequency of 1560 kc., the carrier generator utilizes the triode section of a 6U8 triode-pentode. Included in the plate circuit of the oscillator is the primary winding of an overcoupled 1560-ke. i.f. transformer, which, in conjunction with the tuned secondary, constitutes the r.f. phase shifter. The 12AU7 dual cathode follower accepts the quadrature r.f. components from the latter, and develops the required 10 volts for application to the balanced modulators. The cathode-follower intermediate stage provides isolation between the modulators and the r.f. phase-shift network, and eliminates any stray cross-coupling and undesirable reaction effects upon the latter; at the same time, the carrier source

Fig. 10. Schematic of the v.f.o. circuits.

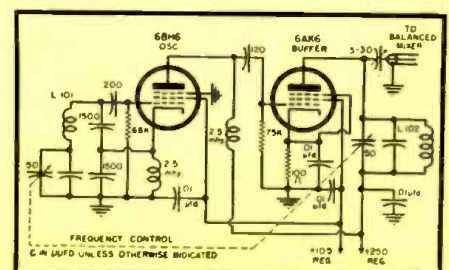

impedance is reduced to a value of less than 1000 ohms while the effective load impedance on the phase shifter exceeds 0.5 megohms. Controls in the cathode circuit of each isolation stage permit adjustment of the respective carrier levels applied to each balanced modulator. The grid of the 6U8 carrier amplifier is driven from the appropriate cathode follower through a variable carrier-insertion control and capacitance attenuator; this stage provides a voltage gain of 30 times and develops up to 50 volts across the balanced output circuit. Amplified carrier voltage is applied through small coupling capacitors to the balanced secondary of T_{101} .

The frequency converter is of the power type, utilizing two type 5763 beam pentodes in a balanced mixer arrangement. Both signal and local oscillator are applied to the control grids with the latter component in phase to produce cancellation in the double-ended output circuit. As the local oscillator operates at 1560 kc. on the low side of the desired output frequency, the sum-frequency components of the heterodyne process are recovered in the tuned plate circuit, and the suppression of the oscillator signal is some 30 db. The balanced interstage transformer is double-tuned and slightly overcoupled to provide reasonably constant response over the required frequency range. Peak oscillator voltage at the grids is 27 volts, while the peak sideband signal to each grid is approximately 7 volts for full output. Under these conditions, the conversion gain of the mixer stage is of the order of 9 times, and the maximum power output for linear operation exceeds 3 watts with a total plate power input of 12 watts.

The push-pull 829-B linear amplifier operates class AB₁, with a maximum d.c. grid current of 2.5 ma. and a peak plate power input of 130 watts; at these ratings, the r.f. power output is approximately 60 watts. Quiescent plate input at a plate voltage of 550 volts is between 20 and 25 watts for both tube sections. Operation is class AB₁ when the stage is used to feed an antenna system directly; when operated as a driver for the 600-watt linear amplifier, the power levels are considerably lower and class AB₁ operation provides more than adequate driving power. The independent 250-volt screen supply for the 829-B stage is stabilized by means of voltage regulator tubes, and the -30 volt fixed bias supply is of the low-impedance type using selenium rectifiers and large filter capacitors. Neutralization and parasitic-suppression measures are included in the design. To insure a reasonably constant load on the high-level mixer stage, and to improve the regulation of the r.f. grid-driving voltage, the secondary of the input trans-

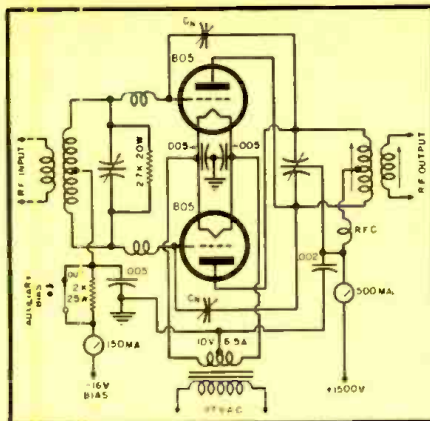

Fig. 11. The 600-watt linear amplifier.

former is damped with a resistance load of 12,000 ohms.

Heterodyne Oscillator

Figure 10 shows the v.f.o. circuits. The oscillator is a series-tuned electron-coupled type, using a 6BH6 pentode, in which frequency stability approaching that of a crystal-controlled oscillator is obtained by virtue of heavy capacitance-loading of the tube grid-cathode circuit. The plate of the oscillator operates into an untuned load, and is capacitance-coupled to the 6AK6 buffer-doubler stage. This stage is gang-tuned with the oscillator; it operates straight through for frequencies up to 4.0 mc., and as a frequency multiplier for higher frequencies. The oscillator-buffer output is at all times 1560 kc. lower than the final output frequency. Output voltage from the v.f.o. system averages 40 to 50 volts r.m.s. over the tuning range, and is coupled to the grids of the frequency converter through a small variable capacitor to permit adjustment of the mixer excitation level. In accordance with usual practices, the plate and screen voltage supplies for the v.f.o. are regulated.

Linear Amplifier

The 600-watt linear amplifier of Fig. 11 utilizes two type 805 high- μ power triodes of 125-watt rated plate dissipation in a neutralized push-pull circuit arrangement. D.C. operating voltages and driving signal levels are such that operation of the stage is class B at all times. Circuit design is conventional with the possible exception of the grid-damping resistor included for purposes of improved driving voltage regulation and load impedance stabilization for the driver stage, as outlined previously. This resistor dissipates approximately 22 watts under maximum signal conditions, and the total effective driving power required by the amplifier is of the order of 28 to 30 watts. Tuning capacitances in both grid and plate circuits are somewhat larger than usual for the frequency of operation, thus

maintaining the reasonably high operating Q desirable for linear operation of a class B system and assisting in harmonic reduction as well as facilitating load coupling. In keeping with the requirements for a "stiff" source of bias voltage, the -16 volt grid bias is derived from a battery supply. Facilities are included for switching in auxiliary grid-leak bias for class C c.w. operation. Peak power input to the amplifier with a 1500-v. plate supply is slightly under 600 watts, with an r.f. power output of approximately 350-360 watts. The maximum signal d.c. grid current is between 40 and 50 ma. Over-all measurements of the entire system indicate less than 10% deviation from linear input-output characteristics up to the operating levels given.

Carrier-Controlled Relay

(Continued from page 13)

power supply is connected to ground, will remove the negative bias voltage from the cathode of V_1 . The anode voltage of V_1 will then be very high and the control relay, RL , will be continuously energized.

RL is a sensitive relay for use in the anode circuit of a vacuum tube. It has a coil resistance of 5000 ohms, and possesses two separate sets of double-throw contacts which are used to switch the recorder or other device being controlled.

The power supply is a conventional transformer-full wave rectifier combination. In order to stabilize the unit against the effects of varying line voltage, the output of the filter is regulated by two voltage regulator tubes in series, V_2 and V_3 .

To adjust the unit for proper operation, the receiver is tuned to a frequency at which no signal is received and threshold control, R_0 , advanced until the control relay is energized. This control is then carefully backed off until the relay is de-energized. Proper operation can then be checked by tuning the receiver so that a signal is received. It may be necessary to make slight adjustments in R_0 to arrive at the desired setting.

Another of the many possible uses of this carrier-controlled relay is in a radio relay system where it is desirable to keep the repeater transmitter on standby until intelligence is to be transferred to the system. A rear view of the complete unit is shown in Fig. 1.

PHOTO CREDITS

PAGE	CREDIT
3, 4, 5	U. S. Air Force
10, 11, 12	Signal Corps Engineering Labs.
13	Haller, Raymond & Brown, Inc.

FREED Instruments & Transformers

Famous For **QUALITY • DEPENDABILITY • ACCURACY**



No. 1030
Low Frequency
"Q" Indicator



No. 1020B
Megohmmeter

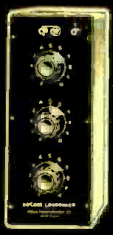

Decade
Inductors



No. 1040
Vacuum Tube Voltmeter

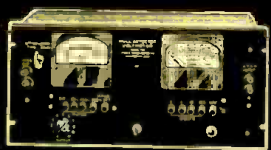

No. 1210
Null Detector &
Vacuum Tube Voltmeter



No. 1010
Comparison Bridge



No. 1110A
Incremental Inductance
Bridge

FREED MILITARY PULSE TRANSFORMERS IN STOCK FOR IMMEDIATE DELIVERY

HERMETICALLY SEALED PULSE TRANSFORMERS for use in blocking oscillators, low level interstage coupling, and modulator outputs. Made in accordance with MIL-T-27 specifications. These pulse transformers are designed for maximum power, efficiency and optimum pulse performance. Balanced coil structures permit series or parallel connection of windings for turn ratios other than unity. Pulse characteristics, voltages and impedance levels will depend upon interconnections made.



DM-12



DM-18



DM-8



DM-01

CATALOG NUMBER	APPLICATION	PULSE VOLTAGE KILVOLTS	PULSE DURATION MICRO-SECONDS	DUTY RATIO	TEST VOLTAGE KV., RMS	CHARACTERISTIC IMPEDANCE OHMS	CASE SIZE
MPT-1	Blocking oscillator or interstage coupling	0.25/0.25/0.25	0.2-1.0	.004	0.7	250	DM-12
MPT-2	Blocking oscillator or interstage coupling	0.25/0.25	0.2-1.0	.004	0.7	250	DM-12
MPT-3	Blocking oscillator or interstage coupling	0.5/0.5/0.5	0.2-1.5	.002	1.0	250	DM-18
MPT-4	Blocking oscillator or interstage coupling	0.5/0.5	0.2-1.5	.002	1.0	250	DM-18
MPT-5	Blocking oscillator or interstage coupling	0.5/0.5/0.5	0.5-2.0	.002	1.0	500	DM-12
MPT-6	Blocking oscillator or interstage coupling	0.5/0.5/0.5	0.5-2.0	.002	1.0	500	DM-12
MPT-7	Blocking oscillator, interstage coupling or low power output	0.7/0.7/0.7	0.5-1.5	.002	1.5	200	DM-18
MPT-8	Blocking oscillator, interstage coupling or low power output	0.7/0.7	0.5-1.5	.002	1.5	200	DM-18
MPT-9	Blocking oscillator, interstage coupling or low power output	1.0/1.0/1.0	0.7-3.5	.002	2.0	200	DM-18
MPT-10	Blocking oscillator, interstage coupling or low power output	1.0/1.0	0.7-3.5	.002	2.0	200	DM-18
MPT-11	Blocking oscillator, interstage coupling or low power output	1.0/1.0/1.0	1.0-5.0	.002	2.0	500	DM-01
MPT-12	Blocking oscillator, interstage coupling or low power output	0.15/0.15 0.3/0.3	0.2-1.0	.004	0.7	700	DM-8

SEND FOR COMPLETE CATALOG OF
FREED INSTRUMENTS AND TRANSFORMERS

FREED TRANSFORMER CO., INC.

1719 WEIRFIELD ST. (RIDGWOOD) BROOKLYN 27, N.Y.

TO GIVE THE MOST IN

service and performance



CONTROLS



SWITCHES



CAPACITORS

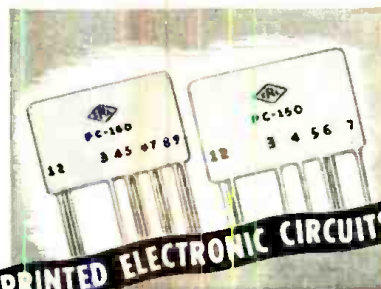

PRINTED ELECTRONIC CIRCUITS

... concentrate your
5 major electronic
component problems
with the industry's
most experienced and
No. 1 electronic
component source



CERAMICS

see next 2 pages
for details

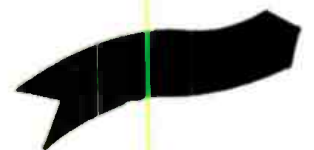

1 CONTROLS

— to meet your service requirements. You'll find a type and model for all popular radio, TV sets, plus other electronic gear.



Model B16 Radiam®
Miniature



Twin and dual concentric Radiahms

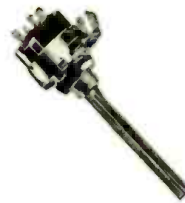

Model B Blue Shaft®
Radiahms



Wirewound Radiam
three and four watt

2 SWITCHES

— hundreds of variations possible. Engineered to give you widest flexibility for all types of applications.



PA-2000 Miniature
Rotary,
Steatite Insulation

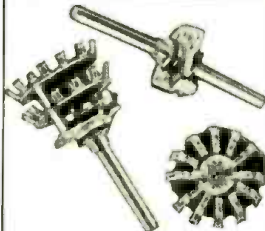

1400 Series, Standard
Rotary, Phenolic
Insulation

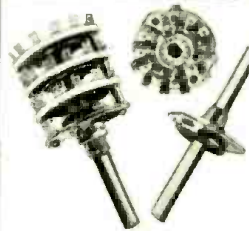

2500 Series Standard
Rotary,
Steatite Insulation



Small General
Purpose and Tone



PCH-4 TV Attenuator

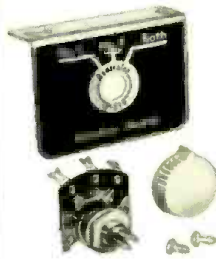

Dual Speaker Switch



Complete Switch Kits

3 CAPACITORS

— the world's greatest line of ceramic capacitors.

For jobs that demand the best in guaranteed TV-AM-FM servicing.

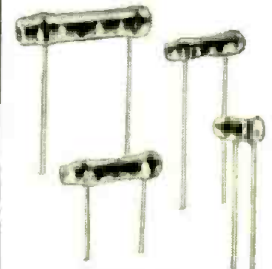

BC Tubular



TV HI-VO-KAPS®

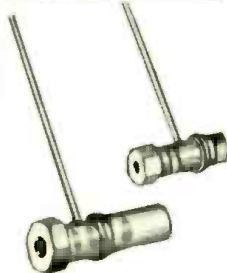

Stand-off

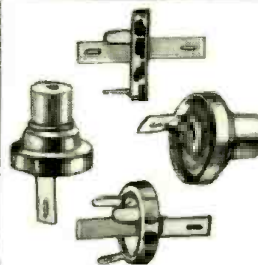

Button-Style



Feed-Thru HI-KAPS®

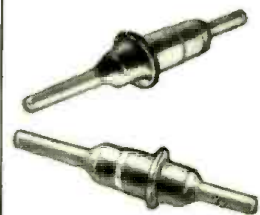

Miniature Feed-Thru
HI-KAPS®

4 PRINTED ELECTRONIC CIRCUITS

— offering you a new, proved way to reduce extra parts, time, errors and costs—a Centralab "first."

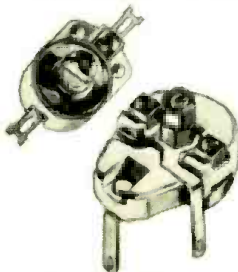

Ceramic Trimmers

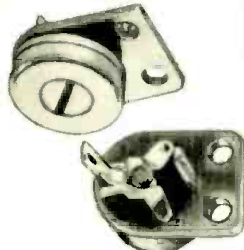

Miniature
Ceramic Trimmers

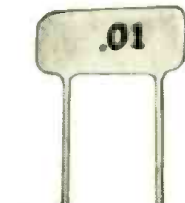

Ceramic Min-Kaps®

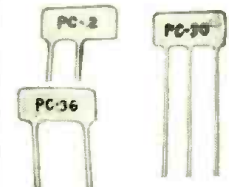

Miniature Resistor and
Resistor-Capacitor
Units

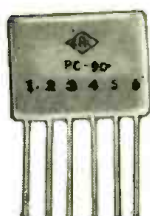

Pentode Couplates®

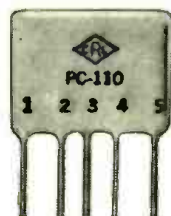

Filplate†
(by-pass and filter
application)

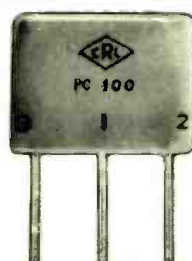

Vertical Integrator

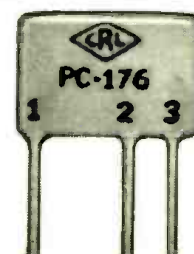

Special Plates

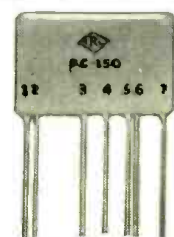

Audet®
(audio-detector plate)

For Sale!

These and 100,001 other Centralab quality electronic components

HERE's a perfect check list to determine your electronic needs. And there are hundreds of variations available to you. Whether you need single items or dozens — no other single manufacturer can offer you such a wide choice of standard fastest-for-servicing parts. That's why Centralab is the industry's No. 1 electronic component source . . . and keeps your distributor supplied with the latest developments in the fast-changing electronics field.

You know CRL parts are your best value because each is backed by a written guarantee. That means they're safest for servicing. And you'll agree that's mighty important for building consistent customer satisfaction.

So when you need parts, look for the familiar blue and white CRL package — the product inside is the result of more than 50 years of electronic experience. This experience has pioneered many profit-building "firsts" for you!

†Trade Mark

Centralab

A Division of Globe-Union Inc.

Milwaukee 1, Wisconsin

In Canada, 804 Mt. Pleasant Rd. Toronto 12, Ont.

And here's where to get all these profit-makers . . .

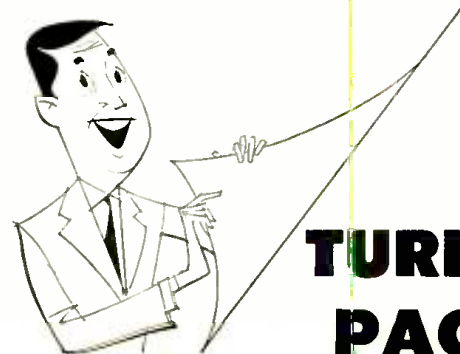

TURN PAGE



Type AB Adashaft® Radiohms



Compentrol
Infinitely variable
loudness control

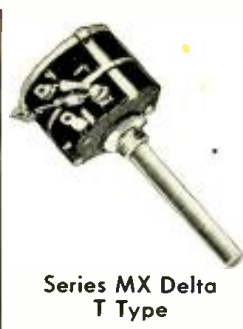

Series MX Delta
T Type

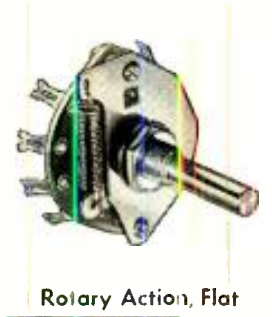

Rotary Action, Flat



Lever Switch



Ham Type

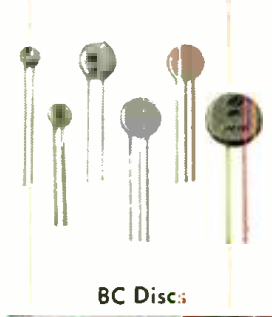

BC Discs



TC Tubular



Type MD Molded Disc



High Accuracy
Capacitors

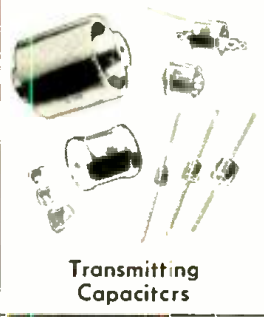

Transmitting
Capacitors



Tubular Ceramic
Trimmer

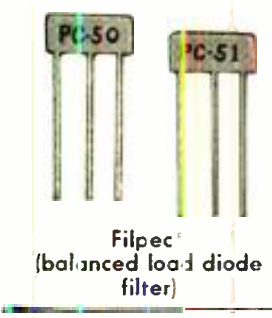

Filpec[†]
(balanced load diode
filter)

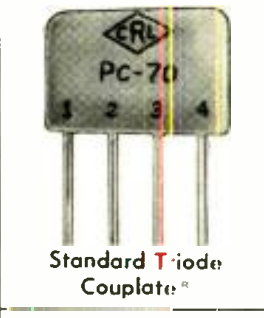

Standard Triode
Couplate[®]

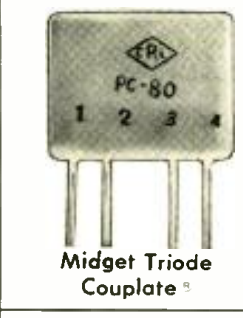

Midget Triode
Couplate[®]

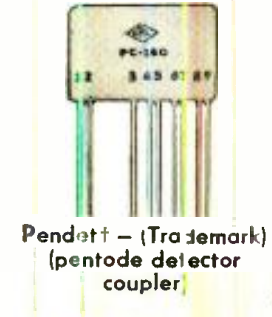

Pendett[†] — (Trade mark)
(pentode detector
coupler)

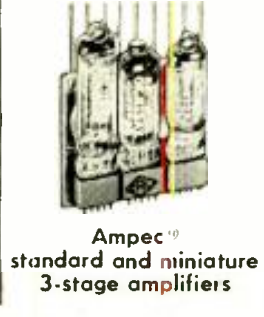

Ampec[®]
standard and miniature
3-stage amplifiers



P. E. C. Kits



This man can save you service-time, work and money

YOUR Centralab distributor can save you plenty of service time, work and money, because he's generally 100% first with the latest. That means he carries complete stocks of all the genuine CRL parts shown on these pages. Parts are factory-specified type equipment on practically all major radio, TV sets and other electronic gear. And because CRL parts are more extensively used in the industry, many are exact duplicates of the original part.

And here's another important point to remember. All CRL parts are attractively packaged — some in moisture-

proof containers — with technical specifications clearly imprinted. There's no doubt about tolerances, test and working voltages, capacity and other data. You get *exactly* what you ask for!

Remember, when you use genuine Centralab fastest-for-servicing replacements you have assurance of a lasting repair job. Because they are exact, you work faster . . . make a cleaner installation . . . insure greater customer satisfaction.

Yes, to give the most in service and performance — *and at a good profit*, it will pay you to make Centralab your source for all your major electronic components. And the man to see is your nearby Centralab distributor — he'll fill your orders swiftly and exactly! For detailed information tear out coupon and send to:

Centralab, A Division of Globe-Union Inc.
910-K E. Keefe Ave., Milwaukee 1, Wisconsin

Please send me Catalog 28 covering Centralab products.

Name.....

Title.....

Company.....

Address.....

City.....Zone.....State.....

Centralab

A Division of Globe-Union Inc.
Milwaukee 1, Wisconsin

In Canada, 804 Mt. Pleasant Road, Toronto 12, Ontario

RADIO & TELEVISION NEWS

CREI prepares you quickly for success in

The future is in your hands!

The signs are plain as to the future of the trained men in the electronics industry. It is a tremendous industry, and—at the present time there are more jobs than there are trained men to fill them. But—when there's a choice between a trained and untrained applicant, the trained man will get the job. Your biggest problem is to decide on—and begin the best possible training program.

CREI Home Study . . . The Quick Way to Get There.



Since 1927, CREI has given thousands of ambitious young men the technical knowledge that leads to more money and security. The time-tested CREI procedure can help you, too—if you really want to be helped. CREI lessons are prepared by experts in easy-to-understand form. There is a course of instruction geared to the field in which you want to specialize. You study at your convenience, at your rate of speed. Your CREI instructors guide you carefully through the material, and grade your written work personally (not by machine).

Industry Recognizes CREI Training.

CREI courses are prepared, and taught with an eye to the needs and demands of industry, so your CREI diploma can open many doors for you. Countless CREI graduates now enjoy important,

good-paying positions with America's most important companies. Many famous organizations have arranged CREI group training for their radio-electronics-television personnel. To name a few: All America Cables and Radio, Inc.; Canadian Aviation Electronics, Ltd.; Canadian Broadcasting Corporation; Columbia Broadcasting System; Canadian Marconi Company; Hoffman Radio Corporation; Machlett Laboratories; Glenn L. Martin Company; Magnavox Company; Pan American Airways, Atlantic Division; Radio Corporation of America, RCA Victor Division; Technical Appliance Corporation; Trans-Canada Air Lines; United Air Lines. Their choice for training of their own personnel is a good cue for your choice of a school.



Benefits Felt Right Away.

Almost immediately, you feel the benefits of CREI training. Your employer, when informed of your step toward advancement (only at your request), is certain to take new interest in you and in your future. What you learn in CREI Home Study can start helping you do a better job immediately.

- BROADCASTING
- TELEVISION
- MANUFACTURING
- COMMUNICATIONS
- SERVICING
- AERONAUTICAL ELECTRONICS

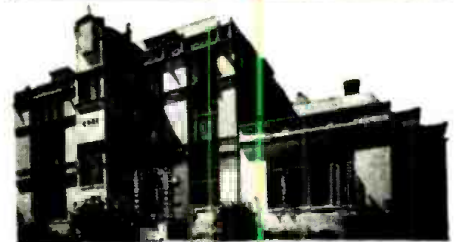

CREI also offers Resident Instruction

at the same high technical level—day or night, in Washington, D. C. New classes start once a month. If this instruction meets your requirements, check the coupon for Residence School catalog.

INFORMATION FOR VETERANS

If you were discharged after June 27, 1950—let the new G. I. Bill of Rights help you obtain resident instruction. Check the coupon for full information.

Get this fact-packed booklet today. It's free.

Called "Your Future in the New World of Electronics," this free illustrated booklet gives you the latest picture of the growth and future of the gigantic electronics world. It includes a complete outline of the courses CREI offers (except Television and FM Servicing) together with all the facts you need to judge and compare. Take 2 minutes to send for this booklet right now. We'll promptly send your copy. The rest—your future—is up to you.



MAIL COUPON TODAY

CAPITOL RADIO ENGINEERING INSTITUTE

Dept. 121, 3224 16th St., N.W., Washington 10, D. C.

Send booklet "Your Future in the New World of Electronics" and course outline.

CHECK FIELD OF GREATEST INTEREST TV, FM & Advanced AM Servicing Aeronautical Radio Engineering
 Practical Radio Engineering Broadcast Radio Engineering (AM, FM, TV)
 Practical Television Engineering

Name.....

Street.....

City..... Zone..... State.....

Check— Residence School Veteran

CAPITOL RADIO

ENGINEERING INSTITUTE

An Accredited Technical Institute • Founded in 1927

3224 16th Street, N.W.

Washington 10, D. C.

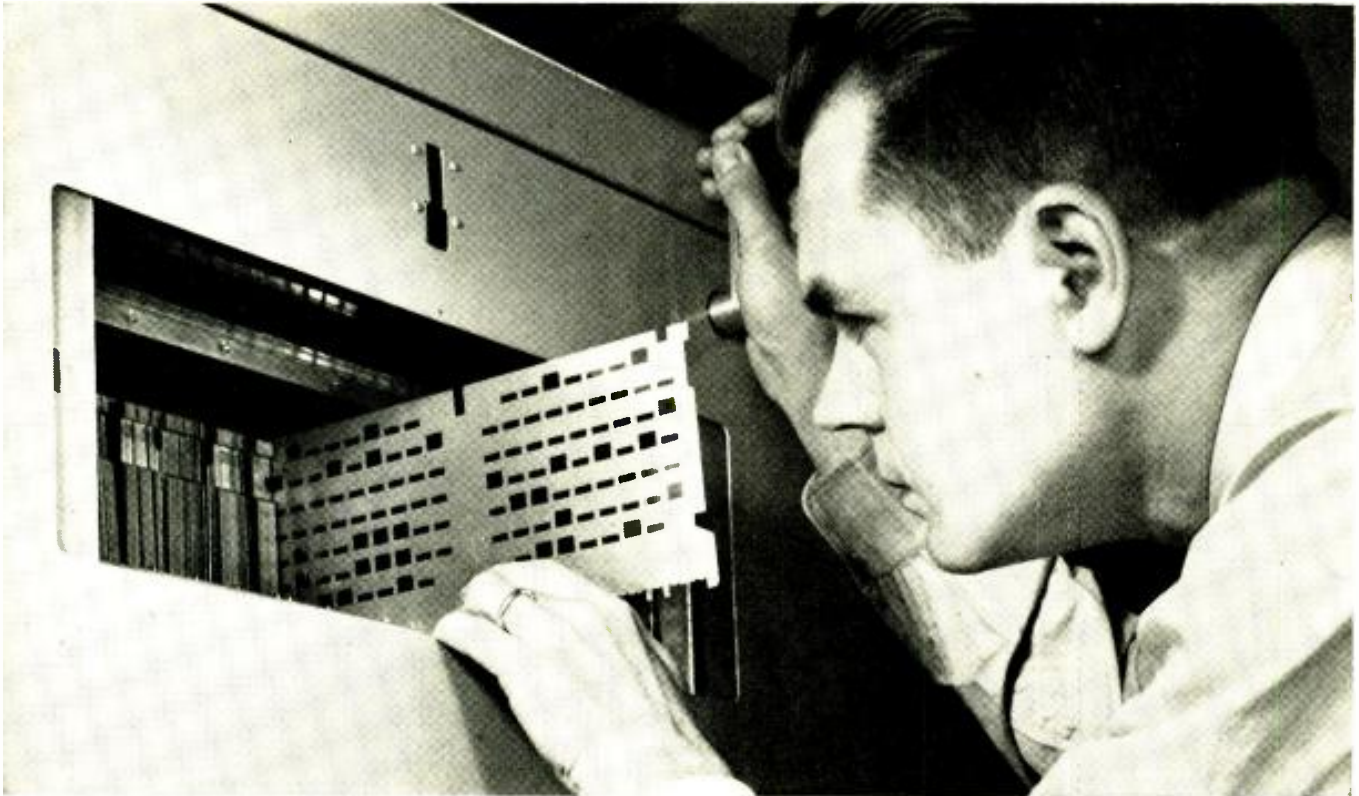

CARDS FOR CONVERSATION

To find out how to route Long Distance calls a dial system needs lots of information—fast. To provide it Bell Laboratories engineers developed a new kind of card file—one that dial systems can read.

Punched holes on metal cards tell how calls should be handled. When a call arrives the dial system “asks” the “card file” how to proceed to a particular area. Instantly the appropriate instruction card is displaced so that its pattern of holes is projected by light beams on a bank of Phototransistors. In a flash the Phototransistors signal switches to set up the best connection. Cards are quickly changed when new instructions are needed.

The “card file” will have its widest use in speeding Long Distance calls that are now dialed by a telephone operator and may one day be dialed by you personally. It is another example of how Bell Telephone Laboratories helps telephony to grow, as costs are kept down.

Checking perforated metal card in Bell's new “card file” which uses Phototransistors to help route Long Distance telephone calls along the best routes. If the first voice-way is in use, a “detour” is swiftly found. The equipment is known in telephony as a “card translator.”

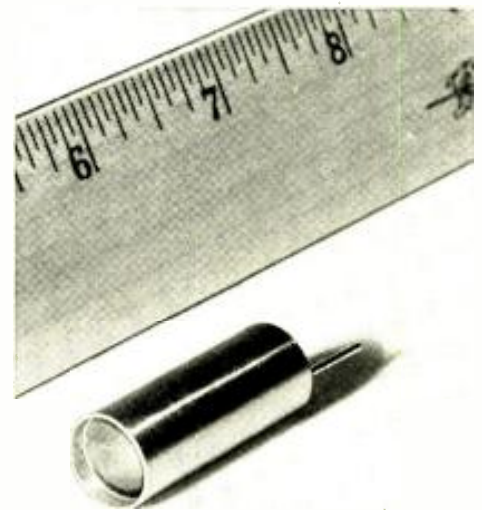

New Phototransistor unit. Light entering the cylinder is focused by the lens on a piece of germanium that responds by generating current. Like the Transistor, the Phototransistor was invented in Bell Telephone Laboratories.



BELL TELEPHONE LABORATORIES

IMPROVING TELEPHONE SERVICE FOR AMERICA PROVIDES CAREERS FOR CREATIVE MEN IN SCIENTIFIC AND TECHNICAL FIELDS

RADIO & TELEVISION NEWS



RAYTHEON

the new

SERVICE SAVER

SPEEDS SERVICE—MAKES MONEY—PLEASES CUSTOMERS

How'd you like to know what's wrong with a customer's TV receiver *before you make your service call*? You do with the new RAYTHEON TV SERVICE SAVER plan.

Here's how this wonderful new Raytheon servicing method works:

Both you and your customer have booklets in which are photographs showing 40 different picture conditions that may occur on the screen of a defective TV receiver. From 90 to 95% of all the troubles that may develop in a TV receiver are covered by these pictures. Illustrations are numbered and when a set falters, the

customer simply finds the picture in the booklet that matches the condition on the screen and then calls you and tells you what number it is, and which of 5 sound conditions exist.

Your booklet and a wall chart which you can place near your phone show the same set of numbered picture patterns, and in addition the booklet explains exactly what tubes, components or circuits may be causing the trouble and suggests what and where to test.

This pre-call knowledge of what ails a receiver helps you to greater profit in three ways: (1) You can go on a job with complete technical information about the required repair; (2) You can go on the job with all necessary parts and tubes; (3) You can clean up nuisance calls and avoid many needless call-backs by telephone. Then, too, it means satisfied customers — customers who see you go right to the root of the trouble and make repairs quickly and expertly.

Be sure to ask your Raytheon Tube Distributor how you can get in on this exclusive servicing asset — the RAYTHEON TV SERVICE SAVER plan. Act now, and be the first in your locality.



RAYTHEON

RAYTHEON MANUFACTURING COMPANY

Receiving Tube Division
 Newton, Mass. Chicago, Ill. Atlanta, Ga. Los Angeles, Calif.

Excellence in Electronics

RAYTHEON MAKES ALL THESE: RECEIVING AND PICTURE TUBES • VARIABLE SUBMINIATURE AND MINIATURE TUBES • GERMANIUM DIODES AND TRANSISTORS • NUCLEONIC TUBES • MICROWAVE TUBES

craftsmen national advertising is Taylor made to bring you new high fidelity customers!

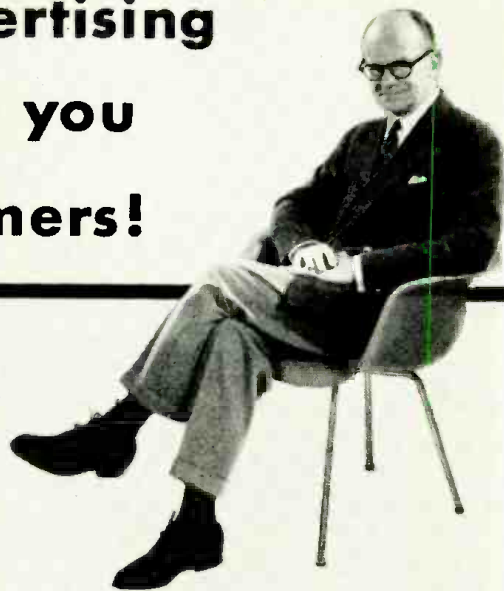

Deems Taylor . . . known to millions of Americans as the world's greatest authority on music . . . once again spearheads Radio Craftsmen national advertising with the High Fidelity Story. Through Craftsmen full page advertisements in scores of the nation's leading magazines Mr. Taylor, in interesting and informative columns, will be telling more than 2,500,000 readers—key prospects for you—the distinct advantages of unit High Fidelity. Plan now to squeeze every ounce of value out of this great promotion by featuring the complete Craftsmen line. Write today for details.



high fidelity units by craftsmen can give you one of these distinctive home music installations

Deems Taylor says—
"better listening can be better looking, too!"

Fidelity from Deems Taylor

high fidelity by craftsmen
means distinctly better listening

Month After Month in popular magazines, carefully selected to reach your customers and prospects, smashing full page advertisements like these will be pounding home the Taylor story . . . the High Fidelity Story . . . the Craftsmen Story!

Cash in on craftsmen advertising— order these sales helps today!

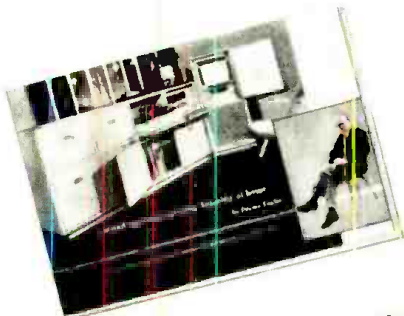

Color Displays

Outstanding new window and counter display materials for the complete Craftsmen "Assembly," individual units, Deems Taylor booklet. Die-cut, attention getting cards that stop them in their tracks—and sell!



Deems Taylor Booklet

Revised edition including new installation photos and complete Craftsmen line. Lithographed in color, 24 pages of information on High Fidelity so basic, so clear you'll want to use it as a selling tool!



Consumer Literature

Attractive, hard-selling folders promoting the Craftsmen "Assembly" and the complete Craftsmen line. Useable as envelope stuffers, imprint space provided. Complete technical literature available in quantity.

the  craftsmen line  is the
shortest distance  between sales 

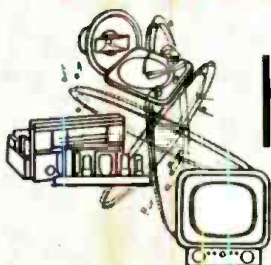

high fidelity by craftsmen®

means distinctly better listening

the radio CRAFTSMEN, inc., Dept. L-10, 4401 N. Ravenswood Ave., Chicago 40, Ill.



“I’m glad I waited...”

Here’s how I solved a problem that bothered me . . . and may be bothering you.

Many of my favorite recordings happen to be 78’s. They mean as much to me as any of my newer LP’s or 45’s. Changing pickups was often a real nuisance—and yet I wasn’t willing to give up the superior quality of my two Pickering cartridges.

Last fall my dealer offered a suggestion. “Wait a little longer,” he said. “You’ll be glad you did.”

He was right. I now have Pickering’s new turn-over cartridge. A simple flip of the handy lever and I’m ready to play any favorite that fits my mood—whether it’s standard or microgroove. *More than that, I’d swear my recordings sound better than ever.*

I’m glad I waited . . . but you won’t have to.

Ask your dealer to show you this convenient new turn-over cartridge. Have him demonstrate it. See if you, too, don’t hear the difference!

PICKERING and company incorporated • Oceanside, L. I., New York

PICKERING PROFESSIONAL AUDIO COMPONENTS

“For those who can hear the difference”

... Demonstrated and sold by Leading Radio Parts Distributors everywhere.
For the one nearest you and for detailed literature, write Dept. C-3



FREE! A FAMOUS CBS-HYTRON Soldering Aid to every contestant in this, your BIG *Certified* QUALITY SERVICE CONTEST!

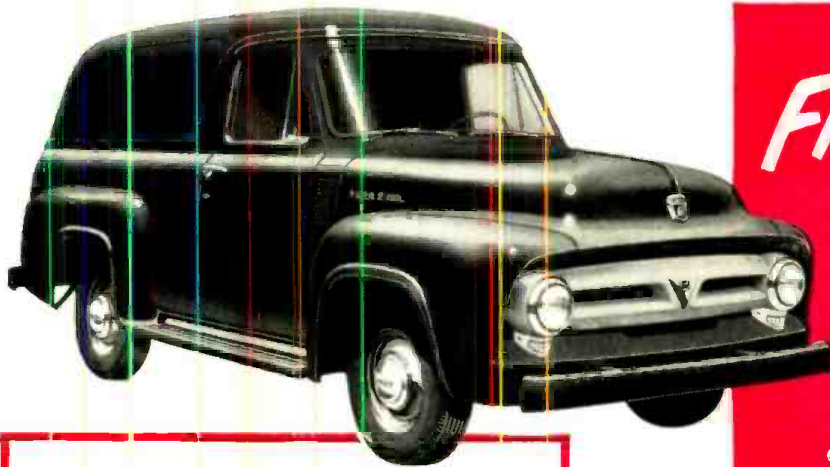

FIRST PRIZE
... FORD
PANEL TRUCK
 (painted with your name and address and delivered to your door)

9 Other BIG Prizes!!

- Second Prize: \$1000 in Savings Bonds
- Third prize: 600 in Savings Bonds
- Fourth prize: 500 in Savings Bonds
- Fifth prize: 400 in Savings Bonds
- Sixth prize: 300 in Savings Bonds
- Seventh prize: 200 in Savings Bonds
- Eighth prize: 100 in Savings Bonds
- Ninth prize: 50 in Savings Bonds
- Tenth prize: 25 in Savings Bonds

Get an ENTRY BLANK with the EASY CONTEST RULES from your CBS-HYTRON DISTRIBUTOR

On this entry blank, complete in 25 additional words or less: "I like the CBS-Hytron *Certified* Quality Service plan because . . ." Sign your name, then *print* your name and address below your signature. Ask your Distributor's Salesman or Counterpart to help you. *Be sure to print his name and company on line indicated.* (If you win, he wins.) Mail to CBS-Hytron, Dept. (A), A Division of Columbia Broadcasting System, Inc., Danvers, Massachusetts.

FACTS ABOUT YOUR *Certified* QUALITY SERVICE Plan

If you could advertise nationally, chances are you'd do just what CBS-Hytron is doing for you. You'd tell the world in LIFE and the POST that you promise quality TV and Radio service, parts, and tubes . . . and at fair charges. And that's just what CBS-Hytron is doing for you with advertisements that sell you as a *Certified* Quality Service dealer . . . a dealer in whom the public can have confidence.

You'd identify your service repair shop as the one people are reading about in the magazines.

You'd use a *Certified* Quality Service decalcomania on your door. You'd use a *Certified* Quality Service window streamer and the big LIFE and POST easel display blow-up. Above all you'd use *Certified* Quality Service tags that tell your customer he is getting more for his money when he

calls your service repair shop . . . because you *Certify* the quality of service, parts, and tubes . . . and at fair charges.

Yes, by using all this material, and more to come, you cash in on your big *Certified* Quality Service advertising campaign. Get your kit. It contains all the material you need to identify you as a *Certified* Quality Service dealer. Ask your CBS-Hytron distributor for *special deal*.

To be eligible for Contest prizes, you must be actively participating as a *Certified* Quality Service dealer by using the CBS-Hytron *Certified* Quality Service Promotion Kit; including tags, decalcomania, window streamer, and easel display blow-up. Awards will not be made to any dealer or serviceman not participating by December 15, 1953.

GET YOUR KIT AND CONTEST ENTRY BLANK TODAY! ASK YOUR DISTRIBUTOR . . . OR MAIL COLPON,

BUT DO IT NOW!



Manufacturers of Receiving Tubes Since 1921



CBS-HYTRON, Danvers, Massachusetts
 A Division of Columbia Broadcasting System, Inc.

A member of the CBS family . . . CBS Radio • CBS Television • Columbia Records, Inc. CBS Laboratories • CBS-Columbia, Inc. • and CBS-Hytron

CBS-HYTRON, Danvers, Mass.

Please rush me the *Certified* Quality Service promotion kit, containing:

1. 18- by 28-inch LIFE and POST easel display . . .
2. New *Certified* Quality Service decal . . .
3. 8- by 23-inch window streamer . . .
4. AND 250 *Certified* Quality Service tags imprinted with MY name and address.

HERE IS MY 3-LINE IMPRINT:

Name _____ (please print)

Street _____

City _____ State _____

I enclose \$2.00 to cover the cost of imprinting.

Signed: _____

P.S. Please send me also entry blank with easy Contest rules.

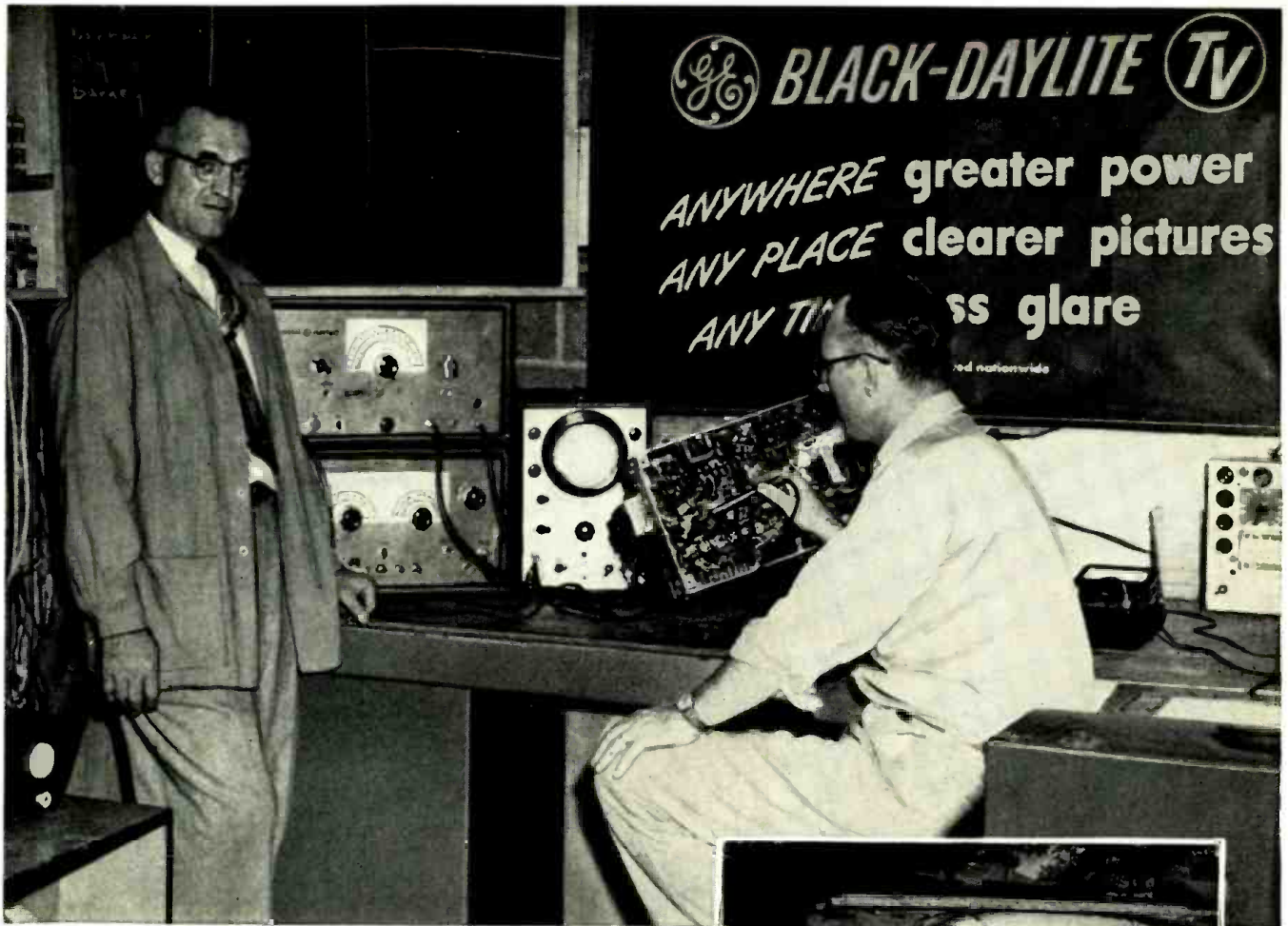

GE BLACK-DAYLITE TV

ANYWHERE greater power
ANY PLACE clearer pictures
ANY TIME less glare

and nationwide



"PROMPT, EFFICIENT SERVICE SELLS TV,"

Says G-E Dealer E. H. ENGLE, Home Supply Co., Portsmouth, Ohio

G-E Field Clinics will help solve your TV Service Problems. Mr. Engle attributes 75 per cent of his new sales to currently satisfied customers—and prompt service is the reason. He says, "G-E Field Clinics have shown us how to organize our operation more efficiently."

You too will find it profitable to attend one of these G-E Field Clinics. General Electric Field

Engineers are holding clinics through the country. They are open to *all* TV Servicemen without charge. G-E engineers demonstrate simple ways to diagnose and correct TV troubles—and answer your questions on all phases of TV service.

Ask the Service Manager at your G-E TV distributor's to sign you up for the next G-E Field Clinic in your area.

General Electric Company, Radio & Television Department, Electronics Park, Syracuse, New York

You can put your confidence in—

GENERAL  ELECTRIC

FACTS

you want to know ABOUT HIGH FIDELITY REPRODUCTION

Here for the asking is valuable information for everyone—for the hi-fi enthusiast, music lover or professional expert. Includes important facts about the foremost selection of high fidelity reproducers to suit every taste and budget. Send now for the Bulletins you want.

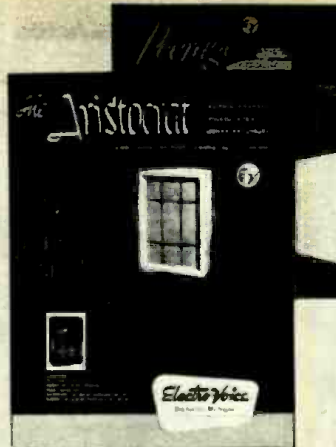

BULLETIN 189. Tells how to add octave of bass (and better highs) with E-V ARISTOCRAT Klipsch licensed folded horn corner enclosure and 12" complementary speaker systems. Includes complete data on PEERAGE sound equipment console.



BULLETIN 185. Tells about E-V REGENCY folded horn enclosure with built-in corner for 15" coaxial speakers or separate 2- and 3-way speaker systems. Has full data on E-V BARONET corner enclosure for 8" speakers.

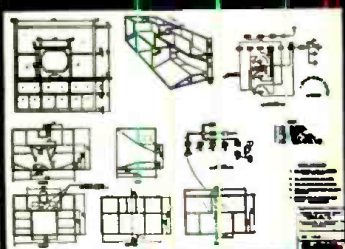

BULLETIN 172. Chart for building complete high fidelity Residence Entertainment Center with Ideal reproducer system. Includes space for all audio components, radio-phonograph, television receiver, etc.

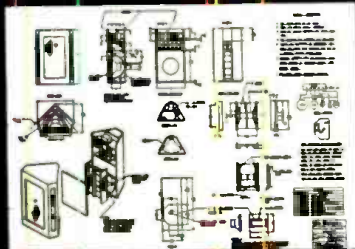

BULLETIN 173. Construction drawing details and mounting information on how to build the famous E-V PATRICIAN folded horn corner enclosure for today's outstanding 4-way reproducer system.

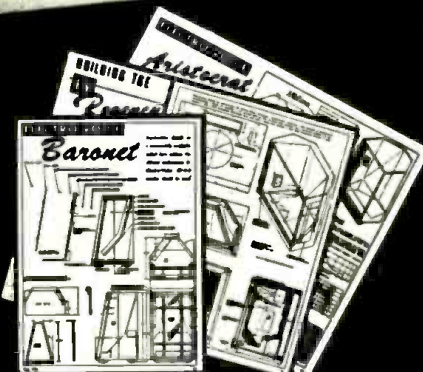

BULLETIN 174. How to build BARONET corner enclosure for 8" speaker.

BULLETIN 175. Construction drawing on E-V ARISTOCRAT corner enclosure for 12" speaker systems.

BULLETIN 176. Building E-V REGENCY enclosure for 2-way and 3-way systems.



BULLETIN 196. Explains about E-V PATRICIAN 4-way audio reproducer in custom-crafted corner enclosure—Hi-Fi experts say; "finest of all."

BULLETIN 199. Tells about the magnificent new GEORGIAN 4-way reproducer in folded horn enclosure.



BULLETIN 197. Gives full information about the revolutionary CDP compound diffraction projector for outdoor full-range high fidelity reproduction. Used also as pressure type mid-range driver for hi-fi multi-way systems.

BULLETIN 198. New ultra-linear, wide range, constant amplitude ceramic phonograph cartridge described in full detail.

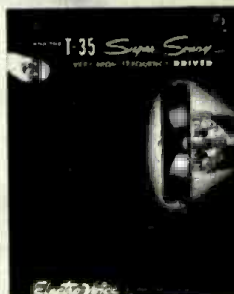

BULLETIN 194. Tells how you can enjoy at least one more octave of silky highs by adding T-35 Super Sonax very high frequency driver to your extended range single speaker for a 2-way system, to your coaxial for 3-way, or to separate multiple 2-way for super 3-way.

BULLETIN 193. Illustrated 8-page folder shows the most complete selection of authentically styled richly finished folded horn corner enclosures with complementary loud-speaker systems.

CONDENSED CATALOG 116. Full 8-page digest of information on the many products created by E-V; high fidelity enclosures, speakers, speaker systems, microphones, phonograph pickup cartridges, television accessories.



Any one individual Bulletin will be sent to you **FREE**

For a Complete Set of all the Bulletins including new 16-page book "Temples of Tone," send 50¢ in coin or stamps.



Interesting New 16-Page "Temples of Tone" tells the High Fidelity Story—explains how to select your Hi-Fi System.

ELECTRO-VOICE, INC., BUCHANAN, MICHIGAN

As checked—Send one bulletin free or complete set for 50¢.

- | | |
|---|--|
| <input type="checkbox"/> Bulletin No. 189 on Aristocrat and Peerage | <input type="checkbox"/> Bulletin No. 175 on Aristocrat Construction |
| <input type="checkbox"/> Bulletin No. 185 on Regency and Baronet | <input type="checkbox"/> Bulletin No. 176 on Regency Construction |
| <input type="checkbox"/> Bulletin No. 196 on the Patrician | <input type="checkbox"/> Bulletin No. 197 on CDP Sound Projector |
| <input type="checkbox"/> Bulletin No. 199 on the Georgian | <input type="checkbox"/> Bulletin No. 194 on T-35 Super Sonax |
| <input type="checkbox"/> Bulletin No. 172 on Entertainment Center | <input type="checkbox"/> Bulletin No. 193 on Folded Horn Enclosures |
| <input type="checkbox"/> Bulletin No. 173 on Patrician Construction | <input type="checkbox"/> Catalog No. 116 on all E-V Products |
| <input type="checkbox"/> Bulletin No. 174 on Baronet Construction | <input type="checkbox"/> Bulletin No. 198 on Ultra-Linear Cartridge |
| <input type="checkbox"/> Complete set of all Bulletins including new 16-page Temples of Tone—50¢ (coin or stamps) enclosed. | |

NAME _____

ADDRESS _____

CITY _____ ZONE _____ STATE _____

Electro-Voice

BUCHANAN, MICHIGAN

Export 13 East 40th St. New York 6 U.S.A. Cables Arlab

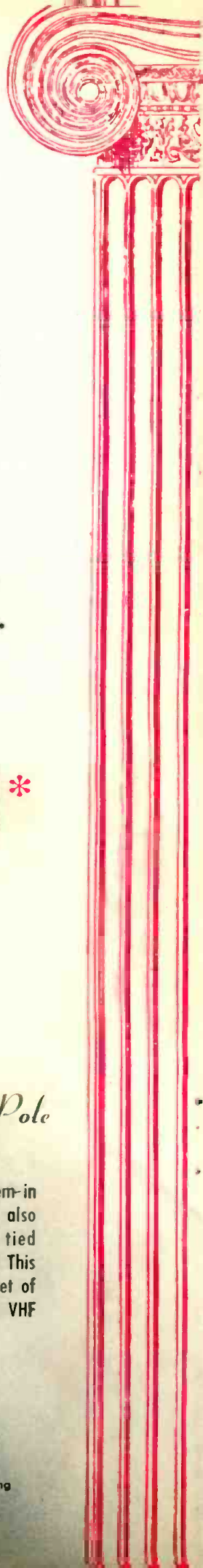
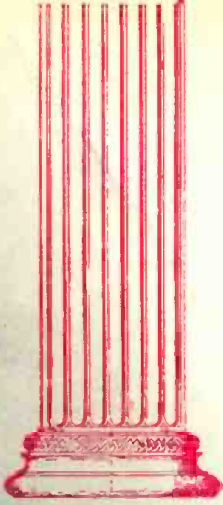

CHANNEL MASTER

introduces a

basically *new type*
of VHF antenna

the CHAMPION*

the highest gain
all-channel VHF antenna
ever developed!

Featuring the unique new "Tri-Pole"

TRIPLE-POWERED DIPOLE

The "Tri-Pole" is a new antenna system-in which the Low Band folded dipole also functions as three folded dipoles tied together in phase on the High Band. This is the heart of the Champion, the secret of its phenomenal performance on all 12 VHF channels.

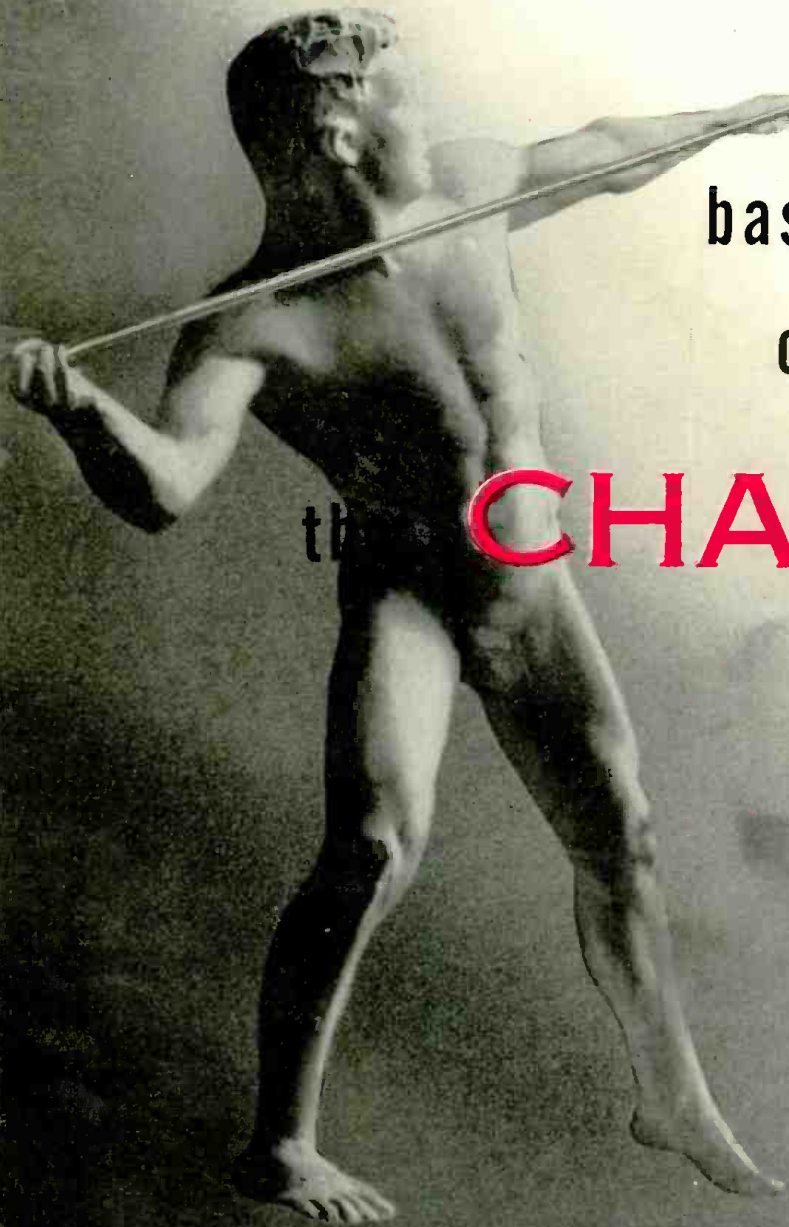

the **CHAMPION** is the most sensitive all-channel VHF antenna ever designed!

Stacked **CHAMPION** provides:
11-13 D B High Band gain
6½-7½ D B Low Band gain

Here is a totally NEW kind of antenna, completely different — in principal and performance — from any VHF antenna you've ever seen! Since the lifting of the TV freeze means a gradual disappearance of the single-channel VHF area, the VHF antenna of the future will be a *multi-channel* antenna. Prepare now for outstanding reception on *all* VHF channels — present and future — with Channel Master's super-sensitive **CHAMPION**! Outperforms every all-channel VHF antenna made today — and many Yagis, too!

COMPARE these features with the antenna you are now using:

- Folded dipoles throughout — give close to 300 ohms impedance across the entire band.
- Screen-type reflector provides high uniform gain on every channel, 2 through 13. *Not* frequency sensitive — this reflector provides more than twice as much extra gain as straight bar reflectors.
- Phase-correcting harness is built-in and fully assembled; the only wiring you do is to attach the lead-in.
- All-aluminum construction . . . lightweight, durable, non-corrosive.

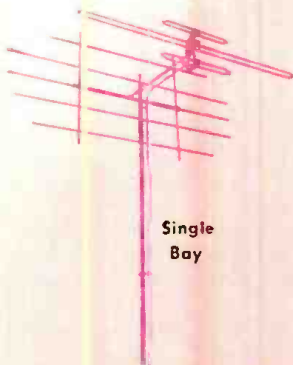

Single Bay

MARVEL OF PRE-ASSEMBLY

assembles faster than a 5-element yagi!

Collapsed "Pop-Up" screen opens instantly — no loose rods, elements or hardware. "Tri-Pole" assembly features automatic Spring Lock Action — all dipoles snap permanently into place without wing nuts or any other hardware.

It's a **CHAMPION** in any area!

- 1-bay—local areas
- 2-bay—secondary and fringe areas
- 4-bay—super-fringe areas

THIS ANTENNA...

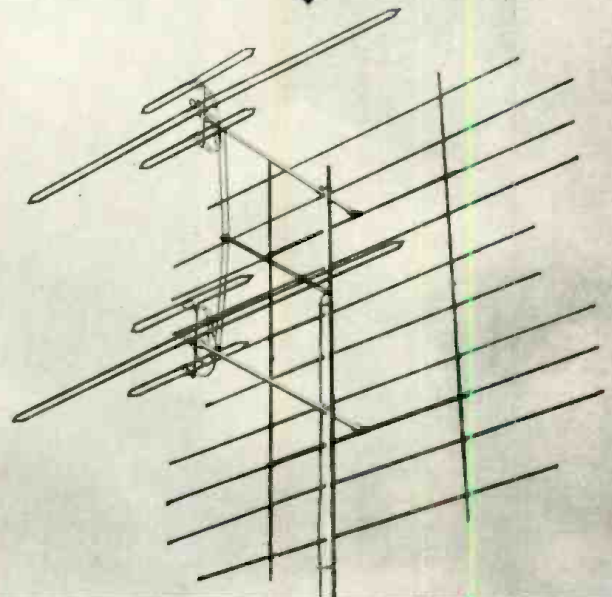

OUT-PERFORMS:

this ...



this ...

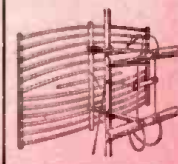

this ...



or this ...



The 2-Bay **CHAMPION** actually gives you the performance of:

- Separate 5-element Yagis for every Low Band channel!
- Separate 10-element Yagis for every High Band channel!

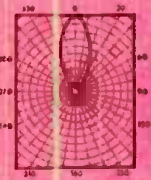
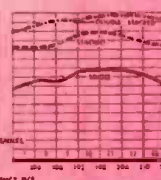
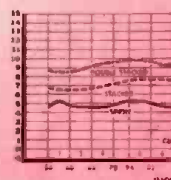

channel 10

Model No.		List Price
325	Single Bay	\$20.83
325-2	2-Bay	\$42.36
325-4	4-Bay	\$88.89
Separate Stacking Harness:		
325-3	2-Bay Harness	\$ 2.08
325-5	4-Bay Harness	\$ 4.15

Send for complete technical literature.

CHANNEL MASTER CORP.

ELLENVILLE, N. Y.



TUNG-SOL TECHNICAL DATA BOOKS



T-58—Two volumes—nearly 700 pages of data on 600 types of tubes.



T-70—More than 160 pages of data.



T-31—More than 300 blue-print-type base diagrams for more than 1100 tube types.

When opened, all books lie flat for easy reference.

These handy, easy-to-use books contain all the information that set designers, equipment designers and service dealers need for everyday use. They are the most practical tube reference books in the industry, with technical information and charts compiled for fast reading. Take the trouble out of electron tube trouble-shooting. Get TUNG-SOL Electron Tube Technical Data Books. Ask your distributor's salesman, or write to Tung-Sol Electric Inc., Newark 4, N. J.

TUNG-SOL® ELECTRON TUBES

and all the technical help that goes with them.

Within the INDUSTRY

JOHN SCHWEIGHAUSER has been named to the post of "antenn-gineer" at *Snyder Manufacturing Company* of Philadelphia.



He will call on the company's distributors and service dealers in the capacity of sales engineer. He will acquaint the trade with new *Snyder* television antennas and accessories and, under the personal supervision of Matt Mandl and Ed Noll, the company's electronics engineers, will work with distributors and service dealers on engineering problems. He will also engage in field survey and sales promotion activities.

He will make his headquarters at the company's Philadelphia plant.

JOSEPH H. MORIN has been named sales promotion manager of *Howard W. Sams & Co., Inc.*, publishers of "Photofact" service, electronic technical manuals, and books. He was formerly distributor sales manager of *Shure Brothers, Inc.* of Chicago . . .

JOE STARR is the new assistant sales manager of the manufacturers' division of *Pyramid Electric Company* of North Bergen, N. J. He has been associated with the condenser industry since 1939 . . . *Ellinger Sales Corp.* of Chicago has named **AL LINKE** president and treasurer, succeeding the late **FRED ELLINGER** who passed away this past summer . . . **THOMAS M. FITZGERALD, JR.** has joined *P. R. Mallory & Co., Inc.* as sales manager of the Capacitor Division. He comes to the company from the *Stewart-Warner Corporation* where he was chief administrative engineer of the *South Wind Division* for a period of two years . . . The newly-created position of sales promotion manager for *Scott Radio Laboratories* is being filled by **WILLIAM T. DEAN, JR.** He was formerly district manager for *Packard Motor Sales* in St. Louis . . .

Erie Resistor Corporation has named **ALLEN K. SHENK** and **JEROME D. HEIBEL** as vice-presidents of the firm. Mr. Shenk will be in charge of sales while Mr. Heibel will be responsible for research and engineering . . . **KATHERINE CROWLEY** has been appointed executive vice-president of *Henry L. Crowley & Company, Inc.* She has been vice-president and assistant to the president of the firm for some time . . . **HAROLD BLUMENTHAL** is the new sales manager of the manufacturers' division of *Shure Brothers, Inc.* He has served the firm as a sales engineer for six years . . . **SAMUEL PORTNOY** has been appointed general

traffic manager of *Emerson Radio and Phonograph Corporation* . . . **NAT WELCH** has been named sales manager of *Orradio Industries, Inc.* of Opelika, Alabama. The company makes the "Irish" brand of magnetic recording tape . . . **ISRAEL MELMAN**, formerly engineer in charge of the advanced development laboratory at *CBS-Columbia, Inc.* has been advanced to chief engineer of the special products division . . . **PAUL MATHES** has joined the staff of *Trio Manufacturing Co.*, Griggsville, Ill., as advertising manager. He was formerly with the industrial design section of *International Harvester's Refrigeration Division*.

G. A. BRADFORD has been named manager of advertising and sales promotion for the *General Electric* radio and television department. He will make his headquarters at Electronics Park, Syracuse.



He is a native of Caldwell, N. J. and graduated in 1936 from Colgate University. Shortly after his graduation he joined *General Electric* and since that time has been engaged in various accounting, sales, and advertising positions with the company. Prior to his present appointment he was advertising manager of the tube department.

A. L. Champigny succeeds Mr. Bradford as advertising manager of the tube department. He has been with the company since 1941.

TRIO MANUFACTURING COMPANY recently completed a 24,000 square foot addition to its Griggsville, Illinois plant. The new building houses manufacturing, product research, testing, development, and improvement facilities . . . **AUDIO DEVICES, INC.** has opened a new office at 6124 Milwaukee Avenue, Chicago. Brewster Freifeld will be in charge of the new office . . . **KIMBLE GLASS CO.** is completing a new warehouse in Columbus, Ohio, which will provide 200,000 square feet of floor space. Truck docks and railroad spur tracks will facilitate shipping from the new warehouse . . . **W. H. BRADY COMPANY**, manufacturers of self-sticking industrial products has moved into new quarters at 727 W. Glendale Ave., Milwaukee 12, Wisconsin . . . **HELDOR MFG. CORP.** has moved its plant and offices to 238 Lewis Street in Paterson, N. J. An increased demand for the company's line of transformer cans, condenser cans, component parts, etc. necessitated the

Use the JFD Cascade Yagi...

Put an end to "GOLDFISH BOWL" reception!

For sets whose TV world is as limited as the goldfish world, JFD teams up the gain and directivity of the Yagi with the broad band coverage of the all-channel antenna. The JFD Cascade Yagi crashes through the fringe barrier to bring brilliant VHF reception to formerly barren TV areas. Noteworthy too: the famous JFD "Baline" Balanced Line design, the aircraft aluminum construction and the "Quik-Rig" pre-assembly. Write for bulletin 207A.

Order today in 5 or 10 element designs (5B or 10B series)

JFD MFG. CO., BROOKLYN 4, N. Y.
World's largest manufacturer of television antennas and accessories

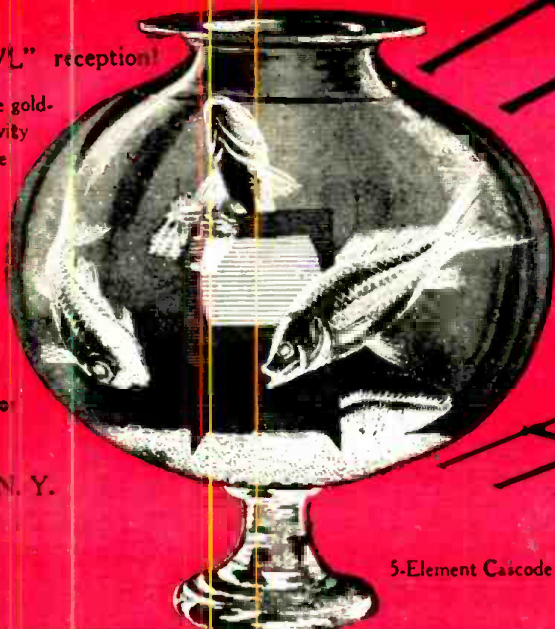

5-Element Cascade Baline Yagi

Models
5B26 5B2345
5B345 5B3456
5B456 5B713

10-Element
Cascade Baline Yagi
Models
10B26
10B2345
10B3456
10B456
10B713

NEW JFD "3-in-one" LIGHTNING ARRESTER

No. AT110 with hardware for wall or window sill mounting, \$1.50, list.

No. AT110S with stainless steel strap for pipe mounting, \$1.75 list.

Both feature the patented JFD strain-relief lips which prevent contact washers from ripping the lead-in wires apart!



one for all... all for one

1. for UHF or VHF tubular twin lead
2. for VHF flat twin lead
3. for VHF or UHF open wire

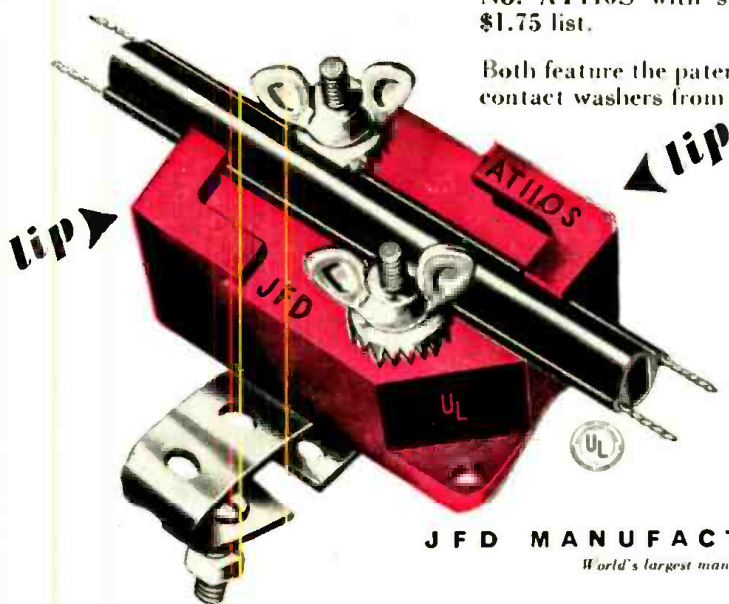

Burton Brown Advertising

JFD MANUFACTURING COMPANY, INC.

World's largest manufacturer of tv antennas and accessories; Brooklyn 4, New York

metamorphosis of an antenna

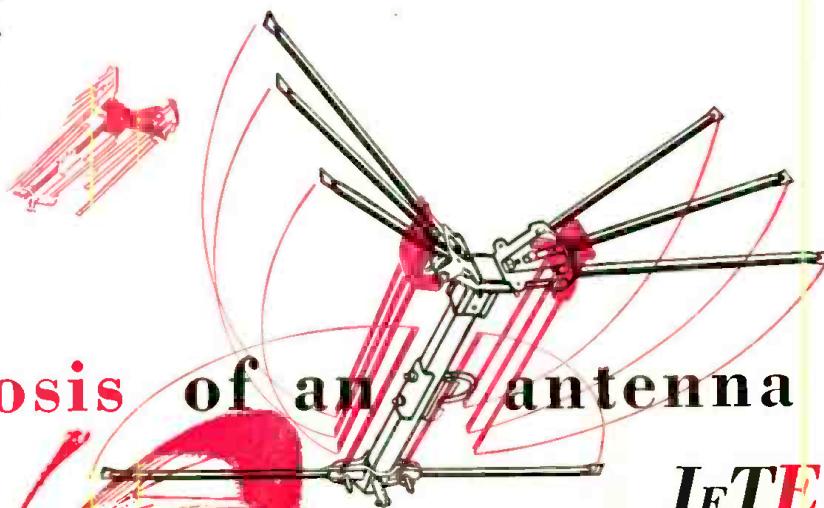

Like a butterfly emerging from a cocoon, the JFD JETENNA is practically ready for work when it emerges from the carton! No other fan conical assembles so fast - performs so well. Available in single two or four bays including model: JET 660, JET 661, JET 664. Write for bulletin 165.

JETENNA

JFD MFG. CO., BROOKLYN 4, N. Y.
World's largest manufacturer of TV antennas and accessories



my Radio
and **T.V.**

REPAIR SECRET?

OHMITE®
DEPENDABLE REPLACEMENTS

Little Devil® COMPOSITION RESISTORS



Tiny, yes . . . but what dependability, ruggedness, and stability! And they provide an extra margin of safety—being rated at 70C rather than 40C. Completely sealed and insulated by molded plastic, they meet all JAN-R-11 requirements . . . are available in 1/2, 1, and 2-watt sizes in all RTMA values.

TYPE AB NOISE-FREE POTENTIOMETERS

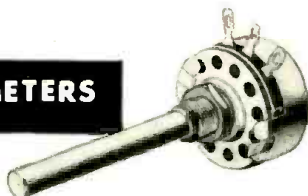

Because the resistance material in these units is solid-molded—not sprayed or painted on—continued use has practically no effect on the resistance. Often, the noise-level decreases with use . . . and they provide exceptionally long, trouble-free service. Rated at 2 watts, with a good safety factor.

BROWN DEVIL® AND DIVIDOHM® RESISTORS



BROWN DEVIL fixed resistors and DIVIDOHM adjustable resistors are favorite vitreous-enameled units! DIVIDOHM resistors are available in 10 to 200-watt sizes; BROWN DEVILS in 5, 10, and 20-watt sizes.

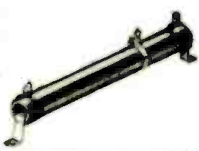

WRITE FOR STOCK CATALOG
OHMITE MFG. CO.
3634 W. Howard St.
Skokie, Illinois
(Suburb of Chicago)



Be Right With . . .
OHMITE
RHEOSTATS • RESISTORS • TAP SWITCHES

move . . . **PACIFIC MERCURY TELEVISION MFG. CORP.** of Van Nuys, California is constructing a new TV manufacturing plant, the first of the company's million-dollar building program. The new plant will provide an area of 122,000 square feet for executive offices, research, engineering and production departments, and television receiver assembly lines . . . **ELECTRO-MEC LABORATORY** has moved into a new plant at 21-09 43rd Avenue, Long Island City, N. Y. which provides over 150,000 square feet of floor space for manufacturing and engineering applications . . . **K-G ELECTRONIC CORP.** has moved its factory and offices to a new, modern building at 2738 N. Sheffield Ave., Chicago. The company makes a line of indoor television antennas.

G. W. MOLER is the new general sales manager of *Potter & Brumfield* of Princeton, Indiana. He was formerly manager of the firm's sales office in Washington, D. C.



In his new capacity he will be in charge of all sales programming, customer relations, and sales personnel training and supervision.

Before joining the company he was active in electronic engineering and sales in the Washington, D. C. and Philadelphia areas, having held highly responsible development engineering and planning positions in both government and industry.

H. J. SCHULMAN of the *Allen B. DuMont Laboratories, Inc.* has been appointed chairman of the RETMA Service Committee.

He succeeds R. J. Yeranko of the *Magnavox Co.* as chairman of one of the association's most active and progressive groups. The Service Committee, through cooperation with Better Business Bureaus, has done much to improve relations between television set owners and service technicians.

The new vice-chairman of the committee is John F. Rider of *John F. Rider Publisher Inc.*, who succeeds F. B. Ostman of *Caphart-Farnsworth Corp.*

FLOYD A. TIMBERLAKE has been appointed broadcast lake sales representative in RCA's central region with headquarters in Chicago.



He served as television operations supervisor of the central division of ABC in Chicago before joining RCA.

He has also served on the engineering staffs of several stations in and around Chicago as well as chief engineer for the city of Gary, Indiana, where he installed the first FM system for the

(Continued on page 187)

RADIO & TELEVISION NEWS

NO OTHER UHF ANTENNA COMBINES ALL

1 Extra
high
gain

2 All
channel
reception

3 Sharp
vertical
and horizontal
directivity

3

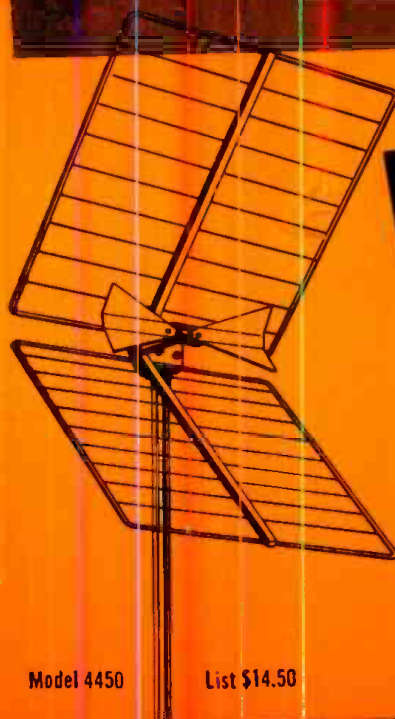

WALSCO

CORNER REFLECTOR

Not **1**... Not **2**... but all **3** combined
for amazing picture clarity

NOTHING... *absolutely nothing* compares with
WalSCO's Corner Reflector. It's the only UHF
antenna that offers a 3-way *combination* that
produces sharper, clearer TV pictures. Truly a
masterpiece in precision electronic engineering.

WALSCO *A Model to Fit Every Installation*

Walter L. Schott Co.
3225 Exposition Place
Los Angeles 18, California

COMPARISON CHART

	High Gain	All channel Performance	Sharp Directivity
WALSCO CORNER REFLECTOR	YES	YES	YES
ANTENNA B	NO	YES	NO
ANTENNA C	NO	YES	NO
ANTENNA D	YES	NO	YES

Overseas Representative: Ad Auriema, Inc., 89 Broad St., New York 4, New York



**"OUR CUSTOMERS TELL US
THAT THE PICTURES ARE
BETTER THAN WHEN THEIR
SETS WERE BRAND-NEW."**

*Says W. T. Gerlach
Roselle Radio and TV Service
1027 Chestnut St., Roselle, N. J.*

"Since the first TV sets were delivered in this area, we've installed almost every type and brand of picture tube, but we've yet to find any that gives a picture like the G-E Aluminized Tube.

"Our tube customers are not only satisfied—they are downright pleased! As a result, more than two out of every three tubes we are installing are G-E Aluminized Picture Tubes."

"2 OUT OF EVERY 3 TUBES ARE G-E ALUMINIZED

Give your customers TV's finest picture—and make more money!

"65% OF OUR PICTURE TUBES SOLD ARE G-E ALUMINIZED. ONE OWNER TELLS ANOTHER."

*Says Kenneth L. Middleton . . . HILLENS
740 N. Garey Ave., Pomona, Cal.*

"GENERAL ELECTRIC ALUMINIZED PICTURE TUBES ARE ONE OF MY REAL BIG MONEY-MAKERS!"

*Says Norman Foster . . . Foster Television
2922 Milwaukee Ave., Chicago, Ill.*



**BRAND-NEW
MIRROR DISPLAY**

Eye-evidence why a G-E Aluminized Tube is up to 100% brighter. The mirror does it! . . . This 3-color display with polished, gleaming mirror sticks front or back to any flat surface—your store-window, door, or wall. A real attention-getter!

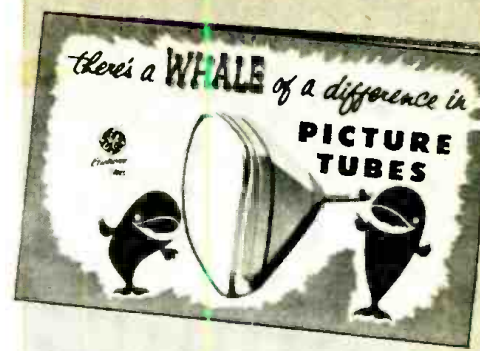
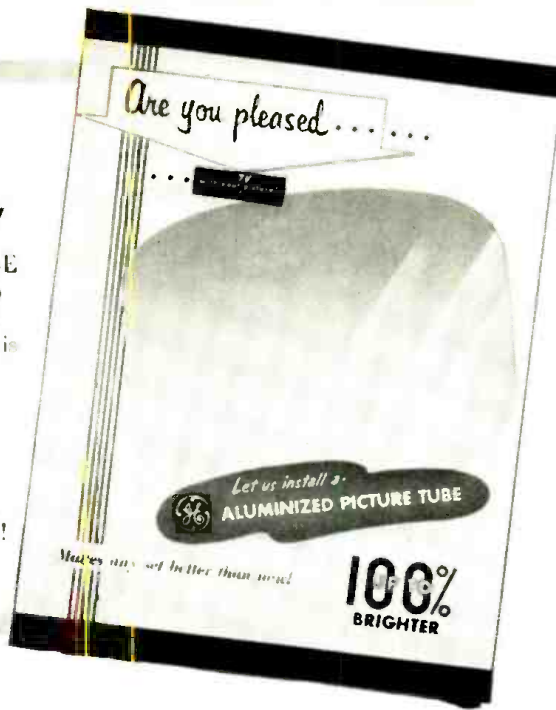

FACT-CRAMMED BOOKLET FOR TV OWNERS

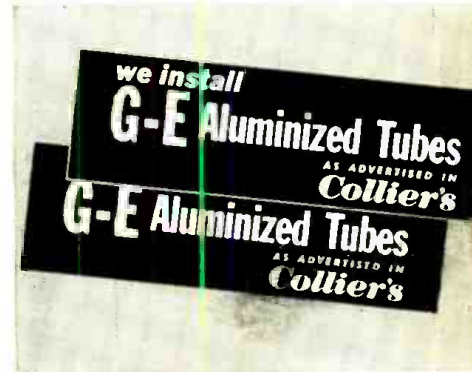

COLORFUL STREAMERS

WE INSTALL PICTURE TUBES!"

Ask for new 6-piece promotion kit!

All these helps are waiting for you at your G-E tube distributor!

GET the full kit of G-E Aluminized Tube sales aids! Use them to sell better-than-new TV! It's a sure-fire way to lick competition from inferior picture tubes offered to your customers.

This mirror, booklet, and other helps will work hard for you, developing profitable tube sales. General Electric further supports your efforts by a strong coast-to-coast advertising campaign to TV owners. Ads in LIFE, COLLIER'S, and TV GUIDE, reaching some 40,000,000 readers, tell why the G-E Aluminized Tube is brighter, better, the finest tube any set can have!

Today many leading TV builders are featuring new-model receivers with General Electric Aluminized Tubes. Demand for replacement tubes will skyrocket as the finer performance of the aluminized tube is made known by enthusiastic set owners.

Take a tip from successful service dealers everywhere! Sell TV's finest picture profitably! Tube Department, General Electric Co., Schenectady 5, New York.



161-1A7

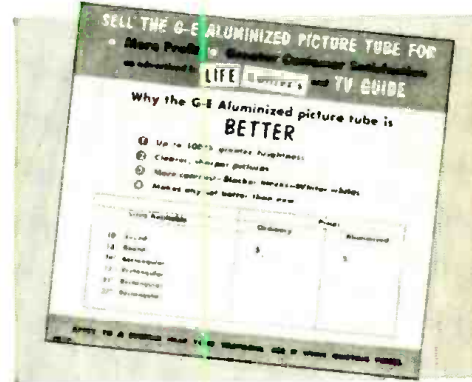

PHONE-SELLING PRICE GUIDE



MAIL CARD THAT BUILDS INQUIRIES



NEWSPAPER AD MAT

New! 7 INCH PUSH-PULL OSCILLOSCOPE

Only **EICO** Has All These Features:

VERTICAL FREQ. RESPONSE:
flat ± 2 db 10 cps - 1 mc

VERTICAL SENS.: .01 volts rms/Inch

HOR. FREQ. RESP.: flat ± 0 db 10 cps - 200 kc, -4 db at 500 kc

HOR. SENS.: .3 volts rms/Inch

SWEEP RANGE: 15 cps-100 kc

3-STEP FREQ.-COMPENSATED ATTENUATOR eliminates freq. distortion, overloading.

CATHODE FOLLOWER inputs to both amplifiers

PUSH-PULL outputs in both amplifiers

RETURN TRACE BLANKING

INT. VOLTAGE CALIBRATOR

V & H TRACE EXPANSION & CENTERING:
1.5X full screen without distortion.

DIRECT CONNECTION to vert. CRT plates. **KIT \$79.95. WIRED \$129.50.**

PHASING CONTROL of internal 60 cps sine wave sweep.

AT FRONT PANEL: intensity mod. input; 60 cps, sawtooth outputs.

Famous EICO amazing feature-packed economy-priced 425K 5" PUSH-PULL SCOPE KIT \$44.95. WIRED \$79.95.



MODEL 470K

- AC & DC volts: 0-5, 10, 100, 500, 1000 V (30 KV with HVP-1 probe).
- 5 ohm ranges from .2 ohm to 1000 meg.
- DC input Z 26 meg.
- $4\frac{1}{2}$ " meter movement in can't-burn-out circuit.
- 1% mult. resistors.



221K VTVM KIT \$25.95. WIRED \$49.95.

HIGH VOLTAGE PROBE \$6.95

- Extends range of VTVMs & voltmeters to 30 KV.



PIX TUBE ADAPTER for Tube Testers \$4.50. Checks TV picture tubes while in set.



- Illum. gear-driven "Speed Rolchart."
- New lever-action switches for individual testing of every element.
- Tests all conventional & TV tubes.

625K TUBE TESTER KIT \$34.95. WIRED \$49.95.

COUNTER CABINET for above: add \$10.00 to Kit or Wired Prices.

- Continuous coverage of all TV & FM freqs. from 500 kc to 228 mc.
- Sweep width variable 0-30 mc.
- Crystal marker oscillator, variable amplitude.

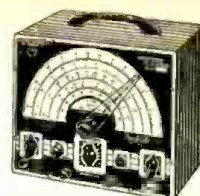

360K SWEEP GEN. KIT \$34.95. WIRED \$49.95.



- Large $7\frac{1}{2}$ " meter, can't-burn-out circuit.
- AC/DC volts: 0-5, 10, 100, 500, 1000 (30 KV with HV Probe).
- 5 ohms ranges from .2 ohm to 1000 meg.
- DC input Z 26 meg.
- 1% mult. resistors.

214K VTVM KIT \$34.95. WIRED \$54.95.



- Measures & tests all resistors; .5 ohm to 500 megohms.
- Every type condenser, 10 mmf to 5000 mfd.
- 0-500 DC voltage source for capacitor leakage testing.

950A-K R-C BRIDGE & R-C-L COMP. KIT \$19.95. WIRED \$29.95.



- Audibly signal traces all IF, RF, Video & Audio circuits from ANT to SPKR or CRT in all TV, FM, AM, etc. without switching.
- Germanium crystal diode probe responsive to over 200 mc.
- Integral test speaker.

145K SIG. TRACER KIT \$19.95. WIRED \$28.95.



- Fundamentals 150 kc to 34 mc, harmonics to 102 mc.
- 5-step band switching.

320K SIG. GEN. KIT \$19.95. WIRED \$29.95.



322K SIG. GEN. KIT \$23.95. WIRED \$34.95.

- Resistance values from 0 to 99,999 ohms with 0.5% precision.
- All resistors have 0.5% accuracy.

1171K RES. DECADE BOX KIT \$19.95. WIRED \$24.95.



536K MULTIMETER KIT \$12.90. WIRED \$14.90.

526K MULTIMETER KIT \$13.90. WIRED \$16.90.

- 1000 Ω/V , 31 ranges
- DC/AC volts: Zero to 1, 5, 10, 50, 100, 500, 5000.
- DC/AC Current: 0-1, 10 ma; 0.1, 1 A.
- Ohms: 0-500, 100 K, 1 meg.

- Complete sine wave coverage, 20-200,000 cps in 4 direct-reading ranges.
- Complete square wave coverage, 60-50,000 cps.
- Cathode follower output circuit.

377K SINE & SQUARE WAVE AUDIO GEN. KIT \$31.95. WIRED \$49.95.



- 20,000 Ω/V ; 31 ranges.
- DC/AC/Output volts: 0-2.5, 10, 50, 250, 1000, 5000.
- DC Current: 0-100 ua; 10, 100, 500 ma; 10 A.
- Ohms: 0-2K, 200K, 20 meg.

565K MULTIMETER KIT \$24.95. WIRED \$29.95.

555K MULTIMETER KIT \$29.95. WIRED \$34.95.

1% precision resistors

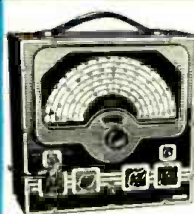

- Covers range of 75 kc to 150 mc.
- 7 calibrated scales: accuracy better than 1%.
- Bandsread vernier tuning.
- 4-step RF shielded output multiplier: constant output Z.

315K DELUXE SIG. GEN. KIT \$39.95. WIRED \$59.95.

NOW! ONLY EICO

the largest manufacturer of its kind in the world - gives you **LIFETIME SERVICE & CALIBRATION GUARANTEE***

...the Industry's greatest protection for your test equipment investment!

* at less than our cost of handling (see the EICO Guarantee Card enclosed with each Kit and Instrument).



NEW!
SCOPE VOLTAGE CALIBRATOR KIT 495K KIT \$12.95. WIRED \$17.95.

- Sq. wave output at power-line freq. with full-scale readings of .1, 1, 10 or 100 V. peak-to-peak.
- Accuracy $\pm 5\%$ of full-scale on each range.

NEW!

5V & 12V BATTERY ELIMINATOR KIT 1050K KIT \$29.95. WIRED \$38.95.

- DC output: 0-8 V or 0-16 V.
- Continuous current rating: 10 A at 6 V, 6 A at 12 V.
- Intermittent current rating: 20 A at 6 V, 12 A at 12 V.
- Separate Voltmeter & Ammeter.

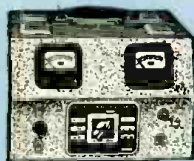

NEW!

DECADE CONDENSER BOX KIT 1180K KIT \$14.95. WIRED \$19.95.

- All capacitors precision silver mica, accuracy $\pm 1\%$.
- Range from 100 mmf - 0.111 mfd in steps of 100 mmf.
- Smooth-action positive detent ceramic switches.

Prices 5% higher on West Coast. Specifications and prices subject to change without notice.



Write NOW for FREE latest Catalog R-II

You build EICO Kits in one evening, but ... they last a lifetime!

And you SAVE OVER 50%! See the famous EICO line TODAY, in stock at your local jobber.

ELECTRONIC INSTRUMENT CO., Inc., 84 Withers Street, Brooklyn 11, N. Y.

A Dual Channel

RECORDING SYSTEM

By

OLIVER READ*

Fig. 1. Three Par-Metal relay racks and a custom turntable console contain the essential components for an audio transmission laboratory. Dual channels permit a study of binaural and other stereophonic effects. Broadcast techniques permit choice of circuitry.

THERE are literally hundreds of audio enthusiasts, experimenters, and dyed-in-the-wool hi-fi listeners who have asked for specifications and design data on various audio systems intended for experimental purposes and for the study of audio in general. In addition, personnel of distributors and other firms engaged in selling hi-fi equipment have asked for suitable systems which would lend themselves to the demonstration of the various preamps, power amps, and miscellaneous components used in hi-fidelity play back systems.

Dual channels and the extensive use of jack panels provide complete facilities for binaural and monaural recording, dubbing, and playback.

In our own case, a system was needed in our audio-transmission laboratory (front cover) in order to have a flexible setup adapted to numerous requirements that would be complete, versatile, and of such circuitry as to be highly flexible for the interchange of components.

In addition to basic requirements for a composite record-reproduce system, it was necessary that the circuits be readily accessible for every type of audio measurement. Because floor space was limited, and due to the desirability of having the equipment portable (in the sense that the components could be moved *en masse* to a new location), relay racks were used to house the essential gear.

While not intended, in its present form, for use in the broadcast or recording studio, it does, nevertheless, lend itself to easy modification for such a purpose. Another almost daily

Part 1. Introduction to a composite record-reproduce system which uses high-quality, commercially-available components.

use for the equipment would be the availability of various components which could be set up rapidly for purposes of comparison of performance and for a complete analysis of characteristics of the equipment. With the introduction of "Certified Record Review" in this magazine we felt that a change of setup of components each month was certainly an intelligent approach to the playback of recordings submitted for review. Accordingly, this equipment will be used on occasion for purposes of record and tape reviews.

Requirements

The interest in "3rd-dimensional" reproducing systems is fast reaching a peak. Our interest is mainly that of experimenting with various "effects" which may be obtained by using various tricks of the trade with binaural (and other multi-channel techniques) and with conventional monaural channels. For that reason the entire system, with the exception of the bridging bus, is set up in duplicate. The components in this system (Fig. 1) are representative of the many fine high-fidelity units now widely used, both in industry and by the audiophile. Obviously, it is not possible for an individual to use all of

this equipment in any one system, our sole purpose being to utilize those units which were on hand at the time the system was constructed. In all cases, substitutions can be made, providing the components possess similar characteristics. Certain experiments dictated the use of four specific types of power amplifiers (*Williamson*, *McIntosh*, all-triode, and output-transformerless) for study.

Description

All of the various components are arranged so that the cabling of circuits may be carried out following best engineering practice. Complete details on this wiring, cabling, and jack circuitry, as well as the extensive relay controls, will be discussed later in this series of articles. The *Par-Metal* relay rack, shown on the right, includes the two vu meters—one connected to the bridging bus—the other to the power-level circuits; two AM-FM tuners—both having cathode-follower outputs; two preamp-equalizers—both having similar characteristics and both containing complete facilities for equalizing various recording characteristics, as well as providing complete treble and bass control; three double jack panels—each comprising 24 jacks which are used in this system; a line amplifier for the feeding of the bridging bus; two power amplifiers—one of 20 watts—the other with a rated output of 50

* Editor and Assistant Publisher, RADIO & TELEVISION NEWS and RADIO-ELECTRONIC ENGINEERING.

watts; and three barrier terminal strips for the termination of all circuits connected within rack #1.

The center rack contains the "Network" tape recorder (monaural) and below that is mounted the binaural tape equipment. Directly below the binaural amplifier is a control panel (Fig. 4 left) comprising a series of toggle switches which are used in conjunction with a relay system that permits the setting up of various preamps, tuners, or power amplifiers in predetermined combinations and with a master control switch, so that the preset equipment is actuated by means of a master control switch. This technique permits a combination of equipment to be actuated as a group when required, without the necessity for turning on or off the individual units used in any immediate setup. Below the control panel are two more power amplifiers (to be described later) which are used to drive the disc recording cutters and for monitoring purposes. The lower panel on this rack also contains three barrier-type terminal blocks and a rectifier-type supply furnishing 6 volts d.c. to the relays and to the meter lamps.

The remaining rack includes a timer clock which operates in conjunction with the master control switch so that off-the-air recording, for example, can be made at a preset time (handy when no operator is available). The panel also includes an elapsed time meter which is a handy device for keeping a record of the total time the equipment is in use; and finally, a vibrating-reed frequency meter which is used in special applications in or-

der to sync various portable recorders fed to the bridging bus when dubbing. Below the meter panel is an intermodulation analyzer (a much-needed accessory for the serious audio experimenter) and below that a 5-inch oscilloscope for the observation of waveforms, etc., followed in order by an audio-frequency meter for checking unknown audio frequencies, a laboratory-type audio oscillator, and a square-wave generator.

It was found convenient to have various audio test gear available for use at all times and, by means of the patch cords, these are readily connected to various components at the jack panels.

Recording Table Console

The console seen at the right of Fig. 1 contains two identical professional disc recorders, both equipped with 500-ohm magnetic cutters.

Details of the layout of the components mounted on the console are better shown in Fig. 3. The lever-type switch in the center panel is used to transfer the recording signal from one cutter to the other, and the toggle switch in the center foreground panel is the control switch for the FM oscillator used in conjunction with the *Weathers* system. Two high-quality, broadcast-type arms, used in conjunction with magnetic cartridges, are available for both standard and LP playback. The condition of a stylus is readily checked by means of the new *Audak* "Stylus-Disk." Both of the magnetic cartridges are of the turnover or rotating type, and both are equipped with diamond points. They are representa-

tive of the many fine playback components now available to the hi-fi enthusiast.

The disc recorders are normally used with a feed screw giving a pitch of 136 lines-per-inch. On occasion, when dubbings are made from tape masters, a substitute feed screw is made to increase the pitch to 220 lines. Both cutting styli are equipped with a heating coil fed from an r.f. oscillator to permit application of the professional "hot stylus" technique.

The console proper (not shown in the photo) provides ample storage for 16-inch transcriptions and for miscellaneous items used with the system. Tapes are stored under more ideal temperature and humidity conditions in a storage container to be described later. The console was entirely home built using 1/2" plywood, and is just large enough to comfortably cradle the two turntable chassis with a separating strip 3" wide to allow for the overhang of one of the cutting mechanisms, as shown. The height of the console, if one cares to duplicate this design, should be determined according to the height of the individual. We have found a good rule of thumb is that a comfortable height is one where the top of the turntable coincides with the belt line of the operator.

The speaker enclosure seen in Fig. 1 contains the *Stephens* 500-ohm voice coil speaker for direct coupling to the OTL amplifier.

Maintenance

One of the prime requisites in a recording system, in fact in any quality-electronic equipment, is easy ac-

Fig. 2. Simplified diagram shows how the various equipment is "normalled" in the system. Patch cords and jacks permit extensive circuit changes to set up various combinations of components for disc or tape recording, playback, or for audio measurements.

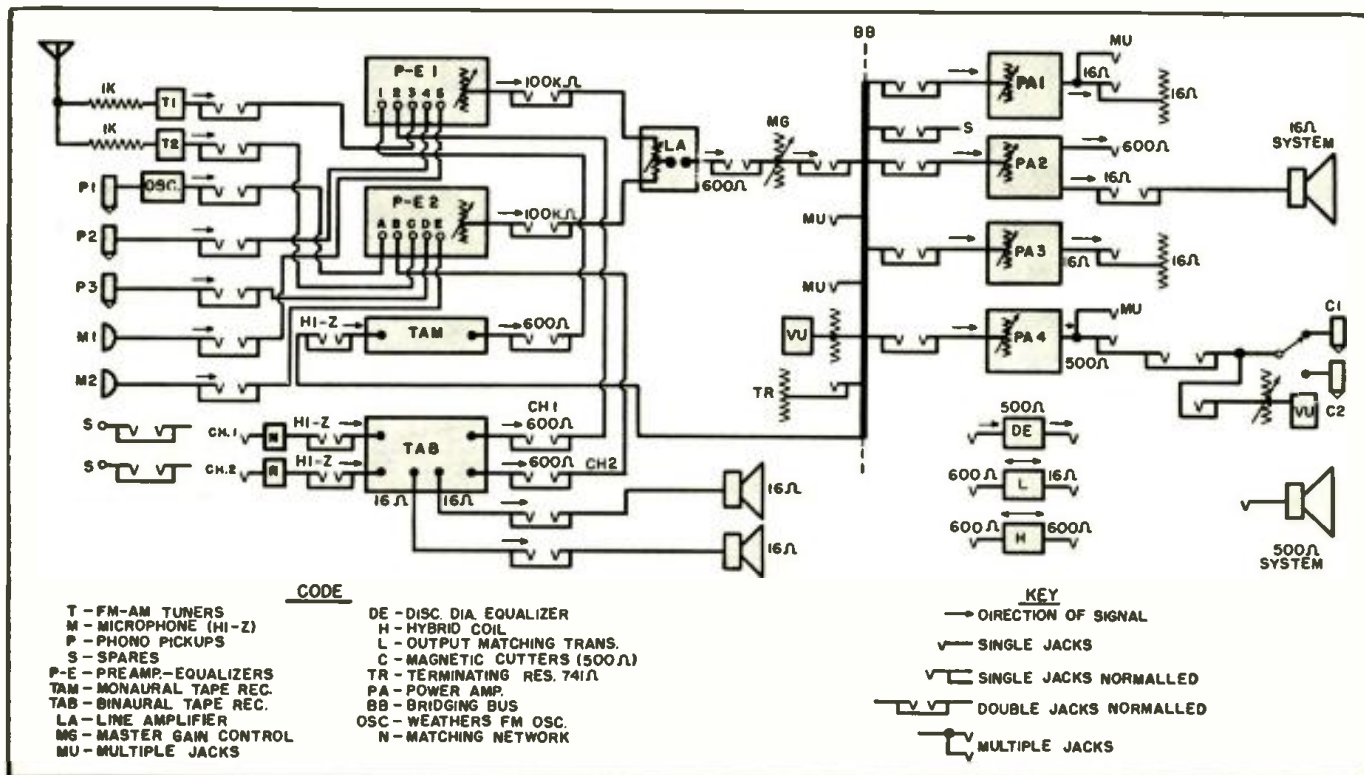

cessibility to every component in the system. Not only is preventative maintenance required, especially with quality tape recorders, but very often manufacturers delight in placing tubes where they are almost impossible to reach.

One of the outstanding examples of good engineering practice is found in the *Concertone* NWA-1 recorder amplifier (Fig. 4 right). The entire panel, which mounts all of the controls and the v.u. meter, may be dropped out as shown in Fig. 4, exposing all tubes, and wiring to the controls on panel, and of equal importance, completely exposing the inside or rear wiring to the several connectors which feed the interconnecting cables. This approach to layout design is an engineer's delight and can, in times of emergency, save many minutes in locating a bad tube or other component. By removing a back plate, all of the remaining components are likewise exposed, as will be seen later in this series.

Space does not permit a complete analysis of the diagram of Fig. 2 which shows, in simplified form, the extensive use of jacks, most of which are "normalled" in all signal circuits. As previously mentioned, this system is designed both for binaural as well as conventional monaural recording and playback. The adoption of 600 ohms impedance for the bridging bus

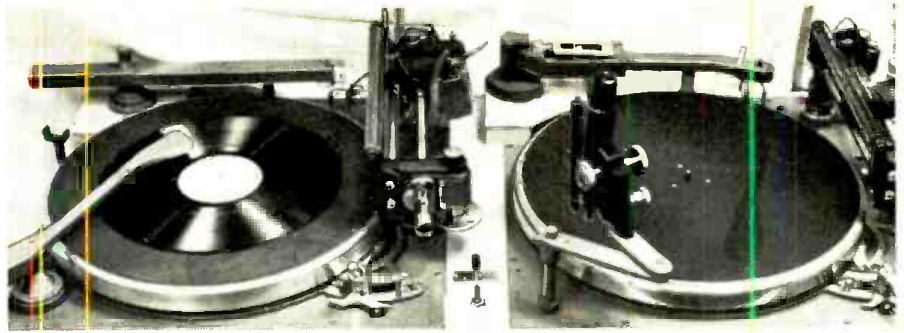

Fig. 3. Console contains two 6N disc recorders, Weathers, Pickering, and G.E reproducers, and a forty-power microscope for groove observation. Storage space for the transcriptions is provided within the console. Tapes have their own storage cabinet.

is not new. It has been used in broadcast and the motion picture industries for many years, and its advantages are well known to the audio engineer. However, the novice usually is confused as to its proper use. It will be the purpose of this present series to explain step-by-step the circuitry of all components used in the system. The information contained will provide several possible solutions to the problems involved in using similar equipments faced by the audiophile.

During construction of the system it became obvious that spare circuits should be provided in each of the three groups of signal circuits: low level, line level, and power level. In addition,

it is well to provide extra jacks in each group so that these will be available for future expansion of the system.

Power amplifiers are generally equipped with a bottom plate which is removed and substituted for by a standard rack panel.

If ventilation is required beneath the chassis, spacers should be used between the panel and the chassis to allow air to circulate properly.

We will continue in the next issue with a complete technical analysis of the system, showing how the various components are properly matched to their respective equipment, and we will explain the use of the jack fields.

(To be continued)

Fig. 4. (Left) *Concertone* Network recorder may be remotely controlled if desired. This model can mount a total of five heads (monaural or multi-track) for stereophonic applications. Magnecorder equipment is a self-contained, two-channel binaural recorder and amplifier. The relay switch panel below contains the master switch and indicator lamps. (Right) Panel of the *Concertone* amplifier. The panel drops forward exposing components for rapid inspection. Operating switches interlock to prevent malfunction.

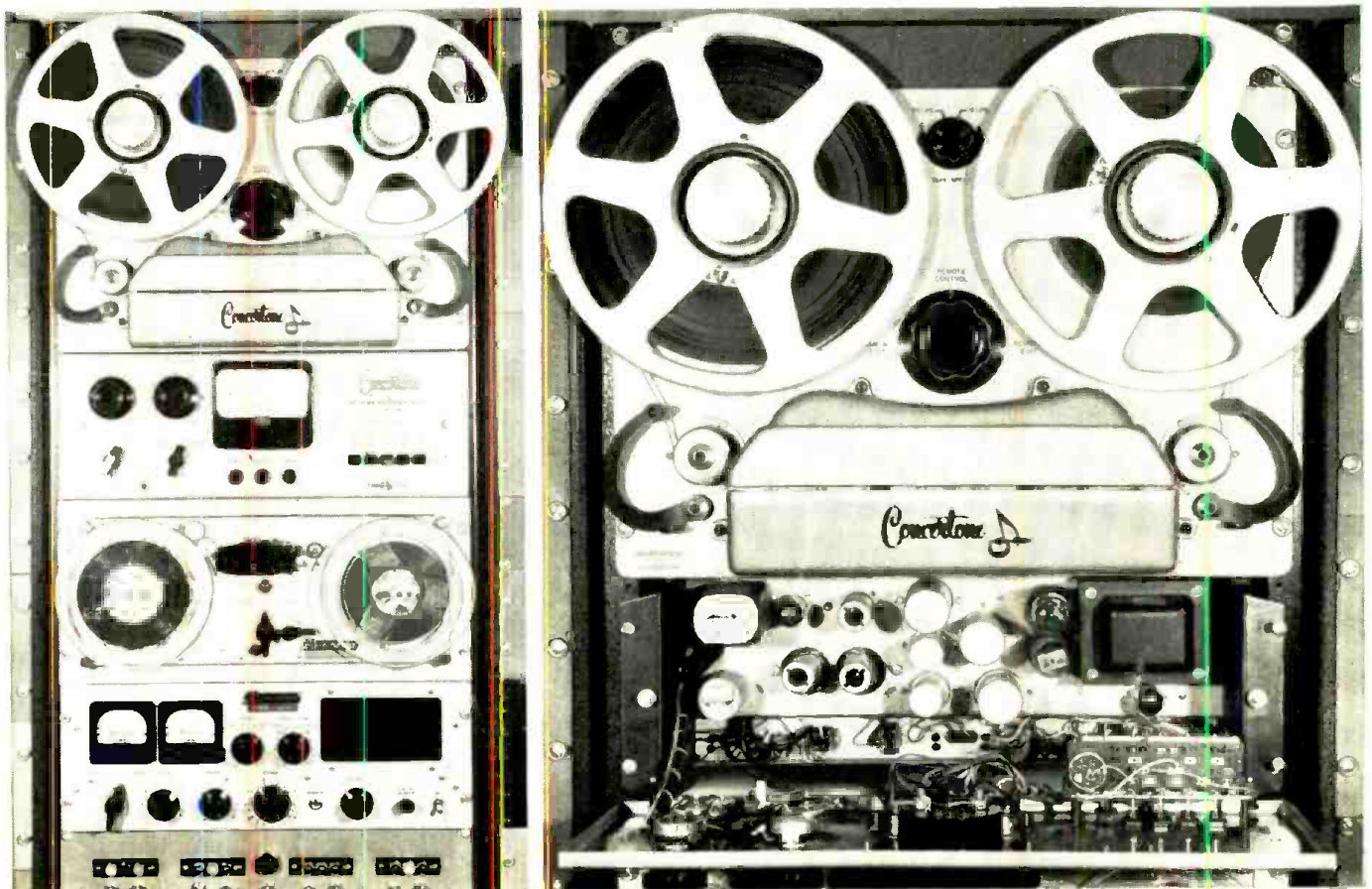

PAGES FROM A TAPE EDITOR'S NOTEBOOK

By DONALD C. HOEFLER

TAPE editing cannot truthfully be called an "ancient and honorable" profession, but despite its youth it is an art whose versatility is constantly marveled at by those it serves. And even we who have worked with and edited magnetic tape almost from its inception, now find ourselves sometimes amazed at the new tricks we are still discovering in the use of this wonderful medium.

In broadcasting the tape editor has relieved one of the greatest sources of ulcers in the business: fear of the clock. No longer does a producer have to suffer nervous prostration to insure that his program runs to exactly twenty-nine minutes, thirty seconds. Now he can rehearse and record the show to the *approximate* time required, and later polish it off in the editing room. By working with the editor in eliminating "fluffs" and generally tightening up production he can present a more polished performance than he could ever do under live conditions, and his program *will* end "on the nose."

The motion-picture soundfilm editor is, of course, the pioneer who has blazed the trail, and he has attained an important place in his industry. Two notable differences, however, exist between him and the tape editor. The film man can *see* the modulation on the track and he can count sprocket holes, and while these visual clues don't make his job any bed of roses, they do offer an advantage over magnetic recording, whose editor must rely entirely upon his ear. But recording on tape and magnetic film is becoming increasingly common in the movie industry (see "Cinemagnetic Recording," RADIO & TELEVISION NEWS, August, 1952), and the motion-picture sound editor is now encountering many of the same problems which will be discussed in this series.

The phonograph record industry has found in tape recording one of its greatest boons. Almost all original masters are now made on tape, which provides infinitely greater protection against deterioration than wax or lac-

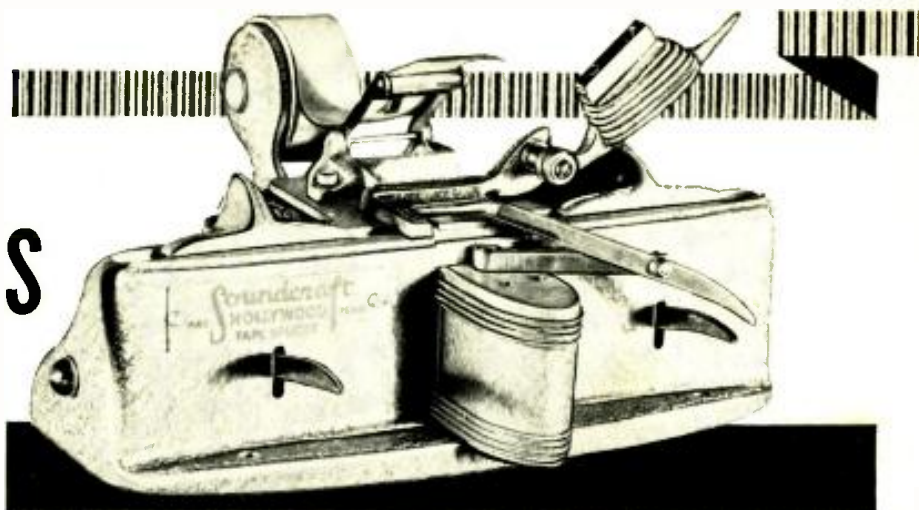

Fig. 1. The Soundcraft Hollywood splicer applies a trimmed patch over the splice.

Part 1. A new series covering professional tape techniques which can be used as is or adapted by the home recordist.

quer. Without tape, the large-scale rehabilitation and reissue of priceless collectors' items would have been impossible. And the competent tape editor has forestalled the retirement of more than one aging star by combining on one tape, into one performance, the best parts of a number of "takes."

The most exciting future possibilities for this art lie in the field of video tape recording. The recording of motion pictures on tape is already a reality, and commercial use of the medium is anticipated for the fairly near future. The man who edits this picture tape will be the one who has developed his audio techniques to a high degree of refinement.

He will not be able to see the given frame at which he wishes to splice, as does the film editor. Instead, he will be looking at a cathode-ray monitor tube as he attempts to "spot" the exact place to cut, and what he will see will look just like a television picture which is out of synchronization. He will have to translate that jumble into an accurate splice between scenes—at the precise spot indicated by the director. Similarly, many of the special optical effects which are now performed by the film editor and television technical director, such as dissolves, wipes, and superimpositions, will devolve upon the video tape editor. He is certain

to become an important contributor to this new art, and his rewards will not be slight.

The most obvious form of tape editing consists simply of cutting and joining, at a given point, two separate sections of tape, in order to accomplish a desired dramatic or musical effect. The simplest tools employed for the job comprise two things: splicing tape and a razor blade or small scissors. In this method the recording tape is cut at the two points which are to be joined, the severed ends are butted together, and the splicing tape is pressed over the joint and trimmed to the width of the magnetic tape. A piece of corrugated cardboard provides a handy cutting board for this operation, and it may readily be replaced when it is cut beyond further usefulness.

It is absolutely essential, however, that the tape used for splicing be one especially manufactured for this purpose. Any substitute will inevitably have an adhesive which runs out from under the edges of the patch, and which will cause adjacent layers of recording tape to stick together. This, in turn, causes "skips" and "wows" with consequent damage to the recorded material.

A refinement of this basic method is desirable, since with only two hands it becomes awkward and tedious, especially when making a large number of splices. The splicer shown in Fig. 2 provides additional "hands" which hold the tape firmly during the cutting, patching, and trimming operations. This unit has the additional advantages that it is simple, compact, and inexpensive, and may easily be mounted permanently on the machine which is used for editing.

A further improvement in patch type splicers is illustrated in Fig. 1. In addition to the holding feature,

Fig. 2. Carson unit which facilitates the making of splices manually with a razor.

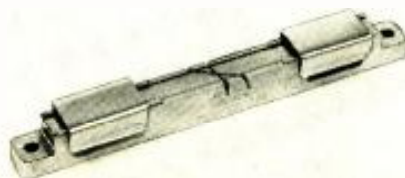



Fig. 3. A recorded tape, prepared by Minnesota Mining & Manufacturing Company, showing the points of greatest magnetization. A complex voice pattern was first recorded and then the pattern "brought out" with iron particles so photo could be made.

this unit also has a built-in cutting tool and a splicing tape dispenser, together with a trimmer which cuts the splicing tape slightly narrower than the recording tape. Due to the precision machining involved in its manufacture, this splicer is fairly expensive and somewhat fragile, but for any job which requires many accurate splices, a unit such as this is well worth the investment.

An entirely different principle in splicing is employed by the unit shown in Fig. 3. This one also performs the holding and cutting functions, but it does not apply a patch over the severed ends. Instead it relies upon a rather precise combination of heat and pressure to cause the plastic base of the tape to melt slightly and fuse together. Since the heat cycle is something under five seconds, splicing with this equipment can be performed at least as fast as with the best patch-type splicers. Of course a number of precision components go into the manufacture of this unit and it is, consequently, rather expensive. But it is unsurpassed for making a number of closely-spaced splices which with the patch type would cause "flutter," and it is excellent for joining old pieces of tape (which of course must be all of the same manufacture and type) into one continuous patch-free length, ready for recording and almost as good as new.

Whatever the splicing method employed, however, a very important precaution to observe is that the cutting tool be completely demagnetized. If it is not, it will certainly induce noise onto the tape at the cut and

may thus ruin a valuable recording. Commercial demagnetizers made for use on whole rolls of tape may be employed for this purpose, and another unit recently introduced for demagnetizing playback heads may be used as well. Since the operation is rather tricky, a few test splices should be made on waste tape before it is assumed that the tool is free from residual magnetism.

A question of considerable importance in splicing is the matter of how the tape is to be cut. The diagonal splice is almost universally used by editors today, and its proponents make numerous and exaggerated claims for its advantages. It is unquestionably true that the diagonal splice has considerably more strength than the square splice cut directly across the tape, but it is not true that the diagonal cut will invariably be undetected by the ear.

In order to aid our understanding of the effect on a recording of each kind of splice we might for a moment consider the parallel in motion pictures, where the diagonal splice was standard practice for many years but has now been discarded in favor of the square splice. The reason is that when the diagonal splice passed through the projector, it caused, for an instant, a picture to be flashed on the screen which was split from corner to corner. Though the wink of an eyelid might permit this broken picture to pass unnoticed, the square splice did even better by allowing the splice to be made *between* frames, where it would never be noticed.

(Continued on page 164)



Fig. 4. Prestoseal tape splicer which uses heat and pressure instead of an adhesive.

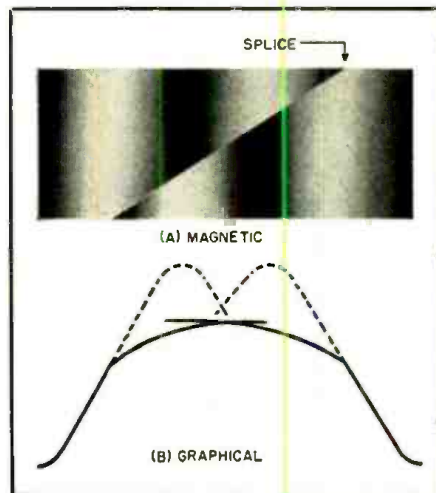

Fig. 5. (A) A diagonal splice which is out-of-phase as shown by the graph of (B).

Fig. 6. Out-of-phase splice showing "skip."

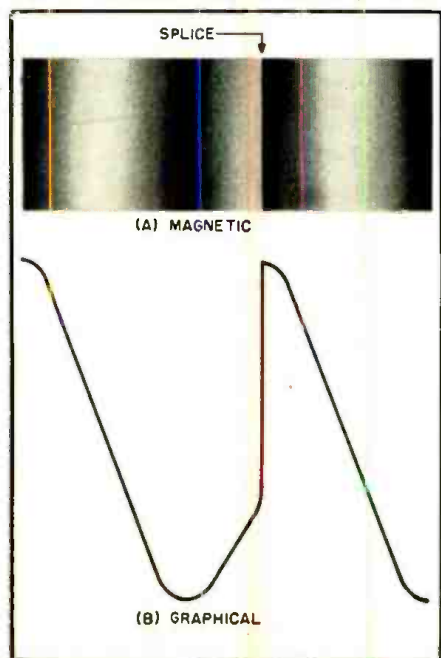
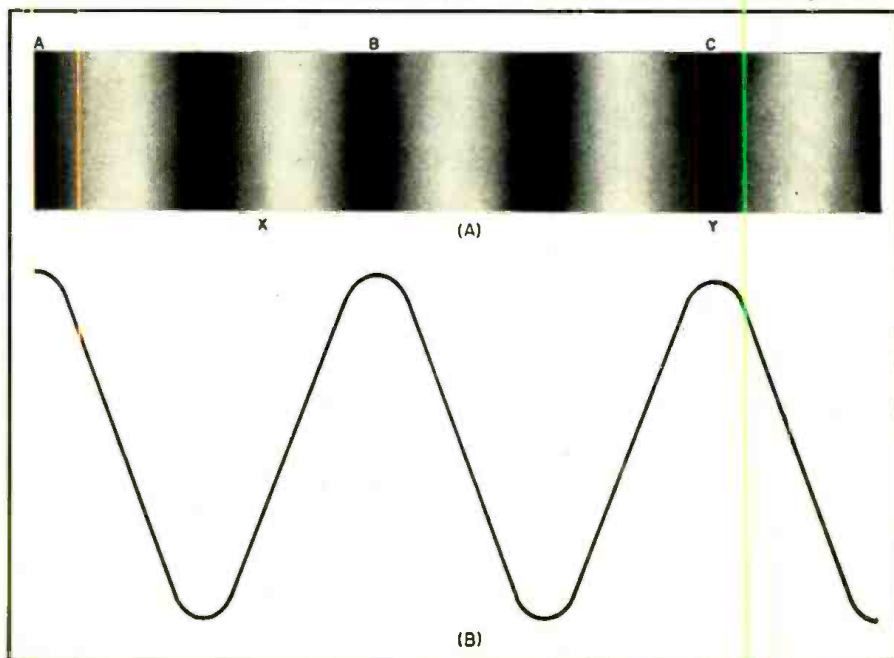

Fig. 7. (A) Magnetic pattern of recorded tape. (B) Graph of sound recorded on tape (A).



INCREASED PROFITS



Fig. 1. Period "breakfront" adapted to serve as a cabinet for a custom installation.

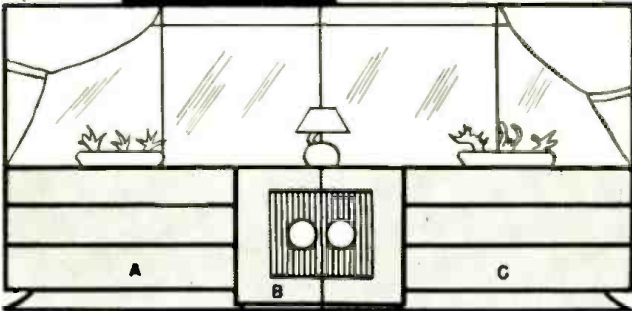

Fig. 2. Under-the-window arrangement of the cabinets.

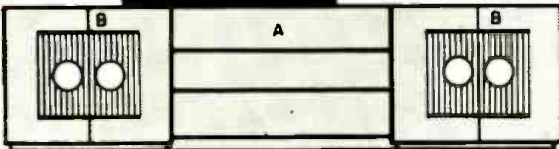

Fig. 3. Another possible arrangement.

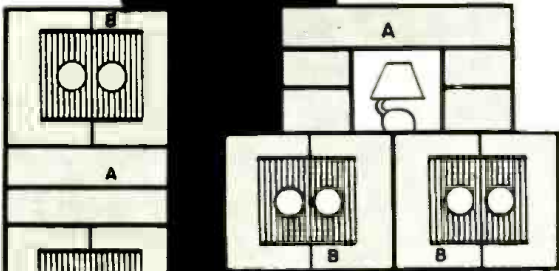

Fig. 4. Stacking to save floor space.

Fig. 5. Stacking to bring TV set up to eye level.

Fig. 6. Symmetrical arrangement for large rooms.

DESPITE numerous articles on the subject, custom-building has not achieved the popularity it deserves. This is largely due to (1) the public's unfamiliarity with custom-building and how it can be made to beautify the home, and (2) the popular misconception that any custom-built item is an expensive luxury. Both these drawbacks to progress can be overcome by acquainting your prospective customers with the many advantages of a custom-built installation. Back up your statements with illustrations and photos of outstanding installations. Use your imagination to create new ideas and arrangements which will bring out the most in your prospective client's own home. And, where your client's finances are limited, use your ingenuity to reduce the cost and standards of the installation to meet his budget.

Since the cost or purchase price is one of the first and most important considerations, let's start with this item. To most people, the words "custom-built" suggest an object of great expense. Therefore, a "custom-built" radio or music system would bring to mind a high-quality system, complete with FM-AM-phono (and possibly television) and housed in luxurious period-style or modern cabinetry such as the breakfront and bookcase installations in Figs. 1 and 7. While such installations are expensive in their deluxe versions, there is no reason why their style or general appearance cannot be reproduced on a plane more suitable to the budget of the average customer.

There is very good business sense involved in fitting the installation to the average customer's budget. First, you stand a much better chance of building up a volume business by catering to the average-income group. These are the same people who comprise from 70 to 80 per-cent of your present clientele. They are the same group who, since the end of World War II, have kept the real estate business at a peak level.

The bulk of private-home construction during the past five years has been in the \$10,000 to \$15,000, or average-income, bracket. Moreover, new-home construction has been paced by home modernization and beautification projects. While these projects include the low and higher-income groups, the majority again are those in the average-income group. The importance of these facts should give an idea of the tremendous potentialities which await custom-building if it is properly "custom-built" for clients within this group.

The total cost of a custom-built installation depends on three factors: cabinetry, circuitry, and the time and material required for completion of the project. Suppose we take each factor separately and see how it could be adapted to the needs of our average-income group.

Cabinetry

Costwise, we might say that circuitry, or the combination of radio, phonograph, and speaker, is the greatest factor and should therefore be considered first. It is more important, however, to first determine what type of housing or cabinet is to be used. Once this has been decided, the adapting to the circuitry of the housing (and to the customer's budget) becomes a matter of course.

Suppose, for a moment, we analyze the four basic cabinet arrangements shown in Figs. 1, 7, 8, and 9. These will suggest various combinations or modifications which will work successfully in a wide variety of cases.

The deluxe, high-fidelity "breakfront" installation of Fig. 1 is more suitable for large homes. We can, however, pick up several pointers which could be used in less pretentious installations or in smaller homes. For instance, the tuner chassis is installed in the left-hand drawer. The regular drawer has been removed and the drawer front made into a drop cover which slides under the tuner when in operation and when closed is identical in appearance to

FROM CUSTOM BUILDING

By JOHN B. LEDBETTER

Every installation is different—a challenge to the ingenuity of the audio technician.

the other two drawers. The center drawer has been arranged to slide forward. The record changer is in this compartment. The "breakfront" installation allows an optimum speaker height of 5 feet, and permits the rear side of the cone to radiate into a large (14-foot) cavity. Such pieces of furniture as bureaus, secretaries, antique writing desks, etc. can be adapted very easily to this type of installation. If the client does not have an adaptable piece of furniture in the room, one can often be found at the auction center, used-furniture store, or through the want-ad sections of your local paper. Much of this type of furniture can be purchased rather cheaply, and when refinished makes a beautiful cabinet for the system.

Many customers will prefer a bookcase installation such as the one in Fig. 7. At first glance this, too, appears to be extremely expensive. The shelves, however, can be made of soft pine 1" x 12" boards, backed if desired by Masonite or beaverboard, or left bare. The cabinet itself can be almost anything, either a modified cabinet base, bureau, etc., or it can be built in the shop. Doors can be of plywood or soft pine, outfitted or painted to match the motif of the room.

A simple, inexpensive adaptation of the bookcase motif is shown in Fig. 2. This arrangement originally was designed for the solarium or front room of a medium-cost home. The top and length of the bookcase were made to coincide with the bottom and width, respectively, of the four front windows of the room. The shelves in this arrangement are 1" x 12" boards, and the cabinet doors are $\frac{3}{8}$ " plywood. The runners are 2" x 4" boards, set back to give a modern appearance. The radio and speaker are installed in the right-hand cabinet, with the record-changer installed in the left.

There is no limit to the various combinations which can be worked out with this arrangement. If desired, the entire bookcase can be constructed as a single unit. Or, it can be first constructed, then sawed into three sections (A), (B), and (C). This permits the unit to be moved easily and provides a greater latitude in rearranging the furniture. The basic structure in Fig. 2 can be changed to those shown in Figs. 3 through 6, or modified to any number of similar arrangements. In the dual-cabinet set-ups (Figs. 3 through 6), one of the cabinets can house the television set. This would be more practical, of course, if the television unit were placed at or near eye-level (top cabinet in Fig. 5).

In its simplest form, the bookcase arrangement can be varnished or painted. For modern arrangements, the cabinet doors and large knobs can be covered with leatherette (relatively inexpensive) and the door centers made of fluted plywood. To match antique furniture, the round knobs can be replaced with wrought iron or bronze handles and hinges.

Small tables, writing desks, etc. can be adapted as shown in Fig. 9. If the object is too small to house the speaker, this item can be mounted behind a door, false picture, in a corner, etc.

The door-type mounting (Fig. 8) is the ideal or "stand-by" for rented apartments or for clients who do not wish to modify their wall structures or furniture. This arrangement allows the optimum speaker height (5 feet from floor) and makes use of the clothing stored in the closet as

(Continued on page 142)

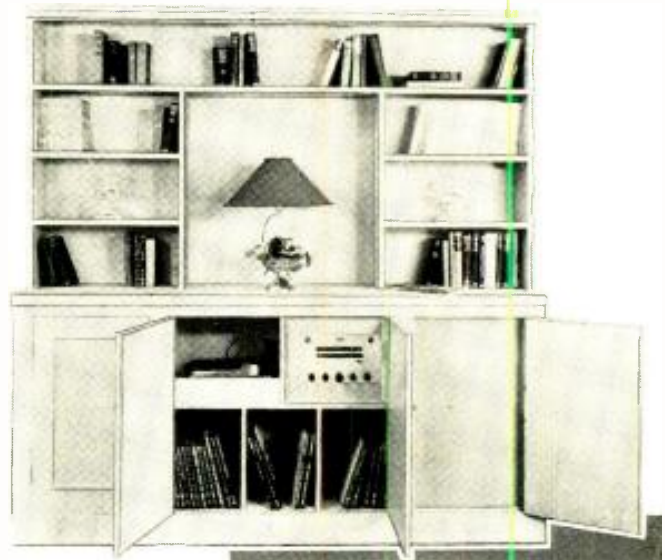

Fig. 7. Radio-phonograph installation in modern manner. Record storage space, book and knickknack shelves included.



Fig. 8. In any home, a coat closet can be used to house a record player, amplifier, and speaker.



Fig. 9. A neat table of armchair height can house a record player and radio for convenient and leisurely listening.

COUNTERBALANCED PICKUP ARMS

By
MORRIS SCOTT DOLLEN



Over-all view of dual turntable with pickup arms. Only a modest mechanical ability and an even more modest purse is required.

Re-record discs, provide musical background for films, or play symphonic music without interruption with these phono pickup arms.

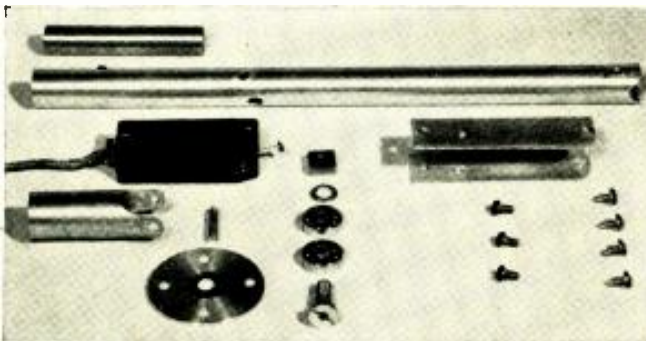

Component parts required for construction of the pickup arm.

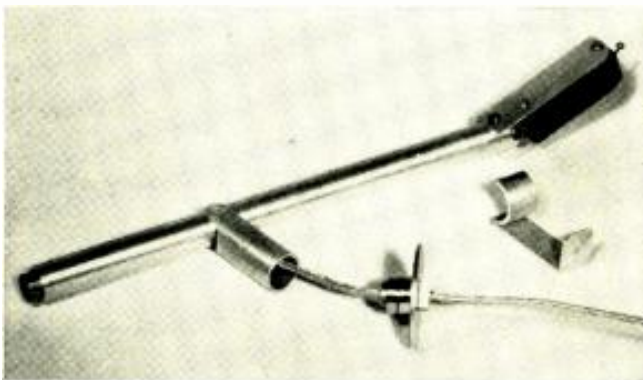

The assembled unit ready for installation on the turntable.

Mechanical details for constructing the turntable arms described in this article.

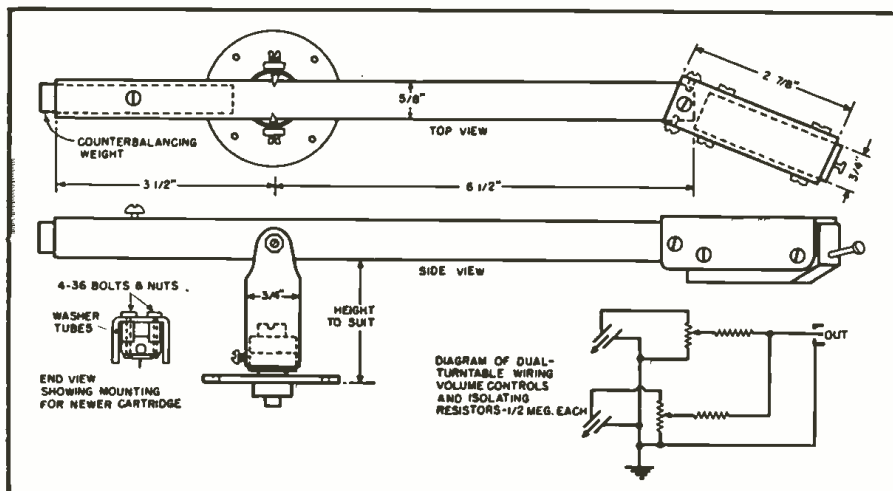

FOR the music enthusiast with a modest ability at simple mechanical work and an even more modest pocketbook, the building of these phonograph pickup arms offers good equipment at small expense. Two of them have been used on a dual turntable cabinet over a period of three years for re-recording discs to tape, playing musical backgrounds for film showings, and continuous playing of symphonic music. The equipment shown is used only for 78 rpm discs up to 12", but could be adapted to all speeds with a different choice of motors and turntables or interchangeable cartridges. Counterbalancing weights on the rear of each arm allow the selection of any reasonable needle pressure.

The pickup arm is made from thin-wall aluminum tubing with an outside diameter of 5/8", although this could be changed to a smaller size if it is available. For this size arm tubing the swiveling support and yoke should be made from about 3/4" tubing. The swivel mounting plate was made from 1/16" aluminum plate, turned on a lathe, four screw holes drilled, and a 1/4" hole in the center. This could be square if a lathe is not available, with slightly bevelled edges. The lateral movement of the arm is accomplished by means of two surplus ball bearings (1/4" hole with 5/8" o.d.) bolted to this plate, with the yoke-tube pressed on to the bearings from above, a thin shim of brass or steel wrapped around the bearings making a tight fit. A set screw in the aluminum tube may help. Be sure to insert a washer under the bottom bearing so the revolving edge clears the base. For this purpose, file a 1/4" hole in a size 6 or 8 brass washer. If a 3/64" hole is drilled down the length of the mounting bolt first, a thin shielded wire will go through, otherwise the wire will have to go outside the yoke tube.

The simplest and most satisfactory bearings to hold the arm in the yoke are pointed set screws working into small holes in the arm, locking them in place with nuts. In the original models, special screws were turned

(Continued on page 173)

RAILROAD YARD LOUDSPEAKER SYSTEMS

By
LEO G. SANDS

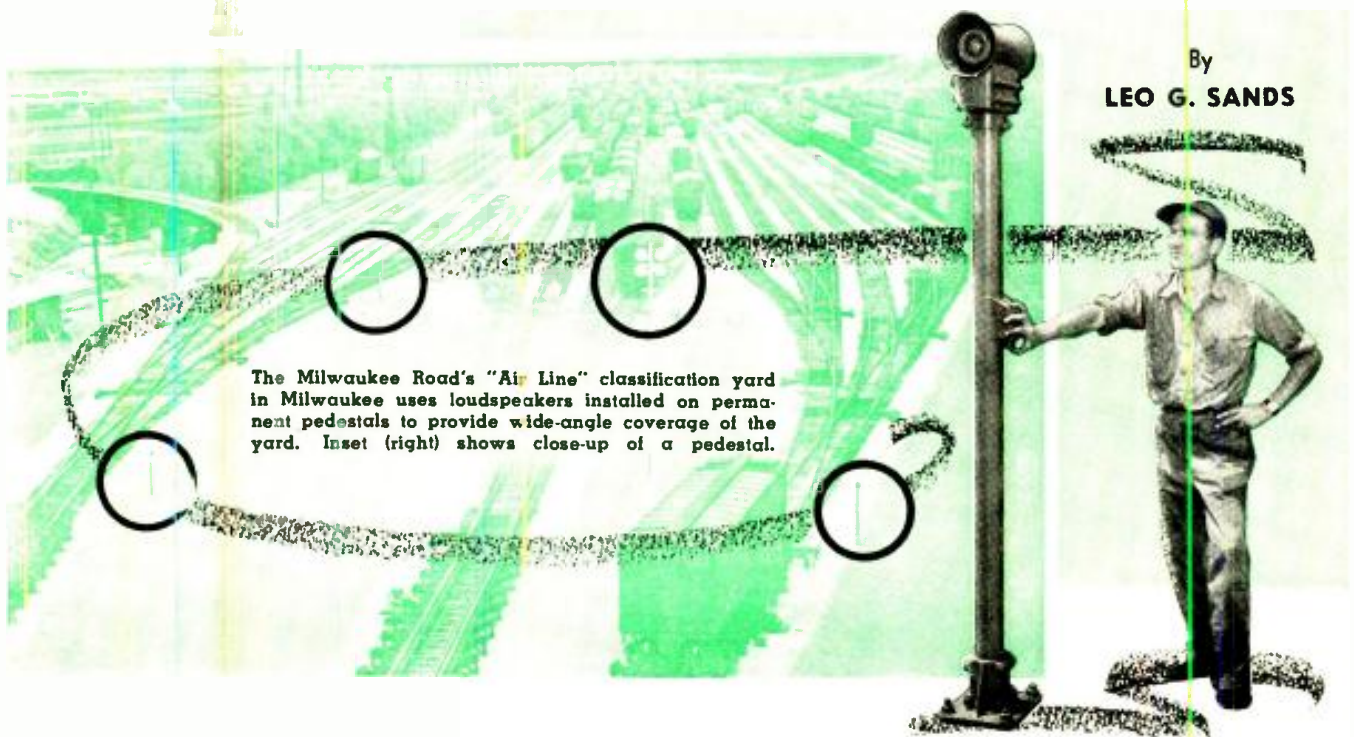

The Milwaukee Road's "Air Line" classification yard in Milwaukee uses loudspeakers installed on permanent pedestals to provide wide-angle coverage of the yard. Inset (right) shows close-up of a pedestal.

BECAUSE radio did not meet all railroad-yard communication requirements, many railroads have installed extensive paging and talkback loudspeaker systems in lieu of or to supplement the two-way radio communication systems.

In classification yards, crews on board radio-equipped locomotives may be contacted by the yardmaster or other supervisor. In many operations such as in "humping," this is a marvelous facility. One of the first permanent railroad-radio systems was installed at the New Castle, Pennsylvania yards of the *Baltimore & Ohio* railroad to facilitate humping of cars when weather conditions made it impractical to rely on the color light signals originally used for signaling to the engineer. Today, many hump operations are directed by radio.

However, in other yard operations, radio provided communication facilities but between the wrong people. The yardmaster could talk to the engineer, but the engineer was not the one he wanted to contact. Instead, the yardmaster is normally required to issue instructions to a supervisor who might be on the desired locomotive or on foot somewhere in the yard.

To make it easier to reach the right man, radio manufacturers designed remote control units which could be installed outside of the locomotive at the front or rear end which would permit the supervisor to operate the locomotive radio without getting inside the engine cab. The engineer could also use his radio as a mobile paging system to call the supervisor to his locomotive.

In some yards, radio with footboard remote controls provided the desired facility. In other yards, more was to be desired. The solution lay in the application of king-size talkback loudspeaking intercommunication systems which operate in much the same manner as office intercom systems.

Loudspeakers mounted on pedestals or close to the ground were installed at strategic points such as near switches, along ladder tracks, etc. These loudspeakers serve both as loudspeaker and microphone and are fed by individual lines from the yardmaster's office. Usually, two loudspeakers facing in opposite directions are mounted atop a pedestal consisting of a piece of heavy pipe held erect by a concrete base.

The specialized problem of covering huge areas with high ambient noise levels is solved by using special sound systems.

The amplifiers and a control console are installed in the yardmaster's office. Many railroads have built ultra-modern tower offices for their yardmasters which resemble airport control towers. From high above the maze of tracks, the yardmaster can see the entire yard and through his loudspeaker system can converse with any of the employees in the yard.

By flipping a switch on his control console, the yardmaster connects his amplifiers to the loudspeaker nearest the person he wants to contact. Stepping on a foot switch, he calls his man who can reply by merely talking back at the loudspeaker even if he is as far as 50 feet away from it. Calls may be originated in the yard to the yardmaster by walking up to the nearest loudspeaker pedestal, pressing a button, and speaking. The act of pressing a button at the remote loudspeaker station may also cause a signal light to operate at the control console to indicate to the yardmaster where the call is originating.

In addition, paging facilities are often provided to permit making announcements or for locating personnel at unknown locations. At least two radio manufacturers are offering portable radio transmitters which permit yard personnel to reply to loudspeaker calls by radio when these portable transmitters are used.

For complete communication facilities, radio is used for communication from yard office to locomotives, paging and talkback loudspeakers are used for contact between yard office and personnel on foot, and portable transmitter-receiver units, like the "walkie-talkie," or portable transmitters are employed for contact between radio-equipped engines or yard office and the man on foot.

Yard loudspeaker systems are a specialized art. The equipment is generally used around the clock, year in and year out. Therefore, it must perform continuously with a

YARD LOUDSPEAKER SYSTEMS INSTALLED IN 1952

Railroad and Location	No. of Control Points	No. of Two-Way Speakers	No. of Paging Speakers
AT&SF			
Corwith, Ill.	1	10	..
B&O			
Pittsburgh, Pa.	1	23	30
B&E			
Conneaut, Ohio	1	..	3
Ajbion, Pa.	1	..	4
C of NJ			
Allentown, Pa.	2	14	14
Elizabethport, N.J.	2	12	6
C&O			
PM District			
Grand Rapids, Mich.	1	46	15
Midland, Mich.	1	21	..
C&NW			
Proviso, Ill.	2	..	5
CB&Q			
Chicago, Ill.	2*
CM&P&P			
Milwaukee, Wis.	3	51	48
Aberdeen, S.D.	1	5	11
Clinchfield			
Dante, Va.	1	..	2
Erwin, Tenn.	1	..	2
D&RGW			
Ogden, Utah	1	5	12
DSS&A			
Marquette, Mich.	1	8	5
EJ&E			
Gary, Ind.	4	56	22
FEC			
Daytona Beach, Fla.	1	2	9
Buena Vista, Fla.	1	3	4
GN			
Great Falls, Mont.	3	..	18
Kelly Lake, Minn.	8	..	12
GM&O			
Bloomington, Ill.	1	33	9
IC			
Chicago, Ill.	2	40	45
LV			
Jersey City, N.J.	1	15	8
L&N			
Bowling Green, Ky.	1	..	2
NC&StL			
Atlanta, Ga.	1	31	12
NYC			
Minoo, N.Y.	1	..	27
CCC&StL			
East St. Louis, Ill.	15	..	45
IHB			
Argo, Ill.	5	..	14
NYC&StL			
Homestead, Ohio	1	9	..
NYNH&H			
E. Bridgeport, Conn.	8	..	10
Providence, R.I.	3	..	5
N&W			
Norfolk, Va.	9	..	12
NP			
Livingston, Mont.	1	5	7
Glendive, Mont.	1	6	8
PRR			
Sodus Point, N.Y.	1	4	..
Philadelphia, Pa.	1	..	8
Reading			
Rutherford, Pa.	5	5	31
St. Clair Scalo, Pa.	1	..	3
StL-SF			
St. Louis, Mo.	1	53	8
Kansas City, Mo.	7	..	5
Amory, Miss.	1	..	4
Soo Line			
North Fond du Lac, Wis.	1	14	6
SOU			
Greenville, S.C.	1	55	15
Spartanburg, S.C.	1	55	15
Pamona, N.C.	1	64	6
Sheffield, Ala.	1	17	..
AGS			
Birmingham, Ala.	5	425	69
CNO&TP			
Cincinnati, Ohio	1	88	..
MT			
Meridian, Miss.	1	..	7
NO&NE			
New Orleans, La.	1	74	12
SP			
Roseville, Cal.	3	130	20
Tracy, Cal.	1	59	..
Fresno, Cal.	1	34	6
Watsonville Jct., Cal.	1	56	..
SP&S			
Portland, Ore.	1	14	8
Vancouver, Wash.	..	10*	..
Wishram, Wash.	..	10*	2*
UP			
Council Bluffs, Ia.	1	73	9
Denver, Colo.	1	54	7
Los Angeles, Cal.	1	61	6
Green River, Wyo.	1	47	5
Virginian			
Sewalls Point, Va.	31	6	24
Wabash			
Decatur, Ill.	2	103	67
Totals	161	1,906	771

*Additions to present systems.

minimum of failures. Much greater power is required than in office-type intercom installations. As many as a hundred or more remote stations must be individually selectable at the control console.

A typical remote station consists of two weatherproof horn-type loudspeakers mounted back-to-back, a line matching transformer in a weatherproof enclosure, and a truly rugged call-button or spring return switch. The loudspeakers are usually mounted atop an eight-foot length of 2½ inch or 3 inch pipe mounted vertically in a cast concrete base. The entire assembly must be rugged. (The term "rugged" is an understatement.)

Miles and miles of underground or overhead cable connect the remote stations to the yard office. Often the cost of the wire and its installation far exceeds the cost of the amplifiers and control console!

Paging horns are usually mounted high on floodlight towers or other tall structures to gain extended coverage. The horns are of the trumpet type utilizing diaphragm-type driver units. Sometimes these horns are mounted in clusters to provide wide-angle coverage.

Railroads have often received complaints from residents near loudspeaker-equipped yards about the high volume level of their paging systems. In the daytime when ambient noise is high the loudspeaker system is not heard far beyond yard limits but in the still of the night, the yardmaster's voice crackles for long distances. A yardmaster normally speaks right into the mike when calling. Unless he resets his volume level, the sound emitted from the loudspeakers may vary greatly in amplitude.

To overcome this problem, some railroad-yard loudspeaker systems employ volume-limiter amplifiers between the microphone and the power amplifiers. One of the popular amplifiers for this purpose is the Bendix "Expressor" amplifier which provides both volume expansion and compression, automatically maintaining constant audio output level.

For talkback purposes, a ten-watt amplifier usually suffices because it is seldom used for operating more than a single remote station at any one time. The same amplifier may be used in reverse to communicate with the control point from the remote station.

In paging, considerably greater power is required. Some systems employ booster amplifiers to deliver several hundred watts of audio to a paging speaker cluster. In some cases all paging speakers are operated together and in others they may be selected individually or in groups.

The control console is an impressive appearing instrument generally built around a steel executive-type desk not unlike a theater pipe organ console. Panels of talkback and paging station selector keys are mounted in front of the operator's position. In the center are usually located a loudspeaker and volume controls. Facilities are provided for switching over to a standby set of amplifiers when necessary.

The amplifiers are often located in another room, usually on the floor below. With two sets of amplifiers it is possible to service one set while the others are in use.

The railroad-yard loudspeaker system has proved its value in service. The proof is the long list of installations. Similar loudspeaker systems are being installed in railroad warehouses and shops. In fact the enthusiasm is so great that at least one of the major railroads features its loudspeaker system in its national advertisements.

The combination of two-way radio and wired loudspeaker systems in railroad yards may someday be supplemented by facsimile to replace pneumatic tubes now used for conveying written data and not too far in the future by television. The B. & O. and RCA recently staged a demonstration of wired television in railroad yard operations which may eventually lead the way to adoption of industrial television by the railroads.

Since the B & O television demonstration took place, many other railroads have expressed interest in closed-

←
Tabulation of installations made by the railroads in a single year as reported by "Railway Signaling and Communications."

circuit television. The *B & O* demonstration illustrated how television could be utilized for checking car numbers. Other applications include the observation of grade crossings and the remote observation of freight cars as they are sliced off at the hump.

Several years ago, the *B & O* tried television on passenger trains for the entertainment of passengers. The results were reasonably acceptable although the problems were many. A special type of antenna had to be devised which would prevent severe picture distortion as the train changed direction. Several other railroads also expressed interest in television for passenger use but the technical problems were greater than the possible value of the entertainment feature.

Telegraph printer networks have been installed by a few railroads for obtaining a constant flow of information on the locations and movements of freight cars so that shippers can be kept informed. This permits shippers to make more efficient plans as they can generally depend on freight cars arriving as per the latest information. Physical and carrier telegraph circuits on wire lines are now being used for interconnecting printer networks. However, it is anticipated that in the near future microwaves will be used for providing many more communications facilities.

Sound equipment has been used on feature passenger trains for many years. However, it was not until after World War II that train sound systems became much more than a converted radio receiver in the lounge car. On some trains music is available only in lounge, club, and dining cars whereas on trains like the *Santa Fe "Chiefs"*, a choice of recorded musical or radio programs is offered passengers in individual rooms on sleeping cars.

Passenger train sound systems are generally of two major types, train-wide and individual car systems. In a train-wide system, a single bank of amplifiers is often used with high-level audio piped to each car.

Practically every passenger depot is equipped with a sound system for announcing the arrival and departure of trains. In the small depot, the sound system is quite effective but in the large big-city terminals acoustics play such havoc that the intelligibility of the sound system leaves much to be desired.

To the outsider it may seem that the railroads are extremely conservative and slow to adopt new ideas. However, when fortified with sufficient facts and information about the many factors that must be considered, it is evident that many of the railroads, particularly since the end of World War II, are absorbing new developments almost as fast as good judgment would dictate. The diesel-electric locomotive is a classic example of the railroads' acceptance of a new idea which can be justified economically.

Radio started slowly on the railroads because the railroads were skeptical and because technological develop-

Yardmaster's office in the control tower at Milwaukee Road's "Air Line" classification yard. The mike at his right is for radio communication with engine crews while mike over desk is for paging and talkback speakers located throughout the yard.

Another type of speaker system control panel for freight yard operation. This one is installed at the *B & O's* Barr Yard.



Adlai S. Hunt, chief engineer for communications and signals of the Baltimore & Ohio, tests the yardmaster call switch at one of the loudspeaker pedestals. Jack Bowen, manufacturer of the speaker equipment used at yard, watches test.

The yard control tower at the Baltimore & Ohio Railroad's Barr Yard in the city of Chicago, Ill.

ments had not reached the stage where radio would meet all of the necessary requirements. Today it meets railroad requirements sufficiently to justify widespread application. The loudspeaker systems discussed here accelerated the demand for better communications and closed the gaps radio did not fill.

Among those who contributed substantially to the advancement of the railroad yard loudspeaker system in its infancy are Douglass Ruff, general communications engineer of the *Southern Railway System* and C. Otis Jett, system telephone and telegraph engineer of the *Union Pacific Railroad*. The portable transmitter used for answering loudspeaker page calls was suggested in 1947 by Preston B. Tanner who was then manager of railroad-radio sales at *Bendix Radio*.

One of the first yards to be equipped with a combination radio and loudspeaker system was the *Union Pacific Railroad's* huge hump yard at Pocatello, Idaho. The *Southern Railway* adopted loudspeakers first and added radio later. They have even gone so far as to use radar to measure the speed of freight cars rolling down the hump.

-30-

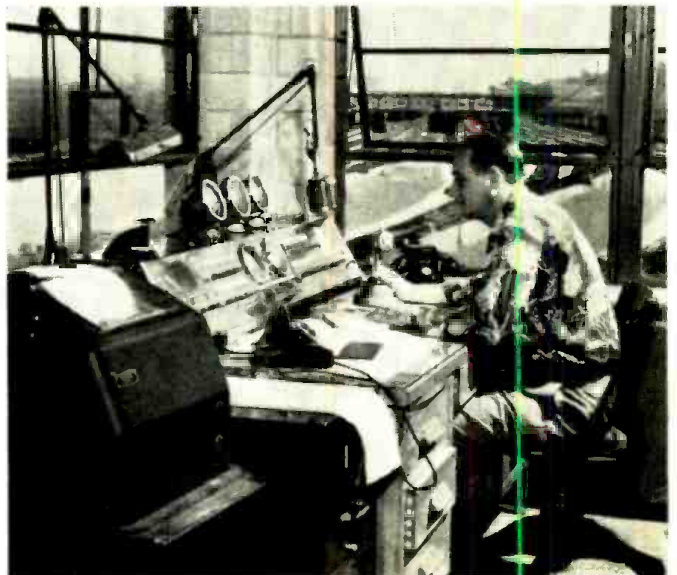

HIGH QUALITY AT LOW COST

By
LOTHAR STERN
Eng. Dept., Allied Radio Corp.

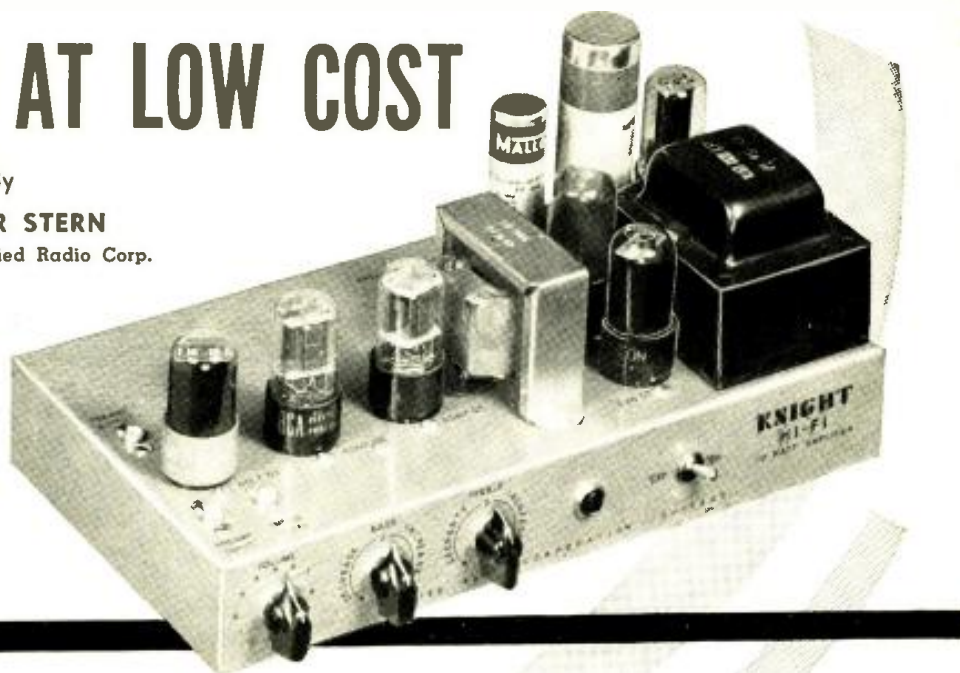

Fig. 1. Over-all view of the 10-watt amplifier built from an Allied kit. The entire unit is housed in a single 7" x 13" x 2" chassis without crowding or hum problems.

THE ever increasing interest being shown in high fidelity radio and phono reproduction has inspired the design of numerous amplifier circuits capable of outstanding performance. Most of these circuits have been built and are in use by thousands of music lovers who are widely proclaiming the merits of their own particular amplifiers. Yet, many people who would like to enjoy good music reproduction have been prevented from doing so by the relatively high cost of the components (especially the output transformer) required for the construction of most good amplifiers. Other discouraging factors have been the need for hard-to-get-items such as matched resistors and condensers or balanced tubes.

To circumvent these obstacles, the engineers of *Allied Radio* have designed an amplifier kit whose per-

Construction details on a compact, single-chassis 10-watt amplifier which is built of standard, non-critical parts.

formance rivals that of some of the finest commercial units, at a small fraction of their cost. Furthermore, the circuit was designed to use standard parts with commercial tolerances and requires no adjustment. It is easily constructed with a minimum of tools and is so flexible that it can form the basis of almost any high quality music system.

While the cost of building this amplifier is less than \$25.00, its performance will please even the most discriminating listener. The characteristics, as measured on a model built with standard parts, are shown in Table 1. While these specifications may vary slightly in other models, depending upon the actual values of the parts used, they will closely approximate those of the original unit if the parts are within standard tolerances.

How was all this accomplished? No, there are no new or trick circuits, but the over-all unit is composed of individual circuits, each designed to compensate, to some extent, for the defi-

ciencies of others. Some of these circuits are of interest because they are not generally employed in other amplifiers. Among the unusual features of the circuit is the use of a direct-coupled amplifier stage and a positive feedback loop in addition to conventional negative feedback. The effects of these will be discussed in greater detail later.

The complete amplifier consists of 6 tubes, including the rectifier. The power supply, power amplifier, and an equalized preamplifier for magnetic cartridges are all on a single chassis. The parts layout was so designed that all of the components comprising the equalized preamplifier are grouped together on one side of the amplifier. This was done purposely so that the preamplifier can easily be omitted in the event that the unit is to be used in conjunction with a radio tuner and a crystal phono cartridge only or if your tuner already incorporates a pre-amplifier. (Many of the better tuners are so equipped.) To keep the cost to a minimum all switches, except the "on-off" switch, were eliminated. In view of the fact that most radio tuners are provided with a "radio-phono" switch, the use of a selector switch on the amplifier would be an unnecessary duplication. Furthermore, the preamp section of the amplifier has its own input and output jacks making it simple to use the selector switch of the tuner by connecting the preamp's output to the phono input of the tuner whose output, in turn, is connected to the tuner input of the power amplifier.

The equalized preamplifier consists

Fig. 2. Relative frequency response at various settings of the tone controls.

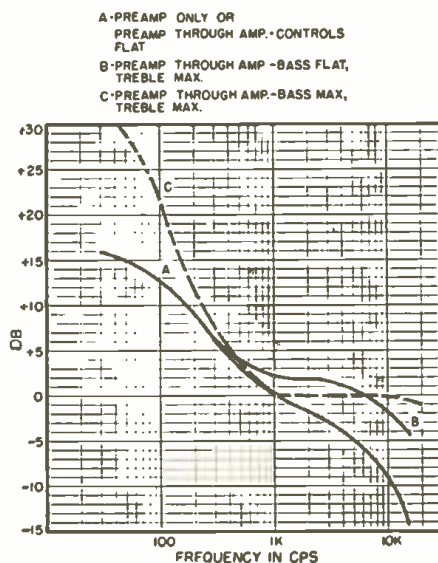

Table 1. Electrical specifications on unit.

Freq. Resp.:	± 1 db 30-20,000 cps (not measured above 20,000 cps)
Harm. Dist.:	Less than .5% @ 1 w., 100-10,000 cps Less than 1% @ 10 w., 80-5000 cps
Int. Dist.:	Less than 1% @ 10 w. (60 and 2000 cps at 4:1)
Amplification: (without preamp)	.5 v. input full 10 w. output @ 1000 cps
Hum and Noise:	-68 db of max. power output
Tone controls:	Bass boost to 13 db. Bass attenuate to -9 db. Treble boost to 10 db. Treble attenuate to -14 db @ 10,000 cps.

of both sections of a 6SL7GT tube. The 39,000 ohm input resistor, R_1 , is a compromise value which will provide a satisfactory cartridge load regardless of the type of magnetic cartridge employed. For optimum results, however, it is suggested that the value of this resistor be changed to equal the recommended load resistance for the cartridge to be used. Proper record equalization is provided by C_3 , R_7 , C_4 , and R_2 in a frequency discriminating feedback circuit. The voltage appearing at the plate, pin 2, of V_{1B} is impressed across C_3 , R_7 , and R_2 in such a way that the portion appearing across the cathode resistor R_2 , is in phase with the signal at the input grid of V_{1A} . This, in effect, cancels a portion of the input signal so that the voltage at the plate, pin 2 of V_{1B} is smaller. The reactance of C_3 increases as the frequency of the signal decreases, thereby making the signal-opposing voltage across R_2 smaller as the frequency is lowered. This, in turn, permits greater amplification at low frequencies and provides the low frequency boost required for proper equalization. The reactance of C_4 is so high at the low frequencies that it does not affect the performance. As the frequency increases, however, the reactance of C_4 becomes smaller and, since C_4 is in shunt with R_2 , this parallel combination decreases in impedance and permits more high frequency voltage to be applied to R_2 . As a result the frequency response curve drops off sharply at the higher frequencies.

Frequency response curves of the preamplifier and amplifier are shown

in Fig. 2. Curve A follows the standard recommended by the Audio Engineering Society and provides correct equalization for long playing and new 78 rpm records. Some of the older 78 rpm records, however, do not have high frequency pre-emphasis. A noticeable loss of highs would result if such records were played through this preamp circuit. If the builder's record collection contains the older type of 78 rpm records it is suggested that a switch be added to the preamp in order to cut out the high frequency de-emphasis condenser C_4 . The preamp can then provide flat reproduction for all records (including the necessary bass boost below about 500 cps.) A diagram showing the added switch is given in Fig. 3.

The signal voltage at the output of the preamp is applied to the tuner input of the main amplifier by means of a jumper made of shielded wire. It is amplified by V_{2A} and impressed across a continuously variable tone control network. Flat frequency response is obtained when the variable arms of the tone controls are in the center position. Boost and attenuation are provided separately for both bass and treble frequencies.

Additional amplification is provided by V_{2B} , and by V_{3A} which is directly coupled to the phase inverter V_{2B} . Note that there is no condenser between the plate of V_{2A} and the grid of V_{2B} . The grid of V_{2B} , therefore, is at the same positive potential with respect to ground as the plate of V_{2A} . The proper bias for V_{2B} is obtained due to the high value of the resistor in its cathode. The plate current of V_{3B} flowing

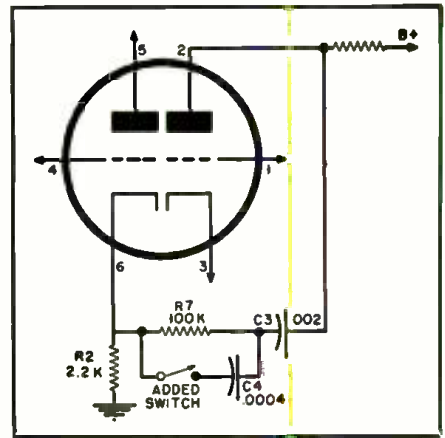

Fig. 3. Adding a s.p.s.t. switch to the preamp. Open switch to play 78 rpm records, close to play LP's or new 78 rpm records.

through R_{20} makes the cathode end of this resistor more positive than the plate voltage of the previous stage, thereby making the grid less positive than its cathode. This arrangement eliminates the need for a blocking condenser between V_{2A} and V_{2B} , and consequently improves the low frequency response of the system.

The phase inverter, V_{3B} , has very little gain due to the large value of R_{20} and the degeneration which results. However, it accomplishes its prime purpose of applying equal voltages of opposite polarity to the output tube grids.

The output transformer is an especially designed unit (available from Allied Radio) having good low frequency response, yet, in keeping with the rest of the amplifier, its cost is

Fig. 4. Complete schematic diagram of the 10-watt amplifier with an optional preamplifier circuit for magnetic cartridges.

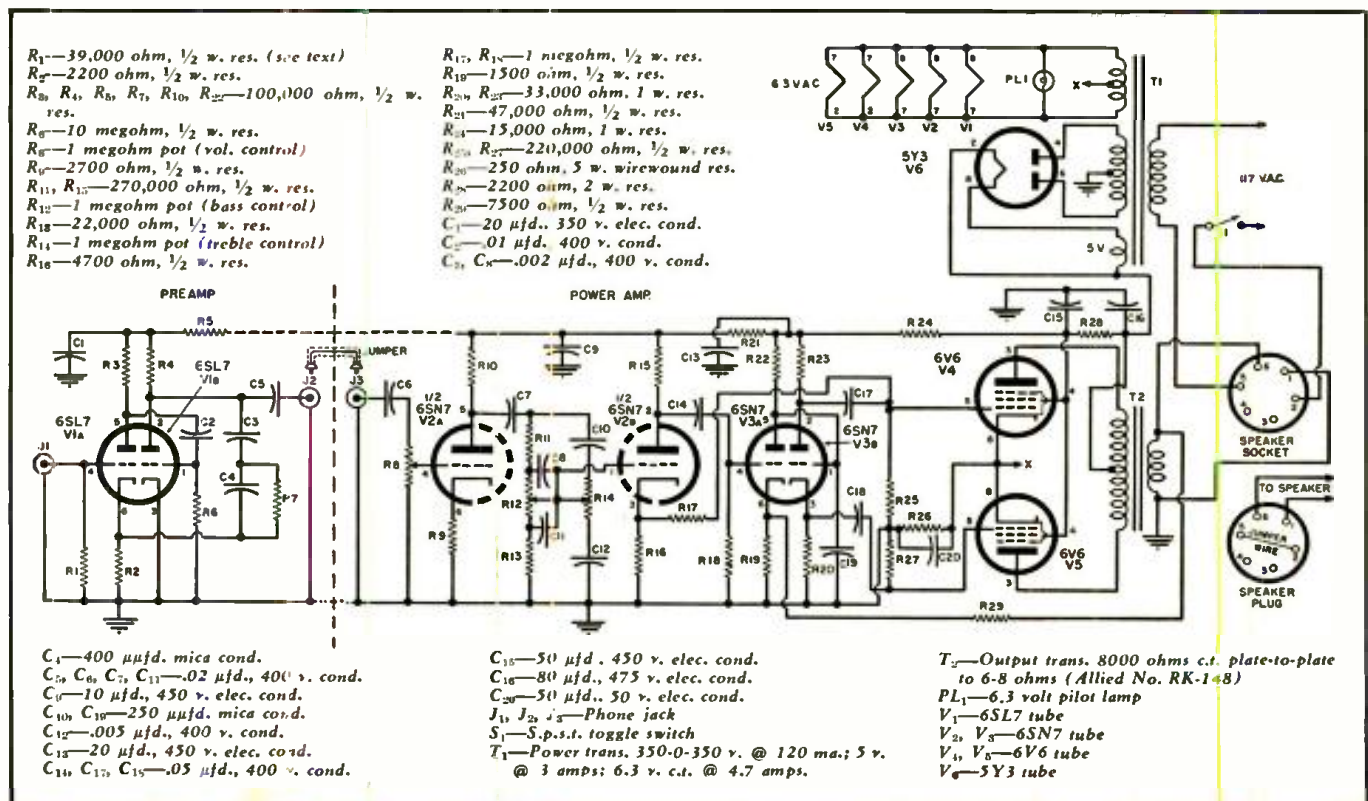

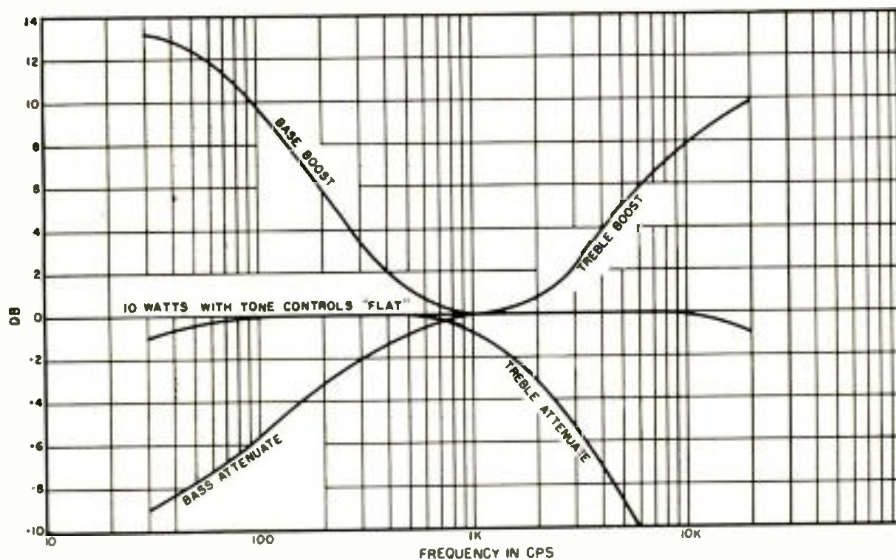

Fig. 5. Frequency response of the entire amplifier. See legends on curves for details.

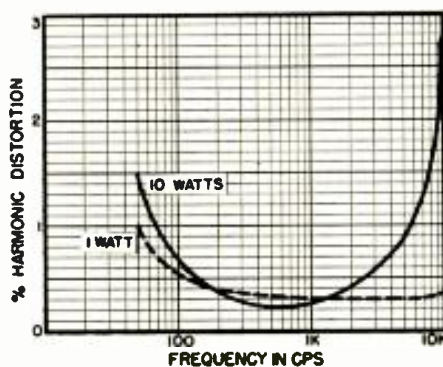

Fig. 6. Harmonic distortion of amplifier.

relatively low as compared with other high quality transformers.

The power supply consists of a power transformer, a full-wave rectifier, and several RC filter sections. These provide excellent filtering as well as decoupling for the various amplifier stages.

A novel feature of the amplifier is the use of both positive and negative feedback. It is a well-known fact that the use of negative feedback in-

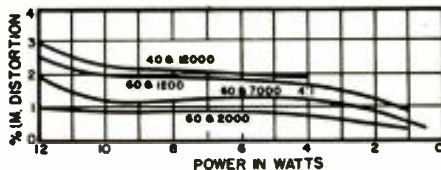
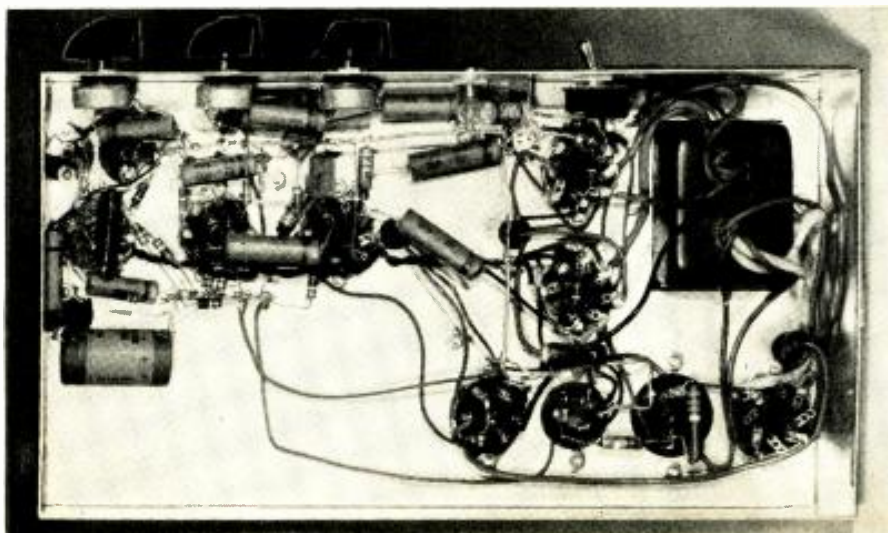

Fig. 7. Intermodulation distortion of unit.

creases the frequency response of an amplifier and considerably reduces distortion. In doing so, however, it materially reduces the gain of a circuit resulting in the need for additional stages of amplification, or requiring a higher signal input for a specified power output. The use of positive feedback increases the gain of this circuit to the point where a .5 volt signal input will provide the full 10 watts of power output. Furthermore, it makes possible the use of more negative feedback than would ordinarily be practical.

The question might arise: "If negative feedback decreases distortion and increases bandwidth, would not positive feedback have the opposite effect?" The answer, of course, is "yes,"

Fig. 8. Under chassis view of amplifier. This layout should be followed closely.



but almost all of the distortion of a properly designed class A amplifier originates in the output tubes and the output transformer. The obvious reason for this is that the level of the signal applied to tubes before the output tubes is relatively small and does not drive these tubes into the objectionable non-linear portion of their characteristic curves.

Now, looking at the circuit, Fig. 4, you will note that the positive feedback is applied from the grid of the output tube to the cathode of the second stage of amplification. (The first stage of amplification merely compensates for the insertion loss of the tone control circuits.) This means that actually 3 stages with negligible distortion provide extra signal amplification. The negative feedback, on the other hand, is taken from the secondary winding of the output transformer and is applied to the cathode of the 3rd amplifier stage. This feedback loop, therefore, encompasses those stages where distortion is greatest, and the benefits of negative feedback are most needed.

Construction of the amplifier is relatively simple. The 7 x 13 x 2 inch chassis is large enough to accommodate all parts without crowding, and a pre-punched chassis is available from *Allied Radio*, if desired.

All ground returns are made to a common bus which is grounded to the chassis at the tuner input jack. This insures circuit stability and minimizes hum due to ground loops. If the bottom side of the chassis is painted it is essential that the paint be scraped off in the vicinity of the input jack so that a good chassis ground will result.

It is essential that the secondary winding of the output transformer be properly phased, or violent oscillation will result. If this occurs when the amplifier is first turned on, merely reverse the two green (secondary winding) leads from the output transformer. The lead that was connected to ground would now be connected to pin 6 of the speaker socket. The lead that was connected to pin 6 would now go to ground.

Notice that a wire jumper must be connected from pin 2 to pin 5 of the speaker plug to complete the a.c. line circuit. The speaker is connected from pins 1 to 6 of the plug. This prevents the application of power to the amplifier unless the speaker is actually connected—a safety feature which protects the output tubes and transformer from accidental damage.

If an output transformer other than the *Allied* unit is used, it may be necessary to change the value of the feedback resistor, R_{23} .

The output transformer was designed for use with a speaker having a 6-8 ohm voice coil. A wide variety of high-quality speakers are available in varying price ranges and the builder should consider the best possible speaker, consistent with his budget, in order to take full advantage of the excellent quality of the amplifier. —30—

THE *Compleat* FIDELITY

By

DON V. R. DRENNER

Engineer, Station KGGF

Over-all view of "The Compleat Fidelity." The cabinet measures 58 $\frac{3}{4}$ " long, 41 $\frac{3}{4}$ " high, with the panels on either side of the television set 19" wide. The sections housing the RC-10 and its vent and the record player and its vent are 19 $\frac{1}{4}$ " high. Locations of other units in the system are clearly indicated.

THE only excuse for high fidelity is enjoyment. If all the test equipment in the world says it's ultra-super-high fidelity and the thing doesn't sound right (and, these days, look right!) then it just isn't fidelity, ultra-high or otherwise.

Fidelity means *faithful*. Live with your Fletcher-Munson curves, then; but let the ears—and eyes—be your criterion, not a piece of graph paper!

If you've got a house, or at least four walls, you can find a place to put the components which comprise a high fidelity system and without taking a second mortgage. Build your own? Maybe. We did that for fifteen years and there was always some little bug that never really got ironed out. At least in the tuners! So when "The Compleat Fidelity" idea came along we decided to buy the tuner and the TV chassis—and maybe build the amplifier.

We decided what we wanted and then rebuilt the house! This is indeed the drastic approach to high fidelity, but you can see from the photograph that installing the stuff in the wall does require some modifications. You can cut a hole and stick it in, or build a new wall. If you've got an ancient bookcase handy, that might solve the problem.

Before you cut that hole, decide what you want. In our case, the following: Tuner; *Craftsmen* RC-10. TV Chassis; *Craftsmen* TV-200. Amplifier; we built our own, but almost any issue of *RADIO & TELEVISION NEWS* will contain plans covering a wide choice of high-quality units. Speaker; *Western Electric* 728-B, mounted in our own baffle-box, in the wall! Record Player; *Webster-Chicago* 127-270, with *G-E* RPX-050 head and diamond stylus. (Our tape machine is a modified German *Magnetophon* R-23—but there are plenty of domestic units available.)

You'll have your own ideas about these, of course; but this choice represents our best buys. To be honest, we've already modified the commercial units. These modifications and details of the speaker housing will all be covered. Information on a cascade booster to improve even the TV-200 and vertical retrace blanking will be given next month while a variable equalizer for the RC-10 will be covered the following month.

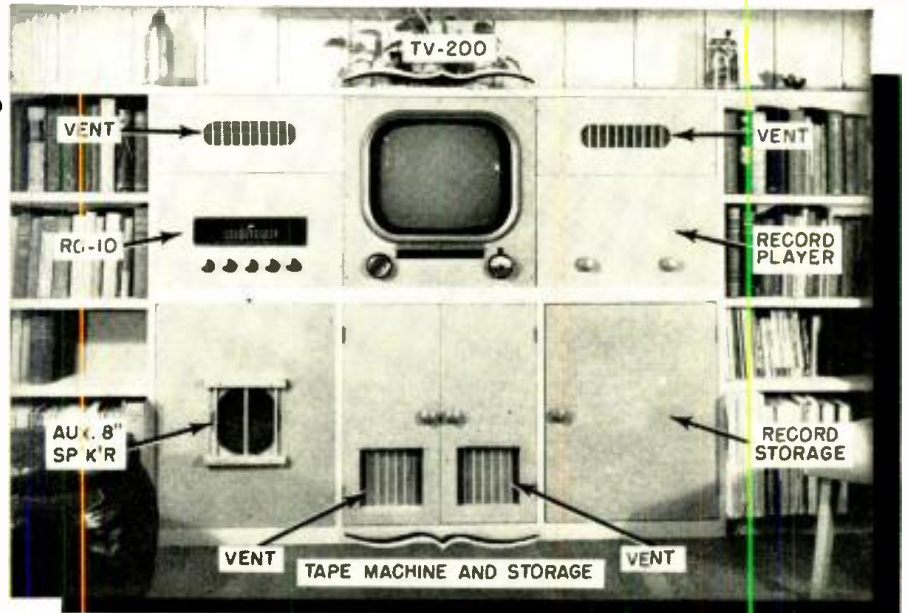

Part 1. One man's ideas on what constitutes an ideal home sound system. Details on various parts of the installation are provided in this and subsequent issues of the magazine.

Now, you can cut that hole. A certain amount of ingenuity, and personal taste, will dictate not only the arrangement but the decorative effect. We housed the units on shelves of asbestos-cement board supported by 1 x 4 inch white pine; and the entire "hole" is lined with this same *Cemesto* board. This is a must if you have, or want to have, fire insurance. Many cities have specific ordinances regarding electronic gear installed in wall cavities, so better check this first.

The front panels of our installation are $\frac{1}{4}$ inch *Masonite*, over which is glued ordinary burlap, or "gunny sack," and then painted. We used a light grey on the burlap and accented

Fig. 1. Details for building and mounting the wall baffle to house W-E 728-B speaker.

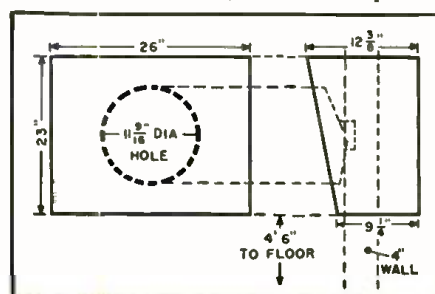

the supporting 1 x 4 inch wood strips in Iris Green. The book cases which run each side of the installation were also painted Iris Green, and a final touch was gold knobs on the doors and record player compartment to harmonize with those of the tuner and TV.

The end of any high fidelity system is the speaker and its enclosure. "The Compleat Fidelity" went a little afield and we hacked a few studs out of the living room wall and mounted the whole thing up and out of the way.

The *Western Electric* 728-B is a 12-inch direct radiation, shallow cone, permanent magnet speaker. Before you condemn the single speaker in these days of multiple cones, tweeter, woofers, and eccentric "waffle-baffles," consider that this 12-inch job will handle 30 watts continuously, has a weight (almost all magnet) of 17 pounds, and a lot of other un-typical specifications. Mounted in a totally-enclosed box of at least 3 cubic feet it will reproduce anything you can hear and shake the walls of your neighbor's house!

We did a little advance experimenting with some other 12- and 15-inch speakers to arrive at the optimum

(Continued on page 148)

AUDIO AT AFIS

By
MAJOR EUGENE F. CORIELL,
USAF
Radio-TV Technical Officer, AFIS



Fig. 1. AFIS control room "A". Rack 1 next to cutting lathes contains limiter and disc recording facilities. Rack 2 includes most of the rack-mounted elements common to both disc and tape channels. Rack 3 carries the tape recorder and also the reverberation generator and the sound-effects filter. These last two items are so located in order to make their panel controls easily accessible to the operator at adjacent console. Staff Sgt. Joseph A. Keddie, chief technician, adjusts levels.

HOW the Armed Forces Information School came to have a radio studio facility is a long and perhaps even intriguing story, told elsewhere,¹ of a succession of studios built at a series of bases and posts. The present article is the story of the current end-product of this saga. AFIS is one of five joint schools operated directly under the Department of Defense, and its top command is rotated among the military services. The present commandant is Rear Admiral Thomas H. Binford. The school is located at Fort Slocum, an island off the shores of New Rochelle in famed Westchester County, New York. The students, like the staff and faculty, are officers and enlisted personnel of the Army, Navy, Air Force, and Marine Corps. Instruction is given in two main fields: (1)

Armed Forces Information School's audio-video installation at Fort Slocum provides studio facilities for trainees.

Conveying information about the services to the public, and (2) Interpreting the military to its own personnel. Allied with this latter mission is the teaching of the administration of military education programs. Among other subjects, the instruction covers the use of the various information media — press, radio and television, photog-

raphy, public speaking, conference and panel techniques, and special events. These two curricula are known respectively as Public Information (PI) and Information and Education (I & E).

Radio is taught by lectures, demonstrations, practice in program writing, and actual production. Students receive no electronic or technical instruction except as regards operation of small portable tape recorders. To provide necessary laboratory facilities for student shows, there is a complete studio plant modeled after commercial facilities and operated and maintained by enlisted staff technicians. The floor plan is shown in Fig. 3. There are two main studios 25 by 35 feet, each with its own control room and announce booth; a small practice and audition studio, an office, and a maintenance shop. There is no transmitter, all student shows being recorded on tape or disc.

The studio plant was laid out primarily for broadcasting and recording, but with an eye toward television. As a result, space allocation and conduit systems will permit possible future installation of basic video gear with minimum rearrangement of the installation. However, since the cost of TV camera chains is prohibitive, television is taught at present by lectures, training films, and field trips to nearby TV studios. Meanwhile, we are working with a standard *Auricon*

Fig. 2. Portion of studio grounding diagram. All amplifier chassis are grounded to their racks. In general, shields of cable pairs inside the racks are soldered to their jack frames which are bonded to the rack. External or cross-connecting pair shields are grounded at one end only. The microphone circuit shown illustrates these principles, the mike case not being considered a ground. Grounds are removable.

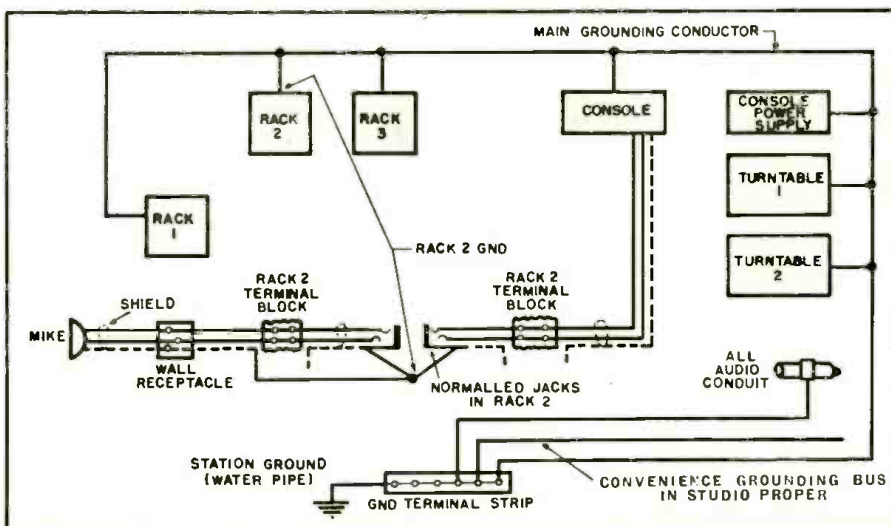

16 mm sound motion picture camera and a *Mauver* film recorder in preparation for teaching television studio and newsreel production by student participation, analogous to our present method of teaching radio. Both the camera and the film recorder can be fed directly from their own microphones out on location, or from the audio console in the studio through a pad and associated matching transformer.

The over-all plant was designed to standard broadcast specifications. Walls between studios and control rooms and between the two back-to-back control rooms are of double cinder-block construction enclosing an air space. This is one of the types of "discontinuous structure" prescribed in acoustic literature² for sound-insulated walls. Windows are double-paned and mounted in double sound-isolated frames. Access to studios and control rooms is given by sound-insulated doors opening from a sound lock. Since the studios were designed primarily for speech, the reverberation time-vs-frequency characteristic was chosen to provide somewhat less liveness than the classical Morris-Nixon curves³ would indicate for a studio of 8000 cubic foot volume. The designed reverberation time—the time required for sound to decay 60 db—averaged over the frequency range of 100 to 5000 cycles is approximately .64 second. This provides considerably more liveness than many speech studios, with consequent improvement in the naturalness of voice reproduction. The ambient or no-program noise level at microphone height ranges from 30 to 35 db. Less than 3 db of this total is contributed by the hiss from the air-conditioning duct system which embodies the usual sound-isolation measures such as duct linings, limited

air velocities, canvas duct couplings, etc.⁴

General Audio Layout

Except for the turntable inputs and monitor speaker outputs of the consoles, all wiring throughout the plant is balanced to ground. In the case of amplifiers and other components constructed unbalanced as a manufacturing convenience, balancing was simply a matter of lifting an input or output connection from the chassis. However, some amplifiers with unbalanced outputs are designed with the output transformer secondary as part of a feedback loop. In such cases, the choice is either to add an isolation transformer or to run unbalanced. We chose the latter with the console monitor amplifier output since it was immaterial whether the monitor speakers were balanced or not. A balanced installation is certainly more expensive from a first-cost viewpoint; however, we feel this is more than compensated for by the greater freedom from crosstalk, r.f. interference, noise, and amplifier instability. The grounding system shown in the diagram, Fig. 2, was laid out with considerable care particularly to preserve these advantages.

Circuit wiring throughout the plant is divided into three level groups, to avoid crosstalk. The low-level group carries circuits ranging from minus 60 to minus 30 dbm, which includes microphones, turntable pickups, turntable preamplifier inputs, etc. The zero-level group, from zero to plus 30 dbm, covers remote lines, cue feeds, and console and tape recorder line outputs. The high-level classification includes all circuits above plus 30 dbm, such as monitor speakers and disc recorder cutting heads. While this leaves an obvious hole in the

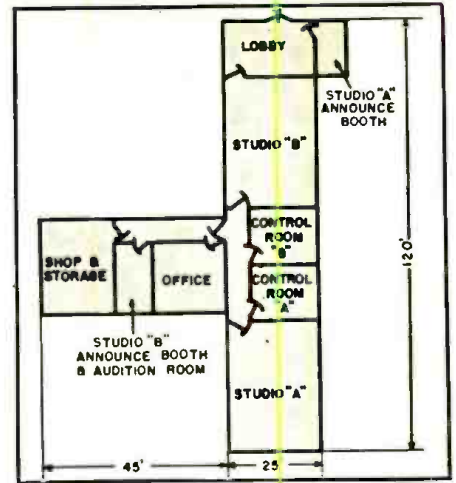

Fig. 3. Floor plan of AFIS radio studio installation. Each studio is 25' x 35'. The announce booth for studio "B" doubles as an audition studio and contains a scaled-down version of the main control room equipment. Trunk lines of all three circuit-level groups tie all rooms, including office and shop, to both control rooms for maximum operational flexibility.



Fig. 4. "Normal-through" jack connection often used in b.c. operations. No patch-cords are needed for ordinary operation as components are connected together through auxiliary or "normal" contacts on jacks. Inserting a cord in either jack removes the associated component from circuit and makes it available on cord for testing or emergency reconnection. The system works equally well with either single or double-type jack assemblies.

level spectrum from minus 30 to zero dbm, the few circuits in this category
(Continued on page 199)

Fig. 5. Simplified block diagram of AFIS studio "B." Direction of signal travel is from left to right except as otherwise indicated by heavy arrow. Console is connected to microphones, limiter, etc., via "normal-through" jacks. Note that tape recorder can be played back through console by way of "normal" contacts on one of the remote line input jacks. All dbm circuit levels shown are 10 db above program peaks.

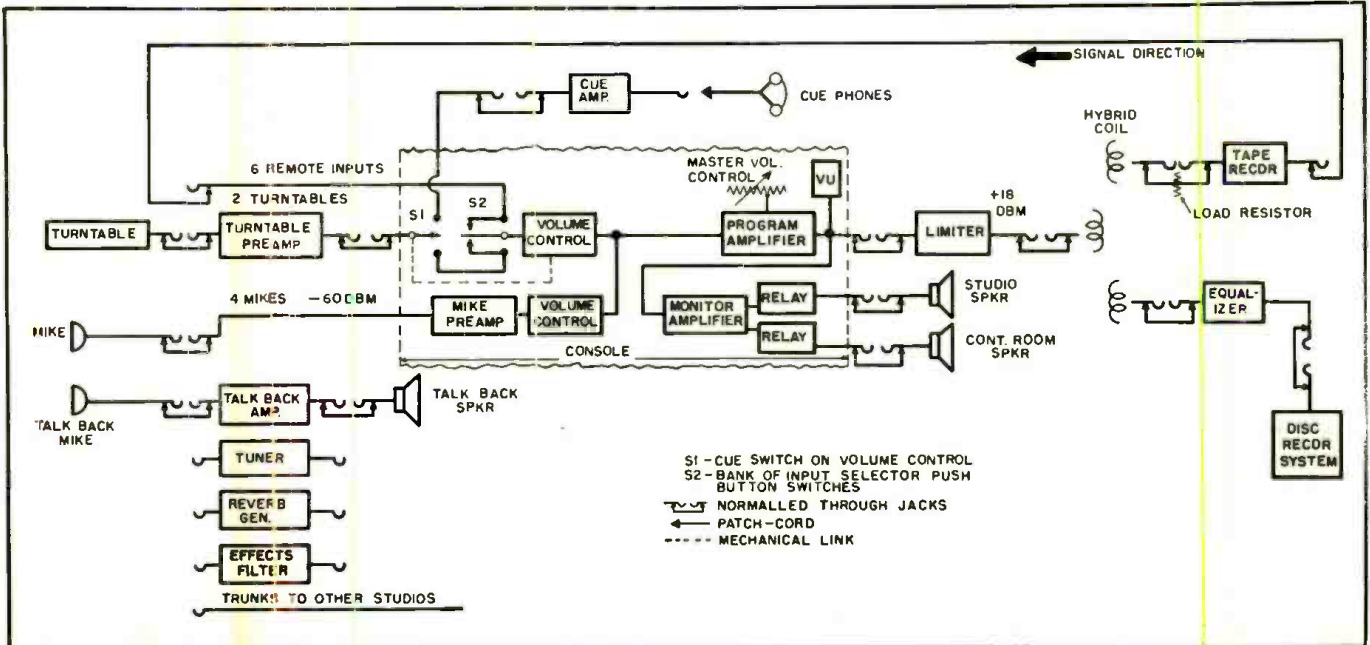



The ELECTRONORGAN

By **RICHARD H. DORF**
Audio Consultant

Fig. 1. Over-all view of the author's "Electronorgan." It is housed in an old organ console which was purchased for 60 dollars.

Part 1. A three-part series covering a musical instrument that really sounds like a pipe organ. Because standard chassis construction is used, it is not hard to build.

AS THE writer has found out from reading letters which filled several mail sacks, there is tremendous interest among electronic enthusiasts in the construction of electronic musical instruments. The expressed preference of a large majority of this group is for details enabling them to build a complete electronic organ, preferably one which sounds and operates like a pipe organ.

The big snag has been, up to now, that although there exist commercially manufactured organs which conform to the desires of amateur builders, they all contain special parts which make construction of an amateur counterpart all but impossible.

In building the "Electronorgan" the writer satisfied two desires. The first was to design and construct an instrument for his own use; and the second was to make available complete instructions for the many amateurs who would like to do the same. The second purpose was kept in mind throughout the design. As a result, the organ contains completely standard parts, all of which are available from ordinary sources without special orders or premium prices.

The "Electronorgan" is not an electronic engineer's toy. On the contrary, it is first of all a fine musical instrument capable of competing against most of the medium-sized pipe organs found in churches and concert halls in the United States. Its tone qualities are uncannily imitative of genuine pipe-organ sounds and its output volume, depending solely on the associated power amplifier and speaker system, can be adapted for a small home or a cathedral. While it will take a good number of hours to build—perhaps two or three hundred—it is a good job for a radio technician or hobbyist because nine-tenths of the work is standard electronic chassis construction. The cost of the parts, depending on whether purchased new at standard prices or bought as surplus, may run between \$150 and \$400.

From the performance standpoint, the specifications of the "Electron-

EDITOR'S NOTE: In response to many requests from our readers for a circuit of an electronic organ, we are presenting this series of articles. As will be evident to those who carefully study the circuit and photographs accompanying this article, the organ is fairly elaborate. Parts for this construction will cost from \$90 to \$350, exclusive of the console, depending on how many of the required parts are available in your junk boxes. All of the required parts are standard and may be purchased at any parts jobber. Two- to three-hundred hours' construction time is required.

Fig. 2. Block diagram of the "Electronorgan." The entire construction is represented.

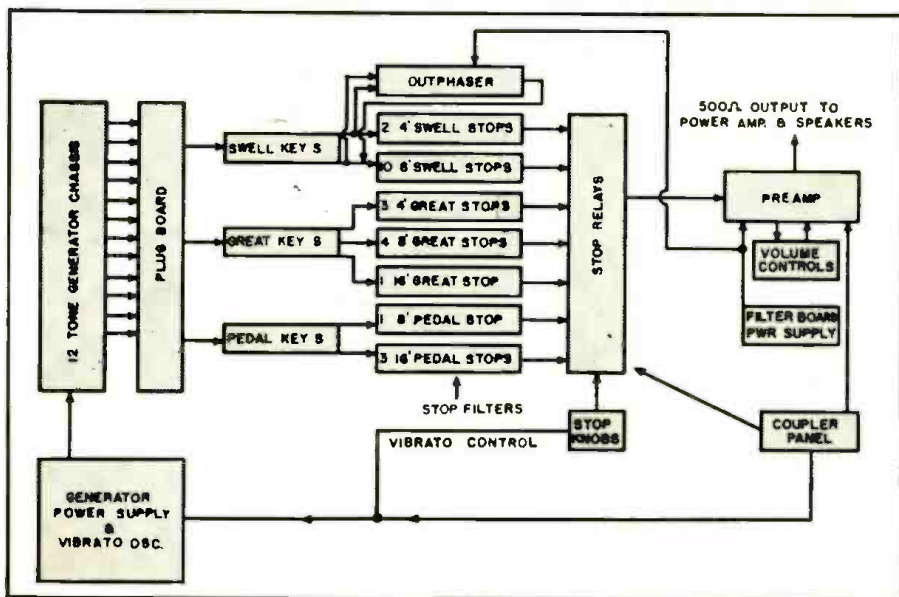

organ" are as follows. There are two manuals (though additional ones may be added without major design changes), and a 32-note pedal clavier. There are 24 stops, 12 for the swell, 8 for the great, and 4 for the pedal. There are two couplers, "Great"-to-"Swell" and "Pedal"-to-"Great." "Vibrato" is available, with two speeds. Separate expression pedals are provided for "Swell" and "Great" manuals, with the pedal clavier volume controlled by either "expression" pedal at the flick of a tab. If a "crescendo" pedal is on the console used, it can be connected with no design changes.

While these are the specifications of the writer's organ, others who build the instrument may vary or decrease the specifications without design changes. A single manual may be used, for instance, without pedals or with a small toe-pedal board. Some constructors may want fewer stops than 24, more couplers or fewer, a single expression pedal—and so on. Any specification up to the maximum may be fulfilled without changes in the design itself.

What is in the "Electronorgan"?

Fig. 1 is a photograph of the writer's console. This console, once housing the controls of a Moller pipe organ, was purchased for \$60 from an organ repair man, complete with manuals, stop knobs, pedals, and bench. It houses the entire "Electronorgan" with the exception of the power amplifier and speaker system, which are separate.

The block diagram of Fig. 2 will serve as an introduction to the "Electronorgan's" innards. The heart of the organ is the tone-generator system which consists of twelve chassis, one for each of the twelve tones in the chromatic scale. Each chassis, such as the one shown in Fig. 3, generates all the octaves of one note for the organ, for instance, all the A's. The twelve generators are powered by a supply on a separate chassis (Figs. 11, 12, 13),

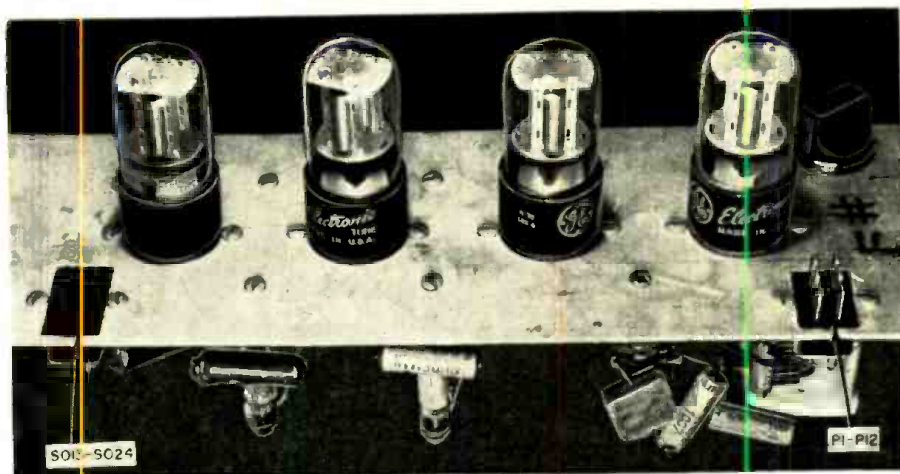

Fig. 3. One of the tone generator chassis. Twelve are required to cover 85 notes.

which also includes the 5-8 cps vibrato oscillator.

The outputs of all the tone-generator chassis are fed to a plugboard whose purpose is to distribute the tones to the key-switch assemblies. As the tones emerge from the generators, all the C's are together, as are all the C-sharps, and so on. The tones are re-grouped in the plugboard so that all the notes for each of the seven octaves are together—the C through B for the lowest octave, etc.

Each manual and the pedal clavier has a key-switch assembly so arranged that when a key is pressed three separate tones to the output of the assembly. If the middle-C key is pressed, for instance, the tone of middle-C is sent to the 8-foot output, that for an octave higher is sent to the 4-foot output, and that for an octave below is sent to the 16-foot output.

From the three key-switch assembly outputs the tones go to the filter-board which contains all the RCL filters which alter tone quality in accordance with the requirements of the organ stops. Each stop consists of a filter whose input is connected to the

output of the appropriate key-switch assembly—"Great," "Swell," or "Pedal"—carrying the appropriate tone register—4', 8', or 16'.

The output of each filter goes to one contact of a normally-open relay. When a stop knob on either side of the console (see Fig. 1) is pulled, a set of contacts is closed. This closes the appropriate relay, allowing tone coming through the associated filter to pass to the preamplifier. One of the stop knobs short-circuits the vibrato oscillator when it is pushed in, giving "on-off" control of vibrato.

The preamplifier, also on the filter-board, has two inputs for "Swell" and "Great," each separately controlled by a wirewound volume-control potentiometer actuated by one of the two "expression" pedals which can be seen in Fig. 4. (The right pedal is the "crescendo" pedal which was on the console as purchased but has not yet been connected.) The outputs of the pedal filters may be connected so as to be volume controlled by either the "Swell" or "Great" shoe; the change-over is made by flicking one of the tablet switches on the coupler panel which can be seen just above the upper manual in Fig. 5. The coupler

Fig. 4. "Expression" pedals. Pedal on right is not connected.

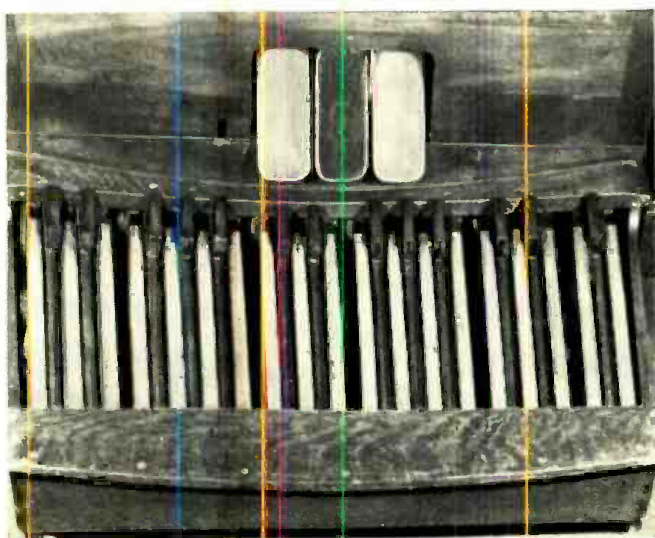
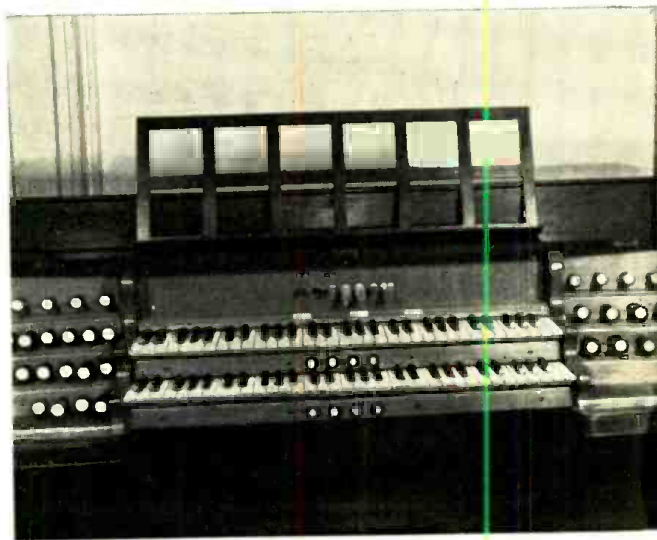
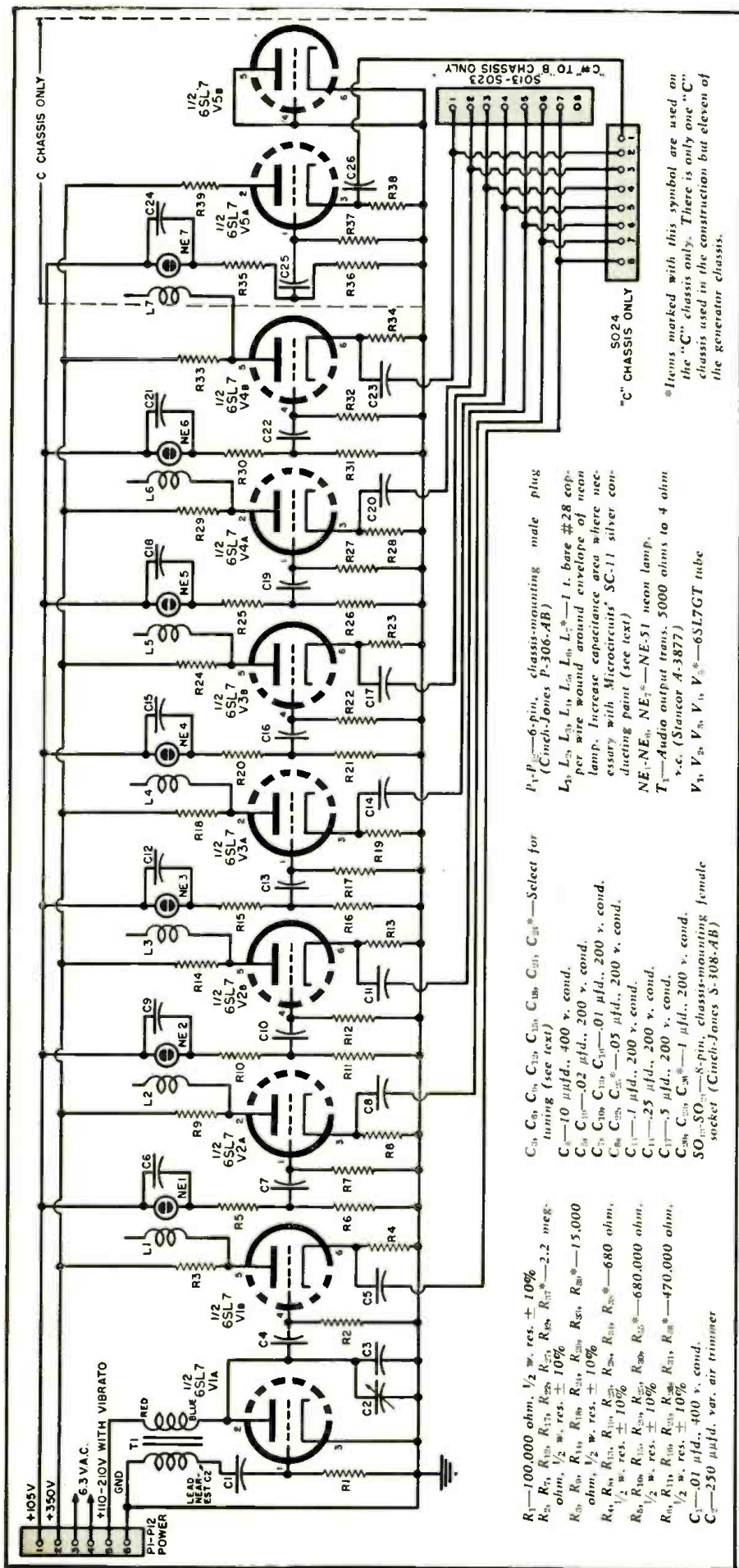

Fig. 5. Close-up of organ manuals showing various controls.





panel also holds the main power-switching button, a pilot lamp, vibrato speed control, and two couplers, of which more later.

The outputs of the two potentiometers are mixed and further amplified. The output of the preamplifier furnishes enough voltage to drive a conventional power amplifier at an impedance of 500 ohms. Two switched outputs are provided, selected by a coupler panel jack, and a bridging headphone jack with its own volume control is provided as well. The pre-amplifier includes a potentiometer controlling over-all volume which may be preset for the desired output level maximum. The preamplifier and out-phaser (explained later) are supplied by a power chassis which is separate.

Generator Chassis

Fig. 6 is a schematic diagram of one of the twelve tone-generator chassis, all of which are alike except that the C chassis has an extra divider to add the necessary extra C (due to the fact that each manual has 5 octaves plus an extra C). While the generator circuit used in the "Electronorgan" might not be suitable for commercial quantity production because of small tolerances in the tuning condensers, it is satisfactory for individual construction since it uses completely standard parts throughout and furnishes the excellent saw-tooth waves necessary for good brilliance with the stop-filter system to be explained later. The generators provide seven octaves and one note—85 notes in all—giving full 16' and 4' ranges. Each chassis, as diagrammed in Fig. 6, provides seven tones, except for the C chassis which gives eight.

The master oscillator for the chassis is V_{1A}, connected as a standard feedback oscillator. The transformer, T₁, is a Stancor A-3877 output transformer, with the primary connected to the plate. The secondary is connected to the grid, providing the feedback. No alteration need be made in the transformer. The plate is tuned by the combination of fixed condenser C₃ and variable condenser C₁, which gives a range of something under three semitones, enough to allow precise tuning even with pianos or other standards which are not exactly up to pitch. The twelve master oscillators are tuned to the frequencies from C₇ (2217 cps) to C (4186 cps.).

The output of the master oscillator is coupled through C₁ to the grid of V_{1B}, which acts as a cathode follower. The output from its cathode through C₅ is the same frequency as that of the master oscillator and for all the twelve chassis gives the highest octave on the organ.

Fig. 6. Complete schematic of one of the tone generator chassis, plus the "C" chassis. Eleven of the regular generators and one of the "C" chassis are required. P₁ through P₁₂ go to SO₁ (Fig. 11) indirectly through a common bus. Sockets SO₁₃ through SO₂₄ are connected to the plugboard to be described in second part of this series.

- P₁-P₁₂—6-pin, chassis-mounting male plug (Cinch-Jones P-306-AB)
- L₁, L₂, L₃, L₄, L₅, L₆, L₇, L₈, L₉, L₁₀, L₁₁, L₁₂—1 t. bare #28 copper wire wound around envelope of neon lamp. Increase capacitance area where necessary with Microcircuits' SC-11 silver conducting paint (see text)
- NE₁-NE₁₂, NE₁₃—NE-51 neon lamp, y.c. (Stancor A-3877)
- V₁, V₂, V₃, V₄, V₅, V₆, V₇, V₈, V₉, V₁₀, V₁₁, V₁₂—6SL7GT tube socket (Cinch-Jones S-308-AB)
- C₃₀, C₃₁, C₃₂, C₃₃, C₃₄, C₃₅, C₃₆, C₃₇, C₃₈, C₃₉, C₄₀—Select for tuning (see text)
- C₁—10 μfd., 400 v. cond.
- C₂—C₁₀—0.02 μfd., 200 v. cond.
- C₃—C₁₀—C₃₀—0.1 μfd., 200 v. cond.
- C₄—C₁₀—C₃₀—0.05 μfd., 200 v. cond.
- C₅—C₁₀—C₃₀—0.25 μfd., 200 v. cond.
- C₆—C₁₀—C₃₀—1 μfd., 200 v. cond.
- C₇—C₁₀—C₃₀—5 μfd., 200 v. cond.
- C₈—C₁₀—C₃₀—25 μfd., 200 v. cond.
- C₉—C₁₀—C₃₀—50 μfd., 200 v. cond.
- SO₁₃-SO₂₄—8-pin, chassis-mounting female socket (Cinch-Jones S-308-AB)
- R₁—100,000 ohm, 1/2 w. res. ± 10%
- R₂, R₃, R₄, R₅, R₆, R₇, R₈, R₉, R₁₀, R₁₁, R₁₂, R₁₃, R₁₄, R₁₅, R₁₆, R₁₇, R₁₈, R₁₉, R₂₀, R₂₁, R₂₂, R₂₃, R₂₄, R₂₅, R₂₆, R₂₇, R₂₈, R₂₉, R₃₀, R₃₁, R₃₂, R₃₃, R₃₄, R₃₅, R₃₆, R₃₇, R₃₈, R₃₉—2.2 meg-ohm, 1/2 w. res. ± 10%
- R₄₀, R₄₁, R₄₂, R₄₃, R₄₄, R₄₅, R₄₆, R₄₇, R₄₈, R₄₉, R₅₀, R₅₁, R₅₂, R₅₃, R₅₄, R₅₅, R₅₆, R₅₇, R₅₈, R₅₉, R₆₀, R₆₁, R₆₂, R₆₃, R₆₄, R₆₅, R₆₆, R₆₇, R₆₈, R₆₉, R₇₀, R₇₁, R₇₂, R₇₃, R₇₄, R₇₅, R₇₆, R₇₇, R₇₈, R₇₉, R₈₀, R₈₁, R₈₂, R₈₃, R₈₄, R₈₅, R₈₆, R₈₇, R₈₈, R₈₉, R₉₀, R₉₁, R₉₂, R₉₃, R₉₄, R₉₅, R₉₆, R₉₇, R₉₈, R₉₉, R₁₀₀—15,000 ohm, 1/2 w. res. ± 10%
- R₁₀₁, R₁₀₂, R₁₀₃, R₁₀₄, R₁₀₅, R₁₀₆, R₁₀₇, R₁₀₈, R₁₀₉, R₁₁₀, R₁₁₁, R₁₁₂, R₁₁₃, R₁₁₄, R₁₁₅, R₁₁₆, R₁₁₇, R₁₁₈, R₁₁₉, R₁₂₀—680 ohm, 1/2 w. res. ± 10%
- R₁₂₁, R₁₂₂, R₁₂₃, R₁₂₄, R₁₂₅, R₁₂₆, R₁₂₇, R₁₂₈, R₁₂₉, R₁₃₀, R₁₃₁, R₁₃₂, R₁₃₃, R₁₃₄, R₁₃₅, R₁₃₆, R₁₃₇, R₁₃₈, R₁₃₉, R₁₄₀—680,000 ohm, 1/2 w. res. ± 10%
- R₁₄₁, R₁₄₂, R₁₄₃, R₁₄₄, R₁₄₅, R₁₄₆, R₁₄₇, R₁₄₈, R₁₄₉, R₁₅₀, R₁₅₁, R₁₅₂, R₁₅₃, R₁₅₄, R₁₅₅, R₁₅₆, R₁₅₇, R₁₅₈, R₁₅₉, R₁₆₀—470,000 ohm, 1/2 w. res. ± 10%
- C₁—0.1 μfd., 400 v. cond.
- C₂—250 μfd. var. air trimmer

V_{11} also has a plate load resistor from which synchronizing voltage is taken for the first frequency divider. The first divider is an ordinary neon-lamp relaxation oscillator consisting of NE_{11} , C_{11} , and the series value of R_{11} and R_{12} . The neon oscillator is tuned by condenser C_{11} to a frequency slightly less than one-half that of the master oscillator. L_1 is a single turn of No. 28 bare copper wire wound around the bulb of the neon lamp. It couples enough voltage, obtained from the plate of V_{11} , capacitively to the electrodes of the lamp to make the lamp fire once for every two synchronizing "kicks." At the same time, the synchronization voltage injected in this way is not sufficient to be detectable in the output of the neon oscillator, which furnishes a good saw-tooth at the desired frequency in the next-to-highest octave of the organ. The writer is indebted for this method of synchronization to Robert M. Strassner, who suggested it in somewhat different form in the January, 1951 issue of "Electronics."

In the neon oscillator the total value of R_{11} and R_{12} determines the free-running frequency. The resistance is split, however, to allow a certain proportion of the saw-tooth output to be fed to the grid of V_{24} , also a cathode follower. The proportioning of R_{11} and R_{12} is such as to allow a maximum of signal to pass to the grid without causing clipping in the tube. The output, appearing at the cathode of V_{24} , is in the next highest octave of the organ. V_{24} is also plate-loaded to provide synchronizing voltage for the next divider, the relaxation oscillator formed by NE_{21} , C_{21} , and R_{21} - R_{22} .

This same dividing process is carried on through the remainder of the string, the lowest tone being produced by the last neon and cathode-follower NE_n and V_n in the range from C (65.41 cps) to C \sharp (34.65 cps). On the C chassis only, half of an extra 6SL7GT V_{24} and an extra neon lamp NE_n produce the lowest tone of the organ, C (32.70 cps).

All the tones are fed to the output connectors SO_1 through SO_{24} , for which the writer used Cinch-Jones S-308-AB sockets. Note the graduated values of the output coupling condensers C_3 , C_5 , C_{11} , and so on. Smaller condensers are usable at the higher frequencies to save space. The same is true, to some extent, of the grid coupling condensers C_{14} , C_{16} , and C_{22} .

The tone generator chassis are simply strips of $\frac{1}{16}$ " aluminum, 4" x 13". This does not give a great deal of space and the use of small condensers is recommended, at least for those of predetermined values. Aerotox type P82 metallized paper units were used by the writer, as well as Centralab tubular ceramics for the smaller values.

The generator power supply is diagrammed in Fig. 11. The heavy heater requirements (49 6SL7GT's) are met by the 20-ampere filament transformer T_3 , which is a Stancor P-6309

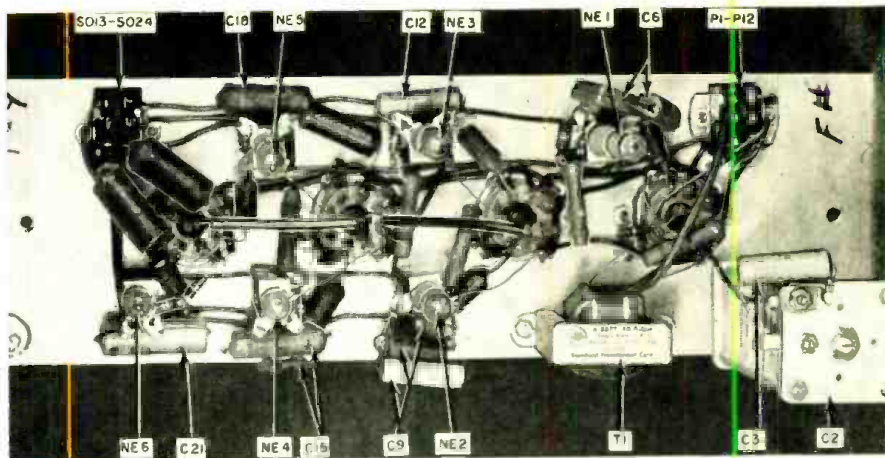

Fig. 7. Bottom view of one of the tone generator chassis showing parts location.

in the writer's model. A separate rectifier filament transformer T_2 is a Stancor P-3026, and the plate transformer T_1 is a Stancor P-8046. This particular part number has been withdrawn from the Stancor line, but the PC-8302 may be used, or any other transformer having similar ratings. For example, the Triad P-5A could be used to replace both T_1 and T_2 . This transformer is rated at 550-0-550 volts, 400 volts d.c. @ 250 ma.; 5 volts @ 3 amps. The plate power requirements are heavy and are just met by the unit selected.

The filter is a dual-section, choke input, and the output from it is fed directly to pin 2 of output connector SO_1 , which goes to a bus from which a lead is drawn at each generator chassis to pin 2 of P_1 through P_{12} in Fig. 6; this is the voltage for the cathode followers.

A regulated supply of 105 volts is furnished for the neon lamps by V_n , an 0C3/VR105. A 10-second thermal delay relay in series with the 105-volt line delays application of voltage to the neons. It was found that if this was not done an instant of full supply

Fig. 9. Master oscillator Lissajous pattern.

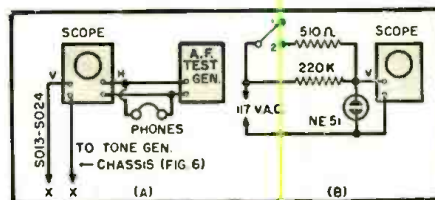

Fig. 8. (A) Test circuit set-up for master oscillators. (B) Circuit for "aging" neons.

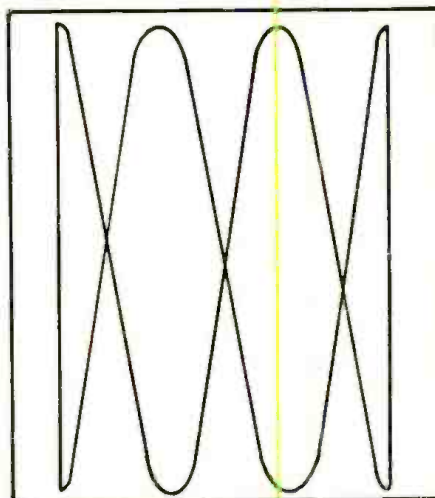
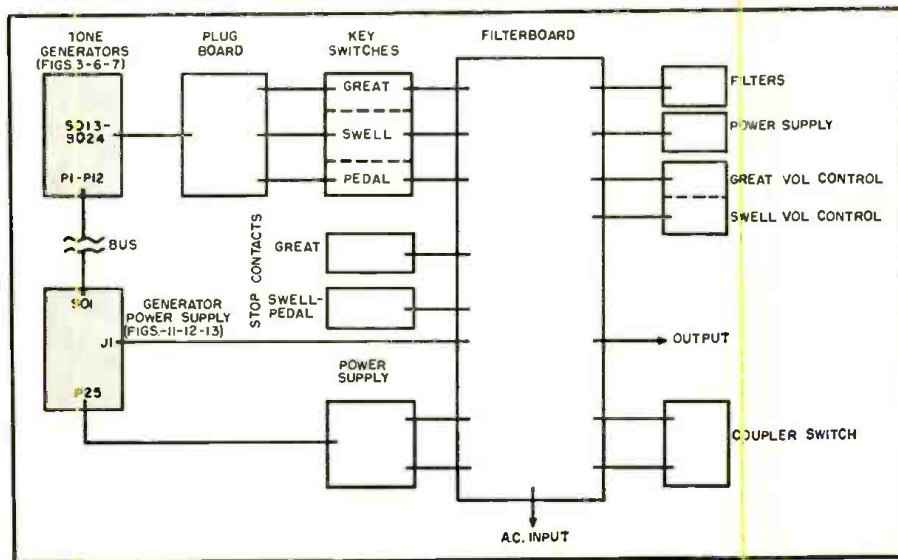

Fig. 10. Chassis interconnection diagram. Only the chassis covered in this article are shown "shaded." Balance of chassis will be interconnected as they are discussed.



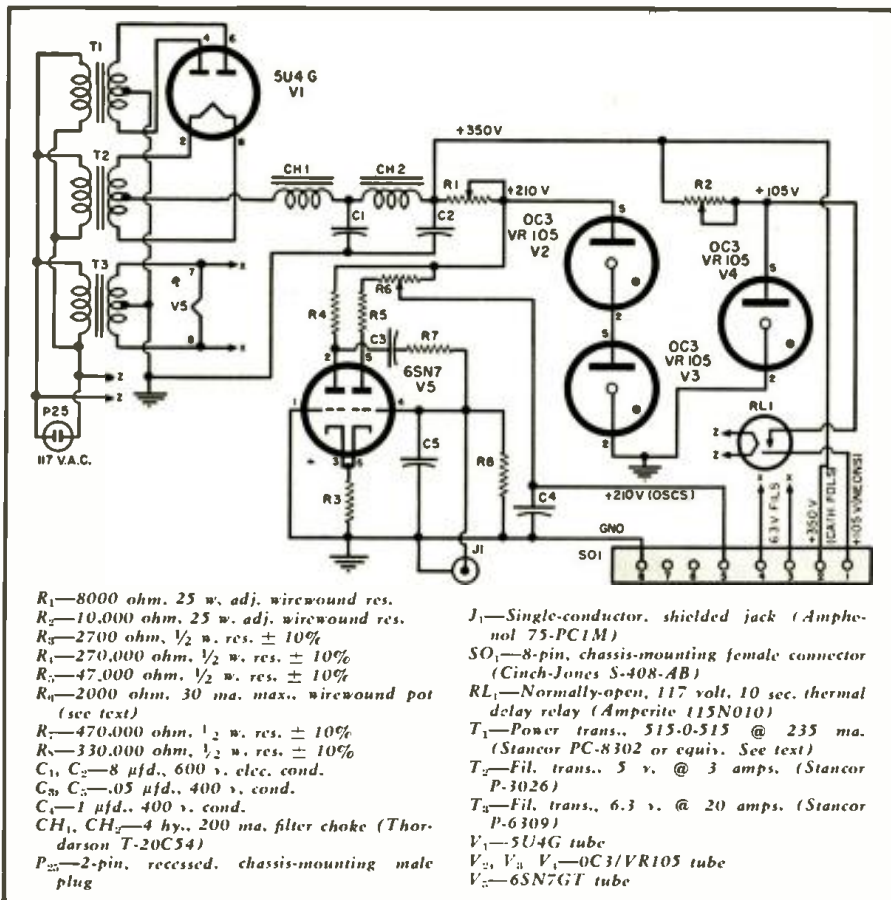

Fig. 11. Complete circuit diagram of the generator power supply unit.

voltage would be applied to the neons before the 0C3 took hold; this would sometimes cause neons to remain ignited rather than oscillating properly.

A second regulator, consisting of *V*₂ and *V*₃, furnishes 210 volts to a simple RC oscillator, *V*₅, operating at the basic vibrato frequency of about 5 cps. Plate voltage for the twelve master oscillators is taken from a point between zero and 2000 ohms down on the output plate load resistance of the vibrato oscillator. With the arm of the potentiometer *R*₆ at the supply end steady voltage is furnished to the master oscillators; when it is moved

toward the plate of *V*₅ the voltage varies (to a degree depending on the setting of *R*₆) at the vibrato frequency. This varying supply voltage causes the master oscillators to shift frequency up and down slightly, giving vibrato to all the tones, since all are synchronized with the master oscillators.

The vibrato is controlled by a switch on the coupler panel and one on a stop knob; both are in parallel with one grid of *V*₅ (pin 4) and the connection is made through *J*₁. With the grid shorted to ground by the stop knob the oscillator stops oscillating and vibrato

is removed. When the coupler-panel "Fast Vibrato" tab is pushed a 1-megohm resistor is shunted across *R*₆, raising the frequency of oscillation and increasing the vibrato rate. This circuit will be described further in Part 3.

Fig. 12 shows the generator power supply. While it may seem a little crowded, there is no reason to make it bigger. If the transformers mentioned are used the chassis need be only 7" x 13" x 2". Fig. 13 shows the underside of this chassis. Note the large-size power output connector, a Cinch-Jones S-406-AB. This is advisable, since a good deal of heater current must be carried. Bus bar should be used for the busses which will carry heater voltage to the twelve generator chassis.

Tuning the Generators

Perhaps the most tedious job in building the "Electronorgan" (except for making the key switches) is selecting the correct condensers to tune the master oscillators and the dividers. The tedium was greatly relieved for the writer, however, by the sense of step-by-step accomplishment of the first real goal as tone after tone of the 85 was brought into action.

There are preliminaries. First the generator power supply should be built and the voltages checked. The nominal 350-volt line will probably be somewhat high and will vary as more or fewer chassis are powered by it.

Next the generator chassis should be punched and the parts installed, with the exceptions of condensers *C*₄, *C*₉, *C*₁₂, *C*₁₅, *C*₁₇, *C*₂₁, and *C*₂₇ in Fig. 6, and the neon lamps. Before the neons are installed each one should be artificially aged with the circuit of Fig. 8B. Make up the circuit, with a bayonet socket where the NE-51 is indicated in the diagram. Adjust the oscilloscope to show a good-sized 60-cycle sine wave when the switch is open, without a neon lamp in the socket.

Now insert a neon lamp in the
(Continued on page 168)

Fig. 12. Top view of the generator power supply chassis showing location of principal components, plug, socket, and jack.

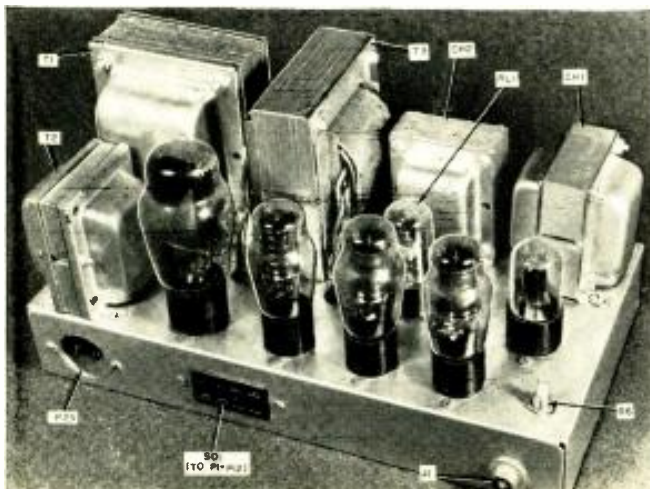
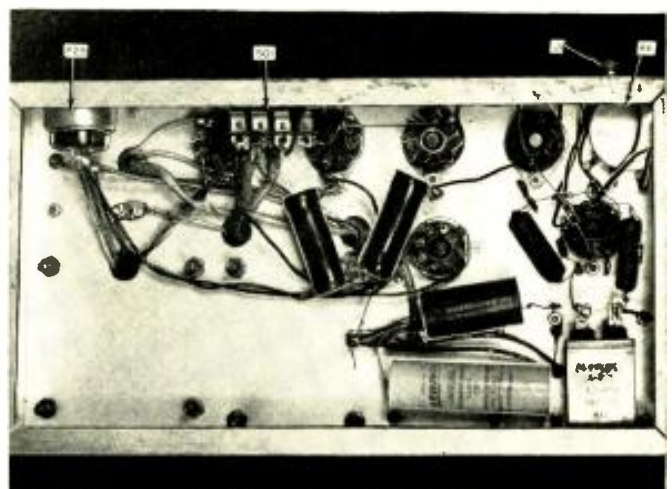

Fig. 13. Underchassis view. The adjustable resistors, specified in Fig. 11, should be used instead of vitreous units shown.



HOW MANY WATTS?

AN ENGINEERING APPROACH TO HOME MUSIC

By R. H. TANNER

Dev. Engr., Northern Electric Co., Ltd.

*A discussion of power requirements for
audio amplifiers used in home systems.*

THIS article is based on two sayings so familiar that they might almost be called proverbs. The first is the famous definition of an engineer as the man who can do for one dollar what anyone else can do for two. The second is the truism that a chain is as strong as its weakest link. Now let us turn both of these propositions around: to do for two dollars what can be done for one is not good engineering even though it may sometimes be good business: a chain is not strengthened by adding one extra strong link anywhere along its length.

With these thoughts in mind, we may now turn to the fact that, whether we like it or not, the quality of music reproduction we get in our homes is dependent not merely on the excellence of our own equipment, but also on the complete broadcasting or recording chain. Let us examine the former in some detail, remembering that the latter is similar in most respects.

Since this article is intended to deal mainly with amplifiers and amplifier design, we will pass lightly over the microphone, turning, however unwisely, a blind eye to its imperfections. Its electrical output is fed to the studio console where it will probably pass through three amplifiers in tandem. From the studio, the signal may go to a master control room where it passes through another similar amplifier, before reaching the program line to the transmitter. The modulation of the high frequency carrier and, to an even greater extent, its subsequent demodulation in the receiver are matters that tend to make an audio enthusiast shudder, but once these processes are complete, the signal (or what remains of it) may be fed into that masterpiece of the designer's art, the high-fidelity power amplifier, and thence to the loudspeaker.

Now, the point of all this is that even in the simplest chain there are probably at least four audio amplifiers other than the one driving the loudspeaker, and if we make the gross assumption that the microphone, transmitter, detector, and loudspeaker introduce negligible distortion of the signal, we may say surely, that if the specification which applies to those program amplifiers is applied to the output amplifier as well we will have a well-engineered chain, with no links unduly weak and no links unduly strong.

In the design of program amplifiers there is one rule of thumb which has stood the test of many years experience throughout the entire broadcasting industry of North America. It is this: if an amplifier is required to produce a program output level of x , v_u , as measured on a volume indicator, then it must be designed for a sine wave output of $x + 10$ dbm at the specified distortion or less.

In view of the degree of feedback normally used in such equipment, which results in a very sharp knee in the dis-

ortion curve, it can be said with considerable certainty that if there were any peaks corresponding to voltages greater than $x + 10$ dbm in the signal at the input of the amplifier, there will be none at the output. The fact that no appreciable distortion has been produced is proof that the 10 db factor of safety is sufficient for all normal purposes.

So now let us apply this same reasoning to the home amplifier. If we can determine what volume indicator reading corresponds to the maximum level likely to be required in the listening room, we can add the same 10 db factor as used in the rest of the chain. The use of an amplifier with a power rating greater than this figure is an unnecessary extravagance, especially in view of the signal handling capabilities of the transmitter and receiver detector, or of the recording cutter and pickup.

The required power can be estimated in several ways. In one practical test a volume indicator was placed across the voice coil of a speaker, the volume was set at a level which was considered adequate by a panel of listeners, and then the corresponding volume was calculated, taking into account the difference in circuit impedance. The figure arrived at was around 500 to 600 milliwatts, for really loud passages.

Confirmation of this figure can be obtained in another way. The conversion efficiency of a loudspeaker is measured as the sound pressure in db above an arbitrary level at a distance 10 feet from the speaker in a dead room, for a voice coil power of 1 watt. Figures for typical speakers are given in Table 1.

Note that none of the super-sensitive, high priced speakers are included in the list.

In a listening room, the reflections from the wall will raise the sound level by a very appreciable amount over the value obtained in a anechoic chamber, as anyone who has tried to carry on a conversation in a dead room will agree. Let us make the conservative assumption that this increase is 10 db. An easy calculation then produces the result that 500 milliwatts fed into any of the listed speakers will produce a level of from 93 to 97 db, or about the level of an elevated train at a distance of 15 feet.

It should perhaps be emphasized at this point that we are talking about the reproduction of music for listening purposes, as opposed to the demonstration of high-fidelity systems. This latter requires yet another 10 db factor to take care of the bass and treble boosts.

In the author's opinion, when the equipment is being used at the normal listening level, there should be no

(Continued on page 172)

Table 1. Conversion efficiency of a group of representative speakers in the moderate price class. See text for test data.

MAKE	MODEL	CONVERSION EFFICIENCY
Jensen	P8S	87
Jensen	P10S	90
Altec Lansing	400B	90
Altec Lansing	600B	88
Western Electric	754A	88
General Electric	S1001D	90

FEEDBACK PREAMP

FOR

LOW-IMPEDANCE

PICKUPS

By GEOFFREY H. GREY

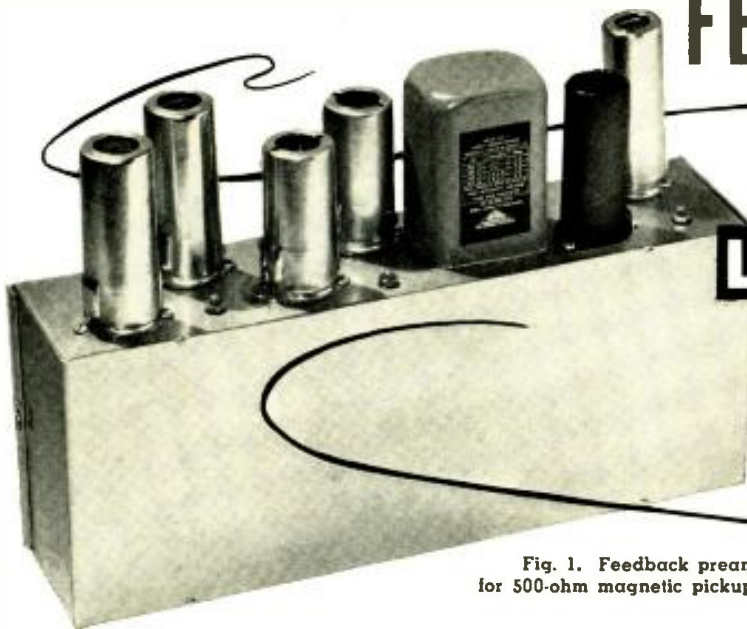

Fig. 1. Feedback preamp for 500-ohm magnetic pickups.

A novel, direct-coupled preamp with a regulated power supply. Standard, non-critical parts are used throughout.

THE common acceptance of the modern "low noise" types of vacuum tube, such as the 12AY7 and 5879, has perhaps been accompanied by a little too much conformity and complaisance, in matters of preamplifier design. It is customary to use the 12AY7, for example, in simple cascade, the two-stage, capacitance-coupled, single-ended, unfeedback amplifier being the most common.

This sort of thing does have the merits of simplicity and economy. Difficulty of construction is minimal, suitable parts values can be found in tube manuals, and the question of distortion can be gently dismissed by reference to the (intended) low level of operation.

The trend is, however, away from unfeedback amplifiers, leading to the state of affairs, already closely approached by some, when the only remaining sources of any form of distortion can be charged against the recording company or the transducer manufacturer. As part of a rebuilding process which followed the purchase of a 500-ohm magnetic pickup, the writer decided to design all the electronic equipment on a feedback basis, with two main stipulations: The realization of an effective 40 db of feedback, or more, over as much of the audible range as possible, and the avoidance of an unreasonable amount of testing.

The general layout was as follows: Pickup-to-input transformer, thence through a feedback amplifier of fairly high over-all gain and low output impedance, then over a long line to the tone control unit. (The preamplifier mounts under the turntable board and the tone control unit is at the armchair.) In view of the proximity of

the motor (a four-pole induction machine), and the transformers of the preamp power supply, a multiple-shielded input transformer was used, in the smallest physical size obtainable, consistent with electrical results of a pleasing nature. This transformer actually has a 600-ohm input. The mismatch due to connection of a 500-ohm pickup to a 600-ohm input is not out of order. It will not affect operation in any way. The photograph of Fig. 1 shows the appearance of the actual preamplifier chassis, on which is also mounted the voltage regulators.

The circuit, Fig. 2, is rather unconventional for audio preamplifiers, although quite ordinary if viewed as an instrument amplifier. Direct coupling is used throughout, except that the transformer is connected to the input grid by a 0.25 μ fd. condenser and the output cathode follower is coupled to the line by another condenser of the same size. The advantage of direct coupling is, of course, that it enables one to build four-stage amplifiers without worrying about the problems of low-frequency stability. This amplifier, with three stages of voltage amplification and one of current amplification, would have been a vastly harder problem if it had not been directly coupled.

Proceeding with a detailed explanation, it will be observed that a 12AY7 is used, with its sections cascaded, in the interests of low hum and noise, followed by a 12AT7, with its sections used as voltage amplifier and cathode follower, respectively. Approximate stage gains are 15, 15, and 30, the last, cathode follower stage being neglected. There is thus a midband gain of 6750, before feedback.

Examination of the feedback loop reveals that the output voltage is divided by 2 (R_{12} and R_{13}), for all frequencies. At frequencies higher than the 10 cps region the 0.25 μ fd. condenser behaves as a short circuit, so that there is a further attenuation in the feedback loop of 30 to 1, the ratio of R_2 and R_1 , so that the feedback voltage is 1/60th of the output voltage, and the over-all voltage gain closely approaches 60. Since the input transformer contributes another factor of ten to the voltage gain, the final over-all gain, from line-to-line, is 600, voltagewise. The degeneration is, in the midband, the ratio of 6750 to 60, numerically, or 115 (41 db).

The purpose of the 0.25 μ fd. input condenser is to prevent the d.c. bias for the input tube, provided by the feedback loop, from being shorted out to ground by the transformer. Another way of looking at this is that the entire output voltage of the amplifier is, at d.c. and very low a.c., fed back to the input (subject to the attenuation of the R_{12} - R_{13} divider). The condenser prevents an undesired division by 30, which would have occurred to both a.c. and d.c., if it had been absent. It is best to have as much d.c. feedback as possible in amplifiers of this type, for then the maintenance of the calculated operating conditions will be more nearly guaranteed. The d.c. gain is not, of course, required in audio equipment, for its own sake, since we cannot make audible use of it!

The interstage coupling networks are returned to -105 volts, derived from an 0B2 which is supplied with well-filtered d.c., so that they attenuate signal voltages as little as possible. As it turned out, d.c. signals are attenuated by about 6 db per stage, while above about 60 cps there is very little attenuation, due to the bypassing of the upper resistor of each pair.

The plate load resistors are chosen on the basis of the gain and bandwidth required in each stage. They

are large enough to furnish sufficient gain (to meet the over-all gain and feedback requirements) and small enough so that control of the internal gain, to avoid oscillations, is not too much of a problem.

The interstage network between the first and second stages serves to introduce a controlled loss, starting below 1 kc. and levelling off before 20 kc., the region where the transformer is starting to let down. This simple expedient suffices to avoid oscillation, although the presence of a transformer, even at the input, is usually very troublesome.

It will be noted that the input arrangements are such as to put the coupling condenser C_1 on the "low" side of the secondary winding. The reason is that this makes for fewer parts hung on the high impedance side, and hence less capacitance across the winding. It is also neater physically, since one terminal of the transformer acts as a tie point for the condenser and the other for the resistor. In this way a very small mechanical configuration and minimum lead length, always advisable in high-impedance, low-level circuits, is obtained. (The whole amplifier was, as a matter of fact, built point-to-point, which can be hard work).

The resistors in the feedback (and throughout the amplifier) were ordinary carbons, although this is not necessarily the best practice. The newer film resistors are, in general, better for this purpose. Wirewound resistors are, of course, expensive and are limited to low frequencies.

Since the input resistance of the amplifier proper is only 100,000 ohms, it did not prove necessary to compensate the feedback dividers, although this was tried at first. The bandwidth is, in any case, limited by the response of the transformer, which starts down at about 30 kc. In the absence of the transformer, and if better high frequency results were desired, trimming of the feedback loop would have been necessary.

Choice of the operating conditions for the various stages was made as follows: It was necessary to limit the power supply voltages to those available from the smallest sizes of stock transformer (the transformer people just don't seem to find it profitable to put out transformers in the 40 to 60 ma. range in much over 250 volts d.c. output). The positive plate supply, after filtering, came out at 275 volts d.c., and this potential was applied to an electronic regulator. Using a 12B4 for the series tube, with a very liberal 95 volt drop across it, the regulator output was 180 volts. This is sufficient for low level devices, although the gain figures will, naturally, be lower than with the usual 300 volt supply.

With reasonable plate currents, the triodes 12AY7 and 12AT7 demand at least 100 volts plate voltage for proper grid bias and hence low grid current. This leaves 80 volts available for the plate load resistors, or, in the

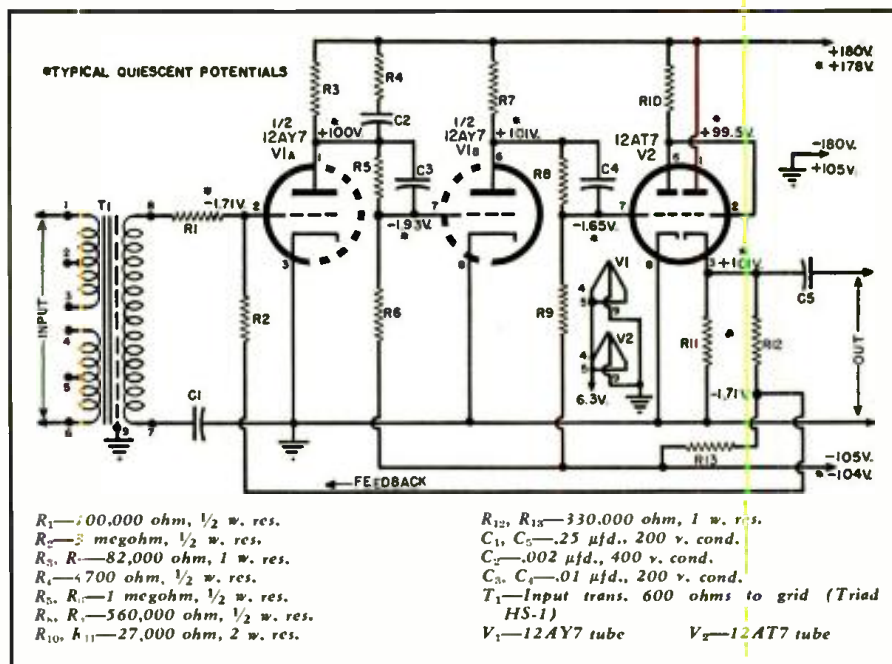

Fig. 2. Complete schematic of preamp circuit designed for 500-ohm magnetic pickups.

case of the last stage, the cathode resistor. One milliampere through each of the 12AY7 stages seemed a good choice, yielding adequate gain, which meant the use of an 82,000 ohm resistor. The last voltage amplifier stage and the cathode follower were run somewhat hotter, at three milliamperes apiece, which meant a 27,000 ohm resistor for each of the 12AT7 sections. These first choices, though

not completely ideal, have proven adequate.

The power supply, Fig. 3, is very simple, even though it is somewhat more elaborate (not complicated) than is usually used with preamplifiers. A 12B4 is used to regulate the positive plate supply, with a 12BY7 as control tube. An OB2 does an adequate though unremarkable job on the

(Continued on page 166)

Fig. 3. The preamp power supply is more elaborate than most but not hard to build.

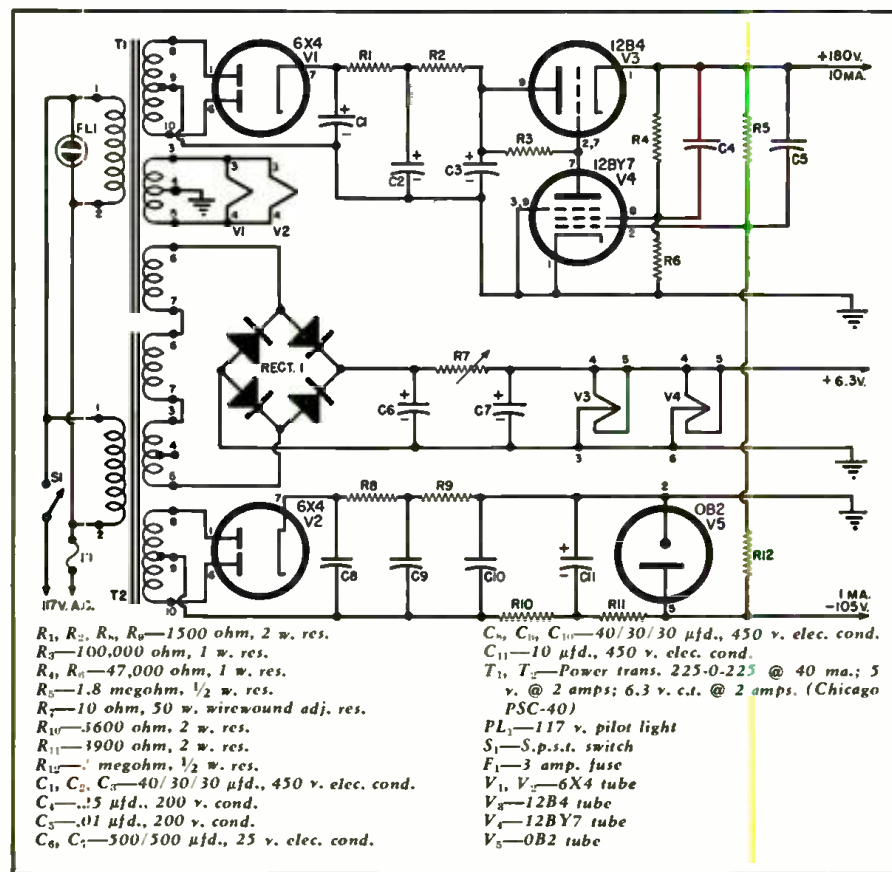

IMPROVING THE

Fold-a-flex

A NEW feature has been added to the original "Fold-a-flex" design, described last month, in order to make provision for an adjustable horn throat. Because of the wide variation in loudspeakers, manufacturers have discovered that in order to obtain optimum bass performance at low distortion from specific loudspeakers the impedance of the air must be matched to that of the mechanical vibrating system. Because the "Fold-a-flex" is not restricted in use to either a flat wall or corner we realized the necessity of providing as many adjustable components as feasible to achieve the best possible results from speakers having dissimilar characteristics.

It is essential in the design of folded horn enclosures to determine, by test, the proper cavity area directly back of the loudspeaker and the dimensions of the rear exhaust ports which act as acoustical low-pass filters.

Laboratory and listening tests on the original "Fold-a-flex" enclosure revealed a tendency, as a "folded horn," of certain loudspeakers to become "boomy" at frequencies below 100 cps. This condition was corrected by making the two fins, X and Y, adjustable as shown in Fig. 1. By making the cavity and slit port combination variable it is possible to set the fins to properly "back load" various loudspeaker cones and to alter the horn flare taper.

The relationship of the two fins to the stationary folded horn fins results in a form of acoustical low-pass filter. In addition, a change of horn flare acts to *simulate* an exponential horn to some degree.

Note that there are two distinct functions of the two fins X and Y. When these are spread to almost engage the two corner horn fins, the sound path, as shown in Fig. 1A, results. Note that the taper of the horn flares becomes greater at this setting. Obviously the two fins should be similarly positioned.

When fins X and Y are nearly closed the sound path will be that of

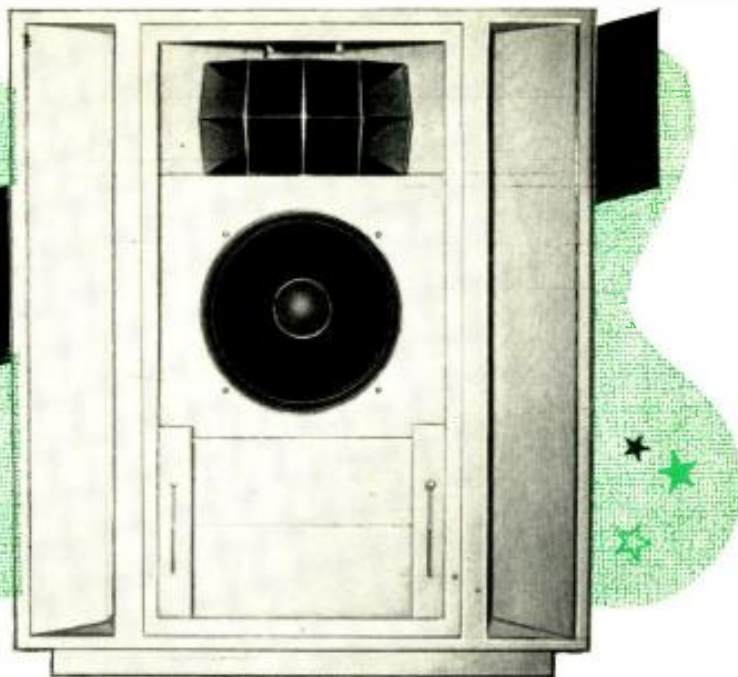

First production model of the Read "Fold-a-flex," as made by Stephens Mfg. Corp., prior to final finishing and mounting of the hardware and grille.

Means for an adjustable low-pass acoustical filter are provided in this improved version of the "Fold-a-flex".

Fig. 1B and the cavity within the area will be radically changed from the characteristics of Fig. 1A. In this position the taper of the flare will depart greatly from that of a true exponential but in certain cases might be desirable providing it would not distort or give a boominess of bass frequencies during reproduction. Actually, a variable cavity is formed by the positions of the fins X and Y. The ultimate test, therefore, is one of listening to the sound and setting the fins for most pleasing results.

The variable fin feature may be eliminated in production models after measurements and where specific loudspeakers are chosen for the enclosure. A considerable saving in production costs results.

The source of sound lies in the realm of physics while the effect of sound is a physiological consideration. The engineering of sound consists of controlling the cause so as to produce the desired effect.

We feel, therefore, that any reproducing system not capable of producing the "desired effect" falls short of serving its purpose.

Fig. 1. Partition fins X and Y are made variable. Optimum throat exhaust (A) and adjustable cavity (B) to load the cone are provided in this "Fold-a-flex" design.

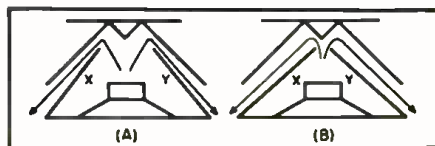

Performance-wise, the "Fold-a-flex" contains all of the ingredients of a highly-efficient loudspeaker enclosure. Because of its adaptability to any normally-encountered room acoustics and to an individual's preference for "satisfactory listening" it does offer a wide range of "characteristics" that lends itself to any installation. The versatility of the "Fold-a-flex" is shown by reference to Fig. 3 which illustrates the many possible enclosure combinations.

The construction of the "Fold-a-flex" enclosure requires a bit of skill in carpentry. Lacking this requisite, the cutting and bevelling of the pieces should be done by a local mill or large lumber dealer. It is imperative that all essential gaskets provide an air seal at points described. Suitable gasket material may be obtained from building supply firms or automotive body works. Half-round vinyl or felt is suitable. Allowances must be made for including the gaskets—depending on the thickness used. Fins X and Y should fit into the cabinet fairly tightly so that the gaskets will be slightly depressed. Lines may be drawn on the inside bottom board of the enclosure to show the positions of fins X and Y as observed by viewing through open ports A and B. The fins are accessible by reaching into the horn ports.

The gasket strip around three edges of ports A and B should be tacked temporarily before final fitting. When hinged in the enclosure, they must bear evenly at all points without binding. Our own models were first as-

sembled with nails (driven with heads exposed). The assembly was then touched up for perfect action of the ports and fins and then taken down for adding the *Kimsul* or *Ultralite* padding. The final step is to carefully glue the assembly and to reinforce the structure with blocks and bracing. The bottom of the cabinet may be secured with screws if preferred.

The dimensions shown in Fig. 2 are for 15-inch loudspeakers. The same design may be followed for an 8-inch loudspeaker by halving the inside dimensions throughout, with the exception of the speaker cut-out hole which should be 7 inches in diameter. Allowances must also be made for variations in wood thickness. One particular model, just completed, follows this formula and the "Fold-a-flex" is constructed with 1/2-inch pine plywood. Results using a *Permoflux* "Royal Eight" speaker, or other 8" speaker of good quality, points to this half-sized enclosure as being well suited to small apartments or wherever space limitations exist.

The "Fold-a-flex" design has been found to provide exceptionally clean reproduction with 2- and 3-way systems. The model (page 68) uses a *Stephens* 103LX low-frequency woofer, an 824H multi-cellular horn with 216 high-frequency driver and 800-cycle crossover network. The height of the cabinet has been slightly increased to accommodate the horn. A partition (shelf) was added to isolate the horn from the main enclosure. The ports have no acoustical effect on the section added for the multi-cellular horn.

Another experimental model (at this writing) uses a *Jensen* G-610 Tri-axial speaker. Listening tests reveal exceptionally clean response throughout the range of the speaker.

Many other speakers are now being tested and performance data will be presented after tests are concluded.

(To be continued)

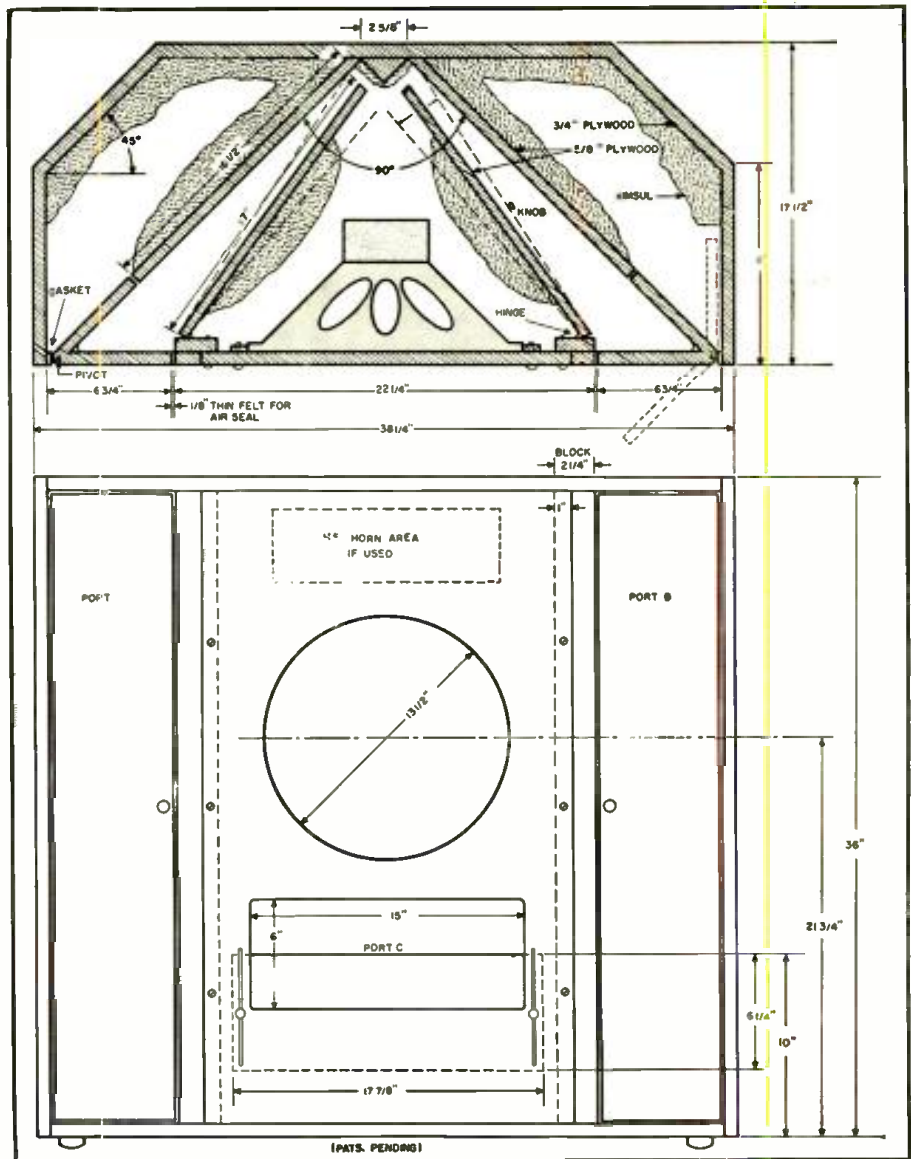
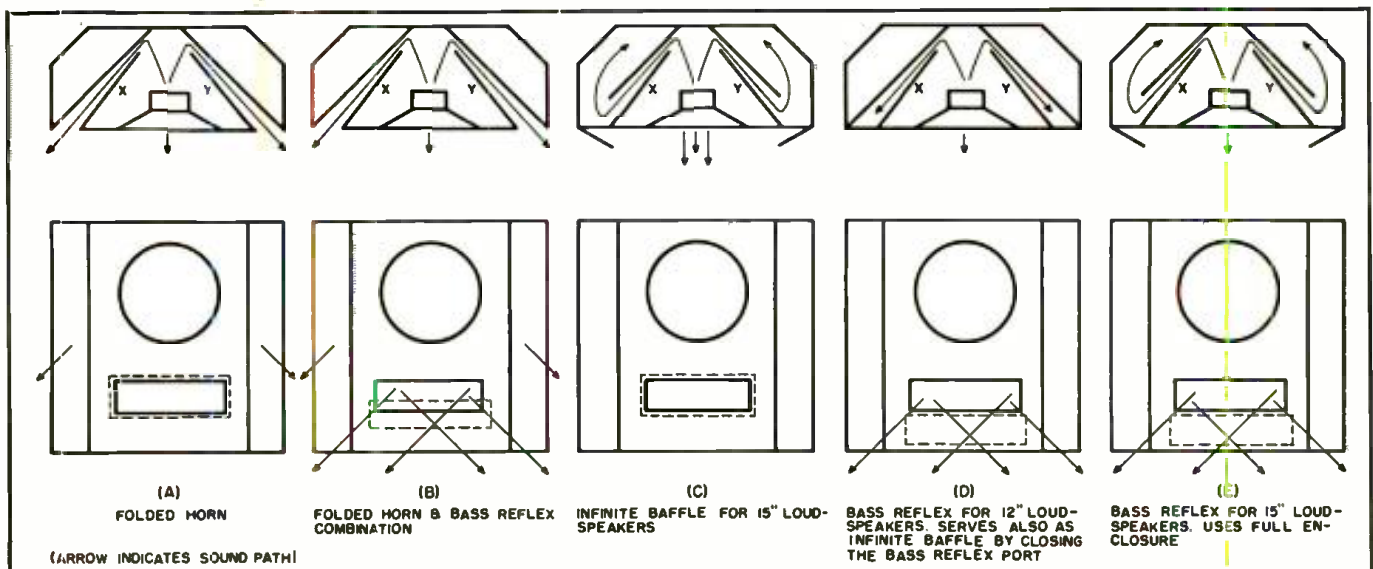

Fig. 2. Latest "Fold-a-flex" design includes the adjustable "V" ports A and B and features variable cavity and horn throat adjustments. The dimensions are for 15" speakers. Space is provided for high-frequency horns for two-way systems.

Fig. 3. Some of the baffle characteristics available in the "Fold-a-flex." The enclosure has been used successfully with one-, two-, and three-way speaker systems. Partition fins X and Y serve to vary the cavity area and to alter the throat as a folded horn. Gaskets mount on top and bottom edges of fins X and Y. Arrows indicate the sound paths when changes are made in ports A, B, and C.



Certified RECORD REVUE

By BERT WHYTE



Born in Belfast, Ireland on Feb. 22, 1920, Mr. Whyte came to this country as a small child. After attending New York schools, he headed for India on a tramp steamer and for a few years traveled extensively on everything from tankers to four-masted schooners. The knowledge of ships thus gained led to a post with the British Ministry of War Transportation before U. S. entry into the War. He was a lab technician in the U. S. Army Medical Corps for 3 years. After his discharge he engaged in importing and exporting in New York until his audio hobby became his life work. He has been audio consultant for Concord Radio of Chicago and sales coordinator for Magnecord. He is now with a new multi-channel sound division of MGM-Loew's, Inc. in New York.

BY THE time you read this, the 1953 New York Audio Fair will have passed into history. If you were lucky enough to have attended, you know how you came reeling out of the Hotel New Yorker, your mind bedazzled with all the fabulous new equipment to titillate your senses and deplete your pocketbook. Yes sir, the manufacturers have all dished up some mighty tasty items for your audio delectation. With the uniformly excellent quality and wide price range of audio equipment, almost everyone can enjoy the benefits of high fidelity sound reproduction. You might say that the "Golden Age of Audio" is upon us, with multi-page spreads in "Life" on the subject and with all the commercial manufacturers climbing on the high-fidelity bandwagon. In the midst of all this rosy aura of optimism, this old curmudgeon is going to sound a few sour notes.

What about? What gripes can I possibly have against all this shiny new equipment? None. None at all. I, too, can appreciate super-featherweight pickups, which are kind to your records as well as kind to your ears. And I can't quibble with amplifiers as clean and pure as the driven snow. Who will argue the merits of mammoth loudspeakers and enclosures good enough to reproduce the last grunts of a wounded hippopotamus? No, I take no issue with the equipment *per se*. But did it occur to you, as you walked around the various exhibits at the fair, that there was a certain frustrating *sameness* about the equipment that you saw and heard? And what was this "sameness" that I'm

in such a tizzy about? Why friends, it was all the *same old point source monaural sound* we've had for years. Sure it was served up in many a fancy new way, but *still* it was the *same type* of sound you got from your *Atwater Kent* a long time ago. Right about here someone is going to yell, "Whyte must be nuts, there was binaural and stereophonic sound all over the Fair." True. Yes, from the exhibit room of some of the tape machine manufacturers and a few others, glorious sound issued forth. Big sound, live and round, *natural* sound. *BUT* was this sound for *YOU*? Could you dash out to your favorite audio emporium and have them deliver a 3-D outfit to your home? Well, maybe a few of you "money-is-no-object" boys could, *but*, and here is the rub, what would you *play* on this equipment assuming you could afford it? Stumped? I know you are. Now let me get to the meat of this epistle and see what light we can throw on the why's and wherefore's.

First of all let me take a stand or two. One, no matter what you call it or how you slice it, multi-channel sound, binaural or stereophonic, the enhancement of sound movement and perspective, *apparent* increase in dynamic range, all these factors add up to an infinitely preferable sound over the ordinary monaural system. I have heard and read all the learned dissertations on binaural sound, *et al*, and what it will and won't do. I can only speak from experience. At the risk of appearing offensively boastful, I think I can truthfully say that I have done more actual binaural or

multi-track recording than anyone in the country (at least in the field of music; naturally telemetering must be excluded). All this recording activity, sometimes under very poor conditions, but mostly under perfectly controlled ideal set-ups, has led to the above conclusion; multi-channel sound and variations thereof *works* and is vastly more satisfying technically and esthetically. OK, you say, how do we get with this new sound without hocking your wife. Not so fast, boys! As I stated earlier, the problem isn't as simple as dollars and cents. In order to enjoy binaural sound in the home, it is necessary to have the following: a tape machine with a pair of stacked heads, two amplifiers, two loudspeakers, and/or twin-channel earphones, and a multi-track recording with the number of tracks corresponding to the number of heads in your outfit. Are all these components available? Yes, *but not the tape!* Oh, I've seen a few tapes advertised, but believe me they are not the kind of thing the readers of this column are used to as far as quality and musical material is concerned. When *are* binaural tapes going to be available? Why doesn't some enterprising company make some? The answer to this isn't simple either. For one thing, no truly satisfactory method of tape duplication has yet been devised.

The most common system, employing many tape machine "dubbers," operating from a master machine, is cumbersome and expensive. Under carefully controlled conditions, this method is capable of producing high-quality tape duplicates. The trouble is in the fact that this is not a *quantity* method. Let me assure you of one fact; the moment binaural sound looks like it's going to pay its own way as a commercial entity, someone will come up with a successful mass production duplicator. In all seriousness, I can tell you I've even seen tentative designs for such a machine. The "kicker" in the above paragraph, if you didn't catch it, was the phrase "commercial entity." We're caught in sort of a vicious cycle. Without the tape and an inexpensive machine to play it on there will never be a mass market for binaural. And *vice versa, ad infinitum*. To get the binaural ball really rolling, someone is going to have to have a lot of faith and a lot of money behind that faith. For the sake of example, let's assume that the duplication problem has been solved. We're *still not in business*, because up to the moment this was written, a *ban* on binaural recording imposed by the Musician's Union precludes the development of a mass market. At about this point, I'm sure you're ready to throw your hands in the air and give up. It is a rather grim picture, isn't it?

Well, there are a few rays of sunshine in the clouds, and given a reasonable amount of luck, and a few carloads of faith and foresight, we'll

(Continued on page 174)

EXPONENTIAL HORN DESIGN

By **JOSEPH F. SODARO**
Registered Engineer

Nomographs and instructions for calculating exponential horn taper and curvature for low- and high-frequency horns.

THE design of an exponential horn requires the determination of contour as well as throat and mouth dimensions in accordance with the frequencies to be propagated. From this design, templates are laid out from which material is cut and the horn constructed. It is the purpose of this article to set forth a procedure, simplified by graphical methods, for the determination of these design parameters.

The exponential horn is shown in Fig. 2. The shape of this horn depends upon an area change according to an exponential. Thus, the area, A_2 , at any distance, l , from a given point is the cross-section area at that point, A_1 , multiplied by e^{kl} . The horn functions as a high-pass filter and the lowest frequency transmitted by the horn is designated the cut-off frequency. The factor k in the exponential e^{kl} is determined by the cut-off frequency.

The horn must be a transition which matches the driver motor to free space. To meet this requirement the mouth must be sufficiently large. The minimum requirement for mouth size is that the perimeter of the mouth is at least one wavelength of the lowest frequency to be reproduced. The cross-section shape may be square, rectangular, circular, triangular, or a combination of these shapes. For example, high-frequency horns often have a circular throat and a rectangular mouth. However, if the design criterion that cross-section area varies exponentially with length is met, this change in cross-section shape is permissible.

The horn flare may be in one dimension or two dimensions. Fig. 1A and B are one dimension while C, D, E, F, G, H, and I are two-dimensional flares. These are front view drawings looking directly into the horn from mouth to throat. These are possible cross-section combinations which are presented merely to show that the designer must be aware of the shape at any point to correctly compute cross-section area. However as the cross-section changes from one geometric figure to another, the change must be gradual and the horn contour must be smooth.

Design Procedure

First determine the throat area. For high frequency drivers this is the area of the coupler unit. The nomograph shown in Fig. 5 has been designed for the rapid evaluation of cross-section areas. If the coupler unit is circular,

locate the diameter on the b scale. On the opposite side of this scale read the cross-section area of this circular section. Determine the throat area for dynamic speaker drivers in a similar manner. A throat area somewhat less than the diaphragm area is desirable in this case. Locate the diaphragm diameter on the b scale and read area on the opposite side as before. If the throat is square locate the base or height on the h scale. On the square area scale opposite read area of the cross-section in square inches. To determine a rectangular section area find the base dimension on the b scale and the height dimension on the h scale. Connect these scale points with a straightedge and read the answer on the rectangular area scale. The area of a triangular section can be determined similarly if b and h scale readings are base and altitude dimensions, respectively. In this case the answer is read on the triangular area scale. All of these procedures are reversible. Thus, for a given area, the figure dimensions can be determined. This method of working from the answer is handy for rectangular and triangular sections where the straightedge can be pivoted on the desired answer while the combinations of dimensions which will yield this answer are observed.

Second, lay out the template drawing using the dimensions given in Tables 1 and 2 accompanying Figs. 3 and 4. For square, circular, and tri-

angular cross-sections a one-view drawing is sufficient. For rectangular cross-sections plan and elevation views are required. Draw the center-line, throat dimension, and cross-lines at intervals separated by a convenient dimension. High-frequency horn contours should be exactly determined with cross-section dimensions at every inch of length or so. In low-frequency horns the approximate shape is generally acceptable. The material used in fabricating the horn also enters into this decision. Pliable materials such as sheet metal can be made to conform to the exact contour while less pliable materials may only approximate the exact exponential shape.

Fig. 6 is a nomograph designed to rapidly give cross-section increase corresponding to a given cut-off frequency. The first scale on the left gives the incremental lengths at which the cross-section increases 10 per-cent (1.1 times) for a given cut-off frequency. The center scale may be used for center-range frequencies. This scale gives incremental lengths at which the cross-section doubles. The third scale gives lengths for cross-section area increases of 10 times for high-frequency horns. To use this chart simply locate the desired cut-off frequency on the f scale and read the distance between cross-lines on the l scale at which the cross-section area is increased by the factor for the scale being used.

Fig. 5 will now give the dimension

Fig. 1. Cross-section shape combinations. See text for complete discussion of shapes.

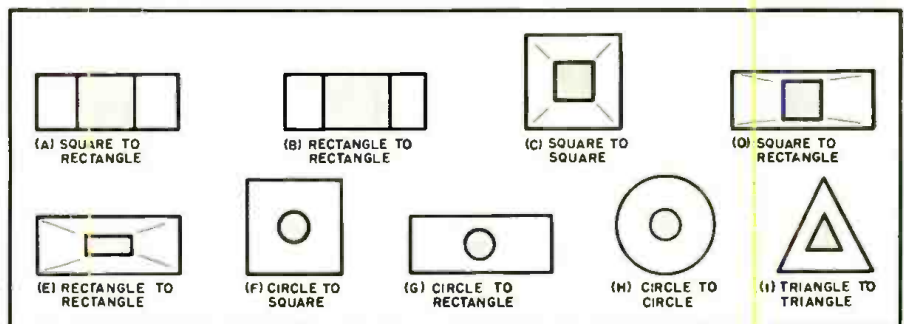

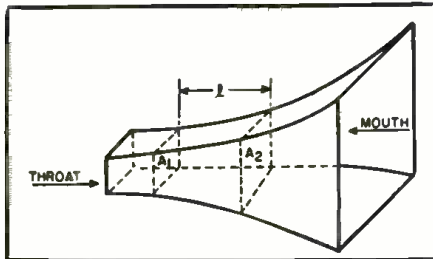

Fig. 2. A conventional exponential horn.

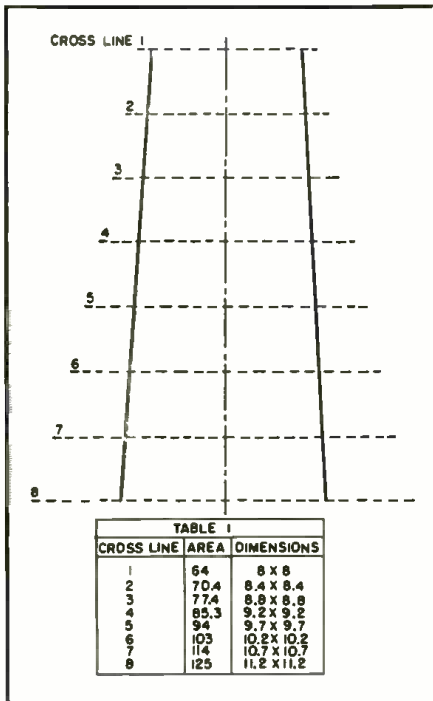

Fig. 3. Details for laying out a low-frequency horn template. The dimensions of Table 1 should be used in construction.

at each cross-line. Start with the throat area and multiply this by the area increase factor from Fig. 6. Locate the new area on Fig. 5 and determine cross-section dimensions. Multiply this area by the factor, locate dimensions on Fig. 5, and continue until all dimensions are determined. The template drawn in this manner, to the proper dimensions, is the plane-projected view of a curved surface. It may be used directly as the material pattern if the flare is gradual. When designing horns with rapid flares it is necessary to rectify this curved surface to obtain an accurate pattern. This process is explained under example 2.

Refer to Fig. 7 which relates frequency (in cycles-per-second) to wavelength (in inches). Locate the cut-off frequency on the f scale and read the corresponding wavelength on the λ scale of this nomograph. The perimeter of the mouth must equal or exceed this value for proper termination of the horn. The perimeter is the sum of the side dimensions for square, rectangular, and triangular horns and 3.14 times the diameter for circular horns.

Examples: As a first example design a horn to be driven by a 10-inch dynamic speaker with cut-off at 30

cycles-per-second and crossover (upper frequency limit) at 800 cycles-per-second. Use a square throat and square mouth cross-section such as that shown in Fig. 1C.

On Fig. 5 locate 10 inches on the b scale and read 79 square inches on the circular area side of the scale. This is the driver diaphragm area. Use a throat area of 64 square inches. Locate this value on the square area scale of Fig. 5, and read 8 inches on the opposite side. Thus, the throat is 8" x 8".

Locate 30 cycles on the f scales of Fig. 6. Read 3.5 inches on the 1.1 scale. Thus, the cross-section area increases 10 per-cent every 3.5 inches. Lay out the correctly-scaled template center-line and cross-lines as shown in Fig. 3.

The cross-section area at cross-line 1, Fig. 3, was 64 square inches. Add 6.4 to 64 to obtain 70.4, a 10 per-cent larger area. Locate 70.4 on the square-area scale of Fig. 5. Read 8.4 inches on the h scale opposite. Add 7 to 70.4 (or multiply 70.4 by 1.1) to obtain 77.4. Locate 77 on the square-area scale and read 8.8 inches on the h scale. Repeat this process to obtain Table 1, a tabulation of horn dimensions at each cross-line. Plot these points on the template and connect with a smooth curve to obtain the horn contour. Since the cross-section is square throughout, this pattern can be used for all sides.

Refer to Fig. 7. Locate 30 cycles-per-second on the f scale and read 440 inches, one wavelength, on the λ scale. At cross-line 8 the mouth perimeter reached 448 inches. This exceeds one wavelength for the lowest frequency to be transmitted and thus is a suitable termination.

As a second example, design the high-frequency horn for this system. The required cut-off frequency is 800 cycles-per-second. The driver has a

coupler of one-inch diameter. The horn cross-section will progress from circular to square as shown in Fig. 1F.

Refer to Fig. 5. Opposite 1 on the b scale read 0.79 square inches on the circular area scale. This is the throat area. Draw the center-line and throat diameter line as shown in Fig. 4.

Refer to Fig. 6. The applicable scales indicate that the horn cross-section area increases 2 times every 0.92 inch or 10 times every 3 inches for a cut-off frequency of 800 cps. Select one-inch cross-line spacings for doubling area which makes the cut-off 735 cps. Draw in the cross-lines. Multiply 0.79 by 2 to obtain 1.58 square inches, the required area at the second cross-line. Since this is to be a square section, locate 1.58 on the square area scale of Fig. 5 and read 1.25 inches on the opposite side h scale.

Again, multiply 1.58 by 2 to obtain 3.16 square inches at the third cross-line. Locate 3.16 on the square area scale of Fig. 5 and 1.25 on the h scale. Repeat this procedure to obtain Table 2. Plot the points. Join all points with a smooth curve.

Use Fig. 7 to determine 16.5 inches, one wavelength, for a frequency of 800 cps. The mouth perimeter is 20 inches at the sixth cross-line which exceeds one wavelength.

Contour $ABCD$ of Fig. 4 is an outline of the assembled horn. This plane view of the curved surfaces which form the sides is not sufficiently accurate for use as a pattern because of the rapid flare. For example, the surface $ABCD$ actually curves out of the page toward the reader. This drawing must be rectified to give a flat pattern. This flattening process may be visualized as pulling edge BC downward while edge AD remains fixed. Thus, each cross-line will move slightly down the page.

A simple curve rectification process is based on the principle that over short arc lengths the chord length equals the arc. Thus, best accuracy is obtained when many short chords are used to approximate the curve. In this case two chords between each cross-line should give a good approximation.

Draw AE , a straight line, tangent to AB at A . With dividers step-off the distance between cross-lines 1 and 2 adjusting dividers until this is done in exactly two steps. Without changing divider setting, step-off an equal length on AE . This locates cross-line 2 on the flat surface. Repeat this procedure for all cross-lines. At these new positions locate widths corresponding to each cross-line. Connect these points to obtain $AFGD$ the required pattern.

This procedure was actually the rectification of the side curvature, but since the same curvature applies to the front of this symmetrical horn, the side curvature may be used. In those cases in which side and front planes have different flares, be sure to rectify the front plane curvature which actually appears on the side view, and then apply this cross-line location to the front view to lay out the pattern.

Fig. 4. Model for preparing the high-frequency horn template which goes from a circular throat to a rectangular mouth. Full-scale template should be prepared from the dimensions shown in Table 2.

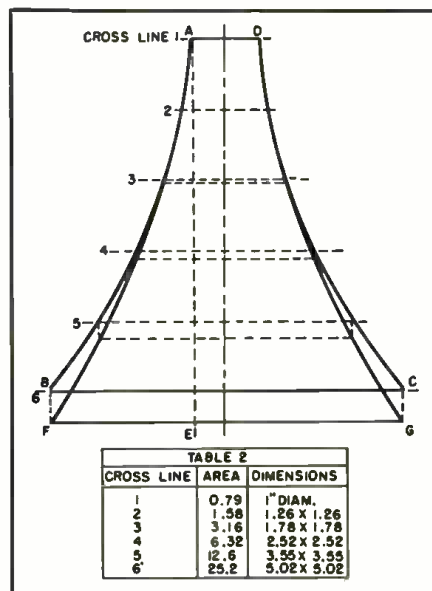

The reader may be interested in knowing that a simple method of converting from decimal to fractional measure if a decimal equivalent table is not available is to multiply the desired fractional denominator by the decimal. Select sixteenths, thirty-seconds, or sixty-fourths to obtain the required accuracy. For example, change 2.6 inches to a fraction. Since this means two inches plus six-tenths of an inch, we multiply 0.6 by 16 to obtain 9.6/16. We could round this off to 10/16 or 5/8. Thus, the equivalent measure is 2 5/8 inches. On the other hand we can multiply 0.6 by 64 to obtain 38.4/64 which gives 3 3/4 or 10 3/32 inches when rounded off.

Construction

We have now presented all of the theoretical data needed to design exponential horns. This, of course is the easiest part. Once designed, however,

the reader is faced with the problem of transferring his computations into wood or metal.

This is, unquestionably, the most difficult part. The problem of obtaining the proper horn curvature is admittedly hard. Manufacturers of such exponential horns have available all of the necessary forming tools. Lacking these, the home constructor is faced with several mechanical problems. The job can be done, however, if the builder possesses the requisite mechanical "know-how."

These horns may be constructed of either metal or wood. Metal horns should, of course, be of heavy material to prevent mechanical vibration in the horn itself.

Appendix

Fig. 5 solves the following equations:

$$A = \pi b^2 / 4 \dots \dots \dots (1)$$

$$A = bh \dots \dots \dots (2)$$

$$A = bh/2 \dots \dots \dots (3)$$

$$A = b^2 \dots \dots \dots (4)$$

in which A is cross-section area, b and h are defined by the drawings on Fig. 5.

The exponential horn area changes in accordance with

$$A_2/A_1 = e^{kl} \dots \dots \dots (5)$$

in which A_2 and A_1 are cross-section areas spaced a distance l , and k is the flare constant. If the cut-off frequency is f then:

$$4\pi f = kc \dots \dots \dots (6)$$

in which c is the velocity of propagation for sound in air. Substituting and taking the log to the base e and solving for l ,

$$l = (\log A_2/A_1) / (4\pi f/c) \dots \dots \dots (7)$$

The nomographs in Fig. 6 solve eq. (7) for $A_2/A_1 = 1.1, 2, \text{ and } 10$ with $c = 13,200$ inches-per-second. Fig. 7 solves the equation,

$$f\lambda = 13,200 \dots \dots \dots (8)$$

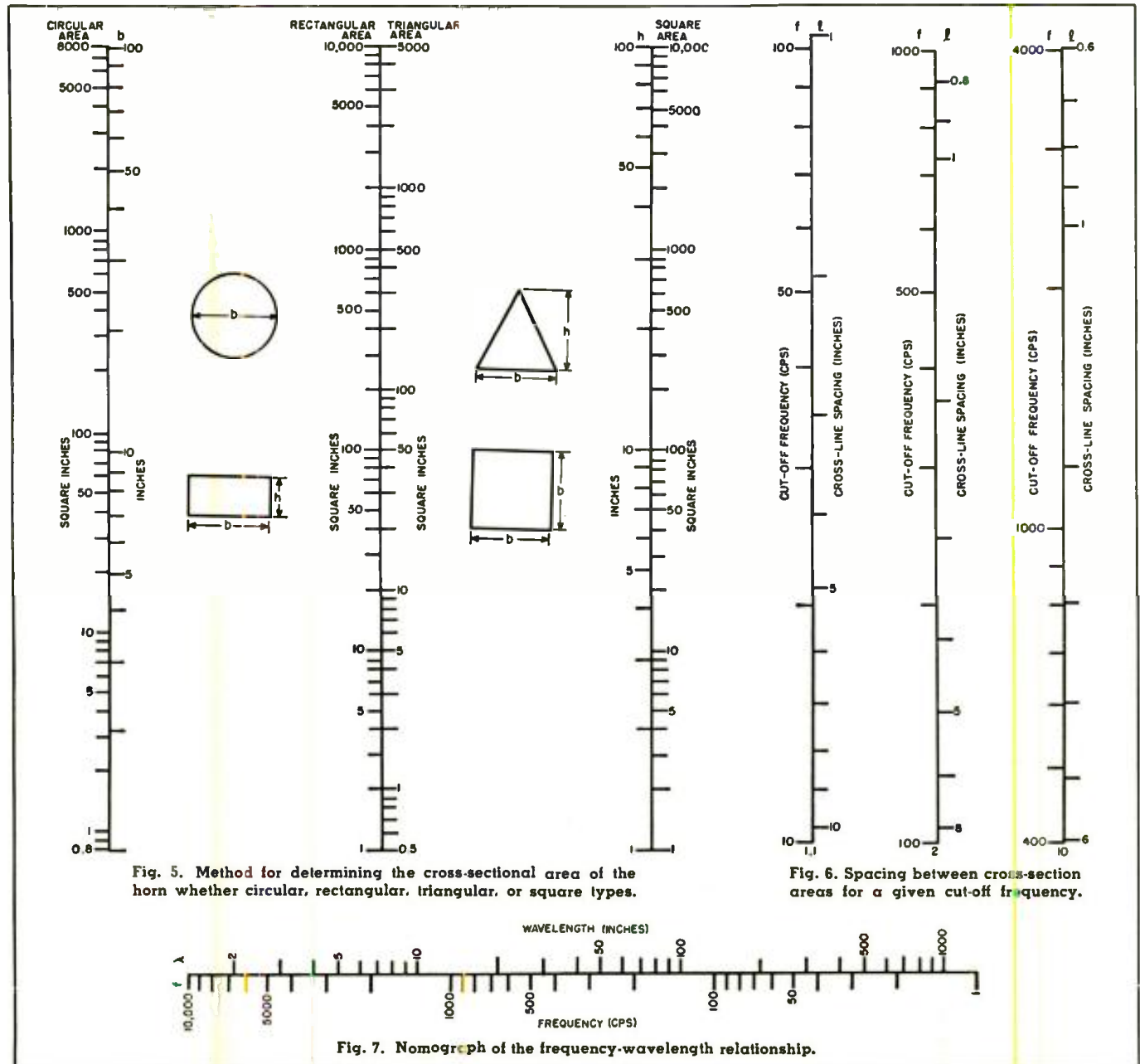

TRANSISTOR GUITAR AMPLIFIER

By LOUIS E. GARNER, JR.

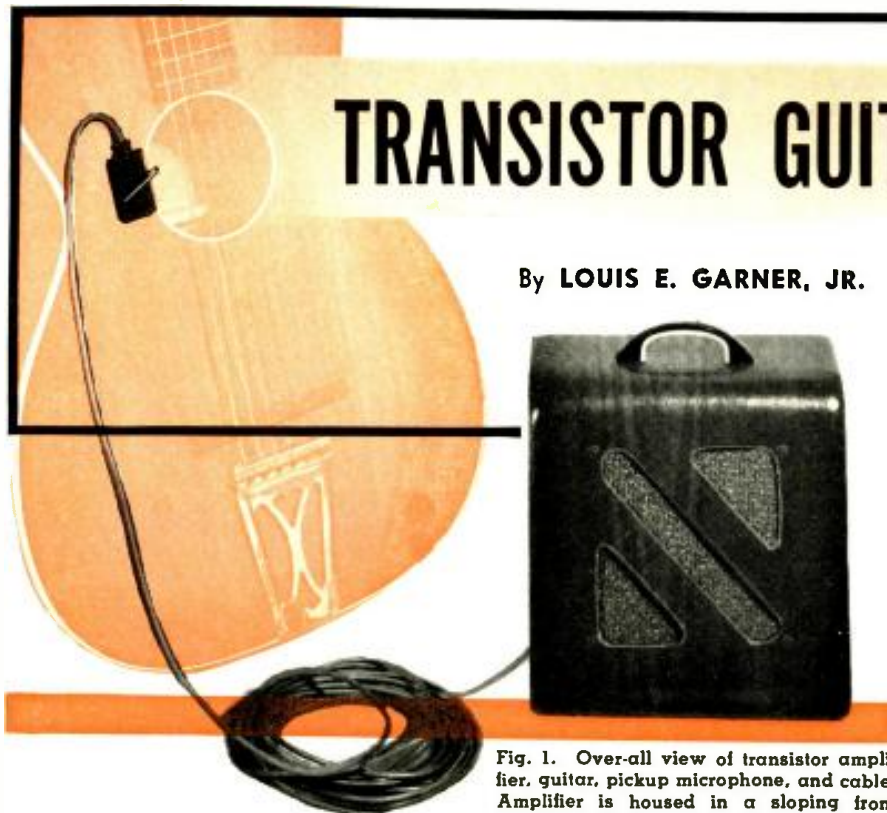

Fig. 1. Over-all view of transistor amplifier, guitar, pickup microphone, and cable. Amplifier is housed in a sloping front panel wall baffle instead of a "cabinet."

This multistage unit uses four transistors, operates from a single 6-volt battery, and will withstand heavy portable use.

A GUITAR amplifier provides an interesting construction project for the experimenter or technician who wishes to "try his hand" at building a multistage, transistor-operated audio amplifier. Such an amplifier is shown in Fig. 1, together with the guitar with which it is used and the pickup microphone and cable.

Interior top and bottom chassis views of the amplifier itself are given in Figs. 3 and 4, respectively.

Although the amplifier shown cannot be considered as a substitute or replacement for a conventional vacuum-tube amplifier because of its low power output (a fraction of a watt), it does offer several advantages over conventional amplifiers for some applications.

First, its small size and light weight make it an ideal instrument for portable use—even a small child can carry it without difficulty. Secondly, since the power supply is self-contained (a battery), the instrument may be used wherever desired—at picnics, lawn parties, weiner roasts, or at similar outdoor functions.

Another advantage is its low maintenance cost. Except for an occasional battery replacement, the amplifier should seldom, if ever, require any adjustment or servicing. It certainly will never require replacement tubes!

Another, perhaps less apparent, advantage of the transistor amplifier over a conventional vacuum-tube amplifier is its over-all ruggedness. With

no tubes to shake out of their sockets, or tube elements to loosen and become microphonic, the amplifier can withstand a considerable amount of "jouncing" in the trunk of an automobile or on the floor of a station wagon.

The transistor guitar amplifier is fairly easy to assemble and wire. The average technician will find that it makes an excellent "week-end" construction project.

Circuit Description

As can be seen by reference to the schematic diagram of Fig. 2, the complete amplifier consists of a two-stage "voltage amplifier" followed by a push-pull output stage.

A Brush "Vibromike" vibration microphone is used on the guitar, with a shielded cable connected between the mike and the input jack (J_1) of the amplifier. The signal obtained from this mike appears across R_1 , which serves as the "Gain" or "Volume" control.

In designing transistor-operated audio amplifiers, it is important that the signal level be controlled in such a fashion as to avoid changing either the base "bias" current or the collector current of any transistor stage.

C_1 serves as a blocking condenser to prevent the comparatively low d.c. resistance of the primary of T_1 acting as a shunt across R_1 . T_1 , in turn, is used to match the high microphone and "Gain" control impedance to the low input impedance of the transistor

amplifier. Thus, a stepdown turns ratio is used in this transformer.

The a.c. signal appearing across the secondary of T_1 is coupled through d.c. blocking condenser C_2 to the base of the first CK721 transistor amplifier stage. R_2 serves as the "base return" resistor and establishes the "bias" current for this stage, being returned to the negative terminal of the power source, B_+ .

An amplified signal appears across the primary of transformer T_2 . This transformer is used to perform a function similar to that of T_1 . Where T_1 serves to match the high microphone impedance to the low input impedance of the transistor amplifier stage, T_2 is used to match the comparatively high output impedance of one amplifier stage to the low input impedance of the succeeding stage. Because of the differences in impedances, different turns ratios are required, and hence different transformer types are used for T_1 and T_2 .

Condenser C_3 and resistor R_3 perform functions similar to C_2 and R_2 , respectively.

The second CK721 transistor stage provides additional amplification, with the output signal appearing across the primary of T_3 .

Transformer T_3 performs two jobs. It acts to match the high output impedance of the second CK721 stage to the low input impedances of the push-pull output stage while, at the same time, providing two signals having a 180° phase difference to properly drive the two output transistors.

C_4 and C_5 serve as d.c. blocking condensers, while resistors R_4 and R_5 are the "base return" resistors for the two CK722 transistors used in the output stage.

A conventional push-pull audio-output transformer, T_4 , is used to match the output stage to the 6" PM loudspeaker used.

The tone control is conventional and consists of C_6 and R_6 , connected across the primary winding of T_4 . As the resistance of R_6 is reduced, C_6 becomes more and more effective in bypassing the higher frequency components of the amplified audio signal. This type of tone control circuit is commonly called a "losser" tone control.

A small 6-volt radio "A" battery is used as the power source for the entire amplifier. A rotary type switch, S_1 , is used in the "A—" lead as the "Power" switch.

The guitar amplifier circuit points up an important feature of transistor

amplifier circuits in general. Although "grounded-emitter" amplifier stages are used throughout, the common "chassis" ground is to "A-." Thus, the "type" of transistor amplifier circuit (grounded base, grounded emitter, and grounded collector) is determined by the method of applying the input signal and the location of the output load, rather than the location of chassis ground. In general, chassis or circuit ground may be made at any point in a transistor amplifier stage, regardless of type.

In this respect, the guitar amplifier may be considered analogous to a vacuum-tube amplifier in which "B plus" and plate return leads are connected to ground, with "B minus" and the tube cathodes above ground potential.

Construction Hints

A sloping front speaker wall baffle has been used as the "cabinet" of the guitar amplifier. Rubber tack feet have been added to the "top" of the baffle, which then becomes the base of the cabinet. A small handle was also added to facilitate carrying the unit. These modifications are readily visible in the photographs.

Both the loudspeaker and the battery power supply are mounted directly in the baffle, with a small clamp provided for holding the battery in place. The rest of the amplifier circuit is assembled and wired on the small aluminum chassis visible in Figs. 3 and 4.

Layout and parts location are not too critical, although standard good wiring practice should be followed. The input and output signal leads should be kept well separated.

No provision is made by the manufacturer for mounting the "Sub-Ouncer" transformers (T_1 and T_2) and it becomes necessary for the builder

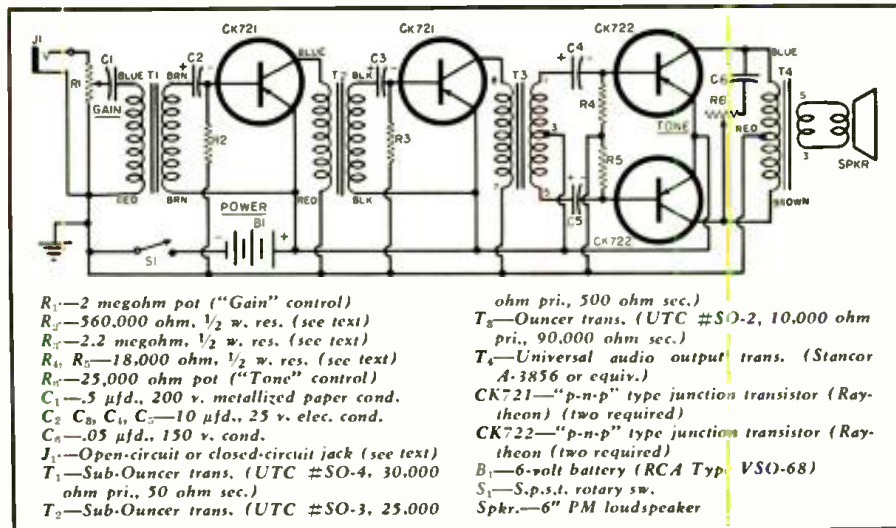

Fig. 2. Complete schematic diagram of the multistage transistor-operated amplifier.

to use his ingenuity in mounting these units. The author employed small "Z" brackets, clearly visible in Fig. 3.

Both the primary and secondary leads of transformers T_1 and T_2 , as well as the primary leads of transformer T_3 , are identified by color-coded leads. All other transformer connections are identified by numbered terminals. The proper connections to use in each case are indicated in the schematic diagram (Fig. 2).

As far as the output transformer is concerned, however, the proper secondary leads to use should be chosen for the particular loudspeaker employed. Although the author used terminals 3 and 5 (as shown in Fig. 2), some other pair of terminals might give better results with a different speaker.

Either an "open" or a "closed" circuit jack may be used for the input (J_1), at the discretion of the builder. For many applications, a closed cir-

cuit jack is preferred, as it reduces the possibility of noise and hum pickup should the "Gain" control be turned up with the "mike" unplugged.

In the author's model, the transistors have been soldered directly in place, but sockets may be provided if desired. Ordinary 5-pin, subminiature tube sockets are suitable, with only three of the pins being used.

Should the builder prefer to solder the transistors in place, special care should be taken to avoid overheating the leads. Transistors are, in many respects, more susceptible to heat damage than are conventional germanium diodes, and many technicians have probably, at one time or another, damaged at least one germanium diode while removing it or installing it in a circuit.

Do not cut the transistor leads too short. Use a clean, well-tinned hot soldering iron and complete each joint quickly. (Continued on page 192)

Fig. 3. Top chassis view showing amplifier in baffle "cabinet."

Fig. 4. Amplifier pulled out to show the under chassis wiring.

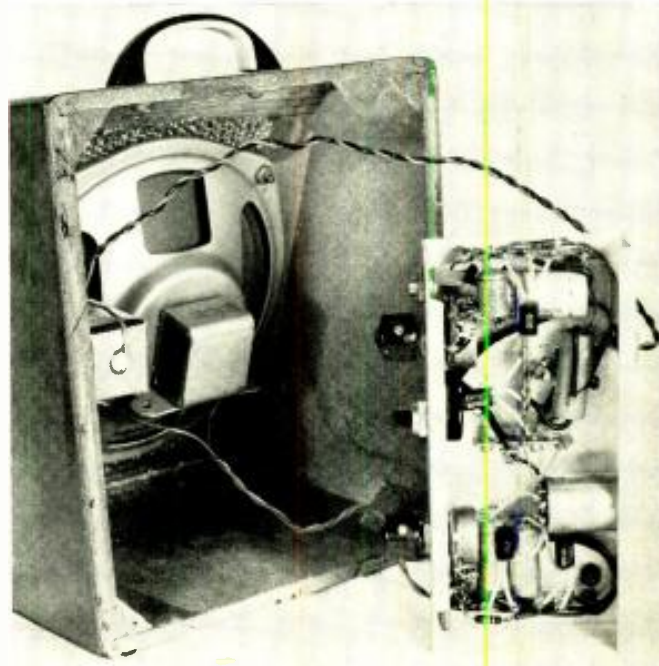
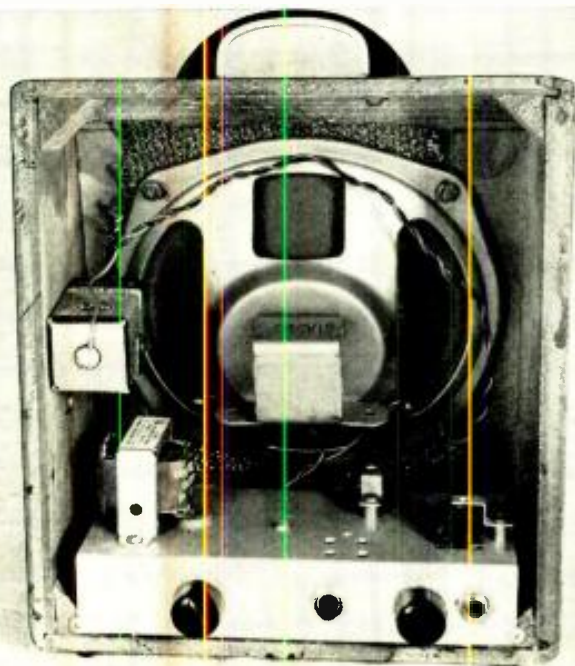

WHICH PHONO PREAMP?

By ALLAN M. FERRES

A flexible design which allows for personal preference as to turnover and cut-off features.

DESIGN is a compromise." Cost, size, flexibility, simplicity, gain, noise, distortion, output voltage, output impedance, power supply requirements—all enter into the design of a preamplifier for a magnetic phonograph cartridge. The many articles describing preamps which their builders have found satisfactory for a given set of conditions show over how wide a range these factors can be varied and still produce a workable piece of equipment.

In complexity, they range from a single-tube amplifier with a fixed low-frequency turnover and a soldering-iron-adjustment of the high-frequency response, to a model with several tubes offering selection of perhaps ten equalization curves to fit every known or estimated record characteristic. In addition to equalization flexibility, the methods of producing the desired response curves also vary. Some designers have found the RC feedback network most suitable, while others use a passive equalizer either between two stages of amplification or between the cartridge and a flat amplifier. In producing a particular playback response, LCR networks are used in some equipment. Tube types also vary, each having its own enthusiastic proponents, with the accompanying claims of low noise and distortion.

Such a wide variation of circuits and claims should not be confusing to the prospective builder of a phono preamp. By approaching the design problems systematically, ideas can be used from each published article to produce a complete preamp which will fulfill the needs of the builder.

The first step in the design is to set down exactly what requirements are to be met and then go about selecting the circuitry which will produce the desired results. It will be found that some requirements are essential and others merely preferable.

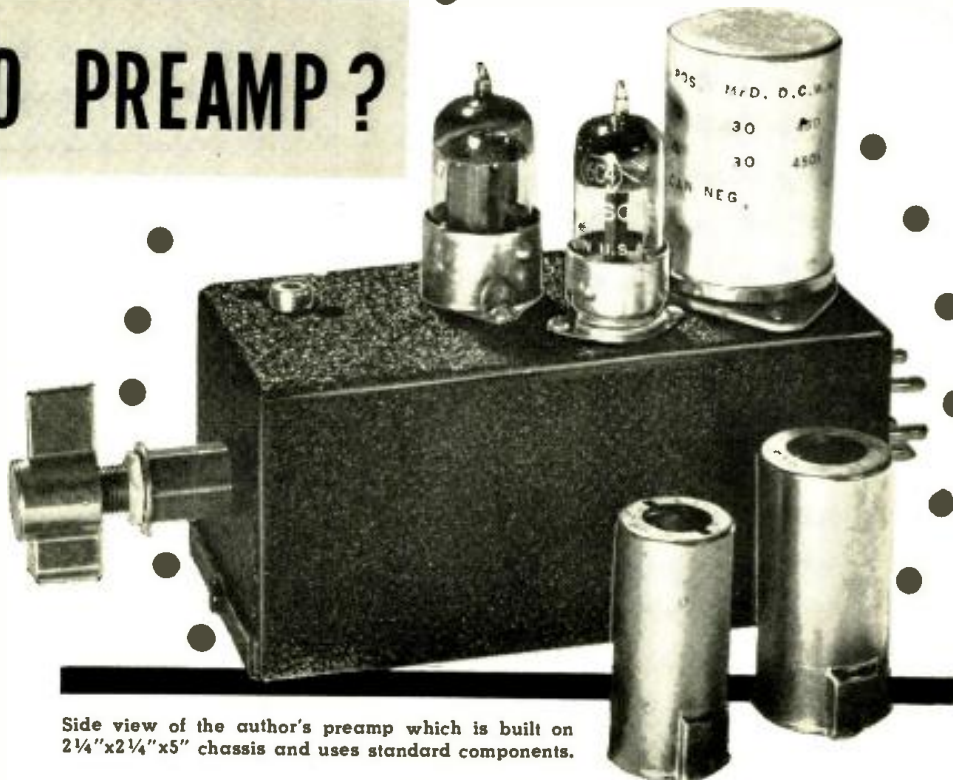

Side view of the author's preamp which is built on 2¼"x2¼"x5" chassis and uses standard components.

Recently, the author had to build a preamplifier for use in a home installation using a "semi-professional" type of turntable with a G-E model RPX-050 cartridge. The essential and the preferable requirements shaped up as follows, together with the factors influencing the decisions made in each case.

Essential Qualities

1. For operating convenience, the preamp was to be mounted near the phonograph motor board. The panel space available dictated an over-all size of about 2½" by 5", with a depth of 7". A 2¼" x 2¼" x 5" utility can with the tubes mounted on the 2¼" x 5" side was tentatively selected.

2. As the audio output lead was to run a distance of fifteen feet to the main amplifier, a low-impedance output was required. Cost and space ruled against an output transformer, so a cathode follower was the choice. The signal voltage handled by the follower was high enough so that hum caused by heater-cathode leakage was insignificant.

3. Because the equipment was to be used and enjoyed by the non-technical members of the household, a single equalizer control with a minimum number of positions was indicated. This was probably the hardest design decision to make. How few frequency response curves can be employed and still produce high-quality reproduction? This factor, more than any other, points up the accuracy of the statement "design is a compromise." Here a knowledge of the recording curves of the various makes of records, as well as the kind of

records most often used, plus an understanding of the sensitivity of the prospective listeners to frequency response, must be combined with your own experience. Fortunately, Mr. Charles P. Boegli's excellent article "New Developments in Phono Equalizers" in the April 1953 issue of RADIO & TELEVISION NEWS provides a complete discussion of the recording characteristics of practically any record which is likely to be used and should be consulted. As LP and both new and old 78 rpm records, as well as NARTB transcriptions were to be played, no help in the reduction of equalization settings was forthcoming on this point.

It was decided to use but one low-frequency turnover, that of 400 cycles, for the following reasons: it was the choice made by the Standards Committee of the Audio Engineering Society as a good compromise between the range of turnover frequencies encountered; the users of the preamp were rather critical, but the equalizing control on the main amplifier could compensate satisfactorily if any bass adjustment was required; and also the fact that most professional preamps, as used in broadcast stations and recording studios, find a single turnover point admissible. Another design feature of this preamp which will be mentioned later can be used by those who find two or more turnover points desirable.

The high-frequency response curves to be included were selected from experience as follows: a flat characteristic, the AES 6-db-per-octave roll-off with the 3-db point at 2500 cycles, for LP's and other records recorded

with pre-emphasis, a flat response out to 6000 cycles with a sharp cut-off beyond this point, and finally a flat response to 3500 cycles with a sharp cut-off. Here, again, the main amplifier, equipped with the usual high-frequency control, provided for minor variations in response when needed. Where the number of equalization steps must be limited, it has been found that including two or three steps with sharp high-frequency cut-offs is more desirable than attempting to match the normal playback curves of 78 rpm records which so often are too noisy to be enjoyed unless their scratch can be sharply attenuated.

4. The cost was not to exceed about \$15. This was met by using RC networks for frequency compensation instead of the more expensive LCR, by employing the previously mentioned cathode follower instead of an output transformer, and by obtaining power for the preamp from the main amplifier power supply instead of from a separate supply. The .45 amp. requirement at 6.3 volts and the 4 ma. load at 300 volts, together with adequate decoupling, made this possible.

Desirable Features

5. The preamp was to be simple to put together, with no specially shaped chassis to construct and using only readily available parts. The original decision to use a standard-size IRC "Channel-lock" utility box of aluminum fitted in well with this requirement. Turret-type sockets were decided upon; their convenience over the more conventional sockets and tie points amply compensated for the slight additional cost. The circuit selected did not require special parts, thus simplifying shopping.

6. Although this amplifier was to be part of a permanent installation, it was realized that from time to time it might be desirable to try other types of tubes or equalizing methods so that if the preamp were built in such a way as to facilitate making such changes, it would be an advantage, provided no great increase in cost or loss of performance would result. The way it worked out, by using the 9-pin and the 7-pin turret sockets, the two-pole selector switch (in the unit built by the author, a single-pole, 4-position rotary switch was used as specified in the parts list), the two-section filter condenser, and a parts layout which avoided crowding, almost any of the dozens of circuits published in the past few years could be accommodated without any additional mechanical work being required.

7. When completed, the preamp was to look like a "semi-professional" piece of equipment, as long as none of the requirements was sacrificed. This more or less took care of itself by the time the other factors had been decided.

The circuit selected was conventional enough. In order to avoid an

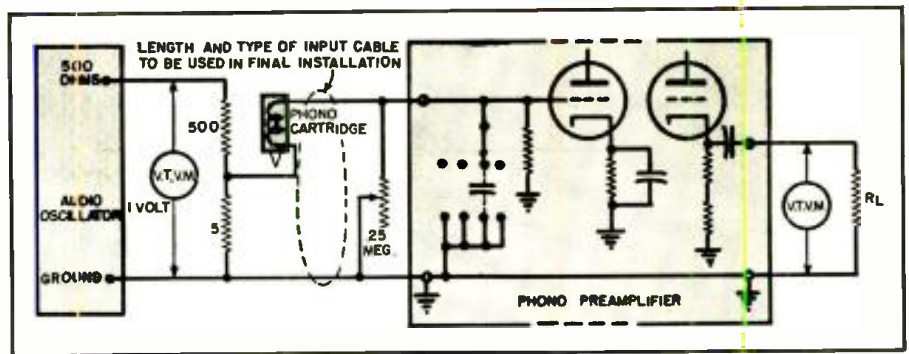

Fig. 1. Set-up for making a frequency run on the preamp. The output vacuum-tube voltmeter is shunted with R_L to furnish a .5 megohm load for preamp.

unbypassed cathode resistor in the first stage, which tends to make hum elimination difficult, the low-pass RC network, consisting of R_6 , R_{10} , and C_6 , was connected between the two sections of a 12AX7. As mentioned earlier, the values shown produce a bass boost of 3 db at about 400 cycles. If a 500-cycle turnover is desired, C_6 can be changed to .015 μ fd. Alternately, C_6 can be made .015 μ fd. and then an additional condenser of .005 μ fd. can be switched across it by using the second section of the selector switch. If both 400 and 500-cycle turnovers are wanted. An 800-cycle turnover is obtained with a capacity of .01 μ fd. and a 250-cycle turnover requires .0314 μ fd.

It must be borne in mind that the usual commercial tolerances of resistors and condensers can be wide enough to preclude exact turnover frequency as calculated. Usually the discrepancy is not serious enough to cause the equalization to be unsatisfactory, but if a close adherence to the design value is desired, then the use of an audio oscillator or test record is necessary. The value of R_{10} can be altered to compensate for variations from the rated capacity of C_6 .

A 100,000 ohm (R_1) resistor is permanently connected across the input

of the preamp from grid to ground, and in switch position #1, with nothing else in this circuit, a flat response is obtained. The high-frequency roll-off required for the AES curve, switch position #2, was obtained by shunting the input circuit with a resistor equal in value to the inductive reactance of the cartridge at the 3 db point. In this case, using the G-E model RPX-050 cartridge, 6800 ohms shunted across the 100,000 ohms produced a response which was down 3 db at 2500 cycles.

Switch position #3, providing a sharp cut-off at 6000 cycles, approaching 12 db per octave, is obtained by shunting the input with a 33,000-ohm resistor and a .0022 μ fd. condenser.

The lowest cut-off frequency, 3500 cycles, on position #4, was effected with a 22,000-ohm resistor and a .006 μ fd. condenser.

The four steps of equalization provided for in this preamp for the G-E cartridge have worked out very well in practice. If the builder intends to use a different make of pickup or finds that he would like to add additional steps, or change the cut-off frequencies from the values used here, it can be done very easily.

Although formulas are available to determine the proper value of capac-

Fig. 2. Response curves obtained with a four-step equalizer. See text for details.

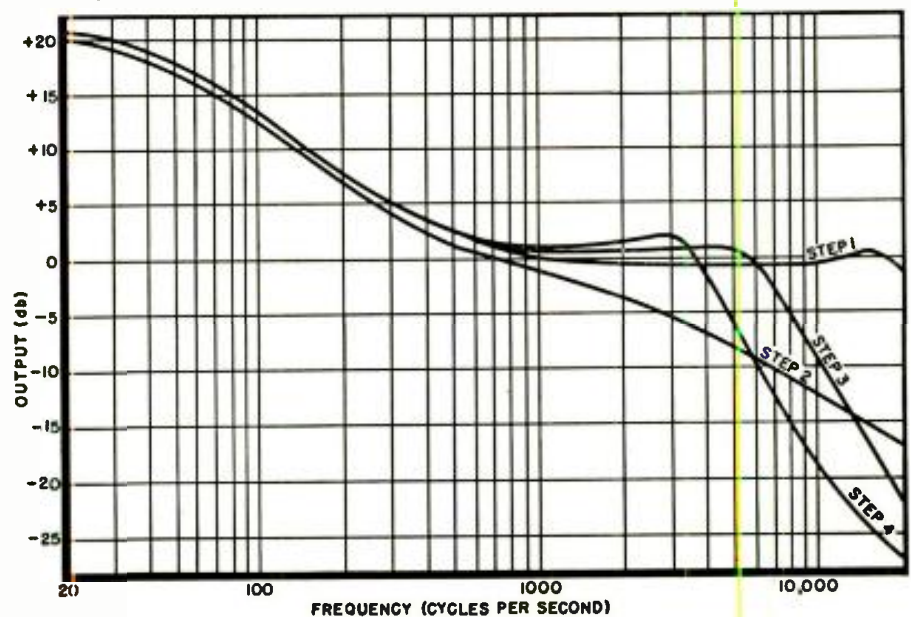

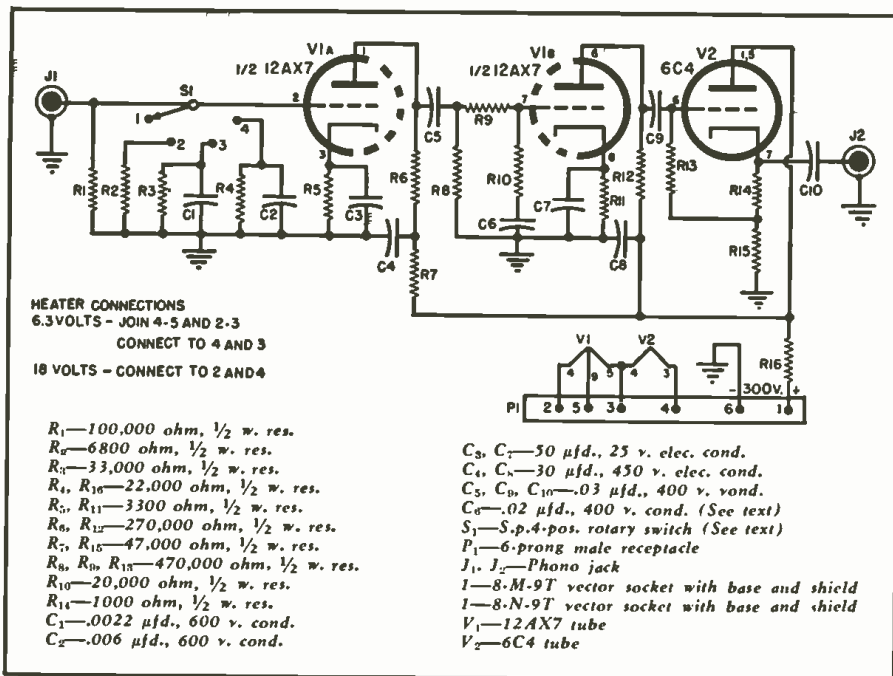

Fig. 3. Schematic of preamp. Necessary power is obtained from associated amplifier.

itance and resistance to use for any cutoff frequency with a cartridge of a given inductance, experience has shown that the experimental method works out better. In this method, a condenser selected within the range from about .0005 to .01 μfd. is temporarily wired between a switch contact and ground, and a .25 megohm pot connected across the condenser with short, unshielded leads. Using an oscillator, as shown in Fig. 1, or a test record, a frequency run is made through the preamp, with the pot set at maximum resistance. A frequency will be found where the gain rises sharply about 5 db or more and then drops off as the frequency is raised. This frequency will be somewhat lower than the cut-off frequency which will be obtained with this condenser and the pot set at the correct

value. If this frequency differs too widely from the cut-off desired, a different condenser should be tried, a larger value for a lower cut-off, or a smaller value for a higher cut-off.

When the correct condenser value has been determined, adjust the pot to a lower resistance setting until the sharp rise in frequency no longer appears. Use the highest value of resistance possible to eliminate the rise. (If the rise is not more than .5 db, it can be ignored.) Measure the resistance setting of the pot and wire in a fixed resistor of the same value, also permanently wiring in the condenser used. For the 6-db-per-octave roll-off used for LP's, the condenser is not required, the frequency at which the roll-off starts being determined by the resistor and the inductance of the cartridge.

Underchassis view of preamp. Turret socket construction makes unit compact.



Although this method may seem to be unscientific, it does eliminate the necessity for determining the inductance of the cartridge, the effective input capacity of the tube, the capacity of the input cable, the accuracy of the equalizing condenser and resistor, and the over-all frequency response of the preamp itself.

If an oscillator or test record is not available, in most cases satisfactory results can be obtained by playing a record and going through the previously-mentioned procedure "by ear." The sudden reduction in surface noise is readily apparent as the pot resistance is reduced and experiments with a few condensers will soon indicate a value which will result in minimum noise with least reduction of the higher frequencies in the music.

The interstage coupling condensers, .03 μfd., may appear small, but their value was chosen to reduce the response below 40 cycles in order to attenuate building and turntable rumble and it is not recommended that their size be increased.

The parts are mounted as shown in the two photographs and should present no problems. The input condensers and resistors are mounted on the selector switch, with the unused lugs of the switch connected to ground to act as tie points. Miniature coupling and bass-boost condensers are used for convenience in mounting the turret sockets.

The heaters were wired as shown in the schematic, Fig. 3, so that they could be operated on either 6.3 volts a.c. or 18 volts d.c., which is in line with the previously mentioned flexibility.

As this preamp delivers about 5 volts across a .5 megohm load from typical 78 rpm records, using the G-E cartridge, and 2 volts from LP's, its output is adequate to work into practically any amplifier which would be used in a home installation. With the power supply used, the unweighted noise was 5 millivolts with a.c. operated heaters and 2 millivolts with d.c. heater supply.

As the panel upon which the preamp was to be mounted was a piece of quarter-inch aluminum, a Mallory type EB247 bushing was attached to the switch bushing to provide sufficient length to pass through the panel and be attached with a 3/8 inch lock nut. Decals were used to mark the four equalizer positions on the panel, eliminating the need for a dial plate.

Although the author's version was specifically designed to take up a minimum of space, other builders may alter the circuit arrangement to suit their particular requirements—housing the preamplifier in any style or type of cabinet desired.

This preamp is now giving satisfaction in the installation for which it was intended and also furnishes the comforting feeling that it can be modified to almost any other circuit or equalization curves without requiring any major re-building.

THE "COMPENTROL"

A COMPACT LOUDNESS ATTENUATOR

By
R. WIENER and N. E. NELSON
Centralab, Div. of Globe-Union, Inc.

Details on a unique control device which provides both bass and treble compensation and incorporates a printed circuit.

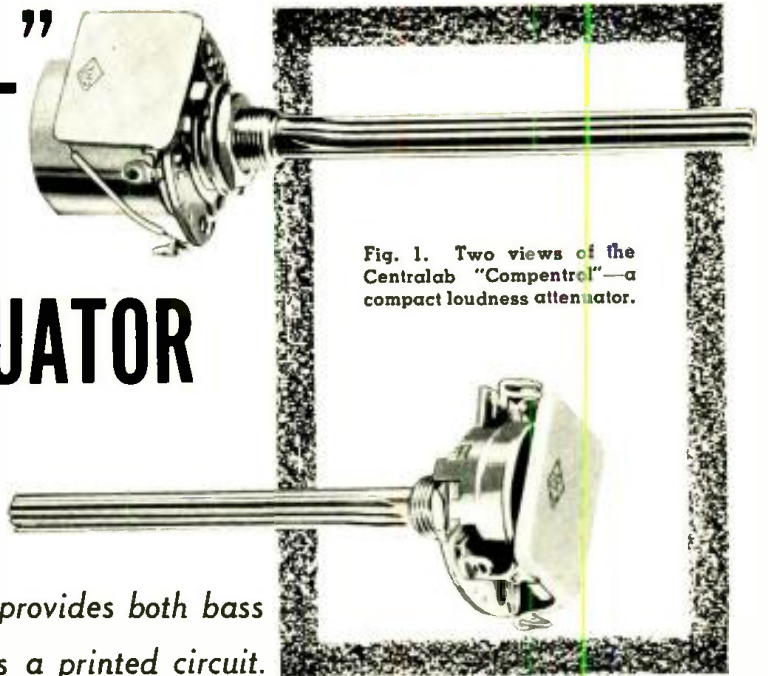

Fig. 1. Two views of the Centralab "Compentrol"—a compact loudness attenuator.

FOR many years manufacturers of better radios, phonographs, television sets, and audio equipment, have used volume controls with one or two taps. These taps were loaded with RC circuits to provide automatic boosting of low frequencies, but with no provision for boost in the treble range. The need for a device which will accomplish both effects is not new, and, indeed, the "loudness level contours" established by Fletcher and Munson,¹ show how loudness levels vary over the audible frequency range at various sound intensities. These established hearing characteristics indicate a definite need for a pronounced boost in frequencies below 800 cycles-per-second, and another, perhaps lesser, boost in frequencies above 6000 cycles-per-second, as volume level is lowered.

Reams of articles have been written on the "pros" and "cons" of compensation. The writers do not propose to add to that controversy, rather they intend to show one solution to the "compensation problem." During the past four years various articles have appeared in trade journals^{2, 3, 4, 5, 6} covering both step-type and continuously variable loudness control devices. Each had advantages and disadvantages, but most were too large or complicated for average home equipment. Commercial models on the market either had this same disadvantage or needed additional amplification for proper operation.

The compensated volume control described here combines all the features that seem so desirable: both bass and treble compensation, small physical size, and simplicity of installation. The unit is trademarked the "Compentrol."⁷ Compact and of very small size, the "Compentrol" consists of a 1 1/4" diameter Centralab Model 2 "Radiohm" and a Centralab Printed Electronic Circuit plate. The control has

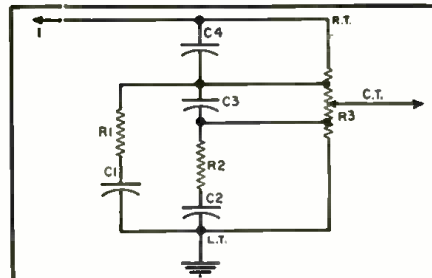

Fig. 2. Diagram of printed circuit plate (PEC) used in the Centralab "Compentrol."

a special resistance taper with two taps, while the PEC plate is of special design having two fixed resistors and four condensers, Fig. 2. The circuit is an adaptation of that described by Wm. O. Brooks.⁸ The response curves at four points are shown in Fig. 3.

Two advantages of Printed Electronic Circuit construction are worthy of special mention. The well-known space saving feature is apparent as inspection of the photograph of Fig. 1 will prove. With the trend to preamplifiers filled with controls and also more complex circuits, a little thought given to saving space is necessary to the audiophile. The PEC, with its six components, adds only the plate thickness, 3/16", to the depth of the control. No more wiring except the conventional three leads to the left, right, and center terminals of the control proper are required. Secondly, the small plate brings all RC leads in close proximity to the terminals on the control, thereby reducing the problem of hum pickup. A third advantage which is due more to the nature of the circuit than to the method of construction is the negligible insertion loss. Since all circuit elements are in shunt, replacement of standard volume controls can be made without any appreciable loss in gain.

The "Compentrol" includes both bass and treble loading circuits. Replacement requires only that the three leads from the present control be connected to the respective three terminals of the "Compentrol." Keep in mind that no connections are to be made to the two taps. When replacing an original tapped-type control, the original bass-compensation RC networks should be removed entirely, and only the remaining three leads should be connected to the three respective terminals of the "Compentrol."

The unit has been tried by the authors in several table model radios. A clock radio with "Compentrol" has been in use for over six months. The unit offers a decided improvement in tone quality over an ordinary volume control giving pleasant listening in a casual environment. "Compentrol" units have been installed in high-fidelity equipment for an even longer time and are recommended highly. Rather than offer detailed instructions for this application, (the authors do not wish to start another rash of "pro" and "con" opinions in the compensated loudness control controversy) we would rather the interested hi-fi fan try it out in conjunction with his own pet theories, and let the writers

(Continued on page 201)

Fig. 3. Response curves (dbv vs frequency) for "Compentrol" and a standard control.

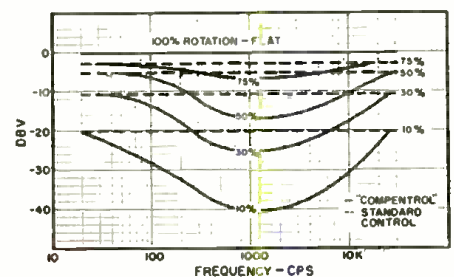

UNIQUE AMPLIFIER FEATURES PHASE SHIFT FOR 3D EFFECT

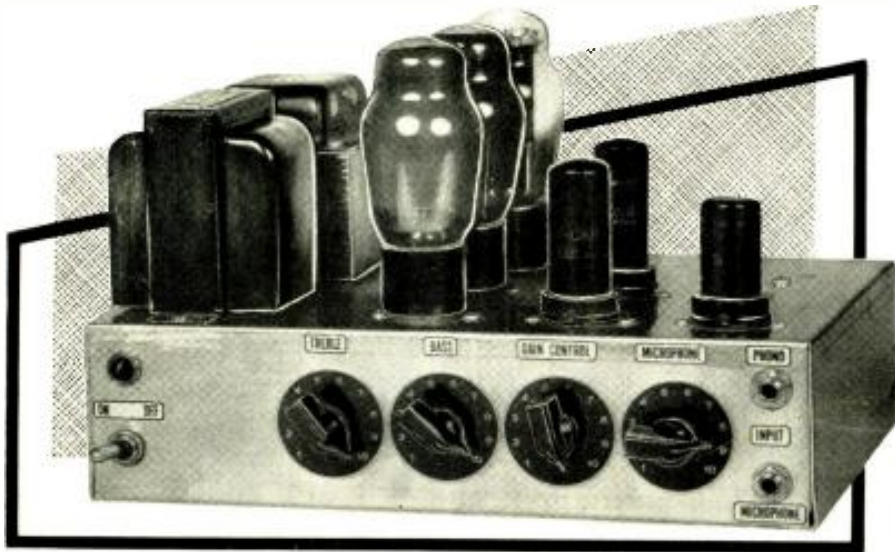

Over-all view of an amplifier built by the author which incorporates the unique phase shifting tone control system described.

By
ALVA R. WILSON

Details on an unusual tone control circuit which may be added to any existing amplifier, radio, or p. a. system.

SO MANY articles have been written about wide-range and high-fidelity amplifiers with their remarkable flat audio frequency characteristics that we would feel slightly apologetic were we to attempt another.

Just to be different, therefore, we are going to describe an amplifier whose audio curve is far from flat. We have designed an amplifier to please the human ear and not an oscilloscope.

Being interested in sound research we began to look around for some sort of solution. Why, we wondered, was it not possible for us to have "presence" and still increase the bass curve enough to allow for the failure of our ears? In other words, why couldn't we change the curve of the amplifier so that, in effect, the "ear curve" was flat and so that all audible tones would sound the same volume level to the ears.

With this thought in mind, in the early part of 1935 we set to work with formulas, slide rule, and the "trial and error" system. It was our intention to build an amplifier whose response, rather than being flat, would have a curve just opposite to that of the average human ear.

Using the standard frequency of "A" 440 cps as the approximate center of the audio frequency spectrum we moved toward the lower end and as the ear's response began falling off, we started increasing the output of the amplifier by the amount the ear's response had fallen. This process was repeated, starting again at "A" 440 and moving toward the high-frequency

end of the audio spectrum. The result was, in effect, a flat response as far as the ear was concerned.

The reasons we had for this last move was a suspicion that the lack of naturalness or "presence" noted in reproduced sound was due as much or more to the loss of the high or extremely high tones, which contain the harmonics of the fundamental tone, as to the loss of the low tones. These harmonics are necessary in order to give each instrument or voice its individuality or "tone color"—without them all tones of the same pitch and volume level would sound exactly alike.

The tone control system as it finally evolved will give the most critical listener a venture into a new world of reproduced sound. The distinctive feature is the use of separate amplifiers for the high and low frequencies, resulting in a distinctive tone quality which permits each instrument in an orchestra to be heard distinctly.

This effect is achieved mainly by adding some phase shift to one-half of the frequency dividing network. This shift is developed across the RCL components in the plate circuit of V_{2A} (Fig. 1), including C_5 , C_6 , R_{12} , R_{13} , and CH_1 . This circuit slows up the electrical impulses being amplified through V_{2A} in comparison to those being amplified through V_{2B} . The output of both tubes is then brought to a common terminal where the combined output is mixed and passed on to the next amplifying tube grid. The effect is as follows: If a musical selection is played through

this system and a chord or group of notes is struck simultaneously by several instruments, all of these tones will not reach our ears at the same instant due to the delay circuit of V_{2A} . This fools the ears into sensing that the various instruments are spaced some distance apart, giving a "third-dimensional" effect. This effect can be increased by adding an extra speaker or two and spacing them a few feet apart.

The basic tone control system, which may be added to any existing radio or amplifier with excellent results, is shown in Fig. 1. However, it must be kept in mind that the rest of the audio system with which it is used must be capable of reproducing a very wide range of frequencies if best results are to be obtained. This means that the audio amplifier must have a push-pull output stage. The output transformer must be of excellent design and material. This will also hold true for the interstage or driver transformer if one is used.

We seldom employ inverse feedback, preferring to use a well matched quality output transformer; however, this circuit has been incorporated in some factory-built jobs with improved results.

Referring to Fig. 1, the incoming audio signal should be at about the output level of a radio tuner, phono pickup, tape or wire recorder (high-impedance tap), or similar sound sources. For low output microphones of the crystal, dynamic, or similar varieties, a single audio amplifying or mixer stage preceding this tone control input would be desirable. R_1 is the master gain control and its setting in relation to R_2 and R_3 is important to the overall frequency response. For extended range it should be kept well open with R_2 and R_3 adjusted at a lower setting for a pleasing room level. For a narrowed frequency range, run R_2 and R_3 at a higher level and R_1 at a lower level, adjusting R_1 and R_3 as previously for pleasant tonal quality and volume. In all cases, R_1 may be used as any volume control once the proper listening preference is established by R_2 and R_3 . Advancing R_3 will increase the

treble response which is amplified through V_{2B} . Similarly, advancing R_9 will increase the bass response which is amplified through V_{2A} .

If the high-frequency response of your radio or amplifier is adequate, R_9 and V_{2B} could easily be the first audio stage and used as is, providing R_1 , R_8 , V_{2A} and its components are connected into the circuit with it, as shown. An inverter or driver stage between this level and the push-pull output stage will be found necessary since considerable energy is required to reproduce the lower bass tones properly.

We have experimented with the components in the plate circuit of V_{2A} for several years and every new bass control circuit that has looked promising has been tried by the author, but none of them have been able to perform as satisfactorily as our original hookup.

Due to its extremely low frequency response and extended gain (well below 60 cps) some caution should be used in laying out this amplifier or a.c. hum will be picked up in low level wiring unless shielded wire is used. Make sure this shielding is of a low capacitance design or a loss of high frequencies may result.

The audio choke, CH_1 , must be mounted well away from any transformers or chokes if the power supply is mounted on the same chassis, otherwise it will pick up magnetic impulses, causing severe a.c. hum.

The purpose of this choke is twofold. It is of such a value that the high frequencies at the output of C_{12} cannot pass back through C_{10} and thus to ground through C_8 , R_{12} , and C_9 . At

the same time it serves to pass the low frequencies (which have been separated from the high by the RC components in the grid and plate circuits of V_{2A}) to the output or coupling condenser C_{10} . In addition, it produces a phase shift between the high and low frequencies at the output condenser C_{10} , giving a three-dimensional tonal effect. Since this is not a resonant circuit the value of CH_1 is not too critical and a midjet type choke of around 20 or 30 henrys at 0 ma. may be used providing care is taken in mounting it with relation to other a.c. components. We normally use the T14C70 choke listed in the parts list since it is shielded and has hum-bucking type windings. Even this choke must be mounted as far away as possible from any a.c. fields.

In some cases we have used midjet a.c.-d.c. chokes mounted on a flexible strap under the edge of the chassis opposite the power transformer, with flexible leads so that it can be moved around in relation to the power transformer. When a position is found where there is no hum, the mounting strap is bent so that the choke remains at this angle when bolted down. In a few rare cases we have had to solder a couple of shielded leads to this choke and mount it completely away from the chassis. A test for hum of this type may be performed by disconnecting one end of C_{10} temporarily. If hum disappears, it is evident that it was being picked up by this choke and a new angle or mounting position must be found.

It will be seen from the foregoing

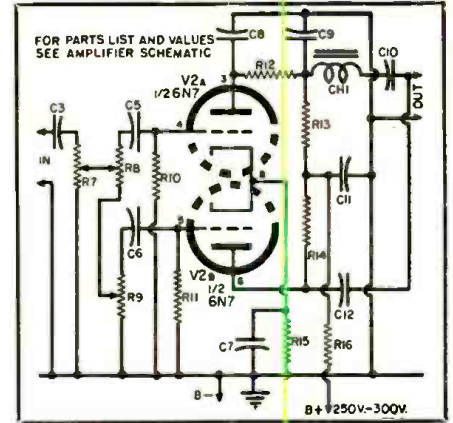
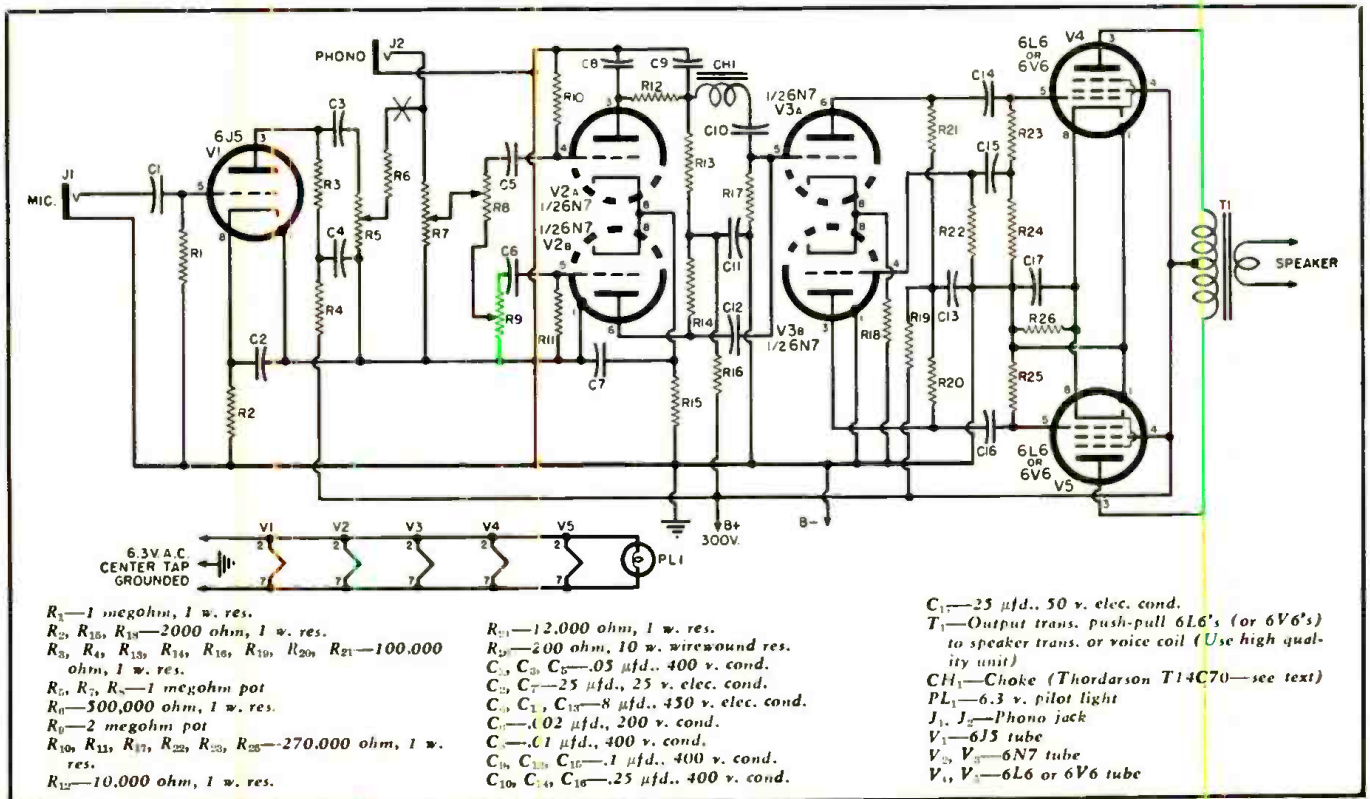

Fig. 1. The "Wilson" tone control system which may be built into any amplifier or radio. See Fig. 2 for the parts values.

that a well-shielded power transformer and filter choke are preferable. While C_{10} is still unsoldered, listen to a musical selection of good quality through the amplifier. This will give you a flat audio characteristic. Then touch C_{10} to its unsoldered terminal and notice the attenuation or depression of the middle frequencies. You will immediately notice a definite change in tonal quality—much more pleasant and natural sounding. This is the flat "ear" response plus phase shift.

A slight amount of hum will be generated if one side of the heater winding is grounded. Therefore, it is preferable to use a transformer with a 6.3 volt winding with a center tap brought out and grounded, leaving both sides of the heaters "floating". If you wish to add this control net-

Fig. 2. An amplifier which incorporates the "Wilson" tone control system. Unless a microphone or other low input device is to be used, all parts left of "X" may be omitted; scratch filter may be used in phono lead between phono pickup and input jack only.



work to an already existing amplifier or radio which has one side of the heaters grounded, and you find it advisable to change this; it can be done by carefully removing the ground from the heater pins and the grounded side of the transformer heater winding. Connect the pins to each other and to this ungrounded transformer winding. Connect a 20-ohm, center-tapped fixed resistor across the entire 6.3 volt winding and ground the center tap to the metal chassis. In some instances we have removed the power supply from the radio or amplifier chassis to a separate small chassis using a plug-in type cable and used the vacated space to build in our tone control network. When this procedure is followed, there is no discernible hum, even with a high level and "no signal" condition.

We have built these amplifiers on bases of many different types and sizes with good results, however our own preferences for materials are: a bright, firm, non-magnetic type for home use while for portable use we use a sturdy bright-plated steel. Clean plated surfaces are good. Painted or finished surfaces may be used if care is taken in establishing a good, clean solid ground by thoroughly removing paint or finish at the ground terminal.

The amplifier featured in this article was built for use in a cafe for reproducing music from a tape recorder and record changer with the occasional use of a microphone. It was built on an 8" x 12" x 3" aluminum base to conserve space. As each constructor will have his own pet ideas and methods as to mounting resistors and condensers we can leave most of the construction to the individual. The under-chassis view shows less wiring than is generally seen below such equipment. This is due to our own preferred meth-

od of construction. All resistors and condensers have one end soldered directly to the tube base terminal in the RC amplifier circuit. This makes for a neat, compact hookup with a minimum of wiring. What is more important, it also confines the components of each stage to its associated tube, thus reducing the chance of stray capacity pickup, etc., as often happens in the terminal strip and cable method.

A good layout for this type wiring is to space tubes 2½" from center to center. The ones near the edges of the chassis should be centered 1½" from the chassis edge and mounted with the heater terminals facing toward the power transformer. At the heater side of the tube sockets mount a two-terminal soldering lug with one insulated terminal under the socket mounting screw. The cathode resistor will lie between this lug and the tube socket, one end to the number 8 pin and the other to the lug's grounded terminal. One end of the grid resistor is connected to its socket terminal and the other end to the same ground lug. The two plate resistors are then connected, one end of each, to the correct socket terminals and the two free ends go to the insulated part on the solder lug. After all condensers and resistors are mounted to their correct terminals, the spare wire leads are pulled through the holes in the terminals, the ends cut off and soldered.

Due to the enormous high frequency gain of this amplifier (especially when the treble control is well advanced) it may be necessary to mount a small grounded metal baffle at the side of the 6L6 nearest the volume and tone controls to prevent self oscillation at extremely high frequencies. These frequencies may be so high as to be completely inaudible in which case

their presence will be evidenced by low output and distortion. A simple test for this condition is to place a fixed .002 µfd. condenser across the two 6L6 plate terminals or from one plate terminal to the metal chassis. This acts as a bypass to short out the high frequency and thereby stop oscillation. It should not be left in permanently or some of the high frequency response will be lost. The tone and output will clear up under this test. To stop this condition try placing the plate leads to the output transformer directly against the metal base, running them as direct as possible and keeping them short and away from associated wiring. If necessary resort to the baffle as outlined previously. A little testing will determine where to place it, or them, permanently to completely eliminate this oscillation.

We have found that a balanced output of the push-pull 6L6 stage is easily obtained by merely selecting two tubes with matched characteristics. This holds true in any well-designed push-pull circuit.

We ordinarily use push-pull 6V6's in the output stage for normal home use and from two to four 6L6's or larger output tubes for auditorium and p.a. systems. The output transformer must, of course, be correctly matched to the tubes and speakers employed.

Audio phase shift is not a new thing in itself, having been used in communication facilities for "scrambled speech", in electric organs to produce a vibrato and chorus effect (*Hammond*), and by others to produce a slow decay of tone in an amplifier, etc., but we believe this is the first attempt to utilize it, as has been done here, to obtain a third dimension effect in sound.

That the results are startling and outstanding has been proven by the fact that anyone hearing this amplifier for the first time is immediately impressed by its "naturalness" and tone color. Comments from these listeners lead us to believe that our time was well spent in developing it and repeated orders for the unit leave no doubt about their "listening preferences".

As a project for the audio technician or the experimentally-minded audiophile, this circuit is worthwhile not only as a departure from the run-of-the-mill amplifier but because of its possibilities for variations.

It should be emphasized that this particular circuit will not "sound good" on the oscilloscope screen but it will satisfy most critical listeners. It restores the "presence" that is so often lacking in amplifiers that show up well on the scope.

At the risk of seeming to "over-sell" this design, the author encourages readers to give this circuit a try to see for themselves whether or not this amplifier does all that it claims. It is a pretty safe bet that you will like what you hear and will be installing it in many of the amplifiers you service.

Under chassis view. By installing resistors and condensers by their own leads at the associated tube sockets, a neat, practically wire-free unit is obtained.

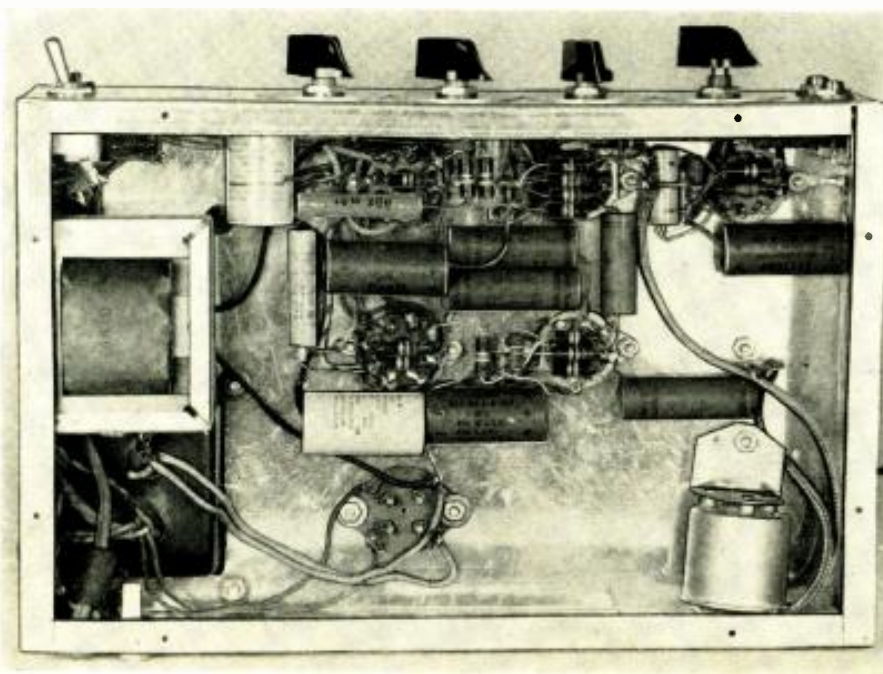

THE ULTRASONIC U-25 ENCLOSURE

By EDWIN C. REYNOLDS
 Ultrasonic Corp., Cambridge, Mass.

Details on a commercially-available, compact, corner-type speaker housing.

THE ever-increasing demand for compact loud-speaker systems of moderate cost has inspired Ultrasonic Corporation of Cambridge, Massachusetts to offer its new U-25 enclosure. This new unit is readily adaptable to home, industrial, and commercial installations.

The bass response of the U-25, free from boom, box vibration, or tinniness, has been achieved by acoustically matching four specially-designed 5-inch permanent magnet speakers with a one-half cubic foot corner enclosure. The cabinet, which measures 13 inches high, 19 inches wide, and 9 1/2 inches deep provides a frequency response from 55 to 11,000 cps with unusually high acoustical efficiency at low input and sound dispersal qualities equivalent, in some respects, to a 16-inch speaker housed in a six to ten cubic foot cabinet.

Good symphonic performance may thus be enjoyed

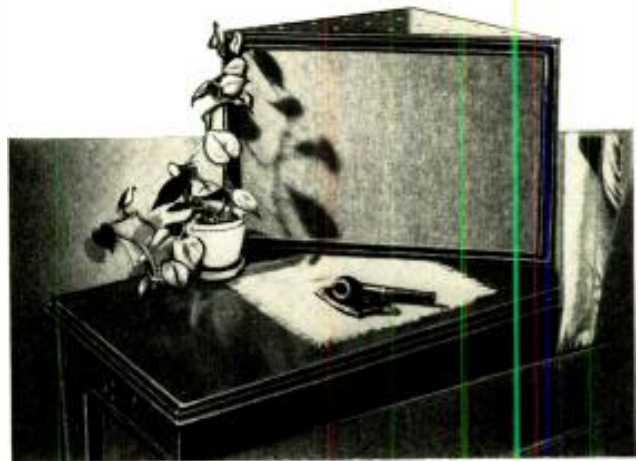

Small size of the U-25 makes it ideal for apartment use.

in the average living room with a power input of only two watts, eliminating excessive cone movement which is the basic cause of distortion in small speakers.

For optimum results and improved bass response, the U-25 has been designed for corner mounting, each wall acting as a segment of the speaker baffle. The cabinet itself is constructed of selected heavy birch plywood, lending itself to either blonde or mahogany finishing and reducing the possibility of undue resonance. In addition, should servicing become necessary at a later date, the U-25 components are, because of the unique cabinet construction, readily accessible.

(Continued on page 146)

Details on the U-25 enclosure incorporating the Baruch-Lang principle. The speakers used are specially designed and are not readily available. Standard 5" units can be used and will give good performance.

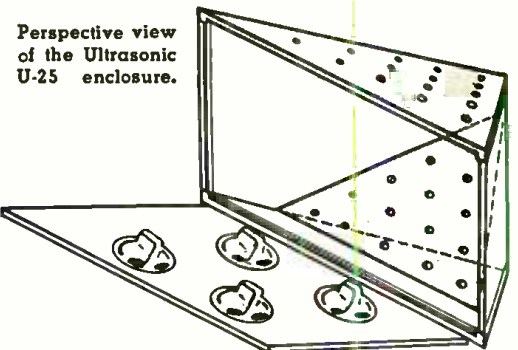
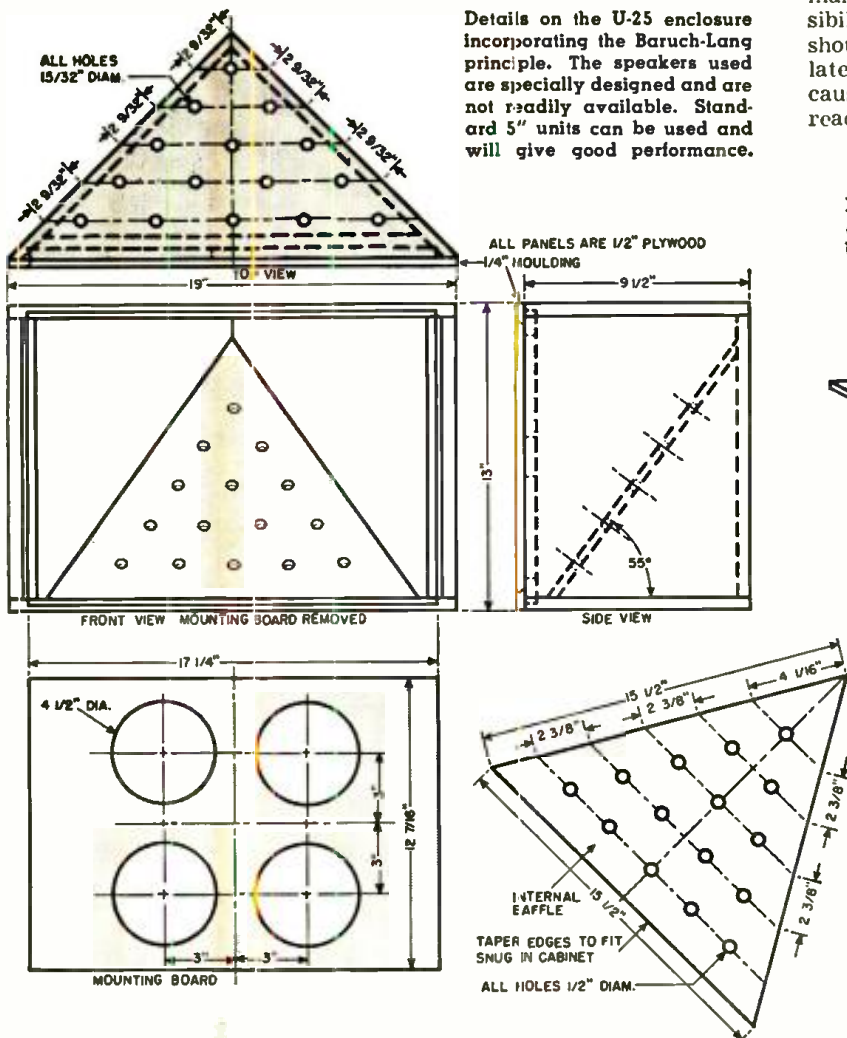

Perspective view of the Ultrasonic U-25 enclosure.

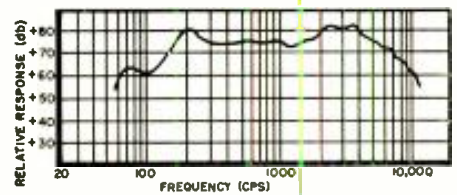

Fig. 1. The frequency response of the U-25 in anechoic chamber. See text for details.

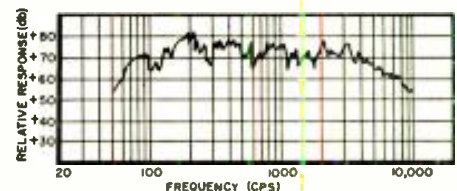
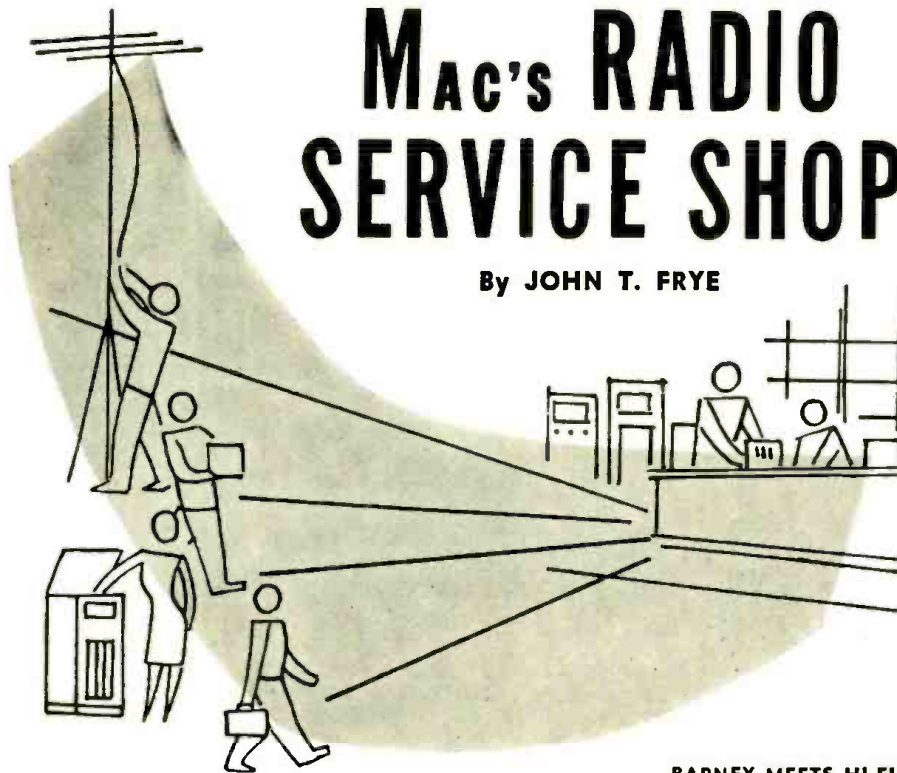

Fig. 2. Response of enclosure when tested in a conventional living room setting.

MAC'S RADIO SERVICE SHOP

By JOHN T. FRYE



BARNEY MEETS HI-FI

BARNEY slammed the door of the service shop in his usual manner as he stepped inside after his lunch hour; but Mac, his employer, noticed that the youth's face wore a preoccupied look not normal to it.

"What's the matter with you, Quiz Kid?" Mac asked. "You look as though you've been trying to read the titles on the revolving juke box records again."

"I feel like it, too," Barney confessed. "I stopped in at *Central Electronics* on the way back to pick up a crystal cartridge, and there were a bunch of hi-fi boys in there shooting the breeze. And do you know what? I couldn't dig but about half of what those jokers were talking about! They kept chattering away about 'crossover and roll-off frequencies,' 'presence,' 'damping factor,' 'boost and droop,' 'pre-emphasis,' 'constant velocity,' 'binaural recordings,' and a whole mess of other terms that sounded to me like so much Greek. Never thought I'd live to see the day when Old Barney would need an interpreter to understand conversation in a radio store."

Mac grinned at the boy's worried concern. "Old Barney would not need an interpreter if he had read those articles on high-fidelity I have been pointing out to him," he remarked. "I tried to tell you quite a while ago that it looked to me as though this hi-fi thing was shifting into high gear and that it would behoove us, as technicians, to keep abreast of what was going on. Just recently I read that the number of high-fidelity enthusiasts already outnumbers the radio amateurs, and this is just the beginning. Radio and TV manufacturers are sitting up and taking notice, and you are going to find them talking more and more

about high-fidelity in connection with their products."

"Are we going into this new field? I thought you were opposed to a service technician's trying to take on work outside his own field."

"I am opposed when the new work is really foreign to the technician's experience and background. For example every now and then someone pipes up and says the radio and TV technician should take on air-conditioning or watch-calibrators or electric organs or electric welding equipment as a service sideline. In many of these cases, he would have to master a whole new field of knowledge to do a good job on the sideline; moreover, he would have to buy new equipment or subject his present equipment to hard usage for which it was never intended. My argument is that if a radio and TV service technician cannot obtain all the business he can do right in his own field, there is something wrong. Since there is a definite recognized shortage of these technicians, he ought to be covered up with radio and TV service. If he is not, instead of trying to invade a new field, he had better improve his mastery of his own."

"But servicing high-fidelity systems is *not* a new field. Hi-fi equipment is simply a refinement and improvement of the audio amplifiers that the service technician has been working on all along. For him not to accept this kind of work would be like a general garageman's refusing to work on a *Cadillac*."

"Won't we have to buy some new equipment?"

"Not right away. We have a good audio sine-wave generator, a good square-wave generator, and a good scope. In addition we have the a.c.

v.t.v.m., the voltage calibrator for the scope, and those audio-frequency test records we bought for testing pickups. Using this equipment, which would be found in about any modern service shop, we can get by for a while. Observing the square-wave response of the amplifier from the scope will give us a good idea of the frequency response of the amplifier being tested."

"What makes you think we'll have to buy other equipment later?"

"Well, it has been discovered that a check of frequency response is not a sure-fire way of being certain the amplifier will sound good to the critical ear. Intermodulation tests have proved to be of more value in evaluating the response quality of an amplifier in terms of what the ear hears. I had been thinking we ought to buy a good intermodulation analyzer a little later, but now I am not so sure this expense will be necessary."

"What changed your mind?"

"An article that appeared back in the March, 1953, issue of *The Aero-vox Research Worker*." It discussed the phase shift method of checking distortion and described the simple, easily-built equipment needed to use this method."

"Tell me more."

"Well, an audio generator feeds a signal into the amplifier being tested that is working into a non-inductive load. The input signal is reversed 180 degrees with respect to the output signal, and the two signals are adjusted to equal amplitudes and fed to separate grids of a twin-triode mixer. Because of the 180-degree phase shift, when the input voltage of the amplifier is rising in a positive direction the output voltage is falling in a negative direction. Since the amplitudes are equal, this means that the resultant output voltage of the mixer will be precisely zero as long as the output voltage of the amplifier is an exact mirror-image of the input voltage. However, if the amplifier introduces any distortion, the output waveshape will no longer be an inverted faithful image of the input. In this case, there will be portions of the input signal curve that are not cancelled by its *alter ego* portions of the phase-shifted output curve, and this difference voltage will show up in the output of the mixer. This output is passed through a flat amplifier and measured by a v.t.v.m. or observed on a scope screen. The amplitude of this difference-voltage compared to the total voltage output of the amplifier gives the measure of distortion introduced by the amplifier."

"What appeals to you about this method?"

"For one thing, it requires a minimum of new equipment. For another, its accuracy is not dependent upon having near-perfect test instruments. You do not have to have a distortion-free signal generator or perfect filters to use it, as you do with some other systems. In the phase-shift method it

(Continued on page 138)

*Depend on Mallory
for
Approved Precision Quality*

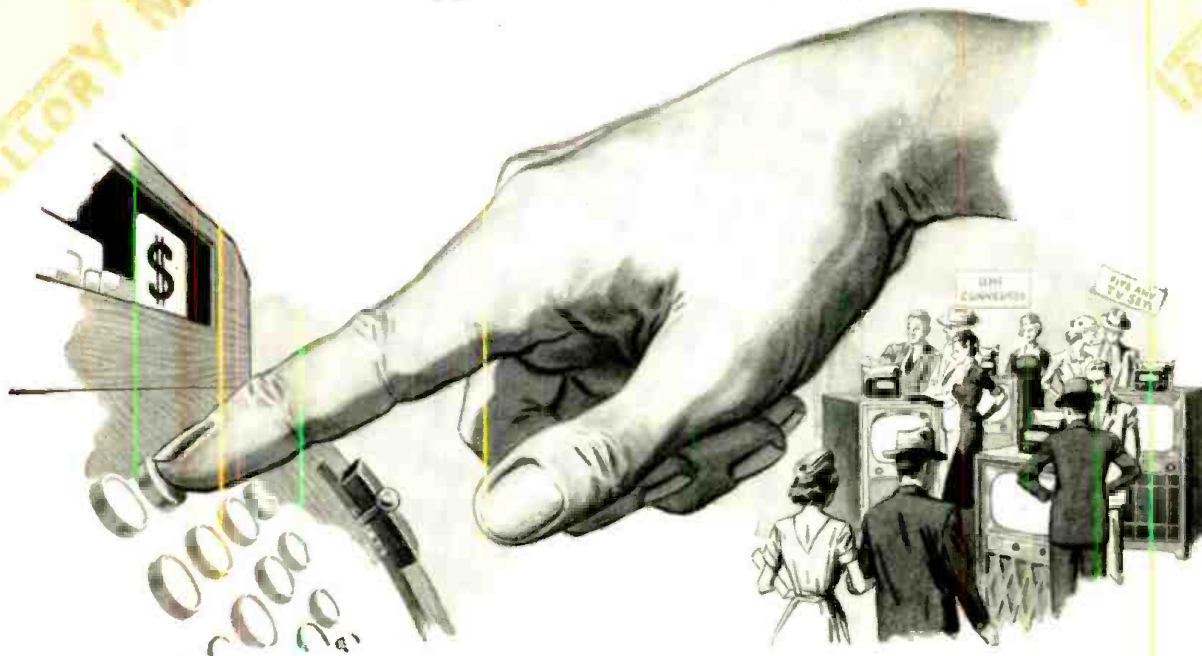

The MALLORY CONVERTER Can Be Your Best Profit Maker in the New UHF Market

When UHF goes on the air in your area, thousands of sets will need converting. The Mallory UHF Converter can become your fastest moving item almost overnight. Be sure you are ready to take advantage of the opportunity... get your full share of the market.

- The Mallory Converter adds *all* UHF channels to any TV set without sacrificing reception of a single VHF channel.
- The Mallory Converter has outsold all other makes in every area where UHF is already on the air.
- A preselector in the Mallory Converter protects against image interference, interference at the IF frequency and oscillator radiation. It insures better selectivity.
- The attractive deep maroon plastic cabinet is smaller than most portable radios.
- The customer has nothing more to buy, no adjustments to make... even if he moves to another broadcast area.

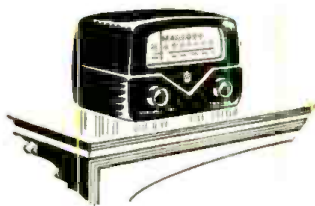

YOUR MALLORY DISTRIBUTOR has complete details on the Converter. It has been an outstanding profit maker in other areas. It can be for you.

Installation is easy too. Simply connect the antenna leads and power lines from the Converter to the set... right in the customer's home.

P. R. MALLORY & CO. Inc.
MALLORY

CAPACITORS • CONTROLS • VIBRATORS • SWITCHES • RESISTORS
RECTIFIERS • POWER SUPPLIES • FILTERS • MERCURY BATTERIES

APPROVED PRECISION PRODUCTS

P. R. MALLORY & CO., Inc., INDIANAPOLIS 6, INDIANA

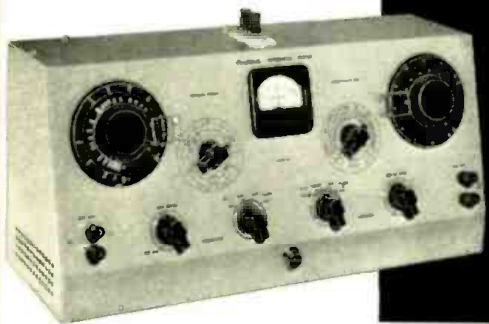

Heathkit IMPEDANCE BRIDGE KIT

MODEL IB-2

\$59⁵⁰

SHIPPING WT.
15 LBS.

Features

- Simpson 100-0-100 microampere meter.
- Completely AC operated.
- Built-in phase shift generator and amplifier.
- Battery type tubes, no warm-up required.
- Newly designed two section CRL dial.
- Single knob D, Q, and DQ functions.
- Special impedance matching transformer.
- New modern cabinet styling.
- ½% precision resistors and silver mica condensers.

Another new, outstanding instrument design so typically characteristic of Heathkit operation in producing high quality instrument kits at the lowest possible price. A new, improved model Impedance Bridge kit featuring modern cabinet styling, with slanted panel for convenience of operation and interpretation of scales at a \$10.00 price reduction over the preceding model. Built-in adjustable phase shift oscillator and amplifier with all tubes of the battery operated type completely eliminates warm-up time. The instrument is entirely AC line operated. No bothersome battery replacements.

The Heathkit IB-2 Impedance Bridge Kit actually represents four instruments in one compact unit. The Wheatstone Bridge for resistance measurements, the Capacity Comparison Bridge for capacity measurements, Maxwell Bridge for low Q, and Hay Bridge for high Q inductance measurements. Read Q, D, DQ all on one dial thereby eliminating possible confusion due to the incorrect dial reference or adjustment. Only one set of instrument terminals nec-

essary for any measurement function. Panel provisions provided for external generator use.

A newly designed two section CRL dial provides ten separate "units" switch settings with an accuracy of .5%. Fractions of units are read on a continuously variable calibrated wire-wound control. A special minimum capacity, shielded, balanced impedance matching transformer between the generator and the bridge. The correct impedance match is automatically switch selected to provide constant load operation of the generator circuit. The instrument uses ½% precision resistors and condensers in all measurement circuits.

The new Heathkit IB-2 provides outstanding design features not found in any other kit instrument. The single low price includes the power supply, generator, and amplifier stages. No need to purchase separate instrument accessories in order to obtain the type of operation desired.

Heathkit AUDIO WATTMETER KIT

MODEL AW-1

\$29⁵⁰

SHIPPING WT.
6 LBS.



A new Heathkit design for the audio engineer, serious hi fi enthusiast, recording studio, or broadcast station; the Heathkit Audio Wattmeter Kit. This specialized instrument instantly indicates the output level of the equipment under test without requiring the use of external load resistors. All readings are taken directly from the calibrated scales of a 4½" 200 microampere Simpson meter.

The Heathkit Audio Wattmeter features five full scale power measurement ranges from 5 milliwatts up to 50 watts with db ranges of -15 db to +48 db. The instrument has a power measurement rating of 25 watts continuous and 50 watts maximum for intermittent operation. Non-inductive resistance load impedances of 4, 8, 16, and 600 ohms are provided through a panel impedance selector switch. Frequency effect is negligible from 10 cycles to 250 kc. A conventional VTVM circuit utilizes a 12AU7 twin triode tube. The meter bridge circuit uses four germanium diodes for good linearity.

With the Heathkit AW-1 desired information can be obtained instantly and conveniently without bothering with the irksome setups and calculations usually required. Useful for power curve measurements, frequency response checks, monitoring indicator, etc. Convenient calibration directly from 110 volt AC line source. This new instrument will help to supply the answers to your audio operating or power output problems.

Heathkit LABORATORY GENERATOR KIT

MODEL LG-1

\$39⁵⁰

SHIP. WT.
16 LBS.



Another welcome new addition to the popular line of Heathkit instruments, the Heathkit Laboratory Generator. Specifically designed for flexibility of operation, accuracy and versatility beyond the performance level provided by the conventional service type generator. Frequency coverage of the Colpitts oscillator is 150kc to 30mc in five convenient ranges with provisions for internal or external modulation up to 50%, and .1 volt RF output throughout the frequency range. Panel mounted 200 microampere Simpson meter for RF "set reference level" to provide relative indication of RF output. Individually shielded oscillator and shielded variable and step attenuator provide flexible control of RF output.

The circuit features a 6AF4 high frequency oscillator, a 6AV5 amplifier with grid modulation, 12AU7 400 cycle oscillator and modulator, OB2 voltage regulator tube, and a selenium rectifier for the transformer operated power supply. The smart professional instrument appearance and over-all flexibility of operation will prove a decided asset to any industrial or educational laboratory. The Heathkit Laboratory Generator sets a new level of operation, far superior to any instrument in this price classification.

HEATH COMPANY • Benton Harbor 15, Mich.

CHECK THESE *Features*

- ✓ New 5U1 CR tube
- ✓ Re-trace blanking
- ✓ Voltage regulation
- ✓ Extended band width
- ✓ Peak-to-peak calibrating provisions
- ✓ Good square wave response
- ✓ Astigmatism control
- ✓ New heavy duty shielded power transformer

NEW 5" *Heathkit*
**OSCILLOSCOPE
 KIT**
 MODEL O-9
\$59⁵⁰
 SHIPPING
 WT. 28 LBS.



Announcing the latest addition to a brilliant series of Heathkit Oscilloscopes, the new Model O-9. This outstanding instrument incorporates all of the features developed and proven in the production of well over 50,000 kits, in addition to a host of many new design features for truly outstanding performance. This new scope features a brand new (no surplus) commercially available 5U1 CR cathode ray tube for fine focusing, high intensity, and freedom from halation. The 5" CR tube is the standard size for design and industrial laboratories, development engineers, and service men. The only size CR tube entering a wide range of types, colors, phosphors, and persistence. The answer to good oscilloscope performance lies in improved basic design and operating characteristics, and not in the use of larger CR tubes.

VERTICAL AMPLIFIER—New extended band width vertical amplifier with sensitivity of .025 volts per inch, down 3 db at 2 mc, down only 51/2 db at 3 mc. Three step vertical input attenuator, quality ceramic variable capacitors for proper input compensation, provisions for calibrated 1 volt peak-to-peak reference, with calibrated screen for direct reading of TV pulses.

HORIZONTAL AMPLIFIER—New input selector switch provides choice of horizontal input, CO cycle sweep input, line sync, internal sync, and external sync. Expanded horizontal sweep produces sweep width several times the cathode ray tube diameter. New blanking amplifier for complete retrace blanking and new phasing control.

POWER SUPPLY—New high voltage power supply and filtering circuit for really fine hairline focusing. New heavy duty power transformer with adequate operating reserve. Voltage regulated supply for both vertical and horizontal amplifiers for absolutely rock steady traces and complete freedom from bounce and jitter due to line variations.

The acid test of any oscilloscope operation is the ability to reproduce high frequency square waves and the new Heathkit O-9 will faithfully reproduce square waves up to 500 kc. This is the ideal all around, general purpose oscilloscope for educational and industrial use, radio and TV servicing, and any other type of work requiring the instantaneous reproduction and observation of actual wave forms and other electrical phenomena.

Heathkit **LOW CAPACITY
 PROBE KIT**



NO. 342
\$3⁵⁰ SHIP. WT.
 1 LB.

Oscilloscope investigation of high frequency, high impedance, or broad bandwidth circuits encountered in television work requires the use of a low capacity probe to prevent loss of gain, distortion, or false service information. The Heathkit Low Capacity Probe features a variable capacitor to provide the necessary degree of instrument impedance matching. New probe styling with bright polished aluminum housing and polystyrene probe ends.

Heathkit
**SCOPE DEMODULATOR
 PROBE KIT**



NO. 337-B
\$3⁵⁰
 SHIP. WT. 1 LB.

In applications such as trouble shooting or aligning TV, RF, IF, and video stages, the frequency ranges encountered require demodulation of signals before oscilloscope presentation. The newly-styled Heathkit Demodulator Probe in polished aluminum housing will fulfill this function and readily prove its value as an oscilloscope service accessory. Detailed assembly sheet provided, including instructions for probe operation.

Heathkit
VOLTAGE CALIBRATOR KIT

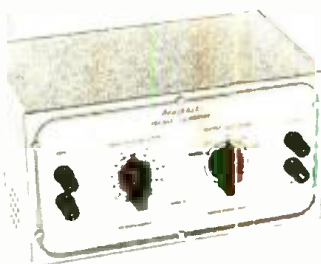

MODEL VC-2
\$11⁵⁰
 SHIPPING WT.
 4 LBS.

The Heathkit Voltage Calibrator provides a convenient method of making peak-to-peak voltage measurements with an oscilloscope by establishing a relationship on a comparison basis between the amplitude of an unknown wave shape and the known output of the voltage calibrator. Peak-to-peak voltage values are read directly on the calibrated panel scales. To offset line voltage supply irregularities, the instrument features a voltage regulator tube.

With the Heathkit Voltage Calibrator, it is possible to measure all types of complex wave forms within a voltage range of .01 to 100 volts peak-to-peak. A convenient "signal" position on the panel switch bypasses the calibrator completely and the signal is applied to the oscilloscope input thereby eliminating the necessity for transferring test leads.

Heathkit
**ELECTRONIC SWITCH
 KIT**

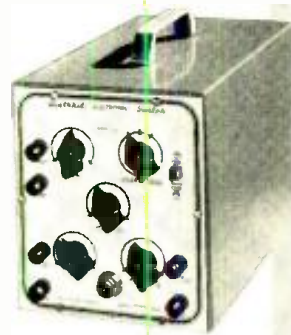

MODEL S-2
\$23⁵⁰
 SHIP. WT. 11 LBS.

The basic function of the Heathkit S-2 Electronic Switch Kit is to permit simultaneous oscilloscope observation of two separate traces which can be either separated or superimposed for individual study. A typical example would be observation of a signal as it appears at both the input and output stages of an amplifier. It will also serve as a square wave generator over the range of switching frequencies, often providing the necessary wave form response information without incurring the expense of an additional instrument.

Continuously variable switching rates in three ranges from less than 10 cps to over 2,000 cps. Individual controls for each input channel and a positioning control. The five tube transformer operated circuit utilizes two 6SJ7, two 6SN7, and one 6X5 tubes. Buy this kit and enjoy increased versatility of operation from your oscilloscope.

HEATH COMPANY • Benton Harbor 15, Mich.



Heathkit VACUUM TUBE VOLTMETER KIT

MODEL V-6

\$24⁵⁰

SHIPPING WT. 6 LBS.

The beautiful Heathkit Model V-6 VTVM, the world's largest selling kit instrument, now offers many outstanding new features in addition to retaining all of the refinements developed and proven in the production of over 100,000 VTVM's. This is the basic measuring instrument for every branch of electronics. Easily meets all requirements for accuracy, stability, sensitivity, convenience of ranges, meter readability, and modern styling. It will accurately measure DC voltages, AC voltages, offers tremendous ohmmeter range coverage, and a complete db scale for a total of 35 meter ranges.

New 1½ volt full scale low range provides well over 2¼" of scale length per volt. Upper DC scale limit 1,500 volts. DC ranges 0-1.5, 5, 15, 50, 150, 500, 1,500 volts full scale. AC ranges 0-1.5, 5, 15, 50, 150, 500, 1,500 (1,000 volts maximum). Seven ohm-

meter ranges from .1 ohm to 1,000 megohms. For added convenience a DC polarity reversing switch and a center scale zero adjustment for FM alignment.

The smartly styled, compact, sturdy, formed aluminum cabinet is finished in an attractive gray crackle exterior. The beautiful two-color, durable, infra-red, baked enamel panel further adds to the over-all professional appearance.

Top quality components used throughout. 1% precision resistors — silver contact range and selector switches — selenium rectifier — transformer operated power supply. Individual calibration on both AC and DC for maximum accuracy. DB scale printed in red for easy identification, all other scales a sharp, crisp black for easy reading. A variety of accessory probes shown on this page still add further to over-all instrument usefulness.

Features

- ✓ New 1½ volt full scale low range
- ✓ 1,500 volt upper limit DC range
- ✓ Increased accuracy through 50% greater scale coverage
- ✓ High impedance 11 megohm input
- ✓ Center scale zero adjust
- ✓ Polarity reversal switch
- ✓ 1% precision resistors
- ✓ Clearly marked db scales

Heathkit 30,000 VOLT DC PROBE KIT

For TV service work or any similar application where the measurement of high DC voltage is required, the Heathkit Model 336 High Voltage Probe Kit will prove invaluable. A precision multiplier resistor mounted inside the two-color, sleek, plastic probe body provides a multiplication factor of 100 on the DC ranges of the Heathkit 11 megohm VTVM. The entire kit includes precision resistor, two-color plastic probe, tip connector spring, test lead, phone plug panel connector, and complete assembly instructions.



No. 336

\$4⁵⁰

SHIP. WT.
2 LBS.

Heathkit AC VACUUM TUBE VOLTMETER KIT

MODEL AV-2

\$29⁵⁰

SHIPPING WT.
5 LBS.

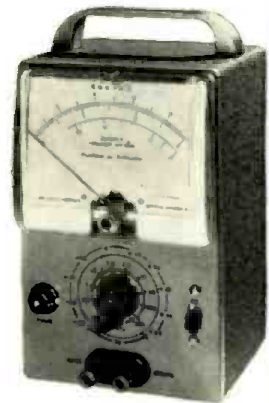

The new Heathkit AC VTVM that makes possible those sensitive AC measurements required by laboratories, audio enthusiasts, and experimenters. Especially useful for hum investigation, sensitive null detection, phono pick-up output measure-

ments, making frequency response runs, gain measurements, ripple voltage checks, etc. Low level measurements are easy to make because of the complete voltage coverage of the instrument and the one knob operation.

The large 200 microampere Simpson meter has clearly marked and easy to read meter scales. Ten voltage ranges covering from .01 rms full scale to 300 volts rms full scale, with frequency response ± 1 db from 20 cycles to 50,000 cycles. Instrument input impedance 1 megohm, ten db ranges from -52 db to +52 db. For stability and good linearity characteristics the meter bridge circuit features 4 germanium diodes. Attractive instrument styling, a companion piece for the popular Heathkit VTVM and the new AW-1 Audio Wattmeter.

No. 338-B

Heathkit PEAK-TO-PEAK PROBE KIT

Now read peak-to-peak voltages on the DC scales of the Heathkit 11 megohm VTVM. Readings can be directly made from the VTVM scale without involved calculations. Measurements over the frequency range of 5 kc to 5 mc. Use this probe to extend the usefulness of your VTVM in radio and TV service work. The Peak-to-Peak Probe Kit features the new polished aluminum housing with two-color polystyrene probe ends. Detailed assembly sheet including instructions for probe operation.



\$5⁵⁰

SHIP. WT. 2 LBS.

Heathkit RF PROBE KIT

The Heathkit RF Probe used in conjunction with any 11 megohm VTVM will permit RF measurements up to 250 mc, $\pm 10\%$. A useful, convenient accessory for those occasions when RF measurements are desired. The RF probe body is housed in the new, smartly-styled polished aluminum probe body featuring two-color polystyrene probe ends and a low capacity flexible shielded test lead. The kit is complete with all necessary material and a detailed assembly sheet as well as instructions for probe operation.



No. 309-B

\$3⁵⁰

SHIP. WT. 2 LBS.

HEATH COMPANY • Benton Harbor 15, Mich.

CHECK THESE *Features*

- ✓ 20,000 ohms per volt DC sensitivity, 5,000 ohms per volt on AC
- ✓ Polarity reversal switch
- ✓ 1% precision multiplier resistors
- ✓ 50 microampere 4½" Simpson meter
- ✓ Meter ranges for service convenience
- ✓ New resistor ring-switch assembly
- ✓ Total of 35 meter ranges
- ✓ New Modern cabinet styling

NEW *Heathkit*
**MULTIMETER
KIT**

MODEL MM-1

\$26⁵⁰

SHIPPING WT. 6 LBS.



The most important Heathkit announcement of the year, the new 20,000 ohms per volt Heathkit Multimeter, Model MM-1. The universal service measuring instrument, accurate, sensitive, portable, and completely independent of AC line supply. Particularly designed for service use incorporating many desirable features for the convenience of the service man. Full 20,000 ohms per volt sensitivity on DC ranges—5,000 ohms per volt sensitivity on AC—polarity reversal switch, no bothersome transferring of test leads—1% precision multiplier resistors—large 4½" recessed non-glare 50 microampere Simpson meter—conveniently slanted control panel—recessed safety type banana jacks—standard universally available batteries—rugged practical sized cabinet with plastic carrying handle, and a total of 35 calibrated meter ranges.

RANGES

Voltage ranges selected entirely for service convenience. For example 1½ volt full scale low range for measuring portable radio filament voltages, bias voltages, etc., 150 volt full scale range for AC-DC service work, 500 volt full scale range for conventional transformer operated power supply systems. Complete voltage ranges AC and DC, 0-1.5—5—50—150—500—1,500—5,000 volts. DC current ranges, 0-150 microamperes—15 milliamperes—150 milliamperes—500 milliamperes—15 amperes. Resistance measurements from .2 ohms to 20 meg-

ohms x 1 x 1,000 x 10,000.
DB coverage from -10 db to +65 db.

CONSTRUCTION

Entirely new design permits assembly, mounting and wiring of precision resistors on a ring-switch assembly unit. The major portion of instrument wiring is completed before mounting the ring-switch assembly to the panel. No calibration procedure is required, all precision resistors readily accessible in event of replacement.

CABINET

Strikingly modern cabinet styling featuring two piece construction, durable black Bakelite cabinet, with easy to read panel designations. Cabinet size 5½" wide x 4" deep x 7½" high. Good cabinet physical stability when operated in vertical position.

The Heathkit MM-1 represents a terrific instrument value for a high quality 20,000 ohms per volt unit using all 1% deposited carbon type precision resistors. Here is quality, performance, functional design, and attractive appearance, all combined in one low priced package.

Heathkit
BATTERY TESTER KIT



MODEL BT-1

\$8⁵⁰

SHIP. WT.
2 LBS.

The Heathkit Battery Tester measures all types of dry batteries between 1½ volts and 50 volts under actual load conditions. Readings are made directly on a three color Good-Weak-Replace scale. Operation is extremely simple and merely requires that the test leads be connected to the battery under test. Only one control to adjust in addition to a panel switch for "A" or "B" battery types. The Heathkit Battery Tester features compact assembly, accurate meter movement, and a three deck wire-wound control, all mounted in a portable rugged plastic cabinet. Checks portable radio batteries, hearing aid batteries, lantern batteries, etc.

Heathkit
HANDITESTER KIT



MODEL M-1

\$14⁵⁰

SHIPPING WT.
3 LBS.

The Heathkit Model M-1 Handitester readily fulfills major requirements for a compact, portable volt ohm milliammeter. Despite its compact size, the Handitester is packed with every desirable feature required in an instrument of this type. AC or DC voltage ranges full scale, 0-10—30—300—1,000—5,000 volts. Two ohmmeter ranges, 0-3,000 and 0-300,000. Two DC current measurement ranges, 0-10 milliamperes and 0-100 milliamperes. The instrument uses a Simpson 400 microampere meter movement, which is shunted with resistors to provide a uniform 1 milliamper load on both AC and DC ranges. Special type, easily accessible, battery mounting bracket—1% deposited carbon type precision resistors—hearing aid type ohms adjust control. The Handitester is easily assembled from complete instructions and pictorial diagrams. Necessary test leads are included in the price of this popular kit.

HEATH COMPANY • Benton Harbor 15, Mich.



New *Heathkit* 12 Volt
**BATTERY
ELIMINATOR KIT**

MODEL BE-4

\$31⁵⁰

SHIPPING WT.
18 LBS.

CHECK THESE *Features*

- ✓ Either 6 or 12 volt operation
- ✓ Continuously variable voltage output
- ✓ Constant ammeter and voltmeter monitoring
- ✓ Automatic overload relay — self-resetting
- ✓ Two 10,000 mf condensers
- ✓ New 18 disc split type heavy duty rectifier unit
- ✓ Fuse protection

Here is the new Heathkit Battery Eliminator necessary for modern, up-to-date operation of your service shop. The Heathkit Model BE-4 furnishes either 6 volts or 12 volts output which can be selected at the flick of a panel switch. Use the BE-4 to service the new 12 volt car radios in addition to the conventional 6 volt radios.

This new Battery Eliminator provides two continuously variable output ranges, 0-8 volts DC at 10 amperes continuously, or 15 amperes maximum intermittent; 0-16 volts DC at 5 amperes continuously or 7.5 amperes maximum intermittent. The output voltage is clean and well filtered as the circuit uses two 10,000 mf condensers. The continuously variable voltage output feature is a definite aid in determining the starting point of vibrators, the voltage operating range of oscillator circuits, etc. Panel mounted meters constantly monitor voltage and cur-

rent output and will quickly indicate the presence of a major circuit fault in the equipment under test. The power transformer primary winding is fuse protected and for additional safety an automatic relay of the self-resetting type is incorporated in the DC output circuit. The heavy duty rectifier is a split type 18 plate magnesium copper sulfide unit used either as a full wave rectifier or voltage doubler according to the position of the panel range switch.

Here is the ideal battery eliminator for all of your service problems and as an additional feature, it can also be used as a battery charger. Another new application for the Heathkit Battery Eliminator is a variable source of DC filament supply in audio development and research. More than adequate variable voltage and current range for normal applications.

Heathkit VIBRATOR
TESTER KIT

Your repair time is valuable, and service use of the Heathkit Vibrator Tester will save you many hours of work. This tester will instantly tell you the condition of the vibrator being checked. Checks vibrators for proper starting and the easy to read meter indicates quality of output on a large Bad-?-Good scale. The Heathkit VT-1 checks both interrupter and self rectifier types of vibrators. Five different sockets for checking hundreds of vibrator types.

The Heathkit Vibrator Tester operates from any battery eliminator capable of delivering continuously variable voltage from 4 to 6 volts DC at 4 amperes. The new Heathkit Model BE-4 Battery Eliminator would be an ideal source of supply.

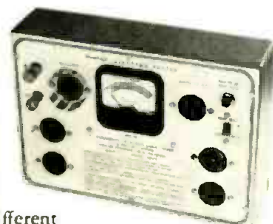

MODEL VT-1
\$14⁵⁰
SHIPPING WT.
6 LBS.

NEW *Heathkit* VARIABLE VOLTAGE
ISOLATION
TRANSFORMER KIT

The new Heathkit Isolation Transformer Kit provides line isolation for AC-DC radios (not an auto transformer), thereby eliminating shock hazard, hum problems, alignment difficulties, etc. The output voltage is variable from 90 to 130 volts AC and is constantly monitored by a panel mounted AC volt meter. Use it to increase AC supply voltage in order to induce breakdown of faulty components in circuits thereby saving service time. Use it also to simulate varying line voltage conditions and to determine the line voltage level at which oscillator circuits cease functioning, particularly in three-way portable radios. Rated at 100 watts continuous operation and up to 200 watts maximum intermittent operation. A useful radio and TV service tool.



MODEL IT-1
\$16⁵⁰
SHIP. WT. 9 LBS.

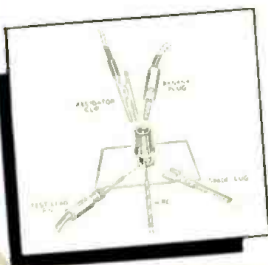

Heathkit
BINDING POST

Binding post kit now available so that standardization of all instrument connectors is possible. This new, five-way binding post will accommodate an alligator clip, banana plug, test lead pin, spade lug, or hook-up wire. Sold in units of 20 binding post assemblies. Each assembly includes binding post, flat and shoulder fiber washers, solder lug, and nut. 120 pieces in all. Kit 362, \$4.00.



Heathkit
TECHNICAL
APPLICATION BULLETINS

An exclusive Heathkit service. Technical application bulletins prepared by recognized instrument authorities outlining various combinations of instrument applications. Available now with 40 four-page illustrated bulletins and an attractive flexible loose-leaf binder. Only \$2.00. (No c.o.d. on this item, please.)

HEATH COMPANY • Benton Harbor 15, Mich.

CHECK THESE *Features*

- ✓ INCREDUCTOR controllable inductor sweep
- ✓ TV and IF sweep deviation 12-30 mc
- ✓ 4 mc- 220 mc continuous frequency coverage
- ✓ Oscillator operation entirely on fundamentals
- ✓ Output in excess of 100,000 microvolts
- ✓ Automatic amplitude circuit
- ✓ Voltage regulation
- ✓ Simplified operation

NEW *Heathkit*
**TV ALIGNMENT
GENERATOR
KIT**

MODEL TS-3

\$44.50

SHIPPING WEIGHT
18 POUNDS

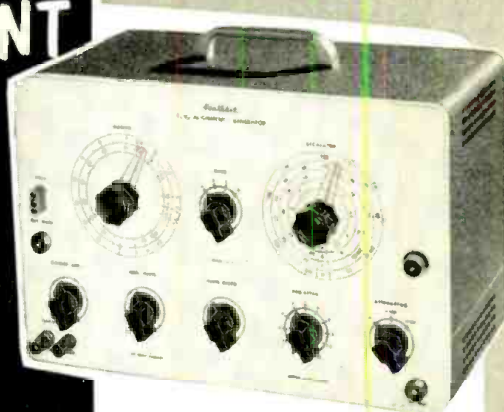

Proudly announcing an entirely new, advanced model TV and FM Sweep Generator, the Heathkit Model TS-3. This new design provides features and combinations of functions not found in any other service type instrument. Every design consideration has been given to the requirements of the TV service man to provide a flexible, variable sweep source with more than adequate RF output and complete frequency coverage throughout the TV and FM spectrum.

The frequency range of the TS-3 is from 4 mc to 220 mc in four switch selected ranges. All frequency ranges are overlapping for complete coverage. A particularly important feature of the instrument is that the oscillator operates entirely on fundamentals, thereby providing complete freedom from spurious oscillation and parasitics normally encountered in beat frequency type oscillators. This circuitry assures a much higher total RF output level and simplifies attenuation problems.

The new TS-3 features an entirely new principle of sweep operation. Sweep action is entirely electronic with no moving parts or electro-mechanical devices so commonly used. The heart of the sweep system is a newly-developed INCREDUCTOR controllable inductor. With this system, the value of inductance of each oscil-

lator coil is electrically varied with an AC control current, and the inductance variation is achieved by a change in the magnetic state of the core on which the oscillator coils are wound. This system provides a sweep deviation of not less than 12 mc on all TV frequencies, and up to a maximum of 30 mc on TV IF frequencies. The high RF output level throughout the instrument frequency range overcomes the most common complaint of the older type sweep generators. A new, automatic amplitude control circuit maintains the output level flat to ± 2 db throughout the instrument range. For convenience of operation a low impedance 50 ohm output is used.

Operation of the instrument has been simplified through the reduction of panel controls and separate panel terminals provide for external synchronization if desired. The circuit uses a voltage regulator tube to maintain stable instrument operation. A built-in variable oscillator marker further adds to flexibility of instrument operation. Provisions are also made for the use of an external marker, such as your service type signal generator, if desired. Use the Heathkit TS-3 for rapid, accurate TV alignment work, and let it help you solve those time consuming, irksome problems so frequently encountered.

NEW *Heathkit*
SIGNAL GENERATOR KIT

MODEL SG-8

\$19.50

SHIPPING WEIGHT
8 POUNDS



Announcing the new Heathkit Model SG-8 service type Signal Generator, incorporating many design features not usually found in an instrument in this price range. The RF output is from 160 kc to 100 mc in five ranges, all on fundamentals, with useful harmonics up to 200 mc. The RF output level is in excess of 100,000 microvolts throughout the frequency range.

The oscillator circuit consists of a 12AT7 twin triode tube. One half is used as a Colpitts oscillator, and the other half as a cathode follower output which acts as a buffer between the oscillator and external load. This circuitry eliminates oscillator frequency shift usually caused by external circuit loading.

All coils are factory wound and adjusted, thereby completely eliminating the need for calibration and the use of additional calibrating equipment. The stable low impedance output features a step and variable attenuator for complete control of RF level. A 6C4 triode acts as a 400 cycle sine wave oscillator and a panel switching system permits a choice of either external or internal modulation.

The transformer operated circuit is easy to assemble, requires no calibration, and meets every service requirement for an adjustable level variable frequency signal source, either modulated or un-modulated.

NEW *Heathkit*
BAR GENERATOR KIT

MODEL BG-1

\$14.50

SHIPPING WEIGHT
6 POUNDS



The Heathkit BG-1 Bar Generator represents another welcome addition to the fast growing line of popular Heathkits. The station transmitted test pattern is rapidly disappearing, and the bar generator is the logical answer to the TV service man's problem in obtaining quick, accurate adjustment information without waiting for test patterns.

The Heathkit BG-1 produces a series of horizontal or vertical bars on a TV screen. Since these bars are equally spaced, they will quickly indicate picture linearity of the receiver under test. Panel switch provides "stand-by position" — "horizontal position" — "vertical position." The oscillator unit utilizes a 12AT7 twin triode for the RF oscillator and video carrier frequencies. A neon relaxation oscillator provides low frequency for vertical linearity tests. The instrument will not only produce bar patterns but will also provide an indication of horizontal and vertical sync circuit stability, as well as overall picture size.

Instrument operation is extremely simple, and merely requires connection to the TV receiver antenna terminal. The unit is transformer operated for safety when used in conjunction with universal or transformerless type TV circuits.

HEATH COMPANY • Benton Harbor 15, Mich.



NEW *Heathkit* TUBE CHECKER KIT

MODEL TC-2

\$29⁵⁰

SHIP. WT. 12 LBS.

The new Model TC-2 Heathkit Tube Checker features many circuit improvements, simplified wiring, new roll chart drive and illumination of roll chart. The instrument is primarily designed for the convenience of the radio and TV service man and will check the operating quality of tubes commonly encountered in this type of work. Test set-up procedure is simplified, rapid, and flexible. Panel sockets accommodate 4, 5, 6, and 7 pin tubes, octal and loctal, 7 and 9 pin miniatures, 5 pin Hytron and a blank socket for new tubes. Built-in neon short indicator, individual three-position lever switch for each tube element, spring return test switch, 14 filament voltage ranges, and line set control to compensate for supply voltage variations, all represent important design features of the TC-2. Results of tube tests are read directly from a large 4½" Simpson three-color meter, calibrated in terms of Bad-?-Good. Information that your customer can readily understand. Checks emission, shorted elements, open elements, and continuity.

The use of closer tolerance resistors in critical circuits assures correct test information and eliminates the possibility of inaccurate test interpretation. Improvement has been made in the mechanical roll chart drive system, completely eliminating diagonal running, erratic operation, and backlash. The thumb wheel gear driven action is smooth, positive, and free running. As an additional feature, the roll chart is illuminated for easier reading, particularly when the tube checker is used on radio or TV home service calls.

Wiring procedure has been simplified through the extended use of multi-color, color coded wires, providing a harness type installation between tube sockets and lever switches. This procedure insures standard assembly and imparts that "factory built" appearance to instrument construction. Completely detailed information is furnished in the new step-by-step construction manual, regarding the set-up procedure for testing of new or unlisted tube types. No delay necessary for release of factory data.

The new Heathkit Tube Checker will prove its value in building service prestige through usefulness—simplified operation—attractive professional appearance. Don't overlook the fact that the kit price represents a savings of \$40.00 to \$50.00 over the price of a comparable commercially built instrument. At this low price, no service man need be without the advantages offered by the Heathkit Tube Checker.

CHECK THESE NEW *Features*

- ✓ Simplified harness wiring
- ✓ Improved, smooth, anti-backlash roll chart action
- ✓ Optional roll chart illumination
- ✓ Individual element switches
- ✓ Portable or counter style cabinet
- ✓ Spare blank socket
- ✓ Contact type pilot light test socket
- ✓ Simplified test set-up procedure
- ✓ Line adjust control
- ✓ 4½" three-color meter

New

HEATHKIT

PORTABLE
TUBE CHECKER
KIT

MODEL TC-2P

\$34⁵⁰

SHIP. WT. 14 LBS.



The portable model is supplied with a strikingly attractive two-tone cabinet finished in rich maroon, proxylin impregnated, fabric covering with a contrasting gray on the inside cover. Detachable cover, brass-plated hardware, sturdy plastic handle help to impart a truly professional appearance to the instrument.

PORTABLE TUBE CHECKER CABINET as described above will fit all earlier Heathkit TC-1 Tube Checkers. Shipping weight 7 lbs. Cabinet only, 91-8, \$7.50.



Heathkit TV PICTURE TUBE
TEST ADAPTER

No. 355 **\$4⁵⁰**
Ship. Wt. 1 Lb.

The Heathkit TV Picture Tube Test Adapter used with the Heathkit Tube Checker will quickly check for emission, shorts, etc., and determine picture tube quality. Consists of standard 12 pin TV tube socket, four feet of cable, octal socket connector, and data sheet.

Heathkit POWER SUPPLY KIT



MODEL PS-2

\$33⁵⁰

SHIPPING WT.
17 LBS.

The Heathkit Laboratory Power Supply features continuously variable, regulated voltage output with good stability under wide load variations. A 4½" Simpson plastic enclosed panel mounted meter provides accurate meter output information of voltage or current. All panel terminals completely isolated from the cabinet. Separate 6.3 volt AC supply at 4 amperes for filament requirements. Ripple component exceptionally low, stand-by switch provided to eliminate warm-up time of the five tube circuit.



LABORATORY AND SERVICE SHOP BOOKLETS

"Planning Your Service Business" by John T. Frey, and "Establishing the Industrial Electronics Laboratory" by Louis B. Garner, Jr., are booklets available to Heathkit customers at no charge. These booklets, written by nationally recognized authorities, outline the various requirements and considerations for establishing your own service business or for setting up an industrial electronics laboratory. Full attention is given to various details that are frequently overlooked when projects of this nature are undertaken. Just write in to the Heath Company requesting your free copy, or attach a memo to your next order.

HEATH COMPANY • Benton Harbor 15, Mich.

CHECK THESE *Features*

- ✓ Visual and aural signal tracing
- ✓ Two channel input
- ✓ High RF sensitivity
- ✓ Unique noise locator circuit
- ✓ Calibrated wattmeter
- ✓ Substitution test speaker
- ✓ Utility amplifier
- ✓ RF, audio probes and test leads included

Heathkit VISUAL-AURAL SIGNAL TRACER KIT

MODEL T-3
\$23⁵⁰
SHIPPING WEIGHT
10 POUNDS



An entirely new type of signal tracer incorporating a combination of features not found in any other instrument. Designed expressly for the radio and TV service man, particularly for the servicing of AM, FM, and TV circuits. Here in a five tube, transformer operated instrument are all of the useful functions so necessary for speedy, accurate isolation of service difficulty.

This new signal tracer features a special high gain RF input channel, used in conjunction with a newly-designed wide frequency range demodulator probe. High RF sensitivity permits signal tracing at the receiver antenna input. A separate low gain channel and probe available for audio circuit exploration. Both input channels are constantly monitored by an electron ray beam indicator, so that visual as well as aural signal indications may be observed. The instrument can also be used for comparative estimation of gain per stage.

A decidedly unusual feature is a noise localizer circuit in conjunction with the audio probe. With this system, a DC potential is applied to a suspected circuit component and the action of the

voltage in the component can be seen as well as heard. Invaluable for ferreting out noisy or intermittent condensers, noisy resistors, controls, coils, IF and power transformers, etc. A built-in calibrated wattmeter circuit is very useful for a quick preliminary check of the total wattage consumption of the equipment under test. Separate panel terminals provide external use of the speaker or output transformer for substitution purposes. Saves valuable service time by eliminating the necessity for speaker removal on every service job. The terminals also permit the utilization of other shop equipment, such as your oscilloscope or VTVM. The T-3 Signal Tracer can be used as a high gain amplifier for checking tuners, record changers, microphones, phono crystals, etc.

Don't overlook the interesting service possibilities provided through the use of this new instrument and let it work for you by saving time and money. The kit is supplied complete with all tubes, circuit components, demodulator probe, audio probe, and additional test leads.

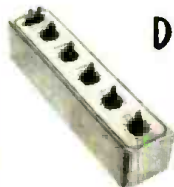

Heathkit DECADE RESISTANCE KIT

MODEL DR-1 The Decade Resistance Kit provides individual switch selection of resistance values using twenty 1% resistors providing a choice of 1 to 99,999 ohms in 1 ohm steps. Ceramic wafer switches, silver-plated contacts, smooth, positive detent action, baked enamel panel, and handsome, polished birch cabinet.

\$19⁵⁰
SHIP. WT.
4 LBS.

Heathkit DECADE CONDENSER KIT

The Heathkit Decade Condenser Kit features silver mica, precision condensers with a rated accuracy of $\pm 1\%$. Capacity values are arranged in three decades from 100 mmf to .111 mf in steps of 100 mmf. Ceramic wafer switches with silver-plated contacts and smooth detent action. Useful in laboratory work, for circuit development.

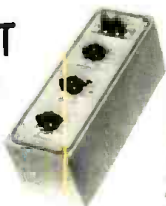

MODEL DC-1
\$16⁵⁰
SHIP WT.
4 LBS.

Heathkit RESISTANCE SUBSTITUTION BOX KIT



MODEL RS-1 The Heathkit Resistance Substitution Box provides individual switch selection of any one of 36 RTMA 1 watt 10% standard value resistors, ranging from 15 ohms to 10 megohms. Many applications in circuit development work, and also in radio and TV service work. Ideal for experimentally determining resistance values and for quickly altering circuit operating characteristics. Entire unit housed in attractive Bakelite cabinet, featuring the new universal type Heathkit binding posts to simplify circuit connections.

\$5⁵⁰
SHIP. WT.
2 LBS.

Heathkit CONDENSER CHECKER KIT



MODEL C-3
\$19⁵⁰
SHIPPING WT.
8 POUNDS

Use the Heathkit C-3 Condenser Checker to quickly and accurately measure those unknown condenser and resistor values. All readings are taken directly from the calibrated panel scales without requiring any involved calculation. Capacity measurements in four ranges from .00001 mf to 1,000 mf. Checks paper, mica, ceramic, and electrolytic condensers. A power factor control is available for accurate indication of electrolytic condenser measurements. A leakage test switch with switch selection of five polarizing voltages, 25 volts to 450 volts DC, will indicate condenser operating quality under actual load condition. The spring return leakage test switch automatically discharges the condenser under test and eliminates shock hazard to the operator.

Resistance measurements can be made in the range from 100 ohms to 5 megohms. Here again all values are read directly on the calibrated scale. Increased circuit sensitivity coupled with an electron beam null indicator increases overall instrument usefulness.

For safety of operation the circuit is entirely transformer operated and the instrument is housed in the attractive, newly-styled Heathkit cabinet, featuring rounded corners, and drawn aluminum panel. The outstanding low kit price for this surprisingly accurate instrument includes necessary test leads. Good service shop operation requires the use of this specialized instrument, designed for the express purpose of determining unknown condenser values and operating characteristics.

HEATH COMPANY • Benton Harbor 15, Mich.



Heathkit AMATEUR TRANSMITTER KIT

MODEL AT-1

\$29.50

SHIPPING WEIGHT
16 POUNDS

Here is the latest Heathkit addition to the ham radio field, the AT-1 Transmitter Kit, incorporating many desirable design features at the lowest possible dollar-per-watts price. Panel mounted crystal socket, stand-by switch, key click filter, AC line filtering, good shielding, etc. VFO or crystal excitation—up to 35 watts input. Built-in power supply provides 425 volts at 100 ma.

This kit features pre-wound coils, single knob band switching, 52 ohm coaxial output, plug in chassis provisions for VFO or modulator and rugged clean construction. Frequency range 80, 40, 20,

15, 11, and 10 meters. Tube line-up 6AG7 oscillator-multiplier, 6L6 amplifier-doubler, 5U4G rectifier. Physical dimensions 8 1/8" high x 13 1/8" wide x 7" deep.

This amazingly low kit price includes all circuit components, tubes, cabinet, punched chassis, and detailed construction manual. The ideal kit for the novice just breaking into ham radio. It can be used later on as a stand-by rig or an all band exciter for higher powered transmitter.

CHECK THESE NEW Features

- ✓ Single knob band switching
- ✓ Pre-wound coils
- ✓ Metered operation
- ✓ 52 ohm coaxial output
- ✓ Crystal or VFO excitation
- ✓ Built-in power supply
- ✓ Rugged, clean construction

NEW Heathkit ANTENNA COUPLER KIT

New Heathkit Antenna Coupler, specially designed for the Heathkit AT-1 Transmitter. The Antenna Coupler can be used with any 52 ohm coaxial input—up to 75 watts power. Low pass filter with cut-off frequency of approximately 36 mc—L section tuning network—neon tuning indicator—rugged, compact construction—transmitter type variable condenser, and high Q coil are all outstanding features. The AC-1 has both inductance and capacity tuning for maximum operating versatility. Dimensions 8 1/8" wide x 4 3/8" high x 4 7/8" deep.



MODEL AC-1

\$14.50 SHIP. WT.
3 LBS.

Heathkit ANTENNA IMPEDANCE METER

Use the Heathkit Antenna Impedance Meter for measuring antenna impedance for line matching purposes—adjustment of beam antennas—phone monitor, etc. It will determine antenna resistance at resonance, match transmission line for minimum SWR, determine receiver input impedance, and provide a rough indication of SWR. Precision resistors, germanium diode, 100 micro-ampere Simpson meter. Dial calibrated from 0-500 ohms. Shielded aluminum cabinet. 7" long x 2 1/2" wide x 3 1/4" deep.



MODEL AM-1

\$14.50
SHIP. WT. 3 LBS.

Heathkit COMMUNICATIONS RECEIVER KIT

MODEL AR-2

\$25.50 SHIP. WT.
12 LBS.



Here is the new receiver kit you have repeatedly asked for, the Heathkit Communications Receiver. The perfect companion piece for the AT-1 Transmitter kit. Many outstandingly desirable features have been incorporated in the design of the AR-2, such as, electrical bandspread for logging and tuning convenience—high gain miniature tubes—IF transformers for high sensitivity and good signal to noise ratio—separate RF gain control with optional automatic volume control or manual volume control, in addition to the conventional audio gain control. Noise limiter—stand-by switch—stable BFO oscillator circuit—headphone jack—transformer operation, etc., all contribute to a high performance standard.

Frequency coverage is continuous from 535 kc to 35 mc in four ranges. For added convenience, various ham bands have been separately identified in respect to their relative placement on the slide rule tuning scale. A chassis mounted, 5 1/2" PM speaker is included with this kit. Tube line up 12BE6 mixer oscillator, 12BA6 IF amplifier, 12AV6 detector AVC audio, 12BA6 BFO oscillator, 12A6 beam power output, 5Y3GT rectifier.

RECEIVER CABINET

Proxylin impregnated, fabric covered, plywood cabinet with aluminum panel designed expressly for the AR-2 Receiver. Part 91-10, shipping weight 5 lbs., \$4.50.



IMPROVED Heathkit GRID DIP METER KIT

\$19.50 SHIP. WT.
4 LBS.

MODEL GD-1B

The invaluable instrument for service men, hams, and experimenters. Useful in TV service work for alignment of traps, filters, IF stages, peaking compensation networks, etc. Locates spurious oscillation, provides a relative indication of power in transmitter stages, use it for neutralization, locating parasitics, correcting TVI, measuring C, L, and Q of components, and determining RF circuit resonant frequencies. With oscillator energized, useful for finding resonant frequency of tuned circuits. With the oscillator not energized, the instrument acts as an absorption wave meter. Variable meter sensitivity control, head phone jack, 500 microampere Simpson meter. Continuous frequency coverage from 2 mc. to 250 mc. Pre-wound coil kit and rack, new three prong coil mounting. 6AF4 high frequency triode.

Two additional plug-in coils are available and provide continuous extension of low frequency coverage down to 355 kc. Dial correlation curves included. Shipping weight 1 lb., kit 341, \$3.00.



HEATH COMPANY • Benton Harbor 15, Mich.

CHECK THESE *Features*

- ✓ First popular priced Q Meter
- ✓ Reads Q directly on calibrated scale
- ✓ Oscillator supplies RF frequencies of 150 kc to 18 mc
- ✓ Calibrate capacitor with range of 40 mmf to 450 mmf with vernier of ± 3 mmf
- ✓ Measures Q of condensers, RF resistance, and distributed capacity of coils
- ✓ Many applications in design and development work
- ✓ Useful in TV service work for checking deflection yokes, coils, chokes, etc.

Heathkit
"Q" METER
KIT

MODEL QM-1
\$44.50

SHIPPING WT. 14 POUNDS



Another outstanding example of successful Heathkit engineering effort in producing a Q Meter Kit within the price range of TV service men, schools, laboratories, and experimenters. This Q Meter meets RF design requirements for rapid, accurate measurement of capacity, inductance, and Q at the operating frequency and all indications of value can be read directly on the meter calibrated scales. Oscillator section supplies RF fre-

quencies of 150 kc to 18 mc. Calibrate capacitor with range of 40 mmf to 450 mmf, with vernier of ± 3 mmf.

Particularly useful in TV service work for checking peaking coils, wave traps, chokes, deflection coils, width and linearity coils, etc. At this low kit price research laboratory facilities are within the range of service shops, schools, and experimenters.

Heathkit INTERMODULATION ANALYZER KIT



MODEL IM-1

\$39.50

SHIPPING WT. 17 POUNDS

The Heathkit IM-1 is an extremely versatile instrument specifically designed for measuring the degree of inter-action between two signals in any portion of an audio chain. It is primarily intended for making tests of audio amplifiers, but may be used in other applications, such as checking microphones, records, recording equipment, phonograph pick-ups, and loud-speakers. High and low test frequency source, intermodulation unit, power supply, and AC vacuum tube volt meter all in one complete instrument. Per cent intermodulation is directly read on the calibrated scales, 30%, 10%, and 5% full scale. Both 4:1 and 1:1 ratios of low to high frequency easily set up. With this instrument the performance level of present equipment, or newly developed equipment can be easily and accurately checked. At this low price, you can now enjoy the benefits of intermodulation analysis for accurate audio interpretation.

Heathkit AUDIO GENERATOR KIT

A Heathkit Audio Generator with frequency coverage from 20 cycles to 1 mc. Response flat ± 1 db from 20 cycles to 400 kc, down 3 db at 600 kc, and down only 8 db at 1 mc. Calibrated, continuously variable, and step attenuator output controls provide convenient reference output level. Distortion is less than .4% from 100 cps through the audible range. The ideal controllable extended frequency sine wave source for audio circuit investigation and development.



MODEL AG-8

\$29.50

SHIP. WT. 11 LBS.

Heathkit AUDIO OSCILLATOR KIT

Sine or square wave coverage from 20 to 20,000 cycles in three ranges at a controllable output level up to 10 volts. Low distortion, 1% precision resistors in multiplier circuits, high level output across entire frequency range, etc., readily qualify this instrument for audio experimentation and development work. Special circuit design consideration features thermistor operation for good control of linearity.



MODEL AO-1

\$24.50

SHIP. WT. 11 LBS.

Heathkit
AUDIO FREQUENCY METER KIT



MODEL AF-1

\$34.50

SHIP. WT. 12 LBS.

The Heathkit Audio Frequency Meter provides a simple and convenient means of checking unknown audio frequencies from 10 cycles to 100 kc at any voltage level between 3 and 300 volts rms with any non-critical wave shape. Instrument operation is entirely electronic. Just set the range switch, feed in unknown frequency into the instrument, and read the frequency directly on the calibrated scale of the Simpson $4\frac{1}{2}$ " meter.

Heathkit
SQUARE WAVE GENERATOR KIT



MODEL SQ-1

\$29.50

SHIP. WT. 12 LBS.

The Heathkit Square Wave Generator provides an excellent square wave frequency source with completely variable coverage from 10 cycles to 100 kc. This generator features low output impedance of 600 ohms and the output voltage is continuously variable between 0 and 20 volts, thereby providing the necessary degree of operating flexibility. An invaluable instrument for those specialized circuit investigations requiring a good, stable, variable square wave source.

HEATH COMPANY • Benton Harbor 15, Mich.



Heathkit WILLIAMSON TYPE AMPLIFIER KIT

MODEL W-2

Particularly designed for custom installations, featuring separate cable connected units for simplicity of installation. Sheet metal work finished in attractive gray hammer-tone for smart appearance. All control shafts of the adjustable length break-off type.

\$69⁵⁰

PRICES OF COMBINATIONS

W-2 Amplifier Kit including main amplifier, power supply, and WA-P1 Preamplifier Kit. Shipping Weight 37 lbs. Shipped Express only. **\$69⁵⁰**

W-2M Amplifier Kit includes main amplifier and power supply. Shipping Weight 29 lbs. Shipped Express only. **\$49⁷⁵**

WA-P1 Preamplifier Kit only. Shipping Weight 6 lbs. Shipped Express or Parcel Post. **\$19⁷⁵**

When selecting an amplifier for the heart of your high fidelity audio system, investigate the outstanding advantages offered by the Heathkit Williamson Type Amplifier. Meets every high fidelity audio requirement and makes listening to recorded music a thrilling new experience.

This outstanding amplifier is offered with optional output transformer

operation, providing either the conventional triode output circuit or the new extended power circuitry in which the screen supply voltage is obtained from separate transformer primary taps. Frequency response within ± 1 db from 10 cycles to 100 kc. Tube complement — 6SN7 cascade amplifier and phase splitter, 6SN7 push pull driver, two 5881 push pull power amplifiers, one 5V4G cathode type rectifier.

Matching preamplifier available providing three switch selected inputs, correct compensation, and individual bass and treble tone controls. Uses 12AY7 (or 12AX7) preamplifier — 12AU7 tone control amplifier.

Particularly designed for the novice kit builder and requires no specialized knowledge or equipment for successful assembly and operation.

NEW Heathkit 20 WATT High Fidelity AMPLIFIER KIT

MODEL A-9A

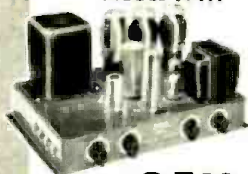

\$35⁵⁰

SHIP. WT. 18 LBS.

A new 20 watt high fidelity amplifier, designed especially for custom audio installations demanding clean reproduction, adequate power, and flexibility to meet individual requirements. Separate treble and bass tone controls provide up to 15 db boost or cut. Four switch selected inputs, each with the necessary compensation for the service desired. Output transformer impedances of 4, 8, and 16 ohms. Preamplifier, tone control, and phase splitter circuits utilize 9 pin twin triode miniature tubes for low hum and noise level. Two 6L6 push pull power output tubes provide full 20 watts power. Frequency response ± 1 db, 20-20,000 cycles. Total harmonic distortion 1% (at 3 db below rated output). Tube line-up: 12AX7 preamplifier, 12AU7 voltage amplifier and tone control, 12AU7 voltage amplifier and phase splitter, two 6L6 push pull pentode power output, 5U4G rectifier. Truly outstanding amplifier performance coupled with low cost.

NEW Heathkit BROADCAST BAND RECEIVER KIT

Another new Heathkit for the student, beginner, or hobbyist. If you have ever had the urge to build your own radio receiver, this kit warrants your attention.

New high gain miniature tubes and IF transformers provide excellent sensitivity and good signal to noise ratio. A built-in ferrite core rod type antenna has been provided. A chassis mounted $5\frac{1}{2}$ " PM speaker provides excellent tone and volume. Convenient phono input. Can be operated either as a receiver or tuner. Simplified construction manual outlines circuit theory. Ideal for students. Tube line-up: 12BE6 mixer oscillator, 12BA6 IF amplifier, 12AV6 detector-AVC-first audio, 12A6 beam power output, 5Y3GT rectifier.

CABINET — Proxilyn impregnated fabric covered plywood cabinet. Shipping weight 5 lbs. Part number 91-9, \$4.50.



MODEL BR-2

\$17⁵⁰ SHIP. WT. 11 LBS.

Heathkit ECONOMY 6 WATT AMPLIFIER KIT

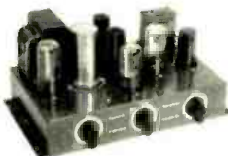

MODEL A-7B

\$15⁵⁰

SHIP. WT. 10 LBS.

The new Heathkit Model A-7B Amplifier offers many unusually fine features not normally expected in this low price range. Either of the two input circuits may be individually switch selected for phono or tuner operation. Separate bass and treble tone controls. Output impedances of 4, 8, and 15 ohms. Push pull beam power output stage for balanced reproduction. Excellent voltage gain characteristics, good frequency response, and full 6 watts power output. 12J5 amplifier, 12SL7 second amplifier and phase splitter, two 12A6 beam power output, one 5Y5 GT rectifier.

A-7C incorporates preamplifier stage with special compensated network to provide necessary gain for operation with variable reluctance or low output level phono cartridge. Circuit is properly compensated for microphone operation. \$17.50.

Heathkit FM TUNER KIT

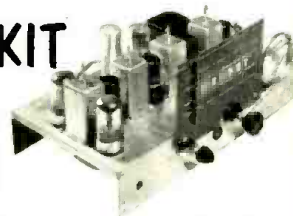

MODEL FM-2

\$22⁵⁰

SHIP. WT. 9 LBS.

The Heathkit FM-2 Tuner was specifically designed for simplified kit construction. Can be operated through the "phono" portion of your radio or with a separate amplifier. The kit features a pre-assembled and adjusted tuning unit, three double tuned IF transformers, and a discriminator transformer in an 8 tube AC operated circuit. Frequency coverage 88 to 108 mc. Experience the thrill of building your own FM tuner and at the same time enjoy all of the advantages of true FM reception.

Free CATALOG

Write for free catalog containing latest price information, schematics, specifications, and descriptions of all Heathkits.

HEATH COMPANY • Benton Harbor 15, Mich.

\$24⁹⁵
VALUE
 for only **\$5.00**
 and 30 Sylvania
 Premium Tokens . . .

*You get
 both chest
 and parts tray*

Between Aug. 1st and Nov. 15th

Servicemen! Here's Your Sylvania

T-N-T CHEST

(TUBE AND TOOL)

The Most Valuable Service Aid You've Ever Seen!

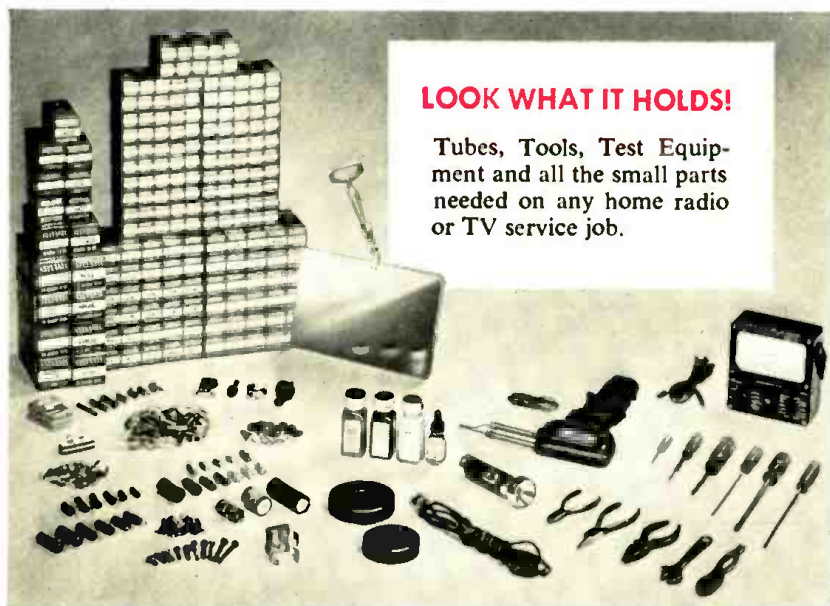

LOOK WHAT IT HOLDS!

Tubes, Tools, Test Equipment and all the small parts needed on any home radio or TV service job.

Talk about a useful servicing aid . . . this Sylvania T-N-T (Tube and Tool) Chest is really it! Carries more tubes, tools and parts than any chest on the market!

LOOK AT THESE FEATURES:

- Bass and fir plywood case
- Waterproof Du Pont Fabrikoid cover
- Holds 187 receiving tubes
- Lightweight folding aluminum tool and parts tray
- Unbreakable plastic handle
- Brass-plated hardware
- Room for mirror and ohmmeter
- It's a complete, portable service shop!

ACT NOW . . . Offer Limited!

This chest is now yours for only \$5.00 and 30 Sylvania Premium Tokens. Offer good only between August 1st and November 15th. See your Sylvania Distributor who has these kits now.



Sylvania Electric Products Inc., 1740 Broadway, New York 19, N. Y.

LIGHTING • RADIO • ELECTRONICS • TELEVISION

In Canada: Sylvania Electric (Canada) Ltd.
 University Tower Building, St. Catherine St., Montreal, P. Q.

Remember, you get 1 Sylvania Premium Token with every 25 receiving tubes or with every picture tube you buy.

RADIO & TELEVISION NEWS

TV COLOR

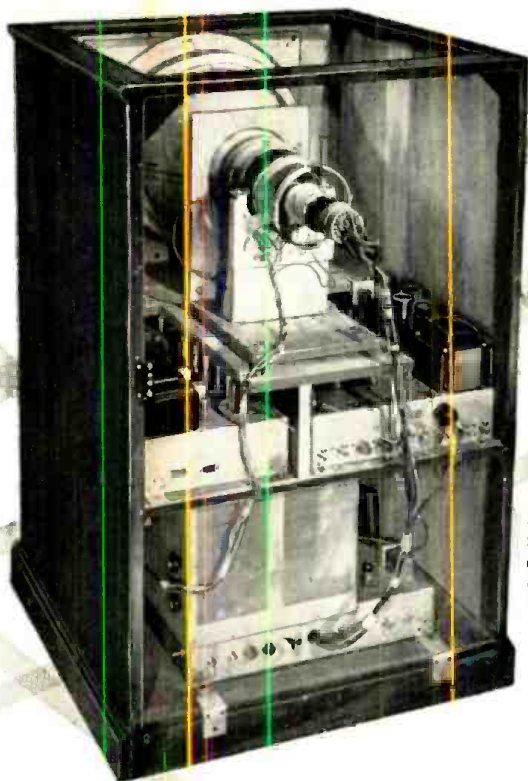

An Emerson experimental color TV receiver. Note the removable top on cabinet to facilitate adjustments.

By **WILLIAM R. FEINGOLD**
Emerson Radio & Phonograph Corporation

Part 2. Explanation of the NTSC color signal and the operation of a color TV receiver.

THE proposed color TV signal specifications of the NTSC have been given a fairly wide printing and distribution by the technical press. However, the full significance of most of these coldly stated facts will be lost on the average reader who has not closely followed the growth of this new aspect of the television art. This article proposes to explain the "why" of these unique specifications and subsequently show how a typical receiver recovers the color information from this signal.

Basic Signal Philosophy

The NTSC started its investigation into the formulation of a color signal with the stated goal that it would produce the best color signal possible within the structure of the present 6 mc. channel and that the signal would be compatible. Starting with this premise the signal is deduced as follows.

Let us suppose that we had a three-color camera putting out green, red, and blue wide-band (0-4 mc.) video signals. Obviously if we could code a transmitter with this 12 mc. of data and then decode it with a proper receiver these three color signals could be used to produce a colored display on a tri-color tube. If we would examine the green, red, and blue camera outputs we would conclude that there must be contained within the structure of these three signals sufficient information so that a signal equivalent to a black and white camera output might be produced from them. Let us call this monochrome signal E_V , and the three aforementioned color signals E_G , E_R , and E_B . These four values are related as follows:

$$E_V = 0.59E_G + 0.30E_R + 0.11E_B \dots (1)$$

The reason a simple mixture of all three signals in equal proportions is not used to give white (or gray) is contained in the unique response of the eye to color intensity. If the eye were to observe three saturated primary colors of equal intensity as measured with a wide-band photometer, the brightness of the colors would *not* appear to be the same. The green color would appear to be twice as bright as the red and about six times as bright as the blue. In monochrome these colors would appear as three different gray tones in exactly the same manner as panchromatic film would render them.

Instead of transmitting the color information as E_G , E_R , and E_B , we can transmit the monochrome component E_V (hereafter called "luminance") and three new values called the color difference components, $(E_G - E_V)$, $(E_R - E_V)$, and $(E_B - E_V)$. In a receiver we would recover E_V and each of the three color-difference voltages. We would then add E_V to each of these color-difference voltages and thereby recover E_G , E_R , and E_B . Note that the

color-difference voltages contain only information pertinent to the color character of the signal.

An examination of these four pieces of information leads us to the conclusion that one item is superfluous. We find that it is not necessary to transmit $(E_G - E_V)$ since E_G is contained in E_V by equation (1). By a simple adding circuit it is possible to recover E_G from the remaining three items.

We have now reduced our color data to E_V , which is the luminance component and treated in the conventional manner, and two color-difference signals $(E_R - E_V)$ and $(E_B - E_V)$.

In order that a single color subcarrier might be used to convey both of these color-difference values simultaneously we have to set up a phase spectrum as shown in Fig. 1. This figure indicates that the phase of the color subcarrier voltage relative to a reference position depends on the color information being transmitted. In other words, if we are transmitting only $(E_R - E_V)$ the subcarrier will take on a phase position 90° or a quarter of a cycle behind the reference position. If we transmit only $(E_B - E_V)$ then the phase position will be 180° or a half cycle behind the reference position. If it is necessary to transmit some of both $(E_R - E_V)$ and $(E_B - E_V)$, a condition brought about by a complementary color like yellow, magenta, or cyan (blue-green), the phase position will be some other angulation, as indicated on the diagram. Note that the phase of the subcarrier is not restricted to just the six shown on Fig. 1. Every hue has a unique corresponding phase position.

The complete color signal has now been reduced to a wide-band 4 mc. luminance component that is the same

Fig. 1. Color difference phase spectrum.

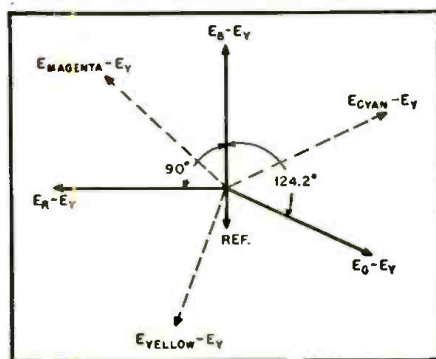

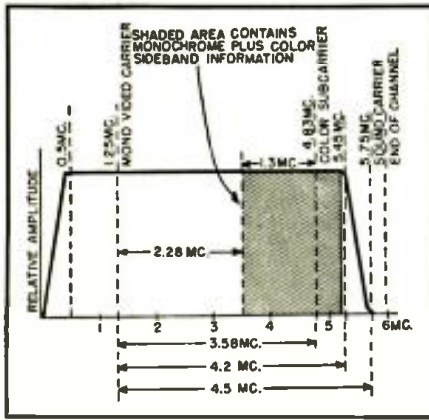

Fig. 2. Color signal characteristics.

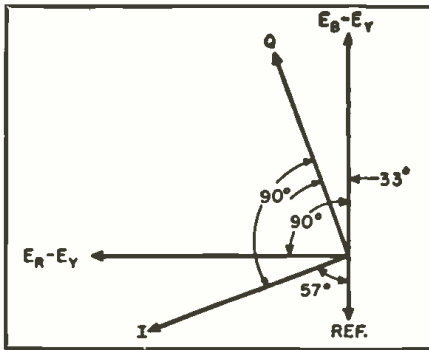

Fig. 3. The phase relationship of the wide-band I and narrow-band Q signals.

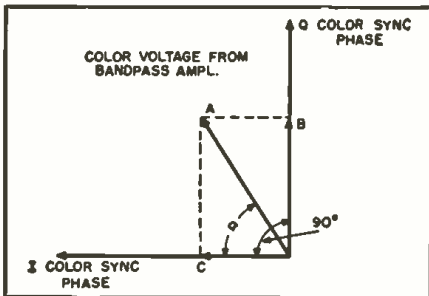
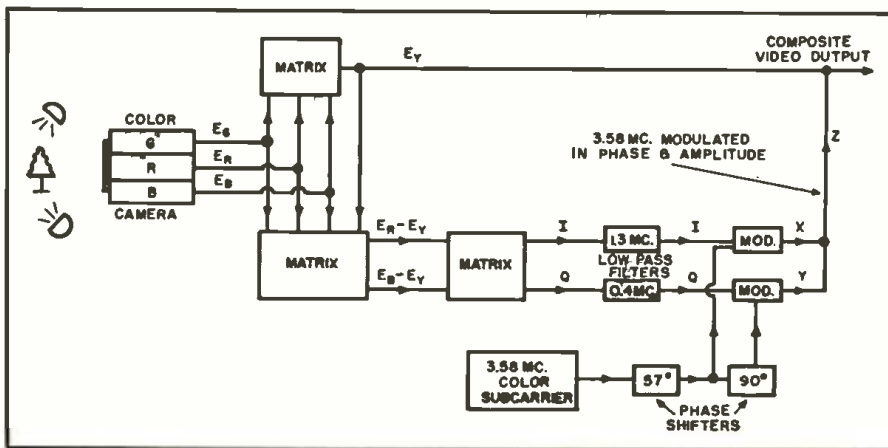

Fig. 4. Detecting I and Q signal voltages from the composite color signal.

as the present monochrome signal, and a subcarrier whose phase identifies the color and whose amplitude indicates its saturation. A large amplitude means a deep red, for instance,

Fig. 5. Simplified block diagram of the video section of a color TV transmitter.



and a small signal, only a light pink. Fig. 2 indicates the subcarrier selected by the NTSC. The reason for this special frequency will be dealt with later. For the moment let us discuss the bandwidth requirements of the color signal and the limitation imposed on us by the 6 mc. channel specification.

For years we have been conditioned to think of a video signal in terms of a wide band of information running the gamut from 60 cycles to 4 mc. This concept is still valid for our luminance signal and it therefore carries all the necessary fine detail. A study of the color data amplitude variation, however, brings out the remarkable fact that the eye is completely insensitive to color in this fine detail area. Comprehensive tests have shown that if this color bandwidth is slowly reduced from 4 mc., the eye only begins to see a perceptible loss in color quality at about 1 mc. and that a tolerable color picture is still present when the color bandwidth is reduced to 0.1 mc. Taking advantage of this phenomenon of the eye the NTSC has decided that certain color components shall have a bandwidth of 1.3 mc. and that others shall have a bandwidth of 0.4 mc. Examining Fig. 2 we see that this narrow-band information fits in at the top of the band as double sideband data while the wide-band information is transmitted with the bulk of its upper sideband missing.

It would have been very simple had the narrow-band data turned out to be $(E_R - E_Y)$ and the wide-band data $(E_B - E_Y)$, but this was not to be. Tests showed that the wide-band color should fall on the orange-cyan axis. In Fig. 3 this signal is called "I" and the narrow-band signal in quadrature with it is called "Q".

The Color Signal

Simply stated, the color signal is put together as follows. See Fig. 5.

The three camera signals E_G , E_R , and E_B are fed to two simple computer-type networks which we call matrices. The output of one is E_Y produced in accordance with equation (1). In a similar manner the other

matrix produces $(E_R - E_Y)$ and $(E_B - E_Y)$. A third matrix changes these two components to a new pair, I and Q, for the sole purpose of allowing the band-limiting operation discussed before. The modulator outputs X and Y are combined, along with E_Y , to form a composite video output. Note that the signals X and Y are each in phase with its respective injected subcarrier at all times. The phase of Z however is another matter. Its phase is dependent on the relative amplitude of X and Y and reflects the color of the original subject matter in accordance with Fig. 1.

Fig. 6 indicates the various signals that would be produced if the original subject matter were three vertical bars of saturated colors green, red, and blue. Fig. 6A is simply E_Y and represents equation (1). Fig. 6B is the combined output of the two modulators with the phase varying from bar to bar. Fig. 6C is the composite video output and is the arithmetic sum of (A) and (B). Note that we have introduced a new parameter called the "Reference Burst." In order that the phase of the 3.58 mc. information contained in each bar has a proper reference, eight cycles of the subcarrier are transmitted along with the signal. This burst of subcarrier is placed just behind the horizontal sync pulse and has a reference phase as shown in Fig. 1.

Although we have described the manner in which the color signal is put together we have apparently overlooked the problem of using a part of the assigned channel for a dual purpose. It is all well and good to glibly discuss a 4 mc. luminance channel and a 1.7 mc. (1.3 mc. lower + 0.4 mc. upper sideband) color channel all in one 4.2 mc. assigned spectrum. There must be more than meets the eye in the fact that the area from 2.28 mc. above the monochrome video carrier to the top of the band is being used for both luminance and color. Will not color data penetrate the luminance channel in some manner and destroy the compatible nature of the signal? The answer to this question would have been an emphatic Yes! had the NTSC not resorted to the ingenious phenomenon of "Frequency Interleaving."

If we take a standard monochrome receiver, operating normally, and inject into its video a sine-wave signal we would expect to see a distinct interference pattern. However, if we carefully vary the frequency of this injected signal we would observe positive frequencies of powerful interference and other frequencies of zero interference. These two conditions correspond to the even and odd multiples of half the line frequency. This technique of setting an extraneous signal to an odd harmonic of half the line frequency to produce zero visibility is called "Frequency Interleaving." Not only does this mean that the color subcarrier will theoretically be invisible, but all its upper and lower sidebands will be invisible too since

they also are odd harmonics of half the line frequency. In actual practice, however, due to the inherent nonlinearities of the system, a slight dot pattern may be visible on some wide-band receivers at close viewing distances. At normal viewing this pattern is not visible.

A second and similar consideration is a possible visible beat produced between the color subcarrier and the sound carrier. This interference too can be made invisible by making this frequency difference an odd multiple of half the horizontal line frequency.

Applying these principles to obtain exact numbers, the NTSC is using a color subcarrier of 455 times half the line frequency and a sound carrier of 572 times half the line frequency. Since the sound carrier must be 4.5 mc. the obvious result is a slight change of horizontal scan. The exact numbers are:

$$\text{Color subcarrier} = 4.50 \times \frac{455}{572} = 3.579545 \text{ mc.}$$

$$\text{Horizontal Frequency (H)} = 3,579.545 \times \frac{2}{455} = 15,734.2 \text{ cps.}$$

$$\text{Field Frequency} = H \times \frac{2}{525} = 59.94 \text{ cps.}$$

The Color Receiver

Fortified with a knowledge of the make-up of the color signal we are now in a position to examine the manner in which a color receiver reconstructs the green, red, and blue video signals, E_G , E_R , and E_B . See Fig. 8.

The tuner, i.f., and sound system are substantially the same as in present black and white sets except for two necessary differences. The tuner and i.f. must have a slightly wider bandwidth. They must extend to 4.0 mc. Note also that a sound detector has been added to the usual video detector. It is customary to extract the 4.5 mc. required for intercarrier sound from the output of the video detector. However, in this receiver the sound attenuation would be excessive at this point, hence the need for a separate sound detector tapped into the i.f. strip before the deep sound traps.

The video detector output is identical to that in Fig. 6C and is first fed to the luminance amplifier. This video circuit is the same as any good monochrome stage except that it has reject traps set to 3.58 mc. Its output is E_V , the same as Fig. 6A.

The video detector output is also passed through the bandpass amplifier. This stage removes E_V from the signal by having a restricted passband from 2.3 to 4.0 mc. This output is identical to Fig. 6B, and is passed on to the I and Q demodulators.

These synchronous demodulators are somewhat new to the television art. Each tube has a 3.58 mc. color sync voltage of known and fixed phase applied to it along with the color information from the bandpass amplifier.

The output at the plate of the demodulator is a voltage that reflects the amplitude of the color voltage and the relative phase with respect to the color sync voltage. Fig. 4 shows a phase diagram with an instantaneous phase relation α between a color voltage "A" from the bandpass amplifier and the color sync fed to demodulator I . The instantaneous output from the I demodulator would be a voltage "C." Since the color sync injected into the Q demodulator lags I by 90° its voltage output would be "B." These voltages "C" and "B" are the instantaneous values of I and Q that we are desirous of recovering.

Having obtained E_V , I , and Q , it is necessary to resort to a computing matrix network to obtain our desired voltages E_G , E_R , and E_B . However before this is done it is essential that E_V , I , and Q be in proper time step. An examination of these three voltages shows that voltage E_V gets to the matrix before voltage I and that I arrives there before voltage Q . We must therefore use a delay line to slow up these fast voltages. Consequently, I is delayed by 0.5 microsecond (approximately), and E_V by 1.2 microsec. These values are typical and will vary from one design to another. Regardless of the actual value required, however, it is necessary that the three voltages arrive in time step at the matrix within 0.05 microsecond if picture quality is not to be impaired.

The delay lines which have been used for this purpose have been either the lumped constant type, as shown in Fig. 7, consisting of a number of inductors and condensers, or the distributed-constant type which is a continuously wound helix fashioned to form a cable. In either case the

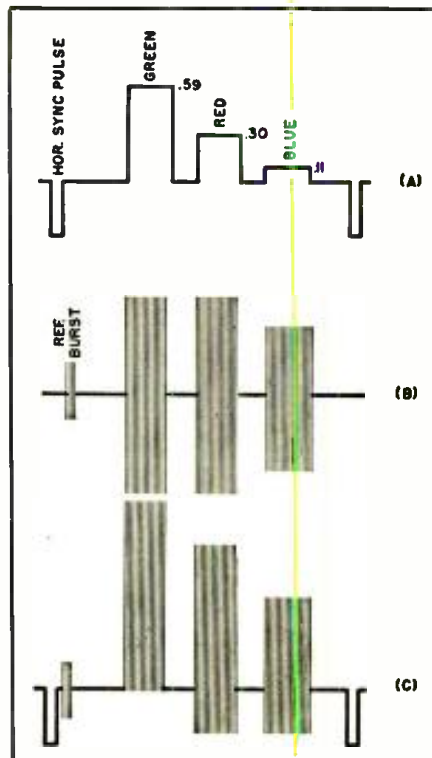

Fig. 6. Video signal for three vertical colored bars. See text for details.

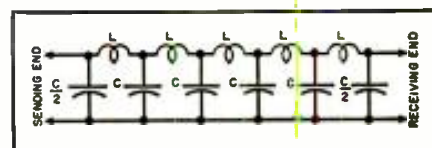
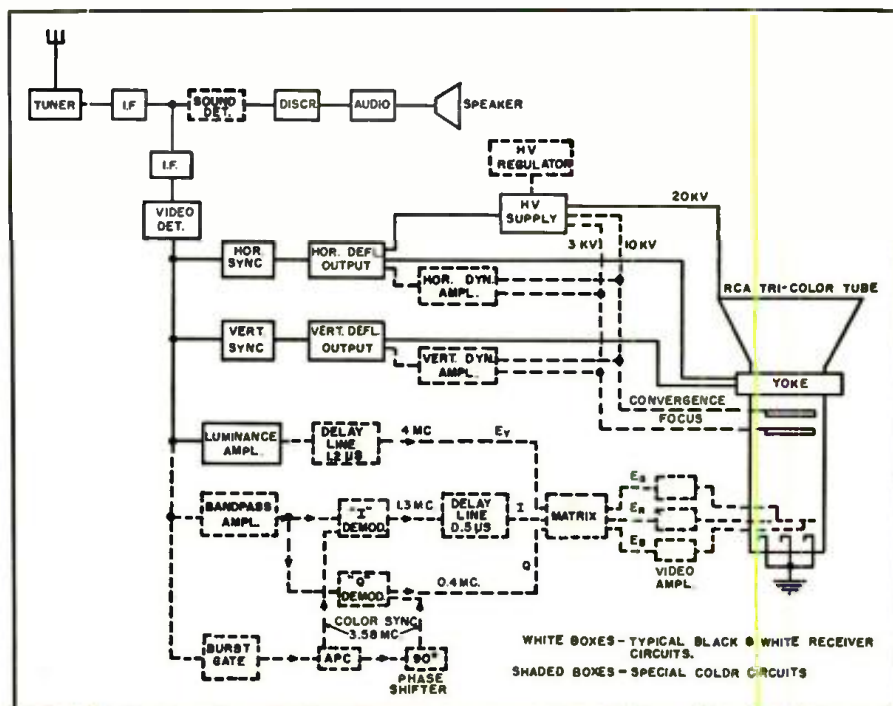

Fig. 7. Lumped constant delay line.

mechanism of operation is the same. A voltage injected at one end is caused to suffer a phase shift as
(Continued on page 227)

Fig. 8. Block diagram of a typical color television receiver using I-Q signals.





IMPS ARE TOPS!

TOUGH LEADS!
Securely anchored and tinned, they'll bend and bend —without breaking!

REALLY RUGGED!
Thermo-setting plastic keeps IMPS looking and performing like new!

Available in 200, 400 and 600 volt ranges —all popular ratings!

WON'T FREEZE OR MELT!
IMPS will operate faithfully at 100° C. (the boiling point of water!)

MOISTURE-PROOF!
Varnished plastic case and tight-fitting lead anchors repel moisture!

All over the country service-engineers are praising the newest and finest molded tubular capacitor—the Pyramid IMP! Order your supply from your local distributor—and for free catalog, write Dept. 59.

PYRAMID ELECTRIC COMPANY
1445 HUDSON BOULEVARD • NORTH BERGEN, NEW JERSEY

A "SMALL-PACKAGE" MODULATOR

By ED BRAUNER, W2URF

A "SMALL-PACKAGE" modulator has been in use at W2URF for over a year, modulating a 30-watt rig, and its performance has been praised by many amateurs who have heard it. Its simplicity makes it ideal for the beginner while its extra features and clean operation are suitable for the old timer. The compactness and ruggedness of the unit make it a "natural" for CD and mobile work.

Features

A carbon mike input is used for mobile work but as no microphone battery is needed the modulator can be used in a fixed location with a conventional power supply of 250 to 300 volts at 150 ma. d.c. and 6.3 volts a.c.

A multi-impedance modulation transformer is used with a rotary switch connected so one can instantly switch from one output impedance to another. This is useful where the modulator will be used with different rigs or under emergency conditions where the plate voltage-to-plate current ratio of the modulated stage may vary because of makeshift power supplies and antennas. It is also useful where the rig is used on different bands with different loadings.

While a power output of 12 to 15 watts may seem very small, it is sufficient for satisfactory modulation of a radio-frequency amplifier of 30 to 40 watts input, such as the popular 807-type amplifier. The modulator has been used with a surplus "Command" transmitter running 30 watts on 75 meters.

The small size and rugged construction make the modulator useful in mobile and emergency work. Tie points, lugs, and lock washers have been used to make the construction as rugged as possible. Shield-base tube sockets and spring-type shields are also used to hold the tubes firmly in place.

Another important consideration is the ease of construction and low cost of the unit. The modulator can be built in three evenings and the total cost of parts should be under \$20.00 at radio supply-house prices. The tubes and some of the other components may be purchased as surplus for considerably less than standard prices. There is nothing critical about the parts values and "junk-box" or surplus components similar to those specified may be used. The modulator is simple to construct and even the

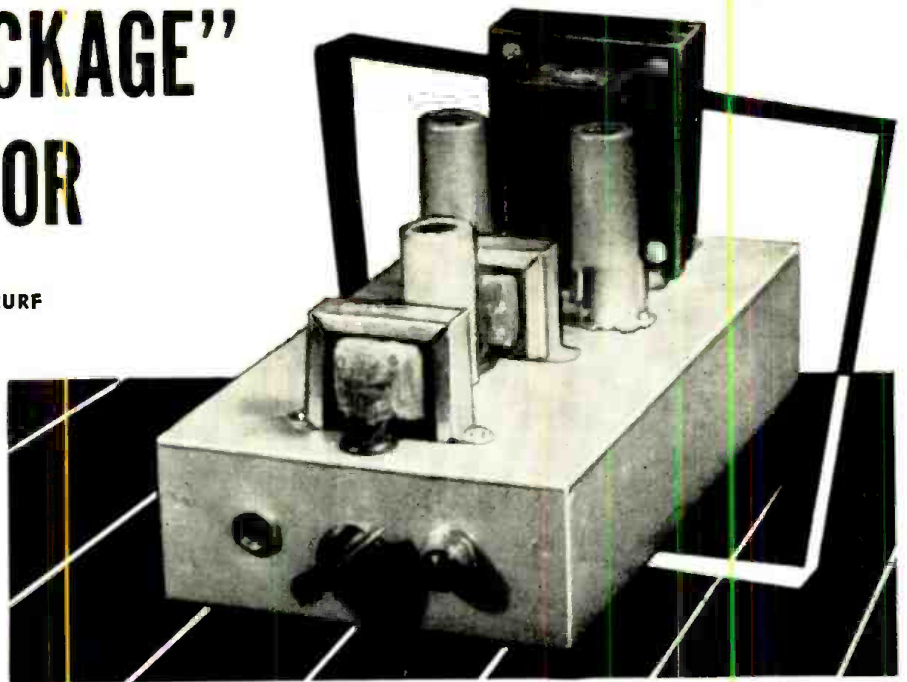

An over-all view of the small-package modulator showing straightforward parts layout.

A versatile, inexpensive low-power modulator for various amateur uses from standby gear to mobile and CD equipment.

beginner will have little trouble in building one.

Circuit

The circuit uses three miniature tubes and consists of a microphone amplifier which is transformer-coupled to a pair of modulator tubes operating under class AB₁ conditions. The microphone amplifier uses a 6C4 triode and the modulator tubes are 6AQ5 pentodes.

A single-button carbon microphone

is fed through a transformer to the 6C4 amplifier. Microphone current is obtained from the 6C4 cathode, eliminating the need for a microphone battery when an a.c. heater supply is used. A .002 μ f. condenser (C_1) is connected across the microphone to prevent r.f. feedback. This was installed after the photographs were taken and therefore does not show in the picture.

The modulation transformer has a (Continued on page 186)

Schematic of the small-package modulator. The microphone current is supplied by 6C4 cathode circuit, eliminating microphone battery. S_1 selects output impedance.

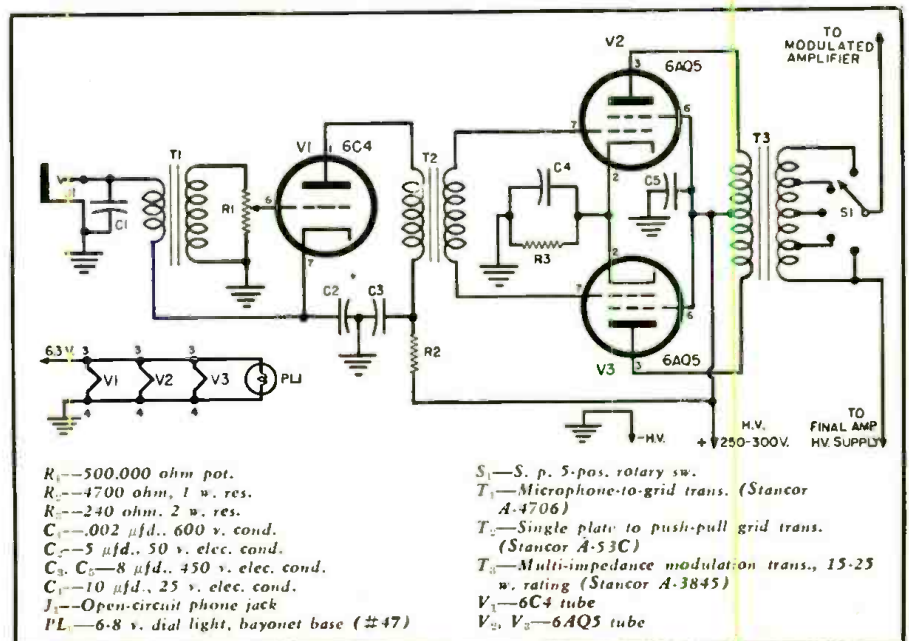

MEET THE

Snivet

By

M. B. KNIGHT

Tube Department, Radio Corporation of America

Another often-encountered TV fault which is easy to cure if you know the cause and method of locating the trouble.

SOME unusual picture disturbances which appear on television screens, such as those shown in Fig. 1, are attributable to "snivets." If you have never heard the word "snivets" before, don't be alarmed; you are not alone. The name is not a familiar one, although snivets have been quite well known in the tube industry for years. Because they often cause noise in radio receivers and picture disturbance in television receivers, we felt that an introduction to snivets might be of some value.

The word "snivets" is not dignified by any Latin or Greek roots, but was coined to describe an effect. It supposedly simulates the sound heard in radio loudspeakers as a result of snivets. The term is used rather loosely to describe both a discontinuity in plate-current of beam power tubes and its effects. The snivet appears near the "knee" of the curve of plate current *versus* plate voltage, particularly at high plate currents. Most beam power tubes show snivets at very high plate-current values. Fig. 2 shows the plate curves of a 6BQ6GT (selected) photographed from a curve tracer; this figure illustrates a snivet at the knee of the top curve.

Cause of Snivets

In a beam power tube, secondary electrons emitted from the plate are prevented from reaching the screen by the suppressor action of a low-potential region between the screen and plate produced by a suppressor element (beam-confining electrode) in conjunction with space-charge effects. The low potential in this region, and the resultant suppression of secondary electrons, is partly dependent upon the amount of plate current flowing. At low current values, beam power tubes are usually slightly under-suppressed and the plate-current curve

has a dip characteristic of tetrodes. The plate-current curve of Fig. 2 shows this tetrode characteristic to a slight extent, as do some of the curves in Fig. 3. At somewhat higher current values, which are the normal peak currents for which the tube is designed, the proper suppression characteristic is obtained. At still higher current values, the tube becomes over-suppressed and tends to develop snivets.

In the top curve of Fig. 2, the continuous curve corresponds to increasing plate current as the plate voltage is increased. As the plate voltage is decreased, however, the curve departs from the original in the region of the "knee" and maintains the high current. At some lower plate voltage, the plate current suddenly drops and returns to the curve traced when the plate current was increasing. The sudden drop is the discontinuity—the snivet. It is evident that the screen current displays a similar discontinuity because the total plate-and-screen current remains virtually constant.

This discontinuity in the current curves has been explained in detail by Salzberg and Haeff¹, who, with due scientific propriety, refer to it as a "hysteresis phenomenon." Their analysis shows that the space charge between plate and screen is at cathode potential during the steep rise of plate current with increasing plate voltage. This space-charge condition is called a "virtual cathode." At the knee of the plate current curve, however, the space-charge potential increases to some value above cathode potential and plate current is virtually independent of plate voltage. As the plate voltage is decreased, the virtual cathode is not re-formed until the plate voltage is lower than the value at which the virtual cathode disappeared during the increasing-current cycle. According to this analysis, beam power tubes

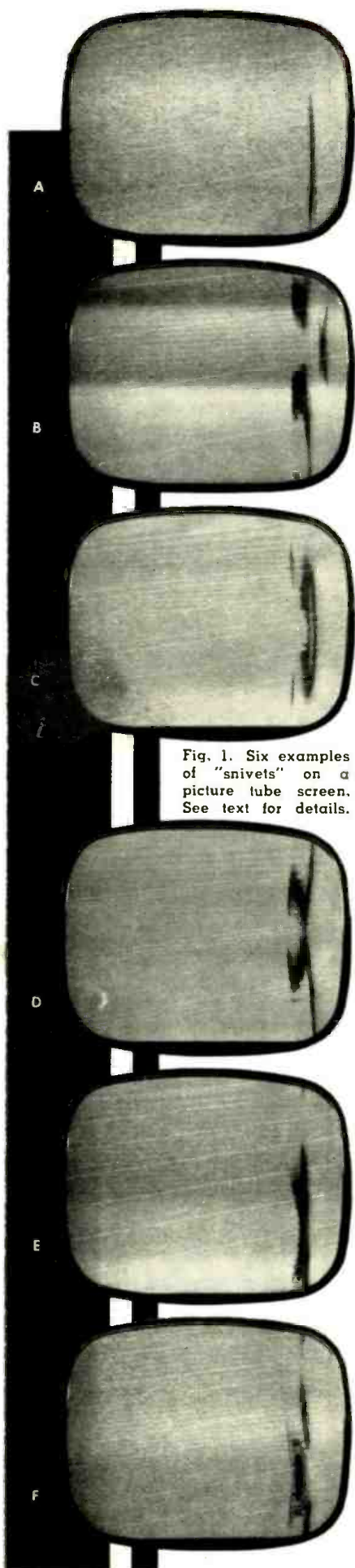

Fig. 1. Six examples of "snivets" on a picture tube screen. See text for details.

would have colossal snivets except that practical tubes necessarily depart from the theoretical parallel-plane structure.

Snivets present a dilemma to tube engineers. The sharp knee of the plate-current curve, which is desirable in beam power tubes for high power output and efficiency, is produced by the same design factors which cause snivets. Devices which reduce field uniformity in the space charge region, such as a conventional suppressor grid, prevent snivets but produce a rounded knee. The designer, therefore, aims for a sharp knee without snivets at the peak current values for which the tube is designed, allowing snivets to appear at higher currents. The published curves for the RCA type 3L6 beam power amplifier indicate snivets at high current values, as shown in Fig. 3, but the knee of the curves is sharp at normal operating currents.

Effect of Snivets

The direct effect of snivets upon an audio or deflection circuit seldom can be detected. The indirect effects, however, are occasionally troublesome. These indirect effects of snivets result from r.f. radiation associated with the very rapid change of plate and screen currents.

Radio receivers using beam power tubes in audio output stages occasionally have snivet trouble. When heard, snivets appear as a rasping noise in the output. The snivet is heard only when the tube is delivering maximum output because the plate voltage and current reach the "knee" only at maximum output. The noise is produced by radiation resulting from the snivet being picked up by the receiver antenna and delivered to the loudspeaker as if it were a normal signal. The r.f. radiation is an essential link in the chain producing the noise; the noise is not heard if phonograph records are played through the same amplifier.

In television receivers, snivet trouble sometimes originates in the horizontal-output tube. The r.f. radiation is picked up in the tuner or i.f. circuits and amplified in the normal manner, causing a picture disturbance. Fig. 1 shows some of the forms snivet disturbance can take in severe cases. These photographs were made by bringing a piece of 300-ohm line connected to the antenna terminals of the tuner close to the horizontal-output tube. The experimental breadboard deflection circuit used was adjusted so that the horizontal-output tube was operating under conditions which were abnormal but favorable for the production of snivets. The six photographs were made in fairly rapid succession, slight adjustments being made in the horizontal drive adjustment, linearity control, and plate supply voltage to obtain the variety in the appearance of the disturbance. The photograph of Fig. 1A represents the least severe disturbance and is prob-

ably more typical of the appearance of snivets in conventional receivers than the other examples. The non-uniformity of the disturbance from top to bottom of the picture results from the alternating magnetic field of the tube heater acting on the space charge in the tube.

Snivets always appear on the right-hand side of the picture because the output tube operates near the knee of its plate characteristics during that part of the scanning cycle. The interference is more likely to show up when no television signal is present; the snivet is seldom strong enough to interfere with a good television signal. Because the interference results from a sharp discontinuity rather than oscillations at a discrete frequency, the writer had expected that snivets would be more troublesome in the low-frequency channels. Observations to date, however, have not borne out that expectation. Although tests in one television receiver showed a more pronounced disturbance on low-frequency channels, the photographs of Fig. 1 were made on Channel 11 and receiver tuning was rather critical. Snivets have also been observed in the u.h.f. band. Possibly resonances in the tube structure and the wiring enhance the radiation at particular frequencies. In some cases, it is also possible that oscillations result from a negative transconductance characteristic sometimes found near the knee¹.

Eliminating Snivet Disturbance

A television technician should be able to clear up snivet complaints rather easily. Because snivets result from particular tube characteristics, substitution of other horizontal-output tubes of the same type is a simple remedy. The offending tubes, which are good in other respects, can be used in stronger-signal areas. The production of snivets is also very sensitive to the operating conditions of the horizontal-output tube. As a result slight adjustment of such con-

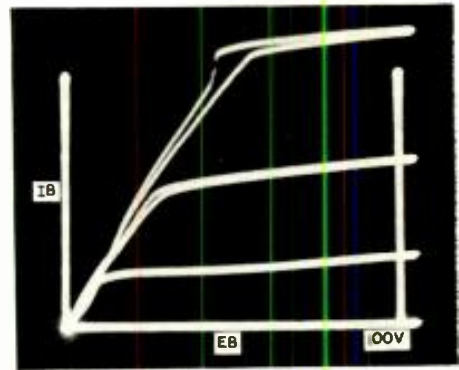

Fig. 2. Plate characteristics of a 6BQ6GT tube selected to illustrate "snivets." Note loop and discontinuity in the top curve.

trols as width, linearity, or drive may cause the disturbance to disappear.

There are many possibilities for minimizing snivet disturbance by circuit or layout changes. Any change which decreases the strength of snivet radiation with respect to the picture signal is helpful. Antenna improvements accomplish this purpose by increasing the desired signal. Physical separation of the deflection circuit from the r.f. and antenna circuits reduces the amount of undesired radiation picked up. Isolating the interfering radiation to a small area and shielding that area should be effective, although this possibility has not been investigated by the writer as yet. This approach would involve the use of small r.f. chokes in series with the plate and screen of the horizontal-output tube and the location of the tube in a high-voltage enclosure having good shielding properties. This general technique was discussed and choke details were given in a previous article².

REFERENCES

1. Salzberg, B. & Haef, A. V.: "Effects of Space Charge in the Grid-Anode Region of Vacuum Tubes." *RCA Review*, Jan., 1938.
 2. Knight, M. B.: "The Snook—Another Weird Effect to Haunt TV." *RADIO & TELEVISION NEWS*, March, 1953.
- Schade, O. H.: "Beam Power Tubes." *Proceedings of the IRE*, Feb., 1938.

Fig. 3. Plate characteristics of a 6L6 indicating "snivets" in highest current curves.

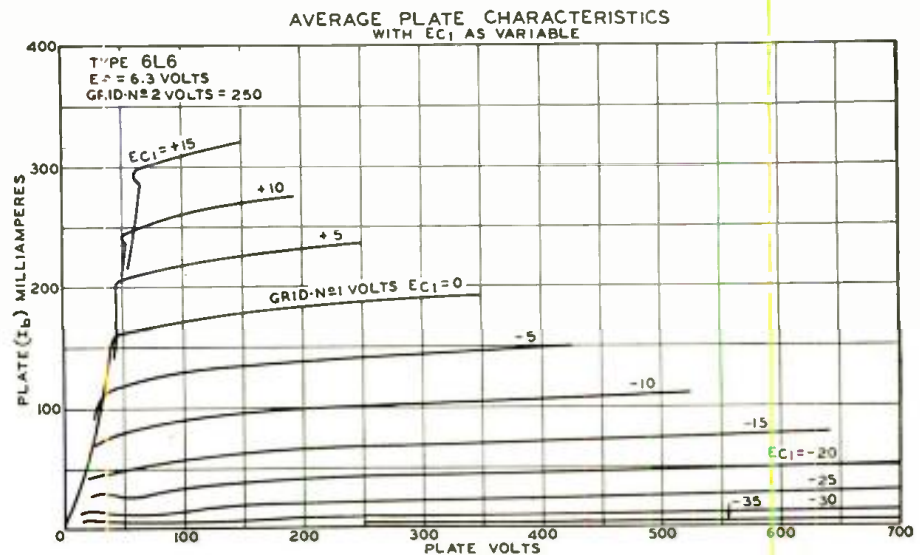

PHILCO TEST EQUIPMENT SPECIFICALLY DESIGNED FOR THE SERVICEMAN

AGAIN PHILCO LEADS THE INDUSTRY

Serviceman's needs seen as Philco's Engineering Goal

This new Philco VHF to UHF adapter pioneers a whole new approach to service problems and at the same time is the most economical and practical unit ever offered. Servicemen are taking full advantage of the introductory demonstrations of this amazing piece of equipment now offered by Philco distributors coast to coast.

The First and Only VHF to UHF Signal Generator Adapter

Continuing its engineering program designed to provide the serviceman with the best possible test equipment Philco Corporation now offers at a fraction of the usual cost an exclusive highly specialized adapter unit for converting the output of VHF TV servicing test equipment to UHF.

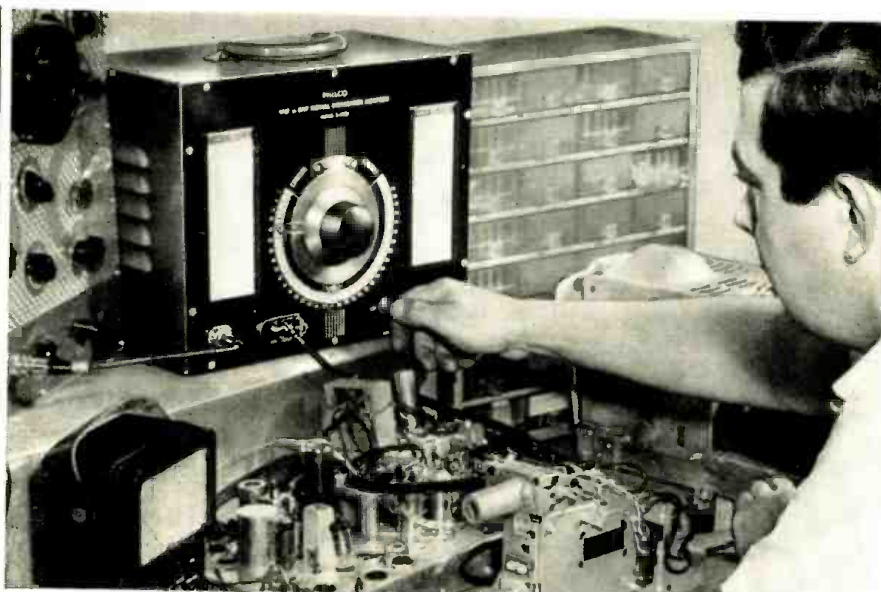

Under the trained eye of a Philco Serviceman the amazing model G-8000 VHF to UHF signal generator adapter is shown in action.

Practical Portable 3-inch Television Oscilloscope

The tremendous growth of television requires the most practical and versatile types of equipment to answer service needs. Philco has such equipment, particularly in its 3" scope which is 2½ times smaller than other 3" units, making it adaptable to either bench use or field servicing. High sensitivity and wide response make it ideal for TV work.



PHILCO CORPORATION

Accessory Division
Allegheny Ave. & "A" St., Phila. 34, Pa.

I am interested in the Philco Test Equipment shown here. Please send me details of your SPECIAL PURCHASE PLAN for obtaining these units.

Please send FREE copy of your new booklet on Philco Test Equipment.

NAME

ADDRESS

CITY STATE



One of the Finest Vacuum Tube Voltmeters ever Designed

Facing up to the task of measuring high impedance circuits where loading effect must be kept to a minimum Philco has again designed a unit which meets the most rigid engineering specifications. All reports indicate this unit is unexcelled for complete and accurate measurements.

"Philco Test Equipment Specifically designed for the serviceman!" That's the theme of Philco's engineering program. A program which you, the serviceman, can depend upon to supply the very finest in service test equipment. Discover how easy it is to own a complete Philco Test Equipment Laboratory. Your Philco Distributor is eager to serve you by offering his new special payment plan to best accommodate your needs. Fill out the attached coupon as shown and mail to Philco Accessory Div.

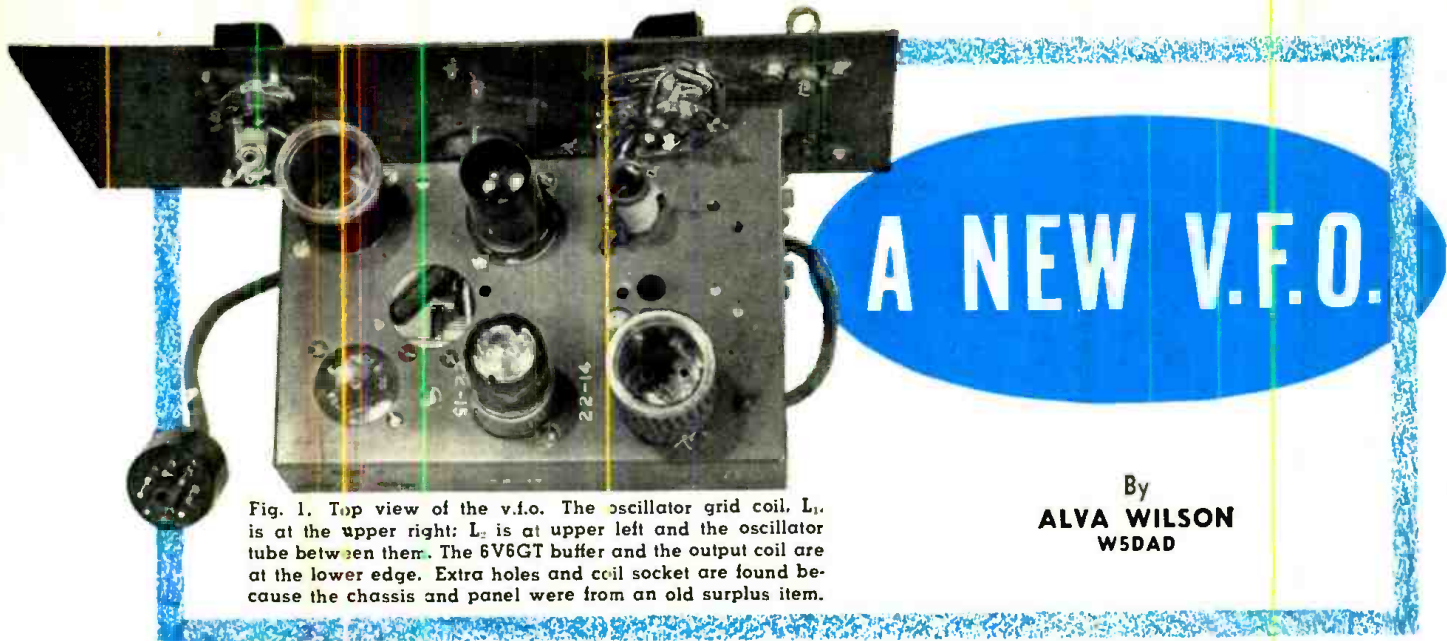

Fig. 1. Top view of the v.f.o. The oscillator grid coil, L_1 , is at the upper right; L_2 is at upper left and the oscillator tube between them. The 6V6GT buffer and the output coil are at the lower edge. Extra holes and coil socket are found because the chassis and panel were from an old surplus item.

By
ALVA WILSON
 W5DAD

A STABLE variable frequency oscillator is a source of joy around any amateur station. Since more "CQ" calls are ending with "looking around this frequency" than ever before, it becomes apparent that if we wish to contact these stations we must be able to move quickly to their frequencies. This means that we will be forced to leave our crystal with its fixed-frequency output, and adopt some means of continuously varying the transmitter frequency to any portion of any amateur band we wish to work. Not only must we have a generator of r.f. energy whose frequency can be continuously varied at will, over a predetermined range, but we must be assured that once it is tuned to any portion of that range it will remain fixed until we wish to change it, irrespective of temperature change, a.c. line voltage fluctuation, any mechanical vibration or shock, etc.

This is admittedly a big order. However, the author is confident that the v.f.o. described in this article will meet these requirements in every way.

The basic circuit of this oscillator is shown in Fig. 2, and an analysis of it will show it to be different from any of the standard types in use today. A 6AG7 was used for the initial experiments.

The common variety of v.f.o. leaves much to be desired. If enough voltage is applied to the tube plate to get an output comparable to a crystal oscillator, the tone is likely to be rough or the frequency unstable, because of excessive heating of the tube. The obvious solution, if we wish to maintain a high output level, would be to use a larger, more expensive tube which would call for a bulkier and heavier power supply. This would not be satisfactory. Being experimentally inclined the author proceeded to investigate the merits of the various oscillator circuits, as far as stability and output were concerned, with the thought in mind that some slight

This unusual circuit offers solutions to the problems of stability, output, and "note" by remarkably simple means.

change might possibly permit one of them to meet the optimum design expectations.

After considerable experimentation the Clapp oscillator seemed to be the circuit which most nearly approached the requirements, and so work was begun. The stability was good and the output fair, but the author could not approve of the "floating" cathode. A rough tone is often the result of having an r.f. potential on the cathode, due to r.f. leakage between the cathode and the a.c. heater elements. This becomes more objectionable as the plate voltage is increased in order to get a desirable output. When the oscillator is used to drive a high-powered transmitter, it will require special shielding, bypassing, etc.

Grounding the cathode in this circuit stopped the tube from oscillating, as would be expected. However, since the grid coil is series-tuned instead of being directly grounded, as in most conventional oscillators, it was a simple deduction that the plate output

could be fed back at this point (with the coil disconnected from the cathode circuit), and that this feedback voltage would have a phase shift of 180°, which would be correct for oscillation. Grounding the cathode was then possible.

In series-tuned oscillators the output sometimes varies or oscillation may stop entirely as the tuning condenser reaches the "open" position, thus compelling the constructor to resort to padding and trimming in order to smooth out a usable tuning range.

The new oscillator described herein will oscillate smoothly over the entire range of the tuning condenser without any extra padding once a suitable amount of feedback from the plate is determined. (The condensers shown shunted across the main tuning condenser in Fig. 3 were left there as the author had originally used values suggested for a Clapp oscillator circuit.)

Constructors should note that a smaller tuning condenser could be used, of a value just large enough to cover the frequency desired, but a small variable padding condenser shunted across this capacitance would still be advantageous in the original calibration of the oscillator, when acting in the capacity of a bandset condenser or for recalibration of the dial at some future date.

Another important feature of this circuit is the fact that a single variable capacitance may be used for the tuning of both the plate and grid inductances, since they both have a common terminal as far as r.f. is concerned. This point is at the lower end of the grid coil. A glance at the circuit diagram (Fig. 2) will show that by connecting a variable condenser

Fig. 2. The basic Wilson circuit. The 6AG7 was used for the original experiments. The circuit was derived from the Clapp oscillator. Plate and grid are tuned by one condenser. Note the grounded cathode.

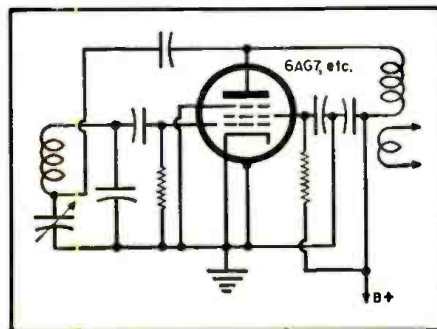

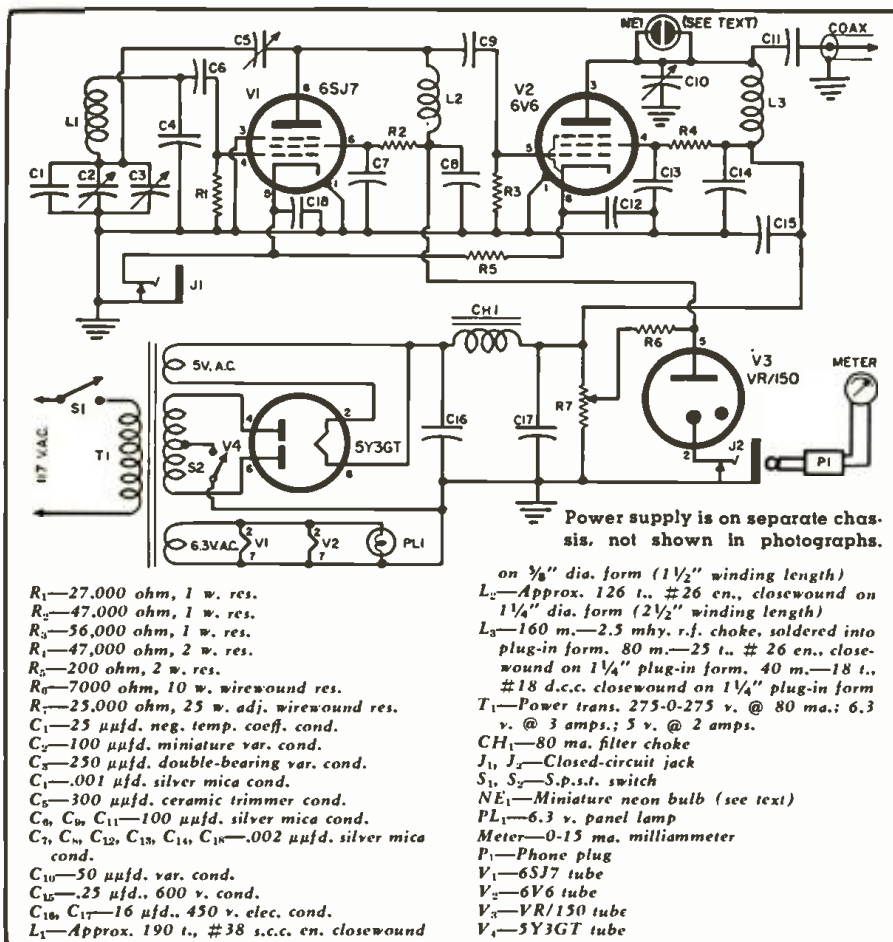

Fig. 3. Schematic of the new v.f.o. As the plate and grid of the 6SJ7 have a common r.f. connection, *C*₃ tunes both coils, eliminating the need for ganged tuning condensers and matched coils. Output of the 6SJ7 is on 160 meters; the buffer multiplies to 80 and 40 meters. *S*₂, the standby switch, is optional (see text).

between this point and ground, the frequency of both inductances will be varied as the capacity is changed. This last item will be appreciated by those who have tried the conventional method of using separate condensers for the plate and grid inductors and ganging them to a single control and then trying to get the two to track perfectly! Deviation from coil specifications by as much as 50% will not affect this tracking.

A big thrill came when the output was measured. With only 250 volts on the plate, a three-turn link was placed over the plate coil. The link was connected through a short piece of coaxial cable to an r.f. ammeter. It was certainly a surprise when the meter indicated a little over one ampere, and it was especially surprising to find that this reading remained practically constant over the entire range of the tuning condenser! This was around two or three times the output expected. At first it was thought that the oscillator was full of parasitics and was oscillating on several frequencies simultaneously, but careful checking proved that only one frequency was evident at the plate coil. Next it was noticed that nearly as much r.f. was present on the grid coil. However, measurement of the grid voltage did not show excessive drive

to this element. Therefore, the tone was "clean" and free from any roughness.

At this point concern was felt for the stability of the circuit. Because of the great amount of r.f. being generated and flowing within a single tube, the author was skeptical about this oscillator being of any practical value, but after having spent so much time up to this point, decided to warm up the frequency meter and communications receiver in order to give it a frequency stability test.

With the receiver tuned to a broadcast station around 1000 kilocycles, the oscillator was tuned to zero-beat with it, and some time was spent leaning back in a chair waiting for it to drift. Several minutes later there was still no indication of drift, and it was necessary to move the dial a little to produce a tell-tale tone to make sure it was still oscillating! It had been warmed up for about thirty minutes before this test was begun.

From a cold start approximately 1000 cycles of drift occur during the first minute of warmup. After that time the frequency is apparently constant regardless of the dial setting. This was far in excess of anything expected, and the suspicion arose that some condenser or resistor was changing its value under warmup, thus pro-

ducing a corrective variation such as is found in a negative-coefficient condenser of the correct value. To check this all resistors and condensers were substituted with others of equal value with no change in performance.

Fig. 3 shows the v.f.o. in a final form, with a buffer-doubler added and with temperature compensation and a suggested regulated power supply. Since only enough r.f. is needed to drive a 6V6 grid, the oscillator plate voltage was reduced to 150 volts, which is held constant by a type VR/150 voltage regulator tube. A 6SJ7 was used as this tube seemed to promise good stability at this voltage. However, a 6AC7, 6SK7, 6AG7 and other tubes of similar type were substituted for the 6SJ7 with very little, if any, change in performance.

The parts layout is not critical, but all parts should be rigidly mounted in order to minimize mechanical vibrations and changes of frequency caused by them. Our original model was of "breadboard" construction and we could move the various components about, thereby changing their relation to one another without interfering with oscillation or output.

A convenient arrangement for wiring as well as symmetrical appearance is to mount the coils *L*₁ and *L*₂ and the 6SJ7 in a straight line about two inches from the front of the chassis and parallel to it, with the tube in the center and a coil mounted approximately two inches to either side. The tuning condenser *C*₃ can then be mounted underneath the tube and toward the front of the chassis. Run a heavy, direct lead from the condenser frame to the common tube ground. A good way to establish this ground is to mount solder lugs under the two screws used to bolt the tube socket down, first being sure that the metal chassis is bright and clean where the screws and lugs come in contact with it. Tighten the screws firmly and then run a wire lead from one lug to the other. Run all leads direct, connecting all condensers and resistors directly to the tube or coil socket terminals, using as short leads as possible. Where a component is grounded, make the ground leads also as short and direct as possible, being sure a tight mechanical connection is made before solder is applied.

The size of the chassis used will depend upon whether a power supply is mounted upon it, the number of buffer-doublers desired between it and the transmitter, etc., so this can be left to the discretion of the individual constructor. If the unit tends to run "hot" with a power supply on the same chassis or because of poor ventilation, a negative-temperature-coefficient condenser, smaller than *C*₆, should be connected across *C*₅. Its value may be found experimentally.

When the coil *L*₂ is tuned to the 160-meter band, we found the output adequate to drive a 6L6 r.f. stage when the latter was tuned to either 80 or 40 meters.

Irrespective of the type oscillator used, it is poor practice to drive an output-type tube directly from it. Therefore, an isolation stage of some type should be used. If your present transmitter has buffer stages in it, they will perform this service providing there are enough stages to multiply the oscillator frequency of 1.8 megacycles to the desired operating frequency of your output stage. The efficiency of the "final" is higher if it is run "straight through."

The author's transmitter operated on all amateur bands from 80 through 10 meters, and had a crystal oscillator and one buffer stage ahead of the power amplifier. This meant that for highest efficiency on 10 meters, the crystal oscillator was operated in the 14-mc. band, the buffer plate coil doubling to the 28-mc. band. The final was tuned to the same frequency as the buffer when the transmitter was to be operated on ten meters. It is apparent that the output of the v.f.o. should be in the 7-mc. band, in order to double or quadruple into the grid of what is normally the crystal oscillator stage of the transmitter.

For such use a 6V6 buffer-doubler of standard design was added, with plug-in coils for the plate circuit. Outputs of 160, 80, and 40 meters are available here. For 160-meter output an r.f. choke is soldered into a tube base or coil form and plugged into the coil socket, and the tuning condenser turned so that the rotor plates are all the way open. This gives sufficient output to drive a following stage on 80 meters and obviates neutralization of the 6V6 to prevent self-oscillation. This would occur should a 160-meter coil be plugged into the socket, thus tuning the plate and grid to the same frequency.

A smooth vernier drive of the 5-to-1 ratio reduction type will be of great value in operating the main tuning condenser C_3 .

The author used a small surplus transmitter base and panel and mounted the parts in holes already punched. Looking at the front of the panel (Fig. 4), the main tuning dial will be seen in the center. At the right of this control is mounted the key jack and a 6.3-volt panel light jewel, while directly above this is the standby switch. (If desired the key itself, or leads to relay contacts may be plugged into the key jack and used for this purpose.) To the left of the main tuning dial is located the dial of C_{10} and a 6.3-volt pilot light bezel with an unmounted-type miniature neon bulb inserted with its leads twisted and soldered to stator posts of C_{10} . The control at top left is the a.c. "on-off" switch to which is connected a pair of shielded leads which run to the power supply. If a different panel is used, the two switches shown mounted at the top of the panel could be more conveniently located at the base of the panel. The panel markings for switches S_1 and S_2 , shown in Fig. 4, should be ignored.

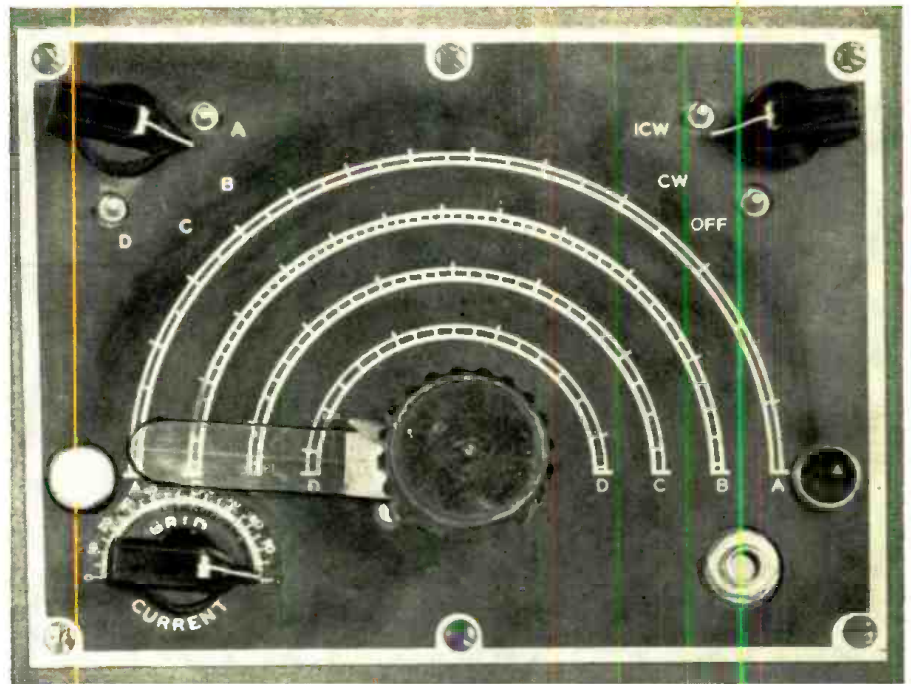

Fig. 4. Front panel of the W5DAD v.f.o. The photograph was made before calibration was completed; at this stage the old numbers have been erased from the surplus dial. The a.c. switch and standby switch are at upper left and right, respectively. Knob at lower left is for buffer-doubler tuning; above it is the neon-bulb tuning indicator for that stage. At lower right are the keying jack and the pilot lamp.

These are the original markings on the surplus panel. Both are single-pole, single-throw switches and are connected to the power supply by means of the cable and plug, Figs. 1 and 5.

The milliammeter shown in Fig. 3 is used to determine correct operation for the voltage regulator and need not be a permanent part of the circuit. The correct current value is 15 ma.

C_3 , the 300- μ fd. "postage stamp" ceramic padder, is mounted by its lugs. One terminal is soldered to the stator connection of C_3 while the other terminal is soldered directly by means of heavy wire to the plate terminal of

the 6SJ7 tube socket, thus making it self-supporting.

In adjusting this condenser, turn the compression screw in until it is tight, then back it up about three-quarters of a turn. Move the main tuning dial through the entire range of the variable condenser, checking at both extreme positions of this dial for constant output. If there is noticeable variation, adjust C_3 until output remains constant over the entire range of the tuning dial. This adjustment is not critical and will be found to be in the neighborhood of 250 μ fd.

(Continued on page 185)

Fig. 5. Under-chassis view of the v.f.o. The tuning condenser is a surplus item that happened to have a good vernier mechanism; only one section is used. It may be replaced by any good double-bearing type 250- μ fd. condenser. The neon bulb connects to both stator posts of C_{10} (lower right). The chassis should have good ventilation. The two variable condensers at right may be replaced by a single unit.

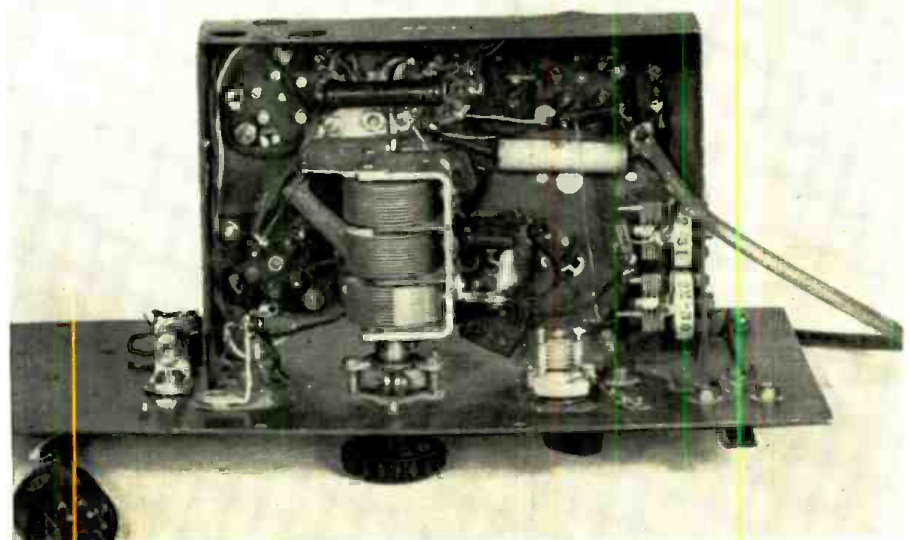

**BUY DIRECT
AND SAVE**

Sweeping the Country!

**'PRE-FAB' COLLINS TUNERS
and
RECEIVERS
AUDIO PRODUCTS CO.**

Collins Audio Products Co. is in no way affiliated with Collins Radio Co.

Two ALL NEW Complete Kits for
Every High-Fidelity Need



FM Tuner Kit

\$55

The FM-11 tuner is available in kit form with the IF Amplifier mounted in the chassis, wired and tested by us. You mount the completed RF Tuning Unit and power supply, then after some simple wiring, it's all set to operate. 11 tubes: 6J6 RF amp, 6AG5 converter, 6C4 oscillator, 6BA6 1st IF, (2) 6AU6 2nd and 3rd IF, (2) 6AU6 limiters, 6AL5 discriminator, 6AL7-GT double tuning eye, 5Y3-GT rectifier. Sensitivity 6 to 10 microvolts, less than 1/2 of 1% distortion, 20 to 20,000 cycle response with 2DB variation. Chassis dimensions: 12 1/2" wide, 8" deep, 7" high. Illustrated manual supplied. Shipping weight 14 lbs.

Each Collins Tuner Kit is complete with punched chassis, tubes, power transformer, power supply components, hardware, dial assembly, tuning eye, knobs, wire, etc., as well as the completed sub-assemblies: FM tuning units, AM tuning units, IF amplifiers, etc., where applicable. Since all these sub-assemblies are wired, tested and aligned at the factory, Collins Pre-Fab Kits are easily assembled even without technical knowledge. The end result is a fine, high quality, high fidelity instrument at often less than half the cost—because you helped make it and bought it direct from the factory. Bring your present reproducing system up to date with a new Collins Tuner.



FM/AM Tuner Kit

\$77⁵⁰

The original 15 tube deluxe FM/AM pre-fab kit redesigned on a smaller chassis. The tuner now measures 14" wide by 12" deep by 7 1/2" high. This attractive new front and dial assembly opens up new applications where space is at a premium. Kit includes everything necessary to put it into operation—punched chassis, tubes, wired and aligned components, power supply, hardware, etc. Kit comprises FMF-3 tuning unit, IF-6 amplifier, AM-4 AM tuning unit, magic eye assembly and complete instructions. All tubes included. Shipping weight 19 lbs.

Selected Basic Components For Special Applications

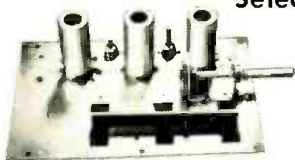

FMF-3 Tuning Unit

\$15²⁵

The best for FM. The most sensitive and most selective type of "front end" on the market. 6 to 10 microvolts sensitivity. Image ratio 500 to 1. 6J6 tuned RF stage, 6AG5 converter, 6C4 oscillator. Permeability tuned, stable and drift-free. Chassis plate measures 6 1/2" x 4 1/2". In combination with the IF-6 amplifier, the highest order of sensitivity on FM can be attained. Tubes included as well as schematic and instructions. Draws 30 ma. Shipping weight FMF-3: 2 1/2 lbs. Dial available @ \$3.85

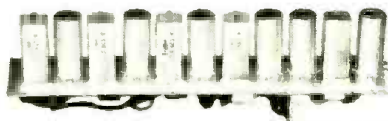

IF-6 Amplifier

\$19⁷⁵

A remarkable value! 6 tubes are used in the IF amplifier: 6BA6 1st IF, (2) 6AU6 2nd and 3rd IF's, (2) 6AU6 limiters and 6AL5 discriminator. High gain, wide-band response (200 KC) for highest fidelity. 20 to 20,000 cycles. Distortion less than 1/2 of 1%. Draws 40 ma @ 220 volts. Chassis plate dimensions: 11-5/16" x 2 1/2" Shipping weight: 3 lbs.



AM-4 Tuning Unit

\$24⁵⁰

Tops in AM superhet performance! A 3-gang tuning condenser gives 3 tuned stages with high sensitivity and selectivity. Assembly is completely wired, tested and aligned ready for immediate use. Frequency coverage 540 KC to 1650 KC at a sensitivity of 5 microvolts. Tubes 6BA6 RF amplifier; 6BE6 converter; 6BA6 IF amplifier and 6AT6 detector. Draws 30 ma @ 220 volts. Mounts on a chassis plate measuring 4" x 7 3/8". Shipping weight 2 1/2 lbs. Dial available at \$3.85.

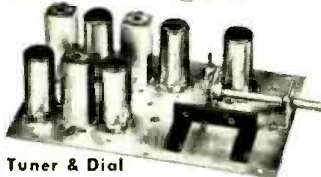

RD-1C Tuner & Dial

\$28⁵⁰

The COLLINS RD-1C FM tuner chassis is unique in the field. A whole, compact FM tuner and dial that fits in the palm of your hand. Convert AM sets to FM/AM receivers for only a few dollars! Unlimited applications where space is at a premium. Use in conjunction with your phonograph amplifier. Full frequency response to 20,000 cycles. Sensitivity 20 microvolts, permeability tuned. Tuning unit and IF amplifier on the same chassis plate. Draws 40 ma @ 100 volts. Tubes: 6AG5 converter, 6C4 oscillator, (2) 6AU6 IF amplifiers, 6AL5 in new ratio detector circuit Shipping weight tuner and dial 5 lbs

**MAIL
COUPON
TODAY**

To: Collins Audio Products Co. Inc.
P.O. Box 368, Westfield, N. J.
Tel. Westfield 2-4390

- FM Tuner Kit FM/AM Tuner Kit Slide Rule Dial Assembly
- FMF-3 Tuning Unit IF-6 Amplifier RD-1C Tuner and Dial
- AM-4 Tuning Unit

NAME _____

ADDRESS _____

CITY _____ STATE _____

Amount for Kit \$..... See weights, add shipping cost \$.....

Total amount enclosed \$..... Check Money Order

WHEN YOU THINK OF TUNERS, THINK OF COLLINS AUDIO PRODUCTS

A.C. FIELDS IN TV RECEIVERS

By
WALTER H. BUCHSBAUM
Television Consultant
RADIO & TELEVISION NEWS

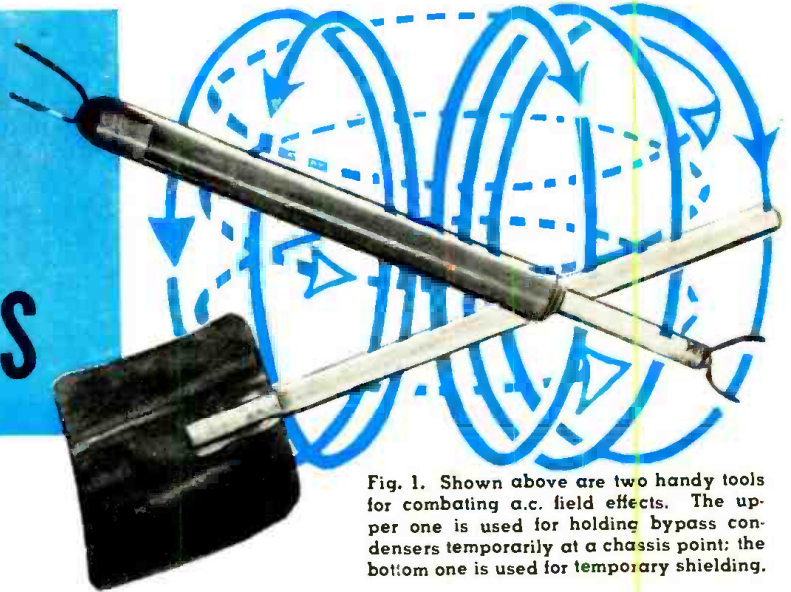

Fig. 1. Shown above are two handy tools for combating a.c. field effects. The upper one is used for holding bypass condensers temporarily at a chassis point; the bottom one is used for temporary shielding.

How to detect and remedy interference effects in picture and sound caused by the TV receiver's own a.c. fields.

MANY defects in TV receivers are not due to simple open or short circuits or bad components. Interference troubles, whether they originate outside the receiver or are caused by some section in the set, are always difficult to locate and repair. This article deals with various types of interference effects due to a.c. fields inside the TV chassis. Some of these effects are often incorrectly attributed to other causes.

Every circuit has electric and magnetic fields surrounding its wires and components but, in a TV receiver, fortunately, only a few sections have fields strong enough to affect the performance of other sections. These troublesome a.c. fields are explained, their interference trouble is discussed, and effective repairs suggested. A few simple gadgets which help in troubleshooting this type of defect are also presented.

Types of Fields

Fig. 2 shows a simple coil such as is used in the r.f. and i.f. sections of a TV set. Passing through the center of the coil are magnetic field lines. They always form a closed loop. At right angles to the magnetic field we see the electric field indicated by dotted lines. The arrows showing the direction of current and the magnetic and electric fields reverse for each cycle of signal frequency. Although a single winding is shown in Fig. 2, the location of both fields will not be changed if two coils are on the same form or a bifilar winding is used.

A more complicated field distribution is shown in Fig. 3; a typical iron core inductance. Whether this is a choke or a transformer, the main magnetic field will be concentrated in the iron laminations. There are also, however, magnetic leakage fields which are strongest in the directions shown. It is usually this magnetic leakage field that links with other components and produces interference. The electric field in iron core transformers is quite weak compared to

the magnetic one and rarely causes interference.

The copper strap on the outside of the coil is used on better type power transformers and acts as a single shorted turn. Magnetic leakage fields will induce a current in the copper and this current, in turn, sets up a magnetic field opposing the original leakage field. Although the copper strap reduces magnetic leakage fields in this manner, it is not really a magnetic shield. The only good shielding material against magnetic fields is "Mumetal," which is used in many oscilloscopes to protect the CRT from stray magnetic fields.

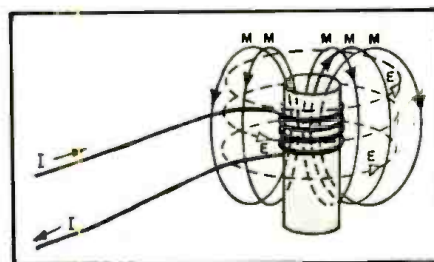
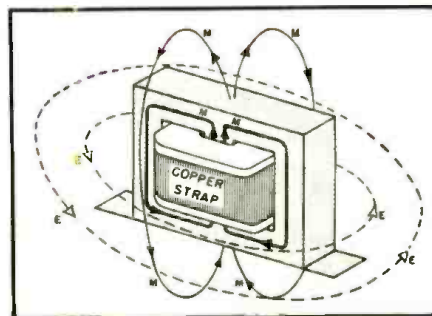

Fig. 2. The magnetic and electric fields associated with a simple air-core coil.

Fig. 3. The magnetic and electric fields issuing from a choke coil or transformer.



Fields Inside the TV Set

Although every current-carrying part has both a magnetic and electric field associated with it, only a few parts of the TV receiver are likely to cause trouble because of these fields.

Every technician is familiar with the shielding used in the r.f. tuner. These grounded shields are plated steel or aluminum, and are effective against the electric fields surrounding the various coils. In the r.f. tuner the shielding serves two main purposes. One is to prevent coupling between the input and output of a tube, and the other is to reduce radiation of the local oscillator signal.

Another possible source of interference exists, however, if the tuner has a corroded or open ground connection, or open r.f. bypass condenser. Under these conditions, the heater or "B+" wires may carry r.f., producing r.f. fields causing feedback and, possibly, oscillations.

Most tuners are designed to minimize the possibility of regeneration at higher "B+" voltage but poor shielding can cause this trouble. An example of this is the following case history.

A popular brand set seemed to oscillate occasionally on only one strong station; weaker stations were received perfectly. In this particular receiver a cascode amplifier was used and the tuner did not receive a.g.c. bias. The defect was only apparent when the a.c. line voltage in the customer's home exceeded 120 volts; usually during the daytime. At the shop, the line voltage was held at 117 volts and no oscillation appeared.

The cause of the trouble was determined as an increased "B+" on strong signals combined with poor shielding. On weak signals the i.f. bias was low,

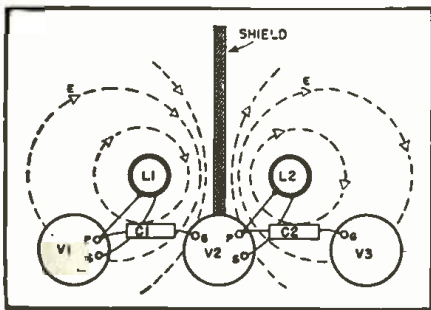

Fig. 4. The effect of a grounded shield on the electric field lines of two coils.

causing i.f. tubes to draw more current. This lowered the "B+" voltage which was also the plate supply for the r.f. amplifier and mixer. On a strong signal, however, the a.g.c. reduced the current through the i.f. section, permitting the "B+" to rise. A poorly grounded shield in the tuner caused regeneration between the r.f. amplifier and the mixer.

This sort of defect is just one example of the effect a.c. fields can have. Other tuner field troubles may not be apparent in the set itself, but may cause interference to neighboring receivers due to oscillator radiation.

The i.f. section is also quite sensitive to a.c. fields because of the large total amplification. A weak field due to the last i.f. coil may be sufficient to cause oscillation when it reaches the input stage of the i.f. section because of the great gain in the system. For this reason, most TV receivers use some shielding in the i.f. section, as shown in Fig. 6. Electrostatic shielding is used because the electric field is usually the most troublesome.

The effect of a grounded shield on the electric field lines is shown in Fig. 4. A typical single-tuned, 3-stage i.f. section has a tunable coil as each plate load (L_1 and L_2 in Fig. 4), and a coupling condenser from each plate to the following grid, C_1 and C_2 . If enough energy is radiated from L_2 to L_1 , the tube V_2 will operate as a tuned-grid, tuned-plate oscillator. A grounded metal plate between the two coils will cause a shift in the field lines, as

shown in Fig. 4. At the shield itself, the electric field from either coil must be zero. If the shield were not grounded, it would still reduce the coupling somewhat, but not nearly as much as when grounded.

Another cause of trouble in the i.f. section is undesirable pickup. The latter is occasionally due to the 60-cycle power frequency being picked up by a.g.c. bias wires which run near the power transformer or "B+" choke. More frequently, the i.f. coils themselves act as resonant antennas and receive amateur or police signals which fall into the i.f. band. A transmitter radiates a strong electric field and the only way to prevent this interference from reaching the i.f. coils is to shield the entire i.f. section. Tube shields and a chassis bottom plate usually reduce this type of interference considerably.

In addition to the r.f. and i.f. sections, a.c. fields also cause trouble in the audio and synchronizing sections. Both audio and synchronizing signals are frequently interfered with by the vertical sweep pulse, a 60-cycle signal. Occasionally, the magnetic field from the power transformer causes hum pickup, but trouble from the vertical sweep is more prevalent. When hum or buzz is not caused by a defective "B+" filter condenser, or receiver misalignment, check for a.c. fields.

When a check with the oscilloscope shows the a.c. hum in the filtered "B+" to be less than $\frac{1}{2}$ volt for 300 volts d.c., chances are that the hum is due to either leakage from heater to cathode in one of the audio stages or else 60-cycle hum picked up by a lead. In most TV sets, the audio leads going to the volume control are shielded and the shield is soldered to ground in several places. If the ground connections have become corroded, the wire may pick up a field either from a nearby power transformer or even from a heater wire running alongside the audio lead.

In one case, the a.c. power leads traveled the entire length of the chassis next to the audio cable. The a.c. switch was mounted on the volume

control and the only ground point for the shielding braid was right at the point where the volume control was grounded. When the volume control became noisy and was replaced, the shielding braid was clipped off at the ground. The new volume control was wired in and the shielding braid left hanging. When the set was turned on, a loud 60-cycle hum was heard which had not been there before. Moving the a.c. leads or grounding the shield of the audio lead reduced the hum. The missing ground connection was then discovered and the defect quickly remedied.

The vertical output transformer has quite a strong field, especially in some of the cheaper-type transformers using a minimum of iron. Buzzing, due to the leakage fields of these transformers, occurs mostly after some repair has been made which changed the path of an audio lead, or where a new and different vertical transformer has been installed. This type of defect is often found in custom-built TV sets or assembled kits, and can be eliminated by moving or rotating either the transformer or the lead picking up the field.

In many TV sets the vertical synchronizing circuit is quite stable, but on medium or weak stations it appears impossible to get good interlace. In a number of cases the lead carrying the vertical synchronizing pulses also picks up the vertical flyback pulse. When viewed on the oscilloscope, only one broad pulse is seen at the grid of the vertical oscillator. If the vertical output tube is pulled out, the broad pulse disappears and the correct integrated synchronizing pulse is visible. The integrated pulse is what should control the vertical oscillator so that it triggers at slightly different times on alternating cycles. This is what produces interlacing. When the feedback of the vertical output amplifier smothers the synchronizing pulse, synchronization may appear stable, but there is no chance for the slight shift in triggering due to the original synchronizing pulse.

In Fig. 5A, not only the magnetic field of the vertical output transformer, indicated in solid arrows, but also the electric field (the dotted circles) act on the lead going to the vertical oscillator grid. If the polarity is right, the radiated pulse will be added to the synchronizing pulse, resulting in poor interlace. When the polarity of the radiated pulse is opposite to that of the synchronizing pulse, the difference between the two might not leave enough pulse for stable synchronization. In either event, the best remedy is indicated in Fig. 5B. Here the transformer is rotated 90 degrees so that the magnetic leakage field lines no longer link with the wire. To remove the effect of the electric field, the wire has been shielded through the use of a grounded copper braid.

Another a.c. field causing occasional trouble in special installations is the loudspeaker leakage field. The mag-

Fig. 5. (A) The magnetic field lines of the vertical output transformer cross the lead carrying vertical synchronizing pulses, impressing an output sawtooth on this line. (B) Proper lead shielding and rotation of the transformer remedy this.

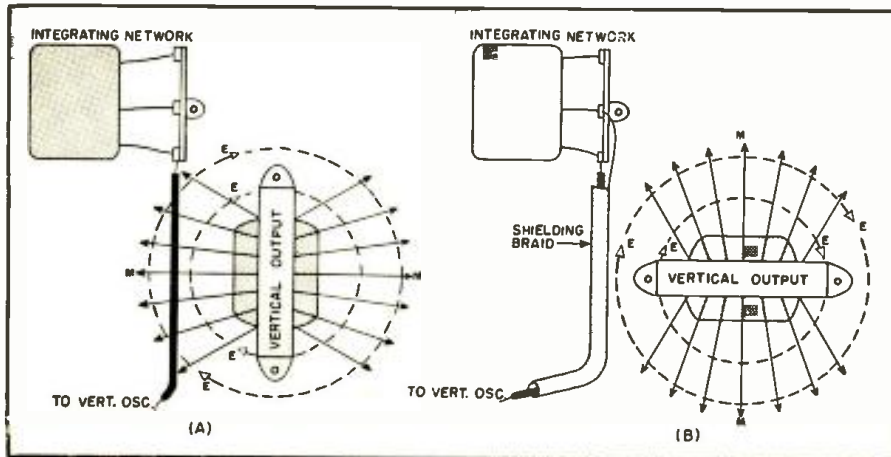

net c field, especially when a dynamic speaker is used, can interact with one of the audio amplifier tubes and cause squealing or howling. For this reason the best remedy is to locate the speaker as far away from the audio amplifiers as possible. This effect of the magnetic field should not be confused with the microphonics which occur when the air vibration due to the speaker action sets the internal structure of some tube into vibration.

The strongest electric a.c. field in the entire TV set is found in the high-voltage section. Because of the relatively high voltage and low current, the electric field surrounding the flyback transformer is much larger than its magnetic field. However, because the electric field is so strong only during the retrace time, few interference troubles result. In the vast majority of TV sets, the HV section is shielded, and in some receivers the leads going to the deflection yoke are also shielded.

Most of the defects due to the high-voltage fields occur outside the shielded cage. Barkhausen oscillation, recognized by the black vertical stripes, especially on weak signals, is often caused in part by linkages with unshielded yoke leads. In most of the older RCA, Emerson, and other sets using an aircore-type flyback transformer, the position and length of the yoke leads are quite critical. The popular remedy for Barkhauser oscillation is to mount a small permanent magnet on the output amplifier tube and locate it at the one spot that removes the oscillation.

The most frequent complaint concerning high-voltage section a.c. fields is the interference caused to nearby broadcast receivers. This is due to the harmonics of the 15,750-cycle flyback pulse which are radiated and picked up in the broadcast band. Better shielding and bypassing of all heater and "B+" leads going into the high-voltage cage should reduce this interference.

Troubleshooting

We have outlined the most frequent defects due to various a.c. fields, and now some hints to make troubleshooting this type of defect easier are in order. For one thing, how can we be sure that an interfering signal is picked up through its field and is not coming through the heater, "B+," or bias supply?

A few simple tests can be made. Use the oscilloscope to check for any interference signal at the heater, "B+," and bias supply points. Bypass these points temporarily near the source of trouble to be sure that no r.f. signal rides in at frequencies that are beyond the range of the oscilloscope.

To bypass some points momentarily, use the insulated cord holder shown in Fig. 1. This is merely a turned-down polystyrene rod having slots at each end. One end holds a 1000 μ fd. ceramic disc condenser; the other end holds a .01 μ fd. condenser. The smaller condenser is used for r.f. and i.f. bypassing; the larger one for

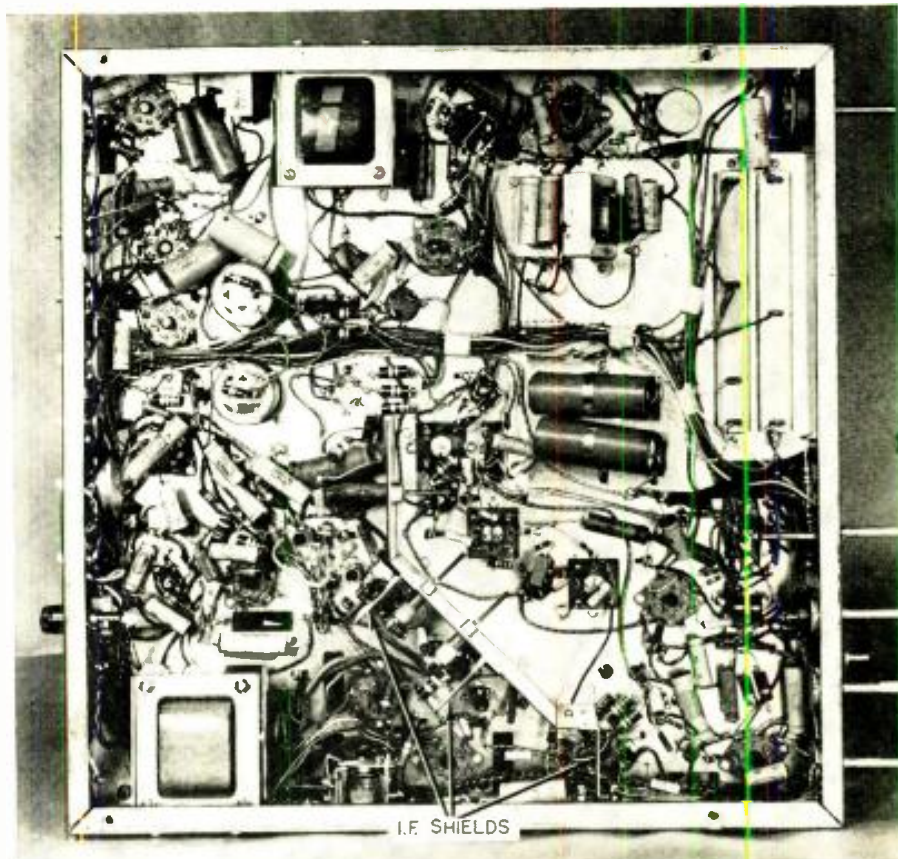

Fig. 6. The underside of a TV set showing the shielding used for the i.f. stages.

video and audio. A simple device like this permits holding a good bypass condenser right at the desired location and observing its effect repeatedly.

To observe a.c. fields at r.f. or i.f. frequencies requires special receivers, but lower frequency fields due to 60 cycle, 15,750 cycle, and audio frequencies can often be seen on the oscilloscope. If the field is an electric field, a single straight piece of wire connected to the oscilloscope cable will pick up enough to show on the screen. For magnetic fields, coil five to ten turns of hook-up wire around a 1-inch diameter form. Connect one side to the oscilloscope ground, and the other to the vertical input.

As mentioned previously, only "Mu-metal" is a good shield for magnetic fields. Soft iron at least $\frac{1}{8}$ inch thick is a fair shield for magnetic fields. The best method for dealing with magnetic field interference, however, is to turn the offending part 90 degrees, or else relocate it.

For electric fields any conducting metal makes a satisfactory shield, especially when it is grounded. The soft copper plate with insulated handle shown in Fig. 1 is another convenient tool for tracing a.c. fields. The copper piece is held down against the chassis between suspected parts. Because it is thin and flexible, it can be bent, twisted, or folded into any shape that the layout of the chassis requires. By adding an insulated handle, accidental touching of "B+" or shorting is avoided.

In some cases it may be desirable to

use a shield which will be effective against electric fields but which will not oppose magnetic field lines. In such places a Faraday shield may be used.

The Faraday shield consists of a sheet of polystyrene or similar insulator, about $\frac{1}{8}$ -inch thick and as long and wide as necessary to cover the area to be shielded. On this sheet is laid out a grid of parallel wires (No. 20) equally spaced from each other by about the width of the No. 20 wire, and soldered at one end only to a ground bus. The wire grid should be cemented to the polystyrene sheet by a few coats of Duco or similar cement. Care should be taken that the wires do not touch each other except along the ground bus.

This shield will effectively ground each electric field it comes in contact with, thereby preventing the fields from impinging on each other. However, the shield does not present a closed circuit to a magnetic field and, therefore, the magnetic field cannot induce currents in it, currents which set up a magnetic field opposing the original one, as explained earlier.

The a.c. fields, both magnetic and electric, are essential to the operation of any TV receiver. The defects caused by the interaction of these fields with other components or other fields are often harder to recognize than ordinary parts troubles. By knowing the location, direction, and effect of the most likely offenders, the experienced technician can easily remedy such defects caused by a.c. fields.

easy...split second installation!



corner reflector *Golden Grid* uhf antenna

Identified by its golden screen

FACTORY-ASSEMBLED

- vibration-proof
- ready to install
- reduces installation cost
 - sturdily constructed
- only 1 mast bracket to attach
- anti-corrosion plating meets government specifications

Exclusive

UHF "WISHBONE" INSULATOR

Only Telco gives you this remarkable "plus" feature

1-2-3 Ready To Go!

- 1 OPEN CARTON . . . REMOVE FACTORY-ASSEMBLED UNIT
- 2 OPEN LIKE A BOOK . . . FASTEN STRUT WIRES
- 3 MOUNT ON MAST . . . JOB COMPLETE

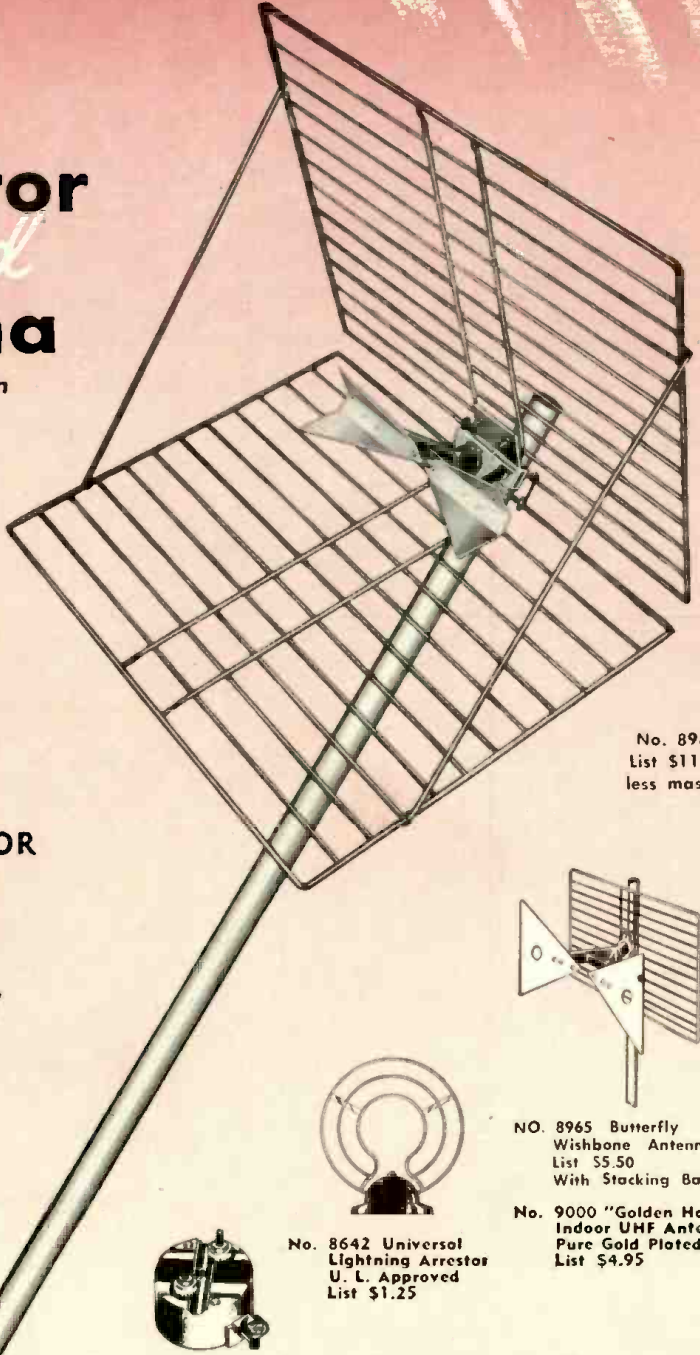

No. 8984
List \$11.75
less mast

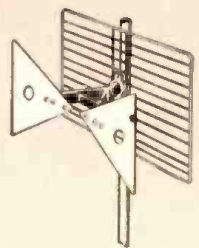

NO. 8965 Butterfly
Wishbone Antenna
List \$5.50
With Stacking Bar



No. 8642 Universal
Lightning Arrestor
U. L. Approved
List \$1.25

No. 9000 "Golden Halo"
Indoor UHF Antenna
Pure Gold Plated
List \$4.95



WRITE FOR FREE TELCO CATALOG



television hardware mfg. co.

DIVISION OF GENERAL CEMENT MFG. CO.
904 TAYLOR STREET., ROCKFORD, ILL.

KNOW YOUR 1954 SYLVANIA TV RECEIVERS

By **WILLIAM NELSON**

Service Dept., Sylvania Electric Products Inc.

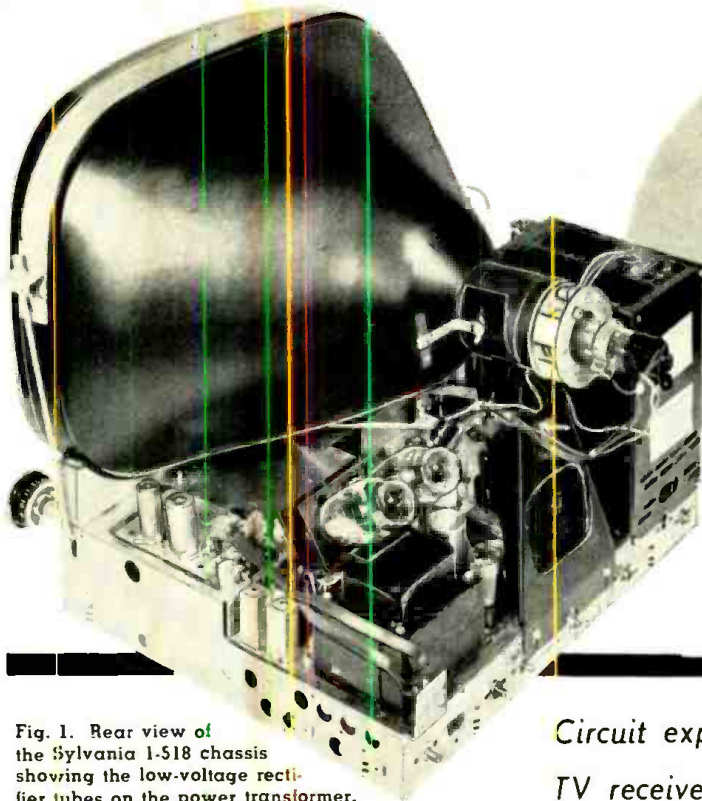

Fig. 1. Rear view of the Sylvania 1-518 chassis showing the low-voltage rectifier tubes on the power transformer.

Circuit explanation and service data for new Sylvania TV receivers, including a complete schematic diagram.

FOR 1954, Sylvania is introducing two 27-inch chassis, a 24-inch chassis, two 21-inch chassis, and a 17-inch chassis. Because the 21-inch 1-518 deluxe chassis utilizes many interesting new circuits, it will be discussed fully in this article.

Tuners

The *General Instrument* u.h.f. tuner used as part of the 1-518 television chassis is a capacitance-tuned type. Its schematic diagram is shown in Fig. 5. Two type 1N82 germanium diodes are used as oscillator doubler and mixer, and a type 6J6 tube functions as the u.h.f. oscillator. The antenna input impedance to the preselector portion of the tuner is a balanced 300 ohms. A push-pull type of oscillator, derived from the *Harley* circuit, is used so that the capacitance of the tuned circuit can be higher since it is split between the two tubes. This makes the tube interelectrode capacitance a small percentage of the total and the 6J6 can be replaced without too much detuning of the circuit. This stage generates a signal of one-half the desired frequency.

The oscillator output is coupled to the oscillator doubler stage, sometimes called a distortion amplifier. At this stage, the frequency of the oscillator output is doubled in such a manner as to place the u.h.f. oscillator operation on the high side of the carrier frequency. Thus, the video i.f. carrier comes through higher than the audio i.f. carrier.

The oscillator doubler output and the preselector output are fed to the mixer stage, consisting of the mixer section of the tuner and the mixer

germanium diode. At this stage, the output signal of the oscillator doubler and the incoming u.h.f. signal are mixed, with the result that a heterodyne frequency is produced within the 44 mc. i.f. band of the TV receiver. The output of the mixer is coupled to the v.h.f. tuner strip, tuned to the receiver i.f. frequency.

As for the replacement of tubes in this u.h.f. tuner, the 6J6 tube and the 1N82 germanium diodes may be replaced without upsetting any of the critical circuits. However, it has been found that if the tube shield is tilted, or the 6J6 tube itself is placed improperly in the socket (tilted to one side but maintaining pin contact), the frequency of the oscillator may be affected. This is indicated by the station not tuning to the proper channel or by a high noise level with a weak signal.

At the present time, due to the shortage of u.h.f. test equipment, it is recommended that these tuners be returned to the distributor for any needed repairs. However, it is expected that simple tube or crystal replacement should be tried first. If you have the necessary equipment, by all means do your best to repair tuners in the field.

A cascode v.h.f. tuner is used in the 1-518 chassis. The channel switching of the cascode tuner is accomplished by a detent-type rotating turret which changes r.f., mixer, and oscillator coils for each channel. The bandwidth of the output of this tuner is 42.1 to 45.75 mc.

The ultimate sensitivity (or minimum usable signal) of a set is not determined by the amplification of the

receiver but by the internal noise generated in the r.f. stage of the tuner. The r.f. amplifier stage is the most critical with respect to noise because the noise that it generates is amplified the most before reaching the picture tube and any noise generated in later stages is usually masked by the greater magnitude of the r.f. amplifier noise. Consequently, any tube noise developed in the r.f. amplifier should be as small as possible.

One of the major sources of noise in a tube is the random fluctuations in the electron flow from cathode to plate. This is called the "shot effect." In multigrid tubes, these random fluctuations are multiplied by the division of current by the individual wires of each grid. Therefore, it is easily seen that pentodes would cause much more noise than triodes. However, until recently, triodes have not been used as r.f. amplifiers because they require neutralization to prevent regeneration and oscillation. This is an extremely critical adjustment at TV frequencies. The cascode tuner circuit eliminates this requirement and combines the high gain and stability of a pentode amplifier with the low noise characteristic of a triode amplifier.

As is seen in Fig. 3, a 6BK7 double triode is used, having a grounded-cathode stage followed by a grounded-grid stage. The gain of the grounded-cathode stage is low enough to eliminate feedback problems. However, neutralizing feedback by *C₁* is used to improve the noise figure and is not necessary for stable operation of the amplifier.

The grounded-grid stage has its grid at a.c. ground through the bypass con-

denser C_3 , 800 μfd . Thus, the input and output circuits are effectively isolated by the shielding action of this grid making the stage inherently stable. This stage is cathode driven. The

cathode-driven amplifier differs from a grid-driven amplifier in that the signal changes the cathode voltage to vary the grid bias instead of changing the grid voltage to vary the grid bias.

The oscillator-mixer stage is of the standard type used in such tuners. The 44 mc. i.f. strips are added to the turret for conversion to u.h.f., permitting the 44 mc. i.f. output of the u.h.f. tuner

Table 1. Alignment procedure for the video i.f. and sound circuits of the Sylvania 1-518 series TV chassis.

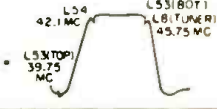
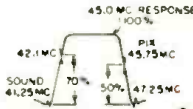
VIDEO I.F. ALIGNMENT						
STEP	SIGNAL GENERATOR		OUTPUT INDICATOR	CONNECT TO	ADJUST	REMARKS
	FREQUENCY	CONNECT TO				
1	39.75 mc. unmodulated	Raised tube shield on oscillator-mixer, V_2 (6J6)	V.T.V.M.	Across diode load resistor, R_{152}	L_{53} (top) for minimum reading	Set the tuner to a free channel. Apply -12 volts between the junction of R_{137} - C_{131} and chassis
2	43.25 mc. center frequency. 10 mc. sweep. Marker generator at 45.75 mc. and 42.1 mc.	Pin 5 of V_2 (6J6) through hole in tuner cover	Oscilloscope	Pin 5 (plate) of V_2 , 6CB6, through detector circuit. See Fig. 4	L_{53} (bottom), L_{54} (tuner), and L_{56} for curve below: 	Remove a.g.c. voltage. Disconnect T_{55} primary from pin 5 of V_2 ; connect a 330-ohm resistor in its place. Lower the V_2 shield. Set the v.h.f. tuner between any two channels.
3	41.25 mc. unmodulated	Same as step 1	Same as step 1	Same as step 1	L_{55} for minimum reading	Same as step 1
4	47.25 mc. unmodulated	Same as above	Same as above	Same as above	T_{56} (top) for minimum reading	
5	41.25 mc. unmodulated	Same as above	Same as above	Same as above	T_{55} (top) for minimum reading	
6	44.0 mc. unmodulated	Same as above	Same as above	Same as above	T_{58} for maximum reading	Reduce signal generator output to keep v.t.v.m. reading between 1 and 2 volts
7	42.0 mc. unmodulated	Same as above	Same as above	Same as above	T_{57} for maximum reading	
8	45.2 mc. unmodulated	Same as above	Same as above	Same as above	T_{56} (bottom) for maximum reading	
9	43.2 mc. unmodulated	Same as above	Same as above	Same as above	T_{52} (bottom) for maximum reading	
10	Repeat steps 3 to 5 inclusive					
11	43.25 mc. center frequency. 10 mc. sweep. Markers at 41.25 mc., 42.1 mc., 45.75 mc., and 47.25 mc.	Raised tube shield on V_2	Oscilloscope	Across diode load resistor, R_{152} , with 33,000-ohm isolation resistor in series with hot scope lead	T_{55} , T_{57} , T_{56} (bottom), and T_{52} (bottom) for response curve below: 	
SOUND ALIGNMENT						
12	Tune to over-the-air TV channel		V.T.V.M.	Pin 5 of V_{11} (6AL5); ground lead to pin 7	T_{52} (bottom); L_{62} for maximum reading	
13	Same as above		V.T.V.M.	Through 100,000-ohm resistor to terminal 5 of T_{52}	T_{52} (top) for zero reading	Connect ground lead of v.t.v.m. to junction of two matched 100,000-ohm resistors connected in series across R_{110}
4.5 MC. TRAP ALIGNMENT						
14	4.5 mc. unmodulated	Pin 2 of V_7	V.T.V.M.	Pin 11 of V_{26} , the picture tube	L_{61} for minimum reading	Short pin 1 of V_6 (4th video i.f. amplifier) to chassis

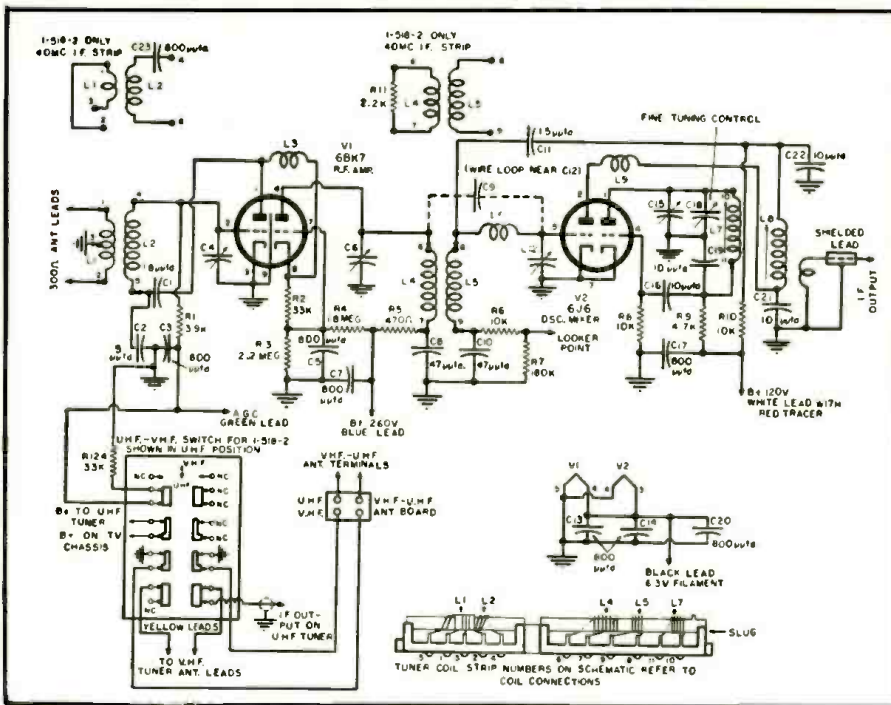

Fig. 3. Schematic diagram of the v.h.f. tuner used with the Sylvania 1-518 series TV chassis. Note the u.h.f.-v.h.f. switch at the lower left corner.

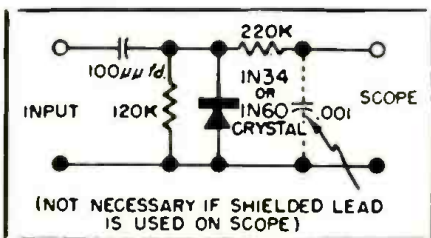

Fig. 4. Detector circuit used in step 2 of the video i.f. alignment procedure.

to feed right through the v.h.f. tuner. The oscillator coils are slug tuned and adjustable from the front of the receiver so that all channels can be adjusted with the fine tuning control, C_{18} , remaining in the center of its range, so that fine tuning will not be

needed when you change channels.

The L_5 slug on the tuner should not be used for correcting split tuning in the fringe as had been done on former Sylvania chassis. It is part of the bandpass stage of the video i.f. and changing its tuning without test equipment may seriously affect the alignment of the receiver.

Video Circuits

The i.f. amplifier consists of four tubes together with their tuned circuits and traps (Fig. 2). The tuned circuits are staggered, that is, each circuit is tuned to a different frequency within the i.f. passband and each circuit is adjusted by means of resistance loading to have a certain bandwidth. The over-all result is to

produce an i.f. response curve which is flat-topped and which passes a band of frequencies from 42.1 mc., at approximately 70% response, to 45.75 mc. (video carrier) at 50% response.

All i.f. transformers and traps are enclosed in a shielding can with the exception of the cathode trap in the 4th i.f. This minimizes radiation at the higher i.f. frequencies. The traps which are included in the i.f. system function to produce high attenuation for a specific frequency. Two of these traps are tuned to attenuate the accompanying sound carrier. One trap is adjusted to attenuate the adjacent channel sound carrier and one trap is adjusted to attenuate the adjacent channel video carrier.

The bandpass stage of the 1-518 chassis is located at the beginning of the video strip instead of at the end as in former Sylvania chassis. The bandpass primary is L_5 on the tuner. Its secondary is L_{53} located on the main chassis. The can next to L_{53} is the link shunt coil, L_{54} , used as a bandwidth coil. Only the position of the bandpass response can be adjusted with the primary and secondary coils; relatively little can be done to its width or amplitude. The incorporation of the link shunt coil gives control over the bandwidth and, hence, the amplitude of the bandpass. This makes the adjustment of the stage much more flexible. The primary and secondary are adjusted so that the picture i.f. carrier, 45.75 mc., is up on the right corner of the response curve and then the link shunt coil is adjusted to shape the curve so that 42.1 mc. is on the left corner. This gives the optimum response and prevents a loss in gain or bandwidth due to coil variations that give too little or too much bandwidth.

Bifilar wound transformers are used in the video i.f. stages. This type of transformer has the primary and secondary wound simultaneously on the coil form giving overcoupling. The overcoupling produces two peaks on its response characteristics. Each transformer is tuned to favor just one of the peaks, the other peak is far enough away and its amplitude is small enough so as to have but a small effect on the over-all response. By using bifilar wound transformers, a maximum transfer of energy from plate to grid is effected. Noise immunity is improved since the grid time constant is lower than when RC coupling is employed. Also, troubles which might result from leakage or failures of coupling condensers are eliminated.

At 44 mc., harmonic radiation becomes an important factor. This shows up as "tweets" or interference patterns in the picture. The high amplitude of the signal at the video detector stage could present serious radiation problems were it not for the use of a crystal diode for a detector. This eliminates components such as a tube socket and heater leads that

(Continued on page 188)

Fig. 5. Schematic diagram of the u.h.f. tuner available for the Sylvania TV sets.

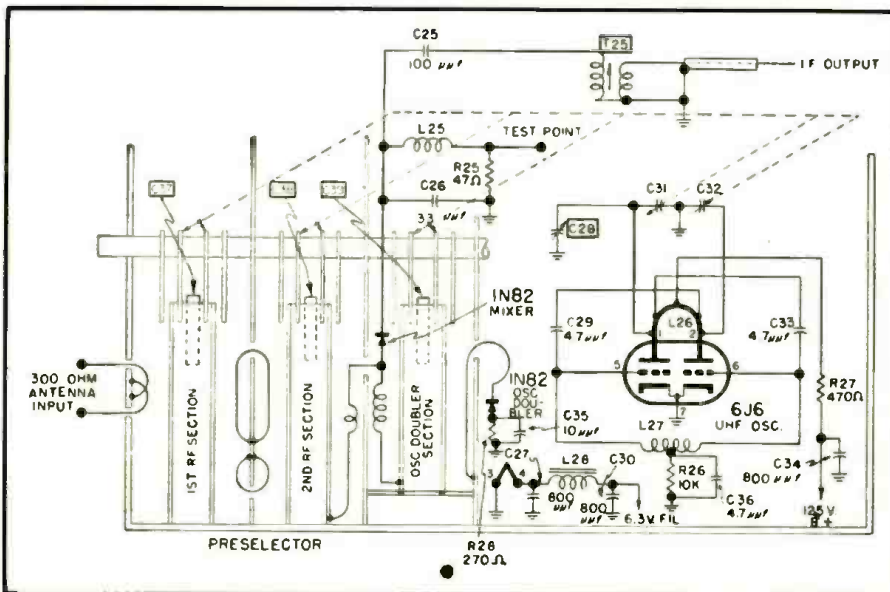

2 NEW SERVICE AIDS . . .

DESIGNED BY AND FOR YOU!

New CBS-HYTRON Tube-and-Tool Caddy ▶

Another Tube Caddy? Yes, but *you* service-dealers helped us design this one. Helped us throw out a dozen almost-right designs. Stayed with us until the CBS-Hytron Tube-and-Tool Caddy became *your* Caddy. Built the way *you* want it.

Your new Caddy has literally dozens of features . . . many unique. Here are only a few: *Roomy* . . . holds 218 tubes! Also all your necessary tools, small parts, volt-ohmmeter, flashlight, and reference data. *Compact* . . . functional design wastes not one inch of space. *Accessible* . . . everything in sight and reach. *Rugged* . . . strong, tip-proof — used safely as seat. *Test Mirror* . . . reversible for protection — mounted in cover supported by adjustable friction hinge.

Sorry, there's just not enough space to tell all. But see your new Caddy yourself at your CBS-Hytron distributor's. He has a red-hot deal for you. He'll show you how *amazingly easy* it is for you to own this unique CBS-Hytron Tube-and-Tool Caddy. See him today.

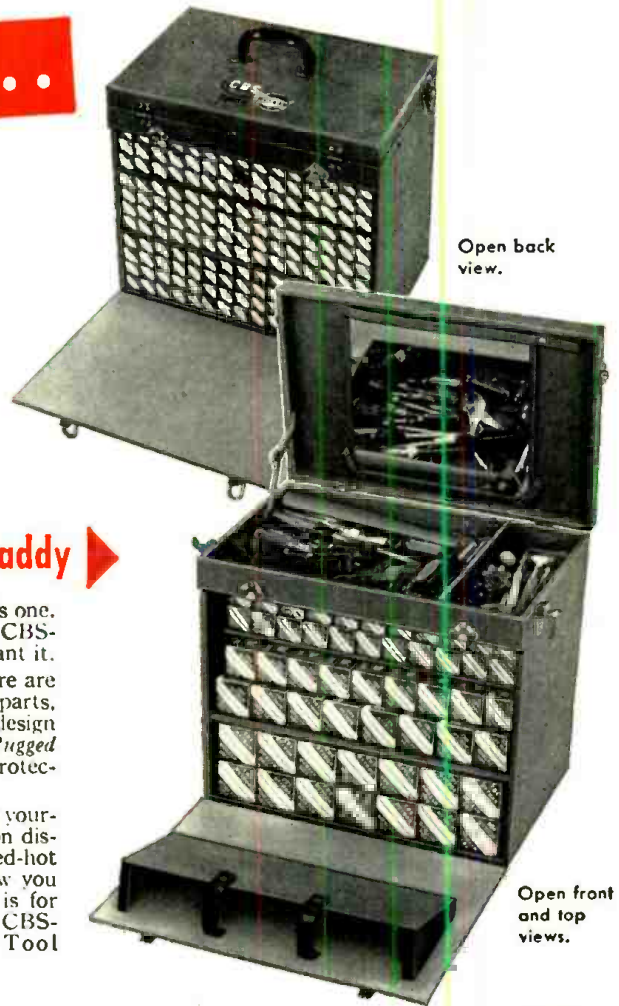

Open back view.

Open front and top views.

◀ New CBS-HYTRON Twin Pin Straightener

Ever wished you had a combination 7-Pin and 9-Pin Straightener? One that was handy, compact, light? But also a precision job, just like CBS-Hytron's original 7-Pin and 9-Pin Straighteners?

Here it is: The new CBS-Hytron Twin Pin Straightener, SH79. Same life-time, wear-and-corrosion-resistant steel dies. Same individually drilled, precision pin-circle holes. Same absence of guide-posts, permitting that final touch of sidewise straightening. The "Twin" is also roll-proof.

And the Twin is only 98¢ net. Get at least two . . . for pocket, tool kit, bench. Call your CBS-Hytron distributor today. Yes, he still has the famous individual CBS-Hytron 7-Pin and 9-Pin Straighteners at only 65¢ each net. Get them, too.



CUTTING YOUR CALL-BACKS WITH CBS-HYTRON CTS-RATED* 5AW4 and 6CU6?

They're the most talked-about tubes in TV today. CBS-Hytron CTS-Rated 5AW4 and 6CU6 are both rated for dependable Continuous Television Service. Heavy-duty work horses, they replace the 5U4G and 6BQ6GT respectively.

Brand new designs, not just improved tubes, the 5AW4 and 6CU6 have big safety factors. Give you long . . . long trouble-free life. Load in those hard-working, heavily

loaded rectifier and horizontal amplifier sockets . . . even in 21-inch jobs.

Start slashing your call-backs with these tubes right now. 5AW4 and 6CU6 are available only from your CBS-Hytron distributor. See him today. Ask for complete 5AW4 and 6CU6 data. Or write direct. Above all, don't let another day slip by without trying these wonderful, new CBS-Hytron CTS-Rated tubes.

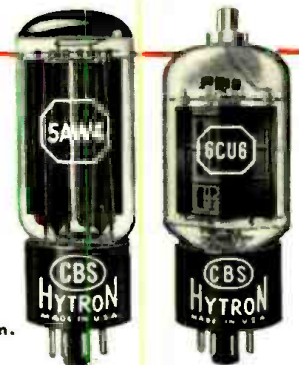

*Rated for Continuous Television Service

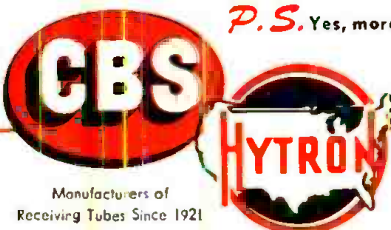

Manufacturers of Receiving Tubes Since 1921

P.S. Yes, more CBS-Hytron CTS-Rated tubes are coming. Watch for them.

CBS-HYTRON Main Office: Danvers, Massachusetts

A Division of Columbia Broadcasting System, Inc.

A MEMBER OF THE CBS FAMILY: CBS Radio • CBS Television • Columbia Records, Inc. CBS Laboratories • CBS-Columbia, Inc. • and CBS-Hytron

RECEIVING . . . TRANSMITTING . . . SPECIAL-PURPOSE AND TV PICTURE TUBES • GERMANIUM DIODES AND TRANSISTORS

A SOUND-ACTUATED

Electronic Switch



Over-all view of the sound-actuated electronic switch. It can be installed in a TV set or any gear it is to control.

By **LT. COMDR. BENJAMIN G. LEWIS, USNR**

Electronics Training Officer, U.S. Naval Air Station, Willow Grove, Pa.

Whistle away TV commercials or turn your audio gear on and off by means of this sensitive switching circuit.

THIS article describes a sound-actuated electronic switch which automatically reverses its action on successive cycles. The switch was originally constructed to provide convenience in switching audio systems on and off. After being tested it was incorporated in the author's television receiver to allow the elimination of the sound output from the loudspeaker when the program material was considered undesirable, when desiring to converse, or when answering the telephone or door. It may readily be adapted for other uses such as opening and closing doors or starting and stopping model trains, airplanes, or boats.

Obviously the simplest method of switching something on and off is to insert a switch in series with it. A method of switching a sound system on and off from anywhere in its vicinity without actually carrying the switch is to trigger off a relay circuit by a sound which can be easily produced by any human being. One such sound is a whistle which most people can do without any accessory equipment.

The design problem was to construct a circuit which would cause a pair of contacts to open when a tone was whistled. The contacts must then remain open, irrespective of normal noise and conversation, until a tone of approximately the same pitch is whistled again, at which time the contacts must close and remain closed until the tone is again whistled, ir-

respective of normal noise in the room. This latter includes sound output from the loudspeaker.

The major advantage of utilizing the whistle to actuate the electronic switch lies in the fact that it has a selectable pitch. This permits the use of a resonant-type amplifier which enables the switch to discriminate against normal sounds, whether from conversation or from the audio system, and only to respond to a whistle of the correct tone.

The whistle has a further advantage in that the electronic switch may receive its energy from a small microphone of cheap construction. The latter follows because a wide frequency range is not only unnecessary but undesirable. The microphone may be small and easily hidden behind a picture or cabinet so that no external connections to the unit are visible. If desired the microphone and electronic switch unit may be installed in a television cabinet. Before actually describing the device the author wishes to state that it has rendered a definite service in allowing undesirable portions of program material to be conveniently eliminated. It also has given great enjoyment in continually astounding the layman, most of whom are amazed to observe that a short, easily produced whistle, sounded from anywhere in the room can cause such reliable switching action.

The circuit consists of a two-stage resonant amplifier, a double diode, two switching triodes and three sensitive

relays. Two relays will suffice if one has double-pole, double-throw contacts. This type was not easily obtainable hence two similar relays, wired in series, were used. Nothing but standard type parts were incorporated, hence the unit is easily reproduced.

Circuit symbols refer to the schematic diagram. The two-stage resonant amplifier consists of V_1 , a high-gain pentode, and V_{2a} , a triode. To provide sufficient gain so that an ordinary crystal microphone could be used, V_1 is a 6AC7 pentode. Caution must be observed in selecting a 6AC7 which is not microphonic. The plate load between the two stages is made resonant by replacing the conventional resistor with an audio reactor and then by shunting the reactor with a capacitance of such a value as to produce a parallel resonant circuit having a frequency whose pitch can easily be whistled. Since the average human whistle is practically a pure sine wave, *i.e.*, carries few overtones or harmonics, all of the energy contained in the whistled note is available to trigger off the circuit.

Experimentation showed that the gain of the amplifier must be carefully adjusted. Oversensitivity resulted in occasional triggering off of the switch by sounds either emanating from the audio system or being produced in the room. Undersensitivity resulted in failure of the whistle to produce the desired switching action from a far corner of the room. Further, it was shown that the selection of an audio reactor with high inductance and low resistance (high "Q"), resulted in such high selectivity that the average human being could not always whistle the correct tone required to trigger off the switch. By utilizing the 500 ohm (d.c. resistance) primary of an old audio transformer as L_1 , the plate load of V_1 , the resonant amplifier had sufficient gain to actuate the electronic switch on picking up tones from about 900-1000 cps, yet discriminated against other frequencies to prevent unwanted or accidental triggering. 900-1000 cps was the frequency the author found easiest to whistle.

The value of C_s , the shunting capac-

itance, is determined by connecting the output of the two-stage amplifier to an a.c. vacuum-tube voltmeter or an oscilloscope. Insert the audio reactor, L_1 , into the circuit. Whistle whatever tone you find most convenient to produce somewhere near the microphone. Observe the output of the amplifier. Add capacitance across L_1 in small increments until a resonant condition, i.e., maximum output, is indicated. Install that value of C_3 permanently into the circuit. If a reactor having a winding whose d.c. resistance is about 500 ohms is used, adequate but not over-selectivity will be achieved.

To further increase the reliability of the circuit in discriminating against ordinary room noise and loudspeaker output, a time delay of approximately one second was introduced in the switching circuits. The configuration of the components producing this delay is described below.

The sequence of operation and functional description of the various circuit components may best be described by considering the action of each switch cycle as follows.

Condition One

All relays open. Switch, which is connected through terminals 2 and 3 on RL_2 , is closed.

a. Microphone picks up sound of approximately correct frequency.

b. Sound is amplified by V_1 and V_{2A} .

c. Output of V_{2A} is connected to a plate and opposite cathode (terminals 4 and 5) of duo-diode, V_3 .

d. The negative rectified output of V_3 , picked off at terminal 3, is grounded through terminals 2 and 3 of relay #2 and for the present has no effect on the circuit.

e. The positive rectified output of V_3 , picked off at terminal 8, charges C_7 through resistor R_8 , introducing a time delay of about one second in the circuit. The positive potential is applied to the grid of V_1 . Unsustained sounds of the correct frequency which are picked up by the microphone and which do not have sufficient amplitude or longevity to charge C_7 to a value positive enough to initiate the switching action, leak off through R_8 .

f. A fixed bias of about plus 12 volts is maintained at the cathode of V_1 . This bias is produced by the bleeder network, R_{10} and R_{11} . With no potential appearing across C_7 , this bias is sufficient to keep V_1 virtually cut off. The plate current of V_1 flows through the coils of relays #1 and #2. These relays are therefore normally open.

g. Relay #3 remains open by virtue of the fact that V_{2B} , whose plate current must flow through the relay coil, is operated at a very low plate voltage, with subsequent low plate current. Note that one end of R_{13} is grounded through contacts 2 and 3 of RL_1 . This reduces the plate voltage of V_{2B} to less than 50 volts.

h. When the positive potential developed across C_7 drives the grid of V_1 sufficiently positive to increase its

plate current to such an extent that RL_1 and RL_2 close, the following connections are made or broken:

1. Terminals 2 and 3 of RL_1 open. The plate voltage of V_{2B} thereby increases, causing an increase in the plate current of V_{2B} . This increased current, flowing through the coil of RL_2 , closes the relay.

2. Terminals 1 and 2 of RL_1 close. Grid V_1 is thereby grounded, preventing any further impulse or transients introduced into the circuit from affecting performance.

3. Terminals 2 and 3 of RL_3 open, disconnecting any loudspeaker or other device which is connected in series with these terminals. (Note: In the circuit as used with a loudspeaker, one side of the secondary of the audio output transformer was grounded and the voice coil was connected so that it could only ground through terminal 3 of RL_3 .)

4. Terminals 1 and 2 of RL_3 close. This grounds the cathode, pin 8 of V_1 , removing the plus 12 volt bias. With its grid and cathode both grounded, V_1 conducts heavily enough to keep RL_1 and RL_2 reliably closed. The series resistor, R_{13} , limits the current flow to a safe value.

5. Terminals 2 and 3 of RL_2 open. This removes the ground from the grid of V_{2B} and connects it directly to the plate, pin 3, of the diode, V_3 . The circuit is now in condition (2).

Condition Two

All relays closed. Switch open.

a. At some future time the microphone again picks up sound of ap-

proximately the correct frequency.

b. This sound is amplified by V_1 and V_{2A} and rectified by V_3 , as before.

c. The negative rectified voltage developed at the plate, pin 3 of V_3 , is applied to the grid of V_{2B} . The positive rectified voltage has no effect, inasmuch as pin 5 of V_1 is now grounded.

d. The amount of negative voltage developed across C_{11} depends upon the longevity, frequency and amplitude of the sound picked up by the microphone. The values of R_{13} and C_{11} were selected to provide reliable reverse switching action with a whistle of medium intensity and duration of slightly over one second. This prevents unwanted sounds from affecting the circuit. Note also that the large condenser, C_{12} , which is placed from the plate of V_{2B} to ground, also adds time delay to the circuit by preventing the rapid change of plate voltage of V_{2B} .

e. As the negative voltage builds up at the grid of V_{2B} , the plate current is reduced. Finally the current is lowered sufficiently to permit RL_3 to open and the following connections are made or broken:

1. Terminals 2 and 3 of RL_3 close, re-connecting the loudspeaker.

2. Terminals 1 and 2 of RL_3 open, ungrounding the cathode of V_1 , and re-applying the plus 12 volt bias to it.

3. Plate current of V_1 immediately drops, opening RL_1 and RL_2 .

4. Terminals 2 and 3 of RL_1 close, reducing the plate voltage of V_{2B} to less than 50 volts. RL_3 therefore remains open even though the sound which the microphone is picking up ceases. (Continued on page 181)

The sound-actuated switch, arranged for operation at a 950 cps resonant frequency.

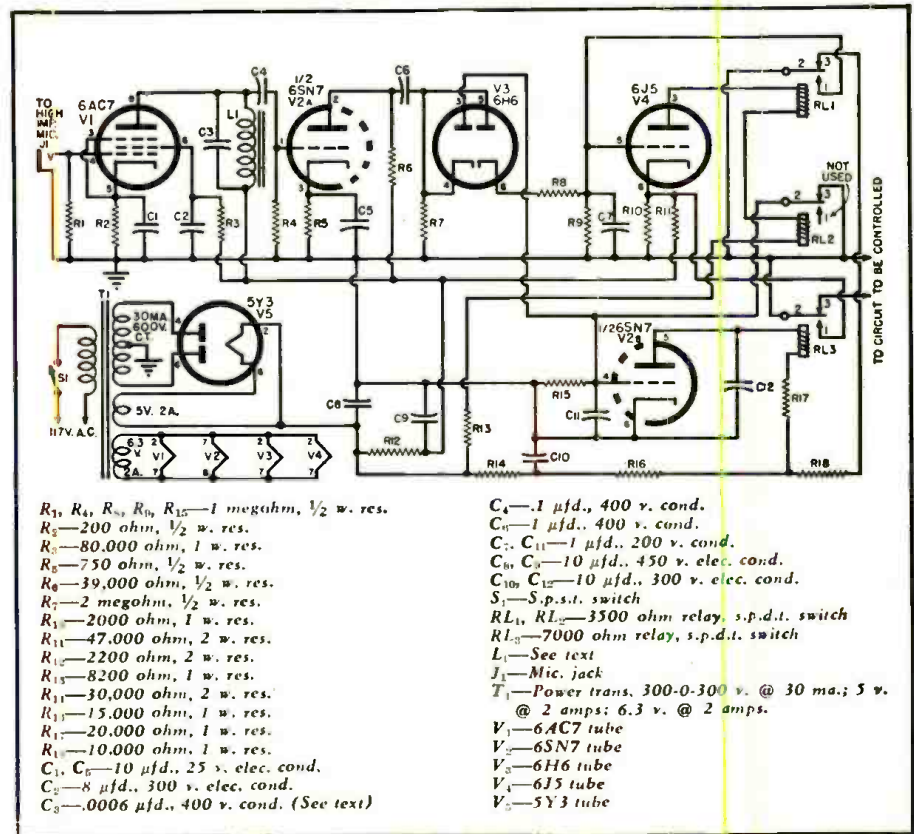

AN EXPANDED-SCALE POWER LINE METER

By J. H. MINTZER

Radio & TV Div., Sylvania Electric Products Inc.



Front and rear views of the home-built unit for monitoring line voltage in the ham shack, service shop, or test bench.

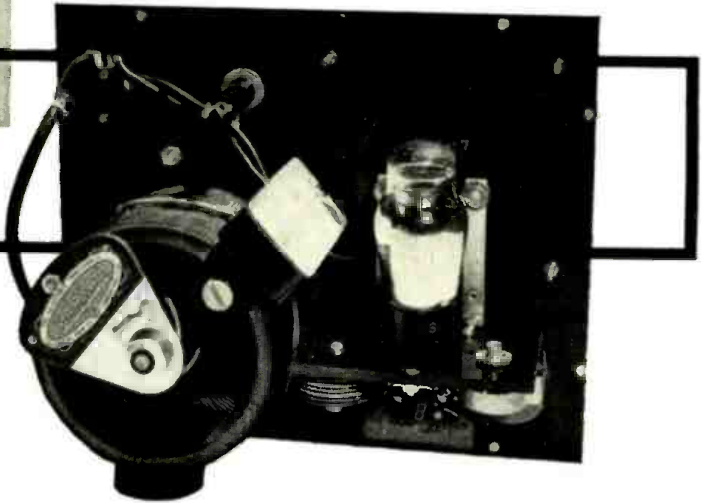

Increased efficiency and better accuracy can be obtained by expanding meter scale to cover portion between 90 and 130 volts.

A HANDY item around any ham shack, service or experimenter's bench is an accurate means of measuring or monitoring the line voltage. This is particularly true if, as in our case, a means for controlling the line voltage, such as a *Variac*, is being used. One of the many points in favor of this accuracy is that all manufacturers' reference voltages for electronic equipment designed to operate on normal line voltage (excluding those with a regulated supply) are based on an input voltage of 117½ volts a.c.

Our line source consisted of the commonly-used *Variac*, a 0-150 volt a.c. meter, and several "out" receptacles housed in a small cabinet. Since we used this source continually, at or near normal line voltage, we came to the conclusion that more accuracy and efficiency could be obtained by expanding the needed section of the meter scale and eliminating the section not used.

After experimenting with several different ideas, we came up with the circuit shown in Fig. 1. The operation is as follows: The line current is rectified to pulsating d.c. by means of the selenium rectifier. Resistor R_1 was selected to allow approximately 20 ma. to flow through the VR-105 at 117 volts a.c. input. The meter and calibrating resistor, R_2 , are shunted across resistor R_1 . When the assembly is connected to the output of a *Variac* and started at zero voltage, it will be found that no meter reading will occur until the input voltage reaches approximately 90 volts. At that time

the peaks will fire the VR-105 and a slight meter reading will be obtained due to the small amount of current passing through the VR tube. As the input voltage is increased, the meter action will be linear to full scale. R_2 can then be adjusted for a full-scale reading of 130 volts. The meter scale will look like the one in the photograph. Condenser C_1 may or may not be required to eliminate the a.c. effect on the meter pointer depending on the amount of damping in the meter being used.

This circuit was checked for accuracy daily over a period of two weeks and then weekly for a period of several months. It was found to vary not more than ½ volt during warmup and could be considered ac-

curate for all practical purposes with zero drift after 10 minutes.

This metering circuit was later substituted in the author's ham rig in place of the 0-150 volt a.c. line meter. It was not only more accurate but more impressive!

The practical technician should be able to adapt this circuit to almost any meter scale expansion required. For example, a VR-150 could be substituted for the VR-105 which would give almost the same expansion for use at 220 volt line measurements. A neon lamp could be used in place of the VR tube and suitable resistors inserted to delay firing time, thereby adapting the meter scale to the suitable range.

Making a meter face should offer no serious problems. Most meter faces are easily removable. A piece of plain white paper can be placed on the face and the scale limits marked. The paper can then be glued on the reverse side of the meter face plate and the proper arc drawn.

A variable a.c. supply and a standard meter should be used to mark the 90 to 130 volt points. If the meter is to be placed in a steel panel in the final assembly, it should also be placed in a steel panel when the calibration marks are plotted—otherwise the marks will be worthless. Those who have access to numbering and lettering facilities can produce a commercial-looking job. Those who do not have these facilities, need only the requisite amount of patience to accomplish the same results. —30—

Fig. 1. Complete schematic for the meter.

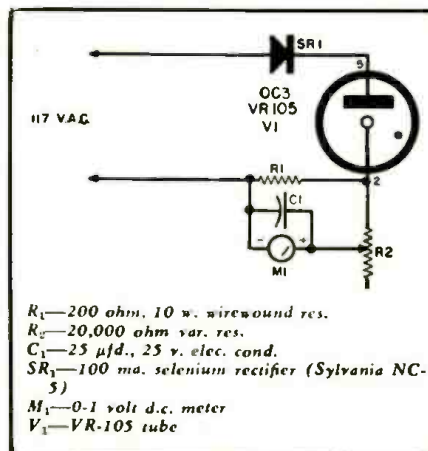

THE BEST SET IS ONLY AS GOOD AS ITS ANTENNA!

The KAY-TOWNES "BIG JACK" IS *not* A NEW ANTENNA

The "BIG JACK", recognized even by competitive manufacturers as the best performing VHF antenna design ever developed HAS BEEN ON THE MARKET FOR MORE THAN 1½ YEARS!

**WE
CHALLENGE**

any other manufacturer
who claims this design
as *his* original
idea!

Model	Type	List Price
BJ-1	single bay	\$16.78
BJ-2	2-bay	\$35.05

- ★ HIGH GAIN ON ALL VHF CHANNELS
- ★ PREASSEMBLED
- ★ 1" HEAVY ALUMINUM BOOM
- ★ CRIMPED & DOWEL REINFORCED HEAVY (7/16" O.D.) ALUMINUM TUBING
- ★ "SURE-GRIP" CAST ALUMINUM MAST CLAMP WILL NOT SPREAD, BEND OR COLLAPSE.

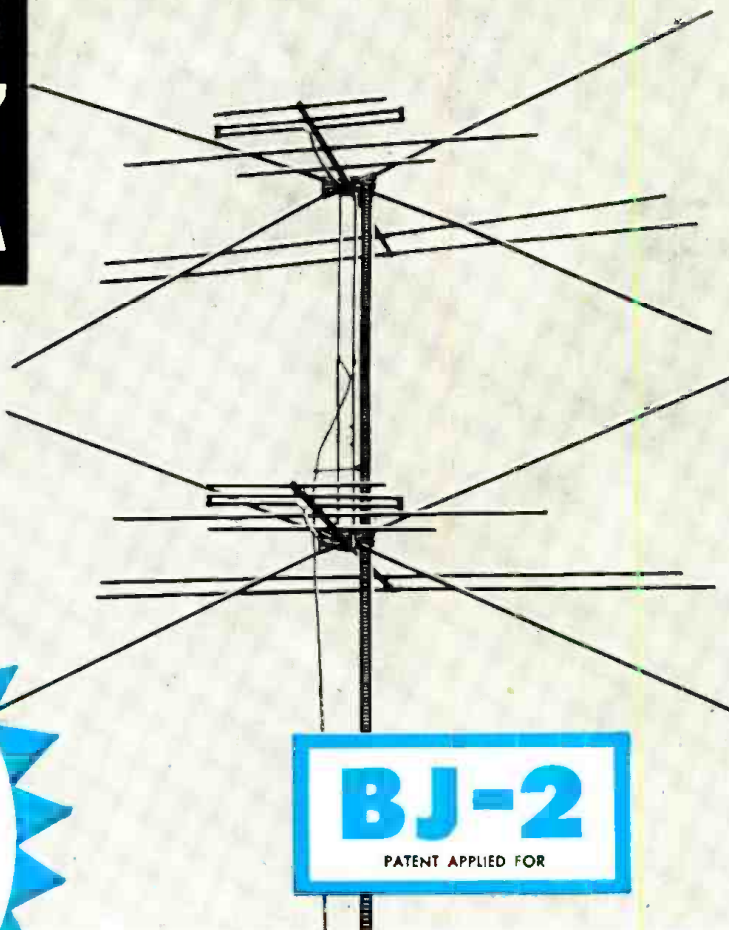

THIS GAIN CHART *Proves* THE SUPERIORITY OF THE K-T "BIG JACK" VHF ANTENNA

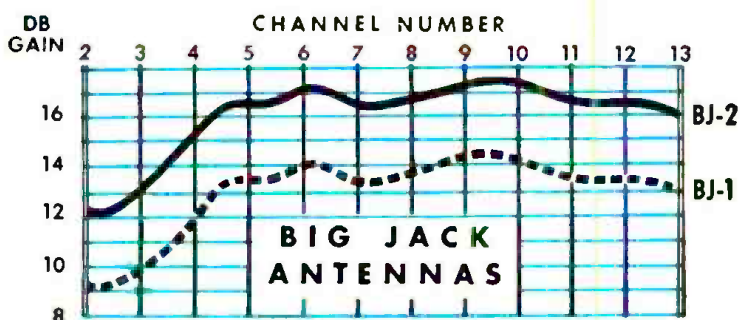

NO OTHER VHF ANTENNA CAN HONESTLY CLAIM THESE "BIG JACK" RATINGS AS A RESULT OF THEIR OWN ORIGINAL ENGINEERING AND DEVELOPMENT

KAY-TOWNES ANTENNA CO. ROME, GEORGIA

Recognized leaders in the field of fringe area antenna design



Fig. 1. Substitution tester, as built into a surplus control box. It may also be built without a surplus unit.

A SIMPLE VERSATILE SUBSTITUTION TESTER

By **FREDERIC T. C. BREWER**

This handy aid furnishes many resistor and condenser values and is also useful for simple signal tracing.

ALTHOUGH modern service shops are equipped with many new and complicated test instruments for performing the more intricate service operations, some service technicians still use the time consuming method of bridging resistors and condensers from the parts drawer instead of adding a simple substitution tester to their instrument rack. This writer has often thought of designing such a unit for his service bench. However, like many good intentions, a slight push was needed to get the project under way. This push was supplied when a war surplus unit with sufficient potentiality was encountered.

The circuit of the substitution tester is simple even though it was designed around a surplus item and it has several unique features which recommend it for new construction.

Aside from providing resistor and condenser substitution, the unit is also a simple signal tracer.

The condenser values it will substitute are: 0.02 μ fd., 0.03 μ fd., 0.05 μ fd., and 0.1 μ fd. at 600 volts; 20 μ fd., 30 μ fd., and 50 μ fd. at 450 volts. However, these values may be changed to suit the individual technician's needs.

Resistance values are provided by an *Ohmite* type AB 2-watt potentiometer with a linear taper. The stock number is CU-1052. This potentiometer has a total resistance of one megohm. The manufacturer states that the minimum resistance is less than 1/25,000 of the total resistance. It turned out to be about 6 ohms for the unit used. Thus, resistance values from 6 ohms to one megohm are available. When the potentiometer is substituted in a circuit, make sure that its wattage rating will not be exceeded.

If this substitution tester is built as new equipment, calibration of the potentiometer is most easily accomplished by obtaining an etched metal dial plate marked 0-10 in 300°. The potentiometer has a rotation of $312^\circ \pm 3^\circ$ and since it has a linear taper each division on the dial will represent about 100,000 ohms. If greater accuracy is desired, more divisions may be added and the actual resistance at each division checked with an ohmmeter. For most electronic work the first method is accurate enough. However, if any resistance value from 6 ohms to one megohm is required, and the value must be accurate, simply connect the

leads from the substitution tester to an ohmmeter and rotate the potentiometer until the proper resistance is obtained. The accuracy of this method is limited only by the accuracy of your meter.

Fig. 1 shows the complete substitution tester, together with test leads, housed in a war surplus type M1-6448 remote control unit. Fig. 2 is the schematic of the substitution tester. As can be seen from Fig. 2, the only additional components needed to convert the M1-6448 to a substitution tester are six condensers and the potentiometer. The numbers beside the condensers (#10, #2 etc.) are the numbers of the terminals on the terminal strip in the M1-6448. Simply connect the condensers to the terminals whose numbers appear in the schematic. Also, connect a wire from terminal #8 to #5, as shown in the schematic.

This wiring may be completed in a few minutes. When it is done, replace the potentiometer which comes with the unit with the *Ohmite* pot. Also, remove the 3300 ohm resistor. (The inside of the M1-6448, before any changes were made, is shown on the left in the photograph of Fig. 3. The unit after it was converted to a substitution tester is shown at the right.)

The wire which was connected to terminal 1 (Fig. 3) of the original potentiometer is wired to the shell of the jack marked "Phone." Also, connect a wire between the shells of the two jacks. The wire which is removed from terminal 2, on the original pot, is wired to the point on the switch where the 3300 ohm resistor was connected. Wire terminal 2 of the *Ohmite* control to the high side of the jack marked "Test." Wire terminal 1 to the switch (to the contact which has the last green wire, in a clockwise direction, connected).

Some service shops may already have some M1-6448 units. If you do not have one and cannot obtain one (they are still available in substantial quantity and for a modest sum in the New York area, and may be available

Fig. 2. Complete schematic diagram and parts list for building substitution tester.

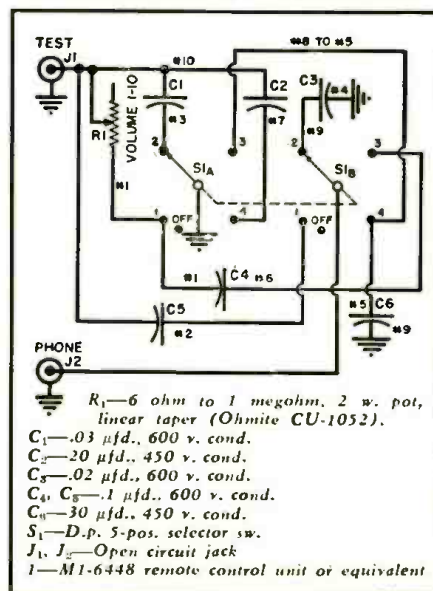

in other parts of the country), the substitution tester may be built in a small utility box by obtaining the necessary parts and following the schematic in Fig. 2.

Circuits provided by the substitution tester are diagrammed in Table 1. Very little switching is necessary to obtain these circuits and only three test leads are used. The phone jack marked "Test" is connected with two of these, a red and a black, by a phone plug. The other test lead is also red and is plugged into the jack marked "Phone." These test leads should have insulated clips for testing in difficult places.

When the red test lead (which is plugged into the jack marked "Phone"), is removed, and high-impedance headphones inserted (with the selector switch in position number 1), the substitution tester becomes a signal tracer. Since for this switch position the potentiometer is in parallel with the phones, it is possible to provide the proper load impedance for circuits which must have a low-impedance load, such as an output transformer secondary; or circuits which must have a high impedance load, such as the plate circuit of a vacuum tube. By turning the selector switch to position number 3 the potentiometer is put in series with the phones making a series signal tracer available. A 0.1 μ fd. condenser blocks the d.c. current from the phones in each case.

There is one safety feature that might be mentioned. The 30 μ fd. condenser is automatically grounded when the selector switch is in position

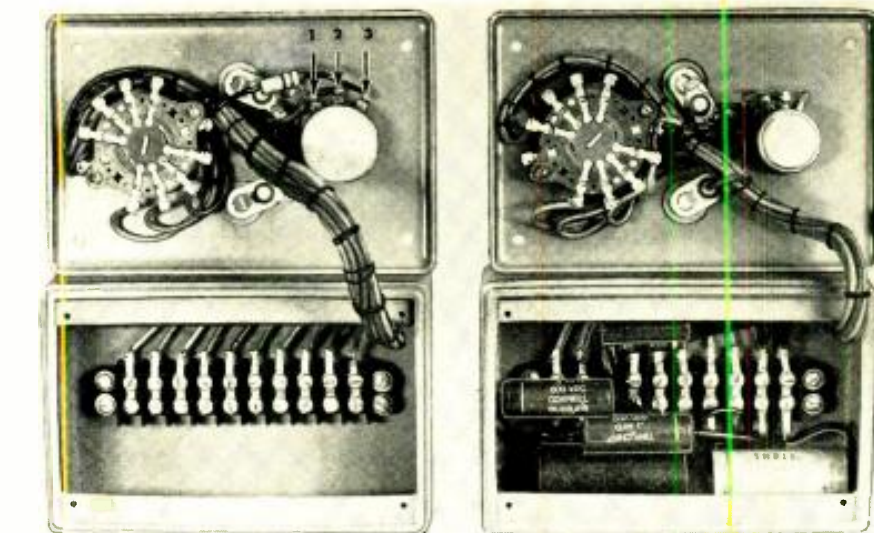

Fig. 3. Left, the war surplus M1-6448 remote control box before conversion. Right, the remote control box after conversion to the substitution tester described here.

number 3. Thus, if it is accidentally left charged it will be automatically discharged when the selector switch is moved from position 4.

As an example of how the substitution tester is used, suppose a radio receiver with a bad hum is in for repair. The power supply filter condensers are likely suspects. This particular receiver is a common a.c.-d.c. table model employing a two-section condenser in the power supply. The condenser values are 30 μ fd. and 50 μ fd. From Table 1 you find that it is possible to substitute both a 20 and a 30 μ fd. condenser in the receiver at the same time. Although these are

not the exact values, bridging them across the two sections of the suspected condenser will reveal whether or not it is faulty and causing the hum. Connect the black test lead to the negative lead in the suspected condenser. The red test leads go to the positive terminals of the condenser. Also, each section of the condenser may be individually bridged with a condenser of the same capacitance with this substitution tester.

After a short time the technician will find he operates this substitution tester automatically and he will also realize it is one of the most useful instruments in his shop. -30-

Table 1. The tester circuits corresponding to each position of the selector switch and set of test leads used.

Circuit	Selector Switch Position	Use Test Leads	Circuit	Selector Switch Position	Use Test Leads
	2	Red test lead from jack marked "test" & black		4	Red test lead from jack marked "phone" & black
	2	Red test lead from jack marked "phone" & black		4	Both red test leads in parallel & black
	2	Both red test leads in parallel & black		1	Two red test leads
	4	Red test lead from jack marked "test" & black		1	Red test lead from jack marked "test" & black
	1	Red & black test leads from jack marked "test" Pair of phones in jack marked "phone" (signal tracer)		3	Red & black test leads from jack marked "test" Pair of phones in jack marked "phone" (signal tracer)

REG. \$117.50 SUPREME TUBE TESTER—V.O.M. ON SALE AT MCGEE FOR \$64.95

**MODEL 600 WITH ROLL CHART
7" VOLT-OHM-METER
BUILT-IN BATTERY TESTER
SALE PRICE \$64.95**



SUPREME MODEL 600

Supreme Model 600-tube tester, dry battery tester, volt ohm meter. All in one gray metal portable carrying case, 16" x 12" x 7 3/4". Large 7" meter, easy to read. Calibrated good-load scale for tube testing with easy to read volt-ohm and millamp scale. Most people can operate this meter without glasses, the printing is so large, as you would expect with a 7" meter. Illuminated roll chart. Push button tube checker operation. Easy to learn how to operate. Battery tester will check all dry batteries under proper load. Has 5 resistance ranges from .1 to 20 megohms. 6 AC-DC volt ranges from 0 to 2500 volts. 4 millamp ranges from 1 to 1000 and 0 to 10 amps. This meter had a regular net price of \$117.50. Our special purchase makes this \$64.95 price possible. Think of it, the battery and VOM part is worth one-half our sale price. Stock No. 600 Supreme tube-tester on sale for only \$64.95 at McGee. Only a limited supply is available. Shipping weight 24 lbs.

SUPREME MODEL 616 TUBE TESTER \$49.95

Supreme Model 616 tube tester and battery tester. Same as Model 600 described above, except does not have volt-ohm-meter. Regular \$87.45 dealers net. Shipping weight 24 lbs. Special sale price only \$49.95.

ESPEY 12-TUBE FM-AM CHASSIS, \$59.95

- ★ BUILT-IN PRE-AMP FOR G. E. VARIABLE RELUCTANCE PICK-UP
- ★ WIDE RANGE AUDIO
- ★ WHY NOT ORDER WITH A COAXIAL SPEAKER AND A RECORD CHANGER? SEE OUR SPECIAL OFFERING

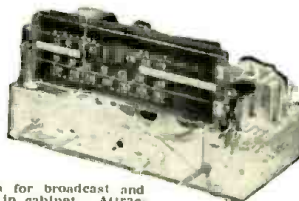

McGee's new 1953 model 12-tube FM-AM chassis. Latest design with phono inputs for all types of record players, crystal or G.E. variable reluctance. Receives standard broadcast, cost 550 to 1700 kc and FM 88 to 108 mc. Wide range audio response (push-pull 6V8 output) and bass boost tone control. Loop antenna for broadcast and 300 ohm line type FM antenna may be installed in cabinet. Attractive lighted slide rule dial. Chassis size, 13 1/2" x 9" high and 9" deep. Complete with tubes: 6BF8, 6BA6, 6BE6, 12AT7, 6AL5, 6SQ7, 12AT7, 2-6VGT and 5Y3GT rectifier. Shipping weight 20 lbs. Stock No. 7C-X Espey 12-tube FM-AM chassis. Sale price, \$59.95, less speaker. Output matches voice coil of our 12" or 15" coaxial speakers.

ESPEY DEAL (1), \$99.95

Espey 7-C chassis complete with 12" coaxial PM speaker CU-14V and WM-9-D G.E. variable reluctance pick-up. Includes 3-speed changer equipped with a G.E. turnabout variable reluctance cartridge. A better home music system than ordinarily available. Espey Deal #1. Sale price \$99.95. With 15" coaxial PM speaker P-15CS instead of CU-14V. \$10.00 extra.

ESPEY DEAL (2), \$118.95

Espey 7-C chassis complete with 12" coaxial PM speaker CU-14V and the English Garrard 3-speed changer equipped with a G.E. variable reluctance turnabout cartridge. Our best home music system. Espey Deal #2. Sale price \$118.95. With 15" coaxial PM speaker P-15CS instead of CU-14V. \$10.00 extra.

28 WATT PORTABLE P.A. SYSTEM ON SALE \$69.95

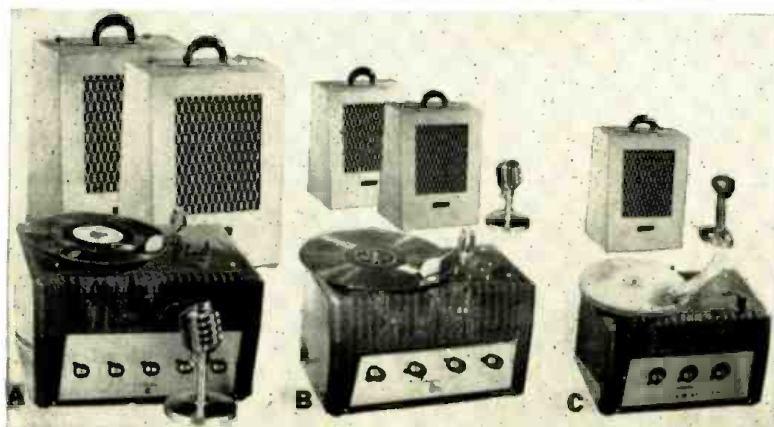

(B) 28-WATT PORTABLE P.A. SYSTEM ON SALE \$69.95

**3-SPEED PHONO TOP—TWO 12" SPEAKERS
HEAVY LEATHERETTE COVERED PLYWOOD PORTABLE CASES**

No. AP-28X, 28 watt portable P.A. system. Heavy duty 7 tube push-pull amplifier with 2 mike inputs and phono input. Separate volume controls and tone control. Output transformer tapped at 4, 8, 16, 25, 250 and 500 ohms. Two heavy 12" PM speakers with 25 ft. cables housed in separate carrying cases with closed back. 21" x 16" x 13". Amplifier with 3 speed phono top for playing all 3 record sizes is carried in one of the cases. This P.A. system has 20 watt output with 28 to 30 watt peak. \$150.00 list P.A. system. No. AP-28X complete with 3 speed phono and speakers as pictured, but less mike. Shipping weight 71 lbs. Sale price \$69.95. Electro-Voice Model 810 crystal mike with cable and desk stand. Regular \$28.50 list, only \$8.95 extra. Floor mike stand \$4.95 extra.

(A) 50-WATT PORTABLE P.A. ON SALE \$99.95

3-SPEED PHONO TOP—TWO 12" SPEAKERS

No. AP-60X, 50 watt portable P.A. system, similar to the AP-28X above. 10 tube, 4-6L6G (push-pull parallel) amplifier with inputs for 2 mikes and phono. Output transformer with 4, 8, 16, 25, 250 and 500 ohms. 2 super heavy duty 12" PM speakers with 25 ft. cables in separate carrying cases with closed back. 21" x 21" x 13". 3 speed phono top plays all 3 size records. Amplifier has 40 watt output with 50 to 60 watt peak. No AP-60X portable P.A. system with 3 speed phono and speakers as pictured, but less mike. Shipping weight 100 lbs. (via express or truck only). Sale price \$99.95. Electro-Voice Model 810 dynamic mike with cable and desk stand. Regular \$45.00 list, only \$11.95 extra. Floor mike stand \$4.95 extra.

(C) 10-WATT PORTABLE P.A. ON SALE \$42.95

3-SPEED PHONO TOP—10" ALNICO PM SPEAKER

AP-10X, 10 watt portable P.A. system. Push-pull 7C5 amplifier with 3 speed phono top, inputs for mike and phono. Separate volume controls and tone control. 10" PM speaker with carrying case 21" x 16" x 13" to house complete system. \$90.00 list P.A. system No. AP-10X. Shipping weight 41 lbs. Sale price \$42.95 (less mike). Crystal mike with non-removable desk stand. \$3.95 extra.

McGEE RADIO COMPANY

Prices F.O.B. K.C. Send 25% Deposit with Order, Balance Sent C.O.D. With Parcel Post Orders, Include Postage

TELEPHONE VICTOR 9045. WRITE FOR FLYER
1422 GRAND AVE., KANSAS CITY, MISSOURI

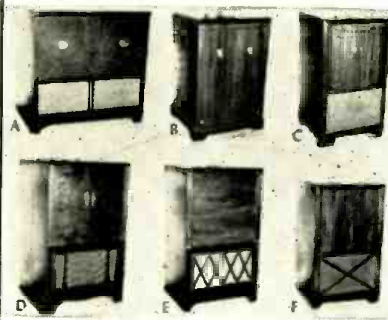

CONSOLE T.V. CABINETS

TERRIFIC SALE TELEVISION CONSOLE CABINETS (A) Radio-T.V. Cab. \$39.95

Stock No. All-170 mahogany console radio-television cabinet, with double doors, 34" high, 35" wide and 21 1/2" deep. The compartment behind the right hand door is 17" wide, 18 1/2" high and 19" deep. Suitable for most 17" TV chassis. Left hand compartment is 14 1/2" wide, 16 1/2" high and 19" deep, for radio chassis or could be adapted to various other uses. Both compartments have blank panels. Handle is cut for an 8" speaker but is large enough to hold a 10". This attractive cabinet cost the TV manufacturer more than our price. Shipping weight 55 lbs. Stock No. All-170, Sale price, \$39.95.

(B) 17" FULL DOOR MAHOGANY T.V. CABINET

Stock No. All-430 mahogany television cabinet with full doors, 36" high, 24" wide and 21 3/4" deep. Furnished with blank panel. Chassis area 22" wide, 17 1/2" high and 18 3/4" deep. Will hold 17" sets easily. Might hold a 20" set, but be sure to check your measurements. Speaker baffles cut for 10" speaker, but will hold a 12" speaker. This fine cabinet will look nice in any home. Offered at way less than it cost the famous TV manufacturer. Shipping weight 80 lbs. Stock No. All-430, Sale price, \$34.95.

(C) 17" 3/4" DOOR MAHOGANY T.V. CABINET

Stock No. All-85 mahogany console television cabinet suitable for most 17" chassis. 35 3/4" high, 20 3/4" wide and 20" deep. Has blank panel. TV chassis area 20 1/2" wide, 17" high and 17" deep. Speaker baffle cut for an 8" speaker but there is room for a 10" or 12" speaker. This is a very attractive, well proportioned TV cabinet. Put your old 10" or 12" set in this and be up to date. Offered at less than cost of manufacturer. Shipping weight 65 lbs. Stock No. All-85, Special sale price, \$29.95.

(D) 21" 3/4" DOOR MAHOGANY T.V. CABINET

Stock No. All-56 mahogany television cabinet with doors, 41" high, 25" wide and 21" deep. Has blank panel. Will hold 17", 20" or 21" TV chassis. However, be sure to check your measurements so that you have room enough for whatever you intend putting in the cabinet. Chassis area is 20 3/4" wide, 19 3/4" high and 18 1/4" front to back. Plenty room for speaker up to 12" diameter. Shipping weight 80 lbs. Stock No. All-56, Sale price only \$39.95.

(E) 21" OPEN FRONT MAHOGANY T.V. CABINET

Stock No. All-46 mahogany television cabinet, 41" high, 23 1/2" wide and 20 1/2" deep. Has blank panel. Chassis area 20 3/4" wide, 21" high and 19 1/2" deep. Will hold 17", 20" or 21" TV chassis. Speaker up to 12" diameter. A terrific cabinet value. Only a limited quantity are available. Shipping weight 70 lbs. Stock No. All-46, Sale price \$29.95.

(F) 17" "OUR LEADER" MAHOGANY T.V. CABINET

Stock No. All-26 mahogany television cabinet with blank panel, 35" high, 20" wide and 20" deep. TV chassis area is 17 1/2" high, 20" wide and 18 3/4" deep. Will hold most 17" sets. Speaker handle is cut for a 12" speaker. Buy this cabinet at the very low price of \$19.95. Only few to sell. Shipping weight 57 lbs. Stock No. All-26, Sale price, \$19.95.

Buy a conversion kit with any of the above cabinets and save \$3.00. You may take \$3.00 off the cabinet price when ordered with one of the picture tube, safety mask, flyback and yoke conversion kits listed on the opposite page.

SPECIAL BARGAIN SALE BUYS

**8 TUBE—2 BAND
WALNUT CONSOLE RADIO
PUSH-PULL OUTPUT
3 GANG TUNING
RECEIVES BROADCAST & SHORT WAVE
SALE PRICE \$42.95**



Beautiful, 8 tube walnut finished console 2 band radio with 3 gang tuning condenser and push-pull output tubes. Receives broadcast 550 to 1600 KC and short-wave 6 to 18 MC. Heavy duty concert tone 8" Jensen PM speaker has exceptionally fine quality. Has illuminated slide rule dial and loop antenna built in cabinet. Tubes are 1A4T, 1A4T, 1A4T, 12SL7, 2-5Y4 and 2-5Y4 rectifiers. Walnut cabinet 37" high, and 24" wide has inlaid sections and fine quality furniture finish. Brand new in factory cartons. Model C-81-B, 8-tube walnut console radio. Shipping weight 40 lbs. Special sale price only \$42.95. Shipped via express or freight only. For 110 volt operation.

3-SPEED PORTABLE RECORD PLAYER

**PLAYS ALL 3 SPEEDS
AND ALL 3 SIZES
Powerful Amplifier
Full Size Speaker
SPECIAL SALE PRICE
ONLY \$15.95**



Our new 1953 model 3 speed record player, now offered at a special saving. Model 7843, 3 speed portable electric record player, with a powerful 2-tube plus rectifier amplifier and full size Alnico V PM speaker. Plays all three speeds and all three sizes. Crystal pickup has an all purpose three-speed needle. Brown reptile finish leatherette case 12 1/2" x 10 1/2" x 6 3/4". Shipping weight 10 lbs. Model 7843, 3-speed portable record player only \$15.95 each.

Write For Your Copy of

McGEE'S GIANT 1954 CATALOGUE

BARGAINS LIKE THESE ON EVERY PAGE

Everything for the Television and Radio Service Man. Up-to-date U.H.F. Television Material.

15 reasons why VEE-D-X IS YOUR BEST CHOICE

UHF ANTENNAS



MODEL BT-U — The aristocrat of Bow-Tie antennas. Superior in both construction and performance. Can be stacked for extra gain. Compare!



MODEL CA-U — Famous Co-linear that has highest gain of all broad band fringe area UHF antennas. Also available in Dual Jr. models for specific area requirements.



MODEL COR-U — The Corner Reflector has 40% higher gain than a single Bow-Tie. Finest construction with rugged Fiberglas boom and solid aluminum elements. Minimizes probing.

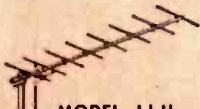

MODEL LJ-U — The UHF Long John. Single-channel, 8-element yagi for primary and fringe areas. Compact, efficient, pre-assembled, easy-to-install.

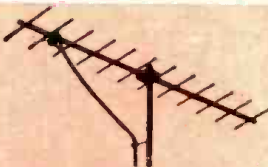

MODEL LLJ-U — The most powerful of all single channel UHF antennas. Has rugged Fiberglas boom and solid aluminum elements.

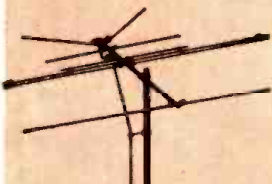

MODEL UQT — Famous Ultra Q-Tee all-channel (2-83) UHF-VHF antenna. Has printed circuit filters — ideal for primary areas.

*Lic. A.A.K. Pats. 2,422,458; 2,282,292; 2,611,086; others pending.

3 NEW IMPROVED MODELS OF THE FAMOUS VEE-D-X MIGHTY MATCH

Finest Most Efficient Cross-over Network Filters Ever Perfected



NEW MM-40 — (Yellow case) (For combining separate UHF and VHF antennas to a single transmission line.) New, more efficient patented "printed circuit." Amazingly low insertion loss. New type terminals. New moisture-resistant case.



NEW MM-40A — The ideal single line termination filter for use at set or converter having separate terminals for UHF and VHF. Patented "printed circuit."



NEW MM-25 (green case) — Permits the use of a single transmission line between separate high and low channel VHF antennas. New improved patented "printed circuit." Amazingly low insertion loss. New type terminals. New moisture-resistant case.



NEW VEE-D-X

UNIVERSAL LIGHTNING ARRESTER
For UHF — VHF — AM — FM
Takes all popular transmission lines flat tubular oval round open wire

MODEL ULA is the finest, most efficient lightning arrester ever perfected. Completely eliminates the need for separate lightning arresters for each type of transmission line. This one arrester takes 'em all. Compact, clean-cut, inexpensive and employs newly developed printed circuits. It literally obsoletes all other lightning arresters.



FREE

Write for your copy of this complete new 36 page pocket guide to the world's finest antenna systems.

VEE-D-X tra Special



the one and only all-channel yagi

Model SP

HIGH GAIN FRONT-TO-BACK DIRECTIVITY

Think of it — all the desirable features of a yagi — yet with all-channel performance in a single, easy-to-install antenna. Technically, the VEE-D-X tra Special is a 9-element hi-low yagi (5-elements on high channel — 4 on low) "T" matched. The hi-low sections are phased together with a new isolation filter MM-25. The ideal antenna for all-channel power — for directivity — and for eliminating interference from unwanted stations. A honey for use with VEE-D-X Rotator.



NEW VEE-D-X ANTENNA ROTATOR

Acclaimed the finest in design, construction and performance. Clean-cut, in-line styling. Fast and easy to install. Beautifully styled Control Console operates with convenient downward pressure. Choice of two colors.

VHF ANTENNAS



MODEL JC — For the most powerful single channel performance. A popular 5-element yagi. Easy-to-install.

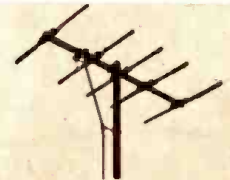

MODEL DC — The famous VEE-D-X low cost 5-element yagi with original VEE-D-X Delta Match construction.



MODEL DX — The famous economy super power yagi. Has 30% higher gain on high channels than any other 10-element yagi. Delta Match and boom braced.

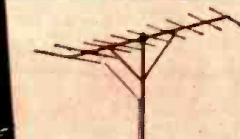

NEW BROAD BAND YAGIS — Finest of all. Available in both 10-element "X" series and 5-6 element "V" series, each in 3 cuttings, cover entire VHF channel range.



MODEL QT — The brilliant Q-Tee all-channel VHF antenna with patented "printed circuit" channel separators. New improved construction and performance. Can be stacked for additional gain.

LaPointe ELECTRONICS INC.

ROCKVILLE, CONNECTICUT

RTN-11

Sendcopies of your new complete antenna booklet.

NAME

STREET

CITY ZONE STATE

RADIO & TELEVISION NEWS

6BQ7A CASCODE 10-METER PREAMP

By
CHARLES A. LOWNSBURY, JR.
W2QKA

If a receiver has satisfactory stability and selectivity but lacks sensitivity at 28 mc. and higher, a solution for the amateur is to add a preamplifier. If the receiver lacks selectivity, resulting in bothersome image response, a preselector would be the logical choice and, by the same token, if receiver operation is poor on the higher frequencies but good on the lower ones, a converter might be used. As selectivity and stability were excellent, image rejection good, and high frequency operation good, and there being only a need for a little more sensitivity at 28 mc. in my *National NC-125* receiver (a common bugaboo with commercially-made, all-band receivers), an r.f. amplifier was deemed a worthwhile investment.

It is fundamentally the same circuit as that appearing in the *ARRL's "Radio Amateur's Handbook"* entitled "6BQ7 Preamplifiers for 50 and 144 Mc." The circuit was revised to cover the 10-meter band.

It is essentially a cascode-type amplifier using the new 6BQ7A dual triode which has recently been made available. This is an improved version of the older type 6BQ7. With the new type, a higher transconductance of 6400 micromhos, compared with 6000 for the 6BQ7, is obtained with a plate current of only 9 ma. The new tube also retains the same low input capacitance, low input loading, and low plate-to-cathode capacitance as its predecessor. These features make the 6BQ7A especially useful in the direct-coupled r.f. stage of television receivers utilizing a driven grounded-grid r.f. amplifier circuit or the cascode type of circuit. Its use in such circuits provides a reduction in noise with resultant improved receiver sensitivity. Each of the triode units is effectively shielded from the other. Consequently, either unit will give stable performance when used in high frequency applications such as driven r.f. grounded-grid circuits and counter circuits, and the whole tube functions very well as a push-pull grounded-grid r.f. amplifier.

Inasmuch as it is a broadband amplifier, omission of C_1 is permissible if a balanced folded dipole antenna and 300-ohm line are used for 10 meters. Its need would become apparent if other types were employed, in or-

The preamplifier, built in a 4"x2"x2 1/4" aluminum box, uses few parts and can be powered from the receiver. It can also be mounted inside the receiver cabinet.

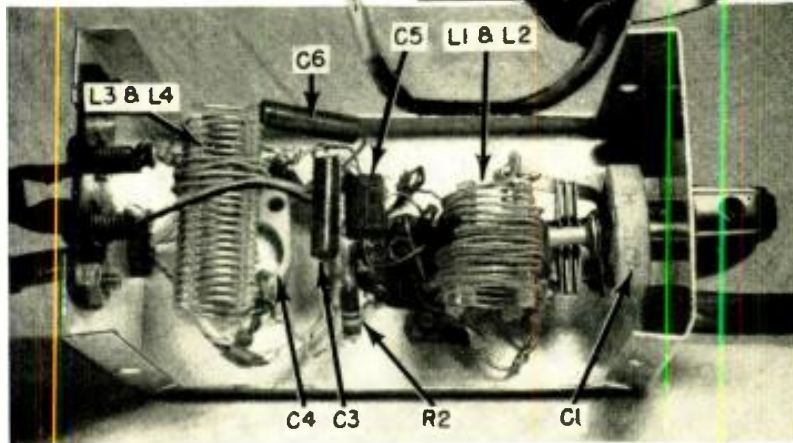

Although many commercially-built receivers lack sensitivity at 28 mc., their performance can be brought up to par with the lower bands with this easily-built broadband preamplifier.

der to peak a non-resonant unbalanced line, etc.

Power was obtained from the receiver itself, a socket at the rear of the NC-125 supplying all necessary voltages. An external power supply of 250 v. d.c. should give maximum

gain, with decreasing voltage resulting in decreased gain.

The entire unit is built into a 4"x2"x2 1/4" "Minibox" aluminum box, and the total cost should be around five dollars.

(Continued on page 182)

Schematic of the 6BQ7A preamp. The tube has advantages over the older 6BQ7. C_1 is optional with balanced feeders. Alternative connections for 75-ohm coax are shown.

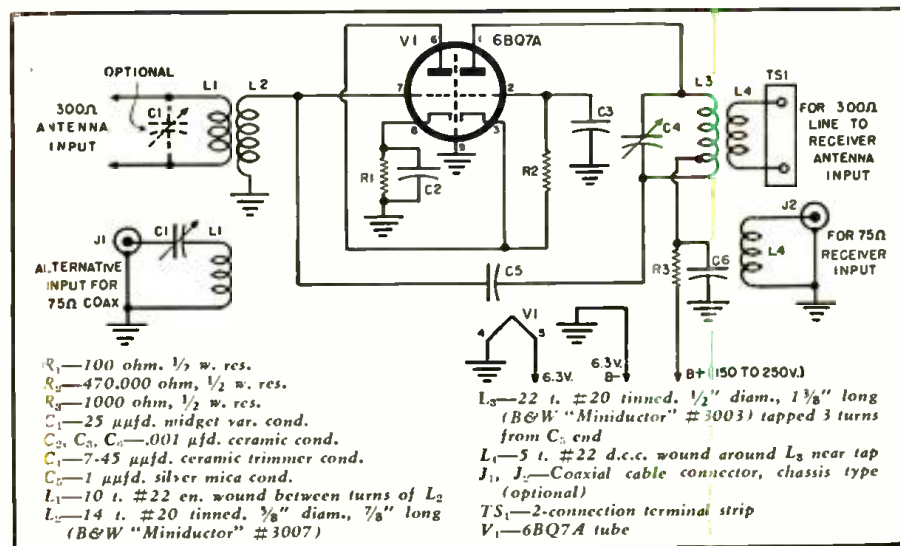

AN ELECTRONIC HOME TEMPERATURE CONTROL

By HARRY W. LAWSON

Complete amplifier, plate relay and bridge adjusting pots shown mounted. Cyclor in a clear plastic tube is at left of chassis. The protective cover was removed.

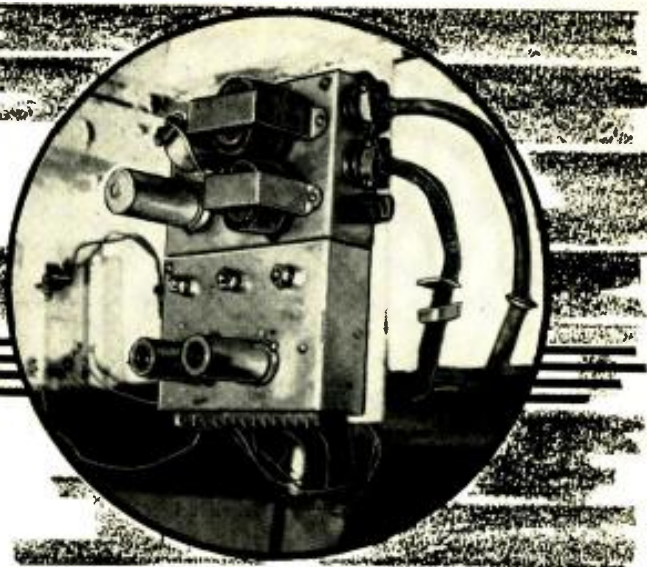

An interesting application of electronics in the home. The unit will hold temperatures within $\pm .2$ degree Fahrenheit.

TEMPERATURE control in most homes today consists of simply turning on and off a source of heat in response to a mechanical room thermostat. This system as it stands has been in use for quite some number of years despite its inadequacies. It is the author's purpose here to describe a sensitive electronic temperature control capable of being constructed with a minimum of complex circuitry.

Two basic reasons, there are more, for the use of such a unit would be in order here. First, the differential of a mechanical thermostat for a given setting is at best $1\frac{1}{2}$ to 2 degrees. This, coupled with the possibility of poor location, may result in a total temperature swing of as much as 8 degrees in certain parts of the house. Second, a 70 degree inside temperature may be fine on a very mild day, however this same inside temperature is no longer satisfactory when outside temperatures drop to the freezing level or below. The first prob-

The "averaging" unit which is installed inside the home. See text for complete data.



lem may be solved by cycling the heat source at a high rate, while maintaining the same actual operating "on" time or duty cycle. The second condition may be vastly improved by sampling the outside temperature and modifying the duty cycle of the heat source in proportion to it. Thus inside temperatures can be kept to within a small fraction of a degree for constant outside temperatures or actually increase a predetermined amount for each degree drop outside.

Several controls of this anticipating nature are available commercially.^{1, 2, 3} They may be mechanical or electronic, or a combination. The control to be described (Fig. 1) consists of an a.c. bridge circuit, a two-stage amplifier, and relay. The a.c. bridge supplies a signal to the amplifier whenever it is unbalanced. The phase of this bridge signal is determined by which side of bridge null the unbalance occurs. One side of balance indicates low temperature and *vice versa*. The first two amplifier stages are relatively straightforward whereas the final relay stage (12AU7) operates with an a.c. plate and bias supply. This last stage is therefore a phase-sensitive relay. Since this relay (RL_2) is a plate-circuit relay with light-duty contacts it is used only to control the power relay whose contacts are rated for the high currents to be encountered.

The bridge circuit in this unit deserves the most attention since it is the error-signal producing device. Almost any temperature-sensitive resistance elements can be used in the bridge. However, the greater the coefficient of resistance, the more sensitive will be the bridge circuit. The author chose to use thermistors since they have a very large coefficient of resistance compared with other mate-

rials (-4% per degree Centigrade at room temperature). Thermistors are also ideal from the standpoint of their nonlinear characteristics either side of 70 degrees F. The bridge is best built with completely variable arms to accommodate standard temperature-sensitive elements available. With the bridge set up as shown, two elements TH_1 and TH_2 are used as the inside sensing units. The resistance R , is the inside temperature control and is mounted in the same case with TH_1 . TH_2 is located in a different part of the house to provide an averaging action. TH_1 is mounted in a weather-proof box on the outside of the house, preferably the north side. The potentiometers located in the upper two bridge arms provide one means of adjusting the inside-outside temperature compensation previously mentioned. The remaining element, TH_3 , is part of the cyclor which governs the "on" time of the heat source. The cyclor is essentially a temperature sensitive element in a plastic cylinder in which is also mounted a small nichrome heater. The heat transfer from heater to sensing element provides the necessary time constant for cyclic operation.

For a description of bridge operation first consider a 70 degree outside temperature as the point at which no heat input is required. This corresponds to bridge balance. As the outside temperature drops, the anticipating element TH_1 immediately unbalances the bridge and as soon as the unbalance is greater than the relay amplifier input differential, the relay closes, operating the power relay. The power relay contacts start the heat source and also supply heat *via* the nichrome heating element to the element TH_2 . Since the element TH_2 is in the same bridge arm as TH_1 , the rise in its temperature balances the bridge, again opening the relays. Upon cooling, the same cycle is repeated. Since the nichrome heater supplies heat to the element TH_2 at a constant rate, the "on" time of the heat source

is governed by initial bridge unbalance and therefore is proportional to the outside temperature. Under ideal conditions, the elements TH_1 and TH_2 would not be necessary. However, since there is always air infiltration and unusual loading, such as sun and wind, these two elements are used to introduce minute room temperature errors. Using the circuit shown, room temperature can be maintained within .2 degree F. By adjusting the two resistances in the upper bridge arms, the outside sensing element can be made to exert more influence over inside temperatures. This results in a higher room temperature for every few degrees drop in outside temperature, usually a .4 degree rise per 10 degrees drop in outside temperature.

Construction of the system is relatively straightforward and simple. It must be remembered that such equipment is to be in operation twenty-four hours a day, throughout the year with resulting stress on components not found in ordinary electronic gear. Therefore, good quality components are a necessity. The temperature sensitive elements used by the author are Western Electric Type 3B thermistors. These are of the washer form and hence provide for ease of mounting (Fig. 3). Their nominal resistance at room temperature (70 degrees) is 30 ohms. Regardless of the type of element used, low impedance is necessary to remove the need for shielding the long bridge leads, on the order of 1000 ohms or less. Correct phasing of all the transformers is necessary for proper operation, hence the plus-minus signs appearing in Fig. 1 showing in-phase winding terminals. These connections may be checked by series connecting the windings concerned and measuring the total voltage with an a.c. voltmeter as shown in Fig. 2. A sum reading will then show proper connections. The cyclor (Fig. 4) built by the author consists of a 1½ inch plastic tube mounted vertically with the nichrome wire wound in the form of a grid across the bottom opening. The element TH_2 is then mounted above the heater in the tube at a distance determined by the cycling rate desired. In the author's control unit this distance is about 3 inches. This will vary depending upon the rate of heat loss from the house.

Setting up the system may seem to be complicated at first, however if it is done in logical order, no trouble should be encountered. All bridge elements should first be connected in their proper positions in the bridge and located in an ambient temperature of 70 degrees. The temperature setting resistance, R_1 , should be adjusted to approximately 22 ohms, the calibration resistance, R_5 , to its midpoint. Resistance R_4 is then adjusted until the voltage as measured with an a.c. voltmeter between points 1 and 2 is equal to that measured between points 2 and 4. R_2 is now set at approximately 680 ohms and the upper half of the bridge is set-up by equat-

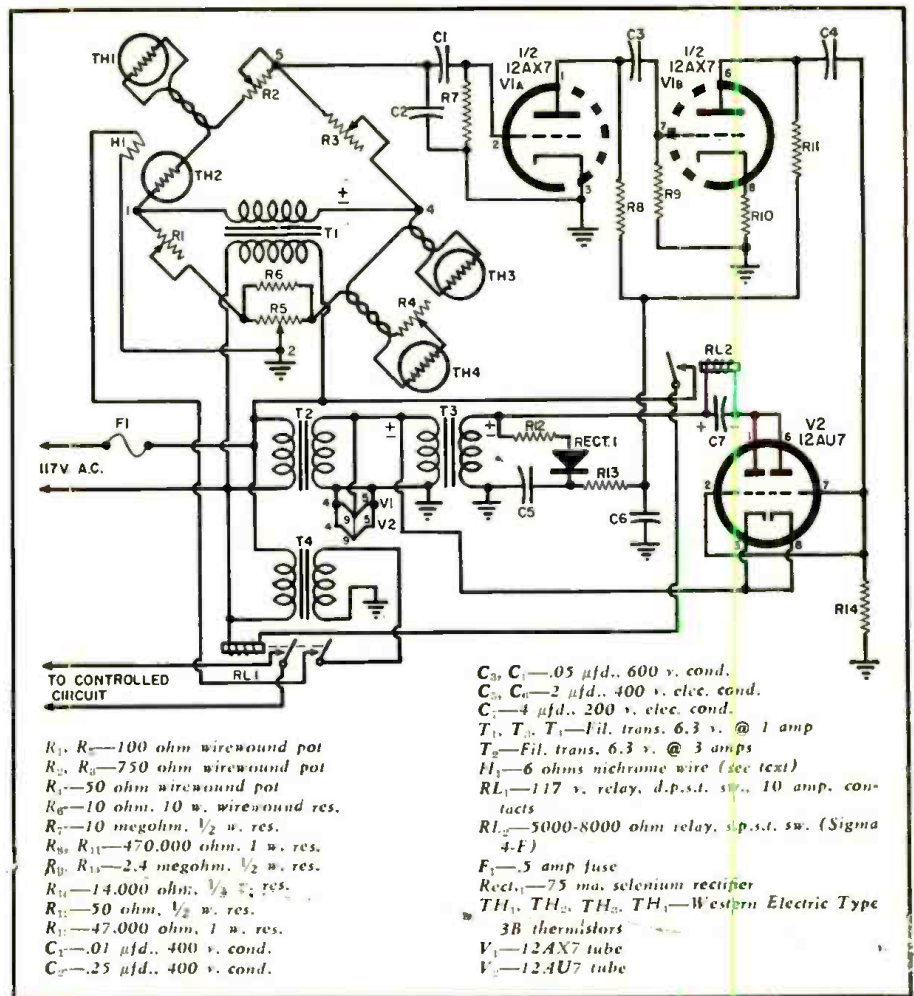

Fig. 1. Schematic of electronic temperature control. Quality parts must be used.

ing voltages 1-5 and 5-4 using R_5 only. Now cooling either TH_1 or TH_3 will cause the plate circuit relay to close and hence the power relay. After this check the sensitive elements may be placed in their permanent locations. Calibration of the temperature setting dial is best and most easily accomplished when the outside temperature is in the neighborhood of 55 degrees. Then with the use of an accurate thermometer, calibration points on this dial may be marked as the inside temperature is raised from 55 to 85 degrees in several steps.

(Continued on page 231)

"Sensing" element installed out-of-doors.

The companion indoor "sensing" element.

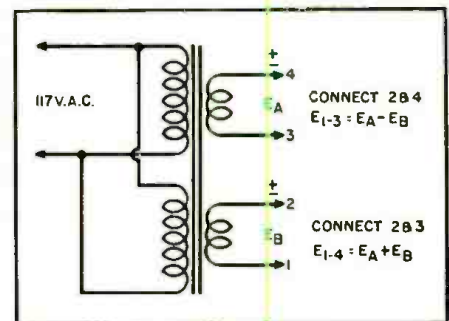
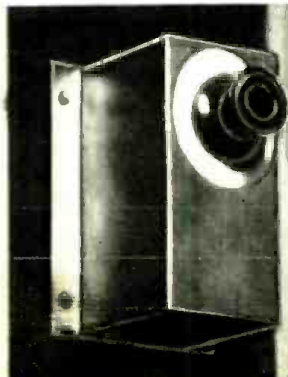
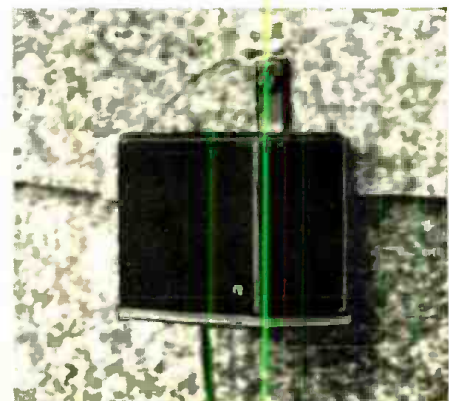
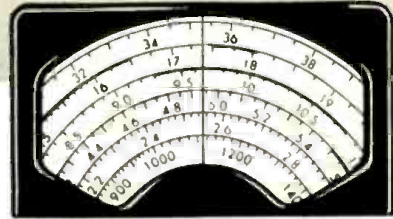

Fig. 2. Circuit for checking the correct phasing of transformers. Series connect windings and measure the total voltage.





International SHORT-WAVE



Compiled by KENNETH R. BOORD

CONGRATULATIONS are extended this month to the pioneer short-wave station, PCJ (Peace, Cheer, Joy), now *Radio Nederland*, and especially to its *International Goodwill Ambassador of the Air*, Edward Startz, on the occasion of the 25th anniversary of "Happy Station" round-the-world broadcasts from Hilversum, Holland.

Significantly, international short-wave broadcasting originated with the "Happy Station." It was over PCJ's experimental short-wave transmitter back in 1926 that Queen Wilhelmina of the Netherlands spoke for the first time to her subjects in the Dutch East Indies. London's famous Big Ben was first heard in Australia via the Dutch station which carried out the relay. As early as 1929, some 20 different languages had been spoken over PCJ's microphone by prominent world personages.

PCJ boasts the only rotating antenna of its type in the world—an ingenious device on eight sets of wheels that slide on rails.

At the outbreak of war in 1940, the Dutch blew up their transmitter and famous antenna at Huizen rather than to allow equipment to fall into the hands of the Nazis. The Gestapo moved in, rebuilt the station with forced labor, and used it to pump German propaganda overseas. But shortly before the Allied invasion of 1944, clever Dutch engineers sabotaged the antenna mechanism so that for the duration of the war all Nazi broadcasts were beamed to the North and South poles. No doubt the polar bears enjoyed excellent reception!

When the Nazis left Holland, they pillaged and looted everything of value, including the "Happy Station's" library of 5000 recordings collected from all over the globe for the entertainment of its listeners. The Germans blew up the station again—but when the liberation came, the undaunted Dutch engineers rebuilt it in record time, and PCJ resumed its "Happy Station" broadcasts to the whole world. Through the efforts of listening friends, and others

throughout the world, the record library has long since been built up and now contains recordings from many lands.

For the past 25 years, the "Happy Station"—largely through the efforts of its polyglot emcee, Edward Startz, world traveler and one of the most colorful of all radio personalities—has created good-will for Holland in the world at large, has promoted mutual understanding between peoples of all nations, and last but not least, has spread *Happiness* to all its listeners in the four corners of the earth!

* * *

Radio Club Notes

Spain—Two days of radio fellowship ("Quarenta y Ocho Horas Felices del Radioaficionado") were enjoyed recently by Santander members of URE (Union Radioaficionados Espanoles), to strengthen already cordial relations among Santander amateurs, and to link last year's First Technical International Conference with the one to be held next year. (Diez, Spain)

USA—Marvin E. Robbins, Indianapolis, Ind., has had to resign as short-wave editor of the Universal Radio DX Club, Hayward, Calif., due to entering the armed services. Good luck, Marv!

* * *

BBC Tops List

In the 1953 "Short-Wave Station Popularity Poll" conducted by the In-

ternational Short-Wave Club, London, top spot went to the BBC's Overseas Service; Radio Australia was in second place, and third-place honors went to the Swiss Short-Wave Service.

ternational Short-Wave Club, London, top spot went to the BBC's Overseas Service; Radio Australia was in second place, and third-place honors went to the Swiss Short-Wave Service.

Notes came from listeners in all parts of the world who were invited to write, in as few words as possible, why they considered their No. 1 choice to be their favorite station. The six top essays were written by Roy Patrick, England; Peter Batten, England; Van H. Ferguson, Tallahassee, Florida; Thomas H. Zieske, Roseville, Michigan; Harold M. Barrowclough, Dunedin, New Zealand, and John Casey, Louisville, Kentucky.

* * *

Around the World

(Note: Between the time this was compiled and when you read it, some stations may have changed to winter schedules; in such cases, you may find schedules *one hour later* than listed herein.—K. R. B.)

Afghanistan—Kabul Radio says it uses 9.975, 25 kw., now in English 1200-1215 daily, with news; on Sun. extends program to 1240 with popular request program, same on Wed. but with classical musical request session. (Scheiner, N. J.)

Albania—Ingelsson, Sweden, reports Radio Tirana, 6.945A, with news 1600-1620, then news in French.

(Continued on page 202)

Edward Startz, international "Goodwill Ambassador of the Air," at PCJ microphone back in the early days of "Happy Station" broadcasting. Program is celebrating 25th year on the air this month.

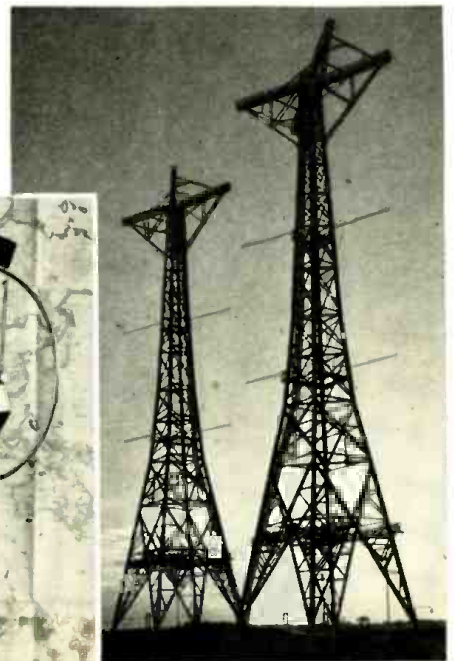

(Note: Unless otherwise indicated, all time is expressed in American EST; add 5 hours for GMT. "News" refers to newscasts in the English language. In order to avoid confusion, the 24 hour clock has been used in designating the times of broadcasts. The hours from midnight until noon are shown as 0000 to 1200 while from 1 p.m. to midnight are shown as 1300 to 2400.) The symbol "V" following a listed frequency indicates "varying." The station may operate either above or below the frequency given. "A" means frequency is approximate.

Send for Your
FREE
Copy of the **NEW 1954**
MIDWEST
TELEVISION and
RADIO Catalog

MIDWEST *Presents*

For 1954 a Completely NEW LINE of
21" and 27" TELEVISION

**CONSOLES
TABLE MODELS**

and
**COMPLETE
CHASSIS**

at
**LOW FACTORY
PRICES**



YOUR CHOICE OF EITHER 12 CHANNEL
VHF or All-Channel VHF-UHF Models

Buy your Television or Radio Direct from the Midwest Factory . . . on
30 DAYS TRIAL . . . Easy Terms . . . and at LOW FACTORY PRICES.
For 34 years Midwest, the world's largest and oldest exclusive Factory-
To-You radio and television manufacturer, has served hundreds of thou-
sands of satisfied customers all over the world.



**EASY TERMS
30 DAYS
TRIAL**



All models
available in
your choice
of mahoga-
ny, walnut
finish or
blond lined
oak.

FACTORY-TO-YOU

Also—Powerful New 1954 World-Ranging
MIDWEST Series 16 RADIOS
In Beautiful Consoles and Complete Chassis

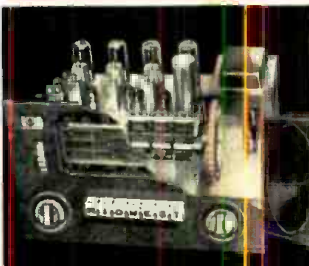

Once again Midwest offers its famous series 16 five band AM-FM radio chassis and the magnificent new Symphony Grand Radio-Phonograph with 3-Speed Automatic Inter-mix Record Player. Also, a complete line of clock radios, table radios, and portables.



WRITE IN NAME AND ADDRESS (PLEASE PRINT) ON COUPON OR 2c POSTCARD

MIDWEST RADIO & TELEVISION CORP.
Dept. C-37, 909 BROADWAY • CINCINNATI 2, OHIO

Please send me your new FREE 1954 Catalog.

NAME _____
ADDRESS _____
CITY _____ ZONE _____ STATE _____

MIDWEST RADIO & TELEVISION CORP.
DEPT. C-37, 909 BROADWAY, CINCINNATI 2, OHIO

MULTI-VOLTAGE POWER SUPPLY



Fig. 1. Over-all view of laboratory-type power supply. It is built on a single chassis measuring 7" x 17" x 3". It uses Thordarson-Meissner T26R00 transformer.

By
GLADE WILCOX
Eng. Dept., Thordarson-Meissner

An ingenious circuit using a TV universal power transformer. Voltages to 380 and currents to 200 ma. are made available.

THE development of the universal power transformer for television replacement has made possible a compact, variable multi-voltage laboratory power supply which offers many advantages to the user. These transformers are multi-tapped in the high-voltage winding and have an adequate number of isolated heater windings to use when it is necessary to isolate circuits or connect them in series or parallel for many television heater applications.

This universal power transformer for television replacement is designed to mount in a compact space and is thus carefully engineered to provide the most power per unit of space within the heat limits of good design.

It is constructed with end shields and is electrostatically shielded to keep line noise from affecting the power supply load.

The demands of a laboratory power supply are such that filament transformers must be mounted on the same chassis or connected externally in order to obtain uncontrolled filament voltages. When a multi-grid tube is used in a test set-up the usual laboratory power supply must be augmented with a second or third supply in order that two voltages may be controlled independently of each other. If this is not done "haywire" dropping resistors and rheostats are used externally. Dropping resistors have the additional disadvantage of being dependent

upon the change in load voltage of the common source. When several circuits are in the test set-up, with one requiring a VR supply voltage in addition to the required variable voltages, this accumulation of power supplies becomes absurdly bulky.

To overcome the disadvantage of utilizing several high-voltage supplies in simple medium- and low-power circuits and to eliminate "haywire" connection of external resistors, rheostats, filament transformers, and VR circuits, this laboratory power supply has been designed around the Thordarson-Meissner T26R00 television replacement transformer. The materials used in building this supply are easily obtainable from radio parts suppliers. The construction is simple and when built on the 7" x 17" x 3" chassis used in this model, it can be mounted in a standard rack. The shielding of the transformer makes it adaptable to many more-than-average test applications inasmuch as line noise and flux radiation are held to a minimum.

Although the supply has the advantage of compactness and standard

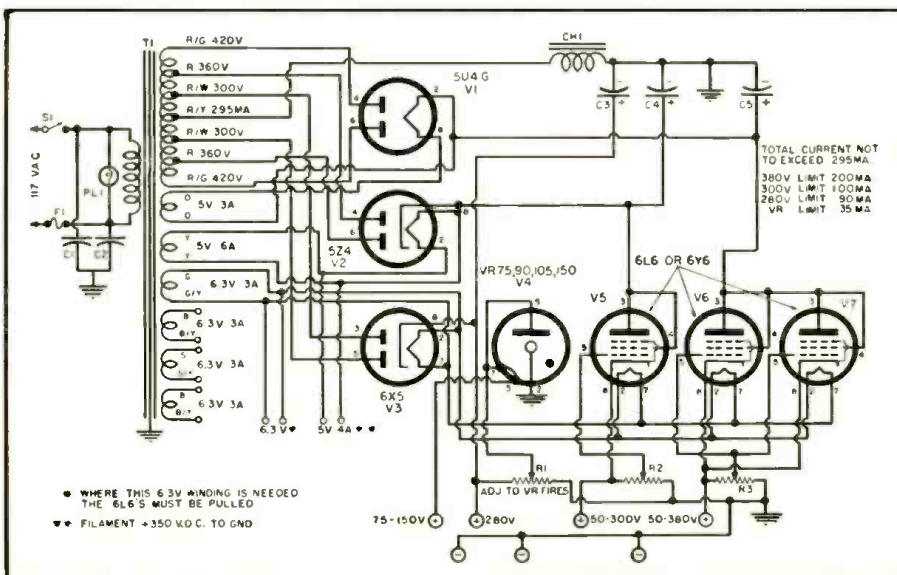

Fig. 2. Schematic of power supply. Color coding indicated for the universal power transformer must be followed carefully.

- R_1, R_2, R_3 —70,000 ohm, 4 w, pot
- C_1, C_2 —.1 μ fd., 400 v, cond.
- C_3, C_4, C_5 —30 μ fd., 450 v, elec. cond.
- CH_1 —7 hy., 300 ma, smoothing choke (Thordarson-Meissner T20C56)
- F_1 —3 amp. fuse
- S_1 —S.p.s.t. toggle switch
- PL_1 —117 v. pilot light
- T_1 —Power trans., 420-0-420 v., 360-0-360 v., 300-0-300 v., @ 295 ma.; 5 v. @ 3 amps.; 5 v. @ 6 amps.; 6.3 v. @ 3 amps.; 6.3 v. at 3 amps.; 6.3 v. @ 3 amps.; 6.3 v. @ 3 amps. (Thordarson-Meissner T26R00 TV replacement type)
- V_1 —5U4G tube
- V_2 —5Z4 tube
- V_3 —6X5 tube
- V_4, V_5, V_6, V_7 —VR75, VR90, VR105, or VR150 (choice of tube to be dictated by voltage desired)
- V_8, V_9, V_{10} —6L6 or 6Y6 tube

30 DAYS LEFT

TO GET THE WESTINGHOUSE UHF SERVICE KIT THAT BUILDS BIG EXTRA SERVICING PROFITS

You Get THIS 32-PAGE UHF CONVERSION AND SERVICING HANDBOOK

It tells and shows you how to convert any model. Tells you when to use tuners, converters, UHF strip replacement, and how! Shows how to solve UHF antenna and lead-in problems. Easy to understand.

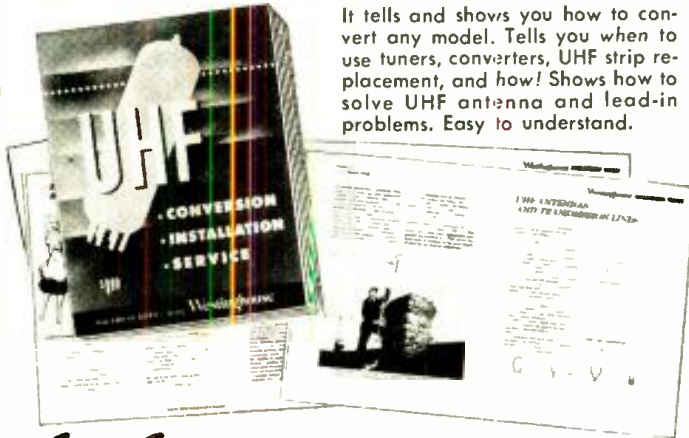

YOURS AT NO COST
with 100 WESTINGHOUSE RELIATRON RECEIVING TUBES
or 4 WESTINGHOUSE RELIATRON PICTURE TUBES

You Get THIS TERRIFIC 3-FOOT, 6-COLOR HEAT-MOTOR DISPLAY

Familiar TV troubles appear in motion on the lighted screen — startle and stop sidewalk traffic. It's the best window display you ever used.



You Get THIS UHF WINDOW STREAMER

That Sells Your Conversion and Servicing Know-How

17" x 34", printed in 4 brilliant colors, it will make you the busiest UHF man in town.



Let us convert your set to receive all stations

We put **NEW LIFE** in your TV and radio sets with **NEW...NEW...NEW...**

Westinghouse RELIATRON TUBES

You Get

THIS FRAMED PRICE-POLICY STATEMENT

Permanent frame with acetate window displays your standard service charges or store policy. Interchangeable inserts provided.



You Get THIS EXCITING LUMINESCENT

"NEW LIFE" WINDOW STREAMER It puts the Westinghouse quality reputation squarely behind you!

You pay Nothing!

That's right. Just look up your nearest Westinghouse Tube Distributor and give him an order for 100 Westinghouse Receiving Tubes or 4 Picture Tubes. He has a Kit waiting for you. But hurry. This offer ends Nov. 30th. If you don't know who your Westinghouse Tube Distributor is, drop a postcard to Dept. G-211, and we'll send you his name.

ET-95031

YOU CAN BE SURE...IF IT'S
Westinghouse

RELIATRON TUBES

T M

WESTINGHOUSE ELECTRIC CORPORATION, ELECTRONIC TUBE DIVISION, ELMIRA, N. Y.

Follow this path to faster, more profitable repair service

If you're like thousands of other busy Service Engineers, you can't afford to sacrifice profit time — hunting for repair parts. That's why it pays to have your Centralab controls on hand when you need 'em — in one of these 3 handy Blue Shaft Control kits. Assortments contain *exact* replacement values you use every day, in plain or switch types, for popular radio and TV sets!



Kit deal B-A
contains 22 controls (8 types) in 1/2 and 1 megohm. All units C₂ audio taper. Standard full-length fluted mill and split-knurl shafts.



Kit deal B-B
newest, revised. Has 22 controls (15 C₂ types,—1000 ohms to 5 megs) plus 4 Fastatch® type K13 line switches.



Handy Plastic-Paks
of 12 controls each in 10 fast moving assortments. You pay for parts only — no charge for metal or plastic containers.

And remember . . . switches are factory-attached and tested for immediate installation. Your Centralab distributor has plenty of Blue Shafts on hand to keep kits well-stocked. Order kits from him NOW. *Trademark

Centralab

CENTRALAB
A Division of Globe-Union Inc.
910-K E. Keefe Ave., Milwaukee 1, Wis.
Please send me Catalog 28 with complete details on Centralab Radio-TV control kits.

Name.....
Firm.....
Address.....
City..... Zone..... State.....

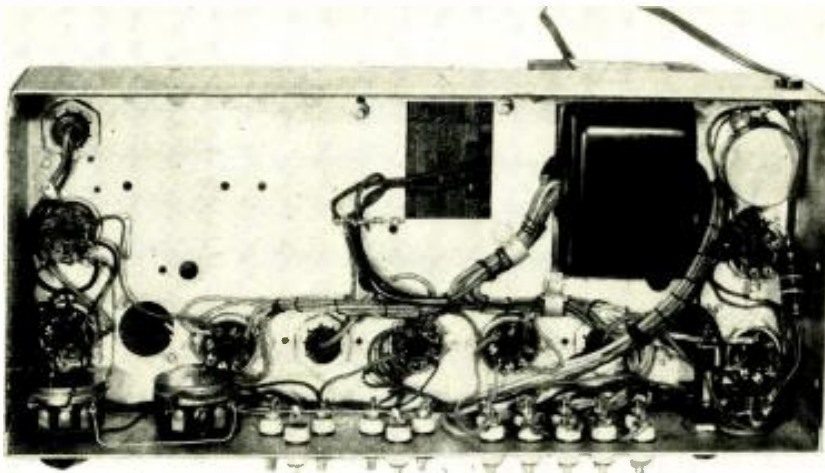

Fig. 3. Underchassis view of power supply. Layout, as shown, should be followed closely.

mounting length, its most outstanding feature is the number of voltages it can furnish: 50-380 volts up to 200 ma.; 50-300 volts up to 100 ma.; 280 volts with a 90 ma. limit; a voltage-regulated source of 75, 90, 105, 150 at 35 ma. (depending on the VR tube used); 5 volts a.c. at 4 amps.; and three 6.3 volt a.c. taps should controlled voltage be unnecessary. These latter low voltages may be connected in series for higher a.c. voltage or the 6.3 volt a.c. taps may be paralleled for higher current drains. Since this is all possible with one transformer, the resulting variable-voltage laboratory power supply becomes a compact assembly.

The layout of parts and construction of the unit can be seen in Figs. 1 and 3 which show top and underchassis views of the assembled model. The total cost of parts for this supply, based on current prices, is \$45.59. It is suggested—after considerable laboratory use—that the pilot light, PL, shown in the 117-volt primary circuit, be included.

When constructing this supply, layout the parts as shown in Figs. 1 and 3. Mount the parts, starting with the tube sockets, which are mounted with the keyways toward the chassis front. Mount the choke and power transformer last as this makes it easier to handle the chassis when mounting the smaller parts.

After the transformer is mounted, the color coded leads can be pulled in place and temporarily connected to determine their location for cabling. Cable the leads and proceed to cut them to length, strip, and solder. The color code is given in the schematic diagram of Fig. 2.

When wiring the power supply, after the transformer leads have been soldered in place, wire the primary circuit first. The wiring may be checked by turning on the power supply and checking the lead bushing heater voltages with a low-voltage a.c. meter and the high voltages on the rectifier plate connection with a high-voltage a.c. meter.

Wire the 6L6 and the 6X5 heat-

ers. Wire the 5Z4 heater. Test by plugging in the tubes and seeing if they light. Then complete the wiring of the controlled high-voltage circuit from the 5U4G rectifier. Test this circuit with a d.c. voltmeter. Next complete the wiring of the low-voltage uncontrolled circuit and the VR tube, then test with a d.c. voltmeter.

The completed laboratory power supply has a calculated ripple reduction factor of .007 at 250 ma. which gives it a .84 per-cent ripple at this current rating. As this is less than 1 per-cent ripple it would appear to be satisfactory for laboratory and service bench use.

-30-

CHOICE CONTACT

OF PARTICULAR interest to amateurs is the item passed on to us by Ken Boord, ISW Editor. Bert Bluman of Israel has written Mr. Boord as follows:

"Six young Israelis, 18 to 25 years of age, sailed some weeks ago from Haifa aboard the yacht 'Israela,' a 32-foot sailing vessel equipped with an auxiliary 15 h.p. engine, for a cruise around the world, via Italy, France, England, then south to South Africa, back to West Africa, across South Atlantic to Brazil, on to USA, south again through Panama Canal, and then across the Pacific.

"Five of the group are sailors and the sixth is my good friend, 4X4AS, who until now was a radio technician at Lydda Airport as well as a very active ham. He is mostly active on 7, 14, 21 mc., and occasionally, also on 28 mc. Though output is less than 30 watts, he is having some fine c.w. and voice QSO's with ZS, W2, W8, W9, W5, VK, ZL's, etc.

"Since an amateur operating from a 32-foot vessel on a round-the-globe cruise is a bit out of the usual, this might interest amateurs. This is not a publicity stunt or propaganda cruise; it is neither politically nor commercially sponsored. I know the six chaps personally. They have put their own savings into this out of pure love of adventure and because they read about 'Kon-Tiki' which caught their imaginations."

May we suggest that all hams be on the lookout for this call as it is bound to be one of the choice contacts of this or any other season. We know that 4X4AS will welcome hearing from you fellows too.

-30-

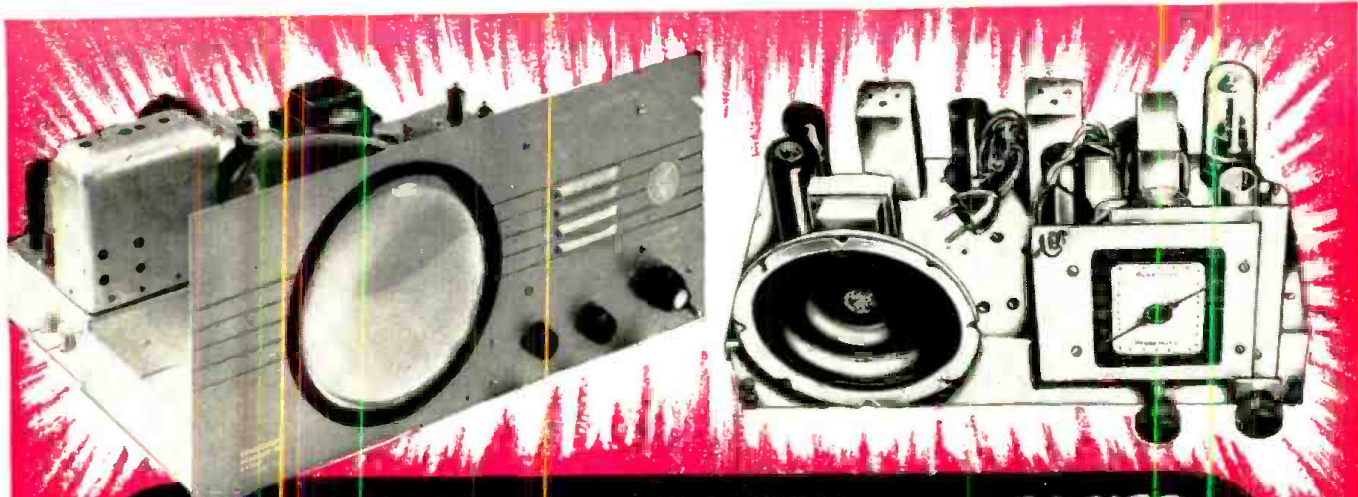

**TRAIN FASTER—TRAIN BETTER—TRAIN EASIER
 IN 10 MONTHS—OR LESS—FOR
RADIO-TELEVISION**

Our 21st Year Training Men for Greater Incomes and Security in Radio-Television

**I SEND YOU
 18 BIG KITS**

of Radio Television parts and equipment. Much of your training will be actual construction and experimentation . . . the kind of truly PRACTICAL instruction that prepares you for your Radio-Television career.



Frank L. Sprayberry
 President
 Sprayberry Academy
 of Radio

NEW! NO OBLIGATION PLAN

**You Have No Monthly Payment Contract to Sign
 Pay For Your Training as You Earn and Learn**

You can get into Radio-Television, today's fastest growing big money opportunity field, in *months* instead of years! My completely new "package unit" training plan prepares you in as little as 10 months or even less! *No monthly payment contract to sign—thus NO RISK to you!* This is America's finest, most complete, practical training—gets you ready to handle any practical job in the booming Radio-Television industry. Start your own profitable Radio-Television shop . . . or accept a good paying job. I have trained hundreds of successful Radio-Television technicians during the past 21 years—and stand ready to train you, even if you have no previous experience! Mail coupon and get all the facts—FREE!



**Valuable Equipment Included
 With Training**

The new Sprayberry "package" plan includes many big kits of genuine, professional Radio-Television equipment. You perform over 300 demonstrations, experiments and construction projects. You build a powerful 6-tube 2-band radio set, multi-range test meter, signal generator, signal tracer, many other projects. All equipment and lessons are *yours to keep* . . . you have practically everything you need to set up your own profitable Radio-Television service shop.

Earn Extra Money While You Learn!

All your 10 months of training is IN YOUR HOME in spare hours. Keep on with your present job and income while learning. With each training "package" unit, you receive extra plans and "Business Builder" ideas for spare time Radio-Television jobs. New television stations everywhere, open vast new opportunities for trained Radio-Television Technicians—and those in training. If you expect to be in the armed forces later, there is no better preparation than practical Sprayberry Radio-Television training.

YOU BUILD the Television set and the powerful superhet radio receiver shown above. IN ADDITION to the other test units shown here (many are not shown because of lack of space). All equipment I send you is **YOURS TO KEEP.**

SPRAYBERRY ACADEMY OF RADIO 111 NORTH CANAL ST.
 Dept. 25-C, Chicago 6, Ill.

**MAIL COUPON
 TODAY!
 NO OBLIGATION**

SPRAYBERRY ACADEMY OF RADIO, Dept. 25-C
 111 North Canal St., Chicago 6, Ill.

Please rush to me all information on your 10-MONTH Radio-Television Training Plan. I understand this does not obligate me and that no salesman will call upon me. Be sure to include 3 books FREE.

Name..... Age.....
 Address.....
 City..... Zone..... State.....

I invite you to get all the facts—
FREE TO YOU 3 BIG
RADIO-TELEVISION BOOKS

I want you to have ALL the facts about my new 10-MONTH Radio-Television Training—without cost! Rush coupon for my three big Radio-Television books: "How to Make Money in Radio-Television," PLUS my new illustrated Television Bulletin PLUS an actual sample Sprayberry Lesson—ALL FREE. No obligation and no salesman will call. Mail coupon NOW!



KESTER

Mac's Service Shop
(Continued from page 84)

Since the most important single step in Radio-Television Servicing is soldering... it's just plain good sense to use the best — KESTER SOLDER... Key Name in Solder for More Than 50 Years.

KESTER SOLDER COMPANY
4235 Wrightwood Avenue • Chicago 39, Illinois
Newark 5, New Jersey • Brantford, Canada

SOLDER

WE ARE QUICK AND CASH BUYERS
We're looking for surplus inventories of all types of electronic parts—receiving, transmitting and special-purpose Tubes. Anything in the radio, TV and electronic field.
SMALL OR LARGE QUANTITIES—SEND US YOUR LIST
Submit samples where possible, amount of each item and prices.
NAT ADELMAN
168 Washington St. New York 6, N. Y.

ON-THE-SPOT BATTERY RECORDER
WALKIE-RECORDALL 8 lb. miniature BATTERY RECORDER-PLAYBACK
Continuous, permanent, accurate, indexed recording at only 5¢ per hr. Instantaneous, permanent playback. Picks up sound up to 60 ft. Records conferences, lectures, dictation, 2-way phone & sales talks; while walking, riding or flying. Records in closed briefcase with "hidden mike"! Write for Detailed Literature.
MILES REPRODUCER CO., INC.
812 BROADWAY Dept. RN 11 NEW YORK 3, N. Y.

NOW... Save MORE on TUBES!

INDIVIDUALLY BOXED • FULLY TESTED • EACH TUBE GUARANTEED FOR SIX MONTHS

Type	Price	Type	Price	Type	Price	Type	Price
1B3GT	\$.69	6A55	\$.50	6K6GT	\$.41	12A27	\$.70
1H5GT	.46	6AT6	.38	6L6G	.80	12BA6	.45
1L4	.57	6AU6	.43	6L6GA	.80	12BE6	.47
1N5GT	.57	6AV6	.38	6S4	.46	12BH7	.63
1R5	.56	6B4G	.96	6SA7GT	.52	12BZ7	.75
1S5	.47	6BA6	.45	6SJ7GT	.47	12SA7GT	.52
1T4	.56	6BC5	.53	6SK7GT	.50	12SK7GT	.50
1T5GT	.71	6BD5GT	.89	6SL7GT	.62	12SL7GT	.61
1X2	.67	6BE6	.47	6SN7GT	.54	12SN7GT	.44
3Q5GT	.65	6BT5	.60	6SQ7GT	.42	12SQ7GT	.44
354	.55	6BG6	1.34	6T8	.78	19BG6	1.39
3V4	.56	6BH6	.57	6U8	.85	19C8	.94
SU4G	.43	6BJ6	.48	6V6GT	.46	19T8	.79
SV4C	.73	6BK7	1.10	6W4GT	.45	25BQ6	.89
SY3C	.34	6BL7	.83	6W6GT	.57	25L6GT	.48
SY3GT	.30	6BQ6	.89	6X4	.34	25Z6GT	.42
6AB4	.46	6BQ7	1.10	6X5GT	.33	35A5	.48
6AF4	1.40	6BZ7	1.10	6Y6G	.59	35B5	.47
6AG5	.54	6C4	.34	7N7	.52	35C5	.47
6AK5	.95	6CB6	.53	12A7E	.38	35L6GT	.47
6AK6	.63	6CD6	1.85	12A77	.68	35W4	.31
6AL5	.40	6F6GT	.45	12A78	.68	35Z5GT	.30
6AN4	1.30	6H6GT	.49	12A79	.55	50B5	.47
6AQ5	.46	6J5GT	.40	12A87	.38	50C5	.47
6AQ6	.42	6J6	.62	12AX7	.80	50L6	.47
6ARS	.38			12AX7	.61	117Z3	.39
						117Z6	.68

Motorola Ballast Tube #17A485459.....30

Each tube is performance-proven. 25% deposit must accompany all orders. Balance C.O.D. All prices F.O.B., N.Y.C. If remittance is made with order, you can deduct 2%. \$1.00 handling charge for orders under \$10.00. Subject to Prior Sale. Importer inquiries invited.

PHILLIPS TUBE CO. 2281 Nostrand Ave. BROOKLYN 10, N. Y. CLoverdale 3-8010-1-2

makes no difference if the signal generator used has distortion in its output or not. As long as the amplifier does not introduce additional distortion, the output voltage will trace out a reversed outline of the input voltage, no matter what the shape of that input signal is, and no distortion will be indicated."

"Don't you imagine there will be some drawbacks to hi-fi service?"

"I know there will be. For one thing, we shall be trying to please perfectionists. Such people are always tough customers. For another thing, many of these people will have a smattering of technical knowledge, and they will be trying to impress us with their knowledge by being especially critical of our work. Out of our experience with the I-could-fix-it-myself - if - I - just - had - the - time - and-the-tools people in radio and TV service, we know that a little knowledge can be a darned exasperating thing.

"On the other hand there will be some satisfaction in working for people who will know and appreciate it when equipment is working as it should. The whole thing is that we must prepare ourselves, both with knowledge and equipment, so that we will know when a high-fidelity sound system is delivering everything of which it is capable."

"I think this is going to be fun," Barney said with his quick enthusiasm. "I'll bet that in a short time I'll be known as Golden Ear Gallagher."

"Well, then, Golden Ear, hear this:" Mac commanded. "I want you to bone up on high fidelity until you give off a musical Middle C every time I whop you on the head. You can start by re-reading Ollie Read's 'The Recording and Reproduction of Sound.' Follow that up with 'High Fidelity Simplified' by Harold D. Weiler. Then go back through our magazine files."

"But what shall I do with my leisure time?" Barney asked sarcastically.

For an answer Mac pulled out a bulky cardboard carton and placed it in Barney's lap. "There is a Williamson amplifier in kit form. Take it home with you and wire it up—and I mean wire it right. I intend to inspect every solder joint in it. Then bring it down here and we'll run every kind of a test on it we can dream up. I've already bought a good high-fidelity coaxial speaker and am building an enclosure for it at home; so by the time we get all this done we ought to have a pretty good knowledge of the subject from both the theoretical and practical points of view."

"Say, you are real gone on this hi-fi stuff, aren't you?" Barney exclaimed.

"Yep," Mac agreed with a teasing grin, "I think it's real crazy!"

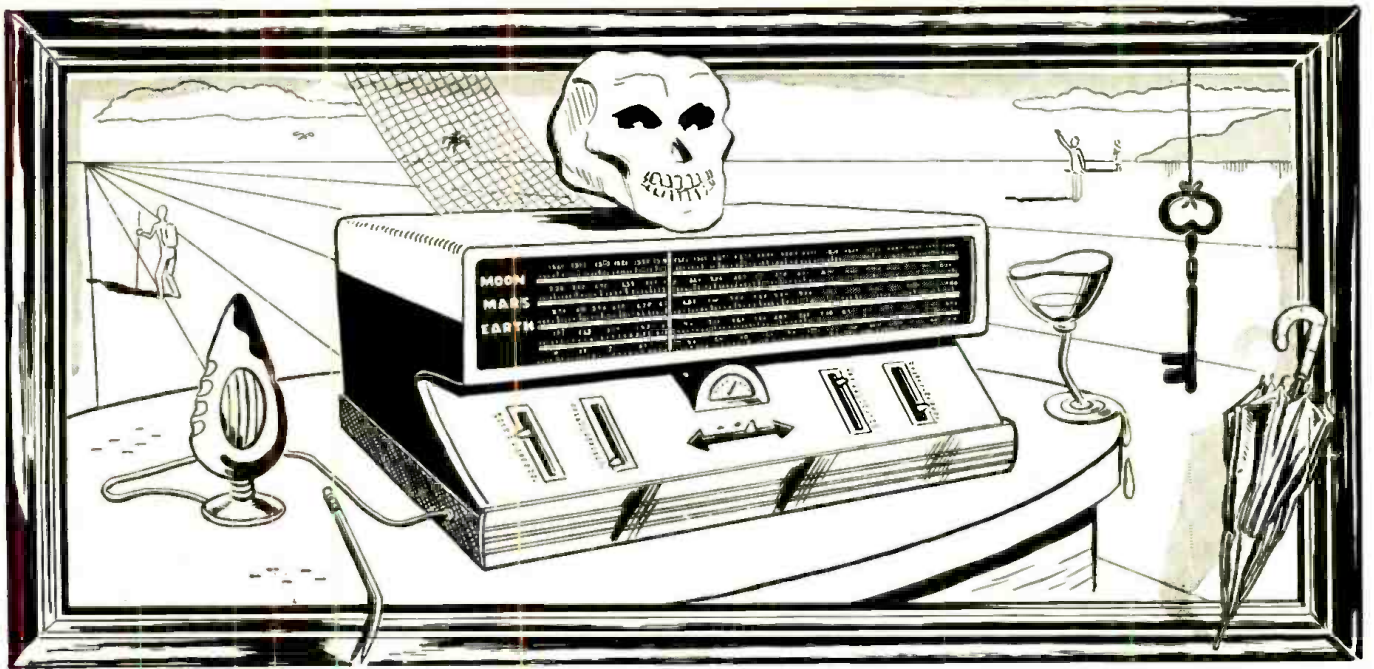

LET'S BE *Realistic*

The time may not be too far off when you'll be QSO-ing the Moon, Mars, and presently undiscovered planets. We wouldn't know about that. But we can tell you that for down-to-earth

bargains you just can't beat our "Surprise" Trade-In Allowances on used test and communication equipment. So get your trade-in deal cookin' today. Wire, write, phone or use the handy coupon.



HALLICRAFTERS SX-71 Less speaker.
Shpg. wt. 51 lbs. Net \$249.95



HAMMARLUND HQ-140X Less speaker.
Shpg. wt. 60 lbs. Net \$264.50

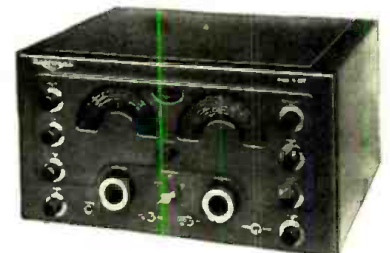

NATIONAL NC-183D. Less speaker.
Shpg. wt. 65 lbs. Net \$383.50



HALLICRAFTERS S-76. Less speaker.
Shpg. wt. 46 lbs. Net \$199.95



JOHNSON VIKING II TRANSMITTER KIT.
Shpg. wt. 85 lbs. Net \$279.50
JOHNSON VIKING II Wired and Tested. Net \$337.50



COLLINS 75A-3 with 3 KC
mechanical filter. Less speaker.
Shpg. wt. 70 lbs. Net \$530.00

All prices f. o. b. St. Louis • Phone Chestnut 1125

Walter Ashe
RADIO CO.
1125 PINE ST. • ST. LOUIS 1, MO.

FREE CATALOG!

RN-1 1-53

WALTER ASHE RADIO COMPANY
1125 Pine Street, St. Louis 1, Missouri

Rush "Surprise" Trade-in Offer on my _____

for _____
(show make and model number of new equipment desired)

Send for new 1954 Catalog.

Name _____

Address _____

City _____ Zone _____ State _____

**Send
for
your
copy
today**

BOEING ELECTRICAL CIRCUITS MADE BY ETCHING PROCESS

By IRVING PETITE

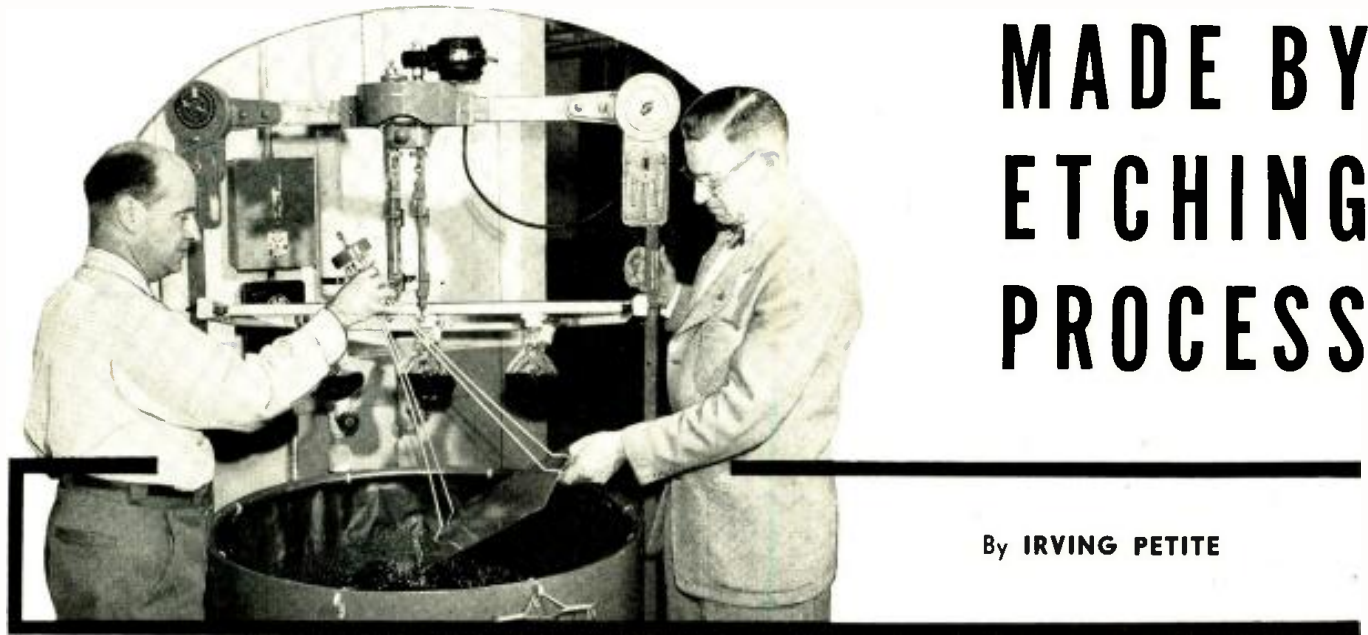

The plate whirler, part of the new equipment for making electrical circuits by an engraving process, used at Boeing's plant.

"Printed circuit" techniques are helping to speed construction of vitally-needed long-range aircraft.



Developing machine contains an alcoholic solution of purple dye, called "cold-top" enamel developing solution. Here John McMaster, chief of the photo template unit, places a plate on the rack prior to lowering it into solution. The plate has a photographic image imprinted on surface.

Herman Hausle holds plate which was etched with straight lines for test purposes. Etching machine contains a ferric chloride solution which eats away copper not protected by photographic image.



A RAPID and economical method of making electrical circuits by a new copper etching process is now in use at Boeing's Seattle plant. The process, borrowed from the radio and television industry—where some manufacturers already use it—makes it possible for Boeing to mass-produce miniature electronic package assemblies through photo-engraving.

Essentially three preliminary steps bring an electronic unit close to the final assembling:

The first step is to photograph an engineer's drawing of the circuit. The negative used is made of a stiff vinylite-base film which is not subject to distortion. The circuit appears on the black negative as transparent lines the exact size and shape of the circuit.

The second step is to transfer the image to a copper plate, bonded on one side of a piece of phenolic electrical insulation board. The board is about 1/16" thick and the copper veneer 3/1000" thick.

The copper plate is coated with a light-sensitive engraver's enamel: cold top. Then the plate is put into a machine that whirls it while it is exposed to ruby infrared lights, thus spreading the enamel evenly and drying it at the same time. The negative is then placed over the plate and the two are held in close contact in a vacuum printing frame. A 95-ampere arc light throws a glaring blue light on the negative. The enamel exposed through the transparent lines of the wiring diagram is thus hardened.

To conclude this step, the copper plate is put in a purple developing solution which washes away the unhardened portions of the enamel. The lines of hardened enamel which remain are turned purple; these lines constitute the wiring diagram on the copper plate.

The final step is to put the plate in an etching tank containing a ferric-chloride solution, to dissolve the copper. The portion of the copper plate protected by purple-enamel lines is preserved, and the balance of the copper plate dissolved. This leaves the wiring circuit in copper on the phenolic board.

Since just two to four minutes are required for each phase of the process described, it is extremely rapid.

The phenolic board has now finished its journey through Department 480, photo template unit, at Boeing's Seattle plant. It is next sent to the factory where holes are drilled through it, as required.

Electronic devices, such as miniature radio tubes, condensers, and resistors, are fastened to the back of the board.

Pins from these devices go through the drilled holes and contact the copper wiring circuit on the other side.

The entire circuit is then floated in a solder bath, circuit side down. All the connections are soldered at once, and the complex assembly is completed in less time than the wiring of some single circuits consumes when standard techniques are used.

For opportunities within your reach



See what the RCA TV Servicing Course offers you

Good-pay jobs. A business of your own.

OPPORTUNITIES FOR GOOD-PAY JOBS in Television are within your reach when you study TV Servicing by the RCA Institutes Home Study Method. Or perhaps you would like to start a TV Service business of your own.

If you are not satisfied with the way your future now stacks up, see how easily

you can change the course of your career. RCA Institutes Home Study Course in TV Servicing is helping thousands of other people to better jobs. It can help you. Right now thousands of opportunities are going begging. There is a critical shortage of trained TV servicemen. This is *your* big opportunity.

Easy-to-understand, illustrated lessons



The entire course is divided into ten units of several individual lessons. You study them at home in your spare time.

Lesson-by-lesson you learn the theory and step-by-step procedures of installing TV antennas, of servicing and trouble-shooting TV receivers. Hundreds of pictures and diagrams help you understand the how-it-works information and the how-to-do-it techniques. You will be amazed how easily you absorb the knowledge of each lesson, how quickly you train yourself to become an experienced technician.

Experienced engineers and faculty prepared the course, grade your lessons



The RCA Institutes course was written and planned by instructors with years of specialized experience in training men by home-study and resident-school methods. The course embodies RCA's background of television experience plus knowledge gained in training several thousand technicians. A study of the course parallels an apprentice's training. Your lessons are carefully examined and accurately graded by friendly teachers who are interested in helping you to succeed.

One of the leading and oldest Radio-Television training schools



Founded in 1909, RCA Institutes, Inc. has been in continuous operation for the past 44 years. Its

wide experience and extensive educational facilities give students, just like you, unsurpassed technical training in the highly specialized field of radio-television-electronics.

RCA Institutes is licensed by the University of the State of New York . . . an affiliate member of the American Society for Engineering Education . . . approved by the Veterans Administration . . . approved by leading Radio-Television Service Organizations.

It costs so little to gain so much

RCA Institutes makes it easy for you to take advantage of the big opportunities in TV Servicing. The cost of the TV Servicing Home Study Course has been cut to a minimum. You pay for the course on a pay-as-you-learn unit lesson basis. No other home study course in TV Servicing offers so much for so little cost to you.

RCA Institutes conducts a resident school in New York City offering day and evening courses in Radio and TV Servicing, Radio Code and Radio Operating, Radio Broadcasting, Advanced Technology. Write for free catalog on resident courses.

SEND FOR FREE BOOKLET—Mail the coupon—today. Get complete information on the RCA INSTITUTES Home Study Course in Television Servicing. Booklet gives you a general outline of the course by units. See how this practical home study course trains you quickly, easily. Mail coupon in envelope or paste on postal card.



MAIL COUPON NOW!

RCA INSTITUTES, INC., Home Study Dept. RN1153
350 West Fourth Street, New York 14, N.Y.

Without obligation on my part, please send me copy of booklet "RCA INSTITUTES Home Study Course in TELEVISION SERVICING." (No salesman will call.)

Name _____ (please print)

Address _____

City _____ Zone _____ State _____



RCA INSTITUTES, INC.
A SERVICE OF RADIO CORPORATION OF AMERICA
350 WEST FOURTH STREET, NEW YORK 14, N.Y.

MONEY MAKERS!

FOR MOBILE-RADIO SERVICE ENGINEERS!

Provide for future expansion in this profitable field, with Lampkin frequency- and modulation-measuring equipment.



For Any Number of Frequencies, AM or FM. The Type 105-B MFM.

The Type 105-B Micrometer Frequency Meter, or MFM, measures center-frequency on any number of nearby transmitters, AM or FM, 0.1 MC. to 175 MC. Performs as signal generator for mobile receivers, 20 MC. up. Meets FCC requirements for mobile services, with accuracy guaranteed better than 0.0025%. Can be checked against WWV. Price \$220.00 net.



The Type 205 FM Modulation Meter for Multiple Mobile Frequencies.

Instantly tunable anywhere, 25 MC. to 200 MC., the Type 205 measures maximum FM deviation due to modulation, as required by the FCC. Indicates 0-25 KC. deviation. Simple to use, easy to carry. No charts or tables. Price \$240.00 net.

Send name and address for literature

Name
 Address
 City..... State.....

LAMPKIN LABORATORIES, INC.
 MFM DIVISION
 BRADENTON, FLORIDA



ARKAY
 world's finest radio kits
 Write for free Brochure
 RADIO KITS, INC., 120 Cedar St., N. Y. 6

MORE CASH

Att.: Schools, Labs, Hams!

Cash in on your surplus Radio Parts & Equipment! We pay more—or trade for something you really need. TV Sets, Mobile Equipment Available for Trade. Write Now!

HARJO SALES CO.
 4109 Burbank Blvd.
 Burbank, Calif. Cable HARJO

opportunities AT BELL TELEPHONE LABORATORIES

A career for you with one of the nation's leaders in research and development in communications and military electronics.

ELECTRONIC TECHNICIANS DRAFTSMEN
ELECTROMECHANICAL TECHNICIANS

Openings require previous training at high school, armed service school, or technical institute level and in general 2 or more years of applicable industrial or military experience.

Applications particularly invited from those who reside within about 100 miles of the Laboratories.

Send your name and address for application, telephone collect within 100 miles for information, or visit us Monday through Saturday. Evening interviews arranged.

BELL TELEPHONE LABORATORIES

WHIPPANY, N.J. (Near Morristown) WHIPPANY 8-1000, Ext. 326
 MURRAY HILL, N.J. (Near Summit) SUMMIT 6-6000, Ext. 3381
 NEW YORK, N.Y., 463 West Street, CHELSEA 3-1000, Ext. 1114



Custom Building (Continued from page 49)

a means of damping sound reverberation. This is done without taking up any of the usable closet space. Phonograph records can also be stored in the closet.

It is both practical and desirable in as many cases as possible to recommend complete high-fidelity music systems. Where the customer's budget will not allow this, why not reduce cost by using his old radio or the chassis from a straight AM or AM-FM set? Television, especially in the larger cities, has so reduced the demand for AM or AM-FM-only receivers that in many cases they can be purchased at near-cost. If these chassis are combined with any of the low-cost record changers and TV chassis now available, a practical, low-cost installation can be obtained. Many communities are not within primary range of either an FM or TV station. In many of these cases the customer's old radio set, if it is of good quality, will make a good chassis for the custom-built unit.

Selling Your Customers

Now that we have discussed some of the cost control factors, the next thing to do is to acquaint your clientele with the fact that you are in the custom-building business. This can be done most effectively by using all available forms of advertising. This includes (1) word-of-mouth, or personal recommendations from satisfied customers, (2) newspaper advertising, (3) telephone solicitations, (4) postcards or mailing forms, and (5) when practical, spot advertising on the local radio stations.

Keep posted on new home-owners; be sure to make appointments, discuss home beautification projects and how a custom-built installation can help. Show prospective clients photos and drawings such as the ones shown in this article. (Many of these photos can be obtained from manufacturers of high-fidelity home music systems if you explain what they are to be for.)

If such pointers as those recommended in this article are followed, there is no reason why custom-building cannot be made into a full-time business. The field is open and is not likely to be saturated for a long time to come.

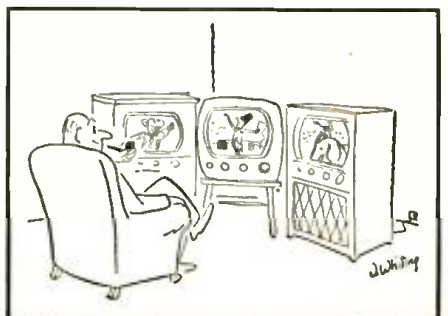

TUBES & PARTS

Write for our free BARGAIN CATALOG

ALL TUBES not guaranteed for one year individually boxed. Very BEST BRANDS available for immediate delivery!

0A46 1.04	2A6 89c	6AH6 1.89	6BH6 69c	6K5GT .69	6S07 .59	7C5 .79	89 12AU7 .79	12SN7GT .99	26 59c	57 79c
0Z4 59c	2A7 .89	6AK5 .89	6BK6 1.19	6K6GT .59	6S07GT 59c	7C6 79c	12AV6 .59	12C07 27	35A5 99	70L7 1.49
1A5GT .79	2B3 .89	6AL5 .89	6BL7 1.19	6K7GT .59	6S07GT 59c	7C7 79c	12AV6 1.19	12SR7GT 69c	35B5 99	71A .87
1A7GT .69	2C34 .79	6A0S .89	6BS6 1.19	6K8GT .59	6S17G .79	7E5 1.15	12AX6 .69	12Z3 95	35C5 99	75 .79
1B3GT .79	2E5 .89	6AK6 .81	6BS6G 1.19	6L6G .69	6T8 .89	7E6 79c	12AX7 .69	12Z3 95	35D5 99	77 .69
1B5 .29	3L4 .74	6AQ7 1.25	6B06GT 1.19	6L6GA 95c	6U6T .69	7F7 79c	12AY7 1.95	14A7 93	35W4 99	79 .69
1B5GT .59	3Q4 .69	6AR5 .79	6B07 1.29	6L6G 1.19	6U6T .69	7F8 79c	12AY7 1.95	14B8 93	35Y5 99	81 .69
1J6GT .69c	3Q5GT .69	6AT5 .69	6B07 1.29	6L6G 1.19	6U6T .69	7F9 79c	12AY7 1.95	14B8 93	35Z5 99	83 .69
1L4 1.29	3V4 .95	6A5S .69	6B07 1.29	6L6G 1.19	6U6T .69	7G0 79c	12AY7 1.95	14B8 93	35Z5 99	85 .69
1L6 1.19	5T4 1.40	6AV5GT .89	6B07 1.29	6L6G 1.19	6U6T .69	7G1 79c	12AY7 1.95	14B8 93	35Z5 99	87 .69
1L6A 1.19	5U4G .59	6AV6 .59	6B07 1.29	6L6G 1.19	6U6T .69	7G2 79c	12AY7 1.95	14B8 93	35Z5 99	89 .69
1L6S .69	5V4G .87	6AX4 .69	6B07 1.29	6L6G 1.19	6U6T .69	7G3 79c	12AY7 1.95	14B8 93	35Z5 99	91 .69
1L6C 1.19	5V4G .87	6AX5 .79	6B07 1.29	6L6G 1.19	6U6T .69	7G4 79c	12AY7 1.95	14B8 93	35Z5 99	93 .69
1L6E 1.19	5V4G .87	6AX6 .69	6B07 1.29	6L6G 1.19	6U6T .69	7G5 79c	12AY7 1.95	14B8 93	35Z5 99	95 .69
1L6F 1.19	5V4G .87	6AX7 .69	6B07 1.29	6L6G 1.19	6U6T .69	7G6 79c	12AY7 1.95	14B8 93	35Z5 99	97 .69
1L6G 1.19	5V4G .87	6AX8 .69	6B07 1.29	6L6G 1.19	6U6T .69	7G7 79c	12AY7 1.95	14B8 93	35Z5 99	99 .69
1L6H 1.19	5V4G .87	6AX9 .69	6B07 1.29	6L6G 1.19	6U6T .69	7G8 79c	12AY7 1.95	14B8 93	35Z5 99	101 .69
1L6I 1.19	5V4G .87	6AX10 .69	6B07 1.29	6L6G 1.19	6U6T .69	7G9 79c	12AY7 1.95	14B8 93	35Z5 99	103 .69
1L6J 1.19	5V4G .87	6AX11 .69	6B07 1.29	6L6G 1.19	6U6T .69	7G10 79c	12AY7 1.95	14B8 93	35Z5 99	105 .69
1L6K 1.19	5V4G .87	6AX12 .69	6B07 1.29	6L6G 1.19	6U6T .69	7G11 79c	12AY7 1.95	14B8 93	35Z5 99	107 .69
1L6L 1.19	5V4G .87	6AX13 .69	6B07 1.29	6L6G 1.19	6U6T .69	7G12 79c	12AY7 1.95	14B8 93	35Z5 99	109 .69
1L6M 1.19	5V4G .87	6AX14 .69	6B07 1.29	6L6G 1.19	6U6T .69	7G13 79c	12AY7 1.95	14B8 93	35Z5 99	111 .69
1L6N 1.19	5V4G .87	6AX15 .69	6B07 1.29	6L6G 1.19	6U6T .69	7G14 79c	12AY7 1.95	14B8 93	35Z5 99	113 .69
1L6O 1.19	5V4G .87	6AX16 .69	6B07 1.29	6L6G 1.19	6U6T .69	7G15 79c	12AY7 1.95	14B8 93	35Z5 99	115 .69
1L6P 1.19	5V4G .87	6AX17 .69	6B07 1.29	6L6G 1.19	6U6T .69	7G16 79c	12AY7 1.95	14B8 93	35Z5 99	117 .69
1L6Q 1.19	5V4G .87	6AX18 .69	6B07 1.29	6L6G 1.19	6U6T .69	7G17 79c	12AY7 1.95	14B8 93	35Z5 99	119 .69
1L6R 1.19	5V4G .87	6AX19 .69	6B07 1.29	6L6G 1.19	6U6T .69	7G18 79c	12AY7 1.95	14B8 93	35Z5 99	121 .69
1L6S 1.19	5V4G .87	6AX20 .69	6B07 1.29	6L6G 1.19	6U6T .69	7G19 79c	12AY7 1.95	14B8 93	35Z5 99	123 .69
1L6T 1.19	5V4G .87	6AX21 .69	6B07 1.29	6L6G 1.19	6U6T .69	7G20 79c	12AY7 1.95	14B8 93	35Z5 99	125 .69
1L6U 1.19	5V4G .87	6AX22 .69	6B07 1.29	6L6G 1.19	6U6T .69	7G21 79c	12AY7 1.95	14B8 93	35Z5 99	127 .69
1L6V 1.19	5V4G .87	6AX23 .69	6B07 1.29	6L6G 1.19	6U6T .69	7G22 79c	12AY7 1.95	14B8 93	35Z5 99	129 .69
1L6W 1.19	5V4G .87	6AX24 .69	6B07 1.29	6L6G 1.19	6U6T .69	7G23 79c	12AY7 1.95	14B8 93	35Z5 99	131 .69
1L6X 1.19	5V4G .87	6AX25 .69	6B07 1.29	6L6G 1.19	6U6T .69	7G24 79c	12AY7 1.95	14B8 93	35Z5 99	133 .69

SPECIAL

10% DISCOUNT

on orders of 100 tubes or more, 5% DISCOUNT on orders of 50 to 99 tubes.

FREE

\$20 list value assortment of filter condensers with order of 50 or more tubes.

Half moon TV Pix tube socket completely enclosed with standard RMA color coded tinned leads 39c ea.

Picture tube brightener \$1.69 ea.



1954 TV Console 21" Travler Model 321-48
A fine mahogany furniture piece for any room setting. New STANDARD CASCOE TUNER. Has built in arrangement for UHF and COLOR.
List \$279.95
Dealer's net \$195.97



Model 300 Precise Oscilloscope
Here is the Buy 7" tube size. Sweep magnifier, complete push-pull from input through output. Vertical sensitivity better than 10 millivolts. Bands 0 - 3db. 0 to FIVE mc. complete with phasing control, blanking control, intensity mod. and self-measurement peak to peak feature, with DC amplifiers throughout as found only in scopes, selling for over \$950. Exclusive, easy maintenance feature.
In kit form \$94.95
Completely wired \$199.50

WELLER SOLDERING GUNS

Brand New Models



Model Watts
WS-100-150 Single heat... \$ 8.77
S-500-275 Single heat... 9.75
WD-135-150-200 Dual heat... 10.73
D-550-275-350 Dual heat... 11.71

FILTER CONDENSERS

Service Dealers Net Price. From stock

50 mfd. @ 25V	19c
30 mfd. @ 30V	19c
3x10 mfd. @ 150V	39c
30-20 mfd. @ 150V	39c
40 mfd. @ 150V	35c
40-40 mfd. @ 150V	40c
40-20-25V @ 150V	39c
80 mfd. @ 150V	39c
8 mfd. @ 450V	27c
8-8 mfd. @ 450V	29c
10-10 @ 450V	39c
10-10 mfd. @ 450V	39c
100-25V	44c
20 mfd. @ 450V	44c
40-400V	39c
30 mfd. @ 450V	39c
420-20 @ 25V	39c

RADAR TYPE TV ANTENNA

For UHF and VHF RECEIVES ALL CHANNELS WE FINALLY DID IT



You ordered so many thousands of these radar type TV antennas, that the cost has come down through the savings of mass production. WE ARE PASSING THESE SAVINGS ON TO YOU! 212 miles reception recorded, 125 miles common. This unbeatable antenna has been reinforced to withstand 150 mile winds. Satisfaction guaranteed or your money back. At this low, low price we cannot mention manufacturer's name.
Less Mast
5 ft. ALUMINUM MAST heavy gauge 1 1/2" diam. with interlocking end. Slip two sections together for a ten-footer.
Each \$19.95
\$1.00

Indoor UHF antenna \$7.61

Outdoor UHF antenna \$4.77

JFD UHF-VHF ANTENNA

Efficient on all channels. Uses conical element and reflector for VHF and "bowtie" for UHF. Equipped with printed circuit antenna coupler for excellent signal transfer into single transmission line. Easy to install.
Only \$11.20



TUBE KITS

3V4, 1T4, 1R5, 1S5	\$2.19
30A4, 1R5, 1S5	List Value \$8.00. Tube Kit only \$1.98
354, 1T4, 1S5, 1R5	List Value \$7.80. 4-Tube Kit only \$1.98
1U4, 354, 1S5, 1R5	List Value \$7.80. All Four Tubes for \$1.98
11273, 1U5, 354, 1R5, 1T4	AC-OC Portable Kit. All for \$2.49
12A7E, 12BA6, 12BE6, 35W4, 50B5	5 Tubes for \$2.59
50L8GT, 35Z5GT, 12SQ7GT, 12K7G, 12SA7G, 5 Tubes	for \$3.22

REGENCY UHF CONVERTER

UNIVERSAL CONVERTERS ALL SETS - the only converter recommended for the 5,000,000 split sound and video TV sets now in use as well as all intercarrier TV sets.
NET \$37.46
Bogen UHF Converter \$11.24
Granco UHF Converter LCU, for efficient tuning of all UHF channels \$22.01



RME converter. All UHF channels \$29.63

BOW TIE REFLECTOR

UHF Antenna Bowtie Reflector Ultra-high Gain. Completely assembled - ready to mount. For all UHF channels - easy to stack for two or four bay.
Single Bay \$2.32
Two Bay, complete \$4.86

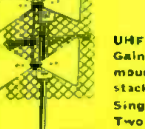

RESISTOR KITS

Insulated 1/2, 1 and 2-watt assortment of most used values, I.R.C. Ohmite, Stackpole, Speer, etc., 100 for \$2.95

300 OHM TWIN LEAD

55 Mil. 100 ft.	\$ 1.89
1,000 ft.	13.95
20 Ga. 80 Mil. 100 ft.	1.89
1,000 ft.	16.95
UHF TUBULAR 300 OHM LINE 1,000 ft.	34.50
100 ft.	\$4.95

P. M. SPEAKERS

12" COAXIAL PM SPEAKERS. High Fidelity with Crossover filter attached. 20 watts. 19,000 cps. response.
8 ohm Voice-Coll. ea. \$12.95
15" COAXIAL SPEAKER. 20-17,500 cps. ea. \$19.95
Very best quality NATIONAL BRANDS. Individually ea. \$1.39
3" ea. 1.59
4" ea. 1.79
6" SPECIAL PRICE. ea. 1.59
8" ea. 3.23
10" ea. \$5.10 12" ea. \$5.95

BY-PASS CONDENSERS

100 Condensers assorted in package \$6.95

600-VOLT .001 .6c .01 .8c .05 mid. .ea. 7c
.002 .6c .02 .8c .2 mid. .ea. 7c
.005 .6c .05 .10c .25 mid. .ea. 12c
.1 .11c .11c .25 mid. .ea. 18c

NEPCO TV WIRE

Twin Lead Type-300 Ohm 20 Gauge-7 Strand No. 28 AWG Copper-weld Wire for Maximum Strength and Maximum Flexibility. Constant Impedance under all conditions. The "Z" Line is an attractive, easy to handle UHF TV lead for maximum signal.
1000 ft. \$47.50 100 ft. \$5.09



TV 2-sel antenna couplers \$1.17 ea.

Flyback Transformer TV Horizontal output, universal replacement, 14,500 V. \$2.49 ea.

TV Antennas

10 Element conical rugged throughout. Only \$3.95
Double bay array, with stacking bars \$7.75
4 Bay array with harness and stacking bars \$14.95
6 Element Conical. Only \$2.95



MISCELLANEOUS BUYS

TRANSFORMER-456 Kc. .29c	Selenium Rectifiers
PILOT LIGHTS, Type No. 47	75 mil. 79c
VOLUME CONTROLS FOR SWITCH, 10 for 39c; 100 for \$2.95	100 mil. 89c
2" shaft, 1 meg. 1/2 meg. 1/4	150 mil. \$1.32
meg. .34c	200 mil. 1.85
SINGLE ION TRAPS .19c	250 mil. 1.85
DOUBLE ION TRAPS .ea. 29c	300 mil. 1.84
OUTPUT TRANSFORMER-for 50L6 29c	350 mil. 2.41
for 6V6, 39c	400 mil. 5.55
6-foot LINE CORD UL .10 for \$1.95	450 mil. 2.91
TV INTERLOCK CORDS .ea. 49c	500 mil. 2.84

TELEVISION PICTURE TUBES

SIZE	PRICE	SIZE	PRICE	SIZE	PRICE
7J4	17.95	16DP4A	19.95	17HP4	22.45
8BP4	23.00	16EP4A	21.45	17TP4A	22.45
10BP4	34.95	16CP4A	19.95	19DP4A	25.45
12JP4	16.95	16AP4	21.45	19FP4	23.95
12UP4A	16.45	16LP4	21.45	20CP4A	24.95
16BP4A	17.95	16RP4A	21.45	21AP4A	28.45
15AP4	21.95	16WP4A	21.45	21EP4A	26.95
18AP4A	19.95	17BP4A	20.95	21FP4	29.95
16CP4A		17GP4A	22.45	21MP4A	29.95
16DP4		17CP4A		24AP4A	59.95
				27AP4	89.95

SEND US YOUR ORDER AND WE WILL SHIP FROM STOCK IMMEDIATELY

TV CONVERSION KITS

Easily Installed consisting of rectangular tube, 70 degree yoke, beautiful mask, flyback transformer and width coil.

17" Conversion Kit, as above, complete	\$24.95
20" Conversion Kit, as above, complete	29.95
21" Conversion Kit, as above, complete	31.95
24" Conversion Kit, as above, complete	69.95
27" Conversion Kit, as above, complete	89.95

70 degree cosine yoke with 4 leads and network \$2.95 ea.

Teleron TV Wave Trap

For VHF Channels 2 through 13. Clears VHF picture, stops interference at once. 30 seconds to attach.
ea. net \$1.75
All UHF channels \$2.75



TENNAKIT

Add to Any Antenna
All-Range Base Mount, UL Approved
Twin Lead Lightning Arrestor, 50 ft.
300 Ohm Twin Lead, 6 Insulated
Screw Eye Stand-Offs, 2 Insulated
Flash Stand-Offs, 5 ft. Weather-Proof
Mast 1 1/2" OD. \$3.95

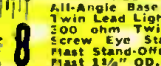

Lifetime Chimney Mount

each 30 ft. of Stainless Steel Strap with HEAVY ZINC BRACKETS for dealers who sell quality Chimney Mount for TV and ant. \$1.49 ea.

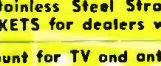

TERMS: 25% DEPOSIT with order, bal. C.O.D. ALL shipments F.O.B. Chicago. ORDERS LESS THAN \$5.00-\$1.00 SERVICE CHG. CABLE ADD.: CONTULAB. These prices supersede all previously advertised prices, subject to change without notice.

All Burgess batteries in stock

NEW!
VOL.4

the book that
**SAVES TV
SERVICE TIME**

HOWARD W. SAMS'
**"TELEVISION TUBE
LOCATION GUIDE"**



Latest
addition
to an
invaluable
series of
Tube Location
Guides

**FIND THE TROUBLE—REPLACE TUBES
WITHOUT REMOVING THE CHASSIS**

You've asked for more—and here it is—the fourth volume that brings you right up-to-date! It's the only book that shows the *position and function* of all tubes in hundreds of TV sets. Helps save your servicing time. Often an operational check in the customer's home—looking at the picture and listening to the sound—gives you the clue to the trouble. Most often, a tube failure is the cause. This invaluable Guide makes trouble diagnosis and tube replacement quick and easy, *without removing the chassis!* Each TV model has its own clear, accurate diagram. Fully indexed for quick reference. All new diagrams covering 1951-1952 TV models. Handy pocket size, 192 pages, 5½ x 8½". Pays for itself on the first job!

ORDER TGL-4. Only.....\$2.00



Own the Complete Library

VOL. 3. Used daily by thousands of TV Service Technicians. Shows location and function of all tubes in hundreds of 1950-1951 TV sets. 192 pages, 5½ x 8½".

ORDER TGL-3. Only.....\$2.00

VOL. 2. Gives tube positions and functions in hundreds of 1949-1950 TV sets. Helps solve tube failure troubles in minutes. 208 pages, 5½ x 8½".

ORDER TGL-2. Only.....\$2.00

VOL. 1. Covers hundreds of 1948-1949 TV sets made by 56 mfrs. Not duplicated in other volumes. 208 pages, 5½ x 8½".

ORDER TGL-1. Only.....\$1.50

Carry Them ALL in Your Tube Caddy

HOWARD W. SAMS & CO., INC.

Order from your Parts Jobber today, or write to HOWARD W. SAMS & CO., INC. 2203 E. 46th St., Indianapolis 5, Ind.

My (check) (money order) for \$..... enclosed. Send the following books:

TGL-4 (\$2.00) TGL-2 (\$2.00)
 TGL-3 (\$2.00) TGL-1 (\$1.50)

Name.....

Address.....

City.....State.....

SIMPLIFIED CRYSTAL I.F. FILTER

By WILLIAM BRUCE CAMERON, W81VJ

Details on an inexpensive 200 kc. filter. Other frequencies can be provided by changing coil and crystal specifications.

WITH ham bands becoming more crowded every day many serious amateurs are building their own receivers, or some sections of them, but most of them are afraid to tackle a crystal filter. The filter described here is cheap, simple, and effective, and can readily be built by the average ham.

The reader may wonder why anyone would want to build a crystal filter when they can be bought, or are already incorporated in good communications receivers. The reason is that the conventional intermediate frequency around 455 kilocycles is too low for good image rejection and too high for good selectivity. To get both good image rejection and good selectivity and still retain the crystal filter requires a triple conversion receiver, or one with a mechanical filter. Mechanical filters are expensive and triple conversion produces headaches, so there is a real need for a low frequency crystal filter.

The filter described operates on 200 kilocycles, since crystals and coils were available on this frequency. The entire assembly is mounted in a small aluminum box. L_1 , L_2 , and L_3 are 200 kc. slug-tuned coils taken from i.f. transformers. L_1 and L_2 are placed as close together as is convenient and L_3 is isolated from them as much as possible. Condensers C_2 and C_3 are twice the value of condensers C_1 and C_4 . Precision values are not required but silver micas are preferred because they will "stay put".

In operation, a 200 kc. signal is fed into the system and L_1 , L_2 , and L_3 are peaked, with C_3 set at minimum capacity. If all is well, that is the total job of alignment. Closing C_3 throws the L_2 circuit out of resonance, reducing the loading on the crystal bridge circuit, and increasing the selectivity at the expense of a slight loss in signal strength. C_1 is the neutralizing or phasing condenser and should equal the crystal capacity when the plates are about half meshed, to allow adjustment for phasing out heterodynes and rejecting audio images of c. w. signals. The proper capacity can be achieved by starting with a condenser somewhat larger than is required and judiciously removing plates until the optimum has been reached. A value of 25 μfd . should be ample in any case. After this has been done, bend the tip of one rotor plate slightly, so that it will

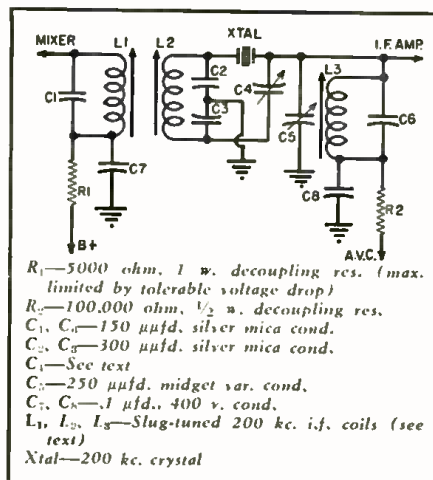

Circuit diagram of 200 kc. i.f. filter.

short out when fully closed, to provide an "off" switch for the filter.

A good source for the alignment signal is a Pierce oscillator using the same crystal which will be used in the filter. That's all there is to the construction and alignment, and the filter will perform as well as any on the market, besides being easier to adjust than the good commercial ones, and permitting crystal filter action on any intermediate frequency for which coils and crystals are available.

The filter is used at W81VJ in a double conversion receiver with a first i.f. of 2745 kc., and with cascaded transformers in the three 200 kc. stages which follow the filter. With this arrangement, excellent image rejection and selectivity are obtained. With the filter in broad position selectivity is about all that can be tolerated for phone, and in the sharp position the bandpass is only a few hundred cycles for c. w.

RETMA PILOT COURSE

THE FIRST class in a pilot course of television technician training, sponsored by the Radio-Electronics-Television Manufacturers Association, was held in New York City with sixty students from the New York area participating.

The new course, which is designed to develop an industry-approved up-grading course for TV technicians, will be used in trade and vocational schools throughout the country. The students were selected on the basis of minimum experience requirements and then qualified only after a personal interview with members of an Industry Advisory Committee.

NO INTEREST!!

Buy on our radically new
Time Payment Plan

NO CARRYING CHARGES!!

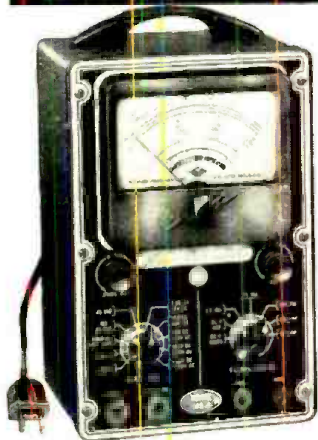

Measures 6 1/4" x 9 1/2" x 4 1/2"

Superior's new
Model 670-A

SUPER METER

A COMBINATION VOLT-OHM MILLIAMMETER PLUS
CAPACITY REACTANCE INDUCTANCE AND DECIBEL MEASUREMENTS

SPECIFICATIONS:

D.C. VOLTS: 0 to 7.5/15/75/150/750/1,500/7,500 Volts
A.C. VOLTS: 0 to 15/30/150/300/1,500/3,000 Volts
OUTPUT VOLTS: 0 to 15/30/150/300/1,500/3,000 Volts
D.C. CURRENT: 0 to 1.5/15/150 Ma. 0 to 1.5/15 Amperes
RESISTANCE: 0 to 1,000/100,000 Ohms 0 to 10 Megohms
CAPACITY: .001 to 1 Mfd. 1 to 50 Mfd. (Quality test for electrolytics)
REACTANCE: 50 to 2,500 Ohms, 2,500 Ohms to 2.5 Megohms
INDUCTANCE: .15 to 7 Henries 7 to 7,000 Henries
DECIBELS: -6 to +18 +14 to +38 +34 to +58

ADDED FEATURE:

The Model 670-A includes a special **GOOD-BAD** scale for checking the quality of electrolytic condensers at a test potential of 150 Volts.

The Model 670-A comes housed in a rugged, crackle-finished steel cabinet complete with test leads and operating instructions.

\$28⁴⁰ NET

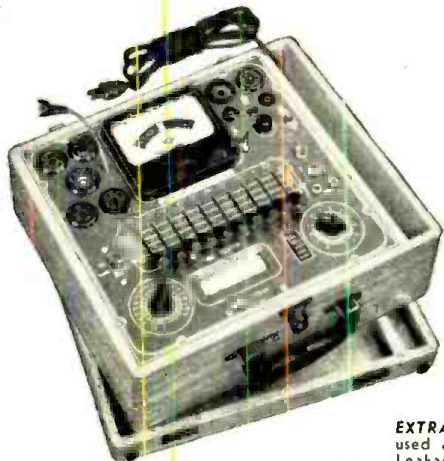

Superior's new
Model TV-11

TUBE TESTER

SPECIFICATIONS:

- ★ Tests all tubes including 4, 5, 6, 7, Octal, Lock-in, Peanut, Bantam, Hearing Aid, Thyatron, Miniatures, Sub-Miniatures, Novals, Sub-minars, I'roximity fuse types, etc.
- ★ Uses the new self-cleaning Lever Action Switches for individual element testing. Because all elements are numbered according to pin-number in the RMA base numbering system, the user can instantly identify which element is under test. Tubes having tapped filaments and tubes with filaments terminating in more than one pin are truly tested with the Model TV-11 as any of the pins may be placed in the neutral position when necessary.
- ★ The Model TV-11 does not use any combination type sockets. Instead individual sockets are used for each type of tube. Thus it is impossible

to damage a tube by inserting it in the wrong socket.

- ★ Free-moving built-in roll chart provides complete data for all tubes.
- ★ Newly designed Line Voltage Control compensates for variation of any Line Voltage between 105 Volts and 130 Volts.
- ★ **NOISE TEST:** Phono-jack on front panel for plugging in either phones or external amplifier will detect microphonic tubes or noise due to faulty elements and loose internal connections.

The model TV-11 operates on 105-130 Volt 60 Cycles A.C. Comes housed in a beautiful hand-rubbed oak cabinet complete with portable cover

EXTRA SERVICE—The Model TV-11 may be used as an extremely sensitive Condenser Leakage Checker. A relaxation type oscil-

lator incorporated in this model will detect leakages even when the frequency is one per minute.

\$47⁵⁰ NET

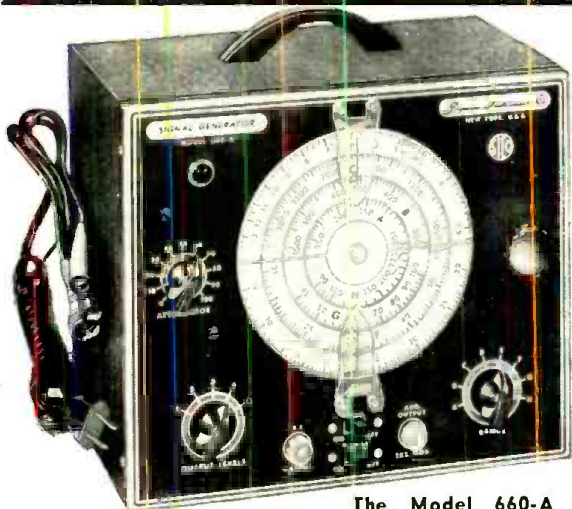

The Model 660-A comes complete with coaxial cable test lead and instructions.

Superior's New Model 660-A AN AC OPERATED
SIGNAL GENERATOR

PROVIDES COMPLETE COVERAGE for AM-FM & TV Alignment

SPECIFICATIONS:

• Generates Radio Frequencies from 100 Kilocycles to 60 Megacycles on fundamentals and from 60 Megacycles to 220 Megacycles on powerful harmonics. • Accuracy and Stability are assured by the use of permeability trimmed Hi-Q coils. • R.F. available separately or modulated by the internal audio oscillator. — Built In 400 cycle sine wave audio oscillator used to modulate the R.F. signal also available separately for audio testing of receivers, amplifiers, hard of hearing aids, etc. • R.F. Oscillator Circuit: A

high transconductance heptode is used as an R.F. oscillator, mixer and amplifier. Modulation is effected by electron coupling in the mixer section thus isolating the oscillator from load changes and affording high stability. • A.F. Oscillator Circuit: A high transconductance heptode connected as a high- μ triode is used as an audio oscillator in a High-C Colpitts Circuit. The output (over 1 Volt) is nearly pure sine wave. • Attenuator: A 5 step ladder type of attenuator is used.

Tubes used: 1—6BE6 as R.F. Oscillator, mixer and amplifier. 1—6BE6 as Audio Oscillator. 1—6H6 as Power Rectifier.

\$42⁹⁵ NET

MOSS ELECTRONIC DISTRIBUTING CO., INC.
Dept. B-82, 38 Murray St., New York 7, N. Y.

Please send me the units checked. I am enclosing the down payment with order and agree to pay the monthly balance as shown. It is understood there will be no carrying interest or any other charges provided I send my monthly payments when due. It is further understood that should I fail to make payment when due, the full unpaid balance shall become immediately due and payable.

Name.....

Address.....

City..... Zone..... State.....

- MODEL 670-A..... Total Price \$28.40
\$7.40 down payment. Balance \$3.50
monthly for 6 months.
- MODEL TV-11..... Total Price \$47.50
\$11.50 down payment. Balance \$6.00
monthly for 6 months.
- MODEL 660-A..... Total Price \$42.95
\$12.95 down payment. Balance \$5.00
monthly for 6 months.
- I enclose \$..... as down payment.
- Ship C.O.D. for the down payment.

Ultrasonic U-25
(Continued from page 83)

Performance-wise, this new unit compares favorably with speakers costing considerably more. Numerous tests have been made to determine the characteristic acoustical response of the U-25 including the two discussed in the following paragraphs.

1. The U-25, when driven by a constant-amplitude, variable-frequency signal generator in a anechoic chamber in which no sound was reflected by the chamber itself, produced a frequency response excluding the complementary effect of reflected sound as indicated in the graph of Fig. 1, "Tests in Anechoic Chamber."

2. The U-25, when driven by the same signal generator and mounted in the corner of a normal room, enabling the walls, ceiling and floor to reflect sound to the microphone receiver, produces the characteristic response of a unit properly mounted in accordance with design specifications and mounting instructions. A reduction of the undesirable high treble response above 3000 cps, as well as increased bass response, may thus be achieved by employing the walls of the room as an auxiliary baffle.

The response, from tests conducted over a frequency range of 20 to 20,000 cps, rose sharply at 55 cycles and remained at an acceptable level from 58 to 11,000 cps. Response of various units tested sloped off at 45 degrees at the high frequency end.

As the frequency response of the U-25 varies greatly according to location, the company suggests that for optimum results the unit be mounted in a corner at ear level with the vent holes inverted.

-30-

6BQ7, 6BZ7 SUBSTITUTE

By IOTTIS ADAMS, JR.

MANY TV service technicians are having difficulty obtaining 6BQ7 and 6BZ7 tubes for those TV sets using the new cascode-type tuner. A good substitute for these tubes, and one requiring only minor modification, is the 12AT7. There have been 20 or more such substitutions made in sets in this area, and the first ones installed are still functioning about four months later. This is a fringe area, yet there is no noticeable signal drop when using a 12AT7 in place of a 6BQ7. The conversion will work on any set on which pin 9 of the 6BQ7 tube socket and one side of the heater circuit are grounded.

To make the substitution, merely tie pins 4 and 5 of the 12AT7 together and then clip off either pin 4 or 5, whichever one is grounded in the socket. This places both halves of the 12AT7 heater in parallel. The pin must be clipped off short enough to prevent it from going into the socket and causing a short in the heater circuit. Also, care must be taken in tying the pins together, or the glass may break. Be sure to plug the tube into the socket in the right way, as it will fit two ways after pin 4 or 5 is clipped off.

-30-

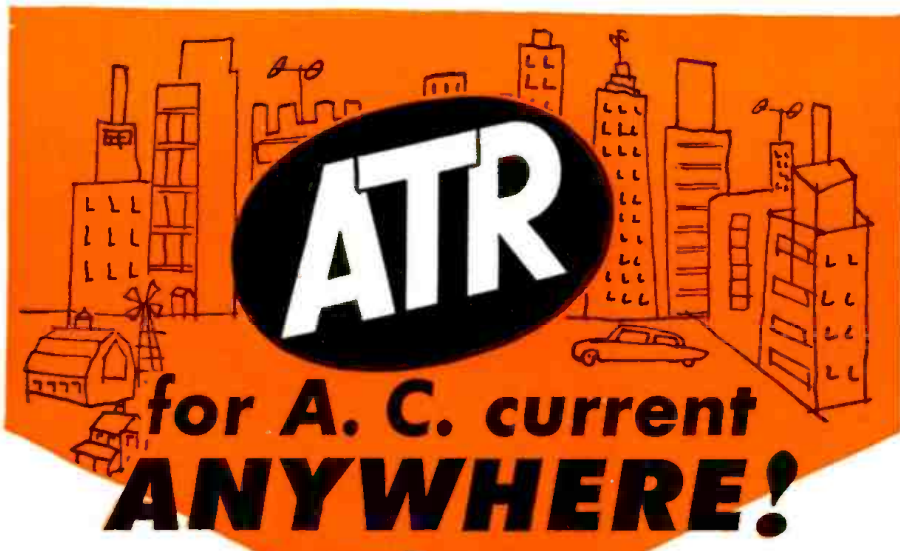

AT NEW
LOW COST

\$ **25⁵⁵**
And Up
Retail Price

INVERTERS

For Inverting D.C. to A.C. . . . Specially Designed for operating A.C. Radios, Tape Recorders, Wire Recorders, Record Changers, Television Sets, Amplifiers, Address Systems, Radio Test Equipment and most small electrical and electronic devices from D. C. Voltages in Vehicles, Ships, Trains, Planes and in D. C. Districts.

Type	Input DC Volts	A.C. Output 60 Cycles	Output Int.	Wattage Cont.	Consumer Net Price
0-LIF	6	110 volts	40	35	\$25.55
12-LIF	12	110	50	35	25.55
* 6-RSD	6	110	85	75	39.25
*12-RSD	12	110	125	100	39.25
32-RSD	32	110	150	100	39.25
110-RSD	110	110	250	150	39.25
*12T-HSG	12	110	250	200	96.45
110AT-RHE	110	110	325	250	56.95

There is an ATR model for most any application.

* Available with leather carrying handle at \$1.00 additional—optional.

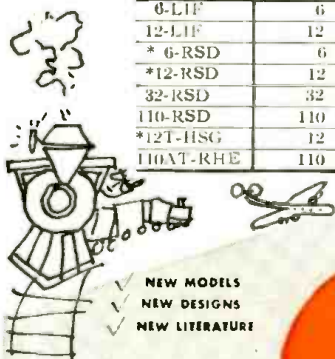

NEW MODELS
NEW DESIGNS
NEW LITERATURE

See your jobber
or write factory

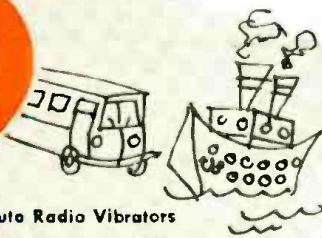

"A" Battery Eliminators, DC-AC Inverters, Auto Radio Vibrators

AMERICAN TELEVISION & RADIO Co.

Quality Products Since 1931

SAINT PAUL 1, MINNESOTA—U. S. A.

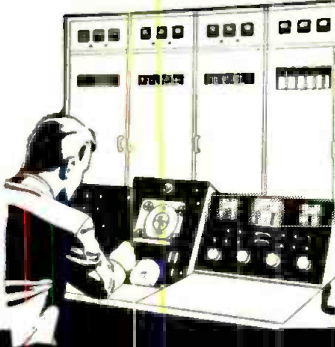

Where Will You Be in **ELECTRONICS** 6 Months from Today?



ADD TECHNICAL TRAINING to your practical experience
Get Your FCC License In A Hurry!

Then Use Our **Amazingly Effective**
JOB FINDING SERVICE

Get This Valuable Booklet **FREE**



TV ENGINEERING INCLUDED IN OUR TRAINING & COACHING

TELLS HOW—

HERE IS YOUR GUARANTEE
 If you fail to pass your Commercial License exam after completing our course, we guarantee to continue your training without additional cost of any kind, until you successfully obtain your Commercial license, provided you first sit for this examination within 90 days after completing our course.

WE GUARANTEE

TO TRAIN AND COACH YOU AT HOME IN SPARE TIME UNTIL YOU GET **YOUR FCC LICENSE**

If you have had any practical experience—Amateur, Army, Navy, Radio repair, or experimenting.

TELLS HOW—

Our Amazingly Effective **JOB-FINDING SERVICE** Helps CIRE Students Get Better Jobs
 Here are a few recent examples of Job-Finding results:

GETS AIRLINES JOB

"Due to your Job-Finding Service, I have been getting many offers from all over the country, and I have taken a job with Capital Airlines in Chicago, as a Radio Mechanic."
 Harry Clark, 4537 S. Drexel Blvd., Chicago, Ill.

GETS FIVE JOB-OFFERS FROM BROADCAST STATIONS

"Your 'Chief Engineer's Bulletin' is a grand way of obtaining employment for your graduates who have obtained their 1st class license. Since my name has been on the list I have received calls or letters from five stations in the southern states, and am now employed as Transmitter Engineer at WMMT."
 Elmer Powell, Box 274, Sparta, Tenn.

GETS CIVIL SERVICE JOB

"I have obtained a position at Wright-Patterson Air Force Base, Dayton, Ohio, as Junior Electronic Equipment Repairman. The Employment Application you prepared for me had a lot to do with me landing this desirable position."
 Charles E. Loomis, 4516 Genesee Ave., Dayton, Ohio.

Your FCC Ticket is recognized in all radio fields as proof of your technical ability.

TELLS HOW— Employers make **JOB OFFERS** Like These to Our Graduates Every Month

Letter from nationally-known Airlines, "We would also appreciate if you would place the following additional advertisement in your bulletin—Wanted—Superintendent of Communications . . . Salary \$666.66 per month."
 Letter from nationally known manufacturer of high quality AM and FM transmitters, "We are very much in need at the present time of radio-electronics technicians and would appreciate any helpful suggestions that you may be able to offer. Salary up to \$412 per month to start."

These are just a few examples of the job offers that come to our office periodically. Some licensed radioman filled each of these jobs . . . it might have been you!

HERE'S PROOF: FCC LICENSES ARE OFTEN SECURED IN A FEW HOURS OF STUDY WITH OUR COACHING AT HOME in Spare Time.

Name and Address	License	Lessons
Lee Worthy 2210 1/2 Wilshire St., Bakersfield, Calif.	2nd Phone	16
Clifford E. Vout Box 1016, Dania, Fla.	1st Phone	20
Francis X. Faersch 38 Beuler Pl., Bergenfield, N. J.	1st Phone	38
S. Sgt. Ben H. Davis 317 North Roosevelt, Lebanon, Ill.	1st Phone	28
Albert Schoell 110 West 11th St., Escondido, Calif.	2nd Phone	23

CLEVELAND INSTITUTE OF RADIO ELECTRONICS
 CARL E. SMITH, E.E., Consulting Engineer, President
 Desk RN-58, 4900 Euclid Bldg., Cleveland 3, Ohio

OURS IS THE ONLY HOME STUDY COURSE WHICH SUPPLIES FCC-TYPE EXAMINATIONS WITH ALL LESSONS AND FINAL TESTS.



GET ALL 3 FREE!
MAIL COUPON NOW

CLEVELAND INSTITUTE OF RADIO ELECTRONICS
 Desk RN-58, 4900 Euclid Bldg., Cleveland 3, Ohio
 (Address to Desk No. to avoid delay)

B I want to know how I can get my FCC ticket in a minimum of time. Send me your FREE booklet, "How to Pass FCC License Examinations" (does not cover exams for Amateur License), as well as a sample FCC-type exam and the amazing new booklet, "Money-Making FCC License Information."

Be sure to tell me about your television engineering course.

Name.....
 Address.....
 City..... Zone..... State.....

Paste on 2-cent postcard or send air mail.



Used by more manufacturers for original equipment than any other brand
OXFORD
 3911 South Michigan Avenue, Chicago 15, Illinois

ORDER OXFORD
 World's Largest Producer of Speakers

OXFORD ELECTRIC CORP.

If You Want SPEAKERS



The Compleat Fidelity

(Continued from page 57)

wall mounting height for our box, and the distances are shown, along with the dimensions, in Fig. 1. Notice that the front panel of the speaker housing is slanted downward. This was done so that the radiation would just about strike the ears when the listener is seated.

The box is constructed of 3/4 inch plywood, glued, and held with screws. It is lined on all sides with 2 inches of cotton quilting—stuff you can buy at any dry-goods store. The cut-out for the speaker has a piece of 1/4 inch mesh hardware cloth over the opening to protect the cone.

The box is left unpainted, since all but about 2 inches is inside the wall. The front is dressed-up with a fancy cloth—suit your wife's taste on this!—held by small strips of redwood or other suitable wood. This serves not only to hold the cover cloth, but con-



Close-up of speaker baffle which is inset in closet wall and projects into the room.

ceals the unpainted 2 inch lip of the box.

A convenient closet allowed us to cut the hole in the wall of the exact outside dimensions of the box. It is held to the wall studs by lag-screws, so that at the low frequencies there are no adjacent vibrations. The whole wall responds nicely at 30 to 50 cycles! (To be continued)

AUTO RADIO SERVICE HINTS

By JACK DARR

WITH the summer driving season just a memory, auto radio technicians will be getting a lot of summer-weary receivers to repair. Most of these jobs will be straightforward affairs involving tube replacement, etc. but there is always the baffler to make life more interesting. A few such bafflers with their solutions are presented below.

PHILCO MODELS CR-4 AND CR-6

If these sets show intermittent operation after two or three weeks of use, the trouble may be the antenna trimmer condenser, C₁, riveted to the side of the cabinet. As this unit is in series with the antenna, a short at either end causes the set to cut out or make popping noises. To repair this condition, bend the connection lugs to clear the brackets, or insert extra mica between the trimmer blades if necessary.

If the set is out of the car, check the small plastic wires to the oscillator coil. These may be shorting intermittently, due to insulation failure.

KAISER-FRAZER SETS

An extremely difficult case of noise in several Kaiser-Frazer auto radios was finally traced to a novel gadget located in the auto instrument cluster.

This unit is called an "Instrument Voltage Regulator," and resembles a bathtub condenser, with two large screw lugs on top (see diagram). The unusual thing about it is that when a bypass condenser is placed from either lug to

ground, the noise gets much louder! To eliminate the noise, an ammeter noise suppressor condenser (.5 μfd., 200 v.) must be connected across the unit, from lug to lug. Be sure to allow enough clearance so that the instrument cluster may be replaced without jamming this condenser. The speedometer cable must be disconnected to allow the instruments to come out far enough for service.

PHILCO-CHRYSLER PD-4908 AND CD-4908

Several of these sets came into the shop with one or both of the 6AQ5 power tubes cracked or dead. This set is mounted directly under the cowl ventilator of the car. Because of the large number of perforations in the back of the radio case, a sudden shower or splash from a puddle causes water to strike these tubes, resulting in breakage of the glass envelope. The remedy for this is to cover the whole back of the set with tape or plastic sheeting. Plenty of ventilation will remain, due to the numerous perforations at the ends of the case.

CHEVROLET 985792 AND MOPAR 600

These sets use a compensating condenser in the oscillator circuit. This unit, C₂₅, 15 μfd., is mounted directly behind the tuner assembly (see diagram), and resembles a tubular ceramic condenser covered with wax. If the set's oscillator is mistracking badly, check this condenser. In an emergency, it may be replaced by an equivalent size ceramic condenser. Retuning will be necessary of course.

Rear of Kaiser-Frazer instrument cluster.

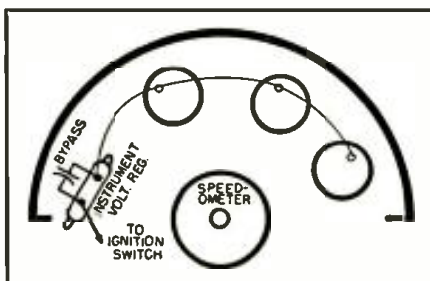

Partial circuit of Chevrolet Model 985792.

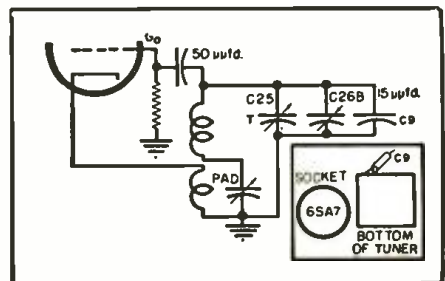

HIGHEST POWERED...

MOST RUGGED

of all rotors

the GREAT, NEW

jeb ROTOR

model JEB-10

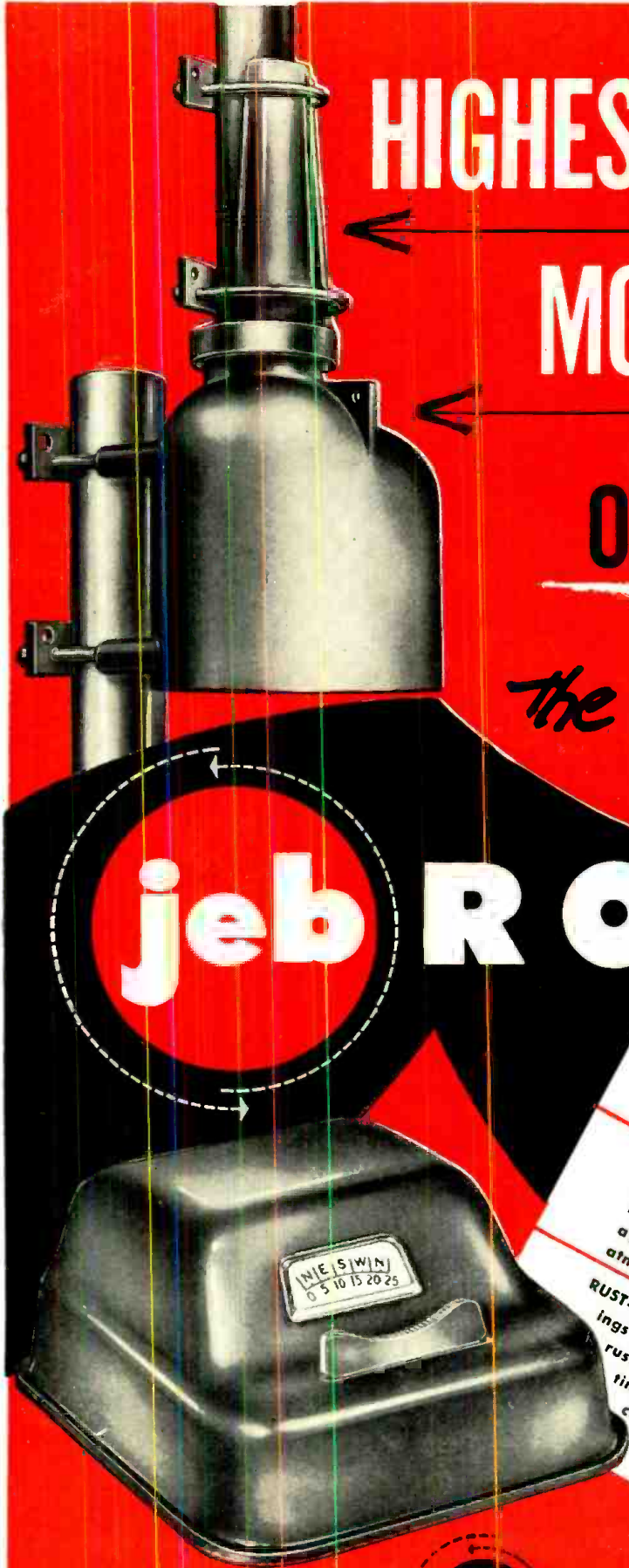

BIGGER MOTOR — (with 3/4" lamination) develops 40 ft. lbs. torque at heaviest arrays!	POSITIVE ALIGNMENT — gears are locked at both ends of shaft; they're bigger, broader — for smoother rotation.
MOISTURE-TIGHT — completely closed aluminum housing with gasket seal against entrance of atmosphere.	NO DRIFT — 2000% greater braking surfacel Also electric cut-offs for strain-free stop at end of rotor travel!
RUST-PROOF thrust bearings... all parts anti-rust finished — lifetime factory lubricated.	Package becomes attractive display!

\$44.95
list

CONTROL CASE—just 2 1/2" high; mahogany color; on/off switch instantly reverses or stops rotor.

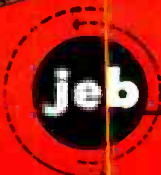

SALES CORPORATION
BROOKLYN 37, NEW YORK

AUDIO

INPUT

FADER

By
L. H. TRENT

A simple circuit which can be used with home-type equipment with an elaborated version for professional applications.

FADER controls are good for changing from one channel to another, but for tape recording or other similar work the operator must be reasonably skilled in their use. With this circuit, you have an automatic fader to switch channels and a mixer circuit in one small package which unskilled personnel can use. To the average constructor of audio equipment, the construction of this unit will present no problems. With long leads on the "channel-cut" switch and fade controls, it is possible to operate the unit from distances up to 50 feet with excellent results.

The operating principle of the circuit is very simple. The rise and fall of a negative bias voltage across an RC circuit is used to bias the remote cut-off

tubes to two times cut-off. As the voltage across the time delay condenser can only rise and fall at the rate determined by the RC delay period, electronic switching from one channel to the other is noiseless.

When the "channel-cut" switch (S_1 , Figs. 1A & B) is thrown up, condenser C_3 is discharged through R_3 to ground. At the same time the exponential rise of the negative voltage in C_1 will cut tube V_1 , as V_2 is permitted to conduct. The charge and discharge time of the RC networks is such that it matches the tube currents at zero.

If, for some reason, it is desired that the signals overlap as the fade is made, it is a simple matter to change the values of R_3 and R_4 , or condensers C_3

and C_4 can be changed. If the values are increased too much, there will be an actual dead period between the channels. However if the values are decreased too much, there will be a period of mixing the signals at too high a level with distortion as the result.

An alternate position to the automatic fade is the manual fade. In this position, both channels are operated at low level for mixing operations, with each channel level controlled independently. By operating each channel with a bias control, there is no critical length of leads to the controls or switches.

The circuit of Fig. 1A is that of a small unit for home use, while that of Fig. 1B is complete for all operations. Fig. 1A has many uses such as connecting a radio and phono to the same amplifier. It is even suitable for use with a recorder. With a few more parts, Fig. 1B can be built, affording complete flexibility of operation on any amplifier with which it is used. Either unit will contribute some gain, and the frequency response (about 50 kc.) is enough for use with a scope. —30—

Fig. 1. (A) A simple fader circuit. (B) A more elaborate version for mixer-fader applications. Switches S_1 and S_2 are wired in such a way that when pots R_{10} and R_{11} are in their maximum counterclockwise position, switches S_2 and S_3 connect to S_1 .

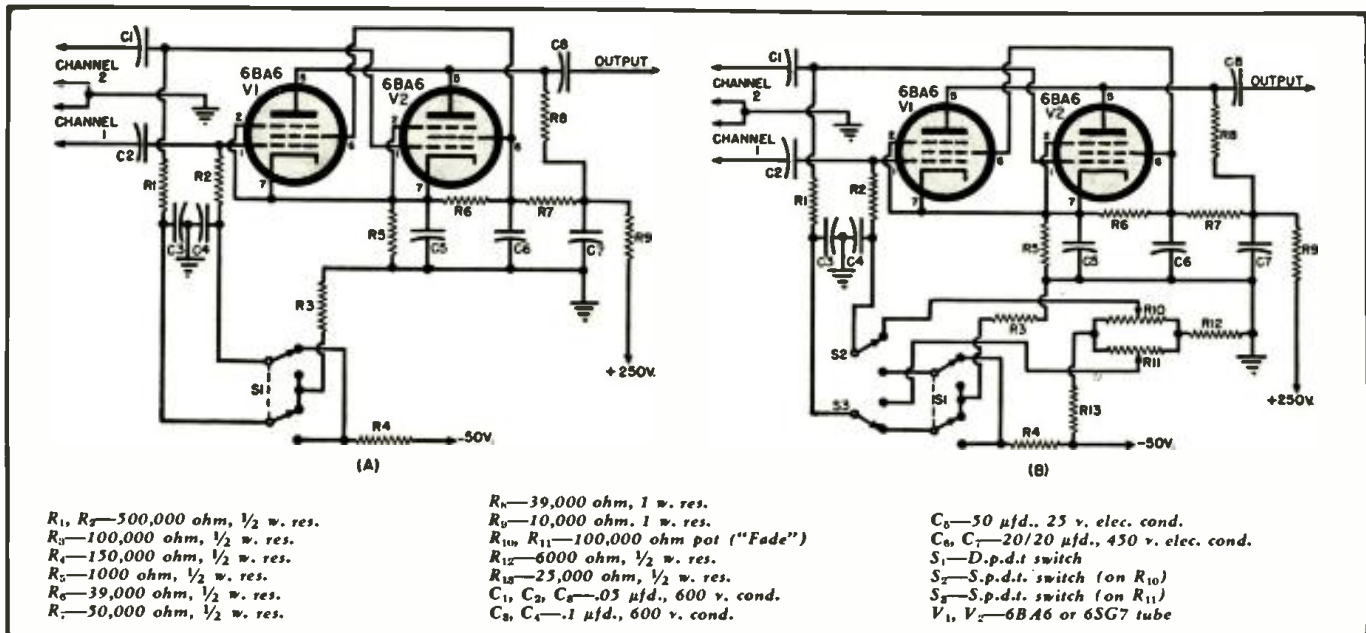

RCA INTERMATCHED HIGH FIDELITY

... to assure you of HIGH FIDELITY EXACTLY AS YOU WANT IT



Now—from RCA—comes the ideal way to achieve *exactly what you want in high fidelity*. You can be confident of top quality—every component in your system bears *the name you know best in electronics*.

For extra assurance—RCA offers a broad selection of components—all designed for top performance in their class—all *intermatched* to work together, regardless of the combination you choose.

Listen to the full line of RCA *Intermatched* high-fidelity components, look at the distinctive cabinet styles, and make your choice. You'll have a completely matched

system that's right for your home and your taste in high fidelity. You'll have a complete system that you can assemble in minutes, with just a screwdriver. And you'll be prepared at any time to add more power or extra coverage—if you feel you need them—without mismatches at any stage.

Hear RCA *Intermatched High-Fidelity* at your local RCA Electronics Distributor's. You'll agree it's high fidelity at its finest. You'll agree it's the sensible approach to high fidelity. For information, for the address of your local distributor, mail coupon below.



The superb LC-1A Speaker—the measure of high fidelity among professional users of sound—now more brilliant than ever with ACOUSTIC DOMES for wide-range reproduction and DEFLECTION VANES for wide-angle sound distribution. Intermatched for top performance with all other RCA components.

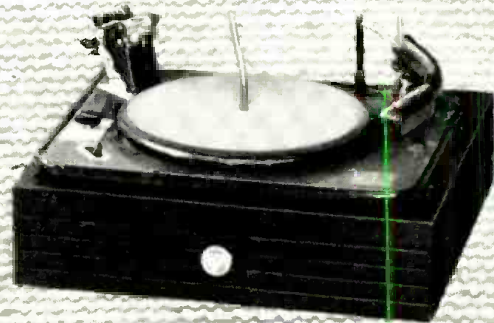

RCA INTERMATCHED CHANGER

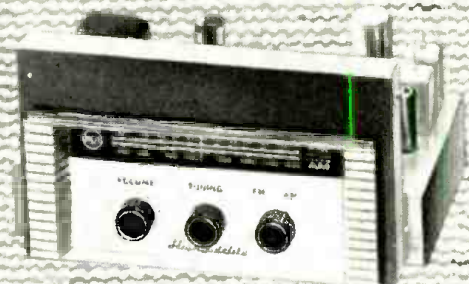

RCA INTERMATCHED TUNERS

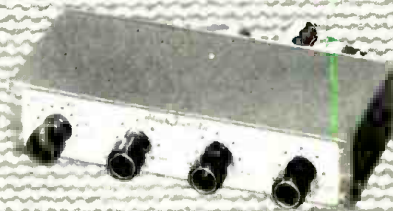

RCA INTERMATCHED PREAMPLIFIER

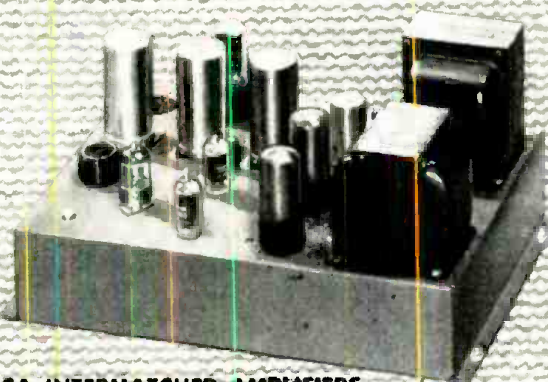

RCA INTERMATCHED AMPLIFIERS



RADIO CORPORATION of AMERICA
ENGINEERING PRODUCTS DEPARTMENT CAMDEN, N. J.

RCA Engineering Products
Dept. 222W, Building, 15-1, Camden, N. J.

- Please send me your new, free booklet on RCA Intermatched high-fidelity equipment.
- Please send me information on the new, complete RCA Victor high-fidelity "Victrola"® phonographs.

Name.....

Address.....

City.....Zone....State.....

CANNON PLUGS



Send for Cannon Bulletin RJC-6
... a special condensed catalog

Covers the Radio, Sound and Miniature Connectors that are available to you through Franchised Distributors, Electrical Wholesalers and Radio Parts Distributors.

TYPE **XL**

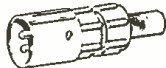

FITTINGS: For audio, instrument and related uses. 3 contacts. 15a max., 14 basic shapes. Latchlock coupling. Available at your Radio Parts Distributor.

TYPE **P**



FITTINGS: For audio, TV and instrument uses. 2 to 8 contacts, 30a max., 16 basic shapes. Universally used in sound and allied applications.

TYPE **O**



FITTINGS: 3-contact oval-shaped plugs and receptacles, equipped with latchlock device. For microphones and related uses. 6 basic shapes. 30a max.

TYPE **UA**



FITTINGS: Designed in cooperation with RMA Committee, combining all features of P, O and XL Series. Gold plated contacts. Rubber relief collar and bushings.

TYPE **45-E**



TEST POINT JACKS: High quality phone tip jacks to accommodate ATMA phone tip for laboratory uses. Rugged construction, nylon insulation precision-made for long life.

TV CONNECTORS:

Specialized "LK" and "LKT" plugs used on television cameras and related equipment.

TYPE **U**



SUB-MINIATURE SERIES: Hermetic sealed, vitreous insulated receptacles and Silcan insulated plugs for instruments, relays, transformers and other sealed components.

TYPE **D**



SUB-MINIATURE SERIES: Gold plated contacts. Rack-and-panel or cord mounted disconnect for portable radio and related equipment. Hermetic sealed if desired.

Additional related audio and power Cannon connectors include Types X, XK, M1, GB and BP, all available through selected Cannon Franchised Distributors. See your classified telephone directory.

CANNON ELECTRIC

Since 1915



CANNON ELECTRIC CO., LOS ANGELES 31, CALIF. Factories in Los Angeles, Toronto, New Haven. Representatives in principal cities. Address inquiries to Cannon Electric Company, Department K-145, Los Angeles 31, California.

NEW EQUIPMENT FOR THE AUDIO TECHNICIAN

For additional information on any of the items described herein, readers are asked to write direct to the manufacturer. By mentioning RADIO & TELEVISION NEWS, the page, and the issue number, delay will be avoided.

RCA'S AUDIO PACKAGE

The Engineering Products Department of Radio Corporation of America has recently introduced a complete line of matched and "power-propor-



tioned" high-fidelity units designed to enable "hi-fi" fans to build systems to their individual tastes.

This new equipment will be marketed individually to preserve the flexibility and freedom of choice demanded by most "hi-fi" enthusiasts. Characteristics are carefully matched, however, to insure maximum performance.

Built around the "Olson" speaker, the line includes a deluxe three-speed automatic record changer, two AM-FM tuners, four different high-fidelity amplifiers, three high-fidelity speakers (8", 12", and 15"), and separate speaker and equipment enclosures.

The company's electronic parts distributors will handle this line.

TAPEMASTER RECORDER

TapeMaster, Inc., 13 W. Hubbard St., Chicago 10, Illinois has recently released a new, compact professional model single-speed tape recorder, the Model HF-500.

The new unit is completely self-contained. It has an internal amplifier and 6" extended-range speaker yet can



be switched to an external amplifier and speaker if desired.

The HF-500 is single-speed (7.5 inches-per-second) and provides full

range response from 30 to 15,000 cps. Signal-to-noise ratio is 50 db or better. Wow and flutter is .3% maximum. A rear-illuminated professional vu meter gives level indication in both record and playback positions.

Bulletin No. 112, describing the Model HF-500 in detail, is available from the company on request.

MASCO AMPLIFIER

Mark Simpson Mfg. Co., 32-28 Forty-Ninth St., Long Island City 3, N. Y. has announced the availability of a new ten-watt amplifier, "The Custom Ten," which features an 8-position equalization switch, wide range frequency response, bass and treble compensated volume control, separate bass and treble tone controls, and low distortion.

With the equalization selector, compensation is provided for the charac-



teristics of TV tuner, radio tuner, crystal phono pickup, plus magnetic phono pickup equalized for five different recording characteristics including the new "Orthophonic" recording curve.

Frequency response of the new Masco unit is 20 to 20,000 cps \pm 1/2 db with 10 watts of power output at less than 1% harmonic distortion. The amplifier is housed in a compact cabinet whose front panel is styled in black and gold.

CRAFTSMEN SYSTEM

The Radio Craftsmen, Inc., 4401 N. Ravenswood Avenue, Chicago 40, Ill. has entered the "audio systems" field with a matched home music assembly.

All the units for a complete home-music system are provided in a single carton, complete with a changer mounting board, all necessary connecting cables, mounting hardware, detailed yet simple connecting instructions, and drawings of typical cabinets, including a horn-loaded corner speaker cabinet.

Included in the assembly, known as

RADIO & TELEVISION NEWS



HERE ARE JUST A FEW OF THE

BIG VALUES

IN THE NEW 156 PAGE 1954 B-A CATALOG

WRITE US, IF YOU HAVE NOT RECEIVED IT



BURSTEIN-APPLEBEE CO.
1012-14 McGee St., Kansas City 6, Mo.

- Send Free B-A Catalog No. 541
- My order attached for items in this ad.

\$..... enclosed.
Name.....
Address.....
City..... State.....

THE WORLD'S MOST SENSITIVE RADIO ANTENNAS

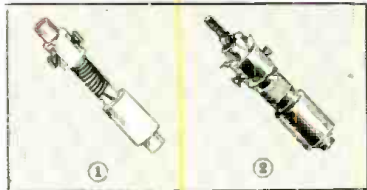

① **FERRI-LOOPSTICK:** For permanent installations—Just set and forget.
14B219. Each... 44c For... **\$3.96**

② **VARI-LOOPSTICK:** For finer tuning—Has micrometer adjustment and 1-hole snap in mount.
14B74. Each... 59c For... **\$5.31**

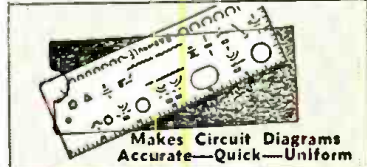

GIBSON RADIO RULE

Ideal for Students, Engineers, Technicians, Amateurs, etc. Makes symbols indicating tubes, meters, coils, transformers, relays, jacks, ground, condensers, switches, and AC connections. Pocket size.
11A314. With Directions, Each **75c**

"FLASH" SOLDERING IRONS



**LIGHT-WEIGHT!
QUICK HEATING!
PERFECT BALANCE!**

Model 75. Quick heating, light-weight, gun grip iron operates directly from 110 volts AC-DC. With $\frac{1}{8}$ " tip.
16A503. Net Each... **\$2.37**

TIP ASSORTMENT



Containing $\frac{3}{8}$ " Pencil, and Craftsman Tips.
No. 16B506. 3 Tips... **75c**

BT HACK SAW

FITS ANY $\frac{1}{4}$ " ELECTRIC DRILL

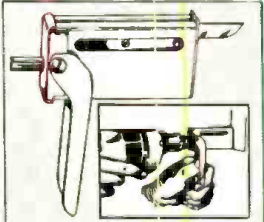

Low priced hack saw attachment that does a whole of a job. Cuts smoothly through wood, metal or plastic, etc. No gears or bearings to wear out; no exposed moving parts except saw blade. Well constructed with all moving parts of hardened, heat-treated steel. Only 1x1 1/2x4" in size, it fits easily into electric drill kit or tool box. Uses standard hack saw blades. Wt. 11 oz. List Price \$4.95.
No. 16B772. NET EACH... **\$3.72**

4-IN-1 HOLE SAW

CUTS 1", 1 1/2", 2" AND 2 1/2" HOLES IN WOOD, PLASTIC AND METAL

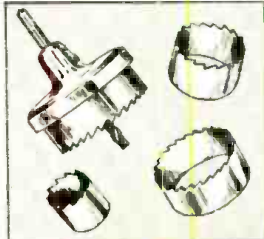

Cuts clean true holes in plastic, wood or metal. Cuts through any $\frac{3}{4}$ " stock. Light but rugged aluminum arbor with pilot drill holds the 4 interchangeable high speed carbon steel saws, sizes 1", 1 1/2", 2" and 2 1/2". Wt. 1 lb. List Price \$4.95.
No. 16B843. NET EACH... **\$3.72**

EXTRA BLADES

16A660. 1". Ea. 42c; 16A662. 2". Ea. 57c
16A661. 1 1/2". Ea. 49c; 16A663. 2 1/2". Ea. 65c

35 MA—130 VOLT SELENIUM RECTIFIER



Very compact $\frac{3}{8}$ "x $\frac{1}{2}$ " dia. in tubular fibre sleeve, sealed with high temp. wax—easy to mount anywhere with the self supporting 2" tinned wire leads.
An exact replacement for Standard B51 and many other TV boosters and ideal for countless other rectifier needs.
No. 15A1172. 35c 10 Lots 29c
Spec. Ea.

INSULATED RESISTORS



Do not confuse with non-insulated, foreign makes etc. offered by others. 50 Assorted top quality 1/2 watt insulated resistors in most popular capacities.
17A871. Per Assort. of 50... **99c**

ASSORTMENT OF 100
Consists of 75- $\frac{1}{2}$ watt and 25-1 watt insulated top quality resistors
No 19B796
Per Assortment of 100... **\$1.49**

6AK5 TUBES



Made by Sylvania and bears the name "Standard" because they were originally intended for use in Standard Boosters—otherwise the identical 6AK5 you would get if buying tubes bearing the Sylvania name and for which you pay up to \$2.06 Net Each (List Price \$3.90 Ea.). Here you get 6 for little more than the regular price of 2 and believe us—they are perfect—new—fully guaranteed—a popular type widely used in Radio, TV, Boosters, etc.
No. 70A98. Pkg. of Six 6AK5 Sylvania Made Tubes... **\$4.79 ONLY**

36 MOLDED PLASTIC TUBULAR CONDENSERS



Compact, yet with the rugged construction needed to withstand the high temperature in TV, Auto and AC-DC sets. Top quality. Fully guaranteed by the maker as well as B-A.
Kit of 36 all 600 Volt: 4 each .001, .002, .005 and 6 each .01, .02, .05, .1.
No. 18A263
Your Cost... **\$3.88**

Kit of 36 Paper Tubulars all 600 volt assorted as above. \$10.50 List Value.
No. 15A389. **\$2.39**
Kit of 36.....

PAPER & MICA CONDENSERS



25 assorted useable capacities paper tubular, paper molded and mica condensers. Regular values up to 25c each.
18B203. A Wonderful Value... **99c**

ROTARY SWITCHES

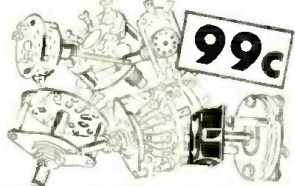

Assortment of TEN—any one of which is worth more than the price of the lot. Anyone experimenting or building will find good use for all.
No. 18A436.
Per Assort. of TEN... **99c**

TRIMMER CONDENSERS



25 Assorted ceramic base mica trimmer condensers popular capacities. Regular cost up to 20c each. You can afford to have several assortments, even if the use is only occasional.
No. 18A156.
PER ASSORT. ONLY... **39c**

SWITCH ASSORTMENT



10 Assorted—toggle, push-button and slide type switches. The use of only several will pay for the lot.
18A935. Per Assort. Only... **\$1.19**

150 FOOT WIRE KIT



Consists of cut lengths up to 7-Ft. long finest quality hook up wire in popular sizes and colors both solid and stranded with various type insulation. Handy anywhere hook up wire is needed. Take our word for it, this is an Outstanding Value priced at a fraction of regular cost. Money Back if not pleased. Shpg. wt. 1 1/2 lbs.
No. 18B316. Per Kit... **88c**

BAKELITE KNOBS



25 Assorted, Brown, Black and Ivory knobs, push-on type to fit standard $\frac{1}{4}$ " knurled shafts as used on most makes of sets.
No. 18A850. Per Assort. of 25... **79c**

5 TO 10 WATT WIRE WOUND RESISTORS



10 Assorted Values flat and tubular 5, 7 and 10 watt top quality Wire Wound Resistors—types that regularly net up to 40c each.
No. 18B930. Per Assort. of 10. **99c**

BURSTEIN-APPLEBEE CO. 1012-14 MCGEE ST. KANSAS CITY, MO.

TERMS: F.O.B. Kansas City. Remit with order, include postage for parcel post shipments.

BUILD 15 RADIOS

AT HOME ONLY

With the New Improved 1954 **\$19⁹⁵**

Progressive Radio "EDU-KIT"

NOW INCLUDES

**SIGNAL TRACER
and
CODE OSCILLATOR**

- FREE TOOLS WITH KIT
- ABSOLUTELY NO KNOWLEDGE OF RADIO NECESSARY
- NO ADDITIONAL PARTS NEEDED
- EXCELLENT BACKGROUND FOR TELEVISION
- 10-DAY MONEY-BACK GUARANTEE



WHAT THE PROGRESSIVE RADIO "EDU-KIT" OFFERS YOU

The "Edu-Kit" offers you a Home Radio Technician Course at a rock-bottom price. You will learn how to identify Radio Symbols and Diagrams; how to build radios, using regular radio schematics; how to wire and solder in a professional manner. You will learn how to operate Receivers, Transmitters, and Audio Amplifiers. You will learn how to service and trouble-shoot radios. You will learn code. You will receive training for F.C.C. license. In brief, you will receive a basic education in Radio exactly like the kind you would expect to receive in a Radio Course costing several hundred dollars.

THE KIT FOR EVERYONE

It is not necessary that you have even the slightest background in science or radio. The "Edu-Kit" is used by young and old; by radio schools and clubs; by the Veterans' Administration for Vocational Guidance and Training. No instructor is required. Instructions are complete, simple and clear. You cannot make a mistake.

PROGRESSIVE TEACHING METHOD

The "Edu-Kit" uses the principle of "Learn by Doing." Therefore you will build radios, perform jobs, and conduct experiments to illustrate the principles which you learn. You begin by learning the function and theory of each of the radio parts. Then you build a simple radio. Gradually in a progressive manner, you will find yourself constructing more advanced multi-tube radio sets, and doing work like a professional Radio Technician. The "Edu-Kit" Instruction Books are exceedingly clear in its explanations, photographs and diagrams. These sets operate on 105-125 V. AC-DC.

The Progressive Radio "EDU-KIT" Is Complete

You will receive every part necessary to build fifteen different radio sets. Our kits contain tubes, tube sockets, chassis, variable condensers, electrolytic condensers, mica condensers, paper condensers, resistors, line cords, selenium rectifiers, tie strips, coils, hardware, tubing, hook-up wire, solder, etc. Tools are included, as well as an Electrical and Radio Tester. Complete, easy-to-follow instructions are provided. In addition, the "Edu-Kit" now contains lessons for servicing with the Progressive Signal Tracer, F.C.C. instructions, quizzes. The "Edu-Kit" is a complete radio course, down to the smallest detail.

TROUBLE-SHOOTING LESSONS

Trouble-shooting and servicing are included. You will be taught to recognize and repair troubles. You will build and learn to operate a professional Signal Tracer. You receive an Electrical and Radio Tester, and learn to use it for radio repairs. While you are learning in this practical way, you will be able to do many a repair job for your neighbors and friends and charge fees which will far exceed the cost of the "Edu-Kit." Our Consultation Service will help you with any technical problems which you may have.

FREE EXTRAS

- Electrical and Radio Tester • Electric Soldering Iron • Book on Television • Radio Trouble-Shooting Guide • Membership in Radio-Television Club • Consultation Service • Quizzes • Training for F.C.C. License.

MAIL TODAY

Your Order Shipped Same Day Received

Send me the "Edu-Kit" with Money-back Guarantee—include All FREE extras.

Check or M.O. enclosed—postage prepaid

C.O.D. (U. S. Only)—I will pay postage

Send further information

Outside U.S.A.—cash orders only: send intern'l M.O. or check U.S. bank Postage Prepaid. "Edu-Kit" for 210-250 V. AC/DC \$22.45.

NAME _____

ADDRESS _____

PROGRESSIVE ELECTRONICS CO.

497 Union Ave., Dept. RN-24, Brooklyn 11, N. Y.

the *Craftsmen* CA1, are; the company's C10 FM-AM tuner; the C400 high-fidelity 10-watt amplifier; a three-speed record changer made to the company's specifications and complete with a G-E "triple play" phono pickup cartridge; and a 12-inch speaker system which includes a wide-angle dispersion, horn-loaded tweeter which is coaxially mounted in a 12-inch woofer for single-point sound distribution and easy, convenient installations.

For further information on this matched home music system, contact firm direct.

SOUND ENSEMBLE

The *Regency Division of I.D.E.A.*, 7900 Pendleton Pike, Indianapolis 26, Indiana has introduced a new professional, high-fidelity ensemble for the home which is so designed that it need not be housed in a cabinet unless the user wishes to do so.

The set is designed to be both functional and attractive. Perforated gold shields house two of the three units. A protective glass top reveals the component assembly.

The ensemble consists of three separate units: a preamp-equalizer, a power amplifier, and the power supply. All units are non-hygroscopic, provid-

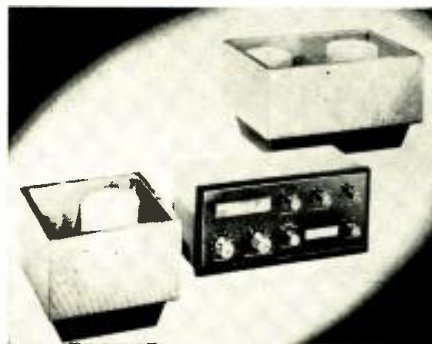

ing complete protection against the adverse effects of moisture. Each unit is individually calibrated and each has an individual response curve which is supplied with the ensemble.

The company will supply full details on the Model 1000 upon request.

ADMIRAL COMBINATION

Admiral Corporation, 3800 Cortland St., Chicago 47, Illinois is now introducing a 20-tube AM-FM radio-phonograph combination for the audio market.

The set features a chromium-plated chassis, a two-way dual speaker system for undistorted response to both high and low notes, and a special adjustment to bring out all tones in various makes of full-fidelity records.

The unit is available in three cabinet styles: 18th Century mahogany, modern blonde oak, and American provincial in maple. The twin speaker system consists of a 15" woofer in a 6.7 cubic foot wood enclosure lined with a special sound-absorbing material and a smaller compression-type tweeter. The former gives distortion-free response from 3500 cycles down to 30 cycles while the tweeter covers

the range from 3500 to 16,000 cps. The combination has independent bass and treble tone controls which do not interact.

The new combination will be offered to the public through selected dealers who are familiar with the high-fidelity field.

JENSEN "DUETTE"

Jensen Manufacturing Company, 6601 South Laramie Ave., Chicago 38, Ill. has introduced a compact, two-

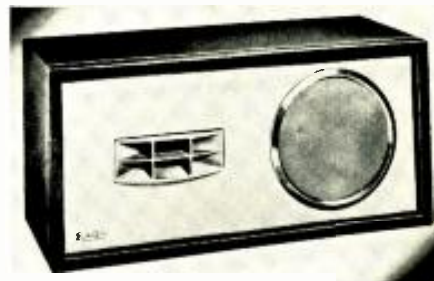

way reproducer which has been trademarked the "Duette."

Incorporating the important elements of a fine, large reproducer, the "Duette" is designed for applications where space is at a premium. It measures just 11" high, 10" deep, and 23 1/4" long. It is constructed to be placed on a bookshelf, end table, desk, or table. Its two-tone pigskin plastic covering is accented with burnished copper trim.

The "Duette" contains a special heavy-duty 8" woofer, a multicell horn tweeter and has impedances of 4 and 8 ohms with a 20 watt power rating.

BATTERY-OPERATED RECORDER

Ectro, Inc. of Delaware, Ohio has recently introduced a completely portable tape recorder equipped for recording, playback, erase, monitoring, and battery recharging.

The "Cub Corder" is housed in a compact, briefcase-type carrying case of long-wearing, scuff-proof, leather-grained plastic. It weighs less than 13 pounds and comes complete with a



shoulder strap for ease of carrying.

It is designed to record for two full hours. The push-button microphone is used to start and stop the unit, for recording and playback, thus making it possible to make recordings while the cover is closed.

RADIO & TELEVISION NEWS

Pre-sold to Millions!



Custom Music Ensemble

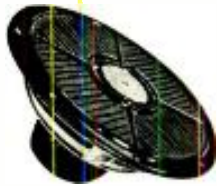

G-E DUAL COAXIAL SPEAKER
Model A1-400

New approach to coaxial speaker design—high sensitivity at low cost. Exceptional balance between speakers with G-E Acoustic Balancer. Newly developed Pressure Equalizer... a wavefront shaping plug... provides smooth tweeter response.



G-E POWER AMPLIFIER
Model A1-300

A medium power, compact amplifier designed to provide needed speaker power. Essential element in the new General Electric "Custom Music" Ensemble. Delivers high-fidelity performance at very low cost.



G-E PREAMPLIFIER-CONTROL UNIT
Model A1-200

Combines functions of equalized pre-amplifier plus adjustable record compensation, program input selection, tone controls and volume control. Matching unit for the "Custom Music" amplifier. Self-powered for use with any installation.



G-E DELUXE TONE ARMS
A1-500 (12") A1-501 (16")

For home or broadcast station use. Compatible with the exceptional quality of G-E cartridges. Calibrated stylus pressure adjustment... 4 to 14 grams. They were developed to improve record reproduction in every installation.

G-E SPEAKER ENCLOSURE
Model A1-406 (6 cu. ft.)

Attractive corner or wall cabinet in hand-rubbed blond or mahogany veneers. "Distributed port" design provides full low frequency response. Tonal range with G-E Coaxial Speaker—40 to 15,000 cycles.



**FOR SUPERIOR PERFORMANCE...
LOW COST...MINIMUM SERVICE...
INSTALLATION ECONOMY!**

● Through the pages of nine top consumer magazines...in display rooms...on FM broadcasts...and at shows millions are discovering—indicating a preference for—the unique features of a G-E Custom Music Ensemble. Here is the single package of *matched high-fidelity equipment* you need to expand your audio business, assure satisfied customers. Get in tune today with the growing popularity of custom audio installations...add to your net profit...with complete General Electric equipment!

Individual components or the complete ensemble now available! Call a local G-E distributor or write for information.

SEND FOR COMPLETE INFORMATION

General Electric Company, Section 9113
Electronics Park, Syracuse, N. Y.

Please send me specifications and other data on the new G-E Custom Music Ensemble.

NAME.....

ADDRESS.....

CITY..... STATE.....

You can put your confidence in—

GENERAL  ELECTRIC

THE New SUPER-ROYAL



High Fidelity Speakers

BY *Permoflux*

WITH THE
Famous Treated Slotted Cone
FOR LOW RESONANCE

This exclusive Permoflux feature, plus New design in magnetic structure, utilizing heavy Alnico 5 ring magnet, results in extended distortion free, low frequency response.

The specially designed single cone radiator reproduces both high and low frequencies with exceptional clearness, and avoids the inherent distortion of coaxial or 2 way systems.

See and hear the Super Royal at your High Fidelity Dealer

Available in 3 sizes
8, 12 and 15 inch.

For descriptive literature write to . . .

Permoflux CORPORATION
4918 Grand Ave., Chicago 36, Ill.
West Coast Plant
236 S. Verdugo Rd., Glendale 5, Cal.

The tape used is of a conventional type and size and may be played back over almost all makes of conventional-type tape recorders with speeds of 1 7/8", 3 3/4", or 7 1/2" per second.

For complete specifications, price, and sales literature write the company direct.

CONTROL UNIT-AMPLIFIER

Beam Instruments Corporation, 350 Fifth Avenue, New York 1, New York has announced the availability of the new acoustical "Q.U.A.D." control unit and its associated 15-watt full-range amplifier.



Both units have been especially designed for the U.S. market. The Q.C. II control unit and combined preamplifier provides push-button switching for three separate inputs and up to eight preselected equalizing combinations for phonograph reproduction. It incorporates an "on-off" switch on the volume control, independent linear treble and bass rise and fall controls, also a audio harmonic filter from level to 50 db per octave, continuously variable. Input sensitivity is from 3 mv. upwards. Plug-in impedance matching units, suitable for almost any input device, are available. Distortion-free level response from 20 to 60,000 cps is provided with attenuation above 20,000 cps. The control unit measures 10 1/2" x 3 1/2" x 6 1/2".

Details on the control unit and pre-amplifier or the 15-watt amplifier are available from the company.

PORTABLE CHANGER

Steelman Phonograph Corporation of Mount Vernon, New York has added an automatic changer portable phonograph to its line for 1954.

Known as the Model #3A6, the new unit features a special inverse feedback circuit and an 8 watt output. It has two 6" speakers, a special high-fidelity cartridge, and dual sapphire needles.

The phonograph incorporates three individual controls for volume, bass, and treble. It is housed in an especially-engineered carrying case which insures good acoustic reproduction. The sun tan fabric covering is designed to blend with any type of home decoration.

STEREOPHONIC AMPLIFIER

Newcomb Audio Products Co., 6824 Lexington Ave., Hollywood 38, Cal., recently premiered its new two-channel, "3-D" stereophonic amplifier designed for home use.

The Model 3D-12 provides two 12-watt high-fidelity channels complete with preamps. Common controls for both simplify operation. All the generally used crossovers are present for both channels plus special equalization for the Cook "B/N" recordings. Both 3-D or conventional monaural programs can be reproduced from tape, records, or radio.

A unique feature of this amplifier is the special selector knob that permits the operator to reverse channels for comparison purposes.

The product will be distributed nationally through the company's established outlets.

"3-D" AMPLIFIER

Livingston Electronic Corporation, Livingston, New Jersey is currently offering a twin-channel amplifier which has been designed specifically to take advantage of the many 3-D sound sources now available.

The new unit consists of two complete 10-watt high-fidelity channels from cartridge to loudspeaker with three twin inputs for disc, tape, and binaural broadcasts. The amplifier contains a binaural-monaural selector switch and speaker reversing switch with separate high and low controls for each channel.

It is supplied with a power supply on a separate chassis with the individual cabinets, each measuring 9 3/4"

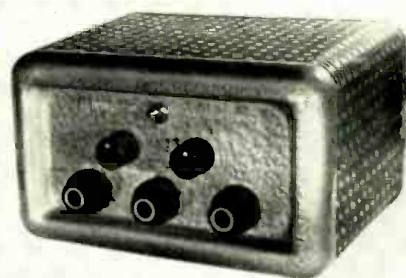

x 8" x 5 3/4", interconnected by a 3-foot cable.

The company will supply further details on request.

ESPEY LINE

Espey Manufacturing Co., Inc. of New York is celebrating its 25th anniversary in the audio field by introducing a new line of AM-FM components.

Known as the "Trophy" models, the line consists of the Model 100 AM-FM radio chassis, the Model 101 AM-FM radio tuner, the Model 200 AM-FM radio chassis, the Model 300 AM-FM tuner, the Model 400 AM-FM deluxe tuner, and the Model 500 deluxe audio amplifier.

All models feature the latest engineering advancements. *Sylvan A. Wolin and Associates* of 409 Grand Ave., Englewood, N. J. is the national sales agency for this line and will supply further data on request.

AUDIO SIGNAL GENERATOR

A new audio signal generator de-

signed for a wide range of service and laboratory applications and for use in the hi-fi sound field has been announced by the Tube Department of Radio Corporation of America.

Designated as the WA-44A, the new instrument features an extended frequency range of from 11 cps to 100 kc. It has a sinusoidal output which has less than two per-cent total harmonic distortion over the range from 30 to 15,000 cps and has a maximum hum level of one-tenth of one per-cent of the rated output. The output voltage varies less than ± 1 db over the entire frequency range.

The generator is a.c. operated from a 50-60 cycle, 105-125 volt power source and contains both high- and low-impedance output circuits. The high and low terminals supply a maximum voltage of 15 volts r.m.s. and 2.5 volts r.m.s. respectively. The instrument also incorporates a terminal which supplies up to six volts at line frequency for use in intermodulation tests.

The instrument measures 7 inches high, 10½ inches wide, and 6 inches deep. It weighs approximately 10 pounds.

"FLEXO-RACK"

River Edge Industries of River Edge, N. J. has introduced its Model 730 "Hi-Fi Flexo-Rack" kit which will provide low-cost temporary installation facilities for audio equipment.

The rack of wood construction and secured by thumbscrews and bolts, can be adapted to accommodate any system to its best advantage. The versatility of this rack can be of help in deciding upon the final cabinet design.

G-E ENCLOSURE

General Electric Company has added a new six-cubic foot speaker enclosure to its "Custom Music Ensemble" line, the Model A1-406.

The enclosure is designed for the company's 12" dual coaxial, high-fidelity speaker but can also be used



with the firm's Models 1201A and 1203A 12" single cone speakers. The cabinet is available in unfinished fruitwood or in hand-rubbed blonde oak or mahogany finishes.

Acoustically, the speaker enclosure permits full tone from 40 to 15,000



THE FISHER HI-LO FILTER SYSTEM • MODEL 50-F

FISHER

Hi-Lo Filter System

■ Here it is at last—America's first electronic *sharp cut-off* Filter System. Suppresses turn-table rumble, record scratch and distortion, etc., with the *absolute minimum* loss of frequency response. *Separate* low and high frequency cut-offs. Can be used with *any* tuner, preamplifier, amplifier, etc. No insertion loss. Uniform response 20-20,000 cycles, ± 0.5 db. Self-powered. All-triode. Beautiful plastic cabinet. *Only \$29.95*

FISHER

Preamplifier-Equalizer

■ Now, professional record equalization facilities are within the reach of *every* record collector. THE FISHER Model 50-PR, like its big brother (Model 50-C) is beautifully designed and built. *Only \$19.95*

THE FISHER PREAMPLIFIER-EQUALIZER • MODEL 50-PR



New!

PROFESSIONAL
AUDIO
EQUIPMENT AT
LOW
COST!

OUTSTANDING FEATURES

- Independent switches for low-frequency turnover and high frequency roll-off. • 16 combinations. • Handles *any* low level magnetic pickup. • Hum level 60 db below 10 mv input. • Uniform response 20-20,000 cycles, ± 1 db. • Two triode stages. • Full low frequency equalization. • Output lead any length up to 50 feet. • Beautiful plastic cabinet, etched brass control panel. • Completely shielded chassis. • Built-in AC switch. Jewel indicator light.

Write for full details

FISHER RADIO CORP.

39 EAST 47th STREET • N. Y.

2 New Ways to Cure... Home-monic distortion



Angle Genesee's new chairside cabinet solves the space and budget conscious audiophile's equipment housing problem to perfection! A proud piece of furniture... for record player, tuner, pre-amp, and amplifier.

And the new A-G corner enclosure makes good speakers sound better! Adjustable baffles. Both in traditional mahogany or contemporary blonde oak! See your dealer or write us — we'll tell you where. Get the full

details now on these and other A-G cabinets, designed for any combination of hi-fi equipment. Replaceable panels permit revision and expansion of sound system.



107 NORRIS DRIVE, ROCHESTER 10, NEW YORK

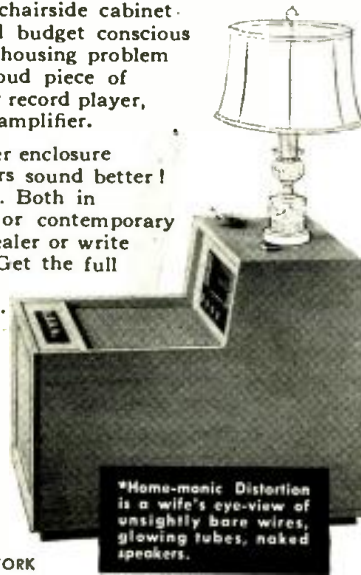

*Home-monic Distortion is a wife's eye-view of unsightly bare wires, glowing tubes, naked speakers.

cycles when used with the 12" dual coaxial speaker. It provides radiation of true bass and extended high frequencies over an angle of 100 degrees. A choice of corner location or against-the-wall placement is offered. The entire front (31½" high and 25½" wide) is covered with a woven lumite cloth. The enclosure is 18½" deep. Back and sides are constructed of plywood, acoustic lined.

MODERN ENCLOSURES

A new line of contemporary enclosures is now being introduced by *Jeff Markell Associates*, 108 W. 14th Street, New York 11, N. Y.

Among the cabinets now available is the RC 123, a radio-phonograph and speaker enclosure. This modern wall unit successfully solves the problem of transmitted vibration from the speaker enclosure to the equipment by shock mounting the speaker enclosure to the wrought iron legs and



allowing a dead air space between the two parts. The speaker enclosure has a volume of 7½ cubic feet.

External dimensions of the enclosure include 43" over-all length, 43" height over-all, and 20" over-all width. The changer compartment measures 18¼" deep, 16" long, and height above mounting level 6" and below mounting level 4½". The tuner-amplifier compartment measures 24" long, 19¼" deep, and 10½" high. The speaker enclosure is 39¾" long, 18" deep, and 18½" high. It is available in a wide variety of decorator finishes.

NEWCOMB AMPLIFIER

Newcomb Audio Products Co., 6824 Lexington Avenue, Hollywood 38, California is in production on a new 25-watt amplifier, the Model E-254.

The unit has a four channel mixer with three mike inputs and a phono input to provide maximum gain and versatility. Special socket knockouts and input contacts make conversion to low-impedance mike inputs comparatively simple when needed.

This particular model delivers 30 watts maximum at less than 5% distortion. Design center rating at 117 volts input is a conservative 25 watts at less than 5% distortion. Frequency response is ± 2 db 40 to 15,000 cps.

-30-

RADIO & TELEVISION NEWS

NEW F. M. AUDIO SYSTEM

Provides startlingly natural duplication of "live" music. Features ultra-linear fixed bias output stage, two speaker dual baffle, bass amplification, and extremely low hum level. Guaranteed illustrated diagrammed construction data \$4.50.

TRIANGLE RADIO LABORATORY
RURAL ROUTE #3, RAVENNA, OHIO

SCHEMATICS—CONVERSIONS FOR SURPLUS GEAR

TRANSISTOR KITS

Walking broadcasting microphone, phono broadcasters, radio receivers built onto Hi-fi headsets, preamplifiers, phono-amplifiers, etc. Send stamped addressed envelope for free data sheets on ready-to-assemble kits.

R. E. GOODHEART, P. O. Box 1220
BEVERLY HILLS, CAL.

MODEL CR-200



Another First by MILLER TELEVISION CO.



Install in 30 seconds.
Comes completely pre-assembled.

UHF Bow-tie Corner Reflector

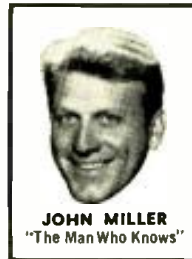

JOHN MILLER
"The Man Who Knows"

A rugged antenna that comes completely pre-assembled. Install in 30 seconds by merely opening like a book. Broad band on all UHF channels. Especially effective in difficult installations. Reflector screen of ¼" aluminum elements with aluminum channel rim. Featuring the new Miller unbreakable UHF molded hi-impact styrene insulator. As with Miller's complete line of realistically priced UHF and VHF antennas, Model CR-200 is ready for immediate delivery with a money back guarantee. Another first from Miller Television... the West's pioneer producer of television antennas.

LIST PRICE
\$8.95

More than 1 million antennas built since 1948



WRITE FOR FREE CATALOG

Miller Television Co., 2840 Naomi
Burbank, Calif.

Gives complete information on Miller UHF and VHF antennas. Write for your copy today, and name of nearest jobber.

NAME
ADDRESS
CITY & STATE

"Color Television"



A special issue containing

• 15 N.T.S.C. Monographs—

The National Television Systems Committee has authorized IRE to publish its long awaited Monographs in the January 1954 special Color Television issue of "Proceedings of the I·R·E" — thus giving them industry-wide distribution for the first time in print.

• 25 additional Color TV articles—

will also appear in this issue, which brings the reader up-to-the-minute on the developments of Color Television. Copies of the first Color Television issue are still available and combined with this second Color Television issue will form a complete bibliography of major historical importance. Also included in the January issue will be a complete listing of the N.T.S.C. system specifications as submitted to the F.C.C.; and field test reports on the system's performance.

in "Proceedings of the I·R·E" January '54

Available to non-members for \$3.00. Extra copies to I R E members are \$1.25. All members get one copy free!

*Another
History
Making
Issue!*



I R E is an organization of 33,312 member-engineers. There are no company memberships. Operating continuously since 1913, its sections meet in 78 cities. 21 specialized Professional Groups widen the scope of its member-services and 40 technical committees help the industry.

"Proceedings of the I·R·E"

Published by

THE INSTITUTE OF RADIO ENGINEERS

1 East 79th Street, New York 21, N. Y.

Please place orders before December 10th.

The ideal
replacement cartridge!

TITONE

Revolutionary High-Fidelity CERAMIC PICKUP

No other pickup offers all
these great advantages

Only 2 models replace 89% of all present cartridges • Ideal for records of all speeds • Hundreds of thousands already used by leading manufacturers as original equipment • No preamplifier or equalizer needed • Unaffected by temperature or moisture • Long life on shelf and in use • Wide adaptability and simple replacement • High sensitivity • Wide frequency range • Low distortion • No hum pickup • Superior tracking ability • Proper groove fit

Replacement Chart and Literature Available



TITONE PLAYAL

— for all records. With replaceable 1- or 3-mil sapphire or 2-mil osmium needle.

\$7.50 List



TITONE TURNOVER

—with unique, replaceable dual sapphire needle assembly. (Only needle rotates).

\$9.50 List

Electronic Applications Division

SONOTONE CORPORATION

Elmsford, New York

Spot Radio News

(Continued from page 18)

permit faster movement of traffic due to closer separation intervals. The development of the system, as a supplementary aid to primary radar for improving air traffic control and increasing flight safety, has been recommended by the Radio Technical Commission for Aeronautics.

Analyzing the need for such a system, RTCA spokesmen pointed out that the complexity of air-traffic control has increased rapidly and steadily in recent years, because of expanding defense needs and increased air traffic at higher altitudes, faster speeds and over longer distances. This condition created a need for a more modern system of air traffic control. Primary radar provided much of the necessary improvement, but meteorological disturbances can cause weakening of the reflected signals and a resulting loss of target. Since primary radar does not provide identification of aircraft in a controlled area, time-consuming maneuvers are necessary to establish the association between an aircraft and its *blip* on the radar scope. In operation, primary ground radar transmits pulse signals which reflect from aircraft as echoes. Only a small part of the energy of the original signal is reflected, however, and a very weak signal is returned to the ground.

Under adverse conditions, these weak signals can be absorbed in the atmosphere to such a degree that no usable reflection is received on the radarscope.

The secondary radar overcomes these shortcomings, since in this improved approach, the ground signal triggers the equipment in the aircraft which transmits a reply pulse signal many times stronger than an echo. In addition, these replies can be coded to provide aircraft identification. This permits the closer spacing of aircraft in the traffic pattern, by eliminating the need for maneuvers necessary with primary radar to associate each plane with a particular *blip* in the scope screen.

The amplified signals from the radar safety beacon improve surveillance by providing continuous tracking of all sizes and types of aircraft under all conditions of weather and restriction of visibility.

At the Air Research and Development Command's Air Development Center at Rome, New York, another unusual radar system has been evolved. In this instance, a turntable radar set is featured; a rotating mount provides Air Force units with single site ground-controlled approach facilities, eliminating the necessity of moving radar sets from one position to another each time the direction of landing aircraft is changed due to wind variations.

The turntable consists essentially of

NEW TV GRANTS SINCE FREEZE LIFT

Continuing the listing of construction permits granted by FCC since lifting of freeze. Additional stations will be carried next month.

STATE	CITY	CALL**	CHANNEL	FREQUENCY (mc.)	POWER* (Vide)
California	Fresno		53	704-710	282
Florida	Jacksonville	WOBS†	30	566-572	18.6
Georgia	Columbus		4	66-72	26.9
Illinois	Evanston		32	578-584	24
Iowa	Cedar Rapids		9	186-192	33.1
	Des Moines	WHO†	13	210-216	316
	Waterloo	KWWL†	7	174-180	50.1
Kentucky	Owensboro	WVJS*	14	470-476	178
Massachusetts	Boston		44	650-656	282
Michigan	Bay City		5	76-82	49
Mississippi	Jackson	WJDX†	3	60-66	100
New Hampshire	Manchester	WMUR†	9	186-192	148
Ohio	Steubenville	WSTV†	9	186-192	229
Rhode Island	Providence	WPRO†	12	204-210	316
Texas	Sweetwater		12	204-210	2.95
Wisconsin	Milwaukee	WMIL†	31	572-578	15.1

Latest Official Call Letter Assignments

Alabama	Birmingham	WABT	13	210-216
Idaho	Meridian	KBOI	2	54-60
Indiana	Elkhart	WSJV	52	698-704
Massachusetts	Boston	WBOS-TV	50	686-692
Maine	Portland	WCSH-TV	6	82-88
North Dakota	Valley City	KXJB-TV	4	66-72
Oregon	Portland	KOIN-TV	6	82-88
Pennsylvania	Lebanon	WLBR-TV	15	476-482
South Carolina	Spartanburg	WSCV	17	488-494
Tennessee	Knoxville	WTSK	26	542-548
Tennessee	Nashville	WSIX-TV	8	180-186
West Virginia	Fairmont	WJPB-TV	35	596-602

*ERP = (effective radiated power, kw.).

.. = Call letters to be announced

† = Temporary call letters.

a rectangular platform on a ring which is supported by rollers on a concrete foundation. The platform and the ring can each be leveled independently of the other. When mounted on the turntable, a precision approach radar can be rotated through 360° in 3½ minutes, making the runway usable from either direction. In the past, approximately a half hour was required to move a radar set from one runway position to another.

At the Armament Laboratory of the Air Research and Development Command's Wright Air Development Center in Dayton, another unique plane control method using radio signals has been announced. Known as the *radio beam coupler*, it permits more effective usage of the VOR-omnirange beacons and other radio tracks on principal airlines of the world. Without any adjustments by the pilot of the pitch knob, the control employs new signal combinations which hold the plane firmly at the proper glide angle, regardless of the changes in air-speed or other deflecting forces from lowering flaps and landing gear, or turbulent air.

The coupler accurately holds a straighter course and automatically compensates for wind drift, while riding omnirange or other beams. In fog, storms, or darkness, when approaching airports on the localizer beam, the new device promptly detects intersection with the glide path, automatically shuts off altitude control, and transfers itself to the glide slope control. Thus, it avoids former hazards of overshooting the glide path, if a pilot fails to engage manually his glide control promptly enough at the intersection of the two guiding beams.

The new technique will be featured not only in military planes, but in commercial aircraft, as soon as priority production is completed.

THE SENATE RADIO-TV Gallery is now undergoing an extensive remodeling job. Over \$30,000 will be spent for a series of new studios for TV and radio, and expanded office and operating facilities. Specifically, there'll be one new studio for TV, which will be about 15 by 20 feet for live shows, while another (about 10 by 15) will be available for film work. Several rooms will be set up for radio and teletype. Lines will be available for the networks and linked to both the radio and TV studios. Alterations are expected to be completed early next year.

DROP-OUTS in applications for TV channels are beginning to concern the Commission. A parade of such actions has occurred recently, and it appears to some in Washington as if the trend will grow. Many are making handsome profits from the shifts, with substantial amounts of expense money being paid to those who agree to surrender their hold on a channel.

In one instance, an applicant, who withdrew his request, received a

November, 1953

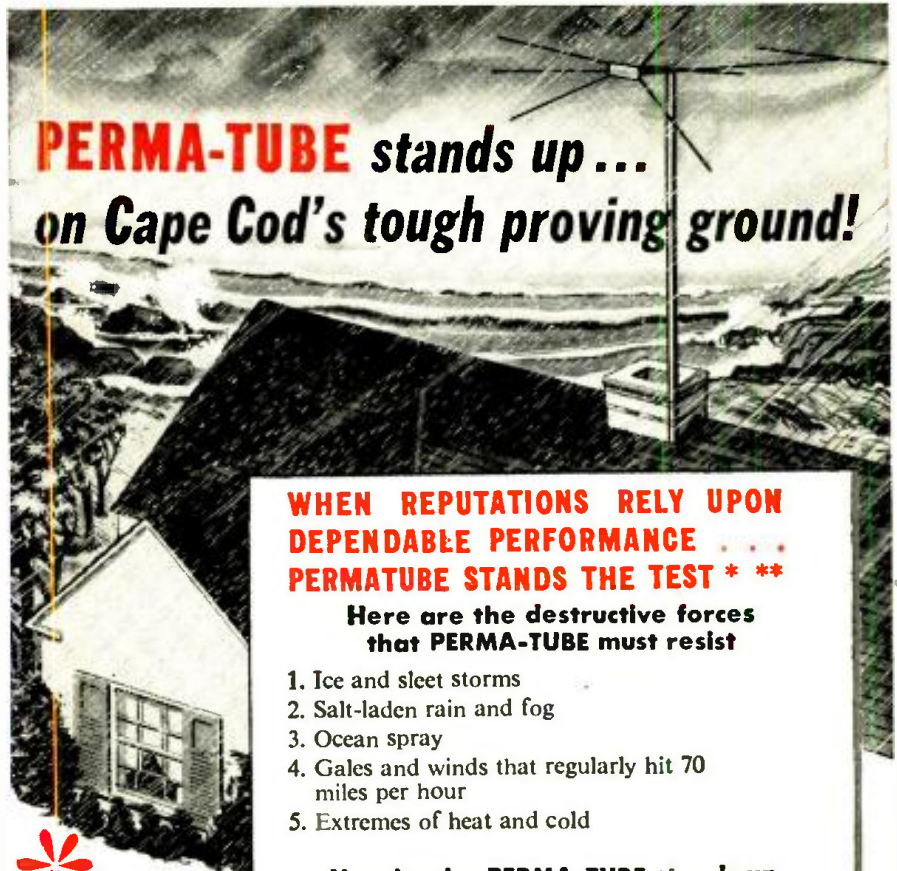

PERMA-TUBE stands up... on Cape Cod's tough proving ground!

WHEN REPUTATIONS RELY UPON DEPENDABLE PERFORMANCE . . . PERMATUBE STANDS THE TEST * **

Here are the destructive forces
that PERMA-TUBE must resist

1. Ice and sleet storms
2. Salt-laden rain and fog
3. Ocean spray
4. Gales and winds that regularly hit 70 miles per hour
5. Extremes of heat and cold

Here's why PERMA-TUBE stands up
under the most severe conditions

1. PERMA-TUBE is STURDY . . . it's made of special, high-strength, J&L steel.
2. PERMA-TUBE IS CORROSION-PROOF . . . it's treated with vinsynite—then coated inside and outside with a metallic vinyl resin base.
3. PERMA-TUBE IS MECHANICALLY SOUND . . . it's the only mast with both ends of the joint machine fitted.

*From the records of Ware Radio Supply Company of Brockton, Massachusetts over 500,000 feet of PERMA-TUBE used on Cape Cod installations—and not a single complaint.

**From the records of Bill Perry—Cape Cod radio and television sales and service expert . . . over 1000 installations of PERMA-TUBE in three years—and not one single mast failure.

Here's proof of how Perma-Tube resists corrosion

Section of ordinary conduit tubing used for TV masts after 96 hours in a salt spray test (A.S.T.M. Designation B-117-49T) to accelerate corrosion. Extensive rust inside the mast has reduced strength—caused rusty water to drain onto the owner's home.

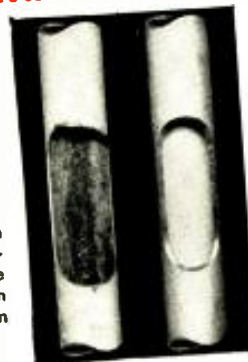

Section of PERMA-TUBE after 500 hours salt spray test shows no evidence of corrosion. Strength has been retained and the chance of rust streaks on owner's home is eliminated. Note sturdier wall thickness of PERMA-TUBE sample.

PERMA-TUBE IS AVAILABLE IN STANDARD LENGTHS . . . DIAMETERS . . . WALL THICKNESSES. FOR COMPLETE INFORMATION MAIL THIS COUPON.

J&L STEEL

Jones & Laughlin Steel Corporation
495 Gateway Center, Pittsburgh 30, Pa.

Without charge Name of nearest distributor
please send me Complete information on PERMA-TUBE

Name _____

Company _____

Address _____

THE NEW

Carry-all
tube caddy



Only \$13.95*
8 x 15 x 21 in.
Available.

MOST COMPLETE,
VERSATILE

A proud new "tube caddy"—
to save even more time and
money for the TV serviceman.
PAYS FOR ITSELF.

Carries up to 262 tubes. A
complete tool and tube kit—
helps technician to give efficient
service that builds confidence.
Ruggedly built with

*Craftsmanship
in Cabinets*



*Net to Service dealer.
Other tube caddies
from \$7.75 to \$14.95.
Write for FREE FOLD-
ER. Sold only thru
Parts Jobbers. Slightly
higher West of Rockies.

ARGOS
PRODUCTS COMPANY
310 MAIN STREET • GENOA, ILLINOIS

thousand dollars as reimbursement for application expenses and an agreement that shortly after the station begins operation, he will be retained as a consultant until he has been paid a total of about \$12,000.

One Commission spokesman reported that officials were quite disturbed about these transactions, for general approval of these switches could deprive . . . "the public of the services of the better-qualified applicant, where the less-qualified applicant is financially able and willing to buy off competing applicants."

This problem, the color situation, shortage of examiners, and the screening of applicants for hearing posts, plus the annual vacation exits, disrupted many normal office routines at the Commission during the summer and early fall months. As a result few grants were issued. The late fall and winter months, however, should see a real spurt in activity and expanding lists of OK's for stations: See page 160 this issue for lists of new grants made

and new call letter assignments issued as this column was being prepared.

WASHINGTON celebrated an unusual birthday a short while ago; that of the transistor. Five years ago, this mighty mite was born, and today it has become quite a factor in the civilian world, and particularly on the military front.

In countless defense projects, this unique device has served to expedite equipment construction, improve performance of the most involved systems, and shrink the size of complex gear.

To the military, the transistor has been one of the most significant developments since the invention of the vacuum tube. Thus, on this fifth birthday, it was hailed and applauded in the Pentagon, at numerous depots throughout the country, and at many plants now engaged in producing transistorized devices for defense.

To the transistor, a roaring salute on this happy occasion. L.W.

NEW TV STATIONS ON THE AIR

(As of October 25, 1953)

The following new stations bring the lists published in previous issues up to date.

STATE, CITY	STATION	CHANNEL	FREQUENCY RANGE (IN MC.)	VIDEO WAVELENGTH (IN FT.)	VIDEO POWER* (IN KW.)
California					
Eureka	KIEM-TV	3	60-66	16.06	17.5
Salinas-Monterey	KMBY-TV ¹	8	180-186	5.43	11.5
Salinas-Monterey	KSBW-TV ¹	8	180-186	5.43	11.5
Tulare-Fresno	KCOK-TV	27	548-554	1.79	500
Colorado					
Colorado Springs	KRDO-TV	13	210-216	4.65	11.3
Georgia					
Columbus	WDAK-TV	28	554-560	1.77	158
Illinois					
Peoria	WTVH	19	500-506	1.96	24
Quincy	WGEM-TV	10	192-198	5.08	316
Rockford	WREX-TV	13	210-216	4.65	47
Springfield	WICS	20	506-512	1.94	18.2
Indiana					
Evansville	WFIE	62	758-764	1.30	180
Louisiana					
Lake Charles	KTAG	25	536-542	1.83	20
Michigan					
Flint	WTAC-TV	16	482-488	2.04	17.4
Minnesota					
Minneapolis	WTCN-TV ²	11	198-204	4.93	316
St. Paul	WMIN-TV ²	11	198-204	4.93	316
Mississippi					
Meridian	WTOK-TV	11	198-204	4.93	31.2
Missouri					
Hannibal	KHQA-TV	7	174-180	5.61	316
Springfield	KYTV	3	80-66	16.06	61
St. Louis	KSTM-TV	36	602-608	1.63	25
New Mexico					
Albuquerque	KGGM-TV	13	210-216	4.65	89
Albuquerque	KOAT-TV	7	174-180	5.61	25
New York					
Albany	WROW-TV	41	632-638	1.55	269
Rochester	WHEC-TV ³	10	192-198	5.08	125
Rochester	WVET-TV ³	10	192-198	5.08	125
North Carolina					
Winston-Salem	WSJS-TV	12	204-210	4.79	316
Winston-Salem	WTOB-TV	26	542-548	1.81	20
Oklahoma					
Oklahoma City	KTVO	25	536-542	1.83	12
Oregon					
Portland	KOIN-TV	6	82-88	11.8	100
Pennsylvania					
Chambersburg	WCHA-TV	46	662-668	1.48	21
Tennessee					
Knoxville	WTSK	26	542-548	1.81	21
Memphis	WHBQ-TV	13	210-216	4.65	316
Texas					
Harlingen	KGBS-TV	4	66-72	14.61	13

*From Station CP application. ^{1,2,3}Share time on air. The frequency of the video carrier = 1.25 + channel lower freq. limit.
Total number of television stations now on the air: 293 (97 of which are u.h.f.)

NEVER BEFORE



-so many
features
packed
into one
Signal
Generator

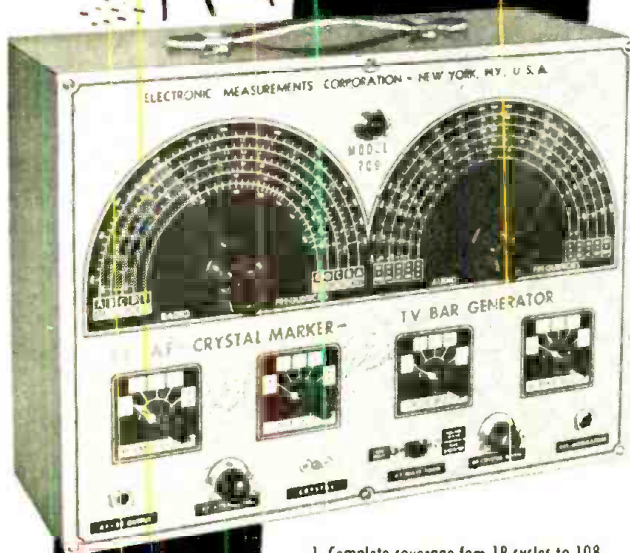

**MODEL
700**

RF-AF
Crystal Marker
TV Bar
Generator

\$55.90

EMC

ELECTRONIC MEASUREMENTS CORP.

280 LAFAYETTE STREET • NEW YORK 12, N. Y.
EXPORT DEPARTMENT 136 LIBERTY STREET, N.Y.C. 6, N.Y.

1. Complete coverage from 18 cycles to 108 megacycles on fundamentals.
2. Bar generator for TV adjustment with a variable number of bars available for horizontal or vertical alignment.
3. Square Wave Generator to 20 kilocycles.
4. Wien Bridge AF oscillator with sine wave output from 18 cycles to 300 kilocycles.
5. Crystal marker and amplitude control.
6. Individually tuned coils.
7. Constant RF output impedance.
8. Stepped RF attenuator.
9. Electrostatically shielded transformer.
10. Thorough shielding.
11. Colpitts RF oscillator from 300 KC to 108 megacycles on fundamentals—up to 216 megacycles on 2nd harmonic.
12. Variable percentage of modulation.

"See It At Your Jobbers"

Write Dept. RN-11, for free Complete Catalog

50 to 12,000 c.p.s.

tonal range

V-M 555 HIGH FIDELITY PHONOGRAPH



V-M tri-o-matic® 555
High Fidelity Phonograph
Model 555-M (Mahogany) \$139.95*
Model 555-O (Limed Oak) \$144.95*

- plays finest records with life-like richness...
- offers beautiful furniture styles!

Enjoy these features of the V-M 555 wherever you care to plug it in:

Two new type sapphire needles in new ceramic cartridge reproduce 50 to 12,000 c.p.s.! • Three 5" ultra-wide range speakers *all facing the front!* • Resonance free, balanced, die cast tone arm! • 3-tube (plus electronic rectifier) amplifier with push-pull output! • Choice of Mahogany or Limed Oak furniture finishes, both with golden grille of expanded metal! • *Siesta Switch* shuts off everything (amplifier too) after last record plays! • Gentle tri-o-matic spindle *eliminates* holders that grip record grooves! Made by V-M Corporation, world's largest manufacturer of phonographs and record changers exclusively.

* Slightly higher in the west.

LOOK FOR THE  "THE RECORDED VOICE OF MUSIC"

Please
mail
this coupon

V-M CORPORATION, Benton Harbor 4, Michigan
Please send complete details on the V-M 555 High Fidelity Phonograph.

Name _____

Address _____

City _____ State _____

REK-O-KUT

The Greatest Name in **TURNTABLES**
For High Fidelity Record Reproduction



Model T-12H

Record reproduction begins with the turntable, and there can be no compromise with turntable quality where the best sound reproduction is desired.

REK-O-KUT has long been famous for outstanding disc recording equipment and this specialized skill has contributed immeasurably to making REK-O-KUT turntables the accepted quality standard among professionals and music lovers alike.

REK-O-KUT turntables are available in two- and three-speed models priced from \$59.50 at leading Dealer-Distributors.

Write for Descriptive Literature.

REK-O-KUT CO.

38-03B Queens Boulevard, Long Island City 1, New York

With this analogy in mind, let us consider Fig. 3, which shows a piece of recorded tape on which the magnetic pattern has been made visible by covering the tape with powdered iron in solution, with the iron particles gathering at the points of greatest magnetization. The first thing to observe here is that the magnetic pattern is exactly at right angles to the tape length. This is customary for the recording and reproduction of sound, although it is of course possible to magnetize the tape lengthwise, and this is sometimes done for special applications, such as synchronization signals.

However, our interest is in the vertical pattern; a simplified version of a magnetized tape appears in Fig. 7A, with its corresponding waveform shown in Fig. 7B. This appears to be a constant sine-wave tone with a full cycle described between points A and B, and B and C.

Now let us suppose that it is necessary to splice between points X and Y. Since we are splicing diagonally we cannot make cuts precisely at those points, but instead will be cutting in each case, on a line which runs at about a 45-degree angle from the desired point. When we join these two sections, we obtain a magnetic pattern like that shown at Fig. 5A, in which the striations at the two ends do not coincide. Thus we conclude that the two ends are *out-of-phase*. This is illustrated graphically in Fig. 5B, where the dotted lines of the two curves show the waveform before the tape was cut, while the solid lines show a flattening of the curve, representing a level drop due to the "fading" effect of the narrowing of the tape. As expected, the two curves are out-of-phase and their sum will not produce a sine-wave resultant. The exact nature of the sound produced in that area will depend upon the angle of the cut, tape speed, the nature of the recorded sound and other factors, but in any case it will be an undesirable effect, and so must be eliminated.

The method of correcting this condition is one well-known to all experimenters: simply "cut and try." Remove a very narrow sliver of tape from either end at the splice, rejoin and listen. It may be necessary to do this several times before a satisfactory splice is produced. It should also be remembered that this trick will only work on a *steady* tone. If it should be attempted on, say, a solo clarinet in a *diminuendo* or *crescendo* passage, it will be almost impossible to perform a perfectly soundless splice because there is the additional problem of a jump in level due to an interruption in the slope of the fade.

The effect of an out-of-phase square splice is quite different, as shown at

SPEAKER RECONING

Complete line Cones, Spiders, Rings and Voice Coils. Custom Built Voice Coils. Low prices. Write for Parts List and Reconing information.

WESTERN ELECTRONICS CO.

3184 West Colfax Denver 4, Colo.

Look, Old Radio Vibrators Repaired

\$1.25 each

30 Day Guarantee

RADIO PRODUCTS SERVICE
P. O. Box 591 SPRINGFIELD, OHIO

Brand New
Set Mfr's
SURPLUS

TUBES

STANDARD
BRAND
WARRANTY

Bulk Packed in Original Mfr's Nested Cartons or Individually Boxed
Every tube meter and chassis tested for top quality... **BRANDED**

1B3GT54	6AC771	6BH649	6SN7GT .. .49	198G6G .. 1.19
1L450	6AH664	6BJ649	6T864	19T864
1R549	6AK564	6BL7GT .. .82	6V6GT44	25BQ6GT . .82
1S455	6AL537	6BQ6GT .. .79	6W4GT44	25L6GT45
1S541	6AQ541	6BQ779	6W6GT44	35B549
1T449	6AG549	6BK771	6X5GT34	35C549
1U449	6AT639	6C434	12AT634	35L6GT45
1U541	6AU639	6C544	12AT760	35W435
1X2A55	6AV639	6C8645	12AU637	3Z5Z31
3Q5GT58	6B4G82	6CD6G ... 1.11	12AU755	50B549
3S449	6BA644	6H641	12BA645	50C549
3V449	6BC549	6J5GT37	12BE645	50L6GT45
5U4G44	6BE641	6J654	12BH756	
5Y3GT39	6BG6G ... 1.19	6K6GT39	12SN7GT . .49	

More than 400 types in stock, include all your needs when ordering.

Orders less than \$10.00—add \$1.00 service charge. Terms: 25% with order, balance C.O.D.
All prices subject to change without notice. F.O.B. New York City.

TRANSAMERICA ELECTRONICS CORP.

120 LIBERTY ST., NEW YORK 6, N. Y.

Fig. 6. Instead of an "area of confusion," we have simply a momentary "skip." It is somewhat easier to get this splice in phase and the results are perhaps more accurate.

Thus the type of splice to use depends upon the given set of conditions. Generally, the diagonal splice is preferable simply because it is stronger. But when the diagonal won't work, the square one often will.

The "area of confusion" as noted may sometimes be used to advantage for special effects. By cutting the tape at a very slight angle with scissors, and thus spreading the splice out over several inches, it is possible to create the effect of a *cross-fade*. The end of one tape actually fades out as the beginning of the other fades in. This is more striking at the lower tape speeds, as it can be spread out over a greater period of time for the same splice length. Thus a splice four inches in length recorded at 3 3/4 ips would produce a very pleasing cross-fade of over one second's duration. But at the higher speeds this trick is seldom worthwhile.

Next month we shall begin some actual practice in editing techniques with hints on professional tricks.

(To be continued)

NEW AES OFFICERS

THE Audio Engineering Society recently announced its new slate of officers for 1954. They are: President, Jerry B. Minter; Executive Vice-President, Albert A. Pulley; Central Vice-President, Robert C. Moyer; Western Vice-President, Boyd McKnight; Secretary, C. J. LeBel; Treasurer, Ralph A. Schlegel; Governors, Richard H. Ranger, Lawrence J. Scully and Walter O. Stanton.

COL. CROSER NAMED

COLONEL KENNETH R. CROSER, USAF, deputy special assistant to the Chief of Staff for Reserve Forces, has been elected chairman of the MARS Advisory Committee for a one-year term. He succeeds Col. William D. Hamlin, Signal Corps, Chief of the Army Communications Service Division, who remains as a member of the committee.

Elected to serve with Col. Croser, as vice-chairman, was Lt. Col. Frank Chilton, Signal Corps. Both of the newly-elected officers hold amateur licenses and are active in the MARS program.

(Left) Col. Kenneth R. Croser, USAF, new chairman of the MARS Advisory Committee and (right) Lt. Col. Frank Chilton, Signal Corps, vice-chairman of the committee.



November, 1953



the Moderne
Model UR-312 Available in Cherry
Mahogany, Blond Mahogany,
or Lined Oak.
User Net: \$ 64.50
Blond and Lined Oak—10% extra

LOOK at the styling ...
LISTEN to the reproduction ...

the new *Musicorner*

by UNIVERSITY



the Traditional
Model UR-311.
In Cherry or
Cordovan Mahogany.
User Net: \$ 64.50

Now you can have good "looking" with good listening! Each University MUSICORNER design is authentic in every detail, and reflects the traditions of the old masters of fine furniture. All genuine woods—hand rubbed! Designed to flatter the decor with stylings that smartly blend with any existing interior.

University Musicorner gives you wide angle coverage, clarity and brilliance with its full front radiation. High power handling ability and distortion control, with an internal and extended horn. And, boosted low frequency response with high efficiency, from its unique integral bass reflex system.

THE HEART OF THE *Musicorner*

Model 6201, 12" coaxial speaker system. A TRUE coaxial dual range system, with woofer, and driver type tweeter, built-in crossover network, and "balance" control. Finest to be had! User Net: \$ 45.00



The exclusive University Diffusicone-12 speaker is acclaimed by experts everywhere! Here, in the economy of one speaker you get dual-horn loading, radial projection, and diffraction—to give unsurpassed fidelity, range, and uniform sound distribution. User Net: \$ 27.00



Model 6200, 12" extended range speaker. Gives highly efficient full-bodied response throughout the operating spectrum. User Net: \$ 21.00



FREE BOOKLET!

describing these
wonderful enclosures in
greater detail.

University LOUDSPEAKERS, INC.

80 SOUTH KENSICO AVENUE • WHITE PLAINS, N. Y.

RIDER TEK-FILE*

packaged
tv
service
information—
factory—
authorized
factory—
approved
for easy
tv servicing —
tailor-made
for more than
3000
receiver models
only
\$2 per pack
(at your jobbers)

Try a pack. If you're not satisfied,
return the pack within 7 days and
your money will be refunded.

JOHN F. RIDER Publisher, Inc.
480 Canal Street, N. Y. 13, N. Y.

* Dependable TV
replacement parts
listings starting with
PACK 57

Feedback Preamp (Continued from page 67)

negative side, also serving as the reference for the positive regulator. Unfortunately, no manufacturers seem interested in making a line of transformers with double (separate) plate supply windings, for dual regulator systems, so that recourse was had to the use of two very small conventional ones.

The 12B4 makes a very fine regulator series tube, for light duty work, since it is roughly a quarter-size version of the 6AS7, it being able to pass quite high currents at very low voltages; the zero-bias current at a plate voltage of 100 volts is about 180 ma. which is very good for a tube with a 4 watt heater. The cathode current maximum rating is presumed to bear the same (4:1) relationship to that of the 6AS7 (240 ma.) as does the heater power and plate dissipation ratings. Since the maximum plate dissipation is 6 watts, then the tube can stand a drop of 100 volts while it is passing a steady 60 ma., and it does not have to go to zero bias to do it.

The 12BY7 was used in place of the usual, and more appropriate, 6AK5 since it is roughly half the price and its extra heater power was, in this case, of no importance. It does a very good job. (It is excellent for such devices as square-wave generators and oscilloscope deflection amplifiers).

In matters of power supplies and transformers for preamplifiers the writer is debating a switch, for the better quality work, from the ordinary E-I cored transformer to the use of toroidal power transformers. The external fields from the ordinary transformer are just too much for magnetic pickups, and if you just have to mount the two in the same cabinet, without spending a fortune for woodwork and putting up with oversize cabinetry, then you have a hum problem. (No data is at hand as to the merits of the "low flux density, for preamplifiers" transformers made commercially for some time).

Recent experiences with (hand-wound) toroidal power transformers for 400-cycle service have led to the writer's current intention to try repeating the experiment at 60 cps, even though the amount of iron and the number of turns will be larger than was the case at the higher frequency. A fairly large iron structure and a somewhat onerous number of turns-per-volt will be needed, but the results should justify the pains. Due to the very low leakage inductance and to the generous wire sizes used, the 400 cps transformers had superior regulation and very low temperature rise. Even with the great advances in compact construction of 400 cps equipment which have lately been made, these transformers were not unduly large and heavy, although they were hardly subminiature. There was no

appreciable external field, and it was this feature that saved a great deal of trouble with hum pickup.

Performance of the preamplifier of Figs. 1, 2, 3 was, as to frequency, 1 db down at 20 cps and 30 kc., limited at both ends by the transformer (although it is a good one). Lesser limitations, the ones one would encounter without the transformer, are, at the low end, the coupling condensers at input and output, and, at the high end, the inevitable capacitances to ground.

Maximum output voltage was "rated" at 20 volts r.m.s. from 20 cps to 20,000 cps, although it will actually do better than this.

In discussing the question of hum, it should be noted that the transformers and rectifiers are on one chassis and the amplifier and regulators on the other, there being also, a d.c. heater supply filtered to about 5% ripple. The final hum at the output of the amplifier, after a voltage gain of 600 from the pickup was 3 mv., or 5 microvolts referred to the input transformer primary. This is mainly 60 cps and, of course, a little noise.

-30-

TRANSISTOR OSCILLATOR

By LOUIS CARCANO

A SIMPLE transistor oscillator circuit is shown in the accompanying diagram. The constants given are for operation at approximately 1 kc. The waveform is excellent.

Resistor R_1 determines the emitter current, hence the collector current. If the oscillator output is heavily loaded, R_1 will have to be made a lower value than that specified. If it is lightly loaded, the value can be made higher.

Resistor R_2 is used to limit the reverse collector current which flows when the collector end of the tuned circuit swings positive. If its value is too low, flat-tops appear on the positive peak of the wave. If the value is too high, oscillation stops. The waveform is better at high values. The value of R_2 depends on the load and on the "Q" of the coil. Use from 10,000 to 20,000 ohms with a high-"Q" toroid coil and from 0 to 1000 ohms with a low-"Q" choke.

The battery voltage is not critical. The drain is about .1 ma. with the values shown. The peak output voltage is about equal to the collector battery voltage.

A crystal diode, with its "anode" polarized toward the collector, can be used to replace R_2 but its performance is just about on a par with the resistor.

Operation is class C.

-30-

Oscillator using "p-n-p" junction transistor.

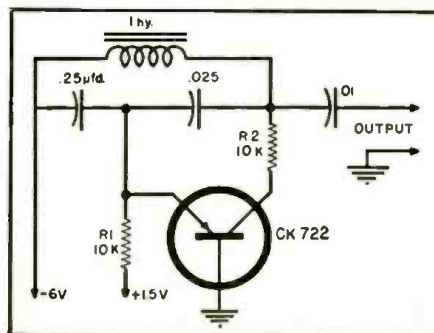

RADIO & TELEVISION NEWS

MOVING TO LARGER QUARTERS . . . BUY NOW!

CRYSTALS

Low Freq.—RT 241 A for SSB, lattice filter, 1/2" spc. 54th harm channels listed by fund. Fractions omitted.

370	388	467	425	444	462	481	501
372	390	409	427	446	464	483	503
374	392	411	429	448	466	485	505
375	394	412	431	450	468	487	507
377	396	414	433	451	470	488	509
379	398	416	435	453	472	490	511
381	400	418	437	455	474	492	513
383	401	419	438	457	475	494	514
385	403	422	440	459	477	496	516
387	405	424	442	461	479	498	

49c each
10 for \$4.00

Radar Indicator unit for conversion to test scope or for use as a modulation monitor. Complete with tubes. But, less 5BP1. Parts alone are worth much more. New . . . **\$9.95**

5BP1, 5CP1 **\$3.95 ea.**

954, 955, CK1005, 1625, 1626, 1619, 33, 34, 9002, 9004, 9006, 6Z7G, 1N5GT 6J5, 12A6, 12SL7GT, 12SQ7GT, 1F4G, 1F5G

10 Assorted for **\$3.00**

DYNAMOTORS: The best dynamotor for conversion to 6V. Multiple windings! After conversion you get choice of 150 or 351 v. at 50 MA or 250 v. at 100 MA. Complete dope sheet furnished. **\$4.65**

BRAND NEW (See "CQ" Aug. Issue) . . . **\$4.65**

BC 223 Tuning Units **\$2.49 ea.**

Walkie-Talkie—BC 322

used, good cond. **\$29.95 ea.**
Aerial for same **2.95 ea.**



BROADCAST BAND and AERO

Ideal for Use in Boats, etc.

MN-26-C Remote Controlled Navigational Direction Finder and communications receiver. Manual DF in any one of three freq. bands, 150 to 1500 KC. 24 V. Self contained dynamotor supply. Complete installation, including receiver, control box, loop, azimuth control, Left-Right Indicator, plugs, loop transmission line and flex. shafts.

LIKE NEW **\$69.50**
MN-26-Y 150 to 325 KC, 325 to 695 KC, 3.4 to 7 mc/cycles, comp. installation **\$69.50**
Receiver alone **35.95**
MN-26-C alone, like new **39.50**
MN-26-Y as is less tubes **5.95**
With tubes, used good **24.95**
MN-20-E Loop, Brand New **6.95**
MN-52 Crank drive, New **2.50**

RT7/APN-1 TRANSCIEVER UNIT—Used as an alternator, it may be converted for signaling control circuits, etc. Used, less tubes, as is **\$4.95**

RL-42 REVERSIBLE MOTOR WITH ANTENNA REEL AND CLUTCH, USED **\$2.75**

SURPRISE PACKAGE

15 lbs. of assorted good radio parts. A real value at **\$1.95**

RT/34 APS 13 TRANSCIEVER used as a tail warning radar on 435 MC. Containing a 30MC IF Strip and various other parts, these unit, have been stripped of IF sections and all tubes, but are an excellent buy if only for parts and IF Strip. used **\$4.95**

MISCELLANEOUS EQUIPMENT

FL-8 used, exc **\$1.19**
BC-906 each **9.95**
BC-347 each **95c**

Hundreds of items in stock. WRITE FOR PRICES. Shipments F.O.B. warehouse. 20% Deposit on orders. Minimum order \$5.00. Illinois residents, add regular sales tax remittance. Prices subject to change without notice.

MONTHLY SPECIAL

BC 455
BC 457
BC 458 **\$5.00** For your choice of any 3. Used, less tubes, as is.

BC-929 3" RADAR SCDFE—brand new **\$19.95**
SELBYN TRANSMITTER: Autodyn Transmitter Assembly for matching to I-82 Indicator, Used excellent condition. ONLY \$7.95, Complete with Indicator. **\$14.95**
BC-683 RECEIVER, 27-38MC, used, excellent **\$39.50**
BC-684 FM Transmitter, 27-38mc, used, exc. **\$24.95**
BC-6C4 FM Transmitter, 20-27 mc, used, exc. **\$11.95**
RA 10 DA Receiver **\$17.95**
RA 10 DB Receiver. **\$34.95**

RA-52 RECTIFIER

Transat controlled to produce high voltage DC from 110 VAC 60 cycle source. Up to 11,500 VDC @ 50 W. Metered high voltage (0-15 KV) and current (0-20 MA). **\$69.95**

ARR Receiver—used, exc. complete—195 kc to 9 mc, used, exc. **\$39.50**
Collin: Auto Tune—Assembly for ARC-1, brand new **\$69.50**
BC-621 receiver (SCR 522), less tubes, 100-150MC **\$14.95**
MN-20LB Receiver exc. **59.50**

	As Is	Less Tubes	Exc. Used	New
BC-451 Receiver, 3 to 6 mc.			\$11.95	—
BC-455 Receiver, 6 to 9 mc.			\$4.95	9.95
BC-456 Modulator			2.95	4.95
BC-457 Transmitter, 5 to 5.3 mc 4.95			—	—
BC-458 Transmitter, 5.3 to 7 mc 4.95			—	—
BC-459 Transmitter, 7 to 9 mc 7.95			14.95	—

Control Boxes, racks, receivers for above in stock—write.

BC-1073 62-80 mc recvr. Like new, less tubes, ea. \$5.95

BC-709 Inter. Amp. New. **3.95**

SCR-625—FAMOUS ARMY MINE-DETECTOR For Pipe detectors, Miners, Oil Companies, Plumbers, etc. This unit is being offered now at a considerable reduction in price. Recently advertised at \$75.50 it is now available in the same brand new wrappings (in suitcase) style carrying case (less batteries). **\$59.50**

SCR-572—Transceiver, complete in case with top bra ket, less tubes **\$29.95**
RU-19—Receiver, complete control box and coils—brand new **\$17.95**

TRANSCIEVER

140-144 mc, 2 meter, used, excellent condition, less dynamotor, less tubes. Only **\$14.95**

WOBULATOR

BUILD TV-FM-AM SWEEP GENERATOR

You can build "Versatile Sweep Frequency Generator with APN-1 magnetic units. **\$ 5.95**
BC-1206 Beacon Receiver 200-400KC. **9.95**
TS 184/AP Test Set **39.50**
APR-2 Radar Search Receiver, 85-1000MC. **95.00**
APR-4 Radar Search Receiver, 38-1000MC. **399.00**
Tuning Units—TN16, TN17, TN18, each **200.00**
IE 19A-SC1522 Test Unit. **295.00**
MG-153 Inverter Used **69.50**
I-222-Signal Generator Used, exc. **125.00**
AN/APT5 Transmitter Like new **189.50**

MG-149F excellent condition. **\$ 89.50**
MG-149H excellent condition. **129.50**

P-206, inverter, like new. **\$12.95**
PE-218, inverter, excellent condition **29.95**

BC-640 **\$795.00**
BC-639 with RA 42 rectifier. **295.00**

AMERTRAN

0 to 130 V. Maximum amperage 100. Like New **\$135.00**

IMPACT SWITCHES Brand new **98c**

BK-22 Relay Unit & terminal box for ADF—Used **\$4.50**

2 Volt Vibrators 10 for. **\$3.00 ea. 39c**

WHILE THEY LAST!

350 ft. of 50 ohm coaxial cable **\$ 9.95**
Attenuator—one cavity type **7.95**
T511 Hand Sets, excellent condition **5.95**
T5 Type, exc., less cord **2.95**
EES Portable Telephone exc. cond. ea. **18.95**
10 assorted electrolytics **.95**
100 astsd. 1/4 and 1 W carbon resistors **.95**
.2-2.2 mfd @ 4000 Volts **1.49**
2 mfd. @ 4000 Volts **2.95**
R-1/ARR-1—220 mc converted with minor alterations becomes a high gain converter with two stages of R. F. amplification—(see "Radio & TV News," Jan., 1949) new **\$4.95**
T5-1—Test Set for above. **4.95**
T-26 Telephone chest unit with F-1 Western Electric Transmitter **\$2.39**

MIKES and HEADSETS

HS-33 Low Impedance Headset exc. \$2.95 new **\$5.45**
HS-23 Headset used 2.50 new **4.50**
CD-307 Ext. cord for HS-23-33. like new **.79**
Throat Mike—T-30. new **.98**
Lip Mike—Navy Type. new **.98**
CW-49505 High Impedance headset complete with headband. Used **98c**
HS-33 Used \$2.45 new **\$5.45**
T-45 Lip Mike. New. **1.75**
HS-30, miniature headset. Used \$1.49, new **2.49**



WILLARD 6 Volt Storage Battery

3 amp. hr., Brand New—3 3/4" x 1-13/16" x 2 3/4" uses standard electrolytic **\$2.39**

WANTED:

All TS, APR, APS, ARC, ARN, SCR, R89 and BC equipment write today! Quote lowest prices in your first letter

R. F. MODULATOR

Complete tunable 205 mc Test Set. With 110 V., 60 cps, power supply, 3-stage audio amplifier, terrific chassis for experimentation, good condition **\$8.95**

TU9—Tuning Unit for BC 375—used, good cond. **\$1.95**

II TUBE UHF TUNABLE RECEIVER **\$7.95**
231-528 mc, less tubes

Shipments F.O.B. warehouse. 20% Deposit on orders. Minimum order \$5.00. Illinois residents, add regular sales tax remittance. Prices subject to change without notice.

BC433 RADIO COMPASS RECEIVER, 200 to 1700 KC, used, excellent condition with tubes \$39.95 used, exc. less tubes **14.95**
used, as is, less tubes and cover, exc. for parts **5.95**

BUY NOW!

R W ELECTRONICS

Dept. N, 3430 S. Michigan Ave., Chicago 16, Ill.

PHONE: HARRISON 7-9374

BUY NOW!

SPECIAL OF THE MONTH

GENERAL ELECTRIC R.F. AMMETER
0.4 Amp R.F., 2 Inch Round, \$2.95
BRAND NEW Ea.
STANDARD BRAND OIL CONDENSER
6Mfd. 1500 V. DC. \$2.95
SPECIAL 2 Ea.

G. E. RELAY CONTROL

(Ideal for Model Controls, Etc.)

Contains a sigma midget 8,000 ohm. relay (trips at less than 2 MA), high impedance choke, bi-metal strip, neon pilot and many useful parts. The sensitive relay alone is worth much more than the total low price of **\$1.25** Each 10 for **\$9.90**

Panel Meters

NEW GOVT SURPLUS
STANDARD BRANDS
2" METERS
DB meter—10 to
+20 \$3.49
0-500 ma DC..... 3.49
3" METERS
0-200 Microamps... \$6.95
0-400 Microamps... 5.95
0-500 Microamps... 5.95
0-200 Millilamp... 4.50
0-1000 Millilamp... 4.50
0-1.5 Volts AC..... 4.95
0-3 Volts AC..... 4.95
4" METERS
0-200 Microamps... \$8.95

OIL CONDENSER BARGAINS

4 MFD-600 VDC \$0.95
10 MFD-600 VDC 1.75
2 MFD-1000 VDC .95
4 MFD-1500 VDC 2.50
6 MFD-1500 VDC 2.95
8 MFD-1500 VDC 3.50
2 MFD-2000 VDC 2.50
4 MFD-2500 VDC 5.95
2 MFD-4000 VDC 5.50
3 MFD-4000 VDC 5.95
1 MFD-5000 VDC 3.95
2 MFD-5000 VDC 5.95
3.75 mfd 660 VAC. 2.45
1 mfd 7500VDC . 1.75
1 12KV DC . 2.95
0.1u. 0.12KV DC . 2.95
5 mfd 660 VAC. . 2.95

NON-INDUCTIVE RESISTORS

Ohmite, 250 Ohm, 100 Watt.

59¢

Special. 5 for \$2.50

SOLA CONSTANT VOLT. TRANSFORMER

Pri. 95-125 volts, 60 cy. Sec. Regulated at 115 volts 30 VA. \$ 9.95

TELRAD FREQUENCY STANDARD

10 KC, 100 KC and 1000 KC output. Crystal controlled. Crystal accurate to .05%. Provision for zeroing crystal 115 V. 60 cy. operation. Complete with 4 tubes. BRAND NEW SIGNAL CORPS SURPLUS. **\$24.75** Ea.

BLOWER MOTOR

Squirrel cage, 140 CFM. 115 volt 60 cy. motor. Extremely quiet. Made by Redmond. BRAND NEW **\$6.95**

HIEMANN CIRCUIT BREAKERS

5 Amperes, 115 V. 60 Cycle. **95¢** Ea.
BRAND NEW 10 for \$8.50

A.C. RELAY

110 v. 60 cy. Model 506. Cutler-Hammer SPST 15 amp. or 1/2 H.P. contacts. NEW **\$1.95** Ea.

MOBILE DYNAMOTORS

MADE BY PIONEER AND EIGOR

6 Volts Input. 425 Volts at 375 MA Output. 6 3/4" Lonk. 4" Diameter. Weight 10 lbs. List Price Approx. \$70.00. BRAND NEW, ONLY **\$24.95**

CARTER SUPER DYNAMOTOR

12 Volts Input. 400 V. Output @ 200 MA Continuous or 375 MA Intermittent duty. Model B420. Designed for Police, Aircraft and Marine Use. Small, rugged and efficient. BRAND NEW, ONLY **\$24.95** Each

CONTINENTAL MOBILE DYNAMOTORS

11 Volts Input, output 475 V. @ 210 millis **\$19.95** Each

WIRE WOUND RESISTORS

Stock too long to list. We can supply most sizes, so order what you need.

10 Watts. From 1 Ohm to 70K Ohms. Ea. \$.15
20 Watts. From 4 Ohms to 50K Ohms. Ea. .20
25 Watts. From 1 Ohm to 100K Ohms. Ea. .30
50 Watts. From 5 Ohms to 100K Ohms. Ea. .40
100 Watts. From 50 Ohms to 100K Ohms. Ea. .50
ADJUSTABLE SLIDER, WIRE WOUND
10 Watts from 1 Ohm to 10K..... \$.25
25 Watts from 20 Ohms to 2.5K..... .35

VACUUM CONDENSERS

50 mmf. 5 KV. General Electric..... \$ 5.95
100 mmf. 20 KV. Jennings..... 12.95

1 MEGOHM, 1% W.W. PRECISION RESISTORS. SMALLCROSS. ONLY **97¢** ea.; 10 for **\$8.95**

BAKELITE CASED MICAS

MFD	VDC	Price	MFD	VDC	Price	MFD	VDC	Price
.001	600	\$.18	.01	1 KV	\$.45	.02	2 KV	\$.90
.002	600	.24	.02	1200	.35	.02	2500	.45
.01	600	.26	.024	1500	.65	.004	2500	.50
.02	600	.26	.033	1500	.75			

Min. Order \$3.00—25% with Order

PEAK ELECTRONICS CO.

66 West Broadway, New York 7, N. Y.
Phone WOrth 2-5439

Electronorgan

(Continued from page 64)

socket and close the switch for about three seconds. The lamp will light brilliantly. When the switch is opened note that the two electrodes of the lamp are evenly illuminated and that the scope shows a clipped sine wave with good, flat tops. Note several times the difference between the electrode illumination and the screen pattern before and after a lamp has been flashed. This will indicate how they should look. The flashing ages the lamps artificially and keeps them from changing characteristics after a time in use. Do not flash the lamps too long as this will destroy their characteristics or burn them out completely. A dot of red nail polish is placed atop each lamp after aging to distinguish it from an untreated lamp.

The lamps may now be installed in their sockets on the generator chassis. Connect the synchronizing links by winding 1 turn of No. 28 copper wire around each lamp, twisting tightly to hold in place, and connecting one end to the appropriate tube plate. Leave a little slack to avoid strain and allow removal of the lamp if necessary. Do not use solder to clinch the twist which holds the loop in place on the bulb. After tuning, a small amount of coil cement or Duco cement may be used for the purpose.

The chassis can be connected individually to the power supply and tuned, but it is much better practice to connect them all to the supply since that will stabilize the power voltages to their final values.

The tuning procedure requires an oscilloscope and a stable audio generator as well as a standard such as a well-tuned piano or other musical instrument which is in tune. In a pinch a good-quality harmonica can be used after making a test with a good musical instrument to see that the harmonica is in tune. For this purpose the standard need not be in perfect tune as long as it is well within about a quarter-tone of true pitch. A pair of headphones or a handy test amplifier is also a necessity. The primary necessity, however, is a large supply of condensers ranging in value from 500 μ fd. to .05 μ fd. If a set of condenser decades covering this range can be obtained much time will be saved, for this is strictly a cut-and-try process. Except for the condensers used to tune the master oscillators, 200-volt ratings are sufficient and age or condition not important.

Begin with any of the master oscillators. Connect the oscilloscope, audio generator, and headphones as indicated in Fig. 8A, with oscilloscope ground to the generator chassis and the high end of the vertical input on pin 7 of SO_{13} through SO_{24} (pin 8 on the C chassis). If the circuit is oscillating some kind of a pattern should show up on the screen; if not, reverse

See Better! Work Better!

LUXO LAMP

—Acclaimed the World over as the best light to work under!

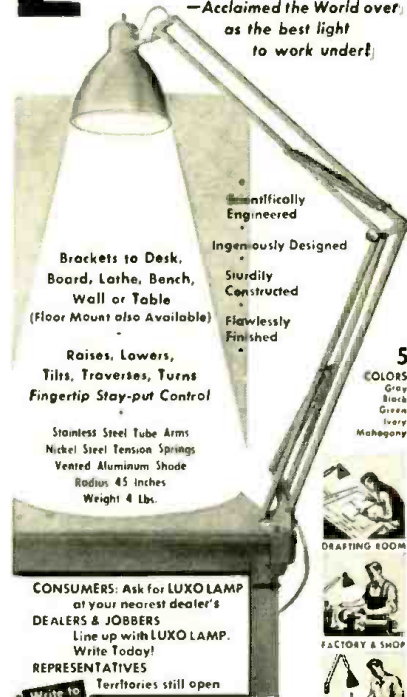

Scientifically Engineered
Ingenuously Designed
Sturdily Constructed
Flawlessly Finished

Raises, Lowers, Tilts, Traverses, Turns
Fingertip Stay-put Control

Stainless Steel Tube Arms
Nickel Steel Tension Springs
Vented Aluminum Shade
Radius 45 inches
Weight 4 Lbs.

CONSUMERS: Ask for LUXO LAMP at your nearest dealer's
DEALERS & JOBBERS: Line up with LUXO LAMP. Write Today!
REPRESENTATIVES: Territories still open

LUXO LAMP CORPORATION
290 MADISON AVE., NEW YORK 17, N. Y.

there must be a reason that more

QUIETROLE
TRADE MARK REG. U.S. PAT. OFF.
is being SOLD!*



More Servicemen are finding that only QUIETROLE, the original, non-conductive, non-inflammable Lubri-Cleaner will assure positive quietness to noisy TV and radio controls and switches. It does so much, yet, costs so little.

Carried by leading jobbers everywhere!



manufactured by
QUIETROLE COMPANY
Spartanburg, South Carolina

RADIO & TELEVISION NEWS

the tuning transformer secondary connections. The frequency of oscillation will be very high.

In the explanation to follow, let us assume that the G chassis is being tuned. The first object is to select a value for C_1 , Fig. 6, which will tune the master oscillator to G (3136 cps) with C_2 at about half mesh. The standard—piano, etc.—is used for the purpose but this is too high a frequency to compare by ear directly. We therefore proceed in these steps:

1. Select the second G above middle C on the piano or other standard and tune the audio generator to it by ear. Note the generator setting.

2. By trial connections, using clips (Mueller double clips are excellent for the purpose) find the condenser value which will produce from the master oscillator a frequency which, when fed to the vertical scope plates, will cause a Lissajous pattern with four vertical waves for one horizontal wave at any setting of C_2 . The frequency will then be four times that of the standard. The pattern will look something like that of Fig. 9. The setting of the audio generator may have to be varied several times to find how the trend is going with various condenser values. When the value is close, recheck the test generator setting with the standard and try to find the value which will give the figure of Fig. 9 with C_2 at about mid-range.

3. Check the correctness of the final value by setting C_2 at minimum capacitance, adjusting the test generator for the pattern, and seeing that the test generator tone is noticeably higher than the G. Then set C_2 to maximum capacitance, reset the test generator for the Lissajous figure, and see that its tone is noticeably lower than G. The master oscillator is now tuned to G, with a reasonable range of adjustment with C_2 .

The values of capacitance are quite critical and it may often be necessary to use two or even three condensers in parallel. It is advisable to have on hand a good supply of 50- μ fd., 100- μ fd., and 200- μ fd. tubular ceramics for trimming purposes. Inexpensive ones can be bought in packages of five in the *Centralab* brand.

Next tune the first neon divider. The procedure is the same, except that the master oscillator itself is used as the standard instead of the piano. Connect the master oscillator to the vertical plates and the output of V_{2A} , Fig. 6, to the horizontal plates. Find the capacitance value for C_1 which will give a 2:1 Lissajous figure with C_2 tuned throughout its range. Since the output of the master oscillator is a clipped sine wave and that of the neon divider a saw-tooth, the Lissajous figure will not have the classic appearance but it will be obvious. The correct value can also be found by listening to the output of V_{2A} with the headset or amplifier. When it is not synchronized (incorrect value) the tone will be very rough and it will not vary as C_2 is tuned. To see that it is

INTERNATIONAL RECTIFIER CORPORATION

EL SEGUNDO
CALIFORNIA

DIRECT
REPLACEMENT

RADIO

TV

Selenium

Rectifiers

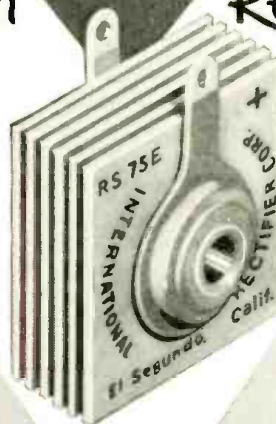

UNIVERSAL
MOUNTING

WIDER
RANGE

Write for
Bulletin JRP-1

INTERNATIONAL RECTIFIER

C O R P O R A T I O N

1521 E. Grand Ave., El Segundo, Calif. • Phone: ORegon 8-6281
CHICAGO: 205 W. Wacker Drive • Phone: Franklin 2-3889
NEW YORK: 501 Madison Avenue • Phone: Plaza 5-8665

ADCO JOE SAYS:



Here are just a few
of our 10,000 Bargains
SAVE MONEY —
ORDER BY MAIL!

CBS - HYTRON 6CU6

**GIVEN FREE WITH
THE PURCHASE OF**

5-6SN7GT }
5-12AU7 } for only **\$24.45**
5-1B3GT }
5-6CB6 }

**SPECIAL
OFFER!**
Replace 6BQ6GT with
new work horse

Directly interchangeable
FORGET . . .

1. Runaway Plate Current
2. High Voltage Arc-overs
3. Shrinking TV Pictures

SELENIUM RECTIFIERS

350 ma. — **\$1.75**
500 ma. — **\$2.02**

Additional 10% discount on lots of 12 assorted.

PHILCO FLYBACK NO. 32 - 8509
Reg. price \$11.10. OUR SPECIAL PRICE \$3.75

PHONO-XTAL

Most popular of all crystal cartridge replacements. 3V. output.

\$1.95 each in lots of 3

**TV TUBE
SOCKETS**
with leads
45c

**TV LINE
CORDS** 29c

SPRAY KLEEN
Contact Cleaners
99c

6"x9" or 7" PM auto
type replacement
speaker
\$2.50

**TV PICTURE
TUBE BRITENER**
\$1.30 ea.

Vertical output trans-
former—3 wire, uni-
versal type . . . \$1.49

10" & 12" FLYBACK
TRANSFORMER
Special—\$1.75

20% deposit on all orders—Balance C.O.D. All Shipments F.O.B. Baltimore.

AMERICAN DISTRIBUTING COMPANY

1200 N. FULTON AVE. — BALTIMORE 17, MD.

**CODE SENDING
RECEIVING SPEED**

Be a "key" man. Learn how to send and receive messages in code by telegraph and radio. Commerce needs thousands of men for jobs. Good pay, adventure, interesting work. Learn at home quickly through famous Candler System. Quality for Amateur or Commercial License. Write for FREE BOOK.
CANDLER SYSTEM CO.
Dept. 2-M, Box 928, Denver 1, Colo., U.S.A.

RCA INSTITUTES, INC.
A service of Radio Corporation of America
50 West 4th St., New York 14, N. Y.

**OFFERS COURSES IN
ALL TECHNICAL PHASES OF
RADIO, TELEVISION, ELECTRONICS**

Approved for Veterans
Write Dept. RN-53 for Catalog

WEATHERS *Debonnaire* new "hi-fi" record player
keeps "turntable scratch"
off the record!



Dust from conventional turntables that gets imbedded in record grooves makes records prematurely noisy. "Debonnaire" turntable never touches the record's playing surface — record rides high on a cushioned float around the spindle, just the size of the record label.

Equipped with superb new Weathers FM light weight tone arm and cartridge, pre-amp, power supply, oscillator, complete controls, assembled ready to plug into your sound system.

Weathers FM Pick-up System

New shock-mounted short tone arm plays at less than one gram of stylus pressure — can't wipe high frequencies off hi-fi records. 20 to 20,000 cycles.



Tone Arm \$14.50
Cartridge \$18.50
Oscillator and
Power Supply \$19.95

Give a Weathers Gift Certificate for Christmas. See your dealer NOW, or write us — we'll tell you where.



BARRINGTON, NEW JERSEY

just one, not two or three octaves below the master oscillator simply listen to the two, one after the other, and judge.

The rest of the dividers are tuned in exactly the same way, each time moving the oscilloscope connections down so that they encompass two tones an octave apart. After the second neon has been tuned its tone can be compared directly by ear with that of the standard to check the tuning range of the assembly.

At that time the vibrato control setting (R_1 in Fig. 11) should also be decided. Adjust the control for the depth of vibrato that sounds about right; since its range is limited, most constructors will want to use all the resistance. This varies the oscillator plate voltage and when it is adjusted the tuning of the master oscillator may change somewhat. After adjustment make sure the oscillator is still in the right range and if not trim C_1 . If the vibrato depth is not sufficient for the builder's taste the 2000-ohm potentiometer may be changed to a 5000-ohm one; but steer clear of the tendency to make vibrato depth too great since that will sound bad at the end of the job, especially if church or concert music is to be played. The power supply (Fig. 13) shows a 5000-ohm unit. Do not change the vibrato setting after it is once made.

The last one or two neons of each string may be hard to tune. At low frequencies the neons seem light-sensitive, so they should be checked with a shield between the lamps and any direct light. If synchronizing over the entire range of C_2 is still difficult, increase the synchronizing-loop capacitance to the lamp electrodes by adding a dot or two of silver conducting paint, available from *Microcircuits Co.* and other printed-circuit paint suppliers. Do not add too much, especially on the higher-frequency neons, as this will make them synchronize at the sync frequency rather than an octave lower.

When this has been done for each of the twelve chassis, the tuning is finished and the generators complete. Do not give up the job, however, until every tone has been double-checked after an hour or so of operation, for the generator is the foundation of the organ and the tones must be on frequency and in sync every time the instrument is turned on. Final tuning will come after the organ is complete, when C_2 will be exactly adjusted with the standard to give each of the twelve tones its precise pitch. This cannot be done, however, unless every neon divider of every string remains in sync through the entire tuning range of the master oscillator.

Parts 2 and 3 of this article will cover construction details on the various filter board circuits, the circuitry for the different organ stops, as well as data on a preamplifier for use with the organ.

(To be continued)

NOW IS THE TIME TO ORDER YOUR Precise OSCILLOSCOPE A FULL 8 1/2" SCOPE—NO OTHER KIT IN THE WORLD LIKE IT

THE OSCILLOSCOPE YOU'VE BEEN SEEKING . . . NO OTHER OSCILLOSCOPE AT ANY PRICE HAS ALL THESE DESIRABLE FEATURES * AVAILABLE IN BOTH KIT AND WIRED FORM

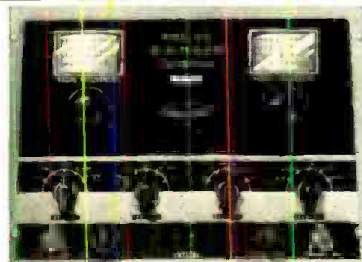

MODEL 630

RF-AF-TV AND MARKER GENERATOR. For the first time in the history of the industry . . . SO MUCH FOR SO LITTLE. 110 MC on fundamentals, 330 MC on harmonics. Pre-tuned RF (within 1%); head; AF from 20 to 20,000 cycles; variable ϕ ; and Ext. Mod.; Cathode Follower and Constant Z output; Stepping attenuator; Speech Amp.; Xtal Marker with Amp. control; RF and AF Standby; Wien Bridge AF; Colpitts RF, illuminated Drum Dials; Coax outputs, Separately tuned coils; Filtered AC; Vernier tuning; Separate RF Shielded; 8" x 11" x 5"; Etched panel. Model 630K . . . \$38.95 (pre-assembled head) **\$33.95**
Model 630W . . . \$53.95 (Factory wired)



PRECISE MODEL 308

1. Full 8 1/2" tube designed specially for this model.
2. Voltage regulation.
3. High frequency—Low frequency—Normal frequency Synchronization Circuit.
4. Separate intensifier anode.
5. Deluxe version of Model 300K.

VERTICAL—Vertical-flat (3db) DC through 5 megacycles with sensitivity of greater than 10 millivolts push-pull (3.94 Millivolts/cm); Con. Stan. Resistance; Push-pull input immediately converted to single-ended normal or reverse phase by shunting bar at inputs 1 and 2; Frequency compensated vertical stepping attenuator selects AC or DC inputs; Push-pull DC amplifiers from input through output; internal electronic mixing through inputs 1 and 2; five-way binding posts.

POSITIONING—Bridge type positioning on vertical and horizontal does not vary tube characteristics.

HORIZONTAL—Frequency compensated stepping attenuator in horizontal amplifier; Push-pull horizontal out.

BLANKING—Internal (return trace blanked), external (return trace not blanked), 60 cycle or 120 cycle Blanking through Blanking amplifier circuit.

SYNCHRONIZATION—External, Internal Positive, Internal Negative, Internal 60 cycle or Internal 120 cycle synchronization.

SWEEP RATE—Driven or non-driven linear sweeps from 1 cycle to 80KC in five ranges (1-10 cycles uses external C circuit); Trigger potentiometer.

MAGNIFIER—Electronic magnifier and magnifier positioner allows any part of a signal to be magnified up to ten times (equivalent to 70 inches of horizontal deflection).

CALIBRATION—Internal square wave calibrator and potentiometer for using oscilloscope at a VTVM on Peak to Peak measurements.

CALIBRATION SCREEN—Edge-illuminated scale and graticule may be turned on or off; filtered screen.

OUTPUTS ON FRONT PANEL—Plus Gate output, Sawtooth output, 60 cycle phasing output, 60 cycle unphased output; Calibration output.

FOCUSING—Astigmatism, focus and intensity control.

CRT—NEW 7" Tube, normally supplied is medium persistence type 7VP1, or 7JP1 may also be used (oscilloscope green trace)—high persistence types available at additional cost.

DIRECT—Deflection plates available from rear of cabinet.

INTENSITY MODULATION—2 modulation through modulation amplifier.

GENERAL—Low loss components; Over-designed fused power supply for additional circuitry; Deeply etched aluminum panel. New parts from original manufacturers—(NO SURPLUS); Steel cabinet, 11" x 14" x 19"; complete with instruction book and all components; Accessories: Model 9121 (MM) Demodulator Probe and Model 960 Capacity Attenuator Probe available at extra cost.

There are many additional features and circuits in Kit Form which may be added to Model 308. Write for descriptive literature.

308K—Kit Form— **\$129.95**

308W—Factory Wired— **\$239.50**

(2 months deliv.)

MODEL 300—Full 7" scope with the same features as Model 308K above except without first five features. Size is 11" x 14" x 17".

300K Kit Form— **\$94.95**

300W Factory Wired— **\$199.50**



MODEL 635

UNIVERSAL AF SINE, SQUARE AND PULSE GENERATOR. For accurate testing audio and video circuits. 1% Ceramic precision resistors; Wien Bridge, variable Z and cathode-follower output; minimum overshoot and roundoff through 100,000 cycles; sine waves through 200 KC. Model 635K . . . \$52.50 (Factory wired) **\$33.50**



MODEL 909

VACUUM TUBE VOLTMETER. 1% Ceramic precision Resistors; Coax DC connector; FM zero alignment scale; burn-out proof circuit. Rugged oversize 4 1/2" meter. Model 909K . . . \$44.98 (Factory wired) **\$25.98**
Model 909W . . . \$44.98 (Factory wired)

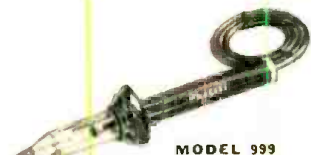

MODEL 999

HIGH VOLTAGE PROBE. Designed for high voltage measurements with special emphasis on Safety, Operational Simplicity and Rugged Construction. Exclusive Features: MULTIPLE INSULATION, MECHANICALLY SHOCKPROOF, CHANGEABLE TIPS, SWIVEL connection. Odds are billions of billions to 1 that no breakdown will occur! **\$6.98**
INTERCHANGEABLE RESISTORS . . . Wired. Only

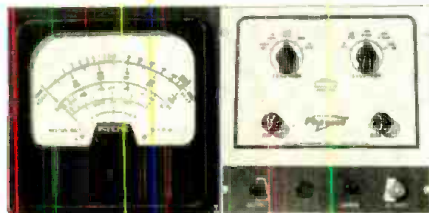

MODEL 907

DELUXE VACUUM TUBE VOLTMETER. Another PRECISE first Vertical or Horizontal construction. GIGANTIC 7 1/2" meter movement; all the unusual values and features of Model 909 in a really DELUXE version. Model 907K . . . \$57.98 (Factory wired) **\$38.98**
Model 907W . . . \$57.98 (Factory wired)



MODEL 468

PRECISE AGAIN LEADS THE FIELD with its New Low-Priced Resistance Decade Box. Ideal for specialized service work. Compact in size for Bench Drawers and Tool Boxes. Engineered with the customary Precise Accuracy and Dependability.

5 Separate Switches, 11 Positions on Each; plus or minus better than 1% for Extreme Accuracy. Readings from 10 OHM to 1,111,110 OHM in 5 Decades. Deeply etched Aluminum Panel; Rugged Construction; Complete with famous Precise Simplified Construction Manual 3 1/4" x 6 1/4" x 2".

468K kit form **\$18.95**

468W factory wired \$24.95

478K—CAPACITY DECADE BOX (Not illus.) kit only \$18.95

478W—CAPACITY DECADE BDX (Not illus.) \$24.95

factory wired.



MODEL 610

RF SIGNAL GENERATOR. The lowest priced signal generator in the field offering:—Same RF head as Model 630; 110 MC on fundamentals; 330 MC on harmonics; 60 and 400 cycle AF; Cathode-follower output; Ext. Mod.; Speech Amp.; Individually tuned coils.

Model 610KA \$28.95 (pre-assembled head) **\$23.95**

Model 610W \$39.95 (wired)

SEND FOR COMPLETE CATALOG

Send 20% deposit with order, balance C.O.D., or, check or money order in advance.

**TEE-VEE
Supply Co.**

All orders are shipped on the same day received

3211-13 Washington Street
Jamaica Plain 30, Mass.

BECOME AN ELECTRICAL ENGINEER



**Bachelor of Science Degree
in 36 months.**

Major in Electronics or Power.
Now, prepare for a career in
these rapidly expanding fields.

This school will prepare you to become an engineer, technician or service man. Previous military, academic or practical training may be evaluated for advanced credit.

Enter Both Radio and Television

In 12 months you can attain the *Radio-Technician's* certificate. An added 6 months course qualifies you for the *Radio-TV Technician's* certificate and the Degree of "Associate in Applied Science." The Technician's course is the first third of the program leading to a Bachelor of Science Degree in Electrical Engineering with a major in Electronics.

Also offered: 12-month Radio-TV service course; 12-month Electronics or Electro Technician Courses; 6-month Electrical Service Course and 3-month refresher and general preparatory classes.

Terms Open Jan, March, June, Oct.

Famous for its Concentric Curriculum. Faculty of specialists. 50,000 former students. Annual enrollment from 48 states and 23 overseas countries. Non-profit. 50th year. Courses approved for Veterans. Residence courses only.



MILWAUKEE SCHOOL OF ENGINEERING

MILWAUKEE SCHOOL OF ENGINEERING
Dept. RN-1153, 1025 N. Milwaukee
Milwaukee 1, Wisconsin

Send: Free 45-page "Your Career" booklet
describing Electrical Engineering Courses;
 Booklet on Careers in Radio-TV.

I am interested in _____
name of course

Name _____ Age _____

Address _____

City _____ Zone _____ State _____

If veteran, indicate date of discharge _____

How Many Watts? (Continued from page 65)

need for tone controls of any sort, except as required to compensate for the whims and fancies of the recording companies. Even here, we can follow the lead set by the Audio Engineering Society and adhere to a single playback curve, in the hope that if enough purchasers of records follow suit, manufacturers will be forced to produce their discs to conform. As long as we provide amplifiers with devices to tailor the frequency response to any curve the record company cares to try, so long will we delay the standardization which is already some 50 years overdue. The only argument with the AES curve is that it might just as well have been a steady drop all the way with no crossovers in the middle.

Another justification for tone compensation may perhaps be made when the equipment has, for one reason or another, to be used at a listening level widely different from the original, when a so-called loudness control can help to make the best of a bad job.

Up till now we have been discussing amplifiers solely as such, with very little reference to what precedes or follows them. We have said, in effect, that a well-designed amplifier with a power output of around 5 or 6 watts with low distortion is all that is necessary for good reproduction, and that anything in excess of this is sheer extravagance. However, there is one important respect in which that statement should be modified. A program amplifier often works into a line, the impedance variations of which would reflect on the amplifier characteristics were it not for the pad which is inserted between the two. A power amplifier works into a loudspeaker which has somewhat similar imperfections, both in its own performance and in its effect on the driving amplifier. Given a perfect loudspeaker, we can adhere to our original statement; as things are, we are forced to compensate for speaker deficiencies by adjusting the output impedance of the amplifier to a low figure, which can be done with considerable ease by the use of negative feedback. But it should be emphasized that a high output impedance in a power amplifier is a defect only because of failings in the loudspeaker.

Confirmation of the views expressed in this article may be found in the "The Saturday Review Home Book of Recorded Music and Sound Reproduction" by Canby, Burke, and Kolodin. In their listening tests, they were able to find very little difference between various amplifiers as far as the output circuits were concerned, and were forced to make their decisions on the basis of the flexibility of the correcting circuits provided. However, in the author's opinion, in doing so they went the wrong way and gave the palm to the most complicated rather than to the simplest.

Now let us see if we can turn what has been said into practical advice to the man who is contemplating a home reproducing system. The author's advice is this: find the least expensive amplifier which will give 5 or 6 really undistorted watts, and a sufficient range of tone correction to suit your tastes or your records and then spend as much as you can afford on the best possible loudspeaker.

TV COMES TO YAKIMA

By JOSEPH A. LENTON, JR.

LOCAL TV reception, long awaited by farmers, ranchers, and townspeople of the fertile Yakima Valley, is now a reality. This area, located in the south central part of Washington State, was formerly able to receive only fringe signals from Spokane or Seattle with the use of high gain antenna arrays and booster systems. They now have their own u.h.f. station, KIMA-TV transmitting on Channel 29, which began broadcasting a test pattern on June 27th and commenced regular scheduled broadcasts as of July 19th.

The transmitter, located on a ridge between the upper and lower Yakima Valleys provides a line-of-sight signal over most of the area. Initially, the station is operating on low power without waiting for the final amplifiers which are to be installed later, hence, any reception over about ten miles from the station exhibits fringe characteristics even with high gain u.h.f. receiving antennas. However, full power output should extend the signal coverage.

Service in this area appears at first glance to present somewhat of a problem. Although the population is well over 100,000, due to the nature of the terrain and the vast rural area served, the local TV technician will often find his service calls from 25 to 50 miles apart. In order to keep service charges down to an amount the customer will accept, the service dealer will have to organize his calls efficiently and may have to work on a smaller profit margin. The over-all prosperity of the area seems quite high however, as dealers report a large percentage of cash sales, so it is possible that the average customer will accept the higher charges due to mileage allowances and travel time without too much complaint.

A second TV station, KIT-TV on u.h.f. Channel 23, is also scheduled to serve this area in the near future. The transmitting antenna is tentatively planned for a spot near the KIMA-TV antenna, which will greatly simplify receiving antenna orientation. Since both stations are u.h.f., it is anticipated that one antenna will serve satisfactorily for both stations in most installations. The antennas proven most satisfactory to date are:

1. Bow-tie with grid reflector, or single yagi for primary areas.
2. Bow-tie with corner reflector, stacked bow-tie with grid reflector, or stacked yagi for secondary or fringe areas.

As usual with u.h.f., the best antenna for satisfactory results varied greatly with the receiver location. The main signal concentration appears to be near the center of the city of Yakima; some dead signal areas were encountered but these may receive a usable signal when the power is increased.

Most people in the vicinity are very enthusiastic about their own local TV station.

Counterbalanced Pickups (Continued from page 50)

and threaded, but as a perfect fit was not easily obtained, loudly recorded passages result in disturbing rattles at this bearing.

The pickup head cover is a piece of $\frac{1}{16}$ " soft aluminum $2\frac{3}{8}$ " by $2\frac{1}{4}$ ", bent around an iron bar in a vise, to make a three-sided box $\frac{3}{4}$ " by $2\frac{3}{8}$ ". By bending a somewhat square end on the arm tube, trimming and fitting, and using 6-32 by $\frac{1}{4}$ " round-head screws, the cover can be mounted on the tube at a 15 to 20 degree angle for proper tracking.

These arms were made to use type B-2 cartridges that were handy at the time, although they have a limited frequency range; the self-tapping screws were installed on each side of the cover to hold the cartridge in. The newer style cartridges that mount with two holes in the top necessitate either a lightweight plastic spacer or two small bushings above to lower this type of cartridge so the stylus will project below the cover.

Counterbalancing weights are cut from brass or iron rod, or cast from lead in cardboard tubes, and locked in place in the rear of each arm.

A box may be made of $\frac{3}{8}$ " to $\frac{1}{2}$ " plywood with 1" x 1" frame and supports for a $\frac{1}{2}$ " to $\frac{3}{4}$ " motorboard. The arm bases should be mounted in positions which result in most consistent tracking throughout the playing of the records. Height of the arms may be altered by length of the yoke tube to fit the turntables used. The box was covered with leatherette glued in place. Later a top was made as a dust cover, but hinges and carrying handle were left off as the outfit was used in only one place.

Arm rests can be made of $\frac{3}{4}$ " strips of $\frac{1}{16}$ " soft aluminum, and the tops padded with leatherette or thin rubber. If the turntable box is to be moved around a lot, some means to prevent the arms from bouncing must be provided. Spring clips will work, or use sponge-rubber covered wood blocks in the cover to press down on the arms when the cover is closed.

Individual connectors and volume controls for each pickup may be used, or, as in the original equipment, a single combined outlet may be preferred. If the latter wiring is used and connected into an amplifier with a volume control directly at its input there will be a loss of high frequencies unless the volume of the amplifier is turned full on.

This turntable outfit could be elaborated into a triple-turntable for more elaborate dubbing, although it would take up quite a bit of space. Some home-movie enthusiasts have found a dual turntable will serve their purposes, with an added arm on one table used to give continuous playing of a single record of sustained sound effects such as wind or waves. -50-

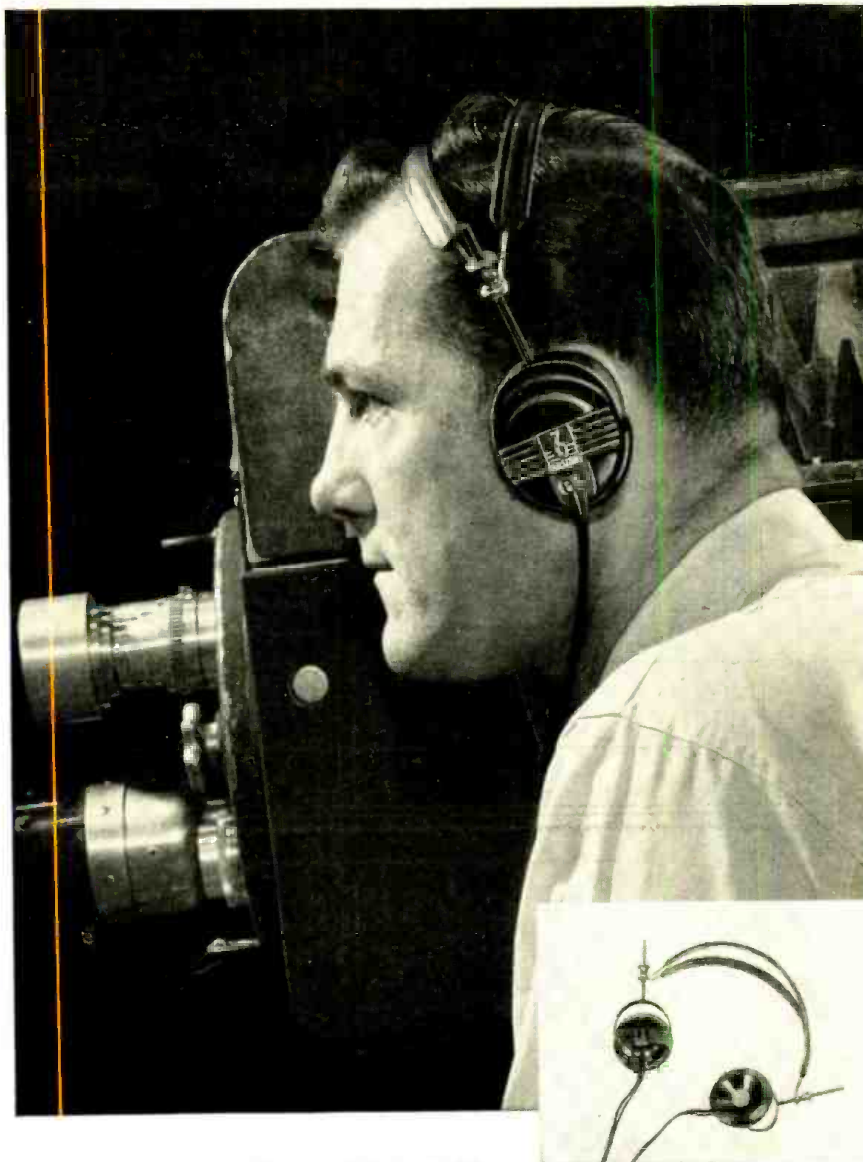

CRYSTAL CLEAR . . . here's the best by Brush!

These Brush Model BA-206 Headphones, designed around the exclusive BIMORPH® crystal-drive element, are your best choice for high fidelity and smooth frequency response. By their nature they draw negligible power and only require modest driving voltages. Hence, these headphones are ideal for monitoring applications... may be used in either high or low impedance circuits and are extremely well suited for multiple installations. They are of rugged, shock-proof construction... light-weight yet powerful. Advanced design gives your ears a smooth, comfortable air-tight fit for excellent bass response. Here is the ultimate in headphone quality at a fraction of the price you'd expect.

Brush crystal products are leaders in their fields because for many years Brush has specialized in research, development and applications of piezo-electric crystal materials. Write for bulletin. Brush Electronics Company, Dept. UU-11, 3405 Perkins Avenue, Cleveland 14, Ohio.

BRUSH ELECTRONICS

INDUSTRIAL AND RESEARCH INSTRUMENTS
PIEZO-ELECTRIC MATERIALS • ACOUSTIC DEVICES
MAGNETIC RECORDING EQUIPMENT
ULTRASONIC EQUIPMENT



COMPANY

formerly
The Brush Development Co.
Brush Electronics Company
is an operating unit of
Clevite Corporation.

Build Your Own Interior - Styled Cabinets

KITS

by **Cabinart**

presenting the

paul klipsch-designed REBEL IV . . .

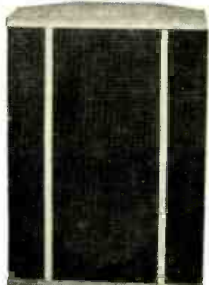

Now you can build your own Klipsch Corner Horn Enclosure and save money — identical in acoustic design to assembled units and easily put together with a minimum of tools. Priced for the home-builder in unfinished birch. **\$36.00** Net for 12" model

\$42.00 Net for 15" model

BASS REFLEX and EQUIPMENT CABINETS

Identical housing for hi-fi components . . . removable panels make future changes easier. Loudspeaker cabinet acoustically designed for either 12" or 15" speaker.

Overall dimensions: 33 1/2" H., 23" W., 16" D. Turn-of-Component: 20" H., 21 3/4" W. (inside dimensions), 15 3/4" deep. Baffle Volume: 6 cubic feet.



All kits include 5/8" white pine plywood cut to size, baffle pre-cut for 12" or 15" speaker, Saran Plastic Acoustic Cloth, Kimsul Acoustic Insulation, Assembly and finishing instructions, hardware, plastic wood, sandpaper and glue.

No. 80 . . . \$27.00 *
(Equipment kit)

No. 8112 . \$18.00 *
(12" speaker)

No. 8115 . \$18.00 *
(15" speaker)

CORNER FOLDED HORN ENCLOSURES

Reproduces a quality of bass heretofore only possible through the use of far more expensive designs.

No. 61 (12" speaker) . . \$19.95 *

No. 63 (15" speaker) . . \$23.95 *

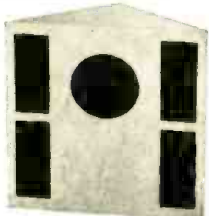

* Prices higher West and South.

Write for free catalog and nearest distributor

Pioneers in radio furniture for high fidelity equipment

G & H WOOD PRODUCTS COMPANY
75 NORTH 11th STREET
BROOKLYN 11, N. Y.

Certified Record Revue (Continued from page 70)

have our binaural sound. Here are some happier facts to relate to you: I've been up to the headquarters of the American Federation of Musicians, in New York. After setting up my trusty *Magnecorder*, I proceeded to demonstrate binaural sound. Everyone there, from top executive down through their secretaries and stenographers was thrilled and entranced with what they heard. Why then the aforementioned ban? It's simply a matter of existing contracts between the Federation and the recording companies. When these contracts were written 5 years ago, no provisions for the release of material on tape was made as at that time, tape was nothing more than a swaddled infant. Happily, these contracts are up for renewal in Dec. of this year, and it is generally presumed that all forms of tape, monaural and multi-track, will be given the green light. It is very much to the musicians' benefit that this occur. If you think of monaural and binaural tapes as a logical extension of the revolution which produced the long-play and the "45" records, you'll see what I mean. In other words, a given piece of music, say Beethoven's 5th, could be released as an LP, a set of 45 rpm, as a monaural tape, and as a binaural, multi-channel tape. This multiple release would add further revenue to the Musicians Performance Fund. To anticipate a question of, "What about one guy buying a tape and letting his pals dub it," the answer is easy. Believe me, even professionals have trouble making a satisfactory dub. The technical capacities of the average home user and his equipment are insufficient to cope with the complexities of dubbing.

You may ask, "How long will we have to wait for repertoire, if the Union OK's tape?" The chances are very good that some tape will be immediately available, because for some time certain companies have been recording multi-channel and then post-mixing from each channel to get the best possible monaural balance. Naturally, by eliminating post-mixing, you have a multi-channel tape available for release if and when the Union decides to allow this new medium its support.

As for the equipment end of this binaural business, let me say this: having been in the tape machine business, I know a little bit about production costs and figures and what can and cannot be done. There may be howls from some of the ostriches in the industry who hide their heads in the sand, but I am here to state *unequivocally* that a binaural tape machine can be built with quality more than adequate for the average music lover for less than 250-300 dollars. Naturally, I'm not referring to some super-duper job with hysteresis sync

motors. The unit I envision will have very respectable motion and distortion characteristics, and the three watts from a pair of simple push-pull amplifiers will be more than enough output. And you would be surprised at the number of people who thought they were listening to wide range material when actually they were hearing 3 3/4 and 7 1/2 inches-per-second binaural music.

One final word. I have purposely avoided mention of binaural on disc as it is at present. With all due respect to Mr. Cook for his courage and initiative, I don't feel that his system is the answer. The synchronization problems of double pickups are still formidable, and more than that, the use of two channels on an LP side negates the greatest advantage of long-play records, the time factor. A maximum of 14 minutes-per-side, severely limits the repertoire which can be recorded. The ideal disc system would be, of course, multi-channel sound utilizing *one stylus*. I'll leave you with this teaser: it appears possible to *do* this and someone is working on the project!

Equipment used this month: *Pickering* turnover cartridge, *Pickering* equalizer-preamp, *Fisher* 50A amplifier, *Thorens* changer, *Jensen* G 610 Triaxial in the "*Read Fold-a-flex*."

PROKOFIEV

SYMPHONY #7

Philadelphia Orchestra conducted by Eugene Ormandy.

LT. KIJE

Royal Philharmonic Orchestra conducted by Efreim Kurtz. Columbia ML 4683. NARTB curve. \$5.45.

I wish the people who are responsible for the coupling on LP records would think twice before they take the plunge. Here is a typical example of what not to do. Sure, both pieces of music are compatible, but goshamighty, there are two other records already issued with Lt. Kije as the flip side, and if you like Prokofiev, you already own them! Certainly we want the last of Prokofiev's symphonies, but not the good Lt. again. Musically, this is both up to expectations and disappointing at the same time. There are some moments of very good writing, marred by a great deal of trite nothing and smelling I fear, a little of Prokofiev's unwilling subservience to political ideology. I cannot venture an opinion on Ormandy's conducting, since I have never heard the score except on this record. All the notes seem to be in their proper place and no doubt it is a competent job. Soundwise, this is typical of recent Philadelphia stuff. Big hall resonance, well balanced ensemble work. Good high end, but rather tubby bass. Surface noise was minimal and Eureka!; the recording curve was exactly as published, something that doesn't always happen these days. If you're a devotee of Prokofiev (and I am) this is a worthwhile addition to your library.

Newest

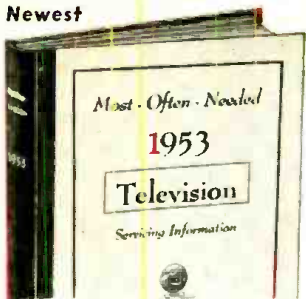

AMAZING OFFER in TV SERVICE MANUALS A FULL YEAR'S TV MATERIAL IN A GIANT BOOK — \$3

NEW SPECIAL OFFER

These mammoth television service manuals are now available to you at only \$3 and \$2 each. These are amazing bargains and defy competition. Each manual is a virtual treatise on practical TV repair and should sell for at least twice the low price. Only SUPREME can offer such values based on tremendous volume-sales. The best for less.



The repair of any television set is really simple with Supreme TV service manuals. Every set is covered in a practical manner that will simplify troubleshooting and repair. This is the help you need to find toughest faults in a jiffy. Each \$3 TV volume covers a whole year of service material. New UHF Units manual at only \$1.50 has everything on UHF. Be wise, buy Supreme Manuals only once each year instead of spending dollars every week for not needed data.

RADIO-ELECTRONICS

NEW AMAZING HOME-STUDY COURSE OFFER



Here is the most amazing bargain in electronic training. For only \$3.95 (full price), you receive a complete course of 53 large lessons. Covers every topic of radio, electronics, with large lessons on TV, FM, audio, etc. As an extra, every page has teacher-comments to guide you and supply additional help. Includes self-testing questions, 427 drawings, pictures, and diagrams. Compares lesson-by-lesson with the best \$200 home-study correspondence courses. Special price, complete, 3 in-1 volume, 53 lessons, only.....

\$3.95

Large, 3-volume course

Just Out

RADIO DIAGRAMS



Here is your complete source of all needed RADIO diagrams and service data. Covers everything from most recent radios to pre-war old timers; home radios, auto sets, combinations, cleaners, and portables. Sensational values. Still sold at pre-Korean prices. Only \$2 for most volumes. Every Radio manual contains large schematics, all needed alignment facts, parts lists, voltage values, trimmers, dial stringing, and helpful service hints. Volumes are large in size, 8 1/2 x 11 inches, about 192 pages. See coupon at right for a complete list of these low-priced manuals.

COVERS ALL POPULAR TV SETS

Supreme TV manuals have all needed service material on every popular TV set of every important manufacturer. Here is helpful, practical, factory-prepared data that will really make TV servicing and adjustment easy for you. Benefit and save with these amazing values in service manuals. These giant TV manuals have complete circuits, alignment facts, test patterns, response curves, service hints, all recommended changes, voltage charts, waveforms, and many double-page diagram blueprints. Here is your TV service material to help you do more expert work quicker; and priced at only \$3 and \$2 per manual covering a full year of material. Be ready to repair any TV set by having in your shop all seven TV volumes listed in coupon below. The new 1953 UHF Converters manual at only \$1.50 has everything you need on UHF. Write us today. Immediate shipment. Order for a 10-day trial.

NO-RISK TRIAL ORDER COUPON

SUPREME PUBLICATIONS, 1760 Balsam Rd., Highland Park, ILL.

Radio Diagram Manuals

- New 1953 Manual, \$2.50
- 1952 Radio
- 1951 Diagrams } EACH
- 1950 Manual } \$2.50
- 1949 Radio
- 1948
- 1947
- 1946
- 1942
- 1941
- 1940
- 1939
- 1926-1938 Manual, \$2.50

PRICED
AT ONLY
\$2
EACH

Send TV and Radio manuals checked below and at left. Satisfaction guaranteed or your money back.

- Practical Radio & Electronics Course \$3.95
- 1953 TV Manual, \$3. 1953 UHF Units, \$1.50
- 1952 Television Manual, \$3. 1951 TV, \$3.
- 1950 Television Manual, \$3. 1949 TV, \$3.
- 1948 TV, \$3. 1947 TV & FM, only \$2.

I am enclosing \$..... Send postpaid.
 Send C.O.D. I am enclosing \$..... deposit.

Name:
Address:

Supreme Publications

Sold by all Leading Radio Jobbers

WANTED

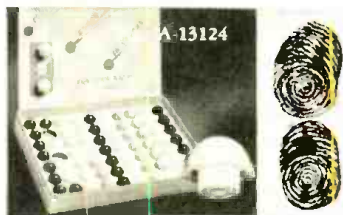

By DEALERS, SERVICEMEN and others.

Suspected of willfully aiding and abetting them in saving time and satisfying customers.

Name . . . WALDOM'S AUTO KNOB ASSORTMENT

Description . . . 70 CRONAME tenite knobs in assorted colors. Knobs are 7/8" in diameter and will fit 3/16" flatted shaft. Set screws included. Housed in attractive display box. Answers to No. A-13124

SPECIAL BULLETIN

Knob Assortments answering to above charge and description have been apprehended by your local parts distributor, assisted by Waldom Electronics Inc., 911 Larrabee St., Chicago 10, Illinois.

NOW! New TELEVISION SPECIALTIES



for UNIVERSAL DESIGN, CONSTRUCTION and REPLACEMENT PURPOSES
A HANDY KIT for any LAB or SERVICE SHOP

CALIBRATED VARIABLE INDUCTANCE KIT

8 Permeability Tuned Coils

- FEATURING
- WIDE INDUCTANCE RANGE, 1 to 1000 µH.
 - INDIVIDUAL INDUCTANCE CURVE SHEET FOR EACH COIL.
 - COMPLETE DATA ON Emission, Impedance, SELF RESONANT FREQUENCY, Q, R & C.
 - ACCURATE UNIVERSAL AND SOLENOID WINDINGS, Q-MAX impregnation.
 - Video Peaking • IF Circuits
 - Radio or TV Tuning • RF Choke

\$4.50 per box

IMPORTANT! TELEVISION ANTENNA ACCESSORIES



TYPE F-1 for 300 ohm LIST \$5.90

TELEVISION INTERFERENCE FILTER
Highly efficient 3-section high pass type. Attenuates all frequencies up to 50MC. Eliminates amateur, xray, diathermy, auto and aircraft interference.

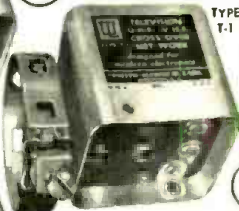

TYPE T-1 LIST \$4.75

UHF...VHF CROSS-OVER NETWORK

Adopts UHF-VHF antenna to single transmission line. Eliminates antenna switches and duplex lead-ins. Saves time and money on installation work.



TYPE R-1 for 300 ohm LIST \$3.85

TWO-RECEIVER TV COUPLER

Allows use of two TV receivers on one antenna. No adjustments or switches. No effect on transmission line impedance.

Ask about these NEW ITEMS at your local distributor, or write for FREE BULLETIN, giving distributor's name and address.

Engineers **UNITED TECHNICAL LABORATORIES** Manufacturers
MORRISTOWN, N. J.

TECH-MASTER *High Fidelity* Amplifier and Preamplifier **KITS**

- Tech Master audio amplifier kits are made with the same "custom-quality" attention that has made Tech-Master the first name in TV chassis. They are built to a standard, not to the price. There have been no compromises . . . every component is the finest obtainable . . . workmanship is meticulous.

UL* WILLIAMSON TYPE AMPLIFIER KIT:
(with power supply.) Famous Williamson circuit with modifications for increased, undistorted power output. Uses specially wound quality output transformer.
Model TM-15A, Kit of Parts . . . Net Price . . . \$49.95

Model TMD-15A, DELUXE KIT: Factory assembled, all major components mounted, ready to wire. Net Price . . . \$59.95

*Ultra linear operation through use of screen-tapped primary output transformer

4 CHANNEL PREAMPLIFIER-EQUALIZER KIT:
Provides complete equalization for virtually all recording characteristics now employed. Extra flexibility provided by independent bass and treble boost and attenuation controls.
Model TM-15P, Kit of Parts . . . Net Price . . . \$19.95

Model TMD-15P, DELUXE KIT: Factory assembled, all major components mounted, ready to wire. Net Price . . . \$29.65

AT ALL LEADING RADIO PARTS DISTRIBUTORS



TECH-MASTER PRODUCTS CO.
443-445 BROADWAY, NEW YORK 13, N. Y.

TECH-MASTER, MAKERS OF CUSTOM-BUILT TV CHASSIS,
QUALITY TV KITS & HIGH FIDELITY AUDIO EQUIPMENT.

Literature
Upon Request

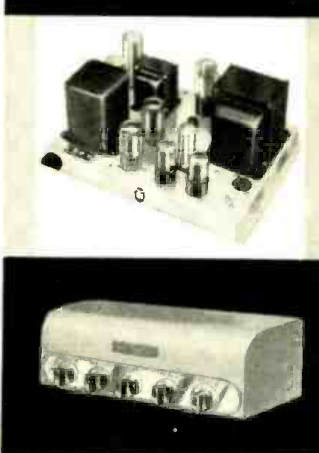

BANTOCK
FINE AT THE FAIR
Royal Philharmonic Orchestra conducted by Sir Thomas Beecham. Victor LHMV 1026. Orthophonic curve. \$5.72.

I wondered how long it would take Victor to get around to this item. This was originally on HMV 78 rpm and for a long time was much sought after by phonophiles in this country as one of the better examples of British recording. And it was good. Converted to LP, the sound is still well above average, being surpassed only by the latest and best. Bantock's score lends itself particularly well to high-fidelity treatment, full of tricky little percussion effects and odd oriental woodwind colorings. This is typical HMV sound with sharply accented highs and good solid bass. Over-all liveness is approaching today's "ideal." No worldshaker, this, but thoroughly enjoyable and refreshing. If you have no provision for Orthophonic curve on your front end try boosting both bass and treble a few db.

ELGAR
ENIGMA VARIATIONS
BRAHMS
VARIATIONS ON A THEME BY HAYDN

NBC Symphony Orchestra conducted by Arturo Toscanini. Victor LM 1725. Orthophonic curve. \$5.72.

I will review here the Elgar side. The Brahms is good musically and soundwise, but I still prefer Toscanini's old version with the New York Philharmonic. The "Enigma Variations" are to me the very best of Elgar. If you are fed up on "Pomp and Circumstance," *ad nauseum*, try this. This is real music. an orchestral *tour de force*. Toscanini gives a vital, taut reading and his orchestra responds sensitively. The most fabulous performance of the work I've ever heard was in Birmingham, England during the War. George Weldon conducted the City of Birmingham Orch. in the Birmingham Town Hall, which is a great stone structure very close architecturally to the Acropolis! Inside is one of the most tremendous organs in the world. When that organ was wound up and the orchestra in full cry, that was a sound to hear! The sound in this version is certainly the best on record, with excellent balance between highs and bass end. Bass end was too thin, but then, this work has some very low passages difficult to engrave on a disc. Surface noise was very low.

PISTON. BARBER. GOULD. et al.
AMERICAN CONCERT BAND MASTERPIECES

Eastman Symphonic Wind Ensemble conducted by Frederick Fennell. Mercury "Golden Lyre Series" MG 40006. AES curve. \$5.95.

Gadzooks! What a sound! I'm almost sorry I heard this recording, because I know I'm going to be blasted with it day and night at every Audio Fair. Yep, it's another of those super-duper demonstration records Mercury

RADIO & TELEVISION NEWS

SELLS ON DEMONSTRATION
THE New DuKane
Tru-Fidelity
TAPE RECORDER



THE FINEST IN TRU-FIDELITY RECORDING

SELLS READILY AT \$299.50

(SLIGHTLY HIGHER WEST OF ROCKIES)

DEALERSHIP AVAILABLE NOW!
MAIL COUPON FOR INFORMATION TODAY!

DUKANE CORP. Dept. RTN-113 St. Charles, Ill.

Send details on the new DuKane Tru-Fidelity Tape Recorder.

I am interested in a dealership.

Name _____

Address _____

City _____ State _____

ESTABLISHED AS "OPERADIO" 1922

South River
★★ NEWS ★★

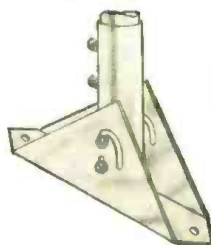

ROOF MOUNT
Model RM-15

This improved model carries the new drop-lock feature, enabling mount to be "walked up" to the vertical position, where it drops and locks securely. Made of heavy-gauge steel and embossed at all critical points, this fixture accommodates masts measuring to 1/2" O.D. Assembled.

Write for your copy of our new 1953 catalog.

In Canada—A. T. R. Armstrong Co., Toronto

SOUTH RIVER METAL PRODUCTS CO., INC.
SOUTH RIVER, N. J.

PIONEER AND OUTSTANDING PRODUCER OF FINEST LINE OF ANTENNA MOUNTS

has been turning out lately. All the adjectives in the world can't describe this one. The bass drum and tympani are there, tremendous, awe-inspiring. The cymbals and snare will shatter you. Positively the cleanest, closest thing to tape I've ever heard. And the music goes right along with the sound. It's racy, martial, jolly, and jazzy. As bands go, this is a new concept, for there are no more than 45 players here; but they are arranged and disposed so cleverly the band sounds far bigger. Mr. Fennell has his youthful players beautifully disciplined and his readings are vigorous and splendid. Silky surfaces and happy conformity to the recording curve are added virtues of this outstanding example of modern recording.

-30-

THE RESISTOR TUBE

By J. R. SCRIVENER

PROBABLY nothing is so easy to put in the wiring diagram as the power resistor. It is not so easy to wire one into the set. Power resistors, their size, connections, and heat output present real problems for the electronic builder.

The bleeder to bring the d.c. supply up to 150 ma. in an amplifier was the particular resistor that inspired this solution to the problem. The resistor was installed in the case of a surplus ballast resistor and plugged into an octal socket mounted on the chassis.

This arrangement is simple. Surplus resistors with can and octal base can be bought for a dime or so. It is a simple matter to remove the element and its mica support. In its place you can use a 10-watt ceramic wirewound resistor. The "hot" end is at the bottom to minimize the danger of a short to the case. The upper lead has to be extended. It is usually at ground potential. The two leads are easily soldered into appropriate pins in the base. Pin 1 is reserved for grounding the case. A wire should be soldered to the case and connected to that pin as a safety precaution.

To help get rid of the 10 watts the case should be perforated to speed up air circulation. The original had eight 3/16 inch diameter holes in the base and one 1/2 inch hole in the top. This arrangement worked fine. A 10 watt resistor brought the case up to about the temperature of a small power tube. This is hot—but not enough to blister the paint or burn your hand on accidental contact.

Besides the reduced space for mounting, this arrangement kept the chassis a lot cooler by taking about a fourth of the internal heating load outside the chassis where the heat could get away. For the experimenter, the plug-in feature saves a lot of rewiring.

-30-

Method for mounting a power resistor in a surplus ballast resistor case. Both time and space are saved by using this system.

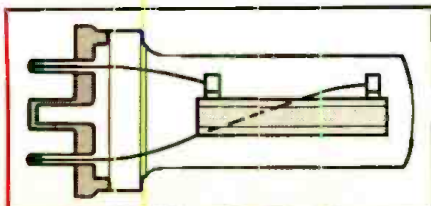

November, 1953

in stock at
ALLIED

**KLIPSCH "REBEL IV"
SPEAKER ENCLOSURE**
by CABINART

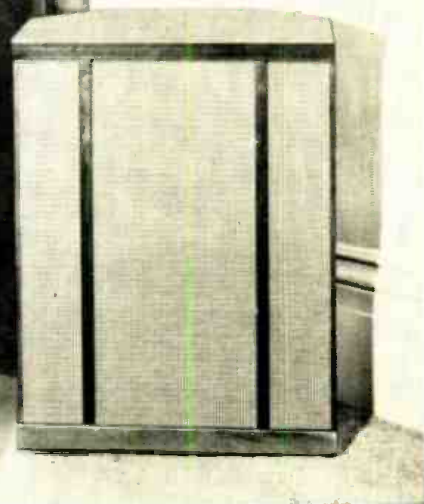

AMAZING CORNER HORN ENCLOSURE AT LOW, LOW COST

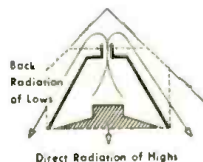

Large enclosure performance within minimum area achieved through principle of "backloading," which increases path length and provides better reproduction of lows. Direct radiation of high frequencies cuts out "Masking."

Unique cabinet design provides easy accessibility to speaker and simplifies external installation.

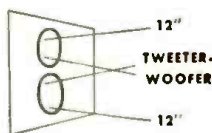

Two-way system performance. So flexible in design so as to provide you wide latitude in determining your listening requirements. Removable panel allows for a variety of speaker combinations. For example, in the 12" Klipsch you can install a single 12", two 12" speakers or a tweeter-woofer combination.



PAUL KLIPSCH DESIGNED FOR 12" OR 15" SPEAKERS

Famous Klipsch corner enclosures at low cost! Achieves remarkably clean, greatly extended bass by means of widely acclaimed backloading design. Both 15" and 12" models have two cut-outs: one for speaker or woofer, one with removable cover plate to permit use with or without tweeter. Models listed below are completely built and finished; available in lustrous French mahogany or in limed oak veneers. Dimensions: 15" model, 32" h., 24" w., 16 1/2" deep; 12" model, 32" h., 21" w., 14 1/2" deep. Shpg. wts., 15" model 42 lbs.; 12" model 38 lbs.

95 SX 376. Model KR4-15. 15" enclosure in French mahogany finish.

95 SX 377. Model KR4-15. 15" enclosure in limed oak finish. Net Each \$87.00

95 SX 374. Model KR4-12. 12" enclosure in French mahogany finish.

95 SX 375. Model KR4-12. 12" enclosure in limed oak finish. Net Each \$69.00

AVAILABLE ALSO AS KITS IN BIRCH, UNFINISHED

Build your own Klipsch and save money! Easy to assemble. Kits are quality birch plywood. Complete with grille cloth, sandpaper, hardware and instructions. Identical in acoustic design to assembled units. Have the ultimate in enclosures at low, low cost.

95 SX 379. Kit for 15" speakers. Net. \$42.00

95 SX 378. Kit for 12" speakers. Net. \$36.00



FREE 268-Page 1954 Catalog

Your up-to-date Buying Guide to the world's largest stocks of High-Fidelity music systems and components, plus everything in Electronic supplies. FREE—write for Allied Catalog today.



ORDER FROM

ALLIED RADIO

100 N. Western Ave.
Chicago 80, Illinois

NEWARK

YOUR KEY TO
★ BARGAINS
★ SPECIAL VALUES
★ SAVINGS

YOU SAVE \$30
 on this ESPEY 512C
 FM-AM TUNER

New Low Price \$69.50

High Fidelity Tuner Chassis. Completely self-powered tuner. Featuring full tonal range with increased selectivity and sensitivity. Tuned RF stage and two high gain IF stages. Built-in pre-amplifier for all magnetic cartridges, with switch for selecting crystal phono. Circuit is drift compensated. Uses 9 tubes including 3 dual purpose types, plus 5Y3GT rectifier, 6 gang tuning condenser. High and low level audio outputs. Phono input on rear of chassis. Complete with tubes, AM and FM antennas, hardware and escutcheon. For 105/125 volts, 60 cycle. Size 13½" W x 8½" H x 9" D. wt., 16 lbs.

96F031. NET..... **\$69.50**

FAMOUS NAME ★
MIDGET CONTROLS

10 of one type.. ONLY \$1.75

Save while quantities last! Flat 2" shaft with all fittings and hardware. All are linear taper except *audio and *series or cathode. Wt., per 10, 1 lb.

No.	Ohms	No.	Ohms	No.	Ohms
U-12	5,000*	U-33	50,000*	U-48	250,000*
U-14	5,000	U-34	50,000†	U-50	500,000*
U-18	10,000*	U-35	50,000	U-51	750,000*
U-19	10,000†	U-36	75,000*	U-53	1 Meg*
U-20	10,000	U-39	100,000*	U-54	1 Meg*
U-21	15,000*	U-40	100,000†	U-55	2 Meg*
U-22	15,000†	U-41	100,000	U-56	2 Meg*
U-24	20,000*	U-42	150,000*	U-57	3 Meg*
U-26	20,000	U-43	200,000*	U-59	3 Meg*
U-28	25,000†	U-44	250,000*	U-65	5 Meg*
U-29	25,000	U-45	250,000†		

TAPPED MIDGET CONTROLS

No.	Ohms	Tap	No.	Ohms	Tap
UT-420	250,000	50,000	UT-443	2 Meg	450,000
UT-425	350,000	70,000	UT-448	2 Meg	250,000
UT-427	500,000	100,000	UT-450	2 Meg	125,000
UT-429	500,000	50,000	UT-451	2 Meg	900,000
UT-431	500,000	225,000	UT-454	2 Meg	400,000

★ **BRUSH MICROPHONE**

While They Last! \$5.95

Originally sold for \$8.61! Response, 50 to 6,000 cycles. Output level, -53 db. High impedance. Has ¾"-27 thread. Brown. Wt., 1½ lbs.

54G350. Special Price..... **5.95**



★ **Newark Specials**

2 Mfd. 600 VDC. General Electric Pyranol-filled capacitor. Flange type mounting. Ceramic pillar terminals, 10/32" studs. Size, 2x2¼x1". Wt., 1 lb. 54G006. 10 for 3.00..... Each 39c.

35 ohm, 50-watt Pot. Ohmite Type "J" wire-wound pot. Heavy ceramic form. ¼" shaft for ⅜" mtg hole. 1 lb. 54G587. 10 for 5.50..... Each 69c

Thordarson T-45166 Output Transformer. Single 6L6 to 2-4-8-500 ohms voice coil. Case size 2½x2½x3" high. Shpg. wt., 5 lbs. 54G5C1. 10 for 12.00..... Each 1.50

Driver Transformer. P.P. 2A3's to grids. Case size, 3¼x2¼x3" high. Shpg. wt., 5 lbs. 54G111. 10 for 15.00..... Each 1.95

Order from Dept. R-11
 FOB Chicago. Include Shipping
 Charges and Insurance.

Send for **FREE** Catalog

NEWARK
 ELECTRIC COMPANY

223 W. MADISON ST. CHICAGO 6, ILL.

A POTENTIOMETER-DECADE ADAPTER: THE "DECAPOT"

By H. J. GOULD

The author's unit is used here with an "Eico" decade box and a "Selectohm" pot. See text for details on hookup used to extend range of standards.

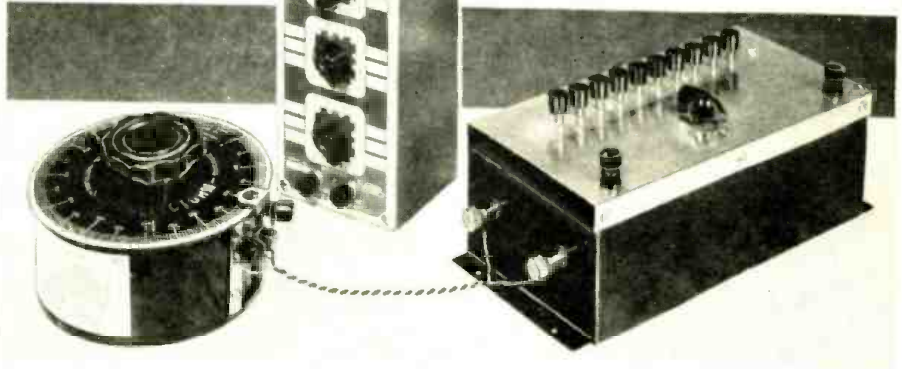

Extend the range of your decade box to 1 megohm by adding this neat unit which eliminates all "haywire" makeshifts.

LOW-COST resistance standards, such as the *Heathkit* and *Eico* decade boxes and the *Selectohm* precision potentiometer, have brought accuracy of measurement within reach of the shoestring experimenter and technician, most of whom read Rufus Turner's discussion of decade applications in the March 1951 issue of *RADIO & TELEVISION NEWS*.

However, because circuit requirements often call for higher ranges than the usual 100,000 ohms, these accurate instruments fail to get the use they deserve. To hook a pigtail resistor (then why not another?) in series with the decade is to lose ground to that "haywiredness" of setup the decade box helped to eliminate. One way of neatly extending the

range might be to mount an additional decade-switch-resistor-set in, or on, the end of the decade box itself. A better way, space limitations being what they are, would be to build a companion unit designed to team up with the resistance standard or double in brass as an independent hundred-thousands decade. Should such a companion piece also expand the range of a 3-terminal element, like the *Selectohm* potentiometer, it would really earn its keep. Mulling over these desiderata led to the development of the unit to be described, suggesting its name.

As the schematic shows, the "Decapot" simply consists of a chain of fixed, precision resistors, any one of which can be substituted by a vari-

Complete schematic of the "Decapot" circuit for increasing resistance decade range.

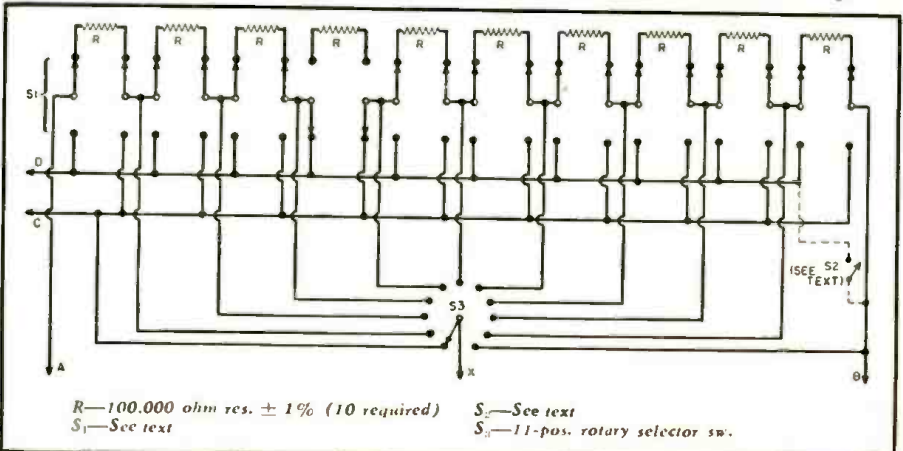

HARVEY



**AUTHORIZED
DISTRIBUTOR**

PRESENTS THE NEW
RCA TV EYE
CAMERA and CONTROL UNIT

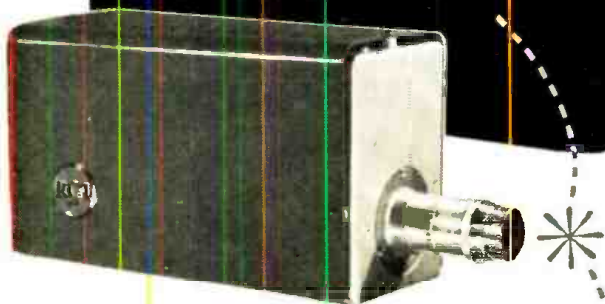

FOR CLOSED-CIRCUIT TELEVISION AT LOW COST

For safe, sure observation of dangerous processes . . . to guard gates and driveways . . . to observe hospital patients, children at play, nurseries . . . to compare signatures and documents . . . to allow large groups to view experiments or operations . . . to show promotional material simultaneously at many different points . . . for greater efficiency, more safety, better control in hundreds of applications.

Dimensions: Camera: 10" x 5" x 3 3/4"
Control Box: 11" x 8" x 6"

- Schools
- Hospitals
- Banks
- Factories
- Dept. Stores
- Prisons

- Lightweight — portable
- Operates through any TV receiver.
- Easily connected to antenna terminals. Requires no alteration of receiver.
- Plugs into any standard AC line.
- One TV Eye System may be hooked up to several different receivers, and several TV Eye Systems may be connected to the same receiver.
- Affords remote operation between control box and TV receiver up to 500 feet.
- Uses standard receiver tubes except for Vidicon.
- For special uses—weather-proof housing, explosion-proof housing, remote panning mechanism and other accessories available.

MI-36250 Camera
MI-36251 Control Unit
MI-36252-2 2" lens
6198 Vidicon (Kinescope)
Complete. **\$995.00**

NOTE: Prices Net, F.O.B., N.Y.C. Subject to change without notice.

Write to Dept. RN-113 for full details.

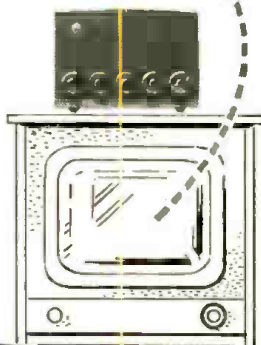

Harvey RADIO CO., INC.

103 West 43rd Street • New York 36, N. Y. • JUdon 2-1500



Top Quality for Top Performance **SOUNDCRAFT MAGNETIC RECORDING TAPE**

QUALITY — that's the reason why popular recording stars insist on Soundcraft Magnetic Recording Tape. They *know* that Soundcraft always delivers the quality performance tape users demand . . . the true, note-for-note fidelity their work requires.

QUALITY, too, is why so many audio fans — in ever-increasing numbers — today use *only* Soundcraft tape for the utmost in listening pleasure. **QUALITY** is why so many servicemen and electronics dealers carry Soundcraft tape.

How about you? Have you tried Soundcraft yet? If not, do it now.

Write for **FREE** booklet on Soundcraft Magnetic Recording Tape

**REEVES
SOUNDCRAFT
CORP.**

Dept. X-11.
10 East 52 St., N. Y. 22, N. Y.



A New Idea

in High Fidelity
Sound Reproduction



FOR ONLY
\$69⁵⁰

Shields ULTRA-LOADING SPEAKER SYSTEM

Scientifically constructed to give maximum sound quality. Extremely versatile, the unit is portable and weighs only 27 lbs. Dimensions: 36" high, 19" deep, 9" wide.



Available with blonde or mahogany finish.

With addition of legs, it serves as a cocktail table.

GET THE FACTS

MAIL COUPON TODAY

Shields Laboratories, Inc.
Please send me your bulletin on the new Shields Ultra-Loading Speaker System.

NAME
ADDRESS
CITY STATE
RTVN-1153

Shields LABORATORIES, INC.
810 N. LINCOLN AVENUE
PITTSBURGH 12, PA.

able 2- or 3-terminal element. Substitution can be accomplished by a row of d.p.d.t. toggle switches (calling for two-handed operation), a row of closed-circuit jacks, or by a 10-position push-button switch of the circuit-transfer type, as shown, this allowing speediest operation.

Depicted in its role of potentiometer-multiplier in the photo, the "Decapot's" end terminals, C and D, connect to the outside terminals of a *Selectohm* pot, the rotor of which effectively slides across 1 megohm in 100,000 ohm segments. Series hook-ups, with a decade box or with the *Selectohm* rheostat-connected, require terminals A and C.

At first, to use the "Decapot" as an independent hundred-thousands decade, a single-position rotary switch (S_2) is connected at O in place of B (dotted line in schematic), keeping connections to the top deck of the unit, leaving the side terminals, C and D, for the "Decapot" function exclusively. Later, because of tests that called for a *tapped* 1-megohm precision pot, S_2 was made an 11-position switch, and another binding post added at X; this gave nine 100,000 ohm taps across the chain, taps in-

dependent of rotor position. Since the photo was snapped prior to modification, the extra top-deck binding post doesn't show.

S_2 also acts as an upper-limit adjustment, making the "Decapot"-*Selectohm* combo usable as a pot with ranges from 0-100,000 ohms to 0-1 megohm in 100,000 ohm jumps.

The "Decapot" principle affords a kind of vernier action. Combined with the *Selectohm*, for instance, it gives a degree of fineness in adjustment equivalent to a 1 megohm pot some four feet in diameter. Along with this goes an effective scale length of over twelve feet, divided into 2000 divisions.

If desired, the power-handling characteristic of the *Selectohm* can be expanded as well. By employing *Dalohm* type RH-25 1% resistors as chain elements (and of course using correspondingly better insulation) the "Decapot" will serve as a 250-watt divider across potentials up to ten kilovolts.

In either high or low power circuits, the "Decapot" makes a mighty useful tool in any shop where economy of operation dictates maximum versatility in all components. -50-

"THE LITTLE HANDFUL" 100 KC. CALIBRATOR

By L. A. CHINERY

A COMPACT, hand-held, 100 kc. signal generator can be built into a tobacco can or lozenge tin. The writer, who was in need of "100 of the best" some years ago, made up this little unit in such a tin, and was able to use it like a probe to inject its signals into receiving gear under test. Since then, however, an appropriate crystal calibrator has been obtained and is now in regular use here, so before memory fades, RADIO & TELEVISION NEWS readers may like the details of the original unit.

Little needs to be said that is not explained in the diagrams, except to remark that L_1 was a four-pi 2.5 mhy. r.f. choke, tapped one pi from ground for the cathode connection, and that C_1 was a 1000- μ fd. mica padding condenser, to be trimmed to proper resonance. With C_1 at maximum capacity, and with the values of the other components as shown in the parts list, the frequency is on the order of 80 kc.,

variable to approximately 110 kc. by varying C. The table shows the approximate capacity needed for reaching 150 kc.

Living in England, the writer's reference frequency for setting up the oscillator was the BBC transmission on 200 kc., the second harmonic of "The Little Handful" being set to beat with this. The transmission is a frequency standard in itself, being correct to a very few parts in one million. Americans could obviously use WWV, or other reliable carriers.

Readable harmonics up to 15 mc. were obtained from this unit when its insulated probe was held near the antenna post of a two-tube receiver. More harmonics and greater output could be realized if an audio pentode, triode connected, was used. Using a metal tube, radiation was observed only from the actual probe, which is a desirable feature. -50-

Drawing of "The Little Handful," with complete schematic diagram and parts list.

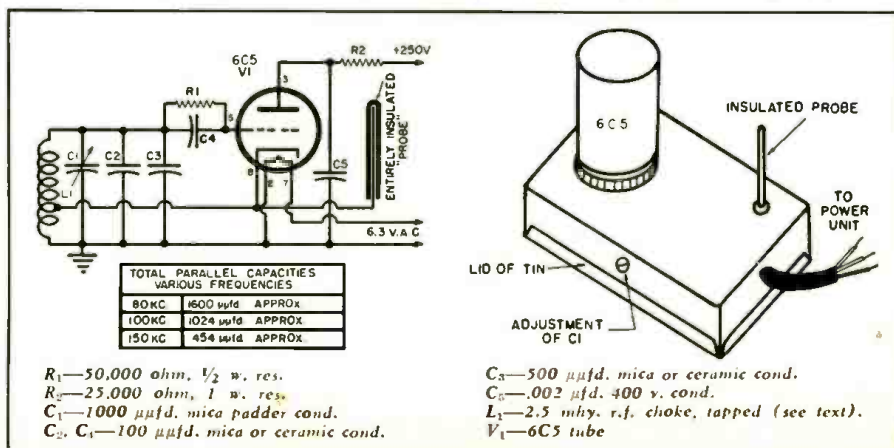

Electronic Switch
(Continued from page 121)

5. Terminals 2 and 3 of RL_2 close, grounding the grid of V_{2B} .
6. Terminals 1 and 2 of RL_1 open, ungrounding the grid of V_1 .

The entire circuit has now been restored to its original condition and another switching cycle may be initiated at any time.

At the instant of opening or closing, the various relays produce transients which would cause circuit oscillation (relay chattering) if not properly filtered and damped. The filter components utilized consist of the RC network, R_{11} , C_{10} , and R_{10} , and the condenser, C_{12} . The values of these components as listed provide consistently reliable results using surplus AN/APN-1 radio-altimeter relays as follows: RL_1 and RL_2 : 3500 ohm coil, circuit symbol K102. RL_3 : 6500 to 7000 ohm coil, circuit symbol K101. These are still obtainable from surplus part dealers. They may be replaced by other plate sensitive relays. This may require changing the values of the filters previously mentioned, as well as the values of the dropping resistors R_{13} , R_{17} , and R_{18} . Values should not have to be changed to any great extent if the replacement relays have approximately the same coil resistance as the relays listed.

Caution must be exercised in the selection of the one microfarad condenser, C_6 . This should be tested for insulation resistance. If the insulation resistance is below 100 megohms enough current may leak through to cause a bias to appear at the grid of V_1 , resulting in unwanted or premature triggering of the switch.

In closing it should be mentioned that the microphone must be carefully placed so that it receives little or no direct radiation from the loudspeaker which is to be switched off.

In accordance with naval regulations, the author wishes to state that this article contains opinions and assertions which are the private ones of the author and are not to be construed as official or reflecting the views of the Navy Department or the naval service at large.

SET PRODUCTION HIGH

THE Radio-Electronics-Television Manufacturers Association has reported that in the January-July period of this year, 4,150,525 television receivers and 7,941,001 radios were manufactured. The television set output during the seven months was over half a million sets above the previous record of 3,606,445 sets in 1951.

Radios with FM circuits manufactured during July totaled 22,986 units out of a total of 674,459 while 5120 of the 316,289 TV sets were equipped with FM tuners.

The total output of TV sets a new record for the seven-month period while radios were nearly 2 million over the same period in 1952.

Complete Professional Service Training



at only a small fraction of the price you might expect to pay!

The NEW Ghirardi SERVICE LIBRARY

FOR BETTER JOBS • BIGGER PAY IN TELEVISION • RADIO • ELECTRONICS

Let these two up-to-the-minute Ghirardi training books teach you to handle ALL types of AM, FM and Television service jobs by approved professional methods—and watch your efficiency and earnings soar!

If broken into lesson form and sent to you as a "course," you'd regard this training as a bargain at \$100 or more. Instead you buy both big books complete for only \$12—and save \$1.25 in the bargain!

Written so you can easily understand every word, these books train you for fast, accurate service on any type of home radio-TV-electronic equipment ever made. Each book is completely modern, profusely illustrated. Each contains the latest data on the latest methods and equipment. Together they form a completely modern service library to help you work faster and lots more profitably. Almost 1500 pages and over 800 clear illustrations show how to locate troubles faster, how to repair them better.

Everything is completely indexed. You can use the books to solve puzzling service problems in a jiffy!

When you buy Ghirardi training books you KNOW you're getting the best—at lowest possible cost!

For over 20 years, Ghirardi books have been more widely used in schools, for military training and home study than any others of their kind.

Radio & Television Receiver TROUBLESHOOTING & REPAIR

This big book is a how-to-do-it guide to professional service methods—the kind that help you get better jobs, bigger pay. For beginners, it is a complete, easily understood training course. For experienced servicemen it is a quick way to "brush up" on specific jobs; to develop improved troubleshooting techniques; or to find fast answers to puzzling service problems on specific types of equipment or components.

Modern test methods of all types are clearly described and their advantages shown. Special problems in hard-to-fix sets are explained. Step by step charts demonstrate professional procedures almost at a glance. The television section includes everything from general trouble shooting and pattern analysis to what to do about fading and propagation troubles; handling intermittents and dozens of other subjects—everything the modern serviceman needs to know. Contains 820 pages and 417 clear illustrations. Price \$6.75 separately.

Radio & Television Receiver CIRCUITRY & OPERATION

It's lots easier to repair ANY radio or television set when you know all about its circuits and just why and how each one works. You locate troubles faster and with less testing. You repair them more efficiently!

This big book gives a complete understanding of modern circuits; teaches you to recognize them quickly; and shows how to eliminate useless testing and guesswork in making repairs. Covers all basic circuits used in modern television and radio receivers as well as phono pick-ups and record players. Contains 669 pages and 417 helpful illustrations. Price separately \$6.50.

10 DAY FREE EXAMINATION

Dept. RN-113, Rinehart Books, Inc., Technical Division
232 Madison Ave., New York 16, N. Y.

Send books checked below for 10-day FREE EXAMINATION. In 10 days, I will either remit price as indicated or return books postpaid and owe you nothing.

Check here to receive books singly:

- Radio & TV Receiver CIRCUITRY & OPERATION (Price \$6.50 separately)
- Radio & TV Receiver TROUBLESHOOTING & REPAIR (Price \$6.75 separately)

Check here for MONEY SAVING COMBINATION—Save \$1.25! Both of the above big books at the special price of only \$12.00 for the two. (Regular price \$12.75—you save \$1.25.) Payable at the rate of \$3 after 10 days if you decide to keep books and \$3 a month thereafter until the total of \$12 has been paid.

Name

Address

City..... Zone..... State.....

OUTSIDE U.S.A.—\$7.25 for TROUBLESHOOTING & REPAIR book; \$7.00 for CIRCUITRY & OPERATION; \$13.00 for both books. Cash with order only. Money refunded if you return books in 10 days.

Only \$12 for the complete training!
See SPECIAL COMBINATION offer in coupon

3 Months to Pay!

more
and more
replacement
problems
are being
solved
this way



for complete
information
write

SARKES TARZIAN, INC.
RECTIFIER DIVISION

415 N. COLLEGE AVE., BLOOMINGTON, INDIANA
IN CANADA: 50 ST. CLAIR AVENUE W., TORONTO

10-Meter Preamp (Continued from page 129)

C_1 should be adjusted (if used) for maximum signal and trimmer C_1 peaked for middle of the band. Peak on either a signal or noise. Because of the zero temperature-coefficient type condensers used, stability is excellent. Mica condensers could be substituted at a sacrifice in stability.

The power cable to the receiver was cut to length after the unit was fastened inside the receiver to give a "permanent" installation; however, a plug could be installed on the amplifier so it could readily be removed.

The entire unit fits snugly inside the NC-125 and makes a worthwhile addition to any communication receiver. A small screw attaching the unit to side wall will suffice, and a gain of approximately 15 db can be expected.

"CUSTOM" LOW VALUE RESISTORS

By L. H. TRENT

WHEN that old tube has given its last gasp in some experimental circuit, don't heave it into the nearest disposal can, because it can still furnish you with material for low range resistors. These resistors will range from 10 to 150 ohms or slightly higher, with a wattage rating of one to 30 watts. The exact wattage rating will depend upon the method of construction.

Many of the circuits in modern equipment use odd value resistors in either the cathode or a voltage divider circuit. Most of the time, these odd values will not be available for experimental checking of some circuit, but it is a simple matter to build the low values needed at practically no expense. With a selection of burned-out tubes and some high value insulated resistors or other forms, almost any value up to 150 ohms can be quickly built to an average accuracy of 3%.

After removing the grid structure from a defective tube, it will be necessary to unwind the wire. The best method is to use needle-nosed pliers and bend the supporting rods inside the winding. This loosens the factory method of clamping the wire in the supports. Once it has been removed from the supports, measure the resistance of the wire.

The next step is to anneal the wire to remove the strains caused by the winding and unwinding processes. This is easily accomplished by sending a current through the wire. A good average to try is about one volt-per-ohm of resistance. Heat the wire to a dull red and keep it at this temperature for at least a minute.

The annealed wire may be wound on a one to ten megohm insulated resistor or on the ceramic form of a burned-out resistor. Either way, wind a fine thread on the form first as a spacer. Then wind the wire in the spaces between the threads. This results in the winding being spacewound for heat dissipation and insulation between the turns. The

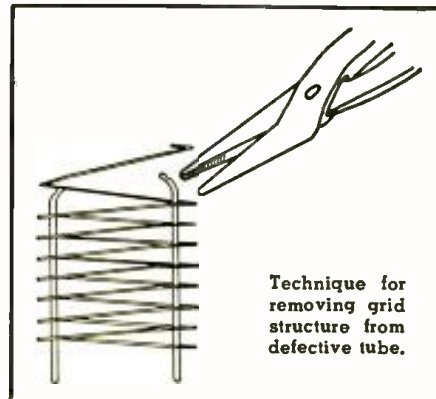

Technique for removing grid structure from defective tube.

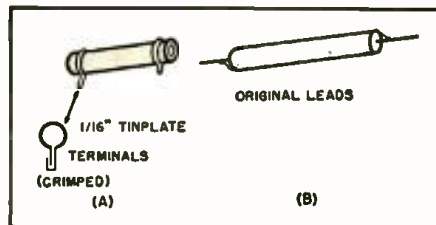

How annealed wire is wound on resistor.

normal resistor leads or small clamp terminals can be used for terminating the resistance winding. When finished with the winding, dip the completed unit in transformer varnish for moisture protection.

To make a five-watt resistor, or one of a higher rating, wind the resistance wire on wire solder or another form of the same size. Remove the solder core and stretch the winding on a mica form of the ballast tube type. The winding should be stretched until the space between the turns is about three times the diameter of the winding. During the war, some ballast tubes were rebuilt with these grid elements and they are still working satisfactorily.

Table 1. Measured values for some of the more common tube types.

Tube	L	G ¹ Res.	L	G ² Res.	L	G ³ Res.	L	G ⁴ Res.	L	G ⁵ Res.
35	12"	4	42"	50						
41	9"	8	16"	3	12"	4				
47	26"	8.5	46"	13S	43"	100				
78	12"	3.5	31"	5.5	24"	45				
6A7	9"	5	***		20"	90	48"	16	84"	28
6SA7		***	***		42"	160	48"	110	19"	40
6SC7	24"	16								
(L—length of wire) *** impossible to salvage										

Concertone

1500 SERIES

Tape Recorders

A model for every requirement

The 1500 Series of Concertone tape recorders with their interchangeable single and dual track heads, covers the recording field from the highest fidelity requirement to the maximum of tape economy. These are the only magnetic tape recorders under \$1000 combining distortion-free, full frequency response with all the tape handling facilities of professional equipment. Designed for custom, console or portable installation. 50-15,000 c.p.s. frequency response with negligible distortion. Straight line tape threading. Plays 5", 7" and NAB 10½" reels.

MODEL 1501

For 7½ and 15 i.p.s. operation.
The basic recorder...\$345.00

MODEL 1503

For 3¾ and 7½ i.p.s.
The basic recorder...\$345.00

MODEL 1502

For 7½ and 15 i.p.s. operation with two-speed hysteresis synchronous direct drive motor for extreme timing accuracy.
The basic recorder...\$445.00

Write for Bulletin 201



1502 Recorder in 504 Case

BEING THERE™

"JUST LIKE



Manufactured by **Berlant Associates**
4917 W. Jefferson Blvd. • Los Angeles 16, Calif.

TV RECEIVER for DX

Description of a television receiver which includes a built-in booster for improved fringe performance.

FOR good TV reception in extreme fringe areas, a receiver must have good sensitivity and sync stability. For television DX-ing, the sensitivity and sync stability should be exceptional. A novel method of providing increased sensitivity in a television receiver designed specifically for DX reception is to incorporate a tunable built-in booster in the receiver. This expedient is used by the *Mattison Television and Radio Corporation* in their "Silver Rocket" 630 television chassis. The broadband booster built into this set is designed to increase the signal strength on Channels 2 to 13 by a ratio up to 10:1 without increasing noise.

Built into the well of the 630 chassis, the booster has a three-position control on the front of the receiver. The booster, whose circuit is shown in Fig. 1, is automatically turned on and off with the receiver, but can be shut off separately if desired (for local reception, for example). It is connected to the antenna terminals of the receiver by a short length of *Federal K111* shielded 300-ohm cable, which eliminates the possibility of regeneration, which may be caused by long leads, and minimizes signal attenuation. The booster is aligned at the same time with the r.f. stages of the receiver, providing maximum bandwidth.

Two 6J6 duo-triode tubes are used in a neutralized push-pull circuit in the booster. Triodes inject less tube noise into the circuit than pentodes;

however, they do not furnish as much gain. The use of push-pull circuits, therefore, brings the gain up without appreciably increasing the noise. One 6J6 tube is used as an r.f. amplifier covering Channels 2 to 6, and the second 6J6 covers Channels 7 to 13. The booster control knob selects the circuit to be used. Two pigtail-type neutralizing condensers (1.2 $\mu\text{fd.}$) are used with each tube for regenerative feedback to improve the amplifier response and to eliminate regeneration. Both 300-ohm balanced and 75-ohm unbalanced antenna inputs are provided.

The booster is self-powered, using a selenium rectifier and isolation transformer. A thermal "on-off" switch automatically applies power to the booster after the power is applied to the receiver, reducing the likelihood of transients affecting the selenium rectifier.

Another feature of this receiver, and one designed to improve the sync stability, is a two-tube sync clipper circuit. One tube functions as a high-frequency clipper, having a short time-constant parallel RC network in its cathode circuit which effectively serves as a low-impedance path to ground for noise pulses; the other tube is a low-frequency clipper which passes a noise-free vertical sync pulse to the sync amplifier, increasing stability.

Thus, increased sensitivity and improved sync stability are provided in a TV receiver which can pull the signal in from distant stations as well as from the local ones.

-30-

Fig. 1. Schematic diagram of the tunable booster built into the Mattison TV set.

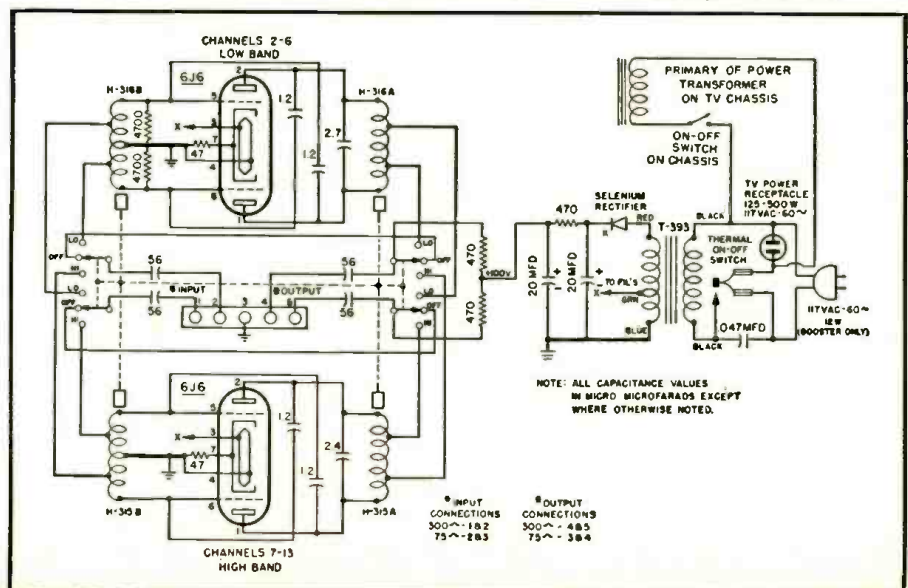

A New V.F.O.
(Continued from page 109)

A fixed condenser of this value works very well, but the variable type is preferable inasmuch as it can be used as a bandset condenser to shift the frequency of the oscillator in either direction by a slight turn of the adjusting screw.

The under-chassis (Fig. 5) view shows a three-section variable condenser, but actually, only one section was used. This particular condenser was used because it was already mounted with a good vernier dial.

At the time the photos were taken, the numerals on the panel scale had been erased prior to calibration. Calibrating the dial is not difficult if you can proceed by "beating" the v.f.o. and a frequency meter (using a receiver to detect zero beat), and filling in check points on the v.f.o. dial.

Using the coils and condensers specified in the text, the v.f.o. will tune from approximately 1700 to 2300 kilocycles when C_3 and C_2 have been properly adjusted. This can be checked against the 160-meter band on your receiver for verification. At this point a grid dip meter or an ordinary absorption-type wavemeter can be used to determine whether you are listening to the fundamental or a harmonic. (A harmonic will give no indication on the wavemeter.)

Since the oscillator's frequency remains on the 160-meter band at all times, it is easy to write in the frequencies on your dial for the rest of the bands. For example, set your dial on the spot that you have determined to be 1750 kc. and start multiplying by two, while writing each result under the same spot on the dial. Thus you would have a calibration of 1750, 3500, 7000, 14,000, and 28,000 kc. for the same dial setting. This procedure may be continued until you have as many check points as you wish.

A few pointers here may be of help to those who wish to build this or any similar equipment. A variable condenser with brass plates (which may be plated) has far less change in capacity (and less frequency drift) per degree of temperature change than does one constructed of close-spaced aluminum or alloys. One with double-bearing construction and with good wiper contacts should be used. Low-loss insulation is preferable for the condenser as well as for the tube and coil sockets and coil forms.

Silver-mica fixed condensers have less capacity change with temperature change than ordinary types (and consequently less frequency change). Coils once completed and tested should be dipped in hot paraffin or coated with *Duco* cement.

Fig. 5 shows two small variable condensers mounted at the left of the main tuning condenser. These were part of the original equipment, and were wired in parallel. We shunted



FOLLOW ARROW FOR BIGGEST STOCK AT LOWEST PRICES

- RADAR—TRANSMITTERS
- RECEIVERS — TUBES — PARTS

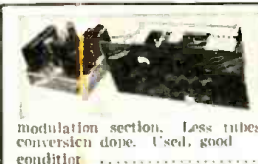

C.A.P. SPECIAL BC-625 VHF TRANSMITTER
Freq. range 100-156 MC. With & crystals, with mod. Ex. cond. **\$9.95**

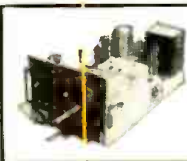

UHF Transmitter
450-710 MC. Tunable Transmitter. 10 W. output. Two 368-type tubes as push-pull oscillators. Wide band video amplifier. Less tubes, with schematic. Excellent cond. **\$8.95**



UHF 420 MC TRANSCIVER
Complete transmitter-receiver unit with 5 stages of 30 MC. IF amplifier. This unit is the famous AFS-13 Radar Set. Less tubes, dynamotor. With schematic. Excellent. Ex. cond. **\$9.95**

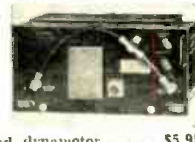

INTERPHONE AMPLIFIER BC-709-B
A 2-position single stage audio amplifier. Uses 1 tube and operates from self-contained batteries. With Instruction Manual and Schematic. **\$3.95**
NEW (less batteries).....

R-28/ARC-5 RECEIVER
100-156 MC. With tubes. Excel. cond. **\$45.00**

MOTOROLA MODEL TR 20.18 MOBILE 2-WAY RADIO. Used condition. **\$150.00**

RADAR TEST EQUIPMENT
TS-1, TS-12, TS-13, TS-15, TS-33, TS-34, TS-35, TS-36, TS-45A PM3.

BEACON RECEIVER BC-1206



Frequency Range—195 KC to 420 KC. IF Frequency—135 KC Receiver Sensitivity—2 Microvolts for 10 Milliwatts output. Output Impedance—300 Ohms and 4000 Ohms to be selected internally. Volume Control—RF Gain Control. Power Supply—24-28 Volts Aerophane Battery. Current— **\$9.95**
75 Amperes.....



R.F. Modulator
Complete Tunable 20.5 MC. Test Set. With 110 V. 60 cps. power supply. 3-stage audio amplifier. Terrific chassis for experimentation. With schematic. Like new. **\$9.95**

Monthly Specials!

ID6/APN4
Made to operate in conjunction with Radio Receiver R-91/A/P/N 4. Unit includes 10 tubes, one 5" scope tube, crystal controlled standard oscillator, sweep circuits, marker pulses. Excellent cond. **\$42.50**

Also available: ID6A, ID6B. Write for quotations.

BC-604 30 W. FM TRANSMITTER. For 20-27 Mc. band. Ideal for 161 meters. Complete with tubes, temperature controlled crystal oven and technical manual with all instructions for BC-603 and BC-601. Less dynamotor and crystals. Excel. cond. **\$12.95**

OAK 2 V. VIBRATOR. New. Each. **39c**
10 for **\$3.50**
MT-77 for BC-412. New. **.95**
UHF MOBILE DIRECTIONAL ANTENNA. New. **.95**

COMMAND EQUIPMENT (SCR-274N)

	Used	New		Used	New
BC-442 ANTENNA RELAY. Less cond.	\$1.95		BC-458 TRANSMITTER. 5.3-7 MC. With tubes	\$9.95	
BC-451 TRANSMITTER CONTROL BOX		5 3.95	BC-459 TRANSMITTER. 7.0 MC. With tubes	9.95	
BC-450 RECEIVER REMOTE CONTROL BOX		2.95	MC-211 90° ANGLE COUPLING UNIT.		\$0.95
MC-215 MECHANICAL DRIVE SHAFT. Per length		2.95	FT-234 MOUNTING RACK for single transmitter	2.95	3.50
BC-496 2-POSITION RECEIVER CONTROL BOX		2.95	FT-226 MOUNTING RACK for 2 Command Sets		3.95
BC-454 RECEIVER 3-6 MC. With tubes	12.95	2.95	FT-221 MOUNTING PLATE for FT-220		1.50
BC-455 4-8 MC RECEIVER. With tubes	9.95	14.95	FT-220 MOUNTING RACK for 3 receivers	2.25	3.95
BC-457 TRANSMITTER. 4.3-3 MC. With tubes	9.95		FT-225 MOUNTING PLATE for BC-456		2.25
			BC-456 MODULATOR. For SCR-274. Complete set of 4 tubes for transmitter	5.75	1.25

Miscellaneous Specials!

H-16U HEADSET. 8,000 ohms.	\$3.95
HS-18 HEADSET. New	2.45
HS-23 HEADSET. High Imp. New	4.95
HS-30 HEADSET. Featherweight type. Low Imp. NEW	\$2.49 USED. 1.49
HS-33 HEADSET. Low Imp. New	6.95
HS-38 HEADSET. Used, excel. cond. NEW	3.50
T-32 DESK STAND MIKE. New	5.95
T-48 DESK STAND MIKE. New	4.95
LIP MIKE. Navy type. New98
MP-22 MOBILE ANTENNA. MOUNTING RACK. Comp. with hardware. Per Pair \$4.95. Ea.	2.95
TU-17 TUNING UNIT. (2-3 MC.) For BC-223 (Nmt). Used	2.95
TU-25 TUNING UNIT. (3.3-5.2 MC.) For BC-223 (Nmt). Used	2.95
L-70 "S" TUNING METER. NEW	2.50
WOBULATOR. See H-48 Dec. '51 RADIO NEWS BC-1023 75 MC. MARKER BEACON RECEIVER. Complete with tubes, mnt. rack. NEW	10.95

250 TL TUBES—Limited Quantity!
Only \$9.95 each
Save \$2.00! Order 2 for only \$17.00

\$5.00 MINIMUM ORDER ACCEPTED. All items subject to prior sale. All shipments F.O.B. warehouse. Calif. residents add tax with remittance. 20% deposit required. Please specify shipping instructions with order. EQUIPMENT WANTED! Highest prices paid for all types of Electronic Gear!

INDUSTRIAL CORPORATIONS

We carry one of the most complete stocks in U. S. of Military Electronic Equipment, Test Equipment, and Aircraft Electronics. Call or write for free catalogue.

ARROW SALES, INC.

Cable Address: ARROWSALES PO Box 5-1110

Mailing Address:
P. O. Box 3878-R, N. Hollywood, Calif.
Office-Warehouse:
7440 Varma Ave., N. Hollywood, Calif.

in stock at **ALLIED**
FOR IMMEDIATE DELIVERY

PENTRON
HI-FI TAPE RECORDER
High Quality! Low Cost!



9T-3M Basic Recording Mechanism

Enjoy the outstanding fidelity and flexibility of good tape recording—and at surprisingly low cost! This smooth operating basic mechanism and preamp-oscillator (below) are perfect for custom installation. Feed directly into amplifier or radio. Speeds: 3.75" and 7.5" per second. Fast forward and rewind (1200 ft. in 40 sec.). Maximum recording time of 2 hours on both tracks at 3.75" speed. Push-pull bias erase circuit assures complete erasure. High-quality 4-pole, shaded-pole motor. Shpg. wt., 13 lbs.

96 RX 587. 9T-3M Basic Recording Mechanism. Net. \$59.75

PRE-7 Preamp-Oscillator

For use with above. Inputs for tuner, phono and mike. Response, ±.3 db, 50-11,500 cps at 7.5" speed. 5 tubes and "Magic Eye" level indicator. Includes jack for headphone monitoring. Shpg. wt., 10 lbs.

96 RX 588. Net. \$39.75



PMC Complete Basic Tape Recorder

The 9T-3M mechanism and PRE-7 preamp-oscillator housed in a handsome portable case. Size: 10½" x 9¼" x 13". With tubes, 5" reel of tape and 7" take-up reel. For 105-125 v., 60 cycle AC. Shpg. wt., 29 lbs.

96 RX 589. Net. \$114.50



We stock all Pentron Recorders and accessories. Write for details.

ORDER FROM

ALLIED RADIO

ALLIED RADIO CORP., Dept. 1-LA-3
100 N. Western Ave., Chicago 80, Ill.

Ship Pentron Model.
\$..... enclosed

Name.....

Address.....

City..... Zone..... State.....

them across the main tuning condenser and they serve as a bandset. They are shown in the diagram as C_2 . Their value may be increased to 125 μfd . thereby eliminating the fixed condenser C_1 for easier initial calibration. This will provide an easier means for preliminary spotting and spreading of the 160-meter band to the desired tuning range. If necessity decrees, a small negative-coefficient condenser of approximately 10 to 25 μfd . may be also shunted across the main tuning condenser to minimize warmup drift. —30—

"Small-Package" Modulator
(Continued from page 103)

tapped secondary winding that provides impedances of 3000, 5000, 6500, and 8000 ohms. The taps are selected by a rotary switch mounted on the rear of the chassis. The fifth position on the switch is used to short circuit the secondary when c.w. is being used. Power must not be applied to the modulator tubes when the modulation transformer secondary is shorted because damage to the transformer may result. The transformer primary is rated at 25 watts of audio and the secondary is rated at 100 ma. d.c. However, the transformer has been operated with 150 ma. d.c. in the secondary for extended periods without damage.

The 6AQ5 tubes are rated at a maximum plate and screen voltage of 250 volts, but a 300-volt supply has been used for greater power output for the past year and the original tubes are still giving satisfactory service. If only 10 watts of audio are needed a 250-volt supply should be used so the tubes will operate within their ratings.

Construction

The modulator is built on a 9½" x 5" x 2" aluminum chassis. The microphone jack, gain control, and a dial light are mounted on the face of one

end of the chassis. The dial light bracket is the type that allows the bulb to be replaced from the front of the chassis by unscrewing the jewel. (The bulb has a bayonet base which will not shake loose in the socket in mobile work as a screwbase bulb would.) The output-impedance tap switch is on the other end-face of the chassis.

Mounted on the top of the chassis from front to rear are: the microphone transformer, 6C4 tube, inter-stage transformer, 6AQ5 tubes, and the modulation transformer. The photographs clearly show the placement of parts so no trouble should be experienced in laying out the unit.

There should be at least one-half inch clearance between the 6AQ5 tube shields and the adjacent transformers to permit adequate ventilation. Standard-size tubes may be substituted for the miniatures without changing the circuit if octal sockets are used. Replace the 6AQ5 tubes with type 6V6 and the 6C4 with type 6J5.

While the design might seem adaptable to an even smaller space than that used, ease of construction and maintenance are more important considerations than small size for the sake of small size.

Operation

To put the modulator in operation it is only necessary to connect the power supply, microphone, and load and to set the impedance tap switch to the proper position. The unit should never be operated without a load on the secondary of the modulation transformer or the transformer will be damaged. The output impedance to be used is determined by dividing the r.f. amplifier plate voltage (in volts) by the plate current in amperes, e.g.,

$$300 \text{ v.} / 0.1 \text{ amp.} = 3000 \text{ ohms}$$

This is, of course, the standard calculation for all plate modulators.

If you want a compact, inexpensive, easily-built modulator for your 30-watt rig, "small package" modulator was designed for you. —30—

Under-chassis view. Parts placement is straightforward, almost following the circuit diagram layout. Octal tubes may be substituted for the miniature types used.

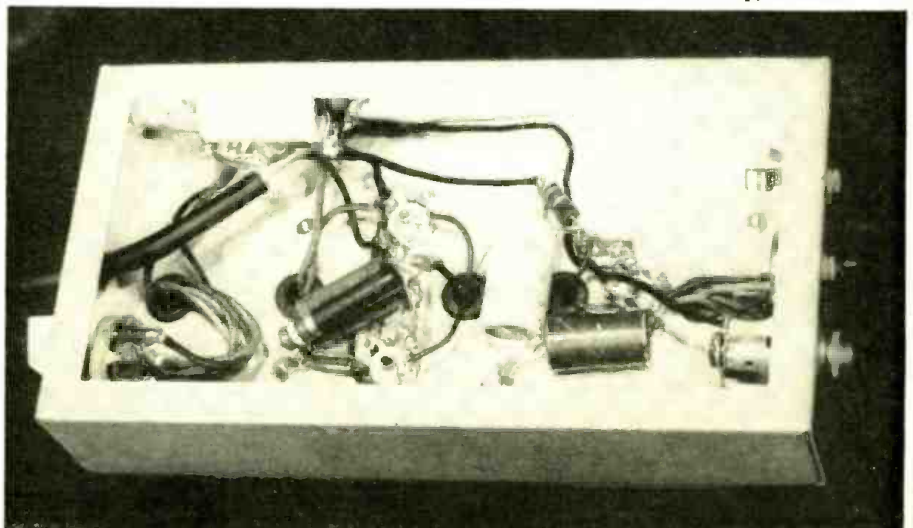

Within the Industry
(Continued from page 36)

police and fire departments, later joining CBS in Chicago in 1940 where he helped install the network's low-band FM station.

Mr. Timberlake is a senior member of the IRE. He is a well-known amateur, with the call of W9RZP for over 20 years.

* * *

TRANSVISION, INC. has set up a special transformer and coil manufacturing division to handle the design, engineering, and manufacture of specialized coils in small quantities. . . **ANDREW CORPORATION** of Chicago has set up a Canadian affiliate, **ANDREW ANTENNA CORPORATION, LTD.**, which will have headquarters in Whitby, Ontario. John W. McLeod has been named manager of the new organization. . .

HUFFORD MACHINE WORKS INC. of El Segundo, California has announced the formation of a new electronic division. Located in a new 10,000 square foot plant at 2201 Carmelina Avenue, Los Angeles, California, the division will specialize in the development and production of d.c. regulated and unregulated rectifier-type power supplies, magnetic amplifier controls, magnetic servo amplifiers, and transformers. . . The purchase of **THE SEALTRON COMPANY** by William C. Sage was announced recently. He has acquired the name and a substantial portion of the assets of the company which is located at 9701 Reading Road, Cincinnati. Officers of the new **SEALTRON CORPORATION** include Mr. Sage as president, H. G. McKnight, vice-president, and Lawrence M. Paul, secretary-treasurer.

* * *

W. WARD WILLETT has been appointed advertising manager of **LaPointe Electronics Inc.**, manufacturers of the "Vee-D-X" line of TV antennas and accessories.



He was formerly sales promotion manager of the **Plax Corp.** and was with **Benton & Bowles** and the **Platt-Forbes** advertising agencies.

Mr. Willett has resided in West Hartford, Conn. since 1946. He is a graduate of Williams College and served in World War II with the ski troops.

* * *

MAX BALCOM, **Sylvania Electric Products Inc.**, has been reappointed chairman of the FETMA educational TV committee for the coming year.

He will head the fifteen-man group which will continue its study of developments in educational TV and encourage projects in the field through the cooperation of individual manufacturers.



NEW SUPPLY ARRIVED!
LIMITED QUANTITY
TRANSMITTER-RECEIVER
Navy Model ABA-1
(CG-43AAG)
Army Model SCR-515A,
known as the BC-645
450 MC—15 Tubes

BRAND NEW—ORIGINAL CARTON
Can be easily converted for phone or CW 2-way communication. Covering for the following bands: 120-450 MC ham band, 450-460 MC for fixed or mobile, 460-470 MC for citizens, 470-500 MC television experimental. Size 10" x 13" x 13". Contains 15 tubes: 4—7F7, 4—7H7, 2—7K6, 2—7F6, 2—955, 1—WE-316A door knob.
Price includes Dynamotor, Control Box, Mount, Tubes. \$34.95



SCR-274N COMMAND and ARC-5 EQUIPMENT

		USED	USED	NEW
		RECEIVERS	EXCELLENT	
BC-453—190 to 550 KC.		\$29.95		\$49.95
BC-454—3 to 6 MC		6.95 (as is)		24.95
BC-455—6 to 9 MC			\$13.95	19.95
1.5 to 2				34.95
		TRANSMITTERS		
A-958—2.1 to 3 MC			14.95	29.95
BC-457—4 to 5.3 MC			14.95	29.95
BC-458—5.3 to 7 MC	9.95			24.95
BC-459—7 to 9.1 MC				29.95
T-15 AIC 5—500 to 800 KC.				29.95

ADDITIONAL EQUIPMENT

BC-456 Modulator				7.29
BC-450 Control Box (3 Receiver)	1.49	1.95		2.75
BC-451 Control Box (Transmitter)	1.29	1.79		2.39
BC-442 Relay Unit (ANT)				5.69
Plugs: PL-147, 148, 151, 152, 153, 154, 155—EACH			1.25	
Flexible Shafts with gear to fit receivers				2.69
3 Receiver Rack	1.79	2.29		2.98
2 Transmitter Rack	1.69	2.39		3.97
Single Transmitter Rack				3.97
DM-33 Dynamotor for Command Set.		2.95		3.95
Mounts for Above Racks		1.95		

HEADSETS

HS-25 high impedance. BRAND NEW with ear pads. . . \$4.65

HS-33 low impedance. BRAND NEW with ear pads, cord and PL54 plug. . . 5.65

CD-307A Cords, 6 ft. NEW. . . \$1.49

HS-16 J high impedance. Includes two receiving units. . . 3.95

HS-16 high impedance—used. . . 98

SPECIAL! HS-33 HEADSET, used. . \$1.89

T9/APQ-2 RADAR TRANSMITTER
80 / 115 V 400-260-26 VDC.
Designed primarily for aircraft operation.

NEW! \$19.95

AS-65/APQ-2 ANTENNA ASSY. FOR APQ-2. COMPLETE—BRAND NEW. . . \$6.95

Field Telephones
Army surplus, completely reconditioned and electrically tested, using 2 flashlight cells and a pair of interconnecting wires. G.I. ARMY FIELD. New \$28.95

Like new \$21.95

SPECIAL! NOW! Fill Your Battery Only Twice a Year with Automatic Battery Recharger

Made by leading Detroit Auto Mfr. Doubles battery life over ordinary care, prevents battery break-downs, fits all cars, instantly installed.

ONLY 69c COMPLETE

SPECIAL! 20 LBS. of ASSORTED RADIO PARTS
A terrific buy at only **\$1.99**

PE 98 12 VOLT DYNAMOTOR
Excellent Condition.
\$22.95

MULTI-TESTER FOUNDATION BIAS METER 1-97A
Complete, Brand New.
Special! \$5.95

MINIMUM ORDER \$2.00
Immediate Delivery — Set 25% deposit on C.O.D. orders. All shipments F.D.B., N.Y.C. (N.Y.C. residents add sales tax to your remittance.)

ELECTRIC MEGAPHONE SYSTEM



For Rural Areas, Hotels, Commercial Steamers, Ball Parks, Etc.

U. S. NAVY type PAE-1 Electric Megaphone equipment is assigned for voice reinforcement in much the same manner as, but to a greater degree than, the familiar acoustic megaphone. Consists of Megaphone Unit which combines a microphone and reproducer in a single assembly. Portable Amplifier which electrically amplifies the output signal of the microphone section of the megaphone and feeds this amplified signal to the reproducer section. Charging Rack for recharging the self-contained storage battery of the portable amplifier. BRAND NEW—A TREMENDOUS VALUE! DEMONSTRATION GIVEN AT EITHER OF **\$149.50**
PLATT'S STORES

TUBES	BRAND NEW!	TUBES
JANI	BOXED!	
1B22 . . . 69c	114B . . . 29c	841 . . . 29c
1B23 . . . 75c	215A . . . 09c	843 . . . 17c
2B22 . . . 49c	221A . . . 29c	864 . . . 19c
2C26 . . . 09c	316A . . . 29c	1626 . . . 19c
2C20A . . . 09c	388A . . . 59c	7193 . . . 19c
3B22 . . . \$1.19	471A . . . \$1.19	0002 . . . 69c
3D6 . . . 39c	512A . . . \$1.19	E114B . . . 49c
7C1 . . . 39c	722A . . . 99c	RK34 . . . 99c
12KR4 . . . 39c	801A . . . 19c	VR22 . . . 14c
15B . . . 39c	820 . . . 39c	VT127 . . . 15c
39/44 . . . 29c		

Special for This Month Only!!
STANDARD BRAND TUBES
For Mail Order Customers Only
6SN7 6V6 6J6 6SL7 12SL7
ONLY 49c Each

LIMITED QUANTITY
SPECIAL! TU-10 TRANSMITTER TUNING UNIT for BC-375
KC. 75% complete, excellent for spare parts. . . \$2.95

TUNING UNITS (TU-18 3000-4500 Kc; TU-25 3500-5250 Kc). Brand New in Original Carton. . . \$6.95
Metal Case to Hold Above Tuning Units. . . \$1.00

SENSATIONAL SALE!
ARC-5/R-28 2 MTR RCVR
\$19.95

Here is the 2-meter superhet you have been looking for! Absolutely one of the BEST available today! Tunes from 100 to 156 Mcs. in four crystal channels. (Easily converted to continuous tuning.) Tube lineup is as follows:
717A—R.F., 717A—Mixer, 2-12SH7—1st and 2nd I.F. 16.0 Mc.
12SL7—1st AVC Spuclch, 12SL7—1st auto-spuclch amplifier.
12A6—2nd audio, 12SH7—R.F. Osc.—4th Harmonic Gen.
717A—Trip, 12th Harmonic Gen. 717A—Dblr.—12th Harmonic.

BEACON RECEIVER BC-1206

Frequency Range—195 KC to 420 KC. IF Frequency—135 KC. Receiver Sensitivity—3 Microvolts for 10 Milliwatts output. Output Impedance—300 Ohms and 4000 Ohms to be selected internally. Power Output—230 Milliwatts, Volume Control—RF Gain Control, Power Supply—24-28 Volts Aerobline Battery. Current—75 Amperes

BRAND NEW—ONLY \$12.95

PRE-AMPLIFIER MODEL K-1
The K-1 is used to amplify output level for microphones and phonographs. Operates on 24-28 VDC. Can be converted to 110 AC. Comes complete with PL 55 plug and 2-foot 119-B cord. 2 terminal blocks and instruction book.

BRAND NEW.SPECIAL! \$3.95

BC-221 Frequency Meter
Real Value! QUANTITY IS LIMITED—so first come, first served. They are just like new, with original calibration charts. Range 125-20,000 KC with crystal check points in all ranges. Complete with crystal and tubes. **\$139.50**
MODULATED TYPE with AC Power Supply \$169.50
Power Supply 189.50
These Frequency Meters are factory treated, checked for frequency alignment and GUARANTEED.

PLATT ELECTRONICS CORP.
DEPT. A, 489 BROOME ST., NEW YORK 13, N. Y.
PHONES: WO 4-0827 and WO 4-0828

Train IN
Great COYNE shops
for big pay jobs

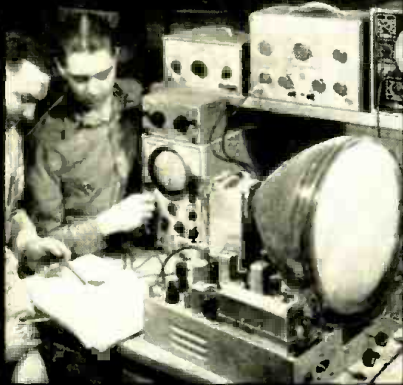

IN Television
- Radio



OR
Electricity
- ELECTRONICS

Learn on REAL EQUIPMENT!
in Best Equipped School of its
kind in U. S.

Prepare for your future NOW! Come to the Great Shops of Coyne. Get practical training in opportunity fields—TELEVISION-RADIO—ELECTRICITY—ELECTRONICS. Prepare for a better job in industry or better service rating if drafted.

WE TRAIN YOU IN CHICAGO

At Coyne you learn on real, full-size equipment. Trained instructors show you how, then you do shop jobs yourself. No previous experience or advanced education needed

Approved for Veterans

Finance Plan—Enroll now, pay most of tuition later. If you need part-time work to help out with living expenses while at Coyne, we'll help you get it. Special tuition plan for men of draft age.

FREE BOOK Clip coupon for Big Free Illustrated Book. No salesman will call. Act NOW.

COYNE
SCHOOL

510 S. Paulina St., Dept. 83-85H
Established 1899
APPROVED FOR VETERANS



B. W. COOKE, Pres.
COYNE School
510 S. Paulina St., Chicago 12, Ill., Dept. 83-85H
Send FREE BOOK and full details on:

TELEVISION-RADIO ELECTRICITY

NAME _____

ADDRESS _____

CITY _____ STATE _____

1954 Sylvania TV Sets

(Continued from page 118)

might produce severe radiation. It is also much easier to completely shield a crystal cartridge than a tube in trying to minimize this harmonic radiation.

A crystal has less capacitive loading than a tube, therefore, the loading of the 4th video i.f. by the crystal video detector results in more gain in that stage. The 1-518 chassis uses a 1N105 crystal for the video detector. This is a 1N60 that can be clipped in to the circuit to make replacement easier.

A positive polarity signal must be fed to the cathode of the picture tube, therefore, the output of the detector is negative. This permits noise limiting in the grid circuit of the 12BY7, since the bias can be adjusted so that any noise burst that is greater than the tip of the sync level would drive the tube to cut-off and thus be eliminated.

Direct coupling is used between the crystal detector and the video amplifier and between the video amplifier and the picture tube for several important reasons. An obvious one is the elimination of the d.c. restorer tube ordinarily required with RC-coupled video amplifiers, permitting grid-leak d.c. re-insertion to be used. Other features are the elimination of signal phase drifting caused by condenser frequency discrimination, and the improved low frequency amplification. Of course, trouble from leaky or shorted coupling condensers is also avoided.

The cathode return of the 12BY7 is through R_{cath} , a 4.3 ohm resistor in the cathode circuit of the 6BQ6. This resistor maintains a bias of about one-half volt on the 12BY7 at maximum contrast and no signal. Thus, the current of the 12BY7 is limited somewhat when these conditions exist, prolonging the life of the tube.

Some of the 4.5 mc. sound i.f. enters the video amplifier. To prevent this signal from reaching the cathode of the picture tube, a series resonant trap consisting of C_{115} and L_{41} is located in the plate circuit of the video amplifier.

A portion of the video amplifier plate voltage is also applied to the cathode of the CRT, helping to provide the bias for the tube.

The 1-518 sound strip has a full complement of 5 tubes giving a noise-free undistorted output. The physical arrangement of the tubes is such that a minimum of trouble is encountered in servicing these circuits.

The sound take-off is at the detector stage through a series resonant circuit tuned to 4.5 mc. Taking the sound off at this point instead of at the plate circuit of the video amplifier avoids the trouble of sound bars getting into the picture. The amplification of the sound i.f. stage is

MERIT PLATE TRANSFORMERS

1100 VCT/150MA	\$ 6.27
1320, 1100VCT/250MA, 40V Vias Tap	8.53
2160VCT/125MA; 1000VCT/150MA	10.58
1800, 1600VCT/225MA	10.14
2900, 2350VCT/300MA	25.28
4200, 3600VCT/300MA	32.34
5800, 4770VCT/300MA (Sq. Cse)	47.04

MERIT FILAMENT TRANSFORMERS

2.5VCT/10AMP/10KV INS	\$ 3.82
5VCT/3AMP/2500V INS	2.65
5VCT/30AMP/2500V INS	7.05
6.3VCT/1AMP/2500V INS	1.76
6.3V/1.2AMP/5KV INS (TV REPL)	2.20
6.3VCT/3AMP; 6.3VCT/3AMP/2500V INS	4.20
5VCT/3AMP; 6.3VCT/3AMP/2500V INS	4.20
10VCT/10AMP/3KV INS	6.17
12.6VCT/2AMP/2500V INS	2.79
25.2VCT/1AMP/2500V INS	2.79
12.6V/7AMP or 25.2V/3.5AMP/2500V INS	6.17

MERIT FILTER CHOKES

15HY/85MA/1500V INS	\$ 2.94
10HY/110MA/1500V INS	2.94
12HY/150MA/1500V INS	3.53
15HY/150MA/2KV INS	5.14
5HY/200MA/1500V INS	4.11
10HY/150MA	3.82
10HY/200MA } 3KV INS	4.70
10HY/250MA	6.47
8HY/300MA	6.76

MERIT UNIVERSAL MODULATION

PRI-2000-20000/50MA Per Side; SEC-2000-20000/50:100MA* 15 WATTS	\$ 6.76
PRI-2000-20000/150MA Per Side; SEC-2000-20000/150:300MA* 60 WATTS	9.85
PRI-2000-20000/220MA Per Side; SEC-2000-20000/220:440* 125 WATTS	13.23

*SERIES—PARALLEL

ALUMINUM CHASSIS

5 1/2x9 1/2x1 1/2	\$.88	7x15x3	\$1.80
4x17x3	1.53	7x17x3	1.91
5x10x3	1.05	8x17x3	2.03
6x14x3	1.65	10x12x3	1.65
7x7x2	.91	10x14x3	2.10
7x9x2	.90	10x17x3	2.28
7x11x2	1.00	11x17x3	2.29
7x13x2	1.20	12x17x3	2.67

All prices F.O.B. our warehouse New York

LEEDS RADIO CO.

75 Vesey St. Dept. A New York City 7

(Advertisement)



"See, I told you a
JENSEN NEEDLE
would guarantee results."

great enough to drive the sound i.f. limiter to limiting action even at the weakest signals.

The ratio detector transformer is enclosed in one shielding can instead of two for better noise immunity. A 6V6 tube is used for the output stage giving 1.6 watts output.

Anti-Noise, Sync, A.G.C. Circuits

One triode of V_{15} , a 12AU7, has the grid and plate tied together so that the tube operates as a diode. This diode is connected in series with the sync pulse take off instead of in parallel, as a diode clamper would be, and therefore, it is called a "gate" circuit. If a noise burst comes riding in on the tip of a sync pulse, at pin 8 of V_{15} , and the plate voltage of the noise gate tube is adjusted close to the sync pulse level, then the noise burst will make the cathode more positive than the plate, causing the tube to cut off and preventing the noise from passing through the tube.

The right half of V_{15} , a 12AX7, is used as a sync separator and is biased below cut-off so that only the positive-going vertical and horizontal sync pulses drive it into conduction. This cuts out all video material which remains below cut-off.

The left half of V_{15} is also used as a sync separator as well as an a.g.c. rectifier. By adding its output to the output of the right triode, the horizontal lock-in range is greatly improved. The condenser C_{20} charges up to a d.c. level proportional to the amplitude of the sync pulses. This puts a fairly constant voltage drop across the cathode resistor, a.g.c. control R_{20} . A portion of this voltage is fed to the grid of the a.g.c. amplifier (V_{15} , a 6AU6) so that its amplification varies with the amplitude of the sync pulse.

A negative-going sync pulse is fed to the grid of the right half of V_{15} , the sync clipper. The bias of this tube is such that the top of the sync pulse and any noise bursts riding on it are clipped off. The output of the sync clipper feeds the vertical sync pulses to the vertical integrator and the horizontal sync pulses to the horizontal discriminator.

Two separate triodes are used for vertical scan. A 6C4 in a blocking oscillator circuit gives very stable operation for the vertical oscillator. The vertical output is a 6AH4 which is a high-gain tube operating well under its limits so that there is little chance for breakdown.

Interlace improvement was accomplished by the addition of condensers C_{21} in the plate circuit of the 6C4, and C_{216} in the plate circuit of the 6AH4. These condensers were added to decrease the horizontal sync pulses that have gotten into the vertical sweep circuits.

The a.g.c. system requires a voltage negative with respect to ground. It is obtained by pulsing a tube which is used as an a.g.c. amplifier. The pulse used is a portion of the horizontal sweep pulse of the correct



70% to 90% off list! TOP TUBE BUYS

All Tubes Individually Boxed! Same Day Service!
Check this list for Fully 1-Year Guaranteed Tubes.

Type	Price	Type	Price	Type	Price	Type	Price	Type	Price
1A5GT	.30	6AB4	.44	6G6G	.52	7N7	.46	2A4	.63
1A7GT	.47	6AF4	.90	6HG6T	.41	7X7	.70	2SAV5	.83
1AX2	.68	6AG5	.48	6ISGT	.37	12A8	.61	2SB06GT	.62
1B3	.65	6AH4	.57	6J6	.52	12AL5	.37	25L6GT	.39
1B7GT	.30	6AJ5	.65	6J7G	.43	12AT6	.37	26	.45
1C5GT	.43	6AK5	.55	6K5	.47	12AT7	.56	27	.39
1E7	.29	6AL5	.38	6K6GT	.37	12A06	.38	32L7	.89
1G4GT	.24	6AQ5	.39	6K7	.44	12A07	.43	35	.58
1G6GT	.30	6AQ6	.37	6L6	.64	12AV6	.39	35B5	.40
1H4G	.30	6ARS	.37	607	.45	12AV7	.59	35CS	.39
1H5GT	.40	6AS5	.50	654	.38	12AX4	.48	35L6GT	.41
1I6	.24	6AT6	.37	658	.53	12AX7	.48	35W4	.37
1L4	.46	6AU4	.68	6SA7GT	.43	12AY7	.95	35Z4	.39
1N5	.46	6AU6	.38	6SD7GT	.41	12BA6	.38	35Z5GT	.39
1P5	.57	6AV5	.83	6SF5GT	.46	12BA7	.60	36	.60
1Q5	.58	6AV6	.53	6SH7GT	.41	12BE6	.45	41	.42
1R5	.45	6AX4	.53	6SH7	.73	12BE5	.39	42	.42
155	.39	6AX6G	.24	6SJ7GT	.41	12BF6	.39	43	.55
174	.45	6B4G	.64	6SK7GT	.41	12BH7	.63	45	.55
17E	.53	6BA6	.39	6SL7GT	.48	12BY7	.65	45Z3	.44
1U4	.45	6BA7	.57	6SN7GT	.52	12BZ7	.65	45Z5	.49
1U5	.39	6BC5	.49	6S07GT	.37	12C8	.34	50B5	.39
1V5	.60	6BD5GT	.59	6SR7GT	.45	12J5GT	.42	50C5	.39
1X2A	.63	6BD6	.45	6SS7	.42	12J7GT	.34	50L6GT	.51
2A5	.30	6BE6	.39	6T4	1.05	12S8	.70	50V7	.50
2A6G	.24	6BF5	.41	6T8	.56	12SA7GT	.55	53	.24
2W3	.38	6BF6	.37	6U4	.60	12SF5	.50	56	.24
2X2	.24	6BG6G	1.25	6U5	.44	12SG7GT	.52	57	.58
3A5	.45	6BH6	.46	6U6	.63	12SK7GT	.53	58	.60
3E5	.46	6BG6	.39	6UB	.61	12SL7GT	.47	70L7GT	1.09
3Q4	.48	6BQ6GT	.69	6V6GT	.39	12SN7GT	.52	71A	.60
3Q5GT	.49	6BQ7A	.95	6W4GT	.44	12SQ7	.46	76	.44
354	.46	6BZ7	.95	6W6GT	.44	12SR7	.49	77	.57
3V4	.47	6C4	.37	6X4	.37	12V6GT	.46	78	.47
5U-G	.50	6C5GT	.39	6X5GT	.37	14J7	.30	80	.35
5W1	.50	6C6	.58	6X8	.75	14A7	.44	83V	.68
5Y3G	.32	6C86	.44	6Y6G	.48	14W7	.30	85	.59
5Y3GT	.32	6CD6G	1.11	7A4	.47	14H7	.44	117L7	.99
5Y4G	.35	6D6	.45	7AF7	.53	19BG6G	.95	117Z3	.37
5Z3	.46	6E5	.48	7B4	.44	19C8	.70	807	1.19
6A7	.59	6F5GT	.39	7C6	.40	19T8	.79	1274	.30
6A8	.62	6F6	.37	7E6	.30	19V8	.89	2050	1.85

NOW! RAD-TEL PARTS AT BIG SAVINGS!

Here's your big opportunity to save as never before on parts you need now. Look at the savings.



NATIONAL TURRET TV BOOSTER
Brand New Factory Boxed
Model TVB-20
\$9.95

ARMY-NAVY HEADSETS
Individually Boxed. Very sensitive. Meets both Army and Navy specifications.
List \$16.00
\$2.95 each per set



12" Magnavox P.M. SPEAKER
Heavy Magnet
List \$11.50
\$5.95



5" UTAH AUTO SPEAKER
3.4 Ohm V.C. - 4 Ohm Field
List \$5.05
79c



4 X 6 INCH QUAM P.M. SPEAKER
Lowest Price Oval Speaker
Alnico 5 Field
List Price \$4.75
\$1.95

RAD-TEL SUPER BUY! RESISTORS
200 TO PKG.

Standard RTMA Coded or Value Printed, Uninsulated, 1/2 Watt, 1 Watt, 2 Watt and some 10 Watt

ASSORTMENT OF 200 for \$1.39



70° YOKE (Mfg. by Todd)
List \$7.50 **\$1.95**



RCA TYPE FLYBACK TRANSFORMER
Type 215T1 **95c**



FILTER CONDENSERS KITS* 150 V
*(10 to 0 p.p.k., minimum)
20-20 **\$2.95**
40-40 **\$3.25**
50-30 **\$3.25**

DRY ELECTROLYTIC CAPACITOR
10 MFD 500 WV 600 Peak
Box of ten (10) **\$2.95**

HI-VOLTAGE CERAMIC CONDENSERS
500 mmtd 10 KV **39c ea.**
500 mmtd 15 KV **49c ea.**
500 mmtd 20 KV **49c ea.**

VERTICAL OUTPUT TRANSFORMER
10-1 Ratio RCA Type
List \$4.50
95c

100 INSULATED RESISTORS Box of 100
50 1/2 & 1/2 Watt, 25 1 Watt, 25 2 Watt **\$2.65**

50 ASSORTED MICAS Box of 50
Regular & Silver Type **\$1.95**

ANODE CAP List \$.75 **19c each**

TERMS: A 25% deposit must accompany all orders—balance C.O.D. All shipments F.O.B. Irvington warehouse. Orders under \$10—\$1.00 Handling Charge. Subject to prior sale.

RAD-TEL TUBE CO.

"Integrity is Our Chief Asset"
Phone: Essex 5-2947
115 Coit Street
Irvington 11, N.J.

Examine FREE



**Prentice-Hall
ELECTRONICS &
UHF LIBRARY**

Edited by W. L. EVERITT

5 VOLUMES 1662 ILLUSTRATIONS

Pay Easy Installments if You Keep Set

Turn to this new, up-to-date Library with complete confidence, for dependable facts on any phase of modern electronic theory and practice. These volumes, by outstanding authorities, give you thorough guidance—clearly written, logically arranged, profusely illustrated.

Electronic Fundamentals and Applications

By Prof. John D. Ryder, Univ. of Illinois

Complete, logical, easy-to-follow treatment of (a) physical principles underlying electron tubes, (b) characteristics of vacuum tubes, (c) all basic tube circuits. Includes: Electron Ballistics, Cathode-Ray Tubes, Emission of Electrons, Space Charge in Vacuum Tubes, Diode Rectifiers, Triodes, Multi-Element Tubes, Small-Signal Amplifier Circuits, Audio-Frequency Amplifiers, Radio-Frequency Amplifiers, Oscillator Circuits, Modulation Systems, Wave-Shaping Circuits, Gaseous Conduction, Gas Diodes, Gas Control Tubes and Circuits, Photoelectric Cells, Solid-State Electronics.

Electromagnetic Waves and Radiating Systems

By Prof. Edward C. Jordan, Univ. of Illinois

Covers entire field of electromagnetic engineering. Includes propagation as well as radiation and transmission. Full treatment of UHF transmission lines, wave guides, antennas, slot antennas, radiation and diffraction, ground-wave and sky-wave propagation.

Ultra High Frequency Engineering

By Thomas L. Martin, Univ. of New Mexico

Theory and technique of ALL the new fields of electronic engineering: Radar, Telemetering, Electronic computing, Facsimile, Television, Blind landing systems, Pulse-time modulation, Ionosphere measurements, . . . and the others.

Networks, Lines and Fields

By Prof. John D. Ryder, Univ. of Illinois

Network transformations and theorems. Resonance, Impedance transformation and coupled circuits. Filters. General transmission line. High-frequency line. Equations of the electromagnetic field. Radiation. Transmission and reflection of plane waves at boundaries. Guided waves between parallel planes. Wave guides.

Elements of Television Systems

By George E. Anner, New York University

Complete basic theory, plus current practice, covering: Closed TV Systems, Commercial Teletexting Systems, Color TV Systems. Gives clear exposition of all phases of picture transmission, including the new technique of dot interlace.

SEND NO MONEY — EXAMINE FREE

Just mail coupon below to get complete 5-Volume Set on 10 DAYS' FREE TRIAL. If not completely satisfactory, return in ten days and owe nothing. Or keep the set and pay only \$6.35 down and \$8 a month for five months until full price of \$45.35 is paid. Decide for yourself—without risk or obligation—just mail coupon to examine Library ten days free.

PRENTICE-HALL, Inc., Dept. M-RN-1153
70 Fifth Avenue, New York 11, N. Y.

Send me the Prentice-Hall ELECTRONICS & UHF LIBRARY (5 Volumes) for ten days' free examination. If fully satisfied in ten days I will send you \$6.35 plus few cents postage and then \$8 a month for five months until full price of \$45.35 is paid. Or I will return the Library in ten days and owe nothing.

Name

Address

City and State

polarity obtained from a separate winding between lugs 1 and 2 on the horizontal output transformer. As seen in Fig. 2 this winding is connected in the plate circuit of the a.g.c. amplifier at points "X" and "Y".

When the 6BQ6 goes into cut-off, developing the high voltage pulse, this pulse induces a current in this a.g.c. winding in the "X" to "Y" direction. This makes the plate of V_{13} , the a.g.c. amplifier, positive with respect to its cathode, so that tube conducts.

To understand how a negative voltage is developed, first trace the path that the tube current must follow when it conducts. Current flows from cathode to plate of the a.g.c. amplifier, then through the flyback winding "X" to "Y", on thru R_{137} and R_{113} to ground. Of course, the current completes its path from ground back to the cathode through the cathode resistor R_{111} . Now remember when current flows through a resistor, the IR drop across it will result in a polarity that is negative on the side that the current enters. Also, the induced pulse in the winding is the force that is causing the current to flow, so no "B+" is needed to make the a.g.c. amplifier conduct. Since current is going in the direction of "Y" to ground through R_{137} and R_{113} , the IR drops across them will be negative with respect to ground. This is the negative voltage that we want for a.g.c. to control the amplification of the first three video i.f. stages. The large condenser C_{131} charges on the initial surges of current through V_{13} and then filters out the 15,750

cycle variations keeping the IR drop across R_{137} and R_{113} uniform. The negative voltage developed across R_{113} is fed into the grid circuits through 1000 ohm isolation resistors, R_{110} , R_{136} , and R_{112} .

How much a.g.c. voltage is developed is determined by how heavily the a.g.c. amplifier conducts. When a strong signal is tuned in, a large amplitude of sync signal is fed to the grid, pin 2, of the a.g.c. rectifier, the left half of V_{13} . This large positive sync signal causes heavy conduction of the a.g.c. rectifier and develops a large IR drop across the a.g.c. control, R_{202} , in its cathode circuit. This gives a positive voltage on the grid of the a.g.c. amplifier making it conduct heavily. A large negative a.g.c. voltage is developed, then, and fed to the grids of the first three video i.f. stages, reducing their gain. On weak signals, the smaller amplitude of sync signal means less conduction in the rectifier which, in turn, produces a smaller bias on the grid of the a.g.c. amplifier and less a.g.c. voltage is developed. Thus, the video i.f. stages are allowed to give more amplification to the weak signal.

It is important in fringe areas that the r.f. amplifier of the tuner give maximum gain to a weak signal. Therefore, it is not desirable to feed a negative a.g.c. voltage of any amplitude to the r.f. stage when receiving weak signals. To effect this, a voltage divider made up of resistors R_{127} and R_{131} is connected between the a.g.c. bus and the 120 v. supply. The polarity of the voltage at the

Top view of the Sylvania 1-518 series TV chassis showing tubes and parts.

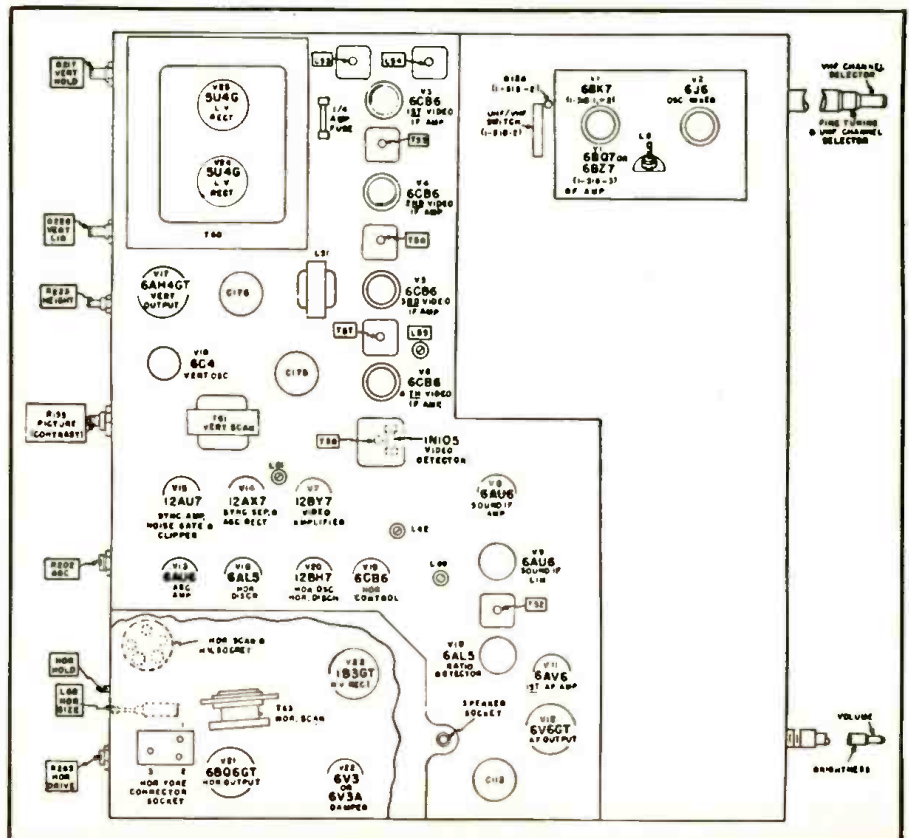

intersection will depend on how much a.g.c. voltage is developed. With a very weak signal, the a.g.c. voltage will be close to zero and the voltage at the center of the voltage divider will be positive. So as not to have a positive voltage fed to the grid of the r.f. amplifier through R_{123} , one of the unused diodes of V_{11} , the 6AV6, has its plate connected to this point. If this point tries to go positive when the a.g.c. voltage is low, the diode will conduct keeping it at ground potential. As the incoming signal gets stronger, the a.g.c. voltage gets more negative until a point is reached where the voltage between R_{122} and R_{121} becomes negative. This occurs when there is about -10 volts on the a.g.c. bus. Then the diode of the 6AV6 no longer conducts, since its plate no longer looks positive with respect to its grounded cathode. Now a negative voltage is fed to the grid of the r.f. amplifier through R_{123} , reducing its gain and preventing overloading of the video i.f. or video amplifier stages by the strong signal.

High-Voltage Circuit

A new 6V3A damper tube with some outstanding features is used in this circuit. The cathode is connected to the top cap of the tube; since a high-voltage pulse is on the damper cathode in this circuit, it puts this hot point inside the high-voltage cage instead of underneath the chassis. Thus, no high voltage or high-voltage pulse exists on the underside of the chassis, preventing probability of shock to technicians troubleshooting the set. This cathode cap also permits the complete high-voltage assembly to be easily removed for replacement or service. The 6V3A has a peak inverse rating (plate-to-cathode breakdown) of 6000 v. compared with 3500 v. for the 6W4. The 6V3A cathode-to-heater breakdown voltage is 6750 v., whereas it is only 2100 v. for the 6W4. Looking inside the tube, one can see that the spacing between the heater and cathode is exceptionally large.

A new autotransformer type of fly-back system is used to develop the high voltage. A much higher pulse is developed, giving 17 kv. at the cathode of the 1B3 high-voltage rectifier. This more efficient system eliminates the need of a voltage doubler circuit which would have another 1B3 and two high-voltage-condensers.

1-520 Chassis

The standard 1-520 chassis is also used by *Sylvania* for 1954 TV sets. This chassis uses a detent-type tuner with a 6BC5 pentode r.f. amplifier and a 6X8 oscillator-mixer tube.

A filtered negative d.c. voltage, obtained from the 1N105 crystal video detector circuit, varies with the strength of the incoming signal and is fed to the r.f. and i.f. stages for a.g.c.

The 1-520 chassis also contains a special sync balancing trimmer for correcting the horizontal sync pulse shape and a noise inverter circuit.

FAMOUS B-29 BOMB SIGHT

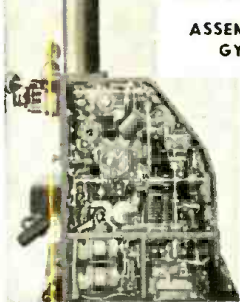

ASSEMBLED BY SPERRY GYROSCOPE CO.

- Experimenters
- Physicists
- Schools
- Research Men
- Mechanics
- Opticians
- Laboratories
- Tech Institutes
- Engineers
- Repairmen
- Manufacturers
- Electricians

Comes in three units—the main body and two interchangeable periscopes, 22 and 68 inches high, alternate parts of an intricate optical system made by Eastman-Kodak Co. Main body is 35x25x14 inches. Contains at least 8 27 VDC motors, electric heater and temp. control, precision sextant, dozens of switches and controls, hundreds of fine gears and driving rods all types. Shipping wt. 250 lbs.
Cost to U. S. Govt. \$21,000. Your Cost BRAND NEW \$295.00

Terrific Transmitter-Receiver Buy! FAMOUS BC-645 450 Mc.—15 Tubes

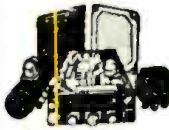

BRAND NEW, in original carton! Easy to convert for phone or CW 2-way communication, covering these bands: 420-450 Mc. Ham Band, 450-460 Mc. fixed or Mobile, 460-470 Citizens Band, 470-500 Mc. TV experimental. Contains 15 tubes: 4-7F7, 4-7H7, 2-7E6, 2-6F6, 2-955, 1-WF-316A, Size 10 1/2 x 13 1/2 x 4 3/4". Wt. 25 lbs.

BRAND NEW \$495.00 each
 CONVERSION DIAGRAM INCLUDED!

PE-101C DYNAMOTOR for above BC-645 **\$4.85**

UHF ANTENNA ASSY. for above BC-645 **\$2.45**

Type		Input		Output		Excellent USED BRAND NEW	
DM-32A	28V	1.1A	250V	15A	4.90	58.95	
DM-33A	28V	5 A.	575V	16A	2.95	5.25	
DM-34D	28V	7 A.	540V	25A			
DM-37	12V	2.8A	220V	080A.	14.50		
DM-40	25.5V	9.2A.	625V	225A.	14.75		
DM-48	14V	3.4A.	172V	138A.	7.40	9.50	
DM-28	28V	2.2A	224V	07A.	4.95	10.50	
DM-21	14V		235V	09A.	6.85	16.50	
PE-73	28V	20 A.	1000V	350A.	9.50	12.50	
PE-86	28V	1.25A.	250V	060A.	2.95	5.50	
PE-94A	28V	10 A.	300V	200A.	7.50	11.50	
PE-94B	28V	10 A.	150V	101A.	8.50	11.75	
PE-94C	28V	10 A.	300V	200A.	10.00	12.75	
PE-98	14V	21 A.	300V	200A.	22.50	45.00	
PE-101	13V	12.6A	400V	125A.	3.75	4.85	
PE-103	26V	6.3A.	9V AC.	1.12A.			
	6V		500V	160A.	27.50	39.50	
	12V		500V	160A.			
PE-104 (Vibrator)	6V	1 A.	84V	09A.	12.50	14.50	
	12V	5 A.	51V	40A.			
DM-414 with filter	28V	2.8A.	220V	080A.		12.50	
PS-225 (with filter)	14V	3.2A.	375V	150A.		10.50	
EICOR Dynamotor D-401	27V	6.05A.	300V	200A.		9.95	
			18V AC	2.2A.			
PE-135A C (with filter)	24V	12 A.	500V	200A.		34.50	
GN-39-F (16" L 8" dia. 50 lbs.)	14.6V	25 A.	1000V	350A.		39.50	

SETCHEL-CARLSON BEACON RECEIVER BC-1206-C
 Receives A-N beam signals. Tubes 195 to 420 Kc. Size 4 x 4 x 6 1/2". Wt. 4 lbs. Complete with 5 tubes.
BRAND NEW \$13.50
 Used, less tubes \$8.95

M:Elroy Automatic KEYS BRAND NEW
 Suitable for keying transmitter, or for code practice. Has photoelectric cell and sensitive relay. Variable speed motor operates on 110 volts 60 cycles AC. or DC. complete with 2-11726 and 1-11717 tubes, your cost **\$27.95**

Sensational Buy! MODULATED BC-221-AK FREQUENCY METER
 BRAND NEW! Limited quantity, first come, first served! Range 125 to 20,000 Kc. with crystal check points in all ranges. Complete with tubes, crystal calibration charts.
 Your cost, BRAND NEW \$210.00
 Used, Excel. Cond. with tubes & crystal. **\$129.50**

HEADSETS

	Excellent USED	BRAND NEW
HS-23 high impedance	\$2.95	\$4.75
HS-33 low impedance	2.45	5.75
HS-30 low imp (featherwt)	1.49	2.45
M-16 U high imp (2 units)		4.95
CD-307A cords, with PL55 plug and JK26 jack, 8' long		1.19

MICROPHONES

T-17 Shure Handmicke 200-ohm carbon single button. Press-to-talk switch. 3' cord & plug. BRAND NEW **\$7.95**
 Used, excellent \$5.50

CARBON HANDMIKE. Sig Corps. 200 ohm single button. Press to talk switch. 4' cable, plug. **\$5.95**
 BRAND NEW

T-45 Lip Mike, navy type **\$0.49** NEW **\$1.45**
 T-30 Throat Mike **.49** NEW **.85**

ARMY FIELD PHONES

Type EEB—Talk as far as 17 miles. Dependable 2-way communication at low cost. Ideal for home, farm, field. Up to six phones can be used on one line. Each phone complete with ringer. Originally cost gov't. \$65.00 each. Excellent Condition, **\$22.25**

SCR-274N COMMAND & ARC-S EQUIPMENT

Type	Excellent USED	BRAND NEW
BC-453 Rcvr. 190-550 Kc.	\$28.50	\$44.50
BC-454 Rcvr. 3-6 Mc.	12.50	24.95
BC-455 Rcvr. 6-9 Mc.	12.95	17.95
BC-456 Modulator	2.75	5.75
BC-457 Xmtr. 4-5.3 Mc.	18.50	29.50
BC-458 Xmtr. 5.3-7 Mc.	9.75	37.50
BC-459 Xmtr. 7-9 Mc.	19.95	24.50
BC-450 3 Rcvr. control box	1.49	2.45
BC-451 Xmtr. control box	1.25	1.95
3 Receiver rack	1.79	2.95
2 Transmitter rack	1.59	3.25
Single Transmitter rack	1.59	3.25

ARC-S-T-23 Transmtr, with tubes. Brand New \$59.50

NEW COMPLETE I.F.F. Equipment RC-188-A
 Originally cost about \$20,000
 ... now buy it for a tiny fraction of cost! Easily converted for Television. Complete assembly consists of Control unit with 5" C.R. Tube, transmitter and receiver assembly (157 to 185 Mc), indicator unit, and Power Supply (450 watts), operating on 110 volts, 60 cycles AC. All assembled, ready to operate. 62 Tubes included: 8-6V6GT, 9-6SL7GT, 14-6SN7GT, 1-5CP1, 2-9006, 1-6Y6G, 2-6ES, 1-100TH, 2-6J5, 2-2C26, 1-3E29, 1-6M6, 7-6A5, 6-6AK5, 1-6C4, 3-2X2, 1-6X5GT, 3-5U4CT. Overall size 55" high, 28" wide, 20 1/2" deep. Shpg. weight 855 lbs. Your cost, complete, BRAND NEW, in original packing **\$350.00**

WILLARD 6-VOLT MIDGET STORAGE BATTERY
 3-amp hr. BRAND NEW. 3 3/8" x 1-13/16" x 2 3/8". Usus standard electrolyte **\$2.65**

WILLARD 2-VOLT STORAGE BATTERY
 20 AMP. HR. BRAND NEW **\$2.69**
 1-QUART ELECTROLYTE FOR ABOVE. ENOUGH FOR TWO CELLS. BOTTLE **\$1.45**
 7-PRONG 2-VOLT VIBRATOR, FOR PORTABLE AND FARM SETS (GE LB530) **\$1.49**

Please include 25% deposit with order—Balance C.O.D. MINIMUM ORDER \$3.00. All Shipments F.O.B. Our Warehouse N.Y.C.

G & G RADIO SUPPLY COMPANY DEPT. N-11
 Phone Cortlandt 7-4605
 51 VESEY STREET • NEW YORK 7, N. Y.
 Branch: 7123 Bryn Mawr Ave., Chicago, Ill.

De MAMBRO SOUND EQUIPMENT CO.

announces

THE OPENING OF ITS NEW BOSTON STORE

Introducing:

One of the nation's finest hi-fi sound studios featuring complete stocks and displays of the following lines:

Stromberg-Carlson	Rek-O-Kut
RCA	Lansing
Radio Craftsman	Browning
Magnecord	Fisher
Bogen	McIntosh

SEND FOR YOUR NEW HI-FI
CATALOG NOW!

DeMAMBRO SOUND EQUIPMENT CO.

1095 Commonwealth Avenue, Boston 15, Massachusetts

TEL.: ALgonquin 4-9000

Guitar Amplifier (Continued from page 75)

Because battery life is long, due to the small current requirements of transistors, the author soldered lead connections directly to the battery terminals. Some builders might prefer to provide a simple socket, however, so that the battery could be easily removed and replaced without using a soldering iron.

No attempt was made to obtain either maximum gain, maximum overall frequency response, minimum distortion, or maximum power output in the model assembled by the author but, rather, parts values were chosen experimentally to give a good compromise between these factors consistent with the characteristics of the transformers and speaker employed. Because of this, the builder may exercise wide latitude of judgement in making circuit modifications to obtain especially desired characteristics.

For example, the 10 μ f. coupling condensers used in the model (C_2 , C_3 , C_4 , and C_5) were chosen because of ready availability. Much smaller coupling condensers will do as well, and values as low as 4 μ f. or even 2 μ f. may be used without changing the low frequency response appreciably.

The low frequency response of the model is limited primarily by the low frequency response of the miniature interstage transformers employed (T_1 , T_2 , and T_3) rather than by the size of the coupling condensers. This does not indicate that the transformers are of poor quality. The small transformers used are of excellent quality, but are simply not designed as "hi-fi" transformers. Their small size precludes using enough iron in their cores to insure good low frequency response.

Should the builder have, or be able to obtain, proper interstage transformers having a wider frequency response, he should not hesitate to use them.

The builder may also find it worthwhile to experiment somewhat with the sizes of those resistors affecting "bias" current and hence individual stage characteristics (R_2 , R_3 , R_4 , R_5). The following technique may be used:

(a) Connect an 0-10 milliammeter in the collector circuit of the stage to be checked.

(b) Connect the "Vert. Input" terminals of an oscilloscope to observe the signal appearing across the output load of the stage (generally the primary or secondary winding of a transformer).

(c) Connect a variable resistor or a resistance substitution box in place of the "base return" resistor.

(d) Connect an audio sine-wave generator to supply a signal to the stage being checked. When connecting the generator, use a blocking condenser if necessary to avoid a change in the d.c. value of the input circuit.

Let me show you how EASY it is to

LEARN TV

the practical way..

D. Gnessin,
Educational
Director

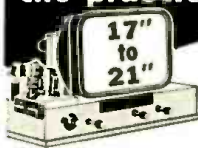

ASSEMBLE A TRANSVISION TV KIT

Pay as You Wire \$ **39**

Down Payment

I WILL HELP YOU to start learning TV the practical way — by assembling a TRANSVISION TV KIT in EASY STAGES. For only \$39 you get PACKAGE #1 (standard first pkg. for all of our kits). This package gives you the BASIC CHASSIS and over 450 TV COMPONENTS with complete Instructions, Drawings, Photos, Service Booklet, and a year's subscription to my "TV and Electronics Notes". When ready, you order the next stage (pkg. #2), etc. Low prices make your complete kit a terrific buy!



**FREE
CATALOG**

Shows 6 Great TV Kits:

EXCLUSIVE: Only Transvision TV Kits are adaptable to UHF. Ideal for FRINGE AREAS. No Previous Technical Knowledge required. Write now!

TRANSVISION, INC., Dept. RN11
NEW ROCHELLE, N. Y.

— MAIL THIS COUPON TODAY —

Mr. D. Gnessin, Educational Director
TRANSVISION, INC., NEW ROCHELLE, N. Y. Dept. RN11

I'm enclosing \$_____ deposit. Send standard kit PACKAGE #1, with all Instruction Material. Balance C.O.D.

Send FREE copy of your new TV Kit Catalog.

Name _____

Address _____

City _____ State _____

Acrosound ★

"300" series ULTRA-LINEAR* TRANSFORMERS FOR ULTRA-LINEAR CIRCUITS

- ✓ optimum placed screen taps for U-L use
- ✓ response ± 1 db 10 cps to 100 kc
- ✓ flat power curve 20 cps to 20 kc
- ✓ the cleanest, most natural sound available

TO-300 for KT 66's, 5881's, 807's
etc. \$24.75 net

TO-310 for 6V6's, 6AQ5's
18.75 net

TO-330 for pp par KT-66's, etc.
39.75 net

Available at leading distributors

Complete data and characteristics of Ultra-Linear Circuits and Acrosound Output Transformers on request.

*Patents Pending

ACRO PRODUCTS CO.
369 Shurs Lane Phila. 28, Pa.

Whether or not a blocking condenser will be required will depend on the output circuit of the generator.

(e) Applying a sine-wave signal to the stage, and observing the output signal on the scope, adjust the value of the "base return" resistor for the desired characteristic — maximum gain, minimum distortion, etc. When making gain checks, be sure to keep the input signal level constant. When checking distortion, be sure the input is not overloaded.

(f) Do not use any value of "base return" resistor that permits more than maximum collector current to flow (5 ma. for the CK721 and CK-722).

A number of possible parts substitutions have already been mentioned but several others are possible. Let us review a few of these.

The *Mullory* type 302424 transistor power supply battery may well be substituted for the battery specified in the parts list. This is a long-life 6.7 volt mercury cell unit.

A larger speaker might well be used instead of the 6" PM speaker used by the author. If a larger speaker is employed, it will be necessary to use a larger case, of course.

If the builder prefers, any other type of cabinet might be substituted for the wall speaker baffle. A standard speaker cabinet, an old receiver cabinet, or even a small "overnight" case might well be used.

The rotary power switch may be left out and a control type switch mounted on either the "Gain" or "Tone" control used instead.

As mentioned previously, the guitar amplifier is not powerful enough to be used as a substitute for a standard vacuum-tube amplifier. Rather, it is designed primarily to supplement the guitar in small gatherings and in the home.

When used in this application, it gives good results, and even permits the guitarist to achieve some interesting musical effects by adjusting the tone control.

In addition, the guitar amplifier has sufficient over-all gain to permit its use with a standard crystal microphone, provided the "mike" is not held too far from the mouth of the speaker, that is, provided a reasonably strong output signal is obtained from the "mike". Used in this application, it permits the technician to perform a number of interesting experiments.

Still another application of the guitar amplifier is to provide loud-speaker output from a crystal or transistor receiver (a resistive load is connected in place of the usual magnetic headphones, and the audio signal appearing across this resistor connected to the input of the amplifier).

Even where the amplifier is not assembled for a specific application, it makes an excellent construction project for the student, technician, or engineer desiring greater familiarity with transistor circuits.

-30-

Smaller than a desk pen — just as convenient

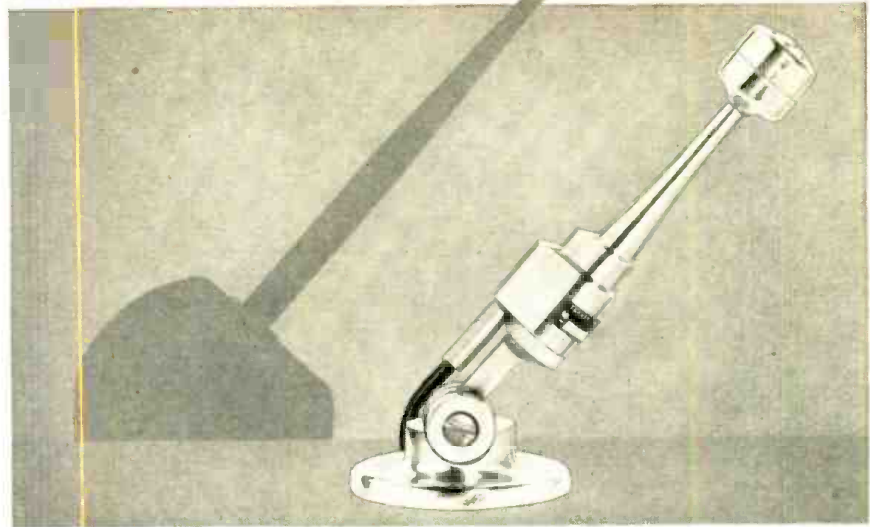

The NEW Turner C-4 Stand for Model 80 Microphone

The new C-4 stand gives complete maneuverability and convenience with the Model 80. It pivots the microphone in a 135° arc for any operational angle — swings parallel to base needing little more packing space than two packs of cigarettes.

The microphone is held firmly by the unique, positive-action hinge, yet moves smoothly and easily to any desired position without adjustment. Microphone quickly and easily removed.

This new, matching stand is solidly built of die-cast zinc overlaid with beautiful satin chrome plate. It is heavy enough to prevent tipping — it will not slide with the weight of the cord. The C-4 stand complements the graceful shape of the Model 80; the combined unit is an attractive but inconspicuous addition to a speaker's table. Ideal for use with wire recorders, public address systems, pulpits, office and factory call systems, amateur operators and other similar uses.

Model C-4 matching stand, 3/8" — 27 thread. List Price.....\$ 5.75
Model 80 Microphone. List Price.....\$15.95



THE TURNER COMPANY

900 17th St., N. E. Cedar Rapids, Iowa

In Canada: Canadian Marconi Company, Toronto, Ont., and Branches
Export: Ad Auriema, Inc., 89 Broad Street, New York 4, N. Y.

ARROW ELECTRONICS offers

RIVER EDGE 700

36" Wide, 32" High
18" Deep
25" along each side

only \$26.97



"IMPROVE IT" KIT

FOR CORNER SPEAKER ENCLOSURES

Fits any size speaker! Start with one speaker and gradually work up to a Two-Way System. All speaker adapters included! Specially engineered to utilize the best features of a bass reflex enclosure and a rear horn loading arrangement.

SEND FOR FREE CATALOGUE, today!

Send 25% deposit on C.O.D.s. Deduct 2% on
Prepaid orders. F.O.B. N. Y. Shipping Wgt.—45 lbs.

ARROW
ELECTRONICS

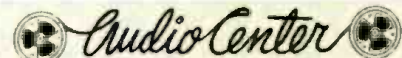

65 Cortlandt St. • N. Y. 7, N. Y. • DlGby 9-4714
215 Front St. • Hempstead, N. Y. • HEMpstead 1-1826

AIREX'S New Co-Channel 630 FA-2 with Genuine FM Armstrong Sound System

3 MONTHS
RMA
GUAR.
ON ALL
PARTS

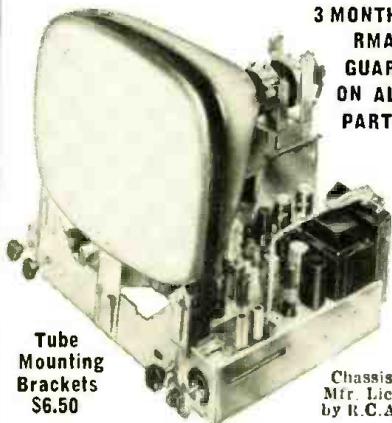

Tube
Mounting
Brackets
\$6.50

Chassis
Mfr. Lic.
by R.C.A.

Here is the most powerful fringe area chassis on the market today... the one TV engineers and servicemen are buying for themselves. Clear, sharp, exceptional reception up to 200 miles.

CHECK THESE EXCLUSIVE FEATURES

- 10 WATT push-pull audio output. Frequency range from 40 to 12,000 cycles • 3 position fringe area switch • Delayed graded AGC system • Standard Coil Cascade Tuner prevents radiation • Retrace Blanking Circuit allows you to raise the brightness without the annoying vertical retrace lines • Heavy duty front focus control • Automatic gain control potentiometer allows you to adjust the threshold sensitivity as low as 4 microvolts & still keep the full 4 MC band width • Improved sync amplifier • Improved automatic brightness control • Set aligned for 21.9 MC. New Ham band will not interfere • Improved fused high voltage power supply gives full 14.5 KV under load. Will handle all picture tubes up to 24 inch with full sweep • Improved video amplifier has a gain of 40 • All moulded plastic condensers give long life & trouble-free operation • Easily adapted to new UHF stations in 2 minutes by just changing a strip in the tuner • Extra heavy duty power transformer with lagre safety factor • 6CB6 tubes in Video IF to give full gain • Extra filtering in power supply for hum & ripple-free operation • Phono Connection & switch on chassis allows you to play your phonograph or tuner through the built-in 10 watt fidelity amplifier • Extra heavy duty focus coil, which runs cool • Full focus cosine yoke.

THE ONLY CHASSIS WITH
PUSH-PULL AUDIO OUTPUT AT

\$169⁹⁵

Fed. Tax
Included

Less C.R. Tube
and Brackets

Complete with 12" ROLA Hi-Fi Speaker
Detailed Service Manual & Schematic—\$1

TV PICTURE TUBE SALE

Standard Brands, Factory
New, Guar. 1 year.

- 17" Tube.....\$27.95
- 20" Tube.....\$34.95
- 21" Tube.....\$39.95
- 24" Tube
(Guar. 6 Mos.).....\$79.95
- 27" Tube.....\$79.95
- Ring and Sleeve
for 24".....\$ 7.50

630 CHASSIS
FOR 27"
OPERATION
PRICE.....\$219⁹⁵

TV GOLD PLASTIC MASKS

- 16" and 17".....\$ 4.95
- 20" and 21".....\$ 7.95
- 24".....\$14.95

BARGAIN CABINET BUY

Beautiful mahogany console Cabinet
cut for 630 FA-2 Chassis. Complete with
mask, glass & tube mounting brackets...
In Blend.....\$59.95

\$49.95

Send for complete cabinet brochure

FREE—New TV—Hi-Fi PARTS CATALOG

All merchandise brand new, factory fresh, guaranteed. Mail & phone orders filled upon receipt of certified check or money order for \$25 as deposit on TV chassis, 20% on other items. Balance C.O.D., F.O.B. N. Y. Prices & specifications subject to change without notice. NO FED. TAXES TO PAY.

AIREX RADIO CORP.

SHOWROOM: 171 Washington St., N. Y. 7
Gramercy 7-9245
MAIL ORDER: 400 Lafayette St., N. Y. 3

WHAT'S New in Radio

For additional information on any of the items described herein, readers are asked to write direct to the manufacturer. By mentioning RADIO & TELEVISION NEWS, the page and the issue number, delay will be avoided.

SUBMINIATURE RESISTOR

The Daven Company, 191 Central Avenue, Newark, N. J. has developed a new precision wirewound resistor, Type 1119, especially for application where a high value of resistance is necessary in a very small resistor size.

This new resistor, although it measures only 21/64" diameter and 25/32" long, is available in values up to 1 megohm. The unit is rated at 1/4 watt and is non-inductively wound. Standard resistance tolerance is ± 1 per-cent although it can be supplied in accuracies to $\pm .05$ per-cent.

Dept. SMR of the company will supply additional information on request.

75-VOLT "B" BATTERY

Burgess Battery Company of Freeport, Illinois has introduced its No. XX50, 75 volt "B" battery to the trade.

The XX50 embodies new construction features which are said to give the battery superior performance and additional power. Full details on this original-equipment and replacement battery are available from the company's distributors.

"EKERADIO"

Ekeradio, 646 N. Fair Oaks Ave., Pasadena 3, California is in production on a miniature receiver which covers both the broadcast and the 160-75 meter short-wave band.

Housed in a plastic hinged case measuring 2 1/2" wide, 3 1/2" long, and 1 1/2" deep, the set weighs 8 ounces with batteries. The headphones weigh



5 ounces. The receiver operates on one hearing aid battery and one penlight cell. The life of the "B" battery is three to four months. The penlight cell runs about thirty hours.

Controls include a volume control and a ball-bearing tuning condenser and the set uses a subminiature tube. The "Ekeradio" comes complete with

batteries, double headset, and antenna kit, completely wired and tested.

TUBE TESTER

The Triplett Electrical Instrument Co., Bluffton, Ohio has developed a new proportional mutual conductance tube tester which has been designed to handle the most perplexing tube testing problems in radio servicing, indus-

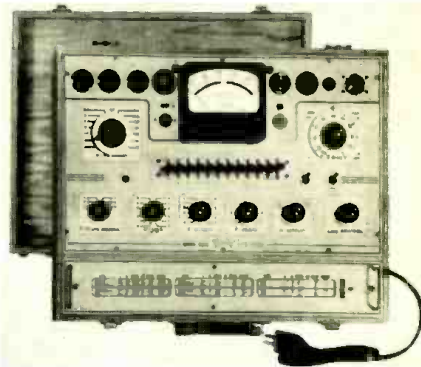

trial, laboratory, theater and p.a. equipment, communications, and many other fields.

The Model 3423 tests tubes by applying a high-frequency signal to the grid and measuring the signal component in the output by a special instrument circuit. This more closely simulates actual operating conditions in the tube under test.

Tubes with widely varying characteristics can be checked without overloading or other damage to the tube because of the wide selection of tube parameters. Its flexible switching ties in with the speedy roll chart for quick, reliable testing.

The case is wood, gray leatherette covered. It measures 14 3/4" x 18 3/4" x 6 1/2".

ASTRON CONDENSER

Astron Corporation, 255 Grant Avenue, East Newark, N. J. has released a new line of condensers which features a new concept in the design, construction, and performance of molded plastic paper units.

Known as the "Blue-Point" condensers, the new components are housed in a tough, non-inflammable molded plastic case and are permanently sealed against heat and moisture by means of a special solid glass-like thermosetting bond that becomes an integral part of the case.

Literature on the new "Blue-Points" is available on request.

RESONANCE INDICATOR

Dynamic Electronics-New York, Inc., 73-39 Woodhaven Blvd., Box 188, Forest Hills, New York has recently intro-

duced its Model 60 resonance indicator which has been designed to correct the major deficiencies in existing, commercial grid-dip meters.

The new unit measures the parallel-resonant frequency of circuits from below 10 mc. to above 1000 mc. Because of the small probe size, hitherto inaccessible passive, unenergized circuits may be checked and isolation of the desired circuit, where many circuits are in close proximity, is assured.

The unit may be used to measure self-resonance of r.f. coils, to search for parasitic resonances, to retune r.f. and i.f. circuits, to provide quick checks for shorted turns and "Q" of coils, etc.—all without applying power to the circuit under test or disturbing the natural environment of the circuit.

CASCADE CONVERTER

Mohawk Electronic Research Laboratories, Inc., R. D. 4, Amsterdam, N. Y. is now in production on a new v.h.f. cascode crystal converter.

Employing only three tubes and measuring just 3" x 3" x 5", the unit is small enough to mount inside a communications receiver cabinet. If desired, as many as five units may be mounted on a standard 7" x 19" relay rack panel.

A 6BQ7A is employed as a cascode r.f. amplifier. One 6J6 combines the functions of crystal oscillator and frequency multiplier while another 6J6 is used as a combined mixer and multiplier.

Usable average sensitivity is better than .5 microvolt and noise figure averages 5 db. The bandwidth of these units is essentially flat over a 6 mc. range but may be peaked to favor any portion desired. The standard i.f. output frequency is 14 to 20 mc. Other frequencies are available upon special order.

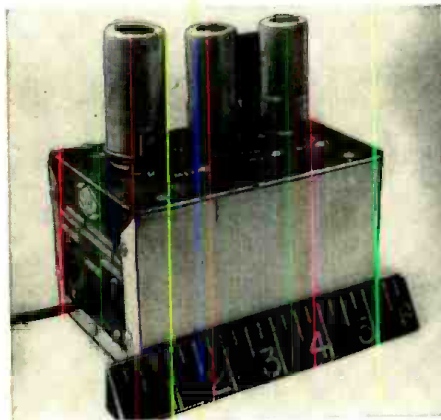

Units are available to cover any 6 mc. segment of the v.h.f. spectrum between 50 and 250 mc.

NEW BANANA PLUGS

The National Company, Inc. of Malden and Melrose, Massachusetts is now in production on a new type of banana plug.

The new unit, the FWT, has many advantages over previous types, according to the company. Molded of mica-filled *Bakelite* in accordance with

November, 1953

The Latest and Best in TV ANTENNAS AND ACCESSORIES from Admiral

World's Largest
Television Manufacturer

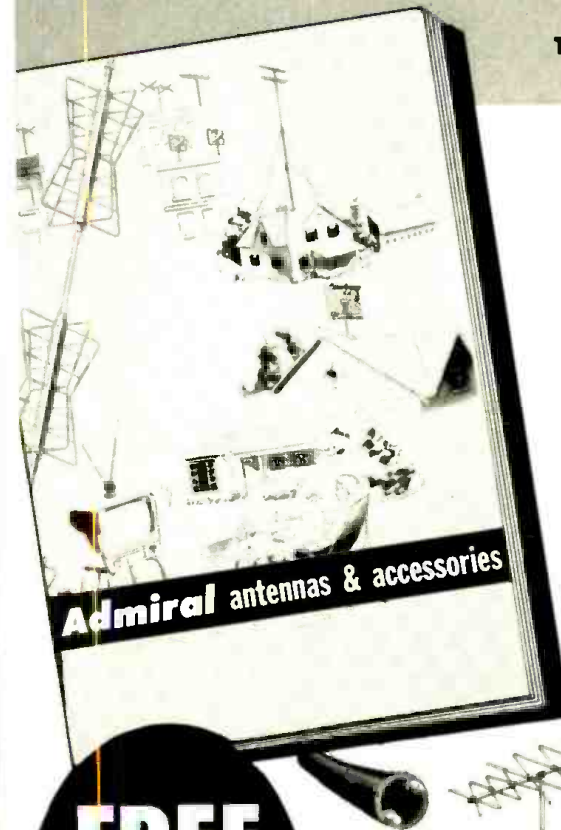

Admiral is first with the best and the mostest. Your Admiral distributor now carries the most complete and up-to-the-minute line of TV antennas and accessories. See the Admiral Catalog for high-gain UHF antennas of the most advanced design . . . rotators . . . all-weather transmission line . . . mast and tower equipment for every type of installation.

Now you can get everything needed from one source, at one time . . . no need to waste time shopping around. Quick, close-to-home service. Admiral prices are lowest. And every item conforms to Admiral's high quality standards. Send for your catalog today!

FREE
Mail coupon for
Admiral
CATALOG

Admiral Corporation, Accessories Division
3800 Cortland St., Chicago 47, Illinois
Please send free catalog.

Name

Address

City State

RT-11

YOUR LATEST BUYING GUIDE—Just Out!

1370 catalog pages of Official parts data

The right part when you need it . . .

This permanent, hard cover Official Buying Guide of the electronics-TV parts and equipment industry with its comprehensive index and detailed descriptive data, eliminates the need for all other files and catalogs. Radio's MASTER catalogs 90% of radio-TV-electronics parts and equipment. Complete descriptions, illustrations, specs, and prices. You compare - substitute - purchase directly from the MASTER.

- 1370 pages
- 85,000 items
- 8"x11"—5 lbs.
- 8,500 illustrations

Go to your nearest supplier or write to:

UNITED CATALOG PUBLISHERS, INC. 110 Lafayette Street, N. Y. 13, N. Y.



\$1.95

Publisher's price \$6.50—your price

through your regular parts distributor

Windsor TUBES

RADIO & TV RECEIVING

**TESTED and
GUARANTEED
for PEAK
PERFORMANCE!**

TO MERIT YOUR CONFIDENCE—to insure your satisfaction—Every tube we ship has been tested in a radio or TV set for **PEAK PERFORMANCE**. Each tube is attractively packaged in individual carton and each WINDSOR Tube you buy carries the full RTMA GUARANTEE!

Type	Each	Type	Each	Type	Each	Type	Each	Type	Each
1A7GT	\$.67	354	\$.61	6B8J6	\$.53	6V3	\$1.09	7L7	\$.85
1B3GT	\$.69	3V4	\$.62	6BK5	\$.76	6V6GT	\$.51	7N7	\$.62
1C6	1.06	5R4GY	1.00	6BK7	\$.97	6W4GT	\$.50	7Q7	\$.62
1E7GT	1.09	5U4G	\$.44	6BL7GT	\$.94	6W6GT	\$.63	7R7	\$.70
1H5GT	\$.91	5V4G	\$.83	6BN6	\$.98	6W8GT	\$.98	7S7	\$.90
1H6	\$.53	5Y3G	\$.37	6BQ6GT	\$.98	6X4	\$.37	7V7	\$.92
1J6	\$.93	5Y3GT	\$.32	6BQ7	\$.92	6X5GT	\$.36	7X6	\$.62
1L4	\$.63	5Y4G	\$.43	6BZ7	1.09	6Y6G	\$.64	7Y4	\$.45
1L6	\$.66	6A8GT	\$.68	6C4	\$.41	7A5	\$.70	7Z4	\$.50
1LA4	\$.82	6AB4	\$.51	6CB6	\$.58	7A6	\$.57	12A6	\$.53
1LA6	\$.80	6AC5GT	\$.82	6CD6G	2.04	7A7	\$.58	12A7	\$.75
1LB4	\$.82	6AG5	\$.59	6D6	\$.63	7A8	\$.56	12A8	\$.75
1LC5	\$.80	6AH4	\$.68	6E5	\$.72	7A9	1.05	12A9	\$.75
1LC6	\$.80	6AK5	1.05	6F5GT	\$.54	7B7	\$.58	12B6	\$.50
1LD5	\$.80	6AL5	\$.44	6J5GT	\$.44	7C4	1.05	12B7	\$.52
1LE3	\$.80	6AQ5	\$.51	6J6	\$.68	7C5	\$.56	12BE6	\$.52
1LG5	\$.80	6AQ6	\$.47	6J7	\$.70	7E5	\$.85	12BH7	\$.69
1LH4	\$.80	6AQ7	\$.75	6K6GT	\$.45	7E6	\$.65	12J5GT	\$.48
1LN5	\$.80	6AR5	\$.42	6K7	\$.70	7E7	\$.85	12SA7GT	\$.57
1N5GT	\$.63	6AS5	\$.55	6L6G	\$.88	7F7	\$.69	12SK7GT	\$.55
1P5	\$.76	6AT6	\$.42	6L6GA	\$.88	7F8	\$.97	12SL7GT	\$.67
1Q5	\$.72	6AU5GT	\$.85	6Q7GT	\$.55	7G7	\$.85	12SN7GT	\$.59
1R4	\$.85	6AUB6	\$.47	6S4	\$.51	7H7	\$.61	12SQ7GT	\$.46
1R5	\$.62	6AV6	\$.41	6S8GT	\$.75	7J7	\$.85	14A7	\$.50
1S4	\$.67	6AX4	\$.72	6SA7GT	\$.57	7K7	\$.85	14AF7	\$.68
1S5	\$.52	6BBG	\$.93	6S7	\$.63			14B6	\$.50
1T4	\$.62	6BA6	\$.50	6S7D	\$.55				
1TS6GT	\$.78	6BA7	\$.66	6S7GT	\$.66				
1U4	\$.61	6BC5	\$.58	6SH7GT	\$.52				
1U5	\$.51	6BD5GT	\$.98	6S7GT	\$.52				
1X2A	\$.74	6BD6	\$.54	6SK7GT	\$.57				
2A7	\$.74	6BE6	\$.51	6SL7GT	\$.68				
2X2	1.43	6BF5	\$.66	6SN7GT	\$.59				
3L4	\$.76	6BF6	\$.43	6SO7GT	\$.46				
3Q4	\$.66	6BG6G	1.47	6T8	\$.85				
3Q5GT	\$.72	6BH6	\$.63	6U8	\$.86				



JAN specifications, it is styled for easy gripping. Leads can be brought directly from the base of the prongs or through a hole at the bottom of the plug. The top of the plug has been

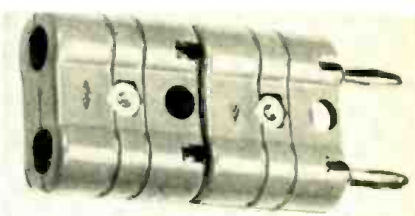

designed to accept additional plugs. All contacts and screws are of nickel-plated brass. Drawings, specifications, and prices may be obtained by writing the Components Division of the company, 61 Sherman Street, Malden, Mass.

POWER SUPPLY

Power Designs Inc., 119-22 Atlantic Avenue, Richmond Hill 19, New York has introduced a new voltage stabilized power supply, the Model 351. Designed to furnish d.c. power to equipment where unusually close performance tolerances, rapid recovery time, and freedom from transient responses are required, the new unit is rated for 100 per-cent duty cycle with regulation held to $\pm .1$ per-cent for line variations from 105 to 125 volts and load variations from zero to maximum output current ratings. Ripple and noise level is less than 1 millivolt, internal impedance is less than .4 ohm, recovery time for instantaneous application of full load from a no-load condition is less than 8 milliseconds, and stability is guaranteed to within .5 per-cent per day.

The instrument gives a true reading measurement of complex and sinusoidal voltages with necessary peak-to-peak or r.m.s. values read directly, for

PEAK-TO-PEAK V.T.V.M.

Radio City Products Company, Inc., 152 West 25th Street, New York 1, N. Y. has announced an advanced design peak-to-peak v.t.v.m., the Model 655.



the analysis of waveforms in video, sync, and deflection circuits. This vacuum-tube voltmeter features peak-to-peak a.c. measurements from .2 volt to 4200 volts on seven ranges; RADIO & TELEVISION NEWS

WRITE FOR Additional Tube Types and Prices. We also stock Special Purpose and Transmitting Tubes at similar savings!

25% DEPOSIT with Order. All Merchandise F.O.B. New York City. For orders less than \$10, add \$1 handling cost. Deduct 2% if full remittance accompanies order. All merchandise subject to prior sale and price change without notice. Dept. N-11.

Windsor ELECTRONIC TUBE CO.
1515-N SHEEPSHEAD BAY ROAD, BROOKLYN 35, N. Y.

CRYSTALS FOR ALL PURPOSES

LOW FREQ.—FT 2A1A for SSB, Iatice filter, 1/2" spc. 54th or 72nd harm channels listed by fund. Fractions omitted.	SCR. 522 1/2" sp	BC-510 2 banana plugs 1/4" spc.
370 392 412 433 494 515	400 459	2030 2415
372 393 413 434 495 516	440 461	2045 2435
374 394 414 435 496 518	441 462	2065 2442 5
375 395 415 436 497 519	442 463	2105 2532 5
376 396 416 437 498 520	444 464	2125 2545
377 397 417 438 501 522	445 465	2131 2557 5
379 398 419 481 502 523	446 466	2145 3202 5
380 401 420 483 503 525	448 469	2155 3215
381 402 422 484 504 526	450 470	2220 3237 5
383 403 423 485 505 527	451 472	2258 3250
384 404 424 486 506 529	452 473	2260 3262 5
385 405 425 487 507 530	453 474	2280 3510
386 406 426 488 508 531	454 475	2282 2 3520
387 407 427 490 509 533	454 475	2155 3215
388 408 429 491 511 534	455 476	2300 3570
390 409 430 492 512 536	456 477	2305 3580
391 411 431 493 513 537	457 479	2320 3945
49¢ EA—10 for \$4.50	458 480	2360 3955
		2390 3995

FT 243—1/2" P IN SPC.
4190 6206 7806 1015 5760 5906 6340 6573 7440
5030 6773 7840 3735 5773 5940 6373 6575 7506 7673
5485 6873 7873 5305 5800 5973 6406 6606 7573 7706 99¢
7773 5677 5806 6273 6450 6640 7606 7973 EA—10
5706 5840 6306 6473 6673 7640 8240 for \$9.00
49¢ EA—10 5725 5873 6325 6506 6706 7650
5740 Add 20¢ postage for each 10 crystals (or less)

NOW!
make any tube tester a picture tube tester with this adapter

395

NO WIRING. Plug this adapter into your present tube tester (any make or model) and onto picture tube. Overall length 49 1/2". Checks any picture tube, electrostatic or magnetic 10" to 30". right inside the cabinet, for cathode emission, shorts, etc. C.O.D., plus postage. Check or M.O., we pay postage. Money back guarantee. ACT NOW! Order Today Direct from

Suporex ELECTRONICS CORP.
DEPT. N 2
23 ATHERTON STREET, YONKERS, NEW YORK
JOBBER: a few choice territories still available!

TWO-STATION INTERCOM
Consists of master and remote station, 20 ft. of 3 wire cable, 115 V operation, AC or DC. Extra wire .05" per ft. **\$16.97**

Do not send postage—we ship best way, collect.

Sun

PARTS DISTRIBUTORS, LTD.
520 TENTH ST., N.W. - WASHINGTON, D.C.

a.c. r.m.s. measurements of .1 volt to 1500 volts on seven ranges. d.c. measurements from .02 volt to 1500 volts on seven ranges, and resistance measurements from .2 ohm to 1000 megohms on seven ranges.

ONAN ELECTRIC PLANTS

Two new gasoline-driven electric plants, rated at 10,000 and 15,000 watts a.c., have been added to the water-cooled line of engine-generators manufactured by *D. W. Onan & Sons, Inc.*, Minneapolis, Minn.

The new "HQ" models are powered by *Continental* 4-cylinder, water-cooled engines and were designed to provide dependable, economical electric power for both primary and standby applications. Special features include an impulse-coupled magneto with special radio shielding which makes starting easier and faster; a sliding battery rack for easier servicing of batteries; a new efficient tested cooling system of



only 10½ quarts, requiring less anti-freeze for outdoor winter operation; and low fuel consumption.

The company will supply full details on request.

INTERLOCK CONNECTORS

Harvey Hubbell, Inc., State & Boswick Ave., Bridgeport, Conn. is currently offering a new line of interlock electrical connectors which feature automatic locking connection that can never disconnect accidentally.

The interlock plug locks automatically when plugged in and can be quickly and easily disconnected when desired. This locked, vibration-proof connection has constant low-contact resistance and actually makes contact on two separate surfaces which are under constant coil spring pressure. Any decrease in contact pressure on one contact surface will be automatically increased on the other surface.

Several different connectors are now available and full details will be supplied by the company on request.

RADIO CONTROL UNIT

Electronic Model Engineering, Inc., 6127 Alta Avenue, Baltimore 6, Md. is in production on a 27.255 mc. superhet receiver which has been designed for all types of radio-controlled airplane and boat models.

The set features high sensitivity, good stability, a tuned r.f. input amplifier, two i.f. stages, five standard battery-type tubes, slug-tuned coils, and small size (3" x 5").

A companion crystal-controlled bat-

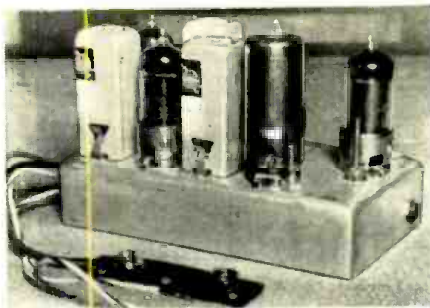

tery-operated transmitter is also available for use with this receiver.

ALLIGATOR CLIP

A fully-insulated alligator clip which greatly facilitates the testing of live circuits in television and radio receiv-

ers, and in electrical equipment in general, has been brought out by the *Insuline Corporation of America*, 3602 35th Avenue, Long Island City 1, N. Y.

The spring-loaded jaws, which are actuated by a thumb button in the body of the clip, hold firmly on conductors up to ¼ inch in diameter. Connection to the clip is made with standard banana plugs. The new clip is available in two body colors: No. 524B in black and No. 524R in red.

SCOPE CALIBRATOR

Electronic Instrument Co., Inc., 84 Withers St., Brooklyn 11, N. Y. has released a newly-designed oscilloscope voltage calibrator, the *Eico Model 495*. The new instrument provides an ac-

YOU'VE HEARD ABOUT THE *Telechief*

It's HERE—Sangamo's new premium molded paper tubular capacitor that will outlast and outperform any other tubular . . . built for better TV performance.

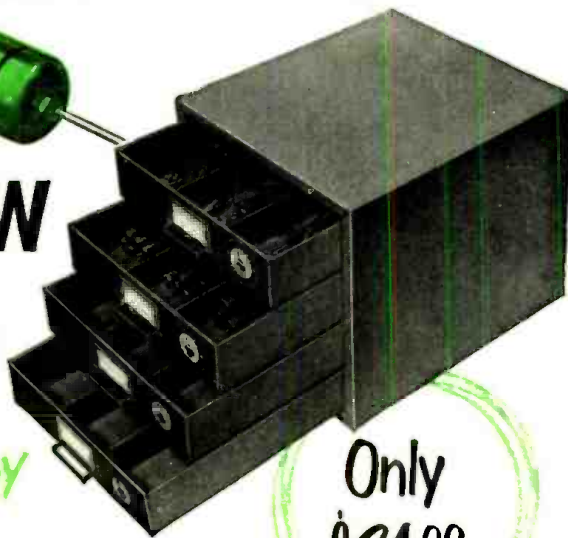

see your jobber for this

SPECIAL INTRODUCTORY OFFER!

Only \$24.00

Slightly higher in Canada

Here's a deal you can't afford to miss. You get a basic balanced inventory of fast-moving "Telechiefs"—assortment based on national popularity—PLUS a heavy gauge steel chest with two extra drawers for small parts—PLUS your choice of 100 attractive folders to promote your business. You get all this for only \$24.00—the dealer net price of the capacitors alone. (They list at \$40.00.)

Get acquainted with the Telechief today—your Jobber has these kits in stock.



You can have 100 of any of these business-building folders without extra cost—a sample of each is enclosed in the kit.

Those who know... choose Sangamo



SANGAMO ELECTRIC CO. MARION ILLINOIS

4 for 53 NEW Trav-Electric CONVERTERS

CHANGE 6 OR 12 VOLT D.C. TO
110 VOLT A.C. 60 CYCLE
Just plug into Cigar Lighter on Dash.



**Trav-Electric
Super**
Model 6-71160
60 cycle
60-75 Watts
\$37⁹⁵
LIST

Size
4"x5"x6"

Operates

- Wire Recorders
- Dictating Machines
- Amplifiers
- Turntables
- Soldering Iron
- Small Electric Drill



**Trav-Electric
Master**
Model 6-51160
60 cycle
40-50 Watts
\$24⁹⁵
LIST

Size
4"x5"x6"

Operates

- Curling Irons
- Small Dictating Machines
- Radios
- Test Equipment, etc.
- Turntables
- Portable Phonographs

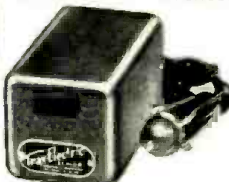

**Trav-Electric
Senior**
Model 6-1160
60 cycle
35-40 Watts
\$15⁹⁵
LIST

Size 2 1/2"x2 1/2"x4 1/2"

Operates

- Test Equipment
- Short, Long Wave Radios
- Turntables
- Portable Phonographs
- Lights
- Electric Shavers, etc.



**Trav-Electric
Midget**
Model 6-11160
60 cycle
10-15 Watts
\$11⁹⁵
LIST

Size 2"x2"x3 1/2"

Operates Test Equipment, All Electric Shavers

Fully Guaranteed

See Your Jobber or Dealer

TERADO COMPANY

MFRS. OF PRECISION EQUIPMENT

1068 RAYMOND AVE. • ST. PAUL 14, MINN.

In Canada write: Atlas Radio Corp., Ltd.
560 King St. West, Toronto 28, Ont.

Export Sales Division: Scheel International, Inc.,
4237 N. Lincoln Ave., Chicago 18, Ill., U. S. A.
Cable Address—Harscheel

curate peak-to-peak voltage measurement of complex TV waveforms required to test and align TV receivers in accordance with the manufacturer's



specifications. It may also be used to calibrate the vertical, horizontal, and intensity axis of any scope.

The unit is available in two forms—factory wired (Model 495) and as a kit (Model 495-K). The company will supply full details on this or any other unit in its test equipment line upon request.

PRECISION RESISTORS

Arnhold Ceramics, Inc., 1 East 57th Street, New York 22, New York is offering a line of "Chemo Carbon" precision resistors for critical circuit application.

Based on a process developed by *Stemag Corp.* of Germany, the new resistors feature smaller temperature coefficients, greater stability under humid conditions, small changes in resistance values over long periods of time, a reduction of noise level and low-frequency characteristics, and greater uniformity in large production runs.

Full details on these precision film resistors have been included in Bulletin 1 which is available from the company on request.

LINE VOLTAGE ADJUSTER

P. R. Mallory & Co., Inc. of Indianapolis has introduced a new line-voltage adjuster and isolation transformer which has been developed especially for radio and television service shops,



industrial service shops, and laboratories.

Designated as the type LVA2, the new unit comes completely enclosed in an enamel metal case. It provides in-

finitely variable a.c. line adjustment from 90 to 130 volts at 1200 watts; infinitely variable low voltage from 0 to 40 volts a.c. at 4 amps in the isolation position or 8 amps in the common line position; and an isolated, infinitely variable 90 to 130 v. a.c. output at 350 watts.

Write the distributor division of the company, P.O. Box 1558, Indianapolis for additional information on this unit.

SEALED TRANSISTORS

General Electric Company, Syracuse, N. Y. has announced production of new all-welded junction transistors with essentially infinite life expectancies.

The new units are evacuated, hermetically-sealed, and of all-welded metal construction. They are the first to have all-welded construction, which eliminates the aging effects of moisture and trapped solder flux fumes.

The welded metal construction allows power ratings of almost one watt,



with two units in a class B push-pull circuit. They have been demonstrated to operate under water at temperatures up to 100 degrees C.

STACKPOLE RESISTORS

The electronic components division of *Stackpole Carbon Company*, St. Marys, Pa. has announced that its standard 1/2 watt fixed composition resistors are now available with specially-formed and trimmed leads for printed circuit applications.

This new feature facilitates the handling of resistors when assembling components on the standard .062" printed wiring base. The hot-tin-dipped leads are cut and formed for a tight "spring fit" and extend through the printed circuit base just far enough for easy soldering. Resistors snap into place.

Samples and full details will be sent to quantity users on letterhead request to the manufacturer.

MIKE CLAMP

Atlas Sound Corp., 1451 39th Street, Brooklyn 18, N. Y. has released its new Model SK-1 "Sky Hook" universal clamp designed to solve many difficult problems of microphone positioning.

The SK-1 fastens securely to almost every type of surface ledge, round pipe, or irregularly-shaped stanchion. Full details from the company. —30—

Audio at AFIS
(Continued from page 59)

are run with the zero-level pairs. No crosstalk has resulted and we save several hundred feet of cable and conduit by the omission. The same circuit-level grouping is carried out in the small audition or practice studio which contains a scaled-down version of the equipment in the main studios. The term "dbm" refers to single-frequency, sine-wave power 10 db above program material peaks read on the vu meter.⁵

Detailed Audio Layout

The principal circuits are shown in the block diagram, Fig. 5. The sources of input signal are four studio microphones, a control room microphone, an announce booth microphone, two RCA 70C1 turntables, and six incoming remote lines from points around Fort Slocum. All of these feed into an RCA 76B5 console or control board, and any one of them may be switched through a standard sound-effects filter or a reverberation (echo) generator, or both.

The 600-ohm line-level output of the console (actually plus 18 dbm) is fed through a limiter amplifier to a UTC LS141 hybrid coil. This is a double-secondary repeat coil or transformer which makes two 600-ohm outputs grow where there was only one before. One of these secondaries feeds through an equalizer to a recording amplifier which drives the two disc recorders fitted with Fairchild hot-stylus gear. This consists of a control box feeding an electrically-heated recording sapphire needle which softens the lacquer coating of the recording disc to provide an extremely quiet cut.⁶ The other hybrid secondary is shunted by a 600-ohm resistor to provide a terminated 600-ohm circuit across which is bridged the high-impedance input of the rack-mounted tape recorder.

All equipment, and all lines, transformers, and pads are set up on jacks. We use the CBS-pioneered single jacks⁷ instead of the conventional broadcast-type double jacks, to save space and eliminate possible polarity errors in patching. The amplifiers and other permanent components of the recording channels are wired together through the auxiliary or "normal" contacts of their jacks as shown in Fig. 4. As a result, no patch-cords need be used for the standard or normal channel line-up and it is easy to see why this arrangement is called the "normal-through" jack system. On the other hand, items used only occasionally, such as sound-effects filters, reverberation generators, remote lines, etc., are patched in as needed. And of course, any of the normalised equipment can be re-connected differently by cords, or patched out of the circuit entirely. This arrangement provides a flexible system which facilitates

ORDER BY MAIL FROM WHOLESALE RADIO

Equal To \$75 Motorized TV Aerial Systems

360° SUPER DIRECTRONIC

Electronically Rotates in All Directions

Exclusive Snyder Engineering and design cuts costs to **\$2495**

Powerful, 24 element 2 bay Directronic antenna is electronically beamed to any transmitter in fringe area by 6-position selector sw. No motors or electricity. Extremely high gain. COMPLETE WITH 6-POSITION DIRECTRONIC BEAM SELECTOR, 100' TUBULAR TRIPLEX CABLE, UNIVERSAL U CLAMPS. Order Snyder model AX-524.

4-BAY SUPER DIRECTRONIC For ultra fringe. Model AX-548. **\$44.95**



Cover All VHF Channels with 2 Arrays SNYDER BROAD BAND YAGIS

- Higher Gain Than Conventional Yagis
- For Fringe and Ultra Fringe

High signal level for sharp, bright pictures. Hi-tenal 3 1/2" aluminum elements: 7 on low band; 9 on high band. Complete with universal U clamps. Easy to assemble. Space-saver design.



RS2-6 for Ch. 2 thru 6 **\$9.95**
RS7-13 for Ch. 7 thru 13 **\$4.95**



ALL CHANNEL UHF BOW TIE & REFLECTOR

All pre-assembled. Just unfold, tighten and erect. Hi-tenal aluminum bow. All-welded steel screen. All-weather zinc-plated. U clamp included. Model UIIF-5.

UHF-5 BOW TIE with Corner Reflector... \$3.49



Stop Fiddlin' With Your Indoor Antenna!!! UHF/VHF DIRECTRONIC INDOOR TV ANTENNA

File of beam selector switch electronically rotate antenna for clearest picture in any channel instantly. Equal to outdoor antenna in metropolitan areas. Channels 2 to 83. Model 3D. **\$6.95**

GENERAL ELECTRIC and WESTINGHOUSE TUBES

O24	\$.083	68E5	\$.103	12A7T	\$.143
1A7GT	1.33	68GGG	2.60	12AU7	1.20
1B3GT	1.33	68K7A	1.60	12AX7	1.28
1B5	1.18	68L7GT	1.60	12BE6	1.03
1K2A	1.30	68Q6GT	1.90	12BH7	1.38
3Q5GT	1.40	6C4	.80	12BY7	1.38
5U4G	.85	6C9GB	2.40	12CY7	1.38
5V4G	1.33	6F5GT	1.00	12SK7	.95
5V3GT	.68	6J6	1.25	12SN7GT	1.18
6AB4	.90	6K5GT	.90	12SQ7	.85
6AQ5	1.10	6L6G	1.60	25W4GT	1.03
6AK5	2.18	6SN7GTA	1.18	25Z6GT	.98
6AL5	.85	6V6GT	1.00	35W4	.68
6AU5GT	1.35	6W4GT	.95	35Z5GT	.70
6AU6	.93	6W6GT	1.20	50B5	1.03
6AV5GT	1.60	6X5GT	.70	60L6GT	.95
6BC5	1.00	7N7	1.10	117Z3	.60

FREE! Write for new value-packed "FYI" bulletin #122 Write for our big audio guide, "Hi-fidelity Magic."

WHOLESALE RADIO PARTS CO., Inc.

311 W. BALTIMORE ST., BALTIMORE 1, MD.

GENERAL ELECTRIC HIGH FIDELITY CUSTOM MATCHED ENSEMBLE



PREAMPLIFIER A1-200. Completely self-contained, self-powered unit functioning as an equalized preamplifier for variable reluctance cartridges. Adj. record compensation. Program input selection. Individual bass and treble tone controls. Loudness control. Inputs: Variable reluctance pick-ups; FM-AM tuner. TV sound or tape recorder. **\$57.95**

POWER AMPLIFIER A1-300. 10 watts output. Freq. response: 30 to 15,000 cps. plus or minus 2 db. 4-8-16 ohm speaker output. **\$47.75**

12" DUAL COAXIAL SPEAKER A1-400. Freq. response: 40-15,000 cps. 8 ohms imp. 25 watts. New features include slotted baffle plate and pressure equalizer. **\$41.95**

DELUXE TONE ARMS. For home or broadcast station use. Calibrated at plus pressure adj. 1 to 10 grams. 12" arm, A1-500-\$24.95. 10" arm, A1-501. **\$25.95**

"The Very Best" says High Fidelity Mag. FISHER HI FIDELITY UNITS

50C PREAMPLIFIER

Complete, professional equalization settings and tone controls; genuine FM loudness control; five inputs with five independent input level controls. 2 cathode follower outputs self-powered.

With blonde or Mah. cab. **\$89.50** Only **\$97.50**

FM-AM Tuner 50-R

Armstrong system, adjustable AFC with switch. Adjustable AM selectivity. Separate AM and FM front ends. Cathode follower output. Extreme selectivity, low distortion. **\$164.50**

50 Watt Amplifier 50-A

Finest all-tube amplifier. Uniform response within .1 db. 20 to 20,000 cycles. Less than 1% distortion at 50 watts. **\$159.50**

PRECISE 300 K 7" SCOPE KIT

Sensitivity—Less than 10 mv.

Has true electronic sweep magnifier. Astigmatism control. Push-pull vertical from input thru output; push-pull horizontal. Internal blanking and Z modulation with blanking amplifier. Driven and non-driven sweep. Over 5 MC flat response (3 db.) DC amplifiers. Cathode follower input on vert. and horiz. Internal calibrator. Horiz. and vert. steering attenuator. NEW 7" tube. Highest sensitivity. COMPLETE WITH ALL TUBES, HARDWARE, AND STEP-BY-STEP CONSTRUCTION BOOK. **\$94.95**

300K	\$.129.50
300K RF-AM-TV & MARKER GENERATOR KIT	\$.33.95
(630KA pre-assembled head \$38.95) (630W wired)	\$.53.95
635K UNIVERSAL AF SINE, SQUARE & PULSE GENERATOR KIT	\$.52.50
(635 wired with blanking amp)	\$.52.50
610K RF SIGNAL GENERATOR KIT	\$.23.95
(610KA pre-assembled head \$28.95) (610 wired)	\$.38.95
907KVFM KIT WITH 7 1/2" METER	\$.36.98
(907 wired)	\$.57.98

FACTORY REPAIRS

ON ALL MAKES AND TYPES OF

TEST EQUIPMENT

Write for BIG NEW FREE Catalogue

GENERAL ELECTRONIC DIST. CO.

98 PARK PLACE, NEW YORK 7, N. Y.

ANOTHER OUTSTANDING JOBBER RADIO SUPPLY & ENGINEERING CO., Inc.

85 Selden Ave. Detroit 1, Michigan

HAS THE SENSATIONAL NEW **EICO** 221-K VTVM KIT IN STOCK!



Now Ready! New Sprayberry Book! "HOW TO CONVERT TV SETS for LARGER PICTURE TUBES"



Covers Step-by-Step Method for Converting any TV Receiver

This new book opens exceptional extra money opportunity for the alert serviceman... converting older small screen TV sets to modern, large screen 17", 21" or 24" receivers. Fully illustrated with diagrams, charts and pictures. Covers every step: planning, wiring, final adjustment. Special introductory price—50c. Mail coin (no stamps please) today.

SEND Only **50c**

SPRAYBERRY ACADEMY OF RADIO 111 N. Canal St., Dept. 49-C, Chgo. 6, Ill.



**24 HOUR
DELIVERY
FROM STOCK!**

RELAYS

Our stock of more than a million relays — in over a thousand different types — is the world's largest. Don't delay your production for want of large or small quantities of relays of any type.

Telephone, wire or write for quotations.



NEW AND MORE
COMPREHENSIVE
**1953
RELAY SALES
CATALOG**
NOW READY

Be sure to send for your copy



Telephone
SEeley 8-4146

**833 W. CHICAGO AVE.
DEPT. 8. CHICAGO 22. ILL.**

troubleshooting, equipment substitution, and special set-ups. This last is a great convenience when the staff includes enthusiastic pioneers continually striving for unusual effects.

The arrangement of the racks is shown in Fig. 1. Rack 1 is located alongside the *Presto* 6N recording lathes and includes from top to bottom the *Western Electric* 1126C limiting amplifier, vu meter, *Presto* 85E disc recording amplifier, *RCA* tube-check voltmeter, *McIntosh* 20W2 recording amplifier, *UTC* 3AX equalizer, and *RCA* BA2C preamplifiers. Rack 2 contains utility amplifiers, *Hallcrafters* SX32 communications receiver, talkback amplifier, main patch panel, utility pad and transformer panel, cueing amplifier, and terminal blocks behind the blank panels at the very bottom. Rack 3 includes the *Stancil Hoffman* R4 tape recorder, patch panel, elapsed-time indicator assembly which totals the hours of use of major equipment items, reverberation generator, *RCA* 4917 sound-effects filter, and *RCA* BA2C preamplifiers to make up for losses in the filter.

Special Features

While the equipment and over-all audio layout conform to standard broadcast practice, the nature of the studios as student laboratories requires additional features not usually found in commercial facilities.⁸ For example, with large numbers of inexperienced personnel coming and going, wires and cables trailing across the floor must be held to minimum number and length. Thus a.c. power is available every eighteen inches from "wired plugmold" run inconspicuously along the top of the baseboard. At the end of the day, a switch at the studio door turns off the power and also kills a red tell-tale light visible through a port in the studio door. Receptacles for all four studio microphone channels are available at several points around the studio in the hollow chair-rail which serves as a wiring duct. This duct also carries utility audio circuits to multiple outlets around the room. One of these circuits provides feed for program phones which may be plugged in by students on some types of shows to obtain aural cues from preceding parts of the program. The chair-rail duct also carries a grounding bus to which student-operated tape machines and sound effects turntables may be grounded to keep down hum.

The "on-the-air" sign is controlled by a separate switch instead of by contacts on the console microphone keys, to permit the sign to be lighted when only student-operated tape recorders are being used. When this very versatile sign goes on, it energizes a relay which silences the studio telephone and intercom and substitutes a red light for the call buzzer. At the same time, another relay switches the talkback amplifier output from the studio speaker to a special pair of studio phones worn by a

New		Standard	
Guaranteed	TUBES	Standard	Brands
0A2	\$1.00	4X150A	22.50
0A3	1.10	5B1	4.50
0A4G	1.00	5C2	42.90
0B2	1.25	5D21	15.00
0C3/VR105	1.00	5F7	1.95
0C3/VR150	1.00	5R4GY	1.25
1A3	1.00	5T4	1.50
1B22	2.00	6AL5W	1.75
1B23	1.25	6AN5	2.90
1B24	9.50		
1B26	2.30		
1B27	1.50		
1N21A	2.50		
1N22	1.25		
1N23	3.25		
1N23B	3.25		
1N34A	.79		
1N38	1.50		
1N58A	1.25		
1N63	2.15		
1N69	2.69	6A5E	2.30
1N70	2.59	6BL6	59.50
2A515	4.75	6BM6	69.50
2C39	12.50	6F4	4.50
2C39A	14.90	6J4	3.25
2C40	8.50	6K4	3.50
2C42	19.95	1E	1.75
2C43	1.95	15R	1.25
2C44	1.19	FG17	3.95
2C46	19.95	FG32	12.95
2C51	1.95	FG57	1.25
2C52	4.95	RG60	16.41
2D21	1.25	FG95	22.00
2E21	1.95	5G10A	2.25
2E24	4.65	V1-127A	2.95
2E25A	4.50	100TH	9.50
2E25B	4.50	250TH	16.50
2K22	22.50	304T	7.95
2K25	28.50	307A	3.95
2K26	55.00	310A	4.95
2K28	35.00	350B	3.95
2K34	150.00	393A	9.95
2K41	125.00	394A	3.95
2K45	110.00	417A	8.50
2K48	99.50	446A	1.19
3A4	1.25	450TH	44.50
3A5	4.95	527	11.50
3B23	4.95	575A	13.95
3B24	4.75		
3B25	4.25		
3B26	3.50		
3B28	6.50		
3C22	72.50		
3C23	9.95		
3C24	1.50		
3C33	9.95		
3C45	12.50		
3E29	11.95		
3F7	1.95	703A	4.50
3GP1	3.95	705A	1.50
3HP7	3.95	707A	8.95
4B24	6.95	707B	14.95
4C27	12.50	715A	5.50
4C28	35.00	715B	8.95
4C37	22.00	715C	14.95
4E37	14.50	717A	9.00
4-125A	22.50	722A	1.95
			3.592
			22.50

**WE PAY
HIGHEST
PRICES FOR
YOUR
SURPLUS!**

**Vacuum
Capacitors**
50-15 \$7.50
50-32 12.50
12-32 10.00
100-20 14.50

Jsh ELECTRONICS
SALES CO. Dept. R-26
7552 Melrose Ave.
Los Angeles 46,
California

STAY ON THE AIR
WHEN POWER FAILS...with
an ONAN Electric Plant



Model 10E1, 10KW A.C.
When storms, floods, or fires interrupt electricity and force you off the air, you lose listeners and income. Guard against loss, assure vital public service during emergencies by installing an Onan Electric Plant. Onan Standby Electric plants serve many network and private stations. Gasoline driven automatic models to 50,000 watts.

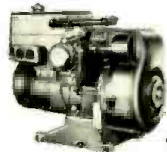

PORTABLE ELECTRIC PLANTS FOR MOBILE RADIO USES
Supply A.C. power for broadcasting at scene of events. Light in weight. Can be carried by hand or in trunk of car. A.C. models: 400 to 3,500 watts.

Onan PRODUCTS Write for FREE Folder
D. W. ONAN & SONS INC.
7899 University Avenue
Minneapolis 14, Minnesota
RADIO & TELEVISION NEWS

student or an assistant instructor. This arrangement silences the studio talkback speaker while on the air—just in case—and at the same time makes it possible for the director to maintain verbal contact with the studio.

Another feature of the studios required by student consideration is size. The studios will each accommodate fifty students seated as an audience for demonstrations. On the other hand, to permit simultaneous use by smaller groups for tape sessions, a heavy double-velvet stage curtain can be drawn across each studio to form two practice rooms. The sound absorption of the curtain makes it possible to operate a tape recorder speaker at medium volume on both sides without serious mutual interference. The control rooms, 14 by 19 feet, are twice the usual size in order to accommodate fifteen students seated as observers.

The philosophy of the Armed Forces Information School is that instruction in program production should be given at the professional level, implemented by a laboratory studio plant of comparable technical performance. The installation described was designed to meet this standard.

REFERENCES

1. Coriell, Eugene F.: "Radio Studio—Military Style." *Signals*, March-April 1950.
2. Knudsen & Harris: "Acoustical Design in Architecture." John Wiley & Sons.
3. "The Control of Sound in Broadcasting Studios." Johns-Manville Company pamphlet.
4. Nixon, George M.: "Acoustic Problems." *Electronics*, May 1948.
5. Chinn, Howard A.: "Audio System Design Fundamentals." *Audio Engineering*, November 1948.
6. Bachman, William S.: "Columbia Hot Stylus Recording Technique." *Audio Engineering*, June 1950.
7. Chinn, Howard A. & Mourou, Robert B.: "Single Jacks for Broadcast Application." *Audio Engineering*, July 1947.
8. Coriell, Eugene F.: "An Instructional Broadcast Studio." *Audio Engineering*, November 1949.

-30-

The "Compentrol"

(Continued from page 79)

hear from them as to their experiences.

The "Compentrol" is currently available in plain and switch type. ½ megohm and 1 megohm values. See *Centralab* catalogue.

BIBLIOGRAPHY

1. Pender & McIlhenny: "Communication Electronics." McGraw-Hill Book Co., New York.
2. Bronberger, David C.: "Loudness Control for Reproducing Systems." *Audio Engineering*, May 1948.
3. Winslow, John: "Full-Range Loudness Control." *Audio Engineering*, February 1949.
4. Turner, J. W.: "Construction Details of a Continuously Variable Loudness Control." *Audio Engineering*, October 1949.
5. Johnson, E. E.: "A Continuously Variable Loudness Control." *Audio Engineering*, December 1950.
6. Dieckel, Ron: "The Loudness Control—An Aid to Higher Fidelity." *RADIO & TELEVISION NEWS*, March 1952.
7. *Centralab Distributor Catalogue* No. 28, page 9.
8. Brooks, William O.: "A Two-Tap Bass and Treble Compensated Volume Control." *Audio Engineering*, August 1951.

-30-

ALL-CHANNEL UHF CONVERTER

B-T LABS

Ultraverter

Model BTU-2

Ultra POWERFUL
Ultra DEPENDABLE

MORE POWER

Employing the newly developed B-T Ultratuner, the B-T Ultraverter, Model BTU-2, provides for reception of all UHF channels on any TV set with quality unmatched by any converter, regardless of price. 'On/off' operation is automatically controlled by the power switch on the TV receiver. Terminals are provided for both VHF and UHF antennas.

Advanced circuit design assures high gain, high stability, and lowest noise performance. A high ratio vernier knob permits easy, accurate tuning on UHF channels from 14 through 83. Tube complement: 6T4/6AF4, 6AB4, and Germanium Diode, 1N72.

\$39.95

B-T LABS

BLONDER-TONGUE LABORATORIES

Manufacturers of TELEVISION AMPLIFIERS, UHF CONVERTERS, MIXERS, DISTRIBUTION UNITS and TV ACCESSORIES

WESTFIELD, N. J.

HIGH GAIN AT LOW COST

R9 PLUS DX SIGNALS POSSIBLE—NO TVI
SMALL AREA REQUIRED FOR INSTALLATION

- 10-20-40 METER GROUND PLANE ANTENNAS ARE PRACTICAL USING OUR LIGHTWEIGHT MOLYBDENUM STEEL WHIPS, COPPER PLATED with baked paint finish. Threaded tapered sections, standard 3/8 threaded stud on bottom section. Five 18 ft. elements suitable for 20 meter ground plane. **\$19.95**
- 32-FOOT VERTICAL WHIP FOR FIXED SERVICES—uses 1/4 heavy duty copper plated steel tapered sections, swell for 20 meters, or use with ground planes for 40 meters. **5.95**
- 16-FOOT MOBILE WHIP ANTENNA. **3.75**

BIFUND NEW DYNAMOTORS

- 12/24 VOLT INPUT, 400V/150 ma. output, will deliver 300V/200 ma. **11.95**
- 12/24 VOLT INPUT, 600V/175 ma. output. **12.95**
- PE-101C DYNAMOTORS, brand new in original cartons, operates on 0, 12, 24 volt input, economical mobile power. **4.45**
- DRY CHARGED PLASTIC CASE STORAGE BATTERIES
- 2 VOLT 20 AMPERE, Willard BB-51. **2.95**
- 4 VOLT 40 AMPERE, Willard BB-40-B. **5.95**
- 6 VOLT 60 AMPERE, Willard BB-40-B. **2.50**
- COMBINATION A & B DRY BATTERY PACK, 4 1/2V, 90 & 150 volts output. Ideal for compact mobile equipment supply. **2.95**
- LINK & BOSCH MOBILE POLICE RECEIVERS, 5 tubes (40 stage) fixed tunable 2-8 mc band, adjustable switch control. Ideal for HAM, C.D., MAR & MARINE MONITOR SERVICES. Used but guaranteed operating condition. Complete with new 6 volt input dynamotor & Jensen 5" PM Speaker. Special. **\$13.95**

BUY ESSCO FOR BEST R/C VALUES

- SIGMA 4F RELAY, 8,000 ohm, top value. **4.95**
 - KURMAN BK-35, 10,000 ohm at 14 ma. SPDT. **4.95**
 - PETERSEN Z9A, 27,235 04 tolerance, W/sockets. **4.95**
 - LORENZ RECEIVER, COMPLETE ready for Inst. **14.95**
 - ESCAPMENT, complete sets, not a kit. **24.95**
 - PARTS KIT TO BUILD YOUR OWN, WITH SIGMA 4F RELAY AND DRILLED BASE. **10.95**
 - OSR TYPE QUENCH COILS for all hard tube sets. **1.75**
 - 2 VOLT VIBRATOR POWER SUPPLY PARTS KIT, complete with drilled chassis. **9.95**
 - PRECISION WESTON 2" SQUARE PANEL METERS 0-5 ma., **\$2.95**; 0-50 ma., **\$3.45**; 0-1 ma., **\$5.95**; 0-500 ua. **5.95**
 - FLAWLEIGHT HOOKUP WIRE, 25 feet of 5 colors. **.35**
 - 1/2" x 1/2" BASE RESISTOR BOARDS FOR ALL RECEIVERS. **\$0.25**; DRILLED BOARDS. **1.00**
 - ESSCO SUPER 5 WATT TRANSMITTER, a 2 tune full 5 watt job with built-in 2 volt battery & power supply. **34.95**
 - COMBINATION FIELD STRENGTH & TEST METER SET, checks transmitter output & for all-round checking, kit/harks incl. precision resistors. **11.95**
 - 9 1/2" R. Sectional whip antenna with top of cabinet mount. **2.95**
 - SIGMA 4F RELAY REPLACEMENT COILS, 2000 & 10,000 ohm units available, for repairing defective relays. **1.25**
 - MICRO-SWITCH KEYSWITCH. **.65**
- SEND FOR FREE CATALOG, MONEY BACK GUARANTEE ON ALL ITEMS, SAVE C.O.D. FEES, include postage, excess refunded.

ELECTRONIC SPECIALTY SUPPLY CO.

58 Walker Street, New York 13, New York

... to servicemen
who really want to
learn to use the
OSCILLOSCOPE

fully and accurately!

A complete
guide to using
the handiest
service instru-
ment of all...
... On all kinds
of jobs!...
Written so you
can really
understand it

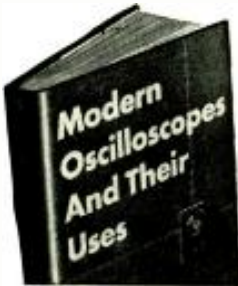

**MODERN OSCILLOSCOPES
AND THEIR USES**

By JACOB H. RUITER, Jr.
of Allen B. DuMont Laboratories, Inc.
326 pages, 370 illustrations, \$6.00



Like most servicemen, you've probably read a lot about oscilloscopes—but still don't know how to use them as well as you'd like to.

If so, here's the book you've been looking for!

In **MODERN OSCILLOSCOPES AND THEIR USES**, Mr. Ruiter starts right at the beginning. He shows how oscilloscopes are designed and how they work. Then he explains exactly how, why and where to use them.

No involved mathematics. No puzzling theoretical discussions. Instead, this world famous authority gets right down to earth in answering the questions that have probably kept you from taking full advantage of the money-making service possibilities in oscilloscopes.

**HOW TO HANDLE TOUGH JOBS
EASIER AND FASTER**



From routine trouble shooting to handling the toughest realigning and adjusting jobs, each operation is carefully explained. These include determining where and how to use the oscilloscope; how to make connections; how to adjust circuit components; how to set the controls—AND, ABOVE ALL, HOW TO ANALYZE PATTERNS.

From dozens of pattern photos you see and learn to recognize patterns that are wrong, nearly right and exactly right!

**SAVE HUNDREDS OF DOLLARS
IN AM-FM-TV SERVICE TIME!**



Busy servicemen have told us that the television service section of **MODERN OSCILLOSCOPES** alone is worth the entire price of the book. Here you get exact procedures for aligning the I-F stages; aligning V-F tuned circuits in the mixer stage; checking gain of the picture I-F stage by stage; troubleshooting the sweep circuits... and dozens of other jobs. Similar big sections cover use of the oscilloscope in AM and FM radio servicing and other electronic uses.

No other type of specific service training can mean so much to you in terms of increasing your efficiency and earning power. Use coupon today!

READ IT 10 DAYS at our risk!

Dept. RN-122, RINEHART BOOKS, Inc.
Technical Division
232 Madison Avenue, New York 16, New York

Send MODERN OSCILLOSCOPES AND THEIR USES for 10-DAY FREE EXAMINATION. If book is satisfactory, I will then send you \$6.00 promptly in full payment. If not, I will return book postpaid in good condition and owe you nothing.

Name.....
Address.....
City, Zone, State.....
Employer's Name and Address.....

Price outside U. S. A., \$8.50, cash only. Money back if you return book within 10 days.

International Short-Wave

(Continued from page 132)

Argentina—LRS2, 9.310, noted closing 2200 in Spanish; classical music weekdays after 2000. (Kahan, Calif.) SIRA, 15.345, Buenos Aires, noted in *English* 1845-1930, excellent level. (Zirkle, Va.)

Australia—VLC9, 9.615, is good level in Eastern North American "morning" beam 0700-0845, news 0715, 0815; DX session Sun. 0830. (Welch, Mass., others)

Belgium—*Belgian Congo*—The Belgian Short-Wave Service is currently scheduled over 6.000, 1300-1600 French, *English*, Swedish; 9.144, 1815-1930, French, Dutch, also 1930-2200 on 9.144; in parallel on 9.655 (OTC, Leopoldville); 1200-1615 in Dutch and French, 9.745; same channel in Portuguese, Spanish 1615-1800; 11.850 in French, Dutch 0700-0800, 1200-1245, 1300-1600; 15.335 in French, Dutch 0600-0800, 1200-1245; 17.860 in *English*, Dutch 0500-0600, in French, Dutch 0600-0800. (ISWC, London; Kroll, N. Y.) OTC, 9.655, Leopoldville, good level in *English* 2000-2200 closedown, relaying ORU. (Boyce, N. J.) ORU, 9.767, Brussels, is good level same time. (Ress, N. Y.)

Bolivia—CP38 or *Radio Illimani* or both may be "looking for a hole;" someone pops up once in a while anywhere from 9.450 to 9.497 at various times 0600-0730 and 2005-2115. (Stark, Texas)

Brazil—A "Radio Cultura" outlet has been noted on 6.165A to 2300 closedown when played several notes of "Smoke Gets in Your Eyes." (Stark, Texas) ZYB8, 11.765, noted 1630; ZYC8, 9.61, heard 1635. (*Mesquita e Sousa*, Portugal)

A new station is "Emissora Universitaria" of the University of the State of Rio Grande do Sul, on the air Mon-Fri. on 3.945 at 1800-2000; mostly classical recordings, with a few lectures in Portuguese by University professors; announces as "the pioneer of the University stations in Brazil." *Radio Difusora Brasileira*, Uberlandia, State of Minas Gerais, now operates in the 126-m. band on 2.340 with call of ZYV30, 500 watts; is scheduled 0530-1200, 1500-2100; wants reception reports and is having QSL cards printed; has been heard in Canada. (Villela, Brazil and others)

British Honduras—*Radio Belize*, 4.950, fair some days with BBC news relay 2000, followed by sports roundup. (Saylor, Va.)

Bulgaria—*Radio Sofia* lists *English* 1500-1515, 1615-1645, 6.070, 7.670; 1800-1815, 2000-2030, 9.700; latter good level 1800-1815. (Boepple, Ohio)

Canada—CFRX, 6.07, Toronto, Ont., is often quite good mornings, afternoons, or evenings (*EST*). (McEwen, S. C.)

China—*Radio Peking*, 15.060AV, noted with *English* 0400-0427. (Saffle DX-ing Club, Sweden) On West Coast,

**!!TV ANTENNA SPECIAL!!
STACKED ARRAY! YOU GET:**
2 TEN-ELEMENT ALL-ALUMINUM CONICAL-X bays,
1 pr. "Q" bars, 2 five ft. 1 1/4"
masts (tapered), 1 pr. Wall Brkts, 30
ft. twin-lead, (shpd. extra)—ALL
FOR..... **\$1195**

6 VOLT DC MOTOR (Delco). Fully cased, dust-
proof, 1 1/2" shaft, O.D. 2 3/4"x4", (4 lbs.)...\$2.95
1 40 HP AC MOTOR (Rohm & Haas) 115V,
1650RPM. With capacitor & switch (4 lbs.)... 4.95
GUN SYNCH. CONTROL BOX (Fairchild MK3).
"Gold-Mine" of Relay, Triggers, Jewel, Fuses, 2.95
60" TV DEFECTION YOKE for 12" & 16" tubes 1.49

SPEAKER REPAIRING MADE EASY!!... with
Ready-To-Install REPLACEMENT CONE & VOICE
COIL ASSEMBLIES. Each complete with Spider,
Leads & Instructions. Send complete specs. or
old cone with order.
Any 4" or 5" Assy \$1.10; Any 6" Assy \$1.50
Any 7" or 7 1/2" Assy \$1.70; Any 8" Assy \$1.80
Any 4"x6" Assy \$1.50; Any 6"x8" Assy \$1.80
(FREE "SPEAKER PARTS MANUAL" NOW READY)

**"NOV SPECIAL" ROTARY BALL-BEAR-
ING SWIVEL ASSEMBLY.** Or: Original
for TV table sets; used also for CHASSIS
SERVICING, DISPLAY WORK, Burred
hardware mid- between 13" O.D. Mason,
ite plates..... **\$595**

EXPERIMENTAL TUBES for test research, etc.
Fil. tested, Kit of 40 anad. recvg. types...\$1.98
HS-30 HEADSET with matching transformer.
8000 ohms Impedance... 2.49
BATTERY CLIPS, 2 1/4" hvy. duty, ea. 10c; 12/1.00
WAFFER TUBE SOCKETS, 4, 5, 6 or 7 pin, or
12 pin... 49c; 6pc. Box... 1.00/3.50
5" PRECISION OIAL & 3 1/4" fluted Knob, Calif.
0-2000-3000. Metal Housed, 1/2" shaft ext... .79
90 OHM-100W. W.W. RESISTOR, Std. Edison
screw base, 7 1/2" L. x 1" O.D. Ea. 69c... 6/3.50

"WOOD CABINETS" ...
Type "B"—Mahogany,
inside: 17x10 1/2 x 13 1/4",
Dial opening: 10 1/2" x 7"
1 1/2".....\$2.49
Type "C"—Mahogany,
inside: 14 1/2 x 8 1/2 x 11"
Dial opening: 6" x 13 1/2"
Type "D"—MIDGET CAB-
INET, Pol. walnut, in-
side: 7" x 5 1/2" x 4". With 4 min. tube
punched chassis..... 1.49
Type "E"—Light Oak, inside: 12 1/4 x 7 1/2 x 7"
Dial opening: 8 1/2" x 13 1/2"
Type "G"—INTERCOM CABINET, Ivory fin-
ish, 16 1/2 x 4 1/2 x 11 1/2". Takes 4" spkr & am-
plifier..... 1.29

IT'S TERRIFIC... OVER 5000 SOLD!! and the
NEW "JUMBO RADIO-ELECTRONICS PARTS KIT" is
now BIGGER & BETTER. HERE'S JUST PART
OF WHAT YOU GET: Ass'd. Condensers,
Resistors, Coils, Switches, Wire, Photo-
facts, TV Tubes, TV Parts, Etc., Ed. Edison
Shpk. wt. 20 lbs.—STILL ONLY..... **\$395**

"DIRECT FACTORY SPEAKER REPAIRS SINCE 1927"
Min. order \$3.00. 20% deposit req. on all C.O.D.'s.
Please add sufficient postage—extra refunded.
LEOTONE RADIO CORP.
67 Bay Street
New York 7, N. Y.

✓ 12-Tube High-Fidelity
FM-AM TUNER —
Over 50% Off!
REG. \$85.00
41⁹⁵

APPROVED 1954 MODEL "V-12"
SOLD ONLY AT BOSTON'S FAMED RADIO SHACK
Radio Shack bought Approved Electronics' EN-
TIRE output of this brilliant tuner, to eliminate
all middleman profits and bring America's music
lovers a bargain NO ONE can duplicate!

FEATURES!
Discriminator
Double-Limiter
Cath. Follower
30-15,000 cps
Tuned-RF FM
Tuned-RF AM
12 Min. Tubes
6-Gang Cond.

Tuner: 8 1/4 W, 5 3/8 H, 8
D. Use with any ampli-
fier. Requires separate
power supply 6.3V AC @
4 amps, 190V DC @ 55
ma., available for only
\$12.05 extra.
HI-FI SYSTEM, \$157.50
Approved tuner and sup-
ply, Bell 2122B amplifier,
Univ. 6200 (12") speaker,
V-M 951GE changer with
G-E pickup. Reg. \$201.55.

ORDER BY MAIL.
ADD POSTAGE
Free!
New 224-page
audio-radio-TV
catalog!
RADIO SHACK CORP
167 WASHINGTON ST., BOSTON 8, MASS.

at that time Peking is best on 10.26 and 10.20; 9.04, 7.50, 6.20A are weak; 11.68, 15.06AV are inaudible. (Balbi, Calif.)

Colombia—"La Voz de Cali," HJEX, 6.196A, Cali, noted signing off 2300. (Stark, Texas) *Radio Sutantenza*, 5.070A, is heard with music 2000-2030, very good level in Sweden. (Ingelsson) Excellent from 0600 with news in Spanish. (Sanderson, Australia) Heard closing with bells, then Colombian National Anthem around 2058. (Bellington, N. Y.) HJCQ, 11.680, Bogota, comes in fair around 2300. (Calos, Calif.)

Cuba—"Radio Reporte del Hora," COCW, Havana, noted to 2400 close-down; signs on 0630; *English* news at a quarter to the hour; gives frequent time checks, commercials, weather announcements. (N. Z. *DX Times*) Noted on m.w. 550 kc. recently. (Scheiner, N. J.) COBZ, *Radio Salas*, 9.03A, Havana, has EBC's "English by Radio" session daily except Sat., Sun. around 1810-1815. (Glowienka, Wisc.)

Czechoslovakia—Prague, 9.55, noted at good level to North America in *English* 1930-2000. 2300-2330. (Parrish, Ga.; Dupre, La.; Zerosh, Pa.)

Denmark—OZF, 9.52, good in *English* 2100-2130 sign-off. (Klein, Va.)

Dutch New Guinea—After testing on 5.045, *Radio Hollandia* has moved to 4.865 where it has some interference from AFRS, Tokyo, 4.860. (N. Z. *DX Times*)

Egypt—When this was compiled, Cairo was widely reported at strong level on 9.615A around 1320-1700 in parallel with 11.815; news 1330; it appears the 9.615A outlet may be one of the new 100 kw. stations of *Radio Cairo*. (Scheiner, N. J.; Fisher, Fla.; Mast, Bellington, N. Y., others) Good level on 11.815 closing 1700. (Boepple, Ohio) Noted on 11.965A at 0030 with Arabic session of news, music. (Sanderson, Australia)

Fiji Islands—ZJV, 5.980, Suva, noted 0345 with musical program and news; on 3.980 at 0445 excellent level in variety program, then news. (Sanderson, Australia)

France—Paris, 7.240, noted 0145 with French-English lesson ("The French Have A Word For It"), beamed to the United Kingdom. (Sanderson, Australia) Heard signing on 1800 over 9.685A after interval signal; very strong level at 1830 sign-on over 11.700. (Smits, Minn.)

French Morocco—*Radio Rabat*, 7.220, noted with call in French and "exact time" 0800, then news in French followed by light music 0810. (Pearce, England)

Germany—AFN, 5.470, Bayreuth, noted on a Sat. 1430, fair level. (N. Z. *DX Times*) The Overseas Service from Cologne, via Hamburg, is scheduled 2030-2330, 5.980, 7.290; 0530-0830, 15.275; 0930-1230, 1300-1600, 1700-2000, 11.795. (WRH) Leipzig, 9.73A, is noted in German 0130. (Malmo DX-aren, Sweden)

Guadeloupe—FG8AH, 9.440A, Basse-Terre, noted closing down 0630.

November, 1953

Only 10% Down... 18 Months to Pay!

hallicrafters

I can SAVE you money... Liberal Trade-ins



S-76 RECEIVER... \$199.95

SX-71 RECEIVER... \$249.95



\$20. Cash Down

\$15.90 per month — 12 months
\$10.90 per month — 18 months

Extra selectivity with double superhetrodyne circuit. One RF, two conversion and 3 IF stages. Range 550-1550 Kc, 1.7-34 Mc in four bands. 8 tubes plus voltage regulator and rectifier. Complete with tubes, less speaker.

\$25. Cash Down

\$19.87 per month — 12 months
\$13.63 per month — 18 months

Double Conversion sharp selectivity, plus built-in NBFM at moderate cost. 11 tubes plus voltage regulator and rectifier. Low down payment.

HALLICRAFTERS RECEIVERS AVAILABLE FOR IMMEDIATE SHIPMENT

MODEL NUMBER	DOWN PAYMENT	CASH PRICE	MODEL NUMBER	DOWN PAYMENT	CASH PRICE	MODEL NUMBER	DOWN PAYMENT	CASH PRICE
S-81	\$ 6.00	\$59.95	S-40B	\$13.00	\$129.95	ST-83	\$13.00	\$129.95
S-82	\$ 6.00	\$59.95	S-53A	\$10.00	\$ 99.95	S-78A	\$ 8.95	\$ 89.50
A-84	\$10.00	\$99.50	S-72L	\$12.00	\$119.95	SX-62	\$35.00	\$349.95
S-36C	\$ 6.00	\$59.95	S-77A	\$13.00	\$129.95	S-72 Port.	\$11.00	\$109.95
R-46 Speak.	\$ 2.50	\$24.95	HT-20 XMTR	\$44.95	\$449.50	SX-88 Rec.	\$50.00	\$499.95



JUST OFF THE PRESS!

Big New WRL 1954 Catalog

Offering the greatest selection of radio & television equipment, parts, and supplies, from "The World's Largest Distributor of Amateur Radio Transmitting Equipment." Order with confidence from "WRL—the world's most personalized radio supply house."

Send for **FREE** Copy

WRITE—WIRE
PHONE 2-0277

WORLD RADIO LABORATORIES
744 West Broadway
Council Bluffs, Iowa

R-11

Please send me: WRL XMTR Info
 Radio Map 25¢ SX-71 Info
 New Catalog S-76 Info
 Used Equipment List New Log Book

Name
Address
City..... State.....



RT34/AP5-13 UHF TRANSCEIVER

Complete 420 mc transmitter-receiver, with RF heads, 5 stages of 20 mc IF, excellent condition, less tubes and dynamotor, with circuit diagram, \$12.95 value—\$4.95. 500 ohm 2 watt carbon pot w/knob and hardware, 3 mc, 7 min miniature tube shield and retainer, 20 for \$1, 420 mc coil assembly, 40c, 10 lug terminal board w/3 condensers and 3 resistors, 20c, 20M wire wound pot, 20c, 2H21 tustratron, 60c, TZ20 triodes, \$1, TS40 AP, 300-1000 mc freq, meter, \$39.95. We can supply parts for AP513. Minimum order \$1. 25% C.O.D. deposit.

KENNEDY ASSOCIATES

2618 Rigby Avenue San Antonio, Texas

GET INTO ELECTRONICS



You can enter this uncrowded, interesting field. Defense expansion, new developments demand trained specialists. Study all phases radio & electronics theory and practice: TV; FM; broadcast; servicing; aviation, marine, police radio. 18-month course. Graduates in demand by major companies, U.S. or equivalent required. Begin Jan., March, June, Sept. Campus life. Write for catalog.

VALPARAISO TECHNICAL INSTITUTE
Dept. RD Valparaiso, Indiana

ANOTHER OUTSTANDING JOBBER
PAYETTE RADIO, LTD.

700 St. James West
Montreal, Canada

HAS THE
SENSATIONAL NEW
TEICO 470-K 7"
SCOPE KIT
IN STOCK!



\$79.95

GRANCO UHF

for superior performance

the only complete
all-channel
UHF converter line



"STAR"

MODEL LCU—Proven all-channel performance everywhere. Coaxial tuning at a new low price!



ALL-NEW "SUPER"

MODEL MTU—Coaxial tuning for unmatched performance... especially in difficult reception areas.



"HIDEAWAY"

MODEL HT-5—At last, a front-end tuner that answers the problem of concealed installation for all-channel reception. Coaxial tuned!

Sold by leading
jobbers everywhere!

Write today for free
bulletin to Dept. T9

GRANCO PRODUCTS, INC.

36-17 20th Avenue
Long Island City 5, N. Y.

Guatemala—TGNC, 11.85, noted 2330-2345 with organ melodies. (Mitchell, N. Y.) TGBC, *Radio Colonial*, 6.565, heard 2110 with popular music, fair level. (Cox, Dela.)

Haiti—*Radio Commerce*, P.O. Box 94, Port-au-Prince, 4VA, 4VB, appears to have settled down on a schedule which includes use of 9.485 around 0630-0800V; and 6.140 at 1600-1930 and 2100-2300 or later. (Scheiner, N. J.; Niblack, Ind., others) 4VEH now has a *mailbag* session called "Listener's Post" on Sat., 0610 over 9.690; is scheduled 0530-0900 daily on 9.690; on Sun. also 1630-1900 on 9.690, 1900-2130 on 9.727; is using new antenna and requests comparison reports. (Fox, West, Va.)

Holland—*Radio Nederland*, 11.73, noted in *English* to North America 1630-1725, good level. (Dodge, Mass.)

Hong-Kong—ZBW3, 9.525, noted 0615 with musical session. (Sanderson, Australia) Heard 0345-0430 with talk in Chinese, then station call in *English*. (Ishikawa, Japan)

Hungary—Budapest, 9.833, noted 2300 with *English*, good level. (Mathery, Ohio)

India—*English* news is scheduled 1930-1940, 11.950, 15.290; 2310-2320, 15.130, 17.705; 0235-0245, 15.380, 17.740; 0830-0840, 11.780, 15.380. (Scheiner, N. J.)

Indo-China (Vietnam)—*English* schedules of *Radio France-Asie*, Saigon, include 1830-1900 on 7.230; 0900-1115, 11.935; 2030-2045, 11.935; news 1830, 2030, 0900; news in French 2045, 1100. (Catch, England, others) Noted on 15.420 at 0445 with *English* service in news, music. Hanoi, 7.408A, heard 0545 with French program of news, music. (Sanderson, Australia) "Voice of Vietnam," 7.288, is fair to good 0900-0930 in French, 0930-1000 close-down in *English*. (Morgan, Calif.)

Iran—*Radio Tabriz* operates on 6.090, 7.5 kw., 2200-2400, 0400-0630, 0830-1130; news in Persian 2300, 0500, 1100. (WRII)

Italy—Rome noted on 11.905A to North America 1920-2200 with news, music. (Miller, N. Y.) Lists this schedule as 1920-2000 on 11.905A and 9.570; at 2145-2200 over 15.40, 11.905A, 11.81, 9.71, 9.57. (Crowell, Pa.)

Japan—*Radio Japan*, Tokyo, has extended schedules—for Pacific Coast of North America 0000-0100, JOA3, 9.695 (*new*), JOB4, 11.780 (*new*); for Hawaii 0200-0300, JOA6, 15.135, JOB4, 11.780; for Australia 0400-0500, JOA6, 15.135, JOB6, 11.725; for North and Central China 0600-0800, JOA3, 9.695, JOB2, 7.180; for Indo-China, Thailand, Burma 0945-1045, JOA3, 9.695, JOB6, 11.725; for India-Pakistan 1100-1200, JOA3, 9.695, JOB6, 11.725; for Europe 1400-1500, JOA3, 9.695, JOB2, 7.180; for South America 1600-1700, JOA6, 15.135, JOB6, 11.725. (Scheiner, N. J.; Ishikawa, Japan)

Kuwait—Al Kuwait, 5.000, still noted around 1245 with Arabic music, but has poor signal now due QRM from MSF, Rugby, England, same channel. (Catch, England)

Lebanon—*Radio Beirut*, 8.036A, noted 1600 with a VOA rebroadcast; news in Arabic 1625A, closed 1630 with march; still has *English* 1000-1100. (Pearce, England)

Libya—Forces Broadcasting Station, 4.965, Tripoli, noted 1545 with popular recordings; closed 1600 "until 0430 GMT" (2330 EST); said "Goodby to listeners in Tripolitania and goodnight to short-wave listeners wherever they may be;" played "God Save the Queen;" woman announcer. (Pearce, England) Lists schedule of 0130-0315, 0700-1800 (Sun. 0200-1800); uses 250 watts through a dipole, center-fed, with coaxial cable. (Scheiner, N. J.)

Official list of Cuban television stations on the air or granted construction permits as of July 15, 1953. Data supplied by Dr. Francisco Palomares Garcia, sub-secretary of the Ministry of Communications and Transportation, Republic of Cuba.

CALL	CHANNEL	CITY	POWER (kw.)	OWNER	ADDRESS
CMA-TV	2	Havana	5	Radiotelevision El Mundo	Calle 23 #55, Vedado
CMUR-TV	4	Havana	5	Union Radio Television	Mazon #52
CMQ-TV	6	Havana	5	Circuito CMQ	Radiocentro, M #312, Vedado
CMBF-TV	7	Havana	5	Radio Universal	Radiocentro, M #312, Vedado
CMGQ-TV	9	Matanzas	5	Circuito CMQ	Radiocentro, M #312, Vedado
CMH-TV	3	Santa Clara	5	Radiotelevision El Mundo	Calle 23, #55, Vedado
CMHQ-TV	5	Santa Clara	5	Circuito CMQ	Radiocentro, M #312, Vedado
CMJL-TV	6	Camaguey	5	Circuito CMQ	Radiocentro, M #312, Vedado
CMKU-TV	2	Santiago de Cuba	5	Circuito CMQ	Radiocentro, M #312, Vedado

CONSTRUCTION PERMITS GRANTED

11	Havana	5	Television del Caribe	Calle 23 #101, Vedado
12	Havana	5	Cadena Azul de Cuba	Prado #53
12	Matanzas	5	Radiotelevision El Mundo	Calle 23 #55, Vedado
10	Santa Clara	5	Union Radio Television	Prado #52
8	Santa Clara	5	Cadena Azul de Cuba	Prado #53
4	Florida	5	Radiotelevision El Mundo	Calle 23 #55, Vedado
9	Florida	5	Cadena Azul de Cuba	Prado #53
11	Camaguey	5	Union Radio Television	Mazon #52
5	Holguia	5	Circuito CMQ	Radiocentro, M #312, Vedado
4	Santiago de Cuba	5	Radiotelevision El Mundo	Calle 23 #55, Vedado
13	Santiago de Cuba	5	Union Radio Television	Mazon #52
12	Holguia	5	Union Radio Television	Mazon #52
7	Santiago de Cuba	5	Cadena Azul de Cuba	Prado #53
8	Holguia	5	Cadena Azul de Cuba	Prado #53
10	Santiago de Cuba	5	Cadena Oriental de Radio	Campanario #215
3	Holguia	5	Radiotelevision El Mundo	Calle 23 #55, Vedado

All addresses given are in Havana, Cuba.

Malaya—Radio Malaya, Singapore, now uses 3.330 which may have replaced 7.200; noted to 1030 weekdays, to 1100 Sun. (*N. Z. DX Times*) Heard on 4.825 at 0545 with UN news, then "Music from the Movies." Noted from Kuala Lumpur, 6.025, at 0445 with church service, organ recital. (Sanderson, Australia)

Mozambique—CR7BJ, 9.766, is being heard again on West Coast with fair level 2300-2400 in *English*. (Balbi, Calif.) Noted on 4.916A with request session called "The Lucky Disc" at 2330. (Saylor, Va.) Heard occasionally parallel around 2345 on 3.490, weak level in Dela. (Cox)

New Caledonia—Radio Noumea is using 3.375 now parallel 6.034A at 0200-0530; signal on 3.375 is strong "Down Under." (*N. Z. DX Times*) Has news in French 0300. (Sanderson, Australia)

New Zealand—Revised schedules of Radio New Zealand are to Australia 1300-1645, ZL8, 9.620; 1700-0145, ZL9, 11.810; 0200 to closedown, ZL8, 9.620; to Pacific Islands 1300-1645, ZL18, 9.520; 1700-0145, ZL3, 11.730; 0200 to closedown, ZL18, 9.520; at present, closedown is 0545 weekdays, 0620 Sat., 0500 Sun.

Norway—Radio Norway, 9.61, is good to West Coast 2300-2400. (Deskins, Calif.)

Pakistan—Radio Pakistan, 3.945, Karachi, is strong level in N.Z. with *English* 1015; also on 5.990 then. Dacca, 4.805, Home Service relay, has a weak signal to 1130 closedown. (*N. Z. DX Times*) Karachi noted on 9.645 at 0445 with Home Service in news for Asia. (Sanderson, Australia) Karachi, 11.885, noted 2030 with news for Southeast Asia, then native music; announces 15.335 (not heard) parallel and says both are 50 kw. (Parrish, Ga., Mast, N. Y., others) Heard on 11.885 at 1000-1030 with music. (Frazier, Texas) Noted with *English* 1015 on 9.484; with slow news in General Overseas Service 1310-1330 on 7.010, 11.650. (Pearce, England) Same noted on the 11.650 channel in Pa. (Parsons) Heard with news 1500 over 11.650; and closing 1614 on 9.645. (Harris, Mass.)

Peru—OAX4T, 9.562A, noted around 2100-2215 or later, excellent level. (Kippel, Colo.; Zerosh, Pa., others)

Philippines—"Voice of Davao" has been heard in Japan, *believed testing*, on 7.230, closing 0915 with Philippines National Anthem. (Japanese Short-Wave Club) DZH9, 11.855, is fair from 0900 to 1200 closedown. (Morgan, Calif.)

Portugal—Lisbon has returned to 11.835 from 11.935 and the 19-m. outlet (formerly 15.125) is now *announced* as 15.030. (Radio Sweden) Noted on *measured* 15.036 at 1030 and to close 1200, when clock struck "5 p.m.;" signed off with "A Portuguesa." (Ferguson, N. C.)

Roumania—Bucharest's new 9.570 channel noted in French 1707; closed 1710. (Bellington, N. Y.) Should have *English* 2200-2230; do not confuse with Warsaw, Poland, which seems to

"share" the channel with Bucharest at various times; *listen for identification!* Noted by Pearce, England, on this channel with *English* 1400A.

Saudi Arabia—Djeddah, 11.950, noted 2330 with Arabic program to Near East. (Sanderson, Australia) Heard near 7.095 at 1335 with talks in Arabic and music; news in Arabic 1355, closed with march-anthem 1410. (Pearce, England)

Spain—Madrid, 9.363, is good level in *English* to North America 1800-1840, 2205-2245. (Kirby, Mo.)

Sweden—Radio Sweden has made these changes—1900-2145, 6.065; 2200-2245, 6.095; 2300-2400, 11.880; 0000-0100, 11.705; 0800-0845, 0900-1100, 1200-1245, 11.880; 1300-1345, 11.705;

1600-1700, 11.880; 1800-1845, 9.620, and 1800-2100, 9.535; all other transmissions—including "Sweden Calling DXers!", the European Service, the relay of Home Service—remain unchanged. (Radio Sweden) Noted by Beatty, Dela., ending *English* on 9.535 at 2145.

Switzerland—United Nations Radio, Geneva, now uses 9.545 instead of 6.675. (ISWC, London) Berne is good signal on 6.165, 9.535 around 2100 in *English* to North America. (Dupre, La.)

Tahiti—Radio Tahiti, 6.980, Papeete, noted in Tahitian language to 0015, then French to 0130 sign-off; *no English noted any more.* (*N. Z. DX Times*)

Taiwan—BED26, 10.080, heard 0515 at good level with Western music.

Built to sell!

utone

THE NEW WALL BAFFLE BY UTAH

The new, luxurious looking UTONE wall baffles will complement the interior of any restaurant, church, school, home, club, tavern or factory . . . wherever speaker housing is needed.

The quality and construction of Utone wall baffles is of the finest, the finest woods matched by the fine production skill of Utah—a pioneer and leader in the sound field for over 30 years.

Utone wall baffles are available in three beautiful finishes and four versatile sizes—Genuine Honduras Mahogany—in red or brown finish, handsome limed oak and natural unfinished wood. Models in 6, 8, 10 and 12 inch sizes.

Utone baffles are also available for delivery complete with rounded speakers.

NOTE THESE UTONE QUALITY FEATURES

- Styled By Master Woodworkers
- High Gloss Lacquer Finish
- Beautiful Matching Grill Cloth
- Free of Vibration and Rattles
- Moisture and Water Resistant
- All Joints Mortised and Secured With Water Proof Glue
- Made from the Finest 5 Ply— $\frac{3}{4}$ and $\frac{1}{2}$ inch Veneer

THE NEW UTONE WALL BAFFLES ARE BUILT RIGHT AND PRICED RIGHT TO SELL!

utah

Write today for catalog and prices

RADIO PRODUCTS CO., INC.
1350 MONROE STREET - HUNTINGTON, INDIANA



OWN THIS GREAT LIBRARY for complete authoritative analyses of all important AUDIO AMPLIFIERS

Only data of its kind available on hundreds of important audio amplifiers. Complete, uniform, detailed analysis of each unit, based on actual laboratory study of the equipment. Includes circuit diagrams, chassis photo views, parts data, full technical coverage. Available in four profusely illustrated volumes—absolutely indispensable to audiophiles, engineers and students.

VOL. 4. Covers 75 audio amplifiers and important tuners produced during 1951 and 1952. Never before available in a single compilation. 352 pages, 8½ x 11".
ORDER AA-4. Only.....\$3.95

VOL. 3. Covers 50 audio amplifiers and 22 FM and AM tuners made during 1950. Detailed data on design and servicing. 352 pages, 8½ x 11".
ORDER AA-3. Only.....\$3.95

VOL. 2. Covers 104 amplifiers and 12 tuners produced in 1949. 368 pages, 8½ x 11".
ORDER AA-2. Only.....\$3.95

VOL. 1. Covers 102 post-war amplifiers and tuners produced through 1948. 352p, 8½ x 11".
ORDER AA-1. Only.....\$3.95

BEST-SELLER ON AUDIO!

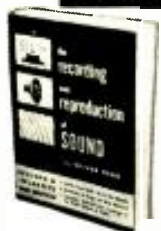

"The Recording and Reproduction of Sound"

Only complete reference on AUDIO! New second edition—over 800 pages. Chapters on sound wave behavior; recording methods; the decibel; phono reproducers; cutting styli; microphones; loudspeakers;

dividing networks; attenuators; mixers; amplifiers; tuners; home music systems—hundreds of other subjects. The great Audio book by Oliver Read—largest-selling in its field.

ORDER RR-2. Only.....\$7.95

HOWARD W. SAMS & CO., INC.

Order from your Parts Jobber today, or write direct to Howard W. Sams & Co., Inc. 2203 East 46th St., Indianapolis 5, Ind.

\$.....enclosed. Send following books:
 AA-1(\$3.95) AA-3(\$3.95) RR-2(\$7.95)
 AA-2(\$3.95) AA-4(\$3.95)

Name.....

Address.....

City.....Zone...State.....

news in Chinese. BED24, 9.820V, heard 0345 with Western music, then news in Chinese. (Sanderson, Australia) BED3, 15.235, and BED6, 11.735, sign on 2300 with news; repeated 0030; signs off 0230; BED3 best, fair to good. (Balbi, Calif.)

Thailand—HSK9, 11.700, Bangkok, noted 0500 with *English* news, music. (Sanderson, Australia; Gay, Calif.) This one noted on *measured* 11.695 at 0810 to 0900 sign-off; all-native at that time. (Ballou, Calif.)

Trieste—British Forces Station. 15.125, noted fading in around 1700-1715; popular recordings; man announcer; signs off 1800. (Ferguson, N. C.)

Turkey—TAV, 17.840A, Ankara, heard 0500 with *English-Turkish* announcements, Turkish news, music. (Sanderson, Australia) TAT. 9.515, is excellent to North America 1815-1900. (Morrill, New Hampshire, others)

University of Istanbul station, 7.030, sent letter verification, listed schedule of 1315-1500; also mentioned would have a 1 kw. transmitter operating soon in the 47-m. band. (Patrick, England)

Uruguay—CXA10, 11.900, opens 0700 and closes 2220; no station breaks, only at end of transmission; no commercials; all-Spanish; usually good level. (Kahan, Calif.)

USI (Indonesia)—Jogjakarta's YDJ2, 5.060, is strong level in N. Z. 0530; YDP, 4.930, Medan, Sumatra, noted at fair level with Indonesian session 1000; also fair signal 1000 over YDM, 5.030, Bukittingi. (N. Z. *DX Times*) YDB2 has moved from 4.910 to 4.960. (Cushen, N. Z.) YDF6, 9.710, Djakarta, heard 0600 with news, music. (Sanderson, Australia) Heard on this channel with news 0945. (Ballou, Calif.) YDB3, 7.27, Djakarta, noted 0935-1045 in Indonesian *only*, fair level in Calif. (Morgan) Occasionally, *Radio Makassar*, 9.555A, can be heard around 0630. (Stark, Texas)

USSR—Moscow uses 17.83. 15.50, 15.17, 15.12. 11.91. 9.66 to North America 0800-0830. (Miller, N. Y.)

Press Time Flashes

According to present plans, your *ISW DEPARTMENT* editor, Ken Boord, will play a program of Christmas organ melodies, by tape transcription, in a special DX broadcast from HCJB, Quito, Ecuador, Thursday, December 17, at 0330 (0830 GMT) with beam to Europe on 15.115, 11.915, 9.745; and repeated at 1600 (2100 GMT) with beam to the South Pacific on 17.890, 15.115, 11.915. Reception reports will be welcomed; HCJB verifies correct reports 100 per-cent; an IRC is appreciated but is not required. (The transfer of transmitting facilities to Pifo, and the use of new antennas, have greatly improved signals from HCJB lately.)

Scheiner, N. J., has just received word from Floyd H. McCoy, operator, that ZBP, Pitcairn Island, broadcasts with 500 watts over a transmitter

Editors and Engineers PUBLICATIONS



Great Thirteenth Edition
RADIO HANDBOOK
THE NEW, GREAT ONE-VOLUME LIBRARY OF RADIO INFORMATION
734 PAGES!

RADIO HANDBOOK. GIANT 13TH EDITION. A one-volume library of radio information with extensive, simplified theory. Detailed how-to-build-it data on dozens of items of practical radio equipment. Book No. E&E-RH13...\$6.00*

RADIOTELEPHONE LICENSE MANUAL. Typical study questions with concise answers for any commercial U.S.A. radiotelephone operators license. Book No. E&E-RL1.....\$3.75*

BETTER TV RECEPTION (in fringe and low-signal areas). **NEW SECOND EDITION.** The standard guide for installation technicians. A popular text for TV enthusiasts. Book No. E&E-TR2.....\$2.50*

WORLD'S RADIO TUBES (BRANS' VADE MECUM). **NEW 9TH EDITION.** Lists over 15,000 tubes from every tube making country. Printed in 16 languages. Book No. E&E-VM9...\$5.00*

SURPLUS RADIO CONVERSION MANUAL. VOL. 1. Practical conversions. Write for list of contents. Book No. E&E-SM1.....\$2.50*
SURPLUS RADIO CONVERSION MANUAL. VOL. 2. Companion to Volume 1. Book No. E&E-SM2.....\$2.50*

*Plus any tax.

BUY FROM YOUR DISTRIBUTOR
ADD 10% ON DIRECT CASH ORDERS TO EDITORS AND ENGINEERS, LTD. BOX 489A SANTA BARBARA, CALIF. (Book orders order from BAKER & TAYLOR, NYC, N. Y.)

HI-FI FACTS AND FIGURES

from **Sun Radio & Electronics Co., Inc.**

FREE 100 Page Audio Book

Absorbing 5000 word article on planning a home music system!

26 matched, pre-tested High Fidelity sets from \$105 to \$1065!

Pictures and facts on hundreds of components and cabinets!

Your complete, handy guide to High Fidelity

Phono Equipment, Tape Recorders, Radio Tuners, Audio Amplifiers, Loudspeakers and TV!

Please rush my FREE Audio Book. SUN RADIO—Dept. RS-11 650 Sixth Avenue, New York 11, N. Y.

Name.....
Address.....
City.....State.....

called the 'Trans-Arctic' with power from a wind-charger; uses a longwave antenna and broadcasts in *English* 2300-0130, 1100-1330. Frequencies that may be used include m.w. 375 kc., 500 kc., or 522.5 kc., and on s.w. by means of crystals 7.859, 9.200, or 12.110. Is designed for "satisfactory" reception distance of only 400 miles; is only for broadcasting purposes, and is not an amateur station; at 1300 and 1900 the station "takes and sends meteorological reports to Fiji."

A new service for *North America* is heard from HSK9, 11.700A, Bangkok, Thailand, at 2300-0030; has news and native music; at 0000, chimes 3 times; good level in Tokyo. (Ishikawa, Japan) When this was compiled, CSA92, 11.090, Ponta Delgada, Azores, was good level at 1430; by now, however, may be on winter schedule of 1500-1600. (Saylor, Va.) According to a projected "Five-Year Plan" to make AIR "an adequate and effective medium for the role it has to play in the social, educational, and cultural advancement of the country," 100 kw. short-wave transmitters are planned for Bombay, Calcutta, and Madras. (*Radio Times of India*) The *English* sessions from TGWA, 9.760, and TGWB, 6.180, Guatemala City, are now 1900-1930 on Mon., Wed., Fri. (Niblack, Ind.)

Acknowledgment

Thanks for your FB reports; sorry space would not permit use of all of them. Keep them coming to Kenneth R. Boord, 948 Stewartstown Road, Morgantown, West Virginia, USA. Good listening, fellows! . . . K.R.B.

POLARITY INDICATOR

By KARL GREIF

OFTEN in audio work or test equipment, it is necessary to plug the apparatus into the 117 volt a.c. line so that a given side of the equipment is common with the ground side of the building wiring. A simple scheme for checking this is shown in diagram.

Connect a NE-2 neon bulb from the side of the line intended to be hot, through a resistor, to an insulated rivet. Plug the equipment into the wall and touch the rivet with your finger. If the neon glows, you're OK. If not, reverse the plug. Do not touch the chassis at the same time, as the lamp will then glow irrespective of polarity.

Scheme for checking equipment polarity.

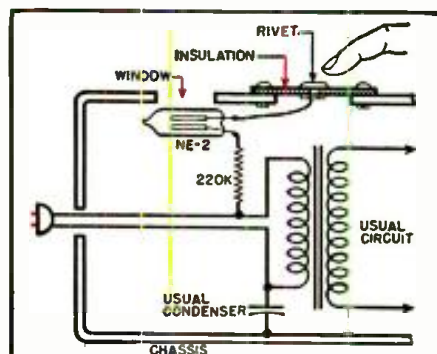

November, 1953

METER AND MULTI-METER BARGAINS

These gorgeous meters are made in Japan to the highest U.S. standards for meters made to sell at double these prices. We had Bureau Veritas (International Inspection Agency) test and inspect them for us at source. They report that the tolerances are MUCH BETTER than the MAXIMUM permissible deviations shown below. Therefore we offer them with an IRON-CLAD, MONEY-BACK GUARANTEE. Both models come with instruction sheet, test leads, and internal dry battery of standard American size, shape, and type. Ideal for service work, experimenters, students, home builders, and the fellow who would rather leave his expensive lab-standard equipment behind when he goes in rough field trips.



(left)
Pocket Model
TK-30 Tester

In genuine Leather carrying case.
\$11.95
Only
(Plus 25c shipping)

RANGES: AC and DC volts 0.15/150/750, 47% DC MA 1-150, 47% Ohms 0-100K, 10%. In rugged black bakelite case and leather carrying case.



(right)
MODEL 27-Z
TESTER

\$9.95
Only
(Plus 25c shipping)

RANGES: AC and DC volts 0.5/25/250/500, DC MA 0.1/1/100/250, Ohms 0-10K, 100%. Black bakelite panel, metal case. Manufacturer claims extreme accuracy and our spot checks show them to be within 1%! Here is a meter to be proud of!

MODEL MO-52 0-1 DC MILLIAMETER (Not Shown)

Standard 2" round panel-mounting meter with hair-line needle indicator. Spot-checks better than 1% accuracy. White face with black calibrating graduations every 0.02 MA (20 ma) . . . **ONLY \$3.95** (Plus 25c shipping charge)

12-CHANNEL TV FRONT END

Famous "Silver Circle" tuner, with original factory instructions. Use for 2-meter converters, receivers, etc. The TV bargain of the Year! Factory rejected for minor damage. Less tubes. . . . **\$1.95 each, 3 for \$5.00** (Shipping wt. each 3 lbs.) Tubes, shields and knobs for above . . . **\$1.25 set, 3 for \$3.00**

NEW 600 VOLT OIL-FILLED FILTER CONDENSERS

10 Mfd, 3" x 1 3/4" x 5 5/8" OA ht. . . . **\$1.95**
4-6 (total 12) Mfd, 2 1/4" x 2 1/2" x 4 1/2" OA ht. . . **2.25**
8-8 (total 16) Mfd, 2 1/4" x 2 1/2" x 4" OA ht. . . **2.95**

AUDIO SUPER-SPECIALS

SUPER HI-Q high cut choke, 0.65 H, 55 ohms DC. Tune with .001-.0004 MF. **ONLY .98c**
LOW CUT, 5 H, 284 ohms. Tune with 1 MF. Or use 25-30 ma filter choke. **ONLY .98c**
QUINCEY Transformers, one for mike to push-pull grids, flat 30 to 15,000 CPS; other for push-pull output, tapel sec., turns 14:1. In unit for resistors, condensers, etc. **BOTH FOR ONLY .98c**
PHASE SPLITTER, or low-level mixer, or hybrid, or push-pull unit. Has 3 windings, each exactly 1:1 to any other, essentially flat 100-15,000 CPS. **BRAND NEW, ONLY .69c**

PE-101-C DYNAMOTOR, Brand new. **\$4.95** (Shipping weight 13 lbs.)
ANTENNA MAST SECTIONS, MS-49, 50, 51, 52, **39c** New, original packing.

G. L. ELECTRONICS 905 S. VERMONT AVE. LOS ANGELES 6, CALIF.

ALL PRICES F. O. B. LOS ANGELES, CALIF. BUYERS ADD SALES TAX

NEW, GUARANTEED 12 VOLT DYNAMOTORS

(D. W. Thomas Engineering Co.)

Ready to Use • Continuous Duty Ratings • Gray Finish



MODEL 1224-1
Output 400V, 350 ma
\$9.95

MODEL 1224-2
Output 600V, 200 ma
\$9.95

Above Prices are less base. Add \$6.00 for base box containing starting relays and filters, as shown. (Shipping wt.: Less base, 11 lbs., With base, 13 lbs.)

GENERATOR ALTERNATOR SPECIAL

Has Magnetic Slip Clutch! Navy NEA, turns with motor or engine. Outputs 28.5 VAC, 25 A, plus 120 V, 800 cy, 1 phase, 1080 VA. Externally controlled self-excitation. Slip clutch maintains 2400-2450 RPM armature speed with drive speeds from 2400 to 4200 RPM. By readjusting clutch and increasing excitation, 400 cycles can be obtained. Or buy it for the magnetic clutch. **New, Only . . . \$9.95**
Good used . . . \$9.95
(Shipping wt.: 40 lbs.)

WESTON SENSITROL 10 MICROAMP RELAY

Built like meter, needle moves into PM magnet which grips it to close contact rated 1 amp. Highly damped, vibration proof. Works directly from photo cells, thermocouples, etc. without amplification. A momentary application of 12 to 30 v. AC or DC, resets it. **A \$69.50 device for only . . . \$12.95**

SENSITIVE POLARIZED RELAY REPLACES SELSYNS

This is the micro-positioning device the Services used instead of selsyns and torque amplifiers. SPDT, both contacts normally open. The POLARITY of an applied 1/2 v (5 ma) determines which contact closes. Use for beam rotators, remote control, etc. Out free data sheet shows this and other bridge circuits for control or alarm devices. In a neat metal box with additional heavier duty relays. **NEW, slightly dirty . . . \$6.95** (Shipping wt. 4 lbs.)

SUPER-SENSITIVE ADJUSTABLE RELAY BK-7B

SPDT. With adjustment arm at "5" on calibrated scale sensitivity is 1/4 ma (1 mw, 2 v) and decreases linearly to 1.5 ma as arm is moved to "40". 1 1/2" x 3 3/8" x 1 1/2". Wt. 6 oz. **NEW, Ship. wt. 1 lb. Only \$1.95, or 10 for \$17.50**

2-IN-1 SENSITIVE RELAY BARGAIN

For any sensitive relay application or for voltage-controlled sequence switching. First set of contacts close at 4 ma, second set at 61/2 ma, 6000 ohms, 1 1/2" x 2 1/4" x 1 1/2". Removed from clean equipment. **Only \$6 each, 3 for \$2.75**

HI-FI HEADSET

Uses annular grooved plastic fibre cones with voice coils as in speakers, and padded charcoal ear muffs to obtain spacing for correct acoustics. Gives finest music reproduction, flat far beyond upper and lower limits of auditory perception. Pair in series has measured impedance of 600 ohms at 400 cycles, obtained with built-in high quality transformers. Checked out with freshly laundered ear pads. **\$7.95** (Shipping weight, 3 lbs.)

13V to 0 V in one volt steps: Tapped transformer, 3 amps out, Input 115 V, 60 Cy. Use for Model Railroad or heaters of surplus receiver. **\$1.89**

MINIATURE 6 VOLT WET BATTERIES



The famous NT-6 Willard 2.4 AH, 6 volt battery. A standard size for model control, etc. Plastic case, only 3 3/8" long, 1 13/16" wide, 2 3/4" high. Uses standard electrolyte.

NEW, boxed . . . \$2.49
Or 4 for . . . 8.50

EASY MONEY!

We're still buying surplus gear. Tell us what you've got, its condition, and your price. If we like it you'll get our check quick.

Dynamotors Offered—All New

Sample at request

DM-21	DY-9	PE-73
DM-25	DY-10	PE-86
DM-28	DY-11	PE-94
DM-32	DY-12	PE-98
DM-33	DY-13	PE-101
DM-36	DY-17	PE-103
DM-40	DY-22	PE-133
DM-42	BD-69	PU-7
DM-53	BD-83	MG-149
DM-53AZ	BD-86	
D-101	BD-87	
0515	BD-93	
0516		

& Other numbers.

18 V. Carbon Pile voltage Regulators, 5/8" Plastic tubing Black & Clear, 5J-26 tubes.

Need DY-17 dynamotors and parts, CU-25 coils. Will buy all types of dynamotors, any quantity. Transmitter, receivers other end equip. & Components. Send list of items available.

Vnts. Dist. Co. 3613 N. Western Pky. Louisville, Ky. Cy-8904



FINE SWISS-IMPORT VALUES

New shock resistant, anti-magnetic Swiss watches offered direct by importer. Both in tarnish proof gold finish with stainless steel backs. Chronograph boasts 3 separate recording dials, sweep second hand with automatic re-ct. radium dial calibrated for telemeter and tachometer readings, and cowhide strap. Dress model has 17 jewel movement, sweep second hand, with calf-skin strap. Rare values at \$14.95 each, ppd. Each with full year guarantee. Satisfaction or money back. (Catalogue available)

THE NASSAU CO.—SWISS DIV.
200 WEST 34TH STREET N. Y. C. I, N. Y.

207

DYNAMOTORS

TYPE	INPUT VOLTS	AMPS	OUTPUT VOLTS	AMPS	PRICE
DM 416	28	6.2	14	3.0	\$ 6.75
DM 33A	28	7.5	540	.170	3.95
BD AR 93	28	3.25	375	.150	7.50
23350	27	1.75	285	.075	3.95
B-19 Pack	12	5.5	275	.110	8.95
DA-3A*	28	10	500	.050	
			300	.260	6.95
			150	.010	
			14.5	5.	
5053	28	14	250	.080	3.95
PE 73 CM	28	19	1000	.350	22.50
BD 69‡	14	2.8	220	.08	12.95
D.402†	13.5	12.2	300	.200	
			8 VAC		12.50
SP 175	18	3.2	450	.06	4.49
DM 25‡	12	2.3	250	.05	6.95

‡ Less Filter
† Used, Excellent
* Replacement for PE 94.

INVERTERS

PE-218-H: Input: 25/28 vdc. 92 amp. Output: 115v. 350/500 cy (500 volt-amperes, NEW) \$14.50
PE-206: Input: 28 vdc. 38 amps. Output: 80 v 800 cy. 500 volt-amps. Dim: 13"x5 1/2"x10 1/2". New. \$22.50
NAVY COR-211095: Input 22-30 VDC/75-60A. OUTPUT: 115V/400 CY. 1 KVA. 8.7A. RPM: 4800. With coupling provision for motor. Brand New Original packing \$150.00

This Month's Special

UNDERWATER MICROPHONES

Originally designed for use in harbor defense equipment, these amazing hydrophones may be coupled to any hi-gain audio amplifier. For listening to undersea sounds such as schools of fish, shrimp, lobster, etc. Ideal for fishermen, explorers, students. Available in two models described below:

JR HYDROPHONE: Consists of a mosaic of 7 crystals encased in a rubber sheath approx. 4" diam. and 4" long. Directivity is essentially horizontal. A matching transformer is "built-in," permitting use of long cable runs without loss. **\$24.50**

M-1 HYDROPHONE: A lattice of 3 crystals encased in a rubber disk approx. 1 inch thick and 6 inches diameter. Directivity is essentially vertical (downward). Complete with amphenol fitting. **\$27.50**

SUPERSONIC OSCILLATOR

FOR EXPERIMENTERS, TEACHERS, TECHNICIANS. DELIVERS 30 WATTS OF R. F. TUNABLE FROM 17.27 KCS. ORIGINALLY DESIGNED AS DRIVER UNIT FOR 300 WATT SONAR SET. OPERATES FROM 115V. 60 CYCLES. BRAND NEW RACK-PANEL SIZE. COMPLETE WITH ALL TUBES. **\$119.25**

CIRCUIT BREAKERS

Heinemann: .01A. 2340 V—insulated for 5000 V. Separate tms. For coil and contact. \$1.95
#1510 M-7 7A. 24 VDC. SCS#3H900-7-3. 1.65
#AM 1614-100: 100 Amps. 24 VDC. 1.65
#AM 1614-80: 80 Amps. 24 VDC. 1.45
#AM 1610-.5: 500 MA. 1000 VDC. Curve 3. SCS#3H900A-50. 2.25
SCS#3H900-10-3: 40 VDC. 10 Amps. 1.65

POWER TRANSFORMERS

Comb. Transformers—115V/50-60 cps Input
CT-15A 550VCT .095A 6.3V/6A. 6.3V/1.8A. \$2.85
CT-341 1050 10 MA.—625V @ 5 MA. 26V @ 4.5A 2x2.5V/3A. 6.3V @ 3A. 9.95
CR 825 360VCT .340A 6.3VCT/3.6. 6.3VCT/3A. 3.95
CT-626 1500V .160A 2.5/12. 30/100. 9.95
CT-071 110V .200A 33/200. 5V/10. 4.95
CT-367 589VCT .050 A 5VCT 3A. 2.25
CT-403 350VCT .026 A 5V/3A. 2.75
CT-931 585VCT .086 A 5V/3A. 6.3V/6A 4.25
CT-456 390VCT 30 MA 6.3V 1.3A. 5V/3A 3.45
CT-931 585VCT 86 MA 5V/3A. 6 V/6A 4.95
CT-442 525VCT 75 MA 5V/2A. 1 CT/2A. 50V 200 MA. 3.85
CT-720 550-0-550V/250 MA. 6.3V 1.8A. 8.95
CT-43A 600-0-600V/.08A. 2.5VCT/6A. 6.3VCT/1A. 6.49
CT-444 230-0-230V/.085A. 5V/3A. 6V/2.5A. 3.49
CT-766 300-0-300V 120MA. 2 X 5V/3A. 2.5V 5A 4.65
CT-129 550-0-550V @ 150MA. 6.3V/4A. 2.5VCT/5A. 5.79
CT-013 450-0-450V @ 200MA. 10V/1.5A. 2.5V/3.5A. 5V 3A. 6.95
PT-786 1500-0-1500V @ 300 MA. 14.95

Filament Transformers—115V50-60 cps Input
Item Rating Each
FT-157 4V/16A. 2.5V/1.75A. \$ 2.95
FT-101 6V/25A. .79
FT-924 6.25V/21A. 2x7.75V 6.5A. 14.95
FT-821 2x26V 2.5A. 16V 1A. 7.2V/7A. 8.95
6.4V/10A. 6.4V/2A. 8.95
FT-463 6.3VCT/1A. 5VCT/3A. 5VCT/3A. 5.49
FT-55-2 7.2V/21.5A. 6.5V/6.85A. 5V/6A. 5V 3A. 8.95
FT-38A 6.3/2.5A. 2x2.5/7A. 2.79
FT-A27 2.5V/2.5A. 7V/7A. TAP 2.5V/2.5A. 16 KV TEST. 12.50
FT-608 6.3V 3A/750V Test. 1.79
FT-873 4.5AV/.3A. 7V/7A. 2.79

Send M.O. or Check. Shipping Chgs. C.O.D.
COMMUNICATIONS EQUIPMENT CO.
131 Liberty St. Dept. N-11 New York City 7, N. Y.

RADIO-TV Service Industry News

AS REPORTED BY THE TELEVISION TECHNICIANS LECTURE BUREAU

THIS past summer the mortality rate in the TV service business was the highest to date in the industry. Starting in May, when the TV viewing lethargy set in, the swiftly receding volume of TV service calls put a financial strain on many small, inefficient businesses forcing the operators to look for jobs that would pay enough to take care of house rent and groceries for their families.

Your editors have travelled a great deal during recent months talking to men in the service business and trying, in particular, to determine the reasons for so many business failures in TV service. It is obvious that when a man launches out on his own in a business he does so with confidence that he will be able to make it a success and get a better-than-average income from it. Yet every summer thousands of men who started their own businesses have to close them up and look for jobs on someone else's payroll.

Why do so many service businesses fail?

Service Charges and Income

Russ Hansen, manager of the contract service department of *Motorola*, has been giving an excellent talk on fundamental *business* practices in the management of a TV service business. One of the basic tenets of successful service business management stressed by Mr. Hansen is that monies paid out for labor must not exceed 40% of the total service labor income of the business.

In a one-man shop this would mean that the operator must do an average of one-thousand dollars a month in service volume, exclusive of replacement tubes and parts, to warrant paying himself a four-hundred dollar monthly income. The other six-hundred dollars a month will be absorbed by other facets of the business that must be maintained if the business is to prosper and grow.

To develop a one-thousand dollar a month service volume the technician who charges only \$2.50 per home call must complete 400 calls per month. This would require the incredible *aver-*

age of 18-plus calls per day during the normal business days of an average month. Even if that volume of business was available to the one-man service operation the supplementary activities involved in handling it would make it an impossibility.

At \$5.00 per home service call the volume required to develop a one-thousand dollar per month gross labor income would be 200 calls or an average of 9 calls per day.

In the average efficiently managed, adequately financed five-man service company field service technicians are able to handle only seven-plus home service calls per day. These men have no responsibilities other than doing the best work they can on the sets they are assigned to service and to keep lost time between calls at a minimum. They do not have to worry about business volume because that is handled by the shop manager or owner. They are able to stock their service cars during their daily stops at the shop to pick up their route sheets or deliver sets pulled for repairs, so they do not lose time running to parts jobber stores for needed supplies. They do not have to spend time poring over a map routing their daily work—that is handled for them by the routing clerk in the office. Yet with all of these routine details handled for them, these experienced technicians are able to accomplish only seven-plus home service calls per day on an average.

The one-man service operator must handle all of these details himself. There is, however, one phase of the business he cannot handle because he must spend a large part of his time on service calls. That is the job of taking the incoming service calls. Men who work out of their homes usually have this detail handled by their wives or some member of the family. Others use a telephone answering service. In most cases neither of these is as effective in maintaining satisfactory customer relations as that accomplished by a girl especially selected for her "telephone personality."

It is amazing how few service operators recognize the vital importance of telephone contacts with prospective

Engineering

WRITERS

ENGINEERS, E. E. or PHYSICS GRADUATES, for preparation of technical manuals...

HUGHES RESEARCH AND DEVELOPMENT LABORATORIES' expanding program for production of radur, electronic digital computers, guided missiles and other military advanced electronic systems and devices requires the following:

1 ELECTRICAL ENGINEERING AND PHYSICS GRADUATES to prepare operating, servicing and overhauling instructions for complex electronic equipment. Those with previous maintenance experience on military equipment preferred. Writers will participate in a three-month program in our technical training school to become familiar with the latest Hughes equipment prior to writing assignments.

2 ENGINEERS EXPERIENCED in the writing and preparation of maintenance manuals for electronic equipment or guided missiles. These specialists will work step-by-step with the people designing, developing and manufacturing the products involved. Experience in the writing of engineering reports is of value.

HOW TO APPLY

Write full details of your qualifications to

HUGHES

Research and Development Laboratories

SCIENTIFIC AND ENGINEERING STAFF
Culver City, Los Angeles County
California

Assurance is required that relocation of the applicant will not cause disruption of an urgent military project.

buyers of the service they have to sell. Your editors have checked the telephone response a customer gets from service businesses in many areas and often are astonished with the reception they receive. A large percentage of small service businesses have the telephone answerer take the prospective customer's telephone number with the statement that the technician is out on a service call and will contact them when he returns to the shop. Quite often the person who answers the phone is either flippant or rude—an excellent way to lose business.

In appraising the reasons for the failure of a number of small businesses your editors found they were all due to inadequate volume of service, bad customer relations, and poor service pricing practices.

Many men drop out of their own service businesses under a cloud of suspicion on the part of some of their service customers. The most common complaints come from the handling of sets pulled to the shop for repairs. Sets brought in that have hard-to-locate defects are sometimes held in the shop for weeks while the technician vainly tries to locate the trouble during his shop time. Customers are stalled with an excuse that a special part had to be ordered from the factory and the set will be repaired and returned as soon as the part arrives.

It would be much better just for their own peace of mind if one-man service business operators would make a deal with a top-flight shop to handle their major service jobs for them. In one case brought to our attention, a technician turned down service calls in an eight-block area to avoid running into two customers whose sets he still had in his shop and had been unable to service. Both were "waiting for parts from the factory." This man finally took the sets to a larger company for service and returned them to their owners when they were repaired. He said that fumbling around with those two sets had cost him four hundred dollars in income. He had spent twenty hours on one set trying to locate the cause of the trouble. This set was repaired in less than two hours in the shop that had a top-flight circuit analyst on the bench with the best precision-type test equipment to assist him.

Investment and Income

A number of studies of service businesses your editors have made over a period of years have indicated that a minimum investment of ten-thousand dollars is required for a TV service business to have all of the elements necessary for continued success and growth.

The main reason given by practically all men who fail in the service business is that they started with inadequate capital and were unable to build up their operating equipment and parts stocks out of service income. These men point in particular to the time lost in trips to their parts distributors' stores to pick up replacement tubes

THE *American* IDEA



"To find and follow the better way" . . . Out of the vision of Dr. George Ellery Hale came the great "American Idea" that resulted in the creation of the "Glass Giant of Palomar"—world's largest telescope—to gather new light from the farthest stars for the searching eye of science.

With us, the "American Idea" is, by directed effort and applied know-how, to continue to lead in bringing you electronic products of the highest quality

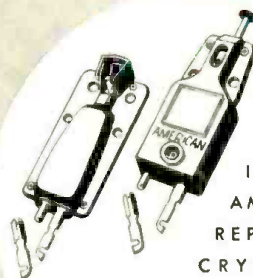

INSIST ON
AMERICAN
REPLACEMENT
CRYSTAL
CARTRIDGES

Send for FREE catalog 46



American microphone co.

370 South Fair Oaks Ave. • Pasadena, 1, Calif.

Stereo-Magnemite*

New
**Portable
Battery Operated
STEREOPHONIC
Tape Recorder**

Stereophonic field recordings can now be made with ease and assured professional results using a choice of three models operating at tape speeds of 15, 7½ and 3¾ ips. to provide frequency responses up to 15,000, 7,500, and 5,000 cycles respectively. 15 and 7½ ips. models meet primary and secondary NARTB standards for flutter, frequency response and dynamic range.

Enables stereo-enthusiasts, sound engineers, researchers, broadcasters and motion-picture producers to economically experiment and efficiently produce ideal recordings with optimum stereophonic effect.

All models measure 8½ x 11 x 10 in. and weigh 17 lbs. Employ two completely isolated channels for recording and playback. Utilize 60 kc ultrasonic bias oscillator. Provide 50 hours of operation from one economical set of standard dry cell batteries.

Incorporates governor-controlled constant speed spring-motor. Stereo-headphone monitoring while recording and playback. Overall dynamic range 50 db. Flutter less than ± 0.1%.

Stereo-cephaloid crystal or dynamic microphone available to produce diffraction and acoustic pickup pattern simulating human stereophonic hearing.

Completely battery-operated stereophonic recording-playback system easily carried and operated anywhere. Uses standard ¼ in. tape on 5 in. reels.

Write for complete technical literature and direct factory prices to Dept. RT



**AMPLIFIER CORP.
of AMERICA**

398 Broadway, N. Y. 13, N. Y.
*T.M. Reg. U.S. Pat. Off.

and parts they were unable to buy in stock quantities. In one case the curiosity of a parts jobber inspired him to keep a record of the number of trips one of his customers made to his store over a period of three months. During that period this man averaged four trips per day to the distributor's store! The distributor figured that each trip required a half hour's time, which added up to fifty hours per month! In other words, this man lost more than a full week of effective working time every month in trips to the jobber's for supplies. Small wonder that his business finally folded up.

In a recent check of the finances involved in a new business started by a competent service businessman, it was found that almost ten-thousand dollars had been invested. This was applied as follows:

Tools and Equipment.....	\$1500.00
Library	350.00
Fixtures and Office Supplies..	750.00
Parts Inventory	3000.00
Truck	2000.00
Cash & Accounts Receivable..	1500.00

Total.....\$9100.00

Comparison With TV's Early Years

When TV first burst upon the business scene radio service dealers were able to get a good start in the business with the addition of service trucks, installation equipment, and a moderate stock of picture tubes and special TV parts and accessories. Although there was a wide variety of TV circuitry employed in the early receivers, alert operators were able to build their service data files from set manufacturers' schematics and service notes.

Through careful handling of contract monies and cautious expansion of their facilities, hundreds of radio service dealers were able to expand their capital structures out of income to meet the growing need for larger replacement stocks. TV test instruments, tools, and other elements necessary for competent service.

The technician who opens his own shop today is faced with the necessity of making a substantial investment in working equipment. A service library, for instance, is a practical "must." A complete complement of standard TV test equipment is absolutely necessary.

The business development job the new service business faces is also an expensive project. You can't develop an income from service unless you have customers for that service. In order to get a satisfactory volume of business you must keep a lot of set owners informed about who you are, where you are located, and why you are better qualified to service TV sets than anyone else in your locality. People are never conscious of service shops or even service needs until they need service. Keeping your name and your facilities before them requires steady, consistent promotion.

Many men who start in business confuse the money they handle with income they can spend for their personal



FINGER STOCK

**Electrical Weather-Stripping
by Eimac —
Now Available!**

Silver-plated, spring alloy, pre-formed finger stock especially suited for electrical "weather-stripping" for TVI-proofing cabinet access doors, etc. Also ideal for making coaxially constructed tube connections and many other uses. Available in 17/32", 31/32", and 17/8" widths.

- Write for new Eimac Catalogue Summary showing Eimac tubes and other accessories.



EITEL - McCULLOUGH, INC.
San Bruno, California

SPECIAL VALUES

VTVM Hewlett-Packard 400A	Exc.	\$100.00
VTVM General Radio 720A.....	Exc.	125.00
VTVM General Radio 190A.....	Like New	250.00
Portable double bridge G.E. 5927123G0001-22 ohms	Exc.	175.00
Wheatstone Bridge Leeds & Northrup No. 5300	Exc.	100.00
Q Meter Boonton Radio 170A 30-200 mc.	Exc.	350.00
Decade Condenser General Radio 219K 1.11 mmf in .001 steps mica.....	Exc.	100.00
Dual Regulated Power Supply G.E. Model ST9A	New	300.00
Audio Oscillator Hewlett-Packard 200C 20-200,000 C.P.S.	Exc.	100.00
Audio Oscillator Hewlett-Packard 202D11 2-70,000 C.P.S.	Exc.	175.00
Tuning fork oscillator 1000 C.P.S. General Radio 813A	Exc.	50.00
Signal Generator Htekok 288X.....	Like New	125.00
Tube Tester Supreme 600	New	59.50
Megohmmeter Weston 796 0-200 megohms. @ 500V.	Exc.	79.50
Standard Signal Generator Ferris 14C.....	Exc.	350.00
VHF Signal Generator 8-330 mc. G. R. 804	Exc.	300.00
Theodolite David White Co.	Exc.	400.00
Theodolite Technicolor Corp.	Exc.	350.00
2K48 Tubes	New	90.00
6BM6 Tubes	New	80.00
A LARGE STOCK OF ART-1, ARC-3, ART-13, APN3A, APN4B, APN9, APR4, ARB, BC-312, BC-342, BC-348, BC433G, BC-611, BC-1300, CRT-3, 196A, 1222, 1E-19A, 1E-35A, 1E-36A, SCR-284, SCR-322, SCR-578, SCR-625, T-8, T9/AP9E, TS-34/AP, TS-100/AP, TS-184/AP, 14C, TS108, TS13, Plugs and Selsyns.....	PUH*	

WANTED

All types of radio and electronic surplus. We especially need: APA10, APN9, APR4, AIN4, ARC1, ARC3, ART13, ATC, BC221, BC342, BC348, BC611, BC721, DY12, DY17, 1100, LM10 to LM18, MG140E, MG140H, PU14, R5 ARN7, R5A/ARN7, SCR718C, TCS, TN16, TN17, TN18, TN54, T83, TN13 AP, TS83, TS35, TS45, TS75, TS76, TS102, TS147 UP, TS148 UP, TS173, TS174, TS175, TS250, TS251, TS323, 11CT, 1F, 1G, 5CT, 5DG, 5F, 5G, 6DG, 6G, 115V, 60 c.p.s. Selysins, and all types of Hewlett Packard, General Radio Co. Measurements Corp. Boonton Radio, Ferris, Leeds & Northrup, and other test equipment.

Please state accurate description, condition, and your lowest price. Explain modification, if any. We pay freight charges.

NEW CATALOG NOW AVAILABLE

PHOTOCON SALES

417 N. Foothill Blvd. Sycamore 2-4131
Pasadena 8, Calif. RYan 1-6751
CABLE: Photocon, Pasadena.

or family needs. That's why they get into trouble with their suppliers by not being able to meet their bills on time. Suppose, in the course of your service work during a month, you sell three-hundred dollars worth of tubes and parts. The amount that you can use out of that three-hundred dollars for other things is less than one-hundred dollars. The balance will have to be used in paying for the stuff.

Labor Charges and Business Size

The biggest mistake made by men who start their own service businesses is thinking that they can make a go of the business by charging less money for their time than the larger shops. Actually, a one-man shop should get more money per hour for its time than larger shops if it is to earn a comparable net income. The one-man service operation will lose far more time proportionately in nonproductive work than the larger shops. The individual operator must spread his time and efforts over too many diverse activities to function with maximum efficiency on any of them.

Recently a very interesting study of service volume in relation to profitable service charges was brought to our attention. A service company whose standard charge of \$4.00 for a home service call was based upon an annual gross service income of \$200,000 found that it started to lose money on those charges when the volume dropped to less than \$125,000. They adopted the standard TV labor charges schedule, copies of which have been offered to readers of this department by the TTLB, to restore their profit margin to a comparative level with what it had been when their volume was \$200,000.

A new TV labor charges chart that was introduced during the month of October is designed to facilitate the figuring of estimates on TV service jobs. This chart will supplement the original TV labor charges chart but is designed for shop use only and not for consumer mailing. It will be available in the form of bristol board 11"x14" wall charts at \$1.00 per copy. Inquiries concerning it should be addressed to TTLB Information Services, P. O. Box 1321, Indianapolis 6, Ind. It will be known as Chart TVL #2.

The original TV labor charges schedule, TVL #1, is available in the form of a consumer mailing piece size 8½"x11", folded to fit a #10 envelop. These are available at a cost of \$3.00 per hundred and may also be ordered from the TTLB Information Services or directly from your parts jobber.

Your editors are conducting a continuing study of costs of service business operation. The results of these studies will be reported from time to time in this department.

Service Business Developments

One of the most significant events in the history of the electronic service industry occurred recently in Texas. It was a state-wide radio and television

RCP VTVM

Model 655

READS PEAK-TO-PEAK VOLTAGES DIRECTLY

ACCURATE MEASUREMENT OF COMPLEX WAVESHAPES

<p>SINE WAVE RMS or Peak-To-Peak... Useful and Necessary—Read Directly With Model 655</p>
<p>PEAKED SAWTOOTH WAVE TV Horizontal Signal... Peak-To-Peak Reading Required—Easily Done Directly with the Model 655.</p>
<p>PULSE WAVE TV Horizontal Deflection... Peak-To-Peak Measurements Needed—Read It Directly on the Scale—Model 655.</p>
<p>COMPOSITE VIDEO WAVE Video Amplifier... Peak-To-Peak Measurements A Must—Do It Directly With The Model 655.</p>



Quickly... Accurately
DO-ALL Model 655.

ONLY \$59.50

... gives a true reading measurement of complex and sinusoidal voltages with necessary peak-to-peak or RMS value read directly, for the analysis of waveforms in video, sync and deflection circuits.

Service as the manufacturers say—the peak-to-peak way. The combination of this P. to P. meter and service notes to match, take the guesswork out of service and speed up your service operation.

Versatility of measurement, built into each Model 655, serves a variety of industrial applications in the service of vibrator power supplies, AC generators and all equipment utilizing any type of waveform or DC.

Match the Model 655 with any peak-to-peak VTVM. You will find that comparable performance can only be found in much higher priced instruments. Comes complete with new "RCP SOLDERLESS TEST LEADS" for operation on 105 to 125 V AC.

FOR TELEVISION SERVICE AND INDUSTRIAL MAINTENANCE

- PEAK-TO-PEAK AC measurements of from .2 V to 4200 V on 7 ranges.
- AC RMS measurements of .1 V to 1500 V on 7 ranges.
- DC measurements of from .02 V to 1500 V on 7 ranges.
- RESISTANCE measurements of from .2 ohms to 1000 Megohms on 7 ranges.

See Your Local Parts Distributor or Write for RCP Catalog RN-11

RADIO CITY PRODUCTS CO., Inc.

152 WEST 25th STREET • NEW YORK 1, N. Y.



DIAMOND \$10.50 NEEDLES

Plus Postage

Our main business is the manufacture of diamond styli for broadcasting stations and high fidelity sound equipment. As a service to the general public we offer to retail your present replaceable needle with a genuine, unconditionally guaranteed, broadcast quality diamond tip for either long-playing or standard records.

Send us your replaceable needle (or complete cartridge except Pickering) together with check or money order for \$10.50 plus 25c for shipping.

THE TRANSCRIBER CO.

178 Green St.—Boston 30, Mass.

RADIO ENGINEERING DEGREE IN 27 MONTHS

Radio engineering is a big field. There's room for you in it—if you're good. Get first-class training at Indiana Tech. Intensive, specialized course, including strong basis in mathematics and electrical engineering, advanced radio theory and design, television, electronics, Modern Laboratories. Low rate. Also B.S. DEGREE IN 27 MONTHS in Aeronautical, Chemical, Civil, Electrical and Mechanical Engineering. G.I. Government approved. Enter December, March, June, September. You can earn part of your expenses right here in Fort Wayne while you are studying.

INDIANA TECHNICAL COLLEGE

9113 E. Washington Blvd., Fort Wayne 2, Indiana
Please send me free information on B.S. Engineering Degree in 27 months as checked.

- Radio-Television Civil Mechanical Aeronautical Electrical

Name _____
Address _____

20-20 PLUS!

S-268-Q
Output
Transformer

±1 db 8—80,000 cycles
80 watts 30—40,000 cycles

20 watts at 10 cycles
40 watts at 15 cycles

Insertion loss
0.3 db

NOW IN STOCK

Primary impedances
8,000CT & 2,000CT

Connected between halved impedances, frequency response is extended at each end; between doubled impedances, ±1 db 15—45,000 cycles.



Write today for the 1953 Peerless Catalog

Perfect with KT-66 and 6146 tubes

PEERLESS
Electrical Products

A DIVISION OF



9356 Santa Monica Blvd., Beverly Hills, Calif.
161 Sixth Avenue, New York 13, New York

service clinic and fair held in Fort Worth under the auspices of the Texas Electronics Association.

This three-day event was held in the Texas Hotel in Fort Worth and was planned, managed, and financed by members of the service industry in Texas. With the Fort Worth Radio & Television Association, Inc., acting as hosts, members of the electronics service fraternity in Texas came in by train, bus, air, and private cars to sit in on a well-planned, skillfully-managed 3-day series of meetings and conferences. Texas is a big state with lots of miles separating the major centers but delegations from every section of the state were numbered among the more than half a thousand registrants at the affair.

Truett Kimzey, head of the top-flight servicing company in Fort Worth that bears his name, as master of ceremonies introduced a program of blue chip speakers during the course of the fast-moving schedule of events. After an address of welcome from the Mayor of Fort Worth, James D. Secrest, executive vice-president of RETMA, set the tone of the meeting in his keynote address, "Let's Build Our Industry Together." He was followed by service leaders Hal Chase, president of the TSA of Michigan, Al Robertson, nationally known service dealer of Oklahoma City, and Forrest L. Baker of San Antonio, former president of the Texas Electronics Association.

Thought—and discussion-provoking addresses were made by industry leaders Mort Farr, past president of NARDA, and John Rider, publisher of *Rider's* service manuals and textbooks. Intensely interesting talks were given by Bill Renner of the *Howard W. Sams Company*; Howard M. Fender, District Attorney of Tarrant County; Duffield Smith, managing director of the Dallas BBB; and Howard M. Chilton, general manager of the Fort Worth Retail Merchants Association.

In his address of welcome, Leonard R. Smith, president of the Texas Electronics Association, pointed out that service businessmen in Texas had no axes to grind with any other segments of the industry. He outlined current service industry problems and discussed some of the present bad practices that are partially responsible for the public's confused thinking about independent TV service businesses.

The affair was financed from the ten dollar registration fees paid by each person who attended. It was the first state-wide service association convention in the history of the industry financed completely by service people and drawing delegations from every section of the state.

More than thirteen hundred members of the service fraternity from all over the state of Iowa registered at the 3-day annual electronic Technicians-Dealer Jamboree in Des Moines sponsored by the *Radio Trade Supply Company* of that city.

The Hotel Savery, one of the leading hotels in the city of Des Moines,

ATLAS RADIALS

FOR CHURCHES

FOR FACTORIES

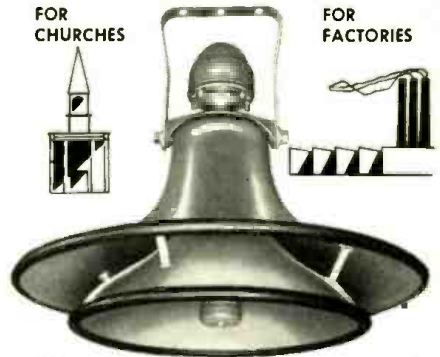

FOR TERMINALS

FOR CARNIVALS

With uniform 360° coverage, non-resonant construction, and 100% storm-proofing, ATLAS Radial Driver Unit Projectors often solve the most difficult sound problems—are excellent for reproduction of speech, chimes and music. For complete details on Radials and the famous ATLAS line of Public Address and Microphone Stand Equipment...

WRITE NOW for FREE Catalog 553



ATLAS SOUND CORP.

1446 39th St., Brooklyn 18, N. Y.
In Canada: Atlas Radio Corp., Ltd., Toronto, Ont.

EARN MORE MONEY— BE A PROFESSIONAL TELEVISION SERVICE TECHNICIAN



STEP INTO THE TOP PAY
\$5,000 — \$10,000 A YEAR
CLASS. 7 MONTHS' SHOP
TRAINING QUALIFIES
YOU.

If you want to reach your goal as a Successful Service Technician you will need plenty of "KNOW HOW" to qualify for the better servicing jobs or profitable shop ownership.

SEND FOR
FREE
BOOK TODAY!

WESTERN TV offers real experience on live equipment in our **BIG SHOPS AND LABORATORIES** in the shortest practical time under expert instructors. Graduates are in big demand because they have the "field experience" necessary for immediate "bench" or supervisory positions. You learn every phase of Radio and TV servicing (AM, FM, VHF, UHF). WTI men win fast promotion... can demand better pay... develop highly profitable businesses of their own with the latest and most **FRACTICAL PERSONALIZED TRAINING BEHIND THEM**. You concentrate all your time on being a **PROFESSIONAL TV SERVICE TECHNICIAN** — non-essential math and engineering theory omitted. **YOU CAN EARN WHILE YOU LEARN**. Special Finance Plan.

APPROVED FOR VETERANS. Find out how you can get into the TOP PAY GROUP — Send for this fact-packed book NOW!

WESTERN TELEVISION INSTITUTE

America's Leading
Television
Servicing School

Western Television Institute Dept. R-113
341 W. 18th St., Los Angeles 15, Calif.
Without obligation, please send FREE fully illustrated booklet. (No salesman will call.)

NAME _____ AGE _____
ADDRESS _____
CITY _____ ZONE _____ STATE _____

RADIO & TELEVISION NEWS

was practically taken over by the electronics service industry for this three-day event. Lectures dealing with both business and technical phases of the service business were presented by industry leaders and an extensive display of the newest products for TV installation and service absorbed the attention of registrants between lectures.

New Consumer Booklet on TV Service

The Dallas Better Business Bureau recently sponsored a new consumer booklet on TV service that effectively covers the dangers of low priced TV service. Titled, "Get Your Money's Worth When Buying Television Service," it says, in part:

"Ruskin once said: 'There is hardly anything in the world that some man cannot make a little worse and sell a little cheaper, and the people who consider price only are this man's lawful prey.'

"And this is particularly true in the television service field.

"In one city more than half a hundred persons complained to the Better Business Bureau within a few days' time about their unsatisfactory experiences with a newly opened TV service firm that had advertised TV home repairs for \$2.65. Inadequately prepared to render competent television repair services, the low price served as a 'gimmick' to get sets into the shop, after which much higher charges were made for unsatisfactory workmanship. Before too long, the firm closed its doors, leaving scores of dissatisfied customers."

The booklet then proceeds to describe the complexities of TV circuitry and explain the expert knowledge and costly equipment required to give competent service. Then it advises readers,

"In the selection of a TV service firm, look with skepticism at those who would lead you to believe they can repair your set at home for a few dollars. Question unlikely 'gimmicks' or 'too good to be true' inducements. Perhaps the dealer from whom you bought your set can recommend a service organization in which he has confidence. And, finally, if in doubt, check with your Better Business Bureau where the reputation of such firms becomes a matter of public record. Doing these things should result in happier and more pleasant television experiences for you."

If you would like to get a copy of this very fine consumer booklet send ten cents in coin or stamps to: The Dallas Better Business Bureau, Dallas, Texas. Request a copy of the booklet—"Get Your Money's Worth When Buying Television Service."

We would like to urge the readers of this column to investigate not only this publication but others mentioned, from time to time, as being available. Professionally produced and carefully planned, they represent a real boost for the technician at a minimum of time and effort on his part.

Communications Receivers



SPECIAL
Contains \$ **69⁵⁰**
All Components **KIT PRICE EACH**
Complete Kit . . .

COMPLETE KIT—This kit is complete with every part necessary to assemble into a finished receiver, including tubes and cabinet. Chassis is punched and marked. Mount the parts, wire it, align it and you have a fine receiver of commercial appearance, that can't be beat for 3 or 4 times the price. Parts layout, schematic diagram and alignment instructions are supplied.

FEATURES:

- 2 Watt P.P. Audio
- Amplified AVC
- Voltage Regulated Oscillator Supply
- Noise Limiter
- Beat Oscillator
- Air Tuned R.F. Trimmers
- 2 Stage Permeability Tuned 455 KC I.F. Plus Crystal Filter
- Phone Jack — Built-in Stand-by Relay
- Operates on 105 to 125 Volts AC or DC Power Source
- Frequency Range 200 KC to 400 KC and 450 KC to 19 MC in Six Bands
- 40:1 Gearing Ratio Dial Drive
- 11 Tubes Plus Selenium Rectifier
- 6SQ7 RF AMP.
- 6SR7V Mixer
- 2-6SQ7 I.F.
- 6HG 2nd Det & N.L.
- 6SF7 AVC AMP.
- 6SL7 BFO & 1st Audio Inverter
- 6SL7 Phase Inverter
- P.P. 25L6GT Audio
- VR-75 Voltage Regulator
- Full Vision Calibrated Dial
- Cabinet 19 1/2" long x 10 1/2" high x 12 1/2" deep
- Finished in fine grain black wrinkle
- Front Panel silk screened to identify each control
- Shpg. weight 45 lbs.
- Shipped Express Only.

FRONT PANEL CONTROLS

- Tuning
- R.F. Gain
- Audio Gain
- BFO-AVC Switch
- BFO Pitch
- Power On-Off
- Stand-by
- Noise Limiter On-Off and Control
- Antenna Trimmer
- Crystal Filter On-Off
- Crystal Phasing
- Selectivity
- Band Change Switch
- Calibrated Dial Face

LIMITED QUANTITIES
Order Now!

ERIE CERAMIC CONDENSERS
500 mfd. 39c | 500 mfd. 29c
20 KV. ca. 15 KV.

WIRE

1/4 lb. spool of #20 hot tinned, solid wire **39c**

2MFD, 2500 VOLT

Aerovox type 2509 oil capacitor rectangular can each **\$4.95**
2 for **8.95**

ORDER TODAY!

TERMS: 25% Deposit with order. Balance C.O.D. Include postage with parcel post orders. All prices F.O.B. Chicago and subject to change without notice. All merchandise subject to prior sale. Minimum order \$5.00.

DUMONT TV TUNERS

Famous continuous tuner covering TV Channels 2 through 13 and the 88 to 108 m.c. FM band. 3 Tube (6AB4—6AK5—6J6) Tuner for Dumont models R-119A and R-112A & R-113. Model R-119A complete with calibrated glass dial. Model R-112A & R-113 complete except for dial. Brand new. Use them for TV tuners, H. F. converters, etc., continuous tuning range from 52 to 216 MC.

Tuner for R-119A **\$10.95**
Tuner for R-112A and/or R-113 **9.95**

SPECIAL PURPOSE TUBES

HK54 \$4.95 | 10KP7 . . . \$10.95
3FP7A 7.95 | 3C24 1.50
5CP1 9.95 | 30ATL 10.95

BOULEVARD ELECTRONICS, INC. DE 2-4458
808-10 W. JACKSON BOULEVARD • CHICAGO 7, ILLINOIS
RADIO AND TELEVISION SUPPLIES

EASY TO LEARN CODE

It is easy to learn or increase speed with an Instructograph Code Teacher. Affords the quickest and most practical method yet developed. For beginners or advanced students. Available tapes from beginner's alphabet to typical messages on all subjects. Speed range 5 to 40 WPM. Always ready—no QRM.



ENDORSED BY THOUSANDS!

The Instructograph Code Teacher literally takes the place of an operator, instructor and enables anyone to learn and master code without further assistance. Thousands of successful operators have "acquired the code" with the Instructograph System. Write today for convenient rental and purchase plans.

INSTRUCTOGRAPH COMPANY

4711 SHERIDAN ROAD, CHICAGO 40, ILLINOIS

ANOTHER OUTSTANDING JOBBER

NIDISCO

713 Newark Ave.
Jersey City, N. J.

55 Store St. Hockensack, N. J. | 294 Passaic St. Passaic, N. J.
650 Anderson Ave. 126 So. Warren St. Cliffside, N. J. | Trenton, N. J.

HAS THE SENSATIONAL NEW **EICO** 1180-K DECADE CONDENSER BOX KIT IN STOCK!

\$14.95

SERVICE HINTS ON SYLVANIA TV SETS

CHASSIS 366

Raster disappears as brightness is turned up.

This condition will occur if L_{100} , the peaking coil in the plate circuit of the video amplifier, is open. (See diagram below.)

For a quick check, put a jumper across L_{100} temporarily. If a normal picture is obtained, replace the coil.

Smear in picture and poor contrast.

This could be due to condenser C_{115} , the .2- μ fd. coupling condenser between V_7 , the 6BF5 video amplifier and the cathode of the picture

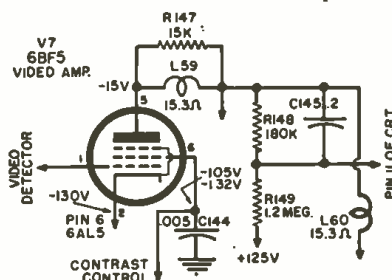

tube, (pin 11), being open. (See accompanying diagram.)

To correct this condition, bridge this condenser with another .2- μ fd. unit.

Noise in sound.

When this condition is accompanied by poor vertical sync and varying contrast, condenser C_{116} , the 60- μ fd., 350-volt electrolytic screen bypass condenser from pin 4 of V_{11} , the 6V6 audio output tube, to the -135 volt line may have a poor internal connection to the can. To check, bridge this condenser with another one of approximately the same voltage ratings.

Blooming or no high voltage.

A hard-to-find cause of either of these symptoms is a shorted condenser, C_{111} , the 25- μ fd., 25-volt cathode bypass across the 270-ohm resistor (R_{112}) in the cathode circuit (pin 8) of V_{11} , the 6V6 audio output tube. If this turns out to be the trouble, replace the 6V6 also.

Horizontal pulling.

This may be due to a leaky C_{172} , the .01- μ fd. coupling condenser between the plate (pin 1) of V_{12} , the 12AX7 sync separator, and the grid (pin 1) of V_{13} , the 6SN7 sync amplifier and clipper. The usual symptom when this condenser is leaky is poor vertical hold. Occasionally, under certain signal conditions and amount of leakage of C_{172} , the vertical stability will be good but there will be poor horizontal lock-in.

Horizontal jitter and intermittent horizontal hold.

Check for a leaky C_{155} , the .1- μ fd. condenser in the control grid circuit (pin 1) of V_{16} , the 6AU6 horizontal control tube.

Ragged edges in picture.

This may be due to shorted turns in the ringing coil, L_{63} , in the plate circuit (pin 5) of V_{17} , the 6SN7 horizontal oscillator. This is sometimes caused by accidentally interchanging the 6W4 damper and the 6SN7 with the set turned on. To check, observe the waveform at the plate of V_{17} . The absence of damping at a portion of the damped sine wave indicates shorted turns at L_{63} .

No picture except when set is detuned.

This condition indicates a lack of a.g.c. voltage. If the a.g.c. amplifier tube (V_{13} , 6SN7) is all right, measure its cathode voltage on pin 6. If the reading is much less than -58 volts, replace R_{164} , the 3600-ohm cathode resistor.

CHASSIS 437-3

Trapezoidal raster.

A shorted or open winding in the horizontal deflection yoke may cause this condition. If the yoke is good, check for an open C_{200} , the .22- μ fd. condenser in the horizontal deflection winding. To test this condenser, merely short it out and see if a normal raster can be obtained.

Decreased picture width.

If the picture is 2 or 3 inches wide, and R_{232} , the 1000-ohm resistor from the blue lead of the horizontal deflection coils to the high-voltage transformer, gets hot, check condenser C_{215} , the .00075- μ fd. unit across one of the horizontal deflection coils. This condenser is probably leaky.

Weak high voltage and blooming or wide foldover in center of raster.

C_{200} , the .2- μ fd. filter condenser in the "B+" boost circuit, could be open causing this condition. Bridge this condenser with either another .2- μ fd. or .1- μ fd. unit to check it.

No high voltage and fuses blow.

In some cases the fuse may not blow, but the 6W4 damper tube may get red. This condition may be due to a shorted C_{200} , the .2- μ fd. filter condenser in the "B+" boost circuit. If this is the case, be sure to check the horizontal size coil (its resistance should be approximately 67 ohms) before returning the set to the customer. A shorted C_{200} may burn out the horizontal size coil.

RADIO & TELEVISION NEWS

The
Best
Seats
in the
House...



You
hear it
all —
as though
you were
there ...
when
you use
a

MODEL 206AX

Stephens TRU-SONIC SPEAKER

Regarded as the international standard in high fidelity sound equipment, STEPHENS speaker systems are used throughout the world by the most discriminating listeners.

It's a SOUND PRINCIPLE
when you say

STEPHENS
TRU-SONIC

MANUFACTURING
CORPORATION

8538 Warner Drive • Culver City, Calif.

STAN-BURN ELECTRONICS

CATHODE RAY TUBE SPECIALS
One Year Guarantee

G. E.		STAN-BURN	
STP4	\$44.95	10BP4	\$11.00
7JP4	17.10	12LP4A	14.20
10BP4A	19.25	14CP4	17.00
10FP4A	24.00	15DP4	19.50
12KP4A	27.10	16AP4	21.60
12LP4A	21.70	16FP4	19.60
12UP4B	28.25	16GP4	21.60
14CP4	24.50	16EP4A	22.60
16AP4A	30.95	16DP/HP4	19.60
16DP4A (N.U.)	28.20	16DP/HP4A	20.60
16GP4	31.25	16KP4	18.50
16KP4/16RP4	26.20	16LP4	20.60
17BP4A	23.90	16LP4A	21.60
17CP4	39.45	17BP4	18.50
19AP4A	32.50	17CP4	21.60
20CP4	37.50	19AP4	23.90
20LP4	37.35	19AP4A	25.90
21EP4A	78.50	20CP4	29.50
24AP4A		21EP4	32.50

ANTENNAE SPECIALS

RED DOUBLE Antenna	1-5	\$2.19	6 or more	\$1.98
10 ELEMENT CONICAL DOWELED INSERTS		2.98		2.79
Folded Hi Straight Low Quick Rig		4.25		3.25
WINDOW CONICALS		4.95		3.75
5 FOOT SWEDGED		.79		.69
10 FOOT SWEDGED		1.39		1.29
NEPCO MASTS		1.69		1.49
42 Mil. TV WIRE		\$ 9.95 M Ft.		
55 Mil. 300 OHM		11.95 M Ft.		
72 OHM COAXIAL		35.00 M Ft.		
12" Heavy Slug Speaker		Special \$3.98		
CHASSIS 630 REGAL with Cascade Tuner		\$149.50		
OPEN FACE CABINET		42.00		

WIRE RECORDERS IN STOCK

PENTRON - Model 9T3C - 2-Speed Time Recorder		Write for Price.
RADIO CRAFTSMAN Model C40C - Hi-Fi Amplifier	Net	42.90
Model C10 - AM-FM Tuner	Net	131.50
Model C50C - Williamson Amplifier	Net	99.50

We also carry MASCO-BOGEI-PILOT, etc. Amplifiers, Pre-Amps, FM Tuners and WEBSTER Tape Recorders.

6x9 PM Speaker	\$ 3.98	630 Vert. output	
7" PM Speaker	3.98	potted	1.29
77J1 G.E. Flyback	1.98	630 Vert. Bocking	.89
7" Yoke	1.98	OSC. XFORM	.89
630 Vert. output	1.98	Cascade Tuners	19.95
upright	1.98	Standard Tuners	17.95
		Dumont 21.25 mc.	14.95

AUTHORIZED DISTRIBUTORS for General Electric, Kenrad, Tung-Sol, National Union, De Wald, Regal, Automatic and General Motors.

Automatic Custom-Built Radios for Plymouth, Ford, Chevrolet and many others, always in stock.

We carry a complete line of HI-FIDELITY and sound equipment. Send us your requests.

We also carry a complete line of popular makes of Radio Tubes at 50% discount. Also many other special purpose and transmitting types, and all electronic parts and equipment, at lowest prices. Send us a list of your requirements for prompt quotations.

Terms: 20% with order. Balance C.O.D. All Prices F.O.B. NEW YORK Warehouse. Minimum order \$5.00. Write for our latest price list and Hi-Fi catalog to Dept. RN-11.

STAN-BURN RADIO and ELECTRONICS CO.
(C.B.S. THEATRE BLDG.)
1697 BROADWAY • NEW YORK 19, N.Y.

**Read
RADIO & TELEVISION NEWS
Every Month**

HI-GAIN TUNER-BOOSTER
LESS TUBES WITH DIAL

\$4.75
COMPLETE WITH TUBES
\$6.00

Solve poor TV reception with a Hi-Gain Booster. Banish weak fringe areas, reduce snow. This unit comes to you as a highly serviceable High-Gain Tuner. Uses 6H6 Tubes in very efficient Hi-Q Circuit. Has 8 tuned circuits using pure silver inductances and individual compensation providing high gain on all channels. Built in 5:1 Vernier Drive.

All necessary parts and instr. included makes highest gain booster on the market for price.

\$10 VALUE FOR \$1.00
130 Assorted 1/2, 1 2W RESISTORS

Shipments cost postpaid when full payment is enclosed. 25% deposit on C.O.D. Send for our new bulletin.

FRANK W. DECRAY & ASSOC.
11842 W. Jefferson Blvd. Culver City, Calif.

No high voltage and R₂₃₁ (6800 ohms) burnt.
Resistor R₂₃₁ goes from the primary of the high-voltage trans-

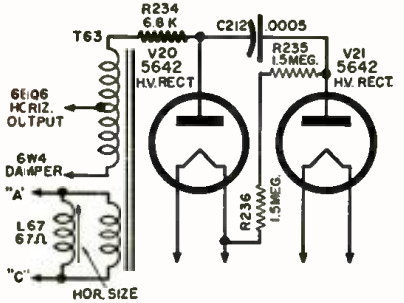

former to the plates of the 5642 high-voltage rectifier tubes. (See accompanying diagram.) This condition may be due to an open winding in the flyback transformer. If the top 5642 has a blown filament in addition to the above, then the trouble is a leaky C₂₁₂, the .0005- μ fd. high-voltage condenser.

No high voltage.
Check for a dead short across condensers, C₂₁₅ or C₂₂₁ (the .00075- μ fd. condensers across the flyback secondaries), by measuring the resistance between terminals A and C (should be over 4 ohms) and B and H (should be 9 ohms). These terminals are located at the rear of the high-voltage cage and are arranged in alphabetical order.

Vertical bars on left side of the screen.
These bars resemble those due to Barkhausen oscillations. If this condition occurs in weak signal areas, reroute the twin-lead between the antenna terminal strip and the tuner along the bottom of the cabinet alongside the chassis apron. Remount the antenna terminal strip on the lower corner (tuner side) of the cabinet. If these bars occur in strong signal areas, try new 5642 high-voltage rectifiers.

Picture overloading in weak signal areas only.
Check the a.g.c. clamper tube which is half of the 6AL5 video detector, as well as the 6SN7 a.g.c. amplifier.

CHASSIS 508
Right side of raster darker than left side.
In addition to this symptom, there is also the possibility of squегging (intermittent horizontal scan) causing a ragged, leaking raster. This condition may be caused by a leaky C₂₀₃, the 20- μ fd. 100-volt condenser in the cathode circuit (pin 8) of the 6BQ6, horizontal output tube.
Insufficient horizontal scan in low line voltage areas.
Lack of width with normal a.c. line voltage is caused by a defective part. To get a little extra width when low line voltage is the cause, however, add a .005- μ fd., 600-volt condenser across C₁₉₉, the .0047- μ fd. condenser in the plate circuit of the a.g.c. amplifier.

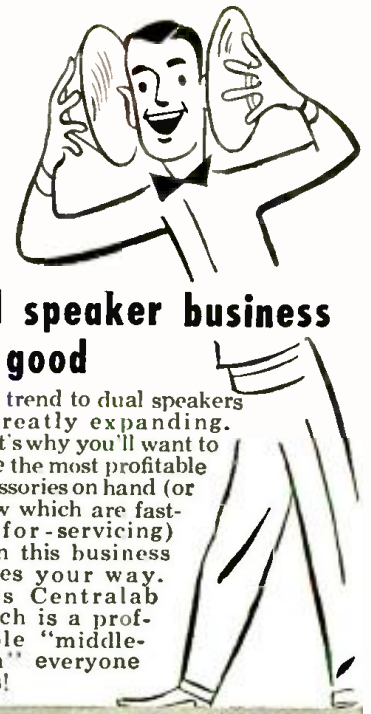

dual speaker business is good

The trend to dual speakers is greatly expanding. That's why you'll want to have the most profitable accessories on hand (or know which are fastest-for-servicing) when this business comes your way. This Centralab switch is a profitable "middle-man" everyone likes!

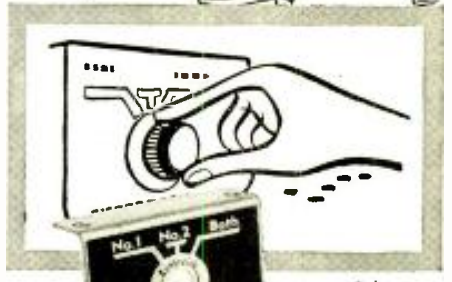

this Centralab dual switch kit makes it better!

switch mounting bracket and dial
white knob
2-self-tapping mounting screws

All parts (except mounting holes) in one box—nothing else to buy

You get the complete assembly for switching between dual speakers such as auto rear seat and front seat speakers, including etched dial-mounting plate and complete installation instructions. Listener selects either speaker or both. Profitably installed, you forget it! Your Centralab distributor has dual switch mounting kits on hand — order a couple NOW.

Centralab

CENTRALAB
A Division of Globe-Union Inc.
910-K E. Keefe Ave., Milwaukee 7, Wis.

Please send me Catalog 28 for additional technical data on dual switch kits.

Name.....
Firm.....
Address.....
City..... Zone..... State.....

The NEW

BROOK

MODEL 22A

Is Creating A Sensation!



10-watt single-chassis power and pre-amplifier combination

- ... so dramatically different, it's a new concept in amplifier design.
- ... so functionally compact, it simplifies any installation.
- ... so exceptionally attractive, it captivates at first glance.
- ... But, FOREMOST, so genuine in HIGH QUALITY AUDIO PERFORMANCE, despite it's unprecedented low cost.

SEE and HEAR the New Model 22A at your local dealer's Sound Department soon. A listening treat awaits you. Write today for free technical information.

Dept. RL-3

BROOK ELECTRONICS, INC.

First in the High Quality Audio Field Since 1934
34 DeHART PLACE, ELIZABETH, N. J.

Connect the .005- μ fd. condenser between lugs 6 and 7 of the flyback transformer inside the high-voltage cage. This is the winding that is in parallel with the horizontal size coil.

No high voltage.

Connect a jumper across the chokes L_{70} (inside the high-voltage cage), and L_{71} (on the bottom of the chassis) that are in the cathode and plate circuits of the 6V3 damper tube. Either choke may be open, and by jumping the one that is open, the high voltage will return.

CHASSIS 1-518

White flashes on picture.

This condition may occur if C_{122} , the .22- μ fd. condenser at the v.h.f. tuner a.g.c. point (green lead), is open. Some of the earlier chassis did not incorporate this condenser. If this trouble is encountered in such a chassis, insert a .22- μ fd. condenser at this point.

Overloading in picture.

If the a.g.c. is all right and the tubes are not at fault, detune the 4th video i.f. (T_{57}) slightly, and

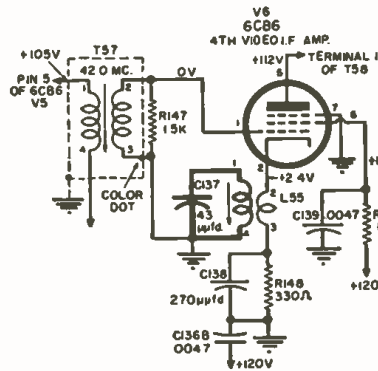

also check the cathode trap in the 4th video i.f. (See diagram.)

Weak picture.

This may be due to a faulty video detector crystal. Check the forward and reverse resistance of the 1N105 germanium crystal detector. It should be about 100 ohms in one direction, and about 200,000 to 300,000 ohms in the reverse direction.

Be sure to observe the polarity of the crystal when replacing it in its holder.

Snowy picture.

C_{122} , the 2- μ fd. condenser in the

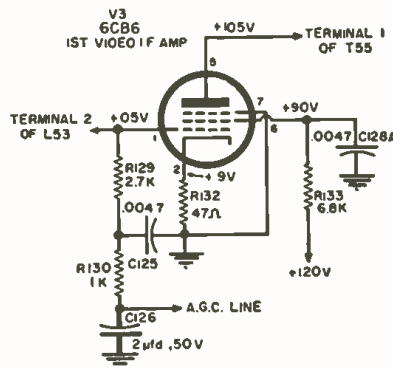

a.g.c. line, may be shorted, caus-

WANT THE BEST IN CAPACITORS?



Type UMP

• Many, many notable advances in the art of capacitor design and manufacture have been made by the ILLINOIS CONDENSER COMPANY. As an example, ILLINOIS CONDENSER COMPANY has recently been awarded a patent on their unique and exclusive molded capacitor construction as featured in the UMP types.

For almost two decades, ILLINOIS CONDENSER COMPANY has been building quality capacitors and regular users include most all of the largest manufacturers of TV and radio sets. Their names literally comprise the "blue book" of electronics.

To meet the ever increasing demand for ILLINOIS electrolytic capacitors, ILLINOIS CONDENSER COMPANY has built new plants and greatly increased production. Why don't you, too, discover why ILLINOIS capacitors are "first choice" of so many!

Write for Catalog!



ILLINOIS CONDENSER CO.
1616 NORTH THROOP STREET • CHICAGO 22, ILL.

HI-FI?



WORLD'S FINEST AUDIO COMPARISON STUDIOS

Music Lovers and Hi-Fi Enthusiasts Make it a MUST to visit the Hudson Sound Comparison Studio nearest you! See, Hear, and instantly Compare the World's Finest Hi-Fi Components, with our ingenious Remote Controlled Push-Button Mechanism... Hear the amazing new electronic Radio, Phono and Recording Equipment that brings Concert Hall "Presence" into your own home at Low Cost!

AND NOW IN NEWARK, N. J...

New Hudson Salesrooms... Complete Stocks, Same Superlative Service as our two N.Y.C. Stores... AND, "Studio 35," Newark's Newest, Finest, and Most Completely Equipped Sound Studio. Lowest Published Prices!

FREE Hudson 1954 HI-FI CATALOG

Finest Manual of Its Kind Contains Everything in High Fidelity Components, Recording Equipment, Replacement Parts and Tubes, TV Chassis and Cabinets for All Types of Installations. Send for your FREE Copy TODAY!

Dept. A 11

Hudson
RADIO & TELEVISION CORP.
ELECTRONIC & SOUND EQUIPMENT

Adjoining Radio City
48 West 48 St.
New York 36
Circle 6-406D

Downtown New York
212 Fulton St.
New York 7
Circle 6-406D

3 GREAT SALESROOMS to Serve You!
35 William St.
Newark, N. J.
Market 4-5151

RADIO & TELEVISION NEWS

ing higher a.g.c. on the tuner. (See accompanying diagram.) If this is the case, the tuner a.g.c. voltage will increase to about -7 volts from the normal -2 to -3 volts.

Squegging (intermittent horizontal scan).

Pull V_{10} , the 6CB6 horizontal control tube. If the raster becomes normal, check condenser C_{205} (.1 μ f.), from the grid circuit (pin 1) to the cathode (pin 2) of the 6CB6.

Intermittent pulling at top of picture.

Check V_{15} , the 6AU6 a.g.c. amplifier. If OK, check for a broken lead to the 5-prong plug of the high-voltage unit. One of the leads connecting the flyback winding for a.g.c. to pins 1 and 5 on the plug may be broken. An ohmmeter check under the chassis, between pins 1 and 5 (large pins), will quickly show if this circuit is open. The resistance should be about 1.5 ohms.

No picture.

Rotate the a.g.c. control. If the sound is normal but there is a dull raster at one end of the a.g.c. control range, and then the sound disappears and the raster gets bright with the a.g.c. control set at the opposite end, check V_{15} , the 12AU7 noise gate tube. A dead noise gate tube will give these symptoms.

CHASSIS 1-51E-3

Noise in picture.

This may be eliminated by increasing the sensitivity of the receiver. To effect this, replace R_{127} , the 1.5-megohm resistor in the a.g.c. delay circuit, with a 1-meg-

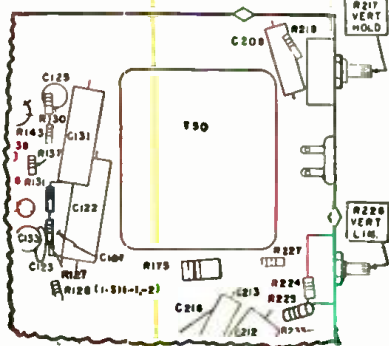

Surplus Sellout Sale!

Radio Altimeter—AN/APN-1. New complete \$65.00 ea.

† CARBON VOLUME CONTROLS—10 for \$1.25

STOCK NO.	RES. OHMS	SHAFT LENGTH	MFR.	PRICE
700A	1K	3/16 S.D.		.18
701A	.13K	3/16 S.D.		.18
702A	.5K	3/16 S.D.	CTS	.18
703A	1.5K	9/32 S.D.	CTS	.18
704A	1.5K	1/2 S.D.	IRC	.18
705A	2K	5/16 S.D.		.18
706A	4K	5/8 S.D.		.18
708A	8K	7/16 S.D.	Stack IRC	.18
709A	15K	1 S.D.	Stack CTS	.18
710A	100K	1 1/8 S.D.	Stack CLARO	.18
712A	15K	5/8 S.D.	Stack IRC	.18
713A	15K	1/2 S.D.	Stack IRC	.18
714A	20K	1/2 S.D.	Stack CTS	.18
717A	20K	1 1/8 S.D.	Stack CTS	.18
718A	20K	1 1/8 S.D.	Stack IRC	.18
719A	20K	1 1/8 S.D.	Stack IRC	.18
720A	22K	5/8 S.D.	Stack IRC	.18
722A	25K	5/8 S.D.	Stack IRC	.18
723A	25K	5/8 S.D.	Stack IRC	.18
724A	25K	1-1/2 S.D.	Stack CLARO	.18
725A	25K	1-1/2 S.D.	Stack CLARO	.18
726A	25K	1-1/2 S.D.	Stack CLARO	.18
727A	25K	1-1/2 S.D.	Stack CLARO	.18
728A	100K	1 1/2 S.D.	Stack CLARO	.18
729A	100K	5/8 S.D.	Stack RF999-1 Mdg	.18
731A	100K	5/8 S.D.	Stack CENTRA	.18
732A	150K	1 1/8 S.D.	Stack CRL	.18
733A	200K	3/8 S.D.	Stack MAL	.18
734A	200K	3/8 S.D.	Stack IRC	.18
735A	200K	3/8 S.D.	Stack IRC	.18
736A	200K	3/8 S.D.	Stack IRC	.18
737A	200K	3/8 S.D.	Stack IRC	.18
738A	200K	3/8 S.D.	Stack IRC	.18
739A	500K	1 1/8 S.D.	Stack CROS.	.18
740A	500K	5/8 S.D.	Stack CTS	.18
741A	500K	5/8 S.D.	Stack CTS	.18
742A	500K	5/8 S.D.	Stack CTS	.18
743A	500K	5/8 S.D.	Stack CTS	.18
744A	800K	5/8 S.D.	Stack CIR	.18
745A	800K	5/8 S.D.	Stack Stack	.18
746A	1 MEG	5/8 S.D.	Stack Stack	.18
747A	1 MEG	1 1/8 S.D.	Stack CTS	.18
748A	2 MEG	5/8 S.D.	Stack IRC	.18
749A	2 MEG	5/8 S.D.	Stack IRC	.18
751A	200 MEG	1/4 S.D.	Stack METER TYPE	.40

S.D. Indicates Screwdriver Slot

† CARBON VOLUME CONTROLS WITH SWITCHES 10 FOR \$1.75

STOCK NO.	RES. OHMS	SHAFT LENGTH	SWITCH	MFR.	PRICE
751A	10K	1/2 S.D.	S.P.S.T.	CRL	.20
752A	10K	1/2 S.D.	S.P.S.T.	CRL	.20
753A	25K	1/2 S.D.	S.P.S.T.	CTS	.20
754A	25K	1/2 S.D.	S.P.S.T.	IRC	.20
755A	75K	1/2 S.D.	S.P.S.T.	IRC	.20
756A	100K	1/2 S.D.	S.P.S.T.	CRL	.20
757A	100K	1/2 S.D.	S.P.S.T.	CRL	.20
758A	1 MEG	1 1/8 S.D.	S.P.S.T.	STACK	.20
759A	1 MEG	1 1/8 S.D.	S.P.S.T.	STACK	.20
761A	5 MEG	1 1/8 S.D.	S.P.S.T.	CRL	.20
762A	5 MEG	1 1/8 S.D.	S.P.S.T.	CRL	.20
763A	10 MEG	1 1/8 S.D.	S.P.S.T.	CRL	.20
764A	10 MEG	1 1/8 S.D.	S.P.S.T.	CRL	.20
765A	300 DUAL	5/16 S.D.	S.P.S.T.	IRC	.40

† TRANSFORMERS—ALL ARE 50-60 CYCLE

1 TRANSFORMER, Power, Filament, and Plate; 22 or 115V/230V, 50/70CP/S; 5 sec; 590V at 55ma 525V at 1.5ma; 6.4V at 3 amp; 6.4V at 0.6 amp. 2.5V at 1.75 amp. Stock No. 500A. PRICE EA. \$5.50
 CHICAGO TRANSFORMER, Radio Power Trans. Pri. V. 210-20-30-40-50. Sec. 1100 V.C.T. Amp. 0.212. Test V. 2500. Size 7" H x 9" x 6". Stock No. 501A. PRICE \$10.50
 CHICAGO TRANSFORMER, Radio Power Trans. Pri. V. 230. Sec. 10 V. 1.5 Amps. Size 3 1/2" x 4 1/2" x 4 1/2". Stock No. 502A. PRICE \$3.50
 CHICAGO TRANSFORMER, Radio Power Trans. Pri. V. 105-10-15-20-25. Sec. 1-1/2 V. 15.6 at 1 Amp; Sec. 2-1/2 V. 12.6 at 1.5 Amp; Sec. 3-1/2 V. 9.6 at 2 Amp; Size 3 1/2" x 3 1/2" x 3 1/2". Stock No. 503A. PRICE \$4.50
 CHICAGO TRANSFORMER, Radio Power Trans. Pri. V. 210-20-30-40-50. Sec. V. 500 C.T. at 130A. Size 4 1/2" x 3 1/2" x 3 1/2". Stock No. 504A. PRICE \$2.25
 COLLINS RADIO, Plate Transformer, Pri. 115V 230V. Sec. 500V.C.T. at 106A. Size 4 1/2" x 3 1/2" x 3 1/2". Stock No. 505A. PRICE \$5.00
 CHICAGO TRANSFORMER, Radio Power Trans. Pri. V. 210-20-30-40-50. Sec. V. 500 C.T. at 6A. Size 4 1/2" x 3 1/2" x 3 1/2". Stock No. 506A. PRICE \$2.50

OIL FILLED CONDENSERS

3 sec. 3X .2mfd at 400VDC. 35" x 5 1/2" x 2 1/2". Elec. Util. Forc Term. Stock No. X409A. PRICE EA. \$2.95
 3 section 1MFD-420V, 2MFD-400V, 1.5 MFD-100V. 25" x 3 1/2" x 1 1/2". Elec. Util. Stock No. X770A. PRICE EA. \$0.70
 Dual 2.5MFD, 1MFD, 400VDC. 2 1/2" x 3 3/4" x 1 1/2". Elec. Util. Stock No. X767A. PRICE EA. \$0.90
 Dual 2 1/2 MFD, 500VDC 1 1/2" x 2 3/4" x 1 1/2". Stock No. X771A. PRICE EA. \$0.60
 1MFD-400VDC. 1 1/2" x 2 1/2" x 1 1/2". Elec. Util. Stock No. X327A. PRICE EA. \$0.40
 1MFD-600VDC. 1 1/2" x 3 1/2" x 1 1/2". Ind. Cond. Porc Term. Stock No. X418A. PRICE EA. \$0.50
 4.5MFD, 400VDC. 2 1/2" x 3 1/2" x 1 1/2". Aerovox. Stock No. X321A. PRICE EA. \$1.00

† G.E. PYRANOL CONDENSERS—10 for \$3.50

Stock No.	Mid.	VWDC	Part No.	Price Each
100A	.05	1000	21F27003	\$0.38
101A	1.0	500	21F21703	.38
102A	.25	1000	22F286	.48
103A	2x .25	400	21F310	.48
104A	.5	1000	22F287	.50
105A	2x .25	400V	22F307	.55
106A	1.0	500	22F348	.42
107A	1.0	500	21F111	.42
108A	1.0	500	21F144	.42
109A	1.0	500	21F145	.42
110A	2x1.0	115VAC	22F462	.60
111A	2x1.0	115VAC-400cy	22F462	.60
112A	2x1.0	115VAC-120cy	22F462	.60
113A	2x.75	400	22F544	.85

† Rotating Loop Antenna MN20E. Price Ea. \$7.98
 † Antenna Changeover Switch 3PD2. Price Ea. .88
 † Plug PL88. Price Ea. .88
 † Antenna Mast AN 104B New. Price Ea. 5.95

† Items indicate that part(s) will be found in our SURPLUS CATALOG with thousands of others. SEND FOR Surplus Catalog No. RN31
 SEND FOR our Standard Radio & TV Parts and Mi-Fidelity Cat. No. RNS11

TERMS: All prices F.O.B. Chicago. Send 25% Deposit with order. Balance sent C.O.D.

Electronic Expeditors
 2909 West Devon Avenue Chicago 45

which the 120 volt "B+" is obtained for the noise inverter V_{11} , 12AU7. Low "B+" voltage develops sync pulse cancellation in this circuit. Make sure that the normal +7 volts is on the cathode (pin 8), and +58 to +60 volts is on the plate (pin 6) of the noise inverter tube, to insure proper operation of this stage. If either rating is less, trouble in that circuit is indicated.

No sound, no picture—high voltage OK. Check for a defective 6Y6G (V_6) audio output tube. —30—

STALLARD REPORTING

By C. H. BOWERS

THE old Spark Gaps are beginning to crackle and static is all over the shack as we hear from various Old Time Wireless Operators. Send in YOUR story if you qualify as an Old Timer of 1912 or thereabouts!

With this issue we uncover an Old Timer, Mr. Otto D. Stallard, Jr., of 5327 Morningside Ave., Dallas 6, Texas, and, as a preface, Mr. Stallard says: "As I look back over the years, it does not seem possible that almost forty-four years have come and gone since my first interest in telegraphy!"

It was in December 1912 that our subject Old Timer obtained his First Class Wireless Operator License and started his career in that connection. His first commercial job was with the Marconi Company in Cleveland, Ohio, as second trick operator in the old Schoefield Building. However, in 1913 he wavered and accepted a wire job with one of the oil companies, but not for long, because by Summer 1915 he shipped out as "Sparks" aboard the "S.S. Northland", sailing between Buffalo and Chicago. Also short trips were made on the "City of Buffalo," out of Cleveland, and on the old side-wheeler, "See and Bee." Jobs were on the increase by this time and ambitious Otto telegraphed for railroads, wireless, Western Union, and oil companies, all within the same year—in fact he moved so fast his luggage was soon reduced to one "bug" slightly used, and a "mill!" His wardrobe, he wore!

In May 1917, Mr. Stallard went into the service as a wireless operator, assigned to the Army Transport Service, Depot Company "L," detached service. There, his first assignment was Chief Operator aboard the Army transport "Thomas," with subsequent duty aboard the transport "Sherman" and a tour on the transport docks.

The call of the oil company proved too strong for Mr. Stallard, however, and on being mustered out of the Army Transport Service, he went with the Magnolia Pipe Line Company as an oil gauger. That was 34 years ago. Today he is Division Superintendent for that company with headquarters in Room 504 Magnolia Building, Dallas, Texas, and would like to hear from any of his old buddies of the brass pounding days.

This sketch concludes with Mr. Stallard's own remarks, "Although I have not worked radio (wireless) for thirty-five years, it does not keep me from listening to the dots and dashes, as well as the phone conversations of both amateurs and professionals, as I have sets at home that cover all the possible bands." —30—

Manufacturers' Literature

Readers are asked to write directly to the manufacturer for the literature. By mentioning RADIO & TELEVISION NEWS, the issue and page, and enclosing the proper amount, when indicated, delay will be prevented.

"WIRELON" ROPES

Rochester Ropes, Inc. of Culpeper, Virginia, has issued an unusual booklet describing the properties and qualities of "Wirelon" ropes.

Constructed of high tensile steel strands and tough, durable nylon, "Wirelon" has numerous applications in radio, television, and radar. The booklet gives descriptions and specifications of the product for such applications.

ASA STANDARDS

The American Standards Association, 70 East 45th Street, New York 17, N. Y., has announced revisions of four of its standards for transformers.

Major revisions in the standards include additions to the terminology and general requirements for transformers, regulators and reactors, and a table to indicate temperature changes and additional information on loading and operation of instrument transformers.

The four publications are as follows: "Terminology for Transformers, Regulators, and Reactors" (C57.10-1953—gratis); "General Requirements for Transformers, Regulators, and Reactors" (C57.11-1953—gratis); "Requirements for Instrument Transformers and Table of Contents" (C57.13-1953—\$1.00); and "Guide for Loading and Operation of Instrument Transformers" (C57.33-1953—35 cents).

TWIST-PRONG ELECTROLYTICS

Astron Corporation, 255 Grant Avenue, East Newark, New Jersey, now has available for distribution copies of its new catalogue supplement, AC-3A covering its expanded line of twist-prong electrolytic condensers.

The new publication provides complete listings of catalogue numbers, capacitance and voltage ratings, case sizes, and list prices of all standard twist-prong units to meet every radio and television replacement need.

THE ONAN STORY

D. W. Onan & Sons Inc., University Avenue S.E. at 25th, Minneapolis 14, Minnesota, is now offering a copy of its new four-color, 40-page institutional brochure entitled "Measurement Factors of a Company and Its Products."

More than 120 eye-catching photographs tell the story of the company's products, what they are and how they are manufactured. Production facilities

ties and methods are described and illustrated.

Copies of this brochure are available on request. Please ask for institutional booklet "Measurement Factors."

MICROPHONE DATA

A new technical bulletin covering its ADA 95D dynamic microphone is now available from the *Turner Company*, 900 17th Street, N.E., Cedar Rapids, Iowa.

This two-color bulletin describes the new microphone in some detail. It is a general purpose unit featuring Alnico V magnets and moving coils. The design is modern, with a special satin-chrome finish.

If your jobber doesn't have copies of this data sheet available, write the company direct.

PARTS CATALOGUE

Electronic Expeditors, 2909 West Devon Avenue, Chicago 45, Illinois, now has available a new 24-page catalogue which covers high-fidelity components, speakers, microphones, tubes, rectifiers, test instruments, meters, controls, resistors, batteries, TV-FM antenna accessories, wire and cable, condensers, transformers, switches, and tube sockets.

One unique feature of this catalogue is a back cover reply card. Realizing that no jobber catalogue could contain complete engineering and design data for all items, the company lists a number for each manufacturer represented to be circled on the reply card. When the card is received, complete literature from the individual manufacturer is forwarded.

SPRAGUE PRICE LIST

A new condensed price list covering all of the company's "bread and butter" service condensers and resistors is now being offered by *Sprague Products Company*, 51 Marshall Street, North Adams, Massachusetts.

Known as P-143, the sheet may be mounted on a wall, under glass on a desk or counter, or any other convenient place to provide ready reference to the most widely used of the company's ratings. The list is printed in easy-to-read dark blue on heavy white paper.

Since catalogue numbers are followed by both net and list prices, jobbers will find it a quick check on prices to dealer customers. In addition, dealers will find it a convenient way to determine the cost to the customer as well as an easy means of checking his inventory.

ALLIED'S 1954 CATALOGUE

Allied Radio Corporation, 100 N. Western Ave., Chicago 80, Illinois has recently released its 1954 general catalogue which lists over 20,000 items in its 268 pages.

The new publication, No. 135, contains 88 pages of rotogravure featuring the latest high-fidelity components, including 32 complete hi-fi systems; television chassis, boosters, rotators

November, 1953

GARRARD RECORD CHANGER

LEAK AMPLIFIER

KT66 TUBES

WHARFEDALE LOUDSPEAKERS

GARRARD STYLUS PRESSURE GAUGE

R-J SPEAKER ENCLOSURES

Britain's Finest Music Reproducing Equipment

We invite you to write for a complimentary copy of "Sound Craftsmanship"...

16 pages illustrating and describing the products of the British Industries group. Here, in concise, useful form, are facts you'll want for planning improvements and additions to your own high-fidelity set.

mail coupon

British Industries Corporation
164 Duane Street
New York 13, N. Y. Dept. R-11

Gentlemen:
Please send a complimentary copy of your booklet "Sound Craftsmanship," to:

Name.....
Street.....
City..... Zone..... State.....

BRITISH INDUSTRIES CORPORATION, 164 DUANE STREET, NEW YORK 13, N. Y.

National Electronics GREATEST Special Purchase BARGAIN

Tremendous Savings While They Last

2 BAY 16 ELEMENT CONICAL ARRAY INCLUDING HIGH BAND ADAPTERS

\$4.65 Each
IN LOTS OF THREE
Single Lots \$4.95

Never before has National Electronics had a BARGAIN like this. We made a special purchase in order to get these sensational prices. And this array has everything. This conical 2-bay 16-element array provides ultra-fine fringe reception. Includes sixteen 1/2 inch airplane type aluminum elements, including in-band adapters for greater gain on the high channels and is complete with one half of stacking bars to each array. These are packed in cartons of three 16-element arrays per carton, with the rods, at \$13.95 per carton. When purchased in single 16-element arrays, separately boxed, your cost is \$ 4.95 each. 3 Two-Bay Arrays per carton without the Rods..... 12.50 carton. 4 Bay Ultra-Fringe Stacking Assembly for Above-Model 4B..... 1.95 set.

FAMOUS ROCKET ZOOM-UP TOWERS

• Sturdy • Reliable • Easiest Installation

Economize with Rocket Zoom-up Towers. Offers a clever, easiest way to make an installation up to 50'. Each section telescopes inside the other—no erect, simply slide out each section in its turn—insert bolt thru section below—tighten to keep mast from turning. Each tower complete with guy blocks, bolts, and a mounting base suitable for peak or flat roof. Handsome and sturdy. Rocket Zoom-ups offer you economy and long life. Order by size.

20'.....	\$ 9.95	30'.....	516.95
40'.....	21.95	50'.....	32.95

(deduct 10% discount in lots of 3)

SUPER SENSATIONAL! BOW TIE UHF REFLECTOR

ULTRA HIGH GAIN
Bargain Priced at
ONLY \$1.95

FOR SINGLE ARRAY
ONLY \$4.45 for Two-Bay Array

We are offering the BIGGEST UHF TV Antenna Bargain ever offered. The single array is designed for metropolitan usage—the two-bay array where greater gain is required—and the 6-bay array for fringe. At this sensational low price this antenna is the BEST BUY on the market. Get your news filled while they last!

In lots of 6, individually cartoned..... 10.95 for 6
4-bay arrays, with tie rods..... \$8.75 ea.
Matching tie rods—per pair..... \$0.50 pr.

Sutco "Metropolitan" UHF CONVERTER

Sutco's new Metropolitan area UHF converter offers the least expensive means of securing UHF reception with your VHF set in metropolitan areas. Easily installed. Attractive bakelite cabinet. Model 37A..... net **\$22.00**

SUTCO CONVERTER BOOSTER

Sutco's fringe-type Converter-Booster provides low-noise UHF conversion. PLUS VHF booster for improving fringe reception. \$34.95 dealer net for Model 21A.

ALL PRICES F.O.B. CLEVELAND, OHIO
Do not remit more than complete purchase price. Pay shipping charges on receipt of goods. 2.5% deposit on all C.O.D. orders. Please. Money-back guarantee.
Prices Subject to Change Without Notice

National Electronics

OF CLEVELAND

THE HOUSE OF TV VALUES

111 Delco Building Cleveland 3, Ohio

THE Original

WRENCH WITH THE SCREWDRIVER ACTION!



SPINTITE

REG. U. S. PAT. OFFICE

120 STYLES and SIZES

for

- ASSEMBLY WORK
- REPAIR WORK
- RADIO
- TELEVISION
- INDUSTRIAL
- AIRCRAFT



STEVENS WALDEN, Inc.
WORCESTER 4, MASS.

and u.h.f. converters; table model and portable radio receivers; professional and home recording equipment; p.a. amplifiers and complete systems; ham receivers, etc.

The balance of the catalogue is devoted to a listing of components and accessories for varied applications.

This comprehensive listing of radio parts of all kinds makes the new catalogue of value to all who work in the electronics field. A copy of this publication is now available from the company on request.

COLOR-CODE CALCULATOR

A color-code calculator covering both condensers and resistors is now being offered by *Centralab*, Dept. G-10, 900 E. Keefe Ave., Milwaukee 1, Wisconsin.

The calculator is printed in full color. By setting seven rotating wheels, capacitance or resistance, tolerance, and temperature coefficient can be read directly. The calculator covers RETMA color code specifications on normal and extended range tubular ceramic condensers and radial or axial lead resistors.

The new calculators will be sold through *Centralab* distributors.

FEDERAL CR TUBE DATA

The Vacuum Tube Department of *Federal Telephone and Radio Company*, 100 Kingsland Road, Clifton, N. J., has issued a new "Television Picture Tube Data Book" which is now available for distribution.

The 8-page booklet covers interchangeability considerations, basing diagrams, bulb outlines, and dimensions and electrical characteristics. The latter information is presented in tabular form for speedy reference.

SIMPSON "DOODLE PAD"

A handy and practical "king-size" desk pad with plenty of room for "doodling" and a generous supply of pages for day-to-day use has been prepared by *Simpson Electric Company* 5200 W. Kinzie Street, Chicago 44, Illinois.

The "doodle pads" are printed in two colors selected for elimination of eye strain, measure 17" x 22", and are padded 50 sheets each with non-slip chip board backing.

The "doodle pads," identified as Form A-1 SPC, are distributed at no cost by *Simpson* representatives. Ask for yours or write the factory direct.

P.A. EQUIPMENT

Newcomb Audio Products Co., 6824 Lexington Ave., Hollywood, California, has released a 20-page catalogue covering public address equipment.

The new publication contains illustrated information on all three lines of the company's amplifiers, portable systems, and accessories, as well as rack and panel assemblies.

"DECOHM" PRODUCTS

An illustrated catalogue covering the "Decohm" line manufactured by *Davis Electric Company* of 230 N. Spring St., Cape Girardeau, Mo., is now available.

for Hi Fi Conversions,
New Installations



AMPLIFIER

You can change an outmoded radio, phonograph or TV receiver into a high fidelity instrument with a VC-6 amplifier. Low cost, yet supplies more power than required by the largest size house . . . so simple to install, anyone can do it. The VC-6 is made for quick, easy mounting. It's compact, light weight. No extensive cabinet alterations. R.T.M.A. guarantee.

Service! The VC-6 cuts your conversion costs — makes more jobs more profitable. Matching speaker systems available.

Push-pull power output—6 watts.
Frequency response 50 to 30,000 c.p.s.
Bass boost of 6DB or treble boost of 6DB from single control.
Impedance—8 ohms
Self-contained power supply,
110 V., 60 cycles, A.C. only
Size 1 3/8" x 3 1/8" x 11" long
Ship. Weight 3 lbs.

ONLY
\$2695

F. O. B. N. Y. C.



Order your VC-6 Amplifier Today!
Quantity Discounts.

VIDEO CORPORATION OF AMERICA
229 West 28th St., New York 1, N. Y.

AMPERITE

Studio Microphones
at P.A. Prices

Ideal for
BROADCASTING
RECORDING
PUBLIC ADDRESS

"The ultimate in microphone quality," says Evan Rushing, sound engineer of the Hotel New Yorker.

• Shout right into the new Amperite Microphone—or stand 2 feet away—reproduction is always perfect.

• Not affected by any climatic conditions.
• Guaranteed to withstand severe "knocking around."



Models

RBLG—200 ohms

RBHG—Hi-imp.

List \$42.00



"Kontak" Mikes
Model SKH, list \$12.00
Model KKH, list \$18.00

Special Offer: Write for Special Introductory Offer, and 4-page illustrated folder

AMPERITE Company, Inc.

561 BROADWAY • NEW YORK 12, N. Y.

Canada: Atlas Radio Corp., Ltd., 560 King St. W., Toronto

RADIO & TELEVISION NEWS

Printed in three colors, the new catalogue provides complete technical data on various molded coil type open relays, hermetically-sealed canister type relays, and television deflection yokes. Information includes operating characteristics, range, and sensitivity of these products.

TV ELECTROLYTICS

A new TV condenser replacement supplement has been issued by *Sprague Products Company*, 51 Marshall Street, North Adams, Massachusetts.

Intended to supplement the company's complete "TV Capacitor Replacement Manual," this attractively-printed brown and yellow card shows listings of the company's "Twist-Lok" electrolytics being used in almost every 1953 model television receiver.

An invaluable aid to service technicians in locations where TV is just opening up, this card is punched for easy wall hanging and has a large area for the distributor's imprint.

Copies of C-451 are available from *Sprague* distributors. Distributors should write to the company direct.

EICO DECAL

Electronic Instrument Co., Inc., 84 Withers Street, Brooklyn 11, New York, has released a colorful business-building decal for service technicians to attach to their windows and vehicles.

The new "Eico" decal sells the technician's ability to his customers and prospects and identifies him as a user of "Eico" laboratory equipment. These three-color decals are being packed with the company's kits and instruments or may be obtained in quantity from the company direct.

RECEIVING TUBES

A complete guide to the company's "Reliatron" receiving tubes to aid design engineers, service technicians, amateurs, and experimenters is now available from Dept. T-329, *Westinghouse Electronic Tube Division*, Box 284, Elmira, New York, for 35 cents.

The 47-page booklet, RU-020, contains characteristics and ratings of over 300 tube types. The guide has been designed for ease of use; tube symbols are easily interpreted and are closely associated with their tabular information. The tabulations are presented in legible style. The only cross references employed associate the tube type to its dimension drawing.

ANDREW PRODUCTS

A new general price list, Bulletin 10-F, has been issued by *Andrew Corporation*, 363 East 75th Street, Chicago 19, Illinois.

This 30-page catalogue covers the company's coaxial cables and transmission lines and antennas and related equipment. Complete descriptive material is provided on a wide range of these products and all of the necessary data for ordering is included.

Write the company direct for a copy of Bulletin 10-F.

ENJOY THE FULL RICHNESS
OF FULL FREQUENCY RECORDING...

The FAIRCHILD

SERIES 215

HIGH-COMPLIANCE

Diamond Cartridge



Now Only \$37.50
WITH FINEST DIAMOND STYLUS

This amazing new cartridge, a radical departure from ordinary cartridge design, achieves near-zero mass of stylus assembly. The result is HIGH COMPLIANCE — accurate, distortion-free tracking which reproduces without listening fatigue the full, rich tonal qualities of the most sensitive recordings.

"Amazed at new purity of sound... clarity... distinctness of orchestral texture... which all add up to something fabulously beautiful!" says B. H. Haggin, noted Record Reviewer.

FAIRCHILD RECORDING EQUIPMENT? 8th Ave. & 154th St., Whitestone, N. Y.
Manufacturers of the World's Finest Professional Sound Equipment

ORDER FROM YOUR AUDIO DEALER or mail coupon for FREE folder

Without obligation, please mail FREE folder, "HI-FI FACTS for the Music Lover"

Name.....

Address.....

City..... State.....

Let MILTON S. KIVER Help You Prepare For U.H.F.-TV And...

TELEVISION SERVICING

Easy to TRAIN AT HOME This Practical Way!

Men with the right training in Television Servicing are in big demand... pull down big pay. T.C.I. TRAINS YOU RIGHT with easy-to-follow technical training designed by servicemen for servicemen! You learn practical, professional type Television Servicing without leaving your present job. Included are money-making extras such as set conversion, master antenna installation, U.H.F. TV and field servicing short cuts. You can start earning Television money after the first few lessons. You earn to test, trouble shoot and repair all types of TV sets the proven, practical way!

HERE'S HOW YOU GET EXPERIENCE!

You train on your own large screen modern television receiver, furnished as part of your course. This set is yours to keep! As an optional feature you can get two weeks of actual field experience out on service jobs and on the repair bench for Chicago's largest independent servicing organization. You learn Television Servicing by actually doing Television Servicing... you get the practical know-how you need to qualify for BIG MONEY in this fast-growing field! Age is no barrier. Many TCI students are over 40!

VETERANS! T.C.I. is approved for G.I. training under Public Law 550. Check coupon.

ACT NOW! Mail coupon for FREE Catalog and SAMPLE LESSON. Write TODAY!



YOU GET and keep modern large screen Television receiver.

YOU DO actual testing, servicing, trouble shooting and repairing

BEGINNERS! LEARN ABOUT NEW BASIC TV COURSE!

You don't need radio experience for practical, home-study training in Basic Television. Start earning money in TV after first few easy lessons. Check coupon for details.

MAIL NOW FOR FREE BOOKLET

MILTON S. KIVER, President
TELEVISION COMMUNICATIONS INSTITUTE
205 W. Wacker Dr., Dept. AT, Chicago 6, Ill.

Flush full facts on practical TV training. I am not obligated. Salesman will not call.

Name..... Veterans: check here

Address.....

City..... Zone..... State.....

BEGINNERS check here for information on Basic Television Course.

TELEVISION COMMUNICATIONS INSTITUTE
205 W. Wacker Dr., Dept. AT, Chicago 6, Ill.

Have you had the
Chassis Touching
JITTERS
Lately?



Adjust-A-Volt

VARIABLE TRANSFORMER

with isolated primary winding lets you service any TV or radio set made without a chance of a "bite" . . . no more chassis touching jitters.



This husky 1/2 KVA electro-statically shielded unit is "Must" test equipment for thousands of service men. Intermittent operating TV or radio sets are checked by dropping line voltage to 105 V or lower to detect a faulty oscillator. Also used to cook a set at 130-140 V to break down intermittent part. On any application where either isolation or a variable transformer is needed Adjust-A-Volt will do the job. Black wrinkle finish, jeweled pilot light and convenient fuse. Write for new 18-page catalog listing all types and sizes, or see your Adjust-A-Volt distributor.

**STANDARD
ELECTRICAL PRODUCTS CO.**

2238 E. THIRD ST. • DAYTON, OHIO

NEW TV PRODUCTS on the Market.....

U.H.F. CONVERTER

Granco Products, Inc., 36-17 20th Ave., Long Island City, N. Y. is now offering two new front-end chassis for all-channel u.h.f. reception.

Termed "Hideaway" units, the Models UJ5 and UJ6 are adaptable to any TV chassis for the purpose of obtaining built-in u.h.f. reception. The Model



UJ5 is designed especially for fringe area reception. It tunes the entire u.h.f. band, utilizing three coaxial tuned cavity elements, two as preselectors and one controlling the local oscillator. The unit also contains a 6AF4 oscillator and a cascode i.f. amplifier. Good signal-to-noise ratio is assured by the absence of wiping contacts and a low noise 1N82 silicon diode mixer. Channels 5-6 are used as the i.f.

The Model UJ6 is a two-cavity, all-channel reception model. Details on either of these converters are available from the company on request.

AUTOMATIC LEVEL CONTROL

Spencer-Kennedy Laboratories, Inc., 186 Massachusetts Ave., Cambridge 39, Massachusetts is now marketing its Model 442 automatic level control for television distribution systems.

The new control is designed to automatically maintain proper signal strength. The unit is designed to compensate for changes in transmission characteristics of the cable due to temperature changes and variation in amplifier performance due to tube aging. Because the Model 442 is a wide-band unit, it will operate equally well on either low- or high-band systems.

Tube failure in the control itself opens up the gain in the associated amplifiers so that the new unit in the system corrects for any variations in the levels. This insures continuous performance and makes replacement

of the tube postponable until a convenient time.

For further information on the Model 442, write the company direct.

REMOTE BOOSTER CONTROL

Blonder-Tongue Laboratories, Inc., 526-536 North Avenue, Westfield, N. J. has introduced a new, two-piece remote control unit which permits any of the company's television amplifiers, u.h.f. converters, or distribution units to be operated automatically from the TV set "on-off" switch.

The power control unit of the Model RC-1 plugs into a 117-volt a.c. outlet and receives the TV set line cord. It contains a thermo-relay, an indicator light, and fuses. The remote portion at the unit to be controlled, feeds a.c. power and accepts TV signals. For outdoor installations, the remote section may be mounted in a weatherproof housing, along with the amplifier or other unit.

The company will supply additional details on this accessory unit upon request.

SCOPE FOR TV

A new 5" television scope, designed to provide all of the features needed by technicians and at low cost, has been released by The Hickok Electrical Instrument Co., 10514 Dupont Avenue, Cleveland 8, Ohio.

The Model 665 is a stable scope with a frequency range from .5 cycle to 700 kc., down 3 db. It features good stability, no drift, less than 1% tilt, and less than 2% overshoot. The accelerating potential is 1775 volts and power



consumption is 35 watts. The square-wave response is flat from 60 cycles to 100 kc.

A unique feature of the scope is the fusing arrangement for the "B+" line. A dual fuse is provided so that the "B+" line is entirely fused. The scope will withstand shock, vibration, and humidity, and has been designed with

RADIO & TELEVISION NEWS

THE NEW TV DYNATRACER

TRACES TV SIGNALS and VOLTAGES

LOCATES DEFECTIVE COMPONENTS INSTANTLY

REQUIRES NO ADDITIONAL EQUIPMENT

Makes Television Servicing Easier, Faster and More Accurate —AT LOW COST

\$495
Fpd.
or C.O.D.
+ Chgs.

Ideal for trouble-shooting television in the field or on the bench. Used under actual operating conditions, will out-perform more expensive testers.

A MUST FOR EVERY ALERT TV TECHNICIAN!

SPECIFICATIONS: The "DYNATRACER" is a self-powered quality instrument designed to trace TV signals through any Video, Sound, Sync, AFC or Vertical and Horizontal Sweep Circuit—will isolate trouble to a stage or component.

ADDED FEATURE: The "DYNATRACER" will also trace voltages and instantly locate open, shorted or intermittent condensers, resistors, coils, speakers, transformers, etc.

COMPLETE INSTRUCTION BOOK ENCLOSED

10-DAY MONEY BACK GUARANTEE

Clip adv., write name and address in margin. Attach \$5.00 Bill, Check or M.O. and mail to

Century ELECTRONICS CO.
8509-21st Ave., Dept. 206, Brooklyn 14, N. Y.

FIX 3 OUT OF 4 Television and Radio Receivers

Just by reading this one book!

TELEVISION AND RADIO REPAIRING

It's easy with these plain, simple directions written for the man with no technical training. You deal only with the things that go wrong in sets—the parts—start doing actual repair work even before you finish the book. Just think—No Math! No Theory! No Lab work!

Just Published!

Television and Radio Repairing

by John Markus • 556 pp., 225 illus., \$7.95

For every television and radio part, no matter what make the set is, Markus shows you how to recognize symptoms of trouble . . . how to test to make sure . . . how to order the new part . . . and how to install it. Here's your chance to share the big money going to servicemen today—without investing a good deal of cash—and by starting right in your own home or working for a service outfit. First repair job pays for the book.

- Shows you how to:
- Test tubes without a tester
 - Eliminate noise in receiver . . . improve d m TV picture
 - Repair, replace, adjust all parts
 - Solder connections
 - Install antennas
 - Run your own service shop profitably
 - and many others

—SEE THIS BOOK 10 DAYS FREE—

McGraw-Hill Book Co., Inc., 330 W. 42 St., NYC 36
Send me Markus' Television and Radio Repairing for 10 days' examination on approval. In 10 days I will remit \$7.95, plus few cents for delivery, or return book postpaid. We pay delivery if you remit with this coupon; same return privilege. **PRINT**

Name

Address

CITY..... Zone..... State.....

Company

Position

RTN-11

This offers applies in U.S. only.

push-pull amplifiers with a vertical sensitivity of .020 millivolt per inch. Horizontal sensitivity is .030 millivolt per inch.

Complete information is available from H. D. Johnson of the company.

TV BAR GENERATOR

Electronic Measurements Corporation, 280 Lafayette St., New York, N. Y. has announced the availability of a new r.f.-a.f. crystal marker-TV bar generator that offers a number of unique features.

The Model 700 provides complete coverage from 18 cycles to 108 mc. on



fundamentals. It provides a bar generator for TV adjustment with a variable number of bars available for horizontal or vertical alignment and a square-wave generator to 20 kc. The unit has a Wien bridge a.f. oscillator with sine-wave output from 18 cycles to 300 kc. and a crystal marker and amplitude control.

Other features include individually-tuned coils, constant r.f. output impedance, stepped r.f. attenuator, electrostatically shielded transformer, and a Colpitts r.f. oscillator from 300 kc. to 108 mc. on fundamentals and up to 216 mc. on second harmonics. A variable percentage of modulation is available.

NEW ANTENNAS

Bruch Manufacturing Corp., 200 Central Ave., Newark, N. J. is now offering a broadband u.h.f. antenna, the rhombic Model #496. The new unit is designed to meet the requirements of primary and secondary signal areas as the sharp directional characteristics of the antenna are especially effective in areas bothered by signal reflections and station interference. Catalogue 53-T is available on request.

Chumel Master Corporation, Ellenville, N. Y. is in production on a new broadband u.h.f. antenna, the "Bow-Flector" Model 408. This antenna is said to provide gain of up to 12½ db stacked and to 10 db single. The new lightweight unit combines speedy, economical installation with high gain. Complete technical literature is available from the company.

Clea Beam, Inc. of Burbank, California has developed a "built-on" TV antenna designed especially for trailers. Known as the "Trailer-Tenna," the new unit anchors to a position 2" above the roof, mounted on a tele-

SEEING'S BELIEVING



No other manufacturer gives you all the facts!

Only Centralab shows you specifications in black-on-white for every ceramic capacitor sold

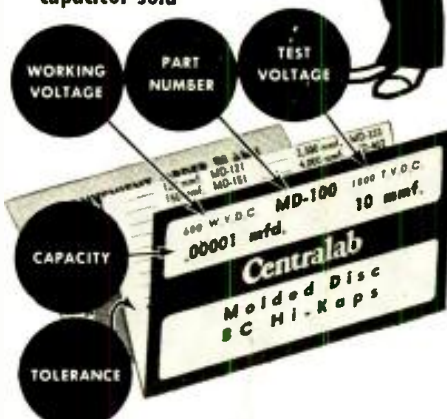

When you buy Centralab ceramic capacitors you get all the facts . . . all the quality . . . all the performance. Unlike ordinary ceramic capacitors or "grab bags," you get full value for your money!

You know beforehand what you're buying, and why you can be sure of a better job. When selling customer service, it just doesn't pay to buy ceramic capacitors in the dark. So be sure, be safe, be satisfied — rely on Centralab every time!



AND BEST OF ALL—YOU PAY NO MORE FOR CENTRALAB CERAMIC CAPACITORS. STOCK UP NOW — GET 'EM IN PACKAGES OF FIVE OR IN HANDY KITS.

Centralab

CENTRALAB
A Division of Globe-Union Inc.
910K E. Keefe Ave., Milwaukee 1, Wis.
Please send me Catalog 28 with technical data on Centralab Ceramic Capacitors.

Name.....

Firm.....

Address.....

City..... Zone..... State.....

WORLD'S LARGEST MANUFACTURER
OF CUSTOM BUILT TELEVISION

MATTISON

SILVER ROCKET 630 CHASSIS

• with TUNEABLE •

**BUILT-IN BOOSTER
for Better DX Reception**

Featuring **NEW CASCODE TUNER**
made for UHF interchangeable
tuning strips and **COSINE YOKE**

Tube
Complement:
28 tubes
3 rectifiers
1 CRT

32

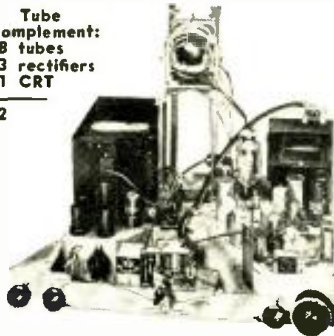

All Channel Booster

- Broad band single knob control pre-amplifier built in to eliminate long leads which may cause regeneration and attenuation of signal.
- **ONLY THE MATTISON 630 CHASSIS HAS AN ALL CHANNEL TUNEABLE BUILT-IN BOOSTER THAT INCREASES SIGNAL STRENGTH UP TO 10 TIMES. THE SILVER ROCKET WILL OUT-PERFORM ANY CHASSIS MADE AND IS PRICED RIGHT TO SELL FAST WITH AN EXTRAORDINARY MARGIN OF PROFIT FOR YOU. ALSO AVAILABLE WITHOUT BOOSTER.**

AVAILABLE FOR IMMEDIATE DELIVERY!
SILVER ROCKET FOR 27" OPERATION

ANNOUNCING
the New
AMBASSADOR
for 1954

The only open
face console
made in every
expensive
decorator
finish . . . on
guaranteed
genuine ma-
hogany, walnut,
oak and other
rare woods!



The **AMBASSADOR 21" and 27"**
Best Looking . . . Best Value, Too!

Full size console for eye level television. Available in every expensive decorator finish. Featuring removable safety glass. ALL CABINETS MADE IN MATTISON'S OWN CABINET FACTORY.

DEALERS! SERVICE DEALERS! Here is your opportunity to become the "important" TV Dealer in your area for THE FINEST CUSTOM-BUILT LINE OF TV RECEIVERS. FREE!! Write for Mattison's merchandising portfolio explaining the "UNASSEMBLED PLAN" and "\$1,000,000 FLOOR PLAN."



Manufactured with integrity

When you buy from Mattison you need only one source of supply! You can buy a Mattison Chassis, a Mattison Cabinet or a complete Mattison TV set!

Mattison Television & Radio Corp.

10 West 181st St., Dept. RN, N.Y. 53, N.Y.

scopic pole when the trailer is in motion. When parked, the antenna can be raised in a few seconds. It will cover both v.h.f. and u.h.f. channels. The antenna comes in kit form and can be installed in a few minutes.

JFD Manufacturing Company, Brooklyn 4, N. Y. is now in production on a new model "JeT213" v.h.f. antenna which provides a flat gain curve for channels 2 to 6 indicating the effect of dual reflector action. It is available completely assembled in either single or two-bay arrays. The company has technical and sales literature available on request.

LaPointe Electronics Inc., Rockville, Conn. is featuring its "Vee-D-Xtra Special," a new antenna designed to combine yagi power and directivity with all-channel performance. It is well adapted for use with the company's new antenna rotator which is also being introduced. The antenna is a high-low yagi phased together with the company's new printed circuit isolation filter. There are five elements for high-channel reception and four elements for low.

Snyder Manufacturing Company, Philadelphia 40, Pa. has a new bow-tie with reflector now available for u.h.f. applications. The UHF-5 is of collapsible space-saver design and is factory pre-assembled. The antenna features aluminum elements, an all-welded heavy-duty reflector screen, and single "U-bolt" installation.

Radio Merchandise Sales, Inc., 2016 Bronxdale Avenue, New York 62, N. Y. has developed a new u.h.f. indoor antenna, the Model IBT-500. The mahogany-colored antenna stands about 8½" high in a heavy metal base which cannot be tipped over. The twin-lead, of generous length, is attached and has spade lugs for easy connection to the set.

United Motors Service Division of General Motors Corporation has nine "area engineered" u.h.f. and v.h.f. television antennas now ready for distribution. Included in the new Delco line are antennas to solve the varied reception problems found in different TV localities. A catalogue picturing each antenna, along with an area map showing the preferred application for which the antenna was designed, is being issued to insure proper installation.

JEB ANTENNA ROTATOR

Jeb Sales Corporation, 41 Wyckoff Avenue, Brooklyn 37, New York has recently introduced a new antenna rotator which is claimed to have at least three times the power of comparable rotators.

The motor has a ¾" lamination and is capable of developing 40 footpounds torque at the antenna mast. Power is transferred through a smooth, anti-rust, lifetime-lubricated gear train. The rotator will handle the largest four-stacked arrays in 90 mph gales, according to the company.

A mahogany control cabinet, which stands just 2½" high, has a highly

STOP

Volume
Control
Noise!



"NO NOISE"

Contains the
amazing new

PERMA-FILM

- ★ **CLEANS!**
Gets rid of dirt and oxidation immediately on contact.
 - ★ **LUBRICATES!**
The drop eliminates scratch, hum and noise.
 - ★ **PROTECTS!**
NEW Perma-Film assures continued top performance.
- The **PERFECT Contact Restorer**
Cleans and restores volume controls, band switches, push button assemblies, electrical contacts.
- **NOT A CARBON TET SOLUTION**
NO NOISE is a scientific formula especially compounded for contacts!

Available in 8 oz. 2 oz. Bot-
tles, quart cans
and 6 oz. spray
can. Servicemen

\$1.00

Nearest Distributor or order direct from
ELECTRONIC CHEMICAL CORP.
813 Communipaw Ave., Jersey City 4, N. J.

ROUND, SQUARE, KEY and "D"
OPENINGS QUICKLY MADE
with Greenlee
Radio Chassis Punches

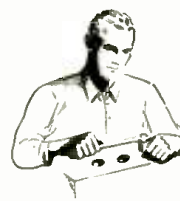

Save hours of hard, tedious work . . . cut accurate holes in chassis for sockets, plugs, controls, meters, panel lights, etc. with GREENLEE Punches. In 1-1/2 minutes or less make a smooth hole in metal, bakelite or hard rubber up to 1/16" thick. Easy to operate . . . simply turn with ordinary wrench. Wide range of sizes. Write for details. Greenlee Tool Co., 1891 Columbia Avenue, Rockford, Ill.



RADIO & TELEVISION NEWS

readable dial giving both compass points and numerical readings. One switch, a convenient rocker arm, instantly stops or reverses the rotator. The rotator goes on when it is operating, but is not connected to the line unless it is operating. The control case operates on 117 volts, 60-cycle a.c. and its input power is 30 watts.

ALLIANCE "TENNA-ROTOR"

Alliance Manufacturing Company, Alliance, Ohio has added two new "Tenna-Rotors" to its line of television antenna accessories.

Both models represent a considerable departure from the styling and appearance of the company's earlier



models. The Model T-10 is a manually-operated unit which features a simplified control bar across the top of the rectangular case. The Model U-83 is fully automatic with a completely restyled and redesigned exterior. It occupies less space than its predecessor model.

Other improvements include a new and stronger die-cast housing on the rotator, faster rotation, new magnetic brake, more accessible terminal block, guy wire attachment on clamp plate, and, on the automatic model, easier synchronization of rotator and control and an increase in the speed of rotation.

"VU-MATIC" CONTROL

Raytheon's Television and Radio Division, 5921 W. Dickens Ave., Chicago 39, Illinois has unveiled its 1954 line of television receivers which feature the company's all-new "VU-matic" control unit.

The new control permits one knob tuning of all 82 v.h.f. and u.h.f. channels, and the switching of v.h.f.-u.h.f. antennas, circuits, and extra amplifiers—all automatically. The new chassis also shuts out picture interference and stops oscillator radiation, according to the company.

NEW ANTENNA MAST

Chammel Master Corporation of Elmhurst, N. Y. has introduced a new antenna mast which features a unique safety device, the "Third Hand."

One of the major features of this mast is an automatic, removable locking device that actually acts as a "third hand", holding mast sections up when the installer lets go. Both hands can actually be removed from the mast at any time during elevation and sections cannot slide down.

THE BEST BUY IN AUDIO

the new H. H. Scott "99"

INCLUDES EQUALIZER — PREAMPLIFIER,
10-WATT AMPLIFIER, AND POWER SUPPLY.
\$99.95
net



THE TYPE 99-A TRANSCRIPTION AMPLIFIER

An H. H. Scott professional equalizer-preamplifier, 10-watt amplifier, and power supply — all complete in only 15 1/4 x 3 3/4 x 9 3/4 inches. Separate turnover and rolloff controls give 9 equalization curves. Continuously variable bass and treble cut and boost. Automatic loudness control with continuously adjustable compensation. Input selector for phono, tuner, tape, and TV. Inputs for magnetic, crystal, and constant-amplitude pickups and for Dynaural noise suppressor and dubbing records on tape. Level control for different pickups. Rumble filter with sharp cutoff below 20 cps prevents subaudible overload. Output tubes automatically balanced; speaker outputs 4, 8, 16, and 500 ohms. Write for free booklet No. RN-11. At only \$99.95, it's your best buy in audio!

A COMPLETE AMPLIFIER

99 **HERMON HOSMER SCOTT, INC.** **99**
"PACKAGED ENGINEERING"
385 PUTNAM AVE. • CAMBRIDGE 39, MASS.

Check! these N.J.R.T. TUBE prices 70% to 90% off list . . .

Type	Price	Type	Price	Type	Price
1A7GT	.45	6AQ5	.37	6SK7GT	.39
1B3GT	.47	6A06	.35	6SL7GT	.46
1H5GT	.38	6AT6	.35	6SN7GT	.50
1L4	.44	6AU4GT	.69	6SQ7GT	.35
1L3	.41	6AU6	.36	6T8	.54
1L3S	.49	6AV6	.35	6UB	.59
1L4S	.49	6AX4GT	.57	6V6GT	.37
1N5GT	.44	6BA6	.41	6W4GT	.42
1R3	.43	6BA7	.57	6W6GT	.45
1S3	.37	6BC5	.42	6X4	.35
1T4	.43	6BD6	.45	6X5GT	.35
1U4	.43	6BE6	.37	7F8	.63
1U5	.37	6BE6G	.92	12AL5	.40
1X2	.52	6BH6	.44	12AT6	.35
3A4	.43	6BJ6	.41	12A7	.54
30A	.46	6BK7	.65	12AU6	.38
3Q4GT	.47	6BL7GT	.60	12AU7	.41
3S4	.44	6BQ6GT	.57	12AV6	.50
3V4	.45	6BQ7	.80	12AV7	.57
5AR4	.50	6BZ7	.89	12AX4GT	.46
5U4G	.45	6C4	.39	12SK7GT	.46
5Y3GT	.30	6CB6	.42	12BA6	.36
5Y4G	.33	6CD6G	1.09	12BA7	.44
5Z3	.37	6F6C	.37	12BE6	.37
6A3	.57	6F6GT	.35	12BH7	.65
6AR5	.49	6J5GT	.40	12SA7GT	42
6AE4	.42	6J6	.50	12SK7GT	.46
6AF4	1.06	6K6GT	.35	12SN7GT	.50
6AF6	.75	6L6	.62	12SQ7GT	.42
6AK5	.41	6S4	.37	12SR7MET	.47
6AJ5	.88	6S8GT	.51	12V6GT	.60
6AK5	.73	6SA7GT	.41	19BG6G	.96
6AL5	.36	6SD7GT	.39	19T8	.77

Guarantee

ALL NJRT TUBES ARE BRAND NEW AND FULLY GUARANTEED FOR 1 YEAR

Type	Price
25BQ6GT	.60
25L6GT	.37
25W4GT	.45
25Z6GT	.35
35A5	.50
35B5	.38
35C5	.37
35L6GT	.40
35W4	.35
35Z3	.43
35Z5GT	.35
42	.40
43	.53
45	.53
50B5	.37
50C5	.37
50L6GT	.39
70L7GT	1.07
76	.42
117Z3	.35
807	.97

T.V. PIX TUBE BRIGHTNER \$1.59
LOTS OF 10 \$1.49

Free 50
assorted condensers with each \$25.00 tube order.

For T.V. sets where voltage supply is low AC LINE BOOSTER \$5.95 with safety fuse and switch



Many 7 volt types not listed. All tubes individually boxed. Minimum order \$10.00. Tubes offered subject to prior sale. Prices subject to change. Orders shipped prepaid if check is enclosed. 25% deposit required on c.o.d. shipments.

SEND FOR FREE TUBE LISTING

NEW JERSEY TELEVISION SUPPLY CO.
906B WESTFIELD AVE., ELIZABETH, N. J. EL 3-6166

CRYSTALS!

In FT 241-A Holders—1/2 in. Pin 5PC. These are designated 54th Harmonic MC freq. Listed by fundamental freq. with fractions omitted.

370	392	414	437	459	477	505
372	394	416	438	460	479	507
374	396	418	440	462	481	509
375	398	420	442	464	483	511
377	400	422	444	466	485	512
379	401	424	446	468	487	514
381	403	426	448	470	488	516
383	405	427	450	472	490	
385	407	429	451	474	492	
387	409	431	453	476	494	
388	411	433	455	478	496	
390	412	435	457	480	498	

5 CRYSTALS... \$3.95 Assorted ONLY \$2.49
10 for... \$7.95
COMPLETE SET!!!!—80 crystals covering above basic freq. including a 500 Kc. crystal. Lowest Price in United States! Only \$12.50.

SPECIAL 500 Kc. Crystal... \$1.25
200 Kc. Crystal... 2.25
All above crystals sent postpaid in U. S. only. Also available in complete sets for SCR-600B, SCR-528, SCR-628, and TRC. Foreign, wholesale, and dealer inquiries invited. NOTE: Crystals guaranteed to oscillate. Frequencies not checked.

SUPREME MODEL 600 Illuminated TUBE & SET TESTER

Tests all latest tubes, seven in. multi-tester tests DC 0-2,500 V. in 7 ranges. AC 0-2,500 V. in 6 ranges. DC current 7 ranges: 0-1,000 microamps, 0-1,000 ma., and 0-10 amps. Ohmmeter, 5 ranges: 0-50 ohms. Output meter and battery tester which tests radio batteries under load. Comes with test leads and gray metal hammerloid case. Size: 11x13x3 1/2 in. Factory guarantee includes 1 year of free tube setting service. BRAND NEW IN ORIGINAL BOXES. You know this set is designed to meet for \$117.50. While they last, our price—the country's lowest, only... **\$63.95**

ARC-4 VHF 2-METER TRANSCEIVER. All tubes. Excellent cond. With conversion data. \$27.50
PE-104 VIBRATOR SUPPLY. Part of RC-654. Trans. Rec. 6 or 12 V. input. Output, positive: 6, 14 and 84 VDC; negative: 1.4, 6, 12, 51 VDC. New with spare parts. \$12.95
EP-8 FIELD TELEPHONE. Excellent condition. Each \$1.50. Per Pair \$32.50
TR-3 SOUND POWERED EF-8 TELEPHONE. Excellent for field, contractors, outdoors, etc. NEW in original box. Each \$35.00. Per Pair \$65.00
MINIATURE 6 V. WET CELL BATTERY. With 6 V. rev. DC motor. F.B. for R.C. boat. 3 1/2x2 1/2x1 3/4". Battery less motor... \$1.49. With motor... \$2.99

HEADSETS

HS-23. High Imp. New, original box. Ea. \$4.50
HS-30. New \$4.49
HS-33. Low Imp. New, original box. Ea. 5.50

HOT TUBE ASSORTMENT!

Transmitter receiving, power, etc. Includes 6AC7, 1A10, 102D, 5Y3, 6GLC, 6SH7, 801, 12AB, etc.
20 assorted tubes... \$4.95

BD-77 DYNAMOTOR. 12 V. input. 1,000 V. output @ 350 mls. New... \$22.95

AIRCRAFT, HAMS & MARINE MEN!

SCR-1R3 12 V. RECEIVER & TRANSMITTER! Covers aircraft, marine and ham bands! Complete with 2 coils, control boxes, tuning head, flex cable, rack and shock mount! Plus 12 V. dynamotor! Individual parts worth \$25.25. Approx. 25w. output. EXCEL. COND. COMPLETE with schematic. Never before sold at this sensationally **\$15.95** low price.

SWINGING CHOKES: 25 henry, 300 ma. Ea. \$3.95
3-INCH "S" METER: 0-200 microamps movement. Dkt over 89 to 10 and 20. Good for AM or FM. New in orig. box... \$5.95

FM WOBULATOR: For TV FM/AM sweep generator. Excellent cond. with schematic... \$5.95

12 V. UHF TRANSMITTER-RECEIVER: Same as APS-13. Complete with 12 V. dynamotor & tubes. Excel. for 420 ham band. Like new... \$22.95

ARC-5 OR 274-N TRANSMITTERS

2-1.3 mes. Brand new... \$19.95
3-4 mes. With tubes... 25.00
4-5.3 mes. With tubes... 8.95
5-3.7 mes. With tubes... 6.95
7-9.1 With tubes... 14.50
T-23 ARC-5 VHF TRANSMITTER. For C.A.P. with tubes 100-136 MC. Crystal control... 29.95

ARC-5 OR 274-N RECEIVERS

Equipped with tuning knobs... \$19.95
10-55 kc. Like new... 24.50
1-5.3 mes. Brand new... 22.50
3-6 mes. With tubes... 10.95
6-9.1 mes. With tubes. Used... 7.95
New... 22.50
6-9.1 mes. Used. Less tubes... 6.95
BC-456 274-N Modulator. Less dynamotor. Excel. cond. 3.95
12 V. COMMAND RECEIVER DYNAMOTOR. New... 12.95
Plus All Accessories Needed for Above. Conversion dope available on request.

Write Today—and ask for FREE CATALOGUE!
All orders F.O.B. Los Angeles. 25% deposit required.
All items subject to prior sale.

COLUMBIA ELECTRONIC SALES

522 South San Pedro St. Los Angeles 13, Calif.

**KEEP UP TO DATE
READ
RADIO & TELEVISION NEWS
EVERY MONTH**

BARGAIN HUNTING? **RADIO SERVICEMEN!**
Write for SENSATIONAL CATALOG
HENSHAW RADIO SUPPLY
3619 TROOST KANSAS CITY, MO.

Another new feature is the "step-up key," a metal stamping that makes for

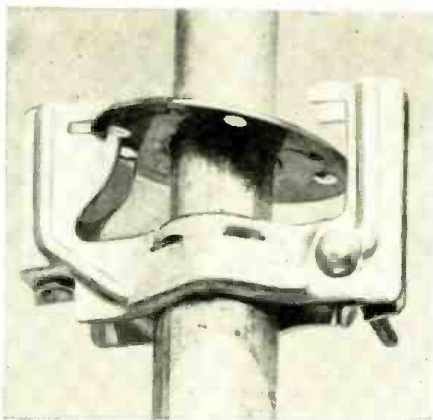

fast, simple mast indexing. This key automatically extends each mast section for elevation—no hardware or locking bolts are needed. Beaded safety rings keep the mast sections completely interlocked and concentric at all times.

Write to the company direct for complete technical literature on these new masts.

BEAD CHAIN

The Bead Chain Manufacturing Co., Bridgeport, Conn. is now suggesting a new use for its versatile bead chain.

With accurate spacing and a new method of closing the end, non-kinking, low-friction bead chain makes a trouble-free belt drive for TV tuners, timing devices, recorders, etc.

Specially designed sprockets fit the individual beads and eliminate slippage and backlash. Tensile strength of bead chains ranges from 15 pounds to 200 pounds depending on the size of the bead and the metal used.

For further information on bead chain applications in the electronic field, write the company direct.

U.H.F. SWEEP GENERATOR

Telonic Industries, 444 South Rural St., Indianapolis, Ind. has introduced a compact u.h.f. sweep generator which is available in two models.

Both models are housed in grey hammerloid enamel cabinets which measure 10" x 12" x 9" and weigh 20



pounds. Both cover the range 420-930 mc. and have sweep widths of 0-50 mc. The Model "S" contains a sweep oscillator only while the Model "SM" incorporates both sweep and marker oscillators.

For full details, catalogue, or other information, please write the company direct.

NEW "TUBE CADDY"

Argos Products Co., Genoa, Illinois has added a fourth "Tube Caddy" to its line of carrying cases for the television technician. The new item, called the "Carry-All Tube Caddy," differs from the other three in that it opens from the top in spread-eagle fashion making three large compartments immediately available.

The new unit can carry up to 262 receiving-type tubes in the various sizes normally required. Since missing cartons are easily spotted, the technician or shop owner can take inventory at a glance. Any of the compartments is also big enough to accommodate a soldering gun, meter, and other equipment.

TV REMOTE CONTROL

A universal TV remote control unit which may be attached to any conventional TV receiver is being offered by Gonset Company, 801 S. Main St., Burbank, California.

Featuring a Standard Coil cascade tuner ahead of a booster amplifier, the unit not only permits channel selection from the viewing position but provides improved reception in fringe areas.

RADIO AMATEUR WEEK?

JESSE KIMMONS, W40V0, Leesburg, Fla. has come up with an excellent idea which has our unqualified support and should carry the endorsement of both the electronic industry and "hamdom."

Jesse suggests that it is about time that a "National Amateur Radio Operator Week" be established to honor the amateur and give public acknowledgement to his invaluable contributions to the public safety.

He has contacted his own Senator and Representative who have pledged their support of the project. Since the requests for "Weeks" have been mounting in recent years, President Eisenhower has decided to proclaim only those "Weeks" established by Congressional action.

Senator George Smathers and Representative A. S. Herlong, Jr. of Florida have expressed their willingness to introduce such a bill providing Jesse can produce sufficient evidence of amateur and industry backing.

In order to determine the feelings of the amateurs themselves, Jesse asks that all hams drop him a QSL card, letter, or post card expressing their views. He will then classify this material by states and Congressional districts and see that the Senators and Representatives for the states represented are notified of the amateurs' desires in this matter. It's up to you fellows!

Although Jesse is acting as an individual amateur in this project, we hope that all who are interested in ham radio will rally around and put this "Week" across.

Send your letters to Jesse at 1304 High Street, Leesburg, Florida. Let's see if we can get this rolling!



TEST EQUIPMENT

Complete Line

DuMont 224-A Oscilloscope		
I-77 Hickok Tube Checker		
I-208 FM Signal Generator		
Hewlett Packard 200C		
I-198	TS16/APN	TS-118/AP
BC-638	TS23/APN	TS-126
BC-1255	TS-24A	TS-127/U
CW1-60ABJ	TS-28/UPN	TS-131
IE-36	TS27/TSM	TS-148/UP
I-95	TS-33	TS-170/ARN
I-96-A	TS34/AP	TS-173/UR
I-122	TS-35/AP	TS-174/UR
I-130A	TS36/AP	TS-175/UR
I-139	TS-45A	TS-182/UP
I-145	TS-59/APN	TS-184A/AP
I-121	TS61/AP	TS-204/AP
I-222	TS89	TS-218
TS-3A/AP	TS92	TS-251
TS10/APN	TS100/AP	TS-323/UP
TS12/AP	TS-102	1-146
TS-13 Spare	TS111/CP	TS-268/U

Paris Kit

Buonton Mod.	LAD Sig. Gen.
78B Sig. Gen.	LAE-2
Buonton Type	LAVOIE Freq. Meter: 300-102F Sig. Gen. 600 Mc.

RADIO AND RADAR

APR-4 New APS3	RC-184IFF
Complete APS-6 New	RC-214
APR-5	Complete RC-224
APS-4 New APS-2	RC-266
Complete MARK 28	
RT34/APS13	PP-104/APT-5
T-85/APT-5	APS-6

BC433 C Radio Compass.....32.50
 AM-26/AIC Interphone Amp.....22.50
 RT-19/ARC-4 Transceiver.....35.00
 APR-1 Absolute Altimeter.....9.95
 CRT-3 Gibson Grl, 2-Channel...75.00

MISCELLANEOUS

Tubes - Selys synchro motors - AN Cannon - British Coaxial fittings, plugs
GOVERNMENTS - AIRLINES
 Send for FREE catalogues on

Communication Equipment	<input type="checkbox"/>
Inverters - Dynamotors	<input type="checkbox"/>
Radio-Radar Test Equip.	<input type="checkbox"/>
Aerial Photographic Equip.	<input type="checkbox"/>

EQUIPMENT WANTED

Semler Industries, Inc.
 6853 Lankershim Blvd, North Hollywood, Calif.

RECORDING TAPE (Plastic Base) 40% OFF (NEW)

WASHINGTON, D. C. WHERE ELSE WOULD THERE BE MORE RED TAPE?
 • 1200 ft. Plastic tape with plastic reel included.
 • Each reel individually boxed.
 • Choice of nationally famous top quality brands such as:
 • Velleux (2906) 3.20; Reeves (SPN-12) 3.20; Audio (1251) 3.20; Scotch (111-A) 3.25; Panacoustic (711-A) 3.25; Irish, Professional Grade (211 RFA) 3.30.
 • Recording studios, schools, radio stations and other large quantity users—write for bulk price.

USED RECORDING TAPE (PLASTIC BASE)

1.99	for 7"-1200 foot
.99	for 5"-600 foot
.59	for 4"-225 foot
.29	for 3"-150 foot

Plastic reels included with all above sizes.

New empty plastic reels in boxes for easy labeling, 3" 10c; 4" 22c; 5" 24c; 7" 30c; 7" Professional reel (2 3/4" hub) 75c ea. EMPTY BOXES: 3" 3c; 4" 5c; 5" 5c; 7" 10c ea.

We carry new recorders, recording blanks, tape, tape recorders, etc. at large savings. PLEASE INCLUDE SUFFICIENT POSTAGE.
COMMISSIONED ELECTRONICS CO.
 2503 Champlain St. N.W., Washington 9, D. C.

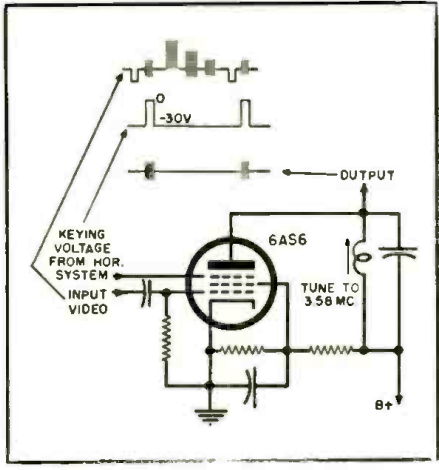

Fig. 10. Typical burst gate circuit.

the oscillator phase. The direct oscillator output is used as the color sync voltage for one demodulator, and a 90° phase shift produces a voltage suitable for the other.

The horizontal and vertical sync and deflection systems are conventional. Any special features will be entirely governed by the peculiar requirements of the picture tube used.

Since, in all probability, the first color receivers released will use the RCA tri-color tube, let us discuss some special requirements of this device. The three beam currents in this tube can total 750 microamperes, almost eight times the current required by present black and white picture tubes. This presents a serious problem with respect to high-voltage stability. This larger beam current causes excessive internal voltage drop in the high-voltage supply. Typical systems have a voltage of 27 kv. at zero beam and 19 kv. of 750 microamperes. Obviously, such a wide variation in high voltage would cause intolerable fluctuations in picture size and brightness. Hence, the need for a regulated supply. Techniques for holding the high voltage variation down to 3% (600 v. in 20 kv.) have been developed and successfully used in field tests.

Fig. 8 indicates that the RCA tube requires horizontal and vertical dynamic amplifiers. This requirement is dictated by the flat-faced geometry of the phosphor and aperture plates. As the beams are deflected from the center of the picture to the edges, they travel a greater distance from the center of the deflection to the screen. In order that the beams remain in focus and properly converged as they deflect across the tube it is necessary that the focus and convergence electrodes have a suitable corrective voltage superimposed on the 3 kv. and 10 kv. d.c. voltages nominally required. These dynamic focus and convergence voltages are obtained from the horizontal and vertical deflection system and fed through suitable shaping amplifiers.

The receiver outlined in this article and shown in Fig. 8 is the basis of a high quality color receiver. Because we have recovered I and Q at the demodulators and applied proper band

L. A. HAM SHACK SELLS FOR LESS
METERS—WESTON • SANGAMO
ALL NEW • ALL D. C. • 2" SQUARE

0-5 Ma	} EACH or 3 for \$9.00
0-15 Ma	
0-50 Ma	
0-100 Ma	
0-200 Ma	
0-300 Ma	

0-2 Ma \$3.95 0-500 Ma \$9.00
 Mfg.'s inquiries: lots over 100

Voltmeter, 2" sq.—0 to 20 Volts.....\$3.29
 DC Voltmeter, 2" sq.—0 to 300 Volts w/Ext. resistance. Complete \$3.95.....3 for \$9.95
 RF Ampmeter, 2" sq.—0 to .5 Amp.....\$3.95
 Ampmeter, 2" rd.—0 to 50 Amps.....\$3.29
 Ampmeter, 2" sq.—0 to 50 Amps.....\$3.29
 3" Round Meters, DC. All New. 0-15, 0-30, 0-300 Mills. \$4.95 Each.....3 for \$11.95
 Milliampmeters, 2 1/2" rd. 0-30 Mills. Each \$3.95
 Milliampmeters, 2" rd. 0-50 Ma. 0 to 5 Ma. movement. Each \$3.29.....3 for \$9.00
 Thermocouple, 2" rd. 350 Milliamp. HF.....\$3.29
 "5" METER. Illuminated face. Full scale reading of 5 ma. A standard value for most "5" Meter Circuits. 2 3/8". Black face. New.....\$2.49
 Amp. Meter. No. 60-0-60. New.....\$1.29

COMMAND AND/OR ARC 5 TRANSMITTERS and RECEIVERS

3-6 MC Receiver.....	New \$17.95
6-9.1 Receiver.....	Used 7.95—New 14.95
Triple Receiver Rack.....	Used 1.95
V.H.F. ARC 5 Transmitter or Receiver, Complete w/tubes.....	Used 24.95
ARC-4 w/tubes. Good.....	Used 22.95

4-5.3 MC Transmitter with tubes \$ 8.95
 5.3-7 MC Transmitter with tubes 8.95
 7-9.1 MC Transmitter with tubes 10.95 \$19.95
 3-4 MC Transmitter with tubes 18.95

DYNAMOTORS—NEW:
 BD-77.....\$24.95 PE-73.....\$9.95

HEAD SETS HS-33..... New \$4.95
 HS-30, single only..... New .95
 HS-23..... Used \$2.95
 Matching Transformer for HS-30...\$9

Cash with order. Calif. orders include 3 1/2% Sales Tax. Please include approximate postage—excess refunded.
L.A. HAM SHACK
 1306 Bond Street, at Pico, Los Angeles 15, Calif.

TRAIN FOR A SUPERVISORY POSITION IN ELECTRONICS

Thorough 2-year course covers electrical circuits and machinery, basic electronics and industrial electronics. Franklin Technical Institute graduates are in demand as junior engineers for research and test work, sales engineering, supervisory work on production lines and drafting room design work. Other engineering and technical courses. Coed. Day, evening, 45th year. Write for catalog.

FRANKLIN TECHNICAL INSTITUTE
 46 Berkeley Street Boston 16, Mass.

SOLAR MODEL CF Exam-eter

A must for the TV serviceman—Solar's famous Model CF is a sturdily constructed, reliable instrument designed to simplify Television and all other servicing.

- Has exclusive patented Quick-Check circuit for qualitative tests and intermittent checks without unsoldering capacitors
- Capacitance bridge—10 mmf to 2000 mf in 4 ranges
- Power factor—0 to 50 percent
- Insulation resistance—3 to 10,000 megohms
- Electrolytic leakage current reads directly on 4 1/2" meter
- Built-in d-c power supply continuously adjustable from 0-550 volts for electrolytic condenser tests at rated voltage
- 100 ohms to 7.0 megohm A-C resistance bridge
- 0-600 volt, D-C vacuum-tube voltmeter
- 10-50 volt A-C vacuum-tube voltmeter
- Quality Components for Long, Trouble-free Service • 115 V. 50-60 cy
- Complete with test leads
- Instruction manual

Price: **\$69.95**
 F.O.B. N. Y.

Ready to operate
 20% deposit with order. Balance C.O.D. Jobbers—Write for discounts.

ARCEE ELECTRONICS CO.
 74 Cortlandt St., New York 7, N. Y.

limiting filters we are taking full advantage of the transmitted color data. However, it is possible to effect some economies at the expense of color quality. How this is done is shown in Fig. 11. Note that by simply shifting the phase of the color sync by 33° we can recover $(E_R - E_Y)$ and $(E_B - E_Y)$ at the demodulator outputs instead of I and Q (See Fig. 3). But now, we must band-limit both channels to 0.4 mc. if we are to eliminate crosstalk between the two channels. This procedure, however, means that the wide-band data present in the original transmitted I information is lost. The resultant voltages $(E_R - E_Y)$ and $(E_B - E_Y)$ are matrixed to produce $(E_G - E_Y)$ and the trio of color difference voltages are applied to the tri-gun cathodes. All three picture grids are tied together and E_Y is applied to them. The final matrixing action to produce E_G , E_R , and E_B is actually accomplished within the picture tube. With E_Y on the grid and $(E_G - E_Y)$ on the cathode, the net voltage from grid to cathode is E_G .

This system has a number of economical features. Only one wide-band amplifier is required, whereas three are needed for the $I-Q$ system. Only one delay line is used since both color difference channels have the same delay. The narrow-band output of the demodulators allows for substantial gains at this point and direct connection to the picture tube cathodes is a possibility without a video boost stage.

This article has attempted to demonstrate how the NTSC has solved the technical problems associated with the formulation of a compatible color signal.

Fortified with a knowledge of this color signal the reader was introduced to the new complexities of a color receiver and the new techniques required to reproduce the color picture. Although many advances in color design are to be expected as manufacturers face the need to reduce costs to compete on the open market, in the main the circuits used will probably be similar to those explained here.

REFERENCE

1. Buchsbaum, Walter H.: "The RCA Tri-color Tube." RADIO & TELEVISION NEWS, November 1951.

Fig. 11. Block diagram of a typical color-difference type TV receiver.

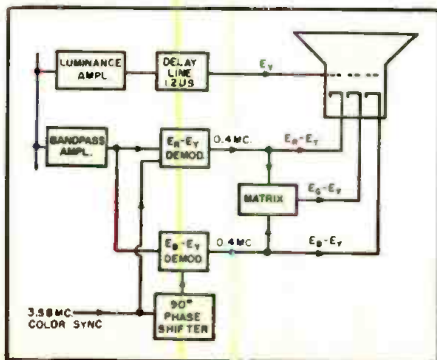

November, 1953



Prescribed by top mfrs.*

For operating and testing DC equipment from AC lines



FILTERED DC POWER SUPPLY

Model B Pat. 2599748

They say: "It's the only one that can withstand continuous high overloads!"

Cooler Operation—Selenium rectifier application and conduction cooling dissipate over 3 times the heat.

Twice the Rectifier Power Rating with EPL Patented Design. Lowest Cost Per Ampere Output.

Output 6v., 1-20 amps. (35 at peak). 2 units in parallel supply 6v. at 40 amps.

Tests 2 Auto Radios with push-button solenoids at same time; also motors, instruments, relays, other low voltage devices.

NEW MODEL C-12 services both 12v. and 6v. auto radios.

* Names on request

ELECTRO PRODUCTS LABORATORIES

4501-Nb Ravenswood Avenue Chicago 40, Ill.

Canada: Atlas Radio Corp., Ltd., Toronto, Ont.

FREE! New Detailed Literature on America's Only Complete Line!

BARGAINS • BARGAINS • BARGAINS

STANDARD BRANDS TUBES

All Brand New Individually Boxed FAR BELOW WHOLESALE COST!

OZ456	GAC71.29	6BG61.99	6SL796	12AV71.14	35Z553
1A787	GAC589	6BM689	6SN786	12AX71.06	50C584
1B399	GAG774	6BK726	6SQ763	12AZ71.59	50B584
1H573	GAM61.39	6BL71.14	6TR1.09	12BA61.72	50L671
1N582	GAK51.44	6BQ61.35	6UR1.14	12BE678	50Y679
1R579	GAK693	6BQ71.49	6V6GT71	12BH798	70L759
1S579	GALS71	6BN61.14	6W473	12SA798	70P759
1L7477	GAQ579	6BZ71.59	6W691	12SK779	117N71.59
1U479	GAQ689	6C466	6X482	12SL799	117P71.59
LUS78	GARS73	6CB687	6X563	12SN791	117Z364
LV279	GAS583	6CD62.59	6X81.09	12SQ769	117Z664
1X2A1.02	GAT572	6AG71	7C571	19T81.29	117Z696
3Q489	GAU51.04	6J563	7F789	25BQ61.35	
3Q599	GAU671	6J699	7N787	25L673	
1S477	GAV51.09	6K671	7Y469	25W478	
1V482	GAV663	6L6CA1.39	12AM71.18	25Z667	
1U465	6BA682	6SA773	12AL571	35B579	
1V474	6BA799	6SC784	12AT662	35C579	
1Y349	6BC586	6SM786	12AT71.07	35L673	
1AB479	6BC71.04	6SJ786	12AUG77	35W474	
1AB759	6BE674	6SK772	12AU794	35Y453	

SPECIAL DISCOUNTS
50 } 5%
100 } 10%
Asst }

Wen SANDER-POLISHER



Here is the unit you have been waiting for. Does everything from sanding your car to polishing your shoes. Large sanding area a full 13 1/2" sq. Lightweight, easy to use. Complete with on-off switch, 6 sheets of sand paper and polishing cloth. Powerful high speed cool operating motor. Choice of 3 colors: Black, Fire-Engine Red, and Marbled Green, 110-120 volts, 60 cycles AC only.

List Price \$13.95
Net Price **\$10.46**

R.M.S. TELEVISION BOOSTERS



Models SP-6, SP-5, SP-6J.

STEVE-EL brings you the booster buy of the year. We bring you these boosters at a price less than manufacturer's cost.

These boosters are brand new/factory aligned in sealed cartons. Complete with circuit diagram and operating instructions. Fully guaranteed. All UL approved. 110-120 Volt AC only.

Model SP-5 Pentode Type For extreme fringe \$8.50
Model SP-6 Pentode Type For extreme fringe 7.95
Model SP-6J Triode Type For semi-fringe 8.95

MINIMUM ORDER \$5.00

STEVE-EL now carries full line of Eico, E.M.C., Pilot, Tech-Master, Pentron, Wen Products, Burgess, Shure, etc. Write for free catalog.

STEVE-EL ELECTRONICS CORP.

Dept. RN-11 61 Reade St., New York 7, N. Y. Cortland 7-0086

BARGAINS • BARGAINS • BARGAINS

BARGAINS • BARGAINS • BARGAINS

www.americanradiohistory.com

CRYSTALS

LARGEST STOCK

IN THE WORLD



In FT 241-A Holders—15 in Pin Nbr. These are designated 5th

or 72nd Harmonic MC freq. Listed by fundamental freq. with fractions omitted.

370	396	419	443	466	491	513
372	397	420	444	468	492	514
374	398	422	445	469	493	515
376	400	424	447	472	495	518
378	401	425	448	473	496	519
379	403	426	450	474	497	520
380	404	427	451	475	498	522
381	405	429	452	476	500	523
383	406	430	453	477	501	525
384	407	431	454	479	502	526
385	408	433	456	480	503	527
387	409	434	456	481	504	529
388	411	435	457	483	505	530
390	412	436	458	484	506	531
391	413	437	461	485	507	534
392	414	438	462	487	508	536
393	415	440	463	487	509	537
394	416	441	464	488	511	538
395	418	442	465	490	512	540

All above crystals sent postpaid. Foreign, wholesale, and dealer inquiries invited. Write for QUANTITY DISCOUNTS.
5 ASSORTED CRYSTALS ONLY.....\$2.75
10 for.....\$4.50

COMPLETE SET—80 CRYSTALS

In above gradations from 370-516 Kc., 54th Harmonic, INCLUDING 500 Kc. & 455 Kc. crystals. Only.....Per set.....\$9.95

COMPLETE SET—120 CRYSTALS

In above gradations from 370-540 Kc., 72nd Harmonic, PLUS 500 Kc. & 455 Kc. crystals. Only.....Per set.....\$14.95

200 KC. CRYSTAL.....Pa. \$2.25
500 KC. CRYSTAL.....Pa. 1.25
1,000 KC. CRYSTAL.....Pa. 3.25

All crystals sold as is.

MISCELLANEOUS BEST BUYS

- ARC-4 TRANSCEIVER: Excellent 2-meter rig. Less tubes and dynamotor. Only.....\$10.95
- 12/24 V. DYNAMOTOR: For ARC-4.....\$7.50
- APS-13 TRANSCEIVER: Complete with tubes and dynamotor. Easily converted to 4 MC. Excellent cond.\$19.95
- RL-42 REVERSIBLE MOTOR & CLUTCH: Used good condition. A HOT buy at only.....\$2.95
- WILLARD 6 V. MIDGET STORAGE BATTERY, 3-amp/hr., 1 13/16" x 2 3/4". Uses standard electrolyte. New.....\$2.49
- 6 V. WET CELL BATTERY: In heavy polystyrene plastic case. 6 x 4 x 4 inches. New.....\$4.95
- PE-73 DYNAMOTOR. Used. As is.....\$3.49
- BARBEQUE MOTOR. AC. New.....3.49
- T-24 MILE. New.....1.25
- TELEPHONE DIAL.....2.49
- 4" MEYER. 0-1 mil. Just add scale. Used.....2.49
- COMPLETE 2-WAY SOUND POWERED COMMUNICATION SET: consists of single unit on each end PLUS 50 ft. of wire. The set COMPLETE only.....\$3.35

All prices are net F.O.B. Los Angeles. All items subject to Prior sale.

J. I. GLASS ELECTRONICS CO.
1615 S. MAIN STREET
LOS ANGELES 15, CALIF.

Supply your own TEST PATTERN



USE MODEL CB-101 UTL PATTERN GENERATOR

TESTS VIDEO AMPLIFIER LINEARITY and PICTURE TUBE PERFORMANCE
\$29.50
MODULATES YOUR TV SIGNAL GENERATOR FOR OVER-ALL TEST OF TV RECEIVER

No more waiting for TV test patterns to be transmitted! No more setting of controls by guess! No necessity of purchasing expensive equipment! Model CB 101 Pattern Generator is designed for the quick, accurate adjustment of the TV picture quality; provides steady pattern of vertical or horizontal bars; makes horizontal and vertical linearity, width and centering easy at ANY TIME, at ANY PLACE.
Also useful in general TV service work, and testing TV tubes. Ask your local distributor about it, or write us direct giving distributor's name and address. FREE 4-page folder.

UNITED TECHNICAL LABORATORIES
BOX 425 G • MORRISTOWN, N. J.

Technical BOOKS

"UHF TELEVISION" by Edward M. Noll. Published by *The Paul H. Wendel Publishing Co., Inc.*, P. O. Box 1321, Indianapolis 6, Ind. 72 pages. Price \$1.00. Paper bound.

This is the seventh TTLB "Notebook" for the service technician. It provides practical technical data on v.h.f.-u.h.f. tuners, u.h.f. antenna performance, u.h.f. propagation characteristics, and u.h.f. converters.

The material on u.h.f. is presented in logical progression covering v.h.f. tuners, basic u.h.f. considerations, and useful u.h.f. service information. Tabular data on u.h.f. television channels and wavelengths in inches at the center frequency are also given.

The tuner data covers everything from tuner performance to troubleshooting. The u.h.f. section is divided into nine headings covering such topics as propagation, antennas, and transmission lines as well as alignment techniques, etc.

The manual contains over one-hundred illustrations and includes block diagrams, schematics, and photographs of components and circuits.

"PRODUCING AND DIRECTING FOR TELEVISION" by Charles Adams. Published by *Henry Holt and Company*, New York. 280 pages. Price \$3.95.

This is a practical, how-to-do-it manual for experienced as well as would-be directors and/or producers.

The text covers such subjects as the television studio, its facilities and personnel; station equipment; special effects; conceiving the television program; directing—theory and practice; directing ad-lib programs; producing and directing panel quizzes; picture composition; lighting; the writer in TV; the actor in TV; the advertising agency in TV; programs for the local station; and budget and cost control.

Photographs of modern studio facilities and line drawings of the points under discussion all help to impress the subject matter on the reader's mind.

"TELEVISION ADVERTISING AND PRODUCTION BOOK" by Irving Settel, Norman Glenn, and Associates. Published by *Thomas Y. Crowell Company*, New York. 465 pages. Price \$6.00.

The book has been prepared as a guide book for advertising agencies, TV stations, advertisers, and students in the preparation of television programs and advertising.

The authors have enlisted the services of a panel of experts who are responsible for individual chapters on their particular specialties. Included are sections on the financial aspects of TV, choosing the right station for your product, conducting research for TV advertising, TV advertising for a national sponsor, TV advertising for the

retail sponsor, mail-order advertising on TV, staging the show, staging facilities, producing TV film commercials, casting, writing the dramatic show, how to sell a TV "package," censorship, the TV department of the agency, publicity for stations and shows, TV coverage and listenership, premiums and their use, and obtaining personnel for television.

Seven appendices listing TV terms, a copy of the television code, etc. are also included to make this a one-volume reference work for all phases of TV production.

"TELEVISION INTERFERENCE" edited by Philip S. Rand. Published by *Remington Rand*. 108 pages. Price \$.25. Paper bound. Available from Miss Anne Smith, *Remington Rand, Inc.*, 315 Fourth Avenue, New York 10.

In this, the third, edition of "Television Interference," the editor has compiled a group of up-to-date articles on the subject of TVI. The thirty articles which comprise this book have been arranged with the most recently published appearing first to provide the reader with the most current data.

All of the articles originally appeared in such electronic publications as: "Successful Servicing," "QST," "Electrical World," "Modern Plastics," "Electronics," "Service," "CQ," and "Popular Science."

Radio amateurs and those concerned with television interference will find this compilation of value as a reference manual.

PHOTO CREDITS

Page	Credit
43, 45	Jay Seymour
46 (top)	Souderland
46 (bottom)	Carson
47 (top left)	Minnesota Mining & Mfg. Co.
47 (top right)	Prestosel
48, 49	Altec Lansing
51, 53 (bottom right)	Milwaukee Road
52	"Railway Signaling and Communications"
53 (top, bottom left)	Baltimore & Ohio
54, 56	Allied Radio Corporation
58	Official Defense Dept. Photo
79	Centralab Div., Globe-Union, Inc.
83	Ultrasonic Corp.
99	Emerson Radio & Phonograph Corp.
104, 105	Radio Corporation of America
115, 116, 118, 122, 130	Sylvania Electric Products Inc.
132	Station PCJ, Bilversum, Holland
131, 136	Thordarson-Melsaner
140	Boeing Airplane Company
165 (bottom left)	Air Force Photo
165 (bottom right)	U. S. Army Photograph

ERRATA

Raytheon Mfg. Co. has reminded us that "Fathometer" is a registered trademark covering the company's depth finders. Our apologies for using it as a generic term in the articles "Radar Protects Fishing Fleets" in our July issue and "Electronics for the Yachtsman" in the August issue.

In the article "An Improvement for Older TV Sets," appearing on page 182 of the September issue, a misstatement appears in the third line of the third paragraph. The sentence should read: "To do it, first short out the tuned circuit and also short the grid of the first triode to 'B', cutting out the sync." The "B+" was incorrect in the original.

In the October "Certified Record Revue" column appearing on page 70 the price quoted for the Chicago Symphony Orchestra's recording of Smetana's "My Fatherland" was incorrect. The album consists of two records each of which are \$5.95 or \$11.90 for the album.

CORONA RADIO KITS

• Easy Assembly • Excellent Reception
SINGLE BAND SUPER



Rocket 115K—Latest superhet circuit for ultimate in sensitive reception and tonal quality. Kit includes all necessary parts, punched chassis, attractive bakelite mahogany cabinet, built-in loop antenna, iron core IF's, big 5" Alnico V speaker. Tubes: 12SK7, 12SA7, 12SQ7, 50L6. Automatic vol. control, beam power output. Tunes 540 to 1700 Kc. Simple step-by-step instructions included. Net **\$14.75**

2 BAND AC-DC SUPER

Plaza R12K—Excellent sensitivity. Tunes standard Broadcast 535 to 1800 Kc, foreign short-wave 8 to 18 Mc. 16 ft. to 30 meters. Features iron core IF's, bass-treble tone control, 5" Alnico PM Spkr., phono jack. Handsome bakelite mahogany cabinet, 11 1/2 x 8 1/2. Tubes: 12SK7, 12SA7, 12SQ7, 50L6, 3Z5. All parts, punched chassis, easy step-by-step instructions included. Net **\$20.75**



3-BAND SUPER Gophermodel R14K Complete Kit Net **\$24.75**

All kits supplied less wire and solder. Please include 25% deposit with C.O.D. Orders. Dept. N-11

CORONA RADIO & TV CO.

136 LIBERTY ST., NEW YORK 6, N. Y.

ELECTRONIC TUBES

URGENTLY NEEDED

CASH PAID FOR:

Radio, TV, Special Purpose, all types, small and large quantities. State types, quantities, prices.

WRITE NOW TO BOX 537

c/o RADIO & TELEVISION NEWS

366 Madison

New York, N. Y.

TV-RADIO SERVICE LIBRARY

HERE IS LATE INFORMATION IN A HANDY FORM FOR RADIO & TELEVISION REPAIRMEN, SERVICEMEN & STUDENTS



2 VOLS. \$6 COMPLETE \$1 A MONTH. PAY ONLY 1 MO. IT PAYS TO KNOW!

AUDELS T.V.-RADIO SERVICE LIBRARY presents the important subjects of Modern Radio, Television, Industrial Electronics, F.M. Public Address Systems, Auto, Marine & Aircraft Radio, Phonograph Pick-Ups, etc. Covers Basic Principles—Construction—Installation—Operation—Repairs—Trouble Shooting. Shows How to get Sharp, Clear T.V. Pictures. Install Aerials—How to Test. Explains Color Systems & Methods of Conversion. 1001 Facts—Over 1260 Pages—625 Illustrations—Parts & Diagrams—Valuable for Quick Ready Reference & Home Study. Tells How to Solve T.V. & Radio Troubles—Answers T.V. & Radio Questions.

Get this information for Yourself.
7 DAY TEST—ASK TO SEE IT!

MAIL ORDER

AUDEL Publishers, 49 W. 23 St., N. Y. 10
Mail AUDELS T.V. RADIO SERVICE LIBRARY 2 Vols. \$6 on 7 days free trial. If O. K. I will remit \$1 in 7 days and \$1 monthly until \$6 is paid. Otherwise I will return them.

Name _____
Address _____
Occupation _____
Employed by _____ RM

Temperature Control (Continued from page 131)

The author has been using this system for approximately 6 months. It has proved extremely satisfactory and contrary to most side-line speculation there has been no increase in fuel consumption. An immediate question may be raised as to the operation of the unit in the event of failure. Since the thermistors used by the author have a negative coefficient of resistance, an open circuit in the bridge sensing arms will produce a continuous demand for heat. To provide a safety high-limit switch to avoid excessive heat in the house, the original thermostat is left in series with the power-relay contacts and set at some high limiting temperature of

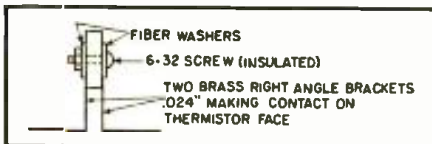

Fig. 3. Method for mounting the thermistors.

perhaps 78 degrees. The opposite extreme failure, that of supplying no heat, can be provided against by connecting a normally-open thermostat across the power-relay contacts, however this latter precaution is not usually necessary. Thus it is possible to minimize either extreme of failure. When the system is installed, small bridge unbalances due to different bridge arm lengths may be compensated by the calibration control. If a greater degree of inside-outside temperature compensation is desired, resistance R_2 may be decreased providing R_1 is decreased the same amount.

Tube life can be expected to be very good once the unit has operated for approximately one-half month or more. Most tube failures can be expected during this first period.

Take a good thermometer around the house at frequent intervals when your present heating system is in operation. You will be surprised, possibly enough surprised to see the advantages which would accrue with an electronic thermostat.

REFERENCES

1. Minneapolis Honeywell Regulator Co., Minneapolis, Minn.
2. Hoffman Specialty Co., Indianapolis 7, Ind.
3. *Electronics*, December 1950.

—50—

Fig. 4. Construction details on the cycler.

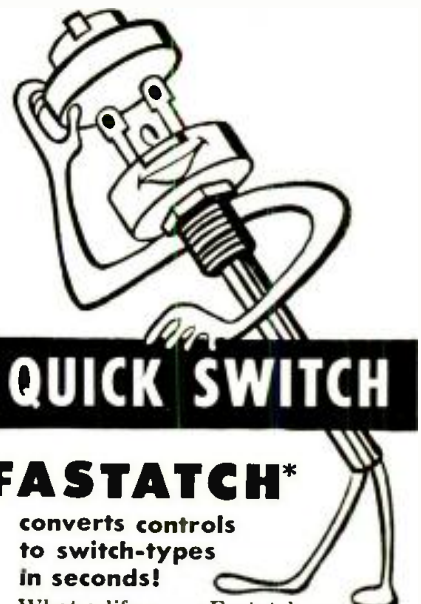
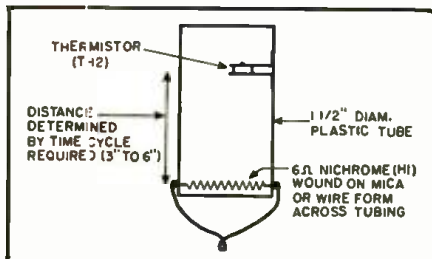

QUICK SWITCH

FASTATCH*

converts controls to switch-types in seconds!

What a life-saver Fastatch can be when you need a TV-AM-FM switch-type control in a hurry. SNAP, it's on in seconds! Saves you valuable bench working time — no ears to bend, no loose parts. Fastatch switch units are perfectly matched to famous Centralab Blue Shaft controls.

Type KB Fastatch switches give you service flexibility unmatched in any other line.



Fastatch converts any plain type control with blue label on back to switch type. Available in 3 styles: SPST, SPDT and universal DPST. Rated at 5 amps — 125 v.a.c.; 1/2 amp — 125 v.d.c.; 12 amps — 12 v.d.c. Underwriter's approved.

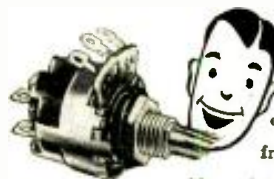

When you're stocking Fastatch units, be sure to get a supply of Blue Shafts too. Available from 500 ohms to 10 megs in a wide variety of tapers and tapped units. You can buy 'em singly or in handy kits. Order this Centralab time-saving combination NOW — your distributor has complete stocks.

Centralab

*Trademark

CENTRALAB
A Division of Globe-Union Inc.
910-K E. Keefe Ave., Milwaukee 1, Wis.
Please send Catalog 28 with additional technical data on Blue Shaft Fastatch switches.

Name _____
Firm _____
Address _____
City _____ Zone _____ State _____

REAL SALE TUBE WHOLESALE PRICES!

Tube Orders Over \$15.00, with full remittance, Prepaid to you in U.S.A.

Stock up now on these amazing tube values! All tubes are of popular brands and fully guaranteed.

0A2	90	6AT6	55	12SH7	63
0A3 VR75	1.05	6AV6	55	12SK7	55
0B2	.80	6AV6	55	12SK7	60
0C3 VR105	.95	6AX4GT	.60	12SL7GT	.65
0D3/VR150	.95	6BB8	.75	12SN7GT	.75
0Z4/OZ4A	.55	6BC5	.62	12SQ7GT	.55
1A7GT	.77	6BE6	.59	12SR7	.69
1AX2	1.05	6BH6	.80	12SX7GT	1.10
1B3GT/8016	.90	6BQ6GT	1.13	14F7	.75
1B27	11.50	6BZ7	1.20	25AV5	1.20
1L4	.60	6C4	.50	25BQ6GT	1.00
1L6	.95	6C6	.65	25L6GT	.62
1N21B	1.95	6CB6	.85	25Z6GT	.52
1N23A	2.05	6CD6	1.95	28D7	1.55
1N23B	2.25	6D6	.75	35B5	.55
1N34A	.75	6F4	3.50	35C5	.55
1N48	.50	6F5	.68	35L6GT	.60
1N54	.79	6F6M	.70	35Z3	.70
1N54A	1.05	6F8G	.85	35T(Eimac)	2.75
1N69	.50	6G6	.85	35Z5GT	.55
1N70	1.25	6H6	.52	50A5	.77
1N81	1.00	6J4	5.10	50B5	.55
1U4	.55	6J5GT	.50	50C5	.60
1R4/1299	.59	6J6	.62	50L6GT	.65
1X2A	.90	6K4M	.75	80	.66
1Z2	3.25	6K4 (Sylv)	2.25	83	1.15
2C39A	13.75	6K4A	2.25	84/624	.65
2C40	7.95	6K6GT	.55	117Z6	.98
2C51	3.90	6K7M	.60	211/VT4C	.88
2021	1.20	6L6G	1.10	250TH	16.95
2E30 (Hyt)	2.05	6L6GA	1.10	274A & B	3.00
2I39	7.95	6L6M	1.50	300B(WE)	7.95
2I61	37.50	6L7	.80	304TH	7.75
2I62	33.00	6N7M	.80	304TL	8.75
2X2	.44	6P7G	.88	310A(WE)	3.95
3A4	.59	6Q7GT	.80	407A(WE)	4.50
3BPI1	9.00	6S7M	.98	408A(WE)	2.50
3B7/2291	.39	6S7GT	.80	717A	.88
3C23(GE)	8.50	6S7	.66	803	3.35
3C24/24G	1.15	6S7GT	.65	805	3.35
306/1299	.35	6S7J	.65	807	1.55
3E29/829B	9.95	6SK7GT (Sylv)	.55	811A	3.55
3Q5GT	.99	6SL7GT	.70	812A	3.60
3S4	.34	6V3	.95	816	1.20
3L4	.90	6V6GT	.66	829	7.95
3V4	.75	6V8/6T8	.99	829B	12.50
3X2500 A3	135.00	6W4GT	.55	830B	2.75
4B24	4.50	6W6GT	.75	832A	3.00
4C35	19.95	6Y6G	.85	866A(JAN)	1.25
4D22	18.50	6Y6G	.85	866A(CBS)	1.75
4X150A	29.95	6X5GT	.77	869B	65.00
4A00A	45.00	7A7	.69	872A	3.75
4X500A	85.00	7B8	.76	911A	4.42
5C22	39.00	7B8	.78	951A	.65
5D21(WE)	15.00	7C4	.29	958A	.65
5R6GY	1.20	7C5	.69	991 NE16	.50
5V4G	.58	7C5	.69	991 NE16	.50
5V4G	.95	7C6	.69	CK1005	.75
5W4G	.80	7C30	85.00	1622/6L6M	1.95
5X4G	.75	7E5	.39	1625	.35
6AB7	.95	7F7	.85	1626	.18
6AC7	.80	7BP7	4.25	1629	.25
6A4	1.39	7H7	.70	2050	1.55
6A5G	.70	7JP4	15.00	5516(Hyt)	7.25
6A7	1.10	12AT7	.80	5528/C6L	5.00
6A8H	.88	12AU7	.85	5551/FG21	57.50
6A8K5	.70	12AW6	.85	5654	1.75
6A8K6	.95	12AX7	.75	5656	10.00
6A1S	1.30	12AY7	1.90	5670	3.50
6A8K5	.77	12BA6	.60	5687	2.95
6A8K6	.98	12BD6	.75	5691	7.50
6A8L5	.53	12BE6	.80	5693	6.25
6A8N4	1.50	12BH7	.98	5814	2.20
6A9S	.48	12BY7	1.03	8020	1.98
6A8S5	.70	12SA7	.69	9002	.85
6A8S6	1.95	12SF5	.70	9003	1.25
6A8S7G	3.50	12SG7	.80	9004	.35

Above is a partial listing of our large stock. You may order types not listed at approx. the same savings. Many new special-purpose types in stock.

ODDS & ENDS!

ERCO MARINE TRANSMITTER-RCVR
4 channels, 12 V. DC, operation, FCC approved. New, complete (less xtls) . . . \$179.50

BRAND NEW VIBRAPACKS
12 V. DC, input, 300 V. DC, @ 125 ma. output. Complete with vibrator . . . \$12.95

TRIMM FEATHERWEIGHT HEADSET
1000 ohms impedance. New orig. boxes \$3.75

WESTERN ELECTRIC CHOKE
8 hy.—300 ma. 65 ohms D.C. resis. Hermetically sealed in steel cases . . . \$4.95

WESTERN ELECTRIC SWINGING CHOKE
6.5—1.3 hy. @ 200-620 ma. 42 ohms. Hermetically sealed in steel cases . . . \$6.95

JENNINGS VACUUM CONDENSER
50 uuf. @ 20,000 volts . . . \$9.95

PANADAPTOR—5 INCH SCREEN
Model SB-1, type 200, 100 Kc. sweep, 115 V. 60 cy. Used, good condition . . . \$49.50

BARRY

ELECTRONICS CORP.

136 F Liberty Street, N.Y. 6, N.Y. REctor 2-2562

Terms: 25% with order, balance C.O.D.
All merchandise guaranteed. F.O.B. N.Y.C.

INDEX OF Advertisers

NOVEMBER
1953

While every precaution is taken to insure accuracy, we cannot guarantee against the possibility of an occasional change or omission in the preparation of this index.

ADVERTISER	PAGE	ADVERTISER	PAGE
Adelman, Nat	138	Littlefuse, Inc.	40
Admiral Corporation	195	Luxo Lamp Corp.	168
Airex Radio Corp.	194	McGee Radio	126, 127
All Channel Antenna Corp.	13	McGraw-Hill Book Co., Inc.	223
Allied Radio Corp.	9, 177, 186	Mallory & Company, P. R.	85, 4th Cover
Altec Lansing Corp.	212	Mattison Television & Radio Corp.	224
American Distributing Co.	170	Midwest Radio & Television Corp.	133
American Microphone Co.	209	Miles Reproducer Co.	138
American Television & Radio Co.	146	Miller Television Company	158
Amperite Company	220	Milwaukee School of Engineering	172
Amplifier Corp. of America	210	Moss Electronics Distributing Co., Inc.	145
Angle Genesee Corp.	158	Nassau Company	207
Arcee Electronics Co.	228	National Electronics of Cleveland	219
Acro Products Company	192	National Radio Institute	3
Argos Products	162	National Schools	41
Arkay Radio Kits	142	Newark Electric Company	178
Arrow Electronics	193	Newark Surplus Materials	227
Arrow Sales	185	New Jersey Television Supply Co.	225
Ashe Radio Company, Walter	139	Ohmite Mfg. Company	36
Atlas Sound Corp.	212	Olson Radio Warehouse	183
Audel, Publishers	231	Onan & Sons, D. W.	200
Barry Electronics Corp.	232	Oxford Electronics	148
Bell Telephone Labs., Inc.	142, 24	Peak Electronics Co.	168
Berlant Associates	184	Permoflux Corp.	156
Blonder Tongue Labs.	201	Philco Corporation	106
Brook Electronics, Inc.	216	Phillips Tube Company, Incorporated	138
Boulevard Electronics, Inc.	213	Photocon Sales	210
British Industries	219	Pickering & Company	28
Brush Electronics	173	Platt Electronics Corp.	187
Burstein-Applbee Company	153	Possner Co.	217
CBS Hytron	29, 119	Premier Radio-TV Supply	143
Candler System	170	Prentice Hall, Inc.	190
Cannon Electric Company	152	Progressive Electronics Co.	154
Capitol Radio Engineering Institute	23	Pyramid Electric Company	102
Centralab	16, 19, 20, 21, 22, 136, 215, 223, 231	Quietrol Company	168
Century Electronics Co.	223	RCA Audio Equipment	151
Channel Master Corporation	32, 33	RCA Institutes, Inc.	141, 170
Cleveland Institute of Radio Electronics	147	R. W. Electronics	167
Collins Audio Products Co., Inc.	110	Radiart Corporation	10
Columbia Electronic Sales	226	Radio City Products, Inc.	211
Commissioned Electronics Co.	228	Radio Corporation of America	2nd Cover
Communication Equipment Co.	208	Radio Craftsmen, Inc.	26, 27
Concord Radio	233	Radio Products Service	164
Corona Radio & T V Co.	231	Radio Shack Corporation	202
Coyne Electrical School	188	Radio Television Training Association	17
DeCray & Assoc., Frank W.	215	Rad-Tel Tube Co.	189
DeForest's Training, Inc.	5	Raytheon Mfg. Company	25
DeMamiro Distributors	192	Reeves Soundcraft Corp.	179
Du Kane Corporation	176	Rek-O-Kut Co., Inc.	164
Editors & Engineers Limited	206	Relay Sales	200
Eitel-McCullough, Inc.	210	Rider Pub., Inc., John F.	166
Electronic Chemical Corp.	220	Rinehart Books	181, 202, 227, 233
Electronic Expeditors, Inc.	218	Sams & Co., Inc., Howard W.	144, 206
Electronic Instrument Company, Inc.	42, 199, 203, 213, 233	Sangamo Electric Co.	197
Electronic Measurements Corp.	163	Sarkes-Tarzan, Inc.	182
Electronic Specialty Supply Co.	201	Schott Co., Walter L.	37
Electro Products	229	Scott, H. H.	225
Electro Voice	8, 31	Semler Industries	228
Fairchild Recording Equipment	221	Shields Labs., Inc.	180
Fair Radio Sales	217	Shonstone	160
Federal Telephone & Radio Corporation	12	South River Metal Products Co., Inc.	176
Fisher Radio	18, 157	Sprayberry Academy of Radio	137, 199
Franklin Technical Institute	228	Stan Burn Radio & Electronics Co.	215
G & G Radio Supply Company	191	Standard Electrical Products	222
G & H Wood Products Co.	174	Stehens Mfg. Company	214
G. L. Electronics	207	Stehens Sales Corp.	227
General Cement Manufacturing	114	Steve-El Electronics Corp.	229
General Electric	30, 38, 39, 155	Stevens Walden, Inc.	220
General Electronics	199	Sun Parts Distributors, Ltd.	196
Goodheart, R. E.	158	Sun Radio & Electronics Co., Inc.	206
Grayburne Corporation	204	Suprex Electronics	196
Greenlee Tool Co.	224	Supreme Publications	175
Hallcrafters Company	7	Sylvania Electric Products, Inc.	98
Harjo Sales Co.	142	TAB	234
Harvey Radio Company	179	Tech-Master Products Co.	176
Heath Company	86/97	Tee Vee Supply Co.	171
Henshaw Radio Supply	226	Television Communications Institute	221
Hudson Radio & T V Corp.	216	Transamerica Electronics	164
Hughes Research & Development Laboratories	209	Terado Company	211
Illinois Condenser Company	216	Transcriber Co.	198
Indiana Technical Institute	211	Transvision, Inc.	192
Institute of Radio Engineers	159	Triangle Radio Laboratory	158
Instructograph Company	213	Trio Mfg. Company	14/15
International Correspondence Schools	11	Triplett Electrical Instrument Co.	6
International Rectifier Corp.	169	Tri-State College	217
International Resistance Co.	3rd Cover	Tung-Sol Electric Inc.	34
JFD Mfg. Company	35	Turner Company	193
J J Glass & Electronics Co.	230	United Catalogue Publishers, Inc.	195
Jones & Laughlin Steel Corporation	161	United Technical Laboratories	175, 230
J S H Sales Co.	200	University Loudspeakers, Inc.	165
Jeb Sales Corporation	149	Utah Radio Products Co.	205
Jensen Industries	188	V-M Corporation	163
Kay-Townes Antenna Company	123	Valparaiso Technical Institute	203
Kennedy Associates	203	Vet's Dist. Co.	207
Kester Solder Company	138	Video Corp. of America	224
L. A. Han Shack	228	Waldom Electronics, Inc.	175
Lampkin Laboratories	142	Weathers Industries	170
LaPointe Electronics Corp.	128	Western Electronics	164
Leeds Radio Co.	188	Western Television Institute	212
Leotone Radio Company	202	Westinghouse Electric	135
		Wholesale Radio Parts	199
		Windsor Electronic Tubes Co.	196
		World Radio Laboratories, Inc.	203

Classified

Rate 50c per word. Minimum 10 words

RADIO ENGINEERING

COMPLETE radio, electronics theory & practice: television; broadcasting; servicing; aviation, marine, police radio. 12 or 18 months. Catalog. Valparaiso Technical Institute, Dept. N, Valparaiso, Ind.

FOR SALE

ISOLATION transformer 35w 117v sec. 117 or 135 plus 6.3v .45a tap. 3 lbs \$2.45 plus postage. Send for flyer. Surplus bought. Empire Electronics Co., 409a Ave. L, Brooklyn 30, N. Y.

DIAGRAMS—Radio \$1.00; record changers, recorders \$1.25. Television with service data \$2.00. Where model unknown, give part numbers. Kramer's Radio Service, Dept. E53, 36 Columbus Ave., New York 23, N. Y.

TUBES and equipment bought, sold, and exchanged. For action and a fair deal, write B. N. Gensler, W2LXI, 136-F Liberty, New York 6, N. Y.

TAPE Recorders, Tapes, Accessories. Unusual Values. Dressner, 624-R East 20th St., N.Y.C. 9.

FREE. Bargain List, tubes bought, sold. Write Mark, Box 14, New York City 72.

ALUMINUM Tubing, angle and channel. Plain & perforated aluminum sheet. Willard Radcliff, Fosterla, Ohio.

NEW Heathkits, completely assembled and tested. Write for prices. Robert Moog, 51-09 Parsons Blvd., Flushing 55, N. Y.

\$59.50 UHF Converter, VHF Booster. \$34.95. Free lists. Ben's Radio, No. Tonawanda 2, N. Y.

USED Televisions \$30 up. W4API, 1420 So. Randolph, Arlington, Virginia.

TV-FM antennas. All types including UHF. Mounts, accessories. Lowest prices. Wholesale Supply Co., Dept. H, Lunenburg, Mass.

THREE tube Phono Amplifiers, with tubes. \$3.98; intercoms with remote station, 25' wire, \$17.50. Chemel, 4701 Wood, Rt. 2, Kansas City, Missouri.

TELEVISION Receivers (used) \$10.00 up. Prices and descriptions 40c. Television, 702 Bridge St., Grand Rapids, Michigan.

RECLAIM large percentage Television Picture Tubes. Equipment and instructions \$6.50. Television, 702 Bridge St., Grand Rapids, Michigan.

CRYSTALS: Tailor made FT-213's \$500 to 8700 KC ±2KC \$1.00 each, .01% \$2.00 each. Hundley Crystal Co., 2951 North 36th, Kansas City 4, Mo.

WANTED

WILL buy all ART-13/type T-47A \$200.00; ART-13/type T-47, \$150.00; BC-318 unmodified \$65.00; BC-318 modified \$50.00; A1N-9 \$200.00; ARC-3 complete \$600.00; R77 Receivers \$300.00; ARC-1 \$300.00; RC-312 \$60.00; RC-312 \$60.00. Ship via Express C.O.D., subject to inspection to: H. Finnegan, 49 Washington Avenue, Little Ferry, N. J.

CORRESPONDENCE COURSES

USED correspondence Courses and Books sold and rented. Money back guarantee. Catalog free. (Courses bought.) Lee Mountain, Pisgah, Ala.

USED Correspondence Courses and Educational Books bought, sold, rented. Free catalog. Educational Exchange, Summerville, Ga.

BUSINESS OPPORTUNITIES

BUY Wholesale 25,000 items, Catalog 25c. Matthews, 1472-R1 Broadway, N. Y. C. 36.

MISCELLANEOUS

SPEAKERS repaired, wholesale prices, guaranteed workmanship. Amprite Speaker Service, 70 Vesey St., New York City 7.

BUSINESS Cards \$2.50, Stickers \$1.50, 1,000. Signal, 927AC, Los Altos, Calif.

TEST Equipment Repaired and Calibrated by Factory Staff. All makes Solar, Simpson, Triplett, Heath, etc. Immediate service. Douglas Instrument Laboratory, 176 Norfolk Ave., Boston 19, Mass.

1000 embossed business cards \$1.50 postage paid. Write sample. Mrs. Vera Wooderson, Bethany, Mo.

November, 1953

IT'S READY NOW!

SEND FOR YOUR GIANT NEW Concord Catalog

1954 EDITION



IT'S GOT EVERYTHING!

- Standard Lines
- Special Buys

IT'S FREE!

Concord Radio
55 Vesey Street, New York 7, N. Y.
Phone Dlgby 9-1132

FAMOUS BRAND! Model 360

SWEEP GENERATOR



Normally \$49.95
OUR PRICE
ONLY \$29.50

Completely Wired, Less Cabinet and Crystal

Here's your chance to get a top-quality sweep generator at a saving of almost 50%! This famous-make laboratory precision instrument fills every alignment need in TV-FM servicing.

- 500 KC Thru 228 Mc continuous sweep
- RF Shielded continuous type attenuator
- Vernier dial calibrated in TV channel numbers
- Crystal marker oscillator with variable amplitude control.
- Latest HF tubes: 6X5GT, 12AU7, 2-6C4.
- 110-120 V AC 60 cy. Wt. 10 lbs.

CONCORD RADIO, 55 Vesey St., New York 7, N. Y. Dept. N-11

Send Giant New FREE Concord Catalog at once to:

Name _____
Address _____
City _____ Zone _____ State _____

COMPARISON PROVES

EICO OFFERS
GREATEST V-O-M values!

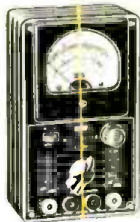

World-renowned **EICO** VOLT-OHM-MILLIAMMETERS

536 KIT \$12.90. Wired \$14.90

526 KIT (with 1% multipliers) only \$13.90. Wired \$16.90

COMPARE EICO Multimeters with any others and you'll agree... only EICO gives you ALL the features you want—PLUS 9 new exclusive EXTRAS—at the LOWEST COST in the industry!

COMPARE the PLUS versatility and performance of ALL THESE 9 EXTRA features: • full-scale ranges of 0-1 volt way up to 0-5000 volts on both AC and DC • grand total of 31 full-scale ranges • Current ranges on both AC and DC • large 3" meter • 100 ma sensitivity • 1000 ohms/volt on both AC and DC • minimum battery-drain ohm ranges • dual rectifier with separate low and high voltage calibration on AC ranges • available in both KIT and WIRED form.

Just think of the amazing value and versatility of these 31 different ranges! DC/AC Volts: Zero to 1, 5, 19, 50, 100, 500, and 5000! DC/AC Current: 0-1 ma, 10 ma, 0.1 Amp, 1 Amp. Ohms: 0-500, 100 K, 1 meg. 6 DB ranges: —20 to +69.

Yes. Comparison proves it... you get the MOST VERSATILITY—and you really SAVE—only with EICO! See the famous complete EICO line of V-O-Ms, scopes, VTVMs, generators, tube testers, battery eliminators, bridges, decade boxes, etc., at your jobber today.

Write for FREE Catalog MR-11 & name of local dealer. Prices 5% higher on West Coast

ELECTRONIC INSTRUMENT CO., Inc.
222 WITHERS STREET, BROOKLYN 11, N. Y.

Now! HANDLE UP TO 90% OF TV TROUBLES by the easy



PICTURE ANALYSIS METHOD!

Cut hours of tedious TV troubleshooting to minutes! Make repairs twice as fast! Operation of Ghirardi's new PIX-O-FIX TV TROUBLE FINDER GUIDE is simplicity itself. Covers all TV receivers.

Just turn dial until actual TV screen photo appearing in PIX-O-FIX "window" matches distorted picture on set being repaired. PIX-O-FIX then gives you all possible causes for this trouble and just where they are likely to be found. But that's only the beginning!

PIX-O-FIX TV TROUBLE FINDER GUIDE

By Ghirardi & Middleton

WHAT TO DO—HOW TO DO IT

Only \$1.

Covers 24 common troubles identified by actual screen photos

• • • 190 possible causes of these troubles localized to receiver stage or section where they are most likely to occur.

• • • 253 step-by-step remedies for these troubles.

• • • 4,500 words in CAUSE AND REMEDY section to show just what to do.

Step-by-step repair instructions follow. Components likely to be faulty are specified. Quick tests are outlined. PIX-O-FIX guides you every step of the way! Remember! PIX-O-FIX is NOT a "fix-it-yourself" gadget for consumers. It is a truly professional device for servicemen, apprentices and students—prepared by two of the nation's foremost service instructors—A. A. Ghirardi and H. G. Middleton.

MONEY BACK IF YOU'RE NOT SATISFIED!

Simply pin a \$1 bill to this ad. Mail with your name and address to the publisher. If not satisfactory, return PIX-O-FIX in 10 days and your \$1 will be refunded promptly. (Price outside U.S.A. \$1.25. Same money-back guarantee).

Dept. RN-113, RINEHART BOOKS, Inc., Technical Div., 232 Madison Ave., New York 16, New York

HERE'S **WHY** IRC EXACT DUPLICATES ARE DOUBLE-MONEY-BACK **GUARANTEED**

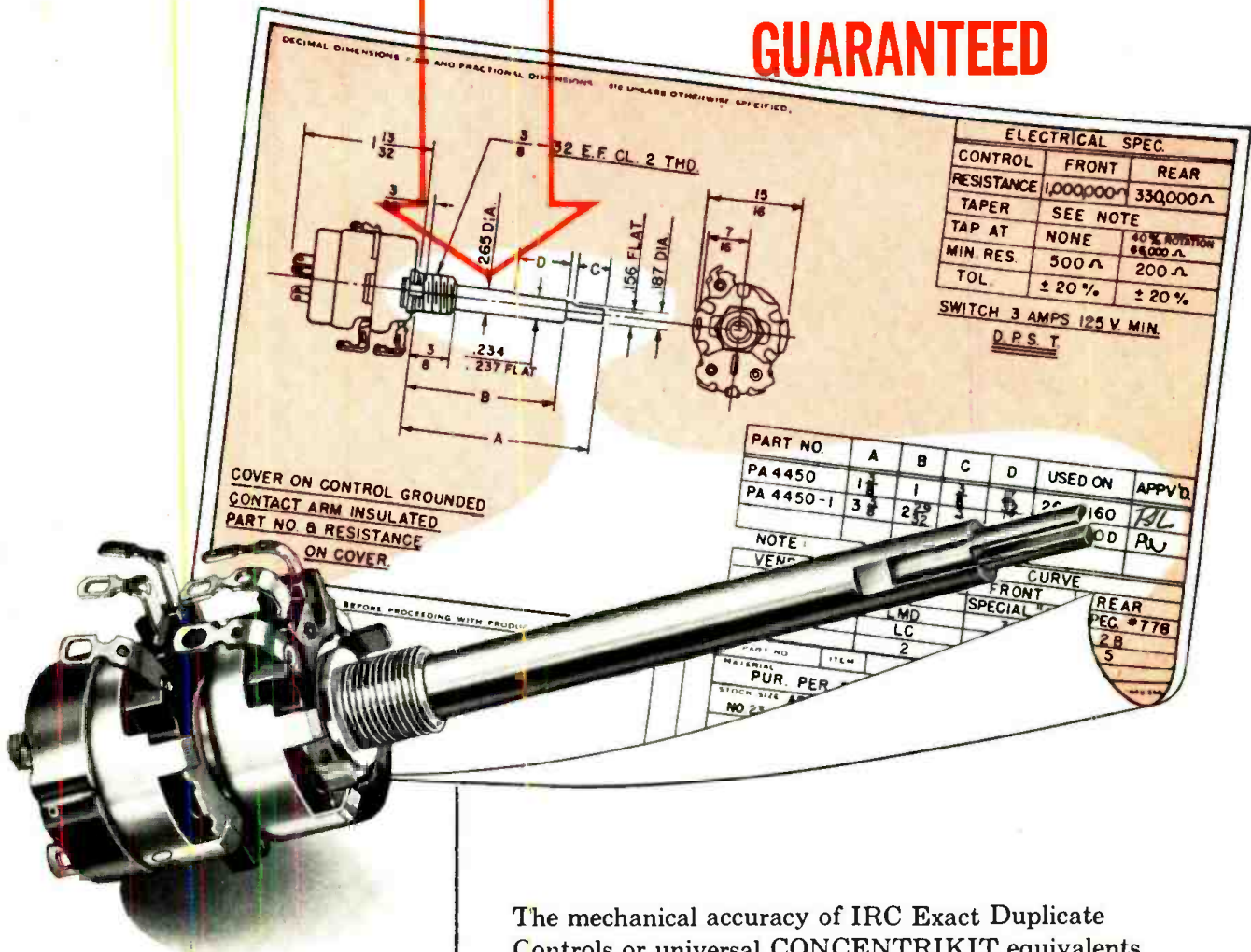

ONLY IRC GUARANTEES
SATISFACTORY MECHANICAL FIT
AND ELECTRICAL OPERATION
OR DOUBLE-YOUR-MONEY-BACK

The typical manufacturer's specifications shown here are exactly duplicated by IRC QJ-180 control. CONCENTRIKIT assembly includes P1-229 and R1-312 shafts with B11-137 and B18-132X Base Elements, and 76-2 Switch.



Wherever the Circuit Says ~~~

The mechanical accuracy of IRC Exact Duplicate Controls or universal CONCENTRIKIT equivalents is based on set manufacturers' procurement prints. Specifications on those prints are closely followed.

Shaft lengths are *never less* than the set manufacturer's nominal length—*never more* than $\frac{3}{32}$ " longer.

Shaft ends are precisely tooled for solid fit.

Inner shaft protrusion is accurately duplicated for perfect knob fit.

Alterations are never needed.

For Exact Duplicate Controls, specify IRC. Most Service Technicians do.

INTERNATIONAL RESISTANCE CO.

415 N. Broad Street, Philadelphia 8, Pa.

In Canada: International Resistance Co., Ltd., Toronto, Licensee



“CALL-BACKS?

Can't Remember a MALLORY Capacitor Ever Letting Me Down ...”

When a service man makes a statement like that, you can be sure he depends on Mallory for all his capacitors. Mallory FP Capacitors are engineered to duplicate the electrical characteristics of the original part in any TV or radio set. However, dependability is only part of the story. Mallory Capacitors will give performance that is equal to... and often better than... the original equipment.

Mallory FP Capacitors are the only fabricated plate capacitors available to the replacement market. They will give long lasting performance at higher temperatures and greater ripple currents ... even at 185° F. (85° C.).

The next time you order capacitors, ask for Mallory FP's. They will put an end to time wasting call-backs. The best costs no more.



For your plastic tubular requirements, be sure and specify Mallory Plascaps®. You can depend on them to end troubles with premature shorts ... leakage ... off center cartridges ... and unsoldered leads.

P. R. MALLORY & CO. INC.
MALLORY

CAPACITORS • CONTROLS • VIBRATORS • SWITCHES • RESISTORS
RECTIFIERS • POWER SUPPLIES • FILTERS • MERCURY BATTERIES
APPROVED PRECISION PRODUCTS

P. R. MALLORY & CO., Inc., INDIANAPOLIS 6, INDIANA

*Depend on Mallory
for
Approved Precision Quality*