

RADIO & TELEVISION NEWS

Sioux Falls, South Dakota

MARCH
1953
35 CENTS
In Canada 40¢

IN THIS ISSUE

YOU AND U. H. F.

TRANSISTORIZE
YOUR AUDIO AMPLIFIERS

MODEL BOAT

RECEIVER CHANGES TO
IMPROVE FRINGE RECEPTION

STEPHENS OTL AMPLIFIER

THE SPOOK

A HAM SHACK
FREQUENCY STANDARD

ELECTRONIC FLASH

ELECTRONIC ORGAN

PHILADELPHIA'S NEW
MOBILE UNIT
(See Page 51) →

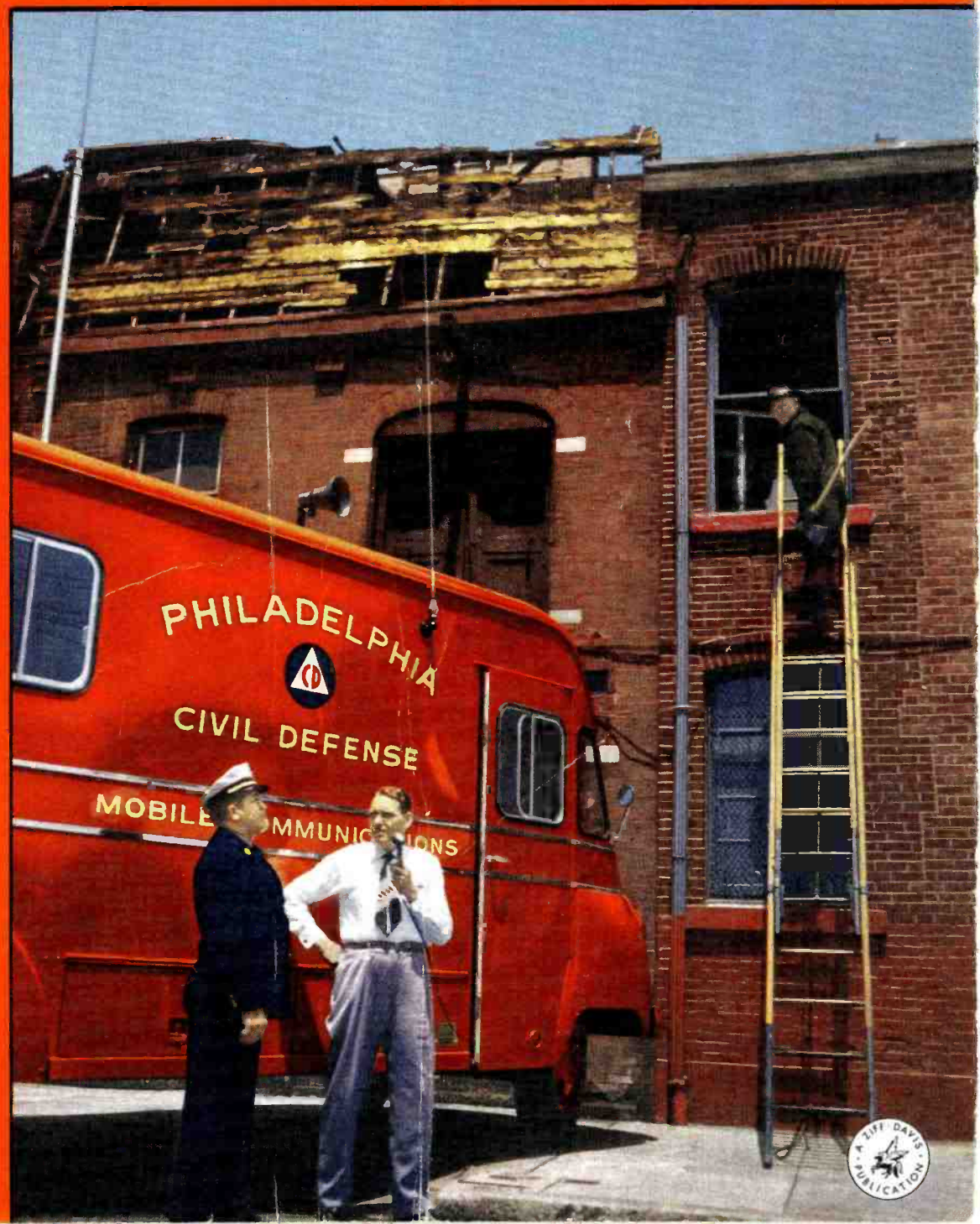

AS A RESULT OF YOUR CALL

The show goes on...

YOU'VE just finished a routine call. Just a few adjustments . . . a couple of tubes . . . and the set works as good as new. Nice the way folks smile appreciatively when you bring that missing picture back to their screen.

Now you've got yourself another steady customer. You know they'll remember you . . . and recommend you to their friends . . . because they're enjoying the finest picture their set can produce. And the RCA Tubes you installed will continue to provide them with long, faithful service. The superior quality of RCA Tubes and Kinescopes is your best measure of protection against the costliness and inconvenience of premature tube failures. It's good to know you can service a receiver . . . and forget about call-backs.

Safeguarding your reputation is a vital, everyday service of RCA Tubes. And that service is yours at no extra charge.

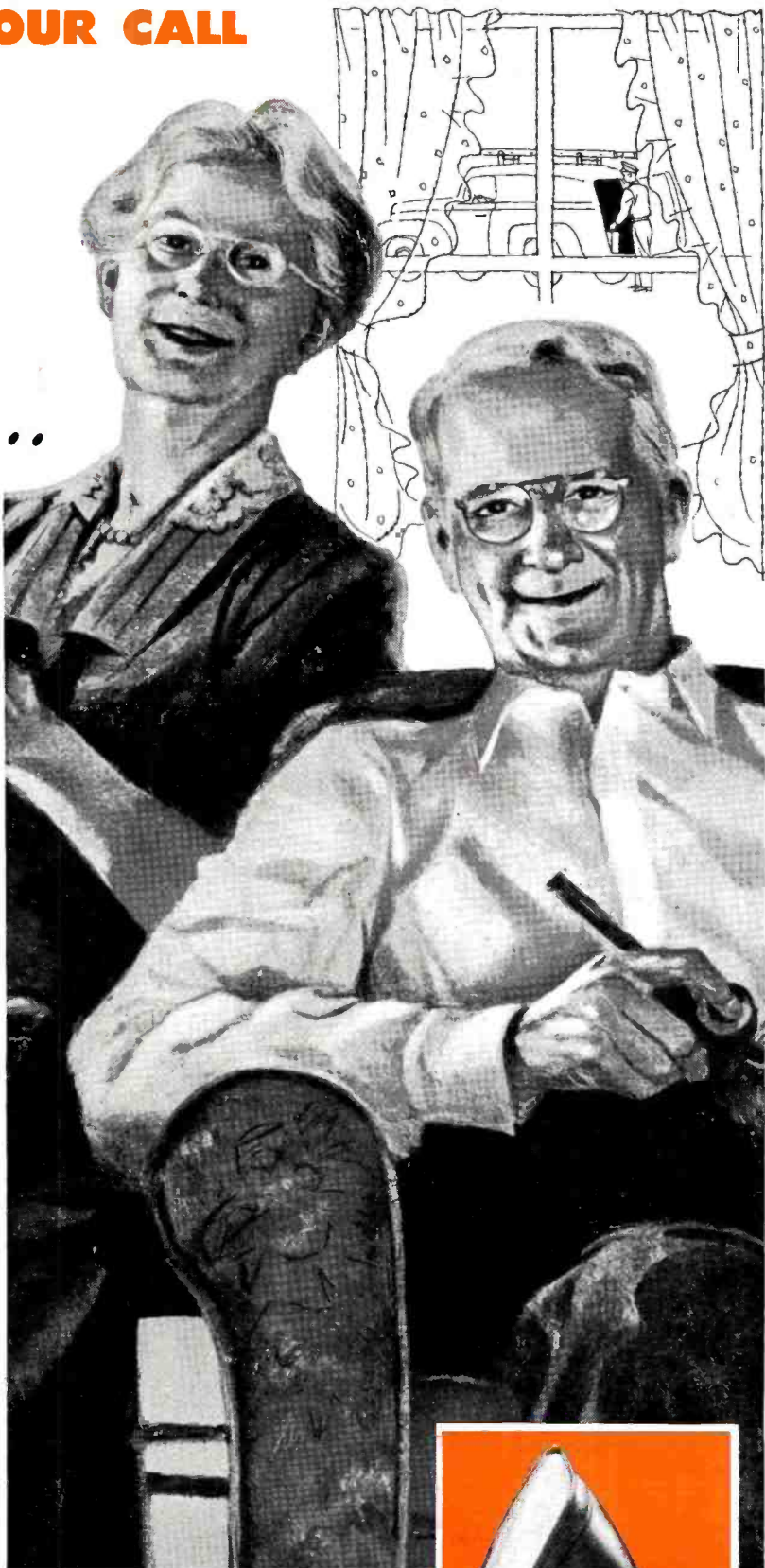

RADIO CORPORATION of AMERICA
ELECTRON TUBES

HARRISON, N. J.

NEW

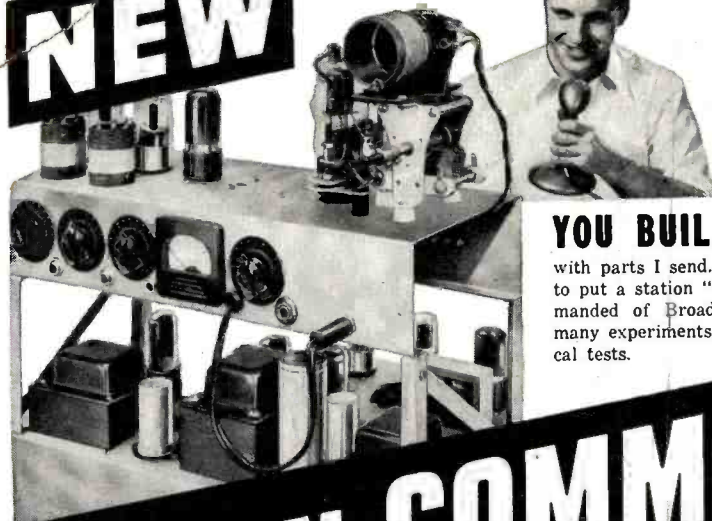

I'LL TRAIN YOU FOR YOUR FCC LICENSE

A Federal Communications Commission Commercial Operator's License puts you in line for a good job in Radio or Television Broadcasting, Police, Marine, Aviation, Two-way, Mobile or Micro-wave Relay Radio. Mail coupon below for 64-page book FREE. It will give you complete facts about my NEW Communications course.



YOU BUILD THIS TRANSMITTER

with parts I send. With this Transmitter you practice how to put a station "on the air." You perform procedures demanded of Broadcast Station Operators, conduct many experiments, make many practical tests.

LEARN COMMUNICATIONS by PRACTICING at Home in Spare Time



YOU BUILD this Transmitter Power Supply used in the basic experiments in RF and AF amplifiers, frequency multipliers, buffers, etc.



YOU MEASURE current, voltage (AC, DC and RF), resistance and impedance in circuits with Electronic Multitester you build. Shows how basic transmitter circuits behave; needed to maintain station operation.

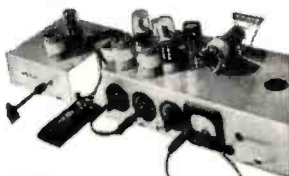

YOU PRACTICE setting up code, amplitude and frequency modulation circuits (put voice, music, etc., on "carrier signals" you produce). You learn how to get best performance.

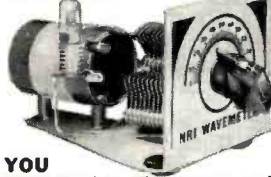

YOU BUILD this Wavemeter and use it to determine frequency of operation, make other tests on transmitter currents.

Get Practical Experience on Circuits Common to Radio & TV

Ever think HOW FAST Radio-Television Communications is changing, developing, growing? Have you considered what this amazing progress can mean to you? Even without Television the industry is bigger than ever before. 105 million home and auto radios, 2900 Radio Broadcasting Stations, 108 TV Stations with 1800 more now authorized. Expanding use of Aviation and Police Radio, Micro-Wave Relay, Two-Way Radio for buses, taxis, etc. makes opportunities for Communications Technicians and FCC Licensed Operators. New jobs, more jobs for beginners! Better jobs, better pay for experienced men!

Television Is Today's Good Job Maker

In 1952, over 18,000,000 homes had TV sets. More are being sold every day. The "Freeze" on building new TV stations has been lifted. The time to act is NOW! Start learning Radio-TV communications. America's fast growing industry offers good pay, a bright future, security. If you are a beginner, my course can help you get FCC License, prepare for the job you

J. E. SMITH, President National Radio Institute Washington, D. C.

For 38 years, the leader in training men for Radio-Television.

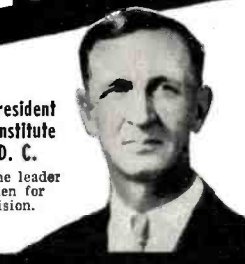

MY COURSE INCLUDES TELEVISION

want. If you've had some training in Radio or Radar, or as a Licensed Operator, my course modernizes, increases the value of your knowledge.

Includes New Developments

Mail coupon now for facts about my practical course in Radio-Television Communications. Let me send you my FREE book. See the nine big Kits of Parts I send that "bring to life" theory you learn. You get practical experience by working on circuits common to both Radio and Television; also lessons on TV principles. Read about the Transmitter you build and operate, about the Electronic Multitester you get. All equipment is yours to keep.

My graduates are filling jobs, making good money in both Radio and Television. Remember, the way to a successful career in Television is through experience in Radio.

Servicing Training Also Offered by N. R. I.

If you prefer a good-pay job in Radio-Television Servicing... or your own money-making Radio-Television Sales and Service Shop, I'll train you at home. My famous Servicing Course also includes many Kits of Radio Parts. You use them to get PRACTICAL EXPERIENCE with circuits common to Radio and Television. I also show you how to make \$5, \$10 a week or more EXTRA MONEY fixing neighbors' Radios while training. Full information in my 64-page book. Mail coupon.

Mail Coupon for Book FREE

Send today! See what my Communications course is like. Find out how I get you ready for a brighter future, better earnings, more security in Radio-Television. Send coupon now in envelope or paste on postal. NO OBLIGATION, NO SALESMAN WILL CALL! My book, sent to you FREE, tells the full story. J. E. SMITH, President, Dept. 3CE, National Radio Institute, Washington 9, D. C. Our 39th year.

Training Leads to Jobs Like These

BROADCASTING Chief Technician Chief Operator Power Monitor Recording Operator Remote Control Operator	GOVERNMENT RADIO Operator in Army, Navy, Marine Corps, Coast Guard Forestry Service Dispatcher	AVIATION RADIO Plane Radio Operator Airport Transmitter Operator TELEVISION Pick-Up Operator Voice Transmitter Operator TV Technician Remote Control Operator
SHIP AND HARBOR RADIO Chief Operator Assistant Operator Radiotelephone Operator	Airways Radio Operator POLICE RADIO Transmitter Operator Service Technician	

I TRAINED THESE MEN



"My position with WNBT is video control engineer on the RCA color project. I owe a lot of my success to your textbooks."—Warren Deem, Malverne, N. Y.



"I am a technician at WTOP in Washington and I like it very much. Most of my radio knowledge was from N.R.I."—John Britto, Hyattsville, Md.



"My first job was with KDLB, obtained for me by your Graduate Dept. Now in charge of Radio Equipment for Police Dept."—T. S. Norton, Hamilton, O.



"A former employer recommended N.R.I. training. Now employed as transmitter operator at WKBO."—Albert Herr, New Cumberland, Pa.

MAIL NOW-BOOK FREE

MR. J. E. SMITH, President, Dept. 3 CE National Radio Institute, Washington 9, D. C.

Mail me your 64-page Book about Radio and Television Communications opportunities and training. (No salesman will call. Please write plainly.)

Name..... Age.....

Address.....

City..... Zone..... State.....

Approved Under G. I. Bill

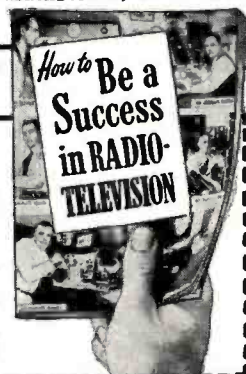

RADIO & TELEVISION NEWS is published monthly by the Ziff-Davis Publishing Company at 185 N. Wabash Ave., Chicago 1, Ill. Entered as second-class matter, July 21, 1948, at the Post Office, Chicago, Ill., under the act of March 3, 1879. Authorized by Post Office Department, Ottawa, Canada, as second-class matter. SUBSCRIPTION RATES: Radio & Television News—one year, U. S. and Possessions, Pan-American countries, and Canada \$4.00; all other foreign countries \$5.00; Radio-Electronic Engineering Edition—one year, U. S. and Possessions, Pan-American countries, and Canada \$6.00; all other foreign countries, \$7.00. Postmaster—Please return undelivered copies under form 3589 to 64 E. Lake St., Chicago 1, Ill.

Editor and Asst. Publisher
OLIVER READ, D.Sc., WIETI

Managing Editor
WM. A. STOCKLIN, S.S.

Technical Editor
H. S. RENNE, M.S.

Service Editor
CHARLES TEPFER

Amateur Radio Editor
N. ROSA, WINOA

Assistant Editors
P. B. HOEFER
M. C. MAGNA

Television Consultant
WALTER H. BUCHSBAUM

Short-Wave Editor
KENNETH R. BOORD

Staff Artist
FRANK SAYLES

Draftsmen
A. A. GANS, W2TSP
J. A. GOLANEK

Advertising Manager
L. L. OSTEN

Midwest Adv. Manager
JOHN A. RONAN, JR.

Western Adv. Manager
JOHN E. PAYNE



COVER PHOTO: Philadelphia's new mobile communications unit which offers complete and flexible facilities for all types of emergency two-way communications or public address work. (Ektachrome by Jay Seymour)

Chairman of the Board and Publisher
WILLIAM B. ZIFF

President
B. G. DAVIS

Secretary-Treasurer
G. E. CARNEY

Vice-Presidents
H. J. MORGANROTH

Production Director

LYNN PHILLIPS, JR.

Advertising Director

H. G. STRONG

Circulation Director

BRANCH OFFICES

CHICAGO (1)

185 N. Wabash, AN 3-5200

LOS ANGELES (14)

Staffer Center, 900 Wilshire Blvd., Mich. 9856

RADIO & TELEVISION NEWS

Reg. U.S. Pat. Off.

First in
radio-television-electronics

Average Paid Circulation over 220,000

Radio News Trademark Reg. U. S. Pat. Office • Television News Trademark Reg. U. S. Pat. Office.

CONTENTS

MARCH, 1953

Model Boat for the 27 mc. Citizens Band.....	Hartland B. Smith, W8VVD	35
Maintenance of TV Antennas.....	M. Bettan & A. S. Price	39
Transistorize Your Audio Amplifiers.....	Charles W. Martel	40
Receiver Changes to Improve Fringe Reception (Part 1).....	Paul Stevens	42
The Stephens OTL Amplifier.....	Frank H. Gilbert	45
You and U.H.F.....	Harold J. Schulman	48
A Multiple Installation for TV Receivers.....	Norman C. Fulmer	50
Philadelphia's New Mobile Unit.....	Edgar P. Grim	51
Build This Electronic Flash.....	Charles I. Hellman	52
U.H.F. Antennas (Part 4).....	Milton S. Kiver	54
A Ham Shack Frequency Standard.....	Richard Graham, W1VJV	56
A Universal Speaker Tester.....	Sidney Lenson & Marvin Tepper	58
Fun with a Home-Built Electronic Organ.....	Jim Kirk, W6DEG, W6JKX	59
Installing Mobile Equipment.....	D. K. Johnson, W5RPO	62
The Spook—Another Weird Effect to Haunt TV.....	M. B. Knight	64
An R.F. High-Voltage Supply for Your CRO.....	Louis E. Garner	66
String-Belt Turntables.....	Albert H. Taylor	68
Mac's Radio Service Shop.....	John T. Frye	70
Binaural Sound Reproduction.....	Glen Southworth	71
New TV Grants Since Freeze Lift.....		76
CRT Tester-Sparker.....	D. Gnessin & H. D. Suesholtz	104
Curing a Focus Problem.....	Jesse Jacobson	112
The Broomstick Boomstick.....	Rob Wagner, W6WGD	116
Radio-TV Service Industry News.....		138
New TV Stations on the Air.....		148

DEPARTMENTS

For the Record.....	The Editor	8	What's New in Radio.....	94
Spot Radio News.....		16	New TV Products.....	158
Within the Industry.....		24	Manufacturers' Literature	170
Short-Wave.....	K. R. Boord	74	Technical Books	172



COPYRIGHT 1953
ZIFF-DAVIS PUBLISHING COMPANY
 Editorial and Executive Offices
 366 Madison Ave., New York 17, N. Y.
VOLUME 49 • NUMBER 3



Member
 Audit Bureau of
 Circulations

SUBSCRIPTION SERVICE: All communications concerning subscriptions should be addressed to Circulation Dept., 64 E. Lake St., Chicago 1, Ill. Subscribers should allow at least two weeks for change of address.

CONTRIBUTIONS: Contributors are advised to retain a copy of their manuscripts and illustrations. Contributions should be mailed to the New York Editorial Office and must be accompanied by return postage. Contributions will be handled with reasonable care, but this magazine assumes no responsibility for their safety. Any copy accepted is subject to whatever adaptations and revisions are necessary to meet the requirements of this publication. Payment covers all author's, contributor's, and contestant's rights, title, and interest in and to the material accepted and will be made at our current rates upon acceptance. All photos and drawings will be considered as part of the material purchased.

RADIO & TELEVISION NEWS

NOW! DTI's GREATEST TRAINING OFFER IN 22 YEARS!

IT'S NEW! IT'S PRACTICAL! IT'S DIFFERENT!

**DTI's
NEW 1953
HOME TRAINING
PROGRAM**

has been re-designed to
**GET YOU FURTHER
FASTER**

in



21 INCH

NOW . . . as a part of our training, you build and keep this outstanding 21-inch—steady—sharp image—D.T.I. quality-engineered TV set. Can be readily converted to receive U.H.F.

TELEVISION RADIO AND ELECTRONICS



**NEW 5-INCH
"SCOPE"**

D.T.I. now also makes it possible for you to build and keep this big 5-inch commercial-type oscilloscope, one of the most useful and versatile pieces of testing equipment used in television today. In fact, it's almost a "must" for the serious-minded TV technician.

**IMPROVED
HOME MOVIES**

D.T.I.'s new 1953 Master Home Training Program provides you with the use of 16 Hollywood-produced reels of film and a 16 mm. motion picture projector to speed your progress.

MILITARY SERVICE!

If you're subject to military service, the information we have for you should prove very helpful.

**ONE OF AMERICA'S FOREMOST
TRAINING CENTERS**

— Established —
1931

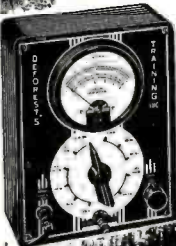

MULTIMETER



HOME MOVIES



DeFOREST'S TRAINING, INC.

AFFILIATED WITH

DeVRY Technical INSTITUTE

CHICAGO 14, ILLINOIS

Here, we believe, is one of the most **PRACTICAL** . . . most **HELPFUL** . . . most **EFFECTIVE** home training programs ever offered to prepare you to earn real money in America's amazing multi-billion dollar opportunity field of **TELEVISION-RADIO-ELECTRONICS**. Now, at home, you can get real practical experience from working on high quality, **FULL SIZE Commercial type equipment**—much like you'll handle when later working in the TV field. **Here's the REAL THING—nothing else like it!**

You get interest-packed lessons. You get 21 shipments of parts—working over 400 construction and test procedures that include building and keeping D.T.I.'s big, new, 5-INCH Oscilloscope and a jewel bearing Multimeter—followed by building D.T.I.'s wonderful new 21-inch tube TV set. You get shop method training—right at home. And to help you understand all-important fundamentals **FASTER . . . EASIER** . . . you use D.T.I.'s unique and effective **HOME MOVIES**. Then upon completing your training, D.T.I.'s Employment Service helps you **GET STARTED** in a good job or your own sales and service business. Get the facts—including the thrilling story of the opportunities ahead in Television.

OTHER TRAINING PROGRAMS AVAILABLE

D.T.I. also offers home training in (a) Television-Radio-Electronics—but without the TV set, (b) full time training in D.T.I.'s big **CHICAGO TRAINING LABORATORIES**—one of the nation's finest. Mail coupon today.

**89 WAYS
TO
EARN
MONEY
IN TELEVISION
RADIO ELECTRONICS**

Get this publication FREE!

**DeFOREST'S TRAINING, INC. RN-3-J
2533 N. ASHLAND AVE., CHICAGO 14, ILL.**

I would like your Opportunity News Bulletin showing "89 Ways to Earn Money in Television-Radio-Electronics"; also, complete facts about the training opportunity made possible by your organization.

Name _____ Age _____
Address _____ Apt. _____
City _____ Zone _____ State _____

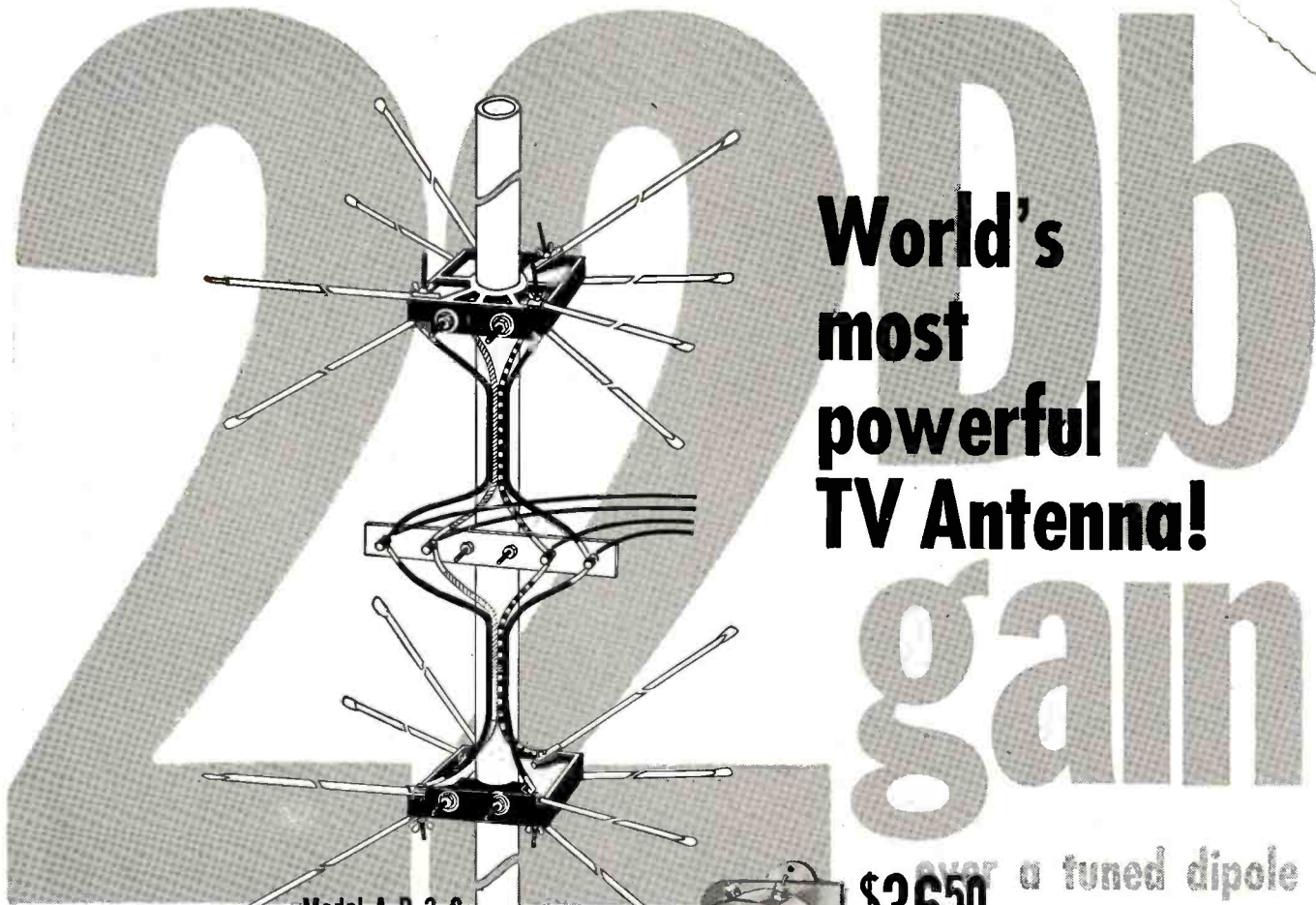

**World's
most
powerful
TV Antenna!**

\$36⁵⁰ over a tuned dipole
LIST PRICE

- **Guaranteed 10 times more powerful than stacked 10 element Yagis.**
- **Receives channel 2-83 from all directions without a rotor.**
- **Broadband UHF-VHF and FM, motorless all direction reception.**
- **Pat. # 2,585,670-2,609,503-2,625,655 others pending.**
- **All aluminum flip-out assembly.**

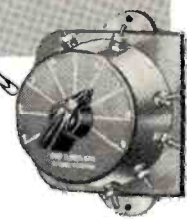

Includes Stacked Antenna Array. 9 Position Switch. Completely Wired Stacking Harness. A.I.M. — Automatic Impedance Matching Coupler.
Individually packaged with complete instructions.

The only TV antenna that instantly beams the television set directly to the signal without a rotor. This antenna brings strong signals from all directions to weak signal areas instantly . . . with a flick of the nine position switch located near the television set.

MONEY BACK GUARANTEE
To outperform any present day antenna array using a rotor motor, including stacked 10 element Yagis, 4 bay conicals, fans, double V's, etc.

Available at local jobbers or write for name of nearest representative

ALL CHANNEL ANTENNA CORP.

70-07 Queens Blvd., Woodside 77, N. Y.

Hickory 6-2304

"I Read You Five..."

Welcome Words! Hear them more often with Hallicrafters



It's true that Hallicrafters equipment lets you hear more. It's equally true that you hear better—and are heard better—when you depend on Hallicrafters equipment. That's why for twenty years Hallicrafters has been top favorite with the most critical expert in the world, the American amateur.

You see, these sets are designed and built specifically for the ham operator. They are planned with an amateur's problems, and pocketbook, in mind. They enjoy the best reputation in the world with this critical group of experts. You can *hear* why every night in the year on the air. Just listen!



Top Selectivity—Low Price! Model SX76. Dual Conversion Super with 50 kc amplifier for tops in selectivity. 500 kc at 6 db down—3.5 kc at 60 db down. Giant 4-in. "S" meter. 540-1580 kc, 1.72-32 Mc in 4 bands. 1 r-f, 2 conversion, 2 i-f stages. 5 pos. selectivity. Phono input jack. 3 watt output. Only \$179.50



A Ham's Dream! Model SX71. Com. Rcvr. especially designed for top ham performance. Double conversion, built-in NBFM limiter stage. 538 kc to 35 Mc, 46-56 Mc in 5 bands. Temp. Comp., voltage reg. 1 r-f, 2 conversion, w i-f stages. Xtal. filter, w-pos. selectivity, 18½" x 8⅞" x 12" deep. Ship. wt. 51 lbs. 115 V. AC, 11 tubes reg., tect. Only \$224.50



TVI Suppressed 100 Watter—Model HT20. The transmitter you've been waiting for! Continuous coverage from 1.7 Mc to 30 Mc. Full band switching, no plug-in coils; choice of 10 crystals. Shielded, filtered r-f compartment plus low-pass 52 ohm coaxial line 115 V. AC, 11 tubes reg. tect. Only \$224.50

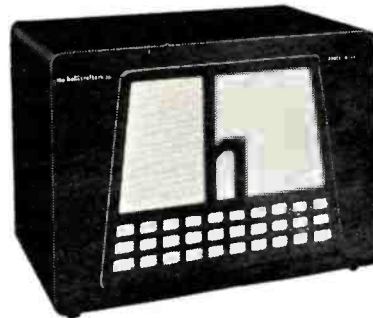

Matched Speaker—Model R46. The perfect speaker for SW. Includes transformer of 500/600-ohm input. Voice coil impedance 3.2 ohms. 10" cone. Gives excellent response for either voice or cw. Heavy construction throughout for years of service. Black finish. 15" x 10⅞" x 10⅞" deep. Only \$19.95

hallicrafters

Chicago 24, Illinois

World's Leading Manufacturer of Precision Radio and Television

Choice of Hi-Fi Enthusiasts!
E-V RADAX
 SUPER-EFFICIENT
 COAXIAL SPEAKERS



Model SP8-B Radax Super-Eight. Unusual bass balance in 8-inch coaxial speaker. Response 35-13,000 cps ± 6 db. 15-20 watts. Imp. 8 ohms. 1 lb. Alnico V magnet. $5\frac{1}{2}$ " depth behind mtg. panel. List Price...\$42.50 Audiophile Net...\$25.50

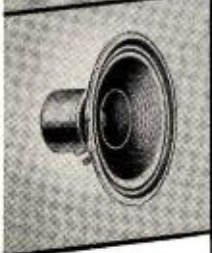

Model SP12-B Radax Super-Twelve. Full range 12-inch coaxial speaker. Response 35-13,000 cps ± 6 db. 15-20 watts. Imp. 8 ohms. 1 lb. Alnico V magnet. $6\frac{3}{4}$ " depth behind mtg. panel. List Price...\$45.00 Audiophile Net...\$27.00

Model SP12 Radax Super-Twelve. Amazing lows and highs in 12-inch coaxial speaker. Response 30-13,000 cps ± 5 db. 25 watts. Imp. 16 ohms. 3 lb. Alnico V magnet. $7\frac{1}{2}$ " depth behind mtg. panel. List Price...\$90.00 Audiophile Net...\$54.00



Model SP15 Radax Super-Fifteen. Fullest range and balance in 15-inch coaxial speaker. Response 30-13,000 cps. ± 5 db. 30 watts. Imp. 16 ohms. $5\frac{1}{4}$ lb. Alnico V magnet. $8\frac{3}{4}$ " depth behind mtg. panel. List Price...\$120.00 Audiophile Net...\$72.00



Enjoy the Range and the Realism

New concepts by E-V create new values for you in the enjoyment of sound reproduction. Unique *Radax* principle and built-in mechanical crossover permit design of the low-frequency cone and high-frequency axial radiator for extended optimum bass and treble response. Heavier "pound-rated" magnets provide more driving power and generous distortion damping factors. These and other E-V quality features assure more listening pleasure.

Hear them at your E-V Distributor
 or Write for FREE Hi-Fi Bulletins

Electro-Voice
 410 CARROLL ST. • BUCHANAN, MICH.
 Export: 13 E. 40th St., N.Y. 16, U.S.A. Cables: Arlob

For the **RECORD.**

BY THE EDITOR

AN ANNIVERSARY CELEBRATION FOR REE

IN July our sister magazine, *Radio-Electronic Engineering* (affectionately known as *REE*) will celebrate its tenth birthday. This magazine, though well known in engineering circles, is probably unknown to our many newsstand readers. I would like to tell you something about it.

REE was started in July, 1943 to fill a long-felt and growing need among electronic engineers for a magazine which would present in simple, easily-understood language, all of the major developments in the broad field of electronics. The original goal was to bring to engineers practical, useful information in a form which would not require an excessive amount of "digesting" of the type required in so many highly technical articles. The steady increase in subscriptions to the present total of well over 20,000 is eloquent testimony that the goal has been achieved.

When first published, the magazine was called "*Radionics*" because we felt that this name vividly expressed the scope to be covered. However, further study and consideration led us to believe that such a name was entirely inadequate and in January, 1944 it was changed to *Radio-Electronic Engineering*. This new name is descriptive of the magazine's contents—the engineering aspects of radio, including television and communications, and of electronics, covering the broad fields of industrial and medical electronics, computers and many others.

You may not be familiar with *REE* because it is available only by subscription to electronic engineers and other qualified personnel. It appears as an insert in a limited number of copies of *RADIO & TELEVISION NEWS*. Subscribers to this special *REE* Edition get all of the material appearing regularly in *RADIO & TELEVISION NEWS* plus all of the material in *REE*—at a subscription cost only slightly higher than that of *R&TN* alone.

REE is a complete magazine in itself. It includes a minimum of five feature articles each month, along with various departments such as New Products, Personals, News Briefs, Technical Books, New Tubes, and a calendar of technical meetings. All material is carefully edited and screened to be of maximum interest and value to readers. Authors are well-known in their respective fields and are thoroughly qualified for their task of passing on useful information to other engineers.

REE has a broad coverage, enabling specialized engineers to keep abreast of developments in fields other than

their own. In recent years, articles have appeared on such diversified subjects as microwaves, electronic computers, medical electronics, television, audio, and industrial electronics. We intend to continue and broaden further this diversified coverage.

The March issue of *REE* is a significant milestone of progress as it marks the appearance of the second annual special Microwave Issue. The first issue, which was published last May, was hailed as the most comprehensive survey of the microwave field ever published. It is still in wide demand. This second issue concentrates more on microwave relay applications in communications and TV, since these applications have been growing by leaps and bounds and show every evidence of continuing to grow. The directory of manufacturers of microwave equipment appearing in the first issue has been carefully checked and brought up to date and a cross-index of product listings added to increase the directory's usefulness. In the majority of cases, the name of the chief engineer, or the engineer responsible for microwave development, has been included for reference purposes.

A comprehensive bibliography of microwave articles appearing in 1952 periodicals is included along with a list of books which have been published in this field. The ten feature articles have all been prepared by engineers who are prominent in the microwave field. We believe that additional readers will find this issue as valuable as the previous one, if not more so. The special Microwave Issue is an annual feature and will continue as such. Other special issues are also being planned for the near future.

We are proud of the acceptance achieved by *REE* among engineers. A measure of this acceptance is the very low-mortality among subscribers. "Once a subscriber, always a subscriber" is apparently an axiom with our readers. We will continue to do our utmost to justify this faith by presenting each month the most complete and authoritative information which we can obtain, and by expanding the scope of *REE* to present information on such outstanding recent developments as transistors and magnetic and dielectric amplifiers.

We hope that you have found this thumb-nail sketch of *REE* interesting and informative. If your curiosity has been aroused, we feel that our purpose of acquainting you with *REE* has been achieved. . . . O.R.

THE ONLY COMPLETE CATALOG FOR
EVERYTHING IN TV, RADIO AND
INDUSTRIAL ELECTRONICS

get your 1953 **FREE**

ALLIED

236-PAGE CATALOG

it's complete
it's value-packed

THE WORLD'S LARGEST STOCKS

- TV and Radio Parts
- Test Instruments
- Hi-Fi and P.A. Equipment
- Custom TV Chassis
- AM, FM Tuners & Radios
- Recorders and Supplies
- Amateur Station Gear
- Builders Supplies
- Equipment for Industry

**QUICK
EXPERT
SERVICE**

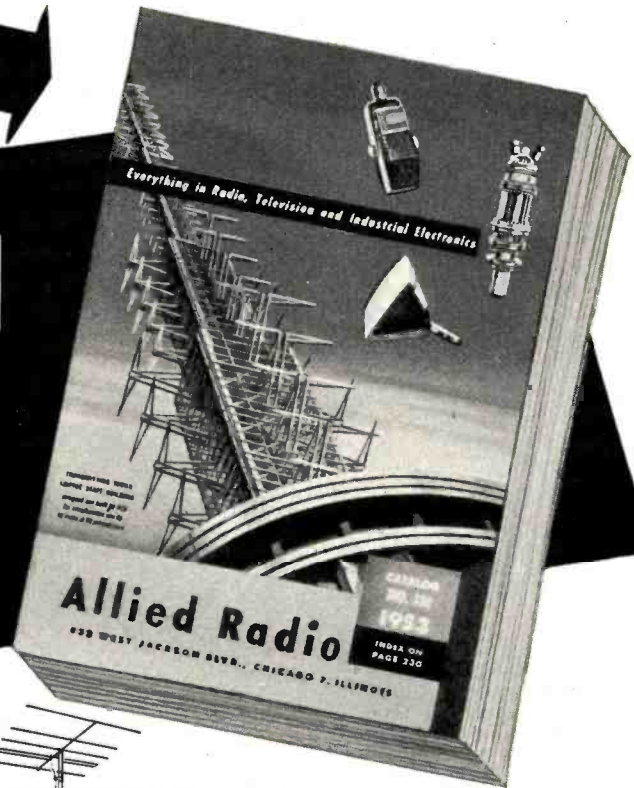

Send for it today!

Here's the *one* authoritative, complete Buying Guide to *Everything in Electronics*—packed with the world's largest selections of quality equipment at lowest money-saving prices. See the latest in TV custom chassis, TV antennas and accessories; AM and FM tuners and radios; High-Fidelity Custom Sound components; latest P.A. Systems and accessories; recorders; Amateur receivers, transmitters and station gear; specialized industrial electronic equipment; test instruments; builders' kits; huge listings of parts, tubes, tools, books—your choice of the world's *most complete stocks* of quality equipment.

ALLIED gives you every buying advantage; speedy delivery, expert personal help, lowest prices, liberal time payment terms, assured satisfaction. Get the latest 1953 ALLIED Catalog. Keep it handy—and save time and money. Send for your FREE copy today!

**EVERYTHING IN
ELECTRONICS**

**SEND TODAY FOR RADIO'S
LEADING BUYING GUIDE**

free

ALLIED RADIO

World's Largest Electronic Supply House

EASY-PAY TERMS

Take advantage of ALLIED's liberal Easy Payment Plan—Radio's best terms—only 10% down, 12 months to pay—no interest if you pay in 60 days. Available on Hi-Fi and P. A. units, recorders, TV chassis, test instruments, Amateur gear, etc.

TV & HI-FI SPECIALISTS

To keep up with developments in TV and High-Fidelity, look to ALLIED! Count on us for *all* the latest releases and largest stocks of equipment in these important fields. If it's *anything* in Television or High-Fidelity equipment—we have it in stock!

ALLIED RADIO CORP., Dept. 1-C-3
833 W. Jackson Blvd., Chicago 7, Illinois

Send FREE 236-Page 1953 ALLIED Catalog.

Name

Address

City Zone State

No fuss



No cuss



When you use Centralab Blue Shaft Controls

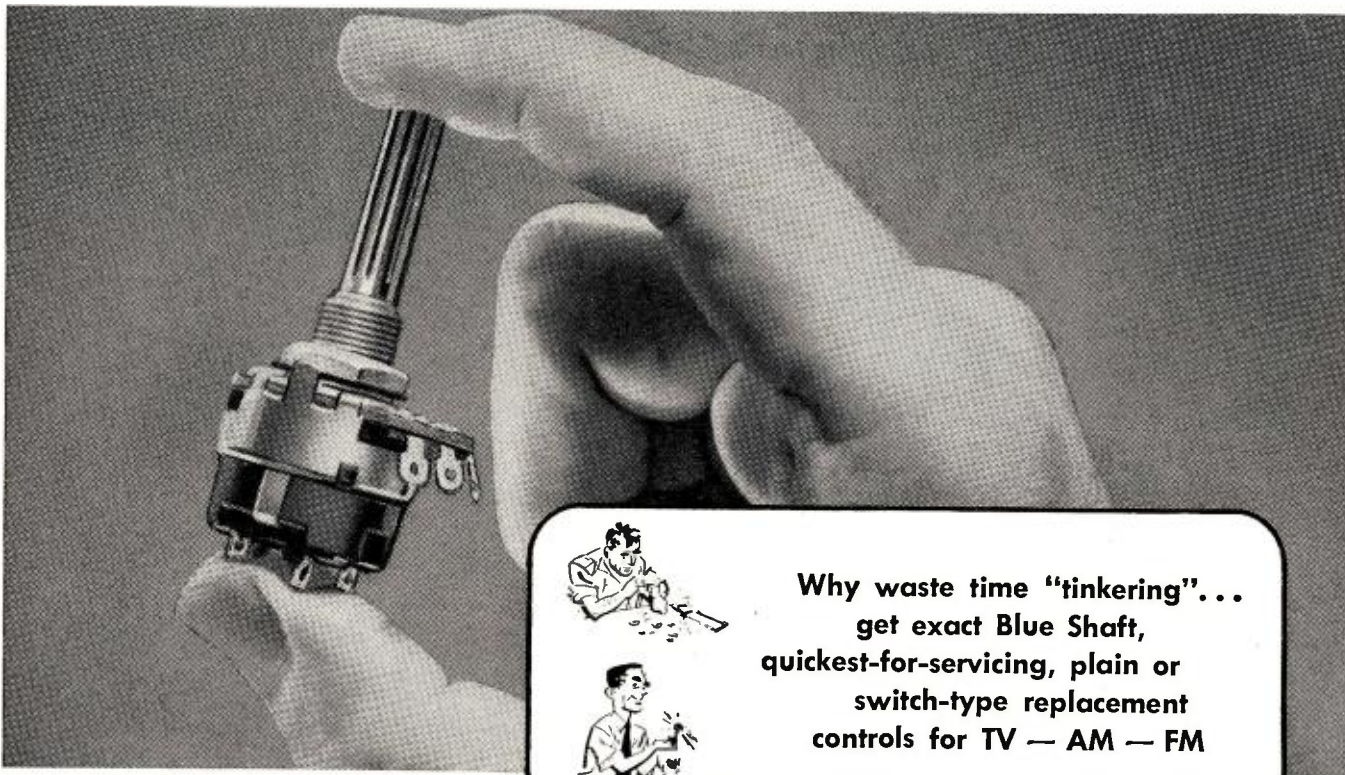

Why waste time "tinkering"...
get exact Blue Shaft,
quickest-for-servicing, plain or
switch-type replacement
controls for TV — AM — FM

**Don't fuss with an assembly job
the factory does better, faster,
and guarantees- at no extra cost.**

Yes, Blue Shaft Controls are your smartest service buy! Why? Because these *exact*, quickest-for-servicing replacements not only save you valuable bench-working time, but they're guaranteed *right* every time!

Why it pays to standardize on Blue Shaft

Centralab's famous Blue Shafts, plain or switch-type, are exclusive service items. The factory-attached and tested, high-amperage universal switches are *exact* for SPST — DPST or 3-wire. Blue Shafts are available in a range from 500 ohms to 10 megs in a wide variety of tapers and tapped units. All Centralab Blue Shaft Controls are packaged singly, or in handy kit assortments in plastic boxes of 12. You can

also get a special metal cabinet containing 22 controls. NO EXTRA CHARGE for the cabinet.

Flexible "Fastatch,"† type KB, converts any plain type control with blue and white label on back cover to switch type . . . in seconds.



SERVICE ENGINEERS — here's more good news
— 26 new Blue Shafts added in '53 line!

Centralab

A Division of Globe-Union Inc.

Milwaukee 1, Wisconsin

In Canada, 635 Queen Street East, Toronto, Ontario

Blue Shafts give you exactness plus LOW COST

Cat. No.	Ohms Max. Resistance	Taper	Circuit Location	List Price
B-60	500,000	C-2 (audio)	Volume or Tone	\$1.00
B-60-S*	500,000	C-2 (audio)	Volume or Tone	\$1.50
B-70	1 megohm	C-2 (audio)	Volume or Tone	\$1.00
B-70-S*	1 megohm	C-2 (audio)	Volume or Tone	\$1.50

*Switch Type

†Trademark

CENTRALAB, A Division of Globe-Union Inc.
910 East Keefe Avenue, Milwaukee 1, Wisconsin

Ask your jobber or write direct for Cat. 28.

Name.....Position.....
Company.....
Address.....
City.....State.....

LEARN RADIO AND



TV INSIDE OUT!

THAT's the way to become an expert Radio or Television service man. Study the bed-rock theories and principles. These are vitally important. Nothing can take their place—not even the most elaborate kits.

Listen to what radioman R. G. Hamlin of Bay City, Michigan, says, "There's no royal road to learning. I am convinced more than ever after examining the lessons of friends who were lured by the alleged short-cut methods of competitors . . . 'understandability' and 'rememberability' are of utmost importance and I.C.S. lessons qualify on both counts."

I.C.S. offers you two new courses in radio and television servicing—one for beginners, the other for experienced amateurs.

The beginner's course, Radio and Television Servicing with Training Equipment, is extremely thorough. You get extra texts featuring experiments and job assignments. You get equipment second to none. Matched

parts for an excellent 5-tube superheterodyne receiver. Your own professional-quality multimeter. A complete single generator kit. High-grade servicemen's tools. "Rider's Perpetual Trouble-Shooter's Manual." The principles of Television including the most-up-to-date developments (VHF and Color TV, for example).

The second course quickly reviews the essentials then goes step by step into advanced phases of Radio and Television, including modern methods of installation and repair. Course contains valuable supplementary material. For example, you get a special book giving characteristics of all tubes used in Radio and Television receivers.

Learn by doing! That's the world-famous I.C.S. method. Thoroughly practical. Completely modern. Success proved. The coupon below brings you full details—on Radio and Television Servicing or any of the more than 400 I.C.S. Courses. Mark and mail it *today!*

INTERNATIONAL CORRESPONDENCE SCHOOLS



BOX 2249-B, SCRANTON 9, PENNA.

Without cost or obligation, send me "HOW TO SUCCEED" and the booklet about the course BEFORE which I have marked X:

- | | | | | |
|---|---|---|---|--|
| <p>ART</p> <ul style="list-style-type: none"> <input type="checkbox"/> Commercial Art <input type="checkbox"/> Magazine and Book Illustrating <input type="checkbox"/> Cartooning <input type="checkbox"/> Show Card and Sign Lettering <input type="checkbox"/> Fashion Illustrating AUTOMOTIVE <input type="checkbox"/> Automobile, Mechanic <input type="checkbox"/> Auto-Elec. Technician <input type="checkbox"/> Auto Body Rebuilding and Refinishing <input type="checkbox"/> Diesel—Gas Engines AVIATION <input type="checkbox"/> Aeronautical Engineering Jr. <input type="checkbox"/> Aircraft Engine Mechanic <input type="checkbox"/> Airplane Drafting BUILDING <input type="checkbox"/> Architecture <input type="checkbox"/> Arch. Drafting <input type="checkbox"/> Building Contractor <input type="checkbox"/> Estimating <input type="checkbox"/> Carpenter and Mill Work <input type="checkbox"/> Carpenter Foreman <input type="checkbox"/> Reading Blueprints <input type="checkbox"/> House Planning <input type="checkbox"/> Plumbing | <ul style="list-style-type: none"> <input type="checkbox"/> Heating <input type="checkbox"/> Steam Fitting <input type="checkbox"/> Air Conditioning <input type="checkbox"/> Electrician BUSINESS <input type="checkbox"/> Business Administration <input type="checkbox"/> Certified Public Accountant <input type="checkbox"/> Accounting <input type="checkbox"/> Bookkeeping <input type="checkbox"/> Stenography and Typing <input type="checkbox"/> Secretarial <input type="checkbox"/> Federal Tax <input type="checkbox"/> Business Correspondence <input type="checkbox"/> Personnel and Labor Relations <input type="checkbox"/> Advertising <input type="checkbox"/> Retail Business Management <input type="checkbox"/> Managing Small Business <input type="checkbox"/> Sales Management <input type="checkbox"/> Salesmanship <input type="checkbox"/> Traffic Management CHEMISTRY <input type="checkbox"/> Chemical Engineering <input type="checkbox"/> Chemistry <input type="checkbox"/> Analytical Chemistry <input type="checkbox"/> Petroleum—Nat'l Gas <input type="checkbox"/> Pulp and Paper Making <input type="checkbox"/> Plastics | <p>CIVIL, STRUCTURAL ENGINEERING</p> <ul style="list-style-type: none"> <input type="checkbox"/> Civil Engineering <input type="checkbox"/> Structural Engineering <input type="checkbox"/> Surveying and Mapping <input type="checkbox"/> Structural Drafting <input type="checkbox"/> Highway Engineering <input type="checkbox"/> Reading Blueprints <input type="checkbox"/> Concrete Construction <input type="checkbox"/> Sanitary Engineering DRAFTING <input type="checkbox"/> Aircraft Drafting <input type="checkbox"/> Architectural Drafting <input type="checkbox"/> Electrical Drafting <input type="checkbox"/> Mechanical Drafting <input type="checkbox"/> Structural Drafting <input type="checkbox"/> Sheet Metal Drafting <input type="checkbox"/> Mine Surveying and Drafting ELECTRICAL <input type="checkbox"/> Electrical Engineering <input type="checkbox"/> Electrician <input type="checkbox"/> Electrical Maintenance <input type="checkbox"/> Electrical Drafting <input type="checkbox"/> Electric Power and Light <input type="checkbox"/> Lineman HIGH SCHOOL <input type="checkbox"/> High School Subjects | <ul style="list-style-type: none"> <input type="checkbox"/> College Preparatory <input type="checkbox"/> Mathematics <input type="checkbox"/> Commercial <input type="checkbox"/> Good English MECHANICAL AND SHOP <input type="checkbox"/> Mechanical Engineering <input type="checkbox"/> Industrial Engineering <input type="checkbox"/> Industrial Supervision <input type="checkbox"/> Foremanship <input type="checkbox"/> Mechanical Drafting <input type="checkbox"/> Machine Design-Drafting <input type="checkbox"/> Machine Shop Practice <input type="checkbox"/> Tool Design <input type="checkbox"/> Industrial Instrumentation <input type="checkbox"/> Machine Shop Inspection <input type="checkbox"/> Reading Blueprints <input type="checkbox"/> Toolmaking <input type="checkbox"/> Gas—Electric Welding <input type="checkbox"/> Heat Treatment—Metallurgy <input type="checkbox"/> Sheet Metal Work <input type="checkbox"/> Sheet Metal Pattern Drafting <input type="checkbox"/> Refrigeration POWER <input type="checkbox"/> Combustion Engineering <input type="checkbox"/> Diesel—Electric <input type="checkbox"/> Electric Light and Power | <ul style="list-style-type: none"> <input type="checkbox"/> Stationary Steam Engineering <input type="checkbox"/> Stationary Fireman RADIO, TELEVISION, COMMUNICATIONS <input type="checkbox"/> General Radio <input type="checkbox"/> Radio Operation <input type="checkbox"/> Radio Servicing—FM <input type="checkbox"/> Television <input type="checkbox"/> Electronics <input type="checkbox"/> Telephone Work RAILROAD <input type="checkbox"/> Locomotive Engineer <input type="checkbox"/> Diesel Locomotive <input type="checkbox"/> Air Brakes <input type="checkbox"/> Car Inspector <input type="checkbox"/> Railroad Administration TEXTILE <input type="checkbox"/> Textile Engineering <input type="checkbox"/> Cotton Manufacture <input type="checkbox"/> Rayon Manufacture <input type="checkbox"/> Woolen Manufacture <input type="checkbox"/> Loom Fixing <input type="checkbox"/> Finishing and Dyeing <input type="checkbox"/> Textile Designing HOME ARTS <input type="checkbox"/> Dressmaking and Designing <input type="checkbox"/> Cookery <input type="checkbox"/> Tea Room Management |
|---|---|---|---|--|

Name _____ Age _____ Home Address _____

City _____ State _____ Working Hours _____ A.M. to _____ P.M.

Occupation _____

Special tuition rates to members of the Armed Forces. Canadian residents send coupon to International Correspondence Schools Canadian, Ltd., Montreal, Canada

Dealers find
the **NEPCO** line

*Reduces
Stocks*

*Reduces
Call Backs*

*Increases
Goodwill*

*Increases
Profits*

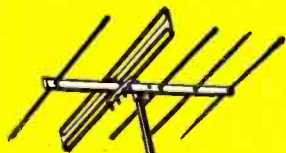

MASTER OF THE
ELEMENTS



THE
NEPCO

LINE

INCLUDES:

- YAGI ANTENNAS ● CONICAL ANTENNAS
- UHF ANTENNAS ● MASTING ● EAVE MOUNTS
- WALL BRACKETS ● VENT MOUNTS ● ROOF MOUNTS
- CHIMNEY BANDING ● CHIMNEY MOUNTS ● GUY RINGS
- BANDING & MAST CLAMPS ● ADD-A-TOWER PLATES ● TV WIRE

National Electric Products

RADIO AND TELEVISION DEPARTMENT, PITTSBURGH, PA.

**TV set owners want
a better picture, longer**
Here is the answer

Today, TV set owners are demanding better reception. Often the *trouble is in the antenna installation, not the set*. A corroded antenna (and most antennas are corroded if they have been up a while) or cracked and crazed down-leads (and most polyethylene leads are faulty after 10-12 months) can cause a deteriorated picture. *Nothing* you do to the set can correct this condition. A *new and better* antenna installation is the answer.

The NEPCO Line of antennas and TV installation materials eliminates this condition.

It was designed to meet the pressing demand for *better* electronic equipment—with more built-in ruggedness and corrosion-resistance than any line now known.

The NEPCO line was designed with YOU in mind:

- Provides *maximum* number of installations with a *minimum* number of parts from jobbers. Your stocks are kept at a minimum.
- Its high quality eliminates costly call backs . . . saves you time, trouble and tempers . . . improves customer goodwill.
- Eliminates rust streaks—a common customer complaint.
- Provides *quicker* installations . . . goes up fast . . . easy to handle . . . easy to carry.

Remember, a better installation using better materials will insure more satisfied customers.

These other features will "spark" your TV sales:

- All mounts made of rigid, heavy gauge steel.
- Unique adjustable mast clamp with one-bolt mounting.
- Two 15' stainless steel chimney bands with each chimney mount.
- Over 100 installation combinations possible with minimum inventory.
- Slotted, hex-head bolts standard equipment . . . all zinc-coated plus baked-enamel finish.
- Exclusive antenna mast clamp with positive alignment in all planes.
- Patented imbedding type screw for positive electrical and mechanical locking.

**ORDER A BALANCED STOCK
FROM YOUR JOBBER TODAY**

CHIMNEY MOUNTS

Made of $\frac{1}{8}$ " x $1\frac{3}{4}$ " steel, zinc-coated plus baked-enamel finish. One-screw mast clamp adapts to $1\frac{1}{2}$ " size masting. Complete with 30' stainless steel chimney band, eyebolts and NEPCO'S quick, positive banding clamps.

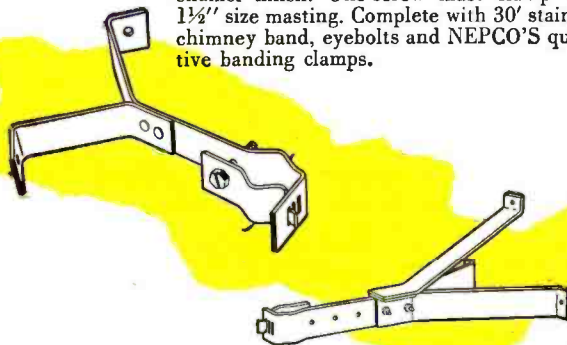

WALL BRACKETS

Fabricated of $\frac{1}{8}$ " x $1\frac{3}{4}$ " steel, heavily zinc-coated with baked-enamel finish. One-screw mast clamp adjustable to $1\frac{1}{2}$ " masting. Hex head slotted bolts to speed erection time.



**SPACE SAVER—
BIG, FLAT BOXES FOR TV WIRE**

NEPCO "Zee" Line comes in strong, flat cartons. Easy to stack, easy to handle, easy to pull out for cutting to any desired length. NEPCO "Zee" Line is low-loss UHF, TV receiving wire.

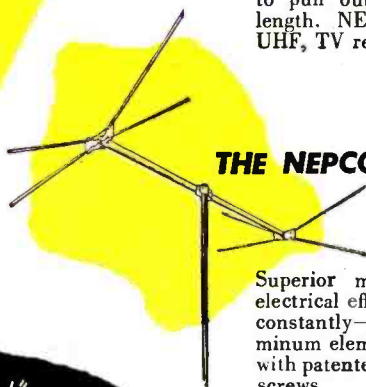

**THE NEPCO CONICAL ANTENNA
IMMEDIATE
DELIVERY**

Superior mechanical features maintain electrical effectiveness and performance—constantly—regardless of conditions. Aluminum elements are permanently secured with patented "vibration-proof" imbedding screws.

- All parts heavily zinc-coated plus baked-enamel finish.

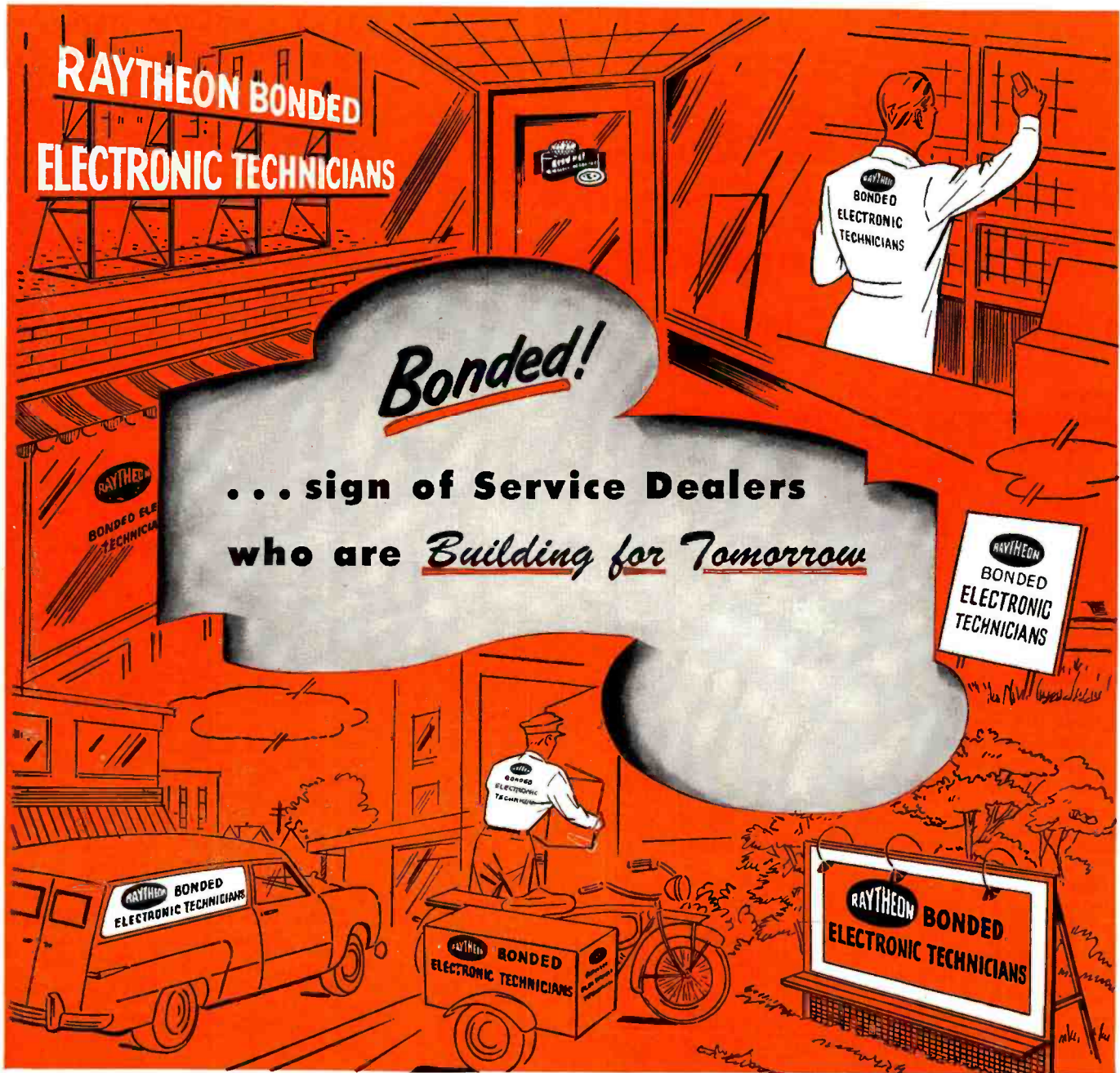

RIGHT... FOR SOUND AND SIGHT!

WHEREVER you see Service Dealers who are featuring the Raytheon Bonded Electronic Technician Program, you're looking at good businessmen who are as interested in tomorrow as in today. True, the cash-protection of the Raytheon Bond (backed by Continental Casualty Company) and the Raytheon "Code of Ethics" create initial customer confidence and thus stimulate sales right now.

But, more important, the sound, sensible way Raytheon Bonded Electronic Technicians do business insures future profits from an ever-increasing backlog of satisfied customers.

Your Raytheon Tube Distributor will be happy to give you the whole story on the Raytheon Bonded Program, and tell you whether or not you can qualify for this double-barreled asset. Call him today.

RAYTHEON MANUFACTURING COMPANY

Receiving Tube Division
Newton, Mass., Chicago, Ill., Atlanta, Ga., Los Angeles, Calif.

RAYTHEON MAKES ALL THESE:

RECEIVING AND PICTURE TUBES • RELIABLE SUBMINIATURE AND MINIATURE TUBES • GERMANIUM DIODES AND TRANSISTORS • NUCLEONIC TUBES • MICROWAVE TUBES



Excellence in Electronics



Leonard C. Lane, B.S., M.A. President of Radio-Television Training Association, Exec. Dir. of Pierce School of Radio and Television

AMAZING NEW TRAINING PLAN

NOW... YOU CAN BECOME A LICENSED* TV TECHNICIAN

LICENSED TV MEN MAKE MORE MONEY

AT NO EXTRA COST! YOU GET A ROUND TRIP TO NEW YORK CITY

FROM ANYWHERE IN THE U.S. OR CANADA—I pay your way to New York and return, PLUS 2 FREE weeks, 50 hours of advanced instruction and shop training at the PIERCE SCHOOL OF RADIO & TELEVISION. You use modern electronics equipment, including student-operated TV and Radio stations. You go behind the scenes of New York's big Radio-TV centers, to study first hand. And I give you all this AT NO EXTRA COST! (Applies to complete Radio-TV course only.)

Only RTTA makes this amazing offer.

EXTRA FEATURES THAT MEAN MORE MONEY FOR YOU!

Thousands of new job opportunities will be available for you right in your own state, now that the government has lifted restrictions on new TV stations. My simple, successful methods can PREPARE YOU NOW to take your place in America's booming TELEVISION and Electronics industries... help you get the success and happiness that you always wanted out of life. You learn the practical, easy way by using actual parts and equipment in the 15 big Radio-TV kits I send you, including a COMPLETE TV RECEIVER... yours to build and keep.

My Advanced Training Prepares You For Better Jobs Then, after you finish your training for a position as a full-fledged TV Technician—where you can write your own ticket and choose from dozens of fascinating careers—I don't stop there! I continue to train you—AT NO EXTRA COST—to qualify for even better pay in the BETTER JOBS that demand FCC licenses, with my...

FREE* FCC COACHING COURSE
PREPARES YOU AT HOME FOR YOUR FCC LICENSE
THE BEST JOBS IN TV AND RADIO REQUIRE AN FCC LICENSE
Given to every student at NO EXTRA COST after TV Theory and Practice is completed.

SET-UP YOUR OWN HOME LABORATORY WITH THE 15 BIG TELEVISION-RADIO KITS WE SEND YOU (At No Extra Cost)

YOU BUILD AND KEEP ALL THESE UNITS

- INCLUDING BIG SCREEN TV RECEIVER, plus Super-Het Radio Receiver, R.F. Signal Generator, Combination Voltmeter-Ammeter-Ohmmeter, C-W Telephone Receiver, AC-DC Power Supply, Everything Furnished Including All Tubes, and Big TV Tube



NOW! Advanced FM-TV Training For Men Who Know Radio
Prepares You For Higher Pay Jobs In A Few Months
COMPLETE theory and practical training course... complete with kits including large screen TV receiver.
FCC License Coaching Course Included FREE.

ATTENTION! VETERANS!

MY SCHOOLS FULLY APPROVED TO TRAIN VETERANS UNDER NEW G.I. BILL! If discharged after June 27, 1950—CHECK COUPON BELOW! Also approved for RESIDENT TRAINING in New York City... qualifies you for full subsistence allowance up to \$160 per month.



I GET MY GRADUATES GOOD PAYING JOBS

"As Merchant Ship Radio Officer, I receive \$887. for 40-day trip. Your training helped me get this fine position."
—Stanley Nawrocki

I now hold a fine airlines position at LaGuardia Field, New York City, thanks to your excellent training."
—Joseph Rosenberg

"Your excellent instruction helped me get my present job as an airport radio mechanic for American Airlines."
—Eugene E. Basko

"Thanks to your training, I qualified for a good job as a Receiver Tester at Federal Telephone and Radio."
—Paul Frank Seier

Many others working at NBC, RCA, CBS, Dumont, Philco, Emerson, Admiral and other leading firms.

RADIO-TELEVISION TRAINING ASSOCIATION

1629 Broadway, Radio City Station, New York City 19, N. Y.
Approved as a Correspondence School under the laws of the State of New York



BOTH FREE
New Illustrated Book plus Sample Lesson

NO SALESMAN WILL CALL!

Mr. Leonard C. Lane, President RADIO-TELEVISION TRAINING ASSN. 1629 Broadway, Radio City Station New York 19, N. Y.

Dept. T-3

Dear Mr. Lane:

Mail me your NEW FREE BOOK and SAMPLE LESSON that will show me how I can make BIG MONEY in TELEVISION. I understand I am under no obligation and no salesman will call.

Name _____ Age _____

Address _____

City _____ Zone _____ State _____

I am interested in: Radio-TV Advanced FM-TV
VETERANS: If qualified under new G.I. bill, check here

HICKOK

Latest Design
**ELECTRONIC
VOLTMETER**



FEATURES

- Accurate Peak-to-Peak measurements
- Portable, shock-resistant case
- Large 5", easy-to-read meter
- Zero-Center scale

RANGES

DC VOLTMETER

Volts: 0-1200 in 7 ranges
Input Resistance: 10 megohms

OHMMETER

Design Center: 10 ohms
Readability: 0.2 ohm to 1000 meg.

AC VOLTMETER

AC, RMS: 0-1200 in 7 ranges
AC, Peak-to-Peak: 0-3200 in 7 ranges
Frequency Characteristics: 40 cps to 3.5 MC,
and to 250 MC with crystal probe.
Input Impedance: 30 meg. shunted by 150
uuf with dual-probe furnished.

This new HICKOK Model 215 provides laboratory quality, accuracy and dependability. Ideal for the radio-television manufacturer or service shop. Has wide applications in the electronic or industrial fields. Contains the sensitivity and ranges for fast, accurate measurements of sine or complex waves of electronic devices. Test leads are included. Write today for complete information.

THE HICKOK ELECTRICAL INSTRUMENT CO.
10524 Dupont Ave. • Cleveland 8, Ohio

Spot Radio News

* Presenting latest information on the Radio Industry.

By RADIO & TELEVISION NEWS'
WASHINGTON EDITOR

BIDS FOR NEW CHANNELS, which for many months were extremely staid documents, have suddenly emerged from this state of calm and splashed an unusual assortment of odd facts into the news hopper.

In a rare request for a merger of two quests for channels from applicants in Madison, Wisconsin, seeking Channel 3 now, it was indicated that the new bid was prompted by a consolidation of stockholders of both groups into A and B shareowners. And among the latter principals are those who will supply equipment and materials to the new station, such as office furnishings and supplies, paint and varnish, hardware and even auto facilities.

In another unique brief to the Commission, joint operators of two AM and FM stations in Macon asked that a bid for a low-band and their bid for a high-band station be considered simultaneously, even though the broadcasting stations are owned by the same officers. In their application, the broadcasters declared that they were aware of the . . . "policy considerations present when two corporations, each of which is a licensee of a station in a particular community join together as an applicant for a television station to serve that community." However, they added, at present there is no television station in Macon, and thus certainly the applicant for the low channel (13) would be granted a permit without hearing. If the parties to this application proceeded separately without a hearing, it was then noted, the public would have purchased regular-band receivers before the recipient of the high-band grant would be decided, and the problem of building an audience for the high-band station may prove insurmountable. Thus, it was emphasized, granting of this joint application will mean that v.h.f. and u.h.f. will arrive at the same time to Macon, and thus competition on an equal basis will exist. Even though both facilities will be jointly controlled, competition between them would be maintained, the applicants stressed.

Three of the Commissioners (Sterling, Merrill, and Bartley) felt that the grant should be approved, but Chairman Walker demurred declaring that the McFarland Act requires that

the application be designated for hearing . . . "to determine whether a grant of . . . application would serve the public interest."

Commissioner Bartley said he was highly in favor of approval because it would provide competition at an earlier date, provide an opportunity for the high bands to commence operation about the same time as the standard band TV in a new market, and the broadcast stations would continue to compete as long as the conditions agreed upon are followed.

In still another unusual case on file, the *Missouri Broadcasting Corp.*, who own WIL in St. Louis, asked the Commission to refuse the request of WIBV in Belleville, Illinois, for Channel 42, because the application is not in order, since Channel 42 has been assigned to St. Louis and cannot be moved to Belleville, 15 miles away; in addition, Belleville already has an ultra-high channel, 54. Then WIL noted that if the Commission negates the Illinois application, the Channel 42 CP should be awarded to them without further contest; it seems as if the examiners passed over the application originally when they reached St. Louis because of the conflict of channel requests.

With over 1800 grants still to be issued and sizzling arguments due in scores of instances, the days and nights, too, of the Commissioners and examiners will be far from rosy during the new year and most likely, during the next few years.

FULLFILLING ITS PROMISE to speed allocations, the seven air chiefs ended the year with a record commercial grant list of 165, and it is believed that during the winter and spring months, the pace will be substantially stepped up.

Thus far, the books reveal that a total of 283 stations (of all types) have been authorized. Of the 165 who received new commercial allotments, 21 have been awarded special temporary authorization to go on the air. The 108 pre-freeze stations are located in 65 cities in 33 states and the District of Columbia or Washington. Post-freeze grants made during '52 will bring TV service to 112 additional cities.

Only five states have not as yet received TV authorizations: Montana,

HICKOK

"...I use my 215
more than any other instrument..."

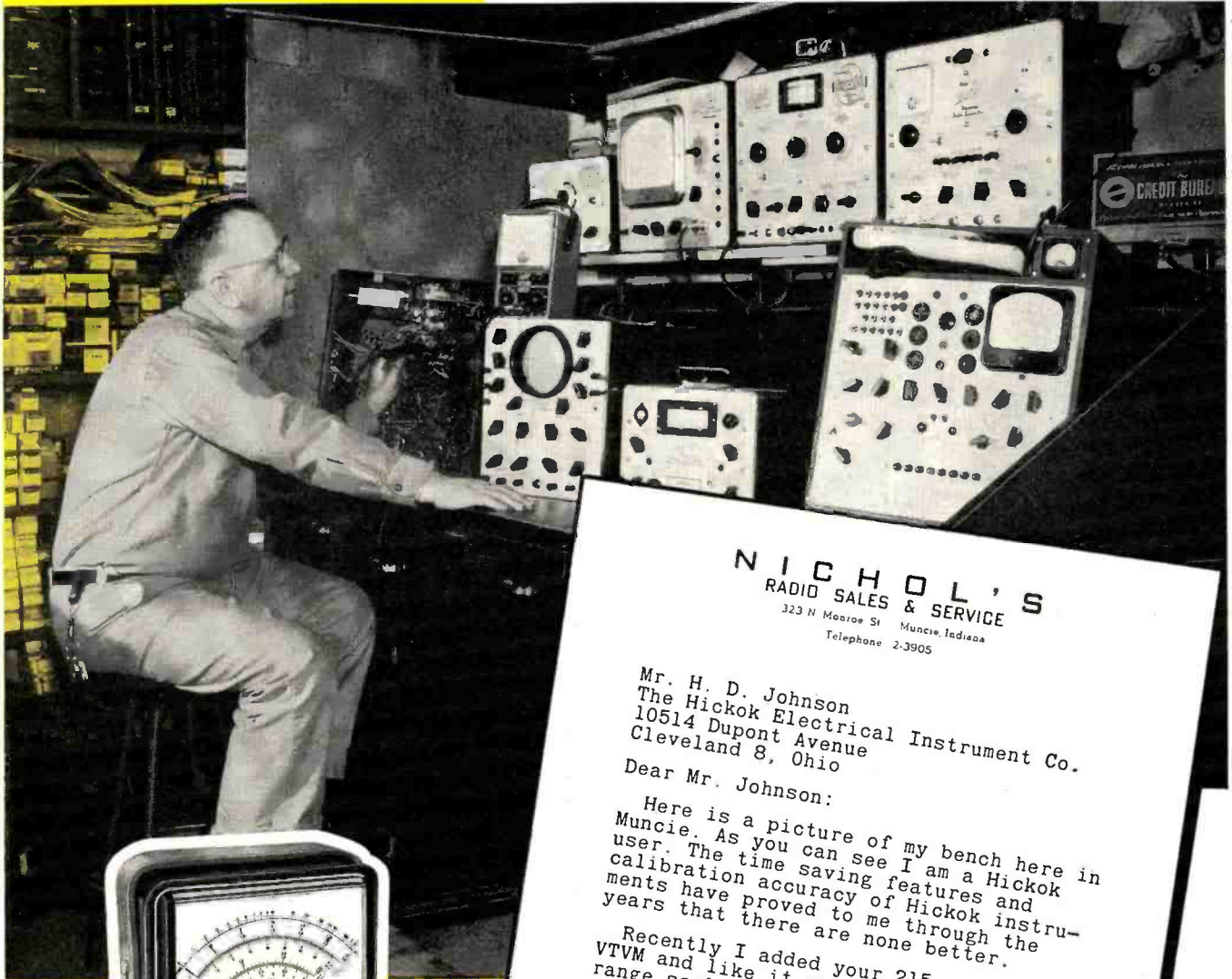

MODEL 215

NICHOL'S
RADIO SALES & SERVICE
323 N. Monroe St. Muncie, Indiana
Telephone 2-3905

Mr. H. D. Johnson
The Hickok Electrical Instrument Co.
10514 Dupont Avenue
Cleveland 8, Ohio

Dear Mr. Johnson:

Here is a picture of my bench here in Muncie. As you can see I am a Hickok user. The time saving features and calibration accuracy of Hickok instruments have proved to me through the years that there are none better.

Recently I added your 215 portable VTVM and like it very much. The long range scales on your new meter are quicker to read. The Peak-to-Peak, Zero-Center and one piece AC-DC, also save me a lot of time. I use the 215 more than any other instrument in my shop, and I can depend on it.

Just wanted you to know that this serviceman really appreciates the high quality and practical design of Hickok equipment throughout these many years.

Sincerely yours
Armer Nichols

THE HICKOK ELECTRICAL INSTRUMENT COMPANY

10514 DUPONT AVENUE

CLEVELAND 8, OHIO

Famous Guns



Volcanic Repeating Pistol
(Smith & Wesson) Caliber .36, 1854 Patent. Forerunners of the famous Smith & Wesson line of hand-guns, the Volcanic pistols marked the beginning of the end for percussion firearms. Their design was revolutionary; instead of the old-time cap and ball, they used special *self-contained* cartridges.



Harpers Ferry Flintlock Pistol,
Caliber .54, 1806 Model. Famous for its accuracy, balance and graceful lines, this handsome pistol was used by both Army and Navy. The Harpers Ferry (Virginia) Armory, in which the pistol was made, was raided by abolitionist John Brown in 1859, and was burned during the Civil War.



**Instant-Heating
Weller Soldering Gun**
for light or heavy work. Dual heat greatly increases tip life. Switch instantly to high or low heat as job requires. Pre-focused spotlights end "blind soldering." Exclusive tip-fastening arrangement assures full, constant heat. High-impact plastic housing. Perfect balance. Low-cost, replaceable tips. Pays for itself in a few months. See at your Distributor or write for Bulletin direct.

Get **SOLDERING TIPS**, new Weller Handy Guide to faster, easier soldering. 24 pages, fully illustrated. Price 10c from your Distributor or order direct.

Weller BETTER FROM GRIP TO TIP

SOLDERING GUNS 810 Packer Street, Easton, Pa.
The Finest Soldering Tool for the Finest Craftsmen

New Hampshire, North Dakota, Vermont, and Wyoming. However, applications are pending for stations in each of these states. Incidentally, Alaska and the Virgin Islands had neither TV authorizations nor applications pending at the close of '52 and there'll probably be no interest in TV service for these areas for a long time.

A list of those who now proudly possess permits to build TV stations, appeared in part, last month. On page 76 of this issue appears a continuation of these listings.

WASHINGTON broadcasters, and radio and TV personalities were prominent on the roster of the Gen. Eisenhower inaugural-ball subcommittee. Among those active were: Thad H. Brown, Jr., of the National Association of Radio-TV Broadcasters, who was on the invitations committee; Ed Morris, *Zenith* distributor, co-chairman of floor committee; Ken Berkley of WMAL, Earl Gammons of CBS and Frank Russell of NBC, who were on the patrons committee. And on the committee on reception to distinguished guests were Phil Graham of WTOP, and Samuel Kauffmann of WMAL, as well as Brown, Morris, and Gammons.

THAT OUTSTANDING SECURITY plan, *Conelrad* (control of electromagnetic radiation), designed to alert and control the operation of all broadcast stations (AM, FM, TV) has become official and nearly 4000 broadcasters have received detailed procedures of operation.

Under the plan, AM stations will be allowed to remain on the air, transmitting on either 640 or 1240 kc. a continuous program featuring special instructions, information, and news on air-raid alert conditions.

Specifically, there are four types of operation which might be used: One is known as "sequential," in which stations are arranged into groups or clusters of two or more stations, located in one or more municipalities, counties, or states, all using the same or both frequencies, mentioned above. Stations will go on and off the air in a non-cyclic sequence with periods varying from 5 to 40 seconds. The second type is an "on-off," which applies to individual stations or cluster outlets, with the Commission controlling power for maximum effectiveness. Air time of the individual outlets will be about 10 to 30 seconds, and off-air time will be about 3 to 6 minutes; outlets will implement air time of cluster groups. In the third group, a pulsating system is used, with power of transmitters on the air varied over a certain range. And in the fourth class a sync method is used, with two or more stations in a given area on the air at the same time, all assigned the same frequency and power regulated by the Commission. It is reported that most stations will use the "sequential" and "on-off" methods.

(Continued on page 174)

GET DEPENDABLE PERFORMANCE IN TV TEST EQUIPMENT!



Model ST-4A

**...Accurate Measurements
and Increased Profits, Too!**

COMBINED use of these G-E units takes guesswork out of test measurements. With good linearity and amplitude characteristics G-E equipment eliminates misleading results from distorted patterns. Your technicians will handle more work...handle it more efficiently...add to your profits and your reputation!

Sweep Generator ST-4A. Outstanding in performance and varied in application. Adjustable linear sweep that is all-electronic...no moving mechanical parts. Covers all broadcast TV channels. Good attenuation and extremely low leakage plus continuously variable center frequency.

Marker Generator ST-5A. Marks all the critical frequencies on a pass band as well as having continuous coverage. Designed to give fast manipulation with crystal controlled accuracy for outstanding performance. Features separate crystal on each TV channel with simultaneous picture, audio and trap markers on both channel and intermediate frequencies.

Oscilloscope ST-2A. Reports from thousands indicate this scope does the job they need in TV circuit work. Used in conjunction with the G-E Sweep and Marker you have an unbeatable combination. Special features include wide frequency response plus DC amplifier to adapt the equipment to other applications.

Balanced Output Adaptor ST-8A. Converts single-ended Sweep Generator output to balanced output for 300 ohm television receiver work.



Model ST-5A



Model ST-2A



GENERAL  ELECTRIC

General Electric Company, Section 933
Electronics Park, Syracuse, N. Y.
Please send me complete specifications on G-E
TV Test Equipment.

NAME.....
COMPANY.....
ADDRESS.....
CITY.....STATE.....

FAR BETTER RECEPTION

IN EVERY LOCATION

with Sensational New

TRIO ZIG-ZAG

Patent Pending

TV ANTENNAS



ZZ4A



ZZ6A

SUBURBAN MODELS

Models ZZ4A and ZZ6A give you all-channel (2 thru 13) reception in ONE SINGLE BAY ANTENNA. The Model ZZ4A has excellent gain and is designed for suburban areas. Model ZZ6A has even greater gain and provides excellent all-channel reception in near fringe areas.

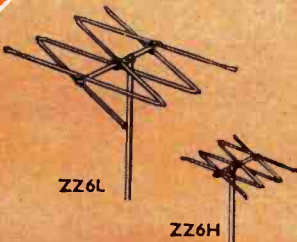

ZZ6L

ZZ6H

NEAR FRINGE MODELS

For near fringe area reception, the Models ZZ6L and ZZ6H are recommended. Model ZZ6L covers Channels 2 thru 6, Model ZZ6H is for Channels 7 thru 13. Both antennas offer high gain with patterns and front-to-back ratios similar to cut-to-channel yagis.

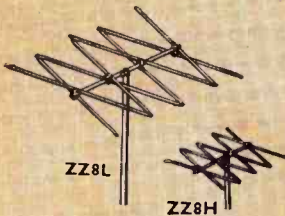

ZZ8L

ZZ8H

FRINGE MODELS

Models ZZ8L and ZZ8H were designed for normal fringe area reception and provide clear, snow-free pictures. Forward lobe patterns and front-to-back ratios are similar to a good single channel, multi-element yagi.

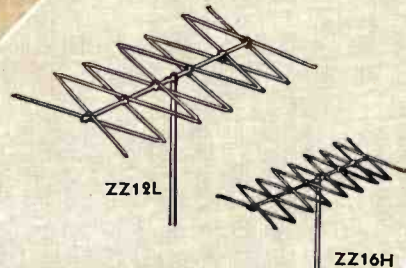

ZZ12L

ZZ16H

ULTRA FRINGE MODELS

The extremely high gains of the ZZ12L and the ZZ16H models provide unequalled reception in ultra-fringe areas. Model ZZ12L covers Channels 2 thru 6 and Model ZZ16H, Channels 7 thru 13. These two models when stacked, are fed with only one 300 ohm line and provide ALL VHF CHANNEL RECEPTION. Line match is excellent and front-to-back ratios are unusually high.

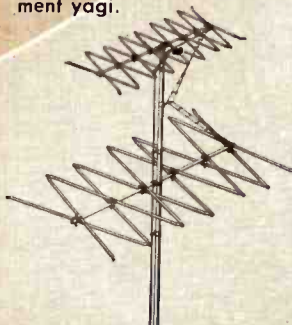

ZZ12L and ZZ16H are stacked for all VHF Channel Reception

* To provide even greater strength, TRIO Antennas now have stamped steel element clamps.

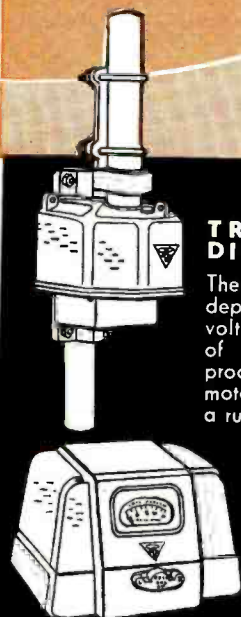

TRIO ROTATOR AND DIRECTION INDICATOR

The TRIO Rotator is America's most dependable — has two powerful 24 volt motors — one for each direction of rotation. Absolutely weather-proof, permanently lubricated. All motors, shafts and gears mounted on a rugged, one-piece casting for true alignment, strength and longer life. Every TRIO Rotator fully guaranteed for two years! Beautiful Direction Indicator has "finger tip" control — no need to hold knob for rotation. A touch of the finger starts it — a touch stops it!



TRIO

TRIO MANUFACTURING COMPANY

GRIGGSVILLE, ILLINOIS

Depend on Mallory
for
Approved Precision Quality



Get More Jobs Done In A Day

There's no profit in sets waiting to be repaired. Profits depend on turning out more jobs . . . and cutting down on time wasting call-backs.

Midgetrols® are designed for fast, easy installation in any set, TV or radio.

Round tubular shafts can be cut accurately and quickly . . . fit split-knurl or flatted-type knobs.

AC switches can be attached instantly without disassembling the control.

Their unique design simplifies inventory problems . . . always available from your Mallory Distributor.

Midgetrols are engineered to duplicate the precise characteristics of original equipment. They will give equal . . . and often better performance and life than the original control.

Save time . . . find extra minutes to turn out more finished jobs . . . be sure of dependable, precision quality for all your TV and radio repairs . . . ask for Mallory Midgetrols the next time you call your distributor.

Another time saver. Get your copy of the Mallory Control Guide. It is a complete cross reference between set manufacturers' part numbers and the equivalent Mallory control.



P. R. MALLORY & CO. Inc.
MALLORY

CAPACITORS • CONTROLS • VIBRATORS • SWITCHES • RESISTORS
• RECTIFIERS • VIBRAPACK® POWER SUPPLIES • FILTERS

APPROVED PRECISION PRODUCTS

*Reg. U.S. Pat. Off.

P. R. MALLORY & CO. Inc., INDIANAPOLIS 6, INDIANA

ULTRA FAN series — Complete VHF-UHF coverage

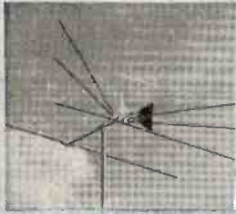

single bay — model no. 413

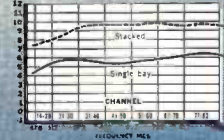

Today's most sensitive All-YU* antennas! The Ultra Fans actually operate on *three* separate electronic principles — automatically:

1. Low Band VHF (Channels 2-6) . . . Conical antenna with parasitic reflector
2. High Band VHF (Channels 7-13) . . . Large diameter V antenna
3. UHF (Channels 14-83) . . . Triangular dipole with sheet reflector

One set of All-YU* stacking rods provides highest VHF and

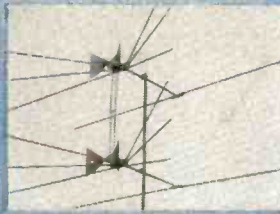

stacked — model no. 4132

UHF gain. Each Ultra Fan has its own 2-stage inter-action filter, so that only one transmission line to the set is required.

*All VHF, all UHF



ULTRA DAPTER
model no. 414

Instantly converts all Channel Master Super Fans into high gain, all-channel, VHF-UHF antennas. Features a built-in inter-action filter.

Your best bet for UHF!

CHANNEL MASTER Ultra-Tennas

America's most complete — most effective — UHF antenna line.

Channel Master's advanced engineering pays off again! While rain caused hundreds of UHF antennas to FAIL recently in Portland, *not one Channel Master antenna dimmed or shorted out a picture!* The facts speak for themselves: Rain or shine, Channel Master antennas out-perform all others.



ULTRA BOW
model no. 401

The basic UHF antenna for primary signal areas, and the outstanding member of the bow-type antenna family.

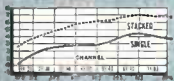

Only Channel Master Antennas are designed to eliminate the "TWIN TERRORS" OF UHF RECEPTION:



- Vibration, which causes picture flicker.
Eliminated by Channel Master's Ultra-Rigid construction and advanced mechanical design.
- The accumulation of dirt or moisture around the antenna terminals, which dims and eventually shorts out the TV picture.
Eliminated by Channel Master's sensational "free-space" terminals which prevent the accumulation of foreign deposits at the feed points.



ULTRA BOW
with
SCREEN
REFLECTOR
model no. 403

Can be stacked in 1, 2, and 4 bays. High, all-channel UHF gain, excellent front-to-back ratio.

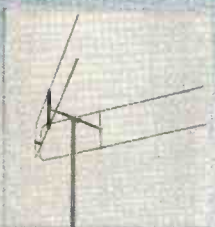

ULTRA VEE
model no. 404

- Good UHF gain
- Low VHF gain
- The most rigid UHF antenna of its type and size.

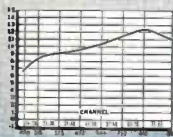

Gain: 11 DB, single
14 DB, stacked

DELTA WELD

Wide Band
10 Element
UHF Yagi

Custom-designed for full coverage of your specific area! Brilliant high gain performance across as many as 23 different channels.

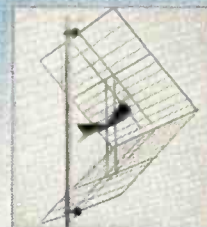

CORNER REFLECTOR
model no. 405

The outstanding all-channel UHF FRINGE antenna. Now — can be stacked for even greater gain.

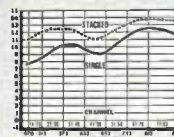

Sold through the nation's leading distributors

CHANNEL MASTER CORP.
ELLENVILLE, N. Y.

Write for complete technical literature



ULTRA-TIE model no. 9034
Electronic Inter-Action Filter

JOINS separate antennas into a single VHF-UHF antenna system, for use with a single transmission line.

SEPARATES VHF and UHF signals at the set or converter where separate inputs are provided.

The only filter with "free-space" terminals.

NOW—read this true story of

UHF ANTENNA FAILURE IN PORTLAND!

GARRETSON RADIO SUPPLY, INC.

INDUSTRIAL DIVISION
2416 SECOND AVENUE



SEATTLE 1, WASHINGTON
SE. 0640 • MU 0422

January 22, 1953

Channel Master Corporation
Napanoch Road
Ellenville, New York

Attn: Harold Harris

Dear Harold:

Now that the UHF station, KPTV in Portland, Oregon has been on the air for a few months, it may interest you to know some of the results of antenna performance.

Antennas of all descriptions, both multi-channel and single channel UHF have been installed in the Portland area. The results in most cases were fair, however in some instances certain types of antennas specifically for the UHF channels failed completely to perform. Several of the so called "all channel" antennas performed in strong signal areas, but failed completely where gain was needed, or ghost problems were encountered. These results were obtained while the weather in Portland was good.

For the past few weeks it has been raining consistently in the Portland area and the antenna failures have been numerous, due to the shorting out of the terminal connection at the antenna. The result -- antenna crew men have been out drilling small holes in the terminal blocks trying to provide as much air insulation as possible. Certain types of antennas, which used an isolation filter at the antenna also had their troubles. In many cases this filter broke down and moisture leaked into the filter, causing it to short out at the terminal.

Many of the Channel Master UHF antennas have been sold and installed by our dealers in Portland, with no complaints whatsoever. In all cases, the antennas have given excellent performance and provided clean pictures, regardless of weather conditions. This, we feel, is the result of research and engineering, and the foresight to foresee the many problems which would confront the UHF antenna.

The use of your free-space terminals has forestalled any problems of signal loss due to moisture conditions and in all cases, our dealers tell us that the Channel Master antennas live up to the published catalog information.

May we offer our congratulations on an excellent unit - and let's keep them rolling!

Very truly yours,

GARRETSON RADIO SUPPLY, INC.

Faige C. Lundberg
By: Faige C. Lundberg

VMH/pl

Look to Channel Master for UHF— IT PAYS OFF!

B&WMODEL
600

Dip Meter

- ★ Frequency Range—1.75 to 260 MC. in 5 Bands
- ★ Adjustable Sensitivity Control
- ★ Wedge-shaped for Easy Access in Hard-to-get-at Places
- ★ Rust Proof Chassis, Sturdy Aluminum Case
- ★ Monitoring Jack and Diode Switch
- ★ Powered by 110 V. A.C. Line

NEW LOW PRICE
\$39⁷⁵
net

A HIGHLY USEFUL INSTRUMENT FOR THE

Service Man • Experimenter
Lab. Technician • Engineer • Amateur

The New B & W Model 600 Dip Meter provides you with a convenient means of doing the job in a minimum of time with dependable accuracy.

It is an extremely sensitive and reliable piece of test equipment having innumerable uses in the Ham Shack, Service Shop, Electronic Laboratory, or Production Plant.

Armed with this versatile and indispensable instrument, you eliminate the guess-work during measurement of—tank circuit frequencies, antennas, feed line systems, parasitics, and other pertinent tuned circuit characteristics, with speed and accuracy.

The handy instruction manual furnished with each instrument covers full information on how to use the Model 600 as an Absorption Meter, Auxiliary Signal Generator, R. F. Signal Monitor, and several special applications as well. See it at all leading electronic parts distributors throughout the U. S. A. and Canada; or write for descriptive bulletin.

BARKER & WILLIAMSON, Inc.
237 Fairfield Ave., Upper Darby, Pa.

Within the INDUSTRY

RICHARD A. GRAVER, vice-president and general manager of the *Capehart-Farnsworth Corp.*, has been appointed vice-president and director of marketing of the *Hallcrafters Co.*

In his new capacity, Mr. Graver will be in complete charge of all merchandising, marketing, and advertising activities of the company.

Before joining *Capehart-Farnsworth*, he was vice-president in charge of the electronics division of *Admiral Corporation*. Prior to joining *Admiral*, he was district sales manager in charge of all products for *RCA* in Chicago.



AEROVOX CORP. has purchased **ACME ELECTRONICS, INC.** of Pasadena. It will be operated as a wholly-owned subsidiary under the continuing management of Hugh P. Moore as president . . . **MOTOROLA INC.** has announced the organization of a wholly-owned subsidiary corporation, **MOTOROLA COMMUNICATIONS AND ELECTRONICS, INC.** It will distribute the products made by the communications and electronics division of the parent company . . . **R. B. BARNHILL & ASSOCIATES** has been recently organized as a manufacturers' representative firm by R. B. Barnhill, former commercial sales manager of the Radio Division of **BENDIX**. The new company has headquarters at 412 Woodbine Ave., Towson 4, Md. . . **THE RADIO CRAFTSMEN, INC.** has established the **HI-FIDELITY MFG. CORP.** in West Palm Beach to act as a supplier of tuners, amplifiers, and eventually television chassis for the parent company. The plant of the new Florida subsidiary is at 2501 Belvidere Rd. . . **NAJESCO, INC.** has been formed by **JERROLD ELECTRONICS CORP.** to act as exclusive agents for the sale of the company's test equipment. The firm is located at 1449 S. 26th St., Philadelphia 46 . . . The firm of **HARMAN-KARDON, INC.** has been established at 52 W. Houston St., N. Y. C. as successors to **KARDON MFG. CORP.**

* * *

GRADY L. ROARK has been appointed manager of equipment tube sales for *General Electric's* Tube Department.

He has been central regional manager for equipment tube sales with headquarters in Chicago since 1950. In his new position he will be located at the Tube Department headquarters in Schenectady and will direct the sales of *G-E* receiving, cathode-ray, industrial, and transmitting tubes to manufacturers of electronic equipment.

Mr. Roark joined *G-E* on the company's test engineering program in 1933.

* * *

DR. V. K. ZWORYKIN, pioneer researcher in electronics, has been awarded the 1952 Edison Medal by the American Institute of Electrical Engineers.

Dr. Zworykin, who is vice-president and technical consultant of the *RCA Laboratories Division*, was cited for his "outstanding contribution to the concept and design of electronic components and systems."

* * *

ARTHUR L. CHAPMAN has been named to the newly-created post of vice-president in charge of electronics operations for *Sylvania Electric Products Inc.* . . . **MAX BAUME** is now with *Brook Electronics, Inc.* as sales manager. He was formerly head of the sound department of *Hudson Radio* . . . *Mark Simpson Mfg. Co., Inc.* has appointed **RALPH AASEN** as chief engineer and **G. LEON**

ELECTRO DEVICES, INC. has acquired a two-story building at 4-6 Godwin Ave., Paterson, N. J. The new facilities will permit expanded production of electronic motor speed controls . . . **PHILCO** recently purchased a plant in England and is now making available 10 radio receiver models. Production of television sets is expected to start in approximately six months . . . **BELCO INDUSTRIAL EQUIPMENT DIV., INC.** is now occupying its newly-erected plant at 100 Pennsylvania Ave. in Paterson, N. J. . . . **WARWICK MFG. CORP.** has purchased the Zion, Ill. building of **MARSHALL FIELD & CO.** The building contains 200,000 sq. ft. of space . . . **G-V CONTROLS INC.** of East Orange, N. J. has acquired additional space at 28 Hollywood Plaza which will double the manufacturing facilities of the firm . . . **RESISTANCE PRODUCTS CO.** has opened a new plant at 914 S. 13th St., Harrisburg, Pa. The plant will be used in conjunction with the company's present facilities at 714 Race St.

* * *

* * *

* * *

* * *

* * *

* * *

* * *

* * *

* * *

* * *

* * *

Sweeping the Country!

**BUY DIRECT
AND SAVE**

'PRE-FAB'

COLLINS TUNERS and RECEIVERS

AUDIO PRODUCTS CO.

Collins Audio Products Co. is in no way affiliated with Collins Radio Co.

Two ALL NEW Complete Kits for
Every High-Fidelity Need



FM Tuner Kit

\$55

The FM-11 tuner is available in kit form with the IF Amplifier mounted in the chassis, wired and tested by us. You mount the completed RF Tuning Unit and power supply, then after some simple wiring, it's all set to operate. 11 tubes: 6J6 RF amp, 6AG5 converter, 6C4 oscillator, 6BA6 1st IF, (2) 6AU6 2nd and 3rd IF, (2) 6AU6 limiters, 6AL5 discriminator, 6AL7-GT double tuning eye, 5Y3-GT rectifier. Sensitivity 6 to 10 microvolts, less than 1/2 of 1% distortion, 20 to 20,000 cycle response with 2DB variation. Chassis dimensions: 12 1/2" wide, 8" deep, 7" high. Illustrated manual supplied. Shipping weight 14 lbs.

Each Collins Tuner Kit is complete with punched chassis, tubes, power transformer, power supply components, hardware, dial assembly, tuning eye, knobs, wire, etc., as well as the completed sub-assemblies: FM tuning units, AM tuning units, IF amplifiers, etc., where applicable. Since all these sub-assemblies are wired, tested and aligned at the factory, Collins Pre-Fab Kits are easily assembled even without technical knowledge. The end result is a fine, high quality, high fidelity instrument at often less than half the cost—because you helped make it and bought it direct from the factory. Bring your present reproducing system up to date with a new Collins Tuner.



FM/AM Tuner Kit

\$77.50

The original 15 tube deluxe FM/AM pre-fab kit redesigned on a smaller chassis. The tuner now measures 14" wide by 12" deep by 7 1/2" high. This attractive new front and dial assembly opens up new applications where space is at a premium. Kit includes everything necessary to put it into operation—punched chassis, tubes, wired and aligned components, power supply, hardware, etc. Kit comprises FMF-3 tuning unit, IF-6 amplifier, AM-4 AM tuning unit, magic eye assembly and complete instructions. All tubes included. Shipping weight 19 lbs.

Selected Basic Components For Special Applications

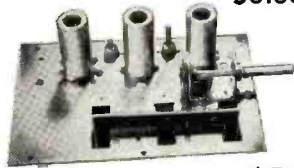

FMF-3 Tuning Unit

\$15.25

The best for FM. The most sensitive and most selective type of "front end" on the market. 6 to 10 microvolts sensitivity. Image ratio 500 to 1. 6J6 tuned RF stage, 6AG5 converter, 6C4 oscillator. Permeability tuned, stable and drift-free. Chassis plate measures 6 1/2" x 4 1/2". In combination with the IF-6 amplifier, the highest order of sensitivity on FM can be attained. Tubes included as well as schematic and instructions. Draws 30 ma. Shipping weight FMF-3: 2 1/2 lbs. Dial available @ \$3.85



IF-6 Amplifier

\$19.75

A remarkable value! 6 tubes are used in the IF amplifier: 6BA6 1st IF, (2) 6AU6 2nd and 3rd IF's, (2) 6AU6 limiters and 6AL5 discriminator. High gain, wide-band response (200 KC) for highest fidelity. 20 to 20,000 cycles. Distortion less than 1/2 of 1%. Draws 40 ma @ 220 volts. Chassis plate dimensions: 11-5/16" x 2 1/2" Shipping weight: 3 lbs.



AM-4 Tuning Unit

\$24.50

Tops in AM superhet performance! A 3-gang tuning condenser gives 3 tuned stages with high sensitivity and selectivity. Assembly is completely wired, tested and aligned ready for immediate use. Frequency coverage 540 KC to 1650 KC at a sensitivity of 5 microvolts. Tubes 6BA6 RF amplifier; 6BE6 converter; 6BA6 IF amplifier and 6AT6 detector. Draws 30 ma @ 220 volts. Mounts on a chassis plate measuring 4" x 7 3/8". Shipping weight 2 1/2 lbs. Dial available at \$3.85.

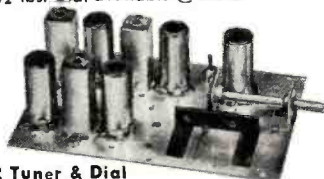

RD-1C Tuner & Dial

\$28.50

The COLLINS RD-1C FM tuner chassis is unique in the field. A whole, compact FM tuner and dial that fits in the palm of your hand. Convert AM sets to FM/AM receivers for only a few dollars! Unlimited applications where space is at a premium. Use in conjunction with your phonograph amplifier. Full frequency response to 20,000 cycles. Sensitivity 20 microvolts, permeability tuned. Tuning unit and IF amplifier on the same chassis plate. Draws 40 ma @ 100 volts. Tubes: 6AG5 converter, 6C4 oscillator, (2) 6AU6 IF amplifiers, 6AL5 in new ratio detector circuit. Shipping weight tuner and dial 5 lbs.

**MAIL
COUPON
TODAY**

To: Collins Audio Products Co. Inc.
P.O. Box 368, Westfield, N. J.
Tel. Westfield 2-4390

- FM Tuner Kit FM/AM Tuner Kit Slide Rule Dial Assembly
 FMF-3 Tuning Unit IF-6 Amplifier RD-1C Tuner and Dial
 AM-4 Tuning Unit

NAME.....

ADDRESS.....

CITY..... STATE.....

Amount for Kit \$..... See weights, add shipping cost \$.....

Total amount enclosed \$..... Check Money Order

WHEN YOU THINK OF TUNERS, THINK OF COLLINS AUDIO PRODUCTS



three TIME-SAVING

OHMITE Little Devil®

RESISTOR ASSORTMENTS

FOR RADIO-TV SERVICEMEN



WITH HANDY
PLASTIC CABINET

ALL FOR THE PRICE OF RESISTORS ALONE!

Here's a handy all-plastic resistor cabinet that's a real time-saver. Five drawers, each with eight individually-labeled compartments, make it easy to locate the right resistor and to maintain visual stock control.

The 1/2-watt assortment contains 150 carefully selected Ohmite "Little Devil," individually marked, insulated composition resistors. The 1 and 2-watt assortments each contain 125 resistors. The assortments include the 40 values (10 ohms to 10 megohms) most frequently used by servicemen.

This cabinet is offered at the price of the resistors alone. See your jobber.



CABINETS CAN BE STACKED ON EACH OTHER
A dovetail joint is provided on top and bottom of each cabinet so they can be stacked one on top of another.

OHMITE MANUFACTURING CO., 4884 W. Flournoy Street, Chicago 44, Ill.

Be Right with **OHMITE**®

RHEOSTATS · RESISTORS · TAP SWITCHES

ARD WERNER as director of sales . . . **JOHN R. SHEARER** is the new sales engineer for the television transmitter division of *Allen B. Du Mont Labs, Inc.* **LYNAL H. WILSON** has been made general manager of *Argos Products Co., Inc.*, electronic cabinet manufacturer . . . **LOU BURZYOKI** is the new chief transformer engineer of *Crest Labs.* . . . **OSCAR E. CARLSON**, former vice-president of *Servo-Tek Products Co.*, has been elected president of *Electro Devices, Inc.*, of Paterson, N. J. . . . **O. E. BISHOP** has been promoted to the post of manager of sales operations for the distributor division of *P. R. Mallory & Co., Inc.* . . . **KJELL GAARDER**, who has been associated with *Webster Chicago, RCA*, and *G-E*, has joined *V-M Corp.* of Benton Harbor, Mich. where he will head all development engineering and production engineering activities . . . **JOHN A. VAN AUKEN** is the new general manager of *Mark Simpson Mfg. Co., Inc.* . . . *Sangamo Electric Co.* has elected **H. LAURENCE KUNZ**, vice-president. He was formerly general manager of the company's Capacitor Division . . . **H. EARLE RUNION** has been named production manager of *Consolidated Engr. Corp.* . . . **PAUL V. PEMBRICKS**, previously head of the methods department for *Hammarlund Mfg. Co.*, has been appointed assistant plant manager of the firm . . . **ERIK ISGRIG**, former account executive with *Earle Ludgin & Co.*, has joined *Zenith* as director of advertising . . . **RAYMOND K. McCLINTOCK** is the manager of new product promotion of *Sylvania Electric Products Inc.* The new post is a recently-created position with the firm. . . . **HENRY FOGEL**, formerly manager of the commercial products division of *Radio Receptor*, has been named president of the newly-organized firm of *Granco Products, Inc.* The company designs, manufactures, and distributes converters for u.h.f. television and u.h.f. measuring instruments . . . **A. A. DYSON**, managing director of *Erie Resistor Ltd.* of England has been included in Queen Elizabeth's New Years Honors List to receive the Order of British Empire. He has been active on many British government electronics planning and production boards.

BYRON C. DEADMAN of *Northern Radio & Television Co.*, Green Bay, Wis., has been elected treasurer of the Radio Parts & Electronic Equipment Shows, Inc., sponsors of the Electronic Parts Show, to fill the unexpired term of Jack A. Berman who resigned recently.



Mr. Deadman has been active in the affairs of the National Electronic Distributors Association, which group he represents on the Show Board.

JEROME KURTZ, navigator and radio operator on a twin-engine Beechcraft NC-67083, has been reported missing
(Continued on page 161)

BUILD A BUSINESS and a REPUTATION!



Replace with Genuine G-E Parts



In a business that's growing rapidly, an ever increasing number of expert servicemen carry the complete line of General Electric replacement parts. They realize the demand for these products and the opportunity G-E units offer to increase sales...add to their reputations.



G-E RECORD COMPENSATOR. "Hit of the New York Audio Fair." Here is a new G-E unit that is sure to build store traffic. Favorite old records sound like new. Modern recordings are interpreted more faithfully. Low cost is a plus feature for volume sales. Lends itself ideally to effective store demonstration.

G-E TONE ARMS. A line designed to bring users the full benefit of our famous variable reluctance cartridges. Stylus replacement requires only a few seconds. Skilled G-E workmanship and quality construction add up to customer satisfaction for many years.

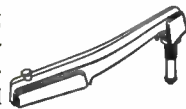

G-E PREAMPLIFIERS. New improved performance. Completely self-contained and ready to operate when connected to a power source. Ease of installation is a factor you'll appreciate. This product goes hand-in-hand with widely accepted General Electric Cartridges.



G-E CARTRIDGES. A complete line of single or dual units to meet every need for quality reproduction. Offers incomparable performance. Deliver smooth, wide range response; low tracking pressure. Available at prices your customers will really appreciate.

G-E WIDE-RANGE STYLI. General Electric manufactured the first wide-range diamond-sapphire* combination! Every stylus is designed to give unexcelled performance up to 15,000 cycles. Engineered to minimize record wear...add quality to the products you carry.

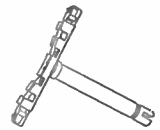

G-E SPEAKERS. 27 models in 8 sizes to choose from. G-E high fidelity speakers stand head and shoulders above the industry in providing peak performance at a modest price. Featuring aluminum base voice coils and Alnico 5 magnets, your customers are assured of a quality product for their listening pleasure.

**Some sapphires are synthetic*

● Contact your G-E Distributor now for the new lucite Record Compensator counter displays, plus many other sales aids that do your selling job for you!



SEND FOR INFORMATION TODAY!

General Electric Company, Section 933
Electronics Park, Syracuse, New York
Please send me information about G-E Parts.

NAME.....

ADDRESS.....

CITY.....STATE.....

GENERAL ELECTRIC

*truly
outstanding*

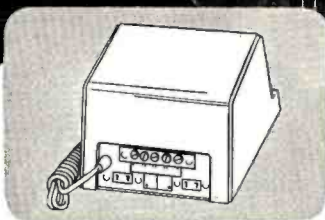

**the perfect partner
to the C•D•R ROTOR**

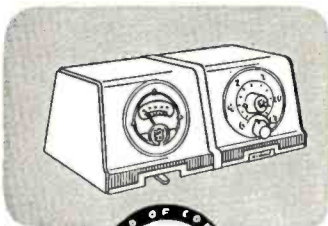

SUBSIDIARY OF



the **RADIART TV BOOSTER**

has all the outstanding features

- ★ *Stand-By Position . . . eliminating "Warm-up" time for Booster.*
- ★ *110 Volt Outlet to plug in TV Set—Power Control through the Booster.*
- ★ *Extra 110 Volt Convenience Outlet . . . plug in Rotor or any Appliance.*
- ★ *High Signal-To-Noise Ratio.*
- ★ *Wide Band Amplification.*
- ★ *Complete Neutralization for Stable Operation*
- ★ *Handsome Mahogany Finish.*

Any way you look at it . . . the RADIART BOOSTER is truly outstanding! Its many features make it superior in performance . . . its handsome design sets it off in a class by itself . . . and it is so flexible . . . with its extra outlet!

THE RADIART CORPORATION CLEVELAND 13, OHIO

VIBRATORS • AUTO AERIALS • TV ANTENNAS • ROTORS • POWER SUPPLIES
RADIO & TELEVISION NEWS

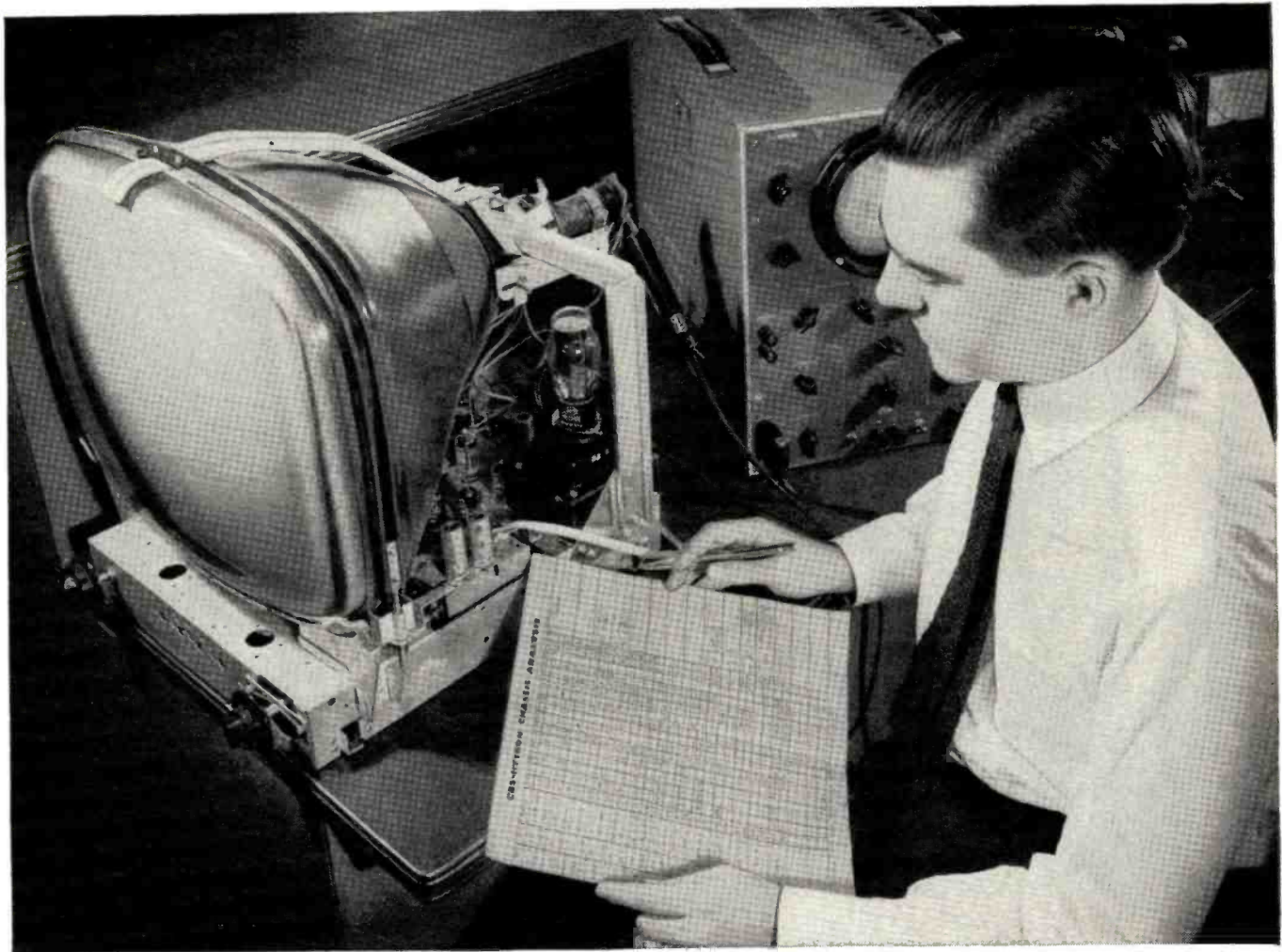

Bring back that New-Set Sparkle with **Performance-Tested Tubes**

Meet John Cunningham, a CBS-Hytron Commercial Engineer. John is beginning at the beginning for you. Socket by socket, he is analyzing the tube requirements of a brand-new TV set design.

John knows the superior performance demanded. He concentrates his know-how on insuring top tube operation within standard specification limits. He tests sample tubes . . . checks analysis data. Working hand-in-glove with the set designer . . . and with CBS-Hytron engineers . . . he assures control of the characteristics of all tubes for this new chassis. Finally he achieves . . . from rectifiers to picture tube . . . the perfect performance all of this engineering team (and you) seek.

Constantly CBS-Hytron carries on teamwork like this. Socket by socket analysis. Day in, day out — with 9 out of 10

leading TV set makers. Both tube and set engineers pool their specialized skills. Scores of the nation's foremost TV set engineers help make endless CBS-Hytron improvements. Help assure you of unsurpassed performance in virtually *all* leading TV sets.

Small wonder that your CBS-Hytron replacement tubes recapture that new-set sparkle. Please your customers. Cut your call-backs. Profit more. Take advantage of CBS-Hytron engineering. Demand CBS-Hytron . . . your logical replacement tube, because it is performance-tested all the way . . . from original to replacement.



MANUFACTURERS OF RECEIVING TUBES SINCE 1921
HYTRON RADIO AND ELECTRONICS CO.

A Division of Columbia Broadcasting System, Inc.
Main Office: Danvers, Massachusetts

NEW... BIGGER... BETTER

FREE!

6th Edition

**CBS-HYTRON
Reference Guide
for
Miniature Electron
Tubes**



- A CBS-Hytron original . . . it's unique.
- All miniatures, regardless of make.
- 250 miniature types . . . 87 new.
- 111 basing diagrams . . . 34 new.
- Similar larger prototypes indicated.
- 8 packed pages of data you need daily.
- And it's FREE!

Get your copy of this old friend brought up to date now. Ask your CBS-Hytron jobber or write direct . . . today!

TRIPPLET
3435

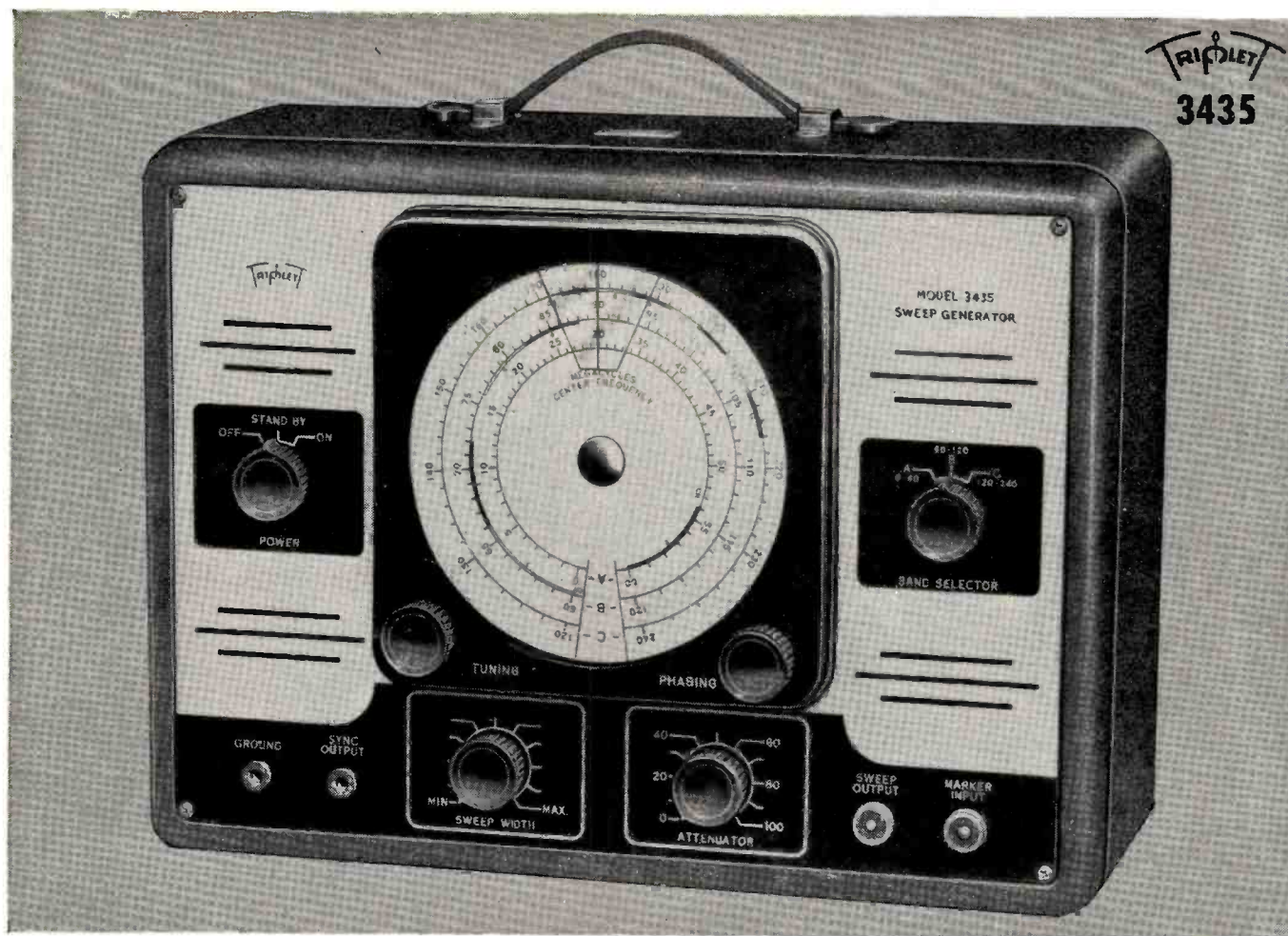

Only \$114⁵⁰ and you're in Profitable TV Testing

Value-wise you can't make a smarter buy. For if you have a good Signal Generator to use as a marker with 3435, this new Triplet Sweep saves you real money! Performance-wise it's Triplet Engineering at its best. There are no complications in use. Continuous range coverage to 240 MC for all TV carrier and IF frequencies. There are no gaps in frequency, and continuous tuning is provided over all TV and FM bands. Note MAIN frequency dial, marked with channels as well as frequencies; continuously variable sweep width, effective from 500 KC to 12 MC; the PHASE controlled sweep voltage for scope horizontal input; the STAND-BY switch for temporary silencing of generator during other testing. These and many other features make Triplet 3435 an outstanding "buy." See it today at your distributor's.

TRIPPLET ELECTRICAL INSTRUMENT COMPANY, BLUFFTON, OHIO

YOU CAN USE ANY A.M. SIGNAL GENERATOR

...but if you are critical you'll appreciate this Wide Range Test Oscillator — Triplet 3432. Five fundamental ranges—165 KC to 40 MC. Two Harmonic ranges 36-120 MC, directly calibrated. Completely Shielded. Seven directly calibrated 330° scales. Illuminated Dial. Try it today.

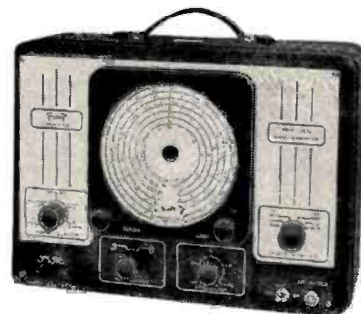

Triplet 3432



Triplet

FOR THE MAN WHO TAKES PRIDE IN HIS WORK



“Check your air, Sir?”



To keep voices traveling strongly through telephone cables, you have to keep water out. This calls for speed in locating and repairing cable sheath leaks—a hard job where cable networks fork and branch to serve every neighborhood and street.

At Bell Telephone Laboratories, a team of mechanical and electrical engineers devised a way to fill a complex cable system with dry air under continuous pressure. Pressure readings at selected points detect cracks or holes, however small. Repairman can reach the spot before service is impaired.

It's another example of how Bell Laboratories works out ways to keep your telephone service reliable—and to keep down the cost to you.

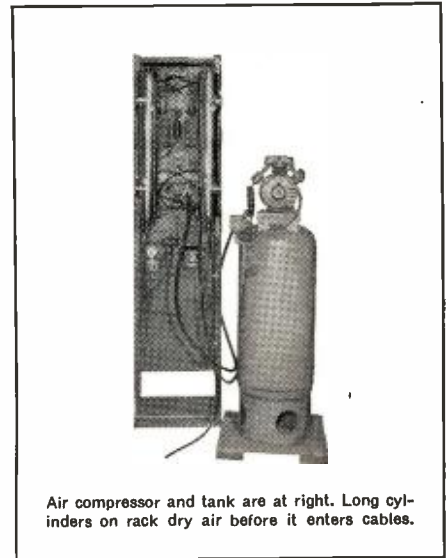

Air compressor and tank are at right. Long cylinders on rack dry air before it enters cables.

He's checking the air pressure in a branch cable, one of scores serving a town. The readings along the cable are plotted as a graph to find low-pressure points which indicate a break in the protecting sheath.



Master meters keep watch over the various cable networks which leave a telephone office in all directions to serve a community. Air enters the system at 7 pounds pressure, but may drop to 2 pounds in outermost sections—still enough to keep dampness out.



March, 1953

BELL TELEPHONE LABORATORIES

Improving telephone service for America provides careers for creative men in mechanical engineering

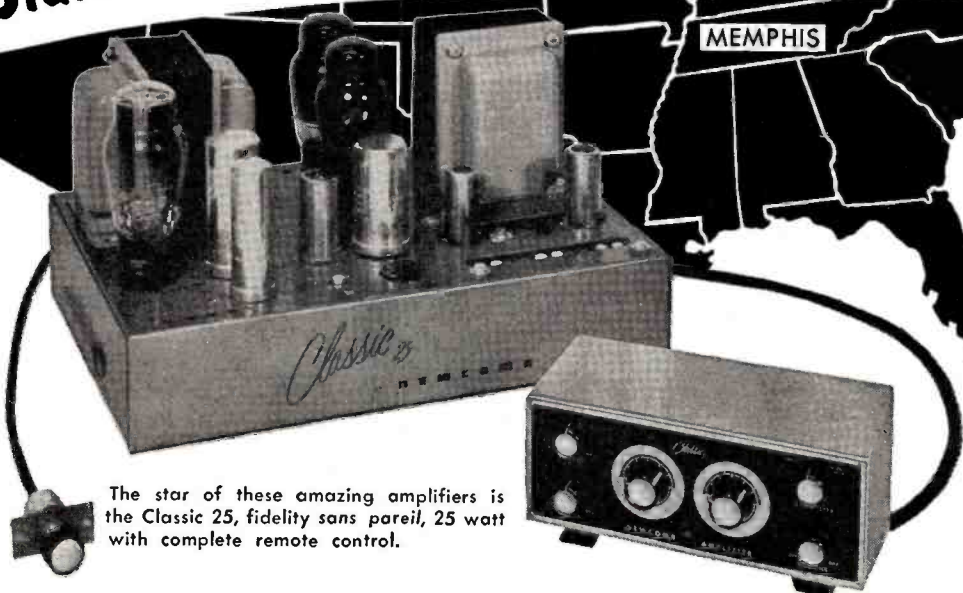

The star of these amazing amplifiers is the Classic 25, fidelity sans pareil, 25 watt with complete remote control.

AMERICA'S FINEST HOME MUSIC AMPLIFIERS

Everywhere they are shown these new amplifiers by Newcomb create a positive sensation. Everyone has a good word for them. Acclaimed at the shows and fairs in New York, Chicago, Memphis and California for their noticeably better sound, unique new features and unbelievable values in every price group. Thousands who have seen them make enthusiastic comments like this:

... "the first really new amplifiers in years" ... "the best record reproduction I've ever heard" ... "they solve the toughest installation problems" ... "the Audi-balance feature really does away with tube balancing problems" ... "Adjusta-panel makes cabinet mounting a breeze" ... "I've never seen anything so beautifully designed for the home" ... "women will love them" ... "I find the A.E.S. response position very pleasing" ... "I want the Classic 25 for myself" ... "the finest coverage yet, there's something here for everyone" ...

Those are the good words everywhere. If you have

not yet seen them for yourself, there's a treat in store for you.

Substantial installation savings

Exclusive Newcomb features make all eight of these new amplifiers easier to install and make possible substantial savings in cabinetry and labor. Models with complete remote control offer a unique design which eliminates the usual necessity of a remote control being near the amplifier, tuner and changer. This permits installation savings frequently greater than the cost of the amplifier itself. These items can now be installed in any out of the way location, leaving only the remote unit and the speaker in the living room, with no messy confusion of wires. All models have "Adjusta-panel" feature to extend control shafts instantly up to 3/4" for easy cabinet mounting. Investigate all the amazing advantages of these amplifiers. You will be thrilled with their outstanding improvements.

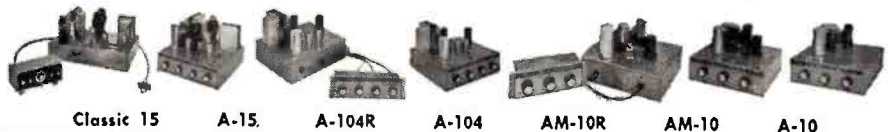

Send for catalog of 8 completely new amplifiers priced from \$39.50 to \$269.50 audiophile net.

Newcomb
15 years of quality leadership



NEWCOMB AUDIO PRODUCTS CO. DEPT. F, 6824 LEXINGTON AVENUE, HOLLYWOOD 38, CALIFORNIA



**TRAIN FASTER—TRAIN BETTER—TRAIN EASIER
IN 10 MONTHS—OR LESS—FOR
RADIO-TELEVISION
Our 21st Year Training Men for Greater Incomes and Security in Radio-Television**

**I SEND YOU
18 BIG KITS**

of Radio Television parts and equipment. Much of your training will be actual construction and experimentation . . . the kind of truly PRACTICAL instruction that prepares you for your Radio-Television career.



Frank L. Sprayberry
President
Sprayberry Academy
of Radio

NEW! NO OBLIGATION PLAN

**You Have No Monthly Payment Contract to Sign
Pay For Your Training as You Earn and Learn**

You can get into Radio-Television, today's fastest growing big money opportunity field, in *months* instead of years! My completely new "package unit" training plan prepares you in as little as 10 months or even less! *No monthly payment contract to sign—thus NO RISK to you!* This is America's finest, most complete, practical training—gets you ready to handle any practical job in the booming Radio-Television industry. Start your own profitable Radio-Television shop . . . or accept a good paying job. I have trained hundreds of successful Radio-Television technicians during the past 21 years—and stand ready to train you, even if you have no previous experience! Mail coupon and get all the facts—FREE!



**Valuable Equipment Included
With Training**

The new Sprayberry "package" plan includes many big kits of genuine, professional Radio-Television equipment. You perform over 300 demonstrations, experiments and construction projects. You build a powerful 6-tube 2-band radio set, multi-range test meter, signal generator, signal tracer, many other projects. All equipment and lessons are yours to keep . . . you have practically everything you need to set up your own profitable Radio-Television service shop.

Earn Extra Money While You Learn!

All your 10 months of training is IN YOUR HOME in spare hours. Keep on with your present job and income while learning. With each training "package" unit, you receive extra plans and "Business Builder" ideas for spare time Radio-Television jobs. New television stations everywhere, open vast new opportunities for trained Radio-Television Technicians—and those in training. If you expect to be in the armed forces later, there is no better preparation than practical Sprayberry Radio-Television training.

YOU BUILD the Television set and the powerful superhet radio receiver shown above. IN ADDITION to the other test units shown here (many are not shown because of lack of space). All equipment I send you is **YOURS TO KEEP.**

Approved for Veterans under the G. I. Bill

**SPRAYBERRY ACADEMY OF RADIO 111 NORTH CANAL ST.
Dept. 25-U, Chicago 6, Ill.**

**MAIL COUPON
TODAY!
NO OBLIGATION**

**SPRAYBERRY ACADEMY OF RADIO, Dept. 25-U
111 North Canal St., Chicago 6, Ill.**

Please rush to me all information on your 10-MONTH Radio-Television Training Plan. I understand this does not obligate me and that no salesman will call upon me. Be sure to include 3 books FREE.

Name..... Age.....
Address.....
City..... Zone..... State.....



**I invite you to get all the facts—
FREE TO YOU 3 BIG
RADIO-TELEVISION BOOKS**

I want you to have ALL the facts about my new 10-MONTH Radio-Television Training—without cost! Rush coupon for my three big Radio-Television books: "How to Make Money in Radio-Television," PLUS my new illustrated Television Bulletin PLUS an actual sample Sprayberry Lesson—ALL FREE. No obligation and no salesman will call. Mail coupon NOW!



320K SIG. GEN. KIT \$19.95 WIRED \$29.95



145K SIG. TRACER KIT \$19.95 WIRED \$28.95



950K R.C. BRIDGE & R-C-L COMP. KIT \$19.95 WIRED \$29.95



360K SWEEP GEN. KIT \$34.95 WIRED \$49.95



New 214K VTVM KIT \$34.95 WIRED \$54.95

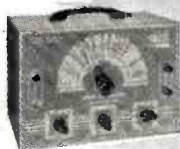

New 377K SINE & SQUARE-WAVE AUDIO GEN. KIT \$31.95 WIRED \$49.95



1040K BATTERY ELIM. KIT \$25.95 WIRED \$34.95



1171K RES. DECADE BOX KIT \$19.95 WIRED \$24.95



625K TUBE TESTER KIT \$34.95 WIRED \$49.95



CRA PIX TUBE ADAPTOR for Tube Tester \$4.50



New 565K MULTIMETER KIT \$24.95 WIRED \$29.95 20,000Ω/v_r 31 ranges



315K DELUXE SIG. GEN. KIT \$39.95 WIRED \$59.95



HIGH VOLTAGE PROBE \$6.95



221K VTVM \$25.95 WIRED \$49.95



470K KIT \$79.95 WIRED \$129.50



425K 5" PUSH-PULL SCOPE KIT \$44.95 WIRED \$79.95

OVER 1/4 MILLION

EICO INSTRUMENTS

in use the world over!

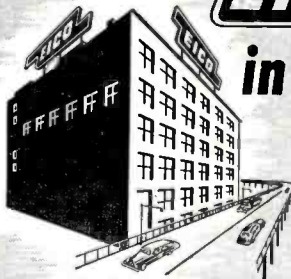

EICO new modern facilities for research, development and production—your greater assurance of . . .

LABORATORY PRECISION AT LOWEST COST

NEW 7" Push-Pull OSCILLOSCOPE

- Boosted vert. sensitivity: 10 mv rms/in.
- Extended flat freq. response: 10 cps—1 MC (±2 db).
- 3-step freq.-compensated attenuator; cathode follower input.
- Internal voltage calibrator; dir.-cal. screen.
- Extended sweep range: 15 cps—100 kc.
- Int. pos. or neg., ext. & line sync.
- On front panel: sawtooth, 60 cps outputs; intensity mod. & ext. sync inputs.
 - Var. phasing of int. 60 cps sweep.
 - Direct connection to CRT plates.

You Build EICO Kits in One Evening, but . . . They last a Lifetime! and You SAVE OVER 50%

YOU be the judge. See the famous EICO line TODAY—in stock at your local jobber—and SAVE!

Write NOW for FREE newest Catalog 3-R.

America's greatest instrument values bear the name—



ELECTRONIC INSTRUMENT CO., Inc., 84 Withers Street, Brooklyn 11, N. Y.

See EICO'S Exhibit Booth No. 4-401 at I.R.E. Show.

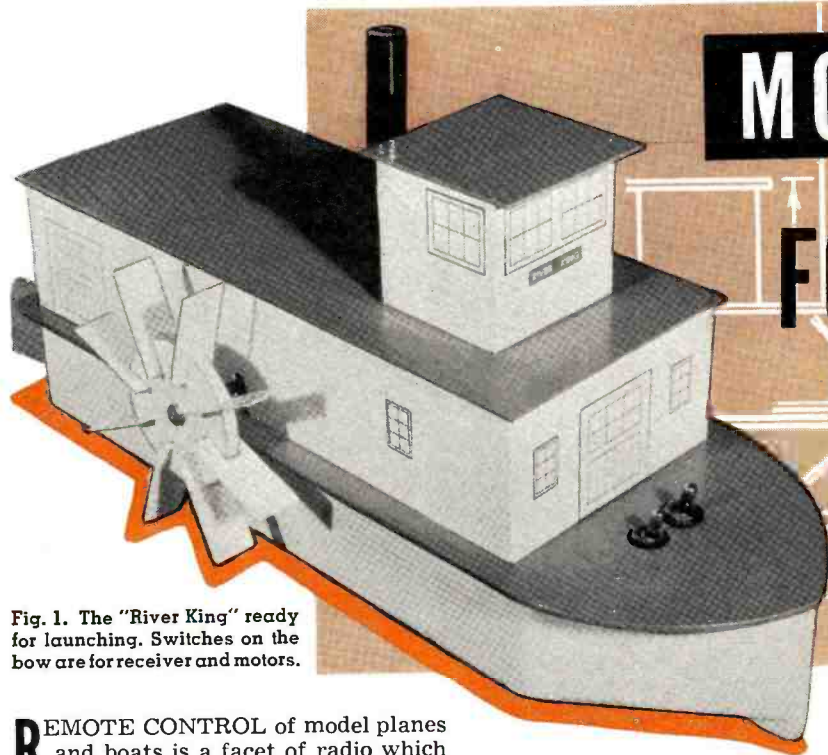

Fig. 1. The "River King" ready for launching. Switches on the bow are for receiver and motors.

MODEL BOAT

FOR THE 27 MC. CITIZENS BAND

By HARTLAND B. SMITH, W8VVD

Here it is! A "Citizens Band" radio control system, easy to build, simple to operate, and no license exam required!

REMOTE CONTROL of model planes and boats is a facet of radio which has long intrigued many hams and experimenters. However, two factors have kept most fellows from taking up this branch of the hobby. In the first place, as each succeeding article on the subject has appeared in contemporary publications, the models, the radio gear, or both have become more and more complicated. Secondly, the possession of a radio operator's license has been a prerequisite to the operation of radio control equipment. Since a large number of licensed hams aren't expert model makers and since many model makers lack operator's licenses, only a few people have so far had the opportunity of experimenting with radio control systems.

The "River King" was designed expressly to meet these two problems. It requires no particular skill to construct and uses a simple one-tube receiver. Any U.S. citizen over 18 can, without taking a technical exam, obtain the necessary Citizens Radio station license for the transmitter.

Although the FCC's rules governing the Citizens Radio Service have allowed radio control on the 460-470 mc. band since June 1, 1949, the equipment specifications for these frequencies have been so stringent that only commercial transmitters have been practical up to now. A recent amendment to the rules, however, has opened the door to inexpensive home-built gear operating on 27.255 mc. Transmitters using this new frequency are designated as "Class C" Citizens Radio Stations and, when registered with the FCC, may be used without an operator's license. The owner takes out a license for the equipment by a fairly simple procedure outlined toward the end of this article.

Unless a fellow is a dyed-in-the-wool model maker, he finds it hard enough to build an airplane that looks like a

plane, let alone flies. On the other hand, almost any piece of wood will float. Thus, a model boat appears to be a logical beginner's choice for a radio control project. Since a flat bottomed hull with no complicated curves to cut makes for easy modeling, a side-wheel river steamer using this type of hull is a suitable prototype from which an approximate copy may be constructed.

The one-tube superregenerative receiver used in the boat is designed around a Raytheon type RK-61 sub-miniature gas triode. With the exception of the plate relay, all receiver parts are standard and can be readily

Fig. 2. The 27-mc. "Citizens Band" transmitter, built in a 3"x4"x5" utility box. The batteries are also housed in this box.



obtained from any well-stocked jobber.

The plate relay I used came from a surplus BC-645 and was originally sealed in a cylindrical can with a 5-prong plug. After being removed from its housing the relay was mounted on top of the receiver chassis. If you can't locate one of these relays, I would suggest that you obtain an 8000 ohm Sigma type 4F. The latter is still available quite reasonably on the surplus market.

The RK-61 has tinned leads in place of base pins. It can be held in place with a small clamp and the leads may then be soldered directly into the circuit. Use a clean, hot, well-tinned iron, preferably one with a small tip. Do the job neatly but as quickly as possible so that too much heat will not be conducted into this small tube.

The receiver filament switch, S_1 and motor switch, S_2 are mounted on the deck, forward of the cabin, and can be operated without removing the superstructure. Two switches are used so that the receiver and motors may be run independently. It is difficult to make precise receiver adjustments while the paddle wheels are revolving.

The smoke stack, an 18" length of $\frac{3}{4}$ " aluminum tubing, acts as a receiving antenna. While much shorter than a resonant 11-meter antenna, it picks up enough signal to produce reliable model response several hundred feet from the small transmitter to be described. Greater antenna length will increase the working range of the

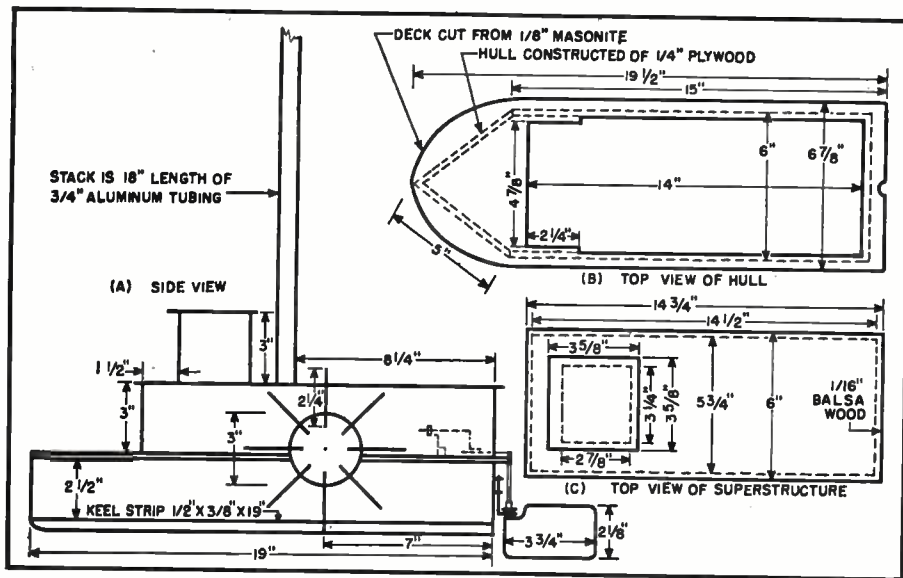

Fig. 3. Construction details of the "River King" radio-controlled river boat. The superstructure is thin balsa wood, the hull $\frac{1}{4}$ " plywood and the deck Masonite. The tall aluminum "smokestack" acts as the antenna for the receiver in the hull.

model, but there seems little point in operating the device very far from the observer. After all, most of the enjoyment in running the boat comes from being able to watch it maneuver. Beyond two hundred feet, it looks pretty small.

The electrical circuits and mechanical linkages used in many radio control systems are quite complex. Transmitters sometimes utilize intricate modulators and keyers which send out specially coded signals that must be translated by the receiver into the proper model maneuver. Actually, it is possible to obtain several different and interesting model responses by merely turning a transmitter carrier on and off.

Examination of Fig. 6 will reveal that the plate relay of the receiver acts as a s.p.d.t. switch. Since the receiver's plate current drops when a signal is picked up, if the transmitter is on, the relay is open and contact Y

receives $1\frac{1}{2}$ volts via the relay armature. When the transmitter is switched off, the receiver plate current increases and the relay closes. Contact X then receives $1\frac{1}{2}$ volts. Relay contact X is connected to finger 1 and contact Y to finger 3 of the rotary selector switch. One lead of the selector switch motor is grounded. The other lead runs to finger 2 on the selector switch. When the transmitter goes on, the switch motor circuit is completed via the relay armature, relay contact Y, finger 3, a segment on the selector disc, and finger 2. The switch motor receives power and the selector disc turns. It can only go a little way, though, because the connection between fingers 2 and 3 is soon broken due to the shape of the segment on the selector disc.

When plate voltage is removed from the transmitter the relay closes and the switch motor is again energized, this time via contact X, finger 1, a

different selector segment, and finger 2. The selector disc turns until fingers 1 and 2 are no longer connected with one another through the disc segment. This time when the disc stops, fingers 4, 5, 6, and 7 make contact with segments which connect the paddle motor to battery, B. Depending on what polarity voltage is applied to this motor by the arrangement of the segments, the paddles will drive the boat either forward or backward. If no segments are in this particular position, the paddle motor, of course, stops. At the same time the selector disc turns, the steering arm also turns, thereby changing the rudder position (see Fig. 5).

With the segment layout shown in Fig. 4, there are six possible maneuvers: 1. Forward straight. 2. Stop. 3. Forward port (left). 4. Reverse straight. 5. Forward starboard (right.) 6. Stop. This arrangement is sufficient to provide a great deal of entertainment while maintaining a relatively simple system. The sequence of operations is such that when going from one desired maneuver to another, the undesired positions through which the selector must pass have little effect on the action of the craft. For example, in going from forward straight to forward starboard, it is necessary to go through positions 2, 3, and 4. At 2 the paddles stop. At 3 the paddles start to go forward, but before they can pick up speed, they are reversed by position 4. Position 5, the one desired, is reached long before the boat starts to back. A time delay circuit could be used to keep the paddles at rest until the selector is in position for the desired maneuver. However, this would be a rather unnecessary complication as each following position more or less nullifies the previous action.

Inspection of Fig. 4 will show that a small portion of the selector switch must be covered with insulating material to avoid shorting the switch contacts as that portion is reached. Scotch tape was used in this model, but if any difficulty occurs with the tape cracking, or the switch fingers tracking adhesive out from under the tape, a few thin coats of polystyrene coil dope or radio service cement can be used instead, if they are allowed to dry sufficiently.

The BC-645 relay is not quite so sensitive as one of the usual radio control types. Nevertheless, if it is adjusted carefully, it will perform very well. In order to correctly set the relay, it is necessary to insert a low range milliammeter in series with the "B-plus" lead of the receiver. First, contact X, the one which controls the spacing between the armature and the pole piece, should be adjusted so that when the relay is energized, the armature just clears the pole piece. If the armature-pole piece spacing is too great, the sensitivity of the relay will be low, while if the armature touches the pole piece, it is apt to stick when the relay is de-energized.

Fig. 4. Pattern for the rotary stepping switch in the receiver. The base is $\frac{1}{4}$ " plywood, 5" in diameter. The switch segments (shaded areas) are thin sheet metal. A $\frac{1}{4}$ " hole is drilled in the center for the shaft, which also drives rudder crank.

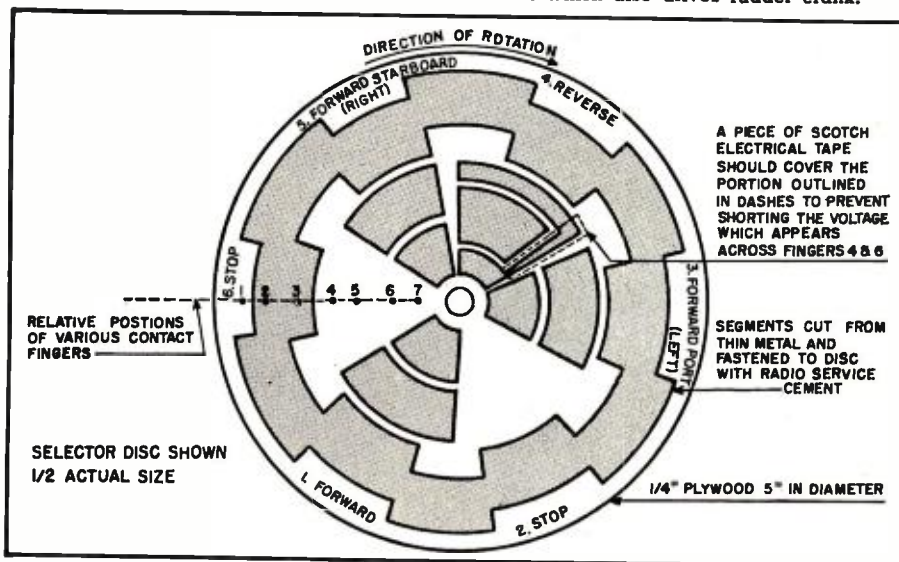

Next, the pull-in and drop-out range should be checked. With "A" and "B" voltages applied to the receiver, advance the regeneration control until the relay can be heard to snap closed, then back off on the control until the relay clicks open. The current difference between pull in and drop out should be no greater than .2 ma. If it is, the spacing between the relay points should be reduced. The relay should close at approximately 1.0 ma. and open at around .8 ma. If more current is required to close the relay, the spring tension should be reduced. If it closes at less than 1.0 ma., the spring tension should be increased. With a more sensitive relay, the pull-in and drop-out range may easily be set to a variation of only .1 ma., thus resulting in somewhat greater control sensitivity.

The process of relay adjustment is not difficult, but you should keep the following points in mind: 1. As soon as the armature-pole piece spacing is set, do not change the position of contact X. Make all changes in contact gap spacing by varying the position of contact Y. 2. Never advance the regeneration control beyond the point where plate current exceeds 1.5 ma., otherwise the life of the RK-61 will be materially reduced.

As soon as the relay is properly adjusted, the receiver can be tuned up. Advance the regeneration control, R_2 , until plate current is between 1.1 and 1.2 ma. The relay will act as a miniature loudspeaker and should give forth with the characteristic squeal of a superregenerator. Have someone operate the transmitter at a distance of at least 100 feet. Tighten antenna coupling condenser, C_1 fairly well and then adjust C_2 until the receiver is tuned to the transmitter's frequency as evidenced by a dip in plate current, accompanied by the opening of the relay and a lack of superregenerative squeal. C_1 should then be readjusted, to find the smallest capacity that gives positive relay operation when the transmitter is switched on.

The no-signal receiver current should be set slightly under 1.2 ma. From time to time as the RK-61 ages, C_1 and the regeneration control will require touching up. When the tube is reaching its limit of usefulness, an idling current of as much as 1.6 ma. may be required to obtain positive pull in action with no signal. Rated life of an RK-61 is between 3 and 10 hours. However, if the idling current is held in the vicinity of 1.2 ma. for as long as possible, the tube will probably last somewhat longer.

The dimensions of the boat are not very critical. The "River King" was my first attempt at marine architecture and it can definitely be improved upon in both appearance and seaworthiness. For example, another $\frac{3}{4}$ " added to the depth of the hull would allow the use of heavier, longer-lived batteries.

The hull is made of $\frac{1}{4}$ " plywood (see Fig. 3). The various pieces can be cut

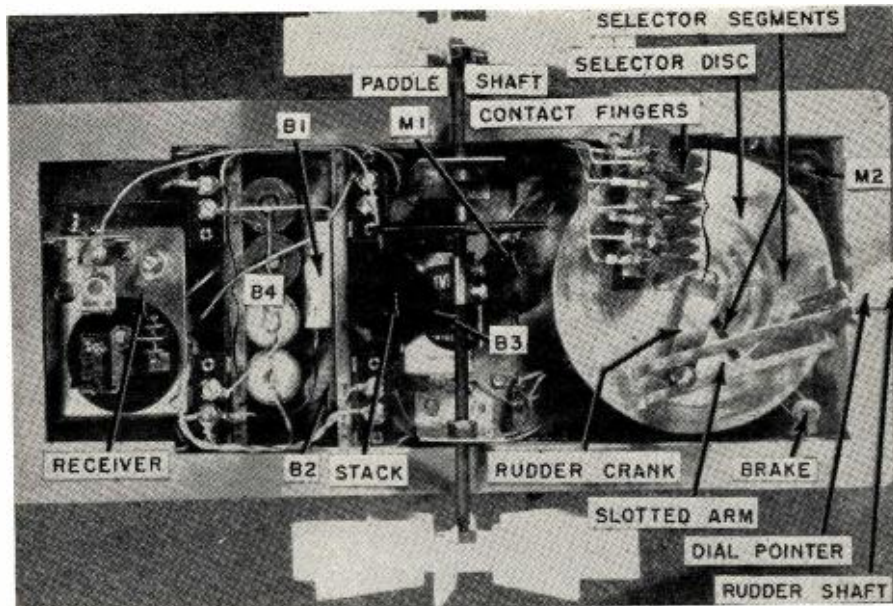

Fig. 5. Top view of the hull, with the superstructure removed. Placement of parts can vary according to materials on hand, but weight should be evenly distributed and heavy items such as batteries kept low in the hull. The paddle shaft is made from two $\frac{1}{4}$ " carriage bolts. At extreme right is the old dial pointer used as coupling between the rudder and the slotted "tiller," which is about $4\frac{1}{2}$ " long and is driven by a homemade crank on the selector switch shaft. Both the rudder and selector switch shafts and bearings are made from old volume controls.

out with either a power or hand scroll saw and then fastened together with waterproof glue such as *Cascophen*. The glue must be applied very liberally and after it sets, all joints should be smeared with an extra coat, thereby insuring watertight joints. It is a good idea to give the inside of the hull a coat of spar varnish so that if

it accidentally gets wet, it won't absorb water. The deck may be cut from a piece of $\frac{1}{8}$ " Masonite and then glued to the hull. The exterior should receive two applications of enamel undercoat and one of high grade enamel.

The boat is powered by a midget plastic-cased motor designed to operate from ordinary flashlight cells.

Fig. 6. Wiring diagram of the receiver, motors, and selector switch contact fingers. The receiver is built on a small "U" chassis which may be homemade and is mounted in the bow. S_1 and S_2 are mounted up on deck. See Figs. 7 and 8.

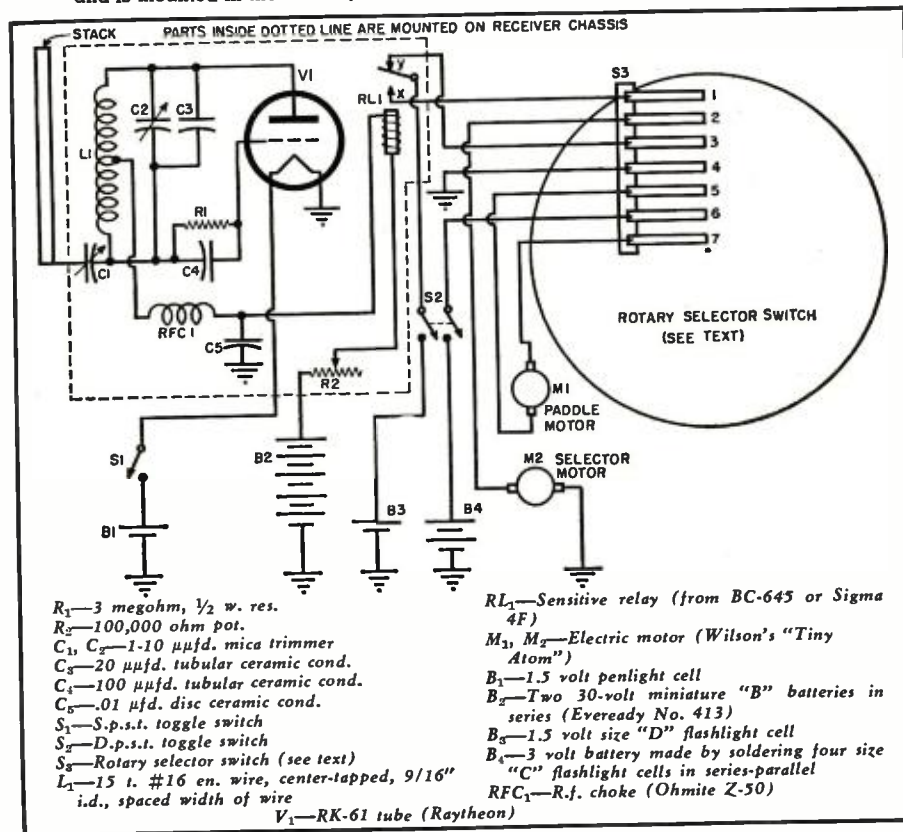

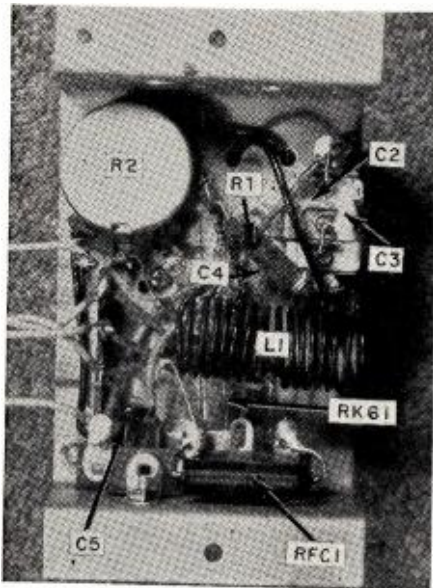

Fig. 7. Bottom view of the receiver. The RK-61 tube, which has no socket, is mounted along the centerline of chassis.

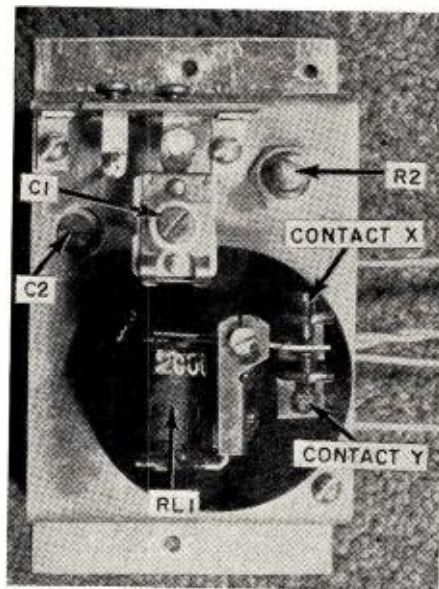

Fig. 8. Top view of the receiver. The relay shown is from a surplus BC-645 but other types may be substituted (see text).

These motors are on sale at toy and model supply stores and are priced from \$1.50 to \$2.00 apiece. Despite a rating of only 1/2000 horsepower, one of these little motors is capable of propelling a model boat at greater than scale speed.

A similar motor drives the selector switch that controls both the direction of paddle rotation and the rudder position. This motor, M_2 , is mounted vertically in the stern (see Fig. 5). The rotating disc portion of the selector is made from a piece of $\frac{1}{4}$ " plywood, 5" in diameter. It must be carefully cut to shape and a groove filed in the edge to receive the rubber band that acts as a drive belt. The shaft and bearing of the selector can be adapted from an old volume control. The control should be dismantled until all that remains is the shaft and its associated panel bushing. This is then fastened to a U-shaped bracket cut from sheet aluminum and the bracket is screwed to a small piece of wood

previously glued to the hull. Put a hole in the center of the selector disc with a $\frac{1}{4}$ " drill and press the disc onto the old volume control shaft. If the disc fits too loosely, one or two applications of service cement to the edges of the hole will reduce its size sufficiently to stop the disc from slipping on the shaft. A spacer bushing keeps the disc at the proper height with respect to the switch motor's shaft.

Since a volume control bearing operates smoothly, it is quite likely that the selector disc may coast from one segment to another, thus going past a desired position. This overshoot problem can be minimized by increasing the pressure of the contact fingers against the disc or by constructing the brake shown in Fig. 9B. Tighten the top nut on the brake only enough to keep the disc from coasting too far. Otherwise, the selector motor will be overloaded and may, at times, lack sufficient power to rotate the disc.

Fig. 9. (A) Selector switch shaft and bearing assembly, taken from an old volume control. (B) Adjustable brake for the rotary selector switch. (C) One of the contact fingers. Length is approximate. (D) Faraday shield for the transmitter.

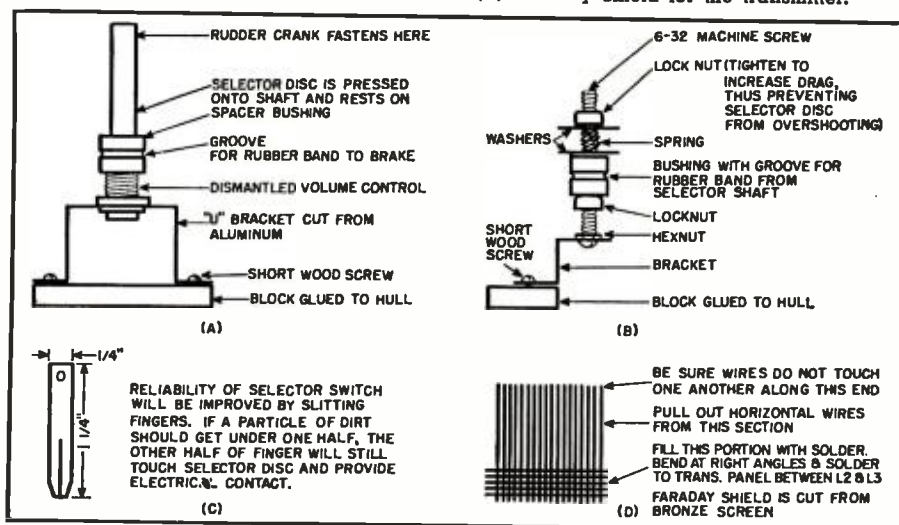

The segments of the selector disc can be fashioned from thin sheet metal. I used heavy copper foil picked up at a surplus store. After the segments have been cut to proper shape, fasten them to the disc with radio service cement. The contact fingers for my switch were cut from the same copper as the segments. Use any metal which is thin and fairly springy.

Rubber bands act as drive belts for both the paddles and the selector disc. No pulleys are required on the motor shafts since the rubber bands are kept in alignment by grooves in the edges of the selector disc and the paddle shaft pulley. The latter item, by the way, was originally a part of the dial mechanism from an old radio. A pulley cut out of $\frac{1}{4}$ " plywood should work just as well.

The paddle wheels are made from 3" discs of $\frac{1}{4}$ " plywood. Eight radial slots $\frac{3}{8}$ " long are cut in the discs at regular intervals as shown in Fig. 3A, and 1" by 2 $\frac{1}{4}$ " pieces of aluminum are forced into the slots. *Cascophen* or radio service cement should be daubed on the ends of the paddles so that they will adhere to the slots. The paddle shaft is made from two $\frac{1}{4}$ " carriage bolts, the heads of which have been cut off, the two bolts then being fastened together with a $\frac{1}{4}$ " shaft coupler. The paddle wheels have $\frac{1}{4}$ " holes drilled in the center and are held in place on the threaded ends of the shaft bolts between nuts and washers. The shaft bearings are simply $\frac{1}{4}$ " holes drilled in two aluminum brackets that support the paddle assembly. The shaft is held in position between the bearings by means of brass collars fastened to the shaft with set screws.

The rudder bearing, salvaged from another discarded volume control, is mounted on a small, L-shaped bracket at the rear of the hull. A piece of lightweight galvanized iron is cut into the shape of a rudder and is soldered to what was originally the potentiometer end of the shaft. An old dial pointer is fastened to the other end of the shaft. The slotted arm, or "tiller," actuated by the rudder crank of the selector switch is, in turn, soldered to the dial pointer (see Fig. 5). If no suitable dial pointer is readily available you can, of course, cut out a small sheet-metal tab, with a $\frac{1}{4}$ " hole for the rudder shaft, and go on from there. The slot in the "tiller" is about $4\frac{1}{8}$ " long. The crank arm is about $1\frac{3}{4}$ " between the center of the selector shaft and the center of the screw-and-nut or whatever you use as a drive pin or "handle." The dimensions of these three items are not critical. The old volume-control shaft will, of course, have to be long enough so that the crank and swinging tiller will clear the top of the wood or plastic strip that holds the selector fingers.

A superstructure must be built to hide the works of the model. The cabin and pilot house are cut from
 (Continued on page 162)

MAINTENANCE OF TV ANTENNAS

By

M. BETTAN & A. S. PRICE

Radio Merchandise Sales Inc.

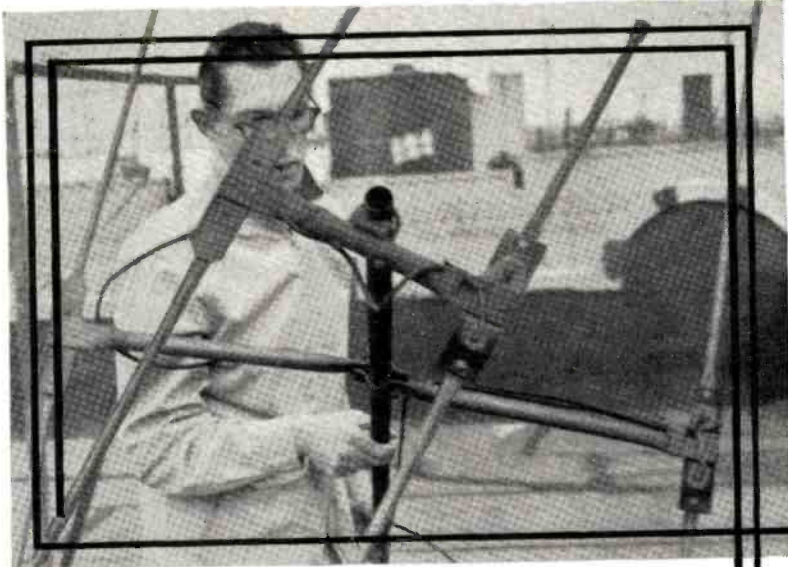

1 TV antenna rusted by average weather, taken down for maintenance. Lead-in connectors are corroded; elements oxidized.

TV antennas rust enough in 1 year to cut signal down. A 20-minute cleanup can return such antennas to good operating condition.

WHEN servicing a TV antenna a standard procedure should be followed. This eliminates wasted time and makes certain that all necessary maintenance points are covered. First, dismount the antenna and inspect it for missing or broken elements, cracked insulators, loose connections, and badly corroded signal take-off hardware. At this point a time and materials cost estimate should be made to determine whether the antenna is worth repairing. If it is necessary to replace too many parts, or if the cleaning and repairing job will take more than approximately one-half to three-quarters of an hour, it will probably not be worth the customer's money or your time to do the job. However, each case must be judged on its own merits. Repairing and cleaning a costly complex stacked array will, in most cases, be cheaper than replacing the antenna. Servicing a simple antenna without broken parts and missing elements (such as is shown in Fig. 1) should take no longer than twenty minutes and is definitely a worthwhile job.

The next step is to check the signal take-off hardware. Disconnect the antenna lead-in wire from the connectors. If the connectors are badly corroded, replace them. It may be necessary to drill them out and therefore it is recommended that you have a portable drill and long extension power cord available for such work.

(Continued on page 120)

4 Elements, signal take-off points, and hardware have been cleaned; the antenna is reassembled, ready for mounting.

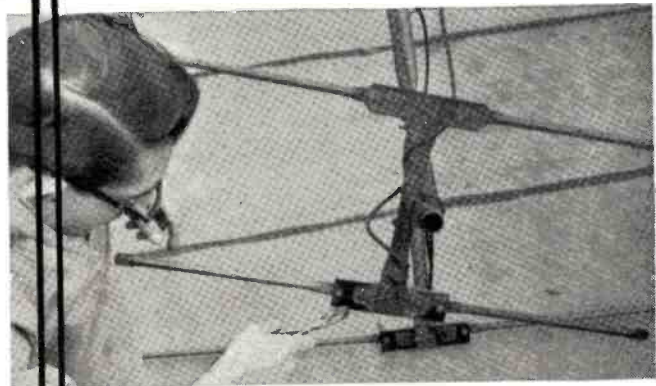
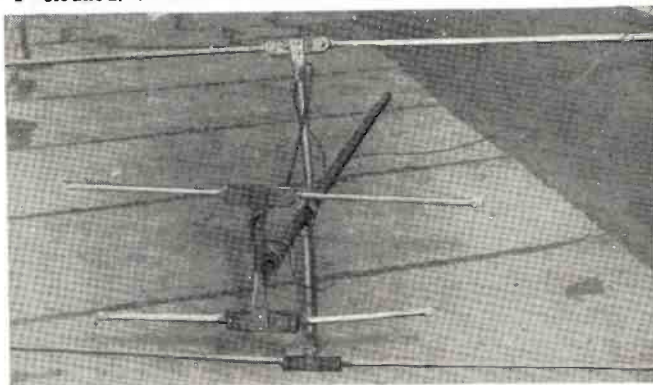

2 Lead-in is disconnected and signal take-off hardware removed. Corroded hardware attenuates input signal.

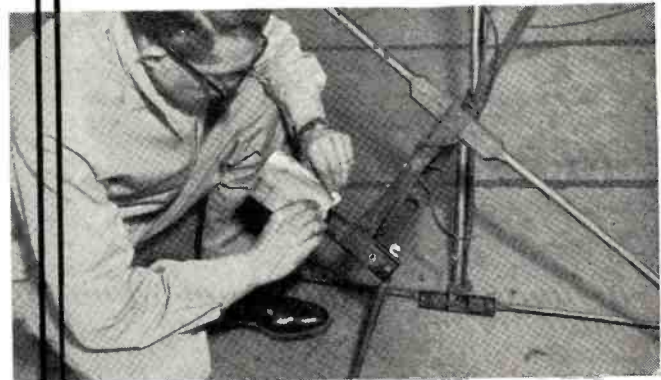

3 Element contact points are sanded down. Note the difference between clean contacts and corroded element.

5 Cleaned antenna is mounted and mast stand-offs are added for the lead-in wire to replace tape used formerly.

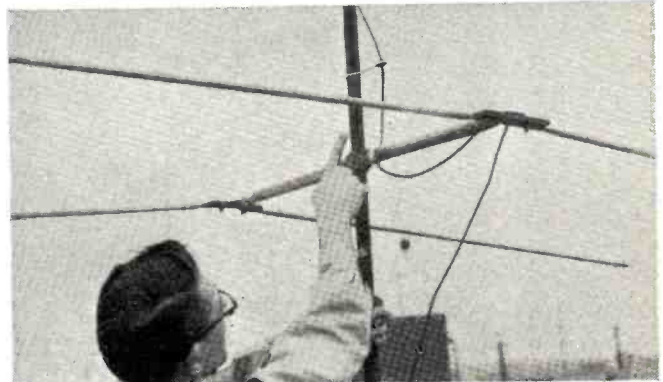

TRANSISTORIZE YOUR

Another interesting application for transistors. Details for constructing several amplifiers are also included.

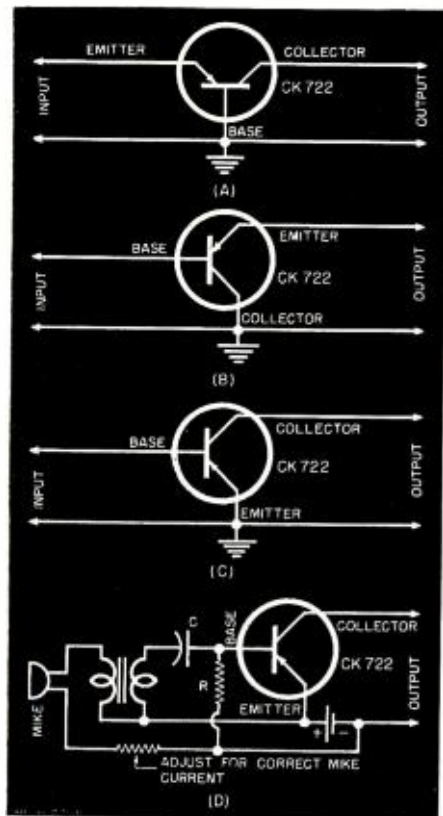

Fig. 1. Typical transistor circuits. (A) grounded base, (B) grounded collector, (C) grounded emitter. (D) carbon mike input.

WE HAVE used electron tubes for so many years that we seldom give any thought to the power required for operation until we find that portable, battery operation is desirable for some new project. However, the engineer or experimenter who builds a junction-transistor amplifier suddenly realizes how much simpler it is to design and assemble for there is no complicated power supply and there are fewer components for each stage of amplification. Furthermore, the operating power is unbelievably low so that small batteries of standard flashlight cell sizes last so long that there is no advantage in using a.c. power sources. This, in time, makes possible very small and compact equipment for which there are many uses. Even though parts of an equipment, such as a portable amateur transceiver, require tubes, the use of transistors where applicable in the circuit, will help to reduce size and weight. As an example, the audio preamplifier might use transistors while the modulator and r.f. stages of the transmitter would use tubes. Likewise, the same transistor amplifier could be used for the audio amplifier for receiving, by using suitable switching.

Other uses for small battery-operated transistor amplifiers are: hearing aids, portable receivers, portable intercoms and variations thereof, portable recorders, record players, sound measuring equipment, etc. In these applications junction transistors provide, in addition to long life and ruggedness, a freedom from microphonics never achieved with tubes even though

tremendous improvements have been made in the CK500 subminiature tube series produced during recent years for hearing aid use and other critical applications.¹

In a recent issue of this magazine² there appears a discussion of transistors and some description of their uses. This present article will discuss the use of junction transistors in audio amplifiers in an effort to indicate to each reader the methods to be used in designing amplifiers for his particular needs.

Junction transistors such as the Raytheon type CK722, may be used in any of three basic circuits. The grounded-base circuit is shown in Fig. 1A. This circuit utilizes the transistor emitter as the signal input element and the collector as the output element. Input impedance is low, output impedance is high, and gain is fairly good. This circuit also exhibits less variation with temperature than the grounded-emitter circuit to be discussed below. For the type CK722 junction transistor, typical input impedance is 1000 ohms, typical output impedance is 100,000 ohms or better and average power gains of 20-22 db can be obtained.

The grounded-collector circuit shown in Fig. 1B provides less gain (about 12 db for CK722) and has less power output capabilities than either grounded-base or grounded-emitter circuits. The lower power output obtainable with this method of connection is due to the limitations on emitter circuit power imposed by the manufacturer's ratings. Grounded-collector circuits are used when high input impedance is required for this may be one or two hundred thousand ohms depending upon the value of load impedance used. For example, a 10,000 ohm load will provide 150,000 or 200,000 ohms' input impedance with type CK722 but this may drop to 50,000 ohms or less if the load is dropped to 1000 ohms.

In contrast to the grounded-base or grounded-collector circuits for which two batteries or a tapped battery are needed, the grounded-emitter circuit requires but one battery and is thus particularly desirable for compact, lightweight, portable amplifiers. It provides typical input and output impedances with CK722 of about 1000 and 40,000 ohms respectively and gives the highest gain, averaging 30 db for this type. The grounded-emitter circuit is more susceptible to tempera-

ture variations although under about 125° Fahrenheit, the temperature effects are usually not serious. Gain decreases as the temperature increases and the higher the temperature the faster the gain decreases for additional increases in temperature.

Let us assume that we wish to design a small portable amplifier using type CK722 *p-n-p* junction transistors to be used by police to listen in on suspects. Because but one battery is required, a grounded-emitter circuit will be used. The first problem is to design the input stage for which carbon, dynamic, and crystal mikes are available. Carbon mikes require operating current from the battery so are not desirable for low battery drain. Fig. 1D shows a possible connection.

Dynamic microphones may be obtained with various impedances, 500 ohms not being unusual. The mismatch would not be critical with microphone impedances as low as 100 ohms. Furthermore, the average dynamic microphone puts out more power for a given sound pressure than crystal microphones except some of the old large types having high capacity. Because our transistor amplifier is really a power amplifier, this is important, for by using the microphone giving the most power, we can obtain desired amplifier performance with a minimum number of transistors. Fig. 3A shows the input amplifier stage using a dynamic microphone directly coupled to the transistor without an input transformer. Fig. 3B shows a variation of this circuit which is equally satisfactory. If a dynamic or magnetic microphone with an impedance appreciably different from 1000 ohms is used, a matching transformer may be employed as indicated in Fig. 3C to give better over-all gain than if the mike is poorly matched to the CK722. Resistor *R* is adjusted for minimum noise and best gain and should result in a collector (output) current of no more than 0.5 milliamperes. *R* will probably be at least 100,000 ohms for CK722 but will depend upon the battery voltage to be discussed later. Condenser *C* must be large enough to pass the lowest frequencies which must be amplified. This condenser *must* be used to allow the base voltage and therefore the collector current to be correctly adjusted by *R*.

Except for the large, high capacity types mentioned previously, the aver-

AUDIO AMPLIFIERS

By CHARLES W. MARTEL
Raytheon Manufacturing Company

age crystal mike will give at least 10 db less power than a dynamic microphone and, in addition all crystal microphones have high impedances which will not match the relatively low input impedance of the grounded emitter CK722 unless coupled through a step-down transformer. The circuit will be identical to that of Fig. 3C except that the transformer primary impedance should be as high as possible (several hundred thousand ohms) and the secondary impedance should be about 1000 ohms. An intercom transformer of the type used to couple the voice coil of a loudspeaker microphone to the input tube grid may be used "in reverse" to obtain a reasonably good impedance match.

With the input circuit determined, the next step is to add transistor stages to obtain the desired gain. The user of this amplifier will listen-in with a small receiver similar to those used for hearing aids or by amateurs so a total gain of 60 to 80 db should be sufficient and will therefore require at least three and probably four stages if transformer coupling is used to obtain maximum gain. Resistance coupling may be employed but at least one additional amplifier stage will be needed for the gain-per-stage with resistance coupling will average about 6 db less than that obtained with transformer coupling. Except for the output circuit to be discussed later, Fig. 2A shows a transformer-coupled amplifier and Fig. 2B a resistance-coupled amplifier using the input circuit of Fig. 3A. The primary and secondary impedances of the inter-stage transformers should match reasonably well the output and input impedances respectively for CK722 in the grounded-emitter circuit as indicated in a preceding paragraph.

In both Figs. 2A and 2B resistor R in each stage is adjusted for the collector current giving best gain, lowest noise, and lowest distortion but no more than 0.5 ma. should be needed per stage. A suitable value for R is usually in the range of 200,000 to 250,000 ohms. Also for both circuits, C must be large enough to give desired frequency response and because it is in series with the input impedance (about 1000 ohms) of the CK722, it must be several microfarads for good low frequency gain. Small size electrolytic condensers are on the market and it is suggested that a 10 or 20 μ f. unit be used. The lowest available voltage ratings are ample, for the maximum voltage in the circuit is two or three volts depending upon the battery used. In the resistance-coupled circuit, R_L must be a compromise between matching the output impedance of the transistor and causing too low

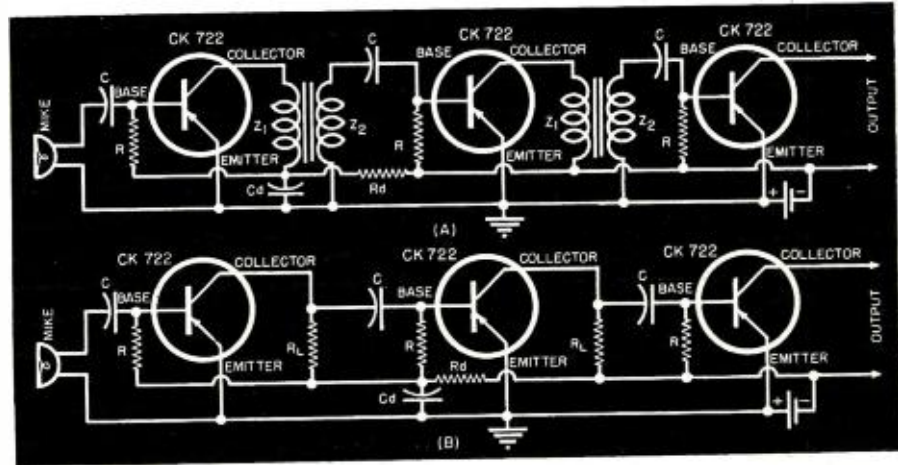

Fig. 2. (A) Transformer-coupled and (B) resistance-coupled amplifiers using transistors.

a voltage at the collector because of the voltage drop in R_L resulting from collector current. 10,000 ohms is about right for CK722.

Note that in each of these circuits (Figs. 2A and 2B) a decoupling filter comprised of R_d and C_d is shown. This is necessary for unless the battery is of extremely low impedance there will be positive feedback resulting from the fact that the battery impedance is common to all stages. It may even be found necessary to add decoupling filters in other stages depending upon the total number in the amplifier, the total gain, etc. Experience has shown that most batteries will cause feedback in a high-gain transistor amplifier for even though the battery impedance is low, it is appreciable compared to the relatively low impedances of the transistors. C_d must be a fairly high capacity if R_d is to be kept small enough to not drop the operating voltages too greatly. For example R_d of 500 ohms and C_d of 40 μ f. or more might be satisfactory but final values can be determined by trial and will depend upon the frequency range of the amplifier as well as the gain, number of stages, etc. In general, the time constant ($C_d R_d$) should be greater than $1/f$ for the lowest frequency passed by the amplifier. (In computing this time constant C_d must be expressed in farads, R_d in ohms, and f in cycles per second.)

Now we come to the output where we wish to operate a small earphone requiring 2 or 3 milliwatts for suitable output. Because we are dealing with a power amplifier operated from a low voltage supply, the output signal will have a voltage swing of only a few volts, never more than the theoretical limit of twice the supply voltage. Crystal phones are of high impedance and depend on larger voltage swings so are not desirable because they re-

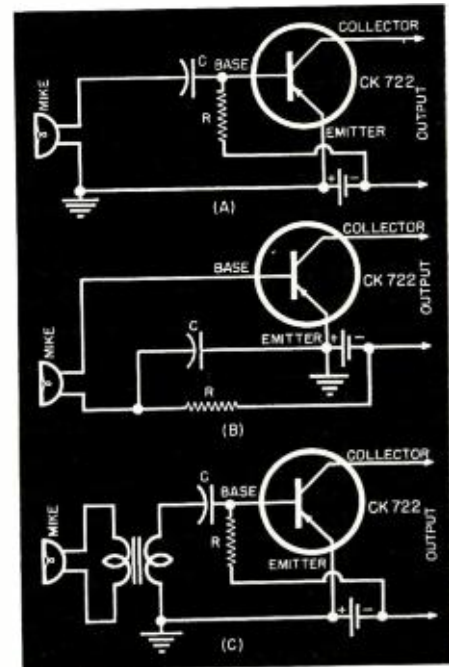
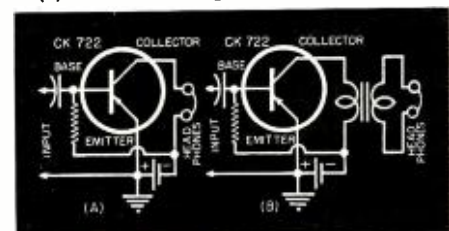

Fig. 3. (A) Dynamic microphone input circuit. (B) Variation of circuit in (A). (C) Transformer-coupled dynamic mike input.

quire a matching transformer. Magnetic phones are readily available with impedances of a few thousand ohms and may be used without transformer
(Continued on page 125)

Fig. 4. (A) Direct-coupled output and (B) transformer-coupled output. See text.



RECEIVER CHANGES TO IMPROVE FRINGE RECEPTION

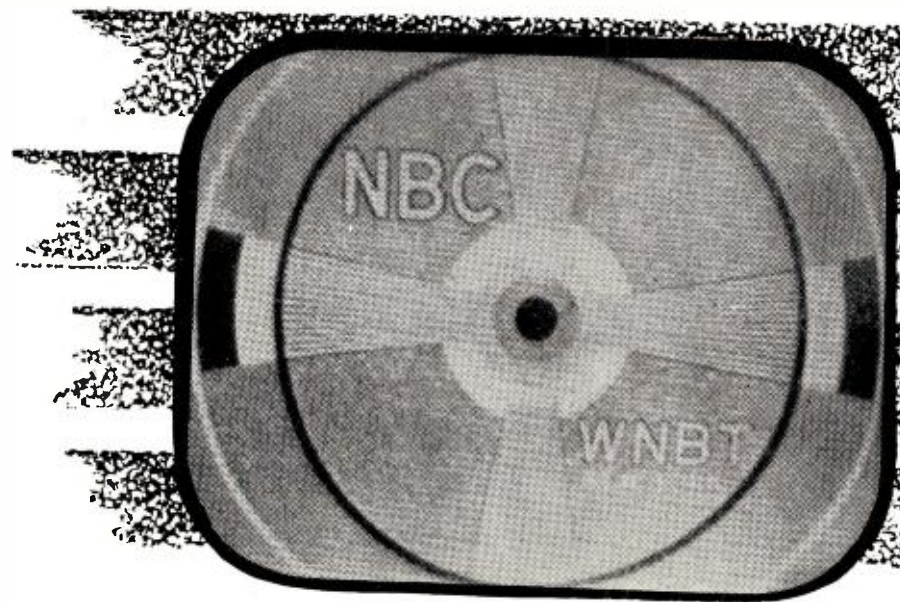

Fig. 1. Test pattern when incoming signal is weak. Note that the snow present reduces definition, as is evident in vertical wedges.

By
PAUL STEVENS

Part 1. A practical discussion on how to increase TV set sensitivity by making tube, a.g.c., and alignment changes.

THE satisfactory reception of TV signals in fringe areas is a problem for TV service technicians and set owners. With the opening up of u.h.f. channels, the problem may be intensified.

The input circuits of a u.h.f. converter—or u.h.f. receiver, for that matter—introduce a considerable loss in signal. Some of the loss occurs in the input coupling circuit; most of it occurs in the conversion process, and is due to poor conversion gain. Not only must this loss be tolerated—there is also the matter of the greater transmission loss of u.h.f. signals compared to v.h.f. signals. The u.h.f. signal loses approximately 10 db more than the v.h.f. signal in transmission. These factors tend to make the signal-to-noise ratio of u.h.f. channels at the cathode-ray tube of the receiver much poorer than the ratio for v.h.f. channels.

The increased power output of many TV transmitters has resulted in considerable improvement in v.h.f. reception, to the extent that the fringe has been pushed back somewhat. There are still many set owners in weak-signal areas, however, who are not happy about their receivers' performance. The undesired symptoms may be divided into two chief categories: (1) Masking of the picture signal by receiver noise, or snow; and (2) Imperfect synchronization.

High-gain antennas and boosters have improved the performance of many receivers in weak-signal areas.

Changes in the receiver design offer another, often less expensive method of increasing set sensitivity. Such changes may be attempted when the set owner, for reasons of economy, cannot go all-out on an antenna installation; or when, in spite of the use of a high-gain, correctly-installed antenna and low-loss line, reception remains unsatisfactory.

Before the service technician begins making the changes to be described, he should be absolutely sure that (1) the antenna system is as well-installed as the circumstances permit, and no troubles are present in it and (2) the receiver is in correct alignment and working perfectly. If the service technician is making the installation himself, he should of course know which antenna and transmission line will bring in best reception, under the conditions present, and within the limitations imposed by the customer's pocketbook. It is assumed that he is thoroughly familiar with installation procedures, and has done his best to bring in a good picture.

When the antenna system or its installation cannot be improved further, the checks described below should be made.

The line voltage should be measured. If it is considerably below 117 volts, the receiver's sensitivity will be reduced appreciably.

Constant-voltage transformers are available that will boost a line voltage which is as low as 80 volts to 117 volts. The price of these trans-

formers is relatively high. Most 300-watt units cost \$35; a 150-watt one is approximately \$30. The unit purchased will have to have the same wattage rating, at least, as the TV receiver to which it is to be attached. The power consumption of TV receivers ranges from about 250 watts to 375 watts. The cost of the transformer will therefore be, on the average, around \$35.

The constant-voltage transformer not only boosts the line voltage to 117 volts—it also keeps it constant at that level, and thus provides voltage regulation. It is, therefore, especially useful in cases where considerable line voltage fluctuations are causing set reception to be impaired from time to time.

The constant-voltage transformer should not be confused with inexpensive voltage-regulating units. These units may keep the a.c. voltage supplied to the set relatively constant in the presence of line surges, but are incapable of boosting the low line voltages.

The next test should be an inspection of all the tubes, to make sure they are all of the correct type. The tube numbers should be checked against the set schematic. In some cases, it may be discovered that some tube with similar characteristics but a lower gain has been substituted for the one specified in the schematic, due possibly to a short supply of the original tube at the factory. The tube (or tubes) should, in such a case, be replaced by another of the correct type.

The d.c. voltage output of the low-voltage rectifier should next be measured, and compared with the voltage specified in the set manufacturer's notes. If the voltage is lower than it should be, even if only by a few volts, one or more tubes (as the case demands) or selenium rectifiers (if these are present) should be substituted, to bring this part of the receiver to optimum operation.

The video amplifier tube or tubes should next be changed, and results

RADIO & TELEVISION NEWS

noted. The gradations in shading of the test pattern's inner circles should be very carefully observed, to see whether there are any changes for the better in their contrast. (It is assumed that a test pattern with such inner circles can be tuned in.)

Substitutes should also be tried for the r.f., i.f., and video detector tubes. These substitutions should be made during the alignment check (described later), because the small increase in gain one tube may provide over another is not apt to be noticeable in a test pattern or picture. When the peak-to-peak amplitude of a test signal is observed on a scope, however, any increase in its amplitude will be very apparent. The small increases resulting from various tube substitutions may, when added up, afford quite a noticeable improvement in picture reception.

When front-end tubes are being substituted three or four tubes should be tried to insure that a tube whose interelectrode capacitances are closest to those of the original tube, is obtained. The one that produces maximum signal output with correct bandpass (as observed on a scope) should be retained.

A slight receiver misalignment may be contributing to the receiver's lack of sensitivity, and this should be checked. The correct i.f. alignment of receivers operating in very weak signal areas is particularly important. The technician should be certain of the accuracy of his signal generator when aligning receivers in fringe areas (which is not to imply that he may be uncertain of its accuracy in other areas).

If all or most of the received channels are very weak, the video i.f. stages should be realigned with *no a.g.c. voltage* applied to the grids of the a.g.c.-controlled video i.f. stages. The test signal applied to the mixer should be so small in amplitude that a signal of no more than about 1/2 volt peak-to-peak amplitude is observed at the video detector output on an oscilloscope.

Such an alignment procedure will far better approximate the conditions under which the receiver is to operate, than the alignment procedure cited in the manufacturer's notes, since the

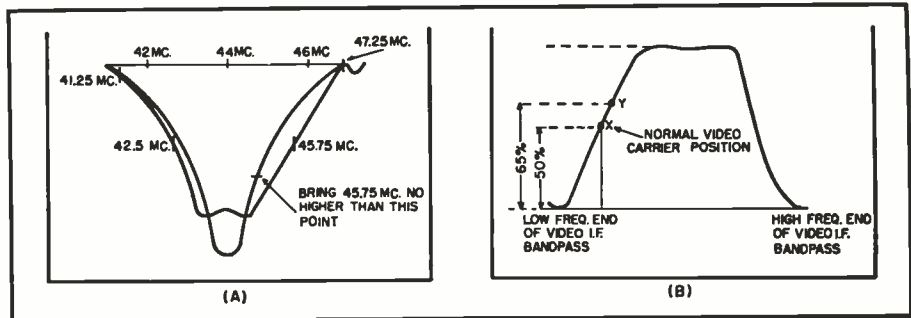

Fig. 2. (A) To peak the response, the bandpass of the tuned circuit must be sacrificed. The broader bandpass curve represents the original response of an assumed video i.f. circuit with a carrier of 45.75 mc. The narrower bandpass curve indicates the higher amplitude response after peaking. The curve is not drawn to scale. (B) How the video carrier may be raised to the 65 per-cent point on the i.f. curve in order to boost the gain of the i.f. tuned circuits in the television set.

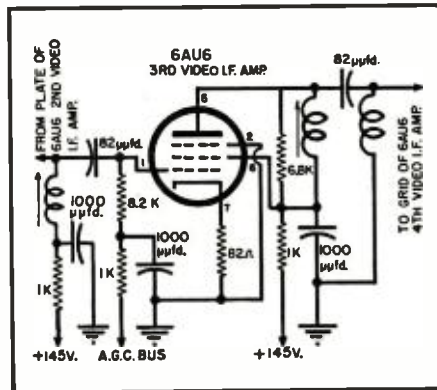

Fig. 3. To narrow the bandpass and increase gain of a video i.f. section the 8200 ohm grid resistor and the 6800 ohm plate resistor can be changed to 16,000 and 12,000 ohms respectively and set realigned. The circuit is a Firestone Model 13-6-44.

latter is usually intended to apply to sets located in medium- and strong-signal areas. Tuned circuits will not provide optimum gain at the desired frequencies when very weak signals are coming in, and the a.g.c. voltage these signals develop is low, if they have been aligned at conditions of medium or strong test signal input, with a relatively large a.g.c. voltage present.

The gain of the i.f. tuned circuits may be boosted if their bandpass is reduced. The definition of the picture will, theoretically, be impaired by such a procedure. Since the excessive snow present in a picture produced by a

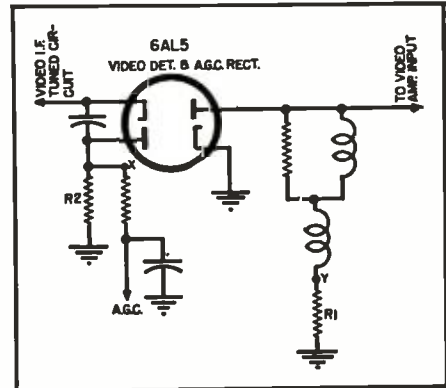

Fig. 4. In a circuit like this, the a.g.c. line may be disconnected at point "X" and connected to point "Y". Since R₂ is smaller than R₁, a.g.c. voltage is reduced. The modification will not be valid if R₁ is returned to a negative voltage source.

very weak signal will not allow 4 mc. definition to be observed anyhow (see Fig. 1), nothing is really sacrificed. The bandpass may be reduced to a minimum of 2.5 mc., and the improved receiver gain obtained on realignment, with the consequent reduction of snow, should prove quite gratifying, even though high-frequency detail is absent (see Fig. 2A).

The bandwidth of the i.f. stages should not, of course, be tampered with if one or more medium- or high-level stations are being received in the area, unless the set owner is willing to impair reception on good channels, to improve it for the weak ones.

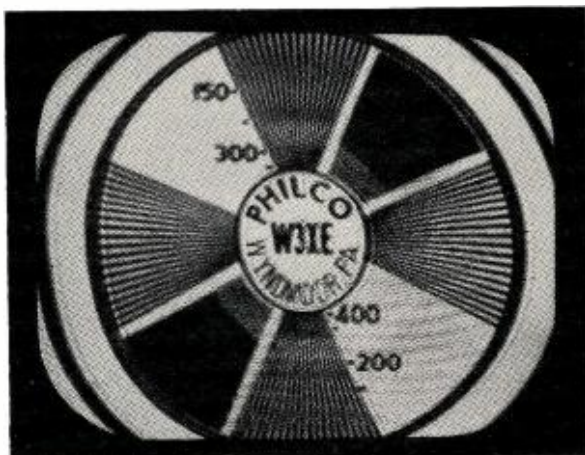

Fig. 5. Effects of regeneration on a test pattern. Note intensification of different parts of vertical wedges (left) and intensification of blacks in bulls-eye region and in lettering and the whites trailing blacks as shown at right.



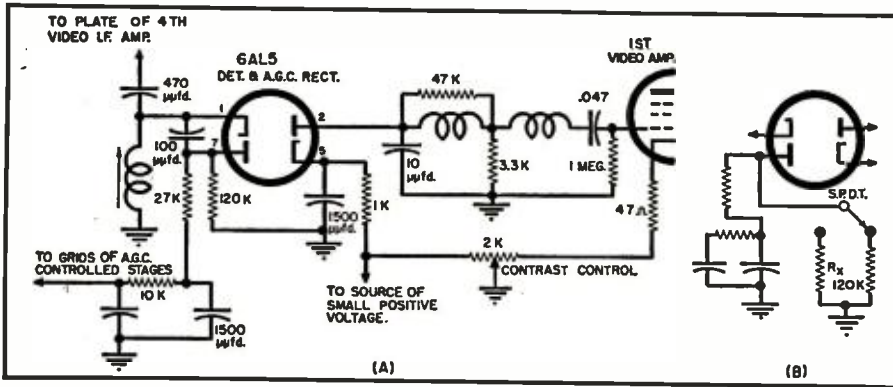

Fig. 6. (A) To reduce a.g.c. voltage in this circuit, the 120,000 ohm a.g.c. load resistor may be changed to one of lower value. A resistor of about two-thirds the value may be tried first, then half value, etc. The a.g.c. system shown has a delay feature and should, theoretically, produce no a.g.c. voltage in the presence of weak signals. Noise pulses may, however, cause appreciable a.g.c. voltage to develop. Circuit is from the Philco 50-T1443. (B) When the presence of medium or strong stations requires a substantial a.g.c. bias, this switching arrangement may be inserted. R_x is a smaller resistor than the 120,000 ohm load resistor which is switched in when the incoming signal is weak. The larger resistor is switched in when the received channel is strong. Switch should be as near a.g.c. rectifier as possible.

Resistors in shunt with grid and plate tuned circuits in the video i.f. stages may have to be increased in some cases, to permit the attainment of adequate gain with reduced bandpass (see Fig. 3). These loading or damping resistors may be replaced, one at a time, by resistors twice their value, and results observed on the response curve as realignment proceeds. (It has been assumed that the technician has access to a sweep generator and an oscilloscope. If he doesn't, he can perform the alignment, or make bandpass checks, by the point-to-point method, using a signal generator and voltmeter.)

The video carrier may be raised from its customary 50% point on the i.f. curve, to about the 65% point (see Fig. 2B). Since the low video frequencies are close to the carrier, large objects in the picture will be better received, and the over-all picture quality will seem better, as the result of such a procedure. Any slight smearing that tends to occur will be masked by the high-amplitude noise signals present on the CRT screen. The background lighting of the picture will also be brighter, since this lighting represents a low frequency.

Placing the video i.f. carrier higher than 65% is not recommended, since it

is apt to result in excessive phase shift at low frequencies, causing smearing to become noticeable (see Fig. 7). Even the snow in the picture may be smeared in such a case. (Clean white snow in the picture is bad enough, but smeared snow is too much.) If smearing is noticeable with the carrier at the 65% point, it should be placed slightly lower on the response curve, and results noted.

Care should be taken to avoid i.f. regeneration in the realignment process. The increased gain of the i.f. tuned circuits increases the possibility of regeneration. The condition will manifest itself by a peak in the response curve that may be noted only when the test signal input is reduced. Sections of the vertical wedges in the test pattern will be intensified, if such peaking is present at the middle- and high-frequency end of the bandpass (see Fig. 5). The alignment should be gone over until all such peaks are eliminated or minimized, and the response is relatively flat. A slight peaking at the high-frequency end of the curve (the one farthest from the video i.f. carrier) is not undesirable in many cases, since it tends to improve picture definition.

The a.g.c. voltage may be reduced or eliminated in fringe areas, to boost

receiver sensitivity. This voltage, which should be very low in the presence of weak signals, may actually be quite large if the noise associated with the incoming signal is large (unless a delayed a.g.c. system is present). The gain of the receiver will be unnecessarily reduced in consequence, and impaired synchronization, insufficient picture contrast, snow, and poor sound may result.

If some medium-level signals are being received, the a.g.c. voltage may be reduced, instead of being entirely eliminated, by disconnecting the a.g.c. feed line from the a.g.c. rectifier (if one is employed) and reconnecting it (see Fig. 4) to the hot side of the video detector output circuit (provided that the detector connections are such that a negative d.c. voltage is produced at its output). This change cannot be made if the resistor is returned to a negative voltage source instead of ground since the a.g.c. voltage may be increased rather than decreased.

Such a circuit change should not be made when one or more strong signals are received, since the receiver will overload (i.e., picture bending, negative picture, complete loss of horizontal sync, etc. may take place) on these signals (see Fig. 8). A switching arrangement can be made up to reduce the a.g.c. on weak signals only, in which case satisfactory reception may be obtained on both strong and weak stations.

The resistor in the plate load of an a.g.c. rectifier, across which the a.g.c. is taken off, may also be reduced in value (see Figs. 6A and 9), to lower the a.g.c. voltage and increase the receiver sensitivity. If overloading on a strong station is to be avoided, a switch may be installed (see Fig. 6B). Before installing any switches of this type, make sure the customer is not the kind of person who will consider it a tax on his energy or intelligence to operate an additional control.

Reduction of the a.g.c. voltage will reduce the ability of the receiver to compensate for fading, changes in contrast when stations are switched, etc. This is, however, a relatively small price to pay for better set sensitivity.

If the sound volume of the TV set is insufficient, all the tubes in the sound
(Continued on page 134)

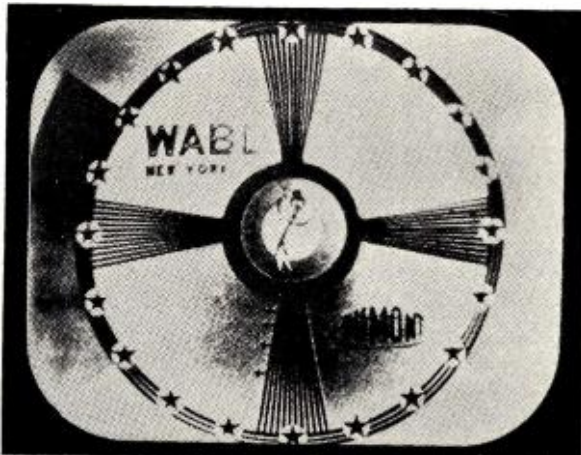

Fig. 7. The effect of smearing on a TV test pattern.

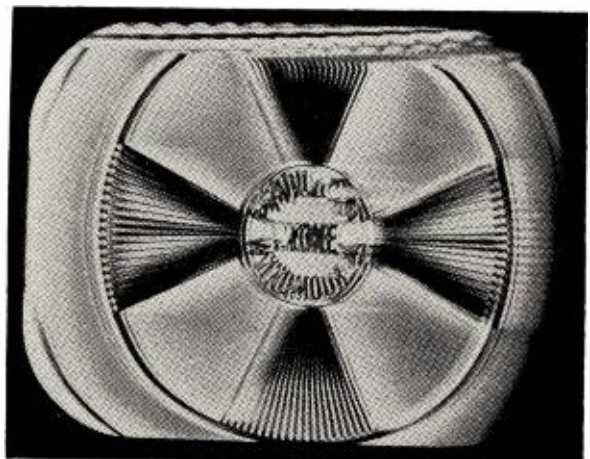

Fig. 8. Effect of overloading. Note reversals of the blacks and whites, tearing at top of picture, etc. Complete loss of sync may take place when overloading is especially severe.

THE STEPHENS OTL AMPLIFIER

By

FRANK H. GILBERT

Stephens Manufacturing Corp.

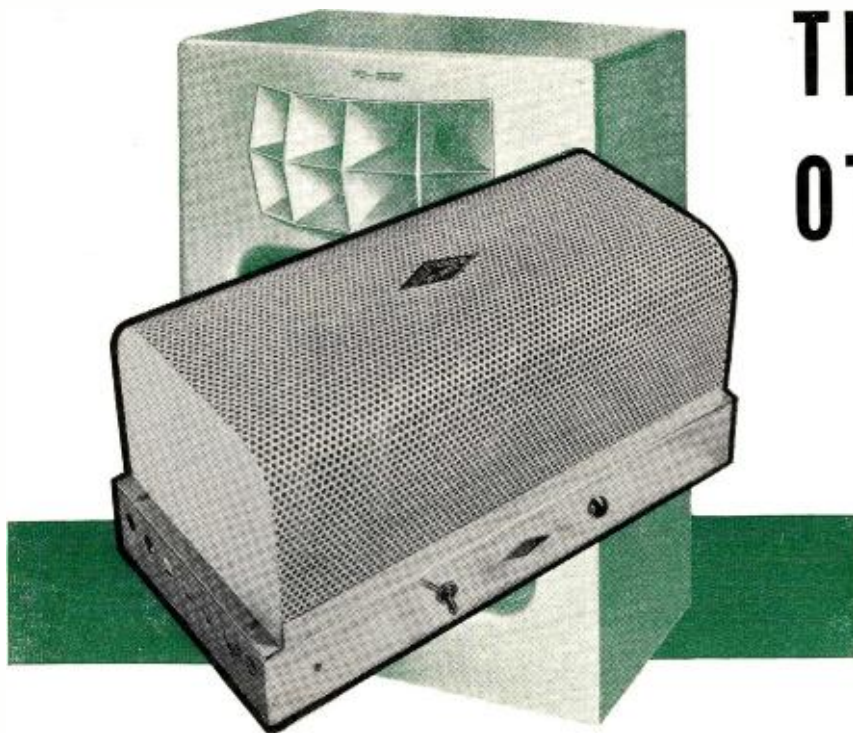

Fig. 1. Over-all view of the Stephens 500D power amplifier. Elimination of output transformer results in smaller unit. Model 5417 speaker system is shown in background.

Performance details on a compact, lightweight power amplifier whose design omits the output transformer.

IN RECENT years, considerable effort has been expended in improving the performance of power amplifiers for use in "high fidelity" sound systems. The techniques of handling resistance-coupled voltage amplifiers to supply relatively distortion-free signals to the output power stage have been well developed, leaving most of the residual distortion in this output stage and its associated matching transformer.

In the past few years, considerable emphasis has been placed on improving the output transformer to permit greater over-all feedback with its attendant reduction of distortion components. Unfortunately, these developments have resulted in increasing the cost as well as the performance of these devices. But even with the improvements already available, the transformer remains the factor limiting the performance of a power amplifier employing this means of coupling to the loudspeaker.

The problem of transferring large amounts of power at very low frequencies was encountered during the war in the aircraft industry in connection with large vibration exciters. This early circuitry was developed through the efforts of R.E. Rawlins and described in an article by Paul Holmes.¹ For some reason, this circuitry was ignored by the audio industry for several years. Recently a method of employing push-pull drive to such an output system was worked out by Sinclair and Petersen of *Gen-*

eral Radio and described in recent literature.² The system employed in the amplifier here described was worked out by the author at the *Stephens Manufacturing Corporation* independently and first shown at the New York Audio Fair in October 1951.

There are several methods of eliminating the output transformer. First, impedance coupling can be employed. This method suffers from the loading effects of the inductance at some low frequency, while the distributed capacity causes phase shifts which limit the high-frequency performance; also several tubes must be employed in parallel to obtain sufficiently low impedance to make direct matching to the loudspeaker load practical. Second, cathode follower output can be employed, but this system is quite inefficient in converting the d.c. power into audio-frequency energy and also requires rather high driving voltages to obtain high power outputs. Both of these latter systems require quite high currents from the power supply system and thus make the use of standard power supply components difficult.

A recent commercial approach to this problem has resulted in an amplifier which operates with quite reasonable conversion efficiency, very low distortion, and negligible phase shift. Further, the elimination of the output transformer results in less weight and smaller size than amplifiers of comparable power. A photograph of this unit is shown in Fig. 1.

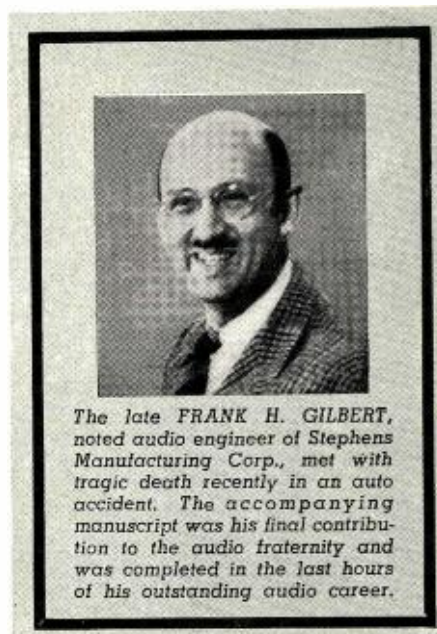

The late FRANK H. GILBERT, noted audio engineer of Stephens Manufacturing Corp., met with tragic death recently in an auto accident. The accompanying manuscript was his final contribution to the audio fraternity and was completed in the last hours of his outstanding audio career.

The most unconventional part of the circuit of this amplifier is in the power and driver stages whose simplified schematic diagram is shown in Fig. 2. It can be seen that these stages are direct-coupled to supply amplification to d.c., thus eliminating any phase shift caused by coupling components. To stabilize the bias on the output tubes, reduce distortion, hum, and noise, 25 db of direct-coupled inverse feedback is applied through the resistor *A* to the cathode of the input triode.

To obtain good high-frequency response it was decided to drive the lower pair of power tubes from a cathode follower so that the input capacity from the power tubes would not cause serious shunting effect on the driving source at the frequencies involved. Linear operation of this driver is assured through a high supply voltage.

Additional feedback to the driving cathode follower is provided by supplying its plate from the output circuit. This arrangement reduces the apparent source impedance at the output tubes to approximately 100 ohms. The reflected input capacity of the lower pair of tubes, because of

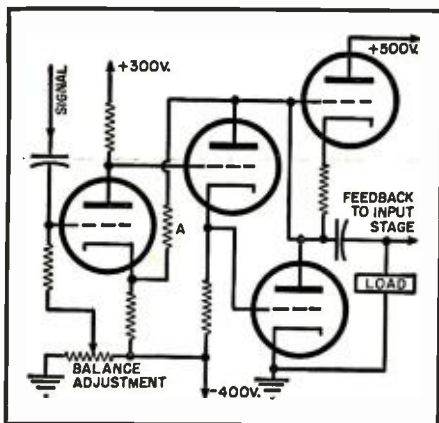

Fig. 2. Simplified schematic of the power and driver stages of Stephens Model 500D.

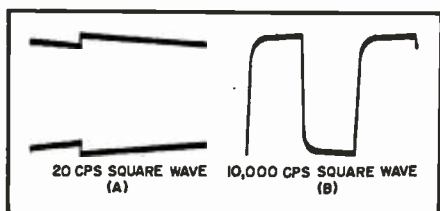

Fig. 3. Transient response of amplifier. (A) at 20 cps and (B) at 10,000 cps. See text.

FREQ. (cps)	OUTPUT (watts)	2ND HARM.	3RD HARM.
20	20	.29%	.32%
5500	20	.13%	.52%

Table 1. Harmonic measurements of 500D amplifier at overload point for 20 and 5500 cps.

Miller effect, is about 200 μ fd. The low driving impedance makes this shunting capacitance have negligible effect in the audio and ultrasonic range.

The upper pair of output tubes receives its driving voltage from the voltage drop across the cathode resistor in which the current is a combined result of the current drawn by the lower tubes and by the load. It should be noted that this driving voltage is 180° out-of-phase with the input signal to the lower grids; thus, the upper and lower tubes are essentially acting in push-pull as far as the audio frequency voltages are concerned.

The d.c. supply is, however, fed to the tubes in series so that the supply requirement is for a high voltage, low current supply. Because of the direct coupled driving system, it is also necessary to have a negative supply below the potential of the cathode return for the lower pair of output tubes. This arrangement can be more conveniently seen in the complete schematic diagram of Fig. 5. Here all potentials in the complete amplifier are shown.

Coupling to the load is accomplished through the use of an electrolytic condenser which serves to remove the d.c. drop across the lower tubes from the load circuit. In practice, this condenser is chosen so that a low impedance is provided for all frequencies in the passband. The impedance thus introduced is still further lowered by

a second negative feedback loop to the first of the voltage amplifier stages.

Coupling into the last three stages from the cascade voltage amplifier is through a condenser with sufficiently high capacity to introduce negligible phase shift at the low end of the audio spectrum. Approximately 11 volts are required to drive the amplifier to full output. This is easily furnished from the conventional two-stage voltage amplifier.

Gain of the final three stages with feedback is approximately 9. Additional feedback around the complete circuit is provided to reduce distortion and noise developed in the input stages. Two values are provided, depending upon the gain required, either 20 or 11 db. With the jumper connected in the output plug, full feedback is applied and a signal of 1.5 volts is required for full output. With the jumper removed, the lower value of feedback is used and the amplifier may be driven to full output from one-half volt.

Correct operating potentials are established on the output tubes by properly setting the bias control, R_8 . This adjusts the d.c. potential on the grid of the direct coupled triode and takes into account the leakage, if any, in the input coupling condenser. The proper setting of this control is that which applies one-half the plate voltage available to the lower pair of tubes. It will be noted that the upper tubes have individual cathode resistors, so that proper current balance is obtained regardless of tube characteristics. This arrangement makes the selection of tubes less critical. It has been found that four tubes of the same make, condition, and age can be juggled to provide essentially equal currents in the two branches as indicated by equal voltage drops measured across the parasitic suppression resistors in the two upper plates.

The power supply considerations, both from the standpoint of filament and plate, are somewhat more com-

plex than in a conventional amplifier. Because of the fact that the output tubes are 2A3's and thus require a different voltage than other tubes in the amplifier and because they employ directly heated cathodes, and so require a center tap, two 2.5-volt center-tapped windings are needed. The floating cathodes of the driver cathode follower and its associated voltage amplifier each require separate heater windings because of their differing cathode potentials, which exceed the tube ratings for heater-cathode potentials. This heater situation is further complicated by the fact that a.c. isolation is required between the various cathodes so that each winding has to be shielded while maintaining a low capacity to ground. The total heater requirement is five windings, two of which are center tapped—twelve leads, in all.

It is obvious from the above that vacuum tube rectifiers for the positive and negative high voltage supplies would make the use of a single power transformer somewhat cumbersome, so selenium voltage doubler type supplies, operating from a single two-lead high voltage secondary, are employed. Both the negative and positive supplies are identical voltage doubler systems operating from a 230-volt winding with two standard 130-volt elements in series; those in the positive supply are 150-milliamperere elements, while those in the negative supply are 65-milliamperere units. Conventional choke condenser filters are used.

With the direct-coupling arrangement employed and the feedback loops providing an apparent output impedance of .8 ohm for the low gain position, virtually all of the power developed by the output tubes is available to the loudspeaker circuit, as the insertion loss of the transformer is not present. The damping of the speaker system then becomes that introduced by the resistance of the voice coil circuit of the speaker system. Such damping effectively smooths resonant effects introduced by enclosures and thus reduces "hangover" present in most systems.

Transient response to the amplifier is shown in the oscillograms of Fig. 3; (A) is taken with a 20 cps square wave and shows approximately 12° of phase shift at this frequency, while (B) shows the performance with a 10,000 cps square wave with slight rounding of the leading corners, indicating the drop in response above 100,000 cps. Response of the amplifier in this higher frequency region is purposely attenuated to prevent r.f. signals from being passed, which might detrimentally affect the performance of the system. The gain of the amplifier is down 30 db at 1 megacycle.

Distortion curves are shown in Fig. 4 for the 2nd, 3rd, and 5th harmonics, as these were the only significant ones found in the amplifier output. The overload point of the amplifier occurs at 20 watts where the harmonic con-

Fig. 4. Distortion curves for the 2nd, 3rd, and 5th harmonics of the 500D amplifier.

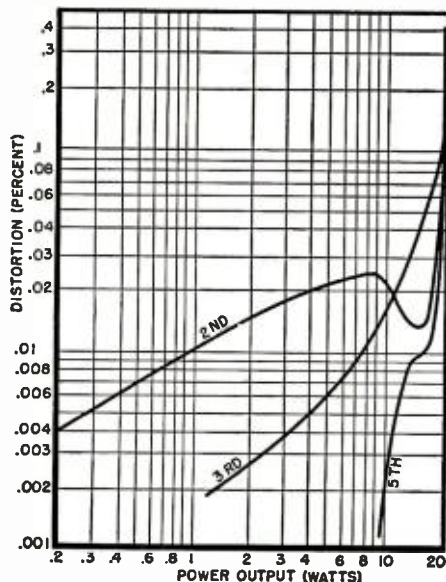

tent is at its highest value. Just below overload, the harmonic content is in the neighborhood of 0.1%, while at normal listening level, in the vicinity of 2 to 3 watts, the distortion is negligible. Harmonic measurement with the sensitivity indicated by these curves was made possible through the use of a newly developed audio oscillator of extremely low distortion³ and a carefully adjusted wave analyzer. It is felt that such harmonic measurements are a much truer measure of amplifier performance than can be obtained by any other type of analysis.

While complete harmonic curves are shown for the 1000 cps frequency, measurements were also made at 20 cps and at 5500 cps at the amplifier overload point, and the results are shown in Table 1. While the distortion at these frequencies is slightly higher, it is still well below that usually found in amplifiers employing coupling transformers.

The principles involved in the design of this particular amplifier can be employed with other tube types and modified arrangement to suit particular applications. This design provides an adequate power level for most "high-fidelity" applications in the home and for sound reinforcement. A recent installation at the Los Angeles County Fair employed five of these amplifiers, driving five theater-type, two-way reproducers to more than adequately cover an open-air grandstand with a seating capacity of twenty-thousand people. Reports of many critical listeners indicated that this system provided clean sound reinforcement of musical program material.

A complete line of single speakers and two-way components is now being manufactured to take full advantage of the capabilities of this amplifier. No point has been overlooked in the design and construction of these speakers to provide the most outstanding performance available when used in combination with the amplifier and high-quality source material.

The 500-ohm output impedance of the amplifier should be directly fed to a 500-ohm voice coil speaker or 500-ohm crossover network for a two- or three-way combination 500-ohm speaker system.

A companion unit for use with this amplifier is the company's #5106 15" coaxial speaker with separate 500-ohm voice coils, 500-ohm network, and six and one-half lb. Alnico V permanent magnet.

However, all of the company's "Tru-Sonic" speakers and speaker systems are available in 500-ohm voice coils from the #5112 12" co-spiral to the full three-way systems. This gives the high-fidelity enthusiast a selection in any price range with an assurance of a perfectly-matched hi-fi audio system. **EDITOR'S NOTE:** Audio enthusiasts who have a sizable sum invested in speakers may be loathe to discard their present units just because they do not happen to have 500-ohm voice

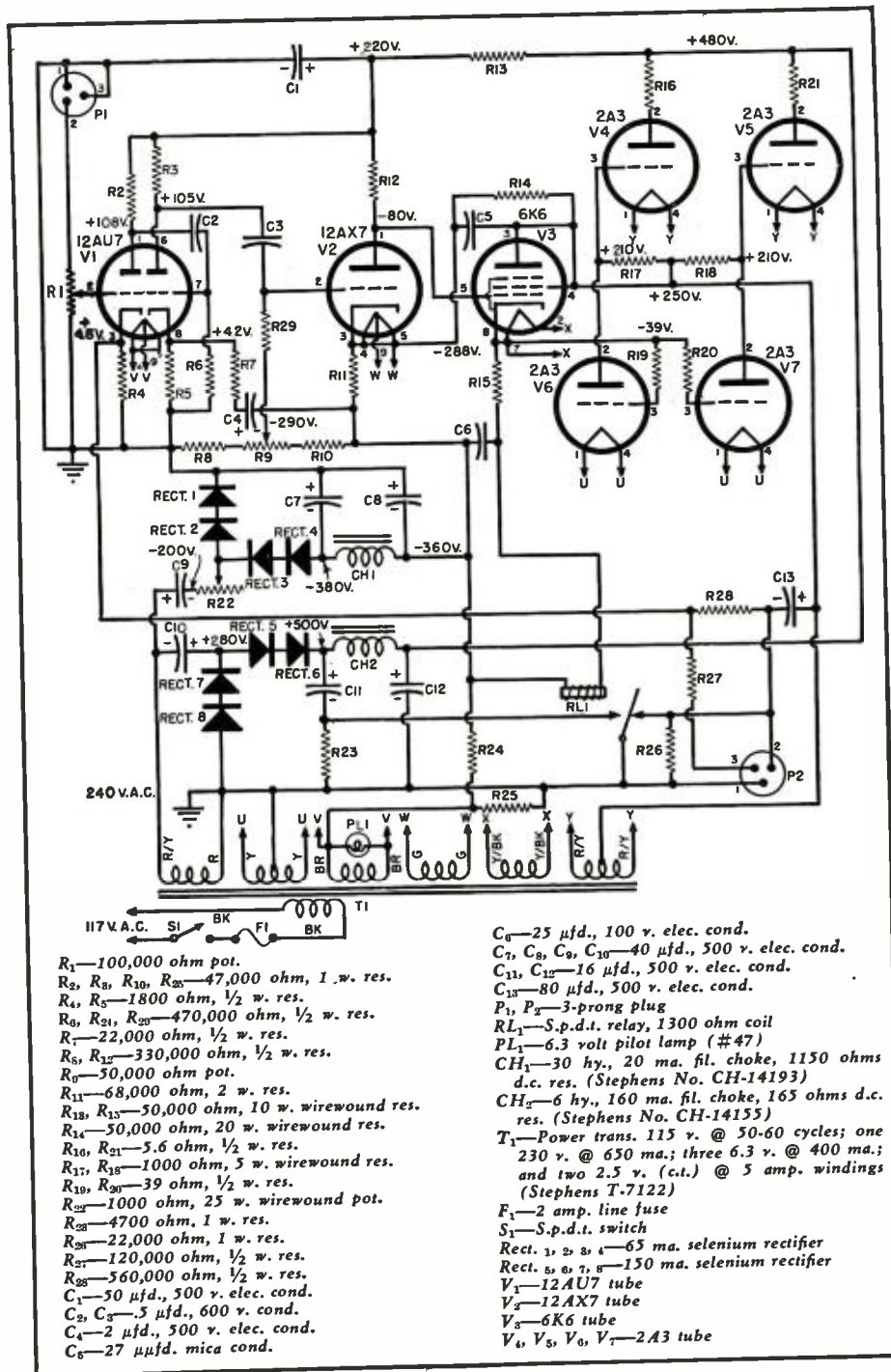

Fig. 5. Complete schematic and parts list covering the Model 500D amplifier. Relay RL₁ limits charging current on condenser C₁₁ until the 6K6 tube starts drawing current. The relay also eliminates "pop" in the output when the amplifier is first turned on by shorting the output until all tubes are in normal operation. The time delay is about 5 seconds. Resistors R₂₇ and R₂₈ are in the feedback circuit. At the present time all of the commercial models of this amplifier are being shipped with pins 2 and 3 strapped together. This increases the feedback 9 db and decreases the gain by the same amount. In this position the driving voltage required for full 20 watts output is 1 1/2 volts. By cutting the jumper, the gain of the amplifier is increased 9 db and requires an input voltage of 1/2 volt. The output impedance of the amplifier is 500 ohms which should be coupled direct to any 500-ohm v.c. speaker or speaker system.

coils. The Stephens Model 500D audio amplifier can be used in sound distribution systems utilizing conventional speakers by employing a 500 ohm-to-voice-coil output transformer. This technique, however, cancels several of the unique advantages of this circuit (elimination of the output transformer with its resultant saving in space and weight). The ideal arrangement

is, still, to use this amplifier with a matching, companion loudspeaker.

REFERENCES

- Holmes, P. J.; "Vibration Exciter for Structural Tests." *Electronics*, December 1946.
- Sinclair & Petersen; "A New Push-Pull Amplifier Circuit." *General Radio Experimenters*, October 1951.
- Better Audio Co., 4638 10th Avenue, Los Angeles, California.

YOU AND U.H.F.

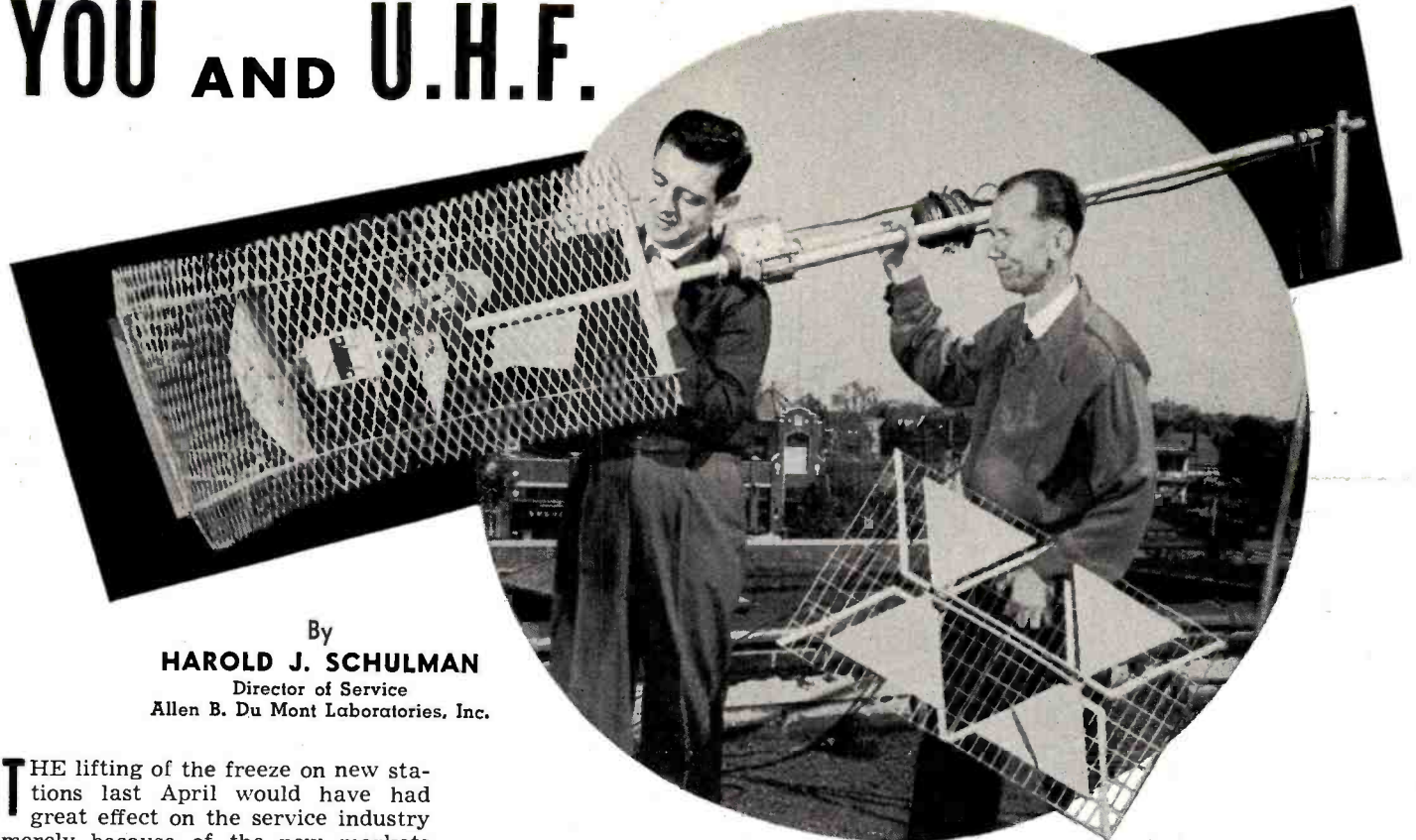

By
HAROLD J. SCHULMAN
 Director of Service
 Allen B. Du Mont Laboratories, Inc.

THE lifting of the freeze on new stations last April would have had great effect on the service industry merely because of the new markets that would be stimulated by the new stations.

But when you add to this the coming to commercial life of a new band of frequencies, called u.h.f. for convenience, it's easy to see why service technicians in every part of the land started asking many basic, practical questions.

Will u.h.f. really work? Can I handle it without too much additional study? What is there different about the handling of u.h.f. installations? And many more.

Since u.h.f. transmission is now a

TYPE	VOLTAGE OUTPUT	
	FRONT	BACK
Single Bow-Tie	6.5	5.5
Single Bow-Tie (with reflector)	8	2
Stacked Bow-Tie	11	10
Stacked Bow-Tie (with reflector)	21	3
Stacked V	20	11.5
Double V	15	9.5
Trombone	12.5	8
Parabolic	12.5	4.5

Table 1. Comparison of relative voltage outputs (measured at second detector) for various u.h.f. antennas.

Table 2. Attenuation losses (in db per 100 feet) for wet and dry lead-in lines.

TYPE	100 MC.		700 MC.	
	WET	DRY	WET	DRY
300-ohm flat	7.3	1.2	26.5	3.6
300-ohm tubular	2.5	1.2	8.2	3.6
RG-11/U	1.9	1.9	6.2	6.2
RG-59/U	3.7	3.7	11.7	11.7

Setting up a u.h.f. dipole with reflector and stacked bow-tie with reflector for tests.

Your u.h.f. antenna installations will be successful by following these pointers from Portland and other cities.

fact in both the East and West, practical answers can now be given to these important questions. Portland (27), Atlantic City (46), York (43), Mobile (48), South Bend (34), Wilkes-Barre (28), and Youngstown (27, 73), and others all report the same excellent results with u.h.f. transmission.

Millions of dollars were spent in research and experimentation during the freeze period. The *Du Mont* experimental station, KE2XDR, and the *RCA* experimental station in Bridgeport, KC2XAK, did yeoman service in providing proving grounds for all manufacturers who wanted to test their own methods of adapting their receivers to u.h.f. Therefore it's no wonder that u.h.f. is working as well as it is.

Now that u.h.f. is a commercial reality let's examine it from four vantage points: (1) the coverage and quality of its signal, (2) the devices used to receive it, (3) the techniques used to install it, and (4) its significance to service technicians.

The u.h.f. coverage has been most thoroughly checked in Portland. We had a crew in Portland even prior to the start of telecasting on September 8, 1952. At that time most television activity centered around closed-circuit demonstrations. The most notable demonstration was conducted under a huge tent during the political conventions. Thousands of Portland people saw television pictures for the first time even though it was only a closed circuit.

Since that time we have conducted many service clinics and observed many installations and receivers in action. Based on our own experience plus that of others, certain conclusions regarding the coverage of u.h.f. can be drawn.

A station can go on the air with a 1 kw. transmitter. This should radiate anywhere from 16 to 20 kw. *erp*. A signal of this magnitude can be expected to provide class A coverage over a radius of 14 miles and class B coverage within approximately 23 miles.

In very flat areas this distance will be increased somewhat, and in hilly areas it will be somewhat decreased, but averaging out the variables of terrain and transmitting antenna height, these figures can be used as a rough guide.

For the future, there is no doubt that this range will be extended. The FCC authorizes u.h.f. stations to go as

high as 1000 kw. *erp*. The range of reception will also be extended as the noise figures in the u.h.f. front end improve. In summary, because of the greater inherent noise in u.h.f. tuners or converter circuits at present, the smaller capture area of the u.h.f. antenna, and the greater transmission line losses, a stronger radiated field is required at u.h.f. than at v.h.f.

It is interesting to note that pictures observed in Portland and in York were free from noise interference, as was predicted with u.h.f. Multi-path signals presented no problem either because of the increased directivity of u.h.f. antennas.

Shadow areas were found in Portland where the signal didn't get through at all. In all cases this could be traced to a foothill, building, or other obstruction in the line-of-sight path from the transmitter. Fortunately, the signal shadow area appears to be about half as long as the light shadow area. Thus, residents living in areas which do not have a clear view of the transmitter, but who live reasonably close to the end of the light shadow, should be able to receive a usable signal, if in close enough. (See Fig. 3).

If the transmitter antenna is atop a tall building in your community, you might spend some profitable moments up in the tower just looking your city over. You might find some of the locations hidden by buildings, hills, or valleys and thus have a clue as to the dead spots you might anticipate.

As an example of the coverage that might be expected, it was estimated that the present Portland station, KPTV, with its present power output, could expect to reach about 90% of the people in the city proper and up to 88% of the 650,000 inhabitants of the greater metropolitan area.

Before we leave coverage, how about fringe signals? Well, reception acceptable to dealers and purchasers was found in some parts of Salem, Oregon, about 40 miles south of Portland—and there were even reports of reception 65 miles away.

U.H.F. Conversion

Since there appears to be no integrated u.h.f.-v.h.f. tuner on the market as yet, almost all devices act as converters. While different manufactur-

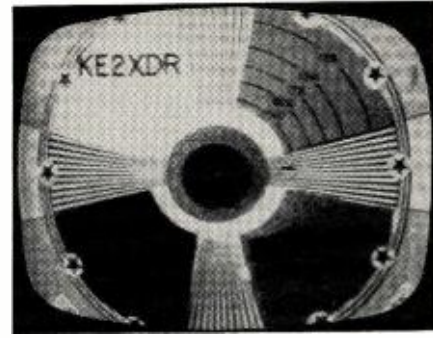
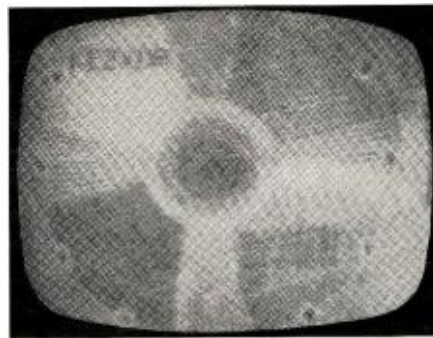

Fig. 2. (Left) Picture obtained using 100 feet of dry 300-ohm ribbon or 300-ohm tubular lead-in lying on roof. (Right) Using RG 11/U coaxial lying on the roof.

ers will make different claims, at the moment one can safely say there is no one "best" device. Some people want to get all channels, while others will be satisfied with just one or two stations in their locality. Some will stress the easy tuning and economy of strip conversion, while others will brag about the built-in tuner that was obtained at additional cost.

When it is all added up we find that each conversion method, like everything else in life, has its advantages and disadvantages. The important thing to remember is that good reception was available to Portland residents with receivers now on the market.

All the present u.h.f. conversion devices were found capable of producing satisfactory pictures. Under different conditions one method may have been a little better than others, but this was usually reversed when a new set of conditions was found. What the receiver did with the signal after conversion down to the i.f. depended, of course, on the inherent performance characteristics of that particular receiver. After all, the u.h.f. portion of the receiver is still concentrated only in the front end. You still have i.f. bandpass, sync circuits, video circuits, etc., to contend with before you finally get your picture onto the cathode-ray tube screen. Further discussion of current conversion methods can be found in the June and July 1952 issues of RADIO & TELEVISION NEWS.

Installation Techniques

Probably the biggest item under the direct control of the service technician is the quality of the installation. Since this is also the most important factor

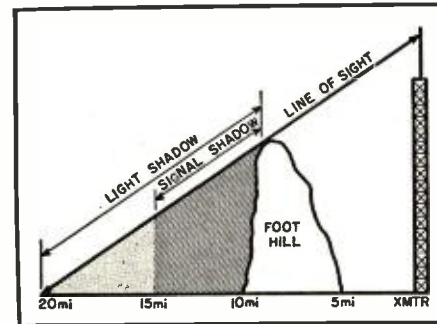

Fig. 3. Signal shadow resulting from u.h.f. transmission is approximately half of corresponding light shadow.

in determining whether or not a customer will enjoy good reception it is worth our while to go over each of the items that go into a good installation. Here we are particularly fortunate because we can draw on both our experiences in Portland and York and our own *Du Mont* experimental lab atop our service department roof in Paterson, New Jersey.

Prior to the on-the-air date in Portland, we gathered as many sample u.h.f.-v.h.f. antennas as were available. We checked their relative performance using the signal put out by the *Du Mont* experimental station KE2XDR. Directivity patterns were carefully plotted. Relative gain and front-to-back ratios can be determined by reference to Table 1. Additional u.h.f. antenna information will be found in the series on "U.H.F. Antennas" which began in the Dec. 1952 issue of RADIO & TELEVISION NEWS.

In general, we found the double-V antenna to be a good all-around antenna in Portland where signal conditions
(Continued on page 128)

Fig. 4. Effects of moisture on transmission lines. (Left) picture obtained with 100 feet of dry 300-ohm ribbon or tubular line. (Center) Picture with 100 feet of wet 300-ohm ribbon lead-in. (Right) With 100 feet of wet 300-ohm tubular line.

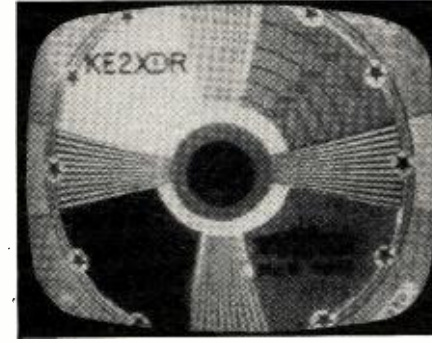
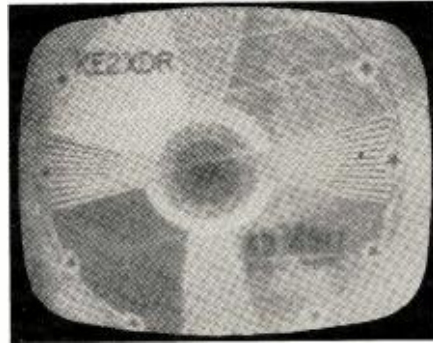
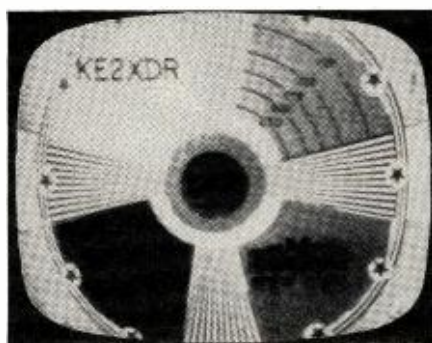

A MULTIPLE INSTALLATION FOR TV RECEIVERS

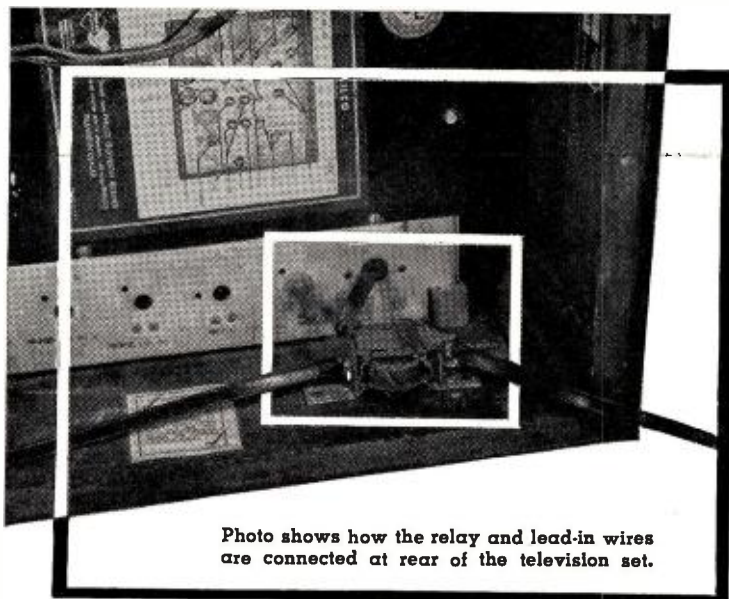

Photo shows how the relay and lead-in wires are connected at rear of the television set.

By
NORMAN C. FULMER

Research Division
Allen B. Du Mont Laboratories, Inc.

Avoid multiple antenna installations by using this novel scheme to connect several auxiliary home TV receivers.

THE popularity of television has reached the stage where it is convenient to have more than one TV set in the home. It is convenient, for example, to have a main TV set in the living room and auxiliary TV receivers in the kitchen (for the wife to watch TV programs, especially cooking instructions, while doing kitchen work), in the bedroom (to watch late evening news programs and movies, and early-morning news programs while dressing), and (heaven forbid!) in the dining room to watch important programs while eating. Auxiliary TV receivers can also be used to advantage in the den or basement recreation room. When a new TV set with a larger screen is purchased, the old small-screen set can be used as an auxiliary set.

Since only one auxiliary TV set is normally used at a time in the home,

the effort and expense of erecting several antennas and lead-in cables, or of installing an antenna coupler (with its attendant loss of signal strength and with several lead-in cables fanning out all over the house to the different TV sets), can be avoided by using a single lead-in cable connected to each TV receiver as shown in Fig. 1A. An inexpensive relay, at each auxiliary receiver, automatically switches the entire signal power of the antenna to whichever TV set is turned on. In lieu of relays, the "on-off" switch in each auxiliary TV set may be replaced with a switch having an extra double-pole, double-throw section.

As shown in Fig. 1A, the antenna lead-in is first connected to the relay switch at the TV set nearest the antenna, such as the one located in an upstairs bedroom. From there, the lead-in wire runs to the next nearest

TV set, etc. This keeps the length of lead-in wire at a minimum. For use with twin-lead lead-in wire, the relays should be of the double-pole, double-throw type. The last TV set connected to the lead-in wire, shown as the main living room set in Fig. 1A, does not need a relay; the ends of the lead-in wires are directly connected to the receiver. At the other TV sets, the incoming lead-in wires are connected to the arm-contacts of the relay, the outgoing lead-in wires are connected to the normally-closed contacts, and the TV set input terminals are connected to the normally-open contacts of the relay. Any number of TV sets can be connected in this manner. To add a new TV set anywhere along the line, merely cut the severed ends and connect the severed ends to the relay at the new TV set.

The energizing coil of each relay may be of the 6-volt a.c. type, in which case the coil leads are connected to the 6-volt filament winding X-X' of the power transformer in the TV set at which it is installed, as shown in Fig. 1B. Alternately, the relay may have a 117 volt a.c. coil, in which case the coil is connected to the a.c. power leads Y-Y' at a point after the "on-off" switch.

When the TV sets are off, the relays connect the TV signal through the entire length of the series-connected sections of the lead-in wire and to the last TV set, which may be operated in the normal manner. When one of the other TV sets is turned on, its relay is energized and automatically connects the entire strength of the TV signal to that set only. Thus, for a few dollars spent for relays, a home can be equipped with several TV receivers which automatically switch onto a single antenna and lead-in system.

The rather simple procedure outlined herein can be performed in a reasonably short time yet provides a much-needed boon to those families with several television receivers.

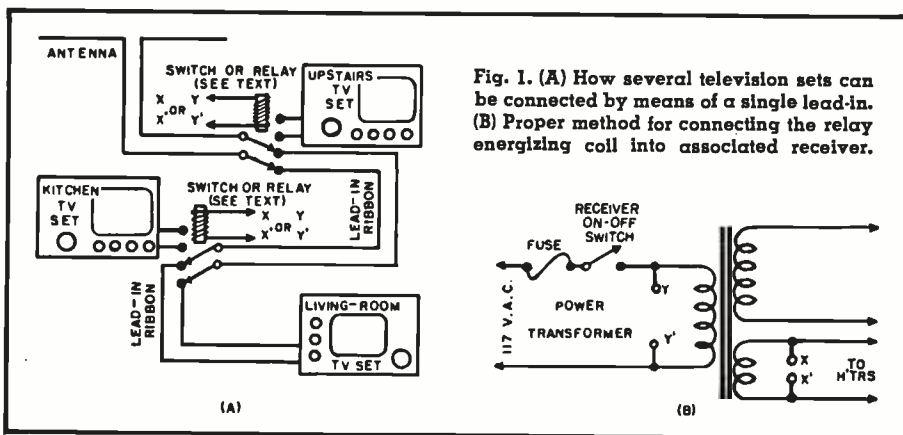

Fig. 1. (A) How several television sets can be connected by means of a single lead-in. (B) Proper method for connecting the relay energizing coil into associated receiver.

PHILADELPHIA'S NEW MOBILE UNIT



By
EDGAR P. GRIM
 Chief, Electrical Bureau
 City of Philadelphia

Over-all view of external equipment on truck, including p.a. system for disaster service. External feeder service is employed if power is available, otherwise generator unit is used.

THE City of Philadelphia, recognizing the importance of uninterrupted communications during emergencies, has acquired a unique mobile communications unit which could well serve as a model for other communities.

Like most large cities, Philadelphia has modern, up-to-date fire and police department communications systems. But, like other large cities, these systems are subject to interruption in case of a major disaster. To insure continuity of communications, the Philadelphia Electrical Bureau and the Philadelphia Civil Defense Council have planned a complete, self-contained mobile communications center for the city.

After months of study, planning, and construction, the city is now provided with the most complete mobile communications center ever devised. It is equipped to handle the entire fire and police communications system from any point within the City of Philadelphia, as well as Civil Defense messages.

The mobile unit is self-supporting in its operation. It has its own 15,000 watt power plant. It is equipped with heating and air-conditioning units, incorporates four powerful movable searchlights on its roof, and carries its own public address system. The unit has fire and police two-way mobile units; fire and police two-way station units; and three bands on the amateur frequencies, thus permitting communications with other cities and towns throughout the United States.

On the left-hand side of the truck, looking from the driver's seat, is the bank of two-way ham equipment which permits coverage of the 2, 10, and 75 meter bands. Anthony Repici, superintendent of radio, is shown making operational tests on this gear. The Bell System two-way radiotelephone equipment, with which the truck is equipped, is also visible in this photo.

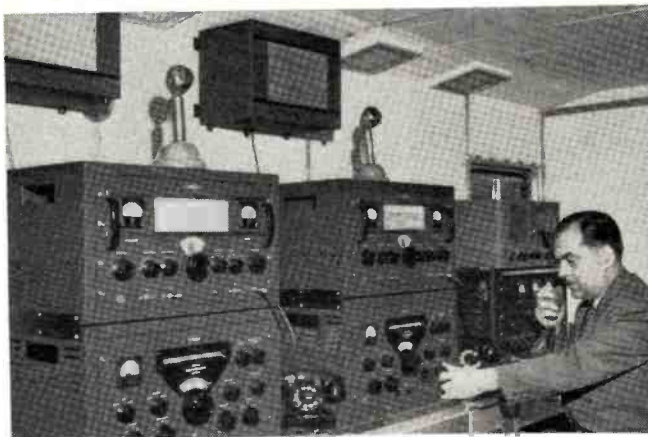

March, 1953

A mobile communications center that "has everything" needed for disaster service.

It is also equipped to permit two-way communications with airplanes and has *Bell* two-way equipment and facilities for handling 16 telephones from the telephone company's stations to the unit.

Since the unit was put into operation on May 17, 1952 it has responded to thirty-seven three-alarm fires and has participated in seven Civil Defense demonstrations.

The unit is operated by members of the Fire Alarm Communications Division under the direction of the author. It is used by the chief of the fire department as his headquarters at the scene of all major fires with the unit's p.a. system being employed to direct personnel and companies to the most advantageous points for fighting the conflagration.

Should you be in Philadelphia and if you should happen to see the "500" on the fire ground, do not hesitate to come in and look us over. If we can be of any help in assembling or disseminating technical information, we will be glad to do so.

Other communities may wish to follow our basic plan for setting up such a communications center or may wish to adapt certain features to their own requirements. —30—

Right-hand side of truck houses two consoles for fire and police mobile system. On top of desk is police base transmitter and receiver, fire transmitter and receiver, and CAA transmitting console. Above is receiver for air-to-ground communications. At extreme right is p.a. amplifier. Note the sound-proofed wall construction that has been incorporated in truck.

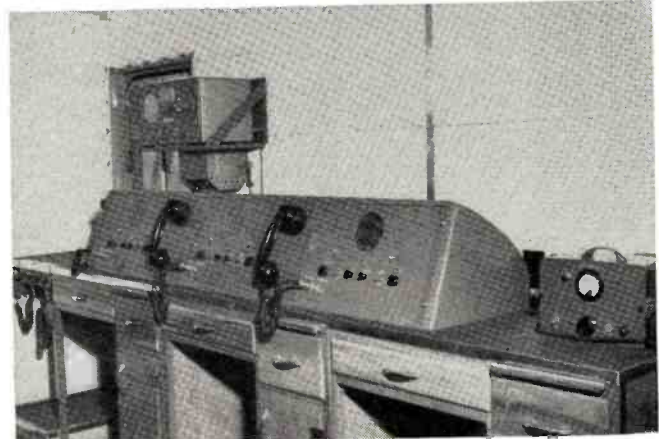

BUILD THIS ELECTRONIC FLASH

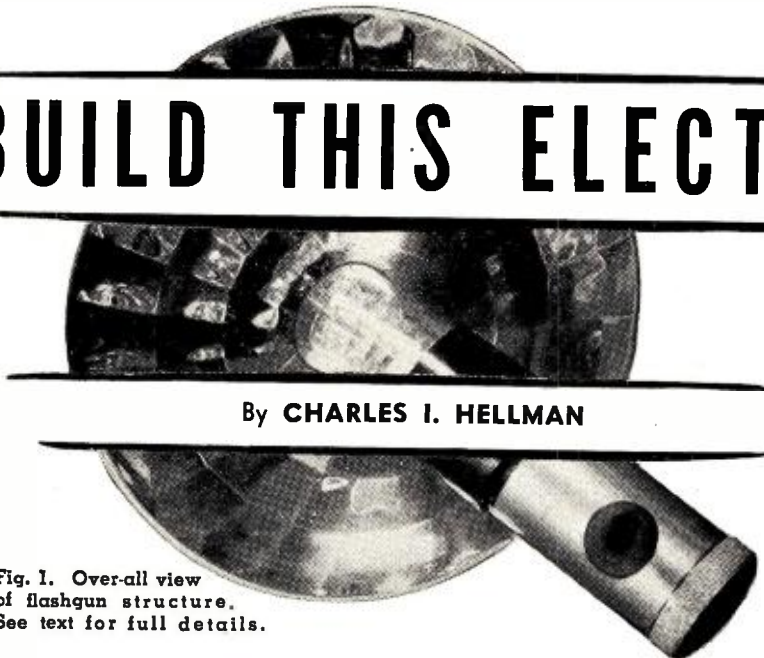

By CHARLES I. HELLMAN

Fig. 1. Over-all view of flashgun structure. See text for full details.

Details on a simple unit using the new low-voltage flash bulbs and related components. Gives 100 watt-sec. flash.

CARLOADS of flashbulbs are sold every year to enthusiastic users. Professionals and amateurs alike have learned that the flashbulb makes possible picture-taking in almost any circumstance. The electronic speed-flash offers two telling advantages so that more and more photographers are turning to it. First, it uses the same bulb for thousands of flashes. Ten-thousand flashes have been exceeded by many lamps. Further, the light pulse is only of one or two thousandths of a second duration. Consequently, even cameras with slow shutter speeds are given effective exposure of less than 1/1000 sec.

Advantages of This Unit

This unit is built around recent advances in components that have made possible new standards of efficiency, portability, and economy. Battery or a.c. operation is conveniently available by means of plug-in units.

Sprague has fabricated new low-loss electrolytic condensers that have phe-

nomenal capacitance ratings in small volume. The *Sprague* Type FF-1 condenser packs 525 μ d. into a cylinder 2 $\frac{1}{8}$ inches in diameter by 4 $\frac{1}{16}$ inches long. It weighs only 11 ounces and has a working voltage of 450 volts d.c.

Kemlite has perfected a speedlamp

EDITOR'S NOTE: The voltages present in this unit are about the same as those found in many radio sets. Use the same precautions in handling this gear. Before checking the unit, discharge the condensers through a 500 ohm wire-wound resistor. Do NOT short them with a screwdriver as the tip will be vaporized by the high storage energy of the condensers.

of high efficiency at only 450 volts and with the excellent capacity of 100 watt-seconds. Furthermore, the trigger transformer is built right into the tube so that wiring is quite simple, particularly for the high voltage trigger circuit. This new type DX lamp is available through *Sprague* electronic parts distributors as catalogue No. FA-100.

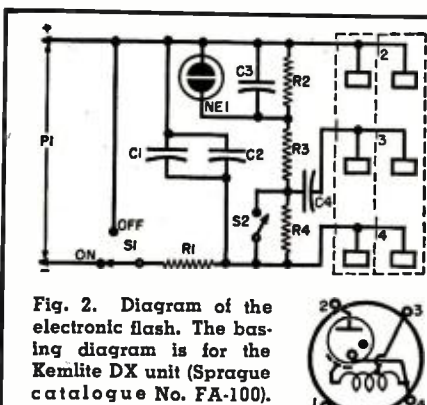

Fig. 2. Diagram of the electronic flash. The basic diagram is for the *Kemlite* DX unit (*Sprague* catalogue No. FA-100).

- R₁—500 ohm, 5 w. wirewound res.
 - R₂—1.5 megohm, 1 w. res. $\pm 5\%$
 - R₃, R₄—3.3 megohm, 1 w. res. $\pm 5\%$
 - C₁, C₂—525 μ d., 450 v. elec. cond. (*Sprague* FF-1)
 - C₃—.05 μ d., 400 v. cond.
 - C₄—.25 μ d., 600 v. cond.
 - S₁—S.p.d.t. switch
 - S₂—S.p.s.t. switch (operated by camera shutter)
 - P₁—Male connector for power supply leads
 - NE₁—Neon bulb (NE-1)
- Parts List for Power Supplies (Fig. 5)
- B₁, B₂—225 v. battery pack (*Eveready* #492)
 - SO₁, SO₂—Female connector
 - S₁—S.p.s.t. switch
 - PL₁—117 volt pilot lamp
 - Rect.₁, Rect.₂—20 ma. selenium rectifier (*Radio* Receptor #16Y1)
 - T₁—Any transformer with sec. voltage of 300 to a maximum of 320 v. (*Stancor* #P6425)

National Carbon Company has made up a "B" type battery pack, #492, supplying 225 volts in a space 5 x 3 $\frac{1}{2}$ x 3 inches. Two of these units are used to give a high voltage supply of 450 directly, without the use of multipliers. The battery supply will deliver about 1500 flashes, at a cost of less than one cent per flash.

These components make possible the design of a speedflash of 100 watt-seconds that outperforms many high voltage units of greater watt-second rating. The higher efficiency results from the use of the high-value storage condensers which increase the flash duration. This insures more effective use of film speed and contrast. Older speedlamps used shorter pulse times which changed the film contrast, requiring considerable overdevelopment to get any useful contrast.

Furthermore, by the use of plug-in units, the speedflash is instantly convertible to battery or a.c. operation.

Finally, the speedflash provides for the use of one or two speedlamps. Poor photographic quality often accompanies the use of a single lamp. The use of two lamps makes possible flash pictures of studio quality.

How Speedlamp Works

Speedlamp uses the pulse technique employed by radar. A large condenser is charged in several seconds to about 450 volts. The condenser is then discharged into a glass tube filled with xenon under pressure. A high voltage from the secondary of a tiny ignition transformer is applied to the tube initiating the discharge of the condenser.

Since the condenser is discharged through the flashtube in about a thousandth of a second, the power is enormous for the short interval, producing the brilliant flash of light that is characteristic of speedflash. The color temperature of the light approximates daylight and is bright enough to make possible camera exposures with small lens apertures. Color films of the daylight type need no filter except for the most critical uses, such as magazine food illustrations, etc.

Building the Basic Unit

The basic unit is built into a plywood box as shown in Figs. 3 and 4. The circuit is shown in Fig. 2.

C₁ and C₂ are the storage condensers. R₂, R₃, R₄ form a voltage divider network for C₃ and C₄. C₃ is used with the small neon lamp to indicate when the storage condensers are adequately charged. The neon lamp begins to blink when the condensers are sufficiently charged. C₄ supplies about 250

volts to pulse the ionization transformer.

R_1 limits the charging rate to C_1 and C_2 , de-ionizes the flash after the condensers are discharged, and also removes the charge on the condensers when S_1 is in the "off" position.

The flashlamps are connected to the power pack with three-prong connectors. The lamps use standard four-prong sockets which are built into any suitable reflector as shown in Fig. 1.

Most synchronizing cords use a standard two-prong line type male plug which fits the female socket in the unit.

All parts are mounted on the panel, except for C_1 and C_2 which are mounted in the box.

The simplicity of the circuit gives the builder considerable latitude in housing the components. The dimensions given are intended as a guide. The unit shown in the photographs was made by a teen-age enthusiast using the simplest tools and is giving a good account of itself.

Powering the Unit

The battery pack is mounted as shown in Fig. 6. It is important to adhere to the polarity markings shown in the diagram, Fig. 5 (right). No other construction work is required.

The diagram for the a.c. pack is shown in Fig. 5 (left). It is advisable to test the output of the pack for voltage and polarity before inserting it into the basic unit. The output voltage should never exceed 450 volts, even at peak line voltage conditions. The a.c. pack is shown in Fig. 7.

The *Stancor* P6425 transformer was not available at the time this unit was constructed. The large surplus transformer shown was used temporarily. It is larger than necessary but worked satisfactorily. The exposed connections were taped over before use.

Flashgun

The flashgun is made by mounting a standard four-prong socket into a support. The actual method will depend on the preference of the builder. The unit shown in Fig. 1 shows the base mounted into part of an old flashgun. The diameter of the metal tubing was sufficient to make a snug fit of the socket. The screw base of the gun was retained to mount the gun on the usual flash bracket.

A universal clamp fitted to a second flashgun makes a versatile two-lamp unit.

Three-wire cable is used to connect the gun to the three-prong *Jones* plug.

Using the Speedlamp

Synchronization of this unit is designed for "X" type or zero delay shutters. This method is used as it is the most reliable type. It is accurate at any shutter speed and never needs adjustment.

Battery Operation

Insert the battery plug-in unit. Connect the synchronizing cord to the

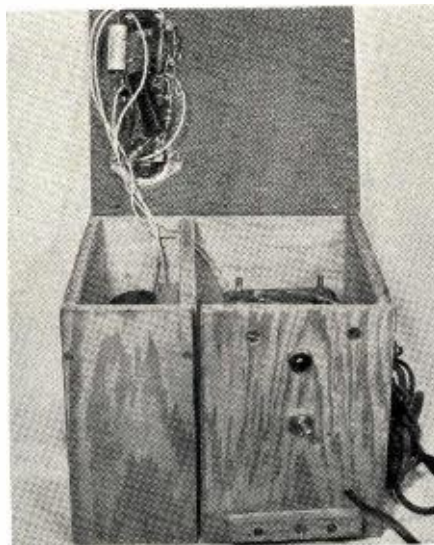

Fig. 3. View of electronic flash cabinet. The storage condensers are in left compartment. The a.c. plug-in unit is shown in place in the right-hand compartment.



Fig. 4. Over-all view of complete unit. The cabinet measures 7"x6 1/8"x6 3/4". The 450-volt battery pack weighs 8 1/2 pounds and will provide approximately 1500 flashes.

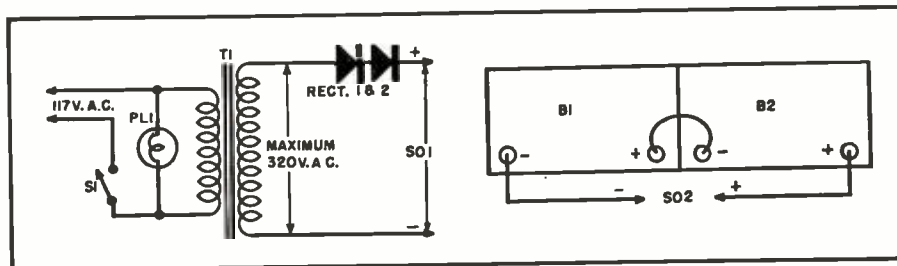

Fig. 5. (Left) Circuit diagram of the a.c. power supply. (Right) The battery pack.

speedflash and camera. Throwing switch S_1 to "on" connects the battery to the condenser. The neon lamp should blink after several seconds. The first time the unit is used after the condensers have idled for several months, this may take about a minute. It soon drops to 5 seconds or so. The blinking neon indicates that the condensers are sufficiently charged for picture taking. Set the lens aperture according to the guide numbers in Table 1. The camera shutter is now released, firing the speedlamp and exposing the film. The neon will go out for several seconds and then glow again giving the "go-ahead signal" for another exposure. The switch should

Film (ASA Rating)	Super XX*	Plus X*	Daylight Kodachrome
	100	50	10
Unit with one lamp	160	120	35
Unit with two lamps	120	80	25

* Developed normally in D76.

Table 1. Guide numbers for different films.

be turned to the "off" position when the picture session is over.

A.C. Operation

This type of operation is particularly useful in the home or studio where power outlets are readily available. Simply plug the a.c. pack into the
(Continued on page 90)

Fig. 6. How the battery pack is mounted.

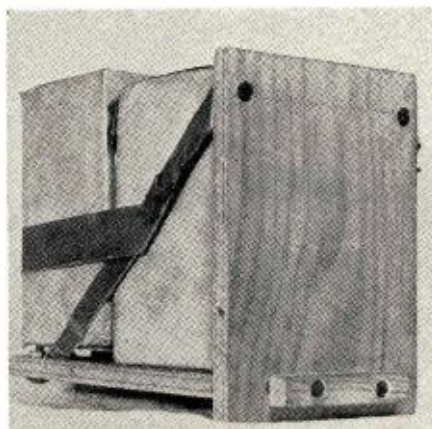
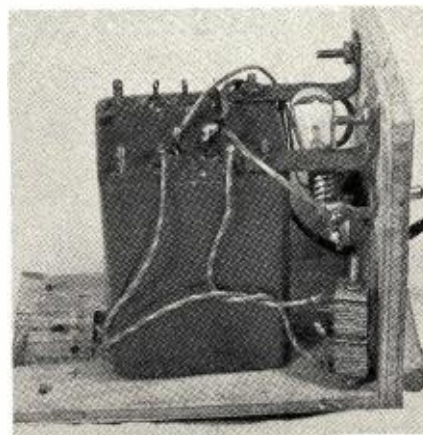

Fig. 7. The a.c. power pack in place.



U.H.F.

ANTENNAS

By

MILTON S. KIVER

Pres., Television Communications Institute

TRANSMISSION lines in common use at v.h.f. frequencies include a 450-ohm open-wire line (Fig. 2), 300-ohm flat and tubular lines, and two coaxial cables, the RG-59U and the RG-11U. See Fig. 1. At 100 mc., the signal-loss-per-100-feet of the open wire line is .35 db, in the 300-ohm lines it is about 1.2 db, in the RG-11U cable it is 1.9 db, and in RG-59U, it is 3.7 db. The open wire line has, by far, the lowest attenuation and, as such, is eminently suited for fringe area installations. Unfortunately, this line is the most difficult one to work with physically and for that reason is not used more widely. Its 450-ohm impedance is somewhat of a hindrance, too, since most antennas and receivers are designed for 300 ohms. However, this is not as serious as you might at first believe. There are practically no television receivers whose input impedance remains constant at 300 ohms for all channels. (The same is true of the so-called 300-ohm twin-lead or 300-ohm antennas.) Thus, simply connect-

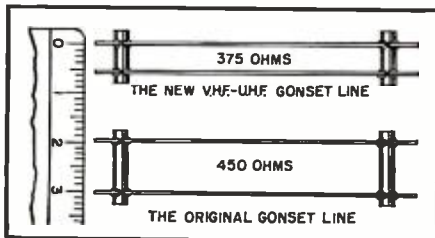

Fig. 2. Two types of transmission line made by Gonset. See text for additional details.

Table 1. Transmission line losses (in db per 100 ft.), as measured by Sylvania Electric.

TYPE	100 MC.		500 MC.		1000 MC.	
	WET	DRY	WET	DRY	WET	DRY
450-ohm open wire*3578	...	1.1
300-ohm tubular.....	2.5	1.2	6.8	3.0	10.0	4.6
300-ohm flat.....	7.3	1.2	20.0	3.2	30.0	5.0
RG-59U	3.7	3.7	9.4	9.4	14.2	14.2
RG-11U	1.9	1.9	5.0	5.0	7.6	7.6

*Estimated values—unknown for wet conditions.

Fig. 1. Four types of transmission lines used in v.h.f. and u.h.f. installations. (A) RG-59U cable, (B) the RG-11U cable, (C) a 300-ohm flat line, (D) 300-ohm tubular.

Part 4. Concluding article covers suitable transmission lines for u.h.f. and practical installation suggestions.

ing the 450-ohm line to the receiver will frequently (although not always) give you as good results as you would obtain by carefully matching the line to an impedance transformer and then making the connection to the receiver.

Recently, a 375-ohm open-wire line was announced. This brings the line impedance closer in value to the standard 300-ohm receiver input and it is doubtful whether a matching network will ever be required with it.

The 300-ohm flat line is the one most extensively employed at v.h.f. frequencies because it is economical, it matches receiver input impedances directly, and its attenuation is comparatively low. In areas where the surrounding noise is high, use of the unshielded open-wire or 300-ohm lines becomes impractical and one of the coaxial cables must be employed.

With increase in frequency to the u.h.f. band, line db attenuation rises, too. Thus, at 500 mc., the open-wire line loss mounts to .78 db, the 300-ohm line loss becomes 3.2 db, RG-11U attenuation increases to 5.0 db and RG-59U loss reaches the rather high figure of 9.4 db. Comparative figures at 500

mc. (near the start of the u.h.f. band) and at 1000 mc. (near the end) are given in Table 1 and it can well be appreciated how carefully the amount of line needed must be reckoned in order that no more than necessary be employed.

An interesting sidelight on line attenuation is the rapid rise in this value in unshielded lines when they become wet. The 300-ohm flat line appears to be most vulnerable in this respect, jumping from a value of 3.2 db (at 500 mc.) when the line is dry to 20.0 db when it becomes wet. What this rise would do even to a strong signal is quite obvious. The 300-ohm tubular is considerably better and hence would be more desirable for installation purposes. No data is available on the attenuation increase in wet 450-ohm open-wire lines although it is not considered to be appreciable. Shielded cables, such as the RG-11U and RG-59U, are not affected at all by inclement weather.

On the newer 375-ohm open-wire line, the manufacturer states that the attenuation rises to 3.1 db from a dry value of 1.9 db. This is at 500 mc. At 1000 mc., both wet and dry line attenuation increase by about 50 per-cent.

The reason for the lower attenuation of the 300-ohm tubular line when it becomes wet is explained by the manufacturer as follows. See Fig. 4. In the flat twin-lead line the field of energy exists, in large measure, outside of the polyethylene ribbon and hence will be affected by dielectric changes such as coating the ribbon with water. Other agents which also

have an effect on line attenuation include snow, salt spray, and dirt.

In the tubular twin-lead, the polyethylene plastic is shaped so that the field of energy set up between the two conductors is largely confined within the surface of the plastic. This thus prevents changes in atmosphere conditions from affecting the line to the same extent as the flat twin-lead.

EDITOR'S NOTE: A new type of tubular line for u.h.f., developed by RCA, is being manufactured by the Anaconda Wire and Cable Co. The line has approximately 270 ohms impedance and attenuation of 3.6 db per 100 feet at 500 mc. and 5.1 db per 100 feet at 900 mc. both wet and dry.

An important factor in keeping over-all attenuation down is the careful routing of the line from antenna to receiver. This is especially true in the case of unshielded lines. Keep the line away from gutters, pipes, or other metal objects as much as possible. Avoid sharp bends in the line. If a bend must be made, have it occur gradually. Finally, secure the line tightly by means of stand-off insulators so that it does not sway in the wind or otherwise alter its position.

Impedance Matching

While it is frequently unnecessary to carefully match 450-ohm impedances to 300-ohm impedances, the same is not true when a 75-ohm impedance is to be connected to a 300-ohm impedance. Here a careful match should be made because of the great disparity between the two values and also because 300-ohm impedances are usually balanced while 75-ohm impedances are not.

A favorite matching device is the elevator transformer. This unit first appeared in v.h.f. receivers and possessed the form shown in Fig. 3. Its purpose was to match the receiver input circuit (which has an impedance of 300 ohms) to either a 300-ohm twin-lead or a 75-ohm coaxial cable.

The elevator transformer consists of two sets of coils as shown in Fig. 5. One set of coils (L_1 and L_2) is closely wound on one form and the second set of coils (L_3 and L_4) is placed on another form. Electrically, each set of coils can be considered as a transmission line having a characteristic impedance of 150 ohms and a length of approximately one-quarter wave at the lowest operating frequency.

Now, if it is desired to match a 75-ohm line to one end and a 300-ohm input circuit impedance to the other end, we would connect the two sets of coils as shown in Fig. 7A. At the 75-ohm end the two coils are connected in parallel. Thus, two 150-ohm impedances in parallel produces a resultant impedance of 75 ohms.

At the other end of the coils, they are connected in series, producing the necessary 300 ohms.

If there are 300 ohms at both ends, the coil arrangement would be as shown in Fig. 7B. Now both ends are connected in series. Finally, a 300-

ohm line can be matched to a set having a 75-ohm impedance as shown in Fig. 7C. Now, it is the input ends of the lines that are connected in series and the output ends that are in parallel. The impedance at one end can be balanced while it is unbalanced at the other end and the match is still effective. Or both ends can be balanced or unbalanced, as desired.

While the elevator transformer (in v.h.f. applications) uses coils that function as transmission lines, it is perfectly possible to achieve the same results using suitable transmission lines. (Transmission line lengths at v.h.f. frequencies would be too cumbersome to be handled readily. At u.h.f. frequencies, however, line length is only on the order of 5 inches or so.) Fig. 6 illustrates how two quarter-wave sections of 150-ohm twin-lead line can be connected to match a 75-ohm impedance at one end to 300 ohms at the other. Following the above discussion, all the other combinations can be obtained as well.

U.H.F. Antenna Installation

The job of locating the best position for the u.h.f. antenna follows closely the present v.h.f. practice of probing. That is, one man will remain at the receiver while a second man will take the antenna, with lead-in, to the roof. The lead-in is then run loosely from the antenna to the receiver following the most likely route of the final installation.

After the lead-in has been connected to both the probing antenna and to the receiver, the set is turned on. The controls should be adjusted so that a picture will be produced if a signal is received. Simultaneous work is now begun by the man on the roof with the unmounted antenna and by the man at the receiver. A two-way communications system enables them to talk with each other.

The man on the roof moves the antenna to various positions and the man at the receiver judges each position in terms of relative signal strength and

Fig. 5. The elevator transformer of Fig. 3 consists of two sets of coils. L_1 and L_2 form one set, L_3 and L_4 the other set.

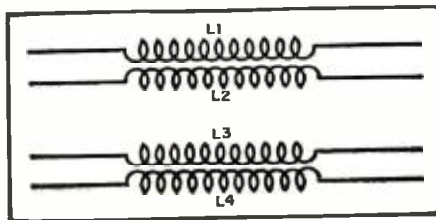

Fig. 6. An elevator transformer using sections of actual transmission lines. This device is widely used on the u.h.f. bands.

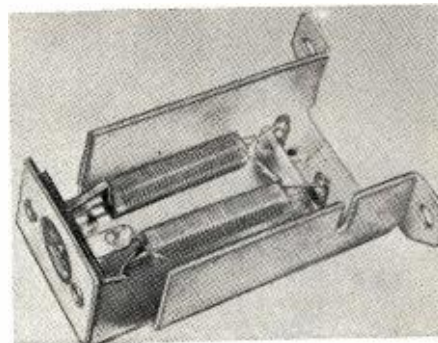
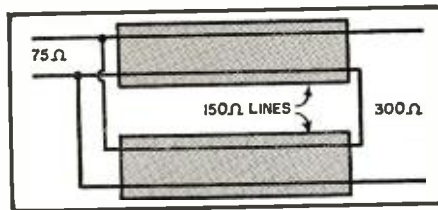

Fig. 3. An elevator matching transformer as used in v.h.f. television receivers.

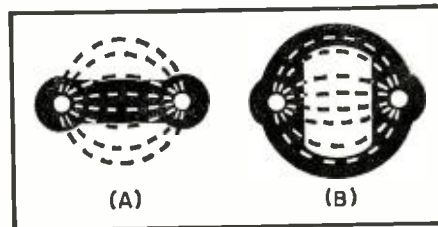

Fig. 4. (A) The field of energy in the flat twin-lead line is largely exposed to weather conditions. (B) In the tubular twin-lead, the field of energy is contained by the tubular construction of the line itself.

picture quality. After all likely and accessible areas of the roof have been probed, the most promising locations are re-tested, until the best single location for the antenna is found.

Experience has shown that where the incoming signal is received directly from the transmitter, a certain amount of leeway in position is possible. This may permit the u.h.f. array to be mounted on the same post holding up the v.h.f. antenna. On the other hand, when the signal is a reflected one, it has been found that position tends to be quite critical. In fact, in the short distance of only six inches, the signal intensity can fluctuate con-

(Continued on page 78)

Fig. 7. Various impedance combinations obtainable with the elevator transformer. See text for details on different connections.

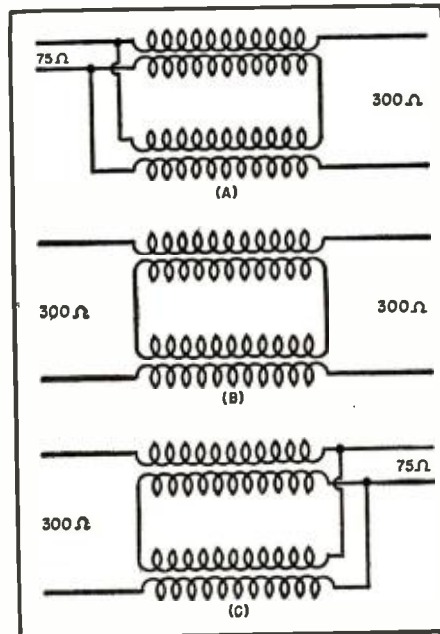

A HAM SHACK

FREQUENCY

STANDARD

By

RICHARD GRAHAM, W1VJV

FOR THE serious ham and experimenter, an accurate method of frequency measurement is an indispensable aid. A frequency standard, along with voltmeters and ohmmeters, is one of the essential tools of the trade. One wouldn't expect to see a carpenter work without the aid of a rule, level, or square, yet many of us continue to hobble along without the electronic equivalents of these basic tools.

Some method of frequency measurement is a legal requirement for the ham. The letter of this law is usually fulfilled by the station receiver. However, the spirit of the law, which was intended to keep all radio services within their assigned bands, is really not fulfilled. This is verified by the continuous and apparently unending stream of pink tickets issued by the FCC. Thus for the ham who likes to work close to the band edges in an effort to find a hole in the over-crowded spectrum, something capable of a higher order of precision is necessary.

As with most all basic tools, there are a host of other uses for this device. Its use in calibrating and maintaining the calibration of the station v.f.o., the grid-dipper, receivers, and signal generators, etc., will soon make you wonder how you did without it for so long!

The unit described provides a selective output consisting of marker frequencies every 1000 kc., 100 kc., and 10 kc. These marker frequencies, which naturally decrease in strength with increasing frequency, are "strong" up to and beyond 30 mc. Of course the word "strong" is a relative term that can mean almost anything, depending on the receiver used, etc. However on the writer's receiver, which incidentally is of the most inexpensive variety, the harmonics of even the 10 kc. multivibrator were definitely in the S9-plus class even at 30 mc. Furthermore, this is accomplished without resorting to any tuning or peaking of the output.

A second switch is provided on the

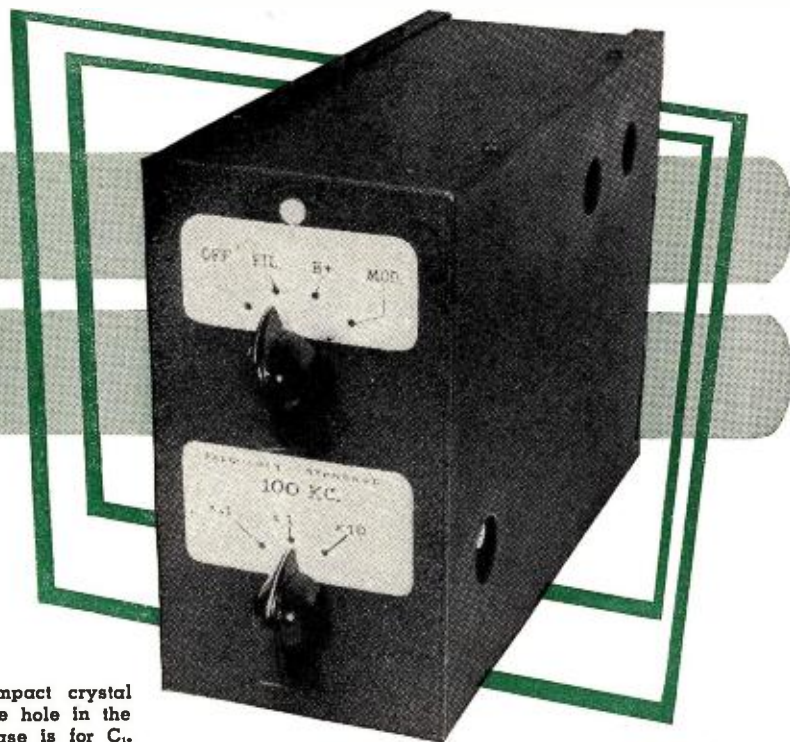

The neat, compact crystal standard. The hole in the side of the case is for C₁.

Check points every 1000, 100, and 10 kc. will let you make full use of crowded bands and avoid "pink tickets".

front panel of the frequency standard to: 1. turn the a.c. to the unit off; 2. turn on the heaters only so that the standard is always ready for instant use; 3. turn on "B-plus," thus placing the unit in operation; 4. modulate the output with a heavy and distinctive 60-cycle note for identification of the frequency standard's output markers. This is particularly helpful in today's crowded amateur bands, since the 60-cycle note is readily identified and differentiated from the mass of other signals on the bands.

The heart of any frequency standard is the crystal. The crystal chosen for use in this unit is a dual-frequency crystal capable of oscillating at either 100 kc. or 1000 kc. depending upon the inductance switched in the circuit. Admittedly this type of crystal is more expensive than most others; however, it has certain other advantages which tend to make the total construction cost no more or possibly even less. Namely, if one purchased a 100 kc. crystal, to produce 1000 kc. markers it would be necessary to use an additional multivibrator, thus adding the cost of another tube and its associated circuit components to the total construction cost. By using a dual-frequency crystal, the oscillator performs both functions directly.

The 1000 kc. harmonics are used for identification of the 100 kc. harmonics only. That is, the 100 kc. mode of oscillation is the position actually used for frequency measuring. The 1000 kc. signals serve to identify the 100 kc. harmonics that coincide with the 1000

kc. harmonics. This is not meant to infer that the 1000 kc. markers are grossly inaccurate. It simply means that the 1000 kc. harmonics are not of the same precision as the 100 kc. signals. Even so, the accuracy of the 1000 kc. harmonics is better than .05% at room temperature. The oscillator in the 100 kc. position is adjusted to zero beat with WWV and any drift experienced will be negligible for most ordinary applications. The drift due to heating in the 100 kc. position is .001%/°C, an insignificant amount except for the most critical applications. However, to make the standard as stable as possible in this respect without going to any extremes, the crystal was mounted below the chassis. Thus when the unit is in the cabinet, the aluminum chassis serves as a sort of heat shield, conducting the heat from the tubes back out to the cabinet to be dissipated.

The oscillator circuit (see circuit diagram) is actually a modified form of the simple tuned-plate type of crystal oscillator circuit, in which the feedback at 100 kc. is aided by the r.f. of the plate circuit flowing through the a.c. divider formed by condensers C₃ and C₄. The screen grid of the 12AU6 serves as the plate of the oscillator. Since it is desired to make the output as rich in harmonics as possible, both the grid-leak resistor and plate resistor of the oscillator tube are larger than what might be considered normal. The oscillator output becomes a series of clipped-off pulses which are very rich in harmonics.

However, because of the high value of the plate resistor the oscillator output is quite low and the usable harmonic output dies off somewhere around 20 mc. Thus it becomes necessary to amplify the oscillator output. A 50B5 is used as the harmonic amplifier. This tube is admirably suited for this application because of its low cost, high transconductance, and its relatively low internal capacitances even though it was intended for audio work. This circuit is quite conventional and straightforward and needs little comment except for the modulation.

As stated previously, modulation of the frequency standard's output is very desirable particularly when counting up from the megacycle marker to some 100 kc. marker. This modulation serves to differentiate the frequency standard signal from any other carriers and heterodynes which serve only to confuse the count. Thus by switching the 50B5 harmonic amplifier from d.c. to a.c. direct from the line, we get a signal which is thoroughly disagreeable to the ear. Although this may sound unusual, such a note serves to make it all the more valuable for identification purposes. Experiments were performed using a nice 800-cycle sine wave for modulation. It was very nice sounding but it also was very easily confused with a heterodyne when attempting to identify the standard signal. The 60-cycle voltage, when applied to the screen, results in a modulation waveform similar to that of an unfiltered half-wave rectifier output and is guaranteed to be easily identified as the signal emanating from the frequency standard.

The 10 kc. markers are locked to the 100 kc. oscillator by using a synchronized multivibrator. The multivibrator using a 12AU7 double triode is quite conventional except for the fact that the synchronizing signal and multivibrator output are taken from the same point, i.e., pin 7 of the 12AU7 multivibrator. This method reduces the switching requirements and also cuts down on the harmonic amplifier grid-circuit-to-ground capacity. This capacitance has a very marked effect on the higher order harmonic strength. Thus in the construction of this unit it is advisable to keep the oscillator plate-circuit wiring and the harmonic amplifier grid-circuit wiring up off the chassis and to make the leads as direct as possible. The potentiometer R_{10} in the grid circuit of the multivibrator is provided to adjust the frequency of the multivibrator to 10 kc. The exact adjustment will be described in detail later. The switch S_2 opens up the cathode of the 12AU7 thus disabling the multivibrator when the frequency standard is used on 100 and 1000 kc.

The power supply is basically an a.c.-d.c. type supply using a 65 ma. selenium rectifier and it more than adequately takes care of the d.c. requirements of the frequency standard. This supply has the advantage of be-

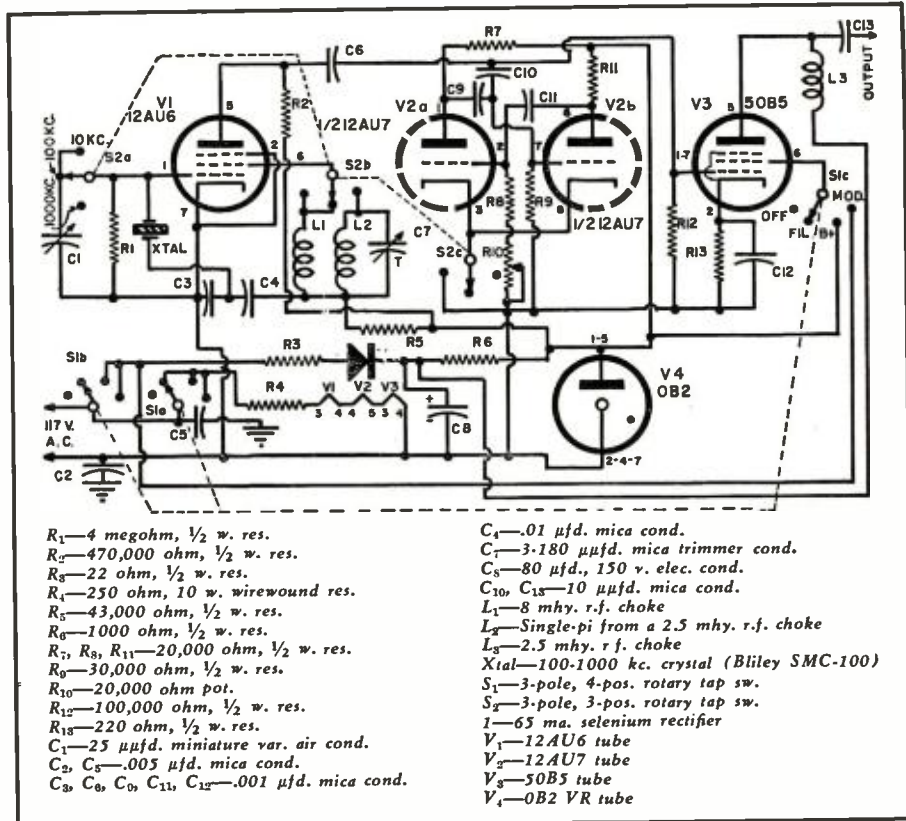

Circuit diagram and parts list for the ham-shack frequency standard.

ing economical, lightweight, and compact. 80 μ fd. worth of capacitance takes care of the filter requirements. An OB2 voltage regulator supplies 108 volts to the oscillator, multivibrator, and screen grid of the 50B5. This voltage regulation helps to further stabi-

lize the unit. It was included more for the multivibrator than for the crystal oscillator itself. This is because the multivibrator free-running frequency is dependent upon the applied plate voltage, among other things. Even
(Continued on page 136)

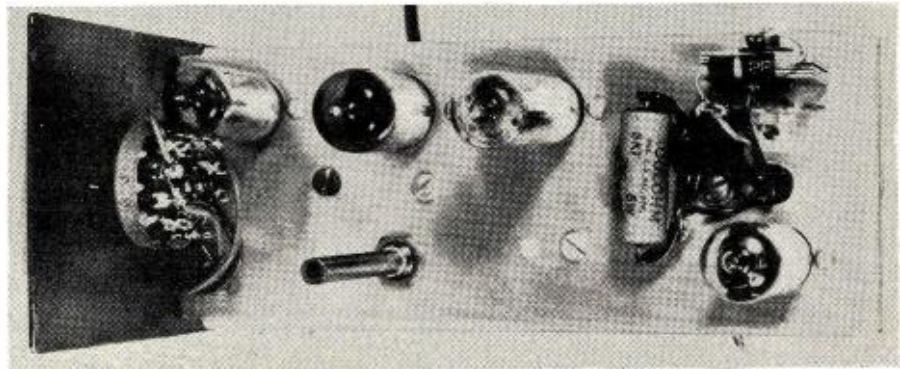

Top view. The tubes are, left to right, 12AU6, 12AU7, 50B5, OB2. The shaft is R_{10} .

Under-chassis view, showing the dual-frequency crystal and compact parts layout.

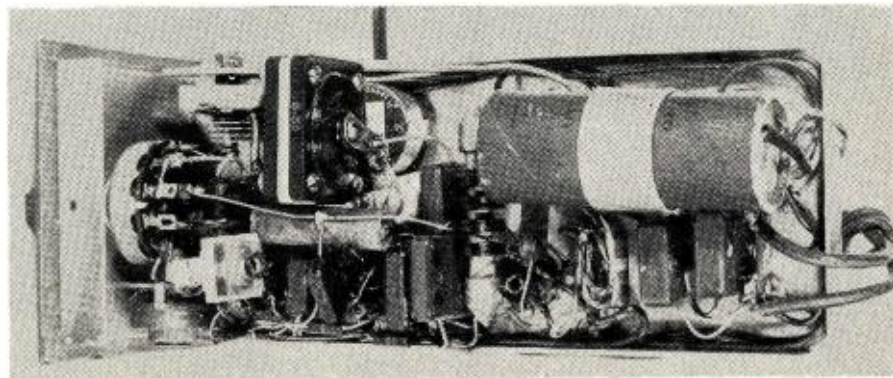

A UNIVERSAL SPEAKER TESTER

By

SIDNEY LENSON

Engr. Dept., Atomic Instrument Co.

and

MARVIN TEPPER

Instr., Mass. Trades Shops School

THE unit to be described can be found in one form or another in many service shops but rarely will you find one as complete and useful as this one.

The unit is economical to build and many of the components can be found in the well-known "junk box". Any investment that has to be made will be repaid manifold in the time it saves in repairing radios, TV sets, and amplifiers.

For example, with this unit in the repair shop it is not necessary to remove the speaker when the set is being hauled in for servicing. This eliminates the possibility of puncturing the cone or otherwise damaging the speaker. The only occasion on which it would be necessary to bring the speaker into the shop would be if the technician felt that the trouble was with the circuit associated with the speaker or the speaker itself.

The outstanding features of this unit include its versatility, the ease with which it can be used, and the few test leads that are required. The unit can be used to replace chokes, field coils, output transformers, speakers, and resistors.

The test speaker may be switched

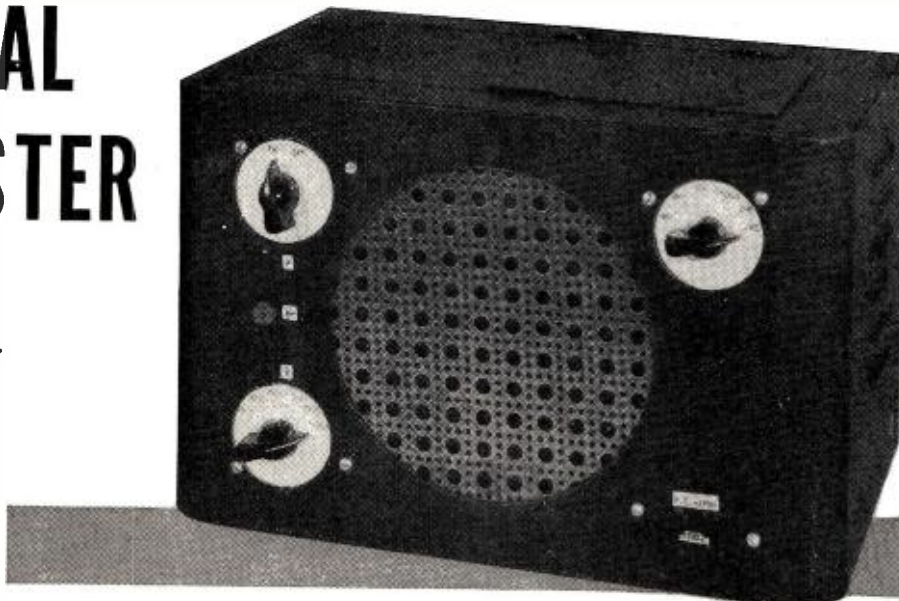

Fig. 1. Over-all view of the home-built test unit. Handlettered dials permit the easy selection of the correct output transformer taps, the function, and v.c. impedances.

Construction details on a handy service instrument which substitutes for chokes, field coils, transformers, etc.

directly to the output transformer in the unit thereby eliminating need for additional leads to an external test speaker.

The primary of the output transformer may be used single-ended or push-pull with either 7000 ohms or 10,000 ohms input impedance. The impedance used will match or closely match all popular output tubes to make it sufficiently universal so that no appreciable difference in quality or power will be noticed. For single-ended input, pin jacks J_1 and J_2 are used. Push-pull input is obtained by connecting J_2 for "B+" and jacks J_1 and J_3 to the tube plates. The input impedance is determined by checking with the tube manual.

The output of the transformer in the test unit is switched by means of S_2 to give either the best match or the desired match.

Setting switch S_2 to "Direct" connects the built-in test speaker directly to the output transformer. By turning the switch to "V.C.", the voice coil of the test speaker is switched to the output terminals, allowing use of the speaker for purely test or substitute purposes.

The speaker in the test unit is a 7" PM job with a large magnet so that it will reproduce with good quality when used with high power consoles, auto radios, and amplifiers. The value of the substitute field and choke may vary.

The unit described was constructed primarily for radio work but an alternate circuit for use in both radio and TV servicing has been incorporated for those seeking this type of test instrument.

The unit is designed so that at all times the choke is placed first in the filtering circuit to provide high a.c. reactance to the ripple frequency. Should the d.c. resistance of the field or choke in the set be larger than the choke in the unit, series resistors can be switched in by means of S_3 until the correct or nearest value is obtained. The value of the total resistance is not critical.

A substitute field and choke circuit (shown dotted on the schematic) is provided if required. By bringing the last resistor of the network out to a pin jack on the front panel, the resistive network, including the choke, can be used as a voltage divider network. With this application in mind, 20 watt resistors were used to prevent overheating. (Continued on page 78)

Fig. 2. Complete schematic diagram of unit. Notice that alternate circuits are provided depending on whether service work is primarily radio or radio and TV combined.

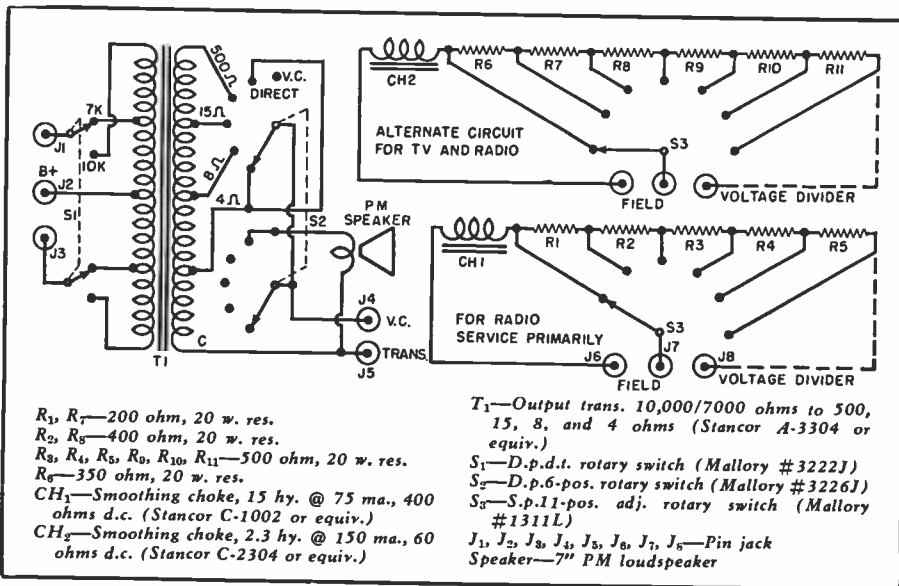

FUN WITH A HOME-BUILT ELECTRONIC ORGAN

By
JIM KIRK, W6DEG, W6JKX

HERE is a new musical novelty which can provide endless hours of enjoyment and entertainment. It consists basically of an "organ" section of 64 notes for playing regular organ chords, and a "melody" or "solo" section of 23 notes, played one note at a time. The "melody" section has a *vibrato* control and a 5-position switch for obtaining various tonal effects.

You can have lots of fun with this rig once it is built and adjusted. You can even have fun building and adjusting it—but that is another story. You don't have to be a musician to enjoy playing this organ—you don't even have to know how to read music. The melody attachment is a cinch for anyone to play with one finger and by ear. It sounds good alone, with the *vibrato* turned on. Of course, to make it sound really good, you need to add chords for harmony but they can be easily learned. There are many schools that will teach you, by mail, to play the piano the modern way. They will generally teach you how to read the melody line, play octaves with the right hand, and add chords with your left. This wasn't the way I learned but several radio customers have shown me various mail order courses that they have used.

With this outfit you play one note at a time with the left hand and add chords with your right, that is, if you want to use the melody attachment. You can leave it turned off or omit it entirely and play the outfit in the orthodox way—if you are a musician.

In the author's opinion you will want to use the melody section, accompanying it by chords on the other section. The *vibrato* dresses it up and the tone colors add variety. The big improvements over my former instrument ("An Electronic Musical Novelty," August, 1950 issue of *RADIO & TELEVISION NEWS*) are the *vibrato* and tone color on the solo section and improved tone on every note, and the addition of a volume control on both sections. The improved tone is especially noticeable on the low notes. They formerly sounded hard and raspy but are now deep and sonorous.

When I entertain friends with this outfit, I often play one piece three ways. I generally use the telephone because I can play to many who can not



The complete unit ready for action. The piano bench, which was removed so that the speakers could be seen, normally slides under control panel and the volume paddles.

Details on a novel instrument which can provide some interesting tonal effects for a modest cash outlay.

visit me in person. I tell them, over the mike, that I am going to play the piece three ways—and for them to take their pick. First I play it as an organ solo. I use tone color number three and lots of volume on the melody attachment to make it stand out. The organ chords are in the background. Then comes a "saxophone solo accompanied by organ." I use tone color number four and not so much volume because it is not required, but enough to make it stand out over the organ chords. Then I use low volume on both melody and organ and sing into the mike. The *vibrato* is used all the time because there is no point in not using it. The *vibrato* switch is turned to "off" when originally tuning to "center frequency."

The reason for choosing 23 notes to the left of the keyboard is that it just works out right. Those are the notes you will need to provide the melody for all popular songs, including the composition that uses such extremes of low and high notes, "My Heart Cries for You."

This contraption is comparatively inexpensive. All parts used in my old instrument have been incorporated in the new unit. The majority of the additional parts required come from war surplus, although standard parts may be substituted if you don't have access to surplus components.

There is nothing very tricky about building this unit. You need only one contact for each key and no special additional keyboard for the melody attachment. You do not need to be a

cabinet maker to supply a cabinet. Caution! Do not immediately take a crowbar and sledge hammer to your piano! Better do as I did—build the organ up experimentally first. When you get to the point where you think it sounds better than your piano—then go ahead and tear the insides out of the piano. The heaviest part of the piano is the "harp" and you will find that the piano moves around much easier when that is removed. It would, of course, be cheaper and better in the long run if you could find some junk piano which could be used for this construction. How the piano sounds is not a factor at all—just so that the cabinet and keys are in good condition.

The panels are of Masonite and are standard size—three 8 $\frac{3}{4}$ " x 19" and three 12 $\frac{1}{4}$ " x 19". In my experimental organ I used aluminum for the panels because aluminum is easy to work and provides a ground return. I could not buy aluminum panels this time so I used aluminum chassis—but they, too, are gone. A "Mini-rack" style rack holds the panels. Aluminum angle was not available for this rack. Brass was available but it was expensive so I settled for steel angle $\frac{3}{4}$ " x $\frac{3}{4}$ " x $\frac{1}{8}$ ", although steel is hard to saw, drill, and tap.

All panel markings are blueprints and the numbers on each panel refer to drawing numbers. I always have blueprints for everything I build as they are handy for servicing or making future changes.

The volume controls are mounted as close as possible to the tubes they con-

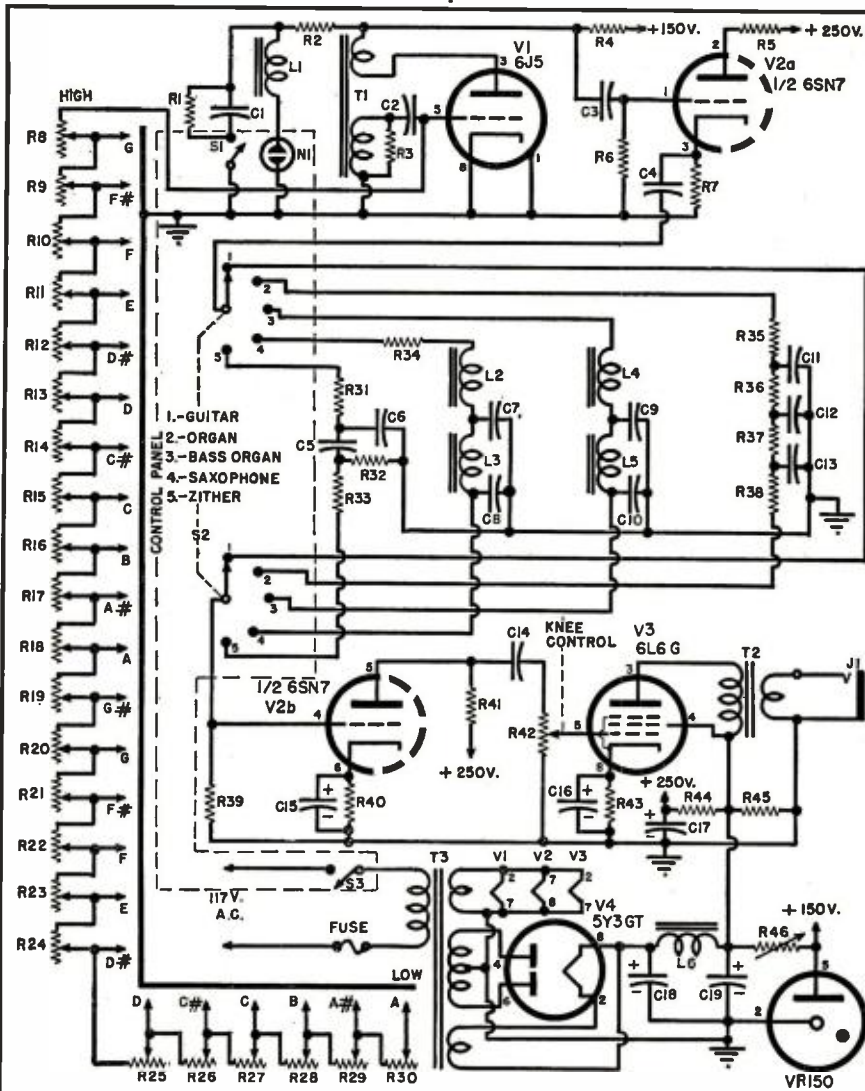

Complete schematic diagram and parts list covering the melody attachment. Although the author used surplus components in his construction, standard parts obtainable from regular radio parts outlets may be used.

- R₁—15 megohm, 1/2 w. res.
- R₂—1 megohm, 1/2 w. res.
- R₃, R₄—100,000 ohm, 1/2 w. res. (in BC 456)
- R₅, R₆, R₇, R₈, R₉, R₁₀—30,000 ohm, 1 w. res. (in BC 456)
- R₁₁—510,000 ohm, 1/2 w. res. (in BC 456)
- R₁₂, R₁₃—1300 ohm, 1 w. res. (in BC 456)
- R₁₄, R₁₅, R₁₆, R₁₇, R₁₈, R₁₉, R₂₀, R₂₁, R₂₂, R₂₃, R₂₄, R₂₅, R₂₆, R₂₇, R₂₈, R₂₉, R₃₀—50,000 ohm pot.
- R₃₁, R₃₂, R₃₃, R₃₄—51,000 ohm, 1/2 w. res. (in BC 456)
- R₃₅, R₃₆, R₃₇, R₃₈—22,000 ohm, 1/2 w. res. (in BC 456)
- R₃₉—500,000 ohm
- R₄₀—600 ohm, 5 w. wirewound res.
- R₄₁—5000 ohm, 10 w. wirewound res.
- R₄₂—20,000 ohm, 10 w. wirewound res. (in BC 456)
- R₄₃—5000 ohm, 10 w. wirewound var. res.
- C₁—25 μfd., 400 v. cond.
- C₂—0.01 μfd., 600 v. cond.
- C₃—1 μfd., 600 v. cond.
- C₄, C₁₄—5 μfd., 400 v. cond. (#5418 in BC 456)
- C₅, C₆, C₇, C₈, C₉, C₁₀, C₁₁, C₁₂, C₁₃—0.06 μfd. mica cond. (in BC 456)
- C₁₅, C₁₆—25 μfd., 25 v. elec. cond. (#5417 in BC 456)
- C₁₇, C₁₈, C₁₉—8 μfd., 450 v. elec. cond.
- L₁, L₄, L₆—#6306 from BC 456 or Stancor A-53-C (use secondary winding)
- L₂, L₃—#6261 from BC 456 or by experiment (see text)
- L₅—Filter choke, 2.3 hy. @ 150 ma. (Stancor C-2304 or equiv.)
- T₁—#6306 from BC 456 or Stancor A-53-C
- T₂—Speaker output trans. 5000 ohms to v.c., Stancor A 3310 or equiv.)
- T₃—Power trans. 372-0-372 v. @ 145 ma., 6.3 v. @ 5 amps., 5 v. @ 3 amps. (Halldorson S-74 or equiv.)
- N₁—NE-51 neon bulb
- S₁—S.p.s.t. switch (Vibrato "on-off")
- S₂—D.p.5-pos. switch ("Tone color" sw.)
- S₃—S.p.s.t. switch (Melody "on-off")
- J₁—Phone jack (to speaker)
- V₁—6J5 tube
- V₂—6SN7 tube
- V₃—6L6G tube
- V₄—5Y3GT tube
- I—VR150 tube

Simplified schematic of main organ. Sixteen audio channels and sixteen volume controls are used to reproduce sixty-four different keys, 4 keys to a channel.

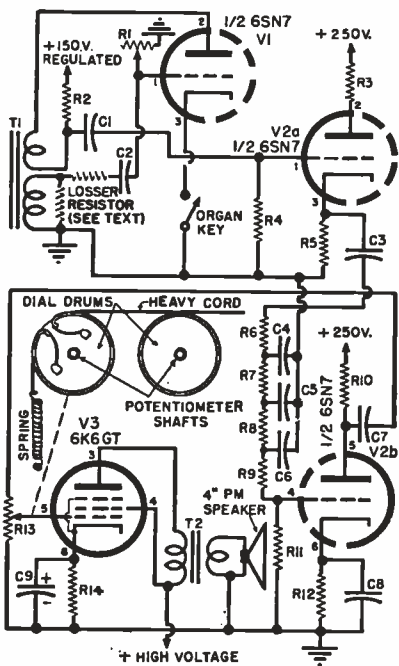

- R₁, R₁₃—500,000 ohm pot.
- R₂—100,000 ohm, 1/2 w. res. (in BC 456)
- R₃, R₇, R₈, R₉, R₁₀—551,000 ohm, 1/2 w. res. (in BC 456)
- R₄—510,000 ohm, 1/2 w. res. (in BC 456)
- R₅, R₁₂—1300 ohm, 1 w. res. (in BC 456)
- R₆—30,000 ohm, 1 w. res. (in BC 456)
- R₁₁—22,000 ohm, 1/2 w. res. (in BC 456)
- R₁₄—600 ohm, 5 w. res.
- C₁—1 μfd., 600 v. cond.
- C₂, C₄—0.01 μfd., 600 v. cond.
- C₃, C₇—5 μfd., 400 v. cond. (#5418 in BC 456)
- C₅, C₆—0.06 μfd. mica cond. (in BC 456)
- C₈, C₇—25 μfd., 25 v. elec. cond. (#5417 in BC 456)
- T₁—#6306 in BC 456 or Stancor A-53-C
- T₂—Speaker output trans., 7000 ohms to v.c. (Stancor A-3878 or equiv.)
- Spkr.—4" PM speaker
- V₁, V₂—6SN7 tube
- V₃—6K6GT tube

Block diagram of the "new" electronic organ. The melody attachment reproduces one note at a time. Has switched vibrato and switched effects. It also has its own speaker and power pack. The main organ has 16 speakers and uses 4 notes to an audio channel. Each audio channel has amplifiers and filters to improve tone. Volume controls on each audio channel are ganged and controlled by the knee.

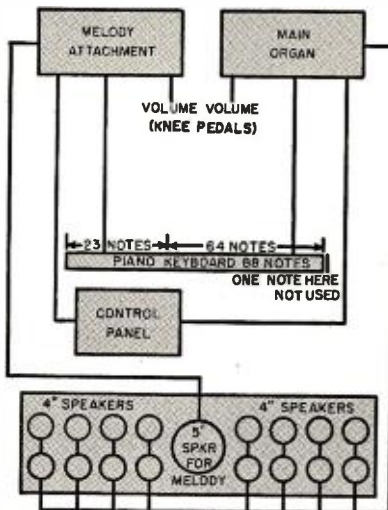

trol in order to avoid hum. The chassis on the larger panels are mounted near the center of the panel. The volume controls are mounted in the center of the front edge of the chassis. Instead of using knobs on the volume controls, little inexpensive (two cents apiece) dial drums are fastened to the shafts. They are crimped to match the half-round shafts and are cemented in place. If the potentiometers have brass shafts, the dial drums can be soldered. On the extreme left-hand potentiometer a spring holds the dial in minimum volume position and all the dial drums are ganged by a heavy dial cord running over pulleys to the knee (organ swell) hinged paddle. It works surprisingly well. It is neither necessary nor desirable to have zero volume. You need only the range from soft to very loud. This makes the scheme simpler because the dial cord does not need to travel far.

The switch controlling tone color had to be mounted near the circuits it controls so a sprocket and chain connects the switch shaft to the shaft mounted under the keyboard.

It is a good idea to experiment with the "losser" resistor. The value of the resistor and whether it is placed in series or parallel depend on the transformer used and the pitch desired. The "losser" resistor not only improves the tone but makes the oscillator more stable so that the organ does not need to be retuned. The greater the value of resistance you use in series, the higher the note becomes and the greater the drop in output. You do not need to worry about the output because you have the amplifiers—but the limits are where the tone is too high for the potentiometer or the oscillator stops oscillating.

A wide field for experiment is in the tone color field. You can try all kinds of filters and name the result. I do not guarantee that tone #4 will sound like a saxophone—I only repeat what one listener named it, and I agreed.

Piano with the front cover removed to show the "works." Panels left to right are the upper-power panel; 16 notes with potentiometers for the lower melody attachment. The neon pilot light is on the front panel but is not visible when the cover is on. The neon glows steadily with the vibrato off and flashes when the vibrato switch is closed; 16 notes and the ganged volume controls.

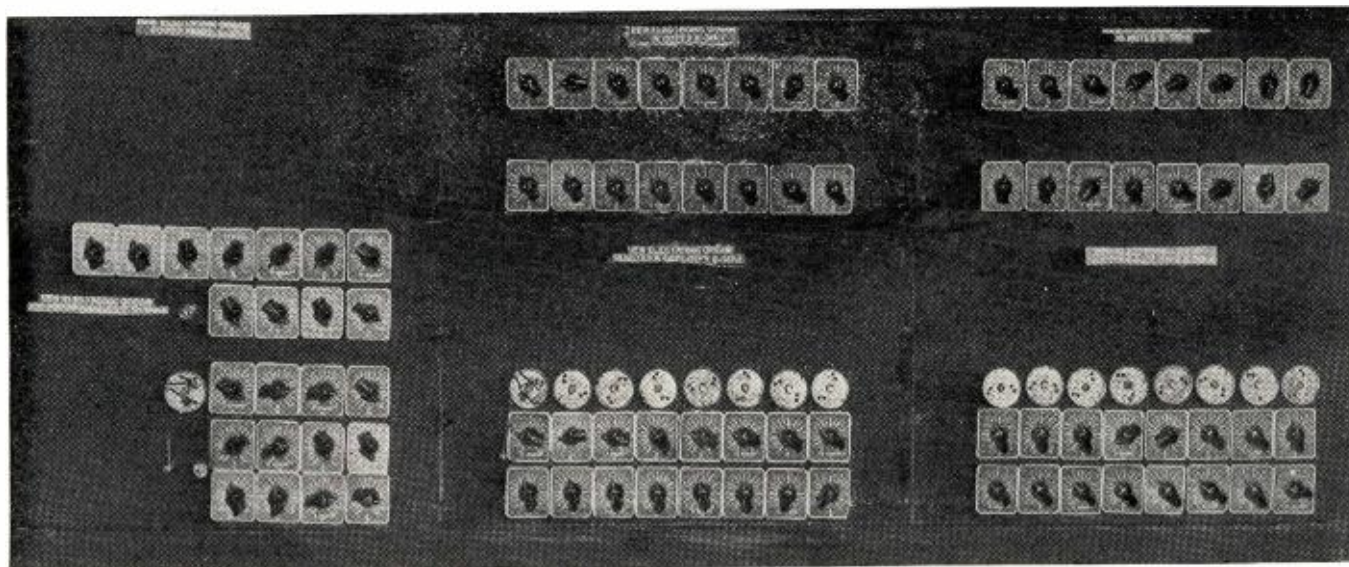

	Note	Freq.	Note	Freq.	Note	Freq.
Low	G #	51	F	175	D #	622
	A	55	F #	185	E	659
	A #	58	G	196	F	698
	B	61	G #	208	F #	740
	C	65	A	220	G	784
	C #	69	A #	233	G #	830
	D	73	B	247	A	880
	D #	77	Middle C	262	A #	932
	E	82	C #	277	B	987
	E #	87	D	294	B #	1047
	F	92	D #	311	C	1109
	F #	98	E	330	C #	1175
	G	103	F	349	D	1245
G #	110	F #	370	D #	1319	
A	117	G	392	E	1397	
A #	123	G #	415	F	1480	
B	131	A	440	F #	1569	
B #	139	A #	466	G	1661	
C	147	B	493	G #	1760	
C #	156	B #	523	A	1865	
D	165	C	554	A #	1976	
		C #	587	B		

Notes included in the main organ along with the frequency for each note.

I favor the chart method of tuning (described in the previously-mentioned article appearing in the August 1950 issue). This is one of those instances where something that theoretically just won't work—does! I can prove it. I can turn the potentiometers every which way and set that 440 cycle "A" by WWV and a calibrated oscillator and oscilloscope. Then I can tune an octave by the chart method and find that the next highest "A" is 880 cycles—as it should be!

My mike is attached to a separate audio amplifier and the speaker is placed near the telephone. An oscilloscope is hooked to the amplifier. It is handy for adjusting the volume controls and for tuning and shows up interesting variations with the tone colors—but it is an unnecessary refinement.

The melody attachment is tuned an octave below the original musical score. This was originally done to get the instrument within my "vocal range" thus eliminating *falsetto* singing. I believe the lower solo sounds better than the treble and I would suggest leaving it tuned to that range.

There is one disadvantage to the method of keying used in the melody attachment. Due to the open grid

	Note	Freq.
High	G	392
	F #	370
	F	349
	E	330
	D #	311
Middle	D	294
	C #	277
	C	262
	B	247
	A #	233
	A	220
	G #	208
	G	196
	F #	185
	F	175
	E	165
	D #	156
	D	147
	C #	139
	C	131
B	123	
A #	117	
A	110	

Notes and frequencies in melody attachment.

which exists when no key is depressed, a "plop" is heard about once every seven seconds. The frequency of this click depends on the capacity in the keying wires as well as other factors. This is one reason why I located the melody attachment close to its keys. Since the volume control is pulled to minimum by the spring when no key is depressed, this click is barely audible. When you press the paddle for

(Continued on page 101)

INSTALLING MOBILE EQUIPMENT

By D. K. JOHNSON, W5RPO

There is money in two-way radio work providing you have the proper tools and the requisite "know-how".

BEFORE World War II when mention was made of mobile "two-way" radio, immediate thought was given to police and fire department radio systems. Such organizations were originally the only ones qualified to obtain licenses and who were interested in using mobile communications. Since that time, the use of radio to communicate with mobile equipment has mushroomed into a major phase of the radio industry. Taxicabs, buses, service and emergency vehicles have all formed extensive communication networks, utilizing considerable radio equipment and representing a respectable buying power in the radio and electronic field.

If one compares the equipment used by police departments operating on 1640 kilocycles and similar frequencies, with the equipment now used in the 30-50 megacycle and the 150-160 megacycle band, the vast changes make the short span of time in which these changes took place, seem much longer. The era of "screwdrivers and chewing gum" has passed. To service this new equipment requires a thorough knowledge of its principles of operation, plus a rather extensive array of test equipment. In many cases the amount of test equipment may be limited, but a greater length of time is required for each repair job.

In the course of maintaining approximately two hundred mobile radio units, in the 30-50, 150-160, and 450 megacycle bands, many simplified, rapid means of installing and servicing such units have been discovered. Many of these "kinks" are simple, but have saved many hours of valuable time.

Occasionally, the average small radio shop will be asked to install a mobile radio unit in a truck, car, or

other type of vehicle. Often the shop owner will hesitate due to inexperience, insufficient knowledge of the equipment, and possibly because of the lack of the proper license. Installation of such equipment does not require the possession of any license, but be certain that any and all tests are made by or under the supervision of the holder of a Second or First Class Radio Telephone License. Any adjustments to the equipment that might affect the radiation of the transmitter in any way, must be made by a licensed technician.

The installation of mobile equipment need not be a "big" job, requiring the major portion of a day. Actually it can be done on the average automobile in a little less than an hour. This installation time is the result of considerable practice and a complete knowledge of the equipment. The correct tools also play a large part in quickly and properly installing mobile radio equipment.

First, examine the car, truck, or vehicle in which the equipment is to be installed. Locate the proper position for the control head in such a way as to be convenient for the operator and yet not interfere with the operation of the vehicle. Generally, right handed operation is to be preferred with the control head mounted in the center, underneath the flange of the dash on the vehicle. The hanger for the microphone should be readily accessible and hold the microphone firmly. In order that no unnecessary holes mar the appearance of the dashboard, mount the microphone hanger on one of the knock-out panels normally used for the broadcast radio, clock, or other accessories, if such a place is available. Such a procedure

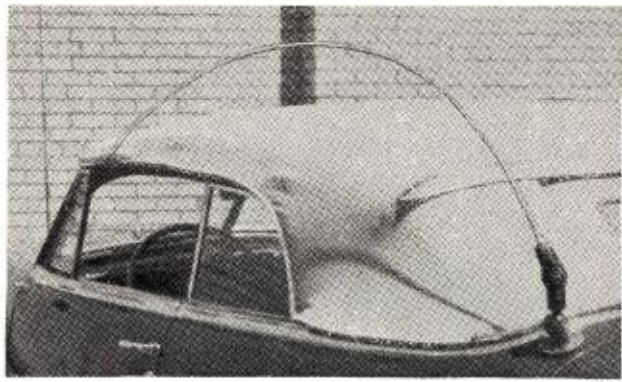

The author's automobile showing use of a "tie-down" hook to make entry into garages and other low-clearance spots easier.

allows the replacement of the panel, which can be done for a few pennies, when the equipment is to be removed.

In most installations it is necessary to pass wires through the fire wall of the vehicle. The "speed-drill" that has proved very effective for this purpose is a large tapered punch. A punch about fourteen inches long with eight inches of taper from three-quarters of an inch to a point, is very suitable. The advantages of punching the holes are many. It is possible to punch a hole in places where a drill cannot reach. The hole made by the punch will have a "rolled" edge and will not cut the insulation of the wire. The rapidity with which a hole can be made by a punch is amazing when compared to the time required for drilling and reaming a hole.

Many pro and con arguments may be advanced for running control cables inside or outside the vehicle. In most automobiles, for long trouble-free cable life, the inside installation gains favor. A small hole in the fiber partition between the rear seat and the trunk allows the cables to pass from the trunk, under the rear seat and floor mat, along the drive shaft housing on the right-hand side to the control head on the dash. By keeping the cables close to the drive shaft housing, the cables are not walked on and do not cause ridges or wrinkles in the floor mat. The placement on the right-hand side of the drive shaft housing prevents interference with the accelerator pedal when passing under the front floor mat. Some type of protective covering is required where the cables pass under the rear seat to

prevent sharp edges from cutting the cables. Such a method of installing control cables provides rapid, safe, weatherproof cable installation. This method eliminates crawling under a vehicle to secure cables as is necessary in outside installations. Control cables placed outside also require some type of weatherproof sheath in order to give reasonable cable life. On certain truck or bus installations it is necessary to place cables out in the weather. In such cases, protective covering should be used.

The placement of the transmitter-receiver unit is often a bone of contention. Most automobiles have a "hump" in the forepart of the trunk to allow for vertical clearance of the differential. This ridge, when large enough, is a good location for the unit. It places the unit where it will not interfere with the normal luggage space of the trunk. The unit may be mounted with self-tapping *Parker-Kalon* screws. If it is necessary to place the unit on the floor of the trunk, due to physical size or for convenience in service, check for clearance between the floor of the trunk and the gasoline tank which is usually directly beneath. Use screws which will not puncture the tank. Place the unit in such a position that when luggage is placed in the trunk, it will not strike the cables or connectors. This often prevents future trouble from this source. In some cases it is beneficial to mount the unit on a piece of plyboard and fasten the board to the floor of the trunk. This is a means of reaching areas of the trunk floor that are not directly above the gasoline tank. Some users believe that the board also gives a certain resiliency which provides protection for the equipment against mechanical shock.

With reference to shock mounting the equipment, the best solution is, *don't*. Some types of equipment available are provided with shock mounting. Even these have disadvantages. Many technicians attempt to mount the units on sponge rubber or spring material in order to ease the bumps for the equipment. A shock-mounted installation must be very carefully engineered for the individual vehicle in order for it to be helpful rather than detrimental. Most radio technicians are not equipped to make such an installation. Unless you are fully familiar with the engineering principles involved in a proper shock mounting, fasten the equipment solidly to the vehicle and allow the rubber tires to do the job. Most available mobile equipment is constructed to operate under extremely rugged and adverse conditions and unless the manufacturer definitely recommends a particular type of mounting, fasten the transmitter unit firmly to the floor of the vehicle.

When the unit, cables, and control head have been mounted to the satisfaction of both the user and the installer, only one item remains before turning the switch—installing the antenna. The procedure for mounting

the antenna will be determined somewhat by the operating frequency of the equipment and the type of antenna to be employed. Equipment operating in the 30-50 megacycle range will undoubtedly use the conventional one-quarter wavelength whip with some type of spring mount or base. The base for the antenna may be mounted on any type of surface as long as it is reasonably flat for at least the area of the base itself. This area is generally a circle approximately four inches in diameter. Choose a location for the antenna which will keep it as clear of the body of the car as possible and also provide a certain amount of height. Normally this location will be above rear fender or on the flat surface found above the luggage compartment door on most types of automobiles. Be certain that clearance is present inside the trunk and that there are no seams or flanges on the underside of the location chosen. There are several means of cutting the necessary hole for the antenna base. One of the various types of hole cutters will do nicely. The method of drilling a circle of small holes and removing the center may also be used. The edges of the hole are concealed so that an extremely smooth edge is not necessary. Clean paint and undercoating material from the underside of the surface surrounding the hole. In mounting the spring base, be sure that good ground connections are made by the grounding screws. Improper grounds at this point very seriously affect the performance of the radio installation. After the spring base has been bolted into position, loosen the orienting screws and place the spring as near to vertical as possible. Attach the whip antenna and after checking vertical positioning, lock the spring into position. The addition of a "tie-down" hook, while not provided by the manufacturer, is greatly appreciated by the user. A small piece of steel wire should be bent into the figure "S." This should be placed in such a position that it can be reached

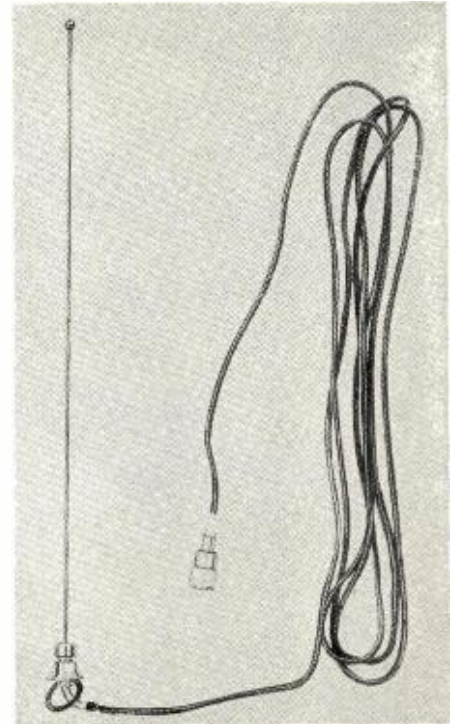

Mobile antenna for 152-162 mc. band. Antenna is mounted through metal roof of car. Car top serves as a ground plane.

through the window of the vehicle for releasing the antenna. Mount the hook with a very short self-tapping screw on the drip moulding above the window. A piece of plastic or rubber sleeving placed over the wire will prevent rattle.

Equipment operating in the 150-160 megacycle band requires a different type of antenna and accordingly presents different problems in installation. There are two popular types of antennas in use: the quarter-wave coaxial type which utilizes a quarter wavelength coaxial skirt to provide vertical directivity, and the more popular roof-top or "hat-pin" antenna. The coaxial type of antenna is generally mounted in much the same man-

(Continued on page 110)

Over-all view of completed installation showing placement of antenna and units.



THE SPOOK

ANOTHER WEIRD EFFECT

TO HAUNT TV



Fig. 1. Hand-made r.f. chokes used for minimizing spook problem.

By

M. B. KNIGHT

Tube Department, Radio Corporation of America

A simple solution to the problem of electromagnetic radiation from horizontal deflection circuits of set.

A NUMBER of interesting phenomena, sometimes not anticipated in fundamental studies, have cropped up in the electronic art. These phenomena often are identified by colorful names which are intriguing in themselves. The "spook," an interference effect in television receivers, may be destined to take its place in the language of the trade with such terms as "ghost," "barks," "motorboat," "birdies," "snow," and "jitter."

Description of Spook

The spook originates as electromagnetic radiation from the horizontal deflection circuits of television receivers and is picked up by the sensitive r.f. or i.f. circuits of the receivers. Like any other signal in the r.f. or i.f. circuits, the spook signal is amplified, detected, and applied to the grid or cathode circuit of the kinescope. When seen in the picture, it appears as a narrow vertical band very close to the left-hand edge of the raster and resembles the more familiar interference from Barkhausen oscillations in the horizontal-output tube. If the television signal is weak compared to the spook signal, the line is black and has ragged edges as shown in Fig. 2. If the television signal is of normal strength, the line is not black but has within its margins crawling diagonal lines which are caused by heterodyning between the television signal and the spook signal. The appearance of the spook when the television signal is of normal strength is shown in Fig. 3. Despite the similarity to Bark-

hausen oscillation, several distinguishing features establish the spook as a separate effect: (1) The line is always in the same place in the raster, very near the left-hand edge. (2) The interference, if picked up in the r.f. circuits, is always strongest on the lower-frequency channels, whereas Barkhausen may be more pronounced on either the low or high-frequency channels. (3) Experiments show that the radiation does not come from the horizontal-output tube, nor do the usual cures for Barkhausen oscillation, such as magnets, have any effect on it.

Actually, the spook seldom has a serious degrading effect upon receiver performance. Because of its location on the raster, it is usually within the blanking period and it is almost always off the kinescope screen because receivers are normally adjusted to have a good margin of deflection width. The more common degrading influence of the spook is that it upsets the receiver synchronizing circuits. Because of the action of the detector circuit, the spook shows up in the video circuits as a pulse in the "black" direction, similar to the sync pulses. If it is of sufficient amplitude, the spook pulse will pass through the sync amplifier along with the regular sync pulses and may impair the operation of the horizontal a.f.c. circuits.

Occasionally, two receivers are close enough together so that one picks up the spook interference from the other. The resulting picture disturbance is quite objectionable; if the receivers are tuned to different stations (the

line-scanning frequencies of which may differ slightly), the spook line may move back and forth across the picture.

Discovery of Spook

To the best of our knowledge, the spook phenomenon passed unnoticed, or at least uncommented upon, for three or four years of commercial receiver production. There are several reasons for this delay. First, because of the usual practice of scanning beyond the kinescope mask, the spook line is rarely seen. Second, because the intensity of the spook radiation is a function of the deflection power, it has become more evident as larger kinescopes, having larger deflection angles and accelerating voltages, have come into popular use. Third, the older deflection circuits were susceptible to Barkhausen oscillations, and the spook, even if observed, could easily be dismissed as Barkhausen.

The advent of modern high-efficiency deflection circuits, however, called attention to the spook as a unique effect. The writer's first encounter with the spook occurred about two years ago during the development of the RCA-223T1 horizontal-deflection transformer. The narrow vertical band appeared to be due to Barkhausen oscillation; further investigation, however, showed that cause to be unlikely because careful measurements established that the plate voltage of the horizontal-output tube was not negative at any time during the scanning cycle. Other engineers observed the effect at about the same time and established that it was not Barkhausen. No parasitic oscillation could be found and the mysterious nature of the effect caused it to be dubbed the "spook." The name seemed apt and has persisted. The effect was distressing to receiver designers, mainly because of its elusive nature, and efforts were made by the writer to locate the cause. After some investigation, a reasonable explanation was found, and methods of minimizing the interference were easily devised.

How Spook Is Generated

In the investigation of the nature and cause of the spook, a separate

television receiver was used to search for the most prominent source of radiation. Although some radiation could be detected from most parts of the deflection circuit, the damper tube and its leads produced the strongest radiation.

Scrutiny of the current waveforms in the horizontal deflection circuit showed that the spook line appears at the same instant that the damper tube begins conduction, approximately one microsecond after the completion of retrace. The damper tube plate current rises from zero to its maximum value of 350 to 400 milliamperes very rapidly. The rise time of the current was not measured precisely, but available equipment indicated that it was 0.1 microsecond or less. At any rate, it was apparent that the electromagnetic fields associated with such a rapid change of current and voltage must contain many high-frequency harmonics. It could be expected, therefore, that the high-frequency harmonics could be radiated to the signal circuits of the receiver.

This theory was checked by exploring the radiation spectrum with a communications receiver. The receiver was tuned from about 300 kilocycles to 18 megacycles and a signal was detected at every harmonic of 15,750 cycles. A more significant observation was that no other signal was detected. The intensity of the harmonics diminished steadily as the receiver was tuned to higher frequencies. In addition, spook interference was found to be most severe on television Channel 2 and was successively less severe on higher-frequency channels. If the harmonics were being radiated as a result of the rapid plate-current change in the damper tube, it would be assumed that high-frequency harmonics would be of less amplitude than low-frequency harmonics.

Small r.f. chokes were placed in the leads to the damper tube at the socket and the radiation was reduced considerably. The residual radiation came almost entirely from the internal structure of the tube itself. Further tests confirmed that the interference

originated with the rapid change in the damper-tube plate current.

Minimizing Spook Interference

The rapid rise of plate current in the damper tube is inherent in the proper operation of deflection circuits. Practical means for slowing down the increase in current are not at hand, and it is not expected, therefore, that the spook can be eliminated entirely. It is possible, however, to reduce considerably the detrimental effects.

One approach to the problem of reducing spook interference is to minimize the susceptibility of the r.f. and i.f. circuits to the radiation by physically separating the r.f. and i.f. circuits from the deflection circuits. This separation is chiefly a chassis design problem; good chassis layout in this respect is normal in commercial receivers. The technician is more concerned with the installation of the receiver; he should be sure that the antenna lead-in is dressed away from the deflection circuits. Not much can be done along this line if an in-cabinet antenna is used.

A second approach to this problem is to minimize the radiation from the deflection circuits. Because the damper tube and its leads can be thought of as a transmitting antenna which radiates the spook, a logical approach is to make the transmitting antenna as small as possible and to provide a shield between this "antenna" and the receiver r.f. and i.f. circuits. It was mentioned before that insertion of r.f. chokes in the leads to the damper tube limited the "antenna" to the tube structure itself. The value of the chokes is not critical, but must be large enough to be effective in the television band without being so large that ringing is caused in the deflection circuit. Chokes having inductance values between 1 microhenry and 5 microhenrys are suitable and are available commercially. Chokes for the plate and cathode circuits can be made by winding approximately 30 turns of AWG #28 enamel or *Formex* wire on a one-watt resistor. Ordinarily, it is not important to insert chokes

in the heater circuit. If heater chokes are used, however, wire at least as large as AWG #20 should be used to carry the heater current. The stiffness of this size wire makes a coil form unnecessary; a coil of approximately 20 turns about $\frac{3}{8}$ inch in diameter is adequate. Fig. 1 illustrates typical hand-made chokes.

After chokes have been placed in the damper tube leads, it is desirable to shield the tube from the receiver r.f. and i.f. circuits. The high-voltage enclosures used in most receivers provide adequate shielding. The shield should be inspected to see that it is grounded at as many points as possible. If there are any large holes in the enclosure, they may be covered with ordinary copper wire screen to improve the effectiveness of the shield. Capacitive coupling between the damper tube and any leads which come out of the high-voltage enclosure should be minimized by careful lead dress. A close-fitting shield around the tube, however, is neither necessary nor desirable because of the resultant increase in bulb temperature.

In the commercially popular auto-transformer and direct-drive types of deflection circuits, experience has indicated that spook interference can be greatly reduced by the addition of only one r.f. choke. In such circuits, most of the radiation usually comes from the "B+" lead which is connected to the plate of the damper tube. (The cathode lead is quite well shielded by the high-voltage enclosure.) The r.f. choke, therefore, should be placed in the plate lead of the damper tube at the socket. The addition of a condenser of approximately 100 μfd . between the chassis and the "B+" side of the choke may give further improvement.

The techniques suggested for reducing spook interference are not all-inclusive. Each type of deflection circuit and each mechanical layout requires individual attention. It is expected, however, that an understanding of the source of the interference will be of help to the troubleshooter when spook problems appear.

-30-

Fig. 2. Appearance of "spook" interference with weak signal.



Fig. 3. "Spook" interference with signal of normal strength.



AN R. F. HIGH-VOLTAGE SUPPLY FOR YOUR CRO

By
LOUIS E. GARNER

Borrow a trick from TV set manufacturers and improve performance of your scope.

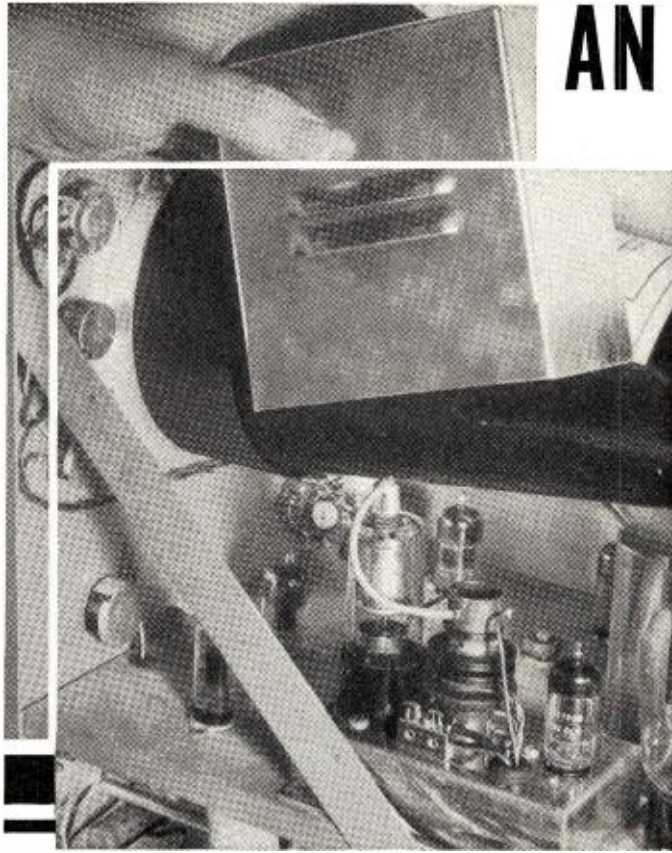

Fig. 1. Commercial scope in which the 60-cycle supply has been replaced by the high-voltage supply described in this article.

WHEN r.f.-type high-voltage power supplies first became popular, television receiver manufacturers immediately recognized their advantages and most of the electrostatic TV receivers manufactured employed such supplies. Even a few electromagnetic sets were made in which r.f.-type high voltage supplies were used (instead of the currently popular kickback type of high-voltage supply). Cathode-ray oscilloscope manufacturers, for one reason or another, have not been too quick to incorporate such supplies in their instruments.

There are a few relatively expensive laboratory-type scopes available in which such supplies are used (in modified form), but the majority of scopes sold employ a 60-cycle high-voltage supply, generally requiring a special power transformer and utilizing a circuit similar to that shown in Fig. 4.

The same advantages which made the r.f. high-voltage supply so ideal for TV work apply to its application as the high-voltage supply for a CRO. First, as a high impedance supply, it is safer to work with. Secondly, because of the high frequencies used, it is relatively easy to get adequate filtering with comparatively low capacity (and hence low cost) filter condensers. This fact is doubly important in that a great degree of freedom from 60-cycle intensity modulation can thereby be achieved.

Coupled with these facts is the ease of obtaining higher d.c. voltages which result not only in greater spot brightness, but also in a sharper and clearer

trace. High spot brightness is especially important when working with rapid sweeps and with sharp pulses. When pulses or square waves with a short rise time are observed, the leading edge of the signal may be lost entirely unless a high degree of spot brightness can be achieved.

These factors alone make it desirable to add such a supply to an existing CRO, as was done by the author. For new scope construction, several additional advantages accrue to those

Fig. 2. Circuit diagram of the r.f. high-voltage supply to be used with scopes.

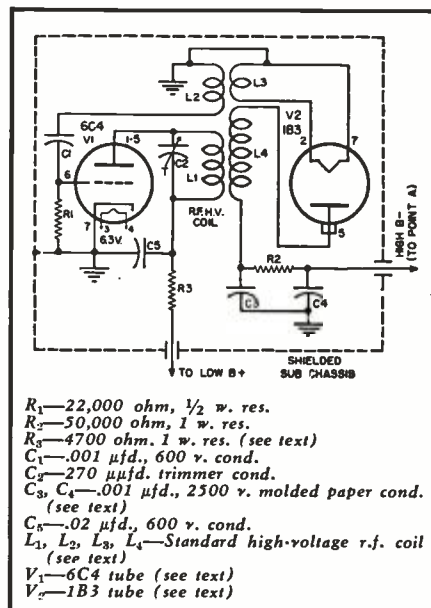

just listed. First, the need for a special scope transformer (see Fig. 4) is eliminated, and an ordinary receiver power supply transformer may be used for the scope. In these days of increasing parts shortages this is an important advantage. In addition, however, the need for high-capacity, high-voltage filter condensers is eliminated.

Unfortunately, the r.f. high-voltage power supplies used in TV receivers cannot be used directly in the average CRO without modification. For the most part, these supplies deliver from 4500 to 6000 volts. Since the average service-type scope employs from 900 to 1500 volts as accelerating potential, going to a voltage this much higher might cause a number of undesirable effects. First, of course, almost all coupling condensers to the deflecting plates would have to be replaced. All controls in the high voltage circuit (such as the "Intensity" control) would have to be better insulated from ground. The sensitivity of the scope would be reduced severely, and it might even become necessary to incorporate additional stages to obtain even partially satisfactory gain. And, finally, most TV r.f. high-voltage supplies deliver a voltage that is positive with respect to ground while the majority of scopes require an accelerating potential negative with respect to ground (see Fig. 4).

It is possible, however, to make basic modifications in the average r.f. high-voltage supply so that from 1500 to 2500 volts d.c. are supplied, and with a potential negative with respect to ground. This moderate increase in accelerating potential, while giving a noticeably brighter and sharper spot, is generally not enough to require changes in other parts of the scope nor to reduce the sensitivity appreciably. (NOTE: the loss in sensitivity is

due to the increased "stiffness" of an electron beam produced by a high accelerating voltage.)

Circuit Description

The circuit used by the author is given in Fig. 2. As can be seen, a triode tube, V_1 , is connected as a tickler feedback oscillator, with secondary coils L_3 and L_4 coupled to the primary coil L_1 . L_4 has many more turns than L_1 , so that a voltage step-up occurs between primary and secondary windings due to the turns-ratio. In addition, however, C_2 may be adjusted to change the oscillator frequency. By careful adjustment, the oscillator frequency may be made equal to the resonant frequency of L_4 plus the distributed wiring capacities and the internal capacity of the rectifier tube V_2 . Thus, resonance step-up may be added to the turns-ratio voltage step-up to increase the r.f. voltage applied to the rectifier tube.

A specially-designed rectifier tube is used so that its filament may be supplied directly from the r.f. oscillator by means of L_4 .

Thus far, as we have seen, the r.f. supply is quite conventional. But there are differences between the circuit shown in Fig. 2 and conventional TV high-voltage supplies. In most TV high-voltage supplies, the lower end of L_1 is connected to the lower end of L_4 and the high-voltage output is obtained from the filament (cathode) of V_2 , which is left ungrounded. In such a case, the high d.c. voltage obtained is positive with respect to ground.

To make the necessary changes in a TV high-voltage supply, first identify winding L_4 by carefully tracing the wiring. Disconnect the lower end of this coil, and use this as the d.c. supply source (connected to R_2 and filter condenser C_2). Connect the filament of the rectifier tube directly to ground. In this manner, an accelerating potential, negative with respect to ground, may be easily obtained.

For those few scopes in which an accelerating potential positive with respect to chassis ground is required, the more conventional circuit may be employed, as shown in Fig. 3.

Construction Hints

For best results, the entire r.f. high-voltage supply should be constructed on a separate chassis, and a complete shield provided. When care is taken in layout and construction, the r.f. supply may be directly substituted for the 60-cycle type of high-voltage supply without any chassis changes in the scope proper.

Fig. 5 is a view of a commercially-built CRO in which a 60-cycle high-voltage supply, similar to that shown in Fig. 4, is employed, supplying approximately 1500 volts. The small rectifier tube (5Y3) is the high voltage rectifier.

Fig. 1 is the same scope with an r.f. high-voltage supply substituted for the 60-cycle supply. The shield of the r.f. supply has been removed to show de-

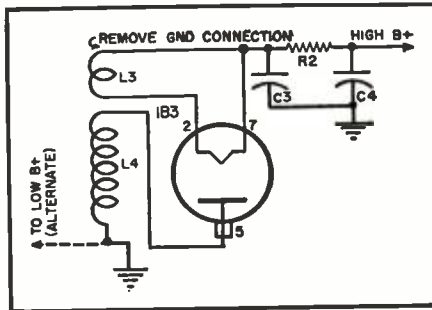

Fig. 3. How the r.f. high-voltage supply is connected into those oscilloscopes having an accelerating potential positive with respect to the chassis ground.

tails of construction. In order to incorporate the r.f. supply in this particular scope, it was only necessary to drill four small holes in the chassis for mounting screws. It wasn't even necessary to remove the high-voltage rectifier tube socket! Filament ground and low "B plus," as well as high "B minus" leads, were brought down through the key-hole of the former high-voltage rectifier tube socket.

The author used a special coil obtained from Stanwyck for L_1 , L_2 , and L_4 , adding L_3 by using two turns of plastic insulated #20 gauge wire. If the proper coil is not available to the builder, use a conventional TV r.f. high-voltage supply coil (which can be obtained from almost any wholesale radio supply house), removing one or more "pi's" from the high-voltage winding as may be necessary to obtain the desired high voltage.

V_1 may be a 6C4, 6C5, 6J5, triode-connected 6AQ5, 6V6, 6K6, or any similar tube. As the tubes are varied, or as the low "B plus" obtained from the CRO low-voltage power supply va-

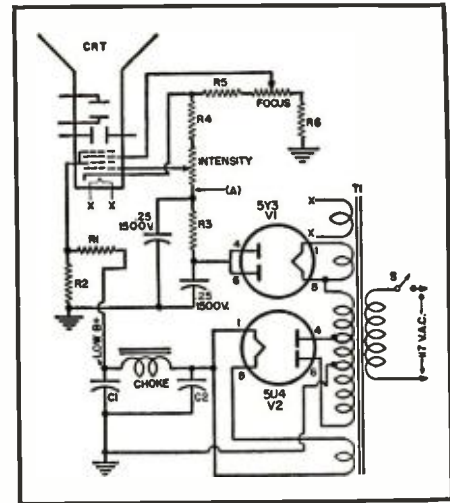

Fig. 4. A conventional oscilloscope circuit which uses a 60-cycle h.v. supply.

ries, it may be found desirable to alter the values of R_1 or R_2 to obtain optimum results. Particular care should be taken that the maximum voltage applied to the plate of V_1 does not exceed the maximum rating recommended by the tube manufacturer for the tube used. Increase R_2 as much as is necessary to accomplish this.

The rectifier tube, V_2 , may be a type 1B3, which is easily obtained, but, if preferred, the builder may use tubes designed for a similar application such as miniature types 1X2 and 1V2.

The high-voltage filter condensers, C_3 and C_4 , may be varied to suit the voltages obtained. The author used 2500 volt condensers since his supply delivered approximately 2300 volts. If a lower output voltage is to be used, condensers with a lower working volt-

(Continued on page 167)

Fig. 5. Top view of scope (Fig. 1) before r.f. high-voltage supply was added.

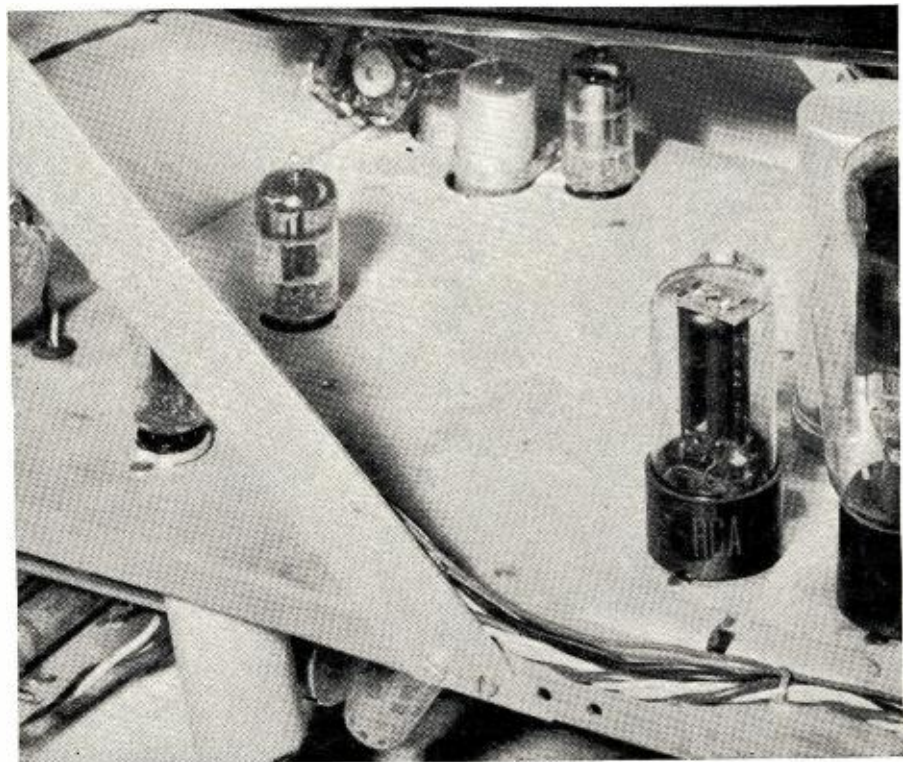

STRING-BELT TURNTABLES

By
ALBERT H. TAYLOR

TURNTABLES in mass-produced home record players are usually unworthy of a good reproducing system. The light pressed-metal plates never saw a lathe, the center pegs are often out of true, and hum and vibration are coupled to the pickup. This writer has never seen any really good commercially-built turntables except high-priced broadcast station models. For those of us with high-fidelity tastes and low-fidelity purses, the only recourse is to build our own.

The belt-driven turntable, although used by *Western Electric* in at least one broadcast station reproducer and by *Universal* in a professional recorder, seems to have been overlooked by enthusiasts. It offers a simple and relatively inexpensive way to beat the bugbears of hum, mechanical vibration, and wow, and also to accommodate the several record speeds now in vogue and any others yet to come. The work that must be hired done, if one has no lathe, can be kept to a minimum and carried out by any conscientious machinist on a 12" lathe such as many garages have. The driving motor can be almost anything that runs at some constant speed, though for most users the obvious motor to use is one from some inexpensive available single-speed turntable.

S.S. White endless round dental drill belting is recommended for the belts and is made in various stock lengths. However, the author prefers to splice a still better belt from chalk line, macramé cord, or cod line, using the *Transmission Splice*^{1,2}. This splice makes no bump and holds even at very high speeds. Tweezers and a big needle and perhaps a reading glass are recommended for the job. In either case, the belt groove in all pulleys must have a flat bottom $\frac{1}{8}$ " wide for accurate speed ratios with these belts. The $\frac{1}{8}$ " depth will do but $\frac{1}{4}$ " demands less critical alignment to keep the belts on. Once the turntable gets going, the belts do not slip at all unless the pulleys are too small.

Whatever motor is used, the relative sizes of the motor and turntable pulleys for each desired speed must satisfy the equation:

$$\frac{d_m}{d_t} = \frac{s_t}{s_m} \dots \dots \dots (1)$$

where:

- d_m = motor pulley dia. at bottom of belt groove
- d_t = turntable dia. at bottom of belt groove
- s_m = motor speed in rpm
- s_t = turntable speed in rpm

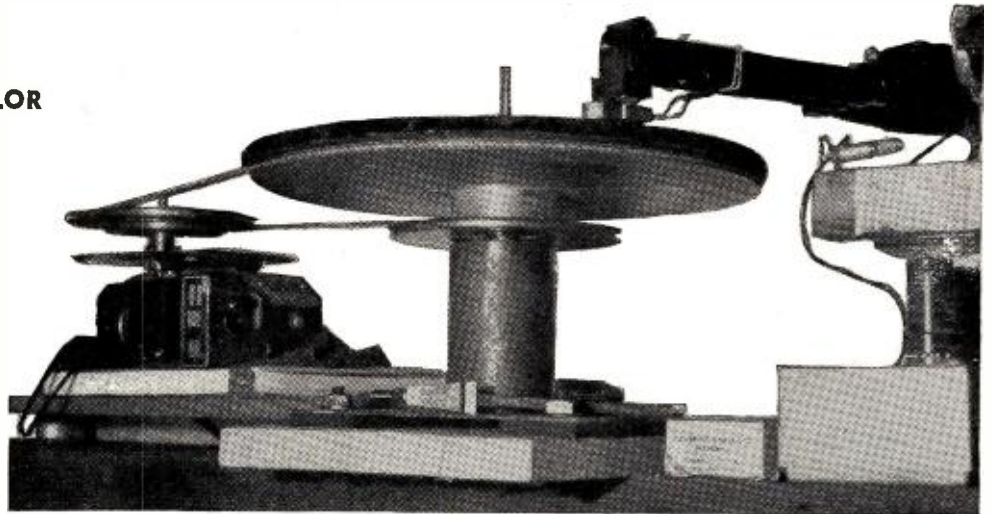

Fig. 1. String-belt turntable and motor for three speeds. The light under the pickup silhouettes the diamond to facilitate placing it accurately in the record groove.

Complete construction details for building a belt-driven turntable which has a minimum of wow, rumble, or flutter.

A high-speed motor, such as an 1800 or 3600 rpm unit, would require a two-step reduction with two belts and an intermediate countershaft bearing two pulleys in order to avoid using small pulleys that will slip. The equation then becomes:

$$\frac{d_m d_2}{d_t d_1} = \frac{s_t}{s_m} \dots \dots \dots (2)$$

where:

- d_1 = dia. at groove bottom of countershaft pulley belted to motor
- d_2 = dia. at groove bottom of countershaft pulley belted to turntable

This was the drive which the author saw on a *Universal* recorder.

If the belt-driven turntable is 12" (outer diameter), the diameter at the bottom of the groove is 11.75". Table 1 gives the groove-bottom diameters of the motor pulleys for driving the turntable at the present three record speeds with a 78.26 rpm motor. Over-all diameters will, in all cases, be $\frac{1}{2}$ " greater if the grooves are $\frac{1}{4}$ " deep as recommended. This is the simplest

arrangement but it requires a large and heavy three-step pulley on the motor. An alternative is to put an additional pulley underneath the turntable and make its diameter equal to that of one of the motor pulley steps, say 5.004". The belt positions are then as given in Table 2. A further reduction in the required steel can be achieved by making the second step of the motor pulley 2.875" at the groove bottom as indicated in Table 3.

Of course, the turntable could be driven at all speeds by a single pulley underneath and a small three-step pulley on the motor; but this would save no more material and might make the motor pulley for 33 $\frac{1}{3}$ rpm so small that it would slip. It would only be worth risking in an ornamental installation where the belt must be kept out of sight under a deck.

Fig. 1 shows the author's turntable with the belt arranged to drive it at 33 $\frac{1}{3}$ rpm with a 78.26 rpm motor. The pulley combinations for the three speeds are given in Table 3. The motor, which is shock-mounted to isolate its hum and vibration from the turntable pedestal and the pickup base, is simply slid toward or away from the turntable to keep the belt tight with the various pulley combinations. It could be on skids or rollers with a cord and a weight over the end of the shelf, or stationary with an idler to take up slack; but all this is unnecessary. Alignment is preserved by shoving chocks of the right thickness under the motor. With a longer belt and/or agate fishpole guides put on before the belt is spliced, no height adjustment would be necessary. This very simple arrangement has been wholly satisfactory for twelve years. Undesired

Fig. 2. Cross section of turntable shown in Fig. 1—the author's "deluxe" version. See text for identification of the parts.

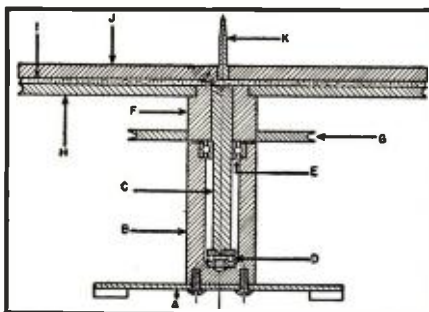

sounds are completely eliminated and even a very noisy, hunting, eccentric synchronous motor formerly used made no trouble so long as the belt was not drawn too tight. The terrific moment of inertia of the turntable absorbed any pulsations that managed to get through the belt.

The writer prefers the simplicity and visible action of this open installation; but should some enthusiast's wife find it unsightly, it could readily be put into a conventional cabinet of ordinary width by putting the motor underneath and leading a lengthened belt around guide pulleys such as those sold by *Cenco* for physics laboratories. The belt could even be shifted by a lever with the help of the fishpole guides, which are analogous to the chain-shifting "derailleurs" used on French bicycles.

Details of Turntable

In Fig. 3 the turntable of Fig. 1 is removed from its pedestal and inverted to show the bearings. Only the top race of the lower thrust bearing is shown, the rest of it remaining on the pedestal. Fig. 2 shows the same turntable to scale in cross section. The lettered parts, as illustrated in Fig. 2 are as follows:

- A. Base, $\frac{1}{8}$ " sheet steel
- B. Pedestal, bored from 2" steel rod stock
- C. Shaft, turned from $\frac{5}{8}$ " or $\frac{3}{4}$ " steel rod stock
- D. Ball thrust bearing; this bearing also centers when loaded
- E. Radial ball bearing, metric size just under $\frac{5}{8}$ "
- F. Hub, turned from 2" steel rod stock. Press fit on part C
- G. Auxiliary drive pulley, turned from $\frac{1}{4}$ " steel. Groove bottom diameter 5.00", o.d. $5\frac{1}{2}$ ". Press fit on part F
- H. Main plate, turned from $\frac{1}{4}$ " steel. Groove bottom diameter 11.75", o.d. 12". Press fit against shoulder on part F
- I. $\frac{1}{8}$ " sponge rubber pad
- J. Upper plate, ground on *Blanchard* grinder from $\frac{3}{8}$ " hot-rolled machine steel. Turntable cloth glued on top after painting with red lead. Weight 17 lbs. In 1940 this plate cost \$2.00 for steel and \$6.00 for machining. Machining additional plates at same setup was quoted at \$1.50 each
- K. Removable peg, turned from brass. It should have an accurate slip fit with part J.

Note! The finishing cuts on parts F and H were taken and the groove in part H was turned *after* assembly of parts C, F, and H and with the assembly mounted between centers in a lathe. Part G was added 11 years later.

Observe that this deluxe turntable is elaborately protected against mechanical noise coupling even from its own bearings. The massive upper plate and peg have no contact with any other parts save through the sponge rubber pad. They are centered

TT RPM	MOTOR PULLEY	TT PULLEY
33 $\frac{1}{3}$	5.004	11.750
45	6.756	11.750
78.26	11.750	11.750

Table 1. Groove-bottom diameters of the motor pulleys for driving the turntable at the present three record speeds using a 78.26 revolutions-per-minute motor.

TT RPM	MOTOR PULLEY	TT PULLEY
33 $\frac{1}{3}$	5.004	11.750
45	6.756	11.750
78.26	5.004	5.004

Table 2. Belt positions when an additional pulley is used underneath the turntable. In this instance the diameter equals that of one of the motor pulley steps. See text.

TT RPM	MOTOR PULLEY	TT PULLEY
33 $\frac{1}{3}$	5.004	11.750
45	2.875	5.004
78.26	5.004	5.004

Table 3. Groove bottoms to permit a reduction in the amount of steel required in the construction. This is achieved by making the second step of the motor pulley 2.875 inches at groove bottom. See text.

by using a *Starrett* toolpost indicator (lying under the turntable in Fig. 1) against the peg or the rim, or by poking an accurately fitted pointed rod through the hole in the big plate (part J) and a hole made by temporarily removing a disc from the rubber, to engage the center hole in the shaft (part C). One could also use a pickup on a perfectly true record (if there is one), mount a small mirror on it, and watch the reflected spot on a distant wall. Once centered, the plate stays put indefinitely. It can be cemented if the cement dries slowly enough to allow centering.

A heavy auxiliary plate thus cush-



Fig. 3. Turntable (Fig. 1) showing bearings.

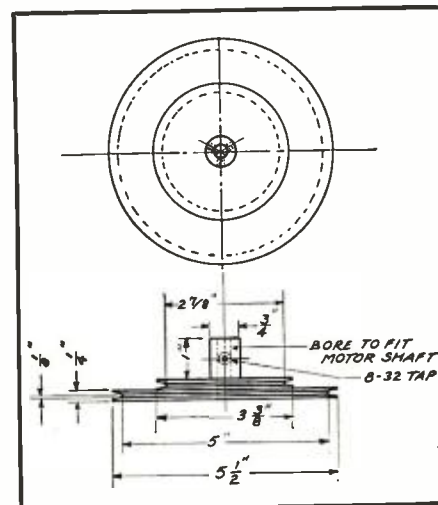

Fig. 4. Design of two-step motor pulley used in Fig. 1. With it, a 78.26 rpm motor will drive a turntable of 11.75" groove-bottom diameter at three disc speeds.

ioned has also been used on various turntables directly. It is very effective provided they don't wobble and their bearings will stand the load. It is usually necessary to saw off the original uncushioned peg.

The long removable peg has proven a great convenience in handling records without stopping and starting the
(Continued on page 168)

Fig. 5. A long, removable peg with a shoulder facilitates the changing of records.



MAC'S RADIO SERVICE SHOP

By JOHN T. FRYE

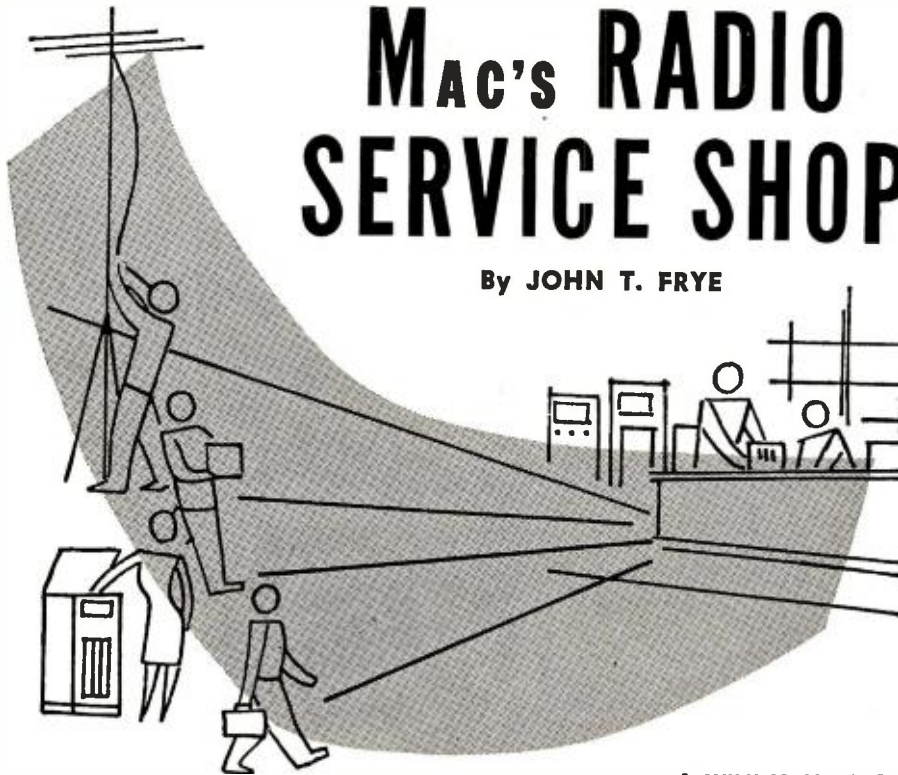

A WINDY SUBJECT

BARNEY stormed into the service shop in his usual going-to-a-fire manner but stopped short as he caught sight of Mac, his employer, sitting at the service bench toying with several soda straws.

"So!" the youth said accusingly. "You and Miss Perkins wait until I am away to have a round of sodas sent in, eh? Of all the sneaky, low-down, back-biting, ungrateful, penny-pinching—"

"Whoa, Buster, whoa!" Mac interrupted. "Hell apparently hath no fury like that of a glutton who thinks he has missed out on something to eat, but this time you are blowing your top over nothing. These straws are not the debris of secret gorging on the part of Matilda and myself. I was just using them for some experimenting."

"What kind of experimenting?" Barney demanded suspiciously.

"Sunday I spent several hours driving around looking at the damage done to TV antennas by that big wind we had Saturday night. In several cases I saw damage that puzzled me, and I am using these straws for model masts and towers, employing light thread for guy wires, in an attempt to discover why the antennas were damaged in the way they were."

"They really took a licking, didn't they?"

"Yes, but considering that some of those gusts were estimated to hit peaks of 80 miles-an-hour, it is surprising there was not more damage. Insurance men tell me they do not think they will have more than one claim in every eight installations covered. In view of the high and elaborate antenna systems that must be used to get a signal in this ultra-

fringe area, that percentage is amazingly low."

"I think that fifty-mile-an-hour wind we had about a year ago mussed up the signal-sniffers a lot worse."

"You're right, and it is interesting to note that the big damage done then was to pipe-mast installations, while this time the pipe jobs came through practically unscathed."

"Why do you suppose that was?"

"The boys learned then that just guying the top of a twenty-foot section of pipe is simply not enough; so practically every pipe-mast is now guyed both at the top and in the middle. This, when properly done, makes a very sturdy job; and on top of that the pipe-masts seldom go higher than twenty or thirty feet. Tower jobs, on the other hand, are rarely shorter than this and often go up to better than a hundred feet. Then, too, we are likely to rely more on the rigidity of the tower and fail to give it the adequate guying we would give a flexible pipe. This is all well and good in a stiff breeze, but when the wind reaches a gale, as it did here Saturday night, good guying becomes as important to the tower as it does to the pipe."

"What happened to the antennas mostly?"

"A variety of things. In each case the wind hunted out the weakest point of the installation. In many cases the guy wires either broke or tore loose from their moorings and let the whole business crash to the ground. In other instances a top guy broke while the lower ones held, and then the tower usually broke square off just above or just below the bottom guys. More common were the cases in which the antenna masts bent over or broke off

just above the motor, or the cases in which the pipe on which the motor was mounted suffered the same fate. Lots of the conicals lost antenna elements, and I saw one conical in which an insulating block had broken, allowing half of the antenna to fall to the ground.

"Few yagis shed their elements, but a great many of them either turned on the mast or turned the mast in the tower clamps so that they ended up pointing the wrong way. Fellows repairing the damage tell of a few cases in which an antenna with a large surface in a vertical plane, supported on top of a high tower, actually twisted the tower itself and did such a good job of wracking the structure that practically every rivet was loosened."

"What would you say were the installation mistakes that let all this happen?"

"Well, first, let's remember that these 'mistakes' are very easy to spot when looking through the spectacles of hind-sight, as we are now; but before we had a chance to see what a strong wind can do, we'd probably have made the same errors. Let's call them 'lessons of experience' rather than mistakes.

"The first lesson is: don't try to go too high for the guying area available. When a broadcast station puts up an antenna, it puts it in the middle of several acres of ground so that it can be supported as it should; but a TV owner often tries to go nearly as high and keep all of his guy stations inside his own small city lot. If you ever helped raise a tower, you know that when you are standing close to the base with a guy, you have a heck of a time holding the tower upright in even a slight breeze; but if you back off so the guy makes about a 45 degree angle with the tower, you can hold it easily with one hand. When guys must be anchored close to the base, they are subjected to terrific strain, and a large part of their strength is wasted in a force that tries to telescope the tower endways.

"Another fault lies in locating the guys 'conveniently' rather than where they should be. 'Make it easier to mow,' 'Make 'em less conspicuous,' and 'Want to keep 'em all on the house' are some of the excuses given for failing to support the tower equally in all directions, and this invariably leads to trouble. Not guying often enough is another error. When the tower manufacturer recommends guying every thirty feet, he means just that; and if you go over thirty feet, he means that you should use two sets of guys even if you do not go on up to sixty feet. I can show you with these straws that if you fail to do this, a big antenna can exert a leverage against the restraint of guy wires affixed only to the top and make the tower buckle in the middle.

"Improper anchoring of guys is another common weakness. Antenna towers are usually put up on calm

(Continued on page 132)

BINAURAL SOUND REPRODUCTION

By
GLEN SOUTHWORTH

THE reproduction of sound in its proper spatial perspective has been of interest to engineers and musicians since the early thirties, and various demonstrations of the desirable effects obtainable have been made from time to time, including special radio broadcasts and motion picture sound tracks as well as concert hall performances.

There are several decided benefits to be gained by reproducing sound over two or more separate channels. In the case of music, spatial perspective makes it possible to localize individual instruments, thereby giving added clarity. Similarly, counterpoint is more easily perceived and the listener may use a flexible form of tone or balance control through his location in the listening environment or by manipulation of the gain controls of the various channels thus changing the audible intensity of particular instruments rather than frequency ranges.

Although most often considered from the standpoint of high quality music, binaural reproduction has useful applications in virtually every phase of sound work. The use of spatial perspective in public address and sound reinforcement should be of interest and the increasing development of this technique is to be expected in both the motion picture and the radio broadcast fields. Likewise, in the expanding field of business recording multiple channel techniques hold promise of clearer, more intelligible conference records.

In general, there are two main techniques of binaural recording and reproduction. One of these is to use two or more microphones widely separated in order to pick up various sound sources with a minimum of interaction. In practice, usually two or three reproducing channels are considered sufficient. A second system is known as the "artificial head" and uses two identical microphones spaced about six inches apart and with a mass of some material separating them. While the first system works on the basis of sound amplitude, the artificial head works on the basis of phase differences at low and medium frequencies and amplitude discrimination at the high frequencies. Although a system of this kind can be very effective, inasmuch as only two channels are required to give the illusion of a complete spatial spread, it suffers from the fact that the two chan-



Over-all view of the twin, high-gain power amplifiers built by the author. A common power supply is used.

A discussion of binaural reproduction and a description of equipment suitable for producing this type of effect.

nels, from microphones to loudspeakers, should be very nearly identical. As very wide phase differences can be caused by acoustics in the auditioning location and the listener's position therein, this type of reproduction does not seem too satisfactory for group listening and appears to work best with headphones, which exclude the effect of outside acoustics.

Up until recent years the development of binaural reproduction seems to have been retarded by the lack of convenient recording techniques. Although phonograph records have been made with two separate sound tracks, tracking error can cause a considerable lack of synchronization unless the playback heads are suspended from an overhead bar, in which case they will track correctly, like the conventional overhead cutting mecha-

nisms. However, the problem of starting the two needles in the correct grooves still remains. Recording on film has been used with success for multiple sound track operation but is generally a somewhat expensive and inconvenient operation.

The development of tape recording to its present state provides an almost ideal medium for multiple channel recording, and a number of relatively inexpensive dual-track recorders currently available may be adapted for the simultaneous recording of two separate sound tracks. If desired, no modifications need be made on the original machine other than the mounting of an additional half track record-playback head on the tape mechanism in such a manner as to cover the unrecorded half of the tape. A separate recording amplifier and bias supply may then be

A simple, three-stage amplifier for recording with a high impedance tape head. System may also be used for the preamplifier during the playback.

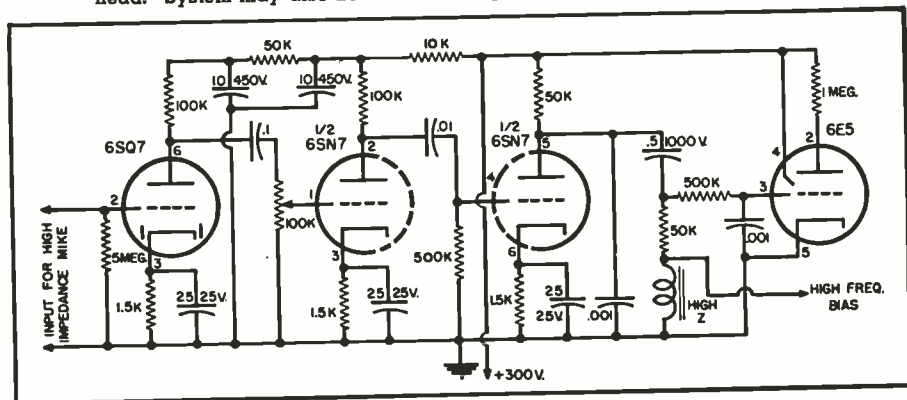

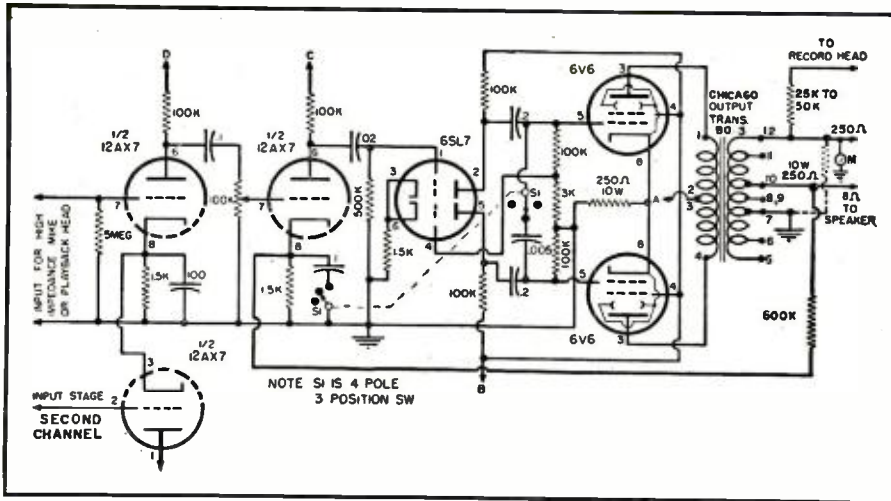

One of the two identical high-gain power amplifiers used in the dual-channel system. Both amplifiers are constructed on the same chassis and use a common power supply. Audio voltage for the tape recording is secured from the 250-ohm taps on the output transformers while individual vu meters are likewise connected to the 250-ohm impedances. Lettered connections go to corresponding terminals on power supply diagram.

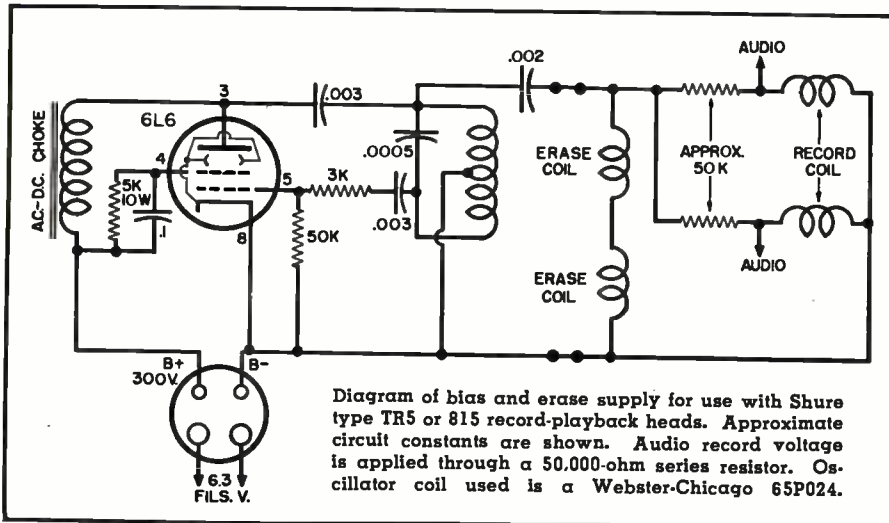
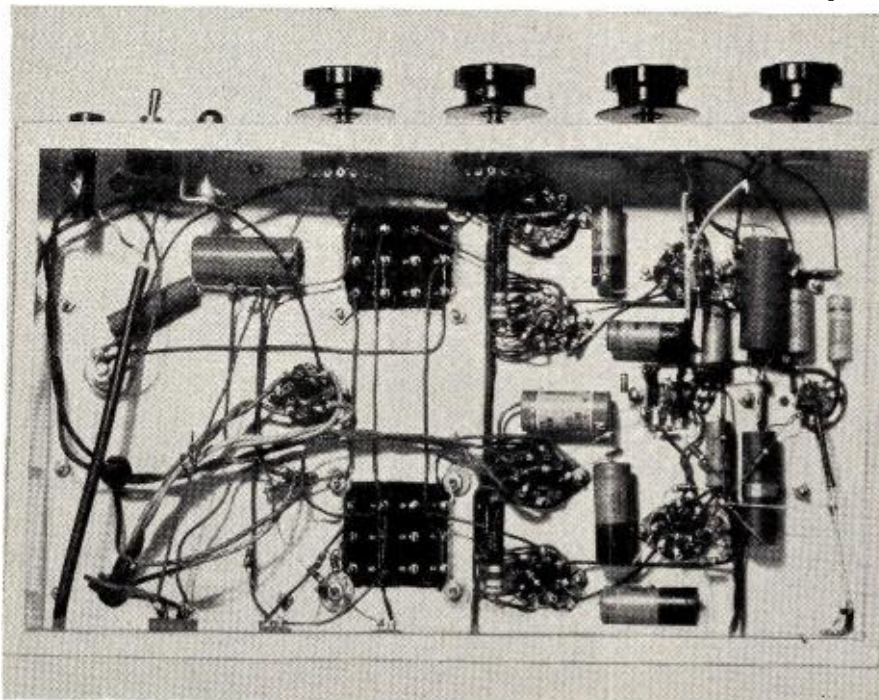

Diagram of bias and erase supply for use with Shure type TR5 or 815 record-playback heads. Approximate circuit constants are shown. Audio record voltage is applied through a 50,000-ohm series resistor. Oscillator coil used is a Webster-Chicago 65P024.

Under chassis view of two-channel amplifier system showing general parts layout.



connected to the extra head whenever it is desired to make multiple channel recordings.

It should be noted that the ability to record and play back two simultaneous recordings has several decided advantages in conventional monaural sound work. One example of this is the recording made for broadcast or other purposes at a remote location. In many instances the only indication of audio quality is obtained from a set of headphones with which it is hard to make accurate judgments as to tonal balance. By widely spacing the microphones for the two separate channels a wide variation of tonal structure may be obtained and the two channels may subsequently be mixed in the studio for best balance. Similarly, dubbing may be easily accomplished with only one machine and without loss of fidelity by monitoring the original sound track while inserting the desired material on the other track and later playing both tracks simultaneously. Likewise, benefits from the standpoint of reliability may be expected due to the fact that the use of two channels in making an original recording gives an extra safety factor in the event that one of the tracks is defective due to faulty microphone connections, amplifier, or clogged tape head.

The accompanying photographs and schematics illustrate an experimental two-channel system built by the author. In order to have as versatile a unit as possible, two separate power amplifiers were constructed on the same chassis with sufficient gain for either microphones or magnetic playback heads. As a result, the system may be used for public address or sound reinforcement, such as in stage productions, for either tape or disc recording, and for dual-channel playback. Similarly, it may be easily adapted for dual-channel operation from conventional sources such as radio or phonograph recordings by attenuating the high frequencies in one channel and the lows in the other, thus giving a semblance of binaural reproduction.

A number of design features of the two-channel system should be noted for the benefit of the constructor. It should be realized that the main point of distinction between magnetic recording and other systems is in the use of high frequency bias. For this reason the bias supply of the recording system has been designed as a separate unit in the event that the experimenter already has equipment available for use. The Shure type TR5 or 815 dual-track recording heads used by the author require a peak recording current of from .2 to .5 milli-ampere which is easily obtained by feeding the record coil from the 250- to 500-ohm output winding of an amplifier through a 25,000- to 50,000-ohm series resistor. Thus, any high gain amplifier capable of delivering 10 to 20 volts across 50,000 ohms may be used in combination with a suitable

high frequency bias supply for recording purposes.

Due to the relatively low output of the tape during the playback cycle, precautions must be taken to keep the noise level of the amplifier and associated equipment as low as possible. The effects of ground loops in introducing hum are well known, but a problem of increasing proportions is that of reducing other noises such as hiss. In many instances, the plate resistors of the input stages, as well as the cathode resistors, if not adequately bypassed, may cause a great deal of high frequency noise of an objectionable nature and for best results highly stable resistors should be used in these locations. Although the nominal impedance of the type TR5 record-playback head is about 1600 ohms it appears to work quite satisfactorily into the 500-ohm impedance of an input transformer such as the *Chicago* type BI-7 and provides a considerable amount of additional hum and noise-free gain. Similarly, the use of input transformers of this nature is necessary in order to take advantage of the desirable qualities of professional low-impedance microphones. If used they should be mounted as far from the power transformer as possible, and connected by means of low capacity microphone cable.

A common power supply is used for the two amplifier channels and is shown using a choke input filter to provide a lower voltage for longer component life. If higher output is desired, additional plate voltage can be obtained by placing another filter condenser between the rectifier cathode and ground. High quality output transformers with balanced high and low impedance windings are used, making the system adaptable for use with conventional speakers or for driving telephone lines or remote speakers for special purposes. In the circuit shown, simultaneous tone control of both channels is accomplished by a multiple switch although the channels may be individually controlled if desired.

Changeover from record to playback cycles is accomplished manually by removing the recording head connections from the output sockets and inserting them at the microphone input and likewise connecting the loudspeakers to the output. Although not as convenient, this arrangement is much more flexible and less complicated than if automatic switching of the circuit elements were used.

In mounting an additional record-playback head on a tape mechanism, several factors should be considered. One of the first of these is to be sure that the head is not positioned in such a manner as to cause serious hum pickup from motor or transformer fields. A second factor of importance is to insure that the tape will be pulled smoothly across the head with a minimum of flutter or side sway. Small tape guides with quarter-inch slots and a pressure brush may be

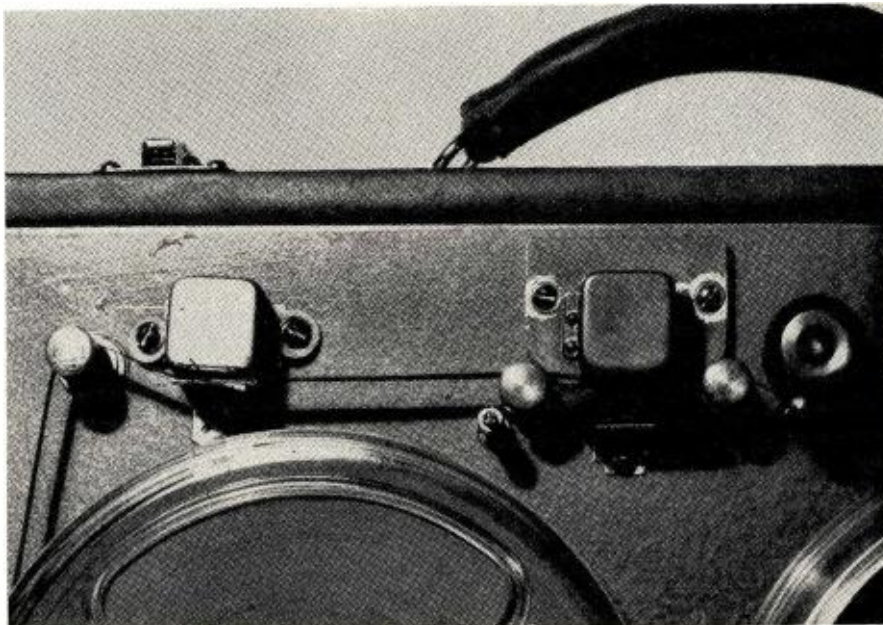

Close-up view of the tape recorder showing how second recording head is mounted.

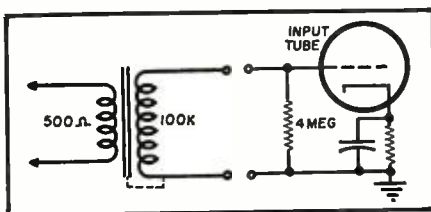

Connection for low impedance microphones. Input transformer should be as far from power transformer as possible and a few feet of low capacity mike cable used to connect high impedance side of transformer to grid of the input tube.

desirable to minimize these effects, but should not introduce too much drag on the tape. If it is necessary to play tapes of a multiple channel nature on more than one machine the distances between the two playback heads must be kept to close tolerances. A variation of one-sixteenth inch may be acceptable if widely spaced microphones are used, or for dubbing purposes, as at the 7.5 inch tape speed this will correspond to a delay of

(Continued on page 100)

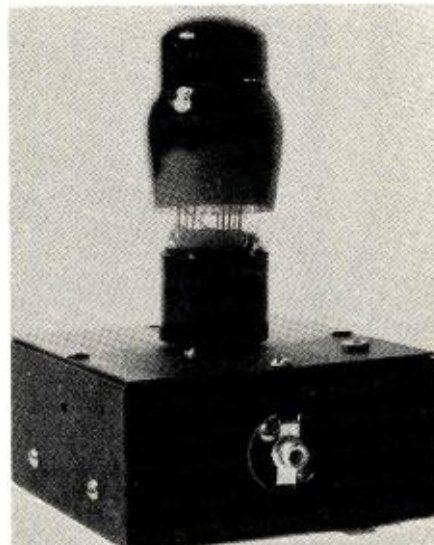

The high-frequency bias supply can be constructed on a compact and separate chassis. If the builder has this equipment available he may use it instead of building this unit—which is why it was built separately.

Schematic of the common power supply for the two amplifier channels and bias supply.

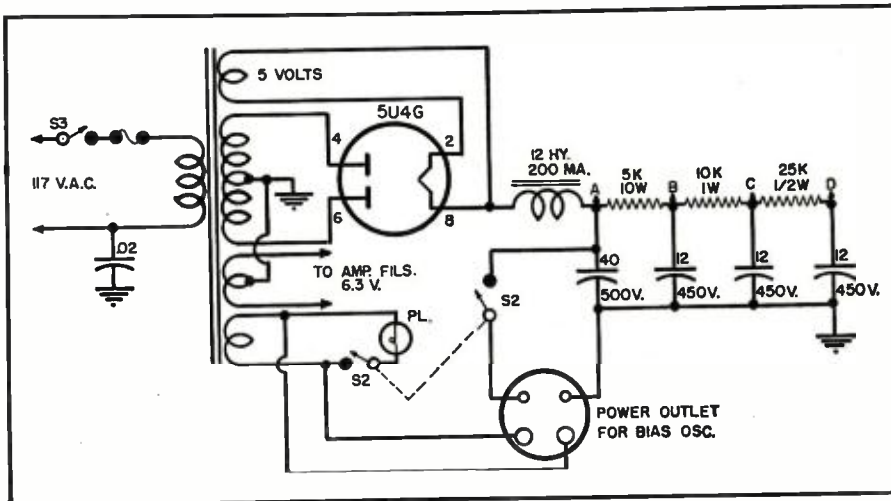



International SHORT-WAVE

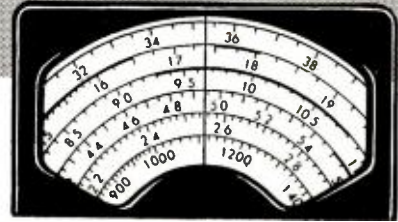

Compiled by KENNETH R. BOORD

IT IS a pleasure to dedicate the March *ISW DEPARTMENT* to *Kol Zion Lagolah* ("The Voice of Zion") of the World Zionist Organization, P. O. Box 754, Jerusalem, Israel. Thanks for this material go to Anson Boice, Connecticut, editor for the "United 49'ers Radio Society"; Deborah Landman of the English Section, *Kol Zion Lagolah*, and to "KARNENU," the Jewish National Fund's monthly magazine.

As the clock struck midnight on March 11, 1950, a new voice went vibrating across the world. A man in London, twiddling knobs, suddenly heard a Londoner speak in Jerusalem. A Parisian Zionist caught the news of Israel coming over the ether in pure Parisian French. A SWL at a receiving set in Boston was astonished to pick up a commentary on Middle East affairs in Yiddish. Ever since that first venture in the atmosphere, *Kol Zion Lagolah* has broadcast every "night" from Jerusalem for three quarters of an hour in three languages (this broadcasting time has now been extended and includes periods in *English*, French, Yiddish, and Hebrew).

Naturally, the English Service has the largest potential audience, but this is limited largely to European listeners and to SWL's in other parts of the world who have powerful receivers. However, rebroadcasts of *Kol Zion* programs are achieving much popularity in the United States and Canada where 70 stations which operate from

widely dispersed towns present weekly "Vistas of Israel" and a *Kol Zion* liaison office by this time should have been opened in the United States. A half-year's visit to Israel by one of the script-writers of the Jewish Theological Seminary program, "The Eternal Light," which is aired over the network of the *National Broadcasting Company*, brought Jerusalem nearer to New York City.

Kol Zion started with one recording machine and a dozen tapes! The shortage of producers, studios, English-perfect actors, and above all, scripts, has never vanquished the small, stubborn team responsible for the English Service. Even for Israel—which specializes in adapting square pegs to round holes—the personnel embraces a goodly variety of backgrounds—Geoffrey Wigoder, Oxford Rabbinical scholar, supervises the efforts of Edward Ellison, foreign correspondent; Deborah Landman, formerly a social worker, and Anita Davis, ex-Unity Theater actress. None of the staff had radio experience before they began to turn their lofty Arab mansion into a flurry of flying manuscripts and sudden atmospherics. Yet somehow, pro-

(Note: Unless otherwise indicated, all time is expressed in American EST; add 5 hours for GCT. "News" refers to newscasts in the English language. In order to avoid confusion, the 24 hour clock has been used in designating the times of broadcasts. The hours from midnight until noon are shown as 0000 to 1200 while from 1 p.m. to midnight are shown as 1300 to 2400.) The symbol "V" following a listed frequency indicates "varying." The station may operate either above or below the frequency given. "A" means frequency is approximate.

grams get written and plaintive liturgical melodies mingle with the more lively Hora.

The National Institutions—the World Zionist Organization, Keren Hayesod, and Keren Kayemeth Leisrael—together finance *Kol Zion Lagolah*. Under the direction of Mordechai Avida, it has proved a first-class ally in linking the scattered legions of Zionism by spreading information on the work being accomplished.

That dry, statistical word "afforestation" took on new life when *Kol Zion* visited the Weizmann Forest and described Viscount Samuel and Lord Nathan planting the first saplings. Afterwards, the late President Weizmann heard the recordings as he lay ill in his Rehovot home. Recently, Swedish audiences had the chance of listening to speeches honoring the late Count Bernadotte at the inauguration of the Bernadotte Forest.

Sandwiched between Hebrew lessons and a quiz on Jewish history, a series of talks and tunes of the Chassidic Rabbis come to charm lovers of the picturesque.

"Music—which occupies a large percentage of broadcasting hours—is able to convey our strange heterogeneous Israel better than any other medium," *Kol Zion* officials point out. "Before the Israel Philharmonic left on its American tour, *Kol Zion* recorded a rehearsal with Leonard Bernstein's directions and suggestions, together with an interview later sent to the United States and rebroadcast there."

National events together with the Orchestra's tour received their full share of publicity. The Maccabiah and Independence Day programs carried thousands of isolated Jewish families into the heart of Israel to hear for themselves the singing and cheering. Greatest "live" success to date has been the coverage of the 23rd Zionist Congress in Jerusalem. At last, *Kol Zion* enjoyed adequate studio facilities and an up-to-the-minute system of reporting, even recording the simultaneous *English* translations from Hebrew and Yiddish speeches.

The mere fact that *Kol Zion* comes straight from Israel is enough to ensure an eager audience—however little Hebrew its members comprehend. A letter from one grateful listener in Ireland—blind—or from the Scottish grandfather who "was allowed to stay up and listen with the family" com-

(Continued on page 122)

Sylvia Berger, scriptwriter for "The Eternal Light" program (aired over the NBC in the United States), makes a recording in an immigrant village in Israel.





Corner Reflector No. UHF400



"Bowtie-Flector" No. UHF600



Ultra V-Beam No. UHF500

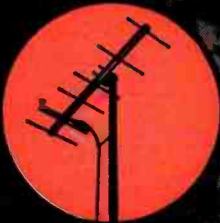

YAGIS No. UHF300 Series for Channels 14 to 83

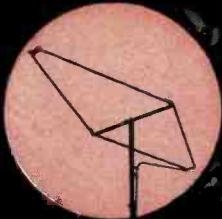

Rhombic No. UHF 200

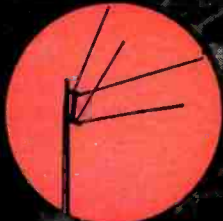

"Double-Yee" No. UHF100

When there are new worlds to conquer, JFD will do it!

Now our engineers have combined the famous JFD VHF Jetenna and UHF bowtie antenna into a miracle performer that pulls in all channels—from 2 to 83. Use it with the especially developed filter network* for perfect reception, completely free of inter-spectrum interference. Pre-assembled construction, all aluminum, even to solid aluminum dowels.

Write for the new 1953 JFD dealer almanac on your letterhead—36 pages of the widest TV antenna and accessory line in the industry.

*optional

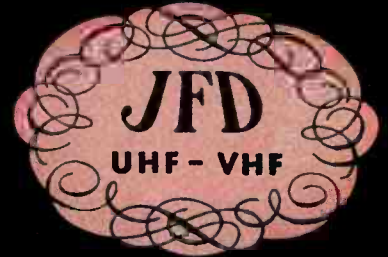

it's out of this world!

new, VHF-UHF All-Channel Antenna —the Jet 283

one antenna—one transmission
line for all channels from 2 to 83

JFD MFG. CO., Brooklyn 4, N. Y., Bensonhurst 6-9200

world's largest manufacturer of tv antennas and accessories



Burton brown advertising

HARVEY

The House
of Audio.



THE ORIGINAL WILLIAMSON HR-15 AMPLIFIER KIT

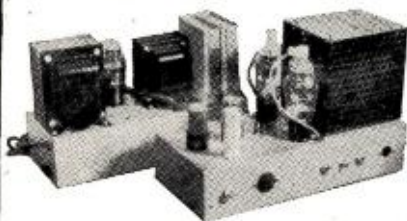

The famous, original Williamson HR-15 . . . still acclaimed the leader . . . in kit form, with the Partridge Output Transformer specified by Williamson in his original design. Assemble this kit, and in 3 hours or less, enjoy the finest sound you ever heard. Operates on a tuner, phono-preamp, crystal pick-up, or other signal source. Absolute gain is 70.8 db with 20db of feedback. Frequency response: $\pm .5$ db, from 10 to 100,000 cps. Output impedances to match all speakers from 1.7 to 109 ohms. Kit is complete with 5 tubes (1-5Y4, 2-6SN7, and 2-5881 (or 807 if requested), 2-Punched Chassis, 2-Resistor Mounting Strips, Sockets, Partridge WWFB Output Transformer, Assembly Instructions, and All Other Necessary Parts for Amplifier and Power Supply. **\$76.50**

PARTRIDGE OUTPUT TRANSFORMERS

Available Separately. WWFB. **\$26.00**

NOTE: HR-15 may be had with British KT-66 Output tubes for \$3.00 additional.



R-J SPEAKER ENCLOSURES FLOOR MODELS

Designed for use with ANY 12 or 15 inch speaker, this new sensation in high fidelity has no counterpart in anything available today. The R-J is a new concept. Large enough only to accommodate the speaker, it reproduces tones to the lowest limits of audibility, cleanly and without hangover. The R-J is the amazing solution to the problem of space versus quality.

Model FM (Mahogany) **\$49.95**
Model FB (Blonde) **54.50**
Model F15UM (Unfinished Mahogany)
15" only **43.35**
Specify for 12 or 15 inch speaker.

Model FM (Mahogany) **\$49.95**
Model FB (Blonde) **54.50**
Model F15UM (Unfinished Mahogany)
15" only **43.35**
Specify for 12 or 15 inch speaker.



WHARFDALE Super 12-CS-AL 12-IN. LOUDSPEAKER

Generally regarded as one of the finest British speakers, the 12-CS-AL has a remarkably smooth response from 30 to 18,000 cps when adequately baffled. Extremely low cone resonance reduces transient distortion to an absolute minimum, and contributes to clean, fundamental bass without 'boom'. High frequency response is free of harsh, strident quality normally experienced in sharply peaked upper registers. Nominal impedance is 15 ohms; Power Handling, 12 watts; Weight, 18 1/4 lbs.; and Cone Resonance between 35 and 45 cps. **\$61.95**

ably smooth response from 30 to 18,000 cps when adequately baffled. Extremely low cone resonance reduces transient distortion to an absolute minimum, and contributes to clean, fundamental bass without 'boom'. High frequency response is free of harsh, strident quality normally experienced in sharply peaked upper registers. Nominal impedance is 15 ohms; Power Handling, 12 watts; Weight, 18 1/4 lbs.; and Cone Resonance between 35 and 45 cps. **\$61.95**

NOTE: Prices Net, F.O.B., N.Y.C.
Subject to change without notice.



Harvey

RADIO COMPANY, INC.

103 W. 43rd St., N. Y. 36, N. Y. • LU 2-1500

NEW TV GRANTS SINCE FREEZE LIFT

Continuing the listing of construction permits granted by FCC since lifting of freeze. Additional stations will be carried next month.

STATE	CITY	CALL**	CHANNEL	FREQUENCY (mc.)	POWER (Video)*
Alabama	Birmingham	WSGN-TV	42	638-644	1000
"	Birmingham	WJLN-TV	48	674-680	230
Arizona	Tucson	KCNA-TV	9	186-192	25
California	Bakersfield	29	560-566	20.5
"	Los Angeles	KPIK	22	518-524	540
Colorado	Colorado Springs	KKTV	11	198-204	250
Connecticut	New London	26	542-548	105
Florida	Lakeland	16	482-488	85
"	W. Palm Beach	WIRK-TV	21	512-518	22
Idaho	Boise	7	174-180	51
Illinois	Danville	WDAN-TV	24	530-536	19
"	Peoria	WTVH-TV	19	500-506	95
Indiana	Lafayette	59	740-746	20
Louisiana	Baton Rouge	40	626-632	290
"	Lake Charles	25	536-542	20
"	Monroe	KNOE-TV	8	180-186	175
"	Monroe	KFAZ	43	644-650	77
Maine	Bangor	WABI-TV	5	76-82	1.9
Maryland	Baltimore	60	746-752	105
Michigan	Muskegon	35	596-602	269
Mississippi	Meridian	30	566-572	210
Missouri	Festus	14	470-476	170
Nevada	Reno	8	180-186	3
New York	Buffalo	59	740-746	91
"	Buffalo	WBUF	17	488-494	165
"	Watertown	48	674-680	185
Ohio	Lima	WIMA-TV	35	596-602	91
"	Zanesville	WHIZ-TV	50	686-692	91
Oklahoma	Lawton	7	174-180	10
Pennsylvania	Altoona	10	192-198	316
"	Bethlehem	WLEV-TV	51	692-698	2.25
"	Harrisburg	WHP-TV	55	716-722	240
"	Johnstown	56	722-728	91
"	New Castle	WKST-TV	45	656-662	20.5
"	Reading	WHUM-TV	61	752-758	260
"	Reading	WEEU-TV	33	584-590	225
"	Scranton	WTVU	73	824-830	11
"	Scranton	WGBI-TV	22	518-524	290
"	York	WNOW-TV	49	680-686	96
"	York	WSBA-TV	43	644-650	170
"	Wilkes-Barre	WBRE-TV	28	554-560	1000
"	Wilkes-Barre	WILK-TV	34	590-596	250
"	Williamsport	WRAK-TV	36	602-608	21
"	Philadelphia	WIP-TV	29	560-566	275
South Carolina	Charleston	WCSC-TV	5	76-82	100
"	Columbia	WCOS-TV	25	536-542	89
"	Columbia	WNOK-TV	67	788-794	680
South Dakota	Sioux Falls	KELO-TV	11	198-204	57
Tennessee	Chattanooga	WOUC	49	680-686	20
"	Chattanooga	WTVT	43	644-650	275
Texas	Amarillo	KGNC-TV	4	66-72	100
"	Amarillo	KFDA-TV	10	192-198	56
"	Austin	18	494-500	216.5
"	Austin	KTBC-TV	7	174-180	109.6
"	Austin	KTVA	24	530-536	280
"	El Paso	KTSM-TV	9	186-192	64
"	El Paso	KROD-TV	4	66-72	56.3
"	El Paso	KEPO-TV	13	210-216	120
"	Galveston	KGUL-TV	11	198-204	59

*ERP=(effective radiated power). **Call letters without TV suffix from application files and subject to change; except where included in calls such as KKTV or WTVT.
.. = Call letters to be announced.

For opportunities within your reach

See what the RCA TV Servicing Course offers you

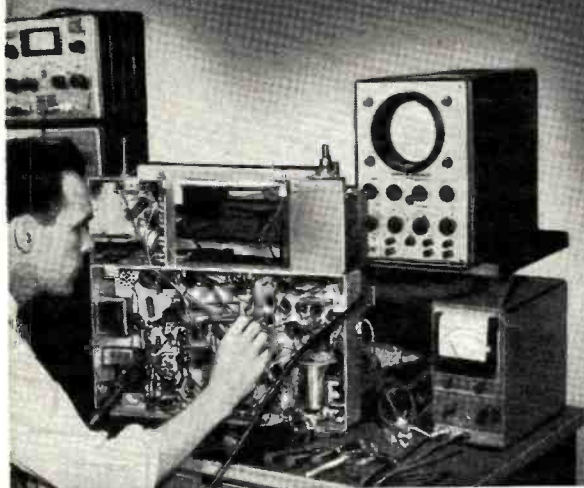

Good-pay jobs. A business of your own.

OPPORTUNITIES FOR GOOD-PAY JOBS in Television are within your reach when you study TV Servicing by the RCA Institutes Home Study Method. Or perhaps you would like to start a TV Service business of your own.

If you are not satisfied with the way your future now stacks up, see how easily

you can change the course of your career. RCA Institutes Home Study Course in TV Servicing is helping thousands of other people to better jobs. It can help you. Right now thousands of opportunities are going begging. There is a critical shortage of trained TV servicemen. This is *your* big opportunity.

Easy-to-understand, illustrated lessons



The entire course is divided into ten units of several individual lessons. You study them at home in your spare time.

Lesson-by-lesson you learn the theory and step-by-step procedures of installing TV antennas, of servicing and trouble-shooting TV receivers. Hundreds of pictures and diagrams help you understand the how-it-works information and the how-to-do-it techniques. You will be amazed how easily you absorb the knowledge of each lesson, how quickly you train yourself to become an experienced technician.

Experienced engineers and faculty prepared the course, grade your lessons



The RCA Institutes course was written and planned by instructors with years of specialized

experience in training men by home-study and resident-school methods. The course embodies RCA's background of television experience plus knowledge gained in training several thousand technicians. A study of the course parallels an apprentice's training. Your lessons are carefully examined and accurately graded by friendly teachers who are interested in helping you to succeed.

RCA Institutes conducts a resident school in New York City offering day and evening courses in Radio and TV Servicing, Radio Code and Radio Operating, Radio Broadcasting, Advanced Technology. Write for free catalog on resident courses.

One of the leading and oldest Radio-Television training schools



Founded in 1909, RCA Institutes, Inc. has been in continuous operation for the past 44 years. Its

wide experience and extensive educational facilities give students, just like you, unsurpassed technical training in the highly specialized field of radio-television-electronics.

RCA Institutes is licensed by the University of the State of New York . . . an affiliate member of the American Society for Engineering Education . . . approved by the Veterans Administration . . . approved by leading Radio-Television Service Organizations.

It costs so little to gain so much

RCA Institutes makes it easy for you to take advantage of the big opportunities in TV Servicing. The cost of the TV Servicing Home Study Course has been cut to a minimum. You pay for the course on a pay-as-you-learn unit lesson basis. No other home study course in TV Servicing offers so much for so little cost to you.

SEND FOR FREE BOOKLET—Mail the coupon—today. Get complete information on the RCA INSTITUTES Home Study Course in Television Servicing. Booklet gives you a general outline of the course by units. See how this practical home study course trains you quickly, easily. Mail coupon in envelope or paste on postal card.



MAIL COUPON NOW!

RCA INSTITUTES, INC., Home Study Dept. RN353
350 West Fourth Street, New York 14, N.Y.

Without obligation on my part, please send me copy of booklet "RCA INSTITUTES Home Study Course in TELEVISION SERVICING." (No salesman will call.)

Name _____ (please print)

Address _____

City _____ Zone _____ State _____



RCA INSTITUTES, INC.
A SERVICE OF RADIO CORPORATION of AMERICA
350 WEST FOURTH STREET, NEW YORK 14, N.Y.

The C-800 is here
to bring you new
record performance!



the new
craftsmen 800

FM-AM TUNER

with built-in phono
preamplifier and
record equalizer

Now—Craftsmen brings you a tuner that matches all your finest records... is setting new records for versatility, too. The C-800 is further evidence that Craftsman leadership in high fidelity is something you can put your finger on, something you can hear.

- Front-panel-selected equalization for AES, LP or EUROpean recording characteristics. Inverse feedback compensated dual-triode phono preamp for correct turnover and roll-off characteristics.
- Improved AM reception. Wider bandwidth for better fidelity, and sharper IF bandpass "skirts" for greater selectivity.
- Double-shadow tuning eye and AFC (no drift) on FM simplifies tuning. Front-panel AFC cut-out for tuning weak stations.
- Efficient new layout. Bottom plate, completely shielded chassis minimize oscillator radiation, assure tuner isolation.
- Cathode follower audio output for remote installations; 2 volts at less than 1/2% dist. Detector output also has cathode follower for recording applications.
- Bass and treble controls continuously variable from attenuation to boost—flat position clearly marked. Selector positions: FM, FM with AFC, AM, TV, LP, AES, EUR, and SPare.
- Mahogany-finish wood cabinet available.

HIGH FIDELITY—LOW COST! C-400 audio amplifier offers 10 watts ± 1 db., 15—20,000 cps., less than 1% distortion. New streamlined chassis design.

Write
today for
information

THE RADIO

craftsmen INC.

Dept. R-3, 4401 N. Ravenswood Ave.
Chicago 40, Ill.



U.H.F. Antennas
(Continued from page 55)

siderably. This applies to vertical placement as well as to horizontal position.

Keep lead-in lines from separate v.h.f. and u.h.f. antennas away from each other. Any undesirable u.h.f. signals picked up by the v.h.f. array can be transferred from the v.h.f. lead-in line to the u.h.f. lead-in line if the two lines come close enough to each other. Generally a six-inch separation will prevent this type of signal transfer.

In areas where there is no trouble from ghosts, choosing the best location for the u.h.f. antenna can be quickly carried out using a field intensity meter. Since u.h.f. meters are not yet available, any of the v.h.f. instruments which use a *Standard Coil* tuner can be adapted to u.h.f. by simply replacing some of the unused v.h.f. channel strips with appropriate u.h.f. strips. *Simpson, Transvision, and Approved Electronics* field intensity meters fall in this category.

The type of antenna to be used will depend, to a large extent, on the strength of the received signal and on the interference conditions existing at that location. Near the transmitter, a simple array such as the fan dipole may prove quite satisfactory. Farther out, a stacked "V", a parabola, or even a rhombic array may be required. These are capable of greater gain and sharper directivity, if this latter feature is required. In very weak signal areas, stacked dipoles, yagis, and stacked rhombics would probably bring in whatever signal is present.

In u.h.f. installations, the admonition to raise the antenna as high as possible will generally pay off. That is, a definite signal increase with height is generally noticeable, although exceptions will be encountered from time to time. Of course, this must be tempered by the fact that the higher the antenna, the greater the amount of lead-in required and sometimes the increased lead loss can offset the stronger signal.

The increase in signal strength with height is not a smooth transition, but rather one that varies between minimum and maximum. Thus, as you go up, the signal strength will rise, then decrease somewhat with further height, then rise again, etc. This variation is due to the fact that the signal present at the antenna is a combination of a direct ray and a ground reflected ray. Where these two rays combine in-phase, signal strength is high; where they combine out-of-phase, signal strength obviously would be lowered.

You may also find a similar variation as you move the antenna horizontally although here the presence of buildings, towers, foliage, hills, etc., has a greater disturbing effect.

The rise in operating frequency

brings with it additional effects aside from those already noted. For one thing, the ability of the wave to pass around objects and obstacles in its path decreases as the size of these objects approach and exceed the wavelength of the passing signal. Thus, a high tower or a long chimney stack may appear inconsequential to frequencies of 50 mc. or less; to 550 mc. waves, it may become quite formidable, and in many instances, unpassable. Also, at ultra-high frequencies it has been observed that the growth of leaves and other foliage in the spring and summer can reduce the strength of otherwise strong signals. Sometimes, a usable picture in the winter will become completely unusable in the spring and summer. This point must be kept well in mind during fall and winter installations when foliage may be sparse or missing. In the summer, with the greenery in full bloom, signal areas found to be useful can be depended upon to maintain or even increase in signal intensity during the colder months of the year.

The sensitiveness of short waves to small and moderately sized obstacles is further demonstrated when indoor u.h.f. antennas are utilized. It has been found that these are generally unsatisfactory except in the strongest signal areas and even here, wide fluctuations in signal strengths have frequently been found to occur whenever anyone walked in front of the antenna. Where it is impossible to erect roof antennas, due to certain restrictions, then window-mounted arrays are next preferred. Only as a last resort should indoor antennas be attempted.

EDITOR'S NOTE: Those desiring additional information on u.h.f. practices are referred to Mr. Kiver's forthcoming book "U.H.F. Antennas, Converters, and Tuners" to be published by Howard W. Sams & Co., Inc., 2203 E. 46th St., Indianapolis 5, Indiana.

—50—

Speaker Tester
(Continued from page 58)

The physical layout of the unit (see Fig. 1) is not important as there is no oscillation problem. It can be set up and wired in any manner, such as on a panel, in a wooden case, or in any other available housing.

The dials were made by marking the proper values and letters on cardboard cut to dial size then covered with a thin sheet of *Plexiglas*. The panel mounting nuts on the switches also serve to hold down the dials and their covers.

For fast servicing with popular-brand radio and TV sets, plugs may be made with the proper test leads to enable the technician to quickly plug the substitute speaker into the set. This eliminates extra handling and makeshift connections.

—50—

Let HEATHKITS CREATE AN ELECTRONICS LABORATORY OR SERVICE SHOP FOR You

New Free
MANUALS SHOW YOU HOW!

Here is visual proof of the top-dollar value offered only by Heathkits. Think of the tests made possible through the use of suggested combinations as shown below. When more instruments are required, additional Heathkits can be selected from the greatest kit instrument line ever offered.

PLANNING YOUR SERVICE SHOP

BY JOHN T. FRYE



Here is complete first-hand information written in a refreshing authoritative style by a man with over a quarter century of experience in radio and TV work. In this booklet John T. Frye discusses all factors involved in establishing a service business. Consideration is given to the type of business, location, selection of tools and instruments, bookkeeping procedures, job records, business promotion, and other similar subjects. Full explanation of the method used in computing service charges and how to establish a rate which will insure a fair and profitable return on your investment will prove very helpful. This booklet is available to Heathkit customers at no charge. Write for your free copy.

ESTABLISHING THE INDUSTRIAL ELECTRONICS LABORATORY

BY LOUIS B. GARNER, JR.

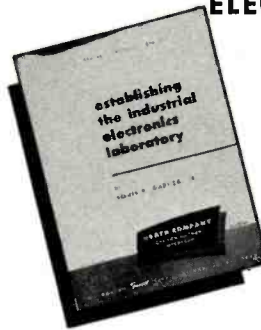

A service offered by the Heath Company for the direct assistance of those involved in laboratory work. In this booklet, by Louis B. Garner, Jr., full consideration has been given to all factors required in establishing an electronics laboratory. Information regarding the type of laboratory—laboratory layout—space allotment—lighting and service facilities—personnel—heating and air conditioning, etc. Work benches, as well as other details such as desks, shelves, cabinets, drafting tables, stools, etc., are discussed. This valuable booklet is offered to Heathkit customers at no charge. Write for your free copy.

BASIC SERVICE SHOP

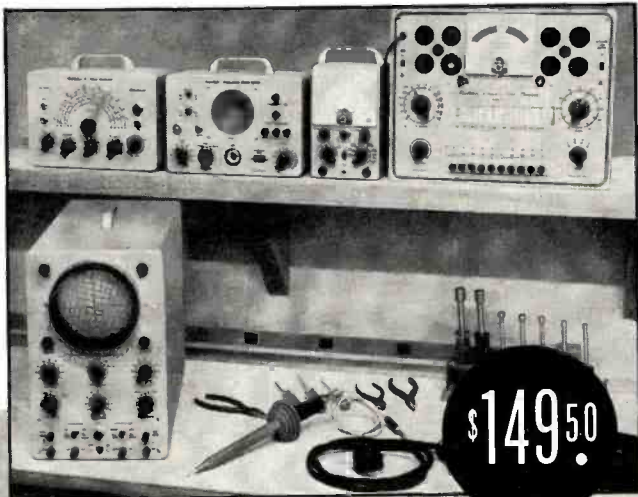

\$149.50

This group of instruments represents a typical combination of basic test equipment required for Radio and TV service work. Here is emphatic proof of the tremendous economy offered only by Heathkits. Seven basic equipment items for less money than the price quoted for a single commercially available instrument such as a general purpose oscilloscope. A serviceman can easily assemble this entire group of instruments in 45 actual working hours.

7 Complete KITS

- Oscilloscope
- VTVM
- Signal Generator
- Signal Tracer
- Tube Checker
- TV Picture Adapter
- High Voltage Probe

TYPICAL LABORATORY

11 Complete KITS

- Oscilloscope
- Voltage Calibrator
- Electronic Switch
- VTVM
- AC VTVM
- Power Supply
- Q Meter
- Decade Resistance
- Decade Condenser
- Resistance
- Substitution Box
- Audio Oscillator

This combination of eleven typical instruments, required for any Electronics Laboratory, clearly illustrates the economy offered by the purchase of Heathkit equipment. Practically an entire basic laboratory for the price of one piece of factory built equipment. These instruments can be assembled by a laboratory technician in approximately 55 actual working hours.

\$263.50



Additional information regarding these instruments will be found on the following pages. Write to the Heath Company for a free

catalogue listing all Heathkits—schematics—specifications and applications.

EXPORT AGENT
ROCKE INTERNATIONAL CORP.
136-40th ST.
NEW YORK CITY (16)
CABLE AREA 5-Y

The HEATH COMPANY

... BENTON HARBOR 15, MICHIGAN

NEW Heathkit "Q" METER KIT

• A HIGH QUALITY Q METER AT LOW COST.

MODEL QM-1

SHIPPING
WT. 12 LBS.

\$39.50

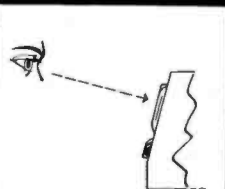
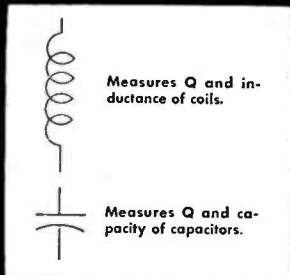

Slant face cabinet for ease in reading the meter.



• First Q METER within the price range of all.

• Read Q's of 0-500 directly on calibrated scale.

• Stable oscillator supplies R.F. frequencies of 150 kc to 18 megacycles.

• Calibrated capacitor with range of 40 mmf to 450 mmf with vernier of ± 3 mmf.

• Simple, easy operation.

• Can be used to measure small inductances or capacitors.

• Measures Q of condensers, RF resistance and distributed capacity of coils.

• Measures capacity by substitution, capacity by resonance, inductance by resonance.

• Slanted panel for convenient operation.

Another outstanding example of progressive HEATHKIT engineering. Now a highly desirable Q METER within the price range of all laboratories, schools and experimenters. No longer is it necessary to deny yourself the many measurement advantages offered by this instrument.

Use the new HEATHKIT Q METER for the following simple basic measurements: capacity by substitution, capacity by resonance, inductance by resonance and Q at the OPERATING frequency all can be read on the calibrated scales. The method used to obtain information regarding the Q of condensers, RF resistance, distributed capacity in coils, etc., is only slightly more involved. In the HEATHKIT Q METER, the generated RF signal is coupled through a cathode follower and injected across a low impedance condenser which is included in the resonant circuit under test. Large $4\frac{1}{2}$ " 50 microampere Simpson meter reads Q directly. The resonating condenser and vernier condenser are calibrated in mmf for substitution method capacity tests. The resonating condenser is also calibrated in effective capacity for resonance tests. The inductance calibration serves for rapid determination of the approximate inductance of a coil. The HEATHKIT Q METER has a generator frequency range of 150 kc to 18 megacycles. Vernier capacity covers ± 3 mmf and the resonating condenser is calibrated from 40 mmf to 450 mmf actual capacity or 40 mmf to 350 mmf effective capacity. Meter reads Q directly up to 250. Higher and lower full scale readings can be obtained by varying the injection voltage levels.

The entire kit consists of 12AT7, 6AL5, 6C4, OD3 and 6X5 tubes, 50 microampere Simpson meter, power transformer, cabinet and all other parts necessary for construction as well as instructions for assembling, testing and operation of the completed instrument.

Heathkit DECADE RESISTANCE KIT

The HEATHKIT DECADE RESISTANCE KIT is widely used by schools, experimenters and laboratories because of the extremely wide resistance range offered and the useful, dependable service provided. The DECADE consists of 5 rotary 2 deck ceramic wafer switches with silver plated contacts and twenty 1% precision resistors in a circuit which provides the resistance range of 1 ohm to 99,999 ohms in 1 ohm steps. The HEATHKIT DECADE RESISTANCE KIT is simple to construct and is housed in a beautiful polished birch cabinet with an attractive panel. The DECADE will furnish years of accurate trouble-free service.

Individual decade sections of above can be purchased separately for special applications.



MODEL DR-1
SHIPPING
WT. 4 LBS.

\$19.50

NEW Heathkit DECADE CONDENSER KIT

Extremely useful in all experimental and design work such as determination of condenser values for: compensating networks, filters, bridge impedances, tuned circuits, etc. Uses all precision silver mica condensers within $\pm 1\%$ accuracy. Values run in three decades from 100 MMFD to 0.111 MFD in steps of 100 MMFD. Smooth acting, positive detent, highest quality ceramic wafer switches make all capacitor values easy to set up and keep losses to a minimum. Low loss dielectric terminal board mounts on outside of panel for easy cleaning. Heathkit binding posts accommodate a wide variety of test leads. Comes complete with all parts, including polished birch cabinet.

Individual decade sections of above can be purchased separately.



MODEL DC-1
SHIPPING
WT. 4 LBS.

\$16.50

EXPORT AGENT
ROCKE INTERNATIONAL CORP.
13 E. 40th ST.
NEW YORK CITY (16)
CABLE AREA-NY

The **HEATH COMPANY**

... BENTON HARBOR 15, MICHIGAN

NEW *Heathkit* OSCILLOSCOPE KIT

• NEW WIDE BAND VERTICAL AMPLIFIER ± 2 DB 10 CYCLES TO 1 MC.

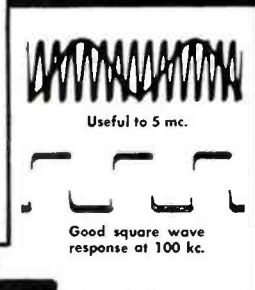
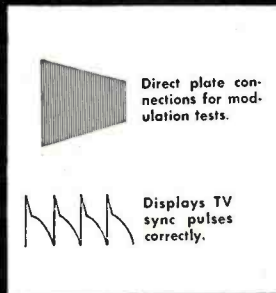

MODEL O-8

SHIPPING
WT. 29 LBS.

\$43.50



- New wider band vertical amplifier ± 2 db from 10 cycles to 1 megacycle useful to over 5 megacycles.

- High sensitivity in vertical amplifier. .025 volts RMS per inch deflection.

- New 3 step input attenuator inpuf ranges X1, X10, X100.

- Terminal board and rear cabinet opening provisions for direct connections to deflecting plates.

- Newly styled formed and ventilated aluminum cabinet.

- Wide band sweep generator, 15 cycles to over 100 kc. Will synchronize with 5 megacycle signal.

- 10 tube circuit featuring push pull operation of vertical and horizontal amplifiers.

- Internal synchronization on either positive or negative peaks.

- Reproduces faithfully the front and back parches of TV sync pulses. Excellent square wave reproduction to over 100 kc.

- Optional Intensifier kit available for 2200 volt operation.

Proudly announcing the new 1953 HEATHKIT Model O-8 OSCILLOSCOPE featuring the finest performance ever offered in this extremely popular kit instrument. Improved wider band vertical amplifier featuring a new 3-step input attenuator affording smooth control of the excellent .025 volts per inch vertical sensitivity. Possibility of overloading the vertical input circuit is minimized. Greater band width in the vertical channel is a decided advantage to TV service men. Permits clear observation of all TV sync pulse detail and excellent square wave reproduction over 100 kc. A handsome, ventilated cabinet with smooth rounded corners and a snug fitting drawn panel adds to the smartly styled professional appearance. Longer life is assured through cooler instrument operation. Push pull output stages in both vertical and horizontal amplifiers for balanced deflection of the spot. All of the many fine features of the previous model have been retained. Rear cabinet access to terminal board for direct connection to CR plates. The entire kit of all 10 tubes, parts, cabinet and panel as well as detailed construction manual for assembly and operation of the instrument included.

Heathkit SCOPE DEMODULATOR PROBE KIT

Trouble shooting or aligning TV, RF, IF and video stages requires demodulation of high frequency signals before Oscilloscope observation. The HEATHKIT SCOPE DEMODULATOR PROBE KIT was specifically developed for this application. Kit consists of a probe housing, crystal diode detector circuit, shielded cable and spade lugs Assembly is simple and the probe will quickly prove its usefulness as an Oscilloscope accessory.

No. 337
SHIP. WT. 1 LB.
\$4.50

NEW *Heathkit* VOLTAGE CALIBRATOR KIT



MODEL VC-1
SHIPPING
WT. 5 LBS. **\$9.50**

Use the Heathkit Voltage Calibrator with your oscilloscope to measure peak-to-peak TV complex waveshapes. TV manufacturer's specifications indicate correct peak-to-peak voltages and this kit will permit making these important measurements.

A big help to engineers in circuit work. Makes peak-to-peak voltage measurements of complex waveshapes of all kinds. Flat topped semi-square wave output of calibrator assures fast and easy measurement of any voltage between .01 and 100V peak-to-peak.

The Voltage Calibrator can remain connected to your oscilloscope at all times for instant use. "Signal" position connects signal under study directly through calibrator and into scope input circuit for direct observation. Eliminates transferring leads from calibrator. *A wonderful scope accessory.*

Heathkit ELECTRONIC SWITCH KIT



MODEL S-2
SHIPPING
WT. 11 LBS.

A few dollars spent for this accessory will increase the usefulness of a scope immeasurably. An electronic switch will open up a whole new field of scope applications for you. The S-2 allows TWO SIGNALS to be observed at the SAME TIME — this important feature allows you to immediately spot phase shift, clipping, distortion, etc. The two signals under observation can be superimposed or separated for individual study. Each signal input has an individual gain control for properly adjusting scope trace patterns. Has both coarse and fine frequency controls for adjusting switching time. Multivibrator switching frequency is from less than 10 cps to over 2000 cps in three overlapping ranges. Kit comes complete including 5 tubes, power transformer, all controls, instruction manual, etc. *Every scope owner should have one!*

\$19.50

EXPORT AGENT
ROCKE INTERNATIONAL CORP.
13 E. 40th ST.
NEW YORK CITY (16)
CABLE RR148-N.Y.

The **HEATH COMPANY**

... BENTON HARBOR 15, MICHIGAN

Heathkit
VACUUM TUBE

VOLTMETER KIT

• NEW 1½ VOLT RANGE ON 1953 VTVM.

MODEL V-6

SHIPPING
WT., 7 LBS.

\$24.50

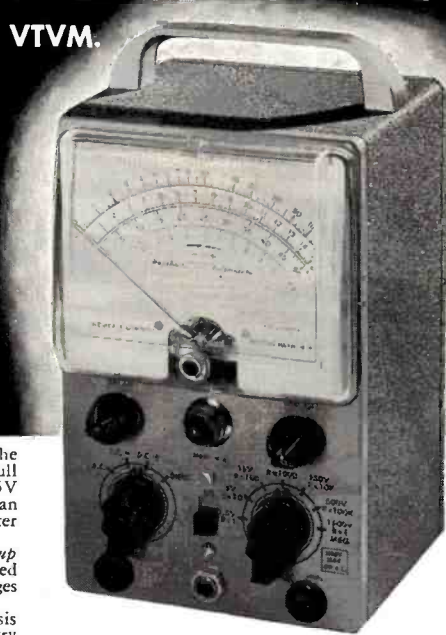
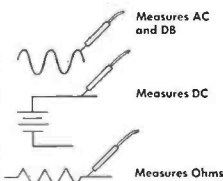
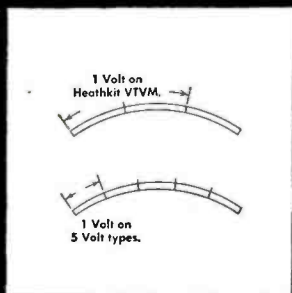

• New 1½ volt low range gives over 2" of scale per volt instead of less than ¾" found on 5 volt range type.

• Increased accuracy due to expanded scales.

• New 1500 volt DC high range gives 50% greater coverage.

• Seven ranges in all. 1½, 5, 15, 50, 150, 500 and 1500 volts DC (1000 volts maximum AC only).

• Provides proper service ranges 150 volts for AC DC work and 500 volts for AC type service.

• High input impedance, 11 megohms minimizes circuit loading.

• Variety of accessory probe kits available.

• 1% precision resistors in multiplier circuits.

• 200 microampere Simpson meter.

• Center scale zero adjust.

• Transformer operated.

• Test leads included.

• New cabinet styling.

• Large, clearly marked meter scales indicate ohms, AC volts, DC volts and DB.

The 1953 Heathkit V-6 VTVM has improved ranges! The lowest range has been moved way down to 1.5V full scale. This gives 3½" of actual scale length for the 1.5V covered — that's 2½ inches per volt!! Now you can make your low level measurements faster and with greater accuracy.

And the upper range has been moved up. Readings up to 1500V DC can be readily made with new, improved VTVM — plus readings up to 1000V on AC. Higher ranges for extended use.

New vertical chassis mounting gives added chassis space for really easy wiring — no tight corners to worry about. Uses only highest quality components throughout, Simpson 200 microampere meter movement combined with 1% precision resistors in multiplier circuit insure highly accurate and dependable readings.

AC and DC voltage ranges are 0-1.5V-5V-15V-50V-150V-500V-1500V. (1000V max. reading on AC) — a total of seven ranges for convenient, accurate readings. Instrument also measures resistance from .1 ohm to over 1 billion ohms in seven handy ranges of RX1, X10, X100, X1000, X10K, X1 Meg. — all convenient multiples of 10 with no skips. Has Db scale in red for easy identification.

New panel has tough baked on enamel finish for freedom from scratches and maximum durability. Modern styled, formed, compact cabinet with rounded edges and crackle finish is truly handsome.

Comprehensive, detailed instruction manual with step-by-step instructions, figures, pictorials, etc. makes assembly a cinch.

Be sure and look over the special accessory VTVM probes below — for added usefulness.

Heathkit R. F. PROBE KIT



SHIP. WT. 1 LBS. **\$5.50**
No. 309

Extends RF range of HEATHKIT 11 megohm VTVM to 250 megacycles ± 10%.

Heathkit 30,000 V. D.C. PROBE KIT



SHIP. WT. 2 LBS. **\$5.50**
No. 336

Provides DC multiplication factor of 100 for any 11 megohm VTVM.

Heathkit PEAK TO PEAK VOLTAGE PROBE KIT



SHIP. WT. 2 LBS. **\$6.50**
No. 338

Reads on DC scale of any 11 megohm VTVM 5 kc to 5 megacycle range.

NEW Heathkit BATTERY TESTER KIT

The new Heathkit Battery Tester measures all types of dry batteries between 1½ volts and 150 volts under actual load conditions. Readings are made directly on a three-color GOOD-WEAK-REPLACE scale that your customers can readily understand. Operation is extremely simple and merely requires that the leads be connected to the battery under test. Only one control to adjust in addition to a panel switch for A or B battery types.

The Heathkit Battery Tester features compact assembly. An accurate meter movement and wire wound control mount in the portable, rugged plastic case.

Use the BT-1 to check portable radio batteries, hearing aid batteries, lantern batteries and photo flash gun batteries.

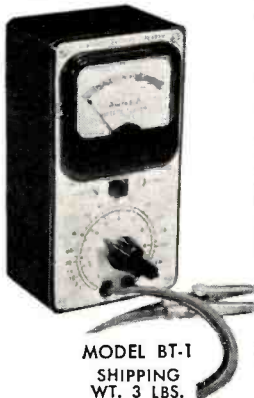

MODEL BT-1
SHIPPING
WT. 3 LBS.

\$7.50

Heathkit AC VACUUM TUBE VOLTMETER KIT

A new AC VTVM that makes possible those sensitive AC measurements required by laboratories, audio enthusiasts and experimenters. Ten full scale ranges of .01, .03, .1, .3, 1, 3, 10, 30, 100 and 300 volts RMS. 10 DB ranges from -52 to +52 DB. Frequency response within 1 DB from 20 cycles to 50 kc. Simpson 200 microampere meter with large plainly marked meter scales. Precision multiplier resistors. Two amplifier stages using miniature tubes. A unique bridge rectifier meter circuit and a clean layout of parts.

Order the AV-2 today and become acquainted with the interesting possibilities offered by this instrument.

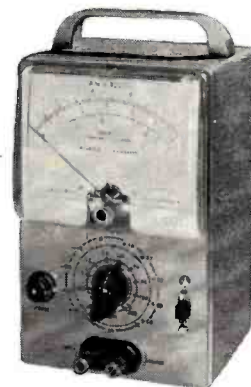

MODEL AV-2
SHIPPING
WT. 5 LBS.

\$29.50

EXPORT AGENT
ROCKE INTERNATIONAL CORP.
13 E. 40th ST.
NEW YORK CITY (16)
CABLE AREA 4-N-Y

The HEATH COMPANY

... BENTON HARBOR 15, MICHIGAN

NEW *Heathkit* GRID DIP METER KIT

• CONVENIENT ONE HAND OPERATION.

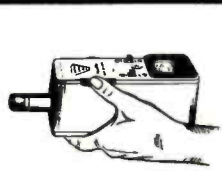
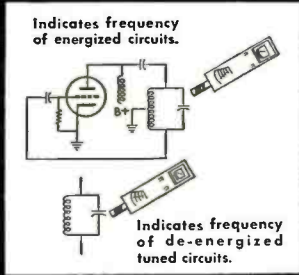

Complete unit easily held and operated with one hand.

MODEL GD-1

SHIPPING
WT. 4 LBS.

\$19⁵⁰



- New GRID DIP METER with assembled calibrated coils.
- Uses quality Simpson 500 microampere meter.
- One hand operation, extremely compact, Only 2½" wide by 3" high by 7" long.
- Variable meter sensitivity control.
- Uses newest type 6AF4 high frequency triode in a Colpitts oscillator circuit.
- Continuous coverage from 2 megacycles to over 250 megacycles in 6 ranges.
- Head phone monitoring jack.
- AC power transformer operated for maximum safety.

Here is the GRID DIP METER KIT you have been asking for. This new HEATHKIT instrument is compact, highly sensitive and easy to use. Housed in a handsome formed aluminum cabinet—rounded corners—durable oven baked finish on panel and cabinet. The entire instrument can be easily held and operated in one hand, tuning accomplished with the thumb wheel drive. This excellent design feature leaves the other hand entirely free for making circuit adjustments. The instrument with many applications — with oscillator energized, use it for finding the resonant frequency of tuned circuits, locating parasitics, determining characteristics of filter circuits, roughly tuning transmitter stages with power off, and neutralizing transmitters. Useful in TV and radio repair work for alignment of traps, filters, IF stages, peaking and compensation networks within the 2 to 250 megacycle range. With the oscillator not energized, the instrument acts as an absorption wave meter and indicates the frequency of radiating power sources. Locates spurious oscillations, as a relative indication of power in various transmitter stages, etc. Phone jack permits monitoring of AM transmitter for determination of radiated hum, audio quality, etc. (Head phones not included). Complete kit includes plug-in coils, tube, all necessary parts and detailed assembly and instruction manual.

Heathkit IMPEDANCE BRIDGE KIT



MODEL IB-1B
SHIPPING
WT. 15 LBS.

\$69⁵⁰

The HEATHKIT IMPEDANCE BRIDGE is especially useful in educational training programs, industrial laboratories and for experimental work. Use it for measuring AC and DC resistance value of resistors,

determination of condenser capacitance and dissipation factor, finding coil inductance and storage factor, electrical measurements work, etc. Quality components: GR 1000 cycle hummer, GR main control, Mallory ceramic wafer silver plated contact switches, ½% precision resistors, etc. The basic circuit is a self powered, 4 arm bridge. Choice of Wheatstone, Capacitance comparison, Maxwell or Hay bridge circuits. Resistance from 10 milliohm to 10 megohm. Capacitance 10 mmf to 100 mfd. Inductance 10 microhenry to 100 henries. Dissipation factor .002 to 1. Storage factor (Q) 1 to 1000. The IMPEDANCE BRIDGE has provisions for external generator use for measurement at other than the 1000 cycle level. Take the guess work out of electrical measurements. The HEATHKIT IMPEDANCE BRIDGE mounted in a beautiful polished birch cabinet with large easy reading panel calibrations will furnish years of accurate, trouble free measurement service.

Heathkit HANDITESTER KIT



MODEL M-1
SHIPPING
WT. 3 LBS.

\$13⁵⁰

The HEATHKIT Model M-1 HANDITESTER fulfills requirements for a portable volt ohm milliammeter. This kit features precision 1% resistors, 3 deck switch for trouble free mounting of parts, specially designed battery bracket, smooth acting ohms adjust control, beautiful molded bakelite case and a 400 microampere meter movement. 5 convenient AC and DC voltage ranges as follows: 10 - 30 - 300 - 1000 - 5000 volts. Ohms ranges 0 - 3000 and 0 - 300,000. DC milliamperes ranges 0 - 10 milliamperes and 0 - 100 milliamperes. The instrument is easily assembled from complete instructions and pictorial diagrams. Test leads are included. Carry the HEATHKIT M-1 HANDITESTER in your tool box at all times for those simple jobs and eliminate that extra trip for additional testing equipment.

EXPORT AGENT
ROCKE INTERNATIONAL CORP.
13 E. 40th ST.
NEW YORK CITY (16)
CABLE ARIAR-N.Y.

The **HEATH COMPANY**

... BENTON HARBOR 15, MICHIGAN

NEW
Heathkit

AUDIO GENERATOR KIT

• RANGE EXTENDED TO 1 MEGACYCLE

MODEL AG-8

SHIPPING
WT. 16 LBS.

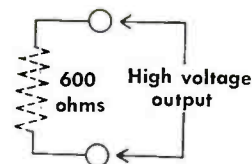

Low impedance output
High voltage output



Sine wave output
from 20 cycles to 1
megacycle.

\$29.50

- Improved design — new low price.
- Frequency coverage in five ranges from 20 cycles per second to 1 megacycle.
- Response flat 1 DB from 20 cycles to 400 kilocycles. Down 3 DB at 600 kilocycles. Down only 8 DB at 1 megacycle.
- Five calibrated output voltage ranges, continuously variable 1 mv, 10 mv, 100 mv, 1 v, 10 v.
- Low impedance output circuit. 600 ohms.
- Distortion less than .4 of 1% from 100 cycles per second through the audible range.
- New HEATHKIT universal type binding posts.
- Durable infra-red baked enamel panel.
- Transformer operated for safe operation.
- Sturdy, ventilated steel cabinet.

A new Audio Generator with features heretofore found in only the most expensive generators. Such features as complete coverage from 20 cycles to 1 Mc — response flat ± 1 db from 20 cycles to 400 Kc, down 3 db at 600 Kc and down only 8 db at 1 Mc.

And it has calibrated output . . . Calibrated continuously variable and step attenuator output controls allow you to easily set calibrated output voltage. Moreover, distortion is less than .4 of 1% from 100 cps through the audible range.

Oscillator section consists of a two stage resistance coupled amplifier (6SJ7 and 6AK6) utilizing both positive and negative feedback for oscillator operation and reduction of distortion. Oscillator section drives a cathode follower output power amplifier (6AK6) which isolates the oscillator from variations in load and presents a low impedance output (600 Ohms). Power supply is transformer operated and utilizes 6X5 rectifier with 2 sections of RC filtering.

An unbeatable dollar value — for here is an audio generator with wide frequency coverage, excellent frequency response, stepped and continuously variable calibrated output, high signal level, low impedance output, and low inherent distortion.

Heathkit AUDIO FREQUENCY METER KIT



MODEL AF-1

SHIPPING
WT. 15 LBS.

\$34.50

The HEATHKIT AUDIO FREQUENCY METER provides a simple and easy way to check unknown audio frequencies from 10 cycles to 100 kc between 3 and 300 volts RMS. The instrument features 7 ranges for accuracy and wide coverage. The meter itself has a quality 200 microampere Simpson movement and large clearly marked scales. The AUDIO FREQUENCY METER is transformer operated and features a voltage regulator tube to maintain constant plate voltage on the second stage. Kit supplied complete with all necessary construction material and a detailed construction manual.

NEW *Heathkit* AUDIO OSCILLATOR KIT

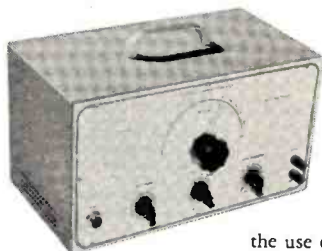

MODEL AO-1
SHIPPING
WT. 14 LBS.

\$24.50

A new Audio Oscillator with both sine and square wave coverage from 20 to 20,000 cycles . . . An instrument designed to completely fulfill the needs of the audio engineer and enthusiast — Has numerous advantages such as high level output (up to 10V obtainable across the entire range), distortion less than .6%, and low impedance output.

Special design features include the use of a thermistor in the second amplifier stage for keeping the output essentially flat across the entire range.

A cathode coupled clipper circuit produces good, clean, square waves with rise time of only 2 microseconds. Oscillator section uses 1% precision resistors in range multiplier circuit for greatest accuracy.

You'll like the operation of this fine new kit.

Heathkit SQUARE WAVE GENERATOR KIT

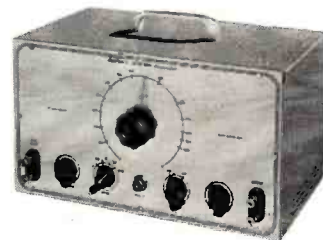

MODEL SQ-1
SHIPPING
WT. 14 LBS.

\$29.50

The HEATHKIT SQUARE WAVE GENERATOR is an excellent square wave frequency source with wide range coverage from 10 cycles to 100 kc continuously variable. This feature makes it useful for TV and wide band amplifier work as well as audio experimentation. The output voltage is continuously variable between 0 and 20 volts. The circuitry consists of a multivibrator stage, a clipping and squaring stage and a cathode follower low impedance output stage. The power supply is transformer operated and utilizes a full wave rectifier circuit with two sections of filtering. Another excellent HEATHKIT value at this remarkable low price. Kit includes all necessary construction material as well as complete instruction manual for assembly and operation.

EXPORT AGENT
ROCKE INTERNATIONAL CORP.
13 E. 40th ST.
NEW YORK CITY (16)
CABLE ARLAB:NY

The **HEATH COMPANY**

... BENTON HARBOR 15, MICHIGAN

NEW *Heathkit* VISUAL-AURAL SIGNAL TRACER KIT

• NEW NOISE LOCATOR AND WATTMETER CIRCUITS.

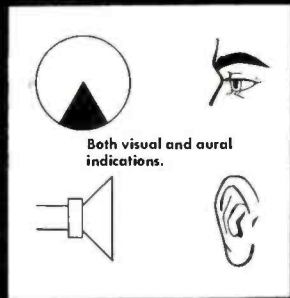

Both visual and aural indications.

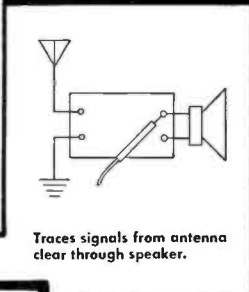

Traces signals from antenna clear through speaker.

MODEL T-3

SHIPPING
WT. 8 LBS.

\$22⁵⁰



- Permits visual signal observation as well as aural operation.
- Two separate input channels.
- Tremendous RF channel sensitivity. Adequate for actual signal detection at receiver input.
- Separate high gain RF and low gain audio channels.
- A unique and useful noise locator circuit.
- Built-in calibrated wattmeter.
- Two separate shielded probes for RF and audio application.
- Additional test leads supplied.
- Substitution test speaker and output transformer eliminates necessity for speaker removal in service work.
- Utility amplifier. Check record changers, tuners, microphones, instrument pickups, etc.
- VTVM and Scope panel terminals.
- 5 tube transformer operated circuit.

The new HEATHKIT VISUAL AURAL SIGNAL TRACER represents one of the most convenient and useful instruments the service man can use in AM, FM and TV service work. The electron ray beam indicator constantly monitors both input channels for visual observation of the signal. Now, see and hear the signal level for easier estimation of signal strength and gain per stage in a receiver circuit. Separate high gain channel and special shielded demodulator probe for RF circuit work. Low gain channel for audio circuit investigation and for use as a noise locator. In this feature, approximately 200 volts DC is applied to a suspected circuit component and the action of the voltage in the component can be seen and heard to determine satisfactory operation. This feature alone will prove tremendously helpful in locating the source of objectionable noises in coils, transformers, resistors, condensers, cold solder joints, controls, etc. A convenient wattmeter permits rapid preliminary check for voltage distribution circuit breakdown as well as transformer failures. Use the T-3 as a universal test speaker and substitution transformer and save service time by eliminating the necessity for speaker removal on every service call. Additional service uses are: as a utility amplifier for checking the output of record changers, tuners, microphones, instrument pickups, etc. Separate panel terminals permit utilization of other shop equipment such as your Oscilloscope or VTVM. Entire kit supplied complete with 5 tubes, all necessary construction material along with a detailed step by step instruction manual for the assembly and operation of the instrument.

NEW *Heathkit* CONDENSER CHECKER KIT



MODEL C-3
SHIPPING
WT. 7 LBS.

\$19⁵⁰

Announcing the new improved Model C-3 HEATHKIT CONDENSER housed in a new smartly styled professional appearing cabinet featuring rounded corners and snug fitting drawn panel. Adequate provisions for ventilation insures longer instrument life through cooler operation. Use the C-3 to accurately measure those unknown condenser and resistor values. All readings of condensers and resistors are read directly on the calibrated scales. Range of condenser measurements is from .00001 mfd to 1000 mfd. Calibrated resistance measurements can be made from 100 ohms to 5 megohms. A leakage test with a choice of 5 DC polarizing voltages will quickly indicate condenser operating quality under actual voltage load conditions. The spring return leakage test switch automatically discharges the condenser under test and eliminates shock hazard. An electron ray beam indicator tube is used in a new leakage test circuit for added sensitivity. The instrument is transformer operated for safety and will prove an extremely welcome addition to your shop equipment. The kit is furnished complete with all necessary parts, test leads and includes a step by step detailed construction manual for assembly and operation.

insures longer instrument life through cooler operation. Use the C-3 to accurately measure those unknown condenser and resistor values. All readings of condensers and resistors are read directly on the calibrated scales. Range of condenser measurements is from .00001 mfd to 1000 mfd. Calibrated resistance measurements can be made from 100 ohms to 5 megohms. A leakage test with a choice of 5 DC polarizing voltages will quickly indicate condenser operating quality under actual voltage load conditions. The spring return leakage test switch automatically discharges the condenser under test and eliminates shock hazard. An electron ray beam indicator tube is used in a new leakage test circuit for added sensitivity. The instrument is transformer operated for safety and will prove an extremely welcome addition to your shop equipment. The kit is furnished complete with all necessary parts, test leads and includes a step by step detailed construction manual for assembly and operation.

Heathkit TV ALIGNMENT GENERATOR KIT

MODEL TS-2
SHIPPING
WT. 20 LBS.

\$39⁵⁰



Here is an excellent TV ALIGNMENT GENERATOR designed to do TV service work quickly, easily and properly. The Model TS-2 when used in conjunction with an Oscilloscope provides a means of correctly aligning TV receivers. The instrument furnishes a frequency modulated signal covering in 2 bands the range of 10 to 90 megacycles and 150 to 230 megacycles. An absorption type frequency marker covers from 20 to 75 megacycles in 2 ranges; therefore you have a simple, convenient means of checking IF's independent of oscillator calibration. Sweep width is variable from 0 to 12 megacycles. Other excellent features are horizontal sweep voltage controlled with a phasing control — both step and continuously variable attenuation for setting the output signal to the desired level — a convenient stand by switch — and blanking for establishing a single trace with a base reference level. Make your work easier, save time and repair with confidence. Order your HEATHKIT TV ALIGNMENT GENERATOR now.

EXPORT AGENT
ROCKE INTERNATIONAL CORP.
13 E. 40th ST.
NEW YORK CITY (16)
CABLE: ARLAB-N.Y.

The **HEATH COMPANY**

... BENTON HARBOR 15, MICHIGAN

Heathkit TUBE CHECKER KIT

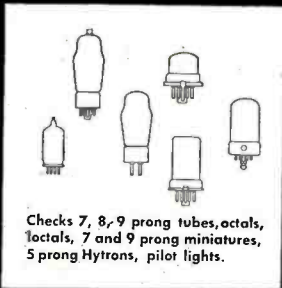

Checks 7, 8, 9 prong tubes, octals, loctals, 7 and 9 prong miniatures, 5 prong Hytrons, pilot lights.

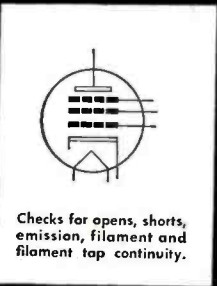

Checks for opens, shorts, emission, filament and filament tap continuity.

MODEL TC-1
SHIPPING
WT. 12 LBS.

\$29.50



- Beautiful counter type birch cabinet.
- 4½" Simpson 3 color meter.
- Simplified setup procedure.
- Built-in gear driven roll chart.
- Checks emission, shorted elements, open elements and continuity.
- Complete protection against obsolescence.
- Sockets for every modern tube.
- Blank for new types.
- Individual element switches.
- Contact type pilot light test socket.
- Line adjust control.

PORTABLE TUBE CHECKER KIT MODEL TC-1P

Same as TC-1 except supplied with polished birch cabinet (with removable lid) instead of counter type cabinet. Shipping weight 14 lbs. **\$34.50**

No. 365 Polished Birch Tube Checker Cabinet only. Shipping Weight: 7 lbs. **\$7.50**

With the HEATHKIT TC-1 TUBE CHECKER test all types of tubes commonly encountered in AM-FM and TV receiver circuits. Test setup procedure is simplified, rapid and flexible. Tube category is read directly on a beautiful 4½" Simpson three color BAD - ? - GOOD scale that your customers can readily understand. Panel sockets accommodate 4, 5, 6 and 7 prong tubes, octals, loctals, 7 and 9 prong miniatures, 5 prong Hytrons, a blank socket for new tubes and a contact type socket for quick checking of pilot lights. Built-in gear driven roll chart for instant reference. Neon short indicator, individual three position lever switch for each tube element, spring return test switch, line set control to compensate for supply voltage variations. At this low price, no service man need be without the advantages offered by the HEATHKIT TUBE CHECKER.

Heathkit TV PICTURE TUBE TEST ADAPTER

Use your HEATHKIT TUBE CHECKER with this new TV TEST ADAPTER to determine picture tube quality. Check for emission and shorts, independent of TV power supply. Consists of standard 12 pin TV tube socket, 4 feet of cable, octal socket connector and data sheet. Quickly prove TV picture tube condition to yourself and your customer.



No. 35 S
Ship. Wt. **\$4.50**
1 lb.

Heathkit RESISTANCE SUBSTITUTION BOX KIT



MODEL RS-1
SHIPPING
WT. 3 LBS.

\$5.50

NEW HEATHKIT RESISTANCE SUBSTITUTION BOX KIT provides switch selection of any single one of 36 RTMA 1 watt 10% standard value resistors, ranging from 15 ohms to 10 megohms. This coverage available in 2 ranges in decades of 15, 22, 33, 47, 68 and 100. Housed in rugged plastic cabinet featuring new HEATHKIT universal type binding posts. The entire kit priced less than the retail value of the resistors alone.

Heathkit BATTERY ELIMINATOR KIT

A clean 6 volt d-c supply source is definitely required for successful automobile radio servicing. Has a continuously variable d-c output from 0 to 8 volts. It can be safely operated at a steady 10 ampere level and will deliver up to 15 amperes for intermittent periods. The voltage output terminals are completely isolated from the chassis to accommodate additional service applications such as supplying bias voltages or d-c substitution voltages for battery operated tube filament circuits.

The output of the Battery Eliminator is constantly monitored by a d-c voltmeter and a d-c ammeter. The circuit features an automatic overload relay of self resetting type. For additional protection, a panel mounting fuse is provided. Build this kit in a few hours and pocket a substantial savings.

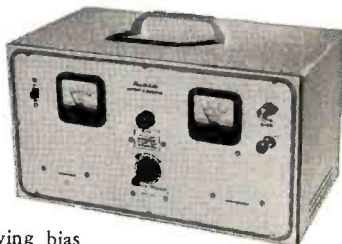

MODEL BE-3
SHIPPING
WT. 20 LBS.

\$24.50

Heathkit VIBRATOR TESTER KIT

Repair time is valuable, and the Heathkit Vibrator Tester will save you hours of work. Instantly tells the condition of the vibrator under test — and the check is thorough and complete. Checks vibrator for proper starting, and the easy-to-read meter indicates the quality of output on large BAD-GOOD scales. Tests both interrupter and selfrectifier types of vibrators. Five different sockets for checking hundreds of vibrators.

Operates from any battery eliminator capable of delivering continuously variable voltage from 4 - 6V at 4 amps. The Heathkit BE-3 Battery Eliminator is ideal for operating this kit.

Faulty vibrators can be spotted within seconds and you're free to go on to other service jobs.



MODEL VT-1
SHIPPING
WT. 7 LBS.

\$14.50

EXPORT AGENT
ROCKE INTERNATIONAL CORP.
13 E. 40th ST.
NEW YORK CITY (16)
CABLE: ARLAB-N.Y.

The **HEATH COMPANY**

... BENTON HARBOR 15, MICHIGAN

Heathkit SIGNAL GENERATOR KIT

MODEL SG-7

SHIPPING
WT. 7 LBS.

\$19.50



Modulated or unmodulated RF output.



400 cycle sine wave output.

- Step attenuated RF output.
- 6 to 1 vernier dial ratio.
- Turret mounted coil sub-assembly.
- Pre-calibrated and adjusted coils.
- Hartley RF oscillator circuit.
- Colpitts oscillator 400 cycle sine wave output.
- Modulated or unmodulated RF output.
- Frequency coverage on fundamentals 160 kc to 50 megacycles in five ranges. 51 megacycles to 150 megacycles on calibrated harmonics.
- RF output in excess of 100,000 microvolts.
- Audio output 1½ to 2 volts.
- AC transformer operated.
- Professionally styled cabinet.
- Infra red baked enamel panel.

The new HEATHKIT Model SG-7 SIGNAL GENERATOR easily fulfills requirements for a controllable, modulated or unmodulated source of variable frequency. A convenient 400 cycle sine wave output is available for audio work. All RF oscillator coils are precision wound and adjusted to calibration before shipment thereby assuring maximum accuracy. The coils, band switch and tuning condenser all mount as a turret assembly so as to offer the advantage of short wiring leads and easy mounting of parts. The RF output circuit is of the low impedance type obtained by the use of cathode coupling to the output jacks. The level of RF output is varied by means of the RF step and RF output control. Use the HEATHKIT SG-7 as an RF signal source modulated or unmodulated for radio repair, laboratory work, experimental testing, 400 cycle sine wave audio testing, checking RF stages, alignment of both AM and FM IF stages, marker generator for TV alignment, etc. The kit is transformer operated and utilizes miniature tubes for ease in handling high frequency. Panel jacks and a convenient switching system permit either external or internal modulation. The entire kit is supplied complete with tubes and all necessary material as well as a detailed step by step instruction manual for the assembly and operation of the instrument.

Heathkit INTERMODULATION ANALYZER KIT



MODEL IM-1
SHIPPING WT. 18 LBS.

\$39.50

The HEATHKIT MODEL IM-1 is an extremely versatile instrument specifically designed for measuring the degree of interaction between two

signals caused by a specific piece of apparatus, or a chain of equipment. It is primarily intended for tests of audio equipment but may be used in other applications such as making tests of microphones, records, recording equipment, phonograph pickups and loud speakers. Use it for checking tape or disc recordings, as a sensitive AC voltmeter, as a high pass noise meter for adjusting tape bias, cutting needle pitch or other applications. High and low test frequency source, intermodulation section, power supply and AC voltmeter all in one complete unit. Percent intermodulation is directly read on three calibrated ranges, 30%, 10% and 3% full scale. Both 4 to 1 and 1 to 1 ratios of low to high frequencies easily set up. At this low kit price YOU can enjoy the benefits of Intermodulation analysis for accurate audio interpretations.

Heathkit LABORATORY REGULATED POWER SUPPLY KIT



MODEL PS-2
SHIPPING WT. 20 LBS.

\$29.50

New HEATHKIT LABORATORY POWER SUPPLY provides continuously variable regulated DC voltage output

from 160 volts to 400 volts depending on load. Panel terminals supply separate 6.3 V. AC supply at 4 amperes for filament circuits. A 3½" plastic cased panel mounted meter provides accurate metered output for either voltage or current measurements. Exceptionally low ripple content of .012% admirably qualifies the HEATHKIT LABORATORY POWER SUPPLY for high gain audio applications. Ideal for laboratory work requiring a reference voltage for meter calibration or for plotting tube characteristics. In service work, it can be used as a separate variable voltage supply to determine the desirable operating voltage in a specific circuit. Use it as a DC substitution voltage in trouble shooting TV circuits exhibiting symptoms of extraneous undesirable components in plate supply circuits. Entire kit, including all 5 tubes now available at this low price.

EXPORT AGENT
ROCKE INTERNATIONAL CORP.
12 E. 40th ST.
NEW YORK CITY (16)
CABLE APLAB-N.Y.

The **HEATH COMPANY**

... BENTON HARBOR 15, MICHIGAN

Heathkit WILLIAMSON TYPE AMPLIFIER KIT

The new HEATHKIT WILLIAMSON TYPE AMPLIFIER incorporates the latest improvements described in Audio Engineering's "Gilding the Lily." 5881 output tubes and a new Peerless output transformer with additional primary taps afford peak power output of well over 20 watts. Frequency response ± 1 db from 10 cycles to 100 kc. allows reproduction of highs and lows with equal crispness and clarity. Harmonic and intermodulation distortion have been reduced to less than $\frac{1}{2}$ of 1% at 5 watts. This eliminates the harsh unpleasant qualities which contribute to listening fatigue. Make this amplifier the heart of your radio system to achieve the fine reproduction that is the goal of all music lovers.

The HEATHKIT PREAMPLIFIER (available separately or in combination with the amplifier kit) features inputs for magnetic or low level cartridges, crystal pickups and tuners, turnover control for LP or 78 type records, individual bass and treble tone controls each providing up to 15 DB of boost or attenuation. Special notched shafts on preamplifier controls and switches adaptable to custom installation. The preamplifier can be mounted in any position and a liberal length of connecting cable is supplied. No radio experience is required to construct this amplifier. All punching, forming, or drilling has already been done. The complete kit includes all necessary parts as well as a detailed step by step construction manual with pictorial diagrams to greatly simplify the construction.

ACROSOUND TRANSFORMER OPTION. If desired, the output transformer with the kit will be the Acrosound output transformer, type TO-300. The use of this transformer permits ultra-linear operation as described in Audio Engineering's "Ultra-Linear Operation of the Williamson Amplifier."



Heathkit FM TUNER KIT

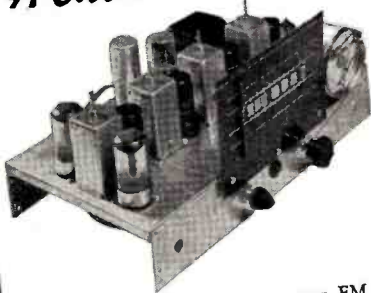

MODEL FM-2
SHIPPING
WT. 9 LBS.

\$22⁵⁰

The HEATHKIT MODEL FM-2 TUNER specifically designed for simplified kit construction features a preassembled and adjusted tuning unit. Three double tuned IF transformers and a discriminator transformer are used in an 8 tube circuit. Smooth tuning is obtained through a 9 to 1 ratio vernier drive using a calibrated six inch slide rule type dial. The usual frequency coverage of 88 to 108 megacycles is provided. Experience the thrill of building your own FM tuner. Operate it through your amplifier or radio and enjoy all the advantages of true FM reception. Transformer operated power supply to simplify connections to all types of audio systems. The kit is supplied complete with all 8 tubes and necessary material required for construction. A complete instruction manual simplifies assembly and operation.

PRICES OF VARIOUS COMBINATIONS

W-2 Amplifier Kit (Incl. Main Amplifier with Peerless Output Transformer, Power Supply and WA-P1 Preamplifier Kit) Shipping Weight 39 lbs.	\$69⁵⁰
W-2M Amplifier Kit (Incl. Main Amplifier with Peerless Output Transformer and Power Supply) Shipping Weight 29 lbs. Shipped express only	\$49⁷⁵
W-3 Amplifier Kit (Incl. Main Amplifier with Acrosound Output Transformer, Power Supply and WA-P1 Preamplifier Kit) Shipping Weight 39 lbs. Shipped express only	\$69⁵⁰
W-3M Amplifier Kit (Incl. Main Amplifier with Acrosound Output Transformer and Power Supply) Shipping Weight 29 lbs. Shipped express only	\$49⁷⁵
WA-P1 Preamplifier Kit only. Shipping Weight 7 lbs. Shipped express or parcel post.	\$19⁷⁵

Heathkit ECONOMY 6 WATT AMPLIFIER KIT



MODEL A-7
SHIPPING
WT. 10 LBS.

\$14⁵⁰

The HEATHKIT Model A-7 amplifier features beam power, push pull output with frequency response flat $\pm 1\frac{1}{2}$ DB from 20 to 20,000 cycles. Separate volume, bass and treble controls. Two input circuits, output impedances of 4, 8, and 15 ohms. Peak power output rated at full 6 watts. High quality components, simplified layout, attractive gray finished chassis, break off type adjustable length control shafts and attractive lettered control panel.

THE MODEL A7A amplifier incorporates a preamplifier stage with special compensated network to provide the necessary voltage gain for operation with variable reluctance or low output level phono cartridges. Excellent gain for microphone operation in a moderate powered sound system. **\$16.50**

Heathkit HIGH FIDELITY 20 WATT AMPLIFIER KIT

The HEATHKIT MODEL A-8 amplifier kit was designed to deliver high fidelity performance with adequate power output at moderate cost. The frequency response is within ± 1 DB from 20 to 20,000 cycles. Distortion at 3 DB below maximum power output at 1000 cycles is only .8%. The amplifier features a Chicago power transformer in a drawn steel case and a Peerless output transformer with output impedances of 4, 8, and 16 ohms available. Separate bass and treble tone controls permit wide range of tonal adjustment to meet the requirements of the most discerning listener. The amplifier uses a 6SJ7 voltage amplifier, a 6SN7 amplifier and phase splitter and two 6L6's in push pull output and a 5U4G rectifier. Two input jacks for either crystal or tuner operation. The kit includes all necessary material as well as a detailed step by step construction manual.



MODEL A-8
SHIPPING WT. 19 LBS.

\$33⁵⁰

MODEL A8-A features an added 6SJ7 stage (preamplifier) for operating from a variable reluctance cartridge or other low output level phono pickups. Can also be used with a microphone. A 3 position panel switch affords the desired input service. **\$35.50**

EXPORT AGENT
ROCKE INTERNATIONAL CORP.
12 E. 40th ST.
NEW YORK CITY (16)
CABLE AREA 8 NY

The **HEATH COMPANY**

... BENTON HARBOR 15, MICHIGAN

Heathkit SUPERHETERODYNE RECEIVER KITS

- High gain dual iron core tuned type IF transformers
- AC transformer operation for safety
- Continuously variable tone control
- Sturdy punched and plated steel chassis
- Ideal for custom installation
- Full AVC action
- Inverse feedback for improved frequency response
- Kit supplied with all necessary construction material except speaker and cabinet. (Available separately if desired).

6 tube all wave circuit.
3 ranges, continuous coverage 550 kc to over 20 megacycles, shipping wt. 11 lbs.

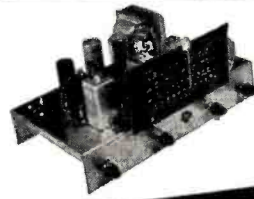

Model AR-1
\$23.50

5 tube broadcast band
550 to 1600 kc coverage,
shipping wt. 11 lbs.

Model BR-1
\$19.50

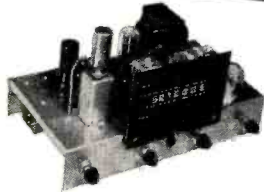

Two excellent radio receiver kits featuring clean design and open layout for simplified construction. Satisfy that urge to build your own radio receiver and select the model which meets your requirements. Both receivers feature continuously variable tone control, a radio phono switch and phono input and an AC receptacle for the phono motor. A six inch calibrated slide rule type dial with a 9 to 1 ratio vernier dial drive insures easy tuning.

SHIPPING INFORMATION

ON PARCEL POST ORDERS include postage for weight shown and insurance. (We insure all shipments.) Don't worry about sending more than the correct amount — if you send us too much, every extra cent will be promptly returned.

ON EXPRESS ORDERS do not include transportation charges. They will be collected by Express Agency on delivery.

ORDERS FROM CANADA must include full remittance for merchandise.

Orders processed on the same day received. Customers notified of unavoidable delay.

U. S. postal or express money orders, bank drafts or checks are acceptable. Do not send loose coins or stamps.

ALL PRICES SUBJECT TO CHANGE WITHOUT NOTICE

EXPORT AGENT
ROCKE INTERNATIONAL CORP.
15 E. 40th ST.
NEW YORK CITY 16
CABLE ARIAL N Y

The HEATH COMPANY

... BENTON HARBOR 15, MICHIGAN

ORDER BLANK

MAIL YOUR ORDER
TODAY TO THE
HEATH COMPANY
BENTON HARBOR 15,
MICHIGAN

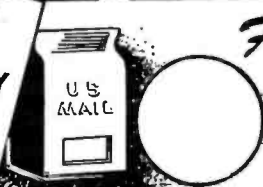

From _____

SHIP VIA

- Parcel Post
 Express
 Freight
 Best Way

(PLEASE PRINT)

QUANTITY	ITEM	PRICE	QUANTITY	ITEM	PRICE
	Heathkit Oscilloscope Kit—Model O-8 (29 lbs.)	\$43.50		Heathkit Square Wave Gen. Kit—Model SQ-1 (14 lbs.)	\$29.50
	Heathkit Intensifier Kit (0-8 only) No. 339 (1 lb.)	7.50		Heathkit AC VTVM Kit—Model AV-2 (5 lbs.)	29.50
	Heathkit Voltage Calibrator Kit—Model VC-1 (5 lbs.)	9.50		Heathkit Intermodulation Analyzer Kit—Model IM-1 (18 lbs.)	39.50
	Heathkit Electronic Switch Kit—Model S-2 (11 lbs.)	19.50		Heathkit Regulated Power Supply Kit—Model PS-2 (20 lbs.)	29.50
	Heathkit Scope Demodulator Probe Kit No. 337 (1 lb.)	4.50		Heathkit Handitester Kit—Model M-1 (3 lbs.)	13.50
	Heathkit T.V. Alignment Generator Kit—Model TS-2 (20 lbs.)	39.50		Heathkit Decade Resistance Kit—Model DR-1 (4 lbs.)	19.50
	Heathkit Q Meter Kit—Model QM-1 (12 lbs.)	39.50		Heathkit Decade Condenser Kit—Model DC-1 (4 lbs.)	16.50
	Heathkit Grid Dip Meter Kit—Model GD-1 (4 lbs.)	19.50		Heathkit Impedance Bridge Kit—Model IB-1B (15 lbs.)	69.50
	Heathkit VTVM Kit—Model V-6 (7 lbs.)	24.50		Heathkit Battery Tester Kit—Model BT-1 (3 lbs.)	7.50
	Heathkit RF Probe Kit No. 309 (1 lb.)	5.50		Heathkit Resistance Substitution Box Kit—Model RS-1 (3 lbs.)	5.50
	Heathkit HV Probe Kit No. 336 (2 lbs.)	5.50		Heathkit F.M. Tuner Kit—Model FM-2 (9 lbs.)	22.50
	Heathkit Peak-to-Peak Volt. Probe Kit No. 338 (2 lbs.)	6.50		Heathkit Broadcast Receiver Kit—Model BR-1 (11 lbs.)	19.50
	Heathkit Visual-Aural Signal Tracer Kit—Model T-3 (8 lbs.)	22.50		Heathkit Three Band Receiver Kit—Model AR-1 (11 lbs.)	23.50
	Heathkit Condenser Checker Kit—Model C-3 (7 lbs.)	19.50		Heathkit Amplifier Kit—Model A-7 (10 lbs.)	14.50
	Heathkit RF Signal Generator Kit—Model SG-7 (7 lbs.)	19.50		Heathkit Amplifier Kit—Model A-7A (10 lbs.)	16.50
	Heathkit Tube Checker Kit—Model TC-1 (12 lbs.)	29.50		Heathkit Amplifier Kit—Model A-8 (19 lbs.)	33.50
	Heathkit T.V. Tube Adapter No. 355 (1 lb.)	4.50		Heathkit Amplifier Kit—Model A-8A (19 lbs.)	35.50
	Heathkit Battery Eliminator Kit—Model BE-3 (20 lbs.)	24.50		Williamson Type Amplifier Kit (Type)	
	Heathkit Vibrator Tester Kit—Model VT-1 (7 lbs.)	14.50		Shipped express only	
	Heathkit Audio Generator Kit—Model AG-8 (16 lbs.)	29.50		WA-P1 Preamplifier Kit (7 lbs.) (Shipped exp. or p.p.)	19.75
	Heathkit Audio Oscillator Kit—Model AO-1 (14 lbs.)	24.50			
	Heathkit Audio Frequency Meter Kit—Model AF-1 (15 lbs.)	34.50			

*Please ship C.O.D. Postage enclosed for _____ lbs.

Enclosed find Check Money Order for _____

**NATIONALLY FAMOUS
VTVM**

4 1/2" meter with adjustable pointer to zero center for TV & FM discriminator alignment. AC-DC Range: 0-5/10/50/100 V. Resistance Range: .2 ohms-1000 megohms. DH scale for audio and gain measurements. Completely wired & tested—ready for use—SPECIAL!
WHILE THEY LAST!.....**\$34.95**



**TOP BRAND
SIGNAL GENERATOR
Model 320**
Freq. Coverage on fundamentals: 150 KC to 1200 KC, 1.3 to 102 megohms on 7 calibrated harmonics. Completely wired & tested—ready for operation.
SPECIAL!.....**\$24.95**

**Radio City Products
Model 449
VOLTOHMETER**
AC-DC output: 1000 V. ohmage up to 2 megohms. In metal case with zero adjusting knob on front panel. Ready for use. ONLY A LIMITED NUMBER LEFT—SO RUSH!
SPECIAL!.....**\$14.95**

TUBES		BRAND NEW! JANI BOXED!		TUBES	
1B2269c	100R49c	86419c
12B23	\$.33	114B29c	95413c
2B2249c	21009c	181829c
2C2609c	221A29c	182549c
3B2A09c	304TH	\$.55	182619c
3B2	\$.15	316A29c	182729c
3C2498c	388A59c	718319c
3CB	\$.45	471A	\$.15	E114898c
7C439c	532A	\$.15	900269c
10Y19c	722A99c	900619c
12KBY39c	801A19c	E114849c
15R39c	8129c	RR3439c
39/4429c	84317c	VR9214c
				VT12715c

**SCR-274N
COMMAND
and
ARC-5
EQUIPMENT**

RECEIVERS		
BC-453—180 to 550 KC.	USED	EXCELLENT NEW
BC-454—3 to 6 MC.	\$29.95	\$49.95
BC-455—6 to 9 MC.		24.95
1.5 to 3.	\$13.95	19.95
		34.95
TRANSMITTERS		
A-958—2.1 to 3 MC.		29.95
BC-458—5.3 to 7 MC.	7.95	17.95
ARC5-T-19—3 to 4 MC.		34.95
BC-459—7 to 9.1 MC.		24.95
T-15 ARC 5—500 to 800 KC.		29.95
ADDITIONAL EQUIPMENT		
BC-456 Modulator	2.49	2.95
BC-450 Control Box (3 Receiver)	1.49	1.95
BC-451 Control Box (Transmitter)	1.29	1.79
BC-442 Relay Unit (ANT)		5.69
Plugs: PL-147, 148, 151, 152, 153, 154, 156—EACH		1.25
Flexible Shalting with gear to fit		2.69
* 3 Receiver Rack	1.79	2.29
* 2 Transmitter Rack	1.69	2.39
* Single Transmitter Rack		3.97
* DM-32 Dynamotor for Command Set		3.97
* DM-33 Dynamotor for Command Set		3.95
* Mounts for 2 Trans. Rack, 3 Rec. Rack, Modulator, & Antenna Relay Unit	1.95	

HEADSETS
HS-33 low impedance with cord and plug, used, fine condition. **\$2.79**
HS-23 high impedance. **BRAND NEW** with ear pads. **\$5.95**
HS-33 low impedance. **BRAND NEW** with ear pads, cord and PL-56 plug. **5.39**
HS-33—**BRAND NEW**—Western Electric.
CD-307A Cord, 6'. **NEW**.....**\$.95**
H-16/U high impedance. Includes two receiving units.....**3.95**
HS-16 high impedance—used.....**2.49**

BC-221 Frequency Meter
Real Value! QUANTITY IS LIMITED—so first come, first served. They are just like new, with original calibration charts. Range 15-20,000 KC with crystal check points in all ranges. Comes with.....**\$129.50**
MODULATED TYPE.....**\$189.50**
MODULATED TYPE with AC Power Supply.....**179.50**
These Frequency Meters are factory tested, checked for frequency alignment and **GUARANTEED**.

TURBO AMPLIFIER
4 tube Amplifier used by U. S. Air Force. 115 V. input at 400 cycles. Without tubes—**BRAND NEW**.....**\$1.19**
SPECIAL

MINIMUM ORDER \$2.00
Immediate Delivery—Send 25% deposit on C.O.D. orders. All shipments F.O.B., N.Y.C. (N.Y.C. residents add sales tax to your remittance.)

PLATT ELECTRONICS CORP.
Dept. A, 489 Broome St., N. Y. 13, N. Y.
PHONES: WO 4-0827 and WO 4-0828
BRANCH STORE: 159 Greenwich St., N.Y.C.

Electronic Flash
(Continued from page 53)

speedlamp. Connect the line cord to the a.c. outlet. Turning a.c. supply switch S₁ on applies power to the step-up transformer. The procedure from this point is the same as for battery operation as outlined previously.

Incidentally it is advisable to use the a.c. pack to start the unit if the condensers need re-aging.

Using the Guide Numbers

In using the unit, the operation will be about the same, photographically speaking, with batteries or a.c. The most important characteristic is the proper use of the guide number for setting the lens aperture. Guide numbers for typical black and white and color films are given in Table 1. Tests should first be made with your photographic equipment to determine any modification of the guide numbers to suit your taste in negative density or contrast.

For example, the guide number for one lamp with "Super XX" film developed in D76 is 160. If the subject is ten feet away, the lens aperture is 160 divided by 10, or 16. The lens should

therefore be set for an f/16 aperture. Development beyond the normal time will result in higher guide numbers. For example, the guide number with "Super XX" film may be increased to 220 with extended developing. However, negative gradation and graininess are impaired. Excellent photographic quality that will delight the photographer will result from the use of the recommended guide numbers. The high shutter speed provided by speedflash relieves the photographer of concern with subject or camera movement. This feature, coupled with the use of small lens apertures, results in sharper pictures that exceed results from any other kind of lighting.

Using Two Speedlamps

Plug in both speedlamps and arrange them to suit your taste in lighting. One light at the camera and the other at 45° to the subject produces pleasing modeling and may be used as a starting arrangement. Use the guide numbers for two lamps as specified in Table 1 and proceed as for picture taking with one lamp.

In closing I would like to express my sincere appreciation to Mr. Sidney Chertok of *Sprague Electric* for his helpful suggestions.

—50—

TV TROUBLESHOOTING WITH AN AMMETER

By NICHOLAS B. COOK

"FOR radio and TV servicing—for almost any kind of electrical troubleshooting—a wattmeter saves hours of painstaking work every day." This is truthful advertising. It is an honest statement of fact, provided you have a wattmeter.

Yet for many technicians the cost of an instrument, even though moderate, is still a factor in the decision to buy or not to buy. And that is why many men feel that a wattmeter is something they can get along without, unwittingly foregoing the great utility and time-saving advantages that such an instrument offers.

But, fortunately, here for once is a case where you can have your cake and eat it too; you can save your money and still buy the near-equivalent of a wattmeter. The answer is, get an inexpensive ammeter. Catalogue listing—"Economy Model—\$2.45."

The writer, thoroughly familiar with the capabilities of wattmeters, has been using a cheap 5-ampere a.c. ammeter on the service bench for many years. It is permanently wired in series with an a.c. outlet so that a set may be tested with the utmost convenience.

The value of an ammeter in auto radio testing is well known. You expect the average set to take 6 or 7 amperes. If the current goes beyond normal you know you have trouble. Without an ammeter the trouble would not be so quickly spotted.

Similarly, the a.c. ammeter gives an immediate indication of abnormal current drain in television receivers. Without this warning, a power transformer could go up in smoke while you're listening for clues. It takes only a minute or so for the high-voltage winding to become, like the fiery furnace, "seven

times hotter, hotter than it ought to be." Usually the smoke pours out while the core is still cool.

A personal experience will emphasize this point. I had replaced a burned-out power transformer in a TV set. The low-voltage rectifier had failed and had been discarded by the customer. Before putting in a new 5U4 I checked the "B plus" line and found it clear. When the set was turned on, the ammeter showed a little better than 2 amperes (normal), then suddenly started climbing. At 4 1/2 amperes I pulled the plug. Investigation revealed that the damper tube broke down as soon as plate voltage was applied. When a new 6X5 was installed, the pointer remained at 2 amperes. In this kind of testing, the great advantage of the ammeter lies in the fact that its indication of trouble is *immediate and continuous*.

In case of an abnormally high reading, removal of the rectifier tube (or tubes) tells at once whether the trouble is ahead of the tube or beyond it. Other components can be disconnected and restored in a logical procedure based upon ammeter readings.

The function of the ammeter, then, is to indicate *current*. Transformer windings and other components are burned out by *current*. In case of trouble, the most destructive variable is *current*. (A fair approximation of "normal amperes" can be obtained by dividing the rated "watts" by the rated "volts.")

In shooting trouble, our concern is not with *precisely how much current*. Faults are gluttons for amperes. Rather, all we need to know is that "too much is too much." This information we can get daily for a lifetime at a total investment of \$2.45.

SYLVANIA PICTURE TUBES

Out-perform, out-last all others tested!

Fifty minutes on . . . ten minutes off . . . hour after hour for 500 consecutive hours, Sylvania Picture Tubes were tested side by side with the tubes of other leading manufacturers.

These intensive tests, made under punishing, accelerated voltages were conducted under supervision of an outside, independent laboratory. Checks were also taken over a 3-month period for emission, leakage, color, light out-put, grid control, and other characteristics.



SEND FOR THE COMPLETE REPORT!



Read the remarkable record.

The chart at right tells the story. Note that *only* Sylvania Picture Tubes showed no failures. And, in over-all point quality, *Sylvania won over all other brands by a wide margin.*

These important conclusions definitely place Sylvania Picture Tubes in the highest rank. They also mean the highest in trouble-free operation . . . better business . . . more satisfied customers for every dealer who orders Sylvania Picture Tubes. For full details about these important tests write today to: Sylvania Electric Products Inc., Dept. 3R-21031740 Broadway, New York 19, New York.

SYLVANIA



RADIO TUBES; TELEVISION PICTURE TUBES; ELECTRONIC PRODUCTS; ELECTRONIC TEST EQUIPMENT; FLUORESCENT TUBES, FIXTURES, SIGN TUBING, WIRING DEVICES; LIGHT BULBS; PHOTOLAMPS; TELEVISION SETS

United States Testing Co. 1415 Park Ave., Hoboken, N. J.			Test No. E-5095 August 8, 1952
Manufacturer	Number of Tubes Tested	Number of Failures	Overall Point Quality
A	8	1	81
B	8	1	78
C	8	6	62
D	8	1	83
E	8	4	67
F	8	5	42
G	8	4	52
H	8	5	30
SYLVANIA	8	NONE	92

THEY INCREASED SERVICE

These service dealers weren't content to sit still and wait for repair jobs to come to them. Like hundreds of others who took part in G. E.'s big 1952 summer promotion, they went looking for business . . . and found it! Here are facts and figures that prove service promotion pays off!



"Every month showed bigger sales!"

"Because of our summer promotion, June service sales were 194 percent of May; July sales 223 percent. August service will equal or exceed July. Newspaper ads, mailing cards, TV spots, radio announcements—we used them all successfully."

LAURENCE T. SAMPLE
Electronic Television of Florida, Inc.
1003 S. W. 27th Ave., Miami, Fla.

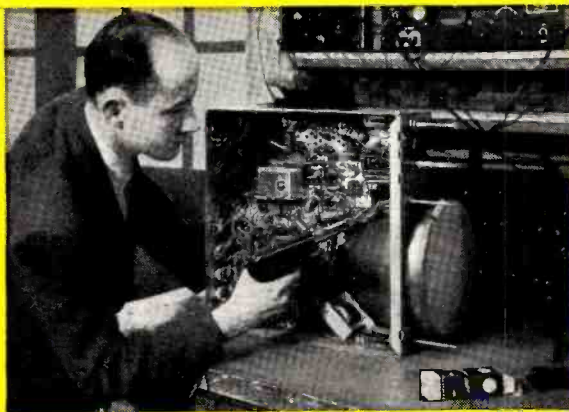

"1952 business was far ahead!"

"Our promotion campaign consisted of three parts: (1) a special TV-check-up mailing, (2) general service mailings, (3) newspaper advertising that featured a prize contest. G-E-tube direct-mail cards were employed. . . . A comparison of our C. O. D. business during the two months shows a 72% increase, 1952 over 1951."

WILLIAM S. WEIL, JR.
Interstate Television Service Co.
1300 N. Third St., Philadelphia, Pa.



"We more than doubled service income."

"We spent half our 1952 advertising budget in an intensive service promotion, using direct-mail, newspaper space, and ads in local-events programs. As a result, our gross income was up 112% from the same months in 1951 when we had put no special emphasis on promotion."

E. J. HORSTMAN
Suburban Television Company
605 W. Hillgrove Ave., La Grange, Ill.

You can put your confidence in—

BUSINESS UP TO 123%!

Now you can do it!

1953's here. It's time to plan ahead for a bigger, better year—for more business through aggressive promotion. The G-E Tube Department can help you with sure-fire aids that work hard beginning the first day you use them. They're described in this brand-new 12-page catalog. You've seen how aids like these paid off for Sample, Weil, and Horstman. Make G. E.'s new catalog *your* blueprint for profits in '53!

Look what you can get!

- **Identification aids**, such as decals, clock, signs, and tube display cartons.
- **Advertising aids**, such as mailing pieces, newspaper ad mats, doorhangers, and streamers.
- **Business aids**, such as job tickets, calling cards, letterheads, and tube-test stickers.
- **Service aids**, such as tube puller, jumper cord, drop cloth, and shop garments.
- **Technical manuals and publications.**

SEE YOUR G-E TUBE DISTRIBUTOR TODAY!

He will be glad to help you get started! Or write direct to Tube Department, General Electric Company, Schenectady 5, N. Y.



Diamond Anniversary

GENERAL  ELECTRIC

161-1A1

★ **HOW** to do faster, better testing with fewer instruments

★ **HOW** to choose the right instrument for each job

★ **HOW** to understand its operating principles

★ **HOW** to evaluate its readings and put them to practical use

★ **HOW** to double the usefulness of your present instruments

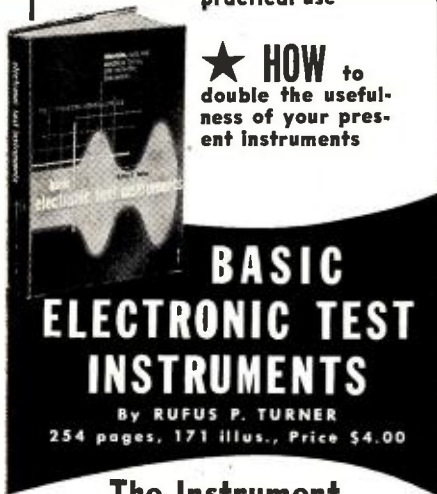

The Instrument Book Written Especially for
• **SERVICEMEN** • **AMATEURS**
• **EXPERIMENTERS**

★ **HERE'S** a brand new book that can save you money on instruments and help you use your present instruments lots more efficiently! Over 60 instruments—from the most modern TV pattern generators to special-purpose bridges—are carefully described. Their uses are fully explained and valuable work-saving short cuts outlined. Included are complete details on simple meters for current and voltage; ohmmeters and V-O-M's; V-T voltmeters; power meters; impedance meters; capacitor checkers; inductance checkers; special-purpose bridges; oscilloscopes (this material alone is worth the entire price of the book to busy servicemen!); r-f test oscillators and signal generators; audio test oscillators; radio frequency and audio frequency measuring devices; audio-amplifier testing devices; r-f signal tracers and tube testers. Among other things, **BASIC ELECTRIC TEST INSTRUMENTS** is a complete training course in the latest instruments including grid-dip oscillators, TV sweep and marker generators, TV linearity pattern generators, square-wave generators, distortion meters and others.

SAVE ON INSTRUMENTS!

You are shown new uses for VOM's, scopes, signal generators and other old standbys. You learn how easy it is to extend the range of many old instruments; how power drain measurements can be used for fast TV troubleshooting; how a useful and accurate bridge can be built from a combination of familiar general-purpose instruments; how to calculate shunts and multipliers; how to measure r-f impedance with a simple T-network; how to measure inductance and capacitance with a grid-dip oscillator and scores of other money-saving "tricks." Just off the press! Read **BASIC ELECTRONIC TEST INSTRUMENTS** for 10 days at our risk!

10-DAY FREE EXAMINATION

Dept. RN-33, Rinehart Books, Inc.
Technical Division,
232 Madison Ave., New York 16, N. Y.

Send Turner's **BASIC ELECTRONIC TEST INSTRUMENTS** for 10-day FREE EXAMINATION. If I decide to keep book, I will then remit \$4.00 plus postage. Otherwise I will return book postpaid promptly and owe you nothing.

Name.....

Address.....

City, Zone, State.....

Employer's Name and Address.....
OUTSIDE U.S.A.—Price \$4.50, cash only. Money back if book is returned postpaid in 10 days.

WHAT'S *New in Radio*

For additional information on any of the items described herein, readers are asked to write direct to the manufacturer. By mentioning **RADIO & TELEVISION NEWS**, the page and the issue number, delay will be avoided.

TURNOVER PICKUP

Pickering & Co., Oceanside, N. Y. has added the Model 260 turnover pickup to its line.

The new unit has an output of 30 millivolts at 10 cm-per-second and will

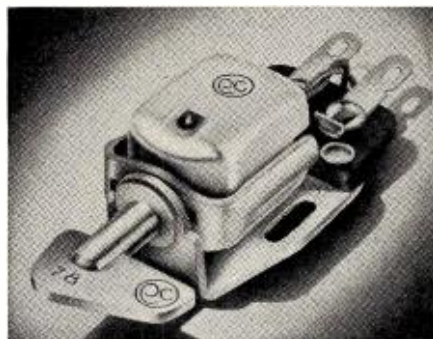

mount easily in any type arm. Detailed literature on the Model 260 is available on request.

WIRELESS INTERCOM

David Bogen Co., 29 Ninth Ave., NYC 14 has a new wireless intercom system on the market.

The "Twin" can be used with two or more stations, with all conversations heard by all stations in the system. Employing power lines as the carrier, the intercom uses a line noise suppression circuit in every unit. Each station contains a transmitter and receiver operating at 175 kc., a frequency which minimizes interference with radios, TV, and other electrical devices.

SMALL RELAYS

Automatic Electric Sales Corp., 1033 W. Van Buren, Chicago 7 has available bantam-sized class "S" relays in hermetically sealed enclosures. The entire unit measures $2\frac{1}{32} \times 3\frac{1}{32} \times 1\frac{1}{2}$ inches and weighs $1\frac{1}{8}$ oz. Mounting studs may be arranged on base or narrow side of housing.

The relay is designed for minimum inductance and maximum make-and-break speeds. It is tamperproof and atmosphere-protected and meets or betters all provisions of MIL-R 6106.

"MINI-PACK" POWER SUPPLY

Jersey City Technical Lab., 880 Bergen Ave., Jersey City 6, N. J. has developed a small selenium rectifier pack for service, experimental, or ham use.

The "Mini-Pack" is designed to plug into a standard a.c. female receptacle. Power is available at screw terminals which are extra long so that spade leads or alligator clips may be connected.

The Model R gives 108 volts regulated, low-ripple d.c. with an OB2 regu-

lator tube. The Model P is a voltage doubler, 10-watt power source, of low ripple d.c. The no-load voltage output is 330 volts.

CONTACT CLEANER

Chemical Electronics Corp., Irvington, N. Y. has developed a combination solvent, lubricator, restorer, and silencer for all electrical and electronic controls and contacts.

Known as the "Ceco Restorer," the new solution is safe even for u.h.f. circuits. It does not affect inductance, capacitance, or resistance and is non-reactive to heat, cold, oil, or corrosives.

NEW SPEAKER LINE

Carbonneau Industries, Grand Rapids, Mich. has added the "Gold Cup" speaker to its line of equipment.

The 10" unit is now available either with 2.15 oz. magnet, 1" voice coil or 1 oz. magnet with 1" voice coil. Either unit supplies flux in the air-gap equivalent to speakers using up to 50% more magnet, according to the company.

UNIQUE CABINET

Jeff Markell Associates, 108 W. 14th St., NYC 11 has added a cocktail table, radio-phono cabinet to its line.

The RC-118 houses a changer, tuner, and amplifier in a compact piece of furniture. Space for the changer is in the step at left while the tuner and amplifier are housed in the long, lower

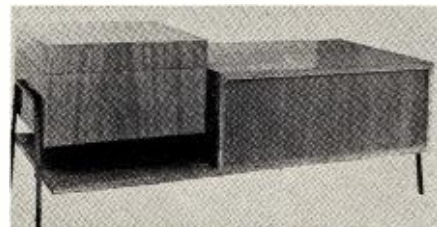

compartment. There is a magazine shelf under the changer compartment and the back is finished with a bookcase behind the tuner-amplifier. Legs are of half-inch square wrought iron.

It is available in twelve finish colors on birch, mahogany, korina, walnut, or oak.

INK FOR TAPE MARKING

Artone Color Corp., 21 W. Third St., NYC 12 has developed a new acetate ink for use on plastics, including recording tapes.

Available in seven colors as well as black and white, the new inks are also obtainable in either opaque or transparent consistencies. The new inks adhere without chipping off, crawling, or rubbing off. They are waterproof, flow



Milt Klein says:

I Want You to Examine... AND TRY THESE FINEST TACKLE BARGAINS

To Use As You Choose For 30 DAYS ABSOLUTELY FREE!

SPINNING & FLY CASTING OUTFIT \$60.75 VALUE! Rod and 2 Reels, \$38.88 All Only

Pay only \$7.80 down on this balanced Custom Crafted Spinning and Fly Casting Outfit! Outfit includes: 1) 1953 Airex "Mastereel" with extra spool, sells alone for \$22.75. 2) H-1's famous top quality Model 7 Auto Fly Reel, capacity 75 yd. G line. Free stripping, beautiful blue anodized finish. 1953 model. Reel value is \$8.00. 3) H-1's finest Registered "Admiral" De Luxe Combination Spinning & Fly Casting Rod, \$30.00 certified value—the finest quality individually Registered Rod specially made by H-1, 7 ft. length, 2 section Tubular Power Glass, Cloth Bag and solid fiber carrying case included. 4) Spinning and Fly Casting Instruction Booklets Included. \$38.88 Rod and "Mastereel" and Auto Fly Reel, all for only \$38.88. Send \$9.88 additional for an excellent assortment of accessories, including plenty of line for both reels, spinning & fly casting lures and all the necessities for successful use of your new outfit.

SAVE \$10.00! AIREX "SPINSTER" & GLASS ROD \$18.50

Pay only \$3.70 down—balance in 6 months on this budget priced but high quality Spinning Outfit consisting of 1) Famous Airex "Spinster" Reel—Greatly improved for '53—sells separately for \$13.50; 2) New 1953 Model H-1 Commodore Solid Power Glass 6 ft. 2 section Spinning Rod; and 3) Spinning Instruction Booklet. Remember—you get 30 days' Free Trial on Everything you buy at Klein's—no matter how you buy! Total value \$28.50. Klein's Full Price \$38.50. Add \$4.95 for complete Spinning Accessory Outfit which includes: beautiful Plastic Box, Extra Reel Nylon, an excellent assortment of lures and 100 yds. of 100 lb. Nylon Spinning Line in your choice of 4, 6, 8, or 10 lb. test.

HEAVY DUTY OUTFIT \$27.30 Value \$19.95

Only \$4.00 Down on the Ideal Rod & Reel Combination for Deep Trolling in Fresh Water, for Musky Sucker casting, for Big Catfish and Carp or for General Salt Water, Boat or Pier Fishing. Outfit includes famous quality-built \$12.00 Value H-1 #520 Heavy Duty Reel features star drag, level wind, push-button control, rugged construction, 150 yard capacity; \$12 Value Solid Power Glass H-1 Model 3676 Rod has detachable wood handle with rubber butt cap, 60" tip, 6'8" overall length, 150 yds. 27 lb. test "Skirr" Nylon Line, \$3.30 Value. Rod, Reel and Line. Certified \$27.30 value. \$19.95

\$42.70 PFLUEGER "SUPREME" REEL & BRISTOL GLASS ROD \$34.95

Only \$7.00 down and six months to pay the balance—only at Klein's. Outfit includes: New 1953 Pflueger "Supreme" level wind and anti-backlash casting reel with all accessories (the world's finest reel sells separately for \$32.95). \$9.75 Value H-1 Registered Tubular Power Glass Casting Rod with carrying case. Certified \$42.70 Value. \$34.95 Both for only \$34.95. Klein's will turn you over the H-1 Registered Tubular Power Glass custom built Casting Rod in your choice of 5 or 5 1/2 ft. lengths—instead of the Bristol Rod. Registered H-1 Rod and "Supreme" Reel both for \$39.95. NEW! SHAKESPEARE PRESIDENT REEL—\$26.70 New 1953 Model Shakespeare "President" Reel sells separately for \$26.70. "President" with the Bristol Model 88 Glass Rod, both for \$28.70, or with \$20.00 Value H-1 Tubular Glass Rod for \$33.70.

1953 GUN DIGEST The Encyclopedia for Shooters! \$2.00 Postpaid

NEW GUNS & SCOPES ON CREDIT! Yes, you can buy any New currently manufactured Handgun, Shotgun, Rifle or Rifle Scope on KLEIN'S EASY CREDIT. Select the New Gun or Scope you want from any manufacturer's or importer's catalog, or from any Ad in any magazine. Use the Order Coupon in this Ad. Send 20% Down Payment. Klein's Policy for 68 Years assures you lowest Fair Trade Prices. \$1.00 Catalog Free with any gun order!

1953 BARGAIN CATALOG—\$1.00 Send \$1.00 (refunded on first catalog order) for Klein's new 1953 Gun & Tackle Bargain Catalog. Contains Gun Trading Dope, many bargains in new & used Handguns, Rifles and Shotguns. Also big tackle section including the finest nationally advertised fishing equipment—at rock bottom prices. All on Credit if you prefer. Catalog ready Mar. 1st. Send \$1.00.

"MASTEREEL" and REGISTERED GLASS SPINNING ROD

Certified Value \$50.25 Both Rod & Reel, Only \$27.95 For value, top quality, and balanced action, this is the best Spinning Rod and Reel Combination in America. For the spinning fisherman who wants the finest! Outfit includes the supreme quality Airex "Bache Brown" Mastereel with extra spool, plus the Horrocks-Ibbotson "Admiral De Luxe" custom built individually Registered \$27.50 value Power Glass Spinning Rod, available in your choice of 6 1/2 ft. Tubular Power Glass or 7 ft. Tubular Power Glass. Both rods have superior action and delicate balance, finest quality genuine specie cork grip, and popular 2 section tip for easy carrying. Lifetime stainless steel guides with beautiful 2 color fancy windings, cloth bag and solid fiber carrying case. Spinning Instruction Booklet included. State choice of 6 1/2 ft. Solid or 7 ft. Tubular Glass Spinning Rod. \$27.95 This Rod & Reel will handle lures from 1/4 oz. to 5/8 oz. Perfectly. All newest improvements in Spinning Rods & Reels for 1953 included! Mastereel separately is \$22.75.

Klein's 68-Year Policy: Full 30 DAY FREE TRIAL on Every Purchase, including Satisfaction Guaranteed or Your Money Back. New Merchandise is Brand Models, Factory Packed and sealed, unless specifically stated otherwise. Pay as you choose: Cash, Credit, C.O.D., or Lay-Away. Pay Only 20% Down on Orders Over \$20.00 Use the order coupon at the bottom of this page, and fill in and sign where requested. Use separate sheet of paper to answer questions required.

NEWEST SPINNING REELS

Spinning Reels: 1) Mitchell, made in France. Includes 2 interchangeable spools of 100 and 300 yard capacity. Available for right or left handed persons, specify. \$29.75 2) Orvis "Pelican" made in Italy. Exquisitely made, mechanically superb. Available for right or left handed persons, specify. \$28.50 3) Micron, custom made in Italy, preferred by many professionals. Reg. \$41.50. \$34.50 4) Heaton "Spin Fast" Specter, 100 or 200 yard capacity Spool, available for right or left handed persons, specify. Reg. \$25.00. \$22.50 5) Airex "Seachomber" Salt Water Spinning Reel, sells alone for \$28.50 or for \$44.50 complete with the \$30.00 value Custom Built & Individually Registered H-1 heavy duty 2 pc. 7 ft. Tubular Power Glass Salt Water Spinning Rod. Salt Water Rod and Reel Value is certified to be \$58.50, both for \$44.50.

\$34.35 H-1 ROD & SHAKESPEARE AUTO FLY REEL \$19.95

Reel Separately is \$9.35 Pay only \$4.00 down and take 6 full months to pay the balance on this great top quality Fly Casting Outfit! Outfit includes: 1) Shakespeare Trout Model 1837 Automatic & Free Stripping Fly Reel. Reel capacity 80 yards "G" line. A flick of the finger automatically takes up the free line. 2) H-1 Tubular Power Glass \$25.00 certified value "Admiral De Luxe" Individually Registered and custom-crafted 3 section 8 1/2 ft. Trout or 9 ft. Bass action Fly Rod. Only H-1 with its slow and careful craftsmanship can turn out such magnificent action as you will find in these beautiful Registered Fly Rods. Cloth case and rod tube included. 3) Fly Casting Instruction Booklet. \$34.35 Value, all for only \$19.95. Send only \$4.95 for a \$7.00 value genuine WEBER fly casting accessory outfit, including Weber fly line, leaders, line dressing and big selection of Weber flies for trout, panfish and bass. All in handy plastic box.

SAVE \$6.55! H-1 FLY ROD AND AUTOMATIC FLY REEL \$9.95

Never before has anyone offered a quality split bamboo fly rod and a fine automatic fly reel at such a ridiculous low price! Famous H-1 "COMMODORE" \$10.00 value 2-section, 8 ft. Tonkin Flame Finish Split Bamboo Fly Rod is perfectly balanced with the famous H-1 UTICA Satin-Aluminum Finish Automatic Fly Reel. \$9.95 Both Rod and Reel only \$9.95. Add \$2.95 for a nice assortment of Fly Lures and Leaders in a beautiful transparent Plastic Fly Box, including 24 yards of good quality level Fly Line.

RUGER 22 AUTO PISTOL 3 models: 1) NEW—All shoot .22 L.R. 2) STANDARD RUGER, 10 shot, 4 1/2" barrel, 36 oz. of perfect balance, \$37.50 amazing accuracy. 3) 6 1/2" Barrel \$57.50 TARGET RUGER, MARK 1; 5 1/4" Barrel \$7.50 TARGET RUGER, MARK 1; 5 1/4" Barrel \$7.50

KLEIN'S Try Any Article 30 Days FREE!

KLEIN'S SPORTING GOODS, INC., Dept. 91 227 WEST WASHINGTON ST., CHICAGO 6, ILL.

KLEIN'S Giant Size \$1.00 Bargain Catalog is sent FREE with any order of \$9.95 or more. CASH, C.O.D. LAYAWAY CUSTOMERS: Enclosed is \$... in Full Payment or 20% Deposit, balance C.O.D. \$1.00 Enclosed 20% Lay Away Deposit. for catalog.

Please rush or hold for me... I understand my money will be refunded in full if I am not 100% satisfied. Firearms Purchasers Sign: "I am not an alien and I have never been convicted of a crime of violence, nor am I under indictment, a fugitive from justice or a drug addict." Signed... Occupation... Age... Handgun shipped outside U.S.A. and its possessions not permitted. Send State Permit if Needed.

CREDIT CUSTOMERS—Please Read and Sign Following Simple Credit Agreement: Also Send Coupon Above. I want Credit. Enclosed is \$... 20% Down Payment. I agree to pay the balance in 6 equal monthly payments, starting 30 days after I receive the merchandise I ordered. I understand there will be no carrying charge if I pay the balance within 90 days. If payment in full is not made in 90 days, I understand a Carrying Charge will be added. The Carrying Charge will be 10% the difference between the selling price and my down payment.

Signed... Be sure to state your age, marital status, own home or rent, employers name and address, length of present employment, two business credit references with complete addresses and one personal reference. Use separate paper for this information.

SALE! Reg. \$6.25 LANDING NET \$3.49

Light weight, quality made, folding landing net. Genuine 100% Nylon netting. Handle extends from 30" to 39"—rubber grip. Weighs only 12 oz. Reg. \$6.25, Sale Price \$3.49

\$17.70 BAIT CASTING OUTFIT \$10.95

Shakespeare "Wonderel" Alone is \$9.75 Outfit includes: 1) Shakespeare "Wonderel" New 1953 first quality all metal Model 1920 level wind and Rod, outstanding \$7.95 value, which features thread locking offset reel seat of finest aluminum and live action tip with stainless steel guides, 4 1/2 or 5 ft. length. Rod bag included. Total Value \$10.95. Klein's Complete Price. \$10.95

SALE! 45 CAL. BRITISH WEBLEY \$19.95 ENGLAND'S FINEST REVOLVER!

Genuine British WEBLEY 4" or 5" barrel Revolvers made in England by world-famed Webley & Scott. Author W.H.B. Smith says of the Webley 45: "One of the finest heavy duty military weapons ever made. This is one of the official revolvers of the British forces. Safe for heaviest loads." 6 shot, double hinged frame break-open action. State choice of caliber: 45 Colt, 45 Auto, 45 Colt, 45 Auto Rim—\$4.75; 455 Webley. Half moon clips free with 45 Auto Colt caliber. Quantity all metal. Very Good to Excellent. \$19.95 Very Good to Excellent. \$24.95 MARK IV Webley's 4" Barrel, 9 3/4" overall, 37 oz. weight. (45 Webley not chambered for 45 Colt.) Very Good to Excellent. \$19.95 Excellent Condition. \$24.95 MARK V & VI Webley's 6" barrel, 11 1/2" overall, 38 oz. weight. Available in round and square butt. (Square butt shown.) Good Condition 6" Webley's... \$19.95 Very Good 6" Webley's... \$24.95 Very Good to Excellent 6" Webley's... \$29.95 Add \$5.95 for finest hand carved holster.

COLT 45 REVOLVERS \$24.95

Top quality Genuine Colt "New Service" Revolvers. State choice of 45 Colt or 45 Auto caliber. The finest service revolver made. Jointless, solid frame, simultaneous ejection, swing out cylinder, post-1945 center fire double action. Square butt, 5 1/2" barrel. Blued. At Klein's in Good Condition, Only \$29.95 Very Good Condition. \$24.95 Very Good to Ex. Condition \$34.95 Finest Hand Carved Holster to fit. \$5.95

Concertone
"Just like being there"

**THE ONLY TAPE RECORDER
UNDER \$1000 WITH ALL THESE FEATURES**

- ★ Designed for Custom, Console, or Portable installation
- ★ 50-15,000 CPS frequency response with negligible distortion
- ★ 3 Heads — Monitor from the tape while recording
- ★ 3 Motors for superb tape motion and fast forward and rewind operation
- ★ Instantaneous selection of 7½ or 15 ips with automatic equalization
- ★ "Straight line" tape threading
- ★ Plays up to 10½ inch reels without extension arms
- ★ Interchangeable heads for single or dual track



MODEL 1501

Professional Users
Net \$345.00

WRITE FOR BULLETIN 201

Manufactured by
Berlant Associates

4917 W. Jefferson Boulevard Los Angeles 16, California



freely, and are resistant to alkali, acids, and oils.

The ink can be used to mark places on the tapes, interruptions, beginnings, ends, and identifications of tapes.

MOBILE TEST GEAR

A new portable frequency and deviation meter for checking radiated carrier frequency, undulation deviation, and other performance data of mobile two-way radio systems has been developed by the RCA Victor Division of Radio Corporation of America, Camden, N. J.

The Type CX-8A is a self-contained, direct-reading instrument which provides facilities for checking radiated



carrier frequency of mobile and stationary radio transmitters to comply with FCC regulations. It can also be used as a field strength meter and as a precise signal source for aligning radio receivers.

It is designed to operate at one or two specified frequencies in the 25-50 or 152-174 mc. range or at other frequencies on special request.

PRINTED CIRCUITS

Five new printed circuits for TV and radio sets have been added to the replacement line by Sprague Products Co., 51 Marshall St., North Adams,

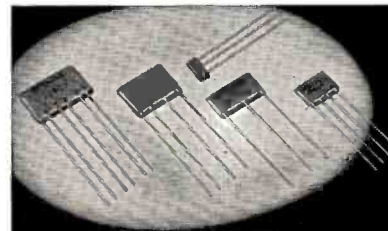

Mass. All of the new items are resistor-condenser networks screen-printed on high dielectric constant ceramic bodies.

Circuit diagrams of these new units are available from the Technical Service Section of the company.

HI-FI SOUND SYSTEM

A new, matched high-fidelity radio-FM-phono system has been introduced by Meissner of Mt. Carmel, Ill. The entire system is matched both electronically and in physical appearance.

The system comes complete with
(Continued on page 144)

**CUT HOLES ½" to 3½"
IN RADIO CHASSIS**

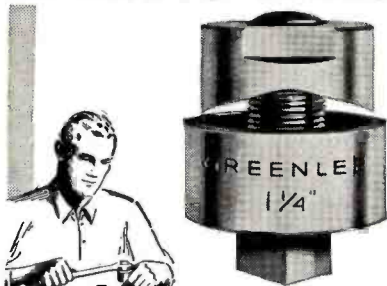

WITH A GREENLEE
RADIO CHASSIS PUNCH

● Save hours of work . . . no reaming or tedious filing. Punch cuts through chassis quickly . . . makes accurate, clean holes for sockets, plugs, and other receptacles. Just turn with an ordinary wrench. There's a GREENLEE Punch in each of these sizes: ½"; ⅝"; ¾"; ⅞"; 1"; 1¼"; 1½"; 1¾"; 1½"; 1¾"; 1½"; 2¼". Write for complete facts. Also get information on Knockout Punches and Cutters for conduit and meter holes up to 3½". Greenlee Tool Co. 1883 Columbia Avenue, Rockford, Illinois.



**OLYMPIC HI-FI VALUES!
ULTRA-LO PRICE!
HI-FI WILLIAMSON TYPE
AMPLIFIER KIT**

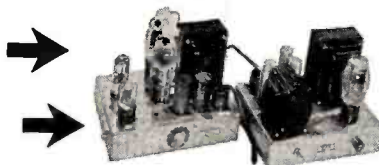

Using Stancor transformers. Easy-to-assemble amplifier kit. Comes with schematic and instruction sheet based on famous Williamson circuit. Frequency response ±1 db. from 20-50 Kc. at 8 watts. Intermodulation distortion is only 3% at 8 watts output. Total harmonic distortion at 1000 cycles is non-existent below 10 watt power level.

SPECIAL
Price Per Kit \$44.95

**KIT OF CBS HYTRON TUBES
FOR ABOVE AMPLIFIER**

Consists of: 2—GL807 2—6SN7GT 1—6U4G
SPECIAL \$7.95 ONLY

IRISH PLASTIC RECORDING TAPE
BRAND NEW! NOT SURPLUS. This First Grade recording tape is ¼ in. wide. Frequency response: 50 to 8,000 cy. Plastic reel included with each.
600 FT. \$1.35 1,200 FT. \$2.10

BEST BUY OF THE MONTH!!!!

10 W. HI-FI PUSH-PULL AMPLIFIER—Fre. response 20-20,000 cps. at less than ½ of 1% distortion. NEW \$32.95

COMING OUR WAY? Be sure and visit our new, Hi-Fi, acoustically designed sound studio!

All orders F.O.B. Los Angeles. Minimum order \$5.00. 25% deposit required with order.

OLYMPIC ELECTRONICS SUPPLY
Distributors
1440 W. Olympic Blvd., Los Angeles 15, Calif.



EARN MORE MONEY AS AN EXPERT

Get Shop-Method
Training at Home in

RADIO TELEVISION ELECTRONICS

One Master Course - One Low Tuition
LEARN ALL PHASES - EARN WHILE YOU LEARN

AS A NATIONAL SCHOOLS GRADUATE THERE'S A PLACE FOR YOU IN THIS EXPANDING INDUSTRY...*Never before* such a *growing* industry as today's Television, Radio and other Electronic fields. This industry needs *you*... TODAY... and it needs you as a *trained* man... the kind of man you will be as a National Schools graduate. So don't wait. Start your National Schools training NOW...and enjoy big money, job security, SUCCESS!

LEARN from EXPERTS! BE A SUCCESSFUL MAN YOURSELF! You learn from men who are themselves successful Radio, Television and Electronics technicians. You learn the *practical* way... *by doing*... with equipment we send you. **And you advance quickly, step by step. Get ALL the facts from FREE book and sample lesson. Mail coupon below NOW. Absolutely no obligation.**



All yours at no extra cost!

Don't put it off! Mail coupon NOW!

You can qualify FAST for these big-pay jobs...plus many more

Radio Station Technician • Your own Sales and Service Shop • District Service Manager • Inspector Technician • Aircraft Radio Inspector • Special Govt. Positions • Service Specialist • Sound Truck Operator • and many others!

ONLY NATIONAL SCHOOLS GIVES YOU THIS PROFESSIONAL



MULTI-TESTER
Ready to use. Easy to operate. Light enough to carry on service calls.

DRAFT AGE? National Schools training helps you get into special service classifications—get higher grades, better pay!

GET YOUR TRAINING FROM THE RADIO-TV CAPITAL OF THE WORLD

Let National Schools—a *resident* technical trade school for nearly 50 years—train you at home for today's unlimited opportunities in Radio-TV.



FREE!

Radio-TV Book & Sample Lesson
JUST MAIL COUPON!

NATIONAL SCHOOLS GRADUATES IN BIG DEMAND. You'll find National Schools graduates in good jobs everywhere. For these are the jobs National Schools *trains* you for. Such complete, shop-method home training can be *your* ticket to success...your key to the job happiness you've always wanted. It's up to you. Mail coupon NOW!

FRIENDLY GUIDANCE AS STUDENT AND GRADUATE. Our special Welfare Department is constantly at your service. Helps you with your technical and personal problems. Gives you the benefit of its wide industry contacts and experience in helping you after graduation. **BOTH RESIDENT AND HOME STUDY COURSES OFFERED.**

NATIONAL SCHOOLS APPROVED FOR G. I. TRAINING

Los Angeles, Calif. • Est. 1905 • In Canada: 193 Hastings St., Vancouver, B.C.

YOU GET ALL THE PARTS INCLUDING TUBES for this superheterodyne receiver... and lots of other equipment...to keep!

NATIONAL SCHOOLS, Dept. RH-33
4000 South Figueroa Street
Los Angeles 37, California

Mail in envelope or paste on postal card

Send me FREE book "My Future in Radio-Television and Electronics." Also a FREE sample lesson. I understand no salesman will call on me and that there is no obligation.

NAME _____ AGE _____

ADDRESS _____

CITY _____ ZONE _____ STATE _____

VETS! Check here if you are a veteran.

ACT NOW

OLSON'S PENNY PROFIT POLICY MEANS GREATER BARGAINS



IMPERIAL DELUXE MODEL
STOCK NO. RA-69

Equipped with a single needle and a long-lasting tip. Plays all speed records, 33 1/3, 45 and 78 RPM. Regular retail price \$47.50. Shpg. wt. 13 lbs.

Single, each \$18.99
In lots of 3, each, only..

GIANT 3-SPEED RECORD CHANGER SALE!

3-SPEED GENERAL INSTRUMENT AUTOMATIC RECORD CHANGER

Automatically Changes All Sizes—7", 10" and 12"

All Speeds—33 1/3, 45 and 78 RPM

All the finest features are incorporated in these General Instrument Record Changers. Records Slide Gently down the center spindle. There is no wobble, no scrape, no slip. No chance of damaging your records. The newly-designed controls are so simple, they explain themselves. No instructions needed. All moving parts in every General Instrument Changer are factory adjusted thus insuring years of trouble-free performance.

These Changers are precision-built by craftsmen who have had years of experience. Every Changer is brand new—in original factory-sealed cartons—and guaranteed 100% by Olson and the manufacturer. Here is one of Olson's most sensational bargains. Believe us—you can't go wrong.

Changer can be connected to any radio or amplifier. Equipped with clever "touch-plate"—a slight press and you can reject or skip a disc and go on to the next one. Has perfect cast parts. Here's a Changer you'll be proud to demonstrate to your friends. You can sell plenty of them too. Operates on 115 Volts AC. 60 cycle. Base size 12"x12 1/2". 3 1/2" above plate and 3 1/4" below. Take your choice of either model.

COMPLETE 3-SPEED RECORD CHANGER AMPLIFIER KIT

Easily Assemble Your Own Automatic Record Player

Stock No. AS-71
\$29.99
FOR ONLY

SEE WHAT YOU SAVE Complete Kit Regular List Price

3-Speed Changer.....\$47.50
Amplifier (Wired)..... 7.50
Set of 3 Tubes..... 4.55
5 Heavy Duty Speakers..... 4.00
Output Transformer..... 1.75
Mounting Base (Pre-Drilled)..... 8.50
Mounting Hardware..... .50
Total List Price.....\$74.35

Here's an outfit that normally retails at \$74.35. Save yourself a pile of money and have fun assembling your own 3-Speed Automatic Record Player. It's easy—can be assembled by anyone in just 30 minutes. All holes are drilled and all mounting hardware is provided. The Amplifier is completely wired. All you have to do is attach the Changer and Speaker wires. Shpg. wt. 20 lbs.



You Get Everything You Need to Easily Assemble Your Own 3-Speed Automatic Record Player. Kit includes:

GENERAL INSTRUMENT IMPERIAL DELUXE CHANGER (Model RA-69—as described to left).

5" PM HEAVY-DUTY SPEAKER AND OUTPUT TRANSFORMER.
3-TUBE AMPLIFIER COMPLETE WITH TUBES
MOUNTING BASE—WITH HARDWARE & INSTRUCTIONS

HI-FI DELUXE MODEL

STOCK NO. RA-113

Equipped with "Turnover" cartridge and dual needle. One side for 33 1/3 and 45 RPM discs and other side for 78 RPM discs. Both sides equipped with precision metal long-lasting tips. Regular retail price \$32.50. Shpg. wt. 15 lbs.

Single, each \$21.99
In lots of 3, each, only..

HIGH GAIN STANDARD COIL TV BOOSTER

★ Latest Model ★ Brand New
★ Reg. List Price \$30.00
★ While they last. Model No. B-51.

\$10.95
Ea.



Just connect one of these Standard TV Boosters to your receiver and get brighter, snappier pictures and less "snow" and interference. Easy to attach. Works on all TV sets. An amazing deal—you can cash in—save money—Order Today. Tunes all 12 channels. Uses a 6AK5 tube and a selenium rectifier. Complete. Operates on 115 V. AC. Shpg. wt. 6 lbs.

SLOTTED SUPER SPACE LINE

LOWER LOSS 300 OHM



STOCK NO. W-115
500 Ft. Spool
Single, Ea. \$7.95
Lots of 2 Spools

This slotted 300 ohm TV line is made to standard specifications in such a manner as to provide maximum slip spacing while maintaining the desirable strength and durability of the usual 300 ohm twin line. Color: Brown, with 22 stranded copper, pure polyethylene 65 mil. wall. Never offered before at such a low price. ORDER EARLY—while supply lasts. Shpg. wt. 7 lbs.

DON'T THROW AWAY OLD PICTURE TUBES

BOOST BRILLIANCE WITH THIS TV



\$2.95

Stock No. T-100

Completely automatic. Easy to install—no tools needed. Just plug into old picture tube that is starting to dim and watch the big change. Works on any Tube—10" to 30" in all AC parallel circuits. Adds months and months of service to use old tubes. Reg. \$5.95. Shpg. wt. 1 lb.

12" Magnavox Speaker and Baffle Close-Out



Shpg. wt. 12 lbs. \$8.95.

Stock No. AS-66
get both for only...

\$7.95
In lots of 4 sets.
One set for \$8.95.

You get Magnavox's fine 12" PM speaker with Alnico 5 magnet. (Same as you'll find in those expensive Magnavox Super Radio-Phono Combinations.) Power output 8 watts. Voice coil fully dustproof. Impedance 6-8 ohms. In addition you get a walnut Speaker Baffle to bring out the full rich, rounded tones of the Magnavox Speaker. Baffle may be mounted on a wall or it will stand on a table. Here's the ideal combination for extension speakers for porches or other rooms. Can be connected to any radio or amplifier. Order 4 or more sets and install them in restaurants, auditoriums, halls.



\$1.69
Stock No. X-298 Shpg. wt. 1 lb.

DELUXE COUNTER

We're letting these go at a fifth of Actual Cost—\$8.50. Keep an accurate count up to 100,000 on transactions, traffic, production, etc. Just touch a lever and it counts.

BIG INSULATED RESISTOR KIT
OLSON SPECIAL PRICE
Contains a carefully selected assortment of 100 in standard resistors. Standard A.M.A. color code. Included are 70- 1/2 watt, 20- 1/2 watt and 2- 1/2 watt resistors. Handsomely packed in a durable pilothin bag. Retail List Price \$15.80. Shpg. wt. 2 lbs.

Stock No. AS-32

OLSON ELECTRIFYING BARGAIN!



You get the complete outfit, including cabinet 3 tubes (6SL7, 6SN7 and 6X4) and wiring diagram.

STOCK NO. RA-111
Single, each, \$5.99
Lots of 3, each.....

\$4.99

THE NEW WONDER OF ELECTRONIC CONTROL CAN BE YOURS FOR PRACTICALLY NOTHING THYRATRON REMOTE CONTROL

SERVICEMEN—HOBBYISTS—HAMS EXPERIMENTERS—RADIO SCHOOLS

Here's the chance of a lifetime to own a genuine Thyatron Electronic Remote Control of your own at a fraction of its regular price! This mighty handful (only 5 1/2"x3 1/2") of miracle control can be made to perform hundreds of practical, fascinating feats of remote control. A complete schematic showing the circuit is included with each unit. It's a steal! Buy it just for the parts alone. Take it apart! Look what you get! Valuable parts and tubes galore that you can so easily use in any other radio, amplifier, etc.—or for experimenting.

- LOOK AT ALL THE PARTS YOU GET**
- 6SL7 and 6SN7
 - GL-5662 Tube
 - 16 Mfd. @ 150 Volts
 - 1 Mfd. @ 200 Volts
 - .02 Mfd. @ 200 Volts
 - 1 Mfd. @ 200 Volts
 - 1 Mfd. @ 200 Volts
 - Control—SPST
 - Pilot Lamp, Type 44
 - Dial Assembly
 - Control Housing
 - Bottom Plate
 - Prong Plug
 - Filament Transformer
 - 240 Ohm 1/2 Watt Carbon
 - 500 Ohm Calibration Control
 - 1 Megohm-1/2 Watt Carbon
 - 2600 Ohm-1/2 Watt Wirewound
 - 1000 Ohm-1/2 Watt Wirewound
 - Switch—SPST
 - 8000 Ohm-10 Watt Wirewound
 - 35 Ohm-1/2 Watt Wirewound
 - 3000 Ohm-1/2 Watt Wirewound
 - 1 Megohm-1/2 Watt Carbon
 - 500 Ohm-1/2 Watt Carbon

POWER CORD makes it easy to connect to 115 V AC line. Consists of 12 ft. heavy rubber covered wire with rubber molded plugs. STOCK NO. W-116, ea., 49c.

Can easily and quickly be modified for Electronic Remote Control of Transmitters. Turn Radio and on and off. Open and Close Garage Doors from your car; etc. Schematic Diagram included at No Extra Cost.

COMPLETE TV ANTENNA

A complete stacked array. Made by a famous manufacturer whose name and brand is on every factory sealed carton. Look what you get: 2 Six-element conical bays, 1 pair "Q" bars, 2 Five-foot mast sections, 60 ft. 300 ohm twin line, 5 Standoff insulators, 1 mounting base, 1 guy ring, 1 clamp hardware. Elements are highest quality aluminum. Reg. list price is \$31.95. Shpg. wt. 15 lbs. Express only.

Stock No. AU-24
\$11.99
Complete Set

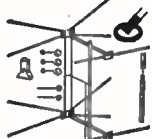

GIANT AKRAD "LOADMASTER" CONDENSER KIT
STOCK NO. AS-20
\$16.95
4-DRAWER STEEL CABINET
FREE!



Here's your chance to get 69 By-Pass and Electrolytic Olson Akrad "LOADMASTER" Condensers all packed in a Big 4-Drawer Chest (10" x 11 1/2" x 10") which we give you absolutely FREE. Treat yourself to a supply of these high-quality Condensers and see for yourself why 150,000 Radio Repairmen insist upon Akrad.

27 Akrad "LOADMASTER" Electrolytic Condensers				42 "LOADMASTER" By-Pass Condensers			
Qty.	Cap.	Volts	Total List	Qty.	Cap.	Volts	List. ea.
10	25	1.00	\$2.00	2	.002	600	.25
2	25	2.00	2.00	3	.005	600	.25
3	20	1.25	6.00	3	.010	600	.30
4	150	1.35	5.75	5	.02	600	.30
4	20-20	1.65	6.60	10	.05	600	.40
5	450	1.25	6.25	10	.1	600	.45
6	16	1.40	5.60	2	.005	1800	.60
				2	.008	1800	.65
				2	.01	1800	.65

6J6 MOST POPULAR TV TUBES—Discount Over 72%

INDIVIDUALLY BOXED • BRAND NEW
MADE BY LARGEST MFG.

Reg. List \$2.50
Single, ea. 99c
Lots of 10. **69c** ea.

Here's the inside story on how Olson bought these fine brand-new tubes. America's largest tube manufacturer made them and was ready to ship to a big company when they suddenly got a cancellation. Olson stepped in and made a deal and bought a terrific quantity. Then we had our "Akrad" brand put on every tube. They're individually boxed and carry the usual 100% Olson Money-Back Guarantee. Order Plenty at This Price.

REAR DECK AUTO SPEAKER KIT FOR ALL CARS

\$2.95 EACH

Install a rear seat speaker in any car, any radio. Complete Kit of parts furnished with easy instructions. Includes beautiful grille and 3-way dashboard switch for operation of front and rear speakers separately or together. Supplied less speaker. Requires popular 6"x9" size speaker.

STOCK NO. AS-81 Shpg. wt. 3 lbs.



SPEAKER FOR AS-81 KIT
Heavy duty—high volume PM 6"x9" speaker with 3.2 ohm voice coil for PL-S-81 installation. Shpg. wt. 6 lbs.

\$3.39 EACH

STOCK NO. S-114

OLSON AKRAD OLSON RADIO WAREHOUSE • 275 E. Market St., Akron & Ohio

MAIL YOUR ORDER TODAY—OLSON WILL RUSH IT RIGHT AWAY!

NO MORE WHEN THESE ARE GONE!



SPECIAL SALE! WILCOX-GAY RECORDIO TAPE RECORDER

2 Full Hours of Recording or Playback—Automatic—Foolproof Push-Button Controls • 2-Speeds • Records • Plays Back • Erases

STOCK NO. \$ **99.50**
AMP-10
BRAND NEW
REGULAR
\$149.95
ONLY... **99**

Order your Wilcox-Gay Tape Recorder for less than Dealer's Cost! This is the finest Recorder Olson has ever offered—at a price that is really give-a-way. We made a real deal and you get the benefit. Five "Freat-o-matic" Push-button Controls allow instant change of all operating functions—fast forward and reverse, record, stop, and playback. The easiest of all recorders to operate. Handles up to 7" reels. Full range of recording times—7" reel records for a full hour at 3.75" per second, plus another hour on other half tape; and at 7.5" per second you get a full recording hour on both halves of tape. Rewinds in less than 3 minutes. Automatically records from FM or AM radio, phonograph, TV or mike. Frequency response—70-8500 cps at 7.5" per second, and 90-6000 cps at 3.75" per second. Output—2 Watts. Maximum Fidelity gained by Automatic Speed Selector. Complete with Controlled Reluctance Mike, Record Lock Button, External Speaker Jack, Full Range Variable Tone and Volume Controls—4 Tubes—6B37, 6AQ5, 12AX7, 6X4 Rectifier, 7 ft. Cord, Neon Recording Indicator, Handsome Removable Cover. Ideal for Office, School, Church, Club, Home, etc. Lightweight, only 23 lbs. complete. Portable size 12"x14"x9". 110-120 Volt 60 cycle AC. U.L. Approved.

RECORDING TAPE—FAMOUS MFR.'S CLOSEOUT



PLASTIC BASE
600 FT. REEL
STOCK NO. X-275
Single, ea. \$1.29
Lots of 10 \$1.49
1200 FT. REEL
STOCK NO. X-249
Single, ea. \$1.99
Lots of 10 \$2.19

Get the buy of your life. Save up to 64% on high quality RECORDING TAPE. A large manufacturer had to sell his inventory and he unloaded the whole deal. Olson now offers you this high grade recording tape at prices which defy competition. Standard 3/4" wide, 1200 ft. long. Frequency response 50 to 8,000 cy. Plastic Reel included with each. Shpg. wt. 1 lb.



**ROLA
12\"/>**

With Matching Output Transformer for 6V6
Rola—a great name in Hi-Fidelity—has built these fine 12\"/>

A MIRACLE in RESISTORS



KIT OF 130 NATIONAL RESISTORS
1/2 WATT—10% TOLERANCE
\$3.66 Stock
COMPLETE KIT YOU GET 13 SIZES 10 OF EACH SIZE ONLY
Less than 3c each. You get 10 each of the following 13 popular values. OHMS: 10,000, 15,000, 22,000, 27,000, 47,000, 56,000, 100,000, 270,000, 330,000, 470,000. MEGS: 1, 4.7, and 6.8. The degree of precision, at a small price. National Resistors are the product of a New Japan, the product of an electronic industry which already enjoys worldwide recognition for unsurpassed excellence. Olson made a deal whereby we obtained 260,000 units at a special price—so we could convince even the most skeptical. Every Resistor stamped with value. Size 3/4"x3/8" with 1" tinned copper leads. Shpg. wt. 2 lbs.

BRAND NEW LATEST 1953 MODEL ESPEY

COMPLETE: With Tubes, Loop Antenna, External Speaker, Knobs, Etc.

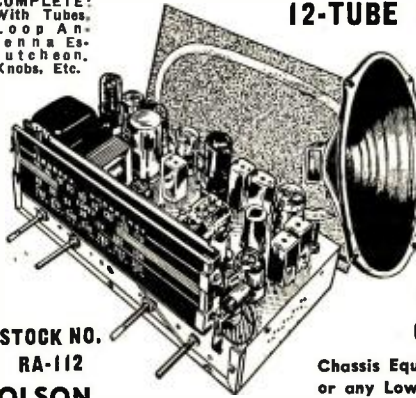

12-TUBE AM-FM RADIO CHASSIS

COMPLETE WITH

12\"/>

LOOK HOW YOU SAVE

12\"/>

DESIGNED FOR QUALITY
CUSTOM INSTALLATIONS

Chassis Equipped with Built-in Pre-Amp for GE or any Low Output Variable Reluctance Pickup

STOCK NO. RA-112
**OLSON
SUPER BARGAIN!**

BOTH FOR ONLY \$66.66

Here's a deal for you! Don't pass it up. We got a terrific bargain by paying cash on the barrel-head. Olson passes it on to you. If we went out to duplicate this offer WE COULD NOT DO SO TODAY. Order Your Outfit Now!

LOOK AT THESE FEATURES: You get a full size AM-FM Chassis including 12 tubes (4 are dual purpose, thus giving you the equivalent of 16-tube performance). Push-Pull Output Audio Stage delivers 10 Full Undistorted Watts. Improved FM Circuit, drift compensated. Built-in Automatic Volume Control, Inverse Feed-back, High-Fidelity assured on both AM and FM channels. Full Range Combination Bass-Treble Tone Control. Slide Tune Dial is indirectly illuminated. Equipped with Loop-Antenna for AM and Folded Dipole Antenna for FM reception. Has provisions for external antennas too. Has Input Jack for both Crystal Cartridge Tone Arm or any Magnetic Low Voltage Cartridge. Also has Microphone input for Public Address use. Fully licensed under both RCA and Hazeltine Patents. Receives standard AM broadcast 550 to 1700 KC and an aperiodic RF Amplifier Stage, 2 Stages of High-Gain Intermediate Frequency Amplification and an advanced design Ratio Detector Circuit which provides Low Noise Level between stations, freedom from AM interference, ease of tuning and ample gain.

High-Fidelity Reproduction is assured through well-engineered Circuits and the use of High Quality Parts throughout. TUBE COMPLEMENT: 1—6BE6, 2—6BA6, 2—12AT7, 1—6SH7, 1—6AL5, 2—6SQ7, 2—6V8GT and 1—6YSGT. Wide Frequency Response is assured by the Push-Pull Output Stage. Chassis size 13 1/2\"/>



OLSON'S 10-PIECE MENNEN • GEM SHAVE KIT

FREE!
Blades • Tube of Popular Mennen Brushless Lather • Bottles of Mennen Cream Hair Oil and Skin Bracer • Attractive, Specially Designed, Carrying Case
Here's an amazing gift that is impossible to buy anywhere. Olson worked hand in hand with Mennen and Gem, the 2 greatest names in shaving aids, to develop a gift that would be unique and yet appeal to all men—and it's yours ABSOLUTELY FREE OF CHARGE. Shave Kit contains: World Famous Gem Featherweight Razor • 5 Super Sharp Gem Console Razors. You can depend upon it to render life-like tone when connected to the chassis. All metal parts are heavily cadmium plated. Full Size Heavy Alnico 5 Magnet is permanently centered. Cone is Full Frequency Construction and the Voice Coil is Fully Damp-proofed both inside and out. A Rare Combination such as this AM-FM Chassis and Magnavox 12\"/>

HOW TO GET OLSON'S SHAVE KIT FREE! Just make out an order totalling \$20 or more from these Olson Ads using Handy Order Blank below. We'll ship your order instantly and include the Olson Shave Kit FREE OF CHARGE. One Kit to a customer. THIS OFFER EXPIRES APRIL 15, 1953.

IT'S EASY TO ORDER FROM OLSON'S

How to order: Order directly from this ad. For convenience use this order blank. Fill in columns below with quantity desired, stock number, description and price. You may send remittance with order (include enough for postage or parcel post shipment), or if you prefer SEND NO MONEY. Olson will ship C.O.D. and you may pay mail or express for merchandise and postage.

MONEY BACK GUARANTEE:
Everything you order from Olson is guaranteed as advertised. If you are not more than satisfied, you may return merchandise for cash refund.

MAIL TO: **OLSON RADIO WAREHOUSE**
275 E. MARKET ST., AKRON 8, OHIO
WE SHIP SAME DAY WE GET YOUR ORDER
Please Minimum Order \$3.00

QUANTITY	STOCK NUMBER	DESCRIPTION	PRICE EACH	TOTAL

NAME	TOTAL
ADDRESS	ADD POSTAGE
CITY	TOTAL AMOUNT
ZONE	STATE

FREE! OLSON'S BIG NEW BARGAIN CATALOG

Get Olson's LOWER-than-wholesale prices from this famous book. STANDARD BRANDS—FRESH STOCK. IMMEDIATE DELIVERY. Catalog is two colors—40 full pages of unbelievable bargains. A new catalog mailed Bi-Monthly—with new low bargains each mailing. Simply note on order blank or write today for your free copy from: **OLSON RADIO WAREHOUSE, 275 E. MARKET ST., AKRON 8, OHIO.**

WANTED! \$500,000.00

WORTH OF Radio and TV Parts, Speakers, Transformers, Tubes, Picture Tubes, Condensers, Resistors, Switches, Wire, Knobs, Coils, Phone Cartridges, Etc. ALSO Partially assembled or complete Radio, Amplifier and Television Chassis. ALSO Test Equipment, Record Players, Automatic Changers, Motors, Microphones, Tone Arms, Meters, Cable, Cabinets, Grille Cloth, Wire or Tape Recorders.

MANUFACTURERS and WHOLESALERS
Here's your chance to dispose of your inventory for cash.
WRITE: **OLSON RADIO WAREHOUSE • ATT'N. I. J. OLSON**
PHONE: Jefferson 9191 • 275 E. Market St., Akron 8, Ohio

OLSON STORES TO SERVE YOU IN:
CLEVELAND, OHIO 2020 Euclid Avenue
CHICAGO, ILLINOIS 623 W. Randolph Street
If you live in or near either of these cities visit our Bargain Stores where you'll find these and hundreds of other Olson Buys.
OLSON HAS OVER 150,000 SATISFIED CUSTOMERS

OLSON RADIO WAREHOUSE • 275 E. Market St., Akron 8, Ohio

March, 1953

99

NEW SURPLUS LOWEST PRICES

MOBILE DYNAMOTORS

MADE BY PIONEER AND EICOR

6 Volts Input, 425 Volts at 375 MA Output, 6 3/4" Long, 4" Diameter, Weight 10 lbs. List Price Approx. \$70.00.
BRAND NEW, ONLY \$27.95
As Above but 12V. Input. **\$24.50**

G. E. RELAY CONTROL

(Ideal for Model Controls, Etc.)

Contains a sigma midget 8,000 ohm, relay (trips at less than 2 MA), high impedance choke, bimetal strip, neon pilot and many useful parts. The sensitive relay alone is worth much more than the total **\$1.25** Each 10 for **\$9.90**
low price of

PANEL METERS

NEW GOVT SURPLUS STANDARD BRANDS 2" METERS
0-10 MA AC. \$2.95
0-15 Volts AC. 2.95
3" METERS
0-200 Microamps . . . \$6.95
0-400 Microamps . . . 5.95
0-500 Microamps . . . 5.95
0-1 Milliamper 4.95
0-10 Milliamper 4.50
0-50 Milliamper 4.50
0-200 Milliamper . . . 4.50
0-250 Milliamper . . . 4.50
0-5 Volt DC (1 MA). . . 4.95
0-10 Volt DC (1 MA) . . 4.95
0-15 Volt DC (1 MA) . . 4.95
0-50 Volt DC (1 MA) . . 4.95
0-150 V. DC (1 MA) . . . 4.95
0-1.5 Volts AC. 4.95
0-3 Volts AC. 7.50
0-150 Volts AC. 7.50
0-1.5 KV DC w/ multiplier 6.95
4" METERS
0-200 Microamps . . \$8.95

METER BUY OF THE YEAR!

2" Simpson Meters
Round bakelite case.
Brand new, original cartons.
0-1 MA DC. **\$3.95**
0-300 Volts DC, 1000 Ohms/v
(1 MA) . . **\$3.95**
DB Meter -10 to +20 **\$3.95**
ANY 3 METERS \$11.50

FILTER CONDENSER BARGAIN

8 x 8 M.F.D., 600 VDC Oil Compound Filled. NEW, but scratched, ONLY **\$.95** each

BAKELITE CASED MICAS

MFD	VDC	Price	MFD	VDC	Price	MFD	VDC	Price
.001	500	\$.18	0.1	1 KV	\$.45	0.2	2 KV	\$.50
.002	600	.24	.002	1200	.35	.005	2500	.55
.01	600	.30	.01	1500	.65	.002	2500	.45
.02	600	.26	.033	1500	.75	.01	2500	.50

WIRE WOUND RESISTORS

5 Watt Ohms: 25-50-84-200-2500 \$.09 ea.
10 Watt Ohms: 25-40-1325-2K-4K \$.13 ea.
20 Watt Ohms: 150-300-750-1K-1.5K, 2.5K, 5K \$.20 ea.
30 Watt Ohms: 100-2500-4500-18K \$.22 ea.

1 MEGOHM, 1% W.W. PRECISION RESISTORS, SHALLCROSS. List Price Approx. \$9.50.
ONLY **97c** ea.; 10 for **\$8.95**

1% PRECISION W. W. RESISTORS IRC—SHALLCROSS

OHMS: 110, 1K, 2K, 2.2K, 2.5K, 5K, 8.5K. \$.35 ea.
OHMS: 25K, 40K, 50K, 120K. \$.49 ea.
MEGOHMS: .1, .2, .5, .8 \$.69 ea.

PLATE TRANSFORMER BARGAIN

Primary 115 Volt, 60 Cy. Secondary 435-0-435 Volts @ 300 MA., 5V @ 3A., 5V @ 3A., 6.3V @ 10A. Electrostatic Shield. Fully Cased **\$5.95** ea.

OIL CONDENSERS
3.75 mfd 680VAC. . . \$2.45
15 mfd 1000 VDC. . . 4.95
1 mfd 2500V. 1.75
1 mfd 3600V. 1.95
1 mfd 7500V. 1.75
5 mfd 7500 VDC. . . 4.95
1 12KV DC. 2.95
0.1x .01 12KV DC. 2.95
5 mfd 800 VAC. 2.95
7 mfd 800 VDC. 1.75

100,000 OHM 150 WATT RESISTOR \$0.59
10 for \$4.99

NON-INDUCTIVE RESISTOR 500 OHM 100 WATT \$0.75 ea.

GE KV METER
0-15 KV DC, 3 1/2" SQ. Bakelite Case, 500 UA movement. Includes 30 Meg. 1% Ext. Multiplier \$9.95

SILVER MICA CAPACITORS
MMF: 60, 340, 750, 780, 1000 \$0.12 ea.

SIGMA PLATE RELAY
10,000 Ohm Coil SPDT \$1.75

HEAVY DUTY FILTER CHOKE
4 HY, 1 Amp, 10KV Ins. Fully Cased \$19.95

FILTER CHOKE BARGAIN
6 Hy 500 MA. Fully Cased . . . \$4.95

PIGTAIL MICAS
MMF: 5, 20, 50, 60, 100, 250, 300, 400, 500, 750, 200, 100, 2000, 3000, 4000, 5000, 6000, 10000 \$0.09 ea.

PEAK ELECTRONICS CO.

66 West Broadway, New York 7, N. Y.
Phone WORth 2-5439

Binaural Reproduction

(Continued from page 73)

about one one-hundredth of a second, which in live listening would be similar to the delay produced by one sound source being ten feet further away. For recordings using the artificial head technique the spacing between the two heads must be kept to a much closer tolerance as fairly exact phase relationships between the two channels must be maintained to above 1000 cycles. As a result, the spacing between heads should be held to within a few thousands of an inch tolerance, a much more difficult procedure.

Operation of binaural equipment makes it necessary to monitor two channels simultaneously. Conventional vu meters may be used on each of the channels for level indication, while a split pair of headphones, with one ear piece being fed by each channel, is of value in judging the audio quality and balance obtained. Although riding gain on two separate channels may at first seem somewhat complicated, in several respects it is simpler than obtaining correct adjustment in conventional equipment in which multiple microphones feed a common output, due to the fact that both headphones and meter readings give indications of the sound pressure at a particular microphone location. However, if convenient, a master gain control for the two channels may be installed through the use of two identical, ganged volume controls.

In playback the best results, musically, usually are found when the two sound sources are somewhat diffused, as this tends to give a better illusion of spatial dispersion. Use may be made of corner radiation to achieve this effect or multiple speaker installations may be used. Likewise a third speaker may be bridged across both outputs and placed in a central location.

Although playback equipment is, of necessity, usually fairly bulky, the low power audio requirements of tape recording mean that a relatively light, compact, and inexpensive two-channel recorder can be constructed for use in the field. A voltage amplifier triode, such as the 6J5, is sufficient to drive a high impedance recording head, while two preceding stages are usually enough for full output from most types of high impedance microphones. A type 6E5 electron eye tube may be used as a volume indicator as it draws negligible audio power and is capable of giving accurate indication of complex waveforms. However, the high frequency response of the eye must usually be attenuated to prevent the bias frequency from presenting an indication, and some difficulty may be experienced in reading the eye under strong light levels.

A number of different types of microphone placement may be made in recording and the best results in musical reproduction are achieved through

MERIT. PLATE TRANSFORMERS

1100 VCT/150MA \$ 6.47
1320-1100VCT/250MA, 40V Bias Tap . . . 8.08
2140VCT/125MA/1000VCT/150MA 9.77
1800-1400VCT/225MA 9.70
2900-2350VCT/300MA 24.11
4200-3600 VCT/300MA 30.58
5800-4770VCT/300MA (Sq. Case) 47.04

MERIT FILAMENT TRANSFORMERS

2.5VCT/10AMP/10KV INS \$ 3.67
5VCT/3AMP/2500V INS 2.50
5VCT/30AMP/2500V INS 4.47
6.3VCT/1AMP/2500V INS 1.45
6.3V/1.2AMP/5KV INS (TV REPL) 2.12
6.3VCT/3AMP:6.3VCT/3AMP/2500V INS. 4.06
5VCT/3AMP:6.3VCT/3AMP/2500V INS . . 4.06
10VCT/10AMP/3KV INS 5.88
12.6VCT/2AMP/2500V INS 2.64
25.2VCT/1AMP/2500V INS 2.64
12.6V/TAMP or 25.2V/3.5AMP/2500V INS 5.88

MERIT FILTER CHOKES

15HY/85MA/1500V INS \$ 2.94
10HY/110MA/1500V INS 2.94
12HY/150MA/1500V INS 3.53
15HY/150MA/2KV INS 5.14
5HY/200MA/1500V INS 4.11
10HY/150MA } 3KV INS 3.82
10HY/200MA } 4.70
10HY/250MA } 6.47
8HY/300MA } 6.76

MERIT UNIVERSAL MODULATION

PR1-2000-2000/50MA Per Side: SEC- 2000-2000/50:100MA* 15 WATTS \$ 6.32
PR1-2000-2000/150MA Per Side: SEC- 2000-2000/150:300MA* 60 WATTS 9.41
PR1-2000-2000/220MA Per Side: SEC- 2000-2000/220:440* 125 WATTS 13.23
*SERIES—PARALLEL

TUBE SPECIALS

NEW—STANDARD BRAND—GUARANTEEDI

7JP4 \$18.50	807 \$2.25
10BP4A . . . 19.50	816 1.17
12LP4A . . . 21.90	866A 1.75
17BP4A . . . 22.90	H75A 4.23
19AP4A . . . 37.50	3A5 1.75
20CP4A . . . 34.75	5R4GY . . . 1.45
12EP4A . . . 38.50	6AS7G . . . 4.25

All prices F.O.B. our warehouse New York

LEEDS RADIO CO.

75 Vesey St. Dept. A New York City 7

Now! HANDLE UP TO 90% OF TV TROUBLES



by the easy

PICTURE ANALYSIS METHOD!

PIX-O-FIX TV TROUBLE FINDER GUIDE

By Ghirardi & Middleton

Only \$1.

Covers 24 common troubles identified by actual screen photos

- • • 190 possible causes of these troubles localized to receiver stage or section where they are most likely to occur.
- • • 253 step-by-step remedies for these troubles.
- • • 4,500 words in CAUSE AND REMEDY section to show exactly what to do.

Cut hours of tedious TV trouble-shooting to minutes! Make repairs twice as fast! Operation of Ghirardi's new PIX-O-FIX TV TROUBLE FINDER GUIDE is simplicity itself. Covers all TV receivers.

Just turn dial until actual TV screen photo appearing in PIX-O-FIX "window" matches distorted picture on set being repaired. PIX-O-FIX then gives you all possible causes for this trouble and just where in the receiver they are likely to be found. But that is only the beginning! Step-by-step repair instructions follow. Components likely to be faulty are specified. Quick tests are outlined. PIX-O-FIX guides you every step of the way! Remember! PIX-O-FIX is NOT a "fix-it-yourself" gadget for consumers. It is a truly professional device for servicemen, apprentices and students—prepared by two of the nation's foremost service instructors—A. A. Ghirardi and R. G. Middleton.

MONEY BACK IF YOU'RE NOT SATISFIED

Simply pin a \$1 bill to this ad. Mail with your name and address to the publisher. If not satisfactory, return PIX-O-FIX in 10 days and your \$1 will be refunded promptly. (Price outside U.S.A. \$1.25 same money-back guarantee.)

Dept. RN-33, RINEHART BOOKS, Inc., Technical Div., 232 Madison Ave., New York 32, New York

an understanding of the nature of an individual composition as well as proper grouping of the instruments in order to emphasize the spatial characteristics of counterpoint as well as soloists with the group. Use of two channels tends to produce less intermodulation and other distortions due to the somewhat greater simplicity of the waveforms handled and therefore permits the achievement of effects not readily obtainable with single channel equipment. It also might be noted that human hearing is capable of depth perception as well as localization in the horizontal plane. This effect is apparently brought about by the ability of the ear to detect modifications of the original sound brought about through reflections of sound from walls or adjacent objects. As a result, the two-channel system may be used for experiments in distance perspective by placing both microphones and playback speakers in a straight line with the listener.

In conclusion, the use of multiple sound channels offers unique advantages in high quality music and sound reproduction, as well as providing extra reliability and versatility for the recording engineer or public address operator. Present day inexpensive dual-track tape machines may be adapted to simultaneous two-channel operation at relatively low additional expense, while recently developed tape copying techniques, as well as the advent of long playing discs, indicate that commercially produced binaural recordings are well within the realm of possibility.

-30-

Electronic Organ
(Continued from page 61)

maximum volume, you are playing a melody. There are no popular songs where a seven second rest is written in the melody and if there were, you could release the volume. There is a way to eliminate this click but it involves the use of another set of contacts on all twenty-three keys and I did not consider it worth the effort. If you will keep a finger on the next key to be played, there will be a continuous melody and no keying will be heard.

"How do I find those exact frequencies for the melody attachment?" A very good question. First, tune the main organ by locating the 440 cycle "A". Then use the chart method to tune the rest of the notes. You will notice that all of the keys in the melody attachment are duplicated in the main organ. Just match the highest key in the melody attachment to the identical key in the main organ. It is a "G" and should be 393 cycles. The potentiometers are all in series so you must begin with the highest note. With that as a basis, tune the remainder of the melody attachment by the chart method.

-30-

UHF-VHF Signal Testing is QUICK, EASY with...

**THE NEW
HEAVY DUTY**

Alprodco EREC-TOWER

TEST SIGNALS UP TO 80 FT. ▶

EREC-TOWER—and only EREC-TOWER—goes up a full 80 feet. You test signal strength anywhere along the way up... determine just exactly how high the permanent antenna must be!

ERECT PERMANENT TV TOWERS ▶

Use the EREC-TOWER as a gin pole to raise permanent antenna towers. With an EREC-TOWER, for example, two men can erect a 100-foot Alprodco Tower in less than two hours. You save time, money, labor on every job!

DEMONSTRATE TV SETS ▶

EREC-TOWER helps you demonstrate sets quickly, anywhere. Here's the ideal way to show razor-sharp pictures to your fringe area prospects... right in their own homes. EREC-TOWER is a real sales closer!

BETTER BUILT

EREC-TOWER is constructed of lifetime aircraft aluminum. Each leg and track (see opposite illustration) is extruded in one solid 24-foot length... will not buckle, crack, stick or rust.

**HEAVY EXTRUDED
ONE-PIECE ALUMINUM
TRACKS**

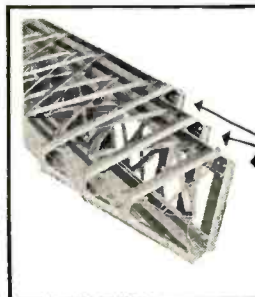

Dealer
Net Price
(For Tower)
\$233.50

FREE! WRITE TODAY for full information and literature on the Alprodco EREC-TOWER as well as Alprodco Aluminum TV-FM-AM Towers.

Alprodco, Inc.

302 E. MAIN ST., KEMPTON, INDIANA
MINERAL WELLS, TEXAS • DUBLIN, GEORGIA

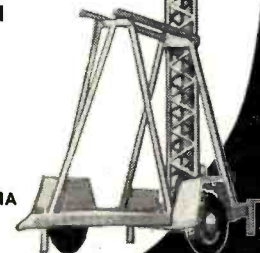

DEALERS-SERVICEMEN-MAKE MORE MONEY-GET ACQUAINTED with McGEE

28 WATT \$150.00 LIST PORTABLE P.A. ON SALE \$69.95



3-SPEED PHONO TOP—TWO 12-INCH SPEAKERS
7-TUBES PUSH PULL 6L6'S HEAVY LEATHERETTE
COVERED PLYWOOD PORTABLE CASES
CRYSTAL MIKE \$8.95 EXTRA

STOCK No. AP-28X. Portable 28 watt public address system. You get a 7-tube heavy duty push-pull 6L6 amplifier with inputs for 2 mikes either crystal or dynamic with separate mixing volume controls. One phono input. Fully variable tone control with high fidelity, wide range frequency response. The heavy duty output transformer has taps for 5, 16, 125, 250 and 500 ohm speaker connections. Two heavy duty 12 inch alnico V P.M. speakers, each with 25 feet of speaker cable. Each speaker is mounted in separate carrying cases. Each case has a snap on back and is large enough to give good speaker baffling. Each case is 21 x 18 x 13 inches. One is used to carry the amplifier. A 3-speed phono motor and pick-up is mounted in the top of the amplifier to play 33 $\frac{1}{3}$, 45 and 78 RPM records. This portable PA system will put out 20 watts all day long and 28 to 30 watts peak audio. McGEE offers you this \$150.00 list portable PA system at a terrific saving.

STOCK No. AP-28X complete portable PA system with 3-speed phono and speakers as pictured (less mike) ship. wt. 71 lbs. \$89.95. Electro Voice model 910 \$28.50 list crystal mike with 20 feet of cable and desk stand \$8.95 extra. Floor type mike stand instead of desk stand \$4.95 extra. (SEE OFFERING TO THE RIGHT FOR WALL SPEAKERS INSTEAD OF THE PORTABLE SPEAKERS.)

28-WATT AMPLIFIER WITH 12-INCH WALL SPEAKERS

The 28 watt amplifier shown to the left is also offered with-out the portable speakers. In their place we will ship two Seebury walnut wall baffle with two heavy duty 12 inch alnico V magnet PM Speakers and 500 ohm line matching trans. Stock No. SS-28R 28 watt amplifier with 3 speed phono top with two 12 inch wall speakers. \$69.95. Extra 12 inch wall speaker \$11.95. Model 910 Electro Voice mike \$8.95 extra. Floor stand \$4.95 extra.



50-WATT PORTABLE P.A. ON SALE \$99.95 3-SPEED PHONO TOP—TWO 12" SPEAKERS

10-tube portable 50-watt public address system. 4—6L6G (push-pull parallel) output tubes. Inputs for 2 microphones, either crystal or dynamic, with separate mixing volume controls. Twin bass and treble tone controls. High fidelity wide range output transformer with taps at 4, 8, 16, 125, 250 and 500 ohms. Complete with 2 super heavy duty 12" PM speakers and 25 ft. cables mounted in separate leatherette-covered carrying cases. 21"x21"x13" and 12"x12"x12" sizes. The amplifier fits in one of the cases for carrying. This amplifier will put out 40 watts all day long and 50 to 60 watts peak with ease. 3-speed turntable and pick-up arm to play all records 33 $\frac{1}{3}$, 45 and 78 RPM is mounted in the top of the amplifier. Stock No. MA-33 \$149.95. This portable P.A. system similar to the 28-watt model pictured above, less microphone. Sale price, \$99.95. Shipping weight, 100 lbs. shipped via Express or Truck only. Regular \$45.00 list. Electro-Voice 610 dynamic microphone with 20 ft. cable and desk stand, \$11.95 extra. For floor stand instead of desk stand, add \$4.95.

10-WATT PORTABLE P.A. ON SALE \$42.95 3-SPEED PHONO TOP—10" ALNICO PM SPEAKER

5-tube portable 10-watt (14-watt peak) public address system. (Push-pull 7C5) U. L. approved amplifier with wide range response. Inputs for microphone and phono, with separate mixing type volume controls. Tone control. 10" Alnico V PM speaker is housed in a leatherette case 21"x18"x13" which holds the amplifier for carrying. 3-speed turntable and pickup arm to play all records 33 $\frac{1}{3}$, 45 and 78 RPM is mounted in the top of the amplifier. List value, \$90.00. Stock No. AP-10X. 10-watt portable P.A. system similar to the 28-watt pictured above, except it has only one case and one 10" speaker, less microphone. Sale price, \$42.95. Shipping weight, 41 lbs. Shipped via Express or Truck only. Crystal microphone with non-removable desk stand, \$3.95 extra when ordered with the AP-10X portable P.A. system.



BRUSH CRYSTAL EAR PHONE WITH CONTROL \$5.49

Simply clip on to the speaker voice coil of any radio or TV set or to an audio amplifier. No soldering necessary. Listen in privately to your favorite programs. The tiny Brush crystal ear phone fits your ear just like a regular hearing aid ear piece. A small remote control box enables using 20 ft. from the radio or TV set. Has its own separate volume control and small matching transformer built-in to operate the crystal from any speaker voice coil. Ideal for hospitals, homes, hundreds of other uses. 10 times more comfortable to wear than conventional earphones. Stock No. BH-500 includes Brush crystal ear piece, remote control box, 20 ft. of cable and instructions. Sale price, \$5.49 complete. Brush crystal earphone with 36" cord. Stock No. BR-51, \$2.95. (You connect it like any crystal earphone diagram furnished.) Accessory kit includes remote control with switch plus coupling capacity and instructions, 99c extra.

INDIVIDUALLY CARTONED ELECTRONIC RADIO & TV TUBES

McGee offers you a wide selection of good quality TV and Radio tube types. Individually cartoned. Our private brand. These are not set mtg's. cuts, but a carefully inspected private line of tubes with a full 6 months' guarantee. Types listed are in stock in good quantity at this time. Thousands sold. Order 50 tubes and take 10% off the listed prices.

024	50.59	6AT6	49	6HG7	59	7H7	79	12J5M	89
1A7	59	6AV6	49	6K7GT	59	7Y4	69	12SJ7GT	89
1B3GT	79	6AV6	49	6L6G	109	12AL6	59	12SN7GT	69
1HG5T	59	6AX4GT	69	654	59	12AG6T	59	12SL7GT	79
1L6	59	6BA6	49	6SA7GT	59	12AT6	49	19B6GT	1.79
1R5	59	6B7	59	6SA7GT	59	12AT7	49	25B6GT	99
1S5	59	6BC5	59	6SF5GT	59	12AV6	59	25C6GT	99
1T4	59	6BD6	49	6SK7GT	39	12AW7	59	32L7GT	79
1X3	59	6E7	59	6SS7GT	69	12AV7	59	35L6GT	59
1U5	59	6F6	59	6SX7GT	69	12AX7	59	35C5	59
3Q4	59	6GG6	1.29	6SU7GT	69	12AX6GT	59	35W4	59
3B5	59	6H6	59	6T8	79	12AY7	59	35L6GT	59
3S4	59	6L6	59	6T8	79	12BA6	59	35C5	59
3V4	59	6K7	59	6V6GT	59	12BE6	59	40	59
6AB4	49	6L7GT	99	6V6GT	59	12BD6	59	50B5	59
6AK5	49	6B6GT	99	6W4GT	59	12BE6	59	50C5	59
6AL5	49	6C4	39	6XS7GT	49	12K6GT	59	50L6GT	59
6AQ5	49	6C8S	59	7A7	69	12Q7GT	59	70L7GT	59
		6CD6G	1.49	7B6	69	12SF5GT	69	11723	39

OUTDOOR SPEAKERS — WALL BAFFLES — 50-WATT BOOSTER AMPLIFIER



25-Watt Weather-Proof Out-Door Speaker \$28.95

8" PM AND LEATHERETTE Baffle, \$4.95
LOTS OF 10, \$4.75

The finest Leatherette Baffle we have ever offered. New self-supporting plastic grill material. Baffle is covered tan with matching grilles. Offered with a good heavy duty 8" Alnico PM speaker with separate voice coil. Stock No. 818. Speaker and Baffle \$4.95 ea.; lots of 10, \$4.75. Baffle only, Stock No. NV-8. \$2.29 ea.; 10 for \$19.95.



50-WATT BOOSTER AMP. \$39.95

2-Mike Pre-Amp \$12.95 Extra, Not a Kit, but a Manufactured Amp.

50-WATT BOOSTER A sensational value. 50 watt booster amp with push-pull parallel 6L6 output tubes. Connect to your present amplifier as a booster or use with PR-2X Pre-Amp to add the use of 2 mikes and 1 volt input. The booster amplifier has one input jack and with 1 volt input gives 50 watts of audio. Booster has a 6 lb. potted case high fidelity output transformer. Matches speaker with 4-16 ohm voice coil also 60 ohm and 250 ohm line. Booster has a 225 mill power supply with 5U4 rectifier. Price includes shipping weight 26 lbs. Sale price \$39.95 ea.

2-MIKE PRE-AMP. Pre-amplifier uses in direct to the PA-5N Booster amplifier. Input furnished with 4 foot cables and plugs for remote control of the 55 watt Booster Amplifier. Small chassis size 3 x 3 1/4 x 4". Stock No. PR-2X, with tubes 7Z7 and 7N7. Net price \$12.95 ea.

ORDER FOR USE WITH ANY P.A. SYSTEM OFFERED ON McGEE'S 2 PAGES OF ADVERTISING

25-WATT HORN 25-Watt Driver and 3 1/2-foot air column re-entrant Trumpet. The 100% weatherproof, horn is spun aluminum, offered to you at a considerable savings. Stock No. MA-33. Shipping weight 20 lbs. Net price \$28.95.

IT'S McGEE FOR COAXIAL SPEAKERS—3-SPEED CHANGERS—FM-AM CHASSIS

McGEE'S \$62.50 LIST 15" COAXIAL SPEAKER, \$21.95

21 OZ. ALNICO V MAGNET—5" TWEETER

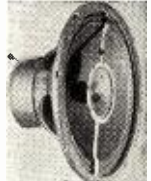

music lover's amplifier. Stock No. MA-15, shipping weight 13 lbs. Net price \$21.95.

This is the finest 15" coaxial PM speaker value that we have ever offered. New 1952 production, of a famous manufacturer of fine speakers. The 15" speaker has a 21 1/2 oz. Alnico V magnet; equal to 68 oz. of the Alnico 3 type magnet. The cone is free floating, of one piece construction. Will reproduce low frequencies down to 20 cps. The 5" tweeter is coaxially suspended and has a ridged cone to reproduce only the high frequencies. It will respond up to 17,500 cps. The high pass filter is concealed under the pot cover, leaving only two wires to connect both the tweeter and woofer to any 8 ohm output transformer of a radio, or high fidelity amplifier. Stock No. G1-15, shipping weight 13 lbs. Net price \$21.95.

12" COAXIAL SPEAKER, \$12.95

McGee offers the new 1952 model 12" coaxial PM speaker of quality you would buy in your finest sets if you were a manufacturer. 12" woofer has 5.8 oz. Alnico V magnet. Tweeter is coaxially suspended and has a metal diffuser. High pass filter is under the pot cover. Only two wires to connect to your radio or audio amplifier. 8 ohm with 20 watt peak and 10 watt average. Shipping weight 8 lbs. Response from 30 to 17,500 cps. Stock No. G1-12, Sale price \$12.95 each; 2 for \$25.00.

ESPEY 12-TUBE FM-AM CHASSIS, \$59.95

- ★ BUILT-IN PRE-AMP FOR G.E. VARIABLE RELUCTANCE PICK-UP
- ★ WIDE RANGE AUDIO
- ★ WHY NOT ORDER WITH A COAXIAL SPEAKER AND A RECORD CHANGER? SEE OUR SPECIAL OFFERING

McGee's new 1953 model 12-tube FM-AM chassis. Latest design with phono inputs for variable reluctance record players, crystal or G.E. variable reluctance. Receives standard broadcast 550 to 1700 kc and FM 88 to 108 mc. Wide range audio response (push-pull 6V6 output) and bass boost tone control. Loop antenna for broadcast and 500 ohm line type FM antenna may be stapled in chassis. Attractive lighted slide dial. Chassis size, 13 1/2" x 9" high and 9" deep. Complete with tubes: 6BD6, 6BA6, 6BA6, 12A7T, 6SH7, 6SQ7, 6SQ7, 12A7T, 2-6V6GT and 5Y6GT rectifier. Shipping weight 20 lbs. Stock No. 7C-X. Espey 12-tube FM-AM chassis. Sale price, \$59.95, less speaker. Output matches voice coil of our 12" or 15" coaxial speakers.

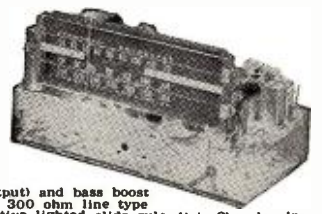

12" JENSEN PM, \$15.95

Another McGee Scoop! Jensen Concert 12" 14 1/2 oz. Alnico V magnet PM speaker, 8 ohm voice coil. Will take 25 watt audio. You gave dollars on this speaker. Ret. \$1.00 to sell. Shipping weight 8 lbs. Stock No. P-12P. Sale price \$15.95; 2 for \$30.00.

G.I. 3-SPEED CHANGER WITH G.E. VARIABLE RELUCTANCE TURN-ABOUT CARTRIDGE \$22.95



Another tremendous McGee Scoop! Brand new General Instrument 3-speed automatic record changers. Complete with RPX-050 G.E. variable reluctance cartridge with turn-about ear. Plays all 3 speeds automatically; 7", 10" or 12" records. Has eject button. Repeats last record. Base size, 12"x12 1/2". Shipping weight 14 lbs. Stock No. 700-GE. Scoop price \$22.95. Repeat same as above, but with Webster flip-over twin needle cartridge. Stock No. G1-700. Sale price, \$21.95 each.

ESPEY DEAL (1), \$99.95

Espey 7-C chassis complete with 12" coaxial FM speaker CU-14Y and VM-950 G.E. 3-speed changer equipped with a G.E. turnabout variable reluctance cartridge. A better home music system than ordinarily available. Espey Deal #1. Sale price \$99.95. With 15" coaxial FM speaker P15-CR instead of CU-14Y, \$10.00 extra.

ESPEY DEAL (2), \$118.95

Espey 7-C chassis complete with 12" coaxial FM speaker CU-14Y and the English Garrard 3-speed changer equipped with a G.E. variable reluctance turnabout cartridge. Our best home music system, Espey Deal #2. Sale price \$118.95. With 15" coaxial FM speaker P15-CR instead of CU-14Y, \$10.00 extra.

ESPEY DEAL (3) \$138.95

Espey 7-C chassis complete with THREE 12" coaxial FM speakers CU-14Y (these three 12" coaxial speakers give a cone area equal to an 18" speaker) and a Garrard 3-speed changer with G.E. variable reluctance turnabout cartridge. Espey Deal #3. Sale price \$138.95.

McGEE RADIO COMPANY

Prices F.O.B. K.C. Send 25% Deposit with Order, Balance Sent C.O.D. With Parcel Post Orders, Include Postage

TELEPHONE VICTOR 9045. WRITE FOR FLYER 1422 GRAND AVE., KANSAS CITY, MISSOURI

LOOK TO McGEE FOR ALL RADIO AND TELEVISION MATERIAL

GENUINE STANDARD COIL T.V. BOOSTER Not Surplus, But Right From the Factory

Latest Model B-51 Standard Coil Television Booster. McGee makes another lucky purchase and as usual, passes the saving on to you. The famous Model B-51, 12 Channel Standard Coil TV booster, which lists for \$35.00, is offered for only \$11.95 each. Brand new, factory cartoned and fully guaranteed by McGee. This top quality single stage booster utilizes printed high frequency circuits, for improved performance on all channels. Uses 6AK5 tube. Average gain, 6 to 7 volts on low channels and 5 or 6 on high channels. No distorting of picture or sound. Has extremely low noise factor. Continuous one-knob tuning and channel selector control switch for off-on and by-passing 300 ohm lead-in to set. Modern design, dark brown plastic cabinet, 8"x4 1/4"x4 1/4". Made for 110 volt. 60 cycle AC operation. Shipping weight 5 lbs. Model B-51, Sale price, \$11.95 each, or buy 2 for only \$22.00.

\$11.95



FRINGE AREA TV RECEPTION IS BETTER WITH OUR McMURDO SILVER TV BOOSTER \$10.95—TWO FOR \$20.00

Read the article on pages 52 and 53 of the December "Radio & TV News." You will see how a booster like the McMurdo Silver Super Sonic was used for fringe area TV reception. We can't guarantee this unusual reception, but we will guarantee this booster to be a sensational value. Continuously variable inductance type tuner from channel 2 including the FM band through channel 13. Self-powered for 110 volts AC operation. Incorporates a 6J6 tube. Input for 300 ohm TV line and 300 ohm output to TV set. Single knob tuning. Attractive plastic case. McMurdo Silver Super Sonic TV-FM booster. Stock No. GB-6B, shipping weight 5 lbs. Sale price, \$10.95 each or two for \$20.00.



20 INCH CONVERSION KIT \$29.95

YOU GET—

- 20HP4—20" PICTURE TUBE
- 20-INCH PLASTIC MASK
- 14 K.V. FLYBACK AND 70° YOKE



Our 20" conversion kit includes a 6-month guaranteed 20HP4, 20" rectangular blackface picture tube, plus a 14,000 volt G.E. built high voltage flyback transformer, plus a matched 70° cosine yoke, plus a 20" rectangular gold trimmed plexiglas mask and suggested diagram. The picture tube is the latest electro-static focus type that requires no focus coil. Shipped via express or truck only. Ship. weight, 40 lbs. Stock No. 20-TP, net price, \$29.95.

17-INCH CONVERSION KIT \$25.95 YOU GET—17BP4A 17" PICTURE TUBE 17-INCH PLASTIC MASK 14 K.V. FLYBACK AND 70° YOKE

17-inch conversion kit with a 17BP4A, 17" rectangular blackface electro-magnetic focus picture tube with 6 months' guarantee, plus a matched 70° cosine yoke, a G.E. built 14,000 volt flyback and a 17" rectangular gold trimmed plexiglas mask and safety shield. Suggested diagram furnished. Shipping weight, 30 lbs. via Express or Truck only. Stock No. 17-4XL, 17" conversion kit, Sale price, \$25.95.



CAPEHART CABINET, \$79.95 BLANK OR CUT TO FIT ESPEY CHASSIS

Buy this cabinet with Espey chassis and the VM changer at the left and have a fine radio-phonograph combination for less than the value of the cabinet alone. This beautiful cabinet was intended for a Capehart \$800.00 combination. It is the finest possible furniture quality cabinet workmanship, 37" high, 40" wide and 21" front to back. Hinged top lifts in two sections. 2 1/2" lid covers the changer compartment and 1 1/2" is the width of the radio compartment. Changer mounting panel is furnished blank. Radio panel is shipped ready cut to fit the 7-C Espey chassis. Baffle is cut to hold 2-1 1/2" speakers. Made of top quality walnut veneer. 1/4" material used throughout. Shipped via truck, rail or express only. Shipping wt., 150 lbs. Stock No. C-175, with parts \$79.95. Stock No. B-175B, with blank changer and radio panel, \$79.95. Buy 2-1 1/2" 32 oz. Alnico PM speakers for use in this cabinet for only \$13.00 (\$7.50 each).

Stock No. C-175, with parts \$79.95. Stock No. B-175B, with blank changer and radio panel, \$79.95. Buy 2-1 1/2" 32 oz. Alnico PM speakers for use in this cabinet for only \$13.00 (\$7.50 each).

COMPLETE RADIO, TELEVISION AND AMPLIFIER KITS AT McGEE

3-WAY PORTABLE KIT \$15.95

A NEW '52 MODEL
New 1952 Model 3-way personal portable radio kit. Operates on 110 Volt AC-DC or 87 1/2 B plus 1 1/2 volt self-contained batteries. Leatherette covered case size, 5 1/2"x3 1/2"x8". Receives broadcast 550 to 1620 Kc. A conventional 2-gang superhet circuit with 456 KC iron core IF's. Incorporates the new super gain stick loop antenna. All plated chassis. Lab. approved circuit—matched parts. Price includes all parts, tubes, diagram, Alnico V FM speaker. A factory quality kit. Stock No. FN-47, shipping weight 7 lb. The complete kit. Less batteries, \$13.95. 87 1/2 V. B, \$1.99; 1 1/2 V. A, 39c extra.

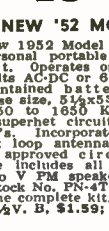

8-Tube Hi-Fi Amplifier Kit \$29.95

A complete kit, including tubes 3-7E5, 2-12AX7, 2-triode plus rectifier diagram and photos. Inputs for radio tuner and any kind of phono pickup or crystal or G.E. variable reluctance) and either crystal or dynamic mike. Output matches 8 ohm voice coil. Twin electronic bass and treble tone controls with range selector switch for either juke box quality with heavy bass response or brilliant symphonic range. Response 18 to 20,000 cps. 8 tube all triode amplifier kit, complete with tubes. Shipping weight 25 lbs. Model TX5. Net \$29.95.



10-Watt Hi-Fi Amplifier Kit \$14.95

A complete kit of parts including 2-12AX7, 2A2, 2-50L6, plus rectifier, diagram and instructions to build a high fidelity amplifier with bass and treble boost. Inputs for radio tuner, crystal and crystal phono pickup. Output matches 8 ohms. Response from 50 to 15,000 cps. Chassis ready punched. Vented cover. Straight forward circuit with twin triode gain stages and 2-50L6 tubes in push-pull. Size, 3 1/4" x 10" x 3 1/2" high. Model AP-10R, ship. wt. 8 lbs. Sale price \$14.95.



RCA 201E1 T.V. TUNER \$7.95

Terrific buy on this RCA tuner. We have a limited quantity of the famous original 201E1, 13 channel completely wired and tested TV front end tuners. Ready to connect to your TV video I.F. strip. Offered at a sacrifice. Price was \$44.00. Now only \$7.95 each, with RCA-13P TV front end tuner. Converter coil type for separate sound as used in the famous 630 chassis. Complete with 3-6J6 tubes, \$7.95. Specify shaft length desired, either 2" or 4".

RCA 201E1 T.V. TUNER
Same as pictured above only new—with 2 3/4" shaft. Stock No. 2201. Sale Price, \$11.95.

3-TUBE SARKES-TARZIAN T.V. TUNER \$9.95

This popular Sarkes-Tarzian Type 3 tuner is widely used. 13 channel rotary type switch with individually tuned coils. Price is complete with diagram and three tubes: 6C4 osc., 6BH6 R.F. and 6AG5 mixer. Regular factory cost is twice our price. Each tuner is wired ready to hook up to a video and sound IF strip. May be used with either inter-carrier or separate sound IF circuits. Has built-in converter coil, built in fine frequency control. Sarkes-Tarzian TV tuner, with 3 tubes. Net price, \$9.95 each. Specify shaft length, either 2 3/4" or 4 3/4".

RCA PRINTED CIRCUIT T.V. TUNER \$14.95

RCA Printed Circuit T.V. Tuner with 6J6 and 6CB6 tubes. Similar mechanically to the standard coil (same knobs fit). Snap-in channel segments. Has 6 1/2" shaft. Used on late Hallcrafters T.V. sets. Stock No. RC-A12. 12 Channel Tuner with Tubes. New, \$14.95. Knobs, 59c.

T.V. TUNER FOR EMERSON \$12.95

For Emerson 650D ETC. Has 2 1/4" insulated shaft and tubes 6BC5—filaments in series—shunted to .6 amps. Stock No. SC-947E. Sale Price, \$12.95. Knobs, 59c.

3 STATION INTERCOM MASTER \$16.95

3-station intercom master housed in chrome plated metal cabinet 7 1/4"x8"x5" sloping front. Full 3-tube amplifier for 110 volt AC-DC operation. Press-to-talk switch is on top of the cabinet and volume control with off-on switch and station selector switch are on either side. May be used from one to 3 sub-stations. (See matching cabinet chrome plated sub-station No. PM-A5). Master is quiet at all times except when press-to-talk switch is pressed at the master or call-back switch is pressed at the sub. Uses 3-wire intercom cable. 3-station intercom master MP-M-A3, shipping weight 10 lbs. Sale price, \$16.95 each. Sub-stations extra. 3-wire plastic intercom cable, 100 ft. for \$1.95, 500 ft. for \$8.95.

INTERCOM SUB STATIONS \$3.95

Chrome plated, with call back switch for a 3-wire intercom master. Size 7 1/2"x8"x5" sloping front. Alnico V PM spkr. Intercom dealers buy at less than present production cost. Limited quantity. Stock No. PM-A5, ship. weight 8 lbs. Sale price, \$3.95 each or 3 for \$10.00. Special 3-wire plastic intercom cable, 100 ft. for \$1.95, 500 ft. for \$8.95.

CAPEHART CABINET FOR 1000 SET—ONLY \$99.95

Beautiful, finest quality walnut combination radio-phonograph cabinet, 42" high, 42" wide and 22" deep. Made for Capehart's finest combination, selling for \$200.00. Has highly polished matched walnut paneling with tubes; \$800. Cabinet cost manufacturer over \$200.00. Has highly polished matched walnut paneling with tubes; \$800. Cabinet cost manufacturer over \$200.00. Has highly polished matched walnut paneling with tubes; \$800. Cabinet cost manufacturer over \$200.00.

10-TUBE RADIO KIT \$29.95

A complete kit of parts to build a AC transformer operated television set. The 12 channel Sarkes-Tarzian tuner is ready wired, as are the 4 tube video IF strip. Circuit is of the conventional design. Do not buy this unless you understand television. It is difficult to wire. We furnish schematic. Kit model WH-20, ship. wt. 40 lbs. less all tubes. Net \$39.95. Kit of 22 tubes, less picture tube \$16.95, 17" 17BP4A, \$19.95, 20HP4, \$25.00.

10 tube broadcast radio chassis kit, complete with tubes; 2-6SK7, 6SA7, 3-6BW7, 1-6SL7, 2-6V6 plus 5Y3 rectifier, diagram and instructions. 3 gang superhet with 8" slide rule dial. Chassis size, 12 1/2"x10"x6 1/2" high. Features push-pull 6V6 high fidelity output. Output matches 3 to 8 ohm voice coil speakers. Inputs for G.E. variable reluctance or crystal phono pickup and crystal mike. Heavy duty power transformer. Model BK-R10 kit less speaker, shipping weight 18 lbs. Net \$29.95.

6-TUBE 2-BAND KIT \$14.95

Popular with schools and colleges for training. 6 tube AC-DC, 2 band radio kit with plastic cabinet. Receives broadcast and 8 to 15 mc shortwave. Full gang superhet with 5" speaker and slide rule dial. Complete kit with tubes: 12SK7, 12K6, 12SK7, 12SQ7, 50L6 and 35Z5, diagram and instructions. Factory quality. Cabinet size 13"x8 3/4"x6 1/4". Shipping weight 12 lbs. Model ME-2. Net \$14.95.

5-TUBE AC-DC KIT \$12.95

Model RS-5. A 5 tube AC-DC straight broadcast kit, housed in the same cabinet as ME-2 above. Complete with tubes. Shipping weight 10 lbs.. Net \$12.95.

AC POWERED BROADCAST TUNER KIT \$12.95

A self-powered, 3-gang superhet tuner kit with R.F. stage. This complete kit is furnished with a diagram, photos and tubes, 6BA6 R.F., 6BE6 oscillator R.F., 6BA6 I.F. detector. 6AL5 diode. AVC, plus rectifier. Connect to any audio amplifier. Ideal for use with our 2020 or 7x5 amplifier kits. Chassis size, 9 1/2"x4 1/4"x1 1/2" high. Shipping weight, 7 lbs. Broadcast tuner kit Model BT-38X. Net price, \$12.95.

SELENIUM RECTIFIERS

Full-Wave Bridge Types

Current (Continuous)	18/14 Volts	36/28 Volts	54/42 Volts	130/100 Volts
1 Amp.	\$1.25	\$2.10	\$3.60	\$7.50
2 Amps.	2.20	3.60	6.50	10.50
2 1/2 Amps.			7.50	13.00
4 Amps.	3.75	6.75	8.75	27.00
5 Amps.	4.95	7.95	12.95	33.00
6 Amps.	5.50	9.00	14.00	33.00
10 Amps.	6.75	12.00	20.00	40.00
12 Amps.	8.50	16.00	25.50	50.00
20 Amps.	13.25	24.00	36.00	90.00
24 Amps.	16.00	31.00	39.50	98.00
30 Amps.	18.50	36.00		
36 Amps.	25.50	45.00		

FLEXIBLE SHAFTS

MC 215
(ALL LENGTHS IN INCHES)

34 163 260
135 186

MC 124
(ALL LENGTHS SHOWN IN INCHES)

23 61 120 175
29 65 140 205
39 103 161 241
52 114 166 348

PRICE MC 124 or MC 215 **2c Per In.**

CIRCUIT BREAKERS

AM 1614-80—28VDC, 80 Amp. \$1.59
AM 1614-100—28VDC, 100 Amp. 1.69
KJ-600V, 115 Amps., up to 1000% overload rating. Trip adj. 10 min.—Inst. **\$21.95**

FILTER CHOKES

Stock	Description	Price
CH-533	13.5H, 1A, 13.5KV Test	\$39.95
CH-366	20H, 3A	6.95
CH-322	.35H/350 MA—10 Ohms DCR	2.75
CH-141	Dual 7H/75 MA, 11H/60 MA 5KV DC Test	4.69
CH-119	8.5H/125 MA	2.79
CH-69-1	Dual; 120H/17 MA	2.35
CH-8-28	2 x .5H/380 MA/25 Ohms	1.79
CH-776	1.28H/130 MA/75 ohms	2.25
CH-344	1.5H/145 MA/1200V Test	2.35
CH-43A	10H/15 MA—850 ohms DCR	1.75
CH-366	20H/300 MA	6.95
CH-999	15HY/15 MA—400 ohms DCR	1.95
CH-511	6H/80 MA—310 ohms DCR	2.45
CH-501	2x5H/400 MA	2.79
CH-188M	5HY/200 MA	1.79
CH-303A	30H/.02A, 2500V Test	1.69
CH-982	SWING 9-60H/4-.05A 10KV	7.95

POWER TRANSFORMERS

Comb. Transformers—115V/50-60 cps Input	Price
CTJ5-2-600VCT/.2A, 5V/6A	\$5.95
CT-15A 550VCT .085A 6.3V/.6A, 6.3V/1.8A	2.85
CT-164 4200V/.002A/12KV Test, 5VCT/3A/12KV Test, 6.3V/0.6A/5400V Test	12.95
CT-341 1050 10 MA.—625V @ 5 MA, 26V @ 4.5A 2x2.5V/3A, 6.3V @ 3A	16.95
CR-825 360VCT .340A 6.3VCT/3.6	3.95
CT-626 1500V .160A 2.5/12, 30/100	9.95
CT-071 110V .200A 33/200, 5V/10, 2.5/10	4.95
CT-367 580VCT .050A 5VCT/3A	2.25
CT-99A 2x110VCT.010A 6.3/1A, 2.5VCT/7A	3.25
CT-403 350VCT .026A 5V/3A	2.75
CT-931 585VCT .085A 5V/3A, 6.3V/6A	4.25
CT-456 390VCT 30MA 6.3V/1.3A, 5V/3A	3.45
CT-931 585VCT 86 MA 5V/3A, 6.3V/6A	4.95
CT-442 525VCT 75 MA 5V/2A, 10VCT/2A, 50V/200 MA	3.85
CT-720 550-0-550V/250 MA, 6.3V/1.8A	8.95
CT-43A 600-0-600V/.08A, 2.5VCT/6A, 6.3VCT/1A	6.49
CT7-501 650VCT/280 MA, 6.3V/8A, 6.3V/5A	6.49
CT-444 230-0-230V/.085A, 5V/3A, 6V/2.5A	3.49
Filament Transformers—115V/50-60 cps Input	Price
FT-674 8.1V/1.5A	\$ 1.10
FT-157 4V-16A, 2.5V/1.75A	2.95
FT-101 6V/.25A	.79
FT-924 5.25V/2A, 2x7.75V/6.5A	14.95
FT-824 2x25V/2.5A, 16V/7A, 7.2V/7A	8.95
FT-463 6.4V/10A, 6.4V/2A	8.95
FT-55-2 7.2V/21.5A, 6.5V/6.85A, 5V/6A, 5V/3A	5.49
FT-986 16V @ 4.5A or 12V @ 4.5A	3.75
FT-38A 6.3/2.5A, 2x2.5V/7A	4.19
FT-A27 2.5V/2.5A, 7V/1A TAP 2.5V/2.5A, 16KV TEST	18.95
FT-608 6.3V/3A/750V Test	1.79
FT-873 4.5V/.5A, 7V/7A	2.19
FT-899 2x5V/A 5A, 29KV Test	24.50
Plate Trans.—115V, 60 cps	Price
PT-699 300/150V/0.5A, 300/150V.05A	\$ 2.79
PT-302 120-0-120V/350 MA	4.69
PT-108 17,600V/144 MA	120.00
PT-671 62V/3.5A	7.95

Send M.O. or Check. Shipping Chgs. C.O.D.
COMMUNICATIONS EQUIPMENT CO.
131 Liberty St. Dept. N3, New York City 7, N. Y.

CRT TESTER-SPARKER

By

D. GNESSIN & H. D. SUESHOLTZ
Transvision, Inc.

Operational data on a new piece of test equipment including the proper TV servicing procedures.



Over-all view of the new Transvision "Tester-Sparker" video test instrument.

THE busy TV technician will welcome the combination service instrument to be described here. The full schematic is shown in Fig. 1. Briefly, the unit consists of a high-frequency oscillator and its related d.c. rectifier. Thus either a.c. for sparking or d.c. for auxiliary high voltage supply is available in the lightweight instrument with its own power supply.

Study Fig. 1. Note the a.c. (or d.c.) from the power line actuates the vibrator. The adjustment screw on the armature contacts can be set with a knob from the front panel for optimum vibration, effectively acting as a voltage potentiometer. The damped oscillations set up in the oscillatory circuit, LC, operate at the natural resonant frequency determined by the component parameters, falling within the low radio-frequency range. The turns ratio of the high voltage "Sparker" winding, inductively coupled to L, is so great that the high-frequency field at the "hot" end of the probe is on the order of 10 kv. or higher.

When the "H.V. Sparker Probe" is applied to any metallic substance, like the pins of a vacuum tube, a spark jumps from the probe to the pins, carrying the high-frequency energy throughout all the metallic parts. The presence of gas within the tube is immediately exposed by a colored fluorescence. Thus the "Sparker" is an indicator for showing up soft tubes. The amount of fluorescence shows the

amount of gas present, varying from the slightest blue tinge in acceptable cases to bright pink and purple in obviously gassy types.

It would be nice to set down a comparator chart so the color of the fluorescence would automatically indicate gas content. This is impossible since so many different types of tubes, made by different techniques of manufacture, create different interpretation of the color results. It is analogous to a physician reading an X-ray. A shadow in one case may be acceptable when all the conditions are known, where in another case it would spell trouble. So, too, with a little experience will the operator of the "Tester-Sparker" soon be able to differentiate between the subtle changes in color and thus determine which is acceptable and which is not.

Sparking a picture tube (or any other vacuum tube for that matter) permits exposure of any foreign substance within the tube, such as high-resistance shorts, dag material shorting the CRT gun, etc., to the high-frequency sparking. The energy heats the foreign material, vaporizing it, thus relieving the short.

For television set analysis the "Tester" portion of the instrument is used. Refer again to Fig. 1. The dotted portion shows the connection for d.c. output. Rather ingeniously the "H. V. Sparker Probe" is pushed into a cavity in the instrument case, permitting the probe tip to engage a spring contact connected to the 1B3 plate. At the same time inductive coupling between the probe winding and a pick-up coil in the case develops a little over one volt which is applied to the 1B3 filament. The rectifier now acts exactly like the high-voltage rectifier in the television chassis, making high-voltage d.c. available at the d.c. probe. This device provides an auxiliary second anode supply which opens a new field of TV analysis.

In the television receiver, failure of

Fig. 1. Circuit diagram of the test unit. See text for explanation of operation.

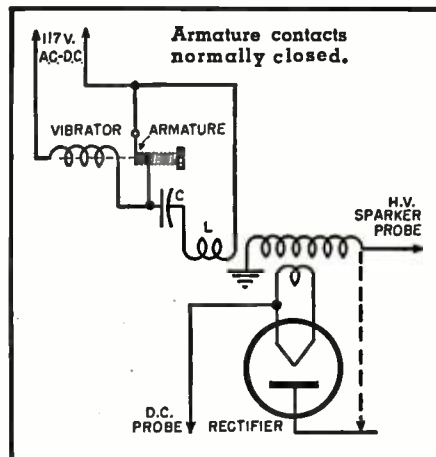

'Give and Take' Month!

IF THAT IS YOUR INCOME, HOW DO YOU EXPLAIN THIS TOP QUALITY EQUIPMENT. HEH?

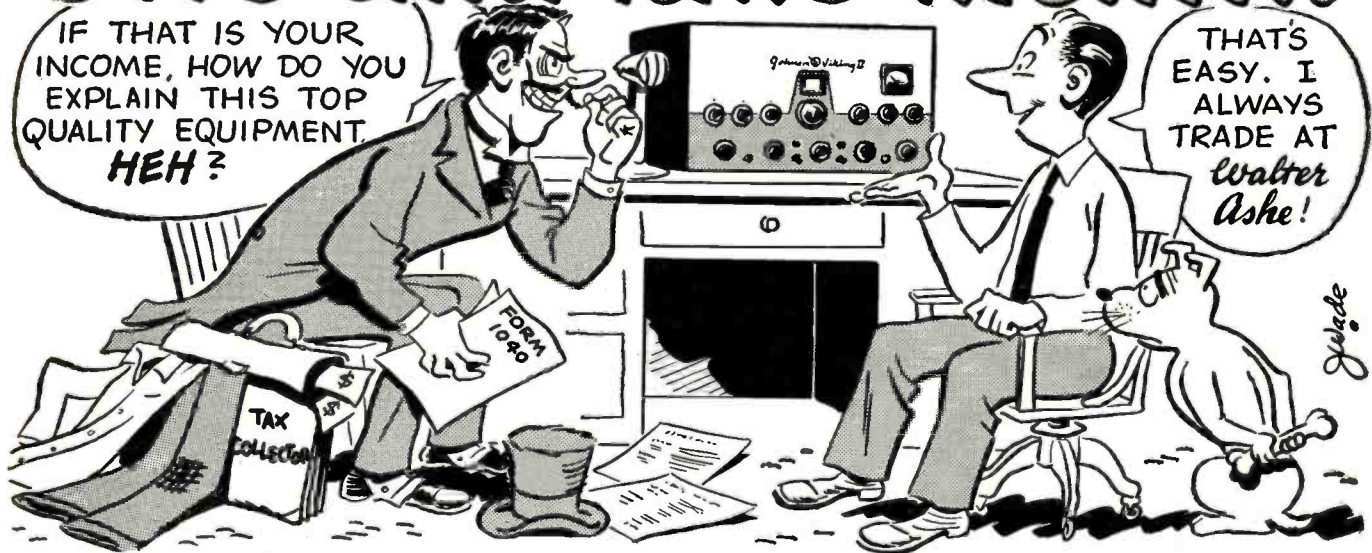

HALLICRAFTERS S-76
Less spkr. Shpg. wt. 46 lbs.
Only \$179.50



HALLICRAFTERS SX-71
Less spkr. Shpg. wt. 51 lbs.
Only \$224.50

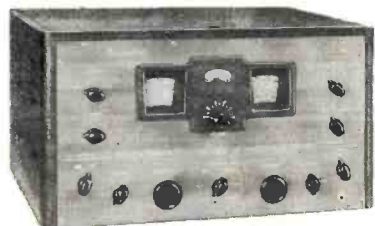

HAMMARLUND HQ-129X
Less spkr. Shpg. wt. 74 lbs.
Only \$239.50

With a "Surprise" Trade-In Allowance on your used test or communication equipment, you not only get what's coming to you, but an extra bonus of satisfaction and real money saving. So join the thousands of Walter Ashe customers who have learned that the one and only "Surprise" trade-in deal on used (factory-built) equipment is so much easier on the pocket book. Get your trade-in deal working today. Wire, write, phone or use the handy coupon below.



NATIONAL HRO-60T
Less spkr. Shpg. wt. 90 lbs.
Only \$483.50



COLLINS 75A-3 with 3 kc Mechanical Filter. Less spkr.
Only \$530.00.



JOHNSON VIKING II TRANSMITTER KIT.
Shpg. wt. 85 lbs. Only \$279.50
JOHNSON VIKING II Wired and tested.
Only \$336.50



NATIONAL NC-183-D
Less spkr. Shpg. wt 65 lbs.
Only \$369.50

All prices f. o. b. St. Louis • Phone CHestnut 1125

Walter Ashe
RADIO CO.
1125 PINE ST. • ST. LOUIS 1. MO.

FREE CATALOG!

WALTER ASHE RADIO COMPANY
1125 Pine Street, St. Louis 1, Missouri

R-53-3

Rush "Surprise" Trade-in-offer on my _____

for _____
(show make and model No. of new equipment desired)

Send new 1953 Catalog.

Name _____

Address _____

City _____ Zone _____ State _____

Send
for
your
copy
today

SCOOP!
AM Radio Tuner
 made especially for any
 630 or 630 DX Chassis.
 Complete, ready to in-
 stall. Fits into well of
 TV chassis.
ROSE Special \$1.495 ea.

SUPER 630 DX-2 TV CHASSIS
 Includes the same features as the 630 DX-1 chassis PLUS the following:
 * Keyed AGC level control
 * Cornell-Dubilier plastic molded condensers
 * 4.5 Megacycle wave trap to eliminate interference
 * Phono input & switch which cuts out high voltage supply
 * RCA matched 70° cosine yoke & Hi-Voltage transformer
 * Four (4) 6CB6 tubes in video IF strip
 * RCA 12" Speaker
 Net price **\$159.50** (less Complete CRT)

New UHF [Another ROSE SCOOP!]
 Channel Strips Immediate delivery **\$895** complete strip



WRITE FOR NEW CATALOG
 MIN. ORDER: \$5.00. 25% with order, balance C.O.D. Include postage with order. All merchandise subject to prior sale. Prices subject to change without notice. F.O.B., New York City.

ROSE Co.'s Supermarket of

SUPER VALUES

Wire, Call, Write, Come-In—Thousands of Bargains!
630 DX CHASSIS [SUPER VALUE]

1953 Model—Advanced Design—Great Saving!
 Includes newest developments—Cascade Tuner—30 Tubes—for 16" to 24" Picture Tube—Wonderful Saving! Adaptable for color and UHF!

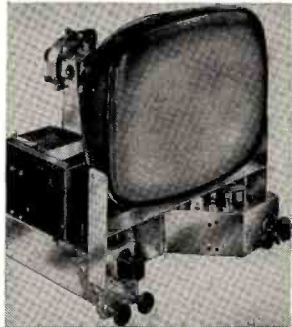

The great 630 with all the up-to-date improvements! Wonderful reception on long range up to 200 miles without a booster is yours today at this low-low price. Gives 3-times normal reception. Special super high-gain standard coil tuner gives greater sensitivity, top performance on any channel. Aligned and tested for 5 hours, molded condensers, 4 microvolts sensitivity, FM sound system, horizontal and linear lock and is directly adaptable for color and UHF.

Model 630 DX-1: RMA Guaranteed—Factory Wired, ready to play. Complete with 12" speaker, hardware and knobs. **149.50** (less CRT)

Universal Mounting Brackets, \$5.95 ea.

Save \$50 on this Decorator TV Cabinet For 17", 20" & 21" Picture Tubes—630 or other Chassis.

Every beautiful cabinet is richly finished of hand rubbed mahogany and made by our own cabinet makers. They are custom styled, guaranteed new and perfect. Includes mask and mounting brackets. Cabinets are also available with blank control panel to fit any chassis. Model 200: Original list \$99.95 Now **\$49.50** Blonde finish, add \$10 Also Deluxe Cabinets, write for catalog

Special Low Prices [SUPER VALUE]
TV Picture Tubes

Full Year's Guarantee—Brand New—Black Face—Standard Brands.
 10BP4 \$19.95 | 20CP4A \$35.95
 12LP4A 22.95 | 21EP4A 38.50
 17BP4A 24.95 | 27EP4 99.50
 All other sizes in stock —equally low priced!

THE ROSE COMPANY

102 Park Place, Dept. R-3, New York 7, N. Y., COrtlandt 7-6195

South River
 ★★ NEWS ★★

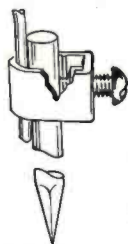

GROUND ROD
Model GND
4'-6'-8'

Made of tough, high strength steel and furnished with either copper or hot-dip galvanized finish. The extended aluminum wire clamp provides a simple means of attaching all sizes of ground lead wire up to 1/4" O.D.

South River Antenna Mounting Accessories are carried by every leading TV Parts Jobber from coast to coast.

Write for your copy of our new 1953 Catalog.

SOUTH RIVER METAL PRODUCTS CO., INC.
 SOUTH RIVER, N. J.

PIONEER AND OUTSTANDING PRODUCER OF FINEST LINE OF ANTENNA MOUNTS

PICBOOST
 RESTORES BRILLIANCE TO DIM TV PICTURE TUBES



EASY TO INSTALL!
NO SOLDERING!
JUST PLUG IN!

Gives new tube brilliance to dim TV picture tubes. Completely automatic. Adds many months of life to wornout tubes. A real help for second year TV contracts. Picboost saves you real money. Order Picboost today.

- Works on any size or type picture tube (including electrostatic focus types)
- No AC power line needed
- Fully tested and guaranteed
- Draws minimum current for safe operation

Model 1F—Parallel brightener
 Model 2F—Series brightener
 Model 3F—Parallel Isolation Unit
 Model 4F—Series Isolation Unit

ADD 25c POSTAGE ON YOUR ORDER, PLEASE

1.95
 Plus 25c Postage

ALMO RADIO CO.

509 ARCH ST. & 6205 MARKET ST. Philadelphia, Pa.
 6th & ORANGE STS. • Wilmington, Del.
 4401 VENTNOR AVE. • Atlantic City, N. J.
 1133 HADDON AVE. • Camden, N. J.
 317 Park Heights Avenue • Salisbury, Md.

any portion of the horizontal oscillator, discharge, amplifier, damper, fly-back, or rectifier circuits or their related power supplies, filament circuits or interconnected components causes failure of the high-voltage supply at the picture tube. Without high-voltage there is no raster. Loss of raster deprives the technician of the most elementary tool in TV analysis—the screen image.

Here we have a vicious cycle: We need the image on the screen to show the distortion or failure of circuit parameters, yet we cannot get the screen image because the failure of one of the involved circuits prevents getting any picture at all!

There is precedent for this new circuit substitution technique. In radio circuits when nothing can be received through the receiver a signal generator squirts an artificial signal through the set so that something gets through to allow service procedures to be applied. So, too, does the "Tester-Spark-er" provide an alternate high-voltage supply to permit a raster to show something to start test procedures.

The instrument provides variable high-voltage output at its clip lead. This is attached in place of the anode cap regularly used. The set's original anode cap is carefully dressed away from the chassis to avoid arcing. The chassis and service instrument are then tied together with common chassis bond to provide ground return. Now, to work:

Remember to keep the "Brightness" control down low to prevent screen burn in case there is no deflection. Turn that control up slowly. If a perfect picture results then manifestly it has been shown that the original high-voltage supplied to the picture tube was unsatisfactory, since the substitute high-voltage supply has provided a perfect picture. Trouble may be sought in the h.v. rectifier with its associated circuits.

It may be that no raster results. Since we know the high-voltage is okay, a further check using a scrap lead from chassis to anode terminal while the auxiliary supply is connected to CRT anode should draw a healthy spark. No spark here is indication the high-voltage is being bled off—probably grounded within the CRT. The next step is to check the CRT and its associated socket supply.

An undeflected spot shows the set has no apparent sweep (either horizontal or vertical) with no high-voltage. This trouble involves both sweep circuits—look for a common supply there.

A vertical line shows at least the vertical sweep is okay. Lack of horizontal sweep has caused the loss of high voltage and the horizontal oscillator and/or amplifier is indicated.

Pronounced foldover at the left is an indication of damper problems and its associated circuit. An open in these circuits would open the h.v. pulse.

Limited horizontal width may be evidence that horizontal excitation is low or is insufficiently amplified to

The ORIGINAL Universal High Voltage TV Filter Ceramicon



By ERIE . . .

the solution for *all* your high voltage TV filter replacement problems

This package contains six (6) Style 413 Erie Universal High Voltage TV Filter Ceramicon and an assortment of 14 adapter terminals.

Carry one of these handy package assortments with you on all your TV service calls. You are assured of having, at all times, the CORRECT RE-

PLACEMENT UNIT for any receiver rated at 20 KV or lower.

If your requirements are for all of one combination of terminals, the Style 413 may also be obtained in handy plastic kits of ten HV Ceramicon bodies. Adapter terminals are supplied in packets of five each of a type.

Order through your jobber.

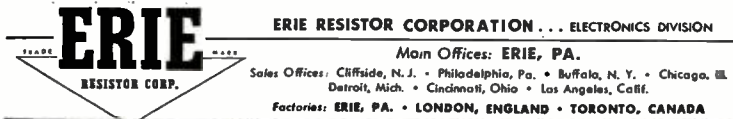

NEW IT'S TERRIFIC! EICO 7 INCH PUSH-PULL SCOPE

HIGHLIGHT FEATURES:

- Boasted vert. sensitivity: 10 mv rms/in.
- Extended flat freq. response: 10 cps—1 MC (± 2 db); useful to 5 MC.
- 3-step freq.-compensated attenuator; cathode follower input.
- Internal voltage calibrator; directly calibrated screen.
- Extended sweep range: 15 cps—100 kc.
- Pos. & neg. waveform analysis; ext. & line sync.
- Sawtooth output & line freq. available at front panel.
- Z-axis intensity modulation & astigmatism control.
- Internal line freq. sine sweep with variable phasing.



KIT
\$79.95
Factory Wired
\$129.50

ORDER NOW!

For full specifications on Model 470 and the complete EICO line, write for latest catalog.

Lafayette Radio

FAMOUS IN RADIO FOR 32 YEARS

NEW YORK 13, N. Y., 100 Sixth Avenue
BOSTON 10, MASS., 110 Federal Street
NEWARK 2, N. J., 24 Central Avenue
PLAINFIELD, N. J., 139 West 2nd Street
BRONX 58, N. Y., 542 East Fordham Road

provide large enough flyback pulse or h.v. Trouble may be between the horizontal oscillator and flyback.

Limited picture size all over indicates presence of both sweeps but insufficient amplitude for either, with insufficient flyback action for high-voltage. The supply common to both sweeps should be investigated.

Raster but no video shows that in addition to lack of high-voltage the set has video trouble. This brings out a very pertinent point: Look for the possibility of more than a single element failure.

None of these failures could have been seen on the screen without the use of an auxiliary high-voltage supply like that of the "Tester-Sparker." Finally, the d.c. high-voltage supply can be used as an insulation tester.

Applying a spark through the test material to ground indicates the ability of the material to resist breakdown under the influence of high voltage. The purple glow that is apparent on the surface of the material does not represent breakdown, but rather ionization of the air.

True insulation breakdown is indicated by a deeper blue spark of a thicker, more substantial nature. It is possible to determine the manner in which an insulator will break down by repetitive sparking at a broken-down point. Inspection will then show whether the material will carbonize or merely break down.

Prolonged d.c. sparking to chassis or physical ground should be avoided, since excessive current may be drawn in this manner, burning out a rectifier tube.

Reference to the over-all view of the instrument shows the knob used for varying the high-voltage output (armature control). Also shown is the top of the 1B3 rectifier projecting through the front panel with the spring contact connected to it. The sparker probe engages this contact through a cavity in the rear of the instrument.

Certain basic safety precautions should be observed in handling this instrument. Since it is high-voltage equipment, *safety first!*

DAYTON HAMVENTION

ON Saturday, March 21st, the Dayton (Ohio) Amateur Radio Assn. will hold its second "Hamvention" at the Biltmore Hotel in Dayton. The all-day program will feature many prominent speakers who will discuss all phases of ham radio.

A representative group of manufacturers will exhibit radio parts and equipment at the "Hamvention."

All classes of ham exams will be given by the FCC and a special program for the ladies has been planned.

A banquet and dance will be held during the evening. Tickets (including the banquet) are \$5.00 in advance or \$5.50 at the door. Hotel rooms can be reserved for those coming from a distance.

All reservations should be made with Ed Pompea, W8FHJ, P. O. Box 701, Dayton 1, Ohio.

NO INTEREST!!

Buy on our radically new

Time Payment Plan

NO CARRYING CHARGES!!

— OUR POLICY —

All merchandise offered on a "try-before-you-buy" basis. If the item you order does not meet with your approval, you may return it, no explanation necessary.

All merchandise offered on easy terms at the net cash price with no interest charges added!

Superior's New Model 770

VOLT-OHM MILLIAMMETER



Model 770 is an accurate pocket-size V.O.M. Measures only 3/4" x 5/8" x 2 1/4".

Sensitivity—1000 ohms per volt

Uses latest design 2% accurate 1 Mil. D'Arsonval type meter. • Same zero adjustment holds for both resistance ranges. It is not necessary to readjust when switching from one resistance range to another. This is an important time-saving feature never before included in a V.O.M. in this price range. • Housed in round-cornered, molded case. • Beautiful black etched panel. Depressed letters filled with permanent white. Insures long-life even with constant use.

- SPECIFICATIONS:**
- 6 A.C. VOLTAGE RANGES: 0-15/30/150/300/1500/3000 Volts.
 - 6 D.C. VOLTAGE RANGES: 0-7.5/15/75/150/750/1500 Volts.
 - 4 D.C. CURRENT RANGES: 0-1.5/15/150 MA. 0-1.5 Amps.
 - 2 RESISTANCE RANGES: 0-500 Ohms. 0-1 Megohm.

\$14.90 NET The Model 770 comes complete with self-contained batteries, test leads and all operating instructions.

Superior's New Model TV-11 **TUBE TESTER**



Operates on 105-130 Volt 60 Cycles A.C. Hand-rubbed oak cabinet complete with portable cover

\$47.50 NET

• Uses the new self-cleaning Lever Action Switches for individual element testing. Because all elements are numbered according to pin number in the RMA base numbering system, the user can instantly identify which element is under test. Tubes having tapped filaments and tubes with filaments terminating in more than one pin are truly tested with the Model TV-11 as any of the pins may be placed in the neutral position when necessary. • Uses no combination type sockets. Instead individual sockets are used for each type of tube. Thus it is impossible to damage a tube by inserting it in the wrong socket. • Free-moving built-in roll chart provides complete data for all tubes. • Phono jack on front panel for plugging in either phones or external amplifier detects microphonic tubes or noise due to faulty elements and loose external connections.

Superior's New Model 670-A

SUPER-METER



Comes housed in rugged, crackle-finished steel cabinet complete with test leads and operating instructions. Size 6 1/4" x 9 1/2" x 4 1/2".

A COMBINATION VOLT-OHM MILLIAMMETER PLUS CAPACITY REACTANCE INDUCTANCE AND DECIBEL MEASUREMENTS

- SPECIFICATIONS:**
- D.C. VOLTS: 0 to 7.5/15/75/150/750/1,500/7,500 Volts.
 - A.C. VOLTS: 0 to 15/30/150/300/1,500/3,000 Volts
 - OUTPUT VOLTS: 0 to 15/30/150/300/1,500/3,000 Volts
 - D.C. CURRENT: 0 to 1.5/15/150 Ma. 0 to 1.5/15 Amperes
 - RESISTANCE: 0 to 1,000/100,000 Ohms 0 to 10 Megohms
 - CAPACITY: .001 to 1 Mfd. 1 to 50 Mfd. (Quality test for electrolytics)
 - REACTANCE: 50 to 2,500 Ohms, 2,500 Ohms to 2.5 Megohms
 - INDUCTANCE: .15 to 7 Henrys 7 to 7,000 Henrys
 - DECIBELS: -6 to +18 +14 to +38 +34 to +58

\$28.40 NET

ADDED FEATURE: The Model 670-A includes a special GOOD-BAD scale for checking the quality of electrolytic condensers at a test potential of 150 Volts.

Superior's New

TV BAR GENERATOR

THROWS AN ACTUAL BAR PATTERN ON ANY TV RECEIVER SCREEN!!



TV Bar Generator comes complete with shielded leads and detailed operating instructions. Only

\$39.95 NET

CONNECTS DIRECT TO ANTENNA POST NO CONNECTION INSIDE RECEIVER

Features.—Can be used when no stations are on the air. • Provides linear patterns to adjust vertical and horizontal linearity • Provides vertical and horizontal sweep signals • Provides signal for testing video amplifiers.

Superior's Model 660-A—A NEW A.C. OPERATED SIGNAL GENERATOR



• Tubes used: 1-6BE6 as R. F. Oscillator, mixer and amplifier. 1-6BE6 as Audio Oscillator. 1-6HG as Power Rectifier. The Model 660-A comes complete with coaxial cable test lead and instructions

\$42.95 NET

Provides Complete Coverage for A.M.—F.M. and TV Alignment

• Generates Radio Frequencies from 100 Kilocycles to 80 Megacycles on fundamentals and from 60 Megacycles to 220 Megacycles on powerful harmonics. • Accuracy and stability are assured by the use of permeability trimmed Hi-Q coils. • R. F. available separately or modulated by the internal audio oscillator. • Built in 400 cycle sine wave audio oscillator used to modulate the R. F. signal also available separately for audio testing of receivers, amplifiers, hard of hearing aids, etc. • R. F. Oscillator Circuit: A high transconductance heptode is used as an R. F. oscillator, mixer and amplifier. Modulation is effected by electron coupling in the mixer section thus isolating the oscillator from load changes and affording high stability. • A. F. Oscillator Circuit: A high transconductance heptode connected as a high- μ triode is used as an audio oscillator in a high-C Colpitts Circuit. The output (over 1 Volt) is nearly pure sine wave. • Attenuator: A 5 step ladder type of attenuator is used.

NEW TIME PAYMENT PLAN ORDER BLANK

MOSS ELECTRONIC DISTRIBUTING CO., INC.

Dept. B-51, 38 Murray Street, New York 7, N. Y.

Please send me the units checked below. I am enclosing the down payment with order and agree to pay the monthly balance as shown. It is understood there will be no carrying, interest or any other charges, provided I send my monthly payments when due. It is further understood that should I fail to make payment when due, the full unpaid balance shall become immediately due and payable.

- MODEL 770 Total Price \$14.90 \$2.90 down payment. Balance \$2.00 monthly for 6 months.
- MODEL TV-11 Total Price \$47.50 \$11.50 down payment. Balance \$6.00 monthly for 6 months.
- MODEL 670-A Total Price \$28.40 \$7.40 down payment. Balance \$3.50 monthly for 6 months.
- TELEVISION BAR GENERATOR Total Price \$39.95 \$9.95 down payment. Balance \$5.00 monthly for 6 months.
- MODEL 660-A Total Price \$42.95 \$12.95 down payment. Balance \$5.00 monthly for 6 months.
- I enclose \$..... as down payment.
- Ship C.O.D. for the down payment.

Signature.....

Name

Address

City..... Zone..... State.....



PREAMPLIFIER-EQUALIZER • MODEL 50-C

THE HIT of the
AUDIO FAIR!

The Fisher Master Audio Control

MODEL 50-C

■ This is the equipment (50-C and 50-A) used to reproduce WQXR's binaural broadcast to the AES Annual Banquet. You can pay considerably more but you cannot buy finer! THE FISHER Master Audio Control can be used with any amplifier. Intermodulation distortion is virtually unmeasurable; complete, professional phonograph equalization settings and tone controls; genuine F-M loudness control; 5 inputs and 5 independent input level controls; cathode follower outputs. Finest preamplifier. Self-powered.

As shown, 50-C: \$97.50

Chassis only, 50-CH: \$89.50

The Fisher All-Triode Amplifier

MODEL 50-A

■ THE FISHER Laboratory Standard Amplifier is, beyond a shadow of a doubt, the world's finest all-triode amplifier—and yet moderately priced! FEATURES: High output—less than .3% harmonic distortion at 40 watts (.08% at 10 watts.) Intermodulation distortion below .8% at 40 watts. Uniform response within .1 db, 20-20,000 cycles; 1 db, 5 to 100,000 cycles. Hum and noise better than 98 db below full output. Quality components used throughout. Beautiful workmanship. \$159.50

Write for illustrated brochure

FISHER RADIO CORPORATION
39 EAST 47th STREET • NEW YORK

ALL-TRIODE AMPLIFIER • MODEL 50-A

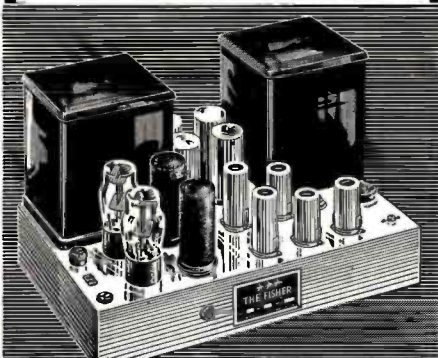

Mobile Equipment

(Continued from page 63)

ner as the spring whip except that a metal tube is used to support the antenna and its skirt, through which the coaxial transmission line is passed. This tube extends through the surface of the automobile with a suitable bushing and is clamped to a substantial point inside the luggage compartment.

The roof-top antenna is mounted near the center of the vehicle roof and the transmission line is passed through to the luggage compartment between the roof and the cloth headliner.

To install a roof-top antenna, the following procedure should be employed. Locate the proper position for the antenna. Choose a location well to the rear of the vehicle. There is very little electrical advantage to be gained by mounting the antenna forward and by shortening the distance between the antenna and the transmitter, line losses are minimized. This shorter distance also makes it easier to install the transmission line. Most manufacturers of roof-top antennas include instructions for loosening the headliner over one of the rear windows and fishing the antenna lead through to the trunk of the vehicle in this fashion. Headliners are usually installed oversize at the automobile factory and then trimmed to size after being firmly anchored into position. It is nearly impossible to loosen a headliner and replace it in such a way as to be unnoticeable. Wrinkles or gaps in the replaced headliner tend to make the completed installation look messy and non-professional. The required hole for the antenna may be best accomplished by drilling a small pilot hole and then reaming to the required size. If a large drill is used initially, the tendency of such a drill to "grab" as it passes through, may tear a hole in the headliner of the vehicle. Drilling a small pilot hole and using a broad taper reamer to enlarge the hole to size eliminates this danger. Thoroughly scrape the paint away from both the top and underside of the opening. This insures a proper ground point for the antenna. A good ground at this point allows the roof of the automobile to act as a ground plane reflector for the antenna providing directivity in the vertical plane of antenna radiation.

The transmission line is installed by using a length of electrician's "fish tape." The fish tape should be long enough to reach from the antenna hole to the luggage compartment with a reasonable amount for handling on each end. In most automobiles, the fish tape can be pushed into the antenna hole in a direction so as to pass directly behind the rear side window, into the luggage compartment. This same path is utilized for electrical system wires in most cars. The transmission line is then fastened to the



ACORN

NEW, NEW
CASCODE TUNER TYPE 2223

Has four times the sensitivity of ANY previous tuner. LESS NOISE, LESS SNOW. Brilliant pictures on all channels. This tuner will operate where others won't or can't. Specifically designed for dependable fringe area reception. Will replace any tuner on 630 or similar chassis. 21.25 MC Sound IF. 25.75 MC Pix IF. Complete with 4-page step by step instruction and installation procedure booklet.



Special . . . \$20.95

CARTER Type B-420 SUPER DYNAMOTOR

A tremendous value at this price! 12 volt input at 12 amps; 400 volt output at 200 ma, continuous. All brand new.



Special. \$23.95

4 1/2" SQ. 0-200 MICROAMP MULTI-METER

Famous make, with multi tester scale. Made specifically for VTM use. Scales 0-1000 ohms; volts d.c. 0-3, 0-10; volts a.c. 0-3, 0-10.



Special \$9.95

10 MFD-600V OIL CONDENSERS

Sprague and C-D. Diam: 2 3/8", Height 3 3/8". Rated at 220V a.c. 99c
Each
Brackets for above, each 15c
Complete with brackets, 3 for \$2.95

CHOKES	
2.5 by 200 mils	62 ohms channel mount . \$1.49
10 by 55 mils	350 ohms channel mount . .69
10 by 75 mils	260 ohms Hermet. sealed .79
10 by 85 mils	200 ohms channel mount . .89
10 by 200 mils	160 ohms channel mount . 1.97
10 by 250 mils	65 ohms upright mount . 2.95
12 by 250 mils	70 ohms upright mount . 2.95
20 by 100 mils	350 ohms Hermet. sealed 1.89
30 by 220 mils	120 ohms upright (Chromeplate) 3.95
32 by 50 mils	640 ohms Hermet. sealed 1.69

HI-FIDELITY OUTPUT TRANSFORMER

Single tube 5000-7500 ohms pri., sec. imp. 4, 8, 15, 50, 200 ohms. Hermetically sealed. 5 watts output. each 99c, 3 for \$2.75

630 SUPER DELUXE TV KIT

Build yourself the finest TV set money can buy with this easy-to-build kit. Standard Cascode Tuner, cosine 70° yoke, original 630 Sync. chain for stability, 16 KV high voltage for brilliance, fast action pulse, keyed AGC, large concert tone 12" PM speaker. Complete with all tubes (less kine) and step by step life-size instructions. Shpg. wt. 68 lbs. less kine and mtg. \$119.44
bracket \$159.95 Mtr. Brackets. . . \$6.95



SLEEPER SPECIALS

2 1/2" Simpson RF 0-8 ammeter. Built-in thermocouple. each \$2.69
Choke: 10 HV; 85 mils; hermetically sealed 400 ohms d.c. each 49c
3 for \$1.35

BATTERY CHARGER

115v 50-60 cy. 6 amp. Charges at 6 amp rate; tapers to 3 amp. Complete with 2" \$8.95
meter. 7" high, 4 1/2" long, 4" wide.

PHOTO FLASH CONDENSERS

Low voltage. Sprague latest type. 525 mfd @ 450v. One condenser equivalent to 50 watt sec. cond. and output unit. Brand new Special. \$11.95
Sprague Electronic Flash Handbook. How to build a popular flash units using above condensers 35c ea. FREE with condensers.

TERMS: 20% cash with order, balance C.O.D. unless rated. Prices F.O.B. our warehouse in N. Y. C. Minimum order \$3. NOTE: Due to conditions beyond our control, prices are subject to change.

Phone WOrth 4-3270

ACORN ELECTRONICS CORP.
76 Vesey St., Dept. N-3, New York 7, N. Y.

fish tape and pulled back through to the antenna opening. This eliminates the necessity for loosening the headliner entirely. The transmission lines should then be attached to the antenna, carefully soldering all connections. In some cases the transmission line is attached to the antenna at the factory and must be pulled in the other direction. The free end of the transmission line should be attached to the end of the fish tape protruding through the antenna opening and then pulled into the trunk of the vehicle. The proper connector may then be attached to the end of the transmission line to allow for connection to the mobile unit.

Installations made in trucks and types of vehicles other than passenger automobiles often require individual consideration as to the problems encountered and the methods to be employed. Generally, certain rules should be followed regardless of the type of equipment. Always remember that the equipment will require service and should be mounted accordingly. Equipment mounted at a point between the front and rear wheels of a vehicle will receive less road shock than when mounted in other locations. Battery leads supplied with the radio equipment are usually sixteen to eighteen feet in length and of heavy copper wire. If the installation is permanent, it may be desirable to shorten this lead as much as possible. This is highly recommended in the higher power types of equipment. Such shorter battery leads will mean higher operating voltage at the unit and consequently fewer eventual service calls. Be certain that the equipment is well grounded to the frame of the vehicle and that all ground and battery cables are tightly connected to prevent voltage drop due to high resistance connections. Try connecting the "hot" battery lead to the starter relay or starter rather than the battery to prevent corrosion of the connection.

When the installation is complete and checked, pause a moment and consider the different conditions of operation that might affect the performance of the mobile radio unit. Driving at night means additional load for the vehicle's electrical system. Headlights, heaters, and many other power consuming devices are operated from the electrical system. All of these may consume power that will then be deducted from the amount reaching the radio. To be certain that the radio is to perform under these conditions of extra load, turn on the lights, heater, or other devices and then check the radio for normal operation. If the equipment operates normally under these conditions, it can be considered ready for the user.

If, after all possible precautions have been taken, the user encounters radio difficulty, remember in his mind, you—the technician—the radioman—are solely to blame. Bear it with a smile and once in a while—the customer may be right!



That's Why Top Service Men Install **PERMA-TUBE** the Mast that's UP TO STAY

Television set owners aren't happy when the set goes out on a big night and the antenna is ruined because an inferior mast failed from inside corrosion or high winds during a storm.

That's why more and more smart service men are protecting their reputations for good work by installing J&L Perma-tube TV masts. They've found that—1. PERMA-TUBE is made of special high-strength J&L steel that stays up in storms that flatten masts of conduit or other types of tubing. 2. PERMA-TUBE is pretreated with vinsynite and then coated inside and out with a metallic vinyl resin base. The result—corrosion proof masting that doesn't weaken or cause ugly rust streaks on the customer's home. 3. PERMA-TUBE is easy and economical to install—the only mast with both ends of the joint machine fitted.

You can get PERMA-TUBE in standard lengths, diameters and wall thicknesses. Write today for complete information and the name of your nearest distributor.

HERE'S INSIDE INFORMATION ON WHAT CORROSION DOES

Section of ordinary conduit tubing used for TV masts after 96 hours in a salt spray test (A.S.T.M. Designation B-117-49T) to accelerate corrosion. Extensive rust inside the mast has reduced strength—caused rusty water to drain onto the owner's home.

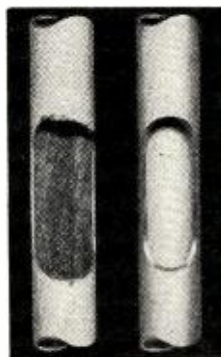

Section of PERMA-TUBE after 500 hours salt spray test shows no evidence of corrosion. Strength has been retained and the chance of rust streaks on owner's home are eliminated. Note sturdier wall thickness of Perma-tube sample.

FOR COMPLETE INFORMATION MAIL THIS COUPON TODAY

**J&L
STEEL**

Jones & Laughlin Steel Corporation
493 Gateway Center
Pittsburgh 30, Pa.

Without charge, please send me: Name of nearest distributor
 Complete information on Perma-tube

Name _____
Company _____
Address _____

WE'LL BUY YOUR OLD PIX TUBES!

Write for amazing offer!
Turn tube loss into profits

CATHODE RAY TUBES

10 INCH (EXCHG. PRICE).....	\$ 9.95
12 INCH (EXCHG. PRICE).....	10.95
14 INCH (EXCHG. PRICE).....	11.95
16 INCH (EXCHG. PRICE).....	15.95
17 INCH (EXCHG. PRICE).....	16.95
19 INCH (EXCHG. PRICE).....	18.95
20 INCH (EXCHG. PRICE).....	19.95
21 INCH (EXCHG. PRICE).....	20.95

ONE YEAR GUARANTEE

Free chassis carrier with each \$10.00 order.

Philco vol. controls (5M, 25M, .35MEG, .25MEG, 50M).....each	\$.39
Mallory vol. control (50M, 500M, 1/2 Meg.).....each	.49
Sight-saver screen 7-17 inch each	.49 to .98
.003-1000 volt condensers.....12 for	.99
Children's electric phonographs (metal base).....each	7.95

U.H.F. CORNER REFLECTOR ANTENNA \$9.95

Covers channels 14-83. Unidirectional high gain on all UHF TV channels. Quick Assembly. Lightweight and strong.

All tubes in Penn Tube Cartons
Current code date guaranteed
Standard R.M.A. Guarantee

1X2	\$.65
5U449
5V486
5Y340
6AL550
6AG572
6AS569
6AU649
6AQ566
6BA663
6BC566
6BG6	1.44
6CB669
6BQ6	1.04
6J5GT49
6C450
6J675
6K655
6S455
6SN773
6V660
6W455
6T863
12AU775
12AT795
12SN775
12BH785
19BG6	1.98
25L670
25W466
1B365
50L6GT57

ALL OTHER TYPES AVAILABLE

Mail orders promptly filled. All prices F.O.B. Chicago. Shipping sent C.O.D. Send M. O. or check only. 20% deposit required on all orders. All merchandise subject to prior sale.

PHONE: IN 3-8006

PENN TUBE COMPANY

Radio and Television Tubes
3547 MONTROSE
CHICAGO 18, ILLINOIS

CURING A FOCUS PROBLEM

By

JESSE JACOBSON

Details on a simple circuit change which can be made to correct TV receiver de-focusing trouble.

A RATHER interesting focusing problem came to my attention recently. Although it may be described as interesting to the technician, it proved to be quite annoying to the TV set owner. Perhaps the word "de-focusing" would be more suitable for describing the situation.

The owner of about 100 TV receivers, who rented these sets to tenants in a midtown hotel, was kept busy making trips to the hotel rooms in order to readjust the focus control. These sets were all of the same make and model and many presented the same symptoms. The picture would slowly go out of focus after playing awhile but could be brought back to normal focus by adjustment of the focus pot. However, after the set was turned off and allowed to cool, the picture would be out of focus when the receiver was turned on again.

An examination of the set showed that replacing the 25L6 tube in the sound section cleared up the trouble but did not guarantee that the trouble would not repeat if and when the tube characteristics changed. The owner of these sets desired a circuit change that would prove to be a permanent cure.

Cause of the Trouble

Fig. 1A shows the focus circuit as used in this model receiver. It may be seen that the current through the focus coil depends on the current flow through the 25L6 sound power tube

plus the current flow through the 6S8 sound discriminator and a.f. amplifier tube. However, the 6S8 tube may be disregarded as the amount of current flow through it is small compared to the 25L6 tube. Thus it may be seen that any change in characteristic of the 25L6 tube would vary the amount of current flow through the cathode-to-plate and cathode-to-screen path, thus causing de-focusing. In other words, loss of emission in the tube or gassing of the 25L6 would cause a loss or increase of current through the focus coil.

The Focus Control

An examination of Fig. 1A shows that a potentiometer is used for the focus control. The pot. acts as a voltage divider to the control grid of the 25L6 tube. Variation of the pot. causes the negative bias, as measured between the control grid and cathode, to become more or less negative. This action controls the plate current through the 25L6 and focus coil. Thus a larger negative bias causes less focus current through the focus coil and *vice versa*. The ohmic value of the focus coil is 2250 and the combined current flow of both tubes is equal to approximately 55 ma. In order to provide stability of the focus circuit, it was found necessary to remove the 25L6 tube from the path of current flow through the focus coil. However, in doing so, the aim was to make as few circuit

Fig. 1. (A) Original focus circuit. (B) Changes made in that part of the circuit below points X, Y, and Z in original circuit to correct the de-focusing trouble.

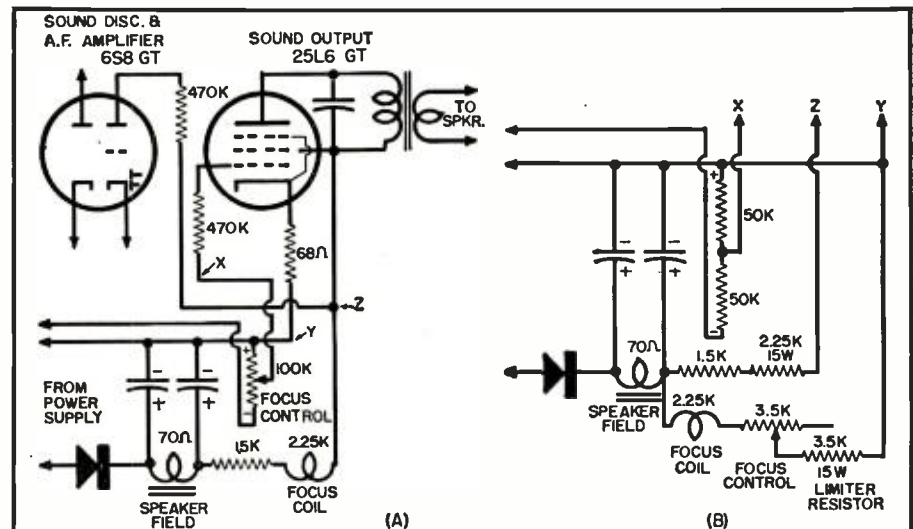

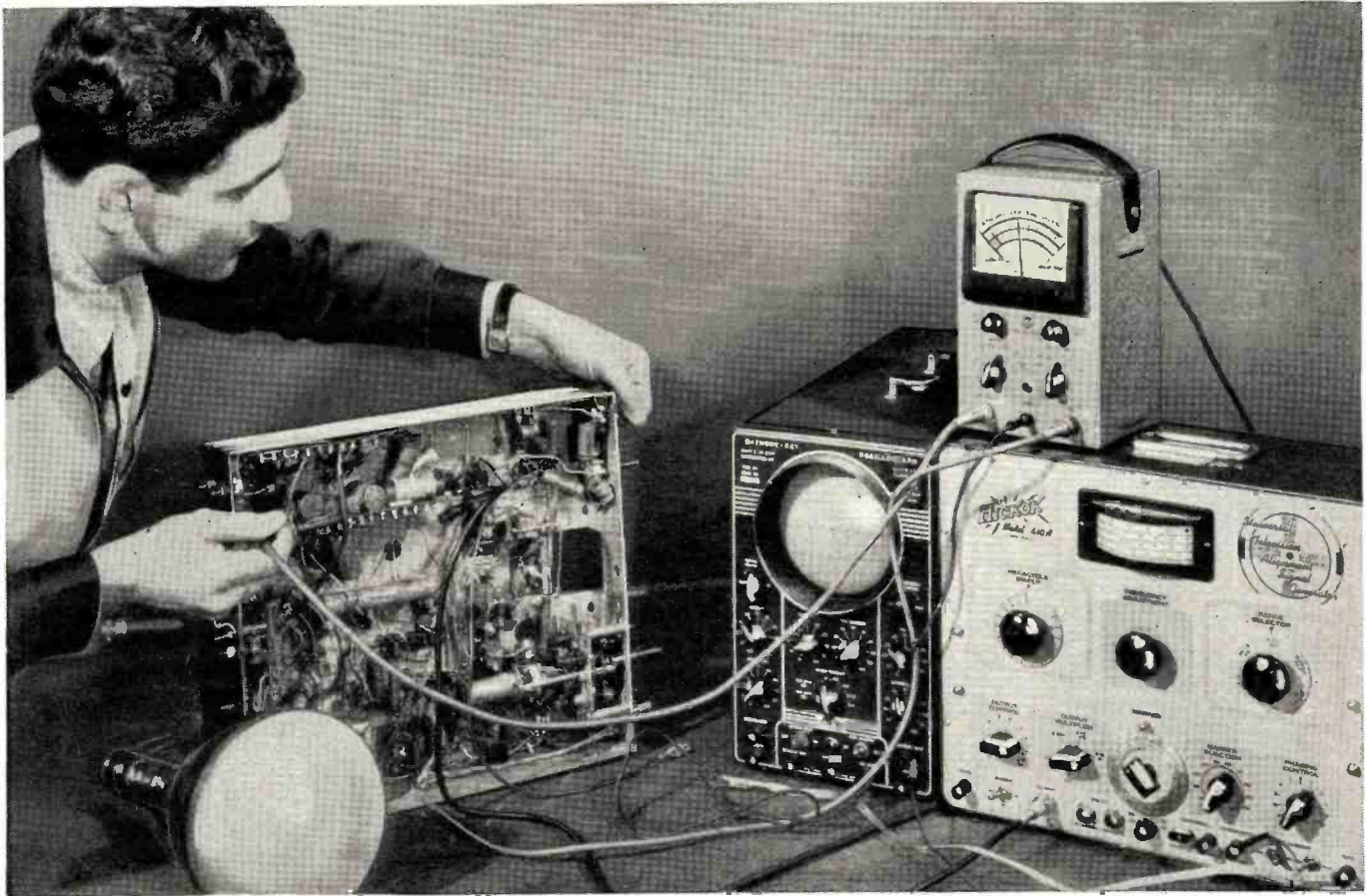

Become an ELECTRICAL ENGINEER IN 36 MONTHS

Bachelor of Science Degree — Major in Electronics or Power

It's estimated that by 1955 there will be *at least* two positions for every engineering and technician graduate. This college offers a tested plan which permits you to enter these vast employment opportunities at an early date. Save a valuable year through optional year-round study. Receive *advanced credit* for prior training gained in the armed forces, other schools or from actual field experience. This school prepares men to become Engineers, Technicians or Servicemen. The Radio-TV Technician courses can be partly applied as credit toward a degree.

ENTER BOTH RADIO AND TELEVISION — 12 months brings you the *Radio Technician's* certificate. An added 6-month course qualifies you for the *Radio-TV Technician's* certificate and the "Degree of Associate in Applied Science."

12-MONTH TELEVISION SERVICE COURSE . . . trains for good servicing jobs and shop ownership in the shortest practical time under expert instructors.

THE PROVEN "UNIT CHASSIS SYSTEM" of teaching was developed here. It "breaks down" the TV set by stages. You learn every component of all types and makes — and are prepared for future design changes, including the advent of color.

TERMS OPEN APRIL, JULY, OCT., JAN.
50,000 former students from all states and 23 overseas countries. Faculty of trained specialists. Modern laboratories and equipment. Approved for Veterans.

Write for free catalog, 48-page pictorial booklet "Your Career" or "Occupational Guidance Bulletins."



MILWAUKEE SCHOOL OF ENGINEERING

NONPROFIT • FOUNDED IN 1903

March, 1953

MILWAUKEE SCHOOL OF ENGINEERING
Dept. RN-353 1025 North Milwaukee
Milwaukee 1, Wisconsin



Without obligation send Catalog for Electrical Engineering, B. S. Degree, major in Electronics; Power; "Your Career", Occupational Guidance Bulletin on: Radio-TV; Electrical Power; Welding; Heating, Refrigeration, Air Conditioning; Mechanical Engineering, B. S. Degree; Preparatory; Television Service.

Name..... Age.....

Address.....

City..... Zone..... State.....

If veteran, indicate date of discharge.....

Thousands depend on PHOTOFACT! THEY TELL YOU WHY

Unsolicited letters tell what the world's finest TV and Radio Data means to Service Technicians



J. S. Hedges
Service Television Co.
514 Main
Beacon, N. Y.

"I have found your schematics most advantageous in my work. Your schematics are not mere diagrams. They rank with the best of instruments for servicing, not only for their preciseness, but also for their noted particulars of the various components employed in radio and TV receivers. Believe me when I say with all sincerity that I think you are the leaders in your field."



Jack Lapine
J & J Dist. Co.
3249 Kildare Road
Cleveland Heights, Ohio

"Words cannot express my appreciation for the wonderful service you have rendered me. It is no wonder that your concern is growing in popularity with the serviceman."



V. L. Bethea
Bethea Electric Service
108 E. Gibson Ave.
McColl, So. Car.

"I would like to express my pleasure at your new system of placing the voltages on the different points in the circuits... a great help... thanks again..."

NOW! GET THE PROOF FOR YOURSELF!

FREE

We'll send you a Free Photofact Folder on any receiver listed in "PF Index & Technical Digest."

Learn for yourself—at our expense—how PHOTOFACT pays for itself by earning bigger repair profits for you! Select any Folder from the PF Index (if you haven't on index, get a copy from your distributor). When you write us for your Free Folder, be sure to state Photofact Set and Folder Number as shown in the Index. Get your Free Folder now. Examine, use, compare—see why you can't afford to be without PHOTOFACT!

HOWARD W. SAMS & CO., INC.
2203 E. 46th St., Indianapolis 5, Ind.

HOWARD W. SAMS & CO., INC.

changes as possible and keep the necessary changes simple.

New Focus Circuit

Fig. 1B shows the new focus circuit that was used to solve this particular problem. The first step was to substitute a 2250 ohm resistor for the focus coil. This simply allowed the original sound power circuit to operate in the normally designed manner. As there was no further need to vary the bias on the 25L6 tube, the original focus pot. was removed and two carbon resistors, each having a value of 50,000 ohms, were substituted in its place. The resistors were placed in series, the center point taking the place of the center lug on the pot. This arrangement placed a normally operating bias on the 25L6 tube, allowing it to draw its normal rated plate current.

The next problem was to obtain d.c. focus current through the focus coil. The amount of current had to be the same as before and also had to be adjustable. Most important, the current must remain steady or else all of this effort would be in vain. It was decided to exclude all tubes from this path of focus coil current and place it in its own independent branch.

Hunting for 45 ma.

Hunting through the circuit for a "spare 45 ma." was the next step. A 2250 ohm focus coil has one advantage and one disadvantage.

Advantage: Low current requirements to obtain focusing due to large number of turns. Therefore it may be placed across a voltage source due its high resistance.

Disadvantage: Cannot be placed in series with the entire "B plus" current source due to excessive voltage drop across coil.

Placing it in series with the entire "B plus" line would, of course, be an ideal condition if the coil resistance was lower. If a tube changed its characteristic and its current flow, it would not be noticeable as it would be "swamped out" by the current flow through the 20 other tubes in the set. However the excessive voltage drop due to the resistance of 2250 ohms, would not allow this type of circuit to be used with this particular coil. It was decided therefore to place it across the output of one of the selenium rectifiers. Before actually placing the focus coil in its new circuit, it was decided to set up an experimental equivalent circuit across the selenium rectifier to see whether the additional 45 ma. would place an excessive load on the rectifier. The circuit consisted of an adjustable wirewound resistor in series with a d.c. milliammeter, adjusted to draw 45 ma. The point of connection was chosen so that the additional current flow would not "rob" any other circuit of its normal current. Note on Fig. 1B that this point is well "in back" of any large resistor values to avoid IR drop. It also precludes the use of tubes and is entirely independent. The trial circuit was left on for an hour and then

for dependable sound, INDUSTRY relies on ATLAS



DR Double-Reentrant Projectors



Paging & Talk-Back Speakers



ALNICO-V-PLUS Driver Units



Dual Speakers



FULL-GRIP, VELVET-ACTION Mike Stands

DEPENDABLE QUALITY:

The latest electro-acoustic research and engineering—and over 20 years of manufacturing know-how—are behind every ATLAS product.

DEPENDABLE SERVICE:

Coast-to-coast and around the world today—in every Industrial, Marine, Railroad, Military, Educational, Civic, U.S. and Foreign Government application—under every kind of climate and noise condition—ATLAS sound equipment is famous for highest efficiency and durability. That's the proof of ATLAS performance dependability.

DEPENDABLE DELIVERY:

Yes, ATLAS gives our Government highest priority. And yes, we too feel the pinch of material shortages. But our customers will continue to get our usual dependable delivery—because we believe in equitable and dependable distribution to all ATLAS users.

DEPENDABLE PROFITS:

Completeness of line, excellence of product, dependable delivery, right prices—that's the ATLAS combination that means high, steady Industrial Sound profits for You!

JUDGE for yourself, COMPARE ATLAS at your local Jobber today. See why ATLAS is the preferred line for utmost dependability. Write NOW for FREE latest Catalog 551



ATLAS SOUND CORP.

1446-39th Street, Brooklyn 18, N. Y.
In Canada: Atlas Radio Corp. Ltd., Toronto, Ont.

BARGAINS!

PANELS removed from Eimac type Computers—Contains at least 24 10-loss octal Sockets. Hdwe. parts... NO JUNK!

Small size: 99c ea. 3 for \$2.50
Large size: \$1.50 ea. 3 for 4.00

TV SERVICING—complete line fully guaranteed Tubes. Ind. boxed. Price List on request.

Sample Listing:
5U4G—55c 1B3—75c 12AU7—75c
6BG6—\$1.25 6BQ6—90c 12AT7—85c

All prices are FOB NY
GREENWICH SALES CO. 59 Cortlandt St. New York 7, N.Y.

ANOTHER OUTSTANDING JOBBER CAMERADIO CO.

1121 Penn Ave.
Pittsburgh 22, Pa.

HAS THE
SENSATIONAL NEW
EICO
470-K 7"
SCOPE KIT
IN STOCK!



\$79.95

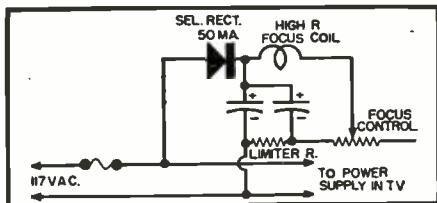

Fig. 2. A separate rectifier focus circuit.

checked for excessive heating of the rectifier. The rectifier, although slightly warmer than normal, did not show any other abnormal signs. Measurement of the voltage at the point of connection before and after connecting the trial circuit showed no appreciable change. It was decided to use this point of connection for the focus coil. It may be seen that this same selenium rectifier supplied the original focus current.

Referring again to Fig. 1B shows that in order to prevent excessive current flow through the focus coil, should the new focus pot. be turned to its minimum resistance position, a limiting resistance is used. The value of resistance, as shown, provided a variation of about 20% from normal focus current when the focus pot. was turned to either extreme.

Applying to Other Sets

The same general idea may be applied to other TV receivers using high resistance focus coils. It is possible to install a small selenium rectifier that will supply focus current independently to the focus coil. However, this is only necessary when it is felt that the additional drain through the focus coil cannot be handled by the original rectifier. Fig. 2 shows this arrangement, using the separate selenium circuit. The selenium rectifier may be of the 50 ma. variety. The focus pot. and limiting resistor may be chosen so as to put the correct focus current in the range, plus or minus 20%, with the focus pot. in either extreme position. The limiting resistor and pot. should both be wirewound and have a sufficiently large wattage rating to prevent overheating and burnout. —50—

Fred J. Lingel, W2ZGY, suggests this method for winding additional turns in the space at the end of a transformer to give an extra filament winding for 12 volt heaters or heater voltage for tubes with the cathode at a considerable voltage above ground. The smooth plastic insulated wire, available in most dime stores, slides through the winding space easily and is tough enough not to ground on the transformer core.

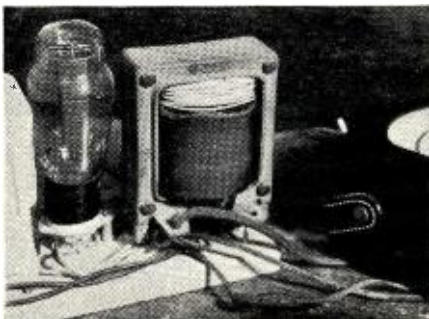

March, 1953

to the
**ELECTRICAL
ENGINEER**

or
PHYSICIST

with experience in

RADAR

or
ELECTRONICS

Hughes Research and Development Laboratories, one of the nation's leading electronics organizations, are now creating a number of new openings in an important phase of their operations.

Here is what one of these positions offers you:

THE COMPANY

Hughes Research and Development Laboratories, located in Southern California, are presently engaged in the development and production of advanced radar systems, electronic computers and guided missiles.

THE NEW OPENINGS

The positions are for men who will serve as technical advisors to government agencies and companies purchasing Hughes equipment—also as technical consultants with engineers of other companies working on associated equipment. Your specific job would be essentially to help insure successful operation of Hughes equipment in the field.

THE TRAINING

On joining our organization, you will work in the Laboratories for several months to become thoroughly familiar with the equipment which you will later help users to understand and properly employ. If you have already had radar or electronics experience, you will find this knowledge helpful in your new work.

WHERE YOU WORK

After your period of training—at full pay—you may (1) remain with the Laboratories in Southern California in an instructive or administrative capacity, (2) become the Hughes representative at a company where our equipment is being installed, or (3) be the

Hughes representative at a military base in this country or overseas (single men only). Compensation is made for traveling and moving household effects, and married men keep their families with them at all times.

YOUR FUTURE

In one of these positions you will gain all-around experience that will increase your value to our organization as it further expands in the field of electronics. The next few years are certain to see large-scale commercial employment of electronic systems. Your training in and familiarity with the most advanced electronic techniques now will qualify you for even more important future positions.

How to apply:

HUGHES

RESEARCH AND
DEVELOPMENT LABORATORIES

Scientific and Engineering Staff
Culver City,
Los Angeles County, California

If you are under thirty-five years of age, and if you have an E.E. or Physics degree, write to the Laboratories, giving resumé of your experience.

Assurance is required that relocation of the applicant will not cause disruption of an urgent military project.

CONCORD TV CLINIC



NATIONAL TURRET BOOSTER

Finest turret tuner ever designed. Built-in Power supply. Brand New! Lots of 8 ea. **\$10.00**
Lots of 3.....\$10.95 ea.
Singly \$11.95



GRAYBURNE TV-I.F. PLUG-IN BOOSTER

Just plug in this complete EXTRA I.F. stage. Improves pix and sound. No switches, no external connections, permanent installation. Shpg. wt. 2 lbs. **\$5.60**
Your Net Cost

Tele-Matic IGNITION FILTER

Compact, shielded, easy to install. Eliminates ignition "signal" interference from TV sets. Shpg. wt. 1 lb. **\$1.18**
Your Net Cost



TUBE BRIGHTENER

Extends pix tube life. Improves emission by increasing fl. temperature. Just plug in. Shpg. wt. 1 lb. **\$1.95**
Your Net Cost

Glarostat Automatic LINE VOLTAGE Regulator

For clear steady TV pictures in areas of fluctuating line voltage. Constant 115 over variation between 90 and 140 volts. Shpg. wt. 6 oz. 300 Watts, Max. Net Watts Max. \$1.18 350 Watts Max. 1.47



Antenna Switch

Vee-DX. Handles 3 separate antenna leads with no capacity loss. Shpg. wt. 1 lb. **\$2.91**



TELEVISION CLARIFIER

Two adjustable knobs tune out or reduce ghosts, tears, other interference. Easily installed in antenna line. 3 3/4" sq. x 1 3/4". Shpg. wt. 1 1/2 lbs. **\$4.40**
Your Net Cost

All Channel "Yagi" \$6.95

Optimum results on all channels. 6 aluminum elements. Fine for fringe areas. "Self-lock" design. 3/8" elements. 1" arm. Shpg. wt. 10 lbs. Lots of 6 each \$6.50

10 CANDOHM RESISTORS

\$1.59 per kit Shielded, insulated, wire-wound. 5 to 50 watt sizes, some tapped. In plastic utility box. Shpg. wt. 2 lbs.

Condenser Bargain!

\$7.95 Per kit Surprise value, 75 asstd. paper bypass, mica, electrolytic, all types, in utility plastic box. Shpg. wt. 10 lbs. Worth over \$20!

100 RESISTORS Carefully selected popular assortment color coded, 1/2, 1, 2 watt sizes. **98c** SPECIAL

Send in your NAME AND ADDRESS and get our mailing list for "limited quantity" buys! Write today—Dept. N-3.

MINIMUM ORDER \$5.00
Address All Mail Orders to Dept. N-3

Concord Radio

55 Vesey Street. Phone
New York 7, N. Y. Dlgy 9-1132

THE BROOMSTICK BOOMSTICK

By **ROB WAGNER, W6WGD**
R.F. Lab., Dalmo-Victor Co.

Three dollars for curtain rods and broomsticks can buy a high-gain, six-element beam with "expensive" performance.

JOHN X. Amateur and Joe Q. Ham operate identical two-meter stations from similar locations. While John exchanges "Q-5" reports with the DX station at Far Acres, Joe fumes and frets, for the Far Acres signal reads "S-zero" at his location.

A wide-spaced, "Q"-matched twin yagi array accounts for DX signal reverberations from John's speaker. The same signal presents a big fat cipher at the bottom of Joe's dipole!

Joe, realizing he should also have a beam, surveys its initial cost, and large neon-lighted dollar signs seem to hang from every element. John saves the day by replacing dollars with sense, showing that a good beam need subtract but 30 thin dimes from the piggy-bank while adding about 10 db to the signal gain.

John X. Amateur has discovered that 1/4" aluminum tubing proves hard to find and harder to pay for. The hardware store no longer stocks solid #6 aluminum clothesline, and metal-foil-wrapped wooden dowels lack staying power when employed as beam antenna elements.

John (a Woolworth customer) bought sixteen curtain rods at a nickel apiece; 80 cents' worth resulted in enough material to provide all elements and "Q"-bars. The rods are thin-walled rolled-metal tubing, 1/4" o.d., measuring 20" in length. Another 20" section of 3/16" o.d. telescopes within. *Volla!* a forty-inch element for the former price of a good cigar!

To support his antenna elements, John bought four 35-cent mop handles (same as broomsticks) at the hardware store. This type of wood was chosen for its light weight, cross-sectional strength, and ready availability. Most broom and mop handles appear to be standardized at an o.d. of 7/8", thus a raid on the wife's broom-closet could result in a saving of \$1.40 plus tax (*this maneuver is not recommended!*).

Thus far, cash investment amounts to \$2.20, plus tax. If the junk box can't yield six standard 1/4" i.d. solid shaft couplings, add about 80 cents to the total. We now possess all main components and have spent only two-thirds of a single sawbuck.

Construction

Remove the little spheres from the ends of the curtain rods. Two reflectors and two directors are made from the one outer and two telescoping sec-

tions. Using the 1/4" o.d. portion of the rod as an element center section, slide a 3/16" tube into each end, arriving at a total length of 40". Solder the junction of the sections, and the two reflectors are almost ready for installation! After making two more elements in similar fashion (directors, 36" long) fill each open end of the tubing to a half-inch depth with solder. We now have four parasitic elements with 1/4" o.d. center sections and 3/16" diameter end pieces.

The antenna's driven elements utilize four additional 1/4" diameter sections, each rod being sawed to a length of 19". Fill each end with solder as before.

To make the "Q"-bars, use the remaining 1/4" curtain rod sections. Two each join at their centers, held together with a pair of shaft couplings. Inasmuch as all open ends have been solder-filled, set-screw pressure serves to make a rigid mechanical joint. A #6-32 machine screw run through each coupling's center provides good electrical connection to the 300-ohm line. Over-all length of each "Q"-bar measures 40". All metallic elements of the beam are now complete—and you have enough 3/16" tubing over to construct that new 220 mc. array!

Fig. 2 illustrates the method of joining the four driven elements and two "Q"-bars to a piece of plastic, such as polystyrene, which both insulates and supports the assembly. Cut two pieces of plastic 1/8" thick, 1" wide, and 3" long and scribe a centerline down the middle of each. The two shaft couplings used in this assembly have a nominal o.d. of 1/2"; file a 1/16th flat

Fig. 1. Dimensions of the broomstick beam. The cross-member #3 is not yet mounted.

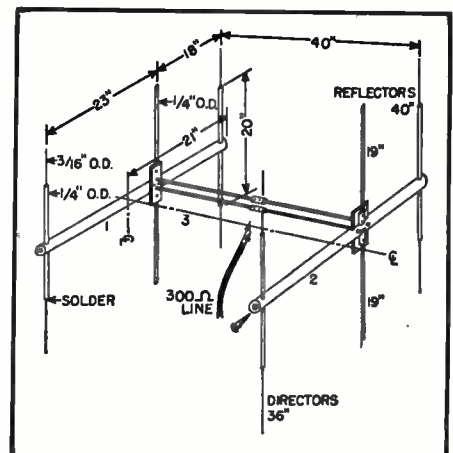



Edward H. Guilford
Executive Vice President

Want To DOUBLE YOUR PAY?

How To Pass **FCC** **COMMERCIAL** **RADIO OPERATOR** **LICENSE** **EXAMINATIONS**

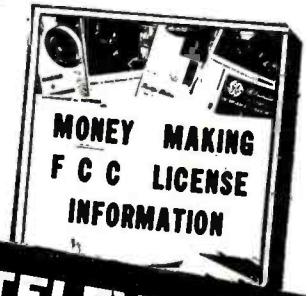

TELEVISION ENGINEERING
Included in our
Training and coaching

GET THIS AMAZING NEW BOOKLET FREE!

TELLS HOW...

WE GUARANTEE TO TRAIN AND COACH YOU AT HOME IN SPARE TIME UNTIL YOU GET **YOUR FCC LICENSE**

If you have had any practical experience—Amateur, Army, Navy, radio repair, or experimenting.

HERE IS YOUR GUARANTEE

If you fail to pass your Commercial License exam after completing our course, we guarantee to continue your training without additional cost of any kind, until you successfully obtain your Commercial license, provided you first sit for this examination within 90 days after completing your course.

TELLS HOW...

Our Amazingly Effective JOB-FINDING SERVICE

Helps CIRE Students Get Better Jobs

Here are a few recent examples of Job-Finding results:

GETS CIVIL SERVICE JOB

"Thanks to your course I obtained my 2nd phone license, and am now employed by Civil Service at Great Lakes Naval Training Station as an Equipment Specialist."
Kenneth R. Leiser, Fair Oaks, Md. Del., McHenry, Ill.

GETS STATE POLICE JOB

"I have obtained my 1st class ticket (thanks to your school) and since receiving same I have held good jobs at all times. I am now Chief Radio Operator with the Kentucky State Police."
Edwin P. Healy, 264 E. 3rd St., London, Ky.

GETS BROADCAST JOB

"I wish to thank your Job-Finding Service for the help in securing for me the position of transmitter operator here at WCBE in Pittsburgh."
Walter Koschik, 1442 Ridge Ave., N. Braddock, Pa.

GETS AIRLINES JOB

"Due to your Job-Finding Service, I have been getting many offers from all over the country, and I have taken a job with Capital Airlines in Chicago, as a Radio Mechanic."
Harry Clare, 4537 S. Drexel Blvd., Chicago, Ill.

TELLS HOW...

Employers Make JOB OFFERS Like These to Our Graduates Every Month!

Letter from Chief Engineer, Broadcast Station, North Carolina. "Need men with radiotelephone 1st class licenses, no experience necessary. Will learn more than at average station for we are equipped with Diesel Electric power, transmitting and studio equipment."

Telegram from Chief Engineer, Broadcast Station, Wyoming. "Please send latest list available first class operators. Have November 10th opening for two combo men."

Letter from Chief Engineer, Broadcast Station, Texas. "Please send list of latest licensed graduates."

These are just a few examples of the job offers that come to our office periodically. Some licensed radioman filled each of these jobs . . . it might have been you!

HERE'S PROOF FCC LICENSES ARE OFTEN SECURED IN A FEW HOURS OF STUDY WITH OUR COACHING AT HOME IN SPARE TIME

Name and Address	License	Lessons
Lee Worthy 2210 1/2 Wilshire St., Bakersfield, Calif.	2nd Phone	16
Clifford E. Vogt Box 1016, Dania, Fla.	1st Phone	20
Francis X. Foerch 38 Beuler Pl., Bergenfield, N. J.	1st Phone	38
S/Sgt. Ben H. Davis 317 North Roosevelt, Lebanon, Ill.	1st Phone	28
Albert Schoell 110 West 11th St., Escondido, Calif.	2nd Phone	23

CLEVELAND INSTITUTE OF RADIO ELECTRONICS
Carl E. Smith, E. E., Consulting Engineer, President
Desk RN-50, 4900 Euclid Bldg., Cleveland 3, Ohio

OURS IS THE
ONLY HOME
STUDY COURSE
WHICH SUP-
PLIES FCC-TYPE
EXAMINATIONS
WITH ALL LES-
SONS AND FINAL
TESTS.



Your FCC Ticket is recognized in all radio fields as proof of your technical ability.

MAIL COUPON NOW

CLEVELAND INSTITUTE OF RADIO ELECTRONICS
Desk RN-50—4900 Euclid Bldg.
Cleveland 3, Ohio
(Address to Desk No. to avoid delay.)

I want to know how I can get my FCC ticket in a minimum of time. Send me your FREE booklet: "How to Pass FCC License Examinations" (does not cover exams. for Amateur License), as well as a sample FCC-type exam and the amazing new booklet, "Money-Making FCC License Information." Be sure to tell me about your Television Engineering Course.

Name.....
Address.....
City..... Zone..... State.....
Paste on two cent postcard or send air mail.

YOU SAVE AT POLY-TECH

GOING MOBILE? CO-AXIAL 6 VDC RELAY. SPDT, WILL HANDLE UP TO 75 W. R.F. uses standard co-ax connectors. Send your order in today b'cuz they'll go like hot cakes. P.P. USA..... **\$6.75**

MOBILE VHF ANTENNA MFD. BY G. E. 152-162 MC, complete with 12 ft. RG58U Coax cable, removable antenna rod, mount, 831SP (PL-259) Coax connector, installation hardware and instructions. Special, only..... **\$2.45**

NOVICE 115V, 60 CY PWR SUPPLY KITS
A 600 VCT 95 MA, 6.3V 3A, 5V 2A; 8 HY 100 MA chokes (2 ea.); 8 x 8 MFD 600 VDC oil capacitors..... **\$6.50**

B Plate transformer 740VCT 305 MA; 5V 6A x 6.3V 6A dual fl. transformer; 4.6 HY 310 MA chokes (2 ea.); 8 x 8 MFD 600 VDC oil capacitors..... **\$12.50**

C IDEAL KIT FOR NOVICE X-MITTER. Transformer 880 VCT @ 125 MA, 2.5V 3A, 5V 3A, 6.3VCT 3A, 7 HY 125 MA choke (2 ea.), Dual 8 MFD 600 VDC oil cap. Chassis, 5U4G, jewel, Tog. Sw., Line cord, Fuse post, Bleeder, Hook up wire and Schematic..... **\$15.95**

D 750 VDC @ 225 MA Pwr Supply, ideal for powering from one source ARC-5 X-Mitters, or any 150 Watt rig. Transf. 750-600-600-750 VDC @ 225 MA, 6 HY 250 MA choke (2 ea.), 6.3V 4A x 6.3V 4A Fil. Transf., 2 MF 1.5 KVDC and 4 MF 1 KVDC oil cap. 5V 4A Fil. Transf. chassis, 5R4GY, bleeder, jewels, Tog. Sws, line cord, **\$29.50** Schematic, etc. Only.....

FREE TELEGRAPH KEY ON REQUEST WHEN ORDERING C & D KITS. For limited time only, act now!

CHOKES

9 HY 95 MA, cased..... **\$1.15**
 15 HY 100 MA, cased..... **1.95**
 10 HY 200 MA, cased..... **2.75**
 15 HY 250 MA, cased..... **3.75**

5 HY 300 MA 70 OHMS, 2 FOR \$4.95

8 HY 400 MA 110 ohms, cased..... **\$5.50**
 6 HY 500 MA 35 ohms, cased..... **7.25**
 .06 HY 3A 1 ohm..... **2.95**
 .02 HY 5A .5 ohm, cased..... **4.95**

1N34 DIODES LIMITED QUANTITY
 10 for only..... **\$3.95**

OIL CAPACITORS

2 MF 600 VDC	\$0.79
4 MF 600 VDC	.99
6 MF 600 VDC	1.65
10 MF 600 VDC	2.99
8 MF 1000 VDC	2.95
20 MF 1000 VDC	8.50
1 MF 1500 VDC	.49
16 MF 1500 VDC	6.95
1 MF 2000 VDC	.79
1 MF 2000 VDC	1.95
2 MF 2000 VDC	2.95
4 MF 2000 VDC	5.50
8 MF 2000 VDC	7.50
5 MF 2500 VDC	2.15
25 MF 3000 VDC	2.90
5 MF 3000 VDC	3.15
3 MF 4000 VDC	9.95
4 MF 4000 VDC	13.50
1 MF 5000 VDC	5.95
2 MF 5000 VDC	10.50
2 MF 6000 VDC	12.95
1 MF 7500 VDC	1.95
.25 MF 15KV DC	52.50
1 MF 15KV DC	69.50

Isolation or Bias Transformer. Prim. 117V, Sec 135V TAP, 6.3V 35W..... **\$1.95**

TUBES

0A2	2 for	\$2.25
0B2	2 for	2.45
0A3/VR75	2 for	2.40
0B3/VR90	2 for	2.60
0C3/VR105	2 for	2.60
0D3/VR150	2 for	2.30
5R4GY	2 for	2.90
3B4TL	2 for	17.95
555	2 for	1.45
807	2 for	3.25
866A	2 for	3.10
854	2 for	.25
8011	2 for	.99

GEIGER TUBE
 Power supply 2" x 2" x 4" Wt. 1 1/2 ozs. Regulated positive high voltage 900 V, load up 20 ma. Variable voltages from 300 to 1600 available. Less 1.5 and 67.5V batteries..... only **\$29.50**
 As above negative Hi Volt, 10 ua..... **\$24.50**

BISMUTH
 Geiger-Mueller detector tube, highly sensitive to Iodine Gamma radiation..... **\$75.00**

GR 50-A Variac 115V in. 115V out @ 40A. Used ex. cond. only **\$95.00**

115V FILAMENT TRANSFORMERS 60 CY

2.5 VCT 10A, 10 KV Insulation	\$4.50
5V 4A 2.5 KV Insulation	1.99
5.0 V 6A, 6.3 V 6A	1.99
5.0 V 12A, 2.5 KV Insulation	5.95
5.0 VCT 20A, 2.5 KV Insulation	6.85
6.3 VCT 3A, 2.5 KV Insulation	4.25
6.3 VCT 6A, 2.5 KV Insulation	4.25
6.3 V 10A, 2.5 KV Insulation, cased	3.95
10 VCT 10A, 2.5 KV Insulation, cased	6.00
Dual 25V 1 Amp	1.95
14.7 V 500A, 250 V Primary	39.50

115V POWER TRANSFORMERS 60 CY

68 to 83 V Half Wave, 1.5A	\$ 1.25
300 V Half Wave .02A	.75
E-57 V Half Wave 3A	2.95
700 VCT 100 MA, 5V 3A, 2.5V 10A	2.25
740 VCT 185 MA, 6.3V 4A, 5V 3A	5.95
800 VCT 200 MA, 5V 2A	3.95
680 VCT 225 MA	2.95
750-600-0-600-750 VDC 225 MA	11.00
3600 VCT 350 MA	29.50

POLY TECH

Dept. C-3, 919 Dawson St., New York 59, N. Y.
 Send for Bulletin
 Murray Hill 6-2650

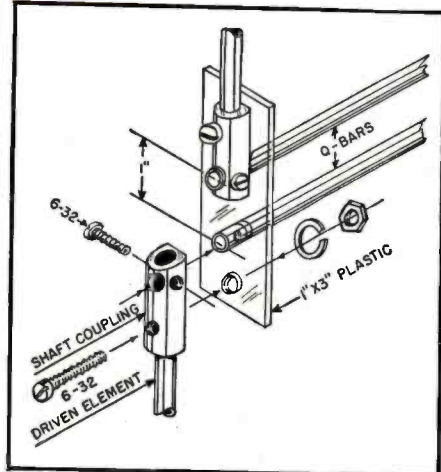

Fig. 2. Detail drawing of the coupling between the driven elements and "Q"-bars.

along one side of each coupling. Place the flat side along the plastic's centerline so that a 1/4" hole may be drilled at right angles to the coupling's vertical plane. Insert the end of one "Q"-bar and tighten the set screw. Repeat the procedure with the second shaft coupling, observing the 1" center-to-center dimensions of the 1/4" holes as shown in Fig. 2. When the second "Q"-bar is secured, repeat the operation for the opposite side of the array.

Place each of the four 19" lengths of driven element upright within the shaft couplings. Drill a #27 clearance hole directly through coupling, element, and plastic, then secure the three pieces with a #6-32 machine screw. Fig. 2 shows that construction is mechanically rigid and electrically sound. The driven element-"Q"-bar assembly is now complete and ready for installation upon the two antenna support booms. These are referred to as "Broomsticks" #1 and #2.

Begin "Operation Broomstick" by cutting two lengths of stock to 42" each. To ensure that all elements will mount in the same vertical planes, place a straightedge along the top of each broomstick's length and scribe a pencil line. Center-punch the line 1/2" in from the end of the stick. Another mark is located 18" down from the first point, and a second center-punch is made at 23" from the 18" mark. "Broomsticks" #1 and #2 are now ready for drilling and notching according to Figs. 1 and 3.

Fig. 3. Dimensions of the notches in the sticks #1 and #2. The assembly of Fig. 2 mounts within the notches, secured by two 6-32 machine screws (see text). Centerlines of the notches are 18" from the mounting holes for the reflector elements.

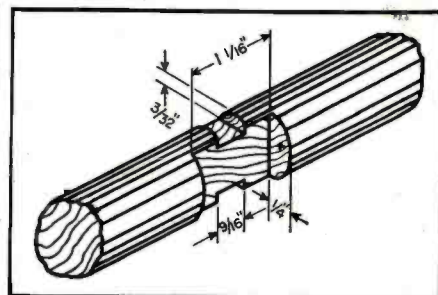

Editors and Engineers PUBLICATIONS



RADIO HANDBOOK, GIANT 13TH EDITION. A one-volume library of radio information with extensive, simplified theory. Detailed how-to-build-it data on dozens of items of practical radio equipment. Book No. E&E-RH13... **\$6.00***

BETTER TV RECEPTION (in fringe and low-signal areas). **NEW SECOND EDITION.** The standard guide for installation technicians. A popular text for TV enthusiasts. Book No. E&E-TR2..... **\$2.50***

RADIOTELEPHONE LICENSE MANUAL. Typical study questions with concise answers for any commercial U.S.A. radiotelephone operators license. Book No. E&E-RL1..... **\$3.75***

ANTENNA MANUAL. A practical, comprehensive book on antennas, for everyone interested in transmission and reception. Over 300 pages. Book No. E&E-AM1..... **\$3.50***

RADIO HANDBOOK, 12TH EDITION. Selected constructional items only. English edition. Book No. E&E-RH12..... **\$3.00***

Spanish edition. Book No. E&E-RHSP12... **\$4.00***

WORLD'S RADIO TUBES (BRANS' VADE MECUM). NEW 9TH EDITION. Lists over 15,000 tubes from every tube making country. Printed in 16 languages. Book No. E&E-VM9... **\$5.00***

SURPLUS RADIO CONVERSION MANUAL, VOL. 1. Practical conversions. Write for list of contents. Book No. E&E-SM1..... **\$2.50***

SURPLUS RADIO CONVERSION MANUAL, VOL. 2. Companion to Volume 1. Book No. E&E-SM2..... **\$2.50***

*Plus any tax.

BUY FROM YOUR DISTRIBUTOR

ADD 10% ON DIRECT MAIL ORDERS TO EDITORS and ENGINEERS, Ltd. BOX 689A, SANTA BARBARA, CALIF. Bookstores order from BAKER & TAYLOR, Hillsdale, N. J.

First... and Still Best!

The original - **QUIETROLE**

TRADE MARK REG. U.S. PAT. OFF.

Available in 3 sizes: 2 oz., 4 oz., 8 oz.

Here is the original, most reliable lubricant-cleanser on the market today... developed after years of research... not a cheap imitation. There is no substitute for QUALITY, try the FIRST... the non-conductive, non-inflammable product. TODAY!

Carried by recognized jobbers... everywhere.

manufactured by **QUIETROLE COMPANY**
 Spartanburg, South Carolina

BIG PROFITS:

Repair CRTs this Easy Way



EVERY SERVICE SHOP CAN MAKE BIG MONEY

with these PATENTED INSTRUMENTS for

1. TESTING picture tubes accurately.
2. REACTIVATING dim or worn out tubes.
3. SPARKING OUT electrical leakage.

CRT TESTER—REACTIVATOR—SPARKER

3 Instruments in 1, making a complete CRT testing and repair unit... It's a combination of the Transvision Tester-Reactivator and a Sparker in one handy unit. It TESTS picture tubes—measures Cathode emission, locates shorts between elements, locates high resistance shorts or leakage as high as 3 meg-ohms. REACTIVATES dim tubes. SPARKS OUT electrical leakage.

\$34.95 net



CRT TESTER—REACTIVATOR

2 Instruments in 1... As a REACTIVATOR it renews brightness and detail of dim CR Tubes, without removal of tube from set. It's also an accurate TESTER same as the above. 110V-60 cycles; wt. 3 lbs.

only \$19.95 net

CRT TESTER—SPARKER

2 Instruments in 1... As a SPARKER, it sparks out electrical leakage between

elements. Saves many picture tubes and small tubes which would usually be discarded. Cathode-grid leakage is an especially common occurrence. The Sparker also gives a rapid check of gas condition of the tube.

As a TESTER it provides a variable 8,000-14,000 V D.C. supply—useful for analyzing hard-to-solve deflection problems... \$25.95 net

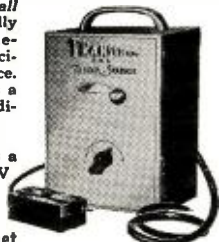

Order direct from factory:

TRANSVISION INC., NEW ROCHELLE, N. Y.

FREE: Sample copy of "TV and Electronics Notes". Or send 50c for year's subscription.

10 DAY TRIAL: Buy and try these fine Instruments for 10 DAYS. Then, if you wish, you may return them. Your purchase price less 10% (our cost of handling and re-packaging) will be promptly refunded.

TRANSVISION, INC.

DEPT. RN-33R NEW ROCHELLE, N. Y.

- () Send me _____ deposit. Balance C.O.D.
 () Enclosed find \$_____ in full. Send prepaid.
 I accept your 10 Day Trial terms.

Name _____
 Address _____
 City _____ State _____

The 1/4" element holes and mounting slot for the "Q"-bar assembly must be made at a right angle with respect to the pencil line's axis to ensure "inline" placement of the elements.

Centered at the 18" mark, the "Q"-bar mounting slot is made with careful application of hack saw and file. Its flat surface supports the plastic insulator at a right angle to the broomstick's lateral axis, placing the vertical antenna rods upon the elements' centerline. Two smaller notches within the slot provide clearance for the bottom ends of the shaft couplings.

When the woodwork has been completed, apply shellac or plastic spray to insulate it against "r.f. termites" and wet-weather deterioration.

Assemble all elements to "Broomsticks" #1 and #2. The complete "Q"-bar section, seated against the flat center of each slot at ends, is drilled through at this assembly, at two convenient points, through both plastic and wood. Two #6-32 machine screws tighten these junctions.

After placing the parasitic elements within their mounting holes, run a small pilot hole into the ends of the broomsticks and through the centers of the elements. Small wood screws then hold the rods tightly in place.

Reduce "Broomstick" #3 to a length which fits snugly between numbers 1 and 2; this dimension is determined experimentally. As the two sides of the array are now separated and spaced by the "Q"-bars, the length of #3 should be approximately 39 1/4" in order to avoid "springing" the "Q"-section.

Fig. 4 shows the over-all boom assembly, and the details illustrate the trick of making a solid joint between right-angle junctions of circular members. Both ends of "Broomstick" #3 should butt solidly against the sides of 1 and 2; no flattening at these points is required, as braces are used.

The local sheet-metal shop should be able to provide enough scraps of thin-gauge galvanized metal to fabricate three pairs of braces, dimensioned

Fig. 4. The final assembly. As all holes are drilled upon assembly, no dimensions are given. Taping the transmission line to vertical member #4 keeps rotation from affecting the electrical connections.

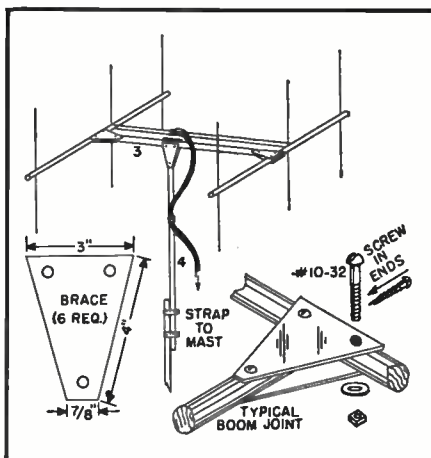

Let me show you how EASY it is to

LEARN TV

the practical way--

ASSEMBLE A TRANSVISION TV KIT



Pay as You Wire

\$39

Down Payment

I WILL HELP YOU to start learning TV the practical way — by assembling a TRANSVISION TV KIT in EASY STAGES. For only \$39 you get PACKAGE #1 (standard first pkg. for all of our kits). This package gives you the BASIC CHASSIS and over 450 TV COMPONENTS with complete Instructions. When ready, you order the next stage (pkg. #2), etc. All stages (or packages) are low priced, making your complete kit a terrific buy! Your completed chassis is a superb 25 tube set (22 tubes and 3 rectifier tubes) with 6" x 9" p.m. speaker — a custom-chassis worth up to 100% above your investment.



FEATURES

Given only in new Transvision TV Kits: No previous technical knowledge required... Easiest to assemble... New A4 circuit gives finest picture and sound... Ideal for fringe areas... Has Automatic Frequency Control... Automatic Gain Control... Retrace Elimination... Never obsolete because color and other developments can be added easily... Choice of 6 Kits.

UHF and REMOTE CONTROL may be had at small additional cost.

EXPORTERS: Foreign system of 625 lines can be accommodated. For complete line of TV Cabinets, ask for folder.

EDUCATIONAL:

No previous technical knowledge required.

With PACKAGE #1, you get my handy 70-page plastic-bound Instruction Book which includes a 20-page Service Section. Also 12 full size (17"x22") Drawings and Photographs, a 64-page Service Booklet, and 1 year's subscription to my "TV and Electronics Notes".

AIDS CAREER:

Do you plan to be a TV Technician, Service-Dealer, or Engineer? You'll benefit by assembling a Transvision TV Kit.

PROFIT 3 WAYS:

You profit by gaining valuable practical knowledge... by saving on servicing costs... and by producing a TV chassis worth up to 100% above your cost.

Used in Naval Reserve Training Program.

FAMOUS EDITOR of a national science magazine says: "... my own assembly (of the kit) produced top-quality results, comparable with any set I've seen and better than most..."

FREE CATALOG

describes 6 great new Transvision TV Kits.

Write to D. GNESIN, EDUCATIONAL DIRECTOR, at: TRANSVISION, INC., Dept. RN3K NEW ROCHELLE, N. Y.

MAIL THIS COUPON TODAY

Mr. D. Gnessin, Educational Director

TRANSVISION, INC., NEW ROCHELLE, N. Y. Dept. RN3K

I'm enclosing \$_____ deposit. Send standard kit PACKAGE #1, with all Instruction Material. I'll pay the balance C.O.D.

Send FREE copy of your new TV Kit Catalog, Cabinet Folder, and Price Lists.

Name _____

Address _____

City _____ State _____

Had we but world enough and time

no one would need monitors but speed in communication is economy and often a life and death matter.



MODEL PR9 FOR 152-174 MC BAND

If you have a police, fire, forestry, pipeline, civil defense, taxi or any other vital 2-way radio system, here is how monitors pay off.

Says Chief McMurtry—of the Sheridan, Indiana, Volunteer Fire Department:

"In the past, the largest obstacles for our Volunteer Fire Department to overcome has been the method of determining the exact location of the fire and beating the traffic there. Speed of course is essential for the efficient operation of any Fire Department. Now, with the Town Police Radio Base Station located in the Department and with the use of 18 PR9 Receivers in the homes of our members we not only learn of the fire before the Town Siren is blown, but we in many cases arrive at the fire before the equipment.... We do not hesitate to recommend this Receiver to any Department."



RADIO APPARATUS CORPORATION
1604 WEST 92ND STREET • CHICAGO 20, ILL.



in Fig. 4. The same shop may let you use their heavy shear to make them.

Reference to Fig. 4 makes construction self-explanatory. #10-32 machine screws secure the boom junctions, resulting in a surprisingly strong construction. Additional cross-bracing between cross member #3 and the vertical support ("Broomstick #4") will not ordinarily be required.

Note that long slender wood screws run through the sides of #1 and 2 into the ends of #3. Another screw passes through the top-center of #3 into the top end of #4. The wood screws are added after the metal braces have been assembled with the broomsticks. Make certain that all assembly angles are 90°.

The completed array should receive a coat of aluminum paint, except that the area comprising the driven-element-"Q"-bar junction should be left uncovered. Metallic paint across these connections would amount to an r.f. short-circuit. It would be a good idea, however, to apply a final weather-proofing layer of plastic spray to the assembly, including all elements.

The 300-ohm transmission line now connects to the 20" center of the "Q"-section, and the array is ready to be secured atop the antenna mast. Fig 4 shows use of two "plumber's tape" pipe clamps which securely strap the lower end of "Broomstick #4" to the top of the antenna mast.

No beam rotator is needed. The entire mast turns by applying hand-power to vise-grip pliers clamped to the bottom of the pole.

As the antenna schematic is shown in most radio handbooks, precise treatment of its gain and pattern need not be made here. Experiment shows the apparent gain over a dipole to be 10 db or greater, and front-to-back ratio to be about 3:1. Minor lobes seem farther down than a well-digger's in-step.

What about Joe Q. Ham these days? He built the "Boomstick" and now enjoys equal status with John X. Amateur in the DX derby! Matter of fact, it might be said that the "Broomstick Boomstick" makes a clean sweep of the entire operation. —30—

TV SERVICE TIP

By JEROME LEINER

HERE is a kink I use for servicing Du Mont sets when the primary winding of the vertical buffer opens. I shunt the primary with a 22,000 ohm resistor and connect the plate side of the primary through a .01 μfd. condenser to the grid of the vertical saw-tooth generator, as shown in Fig. 1.

I have used this idea many times and find that it gives excellent results. —30—

Fig. 1. Servicing Du Mont vertical buffer.

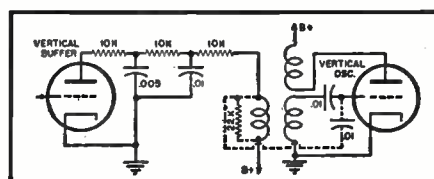

Antenna Maintenance

(Continued from page 39)

After the connectors have been removed, clean the points on the driven elements which make contact with the connectors. For this use fine grain sandpaper. Also, give the elements a general cleaning to remove surface corrosion. Replace the signal take-off hardware with nickel-plated nuts and bolts (or their equivalent) and reassemble the antenna.

When mounting the antenna be sure to use mast stand-offs and inspect the antenna mount itself for loose bolts or cracks. Inspect the ninety-degree bends on chimney straps for cracks and signs of breaking.

In order to properly insure an antenna's life on the rooftop, where it is exposed to weather, the service technician must start his protection at the very beginning. Purchase of a properly designed and manufactured antenna is the first essential protective measure. To eliminate the temptation towards false economy, it is wise to remember that there are no low cost antennas. There are only antennas made from low cost and, consequently, inferior grade material. A poorer quality antenna cannot, even under ideal conditions, stand up as long as an antenna made of better quality components. Softer aluminum, imperfectly plated hardware, inferior plastic for insulators, and low grade metal for crossarms all contribute to the eventual failure of the antenna.

However, even after installing a good quality antenna, the service technician isn't free from his obligation to protect the antenna so that the customer gets the maximum reception out of the installation. In an antenna installation, the picture is no better than the antenna.

Our tests show that a properly protected antenna will have a life of approximately one year. By proper protection we mean that all critical points, such as signal take-off points, nuts and U-bolts, and places where the elements clamp to the insulator, should be sprayed with an acrylic spray, there being many excellent grades on the market.

Once the installation has been correctly protected you can count on about one year of reception equal to that the customer received when the antenna was first installed. The customer should be told, at the time of installation, that after a period of time the elements and hardware will start to corrode. As the hardware corrodes the impedance goes up until ultimately, such a mismatch exists that a very great portion of the signal is lost. Ghosts suddenly appear where there were none before. This is caused by standing waves which have developed because of the mismatch.

After he protects the antenna upon initial installation, the service technician can make a follow-up call, ten



TUBES

ALL TUBES are guaranteed for one year... individually boxed. Very BEST BRANDS available for immediate delivery!

FREE OFFER!

5 lbs. of good usable radio service parts with every 100 tubes ordered; a kit of assorted radio repair hardware free with every 50 tubes ordered!

TUBES and PARTS

WATCH US GROW!

With your help we have increased our space four times. We now handle all the very best brands of original, factory boxed exact replacement parts.

WRITE FOR OUR NEW FREE CATALOG!

024	59c	2X2/879	.74	6A6	.59	6F5GT	59c	6S17	.79	7C5	.89	12AX4	.69
024G		3LP4	1.25	6AV5GT	.89	6F6GT		6S17GT	59c	7C6		12AX7	.69
1A5GT		304	.69	6AV6	.59	6F7	1.59	6S17GT	.69	7C7		12BA6	.59
1A7		3Q5GT	.69	6AX4	.69	6F8G	1.59	6S17GT	.69	7E5		12BA7	1.19
1B3GT	.95	3S4	.69	6AX5	.79	6G6G	.95	6S17GT	.69	7E6		12BE6	59c
1B5	.29	3V4	.95	6AX6	.69	6H6GT	.89	6S17GT	59c	7E7		12BF6	.69
1H5GT	.59	5T4	1.40	6AV5GT	.89	6J5GT	.59	6S17GT	59c	7F7	.89	12BH7	.69
1J6GT		5U4G	.59	6B4E	1.44	6J6	.79	6S17GT	59c	7F8	1.47	12F5GT	.65
1L4	69c	5V4G	.87	6B8GT	1.15	6J7G	.69	6S17GT	59c	7H7	1.19	12H6	.89
1L4A	1.19	5W4		6BA6	.59	6J8G	1.15	6J7G		7H7	1.05	12J5GT	.75
1L6A	1.19	5W4GT	59c	6BA7	.69	6K5GT	.69	6J8	.89	7J7		12K7GT	.69
1L6S	.69	5Y3GT	.45	6BC5	.69c	6K6GT	.59	6J8		7K7		12Q7GT	.89
1L6C		5Y4G	.54	6BC5	1.05	6K7GT	.69	6J8		7L7	.79	12SA7GT	.69
1L6S	1.19	5Y4G		6BD5GT	.89	6K8GT	1.19	6J8		7M7	.69	12SC7	1.05
1L6S	1.19	5Y4G		6BE	.59	6L5G	.69	6J8		7Q7	.79	12SF5GT	.69
1L6S	1.19	5Y4G		6B7	.69c	6L6G	95c	6J8		7R7	1.19	12SF7	.99
1L6S	1.19	5Y4G		6A7	1.21	6L6G	95c	6J8		7S7	1.19	12SG7	.89
1N5GT		6A8GT	.69c	6A8GT	1.69	6L7	1.19	6J8		7V7	.79	12SH7GT	.69
1P5GT		6A8	.69c	6B6	.69c	6M6G	1.40	6J8		7W7	1.19	12SJ7GT	.69
1Q5GT	69c	6A8	1.15	6B7E	.69c	6N7GT	1.19	6J8		7X6	1.05	12SK7GT	.69
1R5		6AC5GT	.89	6B8	.79	6P5GT	.69	6J8		7Y7	.69	12SL7GT	.69
1S4	.99	6A7	1.45	6B8	.79	6Q7GT	.69	6J8		7Y7	.69	12SM7GT	.69
1S4	.99	6A7	1.45	6B8	.79	6R7GT	.69	6J8		7Y7	.69	12SN7GT	.69
1T4	69c	6A7	1.49	6B8	.79	6S4	.59	6J8		7Y7	.69	12SQ7GT	.69
1U4		6A6	1.89	6B7	1.19	6S7GT	1.15	6J8		7Y7	.69	12SR7GT	.69
1U5	.59	6A5	.89	6B7	1.19	6S8GT	1.25	6J8		7Y7	.69	12S7GT	.69
1V	.88	6A6	1.08	6C4	.59	6SA7GT	.69c	6J8		7Y7	.69	12S7GT	.69
1X2A	.89	6A5	.89	6C5GT	.69	6S7GT	.69	6J8		7Y7	.69	12S7GT	.69
2A6	89c	6A5	.89	6C6	.69c	6S7GT	.69	6J8		7Y7	.69	12S7GT	.69
2B3	.89	6A5	.89	6C6	.69c	6S7GT	.69	6J8		7Y7	.69	12S7GT	.69
2B7	.89	6A5	.89	6C6	.69c	6S7GT	.69	6J8		7Y7	.69	12S7GT	.69
2C3A	.60	6A5	.89	6C6	.69c	6S7GT	.69	6J8		7Y7	.69	12S7GT	.69
2C3	.89	6A5	.89	6C6	.69c	6S7GT	.69	6J8		7Y7	.69	12S7GT	.69
		6A5GT	1.29	6C5	.69	6S7GT	.69	6J8		7Y7	.69	12S7GT	.69

TELEVISION PICTURE TUBES

SIZE	PRICE	SIZE	PRICE	SIZE	PRICE	SIZE	PRICE
7-Inch	\$16.95	14-Inch	\$15.95	17-Inch	\$19.95	21-Inch	\$25.95
10-Inch	11.95	15-Inch	17.95	19-Inch	22.95	24-Inch	49.95
12-Inch	13.95	16-Inch	17.95	20-Inch	23.95		

Send us your order and we will ship from stock, immediately.

Metal Tubes \$1.50 extra per tube
Electrostatic Tubes 1.50 extra per tube

ONE FULL YEAR GUARANTEE All Types

TUBE KITS

BEST BRANDS AT BEST PRICES

3Q4, 1T4, 1R5, 1S5.
List Value \$8.00. Tube Kit only... \$1.98

3S4, 1T4, 1S5, 1R5.
List Value \$7.80. 4 Tube Kit... \$1.98

1U4, 3S4, 1S5, 1R5. List Value \$7.80. All Four Tubes for... \$2.49

117Z3, 1U5, 3S4, 1R5, 1T4.
AC-DC Portable Kit. All for... \$2.49

5 Tubes for... \$2.59

12AT6, 12BA6, 12BE6, 35W4, 50B5.
5 Tubes for... \$3.22

50L6GT, 35Z5GT, 12SQ7GT, 12SK7G.
12SA7G. 5 Tubes for... \$3.22

WELLER SOLDERING GUN

For All Types of Soldering

Model Watts

WS-100 150 \$8.77
Single heat

WS-200 275 \$9.75
Single heat

WD-135 150-200 \$10.73
Dual Heat

WD-250 275-350 \$11.71
Dual heat

HOWARD SAMS PHOTOFACTS

Send us the name and model numbers of the television or radio sets you wish to service. We will send the correct Photofact Folder \$1.50 Set—each. Index free on request to Photofact customers.

NEW DAVIS SUPER-VISION TV ANTENNA

Unbeatable for fringe area and DX—The only television antenna with a money-back guarantee. With the new Electronic Dipole Separators, \$2055 less mast

5" aluminum mast heavy gauge 1 1/4" diam. with interlocking end. Slip two sections together for a ten footer each \$1.00

FINNEY ANTENNA

Maximum results in fringe areas. Clear pictures up to 125 miles. High gain, directivity and high front-to-back ratio on all channels. Outperforms two bay Yagi on low band and four bay Yagi on high channels. Ruggedly constructed, corrosion proof. Furnished completely pre-assembled. Easy installation. Full instructions included.

NET \$32.34
10' MAST \$2.00

TV SET SPECIALS!

"FAMOUS NAME TELEVISION SETS!"

- Automatic Gain Control
- Saw Tooth AFC
- Standard Coil Tuner—adaptable to UHF
- All the exclusive features of most expensive sets
- Meet all Standard RTMA requirements
- Finished in luxurious mahogany
- Manufacturer Licensed under RCA Patents:
- 17" Table Model now only \$169.50
- 21" Table Model now only \$189.50
- Console Sets \$20.00 additional.
- Limed Oak Finish \$12.50 extra

TV ANTENNAS

10 Element conical... rugged throughout... only \$3.95

Double bay array, with stacking bars... \$7.75

4 Bay array, with harness and stacking bars... \$14.95

8 Element Conical... only \$2.95

MISCELLANEOUS BUYS

I. F. TRANSFORMER—456 Kc... 19c

PILOT LIGHTS, Type No. 47... 47c

10 for 39c... 100 for \$2.95

VOLUME CONTROLS with SWITCH, 2" shaft 1 meg, 1/2 meg, 1/4 meg... 34c

SINGLE ION TRAPS... ea. 15c

OUTPUT TRANSFORMER—for 50L6 29c for 6V6 39c

UNIVERSAL OUTPUT TRANSFORMER, 12 watt... 99c

CHIMNEY MOUNT for TV ant... 38c

3 SPEED G. I. CHANGER... \$24.95

6 FOOT LINE CORD UL... 10 for \$1.95

TV INTERLOCK CORDS... ea. 49c

P. M. SPEAKERS \$9.95

8" COAXIAL PM SPEAKERS ea. \$9.95

High Fidelity with high pass filter attached. 20 watt; 40-17500 cps. response; 8 ohm Voice-Coil.

12" COAXIAL PM SPEAKERS ea. \$12.95

Very best quality—NATIONAL BRANDS. Individually Packed.

3" ea. \$1.39 8" ea. \$3.23

4" ea. 1.59 10" ea. 5.10

5" ea. 1.59 12" ea. 5.95

6" SPECIAL PRICE ea. \$1.79

300 OHM TWIN LEAD

55 Mil. 1,000 ft. \$10.95

100 ft. \$1.49

20 GAUGE 1000 ft. \$16.95

80 MIL WEB 100 ft. 1.89

21" TV CONVERSION KIT

Consisting of rectangular tube, 70 DEGREE YOKE, Beautiful Mask and FLYBACK TRANSFORMER

complete \$31.95

20" TV CONVERSION KIT, as above, complete \$28.95

17" TV Conversion Kit, as above, complete \$23.95

PREMIER T.V. RADIO SUPPLY

Division of Continental Corp.

3237 W. North Ave. • Chicago 47, Ill.

ARmitage 6-5550

NEW ADDRESS!

CUSTOMERS! We have moved to much larger quarters. Our latest bargain catalog flyer is available! WRITE FOR YOURS TODAY!

TERMS 20% DEPOSIT with order, balance C.O.D. All shipments F.O.B. Chicago. Orders Less Than \$5.00—\$1.00 Service Charge.

RESISTOR KITS

Insulated 1/2, 1 and 2 watt assortment of most used values, I.R.C. Ohmite, Stackpole, Speer, etc., 100 for \$2.95

NEW SUPER POWERFUL ANTENNAS FROM THE COUNTRY'S LEADING TV ANTENNA SPECIALISTS

New Super-gain Fringe MOTORLESS DIRECTRONIC

Now! 24 Elements for Sensational All Channel TV RECEPTION IN ALL DIRECTIONS



New Rocket 24-ELEMENT MOTORLESS DIRECTRONIC ANTENNA

- No Motors
- No Electric Power
- No Ghosts
- High-gain for Fringe Reception in All Directions

Amazing new 24-element Super Directronic provides same clear pictures as hi-priced rotating systems. Provides reception from all directions. You select direction with 6-Position Directronic Beam Selector located at set. Employs New lo-loss tubular TRI-X lead-in. Designed for Superior reception on VHF channels. Model AX-524 includes 2 hi-tensil aluminum elements, 1 set connecting stubs, Universal U-clamps for mast, 6-Position Directronic Beam Switch, and 100 feet of lo-loss Tubular TRI-X lead-in.

AX-524 Directronic as shown **\$26.95**

NEW 48-ELEMENT DIRECTRONIC ANTENNA THE MOST POWERFUL FOR ULTRA FRINGE

Model AX-548—48-element super stacked array is designed especially for deep fringe locations where signal is weak and reception spotty. Array includes 2 Model AX-524 Arrays, special matching stacking harness, 150' Tubular TRI-X lead-in, 6-Position Directronic Beam Switch. Complete—\$49.95

NEW! Rocket Multi-Channel YAGIS

At last—a Yagi antenna with sensational gain on more than 1 channel. New Rocket RB-2-6 and RB-7-13 combine the sensitivity of the yagi with complete coverage of the high and low VHF channels. Protect yourself of the high and low VHF channels. Protect yourself against channel changes by using this amazing new antenna design. For deep fringe use, a stacked array will out-perform even 10- and 12-element single channel yagis. Serviceman array includes 1 double reflector, 2 folded dipoles, and 3 directors. Completely pre-assembled for quick-rig installation.

Model RB-2-6 .. (7-element) Channels 2 through 6 \$10.95
 Model RB-7-13 .. (9-element) Channels 7 through 13 5.95
 Tie Rods for RB-2-6 \$1.30 pr.
 Tie Rods for RB-7-1395 pr.

Rocket 35-foot Mast Kit

Economy mast kit contains 3-10' seamless dualcoated 1 1/2" OD masts, one 5' mast, 300 feet of 6/20 galvanized steel guy wire, and everything else needed including guy rings, mast connectors, insulators, cable clamps, guy hooks, and swivel mounting base.

35-foot Mast Kit **\$15.95** 25-foot Mast Kit **\$11.95**

Lowest Prices on Antenna Accessories

- Mast Steel (Dualcoated 5' crimped) 1 1/4" O. D. \$1.05
- Mast Steel (Dualcoated 10') 1 1/2" O. D. \$1.59
- Mast Connectors for 1 1/4" O. D. Mast. \$1.19
- Chimney Mount Complete with Straps \$1.59
- Peak Roof Saddle (will take up to 1 1/2" O. D.) \$1.59
- Lightning Arrestor—TV99
- Galvanized Steel Guy Wire—6/20 1/2c ft.
- Galvanized Steel Guy Wire—11/20 1/2c ft.
- Rocket Twin-Lead—7/28 stranded 2c ft.
- UHIF-type Tubular 300 ohm Twin-Lead (100' coil) \$4.95
- Rocket Twin-Lead—7/28 stranded \$20.95
- Rocket Open Line Twin-Lead (500' reel) \$20.95
- Mast Stand-off Insulators—3"69
- Stand-off Screw Insulators—3" \$1.49
- Wall Bracket—6" clearance \$2.49
- Wall Bracket—12" clearance \$2.49

ALL PRICES F.O.B. CLEVELAND, OHIO
 Do not remit more than complete purchase price. Pay shipping charges on receipt of goods. 25% deposit on all C.O.D. orders, please. Money-back guarantee. Prices Subject to Change Without Notice
 New Catalog Available

National Electronics OF CLEVELAND THE HOUSE OF TV VALUES
 103 Delco Bldg. Cleveland 3, Ohio

months to a year later, to advise the customer that the protection originally applied is starting to wear off. For a nominal fee, he can take the antenna down, clean it, put in new hardware, and re-spray it, insuring at least another year of satisfactory use out of it.

It is the authors' opinion that a fantastically high percentage of TV ills lie on the roof. Unless the technician is looking for a "quick buck," with no regard to his future or reputation, he must make every possible effort to protect his customer by protecting the antenna.

—30—

International Short-Wave (Continued from page 74)

pensates for all the headaches of a young radio station, the Kol Zion officials believe.

The Kol Zion Lagolah broadcasts—relayed from Jerusalem—are aired over a 7.5 kw. transmitter at Tel Aviv, operating currently 1100-1700 on 9.010A (listed 9.000). The *English Service* is on the air at 1615-1700 closedown; French is heard at 1530. The Israeli Post Office is now constructing a new 50 kw. transmitter which, when in operation, will greatly extend the carrying power of "The Voice of Zion" to a world-wide audience.

Our best wishes go to Kol Zion Lagolah and its personnel for continued and further success in the years ahead!

* * *

Radio Club Notes

Sweden—Arne Skoog, DX Editor, *Radio Sweden* writes that Teknikens Varld's Radio Club, Sveavagen 53, Stockholm 6, Sweden, has now enrolled 10,500 members. Circulation of the fortnightly magazine, *Teknikens Varld*, is 70,000 copies.

USA—Although the National Radio Club is strictly a CBB organization, due to several requests, here's the QRA supplied by Harris, Mass.—National Radio Club, Box 38, Kensington Station, Buffalo 15, New York.

Anson Boice, Conn., editor for "United 49'er's Radio Society," sent along these results of the club's recent DX Contest—top scorer was Gary Tip-ton, LeRoy, N. Y., with 300 U. S. and Canadian stations heard over the week-end of the competition, 241 DX stations, 98 countries and U. S. and Canadian districts, 28 zones, and a grand score of 296,890.8 points. Runners-up were Jehoiakim Arnold, Bermuda; Charles Green, LeRoy, N. Y.; Bette Pearl Elder, Bremerton, Wash.; Chas. McCormick, Jr., Baltimore, Md.; Jim Alfrey, London, England; Jack Hathaway, W9LMC, Rantoul, Ill. The contest was judged by Walter Mulvey, Jr., W1TSZ, New Haven, Conn.

* * *

This Month's Schedules
Afghanistan—Kabul Radio, 9.975, appears to be on the air most days 1030-1045A, but runs longer some days (to 1100 or later); uses *English*.

(Pearce, England; Ridgeway, South Africa, others)

Algeria—Radio Algerie, 9.57, noted with news in French 1515; bad QRM. (Scheiner, N. J.)

Al Kuwait—A station heard on 5.000 at 1230 with vocal Arabic music by a man is believed to be Kuwait in the Persian Gulf. (Pearce, Catch, England) Closedown should be around 1430.

Anglo-Egyptian Sudan—Radio Omdurman has added an *English* newscast aired 1115 on Wed., Sun. (Pearce, England)

Angola—Radio Diamang, Dundo, noted moved from 6.870 to 9.340 where is heard parallel with 7.070 at 1300-1430. (Engberg, Sweden, others) CR6RJ, Radio Clube de Huila, 10.040A, Sa da Bandeira, noted closing 1603 with "A Portuguesa." (Pearce, England) Also noted by Niblack, Ind.

Radio Club de Benguela has been heard on a new channel of 9.502 at 1415-1500; is CR6RF, 350 w. (Radio Sweden) CR6RB, 9.165, Benguela, is heard in Sweden 1330-1400. (*GDX-aren*, Sweden) **Radio Club de Angola**, Luanda, noted parallel on 11.862 and 9.470A around 1510 and closing down 1527 with "A Portuguesa." (Belling-ton, N. Y.) Ridgeway, South Africa, lists current schedule as 1330-1600 (Sat. to 1730, Sun. to 1600). Moca-medes, CR6RM, 7.232, noted from 1300 with Portuguese session, closes weekdays 1500. CR6RD, 9.705, Nova Lisboa, has a session 0600-0800 and afternoons (*EST*) is parallel with 7.105 (formerly 7.096). (Ridgeway)

Argentina—LRA, 9.69, noted opening Spanish session 2000, excellent level in Mass. (Golden) Good in *English* to North America on 17.720 around 1700-1930. (Hoffman, N. Y.) **Radio Splendid**, 9.316A, heard as early as 1800, closing 2300; usually has CWQRM. (Gay, Calif.)

Australia—VLX4, 4.897, Perth, noted 1000 with ABC news; closed 1030 with "God Save the Queen." (Pearce, England) VL16, 6.090, Sydney, noted 0345. (Cox, Dela.)

Austria—Blue Danube Network,

Representatives of the Swiss Broadcasting Corp. in the studios of the Swiss Short-Wave Service in Berne interviewing members of the Mt. Everest Expedition 1952 on their arrival in New Dehli on December 29th. This two-way transmission was arranged in cooperation with All India Radio in New Dehli. From left to right: Russell Henderson of the Swiss Short-Wave Service (English language interview); Jo Excoffier from Studio Geneva (French language); Rene Dittert who took part in the Everest climb earlier this year; and Arthur Welti from studio Zurich (German language broadcast).



RADIO & TELEVISION NEWS

9.617, Salzburg, noted with call 1100; news 1105; heard 0215 with recordings. (Pearce, England) Noted on 5.080 at 1800 when gave weekday schedule as 0200-2000, Sun. 0100-1800. (ISWC, London)

Belgium—ORU, Brussels, was noted recently on 6.000A from 1447 tune-in to 1515 with French session; started *English* for Britain 1515. (Bellington, N. Y.) When this was compiled, ORU had announced use of 9.150 instead of 9.745 to Leopoldville, Belgian Congo, in the beam around 1200-1830A. Was using 9.745 to Africa 2000-2015, with OTC, Leopoldville, relaying on 9.655 to North America; 2015-2100, ORU, 9.745 to Africa, and 6.085 (moved from 6.065) to North America, with OTC 9.655, relaying to North America; 2100-2200, ORU, 9.745, to Africa, 6.085 to North America, and OTC, 9.655, relaying to North America; 2200-2400 sign-off, same set-up in *English* only. (Levy, N. Y., others)

Belgian Congo—Officials of *Radio Congo Belge* sent schedule of OTM1, 6.295, 0000-0130, 1130-1600; OTM2, 9.380, 0000-0130, 1130-1600; OTM4, 11.720, 0515-0730; OTH, 9.210, 0530-0700, 1130-1330; OTH, 11.670, Sun. only, 0500-0700. (Boice, Conn.)

Brazil—ZYK3, 15.145, Recife, noted in *English* at S7 level 1300 recently saying "This is Pernambuco speaking to the world"; woman announcer; is *Radio Jornal do Comercio*. (Niblack, Ind.) ZYK2, 11.825, noted 1518-1528 with *English* identification, directed to Europe, Africa. (Patterson, Ga.) *Radio Cultura*, ZY457, 9.745, Sao Paulo, noted from 0345 to after 0500 and always from around 1530; bad QRM 1530 from Belgium. ZYR61, 4.805, Taubate, is good level in South Africa 1700; gives call every 15 minutes. (Ridgeway) PRK5, 6.000A, Belo Horizonte, noted 1900 with QRM from HJKD, Colombia. (URDXC)

British Honduras—When this was compiled, ZLK2, 4.950, Belize, was being heard with fair signal in Eastern USA around 1830-2030 (*may not be complete schedule*), mostly in *English*, some Spanish. (Bellington, N. Y.; Saylor, Va., others) May also have a transmitter on 6.100A soon.

Bulgaria—*Radio Sofia*, 9.700A, noted with *English* 2000-2030. (Lund, Iowa)

Burma—Rangoon announces *English* for 2015-2030 on 9.543, 6.035; 0115-0145, 9.543, 6.035; 0915-1015, 9.543, 4.775. (Ridgeway, South Africa)

Canada—CHNX, 6.130, Halifax, N. S., is like a "local" from 0700 onwards; CFRX, 6.070, Toronto, Ont., is good level around 1100. (Morrison, R. I.)

Canary Islands—EASAB, 7.305A, noted closing 1800. (Pearce, England)

Cape Verde Islands—Praia noted parallel on 5.885A and 7.130A around 1645. (Bellington, N. Y.) Noted closing on 7.130A at 1700. (Niblack, Ind.)

Ceylon—*Radio Ceylon's* 4.900 channel is seldom reported, but recently was noted at fair level in New Zealand 0915 in Chinese session; is fair level on 17.820 with modern recordings; 0430. (Cushen) Noted on 15.120

BA WHOPPING VALUES

~~\$49.50~~ VALUE **\$24.75**



FAMOUS "APPROVED" MODEL A200 SIGNAL GENERATOR LIMITED SUPPLY AT ONE HALF PRICE!

Extremely stable, built for long, dependable service. 8 BANDS, 100 kc to 75 mc—with 455 kc position indicated in red for quick reference. Large open-face frequency dial has multi-colored scales for 6 over-lapping fundamental ranges from 100 kc to 25 mc, with Band F2, 18-50 mc, and Band F3, 27-75 mc on harmonics. Phase shift audio oscillator and internal modulator for 440 cps., internal or external—and continuously variable from front panel from 0-100%; external modulation possible, 40-30,000 cps. Extremely low leakage on all bands; completely isolated from power line, Ceramic insulated, low drift, wide spaced variable condenser of "invar" metal used as frequency selector. 3-step RF attenuator and continuously variable RP-AT attenuator control—ultra stable 2-terminal RF oscillator. 6SH7 tube as cathode follower output to a coax lead assuring frequency stability regardless of attenuator control setting. Lucite dial pointer with hair-line indicator. Pilot light line indicator. With 4 tubes, cable, instructions. Steel cabinet is 8 x 10 x 12", for operation on 105/120-volt 60-cycle AC. Weight 20 lbs. No. 34B173. \$49.50 Value. NOW WHILE THEY LAST.....\$24.75

"BUILD-YOUR-OWN" WITH MODEL A200K PARTS KIT

Identical to factory-wired Model A-200 described above EXCEPT in KIT form! Complete with 4 tubes, cables, cabinet, operating instructions and circuit and pictorial diagrams for easy assembly. No. 34B175. \$32.50 Value. NOW WHILE THEY LAST ONLY.....\$17.75

\$21.95 RADIO TUNER CHASSIS

Provides simple means of adding Radio to PA systems; to combine with a phono amplifier and phono motor and pickup or record changer for a complete Radio-Phono combination, to add radio to TV sets, to combine with Disc, Tape or Wire Recorders for recording of radio programs, etc. Top quality 4 tube superhet completely wired. Has self contained transformer type power supply, well filtered hum free, no shock hazard. High impedance output in steps 1-5 and 10 volts. Supplied complete with 2 1/2 ft. shielded lead, attached 5' antenna and 4 tubes (6BE6, 6BA6, 6AT6 and 7Y4 rectifier), instructions and diagram. Extremely compact, only 4" x 4" x 5". Ideal for use in built-ins, etc. Tunes standard broadcast. For 115 V 60 cycle AC operation. No. 33A125. Shpg. wt. 2 1/4 lbs. \$21.95 Net Value. While They Last SPECIAL NET EACH.....\$13.88



CHECK THIS SENSATIONAL VALUE!

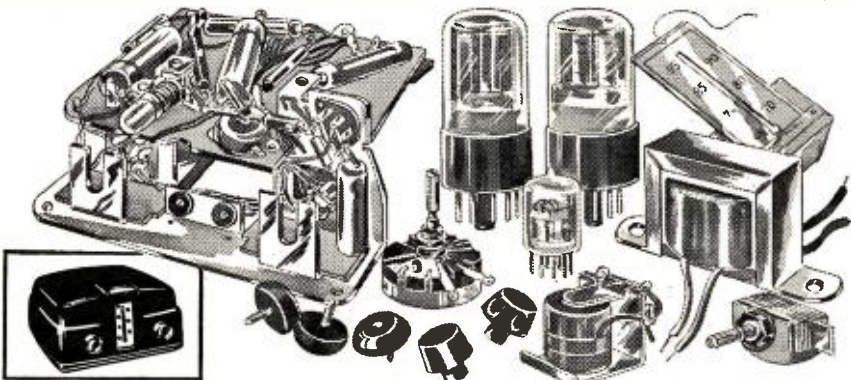

Here is a list of parts useful for many, many applications. Which if furnished individually would regularly cost many times the Crazy Low Price we show. Originally intended as Thyatron Remote Controls for Electric Blankets... but now available at a mere fraction of original cost because the maker had more controls than he could make blankets. Comes completely assembled—can be modified for various remote control uses or easily taken apart for the high quality parts alone. Others offer these identical units as Big Bargains, and truly so, at up to double our prices. Order from B-A Now while they last at the Ridiculous Low Prices below. Complete Assembly, including 1-6SL7GT, 1-6SN7GT, 1-GL562 and Plastic Cabinet as pictured. No. 18B53 Special Each.....\$2.88 10 Lots Each.....\$2.50 *No. 18B48 as above, except less tubes and cabinets. Special Each.....\$1.19 10 Lots Each.....99c

FREE! WRITE US IF YOU DON'T HAVE B-A's BIG 148 PAGE 1953 CATALOG CATALOG NO. 531.

***\$1.19** FOR CHASSIS AND PARTS

\$2.88 COMPLETE WITH TUBES AND CABINET

- 1-115 V-6.3 V., 1 AMP FIL. TRANSFORMER
- 1-S.P.S.T. SENSITIVE PLATE RELAY
- 1-S.P.S.T. SWITCH
- 1-ELECTROLYTIC CONDENSER
- 1-POTENTIOMETER
- 6-CARBON INSULATED RESISTORS
- 7-WIRE-WOUND RESISTORS
- 3-TUBE SOCKETS
- 1-PILOT LAMP
- 1-CHASSIS AND HARDWARE

INCLUDE ALLOWANCE FOR POSTAGE—ALL OVERPAYMENTS WILL BE REFUNDED



BURSTEIN-APPLEBEE CO.

1012-14 M-GEE ST. KANSAS CITY, MO.

great TV news! Fringe Beam

TRADE MARK

Highest POWER-GAIN Antenna ever!

10 Element Yagi with

- ★ 100% more power gain than an 8 element yagi
- ★ 75% more power gain than usual 10 element yagi
- ★ Fringe-Beam gives HIGHEST POWER regardless of number of elements

Extensive tests... under all conditions; in FRINGE, near fringe and primary areas—in the North, South, East and West—conclusively proved that Fringe-Beam outgains any antenna. It's beyond comparison with any in today's market.

Leading installation companies, dealers and servicemen recommend the Fringe-Beam 10 element yagi with full confidence. Customers are grateful.

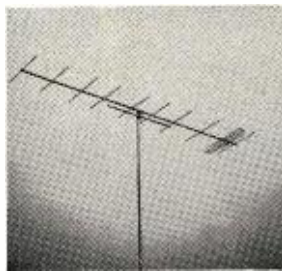

Fringe-Beam
10 Element Yagi

EXCLUSIVE FEATURES:

- Low standing wave ratio, 1.2 to 1 or less for nearperfect match to 300 ohm line
- Boom braced on both high and low channels
- 4-element dipole with large area presents low Q; maximum pick-up and broad response for both picture and sound
- 95% power gain over a single bay when antenna is stacked
- Excellent pattern and front-to-back ratio
- Free stacking bars
- Lightweight, well constructed with seamless tubing, plated screws and nuts with high grade Micarta for low loss insulation. Well balanced, good appearance
- Pre-assembled for fast, easy installation. All elements crimp at ends
- Guaranteed
- Excellent profits
- Assures satisfied customer

JOBBERS—REPS! Some major territories available.

Get complete data; volume sales and unusual profits!

NEAL ELECTRONIC CO.

Huntsville,

Alabama

What to look for in
a record changer...

PRACTICAL • STURDY
PUSHER-TYPE PLATFORM
ON ALL MODELS

Always works

Gentle to records

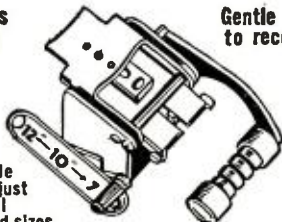

Simple to adjust for all record sizes

One of many features which make
GARRARD

The World's Finest
3 Speed Record Changer

Fully automatic with automatic stop

Can be used with your present set.

MODEL RC 80

\$42.98 net
less cartridges

Garrard Sales Corp. Dept. R-3
164 Duane St., N. Y. 13, N. Y.
Send GARRARD Fact Sheet.

Name.....
Address.....
City.....Zone.....State.....

HI-FI CRYSTAL HAND MIKE... Hi-impedance. Moulded bakelite case. 5 1/2 ft. cable. \$3.95
T-30 THROAT MIKE... with neckband. PL291... .69
EXT. CORD & SWITCH for T-30 mike. \$0.49
Less PL68 \$0.49
T-44A MAGNETIC MIKE original carton \$0.98

Leotone
HIXMAS IN MARCH! with the NEWEST "JUMBO" RADIO PARTS KIT... A "Gold-Mine" of inventory odds & ends including: CONTROLS, SOCKETS, WIRES, RESISTORS, CONDENSERS, SWITCHES and MUCH, MUCH MORE! (Shpg. wt. 20 lbs.) \$3.95

DYNAMIC HEADPHONES (mkII) Moving coil type. High fidelity. With 40' cord & cushions \$2.49
5 FT. SGL. PHONE CORD... tip-clip. ea. 19c; 6/1.00
HS-30 HEADSET... earplug type. W/clip, cord 1.98
HS-30 MATCHING TRANSFORMER 10-h imped. .59
HS-30 "Y" CORD (CD620)... w/clip & lugs. ea. 19c; 6/1.00
HB-30 HEADBAND... new, complete. ea. 23c; 5/1.00
POCKET FLASHLIGHT... 3" long! W/batt. ea. 23c; 10/1.98

MOTOR SPECIAL!! 1/17 H.P. G-E MOTOR... 1725 RPM, 110V.DC. .7 amp. Double 3g shaft. O.D. 4 3/4"x3 1/2". Shpg. wt. 13 lbs. ONLY \$2.95

12 1/2 FT. WHIP ANTENNA... 4 steel screw sections \$1.98
RADIO HARDWARE TREASURE... FULL LB. CAN of: Nuts, Screws, Lugs, Washers, etc. 1b. 89c; 3 lbs./2.49
HI-FREQ. BUZZER... .6V. adjust. (2"x1 1/4") .69
#20 FT. SPEAKER EXT. CORD... tips-lugs. ea. 19c; 3/1.98
#12 SCE MAGNET WIRE... 50 ft. \$1.29; 100 ft./1.98
#32 P.E. MAGNET WIRE... 12 oz. spool. .98

"KINKLESS" SUPER-FLEXIBLE BRAIDED WIRE (32/#40)... WITHSTANDS CONTINUOUS BENDING as in Relays, Speakers, Phones, etc. Cotton core; outside silk braid. ea. 19c; 100 ft./\$32.50

EXPERIMENTAL TUBES... for Test, Research, etc. Fil. tested. Kit of 40 asstd. tvcs. 3 types. \$1.98
TUBE CLAMPS... 1-3/16" or 1-5/16" I.D. ea. 12c; 10/1.00
20 TERMINAL BARRIER STRIP (11 1/2"x3 3/4") \$1.98
8/32 BRASS FEED-THRU Moulded bakelite .59
#20 PUSH-BACK WIRE... Red, Yel., Blue or Blk. ea. 19c; 100 ft./ .89
11 1/2" AC ELECTROMAGNET (O.D. 1"x7/8") 800 ohm coil; 6 oz. pull, cont. duty. ea. 88c; 6/5.00
6 LEATHER HANDLES... dble. sewn, w/hdware .39
S P A K E R ACCESSORIES REPLACEMENT CONES... 4" to 12" incl. free-edge. Less voice coils. \$1.98
SPEAKER REPAIR KIT... Professional adjustment of: Rings, V.C. forms, Spiders, Felt, Chamois Lthr., Cement, Shim Kit & Instructions... 2.49
#100TH CONE & REPAIR KITS FOR ONLY!! \$3.95
ACOUSTICAL FELT CABINET LINING (12" sq. x 1 1/4")... Laminations separate to give 3 sq. ft. ea. 39c; 6/1.98

"DIRECT FACTORY SPEAKER REPAIRS SINCE 1927" SPECIALISTS ON ALL TYPES OF "HIGH-FIDELITY" UNITS Min. order \$3.00. 20% deposit req. on all C.O.D.'s. Full remittance with foreign orders. Please add sufficient postage—excess refunded.

LEOTONE RADIO CORP.
67 Day Street
New York 7, N. Y.

with native program 2205-2230; no English. (Sutton, Ohio) Heard on 11.975 and 7.190 with English programs 0830-1145 (some days to 1215) to India-Pakistan. (Ridgeway, South Africa)

Chile—CE920, 9.200A, noted 1926 with Latin American music, good level but with slight heterodyne and CWQRM. (Bellington, N. Y.) La Voz de Chile para todas Americas has moved from 11.90 to 11.937A; is CE1190 and is heard well in South Africa 0630-2300. (Ridgeway) CE1515, 15.150, Santiago, signs off 2300.

China—Radio Peking noted on 6.050A

(Continued on page 148)

PROGRAM SET

THE Seventh Annual Spring Technical Conference, sponsored by the Cincinnati Section of the IRE, will be devoted exclusively to television.

Held in Cincinnati on April 18th, the program will include papers on "TV and the Bell System," "High-Powered U.H.F. Broadcast System," "Design of TV Receivers Utilizing Non-Synchronous Power," "Selection and Amplification of U.H.F. Signals," "Transient Considerations in the NTSC Color System," "Four-Gun Tube for Color TV Receivers," "Latest NTSC Color Systems," etc.

Advance registration is being handled by Anthony C. Wahl, c/o A. C. Wahl Co., P.O. Box 8, Green Hills 18, Ohio.

—50—

VIDEO DETECTOR FAULT

By GEORGE R. ANGLADO

MOST TV sets manufactured today make use of a germanium crystal as the video detector instead of a vacuum tube.

It does its job well in this particular circuit but usually goes bad in about three to five months' time. The crystal, being mounted under the chassis, develops a high resistance which is caused by heat from the set. This, in turn, makes the picture on the screen appear to be washed out.

To test the crystal, use an ohmmeter and measure the forward and back resistances. The forward resistance should be lower than 400 ohms and the back 10,000 ohms or higher. Any crystal providing a less than 25:1 front-to-back ratio indicates a defective unit.

Using an "Eico" 20,000 ohms-per-volt meter on one of the crystals removed for measurement, the reading was 525 ohms in one direction and 8700 ohms in the other direction, showing the crystal to be below standard.

When a new IN34 was measured, the reading was 120 ohms in one direction and 1.2 megohms in the other direction—indicating a "hot" crystal. When the new crystal was installed, the washed out trouble disappeared and the set returned to normal operation.

When replacing a crystal, be careful not to hold the soldering iron too close as it may be ruined. Do a quick job by heating the terminal in the set first, then shove the lead of the unit in the terminal hole and apply one drop of solder to the connection, letting it drop from the iron. Do not heat the leads of the crystal.

In addition, be sure that the correct crystal polarity is observed when making the replacement.

—50—

Transistor Amplifiers

(Continued from page 41)

coupling as indicated in Fig. 4A. Of course, the d.c. resistance should not be too high or the voltage drop will reduce the collector operating voltage to too low a value. Low impedance phones are fully as satisfactory if there is no objection to using a matching transformer as in Fig. 4B. The approximate load impedance to match the output transistor is found with sufficient accuracy for experimental use by dividing the d.c. voltage at the collector by the d.c. collector current.

A word about transformers. There are many types of transformers with a variety of impedance combinations suitable for use in the circuits discussed. However a small tapped transformer such as UTC types R-27, R-28, R-33, R-38A, R-59, Thordarson types S62, S86, S87, S88, and similar universal types are relatively inexpensive, small, and provide impedance ratios from a few hundred to several thousand times so that optimum coupling can usually be obtained for interstage use as well as for input and output requirements. A mismatch of two to one in the lower level stages may be used without appreciable loss of gain.

The next item in designing this amplifier is that of battery voltage. Three volts is a desirable supply voltage although 1.5 will suffice in many cases. Even higher voltage may be used when larger output power is required. The maximum collector current rating for type CK722 is 5 ma. so with 3 volts supply less the drop in the output transformer or earphone, we can still put 8 or 10 milliwatts in and easily obtain several milliwatts of audio output power. The input resistor in the final stage should be adjusted to give the lowest collector current which will result in sufficient output power to drive the phone for there is no need for using more battery current than necessary. The CK722 transistor has a maximum collector dissipation rating at room temperature of 30 milliwatts which means that with obtainable efficiencies you can if you desire more power output (up to about 20 or 25 milliwatts), operate the final stage at its maximum collector current rating of 5 ma. and a collector voltage of about 10 volts. If this is done, it will save battery power if the stages preceding the output stage are operated from a separate 1.5 or 3 volt battery rather than through a dropping resistor connected to the total available supply voltage.

Although some amplifiers may be usable without a volume control, it is usually necessary that means be provided to adjust the volume to accommodate variations in signal input, changes resulting from battery aging, etc. The volume control problem is not quite as simple as with tubes but one good method for resistance-

Instant **H I A T**

that's "QUICK ON THE TRIGGER"

and "RIGHT ON THE TARGET"

USE THE

WALL
TRIG·R·HEAT
SOLDERING IRON

READY TO SOLDER IN SECONDS



\$11.95



HEAT-CONTROL
Thermostatic Action
guaranteed for the
life of the iron, or
double your money
back!

Yes—the heat is QUICK! Just touch the trigger, and in seconds TRIG-R-HEAT is ready to solder. Heat is RIGHT, too! An amazing, exclusive thermostatic action (without the use of transformers or fragile thermostats), quickly brings TRIG-R-HEAT to "on-the-target" soldering temperature and keeps it there. Iron is never too cool for efficient work—never too hot for the good of the tip. The result—solder doesn't fuse to iron, so tips last two to three times as long as those on irons without this exclusive feature. A built-in spotlight makes dark, hard-to-reach places easy to solder. Wattage starts at approximately 400 watts and idles at about 100 watts. Operates on 115-120 volts, AC or DC. Get Wall TRIG-R-HEAT at your dealer's today!

OVER 20,000,000 SOLDERING PRODUCTS SINCE 1864



WALL MANUFACTURING CO.
GROVE CITY • PENNSYLVANIA

24 HOUR
DELIVERY
FROM STOCK!

RELAYS

Our stock of more than a million relays — in over a thousand different types — is the world's largest. Don't delay your production for want of large or small quantities of relays of any type.

Telephone, wire or write for quotations.



NEW AND MORE
COMPREHENSIVE
1953
RELAY SALES
CATALOG
NOW READY

Be sure to send
for your copy



Telephone
SEeley 8-4146
833 W. CHICAGO AVE.
DEPT. 8, CHICAGO 22, ILL.

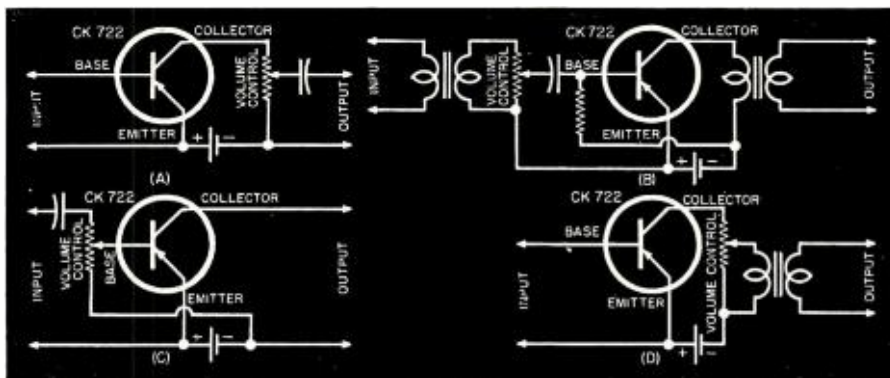

Fig. 5. (A) Volume control for resistance coupling. (B) Volume control for transformer coupling. (C and D) Unsatisfactory volume control circuits. See text.

coupled circuits is illustrated in Fig. 5 where the resistance portion of the control becomes the load for the transistor and the arm of the control supplies the signal to the following stage. The control may be used in any convenient amplifier stage but ordinarily it is well to put it at the "front" of the circuit to aid in preventing overloading of following stages on strong signals. Fig. 5B shows a volume control circuit suitable for use with transformer coupling. In this circuit, the resistance of the control should be at least 10 times (more if possible) the impedance of the transformer secondary.

The volume control cannot be connected in a manner which would vary the base bias, and thus the collector current, so Fig. 5C is a volume control circuit which is *not* satisfactory. Fig. 5D shows another method which is *not* satisfactory because it would vary both collector current and load impedance. Even the insertion of a condenser between volume control arm and transformer primary would not make the circuit desirable because the load impedance would vary with changes in the volume control setting.

Although we assumed that we were designing a transistor amplifier for a particular purpose the reader should understand that this was to give some indication of how to proceed with the design of an amplifier for a typical application. There are infinite combinations of components which may be used and after one has gained some experience in building transistor amplifiers he can readily work out variations such as the use of loudspeakers for both pickup and reproduction as in intercoms, combinations of different transistor circuits such as a first stage using a crystal mike directly coupled to the high input impedance grounded-collector circuit, followed by grounded-emitter stages for maximum gain, and other combinations designed to meet particular ideas and requirements. Also transistors may be used in push-pull class A, class B, and other conventional circuits for greater output so there is no end to the possibilities which may be investigated and employed by those interested in the advantages in small size, lightweight, and low battery drain obtained by

using transistors. Negative feedback in a grounded-emitter circuit may be obtained by an unbypassed resistor in the emitter lead and offers another line of investigation for the experimenter. Negative feedback over more than one stage is possible, as with tubes, but not always as easily accomplished. For example, tertiary windings on transformers appear most promising in transformer-coupled amplifiers for which negative feedback is desired. It is very desirable that the investigator have available an audio signal generator and oscilloscope for use in observing the effect of changes in transistor circuits and operating conditions.

REFERENCES

1. _____; *General Radio Experimenter*, March 1952, page 3.
2. Dixon, Robert K.; "Build This Transistor Receiver," *RADIO & TELEVISION NEWS*, February 1953.

NEW SUN STORE

SUN Radio & Electronics Co. of New York has recently moved into new and modern headquarters at Sixth Ave. and 20th St. in Manhattan.

The 20,000 sq. ft. of floor space (on a single level) will be used for "supermarket" merchandising of parts and equipment. Three sound studios and a TV bar are other unique features of the store.

INCREASING BOOSTER GAIN

By GEORGE R. ANGLADO

INCREASED booster gain and range in the "Regency" and other boosters using the popular 6J6 tube can be obtained by substituting the new 12AT7 for the 6J6.

The 12AT7 has more gain than the 6J6 and will pull in the stations more clearly.

To make the change, the socket must be changed to the novel 9-pin type, the tube connections rewired, and the cathode resistor increased to 200 ohms. Be sure to connect the 12AT7 cathodes (pins 3 and 8) together. Greater sensitivity may be obtained by decreasing the value of this resistor to 100 ohms but care must be taken to see that the plate current does not exceed its maximum value.

The heater transformer is connected so that one side goes to pin 9 and the other side to pins 4 and 5 on the 12AT7.

GREAT NEWS!

Sun Radio

NEW YORK'S FIRST

ELECTRONIC SUPERMARKET

650 SIXTH AVENUE Corner 20th St.

In order to keep up with modern buying trends, Sun Radio has moved to a bigger and more easily accessible location to bring you the first electronic shoppers' world. A paradise of everything electronic in over 20,000 sq. ft. of ground floor space.

CHECK THESE INNOVATIONS:

- *Over 150 ft. of counter space.*
- *Complete displays of all test equipment, transmitters, receivers, etc.*
- *Complete stock of radio and TV replacement parts.*
- *Complete stock of amateur radio equipment.*
- *Self-service TV antenna bar.*
- *3 complete sound studios.*
- *Complete staff of qualified sales personnel.*
- *Easily accessible to Metropolitan New York, New Jersey and Long Island.*

Stop in today. You can't afford to miss our tremendous values during our mammoth opening sale. Come in and browse or buy at your leisure. Every item in our tremendous stock has been specially priced for this event.

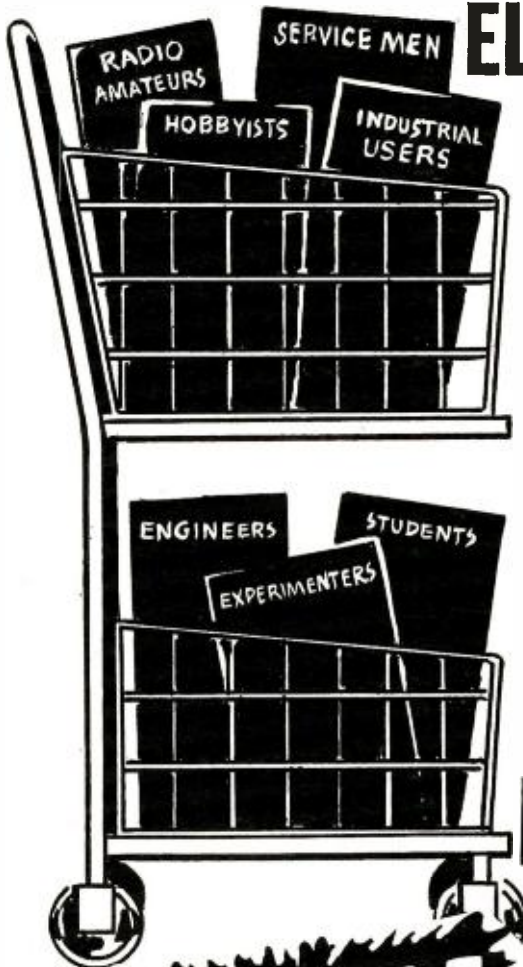

FREE!

over \$1,000.00 in Prizes

Stop in to see our new home, and please don't fail to register so that you may qualify for one of these valuable prizes. Drawing date will be on April 11th, 1953 and all winners will be notified if they are not present. Don't miss out on these great prizes. Stop in today and see the NEW . . . BIGGER . . . BETTER Sun Radio!

FIRST PRIZE

RCA Master Voltomyst WV87A

SECOND PRIZE

Precision 612P Cathode Conductance Tube Tester

THIRD PRIZE

Simpson Model 303 V.T.V.M.

Plus

2 RCA WV77 Junior Voltomyst
5 Eico 221K V.T.V.M. Kits

3 Eico 320 K Signal Generator Kit
5 Superior 770 Volt-ohm-milliameters

10 Weller WD 135 Solder Guns
50 \$5.00 Gift Certificates

85 PRIZES

10 American Beauty #3138 Soldering Guns

Sun Radio & **ELECTRONICS CO. INC.**

650 Sixth Ave. at corner of 20th St., New York, N. Y. OREGON 5-8600
Open Daily & Saturday 8:30 - 6:00



Special Offer On This Complete **RADIO ENGINEERING LIBRARY**

New, Up-To-Date Edition of Famous Library Covers Whole Field of Radio Engineering. Places Latest Facts, Standards, Data, Practice, and Theory At Your Fingertips.

The five big volumes of the new edition of the Radio Engineering Library now include the very latest facts, standards, data, and practice. This Library will help solve hundreds of problems for designers, researchers, engineers, and students in any field based on radio.

Written by leading radio engineers, these books cover circuit phenomena, networks, tube theory, vacuum tubes, amplification, measurements, etc.—give specialized treatment of all fields of practical design and application. They provide you with a complete and dependable encyclopedia of facts.

- 5 Volumes, 3872 Pages, 2770 Illustrations.
- Eastman's **FUNDAMENTALS OF VACUUM TUBES**, 3rd Edition.
- Terman's **RADIO ENGINEERING**, 3rd Edition.
- Everitt's **COMMUNICATION ENGINEERING**, 2nd Edition.
- Hund's **HIGH FREQUENCY MEASUREMENTS**, 2nd Edition.
- Henney's **RADIO ENGINEERING HANDBOOK**, 4th Edition.

SEND NO MONEY

Special Low Price—Easy Terms

On this special offer you get this Library for \$37.50, instead of \$43.50. You save \$6.00 and may pay on easy terms. Mail coupon below to examine the Library FREE for 10 days. No obligation. These books are recognized as standard works; you are bound to need them. So take advantage of this special money-saving offer. *Mail coupon at once!*

McGraw-Hill Book Co., Dept. RTN-3,
327 West 41st St., New York 36, N. Y.

Send for 10 days' FREE trial, the RADIO ENGINEERING LIBRARY. If not satisfied I will return books. Otherwise I will send \$7.50, plus delivery charges, then; and \$6 a month for 5 months. (Reg. price \$43.50; you save \$6).

Name.....

Home Address..... RTN-3

City & State.....

Employed by.....

We'll Pay Delivery Charges if you enclose \$7.50 first payment WITH coupon. Same return privilege for full refund. (Offer applies to U. S. Only.)

You and U.H.F.

(Continued from page 49)

allowed its use. The antenna available commercially is sturdy and economical. It will also save the customer money since it can also be used for v.h.f. when the v.h.f. station opens up later on.

This antenna allows you to select the angle required for optimum reception. Our checks showed that when the angle of the V elements was adjusted to approximately 90° the antenna gave best results on v.h.f. A 60° angle seemed best for u.h.f.-v.h.f. use, while narrowing the angle down to 45° provided best reception for u.h.f. only.

Where multi-path and gain were factors to be considered, the best u.h.f. antenna we tested was the stacked bow tie with reflector.

An interesting development in the u.h.f. antenna field is the increased feasibility of the u.h.f. built-in antenna. In the first place, the very nature of the u.h.f. allows built-in antennas to approach one-half wavelength. And in the second place, transmission line losses may be sufficiently great when long lines are run to cancel any gain achieved through the installation of a roof-top antenna.

In contrast with v.h.f., we were surprised to see the number of indoor or built-in antennas that were giving satisfactory reception. For this reason, don't discount the possibility of using the built-in antenna when the u.h.f. receiver is located in a strong signal area.

After selecting the antenna to be used in an installation, you next have to decide on the location of the antenna. Don't be afraid to spend a little time in covering the entire roof area looking for the best spot. The location and height of the antenna are extremely important for optimum results—much more so than in v.h.f. installations. Nor is it taken for granted that the higher you go the better. When probing a location move your antenna up and down as well as moving it about.

After you have located the antenna site, you still have to transfer the u.h.f. signal to the input circuit. Don't lose what signal you have by using lines with heavy moisture attenuation. Don't run your line down close to the building, roof, or metal objects such as drains or gutters. You will lose too much signal by absorption. Figs. 2 and 4 show you graphically the effects due to moisture and proximity to a roof.

Relative losses due to moisture in transmission lines in db-per-100-feet are shown in Table 2. In practice it was seen that 300-ohm tubular lead became almost standard in Portland. When using this lead-in be sure to seal the top end of the line, and make a rain loop at the bottom before allowing it to enter the home. Also, cut a hole in the bottom of the polyethylene before it enters the house to allow any accumulated moisture or condensation to run out. You wouldn't want this to drip into the customer's home.

When studying Figs. 2 and 4 bear in mind that in each case signal conditions and receiver settings were the same. Fig. 4 illustrates the differences

The nation's first high-power, u.h.f. television transmitter undergoes final tests at General Electric Company's Syracuse, New York plant before being shipped to station WHUM-TV in Reading, Pa. This 12,000 watt unit is expected to be in operation in the near future. As the Federal Communications Commission continues to grant new TV station permits, this scene is being repeated throughout the country as transmitter makers go into high gear to help get stations on the air as quickly as possible. Reading's WHUM-TV has been assigned Channel 61. It will have an erp of 260 kw. by using a low-loss waveguide to carry power to a twenty-five gain antenna.

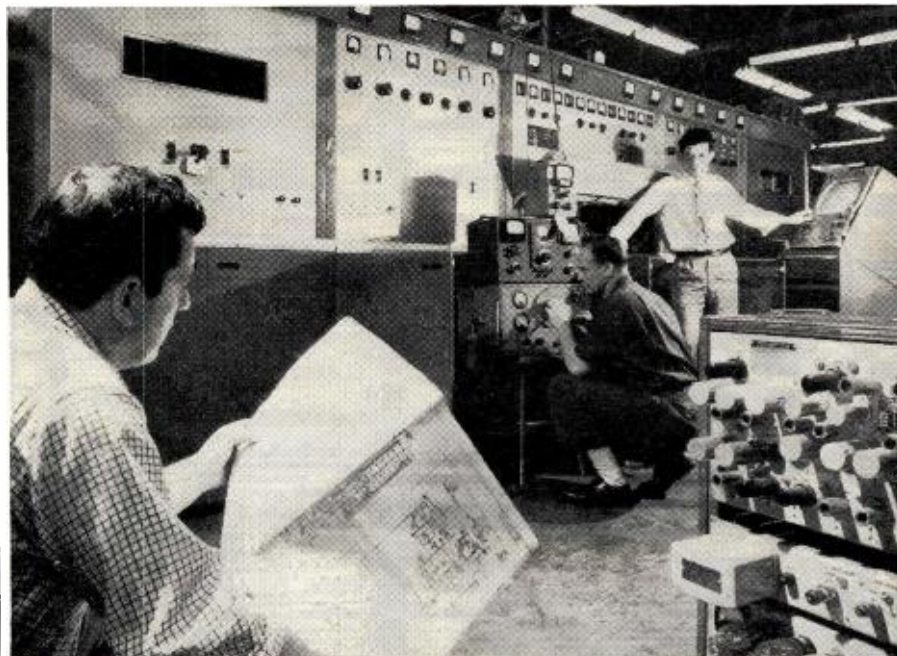

in received picture when the 300-ohm flat ribbon line is compared with the 300-ohm tubular line. The conclusion is obvious: whenever you suspect rainy or damp weather, you'd better stay away from 300-ohm flat line.

The conclusions to be drawn from Fig. 2 show unmistakably that when it is necessary to run your transmission lines close to roofs or other absorbing surfaces, you should use only coaxial cable.

Not included in Table 2 is the open-wire *Gonset* line. While this transmission line has the lowest losses of all tested by our group, we found that the spacings of the line are somewhat critical. When using this line, make sure that during the twists and turns necessary in running a transmission line down to the set, that the spacings are not varied. This would, of course, vary the characteristic impedance.

Unless exceptionally long runs of line are required, it is doubtful that this open wire line will be necessary in many installations.

Significance of U.H.F.

The increased coverage made possible by the new FCC allocations will bring television to many communities not now enjoying this modern miracle. It is hard to realize that until April there were only 108 stations in 65 communities, 43 of which were single channel cities. Fifteen states had no stations at all.

In April the FCC made 2053 channel allocations, about two-thirds of which will be in the u.h.f. band. So you can see that u.h.f. is really making it possible for all America to enjoy television.

The opening of new markets presents unlimited growth possibilities to ambitious service technicians. Good technicians with a knowledge of business principles can strike out on their own in the new station areas where there is a crying need for their expert services.

Industry predictions call for 50,000,000 sets to be in operation in the next five years. This will call for a service force more than double what we have now.

Men now in the industry can serve as a framework for the expansion and training program that must develop.

Now as never before, every conscientious service technician must strive to keep up with industry progress and improve his knowledge and methods. This includes the fields of business practice and customer relations, as well as technical "know-how."

In new areas such as Portland, service technicians will have the benefit of manufacturers' service clinics and a good supply of valuable service literature. But this isn't enough. The service technician should enroll in refresher courses in local trade schools if available.

In areas that have had fringe reception and are now awaiting the advent of local u.h.f. telecasting, the problem

Like money in the Bank...

WALSCO UHF-VHF



AVAILABLE NOW

- A. CORNER REFLECTOR
For fringe and ghost
area reception
- B. REFLECTO-FAN
For local reception
- C. TROMBONE
For combination UHF-VHF
reception

YOU are completely protected when you buy, sell or install WALSCO. Every model is now a "proven performer" . . . thoroughly tested and endorsed in all the new UHF-VHF areas. Designed for all present and future channels. The best high gain, all channel performance and a model to fit every installation

Protect your profit . . . eliminate costly *call-backs*. Install WALSCO, America's most dependable TV antennas. It's like money in the bank!

WALSCO

Walter L. Schott Co.
3225 Exposition Place
Los Angeles 18, Calif.

Overseas Representative:
Ad Auriema, Inc., 89 Broad St.,
New York 4, N.Y.

WRITE FOR COMPLETE PRICE
AND CATALOG INFORMATION—Dept. P-53

MONEY MAKERS!

FOR MOBILE-RADIO SERVICE ENGINEERS!

Provide for future expansion in this profitable field, with Lampkin frequency- and modulation-measuring equipment.



For Any Number of Frequencies, AM or FM. The Type 105-B MFM.

The Type 105-B Micrometer Frequency Meter, or MFM, measures center-frequency on any number of nearby transmitters, AM or FM, 0.1 MC. to 175 MC. Performs as signal generator for mobile receivers, 20 MC. up. Meets FCC requirements for mobile services, with accuracy guaranteed better than 0.0025%. Can be checked against WWV. Price \$220.00 net.



The Type 205 FM Modulation Meter for Multiple Mobile Frequencies.

Instantly tunable anywhere, 25 MC. to 200 MC., the Type 205 measures maximum FM deviation due to modulation, as required by the FCC. Indicates 0-25 KC. deviation. Simple to use, easy to carry. No charts or tables. Price \$240.00 net. Clip below.

Send name and address for literature

Name

Address

City..... State.....

LAMPKIN LABORATORIES, INC.
MFM DIVISION
BRADENTON, FLORIDA



EARN MORE MONEY— BE A PROFESSIONAL TELEVISION SERVICE TECHNICIAN

STEP INTO THE TOP PAY
\$5,000—\$10,000 A YEAR
CLASS. YOU CAN WITH
WTI SHOP TRAINING.



If you want to reach your goal as a Successful Service Technician you will need plenty of "KNOW HOW" to qualify for the better servicing jobs or profitable shop ownership.

SEND FOR
FREE
BOOK TODAY!

WESTERN TV offers real experience on live equipment in our BIG SHOPS AND LABORATORIES in the shortest practical time under expert instructors. Graduates are in big demand because they have the "field experience" necessary for immediate "bench" or supervisory positions. You learn every phase of Radio and TV servicing (AM, FM, VHF, UHF). WTI men win fast promotion... can demand better pay... develop highly profitable businesses of their own with the latest and most PRACTICAL PERSONALIZED TRAINING BEHIND THEM. You concentrate all your time on being a PROFESSIONAL TV SERVICE TECHNICIAN—non-essential math and engineering theory omitted. YOU CAN EARN WHILE YOU LEARN. Special Finance Plan. APPROVED FOR VETERANS. Find out how you can get into the TOP PAY GROUP—Send for this fact-packed book NOW!

**WESTERN
TELEVISION
INSTITUTE**

America's Leading
Television
Servicing School

Western Television Institute Dept. R-33
341 W. 18th St., Los Angeles 15, Calif.
Without obligation, please send FREE fully illustrated booklet. (No salesman will call.)

NAME _____ AGE _____
ADDRESS _____
CITY _____ ZONE _____ STATE _____

!!WANTED!!

In order to supply government and industrial requirements, we are paying top dollar for all types of radio and electronic surplus. We specialize in test equipment and complete radios, such as:

APA, APN, APQ, APR, APS, APT,
ARB, ARC, ARN, ART, ATC, BC,
DY, I, IE, LM, MG, PE, PU, SCR,
TCS, TN, TS, and many others.

WE ESPECIALLY NEED: APA10, APN9,
APR4, APS4, ARC1, ARC3, ART13, ATC,
BC221, BC342, BC348, BC611, BC721,
DY12, DY17, 1100, LM10 to LM18, MG149F,
MG149H, PU14, R5/ARN7, R5A/ARN7,
SCR718C, TCS, TN16, TN17, TN18, TN19,
TN54, TS3, TS13/AP, TS33, TS35, TS45,
TS75, TS76, TS102, TS147/UP, TS148/UP,
TS173, TS174, TS175, TS250, TS251, TS323,
(ICT, IF, IG, 5CT, 5DG, 5F, 5G, 6DG,
6G 115V. 60 c.p.s. Selsyns), and all types
of Hewlett Packard, General Radio Co.,
Measurements Corp., Boonton Radio, Fer-
ris, Leeds & Northrup, and other test
equipment.

Please state accurate description, condition, and your lowest price. Explain modifications, if any. We pay freight charges.

PURCHASING AGENTS, ENGINEERS, EXPORTERS, INDUSTRIAL BUYERS, DEALERS, AND INDIVIDUALS, Please send us your requirements.

WRITE FOR OUR LATEST SURPLUS CATALOG

PHOTOCON SALES

417 N. Foothill Blvd.
Pasadena 8, California

Sycamore 2-4131
RYan 1-6751

will be somewhat different. Here there will be a hard core of experienced technicians who have mastered the intricacies of squeezing the last bit of signal out of a fringe installation. They know what low loss lines are, and the need for proper antennas and replacements.

There is something that service people can do, though, to lighten their load when the new station does go on. In the first place, they can expect a marked increase in telephone inquiries—most of which will be time consuming and nonproductive. Since it is assumed you will be busy enough with your normal work, tying up your phones with inquiries about u.h.f. will hamper your operations. It is therefore suggested, that you prepare yourself for this period by having a little question and answer leaflet made up which will anticipate your customer questions. Will you have converters? How much will they cost? How can I find out what antenna I need? Will my set receive the new station? etc., etc.

By preparing answers to these general questions in advance and mailing them to your customers you can forestall many inquiries and, at the same time, line up some future business.

Extra leaflets should be available, so that when new customers call you, you can cut down the length of your phone conversations by promising to mail a leaflet "that will give you all the answers."

A return work order card should be included in your mailing. This will facilitate bringing in some new business.

Summing up, we see that u.h.f. is here to stay. It works with moderate power. It provides good pictures. It covers the territory well. It can be received with present receivers. It can be installed with reasonable care using techniques with which we are familiar. And finally, it presages an era of industry expansion the likes of which we have never seen before. Stay with it, and you'll get your share of the fun and profit.

-30-

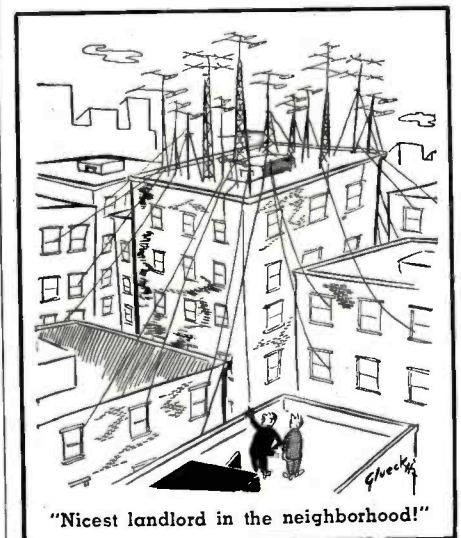

DOWN GO CALL-BACKS

UP GO PROFITS

That's why...



Federal **TV** PICTURE TUBES

**... ARE THE REPLACEMENT
CHOICE OF MORE AND MORE
SERVICEMEN**

**Federal tubes are designed right, made
right, factory-tested to the hilt . . . and
BACKED BY A YEAR'S GUARANTEE!**

FEDERAL is fast-growing in demand as a *profitable* picture tube replacement, because Federal goes the limit to assure your customers *steady satisfaction!*

Every Federal tube must measure up to exacting standards of efficiency for breakdown and stray emission (at max. ratings), ion trap current, central grid cut-off, zero bias beam current, focus voltage current, highlight brightness, leakages, shorts, gas ratio, screen and glass quality . . . plus other characteristics. Tests include the tough 500-hour operation run.

Moreover, a unique, prior-to-shipment check-up follows a 24-hour minimum storage period—an *extra provision for trouble-free performance!*

Start now to protect *your* replacement profits with Federal picture tubes . . . the tubes backed by decades of experience in producing highest-quality vacuum tubes for broadcast, military communications and other major uses.

Consult your Federal distributor, or write Dept. N-159.

FEDERAL POPULAR-SIZE TUBES INCLUDE: 12½ and 16-inch round; 14, 16, 17, 20 and 21-inch rectangular. Write for your free copy of Federal's Television Picture Tube Data Book.

Federal
Telephone and Radio Corporation



VACUUM TUBE DIVISION • 100 KINGSLAND ROAD, CLIFTON, NEW JERSEY
In Canada: Federal Electric Manufacturing Company, Ltd., Montreal, P. Q.
Export Distributors: International Standard Electric Corp., 67 Broad St., N. Y.

"Federal always has made better tubes"

-to Gratify Your Wish for Excellence



BOGEN R-701 FM-AM TUNER

- SUPERS REPRODUCTION
- TECHNICAL SUPERIORITY
- HANDSOME STYLING
- OUTSTANDING PERFORMANCE
- EVERY OPERATING CONVENIENCE

The Model R-701 is a truly superb FM-AM radio receiver designed expressly for the discriminating listener. It provides a quality of performance so brilliantly real and so vastly superior to standard mass produced receivers that it must be heard to be believed. Handsomely styled for custom installation, it is easily adaptable to any wall or cabinet closure. Six position function selector switch, volume control, and separate bass and treble correctors centralize all operation on one panel . . . permit remote location of the audio amplifier.

MODEL HO10 — A superb all triode amplifier providing minimum distortion (less than 0.3% at 10 watts), maximum response (flat 10-50,000 cycles), tremendous dynamic range and overall balance. Ideal for use with the R701 Tuner.

MODEL DO10 — New popular priced Hi-Fi custom Amplifier, designed for use with the new R701 Tuner. Can be mounted directly behind the tuner in most installations. Ten watts output at less than 1% distortion. Response flat 20-20,000 cps.

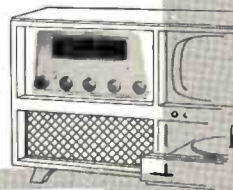

Write for Literature to Desk RT-3



DAVID BOGEN CO., INC.

29 NINTH AVE., NEW YORK 14, N. Y.

A Quarter Century of Electronic Equipment Specialization

EXPERIMENTERS SPECIALS



Sweep Generator Capacitor — Rotating split stator. Cylindrical silver plated rotor concentric to stator. High speed ball bearings. Capacity 5-10 mmfd. Build your own motor-driven television sweep frequency generator.

**Stock No. R-95
Special \$2.75 each**



D-101 Dynamometer. 27 volt input at 1.5 amps. 220 volts dc output at 80 milliamperes. Large quantity available. New—original packing.

**Stock No. R-60
Special \$4.95 each**



Redmond 6 Volt DC Motor — An ideal small dc motor for the experimenter. Operates from 6 volts dc at 3000 rpm. Requires 1.75 amperes for 1/100 horsepower.

**Stock No. R-337
Special \$2.95 each**

Tachometers—Stewart-Warner—0-2000 rpm. \$5.95 ea.
Tachometers—Stewart-Warner—0-4000 rpm. \$6.95 ea.
Ampere Demand Meter—20 amps. Indicates long time average load. See RTN adv. Feb. Special \$3.95 each.
Meters—See RTN adv. January. Hundreds on hand.
Plastic Boxes—13 compartments—10"x6"x1 3/4". \$1.49 each.
Plastic Boxes—18 compartments—10"x6"x1 3/4". \$1.49 each.
Plastic Boxes—18 compartments—8"x4"x1 1/2". \$0.66 each.
Note: All plastic boxes with hinged covers.

Don't forget to check our earlier RTN ads before completing your order. Write for free catalogue of Electronic, Aircraft, Hydraulic and other equipment.

Minimum order \$2.00 F.O.B. Paterson, N. J.

Electro Devices
INCORPORATED
247 BROADWAY PATERSON, N.J.

**MID WINTER SALE
PRICES SLASHED**

T.V. TUBES—ROCK BOTTOM PRICES

In lots of 6 each No. only
6B6G 89c 6C86 39c 6AQ5 38c
19R66 89c 6AK5 69c 6CD6 \$1.05
12AX7 47c 6BQ6 57c 6SA 49c

Tube Special—Broken Keys—Electrically Perfect
12SK7 8 for \$2.00 12A6 29c; 4 for \$1.00
6L6 69c; 4 for 2.25 12K8 49c; 7 for 3.00
Tube Sale—#2A7-55-27-85-31-56-57. No Mixed Ass't. 6 of Any Type \$2.25
Heavy Duty Shielded P.P. Input Trans. \$1.00
Signal Corps Transmitting Keys 1.00
Bat Handle S.P.S.T. or D.P.S.T. Toggle Switch. 25c
2 Gang Var. Cond. 456 K.C. with Osc. Section. 2 3/4" In. Pulley on 3/8" Shaft. 49c
2 Gang S.W. Var. Cond. 50 MMFD per Sec. Double Spaced, 10-20 Meters with Tank Coil 1/4" In. Shaft. 39c
Westinghouse Kuprox Rectifier 0.64 Amp. 28 Volts. Reg. \$11.00 ea. Special. \$1.95

BRAND NEW 10" PHONO RECORDS—Ass't. Jazz—Popular. Rhythm—Blues. Please specify.
12 for \$1.79 or 24 for \$3.00
Single Pole—10 Pos. 2 Gang Switch. 29c
2 piece, 5 pole Male and Female separable Amphenol plugs. Both with Flex. shielded cables. Approx. 5 ft. long. 35c pair. 3 pr. for \$1.00
Grind your own Crystals. Pure Brazilian Quartz. Various sizes and thicknesses. 1/4 lb. pkg. \$1.00
4 Tube Drilled Chassis, 4 1/2"x6 1/2"x1 1/2". 29c each
Signal Corps Phones—2 M. Ohms (8 M. Ohms Imp.). \$1.25
2 Ft. Ext. Cord (and Plug). 40c

VULCAN HEAVY DUTY 100 WATT SOLDERING IRON. Built for U.S.N.—Brand New—Equiv. Sells for \$3.50. OUR PRICE \$2.99

TOBE TUBULAR ELECTROLYTICS
20-20 MFD. 150 V. 49c 30-30 MFD. 150 V. 57c
40-40 MFD. 150 V. 59c

Low-Loss Short Wave Lock Type Air Trimmer
Variable Condensers
5 Pl.—20Mmfd. 14c
7 Pl.—25-30 Mmfd. 15c
8 Pl.—30-35 Mmfd. 16c
14 Pl.—56 Mmfd. 24c
D.P.D.T. SLIDE TOGGLE 15c

1,000 OHM WIRE WOUND POTENTIOMETER. 15c
30 HY-FILTER CHOKE SHIELDED. 3 for \$1.25
PIEZO CRYSTAL HOLDERS. 12 for \$1.00—\$6.00 per C
RCA Band Switches—3 gang, 3 pos. 3 band. 30c 6 gang, 4 pos. 4-5 hand. 40c
Trimmer-Padder Ass't.—all isolantite—singles, dual, triples—100 ass't. \$2.25
ATTENTION: Prospectors, Explorers for Hidden Treasures! Construct a U.S. Army Type of Metallic Mine Detector Amplifier. Amplifier unit only (less tubes and batteries) with cables, headphone cord, and jack. Army wiring diagram. Type AN/PRS-1. \$1.95

MINIMUM ORDER \$3.00—NO C.O.D. SHIPMENTS—PLEASE INCLUDE POSTAGE NEWARK SURPLUS MATERIALS CO. 324 Plane Street, Dept. MA, NEWARK 1, N. J.

Mac's Service Shop
(Continued from page 70)

days, and it is hard to imagine then the tugging, yanking strain that will be placed on those guys by a gusty windstorm. Spike nails are certainly not adequate guy-wire anchors, and ordinary lag-screws through the sheeting is little better, for water seeps down around the threads and rots the wood, allowing the screw to pull out. Unless you can drive creosote-covered lag-screws several inches into dry, seasoned wood, it is best to use long eye-bolts that pass through both the edge of the roof and the protective sheeting beneath the rafters—or if the rafter-ends are not boxed in, you can use a board nailed across a couple of them.

"Don't fasten all the guys from one corner of the tower to a single anchor of this sort. That piles up the strain on it, and if it does go, the whole tower is left unsupported and is certain to fall. Use a separate anchor for each guy. A stake—either iron or wood—driven into the ground is a poor anchor. When the ground is softened by rains or thawing, a surprisingly long rod can be pulled out easily. Either a pipe set in concrete should be used, or a 'dead man' with a large surface area and considerable weight should be buried in a deep hole and a chain, rod, or heavy cable led from it to the surface for fastening to the guys."

"You ought to keep the guys real tight, I suppose."

"Not too tight. While there should not be enough slack to let the tower lunge back and forth, if they are made too tight, especially in warm weather, the shortening with cold weather will put unnecessary strain on them and their insulators. Incidentally, of course, you should never use anything but strain insulators of the type that can break without destroying the support of the guy wire. A few owner-erected towers came down because of this obvious mistake. A few cents expended on cable-clamps for fastening the ends of the guy-wires is also very cheap insurance.

"Another storm-taught lesson is that the required height should be secured with the tower alone, and the mast should be just long enough to mount the antennas and support them a short distance above the top of the tower. Antenna masts that were too long, that were too thin or made of material with insufficient strength, and that had too much high-wind-resistance antenna stacked on them never had a chance. If a fellow wants to use a half-dozen different antennas, he had better put them on two or more separate masts instead of trying to stack them all on the same one."

"How do the insurance companies feel about the situation?"

"Naturally, they are not too happy. Most damaged antennas were covered

by the 'extended coverage' clauses on either the property or the household goods policies; but there were exceptions to this. For example, all antennas erected on mercantile buildings and many on apartment buildings were not covered in this manner but required separate policies. The only safe thing to do is to check with your insurance agent just as soon as the antenna is erected. One installer I know never leaves a new antenna installation without first impressing on the owner that he should get in touch with his agent at once and find out if the structure is insured.

"If there is a single weak spot in an antenna installation," Mac reflected, "a high wind will certainly find it out; so the only thing to do is try to make the job like the fabled One Hoss Shay: without any weaknesses. The tower should be strong enough to support easily the antenna used, and it should be adequately and intelligently guyed. The guy wire used should be of the best, and it should be fastened to anchors that will take more than a breaking pull on the wire. Compression type insulators and cable clamps at all guy wire ends are a *must*. If a motor is used, it should be mounted on a pipe with a two-inch outside diameter; and this pipe—or the bottom of the mast if a motor is not used—should be fastened in the tower so that it cannot turn. The clamping action of the tower hooks is not enough but should be aided by a strong bolt passing through the pipe and clamped to one of the hooks.

"The mast should not be any longer than necessary, and antennas with large wind areas or considerable weight should be mounted as near the bottom of the mast as feasible. Wind-resistance of particular antennas should be considered when choosing a mast."

"Sounds to me like the ideal antenna installer ought to be the kind of guy who wears both a belt and suspenders: one who takes absolutely no chances!" was Barney's grinning comment.

Mobile radio hams in Virginia have the benefit of the State's first department from its regular licensing system: special call-letter license plates. Amateurs with fixed stations only were not accorded the privilege so there is incentive for more W4's to "get rolling."



March, 1953



AN/APS-4
Airborne radar. New.
Complete P.U.R.

AN/APS-6
Airborne radar set. New.
Complete P.U.R.

AN/APR-4
RECEIVER & TUNING UNIT P.U.R.

AN/APS-3
AIRBORNE RADAR SET. Now Complete.... P.U.R.

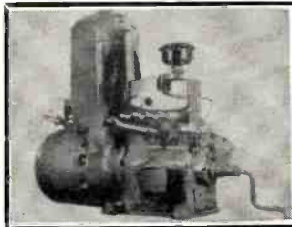

POWER UNIT PU-41/G
Power Unit PU-41/G (Kohler Model 1M21A) is an electric generating set consisting of a 4-cylinder, 4-cycle valve-in-head, liquid cooled, manual starting (crank) gasoline engine directly connected to an a-c generator of the revolving armature type. Engine is rated 4.25 horsepower at 1,200 r.p.m. and consumes approx. 0.45 gallon of fuel per hour at rated load. Generator is rated at 1.5 kilowatts, 60 cycles, single phase, 110 V., 13.6 amperes at 100% power factor. Length: 45"; width: 16"; height: 36". Weight (crated) 880 lbs. New in original box with spare parts.\$475.00

Monthly Specials!
RT-34/APS-13 420 MC. TRANSCIVER with 5 stages of 30 MC. IF amplifier strip. Less tubes & R.F. section. With dynamotor. **\$9.95**
274-N TRANSMITTERS
BC-457 (4-5.3 MC) BC-458 (5.3-MC) BC-459 (7-9 MC) **\$4.50**
Command Transmitters. Limited quantity. Good cond. Less tubes & crystal. Set of three With schematic and data. **\$11.95**

AN/ARC-5
R-28/ARC-5 RECEIVER 100-156 MC. **\$49.50**
With tubes. Like New
T-23/ARC-5 TRANSMITTER 100-156 MC. With tubes. Like New **\$47.50**
BOTH UNITS FOR ONLY **\$92.50**

SCR-625 FAMOUS MINE DETECTOR
For prospectors, miners, oil companies, plumbers, etc. New. **\$59.50**
WHILE THEY LAST!

COMMAND EQUIPMENT (SCR-274N)

	Used	New		Used	New
BC-442 ANTENNA RELAY. Less cond.	\$1.95	\$ 3.95	BC-453 With tubes	\$19.95	
with cond.			Less tubes	14.95	
BC-451 TRANSMITTER CONTROL BOX		1.50	MC-211 90° ANGLE COUPLING UNIT.		\$0.95
BC-450 3-RECEIVER REMOTE CONTROL BOX		2.95	FT-234 MOUNTING RACK for single transmitter	2.95	3.50
MC-215 MECHANICAL DRIVE SHAFT. Per length		2.95	FT-226 MOUNTING RACK for 2 Command Xmtrs.		3.95
BC-496 2-POSITION RECEIVER CONTROL BOX		2.95	FT-221 MOUNTING PLATE for FT-220		1.50
BC-455 6-0 MC RECEIVER. With tubes	9.95	14.95	FT-220 MOUNTING RACK for 3 receiver		2.25
Less tubes	7.95		FT-225 MOUNTING PLATE for BC-456		2.25
BC-454 (3-6 MC) With tubes	9.95		BC-456 MODULATOR. For SCR-274.		4.50
Less tubes	6.95		Complete set of 4 tubes for transmitter		1.95

RADAR TEST EQUIPMENT
TS-3, TS-12, TS-13, TS-15, TS-33, TS-34, TS-35, TS-36, TS-45APM3.

TUBES! NEW! ORIGINAL BOXES!
Limited Quantities Available
250TL..... Ea. \$11.50 250TH..... Ea. \$14.50

ARC-4 TRANSCIVER
140-144 MC. Complete with control box, tubes, 12/24 VDC dynamotor with schematic. This is a special reduction for this month only. **\$32.50**
Like new
MT-101 ARC-4. New **\$4.50**

234-258 MC RECEIVER
11-tube UHF tunable receiver with schematic. New **\$17.95**
Rack **\$3.50**
Control Box **1.50**

Miscellaneous Specials!

TUBES!		TUBES!		TUBES!		TUBES!		TUBES!	
16P4	\$19.95	304TH	\$8.95	3CP1	\$4.95	3FP7	\$2.25	5FP7	\$2.25
16AP4	24.95	304TL	8.95	3BP4	4.95	3AP10	1.49	9002	.89
16DP4	19.95	830-B	2.75	3FP7	2.25	1D	.69	9001	.99

BC-709 INTERPHONE AMPLIFIER. With tubes, less batt. With manual. NEW. 3.95
PE-101 DYNAMOTOR. Used. ONLY FEW LEFT! 1.95
CD-307 EXTENSION CORD. For HS-23-33. NEW
RS-38 MIKE. NEW. 4.95
Used
BC-605 INTERPHONE AMPLIFIER. With dual mike input circuit. NEW. 5.95
RM-13 COMPLETE REMOTE CONTROL BOX. For 3 separate transceivers. With TS-13 handset, de-coupled output meter and EE-8 ringer unit. 110 V. AC operated. Excel. cond. 29.50
FL-8 RANGE FILTER. 1.95

SURPRISE PACKAGE!
20 lbs. of good, useable radio parts **\$2.95**

MP-22 MOBILE ANTENNA. MOUNTING RACK. Complete with hardware. New. \$ 3.95
TU-17 TUNING UNIT. (2-3 MC.) For BC-223 Xmt. Used 2.95
I-70 "5" TUNING METER. NEW. 2.50
WOBUlator. See p. 43 Dec. '51 RADIO NEWS
BC-1023 75 MC. MARKER BEACON RECEIVER. Complete with tubes, mtg. rack. NEW. 10.95
TU-25 TUNING UNIT. (3.5-5.2 MC.) For BC-223 Xmt. Used 2.95

IN-4A L/R TUNING METER. Used \$ 3.95
FL-5 RANGE FILTER. 1.25
TS-13 HAND SET TELEPHONE. NEW. 7.75
BC-1033 75 MC MARKER BEACON RECEIVER. Complete with tubes P.U.R.
FIELD TELEPHONE. EE-8. Complete BRAND NEW. SPECIAL. ONLY 27.50

INDUSTRIAL CORPORATIONS
We carry one of the most complete stocks in U. S. of Military Electronic Equipment, Test Equipment, and Aircraft Electronics. Call or write for free catalogue.

COMBO
BC-624 VHF RECEIVER. Freq. range 100-156 MC. Less tubes & crystals, with conversion dope. Used, good cond. **\$19.95**
BC-625 VHF TRANSMITTER. Freq. range 100-156 MC. Less tubes & crystals, with conversion version dope. Used, good condition. **\$12.95**
BOTH TRANSMITTER & RECEIVER. **\$29.95**
Per Set

\$5.00 MINIMUM ORDER ACCEPTED. All items subject to prior sale. All shipments F.O.B. warehouse. Calif. residents add tax with remittance. 20% deposit required. Please specify shipping instructions with order. EQUIPMENT WANTED! Highest prices paid for all types of Electronic Gear!

ARROW SALES, INC.
Cable Address: ARROWSALES POPLAR 5-1810
Mailing Address: P. O. Box 3878-R, N. Hollywood, Calif.
Office-Warehouse: 7460 Varna Ave., N. Hollywood, Calif.

Valuable Radio-TV Book
FREE

Just for
Examining
COYNE'S
New
6-Volume
Set



*"Applied Practical
Radio-Television"*

ON 7-DAY FREE TRIAL

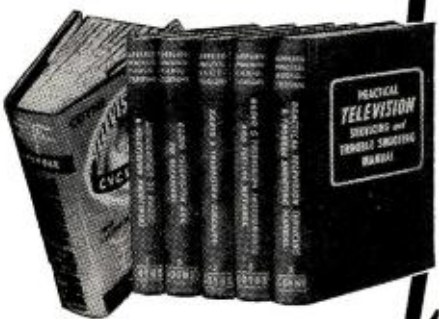

Yours, FREE! Coyne's big, brand new book, "150 Radio-TV Picture Patterns and Diagrams Explained," gives complete circuits and diagrams on the latest radio and TV sets. Easy-to-read, large 8 1/2 x 11" pages, with full instructions on how to read and use the diagrams. You get this valuable book FREE for merely asking to see Coyne's great new 6-book set, "Applied Practical Radio-Television"!

HERE'S "KNOW-HOW" THAT MAKES YOU WORTH MORE!

Coyne's great new 6-volume set, just off the press, gives you all the answers to servicing problems—quickly! For basic "know-how" that's easy to understand, you'll find everything you want in volumes 1 to 5. Over 5,000 practical facts and data, covering every step from principles to installing, servicing, trouble-shooting and aligning all types of sets. Even includes latest information on COLOR TV and UHF, transistors, adapters and converters. For speedy on-the-job use, you get volume 6—the Coyne TELEVISION SERVICING CYCLOPEA. It answers today's TV problems on servicing, alignment, installation and others. In easy-to-find, A-B-C order, cross-indexed.

SEND NO MONEY! Mail coupon for 6-volume set on 7 day free trial. We'll include book of Patterns and Diagrams. If you keep the set, pay \$3 in 7 days and \$3 per month until \$22.50 plus postage is paid. (Cash price \$22.) Or return the library in 7 days and owe nothing. Either way, the book of TV-Radio Patterns is yours FREE to keep! Offer limited. Act NOW!

FREE BOOK COUPON

COYNE ELECTRICAL & TV-RADIO SCHOOL
Dept. 33-T3, 500 S. Paulina St., Chicago 12, Ill.

Rush Coyne's new edition 6-vol. "Applied Practical Radio-TV" set for 7 days' FREE TRIAL per your offer. Include Patterns Book FREE!

Name..... Age.....

Address.....

City..... Zone... State.....

Where employed.....

Check here if you want library sent C.O.D. You pay Postman \$22 plus C.O.D. postage on delivery. 7-day money-back guarantee.

Receiver Changes
(Continued from page 44)

stages should be replaced one at a time, and results noted. It may be possible in some cases to boost the sound signal by using a sound i.f. tube (or tubes) with a higher gain than the one present. Checking the transconductance of the tubes present in these circuits (in a tube manual) against those of similar characteristics and applications, will indicate whether such a procedure is possible.

Decoupling resistors in plate or screen circuits may be shorted (not to ground! of course!) in one or more sound i.f. stages, and improvements noted. (If oscillation or regeneration breaks out—an unlikely contingency—remove the short.) Screen and plate voltages may be raised by connecting the "B+" feed of the sound i.f. stages to a higher-potential point in the rectifier output circuit. Suitable increases in the wattage of resistors in the plate and screen circuits should be made in such cases.

Plate and screen voltage-dropping resistors in the sound i.f. stages may be lowered to boost plate and screen voltages. (Limiter voltages should not be tampered with.) Corresponding bias changes may have to be made in some cases to minimize or remove slight distortions. A slight peaking of the sound i.f. tuned circuits may be made—by ear—to note whether an increase in volume may be obtained without excessive distortion. (If the r.f. oscillator has a tendency to drift, this procedure is not recommended.) In all of the cases cited, the disadvantage of any distortion introduced must be weighed against the improvement in gain.

If a relatively low-gain 1st audio amplifier tube is being employed, it may be replaced by a tube capable of providing a much higher gain (suitable bias changes being made, of course).

When an a.v.c. system is used, the a.v.c. feed to the sound i.f. stages may

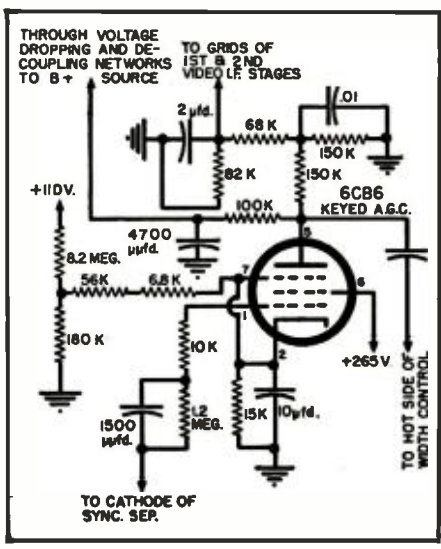

Fig. 9. Keyed a.g.c. voltage reduction. The voltage may be reduced by lowering value of the 82K ohm resistor or increasing the value of the 68K ohm resistor in series with the latter. A conservative procedure would be to increase the value of one resistor by the same amount the other is reduced, thus keeping plate circuit resistance constant and minimizing circuit changes. Alignment of these circuits may be upset and should be checked. Circuit is from an RCA Victor Model 17T53.

be removed, and the grid returns of the a.v.c.-controlled tubes grounded.

A check of the alignment of the sound section should be made after circuit changes in the sound i.f. or detector stages.

In the case of intercarrier receivers, if the sound signal is taken off at the video detector, the take-off point may be changed to the plate circuit of the video amplifier (see Fig. 10) to boost the sound. If a vertical sync buzz becomes audible as a result, the take-off point should be restored to its original point, unless the technician wants to try removing the buzz by careful realignment of the ratio detector or discriminator, and possibly other tuned circuits as well. The sound take-off coil should be retuned if its take-off point is changed.

(To be continued)

Fig. 10. A boost in sound volume may be obtained in intercarrier sets by disconnecting the sound take-off lead from the plate of video detector (pin 2) and reconnecting it to plate of video amplifier (pin 5). Circuit is from an Admiral 14R12.

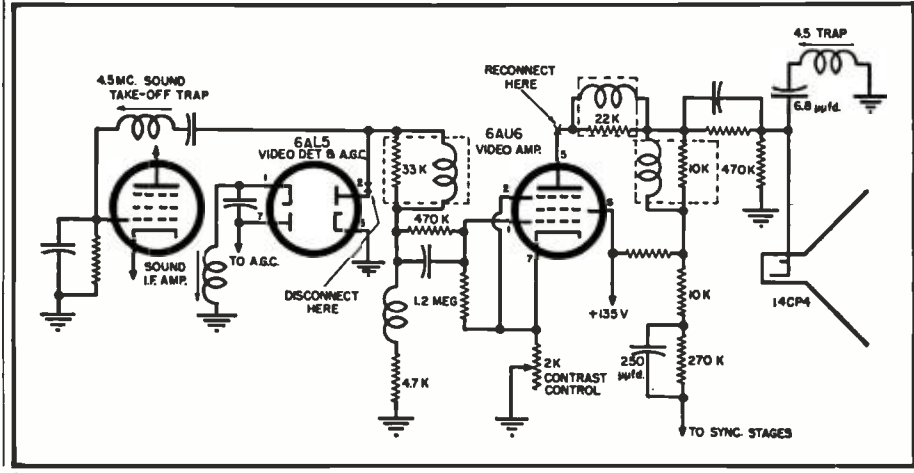



For a Heavenly Soldering Job, Insist on
Ungar's little Angels

Need we say more?

Write for Catalog RN-1

Ungar ELECTRIC TOOLS, INC., Box 312, Venice, Calif.



IT'S A SHAME

to throw away
that beautiful old
Console . . . replace the
obsolete radio with a
modern, easily-installed

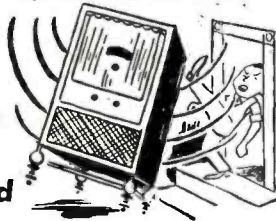

ESPEY AM/FM CHASSIS
(Enjoy Hi-Fidelity Reception)

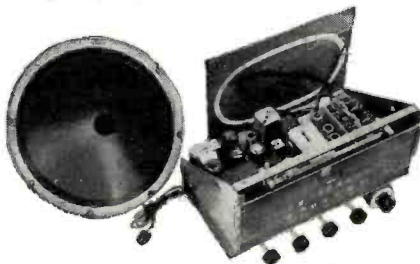

It is not necessary to spend a large sum of money to modernize your old radio or to become a "High Fidelity" enthusiast. ESPEY chassis provide the Highest Quality at moderate prices.

Fully licensed under RCA and Hazeltine patents. The photo shows the Espey Model 511-C, supplied ready to play. Equipped with tubes, antenna, speaker, and all necessary hardware for mounting. NEW FEATURES—Improved Frequency modulation circuit, drift compensated • 12 tubes plus rectifier, and pre-amplifier 12AT7 tubes • 4 dual purpose tubes • High quality AM-FM reception • Push-pull beam power audio output 10 watts • Switch for easy changing to crystal or variable reluctance pick-ups • Multi-tap audio output transformer supplying 3.2—8—500 ohms.

Write Dept. RN-3 for literature and complete specifications on Model 511-C and others.

ESPEY Makers of fine radios since 1928
TEL. TRafalgar 9-7000
MANUFACTURING COMPANY, INC.
528 EAST 72nd STREET, NEW YORK 21, N. Y.

Compare . . .
prove EMC
superiority



model 206
MUTUAL CONDUCTANCE
TUBE TESTER

• Checks mutual conductance on calibrated microhmo scale • Checks tubes for gas content • Detects both shorted and open elements • Tests all tubes from .75V to 117 filament volts • Tests all local, octal and miniature tubes • Checks individual sections of multi-purpose tubes • Built-in roll chart • Uses lever type switches.

MODEL 206P—With hand-rubbed oak carrying case (Illustrated)

\$83.50
MODEL 206C—Sloping counter case
\$79.50



model 205
TUBE TESTER

• Tests all tubes including Naval and sub-miniatures • Completely flexible lever type switching arrangement • Tests all tubes from .75 volts to 117 filament volts by standard emission test • Tests all cold cathode magic eye, voltage regulator and ballast tubes • Has pilot light indicator • Line voltage control compensates for line variations between 105 and 135 volts • Checks for shorts and leakages • Three-color hammerstone panel.

MODEL 205P—with hand-rubbed oak carrying case (illustrated)

\$47.50
MODEL 205C—Sloping counter case
\$46.50



model 204
TUBE-BATTERY-OHM
CAPACITY TESTER

• Tests all tubes including Naval and sub-miniature • Tests all batteries under rated load • Emission testing method gives easy, direct readings • Tests resistance to 4 megohms • Tests condensers from .01 to 1 mfd • Uses four-position lever type switches • Checks condenser leakage.

MODEL 204P—Portable oak case, removable cover (illustrated)

\$55.90
MODEL 204C—Sloping counter case
\$54.90

— See them at your Jobbers —

EMC

WRITE DEPT. RN-3
FOR FREE
COMPLETE
CATALOG OF
THESE AND OTHER
INSTRUMENTS.

ELECTRONIC MEASUREMENTS CORPORATION
280 LAFAYETTE STREET • NEW YORK 12, N. Y.

EXPORT DEPARTMENT 136 LIBERTY STREET, N. Y. C. 6, N. Y.

KESTER

Frequency Standard
(Continued from page 57)

Since the most important single step in Radio-Television Servicing is soldering . . . it's just plain good sense to use the best — KESTER SOLDER . . . Key Name in Solder for More Than 50 Years.

KESTER SOLDER COMPANY
4235 Wrightwood Avenue • Chicago 39, Illinois
Newark 5, New Jersey • Brantford, Canada

SOLDER

OSCILLOSCOPES

ARE
"GOLD
MINES"!

... if you learn how to use them fully on all types of service jobs!

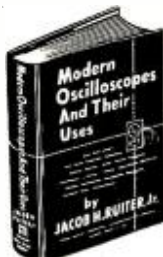

Learn to handle the oscilloscope fully on all types of AM, FM and TV service work—and watch your efficiency and earnings soar!

MODERN OSCILLOSCOPES AND THEIR USES, a fact-jammed 326-page book by Jacob H. Ruiter, Jr., of the Allen B. DuMont Laboratories contains exactly the help you need—written in a way you can clearly understand. It shows you how to use your 'scope for fast accurate work on all types of jobs from troubleshooting to realigning; how to make connections; how to adjust circuit components; how to set controls and how to analyze patterns fast and accurately. 370 helpful illustrations including dozens of pattern photos make things doubly clear.

No other type of specific service training stands to mean so much to you in terms of being able to do better, faster and more profitable work!

- ✓ When, where, why and exactly how to use oscilloscopes
- ✓ How to interpret oscilloscope patterns
- ✓ How to handle tough jobs in less time

MAIL ORDER 10-DAY FREE EXAMINATION

Dept. RN-33, RINEHART BOOKS, Inc.,
Technical Division,
232 Madison Ave., New York 16, N. Y.

Send **MODERN OSCILLOSCOPES AND THEIR USES** for 10-DAY EXAMINATION. If I decide to keep the book, I will then remit \$6.00 plus a few cents postage in full payment. If not, I will return book postpaid and owe you nothing.

Name

Address

City, Zone, State

Employer's Name & Address

OUTSIDE U.S.A.—Price \$6.50 cash only. Money back in 10 days if book is returned.



FINGER STOCK

Electrical Weather-Stripping by Eimac —
Now Available!

Silver-plated, spring alloy, pre-formed finger stock especially suited for electrical "weather-stripping" for TVI-proofing cabinet access doors, etc. Also ideal for making coaxially constructed tube connections and many other uses. Available in 17/32", 31/32", and 17/8" widths.

Write for new Eimac Catalogue Summary showing Eimac tubes and other accessories.



EITEL - McCULLOUGH, INC.
San Bruno, California

though the multivibrator is synchronized and will stay locked in with the 100 kc. oscillator over a wide range of plate voltage, the note out seems to suffer by getting rough and raspy. Voltage regulation is simply good insurance and adds little to the cost.

It will be noted from the schematic that neither side of the a.c. line is connected directly to the metal case or chassis. All the usual ground or chassis connections are made to insulated tie points. However both sides of the line are connected to the chassis through two .005 μ f. condensers, thus serving to ground the chassis and case for r.f.

After the frequency standard has been constructed, there are three adjustments which must be performed before the job can be considered complete. The 1000 kc. oscillator must have its plate circuit tuned by adjusting C, (actually this is the screen grid of the 12AU6). Adjust this trimmer for maximum amplitude of oscillation and then back off a bit. This can be easily found by placing a v.t.v.m. on the grid of the oscillator or if one is not available, simply by observing the S-meter of a receiver tuned to 1000 kc. or one of its harmonics. If no carrier can be found and assuming no wiring errors, back off on C. As with any tuned-plate oscillator the amplitude of oscillation will increase as the capacity is increased up to a point where the oscillation will suddenly cease, i.e., the plate circuit becomes capacitive.

The 100 kc. oscillator is adjusted to zero beat with WWV. Tune in WWV on the frequency that is the strongest in your particular locality. Loosely couple the frequency standard to the receiver, wait for the unmodulated portion of the WWV transmission, and adjust C, for zero beat. If greater precision is desired in this adjustment, connect an oscilloscope directly to the output of the second detector in the receiver and adjust for a straight-line pattern.

Next the multivibrator must be synchronized at the tenth subharmonic of the 100 kc. oscillator. This is done by adjusting the potentiometer R₁₀ in the grid circuit of the 12AU7 multivibrator. First accurately establish on your receiver two adjacent 100 kc. points. This might best be done on the low end of the broadcast band (600 to 700 kc.) where 100 kc. occupies a considerable space. Now switch the frequency standard to 10 kc. operation and count the number of harmonics heard between and including those at the 100 kc. points. Adjust R₁₀ so that ten are heard. The multivibrator is then operating at one-tenth of 100 kc. Considerable leeway will be noted in this adjustment, that is, the multivibrator will stay synchronized with the 100 kc. oscillator.

over a large variation of R_{10} . However the correct adjustment will be when the correct number of harmonics are noted and these signals sound the clearest.

For most applications a piece of wire 10 inches long will serve to provide adequate signal pickup when the frequency standard is placed on the operating table along with the receiver.

The construction of this frequency standard has proved to be one of the most worthwhile additions to our ham shack. It has completely changed our operating procedure. In effect, it has given us about 25% more frequencies since now we can slide up to within a few kilocycles of the band edge—and know for sure that we're not inviting a little pink billet-doux from the FCC.

CARBON COPY

C. H. BOWERS of Portland, Oregon has sent us a carbon copy of a letter he wrote to "Radio Melbourne" and has kindly granted us permission to share his correspondence with our readers.

Mr. Bowers writes: "For some time I have been going to give myself the pleasure of writing 'Radio Melbourne' and expressing my thanks and appreciation for the many hours of entertainment I have enjoyed from 'down under.'"

"I am likewise interested in Sydney as it is just 37 years since my first acquaintance with that great city. In 1915 I was Chief Radio Operator aboard the Yankee Mail Boat 'Sonoma' between San Francisco and Sydney via Honolulu and Samoa. At that time one of your stations was at Pennant Hills, just outside of Sydney. The Navy personnel was laboring with crystal detector receivers and, with effort, could copy code from Honolulu at night. My running mate aboard the liner 'Ventura,' Kenneth Ormiston, as well as myself was pioneering with vacuum tubes and, on one trip, Ormiston brought a number of Armstrong detector tubes to the boys at Pennant Hills, along with an improvised receiver for using same. Much to the amazement of your Navy operators, they were able to read Honolulu any time during the day and many other long range stations unheard before.

"You can understand my interest in listening to your stations in Australia—the GPO clock chime in Sydney, the sound of the Kookaburra, and all the other things that go to make up Australia. In one second, I can ride the ether waves back to Cooee and Bondi Beaches and summer weather when it's bleak and cold here!

"In this location we receive your beamed signals on an 8-foot 'buggy whip antenna' 20 feet off the ground.

"As soon as one development in radio becomes commonplace another advances. We are now concerned with television and the time may soon be at hand when TV waves may be channeled from Australia direct to our shores and vice versa. It is really unfortunate that the present generation has not experienced the same thrill as we who followed radio in 1915.

"All good luck to 'Radio Melbourne' and may you long continue to radiate cheer and good will from under the Southern Cross."

RADAR — COMMUNICATIONS — TEST EQUIPMENT

AN/ARC-1—Transceiver 100-156 mcs	
APA-11—Pulse Analyzer	
APN-1—Airborne Radio Altimeter	
ARC-4—VHF Transceiver 140-150 MC	
ARN-5—Glide Path Receiver	\$69.50
ARN-7—Airborne Direction Finder	
AR-12—Bombing & Receiving Equipment	
BC-223—30-Watt Transmitter 2-5.2 MC	
BC-342—Receiver—1.5 to 18 MC 110r AC	
BC-348—Receiver—1.5 to 18 MC 28v DC	
BC-375E—Radio Transmitter	
BC-639—VHF Receiver 100-156 MC	\$400.00
BC-640—VHF Transmitter 100-156 MC	\$950.00
BC-206—Beacon Receiver 200-400 KC	
RC-103—Airborne Localizer Receiver	
SCR-269—Radio Compass	\$129.50
SCR-274N—Command Equipment	
SCR-284—Field Radio Station	\$365.00
SCR-291—Semi-Portable Direction Finder	
SCR-306—Field Transmitter and Receiver	
SCR-322—VHF Transmitter and Receiver	\$129.50
SCR-536—Handi-Talkie PAIR	\$185.00
SCR-555—Semi-Portable Direction Finder	
SCR-694—Portable Field Transceiver	
SCR-718A-AM-C—High Altitude Altimeter	
T-50—Radio Telegraph Transmitter	
TS-3/AP—S-Band Power Frequency Meter	
TS-4/APN-1—APN-1 Test Set	\$25.00
TS-12/AP—X-Band V.S.W.R. Test Set	
TS-13/AP—X-Band Signal Generator	
TS-14/AP—S-Band Signal Generator	\$400.00
TS-15/AP—Flux Meter	
TS-16/AP—APN-1 Test Set	\$29.95
TS-18/AP—Capacity Divider	
TS-23/APN—SCR-718 Test Set	\$140.00
TS-32/AP—X-Band Frequency Meter	
TS-34/AP—Synoscope comp w/ac	\$290.00
TS-35/AP—X-Band Test Set	
TS-36/AP—X-Band Power Meter	\$140.00
TS-45/APM-3—X-Band Signal Generator	
TS-59/APN—APN-1 Test Set	
TS-61/AP—S-Band Echo Box	\$140.00
TS-62/AP—X-Band Echo Box	
TS-65/AP—300-1000 MC Frequency Meter	\$69.50
TS-89/AP—Pulse Voltage Divider	
TS-98/AP—Pulse Voltage Divider	
TS-102/AP—Range Calibrator	
TS-111/AP—S-Band Wavemeter	
TS-118/AP—Power Meter	
TS-125/AP—S-Band Power Meter	
TS-155/UP—S-Band Signal Generator	
TS-170/ARN-5—L.L.S. Test Set	
TS-184/AP—Test Set	
TS-226/AP—300-1000 MC Power Meter	
TS-268/UP—Crystal Test Set	
TS-278/AP—APS-13 Test Set	
IE-35—SCR-522 Test Set	\$290.00
IE-36—SCR-522 Test Set	
BC-221—Frequency Meter	\$125.00
BC-1277—S-Band Signal Generator	\$275.00
TBN/3EV—Thermistor Bridge	
CW/60/ABM—S-Band Frequency Meter	\$97.50
FLUX METER 500-4000 Gauss	\$32.50
APA-10—Panoramic Adaptor	\$25.00
APA-17—Automatic Direction Finder	
APQ-5—Low Altitude Tracking & Bombing Equip.	
AT-24/APN-2—Antenna	\$3.75

APR-1—Radar Search Receiver 40-3400 MC	
APR-2—Radar Search Receiver 85-1000 MC	
APR-4—Radar Search Receiver 38-4000 MC	
APR-5—Radar Search Receiver 1000-3100 MC	
APR-6—Radar Search Receiver 3000-6000 MC	
APS-2—S-Band Search Radar	
APS-3—X-Band Search Radar	
APS-4—X-Band Search & Homing Radar	
APS-6—X-Band Search & Gun Laying Radar	
APS-15A—X-Band Blind Bombing Radar	
APT-4—Radar Jamming Xmitter 165-780 MC	
APT-5—Radar Jam Xmitter 350-1400 MC	\$189.50
SQ-13—S-Band Marine Radar, Lightweight	
SQ-10—CM Portable Radar	\$850.00
SQ-10—CM Portable Radar	\$850.00
TPS-1—Portable Search Radar	
TPS-3—L-Band Search Radar	
UPN-1 & 2—S-Band Port. Beacon Batt. or 110V AC	
RA-34—Power Supply for BC-375E	\$225.00
RA-62—Power Supply for SCR-522	
RM-1016—Inco. Tape Recorder	
PE-103—Dynamotor Power Supply	\$24.50
GN-58—Hand Cranked Generator W/Legs & Seat	
SCR-578—Gibson Girl (Emergency Xmitter)	
CRT-3—Victory Girl Dual Freq. Emergency Xmitter	
Sound Powered Chest & Headsets MI-2454-B; Type O; Mfg. RCA.	
AS-32/AP-X—Antenna	\$2.75
AN/CRC-7—V.H.F. Handi-Talkies 1212MC Xtal Controlled PAIR	\$200.00
MN/26-Y—Compass Receiver	
BC-733D—Receiver with Tubes	\$18.95
C-3—Navy Sniperscope in Carrying Case	\$400.00
BC-1284—Lighthouse Tube Preamp/ifier	\$6.75
BC-396—Interphone Amplifier	\$6.25
RL-42—Motor Antenna Reel	
30 MC—F.F. Strips Using GAK5	
RD-7/APA-23—Recorder for APR	
AS-27/ARN-5—Antenna	\$3.50
ARA—Receiver—500-1500 KC	\$16.50
ID/80/APA-17—Indicator	
R-28/ARC-5—Receiver—100-156 MC	\$24.50
RM-2—Remote Control Camera	
BC-455—Receiver—6.9 MC	\$16.50
BC-454—Receiver—3.6 MC	\$16.50
BC-800—Transmitter/Receiver	
BC-950—Transmitter—100-156 MC	\$34.50
RA-300—FM Exciter (Mfg. Tempco)	\$19.50
FL-8—Filter FL-5—Filter, Less Cables	
3C-16-D GSAP—Four Camera Computers with All Accessories in Carrying Case	\$14.50

PANEL METERS

2" SQUARE WESTON—SANGAMO

0-20 Volts D.C.	\$2.95	0-5 Ma	\$2.95
0-40 Volts D.C.	2.95	0-500 Microamp	4.95
0.5 Amp. R.F.C.	2.95	0-100 Ma (0-300 scale)	2.95

XMITTING TUBES

0A3/VR75	\$1.04	15R	.69	8661R	7.29
0B3/VR90	.89	28D7	1.85	8695	7.25
0C3/VR10	1.19	30 Spec	3.25	87A	1.19
0D3/VR150	.89	35T	3.25	874	1.19
1B23	9.75	45 Spec	3.32	878	1.39
1B24	9.45	100TH	7.32	885	1.40
1B25	12.50	211	.69	902A	9.95
1B29	2.45	250TH	19.95	918	.95
1N21B	2.50	252TL	17.50	922	1.25
1N22A	1.75	260TL	3.95	923	.95
1N23A	2.39	274B	2.95	927	.95
1N23B	3.69	304TH	7.95	931A	4.35
1N23C	7.10	304TL	7.95	934	.95
1N34A	.88	307A/RK75	3.95	954	.25
1N38A	1.60	316A	1.25	955	.35
1N38B	2.95	328A	8.95	958	.49
2C40	6.95	350A	6.45	957	.45
2C43	14.25	350B	3.95	958	2.50
2C44	1.25	350C	3.95	959	2.50
2C51	1.95	371B	.95	991/NE16	.42
2C51	5.95	371B	.69	1603	4.95
2D21	1.25	378A	7.95	1604	.79
2E22	2.85	394A	3.95	1616	.92
2E24	3.50	417A	8.75	1619	.19
2E26	3.15	434A	17.95	1622	2.45
2K25/	4.46	446B	16.25	1624	1.45
7Z3AB	32.50	446B	3.75	1625	.32
2K28	32.50	575A	13.45	1626	.25
2K33A	24.00	701A	4.65	1630	.75
3AP1	9.95	703A	4.65	1630	.75
3B24	5.25	705A	1.95	1632	.72
3B26	5.25	705A	2.45	1632	.72
3BP1	5.95	714AY	4.95	1851	.51
3C22	75.00	715A	6.39	2051	1.12
3C24/24G	1.75	715B	8.25	2052	1.45
3C45	4.95	715C	19.75	8008	5.95
3CP1	4.95	717A	.89	8011	1.59
3CP1S1	1.95	721A	2.45	8013	2.59
3DP1	24.45	723A	9.50	8013	2.59
3DP1A	7.50	723AB	24.00	8020	.98
3DP1S2A	7.50	724B	3.25	9002	.69
3E21	2.45	725A	2.45	9010	1.10
3E29	1.15	726A	13.95	9003	1.20
3FP7	1.65	730A	29.50	9004	1.30
3GP1	4.39	800	7.75	9005	1.90
4-125A	27.50	802	3.95	9006	.27
4-250A	37.50	803	2.95	C1JA	7.45
4AP10	4.45	804	13.75	CCA	7.45
4C35	32.50	805	3.75	C6J	6.39
4E27/	17.50	806	24.95	CK1005	.48
4E27B	17.50	807	1.59	F127A	7.75
5AP1	3.45	808	2.49	F127A	27.50
5AP4	3.45	809	2.49	F128A	89.50
5BP1	4.45	811	2.85	FG17	4.89
5BP4	4.45	812	2.75	FG27A	4.95
5CP1	4.45	813	11.75	FG32	8.95
5CP7	11.75	814	3.20	FG57	14.95
5D21	8.25	815	3.25	FG81A	3.49
5FP7	2.65	816	1.05	F1015	17.50
5GP1	4.85	826	.69	FG172	33.50
5JP1	24.45	828	9.95	GL34A	29.95
5JP2	22.50	829	10.95	GL502A	1.79
5LP1	19.75	829B	12.25	HF100	8.95
5M21	3.00	830B	7.50	HF300	22.45
6AN5	3.00	832	9.45	HY1148	.69
6AS6	2.25	832A	1.45	ML101	55.00
6AS7	4.10	836A	1.45	ML101	55.00
6C21	4.95	837	2.25	REL21	1.95
6J4	6.75	838	5.75	RK60/1641	2.25
7BP7	6.55	845	3.95	RK65	31.25
7DP4	4.50	849	2.50	RV72	2.95
9LP7	4.95	851	47.50	TV127A	2.45
10BP4	17.45	860	3.95	WL1616	34.50
10Y	9.95	861	22.50	WL676	42.50
12DP7	14.75	865	.98		
15E	1.35	866A	1.35		

WANTED! WANTED!

Needed for Government Defense Projects all types of military electronic gear with the prefix TS, BC, SCR, A1R, APS, etc. Highest prices paid or will exchange for your needs. No offer too small or too large.

Prices subject to change without notice. F.O.B. NYC. Minimum order \$10.00. 20% deposit required. All merchandise guaranteed. Open account to rated firms. Telephone: D1gby 9-0347.

RADIO HAM SHACK inc.

189 GREENWICH STREET • NEW YORK, N. Y.

A MUSICAL MILESTONE

Audax Chromatic Pickup

Wall Street Journal News Story
(Front page, Oct. 30th)

"NEW YORK—How close has the modern phonograph come to perfection?

Inventor Maximilian Weil, maker of the first commercial electronic phonograph pickup in 1926 and holder of some 260 patents in the field, provides an answer at the Audio Fair in N. Y. this week.

The Audax Co., of which he is president, has on hand one of Toscanini's NBC Symphony violinists and a cellist from the New York City Opera, both playing instruments made by the renowned Stradivari, intermittently they put down their bows—and the music is carried on by a disc recording made by the same musicians. The switch, to most listeners, is not discernible."

Audio Engineering, Dec., 1952

(Concerning performance above)

"So excellent was the reproduction that any distinction between the two was largely a matter of guesswork . . ."

Eminent College President, in His Music-Critic-Newspaper Columns . . .

"If it's musical quality you're after, the new AUDAX magnetic reproducer is indispensable."



One single magnetic pickup plays all home records . . . individually replaceable styli with new Compass-pivoted Audax arms to fit record changers.

Convert your POLYPHASE with a replaceable Audax Chromatic Diamond Stylus, now available at leading dealers.

Be sure to obtain the 1953 ELECTRONIC PHONO FACTS Booklet from your dealer.

AUDAX COMPANY
500 Fifth Avenue, New York 36, Dept. C

(Creators of Fine Music Reproducers for Over 25 Years)

RADIO-TV Service Industry News

AS REPORTED BY THE
TELEVISION TECHNICIANS LECTURE BUREAU

ONE of the least publicized but most effective programs of "self-help" for the service industry is that being carried out by the Television Service Association of Michigan. Since an important phase of this program has succeeded because of the cooperation of a Joint Committee on Service which includes executives of Detroit set and parts distributing organizations, the plan merits serious study by parts and set distributors and service businessmen in every marketing area across the country.

The Television Service Association of Michigan is an organization of businessmen engaged in electronics servicing. Parenthetically, we would like to point out that "electronics" servicing covers the entire field of electronic vacuum-tube circuitry but especially television, radio, sound, and industrial electronics equipment.

The TSA program revolves around regular monthly business meetings of the association members which are always attended by executive personnel from set and parts distributing organizations. At each of these meetings a talk on some important facet of business management is given by a competent speaker. Potentially harmful business practices or developments that crop up in the Detroit area are openly discussed and committee reports on investigations are thorough, complete, and factual.

One of the most interesting phases of the TSA-Joint Committee program is the manner in which they handle meetings devoted to technical developments and progress. In order to provide technicians and technical supervisory personnel a maximum amount of important technical information in a minimum of time they hold an annual "new receiver clinic." Competent lecturers are brought in to discuss, in detail, circuit trends in new models and to explain practical techniques in using servicing equipment. Set distributors display representative models of their latest chassis units and have technical personnel in attendance at their booths to cover the questions on circuitry in their receivers.

Recently arrangements were made with the TTLB to have Edward M.

Noll present his lecture on u.h.f. to technicians in the greater Detroit area. The meeting was sponsored by TSA and the Joint Industry Committee on Service. More than 650 people attended this lecture which was given in the main auditorium of the *Detroit Edison Company*.

The most significant proof of TSA progress shows up in the rapid growth of their monthly house organ—"TSA News." This interesting and informative publication has grown from a four-page bulletin into a 12-page magazine which includes a 4-page "consumer section". While distribution of the "TSA News" is restricted to service businessmen and associated businesses in the greater Detroit area, thousands of copies of the consumer section are printed for mailing and personal hand-outs to set owners by TSA member organizations.

(Editor's Note: Service businessmen who would like to see a copy of "TSA News" with its consumer supplement should write to Harold Chase, President, TSA of Michigan, 16311 Grand River, Detroit 27, Mich. However, in requesting a copy we would suggest that you send ten cents for a single copy or one dollar for a year's subscription to pay the handling cost of mailing to you.)

The controlling factors in the splendid success of the TSA program can be crystallized in three elements:

1. TSA is an organization of service businessmen. Their basic motive is to establish the business of electronics service as a stable, profitable, and respected business activity in the greater Detroit area.

2. All phases of their program—both technical and business—are managed by TSA officials and counselled by members of the Joint Industry Committee on Service.

3. The program is actively supported by all leading parts and set distributors in Detroit.

The success of the TSA program, which parallels that of the Associated Radio-Television Service Dealers of Columbus, Ohio, clearly demonstrates one very important fact—that the most pressing problems of the electronics servicing industry can and

Flying Saucers?

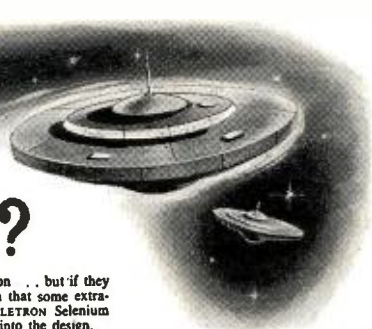

Frankly we don't know if they're fact or fiction . . . but if they are fact it wouldn't surprise us a bit to learn that some extra-terrestrial manufacturer has incorporated SELETRON Selenium Rectifiers and R. R. Co. Germanium Diodes into the design. That's because—as pioneers in the field of electronic development—we've had our hand in some of the most difficult projects and met some of the stiffest requirements ever cooked up! Making drawing board dreams come true are daily chores at Radio Receptor Co.!

GERMANIUM DIODES

Radio Receptor's new Germanium Diodes feature polarity at a glance combined with simplicity of construction and sound design principles. The tapered shape speeds assembly because operators can see at a glance the correct direction of assembly. Users are enthusiastic over the quality of the product which is currently being used in walkie-talkies, computers, TV sets, tuners and other electronic applications.

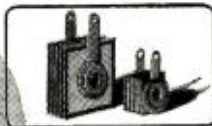
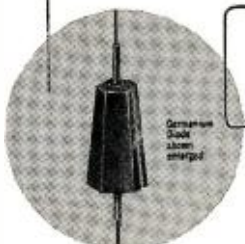

Our Germanium Diodes and Seletron Selenium Rectifiers may hold the answer to many of your problems. Radio Receptor Engineers will be glad to study your requirements and submit their recommendations on both of these products.

Germanium Transistors available in limited quantities.



SELETRON RECTIFIERS

Seletron Selenium Rectifiers, in both miniature and industrial types, are in constant demand by an increasingly large number of engineers throughout the world because they are completely dependable under the most grueling conditions. Years of experience have given Radio Receptor Co. a deep insight into the idiosyncrasies of rectification.

Seletron and Germanium Division

RADIO RECEPTOR COMPANY, INC.

Since 1922 in Radio and Electronics
SALES DEPT., 251 West 19th Street, New York 11, N. Y. • FACTORY: 84 North 9th Street, Brooklyn 11, N. Y.

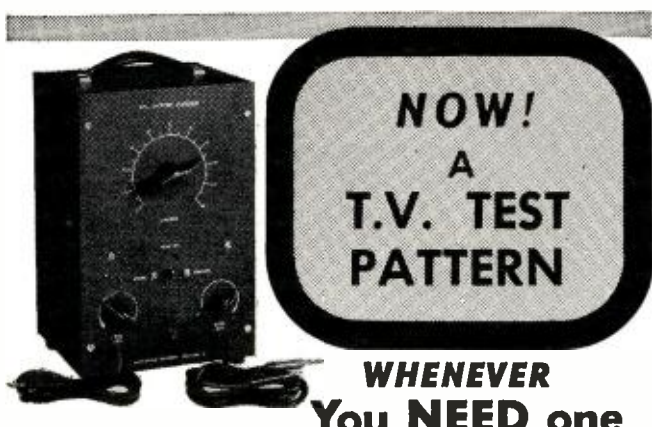

WHENEVER You NEED one

use
MODEL CB-101

UTL PATTERN GENERATOR
SIMPLE • EFFICIENT • ACCURATE
for a STEADY NON-SHIFTING
VERTICAL or HORIZONTAL
TEST PATTERN

HERE'S WHY YOU'LL LIKE IT . . .

- ★ Makes horizontal and vertical linearity, width, height and centering tests.
 - ★ Checks relative gain of video stages; isolates defects in video amplifier.
 - ★ Tests performance of kinescope directly.
 - ★ Checks overall image reproduction when used to modulate TV signal generator.
 - ★ Uses sync impulse of receiver to insure steady line or bar pattern.
 - ★ No removal of chassis necessary; special leads connect to tube pins.
- Ask your distributor about it. Send for free folder No. 32

TESTS VIDEO AMPLIFIER
LINEARITY and PICTURE
TUBE PERFORMANCE
MODULATES YOUR T.V.
SIGNAL GENERATOR
FOR OVER-ALL TEST
OF T.V. RECEIVER

\$29.50
COMPLETE WITH
SHIELDED
LEADS

UNITED TECHNICAL LABORATORIES

Engineers • MORRISTOWN, N. J. • Manufacturers

BUILD 15 RADIOS

AT HOME ONLY
With the New Improved 1953 Progressive Radio "EDU-KIT" **\$19.95**

NOW INCLUDES

**SIGNAL TRACER
and
CODE OSCILLATOR**



- FREE TOOLS WITH KIT
- ABSOLUTELY NO KNOWLEDGE OF RADIO NECESSARY
- NO ADDITIONAL PARTS NEEDED
- EXCELLENT BACKGROUND FOR TELEVISION
- 10 DAY MONEY-BACK GUARANTEE

WHAT THE PROGRESSIVE RADIO "EDU-KIT" OFFERS YOU

The Progressive Radio "Edu-Kit" offers you a home study course at a rock bottom price. Our Kit is designed to train Radio Technicians, with the basic facts of Radio Theory and Construction Practice expressed simply and clearly. You will gain a knowledge of basic Radio Principles involved in Radio Reception, Radio Transmission and Audio Amplification. You will learn how to identify Radio Symbols and Diagrams; how to build radios, using regular radio circuit schematics; how to mount various radio parts; how to wire and solder in a professional manner. You will learn how to operate Receivers, Transmitters, and Audio Amplifiers. You will learn how to service and trouble-shoot radios. You will learn code. You will receive training for F.C.C. license. In brief, you will receive a basic education in Radio exactly like the kind you would expect to receive in a Radio Course costing several hundreds of dollars.

THE KIT FOR EVERYONE

The Progressive Radio "Edu-Kit" was specifically prepared for any person who has a desire to learn Radio. The Kit has been used successfully by young and old in all parts of the world. It is not necessary that you have even the slightest background in science or radio. The Progressive Radio "Edu-Kit" is used by many Radio Schools and Clubs in this country and abroad. It is used by the Veterans Administration for Vocational Guidance and Training. The Progressive Radio "Edu-Kit" requires no instructor. All instructions are included. All parts are individually boxed, and identified by name, photograph and diagram. Every step involved in building these sets is carefully explained. You cannot make a mistake.

PROGRESSIVE TEACHING METHOD

The Progressive Radio "Edu-Kit" comes complete with instructions. These instructions are arranged in a clear, simple and progressive manner. The theory of Radio Transmission, Radio Reception, Audio Amplification and servicing by Signal Tracing is clearly explained. Every part is identified by photograph and diagram. You will learn the function and theory of every part used. The Progressive Radio "Edu-Kit" uses the principle of "Learn by Doing." Therefore you will build radios in a modern manner, according to the best principles of present-day educational practice. You begin by building a simple progressive manner. You will find yourself constructing still more advanced radio sets, and doing work like a professional Radio Technician. Altogether you will build fifteen radios, including Receivers, Transmitters, Amplifiers, Code Oscillator and Signal Tracer.

The Progressive Radio "EDU-KIT" Is Complete

You will receive every part necessary to build 15 different radio sets. Our kits contain tubes, tube sockets, chassis, variable condensers, mica condensers, paper condensers, resistors, line cords, selenium rectifiers, tie strips, coils, hardware, tubing, hook-up wire, solder, etc. Every part that you need is included. These parts are individually packaged, so that you can easily identify every item. Tools are included, as well as an Electrical and Radio Tester. Complete, easy-to-follow instructions are provided. In addition, the "Edu-Kit" now contains lessons for servicing with the Progressive Signal Tracer, F.C.C. instructions, quizzes. The "Edu-Kit" is a complete radio course, down to the smallest detail.

TROUBLE-SHOOTING LESSONS

Trouble-shooting and servicing are included. You will be taught to recognize and repair troubles. You will build and learn to operate a professional Signal Tracer. You receive an Electrical and Radio Tester, and learn to use it for radio repairs. While you are learning in this practical way, you will be able to do many a repair job for your neighbors and friends, and charge fees which will far exceed the cost of the "Edu-Kit." Here is your opportunity to learn radio quickly and easily, and have others pay for it. Our Consultation Service will help you with any technical problems which you may have.

FREE EXTRAS IN 1953

- ELECTRICAL AND RADIO TESTER
- ELECTRIC SOLDERING IRON
- BOOK ON TELEVISION
- RADIO TROUBLE-SHOOTING GUIDE
- MEMBERSHIP IN RADIO-TELEVISION CLUB
- CONSULTATION SERVICE • QUIZZES
- TRAINING FOR F.C.C. LICENSE

The Progressive Radio "Edu-Kit" is sold with a 10-day money-back guarantee. Order your Progressive Radio "EDU-KIT" Today, or send for further information.

We pay shipping charges all over the world, if you send check or money order for \$19.95 with your order. On C.O.D. orders, you pay cost of delivery.

PROGRESSIVE ELECTRONICS CO.
497 UNION AVE., RN-16, Brooklyn 11, N. Y.



OXFORD

Speakers



There is an application for every Oxford Speaker . . . and an Oxford Speaker for every application.

OXFORD ELECTRIC CORPORATION

3911 S. Michigan Ave.
Chicago 15, Illinois

EXPORT: ROBURN AGENCIES
NEW YORK CITY

Preferred for original equipment . . . Proven for replacement!

must be handled on a local or regional basis. It also shows that such programs can be successful if they have the whole-hearted support (including financial) of local parts and set distributors provided the planning and management of the program are left in the hands of service business executives.

National Lecture Programs

Competently prepared and ably presented lectures have proven to be the most effective training medium for technicians actually employed in shop or field service work. Service people have little idea of the high cost of preparing and touring the kind of lectures that service technicians will attend—and learn from.

A good service lecture is one that will "hold" its audience through to its conclusion. It is normal practice to call a mid-lecture "break" in a technical presentation. When a lecturer loses half or more of his audience at the break it is because either his material or his method of presentation was not getting across to service technicians. Usually it is the fault of the material.

It is always a surprise to non-technical people to observe how technicians stay "glued" to their chairs for perhaps two hours listening to a technical presentation and making notes on important points. Yet that always happens when a speaker "knows his stuff" and has prepared his lecture to give a smooth presentation of the material.

What does it cost to prepare a good technical lecture?

Depending upon the subject and the amount of equipment that must be covered, it costs from three to five thousand dollars to prepare the kind of practical, factual lecture that is required to hold the attention of service technicians. The material must be carefully researched; equipment must be used under normal servicing conditions; its preparation must be based upon a complete understanding of actual service problems. There is a wide difference between the theoretical concept of how service should be handled and the actual practices that must be employed to handle service work at a profit. Successful service lecturers understand that difference from personal experience.

Under normal scheduling conditions the average service lecturer can complete only about fifty lectures per year. Considering all of the costs involved which would include the lecturer's salary, traveling expenses, scheduling costs and, of course, the amortization of the lecture preparation cost, the most efficiently planned lecture tour will cost at least \$300-per-lecture to present. This does not include the cost of the hall nor of the announcements and other promotional material necessary to publicize it properly.

Equipment and parts manufacturers have become discouraged with lecture programs because of the small at-

Columbia
GEM OF THE SURPLUS

PORTABLE ELECTRONIC MEGAPHONE
Battery operated. Uses portable radio batteries. FB for marine, fire, police, picnics, etc. Lim. \$39.95
ited quan. NEW SPECIAL

TG-5 CODE PRACTICE KEYS
NOVICES, CW: This is the ticket for getting your ticket! Use to practice sending and receiving. Like new & new. With canvas bag. EACH \$ 5.95
Per Pair Only 15.95

DYNAMOTORS 6 & 12 V.
PE-73: 24 V. in. 1,000 V. out. @ 350 ma.
Used, good cond. \$ 5.95
PE-101: 12 or 24 " in. 400 V. @ 130
ma output. See Dec. '52 CQ for conv.
to 8 VOLTS. Excel. cond. 4.95
BD-77: 12 V. in., 1,000 V. out. @ 350 ma. 14.95
COMMAND RECEIVER DYNAMOTOR: 12
V., used 7.95

WET CELL BATTERIES
24 V. EXIDE AIRCRAFT. New. orig. box. . . \$15.95
12 V. 37 amp @ 5-hr. rate. NEW. 12.95
6 V. 15 amp @ 10-hour rate. New. 9.95
4 V. For TBY Transceiver. NEW. HOT! . . . 4.95

ADJUSTABLE 2-METER TANK COIL: Can also be used for parallel lines. Silverplated. Approx. freq. range 100-200 MC. Will handle a full kw. Excel. cond. SPECIAL \$4.95

EE-8 FIELD PHONE: Checked out, guar.
USED: Ea. \$22.50 USED: Per Pr. . . \$39.50
NEW: Ea. 35.00 NEW: Per Pr. . . 67.50

APN-1 TRANSCEIVER
For 420 MC. A-1 deal for ham or citizens' band. With tubes & schematic. \$17.95
Excel. cond.

STOP! Make extra dough NOW by rushing us your new and used radio gear. We buy it fast at peak-high prices. WRITE TODAY! We will meet and beat any bid!

ARC-5 OR 274-N TRANSMITTERS
2-1-3 mcs. Brand new \$19.95
4-5-3 mcs. With tubes 6.95
7-9-1 mcs. With tubes 5.50
7-9-1 With tubes 14.50

ARC-5 OR 274-N RECEIVERS
.10-.55 kc. \$16.95
1-3-3 mcs. Brand new 24.50
3-3 mcs. Less tubes 5.95
3-8 mcs. With tubes 10.95
6-9-1 mcs. With tubes. Used 10.95
New 22.50
6-9-1 mcs. Used. Less tubes 8.95
MD-7 ARC-5 PLATE MODULATOR. Excel. cond. 14.95

RACK FOR DUAL TRANSMITTER (274-N) 2.95
RACK FOR DUAL TRANSMITTER ARC-5 3.95
TRIPLE RECEIVER RACK 5.00
DUAL RECEIVER CONTROL BOX. BC-496. New 2.95
BC-442-A ANTENNA RELAY with 50 mmfd. condenser. Excel. cond. 3.95
COMMAND RECEIVER FLEX CABLE. 2.95
12 V. COMMAND RECEIVER DYNAMOTOR. New 12.95

BC-625 TRANSMITTER: Part of SCR-522. Freq. range: 100-158 MC. Less tubes. \$13.95
HOT BUY!
BC-624 RECEIVER: Part of SCR-522. Freq. range 100-158 MC. Less tubes. \$19.75
TERRIFIC THE PAIR ONLY \$29.95

4 FT. ANTENNA BALLOON. New \$ 1.19
MICA TRANSMITTING CONDENSER: 12,500 VDC. .004 mfd. New 19.95
All orders F.O.B. Los Angeles. 25% deposit required. All items subject to prior sale.

COLUMBIA ELECTRONIC SALES
522 South San Pedro St. Los Angeles 13, Calif.

DON'T PASS THIS BUY

LINK & BOSCH MOBILE POLICE RECEIVERS. 5 tubes (RF stage) fixed tunable 2-3 mc. adj. squelch control. W/5 volt power supply. 250V/100 ma. IDEAL/Ham. C.D. MARS & MARIN services. Makes hot recvr w/HF converter, used operating cond. With new 5" FM spkr. . . \$12.95

HERE'S YOUR ANSWER TO LOW ANGLE PROBLEM. radiates good DX signs. everywhere. VERTICAL WHIP ANTENNA ASSY. for 10, 15, 20, 40, 80 M 9 1/2 ft. \$1.45; 24 ft. \$3.75; 16 ft. \$3.75; 32 ft. IDEAL for easy lowering of ant. Used w/above units. . . 7.95

NEW 6 & 12 VOLT DYNAMOTOR. 180 V/50 or 200 V/30 ma. higher ratings on 12 V. \$ 11.95

COMPACT ELTRON VIBRATOR PACK. 6v in 90V/30 ma output, will operate on 4 D cells. 2 1/2" dia x 3 1/2" H. Swell for portables 3.95

JAEGER 6" DC CLOCK (made of Kaiser-Frazier) 5" face W/2 panel lamps. draws 3 ma will run on dry cells. L.P. \$17.00 . . . 5.95

WINDLASS MOTOR. 24V 2 HP. 4200 RPM W/HD gear box. output 136 RPM @ 60 ft. lb. torque. With attached relay control box. . 19.75

HAND DRIVE GENERATOR. 8.3/3A, 31.5/2A. 9.95

HAYDON SYNCHRONOUS MOTOR. 24 volts 60 cy will operate on 115V line with series capacitor, high torque geared shaft output. 3 RPHR with capacitor 1.25

WESTERN ELECTRIC #188 MOBILE 32-40 mc RECEIVER. 7 tubes W/BUILTIN SPEAKER. 6V DYNAMOTOR SUPPLY W/HASH FILTER. IDEAL FOR TRUCK OR CAR SERVICE. USED OPERATING CONDITION. \$24.95 less tubes. 21.95

AFSCO AMPLIFIER EQUALIZER. input 2V/800Z. output. 5V/600Z. 2% distortion 0.9%/1000 cy. hi & lo freq. switch varies from minus to 15DB to plus 15DB, suitable for high quality audio systems. 24.95

HIGH QUALITY METERS. 0-5 ma 2" sq. 2.95

EVEREADY #467. 67 1/2 V. B.Bat., outdated but good 1.95

ELECTRONIC SPECIALTY SUPPLY CO.
58 WALKER STREET, NYC 13, N. Y. WALKER 5-8187

tendance these lectures have drawn in recent years. When only a handful of technicians attend a manufacturer's lecture it means that he has spent from thirty to fifty dollars-per-man in attendance to give the lecture in that city.

Attention was sharply focussed on this situation in the Philadelphia area by Paul V. Forte, Executive Secretary of TCA, in an article in the "Almo Broadcaster":

"Last year, in Philadelphia, the attendance of technicians at lectures designed to keep them abreast of progress in the industry was discouragingly low. In only two instances, to this writer's knowledge, were there full turnouts to lectures. One of these was early in the season and the other late in the season, and both sponsored by the Joint Electronics and Radio Committee on Service under the direction of its Technical Advisory Panel. Both of these lectures were presented by the Television Technicians Lecture Bureau.

"In one instance that we know of, one major manufacturer sent a lecture crew and equipment to Philadelphia at an estimated cost of \$1500.00 only to find 27 bona fide technicians in attendance. In another instance, one of the country's most widely known TV personalities found himself addressing 85 people, with only 54 of them known to be technicians. Such things have the result of manufacturers trimming their educational budgets even though they know the considerable need for their programs."

One of the growing problems of the service industry is that an increasing number of service technicians is interested in their work only to the extent that it is a job at which they must work a certain number of hours per day for their weekly paychecks. This is not unusual, of course, because most employed people feel that way about their work. But it poses a serious problem for the service businessman in his need to keep his personnel abreast of the industry's fast-moving developments. It is one of the main reasons why well-planned, comprehensive lectures covering a wide range of products and circuitry are important to him for they help his technicians to acquire a lot of useful, practical information in a minimum of time. They are the kind of lectures that he is glad to pay his service people for the time they spend in attending.

A Preview of Growth

At the year end, Dr. W. R. G. Baker, vice-president and general manager of the Electronics Division of the *General Electric Company* set down an interesting outline of developments anticipated in the course of the present year. Dr. Baker said that he looks for this to be a record year for the electronics industry with the accomplishment of the following tangible results:

1. More than 200 television stations in operation by the end of the year.

March, 1953



TOWN

Simpson

MODEL 488 FIELD STRENGTH METER

Saves service time in TV, antenna installation—makes service profits longer.... Whether installation is fringe in the hills or in the bounce-filled canyons of the city, Model 488 gives you the best location quickly, accurately.... Location of maximum signal areas, antenna orientation, comparison of antenna systems, adjustment of boosters and checking antenna and lead-in installations are only a few of the many functions of Model 488.

You're losing profits without one.... Dealer's net price including operating instructions and shoulder strap, \$98.50.

See your jobber for full information or write Simpson Electric Company, 5200 West Kinzie Street, Chicago 44, Illinois. Phone CO 1-1221.

In Canada: Bach-Simpson, Ltd., London, Ont.

Another reason why Simpson is the world's largest manufacturer of test equipment



Simpson Electric Company advertisement

Country

Custom Styled for Hi-fidelity

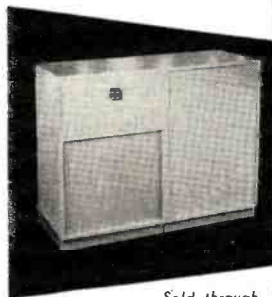

Sold through leading radio parts distributors. Write for free catalog and nearest distributor.

by **Cabinart**



MODEL 28
Equipment Cabinet
72.00
net

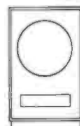

MODEL 27
Speaker Cabinet
48.00
net

Designed for the audiophile, these handsome cabinets will accommodate any combination of high fidelity components. Panels are replaceable for future changes of equipment. The loudspeaker cabinet is acoustically correct, tuned for the average 12" or 15" loudspeaker, pre-cut as requested. Construction is of select birch, with a fine lacquer finish hand-rubbed to a high gloss. All joints are glued and screwed, and lock-joint miters are used throughout, affording utmost rigidity.

Dimensions: 35 1/2" H., 23 1/2" W., 18" D.

Finishes: Blond Birch, Cordovan Mahogany on Birch.

Baffle Area: 6 1/2 cubic feet.

G & H WOOD PRODUCTS COMPANY 75 N.11th ST. BKLYN. 11. N. Y.
Pioneers in radio furniture for high fidelity equipment.

The Famous Family of



High Quality Audio Amplifiers

HAS ANOTHER SCION

The Completely New MODEL 4 PRE-AMPLIFIER



Remote Control
Model 10C4..... 30 Watt
Model 12A4..... 10 Watt

Write for complete technical data, and be sure to listen to the NEW BROOK at your local dealer's Sound Department. Dept. RC3--

BROOK ELECTRONICS, INC.
34 DeHART PLACE, ELIZABETH 2, N.J.



EVERY RADIOMAN

Can Use These

SERVICE HINTS!

Valuable Manual Yours—**FREE!**

Every page of "How to Simplify Radio Repairs" is packed with on-the-bench, practical ideas. Contains photos, charts, diagrams—no fluff—no vague theory. In plain every-day language it gives you priceless suggestions—new servicing ideas. You'll use and benefit from the experience of experts. Partial list of contents: How to Localize Trouble; How to Service Amplifiers; How to Test for Distortion; How to Test Audio Circuits; How to Test Speakers; How to Find Faults in Oscillators; How to Test Radio Parts—and it's all yours—**FREE!** No obligation.

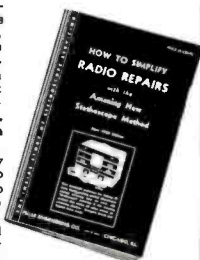

SEND COUPON OR GOVERNMENT POSTCARD FOR YOUR FREE COPY TODAY!

FEILER ENGINEERING CO., Dept. 3-H-3
8026 N. Monticello Ave., Skokie, Ill.
(Suburb of Chicago)

Please RUSH my FREE copy of "How to Simplify Radio Repairs."

Name

Address

City..... Zone..... State.....

EMERGENCY

• PORTABLE RADIO •

TRANSMITTERS

U. S. COAST GUARD • TPC-119-A
POWER OUTPUT 5 WATTS • EMISSION A-2
FREQUENCY RANGE 500 KC

UNUSED! ONLY \$95
AS NEW!

★ MARCH SPECIALS

- R-27/ARC-5* ONLY \$24.50
- R-28/ARC-5* ONLY 29.50
- ARC-4 TRANSCEIVERS* 19.95
* Less Tubes and Dynamotor.
- MARINE SIGNAL LAMPS..... 8.75
- TOWER MASTS, AN223, 35 Ft. ... 49.50
- TELEPHONE HANDSET F-1..New 8.25
- ANTENNA MAST SECTIONS, SET OF 7 (MS49-55) IN BAG..... ONLY 6.50
- ANTENNA MAST INSULATORS, TYPE 106A ONLY 7.50

NEW "SONAR" MOBILES

- SR-9 RECEIVERS\$ 72.45
- MB-26 TRANSMITTERS 72.45
- SRT-120 100-W XMITTERS..... 198.50

Illustrated Specifications on Request

Bigelow
2-6666

Telegraph WUX,
Newark, N. J.

Always Right With Earl White

RADCOM Engineering Co.

8 LIVINGSTON ST. NEWARK 3, N. J.

2. Upwards of 6,500,000 home television receivers produced and approximately 7,500,000 home and portable radio receivers.

3. Continuation of the trend toward larger size picture tubes and advancement in the development of color picture tubes.

4. A continuing high level of production of military electronics equipment, and an increase in total dollar volume of the entire electronics industry over the presently estimated \$4,000,000,000 a year rate.

5. A marked increase in new technological developments both in pure research and applied research areas.

6. A large scale increase in the development and production of germanium devices, including transistors, rectifiers, and diodes.

Discussing television and radio in detail, Dr. Baker had this to say:

"Construction and operation of new television broadcasting stations will create new markets for the sale of television receivers in 1953. These new markets, together with the strong demand for larger size sets in older markets, should result in a substantial increase in 1953 television production over that realized in 1952 or 1951. Total industry production and sale of television sets in 1953 should exceed 6,500,000 units and may come close to the record factory sales of 7,355,000 units in the year 1950. The majority of the new television stations will be broadcasting in the ultra-high-frequency range. Therefore a substantial number of television receivers in the year 1953 will be equipped for both v.h.f. and u.h.f. reception.

"The demand for radio receivers continues strong, and it is estimated that approximately 7,500,000 home and portable radio receivers will be produced and sold by the industry during 1953, an increase of approximately 10 per-cent over 1952 production. We believe that over one third of this 1953 volume will consist of clock radio sets.

"On June 30 of this year (1952), the ban that had existed on new television station construction was lifted by the Federal Communications Commission. Since that date the FCC has issued a large number of new station permits and by year-end it is estimated that the FCC will have granted over 150 new station permits; approximately 45 for new v.h.f. stations and 105 for new u.h.f. stations. It is expected that this high rate of construction permit grants will continue through the first quarter of 1953 and that by the end of 1953 an additional 250 CP's will have been granted making a grand total of 400 since the end of the freeze. These CP holders will spend approximately \$100 million on just transmitters, antennas, and television studio equipment. The industry will ship a large share of this equipment in 1953, and by the end of 1953 over 200 new stations should be in operation. This will bring television to all but the very remote areas of our population.

"At the present time new u.h.f. television station construction permits are being granted faster than the industry can supply equipment and delivery promises on equipment must, of necessity, extend well into 1953. It is hoped that by the end of 1953 the rate of production will have been raised so that improved delivery promises can be offered to new u.h.f. television construction permit holders. The industry, in addition to supplying this requirement for new stations, must also provide amplifiers for existing as well as new stations. These amplifiers will not only improve television service in existing areas, but will also extend the range of stations thereby bringing television service to additional families."

Effect on Service Industry

The most noticeable effect on service of this industry expansion will be to add to the competition for the services of the available experienced TV technicians. The lifting of the freeze has had no material effect on the volume of service business in the older TV areas. Competition has been stiff and fringe operators featuring low-priced service calls continue to crop up in the major cities. However, established well-managed service businesses continue to operate on a healthy basis despite a continuing barrage of fringe and thoughtless competition.

At the present time it is difficult to predict how well independent service businesses will fare in the new u.h.f. areas. The only station that has been on the air commercially for a long enough period to provide continuing propagation and reception information is on a channel, #27, at the low end of the u.h.f. band. Whether the experience gained on this channel will apply on Channels 45 and 61 has yet to be determined.

At the year-end the industry was producing new television receivers at the rate of approximately six to seven million a year. Undoubtedly a large percentage of these sets will be dually equipped to receive both u.h.f. and v.h.f. Set dealers will be pushing these combination receivers while the service industry will be trying to sell conversions of the present v.h.f. sets. It may develop into quite a competitive battle.

A TIME SAVER

By DOYLE D. HOLCOMB

DURING recent years more and more customers are having their present radios equipped with phono jacks to enable them to use the small, inexpensive record players, especially the 45 rpm units.

The most time-consuming part of these "hook-ups" is the installation of a "radio-phonograph" switch. If one is not installed, stations and noise mix with the music.

To avoid this problem, simply bend one of the rotor plates on the antenna section of the gang condenser so when the gang is fully meshed it shorts the antenna section. No noise!



RAFTS OF SURPLUS FROM STANDARD SURPLUS

ARC 5 EQUIPMENT:

TRANSMITTERS

3 to 4 MCS... \$14.95
4 to 5.3 MCS... 8.95
5.3 to 7 MCS... 7.95
All above complete with all tubes and crystal. In excellent condition.

R-4/ARR-2 RECEIVER—

234-258 MCS
Complete with all tubes and dynamotor. Excellent condition... **\$19.95**

RECEIVERS

190 to 550 KC \$16.95
3 to 6 MCS. 9.95
6 to 9 MCS. 9.95

COMPONENTS

MOUNTING RACKS
Single Trans... \$1.00 Ea.
Double Trans... 1.75 Ea.
Triple Rec... 2.25 Ea.
RE-ZARC ANTENNA
RELAY UNIT
Comp. with Meter and 50 cond... Ea. **\$4.50**
MD-7 ARC-5—PUSH
PULL MODULATED UNIT
Comp. w/tubes and dynamotor. Exc. cond... **\$11.50**

ARMY AMMUNITION CANS

Type M-3 50 Cal. Cans 12" Long x 6" Wide x 7 1/2" Deep.
Type M-1 Cans 12 1/2" Long x 3 1/2" Wide x 6 1/2" Deep.
All aluminum with Leather Handle and Hinged Top with Hasp. Use for all your small parts or tools. O.D. Color. Clean them and buff or paint... Each **\$1.50**

HI AMP. TRANSFORMER

11 Volt 65 Amp. Output—115 Volt 60 Cy. Input. Ideal for welding or Heavy Fil. Tubes or Heat-Insul. Approx. Wt. 50 Lbs. SPECIAL at **\$15.95 Ea.**

SCR-285 RADIO SET

Brand new—Consisting of 1-BC429 Receiver (similar to RU-16) and 1-BC430 Transmitter with Coils, and all Tubes, Dynamotor, Control Boxes, Mounting Racks, Instruction Book, Antenna, Relay, etc. Less Cables **\$39.95 set**

DYNAMOTORS

TYPE	INPUT V.	OUTPUT V.	M.A.	PRICE
DM-19C	12	220	80	\$4.95
DM-34	12	220	80	8.95
BB-77	12	1000	350	19.95
PE-86	28	220	80	4.95
DM-36	28	220	80	4.95
DY-2	28	250	60	3.95
ARC-5	28	330	100	1.85
RU-16	28	330	135	6.95
	18	450	100	2.95

REVERSIBLE MOTOR

1/40 H.P. Ball-bearing 3450 R.P.M. In Blast-proof case. Needs only a capacitor for starting. All Brand New—1 1/2" x 60 mm. Special Low Price... **\$4.95**
Starting Capacitor... \$0.69 Ea.

B-3A INTERVALOMETERS

This unit was used to release bomb loads at different time intervals and now can be used ideally for dark room timers, etc. Complete with two 3000 ohm four sensitive relays and other related parts. Excellent Condition... Each **\$6.95**

12 VOLT BLOWER MOTOR

The famous Trade Winds Blower for use on Trucks, Boats, Etc. Ideal for Engine Room use as motor is completely enclosed and Sparkproof. 4" outlet. All Brand New... Each **\$9.95**

ARC-4 TRANSCIEVER

140-144 MC. Ideal for 2 meters. Complete with 20 tubes and control box. BRAND NEW... **\$29.95**

BC 357 MARKER BEACON

75 Mc. uses 1-12SQ7, 1-12CB Tubes. Excellent condition. Less Tubes... \$3.95
With Tubes... **5.95**

MICA CAPACITORS

CAP.	W. VOLTS	PRICE
.001	3000	1.00
.005	3000	2.50
.035	3000	3.50
.006	5000	1.25
.0001	5000	1.50
.00015	5000	1.95
.0002	5000	1.75
.0003	5000	2.25
.062	5000	2.25
.085	5000	2.50
.07	5000	2.35
.1	5000	2.75
.035	1500	2.75
.003	5000	3.25
.05	1500	3.25
.075	1500	3.25
.003	2000	3.25
.01	2000	2.95
.02	2000	3.25
.03	2000	3.25
.000075	2500	3.50
.00025	2500	3.75
.0008	2500	3.50
.0025	2500	3.50
.0015	3000	2.95
.002	3000	3.95
.00015	600	.35
.01	1000	.75
.01	1200	.75
.001	1200	.65
.005	1200	.50
.01	1200	1.50
.002	2500	1.00
.0005	2500	.65
.0025	2500	.75
.0005	2500	.75

All Mail Orders Promptly Filled, F.O.B., San Francisco... All California Orders—Add 3% Sales Tax... Do not send postage stamps. Write for new 1953 free booklet listing our stock and prices on Radio, Electronics, Tools, Hardware, Motors, Wire, Meters, Batteries, Aluminum Sheets, etc. 20% Dep. on all C.O.D. orders. All items subject to prior sale and prices subject to change without notice. On purchases under \$5.00, send full amount.

SIGNALING BLINKER LIGHT

Same Light as used on U.S. Navy Ships for visual signaling between ships. 8" diameter with geared shutter. Use on 110 Volts. Complete with mounting yoke and spare bulbs and parts. All New... Each **\$14.95**

12 VOLT GENERATOR

Same Generator as used in Radio Jeep Generator Unit. 12 Volt, 55 Amp. with V Pulley for connection to motor or engine. Used... Each **\$24.95**
12 Volt, 55 Amp. Regulator for above Generator. Used... **\$12.50**

BC 375 TUNING UNITS

4500 KC-8200 KC: 8200 KC-7700 KC: 7700 KC-10000 KC: 10000 KC-12500 KC. With Vernier Dial and many parts which none are worth 5 times your Low Price of... **\$2.95 per unit**
TU-5 2000 KC to 3000 KC... **\$5.95**

NEW 12 VOLT BATTERIES

For Mobile or light Airplanes. In original factory boxes. Weight: 37 Lbs. Size: 5 1/2" wide x 10" high x 10" high. Signal Corps Type BB-53, 12 Volt, 34 AH.
A real terrific surplus value **\$9.95** while they last. All new... Ea.

MIDGET SELSYNS

AY6 type operates from 6-12 Volts 60 Cycle. Use as both transmitter and receiver. These compact little units draw almost no current and work fine for all remote position indicating applications, OD 2 1/2 x 2 1/2 x 2". Has spring return shaft. All New (Appr. wt. 1 lb.)... Each **\$2.50**
AY-5 Type, same as above but has continuous rotating shaft. These compact units are all new... **\$4.95**

WILLARD 2 VOLT RADIO BATTERY

NEW. Uncharged (Appr. wt. 4 lbs.) TYPE 20-2... Ea. **\$2.50**
Complete set of three with Box and Connections to make a 6 volt, 20 Amp. Hrs. Battery Uncharged (Appr. wt. 15 lbs.)... Set **\$8.95**

2 VOLT VIBRATORS. VBSA Synchronous Type. Used in all portable radios having 2 volt wet cell supply. All new... Ea. **\$1.00**

MODEL GO-9 TRANSMITTER ONLY A FEW LEFT

All brand New. 100 Watts CW or MCW emission. Operates from 110 V., 800 Cycle, easily converted to 60 Cycle operation. Low frequency range, 300 KC to 500 KC. High frequency 3,000 KC to 18,000 KC, using an E.C.O. We furnish complete conversion data with each transmitter. Complete with schematics... **\$59.95**

DIAL TELEPHONES

French type phone made by Kellogg. Can be used for standard extension phone. Used... **\$12.95 Ea.**
With Dial... **\$9.95 Ea.**

TELEPHONE DIALS

Standard Phone Dials ideal for use in any remote control relay circuits... each **\$2.95**

GYRO MOTOR UNITS

Dual Gyro Unit which was used in conjunction with Auto-Fid. equip. Both Gyro Motors mounted on a single base, wired in parallel for 12 or 24 Volt operation. One used as the Azimuth control and the other as an elevation control. When ordering these Units, specify 12 or 24 Volt. Our Price—Special... **\$4.95 ea.**

SOUND POWER HANDSETS

Use these phones without any external or internal voltage supply. Two or more can be used with only 2 wires interconnecting them. Use for TV installation, house to house or house to garage. All new... Per Pair **\$19.95**

SOUND POWERED HEAD AND CHEST SET

Use same way as Hand Set except you have freedom of hands. No Batteries or power source required for operation. Excellent Condition... Per Pair **\$11.95**

HOBBY MOTORS

Operates from 110 Volts 60 Cy. AC. Two Types Geared Motors: Type A: 4 Speeds: 4,000 RPM., 150 RPM., 25 RPM., 5 RPM. Type B: 3 Speeds: 4,000 RPM., 200 RPM., 5 RPM. These motors can be used for Bar-B-Que spits. Home Work shops or any low speed application. Each speed on a separate shaft. Can be used separately or at the same time. All New... Each **\$12.95**

CAPACITORS • FIXED • OIL FILLED

Solar, Pyranol, C.D., Etc.

ALL D.C. VOLTAGE RATINGS

2 MFD. 400 V.	\$0.79	2 MFD. 1000 V.	\$1.25
3X3 MFD. 400 V.	1.95	8 MFD. 1000 V.	3.95
10 MFD. 400 V.	2.95	10 MFD. 1000 V.	4.95
1 MFD. 600 V.	.75	1 MFD. 1500 V.	1.50
4 MFD. 600 V.	1.95	4 MFD. 1500 V.	2.25
5 MFD. 600 V.	1.95	6 MFD. 1500 V.	2.95
6 MFD. 600 V.	1.95	1 MFD. 2000 V.	1.95
7 MFD. 600 V.	1.95	2 MFD. 2000 V.	1.95
8 MFD. 600 V.	1.95	3 MFD. 2000 V.	3.50
8x8 MFD. 600 V.	1.95	4 MFD. 2000 V.	3.95
10 MFD. 600 V.	2.25	1 MFD. 3000 V.	3.95
15 MFD. 600 V.	2.95	2 MFD. 3000 V.	5.95
20 MFD. 600 V.	2.95	1 MFD. 5000 V.	5.95
1 MFD. 1000 V.	1.00		

CAPACITORS TRANSMITTING VARIABLE

K 1 MMFD. to 75 MMFD. 1/4" Spacing... **\$1.95**
*D 12 MMFD. to 125 MMFD. 3000 V. Peak... **3.50**
*E 5000 V. Peak... **3.95**
*F 12 MMFD. to 150 MMFD. 3000 V. Peak... **3.50**
*A 7 MMFD. to 80 MMFD. 1500 V. Peak... **1.00**
* With National "velvet Vernier" Dial.
* New Hammerlung Gardwell, Etc.

STANDARD SURPLUS

1230 Market St., San Francisco 3, Cal.
Telephone HEMlock 1-3106

AUDEL'S TV-RADIO SERVICE LIBRARY

HERE IS LATE INFORMATION IN A HANDY FORM FOR RADIO & TELEVISION REPAIRMEN, SERVICEMEN & STUDENTS

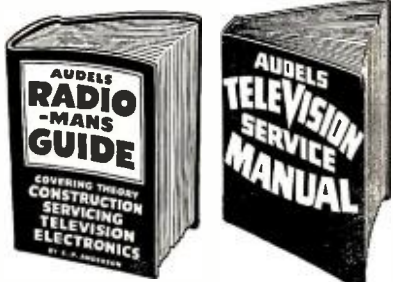

2 VOL. \$6 COMPLETE \$1 Mo.
IT PAYS TO KNOW!

AUDEL'S T.V.-RADIO SERVICE LIBRARY presents the important subjects of Modern Radio, Television, Industrial Electronics, F.M. Public Address Systems, Auto, Marine & Aircraft Radio, Phonograph Pick-Ups, etc. Covers Basic Principles—Construction—Installation—Operation—Repairs—Trouble Shooting. Shows How to get Sharp, Clear T.V. Pictures. Install Aerials—How to Test. Explains Color Systems & Methods of Conversion. 1001 Facts—Over 1260 Pages—625 Illustrations—Parts & Diagrams—Valuable for Quick Ready Reference & Home Study. Tells How to Solve T.V. & Radio Troubles—Answers T.V. & Radio Questions.

Get this Information for Yourself.
7 DAY TEST—ASK TO SEE IT!

MAIL ORDER
AUDEL, Publishers, 49 W. 23 St., N. Y. 10
Mail AUDEL'S T.V. RADIO SERVICE LIBRARY 2 Vols. \$6 on 7 days free trial. If O. K. I will remit \$1 in 7 days and \$1 monthly until \$6 is paid. Otherwise I will return them.

Name _____
Address _____
Occupation _____ RN
Employed by _____

ANOTHER OUTSTANDING JOBBER
RADIO PRODUCTS SALES CO.
1237 - 16th St.
Denver 2, Colorado

HAS THE SENSATIONAL NEW
EICO 470-K 7" SCOPE KIT
IN STOCK! \$79.95

What's New in Radio (Continued from page 96)

everything needed to provide a neat, time-saving installation. The package includes an AM-FM tuner, 3-speed phono-changer, a hi-fi amplifier, and a coaxial speaker. A brochure giving all specifications is available on request.

RESONANCE METER

Premier Mfg. Co., 943 N. Russell St., Portland 12, Ore., is marketing a resonance meter and r.f. detector which comes in a carrying case that includes a basic resonance grid dip meter, impedance and inductance measuring units, r.f. detector probe, and self-contained power.

The unit is dry-battery operated and can be used in the field, laboratory, or shop. The meter with accessories fits into an 8" x 10" x 13" carrying case which weighs 14 pounds in all.

MATCHING CABINETS

Orfeo, 19 E. 48th St., New York 17 is offering a pair of matching cabinets,

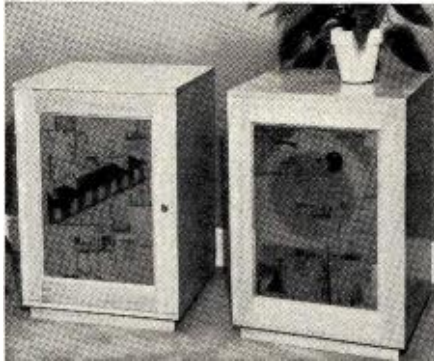

one for equipment and large enough to hold all conventional tuners, amplifiers, and record players and the other a six-foot speaker cabinet.

Available in any finish desired, the new units are constructed of 3/4" mahogany veneer. Covering fabrics for both cabinets are chosen to match the wood finish.

V.H.F.-U.H.F. VARIABLE

A v.h.f.-u.h.f. variable condenser designed for use in tuned circuits that operate at frequencies from 50 to 500 mc. has been developed by *Hammarlund Mfg. Co., Inc.*, 460 W. 34th St., NYC 1.

The "VU" incorporates a unique design which places two condenser sections in series and eliminates the need for contacts to the rotor. The rotor is completely isolated by means of *Pyrrex* glass ball bearings.

BASE STATION ANTENNAS

Mark Products Co., 3547-49 Montrose, Chicago 18 has a new line of omnidirectional, vertically-polarized, high-gain base station antennas available.

Designed for the communications services in the 150 and 450 mc. regions, these antennas are based on a new and different colinear stacking and feed design which permits high gain and good bandwidth. Both three- and seven-element units are in production providing 4 db and 7.2 db gain over a half-wave dipole. Special units are available on a custom basis.

I.F. TRANSFORMERS

Radio Industries, Inc., 5225 N. Ravenswood, Chicago 40 has announced a new Series A line of i.f. transformers which have been designed especially for AM and FM.

The Series A is available in two constructions, one designed for use on standard chassis and the other for use with the new printed circuit chassis. Short terminal lugs for pressure fitting into the lug slot openings are featured for this latter application.

Regency

LARGEST SELLING BOOSTER

at any price!

Burton Browne Advertising

A data sheet covering the new Series A is available from the company.

TRANSISTOR HEARING AID

E. A. Myers & Sons, Inc., of Pittsburgh has announced the development of a hearing aid which uses three transistors, thus eliminating vacuum tubes and the "B" battery.

A capsule size "A" battery, that is said to last 2000 hours, is the only replacement part. The company estimates that operating costs will be only 4% of present operating costs.

SMALL-CRAFT RADIO

Radiomarine Corporation of America, 75 Varick St., NYC 13 has introduced a new radiotelephone transmitter-receiver designed especially for small-boat installations.

Two models of the ET-8050-HP have been designed to comply with latest



and pending FCC regulations. One model, for the inland waterways, ranges from 2000 to 9000 kc. and the second, for the high seas, ranges from 1650 to 18,000 kc. The new eleven-channel radiotelephone features a separate power unit for 32, 115, or 230 volt d.c. or 115 volt a.c. operation. Power output is approximately 85 watts.

COMMUNICATIONS TOWERS

Rohn Mfg. Co., 2108 Main St., Peoria, Ill., has several towers available for radio communications applications.

The standard 12" triangular Type 10 tower may be used for non-guyed applications up to 50 ft. and guyed up to 100 ft. The new Type 20 is a 14" triangular tower which is adequate for heights up to 150 ft.

The towers come in 10 ft. sections for easy erection. They may be climbed for maintenance or servicing.

CLIPPER DIODE AND RECTIFIER

Amperex Electronic Corp., 230 Duffy Ave., Hicksville, L.I., N.Y., has announced the Type 6269, a new, high-vacuum clipper diode and rectifier which is only 2" long without leads and $\frac{3}{8}$ " in diameter.

Designed as a miniature, ruggedized version of the 3B29, this new, external diode operates under more stringent conditions than its prototype.

March, 1953

PE-101C DYNAMOTOR

6 or 12 Volt



(Reprints of original CQ conversion articles - Oct. and Dec., 1952 issues, furnished.)
This is the Dynamotor the Hams have been talking about! Easily adapted to supply 625 V. @ 150 MA. and 325 V. 125 MA. at 12 Volts—or 300 V. 90 MA. and 160 V. 110 MA. at 6 Volts. (Illustration shows modified.) NEW: \$4.95

BATTERY SWITCHING UNIT and METER

Used to switch load from one battery to another—6 to 12 Volts. Contains Weston 2" Meter—0-15 Volt DC Scale for reading battery voltage. 20 Amp DPDT Switch and Indicator. Case size: 4" x 6 1/4" x 2 3/4". NEW: \$2.95

DYNAMOTORS

DYNAMOTOR and BLOWER: 9 Volts DC input; output 450 Volts 60 MA. 4500 RPM. At 6 Volts DC input; output 260 Volts 65 MA. 3000 RPM. \$4.95

INPUT:	OUTPUT:	STOCK No.:	PRICE:
14 V. DC	600 V. 300 MA.	BD-86	\$9.95
12 V. DC	220 V. 70 MA.	DM-24	6.95
12 V. DC	220 V. 100 MA.	DM-18	4.95
14 V. DC	375 V. 150 MA.	DM-375	8.95
14 V. DC	330 V. 135 MA.	DM-330	7.95
14 V. DC	500 V. 500 MA.	PE-59	14.95
12 or 24 V. DC	275 V. 110 MA.	USA/0516	3.95
12 V. DC	250 V. 50 MA.	DM-25	8.95
12 or 24 V. DC	500 V. 50 MA.	USA/0515	3.95
12 or 24 V. DC	440 V. 200 MA.		
28 V. DC	225 V. 100 MA.	D-104	14.95
	250 V. 60 MA.	PE-86	5.95

BC-223 EQUIPMENT

CABLES w/PL-150 ea. end.....	NEW: \$ 2.50
POWER SUPPLY PE-125-AX.....	20.95
MOUNTING for Transmitter.....	1.75
OPERATING MANUAL.....	2.50
TUNING UNIT—TU-17—2 to 3 MC.—NEW, in Case.....	4.50
BC-223 TRANSMITTER—Less Tubes, Meter, and Front Panel.....	4.95

AERIAL WIRE—Phosphorus Bronze #16 Stranded, 200 lb. test. Weatherproof. 150 Ft. on Reel. RL-3 w/Clips.....\$1.50
Telephone Wire—3 Cond. copper & steel, 525 Ft. 4.75

BLOWERS—115 VAC 60 CYCLE



SINGLE TYPE: (Illustrated at top) 100 CFM. 2 1/2" intake; 2" outlet. Complete size: 5" x 6". Order No. IC939.....\$8.95
DUAL TYPE: 100 CFM. 4" intake; 2" Dis. Each Side. Complete Size: 8" x 6". Order No. IC880.....\$13.95
COMPACT TYPE: 108 CFM. Motor built inside squirrel cage. 4 1/2" intake; 3 3/4" Dis. Complete size: 4 1/4" W x 8 3/8" H x 8 3/8" D. Order No. 2C067.....\$14.50

FLANGE TYPE: 140 CFM. 3 1/2" intake; 2 1/2" Dis. Complete size: 7 1/2" W x 7 1/2" H x 6 3/4" D. Order No. IC807.....\$13.95
FLANGE TWIN: 275 CFM. 4 1/2" intake; 3 1/2" x 3" Dis. Complete size: 11 3/4" W x 8 3/8" H x 8-1/16" D. Order No. 2C069.....\$21.95

AIRCRAFT CONTROL CABLE

3/32"—7x7 Strand, Weatherproofed, Galvanized, Preformed, 920 lb. test. Ideal for Television Guying and many other uses. Prices: 4 1/2¢ per Ft.—1000 Ft. or more @ 4¢ per Ft.

TRANSFORMERS AND CHOKES

TRANSFORMERS—110 V. 60 CYCLE PRIMARIES:
5 Volt CT-25A—10,000 V. Ins. OPEN FRAME—5" x 5" x 4 1/2"......\$7.95
6.3 V. 1 Amp.....1.25 24 V. 1 Amp.....1.95
24 V. 1/2 Amp.....1.50 24 V. 6.5 Amp.....5.95
6—24—or 30 Volt 8 Amp.....5.95
Two 12 V. 4 A. windings, gives 12 V. 8 A. or 24 V. 4 A.....5.95
325-0-325 V. 50 MA.—6.3 V. 2.5 A.; 6.3 V. .6 A (Rect. 6x5) Half Shell—2 3/8" x 3 3/8" x 3". No. T-23-28.....2.75
440 VCT/70 MA.—5 V. 2 A.—6.3 V. 4 A.....3.35
460 VCT/90 MA.—5 V. 3 A.; 6.3 V. 4 A.....3.75
175-0-175 V. 40 MA.—6.3 V. @ 2.4 A.; 6.3 V. @ .6 A.; Halfshell 2 3/8" x 2 3/16" x 2 3/8" No. T-23-40.....1.75
350-0-350 V. 90 MA.—6.3 V. @ 3 A.; 5 V. @ 3 A.; Upright—3 1/8" x 3 3/8" x 3 3/8".....3.25

CHOKES

15 Henries—165 MA. 125 ohms.....\$2.95
5 Henries—150 MA. 85 ohms DC—Res. Cased.....1.95
8 Henries—150 MA. 200 ohms.....1.95
5-20 Henries—300 MA. 110 ohms, 1000 V. Ins... 3.95

BC-645 TRANSCEIVER Antennas • Plugs • Mounts Parts, Etc.

TRANSCEIVER—Easily converted to 420 to 500 MC Bands. Instructions furnished for 460-470 MC Citizen Band. Complete with PE-101 Dynamotor, Control Box, Tubes, and Mount.....\$32.95
ANTENNA TWO UHF 1/4 WAVE with Set of 8 Plugs.....\$7.95
MOUNTINGS For: Transceiver: \$1.50—Dynamotor: 75¢ Control Box.....50¢
CONNECTOR PLUGS—Set of 8.....\$4.00
SET OF COILS—1-2-3-4th IF, Oscillator, Ant., Loop, Assy.; Guide and L Rod Assy., etc.....\$5.95

CORDS—CABLES

CD-501 Cord f/GN-45 Generator.....	\$2.50
CD-318 Cord w/PL-68 & SW-141 & JK-48F.....	.89
CD-307 Cord—6.5 Ft. w/PL-55 & JK-26.....	.89
CD-604 Cord w/C-410 Trans. & PL-54 Plug.....	.89
CD-365 Cord for LP-21 Loop.....	1.50
MC-215 Tuning Shaft for 274N.....	2.00

ANTENNA EQUIPMENT

MAST BASES—INSULATED:

MP-132 BASE—Illustrated at left—1" heavy coil spring, 2" insulator. Overall length: 11 1/2". Weight: 2 3/4 lbs. Price.....\$3.95
MP-S-33 BASE—Insulated type with heavy coil spring and 5" dia. insulator. Requires 2" hole for mounting. Weight: 9 lbs.\$5.95

MAST SECTIONS FOR ABOVE BASES

Tubular steel, copper coated, painted, in 3 ft. sections, screw-in type. MS-53 can be used to make any length with MS-52-51-50-49 for taper. Any section.....50¢ Each
Larger Diameter Sections: MS-55-54.....\$1.25 Each

COMMAND EQUIPMENT

BC-457 Transmitter—4 to 5.3 MC.—Used.....\$ 8.95
BC-458 Transmitter—5.3 to 7 MC.—Used..... 7.95
BC-459 Transmitter—7 to 9 MC.—Used..... 14.95
BC-455 Receiver—6 to 9 MC.—Used..... 10.95
BC-456 Modulator—NEW: \$5.95—Used..... 2.95
Transmitter Rack—Single: \$1.50—Dual..... 2.00
Rec. Rack—Dual: \$1.50 Modulator—Mtg..... 1.50
Rec. Dyn.—Used: \$2.95. Trans. Dyn.—Used..... 2.95

TRANS.—REC.—AMPLIFIERS

TA-12B TRANSMITTER with Tubes—Used.....\$39.95
RI/ARR-1 Receiver—easily converted to 220 MC. (See R.N. Jan. 149) Complete w/Tubes. NEW.....\$4.95
RT/7/APN-1 Transceiver—420 MC. Complete with Tubes & Dyn.....NEW: \$24.95—USED: \$19.95
ARB—Receiver—105 to 9050 KC., 4 Bands. Calibrated Dial.....USED: \$29.95
MN-26-C Compass Receiver—150 to 1500 KC. Complete with Tubes & Dyn. NEW: \$29.95—USED: \$19.95
ARC-4 Transceiver—140-144 MC. w/Tubes—Used: \$29.95
BC-1206—200-400 KC. Delco. w/Tubes..... 9.95
BC-216 Amplifier—2 Tubes—6F7, 39/41..... 1.95
BC-367 Amplifier—w/Tubes, less Dyn & Case..... 4.95
BC-605—With Tubes, Used..... 3.95
BC-709—W/Tubes—New: \$4.95..... Used: 3.95
BC-347—Less Tubes—New: \$2.95..... Used: 1.95

REVERSIBLE MOTOR



Motor Reversible—3.7 RPM. 40 lb. torque. 24 Volt DC or AC. Motor size: 5 1/2" x 4-1/32" x 3-5/16". Shaft size: 21/32" x 5/16". Philco No. 441-1008.....NEW: \$5.95
110 Volt AC TRANSFORMER to operate above motor..NEW: \$4.95

POWER SUPPLIES

VIBRATOR TYPE—6 Volt DC input; output 230 Volt DC 50 MA.—not filtered—w/tube. Ideal for Command Receiver operation as receiver is filtered internally. Size: 4 1/2" x 4 1/4" x 3 1/2".....\$5.95
PE-157 POWER SUPPLY—2 Volt Vibrator Supply, operates from BB-54 2 Volt Battery mounted in Case. Output voltage 1.4 V. 1/2 Amp. 125 V. 50 MA. Less Battery, Speaker, & External Power Cord—with Vibrator.....Used: \$4.95
BB-54 2 Volt Dry Battery..... 2.95
MP-28 BA Power Supply & Modulator f/TA-12—New:..... 20.95
Power Supply No. 3 1/2/Mark II No. 19 Radio Set 12 or 24 V. Two PM Dynamotors: 500 V. 50 MA.; 275 V. 110 MA.—New:..... 12.95
PE-104 Vibrator Unit f/BC-654.....Used 10.95
550C Vibrator f/PE-104—New..... 1.95

Address Dept. RN • Minimum Order \$5.00 • Prices F.O.B., Lima, O. • 25% Deposit on C.O.D. Orders

FAIR RADIO SALES 132 SOUTH MAIN ST. LIMA, OHIO

VITAL BOOKS FOR THE TV Service Technician

"Servicing TV in the Customer's Home"

Saves you time, work and chassis-hauling on outside TV service calls. Shows you how to make successful repairs on the spot using these methods: employing VTVM and capacitor probe to trace down trouble; "tube-pulling" to diagnose trouble by observing audio and picture effects; performance tests through analysis of test pattern; adjustment techniques developed for field servicing. Saves time, avoids chassis removal. 96 pages, 5 1/2 x 8 1/2".
ORDER TC-1. Only\$1.50



"Making Money in TV Servicing"

Tells how to start and operate a profitable TV service shop. Covers: overall planning, initial investment, selecting location, finances, budget control, work control, overhead, service charges, purchasing, operating and personnel problems, service contracts, customer relations, collections, advertising, etc. Written by a successful authority in the TV service field—sound, practical advice. 136 pages, 5 1/2 x 8 1/2".
ORDER MM-1. Only\$1.25

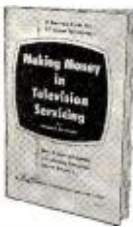

"Television Antennas" New 2nd Edition

A complete treatment of TV receiving antennas, based on actual field experience. Shows how to select proper antennas for given locations; explains how to install and solve troubles. Chapters on: antenna principles; construction; analysis of all commercial types; full installation data and short-cut hints; TV antenna problems and trouble-shooting. Fully illustrated. 224 pages, 5 1/2 x 8 1/2".
ORDER TAG-1. Only\$2.00



"Television Tube Location Guides"

VOL. 3. Shows tube positions and functions in hundreds of important TV sets. Helps save servicing time. Often, looking at the picture or listening to the sound, provides the clue to the trouble. Frequently, a tube failure is the cause. This guide, with its clear, accurate tube placement and function diagrams, makes trouble diagnosis and tube replacement quick and easy, without removing chassis. 192 pages. All new diagrams continuing coverage from Vol. 2.
ORDER TGL-3. Only\$2.00



VOL. 2. Over 200 pages of tube placement diagrams not included in Vols. 1 and 3.
ORDER TGL-2. Only\$2.00

VOL. 1. Over 200 pages of diagrams not in Vols. 2 and 3. ORDER TGL-1. Only\$1.50

"Photofact Television Course"

A full, easy-to-understand explanation of TV principles, operation and practice. Covers Cathode Beam Formations and Control, Beam Deflection Systems, Beam Mod. and Synch.; analyzes CR tubes, camera tubes, voltage supplies, saw-tooth generators, sync. circuits, control functions, antenna circuits, RF input tuning, IF systems, AGC, DC restoration, etc.; with full bibliography and glossary. 208 pages, 8 1/2 x 11".
ORDER TV-1. Only\$3.00



HOWARD W. SAMS & CO., INC.

Order from your Parts Jobber today, or write direct to Howard W. Sams & Co., Inc. 2203 East 46th Street, Indianapolis 5, Ind.

My (check) (money order) for \$..... enclosed. Send the following books:

- TC-1 MM-1 TAG-1
 TGL-3 TGL-2 TGL-1 TV-1

Name.....

Address.....

City.....Zone.....State.....

The 6269 is cooled by liquid-immersion in silicone oil. Maximum peak voltage is 16 kv. and peak current is 250 ma.

Although designed primarily for military radar applications, it exhibits interesting possibilities for use in the high voltage electronic field where space requirements are critical.

NEW SOLDERING UNIT

Sunrise Products Co., P. O. Box 173, Hawthorne, N.J., is introducing a new soldering unit, the Model L-72.

This particular unit features a metal ground plate on which jigs can be mounted and adjustable heat control



which allows the electrodes to heat up instantly to 1250 degrees F.

The unit may be used for soldering condensers, condenser cans, lugs, terminal boards, electronic parts, etc.

A pamphlet describing this equipment is available on request.

TRANSISTOR APPLICATION

Sonotone Corp. of New York City has announced the availability of a new hearing aid which uses transistors to achieve more compact construction.

The new "1010" is the thinnest and smallest (3 oz.) unit the company has ever made. This unit employs a single transistor and two of the company's micro-miniature vacuum tubes.

According to the company, the new circuit design is expected to increase the "B" battery life to more than six months and increase the "A" battery life by 50 per-cent.

SAFETY PLUG

Noma Electric Corp., 55 W. 13th, N.Y. 11, N.Y. has available a safety plug which reduces the hazards of overloaded and shorted electrical circuits.

The plug contains two easily-replaceable safety fuses which blow on a short or overload, leaving the rest of the circuit undisturbed. Appliances and TV sets can be wired to the plug by inserting the wire into it and turning a locking spring.

AUTOMATIC PORTABLE

Califone Corp., 1041 N. Sycamore Ave., Hollywood 38, Calif. has introduced its Model 11AJ automatic portable record player.

The instrument has a 4 watt amplifier and employs an 8" speaker. It is equipped with the latest model Webster

STAN-BURN E-P-A-R-K-E

ANTENNAE SPECIALS

DOUBLE V 3/4"	3-11	12 or more
DOUBLE V 3/8" Dowel	\$2.98	\$2.20
DOUBLE V 1/2" Dowel	3.45	2.45
10 Element Conical 3/4"	3.95	2.95
Folded Hi Straight Low Quick Rig	3.55	2.55
1/2" elements	4.25	3.25
WINDOW CONICALS	4.95	3.75
5 FOOT SWEGDED	1.79	1.29
10 FOOT PLAIN	1.99	
42 MIL.	TV WIRE	
55 MIL. 200 OHM		\$ 9.95 M Ft.
72 OHM COAXIAL		14.95 M Ft.
		45.00 M Ft.

CATHODE RAY TUBE SPECIALS

Standard Brands—Unconditionally Guaranteed
G. E.

STP4	\$43.55	24AP4A	\$73.20
7JP4	18.15	SHELDON	
10BP4A	18.35	10BP4A	14.30
10FP4A	24.40	12LP4A	17.80
12KP4A	27.50	14CP4A	20.35
12LP4A	21.40	15DP4A	22.55
12UP4B	27.10	16FP4A	24.85
14CP4A	20.60	16EP4A	24.85
16AP4A	29.10	16DP/HP4A	24.85
16DP4A	26.65	16JP4A	24.85
16GP4A	27.85	16LP4A	24.85
16KP4/16RP4	25.25	16KP4A	24.85
17BP4A	23.90	17BP4A	24.85
17CP4A	23.90	19DP4A	28.50
19AP4A	34.80	19AP4A	28.50
20CP4A	35.45	20CP4A	30.80
20LP4A	36.95	21EP4A	32.45
21EP4A	37.35	16EP4A Rauland	42.00

CHAS515 630 REGAL with Cascade Tuner \$149.50
OPEN FACE CABINET 42.00

SPECIALS

4 Prong Vibrators, each.....\$ 1.29
Lots of 12 or more..... 1.19
12" Heavy Slug Speaker.....Special 4.98

Audio Devices, Discs and Scotch Tape in Stock
Audio Plastic Red Oxide Plastic tape—
Half-hour spool.....\$2.30 One-hour spool.....\$3.30

WIRE RECORDERS IN STOCK
WILCOX GAY—Model 2A10.....\$ 89.97
PENTRON—Model 9T3C—2-speed Tape Recorder.....Net 134.50

RADIO CRAFTSMAN
Model RC2—Hi-Fi Amplifier.....Net 42.89
Model RC1a—Hi-Fi Tuner.....Net 130.84
Model CR—Williamson Amplifier.....Net 95.45

AUTHORIZED DISTRIBUTORS for General Electric, Kenrad, Tung-Sol, National Union, De Wald, Regal, Automatic and General Motors.

We carry a Complete line of HI-FIDELITY and sound equipment. Send us your requests.

We also carry a complete line of popular makes of Radio and TV tubes at 50% discount. Also many other special purpose and transmitting types, and all electronic parts and equipment at lowest prices. Send us a list of your requirements for prompt quotations. Terms: 20% with order. Balance COD. All prices FOB, NEW YORK Warehouse. Minimum order \$5.00.

Write for our latest price list to Dept. RN-3

STAN-BURN RADIO and
ELECTRONICS CO.
(C.B.S. THEATRE BLDG.)
1697 BROADWAY • NEW YORK 19, N.Y.

CODE SENDING SPEED RECEIVING SPEED

HIGH SPEED WITHOUT NERVOUS TENSION
REVEALING BOOK shows how "crack" operators develop high speed and proficiency. Learn code for Amateur or Commercial Radiotelegraph License, or improve your sending and receiving with the Candler System which develops radiotelegraph experts and code champions FREE
CANDLER SYSTEM CO. Denver, Colo. BOOK
Box 928, Dept. 2-C.

ANOTHER OUTSTANDING JOBBER
GEO. D. BARBEY CO. Inc.
Lebanon, Pa. Reading, Pa. Pottstown, Pa. Lancaster, Pa.
HAS THE SENSATIONAL NEW
EICO 470-K 7" SCOPE KIT
IN STOCK!
\$79.95

LEARN TELEVISION
ELECTRONICS and RADIO
Engineering Laboratory and Classroom
Training. Day and Evening Classes.
Write for Illustrated Catalog
ELECTRONICS INSTITUTE, Inc.
21 HENRY, DETROIT 1, MICH.

changer and has a completely automatic shut-off of the changer and amplifier. An output jack for an external loudspeaker or headphones is provided.

The unit is competitively priced and full details are available on request to the company.

MOBILE MIKE

Electro-Voice, Inc., Buchanan, Mich. is on the market with a new hand-held differential-type, noise-cancelling, high-output, single-button carbon microphone, the Model 208.

It is designed for mobile communications and similar applications. Articulation is at least 97% under quiet conditions, 88% under 115 db of ambient noise.

Frequency response to sound of close origin is substantially flat from 100 to 4000 cps. It comes complete with 5 ft. of 3-conductor cable and weighs 3 oz.

LABORATORY MONITOR

Berkeley Scientific, 2200 Wright Ave., Richmond, Calif. is marketing a general-purpose count rate meter with provision for a visual and/or aural indication.

The Model 1800 has a front panel



control which permits selection of five different meter ranges: 300, 1000, 3000, 10,000, and 30,000 counts per minute. Aural volume control is also provided. Accuracy is $\pm 5\%$. The unit measures $6\frac{1}{2}'' \times 6\frac{1}{2}'' \times 10\frac{1}{4}''$ and weighs approximately 8 pounds. —30—

RESCO EXPANDS

RADIO ELECTRIC SUPPLY CO. of Kingsport, Tenn. has moved to 245 E. Market St. in an expansion program which increases the floor space from 680 sq. ft. to more than 6000 sq. ft.

One of the unique features of this new distributor setup is the inclusion of a meeting hall which has been planned for use by technicians and amateurs in the Kingsport area. The hall is 33 ft. x 17 ft. and will accommodate 50 persons. It is equipped with blackboards and will have facilities for showing manufacturers' movies on various subjects.

Service groups requiring such facilities are invited to get in touch with Resco for scheduling such dates.

—30—

March, 1953

SEE LEO FIRST FOR . . .
hallicrafters

I can SAVE you money . . . Liberal Trade-ins



LEO I. MEYERSON
WØGFQ

SPECIAL NOTICE—NEW SX-73 NOW AVAILABLE AND IN STOCK—\$975.00



\$179.50
S-76 RECEIVER

Extra selectivity with double superhetrodyne circuit. One RF, two conversion and 3 IF stages. Range 550-1550 Kc, 1.7-34 Mc in four bands. 8 tubes plus voltage regulator and rectifier. Complete with tubes; less speaker.



\$224.50
SX-71 RECEIVER

Double Conversion sharp selectivity, plus built-in NBFM at moderate cost. 11 tubes plus voltage regulator and rectifier. Low down payment.

NAME YOUR TERMS • LOW DOWN PAYMENTS • PERSONALIZED SERVICE

HALLICRAFTERS RECEIVERS AVAILABLE FOR IMMEDIATE SHIPMENT

S-81\$49.50	S-40B\$119.95	ST-83\$129.95
S-82\$49.50	S-53A\$ 89.95	S-78A\$ 89.50
A-84\$99.50	S-72L\$119.95	SX-62\$299.50
S-38C\$49.50	S-77A\$119.95	S-72 Portable\$109.95
R-46 Speaker\$19.95	HT-20 XMTR\$449.50		

Famous WRL RADIO REFERENCE MAP 25c



CU on 10-20 & 75 Meters

NEW LOG BOOK 25c

For mobile or fixed station. Spiral binding. Full column log listing all FCC required info. Will accommodate 1,525 stations. "Q" signals, phonetic alphabet, amateur international prefixes.

PHONE 7795

WRITE—WIRE



IT'S NEW! IT'S FREE!

WRL 1953 CATALOG

Send for your copy today. Contains everything new in radio and television. Jam-packed with bargains. Leo I. Meyerson, WØGFQ



Send For FREE Copy

WORLD RADIO LABORATORIES R-3
744 West Broadway
Council Bluffs, Iowa

Please send me:

- Radio Map
- New Catalog
- Used Equipment List
- SX-71 Info
- S-76 Info
- New Log Book

Name

Address

City..... State.....

ANOTHER OUTSTANDING JOBBER
RADIO ELECTRIC SERVICE CO. of Pa., Inc

701 Arch Street
Philadelphia 6, Pa.

HAS THE
SENSATIONAL NEW
TEICO 470-K 7" SCOPE KIT
IN STOCK!



\$79.95

TUBES

All receiving and special purpose types. Real values that will save you 10 to 70%. Call or write today for special price list. State type & quantity for additional listing.

METROPOLITAN SUPPLY CORP.
1133 Broadway, New York 10, N. Y. - CH 3-1105

REMOTE CONTROL

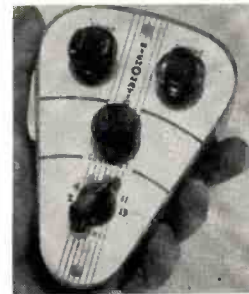

FOR YOUR TELEVISION SET

Fits Any Make or Model
You Make
ADDED PROFITS
INSTALLING REMOTES FOR OTHERS

- * WILL COMPLETELY TURN SET OFF & ON
- * CONTROL VOLUME
- * ADJUST FINE TUNING
- * CHANGE STATIONS
- * ADJUST CONTRAST (All Electronic)

Simple & Complete Instructions
Schematics & Parts List \$1.00.

FREE (with above order)
Catalog listing all parts, manufacturers and prices, or we can supply separate, in kit form, or assembled. Satisfaction Guaranteed—Or Money Refunded

Television Remote Control Co., R-1
820 No. Fairfax Ave., Los Angeles 46, California
Gentlemen: Enclosed find \$1.00 (no stamps) Please send postpaid your complete TV Remote Control Schematics & Parts Catalog.
NAME.....
ADDRESS.....
CITY..... ZONE..... STATE.....

147



type no.
specs.

circuit
diagram

on decals
of TRIAD
power
transformers

Triad Power Transformers—like other Triad transformers—have the essential information right where you want it—on the decal. It simplifies installation—speeds servicing—makes reordering easy. Whether used for replacement, industrial applications, PA amplifiers or amateur gear, they offer small size, maximum efficiency; low temperature rise and low cost. Also, they are "Climate" treated, both coil and core, for protection against moisture and for elimination of lamination chatter. Laminations are painted to prevent rust. Copper straps are used for static shields, grounded to case and core. Leads are color coded, UL approved. Final tests include checking for proper operation. Cases are finished in durable, attractive grey baked enamel.

Write for Catalogs TR-52A and TV-52A



International Short-Wave (Continued from page 124)

around 1030. (Engberg, Sweden) Heard parallel on 10.21A and 7.50 with Chinese music and vocals 1915; the 10.21A channel signs off 1929 but by that time 7.500 was covered by QRM. (Bellington, N. Y.) The 10.21A outlet noted 1730 with news in parallel with 11.69A. (Niblack, Ind.) A Chinese station on 15.58A apparently is *Radio Peking*, heard 0930-1000 parallel with 9.43, 9.04. (Ridgeway, South Africa)

Colombia—La Voz del Norte, 4.875, Cucuta, noted with dance music 2200-2230 when signed off with National Anthem; HJKD, 6.002, *Emisora Nuevo Mundo*, Bogota, noted with classical music 2315-2400 when closed with National Anthem; HJDE, 6.145, Medellin, heard 2000 at good level; HJEX, 6.055A, heard with Spanish commentary 2215-2230, closing 2300 with National Anthem. (Casey, Ky.) HJFR, 4.935, Ibague, is a new station heard evenings (EST), as is HJEQ, 4.915, Popayan. (NNRC) QSL from HJDE,

Medellin, listed short-wave channel as 6.145. (Parrish, Ga.)

Costa Rica—TIHH, 11.972, *Radio Athenea*, noted at good strength with popular North American songs 0900-0915; requested reports to Apartado Postal 2208, San Jose, Costa Rica. (Casey, Ky.)

Cyprus—Limassol, 6.79, noted 0030 with Arabic music and vocals. (Bellington, N. Y.) ZJM7, 11.72, heard with strong signal from around 0930 to close 1145 with Arabic program; male and female announcers; has dictation-speed news in Arabic 1115-1145; a station in Arabic on 6.679A from 1145 to 1400 closedown at poor level is believed Limassol. (Ridgeway, South Africa)

Denmark—Copenhagen now radiates to India-Malaya at 0800-0900 on 15.165 on Tue., Thur., Sat. (and to ships in South Asian waters 0900-0920); the Danish Home Service which tested on 6.060 is again on 7.260 at 1240-1615 using the 50 kw. transmitter. (WRH, others) Still good on 9.52 to North America 2030-2130, 2200-2300. (Saylor, Va.)

Dutch New Guinea—Radio Hollan-

NEW TV STATIONS ON THE AIR

(As of January 10, 1953)

STATE	CITY	STATION	CHANNEL	FREQUENCY RANGE (IN MC.)	VIDEO WAVELENGTH (IN FT.)	VIDEO POWER* (IN KW.)	
Alabama	Mobile	WALA-TV	10	192-198	5.08	316	
		WKAB-TV	48	674-680	1.45	22.5	
Arizona	Tucson	KOPO-TV	13	210-216	4.65	316	
		Colorado	Colorado Spr.	KKTV	11	198-204	4.93
Colorado	Denver	KFEL-TV	2	54-60	17.8	56	
		KBTV	9	186-192	5.25	240	
		Indiana	South Bend	WSBT-TV	34	590-596	1.66
Mississippi	Jackson	WJTV	25	536-542	1.83	180	
		New Jersey	Atlantic City	WFPG-TV	46	662-668	1.48
North Carolina	Asheville	WISE-TV	62	758-764	1.29	23	
		Ohio	Youngstown	WKBN-TV	27	548-554	1.79
Oregon	Portland	WFMJ-TV	73	824-830	1.19	175	
		KPTV	27	548-554	1.79	91	
Pennsylvania	Wilkes-Barre	WBRE-TV	28	554-560	1.77	1000	
		York	WSBA-TV	43	644-650	1.52	170
		Texas	Austin	KTBC-TV	7	174-180	5.61
Texas	El Paso	KROD-TV	4	66-72	14.61	56.3	
		KTSM-TV	9	186-192	5.25	64	
		Lubbock	KDUB-TV	13	210-216	4.65	31
Virginia	Roanoke	WLSL-TV	10	192-198	5.08	250	
		Washington	Spokane	KHQ-TV	6	82-88	11.8
Hawaii	Honolulu	KGMB-TV	9	186-192	5.25	35	
		KONA	11	198-204	4.93	117	

*From station CP application.

Formula for computing wavelength in feet of video carrier:

$$\text{wavelength in feet} = \frac{984}{\text{frequency in mc.}}$$

Total number of television stations now on the air: 131 (10 of which are u.h.f.)

dia, 7.126, is heard 0400-0730. (Japanese Short-Wave Club) Latest schedule from the station lists closedown 0700. (Kary, Pa.)

Ecuador—The Ecuador outlet on 9.557A appears to be parallel with HC1AC, 7.210, Quito; signs off around 2330. (Bellington, N. Y.) Noted by Stark, Texas, as early as 0800.

HC4AS, 4.200, Bolivar, heard 2000-2100 at good level; HC4FF, 4.580V, Esmeraldas, noted signing off 2304; HC2AJ, 4.651, Guayaquil, heard 2130 with fair signal. (URDXC) HCJB, 11.915, noted in *English* 2100-0030; also on 15.115, 9.745, and from 2300 on 6.050A. (Engen, Minn.)

England—The BBC's 104-m. channel, GRC, 2.880, noted at good strength 2300-2400 during General Overseas Service relay; left air abruptly with no special announcements. (Levy, N. Y.)

Ethiopia—Although the schedule of *Radio Addis Ababa*, ETAA, 15.040A, is rather irregular (around 1030-1420 more recently), an *English* newscast is generally radiated around 1330. (Bellington, N. Y., others) *Radio Sweden* says is now using 9.624 for *English* 1400-1430.

Finland—Helsinki was heard recently on 15.190 with an *English* broadcast to the Western Hemisphere at 1430; should be parallel over 17.800, 9.555. (Bellington, N. Y., Callarman, Oregon) The week-day *English* session is now 0700 instead of 0715 over these channels and is rebroadcast on them at 2200A to North America.

French Equatorial Africa—Brazzaville, 11.970, noted on Thursday 1445 with "The French Have a Word for It." (Casey, Ky.) Noted with news 1745, good level, some CWQRM. (Mullen, Mass.) And with news 1550-1600. (Bishop, Ohio)

French West Africa—*Radio Dakar*, 9.560, noted around 1415-1500 with variety program, strong level; should have news in French 1700. (Niblack, Ind.) Heard signing on 0200 with march, French announcements, then setting-up exercises in native. (Saylor, Va.) A station on 4.96A which signs on with "La Marseillaise" 0130A is believed to be *Radio Dakar*; at times appears parallel with Dakar's 11.896A outlet; has news in French around 0230. (Saylor, Va., Bellington, N. Y.)

Germany—Stuttgart, 6.03, was noted recently parallel with Frankfurt, 6.19, at 0232 with classical music. (Bellington, N. Y.) Hamburg, 11.795, noted 0735 with music; man identified in German 0740. (Scheiner, N. J.) Heard on 6.270 at 2349 tune-in; news in German 2350; time pips 2400, then continued talking in German; fair level, QSB; when returned 0103 had setting-up exercises by woman with piano accompaniment. (Bellington, N. Y.)

Greece—Athens appears to be using 7.300 instead of 9.607 for *English* 1430 and for the transmission to North America 2000-2100 (*English* news around 2035). (Ferguson, N. C., Bellington, N. Y.)

Greenland—Angmagssalik has been

**NEW 1953
630 FA-2***

**ONLY AT AIREX...THE MOST
POWERFUL FRINGE AREA
TV CHASSIS MADE**

The CHASSIS That Television Engineers and Servicemen Are Buying for Themselves . . .

This amazingly advanced 31-tube TV chassis is years ahead in engineering and gives you the ultimate in TV viewing and listening pleasure. To assure you trouble free TV our engineering staff has incorporated into the "630 FA-2" design the experiences of hundreds of TV servicemen and engineers. Receiving range includes stations up to 200 miles away. Nothing has been spared to bring you the finest of TV chassis. Only the best and most expensive parts are used. There is no other chassis that compares with the "630 FA-2" * for fringe area reception.

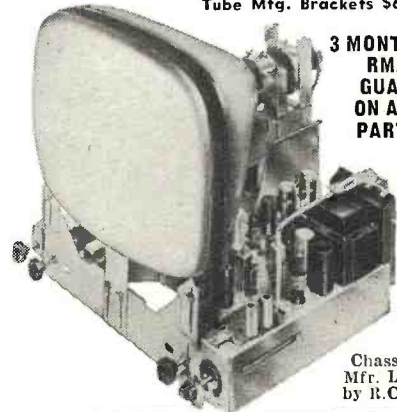

Tube Mtg. Brackets \$6.50

**3 MONTHS
RMA
GUAR.
ON ALL
PARTS**

Chassis
Mfr. Lic.
by R.C.A.

**THE ONLY CHASSIS WITH
PUSH-PULL AUDIO OUTPUT AT**

\$169⁹⁵

Less C.R. Tube
and Brackets

Complete with 12" ROLA Hi-Fi Speaker
(Fed. Tax Incl.)

Detailed Service Manual & Schematic—\$1

✓ CHECK THESE EXCLUSIVE FEATURES ✓

- 10 WATT push-pull audio output. Frequency range from 40 to 12,000 cycles
- Standard Coil Cascade Tuner prevents radiation
- Retrace Blanking Circuit allows you to raise the brightness without the annoying vertical retrace lines
- Heavy duty front focus control
- Automatic gain control potentiometer allows you to adjust the threshold sensitivity as low as 4 microvolts & still keep the full 4MC band width
- Improved sync amplifier
- Improved automatic brightness control
- Set aligned for 21.9 MC. New Ham band will not interfere
- Improved fused high voltage power supply gives full 14.5 KV under load
- Will handle all picture tubes up to 24 inch with full sweep
- Improved video amplifier has a gain of 40
- All moulded plastic condensers give long life & trouble-free operation
- Easily adapted to new UHF stations

- In 2 minutes by just changing a strip in the tuner
- Extra heavy duty power transformer with large safety factor
- 6CB6 tubes in Video IF to give full gain
- Extra filtering in power supply for hum & ripple free operation
- Phono Connection & switch on chassis allows you to play your phonograph or tuner through the built-in 10 watt hi-fidelity amplifier
- Extra heavy duty focus coil, which runs cool
- Full focus cosine yoke.
- Regency UHF Converters, Covers, Complete UHF Band.....**\$32.95**

SUPER 630 DX
30 Tube Chassis
Standard Coil Cascade
Tuner. 12" RCA Hi-Fi
Speaker. Fed. tax incl.
\$154.95

Complete Service
Manual For "630FA"
or Super 630DX—\$1

**OVER 100 BARGAIN-PRICED
CABINETS FOR TV & AUDIO
INSTALLATIONS . . .** Send for
FREE folder and price list. Full
line table models, consoles, con-
solettes and TV-Radio Phono
combinations. Many styles, Ma-
hogany, blonde, etc.

**SEND FOR FREE NEW TV
PARTS & FIDELITY
EQUIPT. CATALOG**

**TV TUBE EXTRA
STANDARD BRANDS
FACTORY NEW**

1ST QUALITY—GUAR. 1 YEAR

17BP4 \$27.95	21" TV tube . \$39.95
20" TV tube 34.95	24" TV tube. 79.95
Ring & Sleeve for 24" Tube \$7.50	
TV Gold Plastic Masks	
16" and 17" . . . \$4.95	24" \$14.95
20" and 21" . . . \$7.95	

All merchandise is brand new, factory fresh & fully guaranteed. Mail & phone orders filled upon receipt of certified check or money order for \$25 as deposit on TV chassis. 20% on other items. Balance C.O.D. F.O.B. N. Y. Prices & specifications subject to change without notice. No Fed. taxes to pay. Prices lower than OPS Regs.

AIREX RADIO CORP.

171 Washington St., N. Y. C. 7, N. Y.
Phone WOrth 2-4029

STRIP-IT A New Precision Tool

For Removing Insulation from Wire and Cable
Designed for the Electronic Industry



- Fits in Tight Spots
- Cuts as Well as Strips
- Speedy, Efficient, Rugged
- Tool Steel Blades for Long Life
- INSTANT Adjustment to All Wire Sizes



Economically
Priced

\$1.95 net

The simple design and fool-proof operation of STRIP-IT makes this a tool that will become indispensable for electronic technicians and assemblers. Held in the palm of the hand, the operation is merely to bite into the insulation, twist, pull, and the wire is ready for the terminal connection. The sliding adjustment bar is set with a touch of the finger. STRIP-IT is engineered for thousands of operations, using only one set of blades.

THE **G and M** SEE YOUR LOCAL DISTRIBUTOR, OR WRITE
MANUFACTURING COMPANY

Norman R. Mac Innis, 1430 Mass. Ave., Cambridge, Mass., National Sales Representative

BARGAINS · BARGAINS · BARGAINS

BARGAINS · BARGAINS · BARGAINS

You can depend on STEVE-EL to come up with "terrific buys"! Here is just a "sample of the hundreds of bargains." Our latest catalog is chock full of 'em. Write today!

TAPE RECORDERS

- Web-Cor tape recorder #210B. \$146.50
- Pentron tape recorder #9T3C. 117.50
- Tape Master tape recorder PT 125 89.50
- Tape Master Power Amplifier #SA 13 69.50

EXTRA SPECIAL

- 3 Tube 6 Watt Power Amplifier Kit.....Less tubes **\$9³⁹**
- 3 Tube Phono Amplifier Wired Amplifier uses 50C5, 35W4, 12AT6Less tubes **2⁹⁸**

PHONO EQUIPMENT

- 78 RPM Phono Motor.....\$2.59
- 3 Speed Phono Motor..... 5.25
- 78 RPM Pick up 2.19
- 3 Speed Twist Pick up..... 4.75

SPEAKERS

Alnico No. 5 P. M.

- 4" PM\$1.33 6" PM ...\$2.49
- 5" PM 1.39 8" PM ... 2.99
- 4x6" PM .. 1.89 10" PM .. 3.59
- 5x7" PM .. 2.28 12" PM .. 4.25
- 4 Prong 6 Volt Auto Vibrators..\$0.97
- "Kine-Lite" Renewals brilliance and contrast of Picture Tube..... 2.49

STEVE-EL ELECTRONICS CORP.

Dept. RN-3 61 Reade St. New York 7, N. Y. COrtlandt 7-0086

OUTPUT TRANSFORMERS

- For 50L6, 25L6, 3Q5, 3V4, 6K6, 6F6 **\$0.46**
- For pair 50L6, 25L6, 6F6, 6K6 **.59**

TUBES

1B3GT63	6SQ742
1U448	6T874
1U548	6U857
15548	6U876
1X263	6V6GT46
5U438	6V883
5W4GT46	8W445
5Y3GT29	8W452
6A762	6X434
6A851	7C642
6AG562	7X762
6AK514	12AT648
6AL541	12AU648
6AU643	12AU756
6BC558	12AV652
6BC786	12AZ754
6BE648	12BA647
6BQ6 1.21	12SA752
6BH662	12SK749
6BJ853	12SL757
6BK786	12SN754
6BQ676	12SQ742
6BQ786	14AF759
6C8648	19T878
6F649	25R677
6J679	25W448
6L6G89	25L648
6SA752	25Z642
6SQ749	35L648
6SK749	35Z633
6SL752	50L648
6SN754	8038

SPECIAL DISCOUNTS

50 Ass't. } **5%** 100 Ass't. } **10%**

heard in Sweden some days 0915-0945 on 7.570. (Radio Sweden)

Guadeloupe—Some days, Basse-Terre, 7.447, is heard well in French around 0600-0630 when signs with "La Marsellaise." (Chatfield, N. Y.)

Guatemala—TGJA, 5.990, noted closing 2400 and announcing return for 0600. (Casey, Ky.) TG2, *Radio Morse*, 6.621, Quezaltenango, and *Radio Colonial's* TGCB, Antigua, 6.570, both sign off with anthem 2205. (Stark, Texas) TG2 noted fairly strong 1845-1900. (Tonsi, Wis.) This one was measured recently as 6.6189. (Rastorfer, N. Y.)

Haiti—According to West Va., 4VEH, 9.865A, Cap-Haitien, is to be silent on Thursdays this year. Bishop, Ohio, notes 4VRW, 10.075V, Port-au-Prince, announcing in both French, *English* 2115. Cox, Del., recently heard 4V2S, 5.591, Port-au-Prince, at fair level in French 1545.

Honduras—*Radio Tela* is now on 6.035 from 6.177; appears to open 0800 and closes 2300A. (Stark, Texas)

Hungary—*Radio Budapest*, 9.833, noted closing *English* session 2000 at good level in Ind. (Niblack) Heard on 6.248 at 1930-1945. (French, Mass.)

Iceland—TFJ, 12.175, Reykjavik, was fair level recently on its Sunday only schedule, 1115-1130 but had bad code interference. (Levy, N. Y.)

India—The *English* news service from All India Radio, Delhi, is scheduled 1450-1500, 7.275, 4.880; 1930-1940, 11.850, 9.630; 2310-2320, 17.705, 15.130, 11.870; 0300-0310, 17.705, 15.160; 0830-0845, 11.780, 9.565; 1045-1055, 15.290, 11.780.

Indo-China (Vietnam)—*Radio France-Asie*, 9.754A, Saigon, noted with news in French 1015, closing with "La Marsellaise" 1030. (Pearce, England) Is heard in Australia on 11.925 at 2030-2130 on Sun.-Wed. and again Fri., but also announces is on the air that time Thur. During the 0900 transmission, some days uses 11.925, other days 11.830 so must be seeking best channel to use. (Radio Australia) Sanderson, Australia, notes the 2030-2130 transmission on 11.830 some days.

Iran—EQO, 3.850A, Teheran, has had an outstanding signal in New Zealand with Arabic news items 0830 lately, many *English* recordings. (N. Z. *DX Times*)

Iraq—*Radio Baghdad* can be heard some days on 6.135 parallel 11.724 with news in Arabic 1400 and with *English* session 1415-1500 closedown. (Bellington, N. Y.) Schedule is 2255-0100, 0400-0600, 0830-1500. (N. Z. *DX Times*)

Ireland (Eire)—Officials of *Radio Eirrean*, Dublin, recently notified Bellington, N. Y., that the station (which had been operating on 15.120 and 9.595) was off the air and that it was not known when it would resume operations.

Italy—Rome is noted with *English* for the East Coast of North America now 1920-2000 over 11.905, 9.575 only. (Bellington, N. Y., others) Heard with news 0425 on 15.120, 17.770; in *English* to Pacific 0400-0445 on 21.560, 17.800, 15.400, and signing on *English* for Far

STAY ON THE AIR
WHEN POWER FAILS...with
an ONAN Electric Plant



Model 10EL, 10KW A.C.

When storms, floods, or fires interrupt electricity and force you off the air, you lose listeners and income. Guard against loss, assure vital public service during emergencies by installing an Onan Electric Plant. Onan Standby Electric plants serve many network and private stations. Automatic models to 35,000 watts.



PORTABLE ELECTRIC PLANTS FOR MOBILE RADIO USES
Supply A.C. power for broadcasting at scene of events. Light in weight. Can be carried by hand or in trunk of car. A.C. models: 400 to 3,000 watts.

Write for FREE Folder

D. W. ONAN & SONS INC.
7895 University Avenue
Minneapolis 14, Minnesota



For
TELEVISION
and other electric
installations

Ground Rods

Low cost drawn steel Ground Rods, heavily copper plated to insure perfect electrical contact—and pointed for easy driving. In 4', 6' and 8' lengths, 3/8" to 5/8" diameter. Send for Bulletin and prices, and use Premax in your TV installations.

PREMAX PRODUCTS
DIVISION CHISHOLM-RYDER CO., INC.

5304 HIGHLAND AVE., NIAGARA FALLS, N. Y.

East 0445 on 17.800, 11.905, 15.400. (Pearce, England)

Jamaica—When this was written, *Radio Jamaica* appeared to be using 4.950 from 0600 to 1600 or later, and 3.360 from around 1600 to 2300 close-down. (Bishop, Ohio, others) Noted on 4.950 at good level 0700-0800. (Chatfield, N. Y.)

Japan—JKL, 9.605, was noted recently parallel JKI, 11.825, at 0115. JKL heard at 1700 with news. (Bellington, N. Y.) Kawachi, 11.800, noted at fair level 1718; has CWQRM at times. (Ballou, Calif.) JOA2, 7.180, noted 0700 with news, then music. (Sanderson, Australia)

Kashmir—*Radio Kashmir* is on a new schedule of 2130-2330 and 0700-1200 on 3.277, and 0200-0330 on 6.110. (WRH, others) Location is Srinagar.

Lebanon—Beirut, 8.036A, noted in French with recordings 1430-1500. (Sutton, Ohio)

Liberia—ELBC, 6.025A, Monrovia, 1 kw., has *English* daily 1050-1845. (*Radio Amateur*, London)

Madagascar—FIQA, Tananarive, is noted some days in Sweden on 7.374A at 1100-1130. (Engberg)

Malaya—BFEB, Singapore, noted signing on 0630 on 9.69 (good) and 7.12 (fair). (Balbi, Calif.) Has replaced 21.72 with 15.31 at 0915-1135. (Ridgeway, South Africa) Kuala Lumpur, 6.025, now has news 0545. (Balbi, Calif., Mast, N. Y.) *Radio Malaya*, 7.200, Singapore, noted with news 0545. (Sanderson, Australia)

Mexico—XEFT, 9.545, Vera Cruz, noted with North American dance music 2200-2215. Usually has bad QRM. (Casey, Ky.) XEBT, 9.625, noted in Spanish 2345 to 0130 sign-off. (Mast, N. Y.) XEKW, 6.030, Morelia, heard signing off 2325 with announcements in both Spanish, *English*; announces sign-on for 0730. (Callarman, Oregon)

Mozambique—CR7IB, 7.258, Beira, noted at high level 1100-1330; probably closes 1530. Lourenco Marques is now using a new channel of 11.955 for its Portuguese network programs 0000-0100, 0430-0630, 1300-1515; 15.285 is used now only 1200-1300; 4.872 is used 1300-1515; 7.262 is used 0430-0630 in parallel with 11.955. (Ridgeway, South Africa)

New Zealand—*Radio New Zealand's* latest schedules are 1300-1515, ZL2, 9.540, ZL9, 11.810; 1530-0145, ZL10, 15.220, ZL4, 15.280; 0200-0545, ZL2, 9.540, ZL3, 11.780. (Engberg, Sweden, others) Is good level on 15.280 around 2400. (Rosenauer, Calif.)

North Borneo—According to station officials, *Radio Sabah*, Jesselton, broadcasts on 7.237 at 2300-2345 Mon.-Sat. with 250 w., fed into a folded dipole antenna one-fourth wavelength above the ground. (Scheiner, N. J.)

North Korea—Pyongyang, 6.25A, noted 0528 at fair level, moderate fading. (Ballou, Calif.) Was logged recently in parallel on 6.200A. (Japanese Short-Wave Club)

Northern Rhodesia—Lusaka, 4.826, noted 1250 with dance music; BBC news relay 1300. (Pearce, England)

at Last!

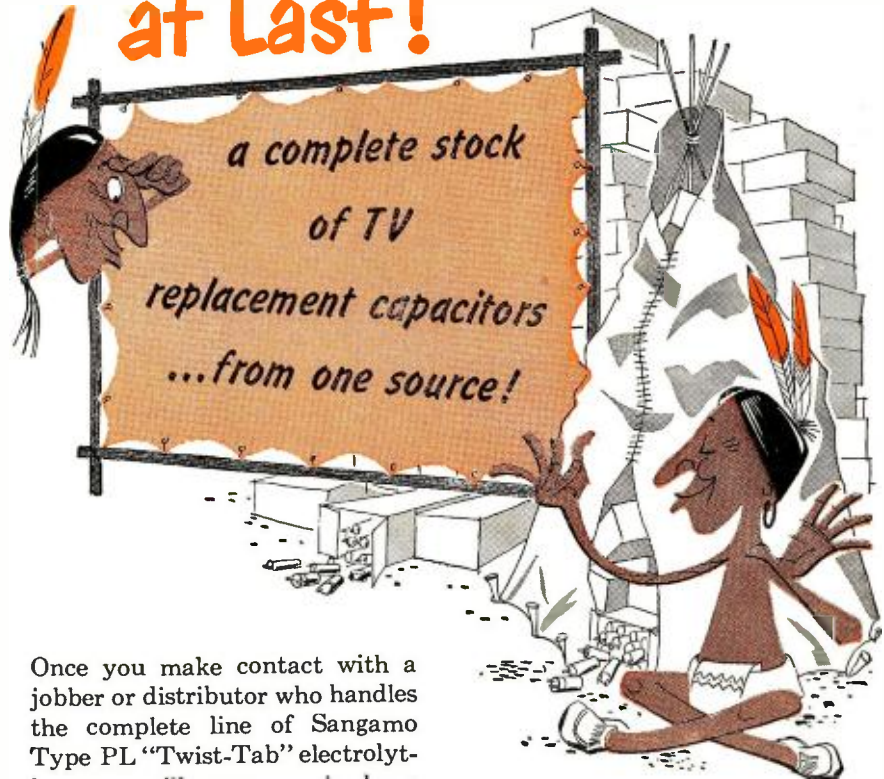

Once you make contact with a jobber or distributor who handles the complete line of Sangamo Type PL "Twist-Tab" electrolytics, you will never again have to "shop around" for odd sizes or capacities. Why?... because the Sangamo line is the most complete in the industry.

Used by all leading manufacturers of TV sets, Sangamo Type PL "Twist-Tab" electrolytics are exact replacements. They assure long life and dependable performance at 85° C and under conditions of high surge voltages and extreme ripple currents often found in TV applications.



Ask your distributor for a copy of the Sangamo TV Replacement Catalog. It's easy to use and helps you choose the right replacement every time.

Deal with your Sangamo "Headquarters."

Those who know... choose Sangamo



SANGAMO ELECTRIC CO. MARION ILLINOIS



• 1220 pages
• 80,000 items
• 8,000 illustrations
• 8" x 11" — 5 lbs.

Publisher's price \$6.50 — your price through your regular parts distributor **\$1.95**

The right part when you need it for service

This permanent, hard cover Official Buying Guide of the electronic-TV parts and equipment industry with its comprehensive detailed index, eliminates the need for maintaining files of small catalogs and manufacturers' literature. RADIO'S MASTER catalogs 90% of TV and electronic equipment. Not merely part number listings — complete descriptions, specifications and illustrations written and compiled by each manufacturer. Enables you to make comparisons or substitutions right now!



UNITED CATALOG PUBLISHERS, INC.
110 Lafayette St., New York 13

NEW!

3 Super Standard Output Transformers

±1 db 20-30,000 cycles
High Efficiency
Small Size

S-510-F, 10 watts
Pri: 10,000ΩCT-8,000ΩCT
Sec: 16-8Ω

S-526-F, 20 watts
Pri: 6,600ΩCT-5,000ΩCT
Sec: 16-8-4Ω

S-542-F, 40 watts
Pri: 5,000ΩCT-4,000ΩCT
Sec: 16-8-4Ω

	Dimensions Inches	Wt. lbs.
S-510-F	2 ⁷ / ₈ -2 ³ / ₄ -2 ¹ / ₂	2
S-526-F	4 ³ / ₈ -3 ¹ / ₈ -2 ³ / ₄	3
S-542-F	4 ¹ / ₂ -3 ¹ / ₈ -3 ¹ / ₈	5 ¹ / ₂



Now in Stock

Write today for the new 1953 Peerless Catalog

PEERLESS
Electrical Products

A DIVISION OF



9356 Santa Monica Blvd., Beverly Hills, Calif.
161 Sixth Avenue, New York 13, New York

Uses all frequencies—7.22, 4.826, 3.275 straight through 0700-1400 closedown now. (Ridgeway, South Africa)

Norway—Oslo, 11.850, noted closing 1900 with *English* identification. (Niblack, Ind.) LLM, 15.175, heard identifying in *English* 0700; asked for reports. (Mast, N. Y.) On Sundays at 1200 has *English* session ("Norway This Week") on this channel. (Buettner, Germany)

Outer Mongolia—Ulan-Bator is heard in Japan on 6.518 irregularly from around 0500 until 1000 closedown; *native music is different from that of China*. (Japanese Short-Wave Club)

Pakistan—Radio Pakistan is at good level on both 7.010, 6.235 in the transmission to Turkey 1430-1515 and to the United Kingdom 1515-1600 closedown. (Engberg, Sweden, others) Noted with news 0730-0740 on 17.835. (Pearce, England) Heard with *English* 2130 on 5.987, high level in South Africa. (Ridgeway) Noted with news and commentary 2015 on 11.914; Dacca, 15.335, heard 2100 with program for local listeners. (Sanderson)

Paraguay—ZPA1, 6.275, good level around 2030 to sign-off 2201A. (Levy, N. Y.)

Peru—Radio Nacional del Peru, OAX4Z, 6.082, noted weekdays with news in Spanish 2000. (Casey, Ky., Niblack, Ind.) Heard closing 2400 with powerful signal in Oregon. (Callarman) OAX4J, 9.330, Lima, noted around 2230; all-Spanish; identified as "Radio Colonial de Lima." (Patterson, Ga.)

Philippines—Far East Broadcasting Co., Manila, is noted in Sweden on the new 17.805 outlet around 0400-0600, has QRM. (Engberg) DZH7, 9.73, noted with fair signal 1715-1800. (Bellington, N. Y.) With *English* announcements 1800 on DZH9, 11.855, of "The Call of the Orient"; weak. (Niblack, Ind.) DZB2, 3.325, noted 0600 at excellent level. (Sanderson, Australia) Radio Free Asia relay, 6.110, heard closing session 1015, good level. (Rose-nauer, Calif.) Schedule now seems 0645-1015A.

Poland—Latest schedule for *English* for Europe from Radio Warsaw is 0130-0200, 5.955, 7.125, 5.995; 1200-1230, 7.175, 9.555; 1230-1300, 6.025, 9.555, 7.145; 1400-1430, 6.025, 9.555, 7.145; 1430-1455 and 1730-1800, 5.955, 7.125, 5.975. (Pearce, England) And for North America—0600-0630, 9.570, 9.555; 0715-0800, 15.120, 9.555; 1715-1800, 1945-2015, 2315-2345, 0030-0100, 6.025, 9.555.

Portugal—A short-wave station in Coimbra is operating on 7.020A at 1300-1500. (Engberg, Sweden) Lisbon lists winter schedule of 1900-2100 to North America and North Atlantic, 6.374, 9.746; 0600-0800 to Macau-Timor, 15.125; 0945-1200 to Goa, Damao, Dieu, 15.125; 1230-1530 to Mozambique, Angola, Sao Tome, 9.740, 11.996; 1600-1830 to Guinea, Cape Verde Islands, Brazil, 9.740, 11.964. (WRH) Lisbon, 11.996A, is good level around 1230. (Cox, Del.)

Portuguese Guinea—Bissau, 5.839A,

RADIO Surplus Buys



CRYSTALS

... in FT 241-A Holders—¹/₂" Pin SPC. Marked 54th OR 72nd Harmonic MC Freq. Listed below by fundamental frequency with fractions omitted.

500 KC Crystals ea. **\$1.95**
1000 KC Crystals ea. **\$3.95**
200 KC Crystals ea. **\$3.95**

370	407	444	476	509
372	408	445	477	511
374	409	446	479	512
375	411	447	480	513
376	412	448	481	514
377	413	450	483	515
379	414	451	484	516
380	415	452	485	518
381	416	453	486	519
383	418	454	487	520
384	419	455	488	522
385	420	456	490	523
386	422	457	491	525
387	423	458	492	526
388	424	459	493	527
390	425	461	494	529
391	426	462	495	530
392	427	463	496	531
393	429	464	497	533
394	430	465	498	534
395	431	466	501	536
396	433	468	502	537
397	434	469	503	538
398	435	470	504	540
400	436	472	505	
401	437	473	506	
402	438	474	507	
403	440	475	508	
404	441			
405	442			
406	443			

\$100 EACH

10 for \$8.00, Postpaid

FOLLOWING CRYSTALS AVAILABLE IN FT 243 HOLDERS ¹/₂" PIN SPACING

3590	5035	7350
4165	5127.5	7450
4280	5285	7750
4335	5660	7875
4350	5730	
4370	6073.3	
4440	6075	
4445	6140	
4540	6150	
4580	6350	
4620	6525	
4635	6700	
4710	6875	
4880	6975	
4980	7075	
4995	7150	

\$100 EACH

11 for \$10.00, Postpaid

PLEASE ENCLOSE FULL AMOUNT WITH ORDER
QUANTITIES AVAILABLE
WRITE FOR YOUR REQUIREMENTS

C & H SALES CO.

BOX 356-FE EAST PASADENA STA. • PASADENA 8, CALIF.

ARKAY

world's finest radio kits

Write for free Brochure

RADIO KITS, INC., 120 Cedar St., N., Y. 6

BEFORE YOU SELL, LET US BID ON YOUR ART-13's

Also need CFI units for above—and will pay top \$5 for BC-788, I-152, and BC-348 receivers.

For Top Prices, Write

BOB SANETT
5404¹/₂ Packard St. Los Angeles, Calif.
Phone Collect REpublic 31127

ANOTHER OUTSTANDING JOBBER RADIO & ELECTRONIC PARTS CORP.

3235 Prospect Ave.
Cleveland 15, Ohio

HAS THE SENSATIONAL NEW
EICO 470-K 7"
SCOPE KIT
IN STOCK!



\$79.95

RADIO & TELEVISION NEWS

noted in Portuguese 1630-1800 when closed with "A Portuguesa"; male announcer. (Ridgeway, South Africa)

Portuguese India—Radio Goa, 9.610, noted on a Sun. at 1030 with "Bringing Christ to the Nations" in English; at 1100 appeared to continue with similar broadcast in a native language. (Pearce, England) Carries "The Old Fashioned Revival Hour" (English) Mon. 1030-1130. (Ridgeway, South Africa)

Rhodes—Latest schedule for relays of VOA by "The Courier" is 6.015, 1200-1645 to Near East, and 1730-2245 to Caucasian USSR; 7.200, 2015-2045, 1615-1645, 1730-1900 to Caucasian USSR.

Roumania—Radio Bucharest noted on 6.210 and 9.254 with English 1530. (Bellington, N. Y.) Announces English for 1500 but when this was written, it was starting 1515; 12.032 is announced as parallel 6.210, 9.254. (Pearce, England) Verified from Strada A. St. Popov Nr. 60-62, Bucharest, Roumania, with new-type card; listed **Radio Romania** on 155 kc.; **Radio Bucuresti** on 854, 1052, 755, and 1457 kc.; **Radio Romania Libera** on 6.210, 9.254, 12.032. (Kary, Pa.)

Saudi-Arabia—Djeddah, 6.175A, noted at nice level from tune-in 2235 to 2315; all-Arabic. (Saylor, Va.)

South Africa—SABC, 9.870, noted 1200 with time pips, then news (on alternate days has news in Afrikaans); has news 1500 and closes 1505. (Pearce, England)

South Korea—Radio Sweden says the new 10 kw. transmitter at Seoul is now on the air using 9.555 at 1600-1830, 2130-0030, 0500-0900; heard at weak level in Sweden by Engberg. HLKA, 7.935A, Pusan, noted by Bal-lou, Calif., at 0615, fair level with slow fading.

Southern Rhodesia—Salisbury, 3.320, noted 1320 with sports results; joined BBC's General Overseas Service 1330. (Pearce, England)

Spain—Many Spanish stations have changed frequencies lately. **Radio Nacional de Malaga** is now on 6.940A; **Radio Mediterraneo**, Valencia, is using 6.995A; **Radio Cartagena** has been heard on 7.370 and also on 7.425 at 1100 and 1600-1700; **Radio Alerta** is operating on 7.500; **Radio Juventud**, Sabadell, is heard at 1700 on 7.345; **Radio Nacional** in Barcelona noted recently on 7.655 at 1100-1600. (Engberg, Sweden)

Spanish Morocco—EA9AH, 6.067, Tetuan, noted closing 1800. (GDX-aren, Sweden)

Surinam—Paramaribo, 15.405, was noted recently from 1437 tune-in to 1456 with a program of music which sounded Hindu; good level, some QSB, no QRM. (Bellington, N. Y.) Noted on 5.757 parallel 15.405 from around 1600. (Ridgeway, South Africa)

Sweden—Radio Sweden, 9.62, noted 2300 with English to Southeast Asia, Australia; weak. (Bellington, N. Y.) Heard on 9.535 at 2315 in English. (Lund, Iowa) Noted on this channel with English 0800. (Chatfield, N. Y.)

ORDER BY MAIL FROM WHOLESALE RADIO

Low Prices • Complete Stocks • Fast Shipments

Tops In TV Antennas

All Directional TV AERIAL

Same Clear Pix as Motor Rotating Aerial Systems Costing Triple! **\$18.95**

FOR FRINGE AREA

COMPLETE with three 3 1/2 ft. masts, 75 ft. 3 cond. cable, Beam selector sw., guy rings and mounting base. Electronically beams complete 360° rotation to give clear pic on all channels. You choose direction with directronic selector sw. mounted on or near TV set. Complete double stacked array with 18 hi-tensil double alloy aluminum elements. AX-599 same as TX-599 less masts, guy ring & mtg. base 16.95

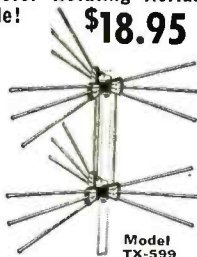

Model TX-599

Three Models Cover All Channels

UHF YAGI TELEVISION ANTENNAS

Model #3A—Channels 14-48 **\$375**
Model #3B—Channels 27-62
Model #3C—Channels 49-83 each

YOUR CHOICE! TV ANTENNAS

\$395 each

HI-LO ARRAY



Was \$4.39

Two folded dipoles (hi & lo) with reflectors. The best all channel folded dipole anywhere near this exceptionally low price. Model AR-21, less mast.

CONICAL ARRAY



Was \$4.95

All channels. Eight hi-tensil aluminum alloy elements. Snyder Model XA-44 less mast.

\$295 each In Lots of 6, Models may be combined for quantity discount.

WRITE FOR FREE F. Y. I. FLYER

ADDRESS ORDERS TO DEPT. RN-3

WRITE FOR FREE HI-FIDELITY GUIDE

WHOLESALE RADIO PARTS CO., Inc.

311 W. BALTIMORE ST., BALTIMORE 1, MD.

PEN-OSCIL-LITE

Extremely convenient test oscillator for all radio servicing; alignment • Small as a pen • Self powered • Range from 700 cycles audio to over 600 megacycles u.h.f. • Output from zero to 125 v. • Low in cost • Used by Signal Corps • Write for information.

GENERAL TEST EQUIPMENT
38 Argyle Buffalo 22, N. Y.

ANOTHER OUTSTANDING JOBBER
VAN SICKLE RADIO SUPPLY CO.
1320 S. Calhoun St.
R. Wayne, Indiana

HAS THE SENSATIONAL NEW **EICO** 470-K 7" SCOPE KIT IN STOCK!
\$79.95

The Famous New Baruch Lang

HIGH FIDELITY SPEAKER SYSTEM

It's Revolutionary! It's Amazing!

4 Specially Designed SPEAKERS COMPLETE WITH CABINET

\$295

General Hi-Fi Model 501



Compact, high-fidelity corner speaker system developed at the famous Mass. Institute of Technology. Baruch-lang principals approach acoustical qualities of larger units costing 4 times this low price. Small space requirements, high output and wide dispersion angle makes it perfect for low cost high fidelity music systems in homes, public buildings, restaurants, schools. Connects easily to phono systems, AM-FM radios, TV. Response 40 to 12,000 cps. at +/- 3db. 13" high, 19" wide, 9 3/4" deep. Wt. 10 lbs. 4 ohms impedance.

The Last Word In Hi-Fidelity! BROOK AMPLIFIERS

Low-mu triodes for best tonal quality. Remote control pre-amp has inputs for tuner, TV and phono; or single chassis units. 8 Position stepped bass and treble control circuits. Frequency response; 15 to 30,000 cycles.

12A4 10 W. amp & pre-amp **\$222**

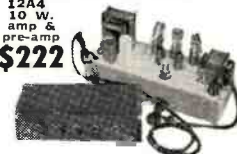

GARRARD 3 Sp. CHANGER World's Finest Record Changer



Fully automatic with automatic stop. Plays all size records, all 3 speeds. Min. cabinet space required: 15 1/2" long, 13 1/4" wide, 5 3/4" clearance above and 3 1/4" below top of motor board. Model RC-80 less cartridge **\$42.30**

BELL 212B 10 WATT HIGH FIDELITY AMPLIFIER



Frequency response: 30 to 15,000 cycles at +/- 3/4 db. Four inputs: radio, crystal, and two magnetic pickups with built-in pre-amp for each. Bass and treble boost with attenuation. Power: 117 V. 60 **\$50.46**



SOUND POWERED PHONES RCA-MI-2454

Complete with 24' of Rubber Covered Wire. **NEW EXPORT PACKED** Shipping weight 6 lbs. **\$9.95 per set** **2 for \$19.50** EACH SET GUARANTEED Brand New. Gov't Cost \$42.00

RCA MI-2475 SOUND

POWERED PHONES

complete with 22' rubber covered cable press to talk switch are light weight, the mic is on a swivel boom that can be moved to any position in front of face. Cost \$62 ea.

BRAND NEW Price **\$1495** Ea. Include postage with order.

McCONNELL'S 3834 Germantown Ave. Phila., Penna. RA 5-6033



Sensational Performance!

MATTISON

SILVER ROCKET 630 CHASSIS
• with TUNEABLE •

BUILT-IN BOOSTER
for Better DX Reception

Featuring NEW CASCODE TUNER
made for UHF interchangeable
tuning strips and 70° COSINE YOKE

Tube
Complement:
28 tubes
3 rectifiers
1 CRT

32

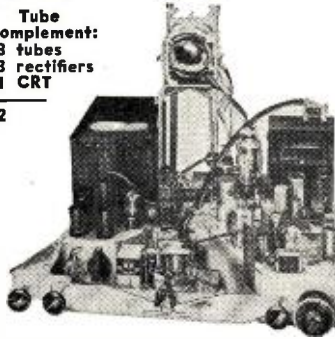

All Channel Booster

- Broad band single knob control pre-amplifier built in to eliminate long leads which may cause regeneration and attenuation of signal.
- ONLY THE MATTISON 630 CHASSIS HAS AN ALL CHANNEL TUNEABLE BUILT-IN BOOSTER THAT INCREASES SIGNAL STRENGTH UP TO 10 TIMES. THE SILVER ROCKET WILL OUT-PERFORM ANY CHASSIS MADE AND IS PRICED RIGHT TO SELL FAST WITH AN EXTRAORDINARY MARGIN OF PROFIT FOR YOU. WRITE FOR CONFIDENTIAL PRICE SCHEDULE.

ALL CABINETS MADE IN MATTISON'S OWN CABINET FACTORY!

ANNOUNCING
the New
AMBASSADOR
for 1953

The only open
face console
made in every
expensive
decorator
finish . . . on
guaranteed
genuine ma-
hogany, walnut,
oak and other
rare woods!



The AMBASSADOR 17" and 21"
Best Looking . . . Best Value, Too!

Full size console for eye level television. Available in genuine mahogany or blond mahogany. Featuring removable safety glass. Dimensions height 42 inches, width 26 inches, depth 23 inches.

DEALERS! SERVICE DEALERS! Here is your opportunity to become the "important" TV Dealer in your area for THE FINEST CUSTOM-BUILT LINE OF TV RECEIVERS. FREE!! Write for Mattison's merchandising portfolio explaining the "UNASSEMBLED PLAN" and "\$1,000,000 FLOOR PLAN."



Manufactured with integrity

Mattison Television & Radio Corp.

10 West 181st St., Dept. RN, N.Y. 53, N.Y.

When you buy from Mattison you need only one source of supply! You can buy a Mattison Chassis, a Mattison Cabinet or a complete Mattison TV Set!

Noted on 11.705 in Swedish 1625; on 15.155 at 0900 in English. (Geisel, W. Va.)

Syria—Radio Damascus, 17.865, noted signing on 0945 with English to India-Pakistan. (ISWC, London)

Tahiti—Radio Tahiti, 6.135, Papeete, heard again around 0100-0130 when closed with "La Marseillaise." (Sutton, Ohio) Should open around 2300.

Taiwan—Taipeh, 10.200, noted recently 1845 at fair level, moderate fading; heard on 9.775 at 0535 with fair signal. (Ballou, Calif.) BED29, 6.095, is heard in South Africa from around 1000 in parallel with BED6, 11.735, and BED7, 7.133A in Chinese dialects. (Ridgeway) BED6, 11.735, noted 2345 with English program of

news and music. (Sanderson, Australia) Heard on 15.235 and 11.735 now at 2300-0200; first hour English; second hour Chinese; third hour Chinese at dictation-speed. (Rosenauer, Calif.)

Tangier—Pan-American Radio, 7.300, relays VOA 1430-1500, then has French session. (ISWC, London) Radio Africa, 7.126, noted closing 1900 after final announcements in Spanish, French. (Catch, England)

Thailand—Bangkok, 11.910A and 6.240, noted with news 0515 and 0615. (Sanderson, Australia) The 7.105 channel carries separate program at that time. (Balbi, Calif.)

Trinidad—VP4RD, 3.275, Port-of-Spain, noted at fair level with news 1845; at times has heavy QRM. (Say-

IMPROVING VIDEO AMPLIFIER OPERATION

By CHARLES ERWIN COHN

I RECENTLY purchased an old 7-inch TV set, a Meck XB-702. Although it provided a picture, its performance was not of the best and I was determined to improve it.

One of the difficulties was a low contrast capability. When the contrast control was turned up to a reasonable level, the picture got fuzzy and a buzz appeared in the audio which, of course, was caused by the sync pulses cutting off the video amplifier. The remedy for this condition lay in improving the output voltage potentialities of this circuit.

An examination of the circuit showed that the screen of the 6AU6 video amplifier tube was connected to the 117-volt line, while the plate of the tube was connected to the same line through a 6800 ohm resistor and an assortment of peaking coils and sound traps. Measurement of the plate voltage showed that it ranged from 25 volts with the contrast full up to 60 volts with the contrast full down. With the 7JP4 kinescope requiring around 100 volts signal for full contrast, it was obvious that low plate voltage was the reason for the trouble.

Fortunately, there was a source of higher voltage available—the sweep multivibrators receiving about 300 volts. The video amplifier plate circuit was

removed from the 117-volt line and re-connected to this circuit. The additional drain of the video amplifier brought the voltage at this point down to 200 volts, but changing the filter resistor in this supply from 10,000 to 5600 ohms restored the original voltage.

Immediately, things began to improve. The video amplifier plate voltage rose to 160 volts with the contrast control full up and 200 volts with the contrast control full down. In addition, the 6AU6 tube was replaced by a 6BA6 to help reduce the set's tendency to sync pulse cut-off. With all these changes, usable contrast rose considerably, with consequent improvement in picture quality and sync action.

Although this was an obsolescent set, this type of video amplifier circuit is used in many modern sets with transformerless power supplies. The simple circuit changes described here offer a way of improving the picture quality of many sets.

Contrary to the opinions of many, I do not believe that the circuits of TV receivers are sacrosanct, but rather that the circuits of many sets, particularly the older or cheaper ones, can be improved by anyone with the patience to experiment and sufficient background to know what he is doing.

-50-

TWENTY-NINTH BOARD of DIRECTORS and OFFICERS RTMA 1952-53



lor, Va.) Heard on 9.625 relaying BBC news 0600, then with recorded music 0615. (West, Va.)

Turkey—The Technical University of Istanbul is now heard on 7.035A most days 1300-1400 with Turkish music and also some classical music. (Engberg, Sweden) In QSL, listed schedule of 1315-1500; said moved to 7.030V from 7.080A to avoid QRM. (Kary, Pa.)

Uruguay—CXA6, 9.623, noted parallel CXA10, 11.90A at 1500. (Ridge-way, South Africa) CXA10 noted in Indiana at strong level around 2000. (Hord)

USI (Indonesia)—Djakarta's new 9.866 channel noted to 1030 when closes with Indonesian National Anthem. (Pearce, England) Has news in Indonesian 0730. (Niblack, Ind.) YDJ2, 7.100A, Jogjakarta, Java, has fair signal 0600 with *English* recordings. (N. Z. DX Times) Djakarta, 11.947A, noted with dance music 0700, signing off 0730. YDB3, 7.27, Djakarta, heard closing with chimes 1130. (Ridgeway, South Africa, Callarman, Oregon)

USSR—*Radio Tashkent*, 6.825, noted with news and commentary 1000-1030, 1100-1130. Is directed to India-Pakistan in *English*. (Pearce, England) Ballou, Calif., reports Alma Ata heard on 9.380 at 0505, fair signal. Heard by Catch, England, on 9.340 at 0200 with light music.

After closing *English* transmission 0230 on 7.180, 5.960A, *Radio Moscow* takes oriental languages, and then is

also parallel on 6.060A and 6.115A. (Callarman, Oregon) Frunze, 5.059A, noted 1445 with *English* session, good level; goes into foreign tongue 1500.

Vatican—HVJ noted with interval signal 1445 on 7.280, 6.030, 5.969A, then opened in German. Noted with news 1000 on 15.120, 9.550, 11.685, 11.740. (Pearce, England, Niblack, Ind., others) Has *English* also 1315 on most of these channels.

Venezuela—YVKR, 4.920, Caracas, noted with North American popular songs 2300-2330, when identified with four chimes, played band march, and left the air; YVMF has news in Spanish 2130-2135 on 4.800; is "Ondas del Lago," Maracaibo. (Casey, Ky.) Widely reported with *English* 1800-1900 is *Radio Rumbos*, 4.970, Caracas; is now using 10 kw. (West, Va., others)

YVKR, 4.920, *Radio Caracas*, signs off 2328, good level, no interference. YVKC, 4.890, noted with *English* 0630-0730, news 0640; uses commercials. (Callarman, Oregon) *Radio Popular*, Maracaibo, has been heard testing on 9.630 at 1730-1800. (Radio Sweden) *Radio Barquisimeto*, YVKJ, 9.510, noted 1500-1630 sign-off. (Sutton, Ohio)

Yugoslavia—*Radio Yugoslavia*, 6.100, Belgrade, noted with news 1645-1700. (Pearce, England) Heard with *English* 0145-0200. (Balbi, Calif.)

* * *

Press Time Flashes

At press time, *Radio Japan* had
(Continued on page 156)

WAREHOUSE CLEARANCE SALE

ALL SURPLUS MUST GO!

BC706D Switch Boxes.....	3 for \$1.00
35MMFD Double Spaced Var. Cond....	3 for 1.00
CD716 Cords W/PL55 & JK56.....	3 for 1.00
BC-347 Interphone Amp.—less tube.....	1.00
Telescoping Whip Ant., 3-ft.....	1.00
Telegraph Key JK-38.....	1.25
Telegraph Key—knee mount.....	.75
Elevator Servo Amp. with tubes.....	3.95
Navy CW Xmtr. 85-105MC, less tubes.....	2.50
Ant. Relay Unit—BC442A.....	3.95
5BP4 Cathode Ray Tube.....	3.95
2-Gang Variable Cond. from SCR-522.....	1.29
3-Gang Variable Cond. from SCR-522.....	1.59

Special Purchase! FM Radio Chassis



88-108 MC—Complete with 6 tubes, built-in antenna and speaker. Product of famous radio and TV maker whose name we promised not to mention **\$16.95**

TWO-STATION INTERCOM SYSTEM



Consists of master and remote station, 20-ft. of 3 wire cable, 115 V operation, AC or DC. Extra wire .05 per ft. . . . **\$17.95**

NOTICE TO ALL HAMS
TRADE-IN your used communications gear on new Hallcrafters, National, RME, Hammarlund, Sonar, Eimac, Gonset, Etc. equipment. Write for FREE ESTIMATE, attention "Pick"—W3PPQ.

FREE QUOTATIONS on hi-fi equipment yours on request. All famous brands of amplifiers, tuners, changers, pick-ups, speakers, etc. Just tell us how much you want to spend and we'll recommend the best matched system your budget will allow!

SUN RADIO
OF WASHINGTON, D. C.
938 F STREET, N. W. WASH. 4, D. C.

Just Out

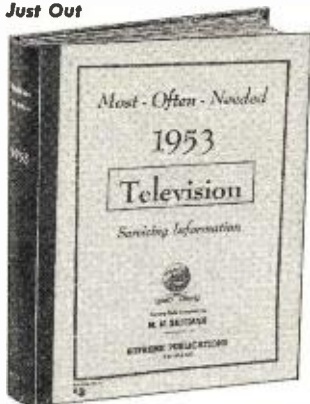

This newest giant volume of the Supreme TV series covers 1953 factory data on all popular television sets of all makes. There are explanations of new circuits, 192 pages of alignment procedure, test patterns, response curves, pages of waveforms, voltage charts, service hints, production changes, and dozens of double-spread circuit diagrams. Manual-style binding (opens flat). Special price, only **3**

New SUPREME 1953 TV Manual

GET IT AT YOUR RADIO JOBBER OR SEND COUPON

COVERS ALL POPULAR SETS

This new *Supreme* 1953 TV manual has all the required service material on every popular television set of every important manufacturer. Here is helpful, practical, factory-prepared data that will really make TV servicing and adjustment easy for you. Benefit and save with this amazing manual scoop. This new giant TV manual, as well as the previous volumes for other years, has complete circuits, alignment facts, test patterns, response curves, service hints, recommended changes, voltage charts, waveforms, and many double-page diagram blueprints. Here is your TV service material to help you do more expert work quicker; and priced at only \$3 and \$2 per manual covering a whole year of material. See coupon below for the complete list of all seven TV volumes, from 1947 to 1953. Order at our risk for a 10-day trial.

AMAZING BARGAIN OFFER

The new 1953 TV manual is the most remarkable value offered by Supreme Publications in their 19 years of business. This mammoth television servicing manual at only \$3, or the TV manuals for previous years for only \$3 and \$2 each, are amazing bargains and defy competition. There is nothing else like them. Each manual is a virtual treatise on practical television repairs. By normal standards, each such large manual packed as it is with practical facts, hundreds of illustrations, diagrams, charts, photographs, and expensive extra-large blueprints, should sell for \$10—but as SUPREME special values they are priced at \$3 and \$2 each. Only a publisher who sold over one million TV and radio manuals can offer such bargains based on tremendous volume-sales. Be ready to repair any TV set by having in your shop all seven *Television Manuals* listed in coupon. Or try the new 1953 TV manual to see what an amazing bargain you get for only \$3. Send no-risk trial coupon.



The repair of any television set is really easy with Supreme TV service manuals. Every set is covered in a practical manner that will simplify troubleshooting and repair. This is the help you need to find toughest faults in a jiffy. Each \$3 volume covers a whole year of material. Be wise: buy Supreme Manuals only once each year instead of spending dollars every week for not needed data.



RADIO DIAGRAMS

Here is your complete source of all needed RADIO diagrams and service data. Covers everything from most recent radios to pre-war old-timers; home radios, auto sets, combinations, changers, and portables. Sensational values. Still sold at pre-Korean prices. Only \$2 for most volumes. Every Radio manual contains large schematics, all needed alignment facts, parts lists, voltage values, trimmers, dial stringing, and helpful service hints. Volumes are large in size, 8 1/2 x 11 inches, about 192 pages. See coupon at right for a complete list of these low-priced manuals.

NO-RISK TRIAL ORDER COUPON

SUPREME PUBLICATIONS, 3727 W. 13th St., Chicago 23, ILL.

Radio Diagram Manuals

- New 1952 Manual, \$2.50
 - 1951 Radio EACH
 - 1950 Manual } **\$2.50**
 - 1949 Radio }
 - 1948
 - 1947
 - 1946
 - 1942
 - 1941
 - 1940
 - 1939
 - 1926-1938 Manual, \$2.50
- PRICED AT ONLY **\$2** EACH

Send TV and Radio manuals checked below and at left. Satisfaction guaranteed or money back.

- New 1953 Television Servicing Manual \$3.
- 1952 Television Manual, \$3. 1951 TV, \$3.
- 1950 Television Manual, \$3. 1949 TV, \$3.
- 1948 TV, \$3. 1947 TV & FM, only \$2.

I am enclosing \$ Send postpaid.

Send C.O.D. I am enclosing \$ deposit.

Name:

Address:

Supreme Publications
Available from Leading Radio Jobbers

March, 1953

155

These practical books make TV servicing EASY



TV MANUFACTURERS' RECEIVER TROUBLE CURES VOL. 1. AND VOL. 2.

A brand new series of practical books. Gives you exact directions for correcting TV receiver "bugs". Each cure is official, factory-authorized, direct from the receiver's manufacturer. It is positive! Helps correct the most difficult faults—picture jitter, hum, instability, buzz, tearing, etc. Vol. 1 covers 12 prominent brands; Vol. 2 contains an additional 11 brands. One service job will more than pay the cost of these books! Vol. 1 over 120 pages (5¼ x 8¼").....\$1.80
Vol. 2 over 120 pages (5¼ x 8¼").....\$1.80

TV SWEEP ALIGNMENT TECHNIQUES

by Art Liebscher, *Test Equipment Specialist*. Never before has there been a book such as this on TV sweep alignment! Exclusive information not generally available to service technicians. Introducing the new Supermark method. Simplified procedures...time-saving...eliminates dual set-ups. Over 100 (5¼ x 8¼") pp., illus. \$2.10

UHF PRACTICES AND PRINCIPLES

by A. Lytel
New, up-to-the-minute. Clear, easy-to-understand book covers both theory and applications of UHF. TV devices, converters, UHF test equipment, circuit components, tubes. 390 (5½ x 8½") pages. Cloth cover.....\$6.60

TV TROUBLESHOOTING AND REPAIR GUIDE BOOK

by R. G. Middleton
The finest practical book to make your TV servicing easy. Spot TV receiver troubles rapidly. Includes receiver waveforms, visual alignment, test equipment kinks, etc. 204 (8½ x 11") pages.....\$3.90

VACUUM-TUBE VOLTMETERS

by J. F. Rider
Completely revised. Covers theory, operation and application — also probes, calibration and testing. Illus. with 432 (5½ x 8½") pages. Cloth cover.....\$4.50

ENCYCLOPEDIA ON CATHODE-RAY OSCILLOSCOPES AND THEIR USES

by Rider & Uslan
The most complete 'scope book ever published. Covers practically every 'scope manufactured during the past 10 years — and applications. 992 (8½ x 11") pages. 3,000 illus. Cloth cover.....\$9.00

FM TRANSMISSION AND RECEPTION

by J. F. Rider & S. D. Uslan
This 2nd edition covers FM from start to finish, including receiver servicing. 460 (5½ x 8½") pages. Cloth cover.....\$4.95
Buy these books now at your jobbers... leading bookstores... or — 3RN

JOHN F. RIDER PUBLISHER, INC.
480 Canal Street, New York 13, N. Y.

moved from 6.069 to 7.180 in parallel with 9.675 in beam to Western North America 0000-0100. (Rosenauer, Calif.) A station announcing as TGTE, Zacatecas, Guatemala, has been noted lately on 6.760 to 2300A sign-off. (Stark, Texas) ISWC, London, says Cayenne, Fr. Guiana, has test transmissions on Wed., Sat. 1800-1900 on 6.200; closes with "La Marseillaise." *Not confirmed.*

Bellington, N. Y., recently noticed the clandestine Basque station on 6.235A at 0238 tune-in when a man was speaking Spanish; at 0245 a man announced "Radio Euzkadi," then played a drum and fife interval signal repeated twice; continued in Spanish; good signal, no QRM.

A clandestine Asiatic station—probably located in Russia—is noted on 8.140 at 1200 to after 1400; frequency varies. A Bulgarian Freedom Station has been heard on 6.265 at 1055-1130. (Engberg, Sweden) Pearce, England, flashes that *Radio Alerta*, Valencia, Spain, has been noted more recently on 6.940 signing off around 1804.

Radio Free Japan, clandestine Communist station believed located in China, has extended its schedule to 2200-2300, 0500-0600, 0700-0830, 1500-1600 on 10.180, 11.896, uses Japanese only. (Radio Australia)

The Japanese Short-Wave Club reports "Voice of Vietnam," Saigon, Indo-China (Vietnam), 9.620, is on the air now 1800-1930, 2215-0030, 0500-1000 (English 0930); *Radio Hue*, 7.205, 1830-1900, 2300-0015, 0500-0800; *Radio Dalat*, 7.265, daily except Sat. 0530-0630 (Sat. 0530-0700); *Radio Hanoi* has moved from 6.165 to 9.670, 1800-1900, 2230-0015, 0500-0830; *Radio Hirondella* ("Radio Swallow"), 7.408A, Hanoi, 2300-0130, 0530-1000. Says *Radio Laos* is heard in Japan on 7.215 with news in French 0800-0815; *Radio Cambodia* operates on 6.090 from Phnompenh; relays *Radio France-Asie*, Saigon, 1815-1845, and has own news in French 0700.

A station heard opening irregularly around 0055 on 4.97A is believed to be Lagos, Nigeria, probably testing. (Bellington, N. Y.)

Sunspot predictions given by SBC, Berne, include March 21; April 20; May 19. (Ferguson, N. C.)

Latest schedule of NWDR, Hamburg, Germany, is 2300-0500, 6.270; 2300-1110, 15.275, 17.845; 2300-1900, 11.795; 1115-1900, 9.735, 17.815; 0550-1900, 7.290; Sun. sign-on is 0000. (Scheiner, N. J.)

The *Voice of America*, New York 19, New York, USA, will now verify correct reception reports on the stations transmitting programs from the USA and from Overseas Relay Bases at Tangier, Munich, Salonika, Rhodes ("Courier"), Honolulu, and Manila. Reports should include station location, call letters (for USA stations), frequency, program details including languages heard, signal strength intelligibility, and interference. (NNRC)

A station announcing Katmandu, Nepal, was heard recently on 9.856 testing in Hindi, Pathani, Tamil, and

ELECTRONIC'S LATEST TROUBLE-SHOOTER

A compact—complete—circuit analyzer

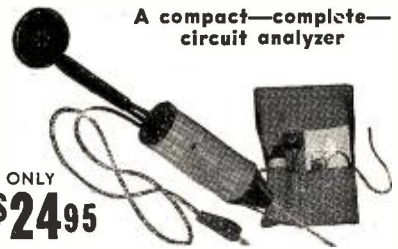

ONLY \$24.95

THE AMAZING TV SERVISSET Model E-C (Pat. Pending)

A precision engineered professional quality electronic test instrument. Ideal for field or bench servicing of Radio, Television, Radar, Communications gear, etc. Now—Quickly—Conveniently—At Low Cost
CHECKS: sync, sweep, video, audio circuits, TV high voltage supplies (DC, RF, or Pulse), low voltage supplies, coils, condensers, resistors, tubes, transformers, speakers, etc. Will localize trouble to a particular stage, determine defective component and can actually be clamped in circuit to restore circuit operation temporarily in 80% of component or tube defects. Ideal for locating and confirming intermittents.

SPECIFICATIONS:

RF & AF Signal Tracer, RF & AF Signal Injector, AC & DC Voltage Indicator 0/60/350/20,000, DC Polarity Indicator 60/350/20,000 volts, Lo ohms 0-3, Hi ohms 0-500k-20 megohms, Testa Condensers .00025-12 mfd., Testa Resistors 2 ohms-20 megohms, 2 Capacitance Sub ranges .01-1 & 4-40 mfd., 3 Resistance Sub ranges 50-500 ohms, 5k-25k, 100k-1 meg.

Will complement your existing equipment and will outperform other testers costing many times more.

A MUST FOR THE MODERN TV AND ELECTRONICS SERVICE ENGINEER.

Comes in handy cloth pouch, complete with all accessories including ALNICO phone, TV high voltage adapter, phone extension cord, test lead, Kilopon adapter and complete detailed instruction Manual, detailing latest TV trouble-shooting techniques. See Serviset at your distributor today. If he can't supply, order direct from factory, \$24.95 postpaid.

LEE ELECTRONIC LABS., INC.
233 Dudley Street Boston 19, Mass.



the Engineered Product

extends useful life of older TV tubes!

manufactured by

Perma-Power COMPANY

Chicago 25, Illinois

Manufacturers of Electronic Equipment Since 1928

RADIO & TELEVISION NEWS

French at 0630; said was "testing to Afghanistan, West Pakistan, India, and outlying lands to the West."

A clandestine "Chinese Patriots Radio," announced as portable and moving from place to place, has been heard in Chinese on 11.695-11.697, is in Chinese and Korean only with anti-Communist propaganda sessions at various hours every fourth day. Radio Athlone, 17.840, Ireland (Eire), was heard recently 0645 closing down what seemed to be a test transmission; said would be back 1315-1345; good quality but weak level. (Mast, N. Y.)

Acknowledgement

Thanks for the good reports. Keep them coming to Kenneth R. Boord, 948 Stewartstown Road, Morgantown, West Virginia, USA K.R.B.

SIGNAL CORPS RECEIVER

EMERSON Radio and Phonograph Corp. has developed a unique immersion-proof and concussion-proof AM receiver for the Signal Corps, the AN/GRR-5.

The new set covers a continuous frequency range of 1.5 mc. to 18 mc. in four bands. The complete set consists of a receiver chassis and power supply chassis housed in a shock-mounted aluminum case. Venting is accomplished by means of a hole through the spare fuse holder. When the cap is tightened, this unit preserves the immersion properties of the set.

Gears are used to obtain a 34:1 ratio of fine tuning knob rotation to gang condenser rotation. For rapid tuning, the fine tuning knob is pulled out, disengaging the fine tuning control and allowing the use of the "manual-preset" tuning knob with a gear ratio of 1.7:1.

The AN/GRR-5 is designed to be operated from dry batteries, storage batteries, or a.c. lines thus making reception possible in fixed installations, field installations, armored and personnel vehicles, gun carriages, etc. A spare parts kit contains tools, extra tubes and vibrators, whip antenna, and headphones for front echelon maintenance and repair work.

Front panel view of the AN/GRR-5 radio receiver being manufactured for the Signal Corps by Emerson Radio & Phonograph Corp.



March, 1953

PRICE REDUCTIONS

ON STANCOR YOKES and FLYBACKS

It's our way of saying, "Thanks for your confidence." Yes, thanks to you, the sale of these Stancor TV components has increased tremendously . . . our costs are lower . . . and we are passing these savings on to you.

These components are the same high quality, triple-tested units you have always received and come to expect from Stancor. At these new, low prices they are even better values than before.

DEFLECTION YOKES

PART NO.	OLD LIST PRICE	NEW LIST PRICE
DY-8	10.75	9.80
DY-8A	11.00	10.00
DY-9	10.75	9.80
DY-9A	11.00	10.00
DY-10	10.75	9.80
DY-10A	11.00	10.00
DY-11A	*	10.00
DY-12A	*	10.00

FLYBACKS

PART NO.	OLD LIST PRICE	NEW LIST PRICE
A-8128	40.50	10.00
A-8129	11.00	10.50
A-8130	11.00	10.00
A-8131	7.00	6.50
A-8132	*	10.50
A-8133	11.00	10.50
A-8134	11.00	10.50

STANDARD TRANSFORMER CORPORATION

3584 ELSTON AVENUE
CHICAGO 18, ILLINOIS



*New items: DY-11A is used in 172 models of 15 manufacturers. DY-12 is used in 160 models of 8 manufacturers. A-8132 is an exact replacement for Muntz TO-0031, used in over 300,000 sets. Ask your Stancor distributor for Bulletin No. 461 listing applications of these units, or write Stancor direct for your free copy.

Stancor Transformers are listed in Photofact Folders, Tek-Files and Counterfacts.

Export Sales: Roburn Agencies, 39 Warren Street, New York 7, N. Y.

YOUR OWN ELECTRONIC MUSIC

How to build and play my latest model electronic organ without a knowledge of music.

Send stamp for details

JIM KIRK, W6DEG,

1552 Church St., San Francisco 14, Cal.

ANOTHER OUTSTANDING JOBBER PENN ELECTRONIC PARTS CO.

5303 Frankford Ave.
Philadelphia 24, Pa.

HAS THE
SENSATIONAL NEW
EICO 470-K 7"
SCOPE KIT
IN STOCK!



\$79.95

Send for free flyer

GET INTO ELECTRONICS

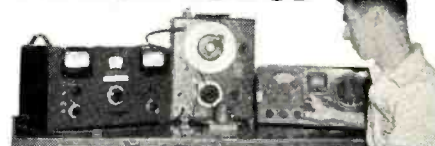

You can enter this uncrowded, interesting field. Defense expansion, new developments demand trained specialists. Study all phases radio & electronics theory and practice: TV; FM; broadcasting; servicing; aviation, marine, police radio. 18-month course. Graduates in demand by major companies. H.S. or equivalent required. Begin Jan., March, June, Sept. Campus life. Write for catalog.

VALPARAISO TECHNICAL INSTITUTE
Dept. RD Valparaiso, Indiana

157

SPINTITE

REG. U. S. PAT. OFFICE

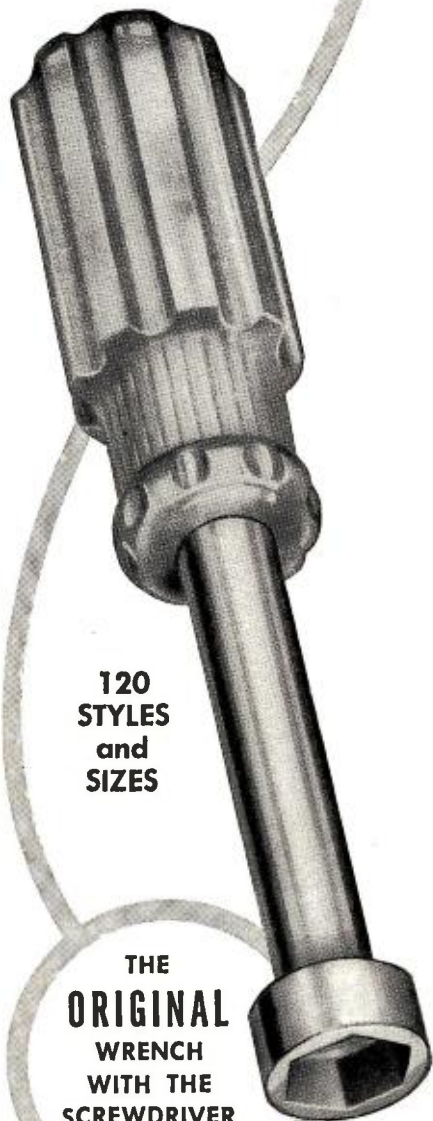

120
STYLES
and
SIZES

THE
ORIGINAL
WRENCH
WITH THE
SCREWDRIVER
ACTION

for

- ASSEMBLY WORK
- REPAIR WORK
- RADIO
- TELEVISION
- INDUSTRIAL
- AIRCRAFT



STEVENS WALDEN, Inc.
WORCESTER 4, MASS.

NEW TV PRODUCTS on the Market

SENSITIVITY TESTER

Service Instruments Co. of 422 S. Dearborn St., Chicago 5 is marketing a new portable sensitivity tester for measuring TV receiver performance in fringe areas.

The "SensiMeter's" microvolt scale is divided into "sensitive," "medium sensitive" and "insensitive" sections which permit the technician to quickly determine the condition of the set. The unit checks from antenna terminals to picture tube.

The company claims that it is possible to determine receiver performance in a weak signal area within three minutes.

Further information is available from the company on request.

FIELD STRENGTH METER

Jerrold Electronics Corp. has announced a new field strength meter, the Model #704, which is designed for both laboratory and field work.

The new unit is direct reading in microvolts with an accuracy of $\pm .8$ db. It has a continuous tuning range from 50 to 220 mc. It separates and measures video, audio, and adjacent channel carriers and locates r.f. interference. A model with a 6-volt vibrator pack (#704-6V) is available at extra cost.

Full details on either or both of these models is available from the

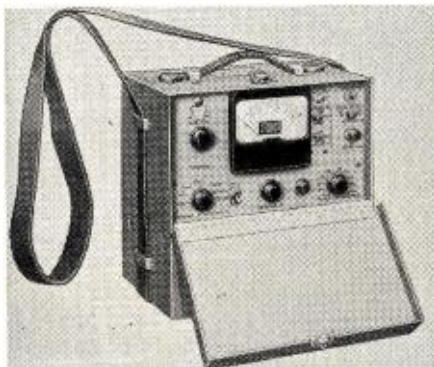

company's new distributing subsidiary, *Najesco, Inc.*, 1449 S. 26th, Philadelphia 46.

CONTROL KITS

P. R. Mallory & Co., Inc., Indianapolis 6, Ind., has made available three new control kits with which it is possible to service over 50 different models of radio and television sets.

Number and types of controls included in each kit were determined on the basis of recent figures showing which controls are most popular in different geographical areas. Six type s.p.s.t., one type d.p.s.t., and one type s.p.d.t. switches are included with each

kit. The kit is housed in a metal cabinet.

Kit 3735 is for the Western states, Kit 3755 is for the Central states, while Kit 3810 is for technicians in the Eastern area.

DYNAMIC ANALYZER

Electronic Beam Corp., 923 Old Neperhan Ave., Yonkers, 3, N. Y. is offering a CRT dynamic analyzer which will attach to any v.t.v.m. and convert it into a CRT tester.

The instrument will permit a check

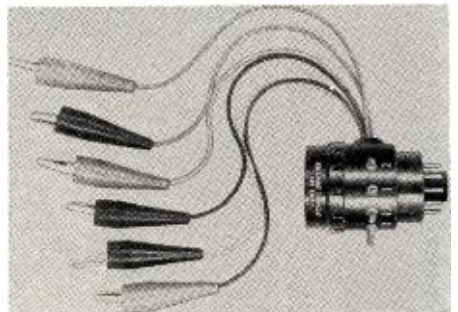

of socket voltage while the TV set is in operation, will check emission of the CR tube, and check the CRT for open or shorted elements and leakage.

The unit comes complete with an instruction manual which provides full details on performing dynamic tests.

U.H.F. ANTENNA KIT

Miller Television Co., 2840 N. Naomi, Burbank, Calif. has developed a u.h.f. antenna kit which contains the necessary parts for assembling six complete u.h.f. antennas. No extra parts of any type are required.

The six antennas which can be constructed include the corner reflector, double bow-tie, double-V, yagi, rhombic, and four-stacked X.

JAMPROOF DRILL

The *Carboloy Department of General Electric Co.* has developed a new drill which eliminates the possibility of jamming while boring through tough masonry, such as bricks, concrete, plaster, slate, or asphalt.

The self-cleaning action of the new drill is due to the shallow, oval spiral and overhang on the tip which keeps the particles moving out of the holes. The drill is tipped with *Carboloy* cemented carbide.

SINGLE-CHANNEL BOOSTER

Channel Master Corp., Ellenville, N. Y., is introducing a new single-channel TV booster, the "Katy-B."

It incorporates a low-noise 6BQ7 tube and a cascode-type circuit. It has a gain of 12 times (22 db) on the

RADIO & TELEVISION NEWS

low band and 6.5 db on the high band. The booster incorporates double-tuned transformers, wound for each specific channel, and an antenna bypass switch. It provides for both 72 and 300 ohm input and output.

CONTACT LUBRICATOR

A new remote control lubricating device for radio and television service



work has been introduced by *General Cement Mfg. Co.*, 919 Taylor Ave., Rockford, Illinois.

Essentially an "oil can" with a flexible tube four inches long, the new unit permits the technician to oil or grease electronic controls and bearings from virtually any position.

TV ANTENNA TOWER

Tele-View Towers Inc., 701-703 49th St., S., St. Petersburg, Fla., has developed a welded aircraft-type-tubing television antenna tower which weighs only 60 pounds, extends to a full height of 40 feet, and telescopes to 20 feet.

A removable crank at the base of the tower operates a telescoping mechanism which permits the tower to be lowered in high winds or, when used for fringe area demonstration work, to be packed away for transportation. The tower can be carried on the roof of any automobile. No guy wires are required. The base of the tower is hinged so that it may be raised from the ground, without climbing, after the antenna itself has been set in place on the mast.

"AUTOCOUPLERS"

Industrial Television, Inc., 369 Lexington Ave., Clifton, N. J., has two new "AutoCouplers" available, the Models IT-117A and IT-118A.

These units permit the operation of two or four receivers from a single antenna. Housed in inconspicuous cabinets, the new units feature micro-loss, interaction suppressing distribution, and adaptability to either twin-lead or open-wire line.

INSULATED TEST CLIPS

Industrial Devices, Inc., Edgewater, N. J., has designed a completely insulated test clip, the Model #1410A.

The plastic insulation covers the entire clip, including the nose. The new

More Profits from the Complete line of SUPERIOR ROHN TOWERS

Standard Self-Supporting ROHN steel TOWER

Proved to be the BEST answer to your Tower needs! Thousands of installations prove ROHN superior in design, construction, and quality. Made in standard 10 ft. sections, using heavy duty tubular steel and electric welded throughout. Tests prove the rugged construction . . . can be climbed . . . no guying needed up to 50 ft. Double-coated with a finish that's permanent and non-corrosive. Quickly installed in cement base. These towers can be used to any height . . . even up to 150 ft. Here's true permanent installation that has real sales appeal. Get the facts — you'll be convinced ROHN is BEST!

— 2 other Rohn Models for you!



<p>ROHN "FOLD-OVER" TOWER This type tower is built by merely using regular Rohn tower sections and an inexpensive Fold-Over kit. Has all the advantages of the standard Rohn tower, but is of the fold-over type that makes it perfect for antenna changing, rotator servicing, experimentation, etc. Kit includes hinged section, boom, reel and cable mechanism, 4 guy anchors and special base section.</p>	<p>ROHN TELESCOPING MAST is quickly installed and raised to desired height in a moment. Heavy-duty galvanized steel tubing in heights from 20 to 50 ft. An absolutely sturdy and durable mast . . . non-corrosive and indestructible. Excellent rigidity at joints. Comes complete with guy rings, and all necessary parts for instant installation. . . can be purchased with or without base. Available in 20, 30, 40, and 50 ft. sizes.</p>
---	---

FULL LINE OF ACCESSORIES:

New Quick "Drive-In" Base for use with standard towers in place of concrete base. Permits instant tower erection. Not recommended under certain conditions, however.



Bases for Rohn Telescoping Masts.



Peak roof mounts for use with standard tower

Flat Roof mounts for use with regular towers on flat surfaces.

House Brackets for added stability.

"Sell the ROHN line . . . where Satisfaction and Quality are Assured."

WRITE PHONE OR WIRE FOR FREE CATALOG AND PRICES!
Designed and Mfg. only by:

ROHN MFG. CO.

Dept. RTN, 2108 Main St., Peoria, Illinois

All Rohn Products Sold only Through Authorized Representatives & Jobbers.

ANOTHER OUTSTANDING JOBBER

NIDISCO

713 Newark Ave. Jersey City, N. J.
55 State St. Hackensack, N. J.
294 Passaic St. Passaic, N. J.
658 Anderson Ave. Cliffside, N. J.
126 So. Warren St. Trenton, N. J.

HAS THE SENSATIONAL NEW **TEICO** 470-K 7" SCOPE KIT IN STOCK!

470K KIT \$79.95 WIRED \$129.50

RADIO ENGINEERING DEGREE IN 27 MONTHS

Radio engineering is a big field. There's room for you in it—if you're good. Get first-class training at Indiana Tech. Intensive specialized course, including strong basis in mathematics and electrical engineering, advanced radio theory and design, television, electronics, Modern laboratories. Low rate. Also B.S. DEGREE IN 27 MONTHS in Aeronautical, Chemical, Civil, Electrical and Mechanical Engineering. G.I. Government approved. Enter March, June, September, December. You can earn part of your expenses right here in Fort Wayne while you are studying.

INDIANA TECHNICAL COLLEGE
933 E. Washington Blvd., Fort Wayne 2, Indiana

Please send me free information on B.S. Engineering Degree in 27 months as checked.

Radio-Television Aeronautical
 Civil Mechanical Electrical

Name

Address

*Are These Your
Selenium
Rectifiers?*



All of us here at the Rectifier Division are rather proud of the parts we play in the production of Sarkes Tarzian "Centre-Kooled" Selenium Rectifiers. Barbara, shown here color-coding, is no exception.

If you are not familiar with the wide variety of applications of Sarkes Tarzian Rectifiers, your inquiry is invited. Our staff of engineers is ready to assist you with your power conversion problems.

Get your FREE copy of the new Embedded Selenium Rectifier catalog B-1. Complete Selenium Rectifier Handbook available at 50c.

Where #s are used—Specify



**Sarkes
Tarzian**

Sarkes Tarzian, Inc.

RECTIFIER DIVISION

Dept. R-2 415 N. College, Bloomington, Ind.

unit can be used in pairs as a source of power for equipment under test without danger of short circuit due to the clips touching each other or other components.

The nylon insulation forms to the shape of the metal clips thus allowing the same degree of flexibility as bare metal clips. They are available in various colors for easy identification on test equipment leads.

DEFLECTION YOKES

Standard Transformer Corp., Chicago, has added four deflection yokes with or without leads and networks.

The new *Stancor* units are the DY-1A, DY-8A, DY-9A, and DY-10A which are basic versions of the DY-1, DY-8, DY-9, and DY-10 respectively. Leads and networks are available on the new models if desired thus eliminating the necessity for removing and replacing network components in applications where they cannot be used.

LINE VOLTAGE BOOSTER

Crest Labs, Inc., 84-11 Rockaway Beach Blvd., Rockaway Beach, N. Y., has introduced the LVB-117 line voltage booster designed to be plugged in between the wall outlet and set.

The unit is automatic, turns on and off with the set, has an overload cut-out to protect against unsafe line volt-

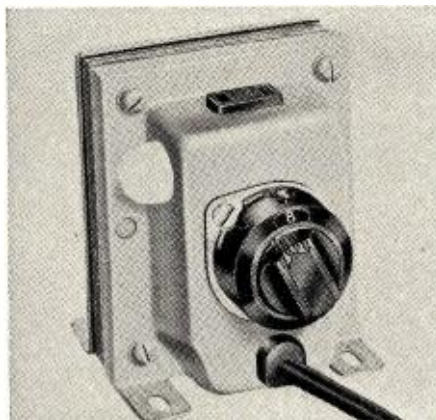

age increases, and a multi-tap selector switch for exact selection of the required boost, plus a visual indicator for precise determination of required boost.

MATCHING TRANSFORMER

Blonder-Tongue Labs of 526 North Ave., Westfield, N. J., now has a Model MT-1 75-300 ohm matching transformer available.

Precision impedance match at its 75 and 300 ohm screw terminals provides a means of eliminating standing waves and line reflections in individual installations as well as in master TV systems.

H.V. RECTIFIERS

International Rectifier Corp., 1521 E. Grand, El Segundo, Calif., has developed two high voltage selenium rectifiers, Type V-75HF and Type V-100HF, for TV applications. Full details on these units are available on request.

ELECTRON TUBE TECHNICIANS

We now have several openings for technicians to work in the fabrication and processing of advanced type electron tube research models.

To qualify for one of these openings you should be experienced in experimental work for research and development in vacuum tubes, which includes the fields of mechanics, electronics, chemistry and high-vacuum techniques.

ADDRESS RESUME OF TRAINING
AND EXPERIENCE TO

HUGHES

RESEARCH AND
DEVELOPMENT LABORATORIES

Technical
Personnel
Department

CULVER CITY,
LOS ANGELES COUNTY,
CALIFORNIA



THREE CONDUCTOR WIRE

Three twisted conductors of 18 gauge. Each conductor has 3 strands copper for conductivity, 4 strands steel for strength. Ideal for intercoms, telephone or any communication work. Tough, durable covering for outdoor or indoor use. Government surplus \pm WT-1/U.

525 foot roll \$4.75 per roll, f.o.b. Cincinnati—rated concerns net ten days, others please mail check or M. O.

LAPIROW BROS.

1649-1657 HOFFNER STREET
CINCINNATI 23, OHIO



RU-18 RECEIVER

Navy 6-tube aircraft receiver with DF loop and antenna input; complete coverage from 190 KC to 13.9 meg.; in 8-coil sets, less tubes; brand new with any 5-coil sets; you name the freq. you desire; F.O.B. shipping wt., 25 lbs. \$19.95

McCONNELL'S 3834 Germantown Ave., Phila., Penna. RA 5-6033

ANOTHER OUTSTANDING JOBBER
THOMPSON RADIO SUPPLIES
135 South Sixth St.
Zanesville, Ohio

HAS THE
SENSATIONAL NEW
EICO 470-K 7"
SCOPE KIT
IN STOCK!



\$79.95

RADIO & TELEVISION NEWS

Within the Industry
(Continued from page 26)

on a routine flight to Goose Bay, Labrador on October 16, 1952. With Mr. Kurtz on the flight was Frank McLaughlin, the pilot.

His wife, Lillian, of 547 Bedford Ave., Brooklyn 11, New York has appealed to Mr. Kurtz' fellow hams for any assistance they can render in helping to locate the missing flyer.

* * *

W. WALTER JABLON has been appointed vice-president in charge of sales by the *David Bogen Company* of New York.

He formerly held the same post at the *Espey Manufacturing Co.* prior to which he was associated with *Hammarlund* for nearly twenty years.



In his new position he will direct the sales of the company's line of p.a. amplifiers and systems, FM and AM radio tuners and amplifiers, intercoms, TV boosters, sound systems, and speaker enclosures.

* * *

CARL H. DICKE, chairman of the board of *Crown Controls Co., Inc.*, died recently at Old Mill Lodge, Medix Run, Pa. He was 50 years old.

He and his brother organized the firm, which manufactures antenna rotators, in 1945. He served as president until 1950 when ill health forced him to turn the presidency over to his son, James F.

-30-

RTMA CO-SPONSORS TV TRAINING COURSE

THE Radio-Television Manufacturers Association will make available, through its Service Committee, a syllabus and companion teaching aids for the training of radio and television service technicians. These courses are designed for both the beginner and the practicing service technician who desires to improve his background in business practices and obtain experience in the latest servicing techniques.

A pilot course, sponsored by RTMA, is now being given at the George Westinghouse Vocational High School in New York City. At present, the course has an enrollment of sixty high-school age students who have signified their intention of entering the servicing field. Two laboratories are being prepared with test equipment and training aids furnished by RTMA. When the labs are completed, it is planned to use them in the evenings for courses held for practicing service technicians.

The RTMA is desirous of extending such aid to service technicians all over the country. Any service organization interested in sponsoring such a course of training in its locality should contact the Service Coordinator, Radio-Television Manufacturers Association, 777 Fourteenth Street, N.W., Washington 5, D.C.

-30-

NOW...AT LOWEST PRICES!

BROADCAST BAND & AERO



Ideal for Use in Boats, etc.
MN-26-C Remote Controlled Navigational Direction finder and communications receiver. Manual DF in any one of three freq. bands. 150 to 1500 KC. 24 V. Self contained dynamotor supply. Complete installation, including receiver, control box, loop, azimuth control. Left-Right Indicator, plugs. 100 p transmission line and flex. shafts.
LIKE NEW \$69.50

MN-26-Y 150 to 325 KC. 325 to 695 KC. 3.4 to 7 megacycles. comp. installation.....\$69.50
Receiver alone.....35.95
MN-26-C alone, like new.....39.50
MN-26-C or MN-26-Y as is less tubes.....13.95
With tubes. Used good.....24.95
MN-20-E Loop, Brand New.....6.95
MN-52 Crank drive, New.....2.50

MONTHLY SPECIAL!

TS10 TEST UNIT

Complete with attenuator, indicators and 350 feet of coaxial cable. Original cost \$300.00. **\$14.95**
New Condition. ONLY.

SCR-274N COMMAND and ARC-5 EQUIPMENT

	EXC. USED (With tubes)	NEW
BC-450 Control Box (3 Receiver).....	\$1.95	\$3.95
BC-456 Modulator.....	\$2.95	4.95
BC-451 Control Box (Transmitter).....	1.95	3.95
BC-442 Relay Unit ANT With Condenser.....	3.95	5.95
Without Condenser.....	1.29	2.95
Flexible Shafting with Gear to AT receivers.....		2.45
3 Receiver Rack.....	2.29	2.98
2 Transmitter Rack.....	2.39	3.97
Single Transmitter Rack.....	2.25	2.95
DM-32 Dynamotor for Command Set.....	3.25	7.95
DM-33 Dynamotor for Command Set.....	2.95	3.95
Shock Mts. for 3 Receiver Rack, 2 Trans. Rack, Modulator or Ant. Relay Unit.....	1.95	2.45

WANTED!

All TS, APR, APS, ARC, ARN, ART, SCR, RB9 and BC equipment... write today!
Quote lowest prices in your first letter

HAND SETS

TS9, excellent condition.....\$4.95
TS13, excellent condition.....5.95
TS Type, exc., less cord.....2.95

SPECIAL!

BC458 TRANSMITTER—3.3 to 7 mc and BC455 RECEIVER—6 to 9 mc (as is, less tubes and crystals).....ONLY \$4.95 each
Both units for.....\$8.95

RT/34 APS 13 Transceiver used as a tail warning radar on 415 MC. Containing a 30MC IF Strip and various other parts, these units have been stripped of RF sections and all tubes, but are an excellent buy if only for parts and IF Strip.....used \$ 4.95
BC 624 receiver (SCR 522), less tubes, 100 A 150.....used 19.95
BC 625 transmitter (SCR 522) less tubes, 100 A 150.....used 9.95
SCR 522 transceiver, complete in case with top bracket, less tubes.....29.95
Transceiver—140-144 mc. 2 meter, used, excellent condition, less dynamotor, with tubes.....only 24.95

PLUGS

Large quantity available!

166 } \$1.25 ea.
167 }
169 }
171 }
172 }

170...\$2.50 ea.
MC277 .49 ea.

ART13-U6U UHU U10U } \$1.25 ea.

MIKES and HEADSETS

HS-33 Low Impedance Headset, exc.\$2.95 new \$4.95
HS-23 Headset.....used \$2.95 new \$4.95
CD-307 Ext. cord for HS 23-33.....like new .79
Throat Mike—T 30.....New .98
Lip Mike—Navy Type.....New .98
Extension Cord and Switch Assembly for lip and throat Mikes.....New .98
CW 49505 High Impedance headset complete with leather headband and rubber cushions.....Used 98c
T-17, Microphone.....Used—exc. \$3.75
HS-28.....exc. \$1.95 new 2.29
HS-30, miniature headset.....used 1.49 new 2.49



DYNAMOTORS

The best dynamotor for conversion to 6v. Multiple windings! After conversion you get choice of 190 or 350 v. at 50 MA or 250 v. at 100 MA. Complete dope sheet furnished.
BRAND NEW (See "CQ" Aug. issue).....\$4.65

WOBULATOR

BUILD TV-FM-AM SWEEP GENERATOR
You can build "Versatile Sweep Frequency Generator" with APN-1 magnetic units.....\$5.95

RT7/APN1 TRANSCEIVER UNIT—Used as an altimeter, it may be converted for signaling control circuits, etc. Complete with 14 tubes and dynamotor they are in good used condition at the amazingly low price of.....\$17.95
Used, less tubes, with wobulator.....9.95

MISCELLANEOUS EQUIPMENT

FL 8 used, exc. \$1.19 BC 347 each.....used 95c
BC 906 each.....9.95

SELSYN TRANSMITTER

Loop Motor and Autosyn Transmitter Assembly for matching to I-82 Indicator. Used, excellent condition.
ONLY \$5.95. Complete with Indicator... \$14.95

RL-42 Reversible Motor with antenna reel and clutch, used.....\$ 2.95
BC-433 RADIO COMPASS RECEIVER, 200 to 1700 KC, used, excellent condition, with tubes, exc. less tubes.....39.95
used, as is, less tubes and cover, exc. for parts.....8.95

ARMY SURPLUS PORTABLE TELEPHONE

Complete with TS 13 handset.....\$14.95 ea.
2 for \$27.50

Shipments F.O.B. warehouse. 20% Deposit on orders. Minimum order \$5.00. Illinois residents, add regular sales tax to remittance.
Prices subject to change without notice.

R W ELECTRONICS

Dept. N, 1712-14 S. Michigan Ave., Chicago 16, Ill.

PHONE: HArrison 7-9374

Unlimited Opportunities in
RADIO ENGINEERING

DEGREE IN 27 MONTHS

Complete Radio Engineering course, including Telev., U.H.F. and F.M. Bachelor of Science Degree also in Mech., Civil, Elect., Chem., and Aero. Eng.; Bus. Adm., Acct. Extensive campus, modern buildings, well equipped labs. Low cost. Prep courses. Personalized, practical instruction. Founded 1884. Placement service. Growing shortage of engineers. Prepare now for unlimited opportunities ahead. Approved for Korean vets. Enter March, June, September, January. Write for catalog.



TRI-STATE COLLEGE

6133 College Avenue, ANGOLA, INDIANA

ANOTHER OUTSTANDING JOBBER

BURROUGHS RADIO Inc.

711 Second Street N.W.
Canton, Ohio

HAS THE SENSATIONAL NEW



470-K 7" SCOPE KIT

IN STOCK!



470K KIT \$79.95 WIRED \$129.50

New Portable Battery-Operated Spring-Motor Tape Recorder



The Magnemite*

For all field recording without AC power! Smaller and lighter than a portable typewriter, the Magnemite* actually makes field recordings that can be played on any studio console equipment. Completely self-powered, the Magnemite* does away with bulky and cumbersome generators, storage batteries and rechargers.

Just check these unusual features:

- Noiseless and vibrationless governor-controlled spring-motor assures constant tape speed.
- 100 operating hours per set of inexpensive flashlight-type dry cell batteries.
- Earphone monitoring while recording, and earphone playback for immediate quality check.
- Operates in any position, and is unaffected by movement or vibration during operation.
- Warning indicator tells when to rewind, and shows when amplifier is on.
- Broadcast models weigh 15 pounds. Slow-speed models weigh only 10 pounds.
- Requires no more desk space than a letter-head, measuring only 11 x 8½ x 5½ inches.

There's a choice of 5 different models for any recording need. High fidelity units, meeting primary and secondary NARTB standards, which record and play back frequencies up to 15,000 cycles, are available for broadcast stations, critical music lovers, and scientific research. For investigation, missionaries, reporters, and general dictation while traveling, there are units which play up to 2 hours per reel of tape.

Write today for complete descriptive literature and direct factory prices.



**AMPLIFIER CORP.
of AMERICA**

398 Broadway, N. Y. 13, N. Y.

*Trade Mark Reg.

Radio Control (Continued from page 38)

lengths of 1/16" by 3" balsa wood, and then fastened together with radio service cement (see Fig. 3). It is absolutely necessary that balsa be used, otherwise the cabin will weigh too much and will make the boat top-heavy. Balsa may be purchased in strip form at almost any store selling model airplane supplies. It is easily worked, the only tool required being a sharp razor blade.

Both the hull and superstructure are finished with a good grade of white enamel. The deck, cabin roof, and pilot house roof are painted gray. Doors and windows may be drawn on heavy paper with India ink, cut out and then applied to the cabin with rubber cement. A hole in the roof allows the cabin to be slipped down over the smoke stack. The superstructure merely sits on the deck and may easily be removed for making receiver adjustments.

Since the motors used in the "River King" are very small, it is important that little power be wasted in friction. Make certain that all bearing surfaces are kept well oiled. The fingers and segments of the selector switch, as well as the points of the receiver relay must be kept very clean. Apply a little carbon tet to them at regular intervals. Steer clear of any kind of contact dope, though, because it will pick up dust and dirt, thus resulting in unreliable selector operation.

The Citizens Radio Service transmitter, designed as a companion for this receiver (Fig. 13), will operate either on the Citizens Service frequency or in the amateur band 26.960-27.230 mc., depending on the crystal used and your license privileges. If you are already lucky enough to be the owner of an 11-meter amateur mobile transmitter, you have little reason to build a whole new rig just for radio control purposes. All you have to do is connect a switch in

Fig. 10. Remote selector switch for use with an 11-meter amateur transmitter. A key or toggle switch may be used instead.

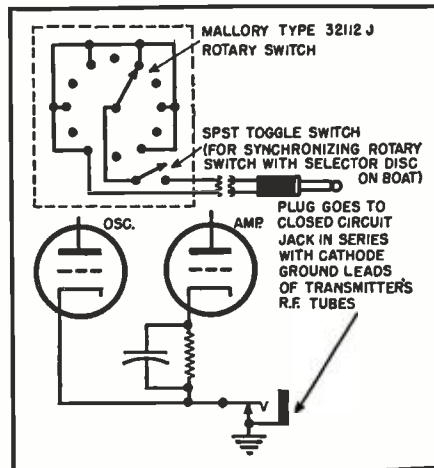

For The NEWEST In Hi-Fi



Featuring the finest in Hi-Fi, Radio, TV and tape recorders . . . presenting the greatest values you've ever seen . . . the NEW Leonard catalogue is now ready for you! Send for your FREE copy today!

LEONARD RADIO, INC.
Dept. RN-1, 69 Cortlandt St., New York 7, N. Y.
Cortlandt 7-0315

TRAIN FOR A SUPERVISORY POSITION IN ELECTRONICS

Thorough 2-year course covers electrical circuits and machinery, basic electronics and industrial electronics. Franklin Technical Institute graduates are in demand as junior engineers for research and test work, sales engineering, supervisory work on production lines and drafting room design work. Other engineering and technical courses. Coed. Day, evening. 45th year. Write for catalog.

FRANKLIN TECHNICAL INSTITUTE
46 Berkeley Street Boston 16, Mass.

AC-DC MUSIC AMPLIFIER

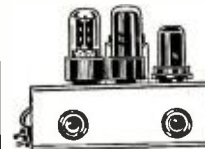

Volume and tone control.
1.5 w. output.
See your jobber.

MICHEL MFG. CO.
227 N. Water St.
Milwaukee 2, Wis.

SCHEMATICS—CONVERSIONS FOR SURPLUS GEAR

NEW LIST! MANY ADDITIONS!
Send stamped, self addressed envelope for List C. Add 25c for chart explaining AN nomenclature.
R. E. BOX 1220
GOODHEART BEVERLY HILLS, CAL.

SPEAKER RECONING

Complete line Cones, Spiders, Rings and Voice Coils. Custom Built Voice Coils. Low prices. Write for Parts List and Reconing information.

WESTERN ELECTRONICS CO.
3164 West Colfax Denver 4, Colo.

ATTENTION

Distributors in Chan. #12 Territory

We are in production on 5, 10 & 12-Element—most efficient YAGI ever designed. MANY TERRITORIES STILL OPEN. We Welcome your Inquiries. ALSO COMPLETE LINE OF UHF ANTENNAS.

FRENCHY RADIO MFG. CO.
164 W. Parker St. Scranton 8, Pa.

ANOTHER OUTSTANDING JOBBER STANDARD ELECTRONICS DIST. CO., Inc.

1497-1505 Main St.
Buffalo 9, N. Y.

HAS THE
SENSATIONAL NEW
EICO 470-K 7"
SCOPE KIT
IN STOCK!



\$79.95

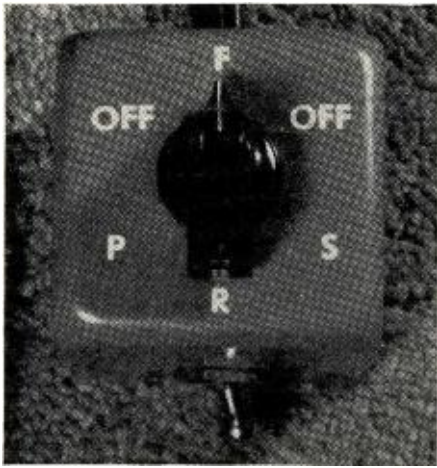

Fig. 11. The ham-rig switch of Fig. 10. It is turned counter clockwise to control the receiver selector switch on the boat.

series with the ground leads to the cathodes of the r.f. tubes as shown in Fig. 10. Although a telegraph key or toggle switch might be used, a rotary switch is superior, because it gives a visual indication of the various ship maneuvers. As long as the switch is not rotated too rapidly, and in a counter clockwise direction, the selector disc on the boat and the switch knob will stay in sync. Should the two get out of step for any reason, a toggle switch in series with the rotary switch may be opened and the knob set to the position corresponding to the maneuver being performed by the boat. Such a switch is shown in the remote-control switch box, Figs. 10 and 11. It is not included in the self-powered Citizens Band transmitter, because the transmitter can be turned off to reset the selector switch and turned right on again, as the 3V4's require no warm-up time.

One precaution must be observed when adapting a mobile rig to radio control. Be sure to key both the oscillator and the final. Otherwise there is a possibility that some r.f. energy will be radiated, even though the final is off. The superregenerative receiver is very sensitive and the slightest amount of r.f. leakage from the transmitter will keep the relay from operating properly.

In those cases where no amateur mobile rig is available, it will be necessary to construct a special radio control transmitter. For greatest convenience and portability, dry battery operation is a "must." Since no great distances are to be covered, only small power output is required. At first thought it might appear that a one tube crystal oscillator would perform the job satisfactorily. However, there seems to be no easy way to obtain adequate power from any of the common 1.4-volt filament tubes when used as oscillators with 11-meter overtone crystals. Even the simplest transmitter for 27 mc. appears to require a minimum of two tubes.

The first circuit I tried employed a crystal near 6800 kc., doubled in the oscillator and also doubled in the final.

March, 1953



70% to 90% off list! TOP TUBE BUYS

All Tubes Individually Boxed! Same Day Service!
Check this list for Fully 90-Day Guaranteed Tubes

Type	Price	Type	Price	Type	Price	Type	Price	Type	Price
0b3/VR90	.75	5U4G	.45	6BF6	.37	6U6	.63	14W7	.60
1A5GT	.30	5V4	.73	6BG6G	1.25	6U8	.61	19BG6G	.95
1A6G	.30	5W4	.50	6BH6	.46	6V3	.93	19C8	.70
1A7GT	.47	5X4	.40	6BJ6	.39	6V6GT	.39	19T8	.79
1AB5	.30	5Y3G	.32	6BK7	.59	6W4GT	.44	19V8	.89
1B3	.65	5Y3GT	.32	6BQ6GT	.59	6W6GT	.44	24A	.63
1B5	.30	5Y4G	.35	6BQ7GT	.95	6X4	.37	25AV5	.83
1B7GT	.30	5Z3	.46	6BZ7	.90	6X5GT	.37	25BQ6GT	.62
1C5GT	.43	6A3	.59	6C4	.37	6Y6G	.48	25L6GT	.38
1E7	.29	6A7	.59	6C5GT	.39	7A4	.47	25T5	.40
1H4G	.30	6AB	.62	6C6	.58	7AF7	.53	25Z6GT	.37
1H5GT	.40	6AB4	.44	6C8B	.44	7B4	.44	25W4	.56
1G6	.30	6AG5	.43	6CD6Q	1.11	7C6	.40	26	.45
1L4	.46	6AJ5	.90	6D6	.45	7E6	.30	27	.39
1LC5	.51	6AK5	.75	6E5	.48	7X7	.70	32L7GT	.89
1N5	.46	6AL5	.38	6F5GT	.39	12A8	.61	35B5	.40
1P5	.57	6A05	.39	6F6	.37	12AL5	.37	35C5	.39
1Q5	.58	6A06	.37	6G6G	.52	12AT6	.37	35L6GT	.41
1R5	.45	6AR5	.37	6H6GT	.41	12AT7	.56	35W4	.39
1S5	.39	6AS5	.50	6J5GT	.37	12AU6	.38	35Z4	.37
1T4	.45	6AT6	.37	6J6	.52	12AU7	.43	35Z5GT	.37
1T5	.53	6AUG	.38	6K6GT	.37	12AV6	.39	36	.60
1U4	.45	6AV5	.63	6J7G	.43	12AX7	.59	41	.42
1U5	.39	6AV6	.37	6J8	.30	12AX4	.48	42	.42
1V	.60	6AX4	.53	6K5	.47	12AX7	.48	43	.55
1X2	.63	6B4G	.64	6K7	.44	12AZ7	.69	45	.55
2A3	.70	6B5	.64	6L6	.64	12BA6	.38	50B5	.39
2X2	1.50	6BA6	.39	6Q7	.45	12BD6	.45	50C5	.39
3A4	.45	6BA7	.57	6S4	.38	12BE6	.39	50C6	.59
3E5	.46	6BC5	.44	6S8	.53	12BF6	.39	50L6GT	.41
3Q4	.39	6BD5GT	.59	6SA7GT	.43	12BH7	.63	50Y6	.46
3Q5GT	.49	6BD6	.45	6SD7GT	.41	12J5GT	.42	50Y7	.50
3S4	.46	6BE6	.39	6SF5GT	.46	12J6GT	.39	57	.58
3V4	.47	6BF5	.41	6SG7GT	.41	12Q7G	.39	58	.60
				6SH7	.73	12S8	.70	70L7GT	1.09
				6SJTGT	.41	12SA7GT	.44	75	.41
				6SK7GT	.41	12SF5	.50	76	.44
				6SL7GT	.48	12SG7GT	.52	77	.57
				6SN7GT	.52	12SJ7	.44	78	.47
				6SQ7GT	.37	12SK7GT	.48	80	.35
				6SR7GT	.45	12SL7GT	.47	83	.68
				6SS7	.42	12SN7GT	.52	85	.59
				6T8	.56	12SQ7	.44	117Z3	.37
				6U4	.60	12SR7	.49	117L7	.99
				6U5	.44	14J7	.30	807	.99

"Integrity is Our Chief Asset!"
Phone: Essex 5-2947

BENDIX 4-CHANNEL E.C.O.

Channel 1 1050-1700 KC | Channel 3 3000-4800 KC
Channel 2 2000-3400 KC | Channel 4 4370-7000 KC

Unit is front end of TA-12B transmitter by band switching each channel is a complete oscillator uses a 6SK7 or 12SK7 in each channel by adding an 807 driver and a pair of 807's for a final you have a 50 watt tube, each osc. section is completely shielded and mounted on an aluminum chassis with var. cond. shafts extended ready to add voltage. GOVT. COST OVER \$150.00 NEW. WHILE THEY LAST. For That New Ham Band 3700 KC. \$5.95

3834 Germantown Ave. Phila., Penna. RA 5-6033

EASY TO LEARN CODE

It is easy to learn or increase speed with an Instructograph Code Teacher. Affords the quickest and most practical method yet developed. For beginners or advanced students. Available tapes from beginner's alphabet to typical messages on all subjects. Speed Range 5 to 40 WPM. Always ready—no QRM.

ENDORSED BY THOUSANDS!

The Instructograph Code Teacher literally takes the place of an operator-instructor and enables anyone to learn and master code without further assistance. Thousands of successful operators have "acquired the code" with the Instructograph System. Write today for convenient rental and purchase plans.

INSTRUCTOGRAPH COMPANY

4711 SHERIDAN ROAD, CHICAGO 40, ILLINOIS

TERMS: A 25% deposit must accompany all orders—balance C.O.D. All shipments F.O.B. Irvington warehouse. Orders under \$10—\$1.00 Handling Charge. Subject to prior sale.

Don't Delay . . . Order Today!

115 COIT STREET
Dept. RN-353
IRVINGTON 11, N. J.

METERS

METERS—WESTON • SANGAMO
ALL NEW • ALL D. C. • 2" SQUARE

0-5 Ma	\$3.29 EACH or 3 for \$9.00
0-15 Ma	
0-50 Ma	
0-100 Ma	
0-200 Ma	
0-300 Ma	
0-500 Ma	

Mfg's inquiries: lots over 100

Voltmeter, 2" sq.—0 to 20 Volts.....\$3.29
DC Voltmeter, 2" sq.—0 to 300 Volts w/Ext. resistance. Complete \$3.95.....3 for \$9.95
RF Ampmeter, 2" sq.—0 to .5 Amp.....\$3.95
Ammeter, 2" rd.—0 to 50 Amps.....\$3.29
Ammeter, 2" sq.—0 to 50 Amps.....\$3.29

3" Round Meters. DC. All New. 0-15, 0-30, 0-300 Mills. \$4.95 Each.....3 for \$11.95
Milliampereters. 2 1/2" rd. 0-30 Mills. Each \$3.95
Milliampereters. 2" rd. 0-50 Ma. 0 to 5 Ma. movement. Each \$3.29.....3 for \$9.00
Thermocouple, 2" rd. 350 Milliamp. HF. ...\$3.29

"S" METER. Illuminated face. Full scale reading of 5 ma. A standard value for most "S" Meter Circuits. 2 3/8". Black face. New.....\$2.49
Cash with order. California orders please include 3 1/2% sales tax. Please include approximate postage—excess will be refunded. What have you in surplus? Submit.

L. A. HAM SHACK
1306 Bond Street, at Pico, Los Angeles 15, Calif.

ATR

AUTO RADIO VIBRATORS

have Ceramic Stack Spacers



A COMPLETE LINE OF VIBRATORS . . .

Designed for Use in Standard Vibrator-Operated Auto Radio Receivers. Built with Precision Construction, featuring Ceramic Stack Spacers for Longer Lasting Life. Backed by more than years of experience in Vibrator Design, Development, and Manufacturing.

NEW MODELS
NEW DESIGNS
NEW LITERATURE

"A" Battery Eliminators, DC-AC Inverters
Auto Radio Vibrators

See your jobber or write factory

AMERICAN TELEVISION & RADIO CO.
Quality Products Since 1931
SAINT PAUL 1, MINNESOTA-U.S.A.

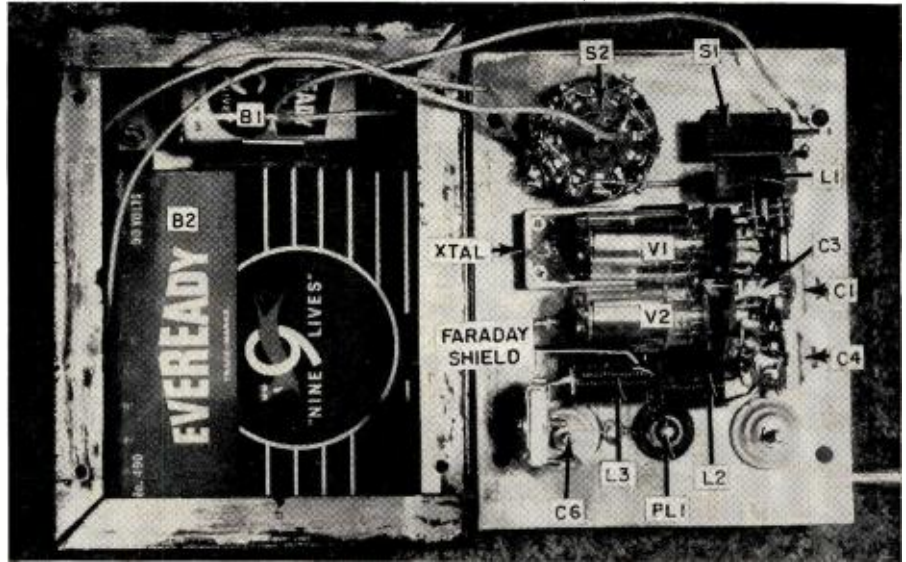

Fig. 12. All transmitter parts are mounted on one cover of a 3"x4"x5" utility box. The tube sockets mount on L-shaped brackets. Holes should be drilled in the case opposite C₁, C₂, and C₃ for adjustment after the cover is fastened to the box.

Usable output was obtained on 27 mc., and since a low frequency crystal is much cheaper than one of the overtone type, the circuit looked quite promising. That is, until a check with an all-wave receiver revealed that the transmitter's output in the vicinity of the twenty-meter amateur band was less than 30 db below the 27 mc. output. Consequently this particular circuit failed to meet the technical requirements for Class C Citizens Radio Stations, which state that spurious emissions must be at least 40 db down.

The transmitter finally evolved is diagrammed in Fig. 13. It uses a 3V4 as a 27 mc. overtone crystal oscillator and a 3V4 amplifier. Checks show that when the 27 mc. signal is 30 db

over S₉, the 54 mc. output is so low that it fails to move the needle of an SX-71 receiver's "S" meter, thus easily meeting the FCC's requirements. There are two main factors which hold the harmonic output to such a low level. The amplifier is operated with only a little more than "Class A" bias, and a Faraday shield (Fig. 9D) reduces capacity coupling between the final tank and the antenna coil.

All transmitter parts are mounted on the front cover of a 3" by 4" by 5" metal utility box, as shown in Fig. 12. Paint should be scraped from the inside of the covers and from the edges of the box so that good electrical contact will be maintained.

The crystal fits into a miniature

Fig. 13. Schematic of the Citizens Band transmitter. Switch S₂ turns the carrier on and off. The receiver selector switch moves one position each time a carrier signal is received. If the transmitter and receiver switches fall out of step, the transmitter can be turned off and S₂ reset to the boat's present maneuver.

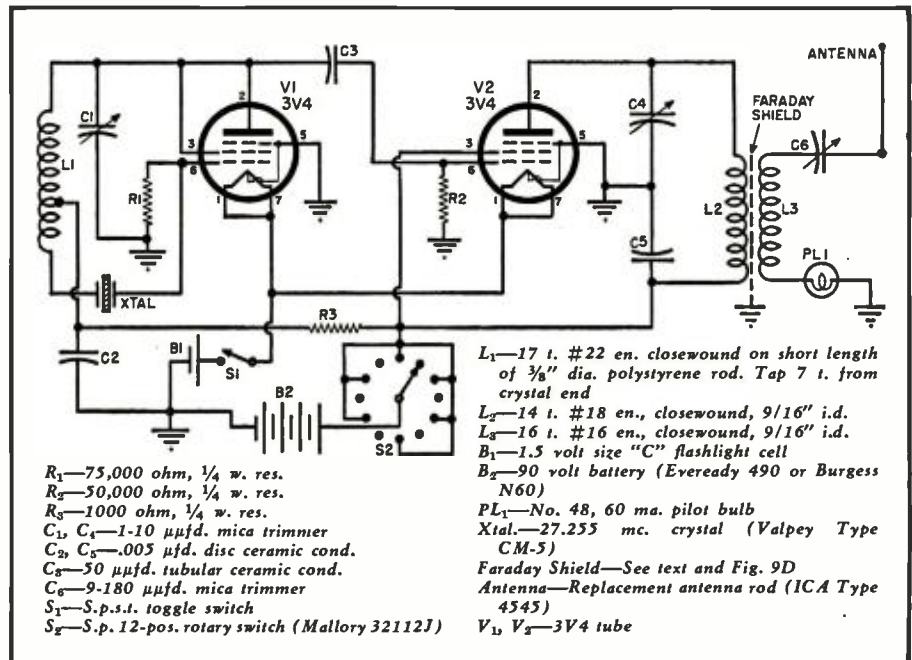

socket made by sawing in half the dual crystal socket from a BC-746A tuning unit. Of course, any small FT-243-type socket may be used, such as the Cinch-Jones #2 KM. unit. The tube sockets are fastened to the panel with small L-shaped brackets.

A pilot bulb in series with the antenna coil gives an indication of output current. It is merely pressed into a rubber grommet in the front panel. No socket is employed, leads being soldered directly to the base of the bulb. The oscillator and amplifier trimmer condensers are soldered to the panel. Two ceramic feedthrough insulators support the 36" telescoping antenna, as shown in Fig. 2, the bottom insulator being used to feed the transmitter's output via C_6 .

An Eveready 490 or Burgess N60 "B" battery will fit into the box and still leave room for a single small flashlight cell to supply filament power. Regular snap-on connectors are used with the "B" battery while a clip-type holder constructed from pieces of aluminum makes for easy "A" battery replacement. The self-tapping screws supplied with the 3" by 4" by 5" box should be removed from the back cover. Replace them with short 6-32 machine screws and nuts. Otherwise, the sharp points of the self tapping screws may work their way into the "B" battery and ruin it. A square of corrugated cardboard used as a buffer between the rear of the transmitter and the batteries will keep the latter from flopping around inside the box. Despite its small size, the life of the "B" battery should be quite long because it furnishes current only when a command is transmitted.

Adjustment of the transmitter is very simple. If you are a ham and plan to employ the 11-meter amateur band, you can make use of the simple instructions which follow. On the other hand, if you expect to operate the transmitter as a "Class C" Citizens Radio Station, the adjustments will have to be made by someone holding a commercial operator's license.

Preliminary tests are made with the front cover removed from the box so a temporary jumper should be run from the cover to the box in order to complete the filament circuit. A milliammeter is then hooked in series with the "B-plus" lead going to the tap switch. Turn on the filaments, make sure the tap switch is on a live spot and note the plate current. If it exceeds 25 ma., the chances are that the crystal is not oscillating. Adjust C_1 until a point is reached where the current drops sharply, denoting crystal oscillation. C_1 should be tuned from minimum to maximum capacity. Somewhere in this range, the milliammeter will show a small dip, probably not more than a mil or so. Set C_1 at this point of minimum current.

Pull the antenna out to its full length and tune C_2 for maximum brilliance of the pilot bulb. When the transmitter is operating correctly, total plate current will be in the

Don't Gamble.....

ON ULTRA HIGH FREQUENCY

"RECEPTION"



..you can count on the....

MI-TEE RAY

UHF ANTENNA

- designed and engineered exclusively for UHF
- all aluminum sturdy construction
- minimum space requirements
- matchless reception
- nationally advertised

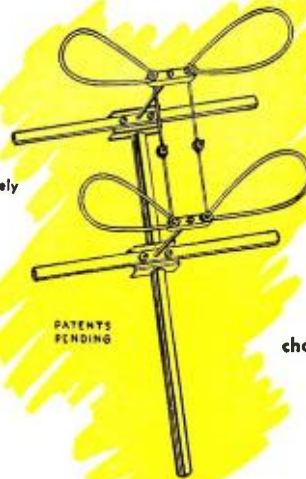

PATENTS PENDING

channel 14

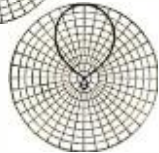
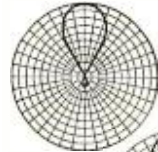

channel 83



INCORPORATED
Pittsburgh 19, Pennsylvania

COMPARISON PROVES

TYPE	PRICE
1B3GT	.53
1L4	.57
1N5GT	.57
1R5	.56
1S4	.61
1S5	.47
1T4	.56
1T5GT	.71
1U4	.55
1U5	.46
1X2A	.67
3Q4	.60
3Q5GT	.65
3S4	.55
3V4	.56
5R4GY	.91
5U4G	.40
5Y3GT	.29
5Y4C	.39
6AB4	.46
6AG5	.54
6AK5	.95
6AL5	.40
6AQ5	.46
6AR5	.38
6AS5	.50
6AT6	.38
6AU6	.43

TYPE	PRICE
6AV6	.37
6B4G	.96
6BA6	.45
6BA7	.60
6BC5	.53
6BD5GT	.89
6BE6	.46
6BF5	.60
6BF6	.39
6BG6G	.34
6BH6	.57
6BJ6	.48
6BK7	.88
6BQ6GT	.89
6BQ7	.84
6C4	.37
6CB6	.53
6CD6G	1.85
6J5GT	.40
6J6	.62



CONFIDENCE PAYS

TYPE	PRICE
12AT6	.48
12AT7	.68
12AU6	.43
12AU7	.53
12AV6	.37
12AV7	.79
12AX7	.61
12BA6	.45
12BH7	.63
12SA7GT	.52
12SK7GT	.50
12SL7GT	.61
12SN7GT	.54
12SQ7GT	.42
19BQ6G	1.39
25BQ6GT	.89
25L6GT	.48
25W4GT	.48
25Z6GT	.42
35L6GT	.47
35W4	.30
35Z5GT	.30
50A5	.48
50B5	.47
50C5	.47
50L6GT	.47
117Z3GT	.39

To insure top quality, we set test each tube in radio and television receivers. All tubes fully guaranteed.

25% deposit with all orders, check or money order. All merchandise F.O.B. New York, New York. Minimum order \$10.00. Orders less than \$10.00 add \$1.00 handling costs. All merchandise subject to prior sale and price change without notice.

Windsor Electronic Tube Company

1515 SHEEPSHEAD BAY ROAD

BROOKLYN 35, NEW YORK

STANDARD BRANDS **TUBES** INDIVIDUALLY BOXED
STANDARD WARRANTY **New Low Prices** BRAND NEW!!

OZ4 ...\$.54	5Y3GT ..\$.39	6BA6 ...\$.54	6F6GT ..\$.54	6W4GT ..\$.54	12SQ7GT\$.63
1B3GT .. .87	6AB461	6BA776	6H657	6W6GT .. .65	198G6G. 1.75
1L465	6AC798	6BC565	6J5GT .. .54	6X449	19T887
1R559	6AG564	6BE657	6J676	6X5GT .. .43	25AV5GT 1.05
1S476	6AG7 ... 1.19	6BF569	6K6GT .. .54	12AT6 .. .47	25BQ6GT 1.08
1S564	6AH6 ... 1.05	6BG6G. 1.69	6L6GA . 1.05	12AT7 .. .76	25L6GT .. .54
1T464	6AK588	6BH672	6SA7GT. .61	12AU6 .. .54	25Z6GT .. .49
1U469	6AL550	6BJ661	6SC776	12AU7 .. .65	35B561
1U561	6AQ554	6BL798	6SF558	12AV7 .. .88	35C561
1X2A .. .75	6AQ649	6BN672	6SH765	12BA6 .. .54	35L6GT .. .61
3Q475	6AR569	6BQ6 ... 1.08	6SJ754	12BE6 .. .58	35W441
3Q5GT .. .72	6AS562	6BQ7 ... 1.08	6SL7GT. .64	12BH7 .. .82	35Z5GT. .39
3S465	6AT646	6C449	6SN7GT. .69	12S4GT. .62	50B561
3V465	6AU654	6C557	6SQ7GT. .49	12SH7 .. .49	50C561
5T4 ... 1.31	6AV5GT. 1.05	6CB665	6SR749	12SK7GT. .63	50L6GT .. .59
5U4G .. .54	6AV646	6CD6G. 1.29	6T879	12SN7GT. .73	117Z3 .. .54
5V4G .. .98	6B4G98	6E576	6V6GT .. .57		

Many other types equally low priced—include all your tube needs with your order.
One of the largest stocks in the country
Min. Order \$25.00. Terms: 25% with order, balance C.O.D.
All prices subject to change without notice, F.O.B. New York City. Mail order division.

TeleVision Materials Corp.
125 Cedar St., New York 6, N. Y. • CORlandt 7-4307

FREE! from **KLIPZON**
Write today for folder.
"THE VERSATILE CRYSTAL PROBE"

Tells how to get V.H.F. performance from your V.T.V.M. or V.O.M. by using KLIPZON SELFHOLDING CRYSTAL PROBES. How to make "one man" TV antenna orientation easy! Other valuable information on timesaving and convenient SELFHOLDING PRODS, CONNECTORS, SHIELDED LEADS and ADAPTORS. See KLIPZON at your local distributor.

UNITED TECHNICAL LABORATORIES
203 LITTLETON RD. • MORRISTOWN, N. J.

RCA INSTITUTES, INC.
A Service of Radio Corporation of America, 350 West 4th St., New York 14, N.Y.

OFFERS COURSES IN ALL TECHNICAL PHASES OF RADIO, TELEVISION, ELECTRONICS

Approved for Veterans
Write Dept. RN-53 for Catalog

ANOTHER OUTSTANDING JOBBER
THE RADIO CENTRE
72 Craig West
Montreal, Canada

HAS THE SENSATIONAL NEW **EICO** 470-K 7" SCOPE KIT IN STOCK! \$79.95

When answering Advertisements be sure to mention **RADIO & TELEVISION NEWS**

KLEIN ELECTRIFYING BARGAIN!
THYRATRON REMOTE CONTROL

SERVICEMEN • HOBBYISTS • HAMS • EXPERIMENTERS • RADIO SCHOOLS

Here's a chance of a lifetime to own a genuine 110V AC Thyatron Electronic Remote Control of your own at a fraction of its regular price! This mighty handful (only 5 3/4" x 5" x 3 1/4") of miracle control can be made to perform hundreds of practical, fascinating feats of remote control. A complete schematic showing the circuit is included with each unit.

IT'S A STEAL! Buy it just for the parts alone. Take it apart. See what you get: over 30 components such as Cabinet, Condensers, Resistors, Transformer, Controls, Dial Assembly, Control Relay, etc. Valuable parts galore that you can so easily use in any other radio, amplifier, etc.—or for experimenting.

HOW CAN YOU LOSE? These parts are certainly worth FIVE TIMES this amazing low cost. The relay alone is worth more than the price we're asking for the entire unit. Besides, consider the filament transformer, condensers, resistors (many of them 1% precisions). No matter how you use it, here's a great Klein Bargain!

PRECISION THYRATRON CIRCUITRY

These amazing Thyatron thermostatic controls can easily and quickly be modified by you for electronic remote control of: Transmitters; Turn radio and TV on and off; open and close Garage Doors from your car; Remote control of Appliances, Machinery, Power Tools; Remote controls for Model Railroads, Planes, Boats, Trucks, Burglar, Fire, Temperature and Rain Alarm Systems; Poultry Brooder Controls, etc., etc.

MANUEL KLEIN CO. 92B Chambers Street New York 7, N. Y. REctor 2-6460

neighborhood of 20 ma. and the bulb should glow brightly. Attach the cover and, through holes drilled in the case, readjust C₁ and C₂ to maximum bulb brightness. C₁ should then be tightened as much as possible. However, if it is set too tightly, the crystal will oscillate erratically, on the wrong frequency, or it may not start at all as the tap switch is rotated. Choose a setting where the bulb lights just as soon as the tap switch hits a live contact.

Finally, the carrier frequency must be checked. If the unit is to work in the 11-meter amateur band all one has to do is make sure that the output appears somewhere in that band. When the transmitter operates as a "Class C" Citizens Station, however, a very critical frequency check must be made. The FCC requires that the carrier be within .04% of 27.255 mc. According to my slide rule, this is a deviation of not more than 10.9 kc. Actually, the transmitter should be much closer to the assigned frequency in order to allow for temperature variations, etc. which can crop up in normal use.

Although no operator's license is required for Citizens Band equipment, a Citizens Radio Station license must be obtained by completing FCC Form 505 and mailing it to the nearest Commission field office. Before filing Form 505, it will pay you to read carefully Part 19 of the Commission's "Rules Governing the Citizens Radio Service." You can obtain it from the Superintendent of Documents, Government Printing Office, Washington 25, D. C. for ten cents in coin.

I've had a great deal of pleasure from the "River King." If you decide to build and operate a similar model, you, too, can look forward to many hours of fun. And don't overlook the fact that a Citizens Station may be operated by anyone, provided he has permission from the licensee. Youngsters, especially, get a kick out of putting the boat through its paces. Maybe you can go in partnership with your son or younger brother—he to build the boat, you to wire the radio equipment. No matter how you go about it, try a radio-controlled model. I know you'll find the effort worthwhile.

BIBLIOGRAPHY

North, William L.; "Radio Control of Model Boat," **RADIO & TELEVISION NEWS**, August 1950.

Ford, Walter B.; "A Six Foot Radio-Controlled Model Boat," **RADIO & TELEVISION NEWS**, July 1951.

McEntee, Howard G.; "Proportional Radio Control," **RADIO & TELEVISION NEWS**, September 1951.

MacNabb, Vernon C.; "Radio Control on the Citizens Band," **RADIO & TELEVISION NEWS**, March 1952.

Good, Walter A. & Good, William E.; "Receivers for Radio-Controlled Models," **QST**, September 1951.

Lawson, Harry W., Jr.; "A Radio-Control System for Models," **QST**, February 1952.

Safford, Edward L., Jr.; "Model Control by Radio," **Gernsback Library No. 43**, Radcraft Publications, Inc., New York.

**FL-8 FILTER
AND
"FILTER FACTS"
BOOKLET**

BRAND NEW!
Both for
\$1.50

CONDENSER TESTER

• One of our best sellers!
Useful, versatile laboratory item, in kit form. Simple, and easy to build in less than an hour. Checks condenser leakage and continuity up to 8 mega. Will test any paper, electrolytic, mica or oil capacitor from 50 mmf. to 50 mfd. Self-contained power supply with neon bulb indicator with socket and bezel. Drilled metal cabinet. Complete instructions and diagrams included with each kit. Only \$5.00.



**SCOOP! NEW WEB-WIP 40M
MOBILE ANTENNA**

In stock the new center-loaded WEB-WIP antenna for 40 meter mobile. Completely weather-proof with fiberglass covering on top wip and fiberglass support column. Highly effective... weight only 22 ounces! Full data available. Net \$18.00

NOVICE 40M CRYSTALS

Frequencies within the new 40M novice band. Net \$2.75 ea.

PHONE PATCH!

Now available, the superior new O-R, #6008 phone patch. Provides you with exactly what you need to patch your phone into transmitter or receiver. Featuring a high-impedance input suitable for xtl mike. Both hi and lo impedance outputs to insure proper match to your particular receiver. Unit is complete—"sure-fire" ready to go to work for you. Only \$4.95 ea.



SENSITIVE RELAY

Miniature type (1 1/2" overall) SP-ST contacts. Coil resistance 6500 ohms. (2 ma.) An excellent relay for voice control or model applications. \$2.50 ea. Manufacturers write for quantity prices.

**SPLINED TUNING NOB
FOR 274N RECEIVERS**

An exclusive O-R item manufactured for us. Fits BC-453, BC-454 and other 274N receivers. This is a really hard-to-obtain item. Only... 89c ea.



TRANSFORMERS-CHOKES:

15 WATT MODULATION TRANSFORMER
Both pri. and sec. adjustable for 2000 to 20,000 ohms. Pri., 50 ma per side max. Sec., 50 or 100 ma depending upon connections used. Excellent for mobile. Only \$6.45 net

60 WATT MODULATION TRANSFORMER
Also universal with both pri. and sec. adjustable for 2000 to 20,000 ohms. Pri., 150 ma per side, sec., 150 or 300 ma depending upon connections used. Only \$9.60 net

825-0-825 @ 225 ma. 6.3 @ 5A. 5V @ 8A. Pri. 110V, 60 cy AC. Size, 4 1/8" x 4 1/8" x 3 1/4". Only \$6.95 ea.

Isolation transformer. Useful for AC-DC supplies. Pri. 117V, Sec. 120V, AC. at 25 ma. Also 6.3V at 1/2 amp. Only \$1.80 ea.

Isolation transformer. Pri. 117V AC. Sec. 120V, AC. at 50 ma. Also 6.3V at 2 amps. \$2.79

920-0-920 or 740-0-740 AC @ 200 ma. Pri. 115V, 60 cycle, AC. Upright shielded case. Excellent for 807's. Only \$10.80 ea.

5V, 25A. Pri. 115V, 60 cy. AC. A real rugged job excellent for 804TL-4-250A etc. Limited quantity. Only \$4.50 ea.

2.5V @ 10A AC. 10,000V insulation. Pri. 115V AC only \$3.39 ea.

350-0-350 @ 300 ma. 6.3 @ 4A. 6.3 @ 8A. 5V @ 8A. Pri. 115V, 60 cy. AC. only \$7.95 ea.

450-0-450 @ 200 ma. Pri. 115V, 60 cy. AC. 5V @ 8A, 6.3 @ 5 amp. In shielded case. Only \$8.90 ea.

350-0-350 @ 350 ma. 6.3 @ 10A. 5V @ 6A. Pri. 115V, 60 cycle. Only \$8.95 ea.

**110V, AC POWER SUPPLY
FOR ANY 274-N RECEIVER**

Just plug it into the rear of your 274-N RECEIVER... any model. Complete kit and black metal case, with ALL parts and diagrams. Simple and easy to build in a jiffy. Delivers 24 volts plus B voltage. No wiring changes to be made. Designed especially for the 274-N receiver. Only \$8.95.

Filament trans. for 274N receivers. Pri. 110V, 60 cy. AC. Sec. 24V @ .6A. An excellent buy at \$1.95 ea.

Minimum order \$2.00. All items subject to prior sale. All prices subject to change without notice. 20% deposit must accompany all orders, balance C.O.D.

OFFENBACH-REIMUS
1564 MARKET STREET
SAN FRANCISCO, CALIF.

H.V. Supply for CRO
(Continued from page 67)

age may be employed, with a resulting savings in cost. On the other hand, if higher accelerating voltages are to be used, correspondingly higher voltage condensers should be installed.

Installation and Adjustment

Once the wiring is finished and the r.f. high-voltage supply tested, it may be installed in the CRO and adjusted for optimum operation.

Sometimes the builder will find that the accelerating potential obtained is much lower than expected. In most cases, it will be found that the high-voltage supply voltage divider ("Intensity Control," R_1 , R_2 , "Focus Control," and R_3 in Fig. 4) offer too much of a load for the high-impedance supply. This difficulty may be easily overcome by changing each resistor and control in the divider circuit, substituting one with exactly twice or three times the original resistance value. Be careful that you follow the same ratio throughout, however, so that the same voltage division will take place as previously as far as ratios are concerned. In this manner, the load on the high-voltage supply may be reduced without changing the ratio of the various voltages applied to the electrodes of the CRT.

The tuning condenser (C_2 in Fig. 2) may be adjusted for near maximum output by watching spot or line brightness. Do not set this condenser for maximum output voltage, however, as a certain degree of instability may result with this setting.

Whether the experimenter wishes to modify an existing scope to reduce 60-cycle intensity modulation, to increase spot brightness, and to improve focus, or to build a new scope without purchasing a special scope transformer, the r.f.-type high-voltage supply offers an ideal solution. The supply may be easily assembled using readily available and inexpensive parts and is much safer to work with than the more conventional 60-cycle type of supply.

-30-



**COMPLETE
TRAINING
FOR BETTER RADIO-TV
SERVICE JOBS**

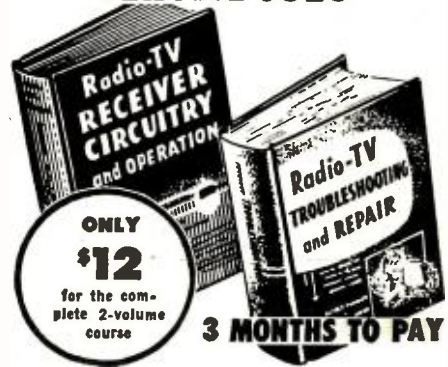

ONLY \$12
for the complete 2-volume course

3 MONTHS TO PAY

Let these two great new Ghirardi training books teach you to handle all types of AM, FM and TV service jobs by approved professional methods—and watch your efficiency and earnings soar!

Completely modern, profusely illustrated and written so you can easily understand every word, these books pave the way to fast, accurate service on any type of home radio-TV-electronic equipment ever made. Each book is brand new. Each contains the latest data on the latest methods and equipment—NOT a re-hash of old, out-of-date material. Each is co-authored by A. S. Ghirardi whose famous RADIO PHYSICS COURSE and MODERN RADIO SERVICING were, for 20 years, more widely used for military, school and home study training than any other books of their type!

**THE NEW Ghirardi
RADIO-TV SERVICE LIBRARY**

Almost 1500 pages and over 800 clear illustrations show step-by-step how to handle every phase of modern troubleshooting and servicing.

**1—Radio and Television Receiver
TROUBLESHOOTING AND REPAIR**

A complete guide to profitable professional methods. For the novice, it is a comprehensive training course. For the experienced serviceman, it is a quick way to "brush up" on specific jobs, to develop improved techniques or to find fast answers to puzzling service problems. Includes invaluable "step-by-step" service charts. 320 pages, 417 illus., price \$6.75 separately.

**2—Radio and Television Receiver
CIRCUITRY AND OPERATION**

This 669-page volume is the ideal guide for servicemen who realize it pays to know what really makes modern radio-TV receivers "tick" and why. Gives a complete understanding of basic circuits and circuit variations; how to recognize them at a glance; how to eliminate guesswork and useless testing in servicing them. 417 illus. Price separately \$6.

New low price . . . easy terms

If broken into lesson form and sent to you as a "course," you'd regard these two great books as a bargain at \$50 or more! Together, they form a complete modern servicing library to help you work faster, more efficiently and more profitably. Completely indexed so you can look up needed facts in a jiffy.

Under this new offer, you save 75c on the price of the two books—and have the privilege of paying in easy installments while you use them! No lessons to wait for. You learn fast—and you learn right!

10-DAY EXAMINATION PRIVILEGE

Dept. RN-33, Rinehart Books, Inc.
Technical Division,
232 Madison Ave., New York 16, N. Y.

Send me GHIRARDI'S NEW 2-VOL. SERVICE LIBRARY. I enclose \$3 and will send you \$3 a month for three months until the total price of only \$12.00, plus a few cents postage, is paid. It is understood I may read the books for 10 days. Then, if not satisfactory, I will return them postage paid and you agree to refund my \$3 and cancel the remaining installments. (Books shipped postpaid for full remittance with order—same return privilege.)

Name

Address

City, Zone, State.....

Employer's Name & Address.....

OUTSIDE U.S.A.—\$13.00 cash only. Same 10-day return privilege with money refunded.

4 for 53 NEW Trav-Electric CONVERTERS

CHANGE 6 OR 12 VOLT D.C. TO 110 VOLT A.C. 60 CYCLE
Just plug into Cigar Lighter on Dash.



Trav-Electric Super
Model 6-71160
60 cycle
60-75 Watts
\$37⁹⁵ LIST

Size 4"x5"x6"

Operates

- Wire Recorders
- Amplifiers
- Soldering Iron
- Dictating Machines
- Turntables
- Small Electric Drill



Trav-Electric Master
Model 6-51160
60 cycle
40-50 Watts
\$24⁹⁵ LIST

Size 4"x5"x6"

Operates

- Curling Irons
- Radios
- Turntables
- Small Dictating Machines
- Test Equipment, etc.
- Portable Phonographs



Trav-Electric Senior
Model 6-1160
60 cycle
35-40 Watts
\$15⁹⁵ LIST

Size 2 1/2"x2 1/2"x4 1/2"

Operates

- Test Equipment
- Turntables
- Lights
- Short, Long Wave Radios
- Portable Phonographs
- Electric Shavers, etc.



Trav-Electric Midget
Model 6-11160
60 cycle
10-15 Watts
\$10⁹⁵ LIST

Size 2"x2"x3 1/2"

Operates Test Equipment, All Electric Shavers

Fully Guaranteed

See Your Jobber or Dealer

TERADO COMPANY

MFRS. OF PRECISION EQUIPMENT
1068 RAYMOND AVE. • ST. PAUL 14, MINN.
In Canada write: Atlas Radio Corp., Ltd.
560 King St. West, Toronto 28, Ont.
Export Sales Division: Scheel International, Inc.,
4237 N. Lincoln Ave., Chicago 18, Ill., U. S. A.
Cable Address—Harscheel

String-Belt Turntables

(Continued from page 69)

turntable. Fig. 5 shows how it is used. The record is threaded onto it and the peg, held by the long upper end, is dropped into the center hole. It need not be released until safely seated. The record is taken off again by simply seizing the peg and lifting, and it spins harmlessly to a stop on the peg. This is much easier and safer than catching the moving record by the edges. Actually, it is possible to handle the records without fingerprinting them at all. A different peg is of course used for 45 rpm records.

Fig. 4 is a design for a two-step motor pulley in accordance with Table 3. This is the motor pulley used in Fig. 1. It may be turned from one piece or assembled from two or three.

Fig. 6 indicates in cross section a suggested design requiring less material and less lathe work than the unit shown in Fig. 2, which was built in 1940 when steel was cheap and the author had access to a lathe. Lettered parts in Fig. 6 are as follows:

- A. Base, hardwood
- B. Bracket and base, hardwood
- C. Shaft, 5/8" or 3/4" steel. Requires no turning if accurate
- D. Ball, hard steel, same diameter as shaft
- E. Babbitted pillow blocks with grease cups, inexpensive but scraped and run-in to good fit if necessary. 2 required
- F. Bottom plate, 1/8" steel
- G. Auxiliary drive pulley, 1/4" steel.

Fig. 6. Design details of an "economy" version of the string-belt turntable unit. See text for identification of lettered parts.

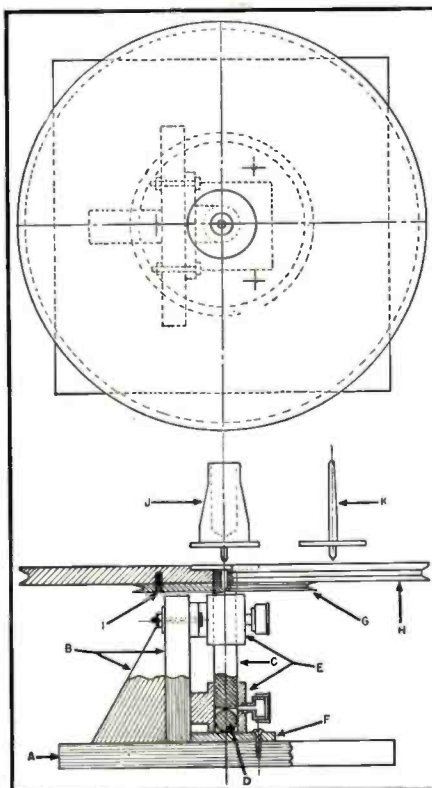

more dough from Generous Joe!

JOE POSSNER Needs Your Equipment for New Operation. Your MONEY rushed by return mail! No Red Tape! Just write one letter: List items, EXACT condition, price you want!

ALL QUERIES ANSWERED IMMEDIATELY
You Get More Because We Have No Stock. We Will Swap - Tell Us What You Want.
Equipment - Relays - Switches
Condensers
Dept. R-2

POSSNER ELECTRONICS
(formerly Electronics Sales Co.)

Phone DUinkirk 8-0508
1223 Venice Blvd. • Los Angeles 6, Calif.

COUPON-OF-THE-MONTH

- I.F. COILS 455 KC (1 1/2"x2 1/2") 3 for 50.99
 - TUBES—STD. BRAND 35Z5 or 35W4 2 for .99
 - FOOT CONTROL—For Auto Radio 2 for .99
 - CONDENSERS—40-40 Mfd. 150V 2 for .99
 - CONDENSERS—40-20 Mfd. 150V PP 2 for .99
 - LOOP ANTENNA—HI GAIN (5"x8") 3 for .99
 - SAPPHIRE PHONO NEEDLES (List \$2.50) 2 for .99
 - OSC. COILS 455 KC (for 12SA7) 4 for .99
 - BY PASS COND. KIT—18 Asstd.99
 - DIAL CORD KIT—100 ft. Asstd. & 6 Springs95
 - GRILLE CLOTH—8 Asstd. 8"x8" & 10 Knots95
- COMBINATION KIT—All above Items—Only 10.00

WITH THIS COUPON—ORDER AT ONCE
Write for Monthly Coupons and Bulletin
RADIO DISTRIBUTING CO., Pasadena 18, Cal.

ON-THE SPOT BATTERY RECORDER

WALKIE-RECORDALL 8 lb. miniature BATTERY RECORDER-PLAYBACK
Continuous, permanent, accurate, indexed recording at only 5c per hr. Instantaneous, permanent playback. Picks up sound up to 80 ft. Records conferences, lectures, dictation, 2-way phone & sales talks while walking, riding or flying. Records in closed briefcase with "hidden mike"! Write for Detailed Literature.

MILES REPRODUCER CO., INC.
812 BROADWAY Dept. RN-3, NEW YORK 3, N. Y.

TEST EQUIPMENT FOR SALE

- I DuMont 304-H
- I DuMont 208-B
- I Hewlett Packard 400C

Very clean and good operation condition.
Box No. 532
c/o RADIO & TELEVISION NEWS
366 Madison Avenue New York 17, New York

BARGAIN HUNTING? RADIO SERVICEMEN!

Write for SENSATIONAL CATALOG
HENSHAW RADIO SUPPLY
3619 TROOST KANSAS CITY, MO.

WILL PAY UP TO \$300 FOR ART-13's

Also need CFI units for above—plus BC-788, I-152 and BC-348 Q and R receivers.
Also interested in other airborne electronics. Top dollar paid. Inquiries answered promptly.

V & H Radio & Electronic Supply Co.
2033 W. Venice Blvd. Los Angeles 6, Calif.
Phone Collect: REpublic 31127

ANOTHER OUTSTANDING JOBBER CLAYTON RADIO PARTS

2749-51 N. Ashland Ave.
Chicago, Illinois

HAS THE SENSATIONAL NEW **EICO** 470-K 7" SCOPE KIT IN STOCK!



\$79.95

Groove bottom diameter 5.00", o.d. 5½"

H. Main plate, ½" steel. Groove bottom diameter 11.75", o.d. 12.25"

I. Pin, steel. 3 required. Press fit in parts G and H

J. Peg for 45 rpm records. Solid if aluminum or dural; otherwise bored out to lighten. Tip is accurate slip fit in hole in part C and shoulder fits flush into part H. The shoulder gives a firmer seat than the short bearing of part K in Fig. 2

K. Peg for 33½ and 78 rpm records. Fits like part J

Notes: (a). Hot-rolled machine steel is recommended for the plate, part H. Cold-rolled steel, though cheaper, may have strains that will cause belated warping. Drill rod is best for the shaft because the ball will not sink into it, but might be difficult to drill for the top center hole. (b). The butt of the shaft is faced off square and has no center hole. For taking the final facing cut from the plate and turning the groove in it, the butt of the shaft should be held in a collet and the top supported by the tailstock center. Part G should also have its groove turned at this time but this may not be possible without a special tool to get at it. Parts G and H are reamed or bored to a press fit on part C after pinning them together. Before they are mounted on part C, they can be held to the face plate of the lathe by bolts through holes such as those seen in Fig. 3.

A professional machinist may have better ways of doing some of these operations, but the procedure suggested will result in an accurate job.

It will be noted that the cushioned separate upper plate has been abandoned in the interest of economy, in Fig. 6 as compared with Fig. 2. In 12 years the sponge rubber has perished so that it no longer cushions much, yet there is no noise as long as noise is kept from the pedestal; hence it is considered unnecessary. The plain bearings of Fig. 6 should be quieter than ball bearings. Further economy could be effected by giving up the special pegs and using a plain one integral with the shaft. Instead of the thick plate, a thin one with a thick rim could be used to provide the same moment of inertia with less weight; but this would require more machining unless cast. An auto fly-wheel from a junkyard might be used with a thin plate on top of it. This is not so fantastic as it sounds: the late Daniel Hilferty, formerly a recording engineer with RCA-Victor, told the author how that company once bought a manhole cover from the city of Camden and machined it into a turntable!

REFERENCES

1. *Graumont and Hensel: "Encyclopaedia of Knots and Fancy Rope Work,"* Cornell Maritime Press, New York, 1945.
2. *Ashley, Clifford W.: "The Ashley Book of Knots,"* Doubleday, 1945.

Federated

FEATURES

A

COMPLETE

STANCOR

LINE

MOBILE TRANSMITTER
Operates as mobile or fixed location unit from A.C. or D.C. power pack.

FEATURING

- Press-to-talk transmission
- Two channel crystal switching
- Self contained antenna changeover relay

SPECIFICATIONS

- (A3) emission
- 25 watt amplifier plate power input
- 27-32 megacycles
- Power req.'s: 400-500 VDC @ 200 MA
6 VAC/DC @ 2.8 AMP

ST-203-A KIT, including all constructional components, less accessories. Amateur's net \$47.50

ST-203-A, completely assembled, wired and tested, less accessories. Amateur's net \$66.75



P-8192 \$2.95

STANCOR CR TUBE BOOSTER. This compact, self-contained device can be used with all electromagnetic picture tubes — regardless of size — where dimming is due to low cathode emission.

COMPARE THESE FEATURES

- No connections to solder — has both male and female connectors
- Does not require AC line connections
- Hi-lo switch provides two levels of brilliance
- Measures only 3½" high, 1½" in diameter
- Does not change CR tube space requirements
- Autoformer construction
- Easy to install

Federated Purchaser

Nation's Only Coast-To-Coast Electronics Distributor

- New York City 7, N. Y., 66 Dey St.
- Newark, N. J., 114 Hudson St.
- Allentown, Pa., 1115 Hamilton St.
- Easton, Pa., 925 Northampton St.
- Los Angeles 15, Cal., 911 So. Grand Ave.

TRAIN *At Home* FOR OPPORTUNITIES IN

UHF-TV

SERVICING

Set Your Own Pace with This Practical Program!

Get in on the ground floor of this fast-growing field. Train now to cash in on the opportunities that are yours in UHF-TV SERVICING with proven, practical T.C.I. training. Here is non-mathematical training that's complete down-to-cases . . . up-to-the-minute. Here is training you take in your spare time, without leaving your present job! Think of it—in your own home you learn TV set conversion, master antenna installation, the latest in UHF-TV, money-making short cuts and much more. You learn to trouble-shoot, test and repair TV sets the only practical way—by actually doing this work yourself!

HERE'S HOW YOU LEARN BY DOING!

You get the experience you need by working on a large screen, modern TV receiver that's given to you with the course and is yours to keep. As an optional feature you get two weeks of field experience on service calls and on the repair bench with one of Chicago's largest independent TV servicing organizations. You profit from the experience and know-how of men in the field. Not through books alone but by actually doing the work yourself, you get the knowledge you need to qualify for opportunities in UHF-TV SERVICING! Age is no barrier. Many T.C.I. students are over 40! Mail Coupon for full facts, FREE Catalog and SAMPLE LESSON. Act NOW!

VETERANS
discharged since June 27, 1950 are eligible for G.I. benefits. Check coupon.

THESE MEN LIKE YOURSELF SAY T. C. I. TRAINS YOU BEST!

"I've almost completed your course now, but I have been servicing TV sets since almost the beginning of the course." E.R.M., Rhode Island.

"Thanks to your course, jobs that used to take me several hours now take but a few minutes to complete." W.L.K., Wash.

"I like the easy way your lessons are presented. I'm very pleased with your course and have recommended it to a friend." L.R.S., Texas.

TELEVISION COMMUNICATIONS INST.
205 W. Wacker Dr., Dept. 1-AH, Chicago 6, Ill.
YES! Rush full facts on UHF-TV training. Include FREE Catalog and Sample Lesson. I am not obligated. Salesman will not call.

Name Veterans Check here

Address

City Zone State

BEGINNERS: Check here for information on Pre-TV Radio Course.

TELEVISION
Communications Institute
205 W. Wacker Dr.,
Dept. 1-AH, Chicago 6, Ill.

MAIL NOW FOR FREE BOOKLET

HIGH SENSITIVITY FREQUENCY VOLTAGE

with this sensational

RCP MODEL 453 NEW MASTER MULTITESTER

- ★ 20,000 OHMS PER VOLT MULTITESTER
- ★ 400 MEGACYCLES ON HIGH FREQUENCY WITH H.F. PROBE INCLUDED
- ★ 25,000 VOLTS WITH SAFETY-HIGH VOLTAGE PROBE INCLUDED



A brilliant new completely self contained unit. The model 453 was designed for direct metering—eliminates warm-up time, grounding, etc. Assures dependable measurements for TV, FM and AM. Included are regular test leads, high-voltage multiplier probe and high frequency probe.

RANGES:

DC VOLTS: 0-2.5-10-50-250-500-1000-5000-25,000 at 20,000 ohms per volt.
 AC VOLTS: 0-2.5-10-50-250-500-1000 volts.
 DC MICROAMPS: 0-110
 DC MILLIAMPS: 0-10-100-500
 OHMS: 0-2000-200,000
 MEGOHMS: 0-2 Meg.-20 Meg.
 DECIBELS: 12 to +3 to 15, 14 to 29, 28 to 43, 34 to 49, 40 to 55

Multiplier and shunts selected within 1% accuracy.

Handsome — with deeply etched brushed aluminum panel mounted in a sturdy hinged cover oak case with compartment for leads. Size 10¼" x 11" x 4".

Wt. 6¼ lbs. Complete, ready to operate. A terrific instrument at . . .

\$49⁵⁰ NET

Write for the new 1953 RCP illustrated catalog to Dept. RN-3

RADIO CITY PRODUCTS CO., INC.

152 West 25th Street



New York 1, N. Y.

MANUFACTURERS' LITERATURE

Readers are asked to write directly to the manufacturer for the literature. By mentioning RADIO & TELEVISION NEWS, the issue and page, and enclosing the proper amount, when indicated, delay will be prevented.

JFD CATALOGUE

JFD Manufacturing Co., Inc., 6101 Sixteenth Ave., Brooklyn 4, N. Y. has issued a 36-page, 3-color television antenna and accessory catalogue, No. 450.

This elaborate publication lists hundreds of items needed by the television installation technician, ranging all the way from complete antenna units to stand-offs, insulators, and other small but important accessories.

TV REPLACEMENTS

Sprague Products Co., 51 Marshall St., North Adams, Mass. is now offering copies of a new 44-page 5th edition of its "TV Replacement Capacitor Manual."

The new publication lists accurate, up-to-the-minute condenser replacements for a total of 2460 receiver models made by 78 manufacturers.

Copies are available free from all *Sprague* distributors or by sending 10 cents, to covering handling and postage, to the company direct.

ANTENNA "HANDI-GUIDE"

A 76-page book which catalogues radio and television antenna systems, antennas, and accessories is now being offered free of charge by *United Catalog Publishers, Inc.*, 110 Lafayette St., New York 13.

The "Handi-Guide" contains data on all types of antenna equipment with detailed specifications, illustrations, descriptions, and prices included. It covers the products of 32 leading manufacturers and includes FM, AM, and u.h.f. antennas, TV towers, masts, TV boosters, auto antennas, insulators, wire, mounting hardware, etc.

ANTENNA FILM

Channel Master Corp., Ellenville, N. Y. is currently using its 45-minute sound-and-color film, "The Antenna is the Payoff," to present pertinent data on antenna installations.

The movie covers basic antenna facts not heretofore available to technicians. The major part of the film is devoted to a presentation of the three standards of antenna performance: gain, directivity, and impedance.

Those interested in arranging showings of this film should contact Harold Harris, vice-president in charge of sales and engineering for the company.

FREE INDEX

Supreme Publications, 3727 W. 13th St., Chicago 23 is offering a copy of the newly-published 1952 edition of its "Index" to readers of this magazine if

a 3 cent postage stamp accompanies the request.

The index cross references all of the publisher's radio and TV service manuals by make and model number. At the present time there are twelve radio manuals and six TV manuals. The index normally sells for 25 cents a copy.

NEWARK CATALOGUE

Newark Electric Co., 223 W. Madison St., Chicago has published a 196-page catalogue which lists thousands of items for industry, labs, high-fidelity, radio, and television.

Whole sections of Catalogue No. 55 are devoted to test gear, industrial equipment and supplies, hi-fi systems and components, TV chassis, accessories, and antennas, ham equipment, etc. Copies of the new publication are available on request.

NEW "RADIO'S MASTER"

United Catalog Publishers, Inc., 110 Lafayette St., NYC 13 has announced publication of a new edition of its completely cross-indexed, fully-illustrated buying guide and reference book.

The new "Radio's Master" contains 80,000 items of current electronic products bound in a hard-covered, permanent edition containing 1220 pages. The buying guide is available through local electronic parts distributors or from the publisher.

REPLACEMENT MANUAL

Ram Electronics Sales Co., Irvington-on-Hudson, N. Y. has published a newly-revised edition of its "TV Replacement Manual."

The 1953 edition contains over 6200 listings—complete with manufacturer's name, chassis numbers, model numbers, and corresponding *Ram* part numbers. The listings are also cross-indexed with *Rider* Manual and "Tek-File" references.

This 32-page manual is available from the company direct or from parts distributors. It sells for \$1.00 a copy.

ANTENNA DATA

Snyder Mfg. Co., Philadelphia 40, Pa. has brought out a new and revised edition of its handy, pocket-sized book "T-V Tenna-Tips."

The new edition carries information on u.h.f. antennas, fundamental antenna types, yagi antennas, the company's indoor "Directronic" TV antenna system, antenna installation "do's and don't's," antenna dimension guide, channel frequencies, helpful hints, and proper feed methods for stacked arrays.

Although listed at \$1.00 a copy, the new book may be obtained without charge by writing direct to Dick Morris at the company address.

CLAROSTAT CATALOGUE

A wide choice of resistors, controls, and resistance devices is included in Catalogue 52 recently issued by *Clarostat Mfg. Co., Inc.*, Dover, N. H.

The catalogue features expanded listings of carbon and wirewound controls, aircraft-type metal-cased power rheostats, miniaturized carbon and wirewound controls, and outdoor-theater L-pads.

Copies are available either from the company direct or from the company's distributors.

TEST EQUIPMENT

Radio City Products Co., 152 W. 25th St., NYC 1, has issued a new 8-page catalogue covering its line of radio and television test equipment.

The new publication describes and illustrates oscilloscopes, tube testers, multi-testers, signal generators, v.t.v.m.'s, in addition to a variety of accessories to be used with these instruments.

Copies of Catalogue No. 135 are available without charge.

TIMING RELAYS

Allen-Bradley Co. of Milwaukee, Wis. is offering a 16-page bulletin featuring its complete line of timing relays.

Fluid dashpot, pneumatic, and electronic timers are fully described. It also contains complete operation and engineering data. Timers are shown in a wide variety of standard enclosures. A selector chart is also included.

MASTER TV SYSTEMS

Blonder-Tongue Laboratories, Inc., 526 North Ave., Westfield, N. J. has issued a new installation manual giving complete technical data on all types of master TV systems.

Entitled "The B-T Unit System for Better Television," the new manual describes the characteristics and functions of each B-T unit and accessory.

TRANSFORMER DATA

Microtran Co., 84-11 Rockaway Beach Blvd., Rockaway Beach, N. Y. has released a new, expanded catalogue covering transistor and standard type transformers. Copies will be forwarded upon request.

CONDENSER DATA

Aerovox Corp., New Bedford, Mass. is now offering copies of its bulletin "Miniature Metal-Cased Capacitors" to interested persons.

The publication contains standard listings, specifications, drawings, how-to-order, and other pertinent data on the company's line of foil-paper condensers which are housed in compact tubular metal cases with vitreous ceramic terminal end seals. -30-

March, 1953

"For those who can hear the difference"
Listen

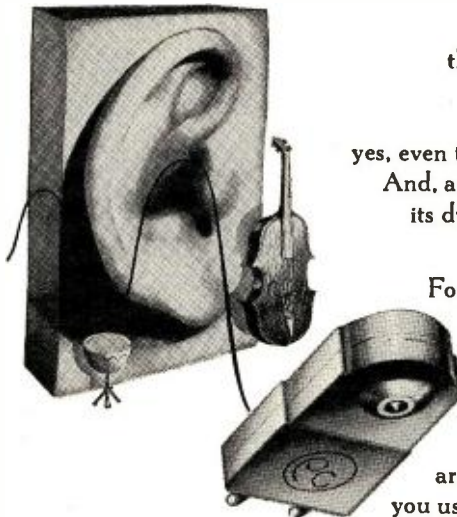

it comes to you
in the subtle shading of a piano . . .
in the clean brilliance of violins,
the purity of a flute. Your ear detects
the sweet mellowness of cellos,
the roundness of a clarinet . . .
yes, even the iridescence of clashing cymbals.
And, as the symphony swells to crescendo,
its dynamic energy adds a flood of color
to your musical canvas.

For those who can hear the difference,
these are the elusive pleasures
that often remain hidden
in the grooves of fine recordings.
These are the thrilling
new listening experiences that
are released for your enjoyment when
you use quality components by Pickering.

PICKERING and company, incorporated

Pickering High Fidelity Components are available through leading Radio Parts distributors everywhere; detailed literature sent upon request. Address Department C-1

Oceanside, L. I., New York



YOUR KEY TO
AUDIO'S BEST BUYS!

TAPEMASTER

MODEL PT-125A BASIC TAPE RECORDER

Low-cost, professional quality tape recorder for use with external amplifier or radio. Dual track, dual speed; records at 3 3/4" and 7 1/2" per second. Response: ± 3 db, 70 to 8000 cycles at 7 1/2"; ± 3 db, 70 to 5000 cycles at 3 3/4". Inputs for radio, phono, and mike. With tubes, tape, reel and cable; less amplifier. Size, 12 1/2 x 12 x 9 1/2". Wt., 21 1/2 lbs.
75F154. NET.....109.50

MODEL SA-13 HI-FI AMPLIFIER AND SPEAKER

Companion unit for above. Response ± 1 db, 30-15,000 cps. Peak output, 8 watts. Less than 1% distortion at 5 watts. Bass control boosts 7 db, attenuates 12 db—at 30 cps. Treble control boosts 12, attenuates 10 db—at 15,000 cps. 7 1/2" accordion type speaker with floating cone. Tubes: 5881, 6SN7GTA, 6C4, 5Y3GT. Size 9 1/2 x 12 x 18 1/2". Wt., 25 lbs.
75F153. NET.....79.50

NEWARK FM-AM RECEIVER CHASSIS

One of the finest high-fidelity values available. This FM-AM chassis is perfect for modernizing old consoles, or as the nucleus of a low-cost high-fidelity music system. Included are such top-notch features as drift-free FM, push-pull audio output, full-range bass-treble tone control, and a phono jack with built-in preamp for magnetic pickups. The chassis is shipped complete with a 12" PM speaker, built-in AM and FM antennas, 12 tubes (including rectifier), all necessary hardware, and an escutcheon. Size, 13 1/2 x 9 x 9". Wt., 20 lbs.
96F034. NET.....69.50

GARRARD MODEL RC-80 3-SPEED CHANGER

The world-famous changer that plays all types of records with watch-like precision. Includes special interchangeable spindle for 45 rpm records. Accommodates most cartridges. Has adjustment for needle force. Size, 15 1/2 x 13 1/4"; requires 5 3/4" above, 3 1/2" below. With plug-in heads, less cartridges. Shpg. wt., 18 lbs.
73F510. NET.....41.45

Order From Department R-33



FREE! Your Copy
of NEWARK'S NEW
CATALOG No. 55
With all
the Latest Releases



223 W. MADISON STREET
CHICAGO 6, ILLINOIS

Technical BOOKS

THE NEW

Regency

VB-1 Voltage Booster*



Get peak performance from your TV set or any electrical device drawing 350 watts or less. This manually operated autoformer maintains full 117 volt power supply. Insures full size TV picture when low line voltage shrinks picture size.

THE VB-1, \$19.95 LIST

*by the makers of the Regency VHF TV booster and UHF TV converter

Ask any radio parts jobber for further information or write:
I.D.E.A., INC., REGENCY DIVISION
7900 Pendleton Pike, Indianapolis 26
Cherry 2466

"UHF PRACTICES AND PRINCIPLES" by Allan Lytel. Published by John F. Rider Publisher, Inc., New York. 380 pages. Price \$6.60.

This is a basic text designed especially for the student or technician who has a working knowledge of standard broadcast receivers.

The author's style is lucid and concise and those encountering u.h.f. theory for the first time should have little trouble grasping the subject matter as presented in this text.

The book itself is divided into eleven chapters. The author introduces the subject matter and makes pertinent comparisons between the ultra-high frequencies and those with which the reader is more familiar, i.e., the broadcast frequencies. He then discusses those features of u.h.f. which differ from the broadcast frequencies, then goes on to cover the electromagnetic radio wave, receiving antennas, transmission lines and wave guides, new types of tuned circuits, oscillator tubes and circuits, receivers and converters, transmitters, developmental vacuum tubes, and test equipment and techniques for u.h.f.

A comprehensive bibliography has been included for the reader who wishes additional information on any phase of the subject.

The text material has been lavishly supplemented with photographs of u.h.f. equipment and circuit diagrams illustrating the various points. Mathematics is held to a minimum and what is included is confined to arithmetical operations. This book is entirely suitable for self-instruction or home-study work.

* * *

"RADIO OPERATING QUESTIONS AND ANSWERS" by J. L. Hornung & A. A. McKenzie. Published by McGraw-Hill Book Company, Inc., New York. 539 pages. Price \$6.00. Eleventh Edition.

In this, the eleventh, edition of a well-known reference work, the authors have completely revised the material to include answers to all questions suggested for study in the FCC Study Guide of 1951 and have added questions on the newer Element VII (aircraft radiotelegraph) and Element VIII (ship radar techniques).

A chart in the front of the book indicates which elements are included in the various classes of licenses and then the pages covering the elements in question are given. In this way the student working on his, say, radio-telephone first license, would cover elements 1, 2, 3, and 4, etc.

The circuit diagrams and photographs used to illustrate the text have been brought up-to-date. A series of appendices contain a wealth of valuable material in tabular or concise form for ready reference.

Any prospective license holder or

USED RECORDING TAPE (PLASTIC BASE)



\$1.99 for 7"-1200 foot
.09 for 5"-600 foot
.69 for 4"-300 foot
.29 for 3"-150 foot
Plastic reels included with all above sizes.

Money cheerfully refunded if you do not find this tape cleanly erased and as good as new. (If you are skeptical and from Missouri send us 12c in stamps and we'll roll you a sample.)

New empty plastic reels in boxes for easy labeling, 3"-10c; 4"-22c; 5"-24c; 7"-30c ea. EMPTY BOXES: 3"-3c; 4"-5c; 5"-5c; 7"-10c ea.

We carry new recorders, recording blanks, tape, tape recorders, etc. at large savings. PLEASE INCLUDE SUFFICIENT POSTAGE.

COMMISSIONED ELECTRONICS CO.
2503 Champlain St. N. W., Washington 9, D. C.

RADIO COURSES

- RADIO OPERATING • CODE
- RADIO SERVICING • ELECTRONICS
- F.M. TELEVISION
- PREPARATION FOR CIVILIAN, MARITIME, ARMY AND NAVY LICENSE REQUIREMENTS.

Write for Catalog T.S.

YMCA

TRADE & TECH. SCHOOL 15 W. 63 St., N. Y. 23
(NDicott 2-8117)

ANOTHER OUTSTANDING JOBBER

DOUGLAS RADIO SUPPLY CO., Inc.

128 Greenwich St.
New York 6, N. Y.

HAS THE
SENSATIONAL NEW
EICO 470-K 7"
SCOPE KIT
IN STOCK!

\$79.95

PAY LESS FOR TUBES

INDIVIDUALLY BOXED • FULLY TESTED • EACH TUBE GUARANTEED FOR SIX MONTHS

Type	Price	Type	Price	Type	Price	Type	Price
1B3GT	\$.69	6AT6	\$.38	6K6GT	\$.41	12A27	\$.70
1H5GT	.46	6AU6	.43	6L6G	.80	12BA6	.45
1L4	.57	6AV6	.38	6L6GA	.80	12BE6	.47
1L6	.58	6B4G	.96	6S4	.46	12BH7	.63
1N5GT	.57	6BA6	.45	6SA7GT	.52	12BZ7	.75
1R5	.56	6BA7	.60	6SJ7GT	.47	12SA7GT	.52
1S8	.47	6BC5	.53	6SK7GT	.50	12SK7GT	.50
1T4	.56	6BD5GT	.89	6SL7GT	.62	12SL7GT	.61
1T5GT	.71	6BE6	.47	6SN7GT	.54	12SN7GT	.54
1X2	.67	6BF5	.60	6SQ7GT	.42	12SQ7GT	.44
3Q5GT	.65	6BG6	1.34	6T8	.78	15BG6	1.39
3S4	.55	6BH6	.57	6U8	.85	19C6	.94
3V4	.56	6BQ6	.48	6V6GT	.46	19T8	.79
5U4G	.43	6BK7	.89	6W4GT	.45	25BQ6	.89
5V4Q	.73	6BL7	.83	6W6GT	.57	25L6GT	.48
5Y3G	.34	6BQ6	.89	6X4	.34	25Z6GT	.42
5Y3GT	.30	6BQ7	.85	6X5GT	.33	35A5	.48
6AB4	.46	6BZ7	.95	6Y6G	.59	35B5	.47
6AG5	.54	6C4	.34	7N7	.52	35C5	.47
6AK5	.95	6CB6	.53	12AT6	.38	35L6GT	.47
6AK6	.63	6CD6	1.85	12AT7	.68	35W4	.31
6AL5	.40	6FGGT	.45	12A86	.43	35Z5GT	.30
6AQ5	.46	6F8G	.93	12AU7	.53	50B5	.47
6AQ6	.42	6HG6GT	.49	12AV6	.38	50C5	.47
6AR5	.38	6J5GT	.40	12AV7	.80	50L6	.47
6A55	.50	6J6	.62	12AX7	.61	117Z3	.39
						117Z6	.68

Motorola Ballast Tube #17A485459 30

Each tube is performance-proven. 25% deposit must accompany all orders. Balance C.O.D. All prices F.O.B., N.Y.C. If remittance is made with order, you can deduct 2%. \$1.00 handling charge for orders under \$10.00. Subject to Prior Sale.

PHILLIPS TUBE COMPANY, 2610 E. 16th Street
Brooklyn 35, N. Y.

SUPER SENSITIVE RELAY BK-7-B
Single pole, double throw. Coil 4000 ohms. Sensitivity accurately adjustable on calibrated scale. At 5 on scale sensitivity is 1/2 milliwatt (1 milliwatt, 2 volts) and from 5 to 50 sensitivity decreases linearly to 1.5 ma (9 milliwatts, 6 volts). Thousands of uses: telemetering, voice-operated or capacity operated or thermocouple operated circuits, sequence circuits, etc. Fully enclosed, 1 1/2" x 3 3/4" x 1 1/4" deep. Weight, 6 oz. With hinged contact-inspection door and screwdriver adjustable stationary contacts. . . . Brand New, Only \$1.95 each, 10 for \$17.50 (Shipping Weight, each, 1 lb.)

A SENSITIVE RELAY!
Closes at 4 to 5 ma. (Extra set of SP/ST contacts for additional sequence, close at 6.5 ma.) Coil 6000 ohms. Sensitivity easily altered by bending limit arm or changing spring. Only 1 1/2" x 2 1/4" x 1 1/4" overall. Dozens of applications, and offered at a "stock up" price. Removed from clean equipment. . . . ONLY \$8c each, 3 for \$2.75 Boxed, reconditioned, like new. . . . \$1.69

12 CHANNEL T-V TUNER
Complete front end, famous make "Silver Circle." Furnished with original factory instructions, test tubes. Dozens of uses; receivers, converters, etc. The TV bargain of the year for builders, amateurs, students. There are 12 channels, 12 sets of controls, no damage. . . . ONLY \$1.95 each, for \$5.00 (Shipping Weight, each, 3 lbs.)

SBP4 CR TUBE. Same as SBP1, except for white screen. . . . BRAND NEW, only \$3.75

NOVICE 80 METER CW XMTR
This is the 4-5-3 MC Command xmtr, which may be easily converted to novice operation. We furnish complete instructions, including keyed photos and before-and-after schematics. . . . \$8.95
EXCELLENT, with tubes. . . . \$7.95
5-3 to 7 Command Xmtr, same as above except requires two more conversion steps. . . . \$7.95 (Shipping Weight, 13 lbs.)

6-9-1 MC Command Receiver, EXCELLENT, with tubes. . . . \$6.95 (Shipping Weight, 8 lbs.)

274N PLUG. 7-prong male plug to fit back of command rxrs. and xmtrs. This is the same plug as used in the racks. NEW, each 21c; five for \$1.00
Local Control Adapter Part. For use with 274N. Exact pot, switch, knobs, etched plate, and instruction data. Ready to mount. . . . \$1.29
SPINE TUNING KNOBS. . . . \$1.79

12 VOLT COMMAND DYNAMOTOR
For receivers SCR-274N, ARA, ARC-5. Plugs onto rear end. 250 V, 60 ma., DY-1/ARR-2X. . . . \$7.95
Guaranteed good condition
Least plus in base. . . . \$9.95 (Shipping Weight, 5 lbs.)

ATTENTION, TELETYPE USERS
We buy and sell teletype equipment. Tell us what you want or what you've got, or both.

A VIBRATOR BUY. 6 or 12 volts, self-rectifying, hermetically sealed. Can take high overloads. With socket and schematic. Specify volts. ONLY 89c

ANTENNA MAST SECTIONS, MS-49, 50, 51, 52. 39c
55. New, original packing. Each

PHASE SPLITTER, or low-level mixer, or hybrid, or push-pull unit. Has 3 windings, each exactly 1:1 to any other, essentially flat 100-15,000 CPS. BRAND NEW, ONLY. . . . 69c

BUILD TV-FM-AM SWEEP GENERATOR
Now you can build the "VERSATILE SWEEP FREQUENCY GENERATOR"! We've got a few more of those vital APN-1 magnetic units. With reprint of the article. (Shipping Weight, 3 lbs.). . . . \$6.95

PRECISION CALIBRATED TUNER
Build a Q-meter or an audio oscillator, a signal generator, a VFO, an ultra-stable receiver, or your name it! Lab-standard accuracy and reliability. 3 gang condenser assembly with 4 "precision dial etched 1.5-12 mc in 3 bands plus a reference scale. Triangular plastic hairline indicator. 50:1 ratio drive assembly, all gears spring-loaded double-section. Has tuning lock. Plates are two single spaced 250 uuf, and one double-spaced 250 uuf section. Use double need section to eliminate drift. . . . \$4.95
ONLY (Shipping Weight, 6 lbs.).

BROADCAST BAND & AERO
MN-26-C Remote Controlled navigational direction finder and communications receiver. Manual DF in any one of three freq. bands, 150 to 1500 KC. 24 V. Self-contained dynamotor supply. Complete installation, including receiver, control box, loop, azimuth control, Left-Right Indicator, plugs, loop transmission line, and flex shaft. . . . \$69.50
BRAND NEW, ORIG. PACK. . . . \$69.50 (Shipping Wt. 75 lbs. Express Collect.)

SUPER HI-FI HEADSET BUY!
Uses annular-grooved plastic fibre cones with voice coils as in speakers, and padded chamolite ear muffs to obtain spacing for correct acoustical load. Gives finest music reproduction, flat far beyond upper and lower limits of auditory perception. Pair in series has measured impedance of 600 ohms at 1000 cycles, obtained with built-in high quality transformers. However, severe mismatching makes no apparent difference. Far superior to crystal phones. Manufacturer's net price is \$45.00 per pair! (Each unit can also be used as high quality dynamic mike with 300 ohm output impedance.) They come to you packed out with freshly impregnated chamolite pads in cellophane bag. . . . ONLY \$7.95 (Shipping Weight, 3 lbs.)

6 V VIBRATOR KIT. Vibrator plus non-synch transformer, two outputs: 700 VCT, 145 ma; 150V plates; 15 V for bias. Using 3U4C can deliver 320 V at 150 ma. (Shipping wt. 6 lbs.) . . . NEW \$2.89

OUTPUT TRANSFORMER. 5000 ohms input to TWO outputs, 300 ohms or 3.5 ohms. Use as output for 12A6, 6V6, etc. or to match speaker or headset. NEW, potted, shielded. . . . \$1.79

EASY MONEY!
We're still buying surplus gear. Tell us what you've got, its condition, and your price. If we like it you'll get our check quick.

G. L. ELECTRONICS
905 S. Vermont Ave., Los Angeles 6, Calif.
All Prices F.O.B. Los Angeles Calif. Buyers Add Sales Tax
SEND FOR OUR LATEST FLYER.

radioman who is planning to up his license grade would do well to work with this text for a complete and comprehensive picture of his exam requirements.

"PHOTOELECTRIC TUBES" by A. Sommer. Distributed by John Wiley & Sons, Inc., New York. 115 pages. Price \$1.90.

This compact little volume wastes no words in tackling the problems involved in the application of photoelectric tubes to various devices.

The first two chapters are devoted to a survey of the principles of photoelectric emission and a brief historical sketch of the work done in the field.

Following this introductory material, the author provides a detailed description of the manufacture and characteristics of photocathodes, devotes three chapters to vacuum, gas filled, and multiplier photocells and their relative advantages and limitations, and then covers applications of photoelectric cells, or tubes.

The text material is accompanied by line drawings and graphs which help to clarify the subject matter. Formulas are used throughout the text but the non-mathematical reader should be able to obtain considerable benefit from this book without knowing the steps by which the formulas are derived.

"ELECTRONICS EVERYWHERE" by Prof. A. M. Low. Published by The John Day Company, Inc., New York. 188 pages. Price \$2.50.

This is a non-technical treatment of a subject about which today's layman is not only vitally concerned but openly curious.

In a thoroughly lucid style the author discusses the fundamental concept of electronics, electronic tubes in radio and television, electronic "feeling" devices (radar, sonar, etc.), electronic controls, fluorescent lighting, electronic heating, electronic music, etc.

Throughout the text the author has dealt with his subject matter in terms and analogies familiar to the reader. This would be an excellent book for the high school student or any adult whose knowledge of electronics is thus far limited to switching on his television set. A thoroughly readable contribution to elementary literature in the field.

"SIM BARTON, GIRL RADIO OPERATOR" by Helen H. Cloutier. Published by Pageant Press, New York. 171 Pages. Price \$2.50.

W8GJX, who has been a ham for over twenty-three years, has drawn freely on her operating experiences to write this novel of a girl radio operator.

Sim Barton, who holds a First Class ticket, has to meet and overcome the opposition of Great Lakes shipping firms, ship captains, and crewmen to a woman aboard ship. By sheer "stick-to-itiveness" Sim manages to land a job on a Lake freighter, first as a "va-

NEW! 2 GREAT BOOKS
By Milton S. Kiver

IF YOU SERVICE TV — YOU NEED THEM!

"TV Servicing Short-Cuts Based on Actual Case Histories"



shows you how to solve commonly recurring troubles

the book that really teaches fast, expert service techniques

This book describes a series of actual TV service case histories, each presenting a specific problem about a specific receiver. The symptoms of the trouble are described and then followed by a step-by-step explanation of how the service technician localized and tracked down the defect. Finally, there is a detailed discussion of how this particular trouble can be tracked down and solved in any TV set. The discussions which follow each case history are invaluable—they explain how to apply the proper time-saving servicing techniques to any TV receiver. Here, in one volume, is the successful experience of experts—to make your service work easier, quicker, more profitable. 100 pages, 5 1/2 x 8 1/2", illustrated. Pays for itself on a single service job.

ORDER TK-1. Only. . . . \$1.50

"HOW TO UNDERSTAND AND USE TV TEST INSTRUMENTS"



shows you how to get the most from your test instruments

Provides basic explanations of how each test instrument operates; describes functions of each control and shows their proper adjustment to place the instrument in operation. Covers: Vacuum Tube Voltmeters, AM Signal Generators, Sweep Signal Generators, Oscilloscopes, Video Signal Generators, Field Intensity Meters, Voltage Calibrators. Describes each in detail; explains functions; tells proper use in actual servicing; shows how to avoid improper indications. Because this book gives you a clear, complete understanding of your test instruments, you get more out of them, save time, and add to your earning power. 148 pages, 8 1/2 x 11", illustrated.

ORDER TN-1. Only. . . . \$3.00

HOWARD W. SAMS & CO., INC.

Order from your Parts Jobber today, or write direct to Howard W. Sams & Co., Inc. 2203 East 46th Street, Indianapolis 5, Ind.

My (check) (money order) for \$ enclosed. Send the following books:

TK-1 (\$1.50) TN-1 (\$3.00)

Name
Address
City Zone State



**HAVING TROUBLE
GETTING FAR AWAY
TELEVISION STATIONS
UP TO 125 MILES
AWAY—OR MORE?**

**WHAT'S YOUR ANSWER
TO THIS QUESTION?**

If you're in FRINGE area — not right next door or fairly close to the television stations you want to get, you need the DAVIS VHF SUPER-VISION ALL-CHANNEL ANTENNA. For ALL CHANNELS.

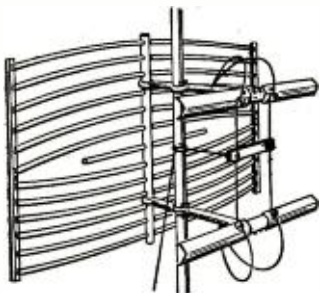

**DAVIS SUPER-VISION
FOR FRINGE AREA & DX**

"The Original Antenna Sold With A Money-Back Guarantee"

Built By America's Fastest Growing Antenna Manufacturer

The DAVIS SUPER-VISION is one of the three basic elements necessary for FINE RECEPTION. It's actually as important as the finest television receiving set. So, when you buy, BUY RIGHT — all the way through: Set, Antenna and Leadline. And the services of a competent television technician to make the installation. If you miss on one, you'll miss what you're really buying: AMERICA'S FINEST TELEVISION RECEPTION.

The DAVIS STORY is a BIG STORY—in performance. Get all the facts. Aside from distance and DX reception, know about the "other ten" important features.

PRICED RIGHT for such fine reception. List only \$34.95. Worth every cent of its cost with "the price forgotten long after fine reception remains."

AT YOUR JOBBERS, or MAIL COUPON TO:

DAVIS ELECTRONICS 1-27
4313 West Magnolia Blvd., Burbank, California
SIRS: RUSH INFORMATION TO ME AS CHECKED BELOW:

Send Free Technical Data on new SUPER-VISION ANTENNA.
 Send Name and Address of NEAREST JOBBER.

Name _____
Street _____
City _____ State _____

RESISTOR KITS

\$1.95
shipped
prepaid

100 assorted useful sizes
1/2-1.2 Watt, 5 and 10%, insulated
Cash with order

LAPIROW BROTHERS

1657 Hoffner St. Cincinnati 23, Ohio

**ANOTHER OUTSTANDING JOBBER
GREEN TELE-RADIO DIST.**

472 Sutter Ave.
Brooklyn, N. Y.

HAS THE
SENSATIONAL NEW
EICO 470-K 7"
SCOPE KIT
IN STOCK!



\$79.95

cation operator" and then as regular Second Radio Officer.

She forces her male co-workers to admit her competence but finally retires from the field to act as full-time "first mate" for Captain Bill Smith.

The story moves along rapidly with career tips neatly woven into the plot. Mrs. Cloutier has made a subtle plea for more radio opportunities for women but whether or not her cry will be heard in the wilderness remains to be seen. The book is a good yarn whether or not it opens the employment rolls to lady ops.

-30-

Spot Radio News
(Continued from page 18)

During the past few months, all of the 50-kilowatt broadcasters have been cooperating in a series of tests, involving round-the-clock skywave programming, not only to familiarize themselves with system operation, but to aid the Civil Defense Administration and the Air Defense Command of the USAF.

Although it is not mandatory for stations to join the plan and stay on the air, over 1000 have signified that they would participate and have spent over one and a half-million dollars of their own funds to make the necessary equipment adjustments.

This unusual deception technique, based in part on a similar plan used successfully in Great Britain during the last war, will eventually involve an outlay of a half-million dollars for line interconnections for programming purposes.

TVI, which a year ago was a wrangling problem harassing amateurs, service technicians, distributors, and others, has now reached a stage featuring exemplary coordinated cooperation among about 200 community committees. In a report on this striking progress, the FCC has revealed that the results have been due to TVI combat committees established in the Central State region (30 committees); Great Lakes (26 committees); Gulf States (18 committees); North and South Atlantic (48 committees); North and South Pacific (52 committees) and Alaska and Hawaii (3 groups). In addition, 30 committees have been proposed.

Amateurs have been particularly active, with two basic cooperating types in operation. Where there are a number of amateur clubs in a metropolitan area, the usual approach has been to pool individual resources into one unified amateur committee. In more isolated areas, individual amateur clubs have provided their own committees on a purely local basis.

Describing the success of the plan, the Commission reports that TVI search activity has decreased the workload of metropolitan interference complaints to the extent that survey time can now be given to cases in

rural areas. In general, this assistance has been found to permit the Commission's field offices to handle more investigations relating to unauthorized operation, and interference to radio services other than broadcast from non-TV and non-amateur sources.

Some rather odd complaints and methods used to track down interference are described in the report. One committee was asked to investigate an interference condition whereby a local TV channel was affected by an "... awful squealing noise" every Friday night during the telecasting of wrestling matches. It developed that on these particular nights, an elderly uncle regularly visited the family reporting the interference to watch the wrestling programs. Investigation further pinned down the interference to weak batteries in a hearing aid used by the uncle, resulting in an oscillating condition within the TV receiver.

Of all the accomplishments of the TVI committees, the one that stands out prominently is its demonstration of the fact that TV viewers and ham enthusiasts can live in the same neighborhood without interfering with each other's enjoyment. Some TV set owners have become so interested in amateur operation, the report discloses, that they have taken advantage of the private-message handling services of ham stations, and others have even joined the amateur fraternity.

Actually, the report reveals, the FCC and its predecessor agencies helped to organize groups outside their own ranks to deal with aural broadcast interference problems long before the advent of TV. The so-called *Chicago Plan* was developed in 1920 by a group of Chicago hams, called together by a local radio supervisor of the Radio Division of the Department of Commerce. A similar plan was later put into effect in Boston.

THE GRAND JOB AMATEURS have done and are doing was further extolled by none other than FCC Commissioner George Sterling, during a talk before the N. Y. Radio Club in the auditorium of the American Red Cross recently.

Scarcely a day goes by, he said, but what an "... amateur station ... somewhere in the country is brought into service to render communication to the public, where it is due to an earthquake, flood, snowstorm, an accident, or because of a death or sickness in the family."

Noting that this is no news to the hams, but it is to the average citizen, the Commissioner stated that "... the service amateurs render to the nation, whether it be in time of peace, emergency, or war, must be constantly kept before the public eye, so that if the time comes when ... the privileges of the amateurs ... are threatened ... they can have the voice of the people back them up in the fight with those who seek to take away ... the

privileges and frequencies . . . of amateurs."

The ability of the hams (of which there are over 117,000 today) to serve in all kinds of emergencies has been one of the important factors which has helped this country retain international frequency allocations for them. They should therefore be on the alert, the Commissioner stressed, to resist any attempts to bypass them, as some branches of the military have attempted recently. He warned that the tendency to consider the use of the facilities of CAP as a civil defense communications service and to contemplate establishing a permanent civil defense communication system, perhaps on amateur bands when considered with a recent development in the MARS system, wherein a marriage of MARS and FCDA for civil defense communications is proposed, led him to believe that perhaps a pattern is developing which could finally result in bypassing the amateurs, with respect to their participation in disasters or civil defense. A very serious constitutional question is raised, the Commissioner declared, when in a democracy like ours, a military organization proposes to engage in a civilian activity such as rendering a civil defense communication service. Amateurs must begin defending themselves against this dangerous and deplorable action, the FCC expert added.

This is a big job, he said, but the amateur has done big jobs before, and given the will to accomplish the purpose, one has no doubt of the results in the future.

Hams and radio fans, too, will be forever grateful for that bold pledge of constant support L.W.

PHOTO CREDITS

Page	Credit
39	Radio Merchandise Sales Inc.
42-43 (Fig. 5 Right)	National Broadcasting Company
43 (Fig. 5 Left), 44 (Fig. 8)	Philo Corporation
44 (Fig. 7)	Station WABD
45	Stephens Manufacturing Corp.
48, 49, 50	Allen B. Du Mont Laboratories, Inc.
51, 64, 65	Philadelphia Police Dept. Photo
51 (bottom)	Philadelphia Electrical Bureau
54	American Phenolic Corporation
55	Radio Corporation of America
63 (top)	Bendix Radio Division
74	Kol Zion Lagolah
104	Transvision, Inc.
122	Swiss Broadcasting Corp.
128	General Electric Co.
134	Radio Manufacturers Assn.
137	Emerson Radio & Phonograph Corp.

ERRATA

In the circuit diagram appearing on page 59 of the January 1953 issue ("Modernizing the SCR-274N Transmitter) the plate and grid of the 1626 oscillator are connected together. This connection should be omitted. C₂ is a Johnson 70F30 not 70F20 as stated.

The diagram accompanying the item "The Backtracker" (page 145 of the January 1953 issue) shows the filament winding on the heater transformer to be 6.3 volts. The value should have been shown as 2.5 volts for the 56 tube used in this circuit.

In Fig. 3, page 64 ("A Low-Cost Audio Oscillator") of the January issue, the positions of R₂ and R₁ should be interchanged and the common terminal for C₂, C₃, C₇, and C₈ should be grounded.

1 MAN TURNS A CRANK... AND UP GOES THIS LOW-COST REINFORCED TOWER



Penn's special hoist permits 1-man erection of this new telescoping tower to heights of 45 feet.* No elaborate equipment required. Mount adjustable to all antenna rotors . . . mast can always be centered over tower. Tower clamp - reinforced at section joints.

The Standard Teletower
Rugged steel braces that reinforce tower also serve as climbing rungs. Straight top design makes climbing easier. Base adjustable to either flat or sloping surfaces. Competitively priced.

Write today for free bulletins and price list.

*Using 20 ft. pole

PENN
Telescoping
Tower

PENN
Teletowers
enna-Mast
Hardware

PENN BOILER & BURNER MFG. CORP., LANCASTER, PA.

New Guaranteed TUBES Standard Brands

New Guaranteed	TUBES	Standard Brands
0A2	\$1.00	6AR6 2.75 815 2.80
0A3/VR75	1.10	6AS6 2.30 828 9.95
0B2	1.40	6F4 4.50 829 9.50
0B3/VR90	.98	829B 11.95
0C3/VR105	1.00	830B 2.75
0D3/VR150	.90	832A 9.25
1A3	1.00	833A 34.95
1B22	2.25	836 3.45
1B23	8.95	837 1.45
1B24	9.50	845 8.50
1B27	14.50	849 24.50
1B32	3.10	851 55.00
1N21B	2.75	852 19.95
1N22	1.25	614 6.95 860 3.75
1N23	1.25	6K4 3.50 861 19.95
1N23A	2.25	6GL 12.95 872A 3.25
1N23B	3.50	15E 1.25 874 1.10
1N34A	.79	15R69 884 1.40
1N38	1.50	250R 8.95 891A 6.50
1N40	8.50	250TH 18.00 894 2.95
1N58A	1.25	304TH 4.25 100569
1N63	2.39	304TL 7.95 958A69
2C39	2.50	607A/RK75 4.25 959 2.95
2C40	9.95	350B 10.05 100569
2C43A	15.00	388A 1.49 1616 1.90
2C44	1.19	394A 3.95 1624 1.45
2C52	4.95	393A 8.95 162539
2D21W	2.49	417A 8.50 162639
2K25	28.50	423A 4.50 1631 1.50
2K28	32.00	423A 4.50 163269
2X2	.89	448A 1.19 2051 1.10
3A4	2.75	464A 10.95 5511 11.00
3A5	1.25	468B 10.50 5635 8.95
3AP1	8.95	701A 4.50 5637 2.75
3B2	4.95	702A 2.75 5638 4.00
3B24	4.95	703A 4.95 5645 2.95
3B24W	7.50	705A 1.50 5846 8.95
3BP1	3.50	707B 14.95 5851 2.75
3C22	80.00	715C 19.95 5870 4.30
3C23	9.95	717A 9.95 5872 2.00
3C24/24G	1.50	721A 1.95 5876 3.95
3C27	2.75	722A 2.95 5878 2.25
3C32	9.95	723A/B 18.95 5886 4.25
3C45	14.95	724B 3.95 5887 4.25
3DP1	3.95	801A 3.95 5894 2.60
3E29	13.95	802 3.95 5702 6.50
3FP7	1.95	803 3.95 5704 4.50
3GP1	3.95	804 3.95 5718 2.95
3HP7	3.95	805 3.25 5726 3.25
4B24	4.50	807W 1.59 5749 3.25
4-12SA	25.00	807W 1.59 619CX 5.95
4X150A	27.50	809 2.95 5749 3.95
4X500A	100.00	810 9.95 5814 3.25
5BP1	4.50	811 2.90 5823 2.95
5BP4	4.50	811 2.90 5844 4.50
5CP1	4.50	812 2.75 5915 1.00
5C50	19.95	812 2.75 6026 2.25
5D21	1.95	50-20 10.00 8005 4.95
5FP7	1.95	50-32 12.50 8012 1.95
5G2	4.50	12-20 10.50 8025 4.95
5R4GY	1.10	12-20 10.50 9001 1.25
6AQ6	1.95	12-32 10.99 900298
6AJ5	4.50	100-20 14.50 9003 1.50
6AK5WE	2.00	812 2.75 900469
6ALSW	3.65	813 11.95 9005 1.50
6AN5	2.75	814 2.95 900669

Complete line of Receiving Tubes. Thousands of other types of Transmitting Tubes. If you don't see it, WRITE. Prices subject to change without notice. Californians add sales tax.

Jsh ELECTRONICS
SALES CO. Dept. R19
7552 Melrose Ave. Los Angeles 46, Calif

New! Up-to-date!



310 pages
170 illustrations



Symptoms of defective operation easily recognized, quickly corrected by illustrations, diagrams and how-to-do-it facts in this new book.

TELEVISION SERVICING

by Walter H. Buchsbaum

Get this brand new, complete handbook for sure-fire working knowledge of TV installation, maintenance and troubleshooting. Tells you step-by-step procedures for audio IF alignment, video IF alignment, aligning RF amplifiers, mixers, oscillators, etc. All possible defects classified for ready reference, thoroughly analyzed to show what is wrong and why . . . and what to do to correct the defect. No mathematical knowledge needed! Practical, authoritative, up-to-the-minute, the perfect handbook for set owners, trainees, and repairmen.

USE IT 10 DAYS FREE

Coupon below brings you "Television Servicing" on FREE trial for 10 days, without obligation. Mail it NOW.

PRENTICE-HALL, Inc., Dept. M-RTN-353
70 Fifth Ave., New York 11, N. Y.

Send me, for 10 DAYS' FREE TRIAL, "Television Servicing." I will return it in ten days and pay nothing—or keep it and send \$1.35 down (plus postage) and \$2 monthly for 2 months.

NAME

ADDRESS

CITY..... STATE.....

SAVE! Send \$5.35 with this coupon, and we'll pay postage and packing.

PARTIAL LISTING OF TUBES AND DIODES IN STOCK

Make Barry your source for FAST-DELIVERY on all types. All tubes individually cartoned and carry Standard RMA Guarantee.

Tube Orders Over \$8.00 with full remittance Prepaid To You in U.S.A.

Prior to shipment, all tubes INDIVIDUALLY retested (not just spot-checked) on our Hickok Mutual-Conductance Tube-Testers to insure you 100% perfect merchandise. For your maximum money's worth, buy in full confidence from TUBE SPECIALISTS. Here is only a partial listing of our large stocks. You may order types not listed at approx. same savings.

0A2\$.90	6B6-G50	50CS50
0A4G1.00	(RCA)1.85	50L6GT55
0B21.10	6BH620	FG-10517.00
0C3/V1801.10	6BQ6GT20	127761.00
0D3/V18088	6BZ1.25	F-123A6.50
1A7GT89	6C445	211 (GE)75
1A890	6CB655	250-TM(GE)18.75
1B3/601680	6CD6-G1.60	274-A & B2.95
1B222.00	6FB-Mtl65	275-A(WE)3.00
1B238.00	6FS-G85	304-TH7.00
1B2712.50	6G6-G85	304T18.75
1A60	6J5GT65	310-A(WE)5.95
1L690	6J662	311-A(WE)6.50
1N21B(Syl.)4.75	6J770	328-A(WE)1.00
1N23A (WE)2.35	6K4 (Syl.)3.50	337-A(WE)3.00
1N23B3.49	6K6GT55	349-A(WE)1.35
1N3484	6K7-M70	350-A(WE)3.95
1N34A(Syl.)84	6K750	359-A(WE)4.00
1N44/400B1.21	6L6-G1.19	371-B85
1N45/400C1.39	6L6-GA1.20	373-A(WE)4.00
1N48 (GE)70	6L6-M80	37764.99
1N48 (Syl.)77	6L780	387-A(WE)2.50
1X2A90	6N7-M80	400-A(WE)2.50
2C43 (GE)13.95	6Q7GT55	403-A(WE)7.50
2C5290	6R5-M98	407-A(WE)5.00
2D211.25	6SD779	408-A(WE)2.75
2E242.50	6S0760	WL-417A8.50
2E301.95	6SM760	421-A(WE)3.50
2J226.50	6S1769	Q1-5591.00
2J3427.00	6SK7GT62	717-A88
2J4824.25	6SL749	151350
2L4934.00	6SN7GT70	8053.25
2K2529.50	6V6GT55	8071.59
2A90	6W6GT85	811-A3.50
1A-F190	6W8GT85	8122.70
1B287.50	6V6-G88	812-A3.50
1B2912.00	6X8GT55	812-A (Hyt.)1.95
1B719.75	7A869	829-B12.25
3B11-F19.50	7A869	832-A8.50
3C23 (GE)9.50	7C685	832-B8.50
3C2712.00	7C3069	8613.95
3C339.00	7F769	86115.00
3D6/129950	7H772	861 (Hyt.)1.95
3E269.95	12A675	872-A (GE)3.95
3Q3GT/G80	12A762	8592.75
3S480	12A762	8592.75
4C3522.50	12A675	161670
4E2713.00	12B757	1622(6L6M)1.95
4-125A22.00	12BA657	1625 (RCA)35
4-250A32.00	12BE657	163170
5B2116.75	12BH71.18	163270
5FF71.95	12SA775	2050 (RCA)1.15
5R40Y1.25	12SF570	20501.15
5U4G55	12SG780	51410
5V4065	12SH763	514 (Hyt.)4.50
5Y3GT42	12SJ769	5528/C6L13.00
6A8A75	12SK769	55289.95
6A8T75	12SL7GT65	5645 (Syl.)8.25
6AC777	12SN7GT70	5646 (Syl.)8.25
6AG565	12SQ7GT63	57022.00
6AG71.25	12TV760	CK-57022.25
6AH61.00	14F780	CK-57442.25
6AJ51.30	19AP4(GE)44.00	CK-58863.00
6AK590	23AV61.25	81075
6AK5-W90	25BQ6GT1.00	892098
6AN52.25	25L6GT64	90101.35
6AT660	25L660	900285
6AU659	25S540	90031.50
6AV649	35C540	900535
6BD680	35L669	900635
6BE695	35Z6GT65	AX990317.75
6BG6-G1.35	4265		

CBS - HYTRON CATHODE-RAY PICTURE TUBES

First Quality in factory-sealed cartons. Full Year Warranty Card on each tube. Remember... no seconds; no rebuilds... Prices include Fed. Tax. C.R. Tubes via Express Collect.

7JP4	18.75	16KP4	28.75	17HP4	25.50
10BP4A	21.00	16RP4	30.00	20CP4A	38.50
12LP4A	21.50	16TP4	30.75	21EP4A	38.50
14CP4	24.00	17EP4A	24.75	21EP4A	38.50
16AP4	31.00	17CP4	25.25	21FP4A	36.00

WESTERN ELECTRIC POWER TRANSFORMER, Pri. 115V 60 cyc. Sec. 930V CT @ 520MA and 5.2V @ 4 Amps. Brand new, boxed. High voltage insulation. ONLY \$9.95

SELENIUM RECTIFIERS-FULL-WAVE BRIDGE TYPES

Current (Continuous)	18/14 Volts	36/28 Volts	54/42 Volts	130/100 Volts
1 Amp.	\$1.35	\$2.15	\$3.70	\$7.50
2 Amps.	2.20	3.60	5.40	10.50
2 1/2 Amps.			6.00	13.00
4 Amps.	3.75	6.75	10.25	
5 Amps.	4.25	7.95	12.95	25.25
6 Amps.	4.75	9.00	13.50	33.00
10 Amps.	6.75	12.75	20.00	40.00
12 Amps.	8.50	16.25	25.50	45.00
20 Amps.	13.25	25.50	39.00	79.50
24 Amps.	16.25	32.50	45.00	90.00
30 Amps.	20.00	38.50		
36 Amps.	25.00	48.50		

New, Selenium Rectifier Transformers

PRI: 115 V., 60 cycles in. } 4 Amps. \$ 8.75
 SEC: 0, 12, 18, 24, and 36 } 12 Amps. \$14.95
 volts } 24 Amps. \$5.75

New Selenium Rectifier Chokes
 4 Amps.-.07 hy.-.6 ohm \$7.95
 12 Amps.-.01 hy.-.1 ohm \$14.95
 24 Amps.-.004 hy.-.025 ohm \$29.95

We can manufacture other Selenium Rectifiers, Selenium Rectifier Supplies, XFMRs., & Chokes. Buy Direct from Manufacturer.



136 Liberty Street, N. Y. 6, N. Y. Rector 2-2562.
 Terms: 25% with order, balance C.O.D. Send a few cents for postage—All merchandise guaranteed. F.O.B. N.Y.C. Remember, you may order tubes not listed!

INDEX OF Advertisers

MAR. 1953

[While every precaution is taken to insure accuracy, we cannot guarantee against the possibility of an occasional change or omission in the preparation of this index.]

ADVERTISER	PAGE	ADVERTISER	PAGE
Acorn Electronics	110	Michel Mfg. Co.	162
Airex Radio Corporation	149	Miles Reproducer Co.	168
All Channel Antenna Corporation	6	Milwaukee School of Engineering	113
Allied Radio Corporation	9	Mosley Electronics	147
Allied Radio	177	Moss Electronics Dist. Co., Inc.	109
Almo Radio Company	106	National Electric Products	12, 13
Alprodec Inc.	101	National Electronics of Cleveland	122
Alice Lansing Corporation	152	National Radio Institute	3
American Television & Radio Company	164	National Schools	97
Amperite Company	177	Neal Electric Company	124
Amplifier Corporation of America	162	Newark Electric Company	171
Arky Radio Kits, Inc.	152	Newark Surplus Materials	132
Arrow Sales, Inc.	133	Newcomb Audio Products Company	32
Ashe Radio Company, Walter	105	Nidisco	159
Atlas Sound Corporation	114	Offenbach & Reimus Company	167
Audak Company	138	Olmitt Mfg. Company	26
Audel & Company, Theo.	144	Olson Radio Warehouse	98, 99
Barbey Company, Geo. D.	146	Olympic Electronics Supply	96
Barker & Williamson, Inc.	24	Onan & Sons, D. W.	150
Barry Electronic	176	Oxford Electronics	140
Bell Telephone Labs, Inc.	31	Peak Electronics	100
Berlant Associates	96	Penn Boiler & Burner Mfg. Company	175
Bogen Company, David	132	Penn Electronics Parts Company	157
Brook Electronics	142	Penn Tube Company	112
Burroughs Radio	161	Perma Power	156
Bursteln-Applebee Company	123	Phillips Tube Company	130
C & H Sales Company	152	Photocon Sales	172
Cameradio	114	Pickering & Company	171
Candler System	146	Platt Electronics	90
Capitol Radio Engineering Institute	107	Poly-Tech Company	118
Centralab, Inc.	140	Possner Electronics	168
Channel Master Corporation	32, 23	Premax Products	150
Chayton Radio Parts	168	Premier Radio Tube Company	121
Cleveland Institute of Radio Electronics	117	Prentice Hall, Inc.	175
Collins Audio Products	25	Progressive Electronics	139
Columbia Electronic Sales	140	Pyramid Electric Company	3rd Cover
Commissioned Electronics Company	172	Quietrole Company	118
Communication Equipment Company	104	RCA Institutes	7, 166
Concord Radio	116	R W Electronics	161
Coyne Electrical School	134, 177	Radcom Engineering Company	142
Davis Electronics	174	Radiart Corporation	28
DeFrost's Training, Inc.	5	Radio Apparatus Corp.	120
Douglas Radio Supply Company, Inc.	172	Radio Centre	166
Editors & Engineers, Ltd.	118	Radio City Products	170
Eitel-McCullough, Inc.	136	Radio Corporation of America	2nd Cover
Electro Devices	132	Radio Craftsmen	78
Electronics Institute, Inc.	146	Radio Distributing Company	168
Electronic Instrument Company, Inc.	34, 152, 153, 157	Radio Electric Service	147
Electronic Measurements Corporation	135	Radio & Electronics Parts Corporation	152
Electronic Specialty Supply Company	140	Radio Ham Shack	137
Electro-Voice	8	Radio Products Sales Company	144
Erle Resistor Corporation	108	Radio Receptor Company, Inc.	139
Espey Mfg. Company	135	Radio-Television Training Ass'n.	15
Fair Radio Sales	145	Rad-Tel Tube Company	163
Federal Telephone & Radio Corporation	131	Raytheon Mfg. Company	14
Federated Purchaser, Inc.	169	Regency	144, 172
Feller Engineering Co.	142	Relay Sales	126
Fisher Radio	110	Rider, John F.	156
Franklin Technical Institute	162	Rinehart Books	94, 100, 136, 167
Frenchy Radio Mfg. Company	162	Rohn Mfg. Company	159
Freteco Television Company	165	Rose Company	106
G & H Wood Products	141	Sams, Howard W.	114, 146, 173
G. L. Electronics	173	Sanett, Bob	168
Garrard Sales Corporation	124	Sanganis Electric Company	151
General Electric Company	19, 27, 92, 93	Sarkis Tarzian, Inc.	160
General Test Equipment	153	Schott Company, Walter L.	129
Goodheart, R. E.	162	Simpson Electric Company	141
Greenlee Tool Company	96	South River Metal Products	106
Green Tele-Radio Distr.	174	Sprayberry Academy of Radio	33
Greenwich Sales Company	114	Stan Burn Radio & Electronics	146
Hallcrafters Company	7	Standard Electronics Dist. Company	162
Harvey Radio Company	76	Standard Surplus	143
Heath Company	79 thru 89	Standard Transformer	157
Henshaw Radio Supply	168	Steve-El Electronics	150
Hickok Electrical Instrument Company	16, 17	Stevens Walden	158
Hughes Research	115, 160	Sun Radio & Electronics Company	127
Hystron Radio & Electronics Company	29	Sun Radio of Washington, D. C.	155
Indiana Technical College	159	Suprem Publications	155
Instructograph Company	163	Sylvania Electric Products	91
International Correspondence Schools	11	TAB	178
JFD Mfg. Company	75	Television Communications Institute	169
J. S. H. Sales Company	175	Television Materials Corporation	166
Jones & Laughlin Steel Corporation	111	Terado Company	168
Kester Solder Company	136	Thompson Radio Supplies	160
Kirk, James	157	Transvision, Inc.	119
Klein Company, Manuel	166	Triad Transformer Mfg. Company	148
Klein's Sporting Goods, Inc.	95	Trlo Mfg. Company	20
L. A. Ham Shack	163	Triplet Electrical Instrument Company	30
LaFayette Radio	108	Tri-State College	161
Lampkin Laboratories	130	Ungar Electric Tool Company	135
Laprow Bros.	160, 174	United Catalogue Publishers, Inc.	151
Lee Electronic Labs, Inc.	156	United Technical Labs.	139, 166
Leeds Radio Company	100	V & H Radio & Electronics	152
Leonard Radio	162	Valparaiso Technical Institute	157
Leotone Radio Company	124	Van Sickle Radio Supply Company	153
McCormell's	153, 160, 163	Wall Mfg. Company	125
McGee Radio Company	102, 103	Weller Electric Company	18
McGraw-Hill Book Company	128	Western Electronics	162
MacInnes, Norman R.	149	Western Television Institute	130
Mallory and Co., R. E.	Fourth Cover, 21	Wholesale Radio Parts Company	153
Mattison Television Co.	154	Windsor Electronic	165
Metropolitan Supply	147	World Radio Laboratories, Inc.	147
		YMCA Trade & Technical School	172

Classified

Rate 50c per word. Minimum 10 words

RADIO ENGINEERING

COMPLETE radio, electronics theory & practice: television; broadcasting; servicing; aviation; marine, police radio. 12 or 18 months. Catalog. Valparaiso Technical Institute, Dept. N, Valparaiso, Ind.

FOR SALE

TAPE Recorders, Tapes, Accessories. Unusual Values. Dressner, 624-R East 20th St., N.Y.C. 9.

TV-FM antennas. All types including UHF. Mounts, accessories. Lowest prices. Wholesale Supply Co., Dept. H, Lunenburg, Mass.

DIAGRAMS Radio, Record Changers, Recorders, T5c; Television with Service Data, \$1.25 up. State manufacturer and model number. Kramer's Radio Service, Dept. F53, 36 Columbus Ave., New York 23, N. Y.

ALL types of Antennas for Amateur and TV. Aluminum Tubing. Willard Radcliff, Fostoria, Ohio.

TUBES and equipment bought, sold, and exchanged. For action and a fair deal, write B. N. Gensler, W2LNI, 136 Liberty, N. Y. 6, N. Y.

WANTED

NEED—#241 Dumont Oscilloscopes #804-C Signal Generators. H. Finnegan, 49 Washington Ave., Little Ferry, N. J.

WILL buy all Art-13/type T-47A, \$200.00, Art-13/type T-47, \$150.00, BC-348 unmodified, \$75.00, BC-348 modified, \$55.00, APN-9, \$200.00, ARC-3 complete, \$750.00, R77 Receivers, \$400.00, ARC-1, \$600.00, BC-312, \$65.00, BC-342, \$60.00. Ship via Express C.O.D., subject to inspection to: H. Finnegan, 49 Washington Ave., Little Ferry, N. J.

WANTED—Top Prices Paid—Navy Selsyns 1DG, 1F, 1CT, 1G, 5DG, 5D, 5CT, 5G, 6G, 7G, etc. and BC-348, BC-221, AN/ART-13, AN/ARC-1, AN/ARC-3, RTA-1B, AN/APR-4. Lectronic Research, 719 Arch St., Philadelphia.

AN/APR-4, other "APR-," "ARR-," "TS-," "IE-," ARC-1, ARC-3, ART-13, everything surplus; Tubes, Manuals, Laboratory equipment. Describe, price in first letter. Engineering Associates, 434 Patterson Rd., Dayton 9, Ohio.

CORRESPONDENCE COURSE

USED correspondence courses and educational books, bought, sold, rented. Catalog free. Educational Exchange, Summerville, Ga.

MISCELLANEOUS

YOUR Tape or Wire Recordings Reproduced onto Disc. 78RPM \$2.85 seven minutes, 33 $\frac{1}{2}$ micro-groove \$3.50 fifteen minutes. Conn. Recording, 14 Parklane, Wallingford, Conn.

BUY Wholesale—25,000 items—Catalog 25c. Matthews, 1472-R6 Broadway, N. Y. C. 36.

SPEAKERS repaired, wholesale prices, guaranteed workmanship. Amprite Speaker Service, 70 Vesey St., New York City 7.

Make Use of the
CLASSIFIED COLUMN

of

RADIO & TELEVISION NEWS

To Advertise and Sell
That Equipment
You No Longer Use.

March, 1953

NEW IT'S TERRIFIC! EICO 7 -INCH PUSH-PULL SCOPE



KIT

\$79⁹⁵

Factory Wired
\$129.50

ORDER NOW!

For full specifications on Model 470 and the complete EICO line, write for latest catalog.

HIGHLIGHT FEATURES:

- Boosted vert. sensitivity: 10 mv rms/in.
- Extended flat freq. response: 10 cps—1 MC (± 2 db); useful to 5 MC.
- 3-step freq.-compensated attenuator; cathode follower input.
- Internal voltage calibration; directly calibrated screen.
- Extended sweep range: 15 cps—100 kc.
- Pos. & neg. waveform analysis; ext. & line sync.
- Sawtooth output & line freq. available at front panel.
- Z-axis intensity modulation & astigmatism control.
- Internal line freq. sine sweep with variable phasing.

ALLIED RADIO

833 W. JACKSON BLVD., CHICAGO 7, ILL.

AMPERITE

Studio Microphones
at P.A. Prices

Ideal for
BROADCASTING
RECORDING
PUBLIC ADDRESS

"The ultimate in microphone quality," says Evan Rushing, sound engineer of the Hotel New Yorker.

• Shout right into the new Amperite Microphone—or stand 2 feet away—reproduction is always perfect.

• Not affected by any climatic conditions.
• Guaranteed to withstand severe "knocking around."



Models

RBLG—200 ohms

RBHG—Hi-imp.

List \$42.00



"Kontak" Mikes

Model SKH, list \$12.00

Model KKH, list \$18.00

Special Offer: Write for Special Introductory Offer, and 4-page illustrated folder.

AMPERITE Company, Inc.

561 BROADWAY • NEW YORK 12, N. Y.

Canada: Atlas Radio Corp., Ltd., 560 King St. W., Toronto

LEARN

Television-Radio Electricity

REFRIGERATION-ELECTRONICS
IN THE GREAT SHOPS OF COYNE

TRAIN QUICKLY! OLDEST, BEST
EQUIPPED SCHOOL OF ITS KIND IN U.S.

Come to the Great Shops of Coyne in Chicago. Get practical training in opportunity fields—TELEVISION-RADIO—ELECTRICITY—ELECTRONICS—vital in Defense Program. Prepare now for a better job in Industry or better service rating.

Approved for Veterans

Finance Plan—Enroll now, pay most of tuition later. If you need part-time work to help out with living expenses while at Coyne, we'll help you get it. Special tuition plan for men of Draft Age.

FREE BOOK Clip coupon for Big Free Illustrated Book. No salesman will call. Act NOW.

B. W. Cooke, President

COYNE

A TECHNICAL TRADE
INSTITUTE CHARTERED
NOT FOR PROFIT
Established 1899
500 S. Paulina, Chicago

ELECTRICITY ★ TELEVISION
RADIO ★ REFRIGERATION ★ ELECTRONICS

B. W. COOKE, Pres.
COYNE School
500 S. Paulina St., Chicago 12, Ill. Dept. 33-85H

Send FREE BOOK and full details on:

TELEVISION-RADIO ELECTRICITY

NAME

ADDRESS

CITY

STATE

AUDIO AMPLIFIERS READY TO GO

Model 305PM 15Wt. Wet Amp. as Pictured Above Features Mike & Photo Inpts. W. Sep. Gain Controls. Latest Compensated Tone Contr. Design. Complete with Tubes. **\$14.98**

Model 200M0 Mike OSC. Broadcasts Through Your Radio with No Direct Connection. **\$14.98**

Model 100P0 Phono OSC. Phonograph Broadcasts Through Your Radio. No Direct Hook-up. W. Tube. **\$4.98**

Model 302PA 3 Tube Phono Amp. Ideal for Custom Building Your Phonograph. **\$4.98**

TUBES. SPECIAL. \$4.98

AUDIO COMPONENTS

GE RPX10 Cartridge. \$4.49
 GE RPX30 Triple Play. \$6.98
 Electrovoice Triple Play. \$6.98
 Pickup Arm & Xtal. H/output. 2.39
 PM 12" Hi-Fi British Speaker 4.98
 PM 12" GE S120ID Speaker. \$19.00
 PM 8" Blue BT-18-1 Perm. X. \$13.00
 PM 5" Speaker. \$10.00
 PM 10" Hi-Fi Woofer & Separate Horn Tweeter. 10 Watts, 40 to 20 Kc. \$19.98
 Crystal Mike & Cable. \$6.98
 Crystal Mike Cartridge (Lapel Type). 2.98
 Crystal Mike Cart. Ceramic Wetrup. 3.98

TELEVISION ANTENNA

TV CONICAL ANTENNA All Channel Sturdy Prefab 13 elements. 100 ft. Copper Twi-nex Cross Bar & Hardware. Brand New. \$5.98

DUBL-STACK CONICAL ARRAY, 18 Elements Hardware, Crossbars & 100 Ft. Copper Twi-nex. \$9.98

DOUBLE-V Ant. All Channel, Sturdy Construct. w/ Mfg. Clearance. \$13.00

WINDOW CONICAL ANT. mounts outside your window. All Channel Receipt. \$3.95

5 FOOT Intersecting Section. Heavy Duty Painted, rustproof. \$9.95

ONE YEAR GTD PICTURE TUBES

10 BP4	\$13.98
10 BP4A	14.49
12" Glass	20.98
12" Metal	21.98
14" Rectangular	20.98
16" Glass	23.98
16" Metal	23.98
17" Rectangular	23.49
19" Round	29.95
21" Rectangular	30.98

Your old pict. tube is worth money, write for trade-in allowance toward RM coded and dated tube with one year guarantee. Ship your defective picture tubes prepaid only. When ordering metal tube, defective metal tube.

TOGGLE SWITCHES

SPST 3A/250V	25c; 5 for \$1.00
SPDT 3A/250V	4 for \$1.00
SPDT BKLC/CD Momentary	49c; 3 for \$2.00
DPST BKLC/CD	89c; 3 for \$2.50
DPST CH/CD 8A/125V	65c; 5 for \$2.95
DPST 20/250V	\$1.25; 3 for \$3.25

RELAY SPECIALS

SP5 min. size 115V/60CY
 SP5 CT 98c; 3 for \$2.75
 SP4 min. size 115V/60CY
 SA CTS \$1.29; 3 for \$3.75
 SP2 2V DC, 5A CTS \$1.98; 6 for \$5.00
 SPNO 115 V AC, 15A CTS
 CTS. \$2.98; 4 for \$10.00

DPDT 2 Amp. Nitrogen Std. \$1.49; 4 for \$5.00
 2 Amp & SPNO Clare Telephone Type 115V/60 Cts. Base \$4.25

TUBES SPECIALS

BROKEN KEYS OR CRACKED ORSE ELECTRICAL V. PERFECT & 90 DAY GTD.
 1B3CT, 6HG, 6K6GT, 6SN7GT, 12SN7GT
 6BG6G, 6BQ6GT, 12SG7, 19B6G, 6L6G, 6L6GA. Each 79c; 3 for \$2.00

ALIGNMENT TOOLS

(Top) Ideal NO-LOSS Alignment Screw-driver. \$1.69
 S. H. A. Sure Grip Knurled Knob. \$1.25
 (Bottom) RELAY Spring Adjuster & Switch. \$1.25
 WECO 293. Each \$1.98; 6 for \$5.00

RHEOSTATS

2 ohm 50 W Model J	5 for \$10.00
6 ohm 25 W Model LH	1.98; 3 for 5.00
15 ohm 25 W Model J	1.98; 3 for 5.00
20 ohm 50 W Model J	2.35; 6 for 12.00
60 ohm 50 W Model J	1.98; 3 for 5.00
100 ohm 50 W Model K	2.25; 3 for 6.00
200 ohm 25 W Model D	1.98; 5 for 9.00
300 ohm 20W Model P	3 for 7.00
35, 500, 5000 ohm Slotted	
2 1/2" shaft. 115V/19c; 3 for 2.00	
1000 ohm 25W Model J	2.10; 5 for 10.00

SOLDERING IRONS & GUNS

"Weller" Gun 115VAC 100 Watt. \$8.69
 "Weller" Gun 115VAC 250 Watt. 8.69
 "Prima" Gun 115VAC Korodless Gun. 7.69

ESICO IRONS 120V AC/DC

55Watt/3/4"Tip/1 1/2" Lng./38Lbs.	\$1.25
60Watt/1/2"Tip/1 1/2" Lng./38Lbs.	1.94
100Watt/3/8"Tip/1 1/2" Lng./5Lbs.	2.55
130Watt/3/8"Tip/1 1/2" Lng./7.5Lbs.	3.17

ESICO INDUSTRIAL CONST. USE IRONS 120V AC/DC

Similar to American Beauty Types as Shown

61A/60W/1/4"Tip/7" Lng./2.50z.	3.20
38/Am.Beauty/317/7" Lng./3.25z.	2.99
Element #38/Am. Beauty 2138/100W 2.00z.	6.10
#58/Am.Beauty/3158/200W/7"Tip 5.30z.	6.30
Element #58/Am. Beauty 3158/200W 5.30z.	6.10
#78/Am.Beauty/3178/300W/7"Tip 6.18z.	6.18
Element #78/Am.Beauty 3178/300W 6.18z.	6.18
#98/Am.Beauty/3198/550W/1 1/4"Tip 10.08z.	10.08
Element #98/Am.Beauty 3198/550W 10.08z.	10.08
Esico Temp Regulating Stand.	4.20

JACKSON IRONS

#230/25W 1/4"Tip/7" Lng./30z.	\$1.30
#33/40W 1/4"Tip/8" Lng./40z.	1.90
#300/Crossbar/2 1/2"Tip/1 1/2" Lng. 2.20	2.20
#85P/85W/5/16"Tip/1 1/2" Lng./5Lb. 1.49	1.49

Kester Solder One Lb. .062. Roll. \$1.08. 5 with any soldering iron. .90 Special

SOCKET ASSEMBLY

For 10 slide lamps. Excellent on-off indicator for control panel. As illustrated with lamps

24V	\$2.98
SLIDE LAMP, type 2	1.50
SLIDE LAMP, type 2T, 12V/18W; 10 for \$1.50	1.50
PILOT LIGHT SOCKET, 1/2 BAYONET	\$3.49
1/2" Jewel. 10 for \$1.50	1.50
PILOT LIGHT SOCKET, 1/2" Jewel, Hi-Polish Finish.	\$6.49

"TAB"

THAT'S A BUY

METER SPECIALS

0-5MADC Tuning Aircraft Mfg. \$1.29
 0-30VDC "AN", Aircraft Type \$1.98; 4/57
 0-60ADC "AN" Type. \$3.25; 3 for \$9.00
 0-15V AC 0-150 Cycles. \$4.98
 0-150VAC WSTGHS 2 1/2" Rnd 60cyc. 3.49
 0-150VAC/25-125cy 3 1/2" sq/RA35. 5.98
 0-1MADC GE 3 1/2" Rnd Bkkt Csd. 5.39
 0-1MADC WSTGHS 3 1/2" Sq. 6.49
 0-50Microamps Weston 301 3 1/2" Sq. 14.98
 0-500MADC 2 1/2" Rnd Bkkt 2 1/2" Csd 4.98
 0-25MADC 3 1/2" Sq. Weston 301. 6.98
 VU-20+3 Weston 301 3 1/2" Sq. 14.98
 0-120MARS 3 1/2" Rnd Weston 301. 14.98

OIL CAPACITORS

Mfd	Each	Mfd	Each	Mfd	Each
4	50wdc	2	1000wdc	12500wdc	95.00
4	150wdc	2	2000wdc	15000wdc	98.98
1-1/3	50	2	2.98	1000	9.98
250wdc	15	4.98	2500wdc	10000	95.00
2x.25	19	1400wdc	.00021	7.45	95.00
300wdc	29	5.139	AC RATED		
400 wdc	25	1500wdc	600dc		
1.2	.39	5	1.49		
1.5	.39	7.5	1.69		
1.5	.69	1	1.79	4	.69
1.8	.98	6	3.98	2	1.25
1.8	1.19	6	3.98	2	1.25
2x.1	1.39	2x.1	1.69	225vac/	
2x.5	.94	1	1.75	630dc	
3x.1	.91	3	3.69	600dc	
3x.25	.99	3	3.69	1000dc	
600wdc	.30	2500wdc	1.25	.63	
.034	.30	3000wdc	1.75	.98	
1.1	.35	4000wdc	2.25	.98	
.25	.42	5000wdc	2.75	.98	
.5	.42	6000wdc	3.25	.98	
1	.52	8000wdc	3.75	.98	
2	.52	10000wdc	4.25	.98	
3	.52	12000wdc	4.75	.98	
4	.52	14000wdc	5.25	.98	
5	.52	16000wdc	5.75	.98	
6	.52	18000wdc	6.25	.98	
8	.52	20000wdc	6.75	.98	
10	.52	22000wdc	7.25	.98	
12	.52	24000wdc	7.75	.98	
15	.52	28000wdc	8.25	.98	
20	.52	36000wdc	8.75	.98	
25	.52	45000wdc	9.25	.98	
30	.52	54000wdc	9.75	.98	
40	.52	72000wdc	10.25	.98	
50	.52	90000wdc	10.75	.98	
60	.52	108000wdc	11.25	.98	
75	.52	135000wdc	11.75	.98	
100	.52	180000wdc	12.25	.98	
150	.52	270000wdc	12.75	.98	
200	.52	360000wdc	13.25	.98	
250	.52	450000wdc	13.75	.98	
300	.52	540000wdc	14.25	.98	
400	.52	720000wdc	14.75	.98	
500	.52	900000wdc	15.25	.98	
600	.52	1080000wdc	15.75	.98	
750	.52	1350000wdc	16.25	.98	
1000	.52	1800000wdc	16.75	.98	
1500	.52	2700000wdc	17.25	.98	
2000	.52	3600000wdc	17.75	.98	
2500	.52	4500000wdc	18.25	.98	
3000	.52	5400000wdc	18.75	.98	
4000	.52	7200000wdc	19.25	.98	
5000	.52	9000000wdc	19.75	.98	
6000	.52	10800000wdc	20.25	.98	
7500	.52	13500000wdc	20.75	.98	
10000	.52	18000000wdc	21.25	.98	

RECTIFIER XFMRs

18.8-19.2-20.4-21.4volts 12 Amp/5.98
 18.8-19.2-20.4-21.4volts 12 Amp/5.98
 18-12-9-CT-9-12-18V/4Amp. 8.75
 18-12-9-CT-9-12-18V/12Amp. 16.75
 36VCT 24V/12 Amp. 12.00
 18V/2A \$2.75; 28-24-20V/4A. 4.69

RECTIFIER CHOKES

4AMP .01 HV .025 OHM \$7.95
 12AMP .01 HV .1 OHM 14.95
 24AMP .004 HV .025 OHM 29.95

BATTERY CHARGER RECTIFIER

10-0-10V (CT) 120 Amp. fan cooled. Replace your old inefficient sulfide rectifier w/new selenium tube. SPECIAL. \$13.75 Write for Quantity Price.

CIRCUIT BREAKER FUSES

PUSH TO RESET
 Amps: 3-5-7-10-15-20
 Each 27c; 4 for \$1.00; 25 for \$5.00; 100 for \$18.00
 Circuit Breaker Fuse 39c
 Please specify current & voltage desired.
 3 for \$1.00; 20 for \$5.98; 100 for \$25.00
 Fuse is 3AG Size. Operates up to 24 volts
 18000c
 Heinmann Magn Bkrs. Amps: 0.2, 2, 3, 5, 7, 9, 12, 15, 20, 30, 35, 40, 60, 75, 90, 120, 150, 200, 250, 300, 400, 500, 600, 800, 1000, 1500, 2000, 3000, 4000, 5000, 6000, 8000, 10000, 15000, 20000, 30000, 40000, 50000, 60000, 80000, 100000, 150000, 200000, 300000, 400000, 500000, 600000, 800000, 1000000, 1500000, 2000000, 3000000, 4000000, 5000000, 6000000, 8000000, 10000000, 15000000, 20000000, 30000000, 40000000, 50000000, 60000000, 80000000, 100000000, 150000000, 200000000, 300000000, 400000000, 500000000, 600000000, 800000000, 1000000000, 1500000000, 2000000000, 3000000000, 4000000000, 5000000000, 6000000000, 8000000000, 10000000000, 15000000000, 20000000000, 30000000000, 40000000000, 50000000000, 60000000000, 80000000000, 100000000000, 150000000000, 200000000000, 300000000000, 400000000000, 500000000000, 600000000000, 800000000000, 1000000000000, 1500000000000, 2000000000000, 3000000000000, 4000000000000, 5000000000000, 6000000000000, 8000000000000, 10000000000000, 15000000000000, 20000000000000, 30000000000000, 40000000000000, 50000000000000, 60000000000000, 80000000000000, 100000000000000, 150000000000000, 200000000000000, 300000000000000, 400000000000000, 500000000000000, 600000000000000, 800000000000000, 1000000000000000, 1500000000000000, 2000000000000000, 3000000000000000, 4000000000000000, 5000000000000000, 6000000000000000, 8000000000000000, 10000000000000000, 15000000000000000, 20000000000000000, 30000000000000000, 40000000000000000, 50000000000000000, 60000000000000000, 80000000000000000, 100000000000000000, 150000000000000000, 200000000000000000, 300000000000000000, 400000000000000000, 500000000000000000, 600000000000000000, 800000000000000000, 1000000000000000000, 1500000000000000000, 2000000000000000000, 3000000000000000000, 4000000000000000000, 5000000000000000000, 6000000000000000000, 8000000000000000000, 10000000000000000000, 15000000000000000000, 20000000000000000000, 30000000000000000000, 40000000000000000000, 50000000000000000000, 60000000000000000000, 80000000000000000000, 100000000000000000000, 150000000000000000000, 200000000000000000000, 300000000000000000000, 400000000000000000000, 500000000000000000000, 600000000000000000000, 800000000000000000000, 1000000000000000000000, 1500000000000000000000, 2000000000000000000000, 3000000000000000000000, 4000000000000000000000, 5000000000000000000000, 6000000000000000000000, 8000000000000000000000, 10000000000000000000000, 15000000000000000000000, 20000000000000000000000, 30000000000000000000000, 40000000000000000000000, 50000000000000000000000, 60000000000000000000000, 80000000000000000000000, 100000000000000000000000, 150000000000000000000000, 200000000000000000000000, 300000000000000000000000, 400000000000000000000000, 500000000000000000000000, 600000000000000000000000, 800000000000000000000000, 1000000000000000000000000, 1500000000000000000000000, 2000000000000000000000000, 3000000000000000000000000, 4000000000000000000000000, 5000000000000000000000000, 6000000000000000000000000, 8000000000000000000000000, 10000000000000000000000000, 15000000000000000000000000, 20000000000000000000000000, 30000000000000000000000000, 40000000000000000000000000, 50000000000000000000000000, 60000000000000000000000000, 80000000000000000000000000, 100000000000000000000000000, 150000000000000000000000000, 200000000000000000000000000, 300000000000000000000000000, 400000000000000000000000000, 500000000000000000000000000, 600000000000000000000000000, 800000000000000000000000000, 1000000000000000000000000000, 1500000000000000000000000000, 2000000000000000000000000000, 3000000000000000000000000000, 4000000000000000000000000000, 5000000000000000000000000000, 6000000000000000000000000000, 8000000000000000000000000000, 10000000000000000000000000000, 15000000000000000000000000000, 20000000000000000000000000000, 30000000000000000000000000000, 40000000000000000000000000000, 50000000000000000000000000000, 60000000000000000000000000000, 80000000000000000000000000000, 100000000000000000000000000000, 150000000000000000000000000000, 200000000000000000000000000000,



IMPS are TOPS!

IMPS WON'T FREEZE OR MELT!
 They'll operate faithfully in temperatures ranging from -40°C . to $+100^{\circ}\text{C}$. (212°F .)—and that's the boiling point of water!



IMPS ARE REALLY RUGGED!

The tough thermo-setting plastic will take an astounding amount of abuse—yet IMPS will still look and perform like new!



IMPS ARE MOISTURE-PROOF!

No moisture can get through the varnished plastic case, or even through the lead anchor points.



IMP LEADS CAN BEND AND BEND!

Tinned leads that are really securely anchored—you'll be amazed at how much punishment they'll take without breaking!

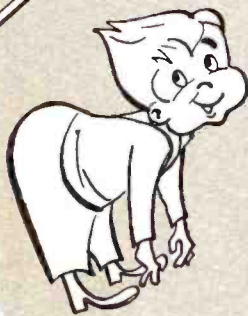

All over the country service-engineers are praising the newest and finest molded paper capacitor—the Pyramid IMP. IMPS are available in all popular 200, 400 and 600 volt ranges. See your distributor.

For free, attractive catalog on IMPS, write Dept. R1
PYRAMID ELECTRIC COMPANY
 1445 HUDSON BOULEVARD • NORTH BERGEN, NEW JERSEY



When UHF comes to your town, here's your "best seller" . . . the MALLORY UHF CONVERTER

THE precision-built, performance-proved Mallory Converter has these sales-building—profit-making features—

- Reception of *all* UHF channels, for *any* TV set, without sacrifice of existing VHF channels.
- Quick, easy installation. No internal changes needed in any set.
- High quality picture definition . . . easy tuning.
- Small, attractive cabinet in deep maroon plastic measures only nine inches wide, seven inches high.

Because the Mallory Converter tunes in *all* channels in *any* area, the customer who has one has nothing more to buy . . . even if he moves to another city.

ASK YOUR MALLORY DISTRIBUTOR to show you the Mallory UHF Converter. Ask him about its success where UHF television is already on the air. For extra sales and profits, make it your "Best Seller" when UHF comes to town.

They are *easy to install*. Connection of antenna leads and power lines from the Converter to the set is all that's needed to install the Mallory Converter. It is done right in your customers' homes . . . in a matter of minutes.

P. R. MALLORY & CO. INC.

MALLORY

CAPACITORS • CONTROLS • VIBRATORS • SWITCHES • RESISTORS
 • RECTIFIERS • VIBRAPACK* POWER SUPPLIES • FILTERS
*Reg. U.S. Pat. Off.

APPROVED PRECISION PRODUCTS

P. R. MALLORY & CO., Inc., INDIANAPOLIS 6, INDIANA

Depend on Mallory
 for
 Approved Precision Quality